



**UNITED STATES  
NUCLEAR REGULATORY COMMISSION  
REGION IV  
611 RYAN PLAZA DRIVE, SUITE 400  
ARLINGTON, TEXAS 76011-4005**

July 31, 2003

James J. Sheppard, President and  
Chief Executive Officer  
STP Nuclear Operating Company  
P.O. Box 289  
Wadsworth, Texas 77483

**SUBJECT: NRC SPECIAL INSPECTION TEAM REVIEW AND NRC STAFF EVALUATION  
OF SOUTH TEXAS PROJECT, UNIT 1, REACTOR PRESSURE VESSEL  
BOTTOM-MOUNTED INSTRUMENTATION PENETRATION LEAKAGE  
INVESTIGATION AND REPAIR ACTIVITIES**

Dear Mr. Sheppard:

This letter is in response to your July 11, 2003, letter which documents your conclusion that restart and operation of South Texas Project (STP), Unit 1, can be conducted safely. Your letter provides a detailed summary of the actions taken by STP as a result of your discovery of minor reactor coolant leakage from two bottom-mounted instrumentation penetrations at STP, Unit 1. Your letter also describes completed repairs and plans for future inspections of Unit 1 and Unit 2 bottom-mounted instrumentation penetrations.

Based on the results of the NRC's Special Inspection Team review and NRC Staff Evaluation, as summarized in the Enclosure to this letter, the NRC has concluded that you have taken all necessary actions with respect to the bottom-mounted instrumentation penetration leakage issue to support the safe restart of STP, Unit 1. The NRC also concluded that your previous inspections and planned future inspections of STP, Unit 2, support the continued safe operation of STP, Unit 2.

The NRC's Special Inspection Team completed a thorough inspection of your activities with respect to the STP, Unit 1, bottom-mounted penetration leakage issue. A public exit meeting providing the findings of our Special Inspection Team was conducted in Bay City, Texas, on July 28, 2003. At this meeting, we informed you that NRC management would complete a review regarding the acceptability of restart of STP, Unit 1, and would provide you written notice of our decision. We also informed you that the inspection report documenting the results of the inspection is expected to be issued within 30 days of the exit meeting.

On April 24, 2003, you provided a letter documenting several actions you would complete to address the bottom-mounted penetration leakage issue. These actions included: (1) investigation of the root cause, (2) determination of the extent of condition, (3) identification and completion of effective corrective actions, and (4) briefing the NRC prior to restart of the unit.

In your letter dated July 11, 2003, and supplemented by letter dated July 17, 2003, you documented completion of these actions. You also documented your commitments to address the long-term monitoring of bottom-mounted penetrations. These commitments included: (1) continuation of visual inspections of the reactor vessel in accordance with your boric acid corrosion control program, (2) performing volumetric and enhanced visual inspections of the Unit 1 penetrations at the next in-service inspection of the Unit 1 reactor vessel, (3) performing ultrasonic examinations of the reactor pressure vessel base metal around repaired penetrations, and (4) performing volumetric examinations of Unit 2 penetrations during the next refueling outage that the core barrel is removed. Additionally, you agreed to not commence heat-up of STP, Unit 1, to Mode 4 until you received written confirmation from the NRC that all necessary NRC actions are complete.

We have completed our review of the information contained in your July 11 and July 17, 2003, letters, the information presented at public meetings at our NRC Headquarters Office on May 1, June 5, and July 17, 2003, and information collected during the conduct of our Special Inspection Team inspection. Our safety reviews considered: (1) the results of your examinations performed to identify the extent of the condition; (2) your implementation of acceptable repairs, including NRC approval of requests for relief from ASME Code requirements; (3) your evaluation of the preliminary root cause of the condition; (4) our assessment of the safety significance of the as-found condition; and (5) your commitments to implement a continued monitoring program. The NRC has concluded from these reviews that STP, Unit 1, complies with all existing regulatory requirements necessary to support the restart of STP, Unit 1. The NRC has also concluded that the operation of STP, Units 1 and 2, is consistent with your obligation to protect the health and safety of the public.

This letter provides our written confirmation that all necessary NRC actions are complete.

With respect to your final root cause analysis and based on information provided by members of your staff on July 30, 2003, it is our understanding that the material sample removed from penetration 46 may have been lost or misplaced prior to arriving at the testing laboratory. The enclosed staff evaluation, which discusses the importance of your testing of samples from penetrations 1 and 46, was drafted prior to the staff being notified of your potential loss of the penetration 46 sample. Although the staff's conclusion regarding the acceptability of STP, Unit 1 for restart is not directly affected by the potential loss of the penetration 46 sample, we wish to emphasize that it is important that you make every effort to locate the sample and test it to provide additional information to support your final root cause determination.

A report documenting the Special Inspection Team inspection will be completed within 30 days of the July 28, 2003, exit meeting. As was discussed at the exit meeting, in addition to the technical details of the inspection, the report will address any regulatory compliance issues associated with the as-found condition of the reactor vessel.

In accordance with 10 CFR 2.790 of the NRC's "Rules of Practice," a copy of this letter and its enclosure will be made available electronically for public inspection in the NRC Public

Document Room or from the Publicly Available Records (PARS) component of NRC's document system (ADAMS). ADAMS is accessible from the NRC Website at <http://www.nrc.gov/reading-rm/adams.html> (the Public Electronic Reading Room).

Sincerely,

**/RA/**

Dwight D. Chamberlain  
Acting Deputy Regional Administrator

Dockets: 50-498, 50-499  
Licenses: NPF-76, NPF-80

Enclosure: Staff Evaluation

cc w/enclosure:  
Tom Jordan, Vice President  
Engineering & Technical Services  
STP Nuclear Operating Company  
P.O. Box 289  
Wadsworth, Texas 77483

S. M. Head, Manager, Licensing  
Nuclear Quality & Licensing Department  
STP Nuclear Operating Company  
P.O. Box 289, Mail Code: N5014  
Wadsworth, Texas 77483

A. Ramirez/C. M. Canady  
City of Austin  
Electric Utility Department  
721 Barton Springs Road  
Austin, Texas 78704

L. D. Blaylock/W. C. Gunst  
City Public Service Board  
P.O. Box 1771  
San Antonio, Texas 78296

D. G. Tees/R. L. Balcom  
Houston Lighting & Power Company  
P.O. Box 1700  
Houston, Texas 77251

STP Nuclear Operating Company

-4-

Jon C. Wood  
Matthews & Branscomb  
112 E. Pecan, Suite 1100  
San Antonio, Texas 78205

A. H. Gutterman, Esq.  
Morgan, Lewis & Bockius  
1111 Pennsylvania Avenue NW  
Washington, DC 20004

C. A. Johnson/A. C. Bakken  
AEP Texas Central Company  
P.O. Box 289, Mail Code: N5022  
Wadsworth, Texas 77483

INPO  
Records Center  
700 Galleria Parkway  
Atlanta, Georgia 30339-5957

Director, Division of Compliance  
& Inspection  
Bureau of Radiation Control  
Texas Department of Health  
1100 West 49th Street  
Austin, Texas 78756

Brian Almon  
Public Utility Commission  
William B. Travis Building  
P.O. Box 13326  
1701 North Congress Avenue  
Austin, Texas 78701-3326

Environmental and Natural  
Resources Policy Director  
P.O. Box 12428  
Austin, Texas 78711-3189

Judge, Matagorda County  
Matagorda County Courthouse  
1700 Seventh Street  
Bay City, Texas 77414

STP Nuclear Operating Company

-5-

Terry Parks, Chief Inspector  
Texas Department of Licensing  
and Regulation  
Boiler Program  
P.O. Box 12157  
Austin, Texas 78711

Susan M. Jablonski  
Office of Permitting, Remediation and Registration  
Texas Commission on Environmental Quality  
MC-122, P.O. Box 13087  
Austin, Texas 78711-3087

Ted Enos  
4200 South Hulen  
Suite 630  
Fort Worth, Texas 76109

ELECTRONIC DISTRIBUTION BY RIV:

- Regional Administrator (**TPG**)
- Deputy Regional Administrator (**DDC**)
- DRP Director (**ATH**)
- DRS Director (**ATG**)
- Senior Reactor Analyst, DRS (**RLB3**)
- Senior Resident Inspector (**GLG**)
- Branch Chief, DRP/A (**WDJ**)
- Senior Project Engineer (**TRF**)
- Section Chief, DRP/TSS (**PHH**)
- Enforcement Coordinator (**GFS**)
- Project Manager, NRR (**MCT**)
- Project Manager, NRR (**DHJ**)
- Section Chief, NRR (**RAG**)
- Project Director, NRR (**HNB**)
- Public Affairs Officer (**VLD**)
- S. Collins, EDO (**SJC1**)
- W. Borchardt, NRR (**RWB1**)
- B. Sheron, NRR (**BWS**)
- L. Marsh, NRR (**LBM**)
- R. Barrett, NRR (**RJB3**)
- W. Bateman, NRR (**WHB**)
- S. Coffin, NRR (**SMC1**)
- M. Mitchell, NRR (**MAM4**)
- S. Bloom, NRR (**SDB1**)

ADAMS:  Yes     No    Initials: nlh  
 Publicly Available     Non-Publicly Available     Sensitive     Non-Sensitive

DOCUMENT: R:\\_STP\2003\ST2003-08-RESTART-LTR-rlb.wpd

RIV:DRA/SRA	C:DRP/A	NRR:PD/PDIV	Acting DRA	
RLBywater:nlh	WDJohnson	HN Berkow	DDChamberlain	
<b>/RA/</b>	TRF for <b>/RA/</b>	RLB = E	<b>/RA/</b>	
07/31/03	07/31/03	07/31/03	07/31/03	

OFFICIAL RECORD COPY

T=Telephone

E=E-mail

F=Fax

## ENCLOSURE

### NRC Staff Evaluation of South Texas Project, Unit 1, Reactor Pressure Vessel

#### Bottom-Mounted Instrumentation Nozzle Leakage Investigation and Repair Activities

## 1.0 INTRODUCTION

This NRC staff evaluation has been prepared to summarize the staff's conclusions regarding topics related to the discovery of reactor pressure vessel (RPV) bottom-mounted instrumentation (BMI) nozzle leakage at South Texas Project (STP), Unit 1. The focus of this staff evaluation is to explain the staff's basis for determining that the restart of STP, Unit 1, and the continued operation of STP, Unit 2, are consistent with the facilities' licensing basis and the continued health and safety of the public. Information discussed in this staff evaluation was contained either in materials presented by STP Nuclear Operating Company (STPNOC, the licensee) at public meetings with the U.S. Nuclear Regulatory Commission (NRC) [References 1-3], information submitted by the licensee in correspondence to the NRC [References 4-12], information included in NRC staff licensing action reviews and NRC staff audits [References 13-14], or information reviewed by NRC staff as part of a Special Inspection Team (SIT) review of the STP, Unit 1, leakage to be documented in NRC Inspection Report 05000498/2003008; 05000499/2003008 [References 15, 16]. In addition, the NRC staff's understanding of, and ability to review in a timely manner, the readiness of STP, Unit 1, to restart has been facilitated by weekly telephone conferences between NRC and licensee staff between May and July 2003.

## 2.0 BACKGROUND INFORMATION AND REGULATORY EVALUATION

STP, Units 1 & 2, are four-loop Westinghouse-designed pressurized-water reactor (PWR) nuclear steam supply system units with each unit having a rated thermal power output of 3853 megawatts. The units' RPVs were constructed by Combustion Engineering (CE) at its Chattanooga, Tennessee facility. The RPV bottom heads were fabricated from typical low-alloy pressure vessel steel (American Society for Testing and Materials classification A-533 Grade B, Class 1), and are 5.38 inches in thickness with a 0.22 inch layer of stainless steel cladding on the inside surface. The units' design included 58 penetrations (i.e., the BMI penetrations) in the bottom head of each unit for the installation of in-core neutron flux monitoring instrumentation. Figure 1 shows a cross-sectional view of a typical BMI nozzle penetration. Each penetration consists of a nominal 1.5 inch diameter hole bored in the RPV bottom head, with a nozzle inserted into the hole and attached to the RPV bottom head by a partial penetration J-groove weld at the inside surface of the head. Each nozzle has a nominal wall thickness of 0.45 inches and an inside diameter (ID) hole of 0.60 inches. At room temperature conditions, a clearance gap of 0.001 to 0.004 inches (1 to 4 mils) between the Inconel Alloy 600 nozzle and the low-alloy steel RPV head was included in the design of the penetrations. The nozzles were fabricated from 1.75 inch diameter Inconel Alloy 600 (an austenitic nickel-based alloy) bar stock and the J-groove welds were fabricated from Inconel Alloy 82/182, the weld wire equivalent of Inconel Alloy 600 base material. The Inconel Alloy 600 bar stock was extensively machined during the fabrication process on both the ID and outside diameter (OD) of the nozzle in order to obtain the dimensions and clearances noted above prior to being welded into the RPV bottom head [Reference 11].

In the context of this NRC staff evaluation, regulatory concerns related to reactor coolant system (RCS) pressure boundary integrity are related to Title 10 of the *Code of Federal Regulations* Section 50.36 (10 CFR 50.36) "Technical specifications." Section 10 CFR 50.36(c)(2)(i) "Limiting conditions for operation," states that:

Limiting conditions for operation are the lowest functional capability or performance levels of equipment required for safe operation of the facility. When a limiting condition for operation of a nuclear reactor is not met, the licensee shall shut down the reactor or follow any remedial action permitted by the technical specifications until the condition can be met.

STP, Unit 1, technical specification (TS) 3.4.6.2.a. states that no RCS pressure boundary leakage is permissible and STP, Unit 1, TS 3.4.10 states that the structural integrity of the American Society of Mechanical Engineers Boiler and Pressure Vessel Code (ASME Code) Class 1, 2, and 3 components shall be maintained.

In addition, Appendix B to 10 CFR Part 50, "Quality Assurance Criteria for Nuclear Power Plants and Fuel Reprocessing Plants," states under Criterion XVI, "Corrective Action":

Measures shall be established to assure that conditions adverse to quality, such as failures, malfunctions, deficiencies, deviations, defective material and equipment, and nonconformances are promptly identified and corrected. In the case of significant conditions adverse to quality, the measures shall assure that the cause of the condition is determined and corrective action [is] taken to preclude repetition. The identification of the significant condition adverse to quality, the cause of the condition, and the corrective action taken shall be documented and reported to appropriate levels of management.

Finally, 10 CFR 50.55a, "Codes and standards," requires, in general, that licensees comply with the provisions of applicable sections of the ASME Code consistent with the Editions and Addenda of the ASME Code incorporated within a facility's licensing basis. In the context of this NRC staff evaluation, with regard to the inspection, evaluation, repair, and replacement of facility components, compliance with the provisions of the Section XI of the 1989 Edition of ASME Code and the provisions of Section III of the 1971 Edition through Summer 1973 Addenda of the ASME Code is required within the STP, Unit 1, licensing basis.

### 3.0 LICENSEE INSPECTIONS

On April 12, 2003, STPNOC personnel performed boric acid corrosion control (BACC) program walkdowns of STP, Unit 1, during the unit's 1RE11 refueling outage as part of the licensee's Generic Letter (GL) 88-05, "Boric Acid Corrosion of Carbon Steel Reactor Pressure Boundary Components In PWR Plants," program. Licensee personnel performed a 100 percent bare metal visual examination of the STP, Unit 1, RPV bottom head as part of the BACC program inspections. Similar inspections had been performed during prior STP, Unit 1 & Unit 2, refueling/forced outages and no evidence of boric acid deposits had been identified. In April 2003, however, licensee personnel identified white deposits around STP, Unit 1, BMI penetrations 1 and 46. Penetration 1 is centrally located 8.5 inches from dead bottom center of the STP, Unit 1, bottom head. Penetration 46 is located on the "hillside" of the RPV bottom head, near the periphery of the RPV, approximately 60 inches (by planar projection) from dead



bottom center of the STP, Unit 1, bottom head. The licensee quantified the amount of observed deposits as 150 milligrams around penetration 1 and three milligrams around penetration 46 [Reference 11].

Licensee personnel obtained samples of the deposits from STP, Unit 1, BMI penetrations 1 and 46 for chemical and isotopic analysis. The licensee's chemical analysis confirmed the presence of lithium and boron in the samples. Lithium and boron comprise the majority of dissolved material in RCS water during normal power operation. Lithium is not present, or is present in much smaller concentrations, in other water sources which could have contributed to the deposits (e.g., reactor refueling pool water which could have reached the RPV bottom head due to refueling pool seal leakage). In order to establish an approximate average age of the deposits, the licensee performed a cesium isotopic analysis to establish the ratio of Cesium-134 to Cesium-137 in the deposits. Cesium-134 and Cesium-137 are both radioactive isotopes having half-lives of 2.06 and 30.17 years, respectively. The ratio of Cesium-134 to Cesium-137 is approximately 1.0 in RCS water with some variance depending on the age of the fuel producing the cesium. The licensee's analysis determined the Cesium-134/Cesium-137 ratio in the sample to be in the range of 0.25-0.30. The licensee concluded this indicated that the samples were, on average, about four years old. Based on the information from the chemical and isotopic analysis of the samples from penetrations 1 and 46, the licensee concluded that reactor coolant pressure boundary leakage was the most likely source of the deposits [Reference 11].

Subsequently, the licensee initiated a nondestructive evaluation (NDE) campaign to inspect the STP, Unit 1, penetrations for evidence of cracking or other degradation. The licensee contracted with Framatome ANP (FANP) to perform the inspections using tooling that had been used previously to conduct inspections of BMI penetrations at several French PWRs. FANP demonstrated the capability of the major elements of the NDE inspection through blind and non-blind testing of the inspection equipment, personnel, and procedures. The major elements of the licensee's NDE campaign for evidence of cracking or other degradation included the following [Reference 11]:

- (1) Ultrasonic testing (UT) of all 58 STP, Unit 1, BMI nozzles from the nozzle ID using axial, circumferential, and zero degree probes to inspect the nozzle wall material for evidence of degradation,
- (2) Enhanced visual testing (EVT-1, defined, in part, by the ability to discern a 0.5 mil wire on a neutral gray background) of the J-groove weld surfaces of all 58 STP, Unit 1, BMI penetrations for evidence of cracking,
- (3) Eddy Current Testing (ECT) using a bobbin coil probe of four nozzles, including penetrations 1 and 46, for evidence of cracking at the ID of the nozzles,
- (4) ECT using an array probe mounted on a pole of eight of the STP, Unit 1, BMI penetration J-groove weld surfaces for evidence of surface-breaking cracks,
- (5) Phased-array UT from the outside surface of the RPV bottom head to inspect penetrations 1 and 46 for evidence of low-alloy steel base material corrosion due to exposure to boric RCS water.

The licensee submitted a preliminary report of its findings in accordance with the requirements of 10 CFR 50.73 in Licensee Event Report (LER) 50-498/2003-003 on June 11, 2003 [Reference 6].

As a result of NDE activities (1) and (3) above, the licensee reported three axially-oriented crack-like indications in the penetration 1 nozzle wall and two axially-oriented crack-like indications in the penetration 46 nozzle wall. As depicted in Figure 2, one of the indications in penetration 1 was characterized as an axial crack with a length of about 1.38 inches, surface breaking on the OD of the nozzle above and below the J-groove weld, as well as surface breaking on the ID of the nozzle. The ID surface breaking nature of this flaw was confirmed by the bobbin coil ETC. The other two indications in penetration 1 were characterized as being small, embedded (i.e., non-surface breaking) cracks near the interface between the nozzle wall and the root pass of the J-groove weld. As depicted in Figure 3, one of the indications in penetration 46 was characterized as an axial crack with a length of about 0.98 inches, surface breaking on the OD of the nozzle above and below the J-groove weld. The other indication in penetration 46 was characterized as an embedded crack having an axial length of 0.95 inches. Figures 2 and 3 were submitted to the NRC as part of the licensee's presentation at a public meeting held at NRC Headquarters on June 5, 2003. However, the UT inspections conducted by the licensee were not demonstrated to be effective for the purpose of examining the subsurface volume of the J-groove weld. Therefore, the licensee's depictions of the indications as shown in Figures 2 and 3 may be incomplete with respect to subsurface cracking of the J-groove weld material. No crack-like indications were identified in any of the other 56 STP, Unit 1, BMI nozzle penetrations [Reference 2].

The results of the UT inspection did, however, identify other features within the BMI penetrations which were deemed to be relevant by the licensee. UT reflectors were observed and characterized as "anomalous conditions" or "discontinuities" at the interface of the nozzle and the J-groove weld in all of the STP, Unit 1, BMI penetrations. The licensee concluded that these discontinuities were potentially evidence of weld lack of fusion, porosity, or some other welding defects from original fabrication. These discontinuities were particularly evident in 7 penetrations, including penetrations 1 and 46. The licensee also concluded that discontinuities in penetrations 1 and 46 were located in the same general azimuthal locations as the crack-like indications. Based on a structural analysis performed by the licensee, the discontinuities were determined to be not structurally significant [References 2 and 11].

The licensee concluded that no cracking of the 58 BMI penetration J-groove welds was evident based on the EVT-1 and ECT examinations of the J-groove weld surfaces [NDE activities (2) and (4) above]. In addition, the licensee concluded based on the phased-array UT examination of the penetration 1 and 46 low-alloy steel base materials [NDE activity (5) above] that there was no indication of wastage of the low-alloy steel due to exposure to borated RCS water which eventually led to the deposits identified at penetrations 1 and 46. Subsequent visual examination of the nozzle bores during the repair of penetrations 1 and 46 (see Section 5.0 below) also supported the conclusion that there was no evidence of low-alloy steel wastage [Reference 11].

#### 4.0 LICENSEE INVESTIGATION AND ANALYSES

Based on the information available from the NDE inspections discussed in Section 3.0 of this staff evaluation, the licensee initiated an investigation to assess potential root causes for the

as-found condition of STP, Unit 1, BMI penetrations 1 and 46, and the potential effects of various BMI penetration failure modes.

#### 4.1 Preliminary Root Cause Analysis

The licensee's investigation of the STP, Unit 1, BMI penetration 1 and 46 degradation was based on a review of operational and fabrication records as well as analytical work which included an evaluation of the expected residual stresses from the J-groove welding process. Additional discussion of the results of the licensee's records review and analytical work will be provided in the NRC staff's SIT report. As documented in the licensee's preliminary root cause report, which was submitted to the NRC staff as an attachment to the licensee's July 11, 2003, letter, the licensee has identified three principal mechanisms/contributing conditions which may have led to the degradation of STP, Unit 1, penetrations 1 and 46 [Reference 11]:

- (1) Welding defects and residual stresses related to initial fabrication processes
- (2) Crack propagation/growth based on fatigue
- (3) Primary water stress corrosion cracking (PWSCC)

Regarding PWSCC, the licensee has stated that several facts are inconsistent with PWSCC as the initiation mechanism for the observed indications:

- (1) No cracks were identified in any penetrations other than 1 and 46. This is not indicative of a random, time-dependent, progressive mechanism such as PWSCC.
- (2) The cracks that resulted in leakage in both penetrations are relatively old based on the isotopic analysis of the leakage deposits and are about the same age. This observation suggests a single event or point in time, rather than a time-dependent process.
- (3) Based on the UT results, the two smaller indications in penetration 1 and the large, embedded indication in penetration 46 do not appear to be in contact with primary water, which would be necessary to support PWSCC.

The licensee has also stipulated that several factors from its review of the STP, Unit 1, BMI penetration fabrication records and the inspection results support the preliminary conclusion that fabrication defects played a significant role in the observed degradation:

- (1) As part of the J-groove weld fabrication process, extensive grinding of the weld surface would have been done, at a minimum, after the completion of the weld root pass, after ½ of the weld had been completed, and after the weld was finished. This grinding was called for in the CE weld fabrication procedures prior to performing required dye penetrant testing. In addition, grinding may have been performed at other points in the welding process at the discretion of the welder based on the need to remove welding defects.
- (2) Welded-over grinding marks may have led to weld lack of fusion and may account for the discontinuities identified in all of the STP, Unit 1, BMI penetrations at the nozzle-to-J-groove weld interface.

- (3) The azimuthal location of the crack indications in penetrations 1 and 46 are located near the edges of discontinuities at the nozzle-to-J-groove weld interface. The licensee postulates that these locations may be areas of high local residual stresses from fabrication and may also be subject to higher cyclic stresses during heatup and cooldown.

Based upon these considerations, the licensee concluded in its preliminary root cause report that, "manufacturing (welding) flaws resulting in excessive stress in the nozzle/weld material leading to crack initiation with low cycle fatigue/ primary water stress corrosion cracking then supporting crack propagation," is the most likely root cause explanation for the degradation observed in STP, Unit 1, BMI penetrations 1 and 46 [Reference 11].

In order to further investigate the potential root causes of the STP, Unit 1, BMI penetration cracking, the licensee has obtained material samples from STP Unit 1 BMI penetrations 1 and 46 for destructive evaluation. The most significant of these samples were obtained by cutting material from the nozzle-to-J-groove weld interface with a specially designed electrical discharge machining (EDM) tool. The sample locations were intended to correspond to the location of the 1.38 inch flaw in penetration 1 and the embedded 0.95 inch flaw in penetration 46. Information gained from the analysis of these material samples is expected to provide additional insights into the initiation and/or propagation of the flaws in STP, Unit 1, BMI penetrations 1 and 46. In addition, during the repair process, the licensee obtained larger samples of the STP, Unit 1, BMI penetration 1 and 46 Inconel Alloy 600 nozzle material from near the RPV bottom head outside surface (see Section 5.0). This material is being tested by the licensee to further investigate the general chemical and material properties of the nozzle material, in particular, to assess the susceptibility of the nozzle material to PWSCC [Reference 11].

From a regulatory perspective, per 10 CFR 50.55a, the licensee also requested relief from requirements of Section XI of the ASME Code in conjunction with its acquisition of material samples by EDM [Reference 7]. Consistent with the requirements of IWA-4320 of Section XI of the 1989 Edition of the ASME Code, EDM is recognized as a thermal removal process, and the Section XI requirements would stipulate that the cut surface left in service would have to be mechanically ground to remove any material heat affected zone/recast layer which may be present as a result of the EDM process. The licensee requested relief from the requirement to grind the EDM cut surfaces on STP, Unit 1, BMI penetrations 1 and 46 because of the impracticality of grinding these surfaces at the bottom of the STP, Unit 1, RPV and because fatigue analyses and corrosion testing performed by the licensee demonstrated that leaving the as-cut surfaces in service would not lead to conditions which could compromise the integrity of the RCS pressure boundary. The NRC staff provided the licensee with verbal approval of this relief request on July 9, 2003. The NRC staff's written approval of this relief request will be issued after this staff evaluation.

The licensee's investigation of these material samples is expected to be completed in mid-September 2003, with the licensee's final root cause report to be submitted to the NRC in conjunction with a supplement to LER 50-498/2003-003 in October 2003 [Reference 11].

## 4.2 Licensee Failure Modes and Effects Analysis

The licensee also analyzed the potential failure modes and effects associated with the degradation observed in STP, Unit 1, penetrations 1 and 46. The results of the licensee's analysis were summarized in the licensee's preliminary root cause report.

The licensee determined that four principal failure modes could result from BMI penetration cracking:

- (1) Minor leakage consistent with what was actually observed from STP, Unit 1, BMI penetrations 1 and 46,
- (2) Major leakage resulting in significant wastage or RPV material which could lead to a loss of coolant accident (LOCA),
- (3) A nozzle break or failure above the J-groove weld releasing loose parts within the RCS, and
- (4) A nozzle break or failure at, or below, the elevation of the J-groove weld resulting in a LOCA.

Regarding (2), the licensee noted that the cracking observed in STP, Unit 1, BMI penetrations 1 and 46 was very tight, leading to low leakage rates consistent with the small amounts of identified deposits. Analysis models developed for the EPRI Materials Reliability Project (MRP) show that reactor coolant leakage rates must be sufficient to reduce local metal temperatures to below 212 °F before boric acid can concentrate and lead to vessel wastage. The identified leakage rates from STP, Unit 1, BMI penetrations 1 and 46, based upon the age of the deposits and the time required to extrude the deposits to the exterior surface of the RPV, would have been considerably less than the rates stipulated by the MRP work. This was corroborated by the fact that no indications of vessel wastage were observed through visual inspections of low-alloy RPV steel of the nozzle bore region or by the phased array UT inspections from the outside surface of the RPV head; and, by the fact that no evidence of low-alloy steel corrosion products was evident in the STP, Unit 1, BMI penetration 1 and 46 deposits. Based on this information, the licensee concluded that failure mode (2) was not a credible event [Reference 11].

Regarding (3), the licensee noted that no circumferential cracking, which could lead to separation of the nozzle, was detected in any of the STP, Unit 1, BMI nozzles. Further, the licensee's analytical stress results showed that the growth of axial cracks above the J-groove weld to the point where nozzle failure could lead to loose parts generation was highly unlikely. Based on this information, the licensee concluded that failure mode (3) was not a credible event [Reference 11].

Regarding (4), the licensee performed failure analyses of the BMI nozzles based upon the postulation of large axial and circumferential cracks. The results of the licensee's analysis indicated that throughwall circumferential cracking of the nozzle below the J-groove weld would have to exceed 304° in extent prior to falling below a safety factor of 3 to nozzle failure. As noted above, no evidence of circumferential cracking was identified in any STP, Unit 1, BMI penetration. For an axially-oriented flaw, a throughwall flaw would have to exceed a length of

5.4 inches prior to falling below a safety factor of 3 to nozzle failure. In addition, weld residual stresses below the J-groove weld would not be sufficient to support continued crack growth beyond the weld region. Based on these analysis results and the licensee's experience with identifying much smaller cracks through its BACC walkdown program, the licensee concluded that failure mode (4) was not a credible event [Reference 11].

Therefore, the licensee concluded that minor RCS leakage was the only credible failure mode associated with BMI penetration cracking based on the evidence and analyses performed to date.

## 5.0 LICENSEE REPAIRS OF STP UNIT 1 PENETRATIONS 1 AND 46

Upon the discovery of the deposits around STP, Unit 1, BMI penetrations 1 and 46, the licensee began the process of designing a potential repair option. The licensee developed a "half-nozzle" repair which was similar in design to those which had been implemented at other facilities for the repair of cracked pressurizer heater penetrations, RCS instrumentation penetrations, etc. This repair option was chosen and characterized as a permanent repair of STP, Unit 1, BMI penetrations 1 and 46. A cross-section of the repair design is shown in Figure 4. The essential elements of the repair design were as follows [Reference 2]:

- (1) The lower portion of the original Inconel Alloy 600 nozzle was cut off flush with the exterior surface of the RPV bottom head.
- (2) An Inconel Alloy 52/152 (the weld wire equivalent of Inconel Alloy 690) temper bead weld pad was welded to the exterior surface of the RPV bottom head at the nozzle penetration.
- (3) A J-groove weld prep was machined into the temper bead weld pad and the remnant of original nozzle which may interfere with the repair installation was bored out of the vessel to a depth of approximately 1.5 inches. Visual inspection of nozzle bores for evidence of low-alloy steel wastage was conducted.
- (4) A new Inconel Alloy 690 nozzle was inserted into the penetration and welded to the temper bead weld pad by an Inconel Alloy 52/152 partial penetration J-groove weld.

The licensee's repair design, therefore, moved the RCS pressure boundary to the exterior surface for the RPV bottom head at the location of the new Inconel Alloy 52/152 J-groove weld.

The licensee's repair design also included a gap between the bottom of the original Inconel Alloy 600 nozzle and the new Inconel Alloy 690 replacement nozzle. This gap was necessary in order to permit thermal expansion of the nozzle halves without the potential for applying interference-related stresses to either the original J-groove weld or the new Inconel Alloy 52/152 J-groove weld. The existence of this gap creates an annular region between the original J-groove weld and the half-nozzle repair in which the low-alloy steel of the RPV bottom head is exposed to borated RCS water. The licensee analyzed the potential for boric acid corrosion of the low-alloy steel in this region. The licensee concluded that due to low oxygen levels in the reactor coolant (except during refueling outages, a condition which was also accounted for) and the stagnant conditions, which are expected to exist within the annular region; corrosion of the

low-alloy steel was predicted to be insignificant through the end of the unit's current operating license with respect to affecting the structural or leakage integrity of the RCS pressure boundary [References 11 and 16].

Further, the licensee concluded that this half-nozzle repair design was acceptable in that it met all the applicable repair and replacement requirements of the ASME Code Editions and Addenda incorporated within the STP, Unit 1, licensing basis, with the exception of the following for which the licensee requested NRC staff approval of relief from ASME Code requirements [Reference 11].

The licensee requested relief from ASME Code requirements to utilize Inconel Alloy 52/152 weld material as part of the repair [Reference 5]. The Edition and Addenda of the ASME Code incorporated within the STP, Unit 1, licensing basis as applied to repair and replacement activities did not address the acceptability of Inconel Alloy 52/152 material. The licensee requested relief to apply ASME Code Cases 2142-1 and 2143-1 to enable the use of Inconel Alloy 52/152 material. The NRC staff approved the licensee's relief request in Reference 13.

The licensee requested relief from ASME Code Section III requirements to utilize applicable provisions of ASME Code Case N-638 to support use of the temper bead welding process as part of the repair [Reference 8]. The 1971 Edition through 1973 summer Addenda of ASME Code Section III is the construction code of record for STP, Unit 1. This Edition and Addenda of ASME Code Section III does not address the temper bead welding process and would instead require the licensee to perform a postweld heat treatment on the Alloy 52/152 weld pad. The NRC staff provided the licensee with verbal approval of this relief request on July 30, 2003. The NRC staff's written approval of this relief request will be issued after this staff evaluation.

The licensee requested relief from 1989 Edition ASME Code Section XI requirements (the Section XI ASME Code edition incorporated into the STP, Unit 1, licensing basis relative to inservice inspection) related to the need to perform successive reexaminations of flaws left in service in the region of the original J-groove welds [Reference 9]. As part of the repair, the licensee moved the RCS pressure boundary to the exterior of the RPV bottom head and did not attempt to remove the original flaw indications found in the STP, Unit 1, BMI penetration 1 and 46 nozzles (although parts of the flaws were in fact removed as part of the EDM material sampling process). Further, the licensee's inspection techniques did not permit the inspection of the subsurface region of the original J-groove welds to ascertain whether any flaws within the welds were also being left as part of the repair. The licensee requested relief from the ASME Code Section XI reinspection requirements based on two general considerations. First, the licensee performed a fatigue analysis which substantiated that even if the original J-groove welds were cracked, the flaws would not grow into the low-alloy steel material of the RPV bottom head and compromise the RCS pressure boundary. Second, the licensee noted that since the RCS pressure boundary of the half-nozzle repair moves to the exterior of the RPV bottom head, the original J-groove weld was no longer considered part of the RCS pressure boundary and the flaws left in service would, therefore, not require reinspection. The NRC staff provided the licensee with verbal approval of this relief request on July 30, 2003. The NRC staff's written approval of this relief request will be issued after this staff evaluation.

On the basis of the information discussed above, and additional considerations discussed in Section 6.0 below, the licensee concluded that the repairs performed on STP, Unit 1, BMI

penetrations 1 and 46 meet all applicable regulatory requirements and are adequate to support restart of STP, Unit 1 [Reference 11].

## 6.0 LICENSEE PLANS FOR FUTURE INSPECTION/MONITORING OF STP, UNITS 1&2

Based on the results of the licensee's inspection, preliminary root cause evaluation, and repair of the STP, Unit 1, bottom head penetrations, STPNOC has committed to several ongoing inspection and monitoring activities for both STP, Units 1 & 2, to support the continued operability of the units [References 11 and 12].

First, STPNOC will continue to perform 100 percent bare metal visual examinations of the STP, Unit 1 and 2 RPV bottom heads as part of the STPNOC BACC inspection program in a manner consistent with how the inspections were conducted for STP Unit 1 in April 2003. This is not a change for either unit, only a continuation of the licensee's established program of performing such inspections during unit refueling outages and during unit forced outages if the unit has been in operation for more than three months and the forced outage is scheduled to be 72 hours or greater in duration. The STPNOC BACC inspection program was demonstrated to be effective with regard to finding very small deposits around STP, Unit 1, BMI penetrations 1 and 46. The licensee has concluded that its established program will be effective at finding evidence of future leakage, if any were to occur, prior to the development of degradation which significantly affects the structural integrity of either unit's RPV. The licensee has determined that this conclusion is valid for both the STP, Units 1 and 2, penetrations which maintain the original nozzle/J-groove weld configuration, as well as for the two repaired penetrations on the STP, Unit 1, RPV bottom head [Reference 11].

Second, STPNOC has committed to perform volumetric and enhanced visual examinations of the STP, Unit 1, penetrations at the next in-service inspection of the RPV, which is currently planned for 2008 or 2009. Although redesigned tooling may be used for the inspections, it is the NRC staff's understanding that this reflects the licensee's commitment to perform inspections equivalent to those identified as NDE activities (1) and (2) in Section 3.0 above. These inspections were demonstrated to be effective at finding and characterizing crack-like indications in the Inconel Alloy 600 nozzle material of BMI penetrations 1 and 46 [References 11 and 12].

Third, STPNOC has committed to perform ultrasonic examinations of the RPV base material around one of the two repaired BMI penetrations for the next two alternate refueling outages (i.e., 1RE13 and 1RE15) to confirm that there are no indications of RPV low-alloy steel wastage from RCS water in the annulus area of the repaired penetrations [References 11 and 12]. It is the NRC staff's understanding that this reflects the licensee's commitment to perform an inspection of either STP, Unit 1, BMI penetration 1 or 46 in 1RE13 and 1RE15 equivalent to those identified as NDE activity (5) in Section 3.0 above.

Finally, STPNOC has committed to perform volumetric inspections of all STP, Unit 2, BMI penetrations at the next refueling outage when the core barrel is planned to be removed. According to the licensee this is currently planned for refueling outage 2RE11 in 2005. Although redesigned tooling may be used for the inspections, it is the NRC staff's understanding that this reflects the licensee's commitment to perform inspections equivalent to those identified as NDE activity (1) in Section 3.0 above [References 11 and 12].



## 7.0 LICENSEE CONCLUSIONS

Based on the information presented above, the following summarizes the licensee's conclusions regarding the identification of leakage from STP, Unit 1, BMI penetrations 1 and 46, the readiness of STP, Unit 1, to restart, and the justification for continued operation of STP, Unit 2 [Reference 11].

- (1) Flaws through the RCS pressure boundary were confirmed by NDE performed on STP, Unit 1, BMI penetrations 1 and 46. The existence of these flaws resulted in STP, Unit 1, being in violation of STP, Unit 1, TS 3.4.6.2.a. and 3.4.10 regarding RCS pressure boundary leakage and RCS structural integrity, respectively.
- (2) Comprehensive NDE was performed to characterize the flaws identified in the nozzle material of STP, Unit 1, BMI penetrations 1 and 46. No crack-like indications were identified in any of the other 56 STP, Unit 1, BMI penetration nozzles and no surface breaking flaws were identified in any of the STP, Unit 1, BMI penetration J-groove welds.
- (3) Based upon the NDE inspection results and the investigation of STP, Unit 1, BMI fabrication records, STPNOC has preliminarily concluded that "manufacturing (welding) flaws resulting in excessive stress in the nozzle/weld material leading to crack initiation with low cycle fatigue/ primary water stress corrosion cracking then supporting crack propagation," is the most likely root cause for the degradation observed in STP, Unit 1, BMI penetrations 1 and 46. STPNOC is evaluating material samples obtained from STP, Unit 1, BMI penetrations 1 and 46 and will incorporate information from these evaluations into STPNOC's final root cause report to be submitted to the NRC staff in October 2003.
- (4) STP, Unit 1, BMI penetrations 1 and 46 were repaired using a "half-nozzle" repair design that relocated the RCS pressure boundary to the outside surface of the RPV bottom head. The design of these repairs was similar to half-nozzle repairs which have been used to repair RCS pressure boundary penetrations at other facilities. The STP, Unit 1, BMI half-nozzle repairs were designed in accordance with the requirements of the ASME Code, except for those aspects for which STPNOC requested relief, and were designed for the life of the facility. Irrespective of the final root cause determination, the licensee does not believe that there is a potential root cause for the identified cracking which would challenge the effectiveness of the repairs.

These repairs, therefore, adequately address the conditions which caused STP, Unit 1, to be in violation of STP, Unit 1, TSs 3.4.6.2.a. and 3.4.10.

- (5) STPNOC has evaluated the potential for BMI penetration failure modes other than minor leakage, including: (1) major leakage resulting in significant wastage of RPV material which could lead to a LOCA; (2) a nozzle break or failure above the J-groove weld releasing loose parts within the RCS; or, (3) a nozzle break or failure at, or below, the elevation of the J-groove weld resulting in a LOCA. Based on analyses conducted by STPNOC and the STP, Unit 1, inspection

results, the licensee has concluded that the available information suggests that BMI penetration failure modes other than minor leakage are not credible.

- (6) STPNOC will implement, or continue, inspection and monitoring programs for both STP, Units 1 and 2 which will ensure that future BMI penetration degradation, if any were to occur, will be identified and corrected prior to the development of flaws which could lead to gross RCS pressure boundary failure (i.e., a LOCA). In addition, the future volumetric NDE of both the STP, Units 1 and 2 BMI penetrations will potentially provide additional insights into the nature and extent of degradation (if any) prior to the development of identifiable leakage deposits.

Based upon these observations, STPNOC has concluded that STP, Unit 1, complies with all existing regulatory requirements necessary to support the restart of STP, Unit 1. STPNOC also concludes that the operation of STP, Units 1 & 2, is consistent with the licensee's obligation to protect the health and safety of the public [Reference 11].

## 8.0 NRC STAFF EVALUATION

The NRC staff has reviewed the information provided by the licensee and evaluated the licensee's conclusions relative to the regulatory requirements stated in Section 2.0 of this staff evaluation and the licensee's obligation to ensure that operation of STP, Units 1 and 2, is consistent with the protection of the health and safety of the public. The NRC staff's conclusions are as follows:

- (1) Regarding STP, Unit 1, TSs 3.4.6.2.a. and 3.4.10, the NRC staff agrees with the licensee's assessment that the flaws identified in STP, Unit 1, BMI penetrations 1 and 46 resulted in the unit being in violation of the stated TS requirements. The NRC staff also agrees that the half-nozzle repairs performed on STP, Unit 1, BMI penetrations 1 and 46 have corrected the as-found condition such that STP, Unit 1, is no longer in violation of the stated TSs.
- (2) Regarding the requirements of Criterion XVI of Appendix B to 10 CFR Part 50 on corrective action, the NRC staff concludes that the licensee's efforts (and planned actions with regard to the evaluation of material samples obtained from STP, Unit 1, BMI penetrations 1 and 46) to inspect, evaluate, and repair the degradation identified in the STP, Unit 1, BMI penetrations were consistent with the stated regulatory requirements.

Further, the NRC staff has concluded that the inspection and monitoring programs proposed by the licensee for STP, Units 1 and 2, are adequate and prudent to prevent potential future BMI penetration degradation from developing to an extent which could lead to gross RCS pressure boundary failure, i.e., in the context of Criterion XVI of Appendix B to 10 CFR Part 50, to prevent the development of "significant conditions adverse to quality" [Reference 16].

- (3) Regarding the requirements of 10 CFR 50.55a, based on the NRC staff's review of information submitted by the licensee and the staff's audit of fatigue and stress calculations associated with the repair design; the staff agrees with the

licensee's conclusion that the repairs effected to STP, Unit 1, BMI penetrations 1 and 46 are consistent with the ASME Code of record incorporated with the STP, Unit 1, licensing basis, with the exception of requests for relief from ASME Code requirements which have been reviewed and approved by the NRC staff [References 10, 13, and 14].

- (4) The NRC staff has concluded that the as-found condition of the STP, Unit 1, BMI penetration degradation was of very low risk significance. The identified degradation was axially-oriented and of insufficient extent to significantly change the probability of initiation of a gross failure of the RCS pressure boundary. In addition, in the hypothetical event of a single STP, Unit 1, BMI nozzle double-ended failure (i.e., a small break LOCA in the bottom head), the NRC staff has concluded that emergency core cooling systems installed at STP, Unit 1, would be adequate to mitigate the accident consistent with the requirements of the STP, Unit 1, licensing basis [Reference 16].
- (5) Finally, the NRC staff has concluded that, at this time, insufficient information exists to substantiate or refute the licensee's preliminary root cause determination. The evaluation of the material samples taken from STP, Unit 1, BMI penetrations 1 and 46 is expected to provide additional information with regard to differentiating between potential causes of crack initiation and propagation, including fabrication defects, PWSCC, fatigue, or some combination of these. Therefore, the NRC staff will not take a position with regard to the licensee's root cause determination until submission of the licensee's final root cause report scheduled to be completed in October 2003.

However, the NRC staff does agree with licensee's conclusion that, based on the identified spectrum of potential root causes for the identified cracking, the final root cause is not expected to challenge the effectiveness of the repairs performed on STP, Unit 1, BMI penetrations 1 and 46 or continued operation of the unit.

Based on these observations, the NRC staff concludes that STP, Unit 1, complies with all existing regulatory requirements necessary to support the restart of STP, Unit 1. The NRC staff also concludes that the operation of STP, Units 1 and 2, is consistent with the licensee's obligation to protect the health and safety of the public.

## 9.0 REFERENCES

- [1] Summary of Meeting with STPNOC Regarding South Texas Project Unit 1 Reactor Vessel and Bottom Mounted Instrumentation Penetration Interface Leakage, June 20, 2003, ADAMS Accession No. ML031710579.
- [2] Summary of Second Meeting with STPNOC Regarding South Texas Project Unit 1 Reactor Vessel and Bottom Mounted Instrumentation Penetration Interface Leakage, July 15, 2003, ADAMS Accession No. ML031920459.

- [3] Slides Presented at Third Meeting with STPNOC Regarding South Texas Project Unit 1 Reactor Vessel and Bottom Mounted Instrumentation Penetration Interface Leakage, July 17, 2003, ADAMS Accession No. ML032090144.
- [4] J. J. Sheppard (STPNOC) to U.S. Nuclear Regulatory Commission Document Control Desk, "South Texas Project Units 1 & 2, Docket Nos. STN 50-498, STN 50-499, Commitment to Investigate and Repair Bottom Mounted Instrumentation Penetration Indications," April 24, 2003.
- [5] T. J. Jordan (STPNOC) to U.S. Nuclear Regulatory Commission Document Control Desk, "South Texas Project Units 1 & 2, Docket Nos. STN 50-498, STN 50-499, Request for Approval of ASME Section IX Code Cases 2142-1 and 2143-1 for the Second Ten-Year Inspection Interval (Relief Request RR-ENG-2-31)," May 15, 2003.
- [6] E. D. Halpin (STPNOC) to U.S. Nuclear Regulatory Commission Document Control Desk, "South Texas Project Unit 1, Docket Nos. STN 50-498, STN 50-499, Licensee Event Report 2003-003, Bottom Mounted Instrumentation Penetration Indications," June 11, 2003.
- [7] S. E. Thomas (STPNOC) to U.S. Nuclear Regulatory Commission Document Control Desk, "South Texas Project Unit 1, Docket No. STN 50-498, Request for Alternatives to ASME Section XI Requirements Associated with Mechanical Processing of Thermally Cut Surfaces, (Relief Request RR-ENG-2-35)," June 13, 2003.
- [8] M. E. Kanavos (STPNOC) to U.S. Nuclear Regulatory Commission Document Control Desk, "South Texas Project Unit 1, Docket No. STN 50-498, "Request for Alternative to ASME Section XI Requirements Associated with Half-Nozzle Repair/Replacement for Bottom Mounted Instrumentation Penetrations (Relief Request RR-ENG-2-32)," June 19, 2003.
- [9] S. E. Thomas (STPNOC) to U.S. Nuclear Regulatory Commission Document Control Desk, "South Texas Project Unit 1, Docket No. STN 50-498, Request for Relief from ASME Section XI Requirements Associated with Characterizing Flaws in Bottom Mounted Instrument Penetration Welds, (Relief Request RR-ENG-2-33)," June 25, 2003.
- [10] S. E. Thomas (STPNOC) to U.S. Nuclear Regulatory Commission Document Control Desk, "South Texas Project Unit 1, Docket No. STN 50-498, Summary of ASME Code Calculations Performed for Repair of Bottom Mounted Instrument Penetrations," July 2, 2003.
- [11] J. J. Sheppard (STPNOC) to U.S. Nuclear Regulatory Commission Document Control Desk, "South Texas Project Units 1 & 2, Docket Nos. STN 50-498, STN 50-499, Additional Information Regarding STP's Commitment to Investigate and Repair Bottom Mounted Instrumentation Penetration Indications," July 11, 2003.

- [12] J. J. Sheppard (STPNOC) to U.S. Nuclear Regulatory Commission Document Control Desk, "South Texas Project Units 1 & 2, Docket Nos. STN 50-498, STN 50-499, Supplement to Commitment to Investigate and Repair Bottom Mounted Instrumentation Penetration Indications," July 17, 2003.
- [13] R. A. Gramm (USNRC) to W. T. Cottle (STPNOC), "South Texas Project Units 1 and 2 - Request for Relief, RR-ENG-2-31, From American Society of Mechanical Engineers (ASME) Code Requirements for Approval of ASME Section IX Code Cases 2142-1 and 2143-1 For the Second 10-Year Inspection Interval (TAC Nos. MB9098 and MB9099)," June 25, 2003.
- [14] Memorandum from K. A. Manoly (USNRC) to R. Gramm (USNRC), "Trip Report: Observation/ Audit at Framatome, Inc., in Lynchburg, VA. of ASME Section III Class 1 Design Calculations in Support of the South Texas Project Unit 1 Half-Nozzle Repair/Replacement Activities. (TAC No.: MB8435)," July 11, 2003.
- [15] Memorandum from D. D. Chamberlain (USNRC) to R. L. Bywater (USNRC), "Charter for the NRC Special Inspection Team at South Texas Project - Review of Licensee Actions Related to Reactor Vessel Bottom Mounted Instrumentation Penetration Leakage," May 5, 2003.
- [16] NRC Inspection Report 05000498/2003008; 05000499/2003008 to be issued August 2003.

Figure 1

# BMI Guide Tube Penetration

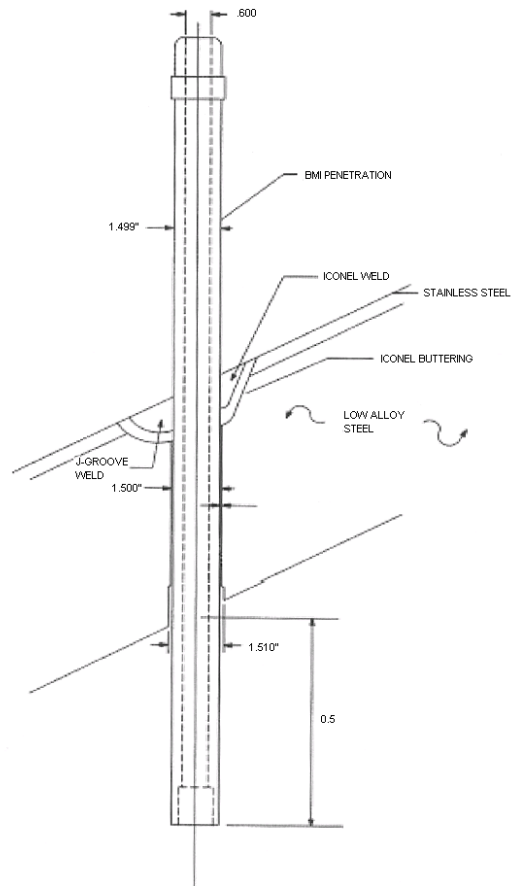

Figure 2

# Penetration #1

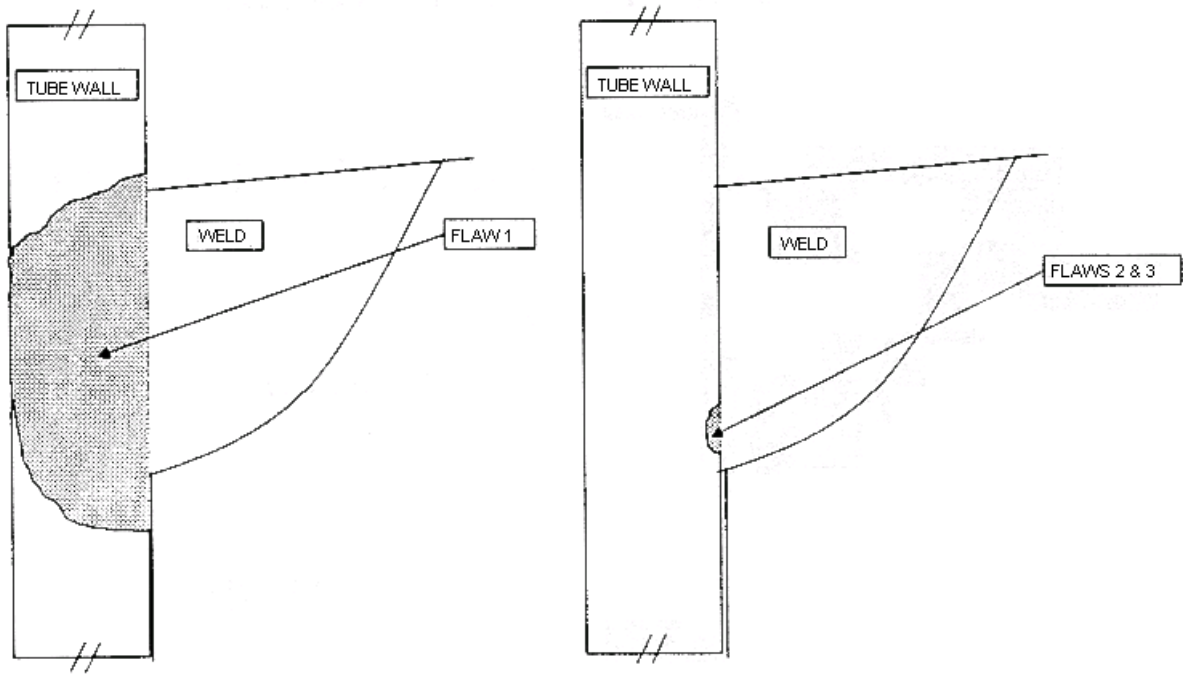

Figure 3

# Penetration #46

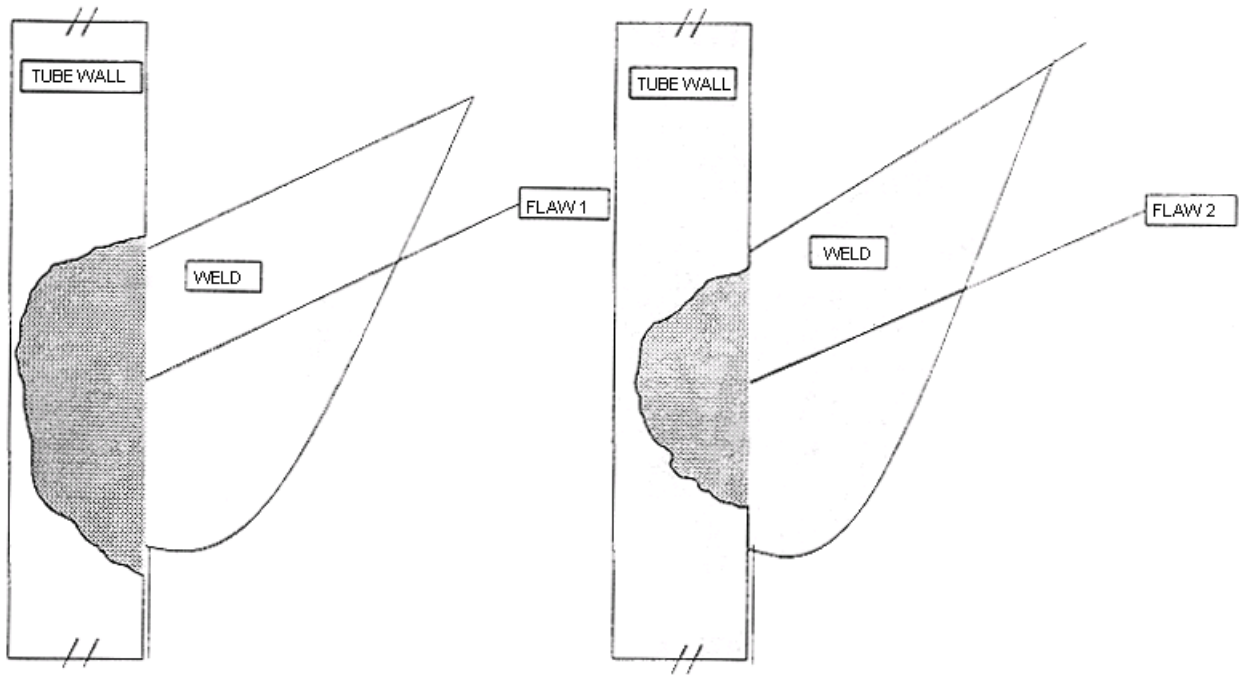



Figure 4

# Half-Nozzle Repair

