

CHAPTER 8

CONCENTRATIONS OF TOTAL SUSPENDED SOLIDS IN EFFLUENT

This section describes the data sources, data selection, data conventions, and statistical methodology used by EPA in evaluating achievable concentrations of total suspended solids (TSS) for the flow-through and recirculating subcategories. Although this chapter presents long-term averages, variability factors, and numeric limitations developed from effluent data, EPA decided not to establish national numeric effluent limitations for TSS, as explained in the preamble to the final rule. When EPA establishes national numeric limitations, EPA generally performs a more rigorous statistical and engineering review of the concentration data associated with the numeric limitations. For purposes of its evaluation of the TSS concentration data, however, EPA considers that these data were useful and of sufficient quality, and that the statistical analyses have provided reasonable results. Thus, EPA has provided information in this chapter about the long-term averages, variability factors, and numeric limitations for this data set. EPA considers these data and results to be valuable information that can be used by permit authorities in developing site-specific permits, although additional review of the data may be appropriate for that purpose.

Section 8.1 provides a brief overview of data sources (a more detailed discussion is provided in Chapter 3) and describes EPA's selection of episode data sets that were used in EPA's evaluation. Section 8.2 provides a more detailed discussion of the selection of the episode data sets for the configurations. Section 8.3 describes excluded data, and Section 8.4 presents the procedures for data aggregation. Section 8.5 describes the procedures for estimation of long-term averages, variability factors, and numeric limitations. Appendix D provides the listings for this chapter. Section 24.1 of the record for the final rule included most of the documents referenced in this chapter.

8.1 OVERVIEW OF DATA SELECTION AND CONFIGURATIONS

To develop the long-term averages, variability factors, and numeric limitations presented in this chapter, EPA used concentration data corresponding to the two options, A and B, described in the NODA, for the flow-through and recirculating subcategories. For purposes of evaluating the TSS discharges, EPA also combined the data from the two subcategories, and labeled the new set as the 'Combined subcategory.'

The TSS data for the analyses described in this chapter were collected from two sources: EPA's sampling episodes and self-monitoring data collected from EPA regional offices and EPA's Permit Compliance System (PCS), and submitted with comments on the proposal. These data are a subset of those described in Chapter 3. This chapter refers to

the data from each facility in terms of ‘sampling episodes’ and ‘self-monitoring episodes.’ All of the data are presented in terms of gross values, that is, the values are not adjusted for TSS concentrations in the source water.

EPA considered the effluent discharges from different configurations associated with raceways and offline settling basins (OLSBs). Table 8.1–1 provides a brief description of each configuration. Figures 8.1–1 through 8.1–5 provide a graphical representation of each configuration.

Table 8.1–1 Descriptions of Technology Configurations

<i>Subcategory</i>	<i>Option</i>	<i>Configuration</i>	<i>Description</i>
Flow-Through	A	1A	Full flow settling basin effluent
		2A	OLSB effluent
		3A	Treated Raceway effluent
		4A	Combined OLSB and raceway effluent
	B	1B	Full flow settling basin effluent
		2B	OLSB effluent
		3B	Treated Raceway effluent
		4B	Combined OLSB and raceway effluent
	N/A	5	Untreated raceway effluent
Recirculating	A	6A	Solids treatment water
		7A	Overtopping water
	B	6B	Solids treatment water
		7B	Overtopping water
Combined	A	2A+6A+7A	Continuous
	B	2B+6B+7B	Continuous

The next section describes the episode and sample point selection for each configuration.

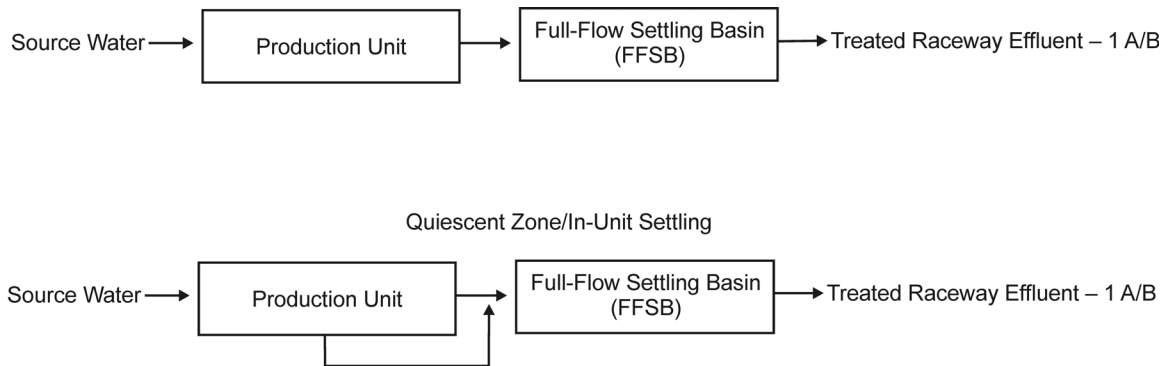

Figure 8.1–1. Schematic of FFSB-FT Effluent Stream

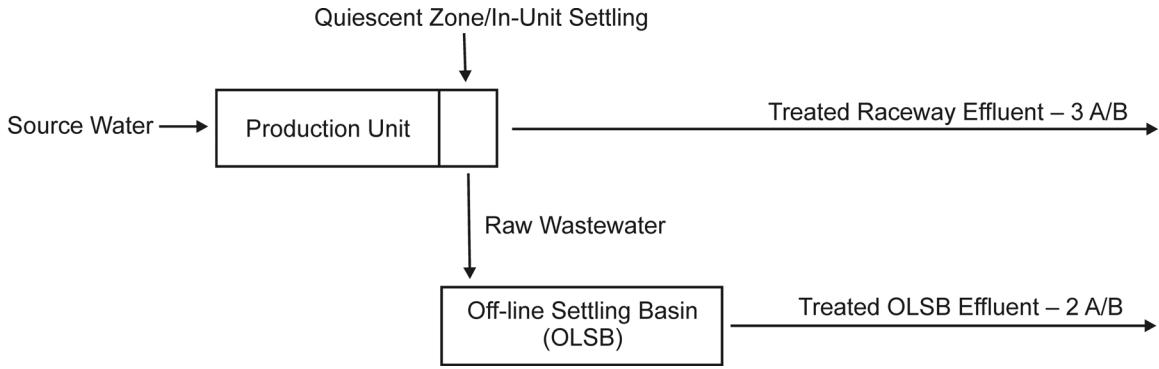
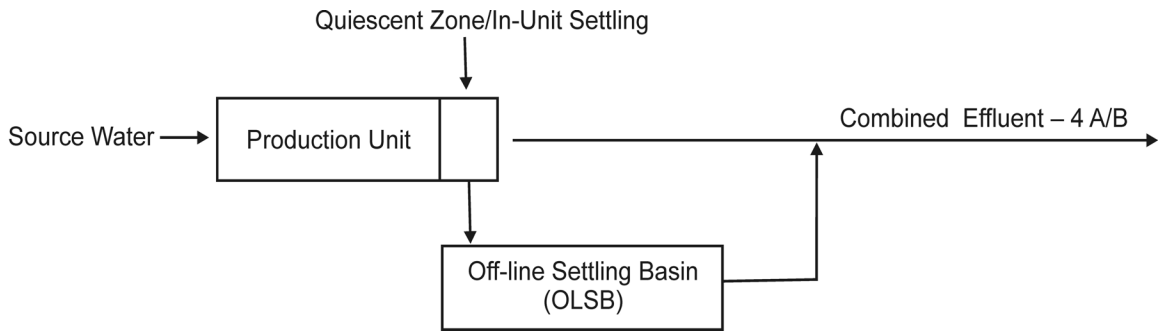

Figure 8.1-2. Schematic of OLSB-Separate Effluent Stream

“4A” Classified Facility



“4B” Classified Facility

Facilities with Structural Technology

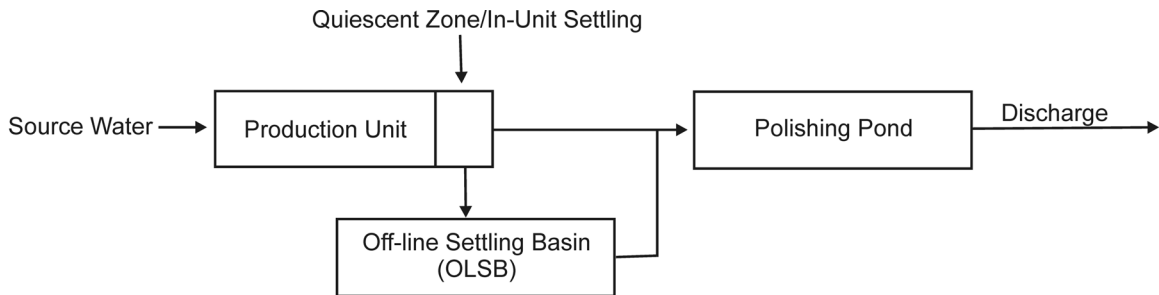

Or “A” Classified Facility + Feed Management

Figure 8.1-3. Schematic of OLSB-Combined Effluent Stream

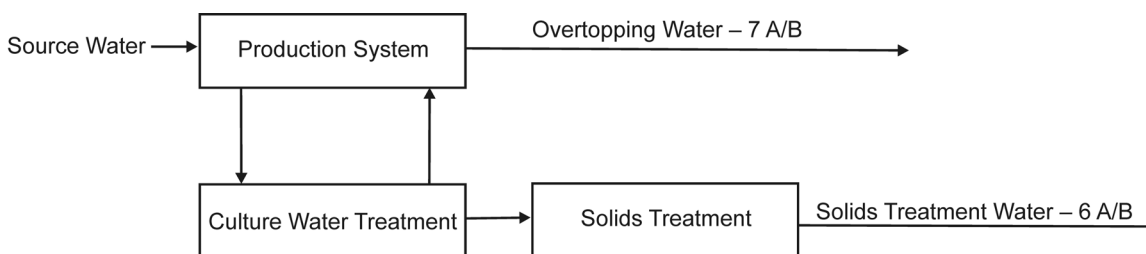

Figure 8.1-4. Schematic of RAS-Separate Effluent Stream

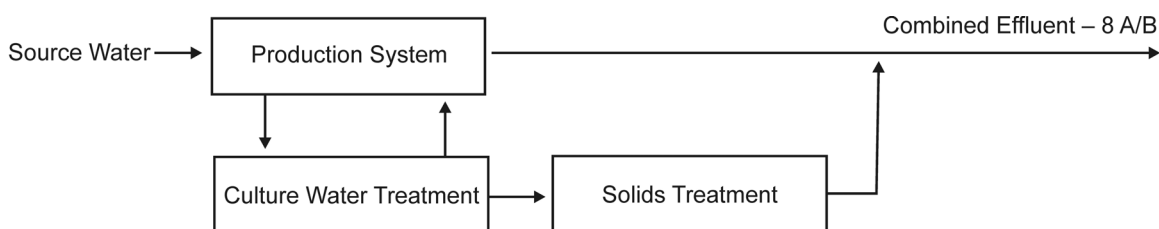

Figure 8.1-5 Schematic of RAS-Combined Effluent Stream

8.2 EPISODE SELECTION FOR EACH CONFIGURATION

EPA qualitatively reviewed the data from the sampling episodes and self-monitoring episodes and then selected episodes to represent each configuration based on a review of the production processes and treatment technologies in place at each facility. The data are listed in *DCN 55101: All Data: Listing of Influent and Effluent TSS Concentration Data* (SAIC, 2004a) and electronically in SAIC, 2004b. Section 8.2 describes the episodes in more detail.

For its evaluations of the TSS concentrations for the final rule, EPA selected a subset of the data. The data from this subset are listed in Appendix C and electronically in SAIC, 2004c. Section 24.1 of the record identifies this subset as the ‘Year 2001 Subset,’ although the subset includes data from other years. First, this subset includes all of the EPA sampling data (episodes 6297, 6439, 6460, and 6495), because EPA had collected detailed information about the processes and treatment systems during the sampling episode. Second, the subset includes the self-monitoring data corresponding to the year 2001, because the questionnaire information allowed EPA to identify the configurations that were utilized by the facilities in 2001. Third, the subset includes the self-monitoring data considered in developing the proposed limitations (DMR01, DMR02, DMR03, and DMR04). The next section describes the data from the four EPA sampling episodes. The following section describes the self-monitoring data. When EPA had data from both its sampling episode and the facility’s self-monitoring, EPA statistically analyzed the data from the sampling episode separately from the self-monitoring episode. This is consistent with EPA’s practice for other industrial categories.

8.2.1 EPA Sampling Episodes

In calculating the numeric limitations, EPA used data from the four EPA sampling episodes: 6297, 6439, 6460, and 6495. If a facility had multiple production and treatment trains that EPA sampled separately, EPA has treated the data as if they were collected from different facilities because the trains were operated independently with different waste streams. In the documentation, the episode identifier is appended with a character, such as “A”, to indicate that the data are from one of the multiple trains. Table 8.2–1 summarizes the episode and sample point selections associated with each configuration of interest. This section describes the sample points selected from each episode for EPA’s evaluation of the TSS concentration data.

Table 8.2–1 Summary of Episode and Sample Point Selection

<i>Subcategory</i>	<i>Episode</i>	<i>Option</i>	<i>Configuration</i>	<i>Influent</i>	<i>Effluent</i>
Flow-through	6297A	B	2B	SP-7	SP-8 (dup SP-9)
	6297B	B	2B	SP-10	SP-11
	6297C	B	2B	SP-12	SP-13(dup SP-14)
	6297D		NA ^b	SP-4	N/A ^c
	6297E	B	3B	N/A ^c	SP-5 (dup SP-6)
	6297F	B	3B	N/A ^c	SP-2 (dup SP-3)
	6297G	B	4B	SP-7	SP-8 (dup SP-9) and SP-5 (dup SP-6)
	6297H	B	4B	SP-10	SP-11 with SP-5 (dup SP-6)
	6297I	B	4B	SP-12	SP-13 (dup SP-14) and SP-2 (dup SP-3)
Recirculating	6439A	A	6A	SP-3	SP-4
	6439B	B	6B	SP-8	SP-9 (dup SP-11)
	6439C ^f	A	7A	SP-2	N/A ^c
Flow-Through	6460A	A	4A	N/A ^c	SP-7 and SP-9
	6460B	A	3A	N/A ^c	SP-7
	6460C	A	2A	SP-8	SP-9
	6460D	B	4B	SP-7, SP-8	SP-10 (dup SP-11)
Flow-through	6495A	A	2A	SP-10	SP-11
	6495B	B	4B	Sp12 and SP-12A	SP-13 (dup SP-14)

^aWhen EPA collected duplicate samples, it assigned a different sample point designation than the sample point for the original sample. The parentheses identify the sample points for the duplicates.

^bAlthough these sample points were not considered in developing the limitations and are labeled as “Not applicable” (NA), EPA used these data to review the overall performance at the facility. EPA has included these data in its data listings and summary statistics.

^cN/A: for purposes of evaluating the configuration, this waste stream was not of interest or the data were not available.

8.2.1.1 Episode 6297

Episode 6297 was conducted on December 11 through December 16, 2000, in Buhl, Idaho, at the Box Canyon trout facility owned and operated by Clear Springs Foods, Inc. Box Canyon is the largest trout-producing raceway system in the United States and has

an average annual production of some 8 million pounds. The facility includes a hatchery consisting of upwelling incubators; 20 raceways and four steel tanks for producing fry; 180 flow-through raceways for growout; and three OLSBs for solids collection. An overall schematic of the facility with the sample point locations is presented as Figure 8.2–1. Surface water from Box Canyon Spring is piped under the Snake River to Box Canyon at a rate of approximately 300 cubic feet per second (cfs). The water is diverted under the river through three steel pipes and through three turbines for electrical energy production. After passing through the turbines, the flow is split among the Blueheart, Eastman, and hatchery sections of the facility. Both the Blueheart and Eastman sections of the facility contain 90 concrete raceways holding approximately 10,000 fish per raceway. Automatic fish feeders are located above each raceway in four different locations. Automated feeding systems are used to feed the fish in the 180 raceways used for growout. All feeding in the hatchery is done by hand. Wastewater treatment operations at Box Canyon include quiescent zones, offline settling basins, and regular vacuuming of raceways. The quiescent zone at the terminal end of each raceway allows fecal material to settle before the raceway water is reused or discharged to the Snake River. Solids are removed from the quiescent zone by vacuuming. The vacuumed solids then flow by gravity to the designated OLSB for each section of the facility.

To evaluate the performance of the OLSBs, EPA considered data for the Eastman, Blueheart, and Hatch House OLSBs, labeled as *episodes 6297A, 6297B, and 6297C*, respectively. For comparison purposes, EPA considered data for the source water, which was labeled as *episode 6297D*. To evaluate the performance of the raceways, EPA considered data for the Eastman raceway (labeled as *episode 6297E*). EPA also considered effluent from the hatch house (labeled as *episode 6297F*). By mathematically combining data from different sample points, EPA considered three other configurations:

1. The Eastman raceway and its OLSB. This was labeled as *episode 6297G*.
2. The Eastman raceway and the Blueheart OLSB. This was labeled as *episode 6297H*.
3. The hatch house and its OLSB. This was labeled as *episode 6297I*.

EPA also received self-monitoring data from the Box Canyon facility and has summarized that information in *Listings for Episode 6297: DMR Data, Summary Statistics, and Estimates* (SAIC, 2002a).¹ EPA also included these data with the self-monitoring data described in Section 8.2.2.1.

¹ In the record, EPA used the reported weekly flows to mathematically combine the data from different sample points. For the few cases where weekly flows were not reported, EPA used the average flow for the month. If a monthly average flow was also missing, then EPA used the maximum flow value reported for the month.

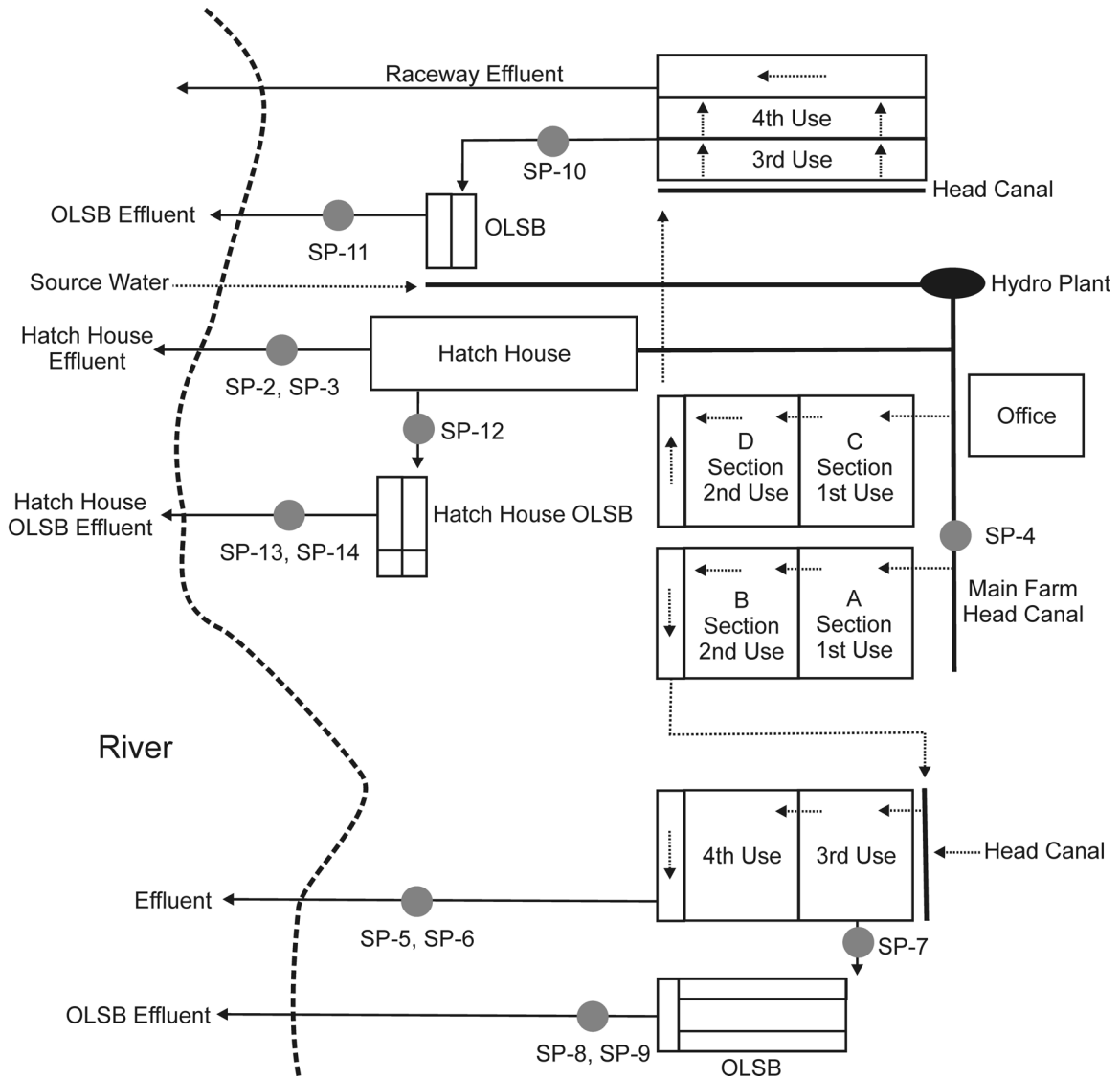

Sampling Points			
SP-2	Duplicate of SP-3	SP-9	Duplicate of SP-8
SP-3	Hatch House Effluent	SP-10	OLSB Influent
SP-4	Source Water	SP-11	OLSB Effluent
SP-5	Raceway Effluent	SP-12	Hatch House OLSB Influent
SP-6	Duplicate of SP-5	SP-13	Hatch House OLSB Effluent
SP-7	OLSB Influent	SP-14	Duplicate of SP-13
SP-8	OLSB Effluent		

Figure 8.2–1. Schematic of Sampling Points and Facility for Episode 6297

8.2.1.2 Episode 6439

Episode 6439 was conducted at Fins Technology, LLC on April 23 through April 28, 2001 in Turners Falls, Massachusetts. Fins Technology, started in 1990 as AquaFuture, Inc, produces about 1 million pounds of hybrid striped bass per year in a recirculating system. It sells live and iced whole fish throughout the U.S. east coast and New England. A unique feature of this facility is its ability to grow hybrid striped bass from egg to foodfish in recirculating systems, all of which are located on-site. Fins Technology uses recirculating system technology to maintain water quality in the growing tanks for the hybrid striped bass. The facility adds less than 10% of the total system volume each day to offset water losses because of filter backwashes and to account for some of the inefficiencies in the recirculating system. Wastewater is generated from solids filtration equipment that maintains process water quality in the recirculating system. Solids are generated when the solids filters are backwashed throughout the day. Additional system overflow (overtopping) water is added to the waste stream and comes directly from the process tanks. Because the facility has claimed its process diagram as CBI, EPA is providing only a brief summary of the process at that facility in Figure 8.2–2.

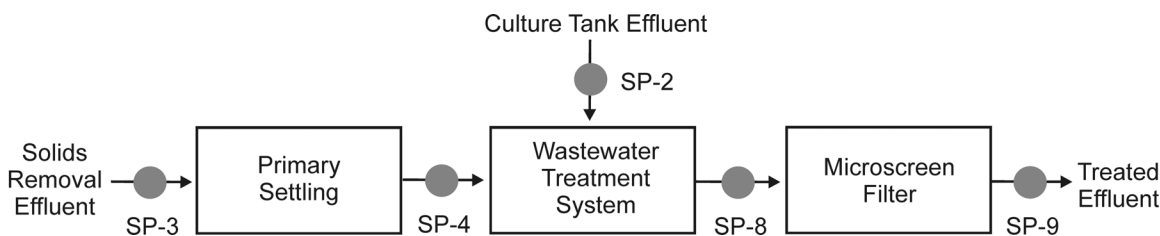

Figure 8.2–2. Schematic of Sample points and Facility for Episode 6439

To evaluate the solids treatment associated with recirculating systems, EPA evaluated the data from primary settling and wastewater treatment. The data associated with the two effluents are labeled as *episodes 6439A* and *6439B*. EPA also evaluated the data from the overtopping, and labeled these data as *episode 6439C*.

EPA notes that the facility had exceeded its permit limits during EPA’s sampling episode. This facility is generally capable of complying with its permit limits of 50 milligrams/liter (daily maximum) and 30 milligrams/liter (monthly average), and therefore, EPA determined that the permit limits more accurately reflected normal operations. EPA also noted that the effluent from the polishing pond was more variable than EPA’s experience with typical performance of polishing ponds.

8.2.1.3 Episode 6460

Episode 6460 was conducted on August 24 through August 29, 2001, in Harrietta, Michigan, at the Harrietta Hatchery trout facility. Harrietta Hatchery is a Michigan Department of Natural Resources hatchery whose mission is to produce rainbow and brown trout for stocking into Michigan waters. Harrietta produces about 1.2 million trout annually. The trout are harvested from Harrietta’s raceways when they are about 5 to 8 inches in length or about eight to ten fish to the pound. Figure 8.2–3 shows the process diagram for the facility associated with this episode. Harrietta uses well water at a rate of up to 5.5 million gallons per day from pumped and artesian wells that flow to the

hatchery and 12 raceways. Wastewater treatment operations at the Harrietta Hatchery include the use of baffles, quiescent zones (sediment traps) in each raceway, a manure storage/settling pond, and a polishing pond. The outdoor growout system consists of 12 covered raceways grouped in three blocks of four. Water flows through each raceway in the block and is collected in a common trough, which is discharged either to an aeration shed or a polishing pond. At the downstream end of each raceway is a quiescent zone where solids settle and are easily vacuumed. The vacuumed solids are diverted into a manure collection/storage basin (or OLSB) adjacent to the polishing pond. A standpipe in each raceway can also be pulled to send water and solids to the OLSB. This OLSB has an intermittent discharge, typically weekly, and only occurred once during EPA’s sampling episode (on August 27, 2001). To accommodate EPA’s schedule, the facility discharged from the OLSB two days earlier than originally scheduled. (See *DCN 55209: Episode 6460 Concentration values of TSS reported on 8/27/2001* (SAIC, 2004d) for a schematic of the concentration levels through the facility on that day.)

To obtain one value for the combined discharges for each day, the Agency mathematically combined the data from the commingled raceway discharge and the OLSB discharge, and labeled them as *episode 6460A*. Because the OLSB discharged on only one day, the daily ‘commingled values’ for the other four days are based on only the raceway discharge. The discharge from one block of raceways, the OLSB, and polishing pond are labeled as *episodes 6460B, 6460C* and *6460D*, respectively.

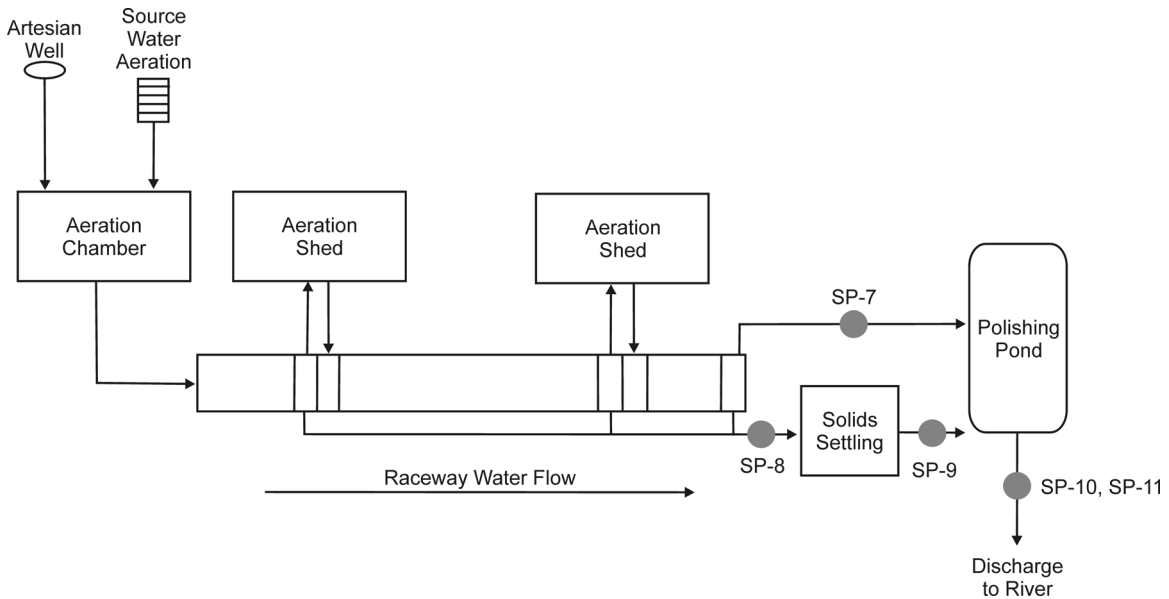

Figure 8.2–3. Schematic of Sample points and Facility for Episode 6460

8.2.1.4 Episode 6495

Episode 6495 was conducted at the Huntsdale Fish Culture Station in Carlisle, Pennsylvania on March 24 through March 29, 2003. Huntsdale is owned by the Commonwealth of Pennsylvania and operated by the Pennsylvania Boat and Fish Commission. The facility’s mission is to produce salmonid and warmwater fish for stocking into Pennsylvania waters. Species produced at the facility include brook trout

(*Salvelinus fontinalis*), rainbow trout (*Oncorhynchus mykiss*), brown trout (*Salmo trutta*), striped bass (*Morone saxatilis*), northern pike (*Esox lucius*), and muskellunge (Muskie) (*E. masquinongy*). Sampling at this facility focused on the flow-through salmonid grow-out production units within the facility.

As shown in Figure 8.2-4, the facility operates three sets of raceways and a hatchery for salmonid production. Source water is obtained from a combination of surface water and eight limestone springs located either on or adjacent to the facility. Average flow through the facility is approximately 8,000 gallons per minute. Spring water used by the facility averages 58 °F year-round. Due to drought conditions over the past two years, the average flow has dropped to about 5,000 gallons per minute, and the facility has had to rely on surface water sources for approximately 1,000 gallons per minute of its flow. The facility also operates 11 ponds for the production of warmwater species. The effluent conveyance system for these ponds is completely separate from the flow-through production system. The warmwater production system was not operating during the sampling episode.

Wastewater treatment operations at Huntsdale include the use of baffles and quiescent zones (sediment traps) in each raceway, a linear clarifier, and polishing pond. Approximately 11.5 million gallons per day of treated wastewater is discharged from the facility. Most of the production water from Huntsdale flows directly to a polishing pond before it is discharged into a ditch that conveys the water to Yellow Breeches Creek. Huntsdale personnel also use several best management practices (BMPs) that help to minimize the discharge of solids and reduce the need to use medicated feeds (antibiotic). The facility uses an extensive feed management program to optimize feeding and meet stringent production goals, which include numbers of individual fish within weight tolerance limits, at specific times of the year.

The daily data for the discharge from the OLSB are labeled as *episode 6495A*. The discharge from the commingled raceway and OLSB is labeled as *episode 6495B*.

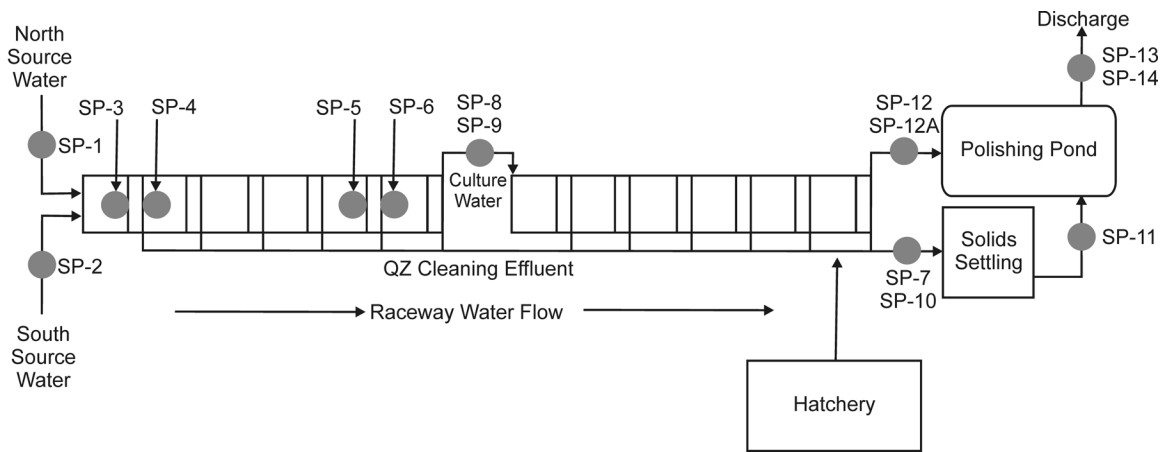

Figure 8.2-4. Schematic of Sample Points and Facility for Episode 6495

8.2.2 Self-Monitoring Data

In calculating the numeric limitations, EPA used self-monitoring data corresponding to the configurations described in Table 8.1–1. In the following sections and in the public record, EPA has masked the identity of the facilities for which it used self-monitoring data. Following the convention used for the proposal which included data from industry discharge monitoring reports (DMR), these episodes are identified only as DMRxx where “xx” is a two-digit number assigned to each self-monitoring episode. The following two sections describe the self-monitoring data considered for the proposal, and additional data incorporated into EPA’s analyses after the proposal.

8.2.2.1 Proposal DMR Data

For the DMR episodes (DMR01, DMR02, DMR03, and DMR04) considered for the proposal, EPA identified the configurations using information from the facility NPDES permit and the responses to the open-ended question (question 10) in the AAP screener questionnaire, “What pollutant control practices do you use before water leaves your property?” After the proposal, EPA re-evaluated its use of these data. All of the self-monitoring data had been collected from 1996 through 1999, which was earlier than the base year, 2001, for the questionnaire. Thus, it is possible that the facility may have changed its operations sometime between 1996 and 2001. Thus, some or all of the self-monitoring data might have been generated by a different configuration than the one that EPA had identified for that facility. For this reason, EPA calculated the episode-specific long-term averages and variability factors from these data sets, but did not include them in the calculation of the configuration-specific long-term averages, variability factors, and numeric limitations. This section describes each of the four data sets in more detail.

For the four sets, EPA reviewed the NPDES permit information for each facility to determine the reporting requirements. The monitoring frequency was typically once per month or once per three months and the samples were typically 8-hour composite samples collected hourly or until five grab samples were collected. Because facilities report multiple parameters in a single report, multiple days are sometimes recorded as the monitoring period for all of the data. Based on the permit information, EPA assumed that each reported value was from a single 24-hour period. For purposes of the statistical analyses and data listings, EPA assumed that the sample date was the one associated with the “Monitoring from” date (starting date of the sampling) listed in the DMR. For purposes of listing the data, EPA assigned the sample point designation SP-1 to the effluent for each episode. The following paragraphs describe each facility.

The facility that provided the episode DMR01 data is the Virginia Department of Game and Inland Fisheries, Coursey Springs Fish Culture Station, Millboro, Virginia, a state fish hatchery that produces brook, brown, and rainbow trout for stocking in public trout streams. The facility uses about 11.5 million gallons per day of spring water and uses quiescent zones and full-flow settling for removing solids from the effluent stream.

The episode DMR02 data are from a state-owned trout production facility for stocking in public trout streams. The facility produces brook, brown, and rainbow trout in raceways. Effluents from the raceways flow into a two-stage settling pond for primary settling and secondary solids polishing. The system flow rate is about 2.8 million gallons per day.

Because the TSS data from DMR02 exceeded the monthly permit limit for one month, EPA excluded these data from the calculations for the configuration-specific long-term averages, variability factors, and numeric limitations.

The episode DMR03 data are from Virginia Department of Game and Inland Fisheries, Marion Fish Culture Station, Marion, VA, another state facility that produces trout, muskellunge, pike, and walleye for stocking in public waters. This facility separately samples its effluents from quiescent zones and a full-flow settling basin below the trout raceways. The facility then mathematically combines the two effluent data values to obtain one daily value for the facility. The facility uses about 2.0 million gallons per day for the trout production part of the operation.

The episode DMR04 data are from the Virginia Department of Game and Inland Fisheries, Buller Fish Culture Station, Marion, VA, a state-owned trout rearing station that produces trout for stocking in public waters. The facility samples its effluents from quiescent zones and a full-flow settling basin, separately, and then mathematically combines the results to obtain one daily value. The facility uses about 0.5 million gallons per day for the trout production.

8.2.2.2 Post-Proposal DMR Data

After the proposal, EPA evaluated TSS concentration data from an additional 51 facilities in the Year 2001 subset of effluent data. EPA obtained these data from EPA regional offices and EPA's Permit Compliance System (PCS), and submitted with comments on the proposal.

If a facility had multiple production and treatment systems or configurations, EPA has treated the data as if they were collected from different facilities because the trains are operated independently with different waste streams. In the documentation, the episode identifier is appended with a character, such as "A", to indicate that the data are from one of the multiple trains (e.g., DMR21A). In addition, each discharge point was assigned a different sample point number (e.g., SP-1, SP-2). For some facilities, EPA received data on the source water, and has designated the sample point to be 'SP-0.' (In the documentation, these data are sometimes identified as 'influent' data.)

In some cases, the reported monitoring frequency was once a month, but the actual sample date was not reported. Or, the monitoring frequency was not reported, but the daily maximum and monthly average values were identical for every month. In these two situations, for purposes of listing the data, EPA assumed that the sample had been collected on the first day of the month. Some other facilities reported the monitoring frequency to be once a week, but did not report the actual sample date. For those facilities, EPA assumed that the samples were collected every 7th day, starting with the 1st day of the month.

8.3 DATA EXCLUSIONS

In some cases, EPA did not use all of the data described in Section 8.2 in calculating the limitations. Other than the data exclusions described in this section, EPA has used the data from the episodes and sample points identified in Section 8.2.

EPA excluded the data for one sample (55949) of the influent during episode 6297 (sample point 12) because it was filtered before measuring the concentration levels. Instead, in its statistical analyses, EPA used the concentration data from another sample (55948) collected at approximately the same time at that sample point, but was not filtered prior to measuring the concentrations.

For the self-monitoring data, EPA compared each reported TSS concentration value to the permit's daily maximum limit. If the concentration value was greater than the limit, EPA excluded the value from its analyses. *DCN 55208: Year 2001 Subset: Comparison of Effluent Data to TSS Daily Maximum Limit in Permit* (SAIC, 2004e) identifies the values that have been excluded.

For two episodes, DMR19 and DMR61, some nondetected measurements were reported as 'zero,' instead of sample-specific detection limits. (See *DCN 55206: Year 2001 Subset: Listing of records with CONC=0 for TSS* (SAIC, 2004f).) Episode DMR19 had only one zero value, and it was for source water. Episode DMR61 had 12 effluent values, of which 8 were reported as 'zero.' EPA calculated episode-specific statistics for this data set, but excluded it from the calculation of configuration long-term averages, variability factors, and numeric limitations.

8.4 DATA AGGREGATION

In some cases, EPA determined that two or more samples had to be mathematically aggregated to obtain a single value that could be used in other calculations. In some cases, this meant that field samples were averaged for a single sample point. In addition, for one facility, data were aggregated to obtain a single daily value representing the facility's influent or effluent from multiple sample points. Appendix C lists the data after these aggregations were completed and a single daily value was calculated. *DCN 55213: Year 2001 Subset: Unaggregated Data for Total Suspended Solids* (SAIC, 2004g) provides the unaggregated data.

In all aggregation procedures, EPA considered the censoring type associated with the data, as well as the measured values to be detected. In statistical terms, the censoring type for such data was NC. Measurements reported as less than some sample-specific detection limit (e.g., <2 milligrams/liter) were censored and were considered to be ND. In the tables and data listings in this document and the record for the rulemaking, EPA has used the abbreviations NC and ND to indicate the censoring types.

The distinction between the two censoring types is important because the procedure used to determine the variability factors considers censoring type explicitly. This estimation procedure modeled the facility data sets using the modified delta-lognormal distribution. In this distribution, data are modeled as a mixture of two distributions. Thus, EPA concluded that the distinctions between detected and nondetected measurements were important and should be an integral part of any data aggregation procedure. (See Appendix E for a detailed discussion of the modified delta-lognormal distribution.)

Because each aggregated data value was entered into the modified delta-lognormal model as a single value, the censoring type associated with that value was also important. In many cases, a single aggregated value was created from unaggregated data that were all

either detected or nondetected. In the remaining cases with a mixture of detected and nondetected unaggregated values, EPA determined that the resulting aggregated value should be considered to be detected because TSS was measured at detectable levels.

This section describes each of the different aggregation procedures. They are presented in the order in which the aggregation was performed: filtrate samples, field duplicates, and multiple sample points.

8.4.1 Aggregation of Filtrate Samples

For SP-12 at episode 6297, the laboratory filtered the samples and processed the aqueous filtrate and filtered solids separately. As a result, for the classical/conventional analytes and the metals pollutants, the laboratory reported two results for each sample. The aqueous filtrate results were reported in weight/volume units (e.g., milligrams/liter), while the filtered solids were reported in weight/weight units (e.g., milligrams/kilogram). EPA aggregated the results as explained in the memorandum *Conversion of Aquaculture Data for Episode 6297* (DynCorp, 2002). *Listing of the Aquatic, Solid, and Combined Filtrate Data for Facility 6297* (SAIC, 2002b) provides the reported (unaggregated) and aggregated values.

8.4.2 Aggregation of Field Duplicates

During the sampling episodes, EPA collected a small number, about ten percent, of field duplicates. Field duplicates are two samples collected from the same sample point at approximately the same time, assigned different sample numbers, and flagged as duplicates for a single sample point at a facility. *DCN 55214: Year 2001 Subset: Individual Field Duplicate Sample Results for Total Suspended Solids* (SAIC, 2004h), provides the individual values for the field duplicates for the sample points identified in Table 8.2–1. (None of the self-monitoring episodes had more than one data value for any day, and thus, this step was not used for self-monitoring episodes.)

Because the analytical data from each duplicate pair characterize the same conditions at the same time at a single sample point, EPA aggregated the data to obtain one data value for those conditions by calculating the arithmetic average of the duplicate pair.

In most cases, both duplicates had the same censoring type. In these cases, the censoring type of the aggregate was the same as the duplicates. In the remaining cases, one duplicate was an NC value and the other duplicate was an ND value. In these cases, EPA determined that the appropriate censoring type of the aggregate was NC because TSS had been present in one sample. (Even if the other duplicate had a zero value,² TSS still would have been present if the samples had been physically combined.) Table 8.4–1 summarizes the procedure for aggregating the analytical results from the field duplicates. This aggregation step for the duplicate pairs was the first step in the aggregation procedures for both influent and effluent measurements.

² This is presented as a “worst-case” scenario. In practice, the laboratories cannot measure ‘zero’ values. Rather they report that the value is less than some level.

Table 8.4–1. Aggregation of Field Duplicates

<i>If the Field Duplicates Are:</i>	<i>Censoring Type of Average is:</i>	<i>Value of Aggregate is:</i>	<i>Formulas for Aggregate Value of Duplicates:</i>
Both NC	NC	Arithmetic average of measured values	$(NC1 + NC2)/2$
Both ND	ND	Arithmetic average of sample-specific detection limits	$(DL1 + DL2)/2$
One NC and one ND	NC	Arithmetic average of measured value and sample-specific detection limit	$(NC + DL)/2$

NC - noncensored (or detected). ND - nondetected. DL - sample-specific detection limit.

8.4.3 Aggregation of Data Across Sample Points (“Flow-Weighting”)

After field duplicates were aggregated, the data from each sample point in facilities with multiple sample points were further aggregated to obtain a single daily value representing the episode’s influent or effluent.

In aggregating values across sample points, if one or more of the values were NC, the aggregated result was considered NC because TSS was present in at least one stream. When all of the values were ND, the aggregated result was considered to be ND. The procedure for aggregating data across streams is summarized in Table 8.4–2. The following example demonstrates the procedure at an episode with discharges on Day 1.

Example of calculating an aggregated flow-weighted value:

Day	Sample Point	Flow (cfs)	Concentration (mg/L)	Censoring
1	Raceway	1	50	NC
1	OLSB	100	10	ND

Calculation to obtain aggregated, flow-weighted value:

$$\frac{(100 \text{ cfs} \times 10 \text{ mg / L}) + (1 \text{ cfs} \times 50 \text{ mg / L})}{100 \text{ cfs} + 1 \text{ cfs}} = 10.4 \text{ mg / L}$$

Because one of the values was NC, the aggregated value of 10.4 milligrams/liter is NC.

Table 8.4–2. Aggregation of Data Across Streams

<i>If the n Observations are:</i>	<i>Censoring Type is:</i>	<i>Formulas for Value of Aggregate</i>
All NC	NC	$\frac{\sum_{i=1}^{n} NC_i \times flow_i}{\sum_{i=1}^{n} flow_i}$
All ND	ND	$\frac{\sum_{i=1}^{n} DL_i \times flow_i}{\sum_{i=1}^{n} flow_i}$
Mixture of k NC and m ND (total number of observations is n=k+m)	NC	$\frac{\sum_{i=1}^{k} NC_i \times flow_i + \sum_{i=1}^{m} DL_i \times flow_i}{\sum_{i=1}^{n} flow_i}$

NC - noncensored (or detected). ND - nondetected. DL - sample-specific detection limit.

8.5 ESTIMATION OF THE NUMERIC LIMITATIONS

In estimating the numeric limitations, EPA first determined an average performance level that a facility with well-designed, well-operated model technologies (which reflect the appropriate level of control) would be capable of achieving. Second, EPA determined an allowance for the variation in TSS concentrations associated with well-operated systems. This allowance for variance incorporates all components of variability, including sampling and analytical variability. Variability factors assure that normal fluctuations in a facility’s systems are accounted for in the limitations. By accounting for these reasonable excursions above the long-term average, EPA’s use of variability factors results in limitations that are generally well above the actual long-term averages. If a facility operates its system to meet the relevant long-term average, EPA expects the facility will have discharges at or below the limitations.

The following sections describe the calculation of the configuration long-term averages and variability factors.

8.5.1 Calculation of Configuration Long-Term Averages

This section discusses the calculation of long-term averages by episode (episode long-term average) and by configuration within each subcategory and option (configuration long-term average). These averages were used to calculate the limitations.

First, EPA calculated the episode long-term average by using either the modified delta-lognormal distribution or the arithmetic average. Listing 8-2 in Appendix D lists the episode long-term averages. EPA has listed the arithmetic average (column labeled “Obs Mean”) and the estimated episode long-term average (column labeled “Est LTA”). If

EPA used the arithmetic average as the episode long-term average, the two columns have the same value.

Second, EPA calculated the configuration long-term average as the median of the episode long-term averages from selected episode data sets that contained effluent data from the configuration. The median is the midpoint of the values ordered (ranked) from smallest to largest. If there is an odd number of values (with n = number of values), the value of the $(n + 1)/2$ ordered observation is the median. If there is an even number of values, the two values of the $n/2$ and $[(n/2)+1]$ ordered observations are arithmetically averaged to obtain the median value.

For example, for subcategory Y configuration X configuration Z, if the four ($n = 4$) episode long-term averages are:

<u>Facility</u>	<u>Episode-Specific Long-Term Average</u>
A	20 mg/L
B	9 mg/L
C	16 mg/L
D	10 mg/L

the ordered values are:

<u>Order</u>	<u>Facility</u>	<u>Episode-Specific Long-Term Average</u>
1	A	9 mg/L
2	B	10 mg/L
3	C	16 mg/L
4	D	20 mg/L

and the configuration long-term average for configuration Z is the median of the ordered values (the average of the 2nd and 3rd ordered values): $(10 + 16)/2$ milligrams/liter = 13 milligrams/liter.

Listing 8-3 in Appendix D provides the *calculated* configuration long-term averages. After calculating the configuration long-term averages, EPA compared these values to the nominal quantitation limit of 4 milligrams/liter in EPA Method 160.2 used to measure TSS concentrations in effluent samples (see Appendix B). EPA has determined that some laboratories, under certain conditions, can measure to levels lower than the nominal quantitation limit. EPA has concluded that these results are quantitatively reliable, and therefore can be used to calculate long-term averages and variability factors. However,

EPA also recognizes that not all laboratories consistently measure to these lower levels. To ensure the numeric limitations reflected “typical” laboratory reporting levels for approved methods in 40 CFR 136 for NPDES compliance monitoring of TSS discharges, EPA ensured that the configuration long-term averages had values equal to or greater than the nominal quantitation limit of 4 milligrams/liter. For configuration 3B (treated raceway effluent), the calculated configuration long-term average was 2.10 milligrams/liter. Because this value is less than 4 milligrams/liter, EPA substituted the value of 4 milligrams/liter as the configuration long-term average. For all other configurations, the calculated configuration long-term averages were equal to or greater than 4 milligrams/liter. Table 8.5–1 provides final configuration long-term averages that EPA considered in its evaluation of the TSS concentration data.

8.5.2 Calculation of Configuration Variability Factors

In developing the configuration variability factors used in calculating the numeric limitations, EPA first developed daily and monthly episode variability factors using the modified delta-lognormal distribution. Listing 8-2 in Appendix D lists the episode variability factors. Appendix E describes the estimation procedure for the episode variability factors using the modified delta-lognormal distribution.

After calculating the episode variability factors, EPA calculated the configuration daily variability factor as the *mean* of the episode daily variability factors for that configuration with the subcategory and option. Likewise, the configuration monthly variability factor was the mean of the episode monthly variability factors for that configuration in the subcategory and option. Listing 8-3 in Appendix D and Table 8.5–1 list the configuration variability factors.

8.5.3 Calculation of Numeric Limitations

EPA calculated each *daily maximum limitation* using the product of the configuration long-term average and the configuration daily variability factor. EPA calculated each concentration-based *monthly average limitation* using the product of the configuration long-term average and the configuration monthly variability factor. Table 8.5–1 provides the configuration long-term average, configuration daily variability factor, and the daily maximum limitation for each configuration.

Table 8.5–1. Configuration Long-Term Averages, Variability Factors, and Numeric Limitations

Subcategory	Option	Configuration	Configuration Long-Term Average (mg/L)	Configuration Variability Factors		Limitations (mg/L)	
				Daily	Monthly	Daily Maximum	Monthly Average
Flow-through	A	2A (OLSB)	22.3	1.48	1.21	33.0	26.9
		3A (Raceway)	4.00	--	--	--	--
		4A (Combined)	9.54	--	--	--	--
	B	2B (OLSB)	26.3	3.24	1.57	85.1	41.2
		3B (Raceway)	4.00	1.99	1.27	8	5
		4B (Combined)	4.17	1.06	1.02	4.44	4.26
Combined	A	2A+6A+7A (Continuous)	22.3	1.48	1.21	33.0	26.9
	B	2B+6B+7B (Continuous)	26.3	3.24	1.57	85.1	41.2

8.6 REFERENCES

- DynCorp, 2002. *Memorandum: Conversion of Aquaculture Data for Episode 6297, from H. McCarty to C. Simbanin, July 24, 2002.*
- SAIC (Science Applications International Corporation, Inc.). 2002a. *Listings for Episode 6297: DMR Data, Summary Statistics, and Estimates.* Reston, VA.
- SAIC (Science Applications International Corporation, Inc.). 2002b. *Listing of the Aquatic, Solid, and Combined Filtrate Data for Facility 6297.* Reston, VA.
- SAIC (Science Applications International Corporation, Inc.). 2004a. *DCN 55101: All Data: Listing of Influent and Effluent TSS Concentration Data.* Reston, VA.
- SAIC (Science Applications International Corporation, Inc.). 2004b. *DCN 55107: Compact Disk with Data from DCN 55101.* Reston, VA.
- SAIC (Science Applications International Corporation, Inc.). 2004c. *DCN 55207: Compact Disk with Data from Appendix C of the Technical Development Document.* Reston, VA.
- SAIC (Science Applications International Corporation, Inc.). 2004d. *DCN55209: Episode 6460 Concentration values of TSS reported on 8/27/2001.* Reston, VA.
- SAIC (Science Applications International Corporation, Inc.). 2004e. *DCN55208: Year 2001 Subset: Comparison of Effluent Data to TSS Daily Maximum Limit in Permit.* Reston, VA.
- SAIC (Science Applications International Corporation, Inc.). 2004f. *DCN55206: Year 2001 Subset: Listing of records with CONC=0 for TSS.* Reston, VA.
- SAIC (Science Applications International Corporation, Inc.). 2004g. *DCN 55213: Year 2001 Subset: Unaggregated Data for Total Suspended Solids.* Reston, VA.

SAIC (Science Applications International Corporation, Inc.). 2004h. DCN 55214: Year 2001 Subset: Individual Field Duplicate Samples Results for Total Suspended Solids. Reston, VA.