

these classes of products, a small business manufacturer must have submitted a proposal for a contract solicitation or received a contract from the Federal government within the last 24 months. The SBA defines "class of products" based on a six digit North American Industry Classification System (NAICS) and the four digit Product and Service Code established by the Federal Procurement Data System.

The U.S. Small Business Administration is currently processing a request to waive the Nonmanufacturer Rule for Other Ordnance and Accessories Manufacturing, NAICS 332995.

Linda G. Williams,

Associate Administrator for Government Contracting.

[FR Doc. 03-16717 Filed 7-1-03; 8:45 am]

BILLING CODE 8025-01-P

DEPARTMENT OF TRANSPORTATION

Federal Aviation Administration

14 CFR Part 39

[Docket No. 2003-NE-21-AD; Amendment 39-13183; AD 2003-11-23]

RIN 2120-AA64

Airworthiness Directives; International Aero Engines AG (IAE) V2522-A5, V2524-A5, V2527-A5, V2527E-A5, V2527M-A5, V2530-A5, and V2533-A5 Turbofan Engines; Correction

AGENCY: Federal Aviation Administration, DOT.

ACTION: Final rule; correction

SUMMARY: This document makes a correction to Airworthiness Directive (AD) 2003-11-23 applicable to IAE V2522-A5, V2524-A5, V2527-A5, V2527E-A5, V2527M-A5, V2530-A5, and V2533-A5 turbofan engines that was published in the **Federal Register** on June 5, 2003 (68 FR 33621). The lists of engine models in the Airworthiness Directives title, the Summary, the Supplementary Information, and the Applicability section are incorrect. This document corrects those listings. Also, paragraph (c) of the regulatory text was incorrectly printed as run-in with the heading Applicability. In all other respects, the original document remains the same.

EFFECTIVE DATE: Effective June 20, 2003.

FOR FURTHER INFORMATION CONTACT: Glorianne Niebuhr, Aerospace Engineer, Engine Certification Office, FAA, Engine and Propeller Directorate, 12 New

England Executive Park, Burlington, MA 01803; telephone (781) 238-7132; fax (781) 238-7199.

SUPPLEMENTARY INFORMATION: A final rule AD, FR Doc. 03-14133 applicable to IAE V2522-A5, V2524-A5, V2527-A5, V2527E-A5, V2527M-A5, V2530-A5, and V2533-A5 turbofan engines, was published in the **Federal Register** on June 5, 2003 (68 FR 33621). The following correction is needed:

§ 39.13 [Corrected]

On page 33621, in the third column, in the Heading Section, in the Airworthiness Directives title, "International Aero Engines AG (IAE) V2522-A5, V2524-A5, V2527-A5, V2527E-A5, V2527M-A5, and V2530-A5 Turbofan Engines" is corrected to read "International Aero Engines AG (IAE) V2522-A5, V2524-A5, V2527-A5, V2527E-A5, V2527M-A5, V2530-A5, and V2533-A5 Turbofan Engines". In the same column, in the Summary section, in the fourth and fifth lines, "V2527E-A5, V2527M-A5, and V2530-A5 turbofan engines" is corrected to read "V2527E-A5, V2527M-A5, V2530-A5, and V2533-A5 turbofan engines".

On page 33622, in the first column, in the Supplementary Information section, in third and fourth lines, change "V2527-A5, V2527E-A5, V2527M-A5, and V2530-A5" to "V2527-A5, V2527E-A5, V2527M-A5, V2530-A5, and V2533-A5". In the same column, third paragraph, fourth and fifth lines, change "V2527-A5, V2527E-A5, V2527M-A5, and V2530-A5" to "V2527-A5, V2527E-A5, V2527M-A5, V2530-A5, and V2533-A5".

Issued in Burlington, MA, on June 26, 2003.

Francis A. Favara,

Acting Manager, Engine and Propeller Directorate, Aircraft Certification Service.

[FR Doc. 03-16690 Filed 7-1-03; 8:45 am]

BILLING CODE 4910-13-P

DEPARTMENT OF TRANSPORTATION

Federal Aviation Administration

14 CFR Part 39

[Docket No. 2003-SW-17-AD; Amendment 39-13215; AD 2003-08-51]

RIN 2120-AA64

Airworthiness Directives; MD Helicopters, Inc. Model 369A, D, E, H, HE, HM, HS, F, and FF Helicopters

AGENCY: Federal Aviation Administration, DOT.

ACTION: Final rule; request for comments.

SUMMARY: This document publishes in the **Federal Register** an amendment adopting Airworthiness Directive (AD) 2003-08-51, which was sent previously to all known U.S. owners and operators of the specified model MD Helicopters, Inc. helicopters by individual letters. This AD requires reducing the retirement life of certain tail rotor blades, performing a one-time visual inspection of each tail rotor blade pitch horn (pitch horn) for a crack or corrosion, and replacing unairworthy tail rotor blades with airworthy tail rotor blades. This AD also requires revising the Airworthiness Limitations section of the helicopter maintenance manual to reflect the reduced retirement life, and reporting information to the FAA within 24 hours following the one-time inspection. The actions specified by this AD are intended to prevent a pitch horn from separating from the tail rotor blade, leading to an unbalanced condition, vibration, loss of tail rotor pitch control, and loss of directional control of the helicopter.

DATES: Effective July 17, 2003, to all persons except those persons to whom it was made immediately effective by Emergency AD 2003-08-51, issued on April 15, 2003, which contained the requirements of this amendment.

Comments for inclusion in the Rules Docket must be received on or before September 2, 2003.

ADDRESSES: Submit comments in triplicate to the Federal Aviation Administration (FAA), Office of the Regional Counsel, Southwest Region, Attention: Rules Docket No. 2003-SW-17-AD, 2601 Meacham Blvd., Room 663, Fort Worth, Texas 76137. You may also send comments electronically to the Rules Docket at the following address: 9-asw-adcomments@faa.gov.

FOR FURTHER INFORMATION CONTACT: Fred Guerin, Aviation Safety Engineer, FAA, Los Angeles Aircraft Certification Office, Airframe Branch, 3960 Paramount Blvd., Lakewood, California 90712, telephone (562) 627-5232, fax (562) 627-5210.

SUPPLEMENTARY INFORMATION: On April 15, 2003, the FAA issued Emergency AD 2003-08-51 for the specified model helicopters, which requires, before further flight, reducing the retirement life of certain tail rotor blades from 5,140, 5,200, or 10,000 hours time-in-service (TIS) to 400 hours TIS, performing a one-time visual inspection of each pitch horn for a crack or corrosion, and replacing unairworthy tail rotor blades with airworthy tail rotor blades. The Emergency AD also requires revising the Airworthiness Limitations section of the helicopter maintenance

manual to reflect the reduced retirement life, and reporting information to the FAA within 24 hours following the one-time inspection. That action was prompted by two reports of cracked pitch horns that failed during flight. In both occurrences, the pilot was able to land the helicopter without further incident. Investigation revealed that the cause of the failures was a fatigue crack in the pitch horns that developed before the tail rotor blade reached its retirement life. This condition, if not corrected, could result in a pitch horn separating from the tail rotor blade, leading to an unbalanced condition, vibration, loss of tail rotor pitch control, and loss of directional control of the helicopter.

Since the unsafe condition described is likely to exist or develop on other MD Helicopters, Inc. Model 369A, D, E, H, HE, HM, HS, F, and FF helicopters of the same type designs, the FAA issued Emergency AD 2003-08-51 to prevent a pitch horn from separating from the tail rotor blade, leading to an unbalanced condition, vibration, loss of tail rotor pitch control, and loss of directional control of the helicopter. The AD requires, before further flight, reducing the retirement life of certain tail rotor blades from 5,140, 5,200, or 10,000 hours TIS to 400 hours TIS, performing a one-time visual inspection of each pitch horn for a crack or corrosion, and replacing unairworthy tail rotor blades with airworthy tail rotor blades. The AD also requires revising the Airworthiness Limitations section of the helicopter maintenance manual to reflect the reduced retirement life, and reporting information to the FAA within 24 hours following the one-time inspection. The short compliance time involved is required because the previously described critical unsafe condition can adversely affect the structural integrity of the helicopter. Therefore, reducing the retirement life of certain tail rotor blades; performing a one-time visual inspection of each pitch horn; replacing unairworthy tail rotor blades; and revising the Airworthiness Limitations section of the helicopter maintenance manual to reflect the reduced retirement life are required before further flight, and this AD must be issued immediately.

Since it was found that immediate corrective action was required, notice and opportunity for prior public comment thereon were impracticable and contrary to the public interest, and good cause existed to make the AD effective immediately by individual letters issued on April 15, 2003, to all known U.S. owners and operators of MD Helicopters, Inc. Model 369A, D, E, H,

HE, HM, HS, F, and FF helicopters. These conditions still exist, and the AD is hereby published in the **Federal Register** as an amendment to 14 CFR 39.13 to make it effective to all persons.

The Emergency AD contained two typographical errors that are corrected in this AD. Paragraph (c) of the Emergency AD stated "400 hours TIS" twice, and the "or" in the listing of part numbers should have been "and".

On July 10, 2002, the FAA issued a new version of 14 CFR part 39 (67 FR 47997, July 22, 2002), which governs the FAA's AD system. The regulation now includes material that relates to altered products, special flight permits, and alternative methods of compliance. Because we have now included this material in part 39, we no longer need to include it in each individual AD.

The FAA estimates that this AD will affect 213 helicopters of U.S. registry, and replacing the tail rotor blades will take approximately 2 work hours per helicopter to accomplish at an average labor rate of \$60 per work hour. Required parts will cost approximately \$2,000 per helicopter. Based on these figures, we estimate the total cost impact of the AD on U.S. operators to be \$2,120 per helicopter, or \$451,560 to replace all the blades in the fleet.

Comments Invited

Although this action is in the form of a final rule that involves requirements affecting flight safety and, thus, was not preceded by notice and an opportunity for public comment, comments are invited on this rule. Interested persons are invited to comment on this rule by submitting such written data, views, or arguments as they may desire. Communications should identify the Rules Docket number and be submitted in triplicate to the address specified under the caption **ADDRESSES**. All communications received on or before the closing date for comments will be considered, and this rule may be amended in light of the comments received. Factual information that supports the commenter's ideas and suggestions is extremely helpful in evaluating the effectiveness of the AD action and determining whether additional rulemaking action would be needed.

Comments are specifically invited on the overall regulatory, economic, environmental, and energy aspects of the rule that might suggest a need to modify the rule. All comments submitted will be available in the Rules Docket for examination by interested persons. A report that summarizes each FAA-public contact concerned with the

substance of this AD will be filed in the Rules Docket.

Commenters wishing the FAA to acknowledge receipt of their mailed comments submitted in response to this rule must submit a self-addressed, stamped postcard on which the following statement is made: "Comments to Docket No. 2003-SW-17-AD." The postcard will be date stamped and returned to the commenter.

The regulations adopted herein will not have a substantial direct effect on the States, on the relationship between the national Government and the States, or on the distribution of power and responsibilities among the various levels of government. Therefore, it is determined that this final rule does not have federalism implications under Executive Order 13132.

The FAA has determined that this regulation is an emergency regulation that must be issued immediately to correct an unsafe condition in aircraft, and that it is not a "significant regulatory action" under Executive Order 12866. It has been determined further that this action involves an emergency regulation under DOT Regulatory Policies and Procedures (44 FR 11034, February 26, 1979). If it is determined that this emergency regulation otherwise would be significant under DOT Regulatory Policies and Procedures, a final regulatory evaluation will be prepared and placed in the Rules Docket. A copy of it, if filed, may be obtained from the Rules Docket at the location provided under the caption **ADDRESSES**.

List of Subjects in 14 CFR Part 39

Air transportation, Aircraft, Aviation safety, Safety.

Adoption of the Amendment

■ Accordingly, pursuant to the authority delegated to me by the Administrator, the Federal Aviation Administration amends part 39 of the Federal Aviation Regulations (14 CFR part 39) as follows:

PART 39—AIRWORTHINESS DIRECTIVES

■ 1. The authority citation for part 39 continues to read as follows:

Authority: 49 U.S.C. 106(g), 40113, 44701.

§ 39.13 [Amended]

■ 2. Section 39.13 is amended by adding a new airworthiness directive to read as follows:

2003-08-51 MD Helicopters, Inc.:
Amendment 39-13215. Docket No. 2003-SW-17-AD.

Applicability: Model 369A, D, E, H, HE, HM, HS, F, and FF helicopters, with tail rotor blades, part number (P/N) 369D21640-501, 369D21641-501, 369D21642-501, 369D21643-501, 500P3100-101, 500P3100-301, 500P3300-501, or 500P3500-701, installed, certificated in any category.

Compliance: Required as indicated, unless accomplished previously.

To prevent a tail rotor blade pitch horn (pitch horn) from separating from the tail

rotor blade, leading to an unbalanced condition, vibration, loss of tail rotor pitch control, and loss of directional control of the helicopter, accomplish the following:

(a) This airworthiness directive (AD) establishes a new retirement life of 400 hours time-in-service (TIS) for the tail rotor blades listed in the Applicability section. For helicopters with an affected tail rotor blade installed that has 390 through 700 hours TIS, remove and replace the tail rotor blade with

an airworthy tail rotor blade within 10 hours TIS.

(b) Before further flight, perform a one-time visual inspection of each pitch horn for a crack or corrosion in the area indicated by Note 2 in Figure 1 of this AD. Paint removal in accordance with Note 1 of Figure 1 of this AD is not required for the visual inspection.

BILLING CODE 4910-13-P

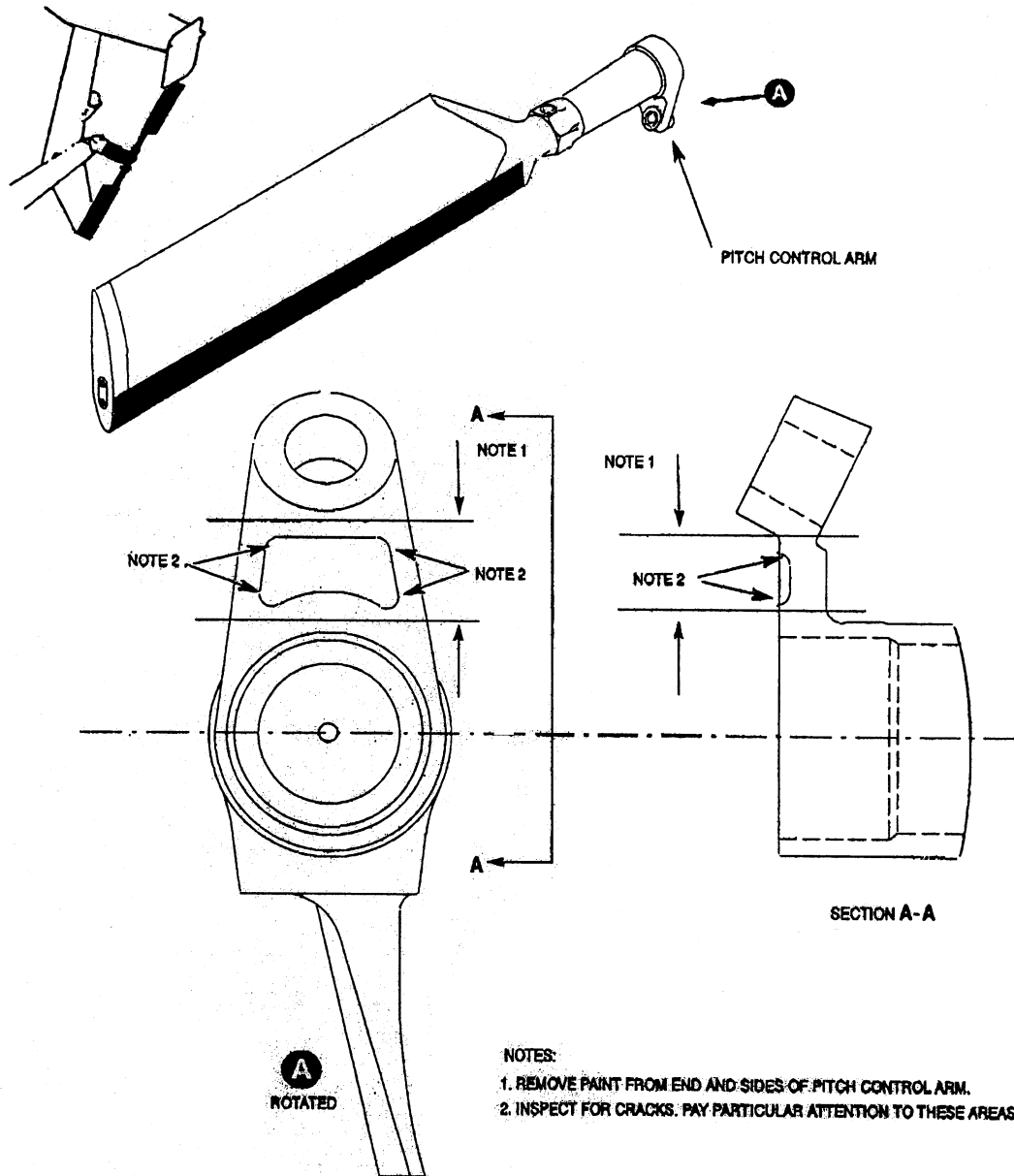

Figure 1. Tail Rotor Blade Assembly Inspection

BILLING CODE 4910-13-C

(c) Revise the helicopter Airworthiness Limitations section of the maintenance manual by making pen-and-ink changes to indicate the new retirement life of 400 hours TIS for the tail rotor blades, P/N 369D21640-

501, 369D21641-501, 369D21642-501, 369D21643-501, 500P3100-101, 500P3100-301, 500P3300-501, and 500P3500-70.

(d) For helicopters with a tail rotor blade installed that has more than 700 hours TIS, a one-time special flight permit to fly it to a

repair facility may be issued only upon completion of an eddy current surface scan of each affected pitch horn (see Figure 1 of this AD). Paint removal in accordance with Note 1 of the Figure 1 of this AD IS required for the surface scan. If a crack is found,

remove the tail rotor blade and replace it with an airworthy tail rotor blade before further flight.

(e) Within 24 hours after completing the requirements of this Emergency AD, report the information requested in Appendix A for all tail rotor blades listed in the Applicability section, including the tail rotor blades that were removed as a result of this AD. Report the information to: Manager, Los Angeles Aircraft Certification Office, ATTN: Fred Guerin, 3960 Paramount Blvd., Lakewood, California 90712, telephone (562) 627-5232. Reports may also be faxed to (562) 627-5210 or emailed to fred.guerin@faa.gov.

(f) Information collection requirements contained in this AD have been approved by the Office of Management and Budget (OMB) under the provisions of the Paperwork Reduction Act of 1980 (44 U.S.C. 3501 *et seq.*) and have been assigned OMB Control Number 2120-0056.

(g) To request a different method of compliance or a different compliance time for this AD, follow the procedures in 14 CFR 39.19. Contact the Los Angeles Aircraft Certification Office, Transport Airplane Directorate, FAA, for information about previously approved alternative methods of compliance.

(h) This amendment becomes effective on July 17, 2003, to all persons except those persons to whom it was made immediately effective by Emergency AD 2003-08-51, issued April 15, 2003, which contained the requirements of this amendment.

Appendix A—Tail Rotor Blade Inspection (Sample Format)

Send within 24 hours to:

Manager, Los Angeles Aircraft Certification Office, ATTN: Fred Guerin, 3960 Paramount Blvd., Lakewood, California 90712.

Fax: (562) 627-5210.

Email: fred.guerin@faa.gov.

Date:

Operator or Company Name:

Name of Contact Person:

Address:

Telephone:

Fax:

Aircraft Serial Number:

Aircraft Registration Number:

Estimated average flight hours per year:

T/R Blade Part Number: Serial Number:

Total Time:

Crack found? (Yes/No): Corrosion Found? (Yes/No)

T/R Blade Part Number: Serial Number:

Total Time:

Crack found? (Yes/No): Corrosion Found? (Yes/No)

T/R Blade Part Number: Serial Number:

Total Time:

Crack found? (Yes/No): Corrosion Found? (Yes/No)

T/R Blade Part Number: Serial Number:

Total Time:

Crack found? (Yes/No): Corrosion Found? (Yes/No)

Comments/Additional Information:

Issued in Fort Worth, Texas, on June 3, 2003.

Mark R. Schilling,

*Acting Manager, Rotorcraft Directorate,
Aircraft Certification Service.*

[FR Doc. 03-16687 Filed 7-1-03; 8:45 am]

BILLING CODE 4910-13-P

DEPARTMENT OF THE TREASURY

Internal Revenue Service

26 CFR Part 1

[TD 9066]

RIN 1545-BA79

Outbound Liquidations Into Foreign Corporations

AGENCY: Internal Revenue Service (IRS), Treasury.

ACTION: Final regulations.

SUMMARY: This document contains final regulations that provide guidance regarding the application of section 367(e)(2) to certain outbound liquidations. The regulations amend the anti-abuse rule by narrowing the scope of the rule to apply only to outbound transfers to a foreign corporation in a complete liquidation of a domestic corporation in which a principal purpose of the liquidation is the avoidance of U.S. tax. The regulations also clarify the application of the anti-abuse rule.

DATES: Effective Date: July 2, 2003.

Applicability Date: These regulations apply to distributions occurring on or after September 7, 1999, or, if the taxpayer has elected to apply the final regulations issued pursuant to TD 8834 to such distributions, to distributions in taxable years ending after August 8, 1999.

FOR FURTHER INFORMATION CONTACT: Milton M. Cahn, (202) 622-3860 (not a toll-free number).

SUPPLEMENTARY INFORMATION:

Background

On August 9, 1999, the IRS and Treasury published final regulations (TD 8834 in the **Federal Register** at 64 FR 43072) under section 367(e)(2) regarding distributions of property in a complete liquidation under section 332 by a domestic corporation to a foreign parent corporation (outbound liquidation) and by a foreign corporation to a foreign parent corporation (foreign-to-foreign liquidations). On November 20, 2002, the IRS and Treasury published a notice of proposed rulemaking (REG-127380-

02 in the **Federal Register** at 67 FR 70031) that would amend an anti-abuse rule in the final regulations to limit its application only to outbound liquidations of domestic corporations, and to clarify what constitutes a principal purpose of tax avoidance for purposes of the anti-abuse rule.

Explanation of Provisions

The final regulations published in 1999 included an anti-abuse rule providing that the Commissioner may require a foreign or domestic liquidating corporation to recognize gain (or treat the liquidating corporation as if it had recognized a loss) on a liquidating distribution if a principal purpose of the liquidation is the avoidance of U.S. tax. § 1.367(e)-2(d). The notice of proposed rulemaking proposed amending the anti-abuse rule under § 1.367(e)-2(d) to limit the application of this rule to outbound liquidations of domestic corporations. The notice of proposed rulemaking also proposed clarifying what constitutes a principal purpose for purposes of the anti-abuse rules in § 1.367(e)-2(d) and § 1.367(e)-2(b)(2)(iii)(C)(1). One written comment responding to the notice of proposed rulemaking was received, but this comment did not request any changes. The public hearing was canceled because no requests were received to speak at the hearing. Accordingly, the proposed regulations are adopted by this Treasury decision without change.

Special Analyses

It has been determined that this Treasury decision is not a significant regulatory action as defined in Executive Order 12866. Therefore, a regulatory assessment is not required. It has also been determined that section 553(b) of the Administrative Procedure Act (5 U.S.C. chapter 5) does not apply to this regulation, and because the regulation does not impose a collection of information on small entities, the Regulatory Flexibility Act (5 U.S.C. chapter 6) does not apply.

Drafting Information

The principal author of these final regulations is Aaron A. Farmer of the Office of the Associate Chief Counsel (International), IRS. However, other personnel from the Treasury and the IRS participated in their development.

List of Subjects in 26 CFR Part 1

Income taxes, Reporting and recordkeeping requirements.