

RULES FOR WHICH COMMENT IS REQUESTED NOW
[Consumer Protection: Lending-Related Rules Category]

Subject	National banks	State member banks	State non-member banks	Thrifts	Holding companies bank ⁴ thrift
Consumer Protection: Lending-Related Rules					
Interagency Regulations					
Fair Housing	12 CFR Part 27	12 CFR Part 338	12 CFR Part 528 (including other non-discrimination requirements).	
Loans in Identified Flood Hazard Areas.	12 CFR Part 22	12 CFR 208.25 [Reg. H].	12 CFR Part 339	12 CFR Part 572.	
Board Regulations					
Consumer Leasing ...	12 CFR Part 213 [Reg. M].	12 CFR Part 213 [Reg. M].	12 CFR Part 213 [Reg. M].	12 CFR Part 213 [Reg. M].	12 CFR Part 213 [Reg. M].
Equal Credit Opportunity.	12 CFR Part 202 [Reg. B].	12 CFR Part 202 [Reg. B].	12 CFR Part 202 [Reg. B].	12 CFR Part 202 [Reg. B].	12 CFR Part 213 [Reg. M].
Home Mortgage Disclosure Act.	12 CFR Part 203 [Reg. C].	12 CFR Part 203 [Reg. C].	12 CFR Part 203 [Reg. C].	12 CFR Part 203 [Reg. C].	12 CFR Part 202 [Reg. B].
Truth in Lending	12 CFR Part 226 [Reg. Z].	12 CFR Part 226 [Reg. Z].	12 CFR Part 226 [Reg. Z].	12 CFR Part 226 [Reg. Z].	12 CFR Part 202 [Reg. B].
Unfair or Deceptive Acts or Practices.	12 CFR 227.11-16 [Reg. AA, Subpart B].	12 CFR 227.11-16 [Reg. AA, Subpart B].	12 CFR 227.11-16 [Reg. AA, Subpart B].		12 CFR Part 203 [Reg. C].
OTS Regulations					
Unfair or Deceptive Acts or Practices.	12 CFR Part 535.	12 CFR Part 226 [Reg. Z].

⁴ Foreign banking organizations that conduct banking operations in the U.S., either directly through branches and agencies or indirectly through U.S. bank subsidiaries or commercial lending company subsidiaries, generally are subject to the same regulatory regime as domestic bank holding companies.

Dated: January 14, 2004.

John D. Hawke, Jr.

Comptroller of the Currency.

By order of the Board of Governors of the Federal Reserve System on January 7, 2004.

Jennifer J. Johnson,

Secretary of the Board.

By order of the Board of Directors, Federal Deposit Insurance Corporation.

Dated at Washington, DC, this 2nd day of December, 2003.

Robert E. Feldman,

Executive Secretary.

Dated: December 17, 2003.

By the Office of Thrift Supervision.

Richard M. Riccobono,

Deputy Director.

[FR Doc. 04-1161 Filed 1-20-04; 8:45 am]

BILLING CODE 4810-33-P; 6210-01-P; 6714-01-P; 6720-01-P

DEPARTMENT OF TRANSPORTATION

Federal Aviation Administration

14 CFR Part 39

[Docket No. 2003-SW-23-AD]

RIN 2120-AA64

Airworthiness Directives; Bell Helicopter Textron, a Division of Textron Canada Model 222, 222B, 222U and 230 Helicopters

AGENCY: Federal Aviation Administration, DOT.

ACTION: Notice of proposed rulemaking (NPRM).

SUMMARY: This document proposes superseding an existing airworthiness directive (AD) for Bell Helicopter Textron, a Division of Textron Canada (BHTC) Model 222, 222B, 222U, and 230 helicopters. That AD currently requires a visual check of each main

rotor grip (grip) and pitch horn assembly without disassembling the main rotor hub assembly (hub assembly), and a visual inspection at specified intervals of each affected grip and pitch horn assembly for a crack using a 10-power or higher magnifying glass. If a crack is found, the existing AD requires replacing each unairworthy grip or pitch horn with an airworthy part before further flight. This action would require those same actions, and would also require an additional inspection of the grip and pitch horn assembly for a crack in the disassembled hub assembly, and replacing any cracked part with an airworthy part. This proposal is prompted by determination that an additional enhanced inspection is needed to ensure the integrity of the hub assembly. The actions specified by the proposed AD are intended to prevent failure of the grip or pitch horn and subsequent loss of control of the helicopter.

DATES: Comments must be received on or before March 22, 2004.

ADDRESSES: Submit comments in triplicate to the Federal Aviation Administration (FAA), Office of the Regional Counsel, Southwest Region, Attention: Rules Docket No. 2003-SW-23-AD, 2601 Meacham Blvd., Room 663, Fort Worth, Texas 76137. You may also send comments electronically to the Rules Docket at the following address: 9-asw-adcomments@faa.gov. Comments may be inspected at the Office of the Regional Counsel between 9 a.m. and 3 p.m., Monday through Friday, except Federal holidays.

FOR FURTHER INFORMATION CONTACT: Charles Harrison, Aviation Safety Engineer, FAA, Rotorcraft Directorate, Safety Management Group, Fort Worth, Texas 76193-0110, telephone (817) 222-5128, fax (817) 222-5961.

SUPPLEMENTARY INFORMATION:

Comments Invited

Interested persons are invited to participate in the making of the proposed rule by submitting such written data, views, or arguments as they may desire. Communications should identify the Rules Docket number and be submitted in triplicate to the address specified above. All communications received on or before the closing date for comments will be considered before taking action on the proposed rule. The proposals contained in this document may be changed in light of the comments received.

Comments are specifically invited on the overall regulatory, economic, environmental, and energy aspects of the proposed rule. All comments submitted will be available, both before and after the closing date for comments, in the Rules Docket for examination by interested persons. A report summarizing each FAA-public contact concerned with the substance of this proposal will be filed in the Rules Docket.

Commenters wishing the FAA to acknowledge receipt of their mailed comments submitted in response to this proposal must submit a self-addressed, stamped postcard on which the following statement is made: "Comments to Docket No. 2003-SW-23-AD." The postcard will be date stamped and returned to the commenter.

Discussion

On July 25, 2002, the FAA issued AD 2002-08-54, Amendment 39-12835 (67 FR 50793, August 6, 2002), with a correction published on August 21, 2002 (67 FR 54259), to require, before

further flight and at specified intervals, visually checking each affected grip and pitch horn for a crack. The AD also requires using a 10-power or higher magnifying glass to visually inspect each affected grip and pitch horn for a crack at specified intervals. If a crack is found, the AD requires replacing each unairworthy grip or pitch horn with an airworthy part before further flight. That action was prompted by three reports of a fatigue crack in the grip and pitch horn found during a routine inspection of the rotor head. The requirements of that AD are intended to prevent failure of the grip or pitch horn and subsequent loss of control of the helicopter.

Since issuing that AD, the manufacturer has determined that a newly developed, enhanced inspection should be required at 2,500 hours time-in-service (TIS) to ensure integrity of the hub assembly. The additional inspections are added to detect cracks that may not be discovered through visual inspections or visual inspections using a magnifying glass with the rotor head assembled, as is currently required.

Transport Canada, the airworthiness authority for Canada, notified the FAA that an unsafe condition may exist on these helicopter models. Transport Canada advises of the need for repeated daily checks and visual inspections at specified intervals, as well as enhanced inspections at specified intervals, of the grip and pitch horn for a crack until the cause of the premature failures is determined. Transport Canada classified these alert service bulletins as mandatory and issued AD No. CF-2002-23R1, dated May 7, 2003, to ensure the continued airworthiness of these helicopters.

These helicopter models are manufactured in Canada and are type certificated for operation in the United States under the provisions of 14 CFR 21.29 and the applicable bilateral agreement. Pursuant to the applicable bilateral agreement, Transport Canada has kept the FAA informed of the situation described above. The FAA has examined the findings of Transport Canada, reviewed all available information, and determined that AD action is necessary for products of these type designs that are certificated for operation in the United States.

This previously described unsafe condition is likely to exist or develop on other helicopters of the same type design. Therefore, the proposed AD would supersede AD 2002-08-54 to require, before further flight and at specified intervals, visually checking each affected grip and pitch horn for a crack. This proposed AD would also

require using a 10-power or higher magnifying glass to visually inspect each affected grip and pitch horn for a crack at specified intervals. If a crack is found, this proposed AD would require replacing each cracked part with an airworthy part before further flight. Additionally, this proposed AD would require, for main rotor hubs with 2,500 or more and less than 4,500 hours TIS, within 300 hours TIS or 6 months, whichever occurs first, inspecting for a crack, and if a crack is found, replacing the grip, pitch horn, or attachment bolts with an airworthy part before further flight. Main rotor hubs with less than 2,500 hours TIS would have to be inspected using a magnetic particle or fluorescent penetrant method upon the accumulation of 2,500 hours TIS.

An owner/operator (pilot) may perform the visual check required by paragraph (a) of this proposed AD. The pilot must enter compliance with paragraph (a) of this AD into the helicopter maintenance records in accordance with 14 CFR 43.11 and 91.417(a)(2)(v)). A pilot may perform this check because it involves only a visual check for a crack in the grip or pitch horn and can be performed equally well by a pilot or a mechanic.

The FAA estimates that this proposed AD would affect 107 helicopters of U.S. registry, and the proposed actions would take approximately 32 work hours per helicopter to accomplish at an average labor rate of \$65 per work hour. The cost of the main rotor grip would be either \$26,226 or \$37,748 and the cost of a pitch horn would be either \$6,863 or \$15,281 (2 pitch horns and 2 grips per helicopter). Based on these figures, the total cost impact of the proposed AD on U.S. operators would be an estimated \$2,080 per helicopter each year or \$222,560 for the entire fleet, and if all parts were replaced, would be \$11,570,766, assuming the most expensive grips and pitch horns were required.

The regulations proposed herein would not have a substantial direct effect on the States, on the relationship between the national Government and the States, or on the distribution of power and responsibilities among the various levels of government. Therefore, it is determined that this proposal would not have federalism implications under Executive Order 13132.

For the reasons discussed above, I certify that this proposed regulation (1) is not a "significant regulatory action" under Executive Order 12866; (2) is not a "significant rule" under the DOT Regulatory Policies and Procedures (44 FR 11034, February 26, 1979); and (3) if promulgated, will not have a significant

economic impact, positive or negative, on a substantial number of small entities under the criteria of the Regulatory Flexibility Act. A copy of the draft regulatory evaluation prepared for this action is contained in the Rules Docket. A copy of it may be obtained by contacting the Rules Docket at the location provided under the caption ADDRESSES.

List of Subjects in 14 CFR Part 39

Air transportation, Aircraft, Aviation safety, Safety.

The Proposed Amendment

Accordingly, pursuant to the authority delegated to me by the Administrator, the Federal Aviation Administration proposes to amend part 39 of the Federal Aviation Regulations (14 CFR part 39) as follows:

PART 39—AIRWORTHINESS DIRECTIVES

1. The authority citation for part 39 continues to read as follows:

Authority: 49 U.S.C. 106(g), 40113, 44701.

§ 39.13 [Amended]

2. Section 39.13 is amended by removing Amendment 39–12835 (67 FR 50793, August 6, 2002), and by adding a new airworthiness directive (AD), to read as follows:

Bell Helicopter Textron, a Division of Textron Canada: Docket No. 2003–SW–23–AD. Supersedes AD 2002–08–54, Amendment 39–12835, Docket No. 2002–SW–22–AD.

Applicability: The following model helicopters with the listed part number (P/N) installed, certificated in any category:

Model	With hub assembly P/N	With grip assembly P/N	With pitch horn assembly P/N
(1) 222 or 222B	222–011–101–103, –105, 107, or –109; 222–012–101–103, or –107.	222–010–104–105; 222–012–104–101	222–011–104–101; 222–012–102–101.
(2) 222U	222–011–101–105, –107, or –109; 222–012–101–103, or –107.	222–010–104–105; 222–012–104–101	222–011–104–101; 222–012–102–101.
(3) 230	222–012–101–105, or –109	222–012–104–101	222–012–102–101.

Compliance: Required as indicated, unless accomplished previously.

To prevent failure of the grip or pitch horn and subsequent loss of control of the helicopter, if either the grip or pitch horn has accumulated 1,250 or more hours time-in-

service (TIS) since initial installation on any helicopter, accomplish the following:

(a) Before further flight and thereafter at intervals not to exceed 8 hours TIS:

(1) Wipe clean the main rotor grip and pitch horn surfaces to remove grease and dirt

in the check area as shown in Figure 1 of this AD:

BILLING CODE 4910–13–P

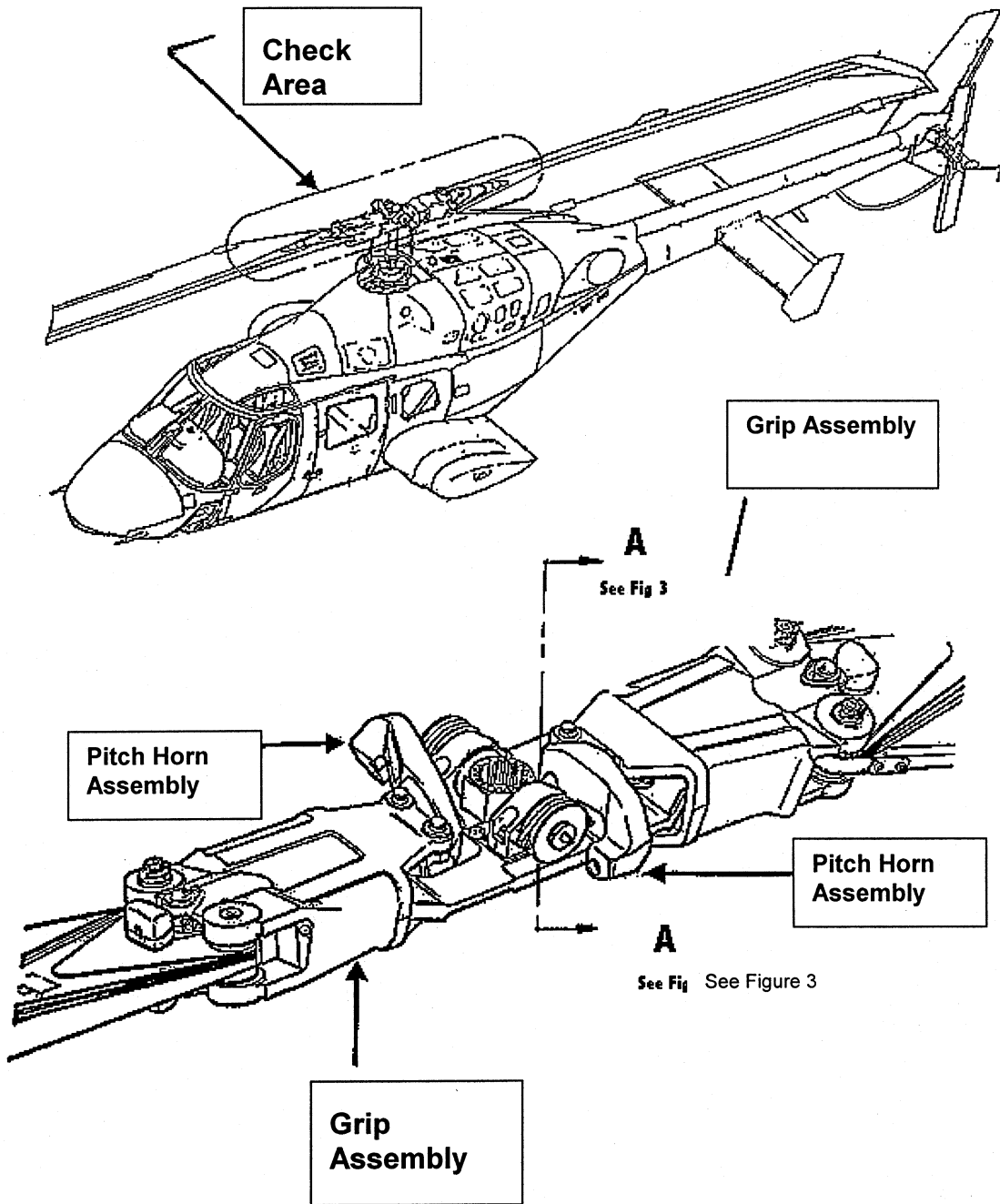
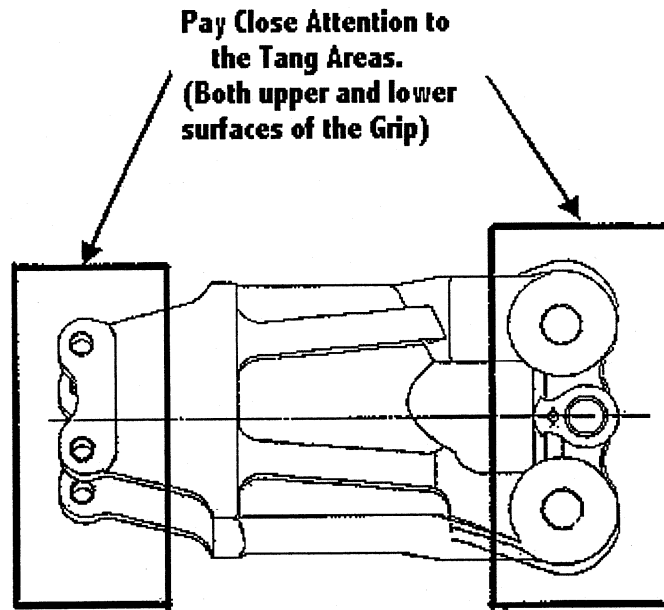

Figure 1

(2) Visually check both main rotor grips for a crack. Pay particular attention to the inboard and outboard tangs portions of the

grip, which are in direct contact with the pitch horns and the main rotor blades and check the area to at least 3 inches beyond the

grip to pitch and grip to blade contact areas as shown in Figure 2 of this AD:



Main Rotor Grip

Entire surface of the grip must be checked

Figure 2

(3) Visually check all visible portions of each pitch horn for a crack. Pay particular attention to the attachment lugs of the pitch

horns, which are in direct contact with the inboard tangs of the main rotor grips, as shown in Figure 3 of this AD, and the four

large bolt cutouts, as shown in Figure 4 of this AD:

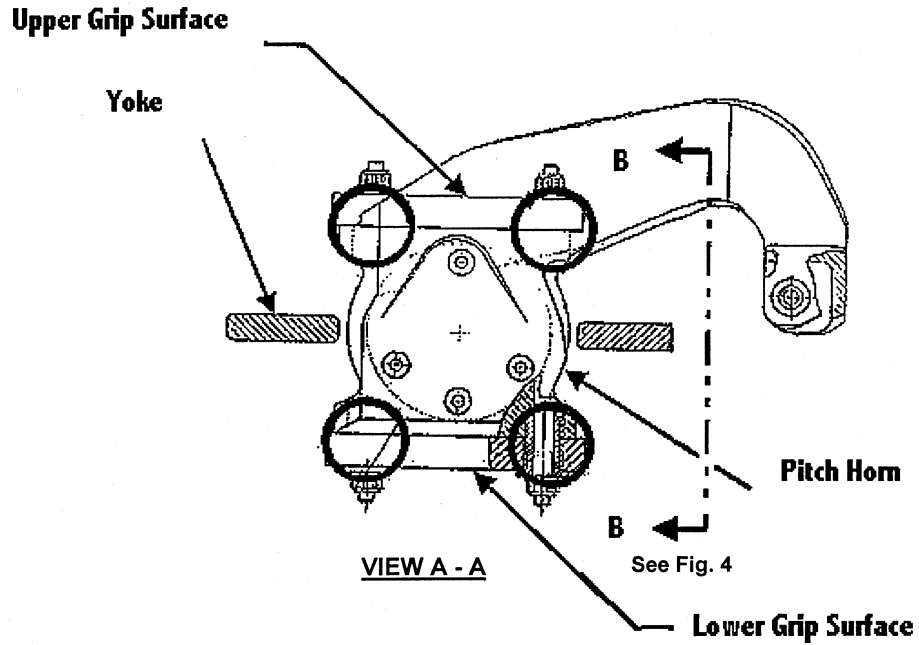

**View from trunnion
looking outboard**

**All visible portions of the pitch horn must be checked.
Pay particular attention to the circled areas shown above and View B-B, Fig. 4.**

Figure 3

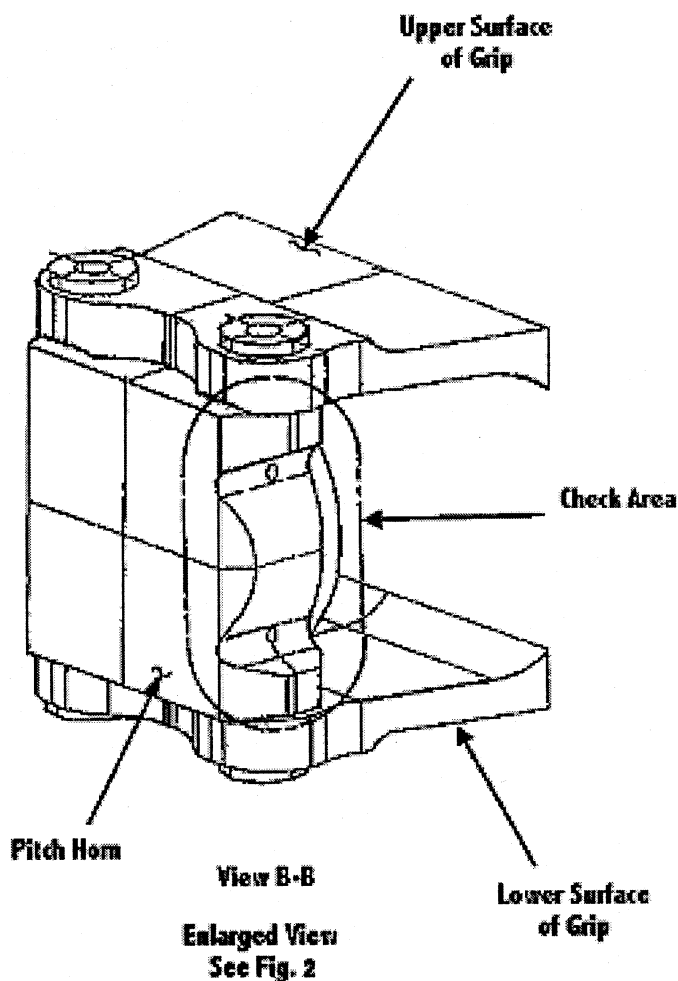

Figure 4

(4) An owner/operator (pilot) holding at least a private pilot certificate may perform the visual check required by paragraph (a) of this AD. The pilot must enter compliance with this paragraph into the helicopter records in accordance with 14 CFR 43.11 and 91.417(a)(2)(v)).

(b) Within 7 days or 10 hours TIS, whichever occurs first, and thereafter at intervals not to exceed 25 hours TIS, without disassembling the main rotor hub assembly (hub assembly) and using a 10-power or higher magnifying glass, inspect each grip and pitch horn assembly for a crack in accordance with paragraphs (a)(1), (a)(2), and (a)(3) of this AD.

(c) Within 300 hours TIS or 6 months, whichever occurs first, for each hub assembly with 2,500 or more and less than 4,500 hours TIS, and within 2,500 hours TIS for each hub assembly with less than 2,500 hours TIS:

(1) Disassemble and clean the main rotor hub assembly.

(2) Inspect the grip and pitch horn assembly using a fluorescent-penetrant inspection method.

(3) Inspect the pitch horn-to-grip attachment bolts and the flapping bearing-to-yoke attachment bolts using a magnetic-particle inspection method. If any of these attachment bolts are made from non-magnetic material, inspect those attachment bolts using a fluorescent-penetrant inspection method.

(4) During reassembly, install new buffers on the pitch horn and flapping bearing assemblies.

(d) If a crack is found, replace the cracked part with an airworthy part before further flight.

Note 3: Bell Helicopter Textron Alert Service Bulletin No. 222-02-93, Revision A, No. 222U-02-64, Revision A, and 230-02-

26, Revision A, all dated March 3, 2003, pertain to the subject of this AD.

(e) To request a different method of compliance or a different compliance time for this AD, follow the procedures in 14 CFR 39.19. Contact the Safety Management Group, Rotorcraft Directorate, FAA, for information about previously approved alternative methods of compliance.

Note 4: The subject of this AD is addressed in Transport Canada (Canada) AD CF-2002-23, dated April 2, 2002.

Issued in Fort Worth, Texas, on January 13, 2004.

David A. Downey,
Manager, Rotorcraft Directorate, Aircraft Certification Service.

[FR Doc. 04-1172 Filed 1-20-04; 8:45 am]

BILLING CODE 4910-13-C