

# The Main Parts Of an Airplane

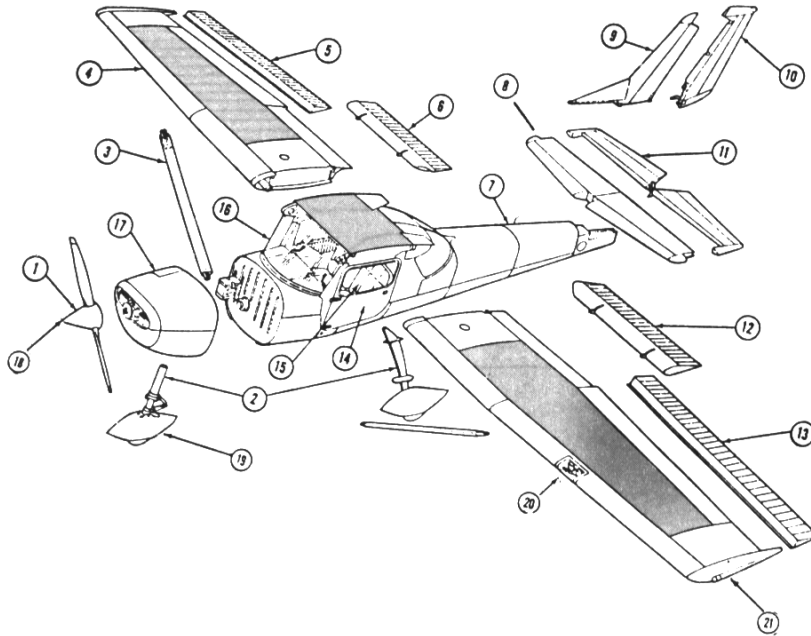

*The Parts of an Airplane*

- |                          |                       |
|--------------------------|-----------------------|
| 1. Propeller             | 12. Left Wing Flap    |
| 2. Landing Gear          | 13. Left Wing Aileron |
| 3. Wing Strut            | 14. Door              |
| 4. Wing                  | 15. Seat              |
| 5. Right Wing Aileron    | 16. Windshield        |
| 6. Right Wing Flap       | 17. Engine Cowl       |
| 7. Fuselage              | 18. Spinner           |
| 8. Horizontal Stabilizer | 19. Wheel Cover       |
| 9. Fin and Dorsal        | 20. Landing Light     |
| 10. Rudder               | 21. Wing Tip Light    |
| 11. Elevator             |                       |



U.S. Department  
of Transportation

**Federal Aviation  
Administration**

Office of Public Affairs  
Aviation Education Program  
APA-158-91

Reprinted by the Aviation Education Program  
Courtesy Cessna Aircraft

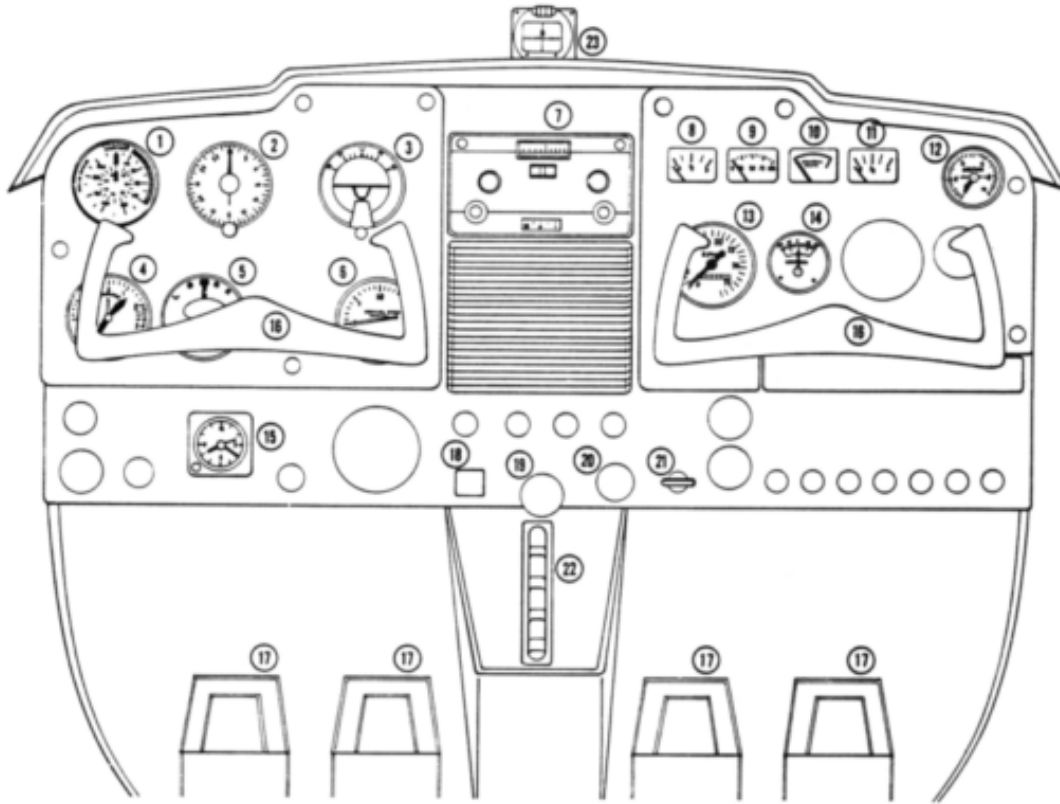

## *Instrument Panel*

- |                                                                                                                                                                                                                                                                                                                                                                                                                                                                                                                                                     |                                                                                                                                                                                                                                                                                                                                                                                                                                         |
|-----------------------------------------------------------------------------------------------------------------------------------------------------------------------------------------------------------------------------------------------------------------------------------------------------------------------------------------------------------------------------------------------------------------------------------------------------------------------------------------------------------------------------------------------------|-----------------------------------------------------------------------------------------------------------------------------------------------------------------------------------------------------------------------------------------------------------------------------------------------------------------------------------------------------------------------------------------------------------------------------------------|
| <ul style="list-style-type: none"> <li>1. Airspeed indicator</li> <li>2. Gyroscopic compass</li> <li>3. Artificial horizon</li> <li>4. Altimeter</li> <li>5. Turn and bank indicator</li> <li>6. Vertical speed (rate-of-climb-descent) indicator</li> <li>7. VHP navigation - comm. radio control</li> <li>8. Fuel gauge (left tank)</li> <li>9. Oil pressure gauge</li> <li>10. Oil temperature gauge</li> <li>11. Fuel gauge (right tank)</li> <li>12. Suction indicator (run by vacuum pump, which activates gyroscopic instruments)</li> </ul> | <ul style="list-style-type: none"> <li>13. Tachometer (measures revolutions per minute of propeller)</li> <li>14. Battery - generator indicator</li> <li>15. Clock</li> <li>16. Control wheel (dual)</li> <li>17. Rudder pedals</li> <li>18. Carburetor heat</li> <li>19. Throttle control</li> <li>20. Fuel-air mixture control</li> <li>21. Wing flaps control</li> <li>22. Trim tab control</li> <li>23. Magnetic compass</li> </ul> |
|-----------------------------------------------------------------------------------------------------------------------------------------------------------------------------------------------------------------------------------------------------------------------------------------------------------------------------------------------------------------------------------------------------------------------------------------------------------------------------------------------------------------------------------------------------|-----------------------------------------------------------------------------------------------------------------------------------------------------------------------------------------------------------------------------------------------------------------------------------------------------------------------------------------------------------------------------------------------------------------------------------------|