Diagnosics and Feedback System Update for NSLS-II Storage Ring

Accelerator System Advisory Committee

October 8-9, 2007

Om Singh
Igor Pinayev

Outline

- Design Goal/ Concepts
- Continuously monitored parameters
- Measured parameters
- Storage Ring Instrumentation
- Diagnostics R&D Program
- Orbit Correction & Feedback
- Orbit feedback Sub-systems
- Schedule/ Cost/ Effort Estimate
- Summary

Design Goal/ Concepts

- Electron beam instrumentation and diagnostics should provide:
 - Fast commissioning – modular & pretested subsystems approach
 - Robust operations with the specified beam parameters
 - Straightforward troubleshooting – built in diagnostics
- Wherever possible use conventional technology with well established experience at existing light sources or other storage rings and fully capitalize on new and state-of-art technology
- R&D activities for the most challenging systems (orbit monitoring and beam size measurement)
- Continuously review the alternate solutions and refine the design over the period of construction of NSLS-II

Continuously Monitored Parameters

- Closed orbit (very high accuracy to maintain orbit better than 10% of beam size)
- Tune for the both planes with 10^{-4} resolution
- Circulating current (0.1% accuracy in ~5 mA - 500 mA current range)
- Beam lifetime (1% over 1 minute in operational range)
- Injection efficiency
- Fill pattern (monitor accuracy 1% of bunch charge)
- Beam dimensions for emittance measurement (10% accuracy)
- Individual bunch length (~ 2 picosecond resolution)
- Coherent bunch instabilities
- Distribution of beam loss pattern (spatial and temporal)

Measured Parameters

- Linear optics - 1% for β -functions, phase advance $2\pi \times 10^{-3}$ (BPMs & Tune measurement)
- Dispersion for both planes - with 1 mm accuracy (BPMs)
- Chromaticity for both planes - with 0.1 accuracy (Tune measurement)
- Coupling - 0.05% absolute accuracy (BPMs)
- Emittance for horizontal plane - 5% accuracy
- Momentum compaction -1% accuracy (undulator beamline)
- Energy spread - 10% relative accuracy
- Beam based alignment of quadrupoles and sextupoles (< 30 microns)
- Synchrotron frequency
- RF system parameters (cavity voltages and phasing)
- Vacuum chamber impedances (Tune measurement)

Storage Ring Instrumentation – 1 of 2

Monitor	Quantity	Function
4-button pick-ups	180+12	Beam position, dispersion, response matrix, turn-by-turn dynamics, coupling
Photon BPMs	6	One per beamline
DC Current Transformer	1	Beam current, Life time measurement
Fast Current Transformer	1	Fill pattern monitoring
PUE & Stripline sets	2	Suppress beam instabilities – transverse feedback system Tune measurement
Additional PUEs	1+2	Beam oscillation monitor; current monitors for top-off
P-i-n diode Loss Monitors	60	Beam loss pattern
Scintillation Loss Monitors	10	Beam losses
Fluorescent screen	1	Injection position and profile measurement

Review committee provided strong comments;
Changes have been incorporated in design

Storage Ring Instrumentation – 2 of 2

Monitor	Quantity	Function
Streak-camera	1	Bunch length & Beam Dynamics Measurement
Beam scrapers	2 sets	Machine studies (beam size, energy aperture), halo
FireWire camera	1	Transverse beam characteristics
Emittance monitor	1	Transverse emittances measurement
Diagnostics Undulator	1	Energy spread, beam divergence, momentum compaction factor (not in baseline)
Pinhole camera	1	Transverse beam size , energy spread
Beam Oscillation monitor	1	Longitudinal & Transverse beam motion frequency spectrum

High Level Applications

- Beam based alignment
- LOCO analysis of the ring lattice
- Coupling correction
- Global orbit feedback

Diagnostics R & D programs – 1 of 3

- Beam Position Monitor

- Optimize RF buttons geometry
 - Minimize block heating issue (high current)
 - Increase delta/sum sensitivity for better reso

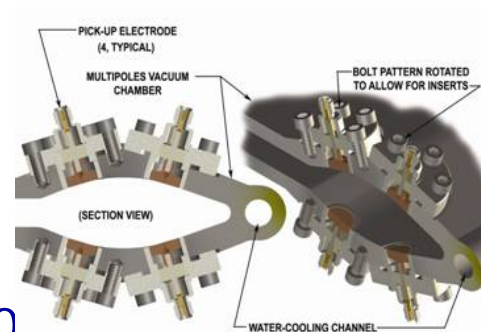

- Characterize commercial (libera) & other bpm electronics

- Evaluate dependence on
 - Beam intensity
 - Beam bunch to bunch variation
 - Thermal effects



- Develop requirement specification as a function of bandwidth, bunch pattern, intensity & others parameters

- Goal → Achieve resolution < 0.1 micron in 100Hz BW

Diagnostics R&D Program (2 of 3)

Support for Precision BPM

Extra-stable BPM Assy. mounted on a low CTE carbon-filament wound composite post.



- Shielded bellows will provide mechanical insulation to the BPM housing
- Carbon filament wound post will provide rigidity, low temperature drifts, and stability
- Additional temperature stabilization of the BPM housing is considered
- Goal – achieve < 0.1 micron mechanical stability for 24 hr
- In addition to mechanical stability, independent monitoring of BPM will also be evaluated

Short ID User BPM Resolution Requirement (vert)

Case A – user bpm at the center of the short ID ($\beta_y = 1.2$ m)

Required beam stability at the center of short ID = $0.3 \mu\text{m}$;

Assuming, bpm electronics resolution & mechanical stability contribute up to $0.1 \mu\text{m}$ each, the feedback system need to make beam stability to **$0.26 \mu\text{m}$ (quadrature calculation)**

Case B – user bpm at the end of the short ID ($\beta_y = 4.8$ m)

Required beam stability at the end of short ID = $0.6 \mu\text{m}$;

Assuming, bpm electronics resolution & mechanical stability contribute up to $0.1 \mu\text{m}$ each, the feedback system need to make beam stability to **$0.58 \mu\text{m}$ – quadrature calculation**

$0.40 \mu\text{m}$ – linear calculation

Case C – user bpm at the end of the short ID (beta y = 4.8 m)

Required beam stability at the end of short ID = $0.6 \mu\text{m}$;

Assuming, bpm electronics resolution & mechanical stability contribute up to $0.2 \mu\text{m}$ each, the feedback system need to make beam stability to **$0.53 \mu\text{m}$ – quadrature calculation**

$0.20 \mu\text{m}$ – linear calculation

Diagnostics R&D programs (3 of 3)

Beam Emittance Monitor

Bending magnet

$\beta_x=3.75$ m, $\sigma_x=43$ μ

$\beta_y=19.6$ m, $\sigma_y=12.5$ μ

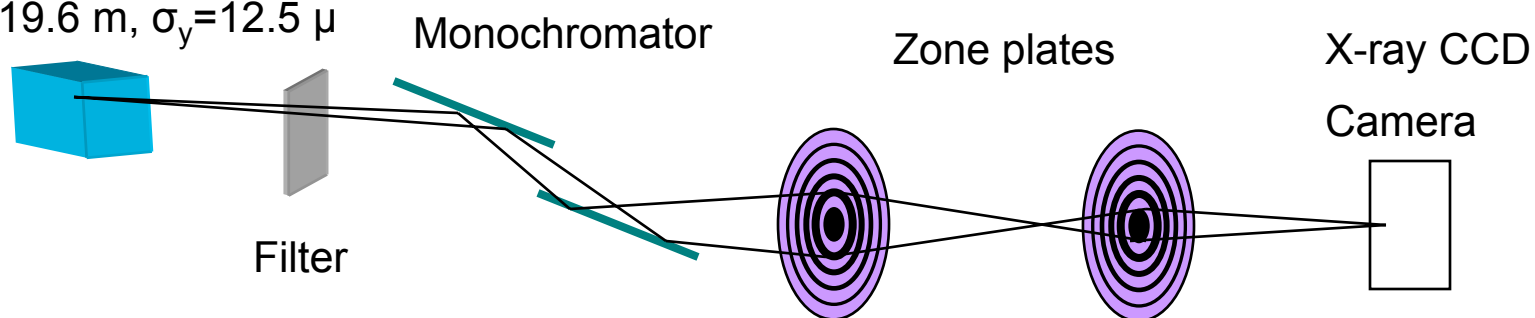

- At KEK-ATF similar system was used for measurement of 1 nm emittance beam.
- X-ray imaging system has magnification ~ 20 and resolution below 2 microns for 3 keV photons.
- Evaluate necessary high resolution imaging system.

Fluorescent Screen

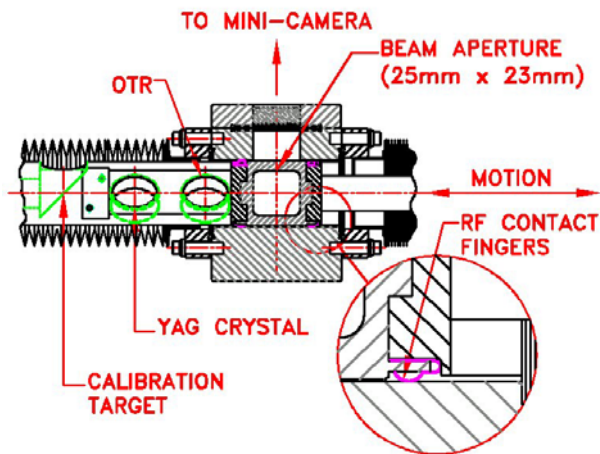
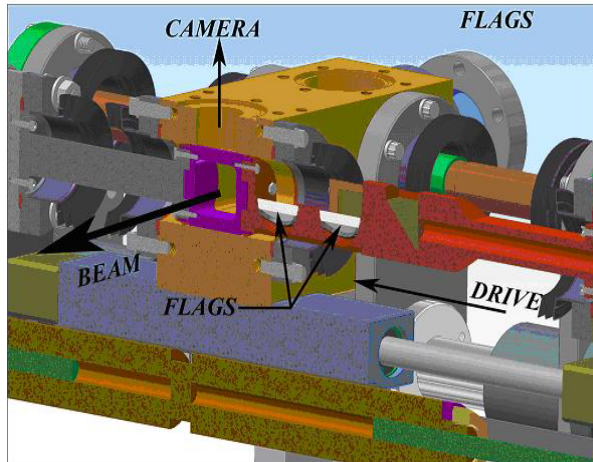

- Screen will provide information on shape and position of the injected beam
- It will be installed into the injection straight immediately after septum
- YAG:Ce flags have 30 microns resolution, which is sufficient for expected beam sizes ($\sigma_x=400\mu$ and $\sigma_y=60\mu$)
- Optical transition radiation screens can be implemented for better resolution
- Four positions
 - fully retracted
 - incoming beam
 - after first turn (injected beam comes through a hole)
 - calibration target
- Spring-loaded RF fingers provide electrical contact to avoid trapped modes for the wakefields

Transverse Feedback System

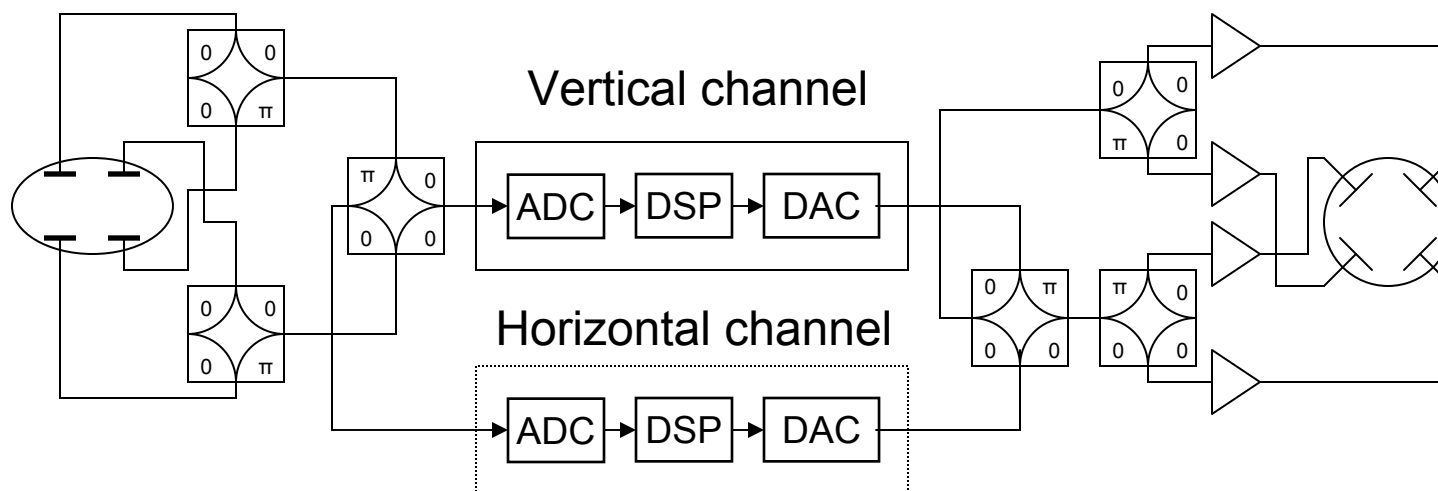

- Libera Bunch-by-bunch is considered
- Beam position signal will be acquired by four 14-bit 125 MHz ADC synchronized with RF
- Feedback signal will be provided by 500 MHz 14-bit DAC
- Output amplitude 2.0 Vpp
- Will be used to suppress bunch instabilities caused by resistive wall impedance
- Bandwidth 100 kHz – 250 MHz
- RF power – 4×100 W

Photon Beam Position Monitors



- Will provide information on photon beam position and angle (to account for errors in the wiggler field)
- Use of photon BPMs will allow sub-microradian pointing stability – lever arm advantage
- Contamination with dipole radiation can be of less concern due to reduced magnetic field in the bending magnet
- Can be used for orbit feedback and/or control of users optics
- 2D translation stages will precisely locate the photon BPM
- Should withstand high power density

Review Committee:

X-ray BPMs will be essential for NSLS-II

Give serious consideration to Decker distortion

Hold Workshop on X-Ray BPM Development

Orbit Correction & Feedback

- Steering Correction

- Global Orbit Feedback
 - ✓ Mode A – Fast system only
 - ✓ Mode B – Slow & Fast systems in parallel

- Feedback Performance Limiting Factors

BPMs and Magnet Layout for One cell

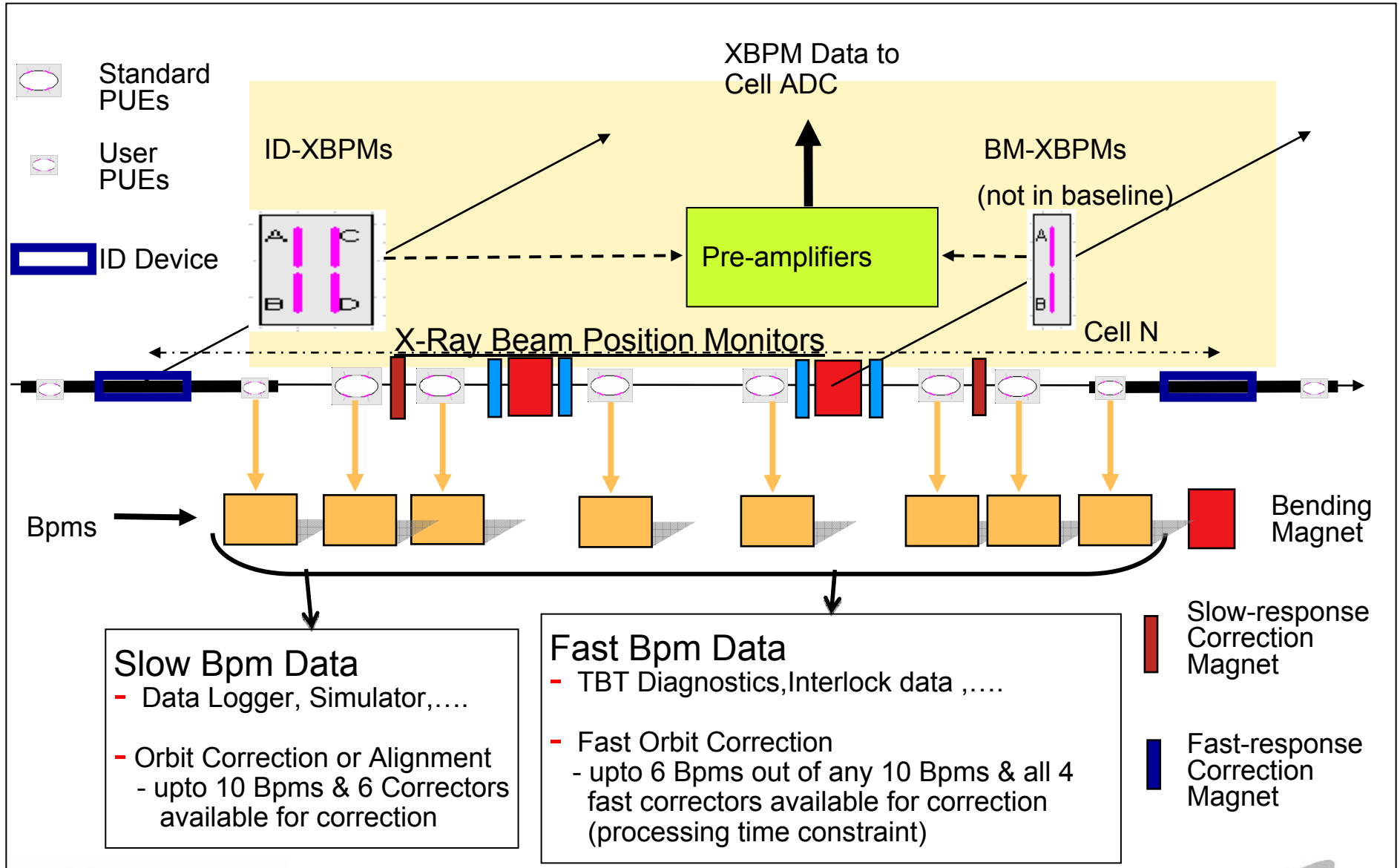

Orbit Correction – Steering Correction

Orbit steering -

- Will Correct orbit once on “as needed” basis to achieve “golden orbit” or “user desired orbit”. Utilizes desired BPMs and correctors. Full strength of all correctors (slow and fast) is 0.8 mrad.
- Usually will apply at the beginning of a start of a fill or a user requested steering request during normal operation (top-up or no top-up).
- Both slow & fast correctors and all RF & X-ray BPMs will be available for correction
- Communication to BPMs and steering IOCs will use the EPICS CA communication mechanism.

Orbit Correction & Feedback – Global Feedback

- **Slow system** corrects for orbit drift; Process rate = 0.1 Hz;
All BPMs & all fast/slow correctors available
- **Fast system** corrects beam disturbances to 100 Hz;
Process rate = 5 KHz; 10 KHz may be possible; Only 6 BPMs & 4 fast correctors available
- Both electron & photon BPMs data will be available for slow and fast feedback systems
- Mode A - Slow system is turned off; Fast system has BW from DC to 100 Hz
- Mode B – Slow feedback and fast feedback (0.2 mHz-100Hz) systems need to work together;
will require feedforward compensation – this technique successfully used at ALS & APS

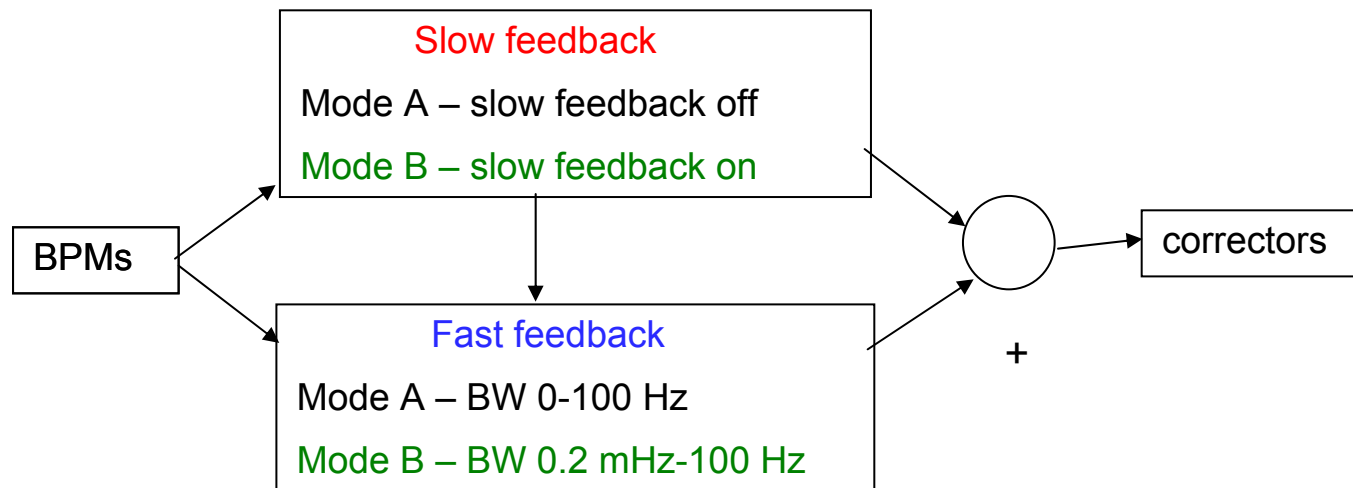

- Feedforward for coupling and beam size effects due to gap changes will also be implemented

Orbit Feedback - Subsystems

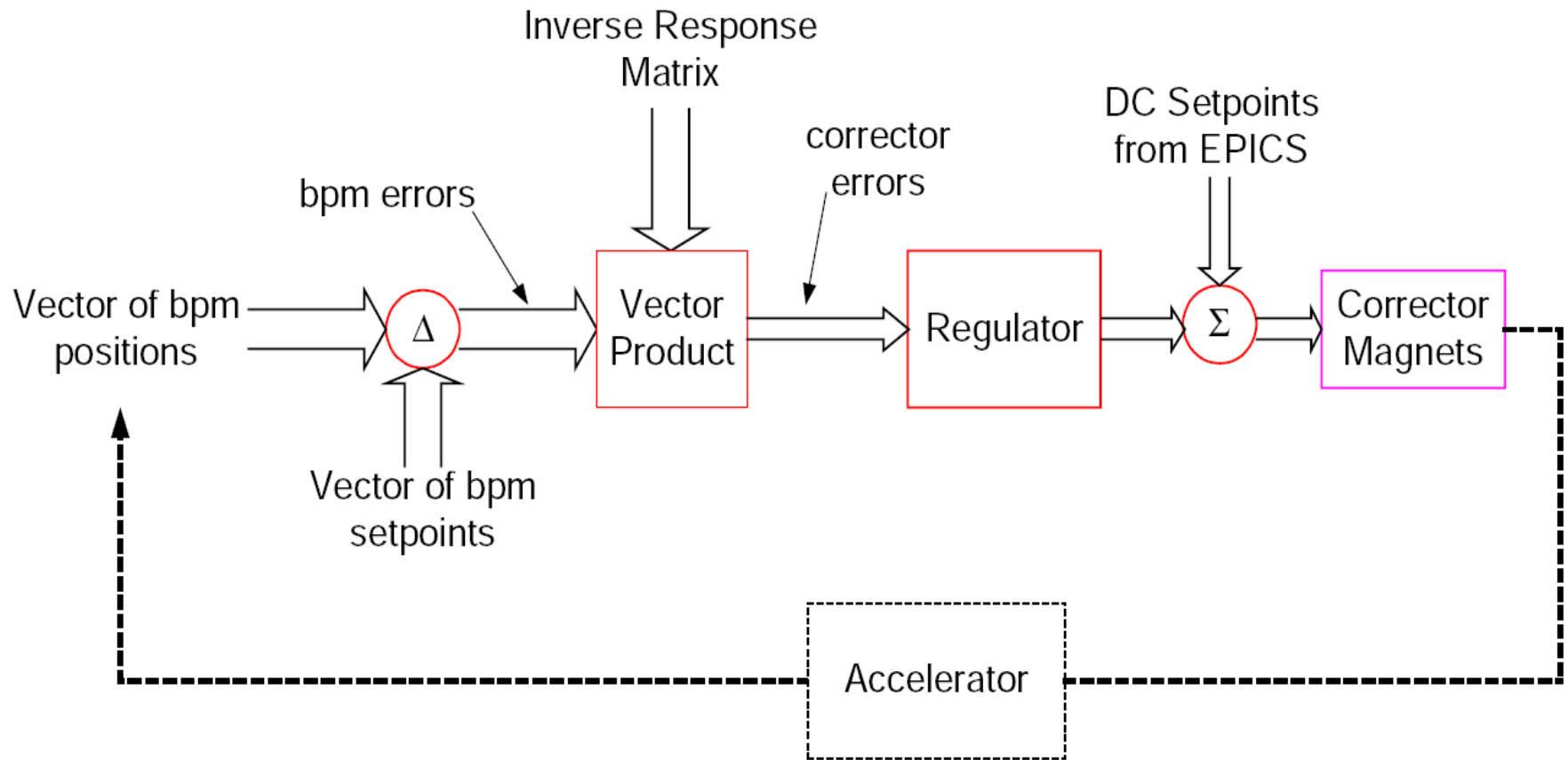

Subsystems & Performance Limiting Factors

1. BPM/ Corrector - Resolution
2. BPM/ Corrector - Responses
3. DSP Processing Power - Process Rate & Orbit Correction Configuration

Beam Motion @ APS ID Source vs Bpm Resolution (Noise)

Cumul RMS 30 Hz band (vert)

Beam Motion = 0.6 micron

RfBpm Noise = 0.35 micron

XBpm Noise = 0.04 micron

Best Resolution –
a) lever arm; b) small range of +/- 1mm

Corrector Resolution – 18 bits → 6.25 nrad per bit; required resolution = 12 nrad

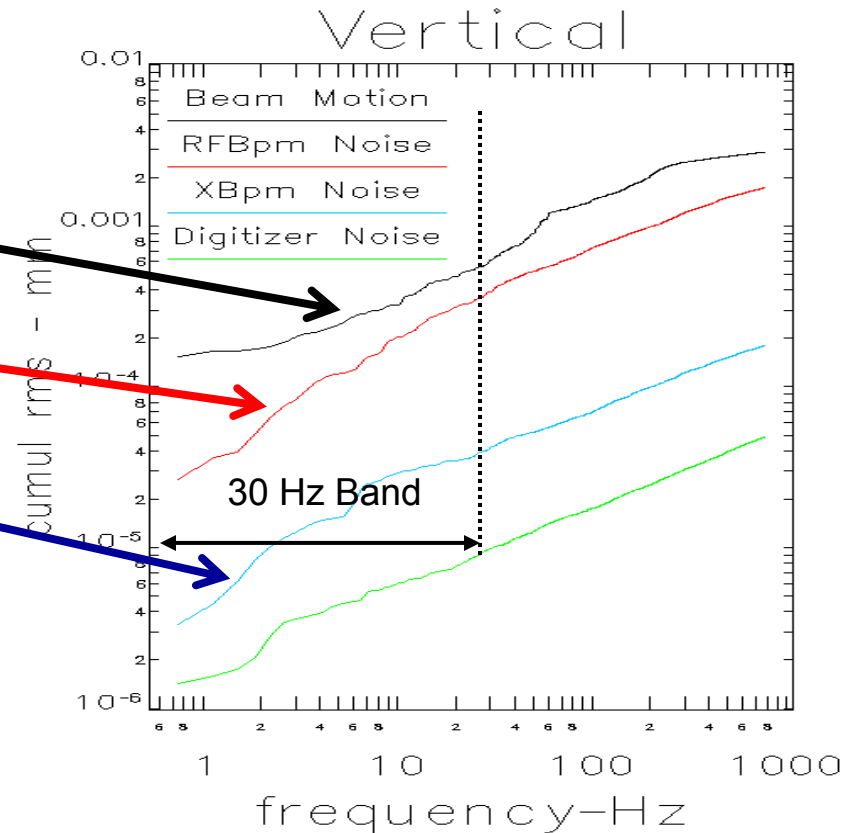

BPM and Fast Corrector* – Response Models (@ APS)

Bpm & Corrector Responses

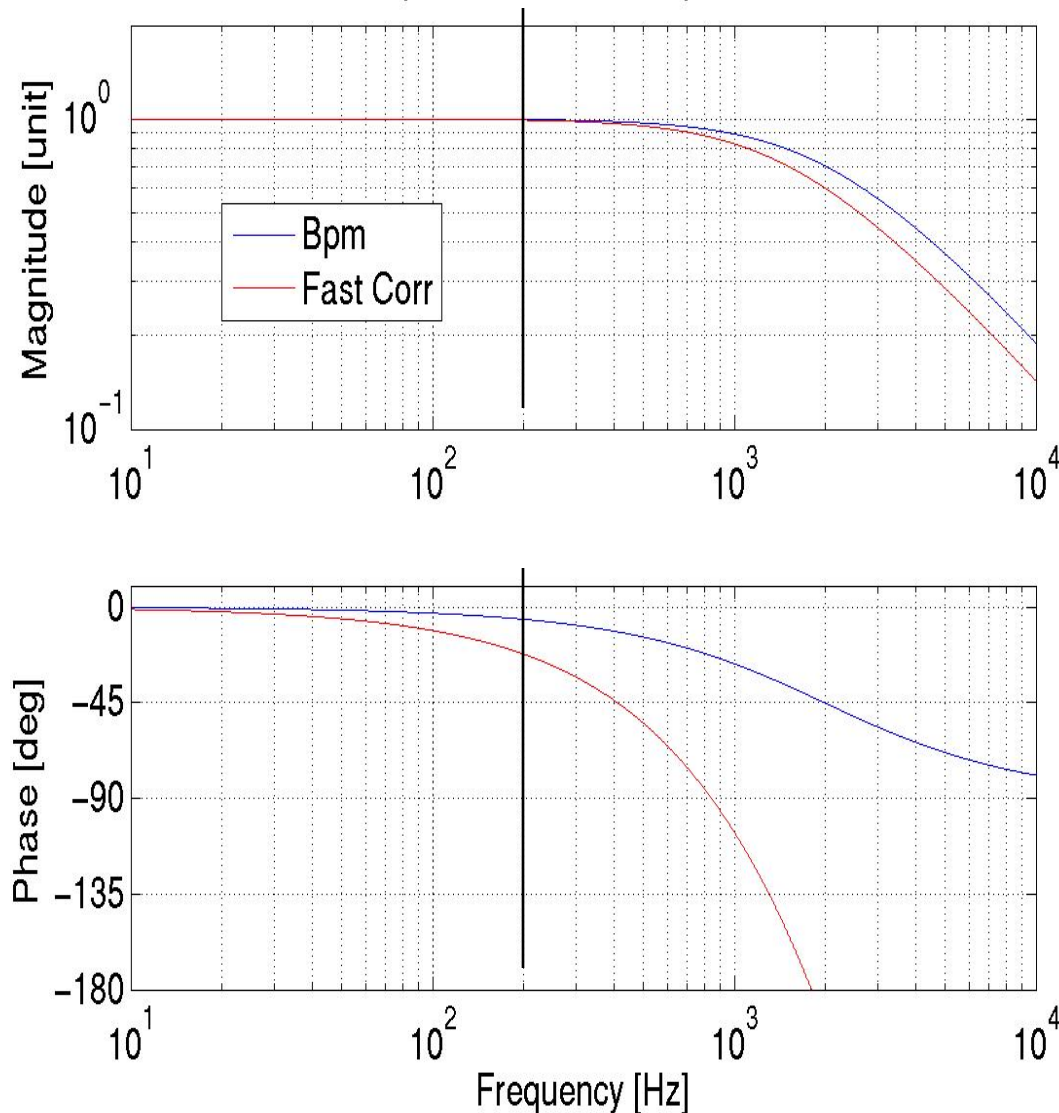

BPM Response

One pole low pass filter @ 2KHz

Fast Corrector

One pole low pass filter @ 1.5 KHz
Delay $\zeta = 0.2$ ms

BPM & Fast Corrector Combined Phase Contribution

@ 100 Hz = 15°
@ 200 Hz = 27
@ 300 Hz = 45
@ 400 Hz = 57
@ 500 Hz = 70

* Fast corrector response includes corrector power supply, magnet & stainless steel chamber response

Optimized Overall Open Loop Responses (Vert) – 1.5 KHz vs 15 KHz

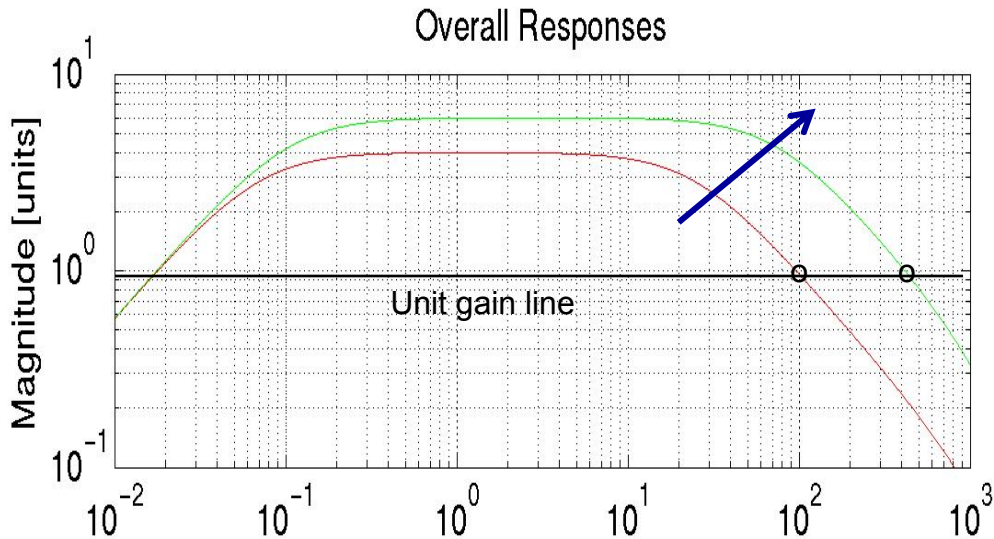

Optimized parameters @ 1.5 KHz s.r.

Digital Process Rate = 1.5 KHz
 ➤ Digitization Phase = $(f/fs) * (360deg)$

Regulator
 ➤ 1 HPF @ 0.07 Hz
 ➤ 1 LPF @ 25 Hz
 ➤ Gain = 4

Orbit Correction Bandwidth
 ➤ 100 Hz

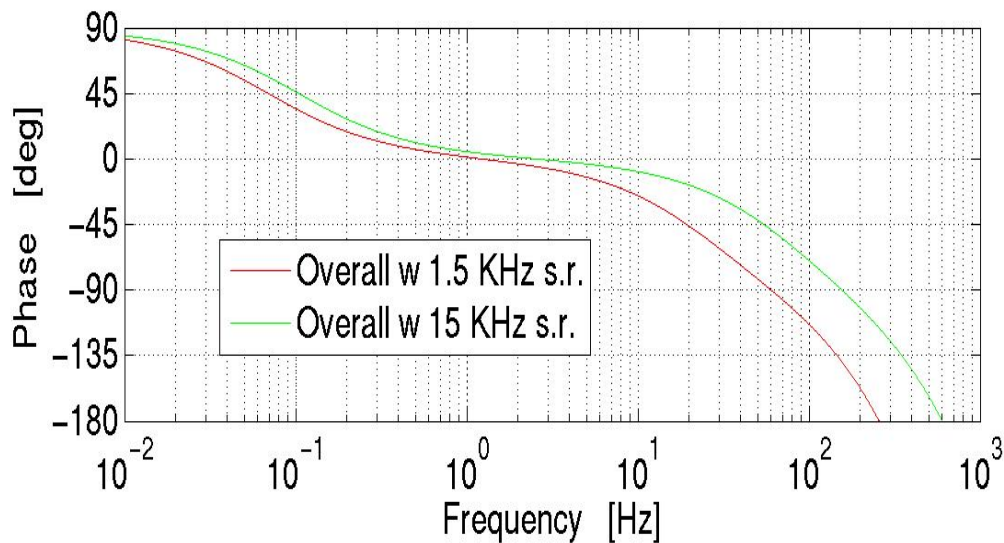

Optimized Parameters @ 15 KHz s.r.

Digital Process Rate = 15.0 KHz
 ➤ Digitization Phase = $(f/fs) * (360deg)$

Regulator
 ➤ 1 HPF @ 0.105 Hz
 ➤ 1 LPF @ 75 Hz
 ➤ Gain = 6

Orbit Correction Bandwidth
 ➤ 400 Hz

Schedule & staffing – Diagnostics & Instrumentation

Schedule	fy08	fy09	fy10	fy11	fy12	fy13
R&D/PED/Design	_____	_____	_____			
Procurement/ assembly/test		_____	_____	_____		
Installation/ commissioning				_____	_____	_____

Staffing	fy08	fy09	fy10	fy11	fy12	fy13
Diagnostics/ instrumentation	_____					
	2 Elec Eng, 2 Elec Tech, 1 Mech Tech					
Accelerator Physics	_____					
	2 Accelerator Physicist					
Other groups	_____					

Summary

- Comprehensive set of diagnostics and instrumentation with extended capabilities has been developed
- The system will allow straightforward commissioning of the storage ring as well as facilitate maintenance and troubleshooting during regular operations
- Most components of beam diagnostics and instrumentation are readily available, mostly from commercial sources, and have been utilized at other light sources
- Diagnostics R&D program has been identified
- High level applications will provide for achievement of ultra-low emittances and reliable operation
- Orbit feedback system strategy is identified

Appendix

BPM Buttons

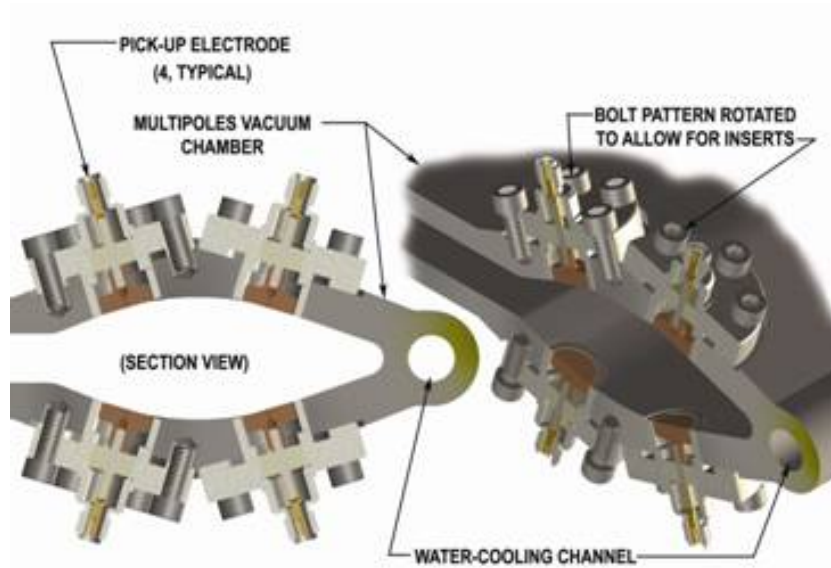

- Design similar to adopted at RHIC
- 5-mm radius buttons
- Stray capacitance 1-4 pF
- Signal level -1.1 dBm for 500 mA at 500 MHz

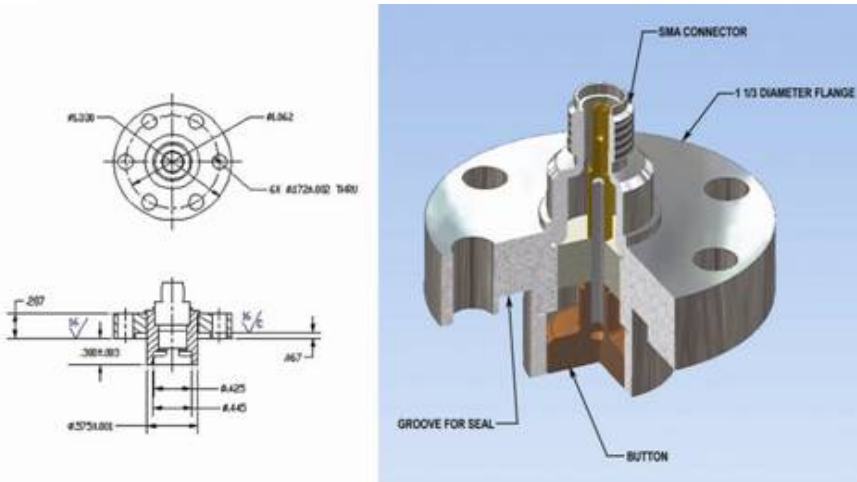

UBPM Optimization @ APS SR

Elliptical Chamber Buttons Assembly

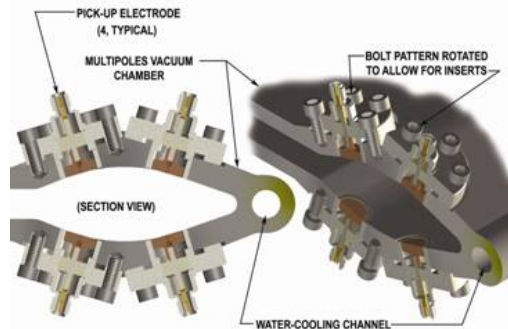

Small Gap ID Chamber 2 Buttons Assemblies

Un-Rotated

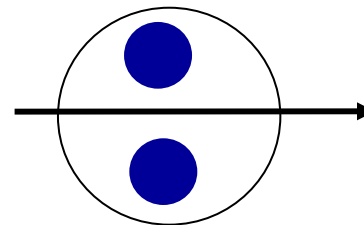

Rotated

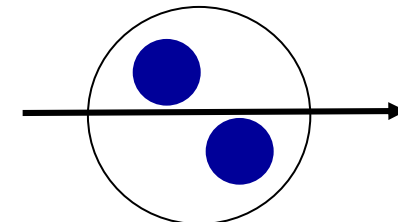

	Elliptical Buttons	Unrotated buttons	Rotated Buttons
Horizontal Sensitivity	0.055	0.360	0.310
Vertical Sensitivity	0.058	0.145	0.245

Increase in vertical position sensitivity due to Rotated Geometry
 0.145 → 0.245 (68% increase)

Parametric Transformer (DCCT)

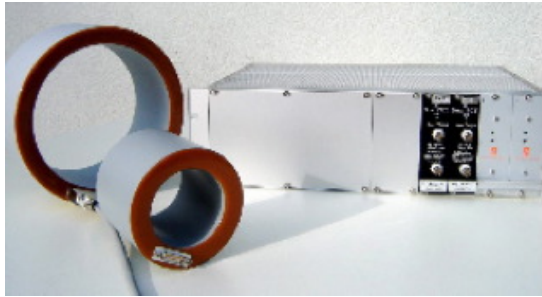

- Bergoz NPCT-115-RHC20-HR-H
- Full scale range from $\pm 20\text{mA}$ to $\pm 20\text{A}$ controlled by TTL levels
- $1 \text{ uA/Hz}^{1/2}$ resolution in every range
- Frequency response DC to 10 kHz
- Linearity error $< 0.1\%$
- NPCT package includes spares for electronics and power supply
- Radiation hardened

Transverse Feedback System

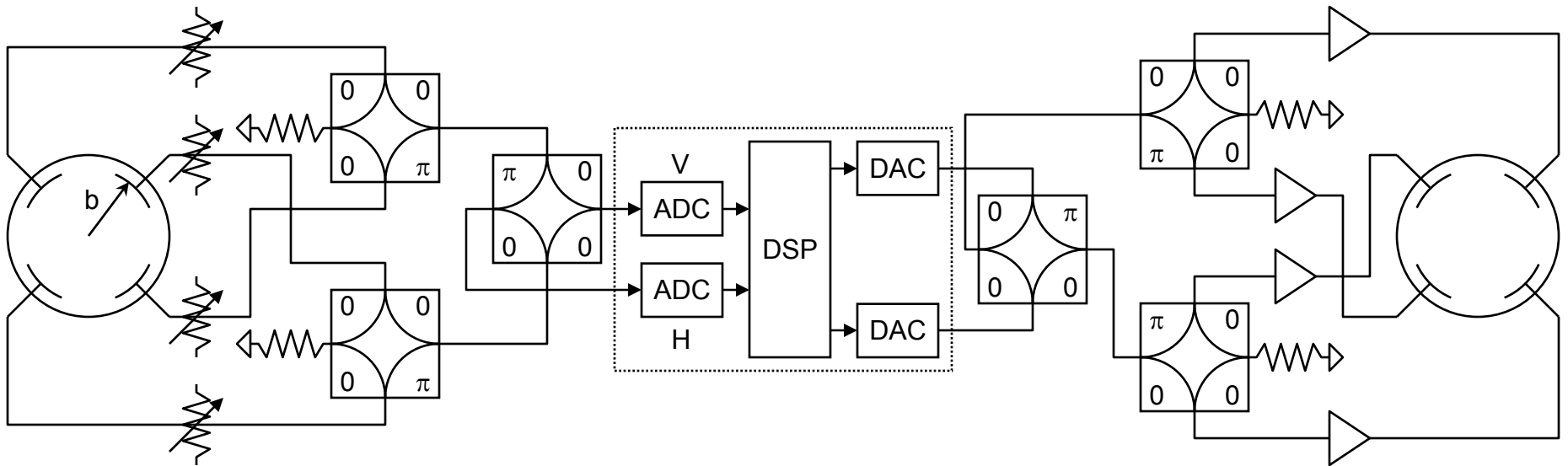

Damping time

Induced beam motion

$$\begin{aligned}
 b &= 25 \text{ mm} & \beta_x &= 10 \text{ m} \\
 l &= 15 \text{ cm} & \beta_y &= 10 \text{ m} \\
 P &= 100 \text{ W} & \Delta_x &= 0.2 \text{ mm} \\
 Z_L &= 50 \Omega & \Delta_y &= 0.1 \text{ mm}
 \end{aligned}$$

$$\tau = T_0 \frac{E/e}{\sqrt{2PZ_L}} \cdot \frac{kb}{\sin kl} \cdot \frac{\Delta_{\max}}{\sqrt{\beta_1\beta_2}}$$

$$\begin{aligned}
 \sigma &\approx \sqrt{\frac{T_0}{\tau_{FB}}} \delta \\
 \delta &\approx 0.1\% \times \Delta \\
 \sigma_x &= 0.2 \mu\text{m} \\
 \sigma_y &= 0.1 \mu\text{m}
 \end{aligned}$$

Transverse Feedback Parameters

- Libera Bunch-by-bunch is considered
- Bandwidth 100 kHz – 250 MHz
- RF power – 4×100 W
- Damping time – 260 μ s for vertical plane ($\Delta_{\max}=0.1$ mm), 500 μ s for horizontal plane ($\Delta_{\max}=0.2$ mm)
- Will be used to suppress bunch instabilities caused by resistive wall impedance
- Beam position signal will be acquired by four 14-bit 125 MHz ADC synchronized with RF
- Feedback signal will be provided by 500 MHz 14-bit DAC
- Output amplitude 2.0 Vpp

Beam Loss Monitoring

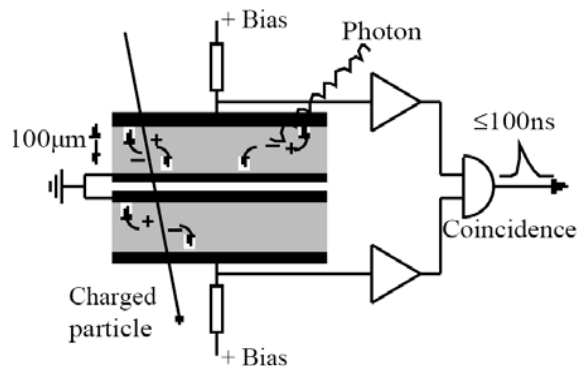

Specifications

- Single particle detection efficiency $> 30\%$
- PIN-photodiode surface 7.34 mm^2
- Spurious count rate $< 0.1 \text{ Hz}$
- Maximum count rate $> 10 \text{ MHz}$
- Count rate @ $6 \times 10^5 \text{ Rad/yr SR photons} \approx 100 \text{ Hz}$
- Same with 3 cm lead shielding $\approx 1 \text{ Hz}$
- Output positive TTL 50Ω
- Cable driving capability $> 200\text{m RG213}$
- Power supply
 - + 5V 170 mA
 - 5V 80 mA
 - + 24V 1 mA
- Size 69 x 34 x 18 mm

CosyLab Interface to BLM

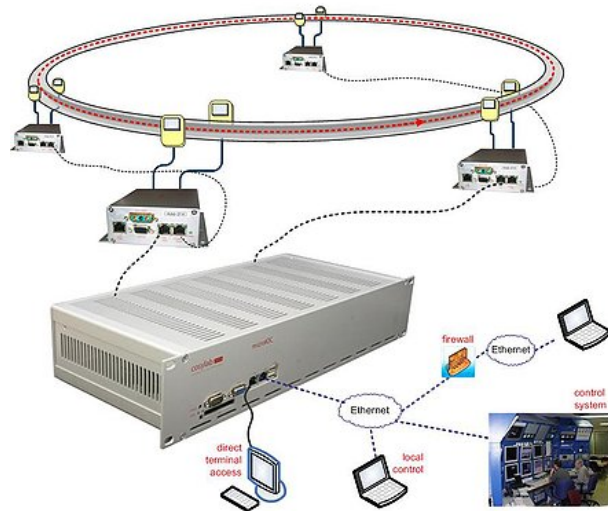

- Small and compact unit interfaces to two BLMs
- Cable length between microIOC and signal conditioner up to 1200 m
- Cable length between signal conditioner and sensor up to 30 m
- Up to 96 sensors can be connected to single microIOC
- Ready to use interface

Bunch Length Measurement



- **C5860 Streak Camera Parameters**
- Spectral response characteristics
200 nm to 850 nm
- Minimal radiant sensitivity
2 mA/W at 240nm,
1 mA/W at 820nm
- Synchroscan frequency
Factory set to 100 MHz
- Temporal resolution (FWMH)
2 ps at 800 nm
- Sweep range
200 ps to $1/6F_s$
- Dual time sweep range
100 ns to 100 ms
- Camera resolution 1280 x 1024 pixels
- Frame rate 8 Hz
- Dynamic range 12 bit

Streak-camera will be shared with booster

Scrapers

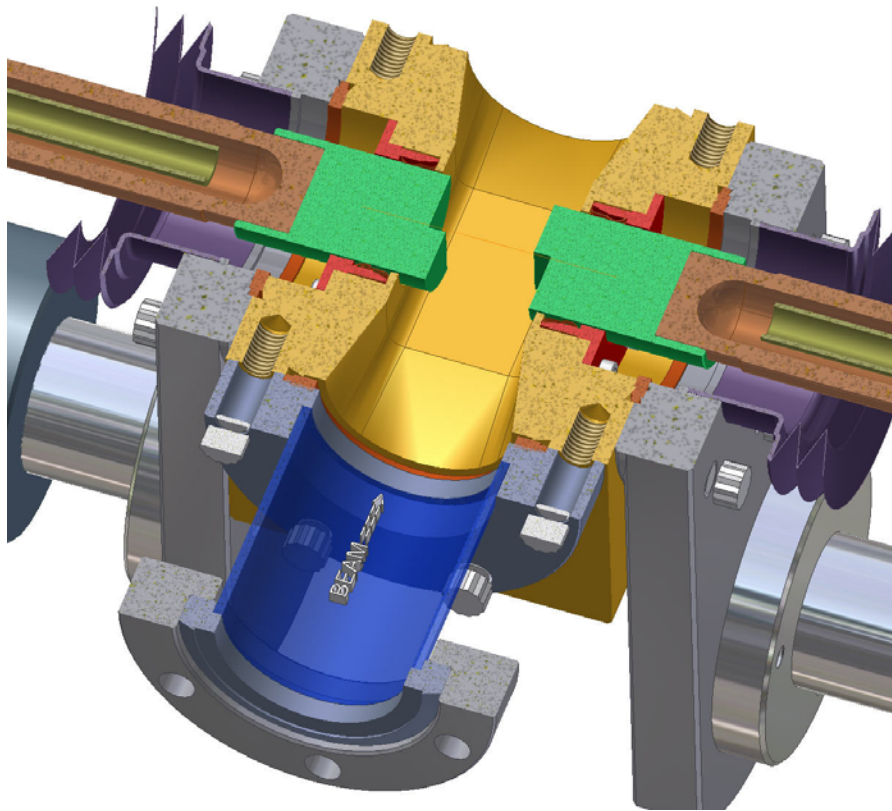

- Will be used to measure aperture and beam lifetime limits
- Possible usage for the protection of the small gap IDs from the scattered electrons will be studied
- Resolution 1 micron
- Reproducibility 5 microns
- Impedance evaluation will be performed during design stage

Diagnostics with Synchrotron Radiation

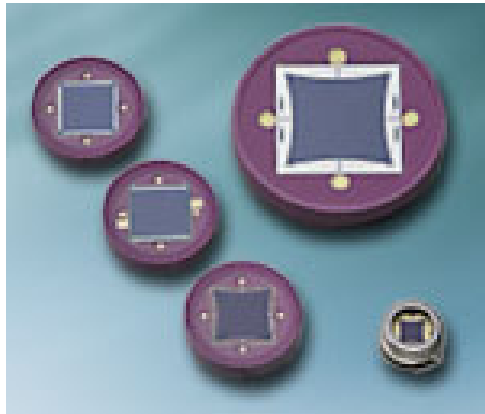

- FireWire Camera eliminates need for frame-grabber
 - Acquisition time from 10 μ s
- Position sensitive diodes provide signal proportional to the displacement of center of gravity
 - 0.3 μ s response time
 - 0.6 μ position sensitivity
 - Will be used to monitor beam motion in the dipole
- Fast photodiodes can be used for bunch length measurements and fill pattern monitoring (bunch purity measurements)

Measurements with Undulator Radiation

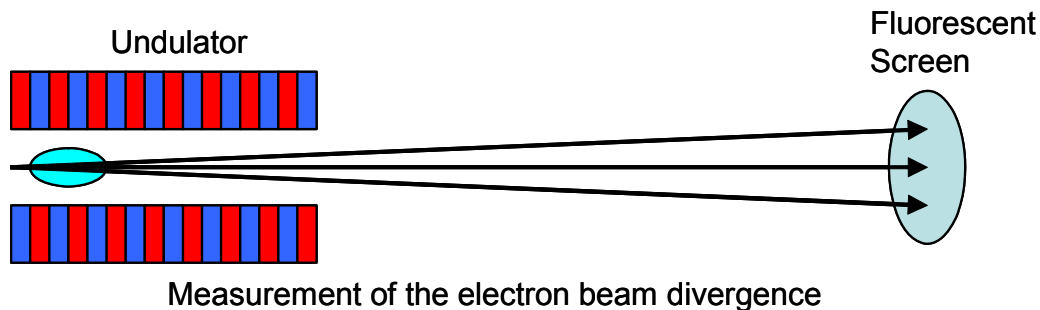

- Will be installed on users beamline with U19 undulator
- Model independent measurement of horizontal emittance

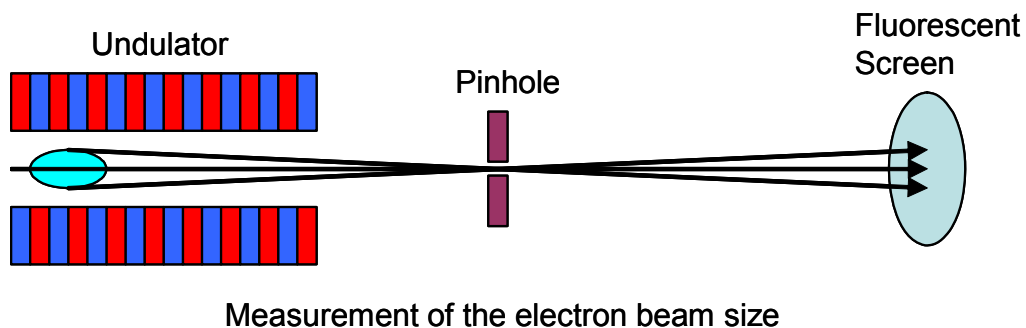

- Will utilize users monochromator
- Energy spread measurement
- Momentum compaction factor measurement

Beam Size Monitor

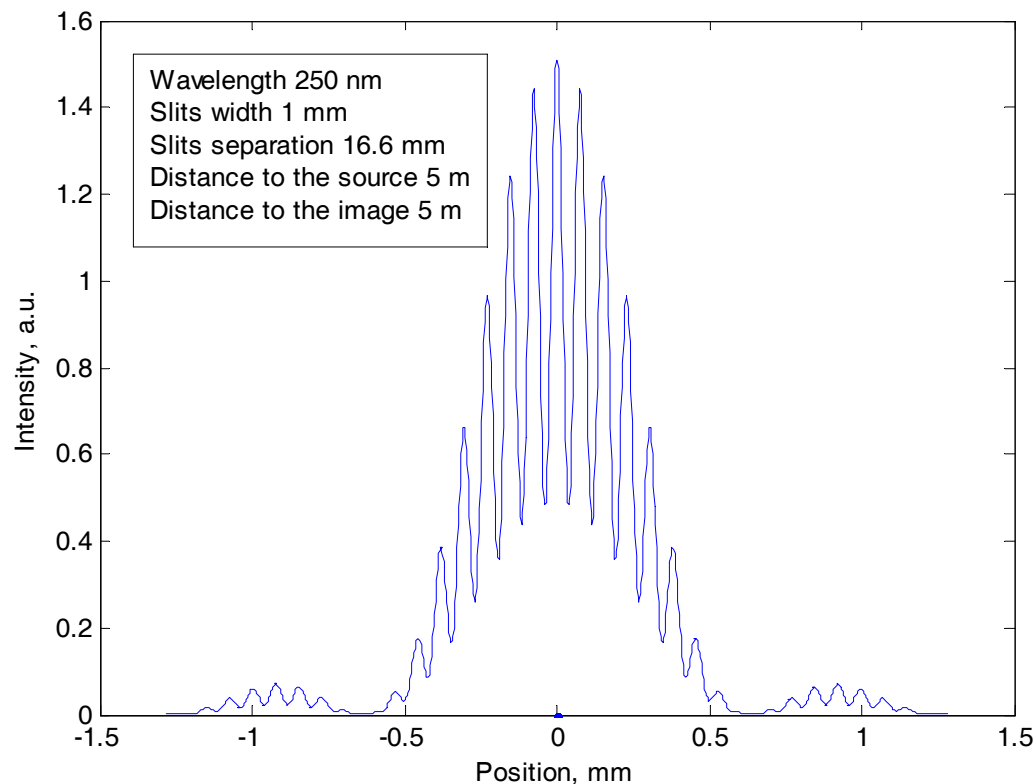
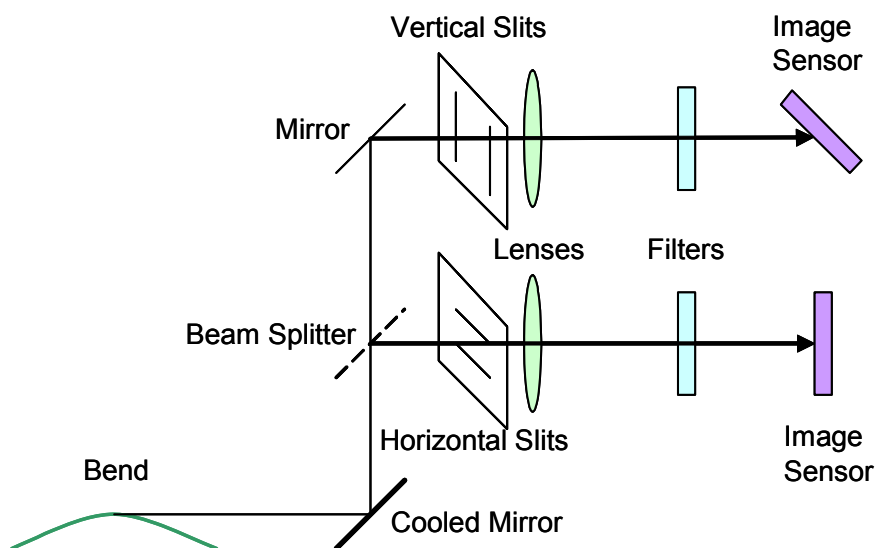

$$\gamma = \exp \left[-2 \left(\frac{\pi \sigma D}{\lambda L} \right)^2 \right]$$

5% error in the visibility measurement
gives 7% error in beam size

- The method is based on measurement of spatial coherency of radiation from a small object
- The method is applicable for beams with sizes below diffraction limit

Tune Monitor

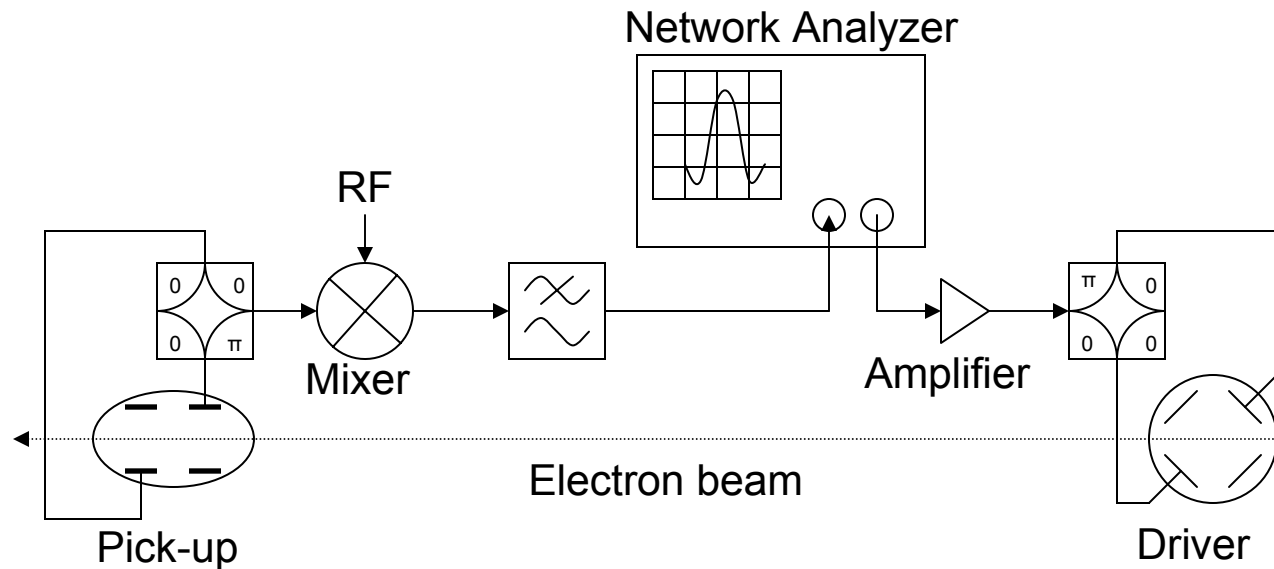

- Electron beam is excited at frequencies below revolution frequency
- Signal with beam motion is acquired at higher frequency and down converted below revolution frequency
- Expected accuracy is better than 10^{-4}

Beam Position Monitors

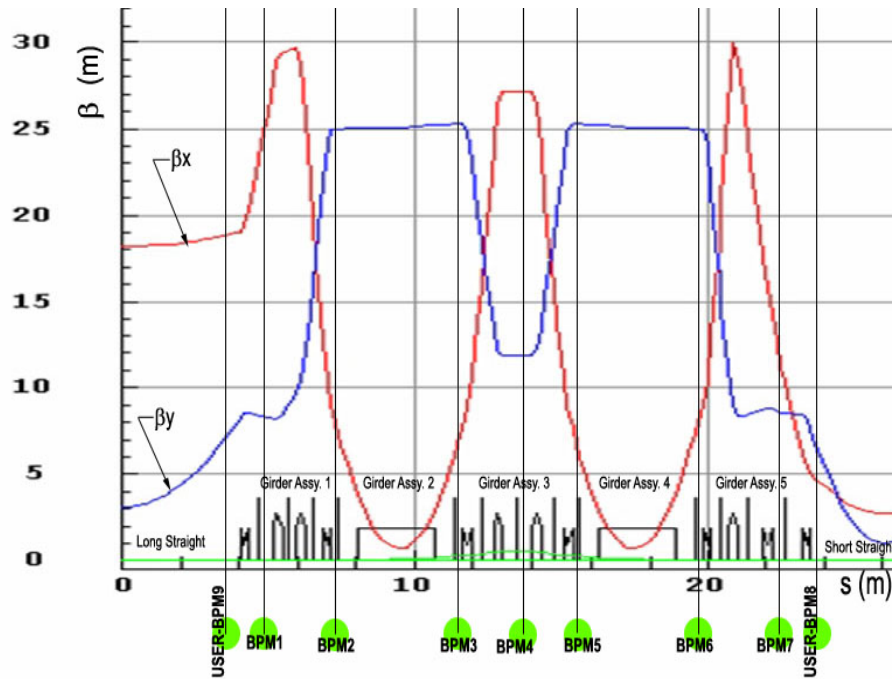

- Six BPMs per cell in the baseline design
- Two extra BPMs per ID
- Turn-by-turn capabilities
- Built-in interlock on beam position
- Excellent accuracy (-93 dB RMS uncertainty with 2 kHz BW)
- Gigabit LAN interface
- For $\epsilon_y = 8$ pm RMS vertical beam size in short straight is $\sigma_y = 2.6$ μm ($\beta_y = 0.8$ m)
- For vacuum chamber with radius $R = 25$ mm position uncertainty is $\sigma_{\text{rms}} = 0.2$ μm
- Bandwidth reduction to 100 Hz gives additional noise reduction
- R&D for long term stability of BPM receivers will be performed