



Interior Signs

- Room Identification
- Conference Room
- Wall Directional
- Ceiling Directional
- Department Identification
- Directories
- Building Entrance
- Letters

Section 6: Interior Signs

▪ Planning	Pages 6-2-1 through 6-2-6
▪ Helpful Hints	Pages 6-3-1 through 6-3-2
▪ Overview	Pages 6-4-1 through 6-4-5
▪ Sign Type Drawings	Pages 6-5-1 through 6-5-66
▪ Specification	Page 6-6-1
▪ Construction	Pages 6-7-1 through 6-7-9
▪ Installation	Pages 6-8-1 through 6-8-6

Planning an Interior Sign Program

The development of an effective working interior sign program requires the coordination of several interlaced criteria.

For an effective interior sign program you have to take in to account to the following:

1. Location of building entrances and elevators.
2. Character and configuration of the corridor system.
3. How do visitors currently walk around the building(s).
4. What is the desired path of travel within the building for visitors and patients.
5. What is the desired path of travel within the building for employees.
6. Location of departments and clinics.
7. A simple clear room numbering system that follows a clear, understandable pattern.
8. Placement of signs in locations where people are expecting them to be.
9. Adequate light on and around directional signs.
10. Which signs can have permanent messages and which ones need to be changeable.

These elements help establish the basis of a clear sign program that communicates and informs in a direct and simple manner.

A sign program for a building, that works well, is one that has been planned as an integrated whole. This means signs are coordinated from the main entrance, to the directional signs and department identification and to room identification signs.

Types of Signs

Interior signs have been identified, on each page, with a description of their use and application.

All rooms in a facility should be labeled with a room number sign. Other types of signs, depending on the room use, then augment this room number sign, a Type IN-03. For example: an IN-04 would be added for labeling a Soiled Utility room or an IN-07 for identifying a Conference Room.

Wall, soffit and ceiling mounted directional signs provide solutions for communicating way finding information in differing building conditions. Typically, ceiling or soffit mounted directional signs are used to display directional information for high traffic destinations like the Pharmacy or Clinics.

Directories in lobbies and at elevator landings serve to assist people in finding or confirming the location of services within a building or in other buildings. Directories, because of their capability to handle a large number of services listing, can include all of the departments or services within the facility.

Sizes of Signs & Lettering

Interior sign sizes that are illustrated in this section have been determined to work in most situations. The size of text shown has also been determined to be the best compromise between readability and being able to fit text on the sign.

When planning a sign program, look for conditions that are within the building where signs will not fit. All buildings have these conditions. When encountered, have the specific sign, at that location, modified in size to fit the specific condition requirements.

Text size on signs has also been predetermined to meet ADA requirements for the vision impaired. Overhead signs require large size lettering and lettering on directional signs should be larger than on room identification signs.

Wayfinding

“Wayfinding” is a term that in recent years has been used to describe the process of finding a destination in the built environment. Signs play an active role in this process by providing the primary form of communication in way finding

In developing a way finding system for the interior of a medical center, or the interior of a support building, you need to follow some common guidelines.

One first needs to identify the paths of travel from originating points to destinations.

In the interior of a building this involves the corridor system from all the building entrances to the locations where patients and visitors are seeking a service. While this is a primary path, a secondary primary path is from that service or location to another service or location within the building. Like going from a Clinic to the Pharmacy.

Identifying destinations people walk to is the process of identifying the paths of transit. Way finding is then communicating to people along this pathway, with appropriate directional signs.

The intersections along the corridor pathway system need to be identified in their importance for communication. Major high traffic corridor intersections require more communication than smaller secondary intersections.

The architectural environments in which these intersections present themselves have an effect on a way finding program. Colors of walls, types of flooring and lighting also affect way finding both in a positive and a negative way.

One must look at the path of travel and the decision points that are necessary to reach the end point and where these decision points are located. At these decision points information must be communicated in a priority of need. Departments and destinations with heavy visitor and patient traffic have the highest priority of communication in way finding.

The priority of need is defined as those departments or services that have the highest percentage of people seeking them. This high demand for information then needs to be communicated with the highest priority on directional signs along the most direct path of travel.

Overhead signs, generally, provide emphasis to high priority directional information. However, with the aged VA population and wheelchair patients, care must be taken with overhead signs to insure that these signs can be seen from a distance. If the viewing distance is too short, those that walk stooped, are in walkers or in wheelchairs will miss these signs.

Wayfinding (Cont'd) Secondary information or information that applies to a small percentage of individuals needs to be evaluated in regard to its importance. Secondary information should be relegated to the bottom of the signs and not even be included if there is no room on the sign.

Typically a person only reads 4 to 8 messages on a directional sign. Any information that is beyond or greater than this is simply not read. Prioritization of communication of information would then in most cases cause the secondary or minor information to be left off the sign because it is not useful.

People that are walking have the opportunity to read more messages than an automobile driver so interior directional signs can contain more listings of information. But, more than 10 listings on a sign results in a sign so large that it is no longer readable and the viewer simply cannot sort through all the information presented, or won't stand there long enough to read everything. When a lot of information needs to be presented, break it down into smaller groups of information. Use 2 directional signs instead of 1. Place all the directional information for one direction on one sign and then use another sign to convey the other directional information.

"You Are Here" maps can sometimes aid in the way finding process but care must be taken to make sure the map is very simple and configured in a manner which it makes very easy to understand. The orientation of these maps, and the amount of information on them, plays a critical role on the understanding of the viewer of what they are looking at.

It is important that "You Are Here" maps be placed in a strategic location where the viewer has a clear orientation to the building based upon the view of the map that they are seeing. Placement also needs to be at a location in the building where the viewer can make connection with major visual objects like an atrium or large "art" or architectural feature.

Remember, once the viewer leaves the map, the visual image in their memory will quite quickly erode. And, once they make the first turn all their orientation will be gone.









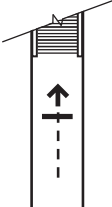

Arrows The proper use of arrows on directional signs is important to insure that the reader quickly understands the correct directional information.

Grouping all the information together that is in one direction and using one arrow is preferred. Using an arrow for each message makes the sign difficult to read.

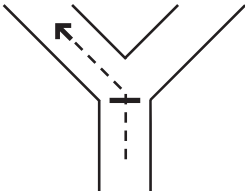

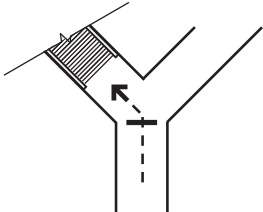

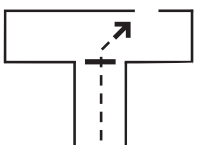

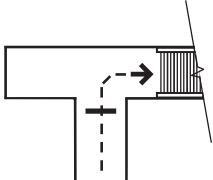

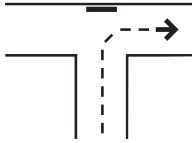

Arrows should be placed in such a manner that they visually precede the message. This allows the reader to understand direction first and information second. It also allows the arrows to be visually separated from text.

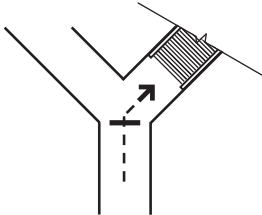
Arrows should always be larger in size than the text they are affiliated with. For example, wall directional signs have a 2-1/2" arrow and the text has a 1 3/8" capital letter size.

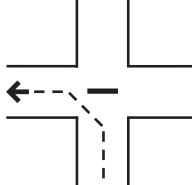
Orientation of arrows is important to effectively communicate direction. The following illustrations give examples of the many varied conditions that can be encountered when providing direction information.

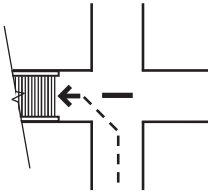
Arrows	Number	Orientation	Location Plan	Interpretation
	①			Straight Ahead
	②			Up
	③			Ahead on Left
	④			Up on Left
	⑤			Ahead on Right
	⑥			Up on Right

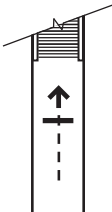
Arrows (Cont'd)

Number	Orientation	Location Plan	Interpretation
7			Right
8			Down on Right
9			Left
10			Down on Left
11			Down
12			Straight Ahead

Sign Placement Correct placement of signs is required for all interior room identification signs.

Refer to the detailed drawings and instructions covered in the Installation Section for each sign type showing the placement position required for its use.

Correct placement of signs will usually mean fewer signs are required. Too many signs in one location can create a cluttered appearance and increase the difficulty for a viewer to find the particular information they are seeking.

Interior lighting, wall colors and material finishes need to be taken into consideration as this impacts the visibility of signs. Locations of glass sidelights, and their width, can require blank glass back ups or other solutions.

Coordination needs to take place with things like chart holders, bulletin boards, pictures and art work as these types of items may have to be relocated to meet the installation requirements of signs. Coordination needs to also take place with Life Safety and Code signs.

Care also needs to be taken to place signs in a manner that allow clear viewing. Placement of signs so they are not obscured by furniture or equipment is critical.

Refer to the detailed drawings and instructions covered in the Installation Section for each sign type showing the placement position required for its use.

Existing Sign Program Before implementing a new interior sign program, perform a through evaluation of the demolition requirements of the current sign program and the effects and impact on the facilities walls, doors and ceilings.

Check to see what is required to patch, seal and repair the building surfaces exposed as a result of removal of old signs or letters. Repairs should be planned to match adjoining surface. Evaluate if tile or stone surfaces going to require repair or refurbishment. Are doors going to need to be refinished or painted.

Make sure the sign demolition scope of work requires the contractor to close off any live electrical connections. Make sure to have existing conductors and conduit removed to the nearest junction box and made it safe.

Be sure to clearly identify any signs that are supposed to remain. It is especially important to identify signs and plaques that relate to special dedications or displays that maybe in the building.

Do not remove any life safety or code signs without having the replacement signs available and installed at the same time the old signs are removed.

The following are some general “Do’s & Don’ts” guidelines that one can refer to when developing a sign program.

key information or instructions that will hopefully reduce some common errors that are made when working out an exterior sign program.

This is not intended to be a training section of the guide, but to provide

General Guidelines

- Never use text smaller than 3” capital letter height when a sign is installed above 84” from the floor.
- All tactile room number signs or other tactile room identification signs are required to meet ADA requirement for height and Braille text.
- Signs do require maintenance and periodic cleaning will extend the life of a sign program.
- If overhead signs are used, make sure they have 84 inches of clearance from the bottom of the sign to the floor.
- Signs identifying electrical closets, mechanical rooms and telecommunication rooms should consist of only the room number which should follow the master building room numbering system. No descriptive name or title should be used nor should they have a unique number system.

Message Content

- Keep sign messages brief. Unnecessary information will confuse the viewer.
- Typically, all signs, with the exception of directional signs, should convey no more than one name, title, concept or thought.
- Use text (words) which are familiar and comfortable to the viewer, and use the same words throughout the sign program.
- On directional and informational signs only provide information necessary to make a decision at that particular location.
- Whenever possible, messages should be presented using positive information.
- On directional signs, do not anticipate decisions that can be made later. Unnecessary or premature information will confuse the reader.
- Messages placed on signs should be concise, preferably with no more than seven to ten words.

Message Layout

- Use upper and lower case text whenever possible. Upper and lower case text is easier to read and is understood faster than text in all capital letters.
- Line-spacing between two different messages should be greater than line-spacing between lines of the same multiple-line message group.
- Generally sign text should be a minimum of 1/2” capital letter height.
- Text should not be run right up to the edge of the sign.
- If a line text needs to be reduced in order to fit on a sign, use only commonly recognized abbreviations, reduce the number of words or reduce the size of the type for the entire message. DO NOT condense the type face.
- The most important message should appear as the first line text and the most important directional information should be at the top of the sign.

Placement of Signs

- Signs should, if at all possible, always be perpendicular to the intended viewer.
- Position signs with a clear line of sight from the viewing point to the sign face.
- Always evaluate the lighting at a sign's location. Lighting conditions can have a big effect on visibility possibly making a particular location unsuitable.
- All signs should be placed in a manner that will be clearly visible at all times.
- Be careful to coordinate ceiling mounted signs so they do not obstruct or block fire sprinkler systems and exit signs.
- Signs may be installed on glass because there is no available wall surface. A blank glass back up is then required to be placed on opposite side of glass exactly behind sign being installed.

This section of the Sign and Environmental Graphic Program Guide provides for all the types of interior signs that would be necessary to sign individual buildings to a complete medical center campus or a off site clinic building.

This section is divided into two parts. The first part identifies all room number and identification signs and directional information and the second part covers way-finding, construction, installation and helpful hints.

The following Overview illustrates the various types of signs in this section. The individual pages on each Sign Type provide more specific information and detailed layouts.

Interior Sign Designations

Each sign in the program guide has been give a specific sign type number designation. This designation provide a common description that can be referenced when programming a site and ordering signs. The following explains how the sign type designations are derived.

IN - 03 .01 A

IN Designates an interior sign.

03 Two digit numbers identifies a particular sign type family like the “signs for use in identifying an Ambulance Entrance”.

.01 The two digit number following the period identifies a specific sign within the sign family.

A The letter designates a specific sign configuration, version and/or layout for graphics.

Overview

Interior Signs

IN-03.01

Room Number Identification



IN-03.01

IN-04.01

Primary Room Identification



IN-04.01

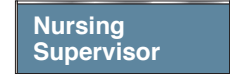

IN-04.02

IN-04.02

Secondary Room Identification

IN-05.01 & .02

Patient Room Identification

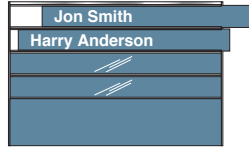

IN-05.01 & .02

IN-05.03 & .04

Patient Room Identification

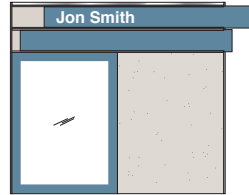

IN-05.03 & .06



IN-06.01, .02, & .03

IN-07.01, .02 & .03

Conference/Meeting Room Sign

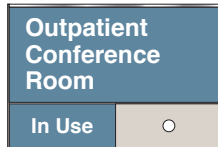

IN-07.01, .02, & .03

IN-08.01, .02, .03 & .04

Prohibit, Instructional & Control Sign



IN-08.01, .02, .03 & .04



IN-09.01, .02, .03, .04, .05, .06 & .07

IN-09.01, .02, .03, .04, .05, .06 & .07

Pictogram & Symbol Sign

IN-09.08, .09

Pictogram & Symbol Sign



IN-09.08, .09

IN-10.01, .02, .03, .04, .05 & .06

Sign Frame

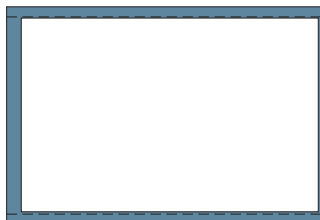

IN-10.01, .02, .03, .04, .05 & .06

IN-11.01, .02, .03 & .04

Informational / Instructional Sign

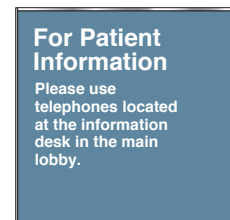

IN-11.01, .02, .03, .04, .05, & .06

Overview

Interior Signs

IN-12.01, .02, .03 & .04
Desk, Counter Sign

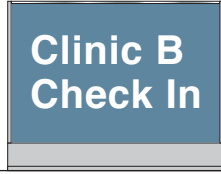

IN-12.01, .02, .03 & .04

IN-13
Perpendicular (Flag) Mount Sign



IN-13

IN-14.01, .02, .03, .04 & .05
Wall Directional Sign



IN-14.01, .02, .03, .04, & .05

IN-14.06
Elevator Lobby Directional Sign



IN-14.06

IN-15.01, .02, .03 & .04
Ceiling Mounted Directional Sign

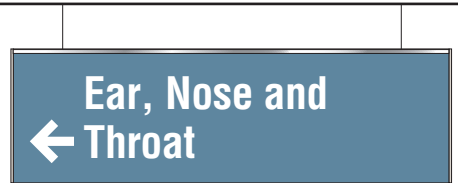

IN-15.01, .02, .03 & .04

IN-15.05, .06, .07 & .08
Ceiling Mounted Directional Sign

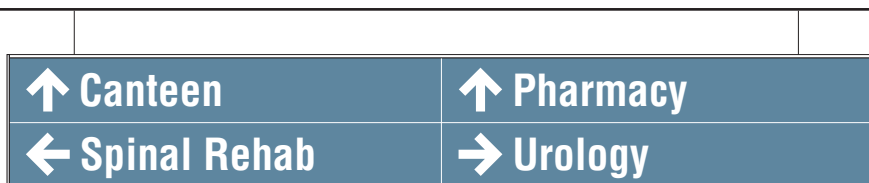

IN-15.05, .06, .07 & .08

IN-15.09, .10, .11 & .12
Soffit Mounted Directional Sign



IN-15.09, .10, .11 & .12

IN-15.13, .14, .15 & .16
Soffit Mounted Directional Sign

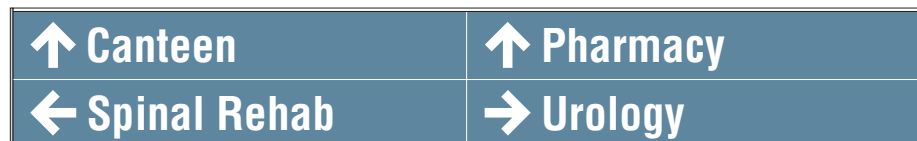

IN-15.13, .14, .15 & .16

Overview

Interior Signs

IN-16.01, .02, .03 & .04
Ceiling Mounted Directional Sign



IN-16.01, .02, .03 & .04

IN-16.05, .06, .07 & .08
Ceiling Mounted Directional Sign

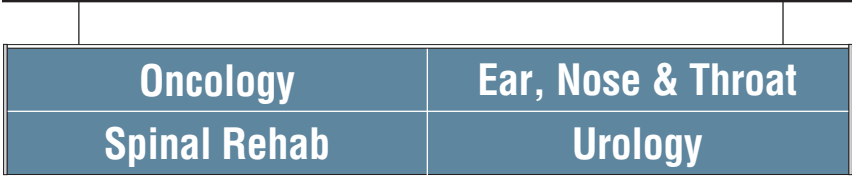

IN-16.05, .06, .07 & .08

IN-16.09, .10, .11 & .12
Soffit Mounted Directional Sign



IN-16.09, .10, .11 & .12

IN-16.13, .14, .15 & .16
Soffit Mounted Directional Sign

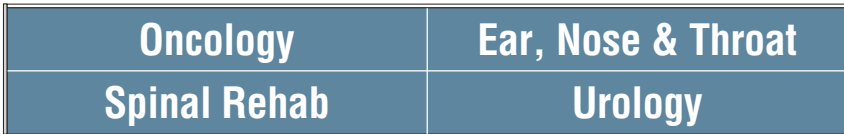

IN-16.13, .14, .15 & .16

IN-17.01
Directory

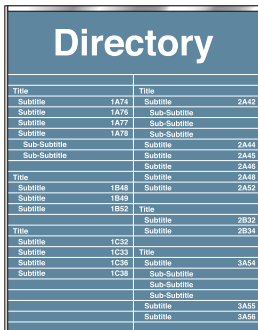

IN-17.01

IN-17.02
Large Directory



IN-17.02

Overview

Interior Signs

IN-17.03
Directory with Map

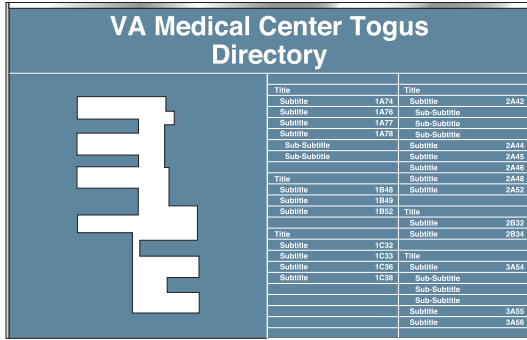

IN-17.03

IN-17.04
Large Directory with Map

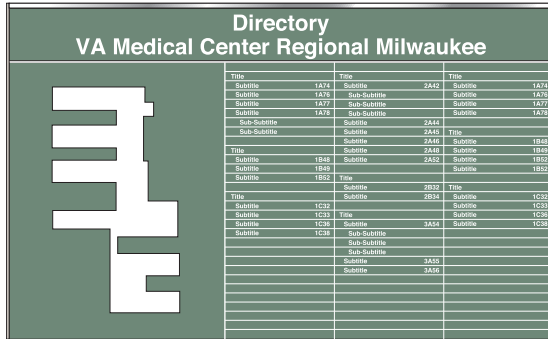

IN-17.04

IN-17.05
Floor Directory

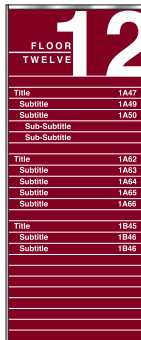

IN-17.05

IN-17.06
Large Floor Directory

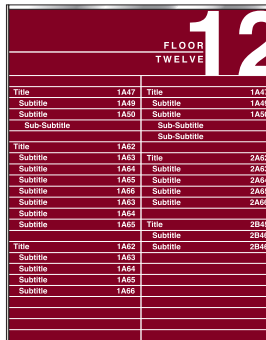

IN-17.06

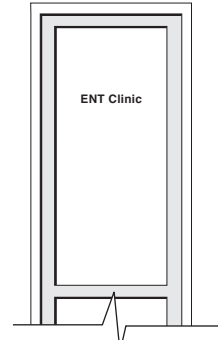

IN-18.01

IN-18.01
Glass Door and Side Light Graphics

IN-19.01, .02 & .03
Dimensional Letters



IN-19.01, 02. & 03

IN-20.01
Informational Sign

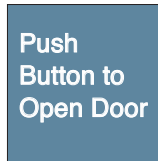

IN-20.01

IN-03.01

Interior Signs

Room Number Identification

Size

76 mm H x 229 mm W
(3" H x 9" W)

Description & Use

Sign is to be placed on all rooms that require identification.

Message Configuration

(Refer to layout drawing for lettering sizes and dimensions)

Sign Components

Sliding Rail Back; Etched Sign Plaque; Aluminum Top Accent Bar; End Cap

Graphic Process

Tactile room number with accompanying Braille.

Colors

Text: Refer to Color Chart.
Background & Accent Bar: Refer to Color Chart

Type Style

Helvetica Medium
Grade 2 Braille

Mounting

Double sided foam tape, silastic adhesive or screw.

Installation

Knob side of door, 1575 mm (63") to top of sign and 50 mm (2") over from door frame.

Recommendations

This sign is to be used for all rooms, but can also be used to identify corridors and alcoves as necessary. Do not use on exterior and stairwell doors.

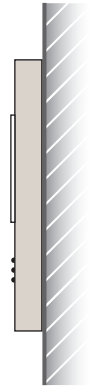

Message Layout A

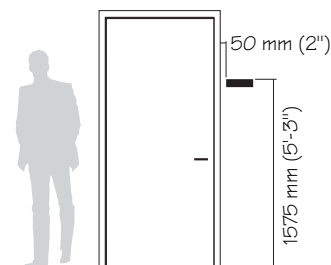
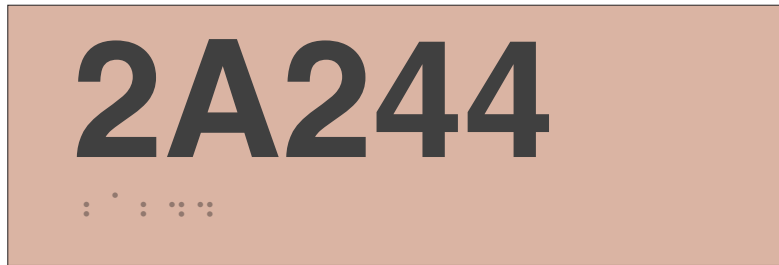

Room Number Identification

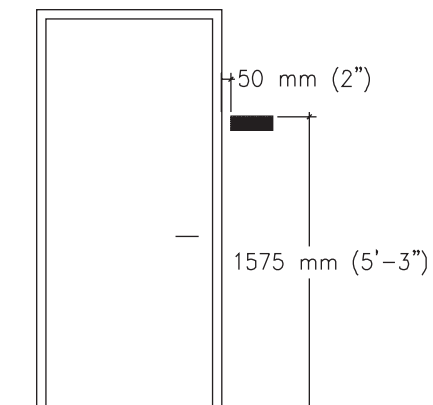
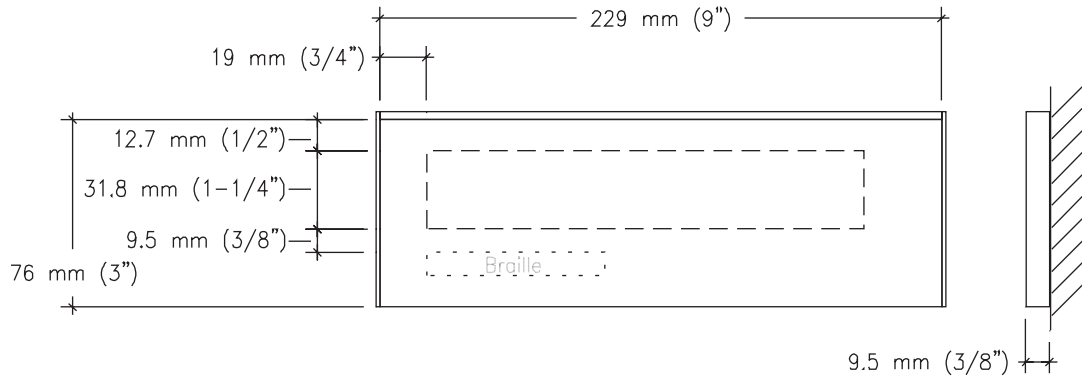

IN-04.01

Interior Signs

Primary Room Identification

Size

152 mm H x 229 mm W
(6" H x 9" W)

Description & Use

This sign always has a Type IN03 as its top sign component. Use this sign to identify the occupant or activity within a room.

Message Configuration

(Refer to layout drawing for lettering sizes and dimensions)
Layout A is suggested for department identification. Layout B for rooms and departments with long words or names. Layout C for rooms with a common name but need specific identification.

Sign Components

Sliding Rail Back; Copy Panel;
Accent Bar; End Caps

Graphic Process

Surface applied vinyl.

Colors

Text: Refer to Color Chart.
Background & Accent Bar: Refer to Color Chart

Type Style & Size

Helvetica Medium
Lettering size is adaptable to allow messages to fit on to the sign. Refer to various layouts for reference.

Mounting

Double sided foam tape, silastic adhesive or screw.

Installation

Knob side of door, 1500 mm (60") to top of sign and 50 mm (2") over from door frame.

Recommendations

It is recommended that this particular sign type become the "building standard" for identification of all rooms.

Signs identifying electrical closets, mechanical rooms and telecommunication rooms should consist of only the room number (Sign type IN-03.01). The room number should follow the master building room numbering system. No descriptive name or title should be used nor should they have a unique number system.



Message Layout A



Message Layout B

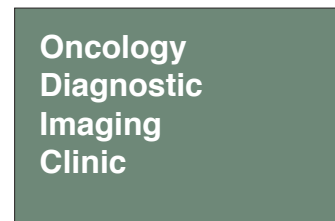

Message Layout C

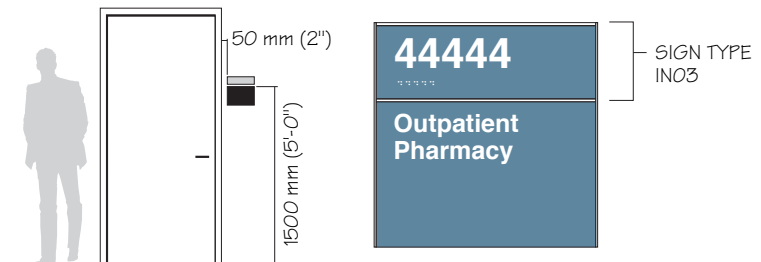
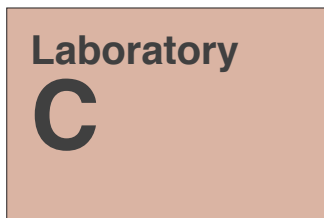

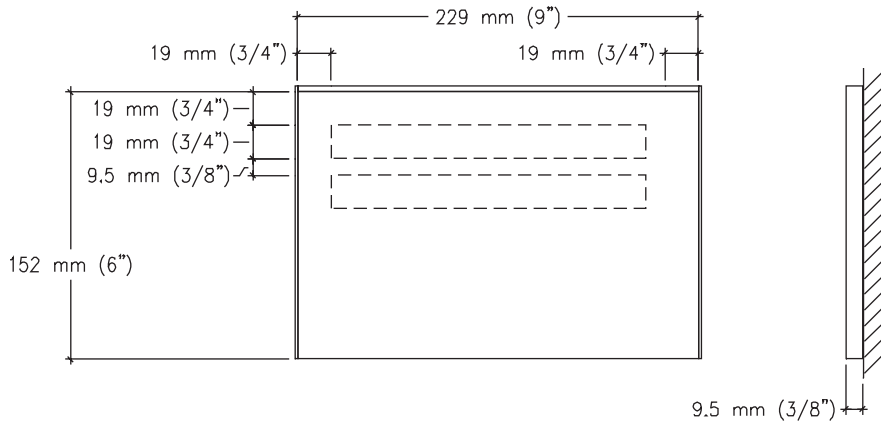

Message Layout A

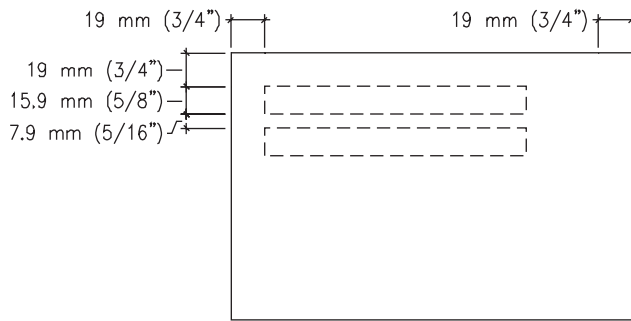

Message Layout B

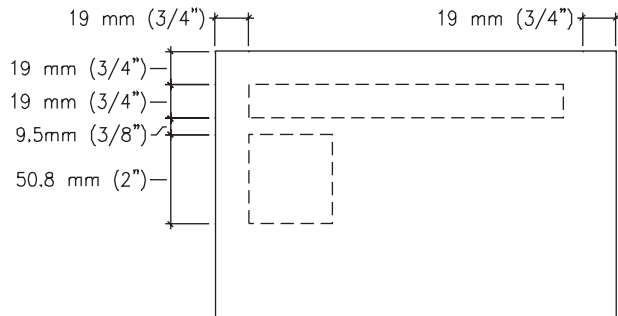

Message Layout C

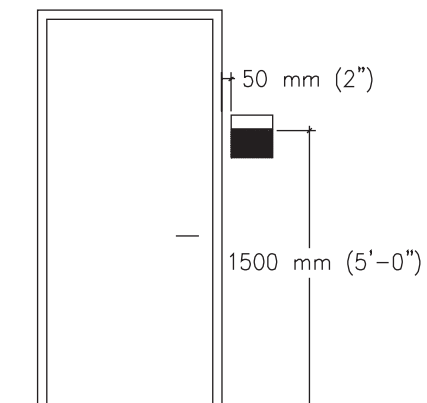

Secondary Room Identification

Sign Size

76 mm H x 229 mm W
(3" H x 9" W)

Description & Use

This sign always has a Type 03 as its top sign component. Use this sign to secondary rooms or rooms that have short names.

Message Configuration

(Refer to layout drawing for lettering sizes and dimensions)
Layout A is suggested for short titles. Layout B is for longer names or titles. Layout C is specific identification by number or letter.

Sign Components

Sliding Rail Back; Copy Panel; Top Accent Bar; End Caps

Graphic Process

Surface applied vinyl.

Colors

Text: Refer to Color Chart.
Background & Accent Bar: Refer to Color Chart

Typography

Helvetica Medium

Mounting

Double sided foam tape, silastic adhesive or screw.

Installation

Knob side of door, 1500 mm (60") to top of sign and 50 mm (2") over from door frame.

Recommendations

This sign is for rooms that do not require long or large text.



Message Layout A

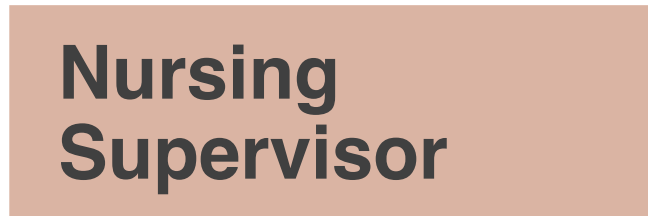

Message Layout B



Message Layout C

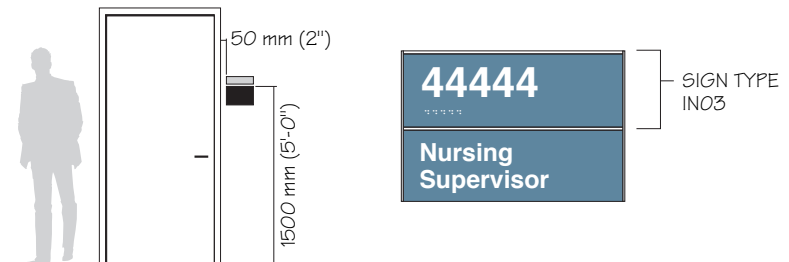

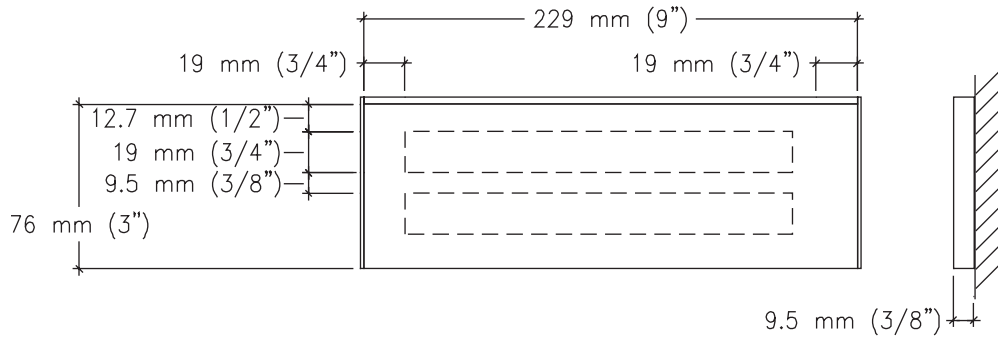

Message Layout A

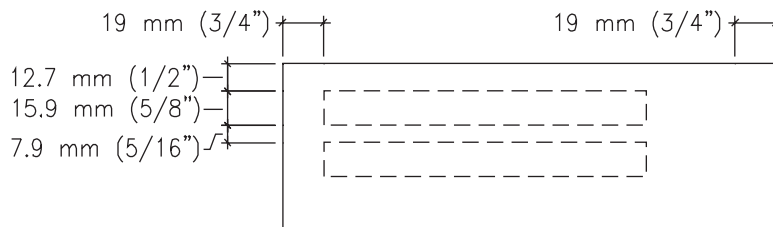

Message Layout B

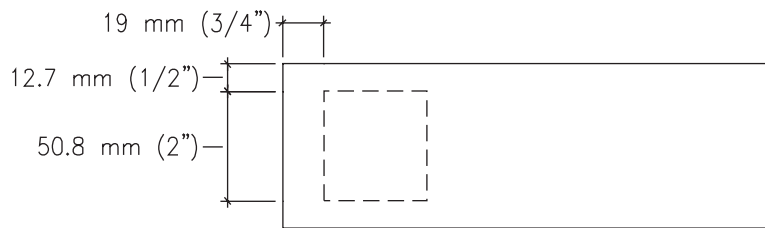

Message Layout C

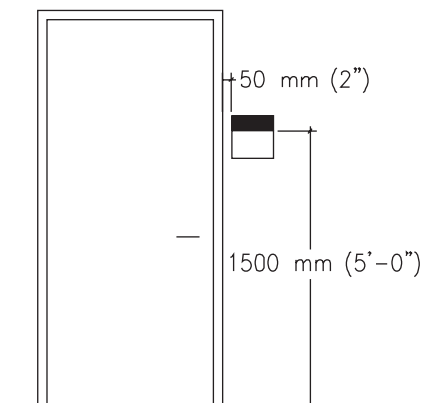

IN-05.01-2

Interior Signs

Patient Room Identification

Size

IN-05.01

152 mm x 229 mm
(6" x 9")

IN-05.02

76 mm x 229 mm
(3" x 9")

Description & Use

This sign always has a type IN03 as its top component. Use this sign to identify the occupant's of a patient room.

Message Configuration

(Refer to layout drawings for lettering sizes and dimensions)
Paper inserts with patient's names are prepared and removed by each Medical Center based upon occupancy of the room.

Sign Components

Sliding Rail Back; Top Accent Bar; Polycarbonate Cover; Paper or Film
Copy Insert; Extruded Insert Holder; Copy Panel; End Caps

Graphic Process

Inserts to be provided by hospital

Colors

Text: Refer to Color Chart.
Background & Accent Bar: Refer to Color Chart

Mounting

Double sided foam tape, silastic adhesive or screw.

Installation

Knob side of door, 1500 mm (60") to top of sign and 50 mm (2") over from door frame.

Recommendations

It is recommended that this sign type be used for patient rooms.

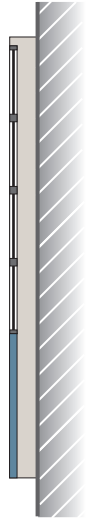
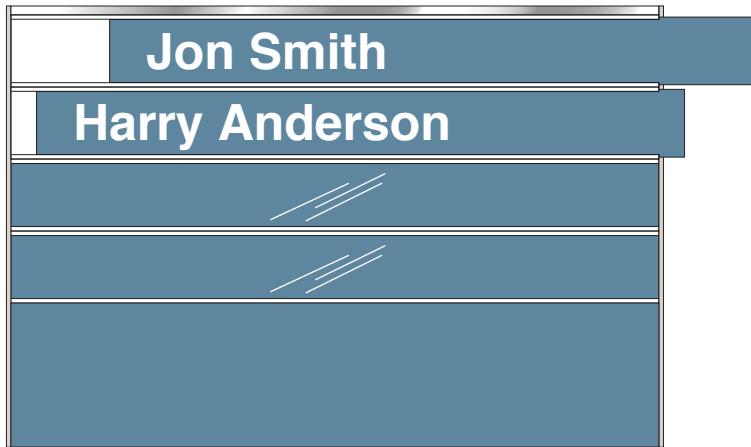

IN-05.01

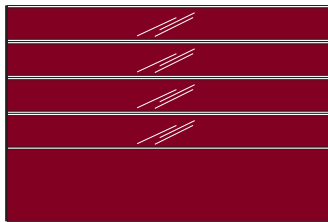

IN-05.02 Layout A

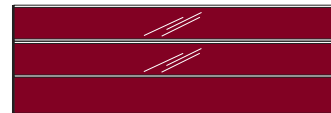

IN-05.02 Layout B

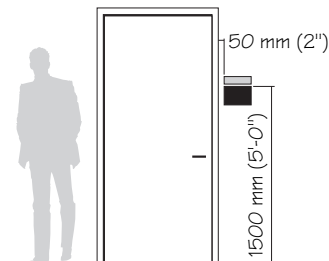
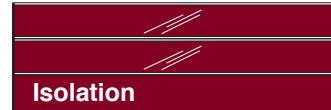

SIGN TYPE IN-03

SIGN TYPE IN-22.01

Patient Room Identification

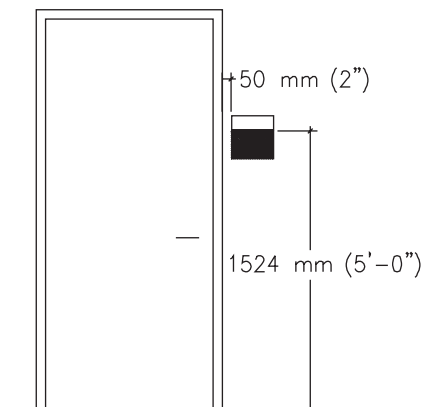
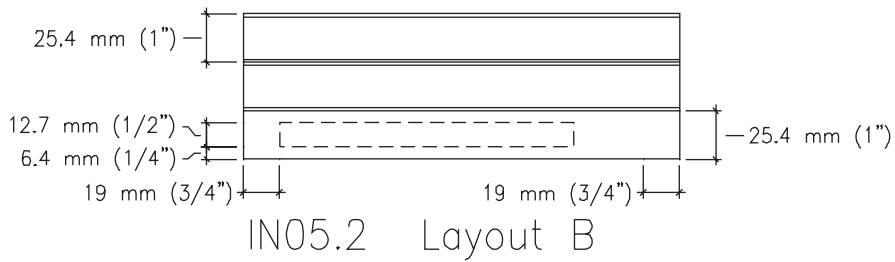
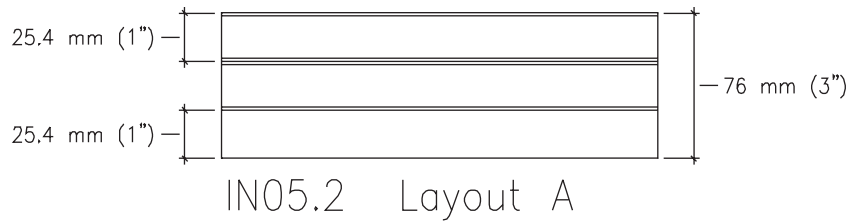
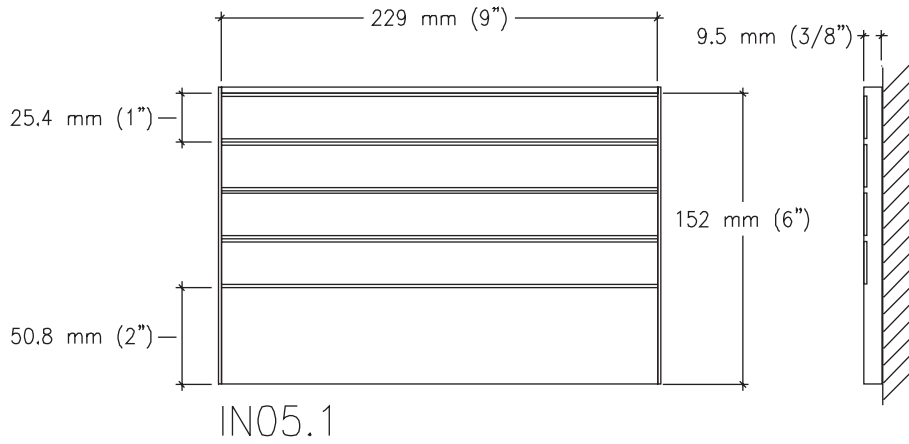

IN-05.03,05

Interior Signs

Patient Room Identification

Size

IN-05.03

330 mm x 305 mm
(1' 1" x 1' 0")

IN-05.05

330 mm x 610 mm
(1' 1" x 2' 0")

Description & Use

This sign always has a type IN03 as its top component. Use this sign to identify the occupant's of a nursing home patient room. Window receives a 4" x 6" photo of the patient which is provided by the facility. The adjacent component is a tack surface for mounting memorabilia.

Message Configuration

(Refer to layout drawings for lettering sizes and dimensions)
Paper inserts with patient's names are prepared and removed by each Medical Center based upon occupancy of the room.

Sign Components

Sliding Rail Back; Top Accent Bar; Polycarbonate Cover; Paper or Film Copy Insert; Extruded Insert Holder; Copy Panel; End Caps

Graphic Process

Inserts to be provided by hospital

Colors

Text: Refer to Color Chart.
Background & Accent Bar: Refer to Color Chart

Mounting

Double sided foam tape, silastic adhesive or screw.

Installation

Knob side of door, 1500 mm (60") to top of sign and 50 mm (2") over from door frame.

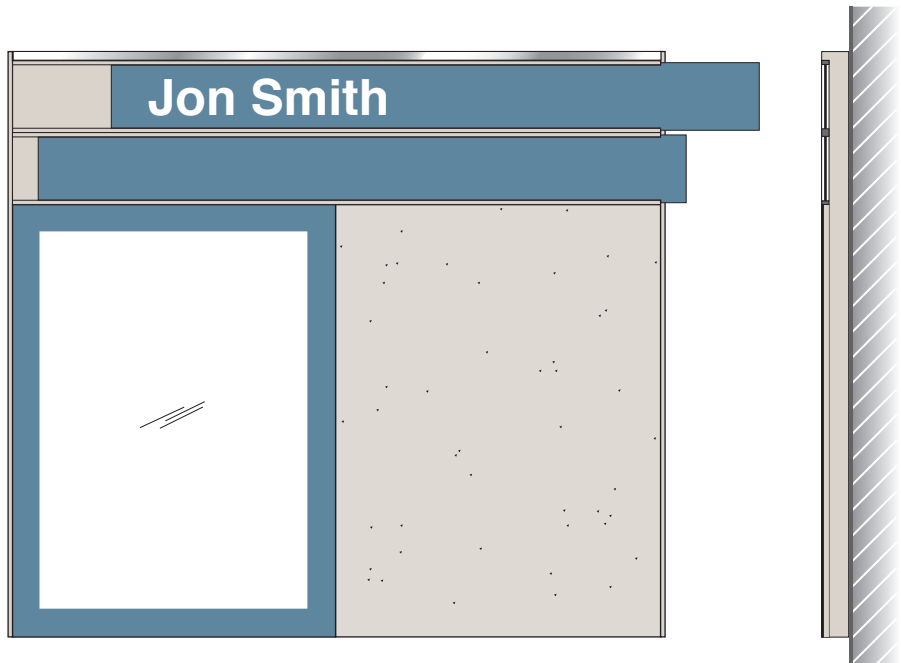

IN-05.03

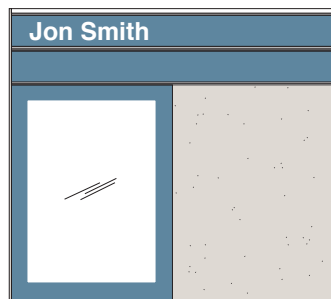

IN-05.05

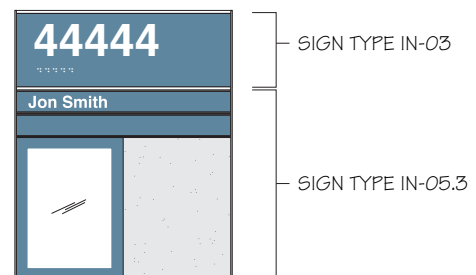
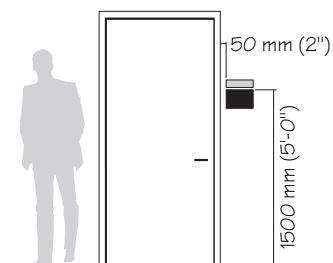
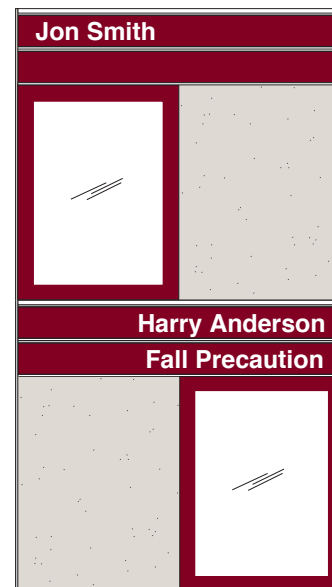

IN-05.03,05 Interior Signs

Patient Room Identification

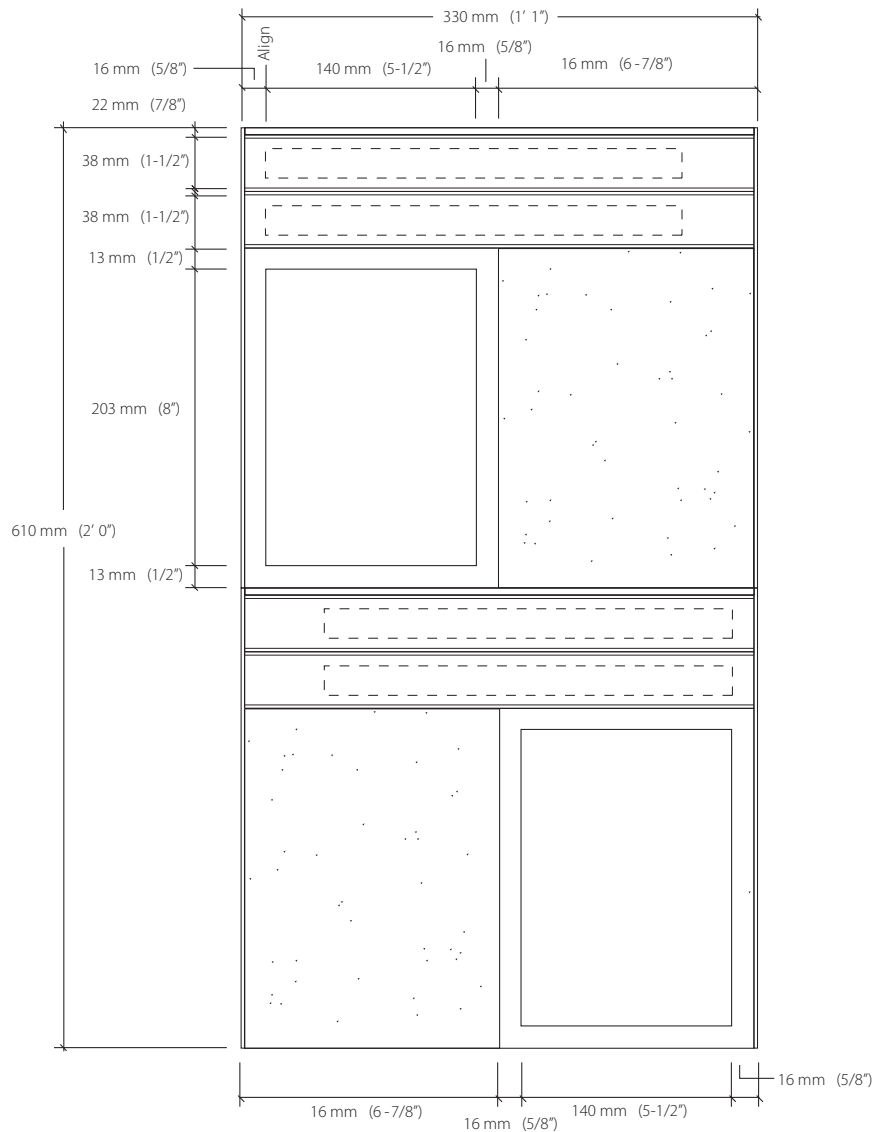
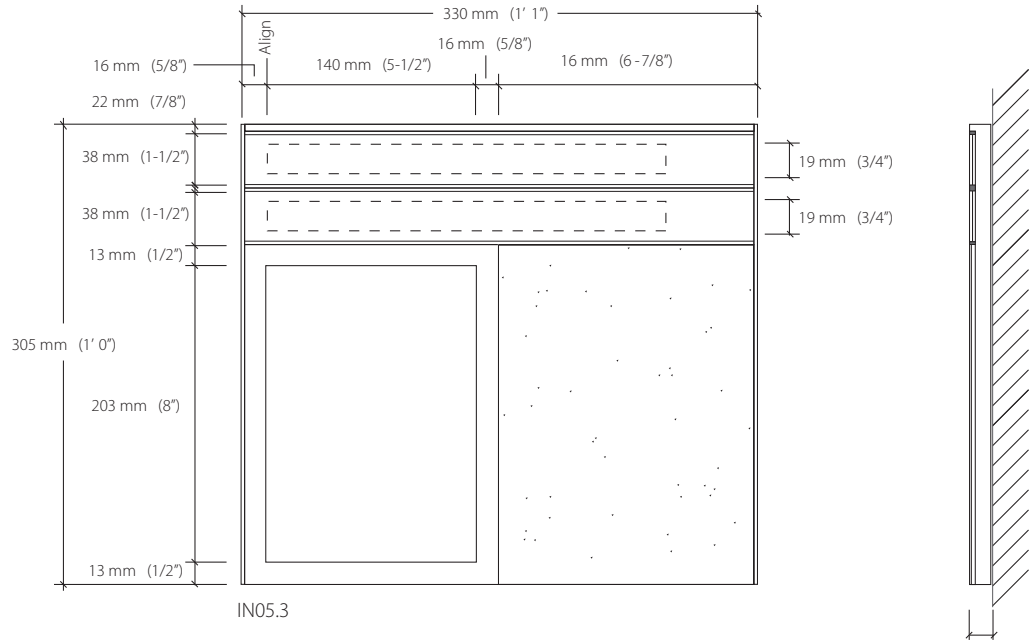

IN05.5

IN-06.01-3

Interior Signs

Patient Bed Sign

Size

IN-06.01
127 mm x 229 mm
(5" x 9")

IN-06.02
229 mm x 229 mm
(9" x 9")

IN-06.03
279 mm x 229 mm
(11" x 9")

Description & Use

Use this sign above patient beds to identify the bed and the patient.

Message Configuration

(Refer to layout drawing for lettering sizes and dimensions)
Insert names are prepared and removed based upon occupancy of the room. Selection of the text to appear behind the slider is to be selected by nursing at a medical center, based on their particular needs.

Sign Components

Sliding Rail Back; Polycarbonate Cover, Extruded Insert Holder, Paper or Film Copy Insert, Slider; Top Accent Bar; End Caps

Graphic Process

Vinyl text.
Name inserts provided by hospital.
Text behind slider is second surface applied.

Colors

Text: Refer to Color Chart.
Background & Accent Bar: Refer to Color Chart

Typography

Helvetica Medium

Mounting

Double sided foam tape, silastic adhesive or screw.

Installation

On headwall above bed.

Recommendations

This sign is for use in patient rooms and is to be coordinated with the needs and function with nursing services.



IN-06.01



IN-06.02

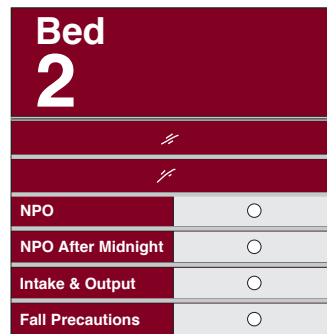

IN-06.03

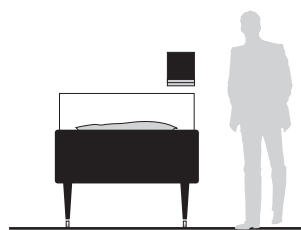
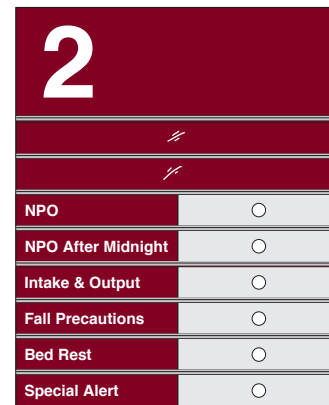

Patient Bed Sign

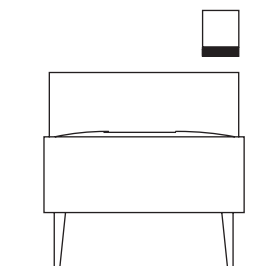
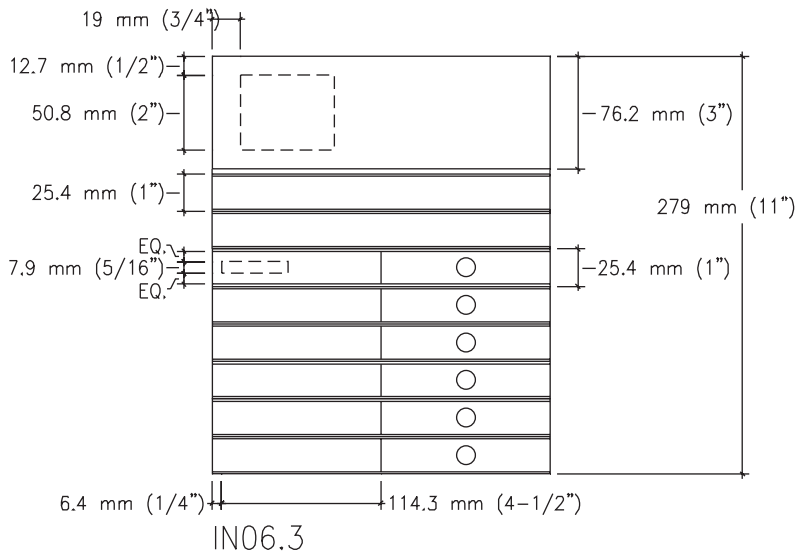
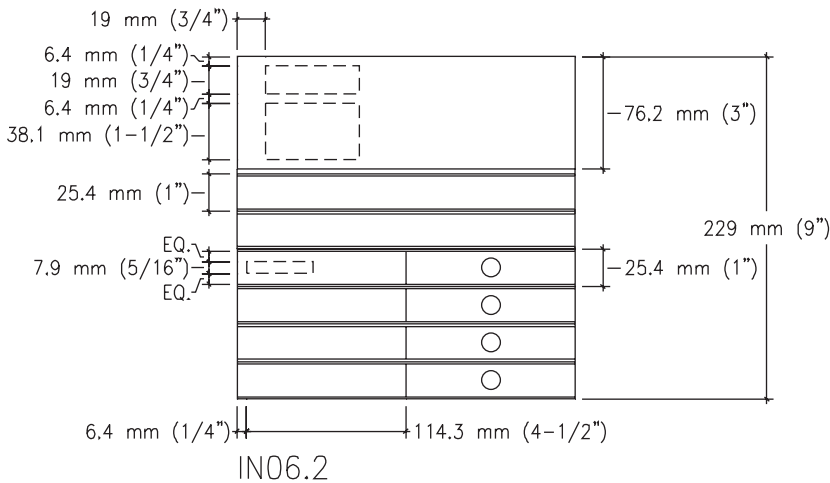
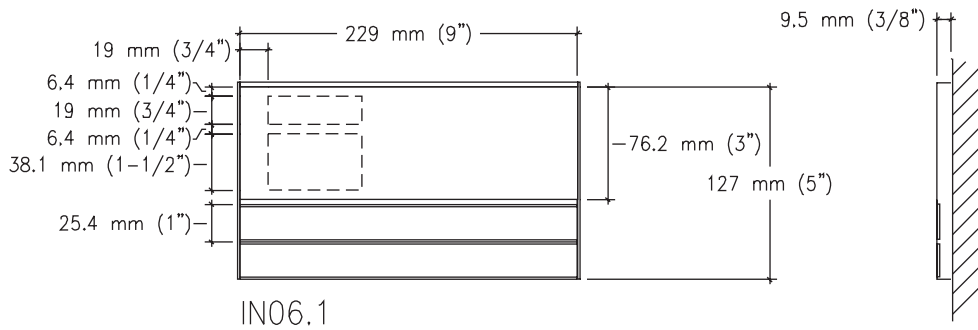

IN-07.01-3

Interior Signs

Conference / Meeting Room Sign

Size

Sign Size

IN-07.01

152 mm x 229 mm
(6" x 9")

IN-07.02

76 mm x 229 mm
(3" x 9")

IN-07.03

152 mm x 229 mm
(6" x 9")

Description & Use

This sign always has a Type 03 as its top sign component. Use this sign for conference rooms, meeting rooms. This type of sign can also be used for exam rooms, treatment rooms, and offices where the occupants may be conducting patient interviews.

Message Configuration

(Refer to layout drawing for lettering sizes and dimensions) IN07.1, Layout A is for conference rooms, Layout B is for exam or treatment rooms. N07.3 Insert messages are prepared and removed based upon occupancy of the room. Selection of the text to appear behind the slider is to be determined by the medical center.

Sign Components

Sliding Rail Back; Polycarbonate Cover, Extruded Insert Holder, Paper or Film Copy Insert, Slider; Top Accent Bar; End Caps

Graphic Process

Surface applied vinyl. IN07.3 name inserts provided by hospital. Text behind slider is second surface.

Colors

Text: Refer to Color Chart.
Background & Accent Bar: Refer to Color Chart

Typography

Helvetica Medium

Mounting

Double sided foam tape, silastic adhesive or screw.

Installation

Knob side of door, 1500 mm (60") to top of sign and 50 mm (2") over from door frame.

Recommendations

This sign is for use on rooms where an indication is needed in the hallway that the room is occupied or an activity is taking place in the room which should not be disturbed.



IN-07.01 (Message Layout A)

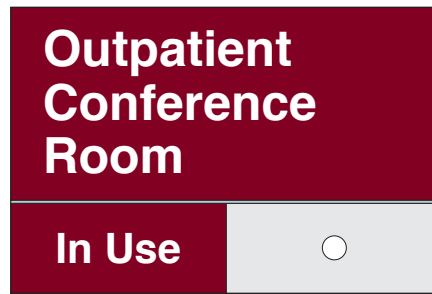

IN-07.01 (Message Layout B)

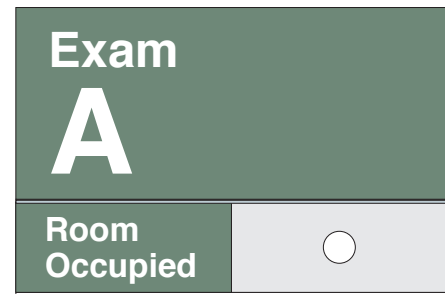

IN-07.02



IN-07.03

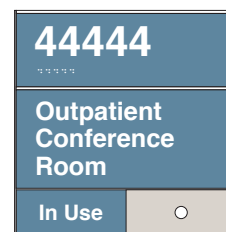
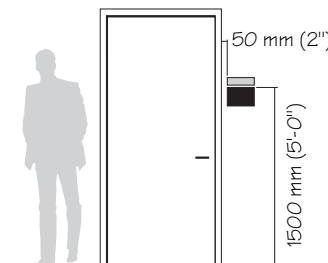
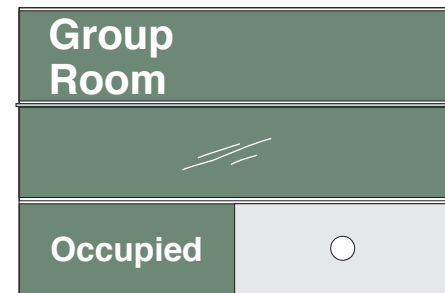

SIGN TYPE IN-03

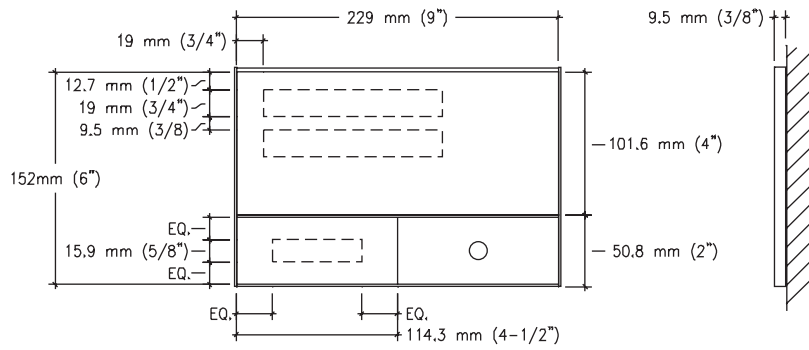

IN07.1 (Layout A)

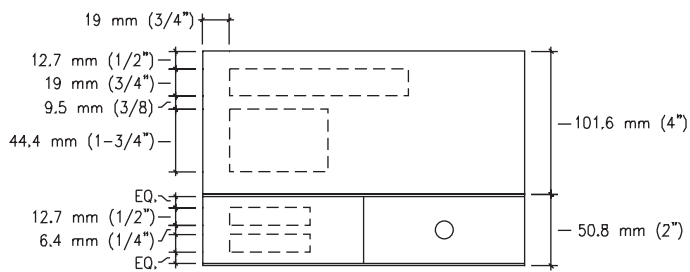

IN07.1 (Layout B)

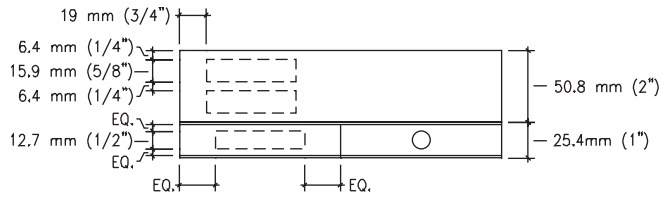

IN07.2

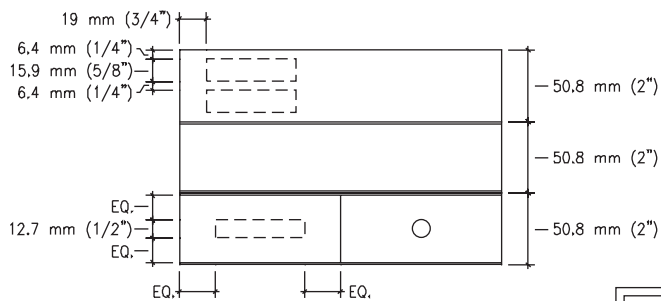

IN07.3

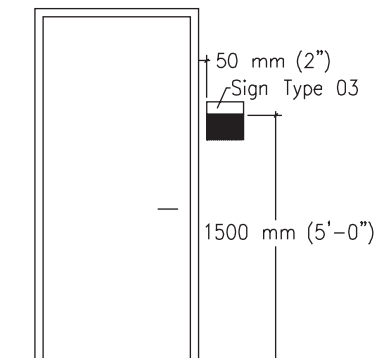

IN-08.01-4

Interior Signs

Prohibit, Instructional & Control Signs

Size

229 mm H x 229 mm W
(9" H x 9" W)

Description & Use

Use these signs to inform in a bold manner.

Message Configuration

(Refer to layout drawing for lettering sizes and dimensions)

Sign Components

Acrylic plaque.

Graphic Process

Silk-screened or surface applied vinyl.

Colors

Text: Refer to Color Chart.

Symbol: Red - B3 and White - T1

Background : Refer to Color Chart

Typography

Helvetica Medium

Mounting

Double sided foam tape or silastic adhesive.

Installation

On wall or door 1575 mm (63") to top of sign and on door, center.

Recommendations

This sign is for use when a strong communication of information is necessary. IN08.4 should be used carefully as it may have a negative reaction on the part of patients and visitors.



IN-08.01



IN-08.02

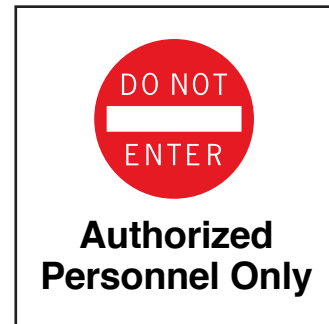

IN-08.03



IN-08.04

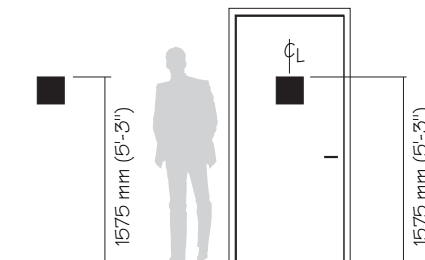
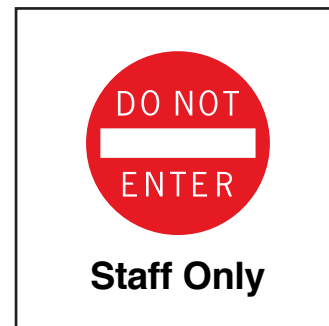

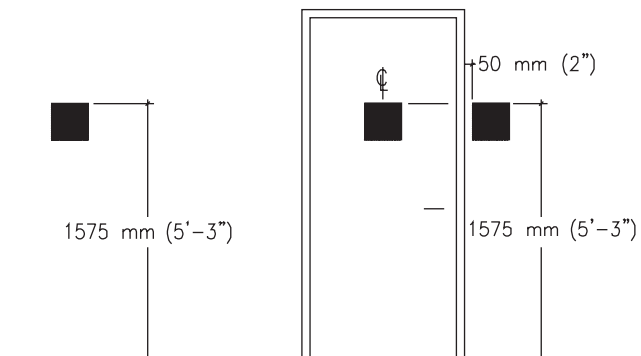
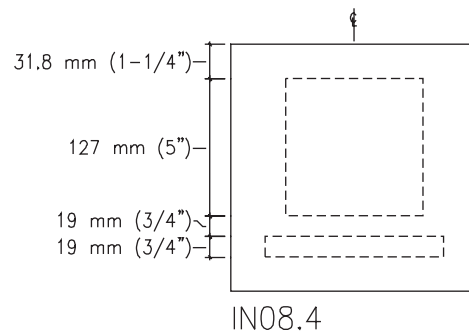
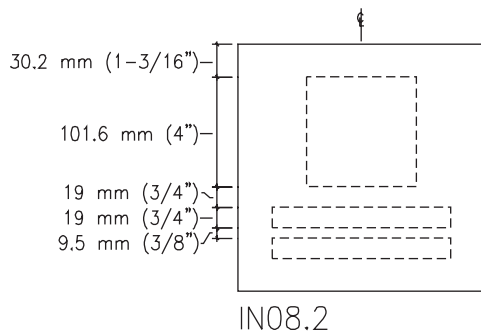
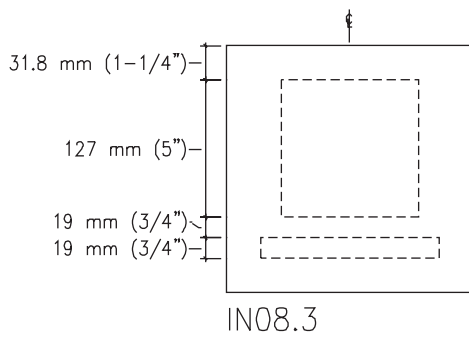
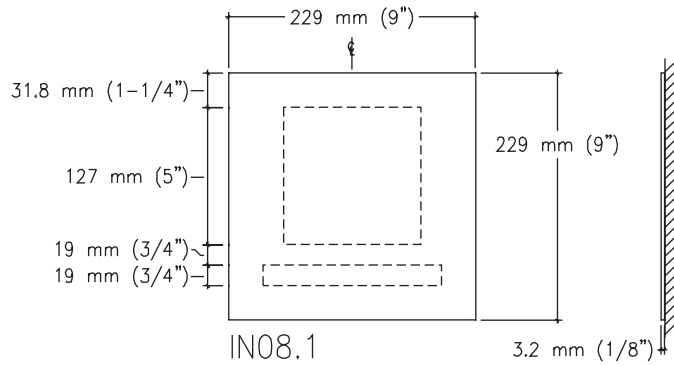

IN-09.01-7

Interior Signs

Pictogram & Symbol Signs

Size

229 mm H x 229 mm W
(9" H x 9" W)

Description & Use

Use these signs to inform with a symbol as well as text.

Message Configuration

(Refer to layout drawing for lettering sizes and dimensions)

Sign Components

Etched sign plaque face laminated to acrylic backing plaque.

Graphic Process

Tactile symbol and text with accompanying Braille.

Colors

Text: Refer to Color Chart.
Background & Accent Bar: Refer to Color Chart

Typography

Helvetica Medium
Grade 2 Braille

Mounting

Double sided foam tape or silastic adhesive.

Installation

On wall or door 1575 mm (63") to top of sign and on door, center.

Recommendations

These signs are for use on restrooms or stair doors or under a Type IN-03 sign.

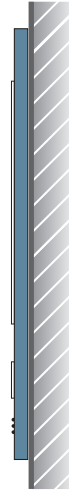
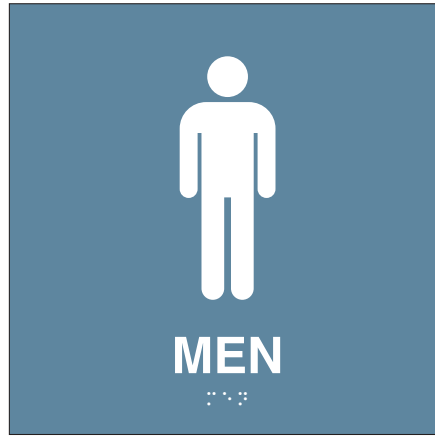

IN-09.01



IN-09.02



IN-09.03



IN-09.04



IN-09.05



IN-09.06

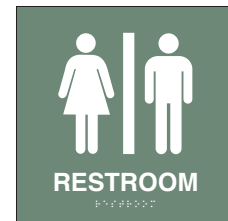

IN-09.07

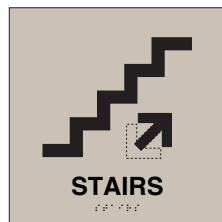

IN-03



IN-09.06



Pictogram & Symbol Signs

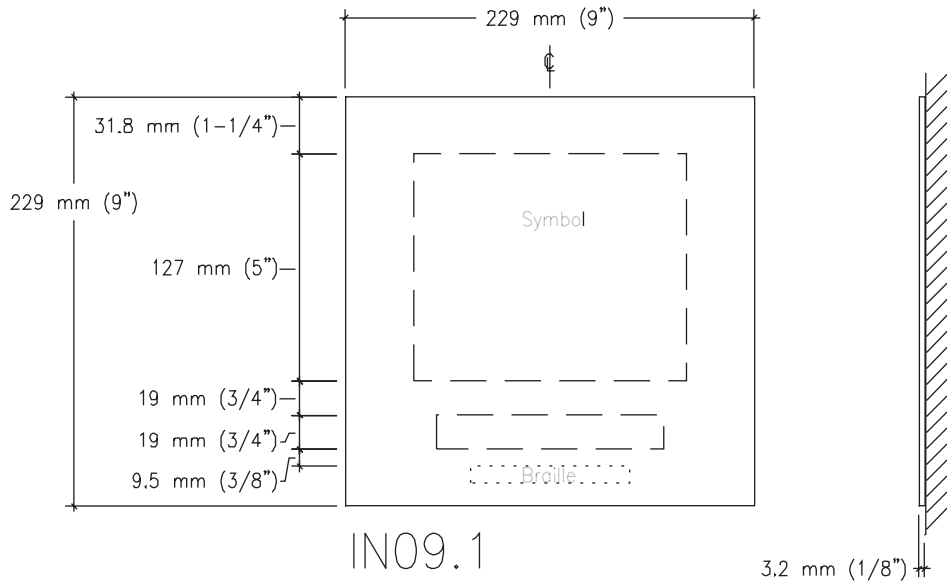

IN09.1

IN09.2

IN09.3

IN09.4

IN09.5

IN09.6

IN09.7

ARROW: Refer to standards for arrow positioning relative to text.

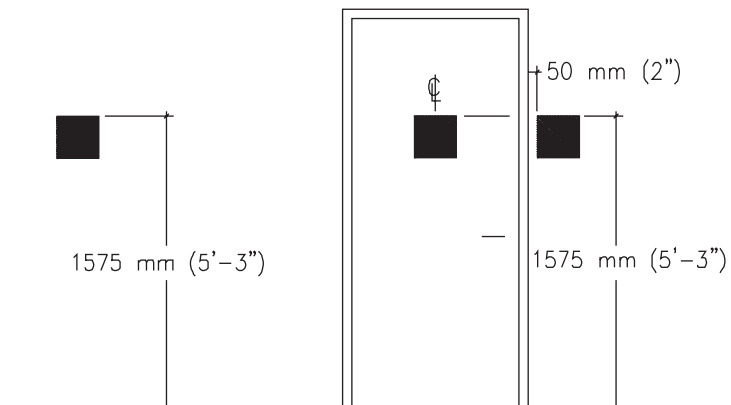

IN-09.08-09

Interior Signs

Pictogram & Symbol Signs

Size

229 mm H x 229 mm W
(9" H x 9" W)

Description & Use

Use these signs to inform with a symbol as well as text.

Message Configuration

(Refer to layout drawing for lettering sizes and dimensions)

Sign Components

Acrylic plaque.

Graphic Process

Silk-screened or surface applied vinyl.

Colors

Text: Refer to Color Chart.
Background & Accent Bar: Refer to Color Chart

**Typography**

Helvetica Medium

Mounting

Double sided foam tape or silastic adhesive.

Installation

On wall or door 1575 mm (63") to top of sign and on door, center.

Recommendations

These signs are for use when a symbol will help communicate.

IN-09.08**IN-09.09**

Pictogram & Symbol Signs

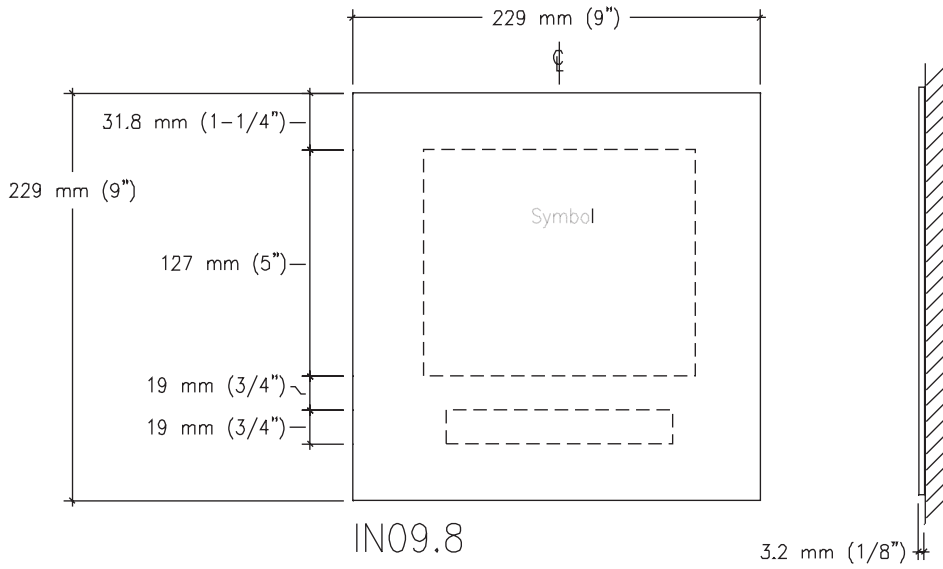

IN09.8

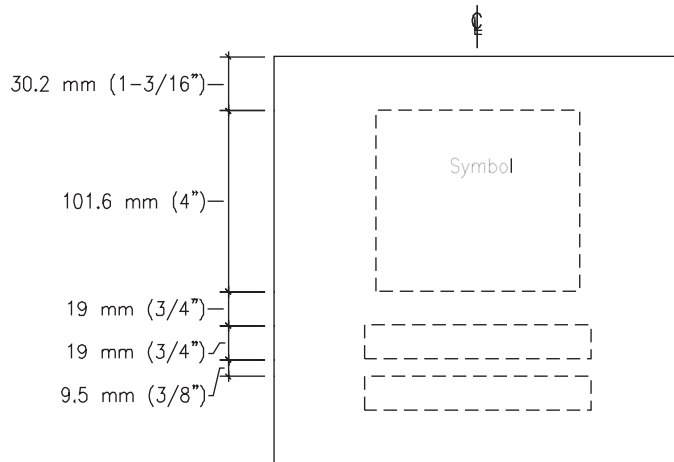

IN09.9

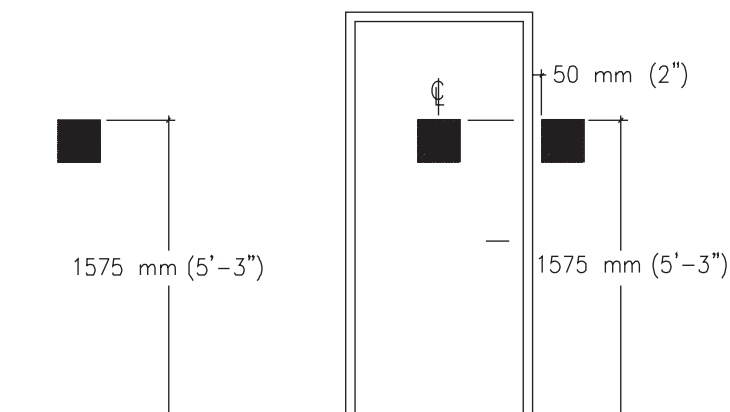

IN-10.01-6

Interior Signs

Sign Frame

Size

IN-10.02
547 mm x 407 mm
(21 1/2" x 16")

IN-10.03
457 mm x 305 mm
(18" x 12")

IN-10.04
305 mm x 457 mm
(12" x 18")

IN-10.05
305 mm x 242 mm
(12" x 9 1/2")

IN-10.06
242 mm x 305 mm
(9 1/2" x 12")

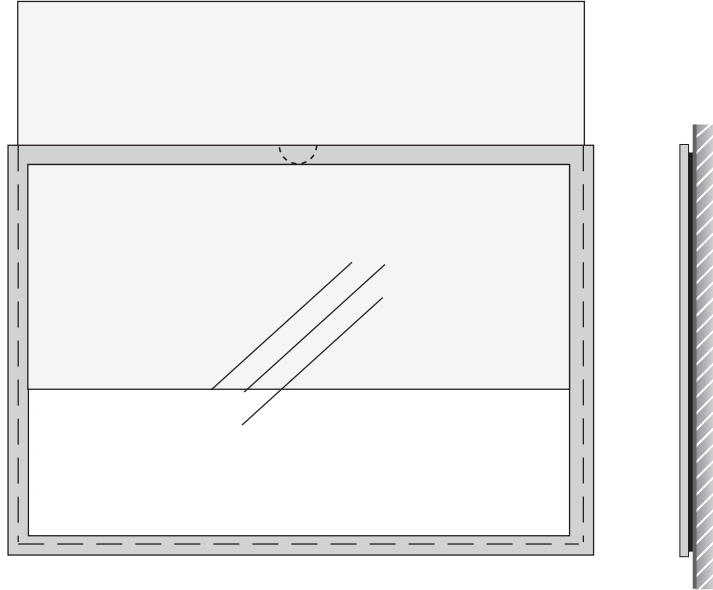

Description & Use

Use these signs to hold posters, fire alarm bell schedules, maps or other information sheets.

- 10.2 14" x 20" paper poster
- 10.3 11" x 17" paper, vertical
- 10.4 11" x 17" paper, horizontal
- 10.5 8 1/2" x 11" paper, vertical
- 10.6 8 1/2" x 11" paper, horizontal

Sign Components

Acrylic plaque.

Colors

Text: Refer to Color Chart.
Background & Accent Bar: Refer to Color Chart

Mounting

Double sided foam tape or silastic adhesive.

Installation

On wall

Recommendations

These signs are for use to hold papers and posters vertically or horizontally.

IN-10.02



IN-10.03

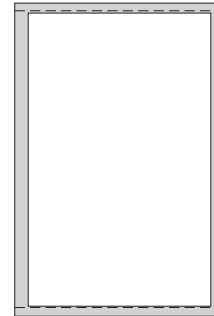

IN-10.04



IN-10.05

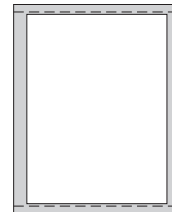

IN-10.06



IN-10.04
IN-10.05
IN-10.06

1500 mm (5'-0")



IN-10.02
IN-10.03

1650 mm (5'-6")

Sign Frame

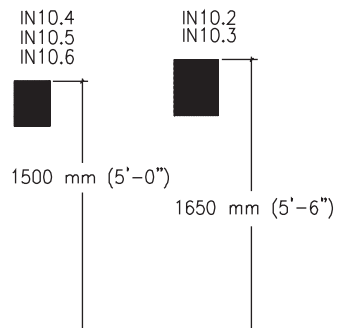
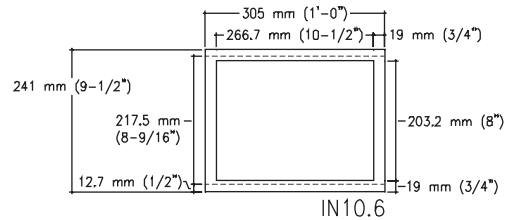
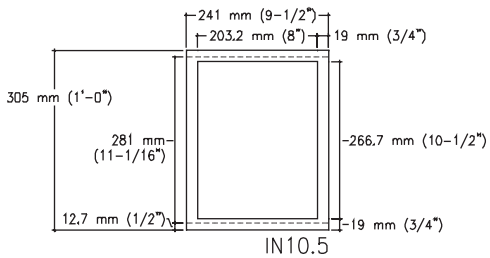
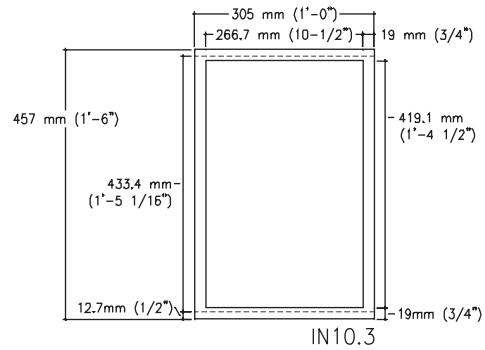
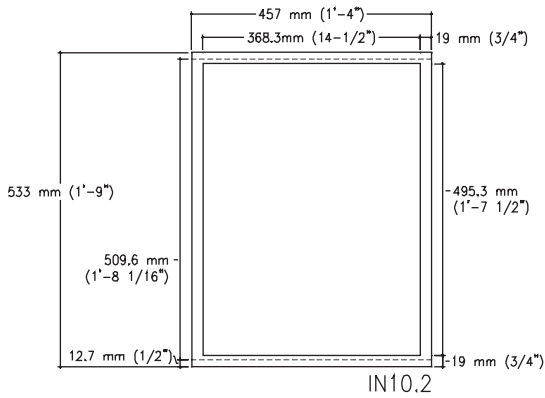
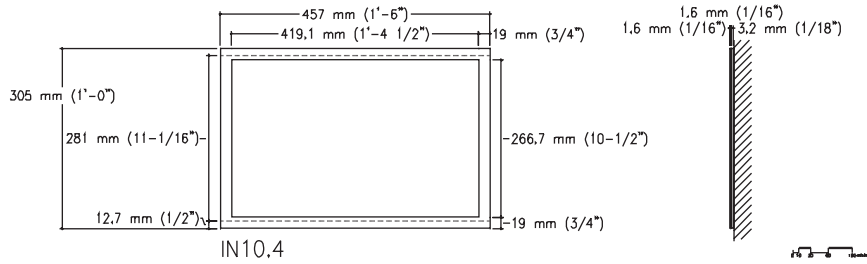

IN-11.01-4

Interior Signs

Informational / Instructional Sign

Size

IN-11.01

229 mm x 229 mm
(9" x 9")

IN-11.02

381 mm x 381 mm
(15" x 15")

IN-11.03

508 mm x 508 mm
(20" x 20")

IN-11.04

152 mm H x 152 mm W
(6" H x 6" W)

Description & Use

Use this sign to communicate miscellaneous information.

Message Configuration

(Refer to layout drawing for lettering sizes and dimensions)
Layouts relate to the size and importance of message.

Sign Components

Sliding Rail Back; Copy Panel; Top Accent Bar; End Caps

Graphic Process

Surface applied vinyl.

Colors

Text: Refer to Color Chart.

Background & Accent Bar: Refer to Color Chart

Typography

Helvetica Medium

Mounting

Double sided foam tape, silastic adhesive or screw.

Installation

On wall

Recommendations

These sign are for use to present brief general messages. Text should be limited to as few a words as possible. Long messages are generally not read.

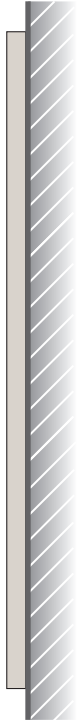
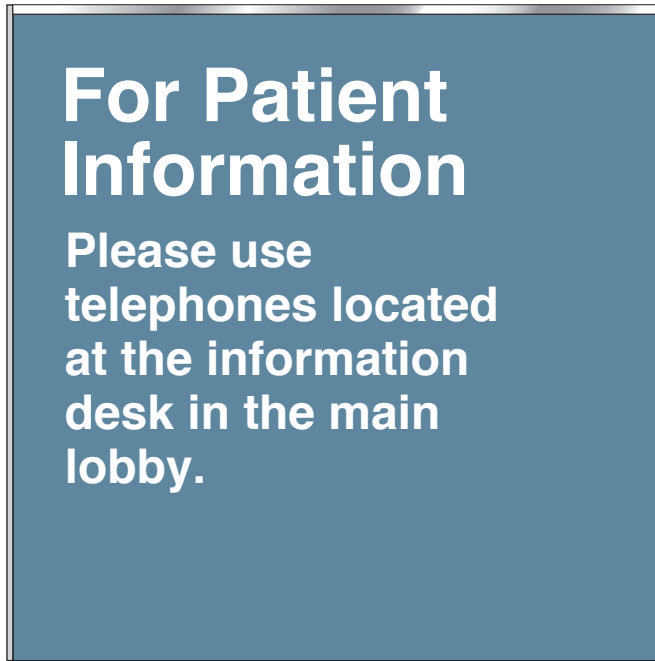

IN-11.01

For Your Information

Ojni naleotj nalihie
akindie majroopa.
Halweo nahia aneio
sojoja marjap naohr
asoow.

IN-11.02

For Your Information

Fraererj nongini niomgi ni usdhon
aoinonio rij n. Gaohr diohionn;dn
jfa'opwej ojjoan au ef esij ej kanfii
ohaofhan. HAouhei feihfia0t0
sijji. Hajkseh ioawul abshrioa.
I'ahowrhini auhfeu aihof aima
sojwo abwirioogs. Kajwhr kkgjo
aihwoaho. Jlaofn elij amwirja
awnapj anwkorjopa.

IN-11.03

Be Informed

Lakeiea nahei naciw anowh amwirj ajshr
aiwirjoan. Bakwoa iehaol ksaw aw
ejfaj naowurh eian. Amakej airhaoinfiao fnia
aiefioa naiv aie aieh. O aoh aebfau naie
aiehaoh ahiw awioh erapont aheioa aniowa
awnaion hai aw9u awiohroahia.

Si usted es un paciente que está recibiendo tratamiento por cualquier forma de cáncer de la prostate, o antes de comenzar a recibir un fármaco para el cáncer de la prostate, le sugerimos que consulte con su médico un número específico de opciones alternativas de tratamiento eficaz, según la Sección 1704.7 del Código de Salud y Seguridad de California.

IN-11.04

For Your Information

Ojni naleotj nalihie
akindie majroopa.
Halweo nahia aneio
sojoja marjap naohr
asoow.

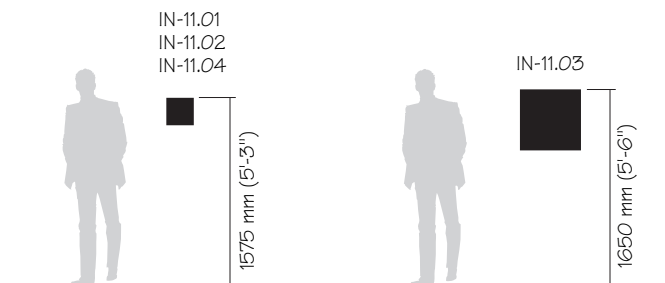

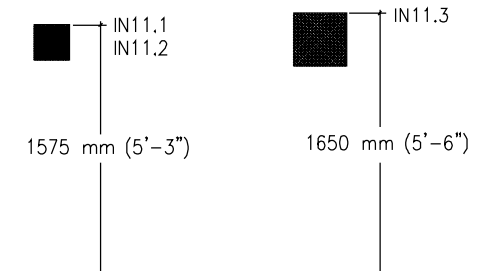
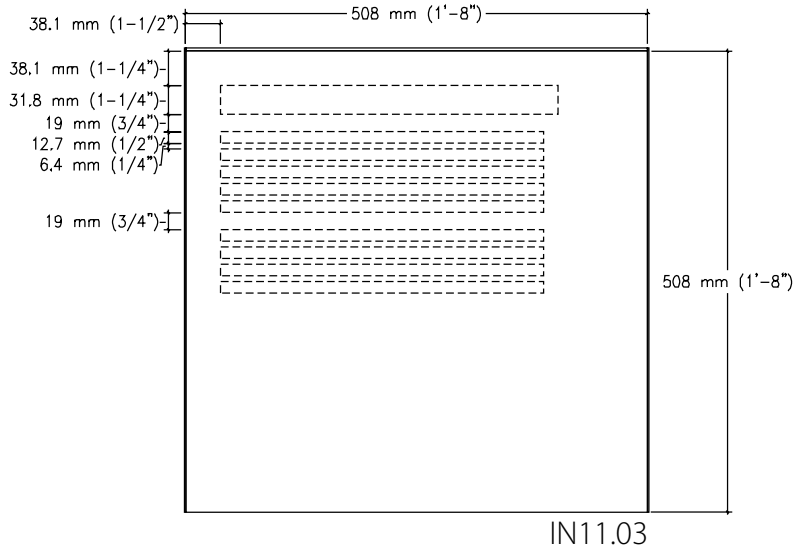
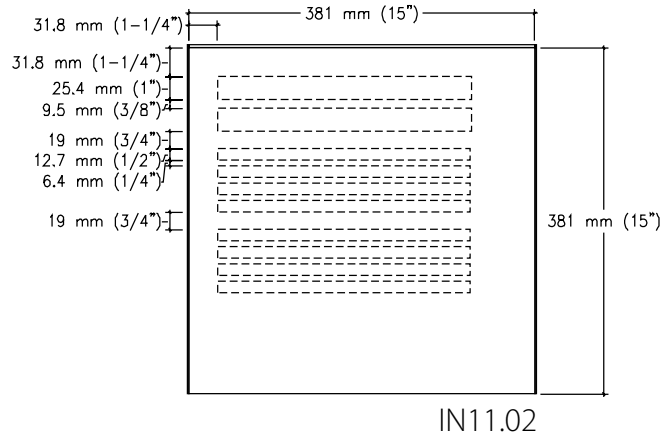
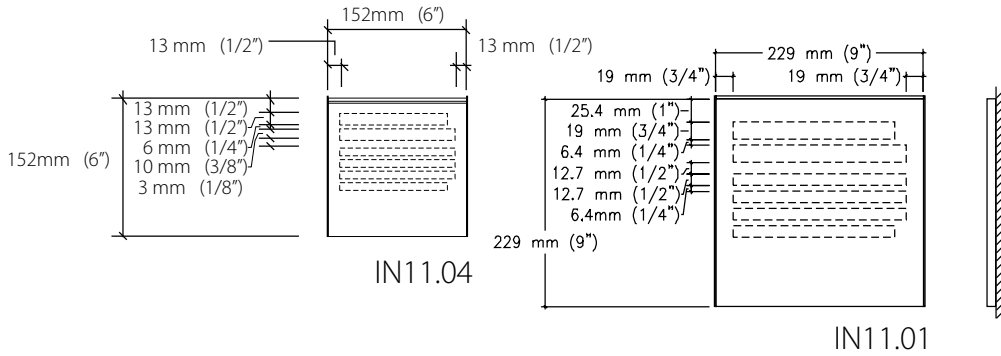

IN-12.01-4

Interior Signs

Desk, Counter Sign

Size

IN-12.01

152 mm x 229 mm
(6" x 9")

IN-12.02

229 mm x 229 mm
(9" x 9")

IN-12.03-04

76 mm x 229 mm
(3" x 9")

Description & Use

Use this sign for messages to be communicated at counters and desks.

Message Configuration

(Refer to layout drawing for lettering sizes and dimensions)

IN12.1 is for titles or titles with a short informational text. IN12.2 is for long titles or titles with a long informational text. IN12.3 is suggested for use as a desk plaque with and individuals name.

Sign Components

Sliding Rail Back; Copy Panel; Top Accent Bar; End Caps, Extruded Aluminum Mounting Bracket

Graphic Process

Surface applied vinyl.

Colors

Text: Refer to Color Chart.
Background & Accent Bar: Refer to Color Chart

Typography

Helvetica Medium

Mounting

Freestanding.

Installation

On counter or desk.

Recommendations

This sign is for use if information does not require long or large text and needs to be removed or relocated based on the function of the counter.

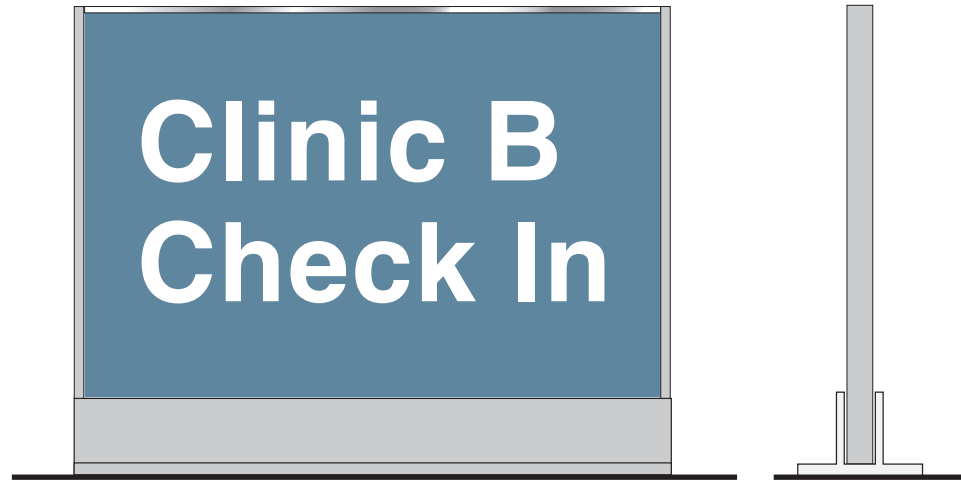

IN-12.01



IN-12.02

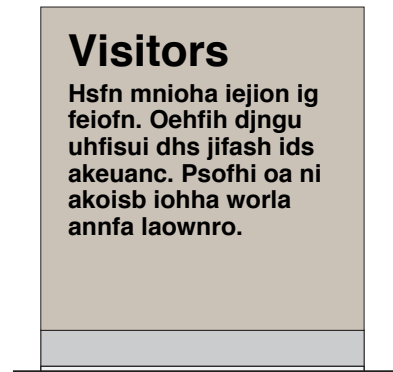

IN-12.03



IN-12.04



Desk, Counter Sign

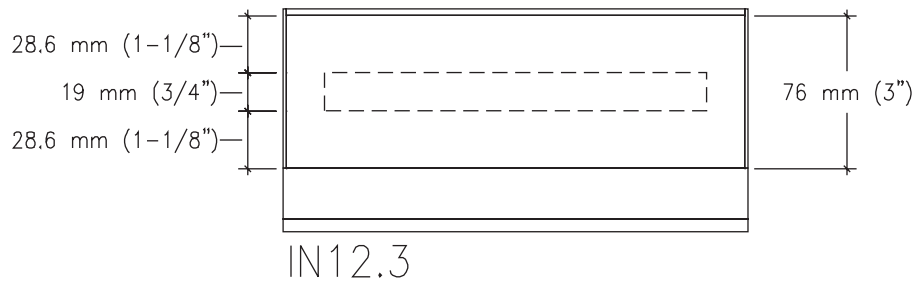
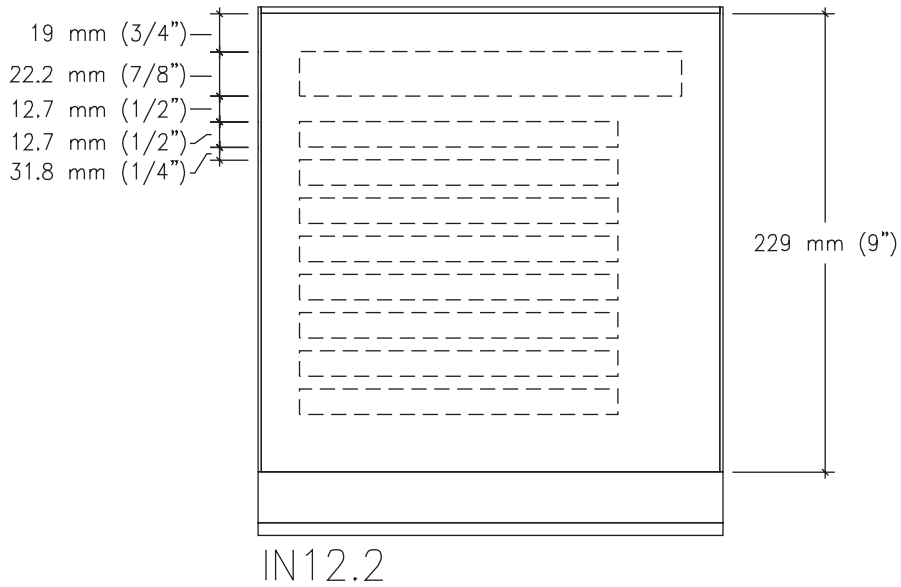
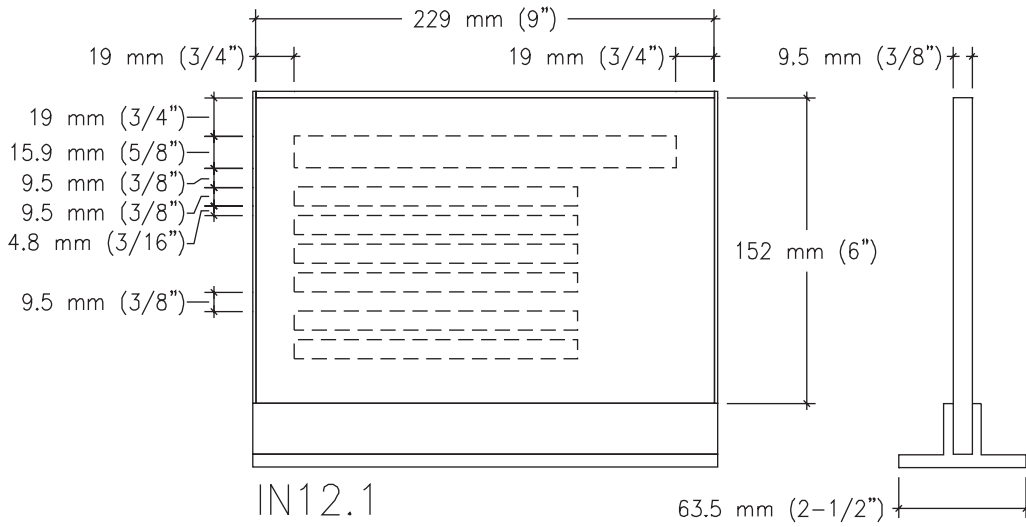

IN-13

Interior Signs

Perpendicular (Flag) Mount Sign

Size

229 mm H x 305 mm W
(9" H x 12" W)

Description & Use

Use this sign for messages to be communicated in corridors on the wall, above doors.

Message Configuration

(Refer to layout drawing for lettering sizes and dimensions)
Layout A is for symbols and title / informational text. Layout B is for directional information. Layout C is for a department name.

Sign Components

Sliding Rail Back; Copy Panel; Top Accent Bar; End Caps, Extruded Aluminum Bracket

Graphic Process

Surface applied vinyl.

Colors

Text & Symbols: Refer to Color Chart.
Background & Accent Bar: Refer to Color Chart

Typography

Helvetica Medium Condensed

Mounting

Wall mount with screws.

Installation

Install on wall above the height of doors, 2100 mm (84") minimum to bottom of sign.

Recommendations

This sign is for use when the service or department is a high traffic area or the service or department is hard to find.

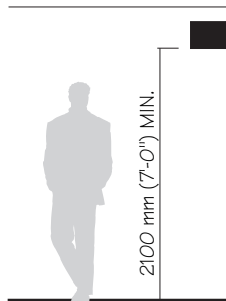
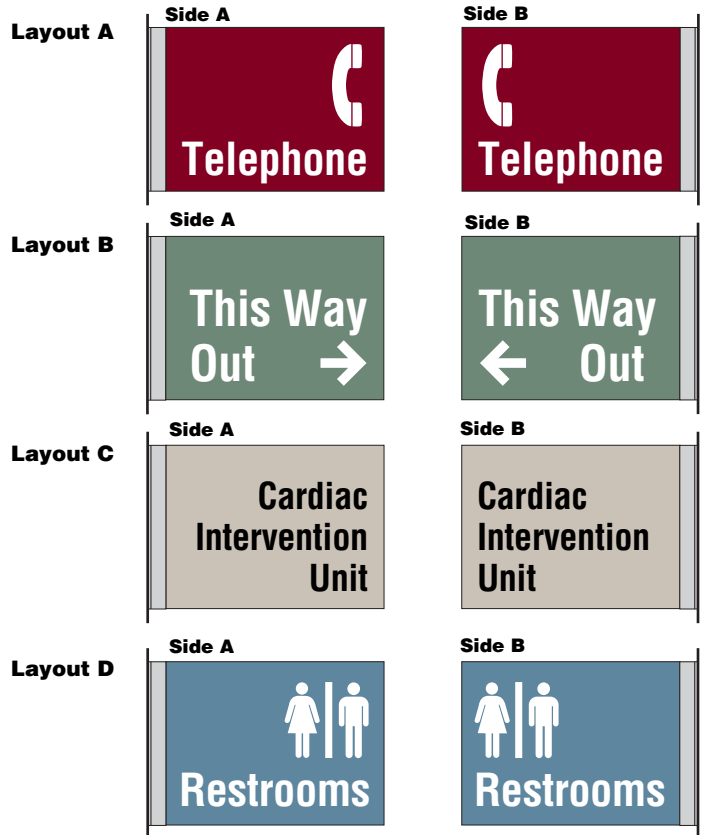
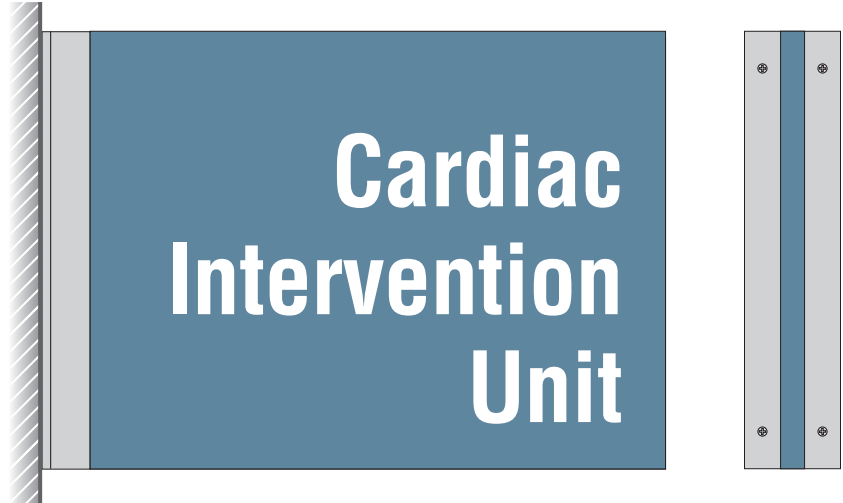

Perpendicular (Flag) Mount Sign

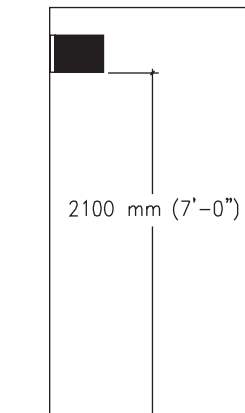
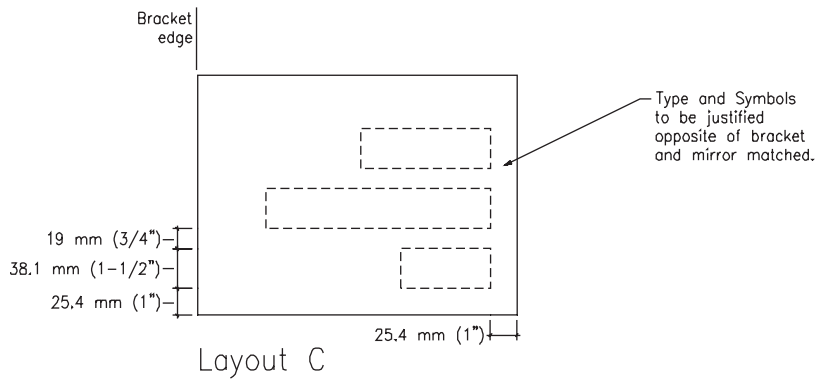
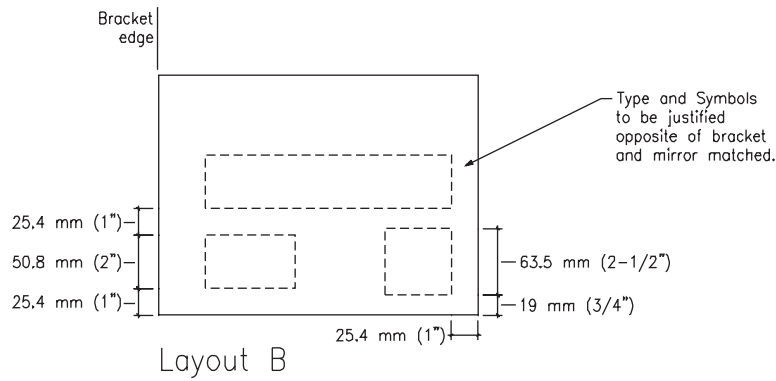
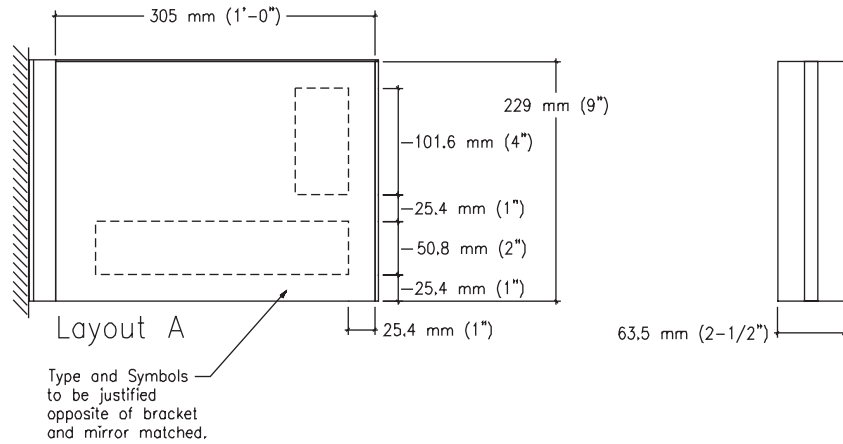

IN-14.01-5

Interior Signs

Wall Directional Sign

Size

IN-14.01
610 mm x 508 mm
(24" x 20")

IN-14.02
762 mm x 508 mm
(30" x 20")

IN-14.03
914 mm x 508 mm
(36" x 20")

IN-14.04
457 mm x 508 mm
(18" x 20")

IN-14.05
305 mm x 508 mm
(12" x 20")

Sign Use & Application

Use this sign for directional information.

Message Configuration

(Refer to layout drawing for lettering sizes and dimensions)

Sign Components

Sliding Rail Back; Copy Panel; Top Accent Bar; End Caps

Graphic Process

Surface applied vinyl.

Colors

Text & Arrows: Refer to Color Chart.
Background & Accent Bar: Refer to Color Chart

Typography

Helvetica Medium

Mounting

Double sided foam tape, silastic adhesive or screw.

Installation

On wall.

Recommendations

This sign is for use in corridors to direct patients and public through the building.



IN-14.01

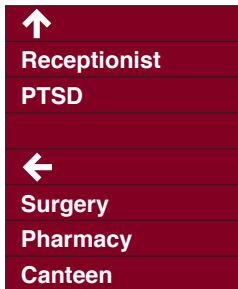

IN-14.02

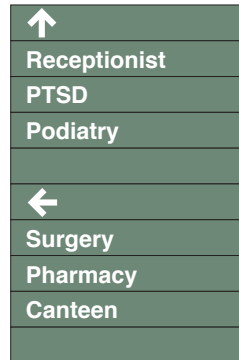

IN-14.03

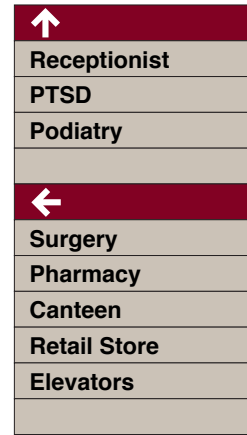

IN-14.04



IN-14.05

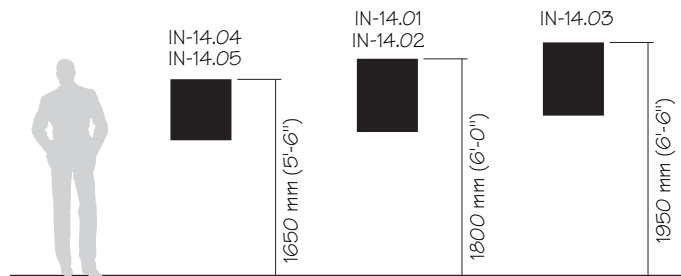
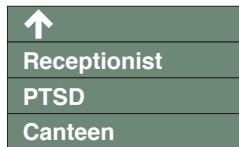

Wall Directional Sign

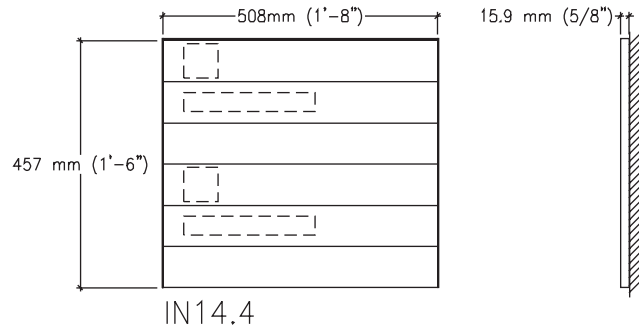

IN14.4

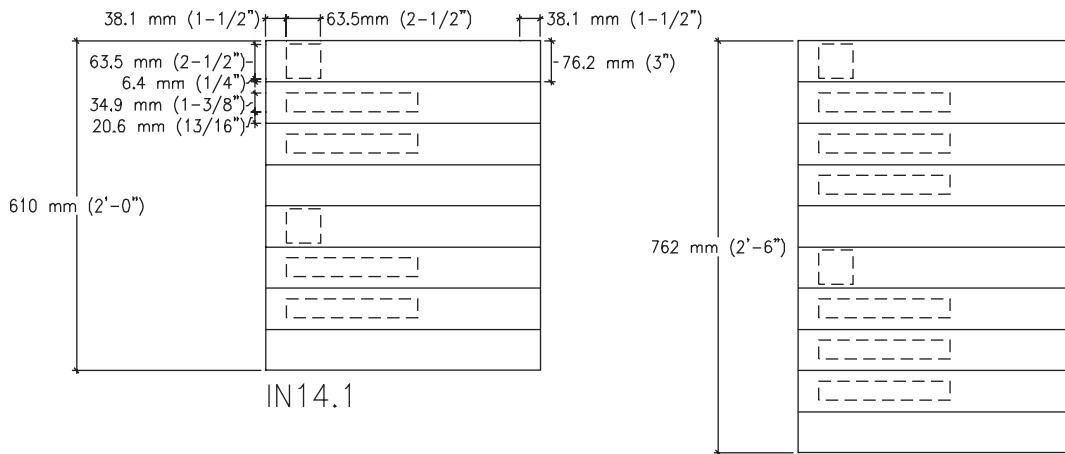

IN14.1

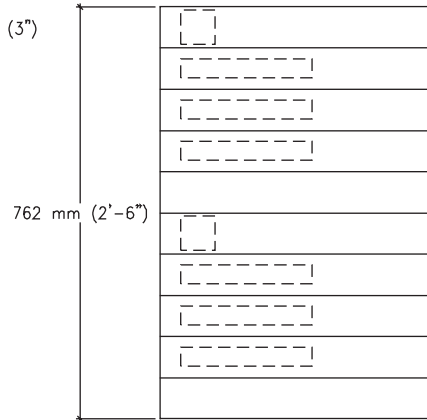

IN14.2

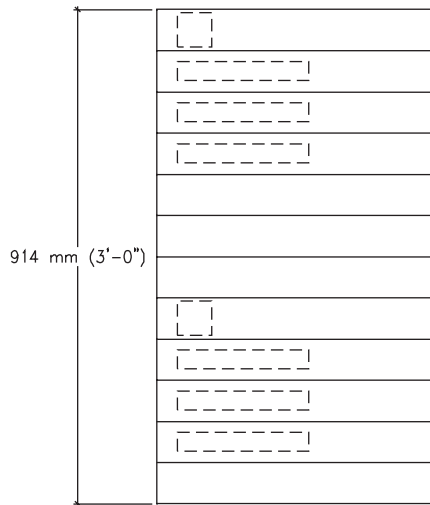

IN14.3

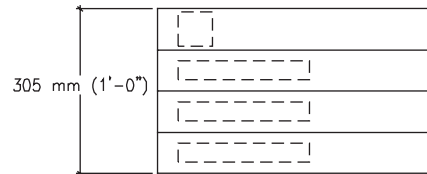

IN14.5

ARROW: Refer to standards for arrow positioning relative to text.

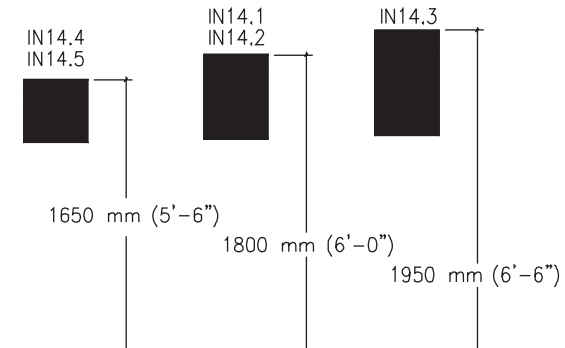

IN-14.06

Interior Signs

Elevator Lobby Directional Sign

Size

229 mm H x 508 mm W
(9" H x 20" W)

Description & Use

Use this sign for directional information in a elevator lobby or stairwell landing. This sign is always a top sign component to a Type 14 sign.

Message Configuration

(Refer to layout drawing for lettering sizes and dimensions)

Sign Components

Sliding Rail Back; Copy Panel; Top Accent Bar; End Caps

Graphic Process

Surface applied vinyl.

Colors

Text: Refer to Color Chart.
Background & Accent Bar: Refer to Color Chart

Typography

Helvetica Medium

Mounting

Double sided foam tape, silastic adhesive or screw.

Installation

On wall.

Recommendations

Use in elevator lobbies, across from the elevators, to direct patients and public. Use at stair landings, across from the door to direct patients and public.

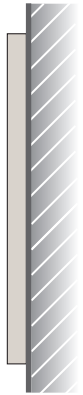

Message Layout A



Message Layout B

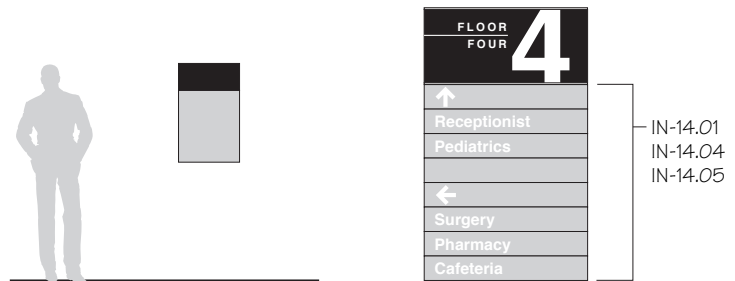

Elevator Lobby Directional Sign

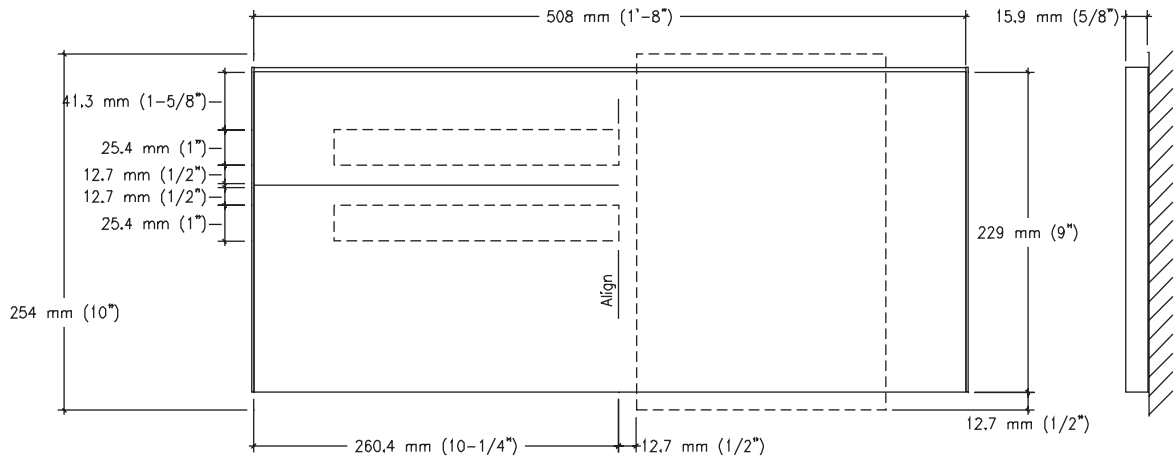

Message Layout A

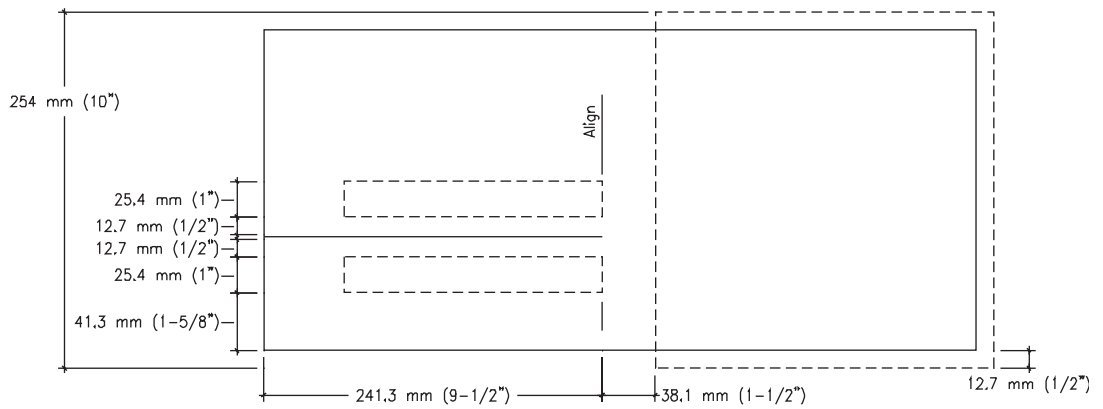

Message Layout B

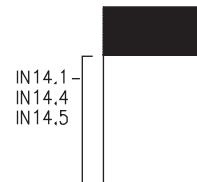

IN-15.01-4

Interior Signs

Size

IN-15.01
152 mm x 1016 mm
(6" x 40")

IN-15.02
305 mm x 1016 mm
(12" x 40")

IN-15.03
457 mm x 1016 mm
(18" x 40")

IN-15.04
305 mm x 1016 mm
(12" x 40")

Ceiling Mounted Directional Sign

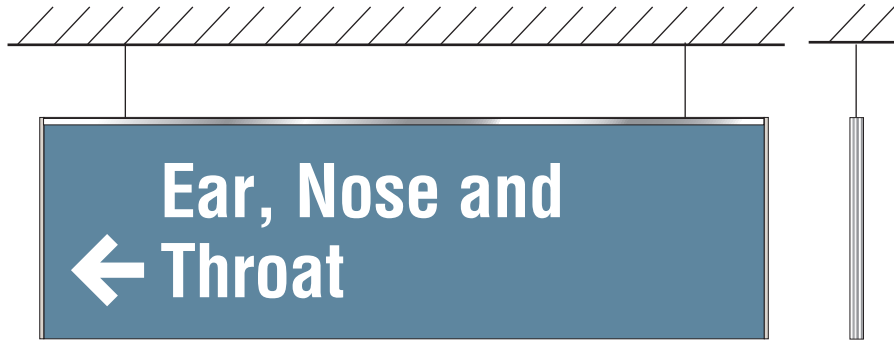

Description & Use

Use this sign for directional information that needs to be communicated overhead. Sign is double sided and both sides can be used for messages.

Message Configuration

(Refer to layout drawing for lettering sizes and dimensions)

Sign Components

Sliding Rail Back; Copy Panel; Top Accent Bar; End Caps

Graphic Process

Surface applied vinyl.

Colors

Text & Arrows: Refer to Color Chart.
Background & Accent Bar: Refer to Color Chart

Typography

Helvetica Medium Condensed
75 mm (3") cap height required for all text.

Mounting

Braided stainless steel wire or rod.
Sign must not be attached directly to "T Grid" or lift out ceiling tile.

Installation

From the ceiling.

Recommendations

This sign is for use in corridors to direct patients and public through the building. Because of required letter height there is a limit to the length of messages and limited number of messages.

IN-15.01

↑ Canteen

IN-15.02

↑ Canteen
← Spinal Rehab

IN-15.03

↑ Emergency
← Spinal Rehab
← Canteen

IN-15.04

← Outpatient
Registration

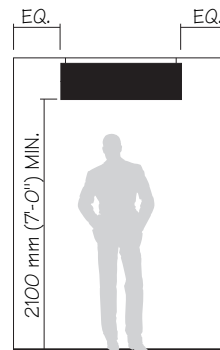

Ceiling Mounted Directional Sign

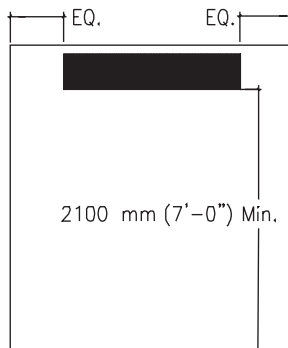
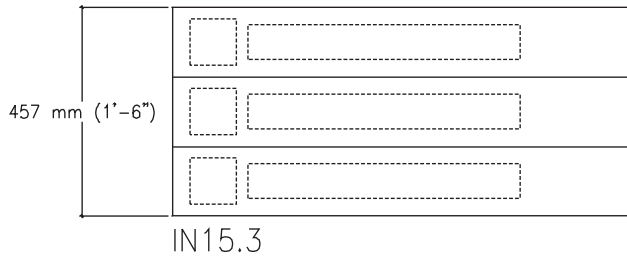
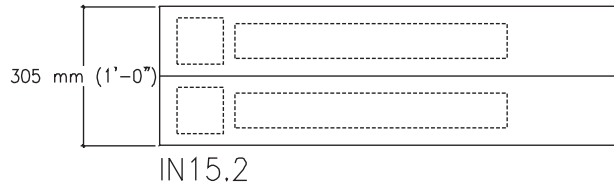
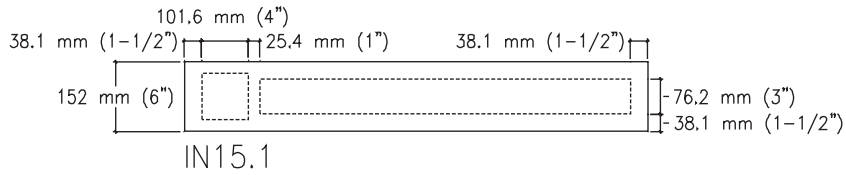
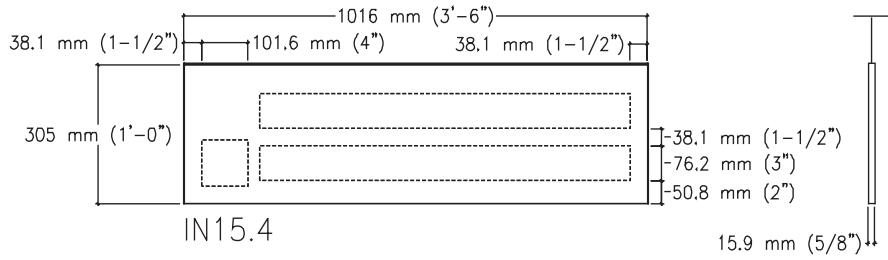

ARROW: Refer to standards for arrow positioning relative to text.

IN-15.05-8

Interior Signs

Ceiling Mounted Directional Sign

Size

IN-15.05
152 mm x 2033 mm
(6" x 80")

IN-15.06
305 mm x 2033 mm
(12" x 80")

IN-15.07
457 mm x 2033 mm
(18" x 80")

IN-15.08
305 mm x 2033 mm
(12" x 80")

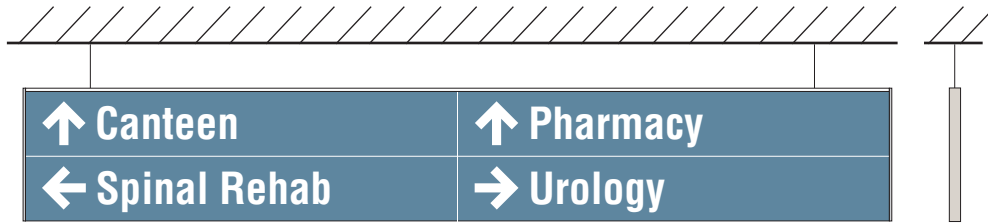

Description & Use

Use this sign for directional information that needs to be communicated overhead. Sign is double sided and both sides can be used for messages.

Message Configuration

(Refer to layout drawing for lettering sizes and dimensions)

Sign Components

Sliding Rail Back; Copy Panel; Top Accent Bar; End Caps

Graphic Process

Surface applied vinyl.

Colors

Text & Arrows: Refer to Color Chart.
Background & Accent Bar: Refer to Color Chart

Typography

Helvetica Medium Condensed
75 mm (3") cap height required for all text.

Mounting

Braided stainless steel wire or rod.
Sign must not be attached directly to "T Grid" or lift out ceiling tile.

Installation

From the ceiling.

Recommendations

This sign is for use in corridors to direct patients and public through the building. Because of required letter height there is a limit to the length of messages and limited number of messages.

IN-15.05



IN-15.06



IN-15.07

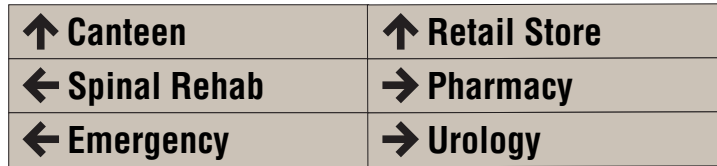

IN-15.08

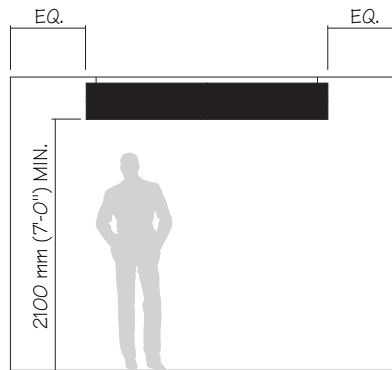
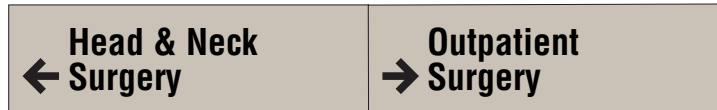

Ceiling Mounted Directional Sign

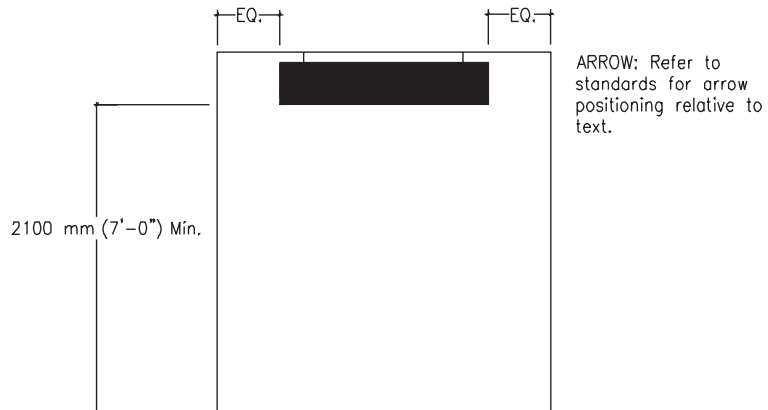
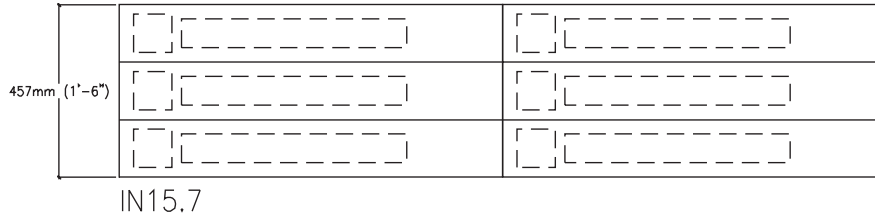
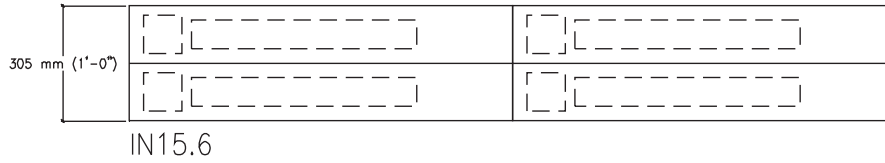
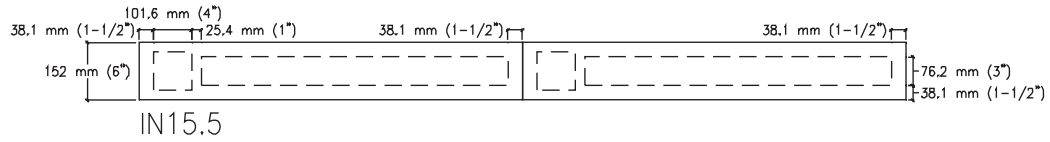
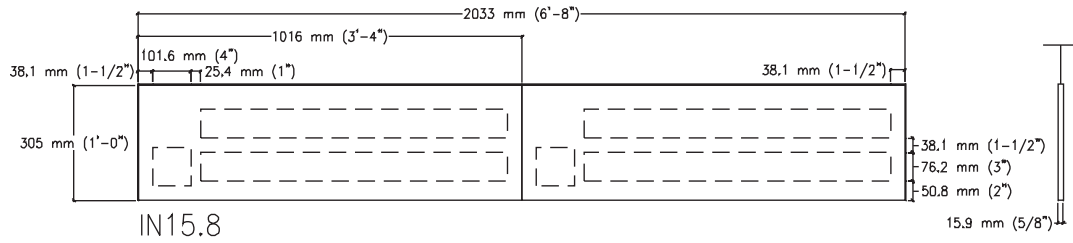

IN-15.09-12

Interior Signs

Soffit Mounted Directional Sign

Size

IN-15.09
152 mm x 1016 mm
(6" x 40")

IN-15.10
305 mm x 1016 mm
(12" x 40")

IN-15.11
457 mm x 1016 mm
(18" x 40")

IN-15.12
305 mm x 1016 mm
(12" x 40")



Description & Use

Use this sign for directional information that needs to be communicated overhead.

Message Configuration

(Refer to layout drawing for lettering sizes and dimensions)

Sign Components

Sliding Rail Back; Copy Panel; Top Accent Bar; End Caps

Graphic Process

Surface applied vinyl.

Colors

Text & Arrows: Refer to Color Chart.
Background & Accent Bar: Refer to Color Chart

Typography

Helvetica Medium Condensed
75 mm (3") cap height required for all text.

Mounting

Double sided foam tape, silastic adhesive or screw.

Installation

On soffits above doors, alcoves and counters.

Recommendations

This sign is for use in corridors to direct patients and public through the building. Because of required letter height there is a limit to the length of messages and limited number of messages.

IN-15.09



IN-15.10



IN-15.11

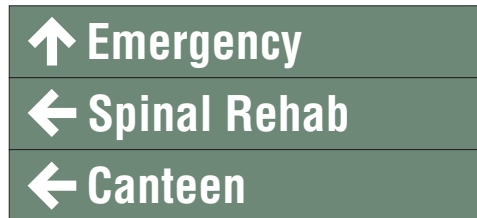

IN-15.12

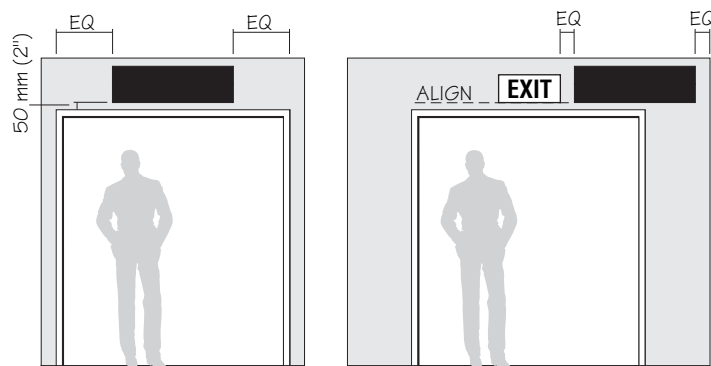

IN-15.09-12 Interior Signs

Soffit Mounted Directional Sign

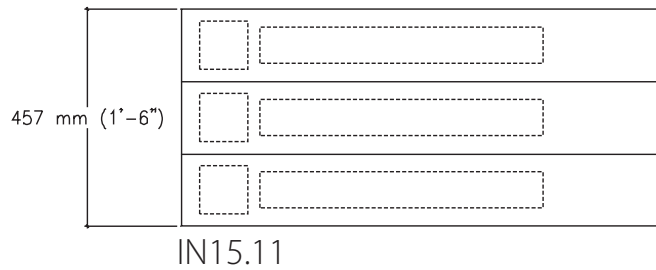
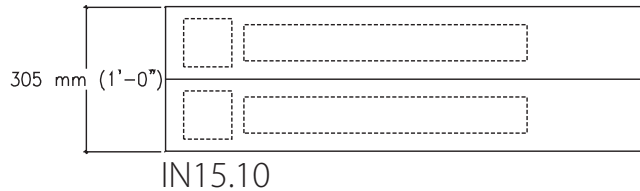
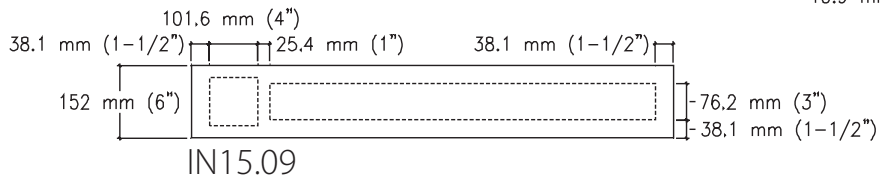
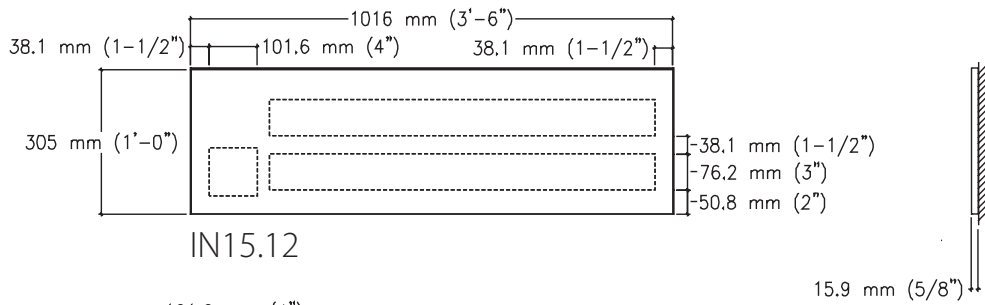

ARROW: Refer to standards for arrow positioning relative to text.

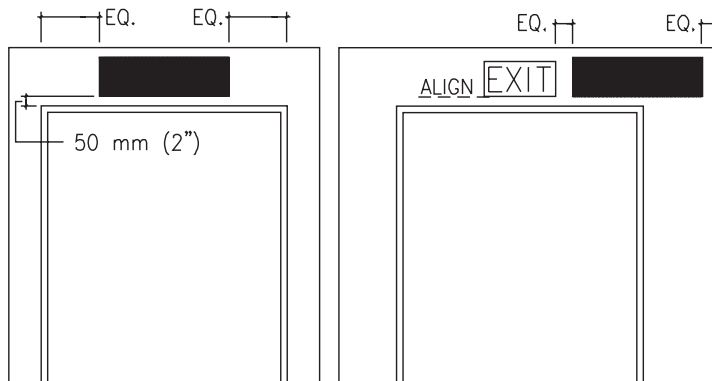

IN-15.13-16 Interior Signs

Soffit Mounted Directional Sign

Size

IN-15.13
152 mm x 2033 mm
(6" x 80")

IN-15.14
305 mm x 2033 mm
(12" x 80")

IN-15.15
457 mm x 2033 mm
(18" x 80")

IN-15.16
305 mm x 2033 mm
(12" x 80")

Description & Use

Use this sign for directional information that needs to be communicated overhead.

Message Configuration

(Refer to layout drawing for lettering sizes and dimensions)

Sign Components

Sliding Rail Back; Copy Panel; Top Accent Bar; End Caps

Graphic Process

Surface applied vinyl.

Colors

Text & Arrows: Refer to Color Chart.
Background & Accent Bar: Refer to Color Chart

Typography

Helvetica Medium Condensed
75 mm (3") cap height required for all text.

Mounting

Double sided foam tape, silastic adhesive or screw.

Installation

On soffits above doors, alcoves and counters.

Recommendations

This sign is for use in corridors to direct patients and public through the building. Because of required letter height there is a limit to the length of messages and limited number of messages.

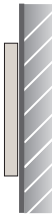
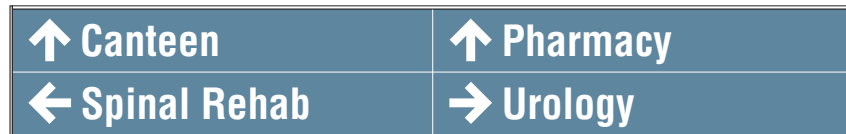

IN-15.13



IN-15.14



IN-15.15

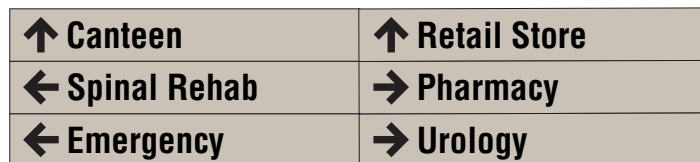

IN-15.16

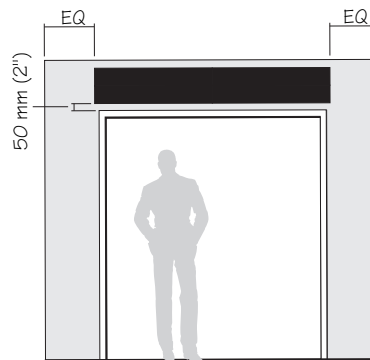

IN-15.13-16 Interior Signs

Soffit Mounted Directional Sign

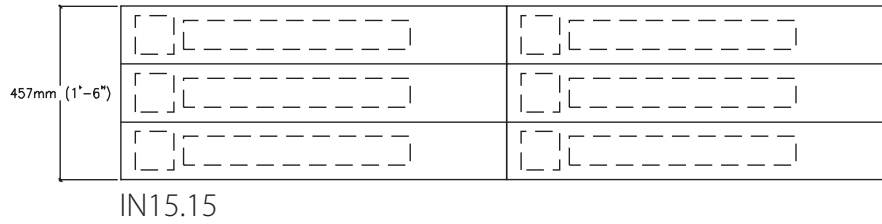
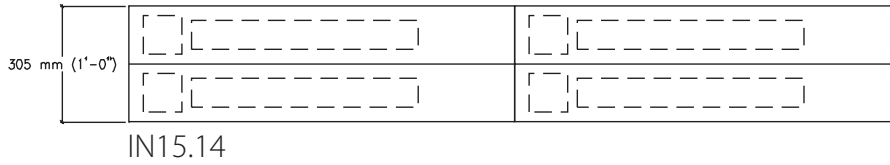
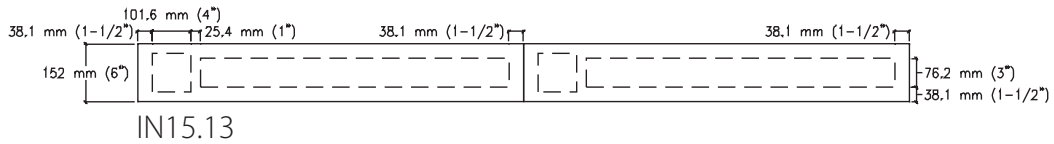
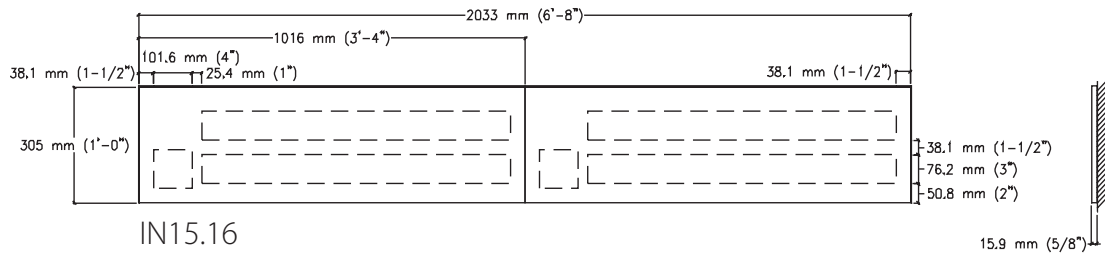

ARROW: Refer to standards for arrow positioning relative to text.

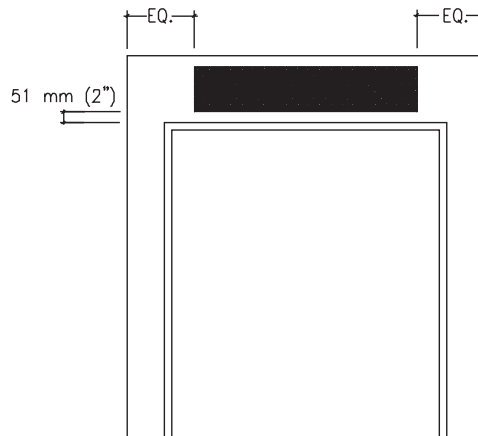

IN-16.01-4

Interior Signs

Ceiling Mounted Identification Sign

Size

IN-16.01
152 mm x 1016 mm
(6" x 40")

IN-16.02
305 mm x 1016 mm
(12" x 40")

IN-16.03
457 mm x 1016 mm
(18" x 40")

IN-16.04
305 mm x 1016 mm
(12" x 40")



Description & Use

Use this sign for identifying a department overhead. Sign is double sided and both sides can be used for messages.

Message Configuration

(Refer to layout drawing for lettering sizes and dimensions)

Sign Components

Sliding Rail Back; Copy Panel; Top Accent Bar; End Caps

Graphic Process

Surface applied vinyl.

Colors

Text: Refer to Color Chart.
Background & Accent Bar: Refer to Color Chart

Typography

Helvetica Medium Condensed
75 mm (3") cap height required for all text.

Mounting

Braided stainless steel wire or rod.
Sign must not be attached directly to "T Grid" or lift out ceiling tile.

Installation

From the ceiling.

Recommendations

This sign is for use throughout a building. Because of required letter height there is a limit to the length of messages and limited number of messages.

IN-16.01

Emergency

IN-16.02

Canteen

Vending

IN-16.03

Canteen

Retail Store

ATM & Vending

IN-16.04

Outpatient Receptionist
& Registration

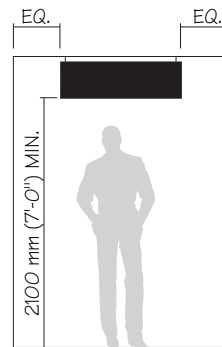

IN-16.01-4 Interior Signs

Ceiling Mounted Identification Sign

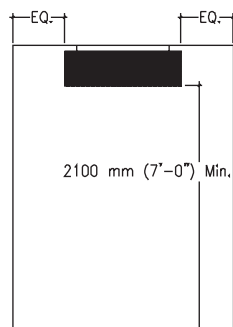
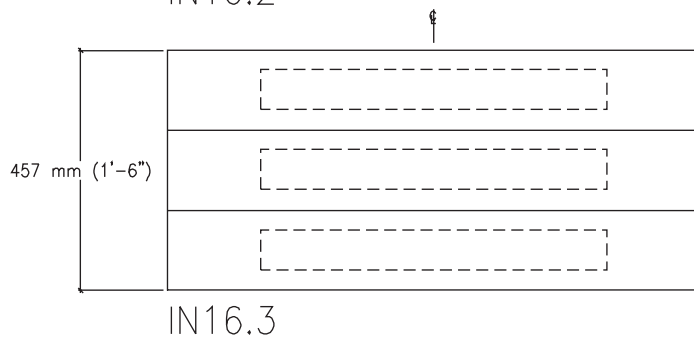
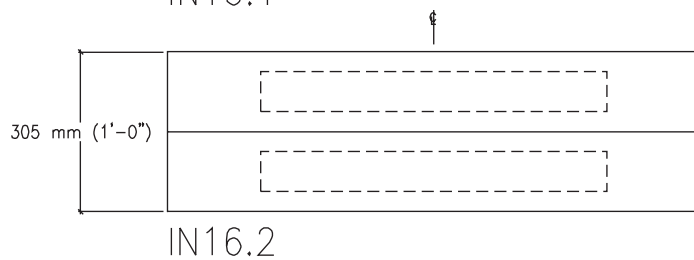
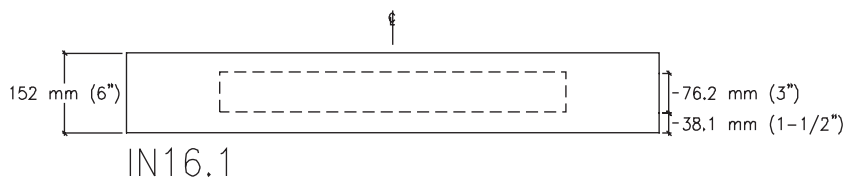
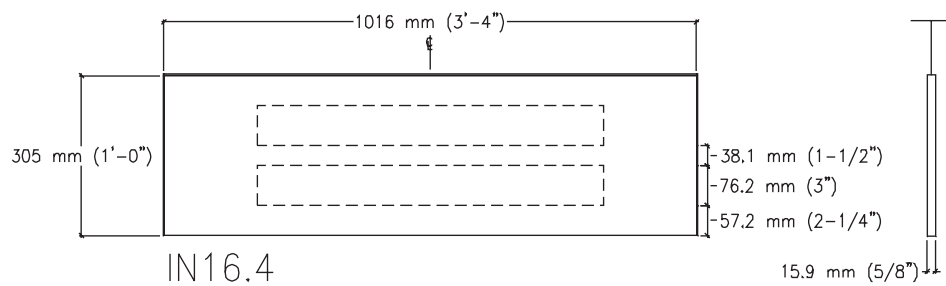

IN-16.05-8

Interior Signs

Ceiling Mounted Identification Sign

Size

IN-16.05
152 mm x 2033 mm
(6" x 80")

IN16.06
305 mm x 2033 mm
(12" x 80")

IN-16.07
457 mm x 2033 mm
(18" x 80")

IN-16.08
305 mm x 2033 mm
(12" x 80")

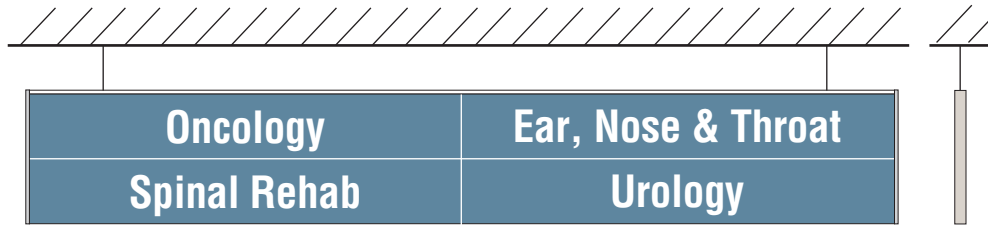

Description & Use

Use this sign for identifying a department overhead. Sign is double sided and both sides can be used for messages.

Message Configuration

(Refer to layout drawing for lettering sizes and dimensions)

Sign Components

Sliding Rail Back; Copy Panel; Top Accent Bar; End Caps

Graphic Process

Surface applied vinyl.

Colors

Text: Refer to Color Chart.
Background & Accent Bar: Refer to Color Chart

Typography

Helvetica Medium Condensed
75 mm (3") cap height required for all text.

Mounting

Braided stainless steel wire or rod.
Sign must not be attached directly to "T Grid" or lift out ceiling tile.

Installation

From the ceiling.

Recommendations

This sign is for use throughout a building. Because of required letter height there is a limit to the length of messages and limited number of messages.

IN-16.05

Oncology	Radiology
----------	-----------

IN-16.06

Oncology	Radiology
Spinal Rehab	Urology

IN-16.07

Oncology	Radiology
Spinal Rehab	PTSD
Canteen	Urology

IN-16.08

Head & Neck Surgery	Outpatient Opthamology
---------------------	------------------------

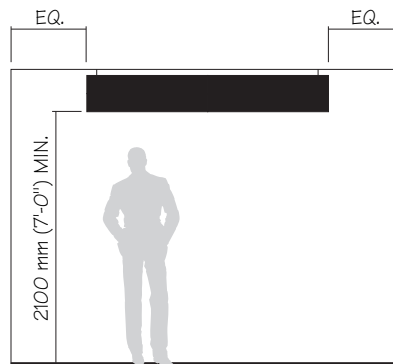

IN-16.05-8

Interior Signs

Ceiling & Soffit Identification Sign

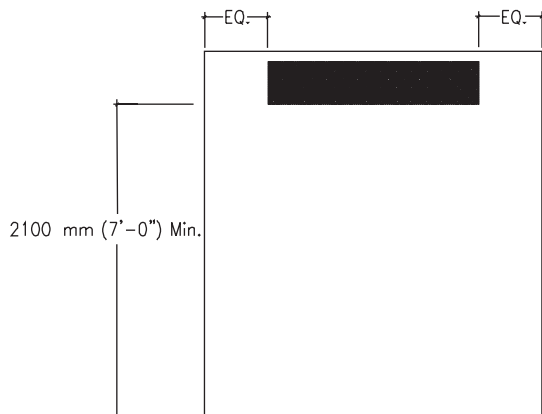
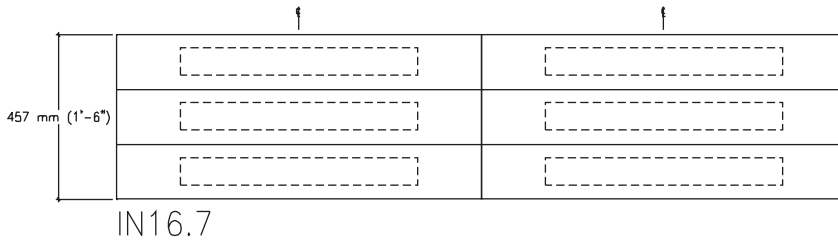
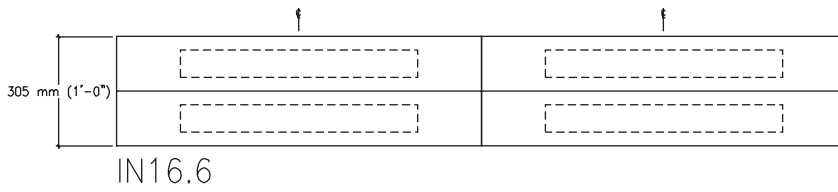
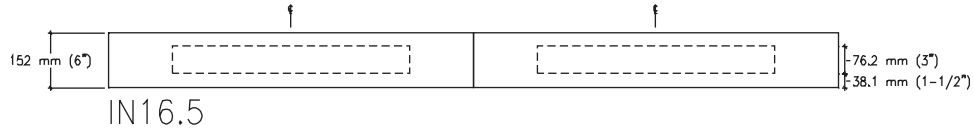
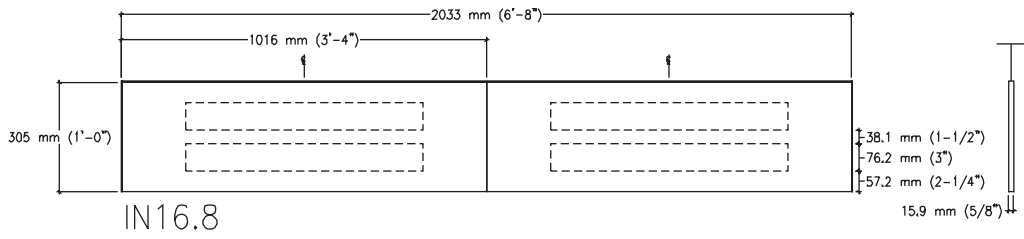

IN-16.09-12

Interior Signs

Soffit Mounted Identification Sign

Size

IN-16.09
152 mm x 1016 mm
(6" x 40")

IN-16.10
305 mm x 1016 mm
(12" x 40")

IN-16.11
457 mm x 1016 mm
(18" x 40")

IN-16.12
305 mm x 1016 mm
(12" x 40")

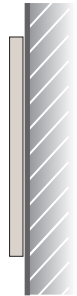

Description & Use

Use this sign for identifying a department overhead.

Message Configuration

(Refer to layout drawing for lettering sizes and dimensions)

Sign Components

Sliding Rail Back; Copy Panel; Top Accent Bar; End Caps

Graphic Process

Surface applied vinyl.

Colors

Text: Refer to Color Chart.
Background & Accent Bar: Refer to Color Chart

Typography

Helvetica Medium Condensed
75 mm (3") cap height required for all text.

Mounting

Double sided foam tape, silastic adhesive or screw.

Installation

On soffits above doors, alcoves and counters.

Recommendations

This sign is for use throughout a building. Because of required letter height there is a limit to the length of messages and limited number of messages.

IN-16.09



IN-16.10



IN-16.11



IN-16.12

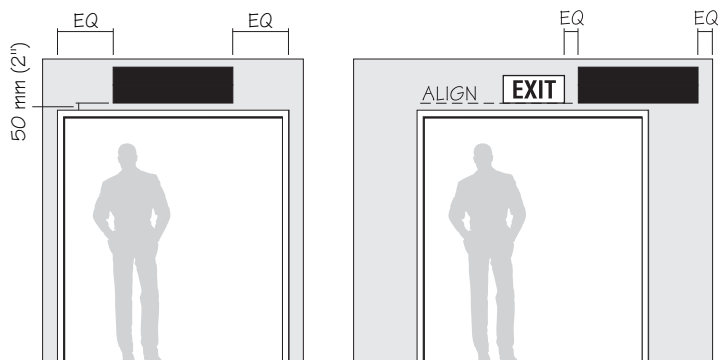

IN-16.09-12 Interior Signs

Soffit Mounted Identification Sign

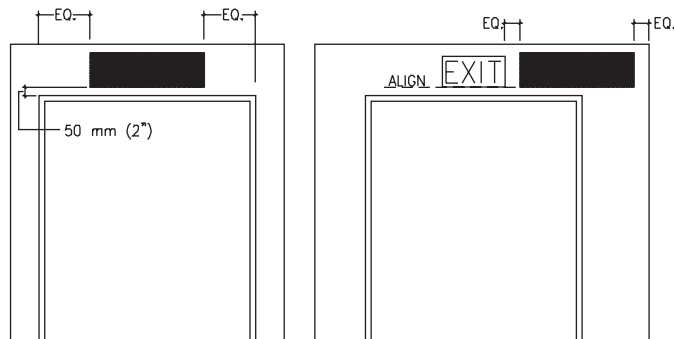
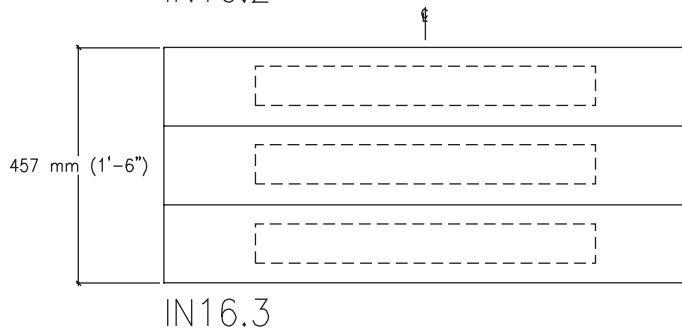
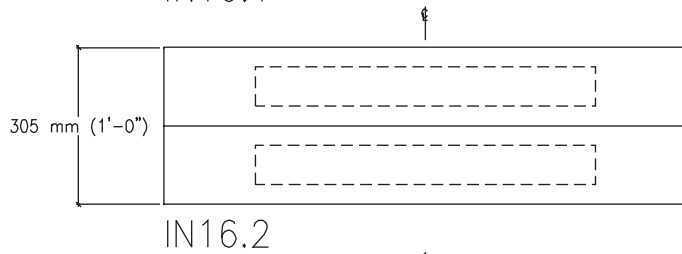
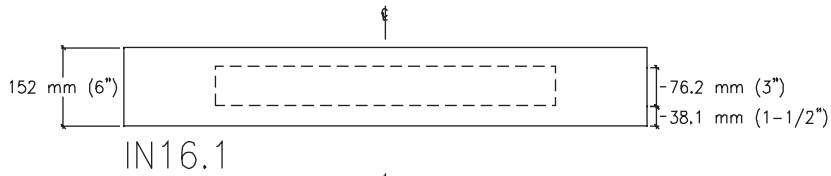
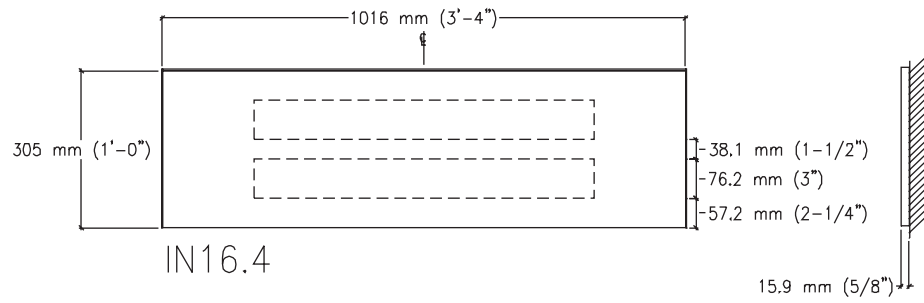

IN-16.13-16

Interior Signs

Ceiling Mounted Identification Sign

Size

IN-16.13
152 mm x 2033 mm
(6" x 80")

IN-16.14
305 mm x 2033 mm
(12" x 80")

IN-16.15
457 mm x 2033 mm
(18" x 80")

IN-16.16
305 mm x 2033 mm
(12" x 80")

Description & Use

Use this sign for identifying a department overhead.

Message Configuration

(Refer to layout drawing for lettering sizes and dimensions)

Sign Components

Sliding Rail Back; Copy Panel; Top Accent Bar; End Caps

Graphic Process

Surface applied vinyl.

Colors

Text: Refer to Color Chart.
Background & Accent Bar: Refer to Color Chart

Typography

Helvetica Medium Condensed
75 mm (3") cap height required for all text.

Mounting

Double sided foam tape, silastic adhesive or screw.

Installation

On soffits above doors, alcoves and counters.

Recommendations

This sign is for use throughout a building. Because of required letter height there is a limit to the length of messages and limited number of messages.

Oncology	Ear, Nose & Throat
Spinal Rehab	Urology



IN-16.13

Oncology	Radiology
----------	-----------

IN-16.14

Oncology	Radiology
Spinal Rehab	Urology

IN-16.15

Oncology	Radiology
Spinal Rehab	PTSD
Canteen	Urology

IN-16.16

Head & Neck Surgery	Outpatient Opthamology
---------------------	------------------------

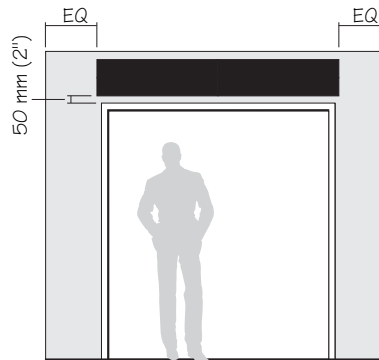

IN-16.13-16 Interior Signs

Ceiling Mounted Identification Sign

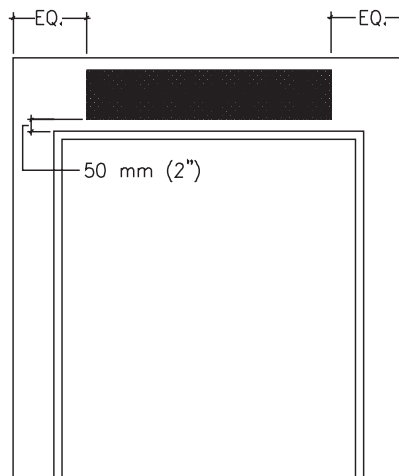
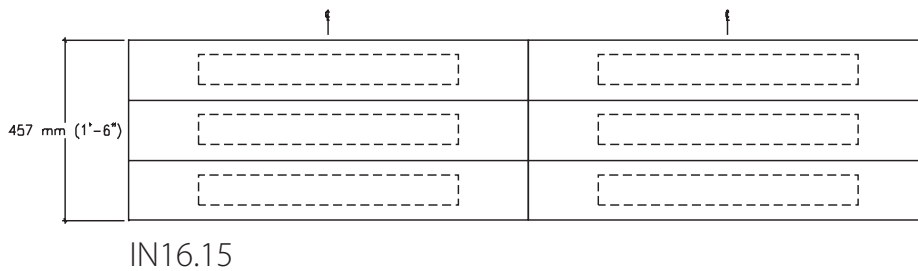
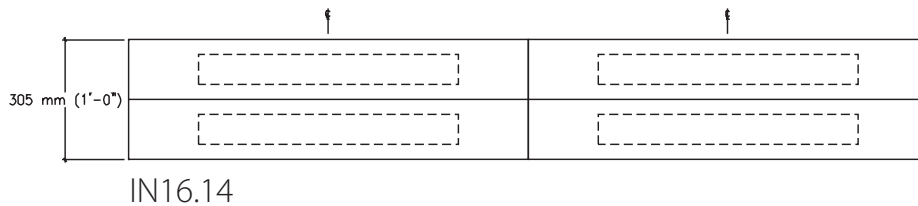
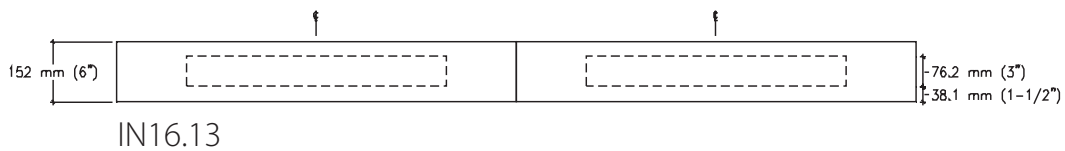
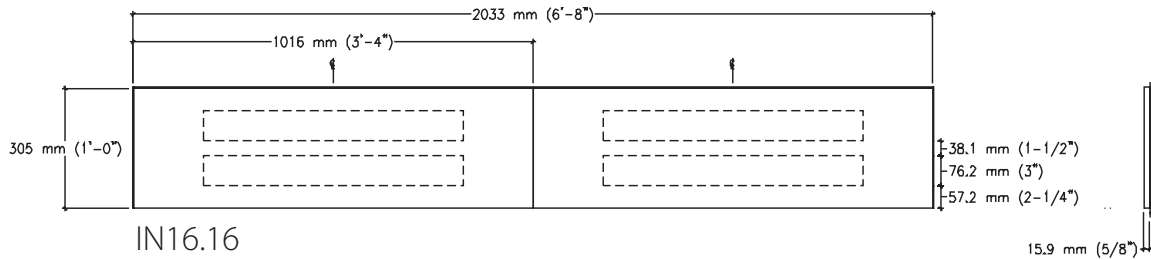

IN-17.01

Interior Signs

Directory

Size

762 mm H x 610 mm W
(2'-6" H x 2'-0" W)

Description & Use

Small size main lobby directory. 48 directory strips.

Message Configuration

(Refer to layout drawing for lettering sizes and dimensions)
Header Layout A is for a basic directory header. Header Layout B is for a directory header to contain the name of the facility. Copy Strip A is for use with the main listings. Copy Strip B is for a secondary listing under a main listing or when the name is too long to fit on Strip A.

Sign Components

Sliding Rail Back; Copy Panel; Top Accent Bar; End Caps

Graphic Process

Surface applied vinyl.

Colors

Text: Refer to Color Chart.
Background & Accent Bar: Refer to Color Chart

Typography

Helvetica Medium

Mounting

Screw.

Installation

On wall.

Recommendations

This directory is for use in the main lobby of small buildings which would typically have no more than 30 to 40 listings. All listings in a directory should be done in alphabetical order. List in the directory only services or departments which have contact with patients and public. Distribute any blank directory strips throughout the directory to provide spacing between groups of listings.

Directory	
Title	Title
Subtitle 1A74	Subtitle 2A42
Subtitle 1A76	Sub-Subtitle
Subtitle 1A77	Sub-Subtitle
Subtitle 1A78	Sub-Subtitle
Sub-Subtitle	Subtitle 2A44
Sub-Subtitle	Subtitle 2A45
	Subtitle 2A46
Title	Subtitle 2A48
Subtitle 1B48	Subtitle 2A52
Subtitle 1B49	
Subtitle 1B52	Title
	Subtitle 2B32
Title	Subtitle 2B34
Subtitle 1C32	
Subtitle 1C33	Title
Subtitle 1C36	Subtitle 3A54
Subtitle 1C38	Sub-Subtitle
	Sub-Subtitle
	Sub-Subtitle
	Subtitle 3A55
	Subtitle 3A56

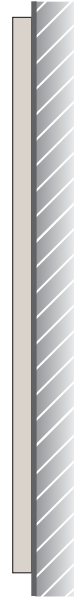

Header (Message Layout A)



Header (Message Layout B)

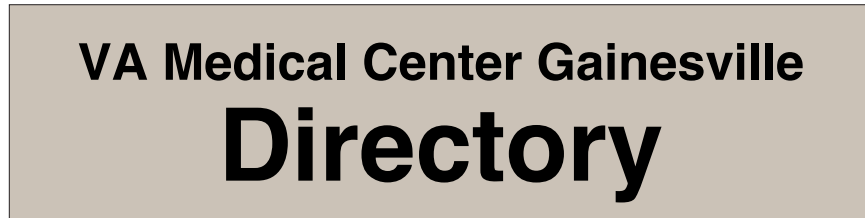

Copy Strip A



Copy Strip B



Copy Strip C



Directory

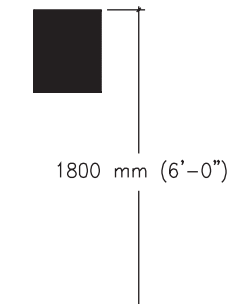
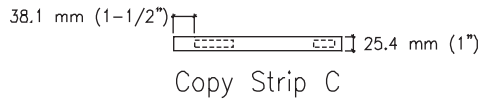
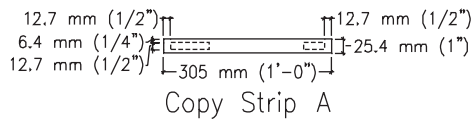
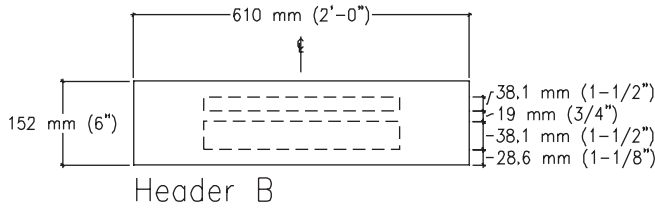
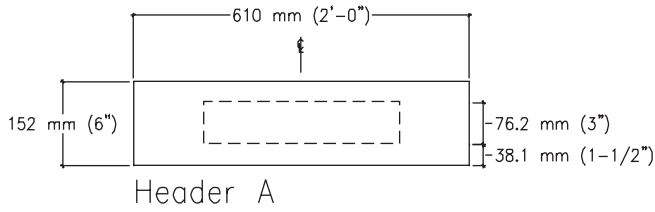
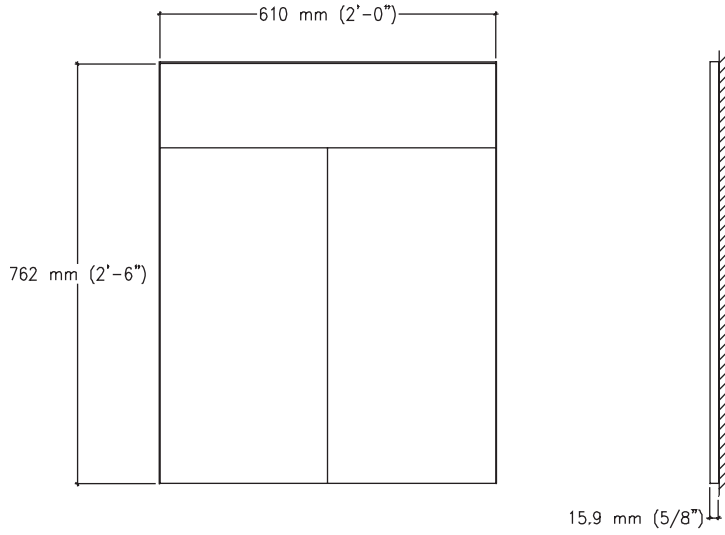

IN-17.02

Interior Signs

Large Directory

Size

915 mm H x 915 mm W
(3'-0" H x 3'-0" W)

Description & Use

Main lobby directory. 90 directory strips.

Message Configuration

(Refer to layout drawing for lettering sizes and dimensions)
Header Layout A is for a basic directory header. Header Layout B is for a directory header to contain the name of the facility. Copy Strip A is for use with the main listings. Copy Strip B is for a secondary listing under a main listing or when the name is too long to fit on Strip A.

Sign Components

Sliding Rail Back; Copy Panel; Top Accent Bar; End Caps

Graphic Process

Surface applied vinyl.

Colors

Text: Refer to Color Chart.
Background & Accent Bar: Refer to Color Chart

Typography

Helvetica Medium

Mounting

Screw.

Installation

On wall.

Recommendations

This directory is for use in the main lobby of small buildings which would typically have no more than 60 to 80 listings. All listings in a directory should be done in alphabetical order. List in the directory only services or departments which have contact with patients and public. Distribute any blank directory strips throughout the directory to provide spacing between groups of listings

Directory					
Title		Title		Title	
Subtitle	1A74	Subtitle	2B37	Subtitle	2B37
Subtitle	1A75	Sub-Subtitle		Sub-Subtitle	
Subtitle	1A77	Sub-Subtitle		Sub-Subtitle	
Subtitle	1A78	Sub-Subtitle		Sub-Subtitle	
Sub-Subtitle		Subtitle	2B40	Subtitle	2B40
Sub-Subtitle		Subtitle	2B41	Subtitle	2B41
		Subtitle	2B42		
Title		Subtitle	2B44	Title	
Subtitle	1B48	Subtitle	2B45	Subtitle	2C50
Subtitle	1B49			Subtitle	2C55
Subtitle	1B51	Title			
		Subtitle	2C50	Title	
		Subtitle	2C55	Subtitle	2C60
Subtitle	1C34	Subtitle		Sub-Subtitle	
Subtitle	1C37	Title		Sub-Subtitle	
Subtitle	1C38	Subtitle	2C60	Sub-Subtitle	
Subtitle	1C42	Sub-Subtitle		Subtitle	2C61
		Sub-Subtitle		Subtitle	2C62
		Sub-Subtitle			
		Subtitle	2C61		
		Subtitle	2C62		



Header (Message Layout A)



Header (Message Layout B)



Copy Strip A



Copy Strip B



Copy Strip C

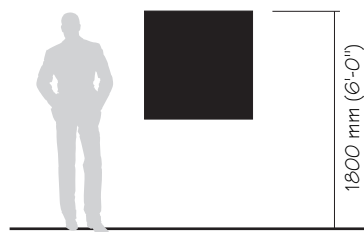

Large Directory

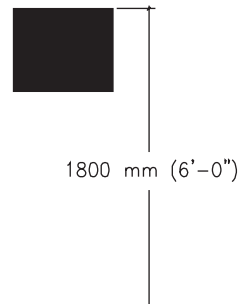
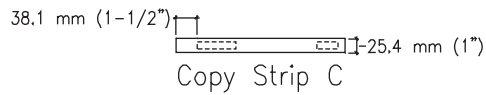
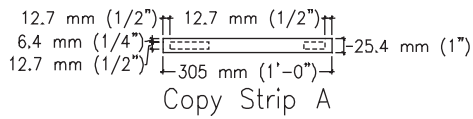
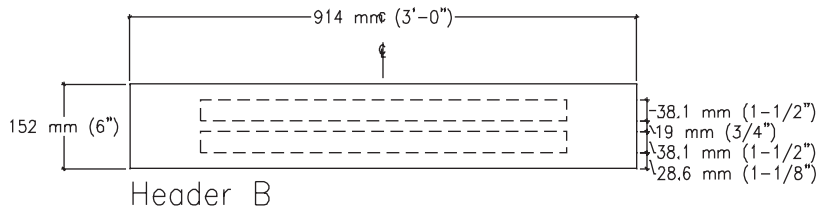
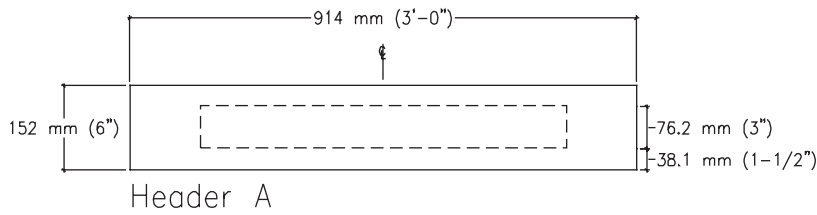
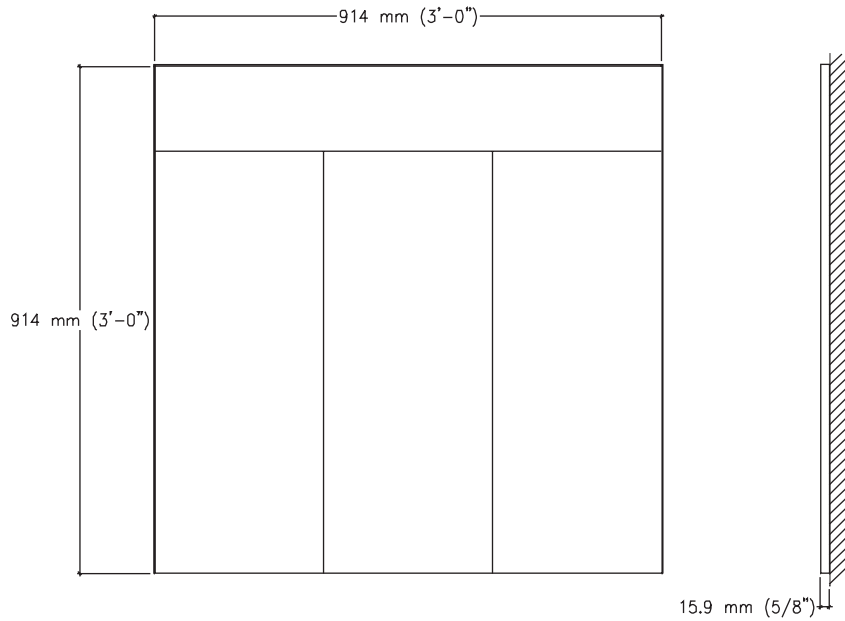

IN-17.03

Interior Signs

Directory with Map

Size

762 mm H x 1220 mm W
(2'-6" H x 4'-0" W)

Description & Use

Small size main lobby directory with a map of the building. 48 directory strips.

Message Configuration

(Refer to layout drawing for lettering sizes and dimensions)
Header Layout A is for a basic directory header. Header Layout B is for a directory header to contain the name of the facility. Copy Strip A is for use with the main listings. Copy Strip B is for a secondary listing under a main listing or when the name is too long to fit on Strip A.

Sign Components

Sliding Rail Back; Copy Panel; Top Accent Bar; End Caps

Graphic Process

Surface applied vinyl.

Colors

Text: Refer to Color Chart.
Background & Accent Bar: Refer to Color Chart

Typography

Helvetica Medium

Mounting

Screw.

Installation

On wall.

Recommendations

This directory is for use in the main lobby of small buildings which would typically have no more than 30 to 40 listings. All listings in a directory should be done in alphabetical order. List in the directory only services or departments which have contact with patients and public. Distribute any blank directory strips throughout the directory to provide spacing between groups of listings. Maps should be simple and show the corridor system, major departments and locations of elevators. If a building has multiple floors, then all floors should be shown. Orientate floor plans to represent the building in the same direction as the map is being viewed.

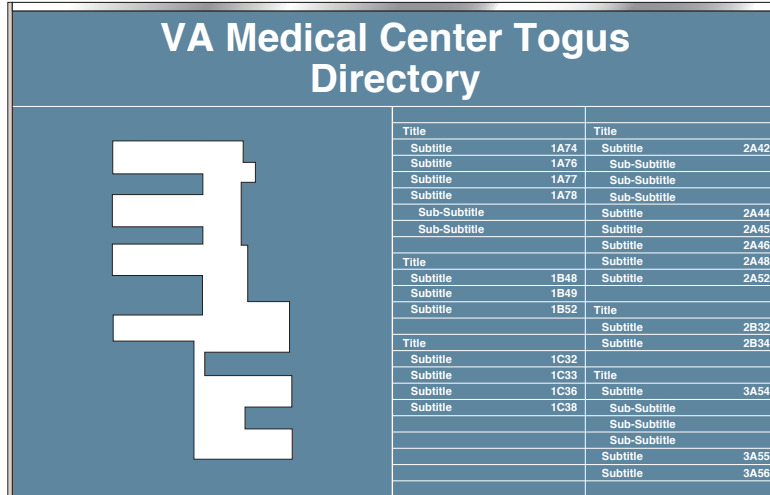

Header (Message Layout A)



Header (Message Layout B)



Map

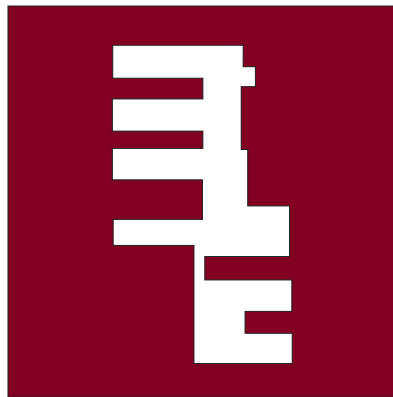

Copy Strip A



Copy Strip B



Copy Strip C



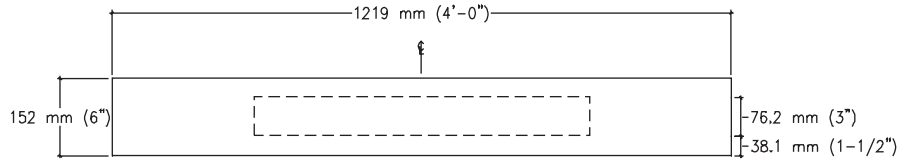
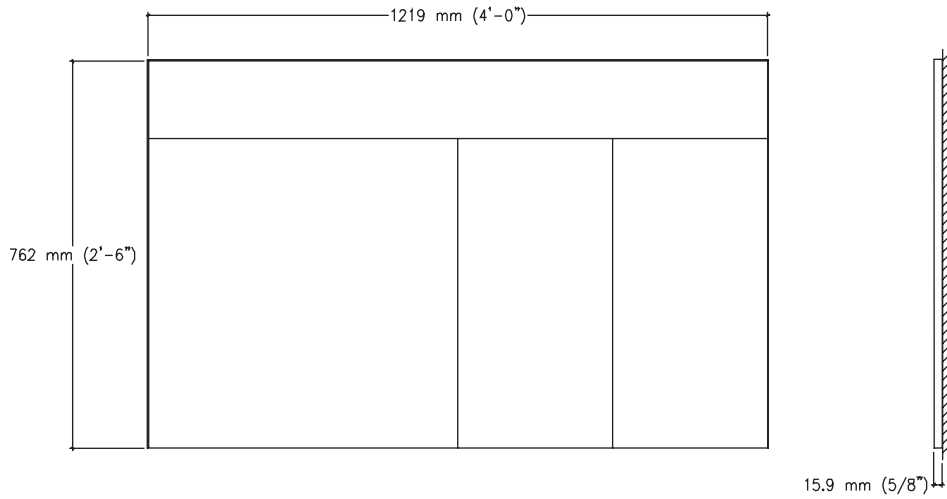

Header A

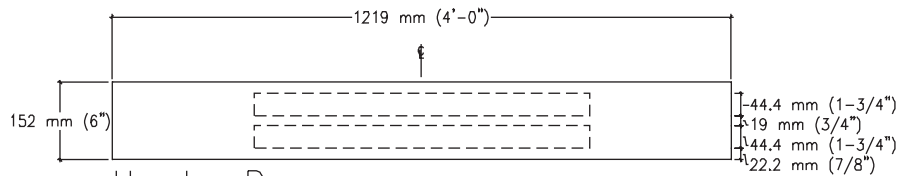

Header B

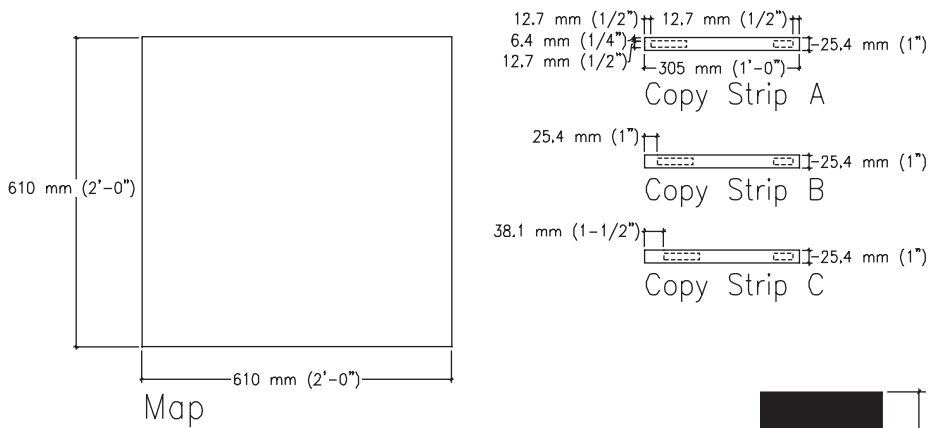

Map

Copy Strip A

Copy Strip B

Copy Strip C

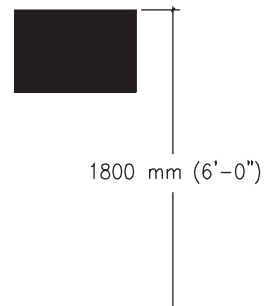

IN-17.04

Interior Signs

Large Directory with Map

Size

915 mm H x 1525 mm W
(3'-0" H x 5'-0" W)

Description & Use

Main lobby directory with a map of the building. 90 directory strips.

Message Configuration

(Refer to layout drawing for lettering sizes and dimensions)
Header Layout A is for a basic directory header. Header Layout B is for a directory header to contain the name of the facility. Copy Strip A is for use with the main listings. Copy Strip B is for a secondary listing under a main listing or when the name is too long to fit on Strip A.

Sign Components

Sliding Rail Back; Copy Panel; Top Accent Bar; End Caps

Graphic Process

Surface applied vinyl.

Colors

Text: Refer to Color Chart.
Background & Accent Bar: Refer to Color Chart

Typography

Helvetica Medium

Mounting

Screw.

Installation

On wall.

Recommendations

This directory is for use in the main lobby of small buildings which would typically have no more than 60 to 80 listings. All listings in a directory should be done in alphabetical order. List in the directory only services or departments which have contact with patients and public. Distribute any blank directory strips throughout the directory to provide spacing between groups of listings. Maps should be simple and show the corridor system, major departments and locations of elevators. If a building has multiple floors, then all floors should be shown. Orientate floor plans to represent the building in the same direction as the map is being viewed.

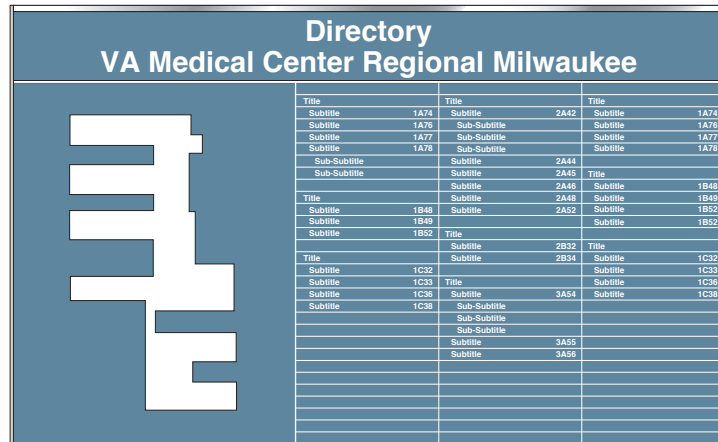

Header (Message Layout A)



Header (Message Layout B)



Map

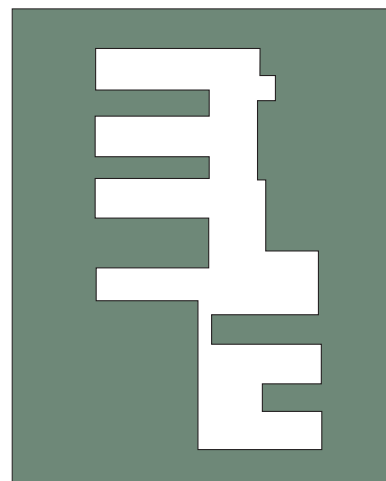

Copy Strip A

Title 1A74

Copy Strip B

Subtitle 1B48

Copy Strip C

Sub-Subtitle 1C49



Large Directory with Map

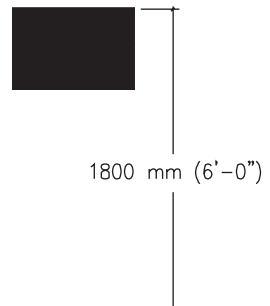
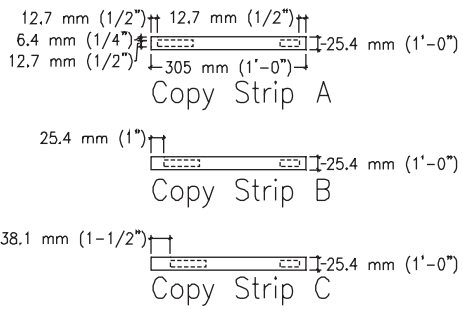
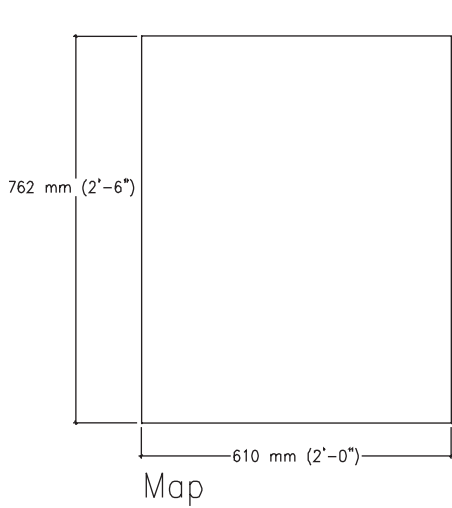
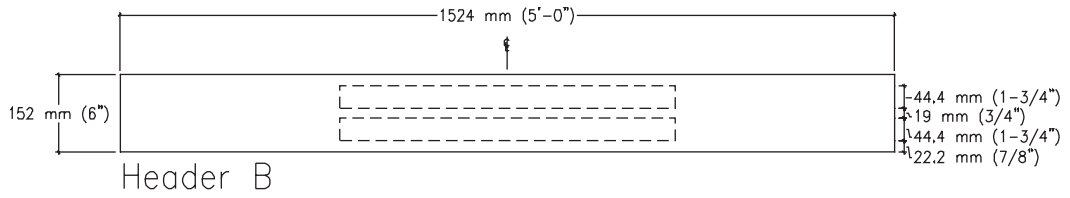
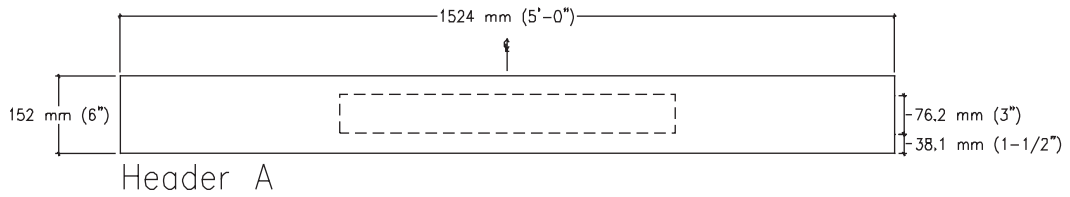
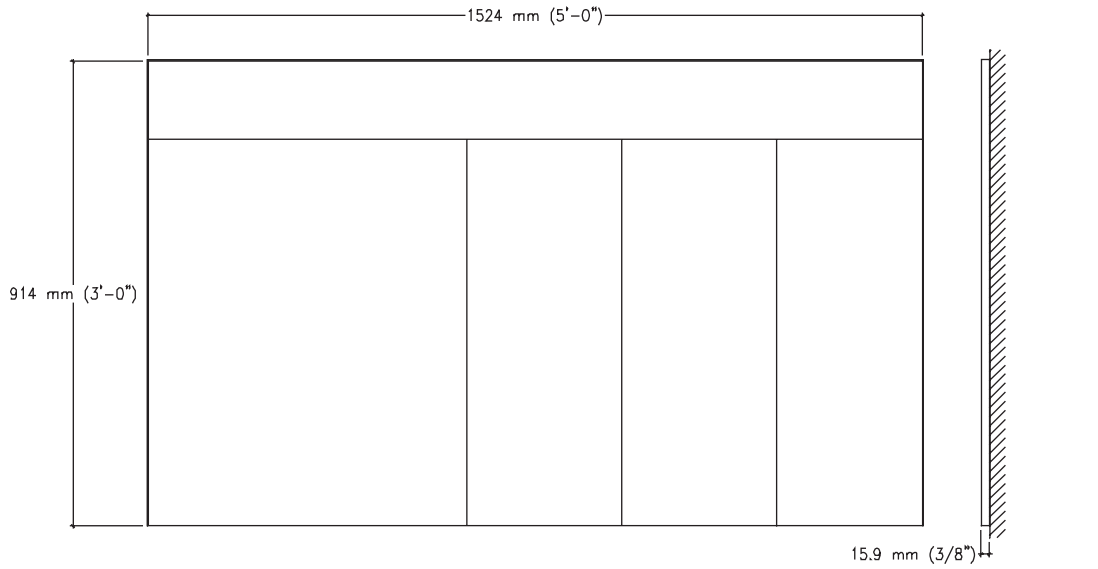

IN-17.05

Interior Signs

Floor Directory

Size

762 mm H x 305 mm W
(2'-6" H x 12" W)

Description & Use

Small size elevator lobby directory.
24 directory strips.

Message Configuration

(Refer to layout drawing for lettering sizes and dimensions)
Header Layout A is for a single digit floor. Header Layout B is for a double digit floor. Copy Strip A is for use with the main listings. Copy Strip B is for a secondary listing under a main listing or when the name is too long to fit on Strip A.

Sign Components

Sliding Rail Back; Copy Panel; Top Accent Bar; End Caps

Graphic Process

Surface applied vinyl.

Colors

Text: Refer to Color Chart.
Background & Accent Bar: Refer to Color Chart

Typography

Helvetica Medium

Mounting

Screw.

Installation

On wall adjacent to elevator.

Recommendations

This directory is for use in the elevator lobbies of small buildings which would typically have no more than 20 listings. All listings in a directory should be done in alphabetical order. List in the directory only services or departments which have contact with patients and public. Distribute any blank directory strips throughout the directory to provide spacing between groups of listings.

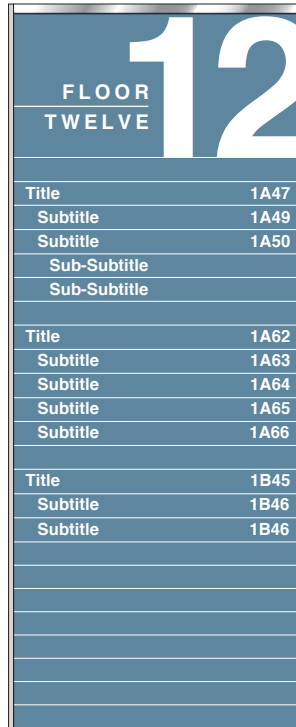

Header (Layout A)



Header (Layout B)



Directory Strip A



Directory Strip C

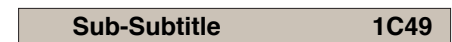

Directory Strip B

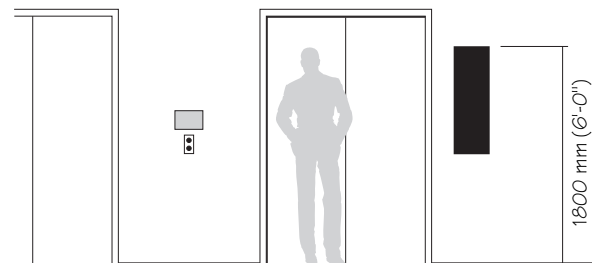

Floor Directory

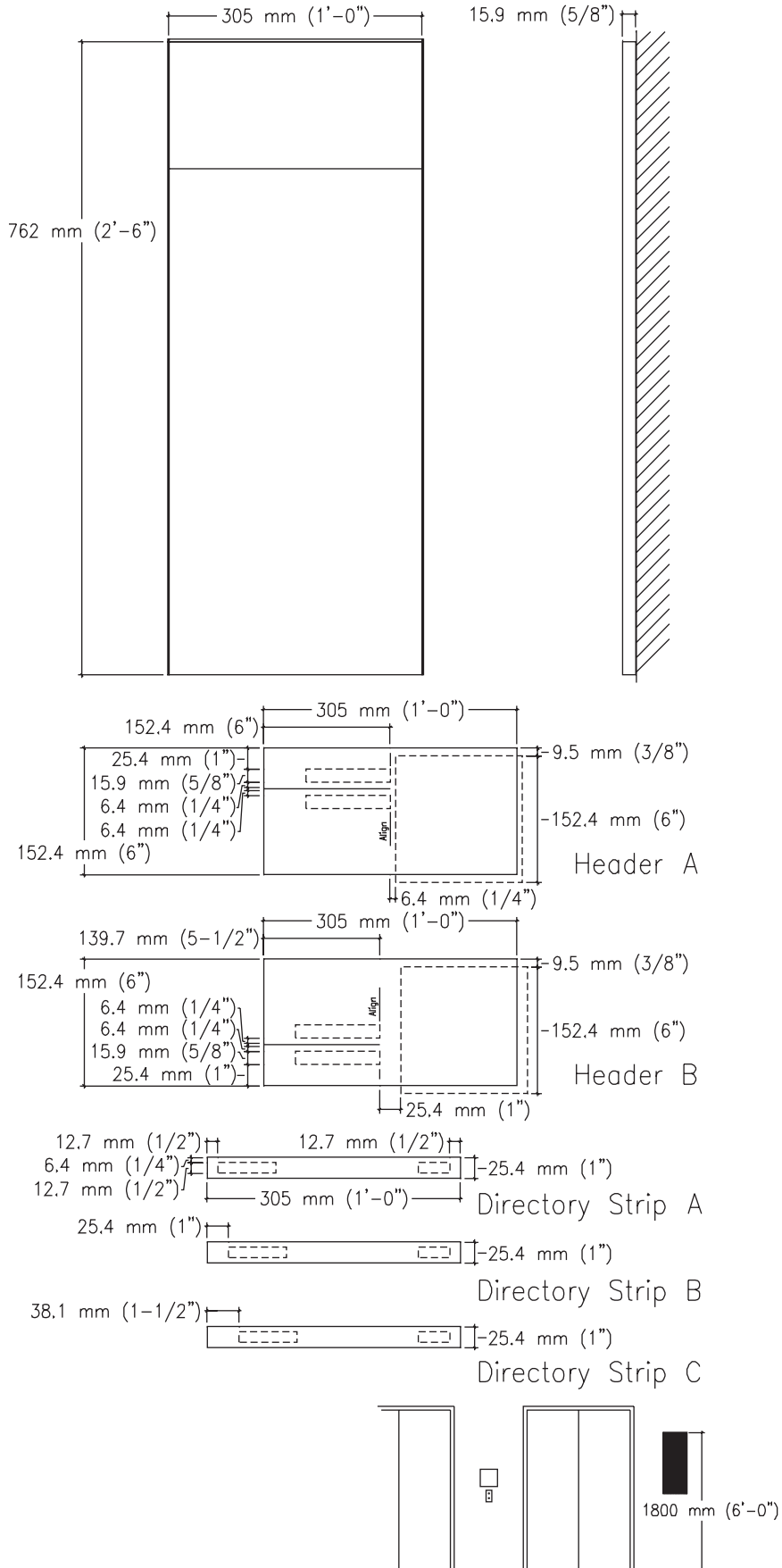

IN-17.06

Interior Signs

Large Floor Directory

Size

762 mm H x 610 mm W
(2'-6" H x 2'-0" W)

Description & Use

Elevator lobby directory. 48 directory strips.

Message Configuration

(Refer to layout drawing for lettering sizes and dimensions)
Header Layout A is for a single digit floor. Header Layout B is for a double digit floor. Copy Strip A is for use with the main listings. Copy Strip B is for a secondary listing under a main listing or when the name is too long to fit on Strip A.

Sign Components

Sliding Rail Back; Copy Panel; Top Accent Bar; End Caps

Graphic Process

Surface applied vinyl.

Colors

Text: Refer to Color Chart.
Background & Accent Bar: Refer to Color Chart

Typography

Helvetica Medium

Mounting

Screw.

Installation

On wall adjacent to elevator.

Recommendations

This directory is for use in the elevator lobbies of small buildings which would typically have no more than 40 listings. All listings in a directory should be done in alphabetical order. List in the directory only services or departments which have contact with patients and public. Distribute any blank directory strips throughout the directory to provide spacing between groups of listings.

FLOOR TWELVE 12			
Title	1A47	Title	1A47
Subtitle	1A49	Subtitle	1A49
Subtitle	1A50	Subtitle	1A50
Sub-Subtitle		Sub-Subtitle	
Sub-Subtitle		Sub-Subtitle	
Title	1A62	Title	2A62
Subtitle	1A63	Subtitle	2A63
Subtitle	1A64	Subtitle	2A63
Subtitle	1A65	Subtitle	2A64
Subtitle	1A66	Subtitle	2A65
Subtitle	1A63	Subtitle	2A66
Subtitle	1A64	Subtitle	2A66
Subtitle	1A65	Title	2B45
Subtitle	1A65	Subtitle	2B46
Title	1A62	Subtitle	2B46
Subtitle	1A63	Subtitle	2B46
Subtitle	1A64		
Subtitle	1A65		
Subtitle	1A66		



Header (Layout A)

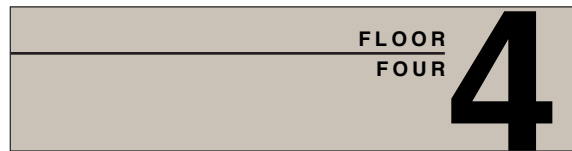

Header (Layout B)



Directory Strip A

Title 1A74

Directory Strip C

Sub-Subtitle 1C49

Directory Strip B

Subtitle 1B48

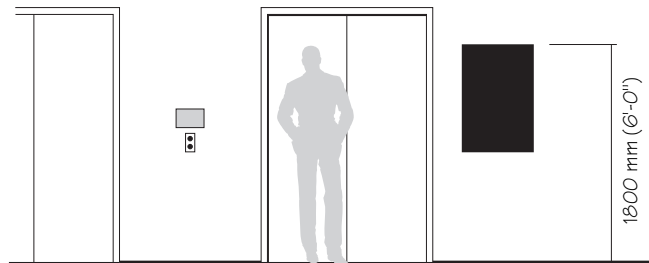

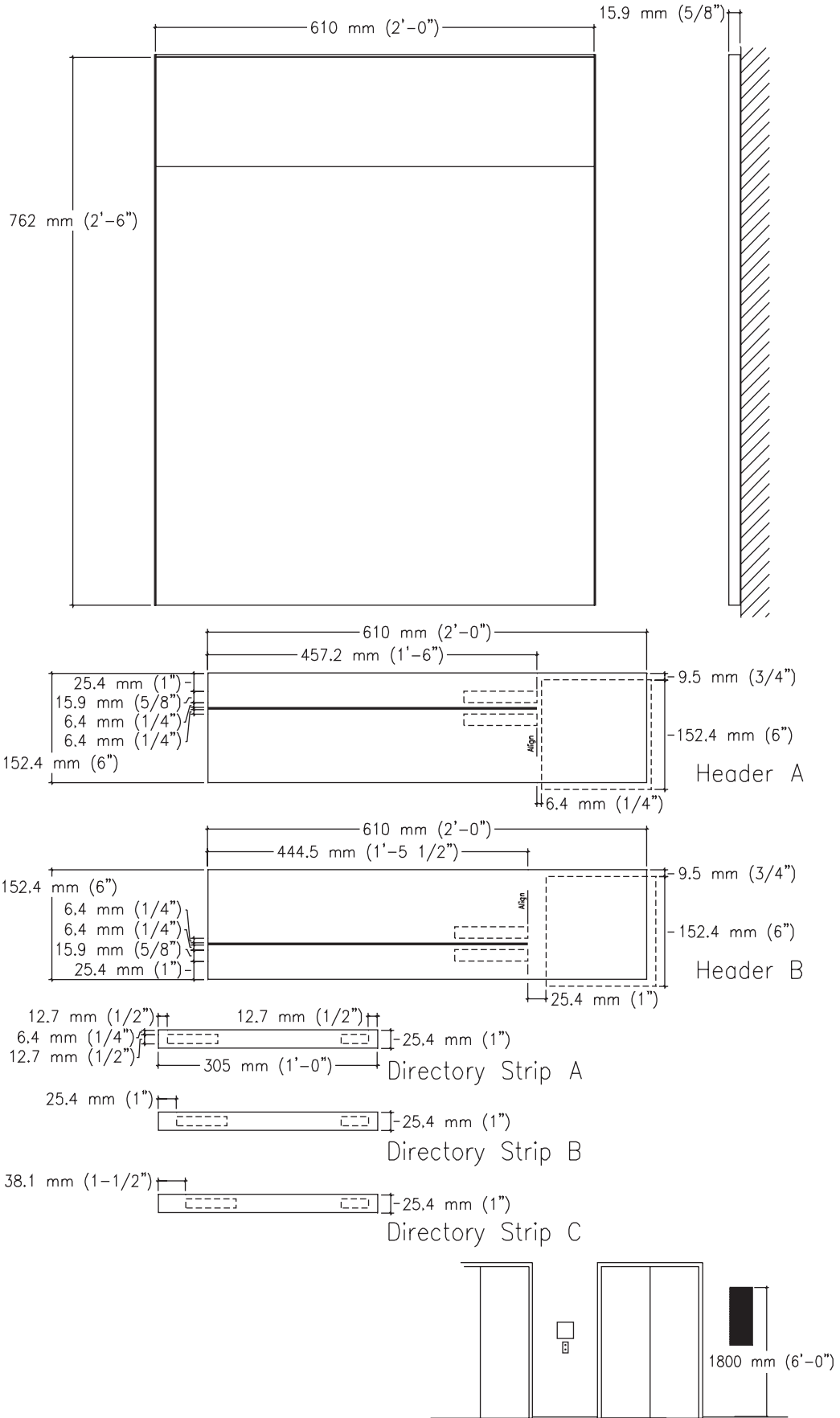

IN-18.01

Interior Signs

Glass Door & Side Light Graphics

Sign

38 mm H
(1 1/2" H)
51 mm H
(2" H)
(Other sizes as needed)

Description & Use

This sign is for use at the entry doors to rooms or departments that are used by patients and public

Message Configuration

(Refer to layout drawing for lettering sizes and dimensions)

Graphic Process

Surface applied vinyl.

Colors

Text: White - T1
Do not use black or colors.

Typography

Helvetica Medium

Mounting

Glass side light and glass doors.

Installation

Apply to front reading surface of glass or second surface of glass with reverse (backward) cut letters.

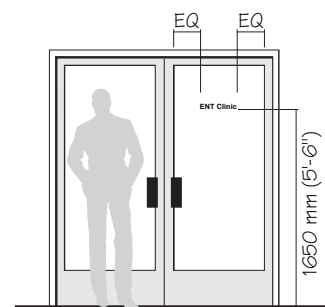
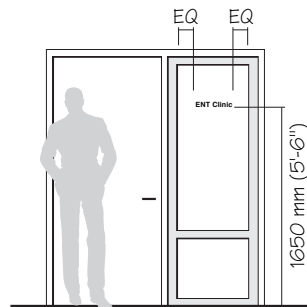
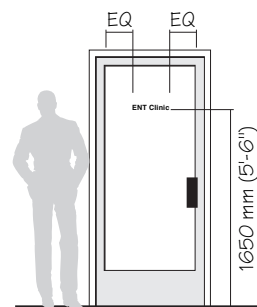
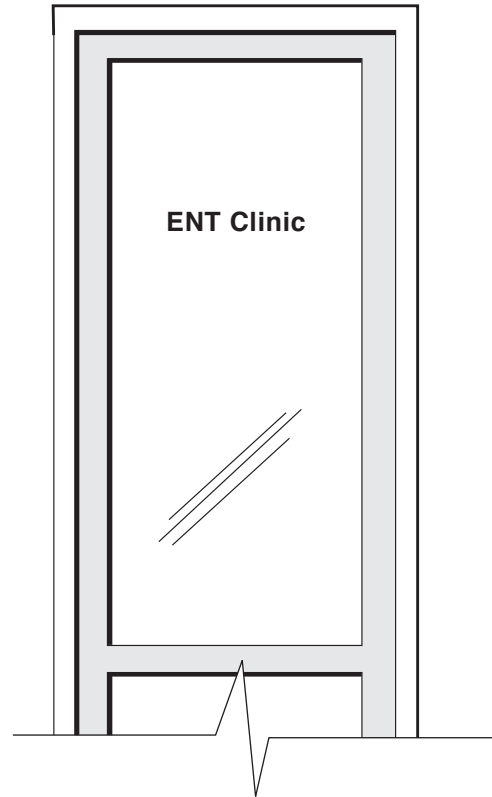



Dimensional Letters

Size

IN-19.01
76 mm H x 10 mm D
(3" H x 3/8" D)

IN-19.02
102 mm H x 10 mm D
(4" H x 3/8" D)

IN-19.03
152 mm H x 10 mm D
(6" H x 3/8" D)

Description & Use

Identification of information counters, major departments or services.

Message Configuration

(Refer to layout drawing for lettering sizes and dimensions)

Sign Components

Painted acrylic.

Graphic Process

Cut out dimensional letters.

Colors

Text: Refer to Color Chart.
Color should have a high contrast with surrounding wall color and surface.

Typography

Helvetica Medium

Mounting

Silastic adhesive or studs and silastic adhesive.

Installation

On walls or soffits.

Recommendations

Dimensional letters provide high impact, high visibility and formal identification. Do not use for departments or services that have frequent relocation's or name changes. Suggested typical uses would be for Information, Check In, Canteen, Pharmacy, etc.

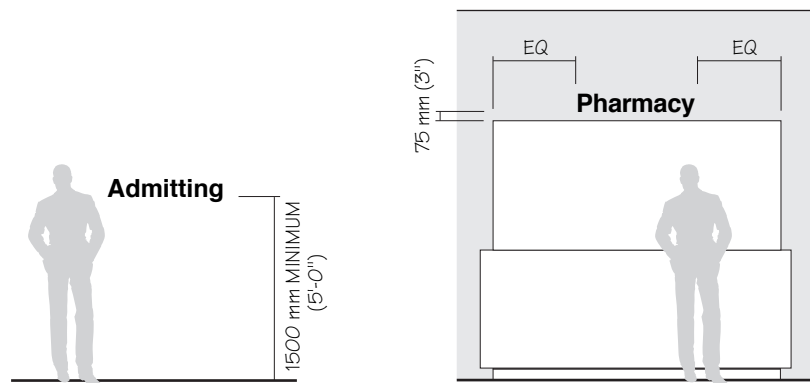

Dimensional Letters

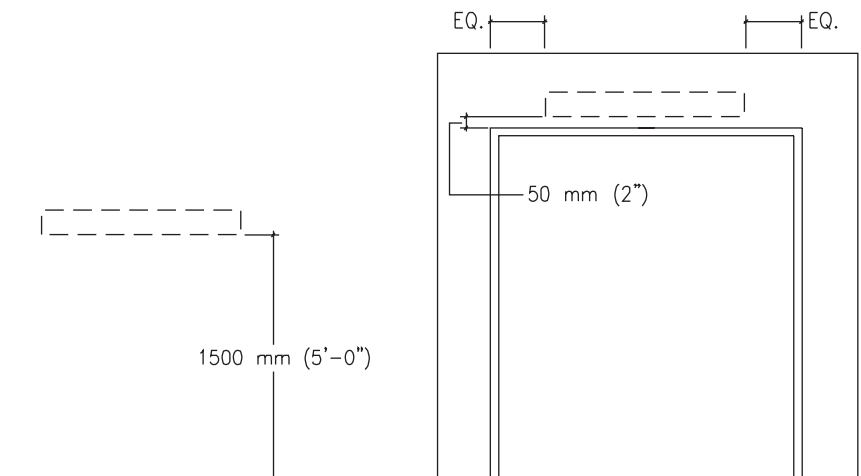
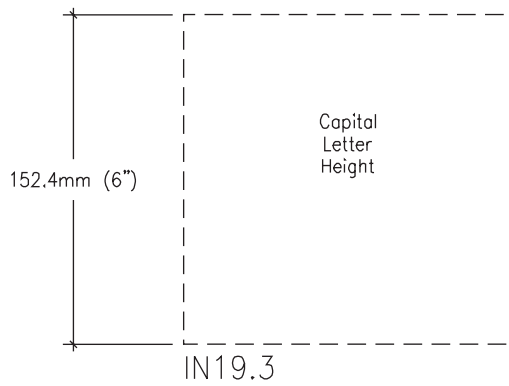
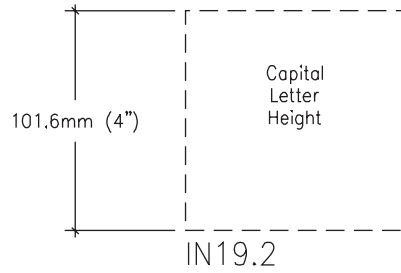
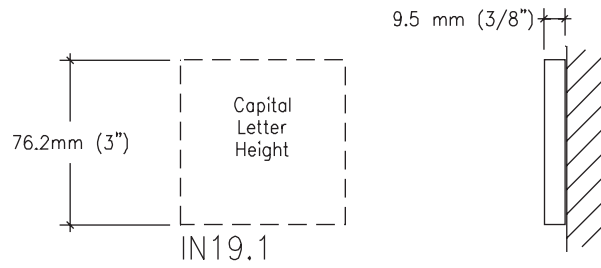

Instructional Sign

Size

152 mm x 152 mm
(6" H x 6" W)

Description & Use

Use this sign above handicap accessible automatic door opening buttons.

Message Configuration

(Refer to layout drawing for lettering sizes and dimensions)

Sign Components

Painted acrylic.

Graphic Process

Silk-screened or surface applied vinyl.

Colors

Text: Refer to Color Chart.
Background: Refer to Color Chart

Typography

Helvetica Medium

Mounting

Double sided foam tape or silastic adhesive.

Installation

On wall 6" above automatic door opening button.

Recommendations

These signs help bring attention and provide direction to doors with automatic opening capability.

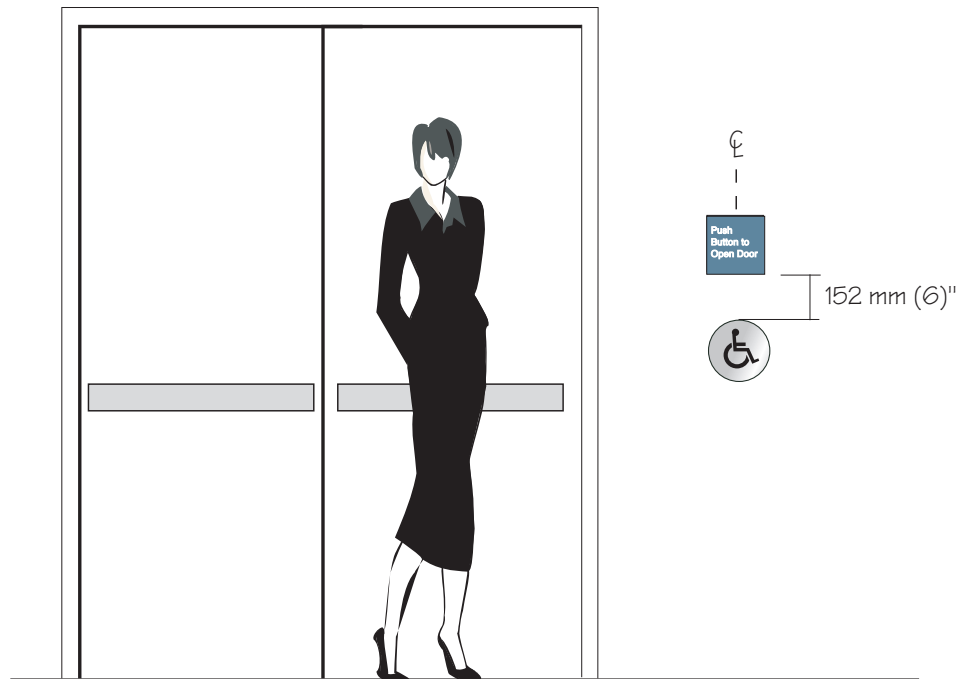
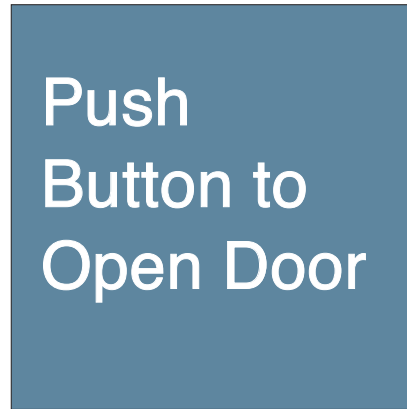

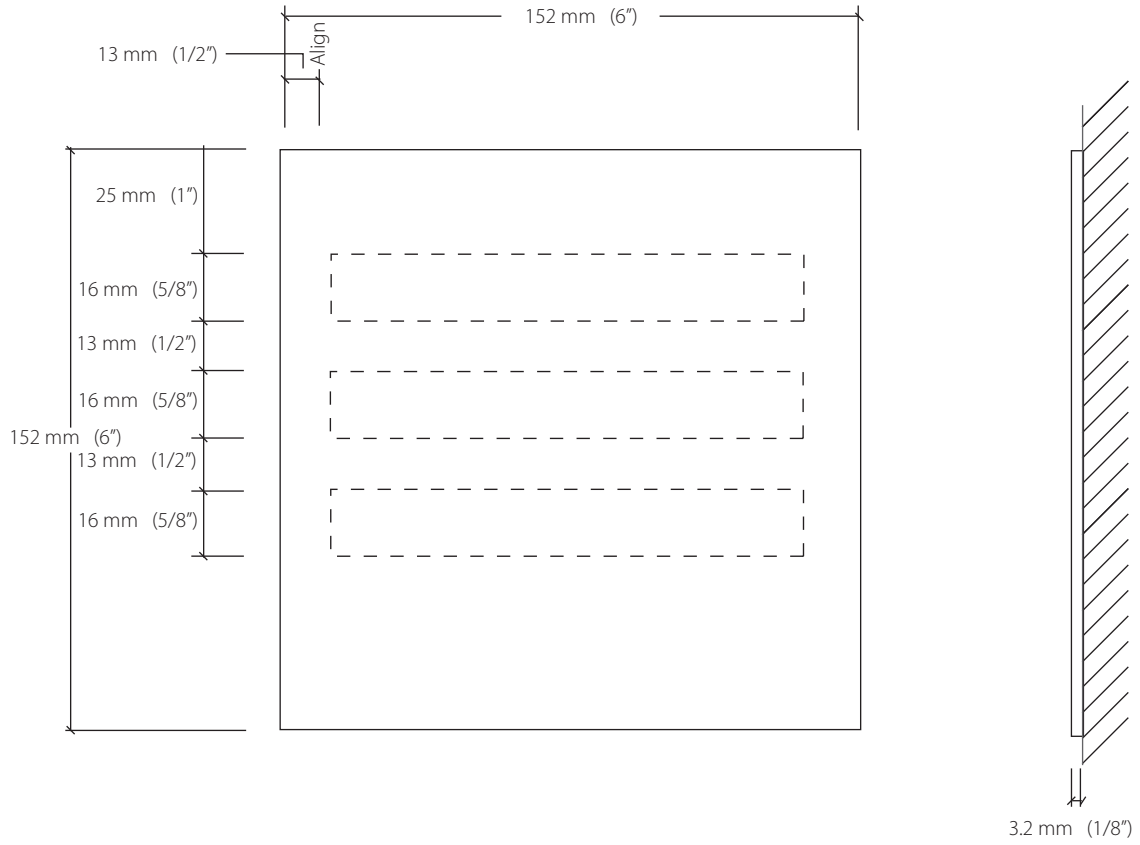

The specifications for interior signs are available in the Master Construction Specifications area of the VA Technical Information Library.

http://www.va.gov/facmgt/standard/spec_10.asp

Refer to Specification 10440.

For more information regarding specifications, contact the Office of Facilities Management, Standards Service.

The specifications will require editing to eliminate signs that are not needed and to adapt the specifications to the specific project for which they are intended.

The specifications require close coordination taking into account the existing sign program at a medical center, sign maintenance and future signing needs.

The sign message schedule is considered a part of the specifications and would comprise the last section. Configuration of the message schedule may vary according to project requirements.

The sign message schedule form, illustrated in the Programming Section of this Handbook, lists the typical information that a sign manufacturer and installer will require.

The sign message schedule needs to be coordinated with a sign location plan drawing showing where signs are to be placed within a building or on the site. See the example in the Programming Section of this Handbook.

The type of interior sign and sign system being selected for a particular application or facility may require several decisions and involve different construction and assembly components to meet the desired requirements. This section provides an overview of the intended criteria for interior sign programs.

Many sign manufacturers currently market extrusions, standard parts and component sign systems that will accomplish the illustrated objectives of the intended interior sign system. These extruded, molded and fabricated component sign systems are acceptable so long as the illustrated and stated specifications are adhered to.

The acrylic interior sign program, that has been in place since 1980, is a program that can be replaced with a component system. This is a sign program that brings new products and solutions to meet various needs of the medical centers. Component systems are available from GSA sign manufacturers and sign manufacturers in the open market place.

The details showing the construction of the sign component system sign types are based on a concept of a component system. The illustrations are intended to show the desired configuration and intent of the various sign types. Sections of the extrusions and various parts are for illustration purposes and have not be engineered or configured for extruding and do not represent a finished form.

With the component system, variations such as beveled and radius shapes in the accent rails and end caps are not shapes that conform to the sign program. Elimination of radius corners reduces costs, provides more flexibility and allow inter-changing of components.

Once a component system is selected, it should eventually become the standard for the facility. The component system has been designed to be compatible with an existing old style acrylic system in size, however there will be a significant difference in appearance.

Both systems encourage the ongoing updating and maintenance of the sign program to be done by the facility. The component system uses vinyl letters or silk screened letters as the method of producing the lettering. Engraving can also be used, but this increases the costs of the signs and the added cost does not provide significant benefits.

The Specification section of the Guide should be read in conjunction with the Construction Details section. This will provide an overview of the interior sign construction requirements, materials and finishes.

The guide illustrates component based sign systems for certain sign type families. These families are Type 03, 04, 05, 06, 07, 11, 12, 13, 14, 15, 16 and 17.

Component systems use various interlocking elements which, when assembled, create a sign. They are available from several manufacturers and these general illustrations represent component systems that slide or snap together.

A benefit of the component system is that it provides flexibility and simplicity in maintaining and adapting signs to ever changing needs. Components from one sign can be interchanged with components from another sign quickly and easily. Existing signs can be added to or modified to perform another function.

Changing directional signs is simple. Adding new text and arrows and rearranging messages is always possible.

While component signs can be installed along side old style acrylic signs, they will appear slightly different. Also, elements of the component system along with several of its benefits are not interchangeable with the acrylic system.

Implementation of a component system requires commitment to that specific manufacturer's system. Review carefully the advantages and disadvantages of various component systems from different manufacturers and talk to facilities that have installed the system that is being considered.

In the following pages, the guide illustrates the sliding rail component system to show how it would apply to the various sign type applications. Other systems may equally apply.

Sliding Rail Component System

The sliding rail component system uses various interlocking elements that slide together to create a sign.



Snap Rail Component System

The snap rail component system uses various interlocking elements that snap together to create a sign.

**Injected Molded Component System**

This component system uses molded plastic pieces that snap together to create a sign.



**Exclusions
Frames & Radius
Corners**

Frames for interior signs are no longer a part of the sign program.

This applies to both thin and thick plastic and aluminum frames.

Radius corner signs and radius corner frames are also not included in the sign program.

Frames have been dropped from the interior sign program for several reasons:

- They significantly increase the cost of signs
- They create difficulties when inserting and removing inserts
- Frames from different manufacturers are not compatible with inserts from different companies
- Frames are quite thick and create a “dirt catching shelf”
- Frames from different manufacturers have such varied “looks” that this creates a disorganized appearance within a medical center.

Radius corners plaques are not a part of the program because they create compatibility problems when trying to maintain a sign program over several years using different manufacturers as suppliers. Radius corner framed plaques are worse and create even more compatibility problems.

If a facility has square corner frames, radius corner frames or radius corner plaques as a part of the current program, that element of the program can be continued if continuity is desired.



Detail 1

Sliding Rail Component System
 Type IN03 & IN04.1
 Room Identification Sign
 Comprised of the following components:

- 1** A Sliding Rail Back utilizing horizontal grooves which are spaced to allow for uniform, modular sizing of sign types.
- 2** An Insert that mounts to the back of the Copy Panels to allow for attachment to Sliding Rail Back by sliding in horizontally from either side.
- 3** Copy Panel which can be made of a variety of materials to allow for different graphic needs.
- 4** End Caps which interlock to form an integral unit, enclosing and securing the changeable Copy Panels to the back.
- 5** Joiners and Accent Joiners that connect separate Sliding Rail Backs together. For example, a Joiner connects a Type IN03 sign to a IN04.1 sign.
- 6** Accent Bar which provides a 3 mm (.125") high decorative trim cap enclosing the top of the sign.



Detail 2

Sliding Rail Component System
 Type IN05.1
 Patient Room Sign
 Comprised of the following components: (see Detail 1 for descriptions of items 1-6)

- 7** Extruded Insert Holder with integral rail grooves for connection with Sliding Rail Back.
- 8** Paper Copy Insert behind a clear textured polycarbonate cover.

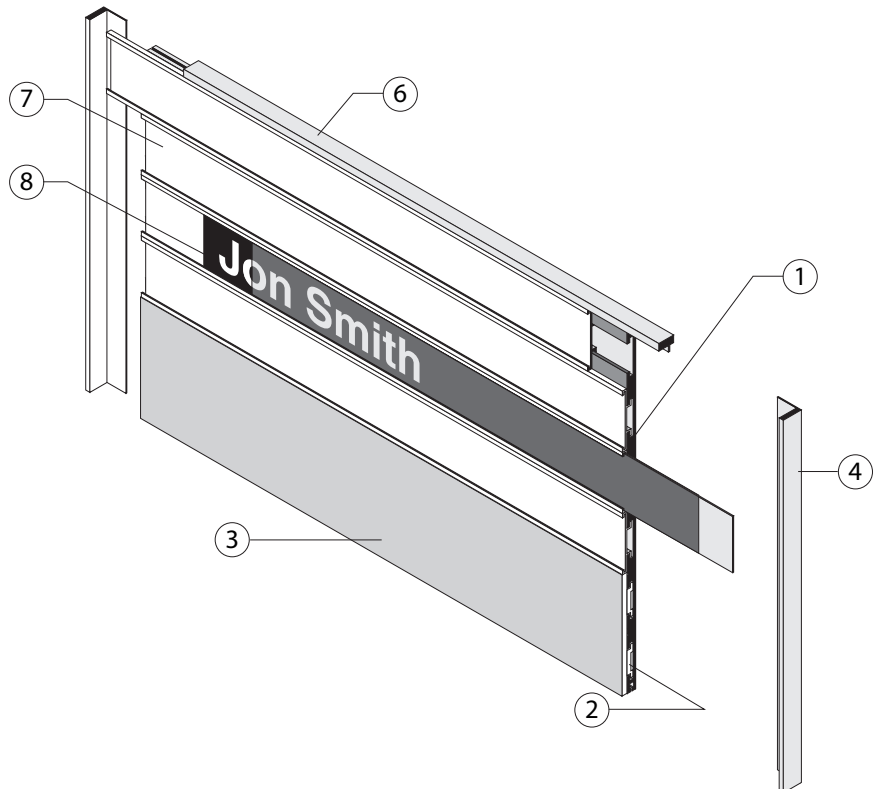

Detail 3

Component System
 Type IN07.1
 Conference, Exam or Treatment
 Room Sign Comprised of the fol-
 lowing components: (see Details
 1&3 for descriptions of items 1-7)

- 9 Metal slider mounts in the Insert
 Holder and slides horizontally.
- 10 Polycarbonate Insert with
 subsurface copy and color.

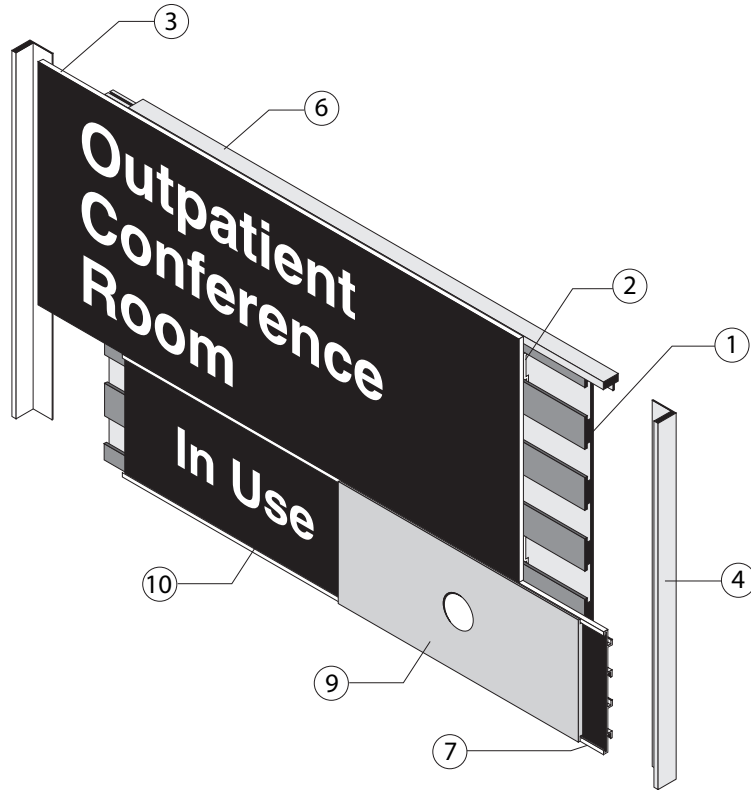

Detail 4

Component System
 Type IN06.2
 Patient Bed Sign Comprised of the
 following components: (see Details
 1, 3 & 5 for descriptions of items
 1-10).

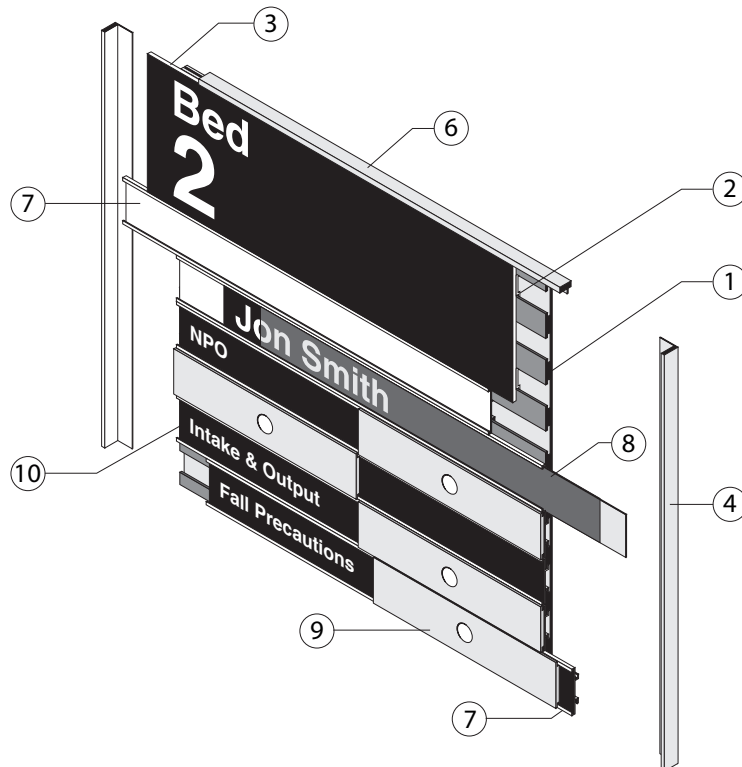

Detail 5

Component System
Type IN14
Wall Directional Sign Comprised of the following components:
(see Detail 1 for descriptions of items 1-6)

11 A double sided Structural Rail Back Panel utilizing horizontal rails which are spaced to allow for uniform, modular sizing of sign types.

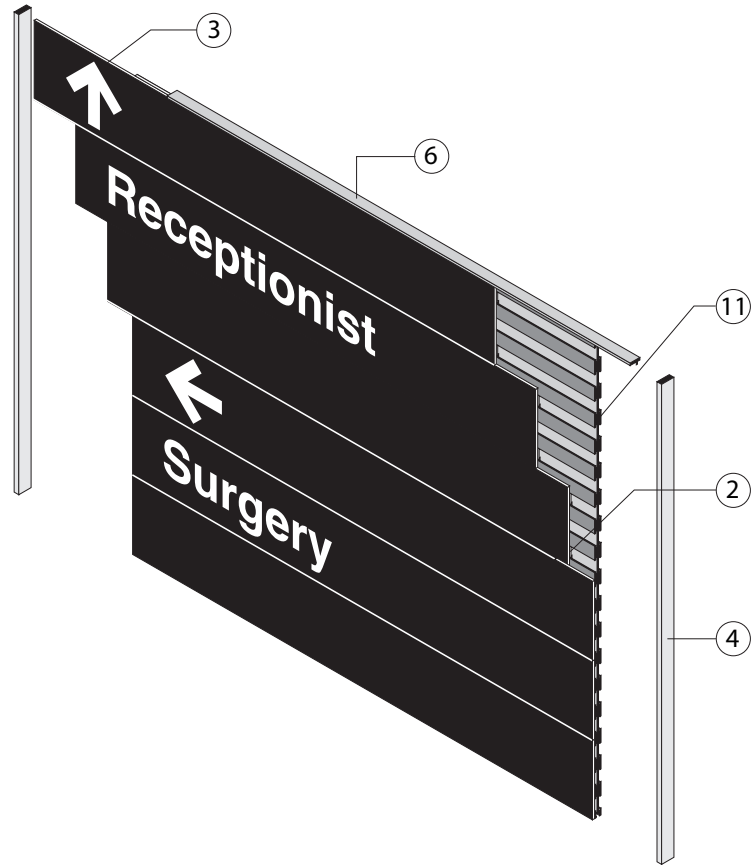

Detail 6

Component System
Type IN15 & IN16
Ceiling Mount Sign Comprised of the following components:
(see Details 1, 9 for descriptions of items 1-6, 11)

12 A rod or braided stainless steel cable for attachment to the ceiling.

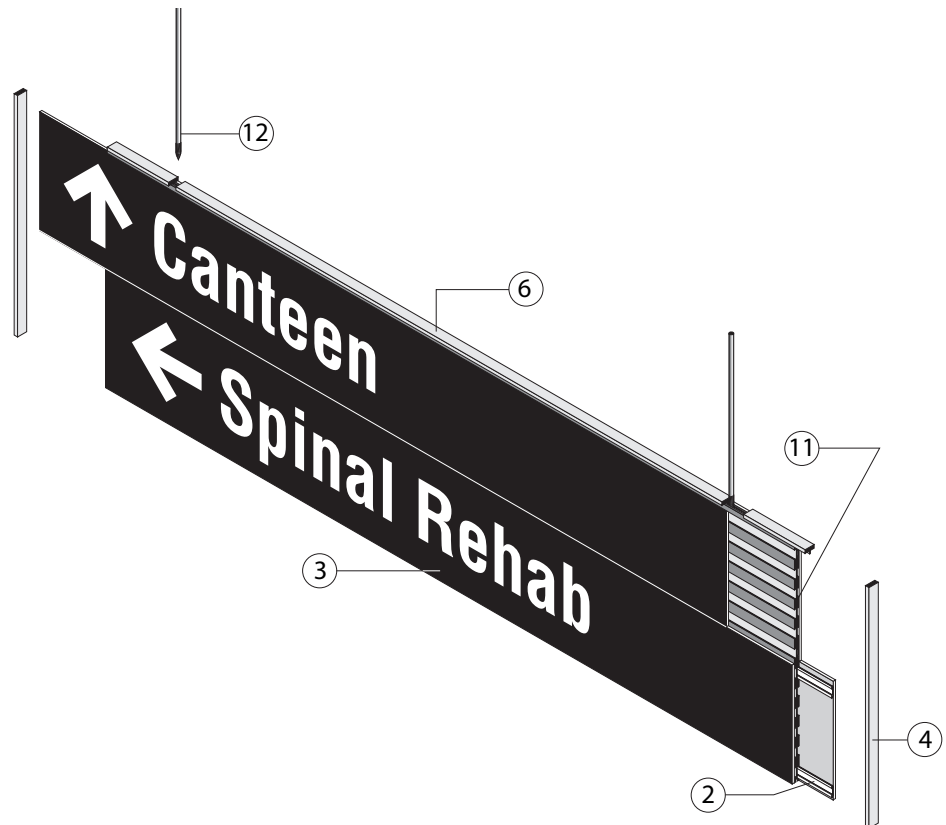

Detail 7

Component System
 Type IN13
 Perpendicular (flag) Mount Sign
 Comprised of the following components: (see Details 1, 9 for descriptions of items 1-6, 11)

13 Extruded aluminum Mounting Bracket.

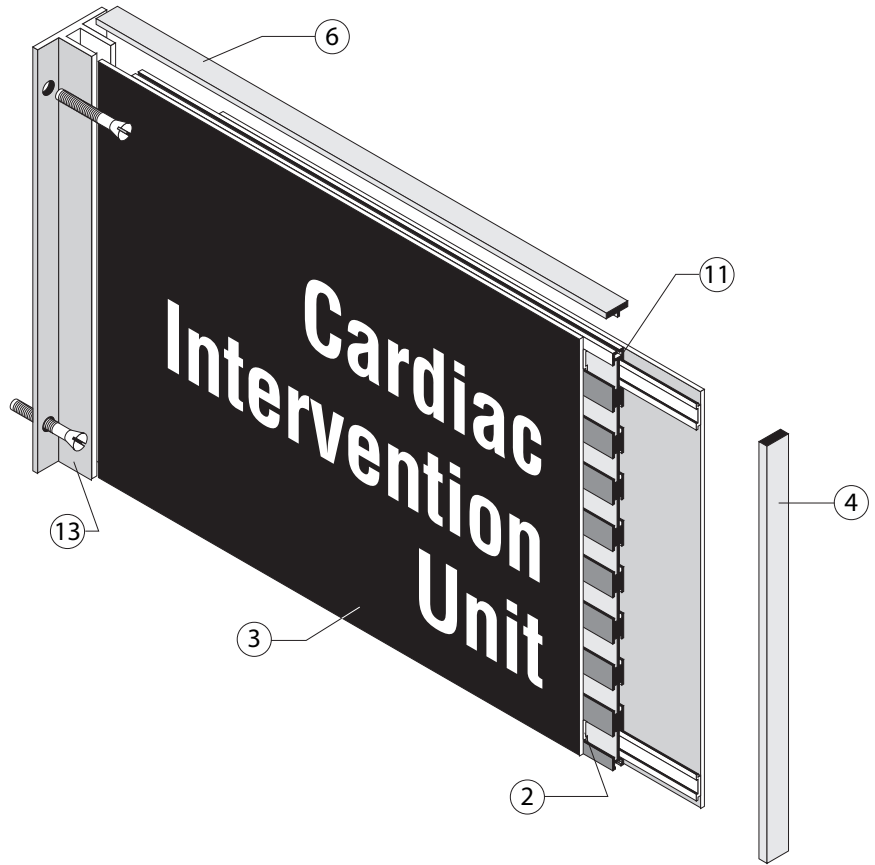

Detail 8

Component System
 Type IN15
 Directory Comprised of the following components: (see Details 1, 9 for descriptions of items 1-6, 11)

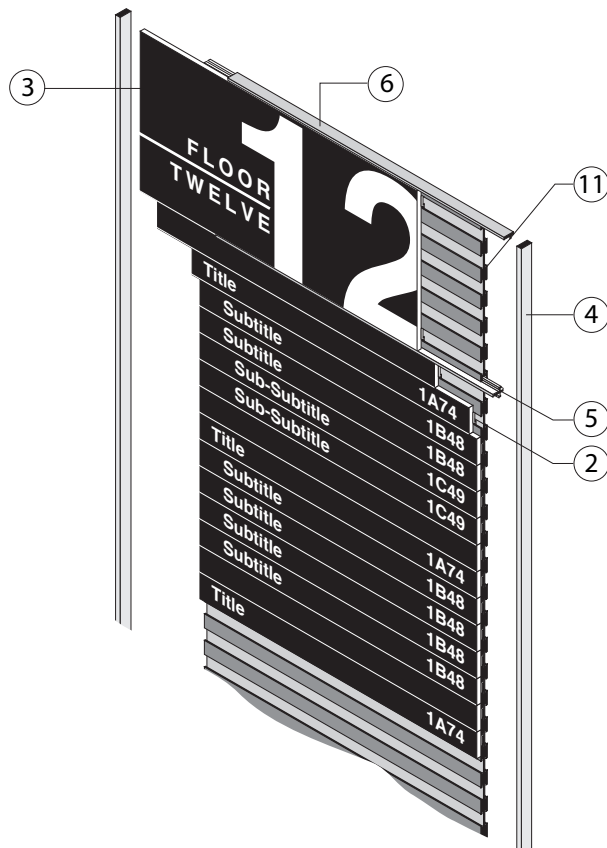

Detail 9

Acrylic System

Type IA16

Directory Comprised of the following components: (see Detail 10 for a description of item j)

o An extruded aluminum Directory Case Frame shaped to hold a hinged door and retain copy strips

p Extruded aluminum Door Frame shaped to hold gasketed double strength glass, hinge and fit within the Directory Case Frame. Door shall contain a key lock for closure.

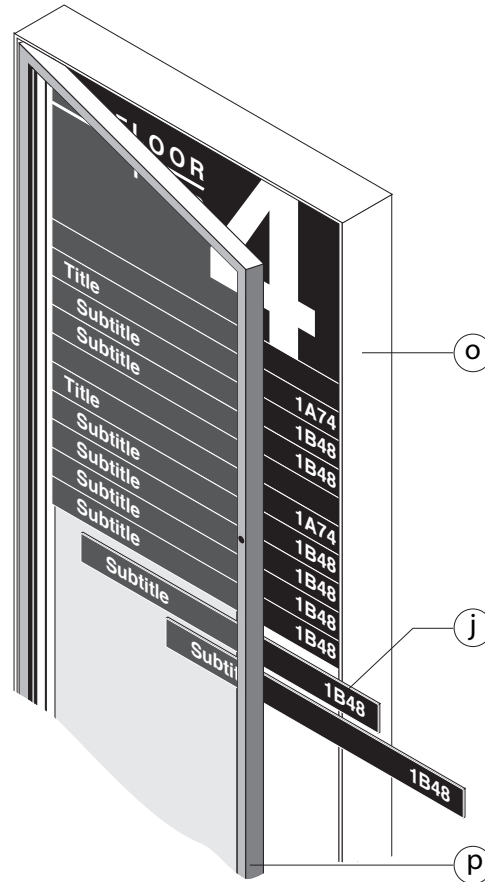

Detail 10

Sign Frame

Type IA03, IA04.1 & IN10

Comprised of the following components:

a A Back Plaque

b Spacers to allow for insertion of Copy Inserts by sliding them in horizontally from either side.

c Copy Inserts which can be made of a variety of materials to allow for different graphic needs.

d Face Plaque made of non-glare, optically clear acrylic that will allow clear reading of Copy Insert text. The Face Plaque is to have a second surface (sub-surface) color applied border to create a window.

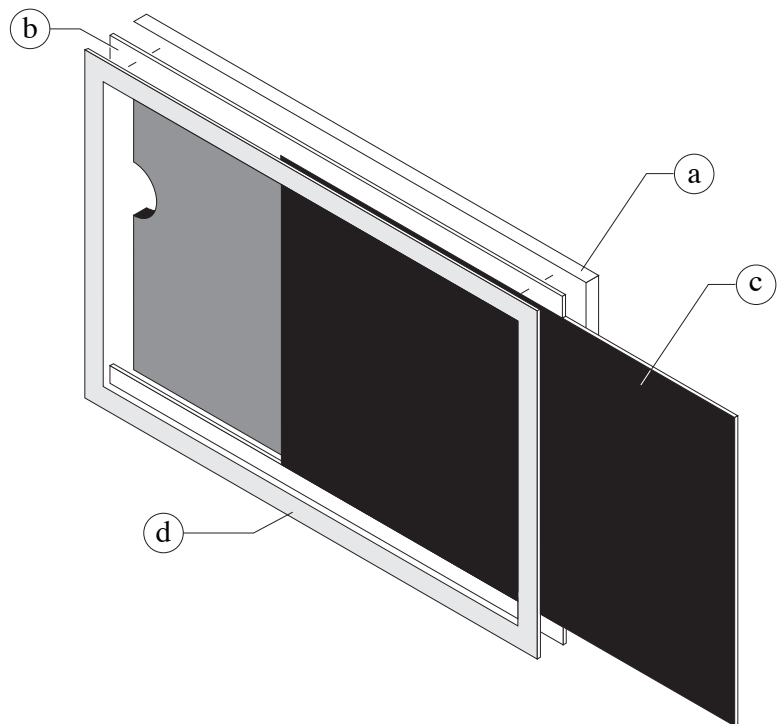

The installation of interior signs requires coordination of several interlaced criteria. Interior signs, especially directional signs, require coordination and careful consideration of the following:

- Criteria**
- Location of building entrances and elevators.
 - Configuration of the corridor system.
 - Desired path of travel within the building for visitors, patients and employees.
 - Location of departments and clinics.
 - A simple clear room numbering system that follows a clear, understandable pattern.
 - Adequate light on and around directional signs.
 - Placement of signs in locations where people are expecting them to be.

Visibility These elements help establish the basis of a clear sign program that communicates and informs in a direct and simple manner.

Interior signs function to communicate to both patients and visitors as well a staff. Their placements need to be planned relative to the intended viewer, particularly directional signs. Sign visibility to the intended user is a principal objective that is the basis of correct sign placement.

Placement Proper sign placement is part of a well-planned interior sign program.

In order to meet ADA guidelines, tactile room number signs must now always be specifically placed on the wall, on the strike/knob side of the door. Ceiling mounted signs require larger lettering size so only short selective message can be communicated. Interior directional signs are intended to communicate directions to visitors and patients and their placement needs to be planned relative to the intended viewer. Sign visibility to the user is a principal objective that is the basis of correct sign placement.

Correct placement of signs will usually mean that fewer signs are required. Too many signs can create a cluttered appearance and increase the difficulty for a viewer to find the particular information they are seeking. Placement of signs where there is sufficient lighting is critical. Care also needs to be taken to place signs in a manner that allow clear viewing.

Colors need to be considered as well, as this has an effect the visibility of signs. Putting directional signs in a color that is different from room identification signs can be helpful to patients and visitors.

Planning A sign program for a building, that works well, is one that has been planned as an integrated whole. All the way from the main entrance sign, to directional signs, room identification signs, informational signs, code required signs and life safety signs.

Detail 1

Installation detail sign type 03, building standard, room number.

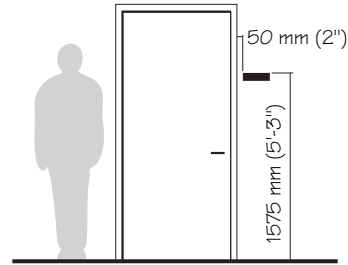

Detail 1

Detail 2

Installation detail sign types 04.1, 04.2, 05.1, 05.2, 05.3, 05.4, 07.1, 07.2, 07.3. Building standard room number and name.

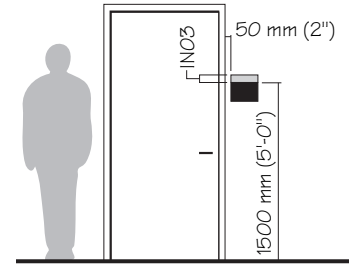

Detail 2

Detail 3

Installation detail sign types 08.1, 08.2, 08.3, 08.4, 09.1, 09.2, 09.3, 09.4, 09.5, 09.6, 09.7, 09.8, 09.9, 09.10, 09.11, 09.12, 09.13, 11.1, 11.2. Building standard.

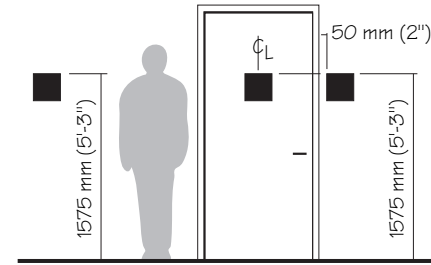

Detail 3

Detail 4

Installation detail sign types 10.4, 10.5, 10.6.

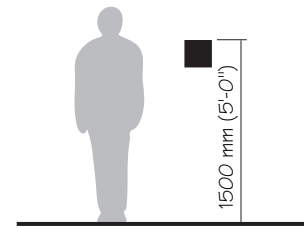

Detail 4

Detail 5

Installation detail sign types 10.2, 10.3, 11.3, 14.4, 14.5

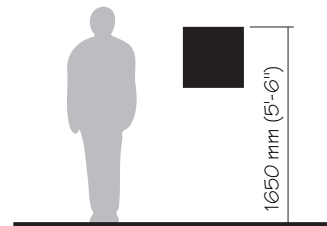

Detail 5

Detail 6

Installation detail sign types 10.1, 14.1, 14.2, 17.1, 17.2, 17.3, 17.4.



Detail 6

Detail 7

Installation detail sign types 14.3

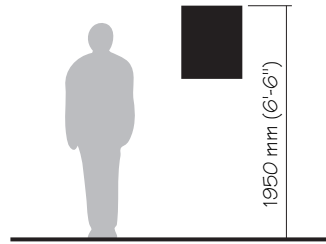

Detail 7

Detail 8

Installation detail sign types 13

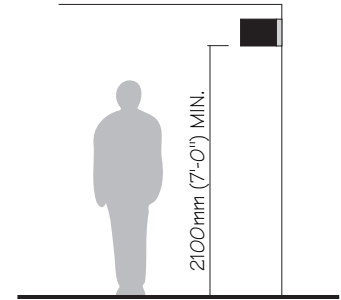

Detail 8

Detail 9

Installation detail sign types 15.1, 15.2, 15.3, 15.4, 16.1, 16.2, 16.3, 16.4.

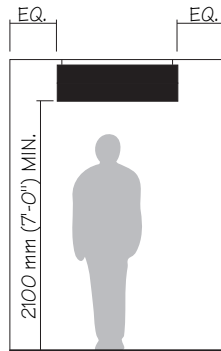

Detail 9

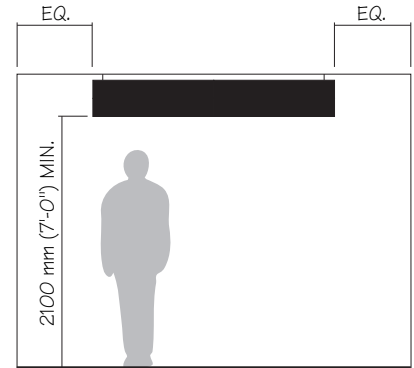

Detail 10

Detail 11

Installation detail sign types 15.1, 15.2, 15.3, 15.4, 16.1, 16.2, 16.3, 16.4.

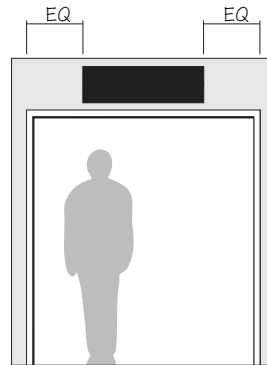

Detail 11

Detail 12

Installation detail sign types 15.5, 15.6, 15.7, 15.8, 16.5, 16.6, 16.7, 16.8.

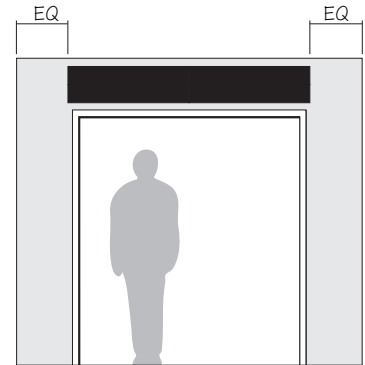

Detail 12

Detail 13

Installation detail sign types 15.1, 15.2, 15.3, 15.4, 16.1, 16.2, 16.3, 16.4.

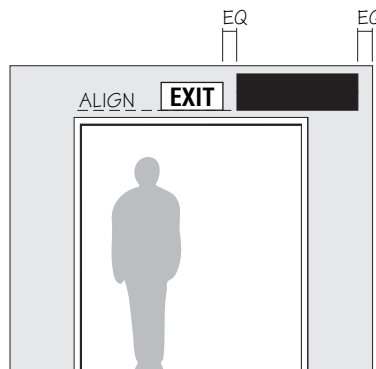

Detail 13

Detail 14

Installation detail sign types 06.1, 06.2, 06.3.



Detail 14

Detail 15

Installation detail sign types 17.5, 17.6.

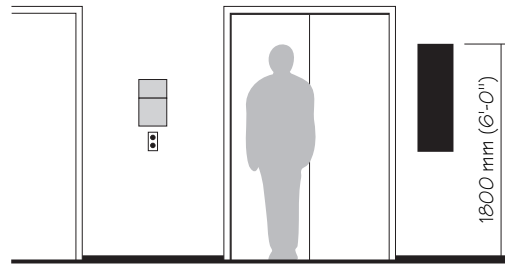

Detail 15

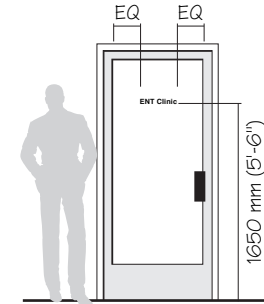

Detail 16

Detail 17

Installation detail sign type 18

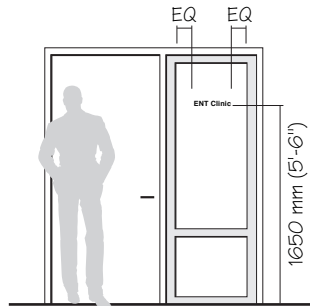

Detail 17

Detail 18

Installation detail sign type 18

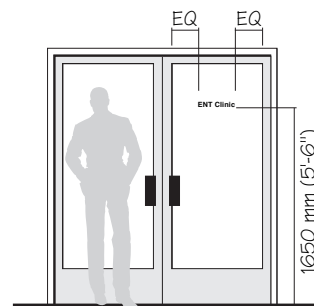

Detail 18

Detail 19

Installation detail sign types 19.1, 19.2, 19.3.

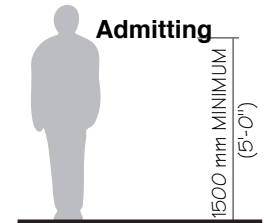

Detail 19

Detail 20

Installation detail sign types 08.2, 08.3, 08.4

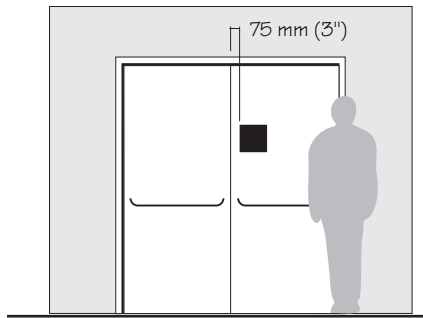

Detail 20

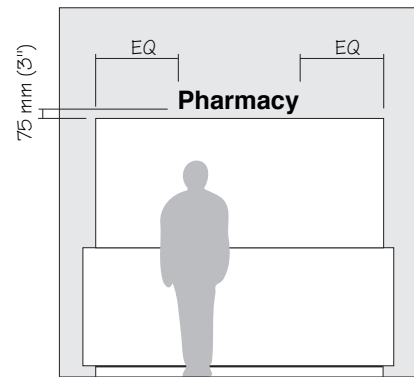

Detail 21

Detail 22

Tile wainscot wall installation guide for room identification signs.

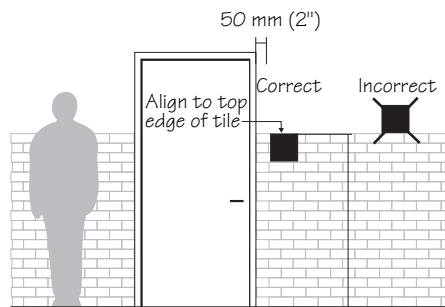

Detail 22

Detail 23

Room identification sign installation guide for Spinal Rehabilitation and Nursing Home facilities.

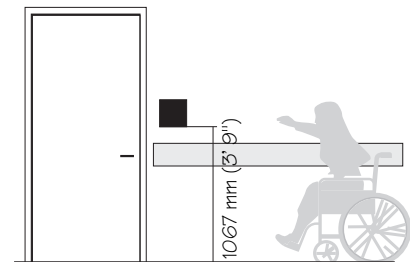

Detail 23

Wall Mounted Sign Detail

Interior wall bracing for heavy signs, directories, cast plaques, etc.

Stud Backing Plate A

1 Max Weight- 25 lbs. point load. If sign load exceeds this use Stud Backing Plate B.

2 Attach plates to 3 studs min.

3 Verify length, height, location & number required.

4 Use #12 Self Tapping Screws when attaching items to backing, U.O.N.

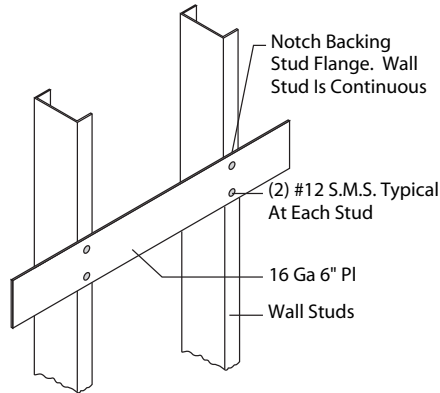

Stud Backing Plate A

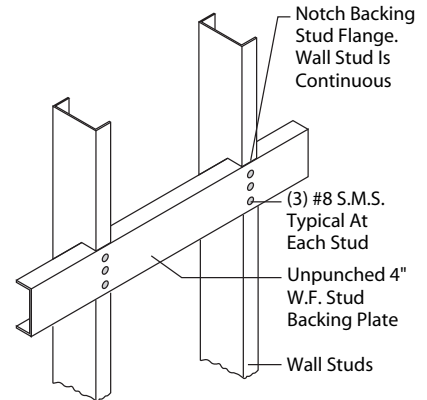

Stud Backing Plate B

Stud Backing Plate B

1 Max Weight- 50 lbs. point load. If sign load exceeds this use Stud Backing Plate C.

2 Attach plates to 3 studs min.

3 Verify length, height, location & number required.

4 Use double stud when stud is supporting more than 2 backing plates

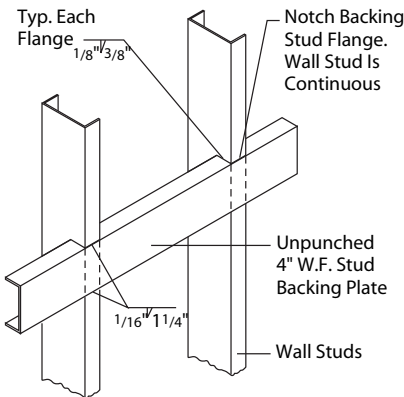

Stud Backing Plate C

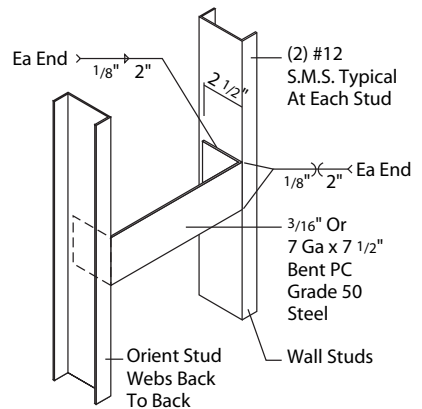

Stud Backing Plate D

Stud Backing Plate C

1 Max Weight- 200 lbs./ft.

2 Attach plates to 3 studs min.

3 Verify length, height, location & number required.

4 Use double stud when stud is supporting more than 2 backing plates.

Stud Backing Plate D

1 Max Weight- 300 lbs. point load.

2 Attach plates to 3 studs min.

3 Verify length, height, location & number required.

Glass Back Up

Certain signs may require that they be installed on glass because there is no available wall surface.

When this situation occurs, a blank glass back up is required to be placed on opposite side of glass exactly behind sign being installed.

This blank opaque glass back up is to be the same size and color as the sign being installed so it effectively covers and hides the mounting of the sign to the glass.

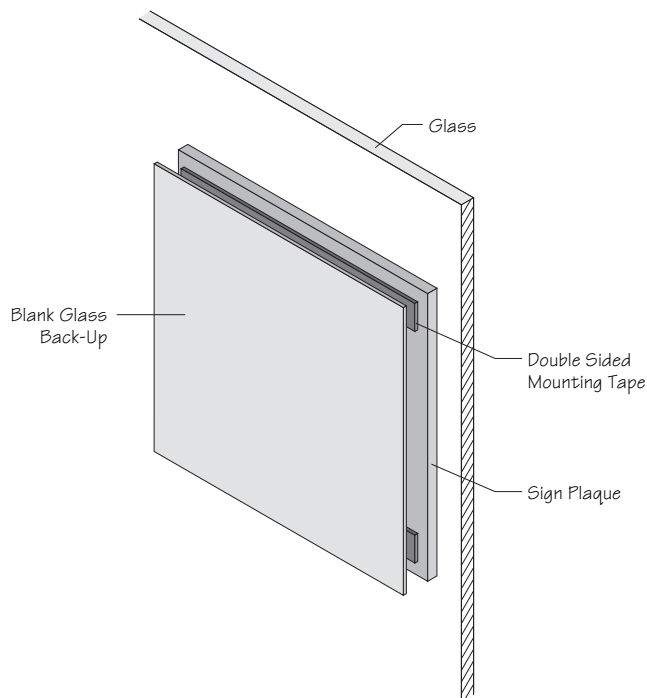

Ceiling Mounted Sign Detail

Use for signs that weigh over 20 lbs. and are mounted from a suspended ceiling system.

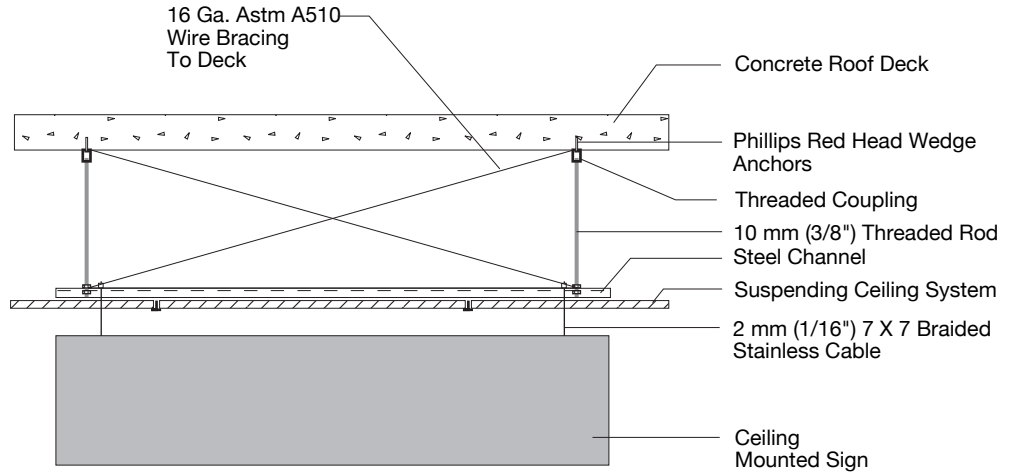

Front View

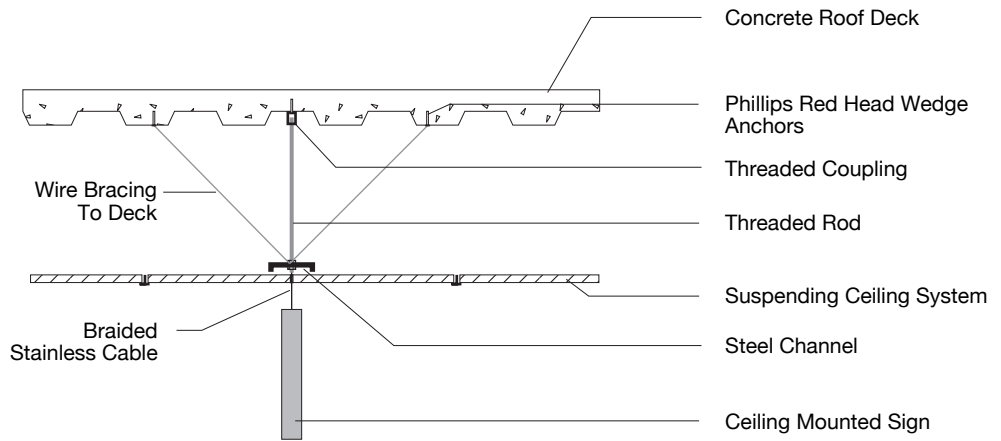

Side View

