



# **Parking Lots and Parking Structures**

---

---

- **Directional**
- **Floor Level**
- **Entrance**
- **Informational**
- **Handicapped**
- **Parking Lot Identification**
- **Parking Structure Identification**
- **Parking Stall**



## **Section 3: Parking Lot & Parking Structure Signs**

▪ <b>Planning</b>	Pages 3-2-1 through 3-2-2
▪ <b>Helpful Hints</b>	Pages 3-3-1 through 3-3-2
▪ <b>Overview</b>	Pages 3-4-1 through 3-4-6
▪ <b>Parking Lot Signs</b>	Pages 3-5-1 through 3-5-14
▪ <b>Parking Structure Signs</b>	Pages 3-6-1 through 3-6-48
▪ <b>Specification</b>	Pages 3-7-1
▪ <b>Construction</b>	Pages 3-8-1 through 3-8-3
▪ <b>Installation</b>	Pages 3-9-1 through 3-9-3



### **Planning an Exterior Sign Program**

The development of an effective working parking lot or parking structure sign program requires the coordination of several interlaced criteria.

For an effective sign program you have to take into account to the following:

1. Character and configuration of the roadway system in the parking lot and the circulation system in the parking structure.
2. How do visitors currently drive around the parking lot or structure.
3. Where do you want visitors to park?
4. What is the desired path of travel on the roadway system, to parking, for visitors?
5. What is the desired path of pedestrian travel from parking to building entrances?
6. Location of building entrances on the facility campus in relation to parking.
7. Location of electricity, its availability and voltage.
8. Adequate light on and around directional signs.
9. Placement of signs in locations where people are expecting them to be.

These elements help establish the basis of a clear sign program that communicates and informs in a direct and simple manner.

A parking structure or parking lot sign program, that works well, is one that has been planned as an integrated whole. From the vehicle directional signs, pedestrian directional signs, building and building entrance identification through parking exit signs.

Another important consideration is that a parking sign program needs to be planned in accord with cohesive organized parking plan for both visitor and employees.

---

### **Types of Signs**

The main parking identification sign for a medical center parking structure should be a large scale illuminated sign. Refer to the exterior signs section for illuminated signs.

Internally illuminated signs within a parking structure should be considered for those locations where important information and directions need to be communicated at night or in low light conditions. A non-illuminated sign that is illuminated with floodlights or a light fixture can be effective as well.

Non-illuminated signs with reflective letters will function quite well for secondary signs. It is a good practice to make all the signs have reflective letters as that will insure the best possibility of being read regardless of a sign's importance.

### Color Coding Options

Parking structures over 3 levels should consider color coding the floor levels in different colors. Colors should be distinctly different from floor to floor. For example, if floor one is Blue, floor two should be Burgundy, floor three, Red, etc.



**B12/B7 Dark Blue/White**  
**T8 Majestic Blue**



**B13/B7 Burgundy/White**  
**T10 Burgundy**



**B3/B7 Red/White**  
**T15 Fire Red**



**B15/B7 Dark Green/White**  
**T12 Deep Green**

The following are some general “Do’s & Don’ts” guidelines that one can refer to when developing a sign program.

key information or instructions that will hopefully reduce common errors that are made when planning and programming a parking sign program.

This is not intended to be a training section of the guide, but to provide

---

**General Guidelines**

- Never use text smaller than 3” capital letter height when a sign is intended to be read from a moving car.
  - Text intended to be read by pedestrians should be a minimum of 1 1/2” capital letter height.
  - Signs do require maintenance. Cleaning and waxing will extend the life of a sign program.
  - Use text (words) which are familiar, easy to understand and comfortable to the viewer.
  - Always use the same words throughout the sign program.
  - All sign messages need to be a minimum of 24” above grade.
  - When selecting a background color for the signs, seek a complementary color to the buildings on campus.
- 

**Type of Sign to Use**

- Always consider the landscaping surrounding a sign when determining a sign’s size. It is important that shrubs and other plants do not hide or obscure the sign.
  - Lettering and sign panel size should be appropriate for the distance and speed at which a sign is viewed.
- 

**Size of Sign to Use**

- Signs intended for a moving vehicle need to be larger and require larger text than a sign intended for a pedestrian.
  - Keep sign messages brief.
  - Unnecessary information on signs will confuse the viewer.
  - Typically, all signs, with the exception of directional signs, should convey no more than one concept or thought.
  - Use text (words) that can be quickly read by the viewer. And use the same words throughout the sign program.
  - On directional and informational signs only provide information necessary to make a decision at that particular location.
  - Whenever possible, messages should be presented using positive
- v

**Message Content**

- Keep sign messages brief.
  - Unnecessary information on signs will confuse the viewer.
  - Typically, all signs, with the exception of directional signs, should convey no more than one concept or thought.
  - Use text (words) that can be quickly read by the viewer. And use the same words throughout the sign program.
  - On directional and informational signs only provide information necessary to make a decision at that particular location.
  - Whenever possible, messages should be presented using positive information.
  - On directional signs, do not anticipate decisions that can be made later. Unnecessary or premature information will confuse the reader.
  - Messages placed on signs should be concise, preferably with no more than seven to ten words.
  - For signs to be read from a moving car, take into account the speed of the car. At a slow speed the driver may be able to read 7 or 8 words. At a faster speed they will only be able to read 4 or 5.
- 

**Message Layout**

- Use upper and lower case text whenever possible. Upper and lower case text is easier to read and understood faster than text in all capital letters.
- Line-spacing between two different messages should be greater than line-spacing between lines of the same multiple-line message group.
- Text should not be run right up to the edge of the sign.
- If a line text needs to be reduced in order to fit on a sign, use only commonly recognized abbreviations, reduce the number of words or reduce the size of the type for the entire message. DO NOT condense the type face.
- The most important message should appear as the first line text and the most important directional information should be at the top of the sign on free standing signs. Signs mounted to the ceiling of a parking garage should have the most important message at the bottom of the sign.

**Placement of Signs**

---

- Signs should, if at all possible, always be perpendicular to the intended viewer.
- Position signs with a clear line of sight from the viewing point to the sign face.
- Always evaluate a sign's location at night as well as in the daylight. Lighting conditions and visibility may change at night making a particular location unsuitable.
- All signs should be placed in a manner that will be clearly visible to driver all times of the year. For example, make sure that snow removal doesn't bury signs.
- Signs that receive spray from irrigation sprinklers will show oxidation from the minerals in the water resulting in a poor appearance. The life of the sign will also be considerably shortened.
- Always consider the landscaping surrounding a sign when determining a sign's location. It is important that trees, shrubs and other plants do not obscure the sign.
- Do not place signs in locations where people may walk into them. Don't place signs any closer than 12" to a walkway.



This section of the Environmental Graphic Sign Handbook provides interior sign guides for all the types of Parking Lot & Structure signs that are necessary to sign any parking area, regardless of size or type of use.

The following Overview illustrates the various types of signs in this section. The individual pages on each Sign Type provide more specific information and detailed layouts.

---

### Parking Lot & Structure Sign Designations

Each sign in the program guide has been given a specific sign type number designation. This designation provides a common description that can be referenced when programming a site and ordering signs. The following explains how the sign type designations are derived.

# EN-01.01.03C

**EN** Designates an interior sign.

**-01** Two digit numbers identifies the Life Safety & Code sign family.

**.28** The two digit number following the period identifies a specific sign type within the sign family.

**.03** The two digit number following the period identifies a specific sub-group of sign within the sign family.

**C** The letter designates a specific sign configuration and/or layout for graphics or symbols.

**Example:** EN-01.01.02B

EN - Interior sign  
01 - Life safety and code required signs  
.01 - Specific sign  
.02 - Sign sub-group  
B - Specific type size layout

# Overview

## Parking Lot Signs

### Sign Type EN-12.01

Post and panel informational signs

#### EN-12.01

Single post and panel sign

#### EN-12.02

Single post and panel sign

#### EN-12.03

Post and panel sign

#### EN-12.04

Single post and panel sign

#### EN-12.05

Single post and panel sign

#### EN-12.06

Blade sign mounted to light pole

#### EN-12.07

Panel sign mounted to wall



EN-12.01



EN-12.02



EN-12.03



EN-12.04



EN-12.05



EN-12.06

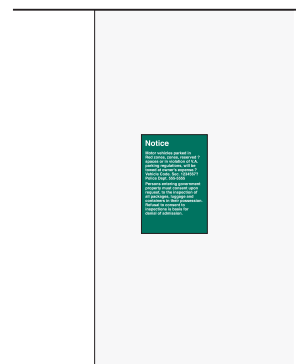

EN-12.07

# Overview

## Parking Structure Signs

### Sign Type PS-01

Non-illuminated directional sign with vinyl lettering

#### PS-01.01

15" Small ceiling hung vehicular directional sign

#### PS-01.02

15" Large ceiling hung vehicular directional sign

#### PS-01.03

22" Small ceiling hung vehicular directional sign

#### PS-01.04

22" Large ceiling hung vehicular directional sign

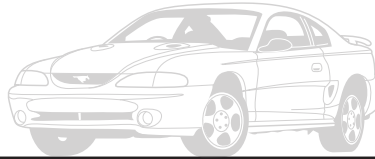

PS-01.01

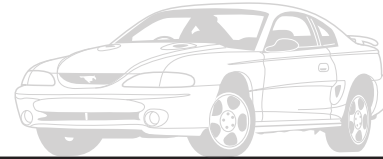

PS-01.02



PS-01.03

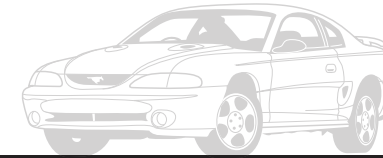

PS-01.04

### Sign Type PS-02

Non-illuminated directional sign with vinyl lettering

#### PS-02.01

15" Small beam-mounted vehicular directional sign

#### PS-02.02

15" Large beam-mounted vehicular directional sign

#### PS-02.03

22" Small beam-mounted vehicular directional sign

#### PS-02.04

22" Large beam-mounted vehicular directional sign

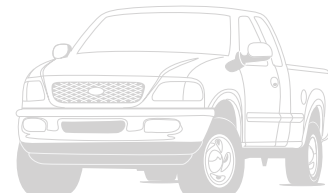

PS-02.01

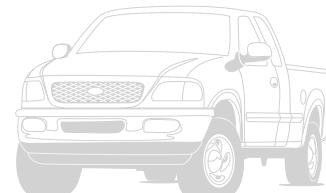

PS-02.02

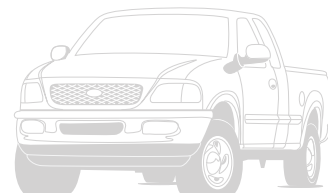

PS-02.03

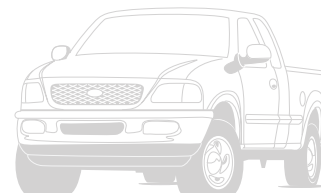

PS-02.04

# Overview

## Parking Structure Signs

### Sign Type PS-03

Wall-mounted directional

#### PS-03.01

Small pedestrian and vehicle oriented sign

#### PS-03.02

Large pedestrian and vehicle oriented sign

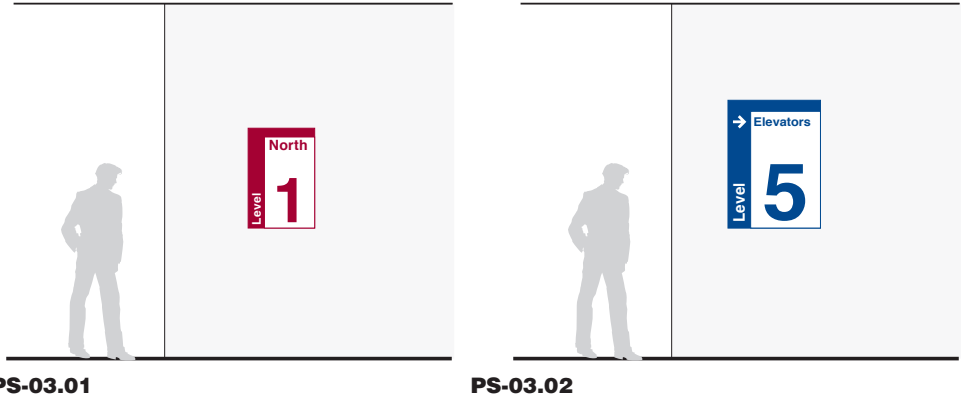

### Sign Type PS-04

Pedestrian oriented wall-mounted informational sign

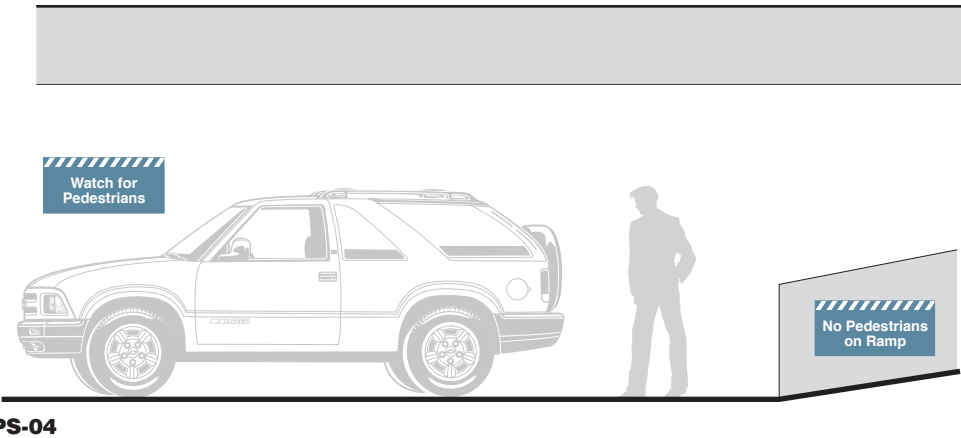

### Sign Type PS-05

Vehicular oriented column level marker

#### PS-05.01

22" Rectangular column marker

#### PS-05.02

16" Rectangular column marker

#### PS-05.03

Round column wrap-around floor level marker

#### PS-05.04

Round column painted floor identification

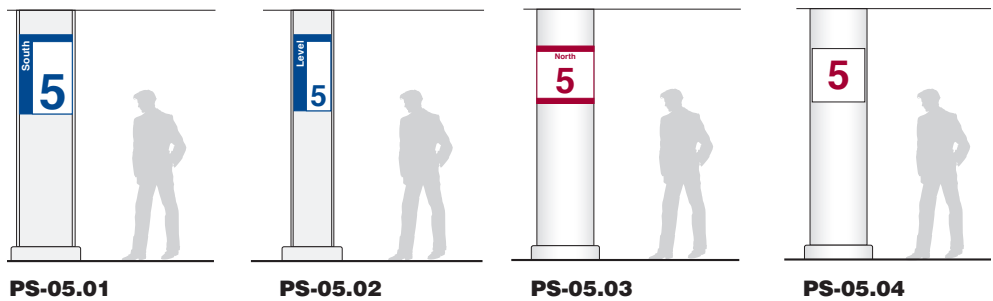

# Overview

## Parking Structure Signs

### Sign Type PS-05.5

Blade sign mounted to light pole



PS-05.5

### Sign Type PS-06

Overhead wall-mounted identification sign

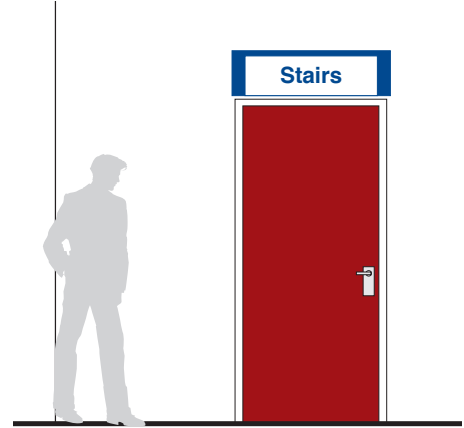

PS-06

### Sign Type PS-07

Elevator and stairwell identification vinyls

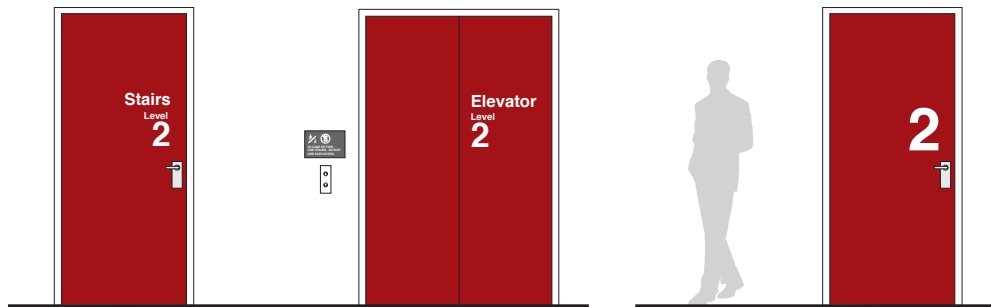

PS-07.1

PS-07.2

### Sign Type PS-08, 09 & 10

Entrance/occupancy signs

#### PS-08

10" Dimensional letters

#### PS-09

Illuminated occupancy sign

#### PS-10

Clearance height "bang bar"

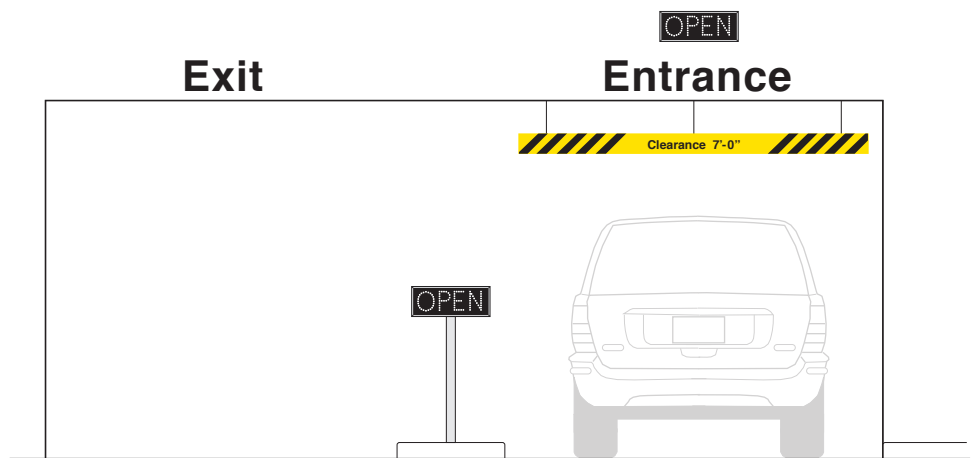

PS-08

PS-10

PS-09

# Overview

## Parking Structure Signs

### Sign Type PS-11

Entrance/Exit sign

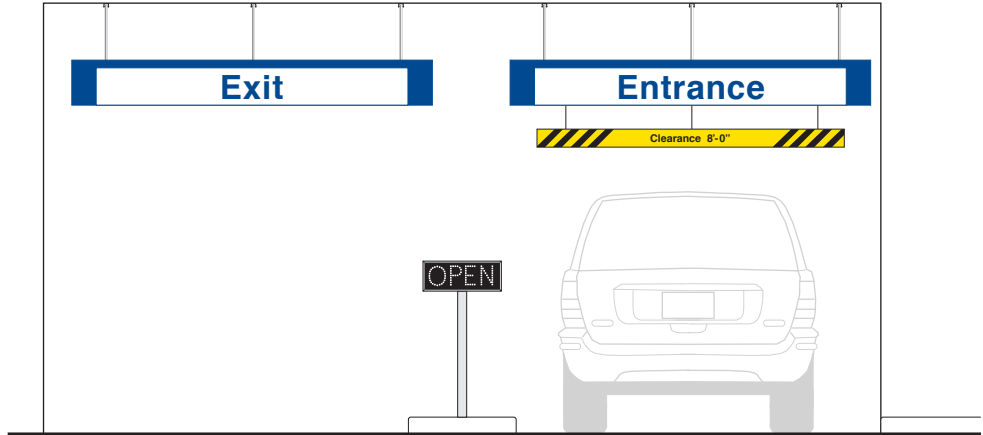

PS-11

### Parking Regulatory

See Exterior Sign Section for more detail.

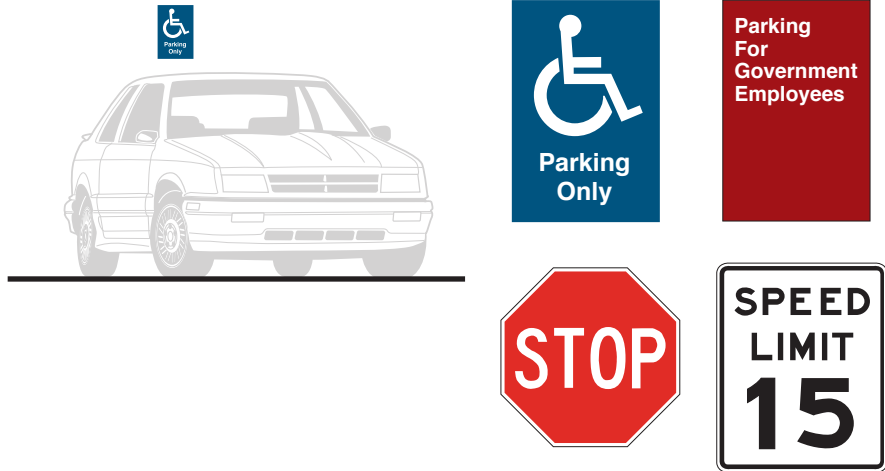

### Informational Signs

See Interior Sign Section for more detail.

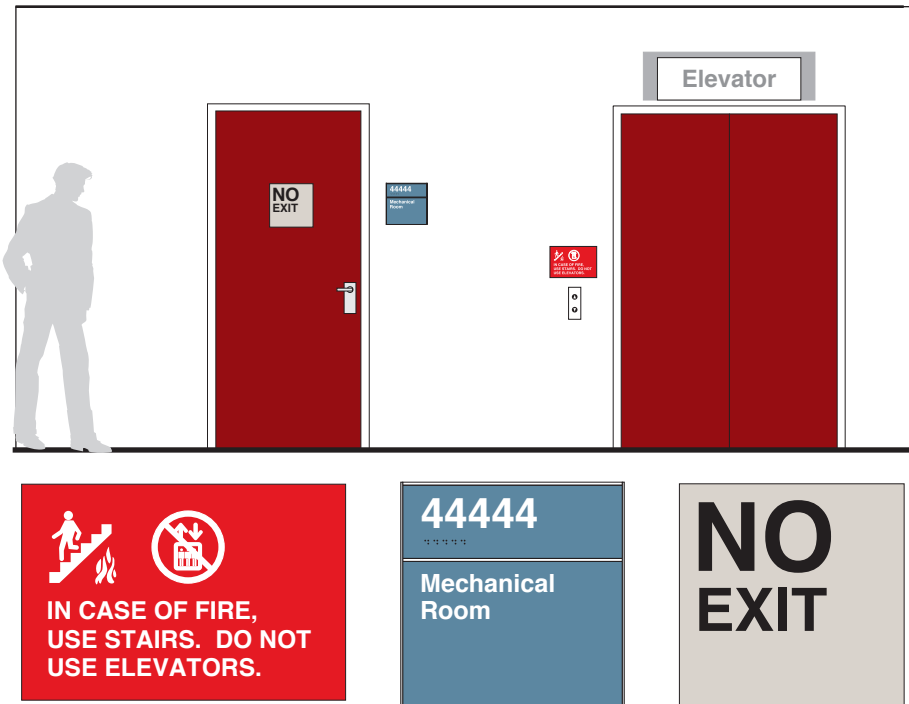

# EN-12.01

## Parking Lot Signs

Post and Panel Informational

Parking Lot

### Size

Sign Face: 914 mm H x 610 mm W  
(3' 0" H x 2' 0" W)  
Overall Sign Height: 1981 mm  
(6' 6")

### Description

Large, non-illuminated post and panel parking lot identification sign  
This sign type is for identifying parking lots to drivers circulating on a roadway system.

### Message Configuration

(Refer to message layout drawing for dimensions)

Message Layout A is for identifying visitor parking lots.

Message Layout B is for use when there is a need to identify the parking lot and label the lot with a number or letter.

### Graphic Process

Surface applied reflective vinyl.

### Colors

Text: White T2  
Background: Refer to Color Chart  
Post: Refer to Color Chart

### Recommendations

Position sign so drivers have a clear, unobstructed view of the sign.

Place signs in a highly visible location adjacent to the driveway entrance to a parking lot.



Message Layout A



Message Layout B



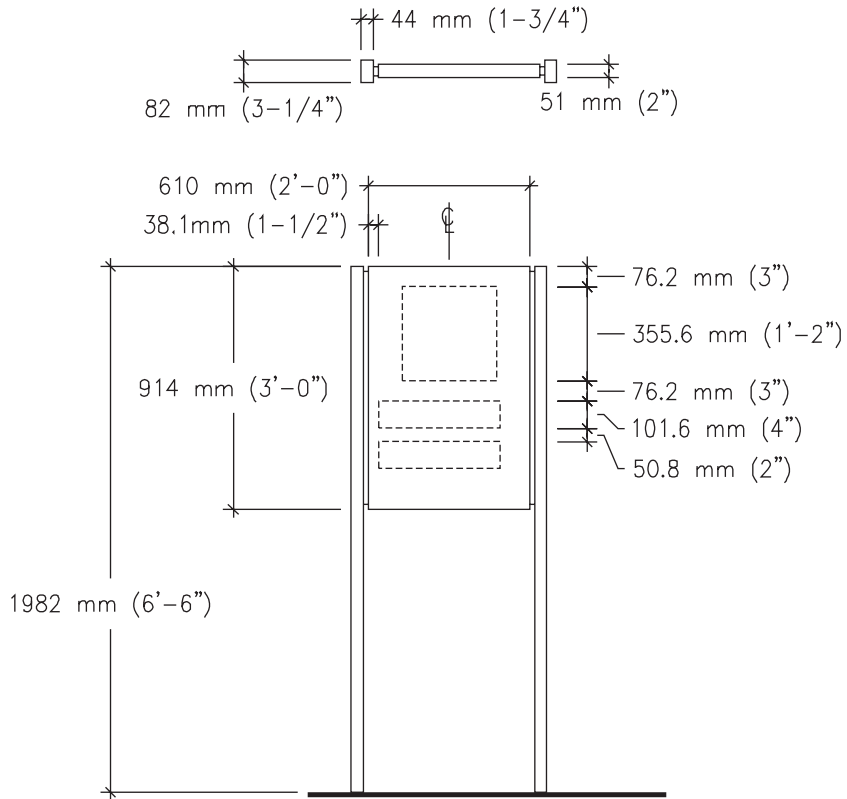

Message Layout A

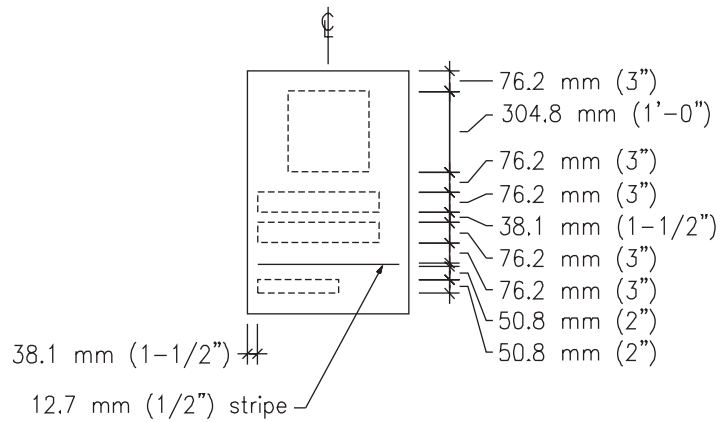

Message Layout B



#### Size

Sign Face:  
914 mm H x 610 mm W  
(3' 0" H x 2' 0" W)

Overall Sign Height:  
1830 mm (6'0")

#### Description

Non-illuminated single post and panel sign with messages directed specifically to drivers. This sign can be used to communicate various informational or instructional messages.

#### Message Configuration

(Refer to message layout drawing for dimensions)

#### Graphic Process

Surface applied reflective vinyl.

#### Colors

Text: White T2  
Background: Refer to Color Chart  
Post: Refer to Color Chart

#### Recommendations

Position sign where message needs to be conveyed.

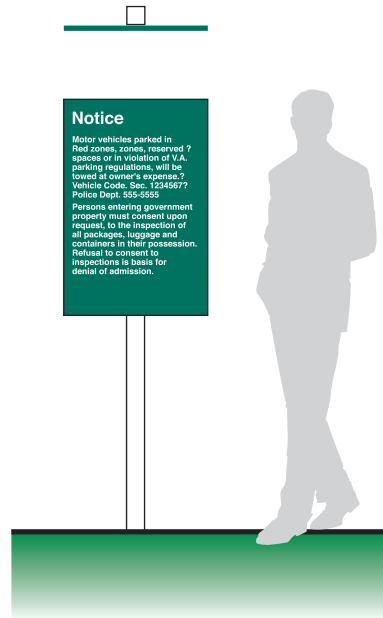

#### Message Layout A

### Notice

Lorem ipsum dolor sit amet, consectetur adipiscing elit, sed diam nonummy nibh euismod tincidunt ut laoreet dolore magna aliquam erat volutpat. Ut wisi enim ad minim veniam, quis nostrud exerci tation ullamcorper suscipit lobortis nisl ut aliquip ex ea commodo consequat. Duis autem vel eum iriure dolor in hendrerit in vulputate velit esse molestie consequat, vel illum dolore eu feugiat nulla facilisis at vero eros et accumsan et iusto odio dignissim qui blandit praesent

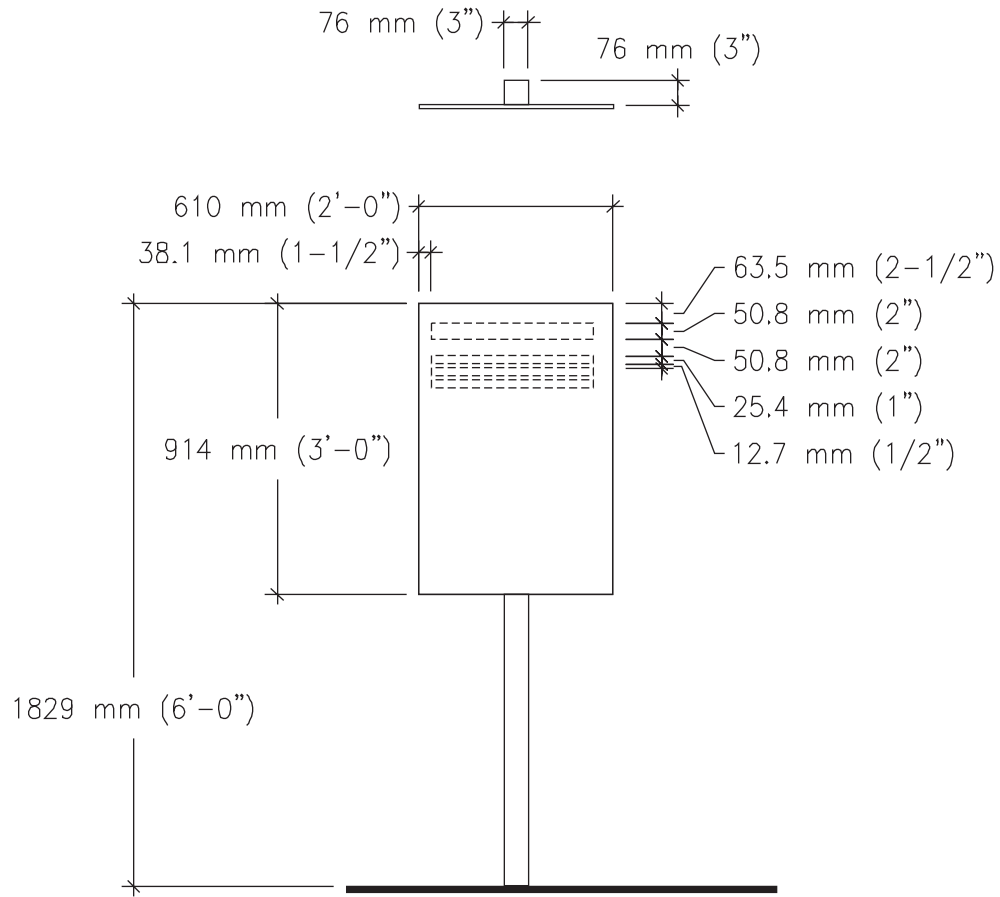

Message  
Layout A

**Size**

Sign Face: 457 mm H x 305 mm W  
 (1' 6" H x 1' 0" W)  
 Overall Sign Height: 1829 mm  
 (6' 0")

**Description**

Non-illuminated single post parking identification and informational sign. This type of sign is for use in identifying or controlling specific parking areas, spaces or stalls.

**Message Configuration**

(Refer to message layout drawing for dimensions)

This sign with symbol or title and the appropriate text shall be used as show in the adjacent examples.

**Recommendations**

Position sign so drivers have a clear, unobstructed view of the sign. Position sign far enough away from curb that automobile overhangs do not come in contact with the sign post.



**Message Layout A**



Other possible messages for this layout

- 1) Visitors Only
- 2) Buses Only
- 3) Authorized Vehicles Only
- 4) On Paved Road Only

**Message Layout B**



Other possible messages for this layout

- 1) Along Roadway
- 2) Any Time
- 3) Fire Lane
- 4) On the Grass
- 5) 00am - 00pm

**Message Layout C**



Other possible messages for this layout

- 1) Director
- 2) Chief of Staff
- 3) Volunteers
- 4) Consultant
- 5) Motorcycle Parking
- 6) Officer of the Day
- 7) Outpatient Only
- 8) Government Vehicle

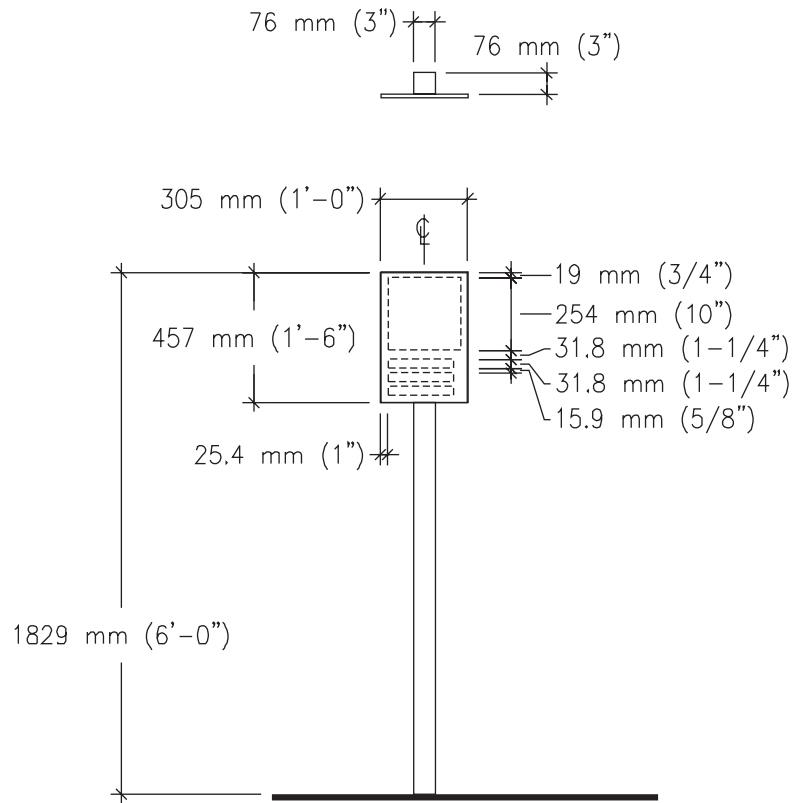

Message  
Layout A and B

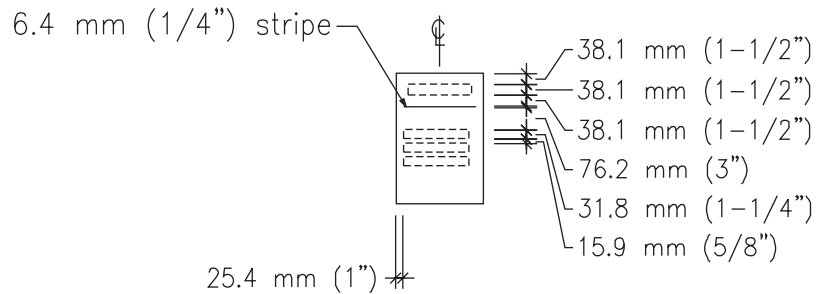

Message  
Layout C

# EN-12.04

## Parking Lot Signs

### Handicapped Parking Stall

Parking Lot

#### Size

Sign Face:  
457 mm H x 305 mm W  
(1' 6" H x 1' 0" W)

Overall Sign Height:  
1830 mm (6'0")

#### Description

Single post, non-illuminated  
handicapped parking stall sign.

#### Message Configuration

(Refer to message layout drawing  
for dimensions)  
Symbol and text must conform to  
layout as shown.

#### Graphic Process

Surface applied reflective vinyl.

#### Colors

Text: White T2  
Background: Blue B2  
Post: Refer to Color Chart

#### Recommendations

Position sign so drivers have a  
clear, unobstructed view of the  
sign.

When placing this type of sign  
near curbs or parking places, be  
sure the sign is set far enough  
back that over hanging front and  
rear of automobiles do not come in  
contact with the sign post.



Message Layout A



Message Layout B



Message Layout C



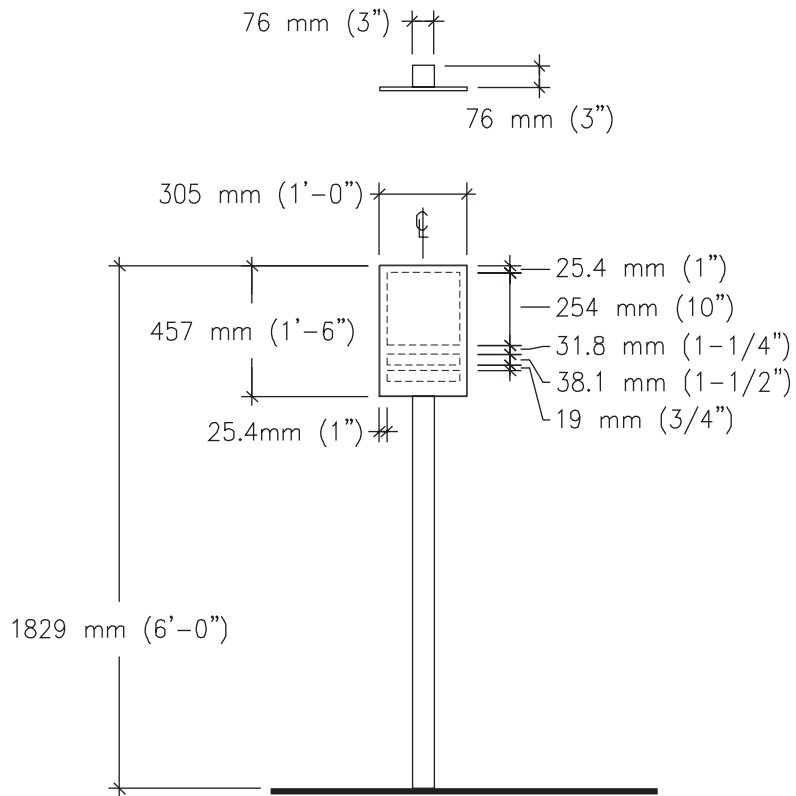

Message Layout A

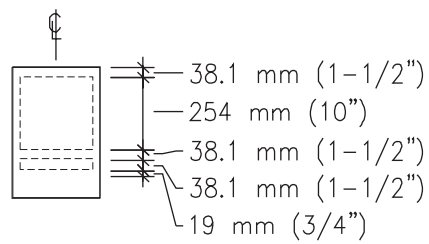

Message Layout B

# EN-12.05

## Parking Lot Signs

Handicapped Parking Area

Parking Lot

### Size

Sign Face:  
610 mm H x 610 mm W  
(2' 0" H x 2' 0" W)

Overall Sign Height:  
1830 mm (6'0")

### Description

Single post, non-illuminated handicapped parking area sign. Identification of handicapped parking areas and directional information regarding access.

### Message Configuration

(Refer to message layout drawing for dimensions)  
Symbol is to remain constant.  
Below symbol arrows, text or text and arrows can be used.

### Graphic Process

Surface applied reflective vinyl.

### Colors

Text: White T2  
Background: Blue B2  
Post: Refer to Color Chart

### Recommendations

Position sign so drivers have a clear, unobstructed view of the sign.

When placing this type of sign near curbs or parking spaces, be sure the sign is set far enough back that over hanging front and rear of automobiles do not come in contact with the sign post.



Message Layout A



Message Layout B



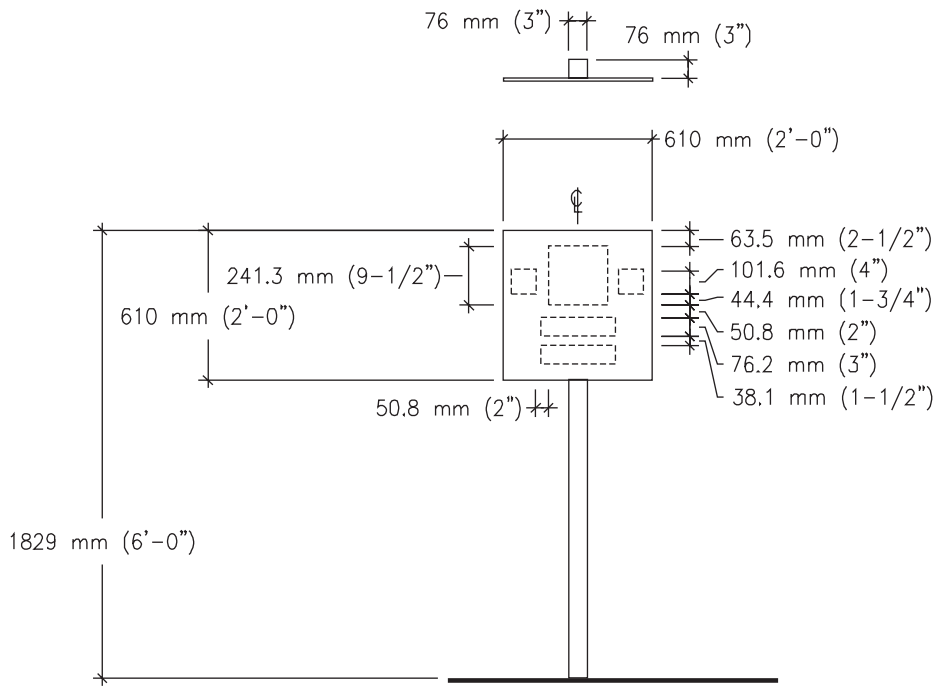

Message  
Layout A

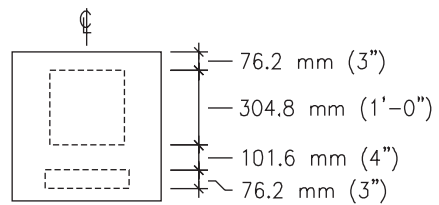

Message  
Layout B



# EN-12.06

## Parking Lot Signs

Post and Panel Informational

Parking Lot

### Size

Sign Face:  
610 mm H x 610 mm W  
(2' 0" H x 2' 0" W)

### Description

Parking lot and parking area identification sign for mounting on light pole in parking lots and parking areas where the size of the parking lot is so large that zone information is needed to assist the drivers in locating their cars. These signs should be double faced on each side of the pole and high enough so that they are clearly visible throughout the parking lot.

### Message Configuration

(Refer to message layout drawing for dimensions.) Message layouts show various applications that might be applicable.

### Graphic Process

Surface applied reflective vinyl.

### Colors

Text: White T2  
Background: Refer to Color Chart  
Post: Refer to Color Chart

### Recommendations

Position sign so drivers have a clear, unobstructed view of the sign. Install the signs in the position that is clearly visible to drivers and pedestrians up and down the path of travel along traffic lanes in the parking lot.

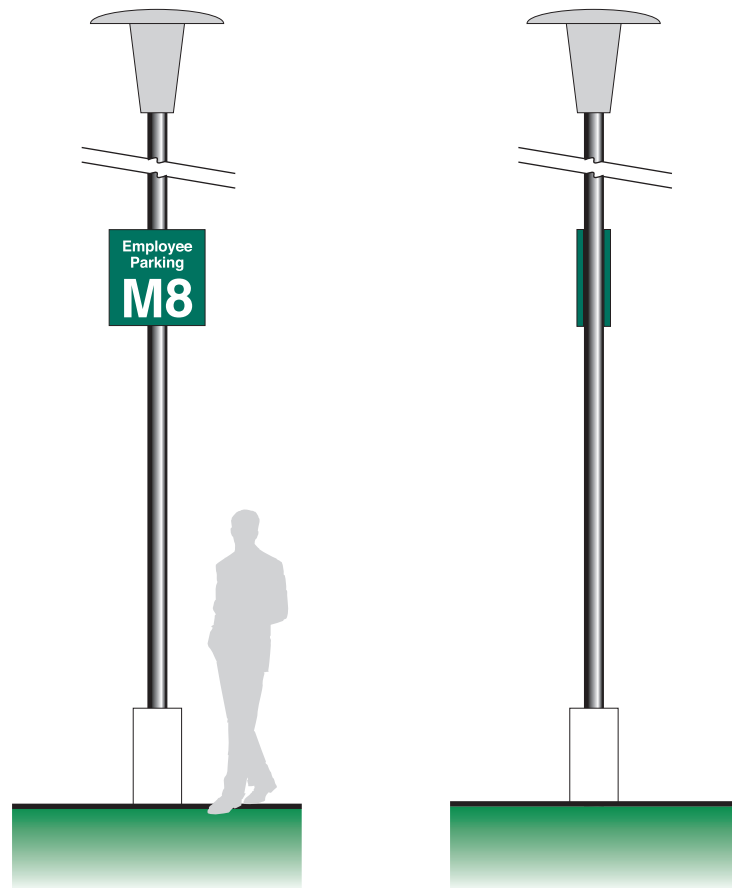

Message Layout A



Message Layout B



Message Layout C



Message Layout D

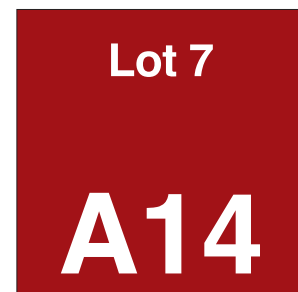

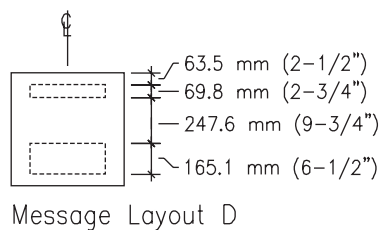
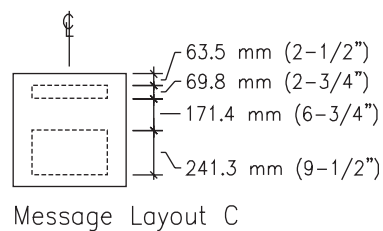
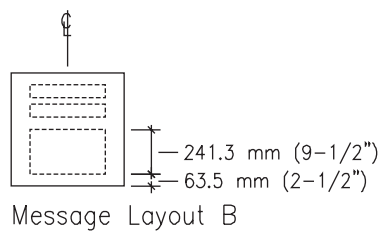
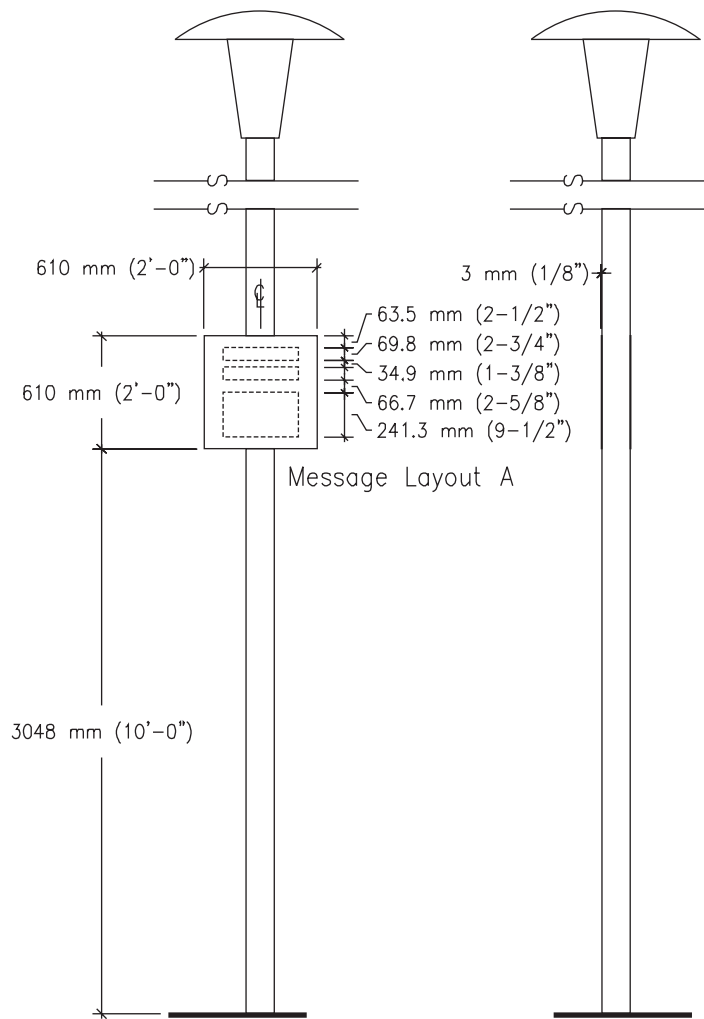

**Size**

Sign Face:  
914 mm H x 610 mm W  
(3' 0" H x 2' 0" W)

**Description**

Non-illuminated panel sign with messages directed specifically to drivers and pedestrian. This sign can be used to communicate various informational or instructional messages.

**Message Configuration**

(Refer to message layout drawing for dimensions)

**Graphic Process**

Surface applied reflective vinyl.

**Colors**

Text: White T2  
Background: Refer to Color Chart  
Post: Refer to Color Chart

**Recommendations**

Position sign where message needs to be conveyed.

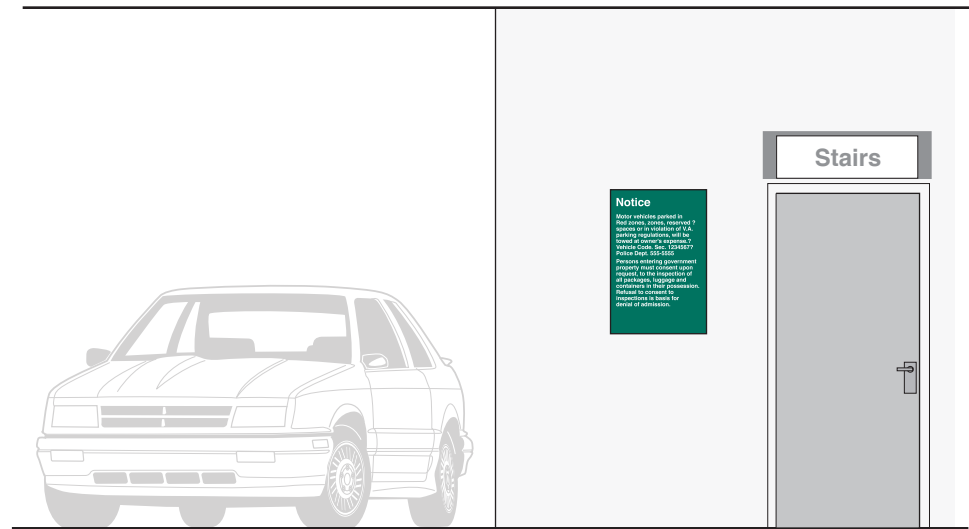

**Message Layout A**

**Notice**

Lorem ipsum dolor sit amet, consectetur adipiscing elit, sed diam nonummy nibh euismod tincidunt ut laoreet dolore magna aliquam erat volutpat. Ut wisi enim ad minim veniam, quis nostrud exerci tation ullamcorper suscipit lobortis nisl ut aliquip ex ea commodo consequat. Duis autem vel eum iriure dolor in hendrerit in vulputate velit esse molestie consequat, vel illum dolore eu feugiat nulla facilisis at vero eros et accumsan et iusto odio dignissim qui blandit praesent

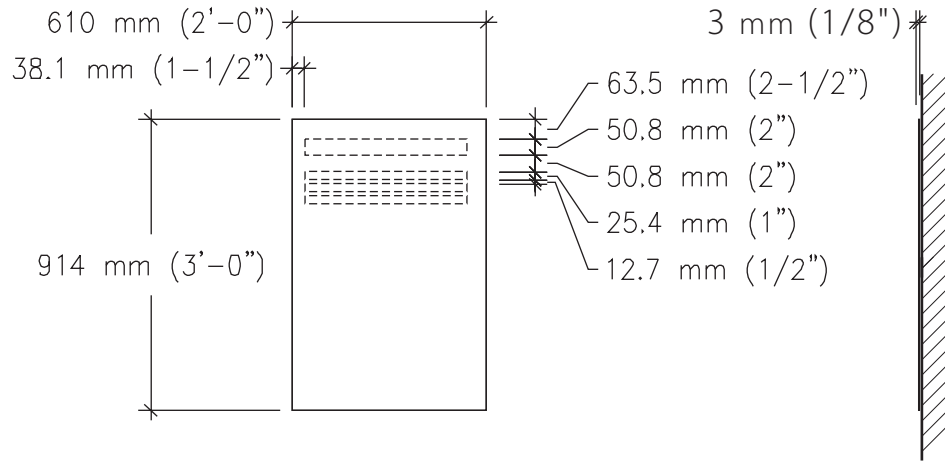

Message Layout A

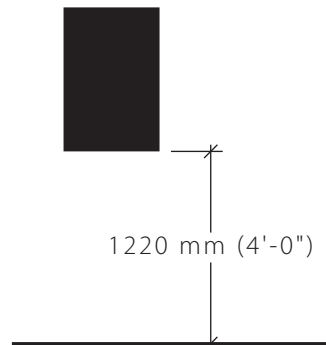

# PS-01.01

## Parking Structure Signs

Large Ceiling Hung Directional

Parking Structure

### Size

Sign Face:  
559 mm H x 3050 mm W  
(1' 10" H x 10' 0" W)

### Description

Non-illuminated, ceiling hung sign. This sign type is directed specifically to drivers providing them information such as the exit, additional parking and the elevators or stairs.

### Message Configuration

(Refer to message layout drawing for dimensions)

Message Layout A allows for 2 message lines at a larger type size.

Message Layout B allows for up to 4 message lines at a smaller type size.

### Graphic Process

Surface applied vinyl.

### Colors

Text: Various, Refer to Color Chart  
Background: Various, Refer to Color Chart

### Recommendations

Position sign so it's visibility is not obstructed by building support beams. Align sign with flow of traffic.

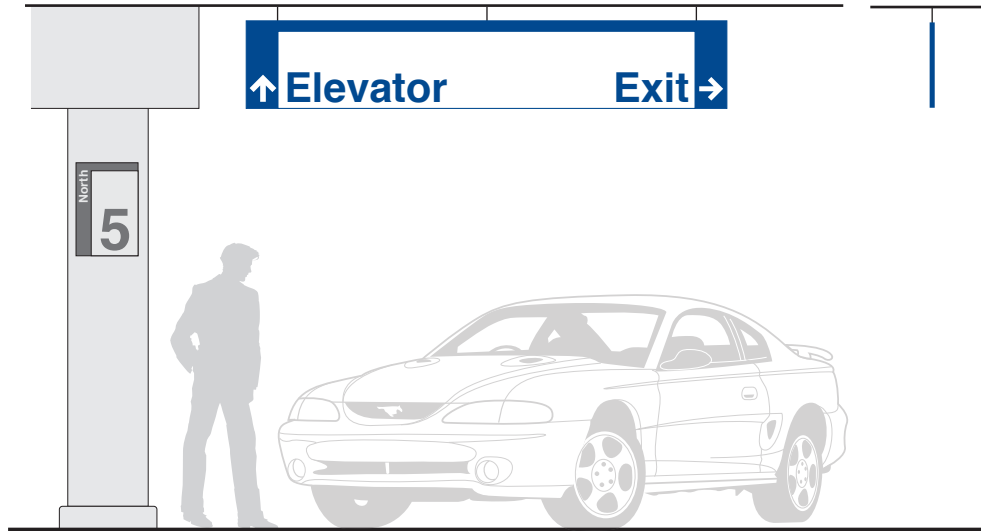

### Message Layout A



### Message Layout B



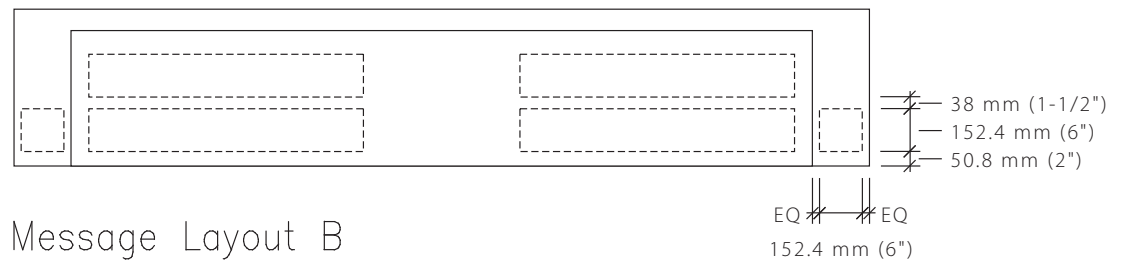
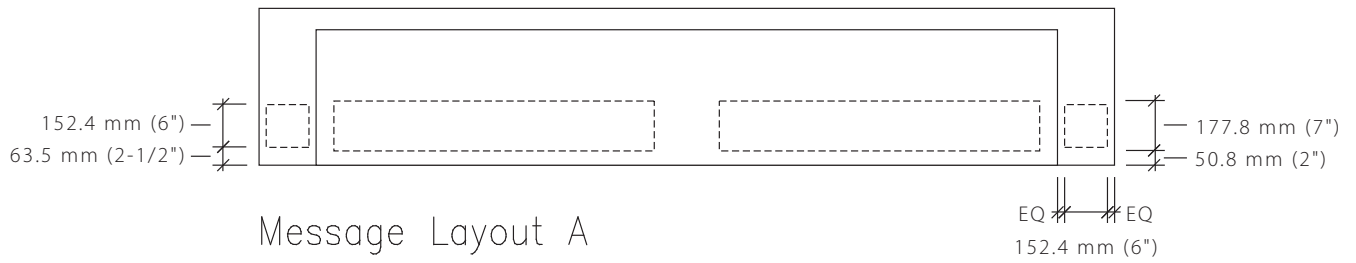
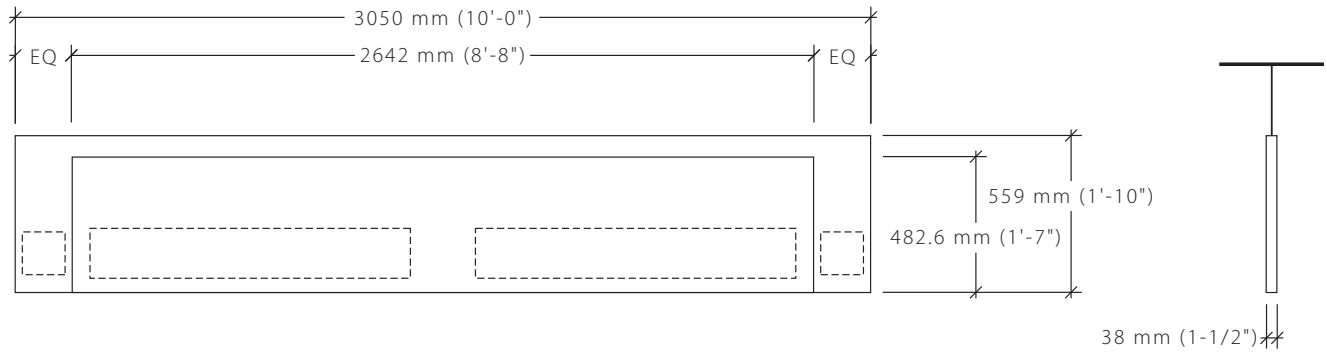

# PS-01.02

## Parking Structure Signs

Small Ceiling Hung Directional

Parking Structure

### Size

Sign Face:  
559 mm H x 1830 mm W  
(1' 10" H x 6' 0" W)

### Description

Non-illuminated, ceiling hung sign. This sign type is directed specifically to drivers providing them information such as the exit, additional parking and the elevators or stairs.

### Message Configuration

(Refer to message layout drawing for dimensions)

Message Layout A allows for 1 message lines at a larger type size.

Message Layout B allows for up to 2 message lines at a smaller type size.

### Graphic Process

Surface applied vinyl.

### Colors

Text: Various, Refer to Color Chart  
Background: Various, Refer to Color Chart

### Recommendations

Position sign so it's visibility is not obstructed by building support beams. Align sign with flow of traffic.

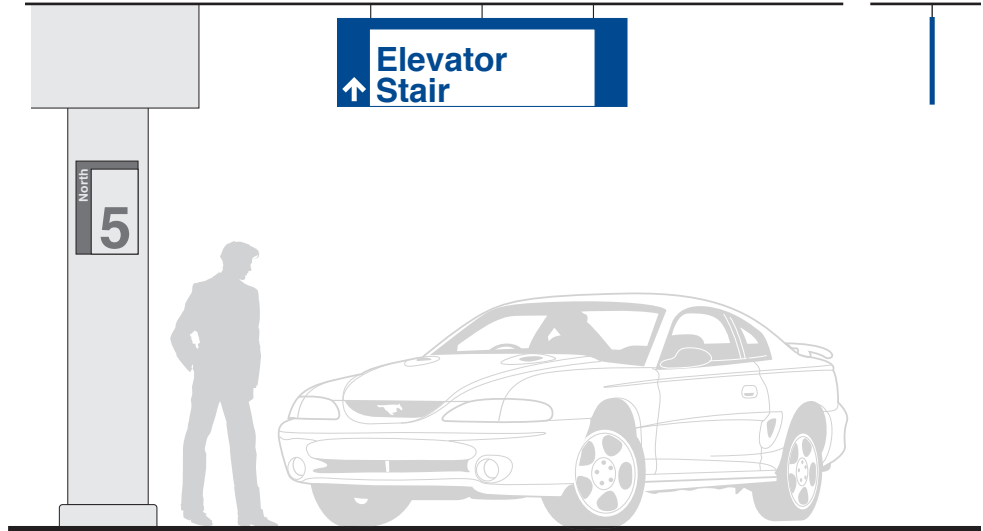

### Message Layout A



### Message Layout B



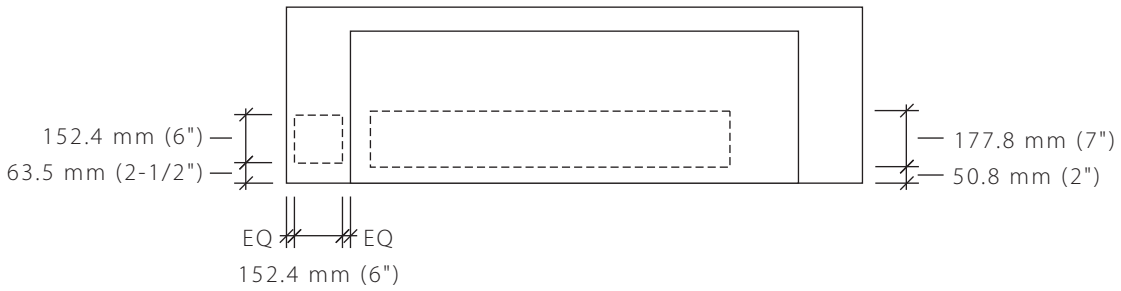
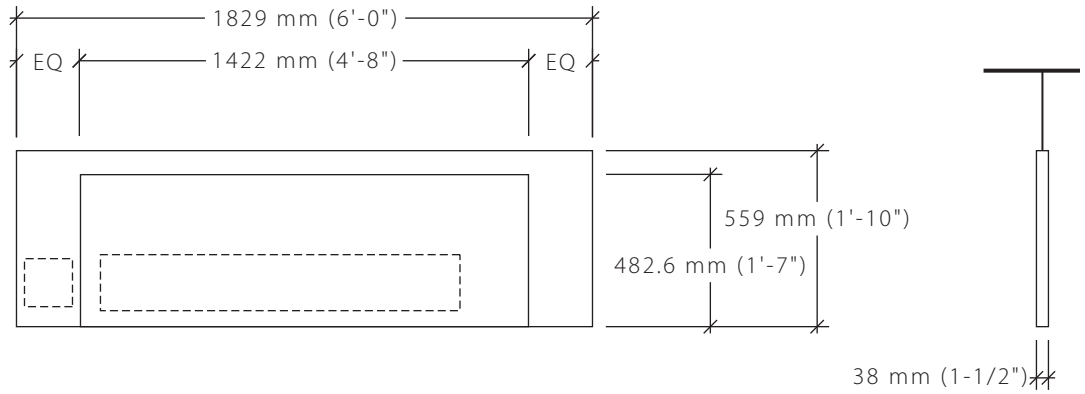

Message Layout A

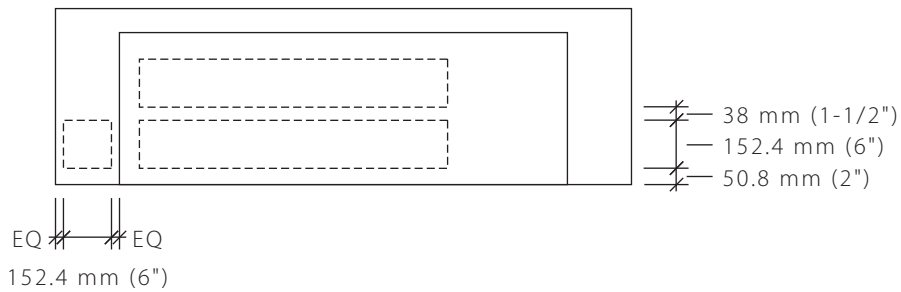

Message Layout B



# PS-01.03

## Parking Structure Signs

Large Ceiling Hung Directional

Parking Structure

### Size

Sign Face:  
381 mm H x 3050 mm W  
(1' 3" H x 10' 0" W)

### Description

Non-illuminated, ceiling hung sign. This sign type is directed specifically to drivers providing them information such as the exit, additional parking and the elevators or stairs.

### Message Configuration

(Refer to message layout drawing for dimensions)

Message Layout A allows for 2 message lines at a larger type size.

Message Layout B allows for up to 4 message lines at a smaller type size.

### Graphic Process

Surface applied vinyl.

### Colors

Text: Various, Refer to Color Chart  
Background: Various, Refer to Color Chart

### Recommendations

Position sign so it's visibility is not obstructed by building support beams. Align sign with flow of traffic.

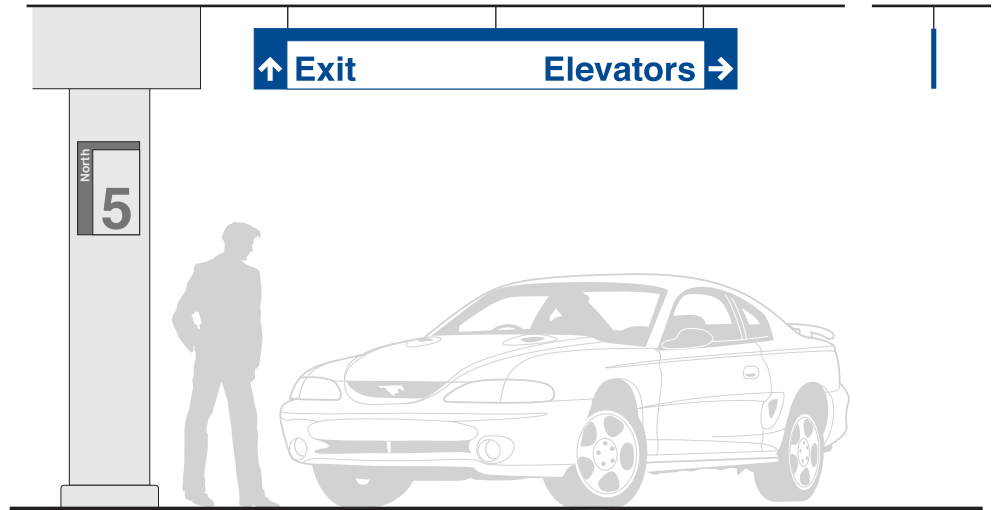

### Message Layout A



### Message Layout B



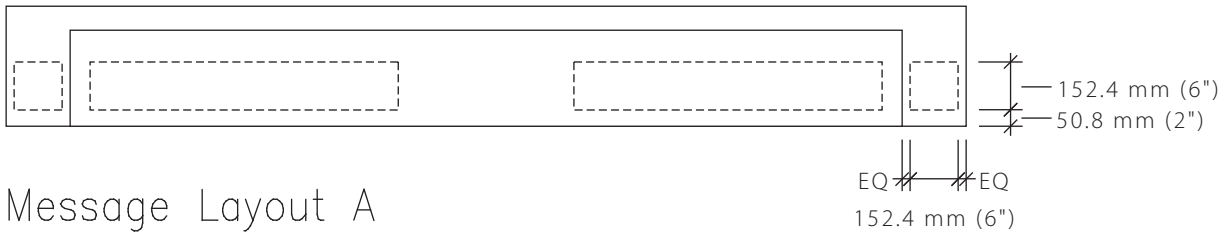
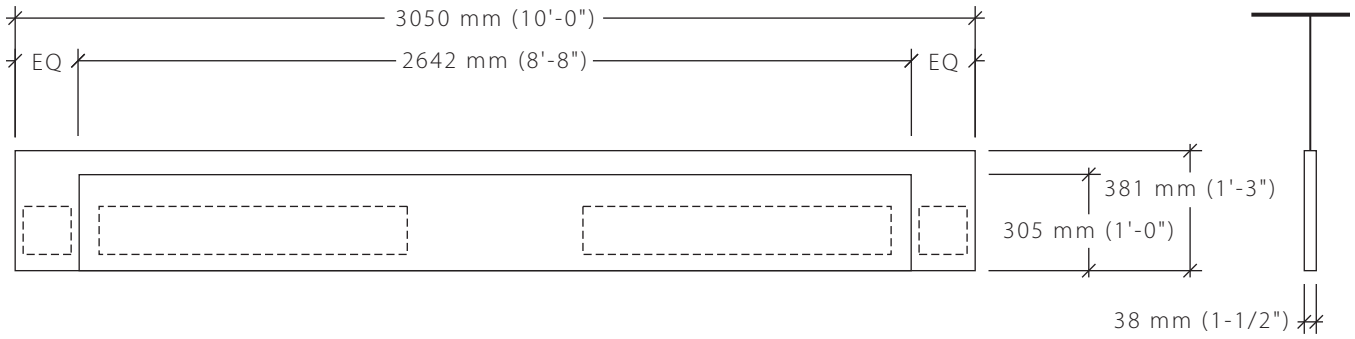

Message Layout A

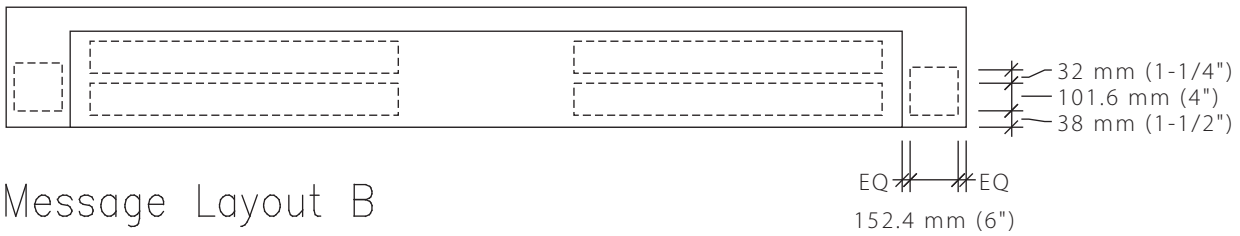

Message Layout B

# PS-01.04

## Parking Structure Signs

Small Ceiling Hung Directional

Parking Structure

### Size

Sign Face:  
381 mm H x 1830 mm W  
(1' 3" H x 6' 0" W)

### Description

Non-illuminated, ceiling hung sign. This sign type is directed specifically to drivers providing them information such as the exit, additional parking and the elevators or stairs.

### Message Configuration

(Refer to message layout drawing for dimensions)

Message Layout A allows for 1 message lines at a larger type size.

Message Layout B allows for up to 2 message lines at a smaller type size.

### Graphic Process

Surface applied vinyl.

### Colors

Text: Various, Refer to Color Chart  
Background: Various, Refer to Color Chart

### Recommendations

Position sign so it's visibility is not obstructed by building support beams. Align sign with flow of traffic.

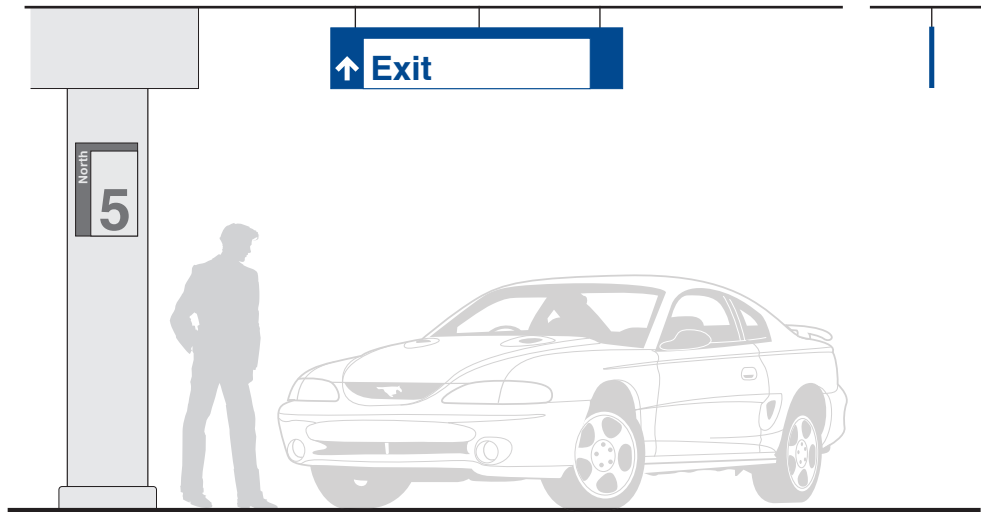

### Message Layout A



### Message Layout B



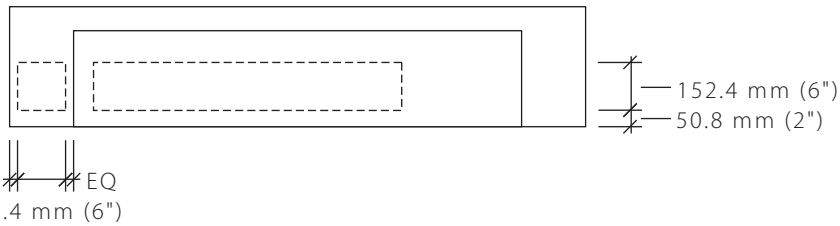
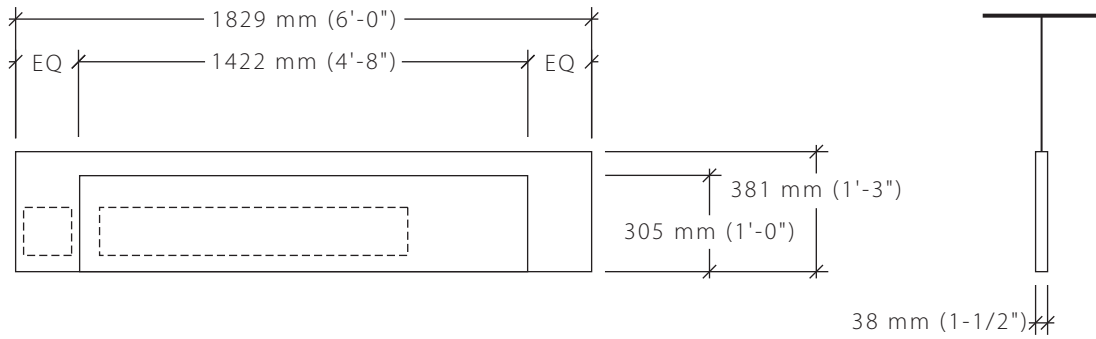

Message Layout A

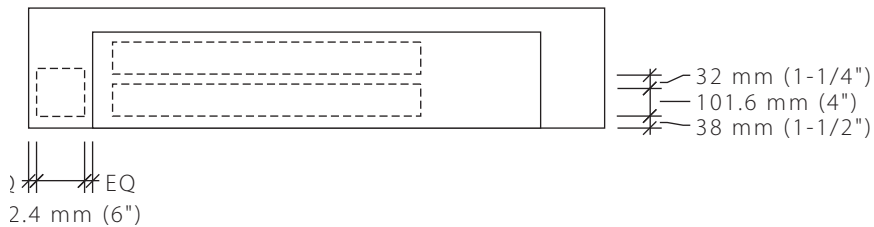

Message Layout B

# PS-02.01

## Parking Structure Signs

Large Beam Mounted Directional

Parking Structure

### Size

Sign Face:  
559 mm H x 3050 mm W  
(1' 10" H x 10' 0" W)

### Description

Non-illuminated, ceiling hung sign. This sign type is directed specifically to drivers providing them information such as the exit, additional parking and the elevators or stairs.

### Message Configuration

(Refer to message layout drawing for dimensions)

Message Layout A allows for 2 message lines at a larger type size.

Message Layout B allows for up to 4 message lines at a smaller type size.

### Graphic Process

Surface applied vinyl.

### Colors

Text: Various, Refer to Color Chart  
Background: Various, Refer to Color Chart

### Recommendations

Position sign on bottom edge of beam/soffit and align sign with flow of traffic.

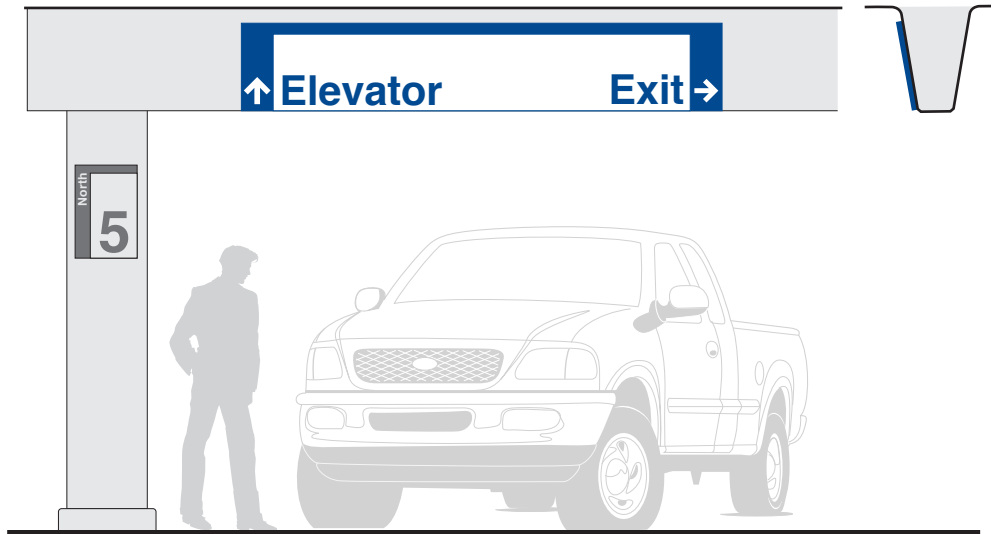

### Message Layout A



### Message Layout B

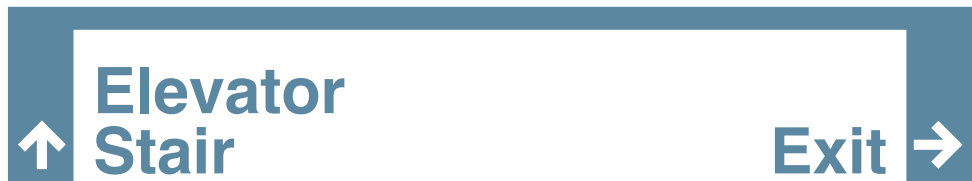

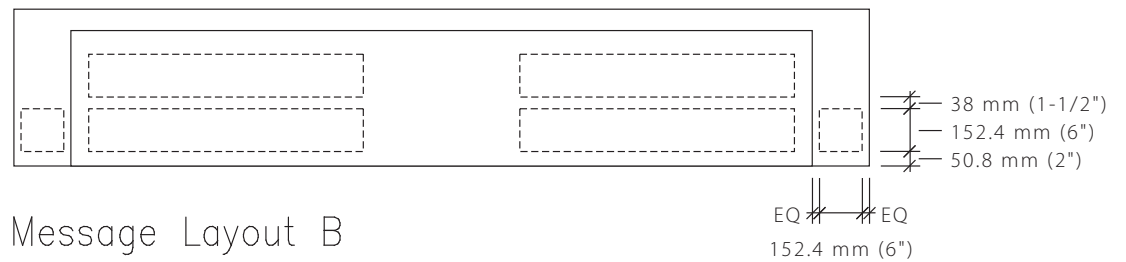
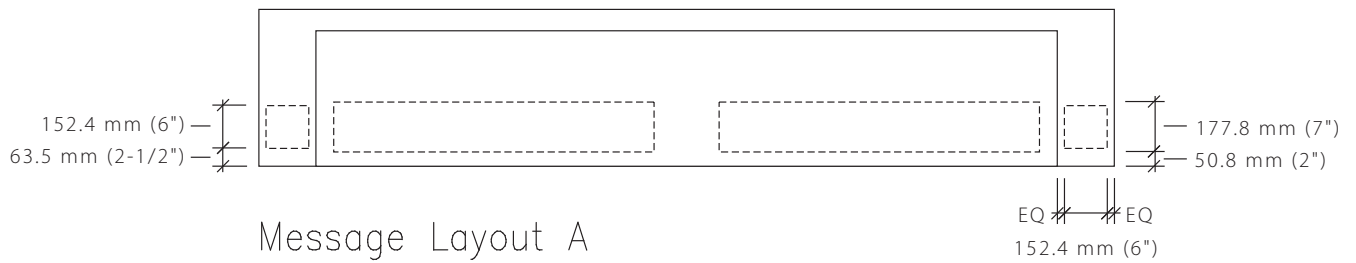
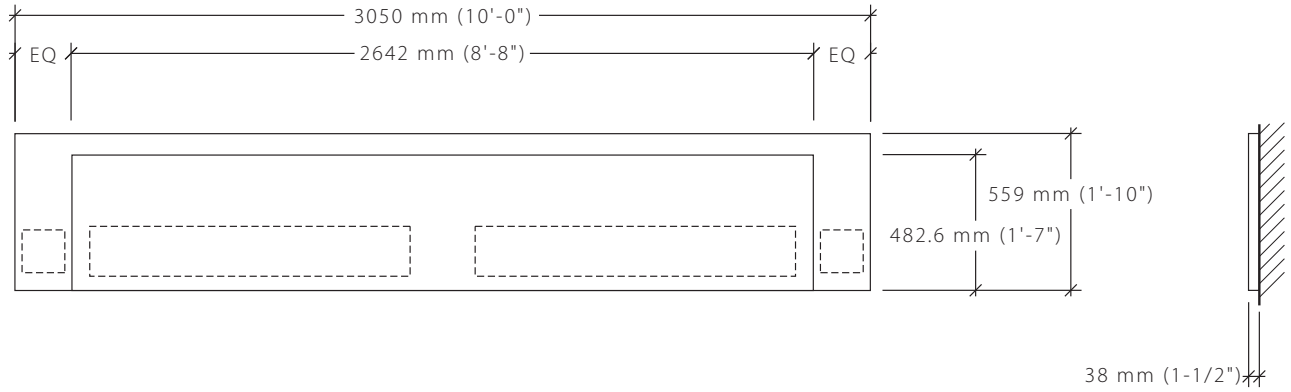

# PS-02.02

## Parking Structure Signs

Small Beam Mounted Directional

Parking Structure

### Size

Sign Face:  
559 mm H x 1830 mm W  
(1' 10" H x 6' 0" W)

### Description

Non-illuminated, ceiling hung sign. This sign type is directed specifically to drivers providing them information such as the exit, additional parking and the elevators or stairs.

### Message Configuration

(Refer to message layout drawing for dimensions)

Message Layout A allows for 1 message lines at a larger type size.

Message Layout B allows for up to 2 message lines at a smaller type size.

### Graphic Process

Surface applied vinyl.

### Colors

Text: Various, Refer to Color Chart  
Background: Various, Refer to Color Chart

### Recommendations

Position sign on bottom edge of beam/soffit and align sign with flow of traffic.

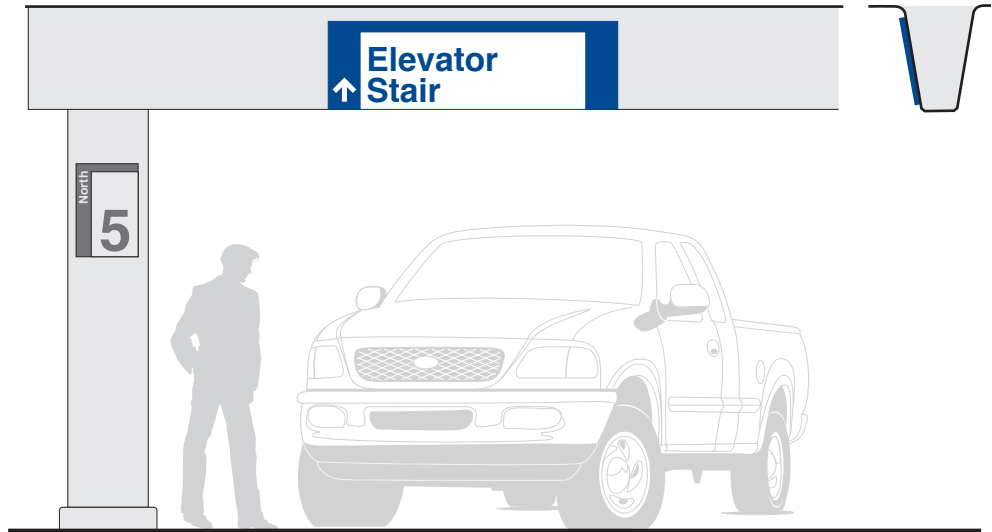

### Message Layout A



### Message Layout B



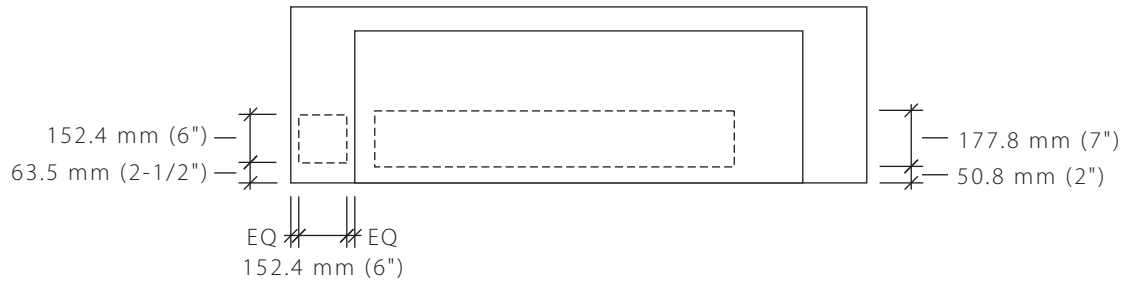
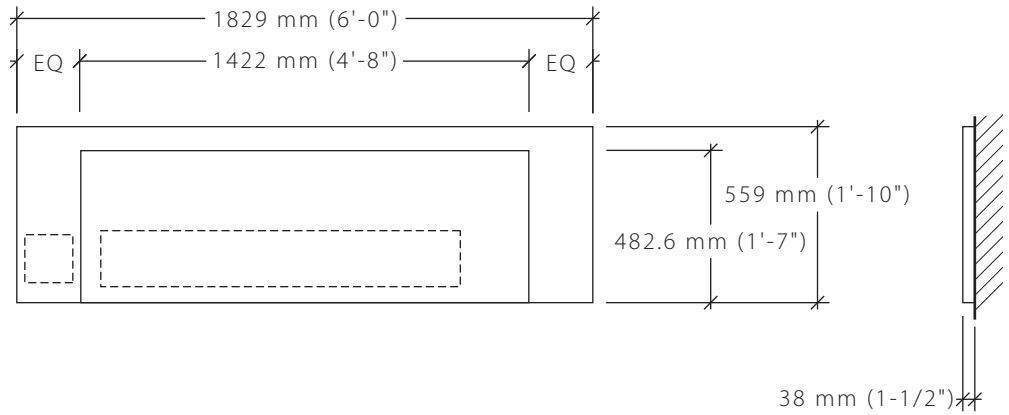

Message Layout A

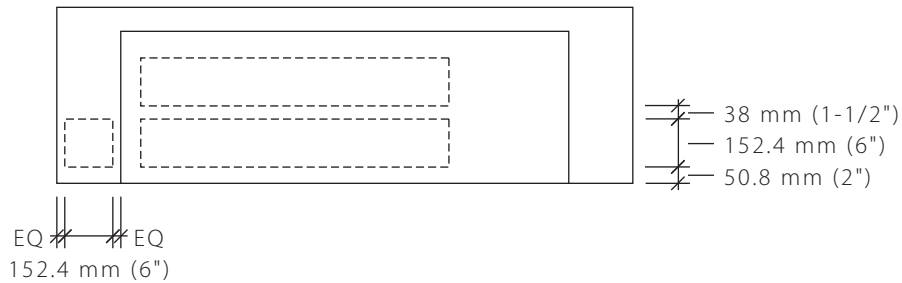

Message Layout B



# PS-02.03

## Parking Structure Signs

Large Beam Mounted Directional

Parking Structure

### Size

Sign Face:  
381 mm H x 3050 mm W  
(1' 3" H x 10' 0" W)

### Description

Non-illuminated, ceiling hung sign. This sign type is directed specifically to drivers providing them information such as the exit, additional parking and the elevators or stairs.

### Message Configuration

(Refer to message layout drawing for dimensions)

Message Layout A allows for 2 message lines at a larger type size.

Message Layout B allows for up to 4 message lines at a smaller type size.

### Graphic Process

Surface applied vinyl.

### Colors

Text: Various, Refer to Color Chart  
Background: Various, Refer to Color Chart

### Recommendations

Position sign on bottom edge of beam/soffit and align sign with flow of traffic.

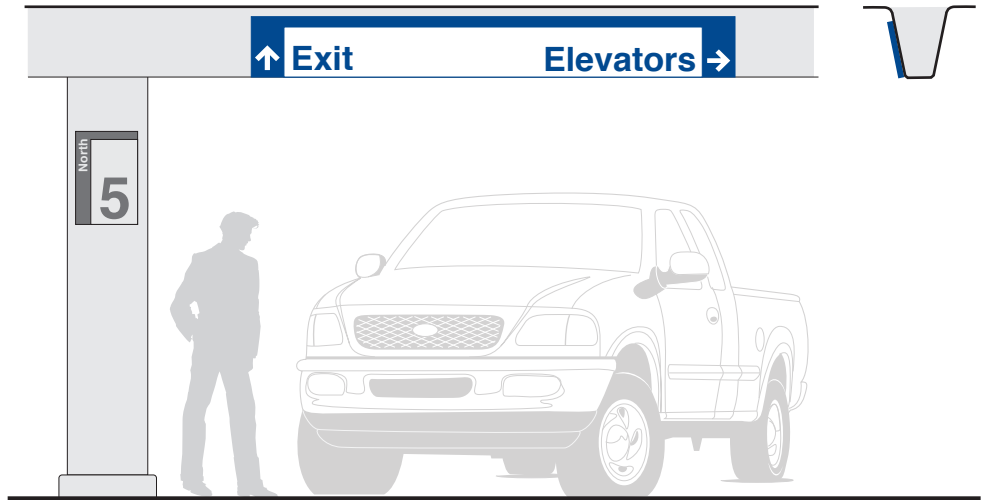

### Message Layout A



### Message Layout B



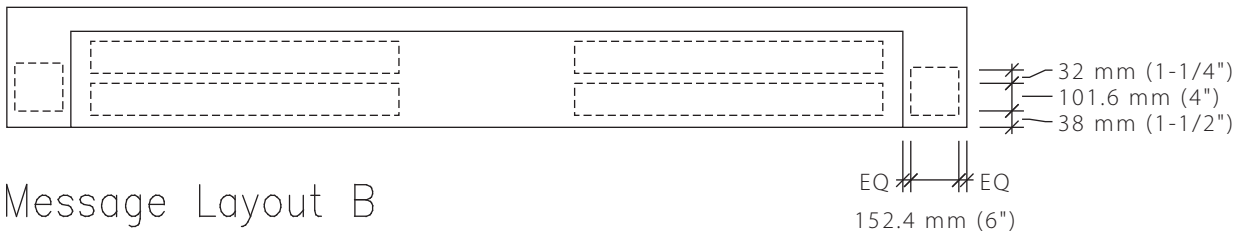
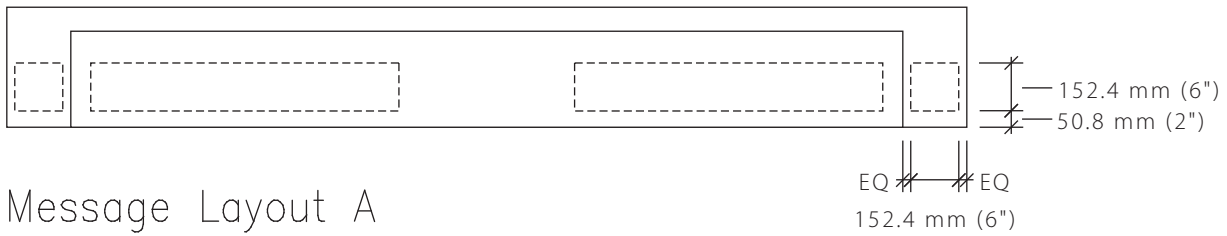
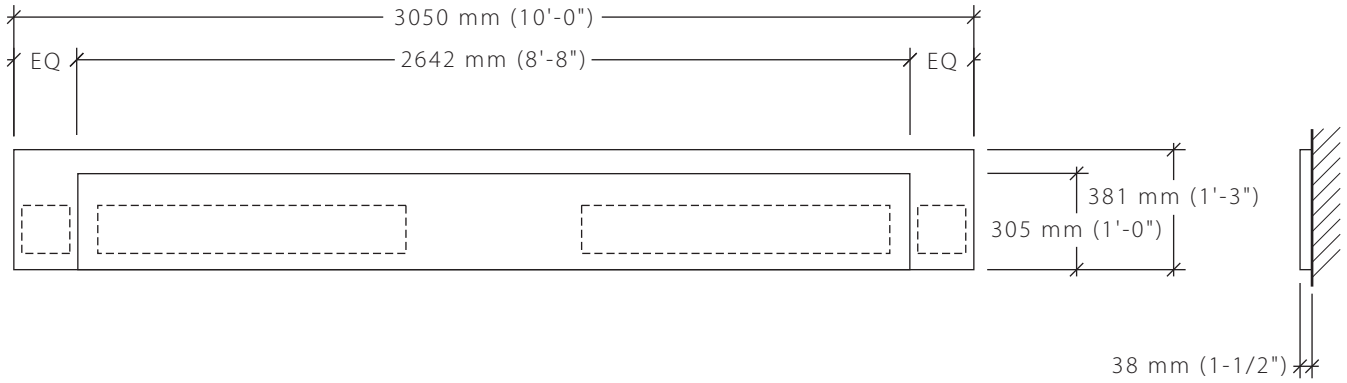

# PS-02.04

## Parking Structure Signs

Small Beam Mounted Directional

Parking Structure

### Size

Sign Face:  
381 mm H x 1830 mm W  
(1' 3" H x 6' 0" W)

### Description

Non-illuminated, ceiling hung sign. This sign type is directed specifically to drivers providing them information such as the exit, additional parking and the elevators or stairs.

### Message Configuration

(Refer to message layout drawing for dimensions)

Message Layout A allows for 1 message lines at a larger type size.

Message Layout B allows for up to 2 message lines at a smaller type size.

### Graphic Process

Surface applied vinyl.

### Colors

Text: Various, Refer to Color Chart  
Background: Various, Refer to Color Chart

### Recommendations

Position sign on bottom edge of beam/soffit and align sign with flow of traffic.

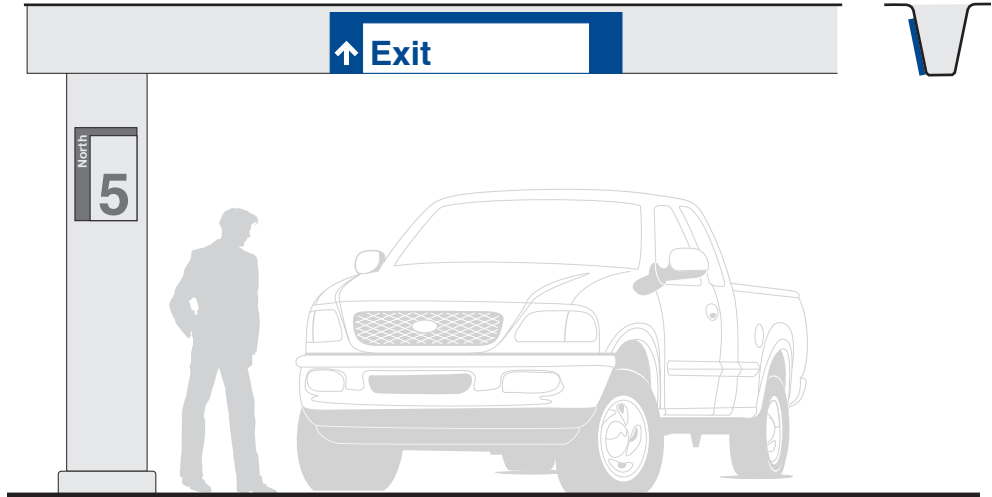

### Message Layout A



### Message Layout B



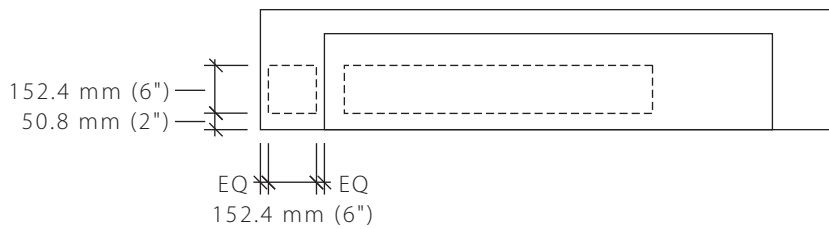
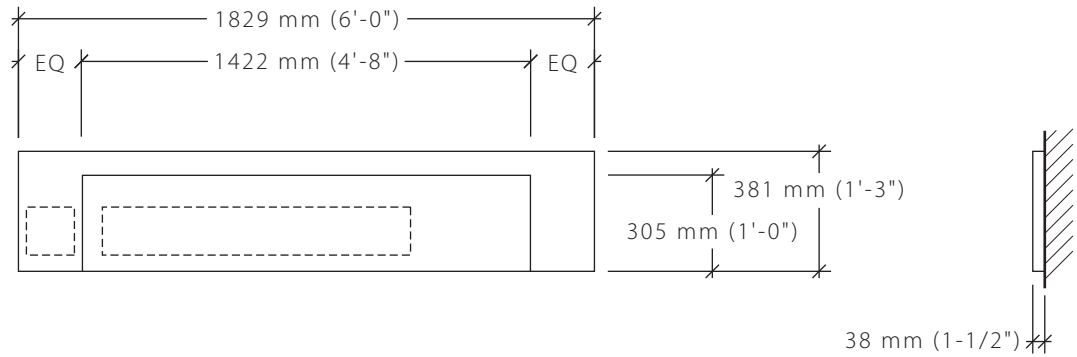

Message Layout A

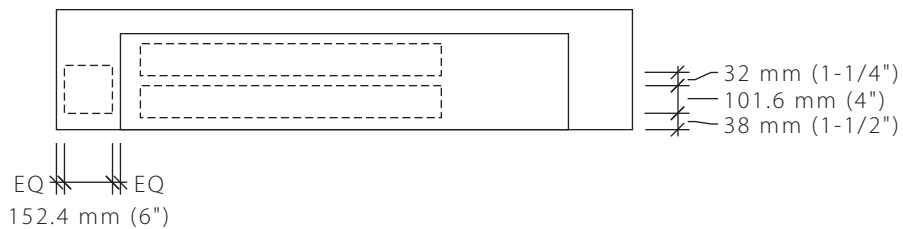

Message Layout B

# PS-03.01

## Parking Structure Signs

Small Wall Mounted Directional

Parking Structure

### Size

Sign Face:  
915 mm H x 610 mm W  
(3' 0" H x 2' 0" W)

### Description & Use

Floor identification and directional information specifically targeted to pedestrians. Floor identification signs to be placed next to or near elevators, and exits.

### Message Configuration

(Refer to message layout drawing for dimensions)

Message layout A is used for directional as well as floor level information

Message layout B is used for floor level identification

Message layout C is used to provide directional information

### Graphic Process

Surface applied vinyl.

### Colors

Text: Various, Refer to Color Chart  
Background: Various, Refer to Color Chart

### Recommendations

Position sign so pedestrians have a clear, unobstructed view of the sign.

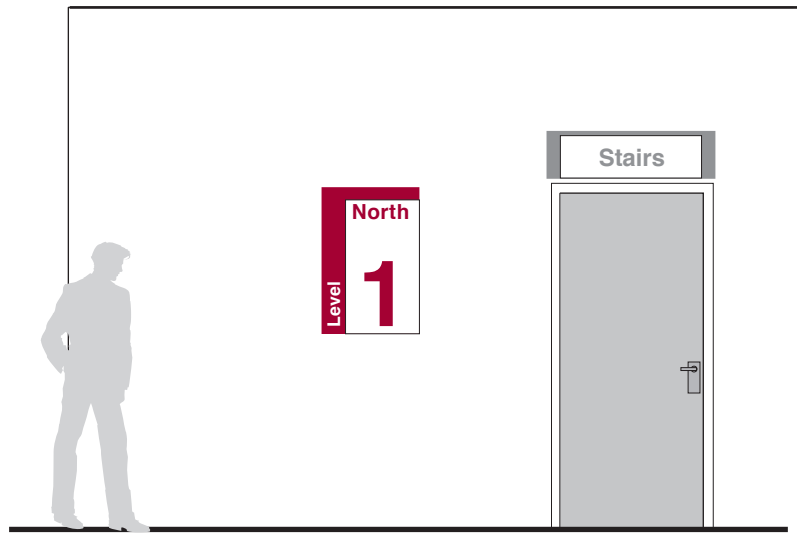

Message Layout A



Message Layout B



Message Layout C



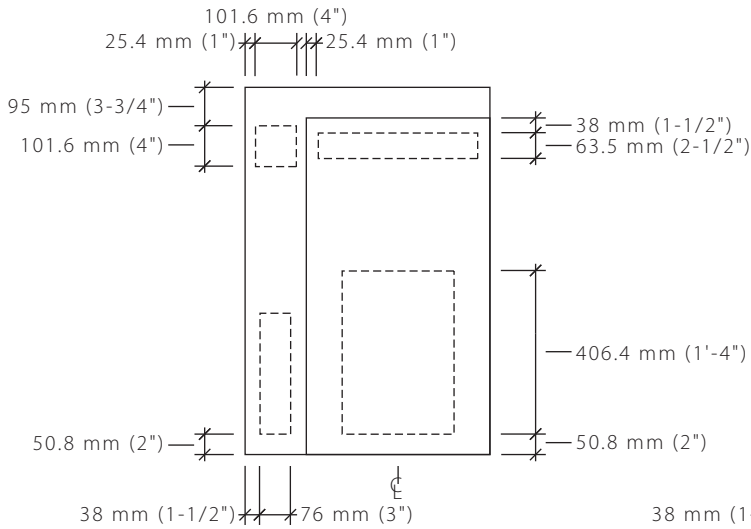
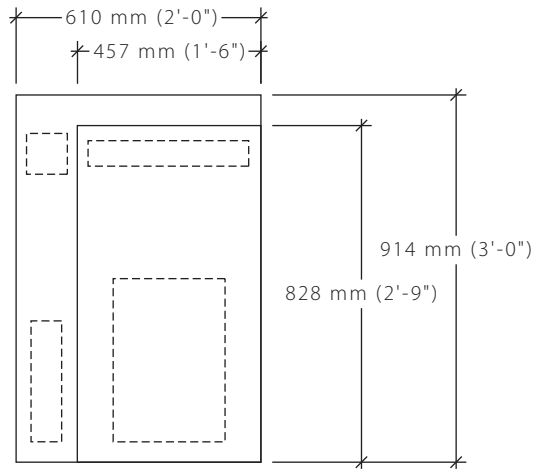

Message Layout A

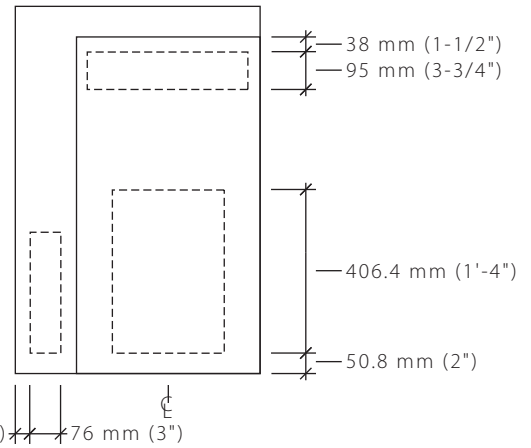

Message Layout B

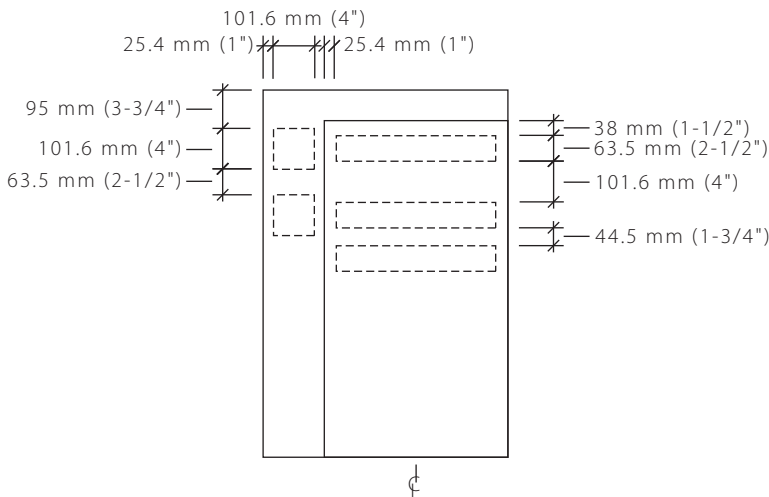

Message Layout C

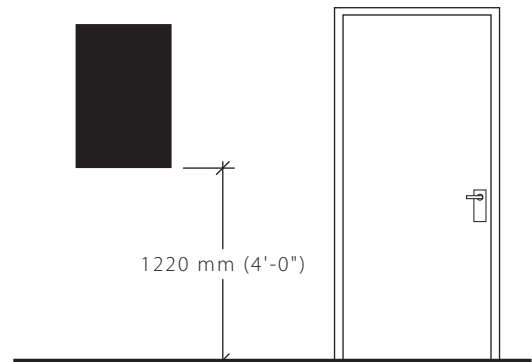

# PS-03.02

## Parking Structure Signs

Large Wall Mounted Directional

Parking Structure

### Size

Sign Face:  
1677 mm H x 1220 mm W  
(5' 6" H x 4' 0" W)

### Description & Use

Floor identification and directional information specifically targeted to vehicular traffic. Floor identification signs to be placed next to or near elevators, and exits.

### Message Configuration

(Refer to message layout drawing for dimensions)

Message layout A is used for directional as well as floor level information

Message layout B is used for floor level identification

Message layout C is used to provide directional information

### Graphic Process

Surface applied vinyl.

### Colors

Text: Various, Refer to Color Chart  
Background: Various, Refer to Color Chart

### Recommendations

Position sign so drivers have a clear, unobstructed view of the sign.

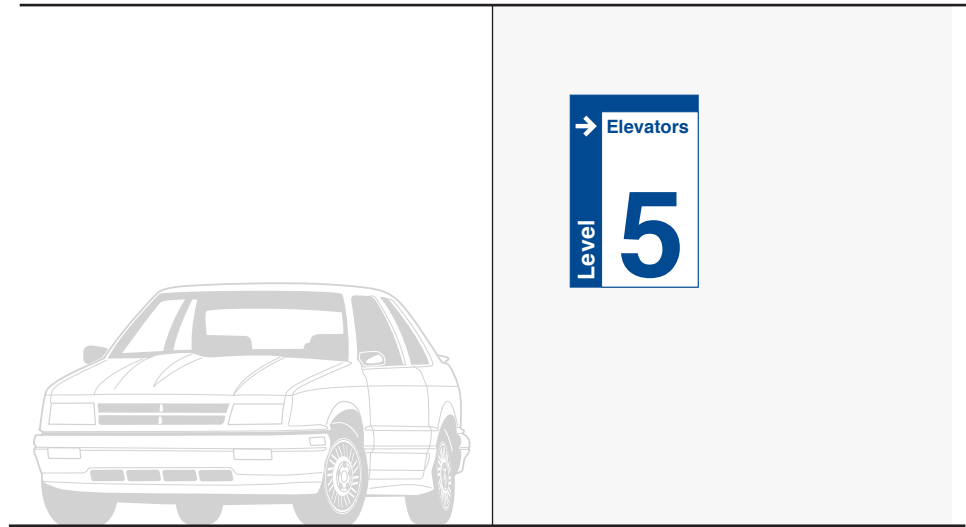

Message Layout A



Message Layout B



Message Layout C



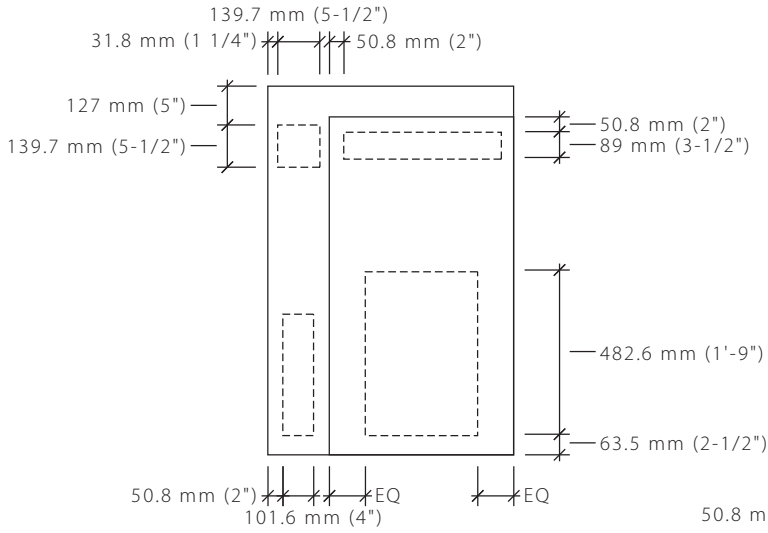
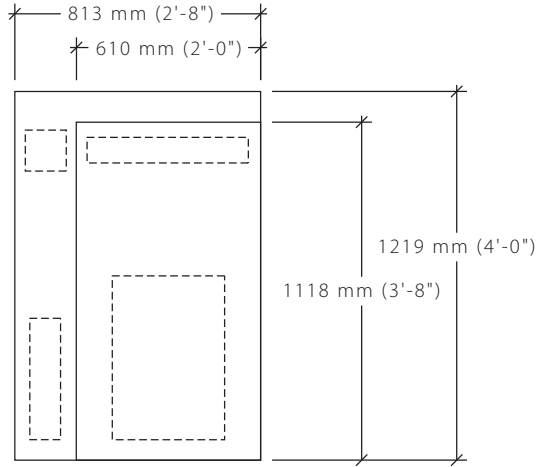

Message Layout A

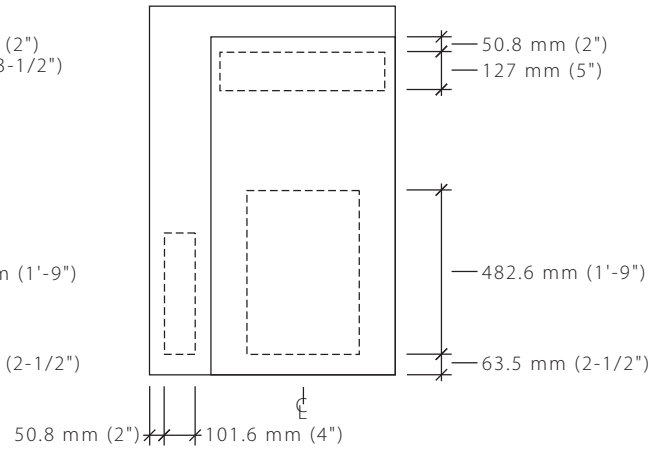

Message Layout B

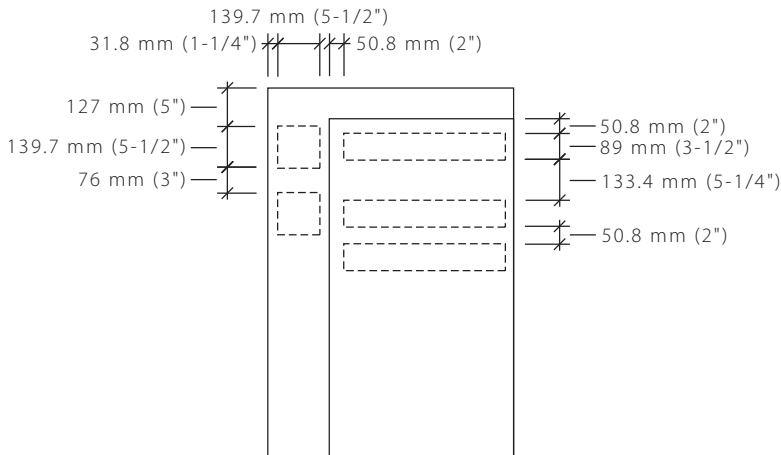

Message Layout C

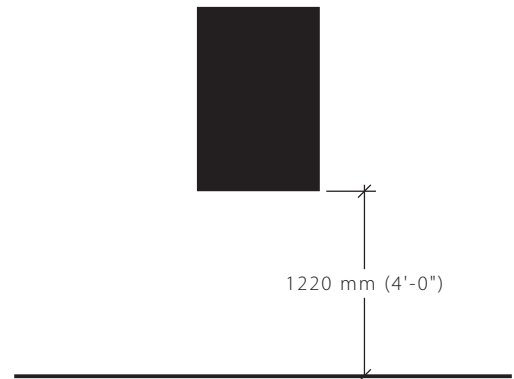



# PS-04.01

## Parking Structure Signs

Wall Mounted Directional

Parking Structure

### Size

Sign Face:  
457 mm H x 1067 mm W  
(1' 6" H x 3' 3" W)

### Description & Use

Precautionary information placed strategically to avoid traffic conflict or accidents.

### Message Configuration

(Refer to message layout drawing for dimensions)

Message layout A is pedestrian regulatory sign.

Message layout B, C, D, E and F are used primarily for vehicular traffic.

### Graphic Process

Surface applied vinyl.

### Colors

Text: Various, Refer to Color Chart  
Background: Various, Refer to Color Chart

### Recommendations

Position sign so drivers have a clear, unobstructed view of the sign.

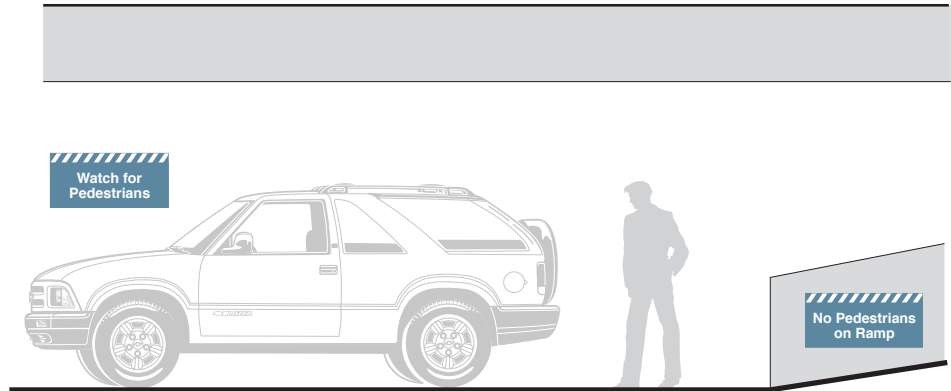

Message Layout A



Message Layout B



Message Layout C



Message Layout D



Message Layout E



Message Layout F



Wall Mounted Directional

Parking Structure

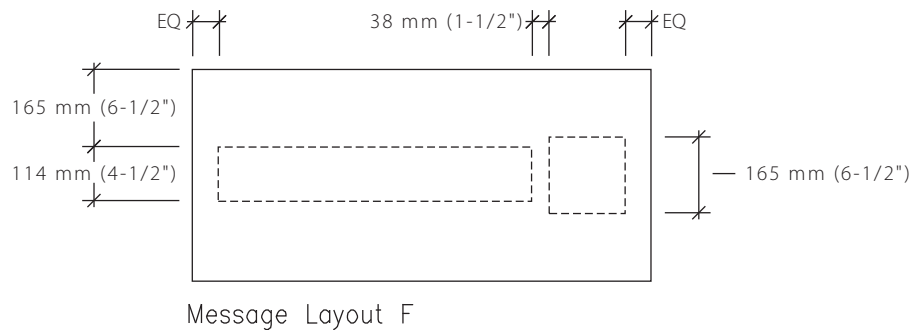
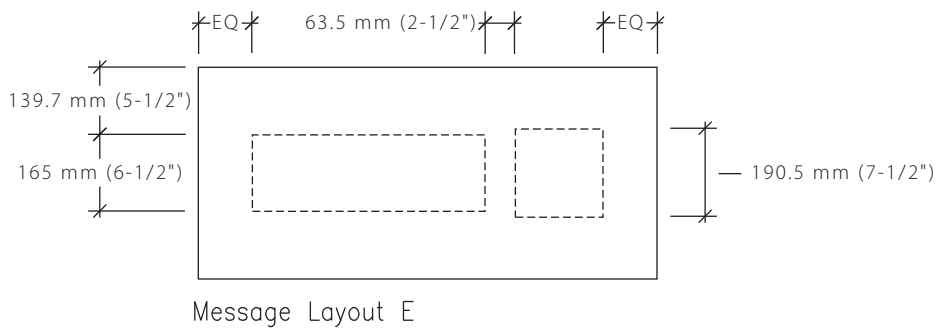
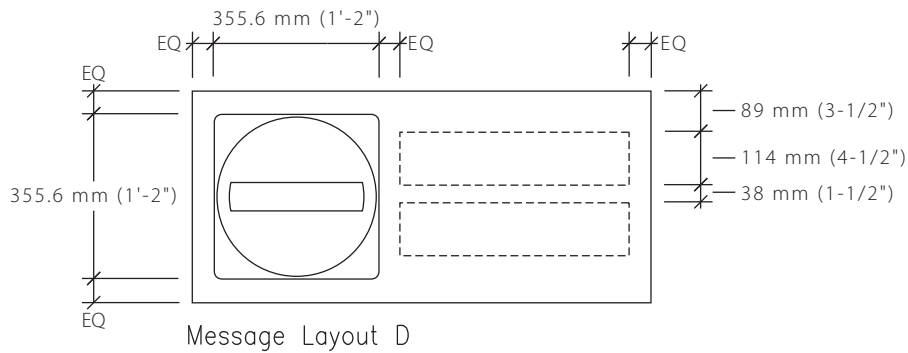
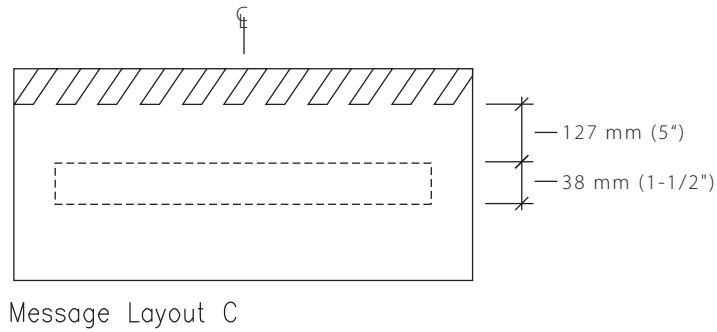
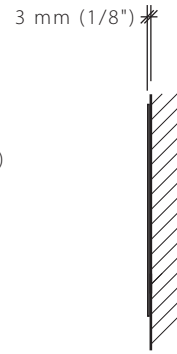
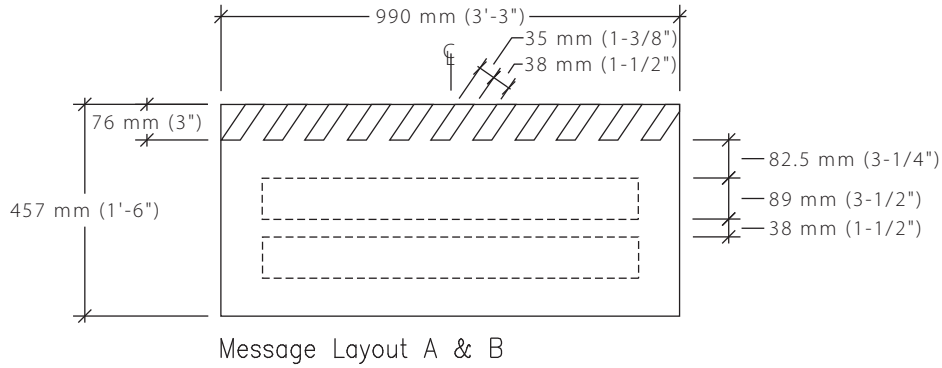

# PS-05.01

## Parking Structure Signs

Square Column Marker

Parking Structure

### Size

Sign Face:  
839 mm H x 559 mm W  
(2' 9" H x 1' 10" W)

### Description & Use

Floor level identification marker for placement on the wide face of the column.

### Message Configuration

(Refer to message layout drawing for dimensions)

### Graphic Process

Surface applied vinyl.

### Colors

Text: Various, Refer to Color Chart  
Background: Various, Refer to Color Chart

### Recommendations

Position sign so drivers have a clear, unobstructed view of the sign.

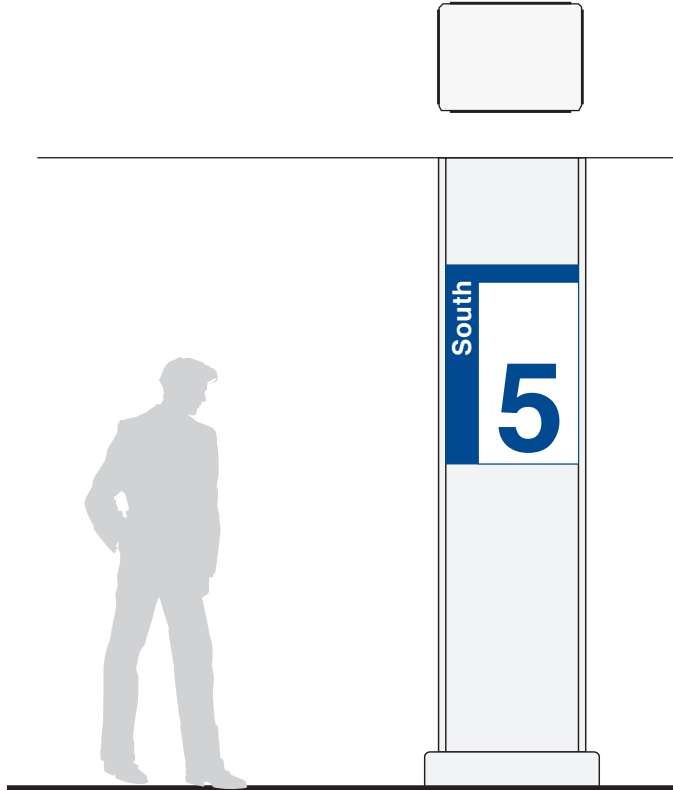

Message Layout A



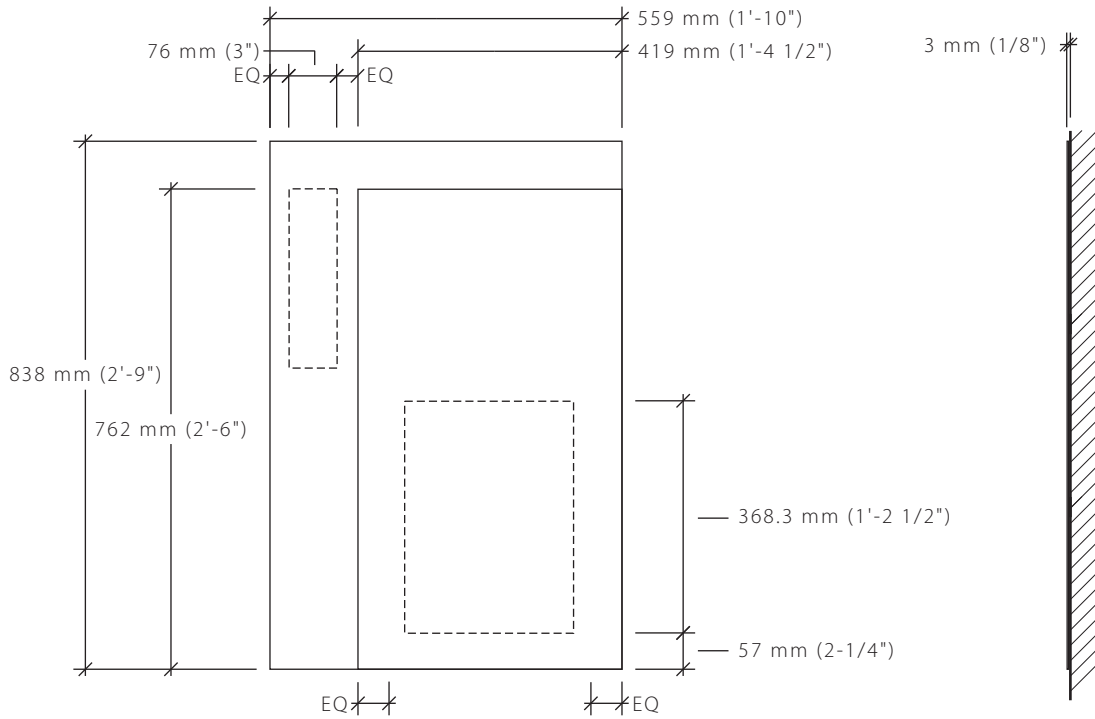

Message Layout A

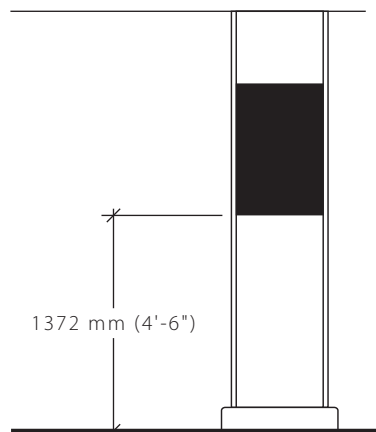

# PS-05.02

## Parking Structure Signs

Square Column Marker

Parking Structure

### Size

Sign Face:  
839 mm H x 407 mm W  
(2' 9" H x 1' 4" W)

### Description & Use

Floor level identification marker for placement on the narrow face of the column.

### Message Configuration

(Refer to message layout drawing for dimensions)

### Graphic Process

Surface applied vinyl.

### Colors

Text: Various, Refer to Color Chart  
Background: Various, Refer to Color Chart

### Recommendations

Position sign so drivers have a clear, unobstructed view of the sign.

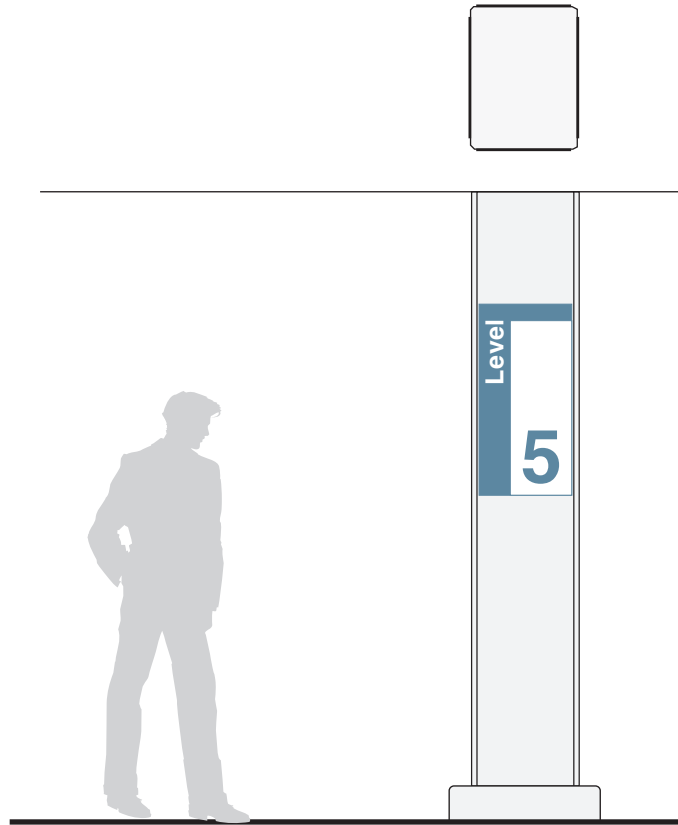

Message Layout A



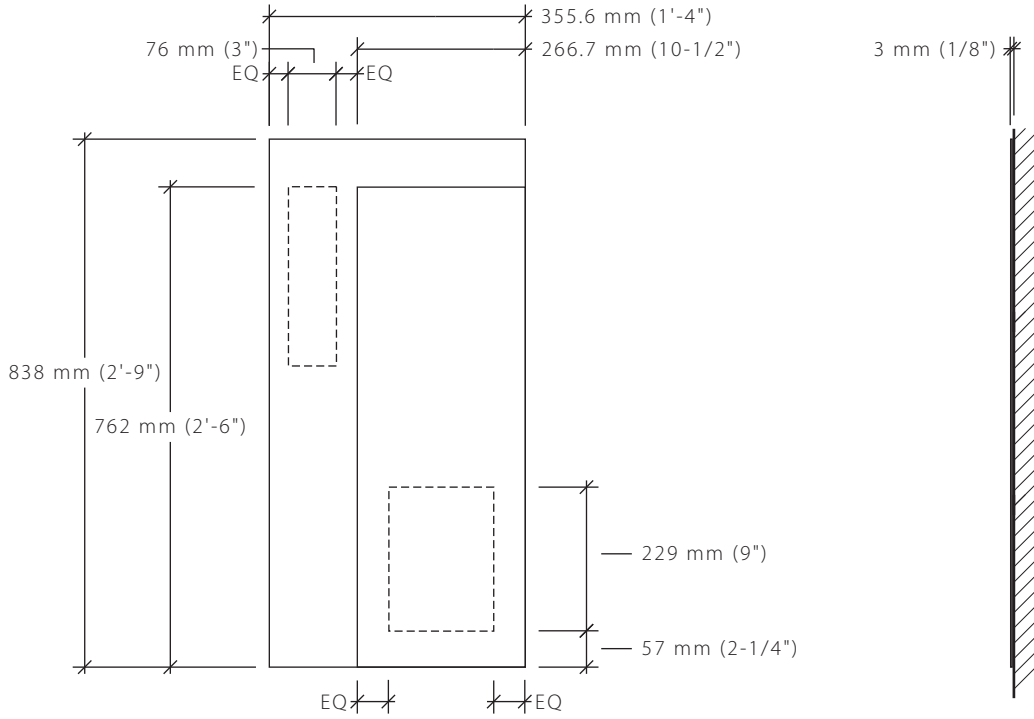

Message Layout A

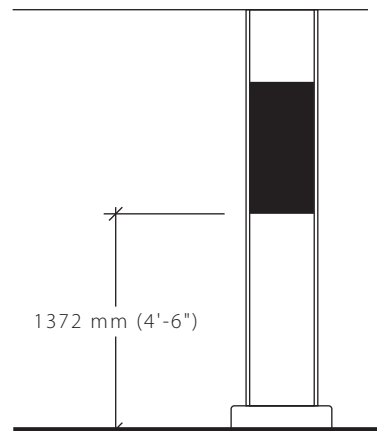

**Size**

Sign Face:  
610 mm H x 610 mm W  
(2' 0" H x 2' 0")

**Description & Use**

Floor level identification marker  
for placement on round columns.

**Message Configuration**

(Refer to message layout drawing  
for dimensions)

**Graphic Process**

Surface applied vinyl.

**Colors**

Text: Various, Refer to Color Chart  
Background: Various, Refer to  
Color Chart

**Recommendations**

Position sign so drivers have a  
clear, unobstructed view of the  
sign.

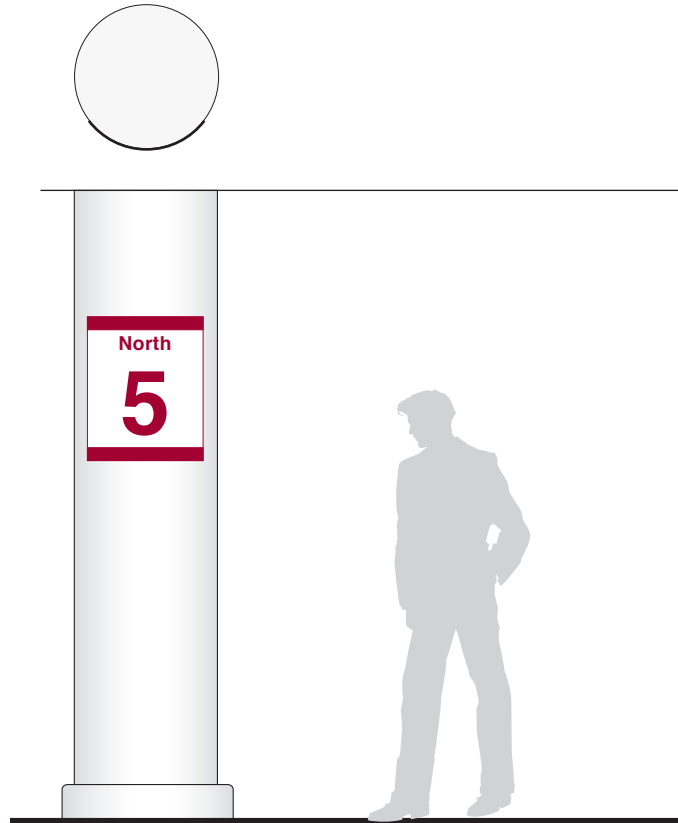
**Message Layout A**

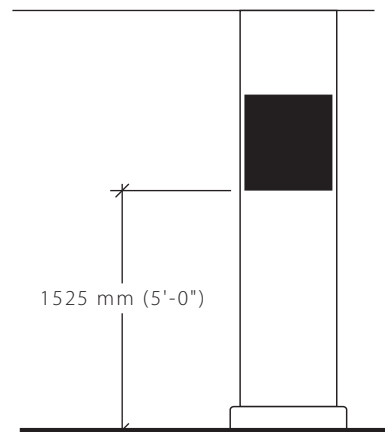
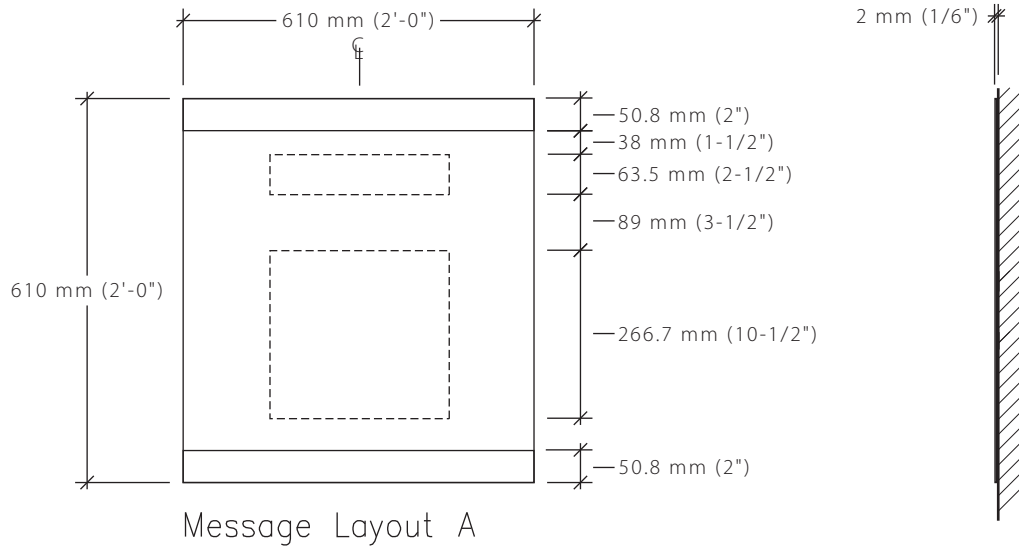



**Size**

Sign Face:  
559 mm H x 559 mm W  
(1' 10" H x 1' 10" W)

**Description & Use**

Floor level identification marker  
for placement on round columns.

**Message Configuration**

(Refer to message layout drawing  
for dimensions)

**Graphic Process**

Surface painted

**Colors**

Text: Various, Refer to Color Chart  
Background: Various, Refer to  
Color Chart

**Recommendations**

Position sign so drivers have a  
clear, unobstructed view of the  
sign.

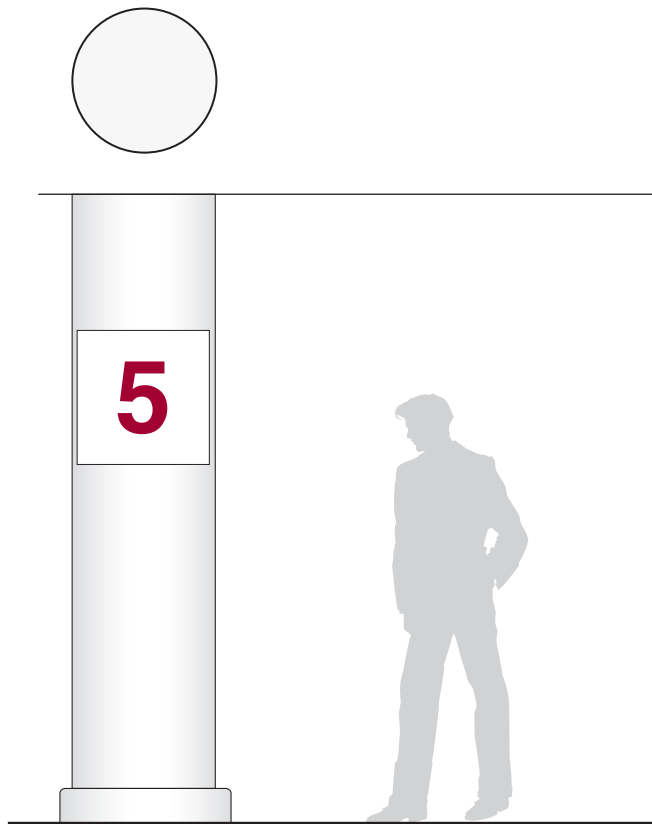
**Message Layout A**

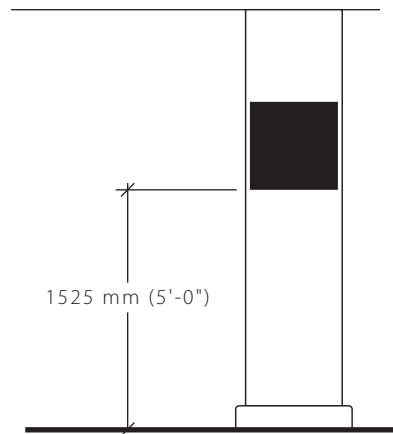
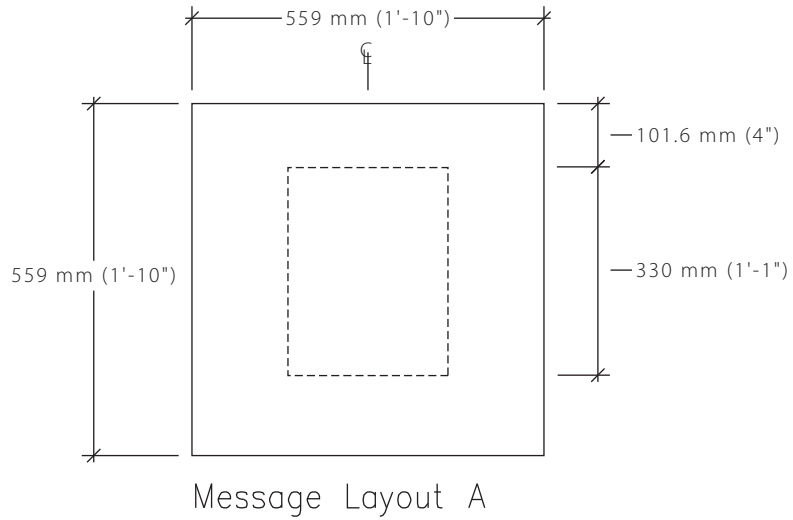

# PS-05.05

## Parking Structure Signs

### Size

Sign Face:  
839 mm H x 559 mm W  
(2' 9" H x 1' 10" W)

### Description

Floor Level identification marker for placement on pole.

### Message Configuration

(Refer to message layout drawing for dimensions)

### Graphic Process

Surface applied vinyl.

### Colors

Text: Various, Refer to Color Chart  
Background: Various, Refer to Color Chart

### Recommendations

Position sign so drivers have a clear, unobstructed view of the sign.

Pole Mount Marker

Parking Structure

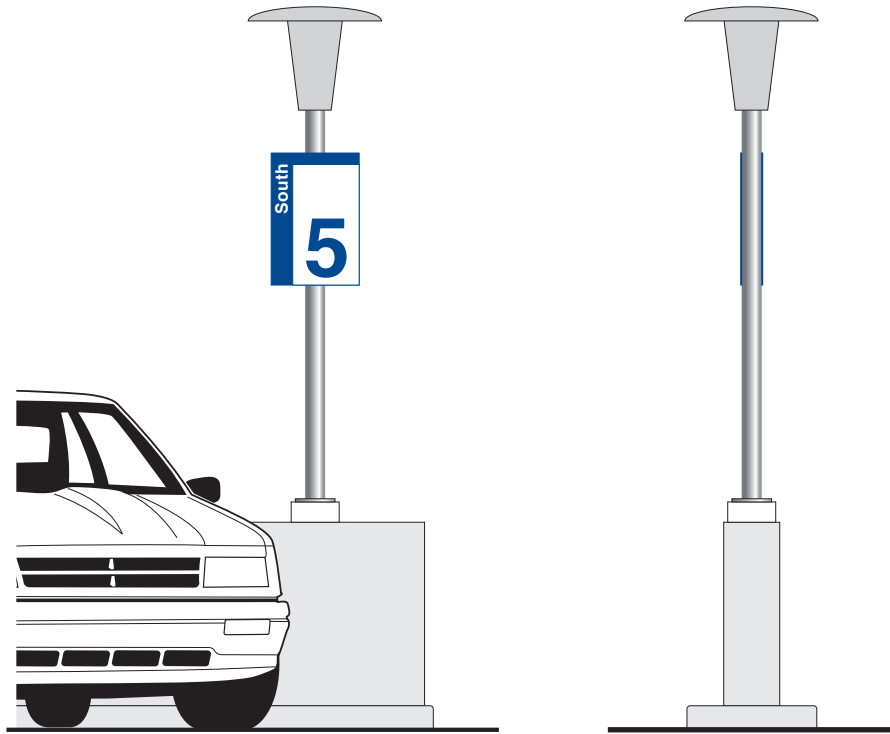

Message Layout A



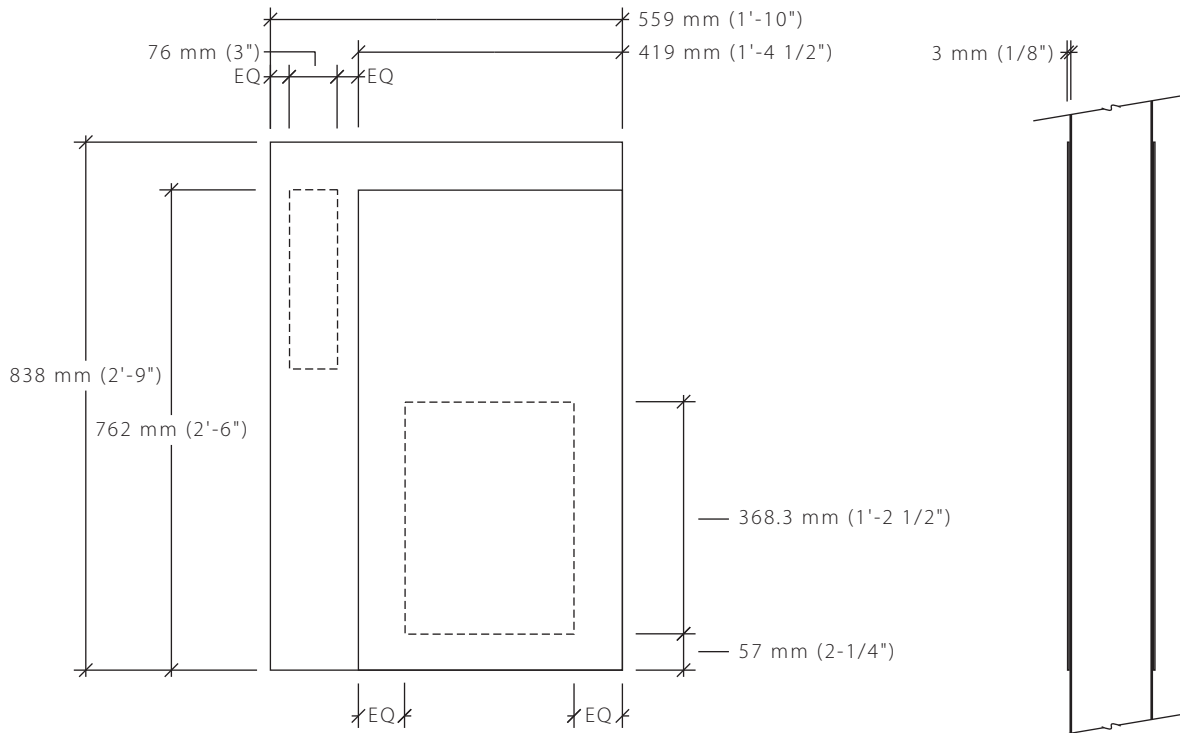

Message Layout A

# PS-06.01

## Parking Structure Signs

Wall Mounted Identification

Parking Structure

### Size

Sign Face:  
305 mm H x 1067 mm W  
(1' 0" H x 3' 6" W)

### Description & Use

Stairwell and elevator identification sign.

### Message Configuration

(Refer to message layout drawing for dimensions)

### Graphic Process

Surface applied vinyl.

### Colors

Text: Various, Refer to Color Chart  
Background: Various, Refer to Color Chart

### Recommendations

Position sign so pedestrians have a clear, unobstructed view of the sign.

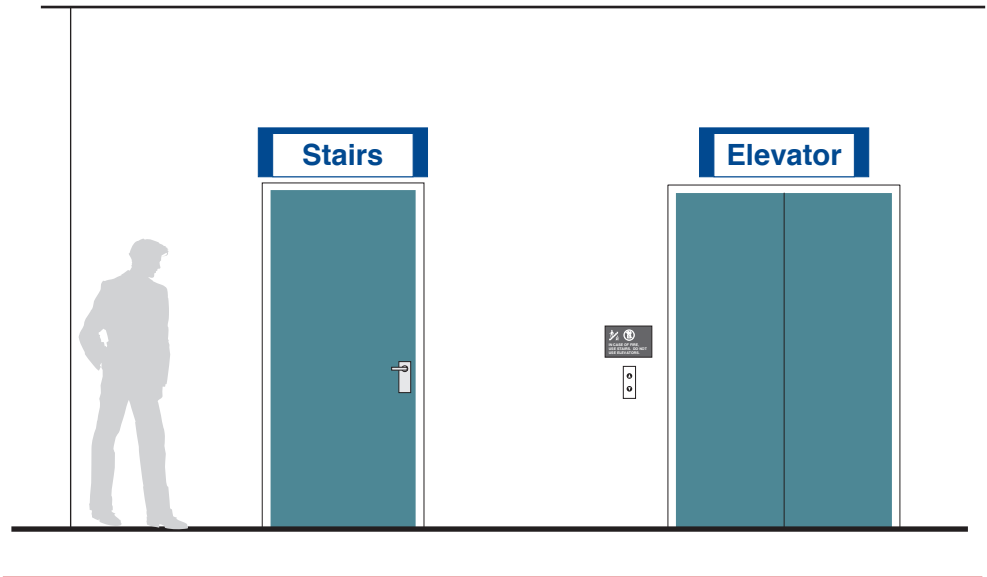

### Message Layout A



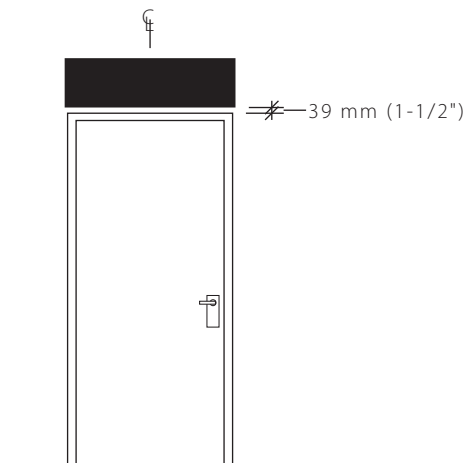
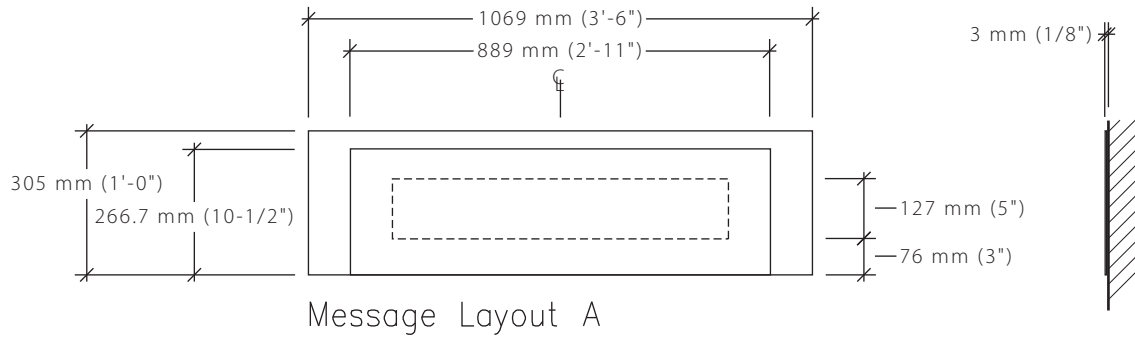

# PS-07.01

## Parking Structure Signs

Floor Level Identification

Parking Structure

### Size

Sign Face:  
(Refer to message layout drawing for dimensions)

### Description & Use

Floor level identification for placement on stairwell and elevator doors.

### Message Configuration

(Refer to message layout drawing for dimensions)

### Graphic Process

Surface applied vinyl.

### Colors

Text: Various, Refer to Color Chart  
Background: Various, Refer to Color Chart

### Recommendations

Position sign so drivers have a clear, unobstructed view of the sign.

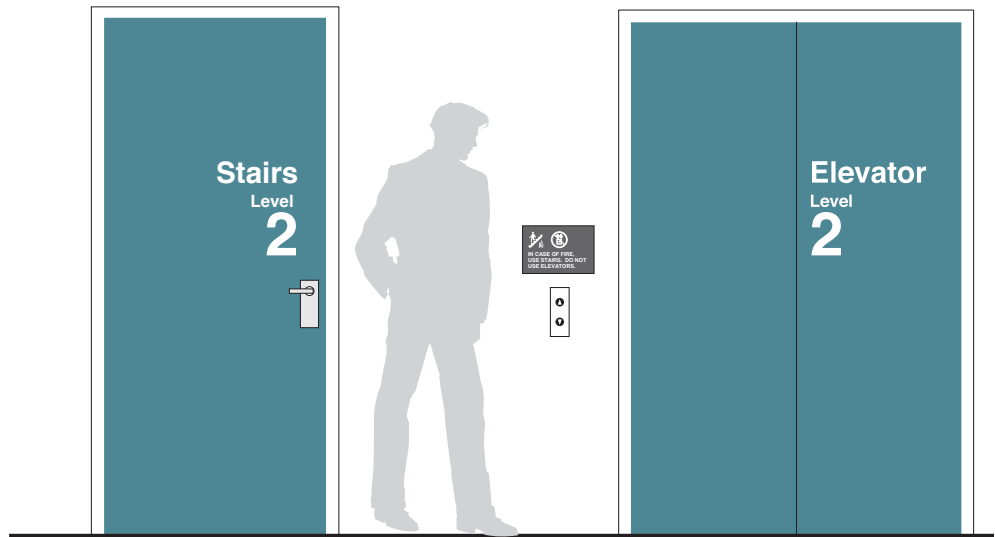

### Message Layout

**Stairs**  
Level  
**2**

### Alternate Layout

**Elevator**  
Level  
**3**

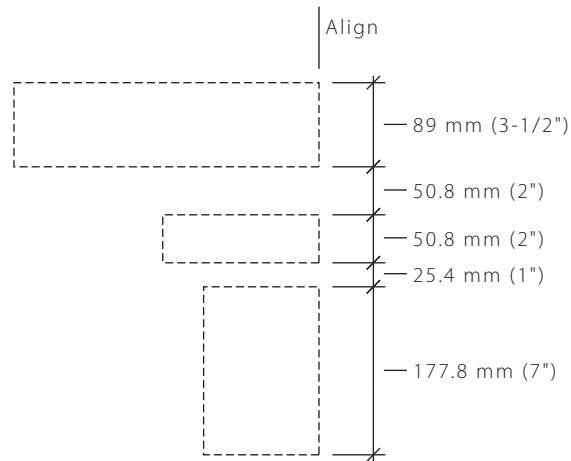

Message Layout A

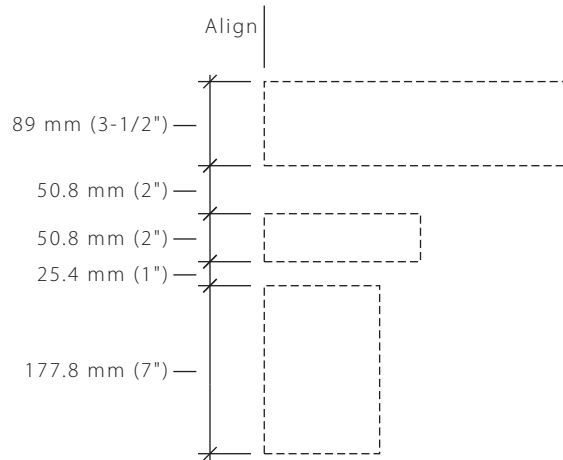

Alternate Layout

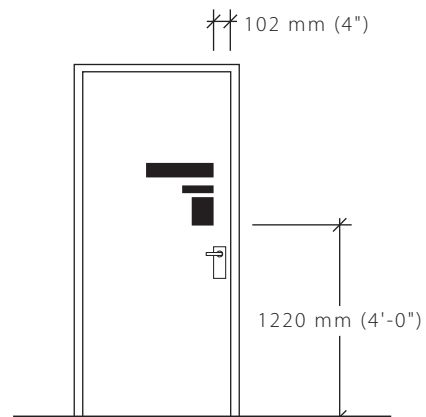



# PS-07.02

## Parking Structure Signs

Floor Level Identification

Parking Structure

### Size

Sign Face:  
25 mm H (1' 0" H)

### Description & Use

Floor level identification  
for placement inside stairwells.

### Message Configuration

(Refer to message layout drawing  
for dimensions)

### Graphic Process

Surface applied vinyl.

### Colors

Text: White, T2

### Recommendations



Message Layout

2

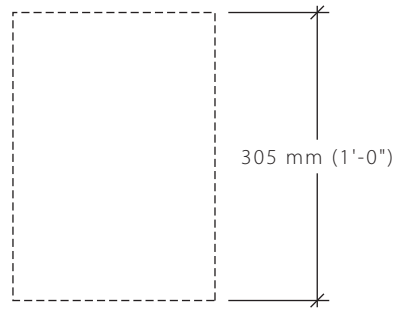

Message Layout A

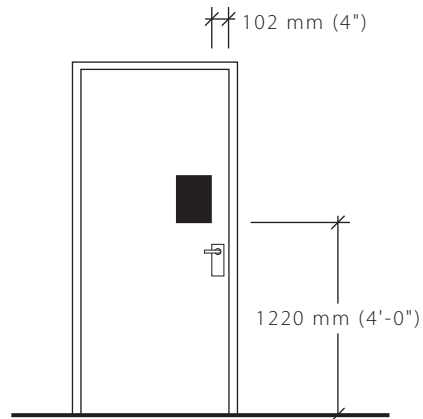

**Size**

254 mm H (10" H)

**Description**

Sign Use & Application  
Individual letters to identify an entrance or exit.

**Message Configuration**

(Refer to message layout drawing for dimensions)

**Graphic Process**

Fabricated or cut out painted aluminum letters

**Colors**

Text: Various

**Recommendations**

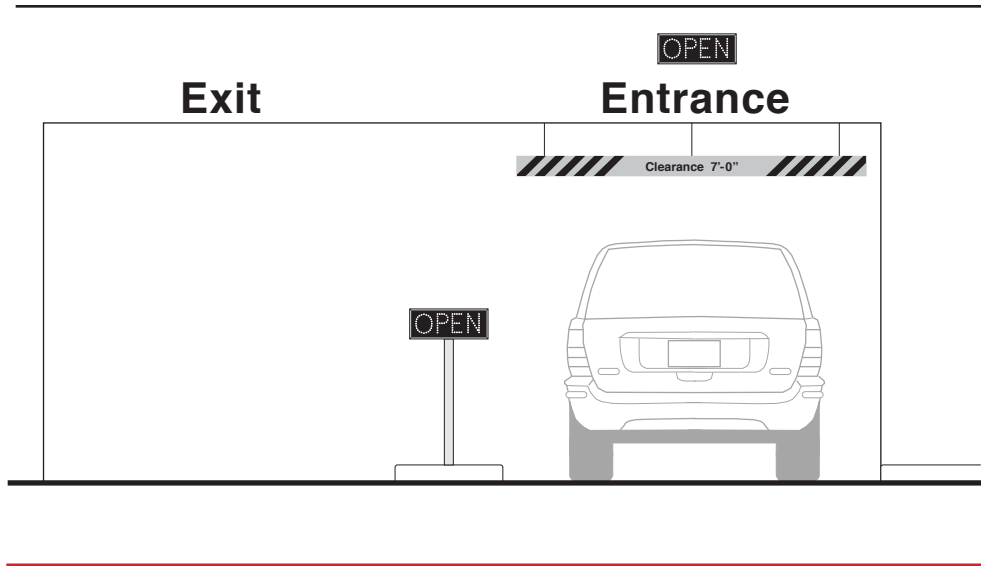

**Exit**



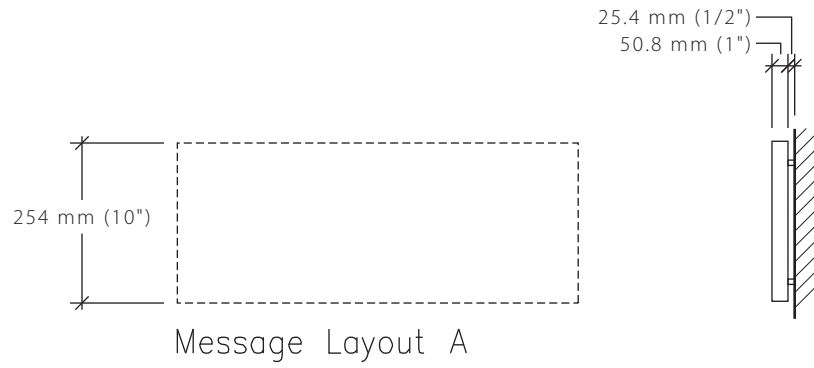

# PS-09

## Parking Structure Signs

### Clearance Height Identification

### Parking Structure

**Size**

Sign Face:  
152 mm H x various lengths  
(6" H)

**Description & Use**

Ceiling hung vehicular clearance identification marker to be placed at all entrances and at grade level changes.

**Message Configuration**

(Refer to message layout drawing for dimensions)

**Graphic Process**

Surface applied vinyl.

**Colors**

Text: Black T4  
Background: Yellow B8, Black B6

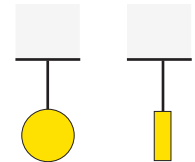
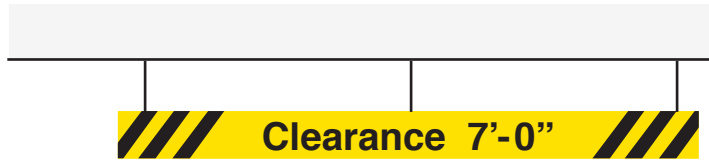
**Recommendations**

PS-09.01 PS-09.02

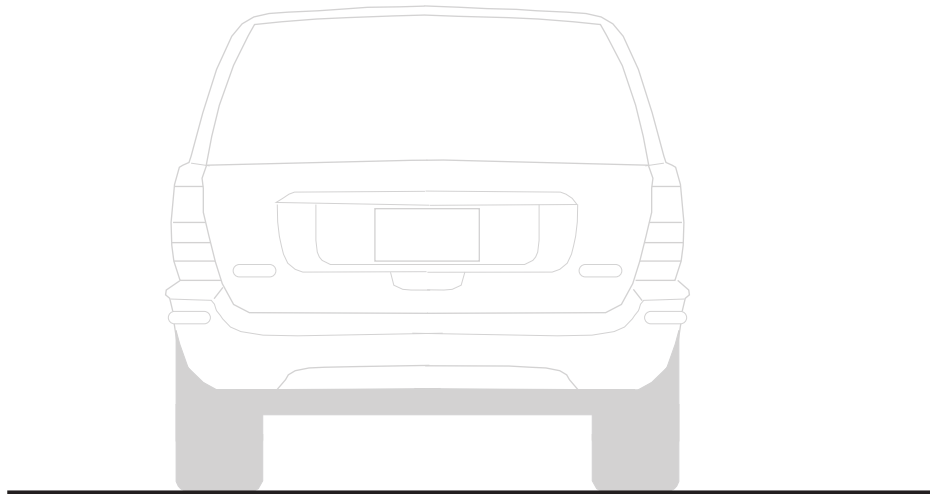
**Message Layout**

(Lengths will vary)

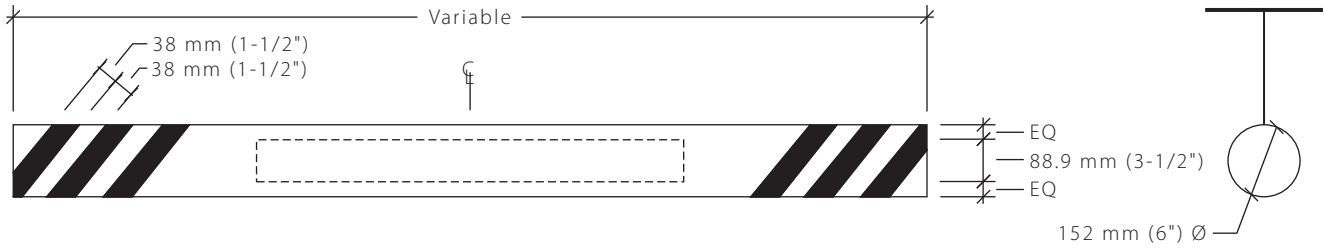

Message Layout A

PS-09.01

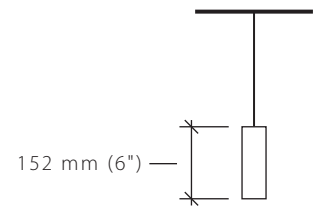

PS-09.02

**Size**

Various applications and sizes

**Description**

Sign use to provide occupancy information of a garage.

**Message Configuration**

(Refer to message layout drawing for dimensions)

**Graphic Process**

Internally illuminated

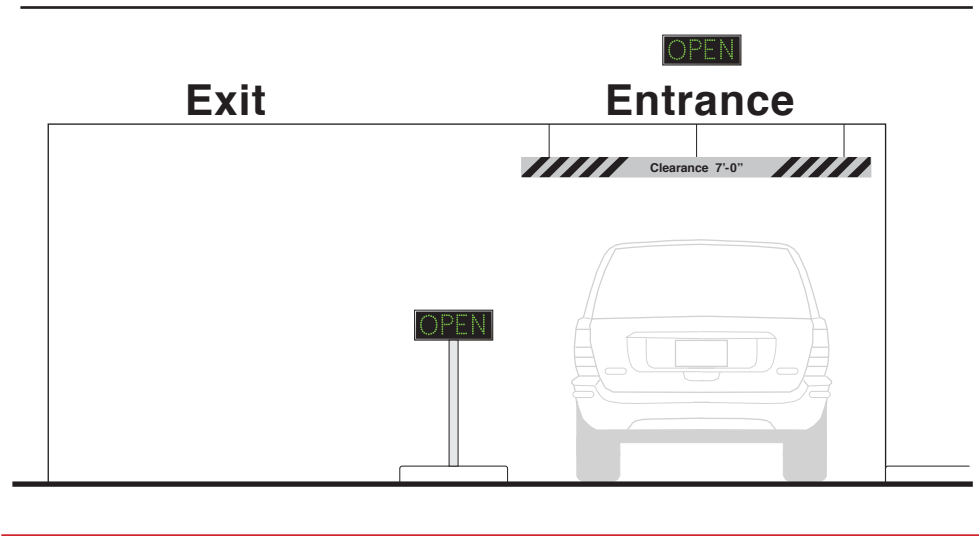

**Message Layout A**

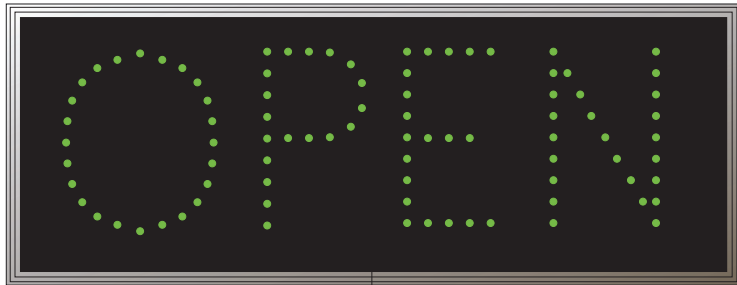

**Message Layout B**

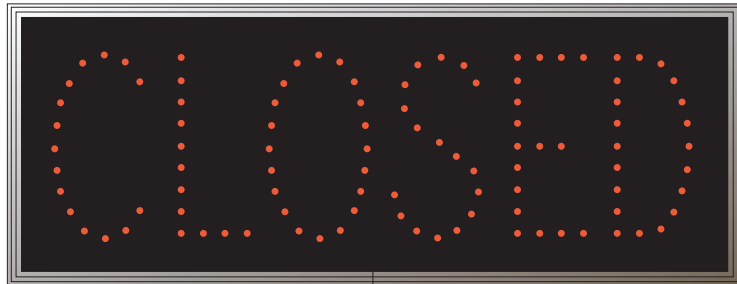

**Message Layout C**

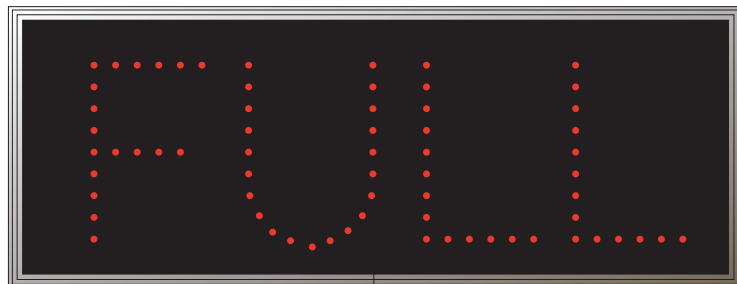

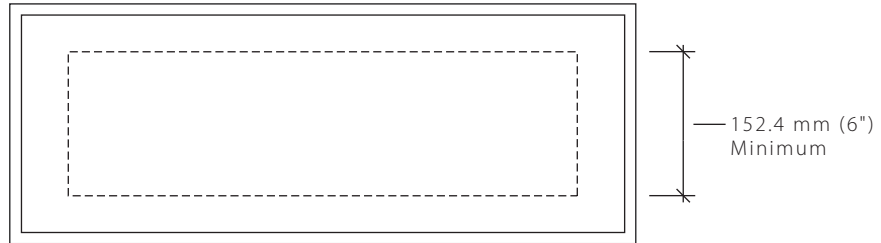

Message Layout A, B & C



### Size

Sign Face:  
559 mm H x 3050 mm W  
(1' 10" H x 10' 0" W)  
Bang Bar:  
152 mm H x various lengths  
(6" H)

### Description

Non-illuminated, free swinging ceiling hung sign with bang bar. This sign type is directed specifically to drivers providing them entrance identification and information.

### Message Configuration

(Refer to message layout drawing for dimensions)

### Graphic Process

Surface applied vinyl.

### Colors

Sign Face:  
Text: Various, Refer to Color Chart  
Background: Various, Refer to Color Chart

### Bang Bar:

Text: Black T4  
Background: Yellow B8, Black B6

### Recommendations

Sign is for parking structure entrances that are high r do not have a surface to mount letters or a sign panel

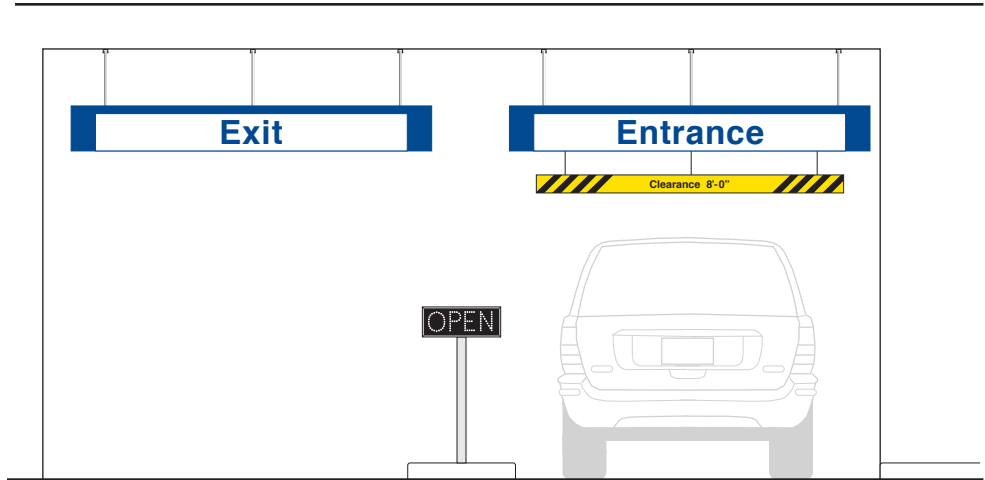

### Message Layout A

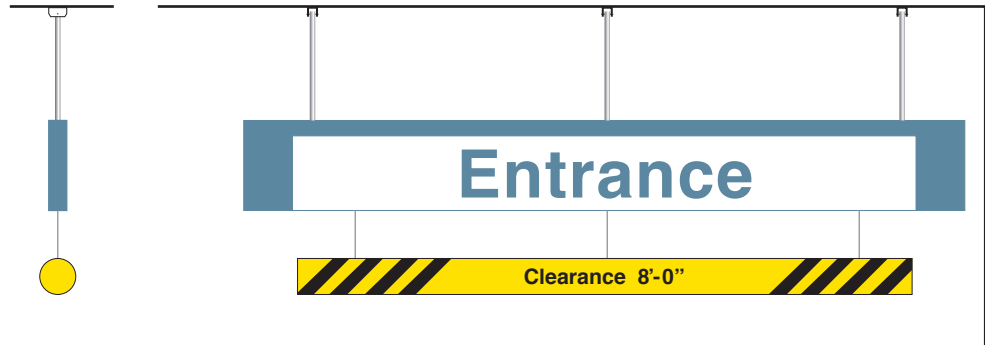

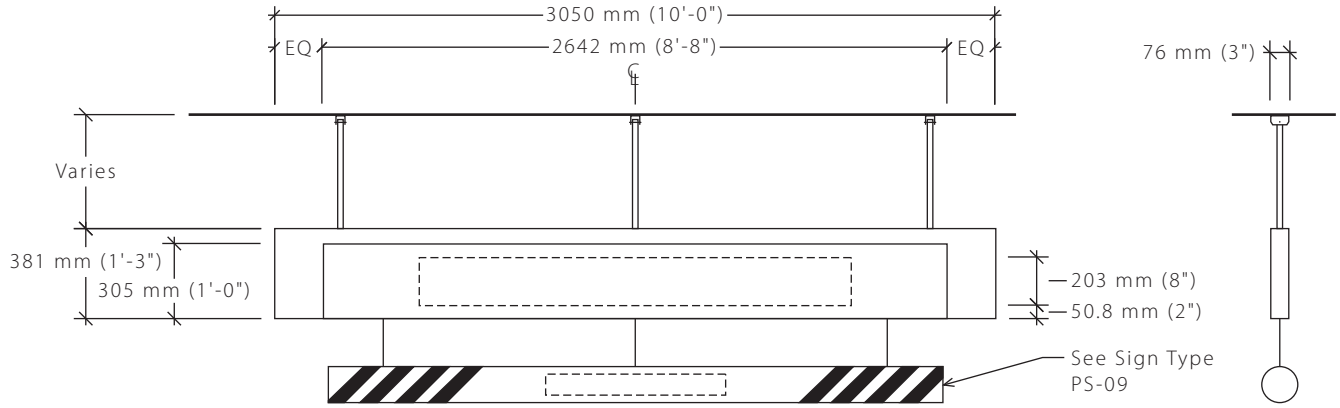

# Parking Structure Signs

Regulatory

Parking Structure

## Size

Sign Face:  
Refer to Exterior Sign Types.

## Description

Parking and traffic regulatory signs.

## Recommendations

Display the most commonly used signs as indicated. If other Traffic Regulatory and Warning Signs are need, refer to MUTCD.

Position sign so drivers have a clear, unobstructed view of the sign.

It should be noted that the decision to use a particular traffic control device at a specific location should be made on the basis of a standard traffic engineering study of the location. Sign size should be based on traffic conditions. Where these conditions are the same, all signs of a similar type should be the same size.

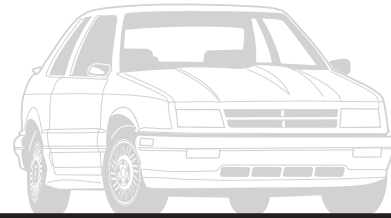

See Sheet EN12.4 for Details



See Sheet EN6.8 for Details



See Sheet EN10.1 for Other Traffic Regulatory Signs and Details



# Parking Structure Signs

Identification Signs

Parking Structure

## Size

Sign Face:  
Refer to Interior Sign Types.

## Description

Information and room  
identification.

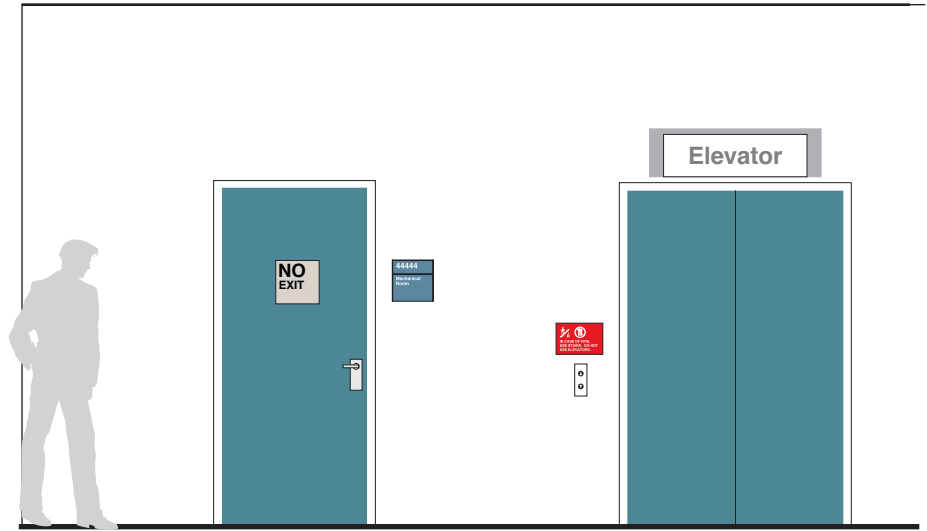

See Sheet IN01.4 for Details



See Sheet IN04.1 for Details

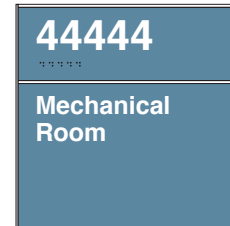

See Sheet IN01.6 for Details



The specifications for exterior signs are available in the Master Construction Specifications area of the VA Technical Information Library.

[http://www.va.gov/facmgt/standard/spec\\_10.asp](http://www.va.gov/facmgt/standard/spec_10.asp)

Refer to Specification 10430. For more information regarding specifications, contact the Office of Facilities Management, Standards Service.

The specifications will require editing to eliminate signs that are not needed and to adapt the specifications to the specific project for which they are intended.

The specifications require close coordination taking into account the existing sign program at a medical center, sign maintenance and future

signing needs.

The sign message schedule is considered a part of the specifications and would comprise the last section. Configuration of the message schedule may vary according to project requirements.

The sign message schedule form, illustrated in the Programming Section of this Handbook, lists the typical information that a sign manufacturer and installer will require.

The sign message schedule needs to be coordinated with a sign location plan drawing showing where signs are to be placed within a building or on the site. See the example in the Programming Section of this Handbook.

### PG Construction Detail 1

Sign Types: PS-01.01, PS-01.02, PS-01.03, PS-01.04

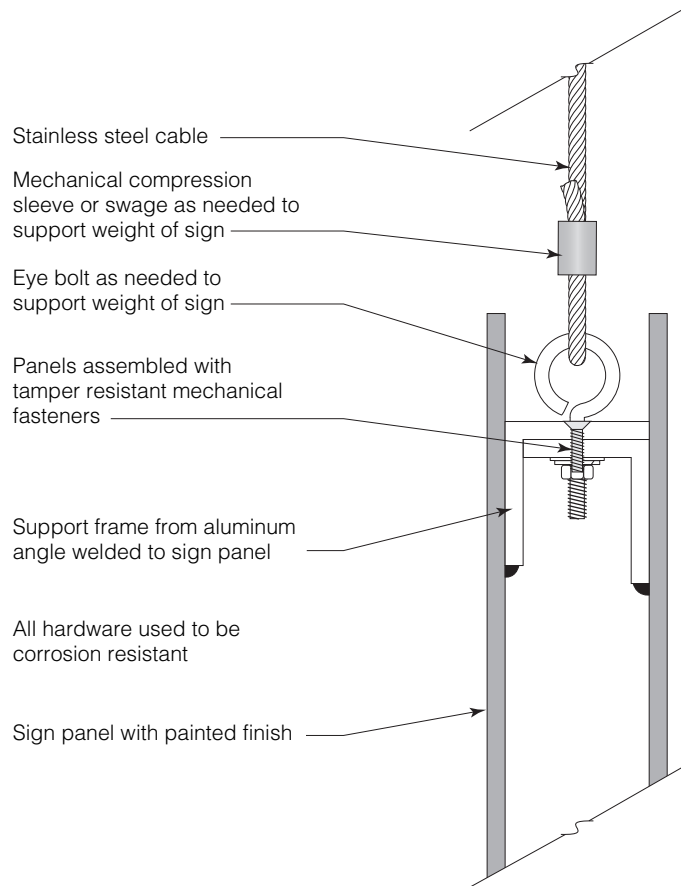

### PS Construction Detail 2

Sign Types: PS-02.01, PS-02.02, PS-02.03, PS-02.04

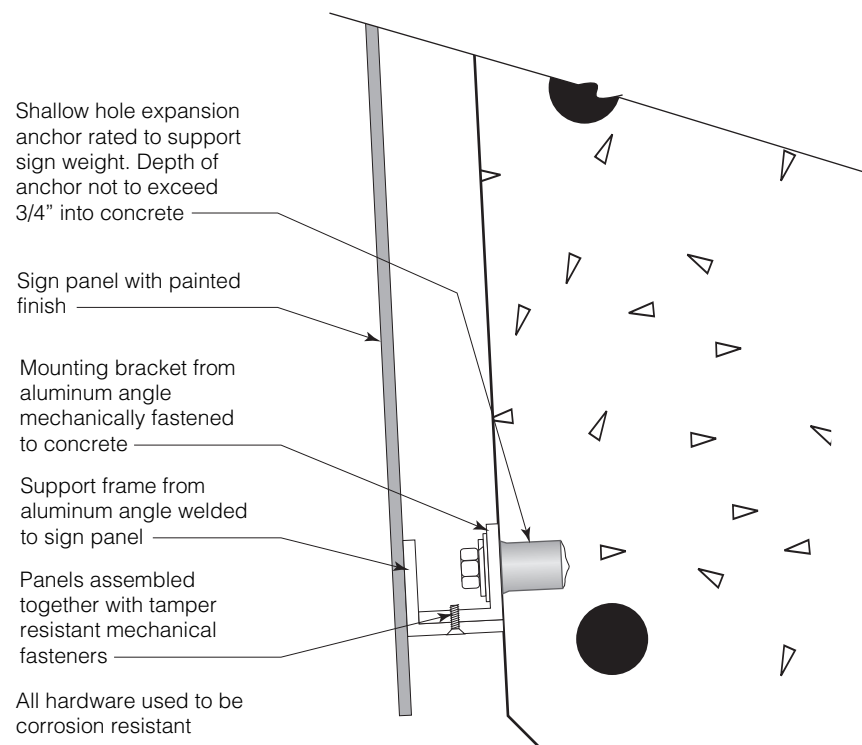

### PS Construction Detail 3

Sign Types: PS-05.01, PS-05.02  
PS-03 & PS-04 similar

Drive rivet nail-in anchor with heads painted to match adjacent color. Depth of anchor not to exceed 3/4" into concrete

Painted aluminum sign panel

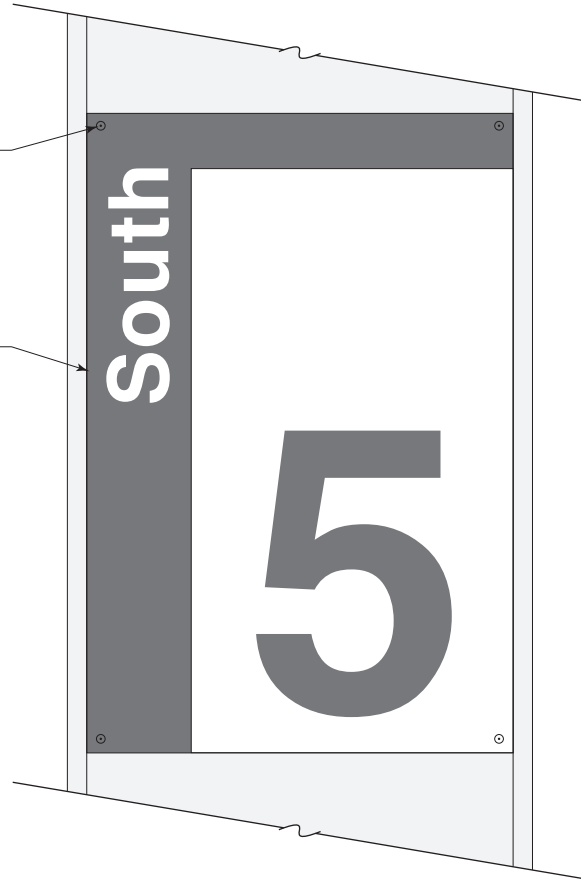

### PS Construction Detail 4

Sign Types: PS-05.03

Drive rivet nail-in anchor with heads painted to match adjacent color. Depth of anchor not to exceed 3/4" into concrete

Painted aluminum sign panel at thickness panel as needed to follow curve of column

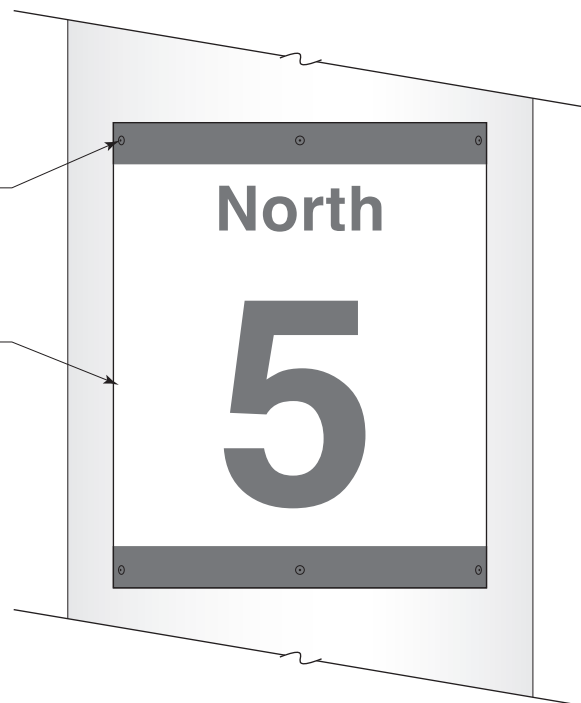

**PS Construction Detail 5**

Sign Types: PS-11

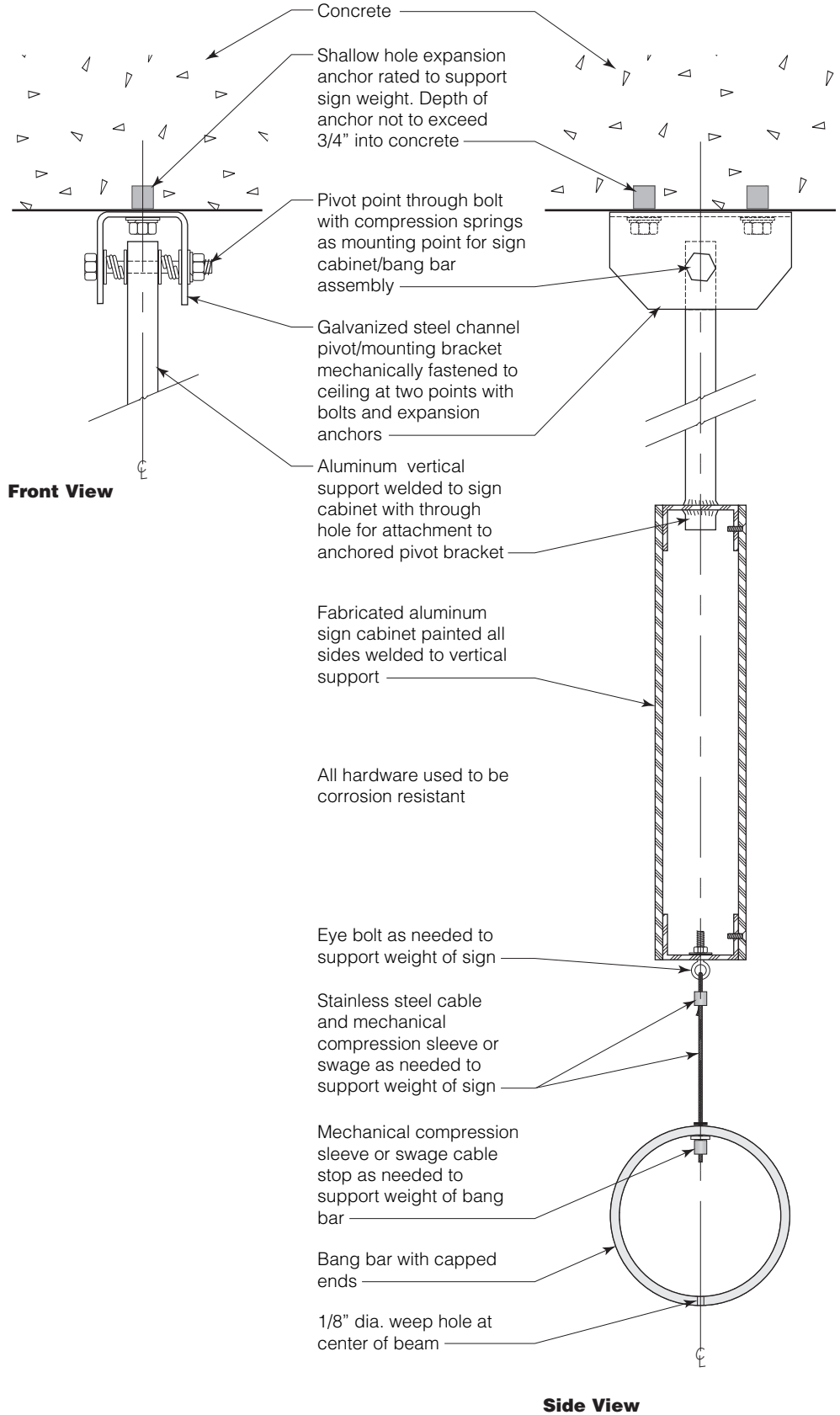



### PS Installation Detail 1

Sign Types: PS-01.01, PS-01.02, PS-01.03 & PS-01.04

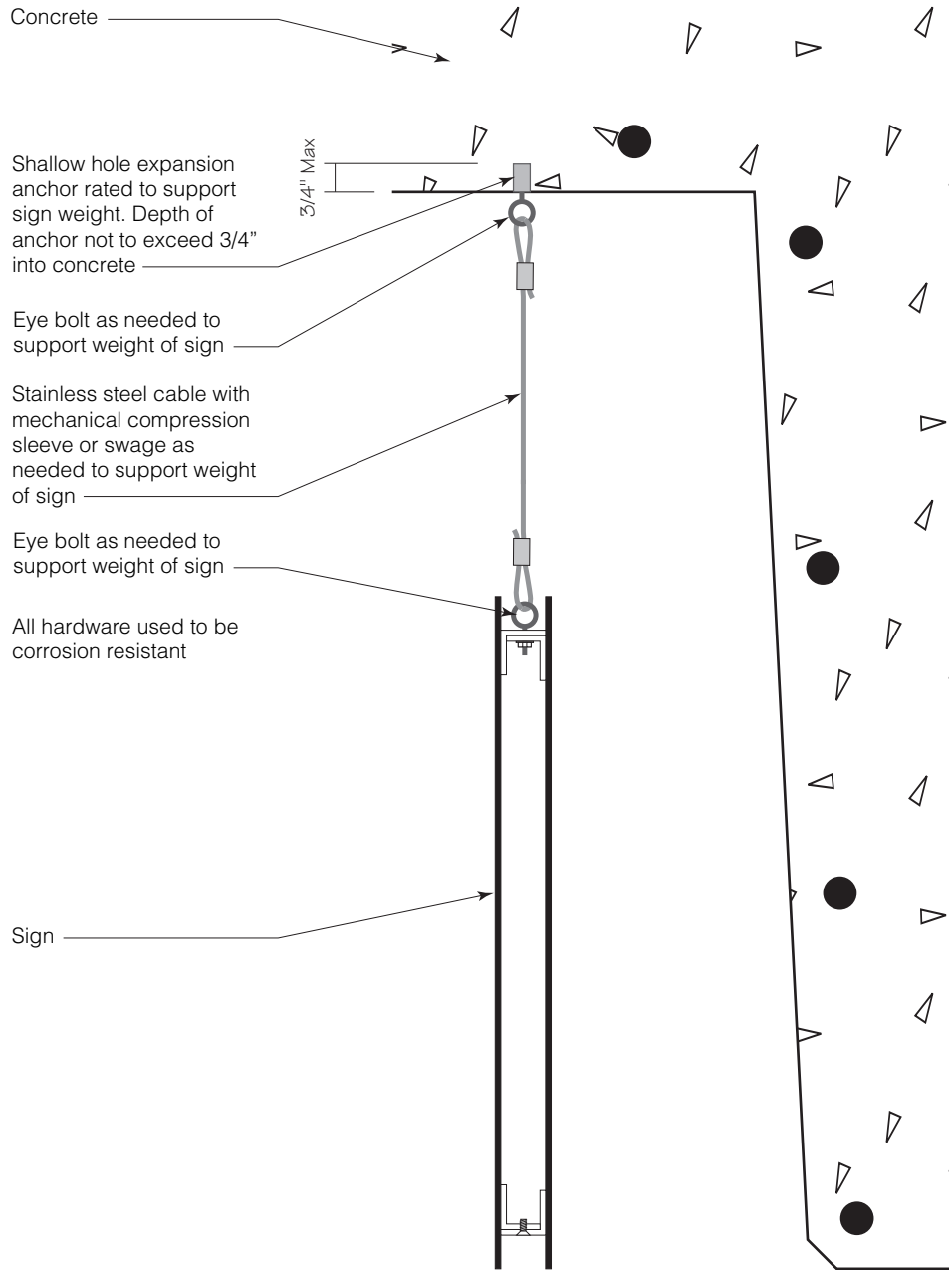

### PS Installation Detail 2

Sign Types: PS-02.01, PS-02.02, PS-02.03 & PS-02.04

Cross bracing cable hanging method to be used on all hanging signs where the ceiling to sign hang distance is 2'-0" or greater or in areas of excessive wind

Shallow hole expansion anchor rated to support sign weight. Depth of anchor not to exceed 3/4" into concrete

Stainless steel cable cross bracing with mechanical compression sleeve or swage as needed to support weight of sign

Concrete

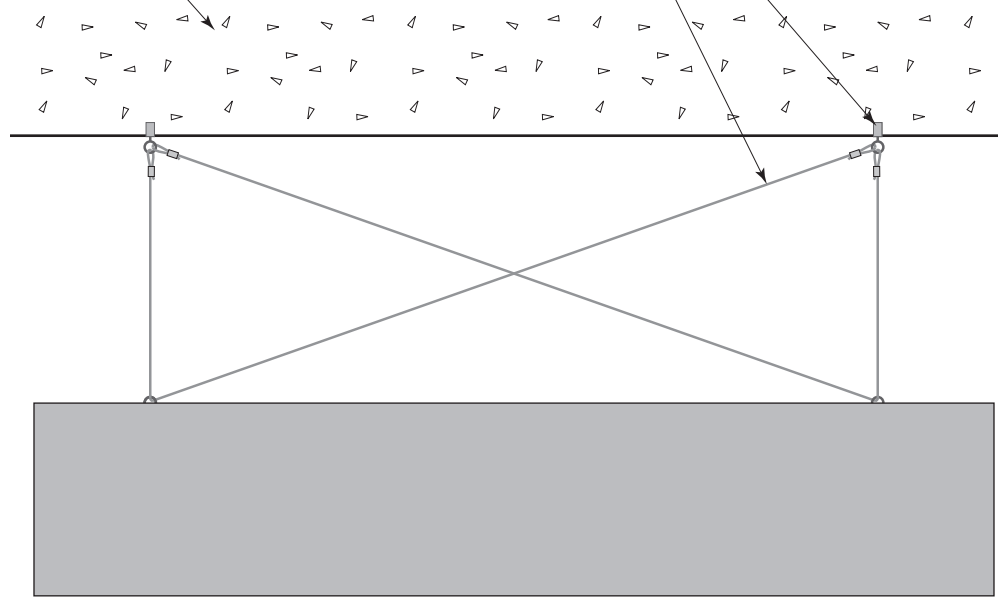

### PG Installation Detail 3

Sign Types: PS-02.01, PS-02.02, PS-02.03 & PS-02.04

Concrete joist

Mounting bracket from interlocking angle with set screw attachment to sign panel

All hardware used to be corrosion resistant

Sign

Shallow hole expansion anchor rated to support sign weight. Depth of anchor not to exceed 3/4" into concrete

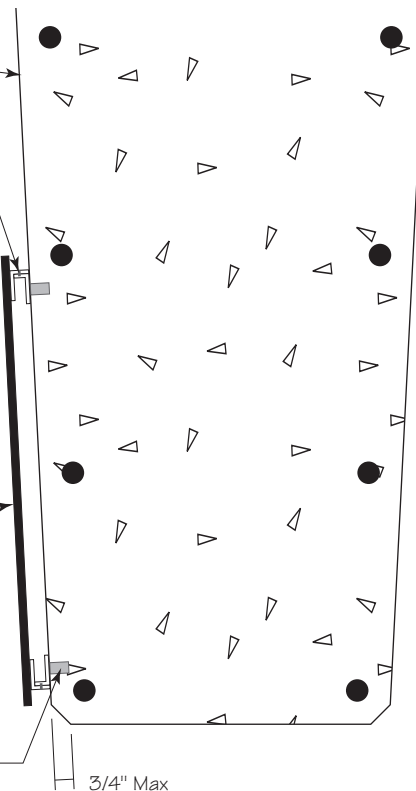

### PS Installation Detail 4

Sign Types: PS-05.01, PS-05.02 & PS-04.1

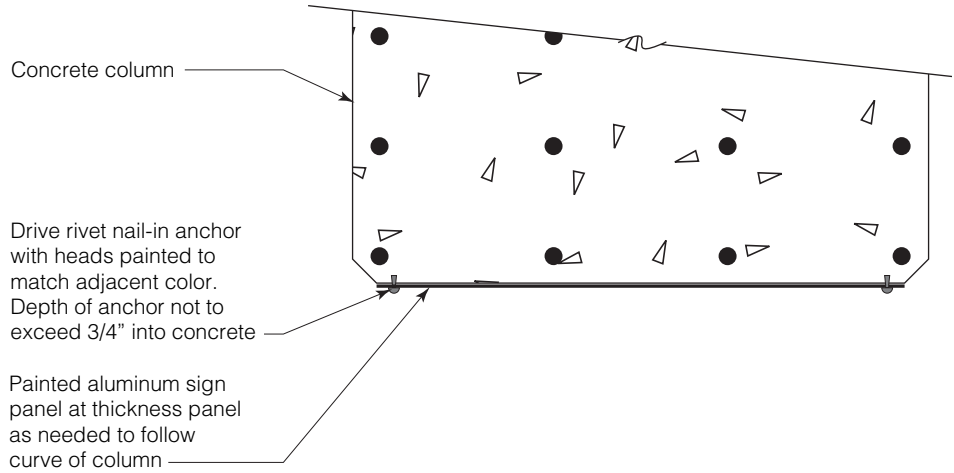

### PS Installation Detail 5

Sign Type: PS-05.03

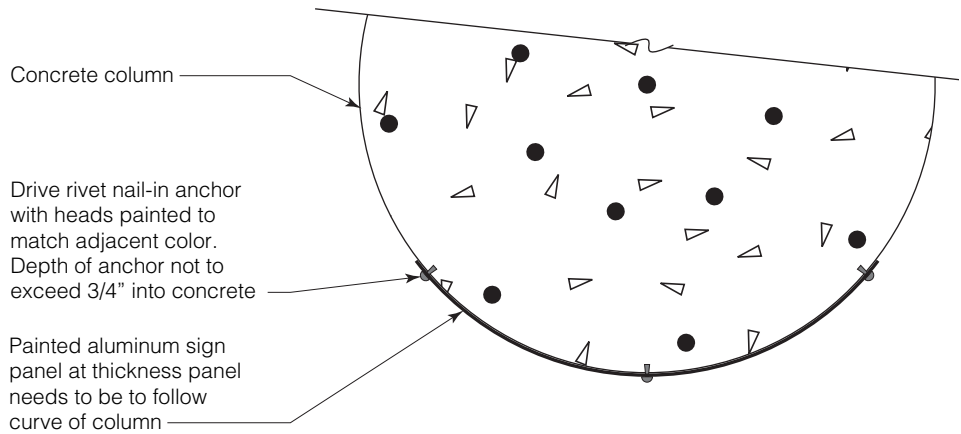

### Wall Mounting: Non-Illuminated Signs

Aluminum wall panel signs shall be fastened with a minimum of 2 mechanical fasteners.

Anchors should be provided in the wall that are suitable for the particular type of wall surface where the sign is being installed.

