

# **DESIGN MANUAL**

**VOLUME 1**

Volume One, the Design Manual, is the primary product of the project. It is intended to be a basic document for the VA and for A/E contractors working on system hospitals. It is structured so that the Office of Construction may adopt it in whole or in part as a Construction Standard, and subject it to regular review and revision. It describes the Building System Prototype Design and suggests a general procedure by which the Design may be utilized on a building project.

## **100 BASIC CONCEPTS**

### **110 THE PROTOTYPE DESIGN**

111	Scope	1- 1
112	Planning Modules	1- 4
113	Building Subsystems	1- 8

### **120 APPLICATION**

121	Procedure	1- 13
122	The Data Base	1- 14

**(BLANK PAGE)**

# 110 The Prototype Design

## 111 SCOPE

### 111.1 ORGANIZATION

The building system developed for Veterans Administration hospitals is presented in the form of a Prototype Design supplemented by a Data Base. The Prototype Design is divided into two basic categories of components: planning modules and building subsystems.

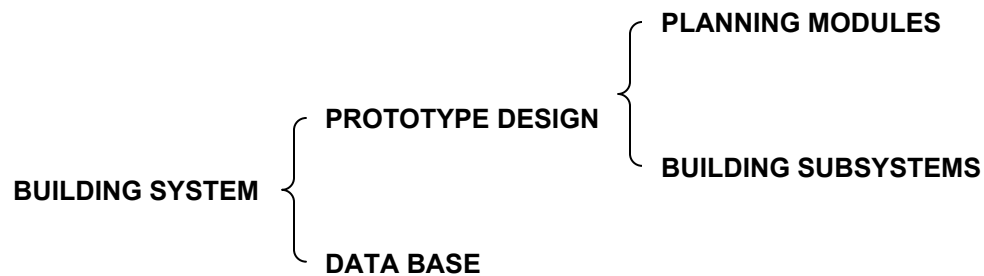

The Design Manual consists of a description of the planning modules and building subsystems, followed by a discussion of design procedure. The Data Base is in a separate volume.

### 111.2 BACKGROUND AND INTENT

#### 111.2.1 A Working Hypothesis

The building system described in this manual was developed in response to a set of problems the Veterans Administration has been experiencing in the design and construction of hospitals.

Briefly, these problems are: rising costs, lengthy periods between programming and occupancy, accelerating obsolescence and inadequate building performance. The general approach has been the application of the so-called “principles of systems integration”. (For a discussion of these principles, see Section 610).

The particular method employed was the direct design of a building system by consultants to the Research Staff of the Office of Construction, on the basis of building products already on the market. There has been no attempt to develop new products or a proprietary “kit of parts”. The innovations suggested by the Prototype Design are in the nature of more or less unconventional ways to use or combine conventional materials and components.

Insofar as these new ways are untested by actual field application, the Prototype Design may be thought of as a “working hypothesis”. Simply stated, the hypothesis is, “If a hospital is designed, constructed, maintained and altered in accordance with the rules and recommendations set forth in the Design Manual, then the problems stated above will all be alleviated to some significant degree.”

### 111.2.2 Long Range Development

On the basis of the evaluation of hospitals utilizing the system, the hypothesis can be tested and modified. The Prototype Design is subject to continual review and revision as experience accumulates. Also, as the original innovations are either rejected or integrated into standard procedures, new innovations can be introduced into the Prototype Design for successive projects.

The building system should thus be viewed as a component within a larger system, namely the VA’s total managerial system for the programming, design, construction, operation and evaluation of hospitals.

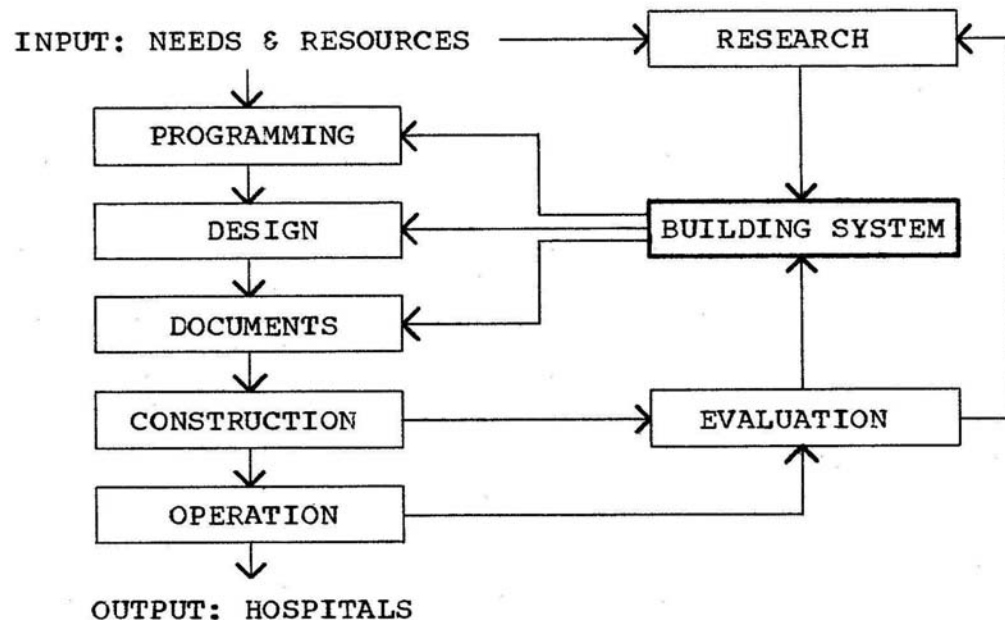

The building system is not intended to substitute for any existing component of the larger system; it is an additional component whose function is to supplement and contribute to the effectiveness of the others.

It performs this function primarily by providing a carefully coordinated set of guidelines for making certain decisions during the building design process, and also by providing a common frame of reference for all components of the larger system.

### **111.2.3 Variability**

Some of the guidelines are so fundamental to the Prototype Design that they establish what must be considered fixed characteristics of the system. If any of these characteristics is significantly modified in the design, construction or alteration of a building, then that building cannot properly be said to be an application of the particular system described in the Manual. These fixed characteristics are discussed under the heading of “Basic Design” at the beginning of each section on the planning modules and the building subsystems. All other characteristics may be considered variable and have the force of recommendations.

If the working hypothesis is to have a fair test, a certain degree of caution must be exercised when introducing variations. One of the underlying causes of the problems to which the system addresses itself is the lack of adequate coordination at certain key points in the conventional design and construction process. The intended beneficial effect of the Prototype Design in many instances depends more on the high level of internal coordination between its characteristics than on the particulars of the characteristics themselves. Thus, when a “variable” characteristic is altered, there is a danger of inadvertently reintroducing a major causal factor of the very problem the system is trying to solve. To assure that the intended level of coordination can be maintained when deviating from any of the guidelines, a careful check must be made on the implications of the change for all other characteristics of the specific design under development.

## 112 PLANNING MODULES

### 112.1 DEFINITION AND FUNCTION

The planning modules are units of building volume, one story high and varying in floor area according to a specific dimensional discipline. They represent large scale assemblies of building subsystems with assured internal capacity for various functional arrangements. Their function is to expedite the preliminary planning of a hospital by providing a simplifying conceptual step between the extreme complexity of a typical hospital program (master plan) and the generation of alternative design configurations for the building. They also provide a basis for initial structural and mechanical design decisions before the detailed program or architectural design has been worked out.

### 112.2 TYPES

There are four types of planning modules: structural bays, space modules, service modules and fire sections.

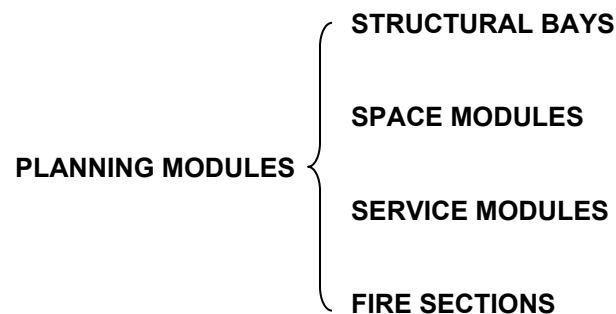

In each case a range of sizes and shapes may be generated for response to variations in program, site and budget.

The larger types of module are built up out of the smaller (See Figure 110-1). The structural bay is thus the basic unit of which all other modules are composed. However, it is the service module which provides the essential “building block” for preliminary design (See Figure 110-2).

### 112.3 THE SERVICE MODULE

A service module is distinguished by the fact that it is served by a single independent horizontal distribution network; it is a unit of service as well as a unit of functional space. It is organized into three basic components: the functional zone below the ceiling, the service zone above the ceiling, and a special structural bay called the service bay located at the boundary.



Figure 110-1. THE PLANNING MODULES

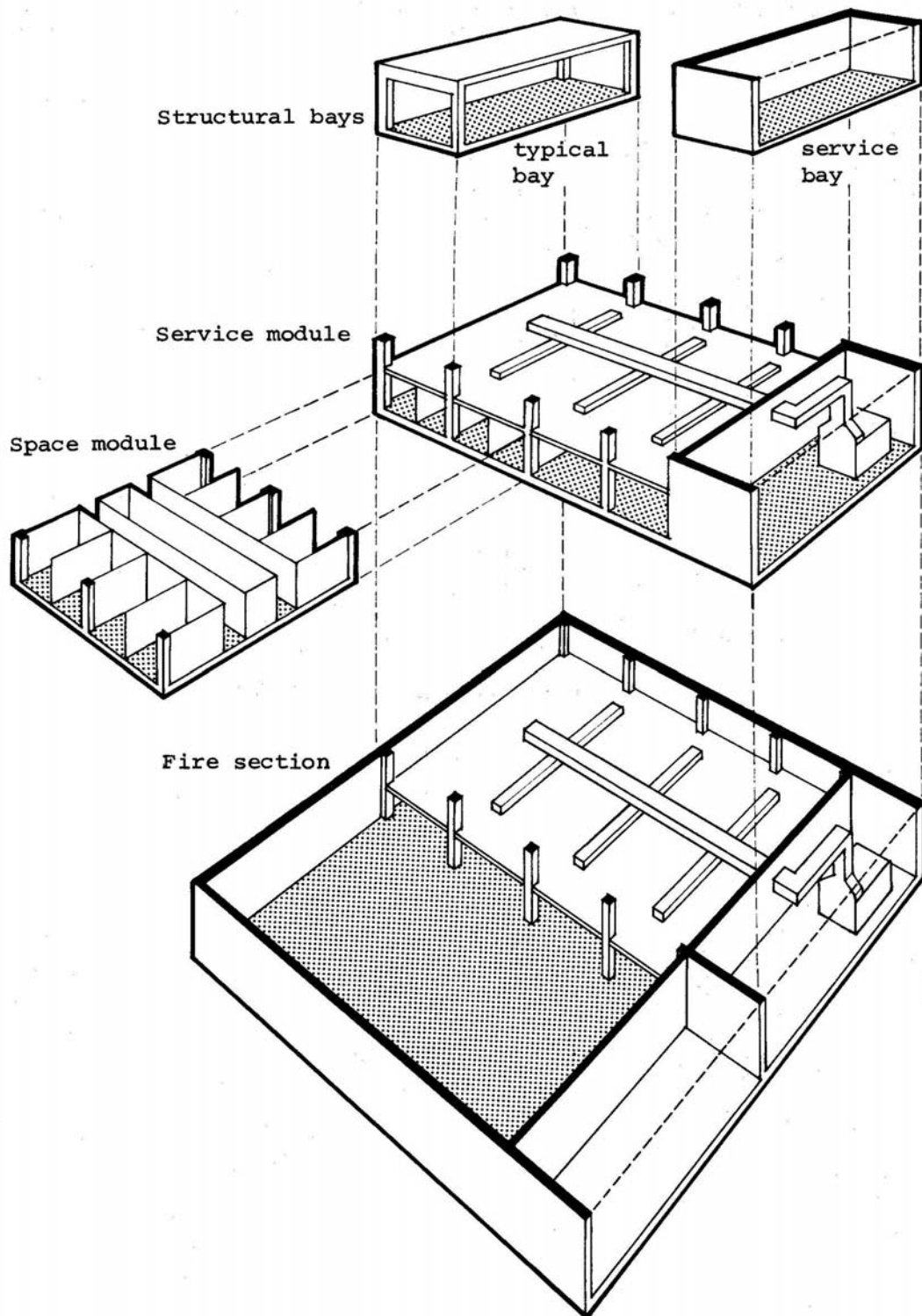
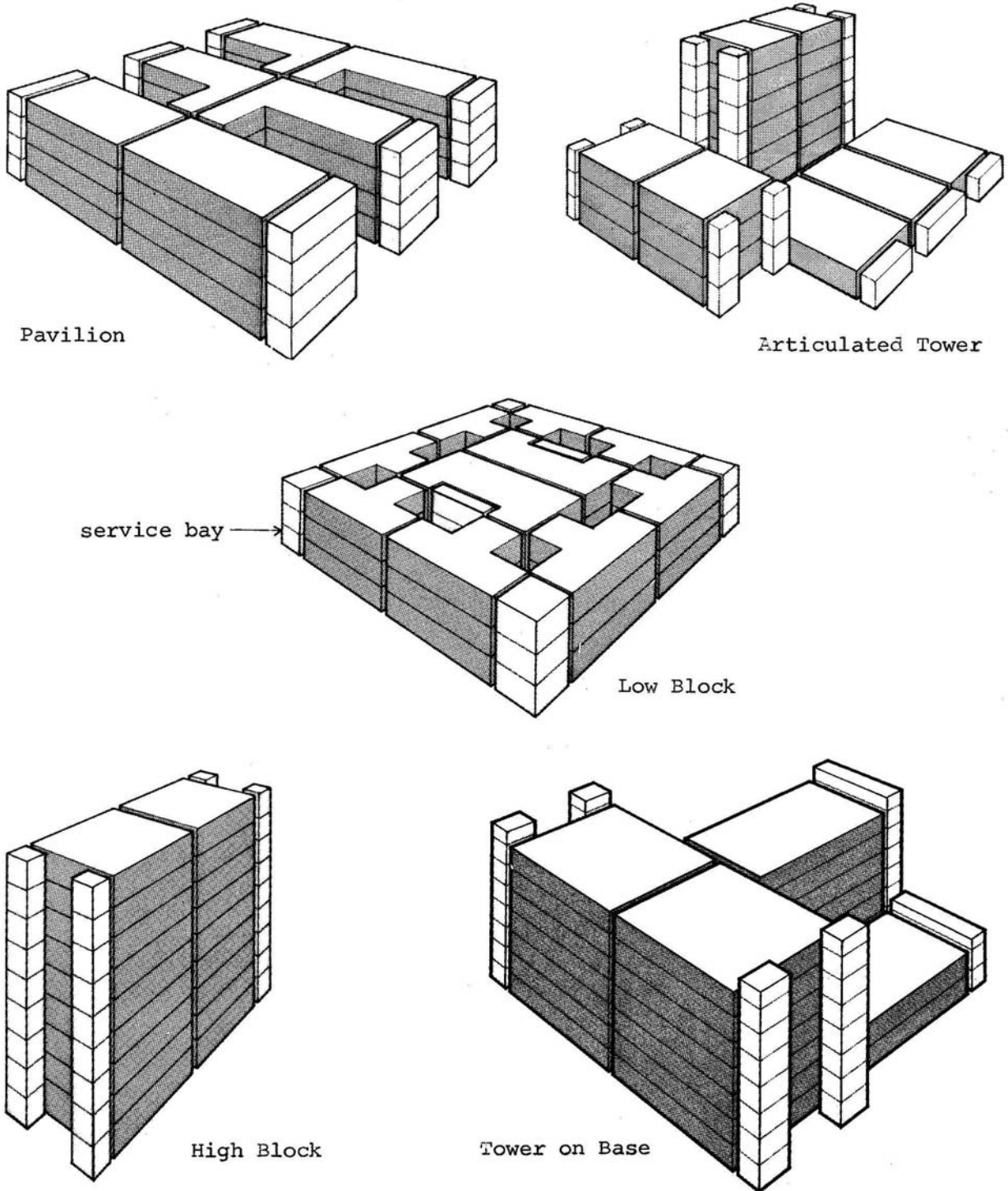

Figure 110-2. THE SERVICE MODULE AS A BUILDING BLOCK FOR ALTERNATIVE BUILDING CONFIGURATIONS



The service bay encloses mechanical and electrical rooms, service shafts, emergency stairs, etc. The arrangement of service modules on successive floors is such that their service bays are stacked. The resulting “towers” provide for main vertical service distribution, as well as for lateral bracing of the structure.

#### **112.4 SPACE MODULES AND FIRE SECTIONS**

Space modules are subunits of service modules occurring in bed-care areas. They have been designed to take into account the special requirements of these areas, such as exterior exposure at the building perimeter (aspect).

Fire sections are building subdivisions providing internal horizontal exits. Service module boundaries will coincide with the boundaries of fire sections, which are arranged according to applicable codes and regulations.

## 113 BUILDING SUBSYSTEMS

### 113.1 INTEGRATED AND NON-INTEGRATED SUBSYSTEMS

Six building subsystems are specifically within the scope of the Prototype Design. They are referred to as the integrated subsystems. Structure, ceiling and partitions are “shell” subsystems, and heating-ventilating-cooling, plumbing and electrical distribution are “service” subsystems (See Figure 110-3).

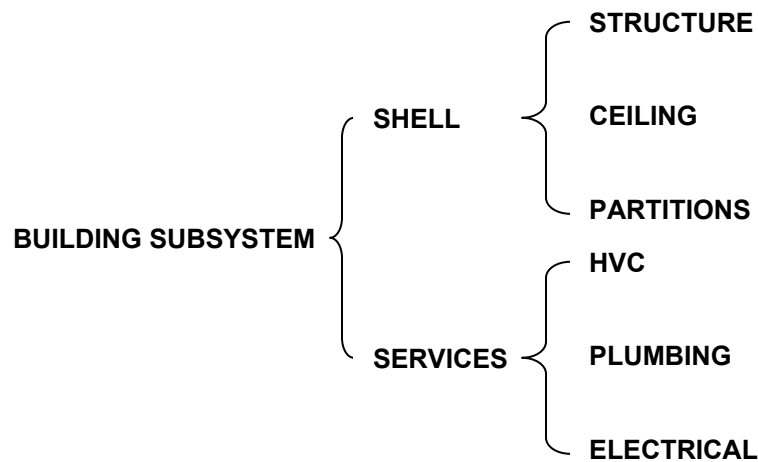

All other subsystems, such as transportation, communication, exterior wall and foundations, have been excluded and are referred to as the non-integrated subsystems.

### 113.2 THE SHELL

The Prototype Design calls for a post and beam, shear wall braced structural system. Shear walls are to be located mainly at the perimeter of the frame, concentrated in the service bays.

The ceiling subsystem is conceived of as a ceiling-platform assembly which, along with a supporting framework, is designed to allow movement of workmen and materials over its entire surface. The platform is hung from the beams above, at a uniform height throughout each fire section. Access to the resulting “interstitial” space is primarily horizontal, via the service bays.

Two-hour partitions required for shaft enclosures and fire section boundaries run from slab to slab. All other partitions are one-hour rated or non-rated and stop at the ceiling-platform.

Figure 110-3. THE BUILDING SUBSYSTEMS

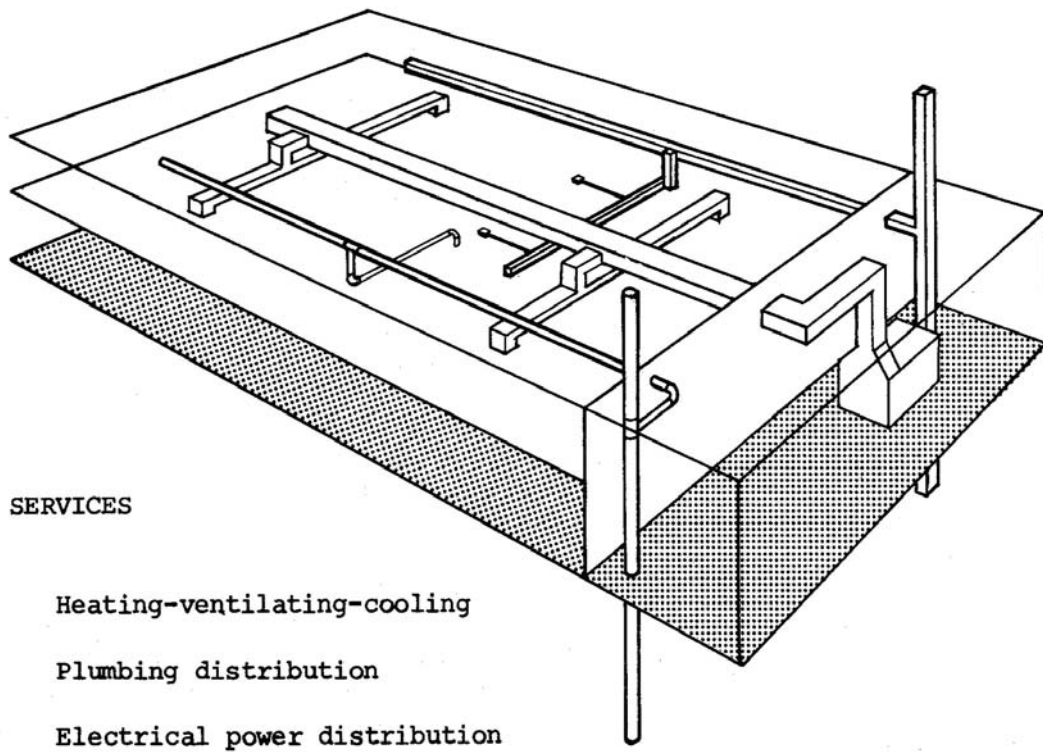
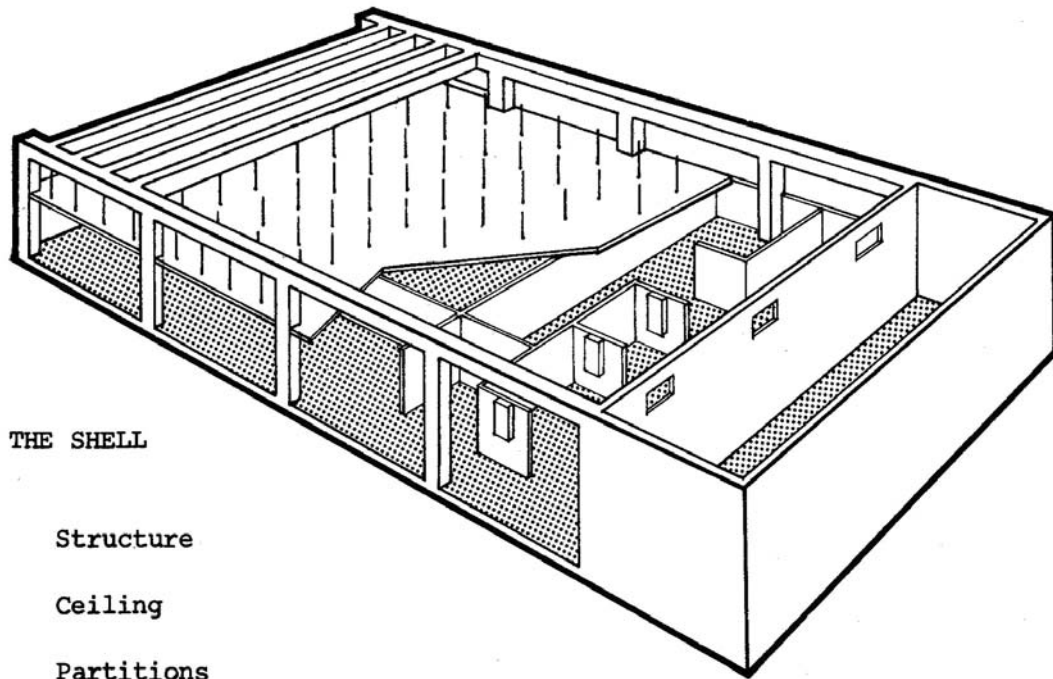

### 113.3 SERVICES

Distribution from the building's central stations to vertical risers should be located in a highly accessible service space, such as a service basement, or a service zone between floors. For purposes of the Prototype Design, it is assumed that the use of a service basement will be the typical case. The pre-organization of this space was not considered appropriate due to the extreme variability of site conditions, hospital size and program, and design configuration. Once the design configuration for a particular hospital has been determined, the service basement can be organized by establishing reserved zones in a manner suggested by the Prototype Design for the service modules.

The principle criterion for the location of service shafts and risers is the minimum obstruction to functional space planning that can be achieved with a reasonably efficient distribution network. Vertical distribution is largely limited to the building perimeter and concentrated in the service bays.

Horizontal distribution within the service module is restricted to the service zone above the ceiling. This zone is organized into a series of subzones, each exclusively reserved for a specific class of service distribution components. With the exception of gravity drains, all services downfeed through the ceiling. Wherever feasible, surface mounted service lines and terminals are clustered and concealed in furred out partition components or in proprietary enclosures.

### 113.4 PERMANENT AND ADAPTABLE COMPONENTS

Certain components of the building subsystems are either assumed to rarely require renovation during the life of the building or are sized in original design to minimize the probability of such a requirement; these components are designated "permanent". They include most structure and ceiling components, two-hour partitions, and certain main distribution lines of the service subsystems. All other components are designated "adaptable" in the sense that they are subject to alteration on a random basis during the life of the building. They are specifically designed to facilitate extension, relocation and replacement. Accessibility to all components for purposes of efficient maintenance is stressed in overall system design, regardless of classification as permanent or adaptable.

## **113.5 DESIGN SPECIFICITY**

### **113.5.1 The Basic Design**

It is the intent of the Prototype Design to have nationwide applicability. Also, it is presently limited to the use of whatever building products are available for each job, since special products have not been developed for the system. No single highly specific building system could be expected to be consistently cost-effective in all possible situations, so the design decisions concerning “fixed characteristics” are only of the type which can reasonably be made in advance of specific construction projects.

### **113.5.2 Generic Design Options**

Within the constraints established by the basic design decisions for each subsystem, a limited number of alternative types of solution has been identified. For example, in response to the performance requirements, the only presently adequate basic class of mechanical system is all-air, within which generic options have been limited to the single-duct and the dual-duct types. The choice between these options, and the detailed design of either, must be performed by the VA and the A/E on a local basis.

### **113.5.3 Detailed Designs**

The detailed design of the various subsystems, including selection of component products, is most effectively executed by the A/E who can respond to the special conditions of a particular site and program. The Prototype Design has gone as far as practical toward making time-consuming decisions and simplifying assumptions in advance without unnecessarily constraining design freedom.

**(BLANK PAGE)**



## 120 Application

### 121 PROCEDURE

The approach to procedure is the same as that taken to the Prototype Design itself in that a highly specific predetermined “system” procedure is considered neither feasible nor desirable. Specific procedures must be tailored to each project as appropriate to program, site, budget, available technology, etc. The Design Manual simply sets forth general guidelines applicable to any project utilizing the building system.

In principle, the system can be used in programming and budgeting. For example, the size of a proposed hospital could be specified as so many service modules of given capabilities, which would allow a variable bed count in the completed facility, and a budget figure could be assigned to each module. However, the Design Manual deals directly only with design and construction. The section on procedure starts with the assumption that a hospital program (master plan) has been generated and a preliminary budget established in the normal manner.

The advantage provided by the planning modules is that preliminary planning can start somewhat earlier than usual. Alternative schematic designs can be generated on the basis of a preliminary program which provides only gross area requirements for nursing units, administrative departments, etc. The modules establish basic structural and service distribution patterns “automatically” with the development of each schematic design. The adaptability of the modules also allows response to program and budget changes to occur more efficiently throughout the entire design and construction process.

In the case of the building subsystems, the tasks of engineering design, architectural detailing, specification writing, etc., can be executed within the framework of existing policies and established responsibilities. The function of the Manual is to provide some basic decisions in advance which can substantially simplify certain time-consuming tasks, plus a coordinated set of criteria to assist in making other decisions. Care must be taken in cost estimating and preparation of contract documents to ensure that the unique characteristics of the Prototype Design are taken into account and clearly communicated. For instance, the integrated subsystems are not presented in the Design Manual according to conventional specification divisions or construction sub-contracts; thus VA Master Construction Specifications used for a system building must be carefully edited to ensure complete applicability to the detailed design, and in some cases, new specification sections may have to be developed.

**122 THE DATA BASE**

To provide a Data Base for the Prototype Design, information on user needs, functional space requirements, costs, labor union restrictions, codes, and various applicable regulations was collected and analyzed. This information can be of considerable value in the selection of generic design options, the development of specific system designs, and in the planning and design of the hospital itself. Therefore it is presented as a supplement to the Design Manual, and to the program (master plan) for each hospital.

The Data Base is subject to growth and change in much the same manner as the Prototype Design. Its scope is presently limited to the material that was particularly relevant to the Systems Integration program. A major addition will be the evaluations of hospital projects utilizing the system.

The Design Manual and Data Base are thus integral parts of the "A/E package" provided to the designer in each building project to assist him in making the most effective use of previous experience within the VA, as well as his own resources.

## **200 THE PLANNING MODULES**

### **210 THE STRUCTURAL BAY**

211	Basic Design	1- 15
212	Capabilities	1- 17

### **220 THE SERVICE MODULE**

221	Basic Design	1- 19
222	Size and Shape	1- 22
223	Service Bays	1- 29
224	Service Zone	1- 36
225	Functional Zone	1- 45

### **230 THE SPACE MODULE**

231	Basic Design	1- 47
232	Space Module Characteristics	1- 50
233	Catalog of Space Module Capabilities	1- 62

### **240 THE FIRE SECTION**

241	Basic Design	1- 77
242	Fire Section Characteristics	1- 79

### **250 PLANNING MODULE APPLICATIONS**

251	Design Configurations	1- 83
-----	-----------------------	-------

**(BLANK PAGE)**

## **210 The Structural Bay**

### **211 BASIC DESIGN**

The structural bay is the basic unit of which all other modules are composed (See Figure 210-1). A special variation of the structural bay called the service bay encloses mechanical and electrical rooms, service shafts, emergency stairs, etc. (See Section 220: The Service Module).

The range of structural bay sizes established for the Prototype Design is based on a constant bay width of 22'6" and a variable bay depth ranging from 40'6" to 58'6" in 4'6" increments plus, where required, an 18'0" cantilever. (See Section 131.5.1.)

These dimensions are derived from the organizational requirements of the nursing unit as the most repetitive and most stable functional unit in the hospital (See Section 230: The Space Module) and subsequently confirmed as suitable for the functional space requirements of the non-bed care portions of the hospital. The bay width is consistent with general VA practice. The bay depths are somewhat greater than those commonly found in VA hospitals, but less than the spans seen in some current projects.

Two features of the narrow structural bay compared to large two-way spans are: it permits a finer adjustment of overall plan shape, and it is a valuable small-scale increment of expansion.

The dimensions of the structural bay are thus derived from the need to achieve certain functional arrangements of space. If in time these arrangements lose validity, new structural bays can be established.

Figure 210-1. THE STRUCTURAL BAY

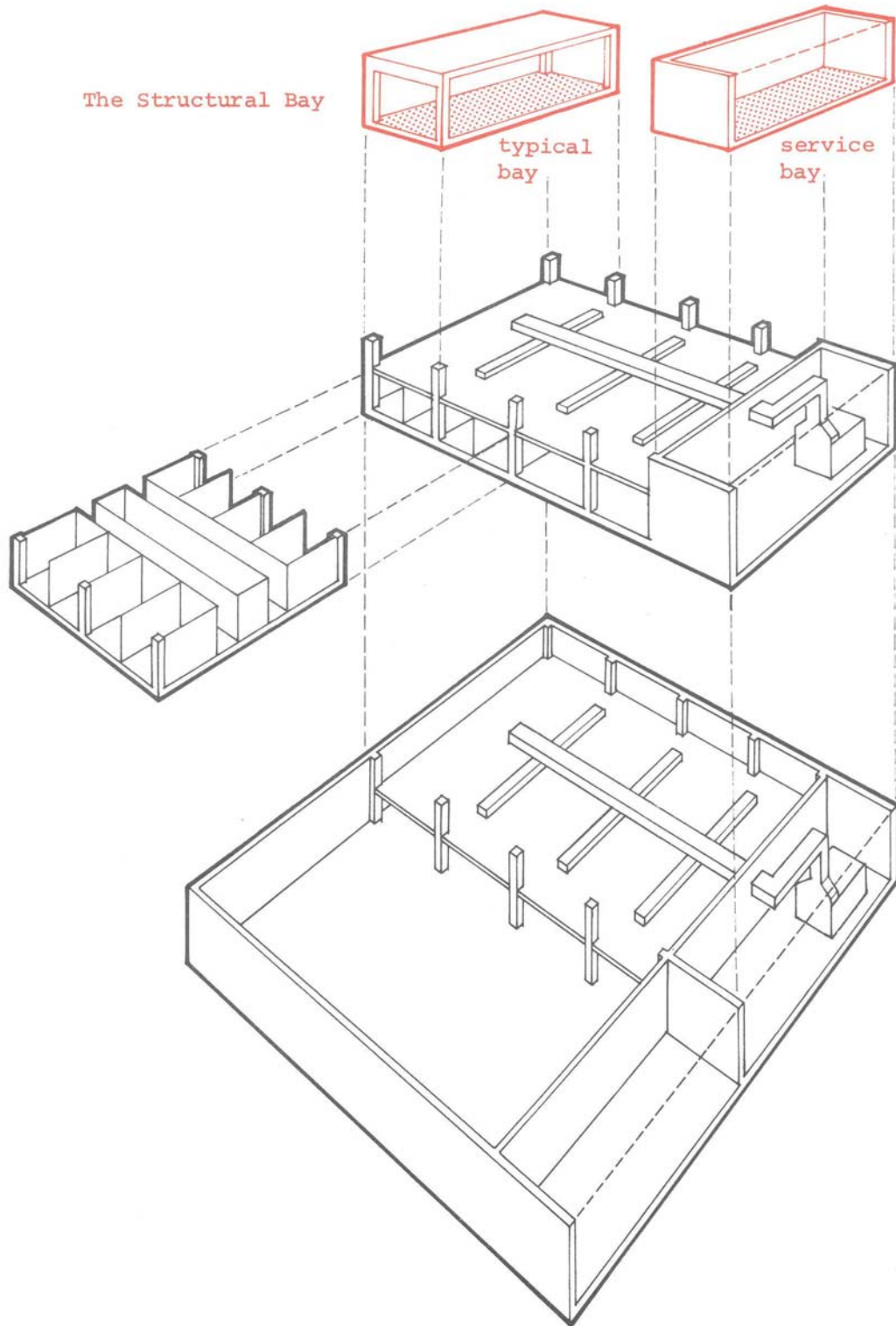

## 212 CAPABILITIES

### 212.1 BANDS OF FREE SPACE

The rectilinear bay system provides bands of free space equal to the bay depth. The minimum dimension of this band is 40'6" and the maximum dimension is 58'6".

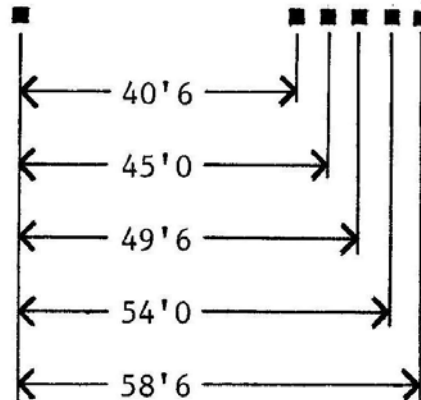

### 212.2 SPECIAL AREAS

#### 212.2.1 Large Column-Free Rooms

Where the occasional large column-free room occurs in the hospital, such as the auditorium, gymnasium, etc., there are no critical organizational relationships that would inhibit its location within one of these bands of free space. The minimum of 40'6" can readily accommodate any auditorium with a seating capacity of up to 200 seats, and a band of 58'6" can accommodate an auditorium with a seating capacity of up to 400 seats.

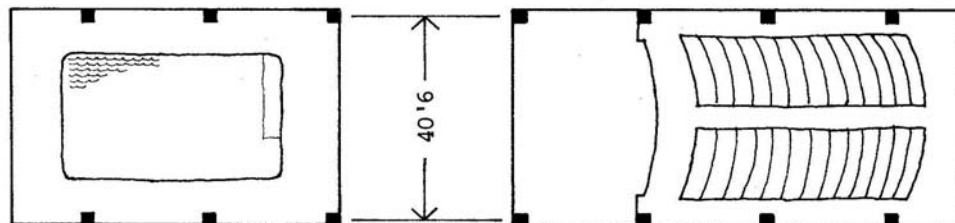

However, the auditorium, gymnasium and swimming pool have other requirements such as height, penetration of slab, etc., that imply some modification to the basic structural system.

In the case of the auditorium and gymnasium, two levels might be used to satisfy the necessary height requirements.

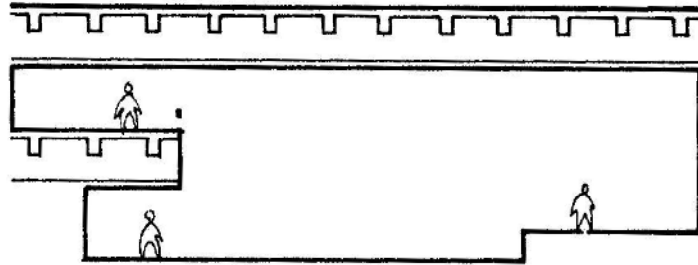

The swimming pool could be located in the basement or on the ground floor because of its weight and to minimize disruption of the service zone.

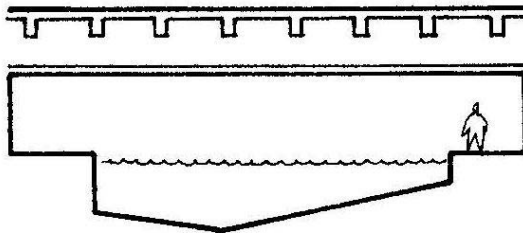

### 212.2.2 Suites of Large Rooms

In the repetitive situation where a number of large rooms occur in a precise organizational pattern, such as Surgery and Radiology, it may become necessary to intersect a line of columns. In these cases, the 22'6" bay spacing becomes critical. As stated previously, this bay width is consistent with general VA practice and the simulation studies in Section 710, Design Rationale, Planning Modules, demonstrate how the organization of these critical areas can be readily achieved within the constraints of the structural system.



## **220 The Service Module**

### **221 BASIC DESIGN**

The service module is a unit of space, one floor in height, served by its own service distribution system including the air-handling unit.

In plan, the service module consists of a number of typical structural bays plus a service bay. In section, the service module consists of the service bay, a functional zone and a service zone.

Air-handling units and/or supply and exhaust ducts, electrical equipment, and all vertical piping and risers are located in the service bay. Distribution from the bay to the functional zone is via the service zone above the ceiling. (See Figure 220-1). Therefore, the functional zone is free from the constraint of vertical service penetrations.

Dimensional characteristics of service modules are determined by the space modules, by the service content and service organization necessary to support the activities housed, and by the overall structural characteristics required for resistance of lateral forces.

The optimum size for an independent service module is about 10,000 square feet, which represents a good compromise between largeness for economy and smallness for adaptability. The actual area of the service module, exclusive of the service bay, will vary according to the size of the structural bay and the plan configuration, and may range from 5,000 to 20,000 square feet, which is currently the maximum size for a fire section.

#### **221.1 BENEFITS**

The service module is the most significant of all the planning components in that it combines and coordinates all the interrelated characteristics of building organization, namely, function, structure, service distribution and fire safety.

##### **221.1.1 Design**

The integration of these characteristics within a single unit of space provides the opportunity to conceptualize a building as an assembly of "building blocks".

Figure 220-1. THE SERVICE MODULE

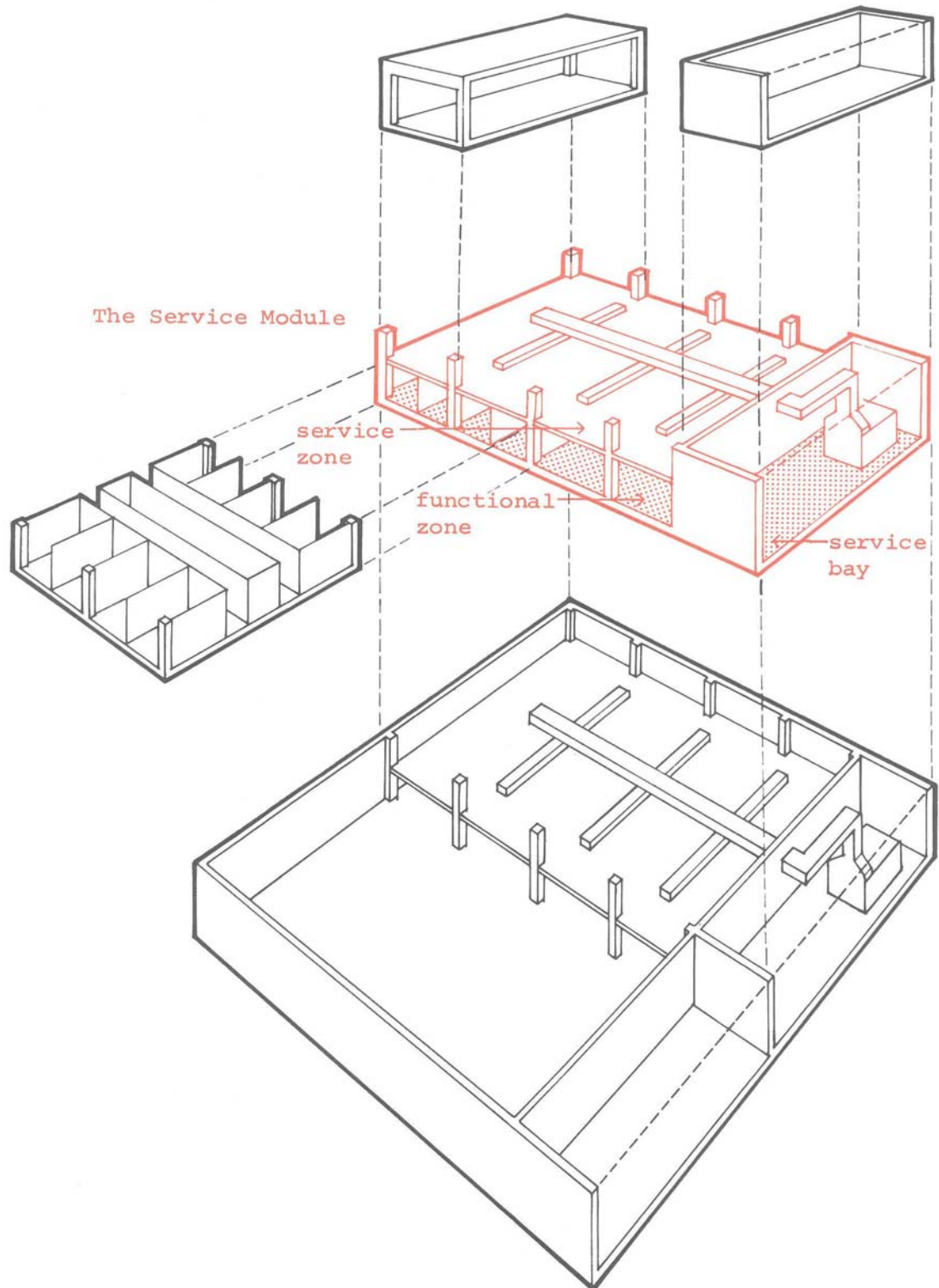

The “building block” concept offers considerable advantage in design, construction, and operation and maintenance.

Once derived, the service module provides a means of manipulating overall plan configuration with the assurance that the subsystem capability remains.

Furthermore, the use of service modules with known assembly characteristics and precoordinated building subsystems can shorten the design process and allow construction to start prior to completion of detailed planning, should this be desired.

### **221.1.2 Adaptability and Variability**

The mechanical independence of the service module permits one unit to undergo alterations while adjacent units can continue to operate unaffected. Some functional areas that do not operate on a 24-hour basis can be shut down when not in use, and some units can use 100% outside air while others use 25%.

## **221.2 DERIVATION**

The service module is directly derived from the requirements for efficient organization of the structural and services subsystems. These establish a scale of space and performance sufficiently generalized to be compatible with a wide range of departmental sizes and environments. In the patient bedroom areas, the service module is more precisely tuned to the functional requirements of the nursing unit by means of the space module. (See Section 230: The Space Module).

## 222 SIZE AND SHAPE

### 222.1 RANGE OF SIZES

The overall dimensions of service modules, exclusive of service bays, vary in length in increments of 22'6", and in width in increments of 4'6".

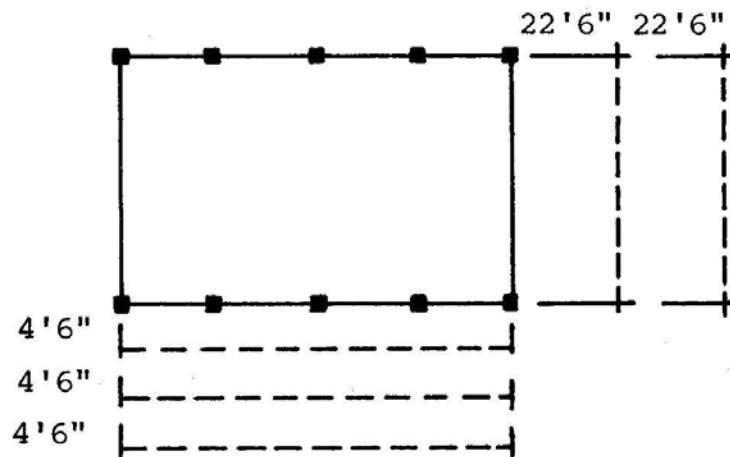

The full range of simple rectangular areas available as service modules, exclusive of service bays, is fixed by structural, services distribution and fire safety considerations. (See Figure 220-2.)

#### 222.1.1 Thermal Expansion Joints

Shear wall locations are limited to the perimeter of service modules, except that they may occur within the service bays. In fact, the wall between a service bay and the rest of the module in which it occurs will normally be a shear wall. Since independent structural units, as defined by thermal expansion joints, cannot exceed 300 feet in any dimension, and each such unit must have a reasonably balanced array of shear walls, most design configurations will involve shear walls spaced closer than 300 feet. Thus, the maximum dimension of a service module could not be larger than this figure.

#### 222.1.2 Diaphragm Proportion

In the patient bedroom areas, where service modules are made up largely of space modules, each service module would have at least two opposite boundaries at exterior walls. Floor slabs, acting as diaphragms spanning between two shear walls, should not exceed a proportion of three to one in length to width.

Figure 220-2. NOMINAL SERVICE MODULE DIMENSIONS

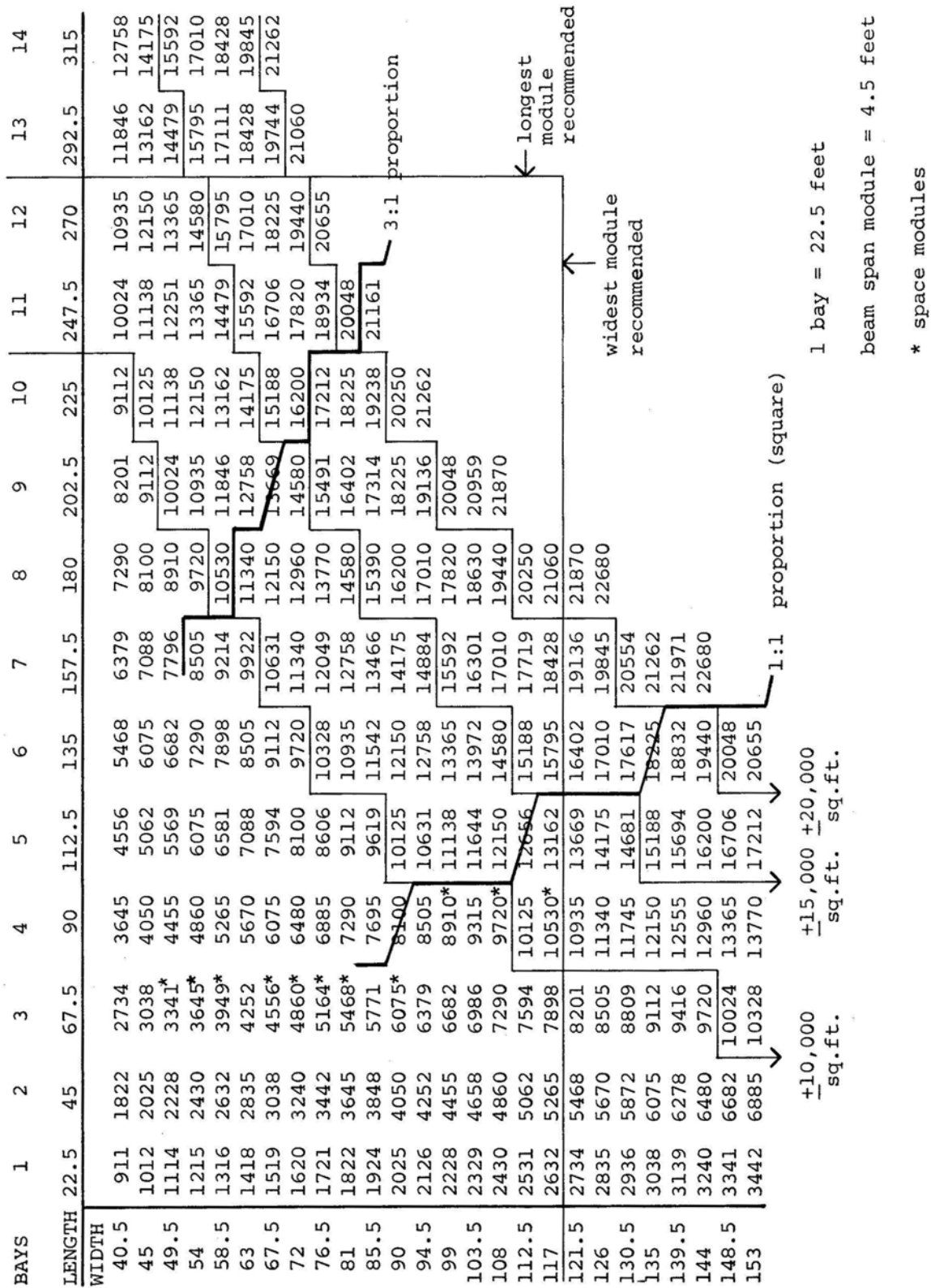

For example: space module type 8 (See Section 233: Catalog of Space Module Capabilities) has an overall width of 90 feet. With a three to one ratio, the maximum length of diaphragm is limited to ten structural bays (225 feet). Thus, no nursing floor service module based on this particular space module type can be longer than 225 feet.

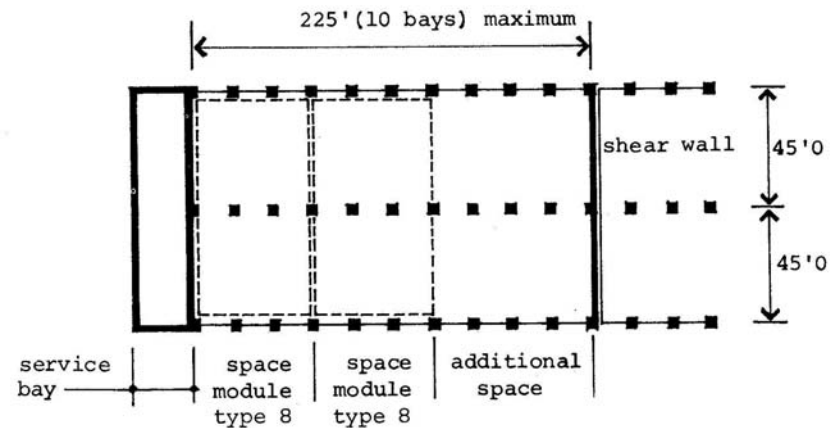

### 222.1.3 Fire Sections

Service modules are optimum at about 10,000 square feet as far as the HVC subsystem is concerned, and fire sections as close to the 20,000 square foot code limit as possible are best for purposes of minimizing obstructions by two hour fire partitions. A relatively efficient combination is two service modules per fire section. However, in situations involving service modules which must be larger than 10,000 square feet, which will be the case when certain space modules are combined, the fire sections will have to be the same size as the service module. In this event, there is a conflict between minimizing the service module and maximizing the fire section, in which a reasonable compromise may be in the neighborhood of 15,000 square feet.

## 222.2 RANGE OF SHAPES

### 222.2.1 Narrow Service Modules

Service modules narrower than about 50 feet are difficult to organize into longitudinal service distribution zones with good accessibility. They also produce a serious problem of coordination where the main distribution lines penetrate the shear wall between the service bay and the rest of the module. These difficulties are significant in a 10,000 square foot module, which if 50 feet wide would be 200 feet long; they would be very serious in a 15,000 square foot module, which at the same width would be 300 feet long. It is therefore not advisable to constitute long service modules of single span bays with less than the 49'6" span provided by the system.

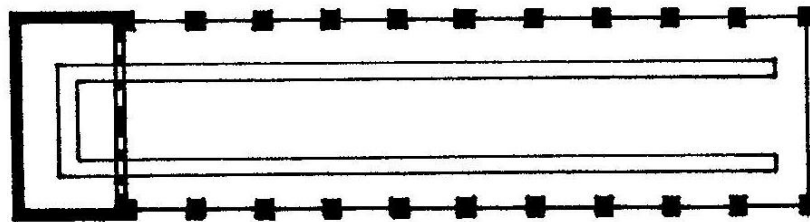

### 222.2.2 Wide Service Modules

The greatest width of service module that can be generated by a double span within the system is 117 feet.

Wider modules would require more than one interior girder. Since modules of the 10,000 square foot optimum size would require two supply trunk ducts, even with a single duct reheat system, it is a simple matter to serve a double span module. A triple span, however, would require either long branches, or an additional trunk duct.

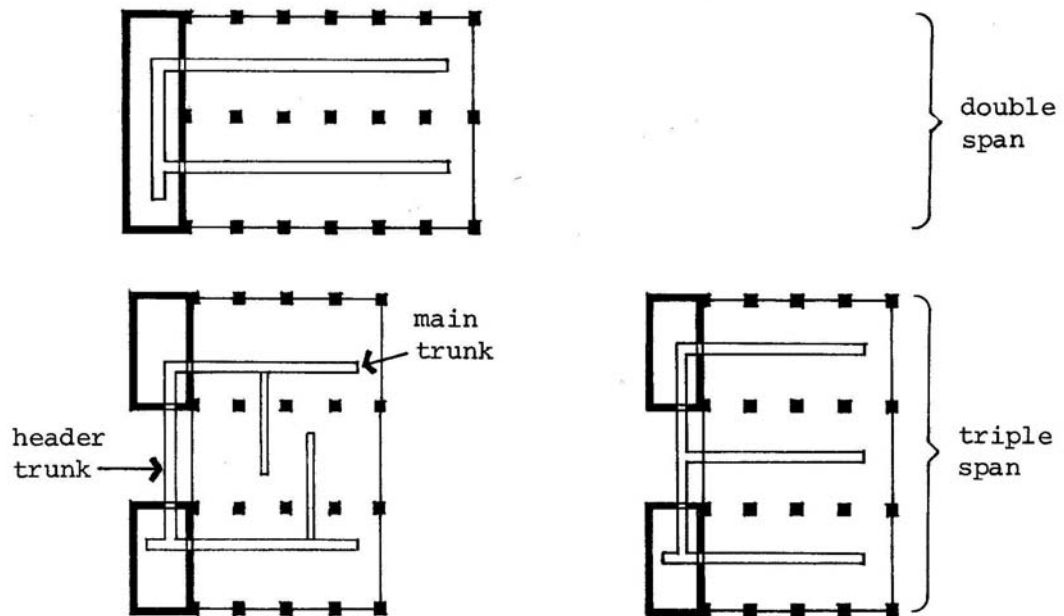

Moreover, 117-foot wide service modules in the 10,000 to 15,000 square foot range would be approximately square, whereas wider modules would be shorter, thus requiring a large amount of header ductwork between main trunks in proportion to the trunks themselves.

### 222.2.3 Special Service Modules

The simple rectangle, discussed previously, is the most effective shape of service module in terms of structure and service distribution.

In the majority of hospital configurations, this shape can be readily maintained but in many larger hospitals courtyards may be required. Courtyards can be readily formed by omitting structural bays from that end of the service module opposite to the service bay.



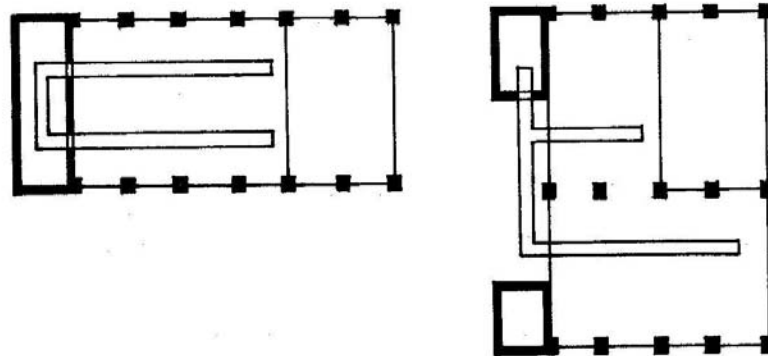

Where courtyards are formed within a single span, the length of the courtyard can vary in increments of the particular beam spacing.

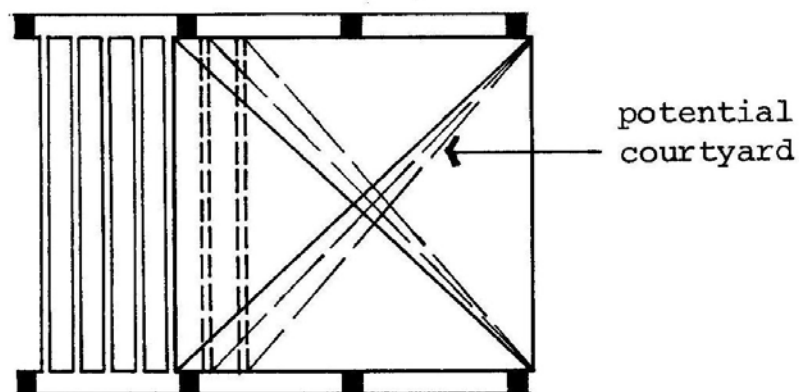

In some configurations, service modules other than rectangles may be appropriate. (See Section 251: Design Configurations.) Service modules can be 'L', 'T', or 'U' shapes provided that the constraints imposed by the structural bay and service distribution are respected.

These service modules may be regarded as single span service modules with a limited number of additional bays attached laterally. Main distribution of the mechanical, electrical and plumbing subsystems is confined to the single span service module and the additional bays are served by branch distribution.

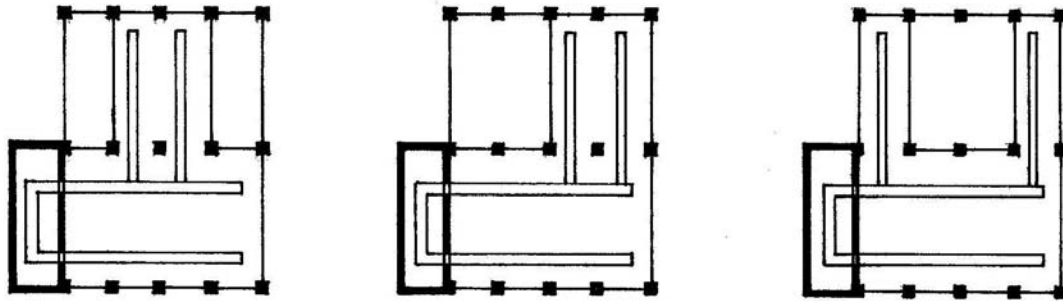

This branch distribution imposes a limit on the density of services that can be provided in these additional bays and the dropped girder restricts access. Therefore, the functions accommodated in these bays should have a low order of service demand.

## 223 SERVICE BAYS

In its simplest form, each service module will contain a service bay which houses all the basic equipment for the three service subsystems and all vertical service distribution to and from the module. The vertical distribution includes all supply services from the central plant and all risers and shafts to roof-level equipment or outlets.

The concentration of all vertical services within the service bay area will leave the functional zone free for planning and replanning without the traditional impediment of service stacks. Locating all service equipment here too also frees the functional zone, and simplifies the organization of the service zone where access and space for equipment would be more complex and cause problems of industrial safety.

### 223.1 TYPICAL ARRANGEMENT

The components of the service bay are the mechanical room, exhaust shafts, electrical room, plumbing and normally an escape stair. All these areas will be entered at the functional zone level. Any required crossover of services from equipment or risers to align with service zone main distribution, such as HVC header ducts or electrical and plumbing runs, must take place within the service bay to avoid overcrowding of the near end of the service zone (See Figure 220-3.)

The service bay will always be located on a side of the service zone parallel to the beams, so that the main service distribution into the service zone is made perpendicular to, and directly under the beams.

The mechanical room will contain typically the air-handling unit for the service module with a direct inlet through an external wall for outside air supply, and the general return/exhaust fan. The exhaust shafts will include general exhaust, and toilet and special exhaust, leading to roof mounted fans. The plumbing risers will include the pressure systems, drainage and piping for heating and cooling water to the HVC system. The electrical room includes all the electrical and communications equipment such as transformers, related switchgear and branch circuit panels, etc., for the service module.

Figure 220-3. TYPICAL SERVICE BAY

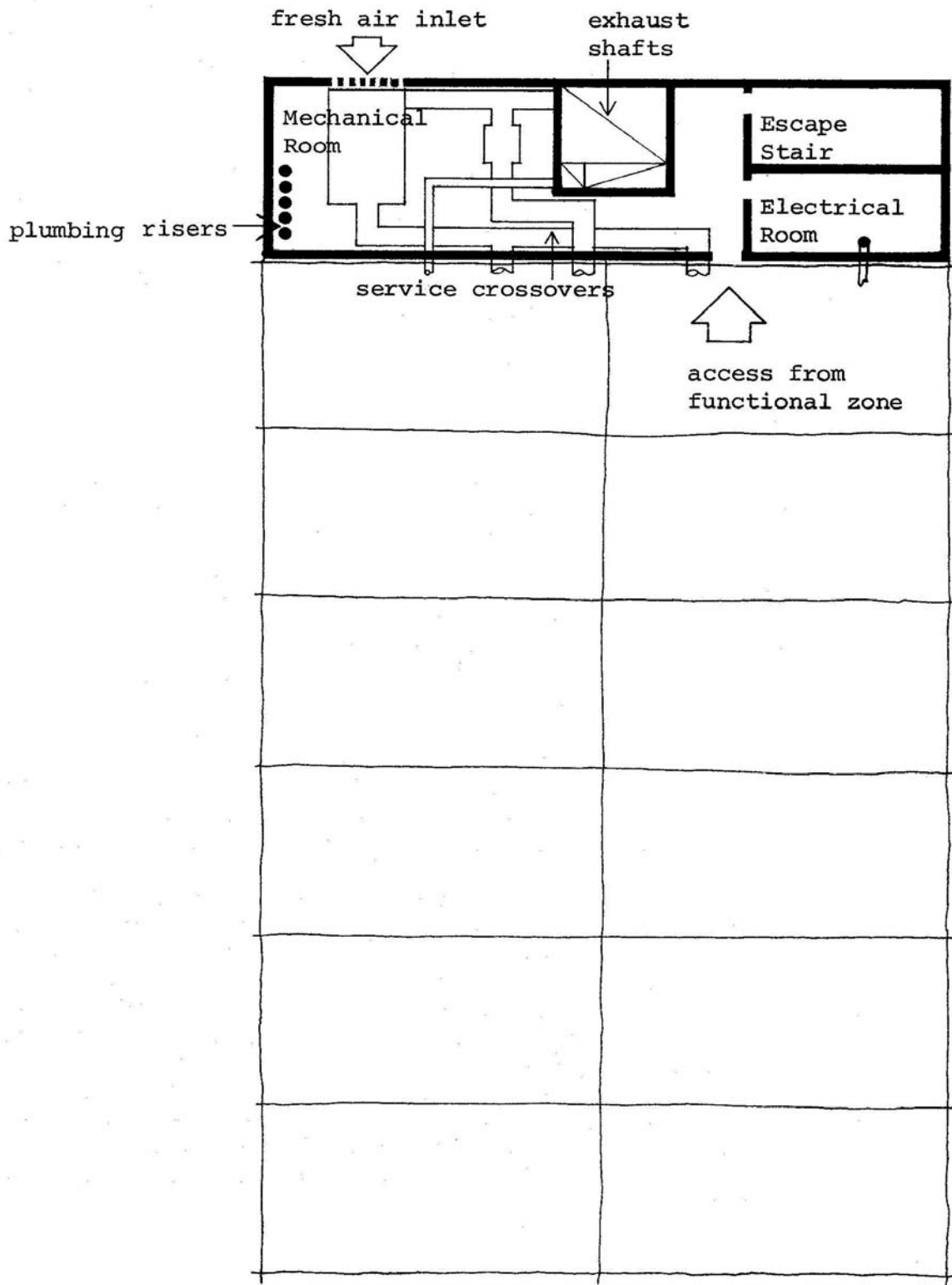

The service bay will provide some of the shear walls for the overall seismic resistance of the structural frame. It will also normally be bounded by two-hour fire partitions (or shear walls) as it always occurs at the boundary of a fire section and also contains special hazard areas.

## **223.2 VARIATIONS**

The organization of service bays described above will be typical for service modules generated from two-aspect space modules and for most other conditions. But there are two important variations:

### **223.2.1 Split Service Bays**

Service modules based on four-aspect space modules will necessitate the use of a split service bay giving an external aspect to the bedrooms between the equipment rooms. Figure 220-4 shows a typical arrangement for this variation. Modules of this type are all comparatively wide; the illustration is based on two bays of 49'6". The service crossovers in this case will take place in an accessible exterior housing placed between the equipment rooms at the service zone level.

### **223.2.2 Internal Service Bays**

The second major variation occurs in large hospital configurations where some service bays must be placed in an internal position between service modules. (See Figure 220-5.) Three special conditions arise in this situation. The first is the omission of the escape stair, as the service bay becomes part of a horizontal exit between the service modules lying to either side. The second condition is the requirement for a maximum width of access between the two functional zones to facilitate circulation. The third condition is the problem of providing outside air to the air-handling units. As discussed under Section 340, the preferred solution is to place these units at roof level and duct down supply air to the service module. This means that the area originally containing the mechanical room becomes a set of supply duct shafts to the various floor levels. In a moderate-rise building these will take up less floor area than a mechanical room and therefore leave more space for the circulation access described above. Where a group of internal service bays are lined up through a building configuration, this is referred to as a service strip. (See Section 411.6.3.)

Figure 220-4. SPLIT SERVICE BAY

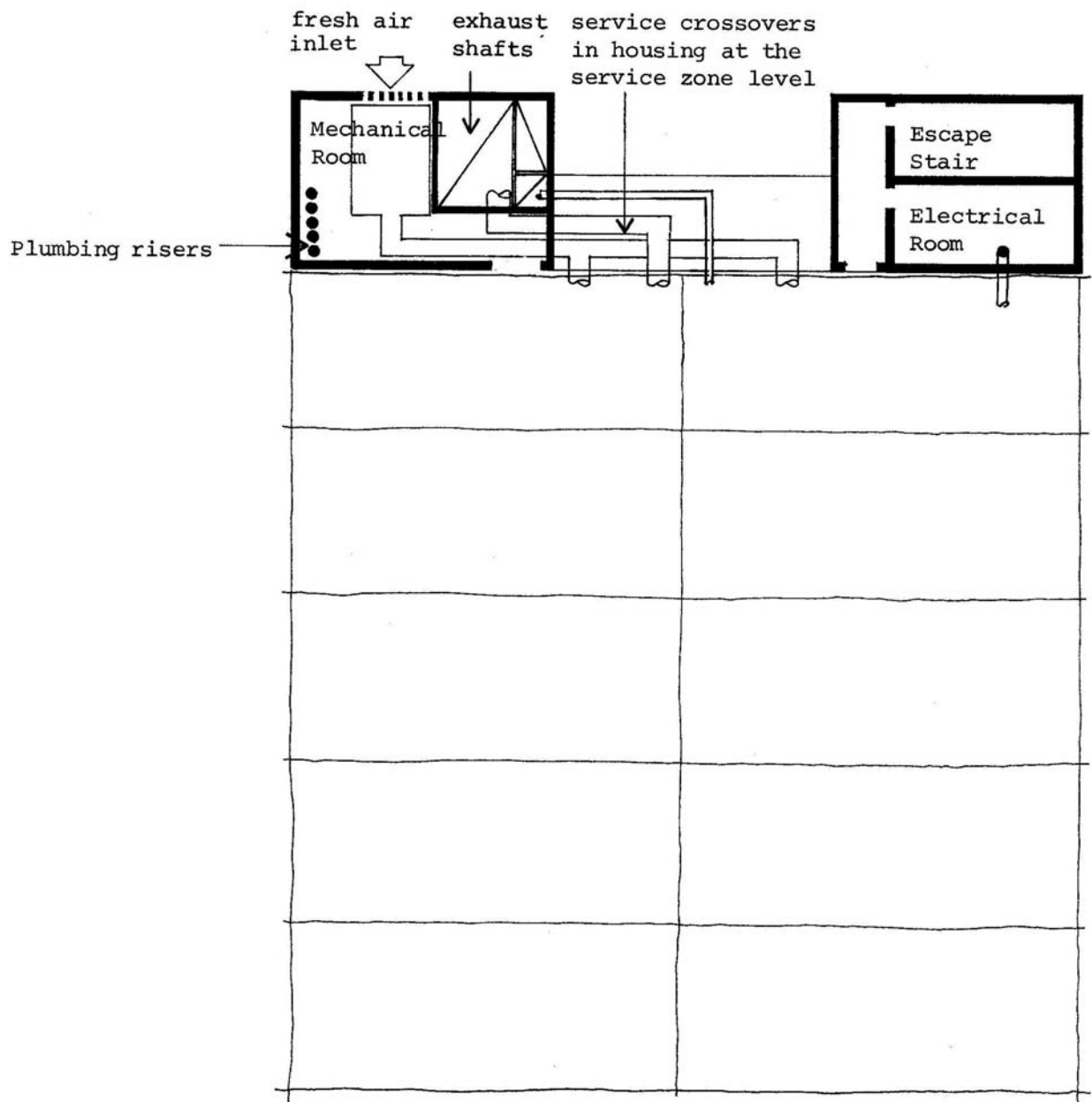
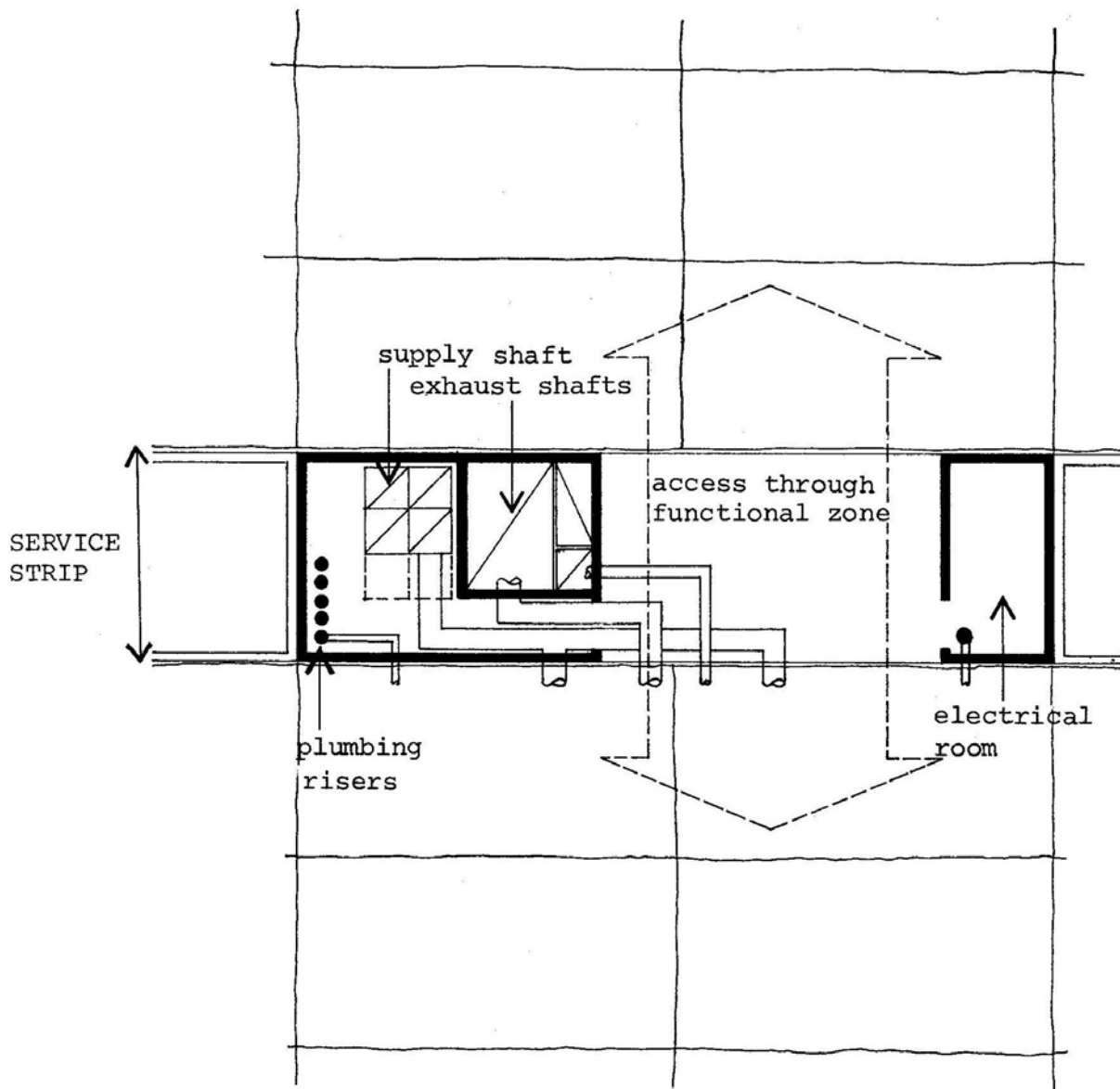

Figure 220-5. INTERNAL SERVICE BAY



### 223.3 LOCATION

The location and design of the service bay is important for fire safety and acoustics. All the elements require two hour fire enclosure and the mechanical room requires acoustic isolation. This isolation can be maintained by absorbent room linings, isolation mounting for equipment and, most important, the sealing of all openings through the shear walls into the functional and service zones. The mechanical room must be designed to allow installation and removal of the air-handling unit through the opening in the exterior wall provided for the outside air inlet. All other equipment change can be handled by service elevators outside the service bay. Appropriate access routes through the functional zone to such elevators will be required for equipment handling.

### 223.4 PRIORITY OF SERVICE

The services distribution and the equipment rooms in any service bay will be designed to handle the service requirements of its own service module. It is, in fact, the service control point for the module.

But to allow for some diversification, it might be appropriate to share service between modules, either in the case of excessively high local service loads, or to share an unusual service. This coupling is simple to achieve where two service modules are in the same fire section, as there is only a smoke stop or plenum barrier between the service zones. Servicing to modules outside the fire section through the two-hour fire partition is also feasible, except that sealing the duct and pipe openings and fire dampering the ducts makes this option more complicated. See diagram below.

Despite the relative ease of this sharing of services, it is highly preferable to avoid the use of these options to simplify the control zones of each service, preserve the simplicity of maintenance, and avoid the complications of fire safety devices.



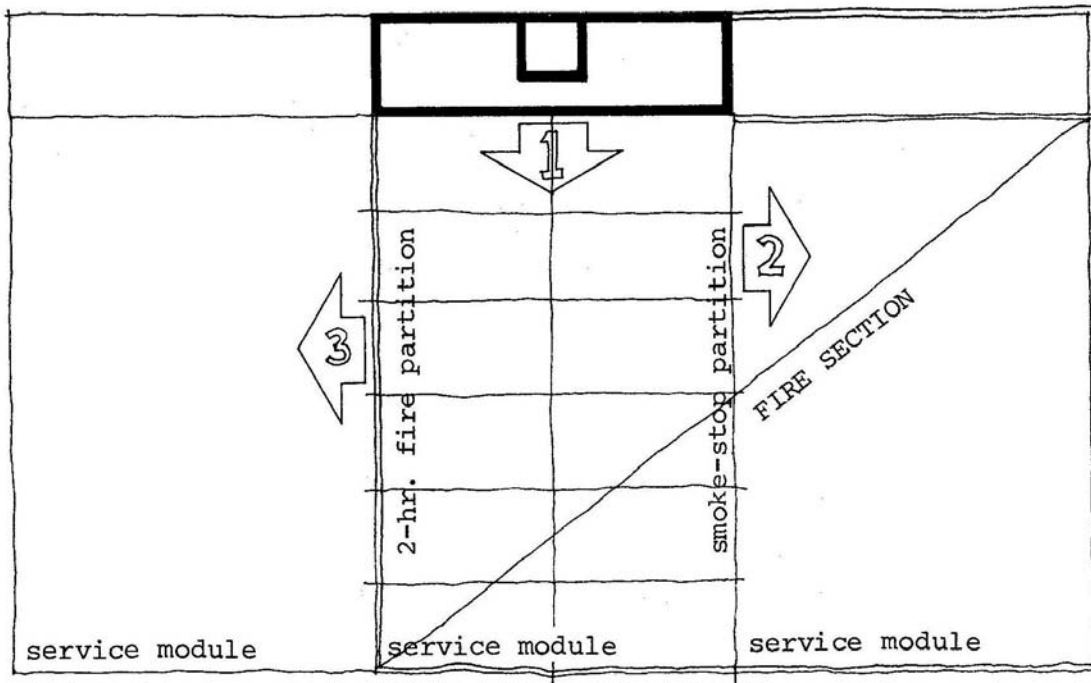

PRIORITY OF SERVICE

## 224 SERVICE ZONE

The service zone carries the horizontal service distribution of the service module. All services are downfed to the functional zone with the exception of the gravity drains from the service module above.

All service runs will be organized on the basis of reserved subzones and channels to simplify design and installation, and to preserve rights-of-way for future service runs. The subzones and channels are organized as follows:

1. Subzones: define the direction of travel of the services. They are horizontal layers of the service zone. The main service distribution lines are all parallel, each connecting to branches at right angles to the mains, and the branches connecting, where required, to laterals at right angles to the branches. The mains and laterals will run parallel to the girders, the branches parallel to the beams.
2. Channels: define a reserved location in a subzone for a particular service. They generally apply only to the main distribution; for example, HVC supply ducts, etc.

With this organization it is obvious that no shortcut or point-to-point routing of services can be permitted without jeopardizing the predictability of initial or future installations.

The working height of the service zone is likely to be about seven feet based on service subzone requirements. This figure is about the maximum acceptable to some authorities before the service zone is considered a separate story, with some consequent regulation disadvantages.

### 224.1 SUBZONES

The following descriptions note the typical contents and criteria for each subzone. See Figure 220-6.

#### S1 Floor Slab.

This subzone equals the depth of floor finish, topping slab and structural slab.

S2 Branch Distribution: parallel to beams.

This subzone will contain the structural beams, pressure piping, and the gravity drainage and vents for the service module above. The calculated depths required for these components will govern the design depth of the subzone.

S3 Main Distribution: parallel to girders.

This is the major subzone and is reserved for main distribution of services through the length of the service zone. It is divided by service into channels. The depth will be governed by the requirements for HVC supply and return/exhaust ducts. (See Section 344.2.)

S4 Branch Distribution: parallel to beams.

This subzone contains the HVC and electrical branches and vents, with the HVC branches governing the design depth.

S5 Lateral Distribution: parallel to girders.

This subzone will take the final service run to its location over the service drop into the functional zone. It will contain HVC flexible duct and terminals, electrical conduit and junction boxes, and final plumbing runs. Any projections from the ceiling construction, such as I-beam strongbacks, will run parallel to the services at this level. The HVC flexible duct and terminals will determine the design depth for this subzone.

S6 Platform/Ceiling

This subzone equals the overall depth of the walk-on platform, ceiling structure and finish.

## 224.2

### CHANNELS

Channels are plan subdivisions of a subzone and define the rights-of-way of particular services. At the S3 level, they provide reserved space for the main distribution of services, both those originally required for the service module and any predicted future need. Figure 220-8 shows a representative set of channels in a service zone of two spans of 40'6". Included are subzones designated for personnel access.

Figure 220-6. SUBZONES: SECTION THROUGH BEAMS

All dimensions are nominal.

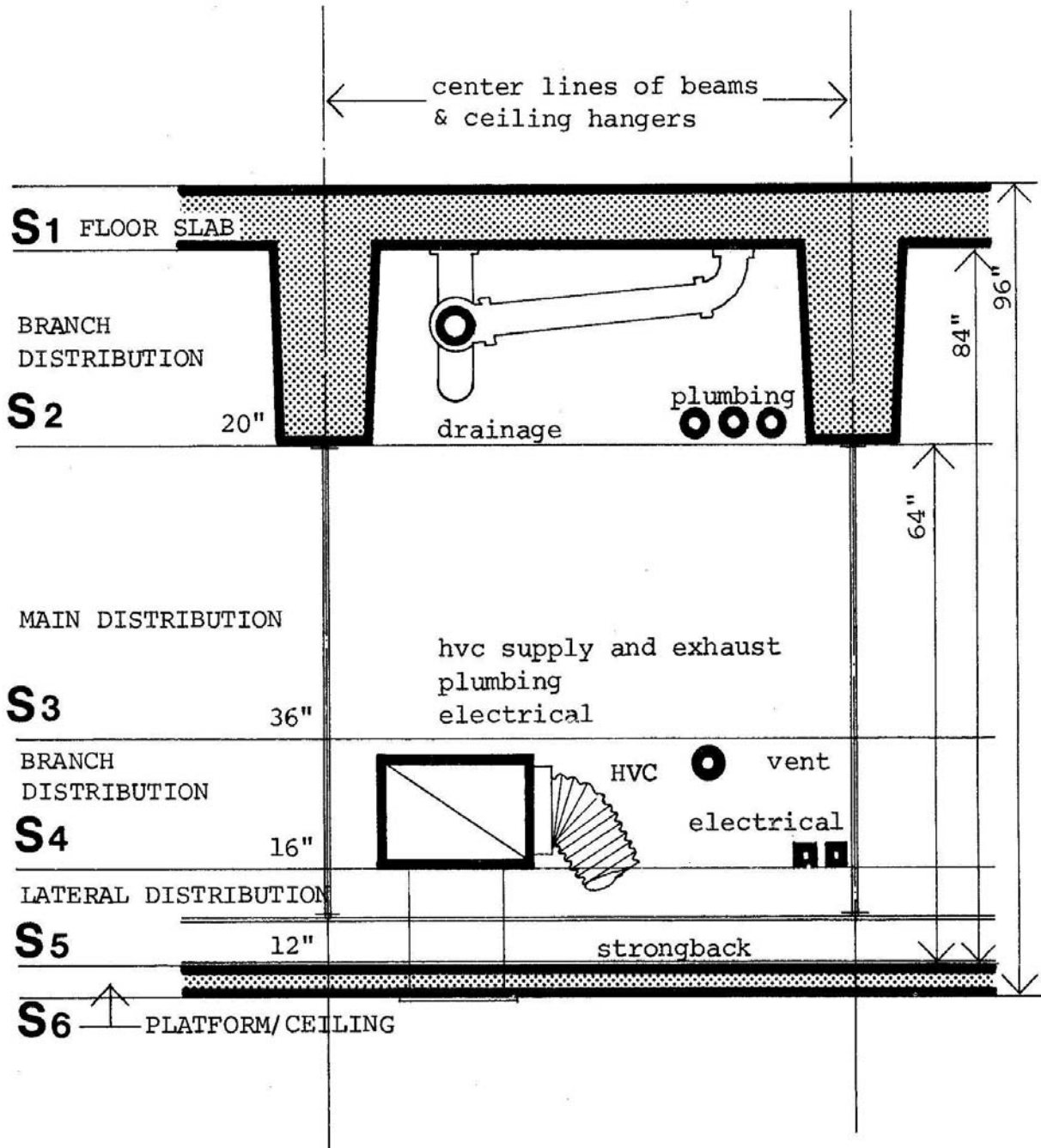
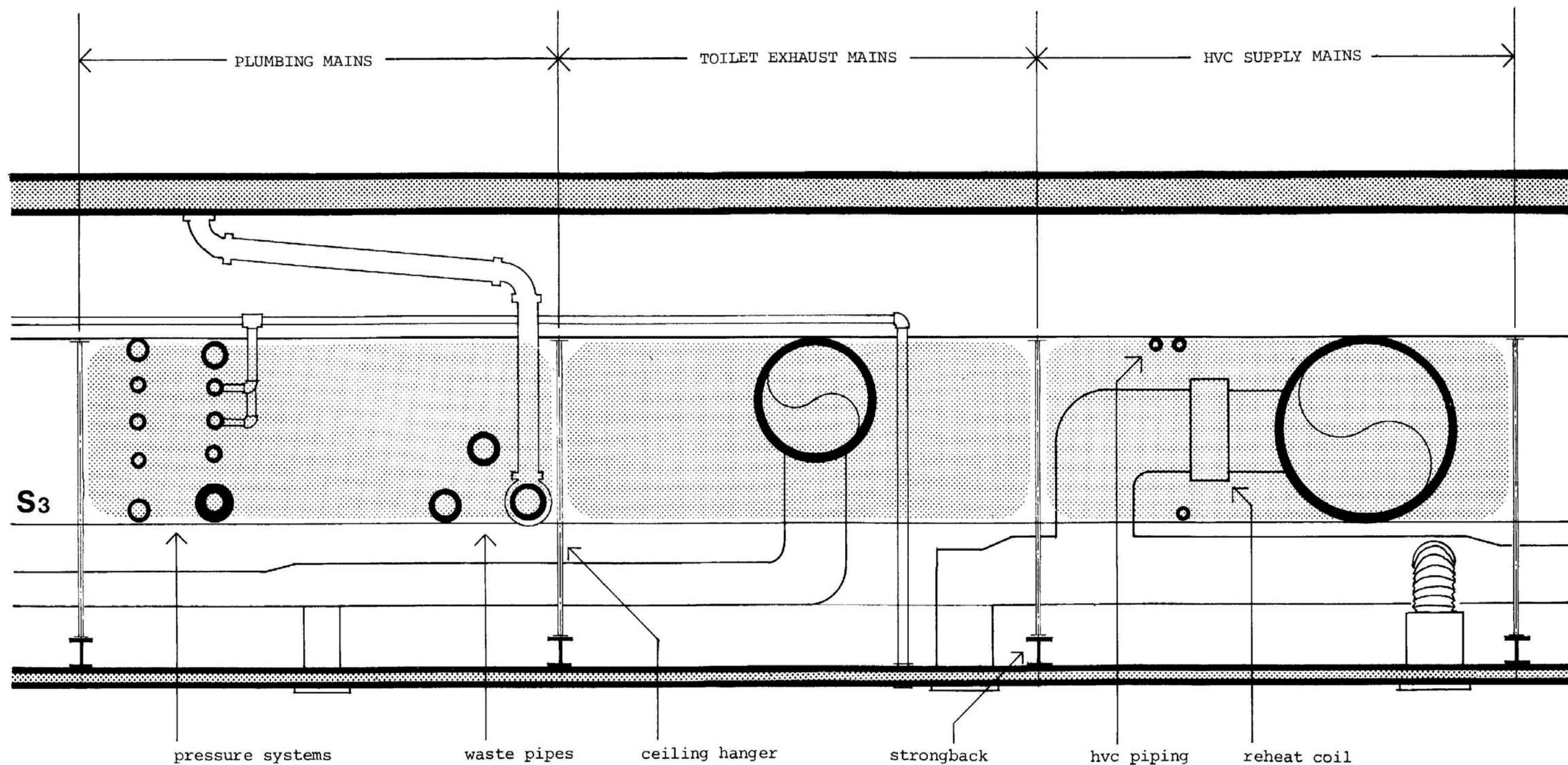
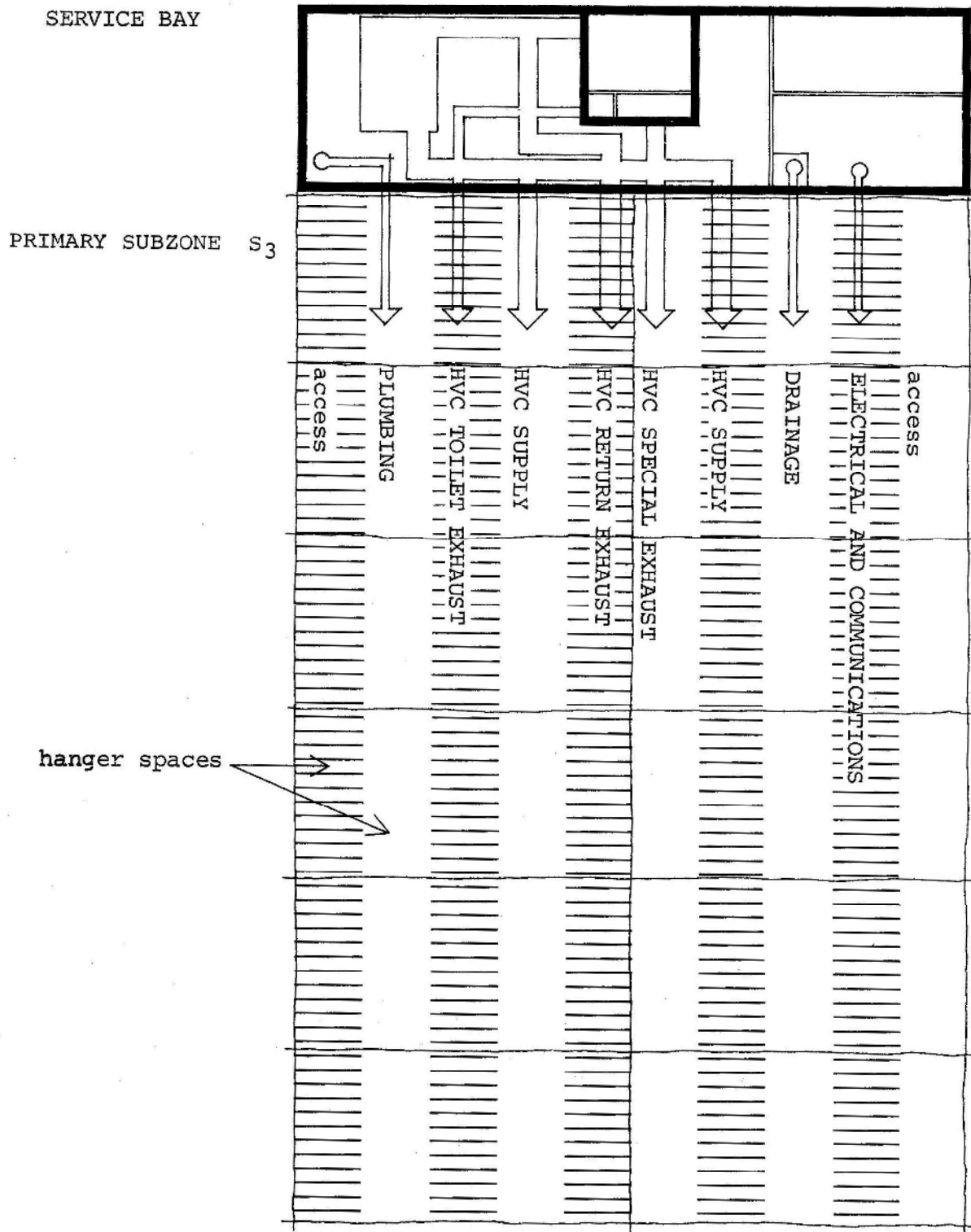

Figure 220-7. CHANNELS: SECTION PARALLEL TO BEAMS



**(BLANK PAGE)**

Figure 220-8. CHANNELS: PLAN



These should be located towards the ends of the cross section to avoid the obstruction of branch ducts and branch services.

The sequence of channels will be controlled by three factors:

1. The position of the source of supply in the service bay. The location of mechanical room, electrical room and plumbing shaft will follow a similar pattern in all service modules.
2. The constraints on openings through the shear wall. These can be estimated on the basis of maximum service requirements for the module, and the shear wall constraints as discussed under the structural subsystem, Section 310.
3. The horizontal space required to connect from each main to the service branches.

The horizontal dimension of the channels will be governed by the width of the service module, the number of channels required and the distance between ceiling hangers. These hangers will serve as the physical reference points for the channels. They can be expected to support approximately 45 - 50 square feet of ceiling each, and therefore, in the case of beam spacing at 5'7-1/2" centers, would be about 8' to 9' on center along the beams. The mains require about this range, for instance, for a single-duct HVC supply main with its associated terminal-reheat coils and ducting. (See Figure 220-7.)

It would be a useful extension of channeling to also divide subzones S2 and S4 into service rights-of-way. The greater diversity of runs in these subzones would make specific rules more difficult, but a careful organization of the branch runs would help preserve predictable areas for future penetration of the floor slab and ceiling respectively. Rules defining a maximum of one HVC branch duct per hanger spacing and carefully considered stacking of plumbing and electrical branches would also give predictable access for maintenance. Figure 220-6 suggests such a branch channeling within subzones S2 and S4.



### **224.3 ACCESS AND MAINTENANCE**

As discussed above, channels reserved for personnel access will be positioned near the edges of the service zone. They will be reached from the service bay by doors through the shear wall. Similar doored openings will allow passage where required to adjacent service zones through the surrounding two-hour fire partitions and shear walls. Secondary access through the ceiling could be provided where convenient.

The service zone must be designed to conform to code provisions for industrial safety. This requirement is simplified by the fact that all major equipment is restricted to the service bay. The service zone must be suitably lit, ventilated and signposted.

It is assumed that maintenance routines will be primarily concerned with a weekly HVC check, and for other services at longer intervals. But if materials-handling systems are routed through the service zone, e.g., pneumatic tubes, tote box carriers, etc., more frequent access to these systems may be necessary.

### **224.4 CONSTRUCTION DESIGN**

As discussed above, the ceiling hanger spacing will define channels. The direction of beams and strongbacks, and the depths of beams will visually locate subzones. This would provide physical references in the service zone both for the initial positioning of services and for later revisions to the layout.

The installation of main distribution and branch ducts will need careful coordination with the ceiling subsystem erection. But as soon as practical, the ceiling should be installed to provide a working platform for the completion of the service distribution.

Where two service zones exist within one fire section, a smoke stop partition should be erected between them. This partition would also provide a plenum barrier where both service zones are used as exhaust/return plenums in the HVC subsystem.

**224.5 ACOUSTICS**

Every precaution should be taken in design and construction to restrict sound transference into the functional zone.

All openings through the shear wall must be closed around the service mains to provide fire security, but the seal should also provide acoustic separation. All openings through the ceiling subsystem for services should be sealed as well. Mufflers may be required where return air boots are used with an exhaust/return plenum HVC system.

Noise generating plumbing should be suspended on isolating devices and precautions should be taken in services layout to prevent noise transmission between service runs causing secondary sound paths to the functional zone.

**225 FUNCTIONAL ZONE**

The functional zone is that portion of the service module which houses the hospital activities, and which can be internally organized in various ways to accommodate the different functions.

**225.1 HEIGHT**

The height of the functional zone is constant on any one floor and is typically 9'0" in the nursing areas and 10'0" in the support areas of the hospital (See Section 722.3).

**225.2 PERMANENT COMPONENTS**

Generally, the only permanent vertical components which occur within the functional zone are the structural columns. Shafts, shear components, and two hour fire partitions are located at the perimeter so as not to interfere with planning freedom (or with horizontal service distribution in the service zone above).

**225.3 PARTITIONS**

Partitions within the functional zone are typically relocatable and do not penetrate the ceiling-platform. (See Section 326.)

There is no explicit planning grid for partitions. However, a dimensional discipline is implied by the spacing of the structural beams in the floor and the spacing of the structural members in the ceiling-platform. These limit the location of service drops and floor drains and, therefore, the location of partitions which are associated with them. (See Section 333.4.)

**225.4 SERVICES**

Except for drains, all services to the functional zone are down-fed through the ceiling from the service zone above. As a general rule, it is recommended that service distribution components should be surface mounted and not housed within partitions. (See Section 723.1 for rationale.)

- 225.4.1** The degree to which surface mounting of services is able to be carried out depends on several factors, such as, cost, asepsis, rate of change, etc., and will vary from one functional area to another and from one project to another.

## 230 The Space Module

### 231 BASIC DESIGN

The space module represents in plan the physical requirements for bed-care functions of the hospital. Space modules are generated from an analysis of current VA nursing unit requirements. Eleven different space modules represent the current range of different VA nursing care programs and different planning solutions to those programs. Each space module represents a different range of performance in terms of area, organization, aspect (perimeter exposure) and functional content.

The space modules are intended to respond in a predictable and repetitive way to VA Master Plan requirements and, accordingly, to form the basis from which functional planning can proceed.

The space module may be the same size or smaller than a service module (exclusive of the service bay), but in no case can be larger than a service module.

The space module functions on the basis that its shell and services will be provided within the service module envelope with assurance of complete compatibility. (Figure 230-1)

Once derived, the space modules were tested with other nursing unit plans and modified where necessary to accommodate various ranges of patient and associated bed-care functions. Thus, the space modules represent a summary of current VA needs, and can be used in preliminary planning to determine the relevant size and shape of the service modules in the bed-care portion of the hospital. Through the bed-care service module, the space module, in many building configurations, also has an indirect effect on the size and shape of the service modules in the rest of the hospital. Traditionally in hospital design, the nursing unit is one of the first functional areas to be resolved and the dimensional disciplines developed there to a large extent establish the framework for the design of the remaining hospital functions. Thus, the concept of the space module is a significant innovation in that it permits the planner to quickly come to terms with the one area of the hospital that has the most direct bearing on the overall organization of the hospital.

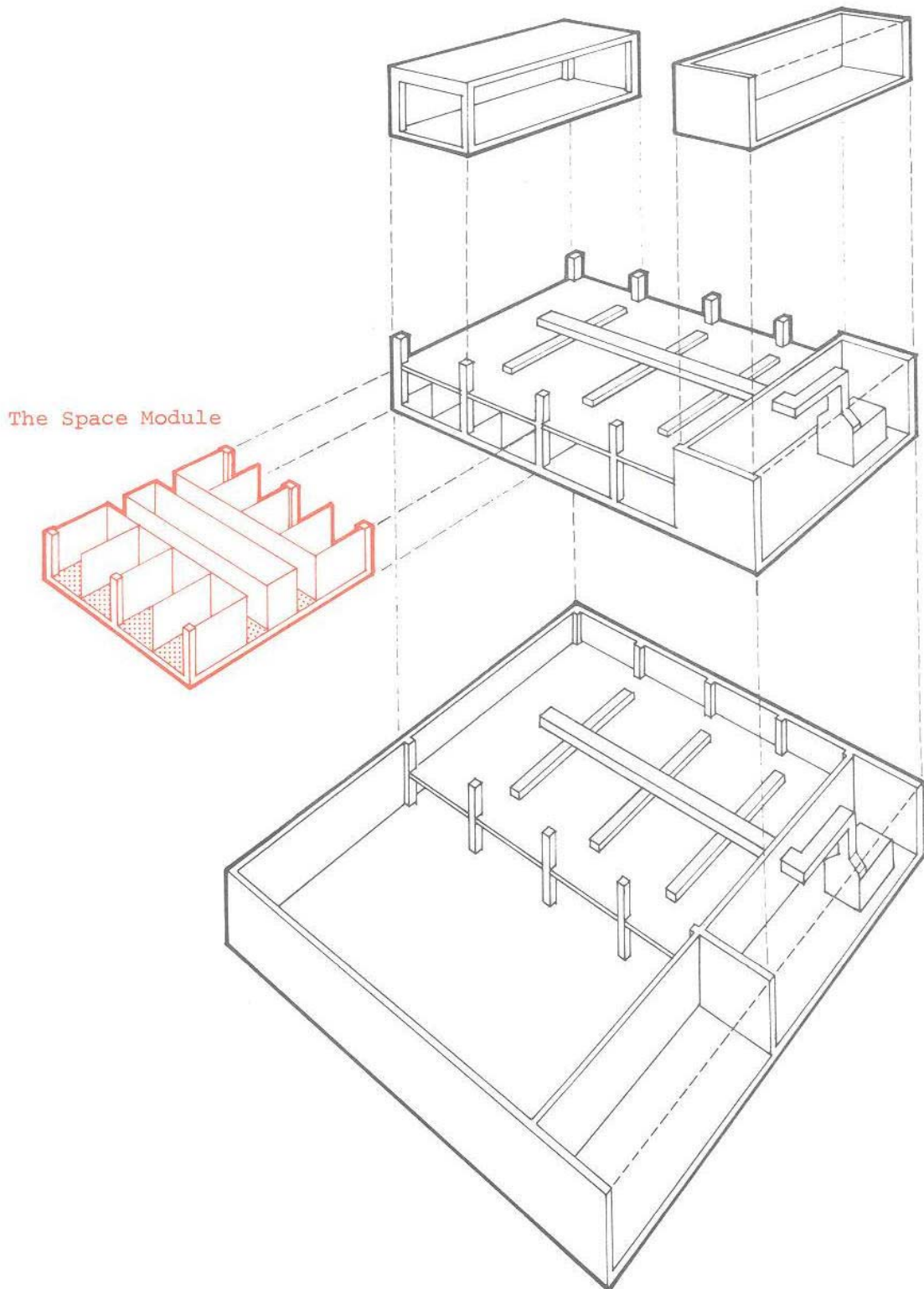
**Figure 230-1. THE SPACE MODULE**

The Space Module summary sheet (Figure 230-8) describes the module types. The catalog of space module capabilities (Section 233) elaborates on the summary sheet and indicates other possible organizational, access and assembly capabilities for each of the 11 module types.

The space module concept should be viewed as a highly dynamic constituent of the Prototype Design. The catalog of space modules represents the present VA philosophy of bed care organization which is constantly subject to reevaluation and change brought about by advancing medical knowledge and technology.

## 232 SPACE MODULE CHARACTERISTICS

### 232.1 DERIVATION

The general nursing unit, which contains the majority of beds in the typical VA hospital, was used as the generating organization for the modules.

The Veterans Administration is currently using a 40-bed general nursing unit pattern with predominantly four-bed rooms. During the investigation of user needs, it was determined that a subdivision providing two 20-bed units would be desirable for periods of intensive nursing activity, i.e., the daytime shift. Furthermore, it was determined that existing levels of nurse staffing could accommodate such a pattern. It was consequently decided to base the space module on a 20-bed general nursing unit with the provision that the module must always be capable of combination with other modules to form 40-bed or larger units.

### 232.2 ASPECT

232.2.1 Aspect refers to the number of perimeter faces available for exposure to natural light and, therefore, the amount of perimeter potentially available for connection either to other space modules and/or a service bay and/or additional space (see catalog of space module capabilities. Section 233.) Two- and four-aspect space modules are included in the system. It will be noted that the four-aspect modules cannot be easily combined with other modules to form a functional entity; therefore, a 40-bed functional unit was used for this module type.

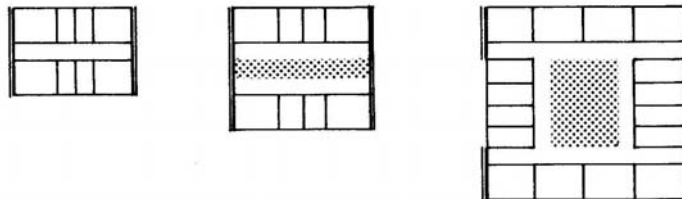

232.2.2 The four-aspect modules can be readily modified to produce three-aspect modules, if required: either a twenty-bed nursing unit by using one-half of the four-aspect modules, or a forty-bed nursing unit by increasing the length of the four-aspect module by one structural bay width.



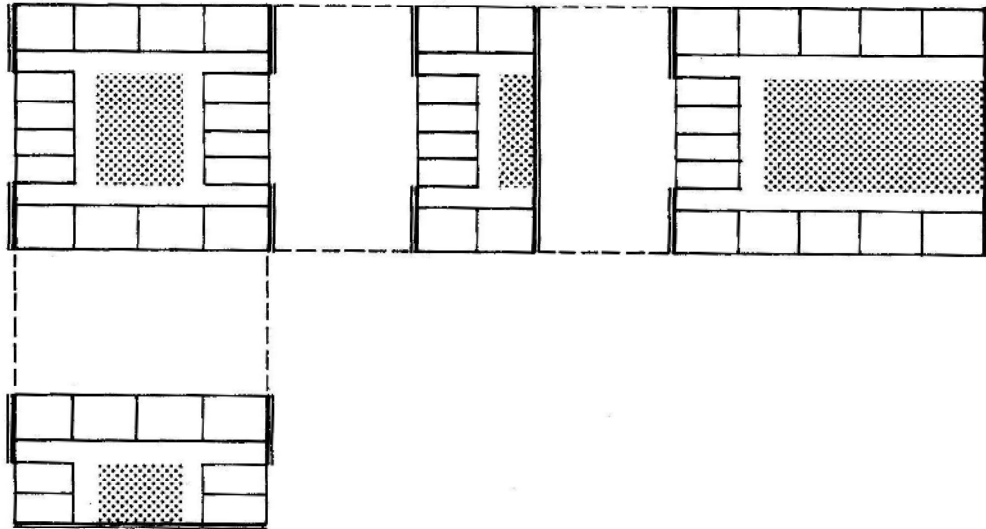

### 232.3 AREA OF SPACE MODULES

The gross area of a nursing unit varies with the number of beds, the sanitary facilities provided in each room and the desired amount of direct patient care support (core). The modules provide a range in approximate area from 3,350 to 6,075 square feet for 20-bed modules and from 8,900 to 10,500 square feet for 40-bed modules. This area will provide sufficient space for a reasonable amount of direct care support adjacent to patient beds and a complete range of bedroom sanitary facilities.

### 232.4 ADDITIONAL SPACE

The space module area can be supplemented with additional space as a means of accommodating functions not necessary for direct patient care support such as education, certain offices, shared diagnostic, treatment or staff facilities, vertical circulation systems, etc. This additional space on the nursing floor can be constructed with the building system but does not possess the organizational characteristics of the space modules. The amount of additional space varies with the hospital program. It is provided by extending the structural frame in increments of one bay.

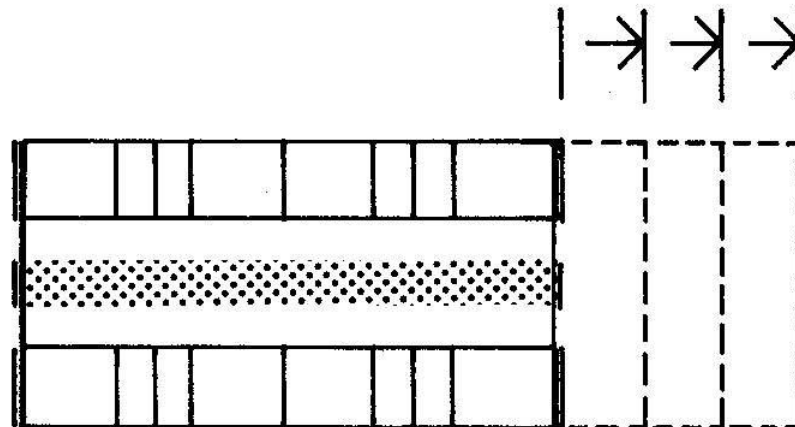

### 232.5 INTERIOR ORGANIZATION

Two basic nursing unit organizations are provided:

1. Core or "race track". The core plan provides a central area (core) for direct patient care support facilities. The core is surrounded by corridors which lie between it and the patient bedrooms. The bedrooms are on the perimeter of the building.

Core plans may be two- or four-aspect. The two-aspect core modules may be joined end to end with each other to form end-entry 40-bed units. They may also be end-attached to a shared section of additional space, forming end-entry 20-bed units. The attachment capability of the four-aspect core modules is limited to their corners. (See Catalog of Space Module Capabilities, Section 233.)

2. Double-loaded corridor. The double-loaded corridor module depends on additional space for direct patient care support facilities and therefore is most effective when two modules share a common central access. (See Catalog of Space Module Capabilities, Section 233.)

### 232.6 PLAN ZONES

The cross-section of a general nursing unit consists of a series of related zones: bedroom, sanitary, circulation and core zones.

The particular combination of one-, two- and four-bed rooms in conjunction with the extent of corridors, sanitary and core facilities, required by the Veterans Administration, will determine the appropriate structural span (See Figure 230-2), hence the module type.

Figure 230-2. PLAN ZONES

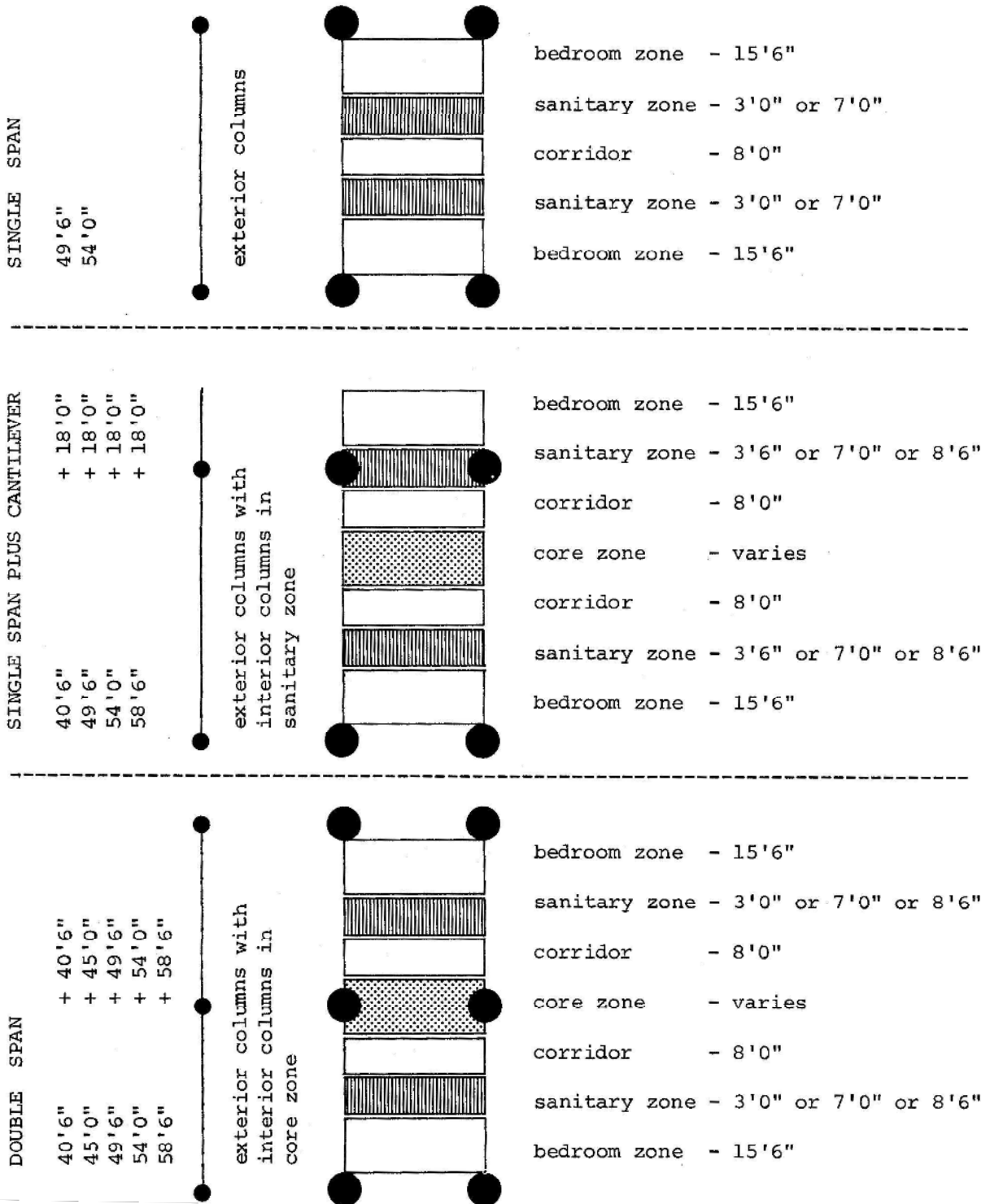

The initial selection of a module type will fix the unit width and consequently the potential capability of each zone. For example, in a double-loaded corridor unit with a width appropriate for handwashing facilities in each room, it is virtually impossible to add toilet facilities at a later date without a reduction in the number of beds. It may be appropriate, therefore, to select a module wider than initially needed to provide future adaptability.

### 232.6.1 Bedroom Zone

The Veterans Administration currently desires optional arrangements of one-, two-, and four-bed rooms. Furthermore, a degree of interchangeability from one type to another is advantageous. To obtain this measure of flexibility, the respective width and depths of the one-, two-, and four-bedrooms must be compatible. The widths are interchangeable by virtue of the 22'-6" structural bay width. (See Section 232.7 and Figure 230-4). Bedroom depths vary as in Figure 230-3. Therefore, to ensure optimum interchangeability, the bedroom zone depth is fixed at 15'-6", the critical minimum dimension for two- and four-bedrooms.

### 232.6.2 Sanitary Zone

This zone contains sanitary facilities for the patient bedroom. Careful studies provided the following options:

- |              |      |   |  |
|--------------|------|---|--|
| option one   | 3'0" | – | lavatory for handwashing only  |
|              | 3'6" | – | lavatory for handwashing only in conjunction with an interior column                             |
| option two   | 7'0" | – | lavatory and toilet or lavatory toilet and shower plus a 4'0" wide bedroom access from corridor. |
| option three | 8'6" | – | lavatory, toilet, shower and nurse-server plus a 4'0" wide bedroom access from corridor.         |

The sanitary zone is primarily a means to determine the appropriate width of space module and need not necessarily occur between bedroom and corridor.

Figure 230-3. PATIENT ROOM CRITICAL DIMENSIONS

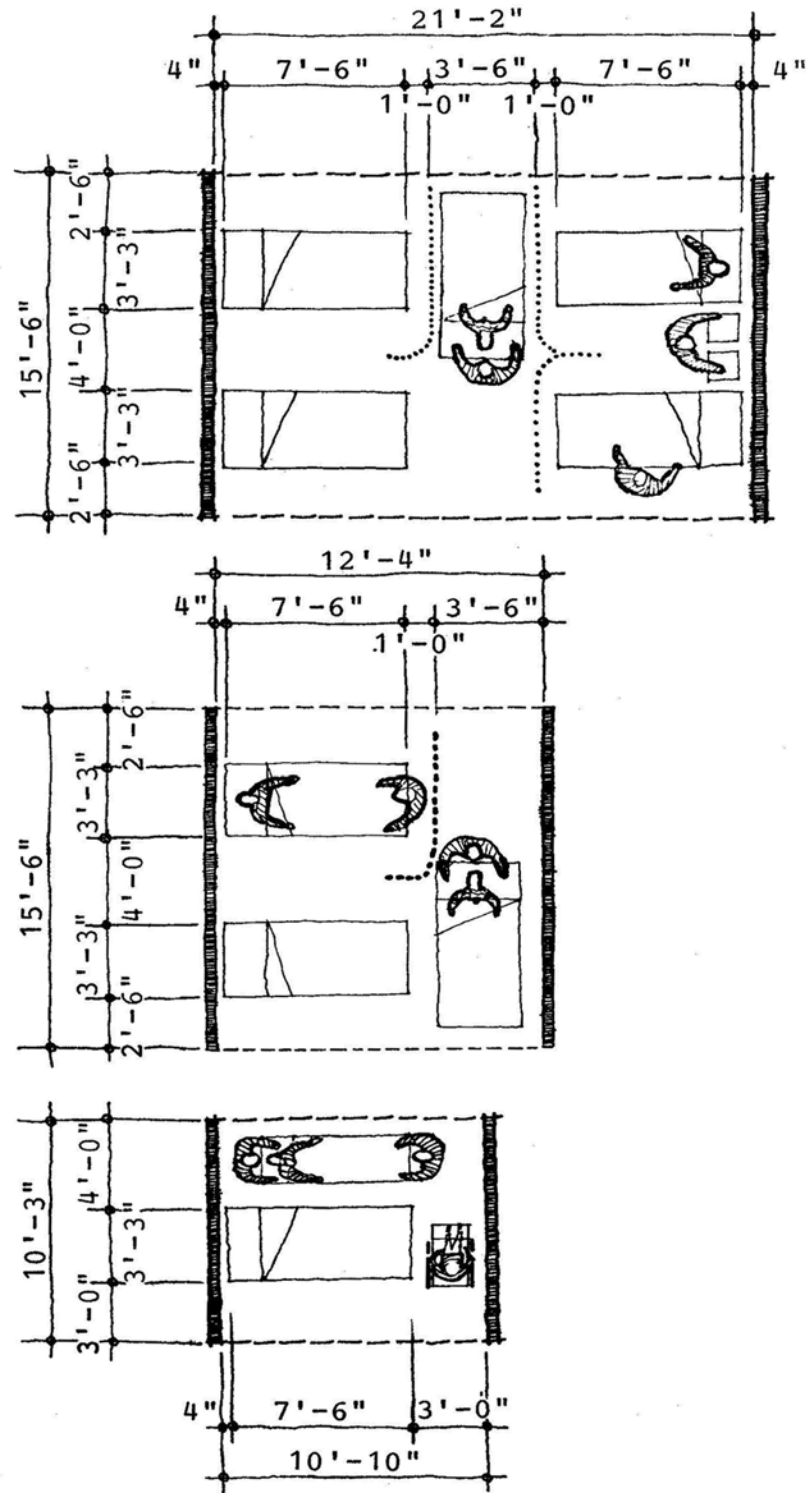

Some plans may locate the sanitary facilities at the exterior wall.

A sample catalog has been prepared to show a variety of plan arrangements of fixtures possible in each of the above options for the one, two and four bedrooms. These plan arrangements also show the accommodation of an interior column when a module type with a single span plus cantilever condition is adopted (See figures 230-2, 5, 6 and 7).

### **232.6.3 Corridor**

Corridor widths are 8'-0" clear.

### **232.6.4 Core**

The core size may be varied: (a) by selecting a particular depth of sanitary zone, (b) by selecting modules of different widths. The designer will, in most cases, also have flexibility in allocating certain functions to the core or additional space. These two options should allow sufficient adaptability in accommodating program variations from facility to facility or from unit to unit.

## **232.7 STRUCTURAL BAY WIDTH**

The width of the structural bay, always 22'-6", is based upon a dimensional discipline for bedroom widths of 4'-6" (see Figure 230-4.) This dimensional discipline has been derived from a study of the comparative critical widths for one-, two-, and four-bed rooms. (See Figure 230-3.)

### **232.7.1 Four-bed Rooms**

Four-bed rooms are 22'-6" wide, center to center, which equals 5 x 4'-6" or one structural bay.

### **237.7.3 One-bed Rooms**

One-bed rooms are 11'-3" wide, center to center, which equals 2.5 x 4'-6" or one-half of one structural bay.

### **237.7.3 Two-bed Rooms**

Two-bed rooms are 13'-6" wide, center to center, which equals 3 x 4'-6" or three-fifths of one structural bay. Three bays are required to create a block of five rooms.

Figure 230-4. BEDROOM WIDTH VARIATIONS

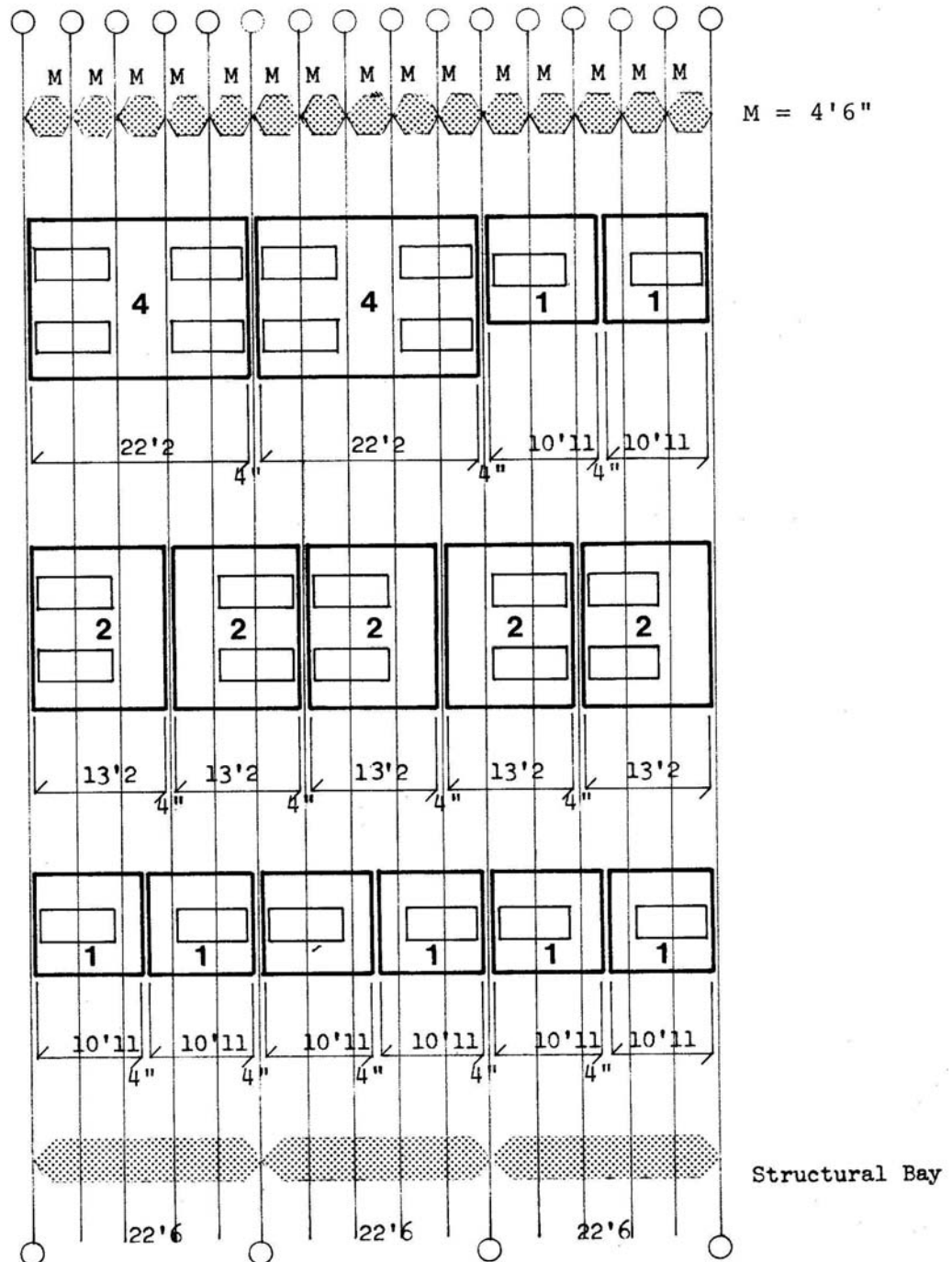

Figure 230-5. SANITARY ZONE OPTIONS: SAMPLE STUDIES

1 - BEDROOM	exterior columns	interior cantilever columns
lavatory toilet shower		
lavatory toilet shower nurserver	 <p data-bbox="1141 1434 1450 1518">                         NOTE:                          The sanitary facility depth available for one-bedrooms ranges from 8'3" to 13'9" depending on the selection of sanitary zone option for multibedrooms. Bathroom plans need not necessarily occupy the full available depth, which may be partially used for the bedroom or corridor.                     </p>	



Figure 230-6. SANITARY ZONE OPTIONS: SAMPLE STUDIES





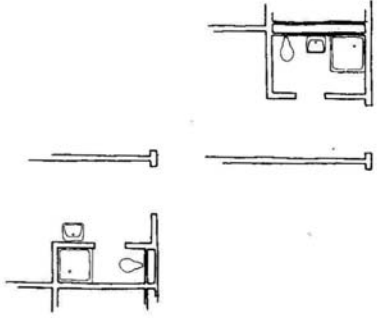
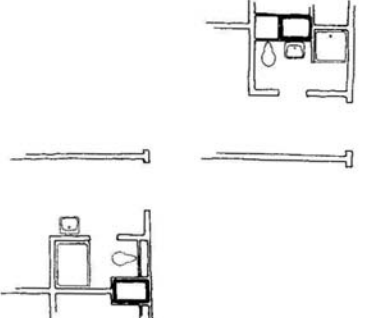
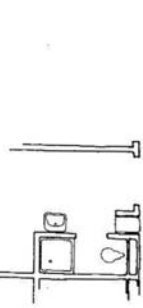
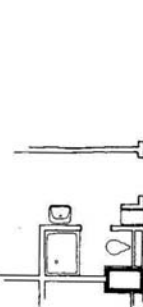



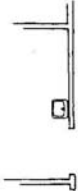

2 - BEDROOM	exterior column	interior cantilever column
Option 1. lavatory		
Option 2. lavatory toilet		
lavatory toilet shower		
Option 3. lavatory toilet shower nurserver		

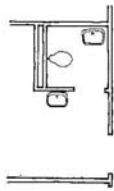
Figure 230-7. SANITARY ZONE OPTIONS: SAMPLE STUDIES

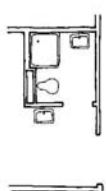
4 - BEDROOM	exterior columns	interior cantilever columns
Option 1. lavatory		
Option 2. lavatory toilet		
lavatory toilet shower		
Option 3. lavatory toilet shower nursery		

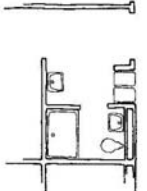
**232.8 PLANNING AROUND COLUMNS**

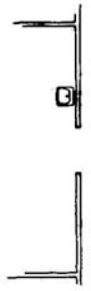
Figure 230-4 indicates that columns always occur on the between-room wall of one- and four-bed rooms. In two-bed rooms, columns will occur in one of three positions. In modules using cantilever beams the column will fall in the sanitary zone. Figure 230-5, 6 and 7 indicate a range of plans for the respective sanitary zones, with particular emphasis on the most difficult conditions, that is, where a column falls within the sanitary zone.

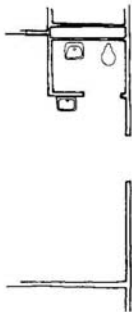
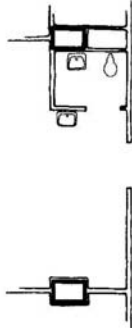
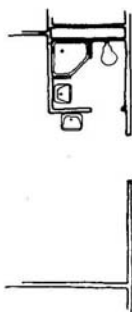
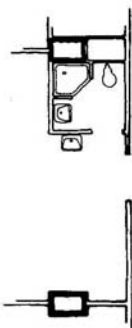
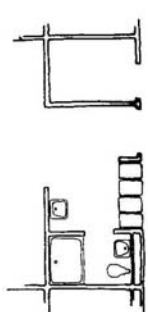
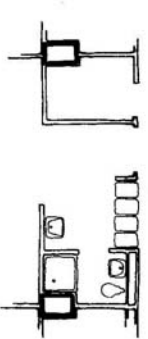
**232.9 MINIMUM COLUMN-FREE AREA**

In addition to providing a range of gross area options, and in the interest of economy, the space modules have been designed to insure a column-free area of sufficient size to permit intensive care units or other functions requiring large unobstructed space. The minimum dimensions of this column-free area are approximately 40 feet by 66 feet. (See Section 712.2.)

**233****CATALOG OF SPACE MODULE CAPABILITIES**

The catalog of space module capabilities indicates certain suggested organizations, access and assembly capabilities and a partial range of functional content for each of the eleven module types. Functional content and patterns of organization are by no means limited to these examples, however.

It is anticipated that the functional capability of the eleven space modules will grow as they are tested and refined within the VA. The more the capabilities of the space modules are known, the more rapid and accurate the design process leading to the commencement of construction can become.

It should be noted that in the catalog of space module capabilities all dimensions and areas are taken to: 1) the outside edge of the cantilever, or 2) the center line of interior and exterior columns.

In addition to the space module catalog, it may be helpful to refer to the example schematic design solution shown in Section 730.

Figure 230-8. SPACE MODULE SUMMARY SHEET

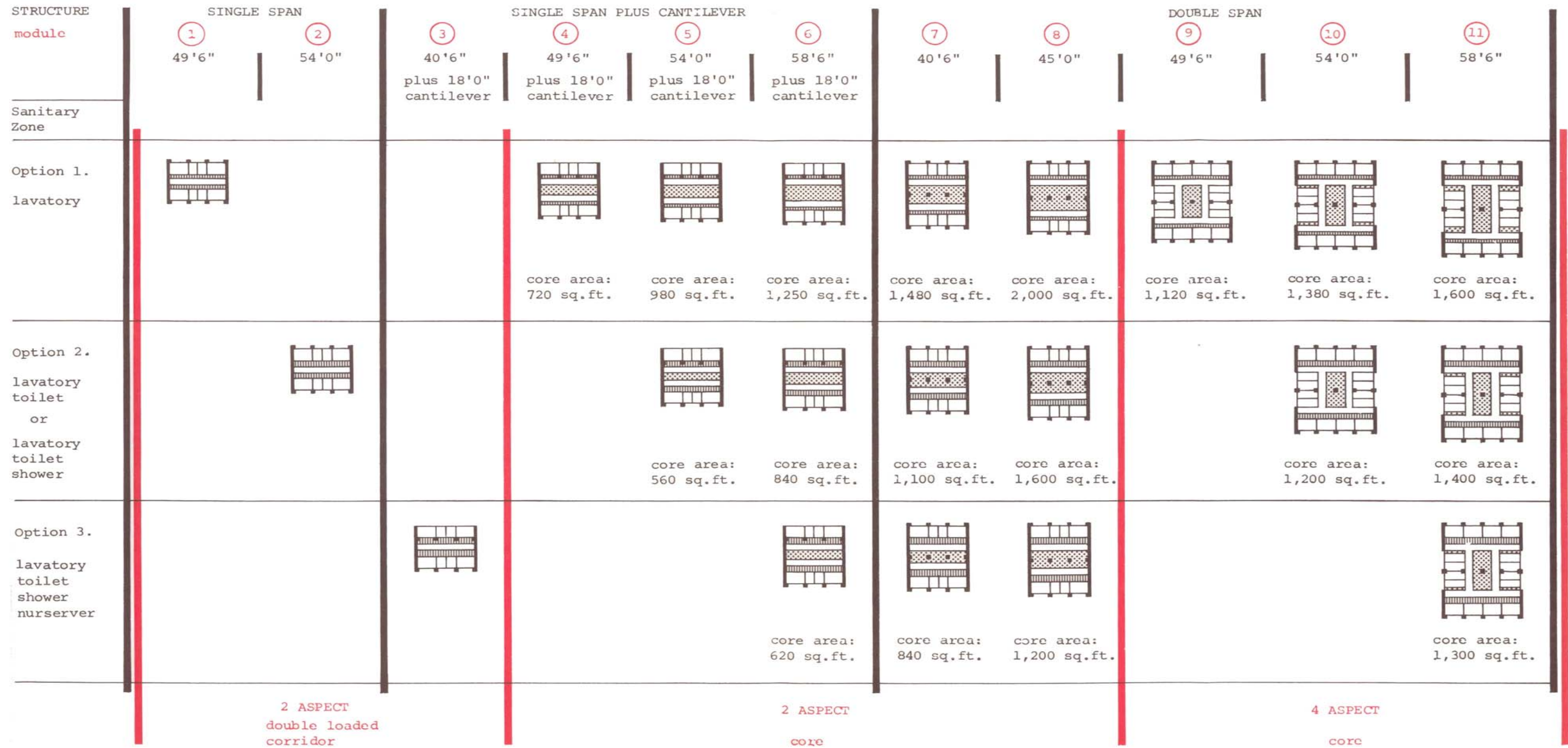

Shaded areas indicate Sanitary Zones and Support Zones (core area). Heavy line indicates the potential interface with either a Space Module and/or a service bay and/or additional space (Catalog of Space Module Capabilities).

**(BLANK PAGE)**

Figure 230-9. SPACE MODULE TYPE 1

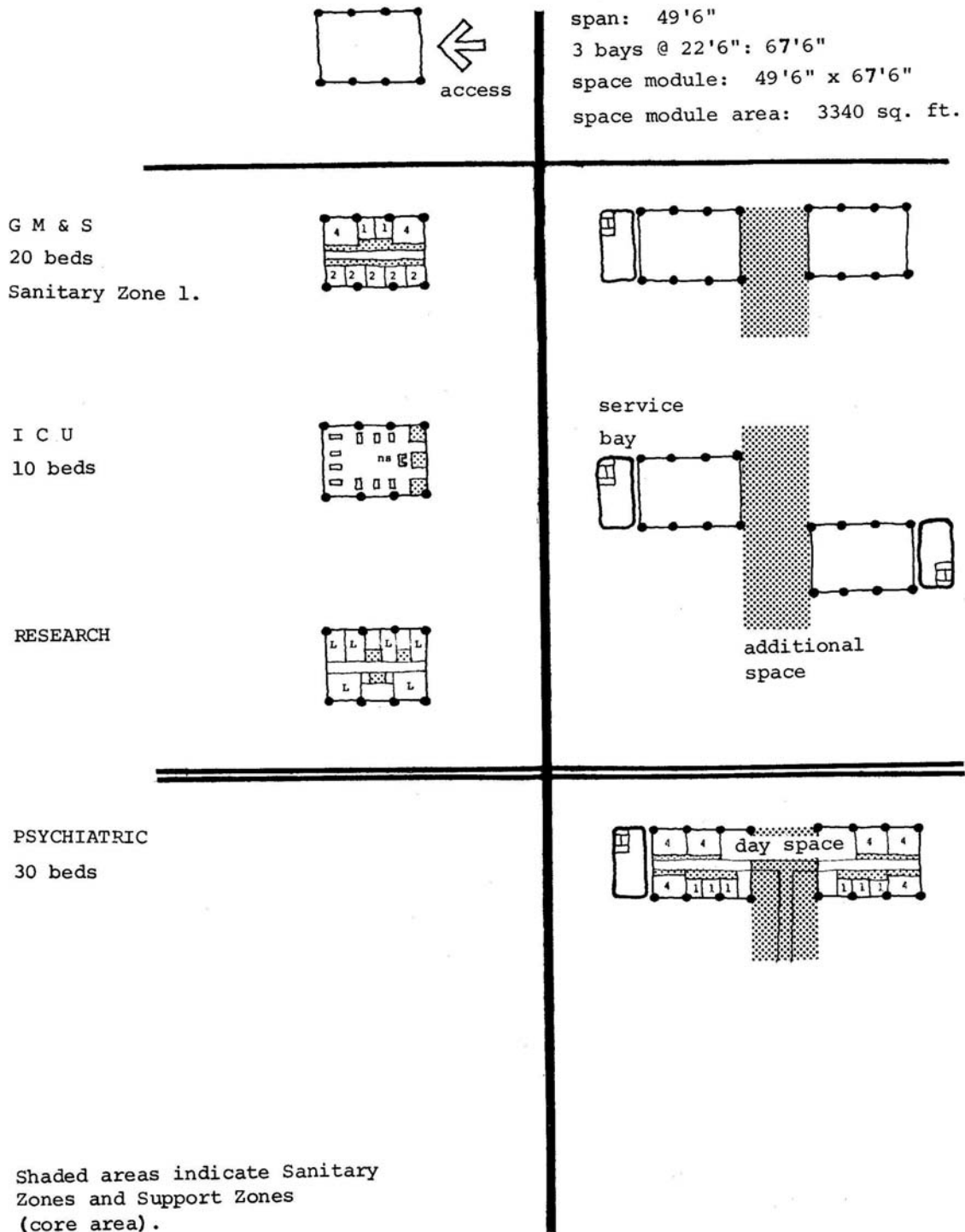

Figure 230-10. SPACE MODULE TYPE 2

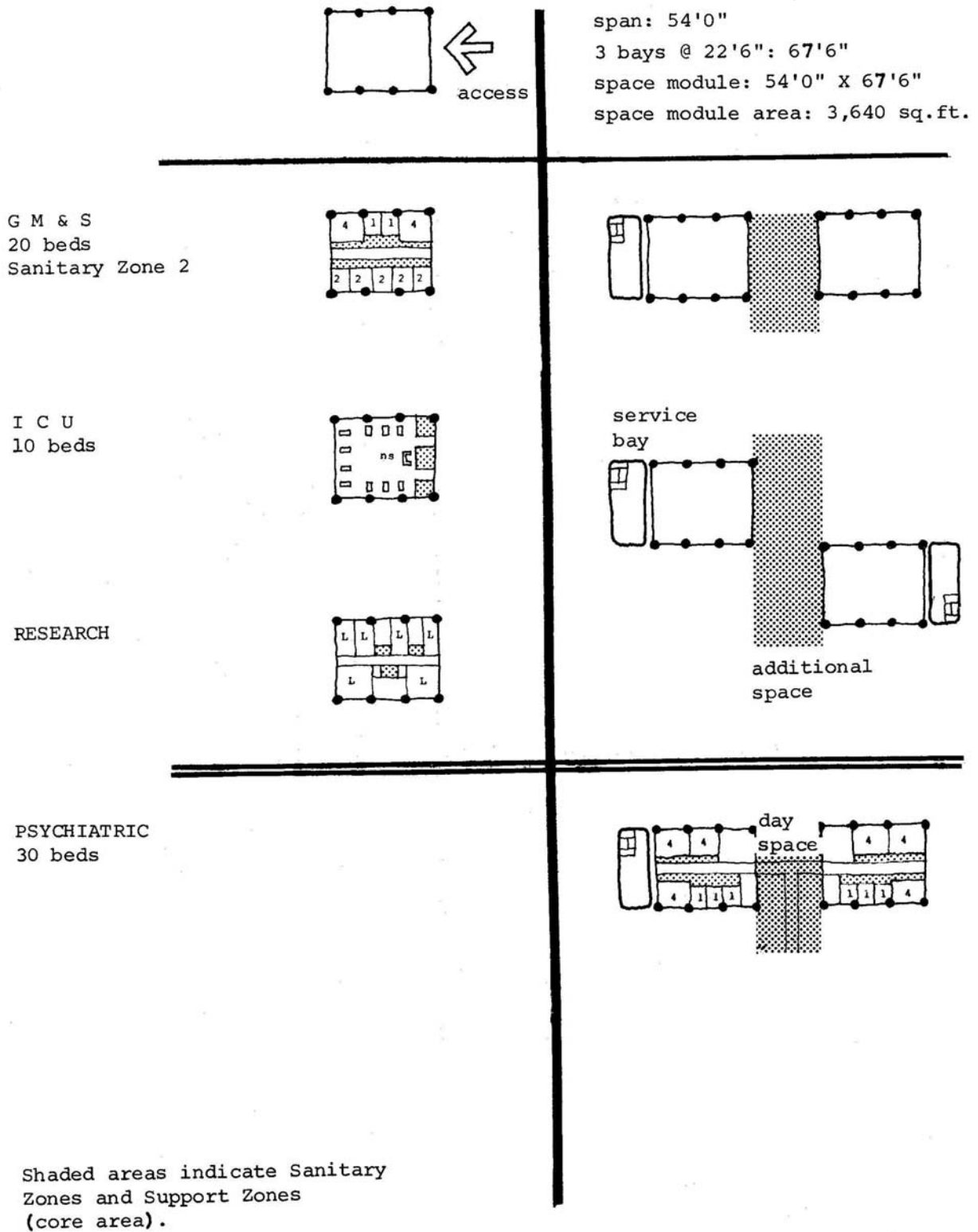



Figure 230-11. SPACE MODULE TYPE 3

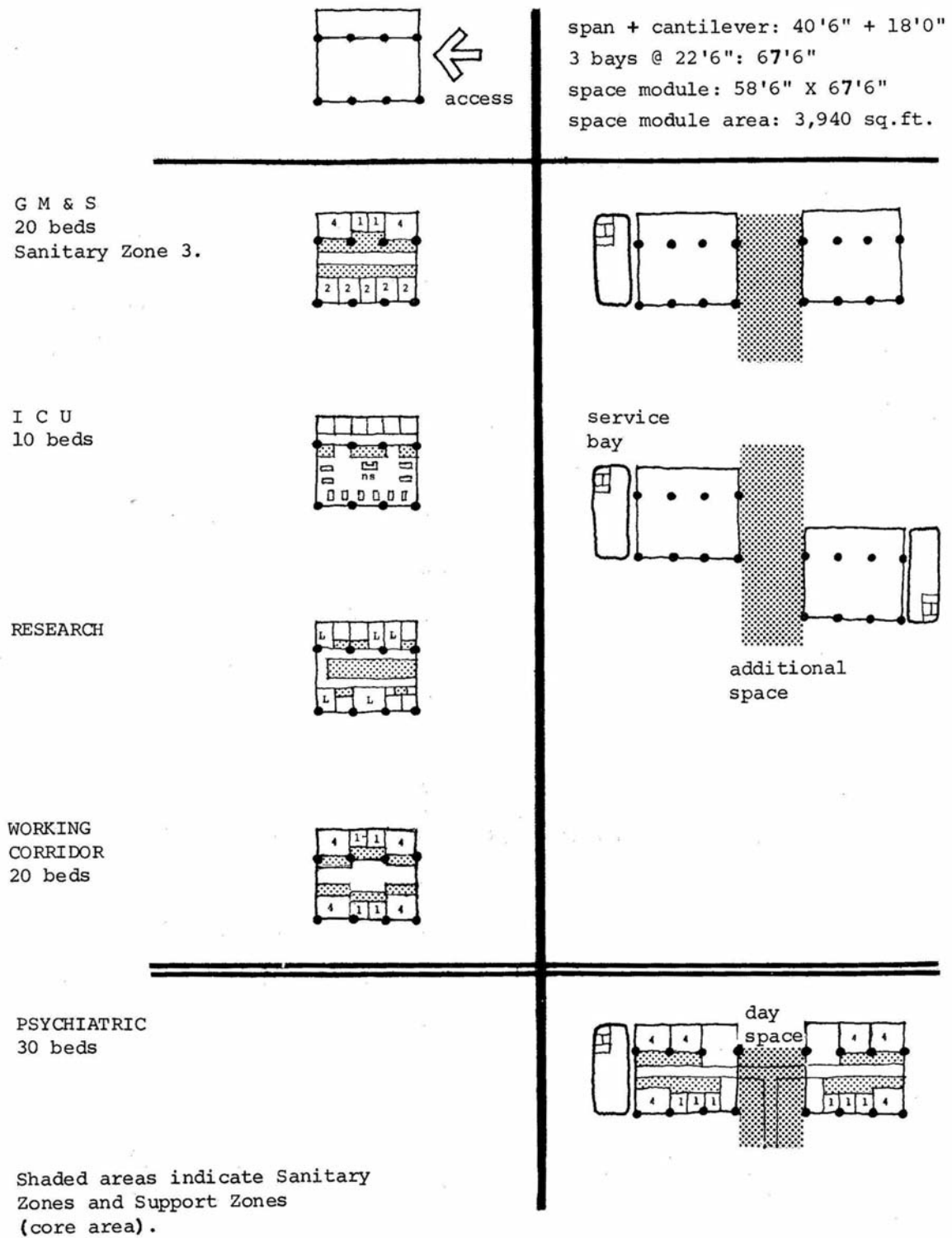

Figure 230-12. SPACE MODULE TYPE 4

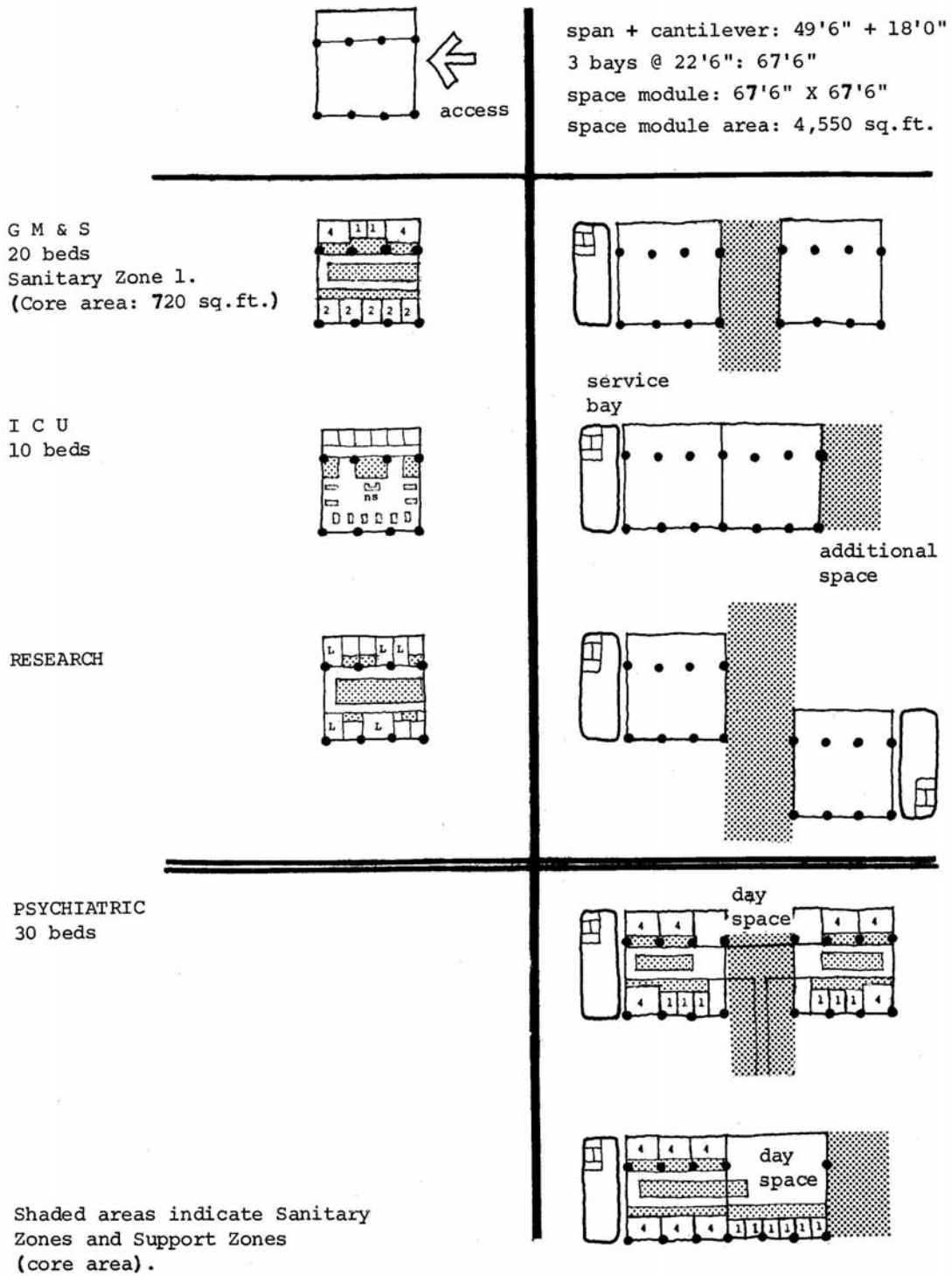

Figure 230-13. SPACE MODULE TYPE 5

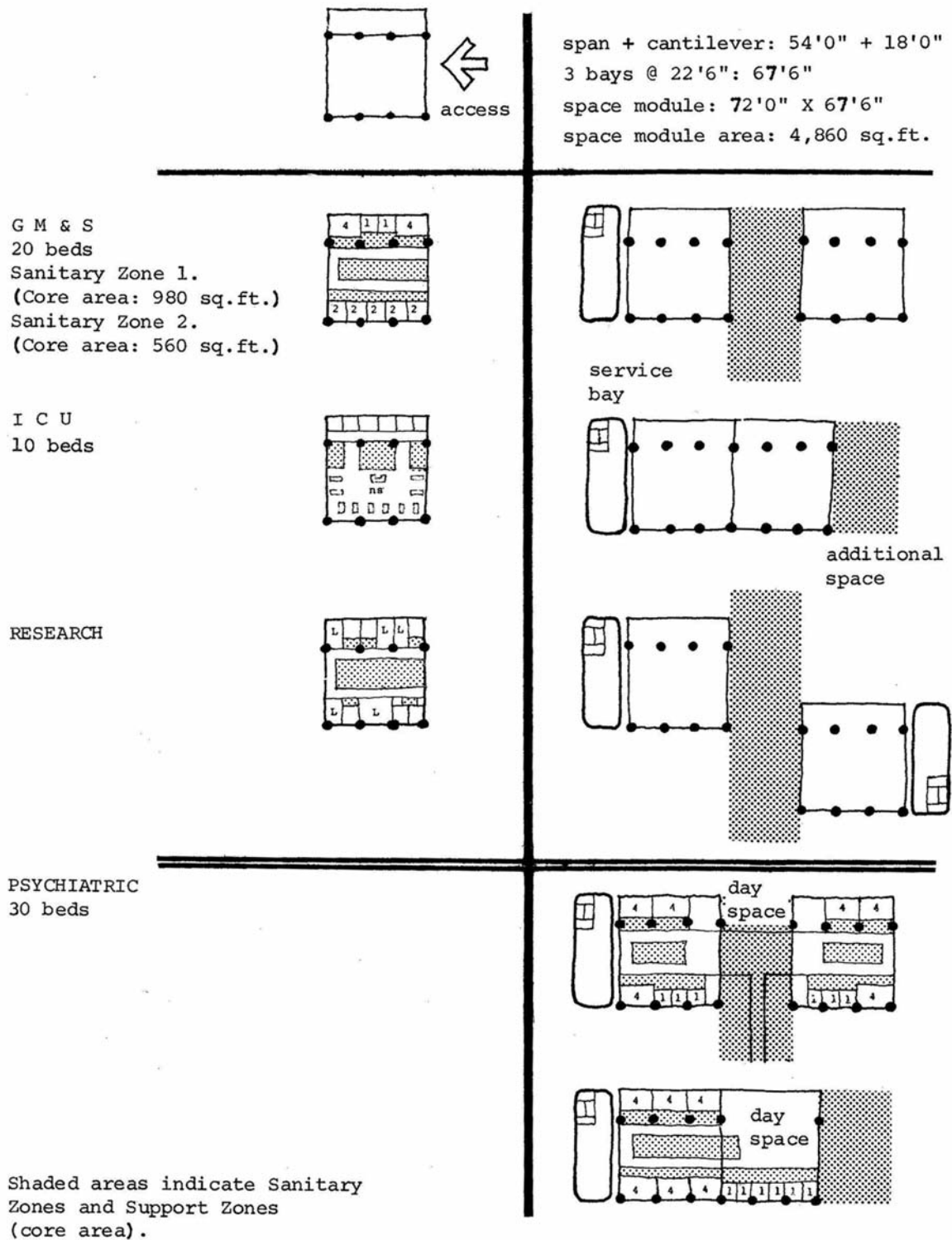

Figure 230-14. SPACE MODULE TYPE 6

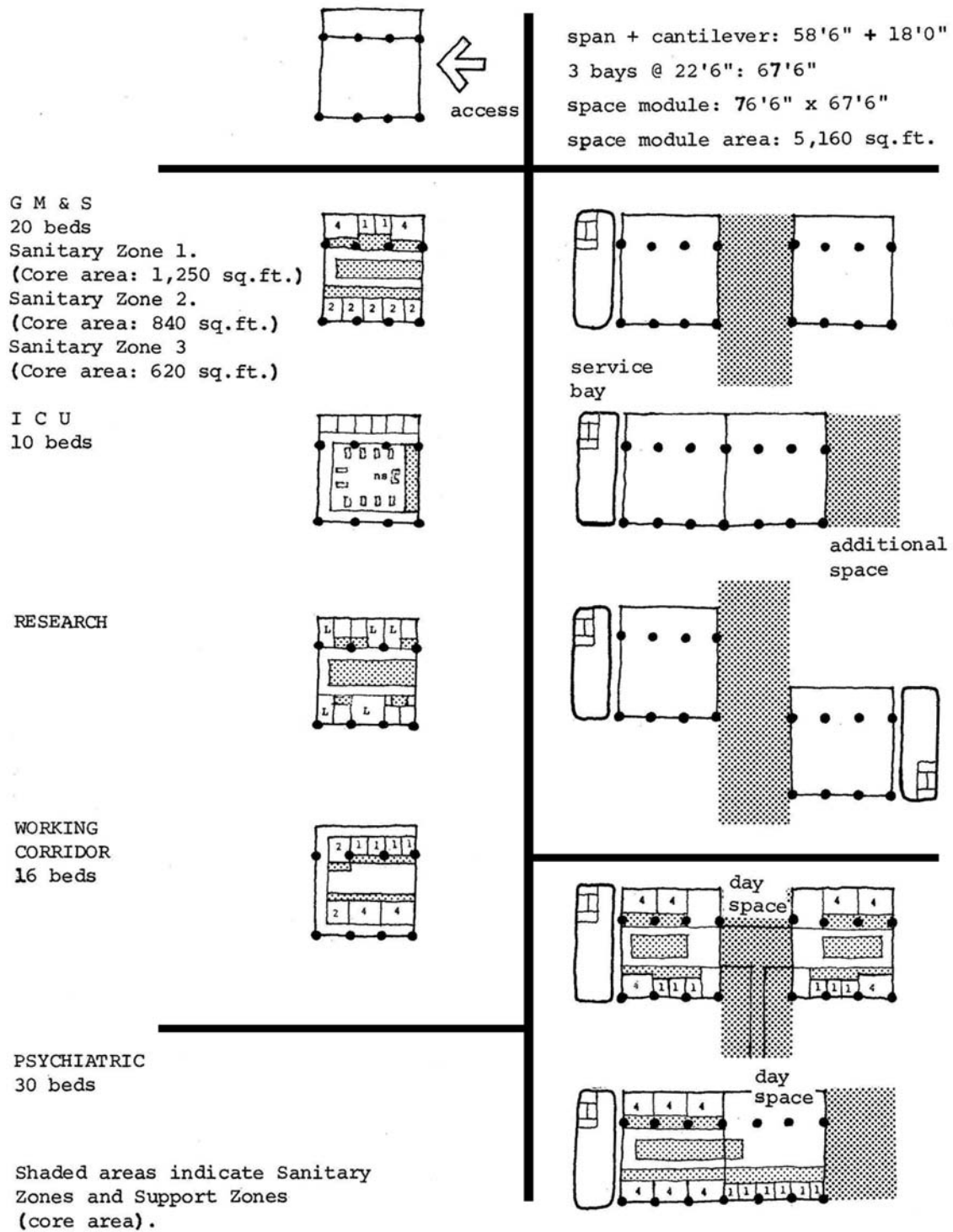
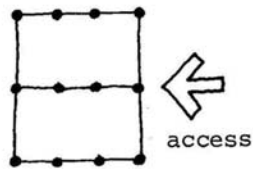
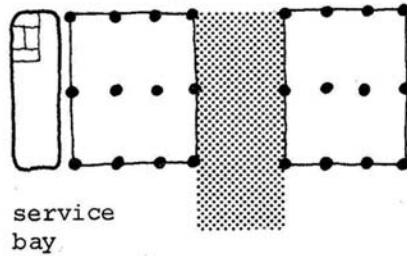
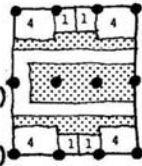

Figure 230-15. SPACE MODULE TYPE 7



2 X span: 2 X 40'6"  
 3 bays @ 22'6": 67'6"  
 space module: 81'0" X 67'6"  
 space module area: 5,460 sq. ft.

G M & S  
 20 beds  
 Sanitary Zone 1.  
 (Core Area: 1,480 sq.ft.)  
 Sanitary Zone 2.  
 (Core Area: 1,100 sq.ft.)  
 Sanitary Zone 3.  
 (Core Area: 840 sq.ft.)



I C U  
 9 beds

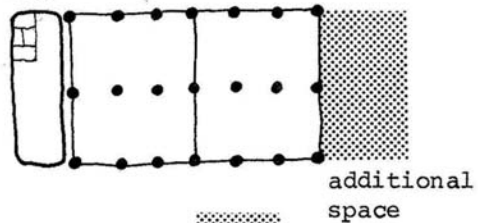
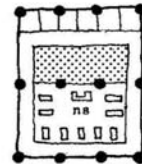

RESEARCH

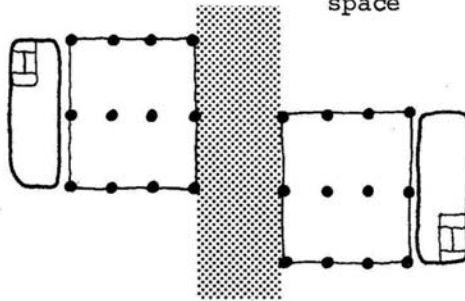
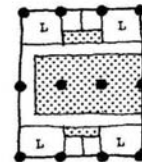

PSYCHIATRIC  
 30 beds

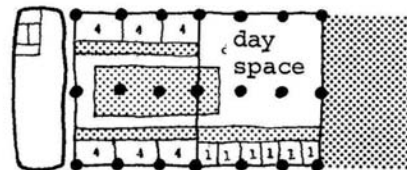
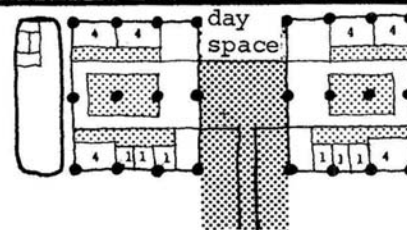

Shaded areas indicate Sanitary Zones and Support Zones (core area).

Figure 230-16. SPACE MODULE TYPE 8

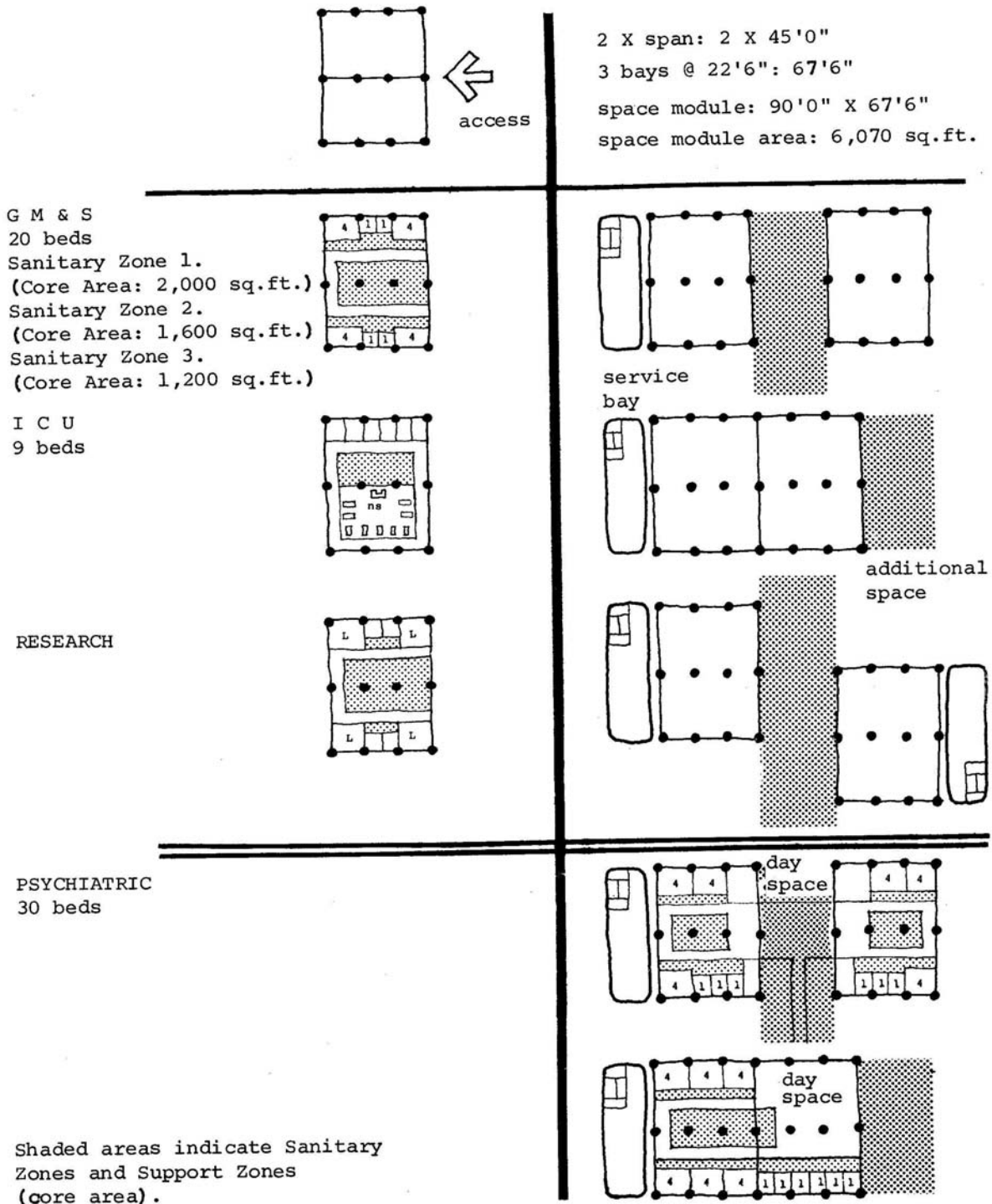

Figure 230-17. SPACE MODULE TYPE 9

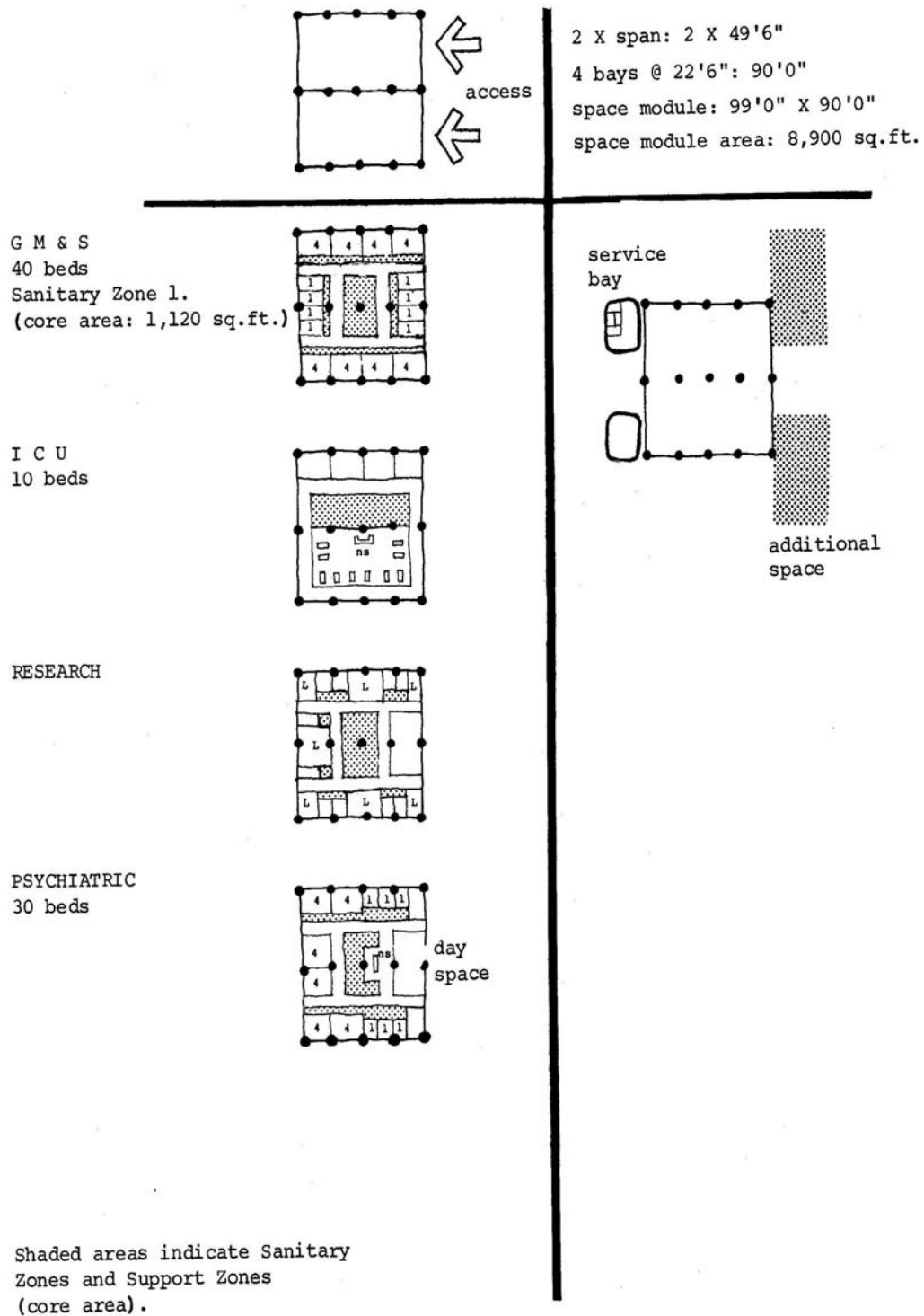

Figure 230-18. SPACE MODULE TYPE 10

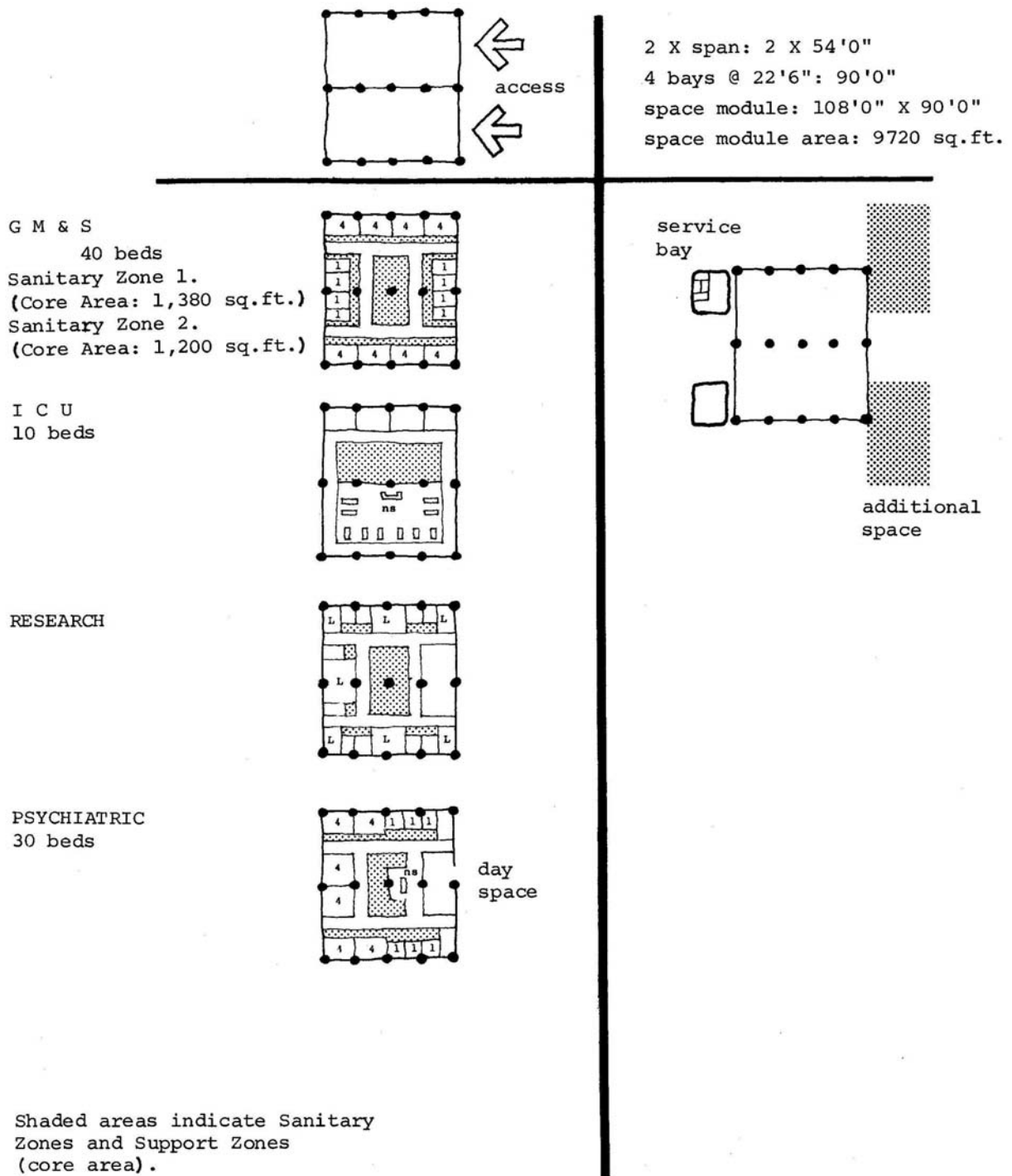
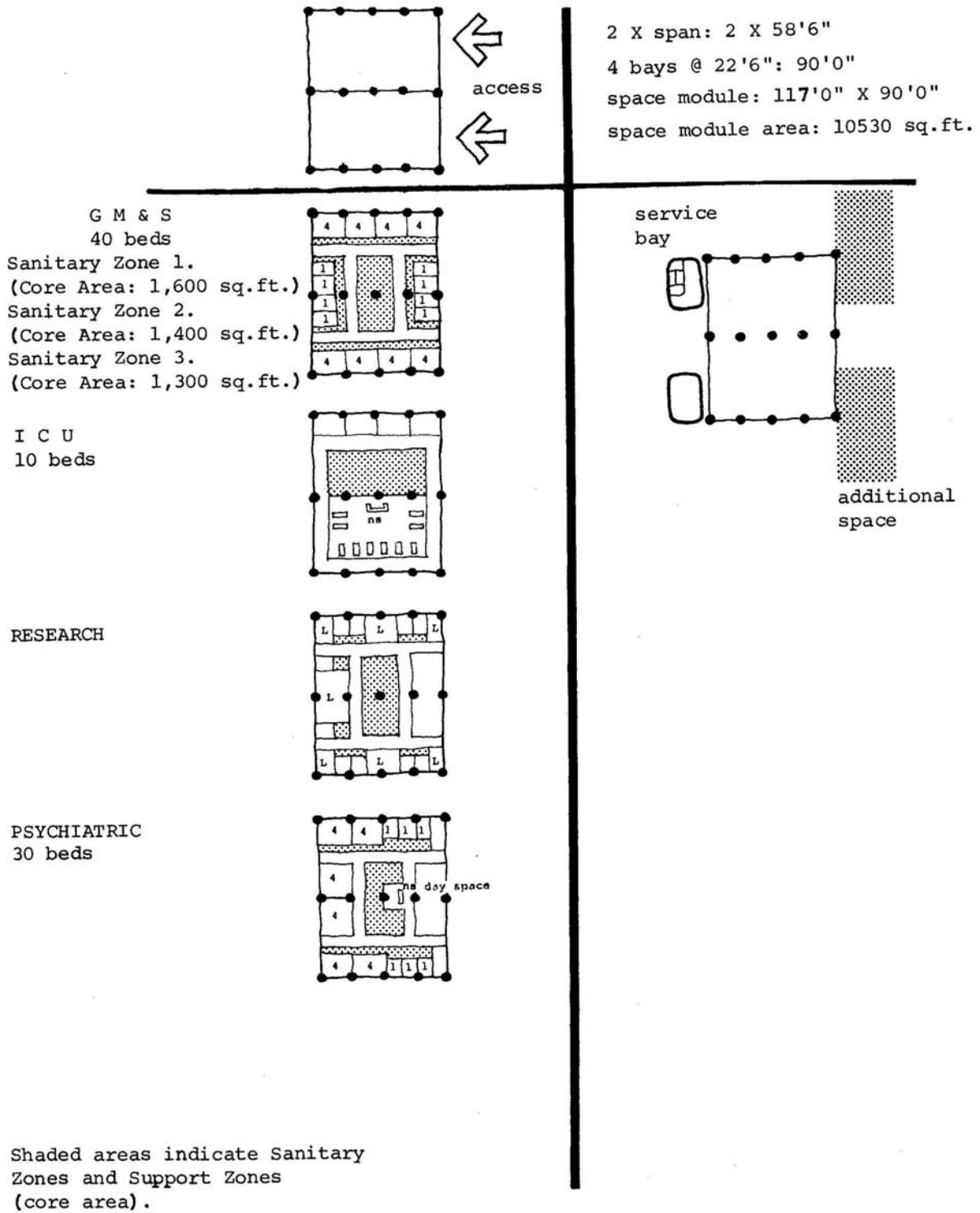



Figure 230-19. SPACE MODULE TYPE 11



**(BLANK PAGE)**

## 240 The Fire Section

### 241 BASIC DESIGN

It is the intent of the Prototype Design to provide a system for the design and construction of buildings in complete compliance with current fire safety codes and regulations. The role of the fire section as a planning module is to ensure that the requirements for fire safety are fully met in a manner that is compatible with the other objectives of the Prototype Design, in particular, functional and mechanical adaptability.

The fire section is a unit of area bounded by two-hour fire partitions, service bay walls and exterior walls, from which it is possible to exit in at least two different directions. The main purposes of the fire section are to contain a fire long enough to enable fire fighting personnel to deal with it, to prevent the migration of smoke and fumes to adjacent occupied areas and to allow the exit of occupants in a safe and expedient manner. Thus, any floor in a hospital can be conceived as an assembly of fire sections. The size, and therefore the number, of fire sections is determined by current codes and regulations, and the overall fire-safety strategy for the building.

In the Prototype Design, the two-hour fire partitions are regarded as permanent components as they must span from structural slab to structural slab, and consequently interrupt the continuity of both the functional and service zones. To the greatest practical extent, the boundaries of the fire section should coincide with the boundaries of the service module. A fire section may consist of one or two service modules depending on the size of the service module. (See Figure 240-1.) The correlation of the service module with the fire section minimizes the disruptive effect of the two-hour partition on the organization of the service zone since the service module is conceived as a mechanically independent unit.

Typically, all other partitions including smoke stop and corridor partitions stop at the one-hour fire-resistive ceiling-platform. They do not interfere with the service zone and thus can be easily relocated during alterations.

Figure 240-1. THE FIRE SECTION

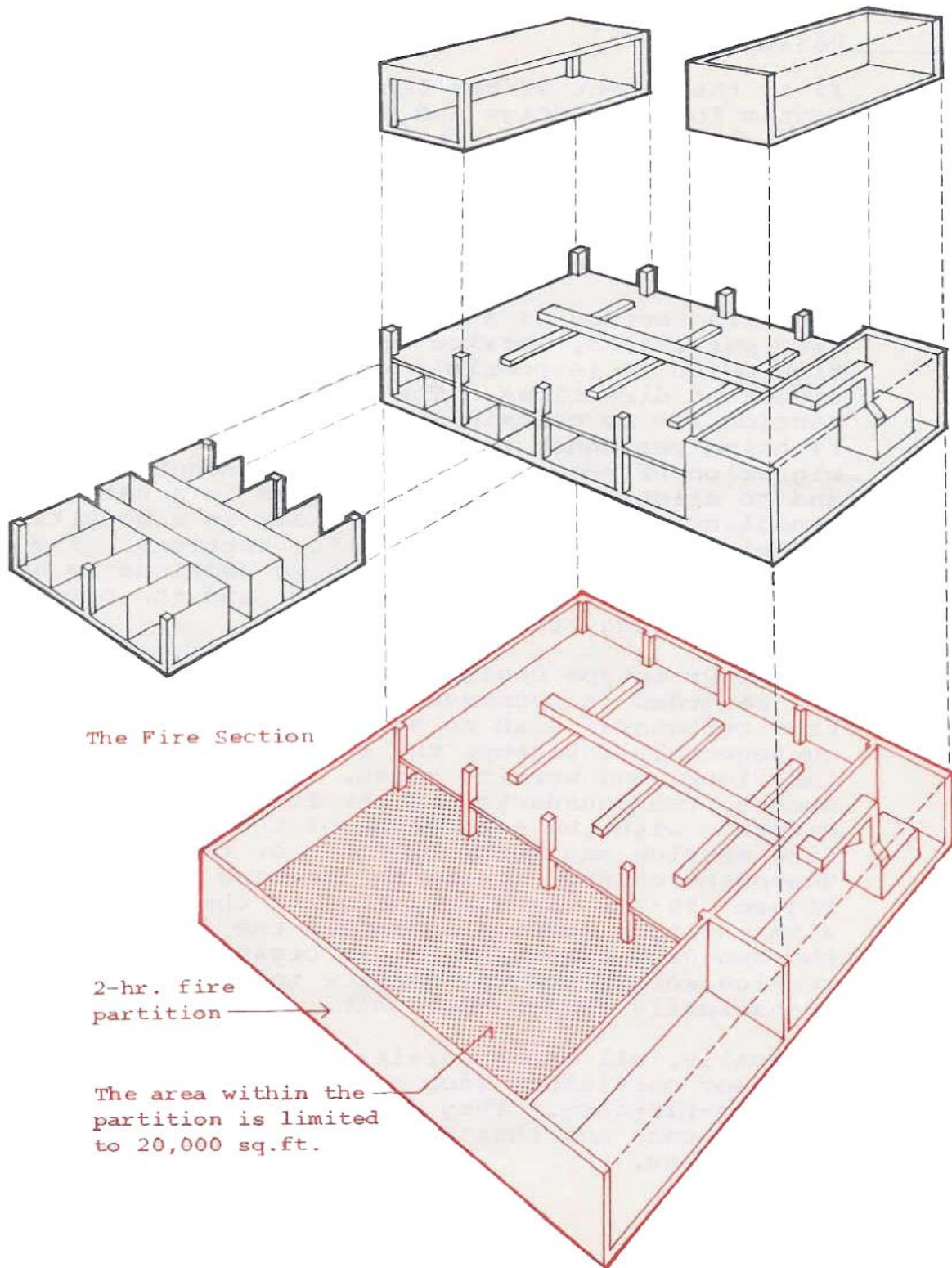

## **242 FIRE SECTION CHARACTERISTICS**

### **242.1 SIZE**

**242.1.1** Use of a fire section approaching the maximum code size of 20,000 square feet will minimize the necessity of expensive fire-rated elements. The optimum service module size (exclusive of the service bay) is about 10,000 square feet. When the sum of the area of two adjacent service modules is less than 20,000, two modules per fire section should be used. When the sum of adjacent service modules exceeds 20,000 square feet, each module will coincide with a fire section.

**242.1.2** It must be noted that fire safety codes and regulations which govern fire section size and existing requirements are subject to constant review and change. For example, much attention is currently focused on the use of automatic sprinklers throughout the hospital. If this concept is implemented, it is reasonable to anticipate that certain relaxations with regard to the size of the fire section and criteria for exit distances may follow.

### **242.2 SHAPE**

Service modules are most efficient when their boundaries are regular and form a simple shape. The fire section boundaries, which are coincidental with those of the service module, should also be simple in shape.

### **242.3 RELATION TO FUNCTIONAL ZONE**

**242.3.1** In a traditional planning sequence, fire separations are determined after all rooms have been configured. Separation walls follow an irregular path along the boundaries of rooms. In applying the system, fire section boundaries are to be determined prior to detailed planning, and establish a regular framework of permanent components within which departmental areas must be planned (See Figure 240-2). The fire sections must be carefully configured and coordinated with internal corridor arrangements to ensure that required exit distances can be maintained.

**242.3.2** A rectilinear system of fire separations imposes minor constraints on planning while offering significant advantages in the organization of service zones. Fire separation walls in the functional zone can be penetrated by fire-rated doors at any point either in initial construction or in subsequent alterations.

**Figure 240-2. FIRE SECTION PLANNING:  
SYSTEM vs. CONVENTIONAL**

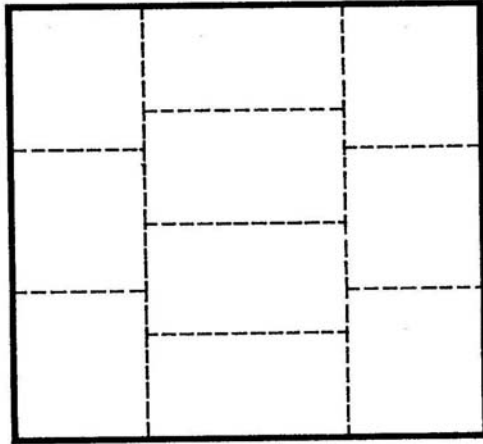

System Design:

Fire Sections establish regular planning framework derived from Service Modules, within which departmental requirements and relationships must be resolved.

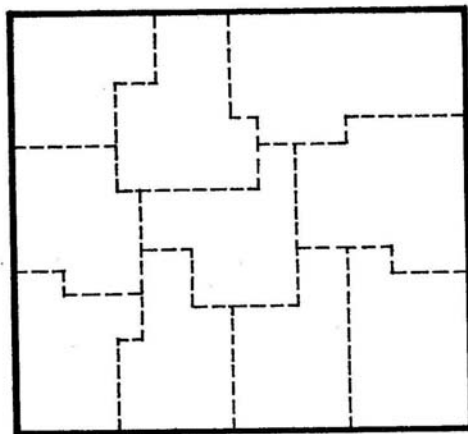

Conventional Design:

Irregular pattern of fire sections defined by 2-hour fire partitions which follow least disruptive route through planned departmental layouts.

The planning constraint is rather one of a need to conform to preset wall configurations. This may require a minor increase in the size of a room or a department. It also requires coordination between fire separation walls and large open areas such as a therapy pool, an auditorium, kitchen-dining area, etc. or open departments such as medical records or certain types of laboratories. These constraints to planning are to a large extent predictable and can be accommodated. As such, they are judged less critical when compared to the alternatives of irregular service zones or relocation of slab to slab fire separations in subsequent alterations.

**242.3.3**

As stated previously, unlike two-hour fire partitions, smoke stop partitions and corridor partitions span from the structural slab to the one-hour fire-resistive ceiling-platform. They are considered adaptable components and can be located along the boundaries of individual rooms. (See Figure 240-3.) There is one exception. If cost and engineering analysis indicated definite advantages, the service zone could be used as a return air plenum. In such a case, all smoke stop partitions would have to span from structural slab to structural slab with appropriate protection to all penetrations. Consequently, the location of these partitions could become critical in terms of maintaining the continuity of the service zone. Where possible, they should be located at the boundary between service modules.

Figure 240-3. PARTITION REQUIREMENTS

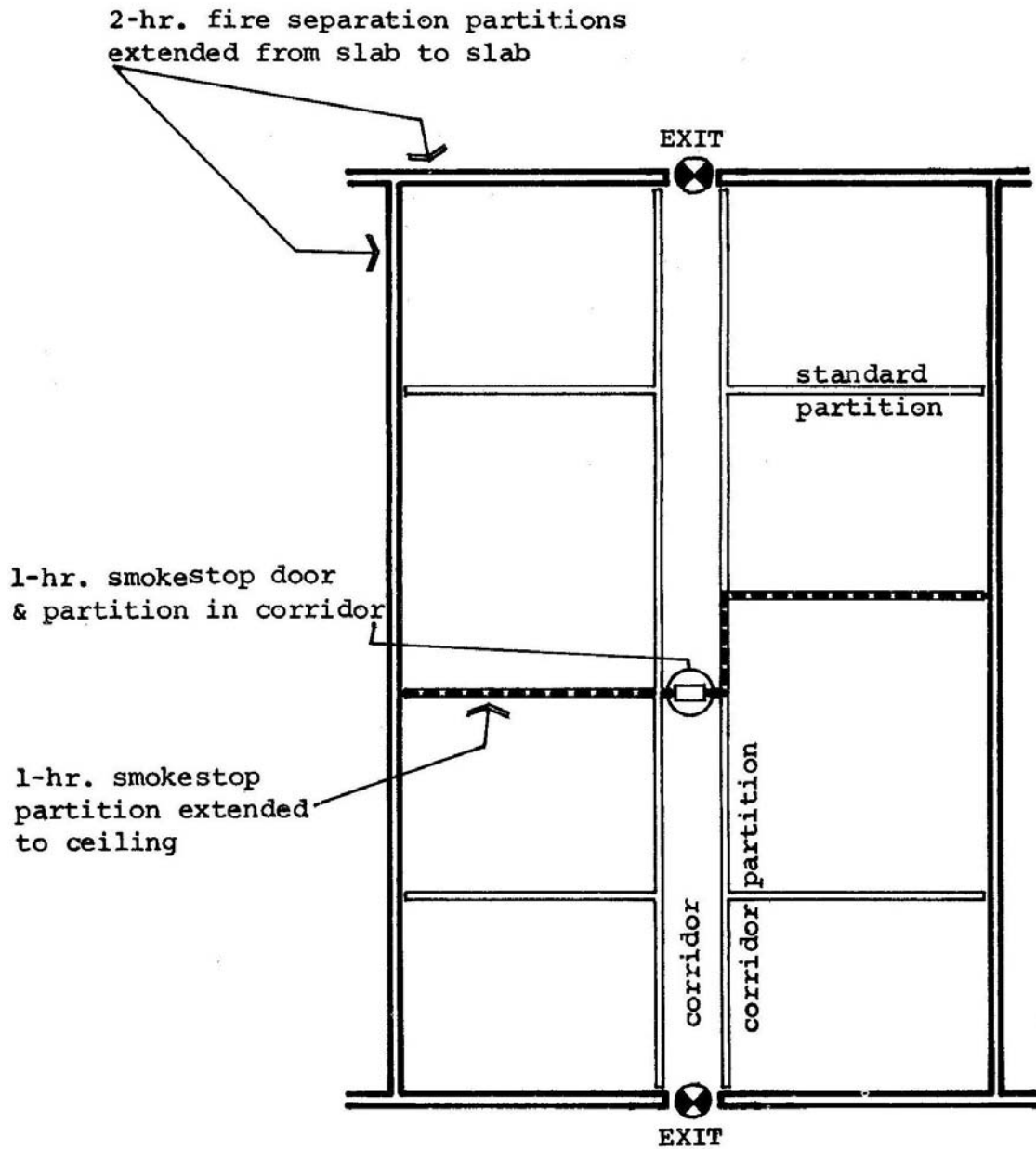



## **250 Planning Module Applications**

### **251 DESIGN CONFIGURATIONS**

A sample range of design configurations have been developed to illustrate the potentials and constraints of the planning module approach. Specifically, a configuration classification system is proposed and the assembly characteristics of each planning module are indicated relative to that system. However, there is no intent to define a preferred set of configurations.

#### **251.1 ASSEMBLY CLASSIFICATION**

##### **251.1.1 A Classification Framework**

Configurations were analyzed and classified by three characteristics:

1. hospital floor size – in this case, the number of beds/floor was used as a measure of size
2. generic hospital types
3. design complexity – defined in terms of simple and compound assemblies – categories which organize configurations by assembly characteristics of the planning modules.

##### **251.1.2 Hospital Floor Size**

The number of beds is a basic measure of the comparative size of configurations. For example, one can examine all basic configurations containing 160 beds per floor and identify a representative sample of various service module assemblies.

##### **251.1.3 Generic Hospital Types**

Hospital types vary in their relationships between the bed care and support areas, and these relationships must be reconciled within the limits of the system.

### 1. Tower separate from a base

Nursing functions are generally separate from the support functions. There is a relative independence of choice of planning modules and assembly patterns between the tower and the support area, although the floor-to-floor heights in the lower bed care floors must be equal to those in the support area to provide horizontal continuity.

Independent subsystem relationships.  
Constant floor to floor height at lower levels.

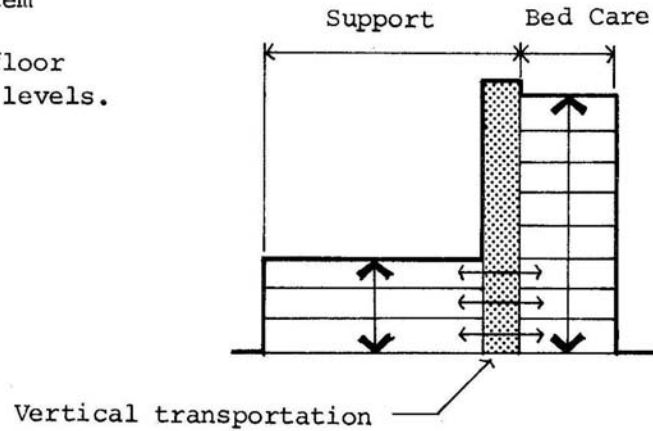

### 2. Tower on a base

The tower on a base needs a maximum of coordination between bed care and support areas since the organization of the tower service module pattern fundamentally affects the organization of the service modules in the base.

Dependent subsystem relationships.  
Constant floor to floor height at lower levels.

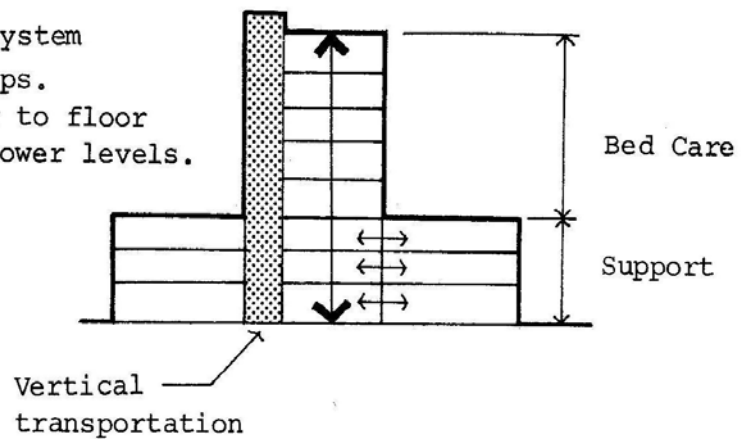

### 3. Horizontal Hospital

The horizontal hospital demands a close coordination of floor-to-floor heights. Because of this contiguity, the higher ceiling required in many support functions may have to be carried over into the bed care area.

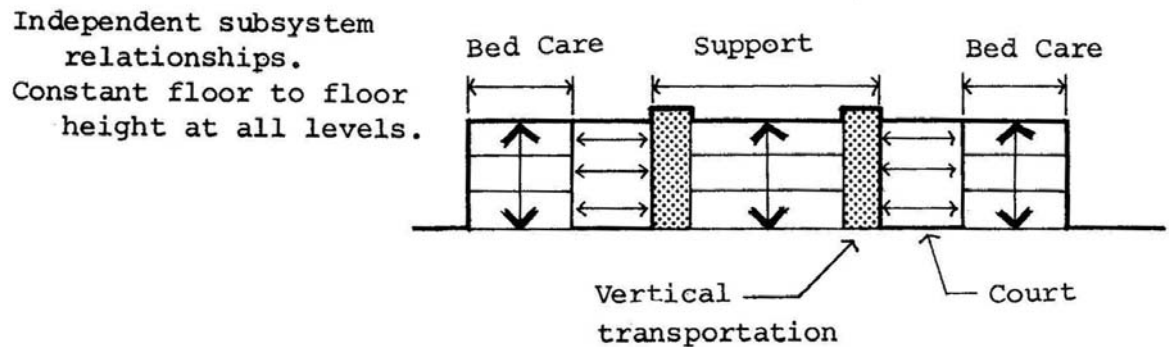

#### 251.1.4 Design Complexity

From an analysis of the assembly characteristics of the relevant building subsystems and planning modules, a consistent pattern emerged which has been used as a means of classifying subsystems and understanding their implications on design configurations.

Plan configurations fall into two broad categories called simple and compound assemblies of service modules. (See Figure 250-1.)

##### 1. Simple Assemblies

Simple assemblies result when the respective disciplines of a unidirectional structural bay and an exterior service bay location are maintained throughout any given configuration.

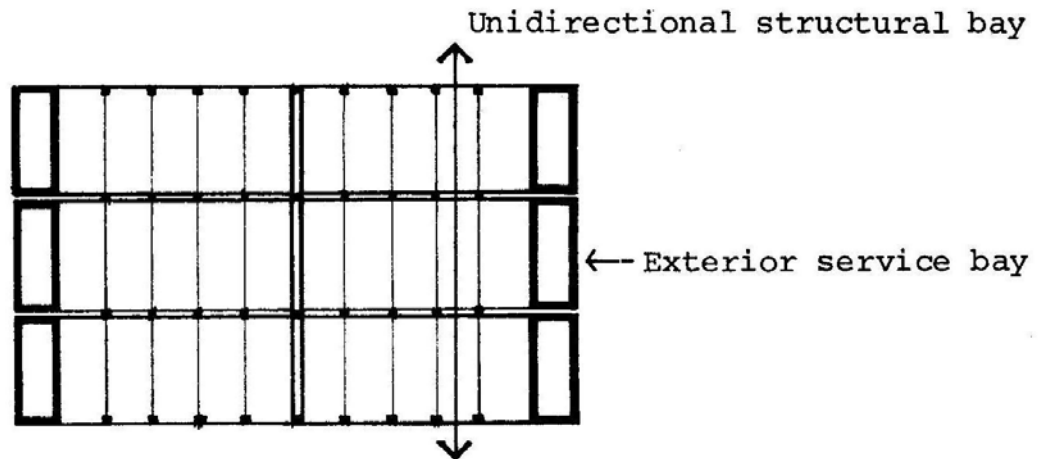

## 2. Compound Assemblies

A compound structural assembly is one which contains structural bays that adjoin one another at right angles. A compound mechanical assembly is one in which an interior service bay is used.

### 251.2 ALTERNATIVE CONFIGURATIONS

Utilizing the three classification headings discussed in Section 251.1 above, a table of configurations can be developed which quickly compares a number of configuration options and thereby speeds the initial design development. Figure 250-2 illustrates the classification framework applied to a number of design configuration alternatives.





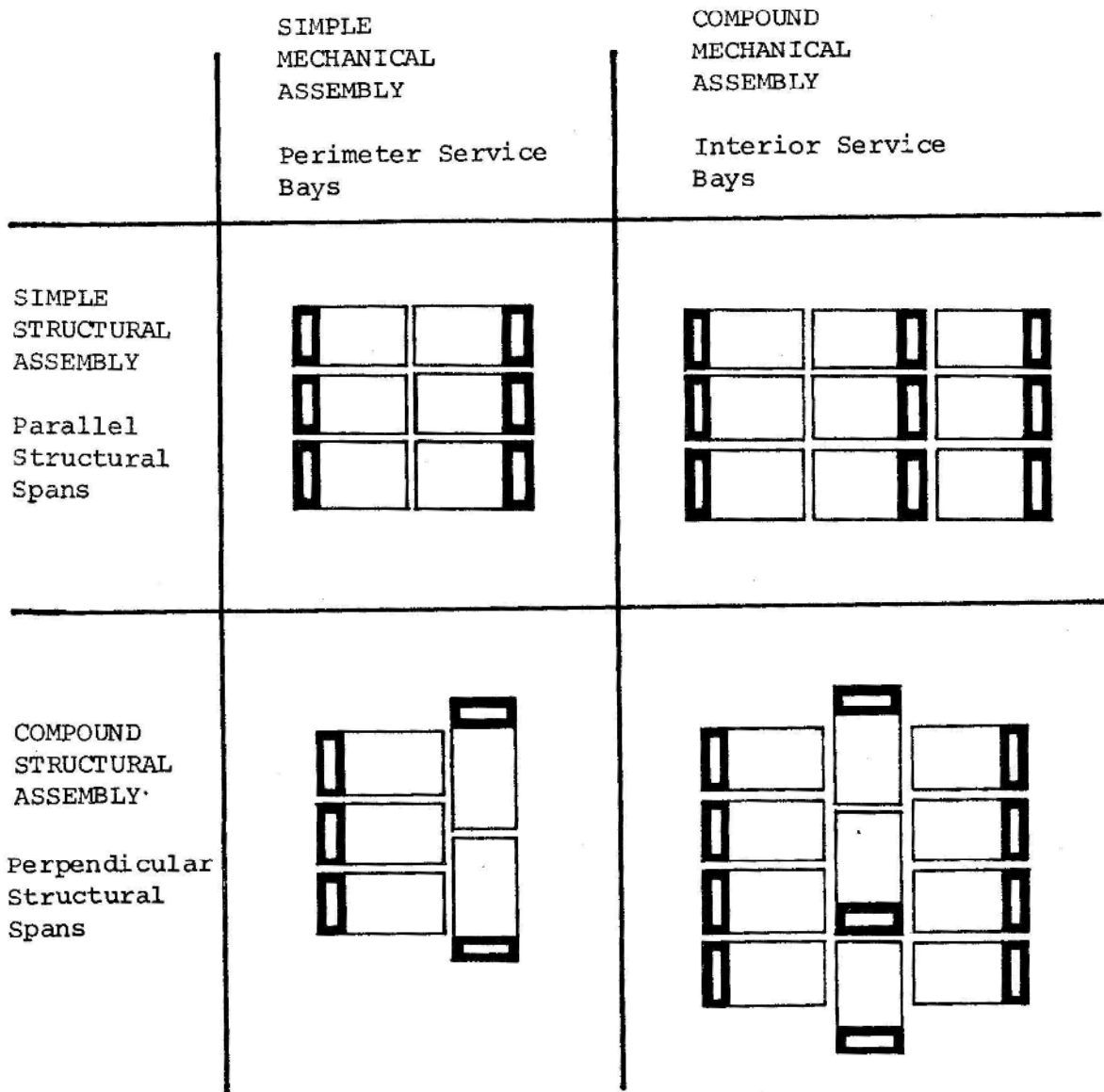

In the chart, groups of configurations occur in vertical columns, each of which is a development of one basic assembly pattern of bed care service modules. Some columns could be extended to illustrate larger configurations, just as other basic assembly patterns could be shown. However, this chart is intended as a demonstration of the way configurations may be classified within the constraints of the system, rather than a complete catalog of system configurations.

The configurations in the chart are diagrammatic so that basic assembly patterns and characteristics can be illustrated.

Figure 250-1. SIMPLE AND COMPOUND ASSEMBLIES



**LEGEND FOR FIGURE 250-2**

	<b>Space Modules</b>
	<b>Additional Space</b>
	<b>Service Bay for Bed Care Service Module</b>
	<b>Service Bay for Support Service Module</b>
	<b>Vertical Transportation</b>
	<b>Service Module containing Support</b>

Note: Service Module containing Bed Care Functions is composed of Space Modules and Additional Space

Figure 250-2. EXAMPLES OF CLASSIFIED CONFIGURATIONS

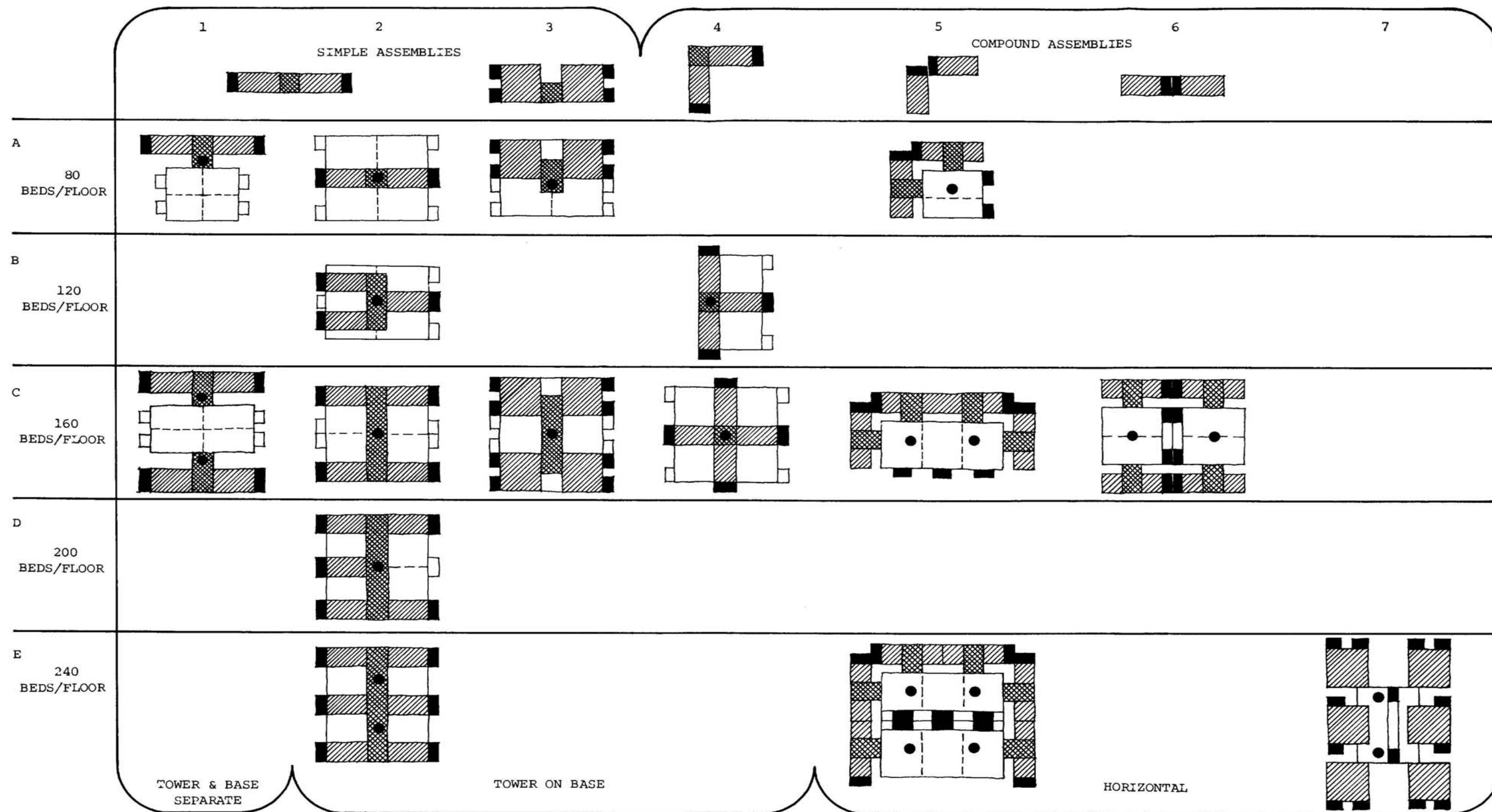

**(BLANK PAGE)**



### 251.3 ASSEMBLY CHARACTERISTICS OF THE SERVICE MODULE

The assembly characteristics of the service module are primarily established by:

1. The structural subsystem
2. The service bay
3. The space module, when the service module occurs in the bed-care portions of the hospital.

#### 251.3.1 The Structural Subsystem

Those features of the structural subsystem which most markedly affect the assembly of modules are the structural bay, the shear wall, and the thermal expansion or seismic separation joint.

##### 1. The Structural Bay

The constant width and variable length of the structural bay produce offset column lines when two space modules or service modules adjoin at right angles. This problem can best be resolved through the use of the 45' span, although the modular structural bay lengths create a regular condition in any case. (See Sections 316.4 and 721.1.2 for further discussion.)

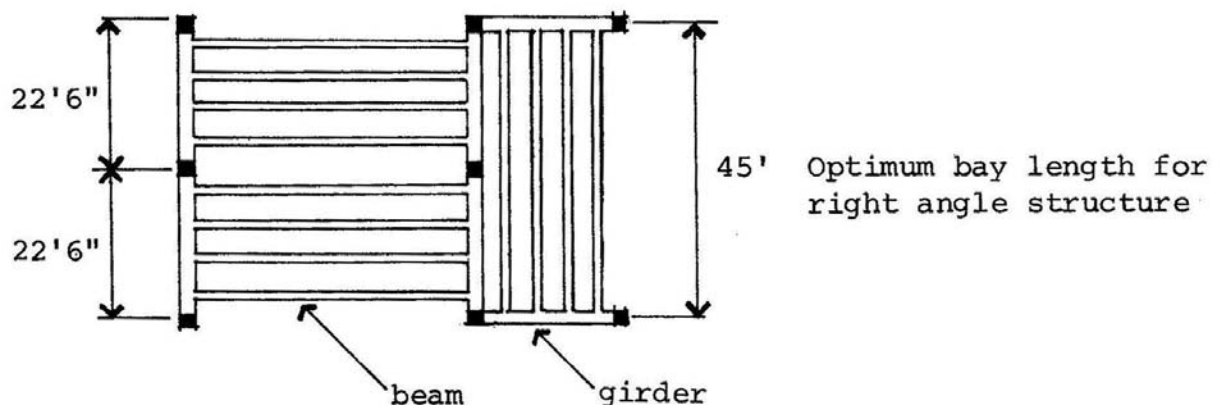

##### 2. Shear Walls

Configurations are affected in several ways by the use of shear walls to resist lateral forces.

The 160' height limit on all configurations is established by the practical limit of the shear wall.

In large buildings shear walls often occur in interior locations because of their relationship to expansion or separation joints. Any shear walls, in addition to those in the service bay, should occur at the service module boundaries to ensure that the service zone is unobstructed. (See Section 316.2 for further discussion.)

### 3. Expansion and Separation Joints

Large buildings should be broken by thermal expansion joints so that dimensions in any direction do not exceed 300 feet (less in areas of large temperature variation). The separation created by an expansion joint often means that shear walls are necessary at that location to assure lateral stability, thereby forming a barrier along the line of the separation. Shear walls are similarly required at seismic separation joints. If the expansion or separation joint can be located on the border of a service module or fire section, the effect of this barrier can be minimized. (See Section 316.1.)

#### **251.3.2 The Service Bay**

In the service distribution system, the only aspect which plays a major role in developing configurations is the arrangement of service bays.

##### 1. The Typical Condition

The service bay typically should have at least one exterior face to facilitate equipment installation and allow a direct fresh air intake. This pattern of perimeter service bay locations provides for the potential of large uninterrupted spaces which are twice the length of one service module, exclusive of the service bay.

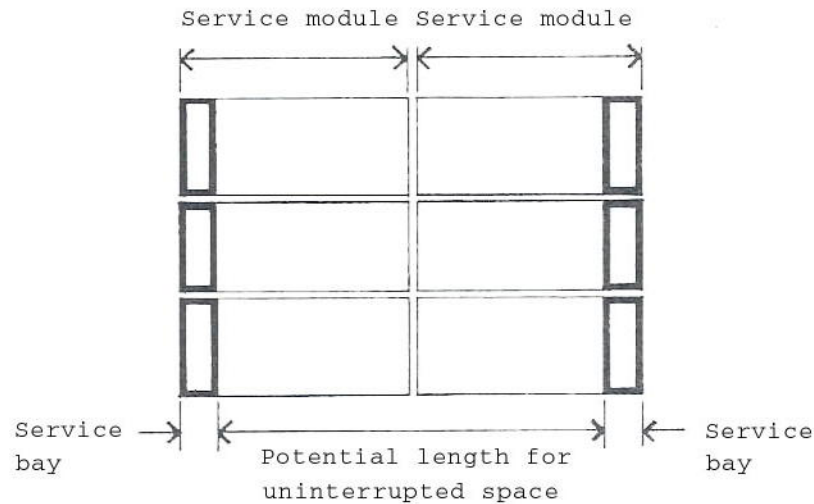

## 2. The Service Strip

An interior service bay often becomes necessary in a configuration where the size or the organization of service modules is such that some portion cannot be served from an exterior service bay.

When the strategy of an independent air-handling unit for each service module is extended to an interior service bay location, an alternative fresh air supply must be found. More importantly, the problems of installation and replacement of mechanical equipment are significantly greater.

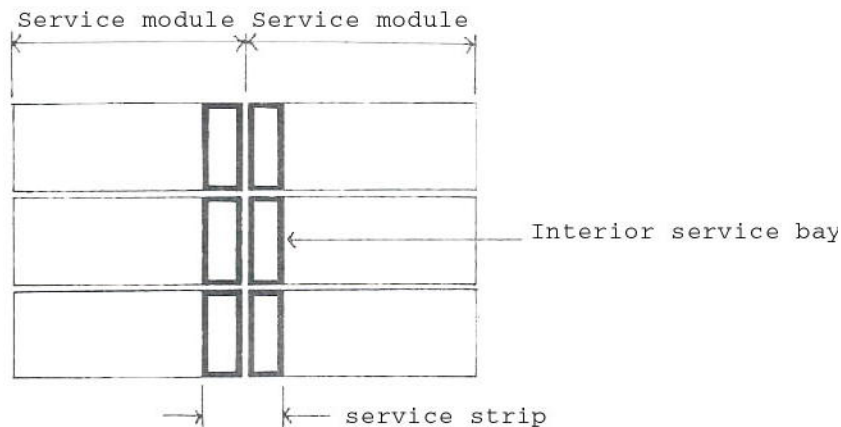

A service strip is defined as any series of adjacent service bays, some of which are interior. The service strip occurs often in compound configurations, and must be accommodated by a special strategy.

Three alternate strategies have been developed for the use of a service strip. However, the detailed resolution of this condition must be accomplished on a project-by-project basis. (See Section 735.1.2 and Figure 730-5 for demonstration of the service strip in the Building Schematic Design.)

- a. The air-handling unit is located adjacent to the service module, and air is ducted to the air-handling unit, either through a vertical shaft or horizontally through the service zone. (See Figure 250-3.)
- b. The air-handling unit is placed in a remote location such as the roof while the electrical room and the main plumbing risers remain in their normal location. Supply and return air are ducted to and from the service module and the air-handling unit. (See Figure 250-4.)
- c. The air-handling unit, and all auxiliary pumps and fans, are located at the service zone level. This would require an increased service zone height. (See Figure 250-5.)

The choice of one of the three alternates for an individual configuration would largely rest on specific programmatic and functional requirements, but Alternate b. best provides for replacement and maintenance of mechanical equipment. Alternates a. and c. would severely complicate the problem of replacing large equipment. Additionally, Alternate c. would require a modified ceiling structure to accommodate the mechanical equipment in the service zone and to deal with the resultant acoustic problems.

A service strip would require a special structure, since the alternates for planning this zone do not suggest a basic design which would suffice for all cases. (See Figure 316.5.)

### **251.3.3 The Space Module**

#### **1. Aspect and Attachment**

When the service module contains bed-care functions, its assembly characteristics are largely dictated by the space module requirements for aspect and attachment to other space or service modules.

**Figure 250-3. SERVICE STRIP ALTERNATE STRATEGY: AIR HANDLING UNIT ADJACENT TO SERVICE MODULE WITH DUCTED SUPPLY**

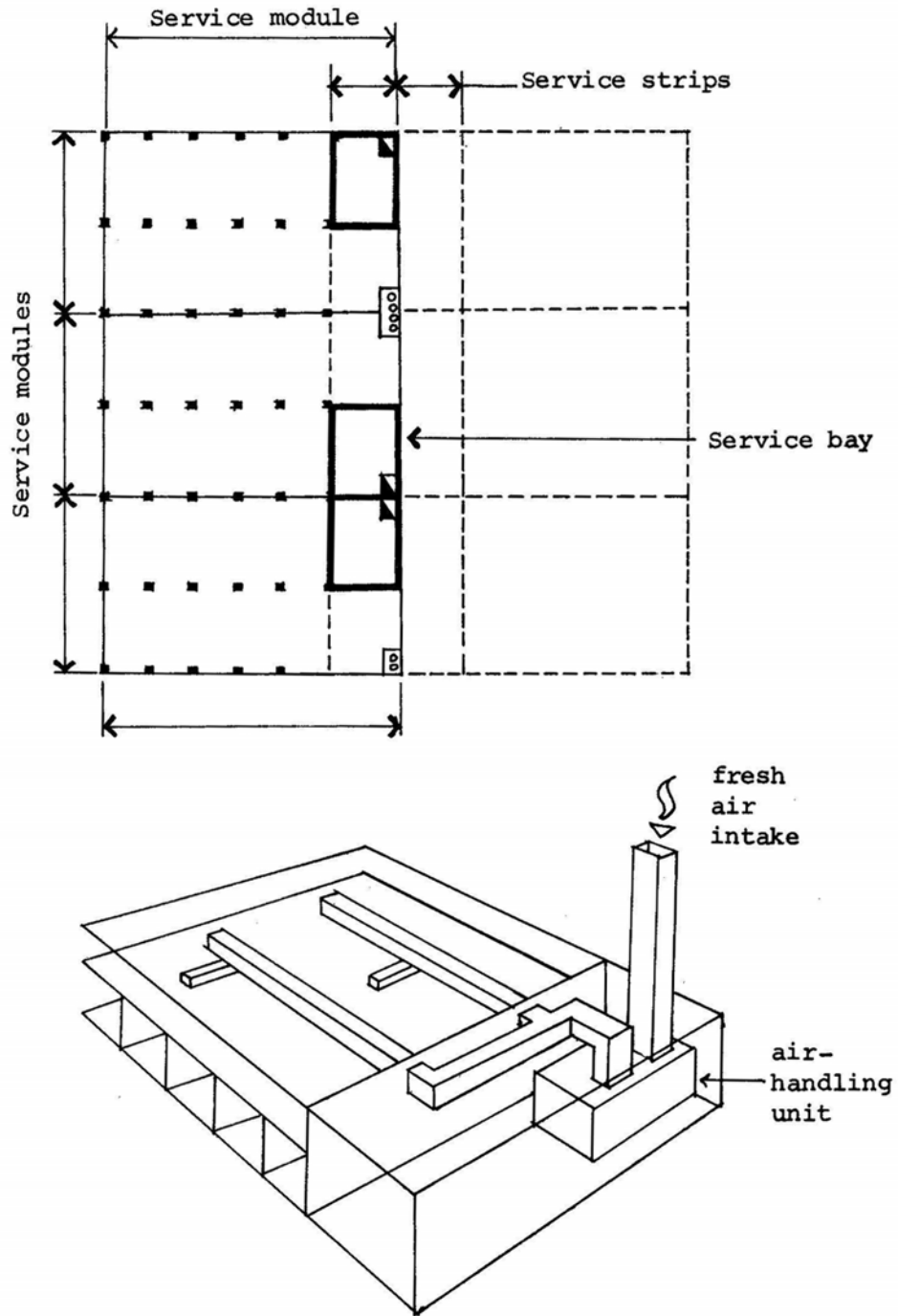

**Figure 250-4. SERVICE STRIP ALTERNATE STRATEGY:  
AIR HANDLING UNIT LOCATED ON ROOF**

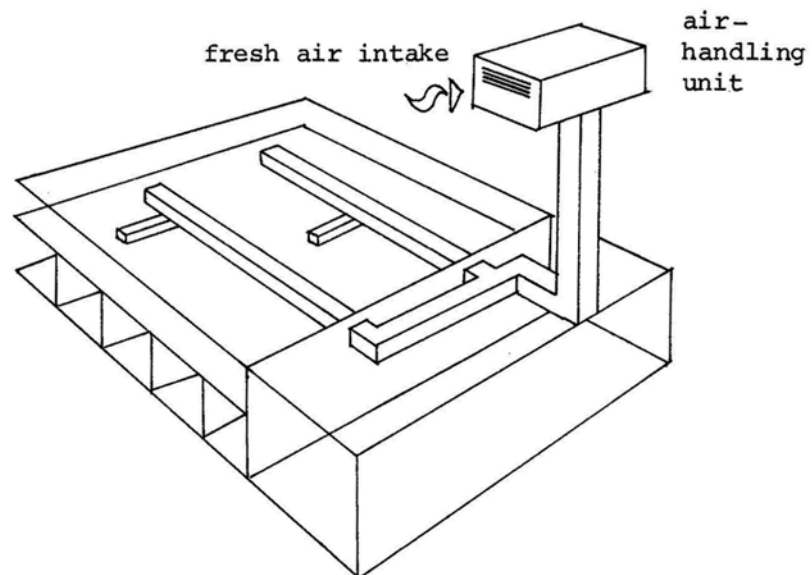
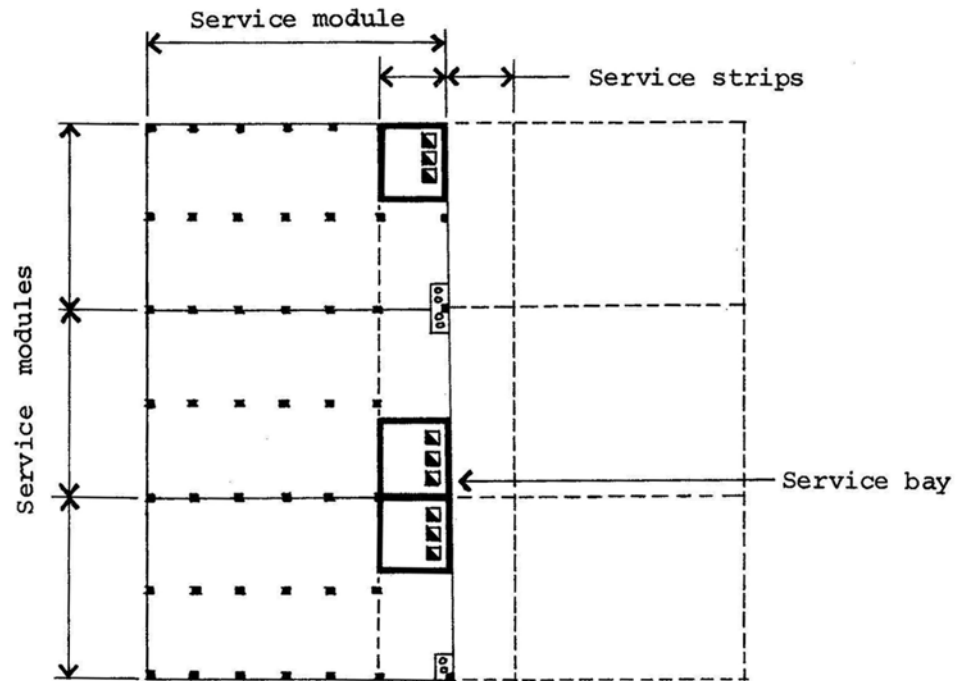

**Figure 250-5. SERVICE STRIP ALTERNATE STRATEGY:  
AIR HANDLING UNIT LOCATED IN SERVICE ZONE  
WITH DUCTED SUPPLY**

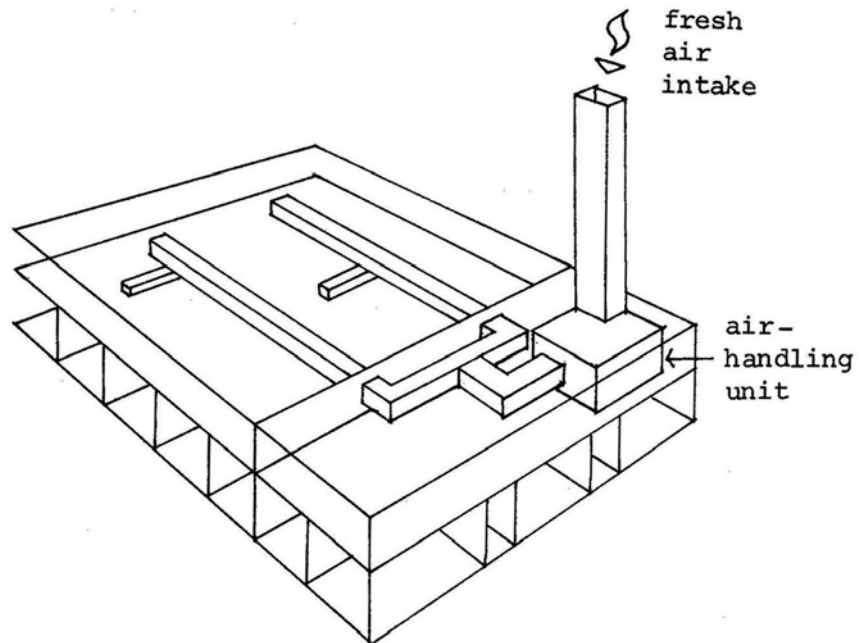
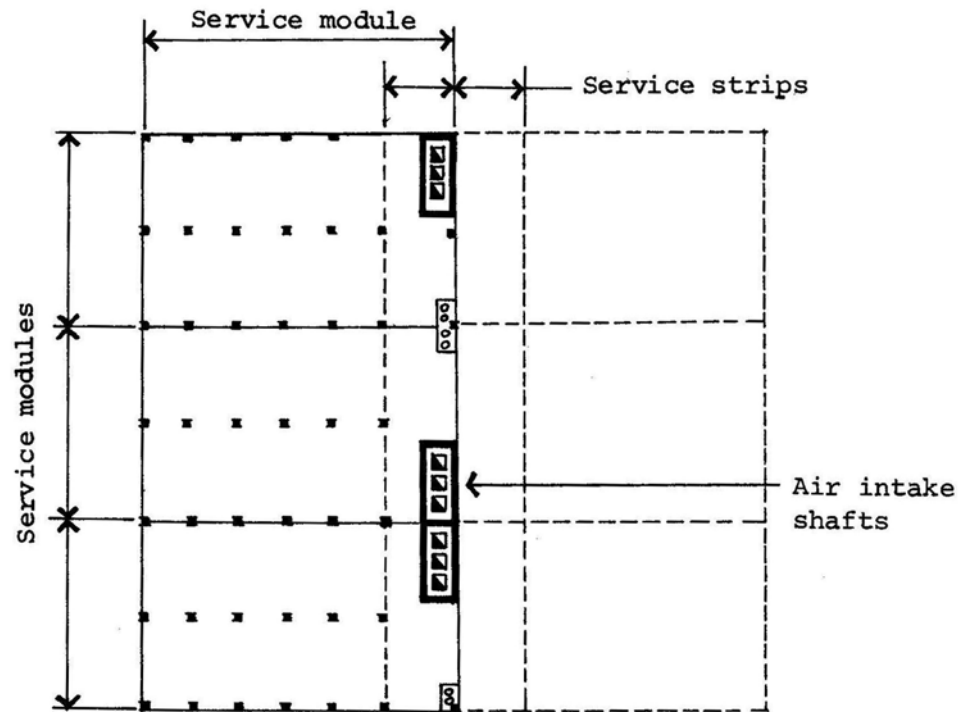

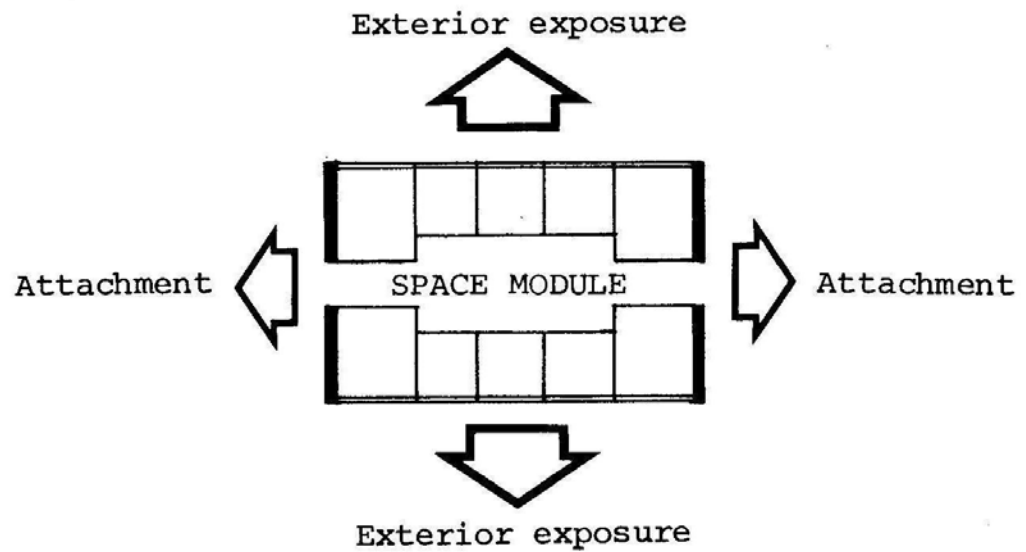
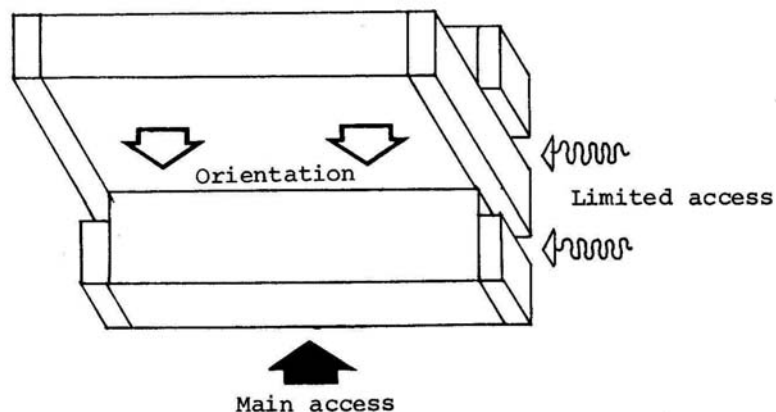

Figure 250-6 illustrates the assembly characteristics of two basic types of space module: the two-aspect 20-bed module and the four-aspect 40-bed module.

## 2. Orientation and Access

The orientation of the service modules containing bed-care functions can also significantly influence the planning of the rest of the hospital. For example, in a tower on a base configuration, the orientation of the nursing tower can determine the assembly of service modules in the base and limit the location of major access points on the ground level.





**Figure 250-6. ASSEMBLY CHARACTERISTICS OF THE SPACE MODULE AND SERVICE MODULE**

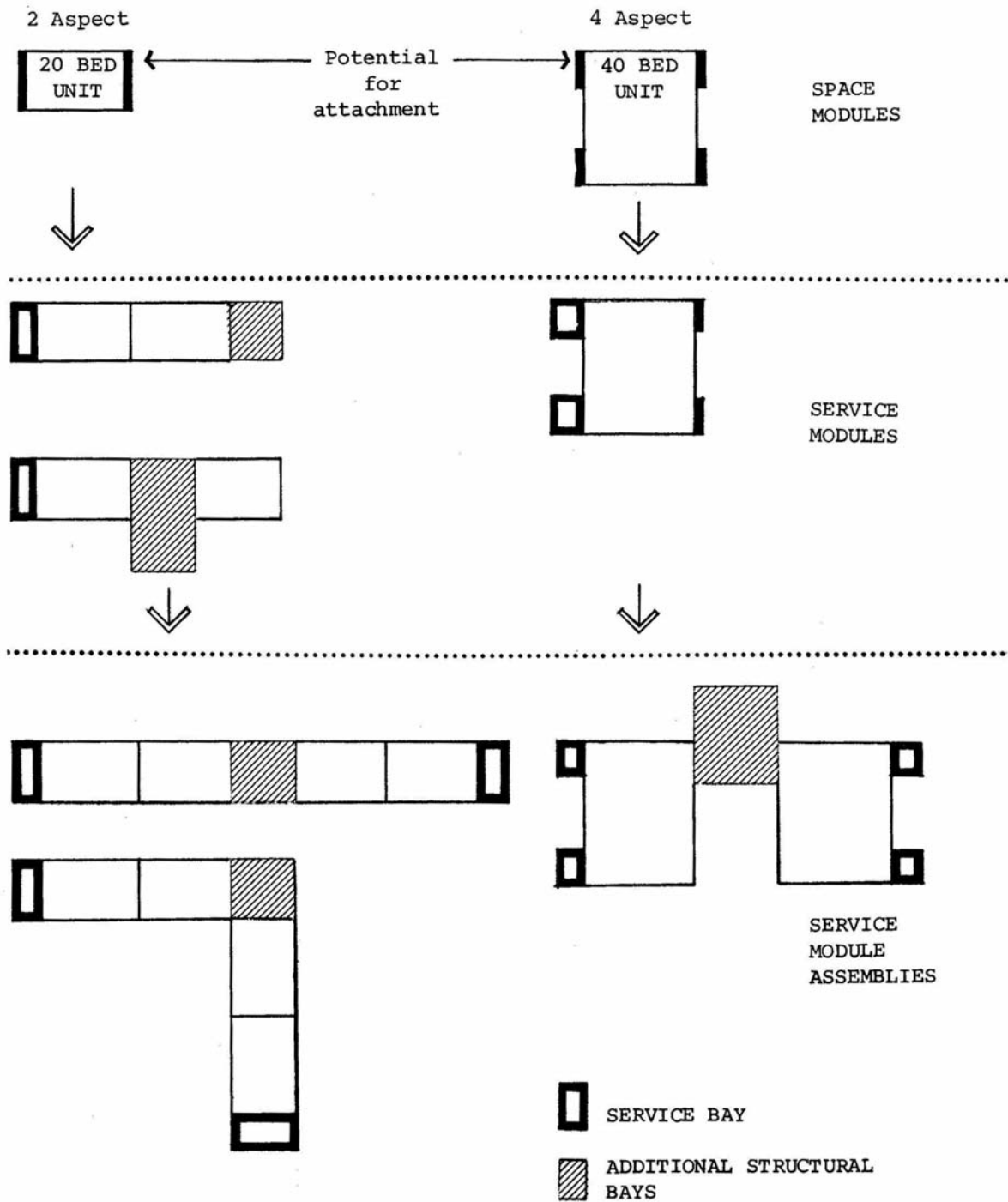

**251.3.4** In the general case, the service module has no external exposure requirement, and can be assembled in a very direct pattern. Using rectangular modules, three sides of the module are available for attachment or access and the modules can be combined, incrementally, in two directions.

Figure 250-7 illustrates this general assembly pattern. This diagram also points out the general configurations which have service strips. A dotted line on the diagram gives an indication of the types of configurations in which an expansion joint becomes necessary.

The assembly of service modules in the support areas is very much a process of adjusting the service module shape and boundaries to the programmatic requirements of the hospital. Detailed resolution of the service module configuration is an integral part of the design process, therefore specific statements about the assembly characteristics are not relevant in all cases. (See Section 735.1.2 for discussion of service modules in the Building Schematic Design.)

#### **251.4 ASSEMBLY CHARACTERISTICS OF THE FIRE SECTION**

Configuration studies are generally initiated through the assembly of space modules or service modules, but the service module and fire section are so interrelated that the fire section becomes a significant consideration. (See Section 240: Fire Sections)

The basic assembly characteristics of the fire section are:

1. Its area must not exceed the 20,000 sq. ft. limit set by current fire safety practice, and,
2. It follows a simple geometry which is derived from the service module; the boundaries of the fire section are coincident with the boundary of the service modules contained within it.

#### **251.5 SUMMARY OF CONSTRAINTS**

A summary of principal assembly characteristics is presented in Figure 250-8. These are keyed to the simple and compound assembly patterns and emphasize the special characteristics which may occur in a compound configuration. The figure also provides a general checklist of characteristics for any additional design configuration studies.

Figure 250-7. SERVICE MODULE ASSEMBLY CHARACTERISTICS

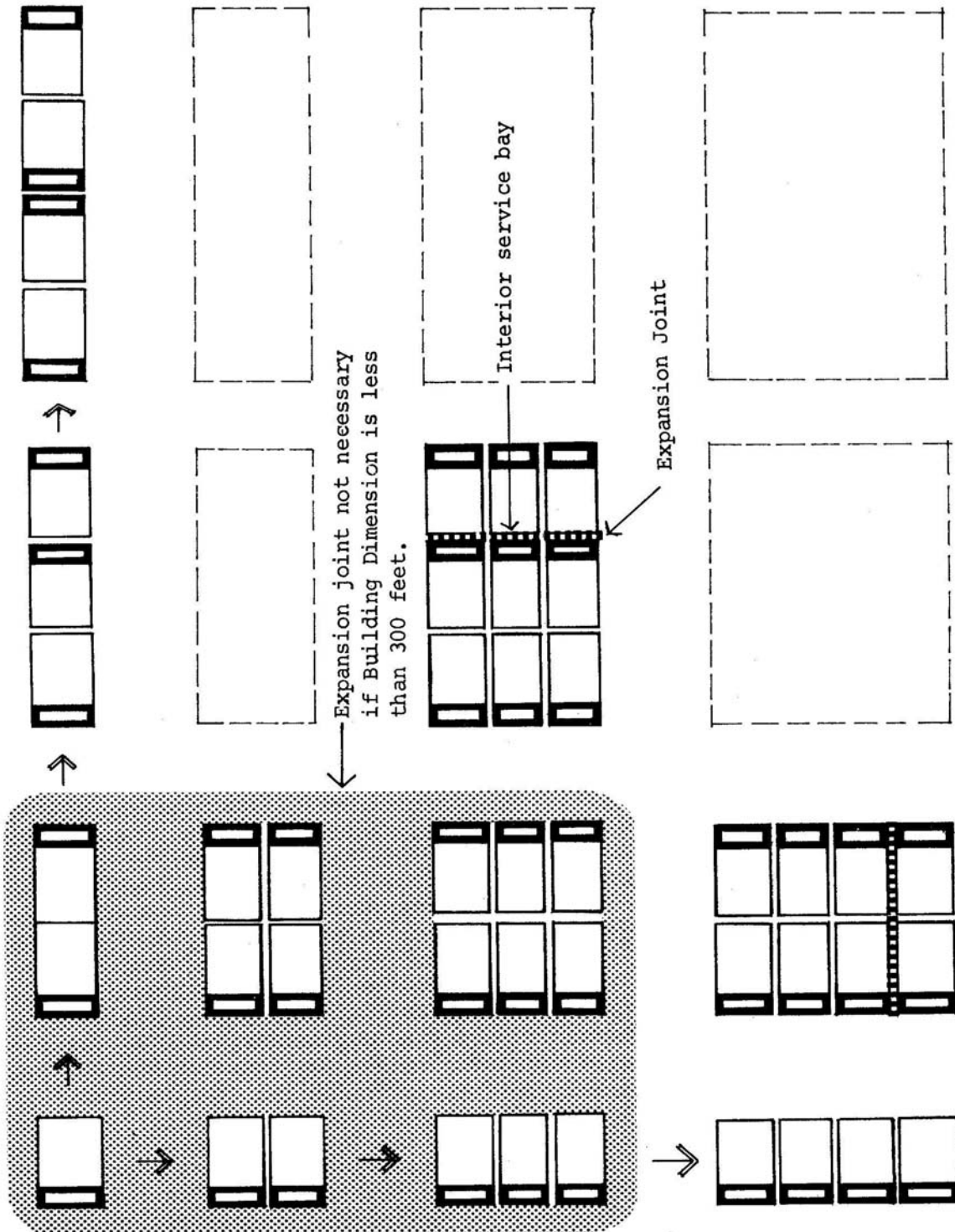

Figure 250-8. SUMMARY OF ASSEMBLY CHARACTERISTICS

	SIMPLE ASSEMBLIES	COMPOUND ASSEMBLIES		
		RIGHT ANGLE STRUCTURE	SERVICE STRIP	300' DIMENSION
STRUCTURAL SUBSYSTEM	<ul style="list-style-type: none"> <li>▪ Structural bays with constant width - 22'6" and variable length from 40'6" to 58'6" at 4'6" increments</li> <li>▪ All spans are directionally consistent</li> <li>▪ Height of shear wall limited to 160'</li> </ul>	<ul style="list-style-type: none"> <li>▪ Reconcile structural change (best accomplished with 45' span)</li> </ul>	<ul style="list-style-type: none"> <li>▪ Special structural strip</li> </ul>	<ul style="list-style-type: none"> <li>▪ Possible need for additional shear walls</li> </ul>
MECHANICAL SUBSYSTEM	<ul style="list-style-type: none"> <li>▪ At least one service bay for each service module</li> <li>▪ The service bay occurs on perimeter</li> <li>▪ Maximum length supply duct is approximately 150'</li> </ul>		<ul style="list-style-type: none"> <li>▪ Adequate fresh air supply</li> <li>▪ Access to air-handling unit for installation and maintenance</li> </ul>	
SPACE MODULE	<ul style="list-style-type: none"> <li>▪ Access to the space module through additional structural bays</li> <li>▪ Orientation of the bed-care areas</li> </ul>			
SERVICE MODULE	<ul style="list-style-type: none"> <li>▪ 10,000 sq.ft. limit exclusive of service bay if two are combined in fire section</li> <li>▪ Aspect, if used for bed care</li> <li>▪ Length limited by mechanical supply and service zone height</li> </ul>	<ul style="list-style-type: none"> <li>▪ Secondary subzones must change direction</li> </ul>		<ul style="list-style-type: none"> <li>▪ Provide expansion joint</li> </ul>
FIRE SECTION	<ul style="list-style-type: none"> <li>▪ 20,000 sq.ft. limit</li> <li>▪ No crossing of service module boundaries</li> </ul>			

## **300 THE BUILDING SUBSYSTEMS**

### **310 STRUCTURE**

311	Basic Design	1-103
312	Generic Design Options	1-108
313	Dimensions	1-109
314	Loading	1-119
315	Other Design Criteria	1-123
316	Special Considerations	1-124
317	Target Costs	1-134

### **320 CEILING**

321	Basic Design	1-137
322	Generic Design Options	1-141
323	Dimensions	1-152
324	Loading	1-155
325	Acoustics	1-157
326	Fire Safety	1-160
327	Other Design Criteria	1-161
328	Target Costs	1-163

### **330 PARTITIONS**

331	Basic Design	1-165
332	Generic Design Options	1-169
333	Dimensions	1-174
334	Strength	1-175
335	Acoustics	1-179
336	Fire Safety	1-181
337	Other Design Criteria	1-183
338	Target Costs	1-186

### **340 HEATING-VENTILATING-COOLING**

341	Basic Design	1-189
342	Generic Design Options	1-191
343	Organization	1-192
344	Design Criteria	1-197
345	Target Costs	1-203

**350 PLUMBING DISTRIBUTION**

351	Basic Design	1-205
352	Organization	1-207
353	Design Criteria	1-210
354	Target Costs	1-213

**360 ELECTRICAL DISTRIBUTION**

361	Basic Design	1-215
362	Organization	1-217
363	Design Criteria	1-219
364	Target Costs	1-225

**370 COORDINATION CHECKLIST** 1-227

## **310        STRUCTURE**

### **311        BASIC DESIGN** (Figure 310-1)

The structural subsystem is designed to accommodate service modules in a variety of building configurations. It includes a framing system for vertical loads and a shear wall or braced frame system for lateral force resistance. A general design approach is described for the structure of the service bays where the configurations and dimensions are not predictable. The configurations and dimensions of the rest of the service module are predictable, however, and a more detailed basic design has been developed. The basic design is limited to the structure above grade; it does not include items such as foundations, retaining walls or exterior walls (See Section 317.2).

#### **311.1      FRAMING SYSTEM FOR VERTICAL LOADS**

##### **311.1.1    Typical Structural Bays**

The basic framing system consists of columns, girders and beams in structural bays approximately two to three times as long as they are wide. The length of the bays is in the span range of forty to sixty feet, the reasons for which are discussed in Section 721.1.1. The bays are spanned in the long direction by closely spaced beams of minimum economic depth, and the beams are supported by, or cantilevered from, girders of similar depth. The use of short primary members with long secondary members results in a shallow layer of structure. The roof is framed in a similar manner, but takes into account different loading criteria. The rationale for the selection of this type of system is discussed in Section 721.2.

This framing system can be utilized in the vast majority of the functional areas of the hospital. It does not apply to service bays and certain functional areas with exceptionally high live loads or special configuration requirements which are listed in Table 310-1. The structure in these areas must be designed by the project A/E as required by the specific conditions.

##### **311.1.2    Service Bays**

The configuration of the service bays will vary but will typically result in a simple beam and slab floor system, framed as necessary for the layout.

Vertical loads will be transferred to the foundations through the solid walls which typically surround the service bay.

### 311.2 LATERAL FORCE RESISTING ELEMENTS

Resistance to lateral forces is by shear elements which may be concrete walls and/or braced frames (usually steel). These elements occur only at the perimeter of service modules and, in some cases, their required locations may be the major determinant of the size of these modules. The shear elements are provided in two forms:

1. Two Dimensional. Walls in one direction.
2. Three Dimensional. Box-like towers containing walls in two directions which enclose service bays, elevator towers and other permanent elements, occurring at the perimeter of the service modules. The towers may be capable of providing resistance in two directions. In the longitudinal direction, lateral forces are typically transmitted to the shear elements through girders or collectors as indicated in the following diagram.

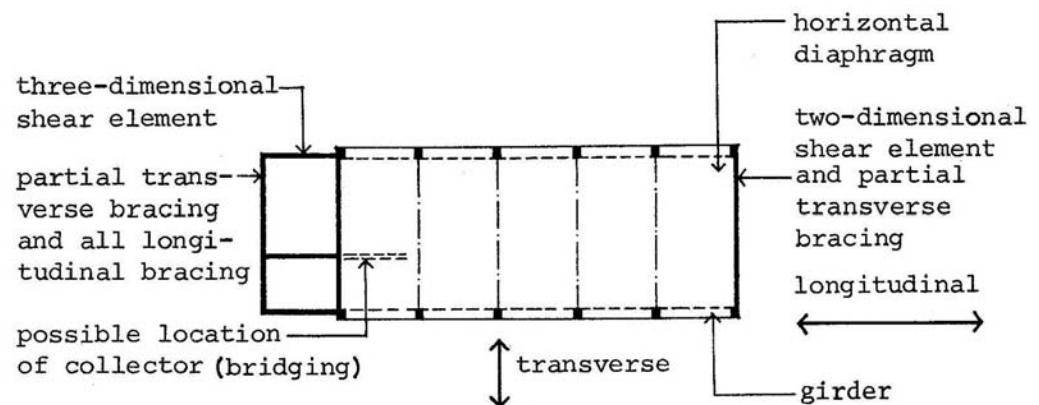

The solid wall and/or braced frame system of resisting lateral forces has been selected for the reasons which are enumerated in Section 721.3.



### 311.3 RELATIONSHIP BETWEEN MAIN STRUCTURAL MEMBERS

(Figure 310-2)

The relationship between the main structure members is illustrated in Figure 310-2. These relationships and the rationale are as follows:

1. The perimeter girder is in the same plane as the beams. The clear space below the perimeter girder facilitates access to the service zone above the ceiling during construction and major alterations.
2. The interior girder is below the beams. This allows for a continuous clear space across the building for service distribution between the beams and also simplifies beam continuity problems.
3. The beams are offset from the column centerlines. The offset beams create a clear zone for drains to drop through the slab in the vicinity of the column centerline where pipe drops frequently occur (e.g., at a shared stack between back-to-back toilets). The offset beams also simplify beam continuity problems.
4. The faces of the columns and girders need not be in the same plane. In no case, however, should the width of the girder be less than the abutting column dimension.
5. Shear elements may be located only at the boundaries of service modules. In some instances, the required locations for shear elements may determine the limits of the service modules. Future expansion of the building should not be jeopardized by the location of shear elements.
6. To ensure uniform patient bedroom widths, the "inside" face of the transverse shear element should not project beyond the column centerline. The other face should not project beyond the outside face of the column.
7. Longitudinal shear elements should preferably be aligned with perimeter girders, i.e., girders directly connected to the horizontal diaphragm.

### 311.4 PERMANENT AND ADAPTABLE COMPONENTS

The entire structure is conceived as permanent for the life of the building, with the exception of a topping slab which is removed as required to depress floor mounted fixtures and to take up the differences in thickness of various floor finishes typical in hospitals. The topping slab is placed over a bond breaker so that, in the case of future alterations, the permissible depth of slab removed is evident. The structural slab must also be capable of accepting changes in the location of those small elements which penetrate it, as described in Section 313.5.4, Paragraph 2.

Figure 310-1. BASIC DESIGN OF STRUCTURAL SUBSYSTEM

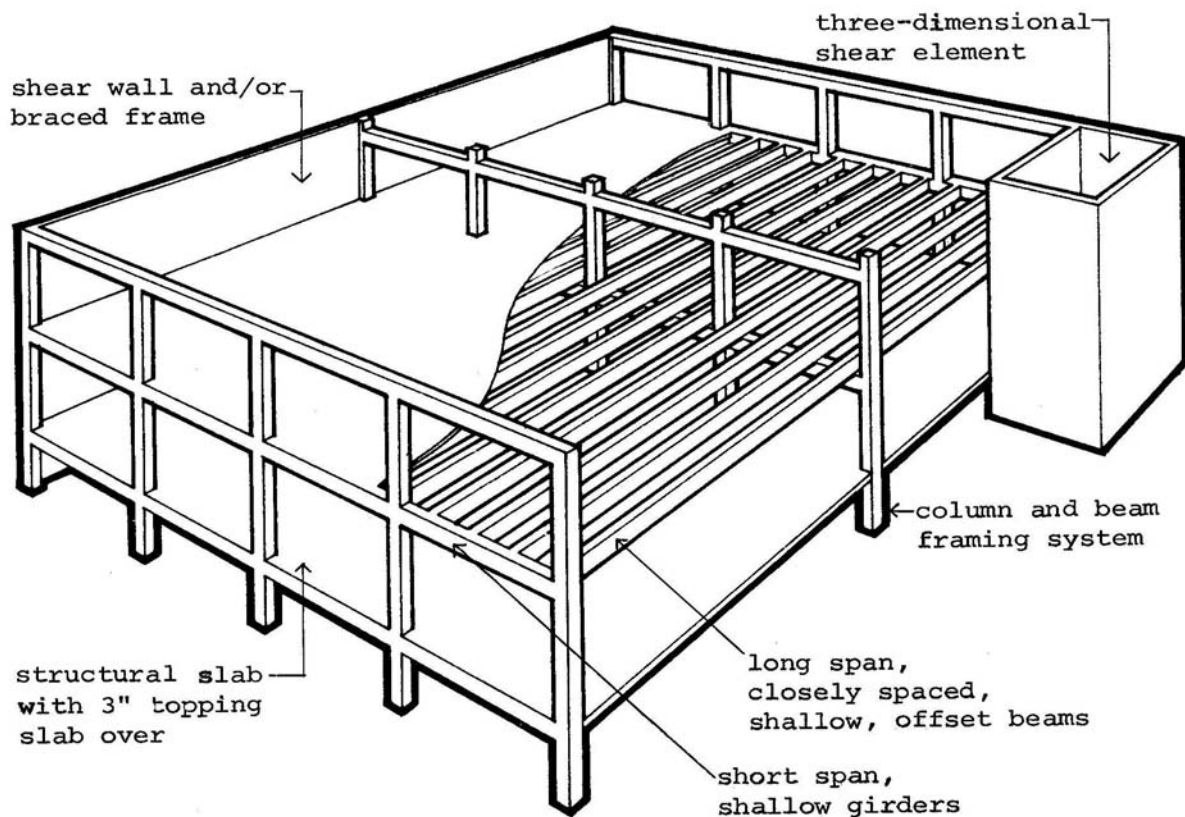

**Figure 310-2. RELATIONSHIP BETWEEN MAIN STRUCTURAL MEMBERS**

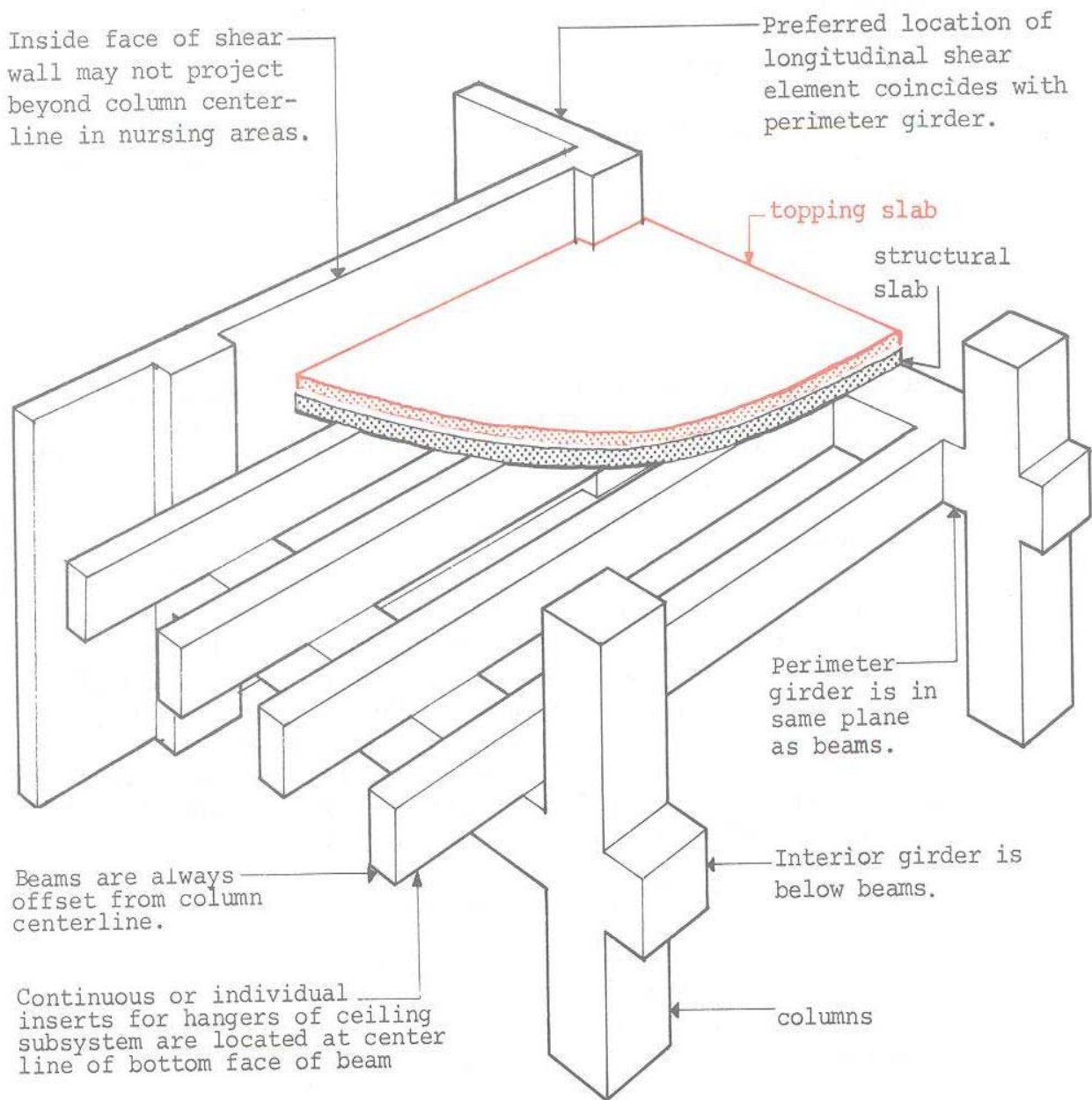

● permanent

● adaptable

## **312          GENERIC DESIGN OPTIONS**

The four systems described below are options for the framing of the service modules exclusive of the service bays. The service bays and the shear elements will typically be cast-in-place concrete, though steel may be used in conjunction with Option 2.

### **312.1        PRESTRESSED CONCRETE BEAMS, CAST-IN-PLACE**

Columns, girders and slabs are cast-in-place reinforced concrete. Beams are post-tensioned pan joists. Under most conditions this system will give the lowest first cost.

### **312.2        STEEL**

Columns, girders and beams are steel. Slab is cast-in-place reinforced concrete. Beams are in composite action with the slab. In some cases, the shorter erection time of steel may offset its higher labor and material cost.

### **312.3        PRESTRESSED CONCRETE BEAMS, PRECAST**

Columns and girders are reinforced concrete, either precast or cast-in-place. Beams are precast, prestressed concrete. Slab is cast-in-place reinforced concrete. Precast members will be appropriate only for a limited range of situations. They should be considered when spans are relatively short and building height is relatively low. Precast columns and girders are not recommended in high seismic load zones.

### **312.4        REINFORCED CONCRETE, CAST-IN-PLACE**

Columns, girders, beams and slab are cast-in-place reinforced concrete. This system may be applicable for the shorter spans, but the depths required to control deflections in general make it undesirable.

## 313 DIMENSIONS

### 313.1 STRUCTURAL BAYS

The column and beam framing system of the Prototype Design includes five structural bay sizes, all of which are 22'6" wide. The lengths range from 40'6" to 58'6", in 4'6" increments. In addition, the length of the bays may be extended by 18'0" cantilevers.

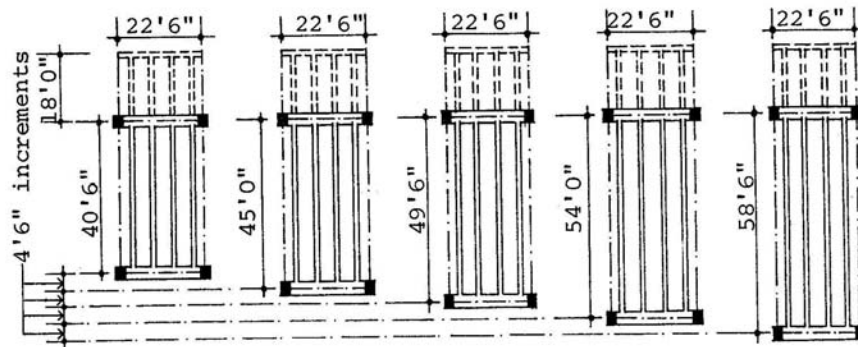

These bay sizes were developed in conjunction with the planning requirements of nursing areas and were then tested for their applicability to the design of the support areas of the hospital. (See Section 710.)

The Prototype Design also includes one other type of structural bay, called the service bay. (See Section 220.) The service bay does not have predetermined configuration or dimensions.

### 313.2 FLOOR-TO-FLOOR HEIGHT

The nominal floor-to-floor height varies between approximately seventeen and eighteen feet. It includes a recommended floor-to-ceiling height of nine feet in the nursing areas, or ten feet in the support areas, plus an allowance for a service zone above the ceiling.

The service zone is approximately eight feet high overall, and extends from the finished ceiling to the finished floor above. The exact height of the service zone is a function of the specific design selected for the ceiling, the structure and the services distribution.

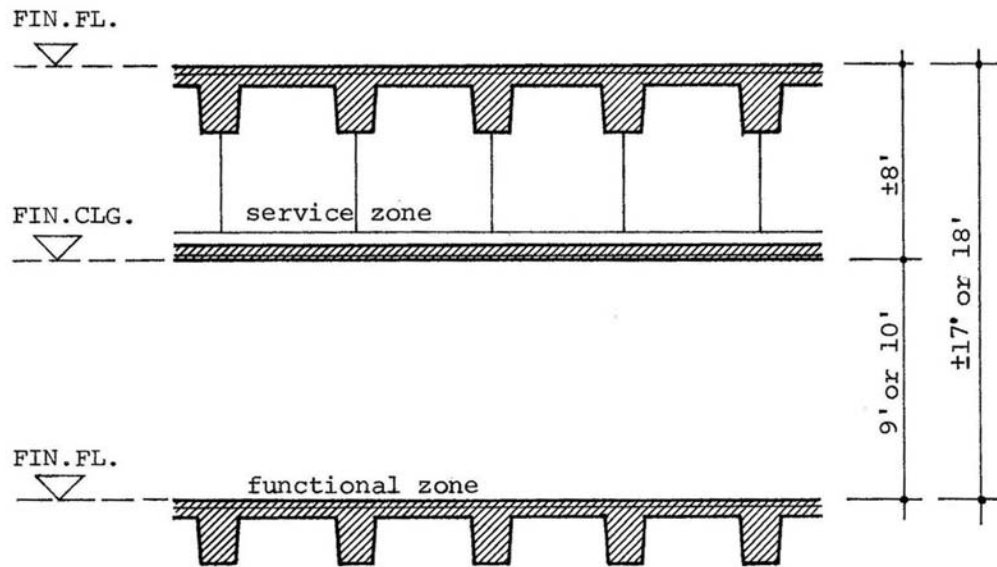

The basic design will enable a two-story space to be achieved by omitting an intermediate floor over a limited portion of the building. The structural acceptability of the location of such a two-story space must be verified by the A/E.

### 313.3 BUILDING HEIGHT

On the basis of the floor-to-floor heights described above, the structural system is appropriate to a range of building heights from two to nine stories above ground.

The Uniform Building Code lateral design requirements change for buildings over 160 feet in height, so for simplicity this height has been used as a limit.

If required, towers over 160 feet in height may be built, but they would require varying degrees of change to the basic structural system depending upon seismic zone, local design wind pressures, and site conditions. See Section 721.4 for discussion of requirements for buildings over 160 feet.

### 313.4 BUILDING WIDTH

In the space modules, a range of building widths from 45'0" to 117'0" is provided by using the five spans and the one cantilever in the three ways illustrated in the following diagram. Only twelve of fifteen possible combinations are used; two are not included because they offer no additional planning possibilities and one - 58'6" single span - is not used because it is considered to be excessively long for a single span.

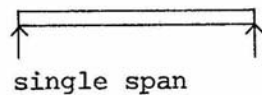

single span

The 45'0" , 49'6" and 54'0" beams are used as single spans.

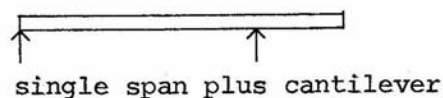

single span plus cantilever

The 40'6" , 49'6" , 54'0" and 58'6" beams are used with the 18'0" cantilever on one end.

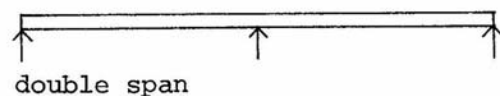

double span

All five long span beams are used as continuous symmetrical double spans.

In the support areas of the hospital, any number and combination of spans, with or without one or two cantilevers, may be used to provide a greater range of building widths in 4'6" increments. (See Table 220-2.) All columns must be continuous down to the foundation.

### 313.5 STRUCTURAL MEMBERS

The structural members must be designed to support the loads described in Section 314. The dimensions given define a dimensional envelope within which any particular structural design can be accommodated. The dimensional envelope is defined to expedite preliminary design and facilitate precoordination with other integrated subsystems.

#### 313.5.1 Columns

The layout of the patient rooms and sanitary zones shown in Section 230 are based on a maximum column size of 32" x 36".

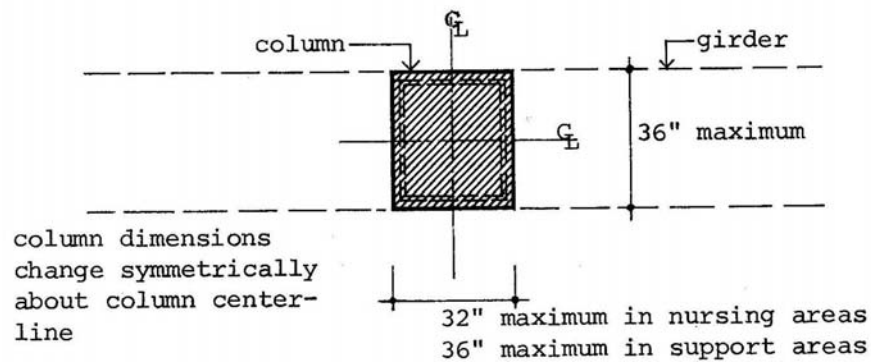

On upper floors, the column cross section may be reduced symmetrically about the column centerline. On the lower floors of eight and nine story buildings, the column cross section may be increased symmetrically about the column centerline to a maximum of 36" x 36". This will require coordination with the plumbing subsystem in that the clear space for pipes passing between the face of the column and the offset beam will be limited where beams are 4'6" on center.

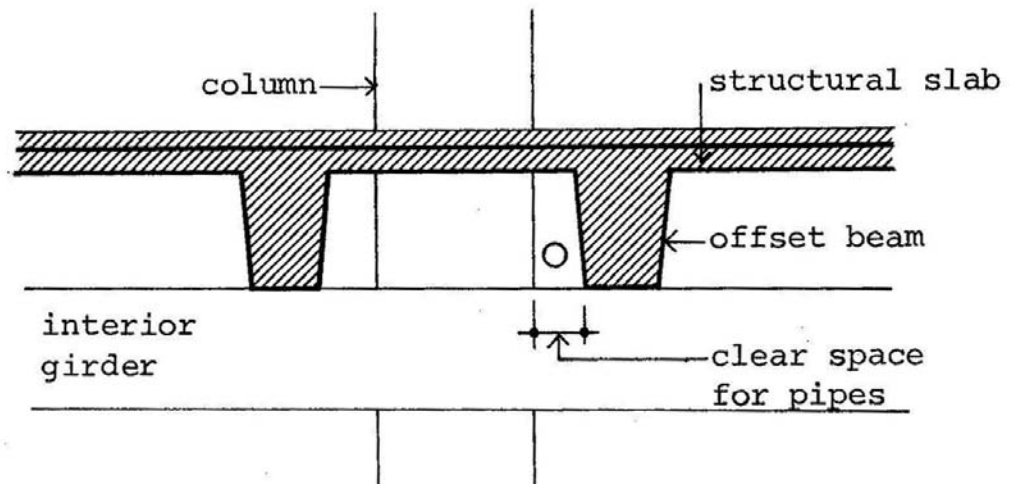

### 313.5.2 Girders

1. Span. The girder span is equal to the structural bay width and is always 22'6" centerline to centerline of columns. This dimension is based on a 4'6" dimensional discipline for bedroom widths. (See Section 230.)
2. Cross-Section. For the same live load conditions, the cross section of the various girders should not change throughout the height of the building.



The width of the girders may not exceed 36" and should not be less than the abutting column dimension. The depth of the girders may not exceed the depth of the zones in which they occur. (See Section 224.1.) On this basis, the maximum depth of the perimeter girders will be equal to the depth of the beams.

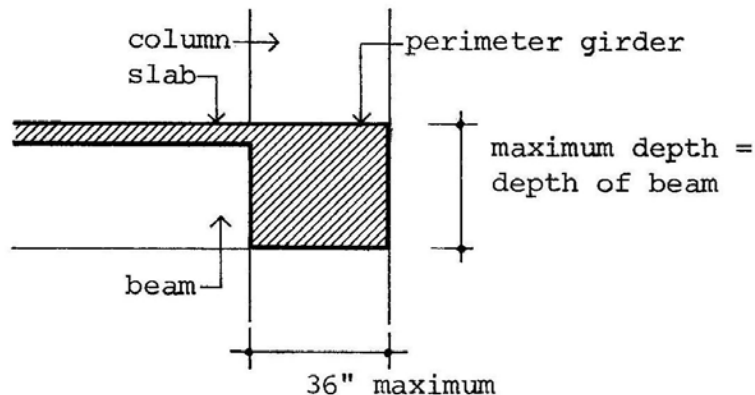

On the basis of a 36" width, the depth of the interior girders is not likely to exceed 27" in the case of a 75 psf live load and 30" in the case of a 115 psf live load. These dimensions should be used for preliminary planning and until the actual depth of zone S3 has been determined. Where the actual depth of zone S3 on a particular project turns out to be greater than 27" or 30", the dimensions of the interior girder may be adjusted accordingly if economies result.

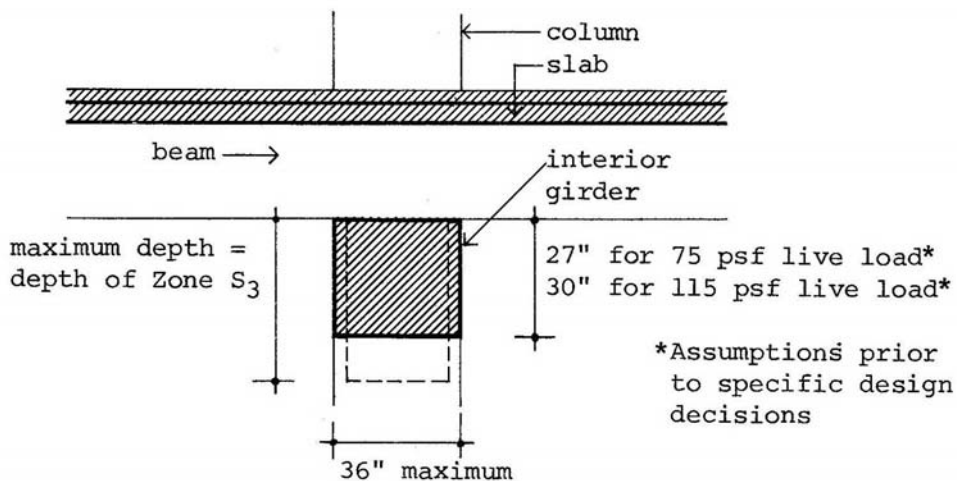

### 313.5.3 Beams

1. Span. The beam spans are equal to the structural bay lengths and range from 40'6" to 58'6" in increments of 4'6" measured from centerline of column to centerline of column. In addition, beams may be cantilevered 18'0". The modular nature of the beam spans is discussed in Section 721.1.2.

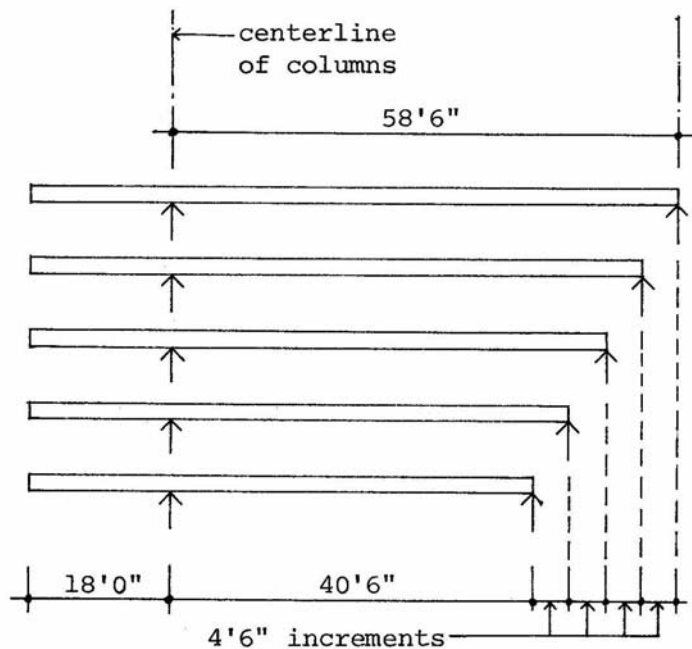

2. Cross-Section. The beam cross-section will generally be affected by choice of material, span, beam spacing, degree of continuity and sequence of construction. The depth, including fireproofing, is not likely to exceed 30" in the case of the 75 psf live load, or 33" where the live load is 115 psf.

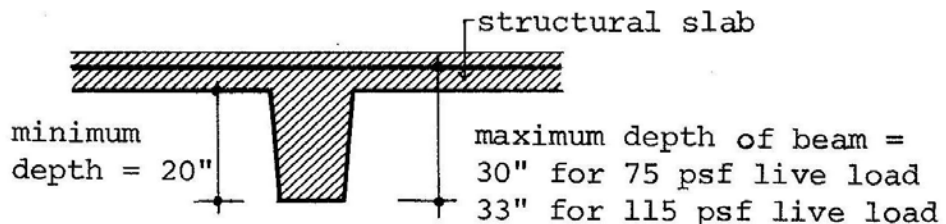

To facilitate definition of the plumbing zone (S2), the dimension between the bottom of the slab and the bottom of the beam should not be less than 20" -- the clearance required by drains, including traps and falls. (See Section 353.2)

3. Beam spacing. The beam spacing will vary with the material selected. A predictable and limited set of conditions is created if the framing of each bay is identical. Therefore, any beam spacing dimension should be a simple fraction of the bay width of 22'6". Suggested spacings range from one-fifth to one-third the bay width, namely 4'6" or 5'7-1/2" center to center in concrete, and 7'6" center to center in steel. The larger beam spacings will permit larger penetrations through the structural slab (See Section 313.5.4, Paragraph 2).

#### **313.5.4 Structural Slab**

1. Depth. The structural slab depth will vary between 4" and 5-1/2". The depth will depend on required fire rating, density of concrete, span length of slab, diaphragm requirements and type of steel deck (where applicable).
2. Penetrations. The floor slab may be penetrated by gravity drains and other comparatively small items such as vertical service shafts for materials handling. Structural limitations on the location of these penetrations are as follows:
  - a. At opening configuration:
    - (1) Penetrations which fit between the beams can be located anywhere required.
    - (2) Larger openings may require bearing walls or other special design. Their location may also be limited by the requirements of the horizontal diaphragm (See Section 316.2).
  - b. At a later date:
    - (1) Cored holes up to 24" diameter may be located anywhere between beams.
    - (2) Larger openings will probably require local reinforcement. Their location may also be limited as described above.

Penetrations are limited not only by structural considerations but also for planning reasons. Penetrations which require bearing walls or continuous enclosures such as shafts should interfere as little as possible with the free area established in both the functional and service zones. For instance, in the nursing areas, vertical service shafts should never be placed within space modules. Their location must also be carefully coordinated with the organization of the service distribution so that they do not disrupt the passage of main horizontal distribution lines in the service zone. For this reason, the preferred location for such elements (e.g., elevator shafts) is outside the service module or at the perimeter furthest away from the service bay.

1. Depressions. A three-inch topping slab of lightweight concrete will accommodate all depressions required in the floor for floor-mounted fixtures and floor drains. Items such as prefabricated audiometric rooms which have a floor thickness greater than 3" will necessitate a ramped threshold to take up the difference in floor levels. At opening configuration, the structural floor slab may be depressed if necessary, provided that the same limitations described in Paragraph 2 above are observed.

### **313.5.5 Shear Elements**

1. Size (plan length and thickness). The required plan length and thickness of shear elements is a function of building height, geographic location and extent of other elements in the building which will resist horizontal forces. The maximum dimensions will result from design for UBC earthquake zone 3, the zone of greatest earthquake susceptibility. The level of lateral loads obtained using UBC regulations for this zone are roughly equivalent to the wind loads for the 45 or 50 wind-pressure areas.
2. Penetration through shear resisting elements. Figure 310-3 illustrates the organization of typical penetrations for service distribution elements that are likely to occur in the solid wall separating a typical service bay from the rest of the service module. In the functional zone, an opening, approximately seven feet wide by seven feet high will accommodate the door between the stairs and a relocatable corridor.

**Figure 310-3. TYPICAL SET OF OPENINGS IN SHEAR WALL BETWEEN SERVICE BAY AND REST OF SERVICE MODULE**

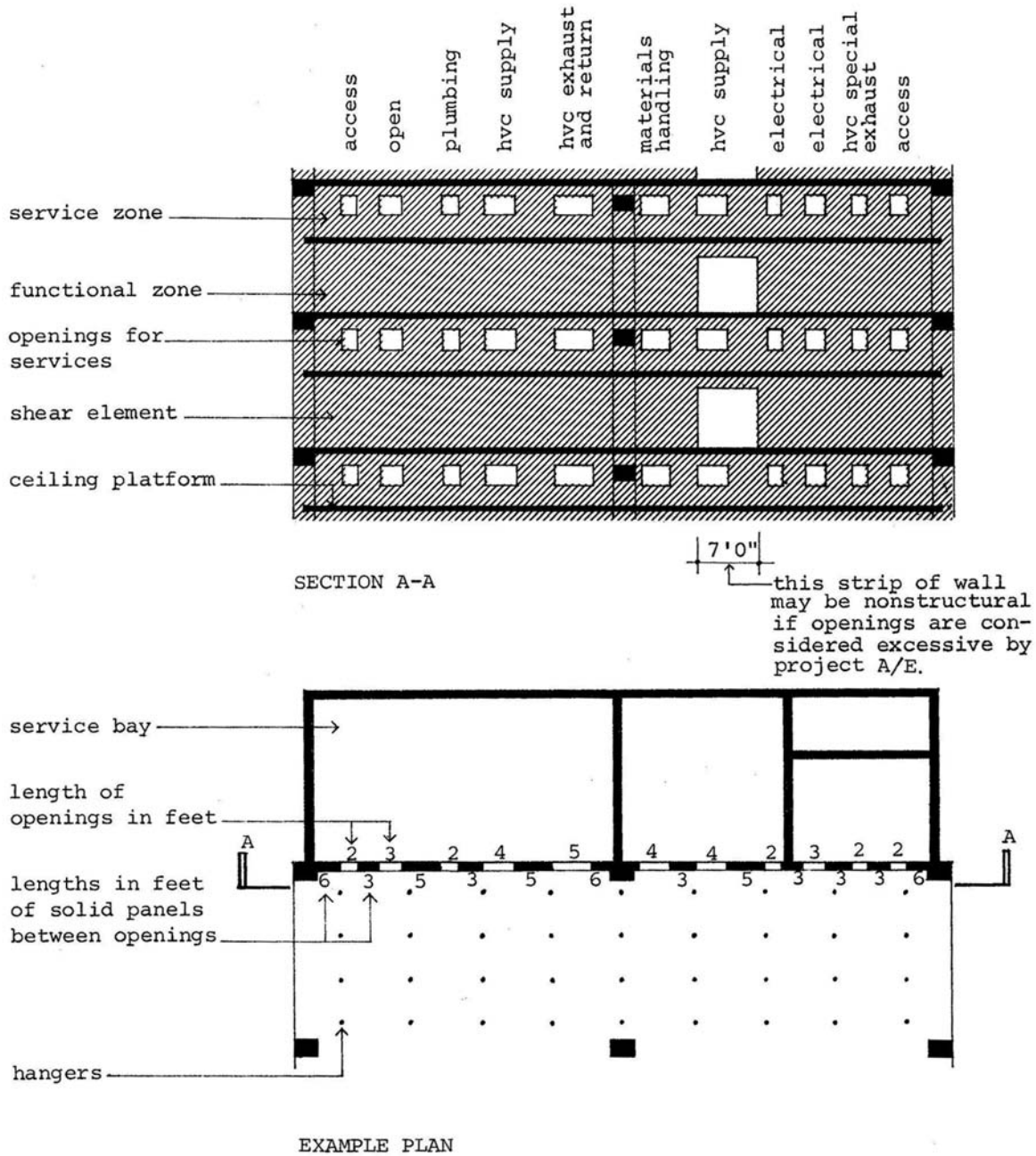

In accordance with general principles which limit the location of penetrations through concrete shear walls, these penetrations are organized as follows:

- a. The edges of the shear wall are free of penetrations. The minimum width of this edge is approximately 3'6".
- b. The penetrations are aligned vertically and horizontally to allow a regular reinforcing pattern.
- c. Where the size and spacing of openings is such that the wall does not act as a single element, that part of the wall is eliminated as a potential shear resisting element.
- d. The spaces between the penetrations are more or less equal, and in the range of three feet.
- e. The combined widths of all the openings in one row is not more than 50% of the plan length of the shear element.
- f. The combined height of all openings above each other is not more than 50% of the height of the shear element.

The principles described above apply to concrete shear walls. The openings in diagonally braced frames are limited only by the size and location of the members themselves.

**314       LOADING****314.1     VERTICAL LOADS**

**314.1.1**     Vertical loads are a combination of dead loads and live loads. The dead loads include the weight of the permanent structure, the ceiling, partitions, topping slab, floor finishes, and mechanical loads. Mechanical loads include ducts, pipes and temporary construction loads but exclude the weight of the equipment. Live loads include all other weights which will be applied to the structure.

**314.1.2**     The structural design of the framing system for the Prototype Design will be based on two categories of live loading. The first will permit a uniform live load of 75 psf, mainly in the nursing areas; the second will be based on a uniform live load of 115 psf, in the support areas of the hospital. For convenience, these two categories are termed Class 75 and Class 115 design loading respectively. Changes in class of design loading should always occur at logical places in the structure such as over girders or at the boundaries of fire sections. Preferably, only one class of design loading would be used on any one floor of the hospital.

**314.1.3**     Certain facilities which may be included in the hospital may actually be required by code to have live load capability in excess of 115 psf. For instance, the National Building Code requires card file rooms to have 125 psf live load capability. These areas are often interspersed with others having requirements lower than 115 psf, so they can generally be balanced to fit within Class 115 design loading.

**314.1.4**     A concentrated load of 2500 pounds over a three by three-foot area in any hundred square feet can be accommodated by both Class 75 and Class 115 loading. The framing system will also be able to accommodate certain higher concentrated loads applied over limited areas. By incorporating structural devices such as demountable slab strongbacks (placed beneath the slab and between the beams), it should be possible for an A/E under certain conditions to accommodate these higher concentrated live loads without changing the system. Items generating these higher loads are listed in Table 310-1 under the category of Modified Class 115 Design Loading. The conditions under which higher loads may be accommodated are dependent upon the specific plan, the beam spans chosen, and the degree of interference with the service distribution elements which would result (See Section 224).

**Table 310-1. DESIGN LIVE LOADS**

Design Live Load	Functional Area	Types of Equipment
Class 75	Nursing areas	
Class 115	Support areas except as listed below	
Modified Class 115	Dietetic Service	Refrigerator, dish-washer, baking oven, exhaust vent, ice-making and storage.
	Deep Therapy	Cobalt accelerators, etc
	Diagnostic Radiology	Tomograph table
	Central Sterile	Automatic cart washer, sterilizer, storage tank
	General	Addressograph, record retriever, power file, vault, trash compactor
	Animal Research	Concrete cages
	Nuclear Medicine	Radio-isotope Equipment
Special Loading	Physical Medicine and Rehabilitation	Hubbard Tank, therapy tank and pool
	ENT Service	Audiometric room
	Laundry Warehouse and Storage Pool Shops Auditorium with stage Service bays	



**Table 310-2. SUMMARY OF VERTICAL DESIGN LOADS**

Source of Load	Design Loads in Service Zone (Ceiling Design)	Design Loads on Floor (Slab Design)	Total Design Loads on Framing System (Beam, Girder, Column Design)
Uniform Dead Load (1)			
Structure	Applicable DL 15	Applicable DL	Applicable DL
Ceiling		15	15
Mechanical		25	25
Partitions		25	25
Topping slab		5	5
Floor finish			
Uniform Live Load			
Nursing area	25	60	75 (2) (3)
Support area	25	100	115 (2) (3)
Concentrated Loads	100 lb. in any 100 sq. ft.	2,500 lb. Over a 3'x3' area in any 100 sq. ft.	

(1) To be calculated by the project A/E.

(2) Reducible on girders and columns according to applicable codes.

(3) Service zone live load is reduced to 15 psf in combination with floor live load.

**314.1.5** All areas where uniform live loads exceed 115 psf and which are beyond the limits of the Modified Class 115 Design Loading category must be designed by the A/E as required by the specific conditions. The live loads in these areas are listed in Table 310-1 under the category of Special Loading. They include the service bays, where the suggested uniform live load is 150 psf.

The design live loads to be applied in various functional areas of the hospital are listed in Table 310-1.

**314.1.6** The roof must be designed in accordance with the governing roof live loading criteria of the particular region as required by local building codes. These loads must be increased as necessary where mechanical equipment is located on the roof.

## **314.2** **LATERAL LOADS**

The structure must be designed to withstand the governing lateral wind and/or seismic loading criteria of the particular region as required by local building codes.

**315 OTHER DESIGN CRITERIA****315.1 FIRE PROTECTION**

The structure must be of fire-resistive construction in accordance with the National Fire Protection Association (NFPA) and the Uniform Building Code (UBC).

**315.2 DEFLECTIONS**

No limit is set upon deflection beyond standard engineering practice, but for compatibility with other subsystems, the floor design with the smallest deflection is preferred. Prestressed concrete or composite steel construction are recommended to meet this criterion.

**315.3 TOLERANCES**

Tolerances must be in accordance with VA Construction Standards and Master Construction Specifications.

**315.4 ACOUSTICS**

The structure in combination with the ceiling must provide ratings of STC 50 and INR +5 between floors. The ratings of the wall between the service bay and the remainder of the service module must be STC 55 and INR +10. (See Figure 320-9.)

Walls and columns must not reduce the vibration isolation provided by floors by acting as flanking paths.

## 316 SPECIAL CONSIDERATIONS

The items included under this section deal generally with structural design issues which may be raised when service modules are assembled into buildings.

### 316.1 BUILDING SEPARATIONS (Figure 310-4)

The assembly of service modules into buildings may result in configurations which require that the structure be made discontinuous at certain locations. This may result from one or both of two conditions.

#### 316.1.1 Excessive Length of Building.

Expansion joints are required where buildings exceed approximately 300 feet in length. These must be located to accommodate changes in building length due to shrinkage or temperature variation. Expansion joint locations are a function of anticipated local temperature changes and will generally be less than 300 feet apart.

#### 316.1.2 Portions of Building having Dissimilar Seismic Response.

Seismic separations are required where the configuration of the horizontal diaphragm (floor slab) forms a “weak link” between building portions of dissimilar seismic response.

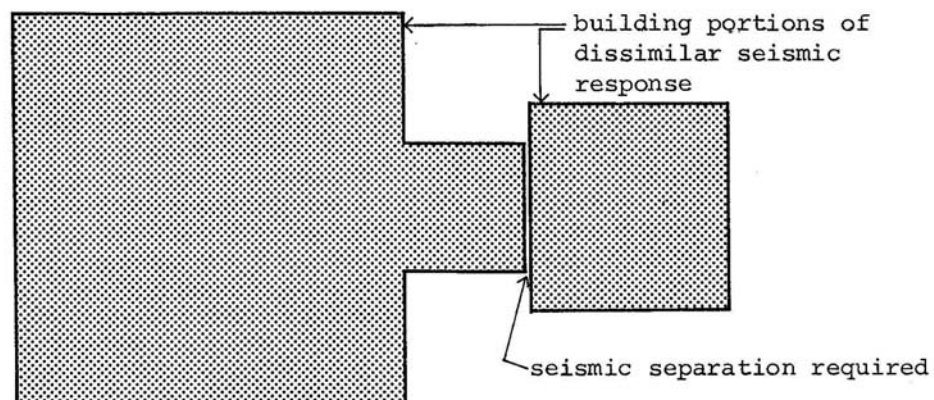

The relationship of building separations to structural members is shown in Figure 310-4. Building separations perpendicular to the beams may be located as required.

Figure 310-4. BUILDING SEPARATIONS

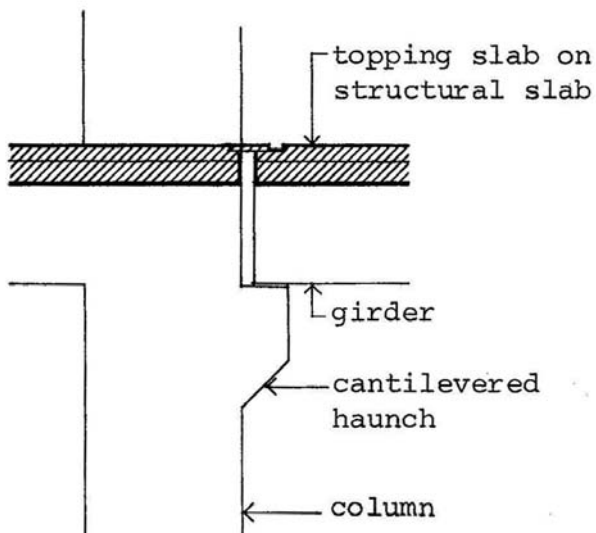

ELEVATION SHOWING EXPANSION JOINT THROUGH GIRDERS: ALTERNATE A

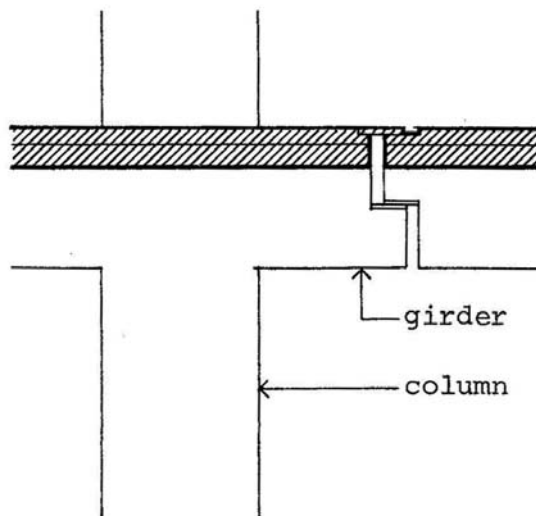

ELEVATION SHOWING EXPANSION JOINT THROUGH GIRDERS: ALTERNATE B

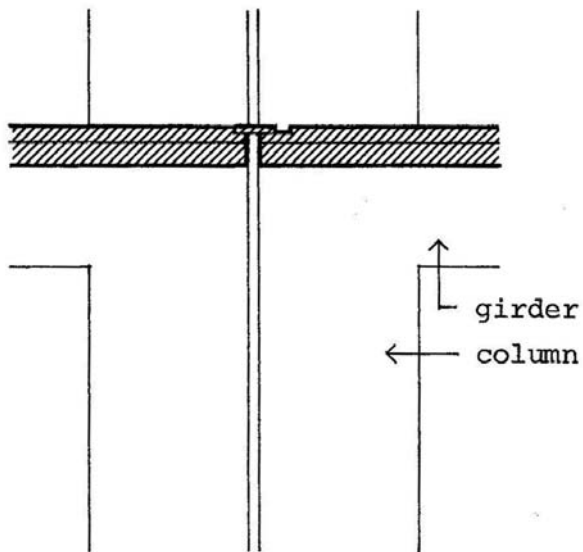

ELEVATION OF GIRDER SHOWING EXPANSION JOINT AT DOUBLE COLUMN

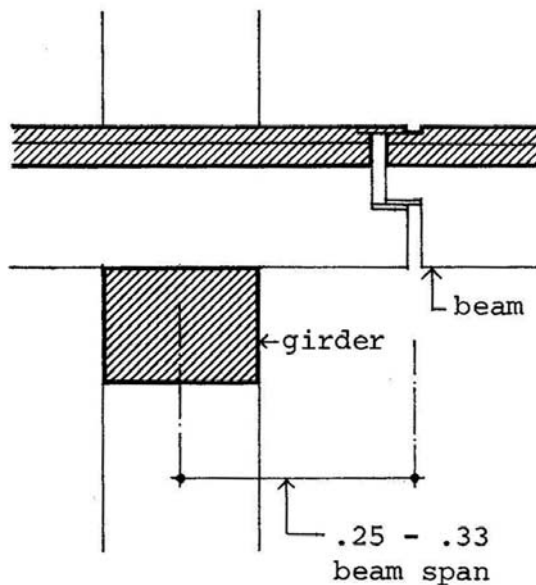

ELEVATION SHOWING EXPANSION JOINT THROUGH BEAMS

Building separations parallel to the beams should occur close to the face of columns. The girder on one side of the separation may be carried on a cantilevered haunch or the girder may be cut at an acceptable location. Double columns may be required in areas of high seismic loading.

When building separations occur, the structure on either side must be designed as independent structural units, each braced by longitudinal and transverse shear elements.

### 316.2 LOCATION OF SHEAR ELEMENTS

The location of shear resisting elements is dependent on the building configuration and on the location of building separations. For instance, shear elements must be located with reference to the location of large openings in the diaphragm, such as two-story spaces, courtyards, etc., and so that all independent structural units are braced in both the transverse and longitudinal directions. To be effective, shear elements should be located so that the maximum ratio of the distance between them to the width of the horizontal diaphragm is 3:1.

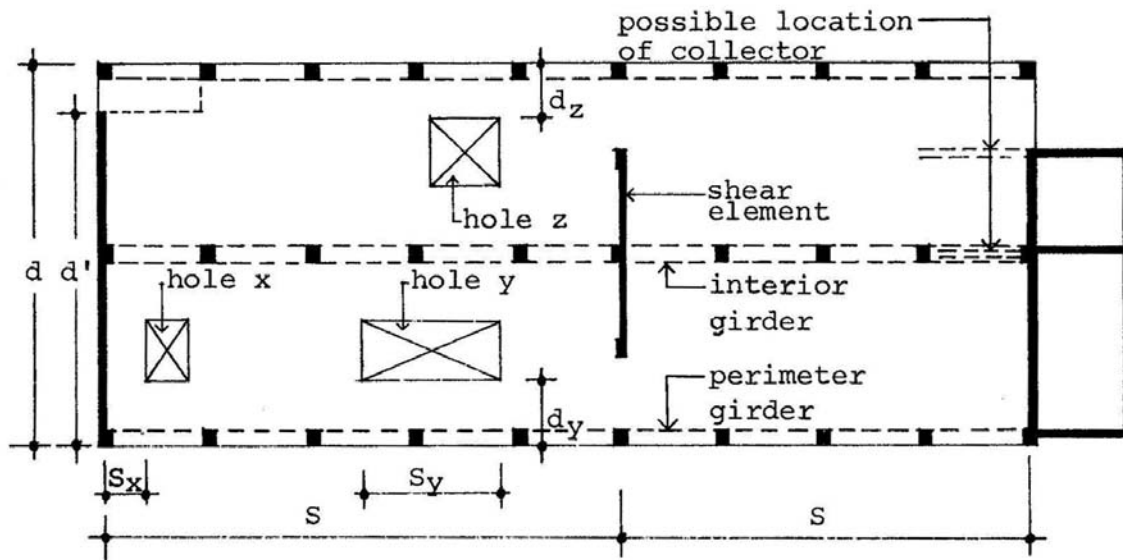

$$S/d \leq 3 \text{ (use } d' \text{ where offset occurs)}$$

$$S_x = \text{Minimum distance of hole x from shear element} = \underline{\pm 4'0''}$$

$$d_z = \text{Minimum distance of hole z from edge of diaphragm} = \underline{\pm 4'0''}$$

$$S_y = \text{Maximum dimension of opening y is limited so that } s_y/d_y \leq 3$$

**Figure 310-5. EXAMPLES OF COLLECTORS FOR LATERAL FORCES**

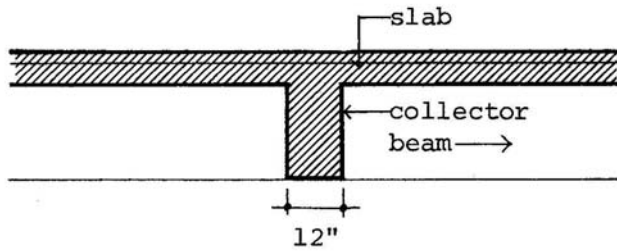

SECTION: ALTERNATE A

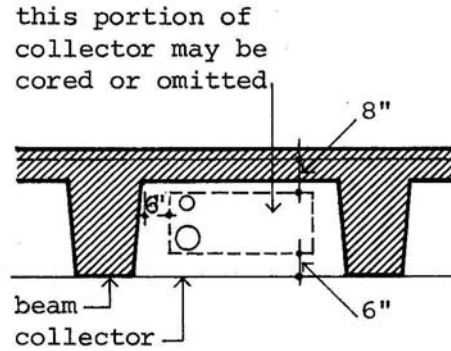

ELEVATION: ALTERNATE A

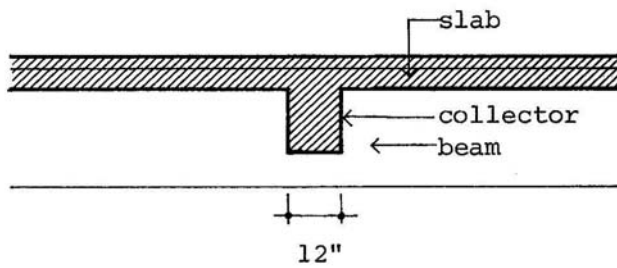

SECTION: ALTERNATE B

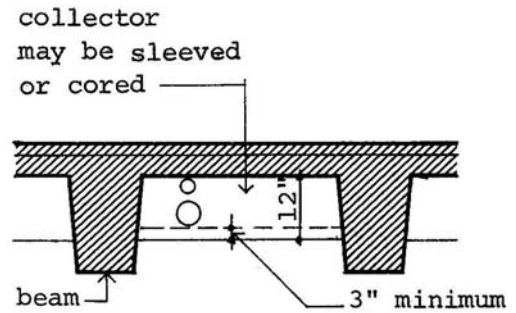

ELEVATION: ALTERNATE B

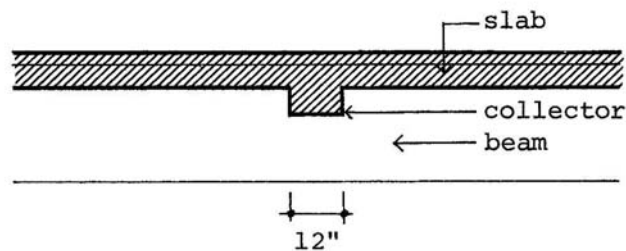

SECTION: ALTERNATE C

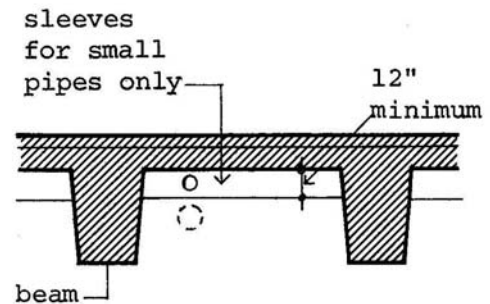

ELEVATION: ALTERNATE C

In some instances, it will not be possible to align longitudinal shear elements with perimeter girders and collectors may be necessary. These collectors can take several forms, examples of which are shown in Figure 310-5. The design of collectors must take into account the location of elements of the plumbing subsystem which occur in the same zone, namely S2. (See Section 224.)

### 316.3 DOUBLE SHEAR ELEMENTS

Under certain circumstances, double shear elements may be required where two service modules abut. If double columns are not introduced at the same time, the face of the shear element will project beyond the column centerline, reducing the width of one or two bedrooms per service module.

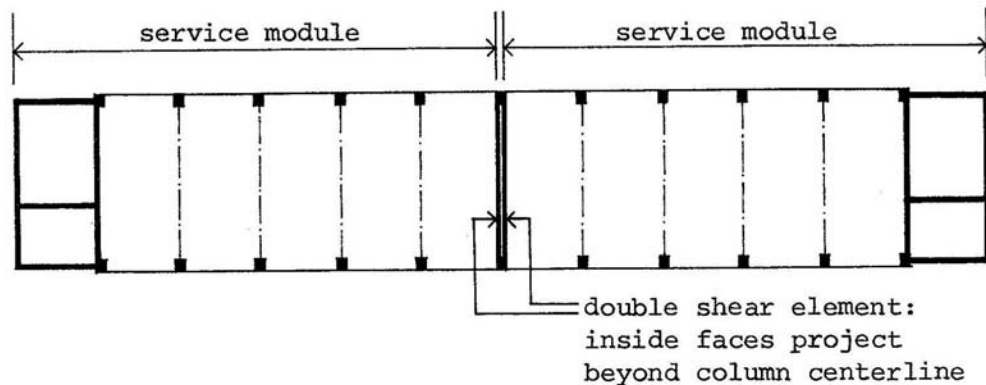

Where double columns are introduced, other modifications to the standard dimensions may result. For instance, when a change of direction in framing is introduced at the same time as double columns, a non-modular bay width may result.

These minor deviations from standard dimensions may result not only from the introduction of double columns or shear elements but also from a variety of other unpredictable circumstances which may arise when service modules are assembled into various building forms. In most cases, deviations of this type will not be serious. For instance, the non-modular beam span falls within the acceptable range of forty to sixty feet and does not interfere with the basic dimensional discipline of the structure.



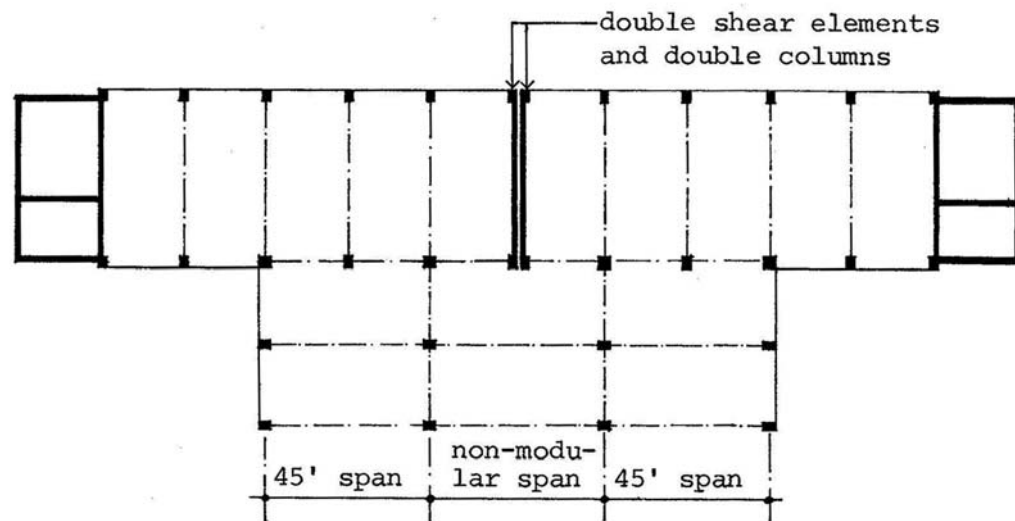

### 316.4 CHANGE OF DIRECTION IN FRAMING (Figures 310-6 and 310-7)

With certain building configurations, it will be necessary to change the direction of the structural framing members through ninety degrees. The structural design will be simpler if the beam span involved is 45'0", since this is an exact multiple of the bay width. In this case, the intersection of the two girders takes place at a typical column location. (See Figure 310-6.) If the beam span is not a multiple of the bay width, the design of the framing is simplified if an additional column can be located at the junction of the perpendicular girders. (See Figure 310-7.) If columns cannot be accommodated at these points, then the girders in one direction must be designed to carry the concentrated load of the girders in the opposite direction. This increase in load varies from 20-50% above the typical girder load. In this case, the typical girder dimensions must be increased approximately as follows:

1. 50% width increase, or
2. 25% depth increase, or
3. a combination of width and depth increase.

**Figure 310-6. ACCOMMODATION OF CHANGE OF DIRECTION OF FRAMING SYSTEM WHEN BEAM SPAN IS 45 FEET**

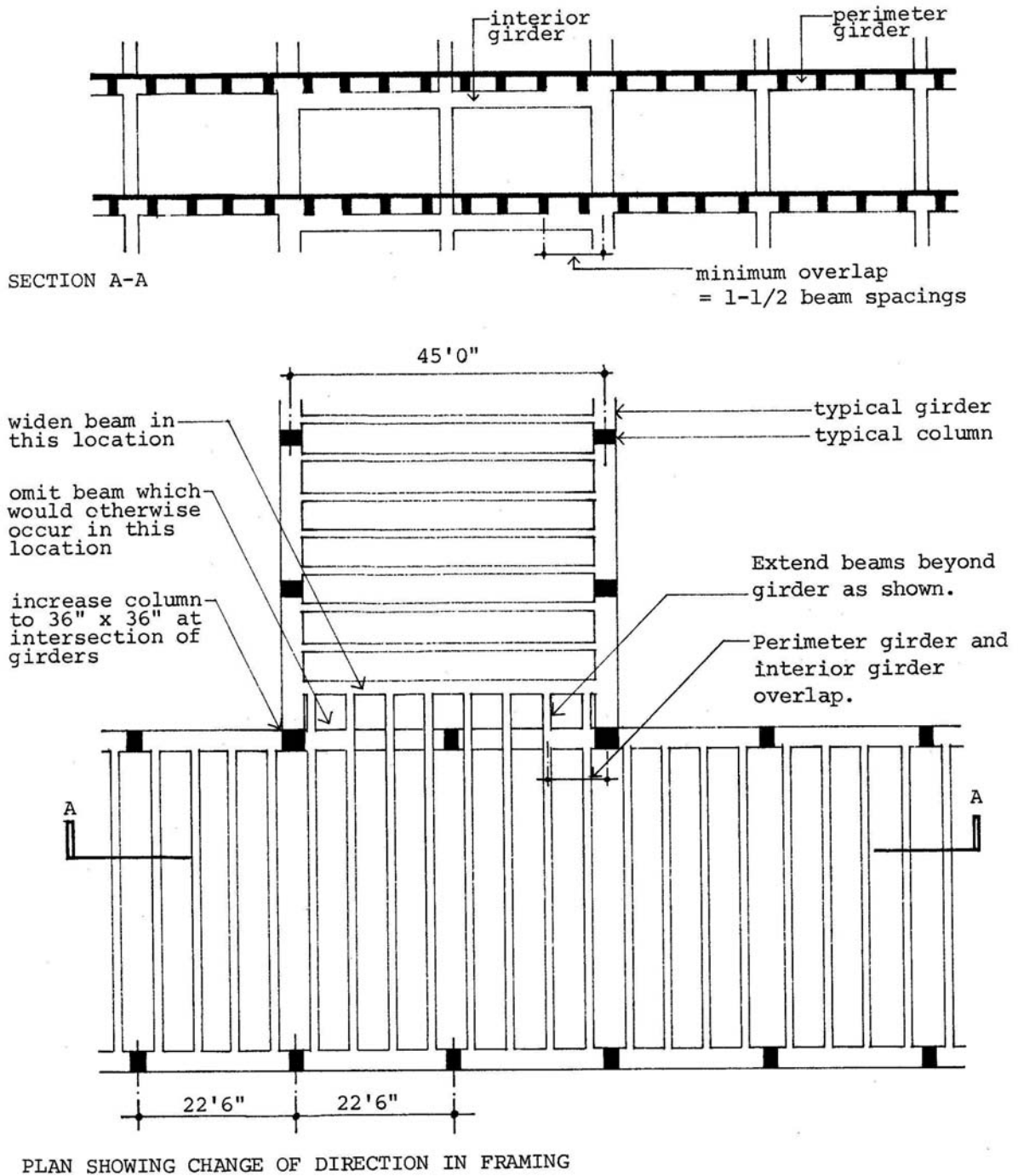

**Figure 310-7. ACCOMMODATION OF CHANGE OF DIRECTION OF FRAMING SYSTEM WHEN BEAM SPAN IS NOT 45 FEET**

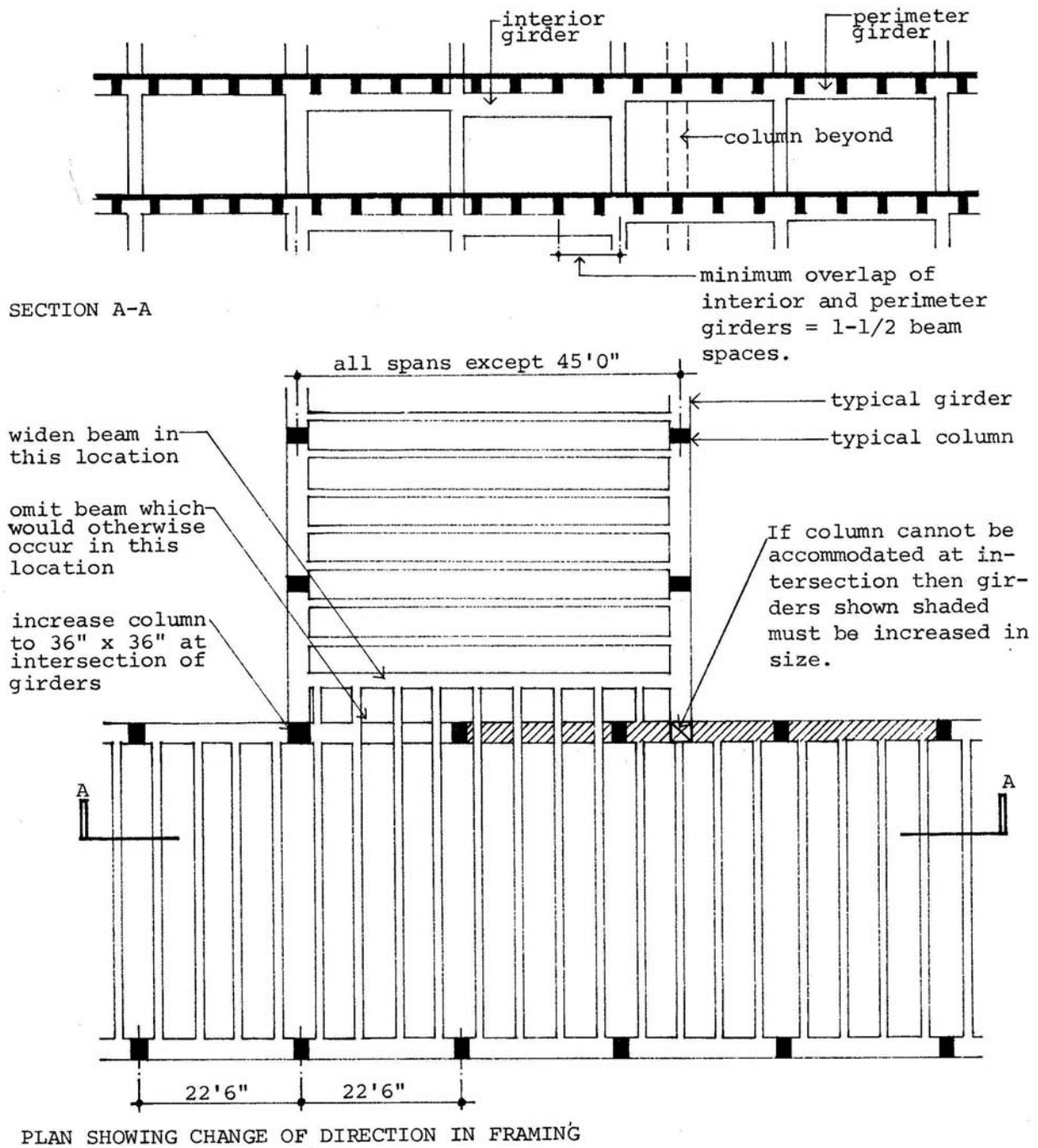

**316.5 FRAMING OF SERVICE STRIPS (FIGURE 310-8)**

When a design incorporates interior service bays, the assembly of the service modules into a building may sometimes result in a continuous service strip, containing both the interior service bays and functional areas. The configuration of this service strip will determine the nature of the structural framing.

In some cases, the framing over the functional area may be the typical column and beam framing of the Prototype Design. In many instances, however, a simple beam and slab or a ribbed slab may be preferable in order to keep the structure as shallow as possible so as not to conflict with the services distribution. The framing for a typical configuration incorporating a service strip is illustrated in Figure 310-8.

Figure 310-8. FRAMING SYSTEM FOR PORTION OF FLOOR WITH SERVICE STRIPS

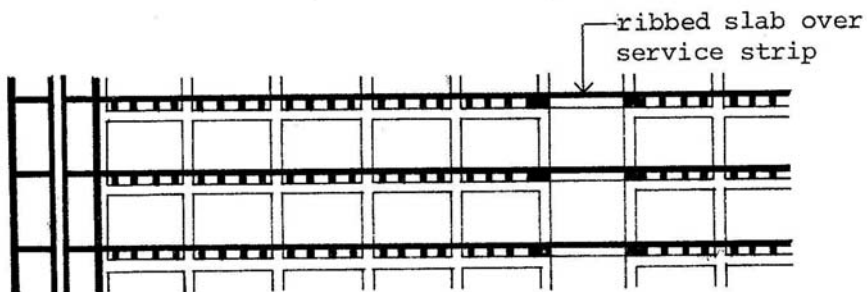

SECTION A-A

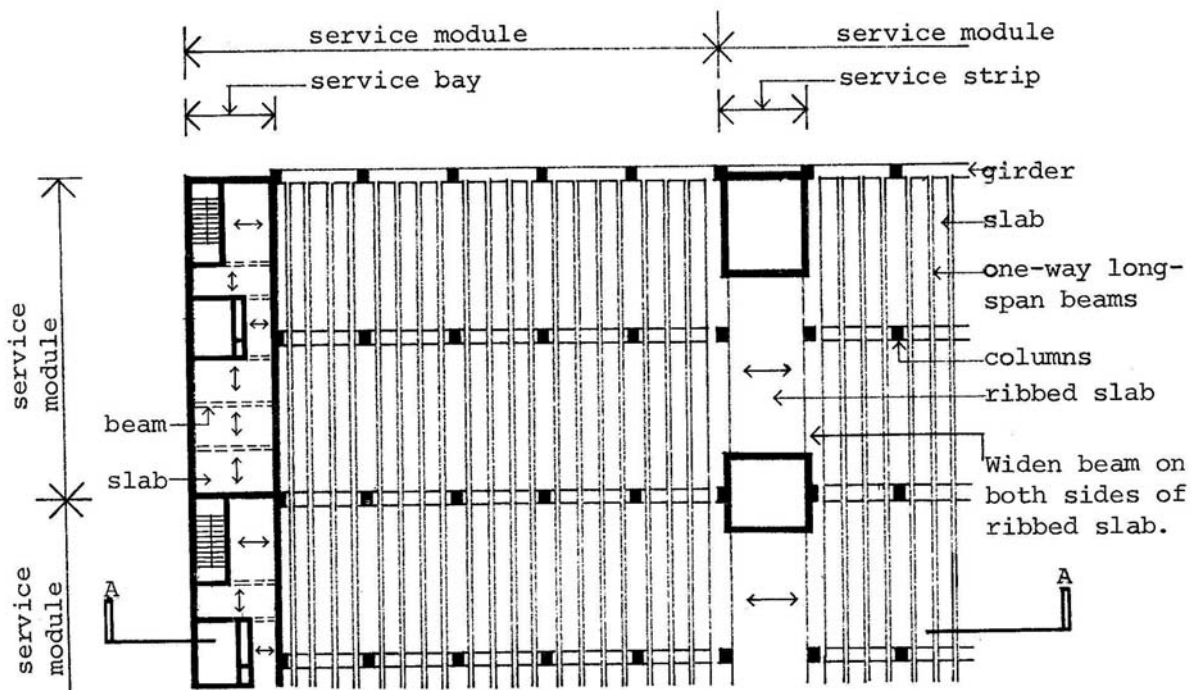

PLAN SHOWING PORTION OF A FLOOR INCORPORATING SERVICE STRIPS

**317 TARGET COSTS****317.1 RANGE**

The cost of the components included in the structural subsystem should range between \$8.00 and \$10.45 per square foot of framing, or \$8.60 and \$11.30 per OGSF of building. (ENR Building Cost Index = 960.) For a discussion of these costs, see Section 751.2.1.

**317.2 SCOPE****317.2.1 Included**

1. Horizontal: primary and secondary spanning members at floors and roof including girders, beams, slabs and topping slabs;
2. vertical: columns and loadbearing walls;
3. lateral bracing;
4. passive fire protection of structural components;
5. provision for structural discontinuities; and
6. attachments for ceiling-platform hangers.

**317.2.2 Excluded**

1. Foundations;
2. slabs on grade;
3. retaining walls;
4. projections above structural roof members such as fascias, penthouses and parapets;
5. canopies;
6. exterior walls;
7. stairs, except where their enclosures acts as vertical support and/or lateral bracing;

8. components of other subsystems, such as tracks, supporting frames and lateral bracing for operable partitions, and hangers for the ceiling and HVC subsystems;
9. attachments for other subsystems, other than attachments for the ceiling hangers; and
10. fire protection of other subsystems.

**(BLANK PAGE)**



## 320 Ceiling

### 321 BASIC DESIGN (Figures 320-1 and 320-2)

The ceiling subsystem consists essentially of a continuous walk-on platform suspended by hangers from the structural beams, with a finished ceiling applied to or suspended from the underside. The platform is hung a sufficient distance below the structural slab so that a horizontally accessible service zone is created above it. Except for two-hour fire barriers, and certain smoke barriers, all partitions stop at the ceiling-platform which is one-hour fire resistive. The height of the platform above the floor is constant in each major segment of the hospital. (The rationale leading to this basic design is discussed in Section 722.)

Ideally, the platform, the supporting framework and the finished ceiling would be one thin sandwich. However, no single material or product is presently available which answers all the design and performance requirements; the ceiling subsystem must therefore be regarded as an assembly of at least four different components, the basic characteristics of which are described below.

#### 321.1 HANGERS

Compared with hanger spacings of conventional ceilings, the steel hangers are widely spaced. They are approximately 1/2"-3/4" in diameter and are attached along the centerline of the bottom of the structural beams. The recommended spacing is such that each supports a maximum of approximately fifty to sixty square feet of platform. The hangers are likely to be used to delineate the secondary subzones in the service zone above the ceiling so the spacing should be coordinated with these subzones. (See Section 224.2.)

Hangers may be attached to steel beams by means of welded studs, and to concrete beams by means of continuous or individual inserts cast into the beams. Hangers are attached to the horizontal supporting framework of the platform via adjustment devices for leveling purposes.

For most combinations of materials and details likely to be selected for the ceiling-platform-framework assembly, sufficient diaphragm action can be developed to transfer all partition lateral loads to the structure and to support the ceiling under seismic loading.

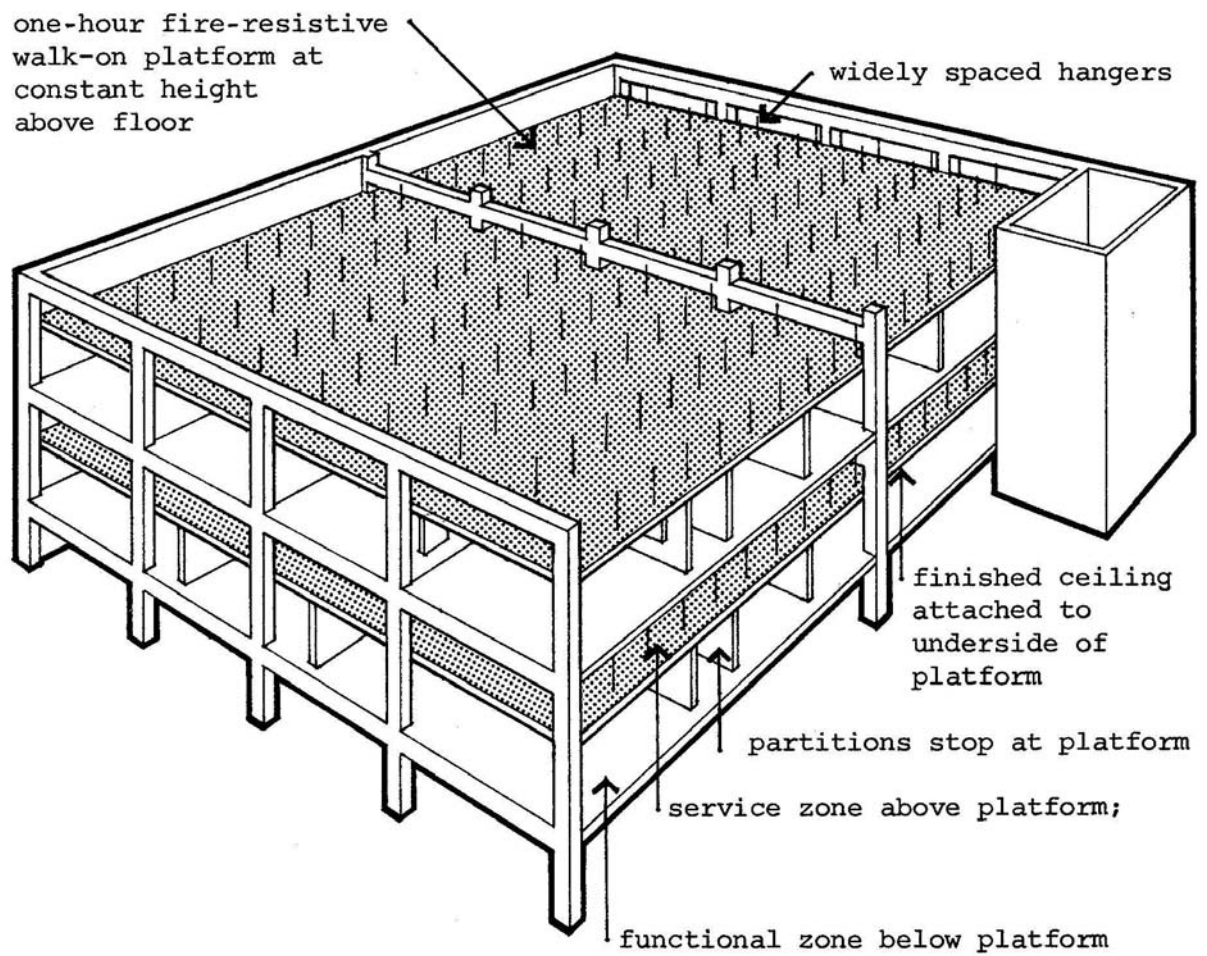
**Figure 320-1. BASIC DESIGN OF CEILING SUBSYSTEM**

When this is not the case, bracing the hangers with one diagonal member in approximately every fifth bay in each direction will suffice. Preference should be given to those designs which do not require diagonal bracing.

### **321.2 SUPPORTING FRAMEWORK**

To allow use of a wide variety of short-span platform materials, an intermediate framework is required between the platform and the hangers.

The platform may span over the framework or may be hung from it, depending upon the nature of the material used. The latter solution is preferred since this reduces the effective overall depth of the ceiling structure. Provision may need to be made for penetration of the framework by service distribution components located in this zone. The extent of such penetrations is minimized if the direction of the main elements of the framework (ribs, joists, etc.) is perpendicular to the structural beams.

### **321.3 PLATFORM**

The platform must meet many of the performance requirements stipulated for the total ceiling assembly with regard to strength, fire resistivity, acoustics, etc. Besides its major function of providing a working platform both during construction and for maintenance and alterations, it must distribute all lateral loads from the partitions to the structure, or to the diagonal braces if it is not used as a diaphragm. Since there is no planning grid, the partitions must be able to be fixed to any point of the platform which should therefore be flush on the underside. Similarly, there must be as few limitations as possible to the location of penetration for services. Cutting and patching holes in the platform must be easy. The platform must provide one-hour fire resistance and an acoustic flanking path barrier if the finished ceiling does not perform these functions.

### **321.4 FINISHED CEILING**

The finished ceiling is attached to the underside of the platform. A finished ceiling without an exposed grid is preferred, since spaces are not organized on the basis of a planning grid.

**321.5 PERMANENT AND ADAPTABLE COMPONENTS**

The hangers and the platform, together with any necessary supporting framework, are permanent components, whereas the finished ceiling is considered adaptable.

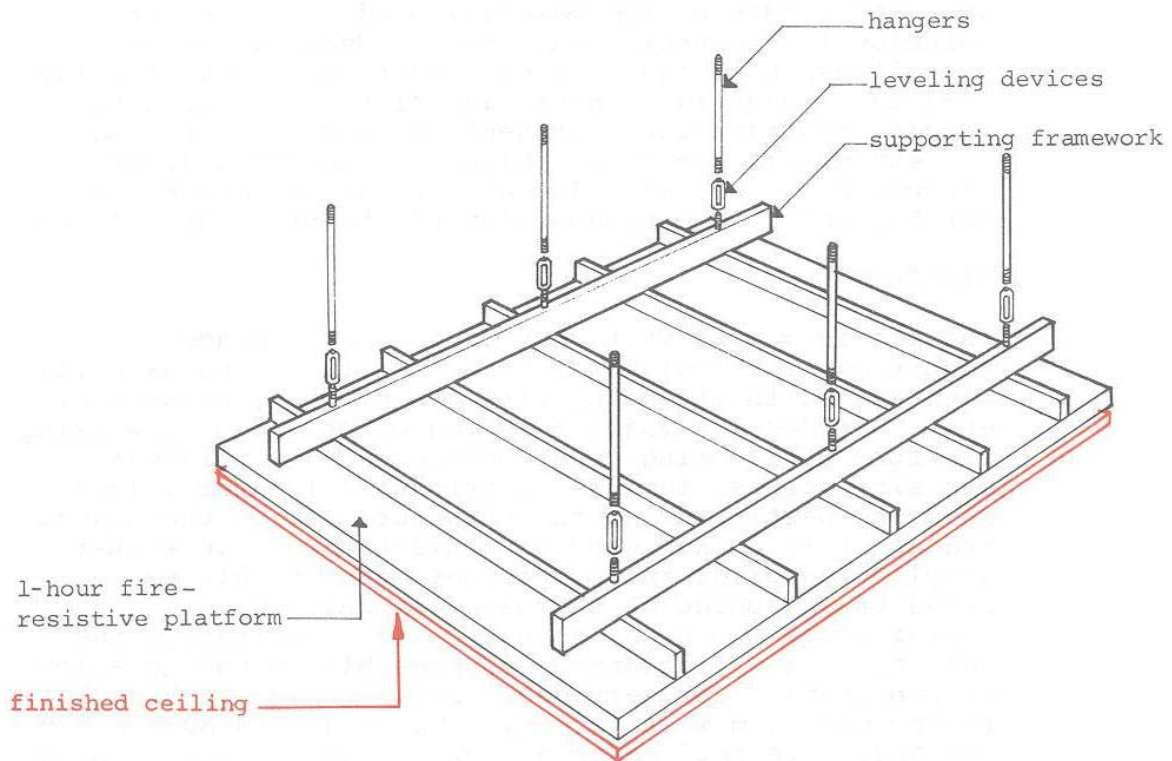
**Figure 320-2. CEILING COMPONENTS**

- permanent
- adaptable

## 322 GENERIC DESIGN OPTIONS

There are several groups of products which meet the requirements of the basic design. Where performance of any two groups is equivalent, preference will be given to lowest cost, both direct and indirect. Indirect costs result from the greater depth and/or weight of one product as compared with another, and from any added costs incurred through construction scheduling considerations.

### 322.1 PLATFORM

The platform closely resembles conventional roof deck systems in many of its performance requirements. Generic design options which generally meet the performance criteria for the platform include the materials and/or assemblies listed below.

#### 322.1.1 Poured Reinforced Gypsum on Steel Tees (Figure 320-3)

1. Advantages and Disadvantages. Of the various fire-rated roof-ceiling or roof deck systems presently available, poured reinforced gypsum appears to be the most appropriate. It is the least costly of the generic design options. It is light in weight, and it is easily cut and patched. In typical roof decks, when holes are made within the 32" tee spacing, no reinforcing is necessary, and when holes are repaired the deck is restored to full strength. It has ICBO approved diaphragm shear values over 1,000 plf and UL two-hour fire rating. (For further discussion of fire safety, see Section 326.)

The main disadvantage of this option is that, although the gypsum deck is strong enough to be walked on and used as a working platform an hour or less after it is poured, it will not dry out completely for at least thirty days under favorable conditions and as much as sixty to ninety days under unfavorable conditions. This need not present a scheduling problem unless it is essential for a finished ceiling to be applied soon after the deck is poured, which is unlikely. If it is necessary to apply the finished ceiling before the deck has thoroughly dried out, there should be no problem if the top surface of the platform is left unsealed and free to dry out from the top. If scheduling permits, a breather type hardener may be applied immediately to the top surface of the gypsum to prevent dusting and increase the wear resistance.

**Figure 320-3. EXAMPLE OF A POURED REINFORCED GYPSUM PLATFORM**

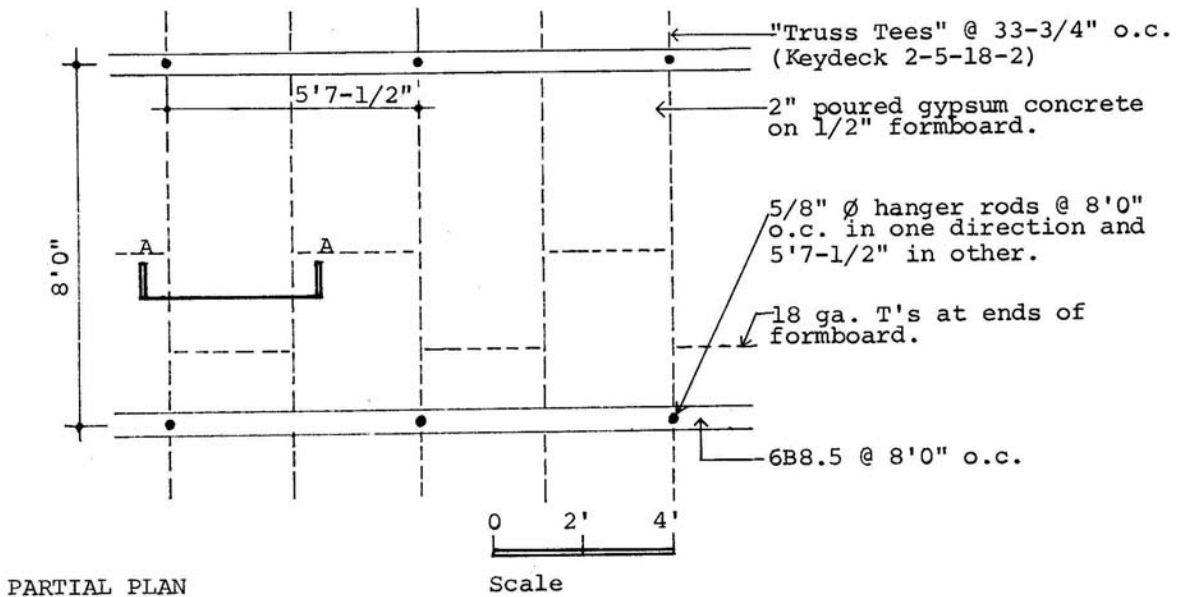
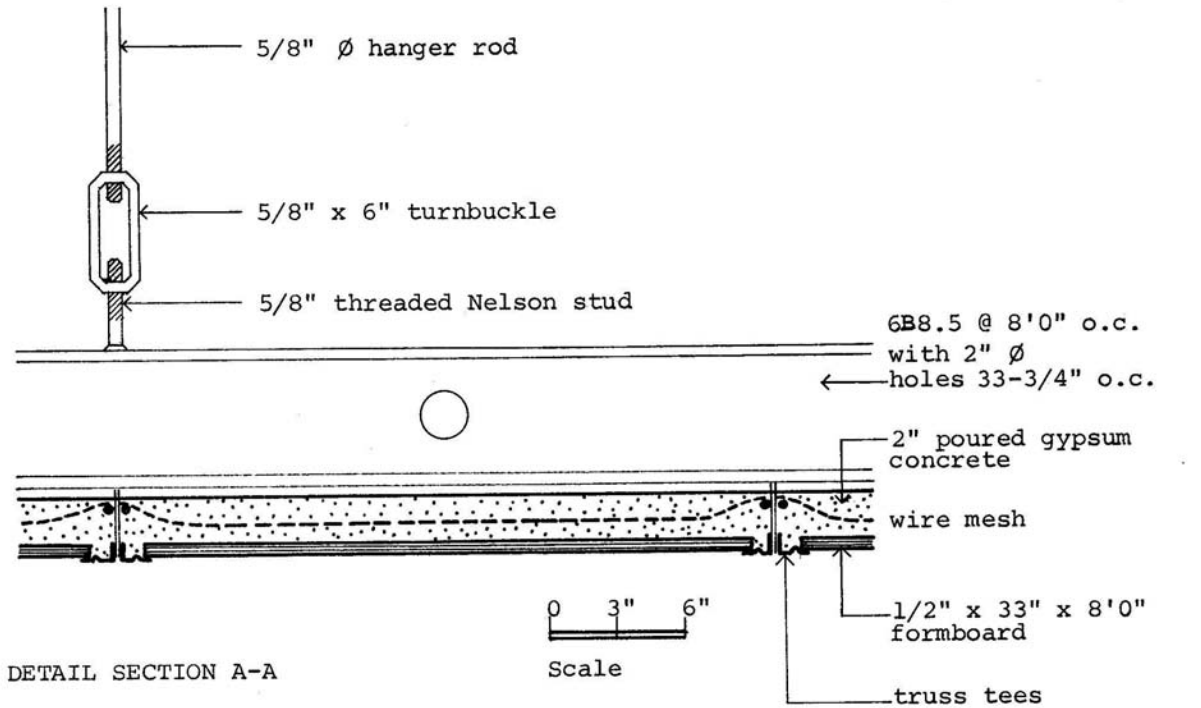

The application of the finished ceiling should be delayed until it has been determined with the aid of a moisture meter that the gypsum deck is sufficiently dry.

Some minor dusting may be caused by abrasion of the walk-on surface; this is not considered to be a problem.

The disadvantages of poured gypsum are not considered to be critical if the ceiling system is properly detailed and if the scheduling implications are recognized.

2. Treatment of Walk-on Surface. The application of a sealant against water penetration is not considered necessary. A hardener may be applied to the top surface of the poured gypsum deck to increase its wear resistance; this is mainly dependent upon scheduling. Any product used should be of the type which allows the gypsum deck to breathe. An example of such a product is Pensco True-Seal, an acrylic resin normally used on exposed aggregate concrete to prevent dusting. (Manufacturer: Federal International Chemical Company, San Carlos, California).

U.S. Gypsum also manufactures a breather type hardener for gypsum. It is a sand and gypsum product called Mastical, which is thicker, heavier and more costly than the acrylic resin. U.S. Gypsum is presently developing a breather-type sealant against water penetration for use over Mastical. This product may be applicable for use on the top surface of the gypsum deck.

3. Specific Design. An example of a specific platform design using poured reinforced gypsum is shown in Figure 320-3. This specific design assumes a structural beam spacing of 5'7-1/2", half of which is 33-3/4". The truss tees have therefore been laid out on a module of 33-3/4" instead of the standard 32-3/4". According to U.S. Gypsum, there would be no premium for this increased formboard width when a minimum quantity of 40,000 square feet is ordered, and there would be no other adverse effects other than the fact that a deviation in detail might affect the existing fire rating.

The spacing of the tees is based on the assumption that the layout of partitions and penetrations through ceilings will be greatly simplified if the platform grid and the structural grid are made to coincide, since they are so close. However, this is not essential.

When partitions occur parallel to and between two truss tees, it may be necessary to fix 16-gauge straps between the tees at approximately 3'0" on center for fixing heavy doors or partitions carrying heavy loads such as lead lining.

### **322.1.2 Precast Lightweight Concrete** (Figure 320-4)

Precast lightweight concrete panels would meet the performance requirements for platform strength, acoustic isolation and fire safety. However, special consideration in joint details would be necessary to eliminate the need for diagonal bracing in seismic zones. Special equipment is necessary to make holes, and patching to full original strength is difficult. Both the direct and indirect costs (greater weight) are higher than those of poured reinforced gypsum.

### **322.1.3 Dry Gypsum Systems** (Figure 320-5)

Dry gypsum systems are not quite as economical as poured reinforced gypsum, but they would eliminate the drying out time required for poured gypsum. An example of a dry gypsum system is illustrated in Figure 320-5. This system utilizes 1"x24"x8'0" laminated "coreboard" panels, similar to U.S. Gypsum's "shaftwall". The system is currently under development by U.S. Gypsum. If testing is undertaken for diaphragm action and for fire resistivity, and if these are successful, it may be that the coreboard system becomes the preferred option in the future.

### **322.1.4 Fire Protected Metal Decks** (Figure 320-6)

Included in this category are assemblies using corrugated steel decks or expanded metal panels which meet the strength requirements of the platform, and materials suspended below the metal deck to satisfy other requirements such as sound attenuation and fire resistivity. This latter material might be a proprietary fire-rated ceiling system or simply two layers of 5/8" gypsum board and appropriate sound insulation. The major disadvantages are the overall depth required, the difficulty in repairing holes and the need for diagonal bracing between hangers.



**Figure 320-4. EXAMPLE OF A PRECAST LIGHTWEIGHT CONCRETE PLATFORM**

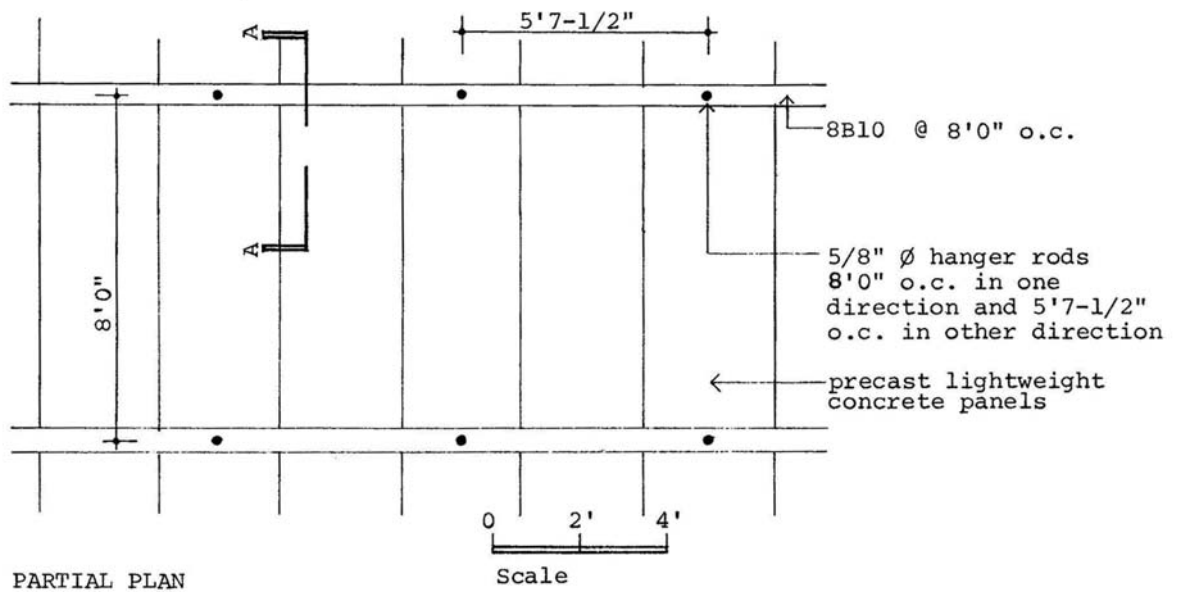
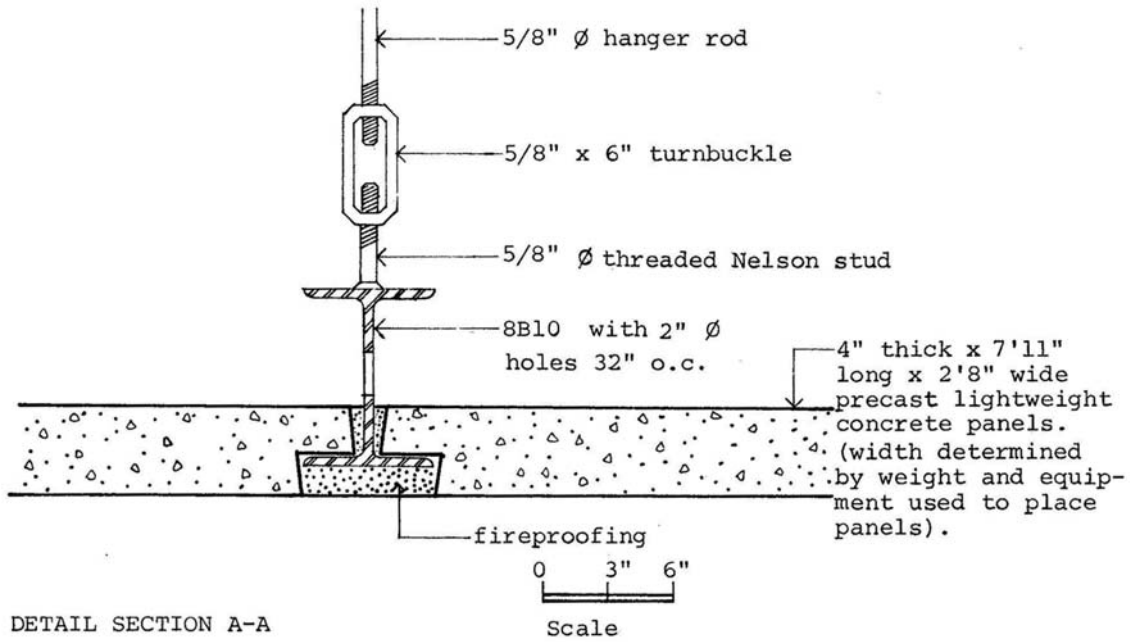

**Figure 320-5. EXAMPLE OF A DRY GYPSUM PLATFORM:  
U.S. GYPSUM "CORE BOARD"**

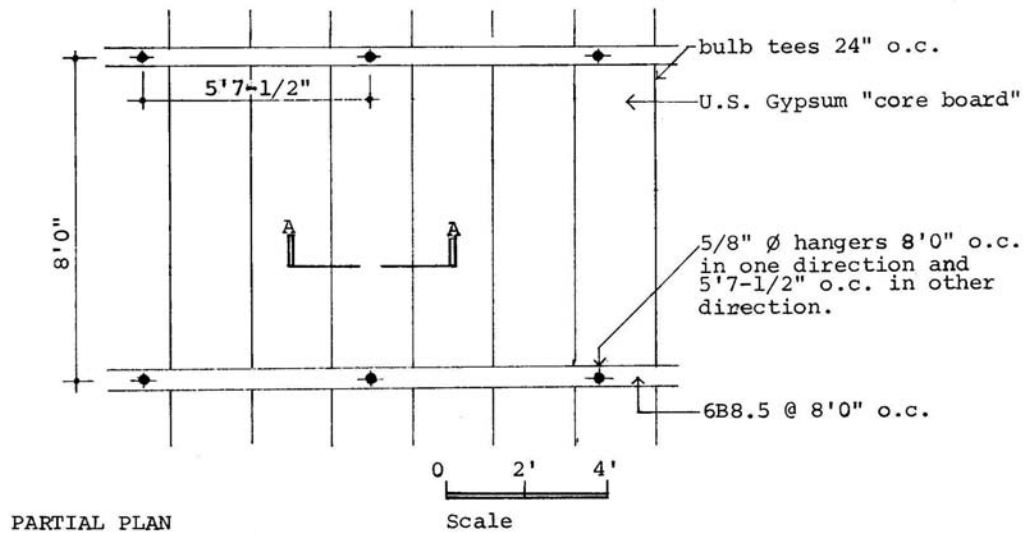
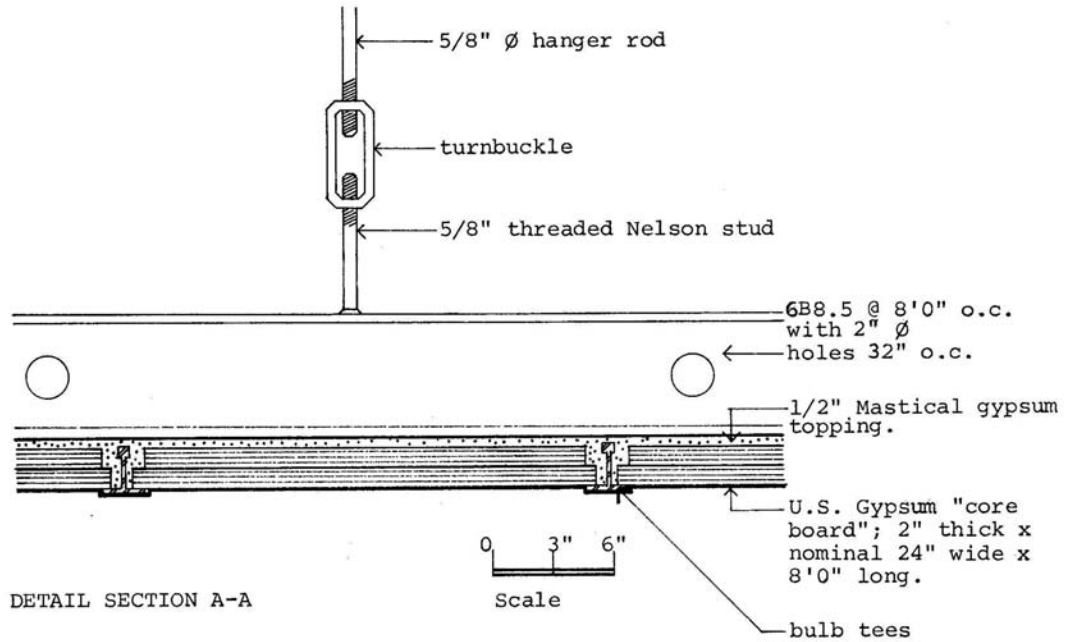

**Figure 320-6. EXAMPLE OF A FIRE PROTECTED METAL DECK PLATFORM**

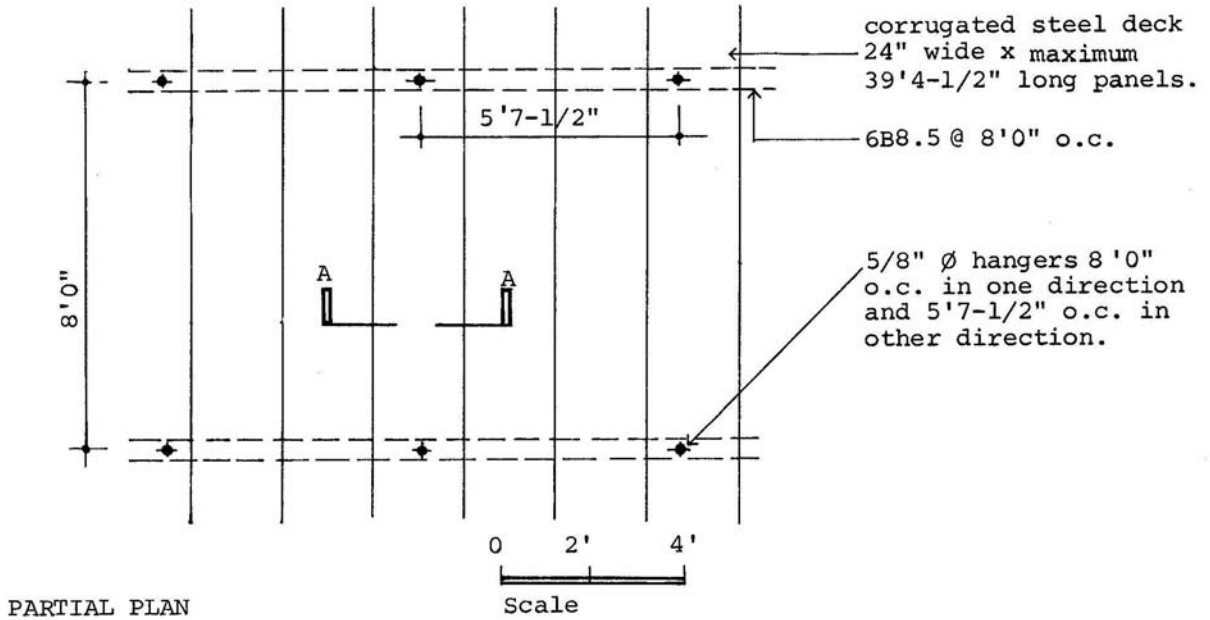
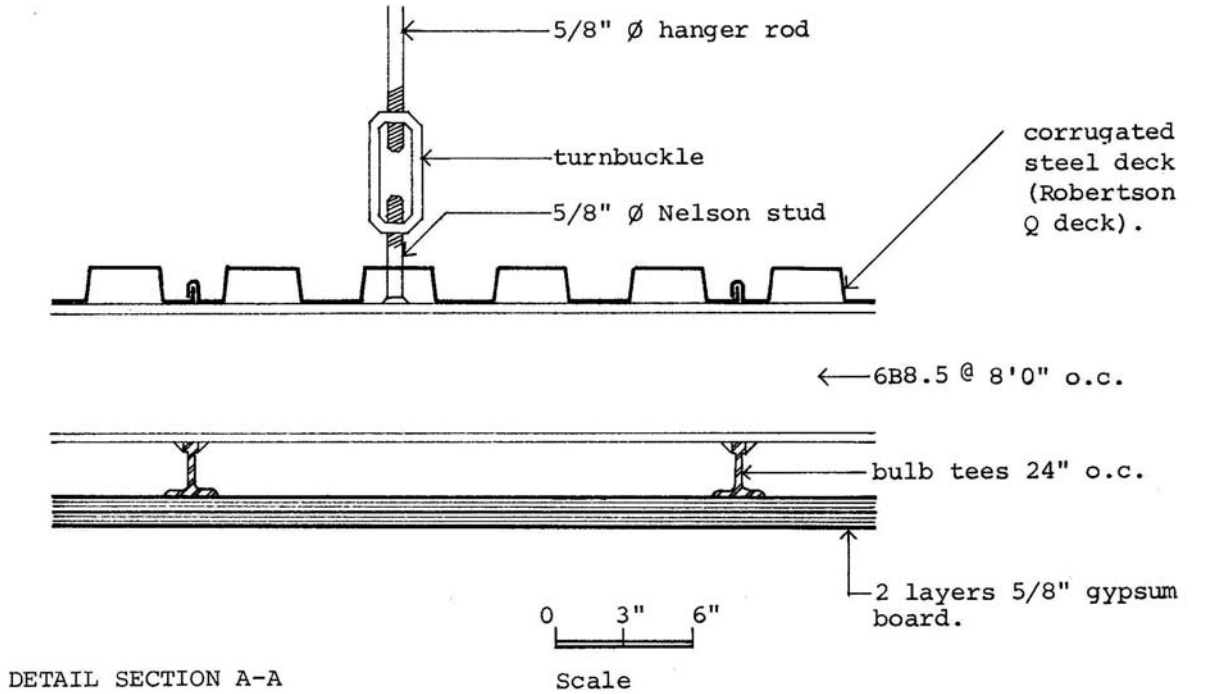

## 322.2 FINISHED CEILING

The three generic design options for the finished ceiling will permit the use of most conventional ceiling materials. Two types of product are not recommended, however; these are products involving wet trades (such as plaster) and those with exposed grids. (See Section 321.4.)

Each of these options offers different advantages, but the rest of the system is basically unaffected by the selection. Certain options may be used in combination provided they involve partitions of the same height.

### 322.2.1 Option 1: Continuous Ceiling, Directly Applied to the Underside of the Platform

In those areas of the hospital where there is no requirement for a variety of surface finishes for the ceiling, where the acoustic rating required between most of the adjoining spaces with acoustically absorbent ceilings is no more than STC 40, and where relocation of partitions is likely to occur frequently, this detail is the preferred option, since it is the least costly both in terms of first cost and for alterations.

The finished ceiling is glued to the underside of the platform and the partition head is fixed to the platform through the finished ceiling.

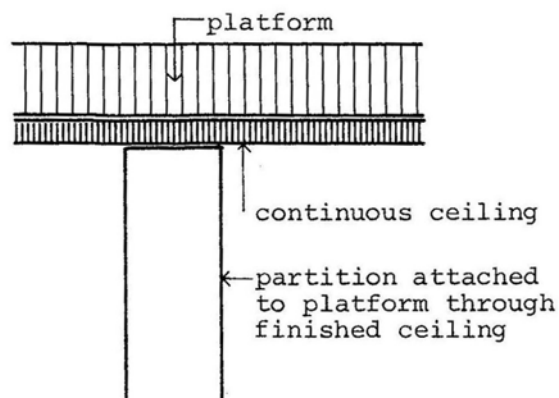

Certain combinations of ceiling and platform options will present minor problems. For instance, fixing partitions to a poured reinforced gypsum platform through a glued-on finished ceiling will present problems in that the partition will sometimes be fastened to the steel tees and sometimes to the poured gypsum deck, necessitating different types of fasteners. Since it is not possible to see where the steel tees occur behind the glued-on ceiling, and since there is no single dimensional grid applicable to all the subsystems (which would establish easily the location of the steel tees), the installation of the partitions will be slightly more complex than if the underside of the platform is all the same material (such as reinforced lightweight concrete). This difficulty is increased during alterations if additional reinforcement for heavy doors, etc., is required at the platform level above the finished ceiling. (See Section 322.1.1, Paragraph 3.)

For this reason, a mechanical fastening would be better than gluing. At present, however, there is no mechanical fastening available which would enable the finished ceiling to be fixed as close to the platform as is possible with glue. Mechanical fastenings presently require 3/4" minimum between the platform and the finished ceiling, whereas dabs of glue take only 1/8". This space of 3/4" or more makes it necessary to interrupt the finished ceiling, not only to achieve acoustic ratings greater than STC 40 but also to enable one hour partitions to be stopped at the rated platform. Continuous ceiling finishes are therefore presently limited to glued-on ceilings.

### **322.2.2 Option 2: Interrupted Ceiling Directly Applied to the Underside of the Platform**

Where acoustic ratings greater than STC 40 are required between adjoining spaces, acoustic tile ceilings will need to be interrupted and a flanking path barrier inserted. This may be done in two ways. Option 2a, which incorporates a strip of dense material above the partition, could be used in conjunction with Option 1, since the heights of the partitions are the same in these two options.

If more than approximately 50% of the partitions require strips at the head, then the cost and inconvenience of this detail will rule in favor of Option 2b, to be used throughout.

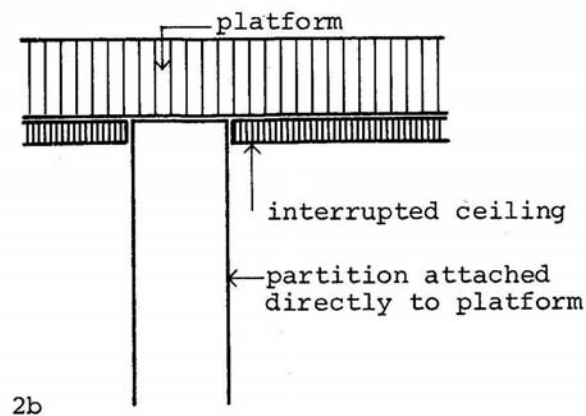
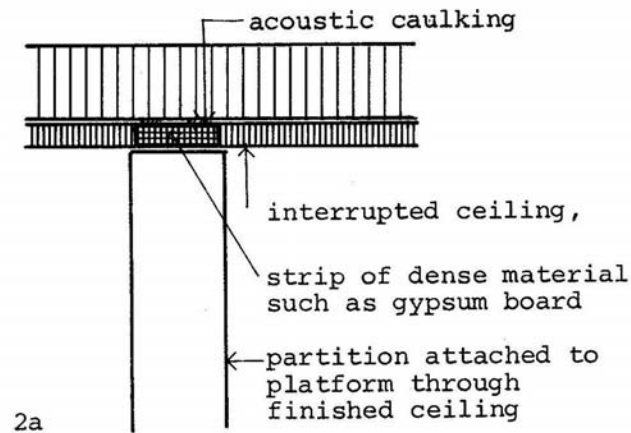

With Option 2b, the finished ceiling is interrupted by the partition itself.

Option 2b costs more than Option 1, but has several advantages. It provides better fixing of the partitions head to the platform; it provides better acoustic isolation; it readily permits different finishes to be utilized in adjoining spaces; it covers the perimeter relief detail required at the partition head (See Section 331.3); it permits the ceiling finish to be applied at a later date than Option 1, thereby avoiding scheduling problems which might arise in connection with the dryingout time for the platform. (See Section 322.1.1.)

Option 2b would be used in conjunction with any mechanically fastened finished ceilings. The metal runners would be fixed to the underside of the platform in a regular, continuous grid, interrupted as necessary by the head channel of the partitions. This regular grid would facilitate future alterations, especially if used in conjunction with a totally accessible ceiling system (such as Armstrong's Accessible Tile System, which could occupy as little as 2-1/4" in depth).

Accessibility is highly desirable, not only because it facilitates alterations but also because it enables maintenance of the acoustic seal at the head of the partition.

### 322.2.3 Option 3: Interrupted Finished Ceiling Suspended from the Platform

This option provides the same advantages as Option 2b described above and would probably be used only in conjunction with it, in those few spaces where recessed lighting or equipment is an essential item.

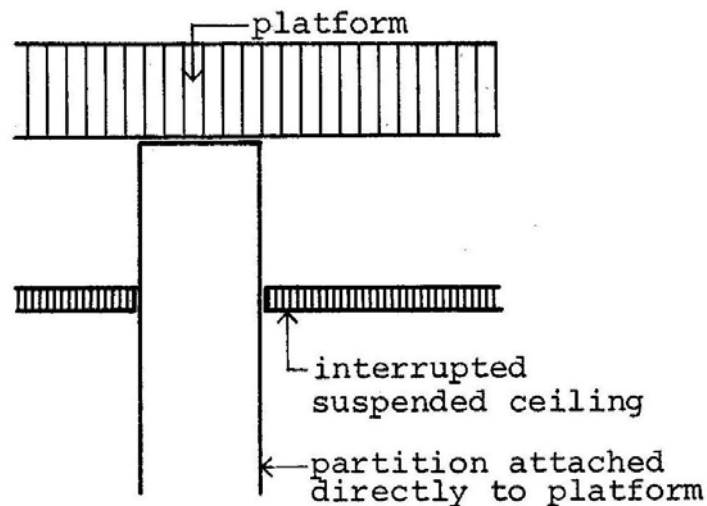

The added space between the platform and the finished ceiling should preferably not be used for service distribution elements which should be exposed for easy access above the platform.

**323 DIMENSIONS** (Figure 320-7)

There are only a few generalized rules concerning the dimensions of the ceiling subsystem. Many of these have already been described in connection with the basic design; they are summarized in this section for convenience.

**323.1 HEIGHT OF FUNCTIONAL ZONE**

The height of the platform above the floor is constant at least in each fire section and preferably throughout each floor. The functional zone (i.e., finished floor to finished ceiling) varies from a recommended height of nine feet (mainly in the nursing areas) to a recommended height of ten feet in the support areas of the hospital.

**323.2 HEIGHT OF SERVICE ZONE**

The platform is suspended below the structural slab at a sufficient distance to create a service zone approximately eight feet high. (See Figure 220-6.)

**323.3 DEPTH OF CEILING STRUCTURE**

A design which minimizes the overall depth of the ceiling structure is preferred. A depth of  $\pm 4$ " excluding the supporting framework is assumed for preliminary planning purposes. (See Figure 220-6.)

**323.4 MODULE**

There is no planning grid to which the ceiling subsystem must conform; partitions can be attached to any point of the platform, though the location of structural beams presents some constraint. (See Section 333.4.) Their location will also be limited by the structural grid of the ceiling subsystem which will make certain portions impenetrable by services. For this reason, the dimensions of the ceiling structure should be coordinated with those of the structural beams where possible. (See Section 322.1.1, Paragraph 3.)

**323.5 HANGER SPACING AND DIAGONAL BRACING**

Each hanger supports a maximum of approximately fifty to sixty square feet of platform. The structural beams will determine the hanger spacing in one direction. This spacing will be 4'6", 5'7-1/2", or 7'6". The width of secondary subzones for service distribution will probably determine the



Figure 320-7. CEILING DIMENSIONS

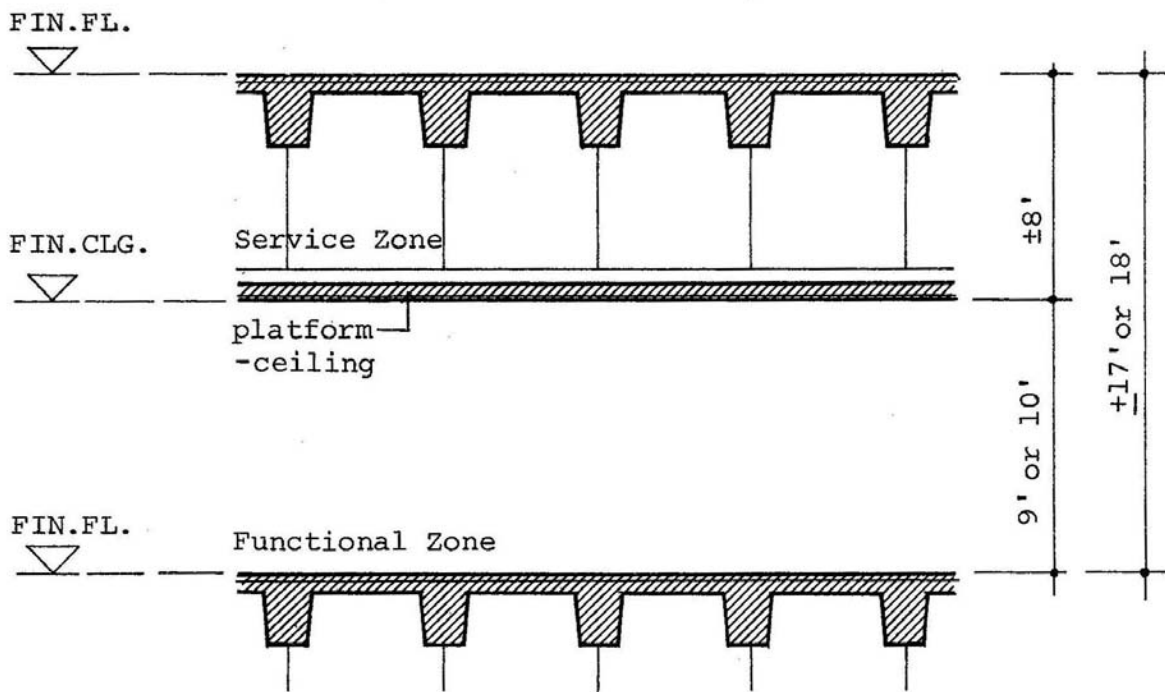

SECTION

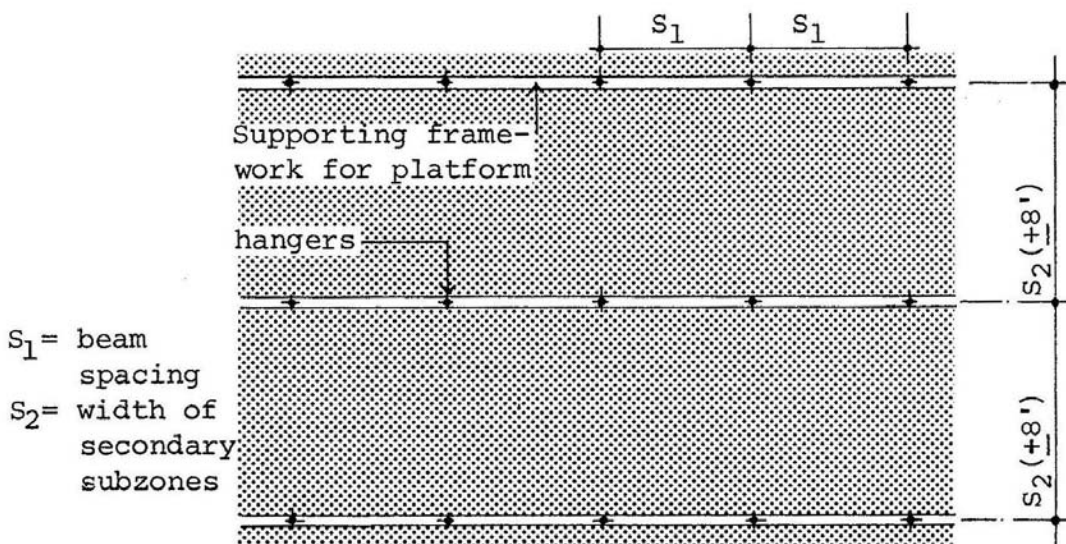

PLAN OF CEILING PLATFORM

spacing in the other direction. (See Section 224.2.) Where diagonal bracing is required, it should be located in approximately every fifth space between hangers in both directions.

### **323.6 SPACING OF MAIN MEMBERS OF SUPPORTING FRAMEWORK**

The main members of the framework which supports the platform are typically hung perpendicular to the structural beams and are spaced to accommodate secondary subzones (approximately eight feet on center).

**324       LOADING****324.1      IMPACT**

All permanent components of the ceiling subsystem (including any fireproofing, and other surface finishes) must be resistant to impact resulting from the activities of workmen and maintenance personnel in the service zone.

**324.2      VERTICAL LOADS**

The design mechanical load for the ceiling subsystem is 15 psf. This is sufficient to support part of the service distribution components and light ceiling mounted items such as light fixtures and cubicle tracks. Besides the 15 psf mechanical load, an additional 25 psf live-load capacity must be provided for construction or maintenance workmen and for temporary construction loads during initial construction or remodeling. This extra 25 psf capacity also allows for local concentrations of mechanical equipment and local ceiling-hung concentrations in the range of 100 pounds in any 100 square feet. Heavier equipment must be supported by the floor below or hung directly from the structure above. (See Figure 320-8.) Exact capacities for ceiling load concentrations will depend on the individual design.

The ceiling should also be capable of withstanding upward point loads of at least 25 pounds over a six-inch square area without appreciable deformation.

**324.3      LATERAL LOADS**

The ceiling is not required to contribute to the lateral force resistance of the structure, but it must transmit all lateral forces developed in partitions, as well as within the ceiling itself, to the structure. (See Section 334.2.) Design which do not require diagonal bracing in order to transmit the lateral loads are preferred.

**Figure 320-8. METHOD FOR SUPPORT OF CEILING-MOUNTED EQUIPMENT FROM STRUCTURE ABOVE**

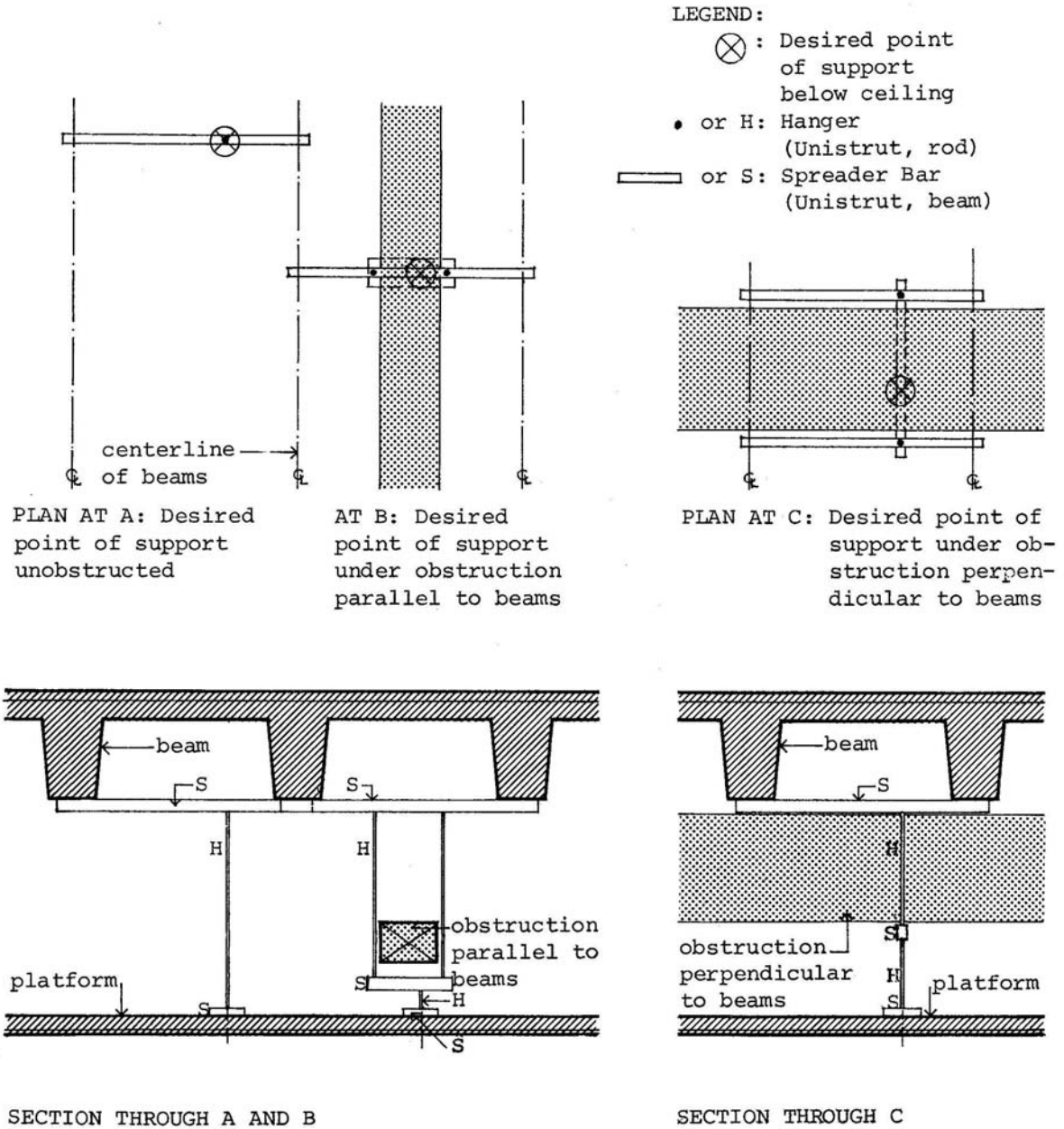

**325 ACOUSTICS** (Figure 320-9)**325.1 COMBINED FLOOR AND CEILING**

The combined floor and ceiling construction should provide ratings of STC 50 and INR +5 between floors. The higher ratings of STC 55 and INR  $\pm 10$  which are required between service areas and patient rooms (Hill-Burton standards) are not applicable to the floor/ceiling construction, since the planning rules of the Prototype Design always separate the service bay from the rest of the service module by means of a two-hour wall, and the ceiling over the functional space is interrupted at this wall. The planning rules also preclude the placement of a service bay over functional space on the floor below.

Since there is no acoustic data currently available for assemblies of a type similar to the Prototype Design, the acoustic performance of the combined floor and ceiling can only be estimated. It is expected that both the impact isolation and the airborne sound isolation from floor to floor will be satisfactory, assuming a fairly dense structure for the platform.

**325.2 COMBINED PARTITIONS AND CEILING**

The ceiling construction must not reduce the sound isolation provided by the partitions. The combined partition and ceiling construction must provide STC ratings as high as 50. In order to achieve this high level of performance in the field, the joint between the partitions and the ceiling must be carefully detailed, installed, and supervised. The degree of supervision during construction can seriously affect the acoustic performance of the system. The joint should be detailed so that acoustic seals are relatively accessible for inspection and repair.

**325.3 PLATFORM**

Materials must be selected in reference to the maximum noise level to be allowed in patient bedrooms and other critical areas. The platform should provide a minimum of STC 40 to protect habitable spaces from noise generated by activity or equipment in the service zone. It is not expected that the platform alone will provide good impact isolation from the floor below, but since the service zone will be infrequently occupied, this is not expected to present any serious problems. Vibration and noise producing items in the service zone should be isolated from direct contact with the ceiling by resilient mounts.

Figure 320-9. ACOUSTIC CRITERIA FOR VARIOUS ASSEMBLIES

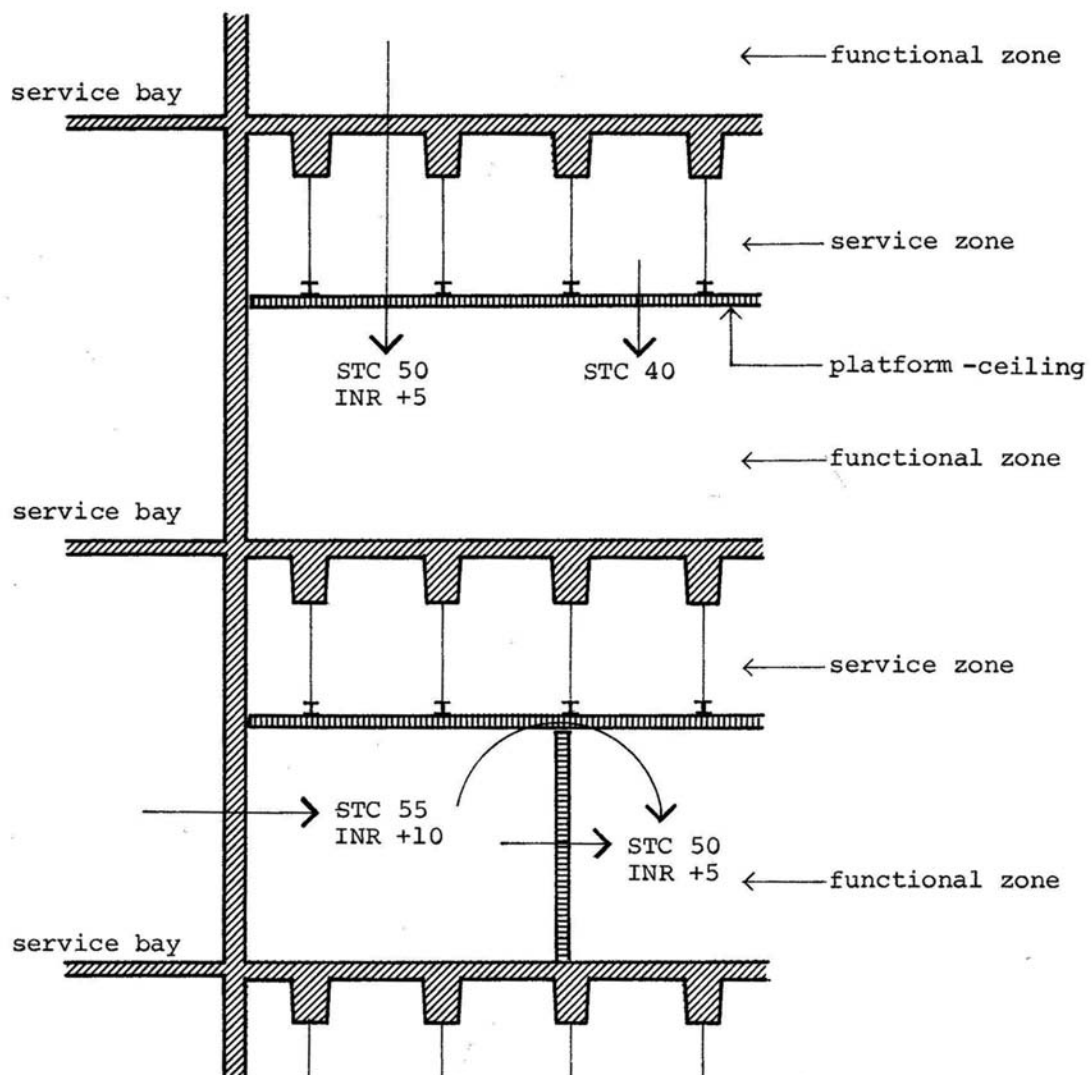

In those spaces where sound isolation between the platform and the floor below is critical, the finished ceiling can be separated from the platform by means of resilient clips.

#### **325.4 FINISHED CEILING**

The lower surface of the ceiling should have an absorption capacity between NRC .60 and .80 in many areas of the hospital. Where continuous, glued-on finished ceilings are used, a high sound-attenuating material (such as USG Aurotone Tile) with a ceiling sound transmission class of 45-49 should be specified to reduce sound transmission over the partition from room to room.

## 326

**FIRE SAFETY**

One of the key characteristics of the system is that, with the exception of two-hour fire barriers, no partitions may penetrate the ceiling even though they may be required to have a fire resistance rating of one hour (as at corridors) or to be smoke barriers. Another critical design feature of the system is the planning requirement that all partitions (except two-hour rated) must be relocatable. The total ceiling, therefore, must be designed to provide the same degree of fire, smoke and fume resistance as the one-hour rated partitions, even though at this time there is no ceiling (as opposed to a floor or roof and ceiling assembly) with an official one-hour rating. A rating is given by the appropriate authorities on the basis of a fire test, and no fire tests have yet been carried out on ceilings as separate entities. Ceilings are presently tested only in their fire protective capacity as part of a floor or roof and ceiling assembly, not as a fire separation element.

In the absence of official ratings, the ceiling subsystem design will be accepted by the appropriate VA authorities (Safety and Fire Protection Staff, Engineering Service, DM&S) if they are of the opinion that it would be structurally sufficient and reasonably smoketight in the event of a fire. For convenience, such a ceiling design is referred to as a one hour rated ceiling. Suitable protection of the ceiling hangers may need to be provided, however. This may take one of several forms. The hangers themselves may be fireproofed, or the openings in the ceiling-platform may be protected by fire dampers, or the functional zone may be sprinklered. The preferred method may vary in different functional areas and/or in different geographical locations where code and cost considerations may influence the choice.

The ceiling must be non-combustible and its materials must not produce noxious or toxic fumes. Maximum flame spread rating of the materials is 25, and maximum smoke-developed rating is 50.



**327 OTHER DESIGN CRITERIA****327.1 DEFLECTION**

The suspension system for the platform must incorporate leveling devices to take up deflection from structure or ceiling dead loads. For compatibility with partitions, actual expected live-load deflection from combined live loads on the structure and ceiling subsystems should produce deflections compatible with the partition/ceiling junction detail; typically, 1/2" can be accommodated. (See Figure 330-3.)

**327.2 TOLERANCES**

Tolerances must be in accordance with VA Construction Standards and Master Construction Specifications.

**327.3 SURFACE CHARACTERISTICS**

It must be possible to glue or mechanically attach any conventional finished ceiling to the underside of the platform.

The walking surface of the platform must have a finish, or capability of receiving finish materials with the following characteristics:

1. Sufficient resistance to abrasion and impact to permit maintenance personnel to walk on the surface without affecting the structural integrity of the platform and without generating a dust problem.
2. Sufficient resistance to moisture so that accidental leaks in pipes will not cause structural failure.
3. Easily penetrated and repaired.
4. See Section 325 and 326 for acoustic and fire safety criteria.

**327.4 ADAPTABILITY**

The platform and suspension system are regarded as permanent parts of the building, whereas the finished ceiling, which may require a wide latitude of performance, is an adaptable component. Adaptability of the platform is, therefore, primarily a question of access to, and support of certain components of other subsystems, as well as the finished ceiling.

### **327.4.1 Penetrations**

Although access to the service zone is primarily horizontal, a reasonable degree of vertical access must also be provided for convenience of engineering personnel and for introduction of equipment. During construction it must also be possible to leave out large areas of the platform temporarily so that primary trunk ducts, etc., can be brought into the service zone.

It must be easy to penetrate the ceiling to relocate or add service distribution components. There should be as little restriction as possible in the locations of these penetrations. When services are relocated, it should be easy to patch unused openings.

### **327.4.2 Support of Adaptable Items**

The platform should provide substantial backing for a variety of ceiling finishes which can be applied, cleaned, repaired, removed or changed without significant damage to the base material. It must also provide support for a wide range of ceiling-mounted items such as cubicle tracks, IV hangers, TV consoles, etc., in a manner allowing simple cutting and drilling of holes as they are installed and patching when they are removed. The ceiling framework should not place undue restrictions on the location of partitions; ideally there would be no restrictions.

**328 TARGET COSTS****328.1 RANGE**

The total cost of the ceiling subsystem will range between \$2.50 and \$4.55 per square foot of ceiling, or \$2.10 and \$3.85 per OGSF of building. (See Section 751.2.2.)

**328.2 SCOPE****328.2.1 Included**

1. Complete suspended ceiling system, including:
2. hangers, braces, edge connectors and trim;
3. leveling devices;
4. access panels; and
5. any materials or devices required to obtain a fire rating of one hour for the ceiling subsystem. (See Section 326.)

**328.2.2 Not Included**

1. Lighting fixtures;
2. fixture mounting devices;
3. attachments and hangers for service distribution elements;
4. welded studs or inserts in structural beams for attaching ceiling hangers;
5. air diffusers, grilles; and
6. special insulation or shielding.

**(BLANK PAGE)**

## **330 Partitions**

### **331 BASIC DESIGN** (Figures 330-1 and 330-2)

#### **331.1 TWO-HOUR PARTITIONS**

Fire sections and vertical shafts must be bounded by two-hour fire barriers. Those barriers that are non-loadbearing, interior partitions are included in this subsystem. They extend from the floor to the underside of the structural slab above. All other performance characteristics are the same as described below.

#### **331.2 OTHER COMPONENTS OF THE PARTITION SUBSYSTEM**

Except for two-hour partitions and certain smokestop partitions, all components of the partition subsystem extend from the floor to the ceiling-platform, and are the same height on any one floor. Included are all types of non-loadbearing interior partitions, interior door sets and glazed units.

All components must provide a wide range of performance in terms of impact resistance, finishes, ease of relocation, fire resistance and acoustics. To maintain the fire resistance and acoustic performance, and to facilitate access to services, service distribution lines should not be located within the partitions but should be surface mounted wherever feasible. The factors governing where to surface mount the services are discussed in Section 337.3.3.

In some instances, it will be necessary to enclose the surface-mounted services with furring. (See Section 332.2.1.) The furring should be extended to the ceiling but kept free of the floor so that maintenance of floors is facilitated. Furring may be site fabricated or shop fabricated depending on the degree of repetition and the numbers required.

#### **331.3 HEAD DETAIL**

Because of the long structural spans involved in the Prototype Design, the detail at the head of all components of the partition subsystem must accommodate deflection by incorporating a “perimeter relief runner” detail. In addition, the head detail must not degrade the acoustic and fire safety performance of the partitions. Fire-rated head details will be required for all rated partitions, and these details should be matched in appearance by the detail at the head of all other components of the subsystem. Rated perimeter relief runner details are illustrated in Figure 330-3.

**331.4 PERMANENT AND ADAPTABLE COMPONENTS**

Two-hour partitions are permanent. All other components of the partition subsystem are considered adaptable.

**Figure 330-1. BASIC DESIGN OF PARTITION SUBSYSTEM**

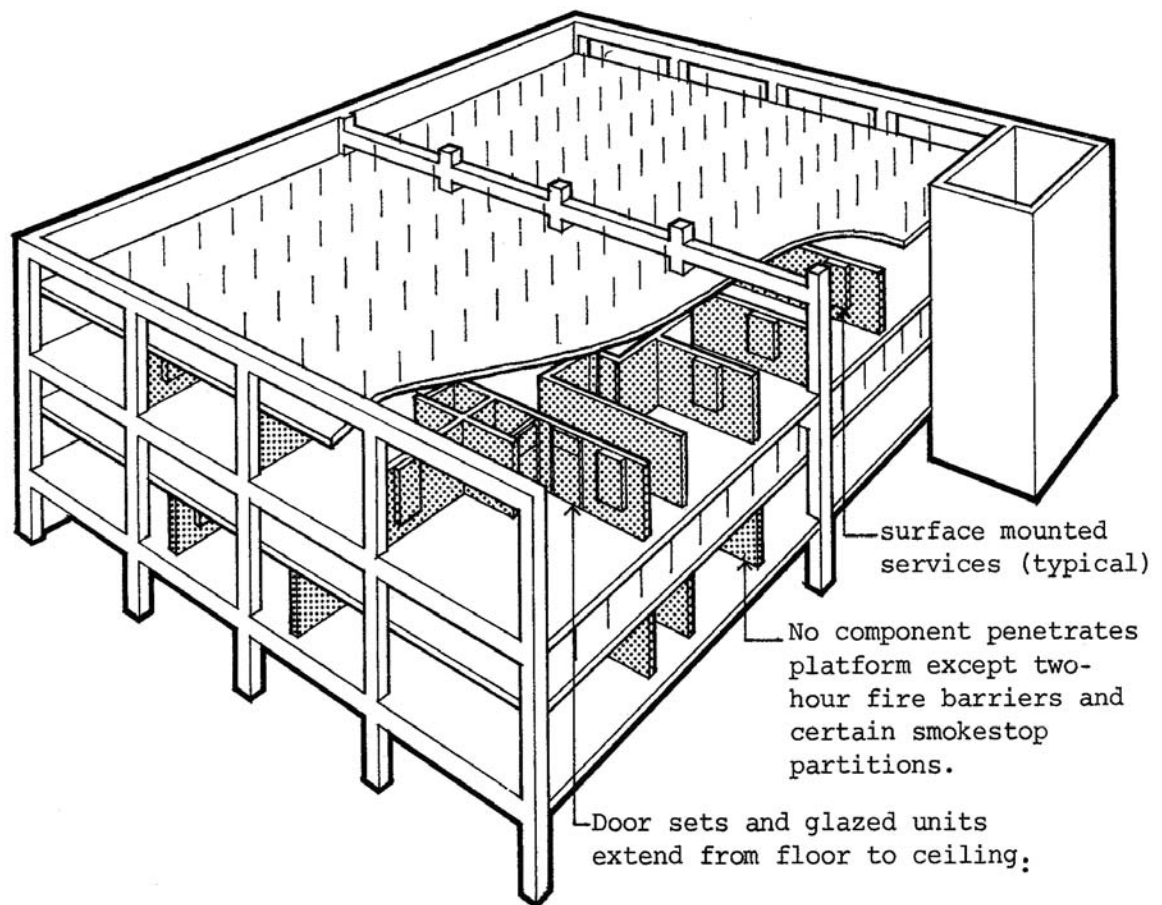

**Figure 330-2. COMPONENTS OF PARTITION SUBSYSTEM**

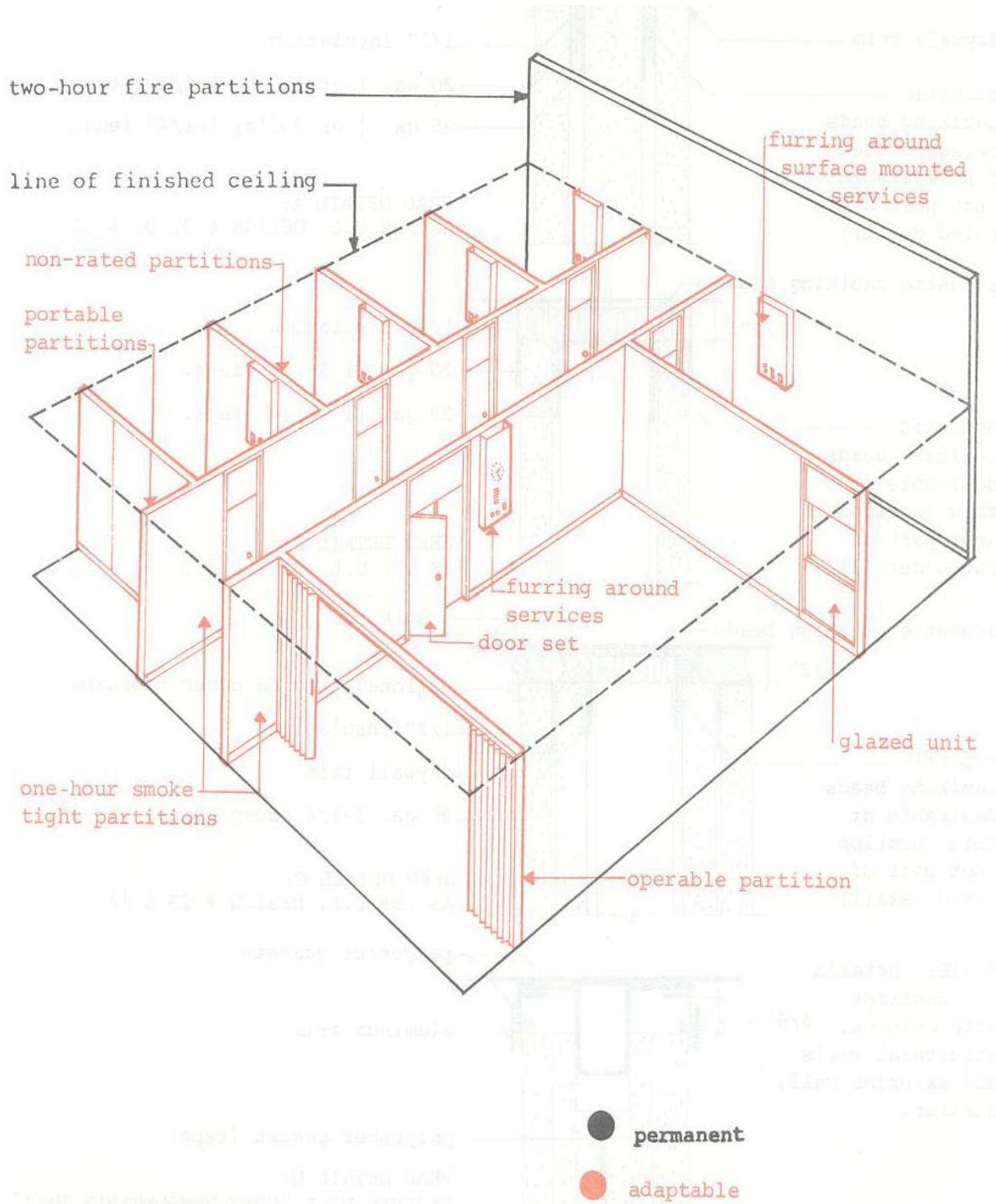

**Figure 330-3. EXAMPLES OF RATED PERIMETER RELIEF RUNNER DETAILS AT HEAD OF PARTITION**

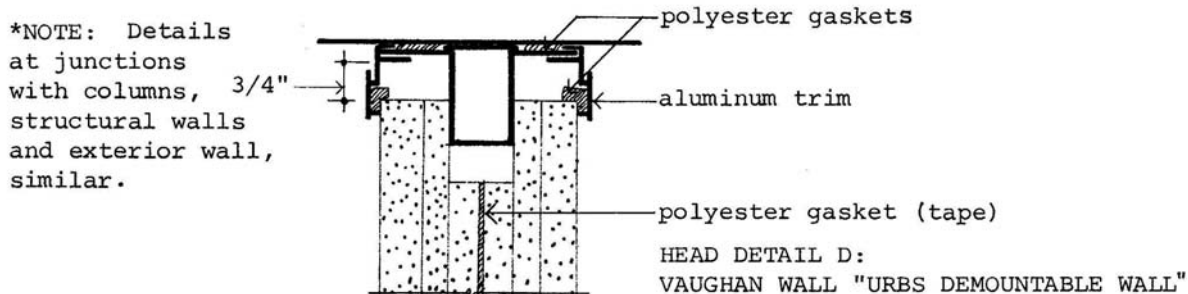
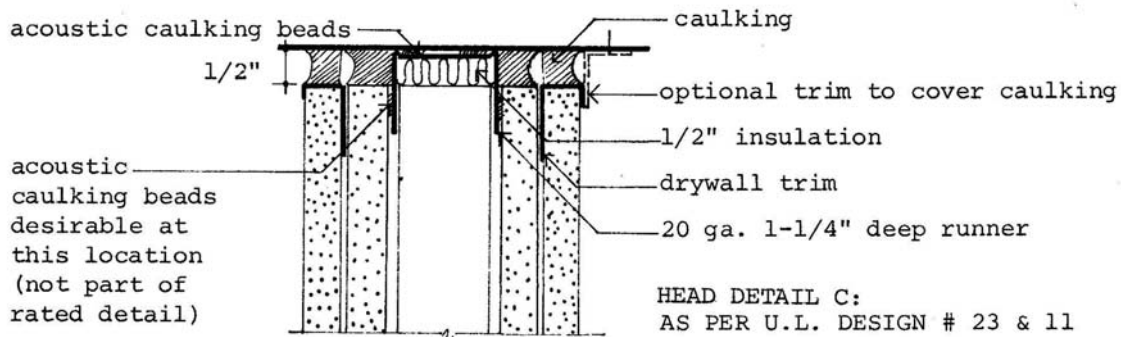
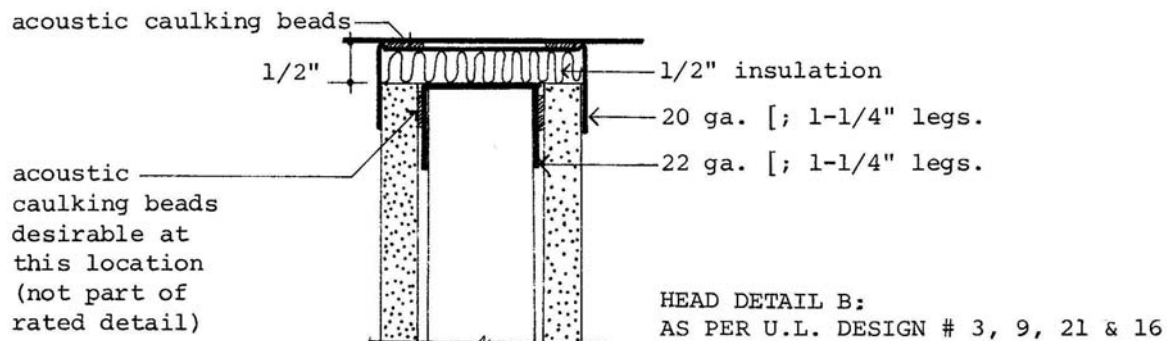
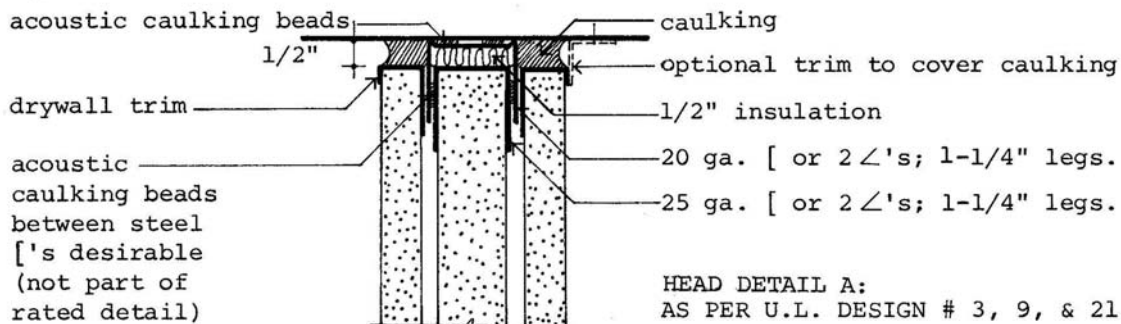



## **332            GENERIC DESIGN OPTIONS**

### **332.1        MATERIALS AND CONSTRUCTION**

#### **332.1.1     Fixed and Relocatable Partitions**

The preferred options for fixed and relocatable partitions are gypsum board on metal studs (Option 1) or laminated gypsum board (Option 2). These provide the highest level and the greatest flexibility of performance when compared with other partition types. (See Section 723.3.) They are capable of meeting any reasonable strength requirement, of accepting any required finish and may be either jointless or panelized, each of which may have advantages in relation to different functional areas of the hospital.

Panelized partitions are generally proprietary, whereas the jointless types are available either as proprietary or non-proprietary systems. Proprietary systems typically have a higher first cost. The advantage of a proprietary system is that all details have been precoordinated and tested so that the level of performance is known and is not as dependent on the quality of supervision during construction as the non-proprietary types. This is particularly important where acoustic, fire safety and deflection criteria must all be met by the same detail, as is the case at the head of the fire rated partitions. At least one proprietary system - by Vaughn Interior Walls, Inc. - has such a detail which has been rated one hour by the University of California, tested for a high level of acoustic performance (STC 50), and designed to provide as much as  $\frac{3}{4}$ " tolerance to take up deflections. (See Figure 330-3, Detail D.)

There are several specific design options available in each of the two preferred generic categories. These are illustrated in Figures 330-4 and 330-5 and discussed in Section 336.

#### **332.1.2     Operable and Portable Partitions**

These are available in a wide variety of types and properties. Where sound isolation is required, the partition should provide a positive seal when partitions are closed. For this reason, as well as for asepsis, those types which use mechanically activated bottom-edge drop-seals and no floor track are recommended. This allows some tolerance for movement of the building structure.

**Figure 330-4. PARTITION GENERIC DESIGN OPTION 1:  
GYPSUM BOARD ON METAL STUDS**

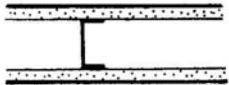
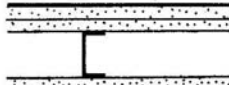
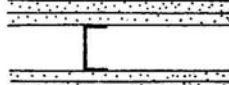
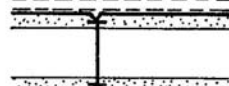
Types Available	STC Rating <sup>1</sup>	Similar UL Design # & Fire Rating <sup>2</sup>	UL Design Has Rated Perimeter Relief Detail <sup>3</sup>	Examples of Similar Proprietary Partitions
a. 	37-43	#2, 1-hr	no	
b. 	41-49			
c. 	45-54	#23, 1-hr #11, 2-hr	yes yes	<u>VAUGHAN WALL "URBS Fixed Wall."</u> 1-hour rated with tested perimeter relief detail by the University of California.
d. 	36-50			<u>U.S.G. "Ultrawall."</u> 1-hour rated by the University of California (8/18/67). No tested perimeter relief detail. Available demountable or fixed; progressive or non-progressive.

1. The higher STC ratings for each basic design are achieved by adding sound attenuation blankets, by varying the dimensions of the various members, and by increasing the number of perimeter acoustic caulking beads.
2. U.L. designs are all class E-1. These designs specify every detail of the tested partition, including dimensions of each component. Other variations of the basic type also exist.
3. See Section 331.3.

**Figure 330-5. PARTITION GENERIC DESIGN OPTION 2:  
LAMINATED GYPSUM BOARD**

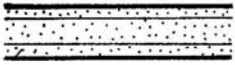
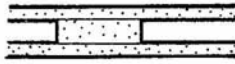
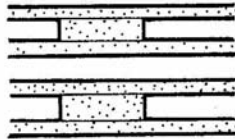
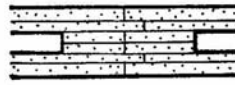
Types Available	STC Rating <sup>1</sup>	Similar UL Design # & Fire Rating <sup>2</sup>	UL Design Has Rated Perimeter Relief Detail	Examples of Similar Proprietary Partitions
a. 	36	#9, 1-hr #3, 2-hr #21, 2-hr	yes yes yes	<u>VAUGHAN WALL "2-1/4" Solid Wall.</u> This design has been 1-hour rated (without perimeter relief detail) by the University of California (5/2/65).
b. 	36	#15, 1-hr #16, 1-hr	yes yes	<u>VAUGHAN WALL "Chase Wall."</u> This design has been 1-hour rated (without perimeter relief detail) by the University of California (11/1/66).
c. 	45-50	#24, 2-hr	no	<u>VAUGHAN WALL "Double Sound Wall"</u> 2-hour rated.
d. 	45-51	#7, 2-hr (Class D-2) #14, 2-hr (Class D-2)	yes yes	<u>VAUGHAN WALL "URBS Demountable Wall."</u> 1-hour rated with tested perimeter relief detail by University of California 9/12/68.

1. The higher STC ratings for each basic design are achieved by adding sound attenuation blankets, by varying the dimensions of the various members, and by increasing the number of perimeter acoustic caulking beads.
2. U.L. designs are class E-1 except where noted. These designs specify every detail of the tested partition, including dimensions of each component.

A standard of quality and performance for the various products may be established by reference to the leading manufacturers, many of whom support a certification program (NSSEA) which combines acoustical and operating requirements.

## **332.2 TYPICAL METHODS FOR HOUSING SERVICES**

The appropriate method of housing services in different functional areas is discussed in Section 337.3.3. This section describes the available options. Specific products are discussed in Section 780.

### **332.2.1 Surface Mounted Services**

1. Services are exposed. This category includes items such as surface-mounted electrical raceways designed to be exposed.
2. Services are contained within proprietary enclosures and hung on the partition, (e.g. patient wall systems and lavatory consoles).
3. Services are surface mounted on the partitions and enclosed with furring. Figure 330-6 illustrates two ways of furring around services using materials and details that match the basic partitions. The metal angles at the corners of Type 2 permit easy access to the services and protect the vulnerable corners of the furring against damage.

Method 1 can be used where only a few items are involved, such as switch drops or electrical supply to power outlets. If several drops are required within one space, it may be preferable to drop only once and run a horizontal raceway at an appropriate level. Method 2 should be used where a cluster of different services can be grouped into a local area, e.g. at a patient bedside or a treatment room. Method 3 is an alternate for method 2 where reduced costs are critical, or where appropriate proprietary enclosures do not exist.

### **332.2.2 Services Within Partitions**

1. In stud space.
2. Between double partitions.
3. In prefabricated "plumbing walls".

Figure 330-6. FURRING AROUND SURFACE-MOUNTED SERVICES

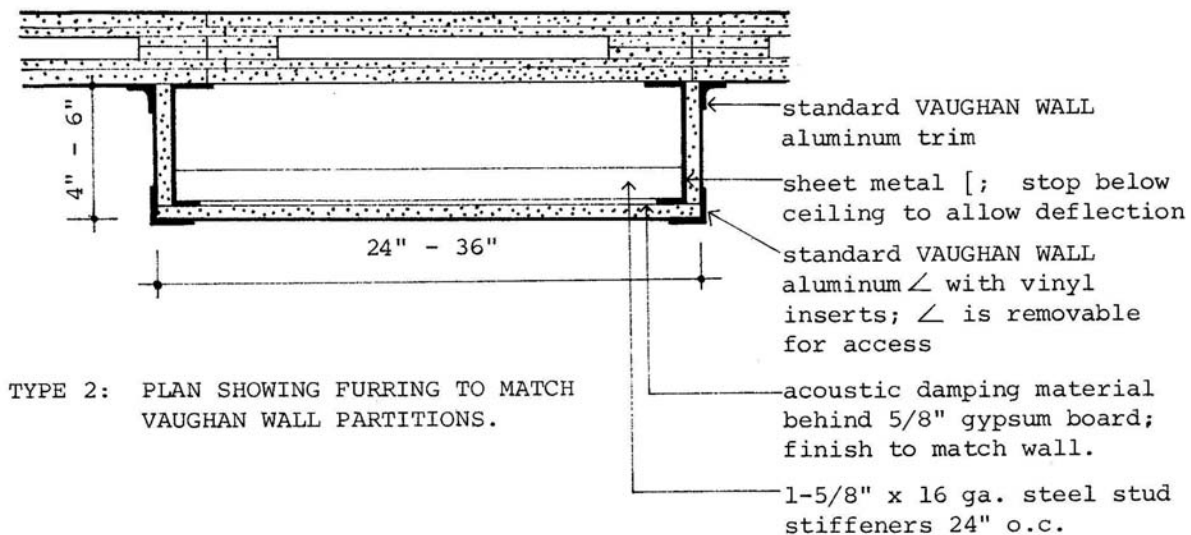
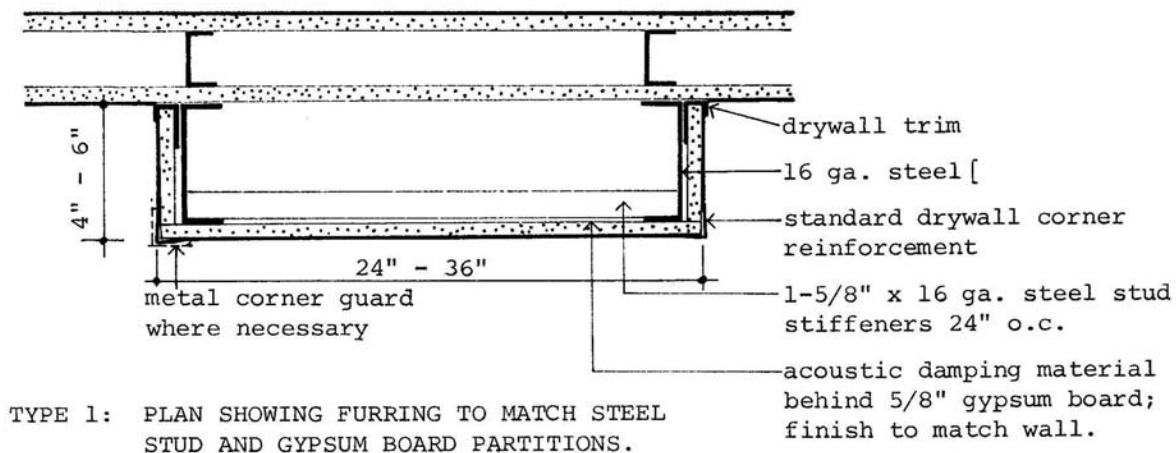

**333 DIMENSIONS****333.1 HEIGHT**

All components of the partition subsystem (except two-hour fire rated partitions) will stop at the ceiling-platform, which will have a uniform height throughout each fire section and preferably throughout each floor. Nursing areas have a nominal floor-to-ceiling height of nine feet. The support areas have a nominal floor-to-ceiling height of ten feet. The exact height of the partitions is a function of the particular detail selected for the partition/ceiling interface. (See Section 322.2.)

**333.2 THICKNESS**

Thickness of partitions may vary as required for loading, fire safety, and acoustic criteria. On the basis of loading criteria and typical construction, the recommended minimum width of metal studs (Option 1) is 3-5/8", whereas the minimum thickness of laminated gypsum partitions is 2-1/4". (See Section 334.3.) Relocatability of door frames is facilitated if all partitions are the same thickness.

**333.3 DOOR SIZES**

Door frames extend from floor to ceiling, surrounding standard height doors with transom panels over. The nominal width of door openings will vary between two and eight feet. The maximum size single leaf permitted is dependent on the weight of the particular door because the lateral load introduced by doors, and impact from door slamming, must be accommodated by the ceiling subsystem.

**333.4 CONSTRAINTS ON PARTITION LOCATION**

No specific partition module or planning grid is required. In many areas of the hospital, a modular partition system with exposed joints will be unacceptable because of aseptic requirements. However, partitions should be located so that plumbing drains do not coincide with structural beams or perimeter girders. Also, the drops for services associated with partitions should not conflict with the structural members of the ceiling-platform. An implied dimensional discipline for partition layouts results from these considerations.

**334 STRENGTH****334.1 IMPACT**

Surface and projecting corners of all components must be designed to withstand high impact in those locations where impact typically occurs, e.g., corridors. A reasonable degree of resistance to impact is achieved by providing two layers of gypsum board, by rails or by covering projecting, vulnerable corners with metal angles. Proprietary systems are often designed with this metal angle as a standard item.

**334.2 LATERAL LOADS**

All lateral stability of the basic partitions, frames for doors, etc., will be provided by attachments to floor and ceiling. (In those instances where the capacity of the ceiling is exceeded, additional supports from the structure above will be required.) Lateral loads on the partitions should be calculated at 10 pounds per square foot. Deflection for lateral load of 5 pounds per square foot should be limited to 1/360 of the partition height. Forces introduced by doors and impact from doors must also be taken into account in the design of the partitions and the door sets.

**334.3 VERTICAL LOADS**

Partitions must be capable of supporting vertical loads from equipment weighing at least 100 pounds per lineal foot of wall, with the load applied 6 inches out from one face of the partition. Heavier loads will be floor supported where possible. In areas where heavier loads are typically wall supported, e.g., X-ray rooms, the partitions in that department will be designed to carry loads up to 200 pounds per lineal foot of wall applied 12 inches out from one face of the partition. To achieve this higher loading capacity, gypsum board on metal studs is required.

**334.3.1 Gypsum Board on Metal Stud Partitions**

The following table is provided as a basis for the design of steel stud partitions in various areas of the hospital.

Stud Size, inches	Stud Gauge	Maximum Loading, lbs/lineal foot	Distance of load from partition face, inches
3-5/8	25	100	6
3-5/8	20	200	6
4 6	18 25	200	12

The stud gauge and size are based on the following assumptions:

1. 10' high partitions
2. studs placed on 24-inch centers
3. regular strength steel ( $F_y = 33,000$  psi)

### 334.3.2 Laminated Gypsum Board Partitions

The table below is based on tests furnished by U.S. Gypsum Company and Vaughn Interior Walls, Inc., and is provided as a guide to the selection of laminated gypsum partitions.

Wall Type (See Figure 330-5)	Maximum Loading, lbs/lineal foot	Distance of load from partition face, inches
2-1/4" Solid Wall	200	6
2-1/4" Chase Wall (single or double)	200	6
3" Urbs Demountable Wall (Sound Wall)	100	6

These wall capacities are based on:

1. 10' high partitions
2. modulus of elasticity = 245,000 psi
3. allowable bending stress = 200 psi



### 334.3.3 Connections

For the range of loads stipulated, typical connections at the floor and at the ceiling are adequate and the capacity of the basic ceiling design is sufficient.

## 334.4 ATTACHMENTS

### 334.4.1 Gypsum Board on Metal Stud Partitions

Generally, except to support very light objects such as room thermostats, no fasteners should be used without horizontal rails or back-up plates, unless they are attached directly to the studs. Surface mounted horizontal rails are far more adaptable than back-up plates though the issue of asepsis may eliminate this option in some areas. The rails may be proprietary or specially designed. Back-up plates can be installed in the conventional manner, i.e., as required to support each predetermined piece of equipment, or it may be economically feasible to install continuous horizontal back-up plates at one or two predetermined heights. The latter method is preferred in that it would facilitate the installation or relocation of equipment at a later date, without the need to cut into the partition face. The required number, size and height of continuous back-up plates will vary in different functional areas of the hospital. The design of the back-up plates is best integrated with the interior elevations of a particular project so that convenient heights and sizes can be determined in relation to typical wall hung equipment in the various functional areas. The sizes of the back-up plates which could be used for various loads are as follows:

1. If the plate acts alone, i.e., if it is located behind the gypsum board, use 3" x 16-gauge if pullout is less than 15 pounds between each stud. (A pullout force of this magnitude could result from supporting on the partition an eight-foot high by twelve-inch deep cabinet weighing 200 pounds per horizontal foot.)
2. For the same force, a 3" x 25-gauge plate may be used if it is located between two thicknesses of gypsum board, i.e., if it acts in conjunction with the gypsum board. This option may also be used in conjunction with laminated gypsum board partitions.

3. Use a 1-1/2" deep x 16-gauge channel notched around the steel studs (and screwed to them) if the pullout is up to 200 pounds between each stud. (A 200-pound pullout force corresponds to the force from a 45 degree bracket supporting a weight of 200 pounds per foot.)

The back-up plates should be in 4'0" lengths so that if necessary, it would be possible to adjust their height behind each 4'0"-wide sheet of gypsum board.

#### **334.4.2 Laminated Gypsum Board Partitions**

All attachments should be made with sheet metal screws with 1-1/2" embedment. These screws have a pullout capacity of approximately 50 pounds and a shear capacity of approximately 100 pounds. In the non-solid walls, screws must be placed to coincide with the 6-inch filler ribs.

**335 ACOUSTICS****335.1 PARTITIONS**

The need for resistance to airborne sound transmission through partitions varies between STC 35 and STC 50. (See Section 510 and 520.) The requirement for STC 55 between mechanical spaces and patient rooms is typically provided by a concrete wall which separates the service bay from the rest of the service module.

The STC of the partitions can be varied by the number and thickness of layers of gypsum board and the inclusion or omission of sound attenuation blankets. (See Figures 330-4 and 330-5.)

Laboratory ratings for sound isolation in general are consistently higher than the performance found in actual field installations. Factors which contribute to poor field performance include “flanking” transmission paths through and around the partition (namely through joints and penetrations, inadequate ceiling and perimeter detailing, etc.) and poor workmanship. Proper construction details at the perimeter of the partitions and close field supervision are extremely important.

All openings and construction joints should be well caulked and sealed airtight, and there should be no penetrations through the partitions. Any gap or hole quickly deteriorates the performance of a partition. This can be shown by the following example:

For a partition having a sound attenuation value of 40 decibels, a .1% opening, i.e., a .04 inch crack around a 3' x 7' door in an 8' x 10' wall, will result in that partition having a net attenuation of 30 decibels. For partitions having greater sound isolation, the same size opening will have a greater effect in reducing its isolating characteristic.

**335.2 DOORS**

Where sound isolation is critical, doors should be selected having sound isolation ratings equivalent to the partitions in which they occur. A 3' x 7' door with STC 30 placed in an 8' x 10' wall with STC 50 would result in a composite rating of approximately STC 36. The cost premium for doors with acoustic ratings above STC 25-30 is significant, however, so the benefit of their use should be carefully weighed.

Suitable gasketing at head, jamb and sill is also required to meet acoustical ratings. This will generally improve the sound rating by approximately 3 decibels. Undercuts and louvers must not be permitted where there is any concern for acoustical privacy.

### **335.3 FURRING AROUND SURFACE MOUNTED SERVICES**

It is necessary to avoid coupling the noise energy from plumbing fixtures, etc., into partitions and furring. Transmission of this noise and vibration can be reduced by use of resilient devices. The enclosure around the surface mounted services should be stiffened and acoustically dampened to minimize noise radiation.

## 336

## FIRE SAFETY

All partition components must be non-combustible. Materials must have a maximum flame spread rating of 25 and a maximum smoke developed rating of 50. When burnt, materials must not produce noxious or toxic fumes.

Partitions surrounding vertical shafts and defining fire sections must be two-hour rated and must extend from slab to slab. Two-hour slab-to-slab partitions may also be required around special hazard areas such as engineering shops, supply areas, etc. To facilitate change, these particular two-hour partitions should be constructed in two sections interrupted by the continuous ceiling-platform.

One-hour partitions, including smokestop partitions, will be required at corridors and other locations defined by code. These need not extend beyond the one-hour rated ceiling-platform. However, each service zone above the ceiling should be designed as a smoke-tight compartment, and "plenum barriers" should be installed where required.

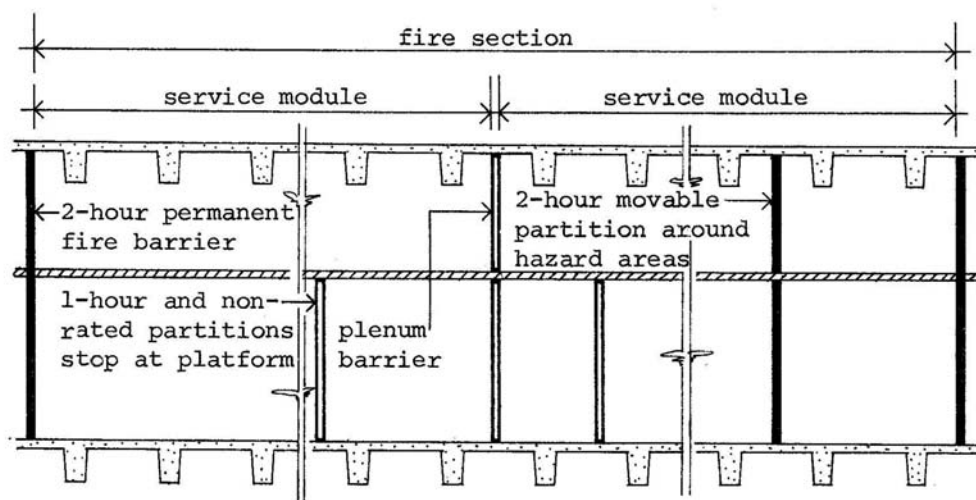

To maintain adaptability, it is important that one-hour corridor and smokestop partitions can be easily relocated by conversion of existing non-rated partitions into rated partitions.

### **336.1 GYPSUM BOARD ON METAL STUD PARTITIONS** (Figure 330 – 4)

Currently, UL Class E-1 partition Design No. 2 (5/8" gypsum board on either side of metal studs at 2 on center) is an acceptable one-hour partition with the exception that it has not been tested with a perimeter relief runner detail at the head.

It is recommended that a partition of similar construction be tested with a suitable relief runner detail in order than an economical partition equivalent to one hour can be provided throughout the hospital.

UL Design No. 23, which incorporates a relief runner detail, is acceptable as a one-hour partition. This partition, however, requires a double layer of wall surface material on each side. In addition, it has a maximum vertical span of 9'0".

UL Design No. 11 is rated for two hours with a relief runner detail. This also requires two layers of wall surface material. The vertical span of this design is acceptable for the range of required ceiling heights.

Until a partition constructed of one layer of gypsum board on each side of metal studs with a suitable relief runner detail has been approved, the corridor and smokestop partitions must consist of UL No. 11 or UL No. 23. Other partitions should be capable of conversion to meet these standards.

### **336.2 LAMINATED GYPSUM BOARD PARTITIONS**

There are several UL one- and two-hour rated partition designs which have been tested with relief runner details at the head. (See Figure 330-3.) Similar proprietary systems are not all UL tested, however. For instance, Vaughn Interior Walls' products are tested by the University of California. These may be accepted by local fire marshals for individual projects.

**337 OTHER DESIGN CRITERIA****337.1 CONTROL JOINTS AND DETAILS**

The junction of all components of the partition subsystem with other subsystems must incorporate appropriate tolerances while maintaining acoustic and fire safety characteristics. All details must be carefully designed and controlled to minimize dirt traps and facilitate maintenance.

**337.2 SURFACE CHARACTERISTICS**

Partitions and all furring must be capable of receiving any typical finish found in hospital buildings. This includes a variety of paints, cement enamel, vinyl wall covering and glazed ceramic tile (See Functional Space Requirements). The preferred generic design options will accommodate all these finishes, including thin set ceramic tile, which can be applied to water-resistant gypsum board. In wet areas, however, ceramic tile must be applied to plaster on expanded metal.

Joints in the partition surface must be minimized in those areas where asepsis is a problem. This requirement is easily accommodated by the preferred options.

**337.3 ADAPTABILITY**

Except for two-hour partitions defining fire sections and enclosing vertical shafts, all components of the partition subsystem are adaptable.

**337.3.1 Relocation**

The basic design of the partition subsystem aims to make the assembly and relocation process sufficiently simple that change is facilitated and in some cases can be undertaken by the regular hospital engineering staff. The uncoupling of the subsystems will permit removal of the partition components without significant damage to adjacent components or disrupting of services to adjacent spaces. The uniform height of partitions and the fact that they have no holes cut in them will facilitate reuse. Panelized partitions will be more easily relocated and are recommended in those areas where frequent change is anticipated and where asepsis is not critical.

### 337.3.2 ACCESS

The need for access into the partition will be minimized by surface mounting the services whenever feasible. (See discussion below.) The need for access to those services covered by furring will vary and the furring details should be selected accordingly. In some cases the ease of cutting and patching the gypsum board or of replacing it will offset the higher first cost of providing more accessible covers.

### 337.3.3 Factors Affecting the Surface Mounting of Services

The strategy used to house services will vary from one functional area to another and from one project to another. It will be affected by several factors, including the cost and availability of suitable proprietary enclosures.

Other factors that will affect the strategy of service distribution within the functional zone include the following considerations:

1. **Aseptic Environments.** Projecting surfaces are a hindrance to the achievement of asepsis required in special areas such as surgery and central sterile supply.
2. **Security Areas.** Access to items which could prove hazardous if misused (e.g. surface-mounted electrical raceways) should be limited in areas such as psychiatric wards.
3. **Housekeeping.** The details of any objects projecting from walls must be carefully considered in relation to standard VA housekeeping methods. For instance, it is desirable to keep all projecting objects free of the floor to facilitate cleaning; and where wall surfaces are frequently washed down, the surfaces of objects hung from that wall should also be easily washable.
4. **Corridor Projections.** In accordance with code requirements, projections in corridors would necessitate increased corridor widths, at least locally where groups of services are required.
5. **Acoustic Performance.** Surface mounting is strongly recommended where the acoustic performance of a wall is critical, such as between two examination rooms.



(See Section 335.1.) Conversely, walls without the same critical acoustic requirements may contain services within them without jeopardizing the required performance.

6. Rate of Change of Services. Where the rate of change of services is not expected to be any greater than that of the partitions (e.g. room thermostats, or switch drops) and where other performance characteristics are not jeopardized, services may be housed within partitions.
7. Costs. An example showing the installation cost of surface mounting services compared with housing them in partitions is described in Section 780. Installation costs for surface mounting are greater but alteration costs are reduced because services can be changed more simply and quickly (with minimum disruption in the functional area) and because materials can be reused.

**338 TARGET COSTS****338.1 RANGE**

The total cost of the partition subsystem will range between \$31.75 and \$56.00 per lineal foot of partition, or \$3.33 to \$5.88 per OGSF of building. (See Section 751.2.3.)

**338.2 SCOPE****338.2.1 Included**

1. All full height (i.e., floor-to-ceiling and floor-to-structural slab) interior, non-loadbearing partitions including fixed, relocatable, operable and portable types;
2. interior door sets required in the above partitions, including doors, transoms over, and floor-to-ceiling frames;
3. hinges and sealing devices required for the above doors;
4. furring around surface mounted service distribution lines;
5. furring around interior columns and shear walls as required;
6. interior glazed units including glass and solid panels, and floor-to-ceiling frames;
7. baseboard and trim (except bases integral with floor);
8. support for wall-hung casework and equipment such as fire extinguishers and hose reel cabinets; and
9. finishes required on above items, including both field and factory applied.

**338.2.2 Not Included**

1. Load bearing, exterior and shear walls;
2. special insulation or shielding;
3. tackboards and chalkboards;

4. plumbing, electrical or other service distribution lines, raceways and terminals housed within or mounted on partitions;
5. wall-hung casework, shelving and equipment; and
6. door hardware, except hinges and sealing devices.

**(BLANK PAGE)**

## **340 Heating • Ventilating • Cooling**

### **341 BASIC DESIGN**

The HVC subsystem design is based on ducted air systems, with each fan unit zoned to supply one service module within the hospital. The fan unit will be placed in the service bay and the ductwork will pass horizontally through the service zone to provide downfeed service via ceiling registers to the functional zone below. (See Figure 340-1.)

Within the limits of specific functional requirements, the generic design option chosen for the HVC subsystem should be the same throughout the hospital. This is desirable for straightforward construction scheduling, simple maintenance organization and optimized adaptability. To achieve this adaptability, the chosen option must be capable of satisfying all of the HVC demand increases or changes projected for the hospital.

Main vertical and horizontal distribution components are considered permanent. The potential difficulty of altering or replacing these large ducts means that they must be sized initially to handle the assumed future maximum air volume for the service modules. Branch distribution components, terminals, controls, air-handling units and other service bay equipment are considered adaptable.

Figure 340-1. BASIC DESIGN OF HVC SUBSYSTEM

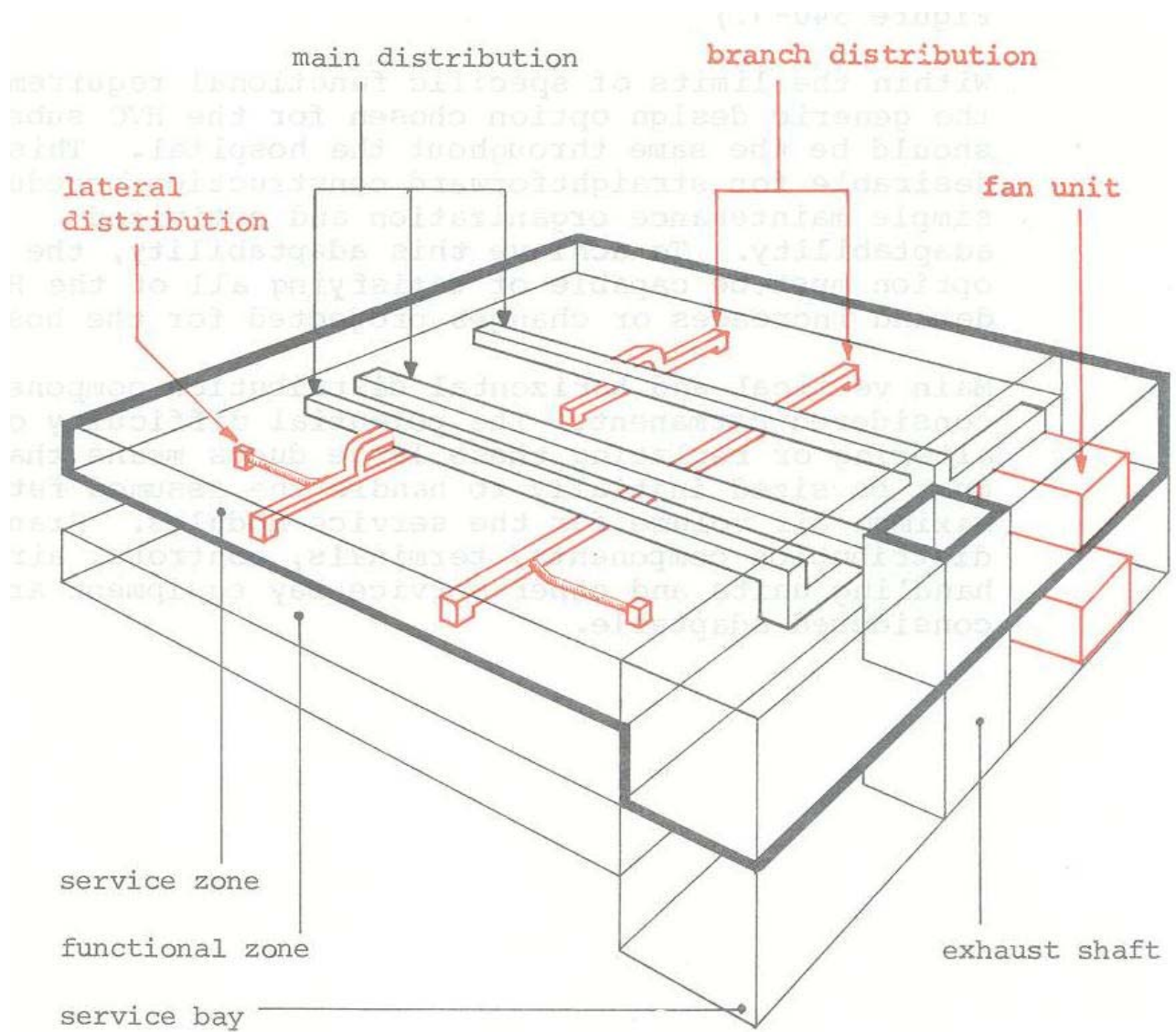

● permanent

● adaptable

## **342           GENERIC DESIGN OPTIONS**

The following are the subsystem options for HVC. A fuller discussion of these choices is given in Section 724.1.

### **342.1       SUPPLY SYSTEMS**

The two major alternatives for supply are low- or medium-pressure terminal-reheat, and the dual-duct mixing-box systems. The only qualification is that close humidity control required for certain areas of the hospital would be difficult to achieve with a dual-duct system, unless total air cooling and humidifying is employed.

Where climatic conditions require it, a mixed system which combines hot water convectors for building perimeter auxiliary heating with a single-or dual-duct system for heating and cooling, is a prime variation.

### **342.2       RETURN AND EXHAUST SYSTEMS**

The system must be capable of handling from 25 to 100 percent outside air. Both return and general exhaust can be extracted through the service zone by either duct or plenum. In the latter case the effects of system leakage and fire hazard need to be taken into account. The fans to the system would be placed in the service bay mechanical room. Special exhaust ducts will be required variously in each service module ducted through the service bay to fans on the roof. They will handle a range of conditions from sets of individual toilets to large areas such as isolation suites.

### 343 ORGANIZATION

The special organization of the service zone and the service bay are discussed in Sections 223 and 224, and the following description defines the relationship of the HVC subsystem to this organization.

#### 343.1 SERVICE ZONE

##### 343.1.1 Subzones

The subzones affected by the HVC subsystem are S3, S4 and S5.

**Figure 340-2. TYPICAL SUBZONE ORGANIZATION FOR HVC DISTRIBUTION: SECTION**

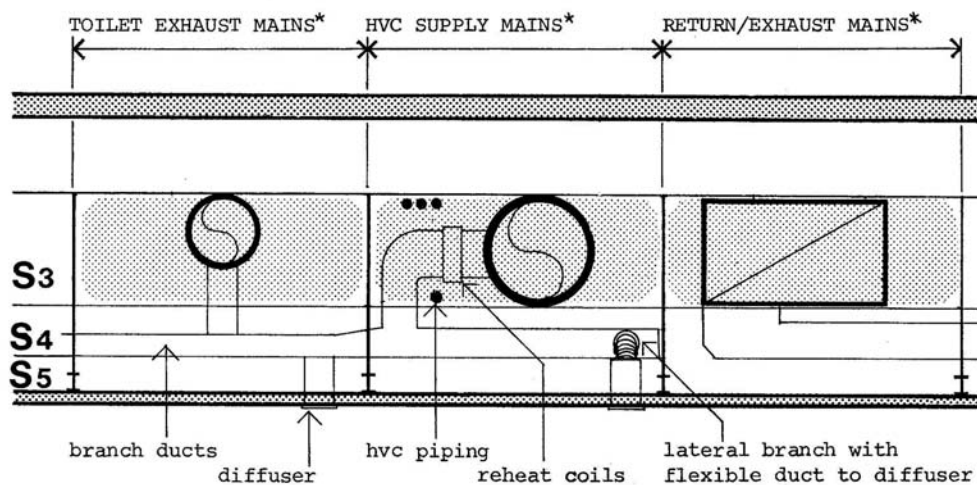

\* Channels within subzone S3.



The depth of S3 will be governed by the requirements of the main supply and return/exhaust ducts. This depth can be expected to be of the order of 36". (This figure is obtained from the duct size calculation described in the Section 344.2 below.) The ducts will be hung directly below the beams.

The S4 subzone will contain the branch ducts which will dictate its vertical dimension. This can be expected to be of the order of 16" including clearance around the ducts. As far as possible, only one branch duct should be run between any pair of ceiling hangers (the hangers placed on beam center lines could be from 4'6" to 7'6" apart.) This will improve access for ceiling penetration below the ducts for other services.

Offsets from the branch ducts to diffusers will be made by flexible duct connections. Regulations limit the length of these connections to twelve feet, which should easily prove sufficient. These flexible ducts would run in the S5 subzone, and if the latter is dimensioned at about 12" in height, will allow ducts up to 10" in diameter with their plenum boxes.

Branches for any special exhaust ducts should also follow the same principle and run between separate hangers from supply branches, and using flexible ducts for offsets.

If a plenum return/exhaust system is used, return air boots will be required at the diffusers. With fire dampers, the boots will project 17" above the bottom face of the ceiling, for an 18" x 18" unit. But as the boots replace a ducted system they can be lined up clear of the supply branches as though a return duct were present.

### **343.1.2 Channels**

The supply duct mains will be divided generally into two in each service zone to reduce the problem of duct size and reduce the lengths of the branch ducts. The two channels for these ducts will be approximately at the third points of the cross section, with the subzones for exhaust/return ducts usually between them. (See Figure 340-3.) The supply ducts and the terminal heaters with supply pipes, or the mixing boxes, will be in the HVC supply channels at the S3 level.

The equipment will be placed on the same side of the ducts at each branch take-off to facilitate installation and maintenance and, with the terminal heaters, allow straight runs of supply and return pipes. (See Figure 340-2.)

The horizontal dimension required to accommodate these supply ducts and their equipment will be the dominant factor influencing the spacing of the ceiling hangers defining these subzones.

### **343.1.3 Plenum Barrier**

In case of a fire section containing two service modules and where the return or exhaust systems use the service zone as a plenum, a plenum barrier must be constructed between the adjacent service zones. This will allow the plenums on either side to be utilized independently.

## **343.2 SERVICE BAY**

### **343.2.1 General**

The service bay contains three groups of components of the HVC subsystem. The first is the air-handling equipment and associated header ducts. The second is the exhaust ducts and shafts. The third is the piping risers including steam and condensate, heating hot water and return, and chilled water and return. These will probably be grouped with risers for the plumbing subsystem to the module. (See Figure 340-3.)

The size of spaces and the arrangement of components should be such that the largest potential units are comfortably accommodated, and any change to the equipment, such as from all-exhaust to a return air system, can be as straightforward as possible. Also, the position of the components should be convenient for the corresponding supply and exhaust secondary subzones in the service zone. The header to the two supply main ducts must be placed within the service bay. This will avoid the constriction of service distribution that would occur if the crossover were made in the service zone itself.

The mechanical room is the control center for the service module HVC system.

Figure 340-3. SERVICE BAY AND CHANNELS: PLAN

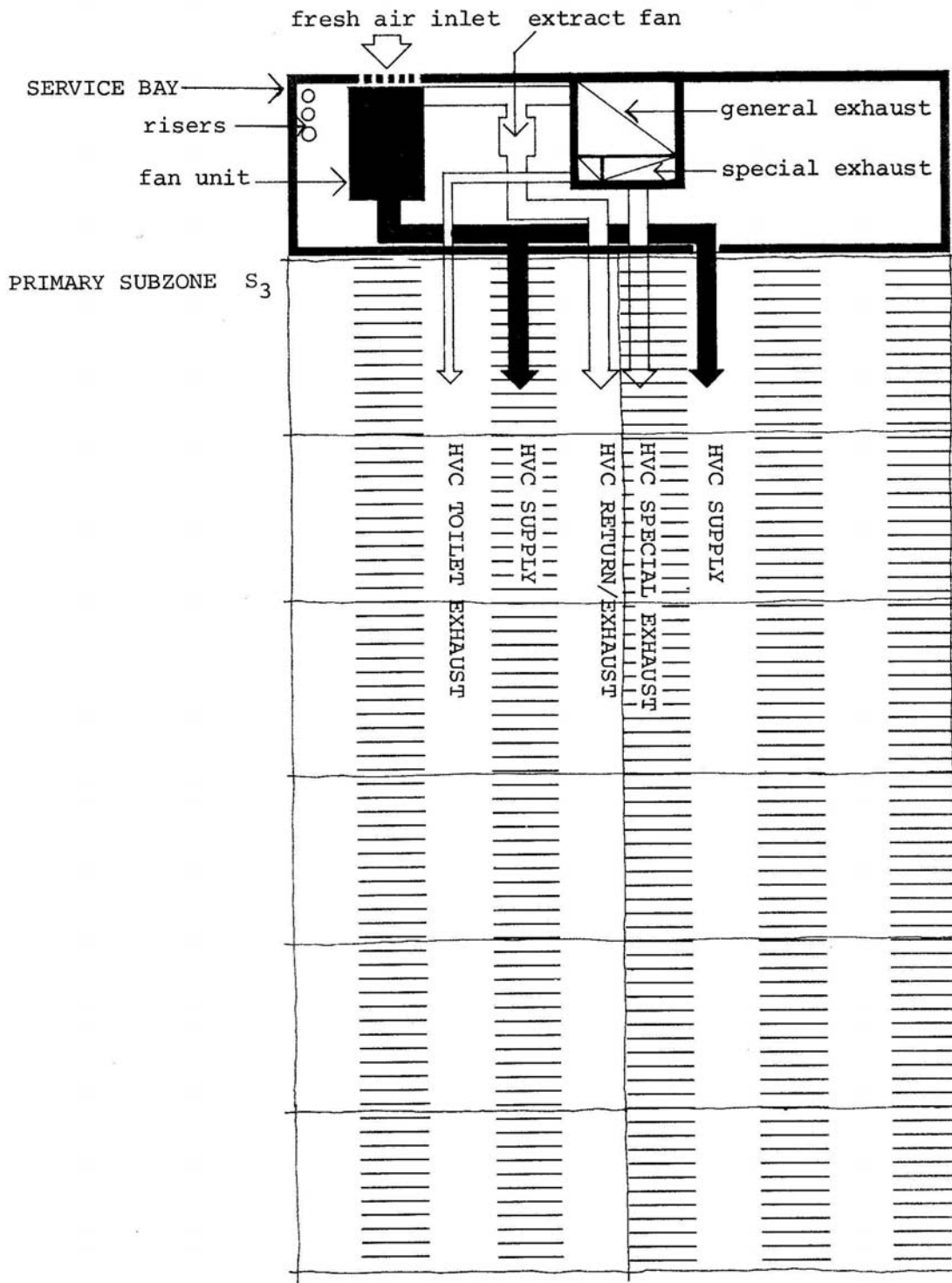

### 343.2.2 Internal Service Bays

As discussed under Section 223.2.2, the overall layout of the hospital could cause some service bay positions to be entirely internal. This would mean for the HVC subsystem, either ducting down outside air to the fan units or removing the fan units to the roof of that stack of service bays. The latter alternative is considered preferable. It would preserve the ease of access for replacement of the fan units and allow simpler routine maintenance on the grouped fans. To preserve the independence of the service module, each would still be served by its individual unit and ductwork. This alternative also replaces the original mechanical room with an area reserved for supply shafts. These could be considerably smaller in bulk than the mechanical room leaving more floor area free to provide circulation connections to the functional zones on either side. This solution will require extra supply ductwork and the larger fan motor horsepower required for the longer distribution as compared with the exterior service bay arrangement.

## **344 DESIGN CRITERIA**

### **344.1 HVC LOAD DISTRIBUTION**

In order to systematically handle the HVC subsystem it is necessary to make assumptions about the general load distribution pattern in a hospital. The variables of air quality and return/exhaust alternatives are discussed later, but the first consideration is the supply load.

Hospitals will vary in c.f.m. per square foot required because of climate, configuration, etc., but the overall pattern of distribution is likely to remain the same. Figure 340-4 illustrates the pattern found in the design of one hospital which is considered typical.

In general, a majority of spaces and departments will require 6 to 8 air changes per hour which requires 1 to 1.5 c.f.m. per square foot with a ten-foot floor-to-ceiling height. Several departments will require up to 15 air changes, or 2.5 c.f.m. per square foot; some individual rooms, such as operating rooms, will also go as high as 30 air changes, or 5 c.f.m., but this would average down considerably over the total area that one fan unit would be serving, to about 2.5 c.f.m. As shown on Figure 340-4, laundries and kitchens will tend to considerably exceed these figures, therefore space modules handling these functions will probably require non typical air systems and fan units.

In recent years, there has been a tendency to boost the number of air changes as well as increased filtration required throughout the hospital to improve asepsis, maintain pressure differentials more adequately and speed up the response of the system to room temperature change. These higher values, sometimes quoted from 10 to 20, and even up to 30 air changes, would increase the figures quoted above and have to be taken into account in the design assumptions.

### **344.2 SERVICE MODULE REQUIREMENTS**

A major factor in sizing service modules is the capacity of available pre-packaged air-handling units. Figure 340-5 is a diagram of the c.f.m. per square foot capacity of three typical units plotted against various service module sizes. The 35,000 c.f.m. unit is about the largest packaged unit available.

Figure 340-4. TYPICAL HVC LOAD DISTRIBUTION

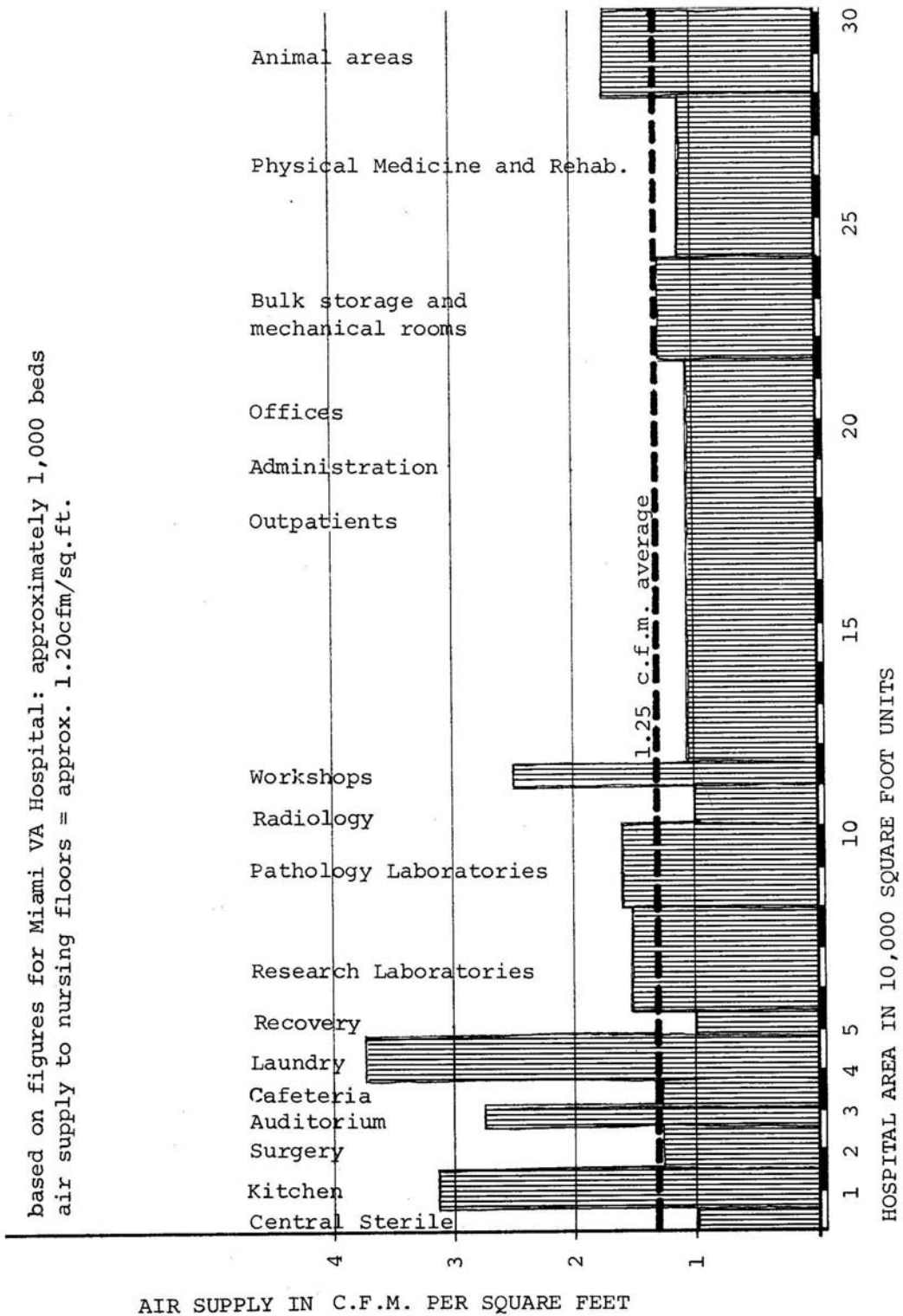

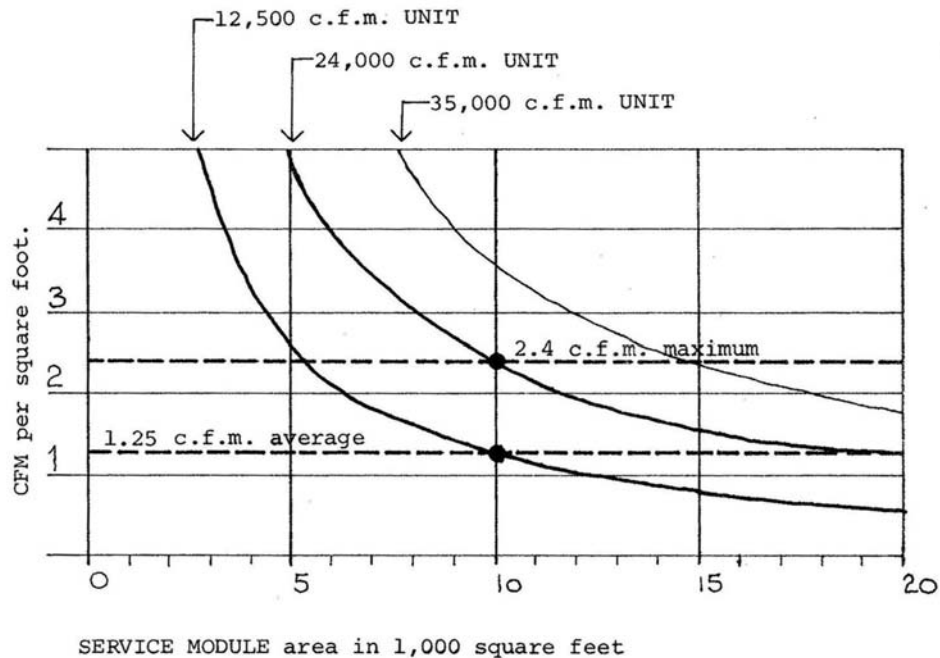
**Figure 340-5. AIR-HANDLING-UNIT CAPACITIES**

A mechanical room designed to house a 24,000 c.f.m. unit would provide the maximum air-supply requirement quoted above of 2.4 c.f.m./square foot to a service module of 10,000 square feet. The smaller unit rated at 12,500 c.f.m. placed in the same mechanical room would provide the average area requirement of 1.25 c.f.m. to the same 10,000 square foot module. As Figure 340-5 shows, it would be possible to increase the size of the service module to 15,000 square feet, using the two larger units, but this would leave little capability for dealing with increased future demands. At 10,000 square feet, the largest fan unit would be also able to handle the laundry and kitchen areas in most schemes.

Three items related to the HVC subsystem are to be considered permanent: the mechanical room size and locations, the openings for ducts in the shear wall in size and location, and the supply and return/exhaust duct mains in the service zone. On the basis of a set of load assumptions similar to those in Section 344.1 above, the maximum size of these elements can be calculated.

For instance, a 10,000 square foot service module with a 2.4 c.f.m. maximum design load would require two eight square foot supply branch ducts, two shear wall openings 4' x 3' and two openings for general exhaust and special exhaust of 5' x 3'. The mechanical room would be sized for the maximum 24,000 c.f.m. unit. These sizes would become standard for all service modules throughout the hospital.

### 344.3 VARIABLE CHARACTERISTICS

In addition to the range of load demands in c.f.m. to the various departments in the hospital, the subsystem must be capable of satisfying various space design conditions.

A typical range would be:

<b><u>CHARACTERISTIC</u></b>	<b><u>MINIMUM</u></b>	<b><u>MAXIMUM</u></b>
Design temperature	70 degrees F.	80 degrees F.
Relative humidity	30 percent	60 percent
Filtration	35 percent	95 percent
Air motion	10 f.p.m.	35 f.p.m.
Recirculation	0 percent	75 percent

Also special areas may require particular modification for odor control, and other areas may need pressure differentials between adjacent spaces, or adaptation of the system to use disinfectant devices for critical asepsis control.

As each service module will be primarily served by one fan unit and recirculation system, the module's performance characteristics would have to be set at the highest value required for its particular functional zone. This would suggest that in the range of possible service module sizes of 10 to 15,000 square feet, it would be preferable to take the lower value as optimum, to reduce the area affected by expensive requirements. In principle, all the permanent components of the HVC subsystem should be designed and laid out to potentially handle the worst case characteristics comfortably.



#### **344.4 FIRE SAFETY**

In general, the HVC subsystem presents problems no different from traditional systems as far as fire safety is concerned. This is true of the plenum return system suggested here, where, as in a tradition plenum design, the detection and control of fire and smoke must be considered carefully.

There is one feature of the subsystem which could lead to a simplification of normal fire strategy. The clear identification of each service module, with its own HVC supply and return, in a particular fire section means that it may be possible to limit emergency HVC measures to only the affected fire section in the case of fire.

#### **344.5 ACOUSTICS**

The general organization of the service module places all noise generating equipment in the subsystem within the service bay. This isolation should be reinforced by the use of isolation bases for equipment, choice of efficient equipment with minimum sound levels, and sound absorbent lining in the mechanical room. But the most important feature is the acoustic sealing of all service openings in the shear wall between the service bay and the service zone. Sound transmission through the ductwork should be restrained by duct linings and sound traps in critical functional areas. To provide adequate duct length to diffusers for reduction of sound transmission, functional areas adjacent to a service bay should be served from branch ducts approximately two hanger spacings away from the shear wall and the diffusers connected by flexible ductwork.

Sound transmission via the plenum, where one is used, should be restrained by mufflers in the return air boots in critical areas.

#### **344.6 ACCESSIBILITY**

Generally, all components of the subsystem should be designed and located so that routine maintenance and repair and minor alterations will cause minimal disturbance to the hospital functions, and also facilitate construction accessibility. Major repairs and alterations must be possible with minimum down time and without interference to more than the area of functional space requiring the change.

**344.7 ADAPTABILITY**

1. Air-handling equipment must be capable of incremental modification to accommodate future changes in performance requirements. It must be convenient for total replacement or modification.
2. Distribution systems must provide reasonably oversized main components to accommodate considerable variation in air volumes over the life of the building. They must be capable of addition and subtraction of branch components without requiring elaborate rebalancing of the whole system. Rebalancing after future alterations, as well as at initial installation, must be efficient, accurate and stable. Flexible ductwork should be considered for branches serving terminals which are specifically expected to be relocated. Future expansion of the hospital should be possible with minimum interruption of mechanical service to the existing building.
3. Terminals should be capable of modification or simple replacement to provide changes of performance in special areas, or throughout large areas, within the range of performance levels described in this section. Individual terminals must be removable for repair or replacement without disrupting or seriously unbalancing any other part of the system.
4. The control system should be designed for convenient and rapid modification to accommodate alterations in plan arrangement or in performance requirements of the mechanical equipment, including reassignment of terminals to thermostats and relocation of thermostats.

**345 TARGET COSTS****345.1 RANGE**

The HVC target cost range is \$4.00 to \$6.50 per OGSF. The lower end is the estimated cost of a decentralized single-duct terminal-reheat system, with plenum exhaust/return, and without a supplementary perimeter convector system. The upper end of the range would be appropriate for a dual-duct mixing-box system, and includes ducted exhaust/return and perimeter convectors. See Section 751.2.4 for further discussion of costs.

**345.2 SCOPE****345.2.1 Included**

The complete heating-ventilating-cooling system for the entire hospital beyond the central plant, including:

1. Decentralized mechanical equipment, such as air-handling units complete with humidifiers, filters, coils and related apparatus;
2. distribution systems, such as ductwork, piping and accessories;
3. general exhaust, toilet exhaust and special exhaust systems, such as for kitchens and fume hoods;
4. plumbing equipment and piping required exclusively for the HVC subsystem;
5. electrical equipment and wiring required exclusively for the HVC subsystem;
6. terminals and terminal devices, such as reheat coils, zone humidifiers, registers and ceiling diffusers;
7. control systems, including smoke detectors;
8. hangers, attachments and sleeves; and
9. thermal and acoustic insulation and vibration isolation.

**345.2.2 Not Included**

1. Central plant equipment, such as boilers, chillers and cooling towers;
2. plumbing and electrical equipment and distribution not required exclusively for the HVC subsystem;
3. grilles and louvers in the exterior wall;
4. special equipment for controlled environment rooms, refrigerators, hyperbaric chambers, etc.;
5. hoods for kitchens and laboratories; and
6. site work and utilities.

## **350 Plumbing Distribution**

### **351 BASIC DESIGN**

The plumbing subsystem will be organized to follow the general pattern of service distribution to and within the service modules. The main risers will be grouped in the service bay and all distribution to the service module will be horizontal through the service zone. All plumbing to the functional zone will be downfed from the service zone, with the exception of gravity drains.

The service bay and service zone spaces designated for plumbing distribution must be adequate for maximum design loads and unused routes will be reserved as a right-of-way for future extensions of the subsystem. (See Figure 350-1.)

Main vertical and horizontal distribution components are considered permanent. Branch distribution components and service bay equipment are considered adaptable.

**Figure 350-1. BASIC DESIGN OF PLUMBING DISTRIBUTION SUBSYSTEM**

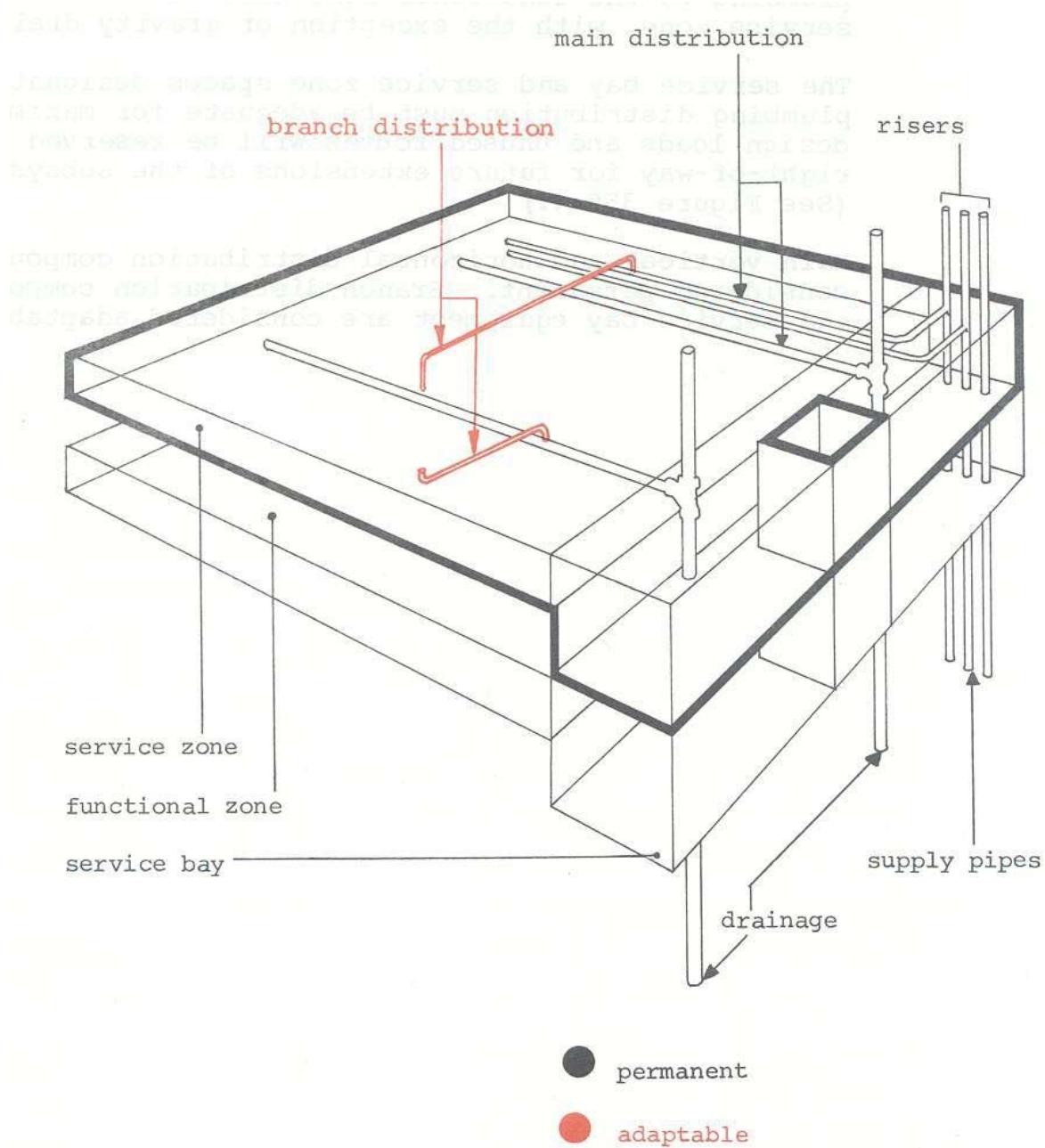

## **352 ORGANIZATION**

The spacial organization of the service zone and the service bay are discussed in Sections 223 and 224, and the following description defines the relationship of the plumbing subsystem to this organization.

### **352.1 SERVICE ZONE**

#### **352.1.1 Subzones**

The main distribution will be run in subzone S3 and all branches will be located in S2. The pressure pipe drops to the functional zone will make any required offsets in the S5 subzone. The range of trap and fall dimensions for the branch drains are discussed in Section 353.2, and with the required structural beam depths will form the criteria for the depth of the S2 subzone (See Figure 350-2).

#### **352.1.2 Channels**

The plumbing mains will be horizontally distributed in a reserved subzone located on the same side of the service zone as the plumbing shaft. In areas of heavy demand, such as nursing units, supplementary runs of medical gases for instance can be run on the opposite side of the zone. The main drain will in any case be divided to run on each side of the girder in the service zone (See Figure 350-3).

The plumbing channels will be organized to carry the maximum design distribution in terms of number and size of pipes. Sleeves for the drains will be located in the shear wall at the lowest point in the subzone.

### **352.2 GENERAL**

Plumbing services not initially required in a service module will have capped-off tees and valves in the plumbing risers. All control valves to any services will be placed at the main in the service bay to concentrate controls. The only exceptions will be the control valves to hazardous gases such as oxygen. These must be placed in the functional zone, fed from the service zone. Typical locations might be a corridor in a nursing unit, or the operating room of a surgical suite. The main distribution pipes should be provided with valved tees at increments along their length for potential branch piping.

Any pumps, motors or other plumbing equipment required for a particular service module will be placed within the mechanical room in the service bay.

**Figure 350-2. TYPICAL SUBZONE ORGANIZATION FOR PLUMBING DISTRIBUTION: SECTION**

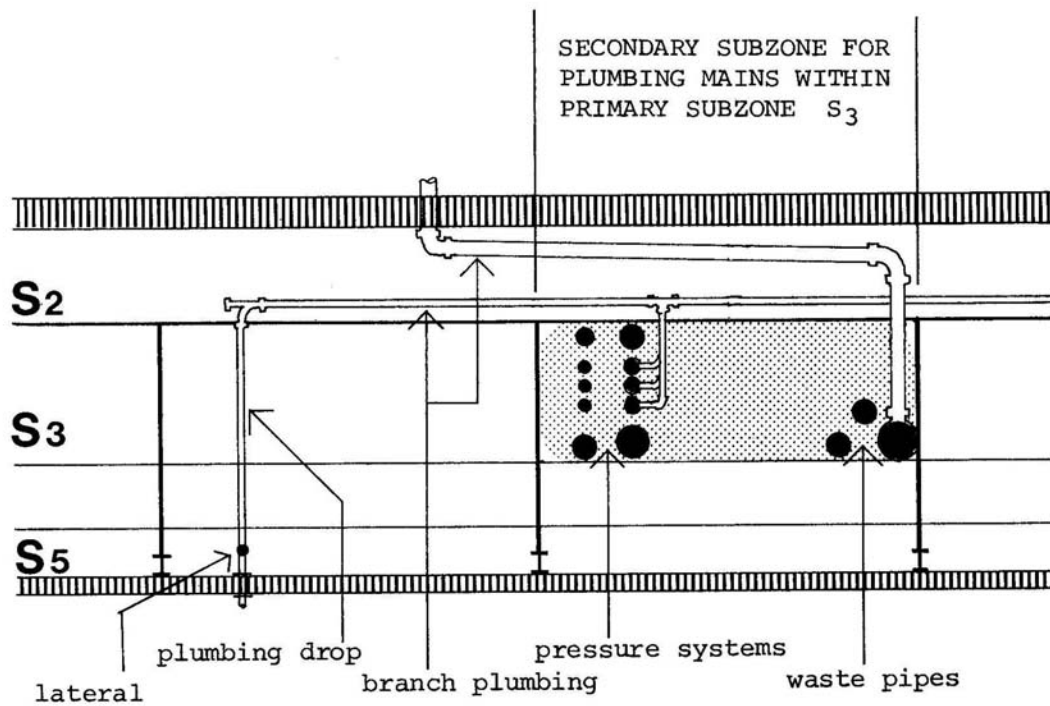
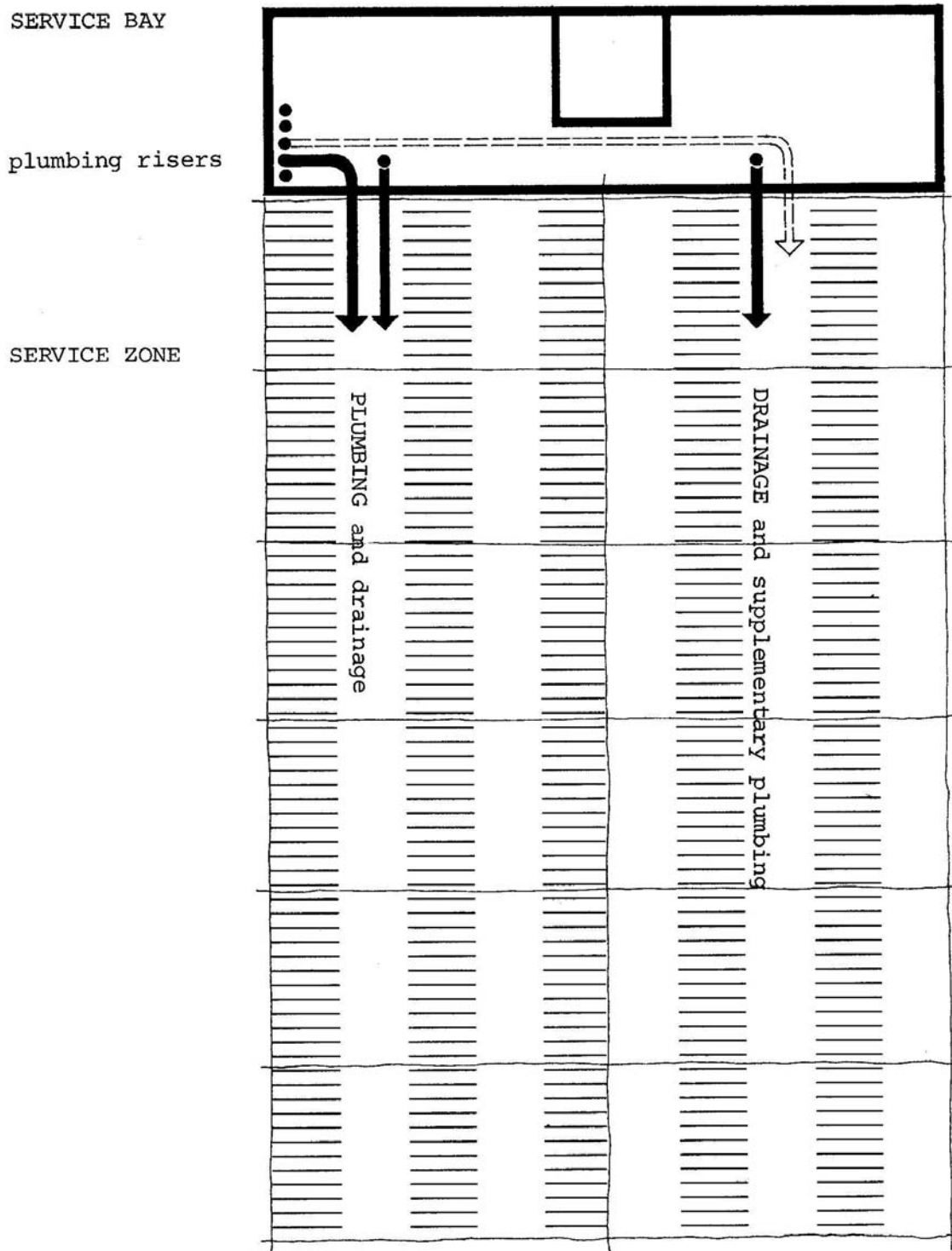



Figure 350-3. CHANNELS FOR PLUMBING DISTRIBUTION: PLAN



**353 DESIGN CRITERIA****353.1 GENERAL**

The plumbing subsystem may be required to provide a maximum demand load anywhere in the hospital, during the building lifetime. Therefore, space allocated to vertical risers and rights-of-way for distribution should be sized for the maximum potential demand. Main risers and main distribution runs when installed should also be sized to the maximum. The major component of plumbing costs is labor, therefore the oversizing of these permanent elements will not significantly increase overall costs. Branch distribution piping could be oversized but, because of the lower diversity of smaller pipes it is not really necessary since a shut-down for replacement of these local runs would cause disturbance only to a relatively small area of the functional zone.

Of all the services in a hospital, plumbing is probably one of the most affected by change; especially cold water services as new users continually create heavier demands. Heaviest service load demands are typically domestic water and soil and waste systems in the nursing units, laundries and kitchens while the greatest diversity of services is found in laboratories, dental clinics and surgery.

**353.2 FLOOR DRAINS**

The critical plumbing dimensions for the S2 subzone is the depth required for floor drains, traps and falls. Assuming an eight-inch floor slab thickness, the following table shows the range of possible dimensions in inches for standard fittings from the bottom of the floor slab to the bottom of the pipe (dimension A in Figure 350-4).

Drain Type	Drain Size		
	2"	3"	4"
floor drain with vertical vent	3	6	8
floor drain with horizontal vent	9	10	10
floor sink with vertical vent	4	8	12
floor sink with horizontal vent	10	12	14

**Figure 350-4. FLOOR DRAIN DIMENSIONS**

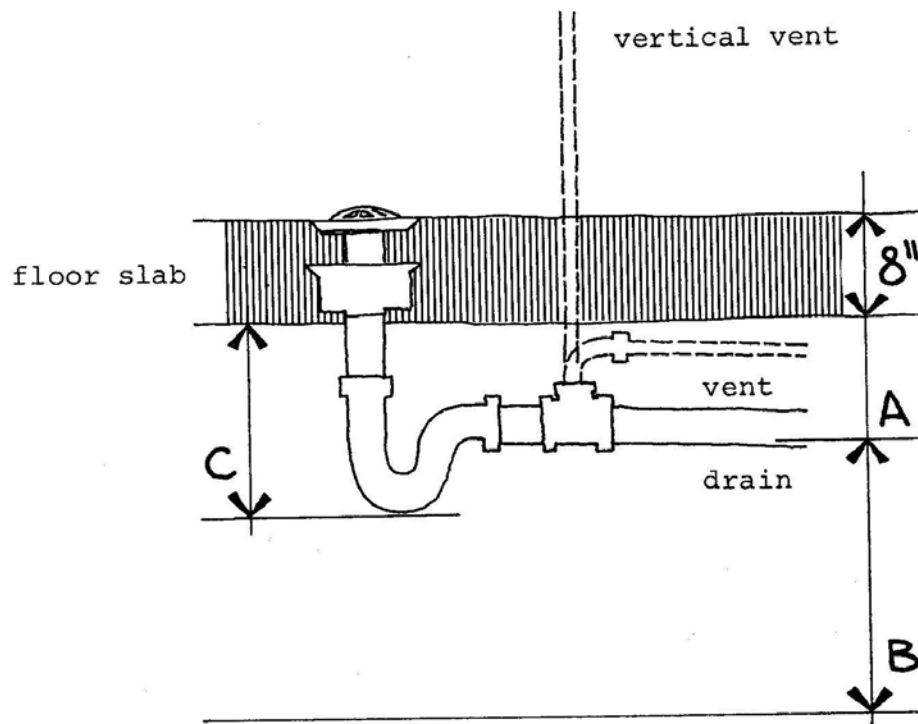

To these dimensions must be added the potential maximum fall of the drain (dimension B in Figure 350-4). Assuming one main drain run between each pair of girders, the minimum structural span of 40'6" would require a maximum fall of 10-1/8", and the maximum span of 58'6" would require 14-5/8", at 1/4" fall per foot run. On this basis the maximum depth of the subzone would be 28-5/8". But this would allow the extreme case of a floor sink with horizontal vent at the furthest position from the main drain. However, these sinks, and such a run, would be extremely rare. Also, most drains will be standard two-inch floor drains or sinks, therefore a subzone depth of the order of 20" to 24" will usually be sufficient. This range would also comfortably contain the depth necessary for any trap (dimension C in Figure 350-4).

In the calculations for space required by drainage, any structural members that are necessary for transferring lateral forces transversely across the beams will need to be taken into account. (See Section 316.2 and Figure 310-5.)

**353.3 ACOUSTICS**

The layout and detailing of the plumbing distribution should be organized to minimize noise transference problems. Potentially noisy or vibrating piping should be secured by isolating hangers and not be allowed to induce noise into surrounding services or construction. The proposed oversizing of pipes will lower velocities and thus further reduce noise problems.

**353.4 FUNCTIONAL ZONE**

Generally plumbing to the functional zone will be surface-mounted on partitions to allow for ease of change without partition damage or loss of acoustical seal. This surface mounting may be achieved by furring out of partition components or the use of separate prefabricated enclosures. The latter include lavatory units, service containers and service walls (such as those used in nursing units in combination with electrical outlets), and prefabricated bathrooms. Where concentrated plumbing loads justify them, prefabricated plumbing walls may be used. (See Sections 322.2 and 780.)

**353.5 ACCESSIBILITY**

All components should be designed and located so that routine maintenance and repair and minor alterations will cause minimal disturbance to patients and will not interrupt hospital activities. Major repairs and alterations must be possible with minimum down time for the space in which they occur, and without interrupting hospital activities in adjacent spaces.

**354 TARGET COSTS****354.1 RANGE**

The cost target range for plumbing distribution is \$2.00 to \$3.00 per OGSF, averaging about \$2.30. These figures are slightly higher than the cost base, but are considered justified by a much greater capacity for future change than is the case with conventional design and construction. See Section 751.2.5 for further discussion.

**354.2 SCOPE****354.2.1 Included**

Complete plumbing subsystem for the entire hospital beyond the central plant, including:

1. Pressure lines: domestic cold water, domestic hot water, natural gas, steam, distilled water, compressed air, sprinklers and standpipes;
2. medical gases: oxygen, medical compressed air, suction and nitrous oxide;
3. gravity lines: soil, waste, condensate, vents and stormwater; and
4. equipment: pumps, motors, storage tanks, etc., which are not part of the central plant and are required for plumbing distribution

**354.2.2 Not Included**

1. Central plant such as boilers, hot water generators, storage and control tanks, meters, etc.;
2. electrical work required in connection with plumbing distribution equipment;
3. distribution required exclusively for the HVC subsystem such as chilled water, heating hot water and steam for humidifiers and heat exchangers; and
4. site work.

**(BLANK PAGE)**

## **360 Electrical Distribution**

### **361 BASIC DESIGN**

The electrical distribution subsystem will provide power to the hospital at 480Y277 volts and 208Y120 volts in both normal and essential distribution networks. The latter includes emergency and critical distribution.

Distribution from the substation and the main risers will use busducts to achieve the largest potential diversity of service. The main risers will always be contained within the service bays. Horizontal distribution through the service zone will generally use wireways, conduit and cable, except in local heavy load areas where a busduct might again be used. All equipment associated with a service module, such as transformers, branch circuit panels, etc., will be placed in an electrical room in the service bay. This room will also house equipment for the communications systems, the distribution of which will generally follow a similar route to the electrical subsystems. All distribution to the functional zone will be downfed from the service zone. (See Figure 360-1.)

Main vertical and horizontal distribution components are considered permanent. Branch distribution components and service bay equipment are considered adaptable.

**Figure 360-1. BASIC DESIGN OF ELECTRICAL DISTRIBUTION SUBSYSTEM**

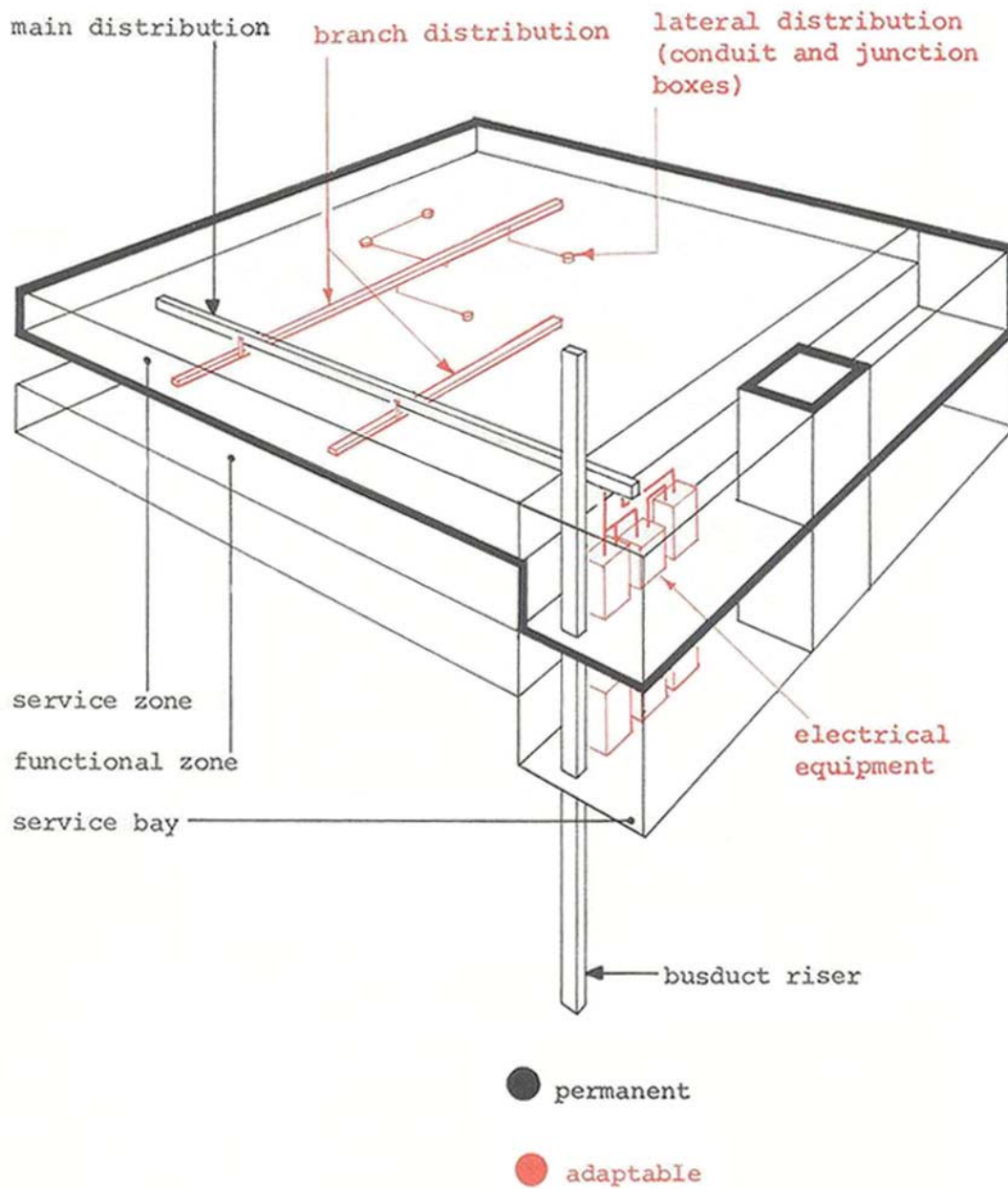



## 362 ORGANIZATION

The spatial organization of the service zone and service bay are discussed in Section 223 and 224 and the following description defines the relationship of the electrical subsystem to this organization.

### 362.1 SERVICE ZONE

#### 362.1.1 Subzones

From the main distribution in subzone S3, the electrical and communication branches will run in subzone S4 in wireways or conduit. The final runs of the conduit and junction boxes for power and lighting will be in subzone S5, between the ceiling strongbacks.

**Figure 360-2. TYPICAL SUBZONE ORGANIZATION FOR ELECTRICAL DISTRIBUTION: SECTION**

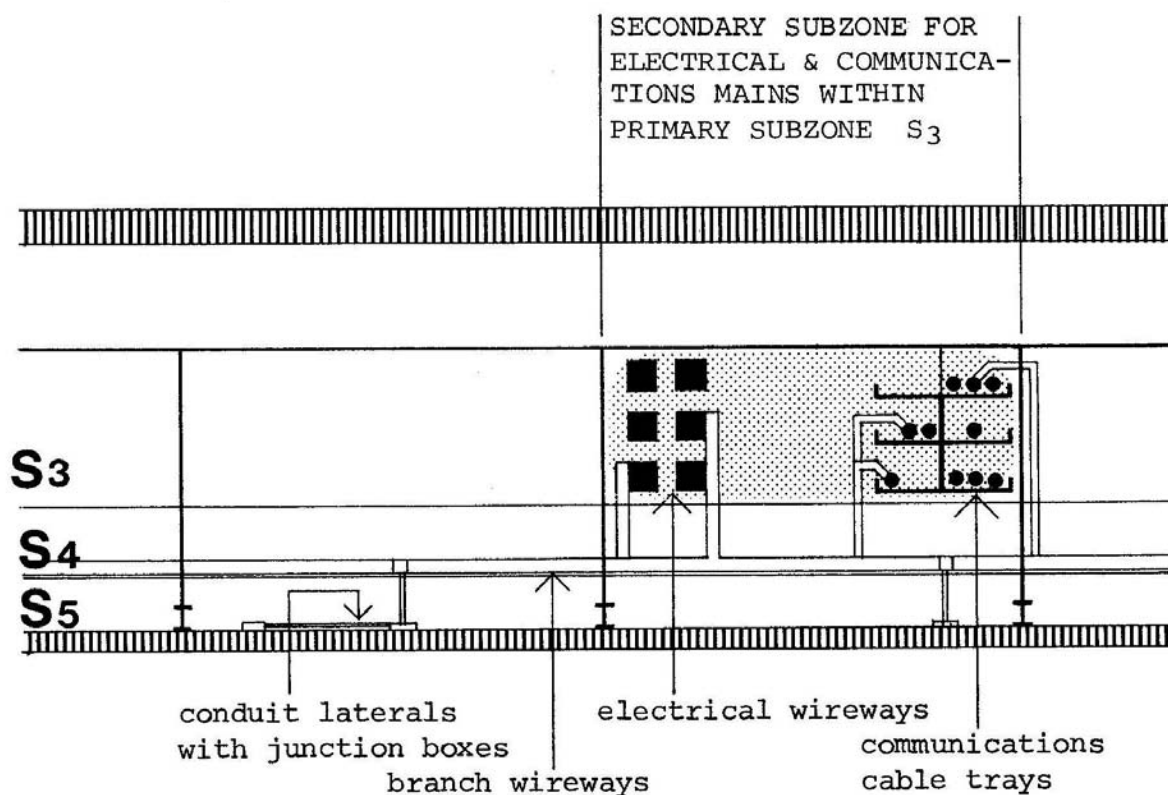

### 362.1.2 Channels

The electrical and communications mains will be horizontally distributed in a channel located on the same side of the service zone as the service bay electrical room. Similarly to the plumbing subsystem, in areas of heavy demand such as nursing units or radiology, a supplementary supply main should be run down the opposite side of the module.

The space reserved for electrical main distribution and branches will be based on the maximum load capacity potential of the service module.

### 362.2 SERVICE BAY

The service bay will contain the electrical room with all equipment for electrical distribution and communications for the service module. This will include all the transformers and the branch panel boards for the 208Y120 volt circuits. The branch circuit runs from these panel boards will not be the most economic, but positioning the panels centrally either in the functional zone or in the service zone would lead either to obstructions during plan changes in the first case, or to a lack of direct access in the latter, and also unnecessarily complicate the problem of industrial safety in the service zone.

The only exception to the centralizing of equipment in the service bay will be the isolation transformers and panel boards for the ungrounded circuits for surgery and ICU areas. They might be located in the functional zone and their location would only change as surgical suite layouts varied. Other transformers are associated with the various networks but are generally provided with the equipment requiring that particular modified supply, for example the voltage transformers for radiology equipment.

The 480Y277 volt distribution will be transformed down to 208Y120 volts at the service bay.

## **363 DESIGN CRITERIA**

### **363.1 LOAD DISTRIBUTION**

The overall strategy of the electrical network is largely governed by load distribution patterns. The following schematic diagrams illustrate the loading pattern of a typical hospital. Figure 360-3 represents the percentage distribution of total load in the electrical systems at two existing Veterans Administration hospitals. This data appears representative for current hospitals of the order of 500 beds.

No attempt was made in the diagram to differentiate between normal and essential distribution as these tend to vary in proportion with local engineering practice and codes. But Figure 360-3 shows that the percentage of the 480Y277 volt system which is transformed and supplied at 208Y120 volts to be approximately 25% of the total load.

The categories that are responsible for most of the continually increasing electrical demand in hospitals are generally those shown in this diagram for the 208Y120 volt distribution. When functional areas such as laboratories expand within a hospital, their heavier than normal environmental requirements also boost the electrical load demand for HVC.

### **363.2 AVERAGE LOAD DISTRIBUTION**

The majority of functional areas within the hospital are supplied with power in two of the categories shown in Figure 360-3, the transformed power at 120 volts (25% of total load) and fluorescent lighting (12% of total load). The figures given for these areas are 4.4 and 2.4 watts per square foot respectively. Therefore it can be assumed for the purposes of general design that a load of 6.8 watts per square foot is the appropriate mean.

Figure 360-4 is a breakdown in detail of the functions which take significantly higher loads and therefore represent design maximums. The high loads demanded by kitchens and laundries would require special busduct supply and should be located close to a substation.

**Figure 360-3. LOAD DISTRIBUTION BY PERCENTAGE OF TOTAL LOAD**

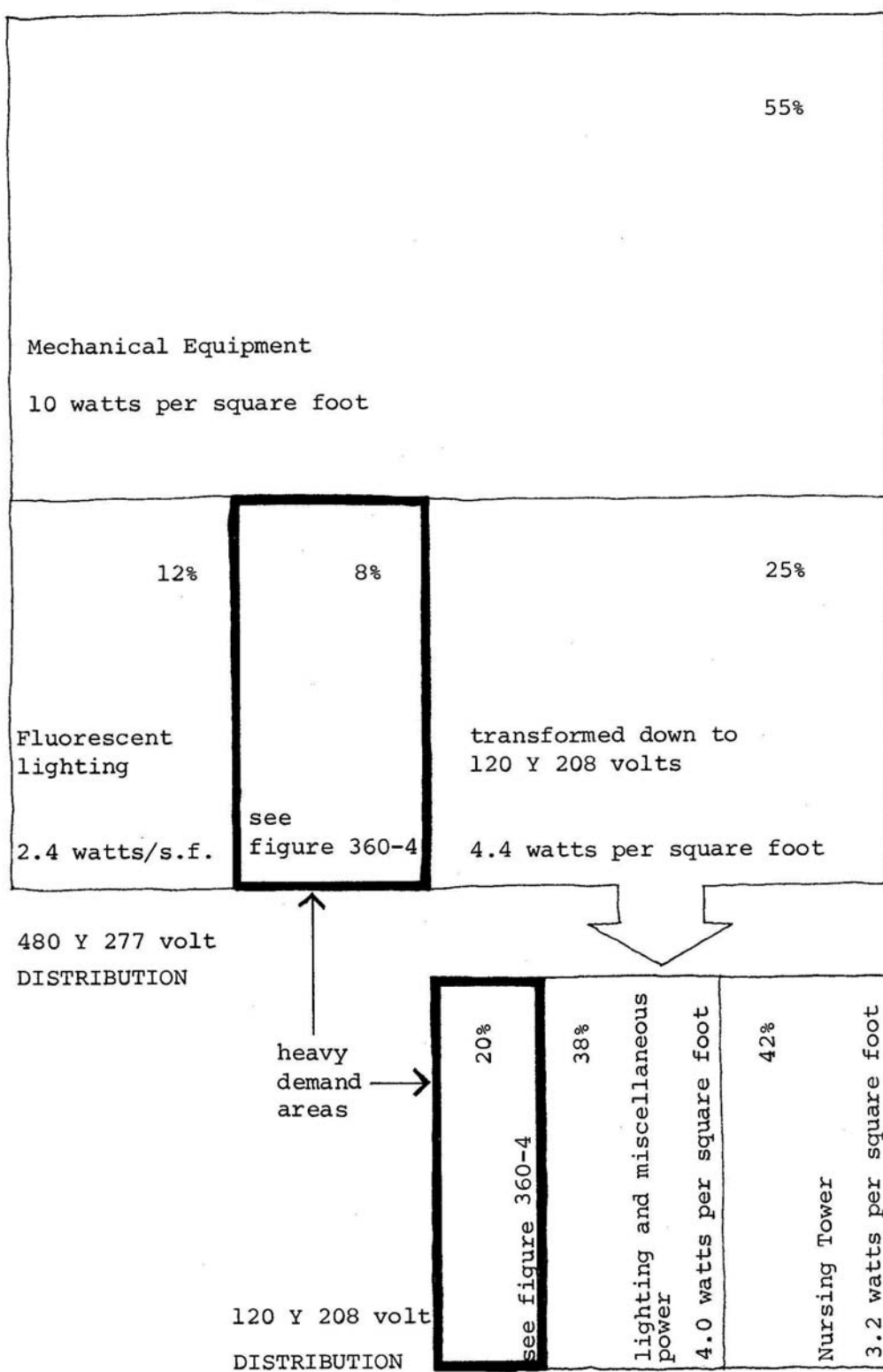

Figure 360-4. LOAD DISTRIBUTION IN HEAVY DEMAND AREAS

480 Y 277 volts  
DISTRIBUTION

	42%	
Laundry		30 watts per square foot
	40%	
Kitchen		24 watts per square foot
Research	8%	2.8 watts/s.f.
Clinical Laboratories	6%	2.3 watts/s.f.
Radiology	4%	3.1 watts/s.f.

0.5 watts/s.f.	Laundry	6%
5.3 watts/s.f.	Kitchen	11%
7.6 watts/s.f.	Research	20%
	Clinical Laboratories	33%
		8.0 watts/s.f.
	Radiology	30%
		17 watts/s.f.

120 Y 208 volt  
DISTRIBUTION

### 363.3 DISTRIBUTION NETWORK

The location of the substation and main switchboard in the distribution system is a primary consideration. VA standards prefer substations to be external, or close to the exterior of the building. But close relationship to heavy demand functions for economy of distribution is also required. Proximity to the motor control centers for central plant equipment, elevator motors, pumps, etc., would suggest central locations in basements or on the roof, but in either case, ease of access for maintenance and replacement must be achieved.

The major horizontal and vertical feeders from the main switchboards to the service modules would be largely permanent installations, with the horizontal feeder distributed at the substation level. The requirements of ease of change or relocation of load output make it necessary to use busducts as extensively as possible for these feeders. The busducts must be completely accessible throughout their length as required by code.

Electrical codes are based on the assumption that the maximum voltage in a standard distribution system will be 300 volts to ground. Therefore three-phase 480Y277 volts would be the expected maximum busduct supply. Also, because of the economic principle of distributing at the highest possible voltage before transforming down, this supply would be minimum.

The optimum capacity for any busduct in the system should be considered as 1600 amps which is generally the most economical size in terms of amps per dollar. Above this size, busduct cost rises disproportionately to current rating. Also, the cost of switch-gear associated with a rating above 1600 amps increases considerably. Where a stack of service modules required a capacity of greater than 1600 amps, it would be desirable to duplicate 1600 amp busducts than go to one with a higher rating not only from the standpoint of economics but also selectively of switchgear.

A 1600 amp busduct could serve 20 service modules of 10,000 square feet at the average load distribution value of 6.8 watts per square foot.

Distribution to these ten service modules would be most easily achieved by a vertical busduct riser via a stack of service bays to avoid penetrating fire section walls horizontally. Duplication of busducts would allow significantly higher loads per square foot.

The main distribution in the service zone will be made with wireways. Their increase in cost over conduit is far outweighed by the ease of addition or deletion of wires in future changes. All connections from the wireways to junction boxes or fittings will be made by conduit.

#### **363.4 SERVICE MODULE REQUIREMENTS**

A service module of less than 15,000 square feet would not allow the most economic use of electrical components. Using standard sized and rated electrical equipment which is easily obtainable off-the-shelf is a key requirement.

Branch circuit panels, using two section panels with 225 amp busing, and 75 KVA transformers could easily handle up to 20,000 square feet, especially where the demand load is divided between normal and essential networks. Thus a 75 KVA transformer could handle two 10,000-square-foot service modules at the 4.4 watts per square foot required for the 120Y208 volt service. Additional panels and transformers could be added within the service bay as required.

#### **363.5 FUNCTIONAL ZONE**

In general, electrical distribution into the functional zone will be surface mounted on partitions, either housed in separate prefabricated components or in furred out extensions of the partitions. (See Sections 332.2 and 780.)

There are many approaches to prefabricated components. They basically represent an attempt to rationalize the diversity of location and type of service outlet required, especially where frequent change is expected. The more elaborate forms, such as patient room consoles or service walls, are often difficult to use effectively because of the haphazard way services are usually designed and installed in current hospitals. The organized and preplanned approach of the Prototype Design should improve this situation. Early assessment of potential demands, even without detailed specification of outlets, should allow for more reasonable and systematic development of such appliances.

In areas where there is a heavy diversity of services, concentration of the outlets together with the plumbing distribution into consoles or service walls is recommended. The console may take the form of a partition-mounted unit, such as an ICU bedhead unit, or a ceiling-hung unit such as those used in operating rooms or laboratories.

In areas requiring minimal servicing, like offices or clinics, the outlets usually must be spread around a room. In this kind of layout, full use should be made of equipment such as electrical distribution poles and surface mounted raceways, the latter both horizontal and vertical. Some components could combine electrical supply and communications circuits. Floor distribution grids within the topping slab can be used where required, for radiology table supply for instance.

### **363.6 ACCESSIBILITY**

All components should be designed and located so that routine maintenance and repair and minor alterations will cause minimal disturbance to patients and will not interrupt hospital activities. Major repairs and alterations must be possible with minimum down time for the space in which they occur, and without interrupting hospital activities in adjacent spaces. Switchboards, circuit breakers and transformers must be readily accessible for convenient maintenance and replacement, and for emergencies.

### **363.7 ADAPTABILITY**

The distribution network should be reasonably oversized and/or provided with excess area to handle future change in demand. It should also be laid out so that it can be logically extended into any future expansion of the building. The various networks must be zoned so that temporary loss of supply through maintenance or alterations will affect only a local area.



**364 TARGET COSTS****364.1 RANGE**

The electrical distribution subsystem is not expected to cost more than the prices given in the cost base. This means that a target cost range of \$2.00 to \$2.50 per OGSF is appropriate. See Section 751.2.6 for further discussion.

**364.2 SCOPE****364.2.1 Included**

All three-phase normal and essential power distribution subsystems, including:

1. All transformers, distribution switchboards, circuit panels, busducts, wireways, conduit, cable trays, hangers, cable, wire, connectors, junction boxes, terminal boxes, etc., as may be required for the complete distribution system, and
2. convenience outlets, receptacles and switches.

**364.2.2 Not Included**

1. Central equipment such as substations, generating equipment, meters, etc.,
2. equipment and wiring required exclusively for the HVC subsystem,
3. building equipment such as elevators, fan units, etc.,
4. local equipment and their motors and transformers, such as for radiology, cold rooms, etc.,
5. communication equipment and signal distribution networks such as clocks, nurse call, computer network, security, etc.,
6. lighting fixtures,
7. distribution system to exterior of buildings and landscape, and
8. site work.

**(BLANK PAGE)**

## 370 Coordination Checklist

In developing specific designs for the integrated subsystems, it is imperative that each decision be made in the context of its possible effects on the characteristics of all other subsystems. The following checklist is intended to serve as an inventory of compatibility considerations. Table 370-1 summarizes the particular considerations applicable to each subsystem.

1. The vertical loads of the ceiling must be supported from hangers attached only to the center of the bottom of beams. Since the spacing of ceiling hangers is thereby set in one direction by beam spacing, hanger spacing in the other direction is likewise affected due to the limited tributary ceiling area which can be supported by each hanger. That is, as the beam spacing is increased (eg, by using a steel structure rather than concrete), the ceiling hanger spacing along the beams must be decreased. Hanger spacing in both directions directly affects the organization of the service zone into secondary subzones. (See also item 23 below.)

The detail of the connection between beams and ceiling hangers will vary with the material selected for the structure. With a concrete structure, a continuous supporting channel could be cast into the bottom of the beams and used for the attachment of service distribution components as well as ceiling hangers. This would be impractical with steel because of fireproofing requirements. (It is not intended that the structure and ceiling be fire rated together as an assembly.) (See Section 321.1.)

2. The acoustic separation between one floor and the next is provided by the combined effects of flooring, structure and ceiling. (See Section 325.1.)
3. Lateral forces in the partitions must be transmitted to the structure via the ceiling as well as directed to columns, shear walls and the floor. Thus the ceiling must be attached to columns and shear walls to properly transmit these forces. However, the ceiling is assumed to not contribute to the lateral resistance of the structure. (See Section 324.3.)

4. All connection details between structural, ceiling, partition and exterior wall components must be designed with due regard to the dimensional and construction tolerances and to the acoustic separation and fire protection requirements of each.
5. Structural design must include a load factor for relocatable partitions as well as permanent partitions. (See Table 310.2.)

The detailed design of the partition system must provide for furring around columns, shear walls and exterior walls where required.

6. Gravity drains are the only component of service distribution which feed through the floor. Since services should not penetrate beams, careful consideration must be given to beam sizing, spacing and location to impose the least possible restriction on the location of drains. Since plumbing fixtures are usually located on partitions, a restriction on the location of drains is also a restriction on the location of those particular partitions. (See Sections 225.3 and 333.4. See also item 14 below.)
7. The structure must provide adequate support and efficient passage for all service components, with minimum penetration of structural components. No service component may penetrate any structural component except shear walls and floor slabs, and such penetration may occur only via openings specifically provided for that purpose by the structural system. (See Sections 313.5.5 and 316.2.) All penetrations must be carefully detailed with regard to acoustic and fire separation requirements. No service components which could ever require access for any reason may be completely enclosed by structural components.

Dimensions of service bays must be adequate to house all required mechanical and electrical equipment, and all required vertical service distribution components, including plenum shafts, with allowance for expansion. (See Section 223.)

If accelerated scheduling techniques are being used, structural design should be expedited to allow the earliest possible bidding of site work and foundations. Service distribution strategy must be sufficiently developed to have determined, or to allow reasonable assumptions about, special foundation requirements, utility services and central plant or station locations.

8. Detailed design of the HVC system requires knowledge of, or assumptions about, glass area and shading factor of the exterior wall, and insulation value of the exterior wall and roof. These characteristics will effect not only HVC operating cost, but also duct size and thus the depth of the service zone and floor-to-floor height.
9. Exterior walls not an integral part of the structure may be curtain walls or infill panels. The inside face of the exterior wall may fall anywhere between the inside and outside faces of the columns, thus allowing some adjustment of bedroom floor area within the planning modules.

A weight of 50 pounds per square foot of exterior wall was assumed for prototype structural design.

10. The weight of flooring and roofing are load factors in structural design. To the greatest practical extent, floor recesses should be accommodated by a non-structural topping slab, which is also a load factor. (See Section 313.5.4 and 314.1.1.)
11. No casework, furniture, fixtures or equipment may be built into the structure. Very heavy equipment may require special structural design, and to the maximum practical extent should be located on lower floors or in special non-system areas of the building. (See Section 314.1.5.)
12. The ceiling must be designed to support some equipment of moderate weight. (See Section 324.2.) Heavier equipment requiring overhead support may be attached directly to the structure above. A method for providing this type of support at any desired point is illustrated in Figure 320-8.
13. Ceiling materials and design should allow for simple partition head attachment, and for efficient relocation of partitions without major damage to these materials. (See Section 321.3.) It is not intended that partitions support any loads from the ceiling, so head details must allow for ceiling deflection as well as transmission of lateral forces. (See Section 331.3.)

14. The ceiling supporting framework should be designed to minimize restrictions on locations of service drops, HVC terminals and lighting fixtures. Restrictions on service drop locations are also, in effect, restrictions on the location of partitions, fixtures and equipment. (See Section 225.3 and 333.4.) Service penetrations must be detailed to maintain the acoustic and fire separation characteristics of the ceiling. (See Section 321.3.)
15. The service zone should be so organized that horizontal access via the service bays will suffice for the greatest possible number of maintenance, repair and replacement tasks. Distribution components requiring a greater degree of access than can be provided in this manner will require suitable access panels in the ceiling. (See Section 224.3.) As far as practical, these panels should be located in areas other than those normally used by patients or having critical aseptic requirements, and outside of main circulation routes. The exterior wall should provide removable spandrel panels at the service zone levels for additional accessibility during major alternations. (See Section 463.)
16. If the service zone is to be used as a return/exhaust plenum, the ceiling and spandrel panels must be reasonably airtight. (See Section 342.2.)
17. Forced-air registers should be located exclusively in the ceiling, and supplementary perimeter convectors, if required, should be located exclusively on the exterior wall. (See Sections 341 and 342.) The only mechanical components that should normally be located in or on partitions are thermostats and their control lines. Certain exceptions to the location of registers may be necessary, such as in surgeries. Perimeter convectors must not be so enclosed in the exterior wall that they cannot be readily removed for maintenance or replacement. All surface must be conveniently accessible for cleaning by standard VA housekeeping procedures.

18. The connection details between the ceiling and the exterior wall and between partitions and the exterior wall must allow for any foreseeable deflection in the exterior wall due to wind loads.
19. To enhance the adaptability of both the partitions and the service distribution subsystems, service distribution lines and terminals in the functional zone should be surface mounted to the maximum practical extent. For a discussion of various methods of enclosing surface-mounted services, and the situations in which an internal location may still be required, see Section 337.3.3. Similarly, lighting on the ceiling should be surface mounted.

All enclosures of surface-mounted services, as well as HVC terminals and controls, should be visually compatible with each other and with the type of casework, furniture and equipment planned for the hospital. Likewise, the location of these services and terminals must not interfere with the typical placement of casework and furniture.
20. Partitions enclosing vertical shafts must have a two-hour fire rating, and an STC rating appropriate for the surrounding spaces and the level of noise generated within the shaft. Adequate access to the interior of the shafts must be provided for purposes of maintenance and alternations. (See Sections 331.1 and 335.1.)
21. Partition base details and selection of flooring materials will depend on whether partitions are scheduled to be installed before or after flooring. (See Section 463.)
22. A wide variety of casework, fixtures and equipment may be supported by partitions, the nature of the connection varying with load. (See Sections 334.3 and 334.4.)
23. The organization of the service zone into primary and secondary subzones of specific dimensions and arrangements must be appropriate to the size, turning radii, terminal frequency and access requirements of the horizontal distribution components of the HVC, plumbing, electrical, materials handling and communication subsystems. It must also allow for a reasonable amount of expansion, and the addition of future services. (See Section 224.)

**Table 370-1. COORDINATION CHECKLIST INDEX**

<u>Integrated Subsystems</u>	<u>Checklist Item Numbers</u>
Structure	1,2,3,4,5,6,7,8,9,10,11,12
Ceiling	1,2,3,4,12,13,14,15,16,17,18,19,23
Partitions	3,4,5,6,13,14,17,18,19,20,21,22
Heat/Vent/Cool	7,8,14,15,16,17,19,20,23
Plumbing distribution	6,7,8,14,15,19,20,23
Electrical distribution	7,8,14,15,19,20,23
<u>Non-Integrated Subsystems</u>	<u>Checklist Item Numbers</u>
Foundations	7
Exterior wall	4,5,8,9,15,17,18
Transportation	7,14,15,19,20,23
Communication	7,14,15,19,20,23
Flooring	2,10,21
Roofing	8,10
Casework, fixtures and equipment	11,12,14,19,22



## **400 PROCEDURE**

### **410 INTRODUCTION 1-233**

### **420 PROBLEM ANALYSIS**

421	System Applicability	1-235
422	Cost and Time Constraints	1-236

### **430 DESIGN DEVELOPMENT**

431	Building Configuration	1-237
432	Schematic Design	1-242

### **440 CONTRACT DOCUMENTS**

441	Communications	1-245
442	Simplification	1-246
443	Production	1-247
444	VA Standards	1-248

### **450 COST ESTIMATING**

451	Subsystem Costs	1-249
452	Target Costs	1-250
453	Functional Area Costs	1-251

### **460 CONSTRUCTION SCHEDULING**

461	Designing for Construction	1-253
462	Interstitial Space	1-255
463	Typical Sequence	1-256

**(BLANK PAGE)**

## 410 Introduction

This volume, the Design Manual, is intended to be a basic document for the VA and for A/E contractors working on systems hospitals. The Manual describes the Building System Prototype Design, and in this section, suggests a general procedure by which it may be utilized in a building project. The intent of this section is to provide an outline guide, both for VA staff and for A/E contractors, to the use of the Manual by all parties concerned in the design of a VA system hospital.

It must be stressed that there is no substitute for a thorough understanding of the content of the Design Manual by all participants of a building design team. The nature of the Design Manual is such that it cannot be compressed or organized into a step-by-step book of instructions. Each participant must use the materials in the way most appropriate to his area of responsibility. Only he can decide the precise way to use the material, because only he is familiar with his role in the design process, and the impact on that role of the concepts presented in this manual.

This outline guide, however, relates the concepts of the Prototype Design to a typical design process. The design process is divided into three broad phases: problem analysis, design development, and contract documents. The problem analysis phase is the analysis of the VA master plan. The design development phase consists initially of studies of building configuration and building schematic design which are comparable to the typical VA block plan layout phase. The essential difference between a building schematic design and the typical VA block plan layout is that the building schematic design contains a significantly greater degree of detail in terms of the structural and mechanical aspects of the building organization; in fact, considerably more detail than the typical VA preliminary drawings. This degree of engineering detail allows, if desired, an early start to working drawings while the preliminary drawings that show detailed room layouts are being completed. The contract documents phase is comparable to the VA working drawing phase. The discussion of these phases (Sections 420, 430, and 440) are deliberately kept general so that the participant, whether he be VA staff member or A/E contractor, can relate these phases in detail of his own activities and terminology.

Two major activities, cost estimating and construction scheduling, are crucial to all three phases, and are discussed at greater length in Sections 450 and 460. For purposes of the outline guide, the design process is assumed not to include accelerated scheduling or construction management. (See Sections 761 and 762 for descriptions of these special procedures.) The activities discussed are limited to those considered essential to provide all necessary information and decisions for each succeeding phase. No attempt is made to specifically define sequence, simultaneity, cycling, or feedback of the activities since these conditions will vary from project to project.

The Prototype Design provides the designer with strong basic concepts in terms of the planning modules and the building subsystems which make up these planning modules. The use of planning modules and integrated subsystems imposes a discipline that must be learned and experimented with. Their assembly is a design activity, dependent for its success on the skill of architects and engineers. Thus, the rules for their assembly can only be suggestive, not absolute.

There is nothing inherent in the Prototype Design that prevents or modifies current VA procedures; that is, the design development of block layouts, preliminary plans and working drawings in sequence. However, the Prototype Design permits parallel development of architectural and engineering design and thus an earlier start for the latter than in the conventional VA project. Specifically, detailed structural, mechanical and electrical design can proceed on the basis of the building schematic design which indicates general departmental arrangements, but not room layouts. The schematic design indicates the nature and disposition of the various planning modules. Engineering considerations will simultaneously influence, and be influenced by, the nature of the planning modules. The Design Manual stresses early engineering involvement and makes mandatory a thorough knowledge of the Design Manual on the part of all engineering participants. This knowledge cannot be limited to the particular discipline of the engineer concerned, for system integration demands a much deeper interdisciplinary understanding than is usual in conventional design.

## **420 Problem Analysis**

### **421 SYSTEM APPLICABILITY**

#### **421.1 PROGRAM (MASTER PLAN) ANALYSIS**

##### **421.1.1 System Exclusions**

One of the initial tasks in the program analysis is to identify those program areas that may be better satisfied without using the discipline of the Building System prototype Design. Such areas may include the central mechanical plant and laundry which might be housed in an industrial type of building at a lower cost than in the main hospital building. Other areas may include psychiatry and nursing home care. These may be detached and housed in single story structures for which the essentially multi-story characteristics of the system are inappropriate.

##### **421.1.2 System Variations**

Similarly, it is necessary to identify those functional areas which must be in the main building but which conflict with aspects of the Building System Prototype Design. These conflicts may be floor-to-ceiling heights, loads, etc., and may require some limited modifications to the Prototype Design in certain locations. These potential modifications can then be incorporated into the general design approach; for example, the location of the gymnasium and swimming pool at the end of the service module remote from the service bay in order not to disrupt the service distribution in the service zone.

##### **421.1.3 Adequacy of Current Space Module Catalog**

The adequacy of the current space module catalog can also be determined relative to the general nursing unit program requirements. A greater emphasis, say, on the provision of one-bedrooms, may indicate a need to develop new space modules.

#### **421.2 SITE ANALYSIS**

The potential influence of climatic, topographic, access, orientation, seismic and subsoil characteristics on building form and height must be considered in terms of the Prototype Design. For instance, service bays represent substantial planning elements which, in conjunction with bed-care service module orientation, may restrict perimeter access.

Also, the structural system is appropriate to a range of building heights from two to nine stories above ground; on small sites taller buildings may be required, necessitating certain modifications to the basic structural system. (See Section 721.4.)

### **421.3 CODE ANALYSIS**

Applicable current codes and regulations must be studied to identify implications for planning and sub-system design. For example, as noted in Section 240, fire safety codes and regulations are subject to constant review and change. Current requirements must be analyzed in order to determine the appropriate fire safety strategy in terms of exit distances, size of fire sections, sprinklers, smoke barriers, etc.

## **422 COST AND TIME CONSTRAINTS**

### **422.1 BUDGET ANALYSIS**

Funds allocated to the project must be analyzed to determine the degree of refinement appropriate for detailed design, for example, in the study of alternative building schematic designs, or the consideration of innovative components for the ceiling-platform system. Estimated functional area cost must be applied to programmed departmental areas to determine where adjustments might best be made to fit the budget.

Reasonable cost targets for both integrated and non-integrated sub-systems must be set. This must be done in the context of the particular characteristics of the local building industry. See Section 450 for further discussion of cost estimating.

### **422.2 SCHEDULE ANALYSIS**

Schedule requirements must be examined to evaluate the desirability and feasibility of various approaches to accelerated scheduling. See Section 761 for a discussion of this subject. (See Section 460 for a general discussion of construction scheduling within conventional procedures.) If phased bidding is to be used, a construction manager is recommended. Construction management is discussed in Section 762.

## **430 Design Development**

### **431 BUILDING CONFIGURATION (PRELIMINARY BLOCK LAYOUT STUDIES)**

#### **431.1 GENERAL BUILDING CHARACTERISTICS**

The study of building configurations establishes a basic building design concept which defines the general characteristics of the building in terms of massing, height, location on site, overall organization, growth potential, etc., and which is an essential preliminary to establishing block layouts.

The use of planning modules enables the designer to interrupt the program requirements at the level of gross area allocations and desirable departmental relationships and to quickly translate these requirements into a number of alternative configurations. These configurations can then be related to the site and their comparative merits evaluated against considerations of access, views, orientation, topography, soil conditions, etc. Thus, all the relevant design factors can be brought together and reconciled on a broad conceptual level at a very early stage.

#### **431.2 SPACE MODULE SELECTION**

##### **431.2.1 Basic Considerations**

The space module in conjunction with the structural subsystem and the service bay (Section 251.3) defines the assembly characteristics of the service module in the bed-care portion of the hospital. Space module selection and the development of configuration options should be pursued simultaneously. Building program definition at this stage may be legitimately quite sketchy, containing only enough information to establish gross configuration.

The general medical and surgical (GM&S) nursing unit should be used as the basis of selecting the appropriate space module types. This is due to the large proportion of the bed-care program represented by these units and their high degree of organizational predictability.

The considerations identified below may be applied in various sequences, and some may need to be applied in several cycles as the selection process narrows. The relative importance of the considerations will vary with the conditions encountered on each specific building project. An example of one application is contained in Section 733.

**431.2.2 Sanitary Zone**

(Refer to Sections 232.6 paragraph 2 and 232.8, and Space Module Summary Sheet Figure 230-8.)

**431.2.3 Internal Organization**

(Refer to Section 232.5 and Space Module Summary Sheet Figure 230-8.)

A decision must be made as to the desirability of providing staff work spaces and other supporting facilities directly adjacent to patient beds. This determines the choice of double-loaded corridor or core type plan.

**431.2.4 Space Module Support Capability**

(Refer to Section 232.6 paragraph 4 and Space Module Summary Sheet Figure 230-8.)

Bedroom and corridor widths are fixed. Therefore, total space module width will be determined by the sanitary zone width and - in other than double-loaded corridor solutions - the core area required for support capability directly adjacent to patient bedrooms. The architect, by selecting a sanitary zone width and determining program requirements for those functions directly adjacent to patient beds, can select the proper structural span by referring to the Summary Sheet, which identifies the area available in each space module for direct care support space.

Where a 40-bed unit is composed of two 20-bed space modules, the core area available in each space module must equal one-half the area required by direct-care support. Also, core areas are not directly comparable to required net areas, as they include partition thicknesses and columns. The space module selected should therefore possess a core area slightly greater than the required direct-care support area. It also may be advisable to provide some additional core area to allow for future increase in direct-care support requirements. This area can be used for ancillary functions initially. Increasing core size will also increase nurse travel distances, however.



### **431.2.5 Internal Space Module Capability**

(Refer to Catalogue of Space Module Capabilities Section 233.)

Once one or more space modules have been selected on the basis of requirements for typical GM&S units, they must be tested against the program for other functional units. Certain space modules will be more suitable for large open areas such as intensive care units or particular organizations required for psychiatry.

## **431.3 CONFIGURATION OPTIONS**

### **431.3.1 Building Height Relative to Beds per Floor**

The bed-care program can now be expressed in terms of numbers of space modules. (See Section 734.1.) The total number of space modules can then be organized into alternative nursing floor configurations based on the assembly capabilities of the respective module types, the number of beds per floor and the height limit of the structural sub-system. (See Section 313.3 and 734.2)

### **431.3.2 Additional Space**

(Refer to Section 232.4.)

Given the appropriate space modules, the selected sanitary zone option, and the size and number of nursing floors, the space program must be studied and gross space allocations made in order to determine the extent of additional space necessary to achieve a balanced set of functions on each floor, an optimum set of relationships within given constraints, and a suitable organization of the major circulation and transportation elements. Inevitably, some degree of discrepancy will exist between this gross space allocation and the original space program.

The extent of area provided by the additional bays on each floor is obviously more critical with a tower on a base type of configuration than with a horizontal type of configuration where there is more opportunity for other hospital functions to conveniently utilize any excess additional space.

### 431.3.3 Service Modules

(Refer to Section 220)

Gross space allocation is now established for the alternative configurations. As stated in Section 221.1, the service module is the most significant of all the planning modules in that it combines and coordinates all the interrelated characteristics of the building organization; namely, function, structure, service distribution and fire safety. At this stage, the dimensional and assembly characteristics of the space modules are manipulated and reconciled within the structural and mechanical characteristics of the service module. Simultaneously, the fire section boundaries are examined to ensure that they respond to the layout and organization of the central support functions of the hospital. Each floor can then be divided into the appropriate number of service modules. Once derived, the layout of service modules sets the number and disposition of service bays. The alternative configurations can be organized as suggested on the example classification chart in Figure 250-2. This provides a useful first estimate of the significantly different types of configurations which are feasible for the particular site. For example, the orientation of the bed-care and service modules in a simple tower-on base configuration can be a major determinant of the disposition of the building which, because of the rows of service bays, may have significant implications in terms of access and growth. (See Section 251.3.3. paragraph 2.) Fundamental seismic considerations may also be a major determinant in building configuration development.

### 431.3.4 Detailed Configuration Development

The most promising configuration options can then be taken to a more detailed level where the service modules are studied relative to the other building divisions, such as the functional units, the fire sections and the structural units in terms of building separations and possible locations of shear walls. (See Section 735.1.2.) Concurrently, circulation patterns and transportation systems relative to desired functional relationships and site constraints are considered in more detail to determine, for example, the effect of the location of vertical transport elements on the structural shear resistance strategy. Comparative cost analyses of the favored options may be undertaken to confirm the choice of configuration.

**431.3.5 Block Plan Concept**

The block plan concept to be developed and refined in schematic design will be that building configuration which satisfies and resolves all the requirements of program, budget, site and system discipline in the most effective manner. Many modifications to the block plan concept may occur in the schematic design stage when requirements are considered at a more detailed level, but typically these modifications will occur within the framework of the general building characteristics established.

It may be that two or three equally satisfactory schemes may all have to be taken to the more detailed levels of schematic design before the final selection can be made.

It is also possible that none of the configuration options are sufficiently satisfactory in which case new space modules and/or new configuration options may have to be developed.

## **432 BUILDING SCHEMATIC DESIGN (BLOCK LAYOUTS)**

### **432.1 PLANNING**

Matching exact departmental area requirements to service module and fire section boundaries is the key activity in this phase. Departmental requirements for proximity and growth capability must be carefully considered in establishing the arrangement of vertical and horizontal circulation elements. The site plan must be completely coordinated with internal circulation patterns in terms of vehicular approaches, parking, emergency access and connections to existing buildings.

### **432.2 BUILDING SUB-SYSTEMS**

Generic design options for the structural, ceiling and heating-ventilating-cooling subsystems must be evaluated and selected during this phase. (The plumbing and electrical sub-systems do not have generic design options, and the selection of a partition option can be postponed until after start of working drawings.) Critical dimensions, such as beam spacing, service bay size and shape, shear wall and construction joint locations, and the sizes of shear wall and diaphragm penetrations, must be established. (See Sections 313 and 316.) Floor-to-floor and overall building heights can then be determined on the basis of the functional zone and service zone heights required.

Available building products must be evaluated to allow development of a movement systems strategy as well as a rational selection of generic design options for the integrated subsystems. If new product development seems appropriate, the feasibility of satisfactorily completing a product development program within the scope of the project budget and schedule must be studied. (See Section 764.)

### **432.3 COST AND TIME**

Alternative construction process strategies must be examined in the context of the current schedule, and the schedule revised if necessary to optimize the process. Cost estimates must be prepared to assist in this analysis, as well as in the final selection of a specific design configuration, building subsystem options, and a transport system strategy.

**432.4 PRELIMINARY DOCUMENTS**

Preliminary planning in terms of detailed room layouts can proceed on the basis of the building schematic design. Concurrently, the start of working drawings and outline specifications can also proceed. Design effort at this stage should focus on the development of information and decisions necessary for the earliest possible start of final contract documents, engineering as well as architectural. Note, for example, that, although detailed room layouts within departments are not required for the start of working drawings, it will be necessary to finalize the overall fire safety strategy in order to locate smoketight compartments, select active and passive fire protection devices, etc.

**(BLANK PAGE)**

## 440 Contract Documents

### 441 COMMUNICATION

Working drawings and specifications appropriate to the unique characteristics of the Prototype Design are absolutely essential to the successful application of the system. Many of the presumed advantages will remain hypothetical if the system rules are not presented explicitly and clearly. Prime contractors can be informed in pre-bid conferences on how to exploit system characteristics in their scheduling, but they will have to work with the prices given to them by the many subcontractors whose major source of information will be the plans and specifications. If the documents fail to adequately express the real situations the various trades can expect to find in the field during systems construction, their prices will be based completely on their customary estimating procedures, and might actually include an additional contingency factor for non-conventional work.

It is particularly important that the system rules be made credible and enforceable through appropriate wording in the General Conditions, and by reference in each section of the specifications to that wording. For example, if a subcontractor who will have to install certain service distribution lines above the ceiling late in the construction sequence can not really be sure that a "reserved zone" will in fact be available to him when he arrives on the job, he can not be expected to figure this potential time-saving convenience in his price. Attention should be given to details which tend to make the system "self-enforcing". In the reserved zone example given above, it would be helpful to the contractor, subcontractors, the supervising engineer and inspectors if the various primary and secondary zones were clearly indicated during construction by appropriate marks, tags, signs, color codes, etc., on the structure and ceiling hangers, with the plans and specifications clearly keyed to these indicators.

**442 SIMPLIFICATION**

One of the advantages offered by the Prototype Design is the standardization of many features which in conventional design and construction present a confusing multiplicity of variable conditions. Each integrated subsystem offers opportunities for greatly reducing the number of variations: regular column spacing, uniform ceiling height, a single partition type for practically all situations, a single type of mechanical system used throughout regardless of zoning, etc. Furthermore, the organization of the building into service modules of simple repetitive geometry allows the standardization of main service distribution layout for most services. This attribute of the Prototype Design can be used to simplify contract documents as well as construction, operation and alteration.

For example, key plans can be drawn in which the building is presented as an assembly of service modules, with an identifying number for each module and an indication of which modules are identical in the organization of main distribution. A typical plan and section for each group of modules can indicate the particular subzoning rules which apply to that group. The detailed service zone plan of each individual module can then be quite symbolic, since much of the dimensional information will be standardized and shown on the "master" drawing for the group.

Functional zone plans (architectural drawings) can be keyed to the same scheme of subdivision by service module. It may in fact be practical to provide each trade or subcontractor with drawings which show only the work within this scope, overlaid on a standard "shell" drawing showing of each module, in addition to coordination drawings showing the major features of all subsystems. (See Section 740 for examples of what such drawings might be like.)



**443 PRODUCTION**

To reduce the time required for the production of contract documents to a minimum, it will be necessary to proceed with structural, mechanical and electrical detailed design and working drawings on the basis of “empty” service modules, that is, modules of specific dimensions to which general functions, departments or parts of departments may be tentatively assigned, but which as yet have no room layouts. The architectural drawings which establish precise layouts must be developed in parallel with the engineering drawings, rather than prior to them as in conventional practice. This head start is very important to engineering design because of the special effort that is required to properly work out the detailed service distribution strategy, particularly the subzone organization of the service zone. Service systems design in turn requires very close coordination with structural design on matters of service bay size, shear wall penetrations, etc.

In a sense, this calls for some reversal of normal procedures in which architectural design may be worked out in considerable detail before even basic engineering design is considered. The intent of the Prototype Design is to allow parallel design development “across the board”, with all disciplines proceeding from the general to particulars in a coordinated manner. The idea is that coordination is most efficient and effective when it takes place at equivalent levels of detail, and as an integral activity in the design process.

The key system device for this purpose is the service module used as a “building block” for schematic design. Each module has an inherent structural and service distribution pattern. Thus, when preliminary planning procedures produce an architectural schematic design, they “automatically” establish basic structural, mechanical and electrical designs. This assumes, of course, that the appropriate engineers have been involved directly in the preliminary planning process.

**444 VA STANDARDS**

All subsystems are to be designed in accordance with applicable VA Construction Standards, and should utilize VA Standard Details and Master Construction Specifications to the maximum practical extent. The Prototype Design conflicts with these standards in only a few minor respects. (See Section 550.) However, development of detailed subsystem designs in accordance with overall system objectives will require some new details and specifications. For instance, the VA Master Construction Specifications do not currently include sections which would adequately cover the unique aspects of the ceiling subsystem such as the platform and supporting framework. Appropriate specifications will have to be developed after a generic design option is selected. Even when the standard details and specifications are applicable, they must be carefully reviewed, and modified if necessary, to ensure complete consistency with the system design

## **450 Cost Estimating**

### **451 SUBSYSTEM COSTS**

During the programming and design of a systems hospital, periodic cost estimates will have to be made for budget control purposes, more or less at the same stages as in a conventional project, and more or less to the equivalent level of detail for each stage. The principal distinction in the systems case will be the structuring of cost summaries around the specific subsystems defined by the Prototype Design, as distinct from the more conventional breakdown along trade and subcontract lines. The function of this organization of cost data is to allow more effective cost/performance tradeoffs to occur during detailed design development by relating each set of targets and estimates to a specific set of building performance characteristics.

The subdivision of the building into relatively independent service modules permits the further structuring of cost figures on a per module basis. To a certain extent, major changes in program or budget during preliminary planning or detailed design can be handled by the addition or subtraction of service modules, leaving the rest of the scheme intact, or by constructing some modules as empty "shells" to be completed as funds become available.

**452 TARGET COSTS**

The “target” costs given at the end of the description of each integrated subsystem, and discussed in more detail in Section 751.2, are ranges that represent the least and most each subsystem can be expected to cost depending on the generic design options chosen and the complexity and quality of the detailed design. All cost figures are in dollars per outside gross square foot of building area (OGSF), are based on a stated scope, include general contractor’s and subcontractors’ overhead and profit, and are derived from costs prevailing in the San Francisco area at a national ENR Building Cost Index of 960.

As soon as a generic design option is selected for a particular subsystems, a more accurate determination of the appropriate target costs is possible. If these selections can be made during preliminary planning, the more realistic targets can be applied to cost estimates of various alternative schematic designs, thus rendering the identification of the optimum design more reliable. At the latest, structural, ceiling and HVC generic design options should be selected early in the design development phase.

In addition to the OGSF figures given, target costs in subsystem units are provided for ceiling and partitions. Thus ceiling costs can be estimated on the basis of total ceiling area, rather than building area, and partition costs can be estimated from linear foot calculations.

**453      FUNCTIONAL AREA COSTS**

The cost base (Section 530) includes an analysis of the costs of the integrated subsystems in two VA hospitals, broken down by functional areas. Structure is not included because its cost can be assumed to be equally distributed throughout.

Cost variations between functional areas are generally quite similar for the two buildings, suggesting their use in refining cost estimates during design development. It could be assumed that the distribution of cost variations will be approximately the same for any VA hospital with a similar set of departments.

The main impact of the Prototype Design on these proportions is to reduce the range of variation in costs by reducing the range of variation in subsystem characteristics. This “leveling out” of functional area differences must be taken into account in applying cost base data to cost estimates of systems construction.

**(BLANK PAGE)**

## 460 Construction Scheduling

### 461 DESIGNING FOR CONSTRUCTION

If construction is to proceed as quickly and efficiently as possible, the detailed design of the building must be deliberately oriented toward a carefully considered sequence of assembly. Since the development of a detailed construction strategy is a prerequisite to the final selection of generic design options for structure, ceiling and HVC, or at least must occur as one aspect of that selection process, it is a subject of concern from the very beginning of the design development phase.

Subsystem design and choice of materials must take into account all factors influencing the efficiency of the total construction process, such as:

1. labor content:
  - a. trades required;
  - b. skills required;
  - c. trade schedules;
  - d. on-site vs. off-site work;
2. transportation, storage and handling,
3. erection sequence and phasing among other subsystems,
4. simplicity of installation,
5. interface conditions between subsystems, such as tolerances, connectors and mutual access,
6. relative independence of installation of each subsystem,
7. working drawing lead time,
8. working drawing complexity,
9. shop drawing requirements,
10. field change capability,
11. possible trade union objections,

12. projected availability of materials and proprietary components,
13. supervision and inspection requirements,
14. support and workspace usable for installation of other subsystems,  
and
15. contingency stockpiling or overordering.



**462 INTERSTITIAL SPACE**

Those characteristics of the Prototype Design which allow simplification of contract documents are also intended to simplify construction. (See Section 440 above.) In addition, the system relies on the use of carefully dimensioned and organized “interstitial space” for significant reductions in construction time. The following characteristics summarize the basic design of the service zone. (See Section 224 for details.)

1. The ceiling system provides a continuous platform throughout the entire service zone, capable of supporting workmen plus a reasonable amount of materials and equipment.
2. The horizontal structure consists of shallow beams and girders, rather than trusses, thus avoiding conflict between service distribution components and truss diagonals.
3. The clear height between the walking surface of the platform and the underside of the structural slab between the beams provides full headroom for working in a standing position.
4. Only shear walls and two-hour partitions penetrate the ceiling-platform and run from slab to slab. All other partitions stop at the ceiling, thus providing open space of up to 20,000 square feet, the maximum size of a fire section. (Large fire sections may be subdivided by smokestop partitions between service modules of about 10,000 square feet each.)
5. The service zone is organized into a set of subzones, each exclusively reserved for a specific class of distribution components. Major equipment is located in the service bays at the functional zone level, not in the service zone.

**463**      **TYPICAL SEQUENCE**

The following outline suggests a possible sequence for starting major overlapping phases in the assembly of a systems hospital:

1. Sitework, foundations and erection of structure proceeds in a conventional manner.
2. Attach ceiling hangers to beams to define subzone boundaries. Start internal service modules first, if there are any.
3. Assemble large distribution components on each floor and raise into final position. Piping and other materials supplied in long sections can be placed in temporary storage racks in the service zone at this time.
4. Install main vertical distribution components and large pieces of equipment in the service bays.
5. Install two-hour partitions.
6. Install the exterior wall, omitting appropriate spandrel panels at the service zone level for the continued delivery of material.
7. Install the platform, omitting appropriate panels for access. (This might also be started prior to installation of the exterior wall.)
8. Install all remaining distribution components above the ceiling while installing the topping slab and partitions below. (Flooring might be installed before the partitions.)
9. Install all remaining heavy building equipment, including elevators and materials-handling systems.
10. Conduct final tests on all operating systems.
11. Complete enclosure of the service zone by installing omitted panels of the platform and exterior wall.
12. Install finishes, casework, fixtures and remaining equipment. (This includes flooring if not already installed.)
13. Conduct final inspections and move in.

## Glossary

Most of the words defined below are basic building systems terminology. For those of wider usage, the particular meaning for building systems is given. A few terms are peculiar to this project.

**ADAPTABILITY.** the ability to respond to, or be readily adjusted to, changing conditions.

**ADDITIONAL SPACE.** portions of service modules in the patient bedroom areas constructed with the building system but not part of a space module.

**ANNUAL OWNING COST.** total owning cost computed as an annual expenditure.

**AREA OF REFUGE.** a fire section considered as a horizontal exit for an adjacent fire section.

**ASSEMBLY.** 1. a group of attached components considered collectively. (Example: a pre-hung door.) 2. a design configuration composed of a specific arrangement of service modules.

**BEDROOM ZONE.** a plan zone at the building perimeter, sized to accommodate patient bedrooms.

**BUILDING CONFIGURATION.** a specific three-dimensional arrangement of building forms. (Example: a tower on a base.)

**BUILDING SCHEMATIC DESIGN.** single line scale drawings defining the size and arrangement of the major areas in a building and the building configuration, used as a basis for design development.

**BUILDING SUBSYSTEM.** one of the coordinated groups of components, each performing a major function, which combine to form a building system.

**BUILDING SYSTEM.** 1. any specific building production process or method. 2. any set of coordinated building components intended for application as a group.

**COMPATIBILITY.** the state of functional, economic and aesthetic coordination between two or more systems or components.

**COMPONENT.** a part, or assembly of parts, in a system.

**COMPOUND ASSEMBLY.** a design configuration in which the structural framing changes direction, and/or some service bays are completely internal.

**CONSTRAINT.** a condition establishing a limit on the nature or effectiveness of a system or activity.

**CONVENTIONAL DESIGN AND CONSTRUCTION.** existing traditional building methods as they are currently applied.

**COST-BENEFIT ANALYSIS.** the comparison of alternatives in terms of the anticipated performance and cost of each.

**COST EFFECTIVE.** 1. comparing favorably to other alternatives in a cost-benefit analysis. 2. providing desired performance at a comparatively low cost.

**CPM.** critical path method.

**CRITICAL PATH.** the particular linear path through a work schedule network determining the shortest time within which all work can be completed.

**CRITICAL PATH METHOD.** a scheduling technique for the identification and control of activities on the critical path.

**DESIGN CONFIGURATION.** a general building plan type, illustrated by a diagrammatic plan.

**DESIGN CRITERIA.** various performance requirements, dimensional rules, descriptions of typical and special conditions, and the like, serving as guidelines in the development of a detailed design from the basic system design.

**DESIGN DETERMINANT.** an independent variable, or general class of such variables, encountered in a design problem, which influences the selection of alternative solutions or the characteristics of a particular solution. (Examples: program, site, budget, codes.)

**DIMENSIONAL COORDINATION.** 1. the selection of dimensions to allow exact fit. 2. the use of a common set of dimensions.

**DOWN TIME.** that part of the life span of a system or component during which it is malfunctioning or out of operation.

**FAST-TRACK.** an accelerated scheduling technique characterized by the overlapping of activities traditionally performed in linear sequence, requiring early commitment to general decisions, but allowing postponement of detailed decisions.

**FEEDBACK.** information on the current effectiveness or an ongoing process of activity, applied to its control or modification.

**FIRE SECTION.** one of at least two areas on a building floor separated by two-hour smoketight assemblies and of such size and configuration that they serve as mutual horizontal exitways.

**FIRST COST.** 1. contract cost. 2. debt service.

**FLEXIBILITY.** 1. adaptability. 2. having alternatives.

**FUNCTIONAL SPACE.** 1. a habitable room or area not assigned exclusively to building equipment. 2. space within the functional zone.

**FUNCTIONAL SPACE REQUIREMENT.** a characteristic a particular functional space must have to satisfy a user need or an applicable regulation or standard.

**FUNCTIONAL UNIT.** a group of rooms interrelated by shared activities or processes. Usually implies close proximity. (Examples: nursing unit, intensive care unit.)

**FUNCTIONAL ZONE.** the horizontal layer of space between the top of a finished floor and the bottom of the finished ceiling immediately above.

**GENERIC DESIGN OPTION.** one of a limited number alternative general types of solution allowed within the basic design of a particular building subsystem.

**HVC.** heating-ventilating-cooling.

**INTEGRATED SUBSYSTEM.** any of the pre-coordinated sub-systems specifically within the scope of a particular building system.

**INTEGRATION.** See SYSTEMS INTEGRATION.

**INTERFACE.** 1. a common boundary between two systems or components. 2. a boundary detail designed to maintain a specified relation between adjacent systems or components.

**INTERSTITIAL SPACE.** unfinished or non-habitable space utilized for building service subsystems, of sufficient size to accommodate workmen and permit maintenance and alteration without disruption of activities in functional spaces. The term usually refers to the space between a ceiling and the floor above. See SERVICE ZONE.

**LEAD TIME.** the length of time preceding an event which must be allowed for all prerequisite activities if the event is to have reasonable chance of occurring as scheduled.

**LIFE COST.** total owning cost during life span.

**LIFE SPAN.** 1. the period between the manufacture of a system or component and the time at which its annual owning cost exceeds the annual owning cost of a replacement. 2. the period between the manufacture of a system or component and the time at which it can no longer meet the needs of its user. 3. the shorter of the two above periods.

**LONG TERM COST.** total owning cost over a specified period of time, typically a theoretical life span.

**MODULAR.** 1. having commensurable dimensions. 2. capable of arrangement with exact fit in more than one sequence or direction. 3. composed of or containing predetermined dimensional and/or functional units such as repetitive structural bays or service modules.

**MODULAR COORDINATION.** dimensional coordination utilizing commensurable dimensions.

**MODULE.** 1. the common divisor of a set of commensurable dimensions. 2. a dimensional pattern restricting the location of a specified building component. 3. a unit of space defined by a special set of dimensional and/or functional characteristics.

**NON-INTEGRATED.** outside the design scope of a particular building system.

**NON-SYSTEM.** non-integrated.

**NON-SYSTEM ASSUMPTION.** an assumption about a characteristic of a non-integrated component used in the design of integrated components.

**OGSF.** outside gross square foot, a unit of total floor area.

**OPENING CONFIGURATION.** the original design configuration of a building or building subsystem developed in response to its original program.

**OPTIMIZE.** 1. to maximize desirable characteristics and/or minimize undesirable characteristics. 2. to establish functional and economic balance among the performance characteristics of two or more systems or components.

**PERFORMANCE CRITERION.** a performance parameter so quantified or described that a system or component can be examined or tested for compliance.

**PERFORMANCE PARAMETER.** a variable characteristic for which a specific value, range of values, or general comparative level must be established to describe a system or component in terms of desired performance.

**PERFORMANCE REQUIREMENT.** a statement to the effect that a certain system or component must comply with a certain performance criterion or set of criteria.

**PERFORMANCE SPECIFICATION.** a performance requirement stated in a legal form to serve as the basis for bidding by manufacturers or contractors on their own designs, often including a detailed test procedure, or reference to a recognized test, by which compliance may be established.

**PLANNING MODULE.** a one-story high unit of building volume with specific dimensional and functional characteristics.

**PLAN ZONE.** a plan area of constant width extending from end to end, or side to side, of a building or a planning module. See BEDROOM ZONE, SANITARY ZONE AND SERVICE STRIP.

**PREFABRICATON.** the on-site or off-site advance manufacture of building systems and components traditionally fabricated in-place during installation.

**PRIMARY SUBZONE.** a horizontal subdivision of the service zone, reserved exclusively for distribution lines oriented in a specific direction relative to the structure.

**PRODUCT.** a material, component or system manufactured off the construction site.

**PROTOTYPE DESIGN.** a basic system design establishing the performance and dimensional limits within which alternative detailed designs may be produced to accommodate specific conditions at various times and places.

**RANGE.** the limits between which a performance parameter may be required or allowed to vary, stated as a criterion.

**RESERVED ZONE.** a specified region within a building volume assigned to the exclusive use of one subsystem or limited set of subsystems, or to a specific function. See FUNCTIONAL ZONE, SERVICE ZONE, PRIMARY SUBZONE AND SECONDARY SUBZONE.

**SANITARY ZONE.** a plan zone between the patient bedrooms and the corridor in a nursing unit, sized to accommodate lavatories, toilet facilities, etc.

**SECONDARY SUBZONE.** a vertical subdivision of a primary subzone, reserved exclusively for the distribution lines of a specific service subsystem or group of subsystems.

**SERVICE BAY.** a structural bay specifically designed to provide for mechanical and electrical rooms and/or various kinds of vertical shafts, located at the perimeter of a service module and typically enclosed in shear walls.

**SERVICE MODULE.** a planning module containing, and served by, an independent horizontal distribution network, typically including its own air-handling unit.



**SERVICE STRIP.** a plan zone containing internal service bays.

**SERVICE ZONE.** the horizontal layer of space between the bottom of a finished ceiling and the top of the finished floor immediately above. See INTERSTITIAL SPACE.

**SIMPLE ASSEMBLY.** a design configuration in which all structure is framed in the same direction, and all service bays are external.

**SPACE MODULE.** a subdivision of a service module in a patient bedroom area, which can be internally organized in various ways to accommodate a range of functions, and which can be incorporated within a variety of design configurations.

**SUBSYSTEM.** 1. a system considered as a component of a larger or more general system. 2. any component, or group of components, which has internally the characteristics of a system. (Example: the distribution components of a mechanical system.)

**SUPPORT AREA.** all hospital areas outside the bed-care area.

**SURGE SPACE.** 1. space assigned to functions whose location within the building is relatively non-critical, and placed adjacent to space assigned to functions whose location is relatively critical, such that expansion of the latter can occur by displacing the former. 2. a zone of functional space at the boundary of two departments which is assigned to the departments in a proportion which may vary over time.

**SYSTEM.** a set whose elements (termed components) are organized toward a common objective, and are characterized by interdependence in their individual contributions to that objective.

**SYSTEMS ANALYSIS.** examination of the effects of the interactions between the components of a system on the individual performance of those elements and on the total performance of the system.

**SYSTEMS APPROACH.** a strategy of problem definition and solution which emphasizes the interaction between problem elements and between the immediate problem and its larger context, and which specifically avoids traditional methods of independent or ad hoc treatment of the various elements.

**SYSTEMS INTEGRATION.** 1. the combination of a group of relatively independent parts into a coordinated whole to improve performance through controlled interaction. 2. the joint use of a component by two or more systems.

**TOTAL OWNING COST.** the sum of all costs, regardless of funding source, attributable to owning a building, or a particular system or component within a building. Owning cost is typically broken down into first, operating, maintenance, alteration and replacement costs.

**TRADE-OFF.** choice between alternatives based on evaluation of differences in characteristics such as cost, performance, appearance, etc.

**UNCOUPLING.** a planning or design activity involving the disconnection or disentanglement of components to alleviate interference or provide clarity.

**UNIT.** 1. a structurally independent assembly performing a specific function or range of functions. 2. a functionally related set of people, equipment, spaces, missions and activities considered collectively for planning and administrative purposes. See FUNCTIONAL UNIT. 3. a module.

**USER NEEDS.** those conditions the users of a building consider necessary or desirable as environment and support for their activities, without particular reference to how such conditions are to be provided.

**USER REQUIREMENTS.** 1. user needs. 2. performance requirements established directly by a user.