

PPL 17

Regional Planning Team Meetings

Region 4 – January 9, 2007  
Region 3 – January 10, 2007  
Region 2 – January 11, 2007  
Region 1 – January 11, 2007

Initial Fact Sheets and Maps

## Demonstration Projects

**Demo 1 Dredged Containment Demo Project (see  
PPL15-16 demo)**

**Withdrawn by Proposer, WP Edwards III**

## **Dredge Containment System for Marsh Creation Demonstration Project**

### **Coast 2050 Strategy:**

- Coastwide Strategy: Dedicated dredging for wetland creation

### **Project Location:** Coastwide

**Problem:** Containment is one of the most critical and costly aspects associated with designing a beneficial use dredge project. If the environment in which the material is to be discharged does not have features conducive to natural containment, such as spoil banks, ridges, or enclosed marsh, then containment must be constructed using rock or earthen levee created from on-site materials. The problem with such containment is that it 1) requires heavy equipment, which increases cost, 2) is dependant upon the soil condition upon which it is placed, and 3) may be limited by subsurface features (e.g. pipelines) that prevent the building of containment by conventional means.

**Goals:** The overall goal of the project is to demonstrate a cost-effective alternative to traditional containment methods for beneficial use dredging, which potentially expands the feasibility of dredging in areas previously considered unsuitable by soil conditions or obstruction.

**Proposed Solution:** Net Gains LLC recently patented a new cost-effective containment technology. The containment system, which can be constructed in 2-3 feet of open water, consists of a filter cloth or geotextile fabric that is anchored by a chain and floated on the surface by an absorbent boom. The containment can be deployed from a small watercraft, such as an outboard or airboat, with minimal labor. To fasten the containment wall in place during hydraulic dredging anchoring poles are deployed around the perimeter of the containment boom. As sediments are introduced into the containment area, dewatering occurs via a stop-log weir located on the periphery of the boom. Boards are added to the weir to contain the material as sediment accretion occurs. Upon completion of the dredging, the material is allowed to settle and dewater and subsequently may be planted with vegetation. Once vegetation becomes established, the containment cloth as well as the flotation boom may be cut away and the anchor poles removed.

**Project Benefits:** The project provides a potentially cost-effective alternative to traditional containment systems and may also expand options for dredge projects in areas limited by poor soil conditions or contains obstructions such as pipelines.

**Project Costs:** The total fully funded cost for the project is \$1,073,163.

### **Preparer of Fact Sheet:**

Ron Boustany, NRCS (337) 291-3067, ron.boustany@la.usda.gov

## **Demo 2 Bioengineered Oyster Reef Project**

# PPL17 DEMONSTRATION PROJECT NOMINEE FACT SHEET

January 24, 2007

## **Demonstration Project Name: Bioengineered Oyster Reef**

### **Coast 2050 Strategy(ies):**

The project is linked to CWPPRA Region 4 Strategy 15: *Stabilizing Gulf of Mexico Shoreline in the Vicinity of Rockefeller Refuge.*

### **Potential Demonstration Project Location(s)**

Region, Basin, Parish, general location

- Region: CWPPRA Region 4
- Basin: Chenier subbasin of the Mermentau Hydrologic Basin
- Parish: Cameron and Vermillion parishes

### **Problem:**

The purpose of this project is to address rapid shoreline retreat and wetland loss in the Rockefeller Wildlife Refuge. The direct Gulf of Mexico frontage and extremely low (250-330psf) soil load bearing capacity present unique engineering challenges.

Local shoreline retreat at the site averages 30.9 ft/yr. The wetlands contained in the refuge provide essential habitat for numerous aquatic and terrestrial species including migratory waterfowl, endangered species and commercially and recreationally important species. Loss of wetlands also threatens to directly expose Highway 82 to storm waves. Highway 82 is the only hurricane evacuation route for residents of the Chenier plain.

### **Goals:**

The goal of this demonstration project is to evaluate the proposed technique as a cost effective technique for protecting the entire Rockefeller Wildlife Refuge given the unique engineering challenges.

The proposed technique should prevent beach erosion for up to Category 1 hurricane conditions, and, where practicable, should remain stable for up to 100 year storm conditions.

The project would be maintained and monitored for up to 5 years.

### **Proposed Solution:**

The demonstration project would consist of an Oysterbreak, approximately 1000' long. The Oysterbreak is a light-weight, modular shore protection device that uses accumulating biomass (an oyster reef) to dissipate wave energy. The Oysterbreak minimizes manufacture and construction costs by minimizing the amount of material initially placed. The Oysterbreak is constructed by placing modular units into an open interlocked configuration. The units are sized to be stable under storm wave conditions. The height and width of the Oysterbreak are designed to achieve a moderate initial wave energy reduction. However, the bioengineered structure is designed to grow rapidly into an open structured oyster reef utilizing specifically designed structural components with spat attractant and enhanced nutrient conditions conducive to rapid oyster growth. As successive generations of encrusting organisms settle on the Oysterbreak, the

structure's ability to dissipate wave energy increases to equal or possibly exceed a comparable solid rock structure with less reflectance problems associated with solid structures.

**Project Benefits:**

If the Oysterbreak successfully prevents beach erosion, approximately 4.5 acres (1,000 ft x 39 ft/yr x 5 yrs x 1 acre/43,560 sq ft) of wetlands will be protected. Secondary benefits include increased habitat diversity and complexity, increased nekton utilization, and recreational fishing benefits associated with natural oyster reefs.

**Project Costs:**

Estimated costs plus 25% contingency is \$1,125,000.

Costs include concrete rings, forms, equipment, labor to construct, deployment of bio-engineered reef, and four (4) years of monitoring of sedimentation rates, flow rates, wave transmission, reflection and dissipation, settlement rates, oyster growth, growth of other sessile species and monitoring of local populations of mobile species (e.g. fish, crabs, snails).

**Preparer of Fact Sheet:**

John D. Foret, Ph.D., NOAA Fisheries Service, (337) 291-2107, [john.foret@noaa.gov](mailto:john.foret@noaa.gov).

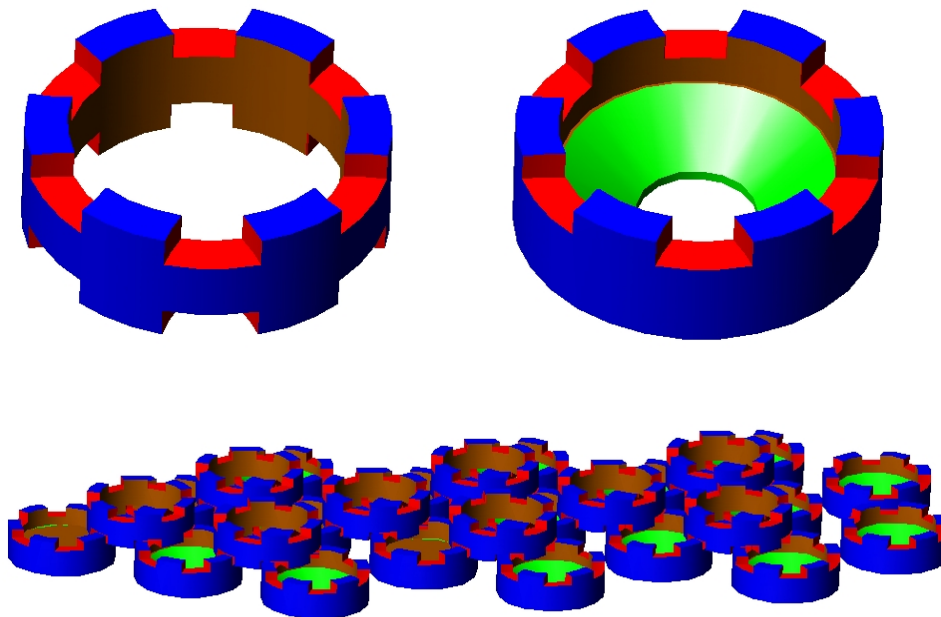





# **Demo 3 Temporary Impact of Dredged Material on Oyster Seed Grounds Project**

## PPL17 DEMONSTRATION PROJECT NOMINEE FACT SHEET

January 24, 2007

**Demonstration Project Name:** Temporary Impact of Dredged Material on Oyster Seed Grounds

Coast 2050 Strategies: The project is linked to the use of dedicated dredging or beneficial use of sediment for wetland creation or protection and other strategies that involve projects requiring disposal of dredge material for access in oyster resource areas.

**Potential Demonstration Project Location(s):**

Region IV, Calcasieu/Sabine Basin, Calcasieu Parish, Calcasieu Lake

**Problem:**

There is a general perception that oyster beds and seed grounds are a major impediment to many coastal restoration projects, particularly on projects that involve direct dredging and disposal of dredged material for access and/or marsh creation in or near oyster resource areas. This possible misconception is also associated with the potential installation and use of sediment delivery pipelines through or near seed grounds and oyster beds. However, it is thought that the true impediment to restoration projects in or near oyster resource areas is the applied limits of construction and materials transportation technologies.

Standard methods for project area access typically involve prop washing or bucket dredging. Marsh creation can result in more than incidental discharge of dredged material into adjacent open waters. Where sediment delivery pipelines are installed in or near open waters, there is always a risk of a pipeline blowout that could result in a damaging sediment discharge. These expected or potential discharges permanently impact oyster beds and larval recruitment by direct deposit, and by suspension and subsequent resettling of sediment.

**Goals:** This demonstration project would analyze existing and potential construction and materials transportation techniques to determine possible low impact/low risk and cost effective measures that could be applied to improve the feasibility of wetland restoration projects in Louisiana's oyster resource and other sensitive marine areas.

**Proposed Solution:**

Currently undefined.

**Project Benefits:**

Enable restoration projects in sensitive oyster resource areas.

**Project Costs:**

Estimated cost to implement demonstration project. \$1 million

**Preparer(s) of Fact Sheet:**

Melanie Goodman, US Army Corps of Engineers, 504-862-1940,  
Melanie.L.Goodman@mvn02.usace.army.mil

# Demo 4 Casted Concrete Shoreline Protection Demo

# PPL17 DEMONSTRATION PROJECT NOMINEE FACT SHEET

January 31, 2007

## **Demonstration Project Name: Casted Concrete Shoreline Protection**

### **Coast 2050 Strategy(ies):**

Coastwide Strategy: Maintenance of Gulf Bay, lake shoreline integrity, and the stabilization of the width and depth of major navigation channels and other water bodies at their point of intersection.

### **Potential Demonstration Project Location(s):**

Interior shorelines

### **Problem:**

Along the coast there are areas where shoreline erosion needs to be addressed and use of rock may be problematic.

### **Goals:**

The goal of this demonstration project is to utilize concrete barriers in place of rock in order to establish shoreline protection/stabilization, and reduce erosion of existing wetlands.

### **Proposed Solution:**

Place casted concrete barrier approximately 20 feet in front of levees to be used as a barrier for stabilization along the shoreline and promote vegetative growth. Oysters can also propagate on the barrier.

### **Project Benefits:**

Protect the shoreline

### **Project Costs:**

Approximately: \$50,000- \$100,000

### **Preparer(s) of Fact Sheet:**

Kelley Templet, LDNR / [kelley.templet@la.gov](mailto:kelley.templet@la.gov) (225) 342-1592

Troy Mallach, NRCS / [troy.mallach@la.usda.gov](mailto:troy.mallach@la.usda.gov) (337) 291-3064

Curt Marcantel, landowner

**Demo 5 Sediment Containment for Marsh  
Creation Project (see PPL 16)**

**PPL 17 DEMONSTRATION PROJECT NOMINEE FACT SHEET**  
1/10/2007

**Project Name Sediment Containment for Marsh Creation**

**Coast 2050 Strategy**

- Management of diversion outfall for wetland benefits
- Dedicated dredging to create restore or protect wetlands

**Project Location**

Coastwide

**Problem**

Small and medium freshwater diversions that flow into broad areas and small dredge projects require confinement and trapping features to form marsh because the materials entering the area are often too dilute or fine to result in any appreciable accumulation. A method to delineate smaller areas to concentrate sediments flowing across an area would improve suspended sediment retention efficiency and allow accumulations to occur within a more timely and cost-effective manner. A sediment trapping mechanism would also allow for taking advantage of finer materials that would otherwise largely flow through the target area or require costly construction of some form of containment.

**Goals**

The overall goal of the project is to demonstrate the effectiveness of a sediment trapping system to strategically define areas of accumulation and improve the efficiency of passive sediment retention in small and medium freshwater diversions as well as mechanized introduction of fluid material to create marsh.

**Proposed Solution**

The project will demonstrate the effectiveness of a sediment trapping system designed for dredge containment to facilitate both sediment retention and accumulation in freshwater diversion that are located in broad areas where sediments tend to dissipate and to demonstrate the ability of the system to perform in small dredge applications. The project will demonstrate that by isolating areas where accumulation can be concentrated accretion rates will be greatly enhanced and speed up marsh creation.

**Project Benefits**

The project will benefit any area in coastal Louisiana by facilitating containment where suspended sediment load is adequate for potential marsh development but retention is low due to broad open water expanse or channelization. The project will also benefit small dredge projects by providing a cost-effective alternative to earthen containment, particularly in areas where construction of earthen containment may be problematic (e.g. flow lines and poor soils).

**Project Cost**

Construction + 25% Contingency = \$650,000

**Preparer of Fact Sheet**

Ron Boustany, NRCS (337) 291-3067, [ron.boustany@la.usda.gov](mailto:ron.boustany@la.usda.gov)

# Sediment Containment System for Marsh Creation

\*Containment System for Dedicated Dredge

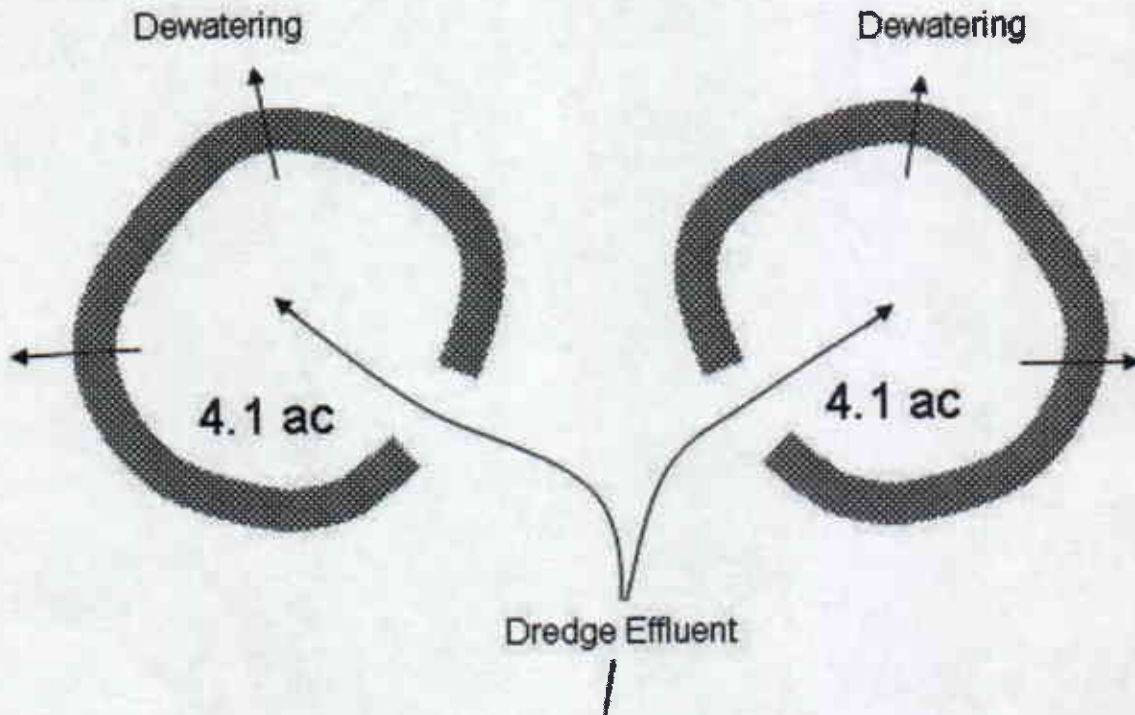

Passive Catchment

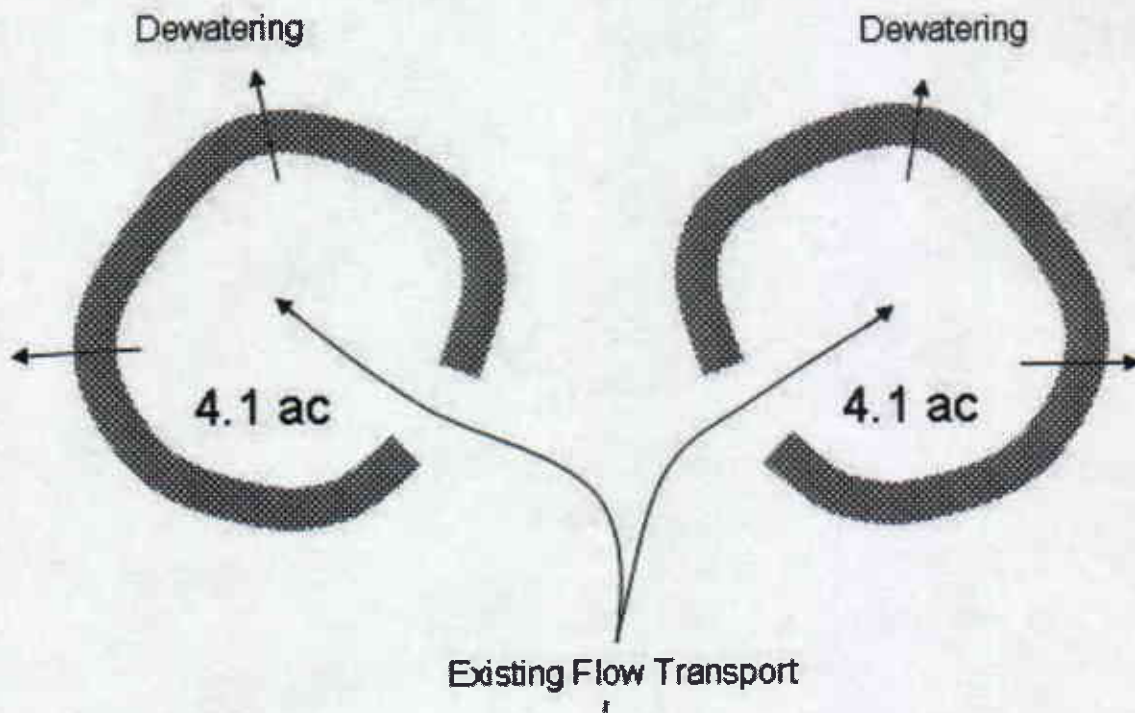

\* Each application will consist of 2 units placed @ 1500' circumference

# **Demo 6 Agrinaut Project -Autonomous Hydroponic Vessels**





**SPARTINA FARMS  
WETLAND NURSERY**  
1332 Briarridge Drive  
Baton Rouge, LA 70810

SPARTINAFARMS.COM  
225-766-9206

The following is a proposal to use a patent pending process titled "A System for Growing Vegetation on an Open Body of Water", to be known as AGRINAUT: Autonomous Hydroponic Vessels (AHV). The sole licensee of the product is Becker Bioengineering, LLC at this time. The control software, programmable computer, interface and database are the intellectual property rights of Space Metrics, LLC. Spartina Farms, LLC is subcontracted for the assembly, planting, maintenance and harvest of the vessels. Spartina Farms, LLC is in affiliation with the Center for Innovation at the University of New Orleans.

**INNOVATION:** AHV are solar powered pneumatically operated platforms of geotextile or biodegradable fiber material hung over iron pipe connected by structural fittings planted with vegetation. The vessels normal programs are to rise and fall into and out of the water in order to create increased plant yield and nutrient transformation. The data acquired from the system denotes operating parameters, water condition, as well as biomass onboard. AHV can be scuttled in hurricane conditions.

**COST:** Louisiana State University College of Business conducted a study of our process the results determined the cost to setup and operate for one year to be \$108,456 per acre. Our vessels can withstand years of cultivation. A single acre of *Spartina alterniflora* sold in trade gallon would have a value of nearly double the initial setup fee (174,240 x \$ value of plant).

**HABITAT ENHANCEMENT:** The main feature of the vessels is that the raising and lowering of the vessel has stimulated increased yields in wetland vegetation. AHV supports wetland species in salt brackish and fresh water areas. Vegetative growth is achieved by altering the tidal period flood or ebb tides to create optimal environments for terrestrial and intertidal species. The vessels can not restrict water flow beneath but are designed to retain freshwater surface runoff in estuarine environments during ebb tides. Bioremediation of particulate and nutrient runoff can be controlled at the surface where plant roots can filter the water for dredge or river diversion mitigation. The vessels provide cover to fish, forage to birds, insects and mammals and support most marsh species. Protecting the oyster reefs from sediment deposition would be addressed by this system.

**DATA ACQUISITION:** Before Hurricane Katrina the vessels were scuttled and recovered after the storm outside of the hurricane protection levee near New Orleans. We are currently designing a wave tank study to understand how the vessels may be used to dampen and survive future storm waves. Altering the artificial tide cycle allows study of flooding effects on wetland species as well as understanding global sea level rise. Biomass

fluctuation is of importance to wetland valuation. Operators are capable of measuring the pressure on the vessels when pneumatically lifted in order to obtain biomass measurements. The correlation of biomass and leaf tissue sample analysis denotes Nitrogen, Carbon, Salt uptake and bioremediation rate. As we send wireless commands to the vessels we can receive water quality measurements as well as vessel parameters these data are assembled into a database for analysis of wetland function.

**PROPOSAL:** A  
**REGION:** LaBRANCHE

Vegetative Planting/ Hydraulic Restoration  
St Charles Parish, LA

Install fresh and salt marsh vegetation in the La\_Branche wetlands to retain fresh water. One acre demonstration operated for one year at a cost of approximately \$100,000 per year. Studies include species diversity, total biomass, relative growth rate, pH, eH, vertical accretion rate.



St Charles Parish, LA LaBranche (Yellow Box)



Vegetative Planting / Hydraulic Restoration



**SPARTINA FARMS**  
**WETLAND NURSERY**  
 1332 Briarridge Drive  
 Baton Rouge, LA 70810

SPARTINAFARMS.COM  
 225-766-9206

The following is a proposal to use a patent pending process titled "A System for Growing Vegetation on an Open Body of Water", to be known as AGRINAUT: Autonomous Hydroponic Vessels (AHV). The sole licensee of the product is Becker Bioengineering, LLC at this time. The control software, programmable computer, interface and database are the intellectual property rights of Space Metrics, LLC. Spartina Farms, LLC is subcontracted for the assembly, planting, maintenance and harvest of the vessels. Spartina Farms, LLC is in affiliation with the Center for Innovation at the University of New Orleans.

**INNOVATION:** AHV are solar powered pneumatically operated platforms of geotextile or biodegradable fiber material hung over iron pipe connected by structural fittings planted with vegetation. The vessels normal programs are to rise and fall into and out of the water in order to create increased plant yield and nutrient transformation. The data acquired from the system denotes operating parameters, water condition, as well as biomass onboard. AHV can be scuttled in hurricane conditions.

**COST:** Louisiana State University College of Business conducted a study of our process the results determined the cost to setup and operate for one year to be \$108,456 per acre. Our vessels can withstand years of cultivation. A single acre of *Spartina alterniflora* sold in trade gallon would have a value of nearly double the initial setup fee (174,240 x \$ value of plant).

**HABITAT ENHANCEMENT:** The main feature of the vessels is that the raising and lowering of the vessel has stimulated increased yields in wetland vegetation. AHV supports wetland species in salt brackish and fresh water areas. Vegetative growth is achieved by altering the tidal period flood or ebb tides to create optimal environments for terrestrial and inter tidal species. The vessels can not restrict water flow beneath but are designed to retain freshwater surface runoff in estuarine environments during ebb tides. Bioremediation of particulate and nutrient runoff can be controlled at the surface where plant roots can filter the water for dredge or river diversion mitigation. The vessels provide cover to fish, forage to birds, insects and mammals and support most marsh species. Protecting the oyster reefs from sediment deposition would be addressed by this system.

**DATA ACQUISITION:** Before Hurricane Katrina the vessels were scuttled and recovered after the storm outside of the hurricane protection levee near New Orleans. We are currently designing a wave tank study to understand how the vessels may be used to dampen and survive future storm waves. Altering the artificial tide cycle allows study of flooding effects on wetland species as well as understanding global sea level rise. Biomass

fluctuation is of importance to wetland valuation. Operators are capable of measuring the pressure on the vessels when pneumatically lifted in order to obtain biomass measurements. The correlation of biomass and leaf tissue sample analysis denotes Nitrogen, Carbon, Salt uptake and bioremediation rate. As we send wireless commands to the vessels we can receive water quality measurements as well as vessel parameters these data are assembled into a database for analysis of wetland function.

**PROPOSAL:** B  
**REGION:** CAMINADA

Habitat Enhancement/ Dredge Mitigation  
 Leeville, LA Wisner WMA

Restore water quality and provide habitat for the estuary in the Wisner WMA. One acre demonstration operated for one year at a cost of approximately \$100,000 per year. Studies include water velocity, turbidity, accretion rate, nutrient uptake and salinity.



Leeville, LA Wisner WMA (Yellow Box)

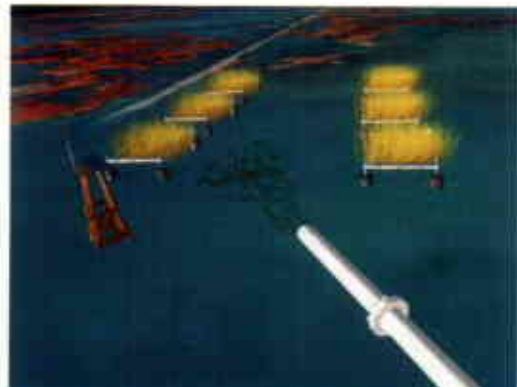

Habitat Enhancement/ Dredge Mitigation



**SPARTINA FARMS**  
**WETLAND NURSERY**  
 1332 Briarridge Drive  
 Baton Rouge, LA 70810

SPARTINAFARMS.COM  
 225-766-9206

The following is a proposal to use a patent pending process titled "A System for Growing Vegetation on an Open Body of Water", to be known as AGRINAUT: Autonomous Hydroponic Vessels (AHV). The sole licensee of the product is Becker Bioengineering, LLC at this time. The control software, programmable computer, interface and database are the intellectual property rights of Space Metrics, LLC. Spartina Farms, LLC is subcontracted for the assembly, planting, maintenance and harvest of the vessels. Spartina Farms, LLC is in affiliation with the Center for Innovation at the University of New Orleans.

**INNOVATION:** AHV are solar powered pneumatically operated platforms of geotextile or biodegradable fiber material hung over iron pipe connected by structural fittings planted with vegetation. The vessels normal programs are to rise and fall into and out of the water in order to create increased plant yield and nutrient transformation. The data acquired from the system denotes operating parameters, water condition, as well as biomass onboard. AHV can be scuttled in hurricane conditions.

**COST:** Louisiana State University College of Business conducted a study of our process the results determined the cost to setup and operate for one year to be \$108,456 per acre. Our vessels can withstand years of cultivation. A single acre of *Spartina alterniflora* sold in trade gallon would have a value of nearly double the initial setup fee (174,240 x \$ value of plant).

**HABITAT ENHANCEMENT:** The main feature of the vessels is that the raising and lowering of the vessel has stimulated increased yields in wetland vegetation. AHV supports wetland species in salt brackish and fresh water areas. Vegetative growth is achieved by altering the tidal period flood or ebb tides to create optimal environments for terrestrial and intertidal species. The vessels can not restrict water flow beneath but are designed to retain freshwater surface runoff in estuarine environments during ebb tides. Bioremediation of particulate and nutrient runoff can be controlled at the surface where plant roots can filter the water for dredge or river diversion mitigation. The vessels provide cover to fish, forage to birds, insects and mammals and support most marsh species. Protecting oyster reefs from sediment deposition would be addressed by this system.

**DATA ACQUISITION:** Before Hurricane Katrina the vessels were scuttled and recovered after the storm outside of the hurricane protection levee near New Orleans. We are currently designing a wave tank study to understand how the vessels may be used to dampen and survive future storm waves. Altering the artificial tide cycle allows study of flooding effects on wetland species as well as understanding global sea level rise. Biomass

fluctuation is of importance to wetland valuation. Operators are capable of measuring the pressure on the vessels when pneumatically lifted in order to obtain biomass measurements. The correlation of biomass and leaf tissue sample analysis denotes Nitrogen, Carbon, Salt uptake and bioremediation rate. As we send wireless commands to the vessels we can receive water quality measurements as well as vessel parameters these data are assembled into a database for analysis of wetland function.

**PROPOSAL:** C  
**REGION:** Mississippi River Gulf Outlet (MRGO)

Shoreline Protection / Wave Damping  
 St Bernard Parish, LA MRGO

Maintain Northern Shoreline of the Mississippi River Gulf Outlet land bridge and Lake Borgne. One acre demonstration operated for one year at a cost of approximately \$100,000 per year. Studies include water velocity, wave height, salinity and sediment accumulation rates.



**St Bernard Parish, LA MRGO (Yellow Box)**



**Shoreline Protection / Wave Damping**

**Demo 7 Beach Angel Project- Zero Velocity Sand Trap**

**Demo 8 Beach Angel Project- Zigzag/ Sand Trap Jetty**

**Demo 9 Beach Angel Project -**

**Continuous Process Sand Dune Building Operation**

**Demo 10 Beach Angel Project-**

**Coconut Beach Protection and Beautification**

**Demo 11 Beach Angel Project -**

**Ethical Mississippi River Dredge Material Disposal**

Coastal Restoration And Protection Proposed Projects Presented to CWPPRA on 1/11/07  
By R. M. Nettles New Orleans, Louisiana

### Beach Angel

Beach Angel is an idea dreamed of in late 2006 by R.M. Nettles to help protect and restore Coastal Louisiana.  
Particularly the Barrier Islands and thier Beaches

The idea is basically to approach coastal industries and request them to donate their surplus large movable equipment (ships, crew boats, jackups, tug boats, airplanes, helicopters, heavy equipment, etc) which Beach Angel would then sell and use the funds for coastal projects  
Industries could take the tax right off and it could be a win win for all involved.

Emphasis on Low Cost High Impact Ideas For coastal protection and restoration

Primaray focus on using on location filled natural fiber pre made bags  
and on site sewn natural fiber tubes and bags  
to trap sand washed inland by the natural wave action and tidal fluctuations

### Proposed Projects

1. Zero velocity Sand Trap Project
2. Zigzag Sand Bag / Sand Trap Jetty
3. 20' Honey Hole, 20'Sand Dunes and 400 HP 40' Dredges ( continuous process sand dune building operation )
4. Ten containers of coconuts 75 miles of beach protection
5. Mississippi River dredge material Disposal

### Grande Terre Zero velocity Sand Trap Project

Place natural fiber sandbags in a single file single row along the Barrier Island Beaches so that the top of the sandbags are even with the low tide waterline.  
Sand Bags would be filled on location using bottom sand pumped from the location of placement using a small trash or dredge pump (5-10 Horsepower)  
This placement would take full advantage of that moment of zero velocity wave action which happens when the last breaker hits the beach and the water and sand begin to get sucked back into the Gulf.  
This sand bag placement would allow the breakers to wash suspended sand over the top of the bag and trap the sand which falls to the bottom at that moment of zero velocity

### Grande Terre Zigzag Sand Bag / Sand Trap Jetty

Place large natural fiber sand filled bags in a zigzag jetty configuration between Grande Terre East and West to attempt to reconnect the islands and better protect the Baataria bay estuary.  
Sand bags would be filled on sight using bottom material pumped into the bags with a small dredge or pump. Bags would be filled where they will lay and would not have to be handled. An opening large enough to allow for vessel passage would be left at the small end of each funnel.

20' Honey Hole, 20' Sand Dunes and 400 HP 40' Dredges ( continuous process sand dune building operation)

Couple a 400 hp 40' dredge with a 400 hp excavator and a farm tractor to make a continuous process sand dune building operation capable of building 50 linear feet of 40' sand dune/protection levee per hour  
In addition to building dunes a similar size trench (Honey Hole) will be created in approximately 20' of water which will provide coastal marine life a place of protection from extreme temperature fluctuation and will concentrate fish for recreational fisherman

Ten containers of coconuts 75 miles of beach protection

Purchase 10 containers of coconuts and plant 4 rows deep on barrier island beaches

10 containers at 15,000 coconuts each equals 150,000 coconuts at 2000 coconuts per mile of beach equal 75 miles of natural beach protection and beautification.  
Will probably have to be replant every 25 years due to hard freezes which rarely happen on the extreme Gulf side of the barrier islands

### Ethical Mississippi River dredge material Disposal

Fill large bulk type natural fiber bags (approximately 2000 lbs each) with Mississippi River dredge material. Use hopper type ships to carry it to disposal sites for coastal nourishment. This method would allow the river silt to be slowly integrated into its new location without shocking the marine environment and provide much needed erosion control.

Contact information:

Rory M. Nettles  
7445 Lindsly Lane  
Ventress, LA 70783

Cell 225-937-8521  
email rorynettles@yahoo.com

**Demo 12      Barrier Islands Mangrove Planting  
Project (No Fact Sheet)**

# PPL17 PROJECT NOMINEE FACT SHEET

## January 2007

### Project Name

Mangrove Plantings for Barrier Island Restoration

### Coast 2050 Strategy

Goal 1: Assure vertical accumulation to achieve sustainability.

Goal 3: Maintain exchange and interface to achieve system linkages,

Coastwide Common Strategies: Vegetative Planting

Regional Ecosystem Strategies: Restore and Maintain Barrier Islands

### Project Location

Barrier Island and/or headlands in the coastal zone.



### Problem

The importance of mangrove swamps has been well established, particularly in estuarine systems. They function as nurseries for shrimp and recreational fisheries, exporters of organic matter to adjacent coastal food chains, and enormous sources of valuable nutrients. Their physical stability helps to prevent shoreline erosion, shielding inland areas from severe damage during hurricanes and tidal waves. However, native mangrove populations in Louisiana have decreased over time and significant decline in their integrity and productivity has been observed. Additionally, regeneration is severely hampered by altered hydrology and other stressors.

Mangrove restoration specialists have documented that the major issue with the failure of mangrove restoration projects is the lack of understand of mangrove hydrology. Although a number of papers discuss the science of mangrove hydrology, their focus has been on tidal and freshwater flows within the forests, and not the critical periods of inundation<sup>1</sup>.

### Proposed Project Features

The proposed project will increase or establish populations of black mangrove, *Avicennia germinanas*, on barrier islands or headlands at a site in coastal Louisiana. Emphasis will be on mangrove hydrology to advance the scientific body of knowledge regarding mangrove restoration techniques. Lewis has stated that the single most important factor in designing a successful mangrove restoration project is determining the normal hydrology (depth, duration and frequency, and of tidal flooding) of existing natural mangrove plant communities (a reference site) in the area in which restoration is to be accomplished. Planting of mangroves will only be necessary if natural recruitment is not likely due to lack of propagules or presence of soil conditions that prohibit natural establishment. The demonstration project will need to be monitored for a minimum of 5 years to allow mangrove plantings to mature.

### Preliminary Project Benefits

Create critical wetland habitat that will promote vertical accumulation of sediments and improve the saltwater wetland interface to restore barrier island habitat functions and values, while advance knowledge of mangrove restoration techniques in coastal Louisiana.

---

<sup>1</sup> Lewis, R.R., and Streever, B. (2000). "Restoration of mangrove habitat," *WRP Technical Notes Collection* (ERDC TN-WRP-VN-RS-3.2), U.S. Army Engineer Research and Development Center, Vicksburg, MS. [www.wes.army.mil/el/wrp](http://www.wes.army.mil/el/wrp)



**Identification of Potential Issues**

Agreements landowners will be needed at identified sites.

**Preliminary Construction Costs**

\$1,000,000

**Preparer of Fact Sheet**

Marnie Winter

Jefferson Parish Department of Environmental Affairs

5-4-736-6443

[mwinter@jeffparish.net](mailto:mwinter@jeffparish.net)

## Reference:

Lewis, R.R., and Streever, B. (2000). "Restoration of mangrove habitat," *WRP Technical Notes Collection* (ERDC TN-WRP-VN-RS-3.2), U.S. Army Engineer Research and Development Center, Vicksburg, MS. [www.wes.army.mil/el/wrp](http://www.wes.army.mil/el/wrp)



TIMOTHY P. KERNER  
MAYOR

YVETTE CRAIN  
TOWN CLERK

CLARENCE MATHERNE, JR  
CHIEF OF POLICE

TOWN OF JEAN LAFITTE  
OFFICE OF THE MAYOR



2654 Jean Lafitte Blvd.  
Lafitte, Louisiana 70067  
Office: (504) 689-2208  
Police: (504) 689-3132  
Fax: (504) 689-7801

March 15, 2005

Miss Marnie Winter  
1221 Elmwood Park Blvd.  
Suite 1006  
Jefferson, LA 70123

Dear Miss Winter:

Enclosed is information about a plant used in certain areas to stop Coastal Erosion. I thought you might be interested in this information.

Sincerely,

Timothy P. Kerner  
Mayor



COUNCIL MEMBERS

LEO E. KERNER, JR.  
MAYOR PROTEM

ELAINE BADEAUX  
SHIRLEY GUILLIE  
VERNA SMITH  
CALVIN LEBEAU

MAR 15 2005

## Mangroves

<a href="#"><u>What Are Mangroves?</u></a>	<a href="#"><u>Why Are Mangroves Important?</u></a>	<a href="#"><u>Mangrove tree Identification</u></a>	<a href="#"><u>Mangrove Removal Regulations</u></a>	<a href="#"><u>Mangrove Pruning Regulations</u></a>	<a href="#"><u>Links</u></a>	<a href="#"><u>References</u></a>
--	---	---	---	---	------------------------------	-----------------------------------

### WHAT ARE MANGROVES?

[TOP](#)

Mangroves are trees and shrubs that grow in tropical and subtropical tidelands throughout the world. Mangroves grow in areas that are frequently inundated with salt water due to tidal activity of gulfs, seas and oceans. Mangroves are able to thrive salt water inundation because of specialized rooting structures (such as prop roots and pneumatophores), specialized reproduction (vivipary or live birth) and the ability to exclude or excrete salt. Mangroves grow exclusively in these tidal areas in large stands or groves to where these areas are referred to as their own ecological community, collectively called mangroves.



In Florida, mangroves include four tree species: red mangrove (*Rhizophora mangle*), black mangrove (*Avicennia germinans*), white mangrove (*Laguncularia racemosa*) and buttonwood (*Conocarpus erectus*). Each mangrove species has a different level of salt tolerance, which in part determines its location in tidal zones.

---

### WHY ARE MANGROVES IMPORTANT?

[TOP](#)

The mangrove community is valued for its protection and stabilization of lowlying coastal lands and its importance in estuarine and coastal fishery food chains. Mangrove forests protect uplands from storm winds, waves, and floods. The amount of protection afforded by mangroves depends upon the width of the forest. Mangroves can help prevent erosion by stabilizing shorelines with their specialized root systems.

The relationship between mangroves and their associated marine life cannot be overemphasized. Mangroves provide protected nursery areas for fishes, crustaceans, and shellfish. Seventy-five percent of the game fish and ninety percent of the commercial species in south Florida are dependent on mangrove ecosystems (Law and Pywell FRC-43). They provide food for a multitude of marine species such as snook, snapper, tarpon, jack, sheepshead, red drum, oyster, and shrimp.

Many animals find shelter either in the roots or branches of mangroves. Mangroves serve as rookeries, or nesting areas, for beautiful coastal birds such as brown pelicans and roseate spoonbills.

---

## MANGROVE TREE IDENTIFICATION

[TOP](#)

### Red Mangrove

### Black Mangrove

### White Mangrove

Buttonwood

---

## MANGROVE REMOVAL REGULATIONS

[TOP](#)

Mangrove trees along natural and many artificial water bodies are protected from removal. Mangrove trees are protected from removal by [Dock and Shoreline](#) regulations, the natural waterway buffer requirement and the Tree Protection Ordinance. In many cases, mangrove trees can not be removed without first obtaining a vegetation removal permit from Lee County. Mangroves are typically [wetlands](#). Impacts or removal of mangrove [wetlands](#) may require permits from state and federal agencies.

---

## MANGROVE PRUNING REGULATIONS

[TOP](#)

Since July 1, 1996, Lee County is generally not involved in the regulation of mangrove tree pruning. Below are state agencies that permit mangrove pruning per the Mangrove Trimming and Preservation Act (Florida Statutes Sections [403.9321-403.9333](#))

### FLORIDA DEPARTMENT OF ENVIRONMENTAL PROTECTION - (DEP)

South Florida District Office  
2295 Victoria Avenue, Suite 364  
Fort Myers, FL 33901  
Telephone (239) 332-6975  
Fax (239) 332-6969  
<http://www.dep.state.fl.us/>

---

## LINKS

[TOP](#)

[Florida Department of Environmental Protections](#)

University of Florida Medical Entomology Laboratory - Mangroves

University of Florida Institute of Food and Agricultural Sciences - Mangroves

University of Florida Medical Entomology Laboratory - Coastal Wetlands

---

REFERENCES

TOP

1. Argo, V. 1963. Root growth claims soil from the sea. *Natural History* 72: 52-56.
2. Chapman, V.J. *Mangrove Vegetation*. Strauss and Cramer GmbH, Germany, 1976.
3. Craighead, Frank C. 1964. Land, mangroves and hurricanes. *Fairchild Tropical Garden Bulletin* 19(4). 4. Davis, J.H. 1940. Ecology and geologic role of mangroves in Florida. *Carnegie Institute* 22: 303-412.
5. Division of Forestry. "Coastal Plants of Florida - A Key to Good Land Management." 1979.
6. Elias, T.S. (1980) *Trees of North America*. Outdoor Life/Nature Books, New York, 1980.
7. Gore, R. "The Tree Nobody Liked." *National Geographic* v. 151(5), 1977. National Geographic Society, Washington, D.C.
8. Harrar, E.S. and J.G. Harrar. *Guide to Southern Trees*. Dover Publications, Inc., New York, 1962.
9. Jimenez, J.A. and A.E. Lugo. (1985) "*Rhizophora mangle* L. - Red Mangrove." SO-ITF-SM-2. U.S. Government Printing Office, Washington, D.C., 1985.
10. Jimenez, J.A. and A.E. Lugo. "*Avicennia germinans* (L.) L. - Black Mangrove." SO-ITFSM-4. U.S. Government Printing Office, Washington, D.C., 1985.
11. Law, Beverly E. and Nancy A. Pyrell *Mangroves-Florida's Coastal Trees* Forest Resources and Conservation Fact Sheet FRC-43 UNIVERSITY OF FLORIDA/Cooperative Extension Service/Institute of Food and Agricultural Sciences
12. Myers, Ronald L. and John J. Ewel *Ecosystems of Florida* University of Central Florida Press/Orlando (1990)
13. Rabkin, R., and Rabkin, J. *Nature Guide to Florida*. Banyan Books, Miami, 1978.
14. Snedaker, S.C. "Mangroves: Their value and perpetuation." *Nature and Resources*. v. 15(3): 6- 13. Unesco: Paris, France, 1978.

15. Snedaker, S.C. and M.S. Brown. "Mangrove Misconceptions and Regulatory Guidelines." Proc. U.S. Fish and Wildlife Service Workshop on Coastal Ecosystems of the S.E. U.S., U.S. Fish and Wildlife Service, Washington, D.C., 1981. p. 61-67.

16. United States Department of Agriculture Soil Conservation Service, "26 Ecological Communities of Florida." 1985.

17. Van Tine, Melissa and Samuel C. Snedaker. 1974. *A bibliography of the mangrove literature*. Resource Management Systems Program, School of Forest Resources and Conservation, Institute of Food and Agricultural Sciences, University of Florida, Gainesville, FL. No pagination. (Prepared for the International Symposium on Biology and Management of Mangroves, October 8-11, 1974, Honolulu, Hawaii.)

18. Workman, R.W. (1980) *Growing Native*. Sanibel-Captiva Conservation Foundation, Inc., Sanibel, 1980.

**[back to Environmental Sciences](#)**

**[return to the top](#)**



# Florida's Mangroves

## "Walking Trees"

Department of Environmental Protection  
Florida Marine Research Institute  
100 Eighth Avenue, S.E.  
St. Petersburg, FL 33701-5095

### What Are Mangroves?

Mangroves are one of Florida's true natives. They thrive in salty environments because they are able to obtain fresh water from saltwater. Some secrete excess salt through their leaves, others block absorption of salt at their roots.

Florida's estimated 469,000 acres of mangrove forests contribute to the overall health of the state's southern coastal zone. This ecosystem traps and cycles various organic materials, chemical elements, and important nutrients. Mangrove roots act not only as physical traps but provide attachment surfaces for various marine organisms. Many of these attached organisms filter water through their bodies and, in turn, trap and cycle nutrients.

The relationship between mangroves and their associated marine life cannot be overemphasized. Mangroves provide protected nursery areas for fishes, crustaceans, and shellfish. They also provide food for a multitude of marine species such as snook, snapper, tarpon, jack, sheepshead, red drum, oyster, and shrimp. Florida's important recreational and commercial fisheries will drastically decline without healthy mangrove forests.

Many animals find shelter either in the roots or branches of mangroves. Mangrove branches are rookeries, or nesting areas, for beautiful coastal birds such as brown pelicans and roseate spoonbills.

### Florida's Mangroves

Worldwide, more than 50 species of mangroves exist. Of the three species found in Florida, the red mangrove, *Rhizophora mangle*, is probably the most well-known. It typically grows along the water's edge. The red mangrove is easily identified by its tangled, reddish roots called "prop roots." These roots have earned mangroves the title, "walking trees." The mangrove appears to be standing or walking on the surface of the water.

The black mangrove, *Avicennia germinans*, usually occupies slightly higher elevations upland from the red mangrove. The black mangrove can be identified by numerous

ed Mangrove (*Rhizophora mangle*)



Black Mangrove (*Avicennia germinans*)

White mangrove (*Laguncularia racemosa*)



Artwork courtesy of U.S. Fish & Wildlife Service

finger-like projections, called pneumatophores, that protrude from the soil around the tree's trunk.

The white mangrove,

*Laguncularia racemosa*, usually occupies the highest elevations farther upland than either the red or black mangroves. Unlike its red or black counterparts, the white mangrove has no visible aerial root systems. The easiest way to identify the white mangrove is by the leaves. They are elliptical, light yellow green and have two distinguishing glands at the base of the leaf blade where the stem starts.

All three of these species utilize a remarkable method of propagation. Seeds sprout while still on the trees and drop into the soft bottom around the base of the trees or are transported by currents and tides to other suitable locations.

Florida's mangroves are tropical species; therefore, they are sensitive to extreme temperature fluctuations as well as subfreezing temperatures. Research indicates that salinity, water temperature, tidal fluctuations, and soil also affect their growth and distribution. Mangroves are common as far north as Cedar Key on the Gulf coast and Cape Canaveral on the Atlantic coast. Black mangroves can occur farther north in Florida than the other two species. Frequently, all three species grow intermixed.

People living along the south Florida coasts benefit many ways from mangroves. Mangrove forests protect uplands from storm winds, waves, and floods. The amount of protection afforded by mangroves depends upon the width of the forest. A very narrow fringe of mangroves offers limited protection, while a wide fringe can considerably reduce wave and flood damage to landward areas by enabling overflowing water to be absorbed into the expanse of forest. Mangroves can help prevent erosion by stabilizing shorelines with their specialized root systems. Mangroves also filter water and maintain water quality and clarity.

### Mangrove Losses in Florida

It is true that mangroves can be naturally damaged and destroyed, but there is no doubt that human impact has been most severe. Department of Environmental Protection, Florida Marine Research Institute scientists are studying changes in Florida's coastal habitats. The scientists are able to evaluate habitat changes by analyzing aerial photographs from the 1940's and 1950's and satellite imagery and aerial photography from the 1980's. Frequently the changes illustrate loss of mangrove acreage. Through researching the history of study sites, these losses are often attributed to human activities.



Tampa Bay, located on the southwest Florida coast, has experienced considerable change. It is one of the ten largest ports in the nation. Over the past 100 years, Tampa Bay has lost over 44 percent of its coastal wetlands acreage; this includes both mangroves and salt marshes.

The next major bay system south of Tampa Bay, Charlotte Harbor is one of the least urbanized estuarine areas in Florida. However there has been some mangrove destruction here also. Punta Gorda waterfront development accounts for 59 per cent of the total loss. An increase in mangrove acreage was noted in parts of the Harbor. This is due to changes in the system. As tidal flats were colonized by mangroves, tidal flat acreage decreased while mangrove acreage increased. Spoil islands, created as by-products of dredging, provided suitable habitat for mangroves.

A changing system was also observed on the Southeast Florida coast in Lake Worth, near West Palm Beach. Lake Worth naturally evolved from a saltwater lagoon to a freshwater lake. Human changes modified the lake back to an estuarine lagoon. Lake Worth has experienced an 87 per cent decrease of its mangrove acreage over the past forty years. Mangroves appear to be replaced by Australian Pines and urbanization. The remaining 276 acres of mangroves occur in very small areas and are now protected by strict regulations.

Another study site included the Indian River from St. Lucie inlet north to Satellite Beach. Indian River is the longest saltwater lagoon in Florida. There are just less than 8,000 acres of mangroves within the study site, but only 1,900 are available as fisheries habitat because of mosquito impoundments. Consequently, 76 percent of the existing mangrove areas are not productive to fisheries. A total of 86 percent of the mangrove areas have been lost to fisheries since the 1940's.

State and local regulations have been enacted to protect Florida's mangrove forests. Local laws vary. Be sure to check with officials in your area prior to taking any action, to determine if a permit is required.

Mangroves are one of Florida's true natives and are part of our state heritage. It is up to us to ensure a place in Florida's future for one of our most valuable coastal resources- mangroves.

This publication was produced at a cost of \$1,995.60 or \$.10513 a copy, to distribute information on Florida's Coastal Environment, funded by the Department of Environmental Protection, Florida Marine Research Institute. Original production funds provided by DER office of Coastal Management through a grant from the U.S. Office of Ocean and Coastal Resource Management, NOAA, under the Coastal Zone Management Act of 1972, as amended.

**Demo 13      Positive Displacement Pump Solution  
Restoration Project**

## **PPL17 DEMONSTRATION PROJECT NOMINEE FACT SHEET**

January 30, 2007

### **Demonstration Project Name:**

Positive Displacement Pump Solution Project

### **Coast 2050 Strategy(ies):**

Coastwide Strategies: Dedicated dredging to create, restore, or protect wetlands  
Offshore and riverine sand and sediment sources

### **Potential Demonstration Project Location(s):**

Coastwide, preferably Region 1, Barataria Basin, Jefferson or Plaquemines Parish

### **Problem:**

Areas in need of restoration are often many miles away from a suitable sediment source or one that would introduce new sediments into the coastal ecosystem. Current pipeline sediment conveyance technology requires booster pumps to convey a sediment slurry farther than about 2-3 miles. Booster pumps add an additional layer of complexity to implementing a project and each require their own operation and maintenance plan. What evidence is there for the nature and scope of the problem in the project area?

### **Goals:**

The goal of this demonstration project is to demonstrate the ability of a newly patented type of pump that has the ability to pump sediment slurry over distances of 10-20 miles without a booster pump. It allows for both high volume and high pressure simultaneously, unlike pumps currently utilized. This allows for more energy efficiency. It also has the flexibility to operate with or without a dredge depending on the compaction of the sediment in the borrow site. It can utilize a jet to suspend sediment or utilize the discharge from a dredge.

### **Proposed Solution:**

A smaller prototype of the new pump technology would be utilized to demonstrate the potential capability to move sediments via pipeline over longer distances than current technology allows without the need for additional booster pumps. Demonstration project details to be further developed.

### **Project Benefits:**

This project would demonstrate the ability of a new type of pump to convey sediment slurry over 10-20 miles without the need for booster pumps. Additional cost-saving and fuel-efficiency benefits of this technology may be demonstrated as well.

### **Project Costs:**

Unknown, to be developed. Prototype pump would be provided.

**Preparer(s) of Fact Sheet:**

Honora Buras, Coastal Restoration Division, La. Dept. of Natural Resources, (225) 342-4103, [Honora.buras@la.gov](mailto:Honora.buras@la.gov)

Rudy Simoneaux, Coastal Engineering Division, La. Dept. of Natural Resources, (225) 342-6750, [Rudy.simoneaux@la.gov](mailto:Rudy.simoneaux@la.gov)

Pat Rousset and Warren Braai, Power Engineering, Inc., (504) 957-8800, [prousset@powerengineeringinc.com](mailto:prousset@powerengineeringinc.com)

## Louisiana Coastline Restoration

### The Pump Solution

### LOUISIANA PUMP, INC.

## Louisiana Post Katrina and Rita

- The combined land-water changes caused by Katrina and Rita exceeded all such changes in coastal Louisiana from previous hurricanes combined.
- Hurricanes from 2004 to 2005 land to water exceeded that up to 72.9 square miles more than the 60 square miles projected to occur from a period of 50 years.
- Land is being lost quicker than it's being restored.
- Hurricanes are going to continue and land is going to continue to be lost unless we restore it faster than we lose it.

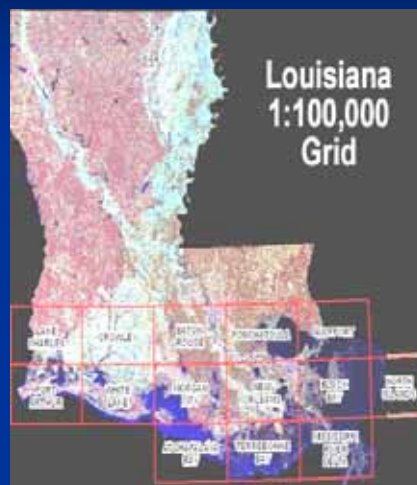

## Louisiana Land Loss

- Map of Land that was lost from 1999 to 2002.
- Louisiana has lost 1,900 square miles of land since the 1930's and we still continue to lose land.
- The blue area shows land lost in 1999 and the dark brown areas shows land lost in 2002.
- We continue to lose 24 square miles per year.

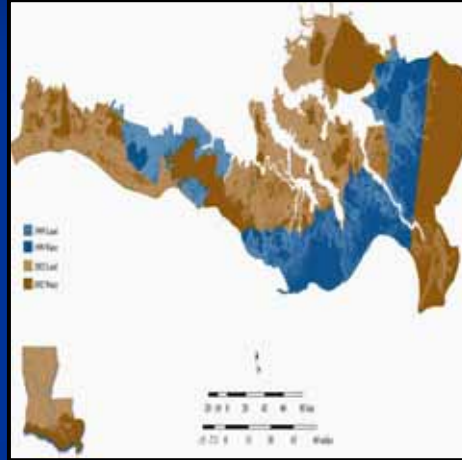

## THE PROBLEM & SOLUTION

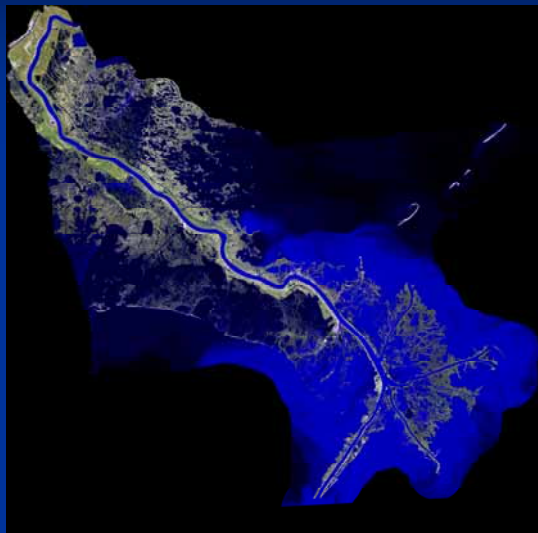

- HOW WAS THE DELTA FORMED IN THE FIRST PLACE?
- WHY NOT NOW?
- CASTING THE LAND TO THE OPEN GULF WATERS.
- WHAT ARE WE WAISTING?

# WHERE IS THE ANSWER

At Percentage of River Flow					
Percent of River Flow	River Flow (cuft/s)	River Sediment Load (tons/day)	River Sediment Load (#/day)	River Sediment Load (#/s)	Days to Raise one sqmi by one foot height
100	600,000	436,000	872,000,000	10,092.59	3.80
90	540,000	392,400	784,800,000	9,083.33	4.23
80	480,000	348,800	697,600,000	8,074.07	4.76
70	420,000	305,200	610,400,000	7,064.81	5.43
60	360,000	261,600	523,200,000	6,055.56	6.34
50	300,000	218,000	436,000,000	5,046.30	7.61
40	240,000	174,400	348,800,000	4,037.04	9.51
30	180,000	130,800	261,600,000	3,027.78	12.68
20	120,000	87,200	174,400,000	2,018.52	19.02
10	60,000	43,600	87,200,000	1,009.26	38.04
5	30,000	21,800	43,600,000	504.63	76.08
4	24,000	17,440	34,880,000	403.70	95.10
3	18,000	13,080	26,160,000	302.78	126.80
2	12,000	8,720	17,440,000	201.85	190.21
1	6,000	4,360	8,720,000	100.93	380.41

# THE PUMP

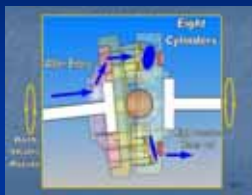

# PRESSURE THE SEDIMENT



# CONFINE THE SEDIMENT

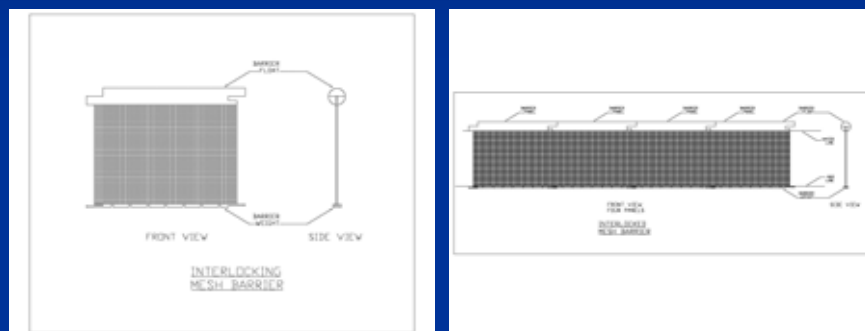



# PUMP IT TO THE GRID

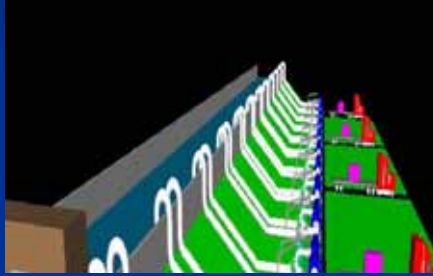

# BUILD LAND

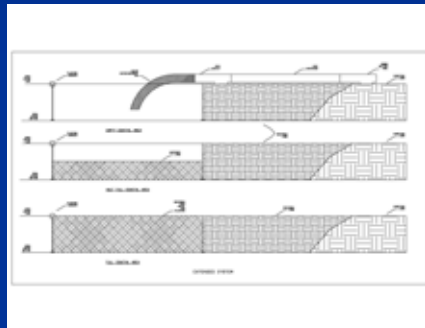
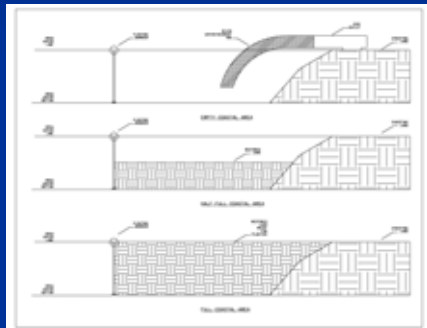

# EXTEND THE COASTLINE

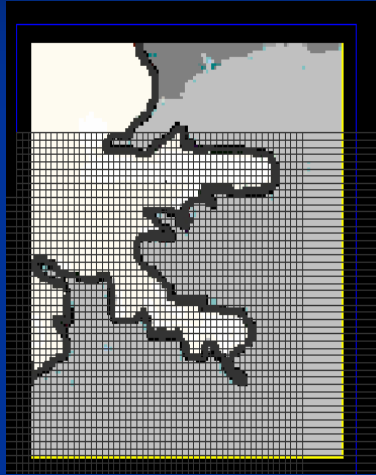

## Land Gain Map

### **Land Gain:**

As a result land can be restored more efficient at a faster rate and using natural resources.

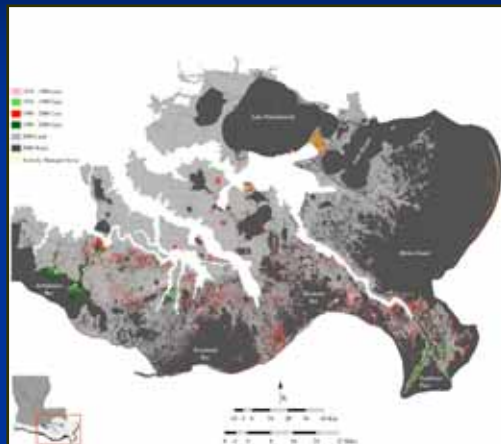

Gray area shows land  
Black area shows water

## **Louisiana Pump, Inc.**

- **3909 Bienville Avenue**  
**Suite 105**  
**New Orleans, Louisiana 70119**  
**Office: 504-486-0525**  
**Fax: 504-486-0524**