

# IMPROVEMENTS IN TECHNICAL EXCELLENCE, COMMUNICATIONS AND DECISION-MAKING



Two groups play a major role in the decisions associated with NASA's Return to Flight effort: NASA's Space Flight Leadership Council and the independent Return to Flight Task Group.

In parallel with Return to Flight activities after the Columbia accident, a team was formed to review the [Columbia Accident Investigation Board's](#) report and recommendations to determine applicability across the agency. This agency-wide group was led by Al Diaz, Associate Administrator for Science and culminated in its team report: "A Renewed Commitment to Excellence."

Additionally, the agency established the [NASA Engineering and Safety Center](#), which focuses more attention and resources on engineering excellence throughout the agency. Though based at the NASA Langley Research Center, Hampton, Va., this group has membership based at agency field centers that are integrated and involved with engineering reviews, challenges and decisions throughout the agency.

While hardware changes were ongoing, internal management and organizational structures were reviewed and updated as appropriate. The Space Shuttle Program Mission Management Team was one of those scrutinized the most following the Columbia accident and has undergone a complete review and restructure under the leadership of Deputy Shuttle Program Manager Wayne Hale, who will chair its meetings each day throughout a Shuttle flight.

More detail on each of the above organizations is below and available on the Internet at [www.nasa.gov](http://www.nasa.gov) and other sites.

## SPACE FLIGHT LEADERSHIP COUNCIL

The Space Flight Leadership Council (SFLC) is the group in charge of the agency's Return to Flight efforts. Established before the Space Shuttle Columbia accident, the SFLC is regularly briefed on the overall activities and progress associated with Return to Flight. When the Space Shuttle Program defines a course of action addressing a CAIB recommendation or other major program issues, the next step is to brief the SFLC during periodic meetings. The SFLC is fully briefed and approves, if necessary, the actions to be taken. Additionally, the SFLC assess overall cost, schedule and policy issues.

The members are:

- **Walter H. Cantrell** (co-chair) – Dep. Chief Engineer for Independent Technical Authority
- **William Readdy** (co-chair) – Associate Administrator for Space Operations
- **Bryan O'Connor** – Chief Safety and Mission Assurance Officer
- **James Kennedy** – Kennedy Space Center Director
- **Jefferson D. Howell** – Johnson Space Center Director
- **David King** – Marshall Space Flight Center Director
- **Thomas Donaldson** – Stennis Space Center Director
- **Michael Kostelnik** – Dep. Associate Administrator for International Space Station and Space Shuttle Programs

## RETURN TO FLIGHT TASK GROUP (STAFFORD-COVEY)

During the investigation following the Columbia accident, the NASA Administrator determined it was in the public interest to establish the [Return to Flight Task Group](#). Co-chaired by former astronauts Tom Stafford and Richard Covey, the group is conducting an independent assessment of NASA's actions to implement the recommendations of the Columbia Accident Investigation Board (CAIB), as they relate to the safety and operational readiness of STS-114. As necessary to their activities, the Task Group consults with former members of the CAIB.

While the Task Group was not chartered to assess the adequacy of the CAIB recommendations, it does report on the progress of NASA's response to meeting the intent of the recommendations and offers observations on safety or operational readiness, as appropriate.

The Task Group draws on the expertise of its members and other sources to provide its assessment to the Administrator and has held meetings and made site visits, as necessary, to accomplish its fact-finding.

Functioning solely as an advisory body, the Task Group established three panels in areas related to its work. The panels report their findings and recommendations to the full Task Group during periodic plenary sessions.

In order to reflect a balance of views, the Task Group consists of non-NASA employees and one NASA non-voting, ex officio member: the Deputy Associate Administrator for Safety and Mission Assurance. Members of the Task Group and panels were chosen from among industry, academia, and government with recognized knowledge and expertise in fields relevant to safety and space flight.



**Return to Flight Task Group**

## SPACE SHUTTLE PROGRAM MISSION MANAGEMENT TEAM

During Space Shuttle missions, the Shuttle Mission Management Team is responsible for oversight of the operations teams during pre-launch and in-flight. The countdown and flight operations are conducted by the operations teams according to rules and procedures approved by SSP Management well prior to real-time events.

While the Mission Operations team leads all nominal flight operations, the MMT provides

guidance to the operations teams for situations that fall outside normal operations, and also redefines programmatic priority when in-flight issues or off-nominal conditions result in conflicting priorities.

Up to and including Columbia's STS-107 mission, actions were biased toward the immediate decision-making required of in-flight operations, which did not adequately address the concerns of individual engineers, the quality of risk assessments, and pedigree of engineering assessments.



**The MMT conducts training from the Mission Control Center in preparation for Discovery's Return to Flight.**

Now, the Mission Management Team is fully engaged and trained to focus on clearer communication processes centered on bringing out differing opinions; maintaining awareness of decisions that impact the remainder of the flight; and ensuring an understanding of the roles and responsibilities of team members and supporting working groups and teams, including data sharing processes and required milestones to support real-time operations.

To ensure that all issues are identified, cataloged and resolved more effectively, a process has been established whereby the Program's Systems Engineering and Integration Office will maintain an integrated anomaly list, which will be briefed and reviewed at each day's MMT meeting. Each issue (or anomaly) will be assigned to a specific office or organization for technical evaluation and will be subject to an independent risk assessment by Safety & Mission Assurance.

The MMT includes one Shuttle Program S&MA core member, and three institutional S&MA advisory members from the Johnson Space Center, Kennedy Space Center and Marshall Space Flight Center. Additionally, the MMT has added the Space Shuttle System Technical Warrant Holder as a core voting member representing the NASA Independent Technical Authority.

Additional improvements were made to MMT internal processes and procedures, including more clearly defining requirements for MMT meeting frequency and the process for requesting an emergency MMT meeting. NASA now will conduct daily MMT meetings beginning with the launch minus two (L-2) day MMT.

Membership, organization, and chairmanship of the preflight and inflight MMT have been standardized. Space Shuttle Program Deputy Manager Wayne Hale will chair both phases of

the MMT - preflight and on-orbit. Membership has been expanded and augmented with each MMT member trained in clearly defined processes for support and problem reporting.

Formal processes have been established for the review of findings from ascent and on-orbit imagery analyses, post-launch hardware inspections, ascent reconstruction, and all other flight data reviews to ensure timely, effective reviews of key data by the MMT.

Procedures for flight MMT meetings have been standardized through the use of predefined templates for agenda formats, presentations, action item assignments, and readiness polls. This ensures that communication and resolution of issues are performed in a consistent, rigorous manner.

As part of an overall agency effort to examine and enhance the safety culture within NASA, Behavioral Science Technology (BST) was hired to assist with understanding and improving culture specifically in the areas of communication, individual consideration, management credibility and decision-making. Locally led implementation teams and former flight directors were invited to observe and assess the MMT process and offer recommendations. This ongoing effort has led to more efficient resolution of critical issues and more open communication among MMT members.

Extensive research on improving communications led to a redesigned MMT meeting room - designated the MMT Command Center - which provides increased seating capacity and communications improvements. Included is a video-teleconferencing capability, a multi-user collaboration tool, and a larger room allowing space for more subject experts and MMT members.



A large “C” shaped table now seats all members of the MMT and invites open communication by eliminating a hierarchical seating arrangement. The MMT Command Center has been operational since November 2004.

To ensure adequate back ups, at least two people have been trained to fill each MMT core position for Return to Flight. This protects the integrity of the integrated MMT process against any core individuals’ inability to perform his or her role for any reason. Verification of each flight-specific team will be presented at the appropriate Flight Readiness Review traditionally held approximately two weeks prior to launch.

The evolution of the MMT is from what previously was an operationally-oriented, problem-solving team to a critical decision-making management body. Technical engineering sub-teams perform the engineering root-cause analysis, technical problem-solving, and identify options and make recommendations to the MMT. This has resulted in more focused decision-making by the MMT and better utilization of the expertise of the MMT membership.

Any action items defined during missions now contain clear delineation of the responsibility of each, which has eliminated some of the pre-Columbia duplication and confusion over roles and responsibilities, particularly in the area of in-flight anomalies.

Risk management is now a major consideration at each MMT meeting. Each identified hazard is required to have a risk assessment performed and presented, so the appropriate risk versus risk tradeoffs can be discussed and dispositioned.

## THE MISSION MANAGEMENT TEAM:

<b>POLLED ONLY ON LAUNCH DAY</b>	1. Lockheed Martin Michoud Space Systems
	2. External Tank
	3. Thiokol Propulsion
	4. Redesigned Solid Rocket Motor
	5. Solid Rocket Booster
	6. Rocketdyne
	7. Space Shuttle Main Engine
8. Marshall Space Flight Center (MSFC) Engineering	
9. Deputy Program Manager – MSFC	
10. Hamilton Sundstrand	
11. Extravehicular Activity (spacewalks)	
12. United Space Alliance (Shuttle prime contractor)	
13. Johnson Space Center (JSC) Engineering	
14. Orbiter	
15. Flight Manager (STS-114)	
16. Mission Operations Directorate	
17. Space & Life Sciences	
18. Flight Crew Operations	
19. International Space Station Program Manager	
20. Department of Defense Mission Support (DDMS)	
21. Launch Integration Manager	
22. Shuttle Processing (Kennedy Space Center)	
23. Deputy Program Manager (KSC)	
24. Systems Engineering and Integration	
25. Flight Operations and Integration	
26. Space Shuttle Program Safety & Mission Assurance	
27. Space Shuttle Technical Warrant Holder	
	<ul style="list-style-type: none"> <li>· MSFC S&amp;MA</li> <li>· KSC S&amp;MA</li> <li>· JSC S&amp;MA</li> <li>· NASA Engineering and Safety Center</li> </ul>

## NASA ENGINEERING AND SAFETY CENTER

The [NASA Engineering and Safety Center](#) is an independent organization chartered in the wake of the Columbia accident to serve as an agency-wide technical resource focused on engineering excellence. The objective of the NESC is to improve safety by performing in-depth independent engineering assessments, testing, and analysis to uncover technical vulnerabilities and to determine appropriate preventative and corrective actions for problems, trends or issues within NASA's programs, projects and institutions. The NESC draws upon engineering expertise within NASA and includes partnerships with other government agencies, national laboratories, universities and industry.

The objective of the NESC is to improve safety by performing various independent technical assessments of issues within NASA programs. A multi-disciplined team of experts, assembled specifically to address the issue at hand, conducts each of these technical assessments. This approach has been modeled after the "tiger team" concept often used by programs to solve challenging problems. Other services and activities of the NESC are:

**Technical Inspections** – Used to evaluate the technical adequacy of a particular area within a program, even if a problem has not yet been detected. Examples of potential inspection areas include: math models, analytical tools, manufacturing procedures, test procedures, vehicle processing, troubleshooting techniques, manufacturing tooling, ground support equipment, or special test equipment.

**Technical Consultation** – An independent evaluation of a specific technical item by representatives of the NESC. This is provided when the scope of a problem or concern does not warrant a full assessment. In addition, a technical consultation also can be provided when an NESC member joins an existing review team or monitors an existing operation or process.

**Technical Support** – The NESC provides support by making its network of experts and resources available to programs, projects and NASA centers. Technical support is funded by the requesting organization and would not be considered an NESC endorsed activity. The NESC remains independent of the activity, and any individuals called upon by the requesting program or NASA center does not perform an independent technical assessment on the same issue.

**Technical Advocacy** – This role provides technical expertise, testing or analysis in support of Safety & Mission Assurance organizations, institutional engineering, and programs and projects as necessary. The NESC promotes positive actions taken by individuals, programs or projects to correct identified technical inadequacies.

**Dissenting Opinions** – The NESC cultivates an environment that encourages and seeks out dissenting opinions. In order to encourage this open environment, and soliciting alternative perspectives, the NESC established a process for addressing dissenting opinions. As a matter of practice, each independent technical review, assessment and analysis seeks dissenting opinions for review and evaluation. These



dissenting opinions are documented and dispositioned in each report and/or briefing.

#### RENEWED COMMITMENT TO EXCELLENCE

An agency-wide team, under the leadership of Al Diaz, Associate Administrator for Science, was commissioned to assess the broader implications of the Columbia Accident Investigation Board's Report on activities agencywide. The final Diaz Team Report, "A Renewed Commitment to Excellence" was released on January 30, 2004.

The team concluded that 85 of the 193 recommendations, observations and findings of the CAIB Report were applicable across the entire spectrum of NASA's activities. The implementation plan for the Diaz Team Report can be found on the Internet at:

[http://www.nasa.gov/pdf/58676main\\_Implementation\\_033004\\_FINAL.pdf](http://www.nasa.gov/pdf/58676main_Implementation_033004_FINAL.pdf)





## SPACE SHUTTLE PROCESSING IMPROVEMENTS



### REINFORCED CARBON-CARBON WING PANELS AND NOSE CAP

During re-entry into Earth's atmosphere and traveling more than 17,000 miles per hour, the Space Shuttle's exterior temperatures can reach up to 3,000 degrees Fahrenheit (1,600 Celsius).

To protect the Orbiters, all external surfaces are covered with various types of Thermal Protection System (TPS) materials. The main types of thermal materials are Reinforced Carbon-Carbon (RCC), low- and high-temperature reusable surface insulation tiles, felt reusable surface insulation blankets and fibrous insulation blankets.

RCC is used on the wing leading edges, the nose cap and an area just behind the nose cap on the lower surface (chin panel), and the area immediately around the forward Orbiter/External Tank structural attachment points. Each wing leading edge consists of 22 RCC panels, numbered from 1 to 22 moving outboard on each wing. Because of the shape of the wing, each panel is unique in size and shape.

The basic RCC composite is a laminate of graphite-filled rayon fabric, further filled with phenolic resin and layered - one ply at a time - in a unique mold for each part, then cured, rough-trimmed, drilled and inspected. To prevent oxidation, the outer layers of the carbon substrate are covered in a .02 to .04-inch-thick layer of silicon carbide in a chamber filled with argon at temperatures up to 3,000 degrees Fahrenheit.

Previous flight history showed that RCC components have been struck by objects, but

never resulted in a complete penetration. Post-flight RCC component inspections for cracks, chips, scratches, pinholes and abnormal discoloration were primarily visual, with tactile evaluations (pushing with a finger) of some regions. Minor repairs to the silicon carbide coating and surface defects were completed at Kennedy Space Center, Florida.

At the time of the STS-107 mission, most of the panels on Columbia's left wing were original parts (built in the 1970s). Only panel 10-left, T-seal 10-left, panel 11-left and T-seal 11-left had been replaced (along with panel 12 on the right wing). Minor surface repairs had been made to several panels and T-seals on both wing leading edges.

After the Columbia accident, the Columbia Accident Investigation Board (CAIB) submitted findings to NASA recommending non-destruction evaluation (NDE) inspection, repair and/or replacement of all wing leading edge panels and associated attachment hardware prior to Return to Flight.

The Kennedy Space Center Space Shuttle processing team began removing and inspecting all wing leading edge panels on the three remaining Shuttles. Beginning in 2003, batches of panels from the wing leading edge and the nose caps, expansion seal and chin panel were removed from the vehicles and sent to Lockheed Vought in Dallas, for NDE inspection.

The traditional NDE methods employed included:

- Through-Transmission Ultrasound (TTU) on all accessible areas.
- Film-based radiology (X-ray) of RCC corners where TTU could not be performed.

- Sampling of the coating using eddy current to determine the silicon carbide coating thickness.

In addition to these traditional NDE methods performed at the vendor for Return to Flight, KSC conducted advanced NDE using Flash Thermography and Through Transmission Thermography on all accessible areas of the RCC panels including the wing leading edge, the nose cap, expansion seal and chin panel of the RCC. This advanced method utilized infrared imaging to characterize internal flaws.

All of these NDE inspections sought to identify internal hidden flaws in the RCC and the outer silicon carbide conversion coating. Any suspect findings would have required additional NDE, including digital radiography and/or computed tomography. Findings then are submitted to an engineering team for evaluation to determine if requirements are met.

It is now a requirement that after Return to Flight and between every mission, flash thermography is performed on the critical areas of wing leading edge, the nose cap, chin panel and expansion seal, in addition to the visual and touch tests. Other advanced NDE methods may be used if warranted.

While some minor repairs were performed at KSC, all necessary repairs and refurbishment to RCC panels was performed by the vendor in Dallas.

Additionally, the nose cap on each vehicle was inspected and only Endeavour's had silicone carbide coating damage that required its removal and replacement with a spare.

## WING LEADING EDGE STRUCTURAL SUBSYSTEM

The Space Shuttle processing team performed modifications to the lower two inches of the front spar to prevent any flow or heat from getting inside and behind the wing edges during launch and landing. The spar is the primary load-carrying structure in the wing to which each of the 22 panels is attached.

Flow restrictors, comprised of a pair of 3/8-inch-diameter knitted Inconel wire springs wrapped in a Nextel fabric sleeve and stuffed with Saffil batting, were added across the four-inch box beam located in the lower RCC access panels 5 through 13. This reduces the effects of temperature on the spar in the event of a breach in the panel or adjacent T-seal.

Also for this reason, a thick strain isolator pad was bonded to the lower spar cap and to the forward-facing corrugations of the spar. Also, the "horse collar" gap filler was redesigned to add a 0.50-in-diameter sleeve at the inner mold line end to increase additional sealing capability in the event of partial tile loss.

## RUDDER SPEED BRAKE

The Rudder Speed Brake (RSB) is part of the Shuttle's tail assembly. Located on the trailing edge of the vertical stabilizer, the RSB provides directional and speed control of an Orbiter. The RSB is driven by four actuators powered by a drive shaft. Like a traditional aircraft, the rudder swings from side to side to steer the Orbiter as it descends through the atmosphere. It also functions as a speed brake to slow the Orbiter down. When braking is needed, the sides of the rudder vertically split into two separate surfaces and flare out to provide air resistance.

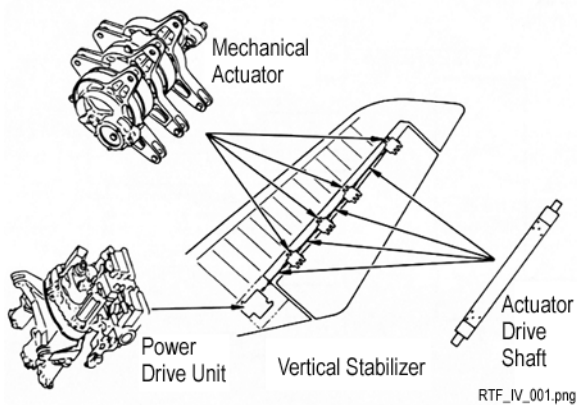

**The Rudder Speed Brake consists of two panels, four actuators and a drive shaft**

In late 2002, internal corrosion was discovered in the body flap actuators of Atlantis (OV-104). Following the finding, the body flap actuators onboard Discovery (OV-103) were inspected and also found to be corroded and in need of refurbishment. Space Shuttles also use the same type of actuator in their RSB assembly. Because of the component commonality, NASA elected to inspect and refurbish the RSB actuators. The RSB actuators became an issue because corrosion inside the units could result in jamming of the RSB.

During the refurbishment of Discovery's RSB actuators, it was discovered that planetary gears in actuator No. 4 had been installed inverted. Gears in Discovery's other actuators also showed pitting and wear. Furthermore, X-ray analysis of replacement stock actuators revealed actuator No. 2 to have its planetary gear improperly installed, as well.



**Actuator inspection using X-ray analysis**

Following identification of the corrosion and planetary gear issues, actuators from all three Orbiters were returned for refurbishment to their original manufacturer, Hamilton Sundstrand. Included in the refurbishment service were replacement actuator No. 2 and Discovery's original actuators. During the refurbishment process, Hamilton Sundstrand was in charge of quality control and ensuring proper reassembly of the actuators.

Upon the return of replacement actuator No. 2, the entire set of replacement actuators was installed on Discovery. This was the first time in Space Shuttle Program history that complete installation of the RSB components was performed entirely at Kennedy Space Center.



**Actuator installation on Discovery**



While the amount of corrosion originally found on the actuators was only minor, a flight limit has been placed on the components. For the initial Return to Flight missions, the actuators will be restricted to five flights. However, the actuator flight limits could be raised to seven missions if post-flight inspections show they are in good condition and working properly.

### FOREIGN OBJECT DEBRIS

Beginning in 2001, debris at Kennedy Space Center (KSC) was divided into two categories: "processing debris" and foreign object debris (FOD). FOD was defined as debris found during the final or flight-closeout inspection process. All other debris was labeled processing debris. This led to the perception that processing debris was not a concern.

NASA and United Space Alliance (USA), subsequently have changed work procedures to consider all debris equally important and preventable. Rigorous definitions of FOD that are the industry standard have been adopted (from National Aerospace FOD Prevention, Inc.). These guidelines and industry standards include FOD, Foreign Object Damage, and Clean-As-You-Go. FOD is redefined as "a substance, debris or article alien to a vehicle or system which would potentially cause damage."

KSC chartered a NASA/USA team selected for its experience in FOD-related disciplines including processing, quality, and corrective engineering; process analysis and integration; and operations management. The team began by fact-finding and benchmarking to better understand the industry standards and best practices for FOD prevention. Members visited the Northrup Grumman facility at Lake Charles, La.; Boeing Aerospace at Kelly Air Force Base, Texas; Gulfstream Aerospace in Savannah, Ga.; and the Air Force's Air

Logistics Center in Oklahoma City, Okla. At each site, the team studied the FOD prevention processes, documentation programs, and assurance practices.

Armed with this information, the team developed a more robust FOD prevention program that not only responded to a Columbia Accident Investigation Board (CAIB) recommendation, but also raised the bar by instituting additional improvements. The new FOD program is anchored in three fundamental areas of emphasis:

- Eliminate various categories of FOD, including "processing debris," and treats all FOD as preventable and with equal importance.
- Re-emphasize the responsibility and authority for FOD prevention at the operations level.
- Elevate the importance of comprehensive independent monitoring by both contractors and the Government.



USA also has developed and implemented new work practices and strengthened existing practices. This reduces the chance of temporary worksite items or debris to migrate to an out-of-sight or inaccessible area, and it serves an important psychological purpose in eliminating visible breaches in FOD prevention discipline.



FOD “walkdowns” have been a standard industry and KSC procedure for many years. These are dedicated periods during which all employees execute a prescribed search pattern throughout the work areas, picking up all debris. USA has increased the frequency and participation in walkdowns, and also has increased the number of areas regularly subjected to them. USA also has improved walkdown effectiveness by segmenting walkdown areas into zones. Red zones are all areas within three feet of flight hardware and all areas inside or immediately above or below flight hardware. Yellow zones are all areas within a designated flight hardware operational processing area. Blue zones are desk space and other administrative areas within designated flight hardware operational processing areas.



Additionally, both NASA and USA have increased independent monitoring of the FOD prevention program. USA Process Assurance

Engineers regularly audit work areas for compliance with such work rules as removal of potential FOD items before entering work areas and tethering of those items that can be removed (e.g., glasses), tool control protocol, parts protection, and Clean-As-You-Go housekeeping procedures. NASA Quality personnel periodically participate in FOD walkdowns to assess their effectiveness and oversee contractor accomplishment of all FOD program requirements.

The new FOD program’s effectiveness is measured by a set of metrics to guide improvements. FOD walkdown findings are tracked in the Integrated Quality Support Database. This database also will track FOD found during closeouts, launch countdowns, post-launch pad turnarounds, landing operations, and NASA quality assurance audits. “Stumble-on” FOD findings also will be tracked. For all metrics, the types of FOD and their locations will be recorded and analyzed for trends to identify particular areas for improvement. Monthly reports to management will highlight the top five FOD types, locations, and observed workforce behaviors, along with the prior months’ trends.

#### CLOSEOUT PHOTOGRAPHY PROCESS

Before areas inside and outside of the Space Shuttle and its External Tank/Solid Rocket Booster stack are sealed for flight, closeout photographs are taken in order to visually document the area at the last moments of access. In part, these photos document differences between actual hardware configuration and engineering drawings. This includes photography of the Orbiter, Space Shuttle Main Engine, Solid Rocket Boosters and External Tank.

Because of the complexity of the Shuttle’s engineering drawing system, the CAIB recommended the photo closeout system be reviewed and upgraded due to potential for errors.



Portions of these requirements were met by the existing closeout photo process, the KSC Quality Data Center film database and the digital Still Image Management System (SIMS) database. However, prior to the digital photography upgrade, images were difficult to locate and retrieve, because the process required substantial cross-referencing of sources.

NASA formed a Photo Closeout Team from the Agency's engineering, quality and technical communities to identify and implement necessary upgrades to the processes and equipment involved in vehicle closeout photography. The Photo Closeout Team divided the CAIB recommendation into two main elements:

- Increase the quantity and quality of closeout photographs. The Photo Closeout Team led an extensive review of existing and potential closeout photo requirements. The multi-center, NASA and contractor team established a revised set of requirements, including improved closeout photography of tools for Extravehicular Activity (EVA) contingency configurations and middeck and payload bay configurations. General closeout photography also is being performed at the time of the normal closeout inspection process. The team also reviewed the closeout photo process, which prompted improved formal photography for KSC-generated documentation, mandatory photography of discrepancies, a standard baseline for photo equipment and photo quality standards.

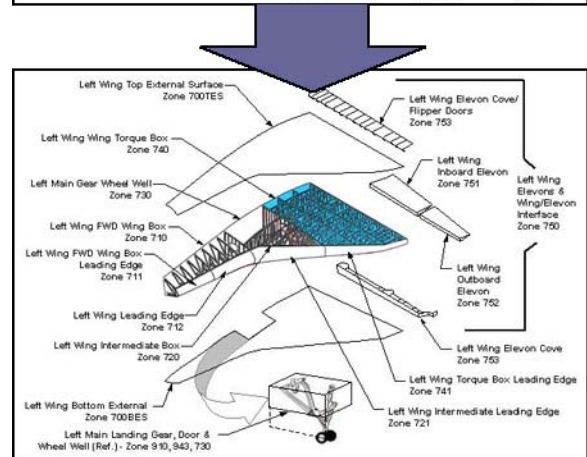
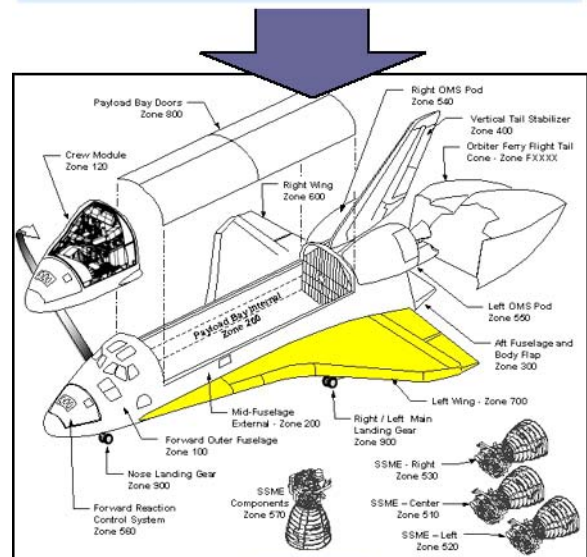
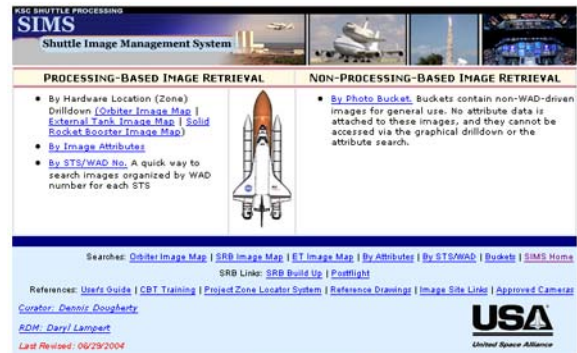

RTF\_IV\_007.png

### Enhanced Still Image Management System (SIMS)

Each of these requirements was incorporated in the photo process. To ensure a comprehensive and accurate database of photos, NASA initiated a training and certification program so that all operators understand and meet the requirements. The ongoing process continually audits photos submitted for archiving.

- Improve the retrieval process through a user-friendly, Internet-based graphical interface system. NASA enhanced the Still Image Management System by developing a web-based graphical interface allowing the engineering community access to Shuttle closeout images. Users now can easily view photos of Orbiter elements and systems. Filters also can be used to limit the search to desired photos. These enhancements enable managers quick and intuitive access to relevant photos, improving their responses to contingencies.

Programs were established to train and certify Quality Control Inspectors, Systems Engineering personnel and end-users at the Johnson Space Center (such as engineers in the Mission Evaluation Room inside Mission Control). The SIMS database also is used as a tool in conjunction with launch simulation scenarios to enhance engineering and mission management training.

#### LAUNCH PAD GROUND SUPPORT EQUIPMENT

Launch Complex 39, Pads A and B originally were built in the 1960s for the Apollo program. Both were used to launch manned spaceflights during Apollo, Skylab, Apollo-Soyuz and Space Shuttle missions. Each was designed to support the concept of mobile launch operations, which means the launch vehicle is transported to the launch pad by large, tracked crawlers for final processing toward launch.



#### FIXED AND ROTATING SERVICE STRUCTURES

Key pad service structures were mobile during the Apollo era, but for the Space Shuttle, two permanent service towers were installed at each pad – the Fixed Service Structure (FSS) and the Rotating Service Structure (RSS).

The FSS stands 347 feet from ground level to the tip of its lightning mast and includes three retractable swing arms providing services or access to the Shuttle on the pad.

The RSS rotates around the orbiter and is retracted before launch and provides protected access to the Orbiter for installation and servicing of payloads at the pad.

Launch Pad 39B is designated the Return to Flight launch pad. To correct the critical debris issue that existed on the pad structure, all of the old zinc coating was removed from the two service structures using abrasive blasting with a coal slag grit called “black beauty.” The structures were re-coated with a layer of zinc paint and an inorganic topcoat. The coating systems on the wing covers of the RSS was changed from the inorganic topcoat to a layer of epoxy, and a coating of polyurethane sealant, which significantly reduces the porosity and prevents future oxidation and debris.

During modifications in 2003, Launch Pad 39A received an upgraded electrical power system and new safety tie-off points. In 1992, all metal structures were abrasive blasted to remove oxidation and repainted as part of corrosion control.

#### UPPER HINGE COLUMN BEARING

Further reviews of the launch pad system indicated the load on the upper hinge column bearing at the top of the hinge between the Fixed Service Structure and Rotating Service Structure was 20 percent over the designed weight. The hinge materials were redesigned to increase their strength.

#### GASEOUS OXYGEN VENT ARM ("BEANIE CAP")

The Gaseous Oxygen (GOX) Vent Arm, located 265 feet above the launch tower, includes duct tips that were redesigned to provide more efficient delivery of heated gaseous nitrogen. The vent arm extends over the External Tank during prelaunch loading of hydrogen and oxygen to provide a means of preventing ice formation on the ET nose cone. Ice formation presents a debris concern to the tile and wing leading edge panels on the Shuttle. The vent arm has a system of heaters and tubing (ducts) that direct heated gaseous nitrogen to the ET nose cone vents to warm the gaseous oxygen and then carry it away from the Shuttle. The new tips as well as a large section of ducting has been built and installed to preclude any ice debris concern at the top of the External Tank.

#### GASEOUS HYDROGEN VENT ARM

The Gaseous Hydrogen Vent Umbilical provides a means of safely transporting hazardous gaseous hydrogen, vented during cryogenic loading from six hours through launch, away from the External Tank to the facility vent system. The vent line and umbilical system is located 215 feet up the

launch tower and attaches to the tank's intertank flight umbilical carrier plate, which provides a vent for the liquid Hydrogen tank portion of the External Tank. It also provides a connect point for the tank's pneumatic and electrical systems.

At liftoff on a previous Shuttle mission (STS-108) the Vent Line/Carrier Plate Assembly contacted the launch tower structure upon retraction into the tower latching mechanism. Several pieces of the assembly broke off, which led to a concern that debris could possibly contact the Shuttle as it lifts off the pad.

A review of the problem revealed that allowable wind conditions for a Shuttle launch could provide enough push to drive the vent line into the launch tower if the wind was from a certain direction and velocity. To prevent it from occurring again under any conditions for a Shuttle launch, the launch tower structure was modified by enlarging the opening that the vent line enters by about nine inches to allow the Vent Line/Carrier Plate Assembly to safely enter the tower structure and engage the latching mechanism under all launch conditions.

#### CRAWLER TRANSPORTER

Before Return to Flight, NASA's two Crawler Transporter vehicles underwent replacement of the 456 tread belt "shoes" on each vehicle. Each of the vehicles has eight belts, and each belt has 57 shoes. Each shoe is 7½ feet long and 1½ feet wide and weighs approximately 2,100 pounds.

Most shoes on the transporters dated back to 1965, when they were built and first put into service for Apollo launches.



KSC system engineers and technicians worked on the sprockets and rollers on each belt before the new shoes were installed. Welding repair and inspection of some of the sprockets and manufacture of some of the rollers were performed in the Launch Equipment Support Facility.

Other upgrades or modifications recently completed on the transporters included completing electrical rewiring of the motor control center and installation of new driver cabs, mufflers, radiators and ventilation systems.



**Crawler Transporter vehicle**





# PREPARING THE EXTERNAL TANK



About six hours before Space Shuttle Discovery's launch, its bright orange 15-story-tall fuel tank is loaded with 535,000 gallons of liquid hydrogen and oxygen.

Just before liftoff, these super cold liquids mix to generate fuel for the Shuttle's three main engines, which gulp it at a rate equal to emptying the average size backyard swimming pool in 20 seconds.

Discovery's tank, designated ET-121, has been redesigned over the course of the last 24 months through testing and implementation of improvements that eliminate the chance of

Shuttle-damaging foam coming off during launch and the climb to orbit. It is undoubtedly the safest, most reliable tank ever built.

The External Tank's aluminum skin is a tenth of an inch thick in most places and is covered with polyurethane-like foam averaging an inch thick, which insulates the propellants, prevents ice formation on its exterior, and protects its skin from aerodynamic heat during flight. About 90 percent of the foam is applied via automated systems, while the remainder is sprayed on manually.



LO<sub>2</sub> Feedline bellows ice

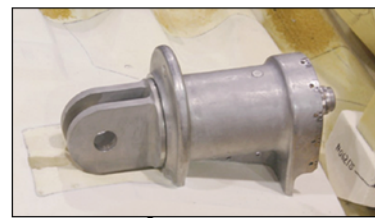

Bipod



LO<sub>2</sub> PAL ramp

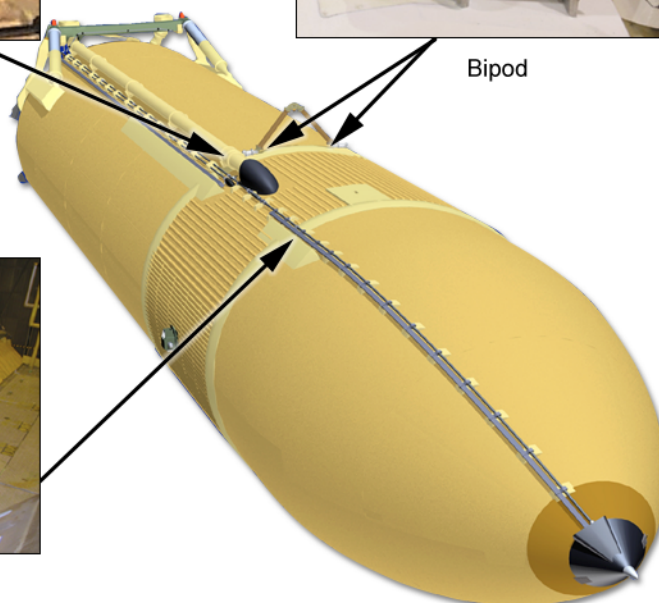

RTF\_V\_001.png

## External tank areas of emphasis

A specially formed piece of foam protecting the Shuttle's forward attach point was determined to have fallen off during Columbia's launch on Jan. 16, 2003, which struck the left wing. This allowed the penetration of superheated air into the wing's interior, weakening the structure. This damage eventually caused the loss of aerodynamic control 16 minutes before landing on Feb. 1, 2003.

Even before the formal report of the [Columbia Accident Investigation Board](#) was released, NASA began modifications to reduce the risk from falling debris during ascent. Several safety improvements and foam application process changes are now followed to ensure nothing larger than .03 pound comes off the tank.

These changes and improvements include removal of the foam around the bipod fitting of the forward attach point; installing a small video camera on the liquid oxygen feedline to document launch; reversing bolts on the flange of the tank's mid-section along with a new spraying procedure for that area; redesigning three bellows on the 70-foot liquid oxygen feedline to the main engines; and implementing a more defined foam spraying procedure on the structural support for the tank's aft orbiter attachment struts.

NASA's Marshall Space Flight Center in Huntsville, Ala., is home to the Space Shuttle Propulsion Office, which manages the tank project overseen by prime contractor Lockheed Martin Space Systems Co., in New Orleans at the Michoud Assembly Facility.

### BIPOD REDESIGN

The External Tank's forward Shuttle attach fitting - called the bipod - was redesigned to eliminate the large insulating foam ramps as a debris source and replace them with electric heaters.

The ramps were in place to prevent ice buildup - another potential debris source - on the two

bipod fittings, which connect the tank to the Orbiter through the Shuttle's forward attach strut.



Development of this redesign concept actually began after some insulating foam from the left bipod ramp area came off during the October 2002 launch of Space Shuttle Atlantis on the STS-112 mission. During launch of Columbia on its STS-107 mission in January 2003, a similar loss prompted NASA's Office of Space Operations (then Office of Space Flight) to mandate a redesign of the bipod ramp.

The foam ramps were wedge-shaped blocks hand sprayed and hand carved to the desired dimensions of about 30 inches by 14 inches by 12 inches to fit over the bipod fittings during the tank's final stages of preparation.



After the Columbia accident, engineering analysis and dissection of existing bipod ramps indicated that hand-spraying over the complex geometry of the fittings was prone to producing

voids and defects that contribute to foam loss during ascent.

The bipod redesign eliminates the foam block allowing the fitting to be mounted atop a new copper plate threaded with four rod heaters placed below each fitting. This prevents ice formation when the tank is loaded with extremely cold cryogenic liquid hydrogen fuel. The copper plate with heaters is sandwiched between the fitting and an existing thermal isolating pad, which reduces heat loss from the copper plate into the extremely cold liquid hydrogen tank.

The heaters are cartridge-type heaters .25 inches in diameter and 5 inches in length with a wire coil inserted into a tube filled with magnesium oxide. Each heater will operate until launch and can produce up to 300 watts of power at 120 volts AC. They will be powered and monitored through connections in the Ground Umbilical Carrier Plate, which separates when the Shuttle is launched.

Control of the heaters will be through ground-based Programmable Logic Controllers that will vary the heater power based on temperature sensors co-located with the heaters at the copper plates. Additional temperature sensors on the bipod fittings will monitor the fitting temperatures to ensure they stay above freezing. To minimize the potential for a launch scrub, the heaters and temperature sensors have built-in redundancy to permit operation even in the presence of certain hardware failures.

Although the original bipod fittings were covered with foam ramps, the bipod spindles, which connected the fittings to the struts, remained exposed. These spindles rotate to account for tank shrinkage that occurs when it becomes extremely cold. These spindles each contained a heater element, which no longer is required. Elimination of the heaters allowed for smaller end covers made from titanium on the fitting. These already are capable of

withstanding higher temperatures caused from aerodynamic heating.



**Bipod installation**

The new bipod design also requires additional cabling to operate the heating system. It includes four circuits on each bipod (totaling eight) that run from the External Tank Ground Umbilical Carrier Plate to the heaters under the bipod fitting.

This new design is an alternative derived from three original redesign options proposed by the project office to the Space Shuttle Program in May 2003.

A variety of verification tests have been performed to ensure the redesign will meet the requirements for safe flight. Structural tests at Michoud verified the redesign's capability to withstand maximum loading. Two thermal tests at Eglin Air Force Base, Fla., verified the heater system's ability to prevent ice formation. Ten wind tunnel tests at Arnold Air Force Base's Engineering Development Center, Tenn., demonstrated the new design's capability to withstand maximum aerodynamic loads without generating debris.

The Thermal Protection System team developed a two-step closeout process to improve the manual spray technique. Verification and validation of this new process was accomplished on a combination of high-fidelity mockups and on an existing External Tank test article in a real production environment.



The bipod redesign is being retrofitted on the eight existing tanks and implemented on all new tanks. This work is being done by Lockheed Martin Space Systems at Michoud. Delivery of the first retrofitted tank to the KSC was on Jan. 5, 2005.

## LIQUID HYDROGEN (LH2) INTERTANK FLANGE

While the External Tank Project Office worked through the redesign of the bipod fitting and the elimination of its foam ramp, a top-to-bottom assessment was conducted in parallel to examine all areas where the tank's foam insulation could potentially come free during flight.

A result of this process led to new requirements for the joint connecting the liquid hydrogen and liquid oxygen tanks. The area between the two is known as the intertank and basically is the structural connection. Flanges are the joint that functions much like a tab, or seam on a shirt, which are affixed at the top and bottom of the intertank. After the flange is bolted to the LH2 and LO2 tanks, the area is insulated with foam.

Testing and analysis revealed that gaseous nitrogen used to purge the intertank area could potentially turn to liquid when exposed to the extreme cold of the liquid hydrogen, which is minus 423 degrees. Once liquid nitrogen is formed inside the intertank area it can seep into any voids, or spaces, in the foam adjacent to the flange near the liquid hydrogen tank. During launch as pressure builds and heating occurs, the liquid nitrogen rapidly returns to a gaseous state and leaks past the flange bolt threads and nuts on the hydrogen side. This phenomenon is known as cryogenic ingestion and permits small foam pieces, or divots, to fall off the tank.

To prevent this, the flange bolts have been reversed and Loctite applied to the threads, which restricts liquid Nitrogen leakage. Additionally, a new mold injection foam closeout process of the intertank stringers was instituted to provide technicians with a less

complex base, which reduces possible spray defects.

Another phenomenon - cryogenic pumping - is caused when surface air is pulled into foam voids as the tank is being fueled. Again, external pressure changes during launch cause the air to expand and push foam divots off the tank.

With these in mind, an enhanced closeout, or finishing, procedure was instituted, which includes improved foam application to the intertank ribbing area as well as to the upper and lower area of the flange. The improved process allows technicians to apply a higher quality product through process verification and more stringent controls. These controls include engineering evaluation of processing parameters; real-time and video surveillance of the process; and dissection/evaluation of "flight like" witness panels.

New requirements established by the Space Shuttle Program allow debris from this area to be no more than .03 pound of mass.

## LIQUID OXYGEN (LO2) FEEDLINE BELLOWS

The next area on the External Tank judged as a potential debris source during the Space Shuttle's climb to orbit was a portion of the liquid oxygen feedline, which includes joints known as bellows. There are five bellows along the 17 inch diameter feedline assembly, which extends externally 70 feet along the right side of the Liquid Hydrogen tank up and into the intertank, and then to the bottom of the liquid oxygen tank.

The liquid oxygen feedline has five bellows. The bellows allow for fabrication and installation tolerances, differences in thermal expansion between the line and the tanks, and relative motion during flight. Two bellows are internal to the intertank, the space between the liquid oxygen tank and the hydrogen tank, and three bellows are on the outside of the tank.

Two of the outside bellows are near the aft end of the External Tank and the last outside bellows is located near the top of the hydrogen tank.

In searching for any area of potential debris, the Space Shuttle Program determined that the original design of the three external bellows could permit ice to form around the outside of the bellows and ultimately that ice could be shaken free during launch and potentially damage the orbiter. Though this ice liberation typically occurs at relatively low speeds during the initial stages of liftoff and the climb to orbit due to vibration, the potential still exists for ice and frost to come off later when it would be a more hazardous debris source.

This prompted a redesign of the bellows to promote condensate runoff and to prevent the formation of ice. Initially, a foam skirt around the bellows rain shield was extended to divert condensate. This modification, called the "drip lip," squared off the edge of the rain shield and allowed the condensate to "drip off."

The previous configuration of the feedline bellows was susceptible to significant ice formation when moisture in the air contacted the cold surface of the un-insulated bellows. Photographs taken before launch indicated ice formation.

Though it was decided that the drip-lip configuration would be flown on STS-114, the External Tank Project Office continued to pursue the option of a heater for the bellows. The installation of the heater was planned for the third Return to Flight tank, ET-119. However, new information from the debris studies, performed by the Space Shuttle Systems Engineering & Integration Office, indicate that ice from the liquid oxygen bellows poses a debris concern to the Orbiter. Therefore, it was determined to add a heater to the bellows for STS-114-Return to Flight to reduce ice formation.

The bellows heater is a copper-nickel alloy metal strip heater, similar to heaters used on the Solid Rocket Motor joints, which will keep the bellows area slightly warmer than freezing, about 40 degrees Fahrenheit. The heater strips are about 53 inches long - the circumference of the bellows - and about 0.5 inches wide. The two heater strips are covered and joined by a silicone gasket that allows the heater to be bonded between the bellows rain shield and end shield. Tabs placed at intervals on the heater assist in its placement on the bellows and allow pull tests to verify the strength of the adhesive bond.

For STS-114, the heater will be placed on the bellows nearest the liquid oxygen feedline fairing. The heater will be turned on shortly after the liquid oxygen tank begins fast fill (about T-5 hours and 10 minutes) and turned off as the countdown resumes at the T-9 minute mark by the ground support equipment that operates prior to launch.

The new modifications significantly reduce the potential for ice buildup on the bellows, which improves the overall safety of the tank.

#### PROTUBERANCE AIR LOAD (PAL) RAMPS

The top-to-bottom assessment of the External Tank's Thermal Protection System led to re-evaluation of other areas in which foam insulation is prone to loss. One of those was the existing design of the Protuberance Air Load (PAL) ramps designed to prevent unsteady air flow underneath the tank's cable trays and pressurization lines.

Two PAL ramps exist on each External Tank. One is near the top of the liquid oxygen tank, close to the nose cone, while the other is below the intertank, near the top of the liquid hydrogen tank. They consist of thick, manually sprayed layers of foam, which could provide a source of debris. The forward 10 feet of the LH2 PAL ramp was removed and replaced to allow



access to the LH2 intertank flange area to implement foam closeout improvements.

An extensive evaluation that included careful dissections to collect data on existing PAL ramps determined location, size and frequency of any voids which are known to promote foam separation due to expansion of trapped air or gases during ascent.

Over the course of six months, seven enhancement sprays were performed on high-fidelity mockups to develop a new spray process, which proved through non-destructive evaluation that not only were fewer voids formed, but those that did form fell into the acceptable range for flight safety.

After comparing all of the data gathered and analyses performed, it was decided that the first two tanks PAL ramps are safe to fly using the current application process with detailed scrutiny of evaluation applied.

An enhanced spray process is in work for future tanks, as well as continued work in developing redesign options including elimination of the ramps; reducing the ramps' sizes by two thirds; or building a trailing edge "fence" on the back side of the cable tray, which would act like a nozzle throat and prevent unsteady flow in that area.

#### ENHANCED IN-FLIGHT IMAGERY

A tiny camera mounted on the External Tank's liquid oxygen feedline fairing will provide real-time views of the orbiter's underside and wing leading edges as well as portions of the tank.

Several locations were evaluated to provide the best possible video documentation, while ensuring that the camera itself would not become a debris source.

An identical camera flew once before on a tank during Atlantis' October 2002 mission. That camera was located in a different location near the top of the liquid oxygen tank and provided

only a partial view of the orbiter and tank. That location was chosen for the dramatic launch and ascent views offered during the first two minutes of flight until obstructed by the plume effect from the Solid Rocket Booster separation motor.

The new location maximizes the field of view and minimizes the chance of the plume associated with the SRB separation.

#### NON-DESTRUCTIVE EVALUATION (NDE)

One of the leading methods for evaluating the performance of redesigns, modifications and upgrades to the Space Shuttle systems – particularly the External Tank – is known as non-destructive evaluation (NDE).

Detecting defects nondestructively in manually applied foam presents a unique challenge. Not only is the foam low in density, which makes it difficult to differentiate defects such as voids from the surrounding porous material, but the foam also is irregular making it difficult to differentiate defects from natural variations in the foam.

A team investigated a dozen non-destructive inspection methods from industry and academia before selecting terahertz imaging and backscatter radiography.

Confidence in these new approaches was initially established by testing a wide variety of samples with different defect types and sizes. Terahertz imaging and backscatter radiology were used on the Protuberance Air Load (PAL) ramps on the first two flight tanks (ET-121 and ET-120). These results provided added confidence in the foam application quality.

Further refinement of the terahertz and backscatter technologies capabilities to detect thin voids and defects in more complex foam areas continues, but is a promising tool for reviewing the foam application process without damaging the foam itself.

## THERMAL PROTECTION SYSTEM CERTIFICATION

With non-destructive evaluation (NDE) as one method for determining the quality of foam application on the External Tank, assessments of the test verification process were conducted for any critical failure possibility.

The team developed a comprehensive plan to review and document Thermal Protection System (TPS) verification data used to certify the tank's structural integrity as well as debris generation potential. The plan called for a detailed review of each failure possibility, critical flight environments and all other applicable test data.

This approach identified possible deficiencies or areas requiring additional data. One of these, for example, focused on understanding internal defects of foam and their potential to generate debris. To address this issue, additional dissection data was gathered to characterize the internal structure of the foam. A flight tank converted into a test article that never would fly a mission provided the perfect source for most of these dissections. Next, a test program was initiated to develop data on what type and size of internal defect would be acceptable under new debris requirements.

This new plan led to several key decisions, including approval of the redesigned bipod TPS and the fly "as is" determination for first flight tank's PAL ramps.

## THERMAL PROTECTION SYSTEM (TPS) VERIFICATION & VALIDATION

One of the more complex approaches to certifying the changes and improvements to the External Tank before flight is to identify the scope of TPS process verification and validation efforts.

This process control dictated the establishment of prerequisites for TPS manual sprays and identified process verification and validation requirements with careful monitoring of their incorporation into the Return to Flight effort.

An integrated process control for the various foam processes was instituted as well as a plan for all tanks in production. After establishing manual spray requirements, tests and dissections were identified that would confirm the process used to certify the foam for flight. Tank dissections, defect testing and margin assessments followed.

The early work, obviously, concentrated on mandatory improvements to the first two flight tanks (ET-121 and ET-120). Attention also was paid to items that were desired on these first tanks, while looking toward longer range TPS improvements.

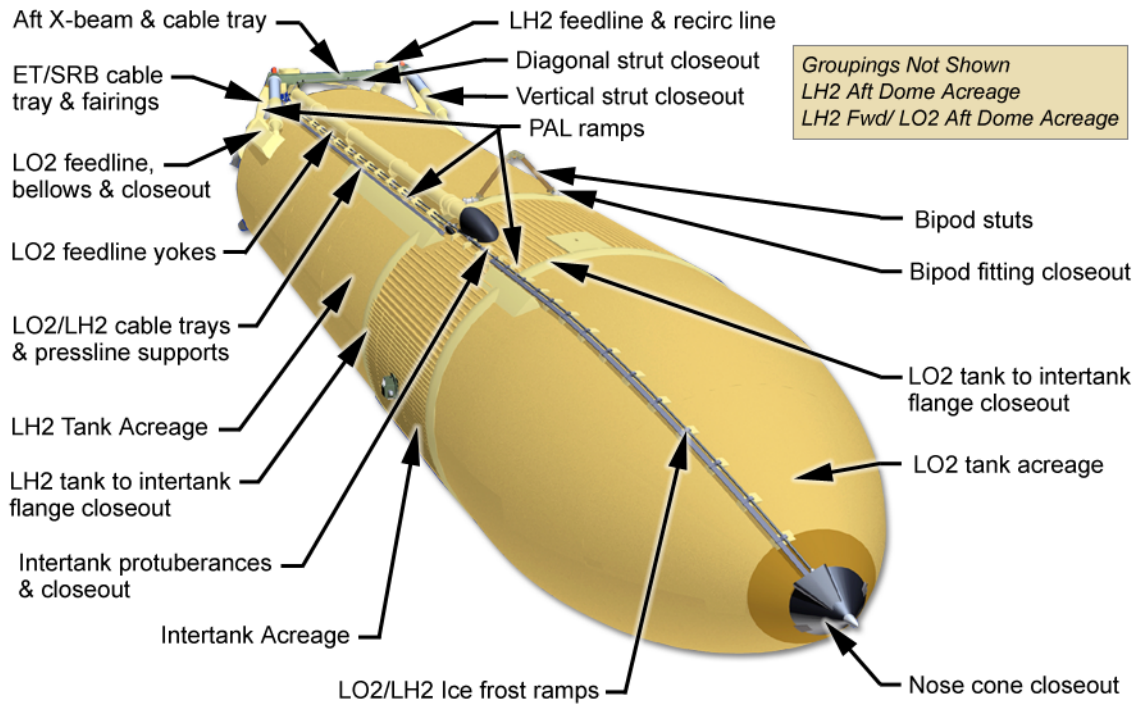

RTF\_V\_002.png

### TPS Applications

# SOLID ROCKET BOOSTER MODIFICATION

## BOLT CATCHER

Part of the Return to Flight effort included identifying every possible area of the Space Shuttle stack (including the Orbiter, External Tank and Solid Rocket Boosters) where potential debris sources existed. One of those identified for redesign was the “bolt catcher” fixed to the forward, or top, of the boosters where they attach to the External Tank. These retainers are designed to capture severed bolts when the boosters separate from the tank approximately two minutes after launch.

Each Shuttle is launched with two bolt catchers, which are located on the boosters. At booster separation, pyrotechnic devices fire to break the bolts that hold them to the tank. The forward bolt is vertically attached to both the Solid Rocket Booster and the External Tank. The canister-like bolt catcher captures the part of the bolt that is retained with the External tank; the other half of the bolt remains with the booster, secured within the forward skirt thrust post.

Though the bolt catcher is mounted on the External Tank, it is considered part of the Solid Rocket Booster element design.

The original bolt catcher design consisted of an aluminum dome welded to a machined aluminum base and bolted to the External Tank’s fittings. It is about 12 inches tall, 8 inches in diameter and weighs about 11 pounds. The inside of the bolt catcher is filled with a metal, honeycomb-like energy absorber to limit the impact of the bolt as it is captured.

The bolt, known as a separation bolt, is about 25 inches long, approximately 3 inches in diameter and weighs about 70 pounds. It has a groove, or separation plane, about 11.5 inches from the top that allows it to break when the pyrotechnic devices fire.

The part of the bolt that remains on the Solid Rocket Booster is inspected after flight to ensure the break was clean. The bolt catcher and the bolt half it captures disintegrate along with the External Tank upon reentry some 45 minutes after launch.

Following the Columbia accident, a series of tests were performed by the Solid Rocket Booster Project Office at NASA’s Marshall Space Flight Center to replicate the loads, or the forces, to which the bolt catcher is subjected during launch. The testing and analysis revealed the bolt catcher had a safety margin that was slightly less than had been previously assessed and required by the Space Shuttle Program, which is 1.4. To achieve the desired safety margin, a redesign effort was undertaken, incorporating a comprehensive testing program.

However, a review of all available still photography and video coverage of the separation on the External Tank revealed that the bolt catchers functioned properly on all flights.

The redesign of the bolt catcher housing now means the unit is made from a single piece of aluminum forging, thus eliminating the weld from the original design. In addition, the wall thickness on the catcher was increased from .125 to .25 inches using a much stronger aluminum alloy (AL7050).

The internal energy-absorbing material also was swapped to one that better absorbs the energy into the bolt catcher when the bolt is released. The original material was a corrugated sheet of aluminum wrapped spirally to attain the cylindrical shape that fit into the bolt catcher. The new design has a more open cell texture, much like a bee’s honeycomb.

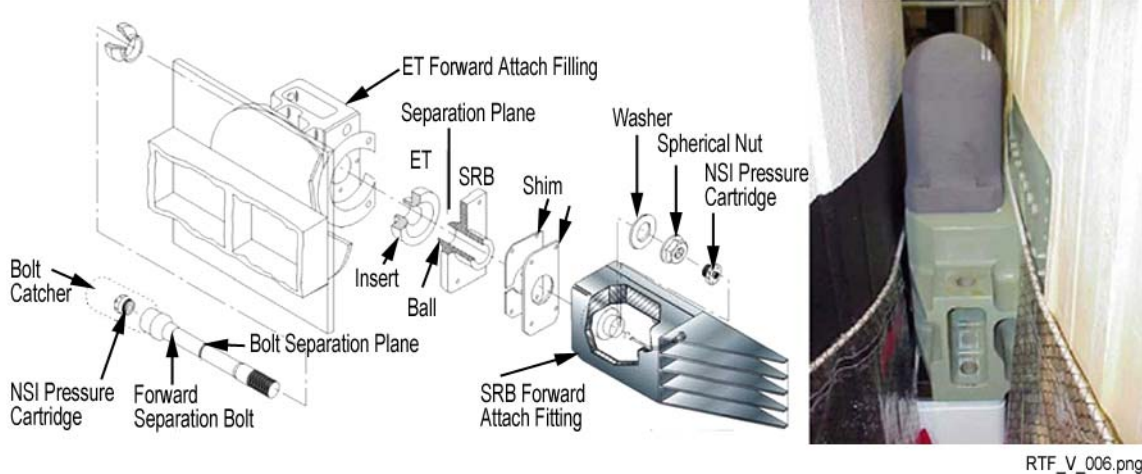

The thermal protection material also is being changed from the original super lightweight ablator to a machined cork covered with a protective paint finish. An ablator or ablative is a material that erodes to dissipate heat, offering a potential for debris during liftoff. Machined cork was selected as its replacement because it has a strong adhesive system that has a proven record of success in other areas on the Solid Rocket Booster. A layer of hypalon paint will protect the cork from moisture.

The External Tank attachment bolts and inserts – those that hold the bolt catcher in place – also were resized from three-eighths inch to nine-sixteenths inch, which adds strength to this area.

A series of static, dynamic and environmental tests of the redesigned bolt catcher then were conducted to determine the design loads and demonstrate the bolt catcher met, or exceeded, the 1.4 factor of safety requirement.

The aft end of the Solid Rocket Booster is attached to the External Tank by three struts, made out of Inconel 718 and designed to react to lateral loads induced during flight. The struts are made in two halves and are held together by aft separation bolts housed inside the struts. When the boosters separate from the

Tank, the bolts are fractured at a predetermined spot by a pyrotechnic device, thus splitting the bolt.

The two halves of the bolt are caught inside the strut halves by honeycomb energy absorbers on each end of the struts. During the past year, the Booster Project tested the strut honeycomb to confirm its capability and its load transfer characteristics. The tests revealed that modifications to the existing hardware were not needed because the current configuration is robust and there are no load or strength concerns.

#### BOOSTER SEPARATION MOTOR IGNITER

Immediately after the Solid Rocket Boosters separate from the External Tank, igniters called booster separation motors ignite and push the boosters away from the tank and Space Shuttle. These igniters have been redesigned to minimize the risk to the Shuttle.

At booster separation, forward and aft motors ignite to serve as small thrusters to prevent the boosters from contacting the tank or Shuttle. Each of the two Shuttle boosters has eight separation motors, which are small solid fuel rocket motors designed to provide 18,000



pounds of thrust in less than 0.8 seconds. At separation, a pyrotechnic charge lights the motor igniter, which also consists of solid rocket propellant. The igniter instantly ignites the motors' solid propellant.

The current redesign effort was initiated in 2003, when erratic performance was noted during open-air igniter testing. The test program was designed to qualify new suppliers for igniter propellant ingredients. A government and contractor anomaly resolution team of engineers concluded that the igniter solid propellant was fracturing. The propellant cracks caused erratic performance characteristics, including excessive peak pressures, pressure oscillation, and shortened burn time.

Based on the potential for erratic igniter performance to affect BSM ballistic performance and produce debris, the igniter Return to Flight team, consisting of NASA, United Space Alliance, and Pratt and Whitney engineers, determined that the igniter should be redesigned before the Shuttle returns to flight.

The team established the overall ground rules for RTF: elimination of all propellant damage mechanisms; qualification of the new design for flight and, installation of BSMs with the new igniter design for STS-114 and subsequent vehicles. Testing on the redesigned igniter began in June 2003 beginning with testing of a broad range of design concepts. The test team chose a final design, which has since undergone 53 tests.

Design changes include beveling the solid propellant grain configuration; modifying the retainer design; and, modifying the adapter to direct loads to the center of the retainer plate. These efforts were undertaken with a parallel activity to tighten controls on propellant and material suppliers.

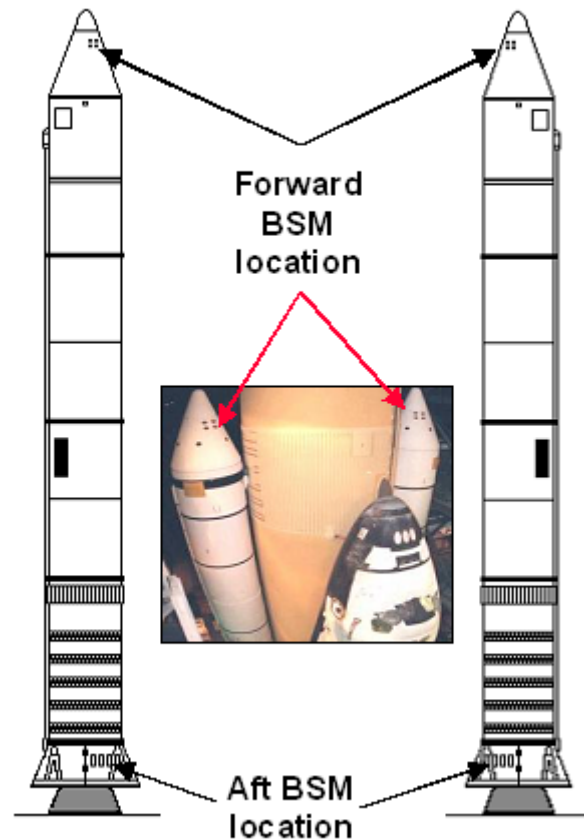

**Solid Rocket Booster separation motors ignite two minutes after launch pushing the boosters away from the Shuttle**



# IMPROVING IMAGERY, DATA COLLECTION FOR SPACE SHUTTLE LAUNCH AND LANDING



Documenting the Space Shuttle's launch has been enhanced to now include a minimum of three different views from ground sites as well as aircraft-based video from angles never before available. These additional views and cameras will provide much higher fidelity footage for engineers assessing whether any debris came off the External Tank during the first two minutes of flight when the vehicle encounters the highest aerodynamic portions of the ascent. A total of 107 ground and aircraft-based cameras will document Discovery's launch and climb to orbit.

The Ground Camera Ascent Imagery System was upgraded following the Columbia accident and also will include ship and ground-based radar to compliment the strategically placed cameras. Changes include additional camera sites, upgrades to the cameras themselves, implementation of High Definition Television (HDTV) for quick look analysis, and mirrored server capability to more easily and quickly allow the sharing of imagery between KSC, JSC, and Marshall.

## GROUND-BASED IMAGING OF LAUNCH

Before 2003, four short-range tracking cameras were used on the launch pads, at camera site two east of the pad, and at camera site six northwest of the pad.

Remotely controlled from the Launch Control Center adjacent to the Vehicle Assembly Building, one camera focused on the top half of the Shuttle and one focused on the bottom half. Camera site six views the hydrogen vent arm (above the tank) as it swings off the tank and also the underside of the Orbiter's left wing. Camera

site two views the area between the orbiter and the tank to observe any potential debris or ice that might fall.

TYPE	NO.	
Infrared (IR)	2	
High Speed Digital Video (HSDV)	2	
70 mm	3	
High Definition (HDTV)	19	
National Television Standards Committee (NTSC)	20	
35 mm	29	
16 mm	32	
<b>TOTAL</b>	<b>107</b>	

LOCATION	TYPE	NO.
Launch Pad 39B (Launch platform & launch tower)	16 mm	30
Launch Pad Perimeter	16 mm	2
	35 mm	5
Short Range Tracking Sites (3)	HDTV	3
	35 mm	6
Medium Range Tracking Sites (6)	70 mm	1
	NTSC	1
	HSDV	2
	35 mm	7
	HDTV	6
Long Range Tracking Sites (11)	70 mm	2
	NTSC	4
	HDTV	5
	35 mm	11
WB-57 Aircraft (2)	Infrared	2
	HDTV	2
Operational Television (OTV)	HDTV	3
	NTSC	9
Public Affairs	NTSC	6
<b>TOTAL</b>		<b>107</b>



For Return to Flight, there are three camera sites designated one, two and six. Two new cameras have been added for camera site one, located northeast of the launch pad. The addition of this tracker ensures a view of the underside of the right wing as well as the area between the External Tank and the Orbiter to track any debris during its roll maneuver just after launch. All camera sites have two film and one HDTV video cameras.

The short-range tracking cameras have 200-mm focal length lenses and are loaded with 400 feet of film, running 100 frames per second. In addition to the film cameras around the launch pads, there are 42 fixed cameras with 16-mm motion picture film.

Medium-range trackers are located at six sites: Three along the coast and three near the Launch Complex 39 area. Placement at these sites provides three views for triangulation, to better characterize any suspect area. These cameras have 800-mm and greater lenses, running 100 frames per second. Three of the cameras have 400 feet of film and two have 1,000 feet. The additional tracking cameras have 150-inch lenses, with 1,000 feet of film. Five of six sites also have HDTV video cameras.



Five long-range trackers have existed north and south of the pads, from Shiloh and Playalinda to Cocoa Beach, ranging from 14 miles north to 20 miles south. These additions will reach as far north as Ponce de Leon Inlet, 38 miles from the launch pads, and south to Pigor, 11 miles from the pads. One of the cameras previously located at Patrick Air Force Base has been converted to be transportable and moved to a location north of the pad.

All the cameras have 400-inch focal length and 100 feet per second capability to provide more data points to better track any debris.

Two of the cameras are part of the Distant Object Attitude Measurement System (DOAMS), located at Playalinda Beach and the Cocoa Beach area. A refurbished five-meter focal length telescope recently was installed in the Cocoa

Beach location. Each of these camera sites also will have HDTV video cameras.

A unique feature of the tracking telescopes is a robotic camera manned by a technician sitting on top and gently manipulating a joystick to map the Shuttle's track through the sky.

## CAMERAS

A variety of cameras and lenses are used to support ascent imaging, including film and digital cameras.

- 35mm film cameras are used at the pad and on short, medium and long range camera sites and provide the highest resolution dictating they are the primary imagery to meet the minimum size requirements for debris identification during ascent.
- HDTV digital video cameras are co-located with many of the 35mm cameras and provide quick look capability. The digital video data provides the ability to conduct expedited post-launch imagery processing and review (quick look) before the film is processed and distributed.
- National Television Standards Committee (NTSC) – backup for sites without HDTV.
- 70mm motion picture film cameras provide “big sky” views.
- 16mm motion picture film cameras are used on the Mobile Launch Platform and Fixed Service Structure of the launch pad.
- Other cameras are located throughout the launch pad perimeter and other locations providing additional quick look views of the launch.

Cameras are either fixed or mounted on a tracker. A variety of trackers are used at the different camera sites, the predominant tracker being a Kineto Tracking Mount (KTM) tracker. All of the trackers within close proximity to the launch pads are remotely controlled. The remaining trackers are remotely or manually controlled on-site.



**Kineto Tracking Mount tracker**



## CAMERA LOCATIONS

The ascent ground cameras provide imagery from the launch platform and on the launch tower itself, as well as from short, medium and long-range sites as mentioned above.

Twenty-two 16mm cameras are on the Mobile Launch Platform...

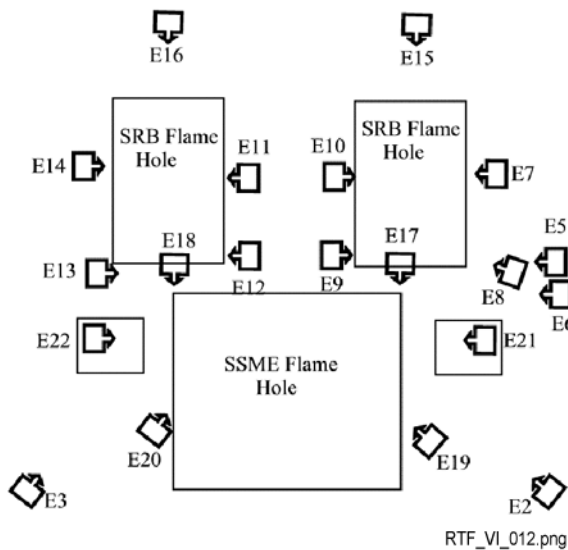

...and eight 16mm cameras are on the launch tower (Fixed Service Structure).

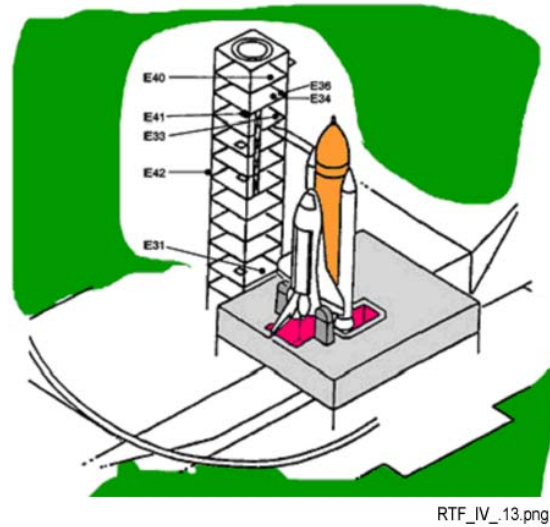

The three short-range camera sites are located within the pad perimeter approximately 422 to 432 yards from the launch pads and include two 35mm cameras and an HDTV camera. These sites provide coverage during the early phases of a launch to image individual portions of the Shuttle stack. Once the vehicle clears the launch tower, these cameras can capture larger portions of the Shuttle, but lose the ability to image and track small debris.

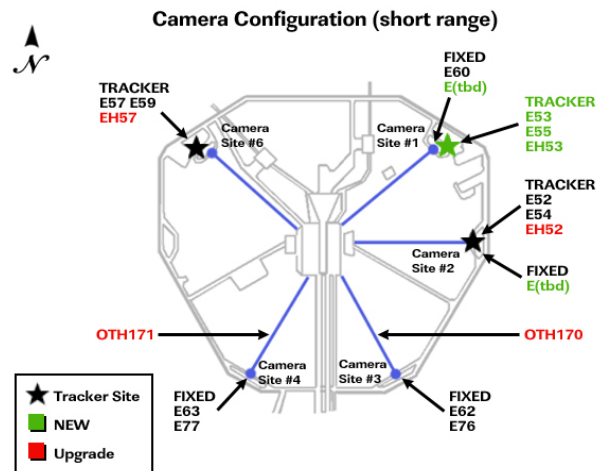

Eleven medium-range sites are located approximately one to six miles away from the launch pads - seven used for Pad 39A and six for Pad 39B. The medium-range sites each have a 35mm camera while 10 of the 11 incorporate

HDTV cameras. Medium-range cameras are used during the early phase of ascent and continue to be used until the distance to the Shuttle becomes too far to identify and track debris.

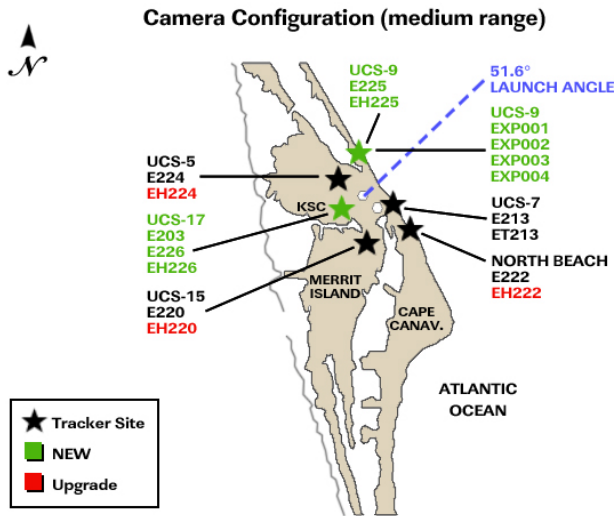

Eleven long-range sites are located approximately four to almost 40 miles away from the launch pads, and support both pads. All of the sites have 35mm cameras, and two have 70mm cameras. Five of the 10 sites have HDTV cameras. Long-range cameras are used during early phases of ascent to identify and track debris and continue to be used as long as the vehicle is visible.

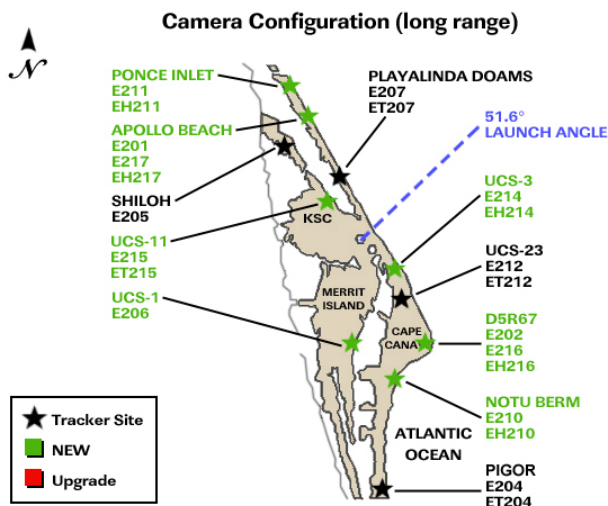

### CAMERA RESOLUTION

- Liftoff to 30 seconds: Objects of 1 inch in diameter or larger, 0.5 foot linear accuracy of debris source and impact location
- 30 seconds to 60 seconds: Objects of 3 inches in diameter or larger, 1 foot linear accuracy of debris source and impact location
- 60 seconds to 90 seconds: Objects of 8 inches in diameter or larger, 3 foot linear accuracy of debris source and impact location
- 90 seconds to booster separation: Objects of 15 inches in diameter or larger, 5 foot linear accuracy of debris source and impact location

### CAMERA OPERATIONS PLAN

All of the cameras are checked pre-launch, and then activated on launch day to capture the ascent imagery. After launch, the 70mm, 35mm and 16mm films are collected and transported to a central location at the Kennedy Space Center before being flown to an off-site processing facility to be developed and copied for delivery to the Johnson Space Center in Houston and the Marshall Space Flight Center in Huntsville, Alabama. The delivery occurs in two steps: one delivery the day after launch and the second delivery two days after launch.

The Quick Look video imagery - HDTV and other formats - is collected and distributed within the first few hours after launch and provided to the image analysis facilities at Kennedy, Johnson and Marshall via a mirrored server available for review anywhere between one and eight hours after launch.

About one hour after launch, the Quick Look imagery consists primarily of views from the short-range cameras and is reviewed by all of the imagery analysis teams. Quick Look imagery consisting of HDTV imagery from the medium and long-range sites will be retrieved and made available to the imagery analysis teams and

Thermal Protection System experts approximately eight hours after launch.

### TAKING THE HIGH GROUND ON ASCENT IMAGING

NASA has implemented use of an aircraft-based imaging system taking advantage of agency WB-57 aircraft based near the Johnson Space Center in Houston. The WB-57 Ascent Video Experiment (WAVE) will be used on an experimental basis during the first two post-Columbia Space Shuttle flights and provide both ascent and entry imagery to enable better observation of the Shuttle on days of heavier cloud cover and areas obscured from ground cameras by the launch exhaust plume. WAVE was initiated to develop the technical and operational capabilities of obtaining video of the Shuttle during launch from an aircraft, which will supplement ground cameras to obtain three useful views.



WAVE includes a 32-inch ball turret system mounted on the nose of each WB-57 aircraft. The turret houses an optical bench providing installation for both High Definition Television and infrared cameras. Optics consists of an 11-inch-diameter, 4.2 meter fixed focal length lens. The system can be operated in both auto track and manual modes from a command and control system in the cockpit, which includes monitors for all three cameras, switch panels and joysticks. All footage will be recorded on board and returned for processing and evaluation shortly after the Shuttle launch.

The two imaging cameras are a HDTV color camera (Panasonic AK-HC900) and a Near Infrared camera (Sensors Unlimited SU640SDV

1.7RT/RS-170). Both share a Celestron fixed field-of-view telescopic lens. In addition, a National Television Standards Committee (NTSC) color acquisition camera will be used to track the Shuttle during ascent.

Approximately two days before launch the two WB-57 aircraft will fly from Ellington Field in Houston to Patrick Air Force Base in Florida.

Two and a half hours before launch, the aircraft will take off from Patrick and enter a holding pattern. One will be positioned north of the Shuttle's flight path and one will be positioned south. The aircraft will be in communication with a WAVE Operations Officer in the Range Operations Control Center who in turn will be in communication with the chairperson of the imagery team in the Launch Control Center.



Twenty minutes before launch the aircraft will enter their final circuit, and about five minutes before launch will begin recording video. The WAVE requirement is for imagery acquisition from 60 seconds after liftoff to 15 seconds after booster separation. However, plans are for the aircraft to track the vehicle from liftoff through Main Engine Cut Off (MECO), which occurs 8 1/2 minutes later. The two aircraft should be about 23 miles (37 kilometers) from the Shuttle at booster separation.

After launch, the aircraft will return to Patrick, and the video will be retrieved from the onboard

recorders and transported to Kennedy. There it will be loaded on the mirrored servers about eight hours later.

The WB-57 aircraft operate out of Ellington Field near Houston under direction of JSC. They are the only two WB-57's still flying today. Identified as NASA 926 and NASA 928, the high altitude weather aircraft can fly day and night with a range of approximately 2,500 miles. Two crew members in pressurized suits pilot the plane to altitudes in excess of 60,000 feet and the aircraft can carry a payload of about 6,000 pounds.

### RADAR TRACKING

For future Shuttle missions, a new wideband and Doppler radar tracking system has been implemented for adequate detection of debris during launch and ascent. Three radars now will digitally record tracking data of the Shuttle from launch until signal is lost with the primary timeframe of interest being launch plus 60 seconds to launch plus two minutes.

Data from each radar site will be stored on a hard disk and backed up on CDs/DVDs, as will be the boresight video used by the radar operators to help track the vehicle.

The three radar systems that will be in place for launch include one C-band and two Doppler X-band.

The Wideband Coherent C-band Radar provides high spatial resolution of debris events, and can detect debris events within the Shuttle vehicle stack. This radar – called the Navy Midcourse Radar – formerly was located at Roosevelt Roads Naval Station in Puerto Rico. It now resides at the site formerly occupied by the National Center for Atmospheric Research, north of Kennedy.



**Wideband, Coherent C-Band Radar**  
 3MW peak transmit power  
 0.5 M range resolution @ 500 Mhz WB LFM  
 15.24 M dish diameter

RTF\_VI\_0019.png

The two Weibel Continuous Pulse Doppler X-band Radars provide velocity and differential Shuttle/debris motion information. Correlation of these two data sets over the three geometries provided for the debris radar system optimizes the insight and probability of detection for very faint debris targets. These radar systems will be located on ships – one mounted on a booster recovery ship downrange of the launch site, and the other on a ship south of the ground track.

The radars are capable of resolving debris at or greater than observed signal strength of minus 50 decibels per square meter (dBsm). Shuttle debris sources have been characterized as typically falling within in the minus 30 dBsm to minus 45 dBsm range. The X-band and the C-band radars were tested in August 2004 during the launch of the Delta II/Messenger spacecraft from the National Center for Atmospheric Research (NCAR) site intended to permanently house the systems.





**Continuous Pulse Doppler X-Band Radar**  
 1.6 KW peak transmit power  
 0.14 M/S Doppler velocity resolution  
 4 x 4 M reflector size

RTF\_VI\_020.png

The radar data will be analyzed at the NCAR site with the C-band data being available in near real-time, while the X-band data (screen captures) will be sent from the ships via satellite link to the NCAR site. The southern ship is expected back in port 6 hours after launch, and the data will be transported immediately to the NCAR site.

### WING LEADING EDGE INSTRUMENTATION

Though impact monitoring is not a requirement for future Shuttle flights, NASA chose to incorporate sensors along the Orbiter wing leading edges to compliment Thermal Protection System inspection by measuring, recording, and transmitting acceleration data to a laptop computer on the flight deck for early transmission to Mission Evaluation Room engineers in the Mission Control Center.

Each wing now has 88 sensors embedded behind the protective Reinforced Carbon-Carbon panels. Sixty-six acquire acceleration data and 22 gather temperature measurements during the Shuttle's launch phase. The temperature sensor data is used to calibrate the impact sensors.

Sensor units made up of three accelerometers, an internal and external temperature sensor and

battery will measure, record and transmit acceleration and temperature data, along with battery voltage to a laptop computer in the crew compartment via a combination of relays and cabling.

Prelaunch, the sensor units are loaded with command files that contain the Greenwich Mean Time (GMT) of launch. Shortly before launch, the units enter trigger mode and at liftoff are activated via a G force switch to begin storing and processing ascent accelerometer data stored at 20,000 samples-per-second-per-channel within the unit's internal memory. Temperature and battery voltage data is stored every 15 seconds.

Ten minutes after launch – after the External Tank separates – continuous data collection will stop. Each sensor unit will process the data to determine the peak acceleration forces that particular sensor experienced during ascent. This summary data, once downlinked to the ground, will be screened and compared to threshold criteria to determine whether any potential impact events occurred.

After processing the data, the system will enter on-orbit mode, meaning only six sensor units will collect acceleration, temperature and battery voltage. The other units will become idle. The specific units in each mode will rotate throughout the flight in order to maximize the battery life of the sensors.

About 1½ hours after launch (completion of the post post-insertion timeline), the crew will connect the wing leading edge system laptop to the onboard computer network and the software will begin to download data from each sensor unit. Commands are sent through the laptop to the 44 sensor units and will download acceleration, temperature and voltage data for each sensor.

A small amount of raw data from liftoff also will be downloaded to be used as a baseline for calculations on the ground. Throughout the

remainder of the flight, the sensor units will be commanded every six hours to download G force peaks, time of occurrence, voltage and temperature files.

As the data files are written to the laptop, they will be extracted from the laptop via ground control by operators in Mission Control and placed on a server for access and evaluation by experts.

Based on the data evaluation of summary data, additional raw data can be requested for areas of interest. Raw data can also be requested based on

findings from telemetry or other imagery sources. A command will download the specific time period needed for further evaluation. Data from each sensor unit is downloaded at a rate equivalent to two minutes for .5 second of raw data to the laptop, so a complete set of raw data will not be downloaded to the laptop.

Post-landing, ground operations personnel at Kennedy will download the remaining raw data for archival and analysis.

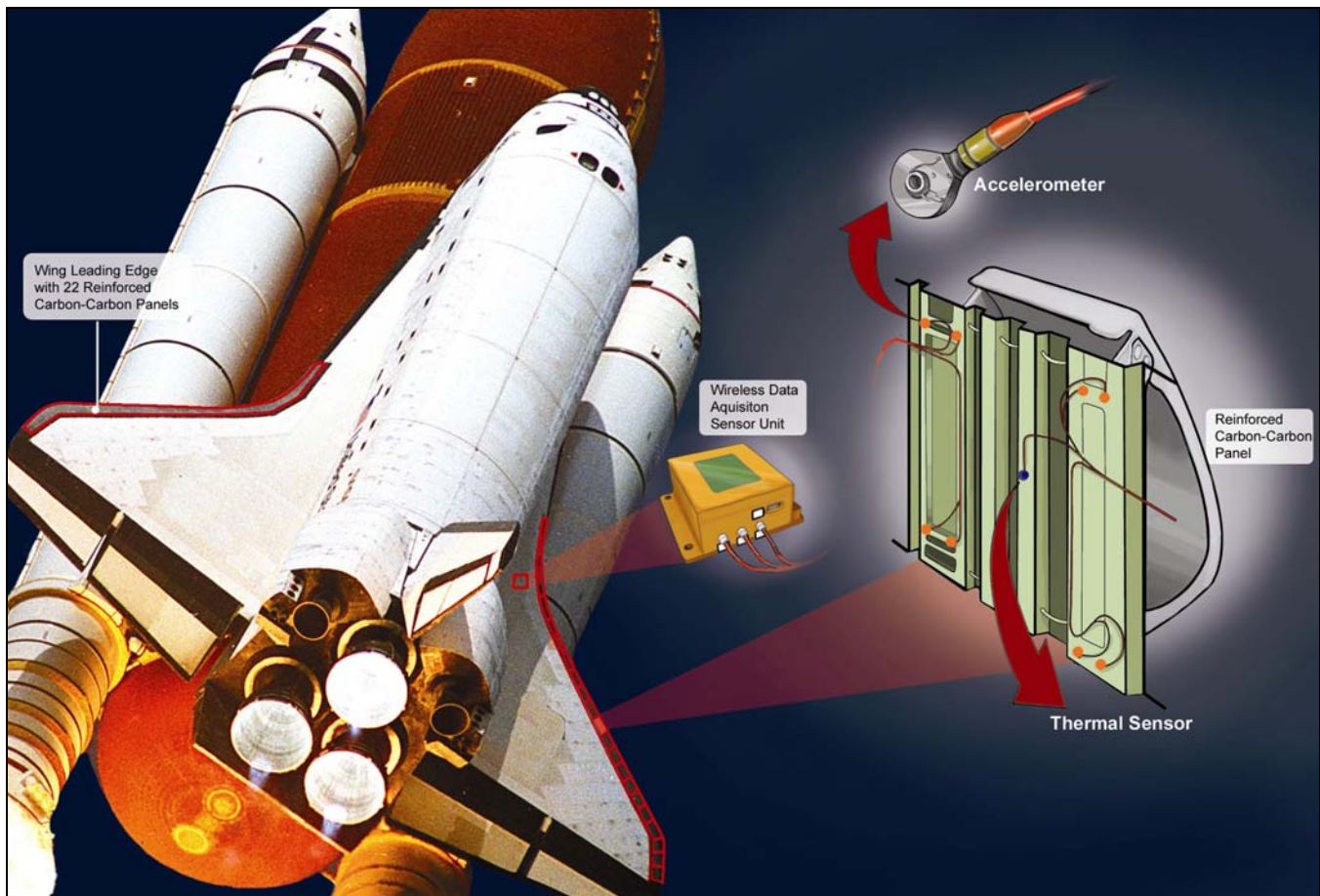

**Wing Leading Edge Impact Detection System**

## WING LEADING EDGE IMPACT DETECTION SYSTEM

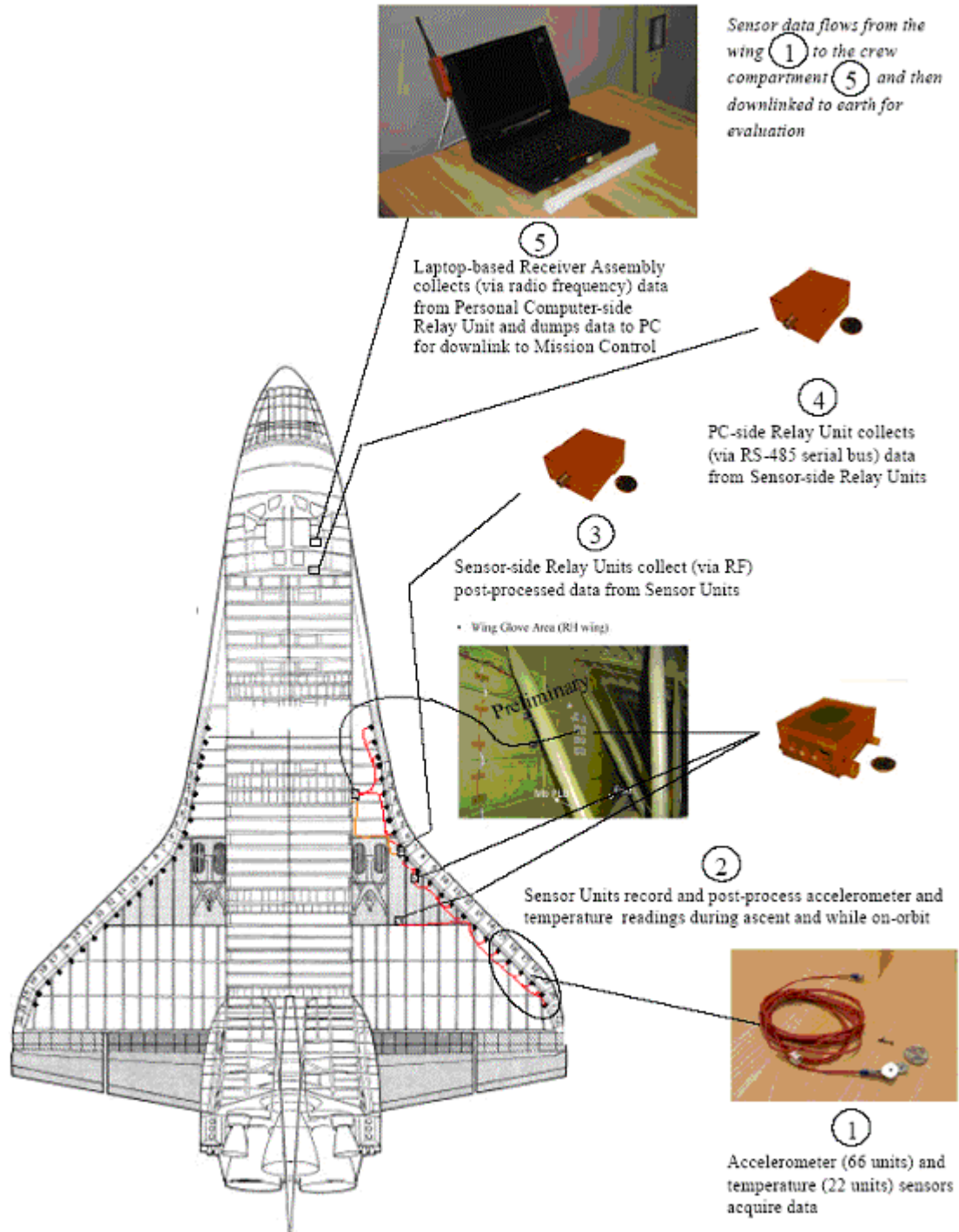



# ENHANCED SHUTTLE-BASED CAMERA VIEWS

New and modified cameras on the Space Shuttle solid rockets, External Tank and on Discovery will greatly increase the views available to verify that there is no hazardous debris or damage during ascent.

The cameras increase the capability to monitor the ascent environment, including debris, and verify the health of the Shuttle's Thermal Protection System and the redesigned portions of the External Tank.

Enhancements include reinstating previously used digital cameras on the Shuttle Solid Rocket Boosters; adding a new video camera to the External Tank; adding a new remote electronic still camera on the underside of the Shuttle to replace a previous film camera in that location; and creating new procedures for crew handheld digital photography of the tank. Handheld cameras used by crew members also have been modified to allow them to take digital images that can be processed onboard the Shuttle as well for transmission to the ground.

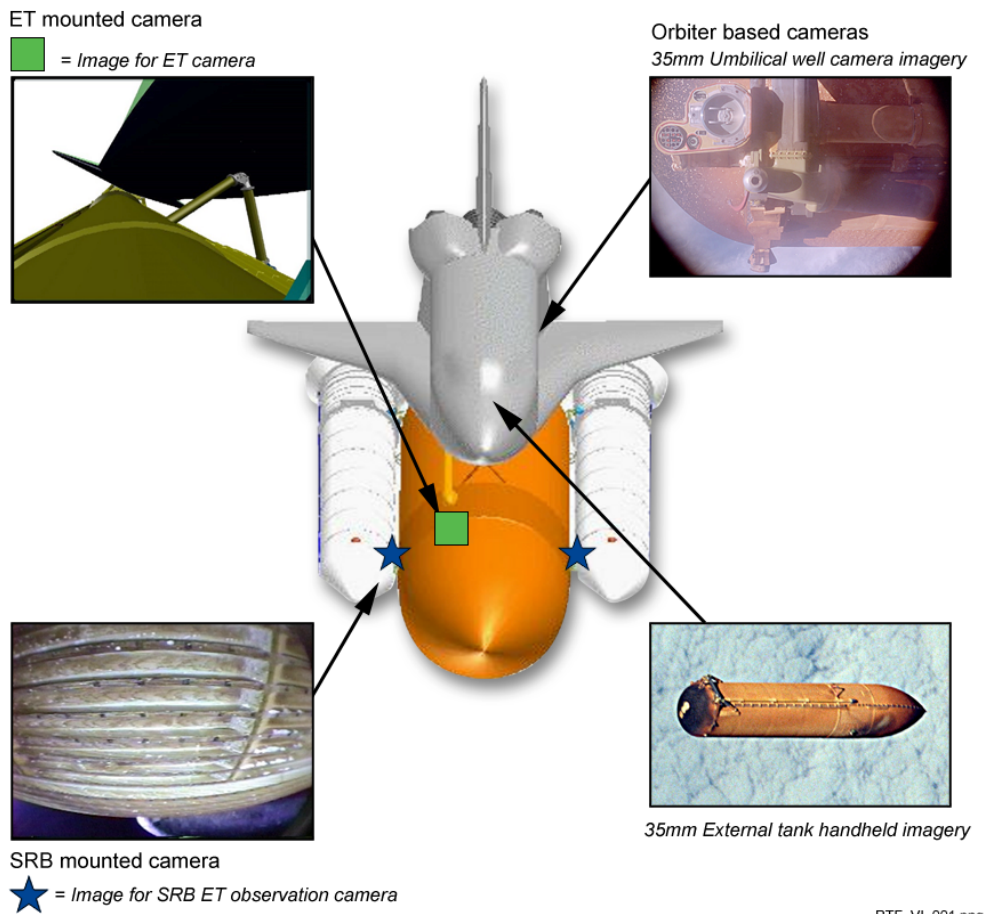

**Cameras on the Space Shuttle boosters, External Tank and Orbiter**



Together, these steps are part of a project known as the Enhanced Launch Vehicle Imaging System (ELVIS). Several new and modified cameras will fly on Discovery's Return to Flight Space mission, STS-114, while additional steps will be phased in over several future flights.

Also on STS-114, a new handheld digital camera and flash will be available to spacewalkers. The digital camera can be used to take electronic images of any exterior surfaces of the Shuttle while spacewalking.

Together, these measures respond to two recommendations made by the Columbia Accident Investigation Board (CAIB).

The tank-mounted camera provides supplementary imaging to that gained through in-flight inspection with the Orbiter Boom and Sensor System to satisfy recommendation R3.4-3. That recommendation called for NASA to provide a capability to obtain and downlink high-resolution images of the underside of the Orbiter wing leading edge and forward section of both wings' thermal tiles. On later Shuttle flights, beginning as early as STS-115, additional cameras added to the solid rockets will provide better views of the wings during ascent.

The use of handheld digital cameras by the crew to document the External Tank after it is jettisoned and the new electronic still camera on the Orbiter underside during STS-114 satisfy recommendation R3.4.2, which called for NASA

to provide a capability to obtain and downlink high-resolution images of the tank after it has separated from Discovery.

#### EXTERNAL TANK-MOUNTED CAMERA

A television camera has been installed on the exterior of the External Tank located several feet above the right bipod area in the liquid oxygen feedline fairing housing. The camera and associated equipment are the same as used on one previous Space Shuttle mission as a technology demonstration - STS-112 in October 2002. However, the position and view of the camera have been changed to provide greater visibility of the Shuttle's underside and tank.

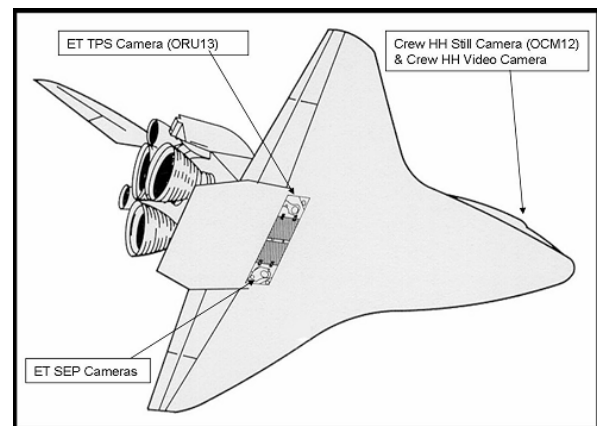

**Shuttle Orbiter-Based Photography for STS-114 Ascent**

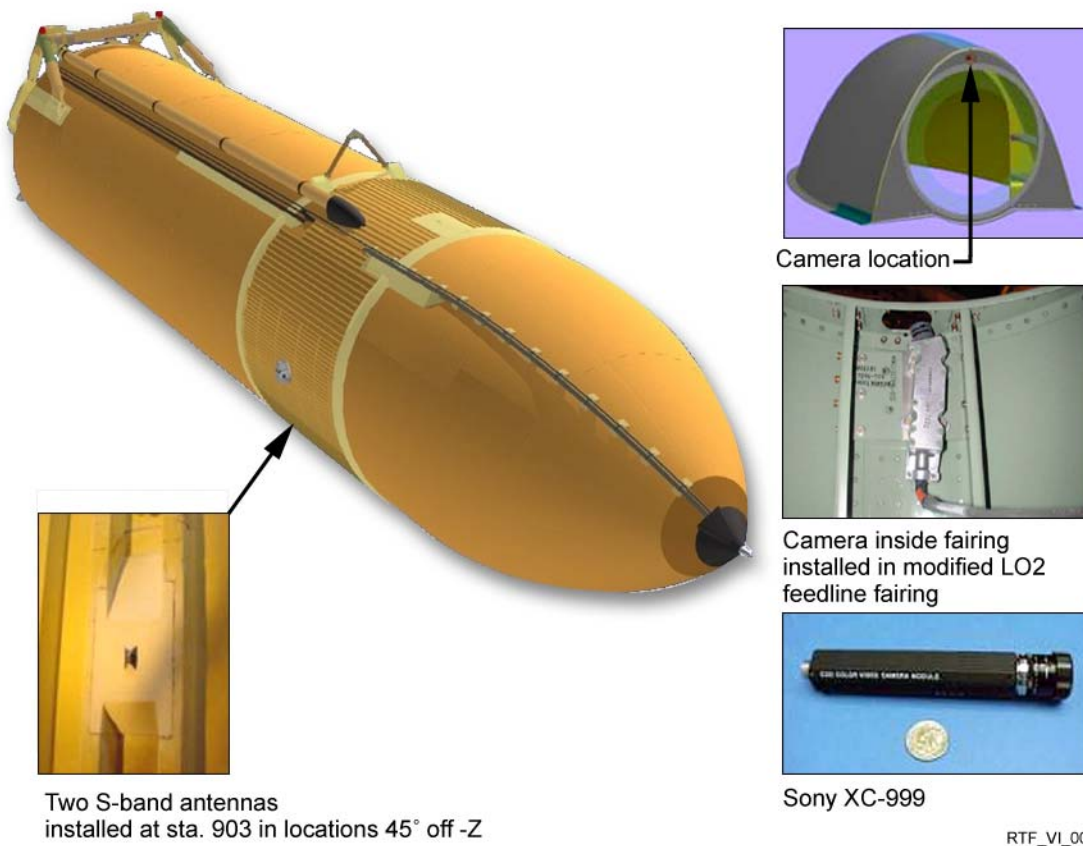

### External Tank Camera Overview

The camera is a Sony XC-999 secured in a modified, space-hardened housing. It is about the size of two C batteries laid end-to-end and is of a type commonly referred to as a "lipstick" camera. The camera's views will be transmitted to the ground in real time via the ground communications station at Merritt Island, Fla., during the Shuttle's climb to orbit.

The transmission occurs through an electronics package located within the central part (intertank) of the ET, which

joins the oxygen and hydrogen tanks. The electronics box houses batteries, a 10-watt transmitter and other equipment. The signal is sent to the ground via antennas located on the exterior back side of the tank, almost directly opposite the camera's location.

The new ET camera is expected to remain in the same configuration as used during STS-114 for all subsequent missions.

## SOLID ROCKET BOOSTER CAMERAS

Previously used cameras - one on the left solid rocket and one on the right - have been reinstated to provide views of the ET intertank for STS-114. The cameras are located in the same locations as on several previous Shuttle flights. The cameras are located just below the nosecone of each booster and do not provide real-time views during launch. Their imagery is recorded for playback after their retrieval from the Atlantic Ocean.

Future plans, beginning several missions after STS-114, include installing two additional cameras on each booster. One camera will be located at the ET attach ring, about one-quarter of the way up each rocket. Another camera will be added to the forward skirt of each booster, where each rocket's nose cone and main body intersect.

The forward skirt cameras will look aft to provide views of the Shuttle wing leading edges. The ET attach ring cameras will look forward to provide views of the wing and fuselage underside tiles. All future cameras will record imagery onboard the rockets for viewing after they have been recovered. They will not provide real-time television views during launch.

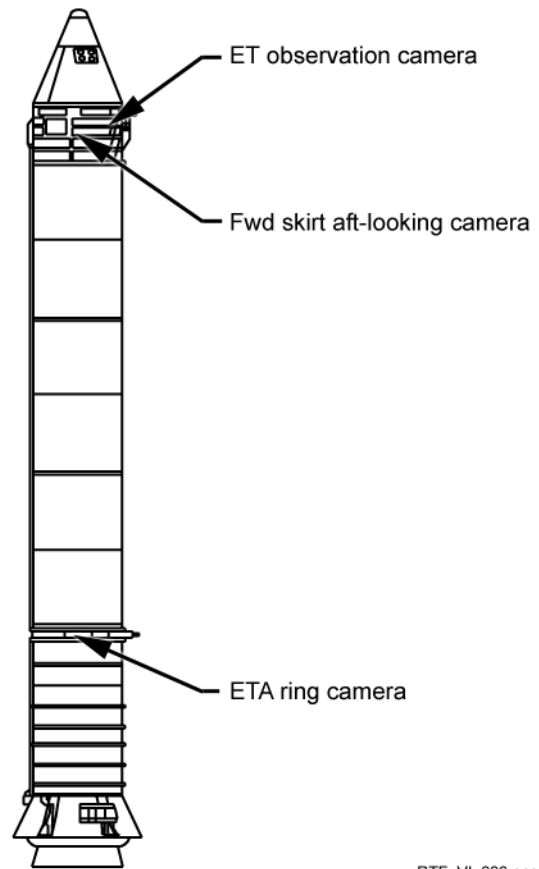

RTF\_VI\_006.png

### SRB-Mounted Cameras

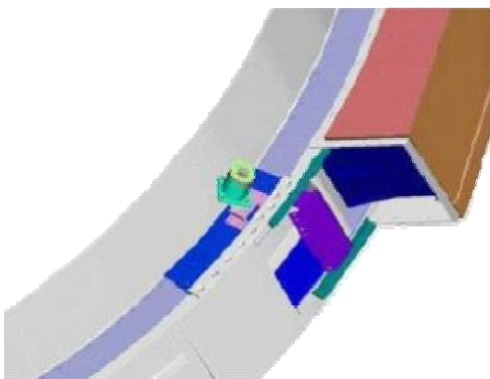

ET Ring Camera Housing Installed

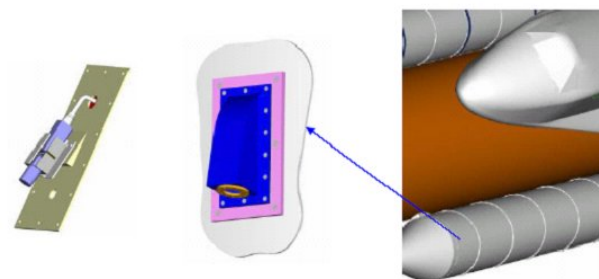

Forward Skirt Aft-Pointing Camera Prototype Housing

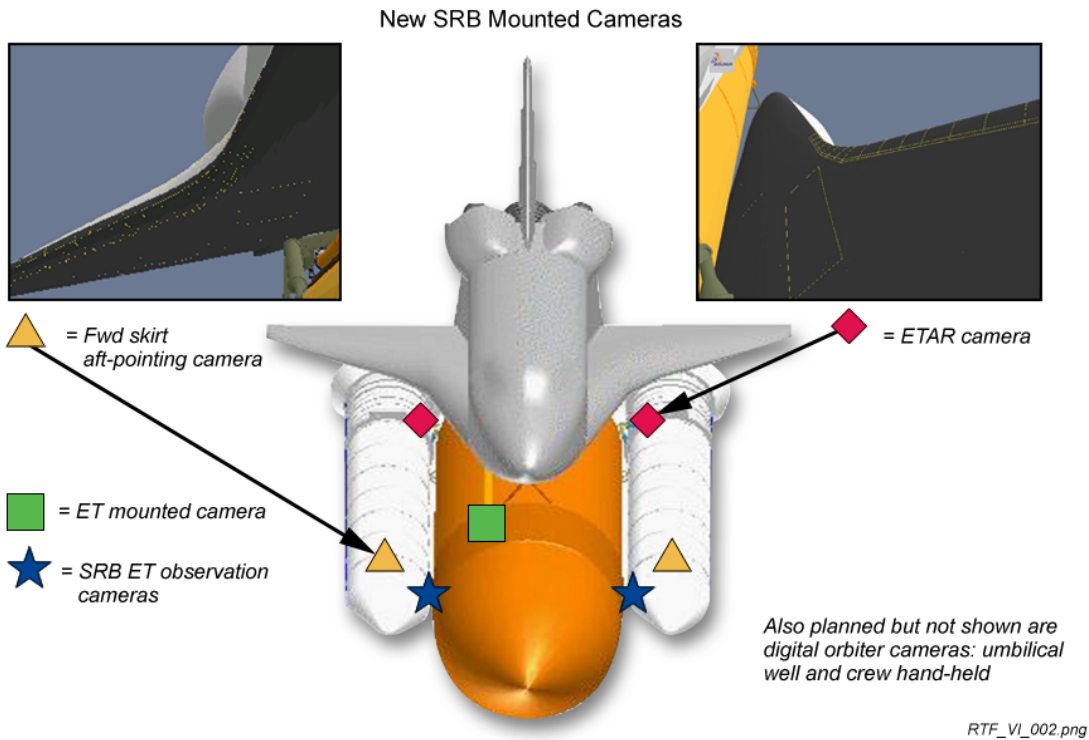

### Camera Configuration: Third Flight & Subs

#### EXTERNAL TANK UMBILICAL WELL DIGITAL STILL CAMERA

For STS-114, a 35mm still camera previously located in the right umbilical well on the underside of the Orbiter on previous Shuttle flights has been replaced with a Kodak DCS760 digital still camera. The new camera will take digital images of the tank after it has separated from the Orbiter and feed them to a laptop computer in the crew cabin. The crew then will downlink those images to Mission Control for analysis early in the flight.

The left umbilical well will continue to have two film cameras as has been flown on previous missions to gather movie imagery for use in analysis after it has been returned to Earth.

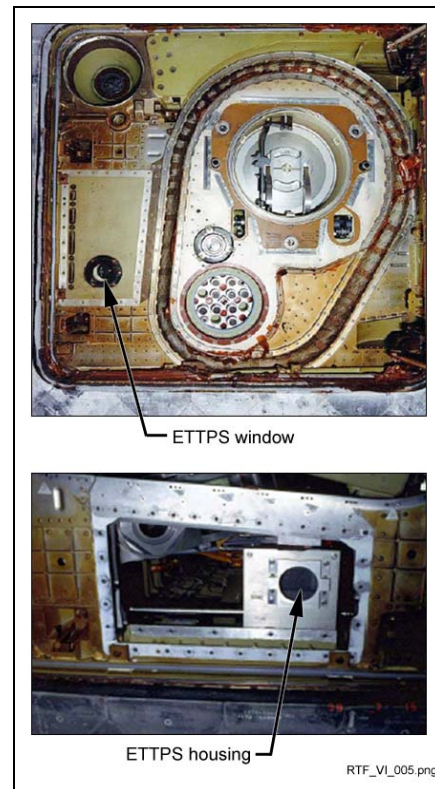

#### Right-Hand Umbilical Well



## CREW HANDHELD PHOTOGRAPHY

The crew's procedures in photographing the External Tank after it has separated from the Orbiter have been modified to use a digital still camera Kodak DCS760. The handheld digital camera has been flown on many past missions, but never before has been used for imagery of the tank after launch. Previously, imagery of the tank was taken by the crew using a handheld film camera and saved for analysis after the Shuttle's return to Earth.

The handheld digital images of the tank taken on STS-114 and subsequent flights will be transferred to a laptop computer and then transmitted to Mission Control early in the mission for analysis.

Along with the photography taken by the umbilical well digital camera, the handheld digital images will assist ground technicians in characterizing the condition of the tank as it was jettisoned. They will assist in characterizing any foam loss and verifying the flight operation of tank design changes that have been made.

To photograph the tank, the Orbiter will be pitched over shortly after the tank has separated to optimize its view from the overhead cabin windows. This maneuver will be done a few minutes earlier during STS-114 than on previous flights. The earlier maneuver will allow the crew to photograph the tank while it is closer, improving the resolution of the imagery.

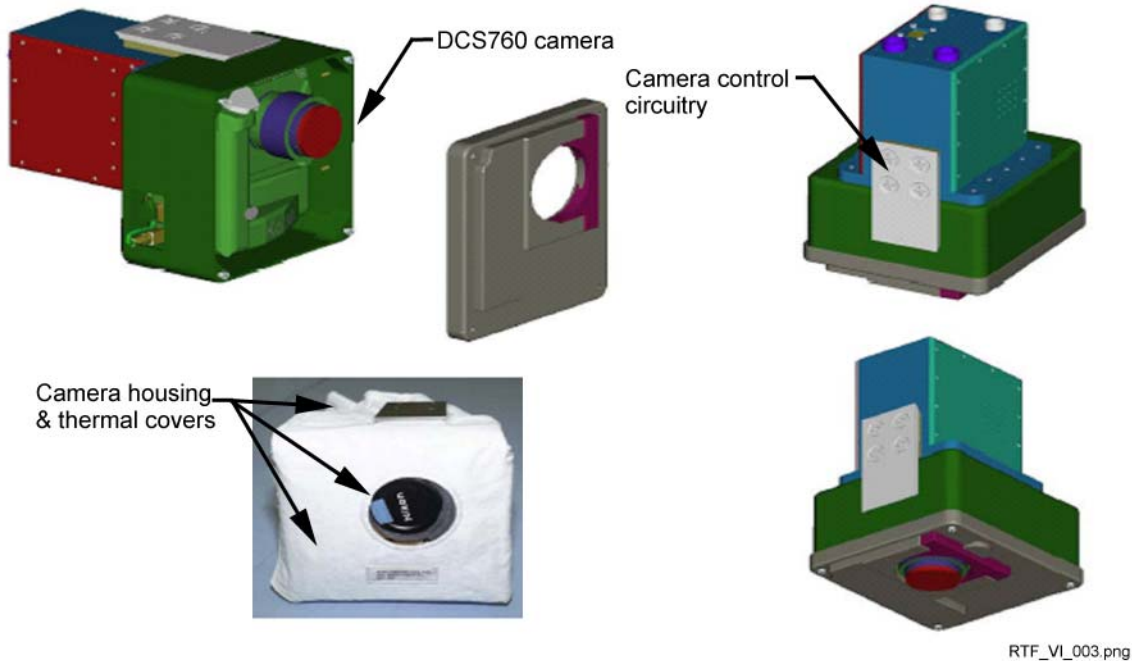

**Digital Umbilical Still Camera System**

## DIGITAL SPACEWALK CAMERA

A new handheld digital camera for use by spacewalkers outside of the vehicle will be flown on STS-114 and subsequent flights. Previously, all handheld cameras used by spacewalkers outside the vehicle had been film cameras. The new Extravehicular Activity (EVA) camera is a Kodak DCS760 camera, the same camera used for digital imagery inside the Shuttle cabin, with some modifications made to equip it for use in the vacuum and extreme temperatures of space. The modifications included a change of lubricants for the camera and a thermal protective covering.

A flash unit also will be available for use with the digital camera during spacewalks. The flash has been modified to remain in an air-tight housing for use in the vacuum of space.

Digital images taken during a spacewalk are stored in the memory of the camera and later brought back inside the Shuttle cabin. Then, they are fed into a laptop computer in the cabin and transmitted to Mission Control. The digital EVA camera may be used to provide images of an inflight repair performed during a mission, to assist an EVA inspection of potential damage or other reasons.

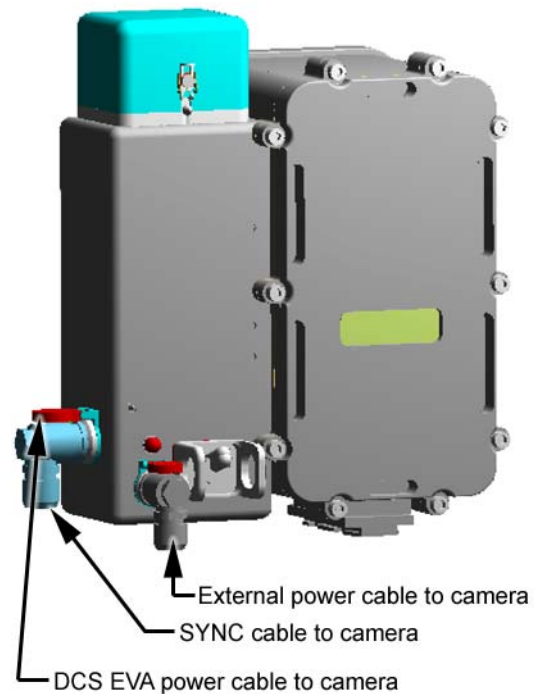

RTF\_VI\_008.png

### EVA Flash Mechanical Design

# IN-FLIGHT INSPECTION AND REPAIR

In addition to improved cameras on the ground and on the Space Shuttle, Discovery's astronauts will conduct close-up, in-flight inspections with cameras, lasers, and human eyes.

The primary tool for on-orbit inspection will be a 50-foot-long Space Shuttle robotic arm extension and associated sensors, known as the Orbiter Boom and Sensor System (OBSS). While the Shuttle's remote manipulator system (SRMS) is capable of inspecting part of the thermal protection system on its own, the OBSS is needed to extend that reach to all critical areas of the Shuttle's wing leading edge and the Shuttle's belly.

The OBSS was assembled by MD Robotics of Brampton, Ontario, Canada, which

manufactures remote manipulator systems for both the Shuttle and the International Space Station. The OBSS combines two 20-foot-long graphite epoxy cylinders originally manufactured as Shuttle arm replacement parts. At one end of the boom is a modified electrical grapple fixture, and on the other end are the imagery systems. The upper and lower booms are joined by a rigid joining fixture, which has an attached modified flight releasable grapple fixture that will be used to hand the boom from the Station arm to the Shuttle arm during docked operation at the complex. Electrical and data cables run the length of the boom, providing power for the sensors while allowing imagery to be transferred through the Shuttle's wiring system to laptop computers and downlink systems in the crew cabin.

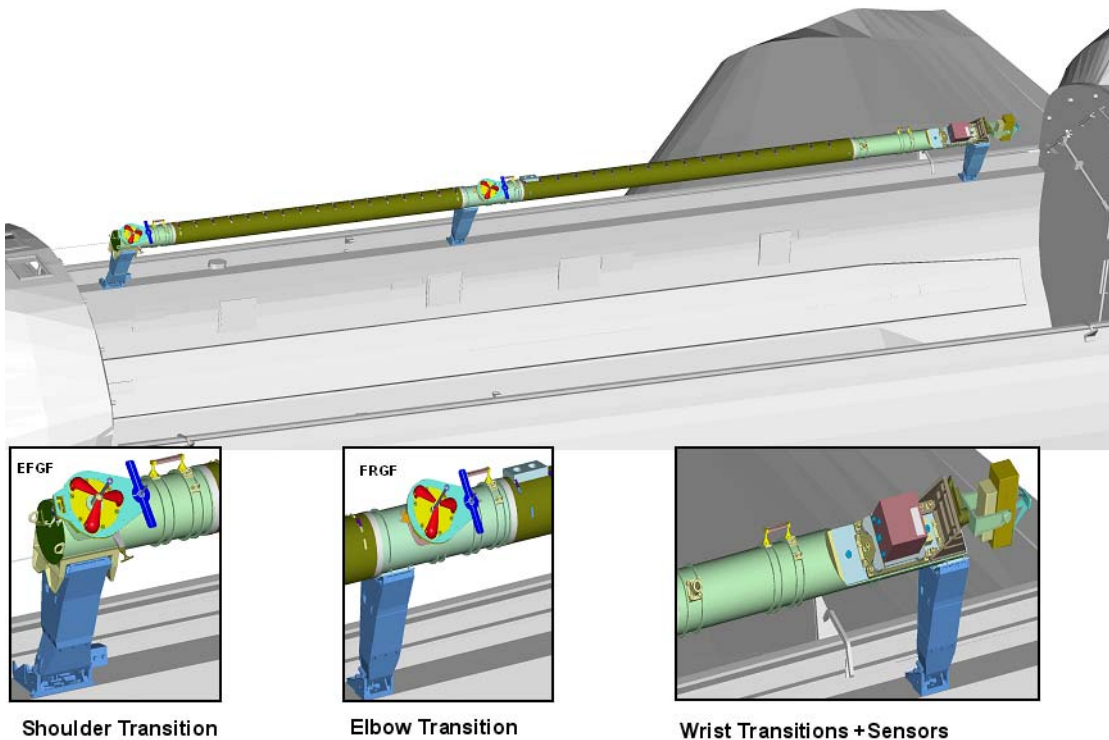

**Orbiter Boom Sensor System Installed on Starboard Sill**

For STS-114, the imagery systems will include a Laser Dynamic Range Imager (LDRI), a Laser Camera System (LCS) and an Intensified Television Camera (ITVC). The LDRI and ITVC are attached to the boom using a standard Pan Tilt Unit (PTU) that will allow them to be pointed at their targets. The LCS is hard-mounted to the side of the boom just behind the other two instruments.

Manufactured by Sandia National Laboratories, Albuquerque, N.M., the LDRI is comprised of an infrared (not visible to the human eye) laser illuminator and an infrared camera receiver. The LDRI can be used to provide either two- or three-dimensional video imagery data; the two-dimensional imagery may be seen by the Shuttle crew on orbit, but three-dimensional data will need to be processed on the ground after being downlinked via the Shuttle's high-bandwidth Ku antenna system that transmits the video through the Tracking and Data Relay Satellite System (TDRSS).

The ITVC is the same low-light, black-and-white television camera used in the Space Shuttle's payload bay. The two imagery systems may not be used simultaneously.

The LCS, manufactured by Neptec of Ottawa, Ontario, Canada, is a scanning laser range finder developed for use aboard the Space Shuttle. The LCS can be used as a 3D camera or to generate computer models of the scanned objects, accurate to a few millimeters at distances of up to 10 meters. Unlike the LDRI, the LCS data is not video, but instead are files collected on a dedicated laptop.

The data is processed on the ground after being downlinked through the Orbital Communications Adapter (OCA) - a high-speed computer modem that uses the Shuttle's Ku antenna system to transmit the data through the TDRSS.

During STS-114, Discovery is scheduled to rendezvous and dock with the International Space Station on Flight Day 3. As the Shuttle pursues the Station on Flight Day 2, the astronaut crew will conduct a thorough inspection of Discovery's wing leading edges and nose cone using the OBSS. Three crew members will take turns, working in pairs, to operate the Shuttle's robotic arm from the aft flight deck, unberth the OBSS from its cradles on the starboard side of the payload bay and conduct the inspection.

Since the LDRI and LCS distance to its target must remain within 10 feet to ensure image quality and because the arm and boom must not contact any of the Shuttle's surfaces in the process, the astronauts use a combination of automated and manual arm operation modes. The surveys are done using automatic mode with the astronauts monitoring its progress. The astronauts will use the manual arm operation mode to move the OBSS from the end of one sequence to the start of the next.

Mission planners expect the Flight Day 2 survey of Discovery's wing leading edges and nose cap to take about seven hours to complete, assuming a maximum scan rate of four meters per minute (2½ inches per second). The scans will be broken into 60- to 90-minute blocks, or sequences, corresponding with specific areas of the Shuttle's thermal protection skin. Engineering experts on the ground will review the data both in real time and after processing on the ground to identify any areas that need additional scrutiny.

Discovery's robotic arm is expected to be used without the boom on Flight Day 2 to conduct video inspections of the upper tile surfaces using the arm's end effector camera. The next day, during the Shuttle's rendezvous with the Station, as Discovery reaches a point 600 feet below the Station, the crew will perform a Rendezvous Pitch Maneuver, a three-quarter-foot per-second backflip, so that its underside faces the Station. The Station crew will use digital still cameras



with 400 and 800 millimeter lenses and a detailed plan to photographically map the Shuttle's underside for about 90 seconds before it continues on to docking. The images will be sent to Earth for inclusion in the collection of data that will be used by the Mission Evaluation Room (MER) and Mission Management Team (MMT) to evaluate the condition of the thermal protection system. That data will be part of the compilation of imagery to allow mission managers to make decisions on how the mission should proceed.

After docking and welcome ceremonies are complete, Shuttle and Station crew members will work together, lifting the OBSS out of the cargo bay using the Space Station Remote Manipulator System (SSRMS) and handing it to the Shuttle arm for use in additional surveys the following day. The Station arm, also known as Canadarm2, will be brought into play because the geometry of the combined Shuttle-Station configuration results in obstructions that prevent the Shuttle arm from maneuvering the OBSS out of its cargo bay cradles. The STS-114 flight plan identifies Flight Day 4 as an additional day for docked surveys, if required, using the OBSS, either to complete parts of the survey that time would not allow on Flight Day 2, or to supplement the survey with "stop-and-stare" scans of sites of potential interest. Some of Discovery's crew will reserve time for these detailed inspections for the last half of Flight Day 4 while other crew members are making preparations for the first spacewalk, which will, among other things, test thermal protection system techniques, tools and devices.

After the in-flight data, images and personal reports from the crew are relayed to the ground, engineers and imagery experts will process and integrate the information with that recorded during launch and the climb to orbit. The Space Shuttle Program's Systems Engineering and Integration Office (SE&I) will work closely with the MER to review and evaluate the information and provide separate damage assessments for

tiles and the Reinforced Carbon-Carbon panels of the wing leading edges and nose cap. Their evaluations and assessments will be presented to the MMT, which is expected to decide by Flight Day 6 whether a spacewalk is needed for an up-close, in-person inspection that could be followed by a hands-on repair.

At this writing, spacewalk designers are actively evaluating a variety of options for placing astronauts close enough to allow detailed inspection and repair of suspected thermal protection system damage. Several different challenges need to be met to enable a spacewalker to perform these tasks.

#### THERMAL PROTECTION SYSTEM ON-ORBIT REPAIR TECHNIQUES

Prevention is NASA's first line of defense against damage to the Space Shuttle's TPS, which defends the vehicle and its occupants against the 3,000-degree, Mach 25 buffeting of re-entry. But quelling debris from the External Tank and Solid Rocket Boosters cannot eliminate all the threats to the Shuttle's tiles and reinforced carbon-carbon wing leading edge panels. On orbit, orbital debris (or space junk) and micrometeoroids also are capable of causing damage.

Although the STS-107 crew had no tested tools or materials available to address the type of damage inspectors have deduced was present during Columbia's re-entry, NASA lost little time in the months following the accident beginning work on viable repair strategies. A Vehicle Inspection and Repair Orbiter Flight Techniques Panel "tiger team" of experts from the TPS engineering, mission operations and extravehicular activity organizations at JSC, working in collaboration with their counterparts at other NASA centers and with contractors, made significant progress in identifying the issues that needed to be addressed, and in devising means of addressing them. The tiger team was able to define preliminary criteria for damage that must be repaired on orbit, identify all critical areas that

must be reached for inspection, identify candidate on-orbit repair materials capable of withstanding the stress of entry, and design initial tools and techniques that would allow spacewalkers to repair critical damage to both tiles and reinforced carbon-carbon segments.

In November 2003, direct responsibility for leading these development projects was assumed by the Space Shuttle Program. The Space Shuttle Program divided and assigned this work to four separate but interactive project teams in its

Orbiter Project Office. These teams were given responsibility for managing design and development of an orbiter boom and sensor system, a set of wing leading edge sensors, a tile repair system, and an RCC repair system. The work of all these teams is ongoing, and is divided into two phases: systems that can be ready to meet the CAIB recommendations in time for the Shuttle's Return to Flight, and long-range projects that have the potential to further enhance the detection and repair needs if given more time.

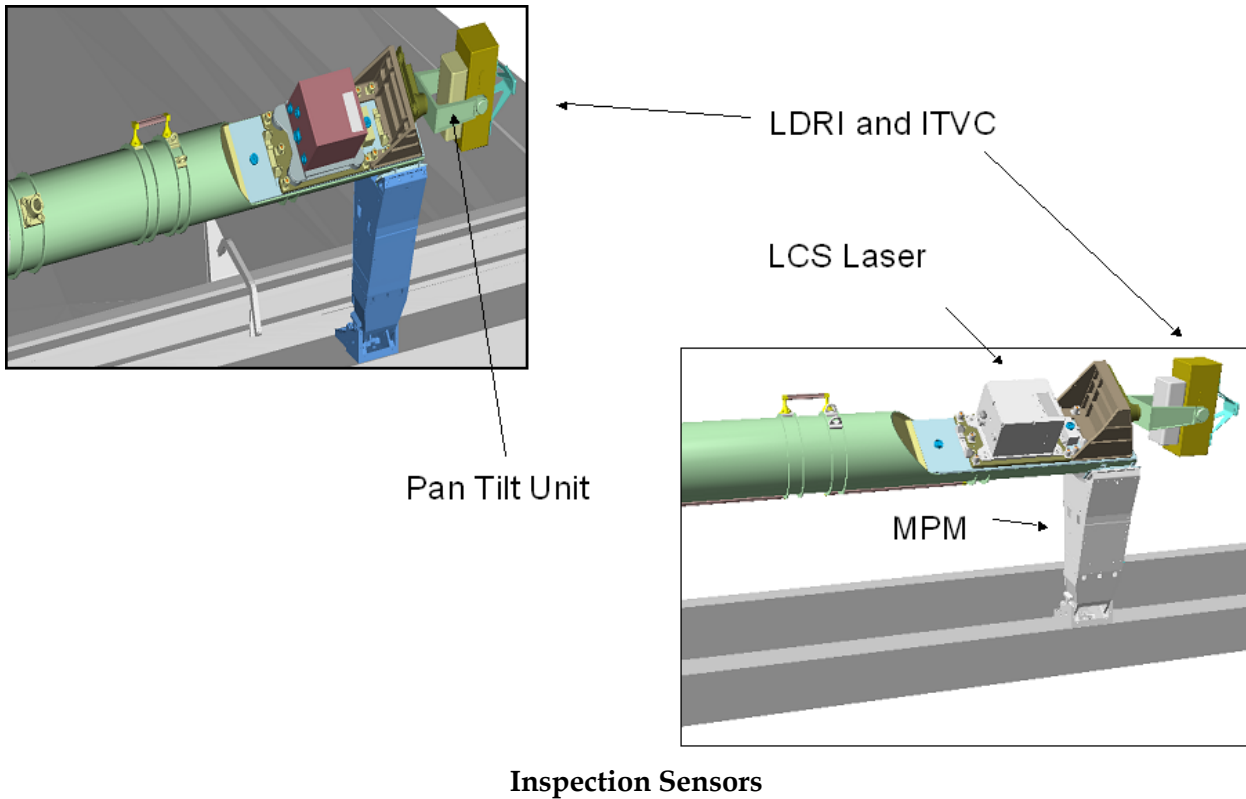

The TPS repair systems developed to date fall into two basic categories, mechanical or chemical, and each type has advantages and disadvantages. Mechanical systems rely on prefabricated materials and fasteners that connect them to the Shuttles' existing protection systems. Chemical systems rely on materials that are applied in a raw form and develop a chemical adhesive bond when applied to the existing protection systems; these must cure in place before being subjected to re-entry conditions. Mechanical installation methods can be tested and validated on Earth, while chemical methods will require testing in

space to validate application techniques and material hardening. A Detailed Test Objective (DTO) for tile repair is being designed for the STS-114 mission, and will test those tile repair tools, techniques and materials that are mature enough in orbit. This DTO will use a series of task boards in the aft section of the Shuttle's cargo bay. The task boards will be returned to Earth for inspection and tests of their ability to withstand the stresses of entry. At this time, three repair methods are scheduled to be tested on STS-114 – two outside the Shuttle in the cargo bay and one inside the crew cabin.

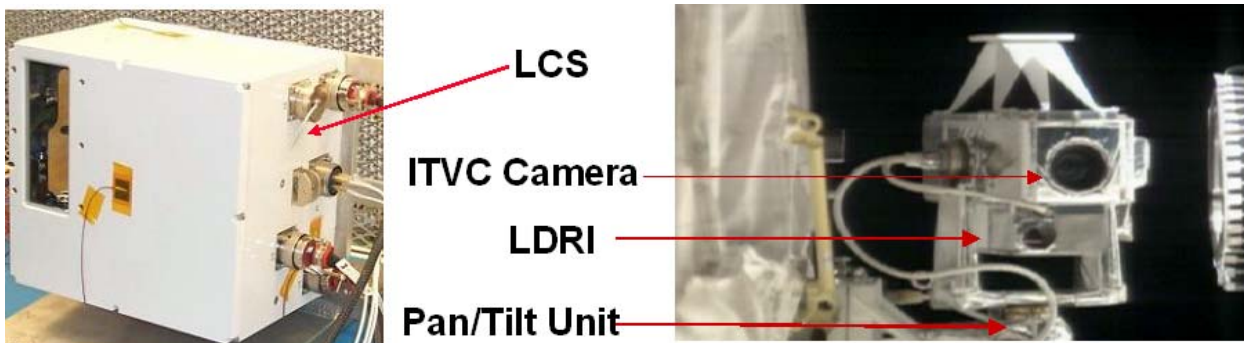

- Neptec Laser Camera System (LCS)
- Triangulates 3D position with a small diameter scanning laser beam
- Sandia Laser Dynamic Range Imager (LDRI)
- Illuminates the FOV with modulated laser light. Images on a camera CCD are processed to provide depth information.
- Designed & flown as an integrated package with an ITVC and pan & tilt unit (PTU)

## TILE

Space Shuttle Program managers recently reviewed the progress of tile repair development teams and selected three options for continued short-term evaluation.

The first is a design revived from incomplete 1970s work to develop an ablative material that could fill gaps caused by tiles that were lost or damaged during launch. Ablative materials, like those used on heat shields that protected early space vehicles in the Mercury, Gemini and Apollo programs, are meant to burn away partially during atmospheric re-entry. Engineers revived the '70s formula for a silicone-based, cure-in-place ablative material and further refined it to fill cavities in tile or to substitute for missing tiles.

The silicone-based material, now known as Shuttle Tile Ablator-54 (STA-54), is manufactured in two parts – a base material and a catalyst – and mixed together during application using a Cure-In-Place Ablative Applicator (CIPAA). This applicator system consists of an EVA backpack with tanks to separately contain the base and catalyst components under pressure, paired hoses to transport the components to the damaged area, and an applicator gun that uses a static mixer to combine the materials as they are extruded into a cavity. Astronauts apply the material – which has a consistency similar to cake frosting when dispensed -- using the CIPAA. Since the material is sticky and intended to adhere to tile, tools such as foam brushes and tampers are used to smooth the repair material without sticking. In addition, the ablative material expands when heated, so astronauts will under-fill cavities to protect against excessive expansion that could disturb the normal plasma flow across the Shuttle's tile surface. The STA-54 material cures and hardens over a period of 24 to 48 hours.

The second method is known as emittance wash application, which uses a repair material being developed primarily for shallow tile damage but also is useful as a primer to improve STA-54 adhesion to tile substrate. The silicon tiles used in the Shuttle's thermal protection system both reject heat and insulate. The white silicon substrate provides insulation, while the black reaction-cured glass (RCG) coating rejects heat. The ability of a material to reject heat is measured in terms of its "emissivity." The RCG coating on tiles has a high emissivity value, while the white substrate has a lower emissivity value, especially as temperatures rise. The science behind the emittance wash repair involves replacing a damaged tile's coating to restore its ability to reject the high temperatures of atmospheric entry.

NASA has developed and will test on STS-114 an emittance wash, which is fine-grit silicon carbide (SiC) granules mixed with a room temperature vulcanizing (RTV) material. Using a dauber-like applicator, the emittance wash can be applied to exposed tile substrate. The emittance wash wicks into the tile substrate, providing a strong adhesive bond, and a high emissivity, or heat rejection value. For small, shallow areas of damage, replacing the RCG coating with the emittance wash will restore enough heat rejection capability for safe entry. For larger or deeper gouges, the emittance wash may be used as a primer for STA-54. Its ability to wick into the tile substrate encourages a stronger bond between the tile and the STA-54 repair material, as well as protection along the edges of the repaired area when they are underfilled to allow for ablative swelling.

The third method is a mechanical repair that uses insulating blankets to fill cavities that are then covered by an overlay of carbon silicon carbonate installed using augers that penetrate directly into healthy tiles. The overlay system consists of Saffil insulation blankets, pre-packaged in a variety of shapes and sizes, which provide radiant heat



protection when installed in the cavity. A thin (0.03 inches) overlay cover made of a high-temperature resistant, flexible material such as carbon-silicon carbide -- which can hold its shape as a shield against plasma flow -- is installed over the damaged tile and insulation blanket using augers screwed directly into adjacent healthy tiles. Around the edges, between the overlay and the existing tile, a fabric gasket is used to prevent hot gasses from penetrating beneath the overlay.

The materials and tools for applying either repair system are continuing to be evaluated in laboratory tests, simulated zero-gravity tests and human-thermal vacuum tests. While tests of

STA-54 at ambient atmospheric pressures and temperatures went as expected, the material exhibited a tendency to bubble when applied in a vacuum and temperatures approximating those of space. Materials tests are continuing to evaluate whether STA-54 can be applied in a manner that allows for relatively uniform bubble sizes and distribution throughout a given repair. Both STA-54 and the overlay system have passed preliminary tests in Arcjet facilities that can mimic the heating and dynamic pressure of atmospheric re-entry, but additional testing is continuing.



**In the Orbiter Processing Facility, STS-114 Mission Specialist Charles Camarda looks closely at the tiles on Discovery. At left is Cindy Begley, lead EVA flight controller. The tiles are part of the Thermal Protection System on the orbiter.**

## REINFORCED CARBON-CARBON

Space Shuttle Program managers recently reviewed the progress of RCC repair development teams and selected two options for continued short-term evaluation. One option is a pre-ceramic polymer designed to repair small cracks and coating losses on the exterior of the RCC panel, while the other is mechanical in nature, designed for repairing holes that penetrate through an RCC panel.

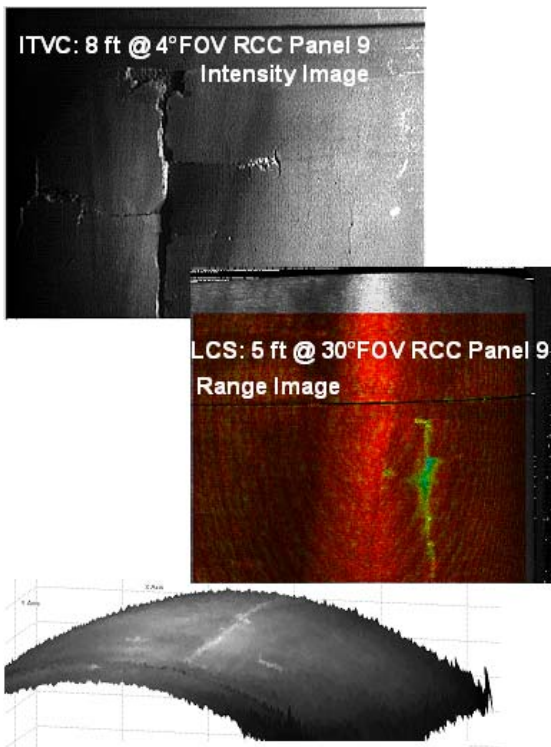

- ITVC
- Good flexibility as a general survey tool
- Low resolution, inherent image defects
- Able to detect small defects under specific conditions
- LCS
- Provides very detailed 3-dimensional information
- Shown to operate while translating
- LDRI
- Valuable performance as both a 2D & 3D imager
- Picture shows an intensity image laid on top of range image, although it appears fuzzy to the untrained eye, it gives a wealth of data

The crack repair option uses a pre-ceramic polymer sealant impregnated with carbon-silicon carbide powder, together known as NOAX (short for Non-Oxide Adhesive eXperimental). It is designed to fix the most likely type of damage caused by small pieces of foam coming off the redesigned external tank. NOAX can be used at any RCC location, and does not require any physical modification of the RCC before affecting a repair. It is expected to repair cracks or coating losses up to .02 inches wide and 4 inches long, but cannot be used to repair holes. The repair procedure for this material may require a separate heating capability for application and/or curing. This could be accomplished by an astronaut installing an EVA heater to the damaged area of the RCC to prepare the surface for application of the repair material. A selection of hand tools similar to putty knives would be used to work the material into the crack and to smooth the surface of the repair. Early testing on the ground has shown promising results that heating the damaged area and the material may not be required to achieve the desired result.

The mechanical “plug” option consists of round, thin (0.03-inch), flexible 7-inch-diameter carbon-silicon carbide cover plates that are designed to flex up to 0.25 inch to conform to the shape of the wing leading edge RCC panels, and a hardware attachment mechanism similar to a toggle bolt, known as TZM. Twenty to 30 unique plug sizes and shapes are needed to provide coverage for all possible RCC panel damage locations. If the hole is not as large as one inch, the astronauts would use a Pistol Grip Tool (PGT) and special bit to drill out the hole. Astronauts would select the appropriate cover plate at the work site, connect the plate to a TZM bolt, and then insert the folded bolt through the hole. By tightening a fastener that extends through the cover plate to the TZM bolt, the astronaut will unfold the toggle inside the RCC panel and tighten it until the cover plate conforms to the exterior shape of the RCC



**In the Orbiter Processing Facility, members of the STS-114 crew take a close look at the Reinforced Carbon-Carbon on the wing's leading edge on Discovery.**

panel. After ensuring any gap between the cover plate and the RCC panel is within tolerances, the astronaut would apply a thin bead of uncured NOAX sealant around the edge of the repair as extra protection against plasma infiltration. The plug concept has the potential to repair damage up to six inches in diameter.

#### ACCESS

Access to damaged sites will be accomplished through a variety of means, depending on whether the Shuttle is at the International Space Station.

On Station missions, techniques are being developed that will allow robotic arm operators to undock and reposition the Shuttle for a Station-based spacewalk repair. Spacewalkers would be positioned at the work site by the Station's robotic arm using a Portable Articulating Foot Restraint (PAFR).

For non-Station missions, access may be gained through the use of the Shuttle's robotic arm or the arm and its 50-foot boom extension, or through use of the Shuttle Aid for Extravehicular Rescue (SAFER). A variety of candidate work platforms are in preliminary stages of development and continue to be evaluated.

#### FUTURE WORK

Several other repair concepts have been proposed for both tile and RCC repair. These include flexible adhesive patches and small area repair plugs for RCC, and hardening of the existing tile system coating. Researchers at a variety of NASA centers and contractor laboratories are continuing to develop these approaches for possible use in the next several years.