

**EEGLE:
EPISODIC EVENTS - GREAT LAKES EXPERIMENT**

**Nearshore-Offshore Transport in the Great Lakes:
Nearshore Physical Oceanography Measurements
Lake Michigan:**

Data Report (May 1997-June 1998)

Y.R. Rao, F. Chiochio, and C.R. Murthy

Aquatic Ecosystem Management Research

National Water Research Institute/Canada Centre for Inland Waters

Burlington, Ontario, Canada L7R 4A6

M.J. McCormick

Great Lakes Environmental Research Laboratory

2205 Commonwealth Blvd.

Ann Arbor, Michigan, U.S.A.

TABLE OF CONTENTS

	Page
Introduction	3
Experimental Data	3
Data Presentation	3
Table 1. Lake Michigan 1997-98. Mooring Summaries.	5
Figure 1. Lake Michigan 1997-98. Location and Designation of Current Meter Moorings.	6
References	7
Appendix A - Mooring_A1-97 Overall Summary Statistics and Rose Histogram Plots.	8
Appendix B - Mooring_A1-97 Monthly Summary Statistics and Rose Histogram Plots.	16
Appendix C - Mooring_A2-97 Overall Summary Statistics and Rose Histogram Plots.	59
Appendix D - Mooring_A2-97 Monthly Summary Statistics and Rose Histogram Plots.	68
Appendix E - Mooring_A4-97 Overall Summary Statistics and Rose Histogram Plots.	117
Appendix F - Mooring_A4-97 Monthly Summary Statistics and Rose Histogram Plots.	124
Appendix G - Mooring_A5-97 Overall Summary Statistics and Rose Histogram Plots.	161
Appendix H - Mooring_A5-97 Monthly Summary Statistics and Rose Histogram Plots.	170
Appendix I - Mooring_CM_1-97 Overall Summary Statistics and Rose Histogram Plots.	219
Appendix J - Mooring_CM_1-97 Monthly Summary Statistics and Rose Histogram Plots.	222
Appendix K - Mooring_V01-97 Overall Summary Statistics and Rose Histogram Plots.	247
Appendix L - Mooring_V01-97 Monthly Summary Statistics and Rose Histogram Plots.	249
Appendix M - Mooring_V03-97 Overall Summary Statistics and Rose Histogram Plots.	259
Appendix N - Mooring_V03-97 Monthly Summary Statistics and Rose Histogram Plots.	261
Appendix O - Mooring_V04-97 Overall Summary Statistics and Rose Histogram Plots.	271
Appendix P - Mooring_V04-97 Monthly Summary Statistics and Rose Histogram Plots.	273
Appendix Q - Mooring_V06-97 Overall Summary Statistics and Rose Histogram Plots.	283
Appendix R - Mooring_V06-97 Monthly Summary Statistics and Rose Histogram Plots.	285
Appendix S - Mooring_V09-97 Overall Summary Statistics and Rose Histogram Plots.	295
Appendix T - Mooring_V09-97 Monthly Summary Statistics and Rose Histogram Plots.	297
Appendix U - Mooring_V12-97 Overall Summary Statistics and Rose Histogram Plots.	307
Appendix V - Mooring_V12-97 Monthly Summary Statistics and Rose Histogram Plots.	309

Introduction

In the Great Lakes, as well as in the coastal oceans the gradients of many biogeochemically important materials (BIMs) are considerably higher in the offshore direction than in the longshore direction (Brink et al., 1992). In the presence of these large gradients, cross-isobath circulation is a primary mechanism for the exchange of material between nearshore and offshore waters. In the coastal regions of the Great Lakes it has been observed that the mean alongshore transport is much larger than the cross-shore transport. However, both the alongshore and cross-shore current components exhibit strong episodic behaviour due to wind forcing. In order to understand the cross-shore transport of BIMs and quantify the physical processes that are responsible for the nearshore-offshore mass exchange, a multidisciplinary research program, EEGLE (Episodic Events Great Lakes Experiment) was recently initiated by NOAA (National Oceanic and Atmospheric Administration) and NSF (National Science Foundation) in Lake Michigan (Eadie et al., 1996).

Experimental Data

The observation strategy for obtaining the cross-shore and alongshore currents, physical environment, and temperature consisted of three components: (a) moored instruments (b) Lagrangian measurements and (c) ship-board surveys. In the moored instrumentation time series of currents, winds, and temperature data were obtained for the field years of 1997 to 2000. A maximum of 17 moorings of ADCPs and VACMs were deployed from the 20 m to 60 m depth contours by GLERL (Great Lakes Environmental Research Laboratory). As a part of the program the National Water Research Institute (NWRI) deployed additional instrumentation consisting of seven SACMs, and two ADCPs in the shallow waters at a depth of 12 m along with two coastal meteorological stations. The complete details of the observational strategy is reported in EEGLE website (<http://www.glerl.noaa.gov/eegle/>). In this first data report we summarize the data from current meter moorings deployed in 1997-98.

Data Presentation

Some of the methods used to display the data here are consistent with the previous CCIW Limnological Summaries (i.e., Bull, Farooqui *et al.*, 1976, Jordan and Bull, 1977). The hourly averaged data are time-series collection of meteorological, current and temperature measurements.

To analyse the wind and current data extensive use were made of rose histograms.

Tabular Statistical Summaries: Hourly values of wind and current data were divided into three speed classes (0-3, 3-7, and greater than 7 m/sec for the wind and cm/sec for the current and into eight compass sectors. The mean duration is defined as the average time a current direction remained in the sector. The mean excursion is the product of the mean duration and the mean current.

The mean scalar speed, mean square speed, mean square (E-W, N-S, U, V), mean velocity and direction and variance are summarised below the table. The mean temperature, as measured by the current meter, is also given.

Wind and current rose histogram plots: Hourly data of wind and current were tabulated and classified by speed and direction. Speed classes were defined as 0 to 3, 3 to 7, and greater than 7 m/sec or cm/sec for wind and current respectively. Direction classes were defined into 8 equal sectors of 45 degrees. Wind and current directions are “towards”.

Table 1. Lake Michigan 1997-98. Mooring Summaries.

A1 Mooring_A1-97	lat/42.101	lon/86.560	0500/02/11/1997 to 0000/15/04/1998	
97-05C-001A002	97-05C-001A003	97-05C-001A004	97-05C-001A005	
97-05C-001A006	97-05C-001A007	97-05C-001A008	97-05C-001A009	
97-05C-001A010	97-05C-001A011	97-05C-001A012	97-05C-001A013	
97-05C-001A014	97-05C-001A015			
A2 Mooring_A2-97	lat/42.113	lon/86.642	0500/02/11/1997 to 0000/15/04/1998	
97-05C-002A004	97-05C-002A006	97-05C-002A008	97-05C-002A010	
97-05C-002A012	97-05C-002A014	97-05C-002A016	97-05C-002A018	
97-05C-002A020	97-05C-002A022	97-05C-002A024	97-05C-002A026	
97-05C-002A028	97-05C-002A030	97-05C-002A032	97-05C-002A034	
A4 Mooring_A4-97	lat/42.174	lon/86.490	0500/02/11/1997 to 0000/15/04/1998	
97-05C-004A004	97-05C-004A005	97-05C-004A006	97-05C-004A007	
97-05C-004A008	97-05C-004A009	97-05C-004A010	97-05C-004A011	
97-05C-004A012	97-05C-004A013	97-05C-004A014	97-05C-004A015	
A5 Mooring_A5-97	lat/42.229	lon/86.613	0500/02/11/1997 to 0000/15/04/1998	
97-05C-005A004	97-05C-005A006	97-05C-005A008	97-05C-005A010	
97-05C-005A012	97-05C-005A014	97-05C-005A016	97-05C-005A018	
97-05C-005A020	97-05C-005A022	97-05C-005A024	97-05C-005A026	
97-05C-005A028	97-05C-005A030	97-05C-005A032	97-05C-005A034	
CM1 Mooring_CM_1-97	lat/42.696	lon/87.021	0000/22/05/1997 to 2300/29/04/1998	
97-05C-001A020	97-05C-001A055	97-05C-001A115	97-05C-001A152	
V01 Mooring_V01-97	lat/41.814	lon/86.870	1500/07/10/1997 to 0500/13/06/1998	
97-05C-001A012	97-05C-001A019			
V03 Mooring_V03-97	lat/41.969	lon/86.955	1600/07/10/1997 to 1700/12/06/1998	
97-05C-003A012	97-05C-003A059			
V04 Mooring_V04-97	lat/41.914	lon/86.680	0300/07/10/1997 to 2200/12/06/1998	
97-05C-004A019				
V06 Mooring_V06-97	lat/41.008	lon/86.800	0100/07/10/1997 to 2000/12/06/1998	
97-05C-006A012	97-05C-006A059			
V09 Mooring_V09-97	lat/42.242	lon/86.419	2200/06/10/1997 to 0400/26/06/1998	
97-05C-009A012	97-05C-009A019			
V12 Mooring_V12-97	lat/42.338	lon/86.635	2100/06/10/1997 to 0500/13/06/1998	
97-05C-012A012	97-05C-012A059			

Figure 1. Lake Michigan 1997-98. Location and designation of the current meter moorings.

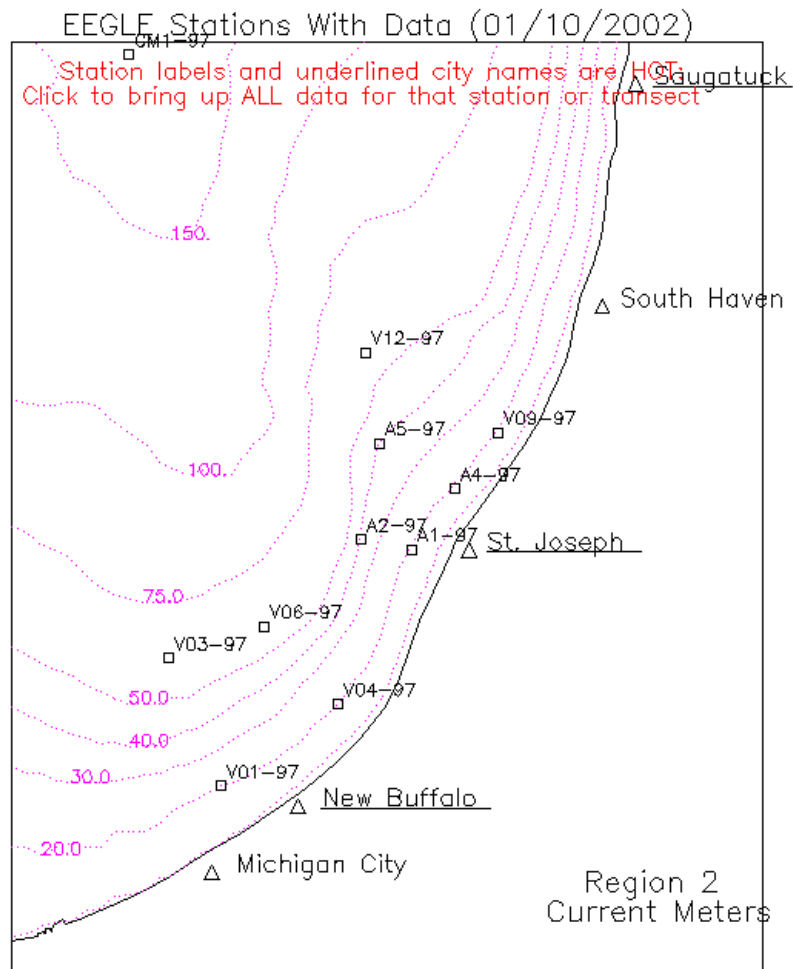
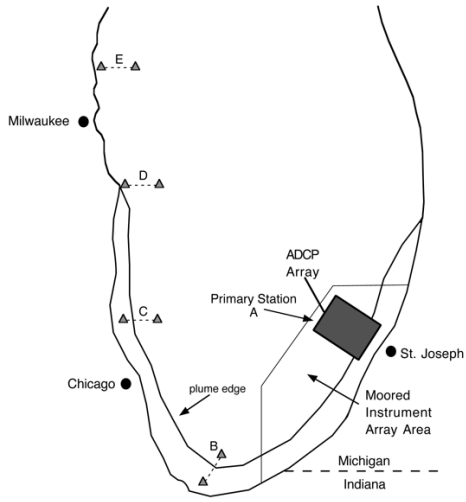

References

Bull, J.A., R. Farooqui et al, 1976. Coastal Zone Limnological Observations in Lake Huron at Bruce Nuclear Power Development, CCIW Paper No. 17, 1976.

Jordan, D.E. and J.A. Bull, 1977. Coastal Zone Limnological Observations in Lake Ontario at Bronte, June 1973-March 1974. Climatology Report, CCIW Paper No. 18, 1977.

Brink, K.H., J.M. Bane, T.M. Church, C.W. Fairall, G.L. Geernaert, D.E. Hammond, S.M. Henrichs, C.S. Martens, C.A. Nittrouer, D.P. Rogers, M.R. Roman, J.D. Roughgarden, R.L. Smith, L.D. Wright, and J.A. Yoder, Coastal Ocean Processes: a Science Prospectus, Woods Hole Oceanographic Institution, Woods Hole, MA, USA. 1992.

Eadie, B.J., D.J. Schwab, G.L. Leshkevich, T.H. Johengen, R.A. Assel, R.E. Holland, N. Hawley, M.B. Lansing, P. Lavrentyev, G.S. Miller, N.R. Morehead, J.A. Robbins, and P.L. VanHoof, Anatomy of a recurrent episodic event: a winter-spring plume in southern Lake Michigan, EOS. Transactions of the American Geophysical Union 77, 337-338, 1996.

Appendix A - Mooring_A1-97. Overall Summary Statistics and Rose Histogram Plots

DATE: 1997/11/02 TO 1998/04/15
 ROSE SUMMARY: WIND AND CURRENT

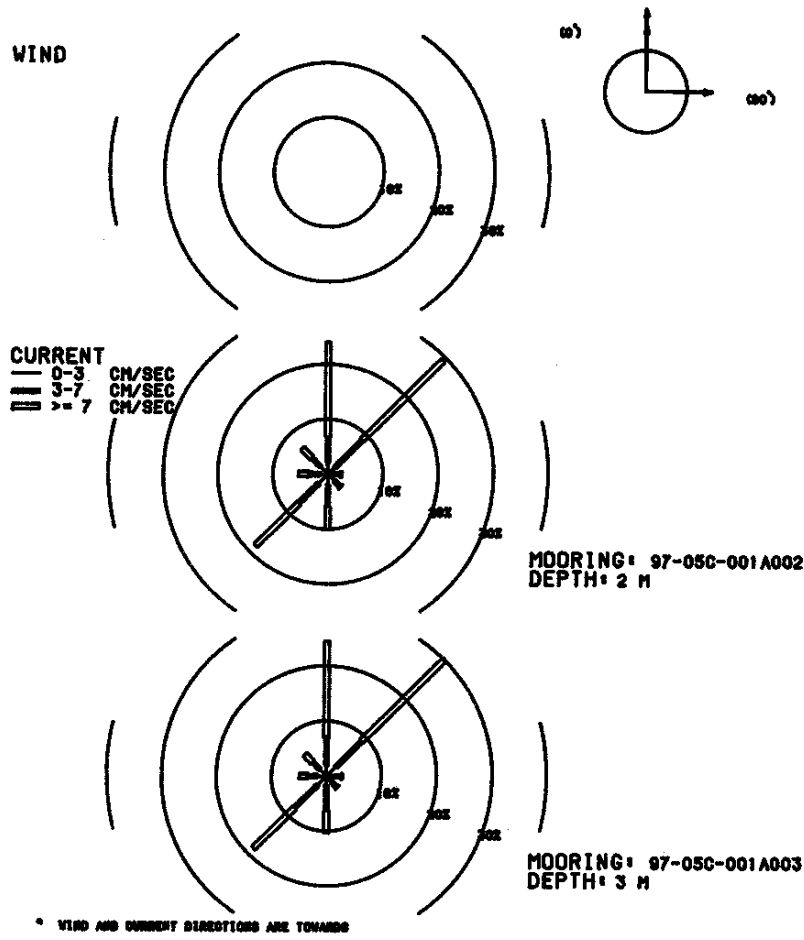

MOORING IS 97-05C-001A002 Depth IS 2 METERS THERE ARE 3932 VALUES

FIRST DAY 1997/11/02/0500
 FINAL DAY 1998/04/15/0000

SHORELINE ORIENTATION IN DEGREES TRUE SPECIFIED AS 90

DIRECTION DEG TRUE	PERCENT OBSERVED	MAXIMUM CURRENT	MEAN DURA- TION	MEAN EXCUR- SION	MEAN CURRENT	MEAN TEMP			
TOWARD	TOTAL	LIGHT	MEDIUM	HIGH	CM/S	HOURS	KM	CM/S	DEG C
90.0	2.6	1.1	1.1	0.4	13.4	1.2	0.2	4.0	3.6
45.0	29.5	1.7	7.0	20.8	46.4	2.9	1.1	10.9	4.0
0.0	24.0	2.1	4.7	17.3	46.4	2.2	1.0	12.2	3.8
315.0	6.6	1.9	2.1	2.5	37.3	1.5	0.4	7.7	3.2
270.0	5.4	1.4	2.0	2.0	22.7	1.4	0.3	6.5	3.0
225.0	18.5	2.2	5.1	11.1	47.3	2.5	0.9	9.6	3.9
180.0	10.1	1.9	4.0	4.3	45.6	1.7	0.4	6.8	4.0
135.0	3.3	1.7	1.5	0.1	10.5	1.4	0.2	3.4	3.4
0	MEAN SCALAR SPEED = 9.6 CM/S		MEAN SQUARE SPEED = 137.0 CM2/S2						
	MEAN SQUARE E-W SPEED = 35.2 CM2/S2		MEAN SQUARE N-S SPEED = 101.8 CM2/S2						
	MEAN SQUARE U SPEED = 35.2 CM2/S2		MEAN SQUARE V SPEED = 101.8 CM2/S2						
	MEAN VELOCITY = 3.8 CM/S,		6 DEG TRUE		MEAN TEMPERATURE = 3.8 C				
	VARIANCE (U,V) = 61.3 CM2/S2		TOTAL HOURS = 3932.						

PERCENT OBSERVED
 LIGHT (0.0 - 3.0) 13.9% MEDIUM (3.0 - 7.0) 27.6% HIGH (GE 7.0) 58.5%

MOORING IS 97-05C-001A003 Depth IS 3 METERS THERE ARE 3932 VALUES

FIRST DAY 1997/11/02/0500
 FINAL DAY 1998/04/15/0000

SHORELINE ORIENTATION IN DEGREES TRUE SPECIFIED AS 90

DIRECTION DEG TRUE	PERCENT OBSERVED	MAXIMUM CURRENT	MEAN DURA- TION	MEAN EXCUR- SION	MEAN CURRENT	MEAN TEMP			
TOWARD	TOTAL	LIGHT	MEDIUM	HIGH	CM/S	HOURS	KM	CM/S	DEG C
90.0	2.9	1.3	1.3	0.3	10.3	1.3	0.2	3.7	3.7
45.0	30.2	2.3	6.5	21.3	42.6	3.1	1.2	10.5	4.0
0.0	24.5	2.0	5.0	17.5	48.3	2.5	1.1	12.1	3.7
315.0	5.6	1.7	1.7	2.1	37.4	1.5	0.4	7.4	3.1
270.0	5.0	1.6	1.8	1.6	21.2	1.4	0.3	5.7	3.1
225.0	18.7	2.2	5.9	10.6	49.2	2.7	0.9	9.4	3.9
180.0	10.4	1.6	4.6	4.1	29.3	1.8	0.4	6.7	3.8
135.0	2.8	1.3	1.5	0.1	8.0	1.3	0.2	3.3	3.3
0	MEAN SCALAR SPEED = 9.5 CM/S		MEAN SQUARE SPEED = 133.7 CM2/S2						
	MEAN SQUARE E-W SPEED = 32.4 CM2/S2		MEAN SQUARE N-S SPEED = 101.2 CM2/S2						
	MEAN SQUARE U SPEED = 32.4 CM2/S2		MEAN SQUARE V SPEED = 101.2 CM2/S2						
	MEAN VELOCITY = 3.8 CM/S,		8 DEG TRUE		MEAN TEMPERATURE = 3.8 C				
	VARIANCE (U,V) = 59.8 CM2/S2		TOTAL HOURS = 3932.						

PERCENT OBSERVED
 LIGHT (0.0 - 3.0) 14.1% MEDIUM (3.0 - 7.0) 28.3% HIGH (GE 7.0) 57.6%

DATE: 1997/11/02 TO 1998/04/15
ROSE SUMMARY: WIND AND CURRENT

WIND

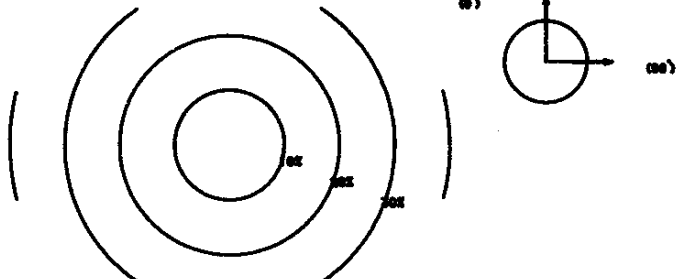

CURRENT
0-3 CM/SEC
3-7 CM/SEC
≥ 7 CM/SEC

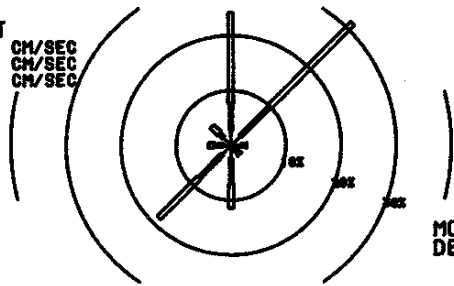

MOORING: 97-05C-001A004
DEPTH: 4 M

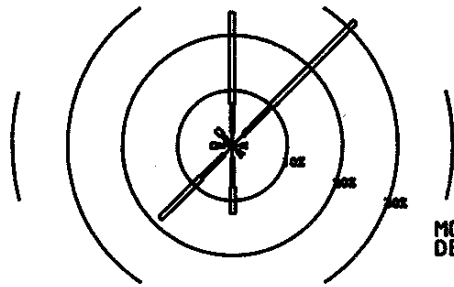

MOORING: 97-05C-001A005
DEPTH: 5 M

* WIND AND CURRENT DIRECTIONS ARE TOWARDS

MOORING IS 97-05C-001A004 Depth IS 4 METERS THERE ARE 3932 VALUES

FIRST DAY 1997/11/02/0500
FINAL DAY 1998/04/15/0000

SHORELINE ORIENTATION IN DEGREES TRUE SPECIFIED AS 90

DIRECTION DEG TRUE	PERCENT OBSERVED			MAXIMUM CURRENT CM/S	MEAN DURA- TION HOURS	MEAN EXCUR- SION KM	MEAN CURRENT CM/S	MEAN TEMP DEG C
TOWARD	TOTAL	LIGHT	MEDIUM	HIGH				
90.0	2.8	1.7	1.0	0.1	8.4	1.5	2.8	3.6
45.0	31.4	2.3	7.4	21.7	43.7	3.4	10.6	4.1
0.0	24.2	2.7	4.9	16.6	45.2	2.5	11.6	3.6
315.0	5.0	1.9	1.1	2.0	35.6	1.5	7.1	3.3
270.0	4.1	1.4	1.6	1.1	21.5	1.4	5.3	3.2
225.0	18.7	2.2	6.0	10.4	48.9	2.9	9.3	4.0
180.0	11.5	2.4	4.6	4.5	23.6	1.9	6.4	3.7
135.0	2.3	1.2	1.0	0.1	8.6	1.3	3.3	3.1

MEAN SCALAR SPEED = 9.3 CM/S MEAN SQUARE SPEED = 129.2 CM²/S²
 MEAN SQUARE E-W SPEED = 30.1 CM²/S² MEAN SQUARE N-S SPEED = 99.1 CM²/S²
 MEAN SQUARE U SPEED = 30.1 CM²/S² MEAN SQUARE V SPEED = 99.1 CM²/S²
 MEAN VELOCITY = 3.7 CM/S, 10 DEG TRUE MEAN TEMPERATURE = 3.8 C
 VARIANCE (U,V) = 57.8 CM²/S² TOTAL HOURS = 3932.

PERCENT OBSERVED
 LIGHT (0.0 - 3.0) 15.8% MEDIUM (3.0 - 7.0) 27.6% HIGH (GE 7.0) 56.6%

MOORING IS 97-05C-001A005 Depth IS 5 METERS THERE ARE 3932 VALUES

FIRST DAY 1997/11/02/0500
FINAL DAY 1998/04/15/0000

SHORELINE ORIENTATION IN DEGREES TRUE SPECIFIED AS 90

DIRECTION DEG TRUE	PERCENT OBSERVED			MAXIMUM CURRENT CM/S	MEAN DURA- TION HOURS	MEAN EXCUR- SION KM	MEAN CURRENT CM/S	MEAN TEMP DEG C
TOWARD	TOTAL	LIGHT	MEDIUM	HIGH				
90.0	2.5	1.4	1.0	0.1	11.1	1.3	3.0	3.5
45.0	31.7	2.7	7.1	21.8	44.6	3.4	10.4	4.0
0.0	24.2	2.4	5.1	16.7	41.4	2.5	11.5	3.7
315.0	4.1	1.3	1.4	1.4	33.7	1.7	6.7	3.1
270.0	3.9	1.5	1.3	1.1	22.7	1.3	5.3	3.0
225.0	18.7	2.2	5.8	10.6	49.2	2.8	9.2	3.9
180.0	12.4	2.2	5.2	5.0	23.6	2.0	6.5	3.8
135.0	2.5	1.3	1.1	0.0	7.3	1.2	2.9	3.3

MEAN SCALAR SPEED = 9.2 CM/S MEAN SQUARE SPEED = 126.6 CM²/S²
 MEAN SQUARE E-W SPEED = 28.6 CM²/S² MEAN SQUARE N-S SPEED = 98.0 CM²/S²
 MEAN SQUARE U SPEED = 28.6 CM²/S² MEAN SQUARE V SPEED = 98.0 CM²/S²
 MEAN VELOCITY = 3.6 CM/S, 12 DEG TRUE MEAN TEMPERATURE = 3.8 C
 VARIANCE (U,V) = 57.0 CM²/S² TOTAL HOURS = 3932.

PERCENT OBSERVED
 LIGHT (0.0 - 3.0) 15.1% MEDIUM (3.0 - 7.0) 28.2% HIGH (GE 7.0) 56.7%

DATE: 1997/11/02 TO 1998/04/15
ROSE SUMMARY: WIND AND CURRENT

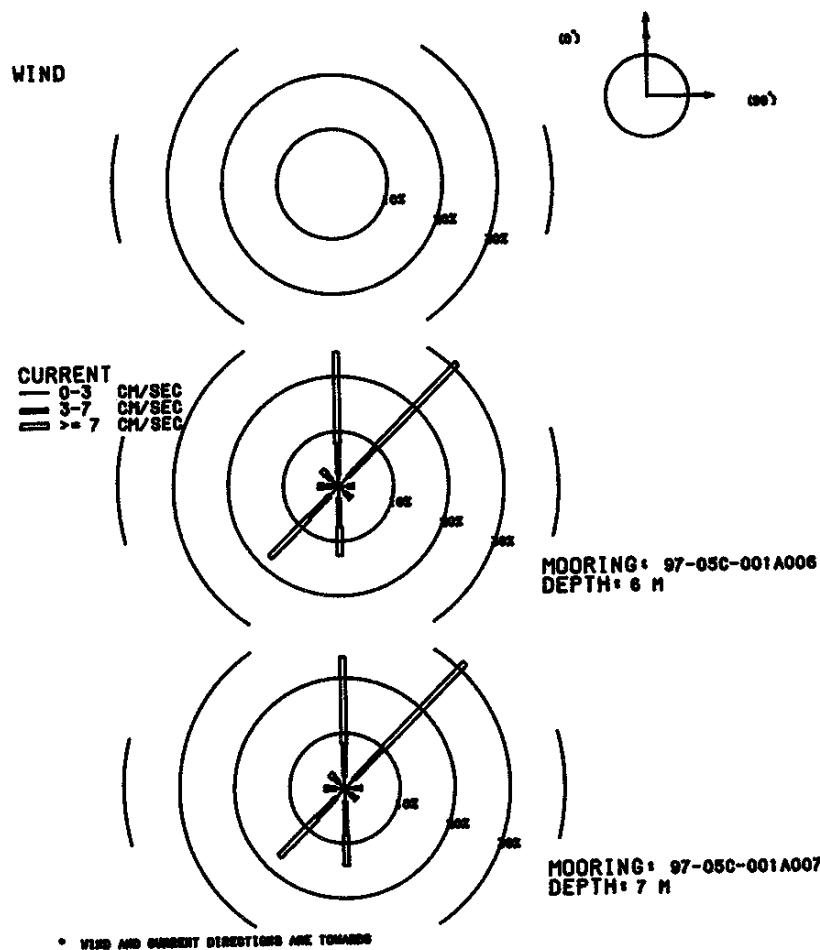

MOORING IS 97-05C-001A006 Depth IS 6 METERS THERE ARE 3932 VALUES

FIRST DAY 1997/11/02/0500
FINAL DAY 1998/04/15/0000

SHORELINE ORIENTATION IN DEGREES TRUE SPECIFIED AS 90

DIRECTION DEG TRUE	PERCENT OBSERVED	MAXIMUM CURRENT	MEAN DURA- TION HOURS	MEAN EXCUR- SION KM	MEAN CURRENT CM/S	MEAN TEMP DEG C
TOWARD	TOTAL	LIGHT	MEDIUM	HIGH	CM/S	
90.0	2.7	1.7	1.0	0.1	7.9	1.3
45.0	31.1	2.4	7.3	21.4	40.1	3.3
0.0	24.5	2.1	5.6	16.8	41.1	2.6
315.0	4.2	1.8	1.2	1.2	32.1	1.5
270.0	3.7	1.3	1.6	0.9	21.2	1.3
225.0	18.0	2.3	5.4	10.3	46.9	2.8
180.0	12.7	2.2	5.1	5.4	22.0	2.0
135.0	3.1	1.6	1.4	0.1	8.8	1.3
0		MEAN SCALAR SPEED = 9.1 CM/S		MEAN SQUARE SPEED = 124.5 CM2/S2		
		MEAN SQUARE E-W SPEED = 27.7 CM2/S2		MEAN SQUARE N-S SPEED = 96.7 CM2/S2		
		MEAN SQUARE U SPEED = 27.7 CM2/S2		MEAN SQUARE V SPEED = 96.7 CM2/S2		
		MEAN VELOCITY = 3.5 CM/S,		14 DEG TRUE		MEAN TEMPERATURE = 3.8 C
		VARIANCE (U,V) = 56.3 CM2/S2		TOTAL HOURS = 3932.		

PERCENT OBSERVED
LIGHT (0.0 - 3.0) 15.4% MEDIUM (3.0 - 7.0) 28.6% HIGH (GE 7.0) 56.0%

MOORING IS 97-05C-001A007 Depth IS 7 METERS THERE ARE 3932 VALUES

FIRST DAY 1997/11/02/0500
FINAL DAY 1998/04/15/0000

SHORELINE ORIENTATION IN DEGREES TRUE SPECIFIED AS 90

DIRECTION DEG TRUE	PERCENT OBSERVED	MAXIMUM CURRENT	MEAN DURA- TION HOURS	MEAN EXCUR- SION KM	MEAN CURRENT CM/S	MEAN TEMP DEG C
TOWARD	TOTAL	LIGHT	MEDIUM	HIGH	CM/S	
90.0	3.0	1.7	1.2	0.0	7.3	1.4
45.0	31.6	2.3	7.6	21.7	40.3	3.5
0.0	23.9	2.2	5.7	15.9	39.7	2.6
315.0	3.7	1.6	1.2	0.9	30.2	1.5
270.0	3.7	1.7	1.4	0.6	17.9	1.3
225.0	17.2	2.2	5.1	9.9	48.7	2.5
180.0	14.1	2.4	6.0	5.7	23.0	2.1
135.0	2.8	1.4	1.4	0.1	7.9	1.3
0		MEAN SCALAR SPEED = 9.0 CM/S		MEAN SQUARE SPEED = 122.0 CM2/S2		
		MEAN SQUARE E-W SPEED = 26.9 CM2/S2		MEAN SQUARE N-S SPEED = 95.1 CM2/S2		
		MEAN SQUARE U SPEED = 26.9 CM2/S2		MEAN SQUARE V SPEED = 95.1 CM2/S2		
		MEAN VELOCITY = 3.4 CM/S,		17 DEG TRUE		MEAN TEMPERATURE = 3.8 C
		VARIANCE (U,V) = 55.4 CM2/S2		TOTAL HOURS = 3932.		

PERCENT OBSERVED
LIGHT (0.0 - 3.0) 15.5% MEDIUM (3.0 - 7.0) 29.7% HIGH (GE 7.0) 54.8%

DATE: 1997/11/02 TO 1998/04/15
ROSE SUMMARY: WIND AND CURRENT

WIND

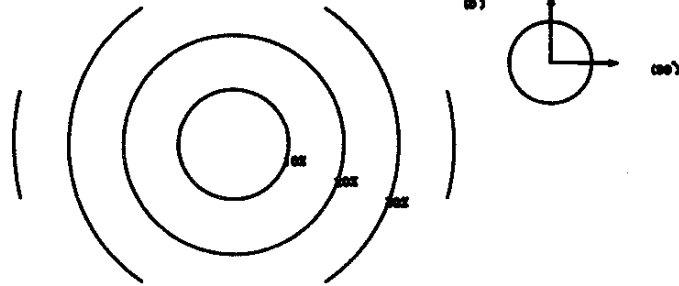

CURRENT
— 0-3 CM/SEC
= 3-7 CM/SEC
≡ >= 7 CM/SEC

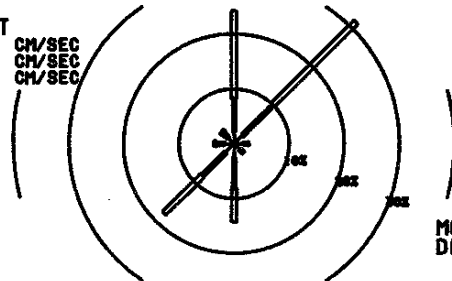

MOORING: 97-05C-001A008
DEPTH: 8 M

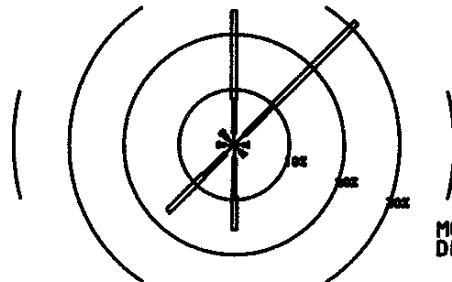

MOORING: 97-05C-001A009
DEPTH: 9 M

* WIND AND CURRENT DIRECTIONS ARE TOWARDS

MOORING IS 97-05C-001A008 Depth IS 8 METERS THERE ARE 3932 VALUES

FIRST DAY 1997/11/02/0500
FINAL DAY 1998/04/15/0000

SHORELINE ORIENTATION IN DEGREES TRUE SPECIFIED AS 90

DIRECTION DEG TRUE	PERCENT OBSERVED				MAXIMUM CURRENT CM/S	MEAN DURA- TION HOURS	MEAN EXCUR- SION KM	MEAN CURRENT CM/S	MEAN TEMP DEG C
TOWARD	TOTAL	LIGHT	MEDIUM	HIGH	CM/S	HOURS	KM	CM/S	DEG C
90.0	2.7	1.7	1.0	0.0	6.6	1.2	0.1	2.7	3.2
45.0	31.4	2.1	8.0	21.3	39.3	3.4	1.3	10.5	4.0
0.0	24.3	2.2	6.1	16.0	36.0	2.5	1.0	10.8	3.8
315.0	3.2	1.4	1.1	0.7	28.1	1.5	0.3	4.9	2.9
270.0	3.7	1.7	1.6	0.5	21.0	1.5	0.2	4.0	2.8
225.0	18.0	2.1	6.0	9.9	49.8	2.6	0.9	9.2	4.0
180.0	14.2	2.5	5.6	6.1	22.9	2.2	0.5	6.7	3.7
135.0	2.4	1.4	1.0	0.0	6.7	1.2	0.1	2.9	3.4
0	MEAN SCALAR SPEED = 9.0 CM/S		MEAN SQUARE SPEED = 120.6 CM ² /S ²						
	MEAN SQUARE E-W SPEED = 26.1 CM ² /S ²		MEAN SQUARE N-S SPEED = 94.5 CM ² /S ²						
	MEAN SQUARE U SPEED = 26.1 CM ² /S ²		MEAN SQUARE V SPEED = 94.5 CM ² /S ²						
	MEAN VELOCITY = 3.3 CM/S,		18 DEG TRUE		MEAN TEMPERATURE = 3.8 C				
	VARIANCE (U,V) = 55.0 CM ² /S ²		TOTAL HOURS = 3932.						

PERCENT OBSERVED
LIGHT (0.0 - 3.0) 15.1% MEDIUM (3.0 - 7.0) 30.4% HIGH (GE 7.0) 54.5%

MOORING IS 97-05C-001A009 Depth IS 9 METERS THERE ARE 3932 VALUES

FIRST DAY 1997/11/02/0500
FINAL DAY 1998/04/15/0000

SHORELINE ORIENTATION IN DEGREES TRUE SPECIFIED AS 90

DIRECTION DEG TRUE	PERCENT OBSERVED				MAXIMUM CURRENT CM/S	MEAN DURA- TION HOURS	MEAN EXCUR- SION KM	MEAN CURRENT CM/S	MEAN TEMP DEG C
TOWARD	TOTAL	LIGHT	MEDIUM	HIGH	CM/S	HOURS	KM	CM/S	DEG C
90.0	2.6	1.7	0.9	0.1	7.8	1.3	0.1	2.6	3.6
45.0	31.4	2.5	7.7	21.2	38.8	3.4	1.3	10.4	4.0
0.0	24.3	2.1	6.1	16.1	34.1	2.5	1.0	10.8	3.9
315.0	3.4	1.6	1.1	0.7	25.9	1.5	0.2	4.4	2.5
270.0	3.1	1.7	1.1	0.3	21.5	1.3	0.2	3.5	2.8
225.0	17.1	2.1	5.6	9.4	50.8	2.8	0.9	9.4	4.0
180.0	15.4	2.4	6.8	6.2	23.0	2.4	0.6	6.7	3.6
135.0	2.7	1.7	1.0	0.0	7.2	1.3	0.1	2.6	3.2
0	MEAN SCALAR SPEED = 8.9 CM/S		MEAN SQUARE SPEED = 119.2 CM ² /S ²						
	MEAN SQUARE E-W SPEED = 25.1 CM ² /S ²		MEAN SQUARE N-S SPEED = 94.1 CM ² /S ²						
	MEAN SQUARE U SPEED = 25.1 CM ² /S ²		MEAN SQUARE V SPEED = 94.1 CM ² /S ²						
	MEAN VELOCITY = 3.2 CM/S,		19 DEG TRUE		MEAN TEMPERATURE = 3.8 C				
	VARIANCE (U,V) = 54.5 CM ² /S ²		TOTAL HOURS = 3932.						

PERCENT OBSERVED
LIGHT (0.0 - 3.0) 15.7% MEDIUM (3.0 - 7.0) 30.3% HIGH (GE 7.0) 54.0%

DATE: 1997/11/02 TO 1998/04/15
ROSE SUMMARY: WIND AND CURRENT

WIND

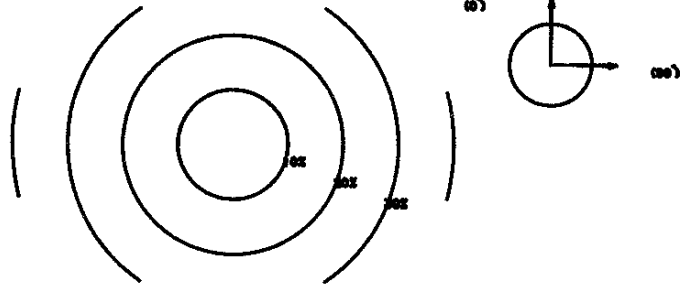

CURRENT

0-3 CM/SEC
3-7 CM/SEC
>=7 CM/SEC

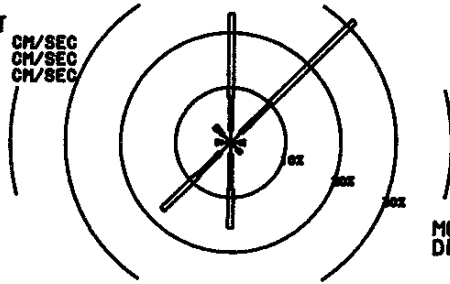

MOORING: 97-05C-001A010
DEPTH 10 M

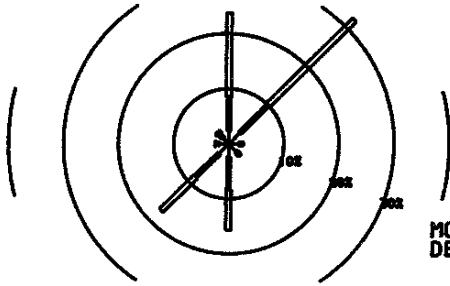

MOORING: 97-05C-001A011
DEPTH 11 M

* WIND AND CURRENT DIRECTIONS ARE TOWARDS

MOORING IS 97-05C-001A010 Depth IS 10 METERS THERE ARE 3932 VALUES

FIRST DAY 1997/11/02/0500
FINAL DAY 1998/04/15/0000

SHORELINE ORIENTATION IN DEGREES TRUE SPECIFIED AS 90

DIRECTION DEG TRUE	PERCENT OBSERVED	TOWARD	TOTAL	LIGHT	MEDIUM	HIGH	MAXIMUM CURRENT CM/S	MEAN DURA- TION HOURS	MEAN EXCUR- SION KM	MEAN CURRENT CM/S	MEAN TEMP DEG C
90.0	2.5	1.7	0.9	0.0	0.0	9.1	1.2	0.1	2.7	3.1	
45.0	31.5	2.6	7.6	21.3	37.7	3.3	1.3	10.6	4.0		
0.0	23.5	2.1	6.1	15.3	33.9	2.4	0.9	10.6	3.9		
315.0	4.1	2.0	1.3	0.8	23.7	1.7	0.3	4.3	2.9		
270.0	2.6	1.5	0.9	0.2	12.5	1.3	0.1	3.2	2.9		
225.0	17.4	2.5	6.0	9.0	52.3	2.6	0.9	9.1	3.9		
180.0	15.6	2.1	6.3	7.2	21.7	2.6	0.6	7.0	3.7		
135.0	2.7	1.8	0.9	0.0	6.8	1.3	0.1	2.6	3.0		

0 MEAN SCALAR SPEED = 8.9 CM/S MEAN SQUARE SPEED = 119.0 CM2/S2
 MEAN SQUARE E-W SPEED = 24.6 CM2/S2 MEAN SQUARE N-S SPEED = 94.4 CM2/S2
 MEAN SQUARE U SPEED = 24.6 CM2/S2 MEAN SQUARE V SPEED = 94.4 CM2/S2
 MEAN VELOCITY = 3.1 CM/S, 20 DEG TRUE MEAN TEMPERATURE = 3.8 C
 VARIANCE (U,V) = 54.6 CM2/S2 TOTAL HOURS = 3932.

PERCENT OBSERVED

LIGHT (0.0 - 3.0) 16.3% MEDIUM (3.0 - 7.0) 29.9% HIGH (GE 7.0) 53.7%

MOORING IS 97-05C-001A011 Depth IS 11 METERS THERE ARE 3932 VALUES

FIRST DAY 1997/11/02/0500
FINAL DAY 1998/04/15/0000

SHORELINE ORIENTATION IN DEGREES TRUE SPECIFIED AS 90

DIRECTION DEG TRUE	PERCENT OBSERVED	TOWARD	TOTAL	LIGHT	MEDIUM	HIGH	MAXIMUM CURRENT CM/S	MEAN DURA- TION HOURS	MEAN EXCUR- SION KM	MEAN CURRENT CM/S	MEAN TEMP DEG C
90.0	2.7	1.8	0.9	0.0	6.4	1.3	0.1	2.6	3.0		
45.0	32.1	2.8	7.3	22.0	37.7	3.2	1.2	10.6	4.0		
0.0	23.8	2.3	6.2	15.3	35.9	2.4	0.9	10.2	3.9		
315.0	3.0	1.5	0.9	0.6	18.7	1.4	0.2	4.3	3.0		
270.0	2.5	1.7	0.7	0.1	11.3	1.2	0.1	2.9	2.8		
225.0	17.3	2.4	6.0	9.0	50.5	2.5	0.8	9.2	4.0		
180.0	15.7	2.4	5.9	7.4	24.5	2.3	0.6	6.9	3.6		
135.0	3.0	2.0	1.0	0.0	6.0	1.3	0.1	2.7	3.1		

0 MEAN SCALAR SPEED = 8.9 CM/S MEAN SQUARE SPEED = 117.8 CM2/S2
 MEAN SQUARE E-W SPEED = 24.2 CM2/S2 MEAN SQUARE N-S SPEED = 93.6 CM2/S2
 MEAN SQUARE U SPEED = 24.2 CM2/S2 MEAN SQUARE V SPEED = 93.6 CM2/S2
 MEAN VELOCITY = 3.1 CM/S, 21 DEG TRUE MEAN TEMPERATURE = 3.8 C
 VARIANCE (U,V) = 54.0 CM2/S2 TOTAL HOURS = 3932.

PERCENT OBSERVED

LIGHT (0.0 - 3.0) 16.8% MEDIUM (3.0 - 7.0) 28.8% HIGH (GE 7.0) 54.3%

DATE: 1997/11/02 TO 1998/04/15
 ROSE SUMMARY: WIND AND CURRENT

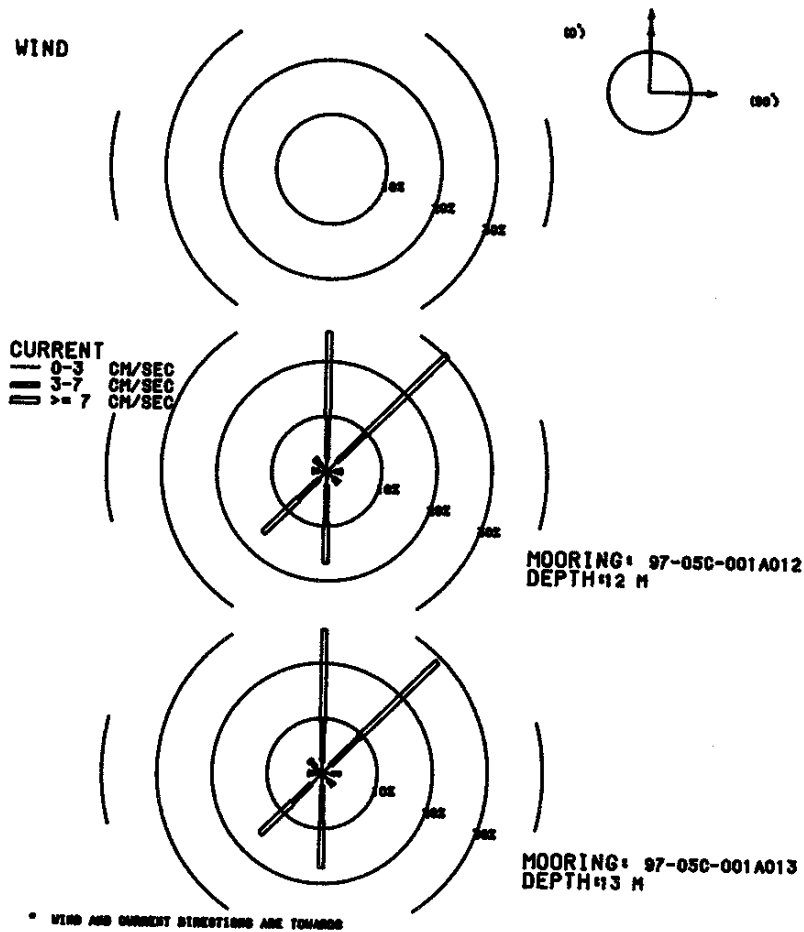

MOORING IS 97-05C-001A012 Depth IS 12 METERS THERE ARE 3932 VALUES

FIRST DAY 1997/11/02/0500
 FINAL DAY 1998/04/15/0000

SHORELINE ORIENTATION IN DEGREES TRUE SPECIFIED AS 90

DIRECTION DEG TRUE	PERCENT OBSERVED			MAXIMUM CURRENT CM/S	MEAN DURA- TION HOURS	MEAN EXCUR- SION KM	MEAN CURRENT CM/S	MEAN TEMP DEG C
TOWARD	TOTAL	LIGHT	MEDIUM	HIGH	CM/S			
90.0	2.7	1.6	1.0	0.1	8.0	1.3	2.9	3.1
45.0	30.4	2.4	7.1	20.9	35.6	3.0	10.6	4.0
0.0	25.4	2.4	7.1	15.9	34.3	2.4	10.0	3.9
315.0	3.2	1.3	1.2	0.6	18.6	1.5	4.4	2.9
270.0	2.6	1.5	1.0	0.1	10.7	1.3	3.1	2.9
225.0	16.1	2.0	5.1	9.0	52.1	2.5	9.6	4.0
180.0	16.8	2.5	6.7	7.5	23.5	2.4	6.9	3.6
135.0	2.9	1.8	1.0	0.1	10.5	1.3	2.8	2.9
0	MEAN SCALAR SPEED = 8.8 CM/S		MEAN SQUARE SPEED = 116.4 CM2/S2					
	MEAN SQUARE E-W SPEED = 23.1 CM2/S2		MEAN SQUARE N-S SPEED = 93.2 CM2/S2					
	MEAN SQUARE U SPEED = 23.1 CM2/S2		MEAN SQUARE V SPEED = 93.2 CM2/S2					
	MEAN VELOCITY = 3.1 CM/S,		21 DEG TRUE		MEAN TEMPERATURE = 3.8 C			
	VARIANCE (U,V) = 53.5 CM2/S2		TOTAL HOURS = 3932.					

PERCENT OBSERVED
 LIGHT (0.0 - 3.0) 15.5% MEDIUM (3.0 - 7.0) 30.3% HIGH (GE 7.0) 54.2%

MOORING IS 97-05C-001A013 Depth IS 13 METERS THERE ARE 3932 VALUES

FIRST DAY 1997/11/02/0500
 FINAL DAY 1998/04/15/0000

SHORELINE ORIENTATION IN DEGREES TRUE SPECIFIED AS 90

DIRECTION DEG TRUE	PERCENT OBSERVED			MAXIMUM CURRENT CM/S	MEAN DURA- TION HOURS	MEAN EXCUR- SION KM	MEAN CURRENT CM/S	MEAN TEMP DEG C
TOWARD	TOTAL	LIGHT	MEDIUM	HIGH	CM/S			
90.0	3.3	1.9	1.5	0.0	6.8	1.4	2.9	3.3
45.0	29.1	2.0	7.2	19.8	34.4	2.9	10.6	4.0
0.0	26.1	2.1	7.1	16.9	33.5	2.6	10.0	3.9
315.0	3.3	1.5	1.4	0.4	18.1	1.5	4.0	2.8
270.0	2.4	1.3	1.0	0.1	10.9	1.2	3.0	2.9
225.0	15.7	2.7	4.8	8.2	53.3	2.5	9.3	4.0
180.0	17.1	2.2	6.5	8.4	31.7	2.7	7.2	3.6
135.0	2.9	1.7	1.1	0.1	8.2	1.3	2.9	2.8
0	MEAN SCALAR SPEED = 8.8 CM/S		MEAN SQUARE SPEED = 114.8 CM2/S2					
	MEAN SQUARE E-W SPEED = 22.2 CM2/S2		MEAN SQUARE N-S SPEED = 92.6 CM2/S2					
	MEAN SQUARE U SPEED = 22.2 CM2/S2		MEAN SQUARE V SPEED = 92.6 CM2/S2					
	MEAN VELOCITY = 3.0 CM/S,		22 DEG TRUE		MEAN TEMPERATURE = 3.8 C			
	VARIANCE (U,V) = 52.9 CM2/S2		TOTAL HOURS = 3932.					

PERCENT OBSERVED
 LIGHT (0.0 - 3.0) 15.5% MEDIUM (3.0 - 7.0) 30.7% HIGH (GE 7.0) 53.8%

DATE: 1997/11/02 TO 1998/04/15
ROSE SUMMARY: WIND AND CURRENT

WIND

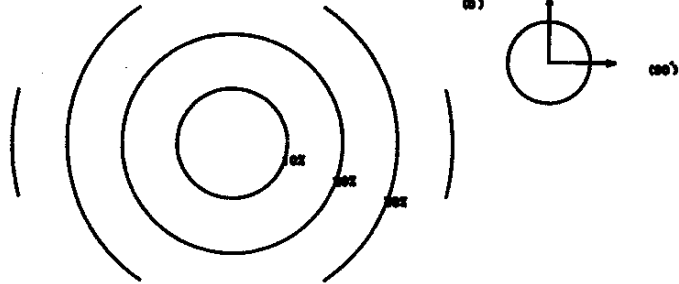

CURRENT
— 0-3 CM/SEC
= 3-7 CM/SEC
≡ >7 CM/SEC

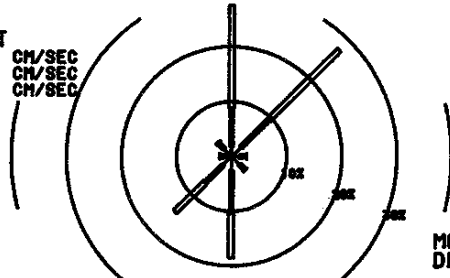

MOORING: 97-05C-001A014
DEPTH 14 M

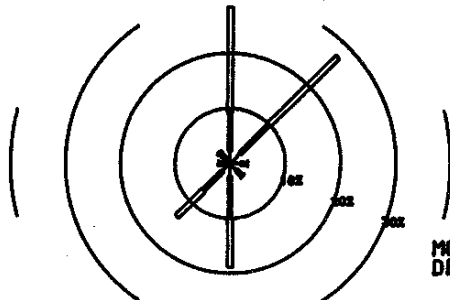

MOORING: 97-05C-001A015
DEPTH 15 M

* WIND AND CURRENT DIRECTIONS ARE TOWARDS

MOORING IS 97-05C-001A014 Depth IS 14 METERS THERE ARE 3932 VALUES

FIRST DAY 1997/11/02/0500
FINAL DAY 1998/04/15/0000

SHORELINE ORIENTATION IN DEGREES TRUE SPECIFIED AS 90

DIRECTION DEG TRUE	PERCENT OBSERVED	MAXIMUM CURRENT CM/S	MEAN DURA- TION HOURS	MEAN EXCUR- SION KM	MEAN CURRENT CM/S	MEAN TEMP DEG C
TOWARD	TOTAL	LIGHT	MEDIUM	HIGH		
90.0	2.7	1.3	1.3	0.0	7.4	1.3
45.0	27.6	2.3	7.1	18.2	32.1	2.6
0.0	27.6	1.8	6.9	18.8	32.3	2.6
315.0	3.6	1.7	1.4	0.4	17.3	1.7
270.0	2.2	1.1	1.0	0.1	13.8	1.2
225.0	14.3	2.1	4.5	7.7	54.9	2.4
180.0	18.6	2.5	7.7	8.3	21.8	2.8
135.0	3.5	2.0	1.4	0.1	11.5	1.4

0 MEAN SCALAR SPEED = 8.8 CM/S MEAN SQUARE SPEED = 114.2 CM2/S2
MEAN SQUARE E-W SPEED = 21.3 CM2/S2 MEAN SQUARE N-S SPEED = 92.9 CM2/S2
MEAN SQUARE U SPEED = 21.3 CM2/S2 MEAN SQUARE V SPEED = 92.9 CM2/S2
MEAN VELOCITY = 3.0 CM/S, 22 DEG TRUE MEAN TEMPERATURE = 3.8 C
VARIANCE (U,V) = 52.5 CM2/S2 TOTAL HOURS = 3932.

PERCENT OBSERVED
LIGHT (0.0 - 3.0) 14.8% MEDIUM (3.0 - 7.0) 31.5% HIGH (GE 7.0) 53.7%

MOORING IS 97-05C-001A015 Depth IS 15 METERS THERE ARE 3932 VALUES

FIRST DAY 1997/11/02/0500
FINAL DAY 1998/04/15/0000

SHORELINE ORIENTATION IN DEGREES TRUE SPECIFIED AS 90

DIRECTION DEG TRUE	PERCENT OBSERVED	MAXIMUM CURRENT CM/S	MEAN DURA- TION HOURS	MEAN EXCUR- SION KM	MEAN CURRENT CM/S	MEAN TEMP DEG C
TOWARD	TOTAL	LIGHT	MEDIUM	HIGH		
90.0	3.2	1.9	1.3	0.1	8.7	1.3
45.0	27.5	2.4	7.1	17.9	31.3	2.6
0.0	28.4	2.2	7.1	19.1	30.7	2.7
315.0	2.9	1.1	1.3	0.4	17.2	1.8
270.0	2.1	1.2	0.8	0.1	12.8	1.3
225.0	13.8	1.9	4.9	6.9	52.7	2.3
180.0	18.9	2.3	7.6	9.0	22.6	3.0
135.0	3.2	1.7	1.4	0.1	11.7	1.3

0 MEAN SCALAR SPEED = 8.6 CM/S MEAN SQUARE SPEED = 110.7 CM2/S2
MEAN SQUARE E-W SPEED = 19.9 CM2/S2 MEAN SQUARE N-S SPEED = 90.7 CM2/S2
MEAN SQUARE U SPEED = 19.9 CM2/S2 MEAN SQUARE V SPEED = 90.7 CM2/S2
MEAN VELOCITY = 3.0 CM/S, 23 DEG TRUE MEAN TEMPERATURE = 3.8 C
VARIANCE (U,V) = 51.0 CM2/S2 TOTAL HOURS = 3932.

PERCENT OBSERVED
LIGHT (0.0 - 3.0) 14.8% MEDIUM (3.0 - 7.0) 31.6% HIGH (GE 7.0) 53.7%

Appendix B - Mooring_A1-97. Monthly Summary Statistics and Rose Histogram Plots

DATE: 1997/11/02 TO 1997/11/30
ROSE SUMMARY: WIND AND CURRENT

WIND

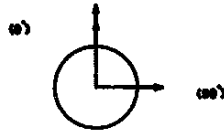
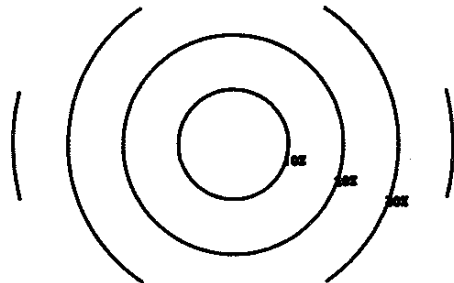

CURRENT
0-3 CM/SEC
3-7 CM/SEC
> 7 CM/SEC

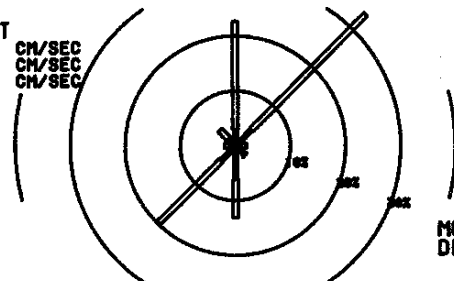

MOORING: 97-05C-001A002
DEPTH: 2 M

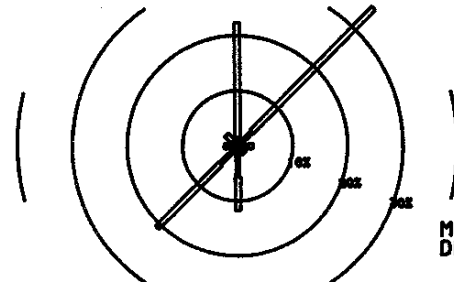

MOORING: 97-05C-001A003
DEPTH: 3 M

• WIND AND CURRENT DIRECTIONS ARE TOWARD

MOORING IS 97-05C-001A002 DEPTH IS 2 METERS THERE ARE 691 VALUES

FIRST DAY 1997/11/02/0500
FINAL DAY 1997/11/30/2300

SHORELINE ORIENTATION IN DEGREES TRUE SPECIFIED AS 90

DIRECTION DEG TRUE	PERCENT OBSERVED	MAXIMUM CURRENT CM/S	MEAN DURA- TION HOURS	MEAN EXCUR- SION KM	MEAN CURRENT CM/S	MEAN TEMP DEG C
TOWARD	TOTAL	LIGHT	MEDIUM	HIGH	CM/S	DEG C
90.0	2.0	0.3	0.7	1.0	13.4	1.3
45.0	33.7	0.4	3.6	29.7	34.2	3.3
0.0	22.7	0.3	2.6	19.8	32.6	2.0
315.0	4.1	0.3	1.4	2.3	20.3	1.5
270.0	2.0	0.1	0.9	1.0	16.0	1.3
225.0	19.8	0.4	3.3	16.1	26.5	2.7
180.0	13.2	0.9	5.2	7.1	25.4	1.9
135.0	2.5	1.2	1.2	0.1	7.7	1.4

0 MEAN SCALAR SPEED = 12.0 CM/S MEAN SQUARE SPEED = 181.0 CM2/S2
MEAN SQUARE E-W SPEED = 47.4 CM2/S2 MEAN SQUARE N-S SPEED = 133.6 CM2/S2
MEAN SQUARE U SPEED = 47.4 CM2/S2 MEAN SQUARE V SPEED = 133.6 CM2/S2
MEAN VELOCITY = 4.0 CM/S, 17 DEG TRUE MEAN TEMPERATURE = 8.5 C
VARIANCE (U,V) = 82.5 CM2/S2 TOTAL HOURS = 691.

PERCENT OBSERVED
LIGHT (0.0 - 3.0) 3.9% MEDIUM (3.0 - 7.0) 19.0% HIGH (GE 7.0) 77.1%

MOORING IS 97-05C-001A003 DEPTH IS 3 METERS THERE ARE 691 VALUES

FIRST DAY 1997/11/02/0500
FINAL DAY 1997/11/30/2300

SHORELINE ORIENTATION IN DEGREES TRUE SPECIFIED AS 90

DIRECTION DEG TRUE	PERCENT OBSERVED	MAXIMUM CURRENT CM/S	MEAN DURA- TION HOURS	MEAN EXCUR- SION KM	MEAN CURRENT CM/S	MEAN TEMP DEG C
TOWARD	TOTAL	LIGHT	MEDIUM	HIGH	CM/S	DEG C
90.0	2.7	0.6	1.3	0.9	10.3	1.6
45.0	35.2	0.6	3.0	31.5	32.7	4.3
0.0	22.4	0.1	1.3	21.0	32.4	2.9
315.0	2.9	0.4	0.7	1.7	22.5	1.7
270.0	2.5	0.6	1.0	0.9	9.3	1.3
225.0	20.8	1.0	3.5	16.4	28.6	3.3
180.0	11.7	0.7	4.8	6.2	29.3	2.1
135.0	1.7	0.9	0.7	0.1	7.2	1.5

0 MEAN SCALAR SPEED = 11.9 CM/S MEAN SQUARE SPEED = 178.5 CM2/S2
MEAN SQUARE E-W SPEED = 44.1 CM2/S2 MEAN SQUARE N-S SPEED = 134.4 CM2/S2
MEAN SQUARE U SPEED = 44.1 CM2/S2 MEAN SQUARE V SPEED = 134.4 CM2/S2
MEAN VELOCITY = 4.1 CM/S, 18 DEG TRUE MEAN TEMPERATURE = 8.5 C
VARIANCE (U,V) = 80.9 CM2/S2 TOTAL HOURS = 691.

PERCENT OBSERVED
LIGHT (0.0 - 3.0) 4.9% MEDIUM (3.0 - 7.0) 16.4% HIGH (GE 7.0) 78.7%

DATE: 1997/12/01 TO 1997/12/31
ROSE SUMMARY: WIND AND CURRENT

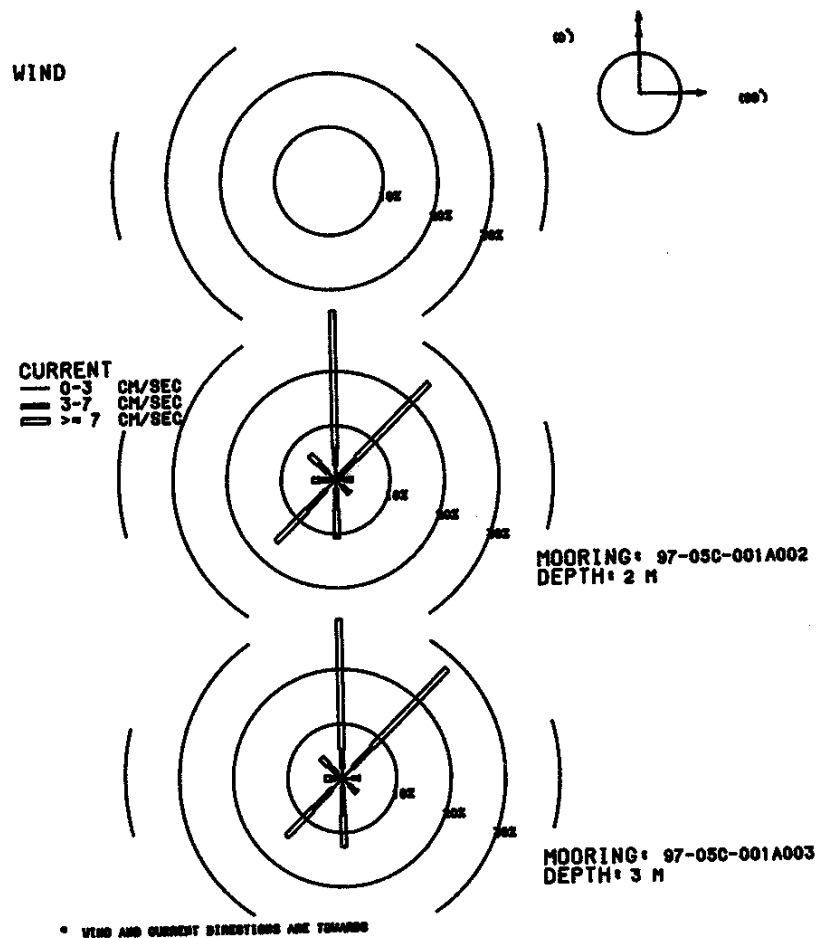

MOORING IS 97-05C-001A002 DEPTH IS 2 METERS THERE ARE 744 VALUES

FIRST DAY 1997/12/01/0000
FINAL DAY 1997/12/31/2300

SHORELINE ORIENTATION IN DEGREES TRUE SPECIFIED AS 90

DIRECTION DEG TRUE	PERCENT OBSERVED			MAXIMUM CURRENT CM/S	MEAN DURA- TION HOURS	MEAN EXCUR- SION KM	MEAN CURRENT CM/S	MEAN TEMP DEG C
TOWARD	TOTAL	LIGHT	MEDIUM	HIGH	CM/S	HOURS	CM/S	DEG C
90.0	3.1	1.5	1.2	0.4	8.3	1.3	0.2	3.5
45.0	24.7	0.9	4.4	19.4	32.6	2.3	1.0	12.1
0.0	31.2	2.7	3.1	25.4	39.2	2.6	1.3	14.4
315.0	6.6	2.0	2.3	2.3	22.7	1.7	0.5	7.6
270.0	4.3	1.2	1.7	1.3	16.1	1.4	0.3	5.5
225.0	15.9	2.6	5.0	8.3	24.8	2.0	0.6	8.1
180.0	10.8	1.6	3.8	5.4	16.7	1.8	0.4	6.8
135.0	3.5	1.6	1.7	0.1	9.1	1.3	0.2	3.7

0 MEAN SCALAR SPEED = 10.5 CM/S MEAN SQUARE SPEED = 157.2 CM2/S2
 MEAN SQUARE E-W SPEED = 28.4 CM2/S2 MEAN SQUARE N-S SPEED = 128.8 CM2/S2
 MEAN SQUARE U SPEED = 28.4 CM2/S2 MEAN SQUARE V SPEED = 128.8 CM2/S2
 MEAN VELOCITY = 5.5 CM/S, 7 DEG TRUE MEAN TEMPERATURE = 4.3 C
 VARIANCE (U,V) = 63.3 CM2/S2 TOTAL HOURS = 744.

PERCENT OBSERVED
 LIGHT (0.0 - 3.0) 14.1% MEDIUM (3.0 - 7.0) 23.3% HIGH (GE 7.0) 62.6%

MOORING IS 97-05C-001A003 DEPTH IS 3 METERS THERE ARE 744 VALUES

FIRST DAY 1997/12/01/0000
FINAL DAY 1997/12/31/2300

SHORELINE ORIENTATION IN DEGREES TRUE SPECIFIED AS 90

DIRECTION DEG TRUE	PERCENT OBSERVED			MAXIMUM CURRENT CM/S	MEAN DURA- TION HOURS	MEAN EXCUR- SION KM	MEAN CURRENT CM/S	MEAN TEMP DEG C
TOWARD	TOTAL	LIGHT	MEDIUM	HIGH	CM/S	HOURS	CM/S	DEG C
90.0	3.2	1.7	1.3	0.1	7.6	1.4	0.2	3.3
45.0	27.8	2.8	5.0	20.0	28.1	2.7	1.0	10.8
0.0	29.3	1.9	3.4	24.1	39.3	2.8	1.6	15.3
315.0	5.4	1.5	2.0	1.9	27.2	1.4	0.4	7.3
270.0	3.2	1.2	0.8	1.2	14.7	1.2	0.2	5.4
225.0	14.8	2.7	5.1	7.0	23.6	2.3	0.6	7.6
180.0	12.6	1.7	5.0	5.9	15.2	2.0	0.5	6.6
135.0	3.6	1.7	1.7	0.1	8.0	1.4	0.2	3.4

0 MEAN SCALAR SPEED = 10.3 CM/S MEAN SQUARE SPEED = 155.7 CM2/S2
 MEAN SQUARE E-W SPEED = 24.8 CM2/S2 MEAN SQUARE N-S SPEED = 130.9 CM2/S2
 MEAN SQUARE U SPEED = 24.8 CM2/S2 MEAN SQUARE V SPEED = 130.9 CM2/S2
 MEAN VELOCITY = 5.6 CM/S, 9 DEG TRUE MEAN TEMPERATURE = 4.3 C
 VARIANCE (U,V) = 62.5 CM2/S2 TOTAL HOURS = 744.

PERCENT OBSERVED
 LIGHT (0.0 - 3.0) 15.3% MEDIUM (3.0 - 7.0) 24.3% HIGH (GE 7.0) 60.3%

DATE: 1998/01/01 TO 1998/01/31
ROSE SUMMARY: WIND AND CURRENT

WIND

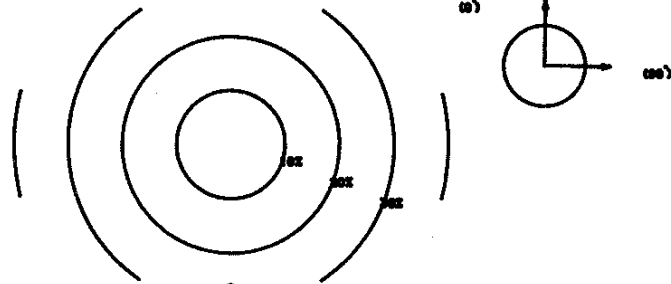

CURRENT
0-3 CM/SEC
3-7 CM/SEC
>= 7 CM/SEC

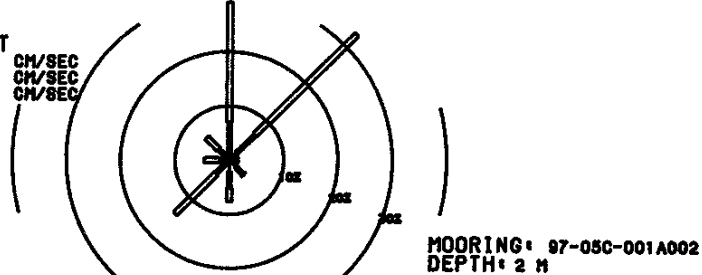

MOORING: 97-05C-001A002
DEPTH: 2 M

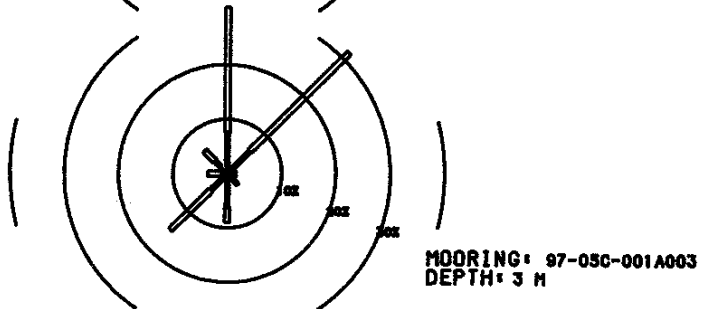

MOORING: 97-05C-001A003
DEPTH: 3 M

* WIND AND CURRENT DIRECTIONS ARE TOWARDS

MOORING IS 97-05C-001A002 DEPTH IS 2 METERS THERE ARE 744 VALUES

FIRST DAY 1998/01/01/0000
FINAL DAY 1998/01/31/2300

SHORELINE ORIENTATION IN DEGREES TRUE SPECIFIED AS 90

DIRECTION DEG TRUE	PERCENT OBSERVED	TOWARD	TOTAL	LIGHT	MEDIUM	HIGH	MAXIMUM CURRENT CM/S	MEAN DURA- TION HOURS	MEAN EXCUR- SION KM	MEAN CURRENT CM/S	MEAN TEMP DEG C
90.0	1.6	0.8	0.5	0.3			9.7	1.0	0.2	4.3	1.5
45.0	33.1	1.6	5.0	26.5			27.0	2.8	1.1	11.4	1.7
0.0	29.2	0.7	6.3	22.2			30.3	2.5	1.2	12.9	1.9
315.0	5.9	1.2	1.5	3.2			19.4	1.4	0.5	8.9	1.9
270.0	4.7	0.3	1.5	3.0			19.5	1.7	0.6	9.5	2.3
225.0	14.1	1.1	2.3	10.8			19.6	3.1	1.1	10.0	1.5
180.0	7.7	2.2	3.0	2.6			14.5	2.0	0.4	5.7	1.4
135.0	3.8	1.7	1.9	0.1			7.0	1.5	0.2	3.4	1.2

0 MEAN SCALAR SPEED = 10.5 CM/S MEAN SQUARE SPEED = 145.0 CM2/S2
MEAN SQUARE E-W SPEED = 32.3 CM2/S2 MEAN SQUARE N-S SPEED = 112.7 CM2/S2
MEAN SQUARE U SPEED = 32.3 CM2/S2 MEAN SQUARE V SPEED = 112.7 CM2/S2
MEAN VELOCITY = 5.6 CM/S, 10 DEG TRUE MEAN TEMPERATURE = 1.7 C
VARIANCE (U,V) = 56.7 CM2/S2 TOTAL HOURS = 744.

PERCENT OBSERVED
LIGHT (0.0 - 3.0) 9.5% MEDIUM (3.0 - 7.0) 21.9% HIGH (GE 7.0) 68.5%

MOORING IS 97-05C-001A003 DEPTH IS 3 METERS THERE ARE 744 VALUES

FIRST DAY 1998/01/01/0000
FINAL DAY 1998/01/31/2300

SHORELINE ORIENTATION IN DEGREES TRUE SPECIFIED AS 90

DIRECTION DEG TRUE	PERCENT OBSERVED	TOWARD	TOTAL	LIGHT	MEDIUM	HIGH	MAXIMUM CURRENT CM/S	MEAN DURA- TION HOURS	MEAN EXCUR- SION KM	MEAN CURRENT CM/S	MEAN TEMP DEG C
90.0	1.6	0.7	0.8	0.1			7.0	1.1	0.1	3.5	1.5
45.0	31.6	0.5	5.2	25.8			27.4	3.6	1.5	11.6	1.7
0.0	30.6	1.3	6.2	23.1			28.6	2.9	1.3	12.4	1.9
315.0	5.9	1.7	1.3	2.8			18.7	1.6	0.4	7.8	1.7
270.0	3.6	0.1	0.9	2.6			17.2	1.6	0.5	9.3	2.3
225.0	14.8	0.9	3.2	10.6			20.1	3.1	1.1	9.8	1.7
180.0	9.0	1.3	4.8	2.8			14.5	1.8	0.4	6.2	1.3
135.0	2.8	1.2	1.6	0.0			5.7	1.2	0.1	3.5	1.3

0 MEAN SCALAR SPEED = 10.4 CM/S MEAN SQUARE SPEED = 142.5 CM2/S2
MEAN SQUARE E-W SPEED = 30.4 CM2/S2 MEAN SQUARE N-S SPEED = 112.1 CM2/S2
MEAN SQUARE U SPEED = 30.4 CM2/S2 MEAN SQUARE V SPEED = 112.1 CM2/S2
MEAN VELOCITY = 5.5 CM/S, 9 DEG TRUE MEAN TEMPERATURE = 1.7 C
VARIANCE (U,V) = 56.2 CM2/S2 TOTAL HOURS = 744.

PERCENT OBSERVED
LIGHT (0.0 - 3.0) 7.9% MEDIUM (3.0 - 7.0) 24.2% HIGH (GE 7.0) 67.9%

DATE: 1998/02/01 TO 1998/02/28
 ROSE SUMMARY: WIND AND CURRENT

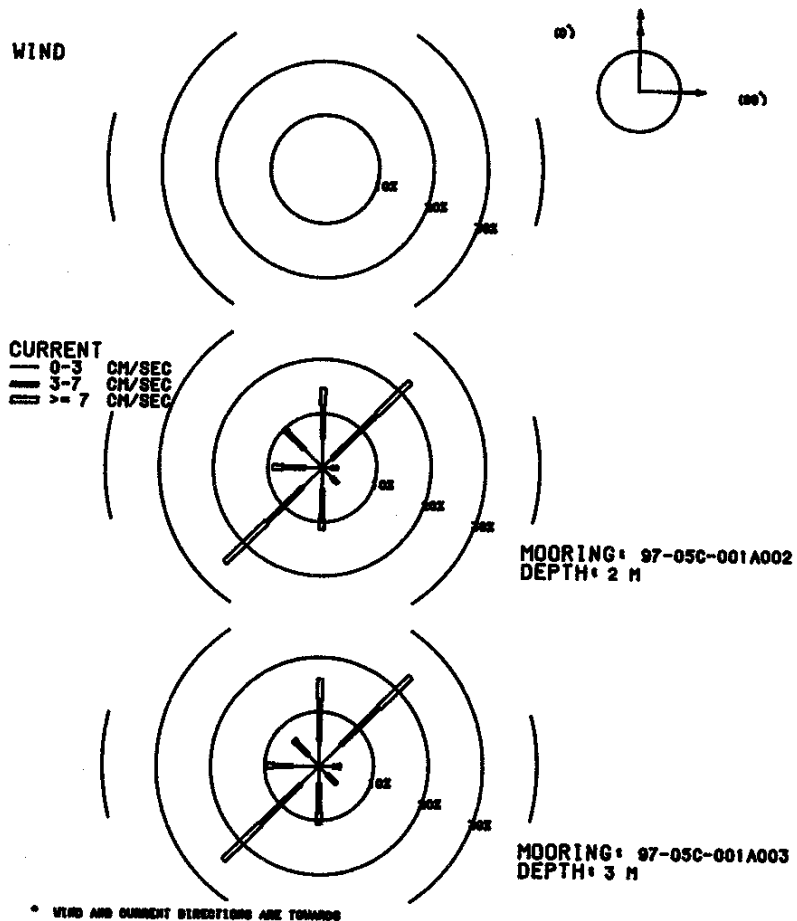

MOORING IS 97-05C-001A002 DEPTH IS 2 METERS THERE ARE 672 VALUES

FIRST DAY 1998/02/01/0000
 FINAL DAY 1998/02/28/2300

SHORELINE ORIENTATION IN DEGREES TRUE SPECIFIED AS 90

DIRECTION DEG TRUE	PERCENT OBSERVED	MAXIMUM CURRENT	MEAN DURA- TION HOURS	MEAN EXCUR- SION KM	MEAN CURRENT CM/S	MEAN TEMP DEG C
TOWARD	TOTAL	LIGHT	MEDIUM	HIGH	CM/S	
90.0	2.8	1.6	1.2	0.0	5.7	1.1
45.0	22.6	2.4	11.6	8.6	20.9	3.2
0.0	14.7	5.4	6.1	3.3	15.4	1.7
315.0	10.1	4.8	4.5	0.9	20.3	1.4
270.0	9.2	3.1	4.2	1.9	16.8	1.4
225.0	25.0	5.1	9.2	10.7	19.3	2.5
180.0	11.5	3.9	5.5	2.1	10.5	1.5
135.0	4.0	2.5	1.5	0.0	6.2	1.4

0 MEAN SCALAR SPEED = 5.7 CM/S MEAN SQUARE SPEED = 47.8 CM2/S2
 MEAN SQUARE E-W SPEED = 18.6 CM2/S2 MEAN SQUARE N-S SPEED = 29.2 CM2/S2
 MEAN SQUARE U SPEED = 18.6 CM2/S2 MEAN SQUARE V SPEED = 29.2 CM2/S2
 MEAN VELOCITY = 0.8 CM/S, 301 DEG TRUE MEAN TEMPERATURE = 1.6 C
 VARIANCE (U,V) = 23.6 CM2/S2 TOTAL HOURS = 672.

PERCENT OBSERVED
 LIGHT (0.0 - 3.0) 28.7% MEDIUM (3.0 - 7.0) 43.7% HIGH (GE 7.0) 27.5%

MOORING IS 97-05C-001A003 DEPTH IS 3 METERS THERE ARE 672 VALUES

FIRST DAY 1998/02/01/0000
 FINAL DAY 1998/02/28/2300

SHORELINE ORIENTATION IN DEGREES TRUE SPECIFIED AS 90

DIRECTION DEG TRUE	PERCENT OBSERVED	MAXIMUM CURRENT	MEAN DURA- TION HOURS	MEAN EXCUR- SION KM	MEAN CURRENT CM/S	MEAN TEMP DEG C
TOWARD	TOTAL	LIGHT	MEDIUM	HIGH	CM/S	
90.0	3.9	2.5	1.2	0.1	8.0	1.2
45.0	23.5	5.5	9.8	8.2	18.6	2.4
0.0	16.1	4.6	7.6	3.9	17.0	1.9
315.0	6.7	2.8	3.1	0.7	24.5	1.4
270.0	9.8	4.9	3.4	1.5	15.8	1.4
225.0	24.7	4.6	10.6	9.5	19.4	2.6
180.0	10.7	3.1	5.4	2.2	13.1	1.6
135.0	4.6	2.1	2.5	0.0	6.1	1.3

0 MEAN SCALAR SPEED = 5.5 CM/S MEAN SQUARE SPEED = 44.8 CM2/S2
 MEAN SQUARE E-W SPEED = 16.7 CM2/S2 MEAN SQUARE N-S SPEED = 28.1 CM2/S2
 MEAN SQUARE U SPEED = 16.7 CM2/S2 MEAN SQUARE V SPEED = 28.1 CM2/S2
 MEAN VELOCITY = 0.6 CM/S, 302 DEG TRUE MEAN TEMPERATURE = 1.6 C
 VARIANCE (U,V) = 22.2 CM2/S2 TOTAL HOURS = 672.

PERCENT OBSERVED
 LIGHT (0.0 - 3.0) 30.2% MEDIUM (3.0 - 7.0) 43.6% HIGH (GE 7.0) 26.2%

DATE: 1998/03/01 TO 1998/03/31
ROSE SUMMARY: WIND AND CURRENT

WIND

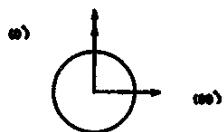
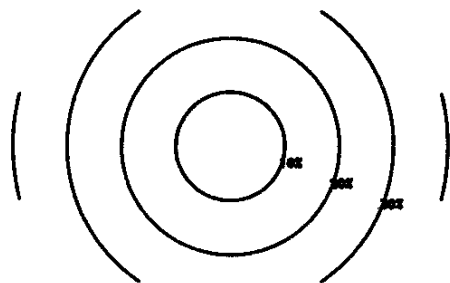

CURRENT

0-3 CM/SEC
3-7 CM/SEC
7 CM/SEC

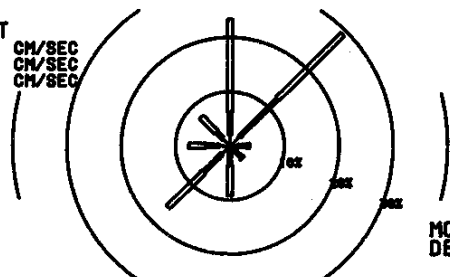

MOORING: 97-05C-001A002
DEPTH: 2 M

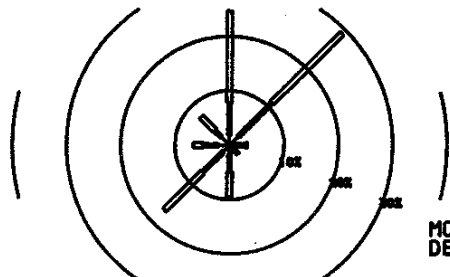

MOORING: 97-05C-001A003
DEPTH: 3 M

* WIND AND CURRENT DIRECTIONS ARE TOWARDS

MOORING IS 97-05C-001A002 DEPTH IS 2 METERS THERE ARE 744 VALUES

FIRST DAY 1998/03/01/0000
FINAL DAY 1998/03/31/2300

SHORELINE ORIENTATION IN DEGREES TRUE SPECIFIED AS 90

DIRECTION DEG TRUE	PERCENT OBSERVED	TOWARD	TOTAL	LIGHT	MEDIUM	HIGH	MAXIMUM CURRENT CM/S	MEAN DURA- TION HOURS	MEAN EXCUR- SION KM	MEAN CURRENT CM/S	MEAN TEMP DEG C
90.0	3.6	1.3	1.7	0.5	11.4	1.2	0.2	4.4	2.5		
45.0	29.2	2.4	9.8	16.9	46.4	3.0	1.1	9.9	2.6		
0.0	23.4	2.0	4.2	17.2	46.4	2.4	1.1	12.8	2.2		
315.0	7.5	1.9	1.6	4.0	37.3	1.5	0.5	10.3	2.3		
270.0	7.7	2.0	2.4	3.2	22.7	1.5	0.4	7.0	2.3		
225.0	16.1	2.0	4.7	9.4	47.3	2.2	0.9	11.9	2.2		
180.0	9.3	0.9	2.7	5.6	45.6	1.7	0.5	8.3	2.0		
135.0	3.2	1.6	1.5	0.1	10.5	1.4	0.2	3.5	2.6		

MEAN SCALAR SPEED = 10.1 CM/S MEAN SQUARE SPEED = 174.4 CM2/S2
MEAN SQUARE E-W SPEED = 53.4 CM2/S2 MEAN SQUARE N-S SPEED = 121.0 CM2/S2
MEAN SQUARE U SPEED = 53.4 CM2/S2 MEAN SQUARE V SPEED = 121.0 CM2/S2
MEAN VELOCITY = 3.7 CM/S, 357 DEG TRUE MEAN TEMPERATURE = 2.3 C
VARIANCE (U,V) = 80.4 CM2/S2 TOTAL HOURS = 744.

PERCENT OBSERVED
LIGHT (0.0 - 3.0) 14.2% MEDIUM (3.0 - 7.0) 28.6% HIGH (GE 7.0) 57.1%

MOORING IS 97-05C-001A003 DEPTH IS 3 METERS THERE ARE 744 VALUES

FIRST DAY 1998/03/01/0000
FINAL DAY 1998/03/31/2300

SHORELINE ORIENTATION IN DEGREES TRUE SPECIFIED AS 90

DIRECTION DEG TRUE	PERCENT OBSERVED	TOWARD	TOTAL	LIGHT	MEDIUM	HIGH	MAXIMUM CURRENT CM/S	MEAN DURA- TION HOURS	MEAN EXCUR- SION KM	MEAN CURRENT CM/S	MEAN TEMP DEG C
90.0	3.2	0.9	2.0	0.3	8.2	1.4	0.2	4.0	2.6		
45.0	29.2	2.2	8.9	18.1	42.6	2.8	1.0	10.1	2.6		
0.0	24.7	1.9	5.9	16.9	48.3	2.3	1.0	11.9	2.2		
315.0	7.4	2.2	1.6	3.6	37.4	1.5	0.5	9.6	2.2		
270.0	6.7	2.0	2.8	1.9	21.2	1.6	0.4	6.3	2.3		
225.0	16.9	1.6	5.2	10.1	49.2	2.2	1.0	12.2	2.2		
180.0	9.5	1.6	3.2	4.7	22.8	1.5	0.4	7.5	2.0		
135.0	2.3	0.9	1.3	0.0	5.4	1.4	0.2	3.0	2.8		

MEAN SCALAR SPEED = 10.0 CM/S MEAN SQUARE SPEED = 169.5 CM2/S2
MEAN SQUARE E-W SPEED = 50.9 CM2/S2 MEAN SQUARE N-S SPEED = 118.5 CM2/S2
MEAN SQUARE U SPEED = 50.9 CM2/S2 MEAN SQUARE V SPEED = 118.5 CM2/S2
MEAN VELOCITY = 3.6 CM/S, 357 DEG TRUE MEAN TEMPERATURE = 2.3 C
VARIANCE (U,V) = 78.4 CM2/S2 TOTAL HOURS = 744.

PERCENT OBSERVED
LIGHT (0.0 - 3.0) 13.3% MEDIUM (3.0 - 7.0) 31.0% HIGH (GE 7.0) 55.6%

DATE: 1998/04/01 TO 1998/04/30
ROSE SUMMARY: WIND AND CURRENT

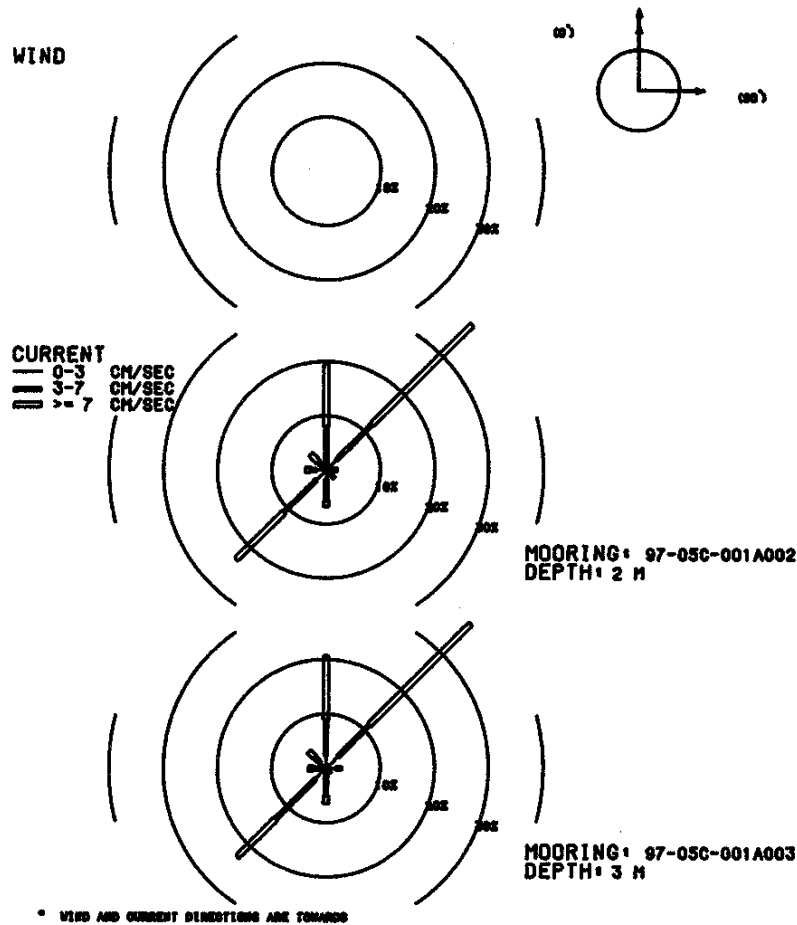

MOORING IS 97-05C-001A002 DEPTH IS 2 METERS THERE ARE 337 VALUES

FIRST DAY 1998/04/01/0000
FINAL DAY 1998/04/15/0000

SHORELINE ORIENTATION IN DEGREES TRUE SPECIFIED AS 90

DIRECTION DEG TRUE	PERCENT OBSERVED			MAXIMUM CURRENT CM/S	MEAN DURA- TION HOURS	MEAN EXCUR- SION KM	MEAN CURRENT CM/S	MEAN TEMP DEG C
TOWARD	TOTAL	LIGHT	MEDIUM	HIGH	CM/S			
90.0	2.1	0.9	1.2	0.0	5.8	1.2	0.1	3.3
45.0	38.0	2.7	9.2	26.1	18.6	3.5	1.1	9.0
0.0	19.6	1.2	6.8	11.6	19.3	1.8	0.5	8.3
315.0	4.2	0.9	1.2	2.1	21.9	2.0	0.7	9.1
270.0	3.9	1.8	1.2	0.9	10.8	1.1	0.2	4.7
225.0	23.4	2.7	8.3	12.5	21.5	3.4	1.0	7.8
180.0	6.8	1.8	3.9	1.2	15.7	1.6	0.3	5.3
135.0	2.1	1.2	0.9	0.0	5.7	1.0	0.1	2.8
0	MEAN SCALAR SPEED = 7.9 CM/S		MEAN SQUARE SPEED = 80.2 CM2/S2					
	MEAN SQUARE E-W SPEED = 24.3 CM2/S2		MEAN SQUARE N-S SPEED = 55.9 CM2/S2					
	MEAN SQUARE U SPEED = 24.3 CM2/S2		MEAN SQUARE V SPEED = 55.9 CM2/S2					
	MEAN VELOCITY = 3.0 CM/S,		14 DEG TRUE		MEAN TEMPERATURE = 5.1 C			
	VARIANCE (U,V) = 35.7 CM2/S2		TOTAL HOURS = 337.					

PERCENT OBSERVED

LIGHT (0.0 - 3.0) 13.1% MEDIUM (3.0 - 7.0) 32.6% HIGH (GE 7.0) 54.3%

MOORING IS 97-05C-001A003 DEPTH IS 3 METERS THERE ARE 337 VALUES

FIRST DAY 1998/04/01/0000
FINAL DAY 1998/04/15/0000

SHORELINE ORIENTATION IN DEGREES TRUE SPECIFIED AS 90

DIRECTION DEG TRUE	PERCENT OBSERVED			MAXIMUM CURRENT CM/S	MEAN DURA- TION HOURS	MEAN EXCUR- SION KM	MEAN CURRENT CM/S	MEAN TEMP DEG C
TOWARD	TOTAL	LIGHT	MEDIUM	HIGH	CM/S			
90.0	3.0	1.8	1.2	0.0	4.3	1.2	0.1	2.4
45.0	37.7	3.0	8.3	26.4	17.0	3.2	1.0	8.8
0.0	20.8	2.4	6.5	11.9	15.3	1.7	0.5	7.7
315.0	4.5	1.5	1.5	1.5	21.8	1.5	0.3	6.2
270.0	3.3	0.6	1.8	0.9	7.6	1.0	0.2	5.0
225.0	23.1	2.7	10.4	10.1	18.9	3.5	0.9	7.4
180.0	6.5	0.9	4.2	1.5	14.1	1.6	0.3	5.3
135.0	1.2	0.9	0.3	0.0	3.3	1.0	0.1	2.5
0	MEAN SCALAR SPEED = 7.5 CM/S		MEAN SQUARE SPEED = 72.2 CM2/S2					
	MEAN SQUARE E-W SPEED = 20.7 CM2/S2		MEAN SQUARE N-S SPEED = 51.6 CM2/S2					
	MEAN SQUARE U SPEED = 20.7 CM2/S2		MEAN SQUARE V SPEED = 51.6 CM2/S2					
	MEAN VELOCITY = 2.8 CM/S,		17 DEG TRUE		MEAN TEMPERATURE = 5.1 C			
	VARIANCE (U,V) = 32.2 CM2/S2		TOTAL HOURS = 337.					

PERCENT OBSERVED

LIGHT (0.0 - 3.0) 13.6% MEDIUM (3.0 - 7.0) 34.1% HIGH (GE 7.0) 52.2%

DATE: 1997/11/02 TO 1997/11/30
ROSE SUMMARY: WIND AND CURRENT

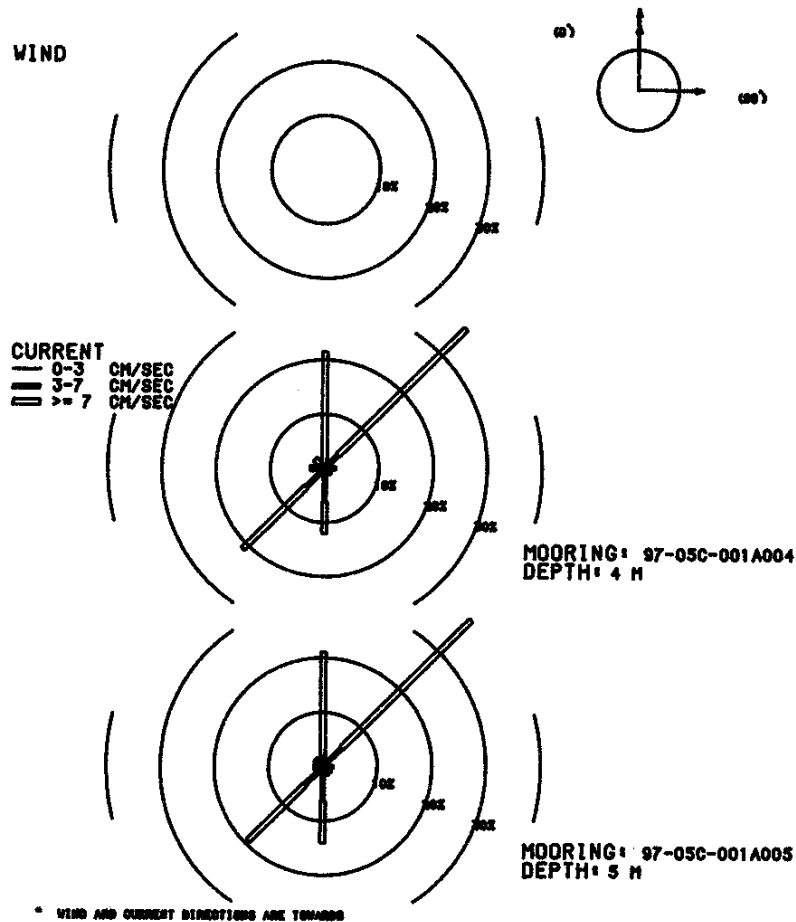

MOORING IS 97-05C-001A004 DEPTH IS 4 METERS THERE ARE 691 VALUES

FIRST DAY 1997/11/02/0500
FINAL DAY 1997/11/30/2300

SHORELINE ORIENTATION IN DEGREES TRUE SPECIFIED AS 90

DIRECTION DEG TRUE	PERCENT OBSERVED			MAXIMUM CURRENT CM/S	MEAN DURA- TION HOURS	MEAN EXCUR- SION KM	MEAN CURRENT CM/S	MEAN TEMP DEG C
TOWARD	TOTAL	LIGHT	MEDIUM	HIGH	CM/S	HOURS	CM/S	DEG C
90.0	2.0	0.7	1.3	0.0	6.7	1.8	0.3	4.0
45.0	36.6	0.7	2.6	33.3	31.8	4.5	2.1	13.0
0.0	21.6	0.0	0.7	20.8	33.0	2.8	1.4	14.4
315.0	2.5	0.4	0.6	1.4	19.1	1.7	0.5	7.8
270.0	2.6	0.3	1.9	0.4	10.4	1.4	0.3	5.2
225.0	21.1	1.0	3.8	16.4	27.8	3.4	1.5	12.0
180.0	12.0	1.0	5.1	5.9	18.3	2.0	0.6	7.9
135.0	1.6	0.9	0.7	0.0	5.8	1.1	0.1	3.3

0 MEAN SCALAR SPEED = 11.8 CM/S MEAN SQUARE SPEED = 173.4 CM2/S2
 MEAN SQUARE E-W SPEED = 41.6 CM2/S2 MEAN SQUARE N-S SPEED = 131.7 CM2/S2
 MEAN SQUARE U SPEED = 41.6 CM2/S2 MEAN SQUARE V SPEED = 131.7 CM2/S2
 MEAN VELOCITY = 4.2 CM/S, 20 DEG TRUE MEAN TEMPERATURE = 8.5 C
 VARIANCE (U,V) = 78.1 CM2/S2 TOTAL HOURS = 691.

PERCENT OBSERVED
 LIGHT (0.0 - 3.0) 5.1% MEDIUM (3.0 - 7.0) 16.6% HIGH (GE 7.0) 78.3%

MOORING IS 97-05C-001A005 DEPTH IS 5 METERS THERE ARE 691 VALUES

FIRST DAY 1997/11/02/0500
FINAL DAY 1997/11/30/2300

SHORELINE ORIENTATION IN DEGREES TRUE SPECIFIED AS 90

DIRECTION DEG TRUE	PERCENT OBSERVED			MAXIMUM CURRENT CM/S	MEAN DURA- TION HOURS	MEAN EXCUR- SION KM	MEAN CURRENT CM/S	MEAN TEMP DEG C
TOWARD	TOTAL	LIGHT	MEDIUM	HIGH	CM/S	HOURS	CM/S	DEG C
90.0	1.9	0.6	1.3	0.0	5.7	1.3	0.2	3.5
45.0	38.4	0.7	4.1	33.6	31.5	5.8	2.7	13.0
0.0	21.1	0.3	1.6	19.2	29.6	3.2	1.5	13.6
315.0	1.9	0.1	0.9	0.9	17.3	2.2	0.6	7.4
270.0	1.6	0.4	0.7	0.4	9.9	1.2	0.2	4.6
225.0	19.4	0.7	3.9	14.8	25.4	3.5	1.5	11.8
180.0	14.0	1.0	5.2	7.8	23.6	2.5	0.8	8.5
135.0	1.7	0.4	1.2	0.1	7.3	1.2	0.2	4.1

0 MEAN SCALAR SPEED = 11.7 CM/S MEAN SQUARE SPEED = 170.0 CM2/S2
 MEAN SQUARE E-W SPEED = 38.5 CM2/S2 MEAN SQUARE N-S SPEED = 131.5 CM2/S2
 MEAN SQUARE U SPEED = 38.5 CM2/S2 MEAN SQUARE V SPEED = 131.5 CM2/S2
 MEAN VELOCITY = 4.2 CM/S, 22 DEG TRUE MEAN TEMPERATURE = 8.5 C
 VARIANCE (U,V) = 76.4 CM2/S2 TOTAL HOURS = 691.

PERCENT OBSERVED
 LIGHT (0.0 - 3.0) 4.3% MEDIUM (3.0 - 7.0) 18.8% HIGH (GE 7.0) 76.8%

DATE: 1997/12/01 TO 1997/12/31
 ROSE SUMMARY: WIND AND CURRENT

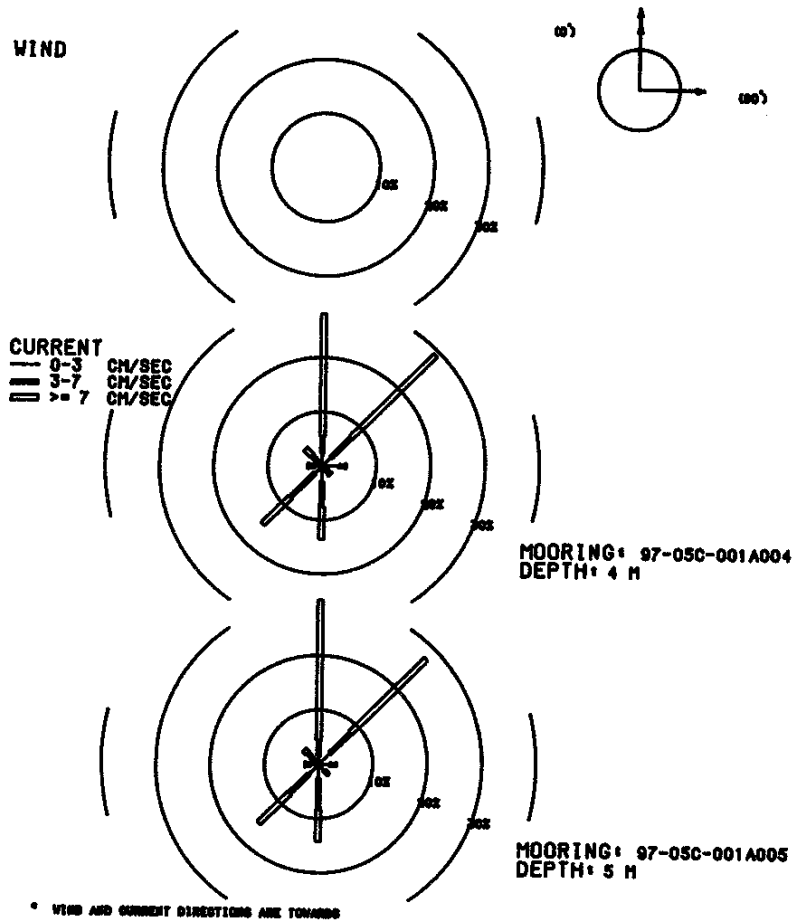

MOORING IS 97-05C-001A004 DEPTH IS 4 METERS THERE ARE 744 VALUES

FIRST DAY 1997/12/01/0000
 FINAL DAY 1997/12/31/2300

SHORELINE ORIENTATION IN DEGREES TRUE SPECIFIED AS 90

DIRECTION DEG TRUE	PERCENT OBSERVED	MAXIMUM CURRENT	MEAN DURA- TION HOURS	MEAN EXCUR- SION KM	MEAN CURRENT CM/S	MEAN TEMP DEG C
TOWARD	TOTAL	LIGHT	MEDIUM	HIGH	CM/S	
90.0	4.4	3.1	1.2	0.1	7.4	1.6
45.0	29.3	2.2	5.2	21.9	25.1	3.3
0.0	28.1	2.4	3.1	22.6	37.3	3.1
315.0	4.4	0.9	1.7	1.7	26.3	1.6
270.0	2.7	1.2	1.2	0.3	13.3	1.2
225.0	15.3	1.9	6.3	7.1	25.5	2.4
180.0	13.6	2.8	4.7	6.0	15.5	2.3
135.0	2.2	0.9	1.1	0.1	7.0	1.2

MEAN SCALAR SPEED = 10.2 CM/S MEAN SQUARE SPEED = 152.0 CM2/S2
 MEAN SQUARE E-W SPEED = 23.8 CM2/S2 MEAN SQUARE N-S SPEED = 128.2 CM2/S2
 MEAN SQUARE U SPEED = 23.8 CM2/S2 MEAN SQUARE V SPEED = 128.2 CM2/S2
 MEAN VELOCITY = 5.4 CM/S, 11 DEG TRUE MEAN TEMPERATURE = 4.3 C
 VARIANCE (U,V) = 61.3 CM2/S2 TOTAL HOURS = 744.

PERCENT OBSERVED
 LIGHT (0.0 - 3.0) 15.5% MEDIUM (3.0 - 7.0) 24.6% HIGH (GE 7.0) 59.9%

MOORING IS 97-05C-001A005 DEPTH IS 5 METERS THERE ARE 744 VALUES

FIRST DAY 1997/12/01/0000
 FINAL DAY 1997/12/31/2300

SHORELINE ORIENTATION IN DEGREES TRUE SPECIFIED AS 90

DIRECTION DEG TRUE	PERCENT OBSERVED	MAXIMUM CURRENT	MEAN DURA- TION HOURS	MEAN EXCUR- SION KM	MEAN CURRENT CM/S	MEAN TEMP DEG C
TOWARD	TOTAL	LIGHT	MEDIUM	HIGH	CM/S	
90.0	3.4	2.0	1.3	0.0	4.7	1.4
45.0	27.7	2.8	5.2	19.6	30.1	2.8
0.0	30.2	1.6	2.8	25.8	36.7	3.1
315.0	3.8	1.2	1.6	0.9	17.9	1.6
270.0	2.6	1.3	1.1	0.1	16.3	1.3
225.0	15.5	2.4	5.1	7.9	28.2	2.3
180.0	14.2	2.6	5.6	6.0	14.8	2.1
135.0	2.7	1.5	1.2	0.0	4.7	1.1

MEAN SCALAR SPEED = 10.1 CM/S MEAN SQUARE SPEED = 147.6 CM2/S2
 MEAN SQUARE E-W SPEED = 22.1 CM2/S2 MEAN SQUARE N-S SPEED = 125.5 CM2/S2
 MEAN SQUARE U SPEED = 22.1 CM2/S2 MEAN SQUARE V SPEED = 125.5 CM2/S2
 MEAN VELOCITY = 5.3 CM/S, 13 DEG TRUE MEAN TEMPERATURE = 4.3 C
 VARIANCE (U,V) = 59.7 CM2/S2 TOTAL HOURS = 744.

PERCENT OBSERVED
 LIGHT (0.0 - 3.0) 15.5% MEDIUM (3.0 - 7.0) 24.1% HIGH (GE 7.0) 60.5%

DATE: 1998/01/01 TO 1998/01/31
 ROSE SUMMARY: WIND AND CURRENT

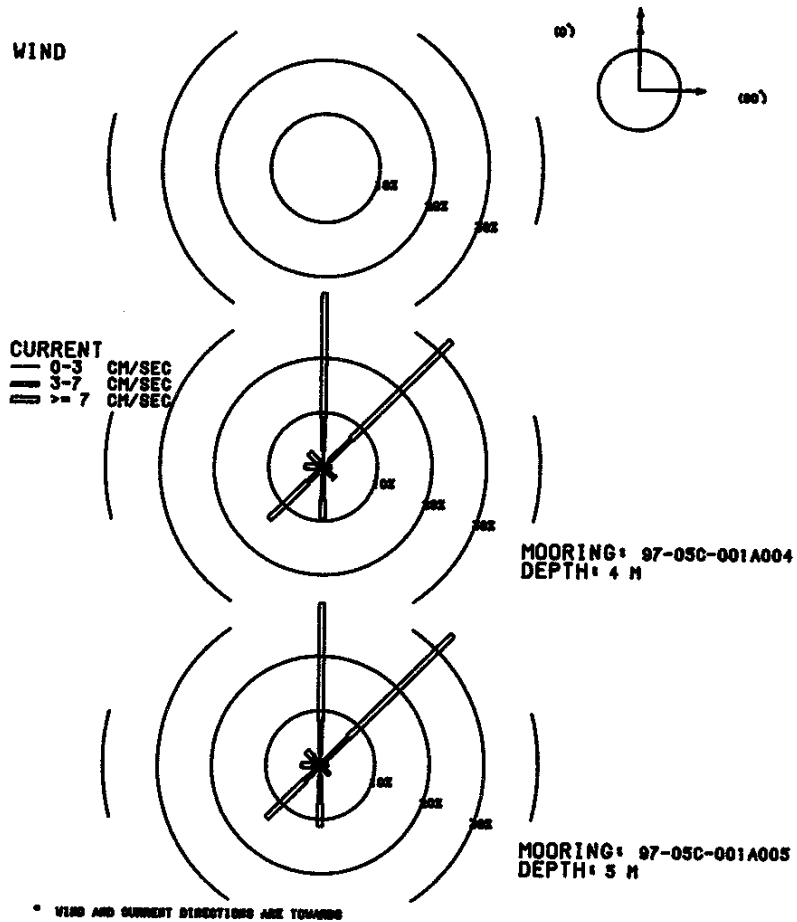

MOORING IS 97-05C-001A004 DEPTH IS 4 METERS THERE ARE 744 VALUES

FIRST DAY 1998/01/01/0000
 FINAL DAY 1998/01/31/2300

SHORELINE ORIENTATION IN DEGREES TRUE SPECIFIED AS 90

DIRECTION DEG TRUE	PERCENT OBSERVED	MAXIMUM CURRENT CM/S	MEAN DURA- TION HOURS	MEAN EXCUR- SION KM	MEAN CURRENT CM/S	MEAN TEMP DEG C
TOWARD	TOTAL	LIGHT	MEDIUM	HIGH		
90.0	1.5	1.3	0.1	0.0	4.0	1.4
45.0	33.1	1.6	5.5	25.9	24.6	3.0
0.0	32.0	3.0	5.9	23.1	30.4	2.6
315.0	3.6	0.7	0.4	2.6	15.3	1.7
270.0	3.4	0.5	0.5	2.3	14.5	1.5
225.0	13.8	1.5	2.4	9.9	19.0	3.1
180.0	9.7	1.5	4.6	3.6	15.5	2.2
135.0	3.0	1.1	1.7	0.1	7.3	2.0

0 MEAN SCALAR SPEED = 10.3 CM/S MEAN SQUARE SPEED = 139.2 CM2/S2
 MEAN SQUARE E-W SPEED = 26.5 CM2/S2 MEAN SQUARE N-S SPEED = 112.7 CM2/S2
 MEAN SQUARE U SPEED = 26.5 CM2/S2 MEAN SQUARE V SPEED = 112.7 CM2/S2
 MEAN VELOCITY = 5.6 CM/S, 12 DEG TRUE MEAN TEMPERATURE = 1.7 C
 VARIANCE (U,V) = 54.2 CM2/S2 TOTAL HOURS = 744.

PERCENT OBSERVED
 LIGHT (0.0 - 3.0) 11.2% MEDIUM (3.0 - 7.0) 21.2% HIGH (GE 7.0) 67.6%

MOORING IS 97-05C-001A005 DEPTH IS 5 METERS THERE ARE 744 VALUES

FIRST DAY 1998/01/01/0000
 FINAL DAY 1998/01/31/2300

SHORELINE ORIENTATION IN DEGREES TRUE SPECIFIED AS 90

DIRECTION DEG TRUE	PERCENT OBSERVED	MAXIMUM CURRENT CM/S	MEAN DURA- TION HOURS	MEAN EXCUR- SION KM	MEAN CURRENT CM/S	MEAN TEMP DEG C
TOWARD	TOTAL	LIGHT	MEDIUM	HIGH		
90.0	1.3	0.8	0.5	0.0	5.2	1.2
45.0	34.1	1.1	6.0	27.0	25.2	3.1
0.0	29.8	2.2	5.9	21.8	30.4	2.6
315.0	3.6	0.5	1.2	1.9	16.1	1.9
270.0	3.5	0.5	0.8	2.2	13.9	1.4
225.0	13.8	0.9	3.0	9.9	17.3	2.6
180.0	11.3	1.9	5.1	4.3	19.3	2.2
135.0	2.4	0.8	1.6	0.0	6.4	1.5

0 MEAN SCALAR SPEED = 10.2 CM/S MEAN SQUARE SPEED = 138.6 CM2/S2
 MEAN SQUARE E-W SPEED = 26.2 CM2/S2 MEAN SQUARE N-S SPEED = 112.4 CM2/S2
 MEAN SQUARE U SPEED = 26.2 CM2/S2 MEAN SQUARE V SPEED = 112.4 CM2/S2
 MEAN VELOCITY = 5.4 CM/S, 15 DEG TRUE MEAN TEMPERATURE = 1.7 C
 VARIANCE (U,V) = 54.7 CM2/S2 TOTAL HOURS = 744.

PERCENT OBSERVED
 LIGHT (0.0 - 3.0) 8.7% MEDIUM (3.0 - 7.0) 24.2% HIGH (GE 7.0) 67.1%

DATE: 1998/02/01 TO 1998/02/28
 ROSE SUMMARY: WIND AND CURRENT

WIND

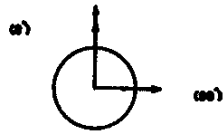
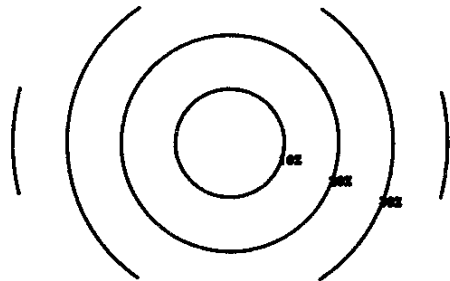

CURRENT

0-3 CH/SEC
 3-7 CH/SEC
 >7 CH/SEC

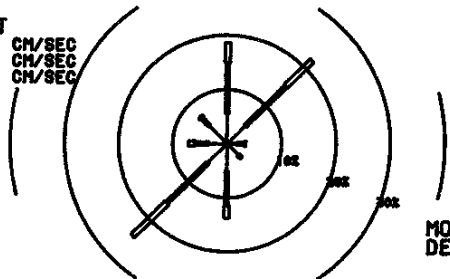

MOORING: 97-05C-001A004
 DEPTH: 4 M

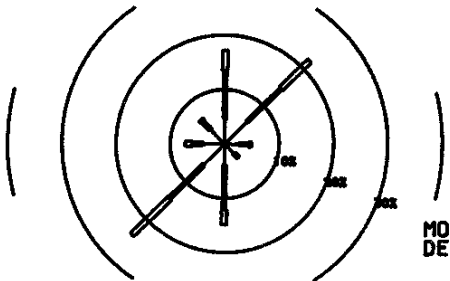

MOORING: 97-05C-001A005
 DEPTH: 5 M

• WIND AND CURRENT DIRECTIONS ARE TOWARD

MOORING IS 97-05C-001A004 DEPTH IS 4 METERS THERE ARE 672 VALUES

FIRST DAY 1998/02/01/0000
 FINAL DAY 1998/02/28/2300

SHORELINE ORIENTATION IN DEGREES TRUE SPECIFIED AS 90

DIRECTION DEG TRUE	PERCENT OBSERVED	TOWARD	TOTAL	LIGHT	MEDIUM	HIGH	MAXIMUM CURRENT CM/S	MEAN DURA- TION HOURS	MEAN EXCUR- SION KM	MEAN CURRENT CM/S	MEAN TEMP DEG C
90.0	3.4	1.8	1.5	0.1	7.9	1.3	0.1	3.0	1.6		
45.0	21.9	4.6	10.4	6.8	19.3	2.6	0.6	6.3	1.6		
0.0	18.6	5.5	9.4	3.7	14.8	2.0	0.4	4.9	1.6		
315.0	7.0	4.6	1.9	0.4	22.1	1.3	0.1	3.2	1.5		
270.0	7.1	3.4	2.5	1.2	14.5	1.3	0.2	4.3	1.6		
225.0	24.4	4.9	10.6	8.9	18.2	2.7	0.7	6.6	1.7		
180.0	13.8	5.1	6.4	2.4	10.8	1.8	0.3	4.5	1.8		
135.0	3.7	2.8	0.9	0.0	4.6	1.1	0.1	2.2	1.9		
MEAN SCALAR SPEED = 5.3 CM/S		MEAN SQUARE SPEED = 41.7 CM2/S2									
MEAN SQUARE E-W SPEED = 14.2 CM2/S2		MEAN SQUARE N-S SPEED = 27.5 CM2/S2									
MEAN SQUARE U SPEED = 14.2 CM2/S2		MEAN SQUARE V SPEED = 27.5 CM2/S2									
MEAN VELOCITY = 0.5 CM/S,		294 DEG TRUE		MEAN TEMPERATURE = 1.6 C							
VARIANCE (U,V) = 20.7 CM2/S2		TOTAL HOURS = 672.									

PERCENT OBSERVED
 LIGHT (0.0 - 3.0) 32.7% MEDIUM (3.0 - 7.0) 43.6% HIGH (GE 7.0) 23.7%

MOORING IS 97-05C-001A005 DEPTH IS 5 METERS THERE ARE 672 VALUES

FIRST DAY 1998/02/01/0000
 FINAL DAY 1998/02/28/2300

SHORELINE ORIENTATION IN DEGREES TRUE SPECIFIED AS 90

DIRECTION DEG TRUE	PERCENT OBSERVED	TOWARD	TOTAL	LIGHT	MEDIUM	HIGH	MAXIMUM CURRENT CM/S	MEAN DURA- TION HOURS	MEAN EXCUR- SION KM	MEAN CURRENT CM/S	MEAN TEMP DEG C
90.0	4.9	2.7	1.8	0.4	11.1	1.3	0.1	3.1	1.6		
45.0	21.9	5.8	8.6	7.4	19.8	2.5	0.5	6.1	1.6		
0.0	17.3	4.6	8.8	3.9	17.0	2.1	0.4	5.2	1.6		
315.0	6.3	3.6	2.2	0.4	18.3	1.4	0.2	3.2	1.5		
270.0	7.3	3.9	2.1	1.3	15.0	1.4	0.2	4.1	1.5		
225.0	24.0	5.5	8.8	9.7	19.1	2.6	0.6	6.7	1.6		
180.0	14.9	3.9	8.2	2.8	10.3	1.7	0.3	4.6	1.9		
135.0	3.6	2.4	1.2	0.0	6.4	1.2	0.1	2.5	1.8		
MEAN SCALAR SPEED = 5.3 CM/S		MEAN SQUARE SPEED = 41.8 CM2/S2									
MEAN SQUARE E-W SPEED = 13.6 CM2/S2		MEAN SQUARE N-S SPEED = 28.1 CM2/S2									
MEAN SQUARE U SPEED = 13.6 CM2/S2		MEAN SQUARE V SPEED = 28.1 CM2/S2									
MEAN VELOCITY = 0.4 CM/S,		289 DEG TRUE		MEAN TEMPERATURE = 1.6 C							
VARIANCE (U,V) = 20.8 CM2/S2		TOTAL HOURS = 672.									

PERCENT OBSERVED
 LIGHT (0.0 - 3.0) 32.3% MEDIUM (3.0 - 7.0) 41.7% HIGH (GE 7.0) 26.0%

DATE: 1998/03/01 TO 1998/03/31
 ROSE SUMMARY: WIND AND CURRENT

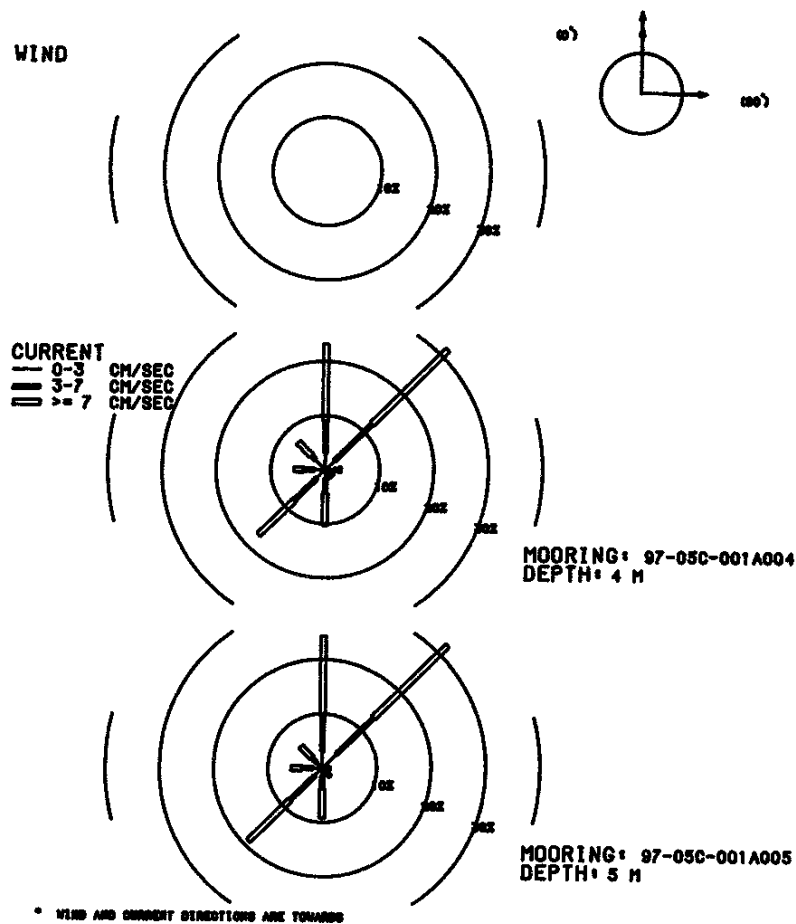

MOORING IS 97-05C-001A004 DEPTH IS 4 METERS THERE ARE 744 VALUES

FIRST DAY 1998/03/01/0000
 FINAL DAY 1998/03/31/2300

SHORELINE ORIENTATION IN DEGREES TRUE SPECIFIED AS 90

DIRECTION DEG TRUE	PERCENT OBSERVED	TOWARD	TOTAL	LIGHT	MEDIUM	HIGH	MAXIMUM CURRENT CM/S	MEAN DURA- TION HOURS	MEAN EXCUR- SION KM	MEAN CURRENT CM/S	MEAN TEMP DEG C
90.0	3.0	1.6	0.9	0.4	8.4	1.6	0.2	3.2	2.7		
45.0	31.6	2.3	9.7	19.6	43.7	3.6	1.3	10.5	2.6		
0.0	23.3	3.1	5.8	14.4	45.2	2.2	0.8	10.5	2.3		
315.0	7.1	2.6	0.9	3.6	35.6	1.7	0.6	9.4	2.1		
270.0	5.8	2.0	2.0	1.7	21.5	1.5	0.3	6.0	2.3		
225.0	17.2	2.2	5.6	9.4	48.9	2.4	1.0	11.6	2.2		
180.0	10.3	1.7	2.6	6.0	23.6	1.6	0.4	7.6	2.0		
135.0	1.7	0.8	0.8	0.1	8.6	1.3	0.2	3.7	2.5		

0 MEAN SCALAR SPEED = 9.7 CM/S MEAN SQUARE SPEED = 160.8 CM2/S2
 MEAN SQUARE E-W SPEED = 48.3 CM2/S2 MEAN SQUARE N-S SPEED = 112.4 CM2/S2
 MEAN SQUARE U SPEED = 48.3 CM2/S2 MEAN SQUARE V SPEED = 112.4 CM2/S2
 MEAN VELOCITY = 3.4 CM/S, 359 DEG TRUE MEAN TEMPERATURE = 2.3 C
 VARIANCE (U,V) = 74.6 CM2/S2 TOTAL HOURS = 744.

PERCENT OBSERVED

LIGHT (0.0 - 3.0) 16.3% MEDIUM (3.0 - 7.0) 28.4% HIGH (GE 7.0) 55.4%

MOORING IS 97-05C-001A005 DEPTH IS 5 METERS THERE ARE 744 VALUES

FIRST DAY 1998/03/01/0000
 FINAL DAY 1998/03/31/2300

SHORELINE ORIENTATION IN DEGREES TRUE SPECIFIED AS 90

DIRECTION DEG TRUE	PERCENT OBSERVED	TOWARD	TOTAL	LIGHT	MEDIUM	HIGH	MAXIMUM CURRENT CM/S	MEAN DURA- TION HOURS	MEAN EXCUR- SION KM	MEAN CURRENT CM/S	MEAN TEMP DEG C
90.0	1.5	0.9	0.5	0.0	6.7	1.2	0.1	3.1	2.5		
45.0	32.3	3.6	9.5	19.1	44.6	3.3	1.2	10.1	2.5		
0.0	24.3	3.1	6.5	14.8	41.4	2.3	0.8	10.0	2.3		
315.0	5.6	1.3	1.3	3.0	33.7	1.8	0.6	9.5	2.1		
270.0	5.8	1.7	2.0	2.0	22.7	1.4	0.3	6.4	2.3		
225.0	19.1	1.9	6.5	10.8	49.2	2.8	1.1	11.2	2.2		
180.0	9.3	1.5	2.3	5.5	21.2	1.6	0.5	7.9	2.0		
135.0	2.2	1.3	0.8	0.0	5.3	1.2	0.1	2.8	2.6		

0 MEAN SCALAR SPEED = 9.6 CM/S MEAN SQUARE SPEED = 155.6 CM2/S2
 MEAN SQUARE E-W SPEED = 46.7 CM2/S2 MEAN SQUARE N-S SPEED = 108.9 CM2/S2
 MEAN SQUARE U SPEED = 46.7 CM2/S2 MEAN SQUARE V SPEED = 108.9 CM2/S2
 MEAN VELOCITY = 3.2 CM/S, 359 DEG TRUE MEAN TEMPERATURE = 2.3 C
 VARIANCE (U,V) = 72.9 CM2/S2 TOTAL HOURS = 744.

PERCENT OBSERVED

LIGHT (0.0 - 3.0) 15.5% MEDIUM (3.0 - 7.0) 29.4% HIGH (GE 7.0) 55.1%

DATE: 1998/04/01 TO 1998/04/30
 ROSE SUMMARY: WIND AND CURRENT

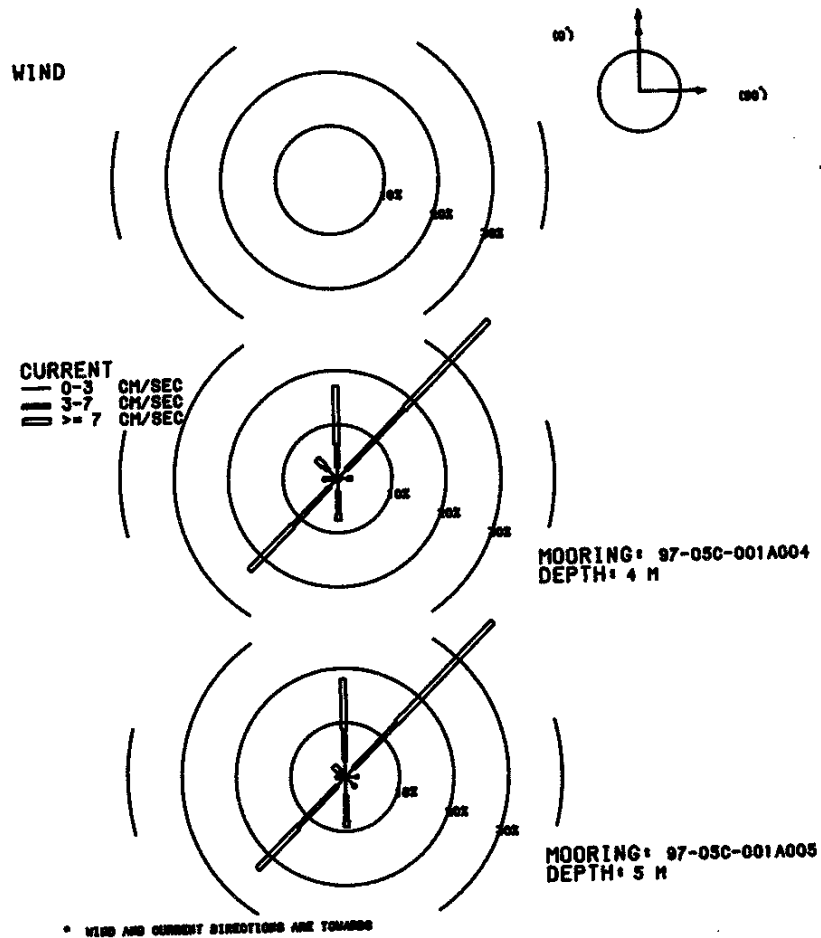

MOORING IS 97-05C-001A004 DEPTH IS 4 METERS THERE ARE 337 VALUES

FIRST DAY 1998/04/01/0000
 FINAL DAY 1998/04/15/0000

SHORELINE ORIENTATION IN DEGREES TRUE SPECIFIED AS 90

DIRECTION DEG TRUE	PERCENT OBSERVED	MAXIMUM CURRENT CM/S	MEAN DURA- TION HOURS	MEAN EXCUR- SION KM	MEAN CURRENT CM/S	MEAN TEMP DEG C
TOWARD	TOTAL	LIGHT	MEDIUM	HIGH		
90.0	2.7	1.8	0.9	0.0	6.7	1.3
45.0	40.4	2.4	15.4	22.6	15.2	3.9
0.0	17.2	2.1	4.2	11.0	15.3	1.8
315.0	5.3	2.4	0.9	2.1	21.0	1.5
270.0	2.7	0.9	1.8	0.0	6.0	1.1
225.0	23.4	2.1	9.8	11.6	19.1	4.4
180.0	7.7	2.4	4.2	1.2	17.7	1.4
135.0	0.6	0.0	0.6	0.0	6.1	2.0

MEAN SCALAR SPEED = 7.4 CM/S MEAN SQUARE SPEED = 71.1 CM2/S2
 MEAN SQUARE E-W SPEED = 19.4 CM2/S2 MEAN SQUARE N-S SPEED = 51.7 CM2/S2
 MEAN SQUARE U SPEED = 19.4 CM2/S2 MEAN SQUARE V SPEED = 51.7 CM2/S2
 MEAN VELOCITY = 2.7 CM/S, 18 DEG TRUE MEAN TEMPERATURE = 5.1 C
 VARIANCE (U,V) = 32.1 CM2/S2 TOTAL HOURS = 337.

PERCENT OBSERVED
 LIGHT (0.0 - 3.0) 13.9% MEDIUM (3.0 - 7.0) 37.7% HIGH (GE 7.0) 48.4%

MOORING IS 97-05C-001A005 DEPTH IS 5 METERS THERE ARE 337 VALUES

FIRST DAY 1998/04/01/0000
 FINAL DAY 1998/04/15/0000

SHORELINE ORIENTATION IN DEGREES TRUE SPECIFIED AS 90

DIRECTION DEG TRUE	PERCENT OBSERVED	MAXIMUM CURRENT CM/S	MEAN DURA- TION HOURS	MEAN EXCUR- SION KM	MEAN CURRENT CM/S	MEAN TEMP DEG C
TOWARD	TOTAL	LIGHT	MEDIUM	HIGH		
90.0	2.4	2.1	0.3	0.0	3.1	1.1
45.0	39.5	2.1	11.6	25.8	17.6	3.9
0.0	18.1	3.0	5.6	9.5	14.3	1.6
315.0	3.0	0.6	0.9	1.5	22.4	1.7
270.0	1.8	0.6	1.2	0.0	4.6	1.0
225.0	23.4	2.1	10.7	10.7	17.0	4.2
180.0	9.2	3.3	4.7	1.2	15.8	1.7
135.0	2.7	2.1	0.6	0.0	3.4	1.5

MEAN SCALAR SPEED = 7.3 CM/S MEAN SQUARE SPEED = 69.5 CM2/S2
 MEAN SQUARE E-W SPEED = 18.2 CM2/S2 MEAN SQUARE N-S SPEED = 51.4 CM2/S2
 MEAN SQUARE U SPEED = 18.2 CM2/S2 MEAN SQUARE V SPEED = 51.4 CM2/S2
 MEAN VELOCITY = 2.6 CM/S, 17 DEG TRUE MEAN TEMPERATURE = 5.1 C
 VARIANCE (U,V) = 31.6 CM2/S2 TOTAL HOURS = 337.

PERCENT OBSERVED
 LIGHT (0.0 - 3.0) 15.7% MEDIUM (3.0 - 7.0) 35.6% HIGH (GE 7.0) 48.7%

DATE: 1997/11/02 TO 1997/11/30
 ROSE SUMMARY: WIND AND CURRENT

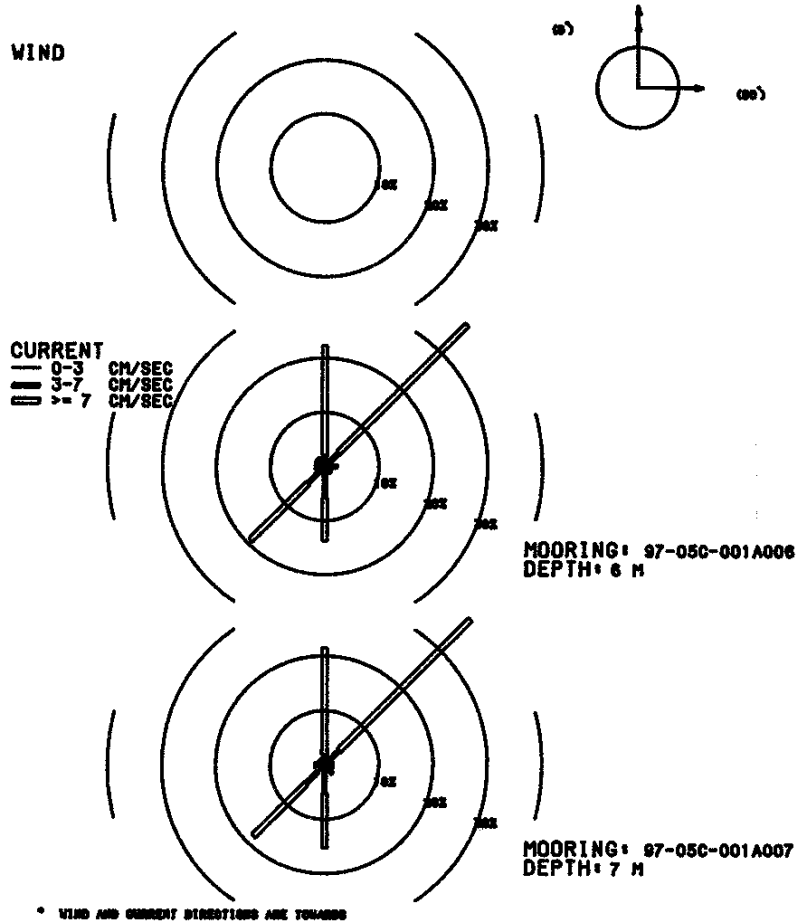

MOORING IS 97-05C-001A006 DEPTH IS 6 METERS THERE ARE 691 VALUES

FIRST DAY 1997/11/02/0500
 FINAL DAY 1997/11/30/2300

SHORELINE ORIENTATION IN DEGREES TRUE SPECIFIED AS 90

DIRECTION DEG TRUE	PERCENT OBSERVED	MAXIMUM CURRENT	MEAN DURA- TION HOURS	MEAN EXCUR- SION KM	MEAN CURRENT CM/S	MEAN TEMP DEG C
TOWARD	TOTAL	LIGHT	MEDIUM	HIGH	CM/S	
90.0	2.3	0.7	1.6	0.0	6.1	1.3
45.0	37.0	0.4	3.0	33.6	30.5	5.4
0.0	22.3	0.7	1.3	20.3	30.0	3.2
315.0	1.9	0.9	0.4	0.6	12.6	1.9
270.0	1.7	0.4	1.2	0.1	8.2	1.3
225.0	19.4	1.4	2.9	15.1	25.4	3.3
180.0	13.7	1.0	4.8	8.0	19.3	2.5
135.0	1.6	0.7	0.9	0.0	5.2	1.2
0		MEAN SCALAR SPEED = 11.6 CM/S		MEAN SQUARE SPEED = 167.8 CM2/S2		
		MEAN SQUARE E-W SPEED = 37.6 CM2/S2		MEAN SQUARE N-S SPEED = 130.2 CM2/S2		
		MEAN SQUARE U SPEED = 37.6 CM2/S2		MEAN SQUARE V SPEED = 130.2 CM2/S2		
		MEAN VELOCITY = 4.2 CM/S,		24 DEG TRUE		MEAN TEMPERATURE = 8.5 C
		VARIANCE (U,V) = 75.0 CM2/S2		TOTAL HOURS = 691.		

PERCENT OBSERVED
 LIGHT (0.0 - 3.0) 6.4% MEDIUM (3.0 - 7.0) 16.1% HIGH (GE 7.0) 77.6%

MOORING IS 97-05C-001A007 DEPTH IS 7 METERS THERE ARE 691 VALUES

FIRST DAY 1997/11/02/0500
 FINAL DAY 1997/11/30/2300

SHORELINE ORIENTATION IN DEGREES TRUE SPECIFIED AS 90

DIRECTION DEG TRUE	PERCENT OBSERVED	MAXIMUM CURRENT	MEAN DURA- TION HOURS	MEAN EXCUR- SION KM	MEAN CURRENT CM/S	MEAN TEMP DEG C
TOWARD	TOTAL	LIGHT	MEDIUM	HIGH	CM/S	
90.0	1.6	0.4	1.0	0.1	7.3	1.6
45.0	37.9	0.6	3.2	34.2	28.9	5.8
0.0	21.6	0.1	1.7	19.7	27.7	3.5
315.0	1.3	0.4	0.4	0.4	11.6	1.5
270.0	1.7	0.4	1.2	0.1	8.5	1.2
225.0	18.5	1.7	3.0	13.7	24.0	3.1
180.0	15.2	1.2	4.1	10.0	23.0	2.6
135.0	2.2	0.7	1.4	0.0	6.3	1.4
0		MEAN SCALAR SPEED = 11.6 CM/S		MEAN SQUARE SPEED = 168.3 CM2/S2		
		MEAN SQUARE E-W SPEED = 38.2 CM2/S2		MEAN SQUARE N-S SPEED = 130.1 CM2/S2		
		MEAN SQUARE U SPEED = 38.2 CM2/S2		MEAN SQUARE V SPEED = 130.1 CM2/S2		
		MEAN VELOCITY = 4.2 CM/S,		26 DEG TRUE		MEAN TEMPERATURE = 8.5 C
		VARIANCE (U,V) = 75.3 CM2/S2		TOTAL HOURS = 691.		

PERCENT OBSERVED
 LIGHT (0.0 - 3.0) 5.6% MEDIUM (3.0 - 7.0) 16.1% HIGH (GE 7.0) 78.3%

DATE: 1997/12/01 TO 1997/12/31
 ROSE SUMMARY: WIND AND CURRENT

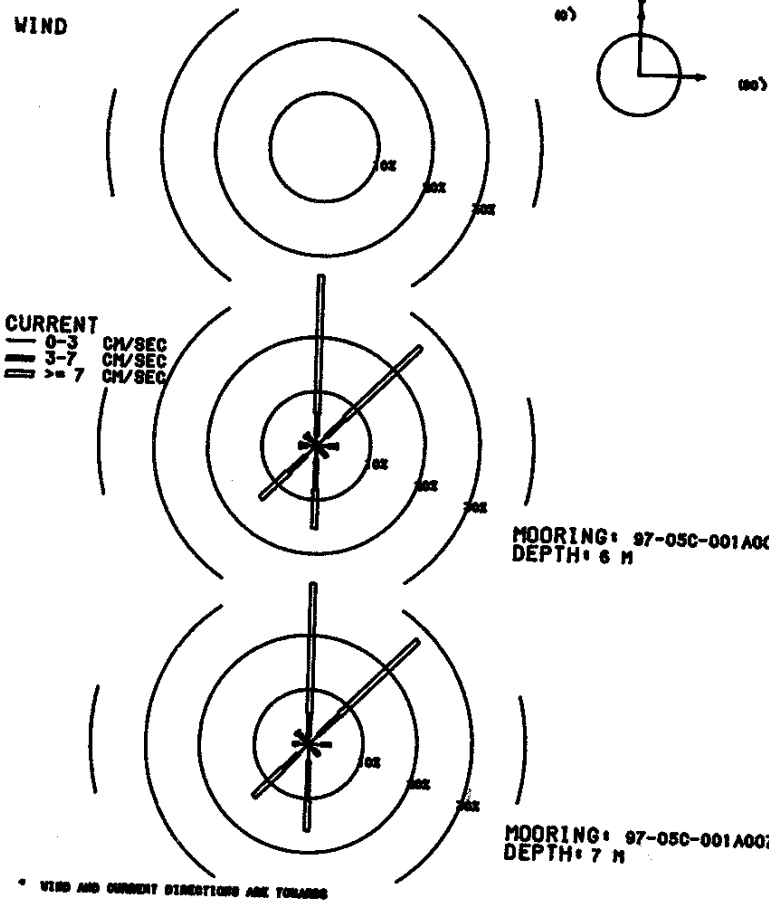

MOORING IS 97-05C-001A006 DEPTH IS 6 METERS THERE ARE 744 VALUES

FIRST DAY 1997/12/01/0000
 FINAL DAY 1997/12/31/2300

SHORELINE ORIENTATION IN DEGREES TRUE SPECIFIED AS 90

DIRECTION DEG TRUE	PERCENT OBSERVED			MAXIMUM CURRENT CM/S	MEAN DURA- TION HOURS	MEAN EXCUR- SION KM	MEAN CURRENT CM/S	MEAN TEMP DEG C
TOWARD	TOTAL	LIGHT	MEDIUM	HIGH	CM/S		CM/S	DEG C
90.0	3.9	2.3	1.5	0.1	7.2	1.7	0.2	4.1
45.0	26.5	2.4	4.8	19.2	25.6	2.9	1.1	4.1
0.0	31.5	1.9	4.0	25.5	33.1	3.2	1.6	4.3
315.0	2.8	1.3	1.1	0.4	14.3	1.2	0.2	4.0
270.0	3.1	1.6	1.1	0.4	12.0	1.3	0.2	4.4
225.0	14.1	2.7	4.3	7.1	25.7	2.1	0.6	4.6
180.0	15.3	2.3	5.8	7.3	15.5	2.6	0.6	4.4
135.0	2.8	1.2	1.6	0.0	6.0	1.2	0.1	4.1

0 MEAN SCALAR SPEED = 9.9 CM/S MEAN SQUARE SPEED = 141.8 CM²/S²
 MEAN SQUARE E-W SPEED = 20.5 CM²/S² MEAN SQUARE N-S SPEED = 121.3 CM²/S²
 MEAN SQUARE U SPEED = 20.5 CM²/S² MEAN SQUARE V SPEED = 121.3 CM²/S²
 MEAN VELOCITY = 5.1 CM/S, 14 DEG TRUE MEAN TEMPERATURE = 4.3 C
 VARIANCE (U,V) = 58.2 CM²/S² TOTAL HOURS = 744.

PERCENT OBSERVED
 LIGHT (0.0 - 3.0) 15.7% MEDIUM (3.0 - 7.0) 24.2% HIGH (GE 7.0) 60.1%

MOORING IS 97-05C-001A007 DEPTH IS 7 METERS THERE ARE 744 VALUES

FIRST DAY 1997/12/01/0000
 FINAL DAY 1997/12/31/2300

SHORELINE ORIENTATION IN DEGREES TRUE SPECIFIED AS 90

DIRECTION DEG TRUE	PERCENT OBSERVED			MAXIMUM CURRENT CM/S	MEAN DURA- TION HOURS	MEAN EXCUR- SION KM	MEAN CURRENT CM/S	MEAN TEMP DEG C
TOWARD	TOTAL	LIGHT	MEDIUM	HIGH	CM/S		CM/S	DEG C
90.0	4.0	2.3	1.7	0.0	5.4	1.4	0.1	3.9
45.0	27.7	2.4	5.2	20.0	27.7	3.3	1.3	4.2
0.0	29.6	1.5	4.2	23.9	32.6	3.5	1.8	4.2
315.0	3.1	1.1	1.7	0.3	12.2	1.6	0.3	4.4
270.0	2.8	2.0	0.8	0.0	6.5	1.4	0.1	3.9
225.0	14.0	2.6	3.9	7.5	26.5	2.1	0.6	4.9
180.0	16.0	3.0	7.3	5.8	14.0	2.2	0.5	4.3
135.0	2.8	1.3	1.5	0.0	4.6	1.2	0.1	4.1

0 MEAN SCALAR SPEED = 9.7 CM/S MEAN SQUARE SPEED = 136.8 CM²/S²
 MEAN SQUARE E-W SPEED = 20.5 CM²/S² MEAN SQUARE N-S SPEED = 116.3 CM²/S²
 MEAN SQUARE U SPEED = 20.5 CM²/S² MEAN SQUARE V SPEED = 116.3 CM²/S²
 MEAN VELOCITY = 4.9 CM/S, 16 DEG TRUE MEAN TEMPERATURE = 4.3 C
 VARIANCE (U,V) = 56.4 CM²/S² TOTAL HOURS = 744.

PERCENT OBSERVED
 LIGHT (0.0 - 3.0) 16.1% MEDIUM (3.0 - 7.0) 26.3% HIGH (GE 7.0) 57.5%

DATE: 1998/01/01 TO 1998/01/31
ROSE SUMMARY: WIND AND CURRENT

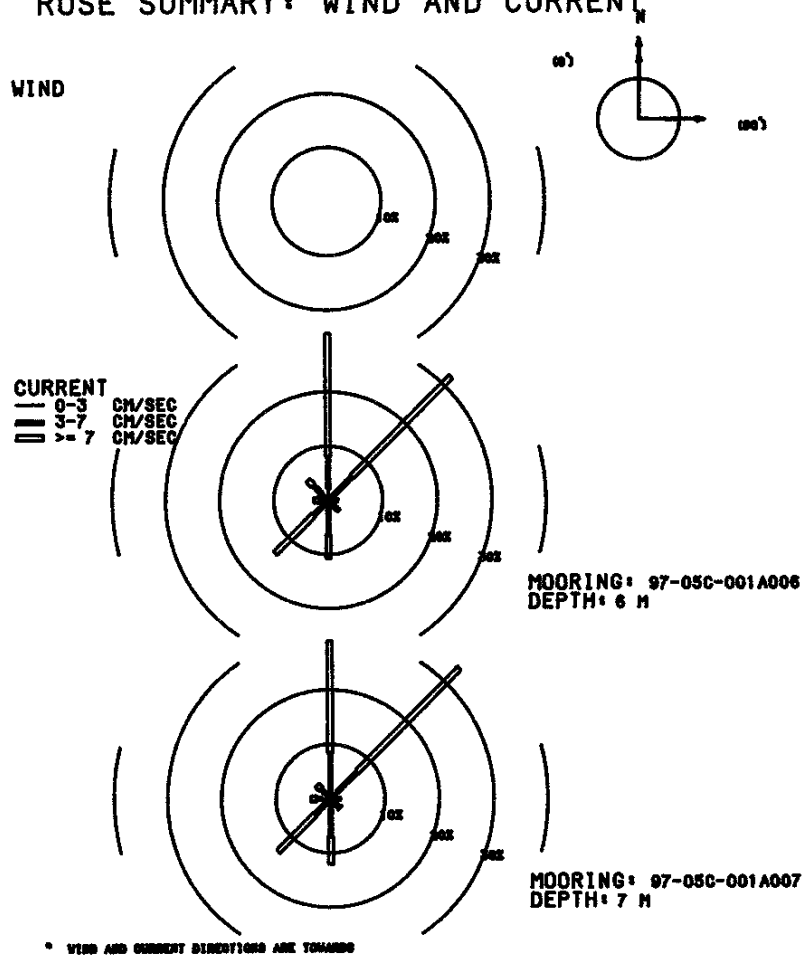

MOORING IS 97-05C-001A006 DEPTH IS 6 METERS THERE ARE 744 VALUES

FIRST DAY 1998/01/01/0000
FINAL DAY 1998/01/31/2300

SHORELINE ORIENTATION IN DEGREES TRUE SPECIFIED AS 90

DIRECTION DEG TRUE	PERCENT OBSERVED	MAXIMUM CURRENT	MEAN DURA- TION HOURS	MEAN EXCUR- SION KM	MEAN CURRENT CM/S	MEAN TEMP DEG C
TOWARD	TOTAL	LIGHT	MEDIUM	HIGH	CM/S	
90.0	1.7	1.5	0.3	0.0	6.5	1.2
45.0	32.1	1.1	5.0	26.1	25.1	3.1
0.0	30.8	2.2	5.9	22.7	30.2	2.8
315.0	5.2	1.6	2.2	1.5	14.2	2.0
270.0	2.7	0.3	1.3	1.1	11.1	1.3
225.0	13.8	0.5	3.2	10.1	18.4	3.1
180.0	10.8	1.3	5.1	4.3	18.9	2.1
135.0	2.8	0.7	2.2	0.0	6.1	1.6

0 MEAN SCALAR SPEED = 10.1 CM/S MEAN SQUARE SPEED = 137.8 CM2/S2
 MEAN SQUARE E-W SPEED = 25.3 CM2/S2 MEAN SQUARE N-S SPEED = 112.5 CM2/S2
 MEAN SQUARE U SPEED = 25.3 CM2/S2 MEAN SQUARE V SPEED = 112.5 CM2/S2
 MEAN VELOCITY = 5.3 CM/S, 16 DEG TRUE MEAN TEMPERATURE = 1.7 C
 VARIANCE (U,V) = 54.7 CM2/S2 TOTAL HOURS = 744.

PERCENT OBSERVED
 LIGHT (0.0 - 3.0) 9.1% MEDIUM (3.0 - 7.0) 25.1% HIGH (GE 7.0) 65.7%

MOORING IS 97-05C-001A007 DEPTH IS 7 METERS THERE ARE 744 VALUES

FIRST DAY 1998/01/01/0000
FINAL DAY 1998/01/31/2300

SHORELINE ORIENTATION IN DEGREES TRUE SPECIFIED AS 90

DIRECTION DEG TRUE	PERCENT OBSERVED	MAXIMUM CURRENT	MEAN DURA- TION HOURS	MEAN EXCUR- SION KM	MEAN CURRENT CM/S	MEAN TEMP DEG C
TOWARD	TOTAL	LIGHT	MEDIUM	HIGH	CM/S	
90.0	1.9	1.2	0.7	0.0	5.8	1.8
45.0	33.7	1.6	5.2	26.9	26.2	3.4
0.0	29.0	1.1	7.3	20.7	30.7	2.8
315.0	3.5	1.2	1.2	1.1	11.8	1.6
270.0	3.6	1.6	0.9	1.1	10.4	1.4
225.0	13.7	0.9	3.1	9.7	17.3	2.5
180.0	12.1	1.1	5.9	5.1	19.5	2.0
135.0	2.4	0.8	1.5	0.1	7.7	1.3

0 MEAN SCALAR SPEED = 10.0 CM/S MEAN SQUARE SPEED = 135.5 CM2/S2
 MEAN SQUARE E-W SPEED = 24.5 CM2/S2 MEAN SQUARE N-S SPEED = 111.0 CM2/S2
 MEAN SQUARE U SPEED = 24.5 CM2/S2 MEAN SQUARE V SPEED = 111.0 CM2/S2
 MEAN VELOCITY = 5.2 CM/S, 18 DEG TRUE MEAN TEMPERATURE = 1.7 C
 VARIANCE (U,V) = 54.3 CM2/S2 TOTAL HOURS = 744.

PERCENT OBSERVED
 LIGHT (0.0 - 3.0) 9.5% MEDIUM (3.0 - 7.0) 25.8% HIGH (GE 7.0) 64.7%

DATE: 1998/02/01 TO 1998/02/28
 ROSE SUMMARY: WIND AND CURRENT

WIND

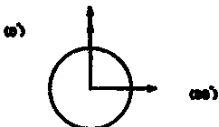
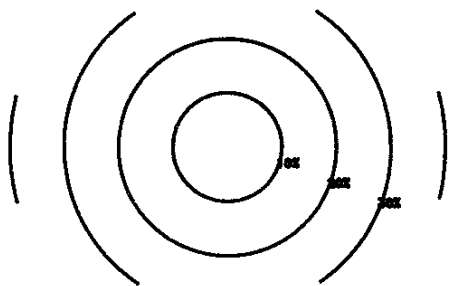

CURRENT
 0-3 CM/SEC
 3-7 CM/SEC
 >= 7 CM/SEC

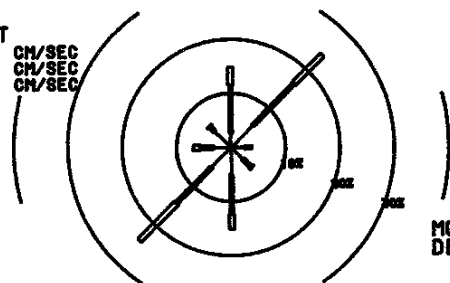

MOORING: 97-05C-001A006
 DEPTH: 6 M

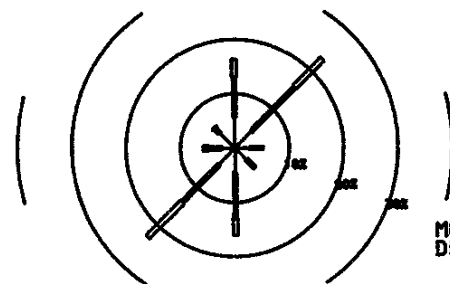

MOORING: 97-05C-001A007
 DEPTH: 7 M

• WIND AND CURRENT DIRECTIONS ARE TOWARDS

MOORING IS 97-05C-001A006 DEPTH IS 6 METERS THERE ARE 672 VALUES

FIRST DAY 1998/02/01/0000
 FINAL DAY 1998/02/28/2300

SHORELINE ORIENTATION IN DEGREES TRUE SPECIFIED AS 90

DIRECTION DEG TRUE	PERCENT OBSERVED			MAXIMUM CURRENT CM/S	MEAN DURA- TION HOURS	MEAN EXCUR- SION KM	MEAN CURRENT CM/S	MEAN TEMP DEG C
TOWARD	TOTAL	LIGHT	MEDIUM	HIGH				
90.0	3.9	2.5	1.3	0.0	6.3	1.4	0.1	2.7
45.0	24.0	5.7	10.9	7.4	18.6	2.8	0.6	6.0
0.0	14.9	2.7	8.8	3.4	18.0	2.0	0.4	5.5
315.0	5.7	4.2	1.2	0.3	21.1	1.2	0.1	2.9
270.0	7.0	3.1	2.5	1.3	14.7	1.3	0.2	4.5
225.0	24.1	5.1	9.2	9.8	19.0	2.8	0.7	6.8
180.0	15.2	5.1	7.3	2.8	11.2	1.7	0.3	4.5
135.0	5.4	3.0	2.1	0.3	7.6	1.2	0.1	3.0

MEAN SCALAR SPEED = 5.3 CM/S MEAN SQUARE SPEED = 42.1 CM²/S²
 MEAN SQUARE E-W SPEED = 14.2 CM²/S² MEAN SQUARE N-S SPEED = 27.9 CM²/S²
 MEAN SQUARE U SPEED = 14.2 CM²/S² MEAN SQUARE V SPEED = 27.9 CM²/S²
 MEAN VELOCITY = 0.4 CM/S, 264 DEG TRUE MEAN TEMPERATURE = 1.6 C
 VARIANCE (U,V) = 21.0 CM²/S² TOTAL HOURS = 672.

PERCENT OBSERVED
 LIGHT (0.0 - 3.0) 31.3% MEDIUM (3.0 - 7.0) 43.3% HIGH (GE 7.0) 25.4%

MOORING IS 97-05C-001A007 DEPTH IS 7 METERS THERE ARE 672 VALUES

FIRST DAY 1998/02/01/0000
 FINAL DAY 1998/02/28/2300

SHORELINE ORIENTATION IN DEGREES TRUE SPECIFIED AS 90

DIRECTION DEG TRUE	PERCENT OBSERVED			MAXIMUM CURRENT CM/S	MEAN DURA- TION HOURS	MEAN EXCUR- SION KM	MEAN CURRENT CM/S	MEAN TEMP DEG C
TOWARD	TOTAL	LIGHT	MEDIUM	HIGH				
90.0	5.2	2.7	2.5	0.0	6.2	1.4	0.1	2.8
45.0	23.1	4.3	11.3	7.4	17.4	2.9	0.6	6.1
0.0	16.4	5.7	7.4	3.3	16.2	2.1	0.4	4.9
315.0	5.4	3.9	1.2	0.3	17.7	1.3	0.1	3.0
270.0	5.8	2.4	2.5	0.9	13.2	1.2	0.2	4.4
225.0	22.9	4.2	9.5	9.2	17.0	2.5	0.6	6.9
180.0	16.1	4.5	8.5	3.1	9.6	1.9	0.3	4.7
135.0	5.2	3.0	2.2	0.0	6.4	1.2	0.1	2.9

MEAN SCALAR SPEED = 5.3 CM/S MEAN SQUARE SPEED = 40.9 CM²/S²
 MEAN SQUARE E-W SPEED = 12.8 CM²/S² MEAN SQUARE N-S SPEED = 28.1 CM²/S²
 MEAN SQUARE U SPEED = 12.8 CM²/S² MEAN SQUARE V SPEED = 28.1 CM²/S²
 MEAN VELOCITY = 0.3 CM/S, 242 DEG TRUE MEAN TEMPERATURE = 1.6 C
 VARIANCE (U,V) = 20.4 CM²/S² TOTAL HOURS = 672.

PERCENT OBSERVED
 LIGHT (0.0 - 3.0) 30.5% MEDIUM (3.0 - 7.0) 45.2% HIGH (GE 7.0) 24.3%

DATE: 1998/03/01 TO 1998/03/31
 ROSE SUMMARY: WIND AND CURRENT

WIND

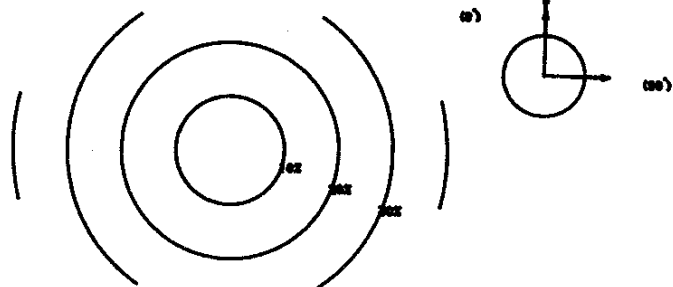

CURRENT

0-3 CH/SEC
 3-7 CH/SEC
 > 7 CH/SEC

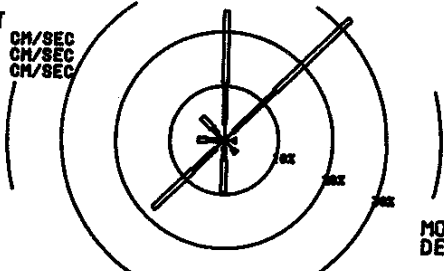

MOORING: 97-05C-001A006
 DEPTH: 6 M

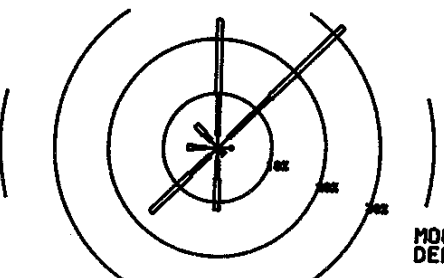

MOORING: 97-05C-001A007
 DEPTH: 7 M

• WIND AND CURRENT DIRECTIONS ARE TOWARDS

MOORING IS 97-05C-001A006 DEPTH IS 6 METERS THERE ARE 744 VALUES

FIRST DAY 1998/03/01/0000
 FINAL DAY 1998/03/31/2300

SHORELINE ORIENTATION IN DEGREES TRUE SPECIFIED AS 90

DIRECTION DEG TRUE	PERCENT OBSERVED	MAXIMUM CURRENT	MEAN DURA- TION HOURS	MEAN EXCUR- SION KM	MEAN CURRENT CM/S	MEAN TEMP DEG C
TOWARD	TOTAL	LIGHT	MEDIUM	HIGH	CM/S	
90.0	2.2	1.6	0.4	0.1	7.9	1.1
45.0	32.3	2.3	10.9	19.1	40.1	2.8
0.0	23.9	3.0	7.5	13.4	41.1	2.0
315.0	5.9	1.6	1.3	3.0	32.1	1.7
270.0	4.8	1.2	2.0	1.6	21.2	1.3
225.0	18.1	2.2	5.8	10.2	46.9	2.4
180.0	9.7	1.2	2.4	6.0	22.0	1.8
135.0	3.1	2.3	0.7	0.1	8.8	1.3

MEAN SCALAR SPEED = 9.5 CM/S MEAN SQUARE SPEED = 152.9 CM2/S2
 MEAN SQUARE E-W SPEED = 45.4 CM2/S2 MEAN SQUARE N-S SPEED = 107.6 CM2/S2
 MEAN SQUARE U SPEED = 45.4 CM2/S2 MEAN SQUARE V SPEED = 107.6 CM2/S2
 MEAN VELOCITY = 3.0 CM/S, 1 DEG TRUE MEAN TEMPERATURE = 2.3 C
 VARIANCE (U,V) = 72.0 CM2/S2 TOTAL HOURS = 744.

PERCENT OBSERVED
 LIGHT (0.0 - 3.0) 15.3% MEDIUM (3.0 - 7.0) 31.0% HIGH (GE 7.0) 53.6%

MOORING IS 97-05C-001A007 DEPTH IS 7 METERS THERE ARE 744 VALUES

FIRST DAY 1998/03/01/0000
 FINAL DAY 1998/03/31/2300

SHORELINE ORIENTATION IN DEGREES TRUE SPECIFIED AS 90

DIRECTION DEG TRUE	PERCENT OBSERVED	MAXIMUM CURRENT	MEAN DURA- TION HOURS	MEAN EXCUR- SION KM	MEAN CURRENT CM/S	MEAN TEMP DEG C
TOWARD	TOTAL	LIGHT	MEDIUM	HIGH	CM/S	
90.0	2.8	2.3	0.5	0.0	4.0	1.2
45.0	32.1	2.7	10.6	18.8	40.3	2.8
0.0	23.7	2.3	7.5	13.8	39.7	2.0
315.0	5.8	1.7	1.6	2.4	30.2	1.4
270.0	5.5	2.3	2.2	1.1	17.9	1.6
225.0	17.1	2.0	5.0	10.1	48.7	2.5
180.0	11.4	2.3	3.4	5.8	21.9	1.7
135.0	1.6	0.5	0.9	0.1	7.9	1.2

MEAN SCALAR SPEED = 9.3 CM/S MEAN SQUARE SPEED = 149.1 CM2/S2
 MEAN SQUARE E-W SPEED = 43.1 CM2/S2 MEAN SQUARE N-S SPEED = 106.0 CM2/S2
 MEAN SQUARE U SPEED = 43.1 CM2/S2 MEAN SQUARE V SPEED = 106.0 CM2/S2
 MEAN VELOCITY = 2.9 CM/S, 3 DEG TRUE MEAN TEMPERATURE = 2.3 C
 VARIANCE (U,V) = 70.5 CM2/S2 TOTAL HOURS = 744.

PERCENT OBSERVED
 LIGHT (0.0 - 3.0) 16.1% MEDIUM (3.0 - 7.0) 31.7% HIGH (GE 7.0) 52.2%

DATE: 1998/04/01 TO 1998/04/30
 ROSE SUMMARY: WIND AND CURRENT

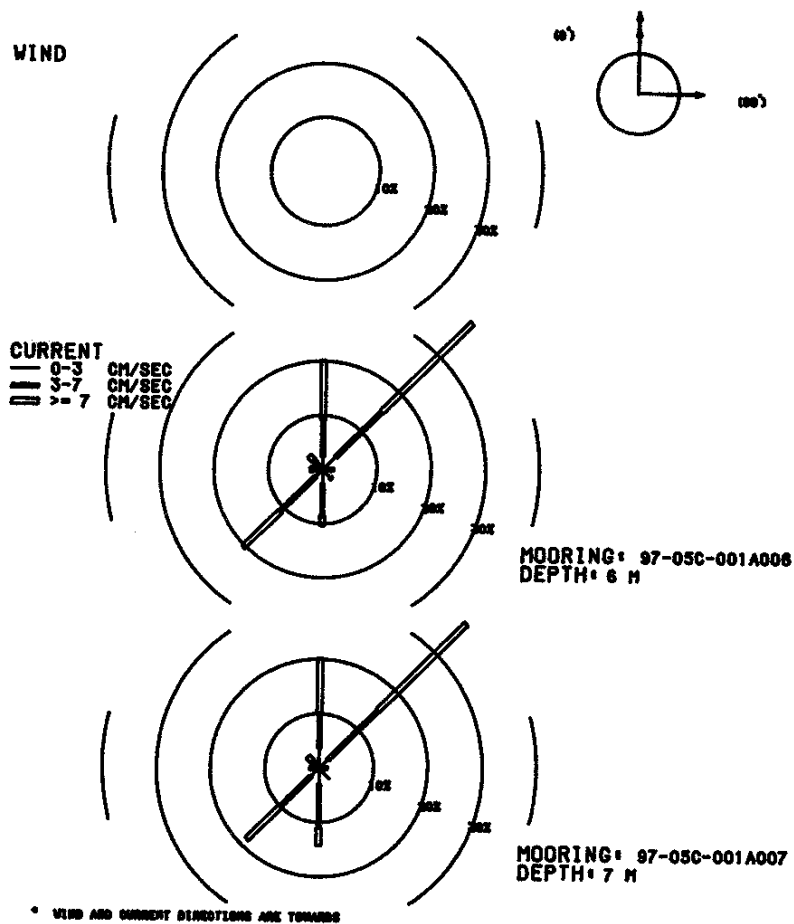

MOORING IS 97-05C-001A006 DEPTH IS 6 METERS THERE ARE 337 VALUES

FIRST DAY 1998/04/01/0000
 FINAL DAY 1998/04/15/0000

SHORELINE ORIENTATION IN DEGREES TRUE SPECIFIED AS 90

DIRECTION DEG TRUE	PERCENT OBSERVED			MAXIMUM CURRENT CM/S	MEAN DURA- TION HOURS	MEAN EXCUR- SION KM	MEAN CURRENT CM/S	MEAN TEMP DEG C
TOWARD	TOTAL	LIGHT	MEDIUM	HIGH	CM/S	HOURS	CM/S	DEG C
90.0	2.1	1.2	0.9	0.0	4.0	1.0	0.1	2.3
45.0	38.6	3.3	11.9	23.4	15.6	4.1	1.2	8.4
0.0	20.2	2.4	6.8	11.0	16.2	1.9	0.5	7.6
315.0	3.6	1.2	1.2	1.2	18.9	1.2	0.3	5.9
270.0	2.4	0.9	0.9	0.6	7.2	2.0	0.3	4.2
225.0	20.5	1.8	9.2	9.5	17.6	3.6	1.1	8.1
180.0	10.4	2.7	5.9	1.8	10.5	1.5	0.2	4.7
135.0	2.4	2.1	0.3	0.0	3.1	1.1	0.1	2.5

MEAN SCALAR SPEED = 7.3 CM/S MEAN SQUARE SPEED = 69.1 CM²/S²
 MEAN SQUARE E-W SPEED = 17.0 CM²/S² MEAN SQUARE N-S SPEED = 52.1 CM²/S²
 MEAN SQUARE U SPEED = 17.0 CM²/S² MEAN SQUARE V SPEED = 52.1 CM²/S²
 MEAN VELOCITY = 2.6 CM/S, 19 DEG TRUE MEAN TEMPERATURE = 5.1 C
 VARIANCE (U,V) = 31.3 CM²/S² TOTAL HOURS = 337.

PERCENT OBSERVED
 LIGHT (0.0 - 3.0) 15.4% MEDIUM (3.0 - 7.0) 37.1% HIGH (GE 7.0) 47.5%

MOORING IS 97-05C-001A007 DEPTH IS 7 METERS THERE ARE 337 VALUES

FIRST DAY 1998/04/01/0000
 FINAL DAY 1998/04/15/0000

SHORELINE ORIENTATION IN DEGREES TRUE SPECIFIED AS 90

DIRECTION DEG TRUE	PERCENT OBSERVED			MAXIMUM CURRENT CM/S	MEAN DURA- TION HOURS	MEAN EXCUR- SION KM	MEAN CURRENT CM/S	MEAN TEMP DEG C
TOWARD	TOTAL	LIGHT	MEDIUM	HIGH	CM/S	HOURS	CM/S	DEG C
90.0	1.5	0.6	0.9	0.0	5.0	1.0	0.1	3.0
45.0	38.0	2.1	13.1	22.8	14.9	3.8	1.1	8.4
0.0	20.2	3.6	6.5	10.1	13.9	1.7	0.4	7.0
315.0	3.0	0.9	0.9	1.2	14.4	2.0	0.4	6.2
270.0	1.8	1.2	0.6	0.0	6.5	1.0	0.1	2.7
225.0	18.7	2.1	8.0	8.6	16.9	2.6	0.7	7.4
180.0	14.2	3.0	8.0	3.3	19.6	2.2	0.5	5.9
135.0	2.7	2.7	0.0	0.0	2.5	1.5	0.1	1.5

MEAN SCALAR SPEED = 7.2 CM/S MEAN SQUARE SPEED = 66.8 CM²/S²
 MEAN SQUARE E-W SPEED = 15.4 CM²/S² MEAN SQUARE N-S SPEED = 51.4 CM²/S²
 MEAN SQUARE U SPEED = 15.4 CM²/S² MEAN SQUARE V SPEED = 51.4 CM²/S²
 MEAN VELOCITY = 2.4 CM/S, 21 DEG TRUE MEAN TEMPERATURE = 5.1 C
 VARIANCE (U,V) = 30.6 CM²/S² TOTAL HOURS = 337.

PERCENT OBSERVED
 LIGHT (0.0 - 3.0) 16.0% MEDIUM (3.0 - 7.0) 38.0% HIGH (GE 7.0) 46.0%

DATE: 1997/11/02 TO 1997/11/30
 ROSE SUMMARY: WIND AND CURRENT

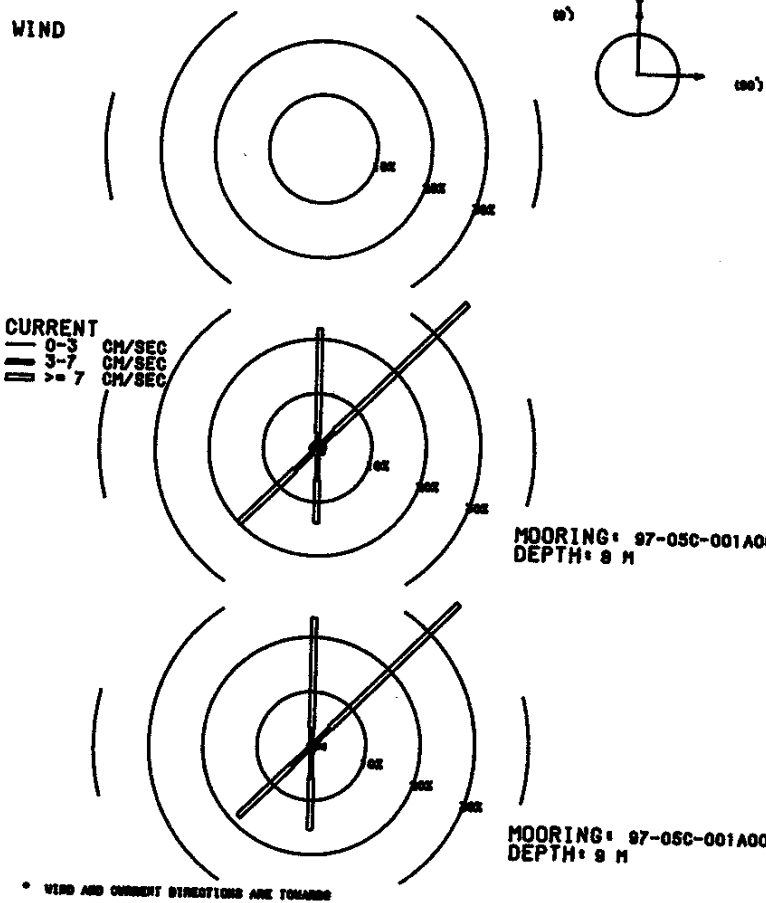

MOORING IS 97-05C-001A008 DEPTH IS 8 METERS THERE ARE 691 VALUES

FIRST DAY 1997/11/02/0500
 FINAL DAY 1997/11/30/2300

SHORELINE ORIENTATION IN DEGREES TRUE SPECIFIED AS 90

DIRECTION DEG TRUE	PERCENT OBSERVED	MAXIMUM CURRENT	MEAN DURA- TION HOURS	MEAN EXCUR- SION KM	MEAN CURRENT CM/S	MEAN TEMP DEG C
TOWARD	TOTAL	LIGHT	MEDIUM	HIGH	CM/S	
90.0	1.4	0.6	0.9	0.0	6.6	1.0
45.0	38.4	0.7	3.5	34.2	28.2	4.9
0.0	22.0	0.4	2.2	19.4	28.8	3.0
315.0	1.2	0.1	0.9	0.1	10.1	2.0
270.0	1.4	0.6	0.9	0.0	6.1	1.4
225.0	20.1	1.4	4.3	14.3	24.3	3.1
180.0	13.9	1.3	4.6	8.0	19.5	2.4
135.0	1.6	0.7	0.9	0.0	6.7	1.1

MEAN SCALAR SPEED = 11.4 CM/S MEAN SQUARE SPEED = 163.6 CM2/S2
 MEAN SQUARE E-W SPEED = 35.9 CM2/S2 MEAN SQUARE N-S SPEED = 127.7 CM2/S2
 MEAN SQUARE U SPEED = 35.9 CM2/S2 MEAN SQUARE V SPEED = 127.7 CM2/S2
 MEAN VELOCITY = 4.2 CM/S, 25 DEG TRUE MEAN TEMPERATURE = 8.5 C
 VARIANCE (U,V) = 73.0 CM2/S2 TOTAL HOURS = 691.

PERCENT OBSERVED
 LIGHT (0.0 - 3.0) 5.9% MEDIUM (3.0 - 7.0) 18.1% HIGH (GE 7.0) 76.0%

MOORING IS 97-05C-001A009 DEPTH IS 9 METERS THERE ARE 691 VALUES

FIRST DAY 1997/11/02/0500
 FINAL DAY 1997/11/30/2300

SHORELINE ORIENTATION IN DEGREES TRUE SPECIFIED AS 90

DIRECTION DEG TRUE	PERCENT OBSERVED	MAXIMUM CURRENT	MEAN DURA- TION HOURS	MEAN EXCUR- SION KM	MEAN CURRENT CM/S	MEAN TEMP DEG C
TOWARD	TOTAL	LIGHT	MEDIUM	HIGH	CM/S	
90.0	2.5	1.0	1.3	0.1	7.0	1.5
45.0	37.6	0.9	3.8	33.0	30.1	4.9
0.0	23.6	0.4	2.7	20.4	28.5	3.2
315.0	0.6	0.0	0.0	0.6	8.1	1.3
270.0	0.7	0.4	0.3	0.0	4.8	1.2
225.0	18.7	0.7	4.2	13.7	23.8	3.7
180.0	15.3	1.2	4.8	9.4	21.9	2.9
135.0	1.0	0.6	0.4	0.0	4.5	1.0

MEAN SCALAR SPEED = 11.4 CM/S MEAN SQUARE SPEED = 162.2 CM2/S2
 MEAN SQUARE E-W SPEED = 33.7 CM2/S2 MEAN SQUARE N-S SPEED = 128.5 CM2/S2
 MEAN SQUARE U SPEED = 33.7 CM2/S2 MEAN SQUARE V SPEED = 128.5 CM2/S2
 MEAN VELOCITY = 4.2 CM/S, 26 DEG TRUE MEAN TEMPERATURE = 8.5 C
 VARIANCE (U,V) = 72.5 CM2/S2 TOTAL HOURS = 691.

PERCENT OBSERVED
 LIGHT (0.0 - 3.0) 5.2% MEDIUM (3.0 - 7.0) 17.5% HIGH (GE 7.0) 77.3%

DATE: 1997/12/01 TO 1997/12/31
 ROSE SUMMARY: WIND AND CURRENT

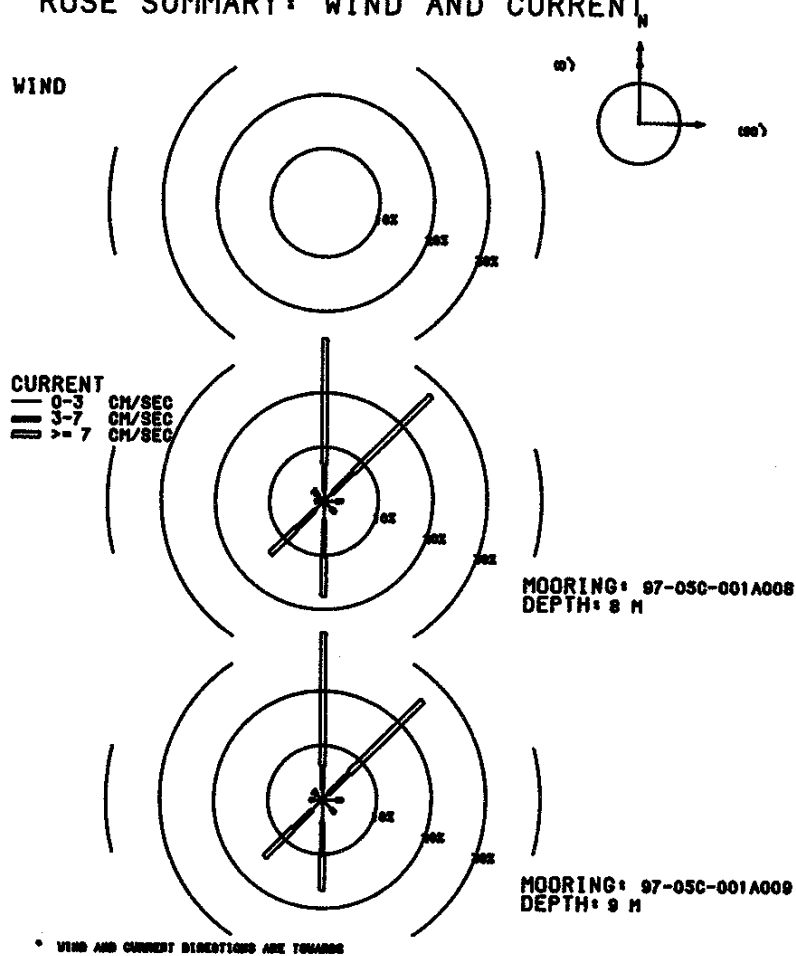

MOORING IS 97-05C-001A008 DEPTH IS 8 METERS THERE ARE 744 VALUES

FIRST DAY 1997/12/01/0000
 FINAL DAY 1997/12/31/2300

SHORELINE ORIENTATION IN DEGREES TRUE SPECIFIED AS 90

DIRECTION DEG TRUE	PERCENT OBSERVED				MAXIMUM CURRENT CM/S	MEAN DURA- TION HOURS	MEAN EXCUR- SION KM	MEAN CURRENT CM/S	MEAN TEMP DEG C
TOWARD	TOTAL	LIGHT	MEDIUM	HIGH	CM/S	HOURS	KM	CM/S	DEG C
90.0	3.5	2.3	1.2	0.0	5.3	1.4	0.1	2.4	4.0
45.0	27.7	2.2	5.4	20.2	29.2	2.8	1.1	11.3	4.1
0.0	30.0	2.0	4.7	23.3	31.1	3.1	1.4	13.0	4.3
315.0	2.8	1.5	1.1	0.3	13.4	1.6	0.2	4.1	4.4
270.0	1.6	0.9	0.7	0.0	4.6	1.1	0.1	2.5	3.7
225.0	13.8	2.3	5.0	6.6	25.2	2.2	0.7	8.1	4.8
180.0	17.6	3.5	6.7	7.4	15.5	2.5	0.6	6.2	4.4
135.0	3.0	1.9	1.1	0.0	4.8	1.2	0.1	2.7	4.2
0	MEAN SCALAR SPEED = 9.6 CM/S		MEAN SQUARE SPEED = 132.4 CM2/S2						
	MEAN SQUARE E-W SPEED = 20.1 CM2/S2		MEAN SQUARE N-S SPEED = 112.3 CM2/S2						
	MEAN SQUARE U SPEED = 20.1 CM2/S2		MEAN SQUARE V SPEED = 112.3 CM2/S2						
	MEAN VELOCITY = 4.8 CM/S,		18 DEG TRUE		MEAN TEMPERATURE = 4.3 C				
	VARIANCE (U,V) = 54.9 CM2/S2		TOTAL HOURS = 744.						

PERCENT OBSERVED
 LIGHT (0.0 - 3.0) 16.5% MEDIUM (3.0 - 7.0) 25.8% HIGH (GE 7.0) 57.7%

MOORING IS 97-05C-001A009 DEPTH IS 9 METERS THERE ARE 744 VALUES

FIRST DAY 1997/12/01/0000
 FINAL DAY 1997/12/31/2300

SHORELINE ORIENTATION IN DEGREES TRUE SPECIFIED AS 90

DIRECTION DEG TRUE	PERCENT OBSERVED				MAXIMUM CURRENT CM/S	MEAN DURA- TION HOURS	MEAN EXCUR- SION KM	MEAN CURRENT CM/S	MEAN TEMP DEG C
TOWARD	TOTAL	LIGHT	MEDIUM	HIGH	CM/S	HOURS	KM	CM/S	DEG C
90.0	3.8	2.6	1.2	0.0	4.4	1.3	0.1	2.3	4.4
45.0	25.9	1.6	5.4	19.0	29.0	3.0	1.2	11.0	4.1
0.0	30.8	2.0	4.2	24.6	29.3	3.5	1.7	13.3	4.3
315.0	2.3	1.3	0.8	0.1	7.3	1.3	0.1	2.9	4.1
270.0	2.3	1.6	0.7	0.0	6.5	1.1	0.1	2.2	4.2
225.0	14.9	2.7	4.8	7.4	25.7	2.5	0.8	8.6	4.9
180.0	16.7	4.0	6.2	6.5	15.3	2.4	0.5	5.8	4.2
135.0	3.4	2.4	0.9	0.0	4.1	1.1	0.1	2.5	3.9
0	MEAN SCALAR SPEED = 9.5 CM/S		MEAN SQUARE SPEED = 131.0 CM2/S2						
	MEAN SQUARE E-W SPEED = 20.0 CM2/S2		MEAN SQUARE N-S SPEED = 110.9 CM2/S2						
	MEAN SQUARE U SPEED = 20.0 CM2/S2		MEAN SQUARE V SPEED = 110.9 CM2/S2						
	MEAN VELOCITY = 4.6 CM/S,		18 DEG TRUE		MEAN TEMPERATURE = 4.3 C				
	VARIANCE (U,V) = 54.8 CM2/S2		TOTAL HOURS = 744.						

PERCENT OBSERVED
 LIGHT (0.0 - 3.0) 18.3% MEDIUM (3.0 - 7.0) 24.2% HIGH (GE 7.0) 57.5%

DATE: 1998/01/01 TO 1998/01/31
ROSE SUMMARY: WIND AND CURRENT

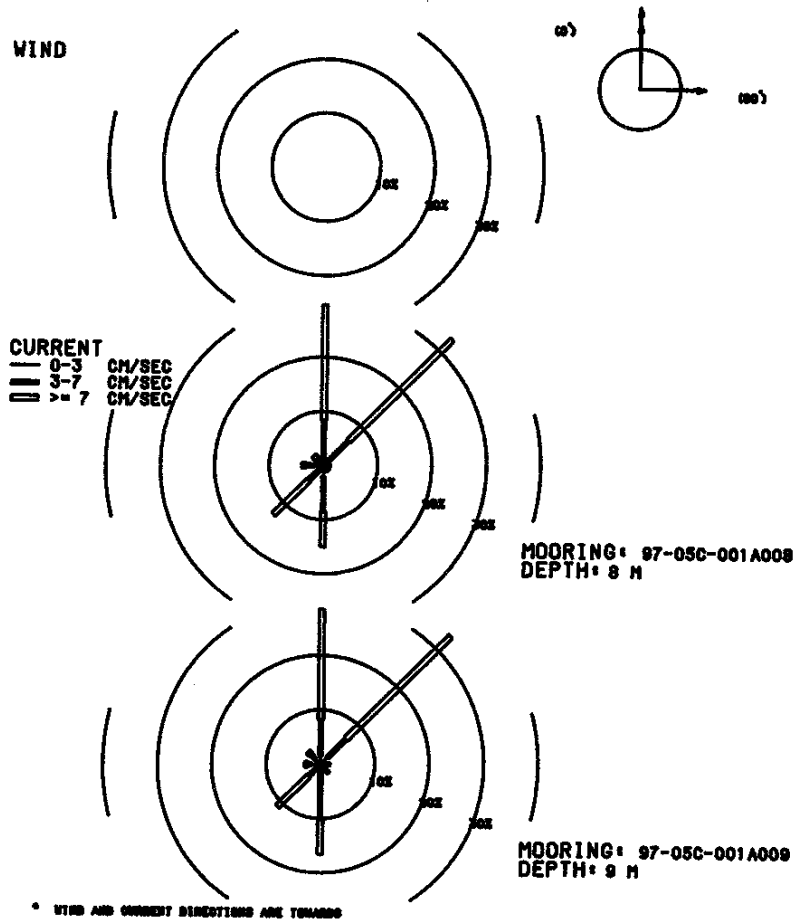

MOORING IS 97-05C-001A008 DEPTH IS 8 METERS THERE ARE 744 VALUES

FIRST DAY 1998/01/01/0000
FINAL DAY 1998/01/31/2300

SHORELINE ORIENTATION IN DEGREES TRUE SPECIFIED AS 90

DIRECTION DEG TRUE	PERCENT OBSERVED	MAXIMUM CURRENT	MEAN DURA- TION HOURS	MEAN EXCUR- SION KM	MEAN CURRENT CM/S	MEAN TEMP DEG C
TOWARD	TOTAL	LIGHT	MEDIUM	HIGH	CM/S	
90.0	1.2	0.8	0.4	0.0	6.6	1.5
45.0	33.2	1.2	5.2	26.7	29.4	1.7
0.0	29.7	1.6	6.7	21.4	31.6	1.9
315.0	2.6	0.7	0.9	0.9	10.7	1.6
270.0	4.0	1.7	1.5	0.8	11.6	1.8
225.0	12.9	1.1	2.7	9.1	17.7	1.9
180.0	15.1	2.0	6.5	6.6	20.4	1.3
135.0	1.3	0.5	0.8	0.0	6.1	1.5

0 MEAN SCALAR SPEED = 10.1 CM/S MEAN SQUARE SPEED = 138.3 CM2/S2
 MEAN SQUARE E-W SPEED = 24.5 CM2/S2 MEAN SQUARE N-S SPEED = 113.8 CM2/S2
 MEAN SQUARE U SPEED = 24.5 CM2/S2 MEAN SQUARE V SPEED = 113.8 CM2/S2
 MEAN VELOCITY = 5.1 CM/S, 20 DEG TRUE MEAN TEMPERATURE = 1.7 C
 VARIANCE (U,V) = 56.2 CM2/S2 TOTAL HOURS = 744.

PERCENT OBSERVED
 LIGHT (0.0 - 3.0) 9.7% MEDIUM (3.0 - 7.0) 24.7% HIGH (GE 7.0) 65.6%

MOORING IS 97-05C-001A009 DEPTH IS 9 METERS THERE ARE 744 VALUES

FIRST DAY 1998/01/01/0000
FINAL DAY 1998/01/31/2300

SHORELINE ORIENTATION IN DEGREES TRUE SPECIFIED AS 90

DIRECTION DEG TRUE	PERCENT OBSERVED	MAXIMUM CURRENT	MEAN DURA- TION HOURS	MEAN EXCUR- SION KM	MEAN CURRENT CM/S	MEAN TEMP DEG C
TOWARD	TOTAL	LIGHT	MEDIUM	HIGH	CM/S	
90.0	1.7	1.2	0.5	0.0	4.8	1.6
45.0	33.6	1.6	4.8	27.2	30.3	1.8
0.0	28.5	1.6	6.6	20.3	30.0	1.8
315.0	3.2	1.2	1.5	0.5	9.1	1.6
270.0	3.0	1.7	0.5	0.7	10.1	1.7
225.0	11.2	0.8	2.2	8.2	20.8	2.0
180.0	16.7	1.3	8.7	6.6	20.9	1.3
135.0	2.2	1.1	1.1	0.0	5.0	1.6

0 MEAN SCALAR SPEED = 9.9 CM/S MEAN SQUARE SPEED = 135.7 CM2/S2
 MEAN SQUARE E-W SPEED = 24.7 CM2/S2 MEAN SQUARE N-S SPEED = 111.0 CM2/S2
 MEAN SQUARE U SPEED = 24.7 CM2/S2 MEAN SQUARE V SPEED = 111.0 CM2/S2
 MEAN VELOCITY = 5.1 CM/S, 22 DEG TRUE MEAN TEMPERATURE = 1.7 C
 VARIANCE (U,V) = 55.0 CM2/S2 TOTAL HOURS = 744.

PERCENT OBSERVED
 LIGHT (0.0 - 3.0) 10.6% MEDIUM (3.0 - 7.0) 25.9% HIGH (GE 7.0) 63.4%

DATE: 1998/02/01 TO 1998/02/28
 ROSE SUMMARY: WIND AND CURRENT

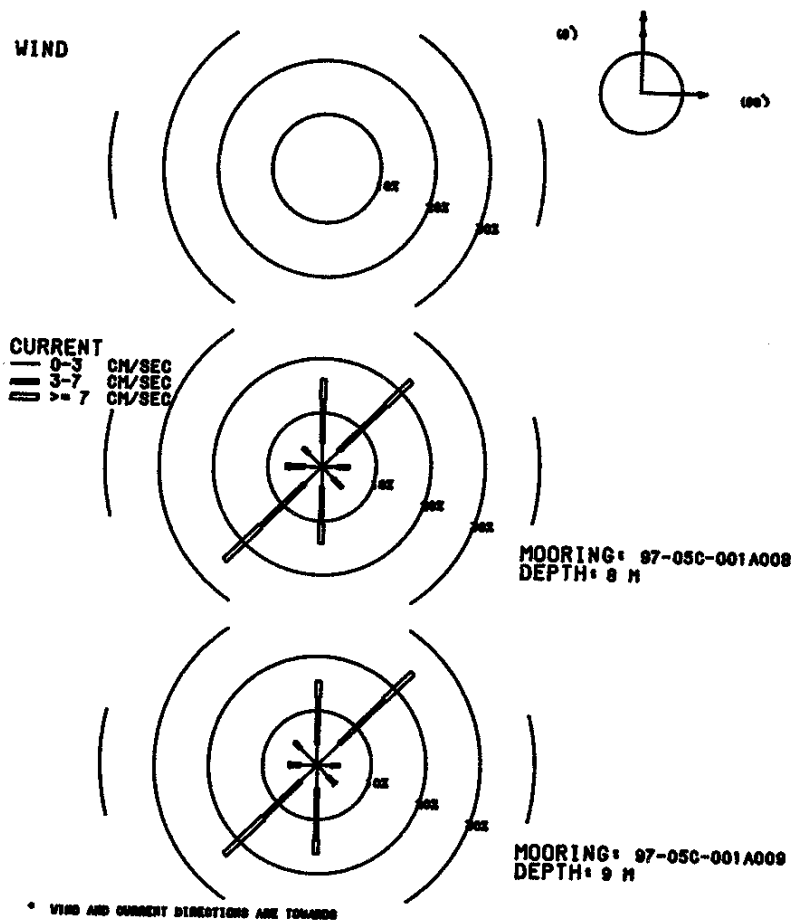

MOORING IS 97-05C-001A008 DEPTH IS 8 METERS THERE ARE 672 VALUES

FIRST DAY 1998/02/01/0000
 FINAL DAY 1998/02/28/2300

SHORELINE ORIENTATION IN DEGREES TRUE SPECIFIED AS 90

DIRECTION DEG TRUE	PERCENT OBSERVED	TOWARD	TOTAL	LIGHT	MEDIUM	HIGH	MAXIMUM CURRENT CM/S	MEAN DURA- TION HOURS	MEAN EXCUR- SION KM	MEAN CURRENT CM/S	MEAN TEMP DEG C
90.0	5.1	2.8	2.2	0.0	6.2	1.3	0.1	2.7	1.6		
45.0	22.8	4.3	11.9	6.5	18.6	2.7	0.6	6.0	1.6		
0.0	16.2	4.5	7.9	3.9	17.2	1.8	0.3	5.4	1.5		
315.0	4.9	3.4	1.5	0.0	5.2	1.4	0.1	2.5	1.6		
270.0	6.7	3.1	2.7	0.9	18.0	1.4	0.2	3.9	1.6		
225.0	24.9	4.3	11.3	9.2	17.9	2.8	0.7	6.6	1.6		
180.0	14.1	3.7	6.7	3.7	12.7	1.9	0.4	5.3	2.0		
135.0	5.4	3.1	2.2	0.0	5.6	1.3	0.1	2.7	1.8		
0	MEAN SCALAR SPEED = 5.3 CM/S		MEAN SQUARE SPEED = 41.3 CM2/S2								
	MEAN SQUARE E-W SPEED = 12.4 CM2/S2		MEAN SQUARE N-S SPEED = 28.9 CM2/S2								
	MEAN SQUARE U SPEED = 12.4 CM2/S2		MEAN SQUARE V SPEED = 28.9 CM2/S2								
	MEAN VELOCITY = 0.3 CM/S,		238 DEG TRUE		MEAN TEMPERATURE = 1.6 C						
	VARIANCE (U,V) = 20.6 CM2/S2		TOTAL HOURS = 672.								

PERCENT OBSERVED
 LIGHT (0.0 - 3.0) 29.3% MEDIUM (3.0 - 7.0) 46.4% HIGH (GE 7.0) 24.3%

MOORING IS 97-05C-001A009 DEPTH IS 9 METERS THERE ARE 672 VALUES

FIRST DAY 1998/02/01/0000
 FINAL DAY 1998/02/28/2300

SHORELINE ORIENTATION IN DEGREES TRUE SPECIFIED AS 90

DIRECTION DEG TRUE	PERCENT OBSERVED	TOWARD	TOTAL	LIGHT	MEDIUM	HIGH	MAXIMUM CURRENT CM/S	MEAN DURA- TION HOURS	MEAN EXCUR- SION KM	MEAN CURRENT CM/S	MEAN TEMP DEG C
90.0	4.2	2.5	1.6	0.0	5.5	1.5	0.1	2.7	1.6		
45.0	24.4	5.7	11.5	7.3	16.9	2.5	0.5	5.9	1.6		
0.0	15.5	3.9	8.6	3.0	17.6	1.7	0.3	5.2	1.6		
315.0	6.0	4.3	1.6	0.0	5.0	1.5	0.1	2.4	1.6		
270.0	5.2	3.0	1.9	0.3	13.3	1.3	0.2	3.3	1.5		
225.0	23.7	4.2	9.5	10.0	18.1	2.7	0.7	7.0	1.6		
180.0	16.4	4.2	9.5	2.7	14.4	1.9	0.3	4.9	1.8		
135.0	4.8	3.0	1.6	0.1	7.2	1.5	0.1	2.6	1.8		
0	MEAN SCALAR SPEED = 5.2 CM/S		MEAN SQUARE SPEED = 41.1 CM2/S2								
	MEAN SQUARE E-W SPEED = 11.9 CM2/S2		MEAN SQUARE N-S SPEED = 29.2 CM2/S2								
	MEAN SQUARE U SPEED = 11.9 CM2/S2		MEAN SQUARE V SPEED = 29.2 CM2/S2								
	MEAN VELOCITY = 0.3 CM/S,		235 DEG TRUE		MEAN TEMPERATURE = 1.6 C						
	VARIANCE (U,V) = 20.5 CM2/S2		TOTAL HOURS = 672.								

PERCENT OBSERVED
 LIGHT (0.0 - 3.0) 30.7% MEDIUM (3.0 - 7.0) 46.0% HIGH (GE 7.0) 23.4%

DATE: 1998/03/01 TO 1998/03/31
 ROSE SUMMARY: WIND AND CURRENT

WIND

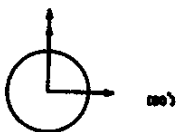
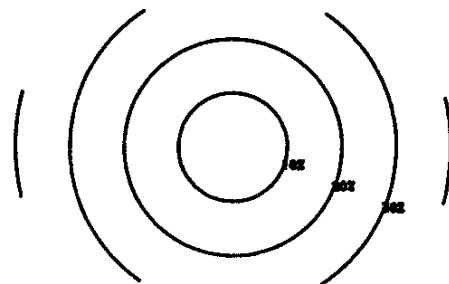

CURRENT

0-3 CM/SEC
 3-7 CM/SEC
 >=7 CM/SEC

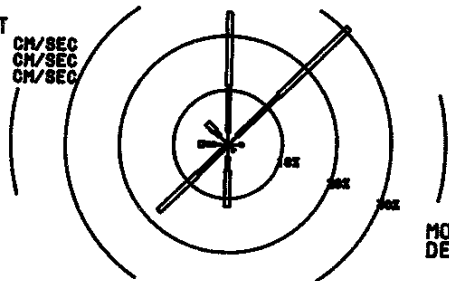

MOORING: 97-05C-001A008
 DEPTH: 8 M

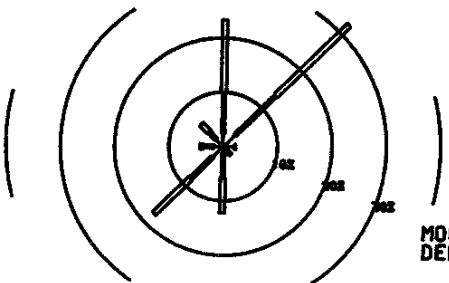

MOORING: 97-05C-001A009
 DEPTH: 9 M

• WIND AND CURRENT DIRECTIONS ARE TOWARDS

MOORING IS 97-05C-001A008 DEPTH IS 8 METERS THERE ARE 744 VALUES

FIRST DAY 1998/03/01/0000
 FINAL DAY 1998/03/31/2300

SHORELINE ORIENTATION IN DEGREES TRUE SPECIFIED AS 90

DIRECTION DEG TRUE	PERCENT OBSERVED	TOWARD	TOTAL	LIGHT	MEDIUM	HIGH	MAXIMUM CURRENT CM/S	MEAN DURA- TION HOURS	MEAN EXCUR- SION KM	MEAN CURRENT CM/S	MEAN TEMP DEG C
90.0	2.8	2.2	0.7	0.0	0.0	0.0	5.5	1.3	0.1	2.4	2.7
45.0	30.9	2.2	10.9	17.9	39.3	3.3	39.3	3.3	1.2	10.5	2.5
0.0	24.5	2.3	8.6	13.6	36.0	2.2	36.0	2.2	0.7	9.2	2.3
315.0	5.5	2.2	1.2	2.2	28.1	1.5	28.1	1.5	0.4	6.7	2.2
270.0	5.4	2.3	2.2	0.9	21.0	1.7	21.0	1.7	0.3	4.6	2.4
225.0	17.7	1.2	6.6	9.9	49.8	2.8	49.8	2.8	1.2	12.0	2.2
180.0	11.6	2.3	2.4	6.9	22.9	2.2	22.9	2.2	0.6	7.7	2.0
135.0	1.6	1.3	0.3	0.0	4.8	1.1	4.8	1.1	0.1	2.2	2.7

0 MEAN SCALAR SPEED = 9.2 CM/S MEAN SQUARE SPEED = 147.1 CM2/S2
 MEAN SQUARE E-W SPEED = 42.0 CM2/S2 MEAN SQUARE N-S SPEED = 105.1 CM2/S2
 MEAN SQUARE U SPEED = 42.0 CM2/S2 MEAN SQUARE V SPEED = 105.1 CM2/S2
 MEAN VELOCITY = 2.7 CM/S, 4 DEG TRUE MEAN TEMPERATURE = 2.3 C
 VARIANCE (U,V) = 70.1 CM2/S2 TOTAL HOURS = 744.

PERCENT OBSERVED
 LIGHT (0.0 - 3.0) 15.9% MEDIUM (3.0 - 7.0) 32.8% HIGH (GE 7.0) 51.3%

MOORING IS 97-05C-001A009 DEPTH IS 9 METERS THERE ARE 744 VALUES

FIRST DAY 1998/03/01/0000
 FINAL DAY 1998/03/31/2300

SHORELINE ORIENTATION IN DEGREES TRUE SPECIFIED AS 90

DIRECTION DEG TRUE	PERCENT OBSERVED	TOWARD	TOTAL	LIGHT	MEDIUM	HIGH	MAXIMUM CURRENT CM/S	MEAN DURA- TION HOURS	MEAN EXCUR- SION KM	MEAN CURRENT CM/S	MEAN TEMP DEG C
90.0	2.3	1.9	0.3	0.1	0.1	0.1	7.8	1.1	0.1	2.2	2.7
45.0	32.3	3.1	10.3	18.8	38.8	3.0	38.8	3.0	1.1	10.0	2.5
0.0	23.4	2.4	7.5	13.4	34.1	1.9	34.1	1.9	0.6	9.4	2.4
315.0	5.8	1.7	2.0	2.0	25.9	1.7	25.9	1.7	0.4	6.6	2.2
270.0	4.3	1.6	2.2	0.5	21.5	1.5	21.5	1.5	0.2	4.7	2.4
225.0	17.7	2.6	5.8	9.4	50.8	2.8	50.8	2.8	1.2	11.9	2.2
180.0	12.2	1.3	4.4	6.5	23.0	2.2	23.0	2.2	0.6	7.7	1.9
135.0	2.0	1.2	0.8	0.0	4.0	1.2	4.0	1.2	0.1	2.3	2.7

0 MEAN SCALAR SPEED = 9.1 CM/S MEAN SQUARE SPEED = 144.9 CM2/S2
 MEAN SQUARE E-W SPEED = 38.9 CM2/S2 MEAN SQUARE N-S SPEED = 106.0 CM2/S2
 MEAN SQUARE U SPEED = 38.9 CM2/S2 MEAN SQUARE V SPEED = 106.0 CM2/S2
 MEAN VELOCITY = 2.5 CM/S, 6 DEG TRUE MEAN TEMPERATURE = 2.3 C
 VARIANCE (U,V) = 69.3 CM2/S2 TOTAL HOURS = 744.

PERCENT OBSERVED
 LIGHT (0.0 - 3.0) 15.9% MEDIUM (3.0 - 7.0) 33.3% HIGH (GE 7.0) 50.8%

DATE: 1998/04/01 TO 1998/04/30
 ROSE SUMMARY: WIND AND CURRENT

WIND

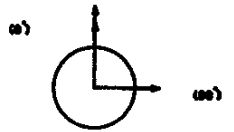
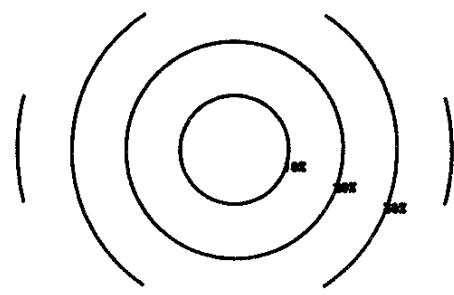

CURRENT
 0-3 CM/SEC
 3-7 CM/SEC
 7- CM/SEC

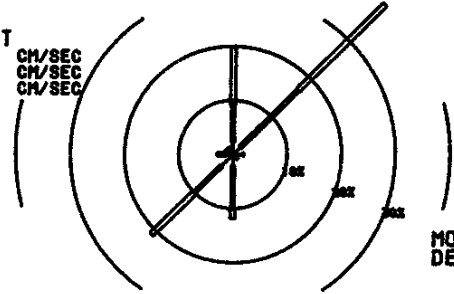

MOORING: 97-05C-001A008
 DEPTH: 8 M

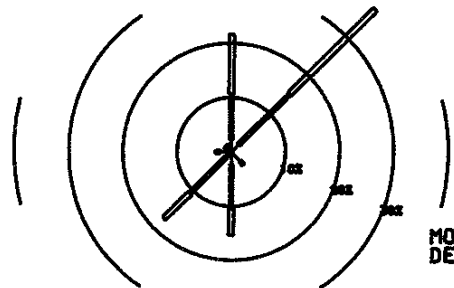

MOORING: 97-05C-001A009
 DEPTH: 9 M

* WIND AND CURRENT DIRECTIONS ARE TOWARDS

MOORING IS 97-05C-001A008 DEPTH IS 8 METERS THERE ARE 337 VALUES

FIRST DAY 1998/04/01/0000
 FINAL DAY 1998/04/15/0000

SHORELINE ORIENTATION IN DEGREES TRUE SPECIFIED AS 90

DIRECTION DEG TRUE	PERCENT OBSERVED	MAXIMUM CURRENT CM/S	MEAN DURATION HOURS	MEAN EXCURSION KM	MEAN CURRENT CM/S	MEAN TEMP DEG C
TOWARD	TOTAL	LIGHT	MEDIUM	HIGH		
90.0	2.1	1.8	0.3	0.0	4.4	1.0
45.0	39.5	1.8	15.1	22.6	16.6	4.3
0.0	19.9	2.4	6.8	10.7	14.1	2.1
315.0	1.5	0.0	1.2	0.3	10.7	1.2
270.0	3.0	1.2	1.8	0.0	6.8	1.2
225.0	21.1	3.0	6.8	11.3	17.5	3.2
180.0	11.9	2.1	8.0	1.8	16.5	1.9
135.0	1.2	0.6	0.6	0.0	3.9	1.0

MEAN SCALAR SPEED = 7.3 CM/S MEAN SQUARE SPEED = 66.9 CM2/S2
 MEAN SQUARE E-W SPEED = 14.8 CM2/S2 MEAN SQUARE N-S SPEED = 52.1 CM2/S2
 MEAN SQUARE U SPEED = 14.8 CM2/S2 MEAN SQUARE V SPEED = 52.1 CM2/S2
 MEAN VELOCITY = 2.4 CM/S, 21 DEG TRUE MEAN TEMPERATURE = 5.1 C
 VARIANCE (U,V) = 30.6 CM2/S2 TOTAL HOURS = 337.

PERCENT OBSERVED
 LIGHT (0.0 - 3.0) 12.8% MEDIUM (3.0 - 7.0) 40.7% HIGH (GE 7.0) 46.6%

MOORING IS 97-05C-001A009 DEPTH IS 9 METERS THERE ARE 337 VALUES

FIRST DAY 1998/04/01/0000
 FINAL DAY 1998/04/15/0000

SHORELINE ORIENTATION IN DEGREES TRUE SPECIFIED AS 90

DIRECTION DEG TRUE	PERCENT OBSERVED	MAXIMUM CURRENT CM/S	MEAN DURATION HOURS	MEAN EXCURSION KM	MEAN CURRENT CM/S	MEAN TEMP DEG C
TOWARD	TOTAL	LIGHT	MEDIUM	HIGH		
90.0	0.3	0.3	0.0	0.0	2.0	1.0
45.0	37.4	1.8	13.4	22.3	16.4	3.7
0.0	21.7	2.4	8.3	11.0	17.3	2.1
315.0	1.5	0.6	0.3	0.6	10.5	1.2
270.0	3.0	2.1	0.9	0.0	5.3	1.2
225.0	17.5	1.2	9.5	6.8	15.5	2.7
180.0	15.4	2.4	8.0	5.0	17.1	2.4
135.0	3.3	2.4	0.9	0.0	3.8	1.4

MEAN SCALAR SPEED = 7.2 CM/S MEAN SQUARE SPEED = 67.2 CM2/S2
 MEAN SQUARE E-W SPEED = 15.1 CM2/S2 MEAN SQUARE N-S SPEED = 52.1 CM2/S2
 MEAN SQUARE U SPEED = 15.1 CM2/S2 MEAN SQUARE V SPEED = 52.1 CM2/S2
 MEAN VELOCITY = 2.4 CM/S, 26 DEG TRUE MEAN TEMPERATURE = 5.1 C
 VARIANCE (U,V) = 30.9 CM2/S2 TOTAL HOURS = 337.

PERCENT OBSERVED
 LIGHT (0.0 - 3.0) 13.1% MEDIUM (3.0 - 7.0) 41.2% HIGH (GE 7.0) 45.7%

DATE: 1997/11/02 TO 1997/11/30
 ROSE SUMMARY: WIND AND CURRENT

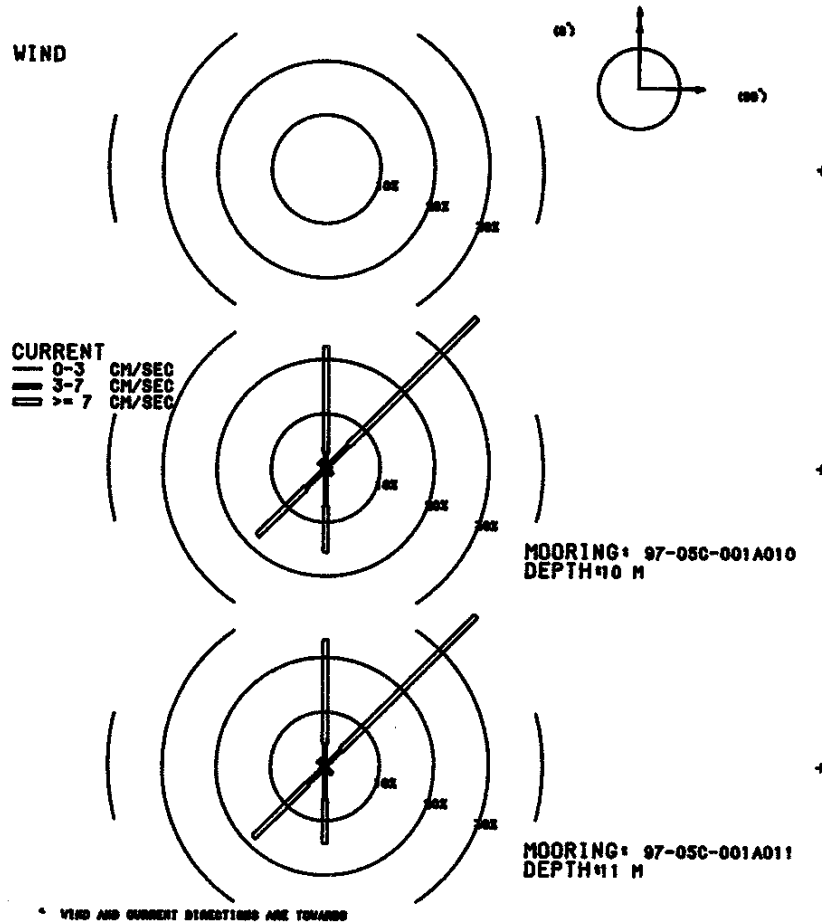

MOORING IS 97-05C-001A010 DEPTH IS 10 METERS THERE ARE 691 VALUES

FIRST DAY 1997/11/02/0500
 FINAL DAY 1997/11/30/2300

SHORELINE ORIENTATION IN DEGREES TRUE SPECIFIED AS 90

DIRECTION DEG TRUE	PERCENT OBSERVED	MAXIMUM CURRENT	MEAN DURA- TION HOURS	MEAN EXCUR- SION KM	MEAN CURRENT CM/S	MEAN TEMP DEG C
TOWARD	TOTAL	LIGHT	MEDIUM	HIGH	CM/S	
90.0	1.0	0.1	0.9	0.0	6.5	1.2
45.0	39.2	1.3	4.5	33.4	27.7	5.0
0.0	22.4	0.4	2.3	19.7	28.5	2.9
315.0	1.6	0.3	1.0	0.3	7.9	1.2
270.0	0.7	0.4	0.3	0.0	6.0	1.7
225.0	17.7	0.7	4.3	12.6	23.6	3.3
180.0	15.6	0.7	6.2	8.7	18.4	2.9
135.0	1.7	0.6	1.2	0.0	6.8	1.5
0	MEAN SCALAR SPEED = 11.3 CM/S		MEAN SQUARE SPEED = 160.6 CM2/S2			
	MEAN SQUARE E-W SPEED = 33.9 CM2/S2		MEAN SQUARE N-S SPEED = 126.7 CM2/S2			
	MEAN SQUARE U SPEED = 33.9 CM2/S2		MEAN SQUARE V SPEED = 126.7 CM2/S2			
	MEAN VELOCITY = 4.3 CM/S,		27 DEG TRUE		MEAN TEMPERATURE = 8.5 C	
	VARIANCE (U,V) = 71.3 CM2/S2		TOTAL HOURS = 691.			

PERCENT OBSERVED
 LIGHT (0.0 - 3.0) 4.6% MEDIUM (3.0 - 7.0) 20.7% HIGH (GE 7.0) 74.7%

MOORING IS 97-05C-001A011 DEPTH IS 11 METERS THERE ARE 691 VALUES

FIRST DAY 1997/11/02/0500
 FINAL DAY 1997/11/30/2300

SHORELINE ORIENTATION IN DEGREES TRUE SPECIFIED AS 90

DIRECTION DEG TRUE	PERCENT OBSERVED	MAXIMUM CURRENT	MEAN DURA- TION HOURS	MEAN EXCUR- SION KM	MEAN CURRENT CM/S	MEAN TEMP DEG C
TOWARD	TOTAL	LIGHT	MEDIUM	HIGH	CM/S	
90.0	0.6	0.3	0.3	0.0	5.5	1.0
45.0	39.2	0.6	3.6	35.0	27.5	4.5
0.0	23.3	0.4	3.8	19.1	26.2	2.6
315.0	1.6	0.9	0.6	0.1	10.5	1.1
270.0	0.7	0.3	0.4	0.0	7.0	1.0
225.0	18.5	0.6	3.9	14.0	25.0	3.5
180.0	14.2	0.9	5.2	8.1	18.7	2.5
135.0	1.9	0.9	1.0	0.0	5.8	1.6
0	MEAN SCALAR SPEED = 11.3 CM/S		MEAN SQUARE SPEED = 159.6 CM2/S2			
	MEAN SQUARE E-W SPEED = 33.7 CM2/S2		MEAN SQUARE N-S SPEED = 125.9 CM2/S2			
	MEAN SQUARE U SPEED = 33.7 CM2/S2		MEAN SQUARE V SPEED = 125.9 CM2/S2			
	MEAN VELOCITY = 4.4 CM/S,		26 DEG TRUE		MEAN TEMPERATURE = 8.5 C	
	VARIANCE (U,V) = 70.3 CM2/S2		TOTAL HOURS = 691.			

PERCENT OBSERVED
 LIGHT (0.0 - 3.0) 4.8% MEDIUM (3.0 - 7.0) 18.8% HIGH (GE 7.0) 76.4%

DATE: 1997/12/01 TO 1997/12/31
ROSE SUMMARY: WIND AND CURRENT

WIND

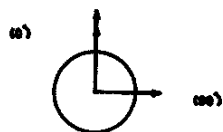
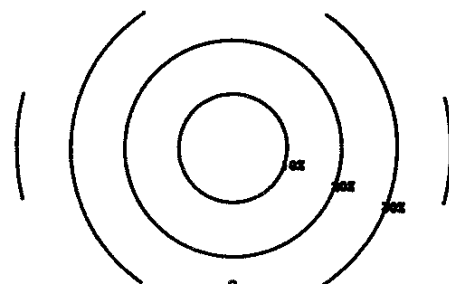

CURRENT

0-3 CM/SEC
3-7 CM/SEC
≥ 7 CM/SEC

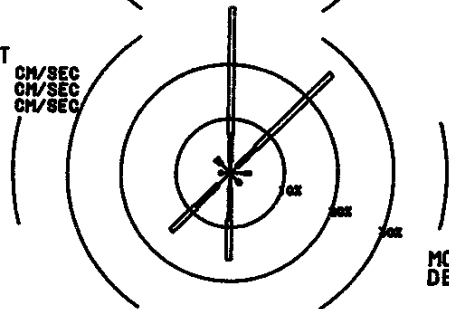

MOORING: 97-05C-001A010
DEPTH 10 M

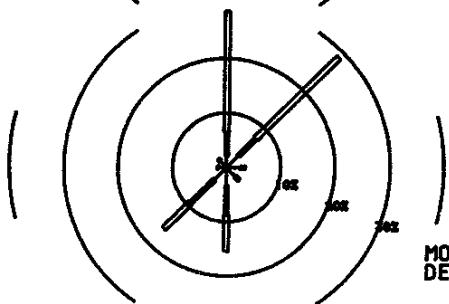

MOORING: 97-05C-001A011
DEPTH 11 M

* WIND AND CURRENT DIRECTIONS ARE TOWARDS

MOORING IS 97-05C-001A010 DEPTH IS 10 METERS THERE ARE 744 VALUES

FIRST DAY 1997/12/01/0000
FINAL DAY 1997/12/31/2300

SHORELINE ORIENTATION IN DEGREES TRUE SPECIFIED AS 90

DIRECTION DEG TRUE	PERCENT OBSERVED			MAXIMUM CURRENT CM/S	MEAN DURA- TION HOURS	MEAN EXCUR- SION KM	MEAN CURRENT CM/S	MEAN TEMP DEG C
TOWARD	TOTAL	LIGHT	MEDIUM	HIGH	CM/S	HOURS	CM/S	DEG C
90.0	3.8	2.7	1.1	0.0	4.5	1.4	0.1	2.5
45.0	26.1	1.7	4.8	19.5	28.6	3.0	1.2	11.5
0.0	30.5	2.2	5.0	23.4	29.2	3.0	1.4	12.6
315.0	3.6	2.4	0.9	0.3	9.6	1.8	0.2	2.9
270.0	2.0	1.5	0.5	0.0	4.5	1.1	0.1	1.9
225.0	15.2	3.0	5.8	6.5	28.4	2.5	0.7	7.8
180.0	16.0	2.7	5.9	7.4	17.5	2.7	0.7	6.8
135.0	2.8	1.9	0.9	0.0	5.9	1.1	0.1	2.8
0	MEAN SCALAR SPEED = 9.4 CM/S		MEAN SQUARE SPEED = 129.6 CM2/S2					
	MEAN SQUARE E-W SPEED = 19.6 CM2/S2		MEAN SQUARE N-S SPEED = 110.0 CM2/S2					
	MEAN SQUARE U SPEED = 19.6 CM2/S2		MEAN SQUARE V SPEED = 110.0 CM2/S2					
	MEAN VELOCITY = 4.6 CM/S,		19 DEG TRUE		MEAN TEMPERATURE = 4.3 C			
	VARIANCE (U,V) = 54.5 CM2/S2		TOTAL HOURS = 744.					

PERCENT OBSERVED
LIGHT (0.0 - 3.0) 18.0% MEDIUM (3.0 - 7.0) 25.0% HIGH (GE 7.0) 57.0%

MOORING IS 97-05C-001A011 DEPTH IS 11 METERS THERE ARE 744 VALUES

FIRST DAY 1997/12/01/0000
FINAL DAY 1997/12/31/2300

SHORELINE ORIENTATION IN DEGREES TRUE SPECIFIED AS 90

DIRECTION DEG TRUE	PERCENT OBSERVED			MAXIMUM CURRENT CM/S	MEAN DURA- TION HOURS	MEAN EXCUR- SION KM	MEAN CURRENT CM/S	MEAN TEMP DEG C
TOWARD	TOTAL	LIGHT	MEDIUM	HIGH	CM/S	HOURS	CM/S	DEG C
90.0	3.5	2.6	0.9	0.0	5.5	1.4	0.1	2.4
45.0	28.9	3.0	4.4	21.5	31.3	2.9	1.2	11.4
0.0	28.8	2.2	4.3	22.3	26.4	3.0	1.3	12.2
315.0	2.2	1.6	0.5	0.0	6.2	1.2	0.1	2.6
270.0	1.7	1.5	0.3	0.0	3.8	1.1	0.1	2.1
225.0	16.1	3.1	6.2	6.9	27.0	1.8	0.5	7.8
180.0	15.5	3.4	5.4	6.7	17.6	1.6	0.4	6.4
135.0	3.4	2.3	1.1	0.0	6.0	1.3	0.1	2.6
0	MEAN SCALAR SPEED = 9.3 CM/S		MEAN SQUARE SPEED = 126.5 CM2/S2					
	MEAN SQUARE E-W SPEED = 20.1 CM2/S2		MEAN SQUARE N-S SPEED = 106.4 CM2/S2					
	MEAN SQUARE U SPEED = 20.1 CM2/S2		MEAN SQUARE V SPEED = 106.4 CM2/S2					
	MEAN VELOCITY = 4.5 CM/S,		20 DEG TRUE		MEAN TEMPERATURE = 4.3 C			
	VARIANCE (U,V) = 53.1 CM2/S2		TOTAL HOURS = 744.					

PERCENT OBSERVED
LIGHT (0.0 - 3.0) 19.5% MEDIUM (3.0 - 7.0) 23.1% HIGH (GE 7.0) 57.4%

DATE: 1998/01/01 TO 1998/01/31
 ROSE SUMMARY: WIND AND CURRENT

WIND

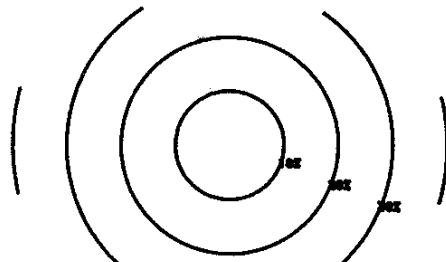

CURRENT

0-3 CM/SEC
 3-7 CM/SEC
 >= 7 CM/SEC

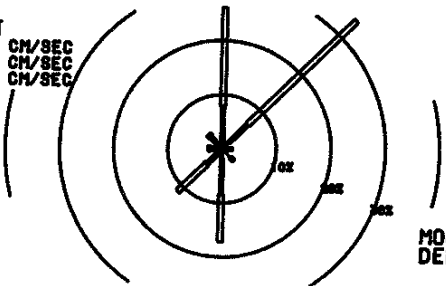

MOORING: 97-05C-001A010
 DEPTH 10 M

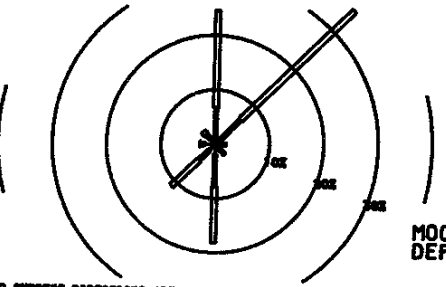

MOORING: 97-05C-001A011
 DEPTH 11 M

* WIND AND CURRENT DIRECTIONS ARE TOWARDS

MOORING IS 97-05C-001A010 DEPTH IS 10 METERS THERE ARE 744 VALUES

FIRST DAY 1998/01/01/0000
 FINAL DAY 1998/01/31/2300

SHORELINE ORIENTATION IN DEGREES TRUE SPECIFIED AS 90

DIRECTION DEG TRUE	PERCENT OBSERVED	MAXIMUM CURRENT	MEAN DURA- TION HOURS	MEAN EXCUR- SION KM	MEAN CURRENT CM/S	MEAN TEMP DEG C
TOWARD	TOTAL	LIGHT	MEDIUM	HIGH	CM/S	
90.0	1.9	0.9	0.9	0.0	6.2	1.0
45.0	34.3	1.6	4.8	27.8	30.6	3.2
0.0	26.1	1.1	6.7	18.3	31.9	2.7
315.0	3.6	1.2	1.9	0.5	9.3	1.9
270.0	2.6	1.5	0.8	0.3	8.1	1.4
225.0	11.3	1.2	2.7	7.4	17.9	2.0
180.0	17.2	1.6	6.9	8.7	20.3	2.9
135.0	3.1	2.3	0.8	0.0	6.0	1.2

MEAN SCALAR SPEED = 9.9 CM/S MEAN SQUARE SPEED = 136.5 CM2/S2
 MEAN SQUARE E-W SPEED = 24.5 CM2/S2 MEAN SQUARE N-S SPEED = 112.0 CM2/S2
 MEAN SQUARE U SPEED = 24.5 CM2/S2 MEAN SQUARE V SPEED = 112.0 CM2/S2
 MEAN VELOCITY = 5.0 CM/S, 24 DEG TRUE MEAN TEMPERATURE = 1.7 C
 VARIANCE (U,V) = 55.9 CM2/S2 TOTAL HOURS = 744.

PERCENT OBSERVED
 LIGHT (0.0 - 3.0) 11.4% MEDIUM (3.0 - 7.0) 25.5% HIGH (GE 7.0) 63.0%

MOORING IS 97-05C-001A011 DEPTH IS 11 METERS THERE ARE 744 VALUES

FIRST DAY 1998/01/01/0000
 FINAL DAY 1998/01/31/2300

SHORELINE ORIENTATION IN DEGREES TRUE SPECIFIED AS 90

DIRECTION DEG TRUE	PERCENT OBSERVED	MAXIMUM CURRENT	MEAN DURA- TION HOURS	MEAN EXCUR- SION KM	MEAN CURRENT CM/S	MEAN TEMP DEG C
TOWARD	TOTAL	LIGHT	MEDIUM	HIGH	CM/S	
90.0	2.0	1.5	0.5	0.0	6.4	1.2
45.0	35.5	0.9	5.5	29.0	31.1	3.4
0.0	24.6	0.9	5.8	17.9	35.9	2.4
315.0	3.2	1.2	1.1	0.9	11.0	1.5
270.0	2.8	1.9	0.8	0.1	7.7	1.2
225.0	11.2	1.5	2.6	7.1	17.8	2.2
180.0	18.1	1.9	5.9	10.3	19.1	3.1
135.0	2.6	1.3	1.2	0.0	4.8	1.2

MEAN SCALAR SPEED = 9.9 CM/S MEAN SQUARE SPEED = 136.6 CM2/S2
 MEAN SQUARE E-W SPEED = 24.5 CM2/S2 MEAN SQUARE N-S SPEED = 112.1 CM2/S2
 MEAN SQUARE U SPEED = 24.5 CM2/S2 MEAN SQUARE V SPEED = 112.1 CM2/S2
 MEAN VELOCITY = 4.9 CM/S, 25 DEG TRUE MEAN TEMPERATURE = 1.7 C
 VARIANCE (U,V) = 56.3 CM2/S2 TOTAL HOURS = 744.

PERCENT OBSERVED
 LIGHT (0.0 - 3.0) 11.2% MEDIUM (3.0 - 7.0) 23.4% HIGH (GE 7.0) 65.5%

DATE: 1998/02/01 TO 1998/02/28
 ROSE SUMMARY: WIND AND CURRENT

WIND

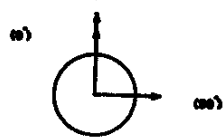
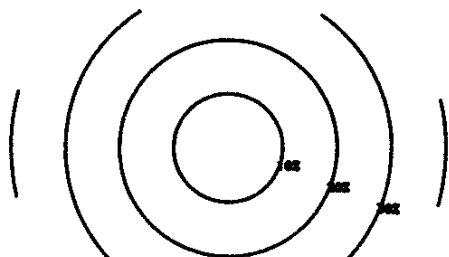

CURRENT
 0-3 CM/SEC
 3-7 CM/SEC
 >=7 CM/SEC

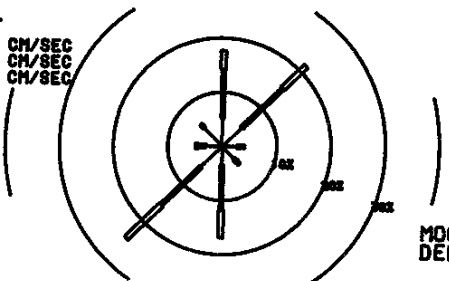

MOORING: 97-05C-001A010
 DEPTH 10 M

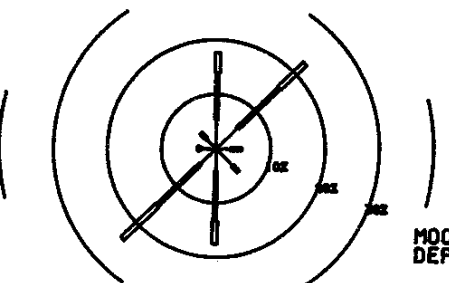

MOORING: 97-05C-001A011
 DEPTH 11 M

• WIND AND CURRENT DIRECTIONS ARE TOWARDS

MOORING IS 97-05C-001A010 DEPTH IS 10 METERS THERE ARE 672 VALUES

FIRST DAY 1998/02/01/0000
 FINAL DAY 1998/02/28/2300

SHORELINE ORIENTATION IN DEGREES TRUE SPECIFIED AS 90

DIRECTION DEG TRUE	PERCENT OBSERVED	MAXIMUM CURRENT	MEAN DURA- TION HOURS	MEAN EXCUR- SION KM	MEAN CURRENT CM/S	MEAN TEMP DEG C
TOWARD	TOTAL	LIGHT	MEDIUM	HIGH	CM/S	
90.0	4.2	2.7	1.5	0.0	4.5	1.4
45.0	21.4	4.9	10.6	6.0	16.5	2.4
0.0	17.7	5.2	8.9	3.6	17.4	2.0
315.0	5.7	4.8	0.9	0.0	5.8	1.2
270.0	4.9	3.0	1.5	0.4	11.7	1.3
225.0	24.6	5.4	10.1	9.1	17.8	2.2
180.0	17.0	3.4	8.3	5.2	15.7	2.0
135.0	4.6	3.1	1.5	0.0	5.4	1.6

MEAN SCALAR SPEED = 5.2 CM/S MEAN SQUARE SPEED = 40.6 CM²/S²
 MEAN SQUARE E-W SPEED = 11.1 CM²/S² MEAN SQUARE N-S SPEED = 29.6 CM²/S²
 MEAN SQUARE U SPEED = 11.1 CM²/S² MEAN SQUARE V SPEED = 29.6 CM²/S²
 MEAN VELOCITY = 0.3 CM/S, 223 DEG TRUE MEAN TEMPERATURE = 1.6 C
 VARIANCE (U,V) = 20.3 CM²/S² TOTAL HOURS = 672.

PERCENT OBSERVED
 LIGHT (0.0 - 3.0) 32.4% MEDIUM (3.0 - 7.0) 43.3% HIGH (GE 7.0) 24.3%

MOORING IS 97-05C-001A011 DEPTH IS 11 METERS THERE ARE 672 VALUES

FIRST DAY 1998/02/01/0000
 FINAL DAY 1998/02/28/2300

SHORELINE ORIENTATION IN DEGREES TRUE SPECIFIED AS 90

DIRECTION DEG TRUE	PERCENT OBSERVED	MAXIMUM CURRENT	MEAN DURA- TION HOURS	MEAN EXCUR- SION KM	MEAN CURRENT CM/S	MEAN TEMP DEG C
TOWARD	TOTAL	LIGHT	MEDIUM	HIGH	CM/S	
90.0	4.8	2.7	2.1	0.0	5.9	1.4
45.0	22.6	5.4	10.6	6.7	18.1	2.5
0.0	17.7	5.4	8.6	3.7	17.7	1.8
315.0	4.0	2.4	1.6	0.0	6.6	1.4
270.0	3.4	2.7	0.4	0.3	10.7	1.1
225.0	24.0	4.0	11.0	8.9	19.1	2.6
180.0	17.6	4.2	9.1	4.3	17.6	2.1
135.0	6.0	4.3	1.6	0.0	5.9	1.3

MEAN SCALAR SPEED = 5.3 CM/S MEAN SQUARE SPEED = 42.0 CM²/S²
 MEAN SQUARE E-W SPEED = 10.9 CM²/S² MEAN SQUARE N-S SPEED = 31.1 CM²/S²
 MEAN SQUARE U SPEED = 10.9 CM²/S² MEAN SQUARE V SPEED = 31.1 CM²/S²
 MEAN VELOCITY = 0.2 CM/S, 200 DEG TRUE MEAN TEMPERATURE = 1.6 C
 VARIANCE (U,V) = 21.0 CM²/S² TOTAL HOURS = 672.

PERCENT OBSERVED
 LIGHT (0.0 - 3.0) 31.0% MEDIUM (3.0 - 7.0) 45.1% HIGH (GE 7.0) 24.0%

DATE: 1998/03/01 TO 1998/03/31
ROSE SUMMARY: WIND AND CURRENT

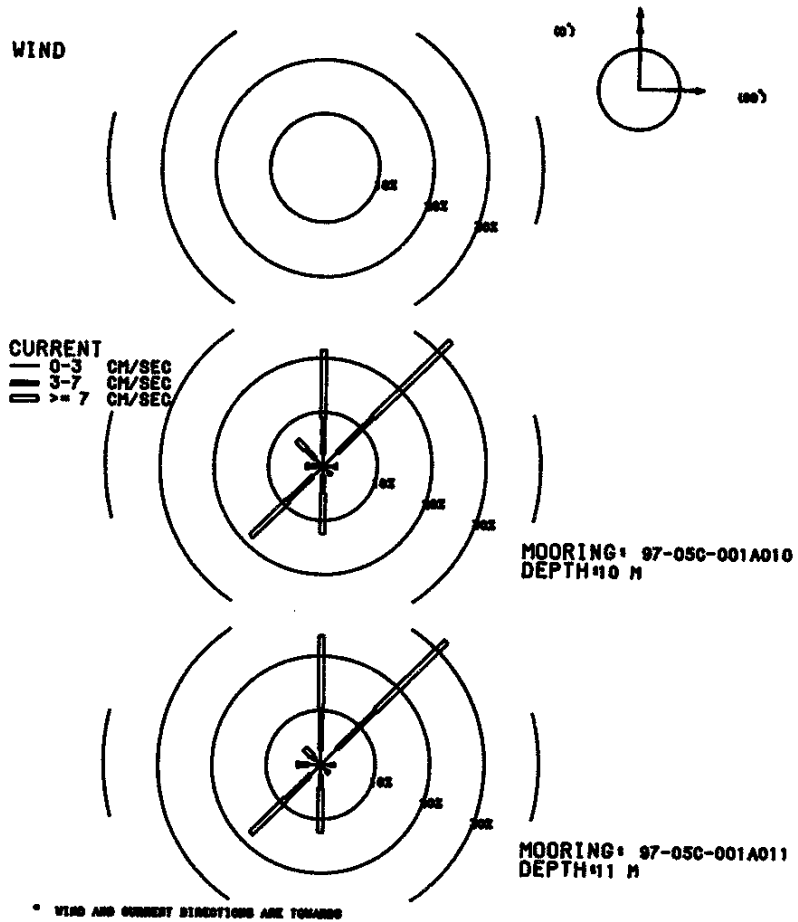

MOORING IS 97-05C-001A010 DEPTH IS 10 METERS THERE ARE 744 VALUES

FIRST DAY 1998/03/01/0000
FINAL DAY 1998/03/31/2300

SHORELINE ORIENTATION IN DEGREES TRUE SPECIFIED AS 90

DIRECTION DEG TRUE	PERCENT OBSERVED	MAXIMUM CURRENT	MEAN DURA- TION HOURS	MEAN EXCUR- SION KM	MEAN CURRENT CM/S	MEAN TEMP DEG C
TOWARD	TOTAL	LIGHT	MEDIUM	HIGH	CM/S	
90.0	2.6	2.0	0.4	0.1	9.1	1.1
45.0	32.9	3.6	9.3	20.0	37.7	3.1
0.0	21.5	2.3	6.6	12.6	33.9	2.0
315.0	6.7	1.9	2.4	2.4	23.7	2.3
270.0	3.1	1.2	1.5	0.4	12.5	1.5
225.0	18.5	2.7	6.3	9.5	52.3	3.2
180.0	12.5	1.6	3.4	7.5	21.7	2.5
135.0	2.2	1.6	0.5	0.0	4.5	1.2
0		MEAN SCALAR SPEED = 9.2 CM/S		MEAN SQUARE SPEED = 147.9 CM2/S2		
		MEAN SQUARE E-W SPEED = 38.4 CM2/S2		MEAN SQUARE N-S SPEED = 109.5 CM2/S2		
		MEAN SQUARE U SPEED = 38.4 CM2/S2		MEAN SQUARE V SPEED = 109.5 CM2/S2		
		MEAN VELOCITY = 2.4 CM/S,		6 DEG TRUE		MEAN TEMPERATURE = 2.3 C
		VARIANCE (U,V) = 71.1 CM2/S2		TOTAL HOURS = 744.		

PERCENT OBSERVED
LIGHT (0.0 - 3.0) 16.9% MEDIUM (3.0 - 7.0) 30.4% HIGH (GE 7.0) 52.7%

MOORING IS 97-05C-001A011 DEPTH IS 11 METERS THERE ARE 744 VALUES

FIRST DAY 1998/03/01/0000
FINAL DAY 1998/03/31/2300

SHORELINE ORIENTATION IN DEGREES TRUE SPECIFIED AS 90

DIRECTION DEG TRUE	PERCENT OBSERVED	MAXIMUM CURRENT	MEAN DURA- TION HOURS	MEAN EXCUR- SION KM	MEAN CURRENT CM/S	MEAN TEMP DEG C
TOWARD	TOTAL	LIGHT	MEDIUM	HIGH	CM/S	
90.0	2.7	1.9	0.8	0.0	5.6	1.1
45.0	32.4	4.2	10.1	18.1	37.7	3.0
0.0	23.8	2.7	7.5	13.6	32.5	2.1
315.0	4.2	1.5	0.7	2.0	18.7	1.6
270.0	4.3	2.3	1.7	0.3	11.3	1.2
225.0	18.0	2.7	6.2	9.1	50.5	2.9
180.0	12.5	1.9	2.4	8.2	24.5	2.5
135.0	2.2	1.6	0.5	0.0	5.0	1.5
0		MEAN SCALAR SPEED = 9.1 CM/S		MEAN SQUARE SPEED = 144.1 CM2/S2		
		MEAN SQUARE E-W SPEED = 36.3 CM2/S2		MEAN SQUARE N-S SPEED = 107.7 CM2/S2		
		MEAN SQUARE U SPEED = 36.3 CM2/S2		MEAN SQUARE V SPEED = 107.7 CM2/S2		
		MEAN VELOCITY = 2.3 CM/S,		7 DEG TRUE		MEAN TEMPERATURE = 2.3 C
		VARIANCE (U,V) = 69.4 CM2/S2		TOTAL HOURS = 744.		

PERCENT OBSERVED
LIGHT (0.0 - 3.0) 18.7% MEDIUM (3.0 - 7.0) 30.0% HIGH (GE 7.0) 51.3%

DATE: 1998/04/01 TO 1998/04/30
ROSE SUMMARY: WIND AND CURRENT

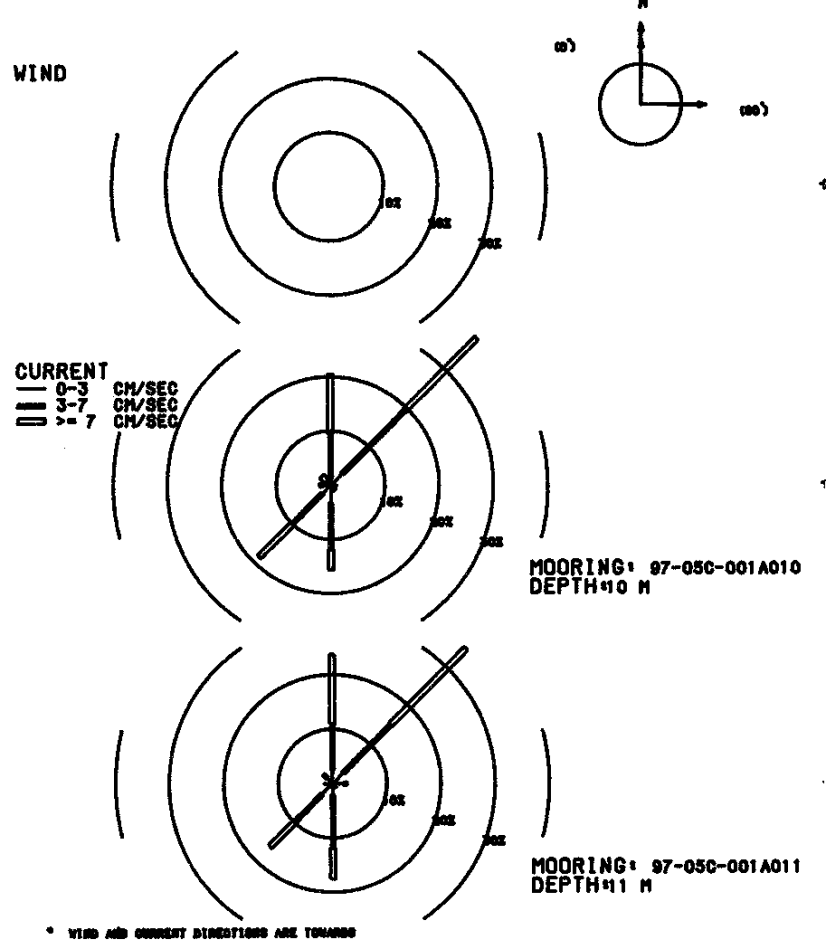

MOORING IS 97-05C-001A010 DEPTH IS 10 METERS THERE ARE 337 VALUES

FIRST DAY 1998/04/01/0000
FINAL DAY 1998/04/15/0000

SHORELINE ORIENTATION IN DEGREES TRUE SPECIFIED AS 90

DIRECTION DEG TRUE	PERCENT OBSERVED	TOWARD	TOTAL	LIGHT	MEDIUM	HIGH	MAXIMUM CURRENT CM/S	MEAN DURA- TION HOURS	MEAN EXCUR- SION KM	MEAN CURRENT CM/S	MEAN TEMP DEG C
90.0	1.2	1.2	0.0	0.0	0.0	0.0	2.1	1.0	0.1	1.6	5.1
45.0	38.3	3.0	16.3	19.0	16.1	3.2	16.1	3.2	0.9	7.8	5.0
0.0	20.5	1.5	8.0	11.0	18.1	1.7	18.1	1.7	0.5	7.6	5.2
315.0	2.4	0.6	0.3	1.5	10.7	1.3	10.7	1.3	0.3	6.2	6.1
270.0	2.1	1.5	0.6	0.0	5.1	1.2	5.1	1.2	0.1	2.4	5.6
225.0	18.7	2.1	7.7	8.9	16.9	2.7	16.9	2.7	0.8	7.7	4.9
180.0	15.7	3.3	8.6	3.9	14.5	2.4	14.5	2.4	0.5	5.2	5.0
135.0	1.2	0.9	0.3	0.0	3.8	1.0	3.8	1.0	0.1	1.9	5.1

MEAN SCALAR SPEED = 7.0 CM/S MEAN SQUARE SPEED = 63.9 CM²/S²
 MEAN SQUARE E-W SPEED = 13.7 CM²/S² MEAN SQUARE N-S SPEED = 50.2 CM²/S²
 MEAN SQUARE U SPEED = 13.7 CM²/S² MEAN SQUARE V SPEED = 50.2 CM²/S²
 MEAN VELOCITY = 2.3 CM/S, 24 DEG TRUE MEAN TEMPERATURE = 5.1 C
 VARIANCE (U,V) = 29.4 CM²/S² TOTAL HOURS = 337.

PERCENT OBSERVED
 LIGHT (0.0 - 3.0) 13.9% MEDIUM (3.0 - 7.0) 41.8% HIGH (GE 7.0) 44.2%

MOORING IS 97-05C-001A011 DEPTH IS 11 METERS THERE ARE 337 VALUES

FIRST DAY 1998/04/01/0000
FINAL DAY 1998/04/15/0000

SHORELINE ORIENTATION IN DEGREES TRUE SPECIFIED AS 90

DIRECTION DEG TRUE	PERCENT OBSERVED	TOWARD	TOTAL	LIGHT	MEDIUM	HIGH	MAXIMUM CURRENT CM/S	MEAN DURA- TION HOURS	MEAN EXCUR- SION KM	MEAN CURRENT CM/S	MEAN TEMP DEG C
90.0	2.7	2.1	0.6	0.0	5.2	1.3	5.2	1.3	0.1	2.2	5.3
45.0	35.0	2.7	12.5	19.9	16.5	3.1	16.5	3.1	0.9	7.9	5.0
0.0	23.7	2.7	8.3	12.8	16.3	2.1	16.3	2.1	0.6	7.6	5.2
315.0	2.4	1.5	0.9	0.0	6.4	1.3	6.4	1.3	0.1	2.7	5.7
270.0	1.5	1.5	0.0	0.0	2.5	1.0	2.5	1.0	0.1	1.7	5.4
225.0	16.3	2.7	6.8	6.8	16.8	2.0	16.8	2.0	0.6	7.6	4.9
180.0	17.5	2.1	9.8	5.6	15.8	2.6	15.8	2.6	0.6	6.1	4.9
135.0	0.9	0.9	0.0	0.0	2.5	1.5	2.5	1.5	0.1	1.3	5.4

MEAN SCALAR SPEED = 7.0 CM/S MEAN SQUARE SPEED = 64.6 CM²/S²
 MEAN SQUARE E-W SPEED = 12.7 CM²/S² MEAN SQUARE N-S SPEED = 51.9 CM²/S²
 MEAN SQUARE U SPEED = 12.7 CM²/S² MEAN SQUARE V SPEED = 51.9 CM²/S²
 MEAN VELOCITY = 2.2 CM/S, 25 DEG TRUE MEAN TEMPERATURE = 5.1 C
 VARIANCE (U,V) = 30.0 CM²/S² TOTAL HOURS = 337.

PERCENT OBSERVED
 LIGHT (0.0 - 3.0) 16.0% MEDIUM (3.0 - 7.0) 38.9% HIGH (GE 7.0) 45.1%

DATE: 1997/11/02 TO 1997/11/30
ROSE SUMMARY: WIND AND CURRENT

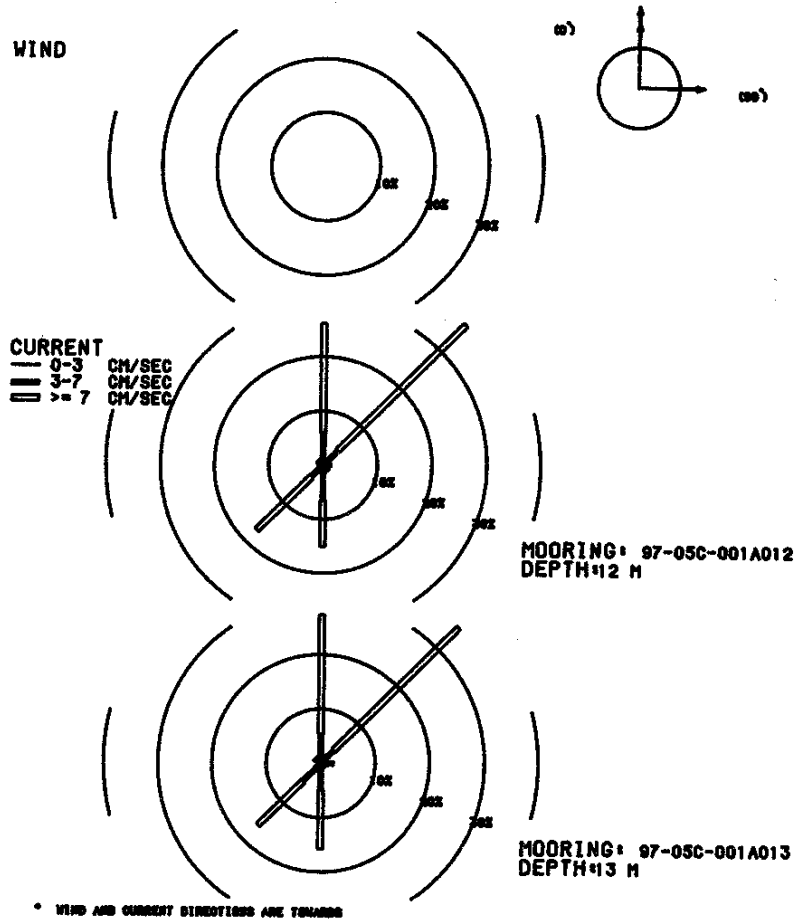

MOORING IS 97-05C-001A012 DEPTH IS 12 METERS THERE ARE 691 VALUES

FIRST DAY 1997/11/02/0500
FINAL DAY 1997/11/30/2300

SHORELINE ORIENTATION IN DEGREES TRUE SPECIFIED AS 90

DIRECTION DEG TRUE	PERCENT OBSERVED	MAXIMUM CURRENT	MEAN DURA- TION HOURS	MEAN EXCUR- SION KM	MEAN CURRENT CM/S	MEAN TEMP DEG C
TOWARD	TOTAL	LIGHT	MEDIUM	HIGH	CM/S	
90.0	1.4	0.4	1.0	0.0	6.6	2.5
45.0	36.9	0.1	3.6	33.1	29.4	4.2
0.0	26.2	0.9	5.1	20.3	25.8	3.0
315.0	1.2	0.6	0.4	0.1	8.0	1.3
270.0	0.9	0.3	0.6	0.0	5.0	1.5
225.0	17.1	0.4	2.5	14.2	23.9	3.5
180.0	15.1	0.4	6.1	8.5	17.8	2.9
135.0	1.3	0.9	0.4	0.0	6.4	1.3

MEAN SCALAR SPEED = 11.3 CM/S MEAN SQUARE SPEED = 159.4 CM2/S2
MEAN SQUARE E-W SPEED = 32.3 CM2/S2 MEAN SQUARE N-S SPEED = 127.1 CM2/S2
MEAN SQUARE U SPEED = 32.3 CM2/S2 MEAN SQUARE V SPEED = 127.1 CM2/S2
MEAN VELOCITY = 4.4 CM/S, 25 DEG TRUE MEAN TEMPERATURE = 8.5 C
VARIANCE (U,V) = 70.0 CM2/S2 TOTAL HOURS = 691.

PERCENT OBSERVED
LIGHT (0.0 - 3.0) 4.1% MEDIUM (3.0 - 7.0) 19.7% HIGH (GE 7.0) 76.3%

MOORING IS 97-05C-001A013 DEPTH IS 13 METERS THERE ARE 691 VALUES

FIRST DAY 1997/11/02/0500
FINAL DAY 1997/11/30/2300

SHORELINE ORIENTATION IN DEGREES TRUE SPECIFIED AS 90

DIRECTION DEG TRUE	PERCENT OBSERVED	MAXIMUM CURRENT	MEAN DURA- TION HOURS	MEAN EXCUR- SION KM	MEAN CURRENT CM/S	MEAN TEMP DEG C
TOWARD	TOTAL	LIGHT	MEDIUM	HIGH	CM/S	
90.0	2.3	0.9	1.4	0.0	5.1	1.8
45.0	35.6	0.1	3.2	32.3	28.6	3.4
0.0	27.4	0.3	5.1	22.0	25.7	2.6
315.0	1.3	0.3	0.7	0.3	8.0	1.5
270.0	0.4	0.3	0.1	0.0	5.1	1.0
225.0	16.2	0.7	3.8	11.7	25.6	2.7
180.0	15.8	0.3	4.6	10.9	17.5	2.9
135.0	1.0	0.1	0.9	0.0	6.9	1.4

MEAN SCALAR SPEED = 11.2 CM/S MEAN SQUARE SPEED = 155.1 CM2/S2
MEAN SQUARE E-W SPEED = 30.4 CM2/S2 MEAN SQUARE N-S SPEED = 124.7 CM2/S2
MEAN SQUARE U SPEED = 30.4 CM2/S2 MEAN SQUARE V SPEED = 124.7 CM2/S2
MEAN VELOCITY = 4.4 CM/S, 25 DEG TRUE MEAN TEMPERATURE = 8.5 C
VARIANCE (U,V) = 68.0 CM2/S2 TOTAL HOURS = 691.

PERCENT OBSERVED
LIGHT (0.0 - 3.0) 3.0% MEDIUM (3.0 - 7.0) 19.8% HIGH (GE 7.0) 77.1%

DATE: 1997/12/01 TO 1997/12/31
 ROSE SUMMARY: WIND AND CURRENT

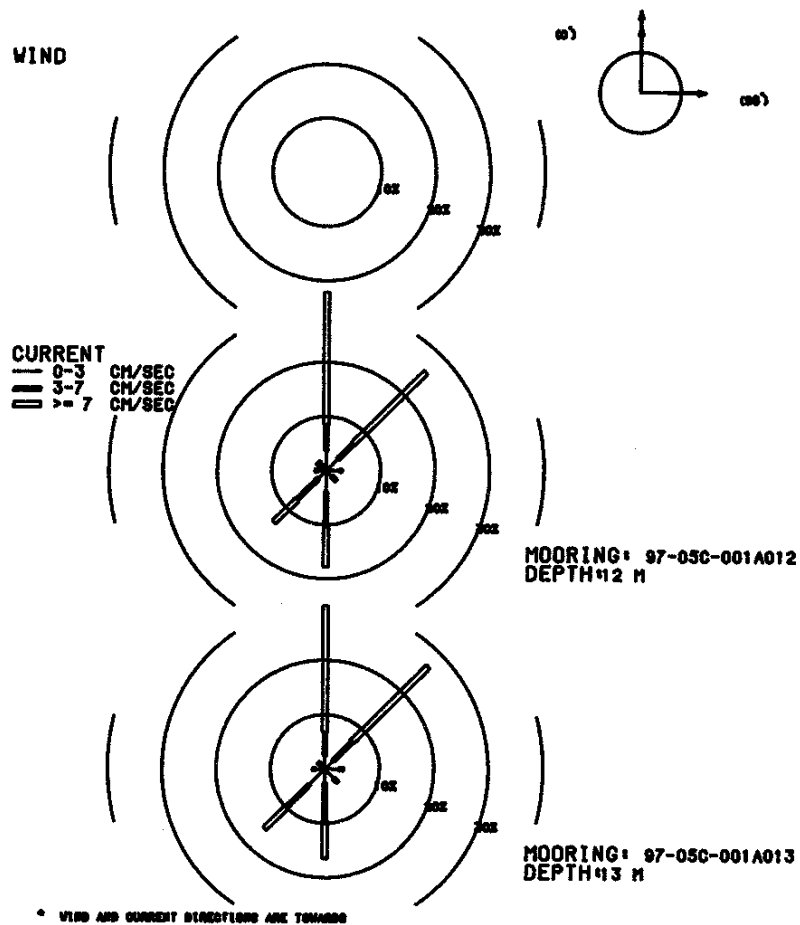

MOORING IS 97-05C-001A012 DEPTH IS 12 METERS THERE ARE 744 VALUES

FIRST DAY 1997/12/01/0000
 FINAL DAY 1997/12/31/2300

SHORELINE ORIENTATION IN DEGREES TRUE SPECIFIED AS 90

DIRECTION DEG TRUE	PERCENT OBSERVED			MAXIMUM CURRENT CM/S	MEAN DURA- TION HOURS	MEAN EXCUR- SION KM	MEAN CURRENT CM/S	MEAN TEMP DEG C
TOWARD	TOTAL	LIGHT	MEDIUM	HIGH	CM/S	HOURS	CM/S	DEG C
90.0	3.0	2.4	0.5	0.0	4.3	1.0	0.1	2.5
45.0	25.8	3.0	4.0	18.8	29.8	2.3	0.9	11.0
0.0	32.9	3.6	4.8	24.5	25.3	2.8	1.2	11.5
315.0	2.2	0.9	0.9	0.3	9.6	1.3	0.2	3.3
270.0	2.0	1.5	0.5	0.0	3.9	1.2	0.1	2.5
225.0	13.6	2.0	5.5	6.0	27.0	1.8	0.5	8.3
180.0	17.9	3.9	6.5	7.5	18.2	2.1	0.5	6.3
135.0	2.7	1.5	1.2	0.0	5.5	1.3	0.1	2.6
0	MEAN SCALAR SPEED = 9.1 CM/S		MEAN SQUARE SPEED = 120.2 CM2/S2					
	MEAN SQUARE E-W SPEED = 18.0 CM2/S2		MEAN SQUARE N-S SPEED = 102.2 CM2/S2					
	MEAN SQUARE U SPEED = 18.0 CM2/S2		MEAN SQUARE V SPEED = 102.2 CM2/S2					
	MEAN VELOCITY = 4.3 CM/S,		19 DEG TRUE		MEAN TEMPERATURE = 4.3 C			
	VARIANCE (U,V) = 50.9 CM2/S2		TOTAL HOURS = 744.					

PERCENT OBSERVED
 LIGHT (0.0 - 3.0) 18.8% MEDIUM (3.0 - 7.0) 24.1% HIGH (GE 7.0) 57.1%

MOORING IS 97-05C-001A013 DEPTH IS 13 METERS THERE ARE 744 VALUES

FIRST DAY 1997/12/01/0000
 FINAL DAY 1997/12/31/2300

SHORELINE ORIENTATION IN DEGREES TRUE SPECIFIED AS 90

DIRECTION DEG TRUE	PERCENT OBSERVED			MAXIMUM CURRENT CM/S	MEAN DURA- TION HOURS	MEAN EXCUR- SION KM	MEAN CURRENT CM/S	MEAN TEMP DEG C
TOWARD	TOTAL	LIGHT	MEDIUM	HIGH	CM/S	HOURS	CM/S	DEG C
90.0	3.5	2.6	0.9	0.0	5.6	1.7	0.1	2.1
45.0	26.7	2.2	4.8	19.8	29.0	3.1	1.3	11.6
0.0	30.1	2.4	4.3	23.4	24.1	3.4	1.4	11.5
315.0	1.7	1.1	0.7	0.0	5.4	1.2	0.1	2.8
270.0	2.3	1.7	0.5	0.0	4.8	1.1	0.1	2.2
225.0	15.6	3.9	5.8	5.9	27.0	2.5	0.7	7.6
180.0	16.5	2.6	6.9	7.1	16.5	2.9	0.7	6.5
135.0	3.5	2.3	1.2	0.0	5.7	1.4	0.1	2.9
0	MEAN SCALAR SPEED = 9.1 CM/S		MEAN SQUARE SPEED = 119.2 CM2/S2					
	MEAN SQUARE E-W SPEED = 18.4 CM2/S2		MEAN SQUARE N-S SPEED = 100.8 CM2/S2					
	MEAN SQUARE U SPEED = 18.4 CM2/S2		MEAN SQUARE V SPEED = 100.8 CM2/S2					
	MEAN VELOCITY = 4.3 CM/S,		20 DEG TRUE		MEAN TEMPERATURE = 4.3 C			
	VARIANCE (U,V) = 50.6 CM2/S2		TOTAL HOURS = 744.					

PERCENT OBSERVED
 LIGHT (0.0 - 3.0) 18.7% MEDIUM (3.0 - 7.0) 25.1% HIGH (GE 7.0) 56.2%

DATE: 1998/01/01 TO 1998/01/31
 ROSE SUMMARY: WIND AND CURRENT

WIND

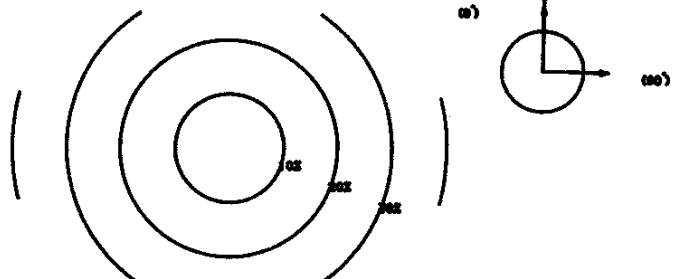

CURRENT
 — 0-3 CM/SEC
 = 3-7 CM/SEC
 ▬ >= 7 CM/SEC

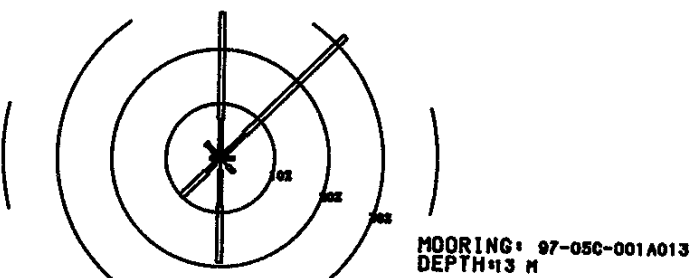
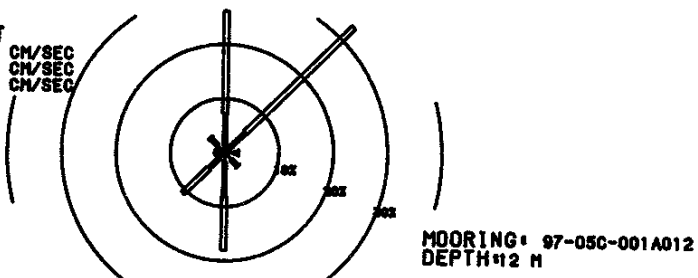

* WIND AND CURRENT DIRECTIONS ARE TOWARDS

MOORING IS 97-05C-001A012 DEPTH IS 12 METERS THERE ARE 744 VALUES

FIRST DAY 1998/01/01/0000
 FINAL DAY 1998/01/31/2300

SHORELINE ORIENTATION IN DEGREES TRUE SPECIFIED AS 90

DIRECTION DEG TRUE	PERCENT OBSERVED	TOWARD	TOTAL	LIGHT	MEDIUM	HIGH	MAXIMUM CURRENT CM/S	MEAN DURATION HOURS	MEAN EXCURSION KM	MEAN CURRENT CM/S	MEAN TEMP DEG C
90.0	2.6	1.7	0.7	0.1	7.8	1.2	0.1	2.7	1.6		
45.0	33.2	0.5	4.8	27.8	34.0	3.2	1.5	12.6	1.9		
0.0	26.2	1.3	5.8	19.1	34.3	2.4	1.0	11.5	1.7		
315.0	3.9	1.9	1.6	0.4	9.3	1.5	0.2	3.6	1.5		
270.0	1.9	0.9	0.7	0.3	7.8	1.3	0.2	3.7	1.8		
225.0	10.8	1.5	2.6	6.7	18.7	2.2	0.7	8.6	2.2		
180.0	18.0	1.6	6.5	9.9	19.7	3.0	0.8	7.7	1.3		
135.0	3.5	1.7	1.6	0.1	10.5	1.2	0.2	3.4	1.6		
0		MEAN SCALAR SPEED = 9.9 CM/S		MEAN SQUARE SPEED = 136.3 CM2/S2							
		MEAN SQUARE E-W SPEED = 24.4 CM2/S2		MEAN SQUARE N-S SPEED = 111.9 CM2/S2							
		MEAN SQUARE U SPEED = 24.4 CM2/S2		MEAN SQUARE V SPEED = 111.9 CM2/S2							
		MEAN VELOCITY = 4.8 CM/S,		26 DEG TRUE		MEAN TEMPERATURE = 1.7 C					
		VARIANCE (U,V) = 56.6 CM2/S2		TOTAL HOURS = 744.							

PERCENT OBSERVED
 LIGHT (0.0 - 3.0) 11.3% MEDIUM (3.0 - 7.0) 24.2% HIGH (GE 7.0) 64.5%

MOORING IS 97-05C-001A013 DEPTH IS 13 METERS THERE ARE 744 VALUES

FIRST DAY 1998/01/01/0000
 FINAL DAY 1998/01/31/2300

SHORELINE ORIENTATION IN DEGREES TRUE SPECIFIED AS 90

DIRECTION DEG TRUE	PERCENT OBSERVED	TOWARD	TOTAL	LIGHT	MEDIUM	HIGH	MAXIMUM CURRENT CM/S	MEAN DURATION HOURS	MEAN EXCURSION KM	MEAN CURRENT CM/S	MEAN TEMP DEG C
90.0	2.6	0.8	1.7	0.0	6.8	1.3	0.2	3.8	1.8		
45.0	32.1	0.9	5.4	25.8	34.4	2.9	1.3	12.3	1.9		
0.0	26.7	1.2	5.9	19.6	28.9	2.5	1.1	11.8	1.8		
315.0	3.8	1.3	2.3	0.1	7.7	1.6	0.2	3.8	1.5		
270.0	1.9	0.7	1.2	0.0	5.7	1.2	0.1	3.4	1.6		
225.0	10.1	1.3	2.3	6.5	19.3	2.3	0.8	9.2	2.0		
180.0	19.2	2.2	6.6	10.5	18.1	3.5	0.9	7.4	1.4		
135.0	3.6	2.0	1.6	0.0	5.9	1.6	0.2	2.8	1.5		
0		MEAN SCALAR SPEED = 9.9 CM/S		MEAN SQUARE SPEED = 135.0 CM2/S2							
		MEAN SQUARE E-W SPEED = 23.8 CM2/S2		MEAN SQUARE N-S SPEED = 111.3 CM2/S2							
		MEAN SQUARE U SPEED = 23.8 CM2/S2		MEAN SQUARE V SPEED = 111.3 CM2/S2							
		MEAN VELOCITY = 4.7 CM/S,		26 DEG TRUE		MEAN TEMPERATURE = 1.7 C					
		VARIANCE (U,V) = 56.3 CM2/S2		TOTAL HOURS = 744.							

PERCENT OBSERVED
 LIGHT (0.0 - 3.0) 10.5% MEDIUM (3.0 - 7.0) 27.0% HIGH (GE 7.0) 62.5%

DATE: 1998/02/01 TO 1998/02/28
 ROSE SUMMARY: WIND AND CURRENT

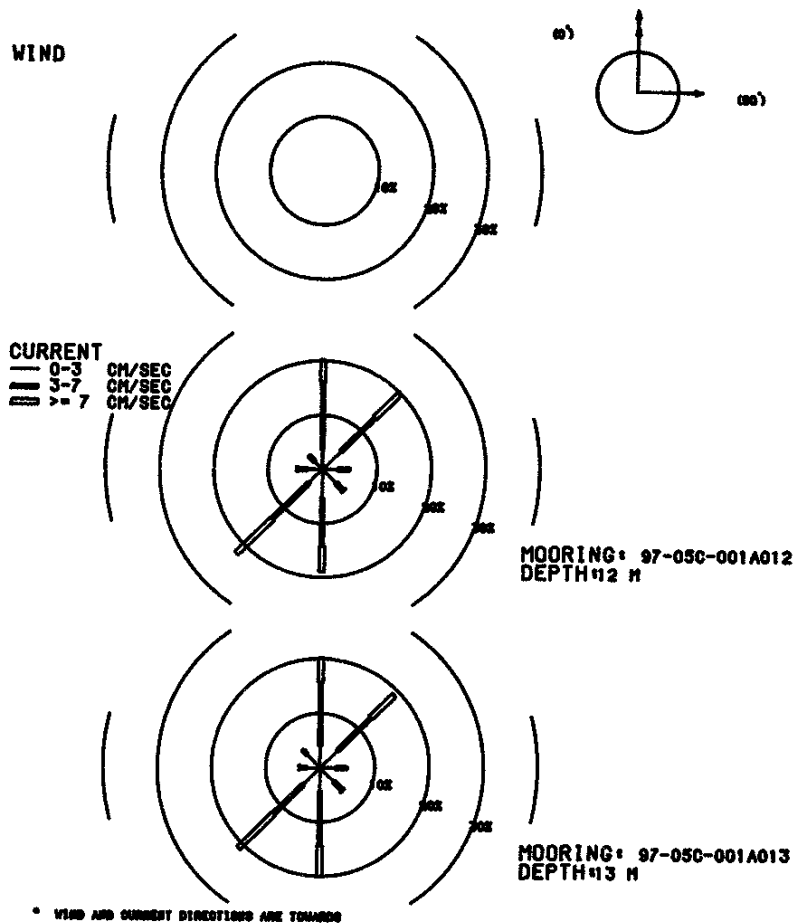

MOORING IS 97-05C-001A012 DEPTH IS 12 METERS THERE ARE 672 VALUES

FIRST DAY 1998/02/01/0000
 FINAL DAY 1998/02/28/2300

SHORELINE ORIENTATION IN DEGREES TRUE SPECIFIED AS 90

DIRECTION DEG TRUE	PERCENT OBSERVED	MAXIMUM CURRENT	MEAN DURA- TION HOURS	MEAN EXCUR- SION KM	MEAN CURRENT CM/S	MEAN TEMP DEG C
TOWARD	TOTAL	LIGHT	MEDIUM	HIGH	CM/S	
90.0	5.1	2.8	2.2	0.0	5.1	1.6
45.0	19.6	4.6	8.8	6.2	16.4	1.6
0.0	20.2	3.6	12.5	4.2	18.1	1.5
315.0	3.6	2.1	1.5	0.0	5.1	1.7
270.0	4.8	2.8	1.8	0.1	9.3	1.8
225.0	22.2	3.4	9.5	9.2	19.0	1.6
180.0	19.0	5.2	8.9	4.9	11.6	1.8
135.0	5.5	3.4	1.9	0.1	8.9	1.8

0 MEAN SCALAR SPEED = 5.3 CM/S MEAN SQUARE SPEED = 41.2 CM2/S2
 MEAN SQUARE E-W SPEED = 10.3 CM2/S2 MEAN SQUARE N-S SPEED = 30.9 CM2/S2
 MEAN SQUARE U SPEED = 10.3 CM2/S2 MEAN SQUARE V SPEED = 30.9 CM2/S2
 MEAN VELOCITY = 0.3 CM/S, 212 DEG TRUE MEAN TEMPERATURE = 1.6 C
 VARIANCE (U,V) = 20.6 CM2/S2 TOTAL HOURS = 672.

PERCENT OBSERVED
 LIGHT (0.0 - 3.0) 28.0% MEDIUM (3.0 - 7.0) 47.2% HIGH (GE 7.0) 24.9%

MOORING IS 97-05C-001A013 DEPTH IS 13 METERS THERE ARE 672 VALUES

FIRST DAY 1998/02/01/0000
 FINAL DAY 1998/02/28/2300

SHORELINE ORIENTATION IN DEGREES TRUE SPECIFIED AS 90

DIRECTION DEG TRUE	PERCENT OBSERVED	MAXIMUM CURRENT	MEAN DURA- TION HOURS	MEAN EXCUR- SION KM	MEAN CURRENT CM/S	MEAN TEMP DEG C
TOWARD	TOTAL	LIGHT	MEDIUM	HIGH	CM/S	
90.0	5.1	2.8	2.2	0.0	5.6	1.5
45.0	19.0	4.3	8.8	6.0	15.4	1.6
0.0	20.2	4.0	11.6	4.6	15.9	1.5
315.0	4.6	3.4	1.2	0.0	5.5	1.7
270.0	3.9	2.5	1.2	0.1	9.7	1.9
225.0	21.1	4.3	7.6	9.2	18.3	1.6
180.0	20.1	4.3	10.0	5.8	12.7	1.8
135.0	6.0	3.6	2.1	0.3	8.2	1.7

0 MEAN SCALAR SPEED = 5.3 CM/S MEAN SQUARE SPEED = 41.3 CM2/S2
 MEAN SQUARE E-W SPEED = 9.7 CM2/S2 MEAN SQUARE N-S SPEED = 31.6 CM2/S2
 MEAN SQUARE U SPEED = 9.7 CM2/S2 MEAN SQUARE V SPEED = 31.6 CM2/S2
 MEAN VELOCITY = 0.2 CM/S, 190 DEG TRUE MEAN TEMPERATURE = 1.6 C
 VARIANCE (U,V) = 20.7 CM2/S2 TOTAL HOURS = 672.

PERCENT OBSERVED
 LIGHT (0.0 - 3.0) 29.3% MEDIUM (3.0 - 7.0) 44.6% HIGH (GE 7.0) 26.0%

DATE: 1998/03/01 TO 1998/03/31
 ROSE SUMMARY: WIND AND CURRENT

WIND

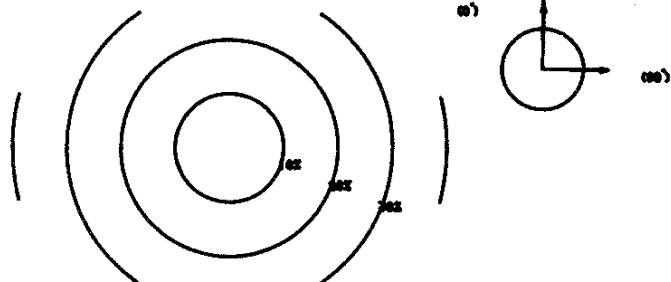

CURRENT
 — 0-3 CM/SEC
 = 3-7 CM/SEC
 ▬ >= 7 CM/SEC

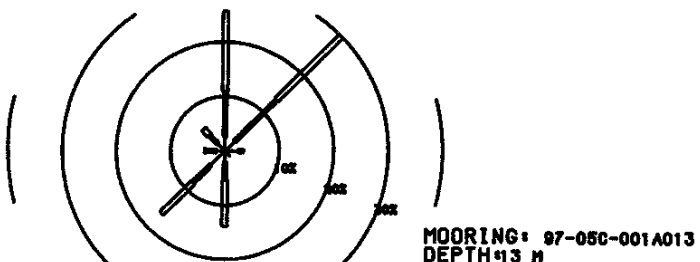
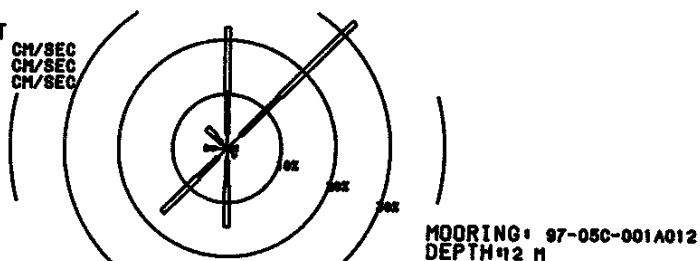

• WIND AND CURRENT DIRECTIONS ARE TOWARDS

MOORING IS 97-05C-001A012 DEPTH IS 12 METERS THERE ARE 744 VALUES

FIRST DAY 1998/03/01/0000
 FINAL DAY 1998/03/31/2300

SHORELINE ORIENTATION IN DEGREES TRUE SPECIFIED AS 90

DIRECTION DEG TRUE	PERCENT OBSERVED			MAXIMUM CURRENT CM/S	MEAN DURA- TION HOURS	MEAN EXCUR- SION KM	MEAN CURRENT CM/S	MEAN TEMP DEG C
TOWARD	TOTAL	LIGHT	MEDIUM	HIGH	CM/S	HOURS	CM/S	DEG C
90.0	1.9	1.1	0.7	0.1	7.8	1.0	0.1	3.1
45.0	33.1	3.5	10.1	19.5	35.6	3.2	1.2	10.0
0.0	22.3	2.7	7.7	12.0	30.4	2.0	0.6	8.9
315.0	5.2	1.3	1.6	2.3	18.6	2.1	0.5	6.6
270.0	4.0	2.2	1.6	0.3	10.7	1.4	0.2	3.3
225.0	16.8	2.3	5.1	9.4	52.1	2.5	1.1	12.5
180.0	14.5	2.2	4.7	7.7	23.5	2.3	0.6	7.7
135.0	2.2	1.9	0.3	0.0	3.3	1.0	0.1	1.8

0 MEAN SCALAR SPEED = 9.1 CM/S MEAN SQUARE SPEED = 143.8 CM2/S2
 MEAN SQUARE E-W SPEED = 34.5 CM2/S2 MEAN SQUARE N-S SPEED = 109.3 CM2/S2
 MEAN SQUARE U SPEED = 34.5 CM2/S2 MEAN SQUARE V SPEED = 109.3 CM2/S2
 MEAN VELOCITY = 2.3 CM/S, 8 DEG TRUE MEAN TEMPERATURE = 2.3 C
 VARIANCE (U,V) = 69.5 CM2/S2 TOTAL HOURS = 744.

PERCENT OBSERVED
 LIGHT (0.0 - 3.0) 17.1% MEDIUM (3.0 - 7.0) 31.7% HIGH (GE 7.0) 51.2%

MOORING IS 97-05C-001A013 DEPTH IS 13 METERS THERE ARE 744 VALUES

FIRST DAY 1998/03/01/0000
 FINAL DAY 1998/03/31/2300

SHORELINE ORIENTATION IN DEGREES TRUE SPECIFIED AS 90

DIRECTION DEG TRUE	PERCENT OBSERVED			MAXIMUM CURRENT CM/S	MEAN DURA- TION HOURS	MEAN EXCUR- SION KM	MEAN CURRENT CM/S	MEAN TEMP DEG C
TOWARD	TOTAL	LIGHT	MEDIUM	HIGH	CM/S	HOURS	CM/S	DEG C
90.0	3.5	2.4	1.1	0.0	5.8	1.2	0.1	2.6
45.0	30.0	2.4	10.9	16.7	31.0	2.7	0.9	9.4
0.0	25.7	2.7	8.2	14.8	33.5	2.1	0.7	9.5
315.0	5.6	1.9	2.2	1.6	18.1	1.7	0.3	5.6
270.0	3.8	1.5	2.2	0.1	10.9	1.3	0.2	3.7
225.0	16.4	3.6	4.6	8.2	53.3	2.5	1.1	12.0
180.0	13.8	2.0	3.4	8.5	31.7	2.6	0.8	8.5
135.0	1.2	1.2	0.0	0.0	2.9	1.1	0.1	2.0

0 MEAN SCALAR SPEED = 9.0 CM/S MEAN SQUARE SPEED = 141.2 CM2/S2
 MEAN SQUARE E-W SPEED = 32.2 CM2/S2 MEAN SQUARE N-S SPEED = 109.0 CM2/S2
 MEAN SQUARE U SPEED = 32.2 CM2/S2 MEAN SQUARE V SPEED = 109.0 CM2/S2
 MEAN VELOCITY = 2.2 CM/S, 8 DEG TRUE MEAN TEMPERATURE = 2.3 C
 VARIANCE (U,V) = 68.2 CM2/S2 TOTAL HOURS = 744.

PERCENT OBSERVED
 LIGHT (0.0 - 3.0) 17.7% MEDIUM (3.0 - 7.0) 32.4% HIGH (GE 7.0) 49.9%

DATE: 1998/04/01 TO 1998/04/30
ROSE SUMMARY: WIND AND CURRENT

WIND

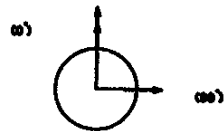
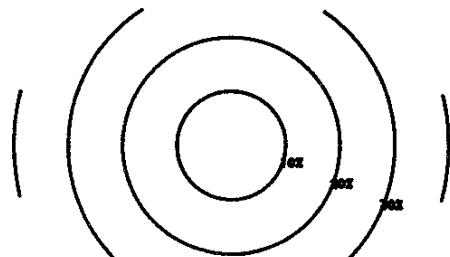

CURRENT

0-3 CM/SEC
3-7 CM/SEC
> 7 CM/SEC

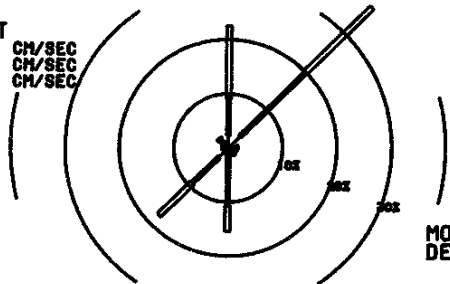

MOORING: 97-05C-001A012
DEPTH: 12 M

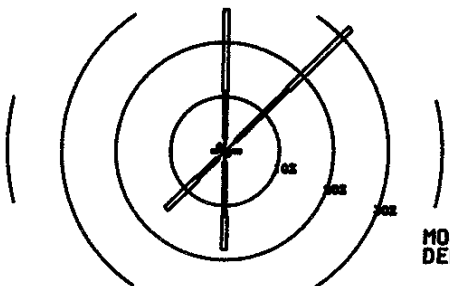

MOORING: 97-05C-001A013
DEPTH: 13 M

* WIND AND CURRENT DIRECTIONS ARE TOWARDS

MOORING IS 97-05C-001A012 DEPTH IS 12 METERS THERE ARE 337 VALUES

FIRST DAY 1998/04/01/0000
FINAL DAY 1998/04/15/0000

SHORELINE ORIENTATION IN DEGREES TRUE SPECIFIED AS 90

DIRECTION DEG TRUE	PERCENT OBSERVED			MAXIMUM CURRENT CM/S	MEAN DURA- TION HOURS	MEAN EXCUR- SION KM	MEAN CURRENT CM/S	MEAN TEMP DEG C
TOWARD	TOTAL	LIGHT	MEDIUM	HIGH	CM/S	HOURS	CM/S	DEG C
90.0	1.8	0.9	0.6	0.3	8.0	1.2	0.2	3.7
45.0	37.1	3.0	16.6	17.5	15.1	3.2	0.8	7.3
0.0	22.6	2.4	6.8	13.4	17.2	1.8	0.5	8.1
315.0	2.4	1.2	0.9	0.3	8.5	1.3	0.2	3.5
270.0	1.2	0.9	0.3	0.0	3.7	1.0	0.1	2.2
225.0	17.8	2.4	6.8	8.6	18.1	2.4	0.7	7.8
180.0	15.4	1.2	9.5	4.7	15.5	2.1	0.5	6.2
135.0	1.8	1.2	0.6	0.0	4.6	1.2	0.1	3.0
0	MEAN SCALAR SPEED = 7.1 CM/S		MEAN SQUARE SPEED = 65.0 CM2/S2					
	MEAN SQUARE E-W SPEED = 13.3 CM2/S2		MEAN SQUARE N-S SPEED = 51.8 CM2/S2					
	MEAN SQUARE U SPEED = 13.3 CM2/S2		MEAN SQUARE V SPEED = 51.8 CM2/S2					
	MEAN VELOCITY = 2.2 CM/S,		27 DEG TRUE		MEAN TEMPERATURE = 5.1 C			
	VARIANCE (U,V) = 30.2 CM2/S2		TOTAL HOURS = 337.					

PERCENT OBSERVED
LIGHT (0.0 - 3.0) 13.1% MEDIUM (3.0 - 7.0) 42.1% HIGH (GE 7.0) 44.8%

MOORING IS 97-05C-001A013 DEPTH IS 13 METERS THERE ARE 337 VALUES

FIRST DAY 1998/04/01/0000
FINAL DAY 1998/04/15/0000

SHORELINE ORIENTATION IN DEGREES TRUE SPECIFIED AS 90

DIRECTION DEG TRUE	PERCENT OBSERVED			MAXIMUM CURRENT CM/S	MEAN DURA- TION HOURS	MEAN EXCUR- SION KM	MEAN CURRENT CM/S	MEAN TEMP DEG C
TOWARD	TOTAL	LIGHT	MEDIUM	HIGH	CM/S	HOURS	CM/S	DEG C
90.0	3.0	1.5	1.5	0.0	4.6	1.1	0.1	3.1
45.0	32.3	2.7	13.6	16.0	14.2	3.3	0.9	7.3
0.0	26.1	2.4	8.6	15.1	16.6	2.5	0.7	8.0
315.0	1.8	0.6	1.2	0.0	5.3	1.2	0.1	3.2
270.0	2.4	1.5	0.9	0.0	5.4	1.1	0.1	2.9
225.0	15.1	1.8	5.3	8.0	17.2	2.4	0.7	8.4
180.0	18.1	2.1	9.8	6.2	15.8	3.0	0.7	6.5
135.0	1.2	0.6	0.6	0.0	5.1	1.0	0.1	3.0
0	MEAN SCALAR SPEED = 7.2 CM/S		MEAN SQUARE SPEED = 65.5 CM2/S2					
	MEAN SQUARE E-W SPEED = 12.7 CM2/S2		MEAN SQUARE N-S SPEED = 52.8 CM2/S2					
	MEAN SQUARE U SPEED = 12.7 CM2/S2		MEAN SQUARE V SPEED = 52.8 CM2/S2					
	MEAN VELOCITY = 2.0 CM/S,		29 DEG TRUE		MEAN TEMPERATURE = 5.1 C			
	VARIANCE (U,V) = 30.9 CM2/S2		TOTAL HOURS = 337.					

PERCENT OBSERVED
LIGHT (0.0 - 3.0) 13.1% MEDIUM (3.0 - 7.0) 41.5% HIGH (GE 7.0) 45.4%

DATE: 1997/11/02 TO 1997/11/30
 ROSE SUMMARY: WIND AND CURRENT

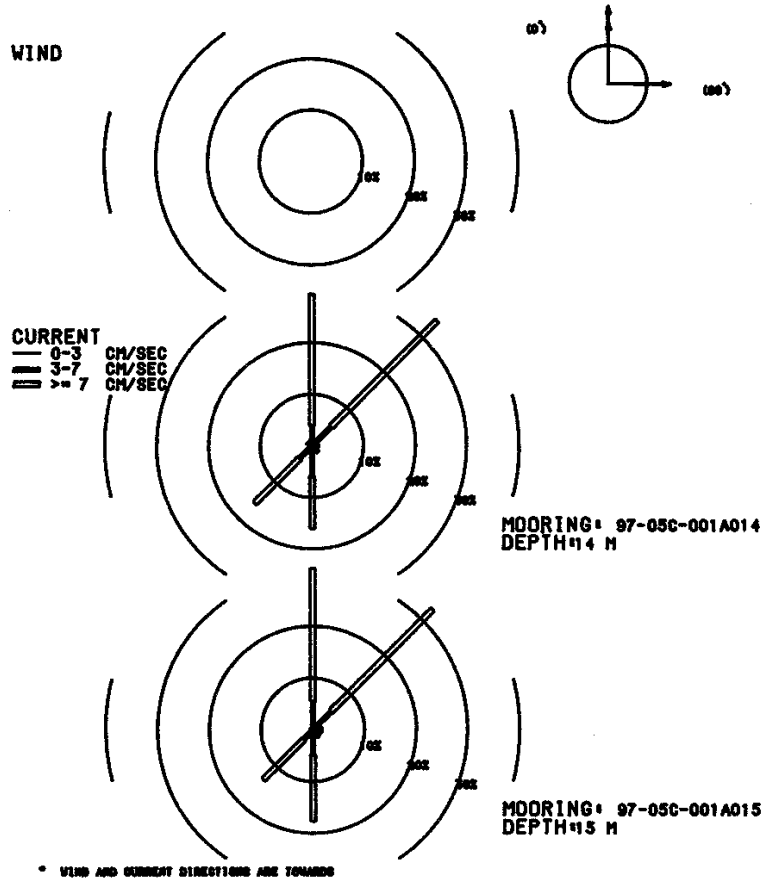

MOORING IS 97-05C-001A014 DEPTH IS 14 METERS THERE ARE 691 VALUES

FIRST DAY 1997/11/02/0500
 FINAL DAY 1997/11/30/2300

SHORELINE ORIENTATION IN DEGREES TRUE SPECIFIED AS 90

DIRECTION DEG TRUE	PERCENT OBSERVED	MAXIMUM CURRENT	MEAN DURA- TION HOURS	MEAN EXCUR- SION KM	MEAN CURRENT CM/S	MEAN TEMP DEG C
TOWARD	TOTAL	LIGHT	MEDIUM	HIGH	CM/S	
90.0	1.3	0.3	1.0	0.0	6.1	1.8
45.0	34.3	0.4	4.8	29.1	28.3	3.1
0.0	29.4	0.3	3.6	25.5	25.1	2.8
315.0	1.0	0.1	0.7	0.1	7.2	1.8
270.0	0.4	0.0	0.4	0.0	4.9	1.5
225.0	15.8	0.9	2.5	12.4	24.6	2.9
180.0	16.1	0.6	5.4	10.1	17.7	2.8
135.0	1.7	0.3	1.4	0.0	5.8	1.5

0 MEAN SCALAR SPEED = 11.2 CM/S MEAN SQUARE SPEED = 155.3 CM²/S²
 MEAN SQUARE E-W SPEED = 29.8 CM²/S² MEAN SQUARE N-S SPEED = 125.5 CM²/S²
 MEAN SQUARE U SPEED = 29.8 CM²/S² MEAN SQUARE V SPEED = 125.5 CM²/S²
 MEAN VELOCITY = 4.5 CM/S, 25 DEG TRUE MEAN TEMPERATURE = 8.5 C
 VARIANCE (U,V) = 67.4 CM²/S² TOTAL HOURS = 691.

PERCENT OBSERVED
 LIGHT (0.0 - 3.0) 2.9% MEDIUM (3.0 - 7.0) 19.8% HIGH (GE 7.0) 77.3%

MOORING IS 97-05C-001A015 DEPTH IS 15 METERS THERE ARE 691 VALUES

FIRST DAY 1997/11/02/0500
 FINAL DAY 1997/11/30/2300

SHORELINE ORIENTATION IN DEGREES TRUE SPECIFIED AS 90

DIRECTION DEG TRUE	PERCENT OBSERVED	MAXIMUM CURRENT	MEAN DURA- TION HOURS	MEAN EXCUR- SION KM	MEAN CURRENT CM/S	MEAN TEMP DEG C
TOWARD	TOTAL	LIGHT	MEDIUM	HIGH	CM/S	
90.0	1.7	0.7	0.9	0.1	8.4	1.1
45.0	32.9	0.3	4.6	27.9	28.0	3.2
0.0	31.3	0.0	5.5	25.8	25.5	3.2
315.0	0.6	0.1	0.4	0.0	5.6	1.3
270.0	0.6	0.0	0.6	0.0	4.2	1.3
225.0	13.6	0.6	1.9	11.1	25.3	2.8
180.0	17.7	0.1	4.6	12.9	18.6	3.6
135.0	1.7	0.6	1.2	0.0	5.8	1.2

0 MEAN SCALAR SPEED = 11.1 CM/S MEAN SQUARE SPEED = 149.6 CM²/S²
 MEAN SQUARE E-W SPEED = 27.5 CM²/S² MEAN SQUARE N-S SPEED = 122.2 CM²/S²
 MEAN SQUARE U SPEED = 27.5 CM²/S² MEAN SQUARE V SPEED = 122.2 CM²/S²
 MEAN VELOCITY = 4.4 CM/S, 25 DEG TRUE MEAN TEMPERATURE = 8.5 C
 VARIANCE (U,V) = 65.4 CM²/S² TOTAL HOURS = 691.

PERCENT OBSERVED
 LIGHT (0.0 - 3.0) 2.5% MEDIUM (3.0 - 7.0) 19.7% HIGH (GE 7.0) 77.9%

DATE: 1997/12/01 TO 1997/12/31
 ROSE SUMMARY: WIND AND CURRENT

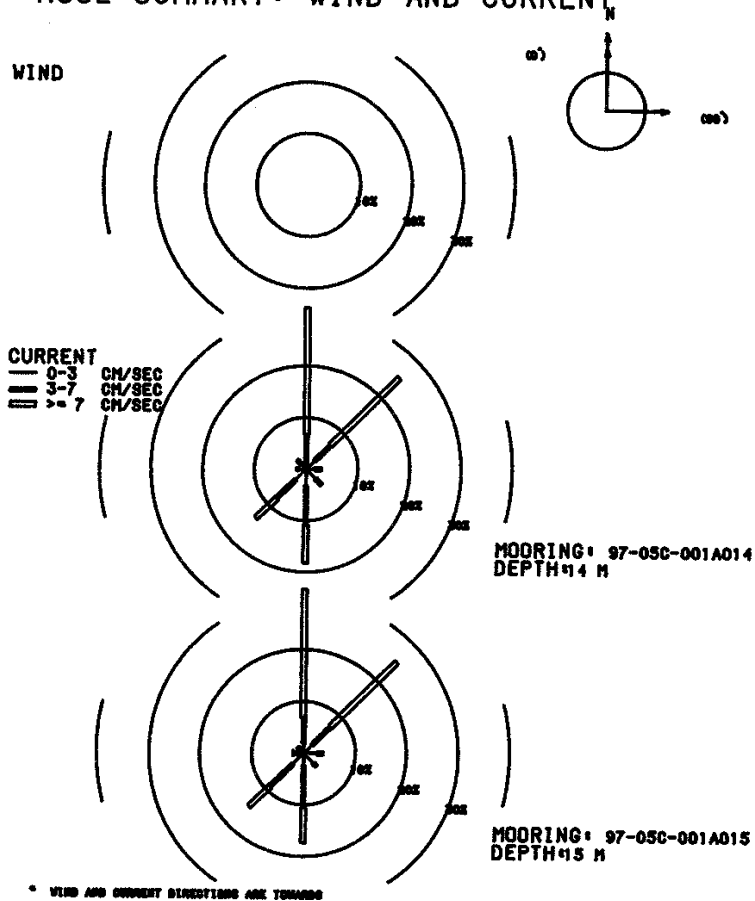

MOORING IS 97-05C-001A014 DEPTH IS 14 METERS THERE ARE 744 VALUES

FIRST DAY 1997/12/01/0000
 FINAL DAY 1997/12/31/2300

SHORELINE ORIENTATION IN DEGREES TRUE SPECIFIED AS 90

DIRECTION DEG TRUE	PERCENT OBSERVED	MAXIMUM CURRENT	MEAN DURA- TION HOURS	MEAN EXCUR- SION KM	MEAN CURRENT CM/S	MEAN TEMP DEG C
TOWARD	TOTAL	LIGHT	MEDIUM	HIGH	CM/S	
90.0	3.0	1.6	1.3	0.0	4.6	1.3
45.0	25.3	2.2	4.3	18.8	29.1	2.5
0.0	31.3	1.2	5.5	24.6	26.7	3.1
315.0	2.4	1.6	0.8	0.0	5.4	1.3
270.0	1.9	1.3	0.5	0.0	4.6	1.2
225.0	13.6	2.8	5.1	5.6	25.5	2.0
180.0	18.3	3.2	7.7	7.4	18.9	2.3
135.0	4.3	2.6	1.7	0.0	6.4	1.3
0		MEAN SCALAR SPEED = 9.0 CM/S		MEAN SQUARE SPEED = 117.6 CM ² /S ²		
		MEAN SQUARE E-W SPEED = 18.0 CM ² /S ²		MEAN SQUARE N-S SPEED = 99.6 CM ² /S ²		
		MEAN SQUARE U SPEED = 18.0 CM ² /S ²		MEAN SQUARE V SPEED = 99.6 CM ² /S ²		
		MEAN VELOCITY = 4.2 CM/S,		20 DEG TRUE		MEAN TEMPERATURE = 4.3 C
		VARIANCE (U,V) = 49.9 CM ² /S ²		TOTAL HOURS = 744.		

PERCENT OBSERVED

LIGHT (0.0 - 3.0) 16.5% MEDIUM (3.0 - 7.0) 27.0% HIGH (GE 7.0) 56.5%

MOORING IS 97-05C-001A015 DEPTH IS 15 METERS THERE ARE 744 VALUES

FIRST DAY 1997/12/01/0000
 FINAL DAY 1997/12/31/2300

SHORELINE ORIENTATION IN DEGREES TRUE SPECIFIED AS 90

DIRECTION DEG TRUE	PERCENT OBSERVED	MAXIMUM CURRENT	MEAN DURA- TION HOURS	MEAN EXCUR- SION KM	MEAN CURRENT CM/S	MEAN TEMP DEG C
TOWARD	TOTAL	LIGHT	MEDIUM	HIGH	CM/S	
90.0	3.8	2.6	1.2	0.0	5.8	1.6
45.0	25.1	2.3	4.8	18.0	27.8	2.5
0.0	31.7	1.9	5.0	24.9	25.2	3.2
315.0	1.6	0.9	0.7	0.0	5.4	1.7
270.0	2.2	1.1	0.9	0.1	7.3	1.3
225.0	14.8	2.8	6.2	5.8	25.3	2.3
180.0	17.3	2.4	8.1	6.9	16.0	2.6
135.0	3.5	2.7	0.8	0.0	4.9	1.2
0		MEAN SCALAR SPEED = 8.9 CM/S		MEAN SQUARE SPEED = 114.1 CM ² /S ²		
		MEAN SQUARE E-W SPEED = 17.7 CM ² /S ²		MEAN SQUARE N-S SPEED = 96.4 CM ² /S ²		
		MEAN SQUARE U SPEED = 17.7 CM ² /S ²		MEAN SQUARE V SPEED = 96.4 CM ² /S ²		
		MEAN VELOCITY = 4.0 CM/S,		21 DEG TRUE		MEAN TEMPERATURE = 4.3 C
		VARIANCE (U,V) = 49.1 CM ² /S ²		TOTAL HOURS = 744.		

PERCENT OBSERVED

LIGHT (0.0 - 3.0) 16.7% MEDIUM (3.0 - 7.0) 27.7% HIGH (GE 7.0) 55.6%

DATE: 1998/01/01 TO 1998/01/31
 ROSE SUMMARY: WIND AND CURRENT

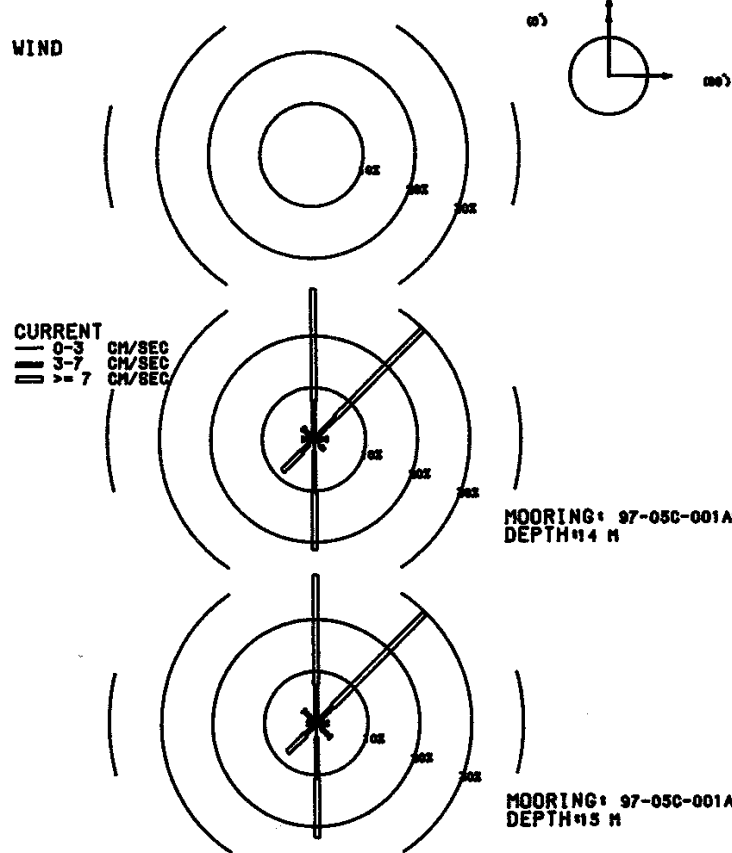

* WIND AND CURRENT DIRECTIONS ARE TOWARD

MOORING IS 97-05C-001A014 DEPTH IS 14 METERS THERE ARE 744 VALUES

FIRST DAY 1998/01/01/0000
 FINAL DAY 1998/01/31/2300

SHORELINE ORIENTATION IN DEGREES TRUE SPECIFIED AS 90

DIRECTION DEG TRUE	PERCENT OBSERVED	MAXIMUM CURRENT CM/S	MEAN DURA- TION HOURS	MEAN EXCUR- SION KM	MEAN CURRENT CM/S	MEAN TEMP DEG C
TOWARD	TOTAL	LIGHT	MEDIUM	HIGH	CM/S	
90.0	2.6	0.9	1.5	0.1	7.4	1.5
45.0	30.0	1.6	4.3	24.1	32.1	3.3
0.0	29.2	0.9	6.5	21.8	28.4	3.2
315.0	3.1	0.9	1.7	0.4	8.9	1.4
270.0	2.3	0.7	1.5	0.1	9.7	1.3
225.0	8.6	1.5	1.9	5.2	19.1	1.9
180.0	21.5	2.4	7.8	11.3	18.8	4.7
135.0	2.8	1.7	1.1	0.0	6.0	1.6

0 MEAN SCALAR SPEED = 9.7 CM/S MEAN SQUARE SPEED = 132.5 CM2/S2
 MEAN SQUARE E-W SPEED = 22.3 CM2/S2 MEAN SQUARE N-S SPEED = 110.2 CM2/S2
 MEAN SQUARE U SPEED = 22.3 CM2/S2 MEAN SQUARE V SPEED = 110.2 CM2/S2
 MEAN VELOCITY = 4.7 CM/S, 25 DEG TRUE MEAN TEMPERATURE = 1.7 C
 VARIANCE (U,V) = 55.4 CM2/S2 TOTAL HOURS = 744.

PERCENT OBSERVED
 LIGHT (0.0 - 3.0) 10.8% MEDIUM (3.0 - 7.0) 26.2% HIGH (GE 7.0) 63.0%

MOORING IS 97-05C-001A015 DEPTH IS 15 METERS THERE ARE 744 VALUES

FIRST DAY 1998/01/01/0000
 FINAL DAY 1998/01/31/2300

SHORELINE ORIENTATION IN DEGREES TRUE SPECIFIED AS 90

DIRECTION DEG TRUE	PERCENT OBSERVED	MAXIMUM CURRENT CM/S	MEAN DURA- TION HOURS	MEAN EXCUR- SION KM	MEAN CURRENT CM/S	MEAN TEMP DEG C
TOWARD	TOTAL	LIGHT	MEDIUM	HIGH	CM/S	
90.0	2.3	0.9	1.1	0.3	8.7	1.3
45.0	29.8	1.1	3.4	25.4	31.3	2.9
0.0	28.6	0.9	6.5	21.2	29.8	2.8
315.0	3.5	1.2	2.2	0.1	8.2	1.6
270.0	1.7	0.8	0.8	0.1	7.4	1.3
225.0	7.9	0.7	2.3	5.0	18.2	1.7
180.0	22.2	2.7	7.9	11.6	20.8	3.5
135.0	3.9	1.5	2.2	0.3	11.7	1.3

0 MEAN SCALAR SPEED = 9.7 CM/S MEAN SQUARE SPEED = 129.4 CM2/S2
 MEAN SQUARE E-W SPEED = 21.6 CM2/S2 MEAN SQUARE N-S SPEED = 107.8 CM2/S2
 MEAN SQUARE U SPEED = 21.6 CM2/S2 MEAN SQUARE V SPEED = 107.8 CM2/S2
 MEAN VELOCITY = 4.6 CM/S, 27 DEG TRUE MEAN TEMPERATURE = 1.7 C
 VARIANCE (U,V) = 54.1 CM2/S2 TOTAL HOURS = 744.

PERCENT OBSERVED
 LIGHT (0.0 - 3.0) 9.8% MEDIUM (3.0 - 7.0) 26.2% HIGH (GE 7.0) 64.0%

DATE: 1998/02/01 TO 1998/02/28
ROSE SUMMARY: WIND AND CURRENT

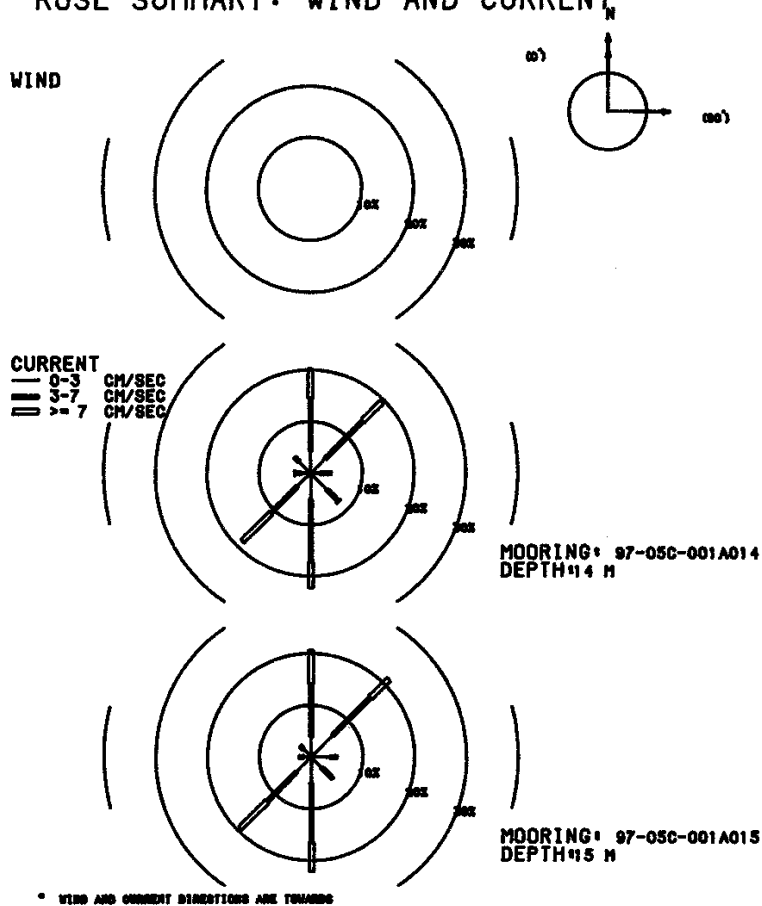

MOORING IS 97-05C-001A014 DEPTH IS 14 METERS THERE ARE 672 VALUES

FIRST DAY 1998/02/01/0000
FINAL DAY 1998/02/28/2300

SHORELINE ORIENTATION IN DEGREES TRUE SPECIFIED AS 90

DIRECTION DEG TRUE	PERCENT OBSERVED	MAXIMUM CURRENT	MEAN DURA- TION HOURS	MEAN EXCUR- SION KM	MEAN CURRENT CM/S	MEAN TEMP DEG C
TOWARD	TOTAL	LIGHT	MEDIUM	HIGH	CM/S	
90.0	4.0	1.9	2.1	0.0	5.6	1.3
45.0	19.5	3.9	10.4	5.2	18.0	2.0
0.0	20.2	4.3	10.1	5.8	16.5	2.0
315.0	4.3	3.1	1.2	0.0	5.9	1.5
270.0	3.1	1.8	1.2	0.1	10.9	1.1
225.0	18.8	3.6	7.3	7.9	18.0	2.4
180.0	22.3	5.1	12.2	5.1	15.4	2.2
135.0	7.7	4.5	3.0	0.3	11.5	1.4
0		MEAN SCALAR SPEED = 5.4 CM/S		MEAN SQUARE SPEED = 41.5 CM ² /S ²		
		MEAN SQUARE E-W SPEED = 9.4 CM ² /S ²		MEAN SQUARE N-S SPEED = 32.1 CM ² /S ²		
		MEAN SQUARE U SPEED = 9.4 CM ² /S ²		MEAN SQUARE V SPEED = 32.1 CM ² /S ²		
		MEAN VELOCITY = 0.3 CM/S,		175 DEG TRUE		MEAN TEMPERATURE = 1.6 C
		VARIANCE (U,V) = 20.7 CM ² /S ²		TOTAL HOURS = 672.		

PERCENT OBSERVED
LIGHT (0.0 - 3.0) 28.1% MEDIUM (3.0 - 7.0) 47.5% HIGH (GE 7.0) 24.4%

MOORING IS 97-05C-001A015 DEPTH IS 15 METERS THERE ARE 672 VALUES

FIRST DAY 1998/02/01/0000
FINAL DAY 1998/02/28/2300

SHORELINE ORIENTATION IN DEGREES TRUE SPECIFIED AS 90

DIRECTION DEG TRUE	PERCENT OBSERVED	MAXIMUM CURRENT	MEAN DURA- TION HOURS	MEAN EXCUR- SION KM	MEAN CURRENT CM/S	MEAN TEMP DEG C
TOWARD	TOTAL	LIGHT	MEDIUM	HIGH	CM/S	
90.0	5.1	3.7	1.3	0.0	5.5	1.2
45.0	21.3	5.8	10.4	5.1	17.2	2.2
0.0	20.7	3.9	10.3	6.5	17.1	2.4
315.0	3.0	2.2	0.7	0.0	6.6	1.4
270.0	2.4	1.5	0.9	0.0	6.2	1.1
225.0	19.5	4.0	8.0	7.4	16.7	2.6
180.0	22.2	5.1	11.5	5.7	13.8	2.6
135.0	6.0	3.0	3.0	0.0	6.7	1.4
0		MEAN SCALAR SPEED = 5.3 CM/S		MEAN SQUARE SPEED = 40.2 CM ² /S ²		
		MEAN SQUARE E-W SPEED = 8.5 CM ² /S ²		MEAN SQUARE N-S SPEED = 31.7 CM ² /S ²		
		MEAN SQUARE U SPEED = 8.5 CM ² /S ²		MEAN SQUARE V SPEED = 31.7 CM ² /S ²		
		MEAN VELOCITY = 0.2 CM/S,		140 DEG TRUE		MEAN TEMPERATURE = 1.6 C
		VARIANCE (U,V) = 20.1 CM ² /S ²		TOTAL HOURS = 672.		

PERCENT OBSERVED
LIGHT (0.0 - 3.0) 29.2% MEDIUM (3.0 - 7.0) 46.1% HIGH (GE 7.0) 24.7%

DATE: 1998/03/01 TO 1998/03/31
 ROSE SUMMARY: WIND AND CURRENT

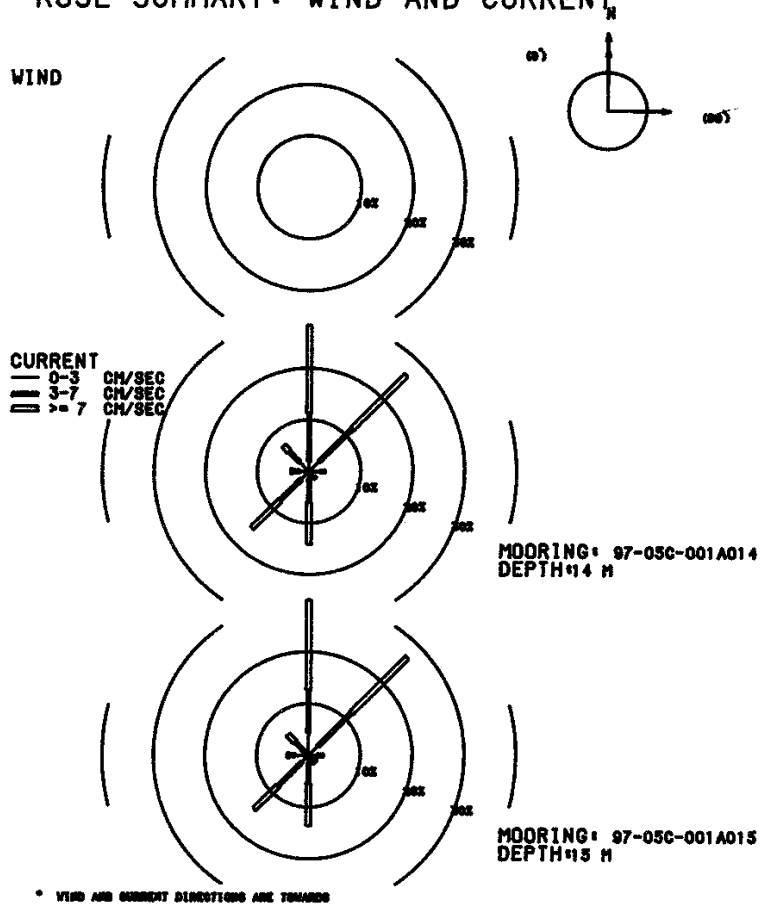

MOORING IS 97-05C-001A014 DEPTH IS 14 METERS THERE ARE 744 VALUES

FIRST DAY 1998/03/01/0000
 FINAL DAY 1998/03/31/2300

SHORELINE ORIENTATION IN DEGREES TRUE SPECIFIED AS 90

DIRECTION DEG TRUE	PERCENT OBSERVED	TOWARD	TOTAL	LIGHT	MEDIUM	HIGH	MAXIMUM CURRENT CM/S	MEAN DURA- TION HOURS	MEAN EXCUR- SION KM	MEAN CURRENT CM/S	MEAN TEMP DEG C
90.0	3.1	2.2	0.9	0.0	5.8	1.3	0.1	2.5	2.4		
45.0	26.5	2.7	9.0	14.8	28.2	2.2	0.8	9.9	2.5		
0.0	28.4	1.9	9.4	17.1	32.3	2.3	0.8	9.4	2.4		
315.0	7.0	2.6	2.8	1.6	17.3	2.4	0.4	5.0	2.5		
270.0	3.5	1.9	1.3	0.3	13.8	1.2	0.2	3.9	2.5		
225.0	15.6	2.0	5.8	7.8	54.9	3.0	1.4	12.8	2.2		
180.0	14.1	1.3	4.6	8.2	21.8	3.2	0.9	8.2	1.9		
135.0	1.9	1.3	0.5	0.0	3.3	1.4	0.1	2.1	2.7		
0		MEAN SCALAR SPEED = 9.0 CM/S		MEAN SQUARE SPEED = 142.3 CM2/S2							
		MEAN SQUARE E-W SPEED = 31.0 CM2/S2		MEAN SQUARE N-S SPEED = 111.4 CM2/S2							
		MEAN SQUARE U SPEED = 31.0 CM2/S2		MEAN SQUARE V SPEED = 111.4 CM2/S2							
		MEAN VELOCITY = 2.3 CM/S,		7 DEG TRUE		MEAN TEMPERATURE = 2.3 C					
		VARIANCE (U,V) = 68.7 CM2/S2		TOTAL HOURS = 744.							

PERCENT OBSERVED

LIGHT (0.0 - 3.0) 15.9% MEDIUM (3.0 - 7.0) 34.4% HIGH (GE 7.0) 49.7%

MOORING IS 97-05C-001A015 DEPTH IS 15 METERS THERE ARE 744 VALUES

FIRST DAY 1998/03/01/0000
 FINAL DAY 1998/03/31/2300

SHORELINE ORIENTATION IN DEGREES TRUE SPECIFIED AS 90

DIRECTION DEG TRUE	PERCENT OBSERVED	TOWARD	TOTAL	LIGHT	MEDIUM	HIGH	MAXIMUM CURRENT CM/S	MEAN DURA- TION HOURS	MEAN EXCUR- SION KM	MEAN CURRENT CM/S	MEAN TEMP DEG C
90.0	3.0	1.6	1.3	0.0	6.8	1.4	0.1	2.6	2.6		
45.0	26.9	2.4	9.0	15.5	24.6	2.3	0.8	9.4	2.5		
0.0	30.1	4.3	8.3	17.5	30.7	2.3	0.8	9.0	2.4		
315.0	5.6	0.8	2.8	2.0	17.2	2.5	0.5	6.0	2.3		
270.0	4.2	2.6	1.2	0.4	12.8	1.3	0.2	3.3	2.5		
225.0	14.8	1.7	6.6	6.5	52.7	2.4	1.1	12.9	2.2		
180.0	13.6	1.5	3.9	8.2	22.6	2.8	0.8	8.2	1.9		
135.0	1.9	1.2	0.5	0.1	7.4	1.4	0.2	3.0	2.2		
0		MEAN SCALAR SPEED = 8.9 CM/S		MEAN SQUARE SPEED = 138.2 CM2/S2							
		MEAN SQUARE E-W SPEED = 28.0 CM2/S2		MEAN SQUARE N-S SPEED = 110.1 CM2/S2							
		MEAN SQUARE U SPEED = 28.0 CM2/S2		MEAN SQUARE V SPEED = 110.1 CM2/S2							
		MEAN VELOCITY = 2.3 CM/S,		8 DEG TRUE		MEAN TEMPERATURE = 2.3 C					
		VARIANCE (U,V) = 66.5 CM2/S2		TOTAL HOURS = 744.							

PERCENT OBSERVED

LIGHT (0.0 - 3.0) 16.1% MEDIUM (3.0 - 7.0) 33.7% HIGH (GE 7.0) 50.1%

DATE: 1998/04/01 TO 1998/04/30
ROSE SUMMARY: WIND AND CURRENT

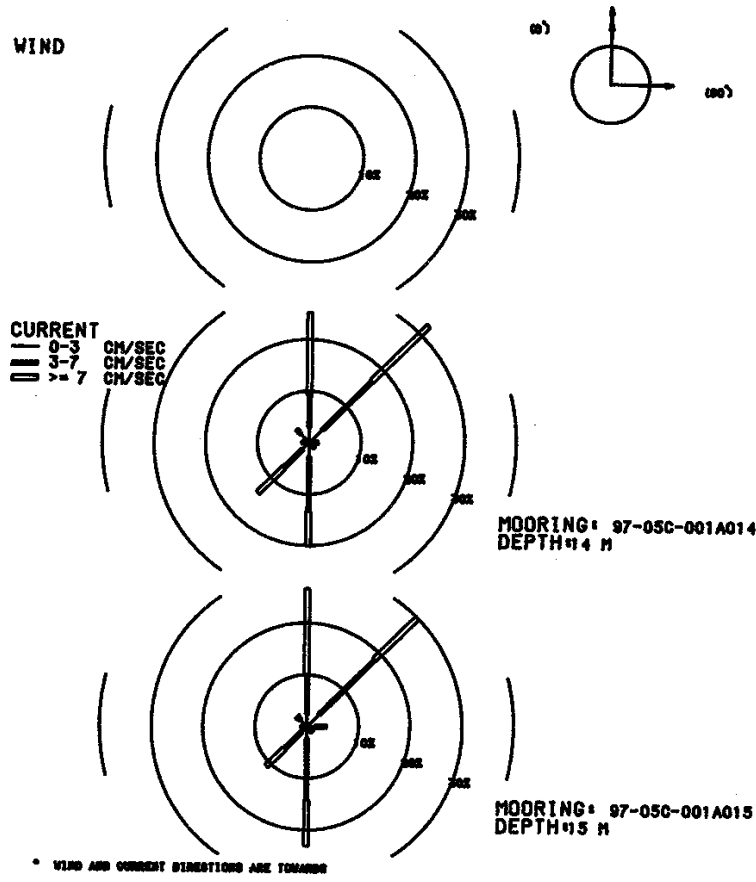

MOORING IS 97-05C-001A014 DEPTH IS 14 METERS THERE ARE 337 VALUES

FIRST DAY 1998/04/01/0000
FINAL DAY 1998/04/15/0000

SHORELINE ORIENTATION IN DEGREES TRUE SPECIFIED AS 90

DIRECTION DEG TRUE	PERCENT OBSERVED	MAXIMUM CURRENT	MEAN DURATION HOURS	MEAN EXCURSION KM	MEAN CURRENT CM/S	MEAN TEMP DEG C
TOWARD	TOTAL	LIGHT	MEDIUM	HIGH	CM/S	
90.0	1.8	0.6	1.2	0.0	5.3	1.2
45.0	32.3	3.6	13.4	15.4	15.2	2.9
0.0	25.2	3.0	6.2	16.0	16.4	2.2
315.0	3.6	2.4	1.2	0.0	5.5	1.3
270.0	1.5	0.9	0.6	0.0	3.8	1.0
225.0	13.9	1.8	5.0	7.1	16.7	2.0
180.0	20.2	2.7	10.7	6.8	16.5	2.6
135.0	1.5	0.9	0.6	0.0	4.9	1.0

0 MEAN SCALAR SPEED = 7.1 CM/S MEAN SQUARE SPEED = 64.2 CM2/S2
 MEAN SQUARE E-W SPEED = 11.1 CM2/S2 MEAN SQUARE N-S SPEED = 53.1 CM2/S2
 MEAN SQUARE U SPEED = 11.1 CM2/S2 MEAN SQUARE V SPEED = 53.1 CM2/S2
 MEAN VELOCITY = 2.0 CM/S, 27 DEG TRUE MEAN TEMPERATURE = 5.1 C
 VARIANCE (U,V) = 30.2 CM2/S2 TOTAL HOURS = 337.

PERCENT OBSERVED
 LIGHT (0.0 - 3.0) 15.7% MEDIUM (3.0 - 7.0) 38.9% HIGH (GE 7.0) 45.4%

MOORING IS 97-05C-001A015 DEPTH IS 15 METERS THERE ARE 337 VALUES

FIRST DAY 1998/04/01/0000
FINAL DAY 1998/04/15/0000

SHORELINE ORIENTATION IN DEGREES TRUE SPECIFIED AS 90

DIRECTION DEG TRUE	PERCENT OBSERVED	MAXIMUM CURRENT	MEAN DURATION HOURS	MEAN EXCURSION KM	MEAN CURRENT CM/S	MEAN TEMP DEG C
TOWARD	TOTAL	LIGHT	MEDIUM	HIGH	CM/S	
90.0	3.9	1.5	2.4	0.0	5.9	1.3
45.0	30.0	3.3	15.1	11.6	15.7	2.5
0.0	26.7	2.4	7.4	16.9	15.7	2.2
315.0	2.7	1.8	0.6	0.3	10.2	1.3
270.0	1.2	0.9	0.3	0.0	3.5	1.0
225.0	11.0	1.5	4.5	5.0	17.4	1.6
180.0	23.1	2.4	11.9	8.9	16.8	3.5
135.0	1.5	1.2	0.3	0.0	5.1	1.0

0 MEAN SCALAR SPEED = 6.9 CM/S MEAN SQUARE SPEED = 61.6 CM2/S2
 MEAN SQUARE E-W SPEED = 10.6 CM2/S2 MEAN SQUARE N-S SPEED = 51.0 CM2/S2
 MEAN SQUARE U SPEED = 10.6 CM2/S2 MEAN SQUARE V SPEED = 51.0 CM2/S2
 MEAN VELOCITY = 1.8 CM/S, 35 DEG TRUE MEAN TEMPERATURE = 5.1 C
 VARIANCE (U,V) = 29.2 CM2/S2 TOTAL HOURS = 337.

PERCENT OBSERVED
 LIGHT (0.0 - 3.0) 14.8% MEDIUM (3.0 - 7.0) 42.4% HIGH (GE 7.0) 42.7%

Appendix C - Mooring_A2-97. Overall Summary Statistics and Rose Histogram Plots

DATE: 1997/11/02 TO 1998/04/15
ROSE SUMMARY: WIND AND CURRENT

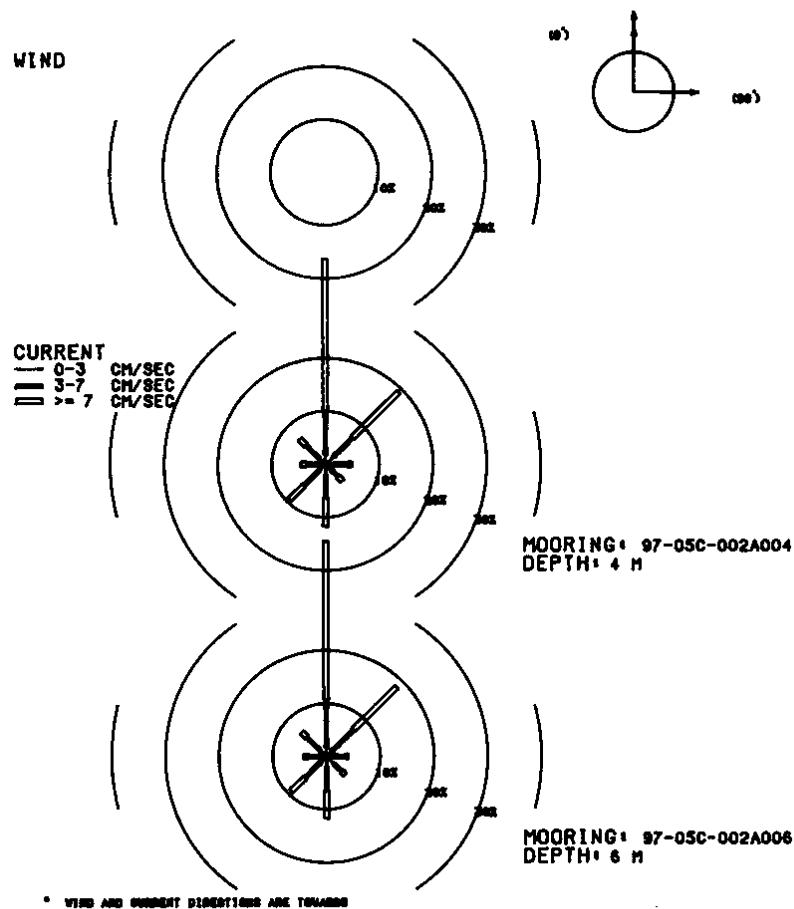

MOORING IS 97-05C-002A004 DEPTH IS 4 METERS THERE ARE 3932 VALUES

FIRST DAY 1997/11/02/0500
FINAL DAY 1998/04/15/0000

SHORELINE ORIENTATION IN DEGREES TRUE SPECIFIED AS 90

DIRECTION DEG TRUE	PERCENT OBSERVED			MAXIMUM CURRENT CM/S	MEAN DURATION HOURS	MEAN EXCURSION KM	MEAN CURRENT CM/S	MEAN TEMP DEG C
TOWARD	TOTAL	LIGHT	MEDIUM	HIGH	CM/S		CM/S	DEG C
90.0	5.0	1.4	2.7	0.9	17.7	1.4	0.2	4.9
45.0	19.3	1.9	5.1	12.2	67.9	1.9	0.9	12.8
0.0	38.7	1.9	8.2	28.7	54.1	3.3	1.5	12.4
315.0	6.8	1.5	3.6	1.7	37.6	1.3	0.3	5.9
270.0	4.7	1.2	2.2	1.2	30.9	1.3	0.3	5.9
225.0	9.4	1.5	4.1	3.7	28.7	1.7	0.4	7.3
180.0	11.8	2.0	4.3	5.5	35.8	1.9	0.6	8.0
135.0	4.5	1.4	1.8	1.2	16.9	1.3	0.3	5.5

MEAN SCALAR SPEED = 10.1 CM/S MEAN SQUARE SPEED = 162.7 CM2/S2
 MEAN SQUARE E-W SPEED = 29.1 CM2/S2 MEAN SQUARE N-S SPEED = 133.5 CM2/S2
 MEAN VELOCITY = 5.6 CM/S, 15 DEG TRUE MEAN TEMPERATURE = 4.3 C
 VARIANCE (U,V) = 65.8 CM2/S2 TOTAL HOURS = 3932.

PERCENT OBSERVED
 LIGHT (0.0 - 3.0) 12.8% MEDIUM (3.0 - 7.0) 32.1% HIGH (GE 7.0) 55.1%

MOORING IS 97-05C-002A006 DEPTH IS 6 METERS THERE ARE 3932 VALUES

FIRST DAY 1997/11/02/0500
FINAL DAY 1998/04/15/0000

SHORELINE ORIENTATION IN DEGREES TRUE SPECIFIED AS 90

DIRECTION DEG TRUE	PERCENT OBSERVED			MAXIMUM CURRENT CM/S	MEAN DURATION HOURS	MEAN EXCURSION KM	MEAN CURRENT CM/S	MEAN TEMP DEG C
TOWARD	TOTAL	LIGHT	MEDIUM	HIGH	CM/S		CM/S	DEG C
90.0	4.1	1.2	2.3	0.5	12.6	1.4	0.2	4.3
45.0	18.6	1.3	5.8	11.6	75.1	2.1	0.9	12.0
0.0	40.5	1.6	9.1	29.8	65.5	3.9	1.9	13.3
315.0	6.5	1.6	3.5	1.4	24.9	1.3	0.3	5.5
270.0	4.3	1.2	2.1	0.9	23.4	1.3	0.2	5.3
225.0	9.3	1.4	4.2	3.7	33.7	1.9	0.5	7.5
180.0	11.7	1.9	4.6	5.2	43.7	2.3	0.6	7.6
135.0	4.9	1.8	2.1	0.9	18.3	1.3	0.2	4.4

MEAN SCALAR SPEED = 10.2 CM/S MEAN SQUARE SPEED = 172.2 CM2/S2
 MEAN SQUARE E-W SPEED = 26.1 CM2/S2 MEAN SQUARE N-S SPEED = 146.1 CM2/S2
 MEAN VELOCITY = 6.0 CM/S, 14 DEG TRUE MEAN TEMPERATURE = 4.3 C
 VARIANCE (U,V) = 68.3 CM2/S2 TOTAL HOURS = 3932.

PERCENT OBSERVED
 LIGHT (0.0 - 3.0) 12.1% MEDIUM (3.0 - 7.0) 33.7% HIGH (GE 7.0) 54.1%

DATE: 1997/11/02 TO 1998/04/15
ROSE SUMMARY: WIND AND CURRENT

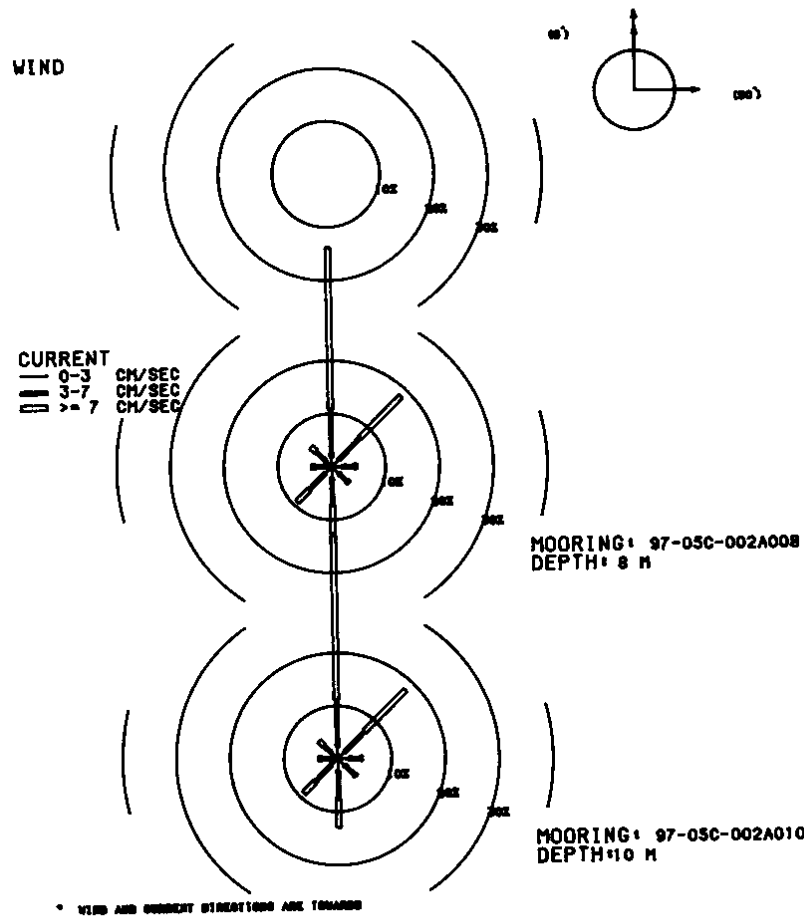

MOORING IS 97-05C-002A008 DEPTH IS 8 METERS THERE ARE 3932 VALUES

FIRST DAY 1997/11/02/0500
FINAL DAY 1998/04/15/0000

SHORELINE ORIENTATION IN DEGREES TRUE SPECIFIED AS 90

DIRECTION DEG TRUE	PERCENT OBSERVED	MAXIMUM CURRENT	MEAN DURATION HOURS	MEAN EXCURSION KM	MEAN CURRENT CM/S	MEAN TEMP DEG C
TOWARD	TOTAL	LIGHT	MEDIUM	HIGH	CM/S	
90.0	4.7	1.8	2.3	0.6	18.0	1.6
45.0	18.5	1.8	5.8	10.9	74.3	2.2
0.0	41.3	1.8	9.0	30.4	68.1	4.1
315.0	5.3	1.4	2.6	1.3	27.9	1.4
270.0	3.9	1.3	1.8	0.8	27.0	1.3
225.0	9.2	1.8	4.3	3.2	35.5	1.9
180.0	12.6	2.1	5.2	5.3	44.5	2.3
135.0	4.5	1.7	2.2	0.6	17.1	1.3

MEAN SCALAR SPEED = 10.2 CM/S MEAN SQUARE SPEED = 173.9 CM2/S2
 MEAN SQUARE E-W SPEED = 25.2 CM2/S2 MEAN SQUARE N-S SPEED = 148.8 CM2/S2
 MEAN VELOCITY = 6.0 CM/S, 14 DEG TRUE MEAN TEMPERATURE = 4.3 C
 VARIANCE(U,V) = 68.7 CM2/S2 TOTAL HOURS = 3932.

PERCENT OBSERVED

LIGHT (0.0 - 3.0) 13.8% MEDIUM (3.0 - 7.0) 33.1% HIGH (GE 7.0) 53.1%

MOORING IS 97-05C-002A010 DEPTH IS 10 METERS THERE ARE 3932 VALUES

FIRST DAY 1997/11/02/0500
FINAL DAY 1998/04/15/0000

SHORELINE ORIENTATION IN DEGREES TRUE SPECIFIED AS 90

DIRECTION DEG TRUE	PERCENT OBSERVED	MAXIMUM CURRENT	MEAN DURATION HOURS	MEAN EXCURSION KM	MEAN CURRENT CM/S	MEAN TEMP DEG C
TOWARD	TOTAL	LIGHT	MEDIUM	HIGH	CM/S	
90.0	4.6	1.9	2.3	0.4	13.4	1.5
45.0	18.1	1.7	5.4	11.0	76.4	2.3
0.0	42.0	2.3	8.9	30.8	68.6	4.5
315.0	4.8	1.6	2.0	1.2	26.4	1.4
270.0	3.6	1.3	1.7	0.6	26.6	1.3
225.0	9.1	1.7	4.3	3.0	36.4	1.8
180.0	13.0	2.2	5.4	5.4	50.8	2.4
135.0	4.8	1.7	2.7	0.4	11.8	1.5

MEAN SCALAR SPEED = 10.1 CM/S MEAN SQUARE SPEED = 173.7 CM2/S2
 MEAN SQUARE E-W SPEED = 24.1 CM2/S2 MEAN SQUARE N-S SPEED = 149.7 CM2/S2
 MEAN VELOCITY = 6.1 CM/S, 14 DEG TRUE MEAN TEMPERATURE = 4.3 C
 VARIANCE(U,V) = 68.3 CM2/S2 TOTAL HOURS = 3932.

PERCENT OBSERVED

LIGHT (0.0 - 3.0) 14.4% MEDIUM (3.0 - 7.0) 32.7% HIGH (GE 7.0) 52.8%

DATE: 1997/11/02 TO 1998/04/15
ROSE SUMMARY: WIND AND CURRENT

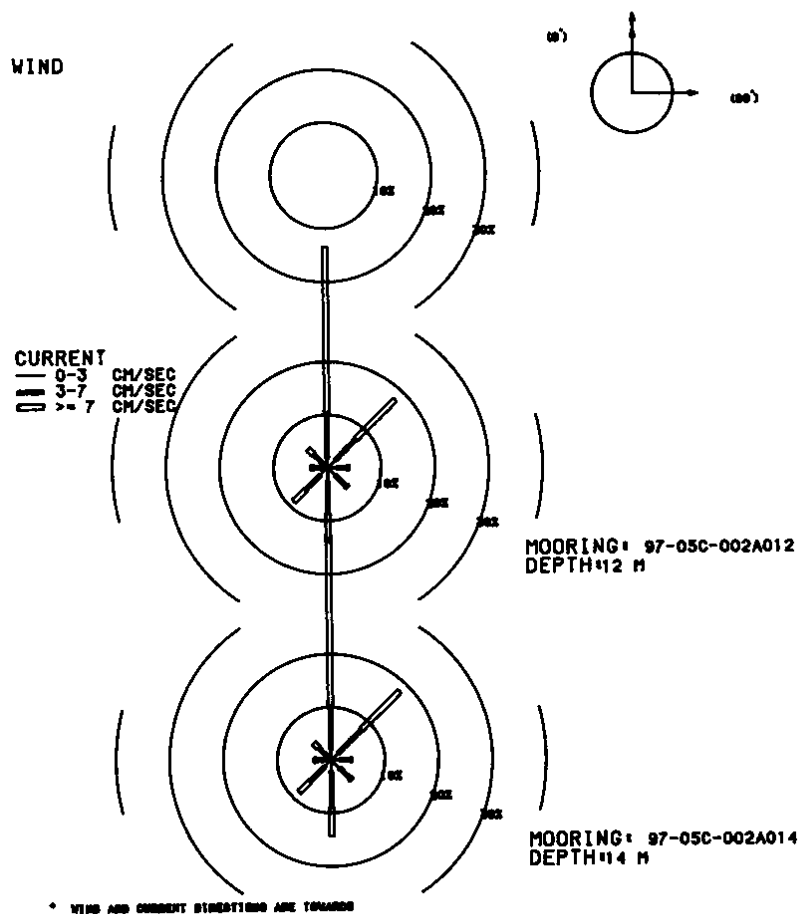

MOORING IS 97-05C-002A012 DEPTH IS 12 METERS THERE ARE 3932 VALUES

FIRST DAY 1997/11/02/0500
FINAL DAY 1998/04/15/0000

SHORELINE ORIENTATION IN DEGREES TRUE SPECIFIED AS 90

DIRECTION DEG TRUE	PERCENT OBSERVED	MAXIMUM CURRENT CM/S	MEAN DURA- TION HOURS	MEAN EXCUR- SION KM	MEAN CURRENT CM/S	MEAN TEMP DEG C			
TOWARD	TOTAL	LIGHT	MEDIUM	HIGH					
90.0	4.1	1.8	1.9	0.5	10.6	1.4	0.2	3.8	4.3
45.0	18.1	2.0	5.5	10.6	73.4	2.4	1.0	11.3	4.3
0.0	41.6	1.9	8.6	31.2	65.0	4.8	2.3	13.5	4.3
315.0	5.1	1.3	2.2	1.5	23.1	1.4	0.3	5.9	3.9
270.0	3.1	1.2	1.3	0.6	24.2	1.4	0.2	4.9	4.4
225.0	8.9	1.9	3.9	3.1	35.4	2.0	0.5	7.0	4.5
180.0	13.9	2.5	6.2	5.2	35.8	2.5	0.6	6.9	4.5
135.0	5.3	1.9	3.0	0.4	9.6	1.7	0.2	3.8	3.9

MEAN SCALAR SPEED = 10.0 CM/S MEAN SQUARE SPEED = 171.6 CM²/S²
 MEAN SQUARE E-W SPEED = 23.2 CM²/S² MEAN SQUARE N-S SPEED = 148.4 CM²/S²
 MEAN VELOCITY = 6.0 CM/S, 14 DEG TRUE MEAN TEMPERATURE = 4.3 C
 VARIANCE (U,V) = 67.7 CM²/S² TOTAL HOURS = 3932.

PERCENT OBSERVED
 LIGHT (0.0 - 3.0) 14.4% MEDIUM (3.0 - 7.0) 32.6% HIGH (GE 7.0) 53.0%

MOORING IS 97-05C-002A014 DEPTH IS 14 METERS THERE ARE 3932 VALUES

FIRST DAY 1997/11/02/0500
FINAL DAY 1998/04/15/0000

SHORELINE ORIENTATION IN DEGREES TRUE SPECIFIED AS 90

DIRECTION DEG TRUE	PERCENT OBSERVED	MAXIMUM CURRENT CM/S	MEAN DURA- TION HOURS	MEAN EXCUR- SION KM	MEAN CURRENT CM/S	MEAN TEMP DEG C			
TOWARD	TOTAL	LIGHT	MEDIUM	HIGH					
90.0	3.9	1.6	2.0	0.3	9.6	1.4	0.2	3.7	4.4
45.0	18.3	1.8	6.2	10.3	74.1	2.3	0.9	11.2	4.3
0.0	41.8	2.0	8.1	31.6	63.9	4.6	2.2	13.5	4.3
315.0	4.6	1.2	2.0	1.3	21.0	1.4	0.3	5.7	3.9
270.0	3.3	1.3	1.4	0.5	24.8	1.3	0.2	4.7	4.2
225.0	8.5	1.7	3.9	2.9	33.6	1.9	0.5	6.9	4.5
180.0	14.3	2.2	6.8	5.3	28.4	2.6	0.7	6.9	4.5
135.0	5.4	2.1	2.8	0.5	10.4	1.6	0.2	3.9	3.9

MEAN SCALAR SPEED = 10.0 CM/S MEAN SQUARE SPEED = 170.7 CM²/S²
 MEAN SQUARE E-W SPEED = 22.4 CM²/S² MEAN SQUARE N-S SPEED = 148.3 CM²/S²
 MEAN VELOCITY = 6.0 CM/S, 14 DEG TRUE MEAN TEMPERATURE = 4.3 C
 VARIANCE (U,V) = 67.2 CM²/S² TOTAL HOURS = 3932.

PERCENT OBSERVED
 LIGHT (0.0 - 3.0) 14.0% MEDIUM (3.0 - 7.0) 33.3% HIGH (GE 7.0) 52.7%

DATE: 1997/11/02 TO 1998/04/15
 ROSE SUMMARY: WIND AND CURRENT

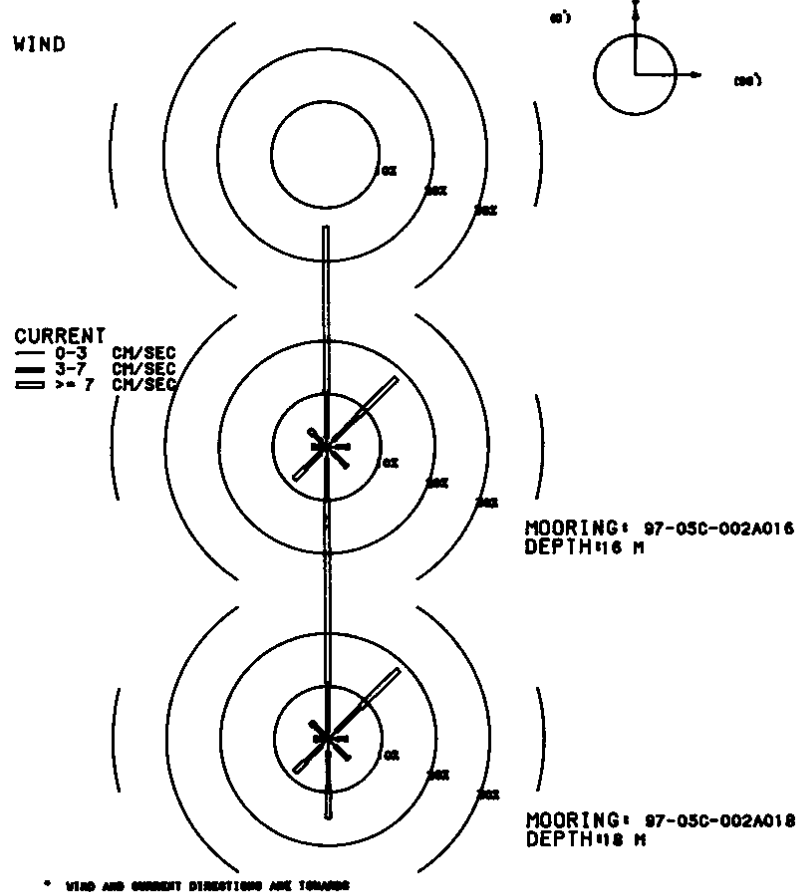

MOORING IS 97-05C-002A016 DEPTH IS 16 METERS THERE ARE 3932 VALUES

FIRST DAY 1997/11/02/0500
 FINAL DAY 1998/04/15/0000

SHORELINE ORIENTATION IN DEGREES TRUE SPECIFIED AS 90

DIRECTION DEG TRUE	PERCENT OBSERVED	MAXIMUM CURRENT CM/S	MEAN DURA- TION HOURS	MEAN EXCUR- SION KM	MEAN CURRENT CM/S	MEAN TEMP DEG C
TOWARD	TOTAL	LIGHT	MEDIUM	HIGH		
90.0	4.1	1.8	2.0	0.3	9.9	1.5
45.0	18.3	1.8	6.4	10.2	74.1	2.4
0.0	41.5	1.8	8.4	31.4	50.2	4.8
315.0	4.5	1.5	1.8	1.2	21.8	1.4
270.0	2.7	1.2	1.1	0.5	27.0	1.3
225.0	8.5	1.6	4.0	2.9	31.6	1.8
180.0	15.0	2.1	7.6	5.3	24.4	2.7
135.0	5.3	1.6	3.3	0.4	9.3	1.5
0		MEAN SCALAR SPEED = 10.0 CM/S		MEAN SQUARE SPEED = 169.8 CM2/S2		
		MEAN SQUARE E-W SPEED = 22.0 CM2/S2		MEAN SQUARE N-S SPEED = 147.8 CM2/S2		
		MEAN VELOCITY = 6.0 CM/S,		14 DEG TRUE		MEAN TEMPERATURE = 4.3 C
		VARIANCE (U,V) = 67.1 CM2/S2		TOTAL HOURS = 3932.		

PERCENT OBSERVED
 LIGHT (0.0 - 3.0) 13.3% MEDIUM (3.0 - 7.0) 34.6% HIGH (GE 7.0) 52.2%

MOORING IS 97-05C-002A018 DEPTH IS 18 METERS THERE ARE 3932 VALUES

FIRST DAY 1997/11/02/0500
 FINAL DAY 1998/04/15/0000

SHORELINE ORIENTATION IN DEGREES TRUE SPECIFIED AS 90

DIRECTION DEG TRUE	PERCENT OBSERVED	MAXIMUM CURRENT CM/S	MEAN DURA- TION HOURS	MEAN EXCUR- SION KM	MEAN CURRENT CM/S	MEAN TEMP DEG C
TOWARD	TOTAL	LIGHT	MEDIUM	HIGH		
90.0	3.6	1.6	1.8	0.2	10.3	1.4
45.0	18.5	2.0	6.4	10.0	73.1	2.3
0.0	41.8	1.6	9.1	31.2	48.5	4.6
315.0	4.5	1.3	2.3	0.9	20.8	1.5
270.0	2.6	1.0	1.0	0.6	27.2	1.3
225.0	8.7	1.8	4.2	2.8	33.4	1.9
180.0	14.9	2.4	7.2	5.4	20.4	2.5
135.0	5.4	1.8	3.1	0.4	9.5	1.5
0		MEAN SCALAR SPEED = 10.0 CM/S		MEAN SQUARE SPEED = 168.8 CM2/S2		
		MEAN SQUARE E-W SPEED = 21.4 CM2/S2		MEAN SQUARE N-S SPEED = 147.3 CM2/S2		
		MEAN VELOCITY = 6.0 CM/S,		14 DEG TRUE		MEAN TEMPERATURE = 4.3 C
		VARIANCE (U,V) = 66.6 CM2/S2		TOTAL HOURS = 3932.		

PERCENT OBSERVED
 LIGHT (0.0 - 3.0) 13.5% MEDIUM (3.0 - 7.0) 35.0% HIGH (GE 7.0) 51.5%

DATE: 1997/11/02 TO 1998/04/15
 ROSE SUMMARY: WIND AND CURRENT

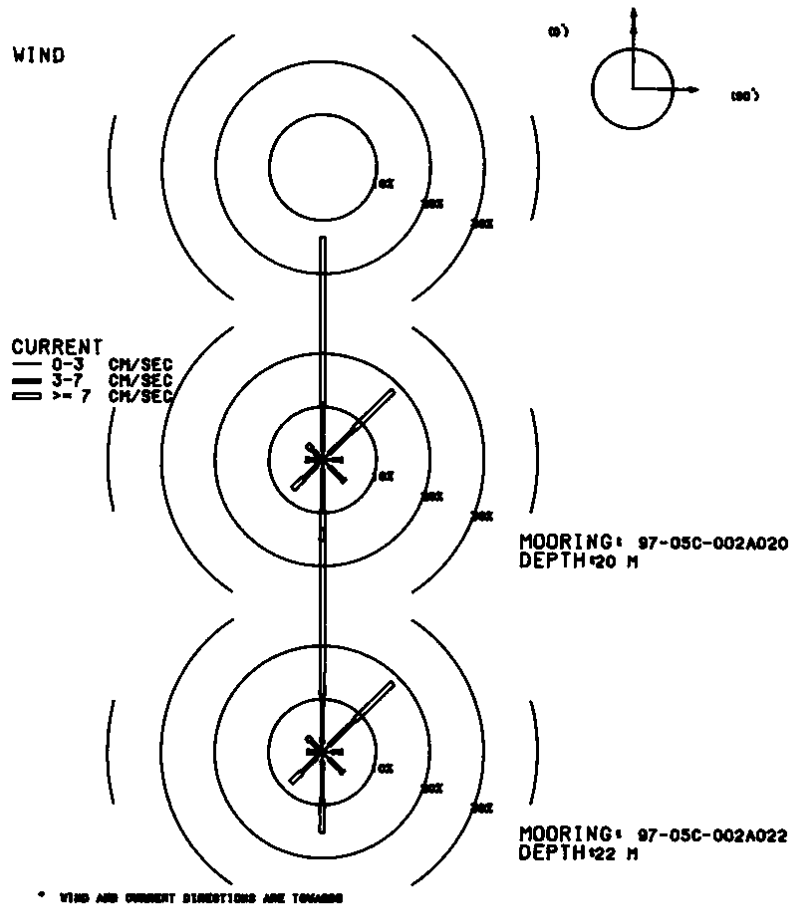

MOORING IS 97-05C-002A020 DEPTH IS 20 METERS THERE ARE 3932 VALUES

FIRST DAY 1997/11/02/0500
 FINAL DAY 1998/04/15/0000

SHORELINE ORIENTATION IN DEGREES TRUE SPECIFIED AS 90

DIRECTION DEG TRUE	PERCENT OBSERVED	MAXIMUM CURRENT	MEAN DURA- TION HOURS	MEAN EXCUR- SION KM	MEAN CURRENT CM/S	MEAN TEMP DEG C
TOWARD	TOTAL	LIGHT	MEDIUM	HIGH	CM/S	
90.0	3.5	1.8	1.6	0.2	9.4	1.4
45.0	18.5	1.6	6.6	10.3	71.9	2.4
0.0	41.9	1.8	8.9	31.3	47.1	5.0
315.0	4.1	1.2	1.7	1.1	21.5	1.3
270.0	3.2	1.3	1.3	0.5	24.5	1.4
225.0	7.8	1.6	3.5	2.8	34.1	1.8
180.0	15.2	1.8	7.8	5.7	22.6	2.6
135.0	5.7	1.9	3.3	0.5	10.6	1.5

0 MEAN SCALAR SPEED = 10.0 CM/S MEAN SQUARE SPEED = 167.9 CM2/S2
 MEAN SQUARE E-W SPEED = 21.3 CM2/S2 MEAN SQUARE N-S SPEED = 146.7 CM2/S2
 MEAN VELOCITY = 5.9 CM/S, 14 DEG TRUE MEAN TEMPERATURE = 4.3 C
 VARIANCE (U,V) = 66.4 CM2/S2 TOTAL HOURS = 3932.

PERCENT OBSERVED
 LIGHT (0.0 - 3.0) 13.0% MEDIUM (3.0 - 7.0) 34.8% HIGH (GE 7.0) 52.3%

MOORING IS 97-05C-002A022 DEPTH IS 22 METERS THERE ARE 3932 VALUES

FIRST DAY 1997/11/02/0500
 FINAL DAY 1998/04/15/0000

SHORELINE ORIENTATION IN DEGREES TRUE SPECIFIED AS 90

DIRECTION DEG TRUE	PERCENT OBSERVED	MAXIMUM CURRENT	MEAN DURA- TION HOURS	MEAN EXCUR- SION KM	MEAN CURRENT CM/S	MEAN TEMP DEG C
TOWARD	TOTAL	LIGHT	MEDIUM	HIGH	CM/S	
90.0	3.8	1.8	1.8	0.2	11.8	1.4
45.0	18.5	1.8	6.8	9.9	71.1	2.4
0.0	42.0	1.8	9.0	31.2	48.6	5.2
315.0	4.0	1.2	1.8	1.0	18.0	1.5
270.0	2.8	1.1	1.4	0.3	24.8	1.4
225.0	8.2	1.6	3.9	2.8	33.6	1.8
180.0	15.2	1.7	7.8	5.6	19.4	2.7
135.0	5.5	2.0	3.2	0.4	9.8	1.5

0 MEAN SCALAR SPEED = 10.0 CM/S MEAN SQUARE SPEED = 168.4 CM2/S2
 MEAN SQUARE E-W SPEED = 20.6 CM2/S2 MEAN SQUARE N-S SPEED = 147.7 CM2/S2
 MEAN VELOCITY = 5.9 CM/S, 14 DEG TRUE MEAN TEMPERATURE = 4.3 C
 VARIANCE (U,V) = 66.5 CM2/S2 TOTAL HOURS = 3932.

PERCENT OBSERVED
 LIGHT (0.0 - 3.0) 12.8% MEDIUM (3.0 - 7.0) 35.7% HIGH (GE 7.0) 51.4%

DATE: 1997/11/02 TO 1998/04/15
 ROSE SUMMARY: WIND AND CURRENT

WIND

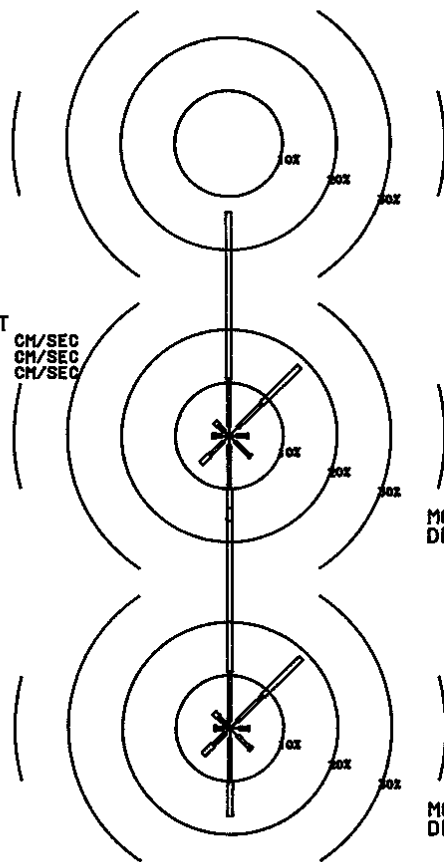

MOORING: 97-05C-002A024
 DEPTH 24 m

MOORING: 97-05C-002A026
 DEPTH 26 m

* WIND AND CURRENT DIRECTIONS ARE TOWARDS

MOORING IS 97-05C-002A024 DEPTH IS 24 METERS THERE ARE 3932 VALUES

FIRST DAY 1997/11/02/0500
 FINAL DAY 1998/04/15/0000

SHORELINE ORIENTATION IN DEGREES TRUE SPECIFIED AS 90

DIRECTION DEG TRUE	PERCENT OBSERVED	MAXIMUM CURRENT			MEAN DURA- TION HOURS	MEAN EXCUR- SION KM	MEAN CURRENT CM/S	MEAN TEMP DEG C	
TOWARD	TOTAL	LIGHT	MEDIUM	HIGH	CM/S				
90.0	3.5	1.3	1.9	0.3	9.9	1.4	0.2	3.8	4.6
45.0	18.5	2.3	6.3	9.9	71.6	2.3	0.9	10.6	4.1
0.0	42.1	1.8	9.0	31.4	49.2	4.9	2.4	13.5	4.4
315.0	3.7	1.2	1.7	0.9	28.9	1.3	0.3	5.3	3.8
270.0	3.1	1.3	1.2	0.6	22.0	1.5	0.2	4.7	4.1
225.0	7.4	1.5	3.6	2.2	34.2	1.9	0.5	6.9	4.4
180.0	16.1	1.7	8.3	6.1	20.5	3.0	0.7	6.8	4.5
135.0	5.6	1.6	3.6	0.3	11.7	1.6	0.2	4.0	3.8
0	MEAN SCALAR SPEED = 9.9 CM/S		MEAN SQUARE SPEED = 167.3 CM2/S2						
	MEAN SQUARE E-W SPEED = 20.5 CM2/S2		MEAN SQUARE N-S SPEED = 146.8 CM2/S2						
	MEAN VELOCITY = 5.9 CM/S,		14 DEG TRUE		MEAN TEMPERATURE = 4.3 C				
	VARIANCE (U,V) = 66.3 CM2/S2		TOTAL HOURS = 3932.						

PERCENT OBSERVED
 LIGHT (0.0 - 3.0) 12.9% MEDIUM (3.0 - 7.0) 35.5% HIGH (GE 7.0) 51.6%

MOORING IS 97-05C-002A026 DEPTH IS 26 METERS THERE ARE 3932 VALUES

FIRST DAY 1997/11/02/0500
 FINAL DAY 1998/04/15/0000

SHORELINE ORIENTATION IN DEGREES TRUE SPECIFIED AS 90

DIRECTION DEG TRUE	PERCENT OBSERVED	MAXIMUM CURRENT			MEAN DURA- TION HOURS	MEAN EXCUR- SION KM	MEAN CURRENT CM/S	MEAN TEMP DEG C	
TOWARD	TOTAL	LIGHT	MEDIUM	HIGH	CM/S				
90.0	3.6	1.7	1.7	0.2	9.7	1.4	0.2	3.5	4.6
45.0	18.8	1.8	6.9	10.1	73.4	2.4	0.9	10.9	4.1
0.0	41.4	1.5	9.2	30.7	49.3	4.9	2.4	13.5	4.4
315.0	4.2	1.1	1.9	1.2	21.5	1.4	0.3	5.7	4.0
270.0	2.9	1.2	1.3	0.4	26.1	1.4	0.2	4.5	3.9
225.0	7.0	1.2	3.2	2.6	31.8	1.9	0.5	7.3	4.5
180.0	16.6	2.0	8.1	6.5	18.8	3.2	0.8	6.7	4.4
135.0	5.6	1.9	3.2	0.5	9.0	1.6	0.2	3.9	4.2
0	MEAN SCALAR SPEED = 10.0 CM/S		MEAN SQUARE SPEED = 166.9 CM2/S2						
	MEAN SQUARE E-W SPEED = 20.4 CM2/S2		MEAN SQUARE N-S SPEED = 146.5 CM2/S2						
	MEAN VELOCITY = 5.9 CM/S,		15 DEG TRUE		MEAN TEMPERATURE = 4.3 C				
	VARIANCE (U,V) = 66.1 CM2/S2		TOTAL HOURS = 3932.						

PERCENT OBSERVED
 LIGHT (0.0 - 3.0) 12.4% MEDIUM (3.0 - 7.0) 35.4% HIGH (GE 7.0) 52.2%

DATE: 1997/11/02 TO 1998/04/15
 ROSE SUMMARY: WIND AND CURRENT

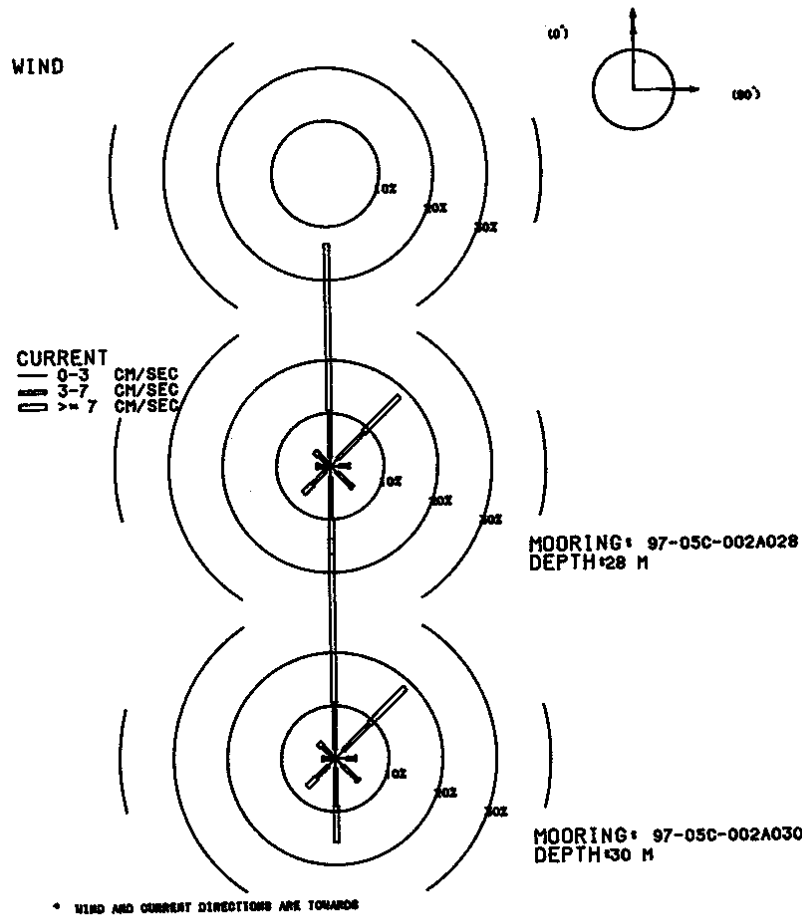

MOORING IS 97-05C-002A028 DEPTH IS 28 METERS THERE ARE 3932 VALUES

FIRST DAY 1997/11/02/0500
 FINAL DAY 1998/04/15/0000

SHORELINE ORIENTATION IN DEGREES TRUE SPECIFIED AS 90

DIRECTION DEG TRUE	PERCENT OBSERVED	MAXIMUM CURRENT	MEAN DURA- TION HOURS	MEAN EXCUR- SION KM	MEAN CURRENT CM/S	MEAN TEMP DEG C
TOWARD	TOTAL	LIGHT	MEDIUM	HIGH	CM/S	
90.0	3.6	1.6	1.8	0.2	8.5	1.4
45.0	18.4	2.0	6.9	9.5	71.8	2.4
0.0	41.9	1.7	8.7	31.5	49.1	5.1
315.0	4.0	1.2	1.7	1.1	21.3	1.5
270.0	2.6	1.0	1.1	0.5	24.8	1.4
225.0	7.1	1.5	3.3	2.4	32.1	1.8
180.0	16.5	2.1	7.6	6.8	20.6	3.2
135.0	5.8	1.7	3.5	0.7	10.1	1.5

MEAN SCALAR SPEED = 10.0 CM/S MEAN SQUARE SPEED = 166.9 CM2/S2
 MEAN SQUARE E-W SPEED = 19.8 CM2/S2 MEAN SQUARE N-S SPEED = 147.1 CM2/S2
 MEAN VELOCITY = 5.9 CM/S, 14 DEG TRUE MEAN TEMPERATURE = 4.3 C
 VARIANCE (U,V) = 66.4 CM2/S2 TOTAL HOURS = 3932.

PERCENT OBSERVED
 LIGHT (0.0 - 3.0) 12.7% MEDIUM (3.0 - 7.0) 34.7% HIGH (GE 7.0) 52.6%

MOORING IS 97-05C-002A030 DEPTH IS 30 METERS THERE ARE 3932 VALUES

FIRST DAY 1997/11/02/0500
 FINAL DAY 1998/04/15/0000

SHORELINE ORIENTATION IN DEGREES TRUE SPECIFIED AS 90

DIRECTION DEG TRUE	PERCENT OBSERVED	MAXIMUM CURRENT	MEAN DURA- TION HOURS	MEAN EXCUR- SION KM	MEAN CURRENT CM/S	MEAN TEMP DEG C
TOWARD	TOTAL	LIGHT	MEDIUM	HIGH	CM/S	
90.0	3.9	2.1	1.8	0.1	9.5	1.5
45.0	18.7	2.1	6.9	9.7	72.0	2.3
0.0	41.4	1.8	8.8	30.9	48.7	4.8
315.0	4.3	1.4	1.8	1.0	17.8	1.5
270.0	2.4	1.0	1.2	0.3	24.2	1.4
225.0	7.5	1.9	3.1	2.5	31.4	1.8
180.0	15.8	1.8	7.1	6.9	20.0	3.1
135.0	6.1	1.9	3.6	0.5	10.1	1.8

MEAN SCALAR SPEED = 9.9 CM/S MEAN SQUARE SPEED = 166.9 CM2/S2
 MEAN SQUARE E-W SPEED = 19.6 CM2/S2 MEAN SQUARE N-S SPEED = 147.4 CM2/S2
 MEAN VELOCITY = 5.9 CM/S, 14 DEG TRUE MEAN TEMPERATURE = 4.3 C
 VARIANCE (U,V) = 66.2 CM2/S2 TOTAL HOURS = 3932.

PERCENT OBSERVED
 LIGHT (0.0 - 3.0) 13.8% MEDIUM (3.0 - 7.0) 34.3% HIGH (GE 7.0) 51.9%

DATE: 1997/11/02 TO 1998/04/15
 ROSE SUMMARY: WIND AND CURRENT

WIND

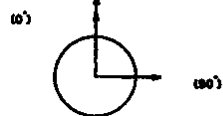
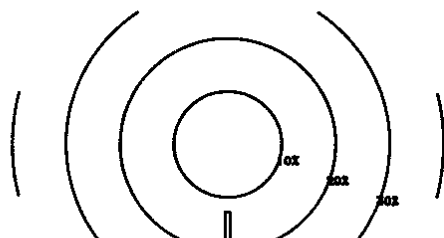

CURRENT

0-3 CM/SEC
 3-7 CM/SEC
 >= 7 CM/SEC

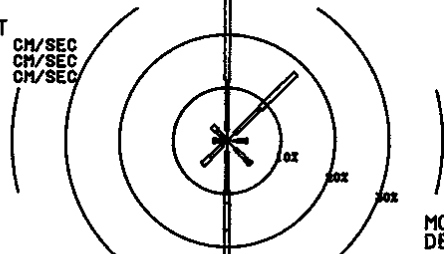

MOORING: 97-05C-002A032
 DEPTH: 32 M

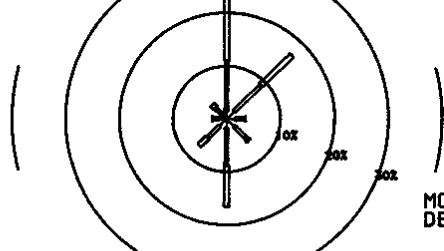

MOORING: 97-05C-002A034
 DEPTH: 34 M

* WIND AND CURRENT DIRECTIONS ARE TOWARDS

MOORING IS 97-05C-002A032 DEPTH IS 32 METERS THERE ARE 3932 VALUES

FIRST DAY 1997/11/02/0500
 FINAL DAY 1998/04/15/0000

SHORELINE ORIENTATION IN DEGREES TRUE SPECIFIED AS 90

DIRECTION DEG TRUE	PERCENT OBSERVED	TOWARD	TOTAL	LIGHT	MEDIUM	HIGH	MAXIMUM CURRENT CM/S	MEAN DURA- TION HOURS	MEAN EXCUR- SION KM	MEAN CURRENT CM/S	MEAN TEMP DEG C
90.0	3.7	1.9	1.7	0.2	10.1	1.3	0.2	3.4	4.7		
45.0	18.0	2.0	6.7	9.4	72.0	2.3	0.9	10.9	3.9		
0.0	42.3	2.1	9.4	30.9	47.9	5.4	2.6	13.3	4.4		
315.0	3.9	1.1	1.6	1.2	19.6	1.7	0.3	5.8	4.2		
270.0	2.5	1.0	1.2	0.4	21.8	1.4	0.2	4.4	4.3		
225.0	6.4	1.3	3.1	2.0	31.8	1.7	0.4	7.0	4.4		
180.0	16.9	2.1	7.3	7.5	20.6	3.3	0.8	7.0	4.4		
135.0	6.2	2.1	3.5	0.6	9.2	1.7	0.2	3.9	4.1		

MEAN SCALAR SPEED = 9.9 CM/S MEAN SQUARE SPEED = 166.7 CM2/S2
 MEAN SQUARE E-W SPEED = 19.3 CM2/S2 MEAN SQUARE N-S SPEED = 147.4 CM2/S2
 MEAN VELOCITY = 5.8 CM/S, 14 DEG TRUE MEAN TEMPERATURE = 4.3 C
 VARIANCE (U,V) = 66.5 CM2/S2 TOTAL HOURS = 3932.

PERCENT OBSERVED

LIGHT (0.0 - 3.0) 13.4% MEDIUM (3.0 - 7.0) 34.5% HIGH (GE 7.0) 52.1%

MOORING IS 97-05C-002A034 DEPTH IS 34 METERS THERE ARE 3932 VALUES

FIRST DAY 1997/11/02/0500
 FINAL DAY 1998/04/15/0000

SHORELINE ORIENTATION IN DEGREES TRUE SPECIFIED AS 90

DIRECTION DEG TRUE	PERCENT OBSERVED	TOWARD	TOTAL	LIGHT	MEDIUM	HIGH	MAXIMUM CURRENT CM/S	MEAN DURA- TION HOURS	MEAN EXCUR- SION KM	MEAN CURRENT CM/S	MEAN TEMP DEG C
90.0	3.6	1.6	1.9	0.1	9.2	1.4	0.2	3.4	4.5		
45.0	17.1	1.9	7.1	8.1	73.9	2.5	0.9	10.3	3.9		
0.0	43.3	1.4	9.6	32.2	49.1	6.2	3.0	13.5	4.5		
315.0	3.8	1.0	1.9	0.9	20.3	1.5	0.3	5.2	4.3		
270.0	2.7	1.3	1.2	0.2	22.3	1.4	0.2	4.0	3.9		
225.0	7.1	1.8	3.2	2.2	32.0	1.9	0.5	6.8	4.3		
180.0	16.6	1.8	7.1	7.7	20.6	3.4	0.9	7.2	4.4		
135.0	5.8	2.0	3.5	0.4	9.8	1.7	0.3	4.1	4.1		

MEAN SCALAR SPEED = 9.9 CM/S MEAN SQUARE SPEED = 167.7 CM2/S2
 MEAN SQUARE E-W SPEED = 18.8 CM2/S2 MEAN SQUARE N-S SPEED = 148.9 CM2/S2
 MEAN VELOCITY = 5.8 CM/S, 14 DEG TRUE MEAN TEMPERATURE = 4.3 C
 VARIANCE (U,V) = 67.2 CM2/S2 TOTAL HOURS = 3932.

PERCENT OBSERVED

LIGHT (0.0 - 3.0) 12.8% MEDIUM (3.0 - 7.0) 35.4% HIGH (GE 7.0) 51.8%

Appendix D - Mooring_A2-97. Monthly Summary Statistics and Rose Histogram Plots

DATE: 1997/11/02 TO 1997/11/30
 ROSE SUMMARY: WIND AND CURRENT

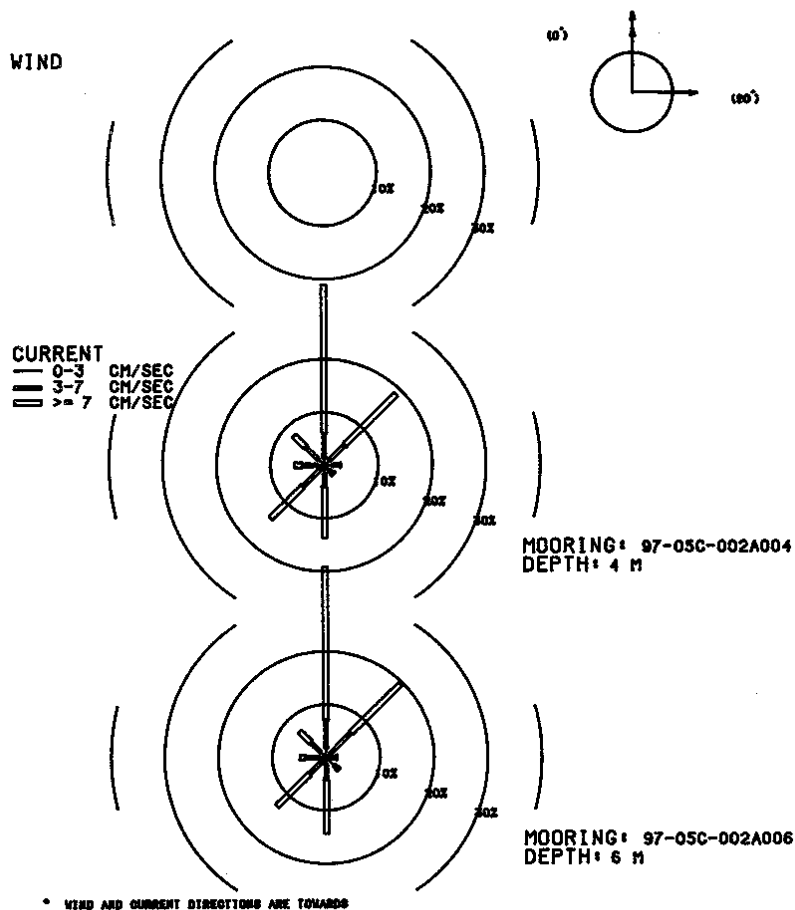

MOORING IS 97-05C-002A004 DEPTH IS 4 METERS THERE ARE 691 VALUES

FIRST DAY 1997/11/02/0500
 FINAL DAY 1997/11/30/2300

SHORELINE ORIENTATION IN DEGREES TRUE SPECIFIED AS 90

DIRECTION DEG TRUE	PERCENT OBSERVED	TOWARD	TOTAL	LIGHT	MEDIUM	HIGH	MAXIMUM CURRENT CM/S	MEAN DURA- TION HOURS	MEAN EXCUR- SION KM	MEAN CURRENT CM/S	MEAN TEMP DEG C
90.0	3.0		3.0	1.4	1.4	0.1	7.5	1.2	0.2	3.7	8.5
45.0	19.0		19.0	1.2	4.2	13.6	35.9	2.0	1.0	14.0	9.1
0.0	34.0		34.0	1.3	4.8	27.9	40.1	2.9	1.5	14.0	8.8
315.0	8.0		8.0	1.4	3.5	3.0	25.9	1.5	0.4	7.0	7.8
270.0	5.6		5.6	1.3	2.7	1.6	13.5	1.3	0.3	5.4	7.8
225.0	14.2		14.2	0.9	4.8	8.5	18.7	1.8	0.6	9.3	7.6
180.0	13.7		13.7	1.6	2.5	9.7	22.9	2.2	0.8	10.6	7.7
135.0	2.5		2.5	1.2	0.9	0.4	16.8	1.0	0.2	5.1	8.4
0 MEAN SCALAR SPEED = 11.3 CM/S MEAN SQUARE SPEED = 182.5 CM2/S2											
MEAN SQUARE E-W SPEED = 30.7 CM2/S2 MEAN SQUARE N-S SPEED = 151.8 CM2/S2											
MEAN VELOCITY = 4.8 CM/S, 5 DEG TRUE MEAN TEMPERATURE = 8.4 C											
VARIANCE (U,V) = 80.1 CM2/S2 TOTAL HOURS = 691.											

PERCENT OBSERVED
 LIGHT (0.0 - 3.0) 10.3% MEDIUM (3.0 - 7.0) 24.7% HIGH (GE 7.0) 65.0%

MOORING IS 97-05C-002A006 DEPTH IS 6 METERS THERE ARE 691 VALUES

FIRST DAY 1997/11/02/0500
 FINAL DAY 1997/11/30/2300

SHORELINE ORIENTATION IN DEGREES TRUE SPECIFIED AS 90

DIRECTION DEG TRUE	PERCENT OBSERVED	TOWARD	TOTAL	LIGHT	MEDIUM	HIGH	MAXIMUM CURRENT CM/S	MEAN DURA- TION HOURS	MEAN EXCUR- SION KM	MEAN CURRENT CM/S	MEAN TEMP DEG C
90.0	2.0		2.0	0.6	1.3	0.1	7.4	1.3	0.2	4.1	9.1
45.0	19.5		19.5	1.0	5.5	13.0	38.4	2.2	1.0	12.0	9.1
0.0	35.9		35.9	1.7	5.4	28.8	36.3	3.3	1.8	14.8	8.8
315.0	6.9		6.9	1.4	2.6	2.9	22.5	1.5	0.4	7.3	7.2
270.0	4.9		4.9	1.3	2.6	1.0	14.4	1.2	0.2	5.1	7.7
225.0	13.0		13.0	0.9	3.5	8.7	20.1	2.0	0.7	9.6	7.6
180.0	14.3		14.3	1.3	2.9	10.1	23.0	2.8	1.1	10.4	7.6
135.0	3.3		3.3	2.0	0.7	0.6	12.4	1.1	0.2	3.6	8.5
0 MEAN SCALAR SPEED = 11.4 CM/S MEAN SQUARE SPEED = 187.9 CM2/S2											
MEAN SQUARE E-W SPEED = 27.1 CM2/S2 MEAN SQUARE N-S SPEED = 160.8 CM2/S2											
MEAN VELOCITY = 5.0 CM/S, 9 DEG TRUE MEAN TEMPERATURE = 8.4 C											
VARIANCE (U,V) = 81.6 CM2/S2 TOTAL HOURS = 691.											

PERCENT OBSERVED
 LIGHT (0.0 - 3.0) 10.3% MEDIUM (3.0 - 7.0) 24.5% HIGH (GE 7.0) 65.3%

DATE: 1997/12/01 TO 1997/12/31
 ROSE SUMMARY: WIND AND CURRENT

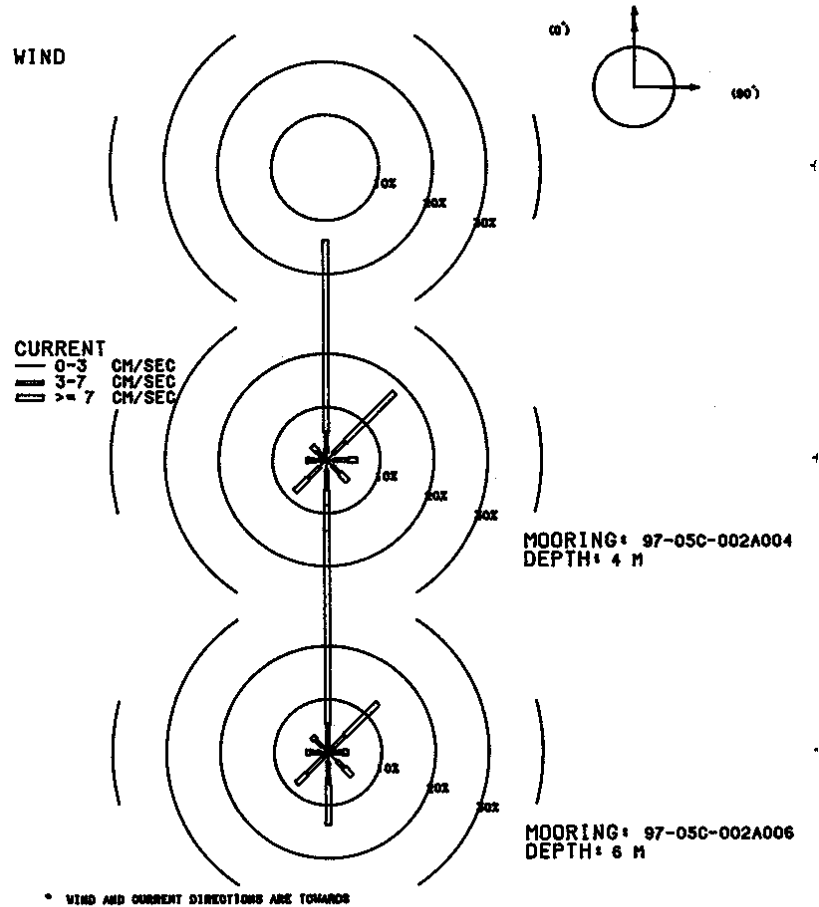

MOORING IS 97-05C-002A004 DEPTH IS 4 METERS THERE ARE 744 VALUES

FIRST DAY 1997/12/01/0000
 FINAL DAY 1997/12/31/2300

SHORELINE ORIENTATION IN DEGREES TRUE SPECIFIED AS 90

DIRECTION DEG TRUE	PERCENT OBSERVED	MAXIMUM CURRENT CM/S	MEAN DURA- TION HOURS	MEAN EXCUR- SION KM	MEAN CURRENT CM/S	MEAN TEMP DEG C
TOWARD	TOTAL	LIGHT	MEDIUM	HIGH		
90.0	5.8	1.2	2.8	1.7	15.5	1.8
45.0	18.0	1.7	3.2	13.0	35.6	1.6
0.0	41.4	1.5	3.9	36.0	41.4	3.2
315.0	3.8	0.7	1.7	1.3	17.1	1.3
270.0	3.8	0.9	2.2	0.7	10.3	1.5
225.0	8.3	1.7	3.1	3.5	22.0	1.6
180.0	13.3	2.0	3.6	7.7	28.4	2.4
135.0	5.6	1.5	2.0	2.2	11.6	1.8

MEAN SCALAR SPEED = 12.0 CM/S MEAN SQUARE SPEED = 216.8 CM²/S²
 MEAN SQUARE E-W SPEED = 28.0 CM²/S² MEAN SQUARE N-S SPEED = 188.7 CM²/S²
 MEAN VELOCITY = 7.2 CM/S, 18 DEG TRUE MEAN TEMPERATURE = 5.6 C
 VARIANCE (U,V) = 82.7 CM²/S² TOTAL HOURS = 744.

PERCENT OBSERVED
 LIGHT (0.0 - 3.0) 11.3% MEDIUM (3.0 - 7.0) 22.6% HIGH (GE 7.0) 66.1%

MOORING IS 97-05C-002A006 DEPTH IS 6 METERS THERE ARE 744 VALUES

FIRST DAY 1997/12/01/0000
 FINAL DAY 1997/12/31/2300

SHORELINE ORIENTATION IN DEGREES TRUE SPECIFIED AS 90

DIRECTION DEG TRUE	PERCENT OBSERVED	MAXIMUM CURRENT CM/S	MEAN DURA- TION HOURS	MEAN EXCUR- SION KM	MEAN CURRENT CM/S	MEAN TEMP DEG C
TOWARD	TOTAL	LIGHT	MEDIUM	HIGH		
90.0	3.8	0.4	2.3	1.1	12.6	2.0
45.0	13.2	0.8	3.6	8.7	38.6	1.6
0.0	46.5	0.7	4.7	41.1	43.2	5.4
315.0	4.2	1.5	1.9	0.8	14.6	1.5
270.0	4.0	1.5	1.7	0.8	13.7	1.4
225.0	8.3	0.9	4.7	2.7	23.3	2.1
180.0	13.7	1.7	4.3	7.7	26.9	3.1
135.0	6.3	2.3	1.9	2.2	18.3	1.5

MEAN SCALAR SPEED = 12.3 CM/S MEAN SQUARE SPEED = 232.2 CM²/S²
 MEAN SQUARE E-W SPEED = 21.9 CM²/S² MEAN SQUARE N-S SPEED = 210.4 CM²/S²
 MEAN VELOCITY = 7.7 CM/S, 14 DEG TRUE MEAN TEMPERATURE = 5.6 C
 VARIANCE (U,V) = 86.9 CM²/S² TOTAL HOURS = 744.

PERCENT OBSERVED
 LIGHT (0.0 - 3.0) 9.8% MEDIUM (3.0 - 7.0) 25.1% HIGH (GE 7.0) 65.1%

DATE: 1998/01/01 TO 1998/01/31
ROSE SUMMARY: WIND AND CURRENT

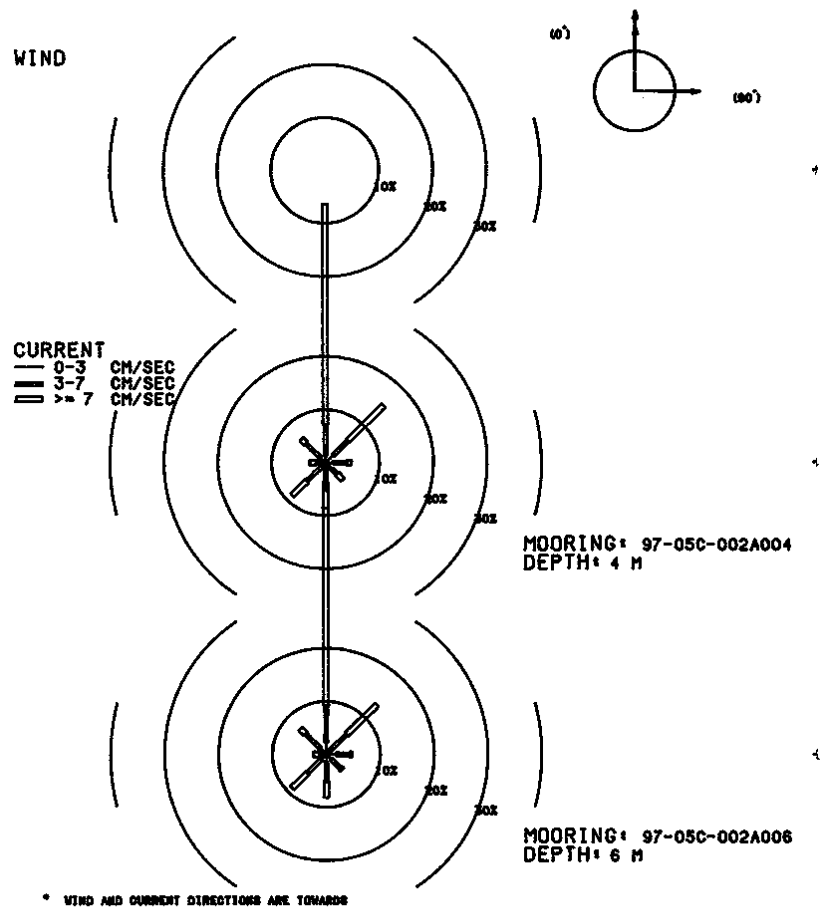

MOORING IS 97-05C-002A004 DEPTH IS 4 METERS THERE ARE 744 VALUES

FIRST DAY 1998/01/01/0000
FINAL DAY 1998/01/31/2300

SHORELINE ORIENTATION IN DEGREES TRUE SPECIFIED AS 90

DIRECTION DEG TRUE	PERCENT OBSERVED	MAXIMUM CURRENT CM/S	MEAN DURA- TION HOURS	MEAN EXCUR- SION KM	MEAN CURRENT CM/S	MEAN TEMP DEG C			
TOWARD	TOTAL	LIGHT	MEDIUM	HIGH					
90.0	4.8	1.3	2.6	0.9	14.2	1.3	0.2	4.9	3.4
45.0	15.3	2.0	3.9	9.4	55.6	1.6	0.8	14.4	3.4
0.0	48.7	1.3	5.9	41.4	53.6	4.4	2.2	13.7	3.2
315.0	6.3	1.3	3.8	1.2	12.9	1.3	0.2	5.1	3.1
270.0	3.0	0.4	1.3	1.2	21.9	1.1	0.3	7.9	3.5
225.0	8.7	0.7	4.2	3.9	20.5	2.0	0.5	7.2	3.2
180.0	8.6	1.1	4.2	3.4	21.1	1.7	0.4	7.1	3.2
135.0	4.6	1.6	1.3	1.6	16.9	1.2	0.3	6.1	3.4

0 MEAN SCALAR SPEED = 11.2 CM/S MEAN SQUARE SPEED = 202.4 CM2/S2
 MEAN SQUARE E-W SPEED = 30.1 CM2/S2 MEAN SQUARE N-S SPEED = 172.4 CM2/S2
 MEAN VELOCITY = 7.6 CM/S, 14 DEG TRUE MEAN TEMPERATURE = 3.2 C
 VARIANCE(U,V) = 72.5 CM2/S2 TOTAL HOURS = 744.

PERCENT OBSERVED
 LIGHT (0.0 - 3.0) 9.8% MEDIUM (3.0 - 7.0) 27.2% HIGH (GE 7.0) 63.0%

MOORING IS 97-05C-002A006 DEPTH IS 6 METERS THERE ARE 744 VALUES

FIRST DAY 1998/01/01/0000
FINAL DAY 1998/01/31/2300

SHORELINE ORIENTATION IN DEGREES TRUE SPECIFIED AS 90

DIRECTION DEG TRUE	PERCENT OBSERVED	MAXIMUM CURRENT CM/S	MEAN DURA- TION HOURS	MEAN EXCUR- SION KM	MEAN CURRENT CM/S	MEAN TEMP DEG C			
TOWARD	TOTAL	LIGHT	MEDIUM	HIGH					
90.0	4.8	1.7	2.6	0.5	8.5	1.4	0.2	4.0	3.3
45.0	13.3	0.5	4.7	8.1	45.7	1.4	0.5	11.0	3.4
0.0	51.2	2.3	7.0	41.9	53.6	4.5	2.4	14.6	3.2
315.0	6.9	1.3	4.0	1.5	13.2	1.5	0.3	5.2	3.3
270.0	2.4	0.4	0.8	1.2	16.9	1.1	0.3	7.2	3.7
225.0	9.0	1.2	3.8	4.0	24.0	2.1	0.5	6.7	3.2
180.0	8.2	1.5	3.6	3.1	27.6	1.8	0.4	6.8	3.2
135.0	4.2	1.2	2.4	0.5	12.8	1.7	0.3	4.6	3.3

0 MEAN SCALAR SPEED = 11.0 CM/S MEAN SQUARE SPEED = 199.0 CM2/S2
 MEAN SQUARE E-W SPEED = 22.5 CM2/S2 MEAN SQUARE N-S SPEED = 176.5 CM2/S2
 MEAN VELOCITY = 7.8 CM/S, 11 DEG TRUE MEAN TEMPERATURE = 3.2 C
 VARIANCE(U,V) = 69.4 CM2/S2 TOTAL HOURS = 744.

PERCENT OBSERVED
 LIGHT (0.0 - 3.0) 10.2% MEDIUM (3.0 - 7.0) 28.9% HIGH (GE 7.0) 60.9%

DATE: 1998/02/01 TO 1998/02/28
 ROSE SUMMARY: WIND AND CURRENT

WIND

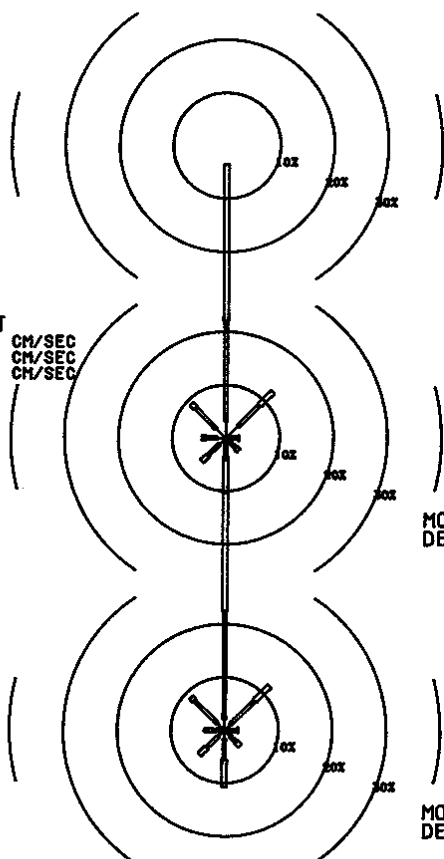

MOORING: 97-05C-002A004
 DEPTH: 4 M

MOORING: 97-05C-002A006
 DEPTH: 6 M

* WIND AND CURRENT DIRECTIONS ARE TOWARDS

MOORING IS 97-05C-002A004 DEPTH IS 4 METERS THERE ARE 672 VALUES

FIRST DAY 1998/02/01/0000
 FINAL DAY 1998/02/28/2300

SHORELINE ORIENTATION IN DEGREES TRUE SPECIFIED AS 90

DIRECTION DEG TRUE	PERCENT OBSERVED	TOWARD	TOTAL	LIGHT	MEDIUM	HIGH	MAXIMUM CURRENT CM/S	MEAN DURA- TION HOURS	MEAN EXCUR- SION KM	MEAN CURRENT CM/S	MEAN TEMP DEG C
90.0	2.5	0.9	1.3	0.3	11.3	1.1	0.2	4.5	2.5		
45.0	12.4	3.1	5.7	3.6	22.3	1.2	0.3	5.9	2.2		
0.0	51.5	3.1	18.9	29.5	22.3	4.2	1.3	8.7	2.2		
315.0	9.1	2.5	5.5	1.0	15.7	1.2	0.2	4.4	2.4		
270.0	4.5	1.5	2.2	0.7	13.4	1.1	0.2	4.6	2.5		
225.0	6.2	1.6	3.1	1.5	10.7	1.3	0.2	4.9	2.4		
180.0	10.4	1.0	3.1	6.2	14.6	2.2	0.6	7.4	2.4		
135.0	3.4	1.2	1.5	0.7	10.3	1.2	0.2	4.6	2.5		

MEAN SCALAR SPEED = 7.1 CM/S MEAN SQUARE SPEED = 69.2 CM2/S2
 MEAN SQUARE E-W SPEED = 8.2 CM2/S2 MEAN SQUARE N-S SPEED = 61.1 CM2/S2
 MEAN VELOCITY = 4.2 CM/S, 5 DEG TRUE MEAN TEMPERATURE = 2.3 C
 VARIANCE (U,V) = 25.9 CM2/S2 TOTAL HOURS = 672.

PERCENT OBSERVED
 LIGHT (0.0 - 3.0) 15.0% MEDIUM (3.0 - 7.0) 41.4% HIGH (GE 7.0) 43.6%

MOORING IS 97-05C-002A006 DEPTH IS 6 METERS THERE ARE 672 VALUES

FIRST DAY 1998/02/01/0000
 FINAL DAY 1998/02/28/2300

SHORELINE ORIENTATION IN DEGREES TRUE SPECIFIED AS 90

DIRECTION DEG TRUE	PERCENT OBSERVED	TOWARD	TOTAL	LIGHT	MEDIUM	HIGH	MAXIMUM CURRENT CM/S	MEAN DURA- TION HOURS	MEAN EXCUR- SION KM	MEAN CURRENT CM/S	MEAN TEMP DEG C
90.0	2.5	0.9	1.5	0.1	8.6	1.2	0.2	3.7	2.5		
45.0	11.9	1.5	6.4	4.0	13.2	1.7	0.4	6.2	2.2		
0.0	51.5	2.1	20.4	29.0	21.5	4.8	1.5	8.7	2.2		
315.0	8.8	1.8	6.1	0.9	17.5	1.3	0.2	4.6	2.4		
270.0	3.9	0.9	3.0	0.0	7.0	1.1	0.2	4.4	2.5		
225.0	6.5	1.5	3.1	1.9	11.1	1.6	0.3	5.2	2.5		
180.0	10.7	1.6	3.9	5.2	12.9	2.4	0.6	6.8	2.4		
135.0	4.2	1.5	1.6	1.0	15.5	1.3	0.2	4.7	2.4		

MEAN SCALAR SPEED = 7.1 CM/S MEAN SQUARE SPEED = 68.7 CM2/S2
 MEAN SQUARE E-W SPEED = 8.1 CM2/S2 MEAN SQUARE N-S SPEED = 60.6 CM2/S2
 MEAN VELOCITY = 4.2 CM/S, 5 DEG TRUE MEAN TEMPERATURE = 2.3 C
 VARIANCE (U,V) = 25.6 CM2/S2 TOTAL HOURS = 672.

PERCENT OBSERVED
 LIGHT (0.0 - 3.0) 11.8% MEDIUM (3.0 - 7.0) 46.0% HIGH (GE 7.0) 42.3%

DATE: 1998/03/01 TO 1998/03/31
ROSE SUMMARY: WIND AND CURRENT

WIND

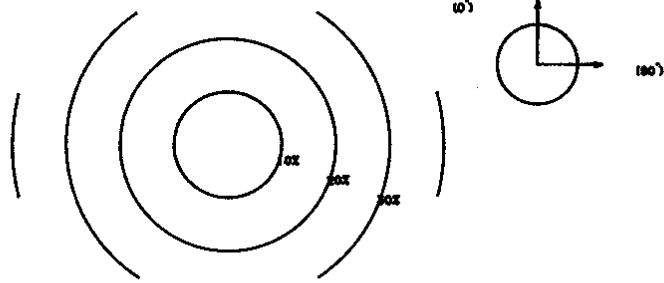

CURRENT

0-3 CM/SEC
3-7 CM/SEC
>=7 CM/SEC

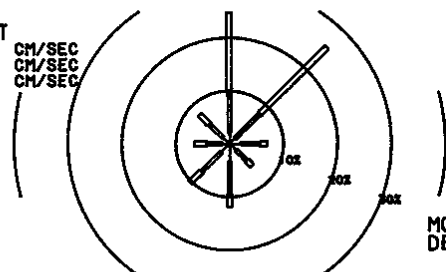

MOORING: 97-05C-002A004
DEPTH: 4 M

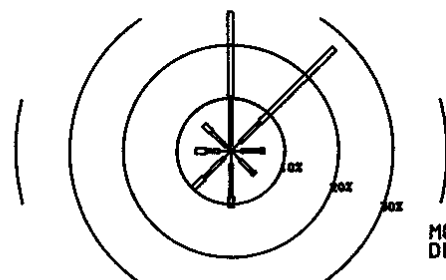

MOORING: 97-05C-002A006
DEPTH: 6 M

* WIND AND CURRENT DIRECTIONS ARE TOWARDS

MOORING IS 97-05C-002A004 DEPTH IS 4 METERS THERE ARE 744 VALUES

FIRST DAY 1998/03/01/0000
FINAL DAY 1998/03/31/2300

SHORELINE ORIENTATION IN DEGREES TRUE SPECIFIED AS 90

DIRECTION DEG TRUE	PERCENT OBSERVED	TOWARD	TOTAL	LIGHT	MEDIUM	HIGH	MAXIMUM CURRENT CM/S	MEAN DURA- TION HOURS	MEAN EXCUR- SION KM	MEAN CURRENT CM/S	MEAN TEMP DEG C
90.0	7.0	2.2	3.5	1.3			17.7	1.3	0.2	4.9	2.6
45.0	25.7	1.5	6.5	17.7			67.9	3.0	1.6	14.9	2.3
0.0	24.7	2.2	7.8	14.8			54.1	2.1	0.7	9.9	2.3
315.0	7.8	1.6	3.6	2.6			37.6	1.2	0.3	7.4	2.4
270.0	6.6	1.5	2.7	2.4			30.9	1.3	0.4	7.7	2.6
225.0	10.3	2.2	5.2	3.0			28.7	1.8	0.5	7.3	2.7
180.0	12.0	3.4	6.2	2.4			35.8	1.4	0.4	6.8	2.7
135.0	5.9	1.6	2.8	1.5			16.5	1.2	0.3	5.8	2.7

0 MEAN SCALAR SPEED = 9.6 CM/S MEAN SQUARE SPEED = 167.9 CM2/S2
MEAN SQUARE E-W SPEED = 50.1 CM2/S2 MEAN SQUARE N-S SPEED = 117.8 CM2/S2
MEAN VELOCITY = 4.6 CM/S, 21 DEG TRUE MEAN TEMPERATURE = 2.5 C
VARIANCE (U,V) = 73.3 CM2/S2 TOTAL HOURS = 744.

PERCENT OBSERVED

LIGHT (0.0 - 3.0) 16.0% MEDIUM (3.0 - 7.0) 38.3% HIGH (GE 7.0) 45.7%

MOORING IS 97-05C-002A006 DEPTH IS 6 METERS THERE ARE 744 VALUES

FIRST DAY 1998/03/01/0000
FINAL DAY 1998/03/31/2300

SHORELINE ORIENTATION IN DEGREES TRUE SPECIFIED AS 90

DIRECTION DEG TRUE	PERCENT OBSERVED	TOWARD	TOTAL	LIGHT	MEDIUM	HIGH	MAXIMUM CURRENT CM/S	MEAN DURA- TION HOURS	MEAN EXCUR- SION KM	MEAN CURRENT CM/S	MEAN TEMP DEG C
90.0	6.2	1.9	3.6	0.7			12.0	1.3	0.2	4.2	2.6
45.0	27.3	2.3	5.4	19.6			75.1	3.0	1.7	15.9	2.2
0.0	26.2	1.1	9.3	15.9			65.5	2.2	0.9	11.7	2.3
315.0	7.0	1.3	3.8	1.9			24.9	1.2	0.3	6.1	2.4
270.0	6.6	2.2	2.4	2.0			23.4	1.3	0.3	5.9	2.6
225.0	9.9	1.7	5.4	2.8			33.7	2.0	0.6	8.7	2.7
180.0	10.6	2.4	6.2	2.0			43.7	1.7	0.4	5.8	2.8
135.0	6.2	2.3	3.4	0.5			9.3	1.2	0.2	3.8	2.8

0 MEAN SCALAR SPEED = 10.2 CM/S MEAN SQUARE SPEED = 199.1 CM2/S2
MEAN SQUARE E-W SPEED = 52.0 CM2/S2 MEAN SQUARE N-S SPEED = 147.1 CM2/S2
MEAN VELOCITY = 5.8 CM/S, 20 DEG TRUE MEAN TEMPERATURE = 2.5 C
VARIANCE (U,V) = 83.1 CM2/S2 TOTAL HOURS = 744.

PERCENT OBSERVED

LIGHT (0.0 - 3.0) 15.2% MEDIUM (3.0 - 7.0) 39.4% HIGH (GE 7.0) 45.4%

DATE: 1998/04/01 TO 1998/04/30
ROSE SUMMARY: WIND AND CURRENT

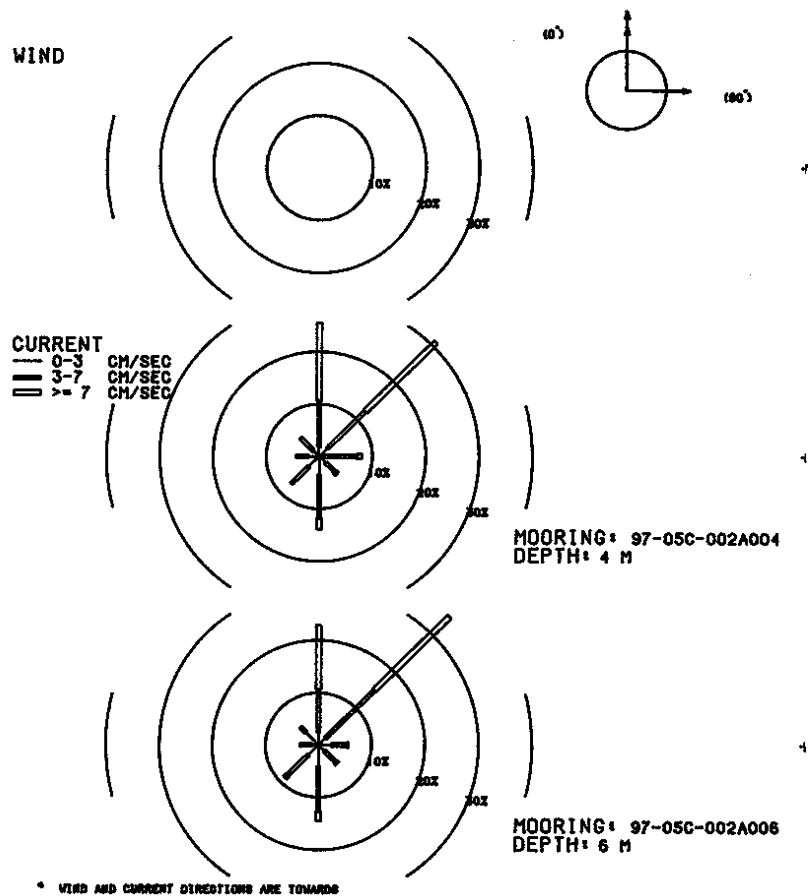

MOORING IS 97-05C-002A004 DEPTH IS 4 METERS THERE ARE 337 VALUES

FIRST DAY 1998/04/01/0000
FINAL DAY 1998/04/15/0000

SHORELINE ORIENTATION IN DEGREES TRUE SPECIFIED AS 90

DIRECTION DEG TRUE	PERCENT OBSERVED	MAXIMUM CURRENT	MEAN DURATION HOURS	MEAN EXCURSION KM	MEAN CURRENT CM/S	MEAN TEMP DEG C
TOWARD	TOTAL	LIGHT	MEDIUM	HIGH	CM/S	
90.0	8.0	0.9	6.2	0.9	9.1	1.4
45.0	30.9	2.1	10.1	18.7	27.7	2.8
0.0	25.5	1.8	8.9	14.8	25.0	2.4
315.0	5.0	1.5	3.6	0.0	6.4	1.0
270.0	4.5	2.1	2.4	0.0	5.2	1.2
225.0	7.4	2.7	4.7	0.0	6.4	1.5
180.0	13.9	3.6	8.3	2.1	10.5	1.9
135.0	4.7	1.8	2.4	0.6	13.4	1.2
0		MEAN SCALAR SPEED = 7.5 CM/S		MEAN SQUARE SPEED = 89.4 CM2/S2		
		MEAN SQUARE E-W SPEED = 21.5 CM2/S2		MEAN SQUARE N-S SPEED = 67.9 CM2/S2		
		MEAN VELOCITY = 4.7 CM/S,		30 DEG TRUE		MEAN TEMPERATURE = 3.6 C
		VARIANCE (U,V) = 33.6 CM2/S2		TOTAL HOURS = 337.		

PERCENT OBSERVED
 LIGHT (0.0 - 3.0) 16.3% MEDIUM (3.0 - 7.0) 46.6% HIGH (GE 7.0) 37.1%

MOORING IS 97-05C-002A006 DEPTH IS 6 METERS THERE ARE 337 VALUES

FIRST DAY 1998/04/01/0000
FINAL DAY 1998/04/15/0000

SHORELINE ORIENTATION IN DEGREES TRUE SPECIFIED AS 90

DIRECTION DEG TRUE	PERCENT OBSERVED	MAXIMUM CURRENT	MEAN DURATION HOURS	MEAN EXCURSION KM	MEAN CURRENT CM/S	MEAN TEMP DEG C
TOWARD	TOTAL	LIGHT	MEDIUM	HIGH	CM/S	
90.0	5.6	2.4	3.0	0.3	8.3	1.4
45.0	34.7	1.8	13.1	19.9	27.9	3.3
0.0	22.8	2.4	8.3	12.2	25.7	2.5
315.0	4.7	3.3	1.5	0.0	5.5	1.1
270.0	3.6	1.2	2.4	0.0	5.0	1.3
225.0	8.9	2.7	5.6	0.6	7.7	1.4
180.0	14.5	4.2	8.6	1.8	9.2	1.9
135.0	5.0	1.5	3.3	0.3	8.2	1.1
0		MEAN SCALAR SPEED = 7.5 CM/S		MEAN SQUARE SPEED = 95.1 CM2/S2		
		MEAN SQUARE E-W SPEED = 20.3 CM2/S2		MEAN SQUARE N-S SPEED = 74.8 CM2/S2		
		MEAN VELOCITY = 4.7 CM/S,		28 DEG TRUE		MEAN TEMPERATURE = 3.6 C
		VARIANCE (U,V) = 36.5 CM2/S2		TOTAL HOURS = 337.		

PERCENT OBSERVED
 LIGHT (0.0 - 3.0) 19.3% MEDIUM (3.0 - 7.0) 45.7% HIGH (GE 7.0) 35.0%

DATE: 1997/11/02 TO 1997/11/30
 ROSE SUMMARY: WIND AND CURRENT

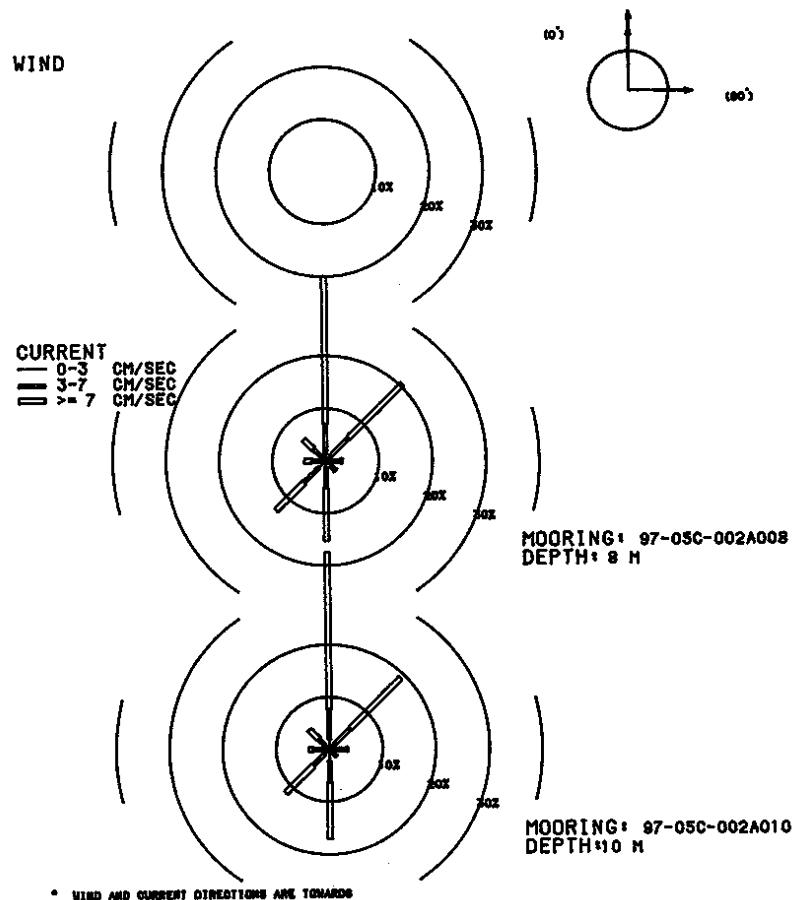

MOORING IS 97-05C-002A008 DEPTH IS 8 METERS THERE ARE 691 VALUES

FIRST DAY 1997/11/02/0500
 FINAL DAY 1997/11/30/2300

SHORELINE ORIENTATION IN DEGREES TRUE SPECIFIED AS 90

DIRECTION DEG TRUE	PERCENT OBSERVED	MAXIMUM CURRENT	MEAN DURATION HOURS	MEAN EXCURSION KM	MEAN CURRENT CM/S	MEAN TEMP DEG C
TOWARD	TOTAL	LIGHT	MEDIUM	HIGH	CM/S	
90.0	3.2	0.7	2.0	0.4	9.7	1.4
45.0	20.5	1.3	4.8	14.5	36.3	2.4
0.0	35.2	1.3	5.8	28.1	34.9	3.6
315.0	5.8	1.0	2.2	2.6	20.1	1.5
270.0	4.1	1.0	1.6	1.4	14.5	1.3
225.0	13.3	1.9	3.8	7.7	22.0	2.1
180.0	15.3	1.2	4.1	10.1	21.3	2.8
135.0	2.6	1.4	1.0	0.1	7.3	1.1

MEAN SCALAR SPEED = 11.3 CM/S MEAN SQUARE SPEED = 184.8 CM²/S²
 MEAN SQUARE E-W SPEED = 27.6 CM²/S² MEAN SQUARE N-S SPEED = 157.2 CM²/S²
 MEAN VELOCITY = 5.0 CM/S, 11 DEG TRUE MEAN TEMPERATURE = 8.4 C
 VARIANCE (U,V) = 79.9 CM²/S² TOTAL HOURS = 691.

PERCENT OBSERVED
 LIGHT (0.0 - 3.0) 9.8% MEDIUM (3.0 - 7.0) 25.2% HIGH (GE 7.0) 65.0%

MOORING IS 97-05C-002A010 DEPTH IS 10 METERS THERE ARE 691 VALUES

FIRST DAY 1997/11/02/0500
 FINAL DAY 1997/11/30/2300

SHORELINE ORIENTATION IN DEGREES TRUE SPECIFIED AS 90

DIRECTION DEG TRUE	PERCENT OBSERVED	MAXIMUM CURRENT	MEAN DURATION HOURS	MEAN EXCURSION KM	MEAN CURRENT CM/S	MEAN TEMP DEG C
TOWARD	TOTAL	LIGHT	MEDIUM	HIGH	CM/S	
90.0	3.5	1.4	1.9	0.1	7.4	1.4
45.0	19.1	0.9	4.8	13.5	34.6	2.4
0.0	37.5	1.9	5.8	29.8	35.8	4.0
315.0	5.4	1.2	1.6	2.6	20.3	1.7
270.0	3.9	1.0	2.0	0.9	16.0	1.3
225.0	11.7	1.3	2.9	7.5	18.1	2.1
180.0	17.1	2.2	4.1	10.9	22.4	2.8
135.0	1.9	1.0	0.9	0.0	6.0	1.0

MEAN SCALAR SPEED = 11.3 CM/S MEAN SQUARE SPEED = 186.0 CM²/S²
 MEAN SQUARE E-W SPEED = 25.4 CM²/S² MEAN SQUARE N-S SPEED = 160.7 CM²/S²
 MEAN VELOCITY = 5.1 CM/S, 11 DEG TRUE MEAN TEMPERATURE = 8.4 C
 VARIANCE (U,V) = 79.9 CM²/S² TOTAL HOURS = 691.

PERCENT OBSERVED
 LIGHT (0.0 - 3.0) 10.9% MEDIUM (3.0 - 7.0) 23.9% HIGH (GE 7.0) 65.3%

DATE: 1997/12/01 TO 1997/12/31
ROSE SUMMARY: WIND AND CURRENT

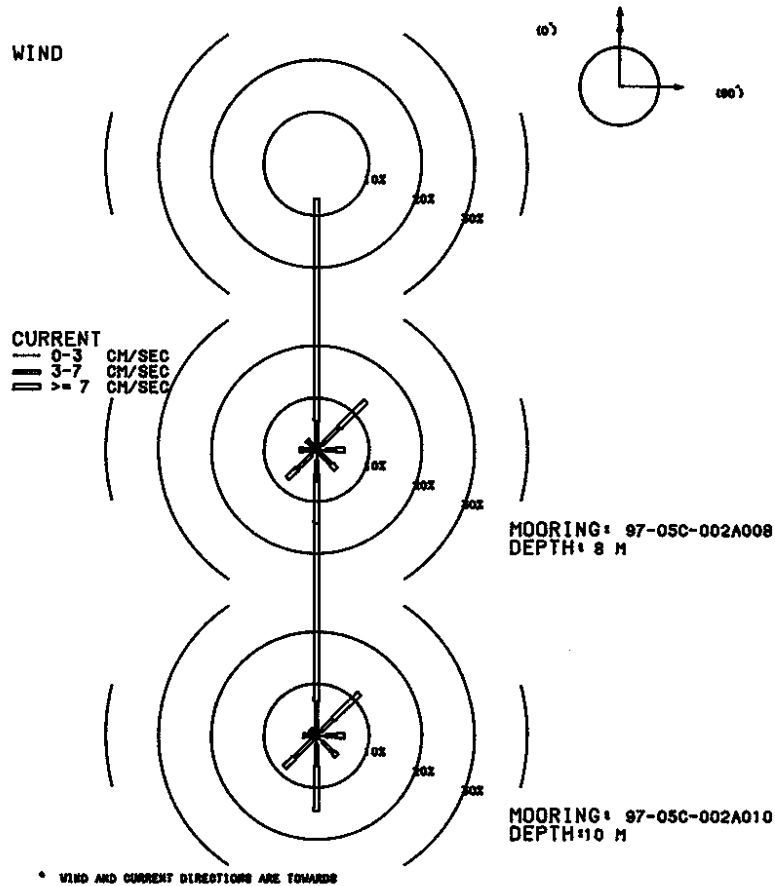

MOORING IS 97-05C-002A008 DEPTH IS 8 METERS THERE ARE 744 VALUES

FIRST DAY 1997/12/01/0000
FINAL DAY 1997/12/31/2300

SHORELINE ORIENTATION IN DEGREES TRUE SPECIFIED AS 90

DIRECTION DEG TRUE	PERCENT OBSERVED	MAXIMUM CURRENT	MEAN DURA- TION HOURS	MEAN EXCUR- SION KM	MEAN CURRENT CM/S	MEAN TEMP DEG C
TOWARD	TOTAL	LIGHT	MEDIUM	HIGH	CM/S	
90.0	5.4	1.7	1.9	1.7	11.9	1.5
45.0	13.3	1.3	4.7	7.3	39.9	1.6
0.0	48.3	1.1	4.4	42.7	43.2	5.5
315.0	2.6	1.2	1.2	0.1	11.0	1.2
270.0	3.2	0.9	1.6	0.7	8.1	1.7
225.0	7.8	1.3	3.9	2.6	21.5	1.8
180.0	14.2	2.0	4.2	8.1	23.6	3.1
135.0	5.2	0.8	3.1	1.3	10.0	1.9

MEAN SCALAR SPEED = 12.3 CM/S MEAN SQUARE SPEED = 235.7 CM2/S2
 MEAN SQUARE E-W SPEED = 19.4 CM2/S2 MEAN SQUARE N-S SPEED = 216.3 CM2/S2
 MEAN VELOCITY = 7.8 CM/S, 13 DEG TRUE MEAN TEMPERATURE = 5.6 C
 VARIANCE(U,V) = 87.5 CM2/S2 TOTAL HOURS = 744.

PERCENT OBSERVED

LIGHT (0.0 - 3.0) 10.5% MEDIUM (3.0 - 7.0) 25.0% HIGH (GE 7.0) 64.5%

MOORING IS 97-05C-002A010 DEPTH IS 10 METERS THERE ARE 744 VALUES

FIRST DAY 1997/12/01/0000
FINAL DAY 1997/12/31/2300

SHORELINE ORIENTATION IN DEGREES TRUE SPECIFIED AS 90

DIRECTION DEG TRUE	PERCENT OBSERVED	MAXIMUM CURRENT	MEAN DURA- TION HOURS	MEAN EXCUR- SION KM	MEAN CURRENT CM/S	MEAN TEMP DEG C
TOWARD	TOTAL	LIGHT	MEDIUM	HIGH	CM/S	
90.0	5.4	1.9	1.9	1.6	10.5	1.7
45.0	11.6	1.2	3.2	7.1	40.2	1.7
0.0	50.3	0.9	5.6	43.7	42.2	7.3
315.0	1.6	1.1	0.4	0.1	9.5	1.5
270.0	2.6	0.8	1.5	0.3	10.6	1.3
225.0	8.6	0.9	5.0	2.7	18.6	1.9
180.0	14.5	1.7	4.0	8.7	22.3	3.1
135.0	5.5	1.6	3.0	0.9	9.3	2.0

MEAN SCALAR SPEED = 12.3 CM/S MEAN SQUARE SPEED = 235.2 CM2/S2
 MEAN SQUARE E-W SPEED = 18.4 CM2/S2 MEAN SQUARE N-S SPEED = 216.8 CM2/S2
 MEAN VELOCITY = 7.9 CM/S, 14 DEG TRUE MEAN TEMPERATURE = 5.6 C
 VARIANCE(U,V) = 86.5 CM2/S2 TOTAL HOURS = 744.

PERCENT OBSERVED

LIGHT (0.0 - 3.0) 10.2% MEDIUM (3.0 - 7.0) 24.6% HIGH (GE 7.0) 65.2%

DATE: 1998/01/01 TO 1998/01/31
ROSE SUMMARY: WIND AND CURRENT

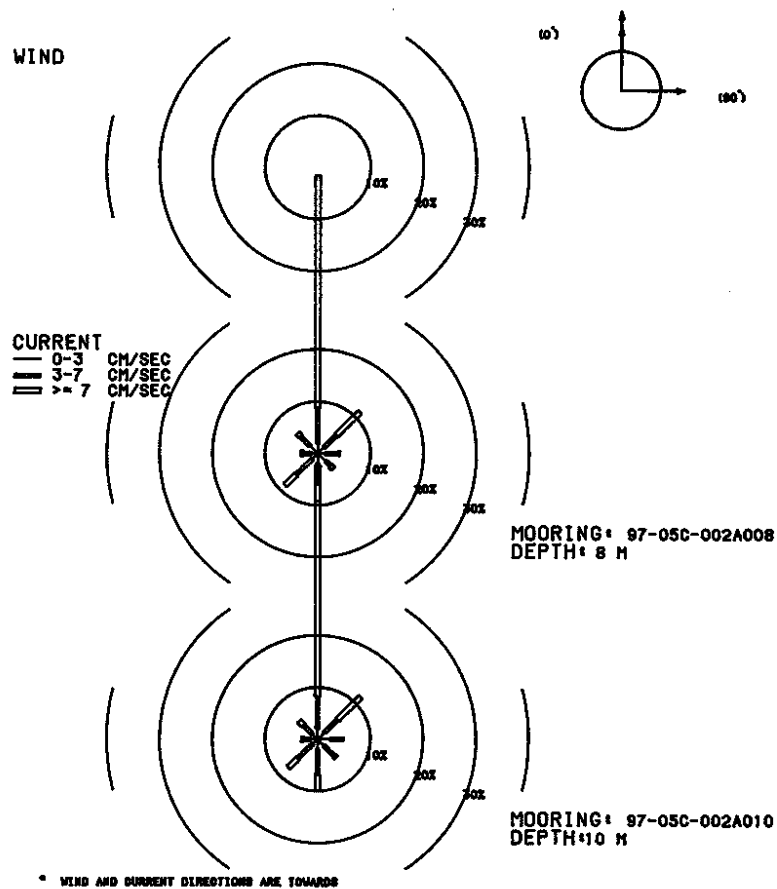

MOORING IS 97-05C-002A008 DEPTH IS 8 METERS THERE ARE 744 VALUES

FIRST DAY 1998/01/01/0000
FINAL DAY 1998/01/31/2300

SHORELINE ORIENTATION IN DEGREES TRUE SPECIFIED AS 90

DIRECTION DEG TRUE	PERCENT OBSERVED	MAXIMUM CURRENT	MEAN DURA- TION HOURS	MEAN EXCUR- SION KM	MEAN CURRENT CM/S	MEAN TEMP DEG C
TOWARD	TOTAL	LIGHT	MEDIUM	HIGH	CM/S	
90.0	4.2	1.3	2.6	0.3	8.3	1.6
45.0	11.3	1.6	3.4	6.3	48.0	1.4
0.0	53.5	1.9	6.9	44.8	50.3	5.2
315.0	5.5	2.0	2.6	0.9	12.2	1.5
270.0	3.4	1.2	1.5	0.7	13.2	1.2
225.0	8.7	1.5	4.3	3.0	25.6	1.9
180.0	9.3	1.9	4.0	3.4	21.0	1.8
135.0	4.2	2.0	1.3	0.8	13.8	1.2

MEAN SCALAR SPEED = 11.0 CM/S MEAN SQUARE SPEED = 201.0 CM2/S2
MEAN SQUARE E-W SPEED = 20.0 CM2/S2 MEAN SQUARE N-S SPEED = 181.0 CM2/S2
MEAN VELOCITY = 7.8 CM/S, 11 DEG TRUE MEAN TEMPERATURE = 3.2 C
VARIANCE (U,V) = 70.5 CM2/S2 TOTAL HOURS = 744.

PERCENT OBSERVED
LIGHT (0.0 - 3.0) 13.4% MEDIUM (3.0 - 7.0) 26.5% HIGH (GE 7.0) 60.1%

MOORING IS 97-05C-002A010 DEPTH IS 10 METERS THERE ARE 744 VALUES

FIRST DAY 1998/01/01/0000
FINAL DAY 1998/01/31/2300

SHORELINE ORIENTATION IN DEGREES TRUE SPECIFIED AS 90

DIRECTION DEG TRUE	PERCENT OBSERVED	MAXIMUM CURRENT	MEAN DURA- TION HOURS	MEAN EXCUR- SION KM	MEAN CURRENT CM/S	MEAN TEMP DEG C
TOWARD	TOTAL	LIGHT	MEDIUM	HIGH	CM/S	
90.0	5.0	2.4	2.6	0.0	6.8	1.5
45.0	11.6	1.7	3.6	6.2	37.6	1.6
0.0	52.7	2.0	6.2	44.5	49.8	5.9
315.0	5.0	1.3	2.4	1.2	12.2	1.4
270.0	3.1	1.3	1.3	0.4	13.2	1.4
225.0	7.8	1.2	4.0	2.6	19.7	1.9
180.0	9.9	2.0	4.8	3.1	21.0	2.1
135.0	5.0	1.7	2.7	0.5	11.2	1.4

MEAN SCALAR SPEED = 10.8 CM/S MEAN SQUARE SPEED = 198.7 CM2/S2
MEAN SQUARE E-W SPEED = 18.0 CM2/S2 MEAN SQUARE N-S SPEED = 180.7 CM2/S2
MEAN VELOCITY = 7.8 CM/S, 12 DEG TRUE MEAN TEMPERATURE = 3.2 C
VARIANCE (U,V) = 69.0 CM2/S2 TOTAL HOURS = 744.

PERCENT OBSERVED
LIGHT (0.0 - 3.0) 13.8% MEDIUM (3.0 - 7.0) 27.7% HIGH (GE 7.0) 58.5%

DATE: 1998/02/01 TO 1998/02/28
 ROSE SUMMARY: WIND AND CURRENT

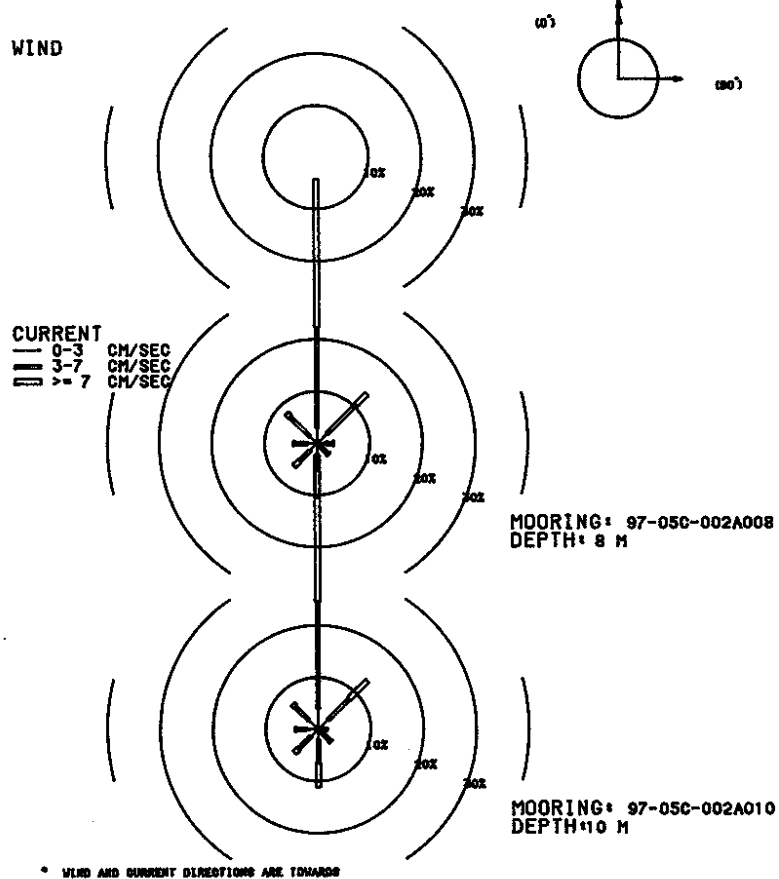

MOORING IS 97-05C-002A008 DEPTH IS 8 METERS THERE ARE 672 VALUES

FIRST DAY 1998/02/01/0000
 FINAL DAY 1998/02/28/2300

SHORELINE ORIENTATION IN DEGREES TRUE SPECIFIED AS 90

DIRECTION DEG TRUE	PERCENT OBSERVED	MAXIMUM CURRENT	MEAN DURA- TION HOURS	MEAN EXCUR- SION KM	MEAN CURRENT CM/S	MEAN TEMP DEG C
TOWARD	TOTAL	LIGHT	MEDIUM	HIGH	CM/S	
90.0	3.1	1.5	1.5	0.1	8.5	2.1
45.0	13.4	2.5	7.9	3.0	18.1	1.4
0.0	50.7	3.0	19.3	28.4	21.8	4.3
315.0	8.2	1.9	5.2	1.0	9.7	1.3
270.0	4.6	1.8	2.5	0.3	8.3	1.4
225.0	6.2	1.9	2.8	1.5	12.7	1.7
180.0	10.6	2.1	3.3	5.2	14.1	2.6
135.0	3.1	1.0	1.6	0.4	17.1	1.1
0		MEAN SCALAR SPEED = 7.0 CM/S		MEAN SQUARE SPEED = 67.5 CM2/S2		
		MEAN SQUARE E-W SPEED = 6.8 CM2/S2		MEAN SQUARE N-S SPEED = 60.7 CM2/S2		
		MEAN VELOCITY = 4.2 CM/S,		7 DEG TRUE		MEAN TEMPERATURE = 2.3 C
		VARIANCE (U,V) = 24.9 CM2/S2		TOTAL HOURS = 672.		

PERCENT OBSERVED
 LIGHT (0.0 - 3.0) 15.8% MEDIUM (3.0 - 7.0) 44.2% HIGH (GE 7.0) 40.0%

MOORING IS 97-05C-002A010 DEPTH IS 10 METERS THERE ARE 672 VALUES

FIRST DAY 1998/02/01/0000
 FINAL DAY 1998/02/28/2300

SHORELINE ORIENTATION IN DEGREES TRUE SPECIFIED AS 90

DIRECTION DEG TRUE	PERCENT OBSERVED	MAXIMUM CURRENT	MEAN DURA- TION HOURS	MEAN EXCUR- SION KM	MEAN CURRENT CM/S	MEAN TEMP DEG C
TOWARD	TOTAL	LIGHT	MEDIUM	HIGH	CM/S	
90.0	1.8	0.7	1.0	0.0	6.6	1.5
45.0	13.2	2.5	5.8	4.9	14.4	1.5
0.0	52.7	4.0	20.5	28.1	21.5	4.4
315.0	6.8	2.4	3.7	0.7	16.4	1.2
270.0	4.5	2.2	1.9	0.3	9.5	1.3
225.0	6.4	1.9	3.4	1.0	10.0	1.4
180.0	11.2	1.9	4.6	4.6	12.9	2.2
135.0	3.4	1.2	1.9	0.3	11.8	1.3
0		MEAN SCALAR SPEED = 6.9 CM/S		MEAN SQUARE SPEED = 65.5 CM2/S2		
		MEAN SQUARE E-W SPEED = 6.3 CM2/S2		MEAN SQUARE N-S SPEED = 59.2 CM2/S2		
		MEAN VELOCITY = 4.2 CM/S,		7 DEG TRUE		MEAN TEMPERATURE = 2.3 C
		VARIANCE (U,V) = 23.8 CM2/S2		TOTAL HOURS = 672.		

PERCENT OBSERVED
 LIGHT (0.0 - 3.0) 17.0% MEDIUM (3.0 - 7.0) 43.0% HIGH (GE 7.0) 40.0%

DATE: 1998/03/01 TO 1998/03/31
ROSE SUMMARY: WIND AND CURRENT

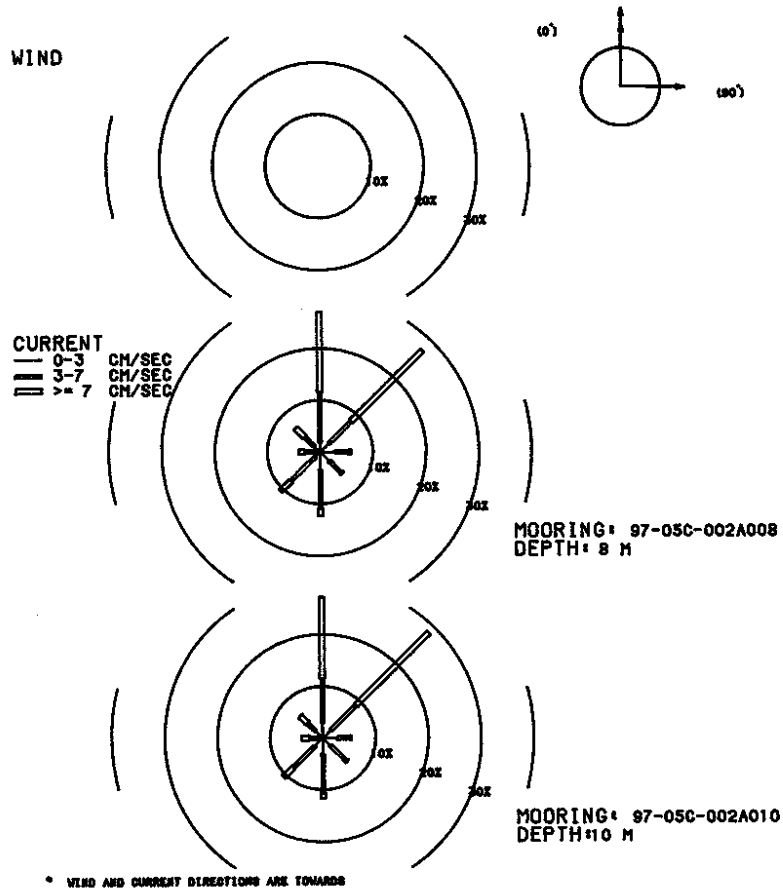

MOORING IS 97-05C-002A008 DEPTH IS 8 METERS THERE ARE 744 VALUES

FIRST DAY 1998/03/01/0000
FINAL DAY 1998/03/31/2300

SHORELINE ORIENTATION IN DEGREES TRUE SPECIFIED AS 90

DIRECTION DEG TRUE	PERCENT OBSERVED	MAXIMUM CURRENT CM/S	MEAN DURA- TION HOURS	MEAN EXCUR- SION KM	MEAN CURRENT CM/S	MEAN TEMP DEG C
TOWARD	TOTAL	LIGHT	MEDIUM	HIGH		
90.0	5.9	2.8	2.6	0.5	18.0	1.7
45.0	27.6	2.3	6.0	19.2	74.3	3.3
0.0	27.0	1.9	9.7	15.5	68.1	2.7
315.0	6.6	1.3	2.7	2.6	27.9	1.5
270.0	4.0	0.8	2.2	1.1	27.0	1.2
225.0	10.6	1.2	6.6	2.8	35.5	2.0
180.0	12.4	3.4	7.5	1.5	44.5	1.8
135.0	5.9	2.4	3.1	0.4	9.4	1.3

MEAN SCALAR SPEED = 10.3 CM/S MEAN SQUARE SPEED = 205.8 CM²/S²
MEAN SQUARE E-W SPEED = 53.1 CM²/S² MEAN SQUARE N-S SPEED = 152.7 CM²/S²
MEAN VELOCITY = 5.9 CM/S, 20 DEG TRUE MEAN TEMPERATURE = 2.5 C
VARIANCE (U,V) = 85.8 CM²/S² TOTAL HOURS = 744.

PERCENT OBSERVED

LIGHT (0.0 - 3.0) 16.1% MEDIUM (3.0 - 7.0) 40.3% HIGH (GE 7.0) 43.5%

MOORING IS 97-05C-002A010 DEPTH IS 10 METERS THERE ARE 744 VALUES

FIRST DAY 1998/03/01/0000
FINAL DAY 1998/03/31/2300

SHORELINE ORIENTATION IN DEGREES TRUE SPECIFIED AS 90

DIRECTION DEG TRUE	PERCENT OBSERVED	MAXIMUM CURRENT CM/S	MEAN DURA- TION HOURS	MEAN EXCUR- SION KM	MEAN CURRENT CM/S	MEAN TEMP DEG C
TOWARD	TOTAL	LIGHT	MEDIUM	HIGH		
90.0	5.4	2.7	2.6	0.1	13.4	1.5
45.0	28.6	2.2	6.7	19.8	76.4	3.5
0.0	27.2	3.0	8.5	15.7	68.6	2.6
315.0	6.0	1.9	2.2	2.0	26.4	1.3
270.0	4.0	0.7	1.9	1.5	26.6	1.4
225.0	10.6	2.2	5.8	2.7	36.4	1.7
180.0	11.7	3.1	7.5	1.1	50.8	1.8
135.0	6.5	2.0	4.2	0.3	8.5	1.4

MEAN SCALAR SPEED = 10.1 CM/S MEAN SQUARE SPEED = 206.7 CM²/S²
MEAN SQUARE E-W SPEED = 52.2 CM²/S² MEAN SQUARE N-S SPEED = 154.5 CM²/S²
MEAN VELOCITY = 5.9 CM/S, 20 DEG TRUE MEAN TEMPERATURE = 2.5 C
VARIANCE (U,V) = 85.8 CM²/S² TOTAL HOURS = 744.

PERCENT OBSERVED

LIGHT (0.0 - 3.0) 17.6% MEDIUM (3.0 - 7.0) 39.2% HIGH (GE 7.0) 43.1%

DATE: 1998/04/01 TO 1998/04/30
 ROSE SUMMARY: WIND AND CURRENT

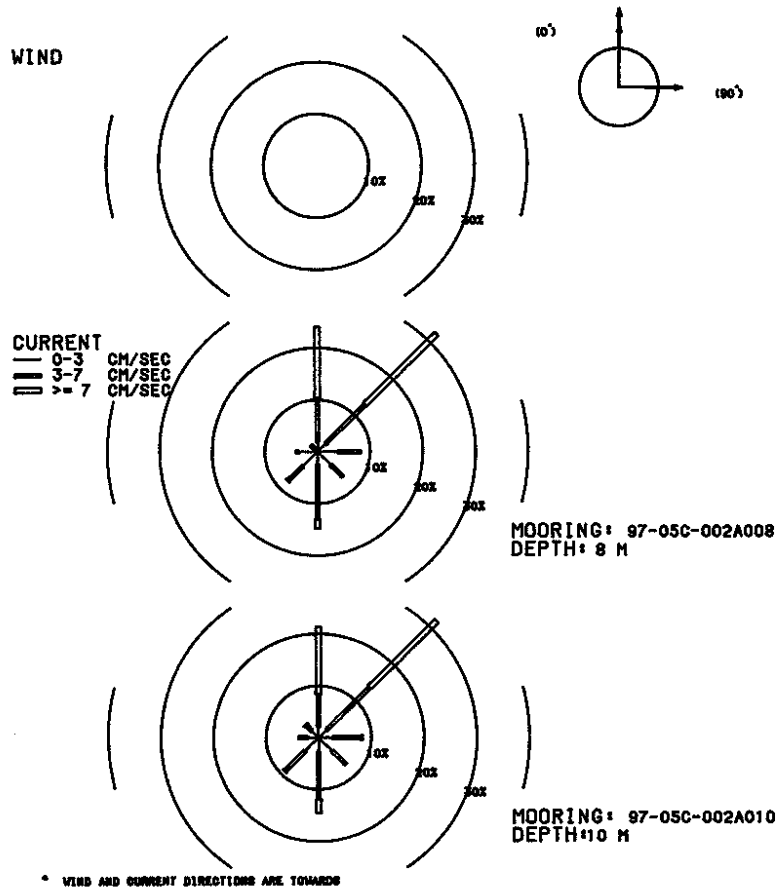

MOORING IS 97-05C-002A008 DEPTH IS 8 METERS THERE ARE 337 VALUES

FIRST DAY 1998/04/01/0000
 FINAL DAY 1998/04/15/0000

SHORELINE ORIENTATION IN DEGREES TRUE SPECIFIED AS 90

DIRECTION DEG TRUE	PERCENT OBSERVED				MAXIMUM CURRENT CM/S	MEAN DURA- TION HOURS	MEAN EXCUR- SION KM	MEAN CURRENT CM/S	MEAN TEMP DEG C
	TOWARD	TOTAL	LIGHT	MEDIUM					
90.0	8.3	3.9	4.5	0.0	7.0	1.5	0.2	3.2	3.6
45.0	32.0	2.1	10.7	19.3	27.9	4.2	1.7	11.1	3.8
0.0	24.0	1.8	8.6	13.6	26.6	2.7	0.9	9.6	3.6
315.0	1.8	0.3	1.5	0.0	6.0	1.2	0.2	3.7	3.4
270.0	4.2	3.6	0.6	0.0	3.9	1.1	0.1	2.0	3.5
225.0	8.0	3.9	3.9	0.3	7.2	1.5	0.2	3.2	3.6
180.0	14.8	2.4	10.7	1.8	9.2	2.1	0.4	4.7	3.5
135.0	6.8	3.6	3.3	0.0	5.5	1.3	0.1	3.1	3.5
0	MEAN SCALAR SPEED = 7.5 CM/S				MEAN SQUARE SPEED = 97.5 CM2/S2				
	MEAN SQUARE E-W SPEED = 19.6 CM2/S2				MEAN SQUARE N-S SPEED = 77.9 CM2/S2				
	MEAN VELOCITY = 4.9 CM/S,				29 DEG TRUE MEAN TEMPERATURE = 3.6 C				
	VARIANCE (U,V) = 37.0 CM2/S2				TOTAL HOURS = 337.				

PERCENT OBSERVED
 LIGHT (0.0 - 3.0) 21.4% MEDIUM (3.0 - 7.0) 43.6% HIGH (GE 7.0) 35.0%

MOORING IS 97-05C-002A010 DEPTH IS 10 METERS THERE ARE 337 VALUES

FIRST DAY 1998/04/01/0000
 FINAL DAY 1998/04/15/0000

SHORELINE ORIENTATION IN DEGREES TRUE SPECIFIED AS 90

DIRECTION DEG TRUE	PERCENT OBSERVED				MAXIMUM CURRENT CM/S	MEAN DURA- TION HOURS	MEAN EXCUR- SION KM	MEAN CURRENT CM/S	MEAN TEMP DEG C
	TOWARD	TOTAL	LIGHT	MEDIUM					
90.0	8.3	2.7	5.3	0.3	8.3	1.4	0.2	3.5	3.6
45.0	31.8	2.1	11.6	18.1	28.8	3.3	1.3	11.2	3.8
0.0	21.4	2.1	6.2	13.1	26.8	2.6	1.0	10.6	3.6
315.0	3.6	1.8	1.5	0.3	7.0	1.5	0.2	3.3	3.5
270.0	3.9	2.1	1.8	0.0	5.5	1.2	0.1	2.9	3.4
225.0	9.2	3.6	5.3	0.3	7.5	1.6	0.2	3.5	3.6
180.0	14.5	2.7	9.2	2.7	8.6	2.1	0.4	4.8	3.5
135.0	7.4	3.6	3.9	0.0	6.0	1.7	0.2	3.3	3.5
0	MEAN SCALAR SPEED = 7.6 CM/S				MEAN SQUARE SPEED = 100.9 CM2/S2				
	MEAN SQUARE E-W SPEED = 20.8 CM2/S2				MEAN SQUARE N-S SPEED = 80.1 CM2/S2				
	MEAN VELOCITY = 4.7 CM/S,				30 DEG TRUE MEAN TEMPERATURE = 3.6 C				
	VARIANCE (U,V) = 39.3 CM2/S2				TOTAL HOURS = 337.				

PERCENT OBSERVED
 LIGHT (0.0 - 3.0) 20.5% MEDIUM (3.0 - 7.0) 44.8% HIGH (GE 7.0) 34.7%

DATE: 1997/11/02 TO 1997/11/30
ROSE SUMMARY: WIND AND CURRENT

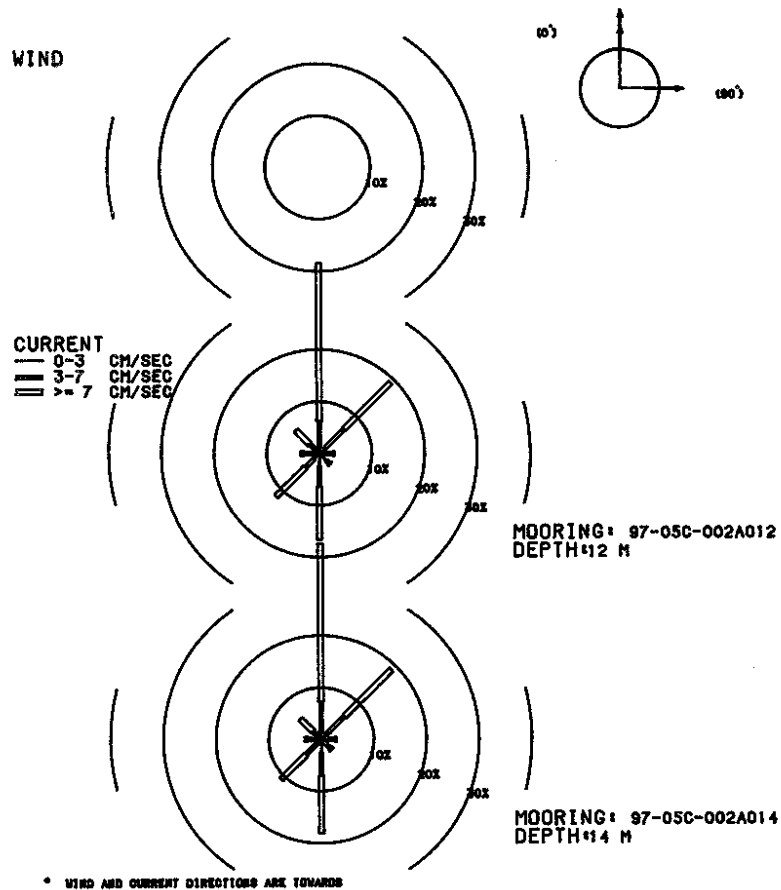

MOORING IS 97-05C-002A012 DEPTH IS 12 METERS THERE ARE 691 VALUES

FIRST DAY 1997/11/02/0500
FINAL DAY 1997/11/30/2300

SHORELINE ORIENTATION IN DEGREES TRUE SPECIFIED AS 90

DIRECTION DEG TRUE	PERCENT OBSERVED	MAXIMUM CURRENT	MEAN DURATION HOURS	MEAN EXCURSION KM	MEAN CURRENT CM/S	MEAN TEMP DEG C
TOWARD	TOTAL	LIGHT	MEDIUM	HIGH	CM/S	
90.0	2.9	0.9	1.7	0.3	10.2	8.8
45.0	19.2	1.3	5.2	12.7	31.2	9.0
0.0	36.6	1.2	5.1	30.4	37.9	8.9
315.0	6.4	0.4	2.2	3.8	21.7	6.7
270.0	3.6	0.7	2.2	0.7	17.7	8.2
225.0	11.7	1.4	2.3	8.0	18.5	7.5
180.0	16.6	2.5	3.9	10.3	22.5	7.8
135.0	2.9	1.9	0.9	0.1	7.6	8.4
0		MEAN SCALAR SPEED = 11.2 CM/S		MEAN SQUARE SPEED = 183.0 CM2/S2		
		MEAN SQUARE E-W SPEED = 24.4 CM2/S2		MEAN SQUARE N-S SPEED = 158.6 CM2/S2		
		MEAN VELOCITY = 5.1 CM/S,		10 DEG TRUE		MEAN TEMPERATURE = 8.4 C
		VARIANCE (U,V) = 78.5 CM2/S2		TOTAL HOURS = 691.		

PERCENT OBSERVED
LIGHT (0.0 - 3.0) 10.3% MEDIUM (3.0 - 7.0) 23.4% HIGH (GE 7.0) 66.3%

MOORING IS 97-05C-002A014 DEPTH IS 14 METERS THERE ARE 691 VALUES

FIRST DAY 1997/11/02/0500
FINAL DAY 1997/11/30/2300

SHORELINE ORIENTATION IN DEGREES TRUE SPECIFIED AS 90

DIRECTION DEG TRUE	PERCENT OBSERVED	MAXIMUM CURRENT	MEAN DURATION HOURS	MEAN EXCURSION KM	MEAN CURRENT CM/S	MEAN TEMP DEG C
TOWARD	TOTAL	LIGHT	MEDIUM	HIGH	CM/S	
90.0	2.9	1.3	1.3	0.3	8.6	9.0
45.0	19.0	1.2	5.1	12.7	35.3	9.0
0.0	37.6	1.3	5.9	30.4	37.3	8.9
315.0	5.6	0.7	1.4	3.5	16.3	6.8
270.0	3.2	0.7	1.9	0.6	11.3	8.2
225.0	10.9	0.9	3.2	6.8	17.9	7.5
180.0	18.1	2.5	4.5	11.1	19.3	7.7
135.0	2.7	0.3	2.2	0.3	8.5	7.9
0		MEAN SCALAR SPEED = 11.3 CM/S		MEAN SQUARE SPEED = 182.7 CM2/S2		
		MEAN SQUARE E-W SPEED = 23.7 CM2/S2		MEAN SQUARE N-S SPEED = 159.0 CM2/S2		
		MEAN VELOCITY = 5.1 CM/S,		11 DEG TRUE		MEAN TEMPERATURE = 8.4 C
		VARIANCE (U,V) = 78.6 CM2/S2		TOTAL HOURS = 691.		

PERCENT OBSERVED
LIGHT (0.0 - 3.0) 8.8% MEDIUM (3.0 - 7.0) 25.5% HIGH (GE 7.0) 65.7%

DATE: 1997/12/01 TO 1997/12/31
 ROSE SUMMARY: WIND AND CURRENT

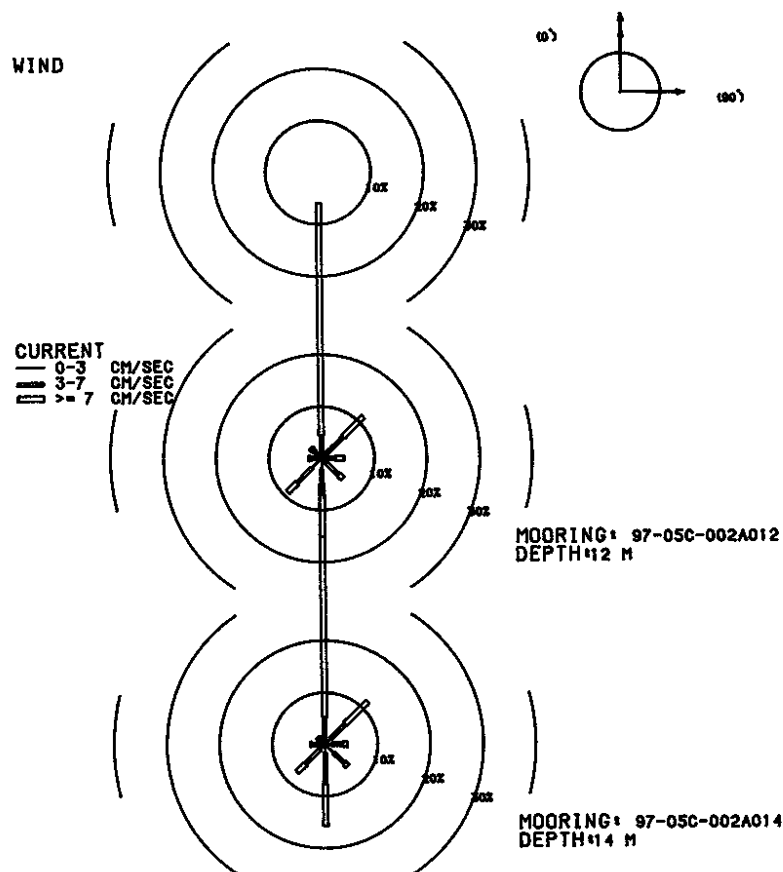

MOORING: 97-05C-002A012
 DEPTH: 12 M

MOORING: 97-05C-002A014
 DEPTH: 14 M

* WIND AND CURRENT DIRECTIONS ARE TOWARDS

MOORING IS 97-05C-002A012 DEPTH IS 12 METERS THERE ARE 744 VALUES

FIRST DAY 1997/12/01/0000
 FINAL DAY 1997/12/31/2300

SHORELINE ORIENTATION IN DEGREES TRUE SPECIFIED AS 90

DIRECTION DEG TRUE	PERCENT OBSERVED	MAXIMUM CURRENT			MEAN DURA- TION HOURS	MEAN EXCUR- SION KM	MEAN CURRENT CM/S	MEAN TEMP DEG C
TOWARD	TOTAL	LIGHT	MEDIUM	HIGH	CM/S			
90.0	4.3	0.8	1.7	1.7	10.6	2.0	0.4	5.8
45.0	11.3	0.9	4.8	5.5	22.2	2.2	0.7	8.2
0.0	49.1	0.5	3.9	44.6	44.2	8.9	5.8	18.0
315.0	2.8	1.3	0.9	0.5	16.5	1.2	0.2	4.3
270.0	2.6	1.1	1.1	0.4	15.7	1.6	0.2	4.3
225.0	9.1	2.6	4.0	2.6	18.2	1.9	0.4	6.0
180.0	15.2	2.2	4.8	8.2	21.3	3.1	0.9	8.0
135.0	5.6	1.2	3.2	1.2	8.8	2.3	0.4	4.8

MEAN SCALAR SPEED = 12.2 CM/S MEAN SQUARE SPEED = 235.8 CM2/S2
 MEAN SQUARE E-W SPEED = 17.0 CM2/S2 MEAN SQUARE N-S SPEED = 218.8 CM2/S2
 MEAN VELOCITY = 7.9 CM/S, 13 DEG TRUE MEAN TEMPERATURE = 5.6 C
 VARIANCE (U,V) = 87.0 CM2/S2 TOTAL HOURS = 744.

PERCENT OBSERVED
 LIGHT (0.0 - 3.0) 10.6% MEDIUM (3.0 - 7.0) 24.6% HIGH (GE 7.0) 64.8%

MOORING IS 97-05C-002A014 DEPTH IS 14 METERS THERE ARE 744 VALUES

FIRST DAY 1997/12/01/0000
 FINAL DAY 1997/12/31/2300

SHORELINE ORIENTATION IN DEGREES TRUE SPECIFIED AS 90

DIRECTION DEG TRUE	PERCENT OBSERVED	MAXIMUM CURRENT			MEAN DURA- TION HOURS	MEAN EXCUR- SION KM	MEAN CURRENT CM/S	MEAN TEMP DEG C
TOWARD	TOTAL	LIGHT	MEDIUM	HIGH	CM/S			
90.0	4.3	1.2	2.2	0.9	9.6	1.7	0.3	4.8
45.0	11.6	1.5	3.9	6.2	23.8	1.6	0.5	8.2
0.0	50.1	1.1	4.2	44.9	41.1	6.9	4.4	17.6
315.0	1.9	0.8	0.7	0.4	13.6	1.3	0.2	4.6
270.0	2.8	0.8	1.7	0.3	13.4	1.5	0.2	4.5
225.0	7.5	1.2	4.0	2.3	18.0	2.3	0.6	6.8
180.0	15.7	1.6	6.0	8.1	20.4	4.0	1.1	7.7
135.0	6.0	2.4	2.7	0.9	10.1	1.6	0.2	4.3

MEAN SCALAR SPEED = 12.1 CM/S MEAN SQUARE SPEED = 232.1 CM2/S2
 MEAN SQUARE E-W SPEED = 15.4 CM2/S2 MEAN SQUARE N-S SPEED = 216.7 CM2/S2
 MEAN VELOCITY = 7.9 CM/S, 12 DEG TRUE MEAN TEMPERATURE = 5.6 C
 VARIANCE (U,V) = 85.2 CM2/S2 TOTAL HOURS = 744.

PERCENT OBSERVED
 LIGHT (0.0 - 3.0) 10.6% MEDIUM (3.0 - 7.0) 25.4% HIGH (GE 7.0) 64.0%

DATE: 1998/01/01 TO 1998/01/31
 ROSE SUMMARY: WIND AND CURRENT

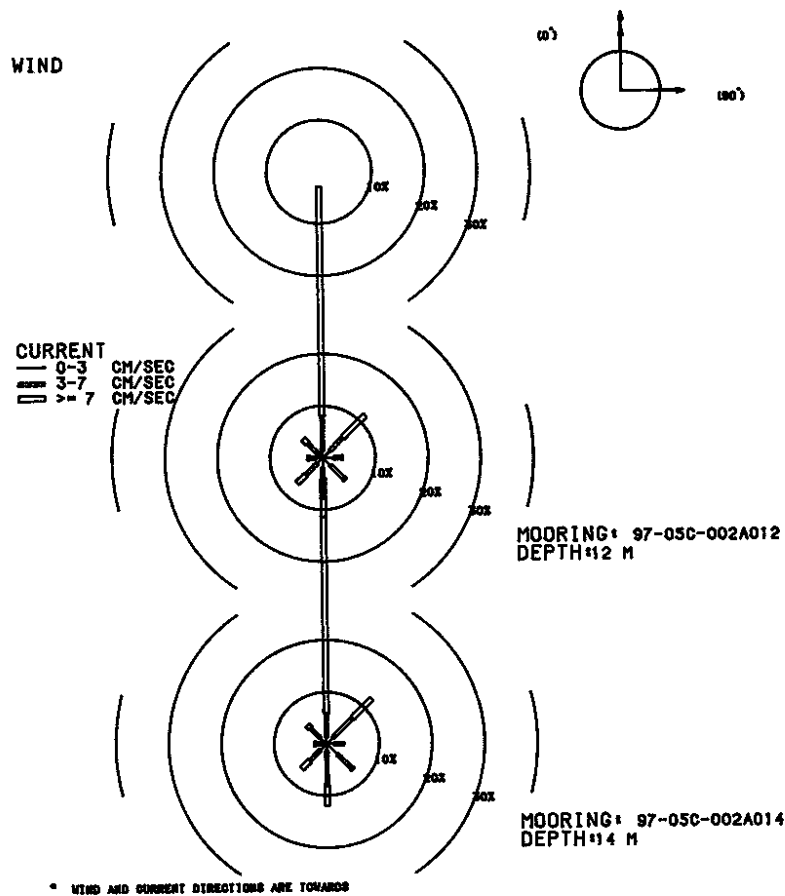

MOORING IS 97-05C-002A012 DEPTH IS 12 METERS THERE ARE 744 VALUES

FIRST DAY 1998/01/01/0000
 FINAL DAY 1998/01/31/2300

SHORELINE ORIENTATION IN DEGREES TRUE SPECIFIED AS 90

DIRECTION DEG TRUE	PERCENT OBSERVED	MAXIMUM CURRENT	MEAN DURA- TION HOURS	MEAN EXCUR- SION KM	MEAN CURRENT CM/S	MEAN TEMP DEG C
TOWARD	TOTAL	LIGHT	MEDIUM	HIGH	CM/S	
90.0	3.8	2.0	1.6	0.1	7.9	1.3
45.0	11.6	1.9	3.5	6.2	35.2	1.8
0.0	52.2	1.5	6.6	44.1	50.3	6.5
315.0	5.2	0.8	3.1	1.3	11.9	1.6
270.0	3.0	1.2	1.2	0.5	14.3	1.3
225.0	6.9	1.5	3.1	2.3	19.0	1.8
180.0	11.4	2.0	5.8	3.6	23.9	2.1
135.0	6.0	2.0	3.6	0.4	9.6	1.7
0		MEAN SCALAR SPEED = 10.8 CM/S		MEAN SQUARE SPEED = 197.9 CM2/S2		
		MEAN SQUARE E-W SPEED = 16.9 CM2/S2		MEAN SQUARE N-S SPEED = 181.0 CM2/S2		
		MEAN VELOCITY = 7.6 CM/S,		11 DEG TRUE		MEAN TEMPERATURE = 3.2 C
		VARIANCE (U,V) = 69.9 CM2/S2		TOTAL HOURS = 744.		

PERCENT OBSERVED
 LIGHT (0.0 - 3.0) 12.9% MEDIUM (3.0 - 7.0) 28.5% HIGH (GE 7.0) 58.6%

MOORING IS 97-05C-002A014 DEPTH IS 14 METERS THERE ARE 744 VALUES

FIRST DAY 1998/01/01/0000
 FINAL DAY 1998/01/31/2300

SHORELINE ORIENTATION IN DEGREES TRUE SPECIFIED AS 90

DIRECTION DEG TRUE	PERCENT OBSERVED	MAXIMUM CURRENT	MEAN DURA- TION HOURS	MEAN EXCUR- SION KM	MEAN CURRENT CM/S	MEAN TEMP DEG C
TOWARD	TOTAL	LIGHT	MEDIUM	HIGH	CM/S	
90.0	3.4	1.5	1.9	0.0	6.7	1.2
45.0	12.2	1.6	5.4	5.2	31.9	1.8
0.0	51.2	1.3	4.6	45.3	50.3	6.7
315.0	5.1	1.6	2.7	0.8	11.3	1.5
270.0	2.4	1.1	0.9	0.4	15.9	1.3
225.0	6.7	1.6	3.0	2.2	18.5	1.6
180.0	12.0	1.3	6.7	3.9	21.1	2.2
135.0	7.0	2.8	3.8	0.4	10.4	1.8
0		MEAN SCALAR SPEED = 10.8 CM/S		MEAN SQUARE SPEED = 196.5 CM2/S2		
		MEAN SQUARE E-W SPEED = 15.1 CM2/S2		MEAN SQUARE N-S SPEED = 181.5 CM2/S2		
		MEAN VELOCITY = 7.6 CM/S,		12 DEG TRUE		MEAN TEMPERATURE = 3.2 C
		VARIANCE (U,V) = 69.5 CM2/S2		TOTAL HOURS = 744.		

PERCENT OBSERVED
 LIGHT (0.0 - 3.0) 12.9% MEDIUM (3.0 - 7.0) 28.9% HIGH (GE 7.0) 58.2%

DATE: 1998/02/01 TO 1998/02/28
 ROSE SUMMARY: WIND AND CURRENT

WIND

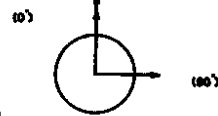
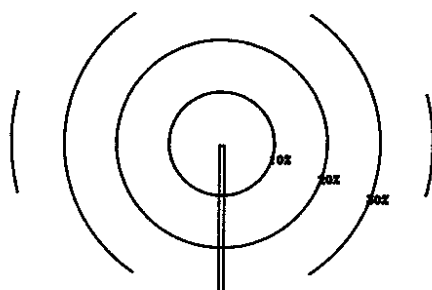

CURRENT

0-3 CM/SEC
 3-7 CM/SEC
 >= 7 CM/SEC

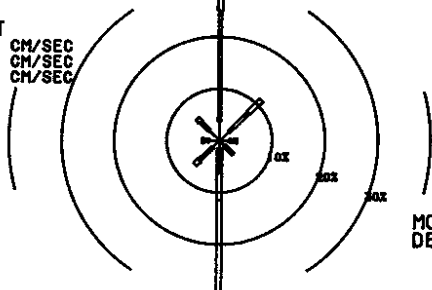

MOORING: 97-05C-002A012
 DEPTH: 12 M

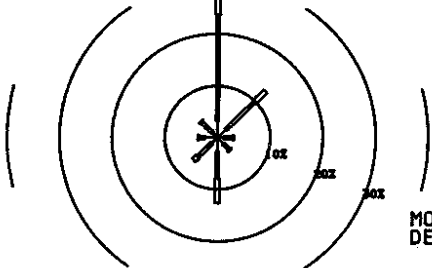

MOORING: 97-05C-002A014
 DEPTH: 14 M

* WIND AND CURRENT DIRECTIONS ARE TOWARDS

MOORING IS 97-05C-002A012 DEPTH IS 12 METERS THERE ARE 672 VALUES

FIRST DAY 1998/02/01/0000
 FINAL DAY 1998/02/28/2300

SHORELINE ORIENTATION IN DEGREES TRUE SPECIFIED AS 90

DIRECTION DEG TRUE	PERCENT OBSERVED	MAXIMUM CURRENT	MEAN DURA- TION HOURS	MEAN EXCUR- SION KM	MEAN CURRENT CM/S	MEAN TEMP DEG C
TOWARD	TOTAL	LIGHT	MEDIUM	HIGH	CM/S	
90.0	3.3	1.8	1.3	0.1	7.8	1.5
45.0	11.2	2.4	5.4	3.4	18.8	1.5
0.0	54.6	3.7	21.3	29.6	21.1	5.2
315.0	6.0	2.7	2.4	0.9	16.5	1.1
270.0	3.3	1.9	1.0	0.3	7.9	1.4
225.0	6.5	1.8	3.6	1.2	9.7	1.7
180.0	11.5	2.1	4.2	5.2	13.5	2.6
135.0	3.7	1.3	2.4	0.0	6.9	1.7

MEAN SCALAR SPEED = 6.8 CM/S MEAN SQUARE SPEED = 64.5 CM2/S2
 MEAN SQUARE E-W SPEED = 6.1 CM2/S2 MEAN SQUARE N-S SPEED = 58.4 CM2/S2
 MEAN VELOCITY = 4.2 CM/S, 8 DEG TRUE MEAN TEMPERATURE = 2.3 C
 VARIANCE (U,V) = 23.5 CM2/S2 TOTAL HOURS = 672.

PERCENT OBSERVED

LIGHT (0.0 - 3.0) 17.7% MEDIUM (3.0 - 7.0) 41.5% HIGH (GE 7.0) 40.8%

MOORING IS 97-05C-002A014 DEPTH IS 14 METERS THERE ARE 672 VALUES

FIRST DAY 1998/02/01/0000
 FINAL DAY 1998/02/28/2300

SHORELINE ORIENTATION IN DEGREES TRUE SPECIFIED AS 90

DIRECTION DEG TRUE	PERCENT OBSERVED	MAXIMUM CURRENT	MEAN DURA- TION HOURS	MEAN EXCUR- SION KM	MEAN CURRENT CM/S	MEAN TEMP DEG C
TOWARD	TOTAL	LIGHT	MEDIUM	HIGH	CM/S	
90.0	3.1	1.2	1.8	0.1	7.0	1.9
45.0	12.8	2.2	7.4	3.1	15.4	1.6
0.0	53.6	3.3	20.4	29.9	22.4	4.9
315.0	4.5	1.2	3.1	0.1	15.8	1.4
270.0	3.7	2.4	1.2	0.1	7.4	1.1
225.0	6.2	1.5	3.7	1.0	9.7	1.6
180.0	12.6	2.7	5.2	4.8	13.3	2.3
135.0	3.4	1.6	1.5	0.3	8.1	1.2

MEAN SCALAR SPEED = 6.8 CM/S MEAN SQUARE SPEED = 64.6 CM2/S2
 MEAN SQUARE E-W SPEED = 5.5 CM2/S2 MEAN SQUARE N-S SPEED = 59.1 CM2/S2
 MEAN VELOCITY = 4.1 CM/S, 8 DEG TRUE MEAN TEMPERATURE = 2.3 C
 VARIANCE (U,V) = 23.7 CM2/S2 TOTAL HOURS = 672.

PERCENT OBSERVED

LIGHT (0.0 - 3.0) 16.1% MEDIUM (3.0 - 7.0) 44.3% HIGH (GE 7.0) 39.6%

DATE: 1998/03/01 TO 1998/03/31
 ROSE SUMMARY: WIND AND CURRENT

WIND

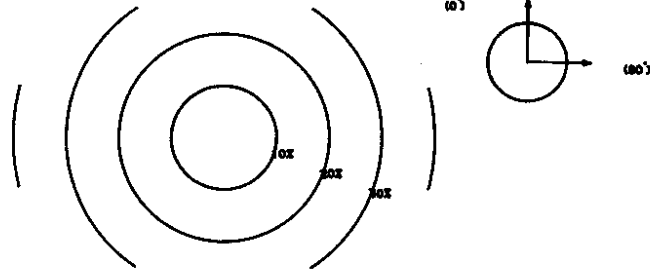

CURRENT
 0-3 CM/SEC
 3-7 CM/SEC
 >= 7 CM/SEC

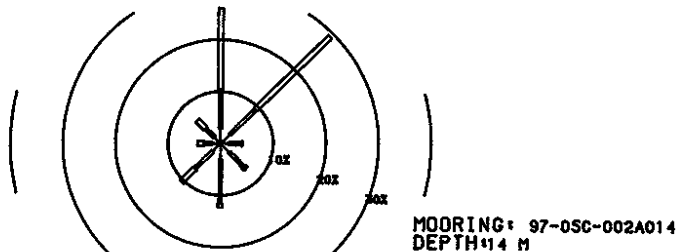
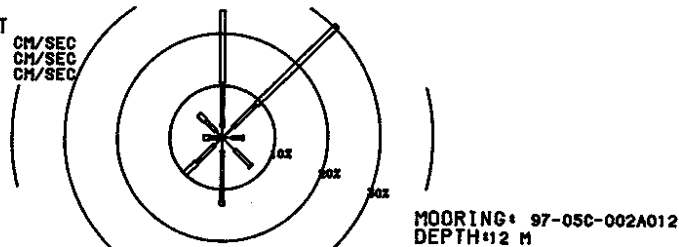

* WIND AND CURRENT DIRECTIONS ARE TOWARDS

MOORING IS 97-05C-002A012 DEPTH IS 12 METERS THERE ARE 744 VALUES

FIRST DAY 1998/03/01/0000
 FINAL DAY 1998/03/31/2300

SHORELINE ORIENTATION IN DEGREES TRUE SPECIFIED AS 90

DIRECTION DEG TRUE	PERCENT OBSERVED	TOWARD	TOTAL	LIGHT	MEDIUM	HIGH	MAXIMUM CURRENT CM/S	MEAN DURA- TION HOURS	MEAN EXCUR- SION KM	MEAN CURRENT CM/S	MEAN TEMP DEG C
90.0	4.0	1.9	2.0	0.1	7.2	1.1	0.1	3.4	2.7		
45.0	30.6	2.8	6.2	21.6	73.4	3.6	2.0	15.3	2.3		
0.0	24.5	2.0	8.5	14.0	65.0	2.4	1.0	11.4	2.3		
315.0	6.3	1.7	2.8	1.7	23.1	1.2	0.3	6.1	2.4		
270.0	3.6	0.7	1.7	1.2	24.2	1.2	0.3	7.3	2.6		
225.0	10.1	2.0	4.8	3.2	35.4	2.0	0.7	9.0	2.7		
180.0	13.0	2.6	9.7	0.8	35.8	2.2	0.4	4.8	2.7		
135.0	7.8	3.4	4.2	0.3	7.4	1.7	0.2	3.4	2.7		

0 MEAN SCALAR SPEED = 10.0 CM/S MEAN SQUARE SPEED = 200.3 CM2/S2
 MEAN SQUARE E-W SPEED = 51.9 CM2/S2 MEAN SQUARE N-S SPEED = 148.4 CM2/S2
 MEAN VELOCITY = 5.8 CM/S, 21 DEG TRUE MEAN TEMPERATURE = 2.5 C
 VARIANCE (U,V) = 83.3 CM2/S2 TOTAL HOURS = 744.

PERCENT OBSERVED
 LIGHT (0.0 - 3.0) 17.1% MEDIUM (3.0 - 7.0) 39.9% HIGH (GE 7.0) 43.0%

MOORING IS 97-05C-002A014 DEPTH IS 14 METERS THERE ARE 744 VALUES

FIRST DAY 1998/03/01/0000
 FINAL DAY 1998/03/31/2300

SHORELINE ORIENTATION IN DEGREES TRUE SPECIFIED AS 90

DIRECTION DEG TRUE	PERCENT OBSERVED	TOWARD	TOTAL	LIGHT	MEDIUM	HIGH	MAXIMUM CURRENT CM/S	MEAN DURA- TION HOURS	MEAN EXCUR- SION KM	MEAN CURRENT CM/S	MEAN TEMP DEG C
90.0	4.2	1.6	2.4	0.1	7.3	1.5	0.2	3.8	2.7		
45.0	29.3	2.4	6.9	20.0	74.1	3.0	1.7	15.6	2.3		
0.0	26.1	3.0	7.4	15.7	63.9	2.5	1.0	11.3	2.3		
315.0	6.3	1.7	2.3	2.3	21.0	1.3	0.3	6.1	2.4		
270.0	4.4	1.6	1.5	1.3	24.8	1.4	0.4	7.1	2.7		
225.0	10.5	2.0	4.8	3.6	33.6	2.2	0.7	8.2	2.7		
180.0	12.4	3.1	8.5	0.8	28.4	2.1	0.4	4.6	2.7		
135.0	6.9	2.4	3.8	0.7	8.7	2.0	0.3	4.0	2.8		

0 MEAN SCALAR SPEED = 10.1 CM/S MEAN SQUARE SPEED = 200.5 CM2/S2
 MEAN SQUARE E-W SPEED = 52.2 CM2/S2 MEAN SQUARE N-S SPEED = 148.4 CM2/S2
 MEAN VELOCITY = 5.9 CM/S, 20 DEG TRUE MEAN TEMPERATURE = 2.5 C
 VARIANCE (U,V) = 82.8 CM2/S2 TOTAL HOURS = 744.

PERCENT OBSERVED
 LIGHT (0.0 - 3.0) 17.9% MEDIUM (3.0 - 7.0) 37.5% HIGH (GE 7.0) 44.6%

DATE: 1998/04/01 TO 1998/04/30
ROSE SUMMARY: WIND AND CURRENT

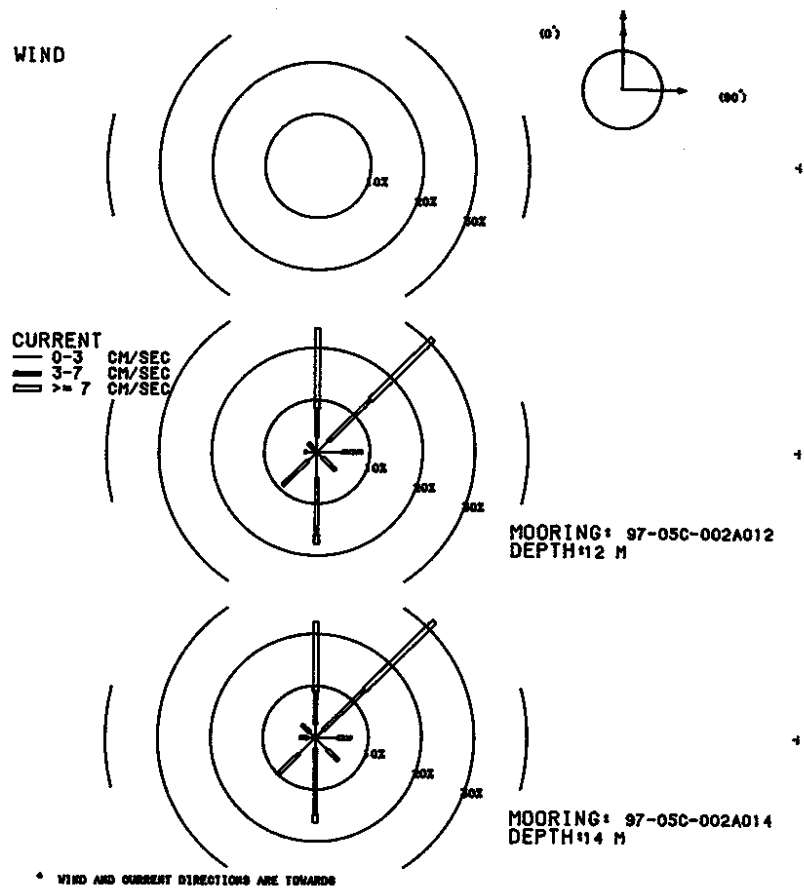

MOORING IS 97-05C-002A012 DEPTH IS 12 METERS THERE ARE 337 VALUES

FIRST DAY 1998/04/01/0000
FINAL DAY 1998/04/15/0000

SHORELINE ORIENTATION IN DEGREES TRUE SPECIFIED AS 90

DIRECTION DEG TRUE	PERCENT OBSERVED	TOWARD	TOTAL	LIGHT	MEDIUM	HIGH	MAXIMUM CURRENT CM/S	MEAN DURA- TION HOURS	MEAN EXCUR- SION KM	MEAN CURRENT CM/S	MEAN TEMP DEG C
90.0	8.6	4.7	3.9	0.0	5.8	1.2	0.1	3.1	3.6		
45.0	30.9	3.0	11.3	16.6	29.8	3.7	1.4	10.8	3.8		
0.0	23.7	3.0	5.3	15.4	28.9	3.0	1.1	10.4	3.6		
315.0	2.4	0.9	1.5	0.0	6.9	1.1	0.2	3.7	3.4		
270.0	2.4	2.1	0.3	0.0	3.6	1.3	0.1	1.9	3.5		
225.0	9.2	2.4	6.8	0.0	6.2	1.7	0.2	3.5	3.5		
180.0	17.8	5.0	11.0	1.8	8.9	2.3	0.4	4.6	3.6		
135.0	5.0	1.5	3.6	0.0	6.5	1.1	0.2	4.0	3.6		
MEAN SCALAR SPEED = 7.5 CM/S		MEAN SQUARE SPEED = 99.0 CM2/S2									
MEAN SQUARE E-W SPEED = 18.9 CM2/S2		MEAN SQUARE N-S SPEED = 80.1 CM2/S2									
MEAN VELOCITY = 4.7 CM/S,		29 DEG TRUE		MEAN TEMPERATURE = 3.6 C							
VARIANCE (U,V) = 38.7 CM2/S2		TOTAL HOURS = 337.									

PERCENT OBSERVED
LIGHT (0.0 - 3.0) 22.6% MEDIUM (3.0 - 7.0) 43.6% HIGH (GE 7.0) 33.8%

MOORING IS 97-05C-002A014 DEPTH IS 14 METERS THERE ARE 337 VALUES

FIRST DAY 1998/04/01/0000
FINAL DAY 1998/04/15/0000

SHORELINE ORIENTATION IN DEGREES TRUE SPECIFIED AS 90

DIRECTION DEG TRUE	PERCENT OBSERVED	TOWARD	TOTAL	LIGHT	MEDIUM	HIGH	MAXIMUM CURRENT CM/S	MEAN DURA- TION HOURS	MEAN EXCUR- SION KM	MEAN CURRENT CM/S	MEAN TEMP DEG C
90.0	6.8	4.2	2.7	0.0	5.3	1.1	0.1	3.1	3.6		
45.0	31.8	2.1	11.0	18.7	29.0	3.8	1.5	11.0	3.8		
0.0	22.3	2.7	6.2	13.4	26.3	2.5	0.9	10.4	3.6		
315.0	3.6	1.5	2.1	0.0	5.6	1.0	0.1	3.6	3.5		
270.0	3.0	1.5	1.5	0.0	4.6	1.1	0.1	2.9	3.4		
225.0	10.1	4.5	5.6	0.0	6.4	1.5	0.2	3.5	3.5		
180.0	16.3	2.1	12.8	1.5	9.7	2.6	0.5	4.9	3.6		
135.0	6.2	3.3	3.0	0.0	6.2	1.5	0.2	3.4	3.6		
MEAN SCALAR SPEED = 7.6 CM/S		MEAN SQUARE SPEED = 98.9 CM2/S2									
MEAN SQUARE E-W SPEED = 19.4 CM2/S2		MEAN SQUARE N-S SPEED = 79.5 CM2/S2									
MEAN VELOCITY = 4.7 CM/S,		29 DEG TRUE		MEAN TEMPERATURE = 3.6 C							
VARIANCE (U,V) = 38.7 CM2/S2		TOTAL HOURS = 337.									

PERCENT OBSERVED
LIGHT (0.0 - 3.0) 21.7% MEDIUM (3.0 - 7.0) 44.8% HIGH (GE 7.0) 33.5%

DATE: 1997/11/02 TO 1997/11/30
 ROSE SUMMARY: WIND AND CURRENT

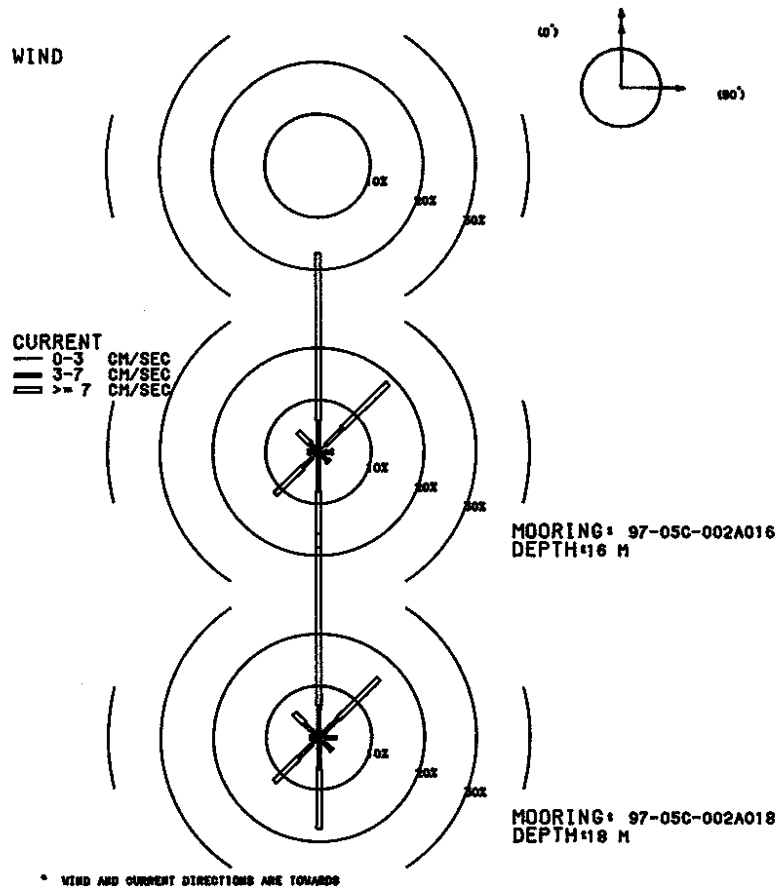

MOORING IS 97-05C-002A016 DEPTH IS 16 METERS THERE ARE 691 VALUES

FIRST DAY 1997/11/02/0500
 FINAL DAY 1997/11/30/2300

SHORELINE ORIENTATION IN DEGREES TRUE SPECIFIED AS 90

DIRECTION DEG TRUE	PERCENT OBSERVED	MAXIMUM CURRENT	MEAN DURA- TION HOURS	MEAN EXCUR- SION KM	MEAN CURRENT CM/S	MEAN TEMP DEG C
TOWARD	TOTAL	LIGHT	MEDIUM	HIGH	CM/S	
90.0	2.7	1.2	1.3	0.3	7.6	1.4
45.0	18.7	1.9	4.6	12.2	34.3	2.3
0.0	38.2	0.9	5.2	32.1	35.0	4.6
315.0	5.5	0.1	2.2	3.2	18.1	2.4
270.0	2.0	0.3	1.0	0.7	13.0	1.6
225.0	11.6	1.7	2.5	7.4	18.6	2.2
180.0	18.5	1.2	6.5	10.9	18.5	3.4
135.0	2.7	0.9	1.4	0.4	8.0	1.1

MEAN SCALAR SPEED = 11.3 CM/S MEAN SQUARE SPEED = 181.6 CM2/S2
 MEAN SQUARE E-W SPEED = 23.0 CM2/S2 MEAN SQUARE N-S SPEED = 158.6 CM2/S2
 MEAN VELOCITY = 5.1 CM/S, 9 DEG TRUE MEAN TEMPERATURE = 8.4 C
 VARIANCE(U,V) = 77.9 CM2/S2 TOTAL HOURS = 691.

PERCENT OBSERVED
 LIGHT (0.0 - 3.0) 8.1% MEDIUM (3.0 - 7.0) 24.7% HIGH (GE 7.0) 67.1%

MOORING IS 97-05C-002A018 DEPTH IS 18 METERS THERE ARE 691 VALUES

FIRST DAY 1997/11/02/0500
 FINAL DAY 1997/11/30/2300

SHORELINE ORIENTATION IN DEGREES TRUE SPECIFIED AS 90

DIRECTION DEG TRUE	PERCENT OBSERVED	MAXIMUM CURRENT	MEAN DURA- TION HOURS	MEAN EXCUR- SION KM	MEAN CURRENT CM/S	MEAN TEMP DEG C
TOWARD	TOTAL	LIGHT	MEDIUM	HIGH	CM/S	
90.0	3.3	1.2	2.2	0.0	5.9	1.4
45.0	16.1	0.9	4.3	10.9	29.4	2.3
0.0	39.2	0.7	5.5	33.0	35.9	5.0
315.0	6.7	1.0	2.9	2.7	17.5	2.3
270.0	1.7	0.4	0.6	0.7	11.3	1.1
225.0	12.0	1.9	3.6	6.5	20.1	1.9
180.0	17.5	0.9	5.2	11.4	20.0	2.9
135.0	3.5	1.3	2.0	0.1	9.5	1.3

MEAN SCALAR SPEED = 11.2 CM/S MEAN SQUARE SPEED = 179.9 CM2/S2
 MEAN SQUARE E-W SPEED = 21.0 CM2/S2 MEAN SQUARE N-S SPEED = 158.9 CM2/S2
 MEAN VELOCITY = 5.1 CM/S, 10 DEG TRUE MEAN TEMPERATURE = 8.4 C
 VARIANCE(U,V) = 77.2 CM2/S2 TOTAL HOURS = 691.

PERCENT OBSERVED
 LIGHT (0.0 - 3.0) 8.2% MEDIUM (3.0 - 7.0) 26.3% HIGH (GE 7.0) 65.4%

DATE: 1997/12/01 TO 1997/12/31
 ROSE SUMMARY: WIND AND CURRENT

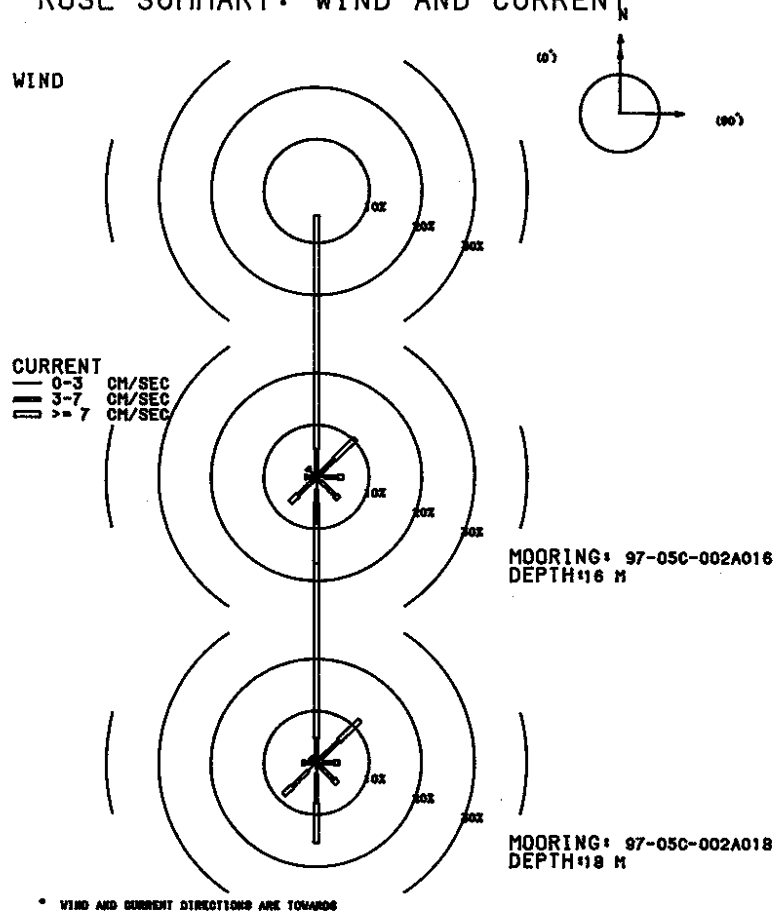

MOORING IS 97-05C-002A016 DEPTH IS 16 METERS THERE ARE 744 VALUES

FIRST DAY 1997/12/01/0000
 FINAL DAY 1997/12/31/2300

SHORELINE ORIENTATION IN DEGREES TRUE SPECIFIED AS 90

DIRECTION DEG TRUE	PERCENT OBSERVED	TOWARD	TOTAL	LIGHT	MEDIUM	HIGH	MAXIMUM CURRENT CM/S	MEAN DURATION HOURS	MEAN EXCURSION KM	MEAN CURRENT CM/S	MEAN TEMP DEG C
90.0	5.1	1.5	2.6	1.1	9.9	2.0	0.3	4.5	5.7		
45.0	10.5	0.4	4.4	5.6	28.0	2.3	0.7	8.9	5.5		
0.0	50.3	0.9	4.4	44.9	41.5	9.6	6.1	17.6	5.6		
315.0	2.4	1.9	0.3	0.3	11.1	1.1	0.1	2.9	5.6		
270.0	2.2	0.8	1.1	0.3	7.9	1.2	0.2	3.8	5.6		
225.0	7.0	1.1	3.8	2.2	19.3	2.1	0.5	7.2	5.8		
180.0	16.7	2.4	6.5	7.8	21.1	3.3	0.9	7.3	5.6		
135.0	5.9	1.1	4.0	0.8	9.1	1.6	0.3	4.9	5.2		

MEAN SCALAR SPEED = 12.2 CM/S MEAN SQUARE SPEED = 234.1 CM2/S2
 MEAN SQUARE E-W SPEED = 14.9 CM2/S2 MEAN SQUARE N-S SPEED = 219.2 CM2/S2
 MEAN VELOCITY = 7.9 CM/S, 12 DEG TRUE MEAN TEMPERATURE = 5.6 C
 VARIANCE (U,V) = 86.1 CM2/S2 TOTAL HOURS = 744.

PERCENT OBSERVED
 LIGHT (0.0 - 3.0) 10.1% MEDIUM (3.0 - 7.0) 27.0% HIGH (GE 7.0) 62.9%

MOORING IS 97-05C-002A018 DEPTH IS 18 METERS THERE ARE 744 VALUES

FIRST DAY 1997/12/01/0000
 FINAL DAY 1997/12/31/2300

SHORELINE ORIENTATION IN DEGREES TRUE SPECIFIED AS 90

DIRECTION DEG TRUE	PERCENT OBSERVED	TOWARD	TOTAL	LIGHT	MEDIUM	HIGH	MAXIMUM CURRENT CM/S	MEAN DURATION HOURS	MEAN EXCURSION KM	MEAN CURRENT CM/S	MEAN TEMP DEG C
90.0	4.3	1.2	2.2	0.9	10.3	1.7	0.3	5.0	5.6		
45.0	11.7	1.2	4.8	5.6	15.5	2.1	0.6	7.7	5.5		
0.0	50.0	0.5	4.2	45.3	39.6	9.3	6.0	17.9	5.6		
315.0	1.5	0.8	0.5	0.1	8.3	1.1	0.1	3.5	5.5		
270.0	2.7	0.9	1.3	0.4	9.3	1.2	0.2	4.7	5.6		
225.0	8.7	2.2	4.3	2.3	20.0	2.2	0.5	6.4	5.7		
180.0	15.5	2.2	5.6	7.7	20.4	3.5	1.0	7.7	5.6		
135.0	5.6	1.1	3.5	1.1	9.3	1.4	0.2	4.8	5.3		

MEAN SCALAR SPEED = 12.2 CM/S MEAN SQUARE SPEED = 235.0 CM2/S2
 MEAN SQUARE E-W SPEED = 14.8 CM2/S2 MEAN SQUARE N-S SPEED = 220.2 CM2/S2
 MEAN VELOCITY = 7.9 CM/S, 12 DEG TRUE MEAN TEMPERATURE = 5.6 C
 VARIANCE (U,V) = 86.3 CM2/S2 TOTAL HOURS = 744.

PERCENT OBSERVED
 LIGHT (0.0 - 3.0) 10.1% MEDIUM (3.0 - 7.0) 26.5% HIGH (GE 7.0) 63.4%

DATE: 1998/01/01 TO 1998/01/31
ROSE SUMMARY: WIND AND CURRENT

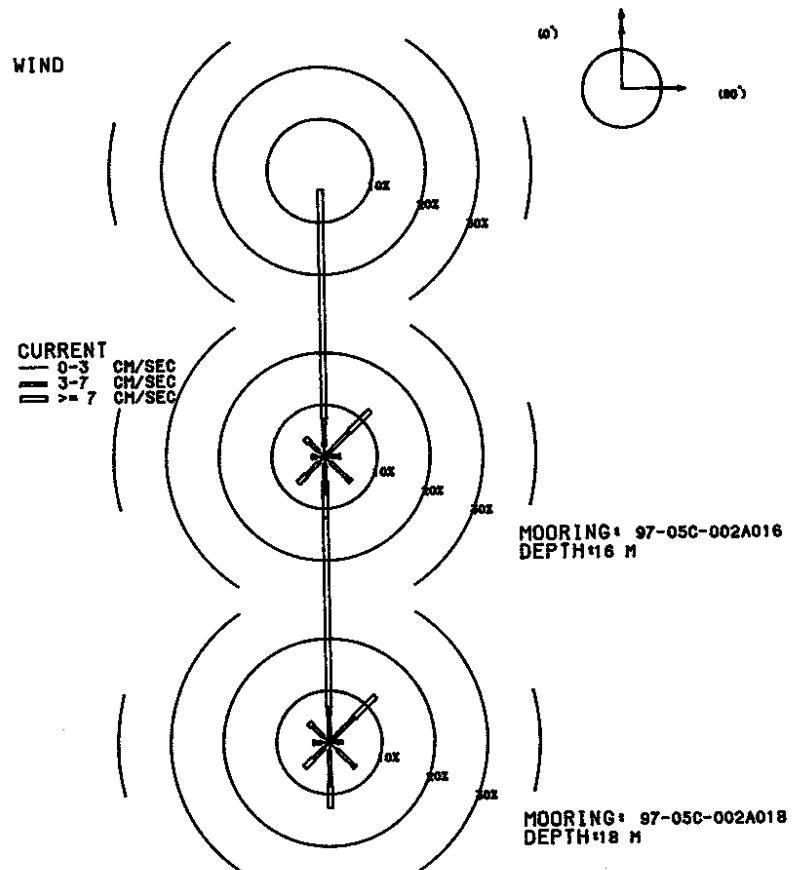

MOORING IS 97-05C-002A016 DEPTH IS 16 METERS THERE ARE 744 VALUES

FIRST DAY 1998/01/01/0000
FINAL DAY 1998/01/31/2300

SHORELINE ORIENTATION IN DEGREES TRUE SPECIFIED AS 90

DIRECTION DEG TRUE	PERCENT OBSERVED	MAXIMUM CURRENT	MEAN DURATION HOURS	MEAN EXCURSION KM	MEAN CURRENT CM/S	MEAN TEMP DEG C
TOWARD	TOTAL	LIGHT	MEDIUM	HIGH	CM/S	
90.0	3.0	1.2	1.6	0.1	7.3	1.2
45.0	12.4	0.5	6.2	5.6	31.4	1.8
0.0	51.3	2.0	5.2	44.1	50.2	6.3
315.0	5.1	1.5	2.6	1.1	14.8	1.5
270.0	2.4	1.5	0.8	0.1	10.1	1.2
225.0	7.1	1.5	3.5	2.2	16.3	1.5
180.0	11.8	1.5	5.8	4.6	19.0	2.1
135.0	6.9	1.6	4.7	0.5	9.3	1.8

MEAN SCALAR SPEED = 10.7 CM/S MEAN SQUARE SPEED = 194.3 CM2/S2
 MEAN SQUARE E-W SPEED = 14.8 CM2/S2 MEAN SQUARE N-S SPEED = 179.6 CM2/S2
 MEAN VELOCITY = 7.5 CM/S, 13 DEG TRUE MEAN TEMPERATURE = 3.2 C
 VARIANCE (U,V) = 69.0 CM2/S2 TOTAL HOURS = 744.

PERCENT OBSERVED
 LIGHT (0.0 - 3.0) 11.3% MEDIUM (3.0 - 7.0) 30.4% HIGH (GE 7.0) 58.3%

MOORING IS 97-05C-002A018 DEPTH IS 18 METERS THERE ARE 744 VALUES

FIRST DAY 1998/01/01/0000
FINAL DAY 1998/01/31/2300

SHORELINE ORIENTATION IN DEGREES TRUE SPECIFIED AS 90

DIRECTION DEG TRUE	PERCENT OBSERVED	MAXIMUM CURRENT	MEAN DURATION HOURS	MEAN EXCURSION KM	MEAN CURRENT CM/S	MEAN TEMP DEG C
TOWARD	TOTAL	LIGHT	MEDIUM	HIGH	CM/S	
90.0	2.6	1.3	1.2	0.0	6.8	1.5
45.0	12.5	1.2	5.5	5.8	31.2	1.5
0.0	50.3	0.8	6.0	43.4	48.5	5.1
315.0	5.4	1.6	2.8	0.9	9.1	1.6
270.0	3.1	1.5	1.5	0.1	9.6	1.2
225.0	6.7	1.3	3.0	2.4	18.4	1.4
180.0	12.6	1.6	6.9	4.2	15.3	2.1
135.0	6.9	2.0	4.4	0.4	8.8	1.7

MEAN SCALAR SPEED = 10.7 CM/S MEAN SQUARE SPEED = 190.7 CM2/S2
 MEAN SQUARE E-W SPEED = 14.9 CM2/S2 MEAN SQUARE N-S SPEED = 175.8 CM2/S2
 MEAN VELOCITY = 7.4 CM/S, 12 DEG TRUE MEAN TEMPERATURE = 3.2 C
 VARIANCE (U,V) = 67.8 CM2/S2 TOTAL HOURS = 744.

PERCENT OBSERVED
 LIGHT (0.0 - 3.0) 11.4% MEDIUM (3.0 - 7.0) 31.3% HIGH (GE 7.0) 57.3%

DATE: 1998/02/01 TO 1998/02/28
 ROSE SUMMARY: WIND AND CURRENT

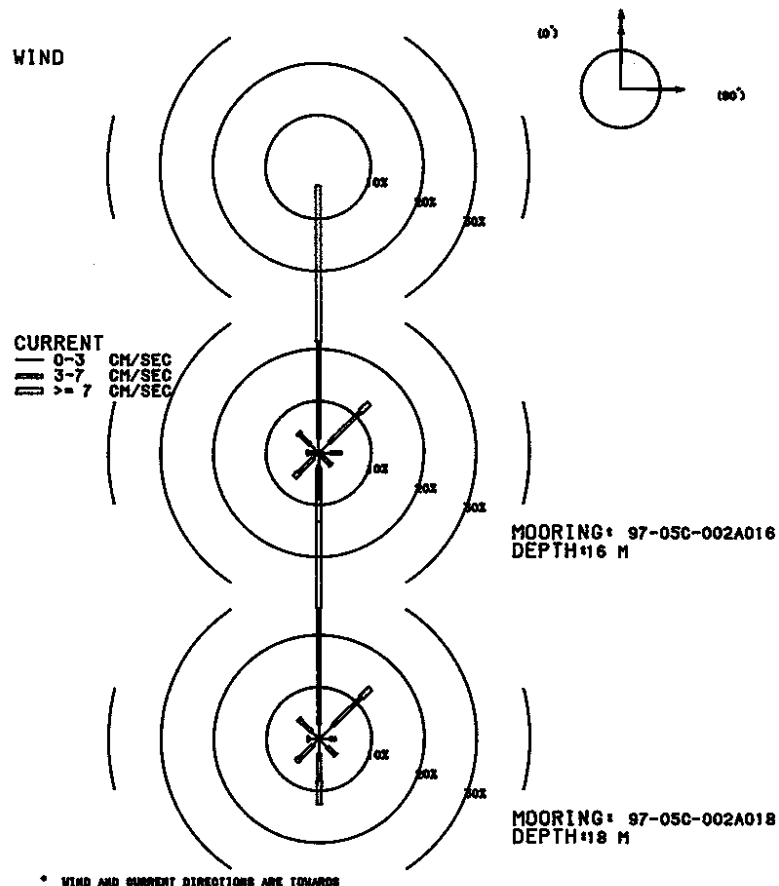

MOORING IS 97-05C-002A016 DEPTH IS 16 METERS THERE ARE 672 VALUES

FIRST DAY 1998/02/01/0000
 FINAL DAY 1998/02/28/2300

SHORELINE ORIENTATION IN DEGREES TRUE SPECIFIED AS 90

DIRECTION DEG TRUE	PERCENT OBSERVED	TOWARD	TOTAL	LIGHT	MEDIUM	HIGH	MAXIMUM CURRENT CM/S	MEAN DURA- TION HOURS	MEAN EXCUR- SION KM	MEAN CURRENT CM/S	MEAN TEMP DEG C
90.0	4.3	2.2	2.1	0.0	7.0	1.5	0.2	3.0	2.6		
45.0	13.5	2.8	8.3	2.4	13.6	1.4	0.3	5.2	2.2		
0.0	51.3	2.8	18.6	29.9	20.1	4.2	1.3	8.8	2.2		
315.0	5.5	2.2	2.8	0.4	8.7	1.2	0.2	3.8	2.4		
270.0	2.2	1.2	0.9	0.1	8.0	1.2	0.1	3.0	2.6		
225.0	6.5	1.5	3.9	1.2	10.5	1.5	0.2	4.7	2.5		
180.0	13.2	2.5	6.4	4.3	14.0	2.9	0.6	5.9	2.3		
135.0	3.3	1.0	2.1	0.1	7.4	1.4	0.2	3.8	2.4		
0	MEAN SCALAR SPEED = 6.8 CM/S		MEAN SQUARE SPEED = 64.6 CM2/S2								
	MEAN SQUARE E-W SPEED = 5.7 CM2/S2		MEAN SQUARE N-S SPEED = 58.9 CM2/S2								
	MEAN VELOCITY = 4.1 CM/S,		9 DEG TRUE		MEAN TEMPERATURE = 2.3 C						
	VARIANCE (U,V) = 23.9 CM2/S2		TOTAL HOURS = 672.								

PERCENT OBSERVED
 LIGHT (0.0 - 3.0) 16.4% MEDIUM (3.0 - 7.0) 45.1% HIGH (GE 7.0) 38.5%

MOORING IS 97-05C-002A018 DEPTH IS 18 METERS THERE ARE 672 VALUES

FIRST DAY 1998/02/01/0000
 FINAL DAY 1998/02/28/2300

SHORELINE ORIENTATION IN DEGREES TRUE SPECIFIED AS 90

DIRECTION DEG TRUE	PERCENT OBSERVED	TOWARD	TOTAL	LIGHT	MEDIUM	HIGH	MAXIMUM CURRENT CM/S	MEAN DURA- TION HOURS	MEAN EXCUR- SION KM	MEAN CURRENT CM/S	MEAN TEMP DEG C
90.0	3.1	2.1	1.0	0.0	5.6	1.1	0.1	2.8	2.4		
45.0	13.8	3.7	7.6	2.5	14.2	1.6	0.3	5.0	2.3		
0.0	52.1	2.8	22.3	26.9	20.7	4.4	1.3	8.5	2.2		
315.0	5.5	1.9	3.3	0.3	7.8	1.3	0.2	3.9	2.3		
270.0	2.2	1.8	0.3	0.1	7.1	1.2	0.1	2.1	2.6		
225.0	6.1	1.6	3.7	0.7	9.2	1.5	0.2	4.5	2.5		
180.0	12.6	2.8	5.2	4.6	12.6	2.2	0.5	6.0	2.3		
135.0	4.5	2.2	2.1	0.1	7.3	1.6	0.2	3.5	2.4		
0	MEAN SCALAR SPEED = 6.6 CM/S		MEAN SQUARE SPEED = 61.7 CM2/S2								
	MEAN SQUARE E-W SPEED = 5.0 CM2/S2		MEAN SQUARE N-S SPEED = 56.7 CM2/S2								
	MEAN VELOCITY = 4.0 CM/S,		10 DEG TRUE		MEAN TEMPERATURE = 2.3 C						
	VARIANCE (U,V) = 22.7 CM2/S2		TOTAL HOURS = 672.								

PERCENT OBSERVED
 LIGHT (0.0 - 3.0) 19.0% MEDIUM (3.0 - 7.0) 45.5% HIGH (GE 7.0) 35.4%

DATE: 1998/03/01 TO 1998/03/31
ROSE SUMMARY: WIND AND CURRENT

WIND

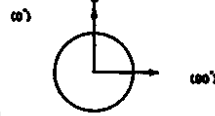
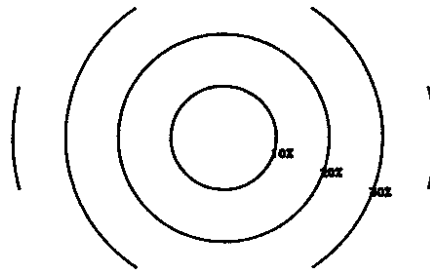

CURRENT
 0-3 CM/SEC
 3-7 CM/SEC
 >= 7 CM/SEC

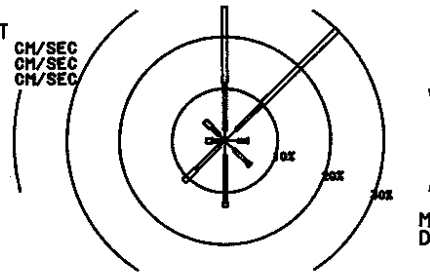

MOORING: 97-05C-002A016
DEPTH: 16 M

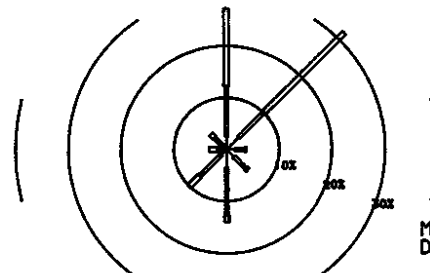

MOORING: 97-05C-002A018
DEPTH: 18 M

* WIND AND CURRENT DIRECTIONS ARE TOWARDS

MOORING IS 97-05C-002A016 DEPTH IS 16 METERS THERE ARE 744 VALUES

FIRST DAY 1998/03/01/0000
FINAL DAY 1998/03/31/2300

SHORELINE ORIENTATION IN DEGREES TRUE SPECIFIED AS 90

DIRECTION DEG TRUE	PERCENT OBSERVED	TOWARD	TOTAL	LIGHT	MEDIUM	HIGH	MAXIMUM CURRENT CM/S	MEAN DURA- TION HOURS	MEAN EXCUR- SION KM	MEAN CURRENT CM/S	MEAN TEMP DEG C
90.0	4.4	2.4	1.9	0.1			8.0	1.5	0.2	3.2	2.7
45.0	30.2	3.0	6.7	20.6			74.1	3.2	1.8	15.6	2.3
0.0	25.8	2.0	9.1	14.7			32.0	2.4	0.9	10.7	2.3
315.0	5.4	1.6	2.0	1.7			21.8	1.2	0.3	6.3	2.4
270.0	3.6	0.9	1.5	1.2			27.0	1.5	0.4	7.7	2.7
225.0	11.0	1.5	6.3	3.2			31.6	2.0	0.6	8.6	2.7
180.0	12.8	2.8	9.1	0.8			24.4	2.1	0.3	4.5	2.7
135.0	6.7	2.4	4.0	0.3			8.4	1.6	0.2	4.0	2.7

MEAN SCALAR SPEED = 10.0 CM/S MEAN SQUARE SPEED = 197.7 CM2/S2
 MEAN SQUARE E-W SPEED = 51.6 CM2/S2 MEAN SQUARE N-S SPEED = 146.1 CM2/S2
 MEAN VELOCITY = 5.9 CM/S, 21 DEG TRUE MEAN TEMPERATURE = 2.5 C
 VARIANCE (U,V) = 81.8 CM2/S2 TOTAL HOURS = 744.

PERCENT OBSERVED

LIGHT (0.0 - 3.0) 16.7% MEDIUM (3.0 - 7.0) 40.7% HIGH (GE 7.0) 42.6%

MOORING IS 97-05C-002A018 DEPTH IS 18 METERS THERE ARE 744 VALUES

FIRST DAY 1998/03/01/0000
FINAL DAY 1998/03/31/2300

SHORELINE ORIENTATION IN DEGREES TRUE SPECIFIED AS 90

DIRECTION DEG TRUE	PERCENT OBSERVED	TOWARD	TOTAL	LIGHT	MEDIUM	HIGH	MAXIMUM CURRENT CM/S	MEAN DURA- TION HOURS	MEAN EXCUR- SION KM	MEAN CURRENT CM/S	MEAN TEMP DEG C
90.0	3.8	1.6	1.9	0.3			8.3	1.3	0.2	3.7	2.6
45.0	31.7	3.1	7.0	21.6			73.1	3.1	1.7	15.2	2.3
0.0	27.2	2.6	9.7	14.9			33.1	2.2	0.8	10.5	2.3
315.0	4.2	0.9	2.3	0.9			20.8	1.2	0.3	5.6	2.5
270.0	3.4	0.4	1.3	1.6			27.2	1.7	0.6	9.4	2.7
225.0	10.2	1.3	5.8	3.1			33.4	2.5	0.7	8.3	2.7
180.0	14.0	3.5	9.3	1.2			20.3	2.1	0.3	4.5	2.7
135.0	5.6	1.9	3.4	0.4			7.3	1.4	0.2	4.0	2.8

MEAN SCALAR SPEED = 10.0 CM/S MEAN SQUARE SPEED = 197.9 CM2/S2
 MEAN SQUARE E-W SPEED = 50.8 CM2/S2 MEAN SQUARE N-S SPEED = 147.0 CM2/S2
 MEAN VELOCITY = 5.9 CM/S, 21 DEG TRUE MEAN TEMPERATURE = 2.5 C
 VARIANCE (U,V) = 81.4 CM2/S2 TOTAL HOURS = 744.

PERCENT OBSERVED

LIGHT (0.0 - 3.0) 15.3% MEDIUM (3.0 - 7.0) 40.6% HIGH (GE 7.0) 44.1%

DATE: 1998/04/01 TO 1998/04/30
 ROSE SUMMARY: WIND AND CURRENT

WIND

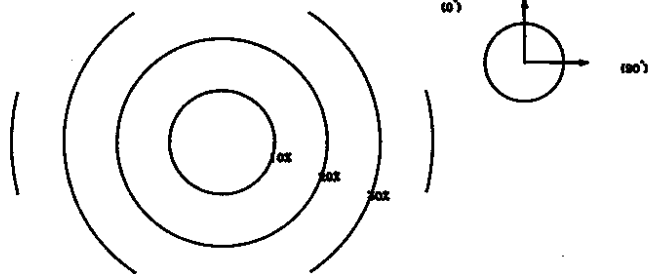

CURRENT
 — 0-3 CM/SEC
 = 3-7 CM/SEC
 = >= 7 CM/SEC

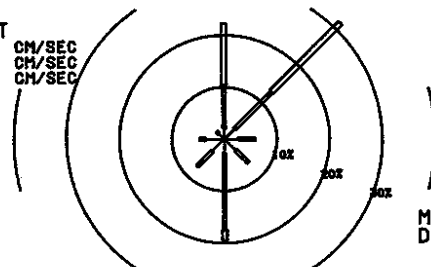

MOORING: 97-05C-002A016
 DEPTH: 16 M

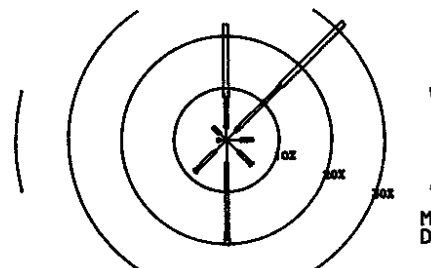

MOORING: 97-05C-002A018
 DEPTH: 18 M

* WIND AND CURRENT DIRECTIONS ARE TOWARDS

MOORING IS 97-05C-002A016 DEPTH IS 16 METERS THERE ARE 337 VALUES

FIRST DAY 1998/04/01/0000
 FINAL DAY 1998/04/15/0000

SHORELINE ORIENTATION IN DEGREES TRUE SPECIFIED AS 90

DIRECTION DEG TRUE	PERCENT OBSERVED	TOWARD	TOTAL	LIGHT	MEDIUM	HIGH	MAXIMUM CURRENT CM/S	MEAN DURA- TION HOURS	MEAN EXCUR- SION KM	MEAN CURRENT CM/S	MEAN TEMP DEG C
90.0	5.9	2.7	3.3	0.0	6.7	1.2	0.1	3.2	3.6		
45.0	31.5	2.7	10.1	18.7	28.0	3.7	1.5	11.3	3.8		
0.0	22.3	2.1	8.3	11.9	25.3	3.1	1.1	9.7	3.6		
315.0	2.1	1.5	0.6	0.0	4.4	1.0	0.1	2.0	3.5		
270.0	4.7	3.6	1.2	0.0	3.9	1.1	0.1	2.2	3.4		
225.0	7.4	3.3	4.2	0.0	7.0	1.7	0.2	3.6	3.6		
180.0	19.6	2.7	14.8	2.1	9.3	2.6	0.5	4.8	3.6		
135.0	6.5	3.0	3.6	0.0	6.4	1.4	0.2	3.6	3.6		

MEAN SCALAR SPEED = 7.5 CM/S MEAN SQUARE SPEED = 97.8 CM2/S2
 MEAN SQUARE E-W SPEED = 18.8 CM2/S2 MEAN SQUARE N-S SPEED = 79.0 CM2/S2
 MEAN VELOCITY = 4.4 CM/S, 31 DEG TRUE MEAN TEMPERATURE = 3.6 C
 VARIANCE (U,V) = 39.2 CM2/S2 TOTAL HOURS = 337.

PERCENT OBSERVED
 LIGHT (0.0 - 3.0) 21.4% MEDIUM (3.0 - 7.0) 46.0% HIGH (GE 7.0) 32.6%

MOORING IS 97-05C-002A018 DEPTH IS 18 METERS THERE ARE 337 VALUES

FIRST DAY 1998/04/01/0000
 FINAL DAY 1998/04/15/0000

SHORELINE ORIENTATION IN DEGREES TRUE SPECIFIED AS 90

DIRECTION DEG TRUE	PERCENT OBSERVED	TOWARD	TOTAL	LIGHT	MEDIUM	HIGH	MAXIMUM CURRENT CM/S	MEAN DURA- TION HOURS	MEAN EXCUR- SION KM	MEAN CURRENT CM/S	MEAN TEMP DEG C
90.0	5.0	2.7	2.4	0.0	5.6	1.9	0.2	3.0	3.6		
45.0	31.8	2.4	12.5	16.9	30.3	4.9	1.9	10.9	3.8		
0.0	22.3	2.4	5.9	13.9	26.0	3.4	1.3	10.5	3.6		
315.0	3.6	1.8	1.8	0.0	5.2	1.2	0.1	3.0	3.4		
270.0	1.8	1.2	0.6	0.0	4.2	1.0	0.1	2.8	3.4		
225.0	8.6	3.0	5.3	0.3	7.9	1.5	0.2	3.9	3.6		
180.0	20.2	4.5	14.5	1.2	8.7	2.3	0.4	4.5	3.6		
135.0	6.8	3.3	3.3	0.3	7.4	1.4	0.2	3.3	3.4		

MEAN SCALAR SPEED = 7.6 CM/S MEAN SQUARE SPEED = 100.4 CM2/S2
 MEAN SQUARE E-W SPEED = 19.1 CM2/S2 MEAN SQUARE N-S SPEED = 81.3 CM2/S2
 MEAN VELOCITY = 4.5 CM/S, 30 DEG TRUE MEAN TEMPERATURE = 3.6 C
 VARIANCE (U,V) = 40.1 CM2/S2 TOTAL HOURS = 337.

PERCENT OBSERVED
 LIGHT (0.0 - 3.0) 21.1% MEDIUM (3.0 - 7.0) 46.3% HIGH (GE 7.0) 32.6%

DATE: 1997/11/02 TO 1997/11/30
ROSE SUMMARY: WIND AND CURRENT

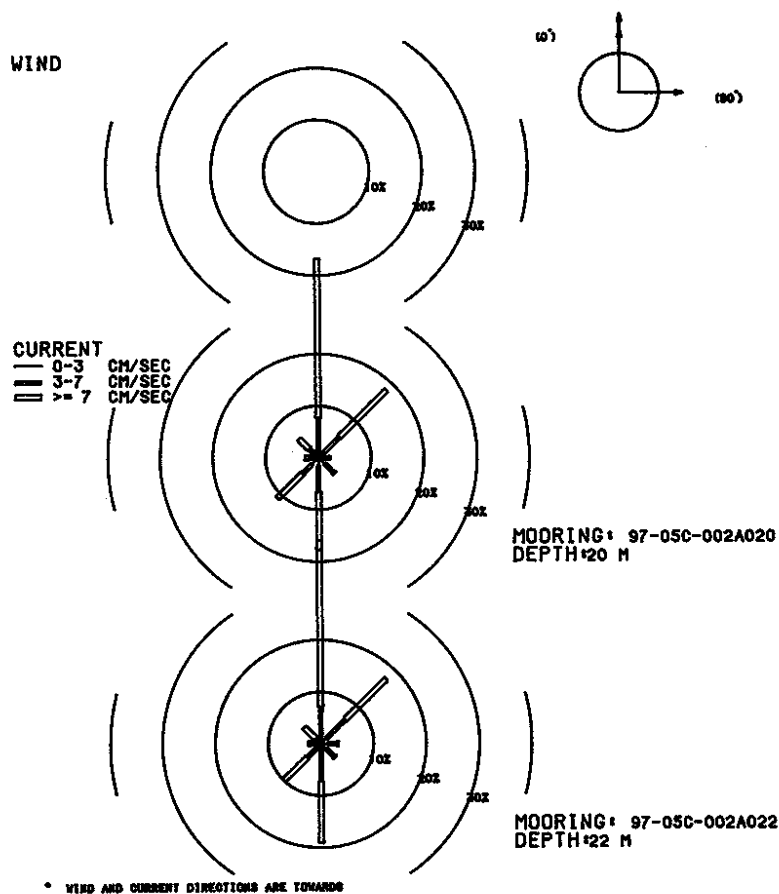

MOORING IS 97-05C-002A020 DEPTH IS 20 METERS THERE ARE 691 VALUES

FIRST DAY 1997/11/02/0500
FINAL DAY 1997/11/30/2300

SHORELINE ORIENTATION IN DEGREES TRUE SPECIFIED AS 90

DIRECTION DEG TRUE	PERCENT OBSERVED	MAXIMUM CURRENT CM/S	MEAN DURA- TION HOURS	MEAN EXCUR- SION KM	MEAN CURRENT CM/S	MEAN TEMP DEG C
TOWARD	TOTAL	LIGHT	MEDIUM	HIGH		
90.0	2.3	0.7	1.6	0.0	6.9	1.5
45.0	18.4	0.7	4.9	12.7	29.4	2.6
0.0	38.4	1.3	6.4	30.7	36.2	5.2
315.0	5.2	0.7	1.6	2.9	17.9	1.8
270.0	2.6	0.7	1.0	0.9	16.1	1.6
225.0	11.0	1.7	2.5	6.8	18.7	2.1
180.0	17.8	1.6	4.9	11.3	20.2	2.9
135.0	4.3	1.6	2.5	0.3	7.7	1.3

0 MEAN SCALAR SPEED = 11.1 CM/S MEAN SQUARE SPEED = 177.5 CM2/S2
MEAN SQUARE E-W SPEED = 21.1 CM2/S2 MEAN SQUARE N-S SPEED = 156.4 CM2/S2
MEAN VELOCITY = 5.1 CM/S, 9 DEG TRUE MEAN TEMPERATURE = 8.4 C
VARIANCE (U,V) = 76.0 CM2/S2 TOTAL HOURS = 691.

PERCENT OBSERVED
LIGHT (0.0 - 3.0) 9.1% MEDIUM (3.0 - 7.0) 25.3% HIGH (GE 7.0) 65.6%

MOORING IS 97-05C-002A022 DEPTH IS 22 METERS THERE ARE 691 VALUES

FIRST DAY 1997/11/02/0500
FINAL DAY 1997/11/30/2300

SHORELINE ORIENTATION IN DEGREES TRUE SPECIFIED AS 90

DIRECTION DEG TRUE	PERCENT OBSERVED	MAXIMUM CURRENT CM/S	MEAN DURA- TION HOURS	MEAN EXCUR- SION KM	MEAN CURRENT CM/S	MEAN TEMP DEG C
TOWARD	TOTAL	LIGHT	MEDIUM	HIGH		
90.0	3.3	1.3	1.7	0.3	7.1	1.4
45.0	17.7	1.4	5.1	11.1	32.6	2.4
0.0	39.1	0.7	6.4	32.0	35.2	5.1
315.0	4.5	0.3	1.0	3.2	17.8	2.8
270.0	2.5	0.7	1.3	0.4	9.2	1.3
225.0	10.1	1.3	2.3	6.5	20.5	1.8
180.0	19.1	1.0	6.2	11.9	19.4	3.1
135.0	3.8	1.3	2.2	0.3	9.6	1.4

0 MEAN SCALAR SPEED = 11.2 CM/S MEAN SQUARE SPEED = 178.8 CM2/S2
MEAN SQUARE E-W SPEED = 20.3 CM2/S2 MEAN SQUARE N-S SPEED = 158.6 CM2/S2
MEAN VELOCITY = 5.1 CM/S, 10 DEG TRUE MEAN TEMPERATURE = 8.4 C
VARIANCE (U,V) = 76.4 CM2/S2 TOTAL HOURS = 691.

PERCENT OBSERVED
LIGHT (0.0 - 3.0) 8.1% MEDIUM (3.0 - 7.0) 26.2% HIGH (GE 7.0) 65.7%

DATE: 1997/12/01 TO 1997/12/31
ROSE SUMMARY: WIND AND CURRENT

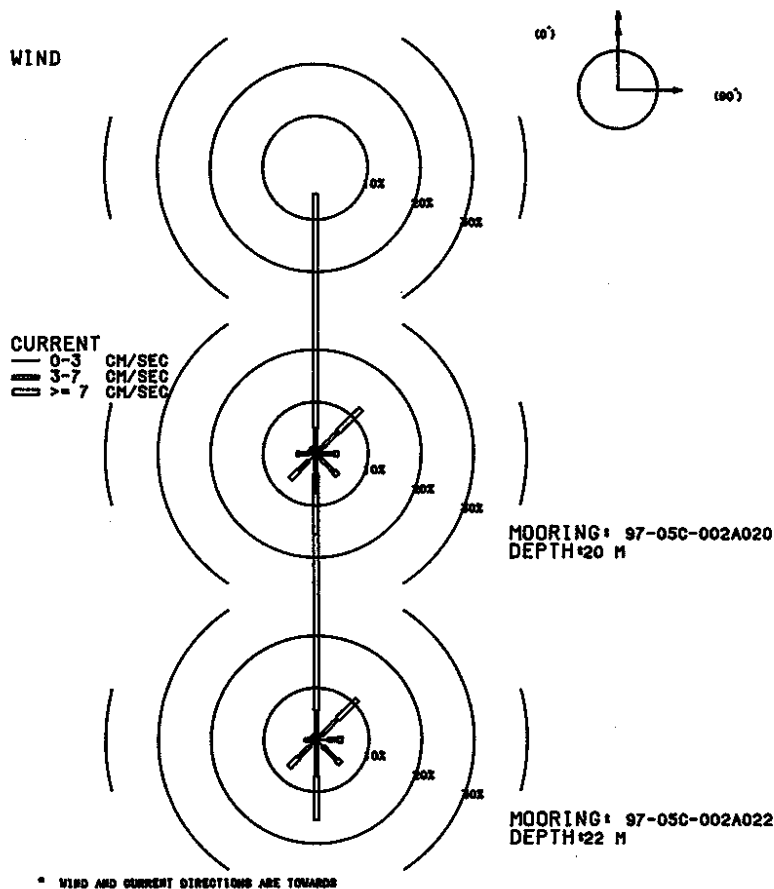

MOORING IS 97-05C-002A020 DEPTH IS 20 METERS THERE ARE 744 VALUES

FIRST DAY 1997/12/01/0000
FINAL DAY 1997/12/31/2300

SHORELINE ORIENTATION IN DEGREES TRUE SPECIFIED AS 90

DIRECTION DEG TRUE	PERCENT OBSERVED	TOWARD	TOTAL	LIGHT	MEDIUM	HIGH	MAXIMUM CURRENT CM/S	MEAN DURA- TION HOURS	MEAN EXCUR- SION KM	MEAN CURRENT CM/S	MEAN TEMP DEG C
90.0	4.3	1.2	2.3	0.8			9.4	1.5	0.2	4.7	5.6
45.0	12.2	0.9	5.1	6.2			28.1	1.8	0.5	7.8	5.6
0.0	50.0	1.2	3.8	45.0			39.0	7.3	4.6	17.6	5.6
315.0	1.5	0.4	0.8	0.3			10.0	1.1	0.2	4.0	5.7
270.0	3.6	1.3	1.9	0.4			9.4	1.7	0.3	4.2	5.4
225.0	6.9	1.9	2.6	2.4			19.2	2.0	0.5	6.7	5.8
180.0	15.6	0.8	6.7	8.1			20.0	3.4	0.9	7.7	5.6
135.0	5.9	1.3	3.5	1.1			9.4	1.4	0.2	4.7	5.1

0 MEAN SCALAR SPEED = 12.1 CM/S MEAN SQUARE SPEED = 231.7 CM2/S2
MEAN SQUARE E-W SPEED = 14.3 CM2/S2 MEAN SQUARE N-S SPEED = 217.5 CM2/S2
MEAN VELOCITY = 7.9 CM/S, 12 DEG TRUE MEAN TEMPERATURE = 5.6 C
VARIANCE (U,V) = 85.0 CM2/S2 TOTAL HOURS = 744.

PERCENT OBSERVED
LIGHT (0.0 - 3.0) 9.1% MEDIUM (3.0 - 7.0) 26.6% HIGH (GE 7.0) 64.2%

MOORING IS 97-05C-002A022 DEPTH IS 22 METERS THERE ARE 744 VALUES

FIRST DAY 1997/12/01/0000
FINAL DAY 1997/12/31/2300

SHORELINE ORIENTATION IN DEGREES TRUE SPECIFIED AS 90

DIRECTION DEG TRUE	PERCENT OBSERVED	TOWARD	TOTAL	LIGHT	MEDIUM	HIGH	MAXIMUM CURRENT CM/S	MEAN DURA- TION HOURS	MEAN EXCUR- SION KM	MEAN CURRENT CM/S	MEAN TEMP DEG C
90.0	5.0	2.2	1.9	0.9			11.8	1.6	0.2	4.0	5.5
45.0	11.0	1.3	4.3	5.4			16.6	2.0	0.6	7.6	5.5
0.0	51.2	1.1	4.6	45.6			40.7	9.1	5.7	17.6	5.6
315.0	1.2	0.8	0.4	0.0			4.7	1.3	0.1	2.1	5.6
270.0	2.3	0.8	1.5	0.0			7.0	1.4	0.2	3.6	5.5
225.0	7.4	1.6	3.2	2.6			18.5	2.0	0.5	6.8	5.9
180.0	15.5	0.8	6.2	8.5			18.0	3.6	1.0	7.9	5.6
135.0	6.5	1.7	3.6	1.1			9.8	1.5	0.3	4.6	5.3

0 MEAN SCALAR SPEED = 12.1 CM/S MEAN SQUARE SPEED = 233.5 CM2/S2
MEAN SQUARE E-W SPEED = 13.0 CM2/S2 MEAN SQUARE N-S SPEED = 220.5 CM2/S2
MEAN VELOCITY = 7.9 CM/S, 12 DEG TRUE MEAN TEMPERATURE = 5.6 C
VARIANCE (U,V) = 85.4 CM2/S2 TOTAL HOURS = 744.

PERCENT OBSERVED
LIGHT (0.0 - 3.0) 10.3% MEDIUM (3.0 - 7.0) 25.7% HIGH (GE 7.0) 64.0%

DATE: 1998/01/01 TO 1998/01/31
ROSE SUMMARY: WIND AND CURRENT

WIND

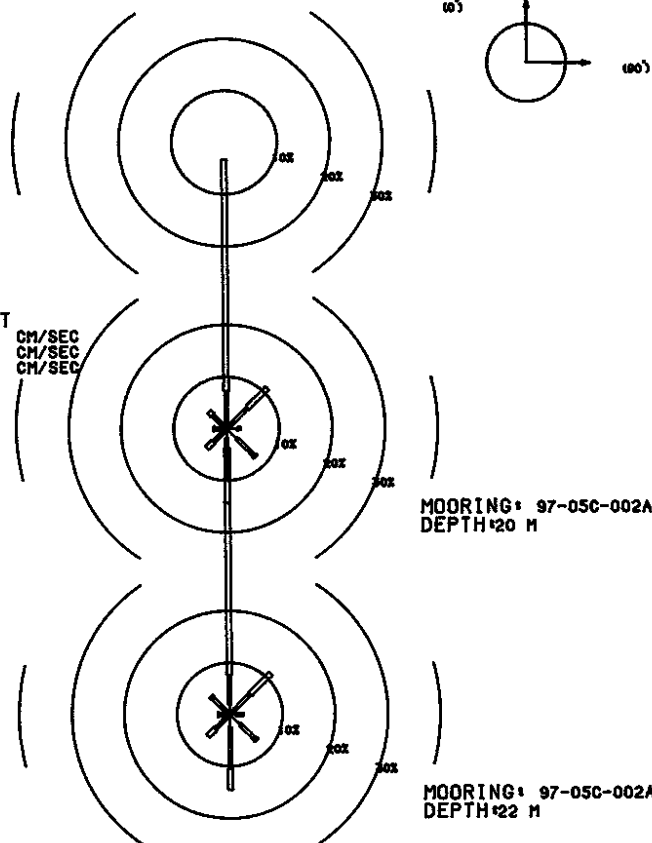

MOORING: 97-05C-002A020
DEPTH 20 M

MOORING: 97-05C-002A022
DEPTH 22 M

* WIND AND CURRENT DIRECTIONS ARE TOWARDS

MOORING IS 97-05C-002A020 DEPTH IS 20 METERS THERE ARE 744 VALUES

FIRST DAY 1998/01/01/0000
FINAL DAY 1998/01/31/2300

SHORELINE ORIENTATION IN DEGREES TRUE SPECIFIED AS 90

DIRECTION DEG TRUE	PERCENT OBSERVED	TOWARD	TOTAL	LIGHT	MEDIUM	HIGH	MAXIMUM CURRENT CM/S	MEAN DURA- TION HOURS	MEAN EXCUR- SION KM	MEAN CURRENT CM/S	MEAN TEMP DEG C
90.0	2.7	2.0	0.7	0.0	5.8	1.1	0.1	2.7	3.5		
45.0	11.0	0.7	5.0	5.4	30.6	1.9	0.5	8.1	3.4		
0.0	51.7	1.2	6.0	44.5	47.1	6.6	3.6	15.2	3.2		
315.0	4.7	0.8	2.8	1.1	12.8	1.4	0.3	5.3	3.2		
270.0	2.4	1.2	1.1	0.1	9.3	1.4	0.2	3.2	3.6		
225.0	5.2	0.7	2.8	1.7	18.1	1.4	0.3	6.5	3.4		
180.0	14.4	1.9	7.5	5.0	14.8	2.4	0.5	6.0	3.1		
135.0	7.8	2.7	4.6	0.5	8.6	1.9	0.3	4.1	3.1		

0 MEAN SCALAR SPEED = 10.7 CM/S MEAN SQUARE SPEED = 191.3 CM2/S2
MEAN SQUARE E-W SPEED = 13.6 CM2/S2 MEAN SQUARE N-S SPEED = 177.7 CM2/S2
MEAN VELOCITY = 7.4 CM/S, 12 DEG TRUE MEAN TEMPERATURE = 3.2 C
VARIANCE (U,V) = 68.4 CM2/S2 TOTAL HOURS = 744.

PERCENT OBSERVED

LIGHT (0.0 - 3.0) 11.2% MEDIUM (3.0 - 7.0) 30.5% HIGH (GE 7.0) 58.3%

MOORING IS 97-05C-002A022 DEPTH IS 22 METERS THERE ARE 744 VALUES

FIRST DAY 1998/01/01/0000
FINAL DAY 1998/01/31/2300

SHORELINE ORIENTATION IN DEGREES TRUE SPECIFIED AS 90

DIRECTION DEG TRUE	PERCENT OBSERVED	TOWARD	TOTAL	LIGHT	MEDIUM	HIGH	MAXIMUM CURRENT CM/S	MEAN DURA- TION HOURS	MEAN EXCUR- SION KM	MEAN CURRENT CM/S	MEAN TEMP DEG C
90.0	2.7	1.2	1.5	0.0	6.5	1.2	0.1	3.2	3.5		
45.0	11.2	0.8	4.7	5.6	30.7	1.7	0.5	8.9	3.5		
0.0	51.3	1.9	5.8	43.7	48.6	6.2	3.4	15.1	3.2		
315.0	5.0	1.1	3.4	0.5	12.7	1.5	0.3	4.9	3.2		
270.0	2.3	1.1	1.1	0.1	10.2	1.4	0.2	3.4	3.6		
225.0	5.9	0.8	3.1	2.0	16.4	1.4	0.3	6.7	3.3		
180.0	14.5	2.4	8.1	4.0	14.8	2.2	0.5	5.8	3.0		
135.0	7.1	2.7	4.2	0.3	8.1	1.8	0.3	4.1	3.2		

0 MEAN SCALAR SPEED = 10.7 CM/S MEAN SQUARE SPEED = 193.1 CM2/S2
MEAN SQUARE E-W SPEED = 13.4 CM2/S2 MEAN SQUARE N-S SPEED = 179.7 CM2/S2
MEAN VELOCITY = 7.4 CM/S, 12 DEG TRUE MEAN TEMPERATURE = 3.2 C
VARIANCE (U,V) = 69.3 CM2/S2 TOTAL HOURS = 744.

PERCENT OBSERVED

LIGHT (0.0 - 3.0) 12.0% MEDIUM (3.0 - 7.0) 31.7% HIGH (GE 7.0) 56.3%

DATE: 1998/02/01 TO 1998/02/28
ROSE SUMMARY: WIND AND CURRENT

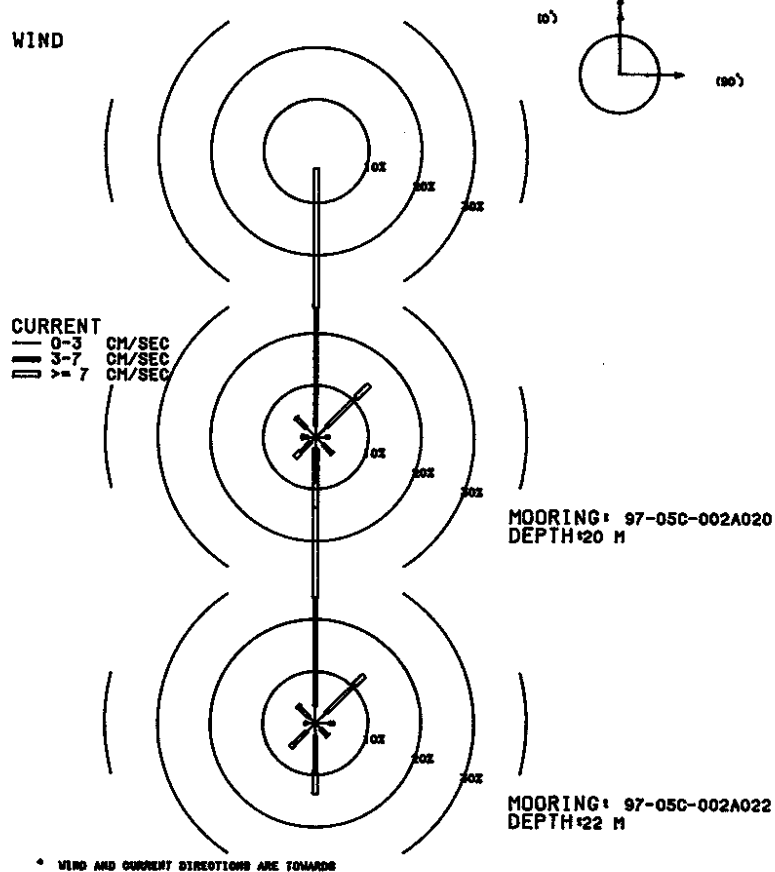

MOORING IS 97-05C-002A020 DEPTH IS 20 METERS THERE ARE 744 VALUES

FIRST DAY 1998/02/01/0000
FINAL DAY 1998/02/28/2300

SHORELINE ORIENTATION IN DEGREES TRUE SPECIFIED AS 90

DIRECTION DEG TRUE	PERCENT OBSERVED	MAXIMUM CURRENT CM/S	MEAN DURA- TION HOURS	MEAN EXCUR- SION KM	MEAN CURRENT CM/S	MEAN TEMP DEG C			
TOWARD	TOTAL	LIGHT	MEDIUM	HIGH					
90.0	2.5	1.9	0.6	0.0	6.1	1.2	0.1	2.7	2.5
45.0	14.3	2.8	7.9	3.6	13.7	1.5	0.3	5.2	2.3
0.0	51.6	2.2	22.6	26.8	21.2	4.6	1.4	8.5	2.1
315.0	5.4	2.5	2.5	0.3	9.7	1.1	0.1	3.5	2.4
270.0	2.7	1.5	0.9	0.3	7.4	1.1	0.1	3.2	2.5
225.0	5.5	1.2	3.0	1.3	9.4	1.4	0.3	5.3	2.5
180.0	13.5	2.4	6.4	4.8	13.8	2.4	0.5	6.0	2.4
135.0	4.5	1.9	2.4	0.1	7.4	1.4	0.2	3.2	2.4

MEAN SCALAR SPEED = 6.7 CM/S MEAN SQUARE SPEED = 62.9 CM2/S2
 MEAN SQUARE E-W SPEED = 5.4 CM2/S2 MEAN SQUARE N-S SPEED = 57.6 CM2/S2
 MEAN VELOCITY = 4.0 CM/S, 9 DEG TRUE MEAN TEMPERATURE = 2.3 C
 VARIANCE (U,V) = 23.5 CM2/S2 TOTAL HOURS = 672.

PERCENT OBSERVED
 LIGHT (0.0 - 3.0) 16.5% MEDIUM (3.0 - 7.0) 46.3% HIGH (GE 7.0) 37.2%

MOORING IS 97-05C-002A022 DEPTH IS 22 METERS THERE ARE 672 VALUES

FIRST DAY 1998/02/01/0000
FINAL DAY 1998/02/28/2300

SHORELINE ORIENTATION IN DEGREES TRUE SPECIFIED AS 90

DIRECTION DEG TRUE	PERCENT OBSERVED	MAXIMUM CURRENT CM/S	MEAN DURA- TION HOURS	MEAN EXCUR- SION KM	MEAN CURRENT CM/S	MEAN TEMP DEG C			
TOWARD	TOTAL	LIGHT	MEDIUM	HIGH					
90.0	3.6	2.7	0.9	0.0	6.7	1.5	0.1	2.6	2.4
45.0	13.1	2.8	7.7	2.5	19.8	1.5	0.3	5.4	2.3
0.0	52.8	3.3	20.8	28.7	20.6	5.1	1.5	8.3	2.2
315.0	4.8	1.6	2.7	0.4	11.5	1.3	0.2	4.2	2.4
270.0	2.1	1.6	0.4	0.0	6.2	1.3	0.1	2.1	2.6
225.0	6.5	2.2	3.4	0.9	10.3	1.6	0.2	4.1	2.5
180.0	13.7	2.4	7.1	4.2	12.8	3.2	0.7	5.8	2.4
135.0	3.4	1.5	1.8	0.1	7.3	1.4	0.2	3.6	2.4

MEAN SCALAR SPEED = 6.6 CM/S MEAN SQUARE SPEED = 62.0 CM2/S2
 MEAN SQUARE E-W SPEED = 5.0 CM2/S2 MEAN SQUARE N-S SPEED = 57.0 CM2/S2
 MEAN VELOCITY = 4.0 CM/S, 9 DEG TRUE MEAN TEMPERATURE = 2.3 C
 VARIANCE (U,V) = 22.9 CM2/S2 TOTAL HOURS = 672.

PERCENT OBSERVED
 LIGHT (0.0 - 3.0) 18.2% MEDIUM (3.0 - 7.0) 44.9% HIGH (GE 7.0) 36.9%

DATE: 1998/03/01 TO 1998/03/31
 ROSE SUMMARY: WIND AND CURRENT

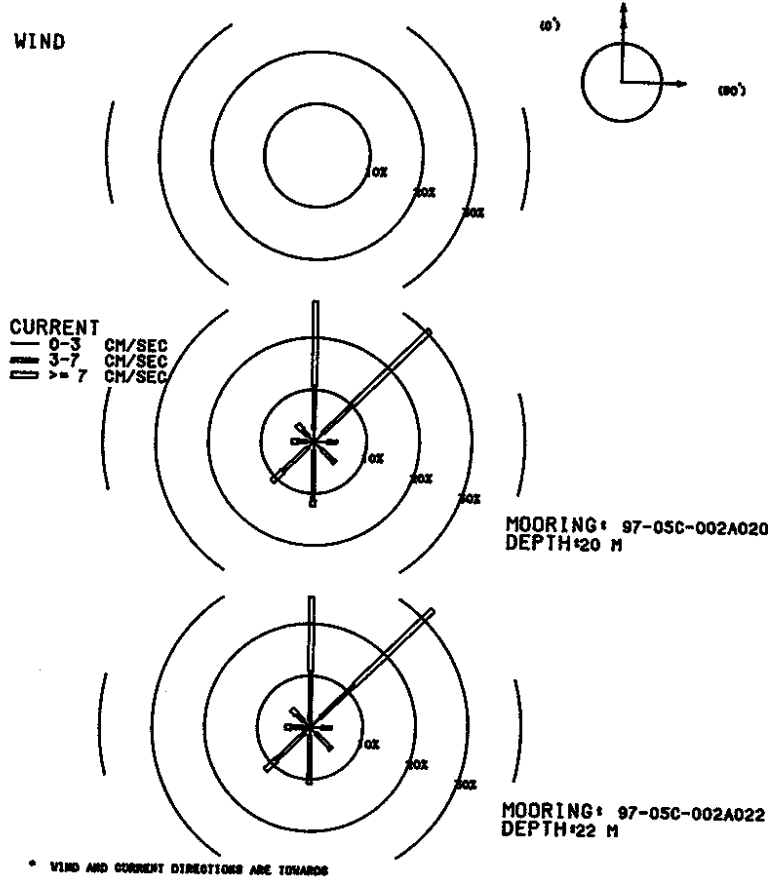

MOORING IS 97-05C-002A020 DEPTH IS 20 METERS THERE ARE 744 VALUES

FIRST DAY 1998/03/01/0000
 FINAL DAY 1998/03/31/2300

SHORELINE ORIENTATION IN DEGREES TRUE SPECIFIED AS 90

DIRECTION DEG TRUE	PERCENT OBSERVED	MAXIMUM CURRENT	MEAN DURATION HOURS	MEAN EXCURSION KM	MEAN CURRENT CM/S	MEAN TEMP DEG C
TOWARD	TOTAL	LIGHT	MEDIUM	HIGH	CM/S	
90.0	4.4	2.6	1.9	0.0	6.4	2.7
45.0	30.6	2.4	7.8	20.4	71.9	2.2
0.0	27.0	2.4	8.3	16.3	32.6	2.3
315.0	4.6	1.6	1.5	1.5	21.5	2.5
270.0	4.2	1.3	1.6	1.2	24.5	2.7
225.0	11.0	1.6	6.6	2.8	34.1	2.7
180.0	12.5	1.7	9.5	1.2	22.6	2.7
135.0	5.6	2.0	3.2	0.4	10.6	2.8
0		MEAN SCALAR SPEED = 10.0 CM/S		MEAN SQUARE SPEED = 196.6 CM2/S2		
		MEAN SQUARE E-W SPEED = 51.2 CM2/S2		MEAN SQUARE N-S SPEED = 145.3 CM2/S2		
		MEAN VELOCITY = 5.9 CM/S,		22 DEG TRUE		MEAN TEMPERATURE = 2.5 C
		VARIANCE (U,V) = 81.1 CM2/S2		TOTAL HOURS = 744.		

PERCENT OBSERVED
 LIGHT (0.0 - 3.0) 15.7% MEDIUM (3.0 - 7.0) 40.5% HIGH (GE 7.0) 43.8%

MOORING IS 97-05C-002A022 DEPTH IS 22 METERS THERE ARE 744 VALUES

FIRST DAY 1998/03/01/0000
 FINAL DAY 1998/03/31/2300

SHORELINE ORIENTATION IN DEGREES TRUE SPECIFIED AS 90

DIRECTION DEG TRUE	PERCENT OBSERVED	MAXIMUM CURRENT	MEAN DURATION HOURS	MEAN EXCURSION KM	MEAN CURRENT CM/S	MEAN TEMP DEG C
TOWARD	TOTAL	LIGHT	MEDIUM	HIGH	CM/S	
90.0	4.2	2.2	2.0	0.0	5.0	2.6
45.0	32.5	2.7	9.0	20.8	71.1	2.3
0.0	25.1	1.2	9.7	14.2	31.9	2.3
315.0	5.0	1.7	1.7	1.5	18.0	2.4
270.0	4.7	1.1	2.6	1.1	24.8	2.7
225.0	11.8	1.3	7.5	3.0	33.6	2.7
180.0	10.9	1.5	8.3	1.1	14.2	2.7
135.0	5.8	1.5	4.2	0.1	7.9	2.8
0		MEAN SCALAR SPEED = 10.0 CM/S		MEAN SQUARE SPEED = 196.4 CM2/S2		
		MEAN SQUARE E-W SPEED = 50.9 CM2/S2		MEAN SQUARE N-S SPEED = 145.6 CM2/S2		
		MEAN SQUARE U SPEED = 50.9 CM2/S2		MEAN SQUARE V SPEED = 145.6 CM2/S2		
		VARIANCE (U,V) = 80.8 CM2/S2		TOTAL HOURS = 744.		

PERCENT OBSERVED
 LIGHT (0.0 - 3.0) 13.2% MEDIUM (3.0 - 7.0) 45.0% HIGH (GE 7.0) 41.8%

DATE: 1998/04/01 TO 1998/04/30
ROSE SUMMARY: WIND AND CURRENT

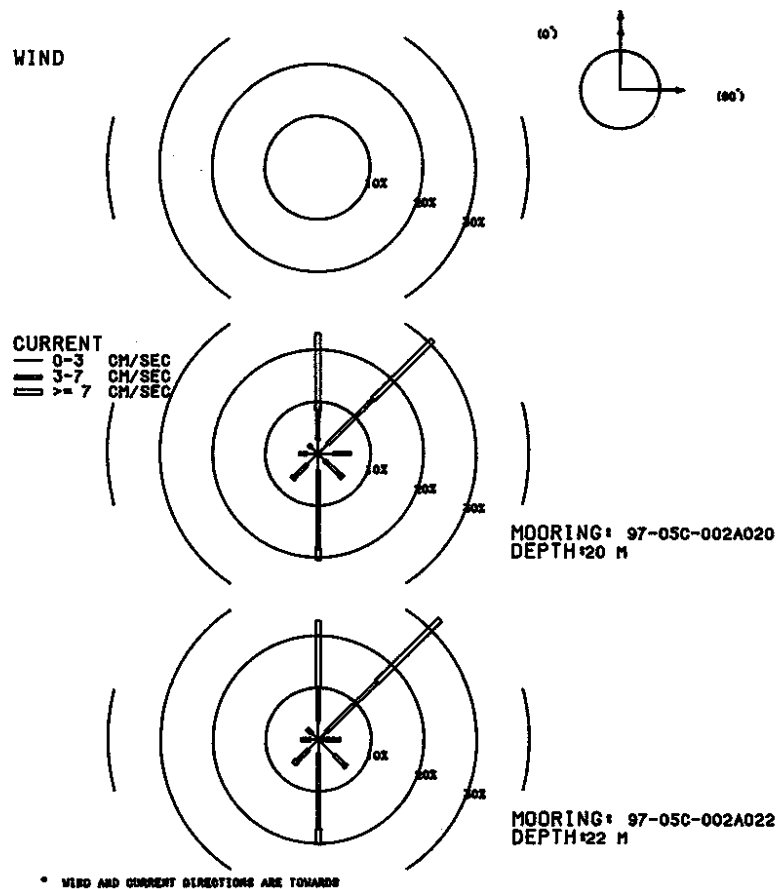

MOORING IS 97-05C-002A020 DEPTH IS 20 METERS THERE ARE 337 VALUES

FIRST DAY 1998/04/01/0000
FINAL DAY 1998/04/15/0000

SHORELINE ORIENTATION IN DEGREES TRUE SPECIFIED AS 90

DIRECTION DEG TRUE	PERCENT OBSERVED				MAXIMUM CURRENT CM/S	MEAN DURA- TION HOURS	MEAN EXCUR- SION KM	MEAN CURRENT CM/S	MEAN TEMP DEG C
TOWARD	TOTAL	LIGHT	MEDIUM	HIGH	CM/S	HOURS	KM	CM/S	DEG C
90.0	6.2	3.0	3.3	0.0	5.1	1.5	0.2	3.1	3.7
45.0	30.9	2.7	12.2	16.0	31.9	3.6	1.4	10.6	3.8
0.0	23.1	2.7	5.6	14.8	28.4	3.4	1.3	10.9	3.6
315.0	2.4	1.8	0.6	0.0	5.2	1.1	0.1	2.3	3.5
270.0	3.6	2.1	1.5	0.0	4.2	1.2	0.1	2.8	3.5
225.0	6.8	3.0	3.6	0.3	8.4	1.4	0.2	3.5	3.5
180.0	20.5	3.3	15.1	2.1	9.2	2.9	0.5	4.7	3.6
135.0	6.5	1.8	4.2	0.6	7.6	1.3	0.2	3.8	3.6
0	MEAN SCALAR SPEED = 7.6 CM/S				MEAN SQUARE SPEED = 101.6 CM2/S2				
	MEAN SQUARE E-W SPEED = 19.4 CM2/S2				MEAN SQUARE N-S SPEED = 82.2 CM2/S2				
	MEAN VELOCITY = 4.5 CM/S,				31 DEG TRUE MEAN TEMPERATURE = 3.6 C				
	VARIANCE (U,V) = 40.8 CM2/S2				TOTAL HOURS = 337.				

PERCENT OBSERVED
LIGHT (0.0 - 3.0) 20.2% MEDIUM (3.0 - 7.0) 46.0% HIGH (GE 7.0) 33.8%

MOORING IS 97-05C-002A022 DEPTH IS 22 METERS THERE ARE 337 VALUES

FIRST DAY 1998/04/01/0000
FINAL DAY 1998/04/15/0000

SHORELINE ORIENTATION IN DEGREES TRUE SPECIFIED AS 90

DIRECTION DEG TRUE	PERCENT OBSERVED				MAXIMUM CURRENT CM/S	MEAN DURA- TION HOURS	MEAN EXCUR- SION KM	MEAN CURRENT CM/S	MEAN TEMP DEG C
TOWARD	TOTAL	LIGHT	MEDIUM	HIGH	CM/S	HOURS	KM	CM/S	DEG C
90.0	4.2	0.3	3.9	0.0	5.2	1.4	0.2	3.9	3.7
45.0	32.6	2.1	13.6	16.9	29.0	4.1	1.6	10.8	3.8
0.0	22.8	3.6	6.5	12.8	27.0	2.9	1.0	9.5	3.6
315.0	3.0	1.8	1.2	0.0	5.0	1.1	0.1	2.4	3.5
270.0	3.3	1.5	1.8	0.0	4.2	1.6	0.2	2.8	3.5
225.0	6.5	2.7	3.0	0.9	8.5	1.3	0.2	4.1	3.5
180.0	20.2	2.7	14.5	3.0	8.7	2.6	0.5	5.1	3.6
135.0	7.4	4.2	3.0	0.3	7.0	1.3	0.1	3.1	3.5
0	MEAN SCALAR SPEED = 7.5 CM/S				MEAN SQUARE SPEED = 98.8 CM2/S2				
	MEAN SQUARE E-W SPEED = 18.8 CM2/S2				MEAN SQUARE N-S SPEED = 80.0 CM2/S2				
	MEAN VELOCITY = 4.3 CM/S,				31 DEG TRUE MEAN TEMPERATURE = 3.6 C				
	VARIANCE (U,V) = 40.1 CM2/S2				TOTAL HOURS = 337.				

PERCENT OBSERVED
LIGHT (0.0 - 3.0) 18.7% MEDIUM (3.0 - 7.0) 47.5% HIGH (GE 7.0) 33.8%

DATE: 1997/11/02 TO 1997/11/30
ROSE SUMMARY: WIND AND CURRENT

WIND

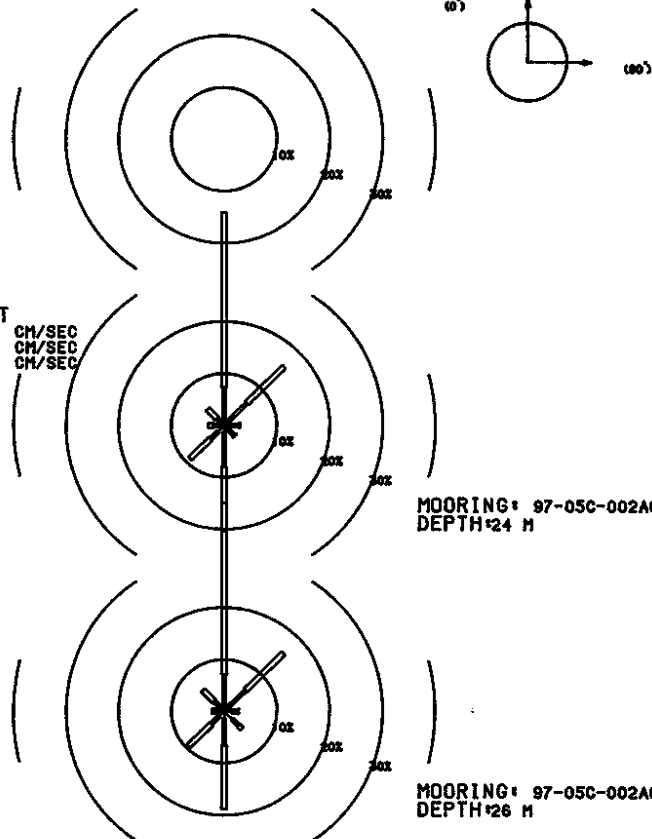

MOORING: 97-05C-002A024
DEPTH: 24 M

MOORING: 97-05C-002A026
DEPTH: 26 M

* WIND AND CURRENT DIRECTIONS ARE TOWARDS

MOORING IS 97-05C-002A024 DEPTH IS 24 METERS THERE ARE 691 VALUES

FIRST DAY 1997/11/02/0500
FINAL DAY 1997/11/30/2300

SHORELINE ORIENTATION IN DEGREES TRUE SPECIFIED AS 90

DIRECTION DEG TRUE	PERCENT OBSERVED	MAXIMUM CURRENT	MEAN DURATION HOURS	MEAN EXCURSION KM	MEAN CURRENT CM/S	MEAN TEMP DEG C
TOWARD	TOTAL	LIGHT	MEDIUM	HIGH	CM/S	
90.0	3.0	1.0	1.7	0.3	9.5	1.4
45.0	16.1	1.4	4.6	10.0	27.9	2.4
0.0	41.0	1.0	6.4	33.6	34.1	5.5
315.0	4.5	0.7	1.2	2.6	15.3	1.9
270.0	3.0	0.7	1.3	1.0	15.3	1.6
225.0	9.1	1.6	2.0	5.5	20.1	1.9
180.0	20.4	1.3	6.7	12.4	20.5	3.5
135.0	2.9	0.7	1.9	0.3	8.4	1.2

MEAN SCALAR SPEED = 11.1 CM/S MEAN SQUARE SPEED = 177.0 CM²/S²
 MEAN SQUARE E-W SPEED = 19.5 CM²/S² MEAN SQUARE N-S SPEED = 157.4 CM²/S²
 MEAN VELOCITY = 5.1 CM/S, 9 DEG TRUE MEAN TEMPERATURE = 8.4 C
 VARIANCE (U,V) = 75.6 CM²/S² TOTAL HOURS = 691.

PERCENT OBSERVED
 LIGHT (0.0 - 3.0) 8.5% MEDIUM (3.0 - 7.0) 25.8% HIGH (GE 7.0) 65.7%

MOORING IS 97-05C-002A026 DEPTH IS 26 METERS THERE ARE 691 VALUES

FIRST DAY 1997/11/02/0500
FINAL DAY 1997/11/30/2300

SHORELINE ORIENTATION IN DEGREES TRUE SPECIFIED AS 90

DIRECTION DEG TRUE	PERCENT OBSERVED	MAXIMUM CURRENT	MEAN DURATION HOURS	MEAN EXCURSION KM	MEAN CURRENT CM/S	MEAN TEMP DEG C
TOWARD	TOTAL	LIGHT	MEDIUM	HIGH	CM/S	
90.0	2.7	1.3	1.3	0.1	9.7	1.4
45.0	15.9	1.2	4.6	10.1	28.2	2.2
0.0	40.1	0.7	6.4	33.0	34.8	5.2
315.0	5.8	0.9	1.7	3.2	18.2	2.0
270.0	2.3	0.6	1.2	0.6	9.8	1.2
225.0	9.6	1.3	2.0	6.2	20.5	2.3
180.0	18.8	1.4	5.1	12.3	18.7	3.5
135.0	4.8	2.2	1.7	0.9	8.4	1.6

MEAN SCALAR SPEED = 11.0 CM/S MEAN SQUARE SPEED = 174.2 CM²/S²
 MEAN SQUARE E-W SPEED = 19.2 CM²/S² MEAN SQUARE N-S SPEED = 154.9 CM²/S²
 MEAN VELOCITY = 5.1 CM/S, 8 DEG TRUE MEAN TEMPERATURE = 8.4 C
 VARIANCE (U,V) = 74.2 CM²/S² TOTAL HOURS = 691.

PERCENT OBSERVED
 LIGHT (0.0 - 3.0) 9.6% MEDIUM (3.0 - 7.0) 24.0% HIGH (GE 7.0) 66.4%

DATE: 1997/12/01 TO 1997/12/31
 ROSE SUMMARY: WIND AND CURRENT

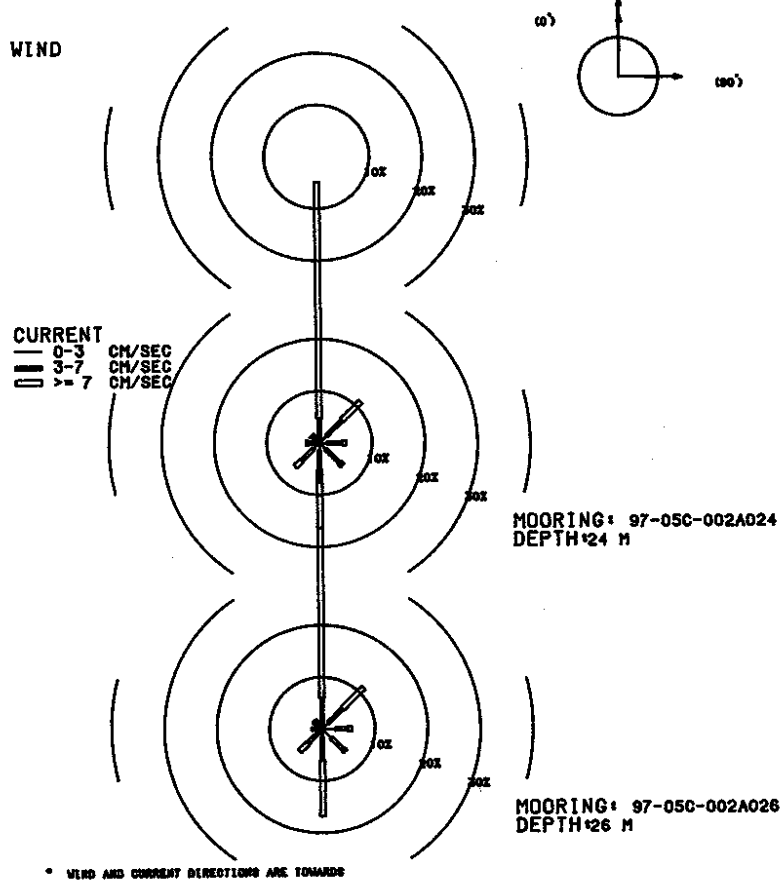

MOORING IS 97-05C-002A024 DEPTH IS 24 METERS THERE ARE 744 VALUES

FIRST DAY 1997/12/01/0000
 FINAL DAY 1997/12/31/2300

SHORELINE ORIENTATION IN DEGREES TRUE SPECIFIED AS 90

DIRECTION DEG TRUE	PERCENT OBSERVED	MAXIMUM CURRENT			MEAN DURA- TION HOURS	MEAN EXCUR- SION KM	MEAN CURRENT CM/S	MEAN TEMP DEG C	
TOWARD	TOTAL	LIGHT	MEDIUM	HIGH	CM/S				
90.0	5.1	1.5	2.8	0.8	9.9	1.8	0.3	4.6	5.6
45.0	11.2	2.0	4.0	5.1	14.7	1.8	0.5	6.9	5.6
0.0	50.1	0.9	3.8	45.4	38.0	9.6	6.1	17.8	5.6
315.0	2.0	1.1	0.7	0.3	28.9	1.1	0.2	4.7	5.3
270.0	2.6	0.8	1.3	0.4	9.8	1.5	0.2	4.2	5.8
225.0	6.5	1.5	3.2	1.7	19.7	2.3	0.5	6.5	5.8
180.0	16.4	1.6	5.9	8.9	19.0	3.9	1.1	7.8	5.6
135.0	6.2	1.6	3.9	0.7	11.7	1.6	0.2	4.4	5.2

MEAN SCALAR SPEED = 12.1 CM/S MEAN SQUARE SPEED = 233.1 CM2/S2
 MEAN SQUARE E-W SPEED = 13.2 CM2/S2 MEAN SQUARE N-S SPEED = 219.9 CM2/S2
 MEAN VELOCITY = 7.9 CM/S, 12 DEG TRUE MEAN TEMPERATURE = 5.6 C
 VARIANCE (U,V) = 85.8 CM2/S2 TOTAL HOURS = 744.

PERCENT OBSERVED

LIGHT (0.0 - 3.0) 11.0% MEDIUM (3.0 - 7.0) 25.7% HIGH (GE 7.0) 63.3%

MOORING IS 97-05C-002A026 DEPTH IS 26 METERS THERE ARE 744 VALUES

FIRST DAY 1997/12/01/0000
 FINAL DAY 1997/12/31/2300

SHORELINE ORIENTATION IN DEGREES TRUE SPECIFIED AS 90

DIRECTION DEG TRUE	PERCENT OBSERVED	MAXIMUM CURRENT			MEAN DURA- TION HOURS	MEAN EXCUR- SION KM	MEAN CURRENT CM/S	MEAN TEMP DEG C	
TOWARD	TOTAL	LIGHT	MEDIUM	HIGH	CM/S				
90.0	5.6	2.4	2.4	0.8	8.9	1.7	0.2	3.9	5.6
45.0	11.3	1.5	4.0	5.8	15.6	1.7	0.5	7.4	5.6
0.0	49.9	0.8	5.2	43.8	39.3	8.1	5.2	17.8	5.6
315.0	2.2	0.8	0.9	0.4	13.6	1.3	0.2	4.9	5.9
270.0	2.0	0.8	1.2	0.0	6.3	1.5	0.2	3.4	5.5
225.0	6.0	0.8	3.0	2.3	18.5	2.0	0.5	7.1	5.9
180.0	16.8	1.6	4.4	10.8	18.8	4.3	1.2	8.1	5.6
135.0	6.2	2.4	3.2	0.5	8.8	1.8	0.2	3.7	5.1

MEAN SCALAR SPEED = 12.1 CM/S MEAN SQUARE SPEED = 232.5 CM2/S2
 MEAN SQUARE E-W SPEED = 12.4 CM2/S2 MEAN SQUARE N-S SPEED = 220.1 CM2/S2
 MEAN VELOCITY = 7.8 CM/S, 12 DEG TRUE MEAN TEMPERATURE = 5.6 C
 VARIANCE (U,V) = 86.0 CM2/S2 TOTAL HOURS = 744.

PERCENT OBSERVED

LIGHT (0.0 - 3.0) 11.2% MEDIUM (3.0 - 7.0) 24.5% HIGH (GE 7.0) 64.4%

DATE: 1998/01/01 TO 1998/01/31
 ROSE SUMMARY: WIND AND CURRENT

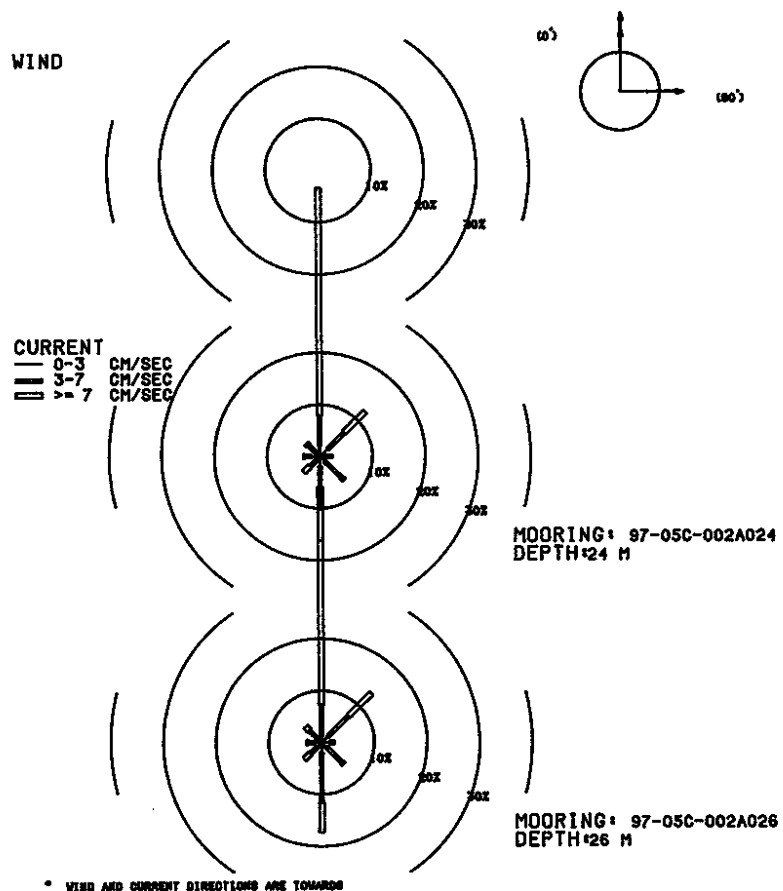

MOORING IS 97-05C-002A024 DEPTH IS 24 METERS THERE ARE 744 VALUES

FIRST DAY 1998/01/01/0000
 FINAL DAY 1998/01/31/2300

SHORELINE ORIENTATION IN DEGREES TRUE SPECIFIED AS 90

DIRECTION DEG TRUE	PERCENT OBSERVED	MAXIMUM CURRENT CM/S	MEAN DURATION HOURS	MEAN EXCURSION KM	MEAN CURRENT CM/S	MEAN TEMP DEG C
TOWARD	TOTAL	LIGHT	MEDIUM	HIGH		
90.0	2.4	1.1	1.3	0.0	6.4	1.4
45.0	12.2	2.0	4.4	5.8	28.4	1.8
0.0	51.6	2.2	5.8	43.7	49.2	7.0
315.0	3.6	0.7	2.3	0.7	7.9	1.4
270.0	3.1	1.6	1.3	0.1	9.8	1.4
225.0	4.3	0.8	1.7	1.7	17.1	1.2
180.0	16.3	1.9	8.2	6.2	17.2	2.9
135.0	6.5	1.3	4.6	0.5	8.5	1.8
0		MEAN SCALAR SPEED = 10.6 CM/S		MEAN SQUARE SPEED = 189.5 CM2/S2		
		MEAN SQUARE E-W SPEED = 13.1 CM2/S2		MEAN SQUARE N-S SPEED = 176.4 CM2/S2		
		MEAN VELOCITY = 7.2 CM/S,		13 DEG TRUE		MEAN TEMPERATURE = 3.2 C
		VARIANCE (U,V) = 68.6 CM2/S2		TOTAL HOURS = 744.		

PERCENT OBSERVED
 LIGHT (0.0 - 3.0) 11.6% MEDIUM (3.0 - 7.0) 29.7% HIGH (GE 7.0) 58.7%

MOORING IS 97-05C-002A026 DEPTH IS 26 METERS THERE ARE 744 VALUES

FIRST DAY 1998/01/01/0000
 FINAL DAY 1998/01/31/2300

SHORELINE ORIENTATION IN DEGREES TRUE SPECIFIED AS 90

DIRECTION DEG TRUE	PERCENT OBSERVED	MAXIMUM CURRENT CM/S	MEAN DURATION HOURS	MEAN EXCURSION KM	MEAN CURRENT CM/S	MEAN TEMP DEG C
TOWARD	TOTAL	LIGHT	MEDIUM	HIGH		
90.0	2.4	1.5	0.9	0.0	6.8	1.3
45.0	13.4	1.6	5.5	6.3	30.4	1.7
0.0	49.2	1.3	5.9	41.9	49.3	5.5
315.0	4.3	0.9	2.3	1.1	12.3	1.3
270.0	2.8	1.3	1.3	0.1	9.5	1.5
225.0	4.6	1.1	1.9	1.6	16.0	1.4
180.0	17.3	1.9	9.7	5.8	17.0	3.6
135.0	5.9	1.1	4.3	0.5	8.7	1.5
0		MEAN SCALAR SPEED = 10.6 CM/S		MEAN SQUARE SPEED = 189.9 CM2/S2		
		MEAN SQUARE E-W SPEED = 13.0 CM2/S2		MEAN SQUARE N-S SPEED = 176.8 CM2/S2		
		MEAN VELOCITY = 7.2 CM/S,		13 DEG TRUE		MEAN TEMPERATURE = 3.2 C
		VARIANCE (U,V) = 69.1 CM2/S2		TOTAL HOURS = 744.		

PERCENT OBSERVED
 LIGHT (0.0 - 3.0) 10.8% MEDIUM (3.0 - 7.0) 31.9% HIGH (GE 7.0) 57.4%

DATE: 1998/02/01 TO 1998/02/28
ROSE SUMMARY: WIND AND CURRENT

WIND

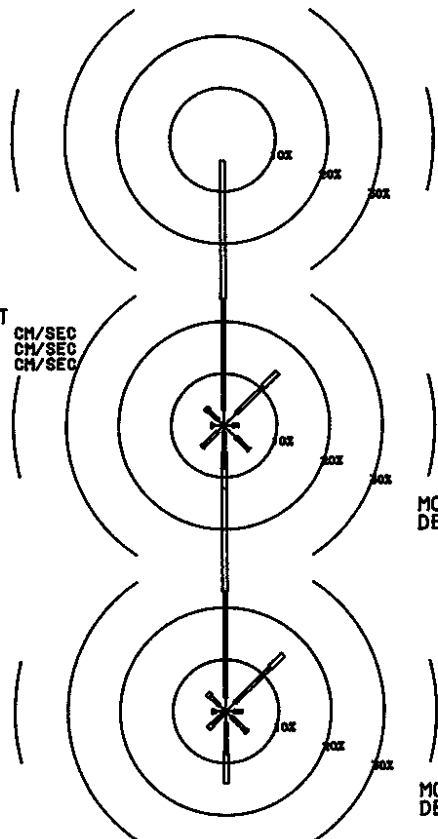

MOORING: 97-05C-002A024
DEPTH: 24 M

MOORING: 97-05C-002A026
DEPTH: 26 M

* WIND AND CURRENT DIRECTIONS ARE TOWARDS

MOORING IS 97-05C-002A024 DEPTH IS 24 METERS THERE ARE 672 VALUES

FIRST DAY 1998/02/01/0000
FINAL DAY 1998/02/28/2300

SHORELINE ORIENTATION IN DEGREES TRUE SPECIFIED AS 90

DIRECTION DEG TRUE	PERCENT OBSERVED	TOWARD	TOTAL	LIGHT	MEDIUM	HIGH	MAXIMUM CURRENT CM/S	MEAN DURA- TION HOURS	MEAN EXCUR- SION KM	MEAN CURRENT CM/S	MEAN TEMP DEG C
90.0	2.8	1.6	1.2	0.0	5.3	1.1	0.1	2.8	2.5		
45.0	14.4	3.3	7.3	3.9	18.1	1.4	0.3	5.4	2.2		
0.0	50.9	3.0	21.4	26.5	21.5	3.8	1.1	8.4	2.2		
315.0	4.8	1.5	2.7	0.6	12.8	1.2	0.2	4.3	2.4		
270.0	2.4	1.9	0.3	0.1	7.4	1.1	0.1	2.7	2.6		
225.0	5.8	1.6	3.9	0.3	9.2	1.8	0.3	4.5	2.6		
180.0	12.2	1.2	7.0	4.0	14.3	3.0	0.7	6.3	2.3		
135.0	6.7	3.1	3.4	0.1	7.0	1.9	0.2	3.4	2.4		

MEAN SCALAR SPEED = 6.7 CM/S MEAN SQUARE SPEED = 61.9 CM²/S²
MEAN SQUARE E-W SPEED = 5.2 CM²/S² MEAN SQUARE N-S SPEED = 56.7 CM²/S²
MEAN VELOCITY = 4.0 CM/S, 10 DEG TRUE MEAN TEMPERATURE = 2.3 C
VARIANCE (U,V) = 23.1 CM²/S² TOTAL HOURS = 672.

PERCENT OBSERVED

LIGHT (0.0 - 3.0) 17.3% MEDIUM (3.0 - 7.0) 47.2% HIGH (GE 7.0) 35.6%

MOORING IS 97-05C-002A026 DEPTH IS 26 METERS THERE ARE 672 VALUES

FIRST DAY 1998/02/01/0000
FINAL DAY 1998/02/28/2300

SHORELINE ORIENTATION IN DEGREES TRUE SPECIFIED AS 90

DIRECTION DEG TRUE	PERCENT OBSERVED	TOWARD	TOTAL	LIGHT	MEDIUM	HIGH	MAXIMUM CURRENT CM/S	MEAN DURA- TION HOURS	MEAN EXCUR- SION KM	MEAN CURRENT CM/S	MEAN TEMP DEG C
90.0	3.1	1.5	1.6	0.0	6.4	1.4	0.2	3.1	2.4		
45.0	15.5	2.2	9.7	3.6	15.2	1.7	0.3	5.4	2.2		
0.0	49.9	2.7	20.4	26.8	20.7	4.5	1.4	8.5	2.2		
315.0	4.9	1.6	2.5	0.7	11.5	1.3	0.2	4.6	2.3		
270.0	2.5	1.9	0.4	0.1	8.7	1.1	0.1	2.4	2.6		
225.0	4.6	1.0	2.5	1.0	8.6	2.2	0.4	5.1	2.7		
180.0	13.8	2.2	6.1	5.5	13.8	3.2	0.7	6.1	2.3		
135.0	5.7	1.5	3.7	0.4	7.8	2.0	0.3	3.9	2.4		

MEAN SCALAR SPEED = 6.7 CM/S MEAN SQUARE SPEED = 62.2 CM²/S²
MEAN SQUARE E-W SPEED = 5.4 CM²/S² MEAN SQUARE N-S SPEED = 56.8 CM²/S²
MEAN VELOCITY = 3.9 CM/S, 12 DEG TRUE MEAN TEMPERATURE = 2.3 C
VARIANCE (U,V) = 23.5 CM²/S² TOTAL HOURS = 672.

PERCENT OBSERVED

LIGHT (0.0 - 3.0) 14.7% MEDIUM (3.0 - 7.0) 47.0% HIGH (GE 7.0) 38.2%

DATE: 1998/03/01 TO 1998/03/31
ROSE SUMMARY: WIND AND CURRENT

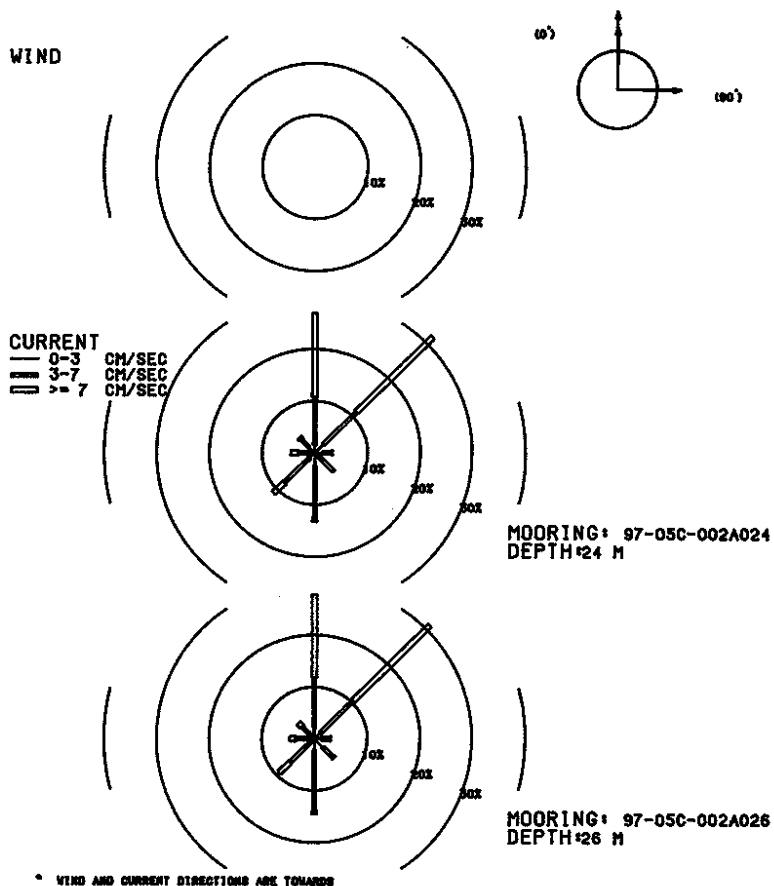

MOORING IS 97-05C-002A024 DEPTH IS 24 METERS THERE ARE 744 VALUES

FIRST DAY 1998/03/01/0000
FINAL DAY 1998/03/31/2300

SHORELINE ORIENTATION IN DEGREES TRUE SPECIFIED AS 90

DIRECTION DEG TRUE	PERCENT OBSERVED	TOWARD	TOTAL	LIGHT	MEDIUM	HIGH	MAXIMUM CURRENT CM/S	MEAN DURA- TION HOURS	MEAN EXCUR- SION KM	MEAN CURRENT CM/S	MEAN TEMP DEG C
90.0	3.4	1.5	1.6	0.3			7.7	1.2	0.2	3.7	2.7
45.0	31.6	2.2	9.0	20.4			71.6	3.5	1.9	15.1	2.3
0.0	26.9	1.5	9.3	16.1			31.1	2.8	1.1	10.6	2.3
315.0	4.2	1.5	2.2	0.5			21.9	1.2	0.2	5.6	2.5
270.0	4.6	1.1	2.0	1.5			22.0	1.9	0.5	6.9	2.7
225.0	11.0	1.3	6.7	3.0			34.2	2.3	0.7	8.4	2.7
180.0	13.3	2.6	10.5	0.3			13.4	2.1	0.3	4.5	2.7
135.0	5.1	0.8	4.3	0.0			6.8	1.8	0.3	4.2	2.7
0 MEAN SCALAR SPEED = 10.0 CM/S MEAN SQUARE SPEED = 195.8 CM2/S2											
MEAN SQUARE E-W SPEED = 50.5 CM2/S2 MEAN SQUARE N-S SPEED = 145.3 CM2/S2											
MEAN VELOCITY = 5.9 CM/S, 21 DEG TRUE MEAN TEMPERATURE = 2.5 C											
VARIANCE (U,V) = 80.7 CM2/S2 TOTAL HOURS = 744.											

PERCENT OBSERVED
LIGHT (0.0 - 3.0) 12.4% MEDIUM (3.0 - 7.0) 45.6% HIGH (GE 7.0) 42.1%

MOORING IS 97-05C-002A026 DEPTH IS 26 METERS THERE ARE 744 VALUES

FIRST DAY 1998/03/01/0000
FINAL DAY 1998/03/31/2300

SHORELINE ORIENTATION IN DEGREES TRUE SPECIFIED AS 90

DIRECTION DEG TRUE	PERCENT OBSERVED	TOWARD	TOTAL	LIGHT	MEDIUM	HIGH	MAXIMUM CURRENT CM/S	MEAN DURA- TION HOURS	MEAN EXCUR- SION KM	MEAN CURRENT CM/S	MEAN TEMP DEG C
90.0	3.1	1.2	1.7	0.1			8.5	1.3	0.2	3.8	2.6
45.0	30.9	1.5	8.9	20.6			73.4	3.7	2.1	15.5	2.3
0.0	27.8	2.2	9.7	16.0			30.6	3.0	1.1	10.4	2.3
315.0	4.3	0.9	2.3	1.1			21.5	1.3	0.3	6.1	2.4
270.0	4.7	1.1	2.4	1.2			26.1	1.7	0.4	6.8	2.7
225.0	9.4	0.8	5.6	3.0			31.8	1.9	0.7	9.4	2.7
180.0	14.5	2.3	11.6	0.7			12.7	2.2	0.4	4.4	2.7
135.0	5.2	2.3	2.8	0.1			7.0	1.4	0.2	3.7	2.8
0 MEAN SCALAR SPEED = 10.1 CM/S MEAN SQUARE SPEED = 195.7 CM2/S2											
MEAN SQUARE E-W SPEED = 50.7 CM2/S2 MEAN SQUARE N-S SPEED = 145.0 CM2/S2											
MEAN VELOCITY = 6.0 CM/S, 21 DEG TRUE MEAN TEMPERATURE = 2.5 C											
VARIANCE (U,V) = 80.2 CM2/S2 TOTAL HOURS = 744.											

PERCENT OBSERVED
LIGHT (0.0 - 3.0) 12.2% MEDIUM (3.0 - 7.0) 45.0% HIGH (GE 7.0) 42.7%

DATE: 1998/04/01 TO 1998/04/30
ROSE SUMMARY: WIND AND CURRENT

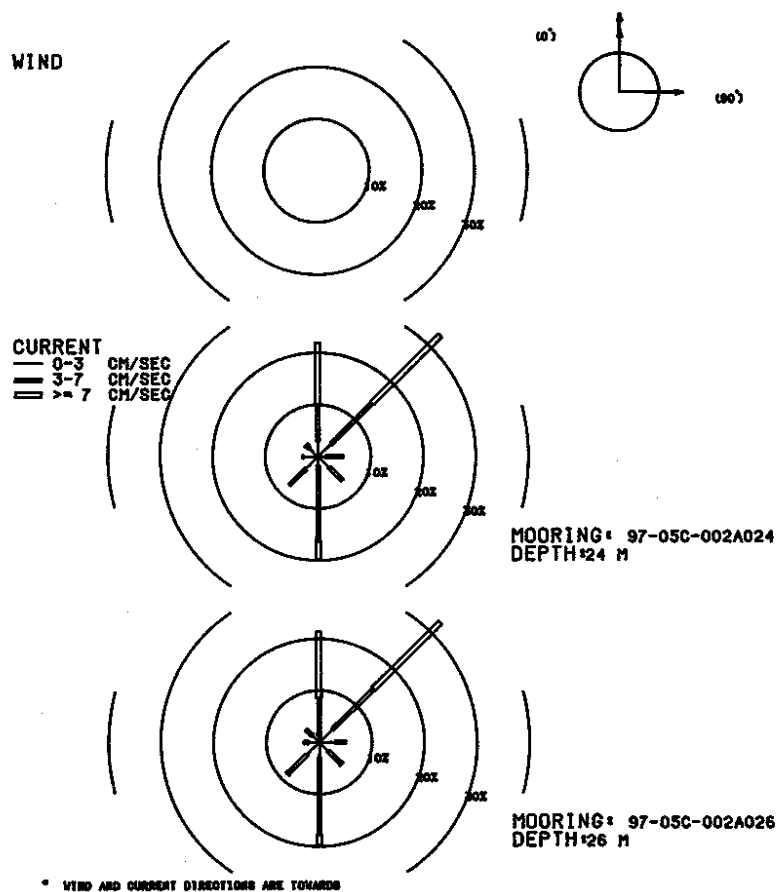

MOORING IS 97-05C-002A024 DEPTH IS 24 METERS THERE ARE 337 VALUES

FIRST DAY 1998/04/01/0000
FINAL DAY 1998/04/15/0000

SHORELINE ORIENTATION IN DEGREES TRUE SPECIFIED AS 90

DIRECTION DEG TRUE	PERCENT OBSERVED	TOWARD	TOTAL	LIGHT	MEDIUM	HIGH	MAXIMUM CURRENT CM/S	MEAN DURA- TION HOURS	MEAN EXCUR- SION KM	MEAN CURRENT CM/S	MEAN TEMP DEG C
90.0	4.7	1.5	3.3	0.0	6.5	1.8	0.2	3.6	3.7		
45.0	32.9	3.6	11.0	18.4	29.0	3.8	1.5	10.8	3.8		
0.0	22.0	3.0	7.1	11.9	26.0	2.6	0.9	9.8	3.6		
315.0	3.3	2.4	0.6	0.3	7.3	1.0	0.1	3.1	3.5		
270.0	3.0	2.7	0.3	0.0	4.7	1.1	0.1	2.2	3.5		
225.0	7.7	3.3	4.5	0.0	6.8	1.4	0.2	3.7	3.5		
180.0	19.9	1.8	14.5	3.6	9.0	2.7	0.5	5.4	3.6		
135.0	6.5	3.0	3.6	0.0	6.8	1.2	0.1	3.2	3.6		
0		MEAN SCALAR SPEED = 7.6 CM/S		MEAN SQUARE SPEED = 100.4 CM2/S2							
		MEAN SQUARE E-W SPEED = 19.1 CM2/S2		MEAN SQUARE N-S SPEED = 81.2 CM2/S2							
		MEAN VELOCITY = 4.4 CM/S,		31 DEG TRUE		MEAN TEMPERATURE = 3.6 C					
		VARIANCE (U,V) = 40.7 CM2/S2		TOTAL HOURS = 337.							

PERCENT OBSERVED
LIGHT (0.0 - 3.0) 21.1% MEDIUM (3.0 - 7.0) 44.8% HIGH (GE 7.0) 34.1%

MOORING IS 97-05C-002A026 DEPTH IS 26 METERS THERE ARE 337 VALUES

FIRST DAY 1998/04/01/0000
FINAL DAY 1998/04/15/0000

SHORELINE ORIENTATION IN DEGREES TRUE SPECIFIED AS 90

DIRECTION DEG TRUE	PERCENT OBSERVED	TOWARD	TOTAL	LIGHT	MEDIUM	HIGH	MAXIMUM CURRENT CM/S	MEAN DURA- TION HOURS	MEAN EXCUR- SION KM	MEAN CURRENT CM/S	MEAN TEMP DEG C
90.0	5.0	3.0	2.1	0.0	5.9	1.5	0.2	3.0	3.6		
45.0	32.6	3.6	11.0	18.1	28.6	3.9	1.6	11.2	3.8		
0.0	21.4	1.2	7.4	12.8	26.0	3.0	1.1	10.4	3.6		
315.0	3.6	1.8	1.8	0.0	4.1	1.2	0.1	2.8	3.5		
270.0	3.0	2.1	0.9	0.0	5.6	1.4	0.1	2.8	3.5		
225.0	8.6	3.3	5.0	0.3	7.2	1.5	0.2	3.8	3.5		
180.0	19.9	3.0	14.8	2.1	8.3	2.9	0.5	4.8	3.6		
135.0	5.9	2.4	3.3	0.3	9.0	1.4	0.2	3.6	3.7		
0		MEAN SCALAR SPEED = 7.7 CM/S		MEAN SQUARE SPEED = 101.6 CM2/S2							
		MEAN SQUARE E-W SPEED = 20.1 CM2/S2		MEAN SQUARE N-S SPEED = 81.6 CM2/S2							
		MEAN VELOCITY = 4.5 CM/S,		30 DEG TRUE		MEAN TEMPERATURE = 3.6 C					
		VARIANCE (U,V) = 40.7 CM2/S2		TOTAL HOURS = 337.							

PERCENT OBSERVED
LIGHT (0.0 - 3.0) 20.2% MEDIUM (3.0 - 7.0) 46.3% HIGH (GE 7.0) 33.5%

DATE: 1997/11/02 TO 1997/11/30
ROSE SUMMARY: WIND AND CURRENT

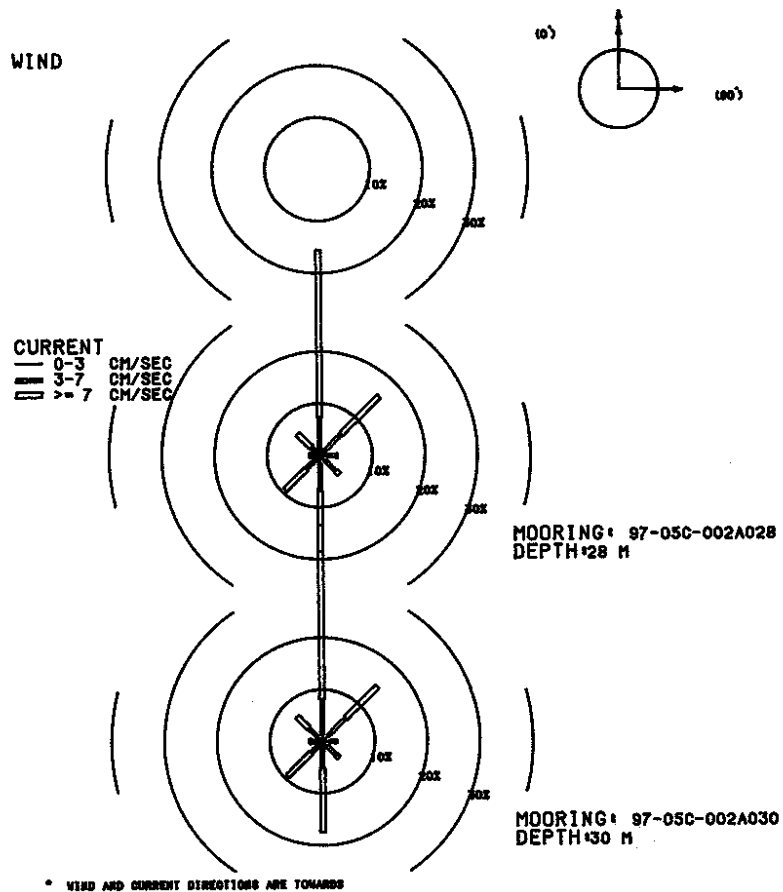

MOORING IS 97-05C-002A028 DEPTH IS 28 METERS THERE ARE 691 VALUES

FIRST DAY 1997/11/02/0500
FINAL DAY 1997/11/30/2300

SHORELINE ORIENTATION IN DEGREES TRUE SPECIFIED AS 90

DIRECTION DEG TRUE	PERCENT OBSERVED	MAXIMUM CURRENT	MEAN DURA- TION HOURS	MEAN EXCUR- SION KM	MEAN CURRENT CM/S	MEAN TEMP DEG C
TOWARD	TOTAL	LIGHT	MEDIUM	HIGH	CM/S	
90.0	3.3	1.4	1.7	0.1	7.9	1.4
45.0	16.1	1.0	4.8	10.3	30.6	2.1
0.0	39.5	0.9	6.5	32.1	35.4	4.6
315.0	5.9	0.4	1.7	3.8	18.7	2.3
270.0	2.0	0.4	0.9	0.7	12.6	1.1
225.0	9.4	0.7	2.9	5.8	21.3	1.6
180.0	18.5	1.6	5.2	11.7	18.8	2.8
135.0	5.2	1.3	2.9	1.0	8.3	1.6

MEAN SCALAR SPEED = 11.0 CM/S MEAN SQUARE SPEED = 173.6 CM²/S²
 MEAN SQUARE E-W SPEED = 18.8 CM²/S² MEAN SQUARE N-S SPEED = 154.7 CM²/S²
 MEAN VELOCITY = 5.1 CM/S, 8 DEG TRUE MEAN TEMPERATURE = 8.4 C
 VARIANCE (U,V) = 74.1 CM²/S² TOTAL HOURS = 691.

PERCENT OBSERVED
 LIGHT (0.0 - 3.0) 7.8% MEDIUM (3.0 - 7.0) 26.6% HIGH (GE 7.0) 65.6%

MOORING IS 97-05C-002A030 DEPTH IS 30 METERS THERE ARE 691 VALUES

FIRST DAY 1997/11/02/0500
FINAL DAY 1997/11/30/2300

SHORELINE ORIENTATION IN DEGREES TRUE SPECIFIED AS 90

DIRECTION DEG TRUE	PERCENT OBSERVED	MAXIMUM CURRENT	MEAN DURA- TION HOURS	MEAN EXCUR- SION KM	MEAN CURRENT CM/S	MEAN TEMP DEG C
TOWARD	TOTAL	LIGHT	MEDIUM	HIGH	CM/S	
90.0	2.9	1.4	1.4	0.0	7.0	1.5
45.0	14.9	1.4	4.8	8.7	26.6	2.1
0.0	41.5	1.3	6.8	33.4	36.5	5.4
315.0	6.8	1.3	2.3	3.2	16.3	2.0
270.0	2.5	0.7	1.4	0.3	9.9	1.4
225.0	9.4	0.9	2.2	6.4	19.2	2.2
180.0	17.5	1.3	3.8	12.4	20.0	3.2
135.0	4.5	1.2	2.6	0.7	8.4	1.7

MEAN SCALAR SPEED = 11.0 CM/S MEAN SQUARE SPEED = 174.8 CM²/S²
 MEAN SQUARE E-W SPEED = 17.6 CM²/S² MEAN SQUARE N-S SPEED = 157.2 CM²/S²
 MEAN VELOCITY = 5.1 CM/S, 7 DEG TRUE MEAN TEMPERATURE = 8.4 C
 VARIANCE (U,V) = 74.3 CM²/S² TOTAL HOURS = 691.

PERCENT OBSERVED
 LIGHT (0.0 - 3.0) 9.6% MEDIUM (3.0 - 7.0) 25.3% HIGH (GE 7.0) 65.1%

DATE: 1997/12/01 TO 1997/12/31
ROSE SUMMARY: WIND AND CURRENT

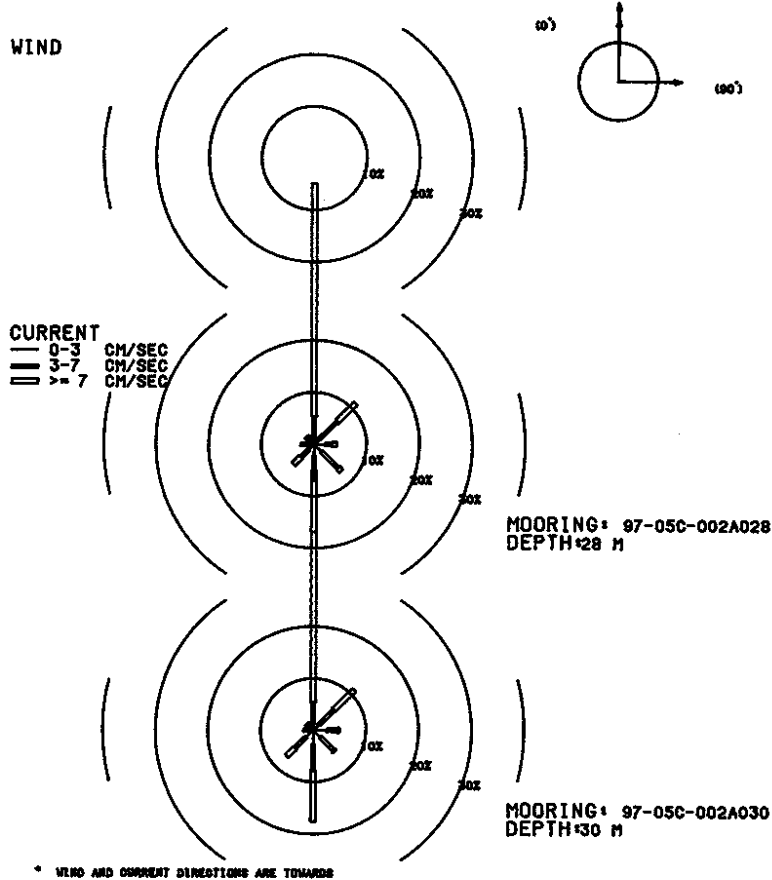

MOORING IS 97-05C-002A028 DEPTH IS 28 METERS THERE ARE 744 VALUES

FIRST DAY 1997/12/01/0000
FINAL DAY 1997/12/31/2300

SHORELINE ORIENTATION IN DEGREES TRUE SPECIFIED AS 90

DIRECTION DEG TRUE	PERCENT OBSERVED				MAXIMUM CURRENT CM/S	MEAN DURATION HOURS	MEAN EXCURSION KM	MEAN CURRENT CM/S	MEAN TEMP DEG C
TOWARD	TOTAL	LIGHT	MEDIUM	HIGH	CM/S	HOURS	KM	CM/S	DEG C
90.0	4.3	2.2	1.3	0.8	8.5	1.5	0.2	4.0	5.6
45.0	11.2	1.3	4.8	5.0	17.1	2.0	0.5	7.1	5.6
0.0	50.1	0.8	4.6	44.8	37.7	9.6	6.1	17.8	5.6
315.0	2.0	0.8	0.8	0.4	13.1	1.2	0.2	4.6	5.7
270.0	2.6	0.9	1.6	0.0	6.7	1.7	0.2	3.7	5.5
225.0	5.5	1.3	2.2	2.0	15.5	1.9	0.4	6.5	5.7
180.0	16.9	2.3	4.7	9.9	20.6	3.9	1.1	8.0	5.6
135.0	7.4	1.9	4.6	0.9	10.1	1.8	0.3	4.5	5.2

MEAN SCALAR SPEED = 12.1 CM/S MEAN SQUARE SPEED = 232.8 CM²/S²
 MEAN SQUARE E-W SPEED = 12.7 CM²/S² MEAN SQUARE N-S SPEED = 220.1 CM²/S²
 MEAN VELOCITY = 7.8 CM/S, 12 DEG TRUE MEAN TEMPERATURE = 5.6 C
 VARIANCE (U,V) = 86.1 CM²/S² TOTAL HOURS = 744.

PERCENT OBSERVED
 LIGHT (0.0 - 3.0) 11.6% MEDIUM (3.0 - 7.0) 24.6% HIGH (GE 7.0) 63.8%

MOORING IS 97-05C-002A030 DEPTH IS 30 METERS THERE ARE 744 VALUES

FIRST DAY 1997/12/01/0000
FINAL DAY 1997/12/31/2300

SHORELINE ORIENTATION IN DEGREES TRUE SPECIFIED AS 90

DIRECTION DEG TRUE	PERCENT OBSERVED				MAXIMUM CURRENT CM/S	MEAN DURATION HOURS	MEAN EXCURSION KM	MEAN CURRENT CM/S	MEAN TEMP DEG C
TOWARD	TOTAL	LIGHT	MEDIUM	HIGH	CM/S	HOURS	KM	CM/S	DEG C
90.0	5.0	2.6	2.0	0.4	9.5	1.5	0.2	3.5	5.7
45.0	11.0	1.5	4.0	5.5	13.9	1.7	0.4	7.2	5.6
0.0	49.9	1.2	4.2	44.5	37.3	7.3	4.7	17.9	5.6
315.0	1.7	0.9	0.5	0.3	8.2	1.1	0.1	3.6	5.6
270.0	1.9	0.4	1.5	0.0	6.4	1.6	0.2	4.1	5.6
225.0	7.1	1.9	3.0	2.3	16.6	1.9	0.4	6.1	5.8
180.0	17.6	2.7	5.1	9.8	18.5	3.1	0.8	7.4	5.6
135.0	5.8	1.9	3.6	0.3	8.3	1.7	0.2	4.0	5.1

MEAN SCALAR SPEED = 12.0 CM/S MEAN SQUARE SPEED = 230.7 CM²/S²
 MEAN SQUARE E-W SPEED = 11.1 CM²/S² MEAN SQUARE N-S SPEED = 219.6 CM²/S²
 MEAN VELOCITY = 7.8 CM/S, 11 DEG TRUE MEAN TEMPERATURE = 5.6 C
 VARIANCE (U,V) = 84.9 CM²/S² TOTAL HOURS = 744.

PERCENT OBSERVED
 LIGHT (0.0 - 3.0) 13.0% MEDIUM (3.0 - 7.0) 23.9% HIGH (GE 7.0) 63.0%

DATE: 1998/01/01 TO 1998/01/31
ROSE SUMMARY: WIND AND CURRENT

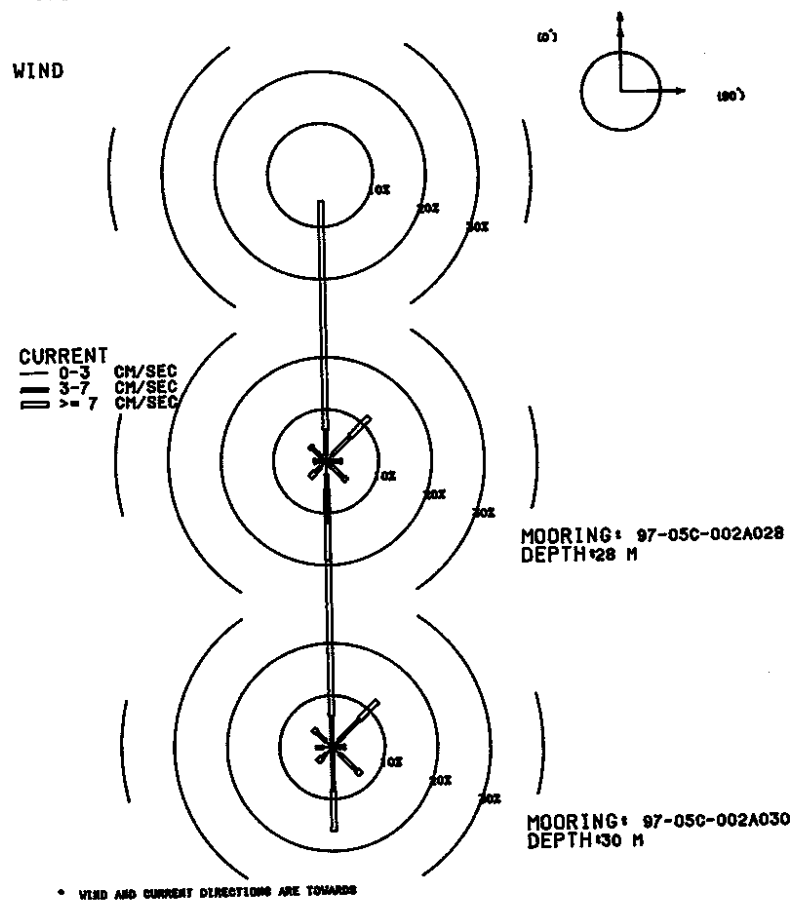

MOORING IS 97-05C-002A028 DEPTH IS 28 METERS THERE ARE 744 VALUES

FIRST DAY 1998/01/01/0000
FINAL DAY 1998/01/31/2300

SHORELINE ORIENTATION IN DEGREES TRUE SPECIFIED AS 90

DIRECTION DEG TRUE	PERCENT OBSERVED	MAXIMUM CURRENT	MEAN DURATION HOURS	MEAN EXCURSION KM	MEAN CURRENT CM/S	MEAN TEMP DEG C
TOWARD	TOTAL	LIGHT	MEDIUM	HIGH	CM/S	
90.0	3.0	1.1	1.6	0.3	8.4	1.3
45.0	11.8	1.5	5.1	5.2	27.5	1.6
0.0	50.0	1.2	4.8	44.0	49.1	6.3
315.0	4.2	1.1	2.6	0.5	9.2	1.7
270.0	2.3	1.1	1.1	0.1	8.8	1.3
225.0	4.3	1.5	1.5	1.3	17.3	1.3
180.0	19.1	2.4	9.4	7.3	17.1	3.2
135.0	5.4	1.2	3.4	0.8	8.9	1.2
0		MEAN SCALAR SPEED = 10.7 CM/S		MEAN SQUARE SPEED = 190.5 CM2/S2		
		MEAN SQUARE E-W SPEED = 12.1 CM2/S2		MEAN SQUARE N-S SPEED = 178.4 CM2/S2		
		MEAN VELOCITY = 7.1 CM/S,		13 DEG TRUE		MEAN TEMPERATURE = 3.2 C
		VARIANCE (U,V) = 70.2 CM2/S2		TOTAL HOURS = 744.		

PERCENT OBSERVED

LIGHT (0.0 - 3.0) 11.0% MEDIUM (3.0 - 7.0) 29.4% HIGH (GE 7.0) 59.5%

MOORING IS 97-05C-002A030 DEPTH IS 30 METERS THERE ARE 744 VALUES

FIRST DAY 1998/01/01/0000
FINAL DAY 1998/01/31/2300

SHORELINE ORIENTATION IN DEGREES TRUE SPECIFIED AS 90

DIRECTION DEG TRUE	PERCENT OBSERVED	MAXIMUM CURRENT	MEAN DURATION HOURS	MEAN EXCURSION KM	MEAN CURRENT CM/S	MEAN TEMP DEG C
TOWARD	TOTAL	LIGHT	MEDIUM	HIGH	CM/S	
90.0	2.4	1.1	1.2	0.1	7.7	1.6
45.0	12.4	1.6	5.9	4.8	29.5	1.8
0.0	49.6	0.5	5.5	43.5	48.7	6.3
315.0	5.0	1.6	2.6	0.8	12.1	1.6
270.0	3.1	1.7	1.3	0.0	6.4	1.4
225.0	3.9	1.9	0.9	1.1	15.0	1.3
180.0	16.1	0.4	8.1	7.7	14.6	4.0
135.0	7.5	1.7	4.7	1.1	10.1	2.1
0		MEAN SCALAR SPEED = 10.7 CM/S		MEAN SQUARE SPEED = 187.4 CM2/S2		
		MEAN SQUARE E-W SPEED = 12.3 CM2/S2		MEAN SQUARE N-S SPEED = 175.0 CM2/S2		
		MEAN VELOCITY = 7.1 CM/S,		13 DEG TRUE		MEAN TEMPERATURE = 3.2 C
		VARIANCE (U,V) = 68.7 CM2/S2		TOTAL HOURS = 744.		

PERCENT OBSERVED

LIGHT (0.0 - 3.0) 10.6% MEDIUM (3.0 - 7.0) 30.2% HIGH (GE 7.0) 59.1%

DATE: 1998/02/01 TO 1998/02/28
ROSE SUMMARY: WIND AND CURRENT

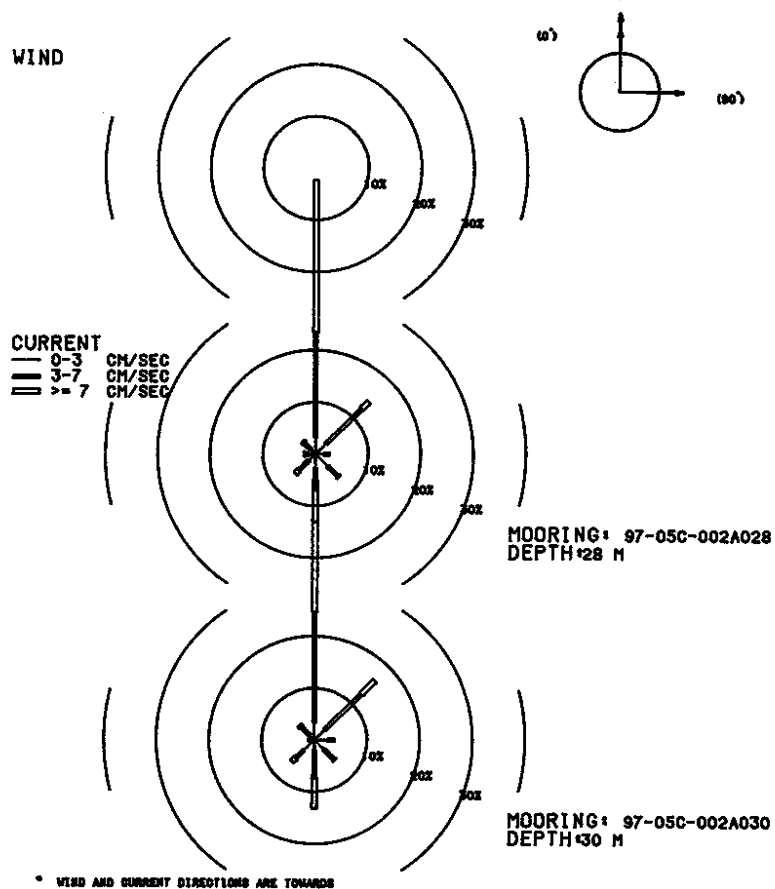

MOORING IS 97-05C-002A028 DEPTH IS 28 METERS THERE ARE 672 VALUES

FIRST DAY 1998/02/01/0000
FINAL DAY 1998/02/28/2300

SHORELINE ORIENTATION IN DEGREES TRUE SPECIFIED AS 90

DIRECTION DEG TRUE	PERCENT OBSERVED	TOWARD	TOTAL	LIGHT	MEDIUM	HIGH	MAXIMUM CURRENT CM/S	MEAN DURA- TION HOURS	MEAN EXCUR- SION KM	MEAN CURRENT CM/S	MEAN TEMP DEG C
90.0	2.7	1.6	1.0	0.0	4.8	1.1	0.1	2.8	2.5		
45.0	14.3	2.8	9.5	1.9	13.9	1.7	0.3	4.7	2.3		
0.0	52.7	3.3	20.1	29.3	22.4	5.3	1.6	8.5	2.1		
315.0	3.4	1.2	1.8	0.4	13.0	1.1	0.2	4.4	2.3		
270.0	2.2	1.3	0.6	0.3	7.8	1.1	0.1	3.3	2.5		
225.0	5.4	1.6	2.8	0.9	9.1	1.9	0.3	4.3	2.5		
180.0	13.1	2.7	4.3	6.1	12.9	2.9	0.7	6.3	2.3		
135.0	6.2	3.3	2.7	0.3	7.8	1.8	0.2	3.3	2.4		
MEAN SCALAR SPEED = 6.7 CM/S		MEAN SQUARE SPEED = 62.6 CM2/S2									
MEAN SQUARE E-W SPEED = 4.8 CM2/S2		MEAN SQUARE N-S SPEED = 57.8 CM2/S2									
MEAN VELOCITY = 4.0 CM/S,		11 DEG TRUE MEAN TEMPERATURE = 2.3 C									
VARIANCE (U,V) = 23.4 CM2/S2		TOTAL HOURS = 672.									

PERCENT OBSERVED
LIGHT (0.0 - 3.0) 17.9% MEDIUM (3.0 - 7.0) 42.9% HIGH (GE 7.0) 39.3%

MOORING IS 97-05C-002A030 DEPTH IS 30 METERS THERE ARE 672 VALUES

FIRST DAY 1998/02/01/0000
FINAL DAY 1998/02/28/2300

SHORELINE ORIENTATION IN DEGREES TRUE SPECIFIED AS 90

DIRECTION DEG TRUE	PERCENT OBSERVED	TOWARD	TOTAL	LIGHT	MEDIUM	HIGH	MAXIMUM CURRENT CM/S	MEAN DURA- TION HOURS	MEAN EXCUR- SION KM	MEAN CURRENT CM/S	MEAN TEMP DEG C
90.0	3.9	2.5	1.3	0.0	6.7	1.6	0.2	2.7	2.6		
45.0	16.2	2.8	9.7	3.7	12.8	1.8	0.4	5.4	2.3		
0.0	50.0	3.4	21.1	25.4	22.8	4.4	1.3	8.4	2.2		
315.0	4.0	1.3	2.1	0.6	11.6	1.4	0.2	4.6	2.4		
270.0	1.2	0.9	0.3	0.0	6.4	1.1	0.1	2.6	2.6		
225.0	6.0	2.8	2.1	1.0	9.9	1.8	0.3	4.0	2.6		
180.0	13.2	1.9	5.4	6.0	13.4	3.6	0.8	6.5	2.3		
135.0	5.5	2.5	2.8	0.1	7.1	1.8	0.2	3.8	2.4		
MEAN SCALAR SPEED = 6.7 CM/S		MEAN SQUARE SPEED = 62.7 CM2/S2									
MEAN SQUARE E-W SPEED = 5.3 CM2/S2		MEAN SQUARE N-S SPEED = 57.4 CM2/S2									
MEAN VELOCITY = 3.9 CM/S,		14 DEG TRUE MEAN TEMPERATURE = 2.3 C									
VARIANCE (U,V) = 23.7 CM2/S2		TOTAL HOURS = 672.									

PERCENT OBSERVED
LIGHT (0.0 - 3.0) 18.3% MEDIUM (3.0 - 7.0) 44.8% HIGH (GE 7.0) 36.9%

DATE: 1998/03/01 TO 1998/03/31
ROSE SUMMARY: WIND AND CURRENT

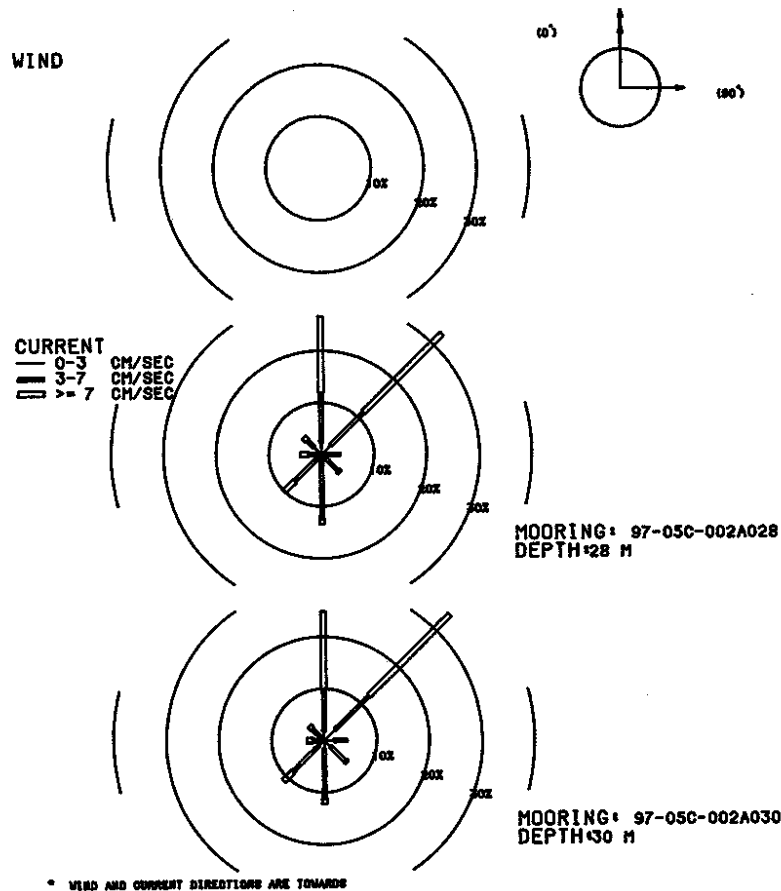

MOORING IS 97-05C-002A028 DEPTH IS 28 METERS THERE ARE 744 VALUES

FIRST DAY 1998/03/01/0000
FINAL DAY 1998/03/31/2300

SHORELINE ORIENTATION IN DEGREES TRUE SPECIFIED AS 90

DIRECTION DEG TRUE	PERCENT OBSERVED	TOWARD	TOTAL	LIGHT	MEDIUM	HIGH	MAXIMUM CURRENT CM/S	MEAN DURA- TION HOURS	MEAN EXCUR- SION KM	MEAN CURRENT CM/S	MEAN TEMP DEG C
90.0	3.6	1.1	2.6	0.0	6.0	1.7	0.2	3.6	2.7		
45.0	32.7	2.4	8.9	21.4	71.8	3.5	1.9	15.3	2.3		
0.0	26.6	2.3	9.5	14.8	31.5	2.5	0.9	10.0	2.3		
315.0	4.7	1.9	1.9	0.9	21.3	1.2	0.2	5.0	2.5		
270.0	4.0	1.1	1.3	1.6	24.8	1.6	0.5	8.1	2.7		
225.0	9.9	0.9	6.2	2.8	32.1	2.5	0.8	8.8	2.7		
180.0	13.4	1.2	11.2	1.1	8.0	2.9	0.5	4.8	2.7		
135.0	5.0	0.5	3.9	0.5	9.1	1.5	0.3	4.7	2.8		
0		MEAN SCALAR SPEED = 10.1 CM/S		MEAN SQUARE SPEED = 195.4 CM2/S2							
		MEAN SQUARE E-W SPEED = 49.7 CM2/S2		MEAN SQUARE N-S SPEED = 145.7 CM2/S2							
		MEAN VELOCITY = 5.9 CM/S,		21 DEG TRUE		MEAN TEMPERATURE = 2.5 C					
		VARIANCE (U,V) = 80.6 CM2/S2		TOTAL HOURS = 744.							

PERCENT OBSERVED

LIGHT (0.0 - 3.0) 11.4% MEDIUM (3.0 - 7.0) 45.4% HIGH (GE 7.0) 43.1%

MOORING IS 97-05C-002A030 DEPTH IS 30 METERS THERE ARE 744 VALUES

FIRST DAY 1998/03/01/0000
FINAL DAY 1998/03/31/2300

SHORELINE ORIENTATION IN DEGREES TRUE SPECIFIED AS 90

DIRECTION DEG TRUE	PERCENT OBSERVED	TOWARD	TOTAL	LIGHT	MEDIUM	HIGH	MAXIMUM CURRENT CM/S	MEAN DURA- TION HOURS	MEAN EXCUR- SION KM	MEAN CURRENT CM/S	MEAN TEMP DEG C
90.0	4.4	1.7	2.7	0.0	6.4	1.4	0.2	3.3	2.6		
45.0	34.0	2.8	9.3	21.9	72.0	3.5	1.9	14.9	2.3		
0.0	24.9	1.7	8.2	14.9	32.8	2.6	1.0	10.5	2.3		
315.0	4.0	1.1	2.0	0.9	17.8	1.4	0.3	5.6	2.5		
270.0	3.4	0.9	1.2	1.2	24.2	1.4	0.4	7.1	2.7		
225.0	11.0	1.5	7.0	2.6	31.4	2.0	0.6	8.8	2.7		
180.0	12.2	1.6	9.5	1.1	8.5	2.0	0.3	4.7	2.7		
135.0	6.0	1.6	4.0	0.4	7.6	1.6	0.2	4.1	2.7		
0		MEAN SCALAR SPEED = 10.1 CM/S		MEAN SQUARE SPEED = 198.4 CM2/S2							
		MEAN SQUARE E-W SPEED = 50.5 CM2/S2		MEAN SQUARE N-S SPEED = 147.9 CM2/S2							
		MEAN VELOCITY = 6.0 CM/S,		23 DEG TRUE		MEAN TEMPERATURE = 2.5 C					
		VARIANCE (U,V) = 81.5 CM2/S2		TOTAL HOURS = 744.							

PERCENT OBSERVED

LIGHT (0.0 - 3.0) 13.0% MEDIUM (3.0 - 7.0) 44.0% HIGH (GE 7.0) 43.0%

DATE: 1998/04/01 TO 1998/04/30
ROSE SUMMARY: WIND AND CURRENT

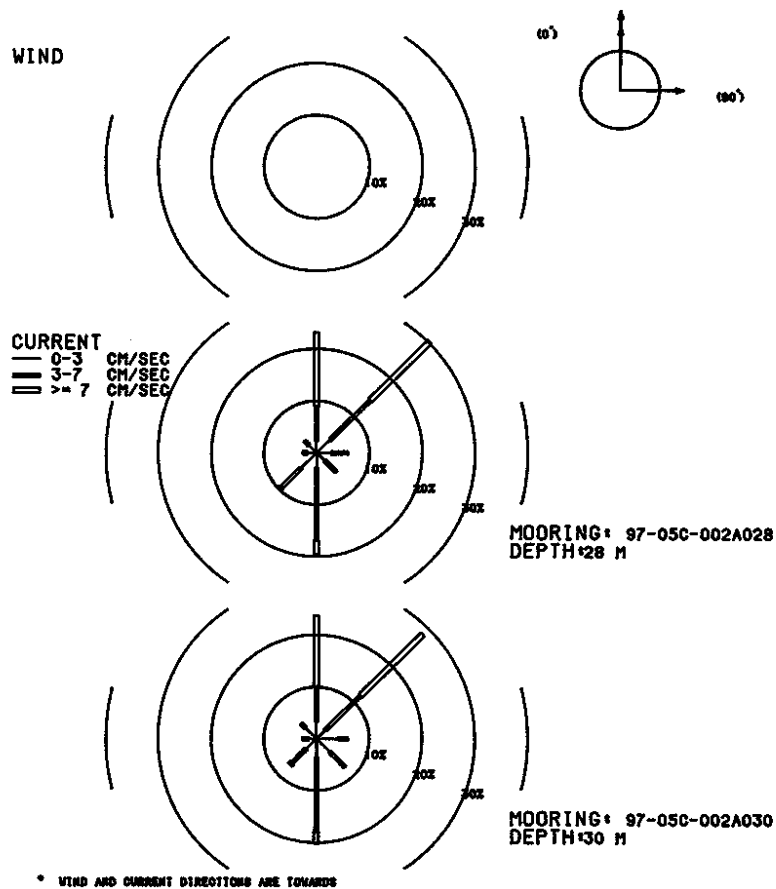

MOORING IS 97-05C-002A028 DEPTH IS 28 METERS THERE ARE 337 VALUES

FIRST DAY 1998/04/01/0000
FINAL DAY 1998/04/15/0000

SHORELINE ORIENTATION IN DEGREES TRUE SPECIFIED AS 90

DIRECTION DEG TRUE	PERCENT OBSERVED	MAXIMUM CURRENT	MEAN DURATION HOURS	MEAN EXCURSION KM	MEAN CURRENT CM/S	MEAN TEMP DEG C
TOWARD	TOTAL	LIGHT	MEDIUM	HIGH	CM/S	
90.0	5.9	2.7	3.3	0.0	6.5	1.3
45.0	30.3	3.6	10.7	16.0	28.9	3.3
0.0	23.1	2.4	6.5	14.2	29.3	3.2
315.0	3.3	2.1	1.2	0.0	5.9	1.1
270.0	2.7	1.8	0.9	0.0	5.7	1.3
225.0	9.8	4.2	5.3	0.3	7.0	1.6
180.0	19.6	3.0	13.9	2.7	10.1	3.7
135.0	5.3	2.1	3.3	0.0	5.8	1.3
MEAN SCALAR SPEED = 7.6 CM/S		MEAN SQUARE SPEED = 101.2 CM2/S2				
MEAN SQUARE E-W SPEED = 18.4 CM2/S2		MEAN SQUARE N-S SPEED = 82.8 CM2/S2				
MEAN VELOCITY = 4.5 CM/S,		29 DEG TRUE		MEAN TEMPERATURE = 3.6 C		
VARIANCE (U,V) = 40.8 CM2/S2		TOTAL HOURS = 337.				

PERCENT OBSERVED
 LIGHT (0.0 - 3.0) 21.7% MEDIUM (3.0 - 7.0) 45.1% HIGH (GE 7.0) 33.2%

MOORING IS 97-05C-002A030 DEPTH IS 30 METERS THERE ARE 337 VALUES

FIRST DAY 1998/04/01/0000
FINAL DAY 1998/04/15/0000

SHORELINE ORIENTATION IN DEGREES TRUE SPECIFIED AS 90

DIRECTION DEG TRUE	PERCENT OBSERVED	MAXIMUM CURRENT	MEAN DURATION HOURS	MEAN EXCURSION KM	MEAN CURRENT CM/S	MEAN TEMP DEG C
TOWARD	TOTAL	LIGHT	MEDIUM	HIGH	CM/S	
90.0	5.9	4.2	1.8	0.0	5.5	1.2
45.0	28.5	2.4	9.5	16.6	29.4	2.8
0.0	23.7	3.3	6.8	13.6	30.8	2.6
315.0	4.2	3.0	1.2	0.0	4.7	1.2
270.0	2.7	1.5	1.2	0.0	5.3	1.1
225.0	7.1	2.7	3.9	0.6	7.8	1.1
180.0	20.2	3.6	14.2	2.4	8.1	3.1
135.0	7.7	3.6	4.2	0.0	5.3	1.7
MEAN SCALAR SPEED = 7.6 CM/S		MEAN SQUARE SPEED = 103.3 CM2/S2				
MEAN SQUARE E-W SPEED = 18.5 CM2/S2		MEAN SQUARE N-S SPEED = 84.9 CM2/S2				
MEAN VELOCITY = 4.5 CM/S,		29 DEG TRUE		MEAN TEMPERATURE = 3.6 C		
VARIANCE (U,V) = 41.5 CM2/S2		TOTAL HOURS = 337.				

PERCENT OBSERVED
 LIGHT (0.0 - 3.0) 24.0% MEDIUM (3.0 - 7.0) 42.7% HIGH (GE 7.0) 33.2%

DATE: 1997/11/02 TO 1997/11/30
 ROSE SUMMARY: WIND AND CURRENT

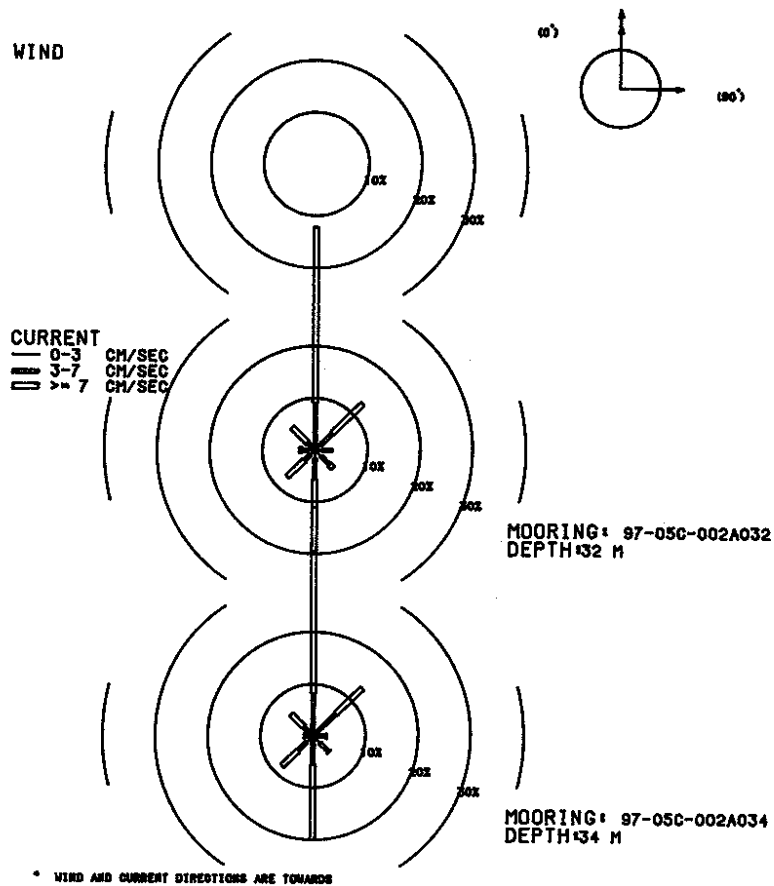

MOORING IS 97-05C-002A032 DEPTH IS 32 METERS THERE ARE 691 VALUES

FIRST DAY 1997/11/02/0500
 FINAL DAY 1997/11/30/2300

SHORELINE ORIENTATION IN DEGREES TRUE SPECIFIED AS 90

DIRECTION DEG TRUE	PERCENT OBSERVED	MAXIMUM CURRENT	MEAN DURA- TION HOURS	MEAN EXCUR- SION KM	MEAN CURRENT CM/S	MEAN TEMP DEG C
TOWARD	TOTAL	LIGHT	MEDIUM	HIGH	CM/S	
90.0	3.3	1.3	2.0	0.0	6.6	1.4
45.0	12.7	1.3	3.2	8.2	32.9	1.8
0.0	42.8	0.4	8.7	33.7	35.5	5.7
315.0	6.2	0.6	1.4	4.2	16.5	2.9
270.0	3.0	1.3	1.2	0.6	10.1	1.5
225.0	7.4	1.3	1.4	4.6	17.0	1.6
180.0	19.5	1.6	4.1	13.9	20.6	3.6
135.0	4.9	1.7	2.2	1.0	8.1	1.7

MEAN SCALAR SPEED = 11.0 CM/S MEAN SQUARE SPEED = 175.9 CM2/S2
 MEAN SQUARE E-W SPEED = 16.7 CM2/S2 MEAN SQUARE N-S SPEED = 159.2 CM2/S2
 MEAN VELOCITY = 5.2 CM/S, 7 DEG TRUE MEAN TEMPERATURE = 8.4 C
 VARIANCE(U,V) = 74.7 CM2/S2 TOTAL HOURS = 691.

PERCENT OBSERVED
 LIGHT (0.0 - 3.0) 9.6% MEDIUM (3.0 - 7.0) 24.2% HIGH (GE 7.0) 66.3%

MOORING IS 97-05C-002A034 DEPTH IS 34 METERS THERE ARE 691 VALUES

FIRST DAY 1997/11/02/0500
 FINAL DAY 1997/11/30/2300

SHORELINE ORIENTATION IN DEGREES TRUE SPECIFIED AS 90

DIRECTION DEG TRUE	PERCENT OBSERVED	MAXIMUM CURRENT	MEAN DURA- TION HOURS	MEAN EXCUR- SION KM	MEAN CURRENT CM/S	MEAN TEMP DEG C
TOWARD	TOTAL	LIGHT	MEDIUM	HIGH	CM/S	
90.0	2.6	0.7	1.7	0.1	7.6	1.6
45.0	13.2	1.3	4.8	7.1	30.2	2.0
0.0	44.0	0.7	7.5	35.7	36.8	6.6
315.0	5.9	0.7	1.7	3.5	16.5	2.7
270.0	1.7	0.6	1.0	0.1	8.3	1.2
225.0	8.2	1.7	2.2	4.3	16.3	2.2
180.0	20.0	0.7	4.8	14.5	20.6	4.5
135.0	4.3	1.9	2.3	0.1	8.0	1.2

MEAN SCALAR SPEED = 11.0 CM/S MEAN SQUARE SPEED = 174.2 CM2/S2
 MEAN SQUARE E-W SPEED = 15.8 CM2/S2 MEAN SQUARE N-S SPEED = 158.4 CM2/S2
 MEAN VELOCITY = 5.1 CM/S, 7 DEG TRUE MEAN TEMPERATURE = 8.4 C
 VARIANCE(U,V) = 74.1 CM2/S2 TOTAL HOURS = 691.

PERCENT OBSERVED
 LIGHT (0.0 - 3.0) 8.4% MEDIUM (3.0 - 7.0) 26.0% HIGH (GE 7.0) 65.6%

DATE: 1997/12/01 TO 1997/12/31
ROSE SUMMARY: WIND AND CURRENT

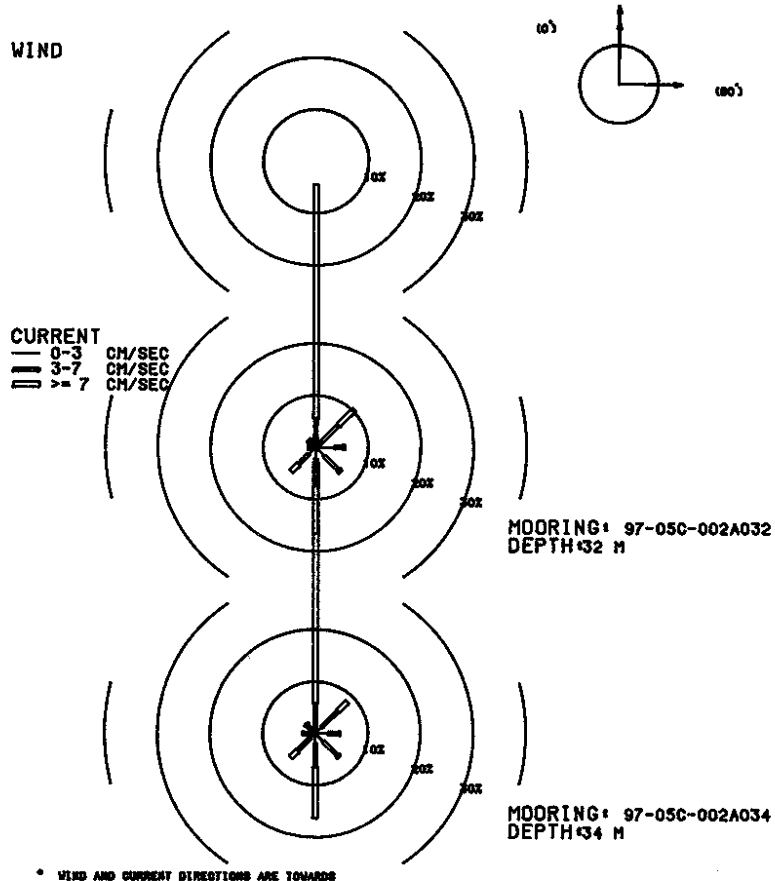

MOORING IS 97-05C-002A032 DEPTH IS 32 METERS THERE ARE 744 VALUES

FIRST DAY 1997/12/01/0000
FINAL DAY 1997/12/31/2300

SHORELINE ORIENTATION IN DEGREES TRUE SPECIFIED AS 90

DIRECTION DEG TRUE	PERCENT OBSERVED	MAXIMUM CURRENT			MEAN DURA- TION HOURS	MEAN EXCUR- SION KM	MEAN CURRENT CM/S	MEAN TEMP DEG C	
TOWARD	TOTAL	LIGHT	MEDIUM	HIGH	CM/S				
90.0	5.6	3.5	1.6	0.5	10.1	1.3	0.2	3.2	5.7
45.0	10.3	0.9	5.1	4.3	15.6	1.6	0.4	7.1	5.7
0.0	50.5	1.3	4.2	45.0	39.7	9.0	5.7	17.7	5.6
315.0	2.0	1.1	0.7	0.3	13.0	1.1	0.1	3.7	6.0
270.0	1.5	0.5	0.7	0.3	9.2	1.2	0.2	4.5	5.7
225.0	6.6	1.9	2.7	2.0	15.7	1.8	0.4	6.0	5.8
180.0	16.7	2.2	5.2	9.3	18.2	3.4	1.0	7.8	5.6
135.0	6.7	2.3	3.9	0.5	9.2	1.7	0.2	3.9	5.1
0	MEAN SCALAR SPEED = 11.9 CM/S		MEAN SQUARE SPEED = 230.0 CM2/S2						
	MEAN SQUARE E-W SPEED = 10.9 CM2/S2		MEAN SQUARE N-S SPEED = 219.1 CM2/S2						
	MEAN VELOCITY = 7.8 CM/S,		10 DEG TRUE MEAN TEMPERATURE = 5.6 C						
	VARIANCE (U,V) = 84.7 CM2/S2		TOTAL HOURS = 744.						

PERCENT OBSERVED
LIGHT (0.0 - 3.0) 13.7% MEDIUM (3.0 - 7.0) 24.1% HIGH (GE 7.0) 62.2%

MOORING IS 97-05C-002A034 DEPTH IS 34 METERS THERE ARE 744 VALUES

FIRST DAY 1997/12/01/0000
FINAL DAY 1997/12/31/2300

SHORELINE ORIENTATION IN DEGREES TRUE SPECIFIED AS 90

DIRECTION DEG TRUE	PERCENT OBSERVED	MAXIMUM CURRENT			MEAN DURA- TION HOURS	MEAN EXCUR- SION KM	MEAN CURRENT CM/S	MEAN TEMP DEG C	
TOWARD	TOTAL	LIGHT	MEDIUM	HIGH	CM/S				
90.0	4.7	2.4	2.2	0.1	9.2	1.5	0.2	3.4	5.6
45.0	8.6	1.6	4.4	2.6	16.6	1.7	0.4	5.9	5.7
0.0	52.2	0.7	5.1	46.4	38.5	10.8	6.8	17.5	5.6
315.0	2.6	1.5	0.7	0.4	10.6	1.1	0.1	3.4	5.6
270.0	2.6	1.1	1.5	0.0	5.7	1.6	0.2	3.5	5.4
225.0	6.6	1.2	3.5	1.9	16.5	2.0	0.5	6.2	5.8
180.0	16.4	1.9	4.6	9.9	18.4	4.4	1.3	8.0	5.6
135.0	6.5	2.2	3.8	0.5	9.8	1.8	0.3	4.1	5.2
0	MEAN SCALAR SPEED = 12.0 CM/S		MEAN SQUARE SPEED = 230.1 CM2/S2						
	MEAN SQUARE E-W SPEED = 10.4 CM2/S2		MEAN SQUARE N-S SPEED = 219.7 CM2/S2						
	MEAN VELOCITY = 7.8 CM/S,		10 DEG TRUE MEAN TEMPERATURE = 5.6 C						
	VARIANCE (U,V) = 85.1 CM2/S2		TOTAL HOURS = 744.						

PERCENT OBSERVED
LIGHT (0.0 - 3.0) 12.5% MEDIUM (3.0 - 7.0) 25.7% HIGH (GE 7.0) 61.8%

DATE: 1998/01/01 TO 1998/01/31
ROSE SUMMARY: WIND AND CURRENT

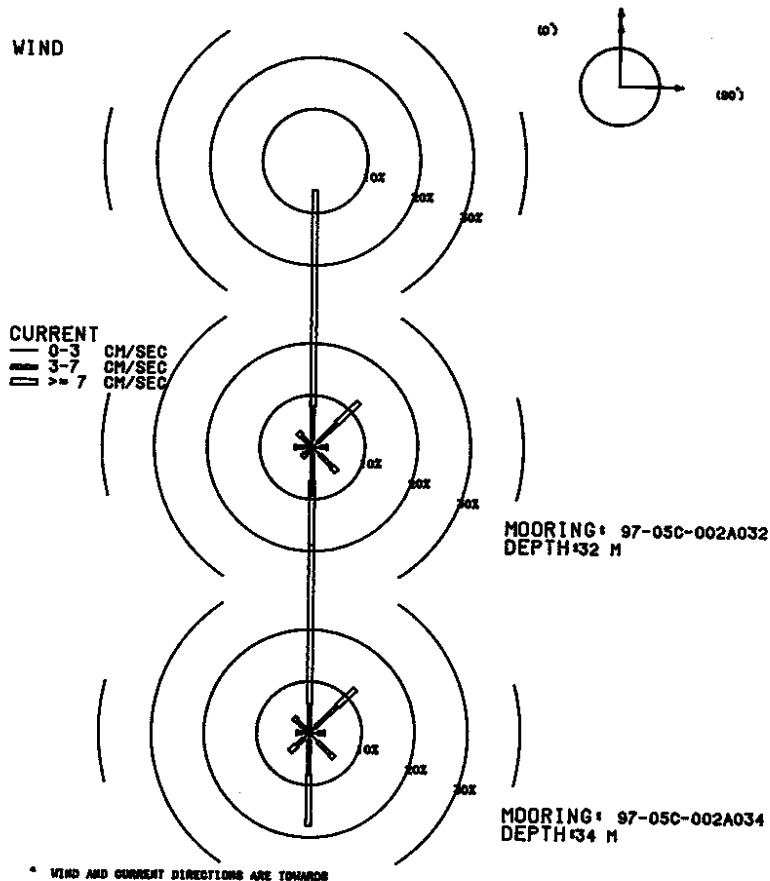

MOORING IS 97-05C-002A032 DEPTH IS 32 METERS THERE ARE 744 VALUES

FIRST DAY 1998/01/01/0000
FINAL DAY 1998/01/31/2300

SHORELINE ORIENTATION IN DEGREES TRUE SPECIFIED AS 90

DIRECTION DEG TRUE	PERCENT OBSERVED	TOWARD	TOTAL	LIGHT	MEDIUM	HIGH	MAXIMUM CURRENT CM/S	MEAN DURA- TION HOURS	MEAN EXCUR- SION KM	MEAN CURRENT CM/S	MEAN TEMP DEG C
90.0	2.8	1.5	1.2	0.1	7.0	1.3	0.2	3.2	3.6		
45.0	12.4	1.3	5.1	5.9	30.0	2.0	0.6	8.2	3.4		
0.0	49.5	1.6	6.2	41.7	47.9	6.1	3.3	15.2	3.3		
315.0	3.9	0.9	2.0	0.9	13.4	1.4	0.3	5.3	3.1		
270.0	3.4	1.6	1.6	0.1	9.6	1.8	0.2	3.4	3.4		
225.0	2.7	0.7	1.2	0.8	11.5	1.1	0.2	5.1	3.4		
180.0	18.8	1.2	7.9	9.7	15.9	4.0	1.0	6.9	3.0		
135.0	6.6	2.0	3.2	1.3	7.9	1.6	0.3	4.5	3.2		
0		MEAN SCALAR SPEED = 10.6 CM/S		MEAN SQUARE SPEED = 187.8 CM2/S2							
		MEAN SQUARE E-W SPEED = 12.3 CM2/S2		MEAN SQUARE N-S SPEED = 175.6 CM2/S2							
		MEAN VELOCITY = 7.0 CM/S,		14 DEG TRUE		MEAN TEMPERATURE = 3.2 C					
		VARIANCE (U,V) = 69.8 CM2/S2		TOTAL HOURS = 744.							

PERCENT OBSERVED
LIGHT (0.0 - 3.0) 10.9% MEDIUM (3.0 - 7.0) 28.5% HIGH (GE 7.0) 60.6%

MOORING IS 97-05C-002A034 DEPTH IS 34 METERS THERE ARE 744 VALUES

FIRST DAY 1998/01/01/0000
FINAL DAY 1998/01/31/2300

SHORELINE ORIENTATION IN DEGREES TRUE SPECIFIED AS 90

DIRECTION DEG TRUE	PERCENT OBSERVED	TOWARD	TOTAL	LIGHT	MEDIUM	HIGH	MAXIMUM CURRENT CM/S	MEAN DURA- TION HOURS	MEAN EXCUR- SION KM	MEAN CURRENT CM/S	MEAN TEMP DEG C
90.0	3.0	1.6	1.2	0.1	7.0	1.2	0.1	3.4	3.3		
45.0	12.2	1.6	5.8	4.8	27.0	1.9	0.5	7.0	3.3		
0.0	48.7	0.3	5.4	43.0	49.1	7.9	4.5	15.7	3.3		
315.0	4.2	0.7	2.7	0.8	12.1	1.6	0.3	4.9	3.2		
270.0	2.4	1.5	0.8	0.1	8.0	1.6	0.2	3.3	3.4		
225.0	5.1	1.6	1.7	1.7	15.5	1.5	0.3	5.7	3.5		
180.0	17.7	1.3	6.7	9.7	15.0	3.7	0.9	7.1	3.0		
135.0	6.7	2.3	3.4	1.1	9.1	1.7	0.3	4.5	3.3		
0		MEAN SCALAR SPEED = 10.8 CM/S		MEAN SQUARE SPEED = 191.4 CM2/S2							
		MEAN SQUARE E-W SPEED = 11.9 CM2/S2		MEAN SQUARE N-S SPEED = 179.5 CM2/S2							
		MEAN VELOCITY = 6.8 CM/S,		13 DEG TRUE		MEAN TEMPERATURE = 3.2 C					
		VARIANCE (U,V) = 72.4 CM2/S2		TOTAL HOURS = 744.							

PERCENT OBSERVED
LIGHT (0.0 - 3.0) 10.9% MEDIUM (3.0 - 7.0) 27.7% HIGH (GE 7.0) 61.4%

DATE: 1998/02/01 TO 1998/02/28
ROSE SUMMARY: WIND AND CURRENT

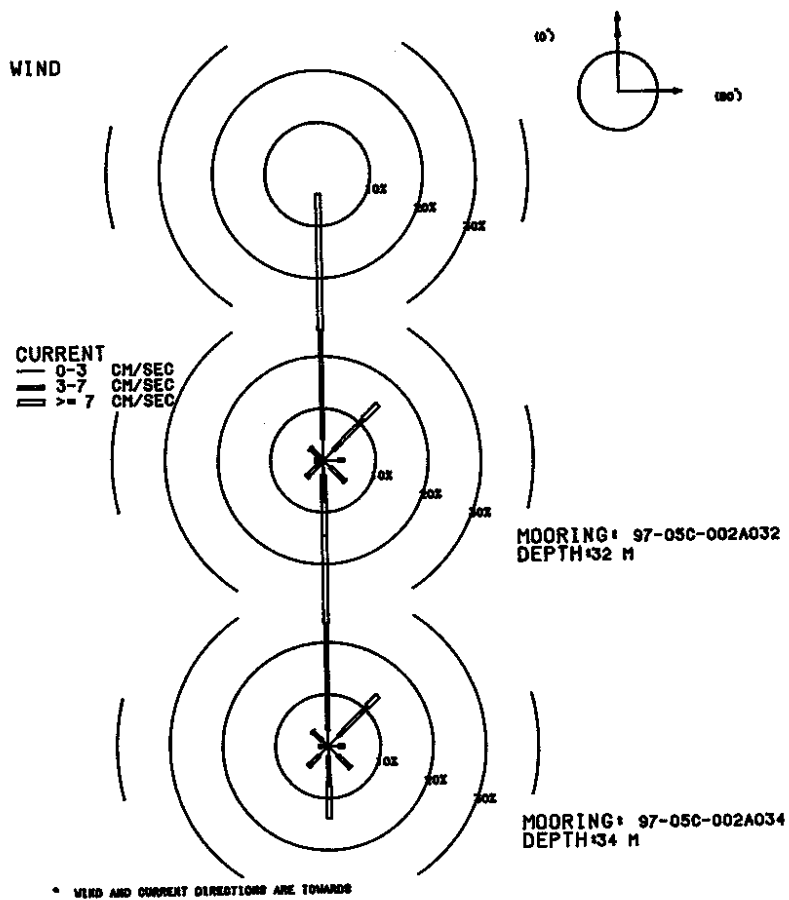

MOORING IS 97-05C-002A032 DEPTH IS 32 METERS THERE ARE 672 VALUES

FIRST DAY 1998/02/01/0000
FINAL DAY 1998/02/28/2300

SHORELINE ORIENTATION IN DEGREES TRUE SPECIFIED AS 90

DIRECTION DEG TRUE	PERCENT OBSERVED	MAXIMUM CURRENT	MEAN DURA- TION HOURS	MEAN EXCUR- SION KM	MEAN CURRENT CM/S	MEAN TEMP DEG C
TOWARD	TOTAL	LIGHT	MEDIUM	HIGH	CM/S	
90.0	4.0	2.8	1.2	0.0	4.6	1.2
45.0	15.0	2.8	8.2	4.0	13.7	1.7
0.0	51.2	4.2	20.8	26.2	22.0	5.3
315.0	3.4	0.7	2.4	0.3	12.3	1.2
270.0	1.5	0.7	0.6	0.1	10.4	1.0
225.0	4.5	1.2	2.8	0.4	10.6	1.8
180.0	14.6	2.8	5.1	6.7	12.8	3.6
135.0	5.8	1.9	3.7	0.1	7.3	1.9
0	MEAN SCALAR SPEED = 6.7 CM/S		MEAN SQUARE SPEED = 61.6 CM ² /S ²			
	MEAN SQUARE E-W SPEED = 5.3 CM ² /S ²		MEAN SQUARE N-S SPEED = 56.2 CM ² /S ²			
	MEAN VELOCITY = 3.8 CM/S,		13 DEG TRUE		MEAN TEMPERATURE = 2.3 C	
	VARIANCE (U,V) = 23.6 CM ² /S ²		TOTAL HOURS = 672.			

PERCENT OBSERVED
LIGHT (0.0 - 3.0) 17.3% MEDIUM (3.0 - 7.0) 44.8% HIGH (GE 7.0) 37.9%

MOORING IS 97-05C-002A034 DEPTH IS 34 METERS THERE ARE 672 VALUES

FIRST DAY 1998/02/01/0000
FINAL DAY 1998/02/28/2300

SHORELINE ORIENTATION IN DEGREES TRUE SPECIFIED AS 90

DIRECTION DEG TRUE	PERCENT OBSERVED	MAXIMUM CURRENT	MEAN DURA- TION HOURS	MEAN EXCUR- SION KM	MEAN CURRENT CM/S	MEAN TEMP DEG C
TOWARD	TOTAL	LIGHT	MEDIUM	HIGH	CM/S	
90.0	3.1	1.9	1.2	0.0	4.8	1.4
45.0	13.5	2.8	7.9	2.8	11.5	1.9
0.0	52.2	3.1	20.5	28.6	20.3	6.4
315.0	4.2	1.5	2.5	0.1	7.9	1.8
270.0	1.8	1.2	0.6	0.0	4.0	1.0
225.0	5.4	2.5	2.2	0.6	8.5	2.0
180.0	13.8	1.9	5.7	6.2	13.7	3.7
135.0	6.0	2.5	3.1	0.3	8.0	2.0
0	MEAN SCALAR SPEED = 6.7 CM/S		MEAN SQUARE SPEED = 62.4 CM ² /S ²			
	MEAN SQUARE E-W SPEED = 4.9 CM ² /S ²		MEAN SQUARE N-S SPEED = 57.5 CM ² /S ²			
	MEAN VELOCITY = 3.8 CM/S,		13 DEG TRUE		MEAN TEMPERATURE = 2.3 C	
	VARIANCE (U,V) = 24.0 CM ² /S ²		TOTAL HOURS = 672.			

PERCENT OBSERVED
LIGHT (0.0 - 3.0) 17.6% MEDIUM (3.0 - 7.0) 43.8% HIGH (GE 7.0) 38.7%

DATE: 1998/03/01 TO 1998/03/31
ROSE SUMMARY: WIND AND CURRENT

WIND

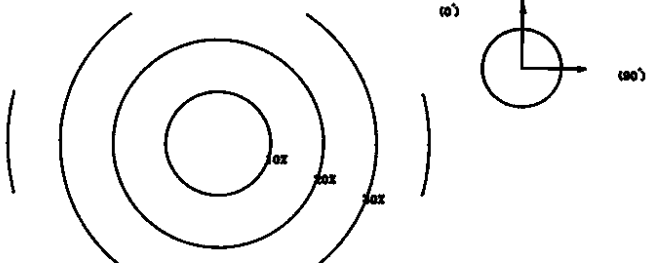

CURRENT
 0-3 CH/SEC
 3-7 CH/SEC
 >=7 CH/SEC

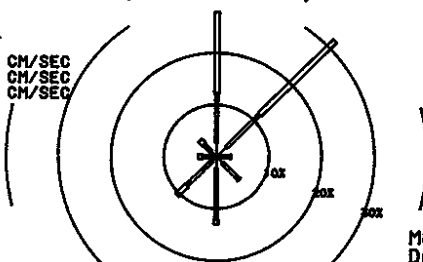

MOORING: 97-05C-002A032
DEPTH 32 M

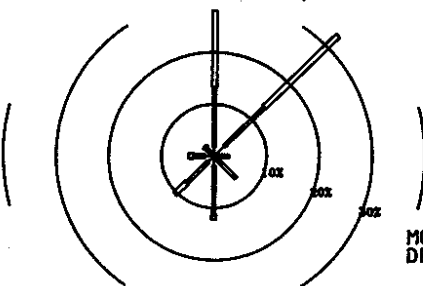

MOORING: 97-05C-002A034
DEPTH 34 M

* WIND AND CURRENT DIRECTIONS ARE TOWARDS

MOORING IS 97-05C-002A032 DEPTH IS 32 METERS THERE ARE 744 VALUES

FIRST DAY 1998/03/01/0000
FINAL DAY 1998/03/31/2300

SHORELINE ORIENTATION IN DEGREES TRUE SPECIFIED AS 90

DIRECTION DEG TRUE	PERCENT OBSERVED	TOWARD	TOTAL	LIGHT	MEDIUM	HIGH	MAXIMUM CURRENT CM/S	MEAN DURA- TION HOURS	MEAN EXCUR- SION KM	MEAN CURRENT CM/S	MEAN TEMP DEG C
90.0	2.8	0.8	1.9	0.1			7.3	1.5	0.2	4.1	2.6
45.0	31.7	2.6	9.0	20.2			72.0	3.5	2.0	15.4	2.3
0.0	27.8	2.7	9.5	15.6			33.3	3.1	1.1	9.9	2.3
315.0	4.4	1.5	1.9	1.1			19.6	2.1	0.4	5.5	2.6
270.0	3.5	0.9	1.7	0.8			21.8	1.4	0.3	6.2	2.7
225.0	10.5	1.1	6.7	2.7			31.8	2.2	0.7	9.2	2.7
180.0	13.0	2.2	9.9	0.9			10.2	2.3	0.4	4.7	2.8
135.0	6.2	1.6	4.4	0.1			7.1	1.7	0.2	4.0	2.7

MEAN SCALAR SPEED = 10.1 CM/S MEAN SQUARE SPEED = 197.6 CM2/S2
 MEAN SQUARE E-W SPEED = 49.9 CM2/S2 MEAN SQUARE N-S SPEED = 147.6 CM2/S2
 MEAN VELOCITY = 5.9 CM/S, 21 DEG TRUE MEAN TEMPERATURE = 2.5 C
 VARIANCE (U,V) = 81.6 CM2/S2 TOTAL HOURS = 744.

PERCENT OBSERVED
 LIGHT (0.0 - 3.0) 13.3% MEDIUM (3.0 - 7.0) 45.2% HIGH (GE 7.0) 41.5%

MOORING IS 97-05C-002A034 DEPTH IS 34 METERS THERE ARE 744 VALUES

FIRST DAY 1998/03/01/0000
FINAL DAY 1998/03/31/2300

SHORELINE ORIENTATION IN DEGREES TRUE SPECIFIED AS 90

DIRECTION DEG TRUE	PERCENT OBSERVED	TOWARD	TOTAL	LIGHT	MEDIUM	HIGH	MAXIMUM CURRENT CM/S	MEAN DURA- TION HOURS	MEAN EXCUR- SION KM	MEAN CURRENT CM/S	MEAN TEMP DEG C
90.0	2.8	0.8	2.0	0.0			6.9	1.2	0.2	3.8	2.7
45.0	33.1	2.7	10.8	19.6			73.9	3.5	1.9	14.8	2.3
0.0	28.0	1.7	11.6	14.7			30.4	3.2	1.2	10.2	2.3
315.0	2.6	0.5	1.7	0.3			20.3	1.1	0.2	5.9	2.5
270.0	4.8	1.7	2.2	0.9			22.3	1.6	0.3	5.6	2.7
225.0	10.5	1.5	5.8	3.2			32.0	1.8	0.6	9.2	2.7
180.0	12.2	1.9	9.5	0.8			9.4	1.8	0.3	4.8	2.7
135.0	6.0	1.1	5.0	0.0			6.9	2.0	0.3	4.4	2.7

MEAN SCALAR SPEED = 10.1 CM/S MEAN SQUARE SPEED = 199.7 CM2/S2
 MEAN SQUARE E-W SPEED = 49.5 CM2/S2 MEAN SQUARE N-S SPEED = 150.2 CM2/S2
 MEAN VELOCITY = 5.9 CM/S, 23 DEG TRUE MEAN TEMPERATURE = 2.5 C
 VARIANCE (U,V) = 82.5 CM2/S2 TOTAL HOURS = 744.

PERCENT OBSERVED
 LIGHT (0.0 - 3.0) 12.0% MEDIUM (3.0 - 7.0) 48.5% HIGH (GE 7.0) 39.5%

DATE: 1998/04/01 TO 1998/04/30
 ROSE SUMMARY: WIND AND CURRENT

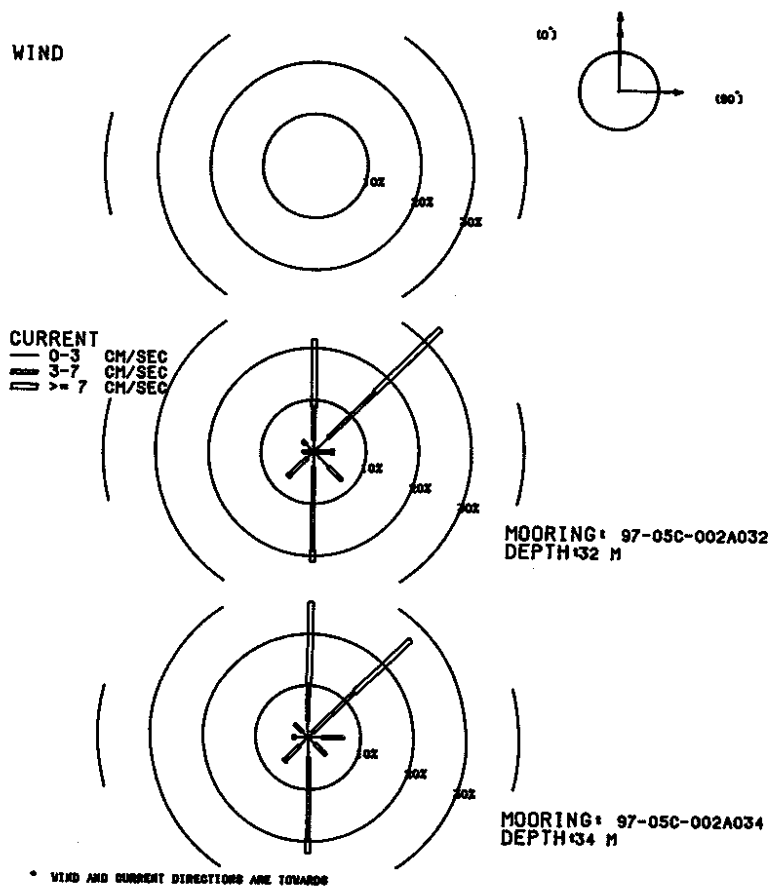

MOORING IS 97-05C-002A032 DEPTH IS 32 METERS THERE ARE 337 VALUES

FIRST DAY 1998/04/01/0000
 FINAL DAY 1998/04/15/0000

SHORELINE ORIENTATION IN DEGREES TRUE SPECIFIED AS 90

DIRECTION DEG TRUE	PERCENT OBSERVED	TOWARD	TOTAL	LIGHT	MEDIUM	HIGH	MAXIMUM CURRENT CM/S	MEAN DURA- TION HOURS	MEAN EXCUR- SION KM	MEAN CURRENT CM/S	MEAN TEMP DEG C
90.0	3.9	0.6	2.7	0.6	8.0	1.2	0.2	4.4	3.6		
45.0	33.8	3.9	12.5	17.5	30.0	3.2	1.2	10.6	3.8		
0.0	21.7	2.4	6.2	13.1	27.3	2.7	1.0	10.3	3.6		
315.0	3.0	2.1	0.9	0.0	5.7	1.4	0.2	3.2	3.5		
270.0	2.1	0.9	1.2	0.0	4.3	1.2	0.1	3.2	3.4		
225.0	6.8	1.8	4.5	0.6	8.7	1.4	0.2	3.9	3.6		
180.0	21.1	3.0	16.0	2.1	9.8	3.2	0.6	4.8	3.6		
135.0	7.7	4.2	3.6	0.0	6.0	1.4	0.2	3.0	3.6		

MEAN SCALAR SPEED = 7.6 CM/S MEAN SQUARE SPEED = 102.6 CM2/S2
 MEAN SQUARE E-W SPEED = 19.0 CM2/S2 MEAN SQUARE N-S SPEED = 83.6 CM2/S2
 MEAN VELOCITY = 4.5 CM/S, 31 DEG TRUE MEAN TEMPERATURE = 3.6 C
 VARIANCE (U,V) = 41.2 CM2/S2 TOTAL HOURS = 337.

PERCENT OBSERVED
 LIGHT (0.0 - 3.0) 18.7% MEDIUM (3.0 - 7.0) 47.5% HIGH (GE 7.0) 33.8%

MOORING IS 97-05C-002A034 DEPTH IS 34 METERS THERE ARE 337 VALUES

FIRST DAY 1998/04/01/0000
 FINAL DAY 1998/04/15/0000

SHORELINE ORIENTATION IN DEGREES TRUE SPECIFIED AS 90

DIRECTION DEG TRUE	PERCENT OBSERVED	TOWARD	TOTAL	LIGHT	MEDIUM	HIGH	MAXIMUM CURRENT CM/S	MEAN DURA- TION HOURS	MEAN EXCUR- SION KM	MEAN CURRENT CM/S	MEAN TEMP DEG C
90.0	6.8	2.7	4.2	0.0	6.7	1.8	0.2	3.5	3.7		
45.0	27.0	1.2	11.3	14.5	29.5	3.6	1.5	11.3	3.8		
0.0	26.1	3.3	7.1	15.7	30.1	3.5	1.3	10.5	3.6		
315.0	3.6	1.5	2.1	0.0	6.2	1.0	0.1	3.0	3.4		
270.0	3.0	2.4	0.6	0.0	5.0	1.2	0.1	2.1	3.5		
225.0	6.5	2.4	3.9	0.3	7.0	1.6	0.2	3.9	3.6		
180.0	22.3	3.9	15.7	2.7	8.8	3.6	0.6	5.0	3.6		
135.0	4.7	1.8	3.0	0.0	6.5	1.3	0.2	3.5	3.6		

MEAN SCALAR SPEED = 7.7 CM/S MEAN SQUARE SPEED = 103.2 CM2/S2
 MEAN SQUARE E-W SPEED = 18.5 CM2/S2 MEAN SQUARE N-S SPEED = 84.7 CM2/S2
 MEAN SQUARE U SPEED = 18.5 CM2/S2 MEAN SQUARE V SPEED = 84.7 CM2/S2
 VARIANCE (U,V) = 41.8 CM2/S2 TOTAL HOURS = 337.

PERCENT OBSERVED
 LIGHT (0.0 - 3.0) 19.0% MEDIUM (3.0 - 7.0) 47.8% HIGH (GE 7.0) 33.2%

Appendix E - Mooring_A4-97. Overall Summary Statistics and Rose Histogram Plots

DATE: 1997/11/02 TO 1998/04/15
ROSE SUMMARY: WIND AND CURRENT

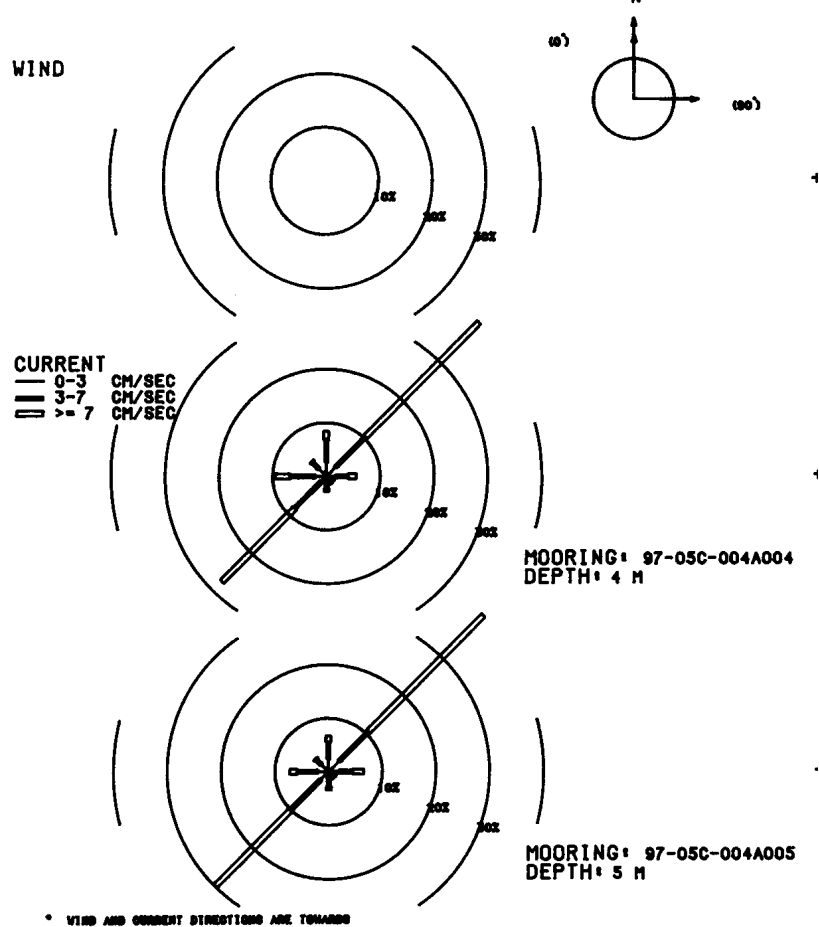

MOORING IS 97-05C-004A004 DEPTH IS 4 METERS THERE ARE 3932 VALUES

FIRST DAY 1997/11/02/0500
FINAL DAY 1998/04/15/0000

SHORELINE ORIENTATION IN DEGREES TRUE SPECIFIED AS 90

DIRECTION DEG TRUE	PERCENT OBSERVED	TOWARD	TOTAL	LIGHT	MEDIUM	HIGH	MAXIMUM CURRENT CM/S	MEAN DURA- TION HOURS	MEAN EXCUR- SION KM	MEAN CURRENT CM/S	MEAN TEMP DEG C
90.0	5.6	1.7	2.3	1.6	18.5	1.6	0.3	5.5	4.6		
45.0	40.4	2.3	8.0	30.1	31.6	7.2	3.0	11.5	4.3		
0.0	8.4	2.6	4.1	1.7	14.5	2.0	0.3	4.7	2.9		
315.0	3.9	1.9	1.7	0.3	12.0	1.5	0.2	3.5	2.8		
270.0	9.6	2.1	4.7	2.8	17.9	2.0	0.4	5.5	3.0		
225.0	27.6	1.5	6.9	19.3	62.9	5.9	2.5	11.6	4.0		
180.0	2.8	0.9	1.4	0.5	18.3	1.7	0.3	4.9	3.9		
135.0	1.6	0.9	0.6	0.1	9.8	1.3	0.1	3.1	3.9		

MEAN SCALAR SPEED = 9.4 CM/S MEAN SQUARE SPEED = 133.8 CM2/S2
 MEAN SQUARE E-W SPEED = 66.1 CM2/S2 MEAN SQUARE N-S SPEED = 67.7 CM2/S2
 MEAN VELOCITY = 1.6 CM/S, 24 DEG TRUE MEAN TEMPERATURE = 3.9 C
 VARIANCE (U,V) = 65.7 CM2/S2 TOTAL HOURS = 3932.

PERCENT OBSERVED
 LIGHT (0.0 - 3.0) 13.8% MEDIUM (3.0 - 7.0) 29.8% HIGH (GE 7.0) 56.3%

MOORING IS 97-05C-004A005 DEPTH IS 5 METERS THERE ARE 3932 VALUES

FIRST DAY 1997/11/02/0500
FINAL DAY 1998/04/15/0000

SHORELINE ORIENTATION IN DEGREES TRUE SPECIFIED AS 90

DIRECTION DEG TRUE	PERCENT OBSERVED	TOWARD	TOTAL	LIGHT	MEDIUM	HIGH	MAXIMUM CURRENT CM/S	MEAN DURA- TION HOURS	MEAN EXCUR- SION KM	MEAN CURRENT CM/S	MEAN TEMP DEG C
90.0	6.6	1.9	2.6	2.1	18.1	1.8	0.4	5.9	4.9		
45.0	41.0	2.7	7.8	30.5	36.3	7.0	2.9	11.8	4.2		
0.0	6.8	2.4	3.2	1.2	18.3	1.6	0.3	4.7	2.9		
315.0	3.5	1.8	1.4	0.3	12.5	1.4	0.2	3.3	2.8		
270.0	7.2	2.0	3.9	1.4	13.7	1.9	0.3	4.8	3.1		
225.0	30.0	2.1	7.9	20.0	61.7	6.8	2.7	11.1	3.9		
180.0	3.5	1.1	1.7	0.7	16.6	1.6	0.3	4.6	3.4		
135.0	1.5	0.8	0.5	0.2	10.7	1.3	0.2	3.4	4.2		

MEAN SCALAR SPEED = 9.5 CM/S MEAN SQUARE SPEED = 139.8 CM2/S2
 MEAN SQUARE E-W SPEED = 71.3 CM2/S2 MEAN SQUARE N-S SPEED = 68.5 CM2/S2
 MEAN VELOCITY = 1.7 CM/S, 43 DEG TRUE MEAN TEMPERATURE = 3.9 C
 VARIANCE (U,V) = 68.5 CM2/S2 TOTAL HOURS = 3932.

PERCENT OBSERVED
 LIGHT (0.0 - 3.0) 14.8% MEDIUM (3.0 - 7.0) 29.0% HIGH (GE 7.0) 56.2%

DATE: 1997/11/02 TO 1998/04/15
ROSE SUMMARY: WIND AND CURRENT

WIND

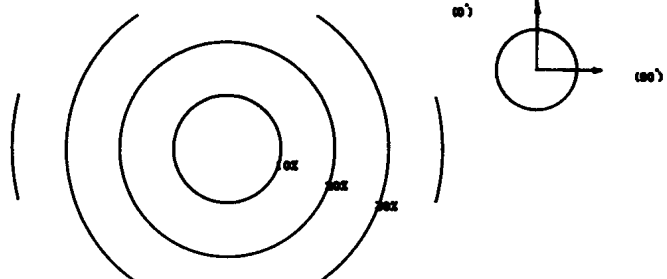

CURRENT
 0-3 CM/SEC
 3-7 CM/SEC
 >= 7 CM/SEC

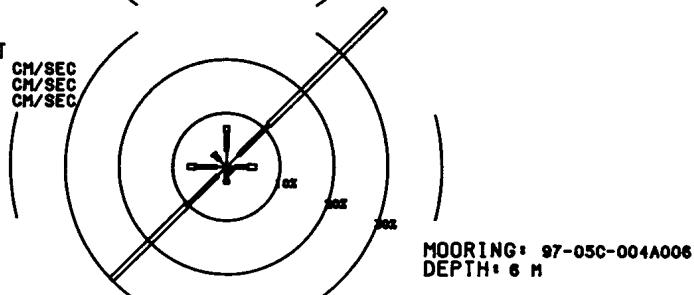

MOORING: 97-05C-004A006
DEPTH: 6 M

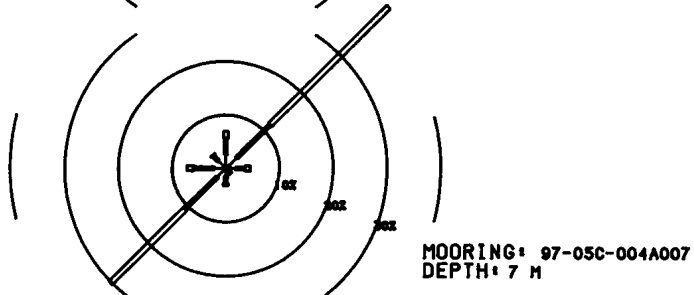

MOORING: 97-05C-004A007
DEPTH: 7 M

* WIND AND CURRENT DIRECTIONS ARE TOWARDS

MOORING IS 97-05C-004A006 DEPTH IS 6 METERS THERE ARE 3932 VALUES

FIRST DAY 1997/11/02/0500
FINAL DAY 1998/04/15/0000

SHORELINE ORIENTATION IN DEGREES TRUE SPECIFIED AS 90

DIRECTION DEG TRUE	PERCENT OBSERVED	MAXIMUM CURRENT	MEAN DURATION HOURS	MEAN EXCURSION KM	MEAN CURRENT CM/S	MEAN TEMP DEG C
TOWARD	TOTAL	LIGHT	MEDIUM	HIGH	CM/S	
90.0	5.5	1.7	2.2	1.7	16.8	1.8
45.0	41.5	3.1	8.0	30.4	34.2	7.7
0.0	7.6	3.0	3.5	1.1	19.0	1.8
315.0	3.4	1.9	1.2	0.3	12.3	1.4
270.0	7.2	1.9	3.9	1.5	17.5	1.7
225.0	30.2	2.4	8.1	19.7	59.3	6.5
180.0	3.1	1.0	1.5	0.6	16.1	1.6
135.0	1.4	1.0	0.3	0.0	8.0	1.2

MEAN SCALAR SPEED = 9.3 CM/S MEAN SQUARE SPEED = 133.5 CM2/S2
 MEAN SQUARE E-W SPEED = 68.5 CM2/S2 MEAN SQUARE N-S SPEED = 65.1 CM2/S2
 MEAN VELOCITY = 1.7 CM/S, 35 DEG TRUE MEAN TEMPERATURE = 3.9 C
 VARIANCE (U,V) = 65.4 CM2/S2 TOTAL HOURS = 3932.

PERCENT OBSERVED
 LIGHT (0.0 - 3.0) 15.8% MEDIUM (3.0 - 7.0) 28.8% HIGH (GE 7.0) 55.3%

MOORING IS 97-05C-004A007 DEPTH IS 7 METERS THERE ARE 3932 VALUES

FIRST DAY 1997/11/02/0500
FINAL DAY 1998/04/15/0000

SHORELINE ORIENTATION IN DEGREES TRUE SPECIFIED AS 90

DIRECTION DEG TRUE	PERCENT OBSERVED	MAXIMUM CURRENT	MEAN DURATION HOURS	MEAN EXCURSION KM	MEAN CURRENT CM/S	MEAN TEMP DEG C
TOWARD	TOTAL	LIGHT	MEDIUM	HIGH	CM/S	
90.0	4.7	1.9	1.7	1.1	15.2	1.6
45.0	42.7	2.7	8.9	31.1	34.0	8.7
0.0	7.0	2.6	3.1	1.2	20.4	1.8
315.0	3.5	2.0	1.3	0.2	11.9	1.4
270.0	7.3	2.2	3.8	1.3	17.7	1.8
225.0	30.2	2.2	8.4	19.6	57.7	7.8
180.0	3.3	1.5	1.3	0.4	11.3	1.6
135.0	1.3	1.0	0.3	0.0	5.4	1.2

MEAN SCALAR SPEED = 9.2 CM/S MEAN SQUARE SPEED = 128.6 CM2/S2
 MEAN SQUARE E-W SPEED = 65.5 CM2/S2 MEAN SQUARE N-S SPEED = 63.1 CM2/S2
 MEAN VELOCITY = 1.7 CM/S, 33 DEG TRUE MEAN TEMPERATURE = 3.9 C
 VARIANCE (U,V) = 62.8 CM2/S2 TOTAL HOURS = 3932.

PERCENT OBSERVED
 LIGHT (0.0 - 3.0) 16.1% MEDIUM (3.0 - 7.0) 28.8% HIGH (GE 7.0) 55.0%

DATE: 1997/11/02 TO 1998/04/15
ROSE SUMMARY: WIND AND CURRENT

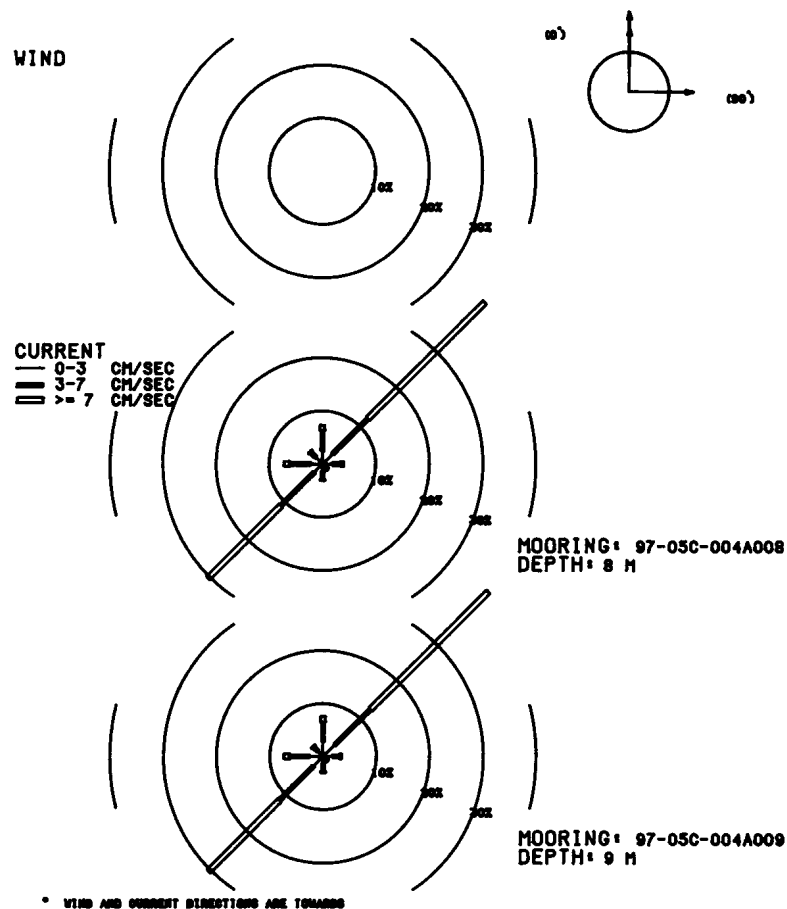

MOORING IS 97-05C-004A008 DEPTH IS 8 METERS THERE ARE 3932 VALUES

FIRST DAY 1997/11/02/0500
FINAL DAY 1998/04/15/0000

SHORELINE ORIENTATION IN DEGREES TRUE SPECIFIED AS 90

DIRECTION DEG TRUE	PERCENT OBSERVED	TOWARD	TOTAL	LIGHT	MEDIUM	HIGH	MAXIMUM CURRENT CM/S	MEAN DURATION HOURS	MEAN EXCURSION KM	MEAN CURRENT CM/S	MEAN TEMP DEG C
90.0	4.0		4.0	1.8	1.5	0.6	13.4	1.4	0.2	4.0	4.5
45.0	43.1		43.1	2.7	9.3	31.1	32.9	8.2	3.3	11.2	4.3
0.0	7.3		7.3	2.4	3.8	1.1	23.3	1.7	0.3	4.6	2.9
315.0	3.3		3.3	1.8	1.4	0.2	11.0	1.6	0.2	3.2	2.8
270.0	7.3		7.3	2.2	4.0	1.1	21.8	1.9	0.3	4.7	3.1
225.0	30.4		30.4	2.2	8.8	19.5	55.1	7.3	2.7	10.4	3.9
180.0	3.1		3.1	1.5	1.4	0.2	9.6	1.5	0.2	3.5	3.6
135.0	1.4		1.4	1.1	0.3	0.0	5.4	1.3	0.1	2.0	3.3
MEAN SCALAR SPEED =		9.1 CM/S		MEAN SQUARE SPEED =		125.9 CM2/S2					
MEAN SQUARE E-W SPEED =		63.8 CM2/S2		MEAN SQUARE N-S SPEED =		62.1 CM2/S2					
MEAN VELOCITY =		1.8 CM/S,		28 DEG TRUE		MEAN TEMPERATURE =		3.9 C			
VARIANCE (U,V) =		61.4 CM2/S2		TOTAL HOURS =		3932.					

PERCENT OBSERVED
LIGHT (0.0 - 3.0) 15.6% MEDIUM (3.0 - 7.0) 30.6% HIGH (GE 7.0) 53.8%

MOORING IS 97-05C-004A009 DEPTH IS 9 METERS THERE ARE 3932 VALUES

FIRST DAY 1997/11/02/0500
FINAL DAY 1998/04/15/0000

SHORELINE ORIENTATION IN DEGREES TRUE SPECIFIED AS 90

DIRECTION DEG TRUE	PERCENT OBSERVED	TOWARD	TOTAL	LIGHT	MEDIUM	HIGH	MAXIMUM CURRENT CM/S	MEAN DURATION HOURS	MEAN EXCURSION KM	MEAN CURRENT CM/S	MEAN TEMP DEG C
90.0	3.5		3.5	1.8	1.3	0.5	13.6	1.3	0.2	3.8	4.3
45.0	43.9		43.9	3.1	9.5	31.3	33.9	8.4	3.3	11.0	4.3
0.0	7.6		7.6	2.8	3.6	1.1	19.0	1.7	0.3	4.4	2.9
315.0	2.7		2.7	1.4	1.1	0.2	11.1	1.3	0.2	3.5	2.8
270.0	7.4		7.4	2.6	3.7	1.2	23.3	1.8	0.3	4.4	3.2
225.0	30.5		30.5	2.5	9.0	18.9	55.0	7.2	2.6	10.1	3.8
180.0	3.1		3.1	1.4	1.4	0.3	12.0	1.4	0.2	3.9	4.0
135.0	1.2		1.2	1.0	0.2	0.0	5.5	1.1	0.1	2.1	3.5
MEAN SCALAR SPEED =		8.9 CM/S		MEAN SQUARE SPEED =		122.6 CM2/S2					
MEAN SQUARE E-W SPEED =		61.3 CM2/S2		MEAN SQUARE N-S SPEED =		61.3 CM2/S2					
MEAN VELOCITY =		1.8 CM/S,		28 DEG TRUE		MEAN TEMPERATURE =		3.9 C			
VARIANCE (U,V) =		59.7 CM2/S2		TOTAL HOURS =		3932.					

PERCENT OBSERVED
LIGHT (0.0 - 3.0) 16.6% MEDIUM (3.0 - 7.0) 29.8% HIGH (GE 7.0) 53.6%

DATE: 1997/11/02 TO 1998/04/15
ROSE SUMMARY: WIND AND CURRENT

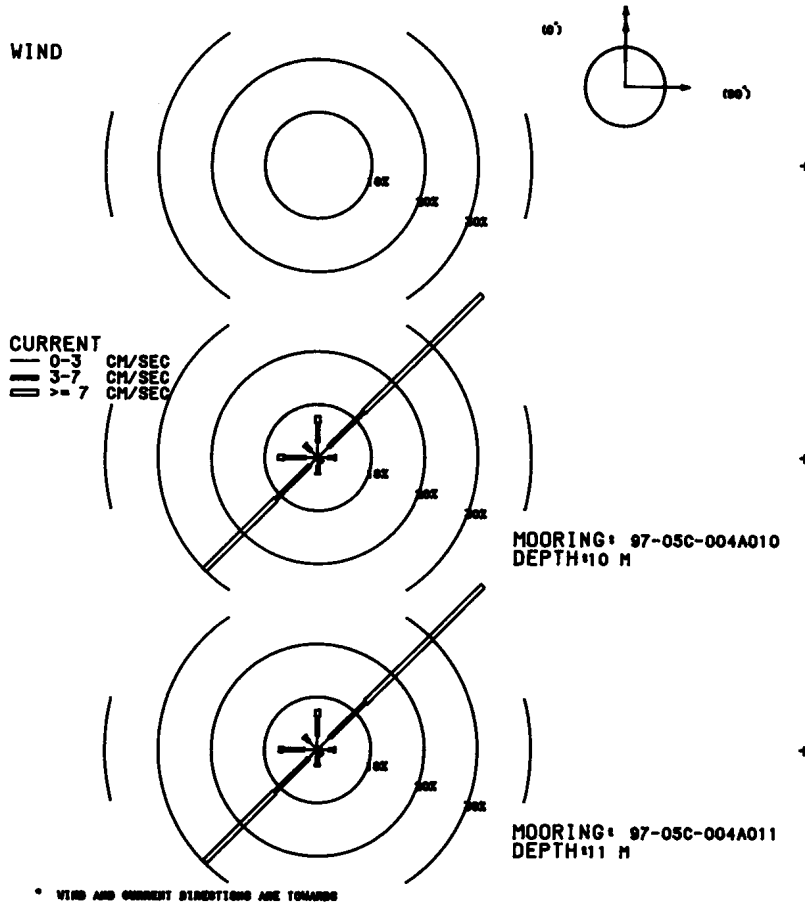

MOORING IS 97-05C-004A010 DEPTH IS 10 METERS THERE ARE 3932 VALUES

FIRST DAY 1997/11/02/0500
FINAL DAY 1998/04/15/0000

SHORELINE ORIENTATION IN DEGREES TRUE SPECIFIED AS 90

DIRECTION DEG TRUE	PERCENT OBSERVED	TOWARD	TOTAL	LIGHT	MEDIUM	HIGH	MAXIMUM CURRENT CM/S	MEAN DURA- TION HOURS	MEAN EXCUR- SION KM	MEAN CURRENT CM/S	MEAN TEMP DEG C
90.0	3.4	1.9	1.2	0.3			13.0	1.4	0.2	3.2	3.7
45.0	43.5	2.8	9.3	31.4			33.4	8.9	3.5	10.9	4.3
0.0	7.8	2.8	3.6	1.3			24.1	1.8	0.3	4.6	3.0
315.0	3.4	1.8	1.4	0.2			11.2	1.5	0.2	3.3	2.9
270.0	7.5	2.3	4.0	1.2			19.1	1.8	0.3	4.6	3.2
225.0	30.0	2.1	9.0	18.9			55.4	6.9	2.5	10.2	3.9
180.0	3.1	1.6	1.3	0.2			13.5	1.3	0.2	3.4	3.7
135.0	1.2	1.0	0.2	0.0			4.6	1.2	0.1	1.9	3.6
MEAN SCALAR SPEED =		8.9 CM/S		MEAN SQUARE SPEED =		120.4 CM2/S2					
MEAN SQUARE E-W SPEED =		59.0 CM2/S2		MEAN SQUARE N-S SPEED =		61.4 CM2/S2					
MEAN VELOCITY =		1.8 CM/S,		24 DEG TRUE		MEAN TEMPERATURE =		3.9 C			
VARIANCE (U,V) =		58.6 CM2/S2		TOTAL HOURS =		3932.					

PERCENT OBSERVED
LIGHT (0.0 - 3.0) 16.4% MEDIUM (3.0 - 7.0) 30.1% HIGH (GE 7.0) 53.5%

MOORING IS 97-05C-004A011 DEPTH IS 11 METERS THERE ARE 3932 VALUES

FIRST DAY 1997/11/02/0500
FINAL DAY 1998/04/15/0000

SHORELINE ORIENTATION IN DEGREES TRUE SPECIFIED AS 90

DIRECTION DEG TRUE	PERCENT OBSERVED	TOWARD	TOTAL	LIGHT	MEDIUM	HIGH	MAXIMUM CURRENT CM/S	MEAN DURA- TION HOURS	MEAN EXCUR- SION KM	MEAN CURRENT CM/S	MEAN TEMP DEG C
90.0	3.4	2.2	0.9	0.3			12.9	1.3	0.1	3.0	3.3
45.0	43.8	3.2	9.5	31.1			33.1	9.3	3.6	10.7	4.3
0.0	7.6	2.6	3.6	1.3			22.4	1.8	0.3	4.6	3.0
315.0	3.6	2.2	1.1	0.3			13.5	1.4	0.2	3.1	3.0
270.0	7.3	2.5	4.0	0.9			18.2	1.8	0.3	4.3	3.1
225.0	29.9	2.2	9.0	18.6			54.2	6.9	2.5	10.1	3.8
180.0	3.1	1.3	1.4	0.4			13.3	1.4	0.2	4.0	4.1
135.0	1.3	1.1	0.2	0.0			4.1	1.1	0.1	2.1	3.2
MEAN SCALAR SPEED =		8.7 CM/S		MEAN SQUARE SPEED =		117.6 CM2/S2					
MEAN SQUARE E-W SPEED =		56.7 CM2/S2		MEAN SQUARE N-S SPEED =		60.9 CM2/S2					
MEAN VELOCITY =		1.8 CM/S,		25 DEG TRUE		MEAN TEMPERATURE =		3.9 C			
VARIANCE (U,V) =		57.2 CM2/S2		TOTAL HOURS =		3932.					

PERCENT OBSERVED
LIGHT (0.0 - 3.0) 17.4% MEDIUM (3.0 - 7.0) 29.8% HIGH (GE 7.0) 52.8%

DATE: 1997/11/02 TO 1998/04/15
ROSE SUMMARY: WIND AND CURRENT

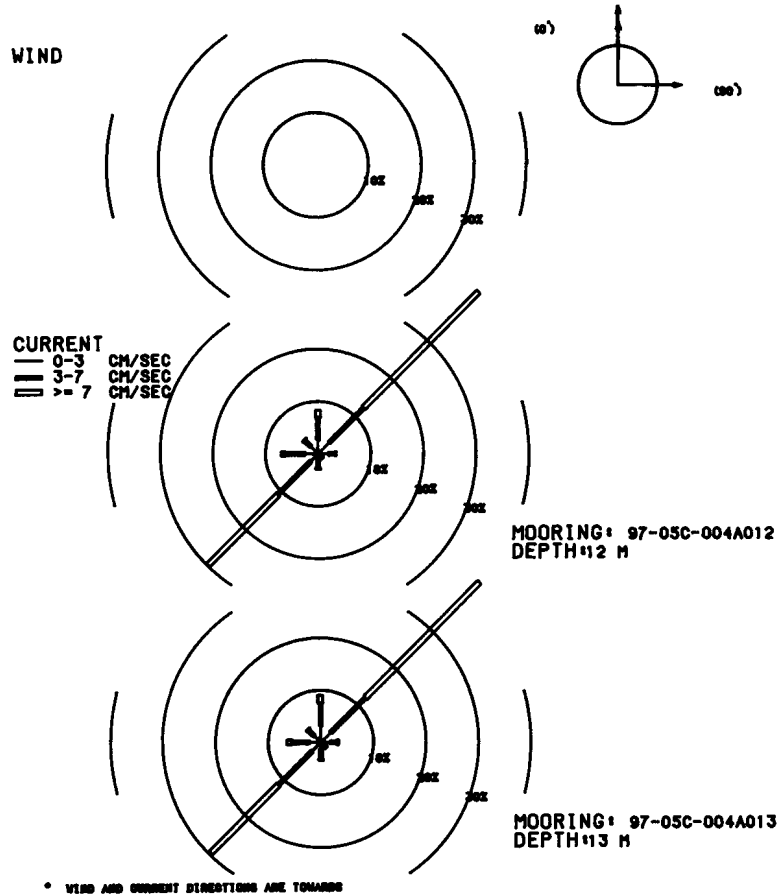

MOORING IS 97-05C-004A012 DEPTH IS 12 METERS THERE ARE 3932 VALUES

FIRST DAY 1997/11/02/0500
FINAL DAY 1998/04/15/0000

SHORELINE ORIENTATION IN DEGREES TRUE SPECIFIED AS 90

DIRECTION DEG TRUE	PERCENT OBSERVED			MAXIMUM CURRENT CM/S	MEAN DURA- TION HOURS	MEAN EXCUR- SION KM	MEAN CURRENT CM/S	MEAN TEMP DEG C
TOWARD	TOTAL	LIGHT	MEDIUM	HIGH	CM/S			
90.0	3.4	2.0	1.3	0.1	10.0	1.3	0.1	2.9
45.0	43.5	3.0	9.2	31.3	32.4	8.5	3.3	10.8
0.0	8.3	2.6	4.3	1.4	21.0	1.7	0.3	4.6
315.0	3.8	2.0	1.6	0.2	12.1	1.5	0.2	3.2
270.0	7.0	2.4	3.9	0.7	19.7	1.8	0.3	4.3
225.0	29.9	2.0	8.7	19.1	55.1	6.9	2.5	10.1
180.0	3.0	1.3	1.4	0.3	11.9	1.3	0.2	3.9
135.0	1.2	1.1	0.1	0.0	3.9	1.1	0.1	1.9
0	MEAN SCALAR SPEED = 8.7 CM/S		MEAN SQUARE SPEED = 116.6 CM2/S2					
	MEAN SQUARE E-W SPEED = 55.5 CM2/S2		MEAN SQUARE N-S SPEED = 61.1 CM2/S2					
	MEAN VELOCITY = 1.9 CM/S,		22 DEG TRUE		MEAN TEMPERATURE = 3.9 C			
	VARIANCE (U,V) = 56.6 CM2/S2		TOTAL HOURS = 3932.					

PERCENT OBSERVED
LIGHT (0.0 - 3.0) 16.4% MEDIUM (3.0 - 7.0) 30.5% HIGH (GE 7.0) 53.1%

MOORING IS 97-05C-004A013 DEPTH IS 13 METERS THERE ARE 3932 VALUES

FIRST DAY 1997/11/02/0500
FINAL DAY 1998/04/15/0000

SHORELINE ORIENTATION IN DEGREES TRUE SPECIFIED AS 90

DIRECTION DEG TRUE	PERCENT OBSERVED			MAXIMUM CURRENT CM/S	MEAN DURA- TION HOURS	MEAN EXCUR- SION KM	MEAN CURRENT CM/S	MEAN TEMP DEG C
TOWARD	TOTAL	LIGHT	MEDIUM	HIGH	CM/S			
90.0	3.4	1.7	1.3	0.3	12.2	1.4	0.2	3.4
45.0	43.0	2.5	9.4	31.0	32.8	8.1	3.1	10.7
0.0	9.1	3.2	4.3	1.6	22.4	1.8	0.3	4.5
315.0	3.5	1.7	1.6	0.2	11.0	1.5	0.2	3.2
270.0	6.5	2.1	3.3	1.0	19.5	1.7	0.3	4.5
225.0	29.7	2.3	9.0	18.3	53.2	6.8	2.4	9.9
180.0	3.5	1.4	1.8	0.3	13.4	1.4	0.2	3.9
135.0	1.4	1.2	0.2	0.0	4.8	1.3	0.1	2.1
0	MEAN SCALAR SPEED = 8.6 CM/S		MEAN SQUARE SPEED = 113.6 CM2/S2					
	MEAN SQUARE E-W SPEED = 52.9 CM2/S2		MEAN SQUARE N-S SPEED = 60.7 CM2/S2					
	MEAN VELOCITY = 1.9 CM/S,		24 DEG TRUE		MEAN TEMPERATURE = 3.9 C			
	VARIANCE (U,V) = 55.1 CM2/S2		TOTAL HOURS = 3932.					

PERCENT OBSERVED
LIGHT (0.0 - 3.0) 16.2% MEDIUM (3.0 - 7.0) 31.1% HIGH (GE 7.0) 52.7%

DATE: 1997/11/02 TO 1998/04/15
 ROSE SUMMARY: WIND AND CURRENT

WIND

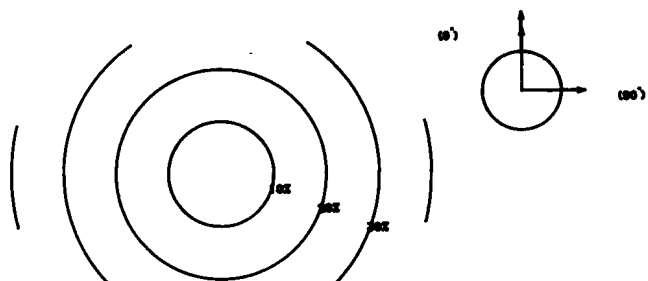

CURRENT
 — 0-3 CM/SEC
 = 3-7 CM/SEC
 ≡ >= 7 CM/SEC

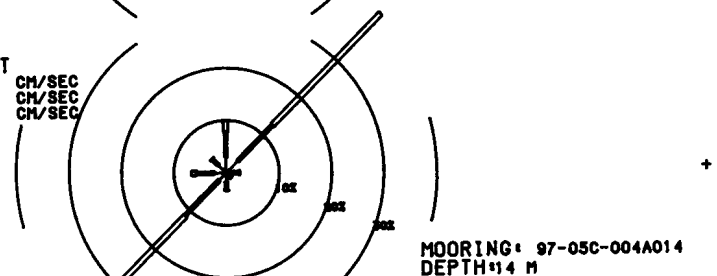

MOORING: 97-05C-004A014
 DEPTH: 14 M

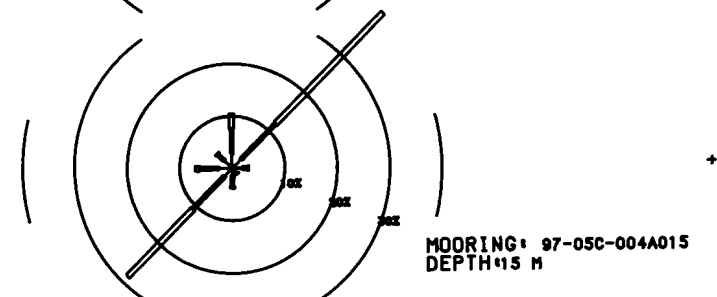

MOORING: 97-05C-004A015
 DEPTH: 15 M

* WIND AND CURRENT DIRECTIONS ARE TOWARDS

MOORING IS 97-05C-004A014 DEPTH IS 14 METERS THERE ARE 3932 VALUES

FIRST DAY 1997/11/02/0500
 FINAL DAY 1998/04/15/0000

SHORELINE ORIENTATION IN DEGREES TRUE SPECIFIED AS 90

DIRECTION DEG TRUE	PERCENT OBSERVED	MAXIMUM CURRENT CM/S	MEAN DURA- TION HOURS	MEAN EXCUR- SION KM	MEAN CURRENT CM/S	MEAN TEMP DEG C
TOWARD	TOTAL	LIGHT	MEDIUM	HIGH		
90.0	2.5	1.2	1.2	0.2	9.2	1.3
45.0	42.3	3.1	9.6	29.7	33.9	7.6
0.0	10.0	3.0	4.8	2.2	23.7	1.9
315.0	3.8	2.1	1.6	0.2	10.4	1.4
270.0	6.7	2.2	3.5	1.0	16.7	1.9
225.0	29.8	1.9	9.4	18.4	53.6	7.8
180.0	3.4	1.7	1.5	0.2	12.9	1.3
135.0	1.4	1.2	0.2	0.0	5.4	1.0

MEAN SCALAR SPEED = 8.6 CM/S MEAN SQUARE SPEED = 112.1 CM2/S2
 MEAN SQUARE E-W SPEED = 51.0 CM2/S2 MEAN SQUARE N-S SPEED = 61.2 CM2/S2
 MEAN VELOCITY = 1.9 CM/S, 18 DEG TRUE MEAN TEMPERATURE = 3.9 C
 VARIANCE (U,V) = 54.3 CM2/S2 TOTAL HOURS = 3932.

PERCENT OBSERVED
 LIGHT (0.0 - 3.0) 16.4% MEDIUM (3.0 - 7.0) 31.7% HIGH (GE 7.0) 51.8%

MOORING IS 97-05C-004A015 DEPTH IS 15 METERS THERE ARE 3932 VALUES

FIRST DAY 1997/11/02/0500
 FINAL DAY 1998/04/15/0000

SHORELINE ORIENTATION IN DEGREES TRUE SPECIFIED AS 90

DIRECTION DEG TRUE	PERCENT OBSERVED	MAXIMUM CURRENT CM/S	MEAN DURA- TION HOURS	MEAN EXCUR- SION KM	MEAN CURRENT CM/S	MEAN TEMP DEG C
TOWARD	TOTAL	LIGHT	MEDIUM	HIGH		
90.0	3.1	1.9	1.1	0.1	11.6	1.2
45.0	41.3	2.4	9.4	29.6	33.7	7.4
0.0	10.5	2.8	4.9	2.8	22.9	1.9
315.0	4.0	2.1	1.8	0.2	12.1	1.3
270.0	7.1	2.5	3.6	1.0	18.6	1.8
225.0	28.6	2.1	8.7	17.9	53.7	6.4
180.0	3.8	1.5	2.0	0.4	11.4	1.5
135.0	1.5	1.3	0.2	0.0	5.2	1.2

MEAN SCALAR SPEED = 8.5 CM/S MEAN SQUARE SPEED = 109.1 CM2/S2
 MEAN SQUARE E-W SPEED = 48.1 CM2/S2 MEAN SQUARE N-S SPEED = 61.0 CM2/S2
 MEAN VELOCITY = 2.0 CM/S, 16 DEG TRUE MEAN TEMPERATURE = 3.9 C
 VARIANCE (U,V) = 52.7 CM2/S2 TOTAL HOURS = 3932.

PERCENT OBSERVED
 LIGHT (0.0 - 3.0) 16.5% MEDIUM (3.0 - 7.0) 31.6% HIGH (GE 7.0) 51.9%

Appendix F - Mooring_A4-97. Monthly Summary Statistics and Rose Histogram Plots

DATE: 1997/11/02 TO 1997/11/30
 ROSE SUMMARY: WIND AND CURRENT

WIND

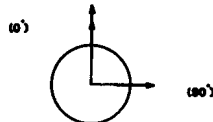
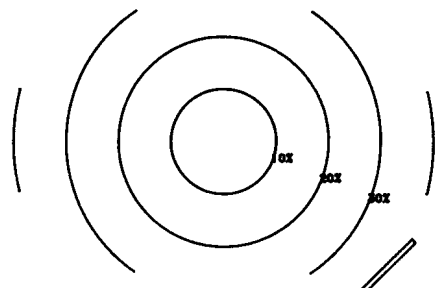

CURRENT
 — 0-3 CM/SEC
 = 3-7 CM/SEC
 >= 7 CM/SEC

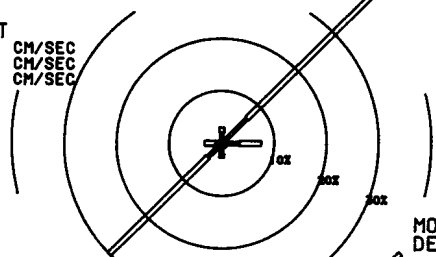

MOORING: 97-05C-004A004
 DEPTH: 4 M

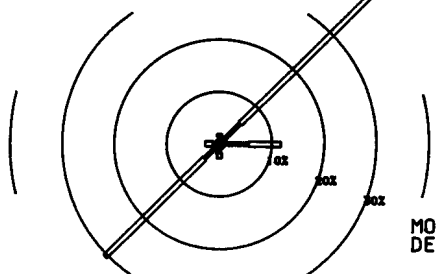

MOORING: 97-05C-004A005
 DEPTH: 5 M

* WIND AND CURRENT DIRECTIONS ARE TOWARDS

MOORING IS 97-05C-004A004 DEPTH IS 4 METERS THERE ARE 691 VALUES

FIRST DAY 1997/11/02/0500
 FINAL DAY 1997/11/30/2300

SHORELINE ORIENTATION IN DEGREES TRUE SPECIFIED AS 90

DIRECTION DEG TRUE	TOWARD	PERCENT OBSERVED	LIGHT	MEDIUM	HIGH	MAXIMUM CURRENT CM/S	MEAN DURA- TION HOURS	MEAN EXCUR- SION KM	MEAN CURRENT CM/S	MEAN TEMP DEG C
90.0	7.5	1.0	2.3	4.2	17.5	1.6	0.4	7.9	8.4	
45.0	51.5	0.3	6.4	44.9	30.0	9.4	4.6	13.7	8.4	
0.0	3.0	0.4	1.6	1.0	11.2	2.1	0.5	6.1	7.9	
315.0	0.7	0.4	0.3	0.0	3.7	1.2	0.1	2.5	8.4	
270.0	3.3	0.4	0.7	2.2	10.8	1.5	0.4	7.2	8.1	
225.0	30.1	0.3	3.3	26.5	31.0	9.9	5.1	14.3	8.8	
180.0	2.7	0.3	1.7	0.7	18.3	1.9	0.4	6.2	8.4	
135.0	1.0	0.4	0.6	0.0	6.8	1.4	0.2	3.2	8.3	

0 MEAN SCALAR SPEED = 12.6 CM/S MEAN SQUARE SPEED = 199.9 CM2/S2
 MEAN SQUARE E-W SPEED = 98.1 CM2/S2 MEAN SQUARE N-S SPEED = 101.8 CM2/S2
 MEAN VELOCITY = 3.0 CM/S, 50 DEG TRUE MEAN TEMPERATURE = 8.5 C
 VARIANCE (U,V) = 95.5 CM2/S2 TOTAL HOURS = 691.

PERCENT OBSERVED
 LIGHT (0.0 - 3.0) 3.6% MEDIUM (3.0 - 7.0) 16.9% HIGH (GE 7.0) 79.5%

MOORING IS 97-05C-004A005 DEPTH IS 5 METERS THERE ARE 691 VALUES

FIRST DAY 1997/11/02/0500
 FINAL DAY 1997/11/30/2300

SHORELINE ORIENTATION IN DEGREES TRUE SPECIFIED AS 90

DIRECTION DEG TRUE	TOWARD	PERCENT OBSERVED	LIGHT	MEDIUM	HIGH	MAXIMUM CURRENT CM/S	MEAN DURA- TION HOURS	MEAN EXCUR- SION KM	MEAN CURRENT CM/S	MEAN TEMP DEG C
90.0	11.7	0.7	4.8	6.2	18.1	2.3	0.7	7.8	8.1	
45.0	48.5	0.3	5.2	43.0	31.6	8.2	4.3	14.6	8.4	
0.0	1.9	0.4	1.0	0.4	14.5	1.2	0.2	5.5	7.7	
315.0	0.9	0.4	0.4	0.0	4.5	1.2	0.1	2.7	7.5	
270.0	2.7	0.3	0.9	1.6	12.0	1.7	0.4	7.1	7.7	
225.0	30.5	0.4	3.5	26.6	30.5	9.6	4.7	13.7	8.8	
180.0	2.7	0.3	1.4	1.0	15.5	1.4	0.3	6.4	8.4	
135.0	1.0	0.4	0.3	0.3	10.7	1.2	0.2	4.9	8.6	

0 MEAN SCALAR SPEED = 12.7 CM/S MEAN SQUARE SPEED = 204.7 CM2/S2
 MEAN SQUARE E-W SPEED = 107.2 CM2/S2 MEAN SQUARE N-S SPEED = 97.5 CM2/S2
 MEAN VELOCITY = 3.5 CM/S, 61 DEG TRUE MEAN TEMPERATURE = 8.5 C
 VARIANCE (U,V) = 96.3 CM2/S2 TOTAL HOURS = 691.

PERCENT OBSERVED
 LIGHT (0.0 - 3.0) 3.3% MEDIUM (3.0 - 7.0) 17.5% HIGH (GE 7.0) 79.2%

DATE: 1997/12/01 TO 1997/12/31
 ROSE SUMMARY: WIND AND CURRENT

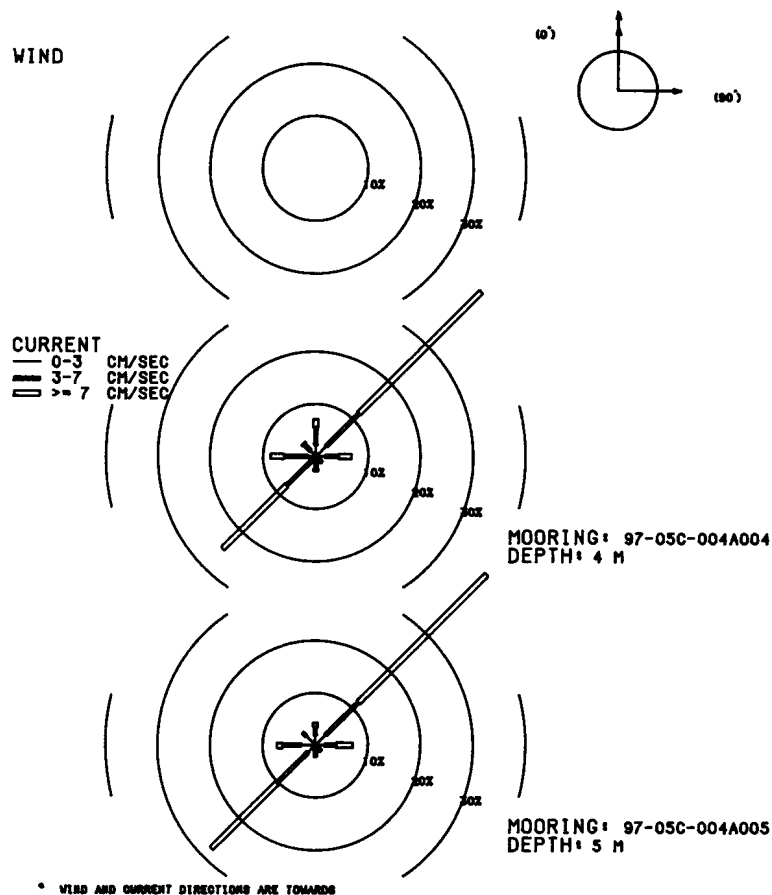

MOORING IS 97-05C-004A004 DEPTH IS 4 METERS THERE ARE 744 VALUES

FIRST DAY 1997/12/01/0000
 FINAL DAY 1997/12/31/2300

SHORELINE ORIENTATION IN DEGREES TRUE SPECIFIED AS 90

DIRECTION DEG TRUE	PERCENT OBSERVED	TOWARD	TOTAL	LIGHT	MEDIUM	HIGH	MAXIMUM CURRENT CM/S	MEAN DURATION HOURS	MEAN EXCURSION KM	MEAN CURRENT CM/S	MEAN TEMP DEG C
90.0	6.9	1.7	2.6	2.6	2.6	16.0	1.6	0.4	6.4	5.2	
45.0	44.5	2.7	8.9	32.9	31.6	6.8	2.6	10.9	4.3	4.3	
0.0	7.1	2.2	3.4	1.6	11.9	1.7	0.3	4.8	3.7	3.7	
315.0	3.5	1.5	1.6	0.4	10.4	1.4	0.2	3.9	4.6	4.6	
270.0	8.6	1.5	4.4	2.7	17.9	1.8	0.4	6.0	4.3	4.3	
225.0	25.0	1.1	6.7	17.2	30.0	5.6	2.1	10.6	4.5	4.5	
180.0	2.8	0.5	1.9	0.4	9.5	1.9	0.4	5.1	4.5	4.5	
135.0	1.6	0.8	0.8	0.0	5.7	1.2	0.1	2.9	5.6	5.6	
0		MEAN SCALAR SPEED = 9.1 CM/S		MEAN SQUARE SPEED = 115.5 CM2/S2							
		MEAN SQUARE E-W SPEED = 63.2 CM2/S2		MEAN SQUARE N-S SPEED = 52.3 CM2/S2							
		MEAN VELOCITY = 2.3 CM/S,		32 DEG TRUE		MEAN TEMPERATURE = 4.4 C					
		VARIANCE (U,V) = 55.1 CM2/S2		TOTAL HOURS = 744.							

PERCENT OBSERVED
 LIGHT (0.0 - 3.0) 12.0% MEDIUM (3.0 - 7.0) 30.2% HIGH (GE 7.0) 57.8%

MOORING IS 97-05C-004A005 DEPTH IS 5 METERS THERE ARE 744 VALUES

FIRST DAY 1997/12/01/0000
 FINAL DAY 1997/12/31/2300

SHORELINE ORIENTATION IN DEGREES TRUE SPECIFIED AS 90

DIRECTION DEG TRUE	PERCENT OBSERVED	TOWARD	TOTAL	LIGHT	MEDIUM	HIGH	MAXIMUM CURRENT CM/S	MEAN DURATION HOURS	MEAN EXCURSION KM	MEAN CURRENT CM/S	MEAN TEMP DEG C
90.0	7.1	1.7	2.2	3.2	17.7	1.7	0.4	7.0	5.3	5.3	
45.0	46.1	2.7	8.9	34.5	34.3	7.1	2.9	11.3	4.2	4.2	
0.0	4.3	1.9	1.6	0.8	11.4	1.1	0.2	4.5	4.0	4.0	
315.0	3.4	2.4	0.9	0.0	4.9	1.4	0.1	2.3	4.3	4.3	
270.0	7.4	2.7	3.5	1.2	13.7	1.8	0.3	4.7	4.2	4.2	
225.0	27.8	1.9	8.3	17.6	30.4	6.1	2.2	10.2	4.6	4.6	
180.0	2.3	0.8	1.5	0.0	6.9	1.3	0.2	3.3	4.4	4.4	
135.0	1.6	0.9	0.7	0.0	6.6	1.5	0.2	3.0	5.8	5.8	
0		MEAN SCALAR SPEED = 9.3 CM/S		MEAN SQUARE SPEED = 125.9 CM2/S2							
		MEAN SQUARE E-W SPEED = 69.7 CM2/S2		MEAN SQUARE N-S SPEED = 56.2 CM2/S2							
		MEAN VELOCITY = 2.6 CM/S,		46 DEG TRUE		MEAN TEMPERATURE = 4.4 C					
		VARIANCE (U,V) = 59.8 CM2/S2		TOTAL HOURS = 744.							

PERCENT OBSERVED
 LIGHT (0.0 - 3.0) 15.1% MEDIUM (3.0 - 7.0) 27.6% HIGH (GE 7.0) 57.4%

DATE: 1998/01/01 TO 1998/01/31
ROSE SUMMARY: WIND AND CURRENT

WIND

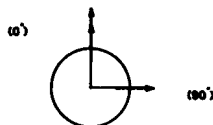
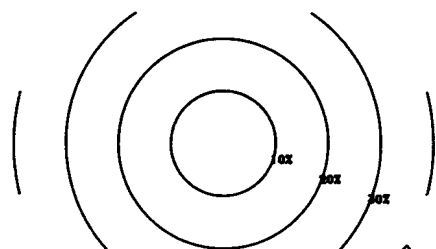

CURRENT
 0-3 CM/SEC
 3-7 CM/SEC
 >= 7 CM/SEC

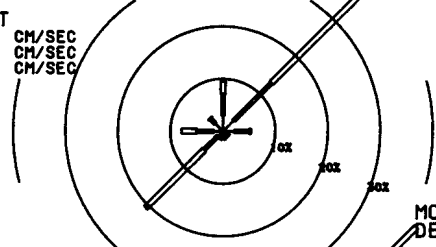

MOORING: 97-05C-004A004
DEPTH: 4 M

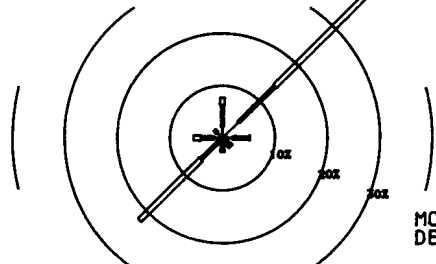

MOORING: 97-05C-004A005
DEPTH: 5 M

* WIND AND CURRENT DIRECTIONS ARE TOWARDS

MOORING IS 97-05C-004A004 DEPTH IS 4 METERS THERE ARE 744 VALUES

FIRST DAY 1998/01/01/0000
FINAL DAY 1998/01/31/2300

SHORELINE ORIENTATION IN DEGREES TRUE SPECIFIED AS 90

DIRECTION DEG TRUE	PERCENT OBSERVED	TOWARD	TOTAL	LIGHT	MEDIUM	HIGH	MAXIMUM CURRENT CM/S	MEAN DURATION HOURS	MEAN EXCURSION KM	MEAN CURRENT CM/S	MEAN TEMP DEG C
90.0	5.4	2.2	2.8	0.4			12.2	1.4	0.2	3.7	1.4
45.0	50.0	2.8	10.2	37.0			30.1	7.8	3.3	11.9	1.8
0.0	9.5	3.0	4.2	2.4			13.2	2.0	0.4	5.0	1.7
315.0	3.5	2.0	1.2	0.3			9.0	1.4	0.2	3.2	1.7
270.0	7.9	1.7	3.2	3.0			11.7	2.0	0.4	5.9	1.5
225.0	20.7	1.3	3.6	15.7			25.1	5.3	2.3	11.8	1.7
180.0	1.6	0.8	0.7	0.1			7.4	1.2	0.2	3.8	1.8
135.0	1.3	0.5	0.7	0.1			9.8	1.2	0.2	4.4	2.0

MEAN SCALAR SPEED = 9.8 CM/S MEAN SQUARE SPEED = 134.3 CM2/S2
 MEAN SQUARE E-W SPEED = 68.5 CM2/S2 MEAN SQUARE N-S SPEED = 65.8 CM2/S2
 MEAN VELOCITY = 3.7 CM/S, 29 DEG TRUE MEAN TEMPERATURE = 1.7 C
 VARIANCE(U,V) = 60.3 CM2/S2 TOTAL HOURS = 744.

PERCENT OBSERVED
 LIGHT (0.0 - 3.0) 14.4% MEDIUM (3.0 - 7.0) 26.6% HIGH (GE 7.0) 59.0%

MOORING IS 97-05C-004A005 DEPTH IS 5 METERS THERE ARE 744 VALUES

FIRST DAY 1998/01/01/0000
FINAL DAY 1998/01/31/2300

SHORELINE ORIENTATION IN DEGREES TRUE SPECIFIED AS 90

DIRECTION DEG TRUE	PERCENT OBSERVED	TOWARD	TOTAL	LIGHT	MEDIUM	HIGH	MAXIMUM CURRENT CM/S	MEAN DURATION HOURS	MEAN EXCURSION KM	MEAN CURRENT CM/S	MEAN TEMP DEG C
90.0	5.2	1.9	3.2	0.1			14.4	1.8	0.2	3.8	1.4
45.0	52.2	4.3	9.7	38.2			36.3	8.6	3.8	12.3	1.8
0.0	7.8	2.2	4.2	1.5			12.9	1.9	0.3	5.0	1.7
315.0	2.2	1.3	0.8	0.0			6.7	1.2	0.1	2.8	1.6
270.0	5.5	1.6	2.4	1.5			11.3	2.0	0.4	5.0	1.5
225.0	22.2	0.9	4.7	16.5			25.7	9.2	3.9	11.7	1.7
180.0	2.7	0.8	1.5	0.4			9.7	2.0	0.3	4.3	1.7
135.0	2.3	1.1	0.7	0.5			10.6	1.3	0.2	4.0	1.9

MEAN SCALAR SPEED = 10.1 CM/S MEAN SQUARE SPEED = 149.7 CM2/S2
 MEAN SQUARE E-W SPEED = 78.8 CM2/S2 MEAN SQUARE N-S SPEED = 70.9 CM2/S2
 MEAN VELOCITY = 3.9 CM/S, 43 DEG TRUE MEAN TEMPERATURE = 1.7 C
 VARIANCE(U,V) = 67.2 CM2/S2 TOTAL HOURS = 744.

PERCENT OBSERVED
 LIGHT (0.0 - 3.0) 14.1% MEDIUM (3.0 - 7.0) 27.2% HIGH (GE 7.0) 58.7%

DATE: 1998/02/01 TO 1998/02/28
 ROSE SUMMARY: WIND AND CURRENT

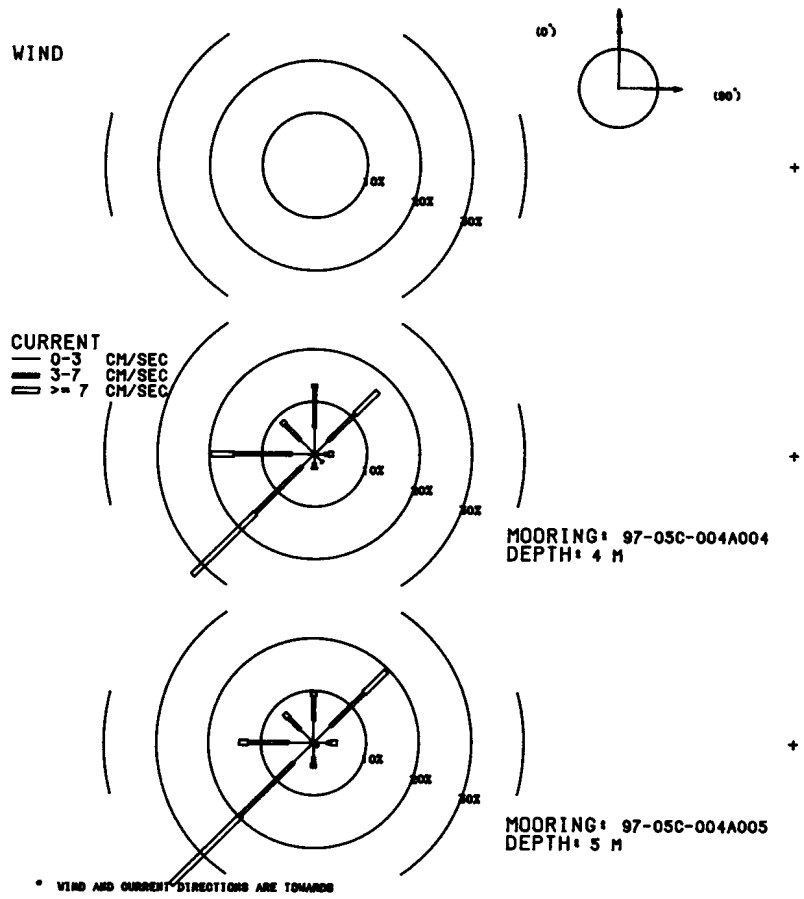

MOORING IS 97-05C-004A004 DEPTH IS 4 METERS THERE ARE 672 VALUES

FIRST DAY 1998/02/01/0000
 FINAL DAY 1998/02/28/2300

SHORELINE ORIENTATION IN DEGREES TRUE SPECIFIED AS 90

DIRECTION DEG TRUE	PERCENT OBSERVED	TOWARD	TOTAL	LIGHT	MEDIUM	HIGH	MAXIMUM CURRENT CM/S	MEAN DURATION HOURS	MEAN EXCURSION KM	MEAN CURRENT CM/S	MEAN TEMP DEG C
90.0	3.6	1.9	0.7	0.9	13.6	1.5	0.2	4.5	1.9		
45.0	17.0	3.6	7.3	6.1	18.0	3.0	0.7	6.6	1.7		
0.0	13.2	5.1	7.6	0.6	11.9	1.9	0.2	3.5	1.5		
315.0	8.8	3.7	4.2	0.9	12.0	1.7	0.2	4.0	1.7		
270.0	19.8	4.3	11.0	4.5	14.6	2.2	0.4	5.2	1.9		
225.0	32.6	3.3	12.5	16.8	21.1	4.5	1.4	8.4	1.8		
180.0	2.8	1.8	0.7	0.3	11.1	1.2	0.2	3.5	2.1		
135.0	2.2	2.1	0.1	0.0	3.1	1.2	0.1	1.6	2.1		
MEAN SCALAR SPEED = 6.0 CM/S		MEAN SQUARE SPEED = 53.1 CM ² /S ²									
MEAN SQUARE E-W SPEED = 31.4 CM ² /S ²		MEAN SQUARE N-S SPEED = 21.7 CM ² /S ²									
MEAN VELOCITY = 2.4 CM/S,		259 DEG TRUE		MEAN TEMPERATURE = 1.8 C							
VARIANCE (U,V) = 23.7 CM ² /S ²		TOTAL HOURS = 672.									

PERCENT OBSERVED
 LIGHT (0.0 - 3.0) 25.7% MEDIUM (3.0 - 7.0) 44.2% HIGH (GE 7.0) 30.1%

MOORING IS 97-05C-004A005 DEPTH IS 5 METERS THERE ARE 672 VALUES

FIRST DAY 1998/02/01/0000
 FINAL DAY 1998/02/28/2300

SHORELINE ORIENTATION IN DEGREES TRUE SPECIFIED AS 90

DIRECTION DEG TRUE	PERCENT OBSERVED	TOWARD	TOTAL	LIGHT	MEDIUM	HIGH	MAXIMUM CURRENT CM/S	MEAN DURATION HOURS	MEAN EXCURSION KM	MEAN CURRENT CM/S	MEAN TEMP DEG C
90.0	4.5	2.5	0.7	1.2	16.3	1.4	0.2	5.0	1.8		
45.0	19.5	4.5	9.1	6.0	17.9	3.0	0.7	6.1	1.7		
0.0	9.8	4.3	4.6	0.9	13.7	1.6	0.2	3.8	1.6		
315.0	7.9	3.6	3.1	1.2	12.5	1.4	0.2	4.1	1.6		
270.0	14.3	4.8	7.7	1.8	10.7	1.8	0.3	4.2	1.9		
225.0	38.2	5.4	14.1	18.8	21.7	4.5	1.3	8.1	1.8		
180.0	4.8	2.8	1.2	0.7	16.6	1.2	0.2	3.7	2.0		
135.0	1.0	0.9	0.1	0.0	3.0	1.0	0.1	1.8	2.3		
MEAN SCALAR SPEED = 6.0 CM/S		MEAN SQUARE SPEED = 55.3 CM ² /S ²									
MEAN SQUARE E-W SPEED = 28.7 CM ² /S ²		MEAN SQUARE N-S SPEED = 26.5 CM ² /S ²									
MEAN VELOCITY = 2.2 CM/S,		247 DEG TRUE		MEAN TEMPERATURE = 1.8 C							
VARIANCE (U,V) = 25.3 CM ² /S ²		TOTAL HOURS = 672.									

PERCENT OBSERVED
 LIGHT (0.0 - 3.0) 28.7% MEDIUM (3.0 - 7.0) 40.8% HIGH (GE 7.0) 30.5%

DATE: 1998/03/01 TO 1998/03/31
 ROSE SUMMARY: WIND AND CURRENT

WIND

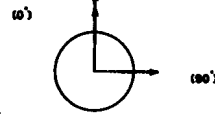
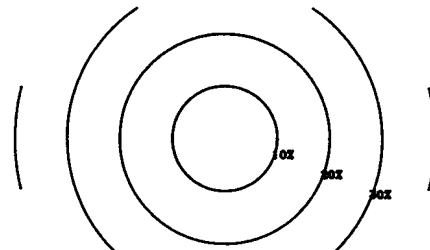

CURRENT
 — 0-3 CM/SEC
 = 3-7 CM/SEC
 □ >= 7 CM/SEC

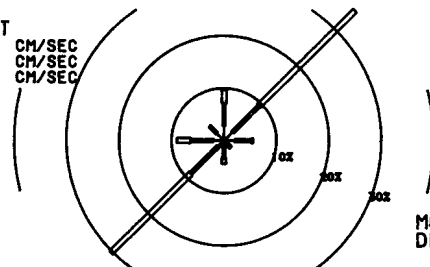

MOORING: 97-05C-004A004
 DEPTH: 4 M

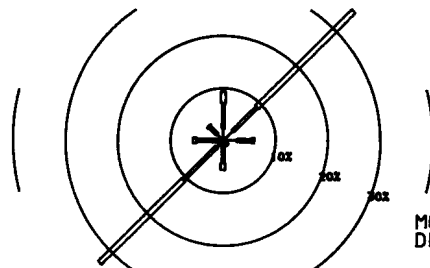

MOORING: 97-05C-004A005
 DEPTH: 5 M

* WIND AND CURRENT DIRECTIONS ARE TOWARDS

MOORING IS 97-05C-004A004 DEPTH IS 4 METERS THERE ARE 744 VALUES

FIRST DAY 1998/03/01/0000
 FINAL DAY 1998/03/31/2300

SHORELINE ORIENTATION IN DEGREES TRUE SPECIFIED AS 90

DIRECTION DEG TRUE	PERCENT OBSERVED	MAXIMUM CURRENT	MEAN DURATION HOURS	MEAN EXCURSION KM	MEAN CURRENT CM/S	MEAN TEMP DEG C
TOWARD	TOTAL	LIGHT	MEDIUM	HIGH	CM/S	
90.0	5.5	2.0	3.2	0.3	18.5	1.7
45.0	35.2	2.2	7.1	25.9	29.9	7.1
0.0	9.7	2.8	4.3	2.6	14.5	2.1
315.0	3.9	1.9	2.0	0.0	6.9	1.3
270.0	9.0	2.0	4.3	2.7	12.9	2.1
225.0	30.4	1.5	7.4	21.5	62.9	7.1
180.0	4.4	0.8	2.6	1.1	8.2	2.5
135.0	1.9	0.9	0.9	0.0	6.9	1.6
0	MEAN SCALAR SPEED = 10.0 CM/S		MEAN SQUARE SPEED = 184.1 CM2/S2			
	MEAN SQUARE E-W SPEED = 80.9 CM2/S2		MEAN SQUARE N-S SPEED = 103.2 CM2/S2			
	MEAN VELOCITY = 0.3 CM/S,		287 DEG TRUE		MEAN TEMPERATURE = 2.6 C	
	VARIANCE (U,V) = 92.1 CM2/S2		TOTAL HOURS = 744.			

PERCENT OBSERVED
 LIGHT (0.0 - 3.0) 14.1% MEDIUM (3.0 - 7.0) 31.9% HIGH (GE 7.0) 54.0%

MOORING IS 97-05C-004A005 DEPTH IS 5 METERS THERE ARE 744 VALUES

FIRST DAY 1998/03/01/0000
 FINAL DAY 1998/03/31/2300

SHORELINE ORIENTATION IN DEGREES TRUE SPECIFIED AS 90

DIRECTION DEG TRUE	PERCENT OBSERVED	MAXIMUM CURRENT	MEAN DURATION HOURS	MEAN EXCURSION KM	MEAN CURRENT CM/S	MEAN TEMP DEG C
TOWARD	TOTAL	LIGHT	MEDIUM	HIGH	CM/S	
90.0	5.9	2.6	2.8	0.5	17.0	1.7
45.0	35.1	2.6	6.5	26.1	33.1	6.1
0.0	9.4	2.3	4.8	2.3	18.3	1.9
315.0	3.9	1.6	2.0	0.3	9.0	1.4
270.0	5.8	0.8	4.2	0.8	13.5	2.3
225.0	33.1	1.6	9.0	22.4	61.7	9.8
180.0	5.6	1.1	3.2	1.3	8.2	2.5
135.0	1.2	0.8	0.4	0.0	4.0	1.1
0	MEAN SCALAR SPEED = 10.0 CM/S		MEAN SQUARE SPEED = 182.8 CM2/S2			
	MEAN SQUARE E-W SPEED = 84.7 CM2/S2		MEAN SQUARE N-S SPEED = 98.0 CM2/S2			
	MEAN VELOCITY = 0.2 CM/S,		316 DEG TRUE		MEAN TEMPERATURE = 2.6 C	
	VARIANCE (U,V) = 91.5 CM2/S2		TOTAL HOURS = 744.			

PERCENT OBSERVED
 LIGHT (0.0 - 3.0) 13.3% MEDIUM (3.0 - 7.0) 32.9% HIGH (GE 7.0) 53.8%

DATE: 1998/04/01 TO 1998/04/30
ROSE SUMMARY: WIND AND CURRENT

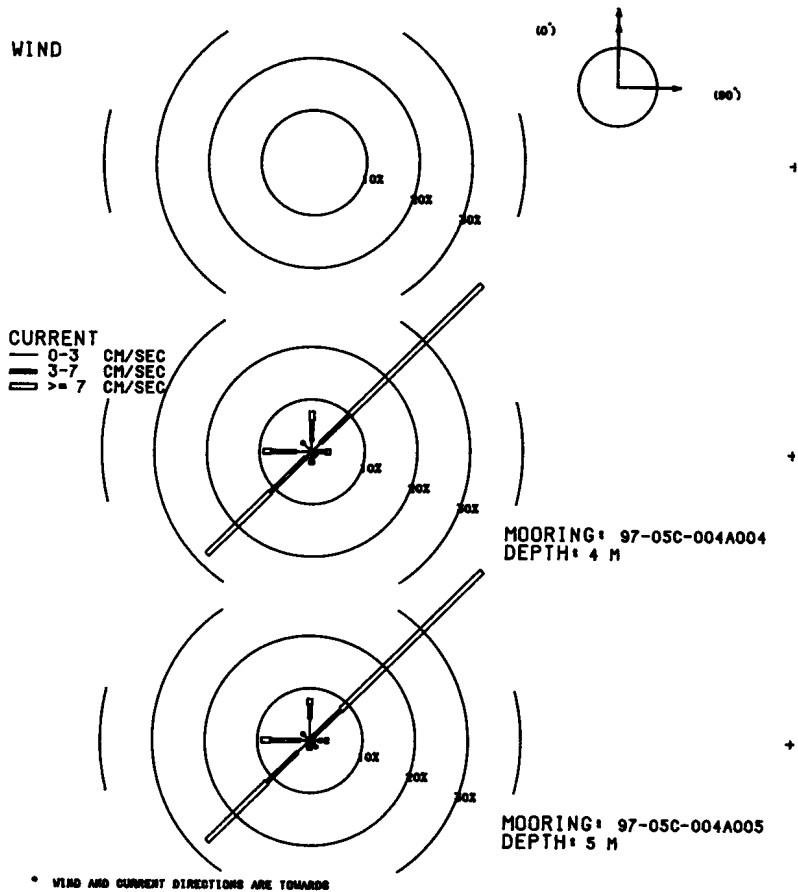

MOORING IS 97-05C-004A004 DEPTH IS 4 METERS THERE ARE 337 VALUES

FIRST DAY 1998/04/01/0000
FINAL DAY 1998/04/15/0000

SHORELINE ORIENTATION IN DEGREES TRUE SPECIFIED AS 90

DIRECTION DEG TRUE	PERCENT OBSERVED	MAXIMUM CURRENT	MEAN DURATION HOURS	MEAN EXCURSION KM	MEAN CURRENT CM/S	MEAN TEMP DEG C
TOWARD	TOTAL	LIGHT	MEDIUM	HIGH	CM/S	
90.0	3.6	0.9	1.8	0.9	8.9	5.7
45.0	45.4	2.4	7.7	35.3	19.1	5.4
0.0	7.7	2.1	3.9	1.8	13.5	5.8
315.0	2.7	2.1	0.6	0.0	3.7	5.6
270.0	9.2	3.0	4.7	1.5	8.3	5.0
225.0	27.9	1.5	9.5	16.9	18.9	4.8
180.0	2.4	1.2	0.6	0.6	9.2	5.2
135.0	1.2	0.3	0.6	0.3	7.1	5.8
MEAN SCALAR SPEED = 8.2 CM/S		MEAN SQUARE SPEED = 87.6 CM2/S2				
MEAN SQUARE E-W SPEED = 38.8 CM2/S2		MEAN SQUARE N-S SPEED = 48.8 CM2/S2				
MEAN VELOCITY = 2.4 CM/S,		30 DEG TRUE		MEAN TEMPERATURE = 5.2 C		
VARIANCE (U,V) = 41.1 CM2/S2		TOTAL HOURS = 337.				

PERCENT OBSERVED
 LIGHT (0.0 - 3.0) 13.4% MEDIUM (3.0 - 7.0) 29.4% HIGH (GE 7.0) 57.3%

MOORING IS 97-05C-004A005 DEPTH IS 5 METERS THERE ARE 337 VALUES

FIRST DAY 1998/04/01/0000
FINAL DAY 1998/04/15/0000

SHORELINE ORIENTATION IN DEGREES TRUE SPECIFIED AS 90

DIRECTION DEG TRUE	PERCENT OBSERVED	MAXIMUM CURRENT	MEAN DURATION HOURS	MEAN EXCURSION KM	MEAN CURRENT CM/S	MEAN TEMP DEG C
TOWARD	TOTAL	LIGHT	MEDIUM	HIGH	CM/S	
90.0	3.6	1.8	1.2	0.6	8.2	5.7
45.0	46.0	0.9	7.4	37.7	19.8	5.4
0.0	8.0	4.2	2.7	1.2	12.3	5.7
315.0	2.1	1.5	0.6	0.0	3.5	5.8
270.0	9.2	1.8	5.6	1.8	9.0	5.1
225.0	27.3	3.3	8.0	16.0	18.1	4.7
180.0	1.8	0.3	0.9	0.6	8.5	5.2
135.0	2.1	0.9	1.2	0.0	6.0	5.6
MEAN SCALAR SPEED = 8.3 CM/S		MEAN SQUARE SPEED = 89.1 CM2/S2				
MEAN SQUARE E-W SPEED = 39.7 CM2/S2		MEAN SQUARE N-S SPEED = 49.3 CM2/S2				
MEAN VELOCITY = 2.3 CM/S,		32 DEG TRUE		MEAN TEMPERATURE = 5.2 C		
VARIANCE (U,V) = 42.0 CM2/S2		TOTAL HOURS = 337.				

PERCENT OBSERVED
 LIGHT (0.0 - 3.0) 14.5% MEDIUM (3.0 - 7.0) 27.6% HIGH (GE 7.0) 57.9%

DATE: 1997/11/02 TO 1997/11/30
 ROSE SUMMARY: WIND AND CURRENT

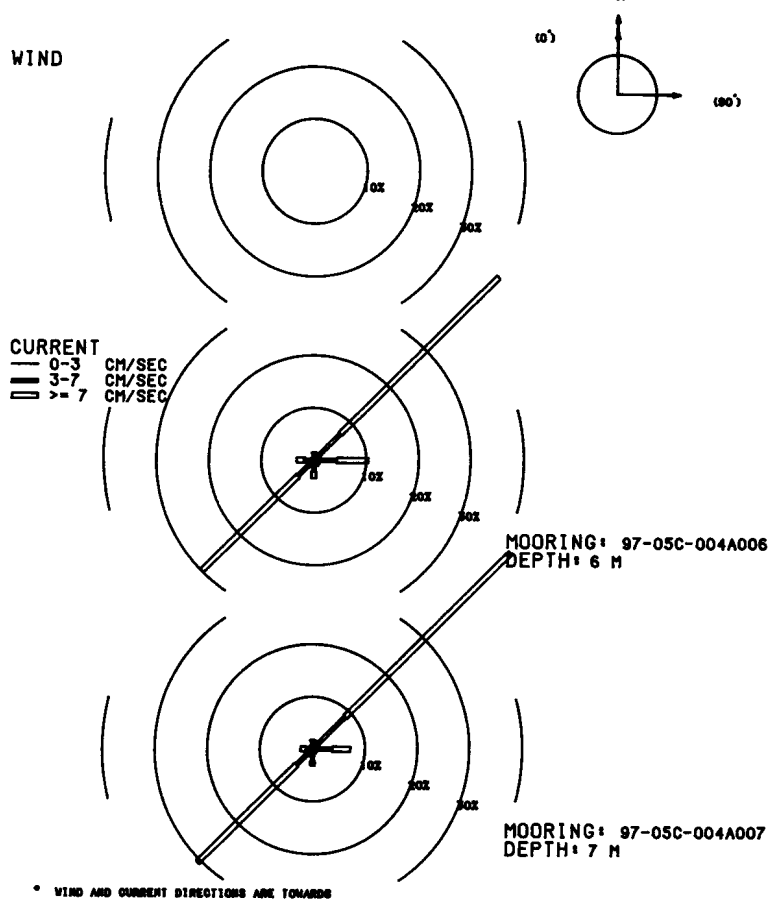

MOORING IS 97-05C-004A006 DEPTH IS 6 METERS THERE ARE 691 VALUES

FIRST DAY 1997/11/02/0500
 FINAL DAY 1997/11/30/2300

SHORELINE ORIENTATION IN DEGREES TRUE SPECIFIED AS 90

DIRECTION DEG TRUE	PERCENT OBSERVED	MAXIMUM CURRENT	MEAN DURA- TION HOURS	MEAN EXCUR- SION KM	MEAN CURRENT CM/S	MEAN TEMP DEG C
TOWARD	TOTAL	LIGHT	MEDIUM	HIGH	CM/S	
90.0	10.4	0.6	3.8	6.1	15.7	2.2
45.0	49.6	0.6	6.5	42.5	32.0	9.3
0.0	1.4	0.4	0.9	0.1	11.0	1.1
315.0	0.4	0.3	0.1	0.0	3.3	1.0
270.0	3.3	0.3	1.4	1.6	12.3	1.8
225.0	30.0	0.7	3.5	25.8	29.5	8.6
180.0	3.5	0.6	1.6	1.3	16.1	1.7
135.0	1.3	0.4	0.9	0.0	5.8	1.8

MEAN SCALAR SPEED = 12.3 CM/S MEAN SQUARE SPEED = 194.0 CM2/S2
 MEAN SQUARE E-W SPEED = 99.8 CM2/S2 MEAN SQUARE N-S SPEED = 94.2 CM2/S2
 MEAN VELOCITY = 3.4 CM/S, 58 DEG TRUE MEAN TEMPERATURE = 8.5 C
 VARIANCE(U,V) = 91.4 CM2/S2 TOTAL HOURS = 691.

PERCENT OBSERVED
 LIGHT (0.0 - 3.0) 3.9% MEDIUM (3.0 - 7.0) 18.7% HIGH (GE 7.0) 77.4%

MOORING IS 97-05C-004A007 DEPTH IS 7 METERS THERE ARE 691 VALUES

FIRST DAY 1997/11/02/0500
 FINAL DAY 1997/11/30/2300

SHORELINE ORIENTATION IN DEGREES TRUE SPECIFIED AS 90

DIRECTION DEG TRUE	PERCENT OBSERVED	MAXIMUM CURRENT	MEAN DURA- TION HOURS	MEAN EXCUR- SION KM	MEAN CURRENT CM/S	MEAN TEMP DEG C
TOWARD	TOTAL	LIGHT	MEDIUM	HIGH	CM/S	
90.0	7.2	0.6	3.2	3.5	13.6	2.2
45.0	53.1	0.9	7.8	44.4	30.6	13.1
0.0	1.7	0.6	1.0	0.1	9.6	1.5
315.0	0.7	0.6	0.1	0.0	3.6	1.2
270.0	2.3	0.3	0.9	1.2	9.7	2.7
225.0	30.7	0.4	3.8	26.5	29.9	12.5
180.0	3.2	0.9	1.6	0.7	11.3	1.6
135.0	1.0	0.4	0.6	0.0	5.4	1.8

MEAN SCALAR SPEED = 12.1 CM/S MEAN SQUARE SPEED = 186.8 CM2/S2
 MEAN SQUARE E-W SPEED = 93.1 CM2/S2 MEAN SQUARE N-S SPEED = 93.7 CM2/S2
 MEAN VELOCITY = 3.5 CM/S, 54 DEG TRUE MEAN TEMPERATURE = 8.5 C
 VARIANCE(U,V) = 87.3 CM2/S2 TOTAL HOURS = 691.

PERCENT OBSERVED
 LIGHT (0.0 - 3.0) 4.6% MEDIUM (3.0 - 7.0) 19.0% HIGH (GE 7.0) 76.4%

DATE: 1997/12/01 TO 1997/12/31
 ROSE SUMMARY: WIND AND CURRENT

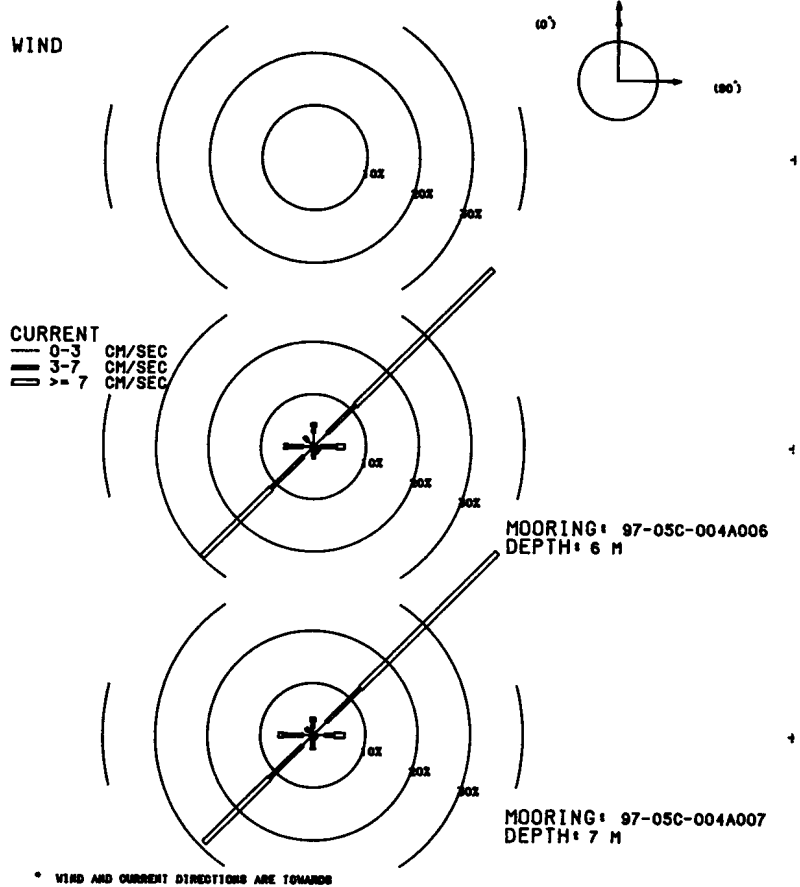

MOORING IS 97-05C-004A006 DEPTH IS 6 METERS THERE ARE 744 VALUES

FIRST DAY 1997/12/01/0000
 FINAL DAY 1997/12/31/2300

SHORELINE ORIENTATION IN DEGREES TRUE SPECIFIED AS 90

DIRECTION DEG TRUE	PERCENT OBSERVED	MAXIMUM CURRENT CM/S	MEAN DURATION HOURS	MEAN EXCURSION KM	MEAN CURRENT CM/S	MEAN TEMP DEG C
TOWARD	TOTAL	LIGHT	MEDIUM	HIGH	CM/S	
90.0	5.9	1.3	3.0	1.6	16.0	1.9
45.0	48.0	3.6	7.5	36.8	32.2	8.9
0.0	4.4	2.7	1.2	0.5	12.0	1.3
315.0	2.6	1.6	0.9	0.0	5.2	1.2
270.0	5.6	2.0	3.0	0.7	9.6	1.4
225.0	29.8	2.7	8.6	18.5	29.9	5.7
180.0	2.3	0.7	1.6	0.0	6.9	1.3
135.0	1.3	1.1	0.1	0.1	8.0	1.0
MEAN SCALAR SPEED =		9.2 CM/S	MEAN SQUARE SPEED =		122.7 CM2/S2	
MEAN SQUARE E-W SPEED =		64.4 CM2/S2	MEAN SQUARE N-S SPEED =		58.3 CM2/S2	
MEAN VELOCITY =		2.5 CM/S,	42 DEG TRUE		MEAN TEMPERATURE = 4.4 C	
VARIANCE (U,V) =		58.4 CM2/S2	TOTAL HOURS =		744.	

PERCENT OBSERVED
 LIGHT (0.0 - 3.0) 15.7% MEDIUM (3.0 - 7.0) 25.9% HIGH (GE 7.0) 58.3%

MOORING IS 97-05C-004A007 DEPTH IS 7 METERS THERE ARE 744 VALUES

FIRST DAY 1997/12/01/0000
 FINAL DAY 1997/12/31/2300

SHORELINE ORIENTATION IN DEGREES TRUE SPECIFIED AS 90

DIRECTION DEG TRUE	PERCENT OBSERVED	MAXIMUM CURRENT CM/S	MEAN DURATION HOURS	MEAN EXCURSION KM	MEAN CURRENT CM/S	MEAN TEMP DEG C
TOWARD	TOTAL	LIGHT	MEDIUM	HIGH	CM/S	
90.0	6.0	2.3	1.7	2.0	15.2	1.7
45.0	49.5	3.6	9.1	36.7	31.0	9.7
0.0	3.4	1.5	1.2	0.7	13.0	1.1
315.0	1.9	1.2	0.7	0.0	5.3	1.4
270.0	6.6	1.9	3.8	0.9	9.2	1.8
225.0	29.0	2.8	8.7	17.5	29.2	6.2
180.0	2.7	0.9	1.6	0.1	9.9	1.4
135.0	0.9	0.8	0.1	0.0	3.2	1.0
MEAN SCALAR SPEED =		9.1 CM/S	MEAN SQUARE SPEED =		118.8 CM2/S2	
MEAN SQUARE E-W SPEED =		59.8 CM2/S2	MEAN SQUARE N-S SPEED =		59.0 CM2/S2	
MEAN VELOCITY =		2.6 CM/S,	38 DEG TRUE		MEAN TEMPERATURE = 4.4 C	
VARIANCE (U,V) =		56.1 CM2/S2	TOTAL HOURS =		744.	

PERCENT OBSERVED
 LIGHT (0.0 - 3.0) 15.1% MEDIUM (3.0 - 7.0) 27.0% HIGH (GE 7.0) 57.9%

DATE: 1998/01/01 TO 1998/01/31
 ROSE SUMMARY: WIND AND CURRENT

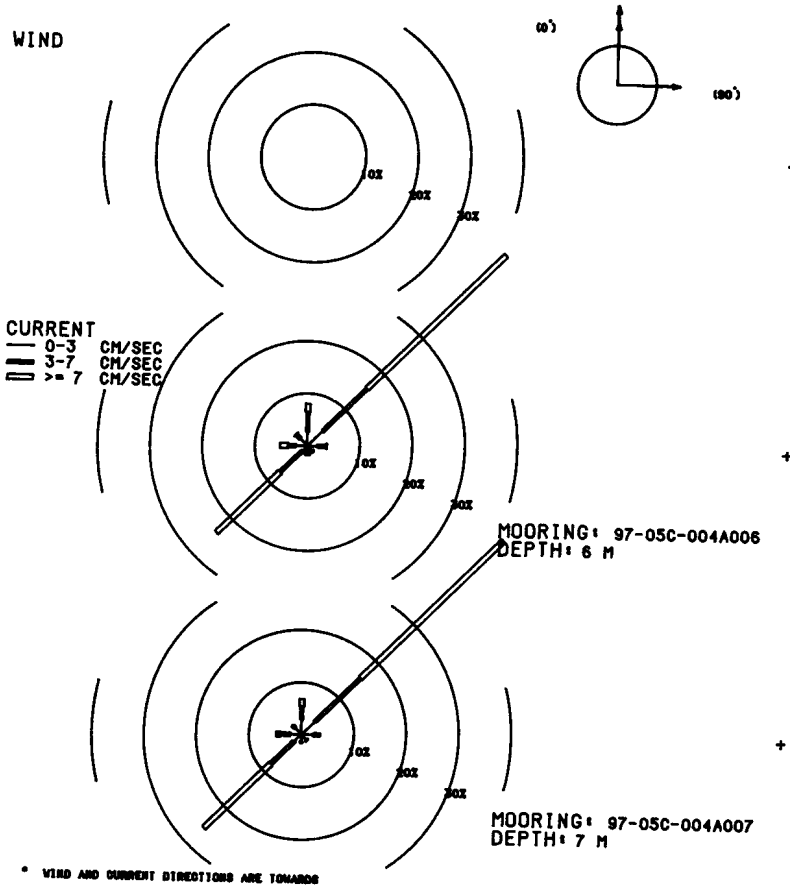

MOORING IS 97-05C-004A006 DEPTH IS 6 METERS THERE ARE 744 VALUES

FIRST DAY 1998/01/01/0000
 FINAL DAY 1998/01/31/2300

SHORELINE ORIENTATION IN DEGREES TRUE SPECIFIED AS 90

DIRECTION DEG TRUE	PERCENT OBSERVED	MAXIMUM CURRENT	MEAN DURATION HOURS	MEAN EXCURSION KM	MEAN CURRENT CM/S	MEAN TEMP DEG C
TOWARD	TOTAL	LIGHT	MEDIUM	HIGH	CM/S	
90.0	3.8	1.9	1.6	0.3	16.8	1.5
45.0	52.6	4.0	11.7	36.8	33.3	1.8
0.0	8.1	2.7	3.8	1.6	12.8	1.6
315.0	3.1	1.9	1.1	0.1	8.2	1.7
270.0	5.2	2.2	1.5	1.6	12.1	1.6
225.0	23.9	1.5	5.6	16.8	24.5	1.7
180.0	1.7	0.9	0.5	0.3	8.3	1.5
135.0	1.6	1.3	0.3	0.0	6.8	1.5
0		MEAN SCALAR SPEED = 9.8 CM/S		MEAN SQUARE SPEED = 141.1 CM2/S2		
		MEAN SQUARE E-W SPEED = 72.1 CM2/S2		MEAN SQUARE N-S SPEED = 69.0 CM2/S2		
		MEAN VELOCITY = 3.8 CM/S,		38 DEG TRUE		MEAN TEMPERATURE = 1.7 C
		VARIANCE (U,V) = 63.5 CM2/S2		TOTAL HOURS = 744.		

PERCENT OBSERVED
 LIGHT (0.0 - 3.0) 16.4% MEDIUM (3.0 - 7.0) 26.1% HIGH (GE 7.0) 57.5%

MOORING IS 97-05C-004A007 DEPTH IS 7 METERS THERE ARE 744 VALUES

FIRST DAY 1998/01/01/0000
 FINAL DAY 1998/01/31/2300

SHORELINE ORIENTATION IN DEGREES TRUE SPECIFIED AS 90

DIRECTION DEG TRUE	PERCENT OBSERVED	MAXIMUM CURRENT	MEAN DURATION HOURS	MEAN EXCURSION KM	MEAN CURRENT CM/S	MEAN TEMP DEG C
TOWARD	TOTAL	LIGHT	MEDIUM	HIGH	CM/S	
90.0	3.6	2.3	1.3	0.0	6.6	1.6
45.0	53.4	3.5	12.1	37.8	32.3	1.8
0.0	6.9	2.8	2.6	1.5	14.7	1.9
315.0	2.4	1.7	0.7	0.0	5.9	1.7
270.0	4.8	2.0	2.0	0.8	11.3	1.6
225.0	25.7	1.9	6.0	17.7	25.1	1.7
180.0	1.6	1.3	0.3	0.0	6.7	1.8
135.0	1.6	1.5	0.1	0.0	4.8	1.4
0		MEAN SCALAR SPEED = 9.7 CM/S		MEAN SQUARE SPEED = 136.1 CM2/S2		
		MEAN SQUARE E-W SPEED = 67.9 CM2/S2		MEAN SQUARE N-S SPEED = 68.2 CM2/S2		
		MEAN VELOCITY = 3.6 CM/S,		38 DEG TRUE		MEAN TEMPERATURE = 1.7 C
		VARIANCE (U,V) = 61.5 CM2/S2		TOTAL HOURS = 744.		

PERCENT OBSERVED
 LIGHT (0.0 - 3.0) 17.1% MEDIUM (3.0 - 7.0) 25.1% HIGH (GE 7.0) 57.8%

DATE: 1998/02/01 TO 1998/02/28

ROSE SUMMARY: WIND AND CURRENT

WIND

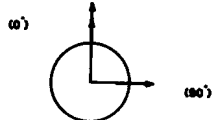
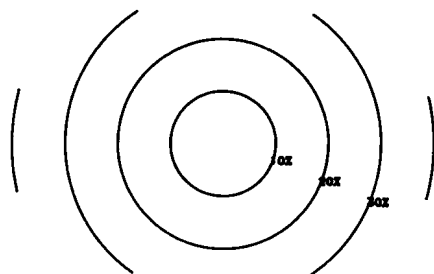

CURRENT

0-3 CH/SEC
3-7 CH/SEC
>= 7 CH/SEC

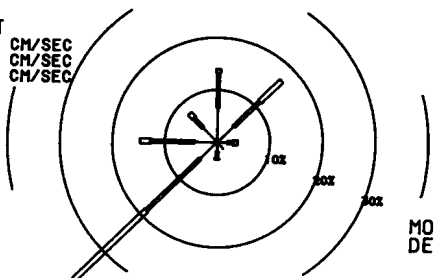

MOORING: 97-05C-004A006
DEPTH: 6 M

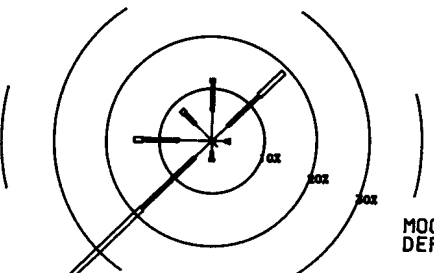

MOORING: 97-05C-004A007
DEPTH: 7 M

* WIND AND CURRENT DIRECTIONS ARE TOWARDS

MOORING IS 97-05C-004A006 DEPTH IS 6 METERS THERE ARE 672 VALUES

FIRST DAY 1998/02/01/0000
FINAL DAY 1998/02/28/2300

SHORELINE ORIENTATION IN DEGREES TRUE SPECIFIED AS 90

DIRECTION DEG TRUE	PERCENT OBSERVED	MAXIMUM CURRENT	MEAN DURATION HOURS	MEAN EXCURSION KM	MEAN CURRENT CM/S	MEAN TEMP DEG C
TOWARD	TOTAL	LIGHT	MEDIUM	HIGH	CM/S	
90.0	3.9	1.9	1.0	0.9	14.0	1.4
45.0	17.0	4.3	6.8	5.8	17.4	3.3
0.0	14.0	6.5	6.7	0.7	12.7	2.1
315.0	7.6	3.9	2.5	1.2	12.3	1.5
270.0	14.7	4.3	8.3	2.1	15.7	1.7
225.0	37.8	4.5	14.1	19.2	21.0	4.8
180.0	3.3	1.8	1.3	0.1	8.5	1.1
135.0	1.8	1.8	0.0	0.0	2.3	1.2

MEAN SCALAR SPEED = 5.8 CM/S MEAN SQUARE SPEED = 52.6 CM2/S2
 MEAN SQUARE E-W SPEED = 28.3 CM2/S2 MEAN SQUARE N-S SPEED = 24.4 CM2/S2
 MEAN VELOCITY = 2.2 CM/S, 248 DEG TRUE MEAN TEMPERATURE = 1.8 C
 VARIANCE(U,V) = 23.9 CM2/S2 TOTAL HOURS = 672.

PERCENT OBSERVED
 LIGHT (0.0 - 3.0) 29.0% MEDIUM (3.0 - 7.0) 40.9% HIGH (GE 7.0) 30.1%

MOORING IS 97-05C-004A007 DEPTH IS 7 METERS THERE ARE 672 VALUES

FIRST DAY 1998/02/01/0000
FINAL DAY 1998/02/28/2300

SHORELINE ORIENTATION IN DEGREES TRUE SPECIFIED AS 90

DIRECTION DEG TRUE	PERCENT OBSERVED	MAXIMUM CURRENT	MEAN DURATION HOURS	MEAN EXCURSION KM	MEAN CURRENT CM/S	MEAN TEMP DEG C
TOWARD	TOTAL	LIGHT	MEDIUM	HIGH	CM/S	
90.0	3.4	2.5	0.7	0.1	10.7	1.1
45.0	19.0	4.2	8.3	6.5	16.1	3.2
0.0	11.9	5.8	5.5	0.6	10.9	1.7
315.0	8.2	4.5	2.8	0.9	10.3	1.4
270.0	14.7	6.2	6.8	1.6	13.4	1.7
225.0	37.4	4.5	14.0	18.9	19.9	5.7
180.0	3.9	2.1	1.3	0.4	8.6	1.4
135.0	1.5	1.5	0.0	0.0	2.3	1.1

MEAN SCALAR SPEED = 5.7 CM/S MEAN SQUARE SPEED = 51.0 CM2/S2
 MEAN SQUARE E-W SPEED = 26.8 CM2/S2 MEAN SQUARE N-S SPEED = 24.2 CM2/S2
 MEAN VELOCITY = 2.1 CM/S, 248 DEG TRUE MEAN TEMPERATURE = 1.8 C
 VARIANCE(U,V) = 23.3 CM2/S2 TOTAL HOURS = 672.

PERCENT OBSERVED
 LIGHT (0.0 - 3.0) 31.3% MEDIUM (3.0 - 7.0) 39.6% HIGH (GE 7.0) 29.2%

DATE: 1998/03/01 TO 1998/03/31
 ROSE SUMMARY: WIND AND CURRENT

WIND

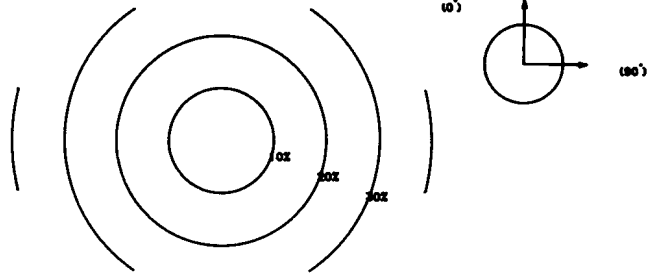

CURRENT
 — 0-3 CM/SEC
 = 3-7 CM/SEC
 ▨ >= 7 CM/SEC

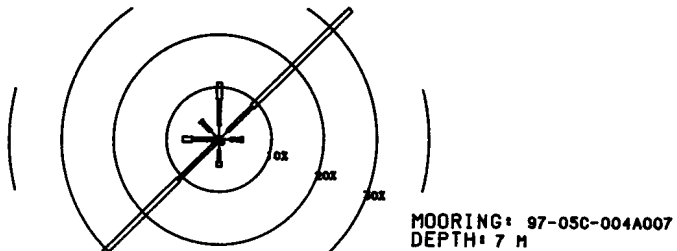
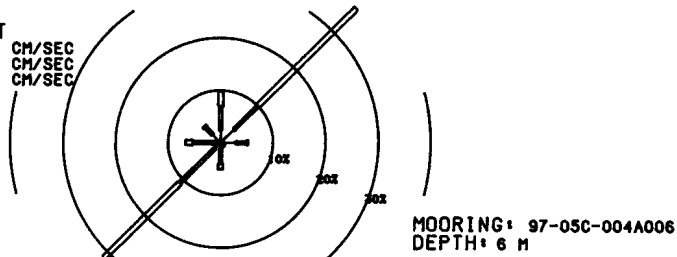

* WIND AND CURRENT DIRECTIONS ARE TOWARDS

MOORING IS 97-05C-004A006 DEPTH IS 6 METERS THERE ARE 744 VALUES

FIRST DAY 1998/03/01/0000
 FINAL DAY 1998/03/31/2300

SHORELINE ORIENTATION IN DEGREES TRUE SPECIFIED AS 90

DIRECTION DEG TRUE	PERCENT OBSERVED	MAXIMUM CURRENT	MEAN DURATION HOURS	MEAN EXCURSION KM	MEAN CURRENT CM/S	MEAN TEMP DEG C
TOWARD	TOTAL	LIGHT	MEDIUM	HIGH	CM/S	
90.0	5.2	2.8	2.2	0.3	8.1	3.2
45.0	36.4	3.5	6.5	26.5	34.2	2.8
0.0	9.8	2.3	4.7	2.8	19.0	2.6
315.0	4.4	2.2	1.9	0.4	10.2	2.5
270.0	6.7	0.8	4.4	1.5	17.5	2.4
225.0	31.3	1.6	9.3	20.4	59.3	2.3
180.0	5.1	1.2	2.8	1.1	8.3	2.6
135.0	0.9	0.7	0.3	0.0	3.7	3.1

MEAN SCALAR SPEED = 9.8 CM/S MEAN SQUARE SPEED = 175.3 CM²/S²
 MEAN SQUARE E-W SPEED = 89.2 CM²/S² MEAN SQUARE N-S SPEED = 86.1 CM²/S²
 MEAN VELOCITY = 0.6 CM/S, 329 DEG TRUE MEAN TEMPERATURE = 2.6 C
 VARIANCE (U,V) = 87.5 CM²/S² TOTAL HOURS = 744.

PERCENT OBSERVED
 LIGHT (0.0 - 3.0) 15.1% MEDIUM (3.0 - 7.0) 32.0% HIGH (GE 7.0) 53.0%

MOORING IS 97-05C-004A007 DEPTH IS 7 METERS THERE ARE 744 VALUES

FIRST DAY 1998/03/01/0000
 FINAL DAY 1998/03/31/2300

SHORELINE ORIENTATION IN DEGREES TRUE SPECIFIED AS 90

DIRECTION DEG TRUE	PERCENT OBSERVED	MAXIMUM CURRENT	MEAN DURATION HOURS	MEAN EXCURSION KM	MEAN CURRENT CM/S	MEAN TEMP DEG C
TOWARD	TOTAL	LIGHT	MEDIUM	HIGH	CM/S	
90.0	4.6	2.2	2.0	0.4	11.1	3.1
45.0	35.2	2.3	6.6	26.3	34.0	2.8
0.0	10.9	2.7	5.0	3.2	20.4	2.5
315.0	5.0	2.3	2.4	0.3	11.9	2.4
270.0	7.0	0.9	4.2	1.9	17.7	2.4
225.0	30.9	1.2	9.7	20.0	57.7	2.3
180.0	5.2	2.2	2.2	0.9	8.2	2.7
135.0	1.2	0.8	0.4	0.0	5.1	3.0

MEAN SCALAR SPEED = 9.6 CM/S MEAN SQUARE SPEED = 166.2 CM²/S²
 MEAN SQUARE E-W SPEED = 89.9 CM²/S² MEAN SQUARE N-S SPEED = 76.3 CM²/S²
 MEAN VELOCITY = 0.8 CM/S, 337 DEG TRUE MEAN TEMPERATURE = 2.6 C
 VARIANCE (U,V) = 82.9 CM²/S² TOTAL HOURS = 744.

PERCENT OBSERVED
 LIGHT (0.0 - 3.0) 14.5% MEDIUM (3.0 - 7.0) 32.4% HIGH (GE 7.0) 53.1%

DATE: 1998/04/01 TO 1998/04/30
 ROSE SUMMARY: WIND AND CURRENT

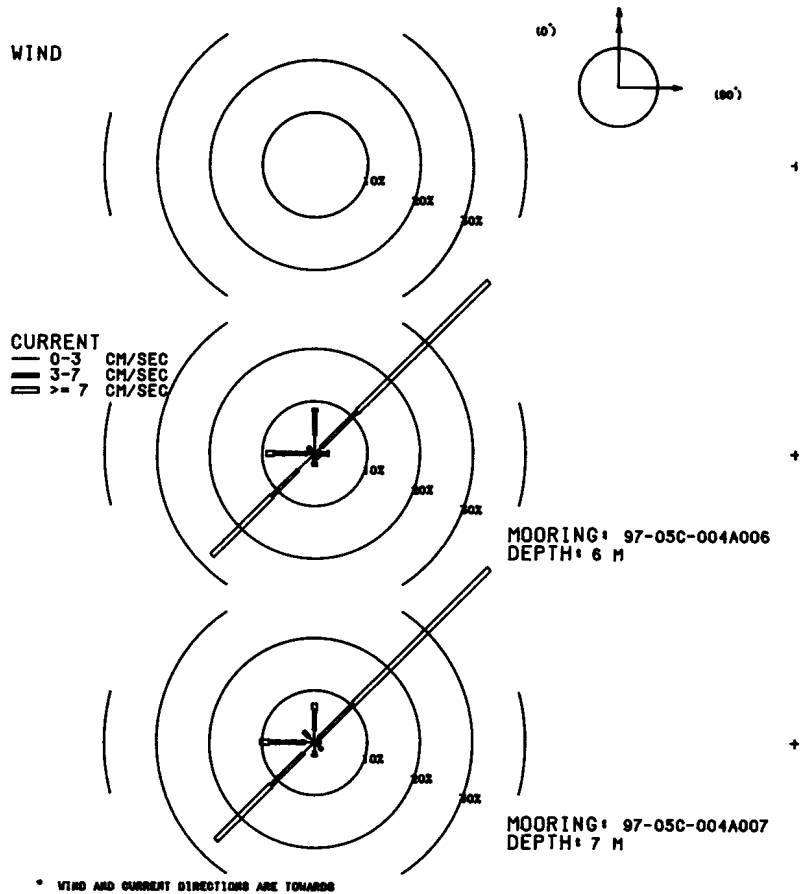

MOORING IS 97-05C-004A006 DEPTH IS 6 METERS THERE ARE 337 VALUES

FIRST DAY 1998/04/01/0000
 FINAL DAY 1998/04/15/0000

SHORELINE ORIENTATION IN DEGREES TRUE SPECIFIED AS 90

DIRECTION DEG TRUE	PERCENT OBSERVED	MAXIMUM CURRENT	MEAN DURATION HOURS	MEAN EXCURSION KM	MEAN CURRENT CM/S	MEAN TEMP DEG C
TOWARD	TOTAL	LIGHT	MEDIUM	HIGH	CM/S	
90.0	2.7	0.9	1.5	0.3	7.3	1.3
45.0	46.6	1.8	9.5	35.3	18.9	12.1
0.0	8.6	3.6	4.5	0.6	11.7	1.6
315.0	1.8	1.2	0.6	0.0	3.5	1.0
270.0	9.2	1.5	6.2	1.5	9.4	2.4
225.0	27.6	4.5	7.1	16.0	20.1	5.5
180.0	2.4	0.9	0.9	0.6	11.4	1.6
135.0	1.2	0.6	0.6	0.0	3.4	1.0
MEAN SCALAR SPEED = 8.1 CM/S		MEAN SQUARE SPEED = 86.0 CM2/S2				
MEAN SQUARE E-W SPEED = 39.6 CM2/S2		MEAN SQUARE N-S SPEED = 46.4 CM2/S2				
MEAN VELOCITY = 2.4 CM/S,		33 DEG TRUE MEAN TEMPERATURE = 5.2 C				
VARIANCE (U,V) = 40.1 CM2/S2		TOTAL HOURS = 337.				

PERCENT OBSERVED
 LIGHT (0.0 - 3.0) 14.8% MEDIUM (3.0 - 7.0) 30.9% HIGH (GE 7.0) 54.3%

MOORING IS 97-05C-004A007 DEPTH IS 7 METERS THERE ARE 337 VALUES

FIRST DAY 1998/04/01/0000
 FINAL DAY 1998/04/15/0000

SHORELINE ORIENTATION IN DEGREES TRUE SPECIFIED AS 90

DIRECTION DEG TRUE	PERCENT OBSERVED	MAXIMUM CURRENT	MEAN DURATION HOURS	MEAN EXCURSION KM	MEAN CURRENT CM/S	MEAN TEMP DEG C
TOWARD	TOTAL	LIGHT	MEDIUM	HIGH	CM/S	
90.0	1.2	0.6	0.6	0.0	6.4	1.0
45.0	46.9	1.2	9.2	36.5	18.9	10.5
0.0	7.4	2.4	3.9	1.2	9.8	1.7
315.0	3.0	1.5	1.5	0.0	6.9	1.1
270.0	10.4	1.8	6.8	1.8	10.3	2.2
225.0	26.4	3.0	8.6	14.8	18.5	5.9
180.0	2.7	1.8	0.6	0.3	8.1	1.5
135.0	2.1	1.5	0.6	0.0	4.4	1.0
MEAN SCALAR SPEED = 8.1 CM/S		MEAN SQUARE SPEED = 85.5 CM2/S2				
MEAN SQUARE E-W SPEED = 39.5 CM2/S2		MEAN SQUARE N-S SPEED = 46.0 CM2/S2				
MEAN VELOCITY = 2.3 CM/S,		31 DEG TRUE MEAN TEMPERATURE = 5.2 C				
VARIANCE (U,V) = 40.2 CM2/S2		TOTAL HOURS = 337.				

PERCENT OBSERVED
 LIGHT (0.0 - 3.0) 13.6% MEDIUM (3.0 - 7.0) 31.8% HIGH (GE 7.0) 54.6%

DATE: 1997/11/02 TO 1997/11/30
ROSE SUMMARY: WIND AND CURRENT

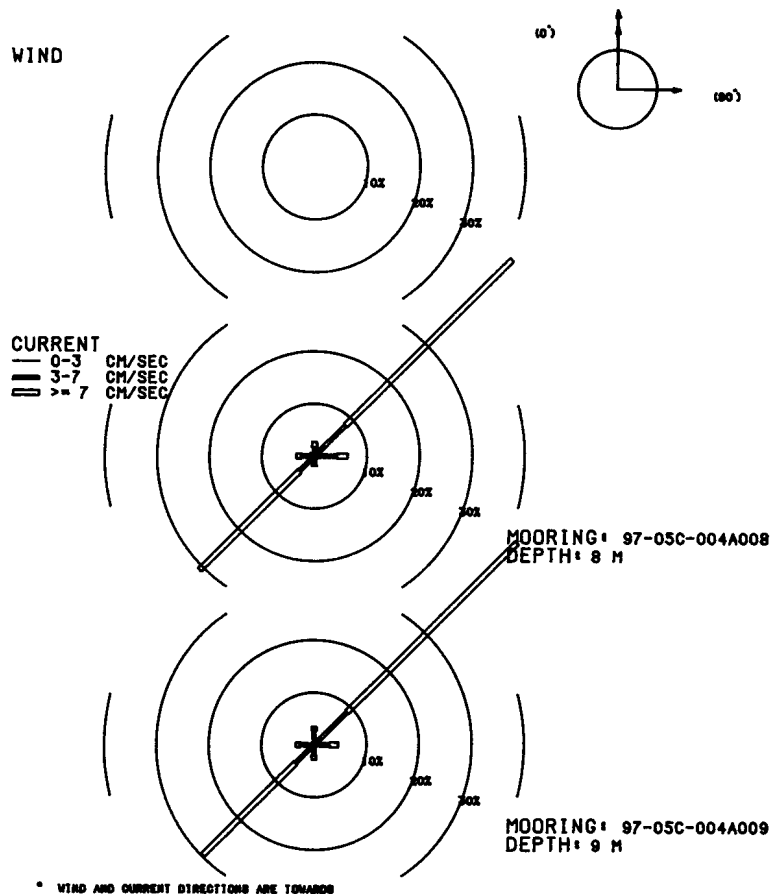

MOORING IS 97-05C-004A008 DEPTH IS 8 METERS THERE ARE 691 VALUES

FIRST DAY 1997/11/02/0500
FINAL DAY 1997/11/30/2300

SHORELINE ORIENTATION IN DEGREES TRUE SPECIFIED AS 90

DIRECTION DEG TRUE	PERCENT OBSERVED	MAXIMUM CURRENT	MEAN DURA- TION HOURS	MEAN EXCUR- SION KM	MEAN CURRENT CM/S	MEAN TEMP DEG C
TOWARD	TOTAL	LIGHT	MEDIUM	HIGH	CM/S	
90.0	6.4	0.4	3.8	2.2	11.6	1.6
45.0	53.1	0.7	7.5	44.9	30.2	10.2
0.0	2.7	0.4	1.2	1.2	16.3	1.4
315.0	0.9	0.9	0.0	0.0	1.5	2.0
270.0	3.5	0.7	1.7	1.0	9.8	2.0
225.0	30.8	0.4	3.5	26.9	28.7	14.2
180.0	1.9	0.3	1.4	0.1	7.4	1.6
135.0	0.7	0.0	0.7	0.0	5.4	1.2
0	MEAN SCALAR SPEED = 11.9 CM/S		MEAN SQUARE SPEED = 181.4 CM2/S2			
	MEAN SQUARE E-W SPEED = 89.7 CM2/S2		MEAN SQUARE N-S SPEED = 91.7 CM2/S2			
	MEAN VELOCITY = 3.3 CM/S,		50 DEG TRUE MEAN TEMPERATURE = 8.5 C			
	VARIANCE (U,V) = 85.3 CM2/S2		TOTAL HOURS = 691.			

PERCENT OBSERVED
LIGHT (0.0 - 3.0) 3.9% MEDIUM (3.0 - 7.0) 19.8% HIGH (GE 7.0) 76.3%

MOORING IS 97-05C-004A009 DEPTH IS 9 METERS THERE ARE 691 VALUES

FIRST DAY 1997/11/02/0500
FINAL DAY 1997/11/30/2300

SHORELINE ORIENTATION IN DEGREES TRUE SPECIFIED AS 90

DIRECTION DEG TRUE	PERCENT OBSERVED	MAXIMUM CURRENT	MEAN DURA- TION HOURS	MEAN EXCUR- SION KM	MEAN CURRENT CM/S	MEAN TEMP DEG C
TOWARD	TOTAL	LIGHT	MEDIUM	HIGH	CM/S	
90.0	4.6	0.9	2.0	1.7	12.6	1.3
45.0	54.6	0.7	8.1	45.7	30.4	11.1
0.0	3.5	1.0	1.7	0.7	16.9	1.5
315.0	0.6	0.3	0.3	0.0	3.7	1.3
270.0	3.5	1.2	1.4	0.9	9.4	1.4
225.0	29.8	0.7	4.2	24.9	29.5	9.8
180.0	2.9	0.3	1.7	0.9	12.0	1.4
135.0	0.6	0.3	0.3	0.0	5.5	1.3
0	MEAN SCALAR SPEED = 11.7 CM/S		MEAN SQUARE SPEED = 176.5 CM2/S2			
	MEAN SQUARE E-W SPEED = 84.4 CM2/S2		MEAN SQUARE N-S SPEED = 92.1 CM2/S2			
	MEAN VELOCITY = 3.4 CM/S,		49 DEG TRUE MEAN TEMPERATURE = 8.5 C			
	VARIANCE (U,V) = 82.7 CM2/S2		TOTAL HOURS = 691.			

PERCENT OBSERVED
LIGHT (0.0 - 3.0) 5.4% MEDIUM (3.0 - 7.0) 19.8% HIGH (GE 7.0) 74.8%

DATE: 1997/12/01 TO 1997/12/31
 ROSE SUMMARY: WIND AND CURRENT

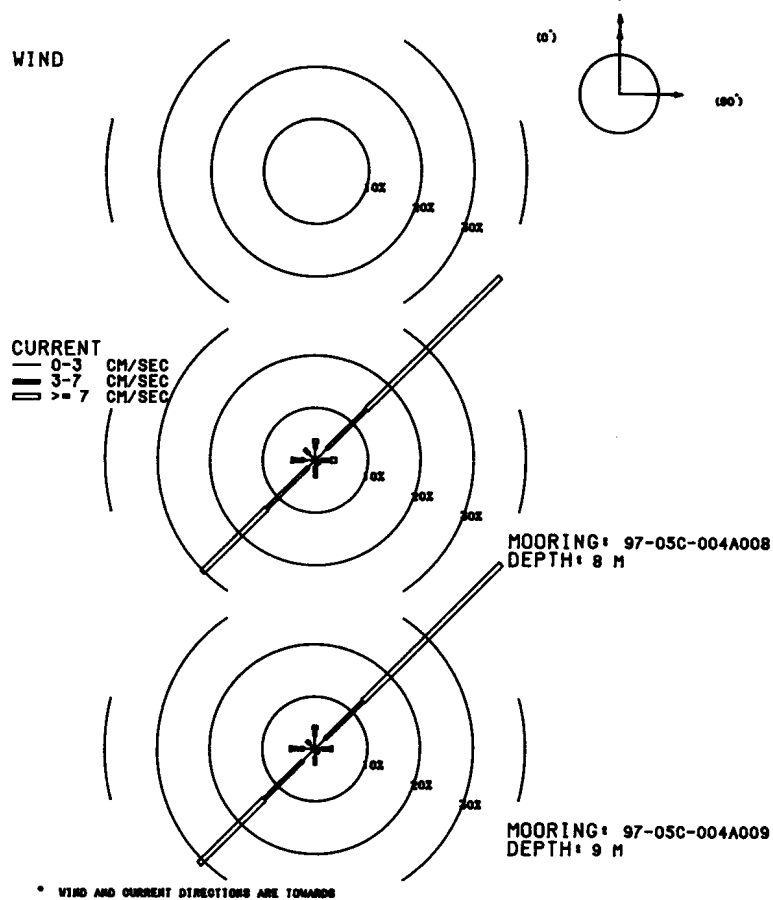

MOORING IS 97-05C-004A008 DEPTH IS 8 METERS THERE ARE 744 VALUES

FIRST DAY 1997/12/01/0000
 FINAL DAY 1997/12/31/2300

SHORELINE ORIENTATION IN DEGREES TRUE SPECIFIED AS 90

DIRECTION DEG TRUE	PERCENT OBSERVED	MAXIMUM CURRENT	MEAN DURA- TION HOURS	MEAN EXCUR- SION KM	MEAN CURRENT CM/S	MEAN TEMP DEG C
TOWARD	TOTAL	LIGHT	MEDIUM	HIGH	CM/S	
90.0	4.0	1.2	1.7	1.1	13.4	1.8
45.0	49.6	3.1	10.6	35.9	30.3	10.5
0.0	4.0	2.3	0.9	0.8	12.0	1.2
315.0	3.0	1.7	1.2	0.0	5.7	1.3
270.0	4.6	2.2	2.0	0.4	8.3	1.4
225.0	30.4	1.9	11.2	17.3	30.1	6.6
180.0	3.4	1.3	2.0	0.0	7.0	1.3
135.0	1.1	0.9	0.1	0.0	3.2	1.1

MEAN SCALAR SPEED = 8.9 CM/S MEAN SQUARE SPEED = 115.8 CM2/S2
 MEAN SQUARE E-W SPEED = 56.7 CM2/S2 MEAN SQUARE N-S SPEED = 59.1 CM2/S2
 MEAN VELOCITY = 2.5 CM/S, 35 DEG TRUE MEAN TEMPERATURE = 4.4 C
 VARIANCE (U,V) = 55.0 CM2/S2 TOTAL HOURS = 744.

PERCENT OBSERVED
 LIGHT (0.0 - 3.0) 14.7% MEDIUM (3.0 - 7.0) 29.8% HIGH (GE 7.0) 55.5%

MOORING IS 97-05C-004A009 DEPTH IS 9 METERS THERE ARE 744 VALUES

FIRST DAY 1997/12/01/0000
 FINAL DAY 1997/12/31/2300

SHORELINE ORIENTATION IN DEGREES TRUE SPECIFIED AS 90

DIRECTION DEG TRUE	PERCENT OBSERVED	MAXIMUM CURRENT	MEAN DURA- TION HOURS	MEAN EXCUR- SION KM	MEAN CURRENT CM/S	MEAN TEMP DEG C
TOWARD	TOTAL	LIGHT	MEDIUM	HIGH	CM/S	
90.0	3.4	1.3	1.6	0.4	13.6	1.3
45.0	50.0	2.7	10.2	37.1	31.1	10.6
0.0	4.4	2.4	1.3	0.7	11.8	1.2
315.0	2.2	1.3	0.8	0.0	5.0	1.0
270.0	4.8	2.0	2.3	0.5	8.8	1.3
225.0	31.0	3.2	10.3	17.5	29.6	6.4
180.0	3.1	1.6	1.5	0.0	6.2	1.4
135.0	1.1	0.8	0.3	0.0	4.0	1.0

MEAN SCALAR SPEED = 8.9 CM/S MEAN SQUARE SPEED = 113.3 CM2/S2
 MEAN SQUARE E-W SPEED = 54.0 CM2/S2 MEAN SQUARE N-S SPEED = 59.3 CM2/S2
 MEAN VELOCITY = 2.5 CM/S, 34 DEG TRUE MEAN TEMPERATURE = 4.4 C
 VARIANCE (U,V) = 53.6 CM2/S2 TOTAL HOURS = 744.

PERCENT OBSERVED
 LIGHT (0.0 - 3.0) 15.5% MEDIUM (3.0 - 7.0) 28.4% HIGH (GE 7.0) 56.2%

DATE: 1998/01/01 TO 1998/01/31
 ROSE SUMMARY: WIND AND CURRENT

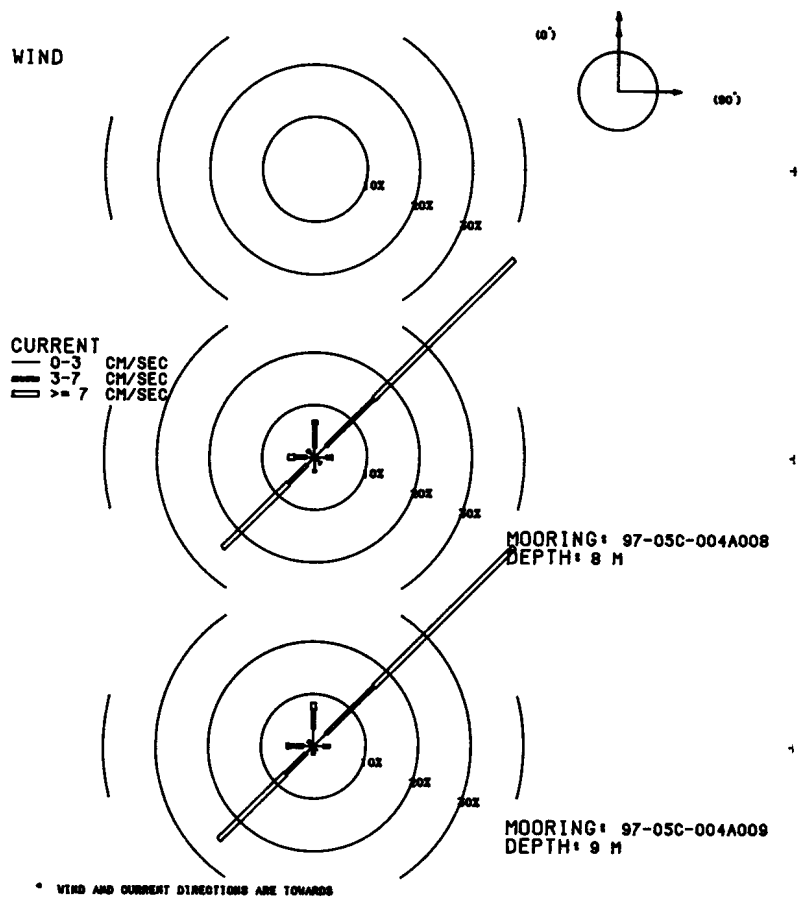

MOORING IS 97-05C-004A008 DEPTH IS 8 METERS THERE ARE 744 VALUES

FIRST DAY 1998/01/01/0000
 FINAL DAY 1998/01/31/2300

SHORELINE ORIENTATION IN DEGREES TRUE SPECIFIED AS 90

DIRECTION DEG TRUE	PERCENT OBSERVED	MAXIMUM CURRENT CM/S	MEAN DURA- TION HOURS	MEAN EXCUR- SION KM	MEAN CURRENT CM/S	MEAN TEMP DEG C
TOWARD	TOTAL	LIGHT	MEDIUM	HIGH		
90.0	3.4	2.2	1.1	0.1	8.0	1.0
45.0	53.6	3.1	12.8	37.8	32.9	9.5
0.0	7.0	1.9	4.4	0.7	13.9	1.7
315.0	1.9	1.5	0.4	0.0	3.7	1.3
270.0	5.1	1.6	2.2	1.3	10.8	1.9
225.0	24.6	2.0	5.0	17.6	24.8	7.6
180.0	2.8	2.4	0.4	0.0	6.7	1.3
135.0	1.6	1.5	0.1	0.0	3.3	2.0
0	MEAN SCALAR SPEED = 9.6 CM/S		MEAN SQUARE SPEED = 135.1 CM2/S2			
	MEAN SQUARE E-W SPEED = 65.5 CM2/S2		MEAN SQUARE N-S SPEED = 69.6 CM2/S2			
	MEAN VELOCITY = 3.7 CM/S,		36 DEG TRUE		MEAN TEMPERATURE = 1.7 C	
	VARIANCE (U,V) = 60.8 CM2/S2		TOTAL HOURS = 744.			

PERCENT OBSERVED
 LIGHT (0.0 - 3.0) 16.1% MEDIUM (3.0 - 7.0) 26.3% HIGH (GE 7.0) 57.5%

MOORING IS 97-05C-004A009 DEPTH IS 9 METERS THERE ARE 744 VALUES

FIRST DAY 1998/01/01/0000
 FINAL DAY 1998/01/31/2300

SHORELINE ORIENTATION IN DEGREES TRUE SPECIFIED AS 90

DIRECTION DEG TRUE	PERCENT OBSERVED	MAXIMUM CURRENT CM/S	MEAN DURA- TION HOURS	MEAN EXCUR- SION KM	MEAN CURRENT CM/S	MEAN TEMP DEG C
TOWARD	TOTAL	LIGHT	MEDIUM	HIGH		
90.0	3.2	1.9	1.3	0.0	6.7	1.1
45.0	53.9	3.4	12.8	37.8	33.9	9.1
0.0	8.3	3.4	3.6	1.3	12.4	1.8
315.0	1.3	1.2	0.1	0.0	6.0	1.1
270.0	5.1	1.9	2.8	0.4	9.3	1.5
225.0	25.3	1.9	5.5	17.9	24.6	9.4
180.0	1.6	0.9	0.7	0.0	5.3	1.3
135.0	1.2	1.2	0.0	0.0	3.0	1.0
0	MEAN SCALAR SPEED = 9.5 CM/S		MEAN SQUARE SPEED = 131.4 CM2/S2			
	MEAN SQUARE E-W SPEED = 61.8 CM2/S2		MEAN SQUARE N-S SPEED = 69.6 CM2/S2			
	MEAN VELOCITY = 3.7 CM/S,		36 DEG TRUE		MEAN TEMPERATURE = 1.7 C	
	VARIANCE (U,V) = 58.9 CM2/S2		TOTAL HOURS = 744.			

PERCENT OBSERVED
 LIGHT (0.0 - 3.0) 15.7% MEDIUM (3.0 - 7.0) 26.9% HIGH (GE 7.0) 57.4%

DATE: 1998/02/01 TO 1998/02/28
ROSE SUMMARY: WIND AND CURRENT

WIND

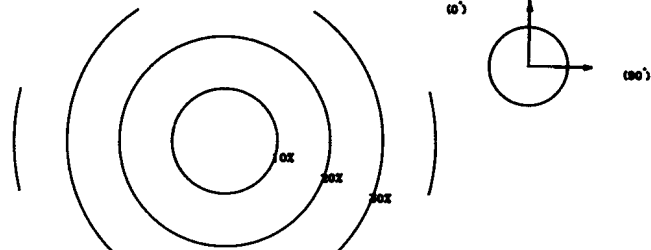

CURRENT

0-3 CM/SEC
3-7 CM/SEC
>= 7 CM/SEC

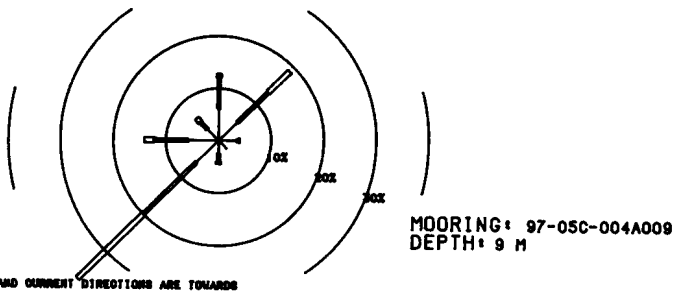
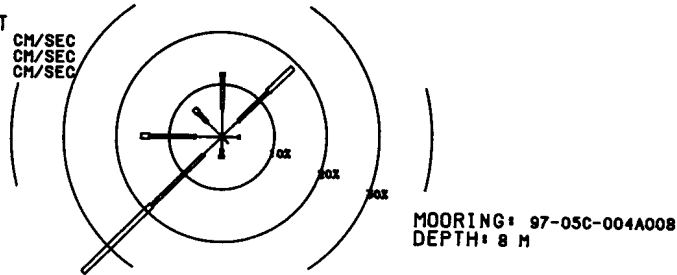

* WIND AND CURRENT DIRECTIONS ARE TOWARDS

MOORING IS 97-05C-004A008 DEPTH IS 8 METERS THERE ARE 672 VALUES

FIRST DAY 1998/02/01/0000
FINAL DAY 1998/02/28/2300

SHORELINE ORIENTATION IN DEGREES TRUE SPECIFIED AS 90

DIRECTION DEG TRUE	PERCENT OBSERVED	TOWARD	TOTAL	LIGHT	MEDIUM	HIGH	MAXIMUM CURRENT CM/S	MEAN DURA- TION HOURS	MEAN EXCUR- SION KM	MEAN CURRENT CM/S	MEAN TEMP DEG C
90.0	3.4	3.1	0.3	0.0	0.0	5.8	1.1	0.1	1.8	1.9	
45.0	18.9	4.3	8.0	6.5	16.7	3.0	0.7	6.4	1.7		
0.0	12.2	5.4	6.2	0.6	12.0	1.6	0.2	3.5	1.6		
315.0	7.4	3.9	2.5	1.0	11.0	1.9	0.2	3.7	1.8		
270.0	15.3	4.9	8.8	1.6	13.3	1.9	0.3	4.2	2.0		
225.0	36.9	4.9	13.7	18.3	20.1	4.9	1.4	7.9	1.8		
180.0	4.0	2.4	1.2	0.4	9.6	1.3	0.1	3.1	1.8		
135.0	1.8	1.8	0.0	0.0	2.3	1.1	0.1	1.3	2.0		
0	MEAN SCALAR SPEED = 5.7 CM/S		MEAN SQUARE SPEED = 50.0 CM2/S2								
	MEAN SQUARE E-W SPEED = 26.5 CM2/S2		MEAN SQUARE N-S SPEED = 23.5 CM2/S2								
	MEAN VELOCITY = 2.1 CM/S,		249 DEG TRUE		MEAN TEMPERATURE = 1.8 C						
	VARIANCE (U,V) = 22.8 CM2/S2		TOTAL HOURS = 672.								

PERCENT OBSERVED
LIGHT (0.0 - 3.0) 30.7% MEDIUM (3.0 - 7.0) 40.8% HIGH (GE 7.0) 28.6%

MOORING IS 97-05C-004A009 DEPTH IS 9 METERS THERE ARE 672 VALUES

FIRST DAY 1998/02/01/0000
FINAL DAY 1998/02/28/2300

SHORELINE ORIENTATION IN DEGREES TRUE SPECIFIED AS 90

DIRECTION DEG TRUE	PERCENT OBSERVED	TOWARD	TOTAL	LIGHT	MEDIUM	HIGH	MAXIMUM CURRENT CM/S	MEAN DURA- TION HOURS	MEAN EXCUR- SION KM	MEAN CURRENT CM/S	MEAN TEMP DEG C
90.0	4.0	3.4	0.4	0.1	7.1	1.1	0.1	2.1	2.0		
45.0	18.9	4.9	8.2	5.8	16.9	3.3	0.7	6.1	1.6		
0.0	12.8	6.1	6.0	0.7	11.3	1.8	0.2	3.5	1.6		
315.0	6.0	3.0	1.9	1.0	10.3	1.3	0.2	3.8	1.8		
270.0	14.1	5.7	6.5	1.9	10.6	2.0	0.3	3.9	2.0		
225.0	37.5	6.0	13.7	17.9	18.8	5.4	1.5	7.6	1.7		
180.0	4.5	2.5	1.5	0.4	8.3	1.2	0.2	3.5	2.0		
135.0	2.2	2.2	0.0	0.0	2.9	1.2	0.1	1.3	2.2		
0	MEAN SCALAR SPEED = 5.5 CM/S		MEAN SQUARE SPEED = 47.5 CM2/S2								
	MEAN SQUARE E-W SPEED = 25.1 CM2/S2		MEAN SQUARE N-S SPEED = 22.4 CM2/S2								
	MEAN VELOCITY = 2.0 CM/S,		247 DEG TRUE		MEAN TEMPERATURE = 1.8 C						
	VARIANCE (U,V) = 21.9 CM2/S2		TOTAL HOURS = 672.								

PERCENT OBSERVED
LIGHT (0.0 - 3.0) 33.8% MEDIUM (3.0 - 7.0) 38.2% HIGH (GE 7.0) 28.0%

DATE: 1998/03/01 TO 1998/03/31
 ROSE SUMMARY: WIND AND CURRENT

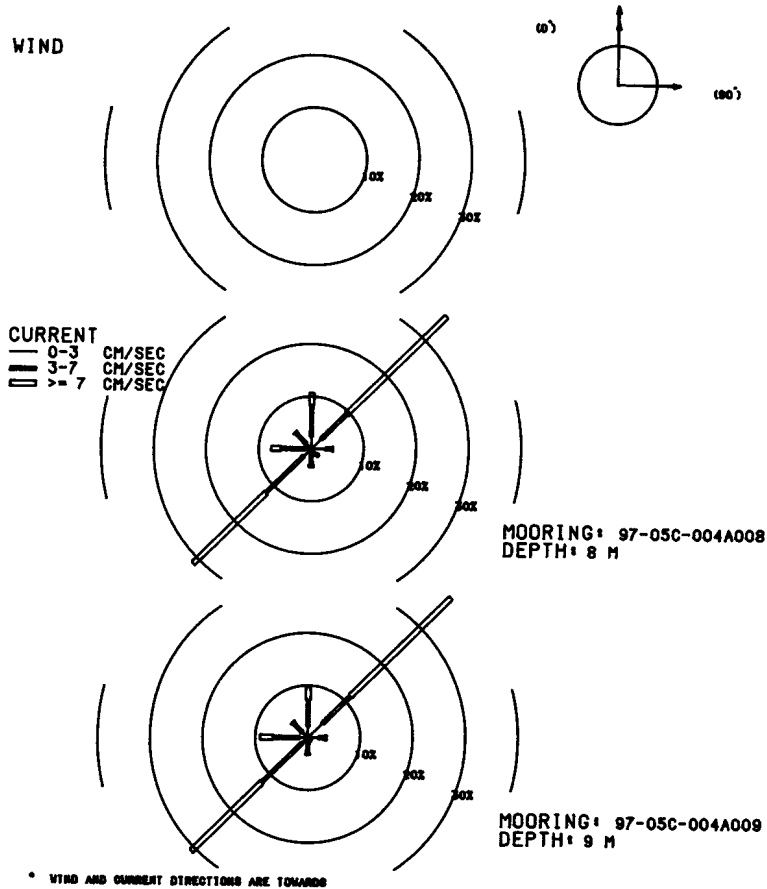

MOORING IS 97-05C-004A008 DEPTH IS 8 METERS THERE ARE 744 VALUES

FIRST DAY 1998/03/01/0000
 FINAL DAY 1998/03/31/2300

SHORELINE ORIENTATION IN DEGREES TRUE SPECIFIED AS 90

DIRECTION DEG TRUE	PERCENT OBSERVED	MAXIMUM CURRENT	MEAN DURATION HOURS	MEAN EXCURSION KM	MEAN CURRENT CM/S	MEAN TEMP DEG C
TOWARD	TOTAL	LIGHT	MEDIUM	HIGH	CM/S	
90.0	4.2	2.7	1.3	0.1	9.5	3.2
45.0	36.2	2.6	6.9	26.7	32.6	2.8
0.0	10.8	2.4	5.9	2.4	23.3	2.5
315.0	4.4	1.2	3.1	0.1	9.7	2.5
270.0	7.7	1.1	4.7	1.9	21.8	2.5
225.0	31.3	2.0	9.9	19.4	55.1	2.3
180.0	3.5	0.8	2.3	0.4	7.9	2.7
135.0	2.0	1.3	0.7	0.0	5.3	2.9
0		MEAN SCALAR SPEED = 9.6 CM/S	MEAN SQUARE SPEED = 163.4 CM2/S2			
		MEAN SQUARE E-W SPEED = 90.6 CM2/S2	MEAN SQUARE N-S SPEED = 72.8 CM2/S2			
		MEAN VELOCITY = 1.0 CM/S,	337 DEG TRUE		MEAN TEMPERATURE = 2.6 C	
		VARIANCE (U,V) = 81.3 CM2/S2	TOTAL HOURS = 744.			

PERCENT OBSERVED
 LIGHT (0.0 - 3.0) 14.1% MEDIUM (3.0 - 7.0) 34.8% HIGH (GE 7.0) 51.1%

MOORING IS 97-05C-004A009 DEPTH IS 9 METERS THERE ARE 744 VALUES

FIRST DAY 1998/03/01/0000
 FINAL DAY 1998/03/31/2300

SHORELINE ORIENTATION IN DEGREES TRUE SPECIFIED AS 90

DIRECTION DEG TRUE	PERCENT OBSERVED	MAXIMUM CURRENT	MEAN DURATION HOURS	MEAN EXCURSION KM	MEAN CURRENT CM/S	MEAN TEMP DEG C
TOWARD	TOTAL	LIGHT	MEDIUM	HIGH	CM/S	
90.0	3.6	2.0	1.2	0.4	8.5	3.2
45.0	38.2	3.9	7.4	26.9	33.1	2.8
0.0	9.7	2.2	5.1	2.4	19.0	2.5
315.0	4.2	1.3	2.6	0.3	11.1	2.4
270.0	9.1	1.6	5.0	2.6	23.3	2.5
225.0	30.9	1.5	10.6	18.8	55.0	2.3
180.0	3.4	0.9	2.2	0.3	8.1	2.6
135.0	0.9	0.5	0.4	0.0	5.4	2.5
0		MEAN SCALAR SPEED = 9.5 CM/S	MEAN SQUARE SPEED = 160.3 CM2/S2			
		MEAN SQUARE E-W SPEED = 90.5 CM2/S2	MEAN SQUARE N-S SPEED = 69.8 CM2/S2			
		MEAN VELOCITY = 1.1 CM/S,	340 DEG TRUE		MEAN TEMPERATURE = 2.6 C	
		VARIANCE (U,V) = 79.7 CM2/S2	TOTAL HOURS = 744.			

PERCENT OBSERVED
 LIGHT (0.0 - 3.0) 14.0% MEDIUM (3.0 - 7.0) 34.4% HIGH (GE 7.0) 51.6%

DATE: 1998/04/01 TO 1998/04/30
 ROSE SUMMARY: WIND AND CURRENT

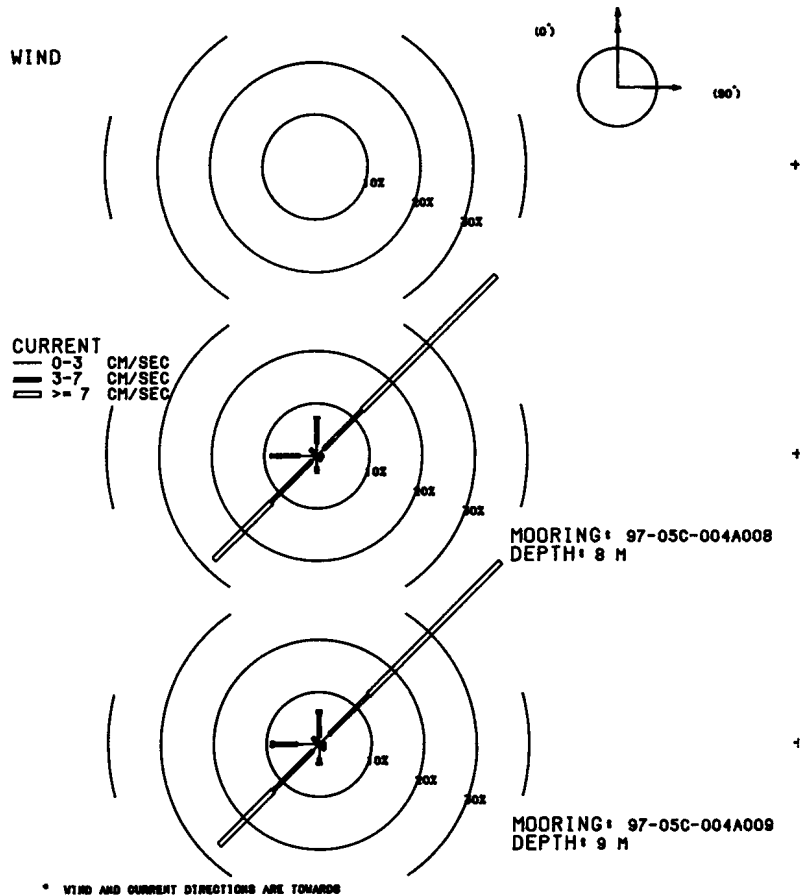

MOORING IS 97-05C-004A008 DEPTH IS 8 METERS THERE ARE 337 VALUES

FIRST DAY 1998/04/01/0000
 FINAL DAY 1998/04/15/0000

SHORELINE ORIENTATION IN DEGREES TRUE SPECIFIED AS 90

DIRECTION DEG TRUE	PERCENT OBSERVED	MAXIMUM CURRENT	MEAN DURATION HOURS	MEAN EXCURSION KM	MEAN CURRENT CM/S	MEAN TEMP DEG C
TOWARD	TOTAL	LIGHT	MEDIUM	HIGH	CM/S	
90.0	1.2	0.9	0.3	0.0	4.1	5.7
45.0	48.4	1.8	10.4	36.2	19.2	5.4
0.0	7.4	2.4	4.7	0.3	7.5	5.6
315.0	1.8	1.2	0.6	0.0	3.7	5.5
270.0	8.9	3.3	5.6	0.0	6.1	5.3
225.0	27.9	1.5	11.0	15.4	18.1	4.7
180.0	3.3	2.1	1.2	0.0	6.7	5.5
135.0	1.2	0.9	0.3	0.0	3.4	5.4
MEAN SCALAR SPEED = 7.9 CM/S		MEAN SQUARE SPEED = 82.6 CM2/S2				
MEAN SQUARE E-W SPEED = 37.5 CM2/S2		MEAN SQUARE N-S SPEED = 45.2 CM2/S2				
MEAN VELOCITY = 2.4 CM/S,		33 DEG TRUE		MEAN TEMPERATURE = 5.2 C		
VARIANCE (U,V) = 38.4 CM2/S2		TOTAL HOURS = 337.				

PERCENT OBSERVED
 LIGHT (0.0 - 3.0) 13.9% MEDIUM (3.0 - 7.0) 34.1% HIGH (GE 7.0) 51.9%

MOORING IS 97-05C-004A009 DEPTH IS 9 METERS THERE ARE 337 VALUES

FIRST DAY 1998/04/01/0000
 FINAL DAY 1998/04/15/0000

SHORELINE ORIENTATION IN DEGREES TRUE SPECIFIED AS 90

DIRECTION DEG TRUE	PERCENT OBSERVED	MAXIMUM CURRENT	MEAN DURATION HOURS	MEAN EXCURSION KM	MEAN CURRENT CM/S	MEAN TEMP DEG C
TOWARD	TOTAL	LIGHT	MEDIUM	HIGH	CM/S	
90.0	1.2	0.6	0.6	0.0	5.7	5.6
45.0	49.0	2.7	10.7	35.6	17.8	5.4
0.0	6.5	1.5	4.5	0.6	9.1	5.6
315.0	1.8	0.9	0.9	0.0	5.1	5.3
270.0	9.2	4.2	4.5	0.6	9.4	5.3
225.0	27.0	1.8	10.7	14.5	18.5	4.7
180.0	3.9	2.7	0.9	0.3	9.9	5.3
135.0	1.5	1.2	0.3	0.0	3.1	5.4
MEAN SCALAR SPEED = 7.8 CM/S		MEAN SQUARE SPEED = 79.0 CM2/S2				
MEAN SQUARE E-W SPEED = 36.5 CM2/S2		MEAN SQUARE N-S SPEED = 42.5 CM2/S2				
MEAN VELOCITY = 2.3 CM/S,		32 DEG TRUE		MEAN TEMPERATURE = 5.2 C		
VARIANCE (U,V) = 36.8 CM2/S2		TOTAL HOURS = 337.				

PERCENT OBSERVED
 LIGHT (0.0 - 3.0) 15.4% MEDIUM (3.0 - 7.0) 32.9% HIGH (GE 7.0) 51.6%

DATE: 1997/11/02 TO 1997/11/30
 ROSE SUMMARY: WIND AND CURRENT

WIND

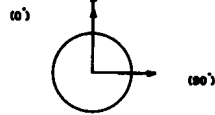
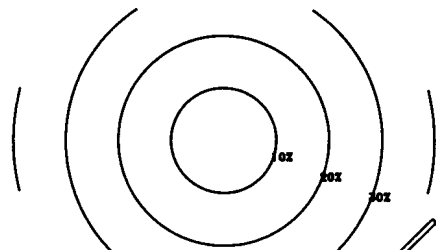

CURRENT
 — 0-3 CM/SEC
 = 3-7 CM/SEC
 ≡ >= 7 CM/SEC

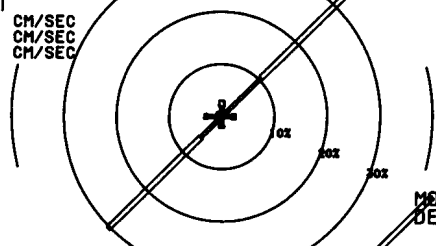

MOORING: 97-05C-004A010
 DEPTH: 10 M

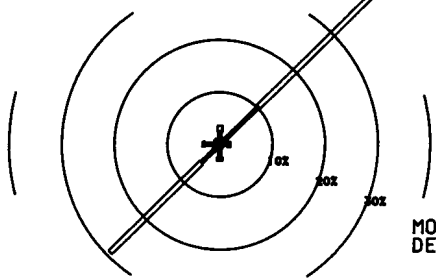

MOORING: 97-05C-004A011
 DEPTH: 11 M

* WIND AND CURRENT DIRECTIONS ARE TOWARDS

MOORING IS 97-05C-004A010 DEPTH IS 10 METERS THERE ARE 691 VALUES

FIRST DAY 1997/11/02/0500
 FINAL DAY 1997/11/30/2300

SHORELINE ORIENTATION IN DEGREES TRUE SPECIFIED AS 90

DIRECTION DEG TRUE	PERCENT OBSERVED	TOWARD	TOTAL	LIGHT	MEDIUM	HIGH	MAXIMUM CURRENT CM/S	MEAN DURA- TION HOURS	MEAN EXCUR- SION KM	MEAN CURRENT CM/S	MEAN TEMP DEG C
90.0	2.6	0.6	1.3	0.7	12.1	1.3	0.3	5.4	8.5		
45.0	56.7	0.6	9.8	46.3	29.2	14.5	6.6	12.6	8.3		
0.0	3.0	0.6	1.3	1.2	17.0	1.4	0.3	6.5	8.1		
315.0	1.2	0.7	0.4	0.0	3.8	1.6	0.2	2.7	7.9		
270.0	3.3	0.7	2.0	0.6	10.2	1.8	0.3	5.1	7.8		
225.0	30.4	0.4	5.2	24.7	27.7	10.5	4.7	12.5	8.8		
180.0	2.2	0.6	1.2	0.4	13.5	1.2	0.2	5.1	8.5		
135.0	0.6	0.3	0.3	0.0	4.3	1.0	0.1	3.2	9.2		

MEAN SCALAR SPEED = 11.6 CM/S MEAN SQUARE SPEED = 172.7 CM2/S2
 MEAN SQUARE E-W SPEED = 80.7 CM2/S2 MEAN SQUARE N-S SPEED = 92.0 CM2/S2
 MEAN VELOCITY = 3.4 CM/S, 44 DEG TRUE MEAN TEMPERATURE = 8.5 C
 VARIANCE(U,V) = 80.8 CM2/S2 TOTAL HOURS = 691.

PERCENT OBSERVED
 LIGHT (0.0 - 3.0) 4.5% MEDIUM (3.0 - 7.0) 21.6% HIGH (GE 7.0) 74.0%

MOORING IS 97-05C-004A011 DEPTH IS 11 METERS THERE ARE 691 VALUES

FIRST DAY 1997/11/02/0500
 FINAL DAY 1997/11/30/2300

SHORELINE ORIENTATION IN DEGREES TRUE SPECIFIED AS 90

DIRECTION DEG TRUE	PERCENT OBSERVED	TOWARD	TOTAL	LIGHT	MEDIUM	HIGH	MAXIMUM CURRENT CM/S	MEAN DURA- TION HOURS	MEAN EXCUR- SION KM	MEAN CURRENT CM/S	MEAN TEMP DEG C
90.0	2.0	0.4	1.0	0.6	12.9	1.6	0.3	5.6	8.5		
45.0	56.6	0.9	9.4	46.3	30.9	15.0	6.8	12.5	8.4		
0.0	3.6	1.0	1.4	1.2	17.1	1.2	0.3	6.5	7.9		
315.0	1.3	0.9	0.4	0.0	5.5	1.1	0.1	2.9	7.3		
270.0	3.3	1.0	1.9	0.4	9.9	1.6	0.3	4.4	7.7		
225.0	29.2	0.4	4.5	24.3	29.1	11.2	5.1	12.5	8.9		
180.0	3.2	0.6	1.9	0.7	13.3	1.8	0.4	5.7	8.4		
135.0	0.7	0.6	0.1	0.0	4.0	1.2	0.1	2.6	8.5		

MEAN SCALAR SPEED = 11.5 CM/S MEAN SQUARE SPEED = 170.2 CM2/S2
 MEAN SQUARE E-W SPEED = 77.1 CM2/S2 MEAN SQUARE N-S SPEED = 93.2 CM2/S2
 MEAN VELOCITY = 3.4 CM/S, 43 DEG TRUE MEAN TEMPERATURE = 8.5 C
 VARIANCE(U,V) = 79.3 CM2/S2 TOTAL HOURS = 691.

PERCENT OBSERVED
 LIGHT (0.0 - 3.0) 5.8% MEDIUM (3.0 - 7.0) 20.7% HIGH (GE 7.0) 73.5%

DATE: 1997/12/01 TO 1997/12/31
 ROSE SUMMARY: WIND AND CURRENT

WIND

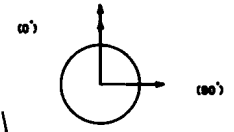
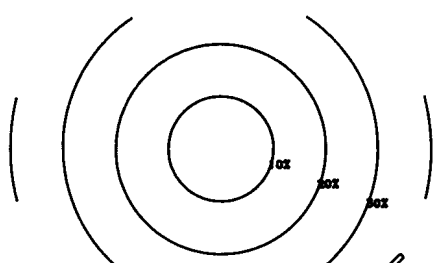

CURRENT
 — 0-3 CM/SEC
 = 3-7 CM/SEC
 ▭ >= 7 CM/SEC

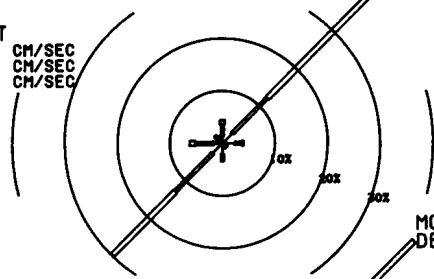

MOORING: 97-05C-004A010
 DEPTH: 10 M

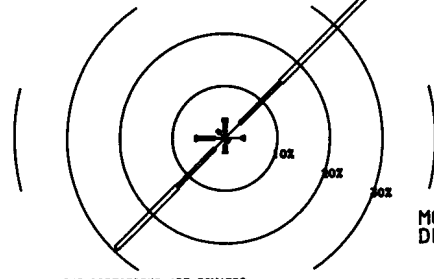

MOORING: 97-05C-004A011
 DEPTH: 11 M

* WIND AND CURRENT DIRECTIONS ARE TOWARDS

MOORING IS 97-05C-004A010 DEPTH IS 10 METERS THERE ARE 744 VALUES

FIRST DAY 1997/12/01/0000
 FINAL DAY 1997/12/31/2300

SHORELINE ORIENTATION IN DEGREES TRUE SPECIFIED AS 90

DIRECTION DEG TRUE	PERCENT OBSERVED	TOWARD	TOTAL	LIGHT	MEDIUM	HIGH	MAXIMUM CURRENT CM/S	MEAN DURATION HOURS	MEAN EXCURSION KM	MEAN CURRENT CM/S	MEAN TEMP DEG C
90.0	4.0	2.3	1.5	0.3			13.0	1.2	0.1	3.0	4.6
45.0	48.7	2.6	9.5	36.6			30.4	9.1	3.5	10.7	4.3
0.0	4.4	1.3	2.3	0.8			10.9	1.3	0.2	4.6	4.4
315.0	2.0	0.9	1.1	0.0			5.8	1.2	0.1	3.0	4.3
270.0	6.3	1.6	3.6	1.1			9.0	1.6	0.3	4.3	4.2
225.0	30.0	2.6	10.2	17.2			29.9	5.9	2.0	9.3	4.6
180.0	3.5	2.0	1.5	0.0			6.2	1.2	0.1	2.8	4.9
135.0	1.1	0.9	0.1	0.0			3.4	1.0	0.1	1.4	3.9
MEAN SCALAR SPEED =		8.7 CM/S		MEAN SQUARE SPEED =		110.9 CM2/S2					
MEAN SQUARE E-W SPEED =		52.0 CM2/S2		MEAN SQUARE N-S SPEED =		58.9 CM2/S2					
MEAN VELOCITY =		2.5 CM/S,		28 DEG TRUE		MEAN TEMPERATURE =		4.4 C			
VARIANCE (U,V) =		52.5 CM2/S2		TOTAL HOURS =		744.					

PERCENT OBSERVED
 LIGHT (0.0 - 3.0) 14.2% MEDIUM (3.0 - 7.0) 29.8% HIGH (GE 7.0) 55.9%

MOORING IS 97-05C-004A011 DEPTH IS 11 METERS THERE ARE 744 VALUES

FIRST DAY 1997/12/01/0000
 FINAL DAY 1997/12/31/2300

SHORELINE ORIENTATION IN DEGREES TRUE SPECIFIED AS 90

DIRECTION DEG TRUE	PERCENT OBSERVED	TOWARD	TOTAL	LIGHT	MEDIUM	HIGH	MAXIMUM CURRENT CM/S	MEAN DURATION HOURS	MEAN EXCURSION KM	MEAN CURRENT CM/S	MEAN TEMP DEG C
90.0	3.8	3.1	0.5	0.1			8.7	1.2	0.1	2.3	4.3
45.0	51.2	4.0	11.0	36.2			31.4	13.1	4.9	10.3	4.3
0.0	3.8	1.2	1.9	0.7			10.1	1.3	0.2	4.5	4.3
315.0	2.2	1.3	0.8	0.0			5.4	1.3	0.1	3.1	4.4
270.0	5.8	2.0	3.4	0.4			8.9	1.4	0.2	4.0	4.1
225.0	29.4	2.7	10.2	16.5			29.0	5.8	1.9	9.3	4.6
180.0	2.8	1.5	1.2	0.1			7.7	1.2	0.1	3.3	5.2
135.0	1.1	0.8	0.3	0.0			3.5	1.1	0.1	1.9	4.5
MEAN SCALAR SPEED =		8.7 CM/S		MEAN SQUARE SPEED =		109.3 CM2/S2					
MEAN SQUARE E-W SPEED =		49.7 CM2/S2		MEAN SQUARE N-S SPEED =		59.6 CM2/S2					
MEAN VELOCITY =		2.5 CM/S,		29 DEG TRUE		MEAN TEMPERATURE =		4.4 C			
VARIANCE (U,V) =		51.6 CM2/S2		TOTAL HOURS =		744.					

PERCENT OBSERVED
 LIGHT (0.0 - 3.0) 16.7% MEDIUM (3.0 - 7.0) 29.3% HIGH (GE 7.0) 54.0%

DATE: 1998/01/01 TO 1998/01/31
ROSE SUMMARY: WIND AND CURRENT

WIND

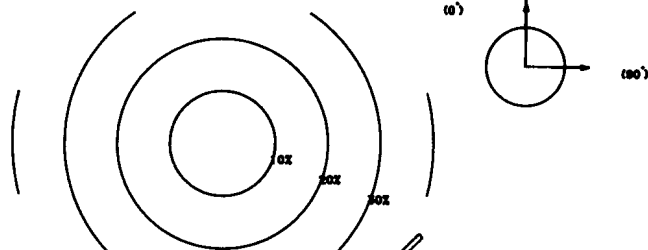

CURRENT
 0-3 CM/SEC
 3-7 CM/SEC
 >= 7 CM/SEC

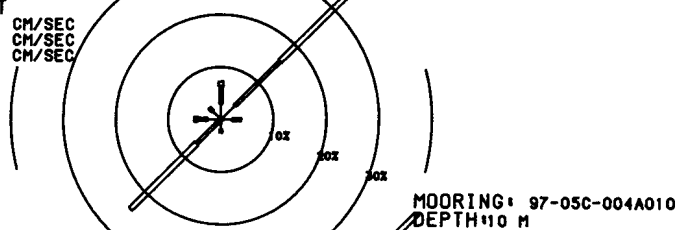

MOORING: 97-05C-004A010
DEPTH: 10 M

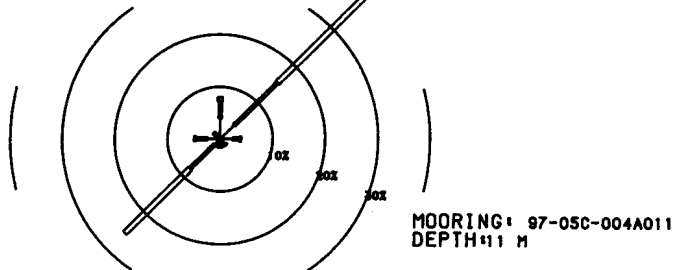

MOORING: 97-05C-004A011
DEPTH: 11 M

* WIND AND CURRENT DIRECTIONS ARE TOWARDS

MOORING IS 97-05C-004A010 DEPTH IS 10 METERS THERE ARE 744 VALUES

FIRST DAY 1998/01/01/0000
FINAL DAY 1998/01/31/2300

SHORELINE ORIENTATION IN DEGREES TRUE SPECIFIED AS 90

DIRECTION DEG TRUE	PERCENT OBSERVED	TOWARD	TOTAL	LIGHT	MEDIUM	HIGH	MAXIMUM CURRENT CM/S	MEAN DURA- TION HOURS	MEAN EXCUR- SION KM	MEAN CURRENT CM/S	MEAN TEMP DEG C
90.0	3.9	2.2	1.7	0.0	0.0	6.5	1.5	0.2	2.9	1.6	
45.0	53.4	3.8	12.0	37.6	33.4	33.4	9.0	3.7	11.3	1.8	
0.0	7.3	3.0	3.4	0.9	10.3	1.6	1.6	0.2	4.2	1.7	
315.0	3.1	2.2	0.9	0.0	4.6	1.5	1.5	0.1	2.4	1.7	
270.0	5.1	2.6	1.9	0.7	9.2	1.5	1.5	0.2	3.7	1.6	
225.0	24.3	0.7	5.8	17.9	24.6	7.9	3.0	10.7	1.7		
180.0	2.6	2.0	0.5	0.0	6.2	1.1	1.1	0.1	2.4	1.7	
135.0	0.4	0.3	0.1	0.0	3.4	1.5	0.1	2.0	1.4		

0 MEAN SCALAR SPEED = 9.4 CM/S MEAN SQUARE SPEED = 129.1 CM2/S2
 MEAN SQUARE E-W SPEED = 59.2 CM2/S2 MEAN SQUARE N-S SPEED = 69.9 CM2/S2
 MEAN VELOCITY = 3.6 CM/S, 34 DEG TRUE MEAN TEMPERATURE = 1.7 C
 VARIANCE (U,V) = 58.0 CM2/S2 TOTAL HOURS = 744.

PERCENT OBSERVED
 LIGHT (0.0 - 3.0) 16.5% MEDIUM (3.0 - 7.0) 26.3% HIGH (GE 7.0) 57.1%

MOORING IS 97-05C-004A011 DEPTH IS 11 METERS THERE ARE 744 VALUES

FIRST DAY 1998/01/01/0000
FINAL DAY 1998/01/31/2300

SHORELINE ORIENTATION IN DEGREES TRUE SPECIFIED AS 90

DIRECTION DEG TRUE	PERCENT OBSERVED	TOWARD	TOTAL	LIGHT	MEDIUM	HIGH	MAXIMUM CURRENT CM/S	MEAN DURA- TION HOURS	MEAN EXCUR- SION KM	MEAN CURRENT CM/S	MEAN TEMP DEG C
90.0	4.0	2.4	1.3	0.3	7.5	1.2	0.1	2.9	1.5		
45.0	52.6	3.6	11.7	37.2	33.1	8.0	3.3	11.3	1.8		
0.0	8.1	3.9	3.4	0.8	12.0	1.7	0.2	3.8	1.7		
315.0	1.7	1.1	0.7	0.0	4.9	1.1	0.1	2.7	1.7		
270.0	5.0	2.4	2.2	0.4	7.5	1.5	0.2	3.5	1.6		
225.0	25.4	1.6	6.3	17.5	21.9	8.6	3.1	10.2	1.7		
180.0	1.6	0.9	0.5	0.1	12.3	1.2	0.2	3.5	1.5		
135.0	1.6	1.3	0.3	0.0	3.6	1.0	0.1	2.4	1.5		

0 MEAN SCALAR SPEED = 9.3 CM/S MEAN SQUARE SPEED = 125.3 CM2/S2
 MEAN SQUARE E-W SPEED = 56.0 CM2/S2 MEAN SQUARE N-S SPEED = 69.2 CM2/S2
 MEAN VELOCITY = 3.6 CM/S, 34 DEG TRUE MEAN TEMPERATURE = 1.7 C
 VARIANCE (U,V) = 56.4 CM2/S2 TOTAL HOURS = 744.

PERCENT OBSERVED
 LIGHT (0.0 - 3.0) 17.3% MEDIUM (3.0 - 7.0) 26.3% HIGH (GE 7.0) 56.3%

DATE: 1998/02/01 TO 1998/02/28
ROSE SUMMARY: WIND AND CURRENT

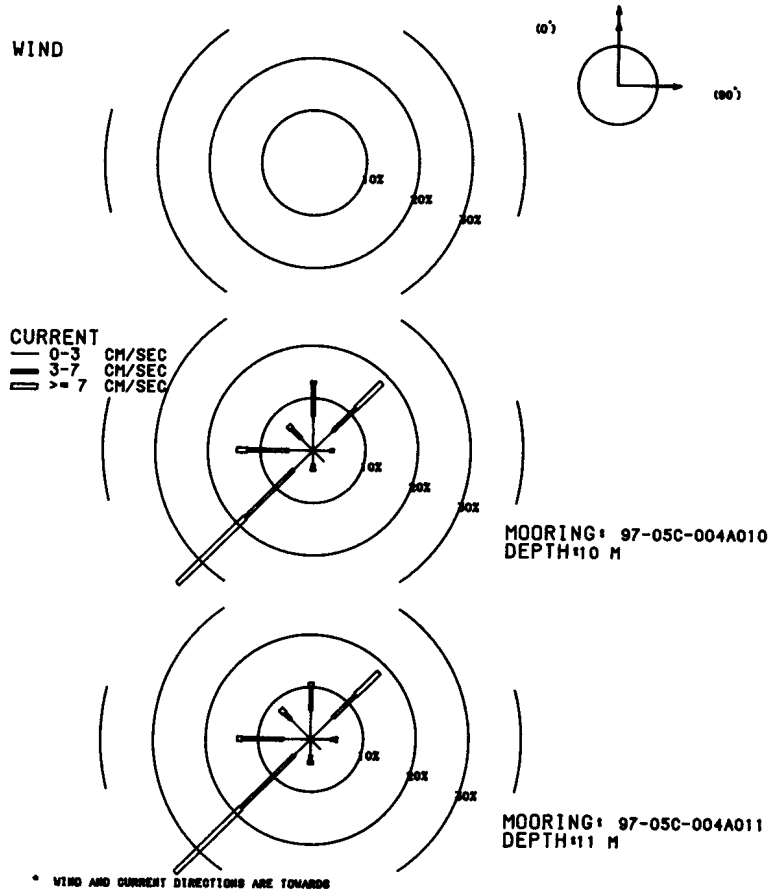

MOORING IS 97-05C-004A010 DEPTH IS 10 METERS THERE ARE 672 VALUES

FIRST DAY 1998/02/01/0000
FINAL DAY 1998/02/28/2300

SHORELINE ORIENTATION IN DEGREES TRUE SPECIFIED AS 90

DIRECTION DEG TRUE	PERCENT OBSERVED	TOWARD	TOTAL	LIGHT	MEDIUM	HIGH	MAXIMUM CURRENT CM/S	MEAN DURATION HOURS	MEAN EXCURSION KM	MEAN CURRENT CM/S	MEAN TEMP DEG C
90.0	4.0	3.3	0.7	0.0	0.0	3.7	1.3	0.1	2.1	1.8	
45.0	18.5	5.4	6.1	7.0	18.4	3.2	0.7	6.4	1.6		
0.0	13.2	6.5	6.1	0.6	10.6	1.8	0.2	3.3	1.7		
315.0	6.7	3.3	2.5	0.9	10.3	1.4	0.2	3.7	2.0		
270.0	14.6	4.6	7.9	2.1	13.0	1.8	0.3	4.2	2.0		
225.0	36.2	5.2	12.9	18.0	19.8	5.0	1.4	7.8	1.7		
180.0	3.9	2.5	1.0	0.3	7.6	1.1	0.1	2.8	1.7		
135.0	3.0	3.0	0.0	0.0	2.8	1.2	0.1	1.8	2.3		
0		MEAN SCALAR SPEED = 5.5 CM/S		MEAN SQUARE SPEED = 47.8 CM2/S2							
		MEAN SQUARE E-W SPEED = 24.9 CM2/S2		MEAN SQUARE N-S SPEED = 22.9 CM2/S2							
		MEAN VELOCITY = 2.0 CM/S,		249 DEG TRUE		MEAN TEMPERATURE = 1.8 C					
		VARIANCE (U,V) = 22.0 CM2/S2		TOTAL HOURS = 672.							

PERCENT OBSERVED
LIGHT (0.0 - 3.0) 33.8% MEDIUM (3.0 - 7.0) 37.4% HIGH (GE 7.0) 28.9%

MOORING IS 97-05C-004A011 DEPTH IS 11 METERS THERE ARE 672 VALUES

FIRST DAY 1998/02/01/0000
FINAL DAY 1998/02/28/2300

SHORELINE ORIENTATION IN DEGREES TRUE SPECIFIED AS 90

DIRECTION DEG TRUE	PERCENT OBSERVED	TOWARD	TOTAL	LIGHT	MEDIUM	HIGH	MAXIMUM CURRENT CM/S	MEAN DURATION HOURS	MEAN EXCURSION KM	MEAN CURRENT CM/S	MEAN TEMP DEG C
90.0	5.1	3.9	0.9	0.3	8.3	1.4	0.1	2.5	1.7		
45.0	18.3	6.0	6.1	6.2	18.3	2.9	0.6	6.0	1.6		
0.0	10.9	5.5	4.5	0.9	13.6	1.7	0.2	3.5	1.6		
315.0	8.2	5.4	1.6	1.2	10.0	1.6	0.2	3.1	1.9		
270.0	14.0	5.2	7.9	0.9	10.7	1.9	0.3	3.7	2.0		
225.0	36.2	4.3	14.3	17.6	20.7	5.3	1.5	7.8	1.7		
180.0	4.8	3.1	1.0	0.6	9.0	1.3	0.1	3.2	2.1		
135.0	2.7	2.7	0.0	0.0	2.9	1.0	0.1	1.5	2.1		
0		MEAN SCALAR SPEED = 5.4 CM/S		MEAN SQUARE SPEED = 46.3 CM2/S2							
		MEAN SQUARE E-W SPEED = 23.8 CM2/S2		MEAN SQUARE N-S SPEED = 22.5 CM2/S2							
		MEAN VELOCITY = 1.9 CM/S,		246 DEG TRUE		MEAN TEMPERATURE = 1.8 C					
		VARIANCE (U,V) = 21.3 CM2/S2		TOTAL HOURS = 672.							

PERCENT OBSERVED
LIGHT (0.0 - 3.0) 36.0% MEDIUM (3.0 - 7.0) 36.3% HIGH (GE 7.0) 27.7%

DATE: 1998/03/01 TO 1998/03/31
 ROSE SUMMARY: WIND AND CURRENT

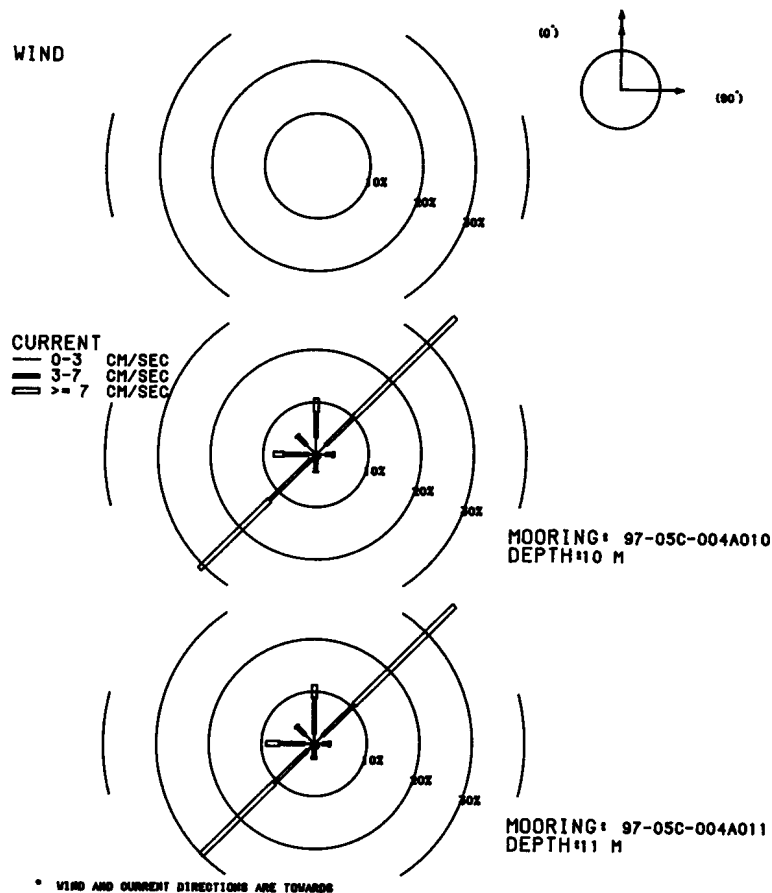

MOORING IS 97-05C-004A010 DEPTH IS 10 METERS THERE ARE 744 VALUES

FIRST DAY 1998/03/01/0000
 FINAL DAY 1998/03/31/2300

SHORELINE ORIENTATION IN DEGREES TRUE SPECIFIED AS 90

DIRECTION DEG TRUE	PERCENT OBSERVED	MAXIMUM CURRENT	MEAN DURATION HOURS	MEAN EXCURSION KM	MEAN CURRENT CM/S	MEAN TEMP DEG C
TOWARD	TOTAL	LIGHT	MEDIUM	HIGH	CM/S	
90.0	3.5	1.9	1.2	0.4	10.0	1.9
45.0	37.2	2.6	7.5	27.2	32.4	7.9
0.0	10.8	3.2	4.8	2.7	24.1	2.3
315.0	5.1	2.6	2.3	0.3	11.2	1.7
270.0	8.1	1.5	4.6	2.0	19.1	2.5
225.0	31.0	1.5	10.9	18.7	55.4	9.6
180.0	3.4	0.8	2.4	0.1	8.6	2.3
135.0	0.9	0.5	0.4	0.0	4.6	1.2
0		MEAN SCALAR SPEED = 9.4 CM/S		MEAN SQUARE SPEED = 157.7 CM2/S2		
		MEAN SQUARE E-W SPEED = 86.9 CM2/S2		MEAN SQUARE N-S SPEED = 70.9 CM2/S2		
		MEAN VELOCITY = 1.1 CM/S, 340 DEG TRUE		MEAN TEMPERATURE = 2.6 C		
		VARIANCE (U,V) = 78.4 CM2/S2		TOTAL HOURS = 744.		

PERCENT OBSERVED
 LIGHT (0.0 - 3.0) 14.5% MEDIUM (3.0 - 7.0) 34.1% HIGH (GE 7.0) 51.3%

MOORING IS 97-05C-004A011 DEPTH IS 11 METERS THERE ARE 744 VALUES

FIRST DAY 1998/03/01/0000
 FINAL DAY 1998/03/31/2300

SHORELINE ORIENTATION IN DEGREES TRUE SPECIFIED AS 90

DIRECTION DEG TRUE	PERCENT OBSERVED	MAXIMUM CURRENT	MEAN DURATION HOURS	MEAN EXCURSION KM	MEAN CURRENT CM/S	MEAN TEMP DEG C
TOWARD	TOTAL	LIGHT	MEDIUM	HIGH	CM/S	
90.0	3.1	1.6	1.1	0.4	9.4	1.4
45.0	37.5	2.3	8.3	26.9	32.7	9.0
0.0	11.3	1.9	6.9	2.6	22.4	2.5
315.0	4.8	2.4	2.2	0.3	13.5	1.4
270.0	9.1	1.9	4.7	2.6	18.2	2.1
225.0	30.1	1.7	8.9	19.5	54.2	7.0
180.0	3.0	0.4	2.2	0.4	7.2	1.6
135.0	1.1	0.7	0.4	0.0	4.1	1.1
0		MEAN SCALAR SPEED = 9.3 CM/S		MEAN SQUARE SPEED = 153.2 CM2/S2		
		MEAN SQUARE E-W SPEED = 85.5 CM2/S2		MEAN SQUARE N-S SPEED = 67.7 CM2/S2		
		MEAN VELOCITY = 1.2 CM/S, 340 DEG TRUE		MEAN TEMPERATURE = 2.6 C		
		VARIANCE (U,V) = 76.0 CM2/S2		TOTAL HOURS = 744.		

PERCENT OBSERVED
 LIGHT (0.0 - 3.0) 12.9% MEDIUM (3.0 - 7.0) 34.5% HIGH (GE 7.0) 52.6%

DATE: 1998/04/01 TO 1998/04/30
ROSE SUMMARY: WIND AND CURRENT

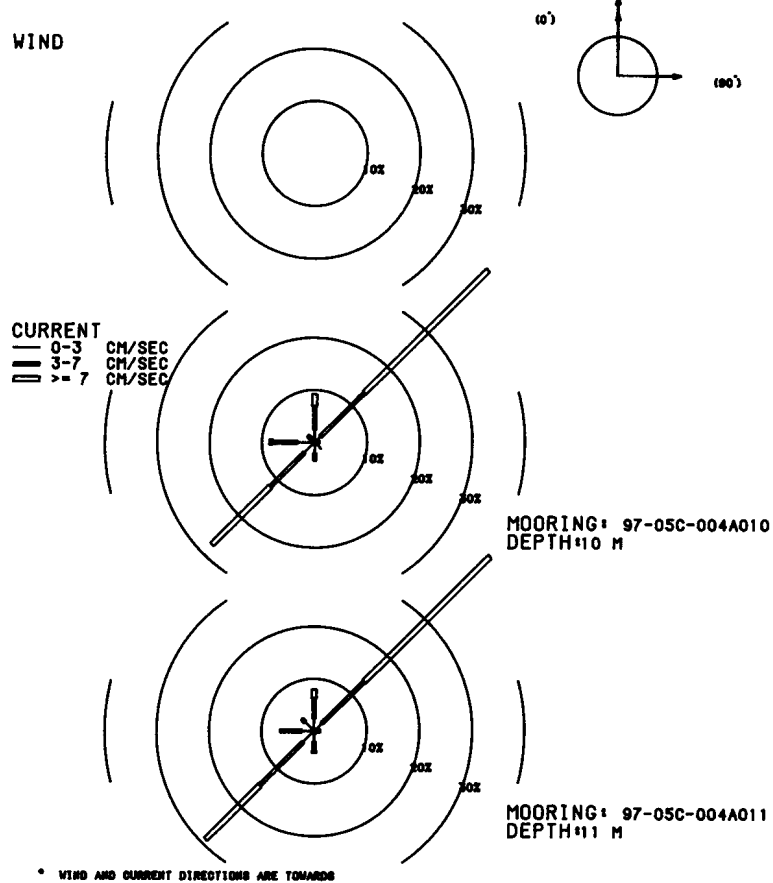

MOORING IS 97-05C-004A010 DEPTH IS 10 METERS THERE ARE 337 VALUES

FIRST DAY 1998/04/01/0000
FINAL DAY 1998/04/15/0000

SHORELINE ORIENTATION IN DEGREES TRUE SPECIFIED AS 90

DIRECTION DEG TRUE	PERCENT OBSERVED	TOWARD	TOTAL	LIGHT	MEDIUM	HIGH	MAXIMUM CURRENT CM/S	MEAN DURA- TION HOURS	MEAN EXCUR- SION KM	MEAN CURRENT CM/S	MEAN TEMP DEG C
90.0	0.9	0.6	0.3	0.0	0.0	0.0	3.6	1.0	0.1	2.7	5.8
45.0	46.6	1.5	11.9	33.2	18.8	14.3	18.8	14.3	4.9	9.6	5.4
0.0	9.2	2.4	4.5	2.4	10.5	2.2	10.5	2.2	0.4	5.1	5.5
315.0	1.8	0.9	0.9	0.0	4.6	1.0	4.6	1.0	0.1	2.7	5.7
270.0	8.6	3.3	4.7	0.6	8.7	1.8	8.7	1.8	0.2	3.7	5.4
225.0	27.6	2.7	9.2	15.7	18.9	5.2	18.9	5.2	1.5	8.0	4.7
180.0	3.6	2.1	1.5	0.0	7.0	1.1	7.0	1.1	0.1	3.0	5.3
135.0	1.8	1.8	0.0	0.0	2.4	1.2	2.4	1.2	0.1	1.4	5.7
0		MEAN SCALAR SPEED = 7.7 CM/S		MEAN SQUARE SPEED = 77.4 CM2/S2							
		MEAN SQUARE E-W SPEED = 35.7 CM2/S2		MEAN SQUARE N-S SPEED = 41.7 CM2/S2							
		MEAN VELOCITY = 2.3 CM/S,		33 DEG TRUE		MEAN TEMPERATURE = 5.2 C					
		VARIANCE (U,V) = 36.1 CM2/S2		TOTAL HOURS = 337.							

PERCENT OBSERVED
LIGHT (0.0 - 3.0) 15.1% MEDIUM (3.0 - 7.0) 32.9% HIGH (GE 7.0) 51.9%

MOORING IS 97-05C-004A011 DEPTH IS 11 METERS THERE ARE 337 VALUES

FIRST DAY 1998/04/01/0000
FINAL DAY 1998/04/15/0000

SHORELINE ORIENTATION IN DEGREES TRUE SPECIFIED AS 90

DIRECTION DEG TRUE	PERCENT OBSERVED	TOWARD	TOTAL	LIGHT	MEDIUM	HIGH	MAXIMUM CURRENT CM/S	MEAN DURA- TION HOURS	MEAN EXCUR- SION KM	MEAN CURRENT CM/S	MEAN TEMP DEG C
90.0	1.2	0.9	0.3	0.0	0.0	0.0	3.0	1.3	0.1	2.2	6.0
45.0	47.2	2.1	11.3	33.8	18.8	15.9	18.8	15.9	5.3	9.3	5.4
0.0	8.0	2.4	3.9	1.8	9.7	2.2	9.7	2.2	0.4	4.8	5.7
315.0	3.3	2.4	0.9	0.0	5.4	1.4	5.4	1.4	0.1	2.6	5.6
270.0	6.5	2.4	4.2	0.0	5.6	2.0	5.6	2.0	0.3	3.5	5.3
225.0	29.1	3.0	11.6	14.5	18.3	6.5	18.3	6.5	1.8	7.9	4.7
180.0	4.2	2.1	1.8	0.3	7.3	1.3	7.3	1.3	0.1	3.1	5.3
135.0	0.6	0.3	0.3	0.0	3.8	1.0	3.8	1.0	0.1	2.7	5.8
0		MEAN SCALAR SPEED = 7.5 CM/S		MEAN SQUARE SPEED = 74.8 CM2/S2							
		MEAN SQUARE E-W SPEED = 34.1 CM2/S2		MEAN SQUARE N-S SPEED = 40.7 CM2/S2							
		MEAN VELOCITY = 2.2 CM/S,		33 DEG TRUE		MEAN TEMPERATURE = 5.2 C					
		VARIANCE (U,V) = 35.1 CM2/S2		TOTAL HOURS = 337.							

PERCENT OBSERVED
LIGHT (0.0 - 3.0) 15.4% MEDIUM (3.0 - 7.0) 34.1% HIGH (GE 7.0) 50.4%

DATE: 1997/11/02 TO 1997/11/30
 ROSE SUMMARY: WIND AND CURRENT

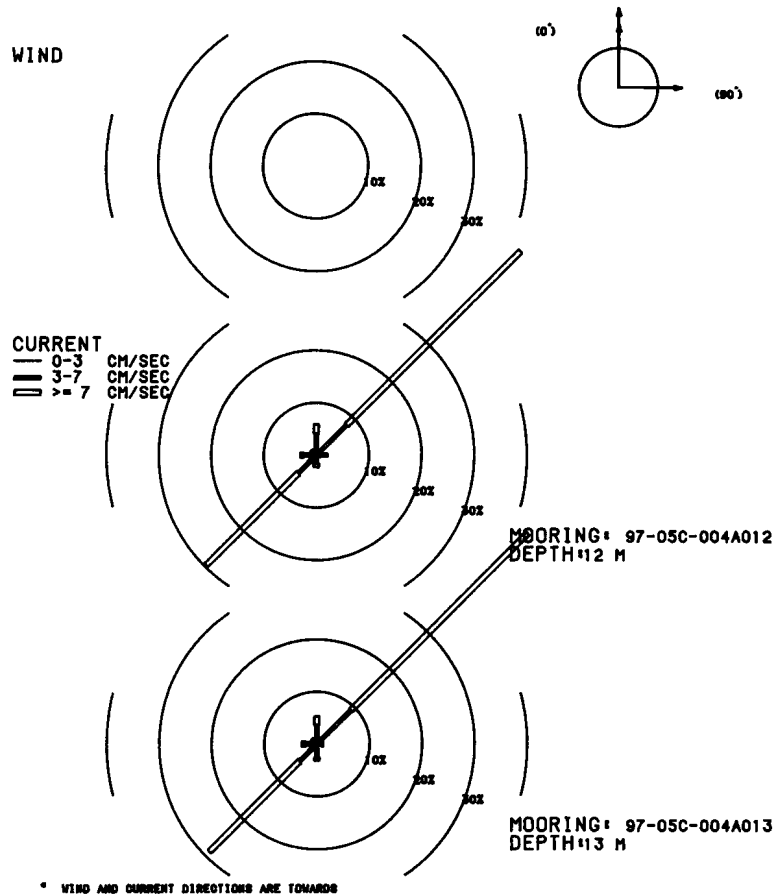

MOORING IS 97-05C-004A012 DEPTH IS 12 METERS THERE ARE 691 VALUES

FIRST DAY 1997/11/02/0500
 FINAL DAY 1997/11/30/2300

SHORELINE ORIENTATION IN DEGREES TRUE SPECIFIED AS 90

DIRECTION DEG TRUE	PERCENT OBSERVED	MAXIMUM CURRENT	MEAN DURATION HOURS	MEAN EXCURSION KM	MEAN CURRENT CM/S	MEAN TEMP DEG C
TOWARD	TOTAL	LIGHT	MEDIUM	HIGH	CM/S	
90.0	2.2	0.4	1.7	0.0	6.8	1.9
45.0	55.0	0.3	7.8	46.9	30.8	20.0
0.0	5.9	0.9	3.2	1.9	13.8	2.2
315.0	1.3	1.0	0.3	0.0	4.7	1.5
270.0	3.0	0.1	2.3	0.6	11.7	1.5
225.0	29.7	0.7	4.1	24.9	28.6	9.3
180.0	2.3	0.1	1.4	0.7	10.3	1.3
135.0	0.6	0.6	0.0	0.0	2.6	1.0
0		MEAN SCALAR SPEED = 11.5 CM/S		MEAN SQUARE SPEED = 168.2 CM2/S2		
		MEAN SQUARE E-W SPEED = 75.4 CM2/S2		MEAN SQUARE N-S SPEED = 92.8 CM2/S2		
		MEAN VELOCITY = 3.5 CM/S,		39 DEG TRUE		MEAN TEMPERATURE = 8.5 C
		VARIANCE (U,V) = 78.1 CM2/S2		TOTAL HOURS = 691.		

PERCENT OBSERVED

LIGHT (0.0 - 3.0) 4.2% MEDIUM (3.0 - 7.0) 20.8% HIGH (GE 7.0) 75.0%

MOORING IS 97-05C-004A013 DEPTH IS 13 METERS THERE ARE 691 VALUES

FIRST DAY 1997/11/02/0500
 FINAL DAY 1997/11/30/2300

SHORELINE ORIENTATION IN DEGREES TRUE SPECIFIED AS 90

DIRECTION DEG TRUE	PERCENT OBSERVED	MAXIMUM CURRENT	MEAN DURATION HOURS	MEAN EXCURSION KM	MEAN CURRENT CM/S	MEAN TEMP DEG C
TOWARD	TOTAL	LIGHT	MEDIUM	HIGH	CM/S	
90.0	1.2	0.3	0.7	0.1	7.1	1.6
45.0	56.7	0.6	8.5	47.6	29.7	18.7
0.0	5.4	1.0	2.6	1.7	15.3	1.7
315.0	1.3	1.0	0.3	0.0	4.4	1.3
270.0	2.9	0.6	1.6	0.7	9.7	1.5
225.0	28.9	0.6	4.1	24.3	27.9	9.5
180.0	3.2	0.9	1.7	0.6	13.4	1.6
135.0	0.4	0.4	0.0	0.0	2.8	1.0
0		MEAN SCALAR SPEED = 11.3 CM/S		MEAN SQUARE SPEED = 163.8 CM2/S2		
		MEAN SQUARE E-W SPEED = 70.4 CM2/S2		MEAN SQUARE N-S SPEED = 93.3 CM2/S2		
		MEAN VELOCITY = 3.5 CM/S,		40 DEG TRUE		MEAN TEMPERATURE = 8.5 C
		VARIANCE (U,V) = 75.8 CM2/S2		TOTAL HOURS = 691.		

PERCENT OBSERVED

LIGHT (0.0 - 3.0) 5.4% MEDIUM (3.0 - 7.0) 19.5% HIGH (GE 7.0) 75.1%

DATE: 1997/12/01 TO 1997/12/31
 ROSE SUMMARY: WIND AND CURRENT

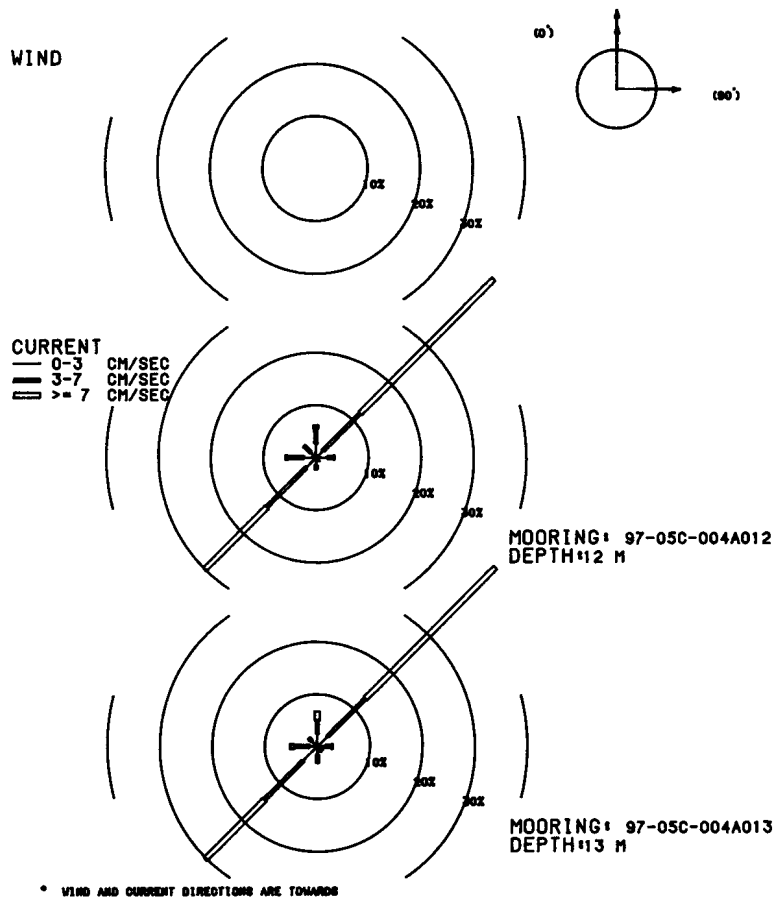

MOORING IS 97-05C-004A012 DEPTH IS 12 METERS THERE ARE 744 VALUES

FIRST DAY 1997/12/01/0000
 FINAL DAY 1997/12/31/2300

SHORELINE ORIENTATION IN DEGREES TRUE SPECIFIED AS 90

DIRECTION DEG TRUE	PERCENT OBSERVED	MAXIMUM CURRENT	MEAN DURA- TION HOURS	MEAN EXCUR- SION KM	MEAN CURRENT CM/S	MEAN TEMP DEG C
TOWARD	TOTAL	LIGHT	MEDIUM	HIGH	CM/S	
90.0	3.5	2.2	1.2	0.1	8.2	4.4
45.0	48.0	1.7	10.1	36.2	29.3	4.3
0.0	6.2	2.7	2.8	0.7	12.9	4.5
315.0	3.2	1.3	1.9	0.0	6.7	4.3
270.0	5.8	2.3	3.2	0.3	9.2	4.2
225.0	30.1	2.7	10.5	16.9	27.4	4.6
180.0	2.3	1.5	0.8	0.0	5.3	4.5
135.0	0.9	0.9	0.0	0.0	3.0	5.0
MEAN SCALAR SPEED = 8.6 CM/S		MEAN SQUARE SPEED = 108.1 CM2/S2				
MEAN SQUARE E-W SPEED = 48.6 CM2/S2		MEAN SQUARE N-S SPEED = 59.5 CM2/S2				
MEAN VELOCITY = 2.5 CM/S,		25 DEG TRUE		MEAN TEMPERATURE = 4.4 C		
VARIANCE (U,V) = 50.9 CM2/S2		TOTAL HOURS = 744.				

PERCENT OBSERVED

LIGHT (0.0 - 3.0) 15.3% MEDIUM (3.0 - 7.0) 30.5% HIGH (GE 7.0) 54.2%

MOORING IS 97-05C-004A013 DEPTH IS 13 METERS THERE ARE 744 VALUES

FIRST DAY 1997/12/01/0000
 FINAL DAY 1997/12/31/2300

SHORELINE ORIENTATION IN DEGREES TRUE SPECIFIED AS 90

DIRECTION DEG TRUE	PERCENT OBSERVED	MAXIMUM CURRENT	MEAN DURA- TION HOURS	MEAN EXCUR- SION KM	MEAN CURRENT CM/S	MEAN TEMP DEG C
TOWARD	TOTAL	LIGHT	MEDIUM	HIGH	CM/S	
90.0	3.0	1.5	1.2	0.3	12.2	4.9
45.0	48.1	2.7	10.2	35.2	30.6	4.3
0.0	6.7	2.4	2.6	1.7	11.8	3.9
315.0	2.3	1.5	0.8	0.0	5.3	4.9
270.0	5.2	1.5	3.0	0.8	11.6	4.5
225.0	30.2	3.8	10.5	16.0	28.0	4.5
180.0	3.2	1.6	1.6	0.0	6.9	4.4
135.0	1.2	1.1	0.1	0.0	4.8	4.2
MEAN SCALAR SPEED = 8.5 CM/S		MEAN SQUARE SPEED = 104.7 CM2/S2				
MEAN SQUARE E-W SPEED = 45.7 CM2/S2		MEAN SQUARE N-S SPEED = 59.0 CM2/S2				
MEAN VELOCITY = 2.6 CM/S,		26 DEG TRUE		MEAN TEMPERATURE = 4.4 C		
VARIANCE (U,V) = 49.2 CM2/S2		TOTAL HOURS = 744.				

PERCENT OBSERVED

LIGHT (0.0 - 3.0) 16.0% MEDIUM (3.0 - 7.0) 30.0% HIGH (GE 7.0) 54.0%

DATE: 1998/01/01 TO 1998/01/31
 ROSE SUMMARY: WIND AND CURRENT

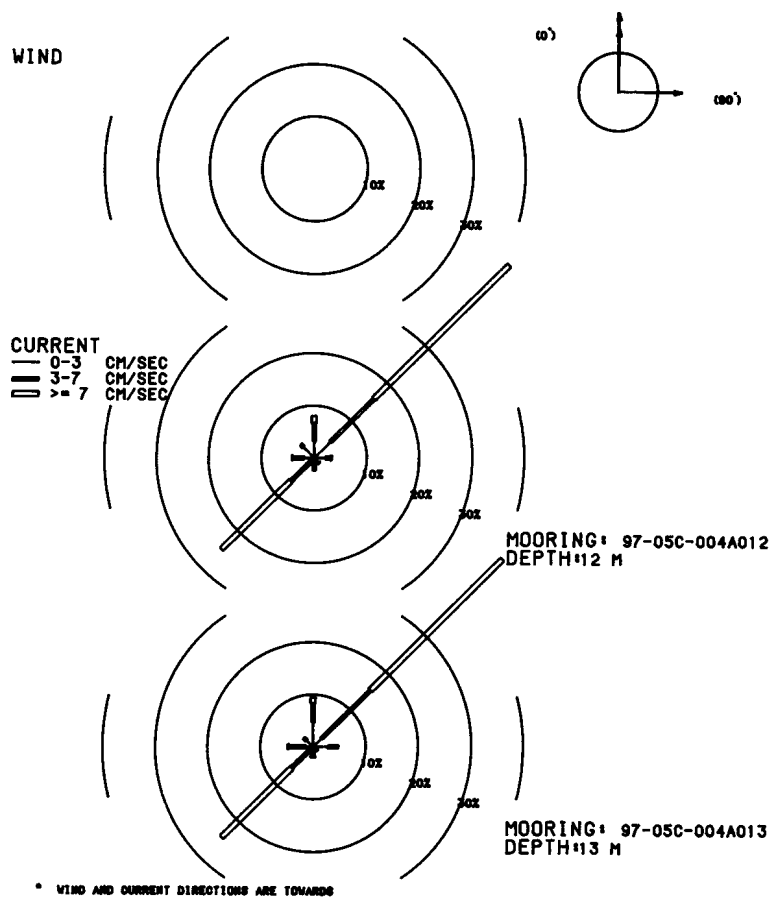

MOORING IS 97-05C-004A012 DEPTH IS 12 METERS THERE ARE 744 VALUES

FIRST DAY 1998/01/01/0000
 FINAL DAY 1998/01/31/2300

SHORELINE ORIENTATION IN DEGREES TRUE SPECIFIED AS 90

DIRECTION DEG TRUE	PERCENT OBSERVED	MAXIMUM CURRENT	MEAN DURA- TION HOURS	MEAN EXCUR- SION KM	MEAN CURRENT CM/S	MEAN TEMP DEG C
TOWARD	TOTAL	LIGHT	MEDIUM	HIGH	CM/S	
90.0	3.4	2.2	0.9	0.3	7.9	1.1
45.0	52.3	4.3	11.7	36.3	32.4	7.1
0.0	8.1	3.2	3.4	1.5	12.6	1.4
315.0	3.6	2.8	0.8	0.0	4.2	1.4
270.0	4.2	1.9	2.2	0.1	7.7	1.7
225.0	24.7	0.9	5.2	18.5	24.6	9.2
180.0	2.4	1.5	0.9	0.0	6.8	1.2
135.0	1.3	1.2	0.1	0.0	3.4	1.1
0	MEAN SCALAR SPEED = 9.2 CM/S		MEAN SQUARE SPEED = 123.7 CM2/S2			
	MEAN SQUARE E-W SPEED = 55.1 CM2/S2		MEAN SQUARE N-S SPEED = 68.6 CM2/S2			
	MEAN VELOCITY = 3.5 CM/S,		34 DEG TRUE		MEAN TEMPERATURE = 1.7 C	
	VARIANCE (U,V) = 55.9 CM2/S2		TOTAL HOURS = 744.			

PERCENT OBSERVED
 LIGHT (0.0 - 3.0) 18.0% MEDIUM (3.0 - 7.0) 25.3% HIGH (GE 7.0) 56.7%

MOORING IS 97-05C-004A013 DEPTH IS 13 METERS THERE ARE 744 VALUES

FIRST DAY 1998/01/01/0000
 FINAL DAY 1998/01/31/2300

SHORELINE ORIENTATION IN DEGREES TRUE SPECIFIED AS 90

DIRECTION DEG TRUE	PERCENT OBSERVED	MAXIMUM CURRENT	MEAN DURA- TION HOURS	MEAN EXCUR- SION KM	MEAN CURRENT CM/S	MEAN TEMP DEG C
TOWARD	TOTAL	LIGHT	MEDIUM	HIGH	CM/S	
90.0	4.8	2.8	2.0	0.0	6.5	1.2
45.0	50.8	2.3	13.0	35.5	32.8	8.0
0.0	9.5	4.7	3.6	1.2	10.6	1.7
315.0	2.4	1.7	0.7	0.0	4.7	1.3
270.0	4.8	1.5	3.1	0.3	9.3	1.6
225.0	24.5	0.5	5.1	18.8	22.3	11.4
180.0	2.0	0.9	0.9	0.1	9.6	1.7
135.0	1.1	0.8	0.3	0.0	3.9	1.3
0	MEAN SCALAR SPEED = 9.1 CM/S		MEAN SQUARE SPEED = 121.4 CM2/S2			
	MEAN SQUARE E-W SPEED = 52.5 CM2/S2		MEAN SQUARE N-S SPEED = 68.9 CM2/S2			
	MEAN VELOCITY = 3.4 CM/S,		32 DEG TRUE		MEAN TEMPERATURE = 1.7 C	
	VARIANCE (U,V) = 54.9 CM2/S2		TOTAL HOURS = 744.			

PERCENT OBSERVED
 LIGHT (0.0 - 3.0) 15.3% MEDIUM (3.0 - 7.0) 28.8% HIGH (GE 7.0) 55.9%

DATE: 1998/02/01 TO 1998/02/28
 ROSE SUMMARY: WIND AND CURRENT

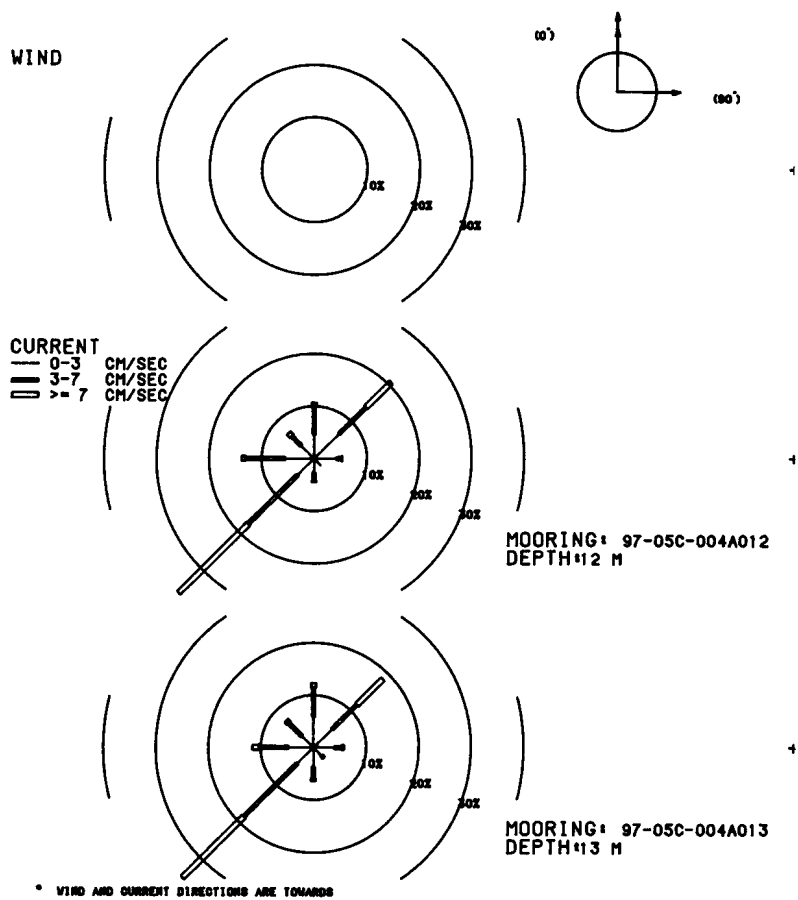

MOORING IS 97-05C-004A012 DEPTH IS 12 METERS THERE ARE 672 VALUES

FIRST DAY 1998/02/01/0000
 FINAL DAY 1998/02/28/2300

SHORELINE ORIENTATION IN DEGREES TRUE SPECIFIED AS 90

DIRECTION DEG TRUE	PERCENT OBSERVED	MAXIMUM CURRENT	MEAN DURATION HOURS	MEAN EXCURSION KM	MEAN CURRENT CM/S	MEAN TEMP DEG C
TOWARD	TOTAL	LIGHT	MEDIUM	HIGH	CM/S	
90.0	5.4	4.2	1.0	0.1	7.7	1.3
45.0	20.7	6.7	7.1	6.8	19.3	3.1
0.0	10.7	4.6	5.5	0.6	11.3	1.6
315.0	6.8	3.4	2.5	0.9	9.4	1.6
270.0	13.8	5.5	7.6	0.7	8.3	1.9
225.0	36.3	4.3	13.2	18.8	18.6	4.8
180.0	4.5	2.7	1.6	0.1	11.9	1.1
135.0	1.8	1.8	0.0	0.0	2.5	1.1

MEAN SCALAR SPEED = 5.4 CM/S MEAN SQUARE SPEED = 45.9 CM²/S²
 MEAN SQUARE E-W SPEED = 23.2 CM²/S² MEAN SQUARE N-S SPEED = 22.6 CM²/S²
 MEAN VELOCITY = 1.9 CM/S, 249 DEG TRUE MEAN TEMPERATURE = 1.8 C
 VARIANCE (U,V) = 21.1 CM²/S² TOTAL HOURS = 672.

PERCENT OBSERVED
 LIGHT (0.0 - 3.0) 33.2% MEDIUM (3.0 - 7.0) 38.7% HIGH (GE 7.0) 28.1%

MOORING IS 97-05C-004A013 DEPTH IS 13 METERS THERE ARE 672 VALUES

FIRST DAY 1998/02/01/0000
 FINAL DAY 1998/02/28/2300

SHORELINE ORIENTATION IN DEGREES TRUE SPECIFIED AS 90

DIRECTION DEG TRUE	PERCENT OBSERVED	MAXIMUM CURRENT	MEAN DURATION HOURS	MEAN EXCURSION KM	MEAN CURRENT CM/S	MEAN TEMP DEG C
TOWARD	TOTAL	LIGHT	MEDIUM	HIGH	CM/S	
90.0	5.8	4.0	1.3	0.4	8.1	1.6
45.0	18.6	4.9	6.7	7.0	16.9	3.0
0.0	12.4	6.0	5.5	0.9	12.3	2.0
315.0	7.3	3.0	3.6	0.7	7.8	1.7
270.0	11.6	4.8	5.5	1.3	11.2	1.8
225.0	35.1	4.3	14.3	16.5	20.1	4.9
180.0	6.4	3.7	2.2	0.4	8.6	1.3
135.0	2.8	2.2	0.6	0.0	3.7	1.1

MEAN SCALAR SPEED = 5.4 CM/S MEAN SQUARE SPEED = 44.6 CM²/S²
 MEAN SQUARE E-W SPEED = 22.0 CM²/S² MEAN SQUARE N-S SPEED = 22.6 CM²/S²
 MEAN VELOCITY = 1.7 CM/S, 245 DEG TRUE MEAN TEMPERATURE = 1.8 C
 VARIANCE (U,V) = 20.8 CM²/S² TOTAL HOURS = 672.

PERCENT OBSERVED
 LIGHT (0.0 - 3.0) 32.9% MEDIUM (3.0 - 7.0) 39.7% HIGH (GE 7.0) 27.4%

DATE: 1998/03/01 TO 1998/03/31
ROSE SUMMARY: WIND AND CURRENT

WIND

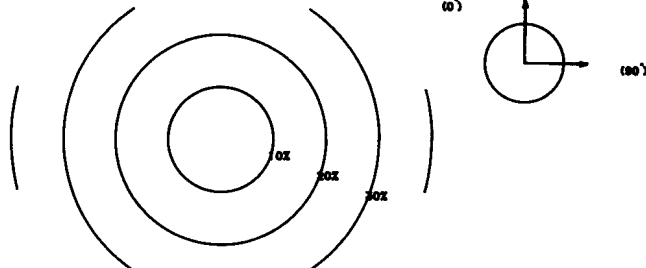

CURRENT
 — 0-3 CM/SEC
 = 3-7 CM/SEC
 ≡ >= 7 CM/SEC

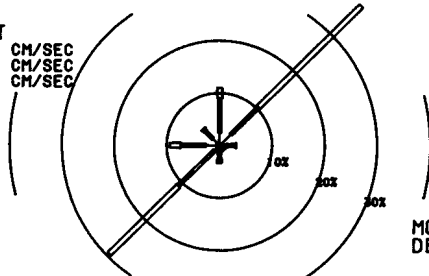

MOORING: 97-05C-004A012
DEPTH: 12 M

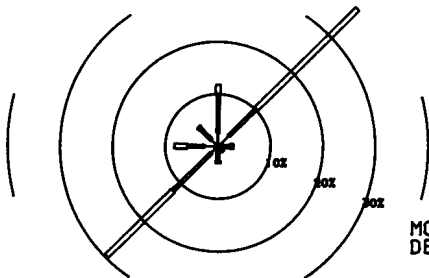

MOORING: 97-05C-004A013
DEPTH: 13 M

* WIND AND CURRENT DIRECTIONS ARE TOWARDS

MOORING IS 97-05C-004A012 DEPTH IS 12 METERS THERE ARE 744 VALUES

FIRST DAY 1998/03/01/0000
FINAL DAY 1998/03/31/2300

SHORELINE ORIENTATION IN DEGREES TRUE SPECIFIED AS 90

DIRECTION DEG TRUE	PERCENT OBSERVED	TOWARD	TOTAL	LIGHT	MEDIUM	HIGH	MAXIMUM CURRENT CM/S	MEAN DURA- TION HOURS	MEAN EXCUR- SION KM	MEAN CURRENT CM/S	MEAN TEMP DEG C
90.0	3.2	1.2	1.9	0.1			10.0	1.6	0.2	3.5	2.9
45.0	37.9	3.0	7.4	27.6			31.4	6.9	2.7	11.0	2.8
0.0	11.0	2.4	6.6	2.0			21.0	2.0	0.4	5.3	2.7
315.0	4.4	1.7	2.4	0.3			12.1	1.6	0.2	3.6	2.6
270.0	9.4	2.6	4.7	2.2			19.7	2.5	0.5	5.5	2.6
225.0	29.4	1.5	9.4	18.5			55.1	8.1	3.5	12.1	2.3
180.0	3.4	0.7	2.0	0.7			9.7	2.3	0.4	5.1	2.5
135.0	1.2	0.9	0.3	0.0			3.4	1.3	0.1	2.1	3.1
0		MEAN SCALAR SPEED = 9.3 CM/S		MEAN SQUARE SPEED = 152.9 CM2/S2							
		MEAN SQUARE E-W SPEED = 83.3 CM2/S2		MEAN SQUARE N-S SPEED = 69.6 CM2/S2							
		MEAN VELOCITY = 1.2 CM/S,		345 DEG TRUE		MEAN TEMPERATURE = 2.6 C					
		VARIANCE (U,V) = 75.9 CM2/S2		TOTAL HOURS = 744.							

PERCENT OBSERVED

LIGHT (0.0 - 3.0) 14.0% MEDIUM (3.0 - 7.0) 34.7% HIGH (GE 7.0) 51.3%

MOORING IS 97-05C-004A013 DEPTH IS 13 METERS THERE ARE 744 VALUES

FIRST DAY 1998/03/01/0000
FINAL DAY 1998/03/31/2300

SHORELINE ORIENTATION IN DEGREES TRUE SPECIFIED AS 90

DIRECTION DEG TRUE	PERCENT OBSERVED	TOWARD	TOTAL	LIGHT	MEDIUM	HIGH	MAXIMUM CURRENT CM/S	MEAN DURA- TION HOURS	MEAN EXCUR- SION KM	MEAN CURRENT CM/S	MEAN TEMP DEG C
90.0	3.0	0.7	1.6	0.7			11.4	1.8	0.3	4.6	3.1
45.0	37.4	2.8	7.4	27.2			32.6	6.8	2.6	10.8	2.8
0.0	11.8	2.6	7.3	2.0			22.4	2.1	0.4	5.3	2.7
315.0	5.2	1.7	3.2	0.3			11.0	1.6	0.2	3.7	2.6
270.0	8.3	2.6	3.2	2.6			19.5	2.4	0.5	5.6	2.5
225.0	29.7	1.7	10.2	17.7			53.2	7.6	3.3	11.9	2.3
180.0	3.2	0.8	2.0	0.4			8.6	1.6	0.3	4.9	2.6
135.0	1.3	1.1	0.3	0.0			3.4	2.0	0.2	2.4	2.8
0		MEAN SCALAR SPEED = 9.2 CM/S		MEAN SQUARE SPEED = 149.2 CM2/S2							
		MEAN SQUARE E-W SPEED = 81.4 CM2/S2		MEAN SQUARE N-S SPEED = 67.8 CM2/S2							
		MEAN VELOCITY = 1.2 CM/S,		349 DEG TRUE		MEAN TEMPERATURE = 2.6 C					
		VARIANCE (U,V) = 74.0 CM2/S2		TOTAL HOURS = 744.							

PERCENT OBSERVED

LIGHT (0.0 - 3.0) 14.0% MEDIUM (3.0 - 7.0) 35.2% HIGH (GE 7.0) 50.8%

DATE: 1998/04/01 TO 1998/04/30
 ROSE SUMMARY: WIND AND CURRENT

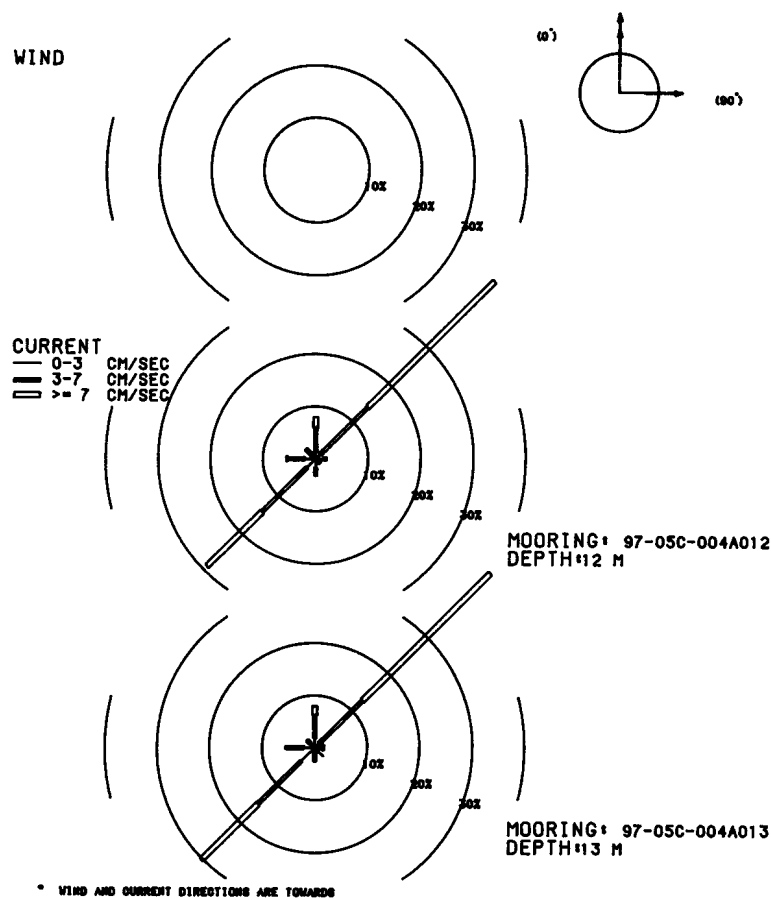

MOORING IS 97-05C-004A012 DEPTH IS 12 METERS THERE ARE 337 VALUES

FIRST DAY 1998/04/01/0000
 FINAL DAY 1998/04/15/0000

SHORELINE ORIENTATION IN DEGREES TRUE SPECIFIED AS 90

DIRECTION DEG TRUE	PERCENT OBSERVED	MAXIMUM CURRENT CM/S	MEAN DURA- TION HOURS	MEAN EXCUR- SION KM	MEAN CURRENT CM/S	MEAN TEMP DEG C
TOWARD	TOTAL	LIGHT	MEDIUM	HIGH		
90.0	2.1	1.5	0.6	0.0	3.9	1.0
45.0	48.1	1.2	12.8	34.1	18.0	13.5
0.0	8.0	1.5	4.5	2.1	8.9	1.9
315.0	2.7	0.9	1.8	0.0	5.0	1.3
270.0	5.6	2.1	3.3	0.3	7.1	1.7
225.0	29.1	2.4	11.9	14.8	17.3	6.5
180.0	3.3	1.8	1.5	0.0	5.8	1.4
135.0	1.2	0.9	0.3	0.0	3.9	1.0
0		MEAN SCALAR SPEED = 7.7 CM/S		MEAN SQUARE SPEED = 74.7 CM2/S2		
		MEAN SQUARE E-W SPEED = 34.1 CM2/S2		MEAN SQUARE N-S SPEED = 40.6 CM2/S2		
		MEAN VELOCITY = 2.4 CM/S,		34 DEG TRUE		MEAN TEMPERATURE = 5.2 C
		VARIANCE (U,V) = 34.6 CM2/S2		TOTAL HOURS = 337.		

PERCENT OBSERVED
 LIGHT (0.0 - 3.0) 12.2% MEDIUM (3.0 - 7.0) 36.5% HIGH (GE 7.0) 51.3%

MOORING IS 97-05C-004A013 DEPTH IS 13 METERS THERE ARE 337 VALUES

FIRST DAY 1998/04/01/0000
 FINAL DAY 1998/04/15/0000

SHORELINE ORIENTATION IN DEGREES TRUE SPECIFIED AS 90

DIRECTION DEG TRUE	PERCENT OBSERVED	MAXIMUM CURRENT CM/S	MEAN DURA- TION HOURS	MEAN EXCUR- SION KM	MEAN CURRENT CM/S	MEAN TEMP DEG C
TOWARD	TOTAL	LIGHT	MEDIUM	HIGH		
90.0	1.8	0.6	0.9	0.3	7.8	1.0
45.0	47.2	1.2	11.6	34.4	18.4	10.6
0.0	8.0	1.8	4.5	1.8	8.7	2.1
315.0	2.1	1.2	0.9	0.0	3.8	1.2
270.0	5.6	2.1	3.6	0.0	5.8	1.7
225.0	30.3	3.6	11.6	15.1	18.7	6.4
180.0	2.7	0.0	2.7	0.0	6.1	1.3
135.0	2.4	2.4	0.0	0.0	2.8	1.6
0		MEAN SCALAR SPEED = 7.5 CM/S		MEAN SQUARE SPEED = 71.7 CM2/S2		
		MEAN SQUARE E-W SPEED = 32.6 CM2/S2		MEAN SQUARE N-S SPEED = 39.1 CM2/S2		
		MEAN VELOCITY = 2.2 CM/S,		39 DEG TRUE		MEAN TEMPERATURE = 5.2 C
		VARIANCE (U,V) = 33.6 CM2/S2		TOTAL HOURS = 337.		

PERCENT OBSERVED
 LIGHT (0.0 - 3.0) 12.8% MEDIUM (3.0 - 7.0) 35.6% HIGH (GE 7.0) 51.6%

DATE: 1997/11/02 TO 1997/11/30
ROSE SUMMARY: WIND AND CURRENT

WIND

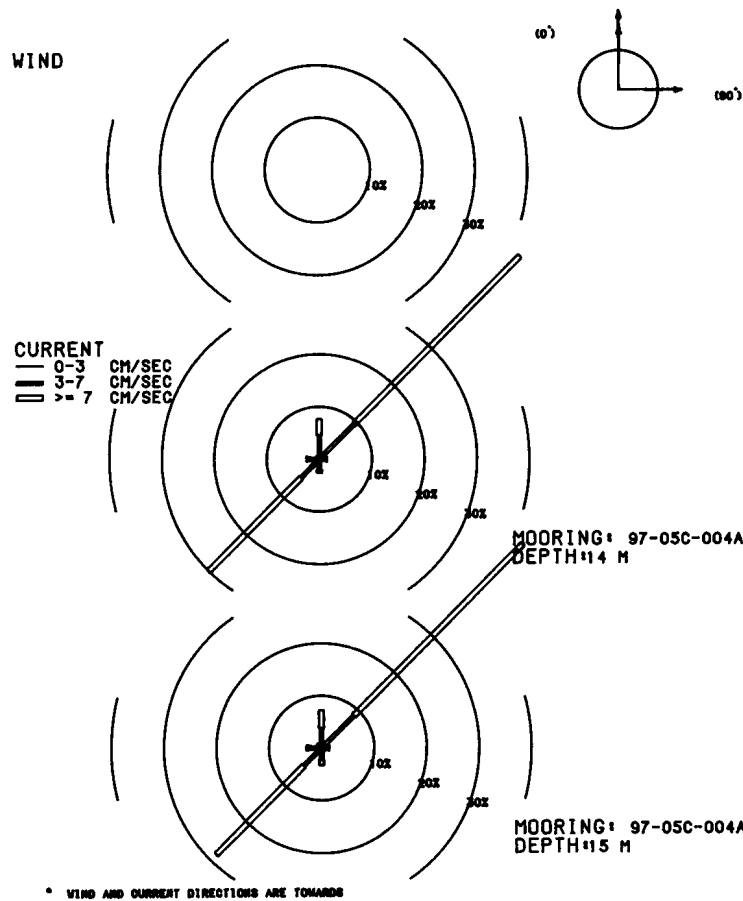

MOORING: 97-05C-004A014
DEPTH: 14 M

MOORING: 97-05C-004A015
DEPTH: 15 M

MOORING IS 97-05C-004A014 DEPTH IS 14 METERS THERE ARE 691 VALUES

FIRST DAY 1997/11/02/0500
FINAL DAY 1997/11/30/2300

SHORELINE ORIENTATION IN DEGREES TRUE SPECIFIED AS 90

DIRECTION DEG TRUE	PERCENT OBSERVED	TOWARD	TOTAL	LIGHT	MEDIUM	HIGH	MAXIMUM CURRENT CM/S	MEAN DURA- TION HOURS	MEAN EXCUR- SION KM	MEAN CURRENT CM/S	MEAN TEMP DEG C
90.0	1.4	0.1	1.2	0.1	9.2	1.7	0.3	4.6	8.4		
45.0	54.4	0.4	9.0	45.0	30.1	19.8	8.9	12.4	8.3		
0.0	7.7	0.9	3.6	3.2	17.8	2.8	0.7	6.8	8.3		
315.0	0.7	0.4	0.3	0.0	6.1	1.2	0.2	3.8	7.7		
270.0	2.5	0.1	2.2	0.1	7.2	1.9	0.3	4.9	8.4		
225.0	30.1	0.6	4.3	25.2	26.7	10.4	4.5	12.0	8.8		
180.0	2.6	0.7	1.3	0.6	12.9	1.1	0.2	4.9	8.3		
135.0	0.6	0.6	0.0	0.0	2.9	1.0	0.1	1.9	8.1		
0		MEAN SCALAR SPEED = 11.2 CM/S		MEAN SQUARE SPEED = 160.2 CM2/S2							
		MEAN SQUARE E-W SPEED = 67.1 CM2/S2		MEAN SQUARE N-S SPEED = 93.1 CM2/S2							
		MEAN VELOCITY = 3.5 CM/S,		35 DEG TRUE		MEAN TEMPERATURE = 8.5 C					
		VARIANCE(U,V) = 74.2 CM2/S2		TOTAL HOURS = 691.							

PERCENT OBSERVED
LIGHT (0.0 - 3.0) 3.9% MEDIUM (3.0 - 7.0) 21.9% HIGH (GE 7.0) 74.2%

MOORING IS 97-05C-004A015 DEPTH IS 15 METERS THERE ARE 691 VALUES

FIRST DAY 1997/11/02/0500
FINAL DAY 1997/11/30/2300

SHORELINE ORIENTATION IN DEGREES TRUE SPECIFIED AS 90

DIRECTION DEG TRUE	PERCENT OBSERVED	TOWARD	TOTAL	LIGHT	MEDIUM	HIGH	MAXIMUM CURRENT CM/S	MEAN DURA- TION HOURS	MEAN EXCUR- SION KM	MEAN CURRENT CM/S	MEAN TEMP DEG C
90.0	1.4	0.4	0.9	0.1	8.1	1.2	0.2	4.3	9.0		
45.0	54.7	0.3	8.4	46.0	28.6	13.5	6.0	12.3	8.3		
0.0	7.2	0.4	3.3	3.5	14.8	2.1	0.5	6.9	8.2		
315.0	1.0	0.7	0.3	0.0	4.4	1.4	0.1	2.5	7.7		
270.0	2.9	0.6	1.9	0.4	9.4	1.7	0.3	4.4	8.3		
225.0	28.5	0.4	4.3	23.7	27.9	9.9	4.3	12.0	8.9		
180.0	3.3	0.7	1.6	1.0	10.6	1.5	0.3	5.3	7.8		
135.0	0.9	0.6	0.3	0.0	5.2	1.2	0.1	3.2	8.9		
0		MEAN SCALAR SPEED = 11.1 CM/S		MEAN SQUARE SPEED = 155.4 CM2/S2							
		MEAN SQUARE E-W SPEED = 61.7 CM2/S2		MEAN SQUARE N-S SPEED = 93.8 CM2/S2							
		MEAN VELOCITY = 3.5 CM/S,		33 DEG TRUE		MEAN TEMPERATURE = 8.5 C					
		VARIANCE(U,V) = 71.6 CM2/S2		TOTAL HOURS = 691.							

PERCENT OBSERVED
LIGHT (0.0 - 3.0) 4.2% MEDIUM (3.0 - 7.0) 21.0% HIGH (GE 7.0) 74.8%

DATE: 1997/12/01 TO 1997/12/31
 ROSE SUMMARY: WIND AND CURRENT

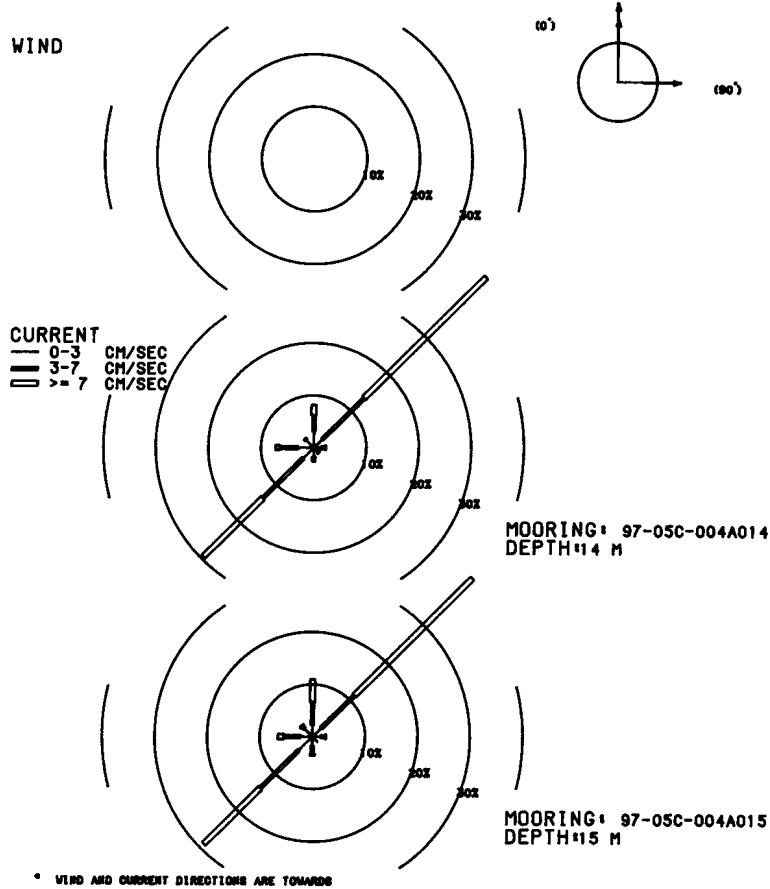

MOORING IS 97-05C-004A014 DEPTH IS 14 METERS THERE ARE 744 VALUES

FIRST DAY 1997/12/01/0000
 FINAL DAY 1997/12/31/2300

SHORELINE ORIENTATION IN DEGREES TRUE SPECIFIED AS 90

DIRECTION DEG TRUE	PERCENT OBSERVED	MAXIMUM CURRENT	MEAN DURATION HOURS	MEAN EXCURSION KM	MEAN CURRENT CM/S	MEAN TEMP DEG C
TOWARD	TOTAL	LIGHT	MEDIUM	HIGH	CM/S	
90.0	2.3	1.3	0.8	0.1	7.6	1.2
45.0	46.2	2.3	11.2	32.8	28.9	8.2
0.0	8.2	3.1	3.1	2.0	14.4	1.4
315.0	2.4	2.0	0.4	0.0	6.1	1.2
270.0	7.3	3.0	3.5	0.8	10.5	1.7
225.0	29.6	2.8	10.8	16.0	28.4	7.1
180.0	2.7	1.7	0.9	0.0	6.4	1.0
135.0	1.3	1.2	0.1	0.0	3.5	1.0

MEAN SCALAR SPEED = 8.4 CM/S MEAN SQUARE SPEED = 102.5 CM2/S2
 MEAN SQUARE E-W SPEED = 44.1 CM2/S2 MEAN SQUARE N-S SPEED = 58.4 CM2/S2
 MEAN VELOCITY = 2.5 CM/S, 20 DEG TRUE MEAN TEMPERATURE = 4.4 C
 VARIANCE (U,V) = 48.3 CM2/S2 TOTAL HOURS = 744.

PERCENT OBSERVED
 LIGHT (0.0 - 3.0) 17.5% MEDIUM (3.0 - 7.0) 30.8% HIGH (GE 7.0) 51.7%

MOORING IS 97-05C-004A015 DEPTH IS 15 METERS THERE ARE 744 VALUES

FIRST DAY 1997/12/01/0000
 FINAL DAY 1997/12/31/2300

SHORELINE ORIENTATION IN DEGREES TRUE SPECIFIED AS 90

DIRECTION DEG TRUE	PERCENT OBSERVED	MAXIMUM CURRENT	MEAN DURATION HOURS	MEAN EXCURSION KM	MEAN CURRENT CM/S	MEAN TEMP DEG C
TOWARD	TOTAL	LIGHT	MEDIUM	HIGH	CM/S	
90.0	2.6	1.6	0.8	0.1	7.0	1.1
45.0	42.9	2.3	8.9	31.7	30.3	6.4
0.0	11.0	2.3	4.3	4.4	13.4	1.5
315.0	3.0	2.2	0.7	0.1	7.5	1.2
270.0	6.6	2.3	3.1	1.2	13.4	1.4
225.0	29.0	3.6	10.2	15.2	26.5	4.5
180.0	3.6	1.7	1.6	0.3	9.6	1.1
135.0	1.3	1.3	0.0	0.0	2.8	1.1

MEAN SCALAR SPEED = 8.3 CM/S MEAN SQUARE SPEED = 99.3 CM2/S2
 MEAN SQUARE E-W SPEED = 40.8 CM2/S2 MEAN SQUARE N-S SPEED = 58.5 CM2/S2
 MEAN VELOCITY = 2.5 CM/S, 16 DEG TRUE MEAN TEMPERATURE = 4.4 C
 VARIANCE (U,V) = 46.5 CM2/S2 TOTAL HOURS = 744.

PERCENT OBSERVED
 LIGHT (0.0 - 3.0) 17.3% MEDIUM (3.0 - 7.0) 29.6% HIGH (GE 7.0) 53.1%

DATE: 1998/01/01 TO 1998/01/31
ROSE SUMMARY: WIND AND CURRENT

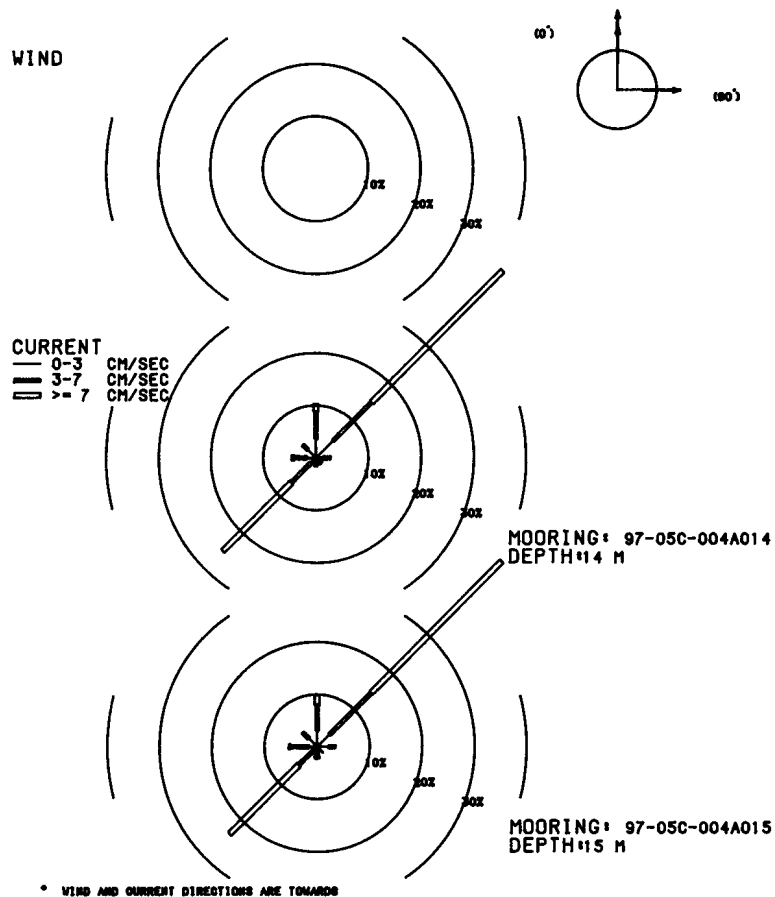

MOORING IS 97-05C-004A014 DEPTH IS 14 METERS THERE ARE 744 VALUES

FIRST DAY 1998/01/01/0000
FINAL DAY 1998/01/31/2300

SHORELINE ORIENTATION IN DEGREES TRUE SPECIFIED AS 90

DIRECTION DEG TRUE	PERCENT OBSERVED	MAXIMUM CURRENT	MEAN DURATION HOURS	MEAN EXCURSION KM	MEAN CURRENT CM/S	MEAN TEMP DEG C
TOWARD	TOTAL	LIGHT	MEDIUM	HIGH	CM/S	
90.0	2.8	1.3	1.5	0.0	6.4	1.2
45.0	50.4	4.6	10.3	35.5	33.9	7.7
0.0	10.3	3.6	5.2	1.5	10.3	1.5
315.0	3.5	2.2	1.3	0.0	4.5	1.3
270.0	4.7	1.7	2.4	0.5	8.7	2.5
225.0	25.1	1.2	5.4	18.5	23.1	11.7
180.0	1.6	1.2	0.4	0.0	6.7	1.1
135.0	1.5	0.9	0.5	0.0	5.4	1.0

MEAN SCALAR SPEED = 9.0 CM/S MEAN SQUARE SPEED = 119.8 CM²/S²
 MEAN SQUARE E-W SPEED = 49.6 CM²/S² MEAN SQUARE N-S SPEED = 70.2 CM²/S²
 MEAN VELOCITY = 3.4 CM/S, 30 DEG TRUE MEAN TEMPERATURE = 1.7 C
 VARIANCE (U,V) = 54.2 CM²/S² TOTAL HOURS = 744.

PERCENT OBSERVED
 LIGHT (0.0 - 3.0) 16.8% MEDIUM (3.0 - 7.0) 27.2% HIGH (GE 7.0) 56.0%

MOORING IS 97-05C-004A015 DEPTH IS 15 METERS THERE ARE 744 VALUES

FIRST DAY 1998/01/01/0000
FINAL DAY 1998/01/31/2300

SHORELINE ORIENTATION IN DEGREES TRUE SPECIFIED AS 90

DIRECTION DEG TRUE	PERCENT OBSERVED	MAXIMUM CURRENT	MEAN DURATION HOURS	MEAN EXCURSION KM	MEAN CURRENT CM/S	MEAN TEMP DEG C
TOWARD	TOTAL	LIGHT	MEDIUM	HIGH	CM/S	
90.0	3.5	2.2	1.3	0.0	6.6	1.1
45.0	49.9	3.2	11.3	35.3	31.8	7.4
0.0	9.9	3.1	4.8	2.0	13.1	1.7
315.0	3.9	2.3	1.6	0.0	5.6	1.1
270.0	5.4	1.6	3.5	0.3	8.7	2.4
225.0	23.5	0.8	4.0	18.7	23.2	12.5
180.0	2.3	0.7	1.2	0.4	11.4	1.5
135.0	1.6	1.6	0.0	0.0	2.9	1.2

MEAN SCALAR SPEED = 8.9 CM/S MEAN SQUARE SPEED = 114.5 CM²/S²
 MEAN SQUARE E-W SPEED = 44.8 CM²/S² MEAN SQUARE N-S SPEED = 69.7 CM²/S²
 MEAN VELOCITY = 3.4 CM/S, 26 DEG TRUE MEAN TEMPERATURE = 1.7 C
 VARIANCE (U,V) = 51.6 CM²/S² TOTAL HOURS = 744.

PERCENT OBSERVED
 LIGHT (0.0 - 3.0) 15.5% MEDIUM (3.0 - 7.0) 27.8% HIGH (GE 7.0) 56.7%

DATE: 1998/02/01 TO 1998/02/28
 ROSE SUMMARY: WIND AND CURRENT

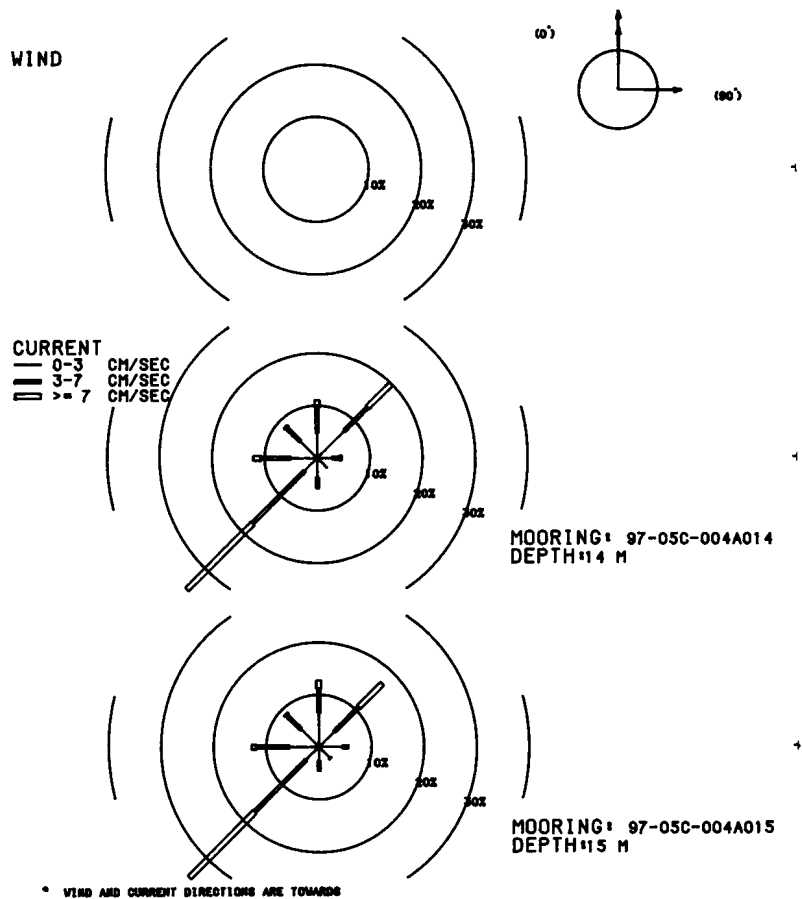

MOORING IS 97-05C-004A014 DEPTH IS 14 METERS THERE ARE 672 VALUES

FIRST DAY 1998/02/01/0000
 FINAL DAY 1998/02/28/2300

SHORELINE ORIENTATION IN DEGREES TRUE SPECIFIED AS 90

DIRECTION DEG TRUE	PERCENT OBSERVED	TOWARD	TOTAL	LIGHT	MEDIUM	HIGH	MAXIMUM CURRENT CM/S	MEAN DURA- TION HOURS	MEAN EXCUR- SION KM	MEAN CURRENT CM/S	MEAN TEMP DEG C
90.0	4.6	2.8	1.5	0.3			9.1	1.6	0.2	2.8	1.8
45.0	19.9	7.3	6.2	6.4			17.7	2.5	0.5	5.8	1.7
0.0	11.0	4.8	4.9	1.3			12.2	1.7	0.2	3.7	1.6
315.0	8.5	4.5	3.6	0.4			8.9	1.4	0.2	3.2	1.8
270.0	12.2	5.1	5.7	1.5			14.3	1.7	0.3	4.1	2.0
225.0	35.3	3.4	14.0	17.9			19.0	5.6	1.6	7.8	1.7
180.0	5.8	3.7	2.1	0.0			6.2	1.4	0.1	2.8	2.0
135.0	2.7	2.7	0.0	0.0			2.8	1.1	0.1	1.6	1.8
0		MEAN SCALAR SPEED = 5.4 CM/S		MEAN SQUARE SPEED = 44.6 CM2/S2							
		MEAN SQUARE E-W SPEED = 21.8 CM2/S2		MEAN SQUARE N-S SPEED = 22.8 CM2/S2							
		MEAN VELOCITY = 1.8 CM/S,		247 DEG TRUE		MEAN TEMPERATURE = 1.8 C					
		VARIANCE (U,V) = 20.7 CM2/S2		TOTAL HOURS = 672.							

PERCENT OBSERVED
 LIGHT (0.0 - 3.0) 34.2% MEDIUM (3.0 - 7.0) 37.9% HIGH (GE 7.0) 27.8%

MOORING IS 97-05C-004A015 DEPTH IS 15 METERS THERE ARE 672 VALUES

FIRST DAY 1998/02/01/0000
 FINAL DAY 1998/02/28/2300

SHORELINE ORIENTATION IN DEGREES TRUE SPECIFIED AS 90

DIRECTION DEG TRUE	PERCENT OBSERVED	TOWARD	TOTAL	LIGHT	MEDIUM	HIGH	MAXIMUM CURRENT CM/S	MEAN DURA- TION HOURS	MEAN EXCUR- SION KM	MEAN CURRENT CM/S	MEAN TEMP DEG C
90.0	5.7	4.5	1.2	0.0			6.1	1.4	0.1	2.2	1.7
45.0	17.1	4.2	6.5	6.4			17.3	2.8	0.6	6.3	1.7
0.0	12.8	6.5	4.6	1.6			13.5	2.0	0.3	3.7	1.7
315.0	8.9	4.8	3.9	0.3			8.0	1.5	0.2	3.2	1.8
270.0	12.8	5.7	6.2	0.9			8.5	1.7	0.2	3.5	1.9
225.0	35.0	3.4	13.8	17.7			19.1	5.3	1.5	7.7	1.7
180.0	4.6	2.7	1.9	0.0			6.2	1.3	0.1	2.8	1.9
135.0	3.1	3.0	0.1	0.0			4.3	1.2	0.1	1.9	2.0
0		MEAN SCALAR SPEED = 5.3 CM/S		MEAN SQUARE SPEED = 42.5 CM2/S2							
		MEAN SQUARE E-W SPEED = 20.7 CM2/S2		MEAN SQUARE N-S SPEED = 21.7 CM2/S2							
		MEAN VELOCITY = 1.7 CM/S,		250 DEG TRUE		MEAN TEMPERATURE = 1.8 C					
		VARIANCE (U,V) = 19.8 CM2/S2		TOTAL HOURS = 672.							

PERCENT OBSERVED
 LIGHT (0.0 - 3.0) 34.7% MEDIUM (3.0 - 7.0) 38.4% HIGH (GE 7.0) 26.9%

DATE: 1998/03/01 TO 1998/03/31
 ROSE SUMMARY: WIND AND CURRENT

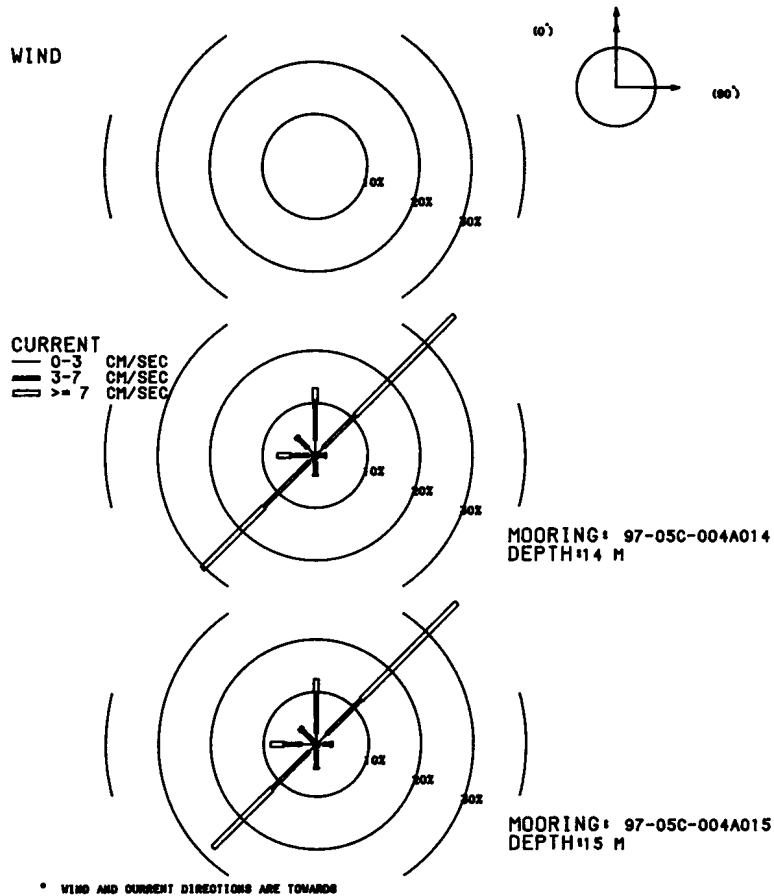

MOORING IS 97-05C-004A014 DEPTH IS 14 METERS THERE ARE 744 VALUES

FIRST DAY 1998/03/01/0000
 FINAL DAY 1998/03/31/2300

SHORELINE ORIENTATION IN DEGREES TRUE SPECIFIED AS 90

DIRECTION DEG TRUE	PERCENT OBSERVED	MAXIMUM CURRENT	MEAN DURA- TION HOURS	MEAN EXCUR- SION KM	MEAN CURRENT CM/S	MEAN TEMP DEG C
TOWARD	TOTAL	LIGHT	MEDIUM	HIGH	CM/S	
90.0	2.0	0.7	1.2	0.1	9.1	1.2
45.0	37.6	2.2	8.6	26.9	31.6	6.8
0.0	12.9	3.0	7.5	2.4	23.7	2.2
315.0	5.1	2.0	2.6	0.5	10.4	1.9
270.0	7.3	1.3	3.4	2.6	16.7	2.2
225.0	30.5	1.7	12.1	16.7	53.6	7.8
180.0	3.9	1.2	2.4	0.3	10.4	1.8
135.0	0.7	0.4	0.3	0.0	3.4	1.2
0	MEAN SCALAR SPEED = 9.2 CM/S		MEAN SQUARE SPEED = 148.5 CM2/S2			
	MEAN SQUARE E-W SPEED = 78.9 CM2/S2		MEAN SQUARE N-S SPEED = 69.6 CM2/S2			
	MEAN VELOCITY = 1.3 CM/S,		348 DEG TRUE		MEAN TEMPERATURE = 2.6 C	
	VARIANCE (U,V) = 73.5 CM2/S2		TOTAL HOURS = 744.			

PERCENT OBSERVED
 LIGHT (0.0 - 3.0) 12.5% MEDIUM (3.0 - 7.0) 38.0% HIGH (GE 7.0) 49.5%

MOORING IS 97-05C-004A015 DEPTH IS 15 METERS THERE ARE 744 VALUES

FIRST DAY 1998/03/01/0000
 FINAL DAY 1998/03/31/2300

SHORELINE ORIENTATION IN DEGREES TRUE SPECIFIED AS 90

DIRECTION DEG TRUE	PERCENT OBSERVED	MAXIMUM CURRENT	MEAN DURA- TION HOURS	MEAN EXCUR- SION KM	MEAN CURRENT CM/S	MEAN TEMP DEG C
TOWARD	TOTAL	LIGHT	MEDIUM	HIGH	CM/S	
90.0	3.1	1.3	1.3	0.4	11.6	1.1
45.0	38.0	2.7	9.4	25.9	33.7	7.6
0.0	12.5	2.2	7.7	2.7	22.9	2.7
315.0	4.4	0.8	3.0	0.7	12.1	1.4
270.0	8.7	2.8	3.4	2.6	18.6	2.2
225.0	27.8	2.0	9.9	15.9	53.7	5.8
180.0	4.7	1.1	3.4	0.3	9.0	1.8
135.0	0.7	0.5	0.1	0.0	3.5	1.2
0	MEAN SCALAR SPEED = 9.1 CM/S		MEAN SQUARE SPEED = 149.1 CM2/S2			
	MEAN SQUARE E-W SPEED = 78.7 CM2/S2		MEAN SQUARE N-S SPEED = 70.4 CM2/S2			
	MEAN VELOCITY = 1.5 CM/S,		355 DEG TRUE		MEAN TEMPERATURE = 2.6 C	
	VARIANCE (U,V) = 73.5 CM2/S2		TOTAL HOURS = 744.			

PERCENT OBSERVED
 LIGHT (0.0 - 3.0) 13.4% MEDIUM (3.0 - 7.0) 38.2% HIGH (GE 7.0) 48.4%

DATE: 1998/04/01 TO 1998/04/30
 ROSE SUMMARY: WIND AND CURRENT

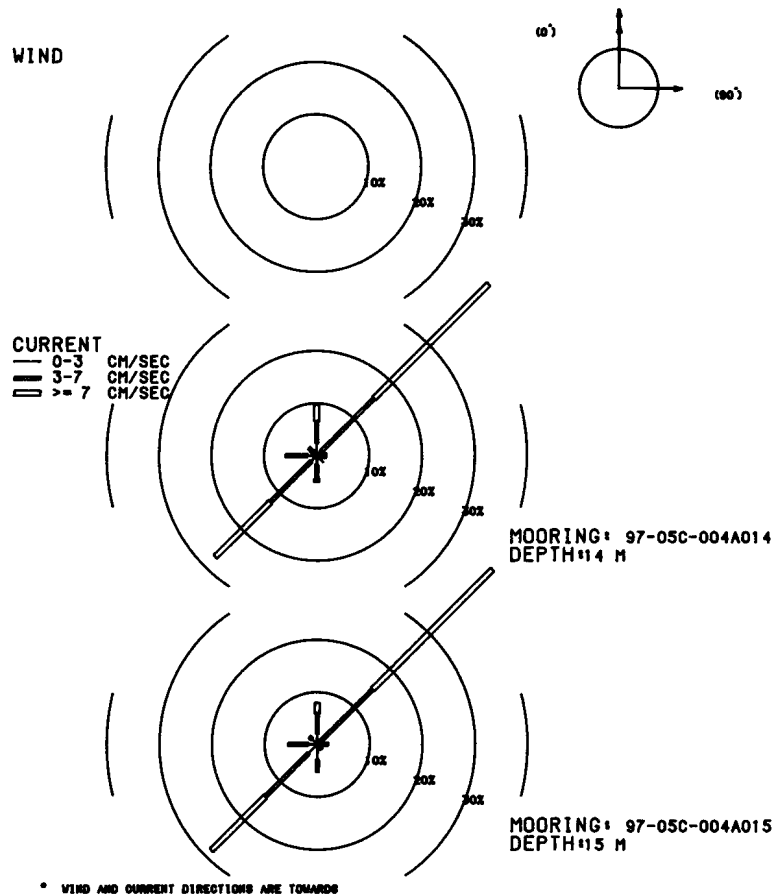

MOORING IS 97-05C-004A014 DEPTH IS 14 METERS THERE ARE 337 VALUES

FIRST DAY 1998/04/01/0000
 FINAL DAY 1998/04/15/0000

SHORELINE ORIENTATION IN DEGREES TRUE SPECIFIED AS 90

DIRECTION DEG TRUE	PERCENT OBSERVED	MAXIMUM CURRENT CM/S	MEAN DURA- TION HOURS	MEAN EXCUR- SION KM	MEAN CURRENT CM/S	MEAN TEMP DEG C
TOWARD	TOTAL	LIGHT	MEDIUM	HIGH		
90.0	1.8	0.9	0.6	0.3	8.0	1.0
45.0	46.3	1.2	14.2	30.9	19.7	9.2
0.0	9.8	2.4	4.2	3.3	9.7	2.5
315.0	2.1	0.9	1.2	0.0	5.7	1.2
270.0	5.9	1.8	4.2	0.0	5.1	1.8
225.0	27.3	1.5	11.0	14.8	17.7	6.6
180.0	5.0	1.8	2.7	0.6	7.8	1.2
135.0	1.8	1.8	0.0	0.0	2.8	1.0
MEAN SCALAR SPEED = 7.5 CM/S		MEAN SQUARE SPEED = 72.2 CM ² /S ²				
MEAN SQUARE E-W SPEED = 32.6 CM ² /S ²		MEAN SQUARE N-S SPEED = 39.6 CM ² /S ²				
MEAN VELOCITY = 2.3 CM/S,		35 DEG TRUE		MEAN TEMPERATURE = 5.2 C		
VARIANCE (U,V) = 33.6 CM ² /S ²		TOTAL HOURS = 337.				

PERCENT OBSERVED

LIGHT (0.0 - 3.0) 12.2% MEDIUM (3.0 - 7.0) 38.0% HIGH (GE 7.0) 49.9%

MOORING IS 97-05C-004A015 DEPTH IS 15 METERS THERE ARE 337 VALUES

FIRST DAY 1998/04/01/0000
 FINAL DAY 1998/04/15/0000

SHORELINE ORIENTATION IN DEGREES TRUE SPECIFIED AS 90

DIRECTION DEG TRUE	PERCENT OBSERVED	MAXIMUM CURRENT CM/S	MEAN DURA- TION HOURS	MEAN EXCUR- SION KM	MEAN CURRENT CM/S	MEAN TEMP DEG C
TOWARD	TOTAL	LIGHT	MEDIUM	HIGH		
90.0	2.1	0.6	1.5	0.0	6.9	1.2
45.0	47.2	0.9	13.9	32.3	17.9	9.4
0.0	8.0	2.1	3.9	2.1	9.0	1.7
315.0	2.1	1.5	0.6	0.0	3.2	1.4
270.0	5.6	1.8	3.9	0.0	7.0	1.7
225.0	28.5	2.4	11.6	14.5	17.6	6.4
180.0	5.3	3.0	2.4	0.0	7.0	1.5
135.0	1.2	0.6	0.6	0.0	4.0	1.0
MEAN SCALAR SPEED = 7.4 CM/S		MEAN SQUARE SPEED = 68.8 CM ² /S ²				
MEAN SQUARE E-W SPEED = 30.9 CM ² /S ²		MEAN SQUARE N-S SPEED = 37.9 CM ² /S ²				
MEAN VELOCITY = 2.1 CM/S,		35 DEG TRUE		MEAN TEMPERATURE = 5.2 C		
VARIANCE (U,V) = 32.3 CM ² /S ²		TOTAL HOURS = 337.				

PERCENT OBSERVED

LIGHT (0.0 - 3.0) 12.8% MEDIUM (3.0 - 7.0) 38.3% HIGH (GE 7.0) 49.0%

Appendix G - Mooring_A5-97. Overall Summary Statistics and Rose Histogram Plots

DATE: 1997/11/02 TO 1998/04/15
 ROSE SUMMARY: WIND AND CURRENT

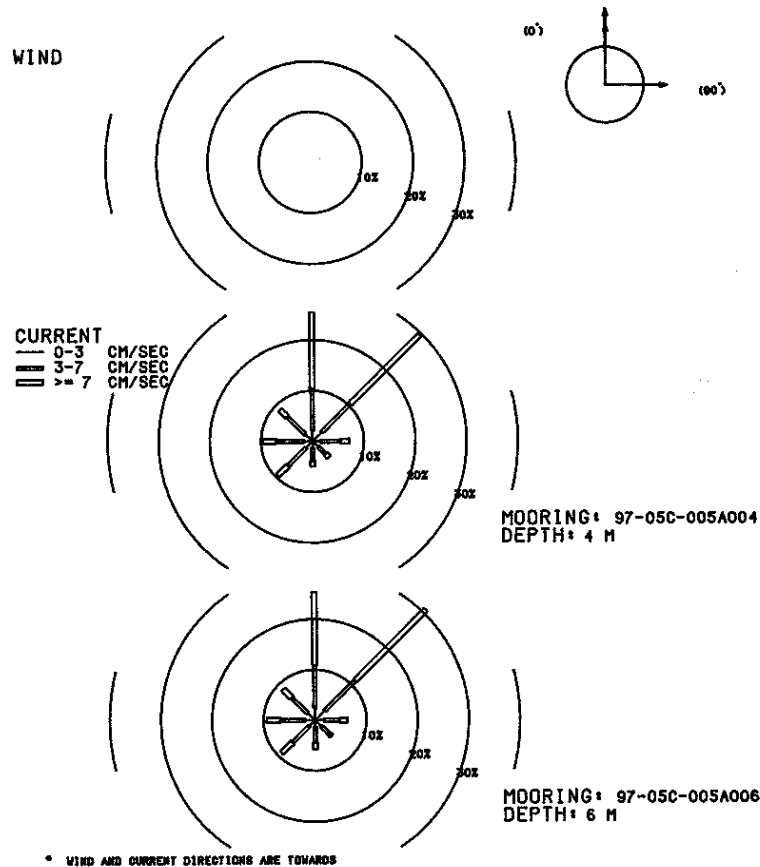

MOORING IS 97-05C-005A004 DEPTH IS 4 METERS THERE ARE 3932 VALUES

FIRST DAY 1997/11/02/0500
 FINAL DAY 1998/04/15/0000

SHORELINE ORIENTATION IN DEGREES TRUE SPECIFIED AS 90

DIRECTION DEG TRUE	PERCENT OBSERVED				MAXIMUM CURRENT CM/S	MEAN DURA- TION HOURS	MEAN EXCUR- SION KM	MEAN CURRENT CM/S	MEAN TEMP DEG C
TOWARD	TOTAL	LIGHT	MEDIUM	HIGH	CM/S	HOURS	KM	CM/S	DEG C
90.0	7.2	1.5	4.0	1.8	21.6	1.4	0.3	5.4	4.9
45.0	29.6	2.5	7.8	19.2	58.7	2.6	1.1	11.3	5.0
0.0	25.5	2.2	8.3	15.1	49.4	2.3	0.8	9.8	4.1
315.0	8.9	2.0	4.9	2.0	49.8	1.6	0.3	6.0	4.1
270.0	9.8	1.6	5.4	2.7	25.1	1.8	0.4	6.0	4.9
225.0	9.6	1.8	5.0	2.8	38.6	1.8	0.4	6.3	4.8
180.0	5.0	1.3	2.5	1.1	24.3	1.4	0.3	5.6	4.7
135.0	4.5	1.5	2.0	0.9	23.3	1.3	0.2	5.1	4.3
0	MEAN SCALAR SPEED = 8.5 CM/S		MEAN SQUARE SPEED = 120.4 CM2/S2						
	MEAN SQUARE E-W SPEED = 37.0 CM2/S2		MEAN SQUARE N-S SPEED = 83.4 CM2/S2						
	MEAN VELOCITY = 4.8 CM/S,		18 DEG TRUE		MEAN TEMPERATURE = 4.6 C				
	VARIANCE (U,V) = 48.5 CM2/S2		TOTAL HOURS = 3932.						

PERCENT OBSERVED
 LIGHT (0.0 - 3.0) 14.4% MEDIUM (3.0 - 7.0) 40.0% HIGH (GE 7.0) 45.6%

MOORING IS 97-05C-005A006 DEPTH IS 6 METERS THERE ARE 3932 VALUES

FIRST DAY 1997/11/02/0500
 FINAL DAY 1998/04/15/0000

SHORELINE ORIENTATION IN DEGREES TRUE SPECIFIED AS 90

DIRECTION DEG TRUE	PERCENT OBSERVED				MAXIMUM CURRENT CM/S	MEAN DURA- TION HOURS	MEAN EXCUR- SION KM	MEAN CURRENT CM/S	MEAN TEMP DEG C
TOWARD	TOTAL	LIGHT	MEDIUM	HIGH	CM/S	HOURS	KM	CM/S	DEG C
90.0	6.3	1.7	3.1	1.5	22.4	1.6	0.3	5.2	4.9
45.0	30.7	2.5	8.6	19.7	58.4	3.0	1.2	11.2	5.0
0.0	25.3	2.4	8.5	14.5	49.1	2.4	0.8	9.6	4.0
315.0	8.7	1.9	4.4	2.4	50.8	1.6	0.4	6.3	4.2
270.0	9.4	1.9	4.8	2.7	27.1	1.7	0.4	5.8	4.8
225.0	9.2	1.5	4.6	3.1	33.1	1.9	0.4	6.3	4.8
180.0	5.8	1.3	3.1	1.3	24.2	1.6	0.3	5.7	4.8
135.0	4.5	1.8	2.2	0.5	26.4	1.5	0.2	4.2	4.3
0	MEAN SCALAR SPEED = 8.4 CM/S		MEAN SQUARE SPEED = 119.2 CM2/S2						
	MEAN SQUARE E-W SPEED = 36.1 CM2/S2		MEAN SQUARE N-S SPEED = 83.1 CM2/S2						
	MEAN VELOCITY = 4.9 CM/S,		18 DEG TRUE		MEAN TEMPERATURE = 4.6 C				
	VARIANCE (U,V) = 47.7 CM2/S2		TOTAL HOURS = 3932.						

PERCENT OBSERVED
 LIGHT (0.0 - 3.0) 15.1% MEDIUM (3.0 - 7.0) 39.3% HIGH (GE 7.0) 45.6%

DATE: 1997/11/02 TO 1998/04/15
ROSE SUMMARY: WIND AND CURRENT

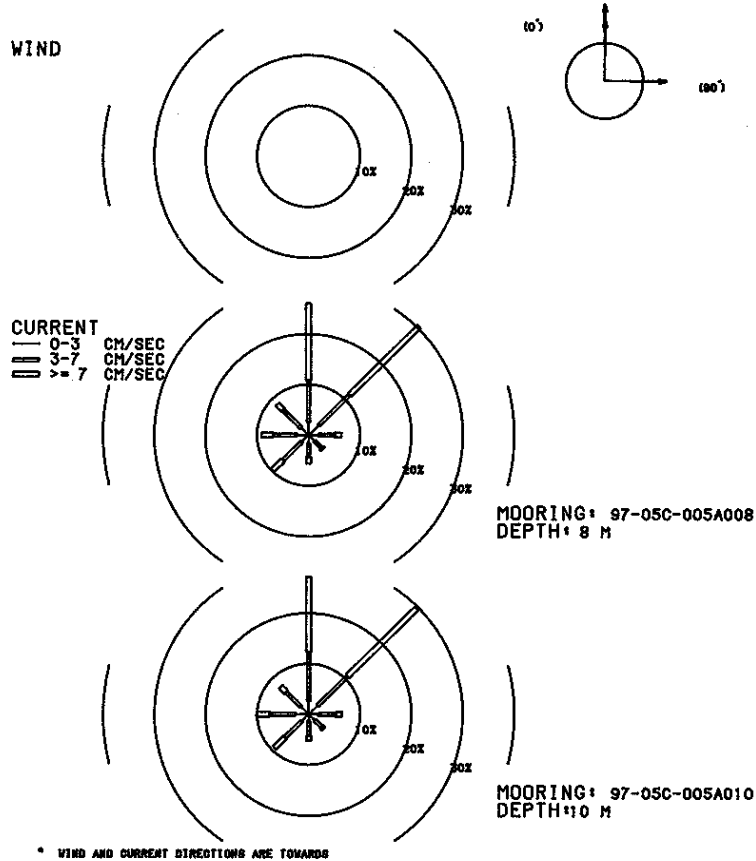

MOORING IS 97-05C-005A008 DEPTH IS 8 METERS THERE ARE 3932 VALUES

FIRST DAY 1997/11/02/0500
FINAL DAY 1998/04/15/0000

SHORELINE ORIENTATION IN DEGREES TRUE SPECIFIED AS 90

DIRECTION DEG TRUE	PERCENT OBSERVED	TOWARD	TOTAL	LIGHT	MEDIUM	HIGH	MAXIMUM CURRENT CM/S	MEAN DURA- TION HOURS	MEAN EXCUR- SION KM	MEAN CURRENT CM/S	MEAN TEMP DEG C
90.0	6.4	1.9	3.2	1.3	21.5	1.6	0.3	5.0	4.7		
45.0	30.4	2.8	8.4	19.2	59.6	3.0	1.2	11.0	5.0		
0.0	26.0	2.5	8.3	15.2	49.7	2.5	0.9	9.6	4.1		
315.0	8.6	1.9	5.1	1.7	49.1	1.6	0.3	5.9	4.2		
270.0	9.1	2.3	4.5	2.3	28.2	1.6	0.3	5.6	4.7		
225.0	9.8	1.8	5.1	2.9	34.0	1.9	0.4	6.1	4.9		
180.0	5.6	1.6	2.7	1.3	24.0	1.6	0.3	5.4	4.8		
135.0	3.9	1.6	1.9	0.4	24.7	1.4	0.2	4.2	4.4		
MEAN SCALAR SPEED = 8.2 CM/S		MEAN SQUARE SPEED = 116.9 CM2/S2									
MEAN SQUARE E-W SPEED = 35.2 CM2/S2		MEAN SQUARE N-S SPEED = 81.7 CM2/S2									
MEAN VELOCITY = 4.8 CM/S,		18 DEG TRUE MEAN TEMPERATURE = 4.6 C									
VARIANCE (U,V) = 46.7 CM2/S2		TOTAL HOURS = 3932.									

PERCENT OBSERVED
LIGHT (0.0 - 3.0) 16.5% MEDIUM (3.0 - 7.0) 39.2% HIGH (GE 7.0) 44.3%

MOORING IS 97-05C-005A010 DEPTH IS 10 METERS THERE ARE 3932 VALUES

FIRST DAY 1997/11/02/0500
FINAL DAY 1998/04/15/0000

SHORELINE ORIENTATION IN DEGREES TRUE SPECIFIED AS 90

DIRECTION DEG TRUE	PERCENT OBSERVED	TOWARD	TOTAL	LIGHT	MEDIUM	HIGH	MAXIMUM CURRENT CM/S	MEAN DURA- TION HOURS	MEAN EXCUR- SION KM	MEAN CURRENT CM/S	MEAN TEMP DEG C
90.0	6.5	1.9	3.4	1.2	22.0	1.5	0.3	4.8	4.5		
45.0	29.7	2.3	8.2	19.1	59.3	2.9	1.2	11.1	5.1		
0.0	27.1	2.6	9.7	14.8	47.0	2.6	0.9	9.2	4.1		
315.0	7.7	2.1	4.0	1.6	51.8	1.5	0.3	5.8	4.1		
270.0	10.1	2.5	5.1	2.5	30.2	1.8	0.4	5.6	4.9		
225.0	9.4	1.8	4.6	3.0	35.3	1.8	0.4	5.9	4.9		
180.0	5.3	1.3	3.0	1.0	26.5	1.6	0.3	5.2	4.6		
135.0	4.1	1.7	2.0	0.5	17.9	1.4	0.2	4.1	4.4		
MEAN SCALAR SPEED = 8.1 CM/S		MEAN SQUARE SPEED = 113.5 CM2/S2									
MEAN SQUARE E-W SPEED = 33.6 CM2/S2		MEAN SQUARE N-S SPEED = 79.9 CM2/S2									
MEAN VELOCITY = 4.8 CM/S,		18 DEG TRUE MEAN TEMPERATURE = 4.6 C									
VARIANCE (U,V) = 45.0 CM2/S2		TOTAL HOURS = 3932.									

PERCENT OBSERVED
LIGHT (0.0 - 3.0) 16.3% MEDIUM (3.0 - 7.0) 40.1% HIGH (GE 7.0) 43.6%

DATE: 1997/11/02 TO 1998/04/15
ROSE SUMMARY: WIND AND CURRENT

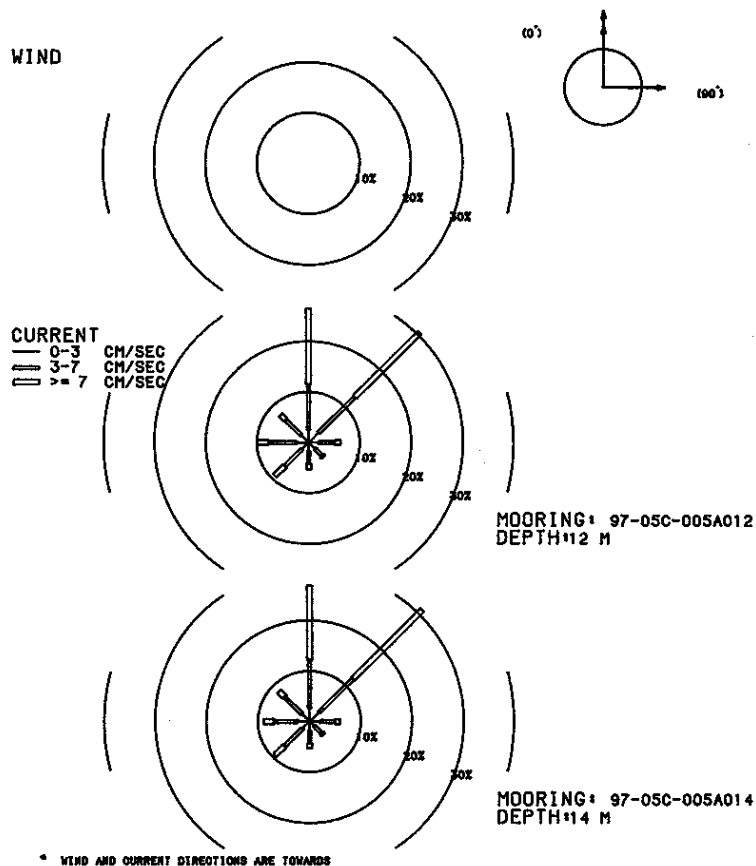

MOORING IS 97-05C-005A012 DEPTH IS 12 METERS THERE ARE 3932 VALUES

FIRST DAY 1997/11/02/0500
FINAL DAY 1998/04/15/0000

SHORELINE ORIENTATION IN DEGREES TRUE SPECIFIED AS 90

DIRECTION DEG TRUE	PERCENT OBSERVED	TOWARD	TOTAL	LIGHT	MEDIUM	HIGH	MAXIMUM CURRENT CM/S	MEAN DURA- TION HOURS	MEAN EXCUR- SION KM	MEAN CURRENT CM/S	MEAN TEMP DEG C
90.0	6.3	2.0	3.1	1.2	15.7	1.7	0.3	4.8	4.7		
45.0	30.7	2.7	10.0	18.0	60.2	3.0	1.1	10.8	5.0		
0.0	26.5	2.4	9.1	15.0	46.8	2.6	0.9	9.3	4.1		
315.0	7.8	1.9	4.4	1.4	51.9	1.6	0.3	5.8	4.2		
270.0	10.0	2.4	5.5	2.2	30.6	1.7	0.3	5.4	4.9		
225.0	9.3	1.8	4.8	2.7	33.4	1.8	0.4	6.0	4.9		
180.0	5.4	1.8	2.4	1.2	22.5	1.5	0.3	5.1	4.8		
135.0	4.1	1.7	1.9	0.5	19.8	1.5	0.2	4.1	4.1		
MEAN SCALAR SPEED = 8.1 CM/S		MEAN SQUARE SPEED = 112.1 CM2/S2									
MEAN SQUARE E-W SPEED = 33.0 CM2/S2		MEAN SQUARE N-S SPEED = 79.1 CM2/S2									
MEAN VELOCITY = 4.8 CM/S,		17 DEG TRUE MEAN TEMPERATURE = 4.6 C									
VARIANCE (U,V) = 44.4 CM2/S2		TOTAL HOURS = 3932.									

PERCENT OBSERVED

LIGHT (0.0 - 3.0) 16.6% MEDIUM (3.0 - 7.0) 41.1% HIGH (GE 7.0) 42.2%

MOORING IS 97-05C-005A014 DEPTH IS 14 METERS THERE ARE 3932 VALUES

FIRST DAY 1997/11/02/0500
FINAL DAY 1998/04/15/0000

SHORELINE ORIENTATION IN DEGREES TRUE SPECIFIED AS 90

DIRECTION DEG TRUE	PERCENT OBSERVED	TOWARD	TOTAL	LIGHT	MEDIUM	HIGH	MAXIMUM CURRENT CM/S	MEAN DURA- TION HOURS	MEAN EXCUR- SION KM	MEAN CURRENT CM/S	MEAN TEMP DEG C
90.0	5.9	2.0	2.9	1.0	14.9	1.5	0.2	4.5	4.5		
45.0	31.2	2.5	9.5	19.2	61.5	3.1	1.2	10.7	5.0		
0.0	26.9	2.7	9.6	14.5	46.7	2.8	0.9	9.3	4.1		
315.0	8.5	2.1	4.8	1.6	47.9	1.7	0.4	5.9	4.2		
270.0	9.0	2.3	4.6	2.1	28.4	1.8	0.3	5.3	4.9		
225.0	9.5	1.9	4.9	2.7	33.7	2.1	0.5	6.1	4.9		
180.0	5.3	1.9	2.5	1.0	20.0	1.5	0.2	4.7	4.8		
135.0	3.7	1.2	2.1	0.4	18.5	1.4	0.2	4.2	4.1		
MEAN SCALAR SPEED = 8.0 CM/S		MEAN SQUARE SPEED = 111.4 CM2/S2									
MEAN SQUARE E-W SPEED = 32.5 CM2/S2		MEAN SQUARE N-S SPEED = 78.9 CM2/S2									
MEAN VELOCITY = 4.9 CM/S,		17 DEG TRUE MEAN TEMPERATURE = 4.6 C									
VARIANCE (U,V) = 43.9 CM2/S2		TOTAL HOURS = 3932.									

PERCENT OBSERVED

LIGHT (0.0 - 3.0) 16.5% MEDIUM (3.0 - 7.0) 41.0% HIGH (GE 7.0) 42.5%

DATE: 1997/11/02 TO 1998/04/15
ROSE SUMMARY: WIND AND CURRENT

WIND

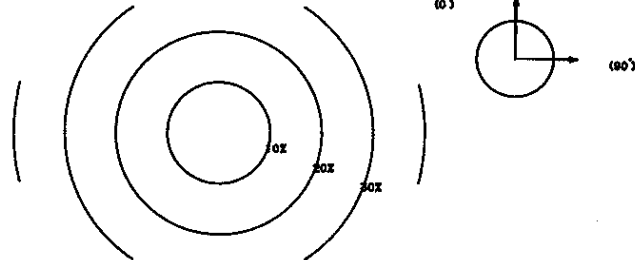

CURRENT
 0-3 CM/SEC
 3-7 CM/SEC
 >= 7 CM/SEC

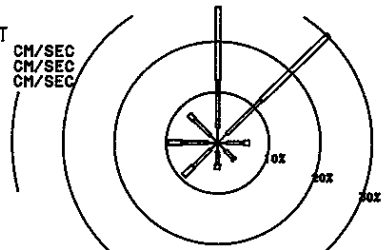

MOORING: 97-05C-005A016
DEPTH 16 M

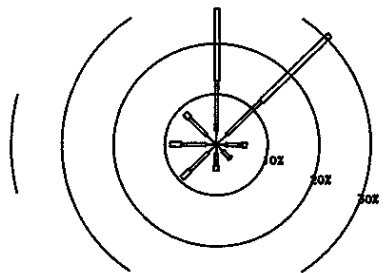

MOORING: 97-05C-005A018
DEPTH 18 M

* WIND AND CURRENT DIRECTIONS ARE TOWARDS

MOORING IS 97-05C-005A016 DEPTH IS 16 METERS THERE ARE 3932 VALUES

FIRST DAY 1997/11/02/0500
FINAL DAY 1998/04/15/0000

SHORELINE ORIENTATION IN DEGREES TRUE SPECIFIED AS 90

DIRECTION DEG TRUE	PERCENT OBSERVED	TOWARD	TOTAL	LIGHT	MEDIUM	HIGH	MAXIMUM CURRENT CM/S	MEAN DURA- TION HOURS	MEAN EXCUR- SION KM	MEAN CURRENT CM/S	MEAN TEMP DEG C
90.0	6.2	1.8	3.3	1.1	12.5	1.6	0.3	4.6	4.7		
45.0	30.3	2.4	9.6	18.3	62.1	3.1	1.2	10.8	4.9		
0.0	26.9	2.9	9.4	14.5	45.3	2.6	0.9	9.2	4.2		
315.0	7.8	2.0	4.4	1.4	49.4	1.6	0.3	5.7	4.3		
270.0	9.6	2.0	5.0	2.7	27.8	1.9	0.4	5.7	4.8		
225.0	9.2	1.9	4.8	2.6	33.3	1.9	0.4	5.9	4.9		
180.0	5.3	1.7	2.5	1.0	18.2	1.7	0.3	4.9	4.8		
135.0	4.7	2.2	2.2	0.3	16.9	1.6	0.2	3.6	4.3		

MEAN SCALAR SPEED = 8.0 CM/S MEAN SQUARE SPEED = 110.1 CM2/S2
 MEAN SQUARE E-W SPEED = 32.2 CM2/S2 MEAN SQUARE N-S SPEED = 77.8 CM2/S2
 MEAN VELOCITY = 4.8 CM/S, 17 DEG TRUE MEAN TEMPERATURE = 4.6 C
 VARIANCE (U,V) = 43.5 CM2/S2 TOTAL HOURS = 3932.

PERCENT OBSERVED
 LIGHT (0.0 - 3.0) 16.9% MEDIUM (3.0 - 7.0) 41.1% HIGH (GE 7.0) 42.0%

MOORING IS 97-05C-005A018 DEPTH IS 18 METERS THERE ARE 3932 VALUES

FIRST DAY 1997/11/02/0500
FINAL DAY 1998/04/15/0000

SHORELINE ORIENTATION IN DEGREES TRUE SPECIFIED AS 90

DIRECTION DEG TRUE	PERCENT OBSERVED	TOWARD	TOTAL	LIGHT	MEDIUM	HIGH	MAXIMUM CURRENT CM/S	MEAN DURA- TION HOURS	MEAN EXCUR- SION KM	MEAN CURRENT CM/S	MEAN TEMP DEG C
90.0	5.9	1.8	3.2	0.9	11.9	1.5	0.2	4.5	4.5		
45.0	31.0	2.9	9.4	18.7	59.0	3.0	1.1	10.7	4.9		
0.0	26.9	2.7	9.9	14.3	44.6	2.6	0.8	9.1	4.2		
315.0	8.7	2.7	4.7	1.3	49.1	1.7	0.3	5.2	4.2		
270.0	9.0	2.0	4.9	2.1	34.9	1.7	0.4	5.7	5.1		
225.0	9.4	2.2	5.1	2.1	32.9	1.9	0.4	5.6	4.6		
180.0	5.2	1.7	2.4	1.0	18.4	1.5	0.3	4.9	5.0		
135.0	3.9	1.8	1.8	0.3	12.2	1.4	0.2	3.6	4.2		

MEAN SCALAR SPEED = 7.9 CM/S MEAN SQUARE SPEED = 108.6 CM2/S2
 MEAN SQUARE E-W SPEED = 31.3 CM2/S2 MEAN SQUARE N-S SPEED = 77.3 CM2/S2
 MEAN VELOCITY = 4.9 CM/S, 17 DEG TRUE MEAN TEMPERATURE = 4.6 C
 VARIANCE (U,V) = 42.5 CM2/S2 TOTAL HOURS = 3932.

PERCENT OBSERVED
 LIGHT (0.0 - 3.0) 17.8% MEDIUM (3.0 - 7.0) 41.4% HIGH (GE 7.0) 40.8%

DATE: 1997/11/02 TO 1998/04/15
ROSE SUMMARY: WIND AND CURRENT

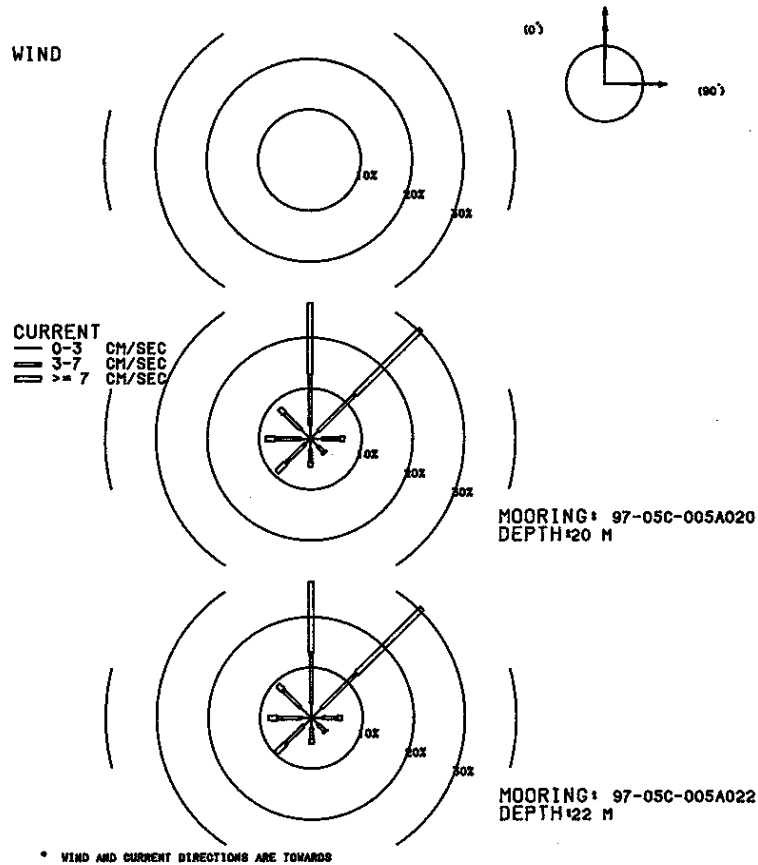

MOORING IS 97-05C-005A020 DEPTH IS 20 METERS THERE ARE 3932 VALUES

FIRST DAY 1997/11/02/0500
FINAL DAY 1998/04/15/0000

SHORELINE ORIENTATION IN DEGREES TRUE SPECIFIED AS 90

DIRECTION DEG TRUE	PERCENT OBSERVED	TOWARD	TOTAL	LIGHT	MEDIUM	HIGH	MAXIMUM CURRENT CM/S	MEAN DURA- TION HOURS	MEAN EXCUR- SION KM	MEAN CURRENT CM/S	MEAN TEMP DEG C
90.0	6.6	2.3	3.5	0.9	12.5	1.5	0.2	4.3	4.5		
45.0	30.5	2.1	10.3	18.1	61.0	2.9	1.1	10.5	4.9		
0.0	26.9	2.6	10.2	14.1	45.4	2.6	0.9	9.2	4.2		
315.0	8.4	2.6	4.4	1.4	45.7	1.7	0.3	5.4	4.2		
270.0	8.7	1.9	5.0	1.9	28.6	1.6	0.3	5.5	4.9		
225.0	9.3	1.5	5.3	2.4	32.6	1.9	0.4	5.9	4.9		
180.0	5.5	2.0	2.6	0.9	18.2	1.6	0.3	4.6	4.7		
135.0	4.0	2.1	1.6	0.4	17.0	1.4	0.2	3.6	4.3		

MEAN SCALAR SPEED = 7.9 CM/S MEAN SQUARE SPEED = 107.9 CM2/S2
 MEAN SQUARE E-W SPEED = 30.6 CM2/S2 MEAN SQUARE N-S SPEED = 77.3 CM2/S2
 MEAN VELOCITY = 4.8 CM/S, 17 DEG TRUE MEAN TEMPERATURE = 4.6 C
 VARIANCE (U,V) = 42.3 CM2/S2 TOTAL HOURS = 3932.

PERCENT OBSERVED
 LIGHT (0.0 - 3.0) 17.1% MEDIUM (3.0 - 7.0) 42.8% HIGH (GE 7.0) 40.1%

MOORING IS 97-05C-005A022 DEPTH IS 22 METERS THERE ARE 3932 VALUES

FIRST DAY 1997/11/02/0500
FINAL DAY 1998/04/15/0000

SHORELINE ORIENTATION IN DEGREES TRUE SPECIFIED AS 90

DIRECTION DEG TRUE	PERCENT OBSERVED	TOWARD	TOTAL	LIGHT	MEDIUM	HIGH	MAXIMUM CURRENT CM/S	MEAN DURA- TION HOURS	MEAN EXCUR- SION KM	MEAN CURRENT CM/S	MEAN TEMP DEG C
90.0	6.0	2.2	2.9	0.9	12.1	1.5	0.2	4.3	4.8		
45.0	30.6	2.9	9.6	18.1	60.5	2.9	1.1	10.5	4.9		
0.0	26.9	2.9	10.0	14.0	46.2	2.5	0.8	9.0	4.1		
315.0	9.3	3.0	4.9	1.4	50.3	1.8	0.3	5.2	4.4		
270.0	8.4	2.0	4.7	1.7	26.7	1.8	0.4	5.5	5.0		
225.0	9.9	2.2	5.0	2.6	30.9	2.1	0.4	5.7	4.7		
180.0	5.1	1.8	2.3	0.9	17.8	1.4	0.2	4.6	4.8		
135.0	3.9	1.9	1.8	0.3	12.0	1.4	0.2	3.5	4.3		

MEAN SCALAR SPEED = 7.8 CM/S MEAN SQUARE SPEED = 106.6 CM2/S2
 MEAN SQUARE E-W SPEED = 29.8 CM2/S2 MEAN SQUARE N-S SPEED = 76.8 CM2/S2
 MEAN VELOCITY = 4.8 CM/S, 17 DEG TRUE MEAN TEMPERATURE = 4.6 C
 VARIANCE (U,V) = 41.8 CM2/S2 TOTAL HOURS = 3932.

PERCENT OBSERVED
 LIGHT (0.0 - 3.0) 18.8% MEDIUM (3.0 - 7.0) 41.2% HIGH (GE 7.0) 40.0%

DATE: 1997/11/02 TO 1998/04/15
 ROSE SUMMARY: WIND AND CURRENT

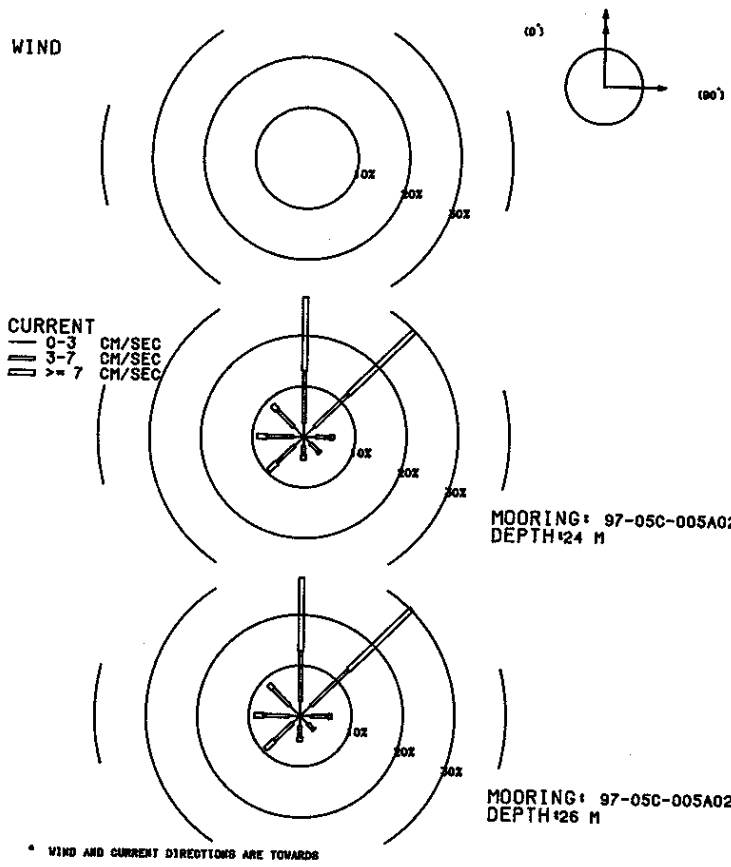

MOORING IS 97-05C-005A024 DEPTH IS 24 METERS THERE ARE 3932 VALUES

FIRST DAY 1997/11/02/0500
 FINAL DAY 1998/04/15/0000

SHORELINE ORIENTATION IN DEGREES TRUE SPECIFIED AS 90

DIRECTION DEG TRUE	PERCENT OBSERVED	TOWARD	LIGHT	MEDIUM	HIGH	MAXIMUM CURRENT CM/S	MEAN DURATION HOURS	MEAN EXCURSION KM	MEAN CURRENT CM/S	MEAN TEMP DEG C
90.0	5.9	2.3	2.8	0.8		11.6	1.6	0.2	4.0	4.7
45.0	30.0	2.9	9.2	17.9		60.3	3.0	1.2	10.5	5.0
0.0	27.6	2.7	10.3	14.6		44.4	2.7	0.9	9.0	4.1
315.0	8.7	2.7	4.6	1.4		47.2	1.8	0.3	5.2	4.3
270.0	9.2	2.1	5.1	2.0		37.0	1.9	0.4	5.4	4.9
225.0	9.6	2.5	4.8	2.3		30.1	2.0	0.4	5.6	4.9
180.0	4.5	1.8	1.8	0.9		16.5	1.5	0.3	4.5	4.4
135.0	4.5	1.8	2.3	0.3		16.2	1.5	0.2	3.6	4.3
MEAN SCALAR SPEED = 7.7 CM/S						MEAN SQUARE SPEED = 106.2 CM2/S2				
MEAN SQUARE E-W SPEED = 29.7 CM2/S2						MEAN SQUARE N-S SPEED = 76.5 CM2/S2				
MEAN VELOCITY = 4.8 CM/S,						17 DEG TRUE MEAN TEMPERATURE = 4.6 C				
VARIANCE (U,V) = 41.5 CM2/S2						TOTAL HOURS = 3932.				

PERCENT OBSERVED
 LIGHT (0.0 - 3.0) 18.8% MEDIUM (3.0 - 7.0) 40.9% HIGH (GE 7.0) 40.2%

MOORING IS 97-05C-005A026 DEPTH IS 26 METERS THERE ARE 3932 VALUES

FIRST DAY 1997/11/02/0500
 FINAL DAY 1998/04/15/0000

SHORELINE ORIENTATION IN DEGREES TRUE SPECIFIED AS 90

DIRECTION DEG TRUE	PERCENT OBSERVED	TOWARD	LIGHT	MEDIUM	HIGH	MAXIMUM CURRENT CM/S	MEAN DURATION HOURS	MEAN EXCURSION KM	MEAN CURRENT CM/S	MEAN TEMP DEG C
90.0	6.2	2.1	3.4	0.7		11.3	1.4	0.2	4.0	4.4
45.0	30.3	2.9	10.2	17.2		60.6	2.9	1.1	10.2	5.0
0.0	27.4	2.9	10.0	14.5		45.6	2.7	0.9	9.3	4.2
315.0	8.7	2.8	4.8	1.2		46.7	1.8	0.3	5.0	4.1
270.0	9.0	2.1	5.0	1.8		37.9	1.8	0.4	5.5	4.9
225.0	9.4	2.0	4.9	2.5		29.9	2.1	0.4	5.7	4.9
180.0	5.1	1.9	2.3	0.9		16.3	1.6	0.2	4.3	4.5
135.0	3.9	2.1	1.7	0.2		16.2	1.4	0.2	3.4	4.5
MEAN SCALAR SPEED = 7.7 CM/S						MEAN SQUARE SPEED = 105.8 CM2/S2				
MEAN SQUARE E-W SPEED = 29.2 CM2/S2						MEAN SQUARE N-S SPEED = 76.5 CM2/S2				
MEAN VELOCITY = 4.8 CM/S,						16 DEG TRUE MEAN TEMPERATURE = 4.6 C				
VARIANCE (U,V) = 41.4 CM2/S2						TOTAL HOURS = 3932.				

PERCENT OBSERVED
 LIGHT (0.0 - 3.0) 18.8% MEDIUM (3.0 - 7.0) 42.2% HIGH (GE 7.0) 39.0%

DATE: 1997/11/02 TO 1998/04/15
ROSE SUMMARY: WIND AND CURRENT

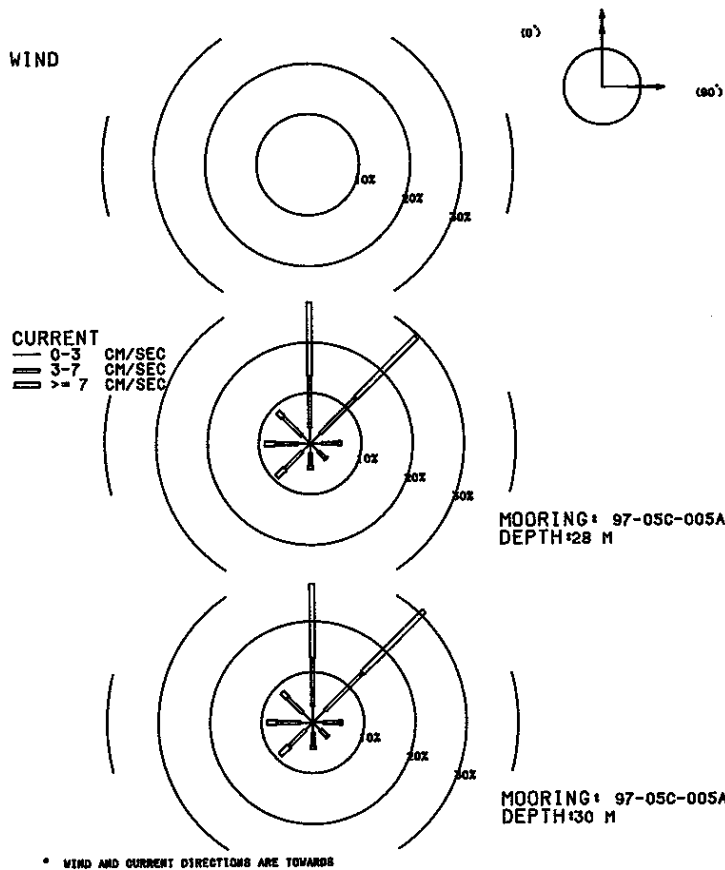

MOORING IS 97-05C-005A028 DEPTH IS 28 METERS THERE ARE 3932 VALUES

FIRST DAY 1997/11/02/0500
FINAL DAY 1998/04/15/0000

SHORELINE ORIENTATION IN DEGREES TRUE SPECIFIED AS 90

DIRECTION DEG TRUE	PERCENT OBSERVED	MAXIMUM CURRENT			MEAN DURA- TION HOURS	MEAN EXCUR- SION KM	MEAN CURRENT CM/S	MEAN TEMP DEG C	
TOWARD	TOTAL	LIGHT	MEDIUM	HIGH	CM/S				
90.0	6.1	2.3	3.2	0.6	10.8	1.5	0.2	3.9	4.2
45.0	29.6	2.7	9.9	16.9	60.0	2.9	1.1	10.3	5.0
0.0	27.9	3.1	10.3	14.5	43.6	2.7	0.9	9.2	4.2
315.0	8.9	2.3	5.1	1.5	46.4	1.9	0.4	5.5	4.5
270.0	8.9	2.5	4.3	2.1	27.1	1.7	0.3	5.3	4.8
225.0	9.3	2.2	4.7	2.3	30.6	2.0	0.4	5.6	4.9
180.0	5.1	2.0	2.4	0.8	16.2	1.7	0.3	4.4	4.6
135.0	4.3	2.3	1.9	0.2	11.0	1.4	0.2	3.3	4.3

MEAN SCALAR SPEED = 7.7 CM/S MEAN SQUARE SPEED = 105.3 CM²/S²
 MEAN SQUARE E-W SPEED = 29.0 CM²/S² MEAN SQUARE N-S SPEED = 76.3 CM²/S²
 MEAN VELOCITY = 4.8 CM/S, 16 DEG TRUE MEAN TEMPERATURE = 4.6 C
 VARIANCE (U,V) = 41.1 CM²/S² TOTAL HOURS = 3932.

PERCENT OBSERVED
 LIGHT (0.0 - 3.0) 19.3% MEDIUM (3.0 - 7.0) 41.8% HIGH (GE 7.0) 38.9%

MOORING IS 97-05C-005A030 DEPTH IS 30 METERS THERE ARE 3932 VALUES

FIRST DAY 1997/11/02/0500
FINAL DAY 1998/04/15/0000

SHORELINE ORIENTATION IN DEGREES TRUE SPECIFIED AS 90

DIRECTION DEG TRUE	PERCENT OBSERVED	MAXIMUM CURRENT			MEAN DURA- TION HOURS	MEAN EXCUR- SION KM	MEAN CURRENT CM/S	MEAN TEMP DEG C	
TOWARD	TOTAL	LIGHT	MEDIUM	HIGH	CM/S				
90.0	5.7	2.1	3.1	0.6	11.2	1.4	0.2	4.1	4.4
45.0	31.0	3.3	10.5	17.2	60.5	2.9	1.0	10.0	4.9
0.0	27.4	3.2	9.6	14.6	45.4	2.6	0.9	9.2	4.3
315.0	8.5	2.8	4.2	1.5	45.4	1.8	0.3	5.1	4.5
270.0	8.9	2.4	4.6	1.9	35.3	1.8	0.3	5.4	4.8
225.0	9.1	2.0	4.5	2.5	29.8	1.9	0.4	5.8	4.8
180.0	5.3	1.9	2.7	0.7	16.6	1.6	0.3	4.3	4.6
135.0	4.2	2.1	1.9	0.2	11.3	1.5	0.2	3.2	4.3

MEAN SCALAR SPEED = 7.6 CM/S MEAN SQUARE SPEED = 104.6 CM²/S²
 MEAN SQUARE E-W SPEED = 28.6 CM²/S² MEAN SQUARE N-S SPEED = 76.0 CM²/S²
 MEAN VELOCITY = 4.8 CM/S, 16 DEG TRUE MEAN TEMPERATURE = 4.6 C
 VARIANCE (U,V) = 41.0 CM²/S² TOTAL HOURS = 3932.

PERCENT OBSERVED
 LIGHT (0.0 - 3.0) 19.9% MEDIUM (3.0 - 7.0) 41.1% HIGH (GE 7.0) 39.1%

DATE: 1997/11/02 TO 1998/04/15
ROSE SUMMARY: WIND AND CURRENT

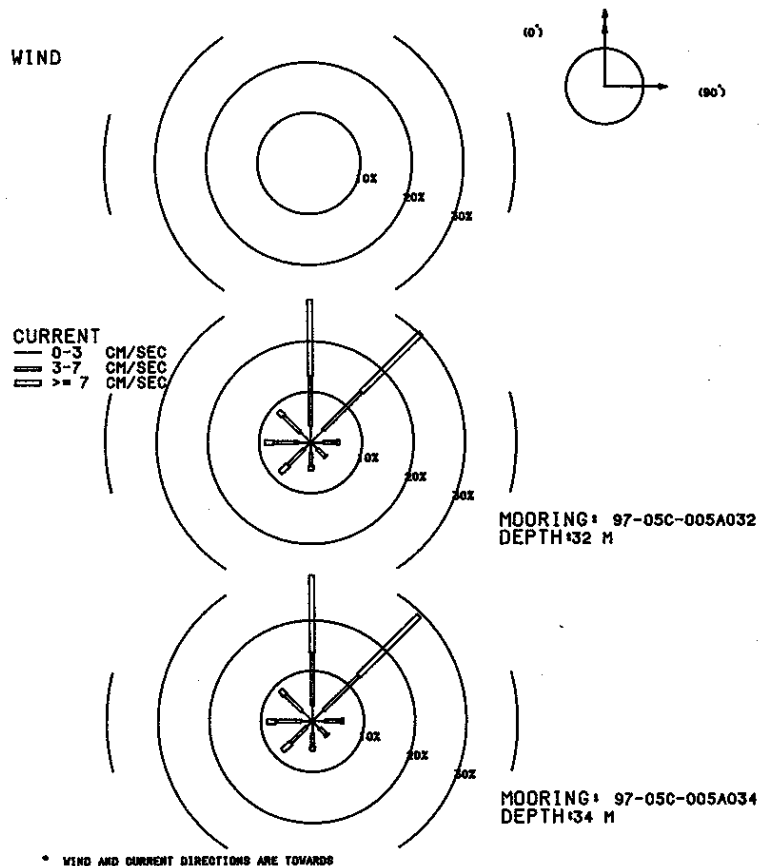

MOORING IS 97-05C-005A032 DEPTH IS 32 METERS THERE ARE 3932 VALUES

FIRST DAY 1997/11/02/0500
FINAL DAY 1998/04/15/0000

SHORELINE ORIENTATION IN DEGREES TRUE SPECIFIED AS 90

DIRECTION DEG TRUE	PERCENT OBSERVED	TOWARD	TOTAL	LIGHT	MEDIUM	HIGH	MAXIMUM CURRENT CM/S	MEAN DURA- TION HOURS	MEAN EXCUR- SION KM	MEAN CURRENT CM/S	MEAN TEMP DEG C
90.0	5.6	2.4	2.6	0.6	11.3	1.6	0.2	3.9	4.4		
45.0	30.4	3.5	10.6	16.4	61.2	2.9	1.0	9.8	4.9		
0.0	28.2	3.3	9.8	15.1	44.8	2.8	0.9	9.3	4.3		
315.0	8.8	2.9	4.5	1.4	45.5	1.9	0.3	5.0	4.3		
270.0	9.0	2.4	4.8	1.7	36.0	1.8	0.3	5.4	4.9		
225.0	8.4	1.8	4.4	2.2	28.6	1.9	0.4	5.8	5.0		
180.0	5.5	2.1	2.5	0.9	12.9	1.6	0.2	4.3	4.5		
135.0	4.0	1.7	2.2	0.1	9.4	1.5	0.2	3.6	4.1		

MEAN SCALAR SPEED = 7.6 CM/S MEAN SQUARE SPEED = 104.2 CM²/S²
 MEAN SQUARE E-W SPEED = 28.2 CM²/S² MEAN SQUARE N-S SPEED = 76.0 CM²/S²
 MEAN VELOCITY = 4.8 CM/S, 16 DEG TRUE MEAN TEMPERATURE = 4.6 C
 VARIANCE (U,V) = 40.6 CM²/S² TOTAL HOURS = 3932.

PERCENT OBSERVED
 LIGHT (0.0 - 3.0) 20.1% MEDIUM (3.0 - 7.0) 41.5% HIGH (GE 7.0) 38.4%

MOORING IS 97-05C-005A034 DEPTH IS 34 METERS THERE ARE 3932 VALUES

FIRST DAY 1997/11/02/0500
FINAL DAY 1998/04/15/0000

SHORELINE ORIENTATION IN DEGREES TRUE SPECIFIED AS 90

DIRECTION DEG TRUE	PERCENT OBSERVED	TOWARD	TOTAL	LIGHT	MEDIUM	HIGH	MAXIMUM CURRENT CM/S	MEAN DURA- TION HOURS	MEAN EXCUR- SION KM	MEAN CURRENT CM/S	MEAN TEMP DEG C
90.0	6.0	2.3	3.2	0.5	9.5	1.5	0.2	3.7	4.3		
45.0	29.5	3.0	9.8	16.8	62.1	2.9	1.0	10.0	4.9		
0.0	28.9	3.2	10.4	15.3	44.2	2.6	0.9	9.3	4.3		
315.0	8.8	2.9	4.5	1.4	47.3	1.7	0.3	5.0	4.4		
270.0	8.8	2.2	4.9	1.8	29.4	1.9	0.4	5.3	4.9		
225.0	8.2	1.6	4.4	2.2	29.1	1.9	0.4	6.0	4.8		
180.0	5.8	2.3	2.7	0.8	14.3	1.7	0.3	4.3	4.4		
135.0	4.0	2.0	1.9	0.2	10.2	1.5	0.2	3.4	4.5		

MEAN SCALAR SPEED = 7.6 CM/S MEAN SQUARE SPEED = 104.2 CM²/S²
 MEAN SQUARE E-W SPEED = 27.9 CM²/S² MEAN SQUARE N-S SPEED = 76.3 CM²/S²
 MEAN VELOCITY = 4.8 CM/S, 16 DEG TRUE MEAN TEMPERATURE = 4.6 C
 VARIANCE (U,V) = 40.6 CM²/S² TOTAL HOURS = 3932.

PERCENT OBSERVED
 LIGHT (0.0 - 3.0) 19.3% MEDIUM (3.0 - 7.0) 41.7% HIGH (GE 7.0) 39.0%

Appendix H - Mooring_A5-97. Monthly Summary Statistics and Rose Histogram Plots

DATE: 1997/11/02 TO 1997/11/30
ROSE SUMMARY: WIND AND CURRENT

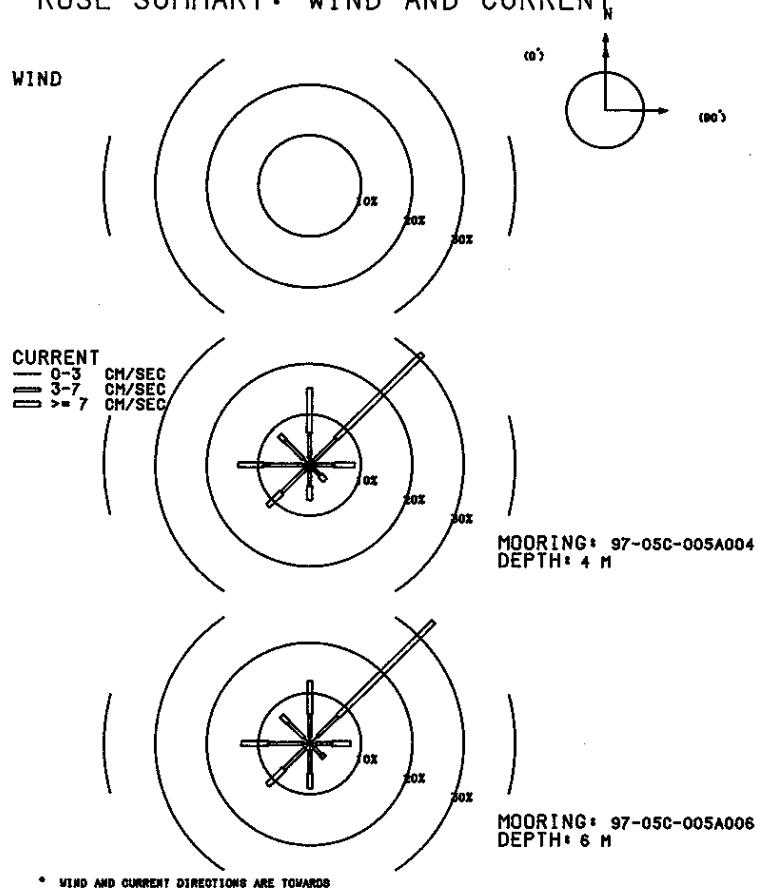

MOORING IS 97-05C-005A004 DEPTH IS 4 METERS THERE ARE 691 VALUES

FIRST DAY 1997/11/02/0500
FINAL DAY 1997/11/30/2300

SHORELINE ORIENTATION IN DEGREES TRUE SPECIFIED AS 90

DIRECTION DEG TRUE	PERCENT OBSERVED	MAXIMUM CURRENT	MEAN DURA- TION	MEAN EXCUR- SION	MEAN CURRENT	MEAN TEMP			
TOWARD	TOTAL	LIGHT	MEDIUM	HIGH	CM/S	HOURS	KM	CM/S	DEG C
90.0	8.8	1.2	3.6	4.1	16.3	1.5	0.4	7.3	8.9
45.0	31.1	1.0	6.4	23.7	32.1	2.7	1.1	11.7	8.9
0.0	15.2	1.3	5.1	8.8	29.9	1.7	0.6	9.5	8.7
315.0	8.2	1.6	5.2	1.4	14.4	1.7	0.3	5.2	8.1
270.0	13.9	0.9	8.1	4.9	12.3	2.5	0.6	6.4	8.0
225.0	11.4	1.0	6.7	3.8	19.3	1.8	0.4	6.4	8.2
180.0	6.9	1.0	3.0	2.9	18.2	1.6	0.4	7.4	8.3
135.0	4.3	0.9	2.0	1.4	12.6	1.4	0.3	5.9	8.3
0	MEAN SCALAR SPEED = 8.6 CM/S		MEAN SQUARE SPEED = 101.7 CM2/S2						
	MEAN SQUARE E-W SPEED = 40.0 CM2/S2		MEAN SQUARE N-S SPEED = 61.6 CM2/S2						
	MEAN VELOCITY = 3.7 CM/S,		26 DEG TRUE		MEAN TEMPERATURE = 8.6 C				
	VARIANCE (U,V) = 44.1 CM2/S2		TOTAL HOURS = 691.						

PERCENT OBSERVED
LIGHT (0.0 - 3.0) 8.8% MEDIUM (3.0 - 7.0) 40.1% HIGH (GE 7.0) 51.1%

MOORING IS 97-05C-005A006 DEPTH IS 6 METERS THERE ARE 691 VALUES

FIRST DAY 1997/11/02/0500
FINAL DAY 1997/11/30/2300

SHORELINE ORIENTATION IN DEGREES TRUE SPECIFIED AS 90

DIRECTION DEG TRUE	PERCENT OBSERVED	MAXIMUM CURRENT	MEAN DURA- TION	MEAN EXCUR- SION	MEAN CURRENT	MEAN TEMP			
TOWARD	TOTAL	LIGHT	MEDIUM	HIGH	CM/S	HOURS	KM	CM/S	DEG C
90.0	8.0	1.2	3.2	3.6	15.6	1.8	0.5	7.3	8.8
45.0	34.2	2.0	5.6	26.5	30.9	3.5	1.4	11.4	8.9
0.0	12.4	1.3	4.5	6.7	30.4	1.5	0.5	9.0	8.8
315.0	7.8	1.6	4.3	1.9	11.3	2.0	0.4	5.2	8.1
270.0	13.3	1.2	6.9	5.2	10.0	2.3	0.5	6.1	8.0
225.0	11.6	1.2	5.9	4.5	16.6	1.9	0.4	6.6	8.2
180.0	8.8	1.3	4.6	2.9	17.3	1.9	0.4	6.5	8.3
135.0	3.9	1.0	2.2	0.7	18.4	1.7	0.3	4.8	8.8
0	MEAN SCALAR SPEED = 8.3 CM/S		MEAN SQUARE SPEED = 97.1 CM2/S2						
	MEAN SQUARE E-W SPEED = 38.9 CM2/S2		MEAN SQUARE N-S SPEED = 58.2 CM2/S2						
	MEAN VELOCITY = 3.5 CM/S,		28 DEG TRUE		MEAN TEMPERATURE = 8.6 C				
	VARIANCE (U,V) = 42.4 CM2/S2		TOTAL HOURS = 691.						

PERCENT OBSERVED
LIGHT (0.0 - 3.0) 10.7% MEDIUM (3.0 - 7.0) 37.3% HIGH (GE 7.0) 52.0%

DATE: 1997/12/01 TO 1997/12/31
 ROSE SUMMARY: WIND AND CURRENT

WIND

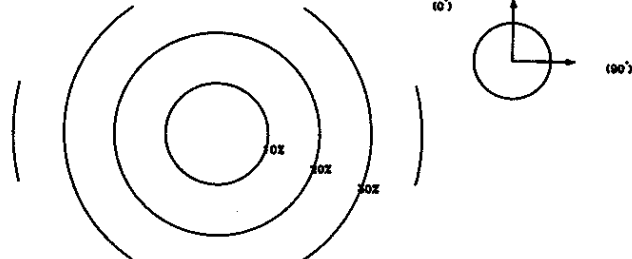

CURRENT
 — 0-3 CM/SEC
 = 3-7 CM/SEC
 = >= 7 CM/SEC

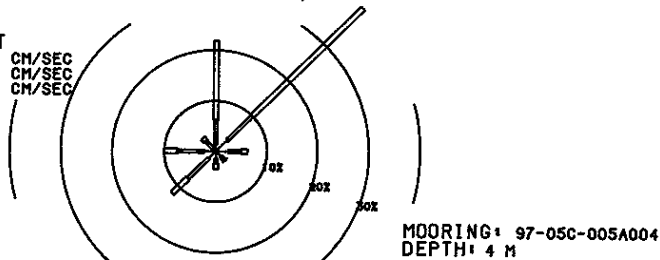

MOORING: 97-05C-005A004
 DEPTH: 4 M

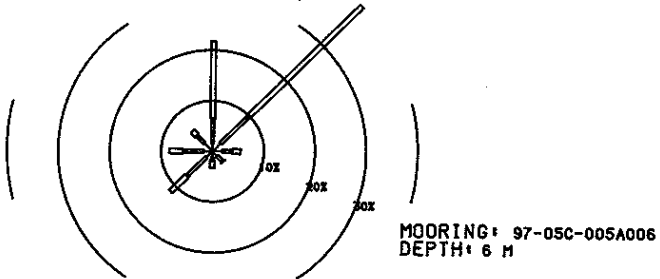

MOORING: 97-05C-005A006
 DEPTH: 6 M

* WIND AND CURRENT DIRECTIONS ARE TOWARDS

MOORING IS 97-05C-005A004 DEPTH IS 4 METERS THERE ARE 744 VALUES

FIRST DAY 1997/12/01/0000
 FINAL DAY 1997/12/31/2300

SHORELINE ORIENTATION IN DEGREES TRUE SPECIFIED AS 90

DIRECTION DEG TRUE	PERCENT OBSERVED	TOWARD	TOTAL	LIGHT	MEDIUM	HIGH	MAXIMUM CURRENT CM/S	MEAN DURA- TION HOURS	MEAN EXCUR- SION KM	MEAN CURRENT CM/S	MEAN TEMP DEG C
90.0	6.2	2.4	2.6	1.2	21.3	1.3	0.2	4.7	5.8		
45.0	40.3	3.1	6.9	30.4	33.8	3.2	1.3	11.2	5.9		
0.0	21.9	1.3	4.8	15.7	33.1	2.1	0.9	12.4	6.0		
315.0	3.6	0.7	2.2	0.8	15.6	1.3	0.3	5.5	6.6		
270.0	10.1	2.3	5.1	2.7	12.4	1.5	0.3	5.4	6.0		
225.0	11.8	1.9	5.6	4.3	14.5	1.8	0.4	6.2	6.1		
180.0	3.5	1.5	0.9	1.1	24.3	1.2	0.3	6.7	5.8		
135.0	2.6	1.5	0.8	0.3	10.5	1.3	0.2	3.6	5.6		

MEAN SCALAR SPEED = 9.3 CM/S MEAN SQUARE SPEED = 129.3 CM2/S2
 MEAN SQUARE E-W SPEED = 35.6 CM2/S2 MEAN SQUARE N-S SPEED = 93.8 CM2/S2
 MEAN VELOCITY = 6.0 CM/S, 23 DEG TRUE MEAN TEMPERATURE = 6.0 C
 VARIANCE (U,V) = 46.7 CM2/S2 TOTAL HOURS = 744.

PERCENT OBSERVED
 LIGHT (0.0 - 3.0) 14.7% MEDIUM (3.0 - 7.0) 28.9% HIGH (GE 7.0) 56.5%

MOORING IS 97-05C-005A006 DEPTH IS 6 METERS THERE ARE 744 VALUES

FIRST DAY 1997/12/01/0000
 FINAL DAY 1997/12/31/2300

SHORELINE ORIENTATION IN DEGREES TRUE SPECIFIED AS 90

DIRECTION DEG TRUE	PERCENT OBSERVED	TOWARD	TOTAL	LIGHT	MEDIUM	HIGH	MAXIMUM CURRENT CM/S	MEAN DURA- TION HOURS	MEAN EXCUR- SION KM	MEAN CURRENT CM/S	MEAN TEMP DEG C
90.0	5.5	1.9	2.0	1.6	22.4	1.4	0.2	5.0	5.8		
45.0	40.9	2.2	7.4	31.3	29.9	3.3	1.4	11.5	5.8		
0.0	21.8	1.6	4.8	15.3	32.2	1.9	0.8	11.5	6.0		
315.0	5.6	2.2	2.2	1.3	11.6	1.3	0.2	4.4	6.5		
270.0	8.5	1.7	4.0	2.7	13.5	1.5	0.3	5.6	6.0		
225.0	11.4	1.6	5.4	4.4	13.5	1.8	0.4	6.0	6.0		
180.0	3.4	1.2	0.7	1.5	24.2	1.2	0.4	8.0	6.3		
135.0	3.0	1.3	1.5	0.1	9.8	1.5	0.2	3.5	5.4		

MEAN SCALAR SPEED = 9.2 CM/S MEAN SQUARE SPEED = 126.1 CM2/S2
 MEAN SQUARE E-W SPEED = 35.2 CM2/S2 MEAN SQUARE N-S SPEED = 90.9 CM2/S2
 MEAN VELOCITY = 6.0 CM/S, 23 DEG TRUE MEAN TEMPERATURE = 6.0 C
 VARIANCE (U,V) = 45.0 CM2/S2 TOTAL HOURS = 744.

PERCENT OBSERVED
 LIGHT (0.0 - 3.0) 13.7% MEDIUM (3.0 - 7.0) 28.0% HIGH (GE 7.0) 58.3%

DATE: 1998/01/01 TO 1998/01/31
ROSE SUMMARY: WIND AND CURRENT

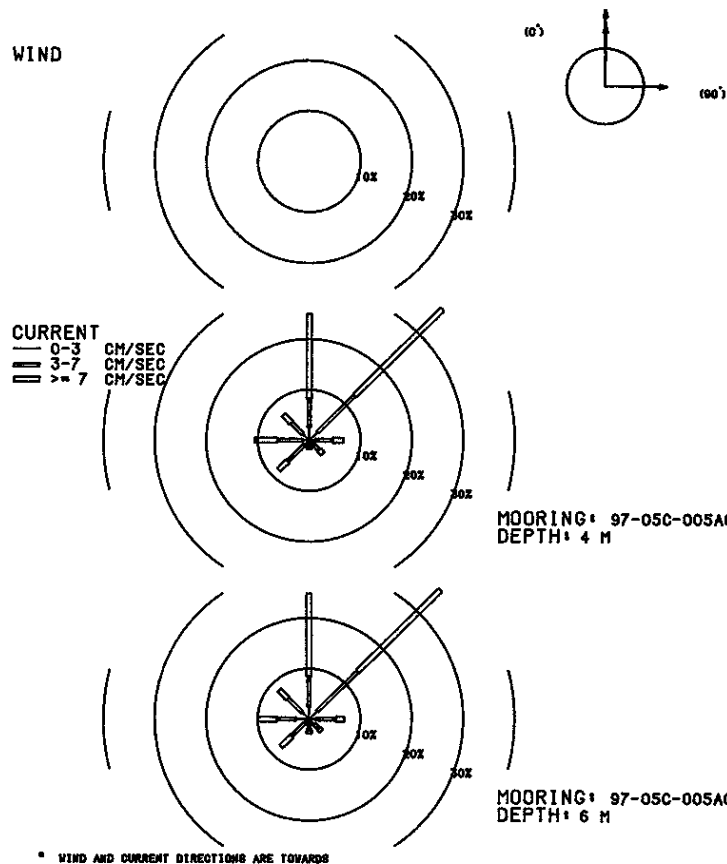

MOORING IS 97-05C-005A004 DEPTH IS 4 METERS THERE ARE 744 VALUES

FIRST DAY 1998/01/01/0000
FINAL DAY 1998/01/31/2300

SHORELINE ORIENTATION IN DEGREES TRUE SPECIFIED AS 90

DIRECTION DEG TRUE	PERCENT OBSERVED	MAXIMUM CURRENT	MEAN DURATION HOURS	MEAN EXCURSION KM	MEAN CURRENT CM/S	MEAN TEMP DEG C
TOWARD	TOTAL	LIGHT	MEDIUM	HIGH	CM/S	
90.0	6.7	1.1	3.5	2.2	13.2	1.5
45.0	36.7	2.2	10.3	24.2	45.8	2.8
0.0	25.0	2.6	5.6	16.8	49.4	2.0
315.0	7.1	1.6	3.2	2.3	32.2	1.4
270.0	10.6	1.2	5.0	4.4	23.6	2.0
225.0	8.3	1.3	4.4	2.6	19.7	1.7
180.0	1.7	0.8	0.8	0.1	8.0	1.3
135.0	3.8	1.3	1.3	1.1	18.0	1.3

MEAN SCALAR SPEED = 9.8 CM/S MEAN SQUARE SPEED = 169.1 CM2/S2
 MEAN SQUARE E-W SPEED = 48.9 CM2/S2 MEAN SQUARE N-S SPEED = 120.2 CM2/S2
 MEAN VELOCITY = 6.5 CM/S, 19 DEG TRUE MEAN TEMPERATURE = 3.7 C
 VARIANCE (U,V) = 63.6 CM2/S2 TOTAL HOURS = 744.

PERCENT OBSERVED
 LIGHT (0.0 - 3.0) 12.1% MEDIUM (3.0 - 7.0) 34.3% HIGH (GE 7.0) 53.6%

MOORING IS 97-05C-005A006 DEPTH IS 6 METERS THERE ARE 744 VALUES

FIRST DAY 1998/01/01/0000
FINAL DAY 1998/01/31/2300

SHORELINE ORIENTATION IN DEGREES TRUE SPECIFIED AS 90

DIRECTION DEG TRUE	PERCENT OBSERVED	MAXIMUM CURRENT	MEAN DURATION HOURS	MEAN EXCURSION KM	MEAN CURRENT CM/S	MEAN TEMP DEG C
TOWARD	TOTAL	LIGHT	MEDIUM	HIGH	CM/S	
90.0	6.9	1.3	3.9	1.6	9.9	2.0
45.0	36.2	2.2	11.2	22.8	46.5	3.2
0.0	24.9	2.4	6.0	16.4	49.1	2.3
315.0	8.2	1.7	4.0	2.4	25.4	1.6
270.0	9.9	2.6	3.6	3.8	21.8	1.6
225.0	7.7	0.9	3.8	3.0	17.5	1.9
180.0	3.0	0.8	1.5	0.7	13.1	1.2
135.0	3.4	1.3	1.3	0.7	14.3	1.4

MEAN SCALAR SPEED = 9.7 CM/S MEAN SQUARE SPEED = 168.1 CM2/S2
 MEAN SQUARE E-W SPEED = 46.8 CM2/S2 MEAN SQUARE N-S SPEED = 121.3 CM2/S2
 MEAN VELOCITY = 6.5 CM/S, 19 DEG TRUE MEAN TEMPERATURE = 3.7 C
 VARIANCE (U,V) = 63.3 CM2/S2 TOTAL HOURS = 744.

PERCENT OBSERVED
 LIGHT (0.0 - 3.0) 13.3% MEDIUM (3.0 - 7.0) 35.3% HIGH (GE 7.0) 51.3%

DATE: 1998/02/01 TO 1998/02/28
 ROSE SUMMARY: WIND AND CURRENT

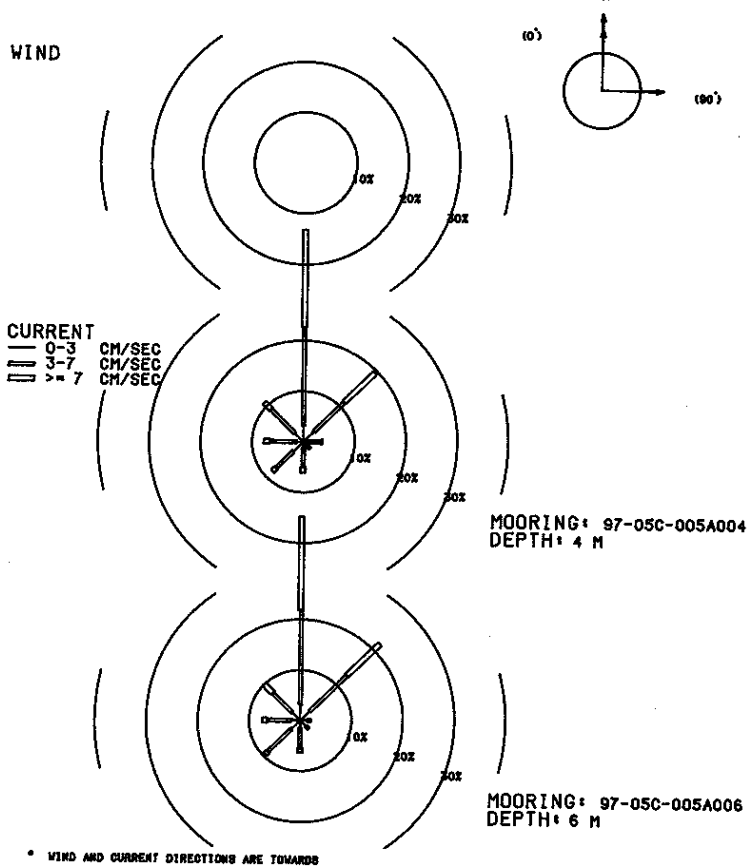

MOORING IS 97-05C-005A004 DEPTH IS 4 METERS THERE ARE 672 VALUES

FIRST DAY 1998/02/01/0000
 FINAL DAY 1998/02/28/2300

SHORELINE ORIENTATION IN DEGREES TRUE SPECIFIED AS 90

DIRECTION DEG TRUE	PERCENT OBSERVED	TOWARD	TOTAL	LIGHT	MEDIUM	HIGH	MAXIMUM CURRENT CM/S	MEAN DURA- TION HOURS	MEAN EXCUR- SION KM	MEAN CURRENT CM/S	MEAN TEMP DEG C
90.0	3.7	0.7	2.7	0.3			10.8	1.1	0.2	4.4	2.6
45.0	19.5	2.8	8.3	8.3			14.6	1.8	0.4	6.8	2.5
0.0	41.8	3.1	19.5	19.2			40.5	3.4	0.9	7.5	2.5
315.0	10.9	2.4	6.5	1.9			9.7	1.7	0.3	4.8	2.6
270.0	7.7	1.3	5.2	1.2			10.3	1.7	0.3	4.8	2.8
225.0	8.3	2.7	4.8	0.9			8.6	1.8	0.3	4.4	2.6
180.0	6.1	1.2	3.9	1.0			11.2	1.6	0.3	5.1	2.6
135.0	1.9	1.0	0.9	0.0			5.5	1.1	0.1	3.0	2.6

MEAN SCALAR SPEED = 6.3 CM/S MEAN SQUARE SPEED = 51.2 CM2/S2
 MEAN SQUARE E-W SPEED = 10.2 CM2/S2 MEAN SQUARE N-S SPEED = 41.1 CM2/S2
 MEAN VELOCITY = 4.0 CM/S, 3 DEG TRUE MEAN TEMPERATURE = 2.6 C
 VARIANCE (U,V) = 17.8 CM2/S2 TOTAL HOURS = 672.

PERCENT OBSERVED
 LIGHT (0.0 - 3.0) 15.3% MEDIUM (3.0 - 7.0) 51.8% HIGH (GE 7.0) 32.9%

MOORING IS 97-05C-005A006 DEPTH IS 6 METERS THERE ARE 672 VALUES

FIRST DAY 1998/02/01/0000
 FINAL DAY 1998/02/28/2300

SHORELINE ORIENTATION IN DEGREES TRUE SPECIFIED AS 90

DIRECTION DEG TRUE	PERCENT OBSERVED	TOWARD	TOTAL	LIGHT	MEDIUM	HIGH	MAXIMUM CURRENT CM/S	MEAN DURA- TION HOURS	MEAN EXCUR- SION KM	MEAN CURRENT CM/S	MEAN TEMP DEG C
90.0	2.1	1.3	0.7	0.0			6.5	1.0	0.1	3.1	2.6
45.0	21.7	2.5	10.1	9.1			16.8	2.1	0.5	7.0	2.5
0.0	40.3	3.1	18.8	18.5			40.0	3.1	0.8	7.4	2.5
315.0	10.1	2.1	5.5	2.5			11.8	1.4	0.2	4.9	2.6
270.0	7.4	1.6	4.8	1.0			8.2	1.7	0.3	4.6	2.8
225.0	9.5	2.4	6.4	0.7			10.2	1.9	0.3	4.4	2.6
180.0	6.4	1.5	4.0	0.9			9.6	2.0	0.3	4.6	2.5
135.0	2.4	1.6	0.7	0.0			4.8	1.2	0.1	2.5	2.7

MEAN SCALAR SPEED = 6.2 CM/S MEAN SQUARE SPEED = 50.9 CM2/S2
 MEAN SQUARE E-W SPEED = 9.7 CM2/S2 MEAN SQUARE N-S SPEED = 41.2 CM2/S2
 MEAN VELOCITY = 4.0 CM/S, 4 DEG TRUE MEAN TEMPERATURE = 2.6 C
 VARIANCE (U,V) = 17.6 CM2/S2 TOTAL HOURS = 672.

PERCENT OBSERVED
 LIGHT (0.0 - 3.0) 16.2% MEDIUM (3.0 - 7.0) 51.0% HIGH (GE 7.0) 32.7%

DATE: 1998/03/01 TO 1998/03/31
 ROSE SUMMARY: WIND AND CURRENT

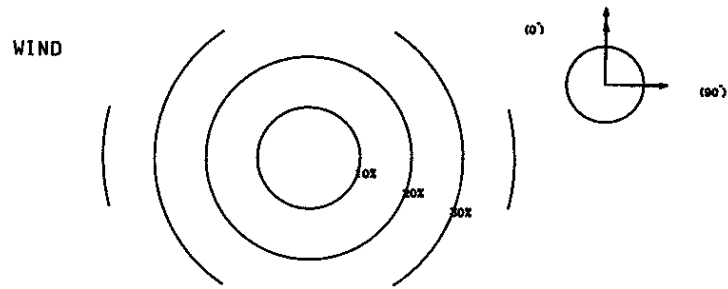

CURRENT
 — 0-3 CM/SEC
 = 3-7 CM/SEC
 = >= 7 CM/SEC

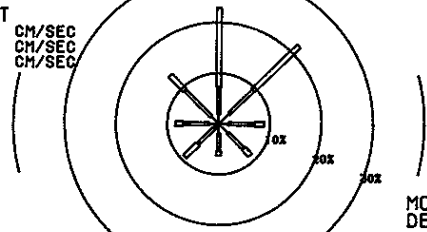

MOORING: 97-05C-005A004
 DEPTH: 4 M

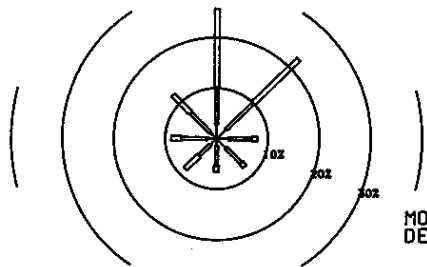

MOORING: 97-05C-005A006
 DEPTH: 6 M

* WIND AND CURRENT DIRECTIONS ARE TOWARDS

MOORING IS 97-05C-005A004 DEPTH IS 4 METERS THERE ARE 744 VALUES

FIRST DAY 1998/03/01/0000
 FINAL DAY 1998/03/31/2300

SHORELINE ORIENTATION IN DEGREES TRUE SPECIFIED AS 90

DIRECTION DEG TRUE	PERCENT OBSERVED	TOWARD	TOTAL	LIGHT	MEDIUM	HIGH	MAXIMUM CURRENT CM/S	MEAN DURATION HOURS	MEAN EXCURSION KM	MEAN CURRENT CM/S	MEAN TEMP DEG C
90.0	8.9	1.9	5.1	1.9	21.6	1.6	0.3	5.2	2.9		
45.0	21.9	2.8	6.6	12.5	58.7	2.5	1.3	14.4	2.6		
0.0	23.0	1.9	5.4	15.7	30.7	2.7	1.0	10.5	2.6		
315.0	13.4	2.0	7.3	4.2	49.8	1.7	0.5	8.0	2.7		
270.0	8.5	1.9	5.0	1.6	25.1	1.5	0.3	6.4	2.7		
225.0	9.3	1.1	4.6	3.6	38.6	2.0	0.6	9.0	2.7		
180.0	6.3	1.9	3.5	0.9	23.6	1.3	0.2	4.7	2.8		
135.0	8.7	2.6	4.3	1.9	23.3	1.4	0.3	5.5	2.8		

MEAN SCALAR SPEED = 9.2 CM/S MEAN SQUARE SPEED = 167.8 CM2/S2
 MEAN SQUARE E-W SPEED = 57.9 CM2/S2 MEAN SQUARE N-S SPEED = 109.9 CM2/S2
 MEAN VELOCITY = 4.5 CM/S, 12 DEG TRUE MEAN TEMPERATURE = 2.7 C
 VARIANCE (U,V) = 73.8 CM2/S2 TOTAL HOURS = 744.

PERCENT OBSERVED

LIGHT (0.0 - 3.0) 16.0% MEDIUM (3.0 - 7.0) 41.7% HIGH (GE 7.0) 42.3%

MOORING IS 97-05C-005A006 DEPTH IS 6 METERS THERE ARE 744 VALUES

FIRST DAY 1998/03/01/0000
 FINAL DAY 1998/03/31/2300

SHORELINE ORIENTATION IN DEGREES TRUE SPECIFIED AS 90

DIRECTION DEG TRUE	PERCENT OBSERVED	TOWARD	TOTAL	LIGHT	MEDIUM	HIGH	MAXIMUM CURRENT CM/S	MEAN DURATION HOURS	MEAN EXCURSION KM	MEAN CURRENT CM/S	MEAN TEMP DEG C
90.0	7.9	2.3	4.6	1.1	15.8	1.6	0.3	4.6	2.9		
45.0	22.4	2.6	7.3	12.6	58.4	3.0	1.5	14.0	2.6		
0.0	25.7	2.8	7.4	15.5	34.1	2.8	1.0	10.0	2.6		
315.0	12.1	1.6	5.5	5.0	50.8	1.7	0.6	9.3	2.7		
270.0	8.9	1.7	5.1	2.0	27.1	1.8	0.4	6.4	2.8		
225.0	8.6	1.6	3.2	3.8	33.1	2.2	0.7	8.6	2.7		
180.0	6.6	1.5	3.9	1.2	22.7	1.3	0.3	5.5	2.8		
135.0	7.8	2.6	4.2	1.1	26.4	1.7	0.3	4.6	2.9		

MEAN SCALAR SPEED = 9.2 CM/S MEAN SQUARE SPEED = 169.7 CM2/S2
 MEAN SQUARE E-W SPEED = 57.4 CM2/S2 MEAN SQUARE N-S SPEED = 112.4 CM2/S2
 MEAN VELOCITY = 4.8 CM/S, 11 DEG TRUE MEAN TEMPERATURE = 2.7 C
 VARIANCE (U,V) = 73.6 CM2/S2 TOTAL HOURS = 744.

PERCENT OBSERVED

LIGHT (0.0 - 3.0) 16.7% MEDIUM (3.0 - 7.0) 41.1% HIGH (GE 7.0) 42.2%

DATE: 1998/04/01 TO 1998/04/30
 ROSE SUMMARY: WIND AND CURRENT

WIND

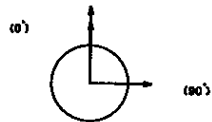
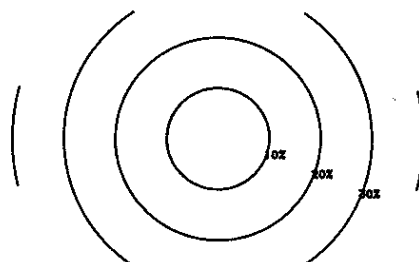

CURRENT

0-3 CM/SEC
 3-7 CM/SEC
 >= 7 CM/SEC

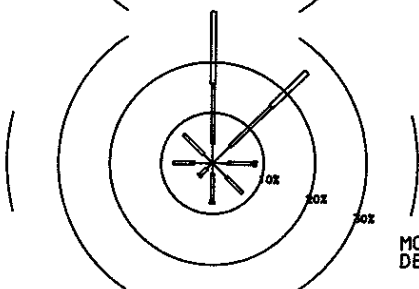
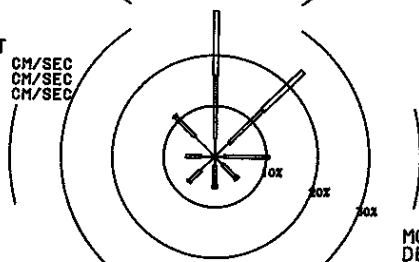

MOORING: 97-05C-005A004
 DEPTH: 4 M

MOORING: 97-05C-005A006
 DEPTH: 6 M

* WIND AND CURRENT DIRECTIONS ARE TOWARDS

MOORING IS 97-05C-005A004 DEPTH IS 4 METERS THERE ARE 337 VALUES

FIRST DAY 1998/04/01/0000
 FINAL DAY 1998/04/15/0000

SHORELINE ORIENTATION IN DEGREES TRUE SPECIFIED AS 90

DIRECTION DEG TRUE	PERCENT OBSERVED	TOWARD	TOTAL	LIGHT	MEDIUM	HIGH	MAXIMUM CURRENT CM/S	MEAN DURA- TION HOURS	MEAN EXCUR- SION KM	MEAN CURRENT CM/S	MEAN TEMP DEG C
90.0	10.7	1.8	8.9	0.0	6.4	1.6	0.2	4.2	3.9		
45.0	24.0	3.9	9.2	11.0	24.6	2.0	0.6	9.0	3.9		
0.0	28.8	3.6	12.5	12.8	22.2	2.0	0.6	7.9	3.9		
315.0	11.3	5.6	5.3	0.3	7.3	1.5	0.2	3.2	3.9		
270.0	5.6	2.7	3.0	0.0	5.9	1.3	0.1	3.3	3.9		
225.0	7.1	3.9	3.0	0.3	8.9	1.4	0.2	3.1	3.8		
180.0	6.2	1.8	3.9	0.6	8.1	1.2	0.2	4.2	3.8		
135.0	6.2	2.1	3.6	0.6	9.6	1.3	0.2	4.4	3.8		

MEAN SCALAR SPEED = 6.2 CM/S MEAN SQUARE SPEED = 64.5 CM2/S2
 MEAN SQUARE E-W SPEED = 15.0 CM2/S2 MEAN SQUARE N-S SPEED = 49.5 CM2/S2
 MEAN VELOCITY = 4.0 CM/S, 24 DEG TRUE MEAN TEMPERATURE = 3.9 C
 VARIANCE (U,V) = 24.4 CM2/S2 TOTAL HOURS = 337.

PERCENT OBSERVED
 LIGHT (0.0 - 3.0) 25.2% MEDIUM (3.0 - 7.0) 49.3% HIGH (GE 7.0) 25.5%

MOORING IS 97-05C-005A006 DEPTH IS 6 METERS THERE ARE 337 VALUES

FIRST DAY 1998/04/01/0000
 FINAL DAY 1998/04/15/0000

SHORELINE ORIENTATION IN DEGREES TRUE SPECIFIED AS 90

DIRECTION DEG TRUE	PERCENT OBSERVED	TOWARD	TOTAL	LIGHT	MEDIUM	HIGH	MAXIMUM CURRENT CM/S	MEAN DURA- TION HOURS	MEAN EXCUR- SION KM	MEAN CURRENT CM/S	MEAN TEMP DEG C
90.0	8.6	3.0	5.0	0.6	7.1	1.3	0.2	3.7	3.9		
45.0	25.8	4.7	11.3	9.8	24.9	2.2	0.7	8.4	3.9		
0.0	30.0	3.9	11.9	14.2	23.6	2.5	0.7	8.1	3.9		
315.0	8.0	2.4	5.6	0.0	6.7	1.6	0.2	3.8	3.9		
270.0	7.7	3.6	4.2	0.0	4.5	1.3	0.1	2.7	3.8		
225.0	3.6	1.5	1.8	0.3	8.6	1.2	0.2	4.0	3.8		
180.0	8.0	2.1	5.6	0.3	8.2	1.9	0.3	4.1	3.8		
135.0	8.3	3.9	4.5	0.0	6.3	1.6	0.2	3.5	3.8		

MEAN SCALAR SPEED = 6.2 CM/S MEAN SQUARE SPEED = 65.7 CM2/S2
 MEAN SQUARE E-W SPEED = 14.6 CM2/S2 MEAN SQUARE N-S SPEED = 51.2 CM2/S2
 MEAN VELOCITY = 4.1 CM/S, 24 DEG TRUE MEAN TEMPERATURE = 3.9 C
 VARIANCE (U,V) = 24.5 CM2/S2 TOTAL HOURS = 337.

PERCENT OBSERVED
 LIGHT (0.0 - 3.0) 24.9% MEDIUM (3.0 - 7.0) 49.9% HIGH (GE 7.0) 25.2%

DATE: 1997/11/02 TO 1997/11/30
 ROSE SUMMARY: WIND AND CURRENT

WIND

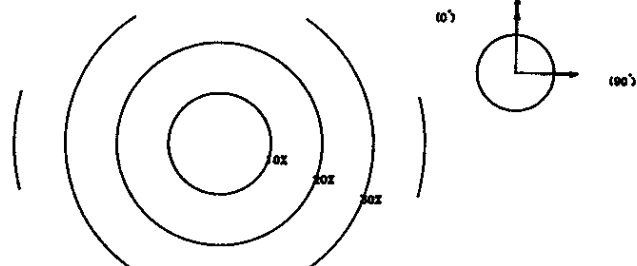

CURRENT
 — 0-3 CM/SEC
 — 3-7 CM/SEC
 — >= 7 CM/SEC

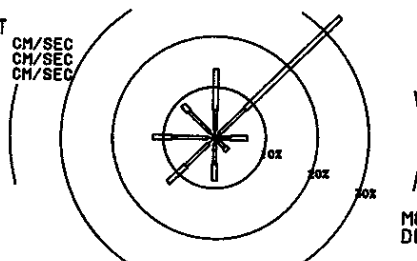

MOORING: 97-05C-005A008
 DEPTH: 8 M

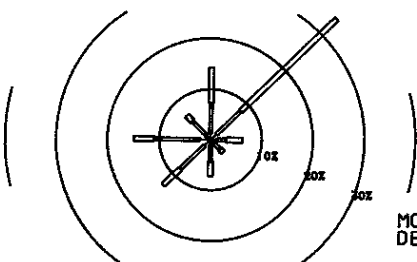

MOORING: 97-05C-005A010
 DEPTH: 10 M

* WIND AND CURRENT DIRECTIONS ARE TOWARDS

MOORING IS 97-05C-005A008 DEPTH IS 8 METERS THERE ARE 691 VALUES

FIRST DAY 1997/11/02/0500
 FINAL DAY 1997/11/30/2300

SHORELINE ORIENTATION IN DEGREES TRUE SPECIFIED AS 90

DIRECTION DEG TRUE	PERCENT OBSERVED	MAXIMUM CURRENT	MEAN DURATION HOURS	MEAN EXCURSION KM	MEAN CURRENT CM/S	MEAN TEMP DEG C	
TOWARD	TOTAL	LIGHT	MEDIUM	HIGH	CM/S		
90.0	6.4	0.7	2.3	3.3	15.8	1.6	
45.0	34.2	1.2	7.1	25.9	32.4	3.7	
0.0	13.6	1.6	3.9	8.1	24.2	1.7	
315.0	9.0	1.6	5.6	1.7	11.2	1.9	
270.0	12.2	1.4	6.9	3.8	11.5	2.0	
225.0	12.7	1.7	6.2	4.8	17.7	2.0	
180.0	8.5	1.3	3.9	3.3	19.9	2.0	
135.0	3.5	1.0	1.6	0.9	11.1	1.5	
0				MEAN SCALAR SPEED = 8.3 CM/S	MEAN SQUARE SPEED = 97.1 CM2/S2		
				MEAN SQUARE E-W SPEED = 37.9 CM2/S2	MEAN SQUARE N-S SPEED = 59.2 CM2/S2		
				MEAN VELOCITY = 3.5 CM/S,	27 DEG TRUE		
				MEAN TEMPERATURE = 8.6 C			
				VARIANCE (U,V) = 42.4 CM2/S2			
				TOTAL HOURS = 691.			

PERCENT OBSERVED
 LIGHT (0.0 - 3.0) 10.6% MEDIUM (3.0 - 7.0) 37.6% HIGH (GE 7.0) 51.8%

MOORING IS 97-05C-005A010 DEPTH IS 10 METERS THERE ARE 691 VALUES

FIRST DAY 1997/11/02/0500
 FINAL DAY 1997/11/30/2300

SHORELINE ORIENTATION IN DEGREES TRUE SPECIFIED AS 90

DIRECTION DEG TRUE	PERCENT OBSERVED	MAXIMUM CURRENT	MEAN DURATION HOURS	MEAN EXCURSION KM	MEAN CURRENT CM/S	MEAN TEMP DEG C	
TOWARD	TOTAL	LIGHT	MEDIUM	HIGH	CM/S		
90.0	6.2	1.2	1.9	3.2	14.6	1.5	
45.0	34.3	1.4	6.7	26.2	29.6	3.7	
0.0	14.3	1.3	5.9	7.1	25.1	1.7	
315.0	6.7	1.0	4.1	1.6	13.0	1.7	
270.0	14.9	2.2	8.8	3.9	12.3	2.1	
225.0	12.9	1.6	6.7	4.6	15.7	1.9	
180.0	7.2	1.0	3.3	2.9	20.3	1.8	
135.0	3.5	0.7	1.9	0.9	17.9	1.6	
0				MEAN SCALAR SPEED = 8.1 CM/S	MEAN SQUARE SPEED = 92.8 CM2/S2		
				MEAN SQUARE E-W SPEED = 35.5 CM2/S2	MEAN SQUARE N-S SPEED = 57.3 CM2/S2		
				MEAN VELOCITY = 3.5 CM/S,	25 DEG TRUE		
				MEAN TEMPERATURE = 8.6 C			
				VARIANCE (U,V) = 40.4 CM2/S2			
				TOTAL HOURS = 691.			

PERCENT OBSERVED
 LIGHT (0.0 - 3.0) 10.4% MEDIUM (3.0 - 7.0) 39.2% HIGH (GE 7.0) 50.4%

DATE: 1997/12/01 TO 1997/12/31
 ROSE SUMMARY: WIND AND CURRENT

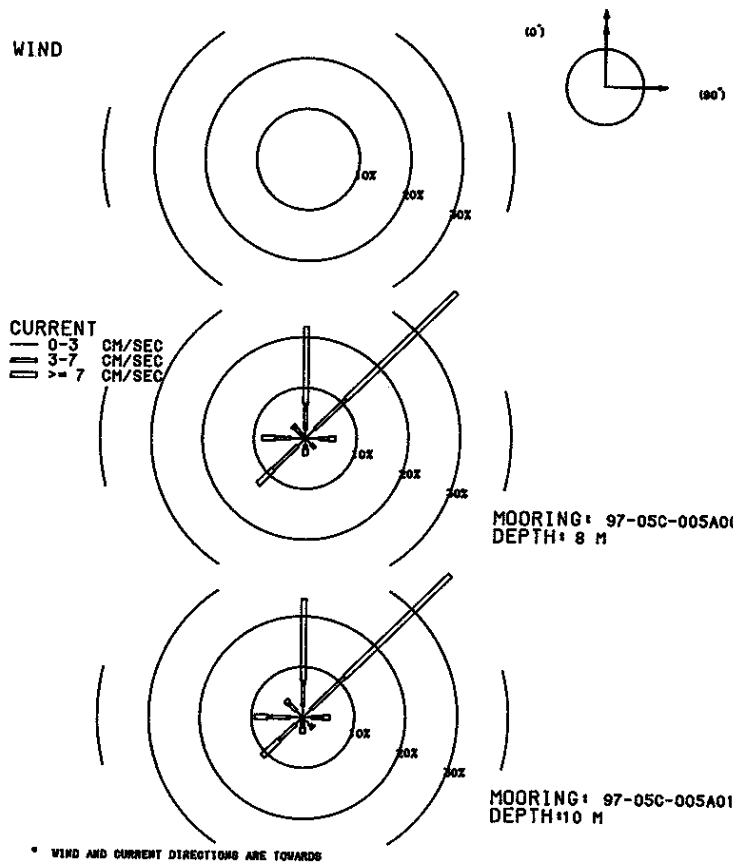

MOORING IS 97-05C-005A008 DEPTH IS 8 METERS THERE ARE 744 VALUES

FIRST DAY 1997/12/01/0000
 FINAL DAY 1997/12/31/2300

SHORELINE ORIENTATION IN DEGREES TRUE SPECIFIED AS 90

DIRECTION DEG TRUE	PERCENT OBSERVED				MAXIMUM CURRENT CM/S	MEAN DURATION HOURS	MEAN EXCURSION KM	MEAN CURRENT CM/S	MEAN TEMP DEG C
TOWARD	TOTAL	LIGHT	MEDIUM	HIGH	CM/S	HOURS	KM	CM/S	DEG C
90.0	5.9	2.7	1.9	1.3	21.5	1.5	0.3	5.3	5.8
45.0	41.1	2.6	8.5	30.1	29.0	3.5	1.4	11.0	5.9
0.0	22.0	1.7	5.1	15.2	31.7	2.1	0.9	11.6	6.1
315.0	3.5	0.9	2.0	0.5	8.0	1.4	0.2	4.5	6.6
270.0	8.5	2.8	3.1	2.6	13.3	1.5	0.3	5.2	6.0
225.0	12.9	2.2	6.6	4.2	14.8	2.2	0.5	5.9	6.0
180.0	3.4	1.3	0.8	1.2	24.0	1.2	0.3	6.6	6.3
135.0	2.7	1.6	1.1	0.0	6.6	1.4	0.1	2.9	5.3
0	MEAN SCALAR SPEED = 9.1 CM/S				MEAN SQUARE SPEED = 122.3 CM2/S2				
	MEAN SQUARE E-W SPEED = 33.5 CM2/S2				MEAN SQUARE N-S SPEED = 88.8 CM2/S2				
	MEAN VELOCITY = 5.9 CM/S,				23 DEG TRUE MEAN TEMPERATURE = 6.0 C				
	VARIANCE (U,V) = 43.6 CM2/S2				TOTAL HOURS = 744.				

PERCENT OBSERVED
 LIGHT (0.0 - 3.0) 15.9% MEDIUM (3.0 - 7.0) 29.0% HIGH (GE 7.0) 55.1%

MOORING IS 97-05C-005A010 DEPTH IS 10 METERS THERE ARE 744 VALUES

FIRST DAY 1997/12/01/0000
 FINAL DAY 1997/12/31/2300

SHORELINE ORIENTATION IN DEGREES TRUE SPECIFIED AS 90

DIRECTION DEG TRUE	PERCENT OBSERVED				MAXIMUM CURRENT CM/S	MEAN DURATION HOURS	MEAN EXCURSION KM	MEAN CURRENT CM/S	MEAN TEMP DEG C
TOWARD	TOTAL	LIGHT	MEDIUM	HIGH	CM/S	HOURS	KM	CM/S	DEG C
90.0	5.2	1.7	2.2	1.3	22.0	1.4	0.3	5.1	5.7
45.0	40.2	2.3	9.1	28.8	31.2	3.3	1.3	10.7	5.9
0.0	23.4	2.3	5.0	16.1	30.5	2.1	0.9	11.3	6.0
315.0	4.7	1.9	2.0	0.8	8.3	1.3	0.2	4.1	6.5
270.0	9.4	2.4	4.4	2.6	12.8	1.6	0.3	5.2	6.1
225.0	11.0	1.9	4.6	4.6	16.1	2.2	0.5	6.1	6.0
180.0	3.2	0.8	1.2	1.2	26.5	1.3	0.3	7.0	6.3
135.0	2.8	2.0	0.7	0.1	8.8	1.4	0.1	2.9	5.4
0	MEAN SCALAR SPEED = 8.9 CM/S				MEAN SQUARE SPEED = 117.6 CM2/S2				
	MEAN SQUARE E-W SPEED = 31.2 CM2/S2				MEAN SQUARE N-S SPEED = 86.4 CM2/S2				
	MEAN VELOCITY = 5.9 CM/S,				22 DEG TRUE MEAN TEMPERATURE = 6.0 C				
	VARIANCE (U,V) = 41.5 CM2/S2				TOTAL HOURS = 744.				

PERCENT OBSERVED
 LIGHT (0.0 - 3.0) 15.3% MEDIUM (3.0 - 7.0) 29.2% HIGH (GE 7.0) 55.5%

DATE: 1998/01/01 TO 1998/01/31
ROSE SUMMARY: WIND AND CURRENT

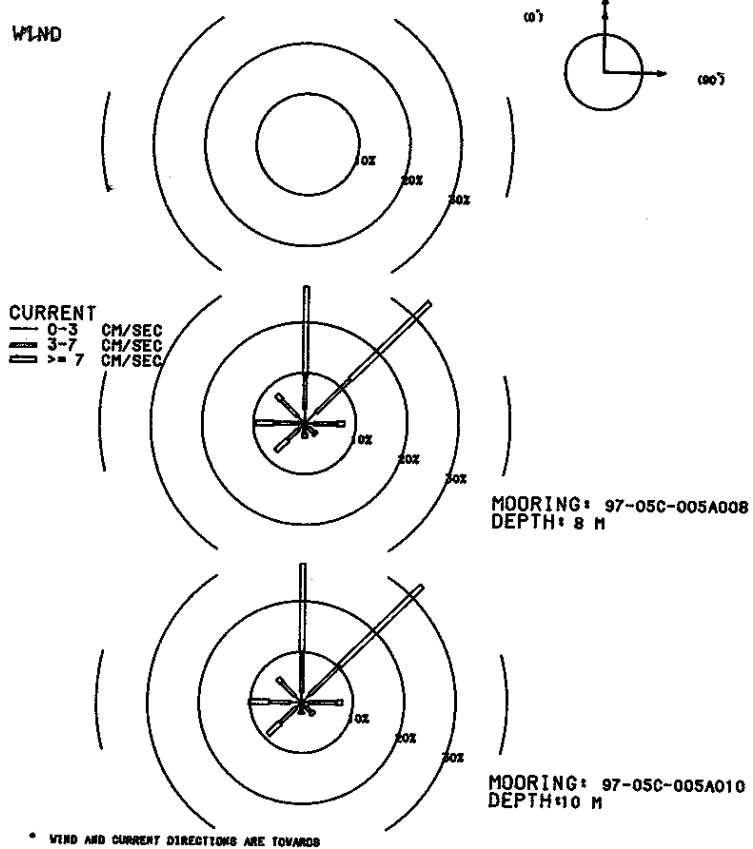

MOORING IS 97-05C-005A008 DEPTH IS 8 METERS THERE ARE 744 VALUES

FIRST DAY 1998/01/01/0000
FINAL DAY 1998/01/31/2300

SHORELINE ORIENTATION IN DEGREES TRUE SPECIFIED AS 90

DIRECTION DEG TRUE	PERCENT OBSERVED	MAXIMUM CURRENT	MEAN DURA- TION HOURS	MEAN EXCUR- SION KM	MEAN CURRENT CM/S	MEAN TEMP DEG C
TOWARD	TOTAL	LIGHT	MEDIUM	HIGH	CM/S	
90.0	7.8	1.7	4.6	1.5	11.6	1.8
45.0	34.1	3.0	9.4	21.8	42.2	3.1
0.0	27.0	2.8	6.6	17.6	49.7	2.4
315.0	7.8	1.9	4.6	1.3	26.3	1.6
270.0	9.5	1.1	5.0	3.5	18.3	1.9
225.0	7.8	1.5	3.1	3.2	18.2	1.8
180.0	2.8	0.4	1.6	0.8	16.9	1.3
135.0	3.1	1.1	1.5	0.5	17.0	1.5
0	MEAN SCALAR SPEED = 9.6 CM/S		MEAN SQUARE SPEED = 164.6 CM ² /S ²			
	MEAN SQUARE E-W SPEED = 44.8 CM ² /S ²		MEAN SQUARE N-S SPEED = 119.9 CM ² /S ²			
	MEAN VELOCITY = 6.4 CM/S,		20 DEG TRUE		MEAN TEMPERATURE = 3.7 C	
	VARIANCE (U,V) = 62.2 CM ² /S ²		TOTAL HOURS = 744.			

PERCENT OBSERVED

LIGHT (0.0 - 3.0) 13.4% MEDIUM (3.0 - 7.0) 36.3% HIGH (GE 7.0) 50.3%

MOORING IS 97-05C-005A010 DEPTH IS 10 METERS THERE ARE 744 VALUES

FIRST DAY 1998/01/01/0000
FINAL DAY 1998/01/31/2300

SHORELINE ORIENTATION IN DEGREES TRUE SPECIFIED AS 90

DIRECTION DEG TRUE	PERCENT OBSERVED	MAXIMUM CURRENT	MEAN DURA- TION HOURS	MEAN EXCUR- SION KM	MEAN CURRENT CM/S	MEAN TEMP DEG C
TOWARD	TOTAL	LIGHT	MEDIUM	HIGH	CM/S	
90.0	7.9	1.5	5.4	1.1	10.0	1.8
45.0	32.9	2.2	8.2	22.6	41.8	2.9
0.0	27.4	2.0	7.9	17.5	47.0	2.8
315.0	6.6	1.7	3.8	1.1	20.0	1.6
270.0	10.3	2.2	4.2	4.0	21.6	1.6
225.0	9.1	1.5	4.3	3.4	19.2	1.7
180.0	2.3	0.8	1.1	0.4	13.3	1.2
135.0	3.4	1.2	1.5	0.7	15.5	1.3
0	MEAN SCALAR SPEED = 9.5 CM/S		MEAN SQUARE SPEED = 161.4 CM ² /S ²			
	MEAN SQUARE E-W SPEED = 42.1 CM ² /S ²		MEAN SQUARE N-S SPEED = 119.3 CM ² /S ²			
	MEAN VELOCITY = 6.3 CM/S,		19 DEG TRUE		MEAN TEMPERATURE = 3.7 C	
	VARIANCE (U,V) = 61.0 CM ² /S ²		TOTAL HOURS = 744.			

PERCENT OBSERVED

LIGHT (0.0 - 3.0) 13.0% MEDIUM (3.0 - 7.0) 36.3% HIGH (GE 7.0) 50.7%

DATE: 1998/02/01 TO 1998/02/28
 ROSE SUMMARY: WIND AND CURRENT

WIND

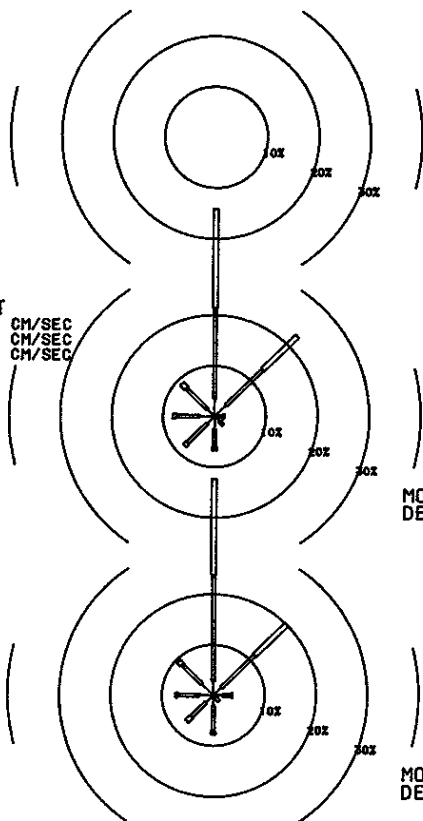

MOORING: 97-05C-005A008
 DEPTH: 8 M

MOORING: 97-05C-005A010
 DEPTH: 10 M

* WIND AND CURRENT DIRECTIONS ARE TOWARDS

MOORING IS 97-05C-005A008 DEPTH IS 8 METERS THERE ARE 672 VALUES

FIRST DAY 1998/02/01/0000
 FINAL DAY 1998/02/28/2300

SHORELINE ORIENTATION IN DEGREES TRUE SPECIFIED AS 90

DIRECTION DEG TRUE	PERCENT OBSERVED	TOWARD	TOTAL	LIGHT	MEDIUM	HIGH	MAXIMUM CURRENT CM/S	MEAN DURA- TION HOURS	MEAN EXCUR- SION KM	MEAN CURRENT CM/S	MEAN TEMP DEG C
90.0	1.9	0.7	0.9	0.3			7.7	1.1	0.1	3.7	2.7
45.0	22.6	3.1	10.0	9.5			16.3	2.0	0.5	6.9	2.5
0.0	40.9	3.6	17.9	19.5			34.7	3.0	0.8	7.2	2.5
315.0	9.1	1.9	5.8	1.3			10.8	1.3	0.2	4.7	2.6
270.0	8.2	3.0	4.5	0.7			8.7	1.4	0.2	3.8	2.7
225.0	8.2	1.9	5.5	0.7			8.7	1.4	0.2	4.2	2.6
180.0	6.7	2.5	3.6	0.6			7.4	1.7	0.2	4.0	2.5
135.0	2.4	1.5	0.9	0.0			6.7	1.1	0.1	3.0	2.7

MEAN SCALAR SPEED = 6.0 CM/S MEAN SQUARE SPEED = 48.9 CM2/S2
 MEAN SQUARE E-W SPEED = 8.9 CM2/S2 MEAN SQUARE N-S SPEED = 39.9 CM2/S2
 MEAN VELOCITY = 4.0 CM/S, 6 DEG TRUE MEAN TEMPERATURE = 2.6 C
 VARIANCE (U,V) = 16.6 CM2/S2 TOTAL HOURS = 672.

PERCENT OBSERVED

LIGHT (0.0 - 3.0) 18.3% MEDIUM (3.0 - 7.0) 49.0% HIGH (GE 7.0) 32.7%

MOORING IS 97-05C-005A010 DEPTH IS 10 METERS THERE ARE 672 VALUES

FIRST DAY 1998/02/01/0000
 FINAL DAY 1998/02/28/2300

SHORELINE ORIENTATION IN DEGREES TRUE SPECIFIED AS 90

DIRECTION DEG TRUE	PERCENT OBSERVED	TOWARD	TOTAL	LIGHT	MEDIUM	HIGH	MAXIMUM CURRENT CM/S	MEAN DURA- TION HOURS	MEAN EXCUR- SION KM	MEAN CURRENT CM/S	MEAN TEMP DEG C
90.0	3.7	1.8	1.8	0.1			7.1	1.3	0.1	3.2	2.7
45.0	20.1	2.1	9.2	8.8			16.4	2.0	0.5	6.9	2.5
0.0	42.7	2.8	21.0	18.9			28.9	3.5	0.9	7.2	2.5
315.0	9.5	3.1	5.4	1.0			9.6	1.6	0.2	4.4	2.6
270.0	7.3	2.7	4.2	0.4			7.4	1.9	0.3	3.9	2.7
225.0	7.3	1.9	4.0	1.3			8.7	1.5	0.2	4.2	2.6
180.0	7.7	2.1	5.2	0.4			9.9	2.0	0.3	4.4	2.6
135.0	1.6	0.6	1.0	0.0			4.9	1.2	0.1	3.4	2.8

MEAN SCALAR SPEED = 6.0 CM/S MEAN SQUARE SPEED = 47.6 CM2/S2
 MEAN SQUARE E-W SPEED = 8.5 CM2/S2 MEAN SQUARE N-S SPEED = 39.1 CM2/S2
 MEAN VELOCITY = 3.9 CM/S, 7 DEG TRUE MEAN TEMPERATURE = 2.6 C
 VARIANCE (U,V) = 16.2 CM2/S2 TOTAL HOURS = 672.

PERCENT OBSERVED

LIGHT (0.0 - 3.0) 17.1% MEDIUM (3.0 - 7.0) 51.8% HIGH (GE 7.0) 31.1%

DATE: 1998/03/01 TO 1998/03/31
ROSE SUMMARY: WIND AND CURRENT

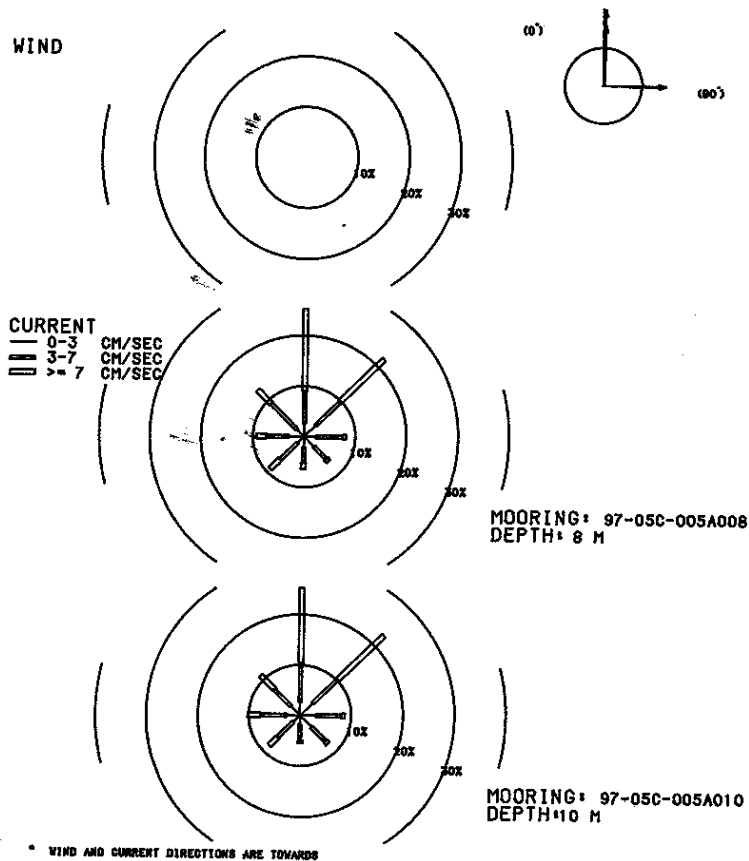

MOORING IS 97-05C-005A008 DEPTH IS 8 METERS THERE ARE 744 VALUES

FIRST DAY 1998/03/01/0000
FINAL DAY 1998/03/31/2300

SHORELINE ORIENTATION IN DEGREES TRUE SPECIFIED AS 90

DIRECTION DEG TRUE	PERCENT OBSERVED	TOWARD	TOTAL	LIGHT	MEDIUM	HIGH	MAXIMUM CURRENT CM/S	MEAN DURATION HOURS	MEAN EXCURSION KM	MEAN CURRENT CM/S	MEAN TEMP DEG C
90.0	8.2	2.3	5.2	0.7	11.5	1.7	0.3	4.3	2.9		
45.0	21.9	3.1	6.6	12.2	59.6	3.0	1.5	14.3	2.6		
0.0	25.3	2.6	6.5	16.3	34.2	3.1	1.2	10.4	2.6		
315.0	12.9	2.0	7.1	3.8	49.1	1.9	0.6	8.4	2.7		
270.0	9.3	3.0	4.3	2.0	28.2	1.7	0.4	6.0	2.7		
225.0	9.1	1.7	4.7	2.7	34.0	2.1	0.6	7.6	2.8		
180.0	6.5	2.0	3.1	1.3	17.9	1.5	0.3	4.8	2.8		
135.0	6.9	2.7	3.4	0.8	24.7	1.5	0.2	4.6	2.9		
0	MEAN SCALAR SPEED = 9.0 CM/S		MEAN SQUARE SPEED = 167.6 CM2/S2								
	MEAN SQUARE E-W SPEED = 58.4 CM2/S2		MEAN SQUARE N-S SPEED = 109.2 CM2/S2								
	MEAN VELOCITY = 4.8 CM/S,		10 DEG TRUE MEAN TEMPERATURE = 2.7 C								
	VARIANCE (U,V) = 72.2 CM2/S2		TOTAL HOURS = 744.								

PERCENT OBSERVED

LIGHT (0.0 - 3.0) 19.4% MEDIUM (3.0 - 7.0) 40.9% HIGH (GE 7.0) 39.8%

MOORING IS 97-05C-005A010 DEPTH IS 10 METERS THERE ARE 744 VALUES

FIRST DAY 1998/03/01/0000
FINAL DAY 1998/03/31/2300

SHORELINE ORIENTATION IN DEGREES TRUE SPECIFIED AS 90

DIRECTION DEG TRUE	PERCENT OBSERVED	TOWARD	TOTAL	LIGHT	MEDIUM	HIGH	MAXIMUM CURRENT CM/S	MEAN DURATION HOURS	MEAN EXCURSION KM	MEAN CURRENT CM/S	MEAN TEMP DEG C
90.0	8.7	3.1	5.0	0.7	14.7	1.4	0.2	4.2	2.9		
45.0	22.7	3.4	6.9	12.5	59.3	2.7	1.4	14.2	2.6		
0.0	25.3	2.7	7.8	14.8	34.6	2.7	0.9	9.6	2.6		
315.0	11.2	2.6	4.7	3.9	51.8	1.6	0.5	9.1	2.7		
270.0	10.3	2.6	5.2	2.6	30.2	1.8	0.4	6.9	2.7		
225.0	8.5	1.7	4.4	2.3	35.3	2.0	0.5	6.8	2.7		
180.0	5.5	1.7	3.2	0.5	16.0	1.4	0.2	4.1	2.8		
135.0	7.8	3.1	4.0	0.7	14.9	1.4	0.2	4.0	2.9		
0	MEAN SCALAR SPEED = 8.9 CM/S		MEAN SQUARE SPEED = 163.2 CM2/S2								
	MEAN SQUARE E-W SPEED = 57.4 CM2/S2		MEAN SQUARE N-S SPEED = 105.7 CM2/S2								
	MEAN VELOCITY = 4.9 CM/S,		11 DEG TRUE MEAN TEMPERATURE = 2.7 C								
	VARIANCE (U,V) = 69.5 CM2/S2		TOTAL HOURS = 744.								

PERCENT OBSERVED

LIGHT (0.0 - 3.0) 20.8% MEDIUM (3.0 - 7.0) 41.3% HIGH (GE 7.0) 37.9%

DATE: 1998/04/01 TO 1998/04/30
 ROSE SUMMARY: WIND AND CURRENT

WIND

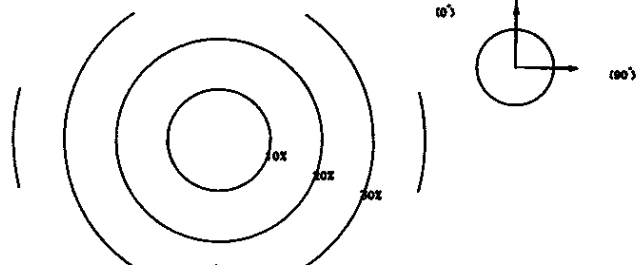

CURRENT
 — 0-3 CM/SEC
 = 3-7 CM/SEC
 = >= 7 CM/SEC

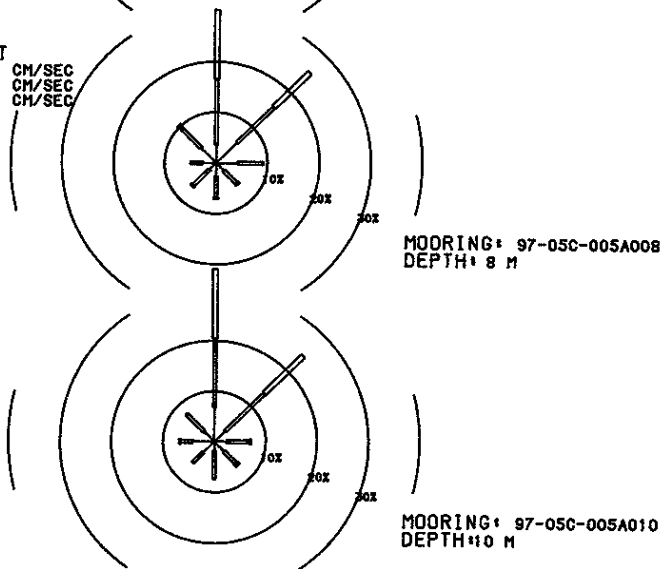

* WIND AND CURRENT DIRECTIONS ARE TOWARDS

MOORING IS 97-05C-005A008 DEPTH IS 8 METERS THERE ARE 337 VALUES

FIRST DAY 1998/04/01/0000
 FINAL DAY 1998/04/15/0000

SHORELINE ORIENTATION IN DEGREES TRUE SPECIFIED AS 90

DIRECTION DEG TRUE	PERCENT OBSERVED	MAXIMUM CURRENT	MEAN DURATION HOURS	MEAN EXCURSION KM	MEAN CURRENT CM/S	MEAN TEMP DEG C
TOWARD	TOTAL	LIGHT	MEDIUM	HIGH	CM/S	
90.0	9.2	4.2	5.0	0.0	6.1	3.9
45.0	25.5	5.6	10.1	9.8	23.5	3.9
0.0	30.3	3.6	13.1	13.6	22.6	3.9
315.0	10.4	4.2	5.6	0.6	12.5	3.9
270.0	5.0	2.7	2.4	0.0	6.1	3.9
225.0	6.5	1.8	4.5	0.3	8.6	3.7
180.0	7.1	2.7	4.2	0.3	10.9	3.9
135.0	5.9	2.1	3.6	0.3	7.6	3.8
MEAN SCALAR SPEED = 6.1 CM/S		MEAN SQUARE SPEED = 64.1 CM2/S2				
MEAN SQUARE E-W SPEED = 13.6 CM2/S2		MEAN SQUARE N-S SPEED = 50.5 CM2/S2				
MEAN VELOCITY = 4.0 CM/S,		22 DEG TRUE		MEAN TEMPERATURE = 3.9 C		
VARIANCE (U,V) = 23.9 CM2/S2		TOTAL HOURS = 337.				

PERCENT OBSERVED
 LIGHT (0.0 - 3.0) 26.7% MEDIUM (3.0 - 7.0) 48.4% HIGH (GE 7.0) 24.9%

MOORING IS 97-05C-005A010 DEPTH IS 10 METERS THERE ARE 337 VALUES

FIRST DAY 1998/04/01/0000
 FINAL DAY 1998/04/15/0000

SHORELINE ORIENTATION IN DEGREES TRUE SPECIFIED AS 90

DIRECTION DEG TRUE	PERCENT OBSERVED	MAXIMUM CURRENT	MEAN DURATION HOURS	MEAN EXCURSION KM	MEAN CURRENT CM/S	MEAN TEMP DEG C
TOWARD	TOTAL	LIGHT	MEDIUM	HIGH	CM/S	
90.0	7.1	2.4	4.5	0.3	9.4	3.9
45.0	24.3	3.0	10.7	10.7	22.3	3.9
0.0	34.1	6.8	13.6	13.6	22.2	3.9
315.0	7.7	2.7	5.0	0.0	6.2	3.9
270.0	6.8	4.2	2.4	0.3	7.5	3.9
225.0	5.9	3.0	3.0	0.0	5.5	3.7
180.0	7.4	1.8	5.6	0.0	6.8	3.8
135.0	6.5	2.7	3.3	0.6	8.0	3.8
MEAN SCALAR SPEED = 6.0 CM/S		MEAN SQUARE SPEED = 63.1 CM2/S2				
MEAN SQUARE E-W SPEED = 13.6 CM2/S2		MEAN SQUARE N-S SPEED = 49.5 CM2/S2				
MEAN VELOCITY = 4.1 CM/S,		21 DEG TRUE		MEAN TEMPERATURE = 3.9 C		
VARIANCE (U,V) = 23.1 CM2/S2		TOTAL HOURS = 337.				

PERCENT OBSERVED
 LIGHT (0.0 - 3.0) 26.4% MEDIUM (3.0 - 7.0) 48.1% HIGH (GE 7.0) 25.5%

DATE: 1997/11/02 TO 1997/11/30
ROSE SUMMARY - WIND AND CURRENT

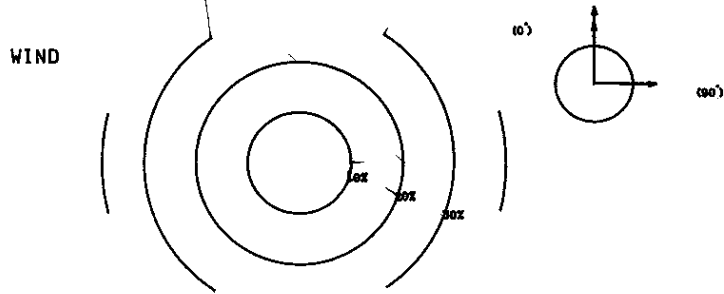

CURRENT
 — 0-3 CM/SEC
 = 3-7 CM/SEC
 = >= 7 CM/SEC

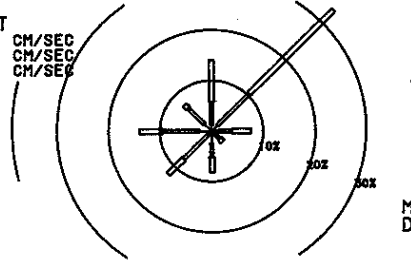

MOORING: 97-05C-005A012
DEPTH: 12 M

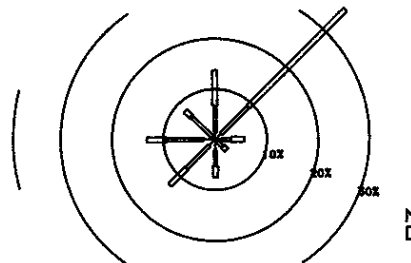

MOORING: 97-05C-005A014
DEPTH: 14 M

* WIND AND CURRENT DIRECTIONS ARE TOWARDS

MOORING IS 97-05C-005A012 DEPTH IS 12 METERS THERE ARE 691 VALUES

FIRST DAY 1997/11/02/0500
FINAL DAY 1997/11/30/2300

SHORELINE ORIENTATION IN DEGREES TRUE SPECIFIED AS 90

DIRECTION DEG TRUE	PERCENT OBSERVED	TOWARD	TOTAL	LIGHT	MEDIUM	HIGH	MAXIMUM CURRENT CM/S	MEAN DURATION HOURS	MEAN EXCURSION KM	MEAN CURRENT CM/S	MEAN TEMP DEG C
90.0	7.7	1.3	2.6	3.8	15.7	2.0	0.5	7.1	8.8		
45.0	33.6	1.6	8.7	23.3	29.2	3.7	1.4	10.9	8.9		
0.0	14.0	1.2	4.6	8.2	22.7	1.8	0.6	8.7	8.8		
315.0	7.4	1.9	4.5	1.0	12.3	1.5	0.3	4.6	8.2		
270.0	14.0	2.3	7.1	4.6	10.8	2.3	0.5	5.6	8.0		
225.0	12.0	0.7	6.9	4.3	13.0	2.0	0.5	6.3	8.2		
180.0	8.2	2.5	2.7	3.0	19.0	1.6	0.4	6.1	8.2		
135.0	3.0	1.0	1.2	0.9	19.8	1.2	0.2	5.4	8.7		

MEAN SCALAR SPEED = 8.0 CM/S MEAN SQUARE SPEED = 89.7 CM2/S2
 MEAN SQUARE E-W SPEED = 33.9 CM2/S2 MEAN SQUARE N-S SPEED = 55.7 CM2/S2
 MEAN VELOCITY = 3.5 CM/S, 25 DEG TRUE MEAN TEMPERATURE = 8.6 C
 VARIANCE (U,V) = 38.8 CM2/S2 TOTAL HOURS = 691.

PERCENT OBSERVED
 LIGHT (0.0 - 3.0) 12.4% MEDIUM (3.0 - 7.0) 38.4% HIGH (GE 7.0) 49.2%

MOORING IS 97-05C-005A014 DEPTH IS 14 METERS THERE ARE 691 VALUES

FIRST DAY 1997/11/02/0500
FINAL DAY 1997/11/30/2300

SHORELINE ORIENTATION IN DEGREES TRUE SPECIFIED AS 90

DIRECTION DEG TRUE	PERCENT OBSERVED	TOWARD	TOTAL	LIGHT	MEDIUM	HIGH	MAXIMUM CURRENT CM/S	MEAN DURATION HOURS	MEAN EXCURSION KM	MEAN CURRENT CM/S	MEAN TEMP DEG C
90.0	5.6	1.2	1.9	2.6	14.9	1.4	0.3	6.4	8.8		
45.0	36.0	1.6	7.5	26.9	29.2	4.4	1.7	10.8	8.9		
0.0	13.7	1.4	5.2	7.1	25.4	2.2	0.7	8.2	8.7		
315.0	8.1	0.7	5.8	1.6	11.9	2.0	0.4	5.5	8.2		
270.0	13.3	2.2	7.2	3.9	10.2	2.4	0.5	5.5	8.0		
225.0	12.6	1.6	6.4	4.6	12.8	2.4	0.5	6.4	8.1		
180.0	7.5	2.2	3.0	2.3	17.2	1.7	0.3	5.8	8.3		
135.0	3.0	0.4	1.6	1.0	18.5	1.2	0.3	5.9	8.8		

MEAN SCALAR SPEED = 8.0 CM/S MEAN SQUARE SPEED = 88.6 CM2/S2
 MEAN SQUARE E-W SPEED = 33.8 CM2/S2 MEAN SQUARE N-S SPEED = 54.8 CM2/S2
 MEAN VELOCITY = 3.5 CM/S, 24 DEG TRUE MEAN TEMPERATURE = 8.6 C
 VARIANCE (U,V) = 38.3 CM2/S2 TOTAL HOURS = 691.

PERCENT OBSERVED
 LIGHT (0.0 - 3.0) 11.3% MEDIUM (3.0 - 7.0) 38.6% HIGH (GE 7.0) 50.1%

DATE: 1997/12/01 TO 1997/12/31
 ROSE SUMMARY: WIND AND CURRENT

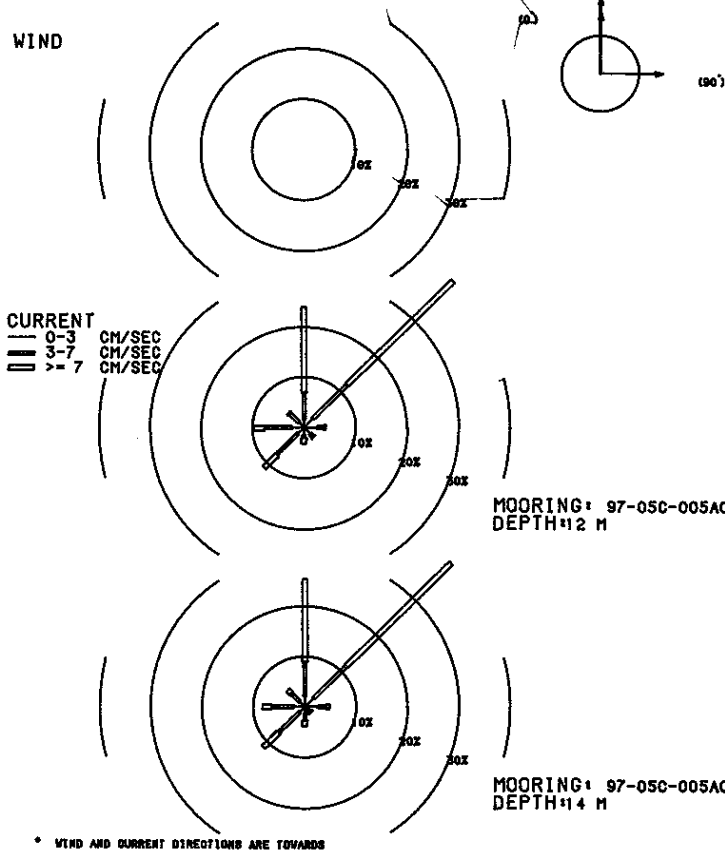

MOORING IS 97-05C-005A012 DEPTH IS 12 METERS THERE ARE 744 VALUES

FIRST DAY 1997/12/01/0000
 FINAL DAY 1997/12/31/2300

SHORELINE ORIENTATION IN DEGREES TRUE SPECIFIED AS 90

DIRECTION DEG TRUE	PERCENT OBSERVED	TOWARD	TOTAL	LIGHT	MEDIUM	HIGH	MAXIMUM CURRENT CM/S	MEAN DURA- TION HOURS	MEAN EXCUR- SION KM	MEAN CURRENT CM/S	MEAN TEMP DEG C
90.0	4.2	2.4	1.3	0.4	12.5	1.3	0.2	3.5	5.7		
45.0	40.9	2.4	9.4	29.0	30.9	3.2	1.2	10.7	5.9		
0.0	23.9	1.6	5.4	16.9	30.0	2.0	0.8	11.5	6.0		
315.0	4.3	1.3	2.6	0.4	8.9	1.5	0.2	3.9	6.5		
270.0	9.8	2.3	5.4	2.2	11.4	1.7	0.3	5.2	6.2		
225.0	11.0	1.7	5.6	3.6	13.2	2.2	0.5	6.1	5.9		
180.0	3.2	1.5	0.5	1.2	22.5	1.3	0.3	6.4	6.2		
135.0	2.7	1.7	0.8	0.1	8.8	1.2	0.1	2.8	5.3		

MEAN SCALAR SPEED = 8.9 CM/S MEAN SQUARE SPEED = 117.5 CM2/S2
 MEAN SQUARE E-W SPEED = 29.7 CM2/S2 MEAN SQUARE N-S SPEED = 87.7 CM2/S2
 MEAN VELOCITY = 5.9 CM/S, 21 DEG TRUE MEAN TEMPERATURE = 6.0 C
 VARIANCE (U,V) = 41.3 CM2/S2 TOTAL HOURS = 744.

PERCENT OBSERVED
 LIGHT (0.0 - 3.0) 15.1% MEDIUM (3.0 - 7.0) 31.0% HIGH (GE 7.0) 53.9%

MOORING IS 97-05C-005A014 DEPTH IS 14 METERS THERE ARE 744 VALUES

FIRST DAY 1997/12/01/0000
 FINAL DAY 1997/12/31/2300

SHORELINE ORIENTATION IN DEGREES TRUE SPECIFIED AS 90

DIRECTION DEG TRUE	PERCENT OBSERVED	TOWARD	TOTAL	LIGHT	MEDIUM	HIGH	MAXIMUM CURRENT CM/S	MEAN DURA- TION HOURS	MEAN EXCUR- SION KM	MEAN CURRENT CM/S	MEAN TEMP DEG C
90.0	4.8	2.6	1.6	0.7	12.5	1.5	0.2	3.9	5.6		
45.0	40.2	2.4	9.0	28.8	29.3	3.8	1.5	10.7	5.9		
0.0	25.3	2.0	6.9	16.4	32.1	2.3	0.9	11.2	6.0		
315.0	4.7	1.3	2.4	0.9	11.6	1.3	0.2	4.8	6.5		
270.0	8.2	2.2	4.3	1.7	12.3	1.5	0.3	5.1	6.1		
225.0	11.3	1.5	5.6	4.2	14.3	2.4	0.5	6.3	5.9		
180.0	3.9	1.5	1.2	1.2	20.0	1.2	0.3	6.0	6.3		
135.0	1.6	0.7	0.8	0.1	7.6	2.0	0.3	3.8	5.3		

MEAN SCALAR SPEED = 9.0 CM/S MEAN SQUARE SPEED = 119.0 CM2/S2
 MEAN SQUARE E-W SPEED = 29.7 CM2/S2 MEAN SQUARE N-S SPEED = 89.4 CM2/S2
 MEAN VELOCITY = 6.0 CM/S, 20 DEG TRUE MEAN TEMPERATURE = 6.0 C
 VARIANCE (U,V) = 41.6 CM2/S2 TOTAL HOURS = 744.

PERCENT OBSERVED
 LIGHT (0.0 - 3.0) 14.1% MEDIUM (3.0 - 7.0) 31.9% HIGH (GE 7.0) 54.0%

DATE: 1998/01/01 TO 1998/01/31
ROSE SUMMARY: WIND AND CURRENT

WIND

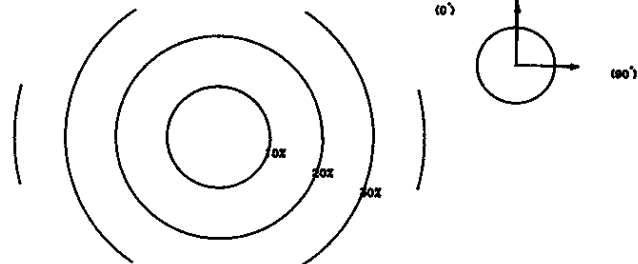

CURRENT
0-3 CM/SEC
3-7 CM/SEC
>= 7 CM/SEC

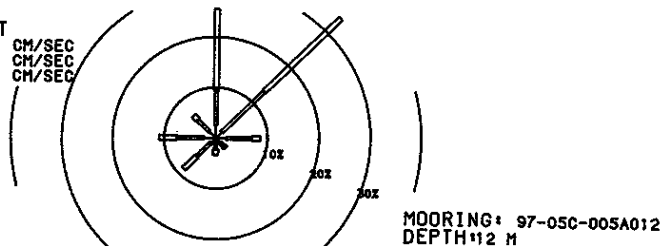

MOORING: 97-05C-005A012
DEPTH: 12 M

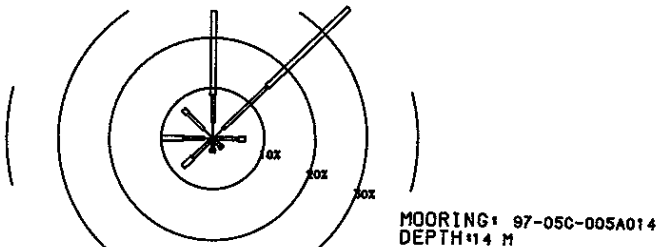

MOORING: 97-05C-005A014
DEPTH: 14 M

* WIND AND CURRENT DIRECTIONS ARE TOWARDS

MOORING IS 97-05C-005A012 DEPTH IS 12 METERS THERE ARE 744 VALUES

FIRST DAY 1998/01/01/0000
FINAL DAY 1998/01/31/2300

SHORELINE ORIENTATION IN DEGREES TRUE SPECIFIED AS 90

DIRECTION DEG TRUE	PERCENT OBSERVED	TOWARD	TOTAL	LIGHT	MEDIUM	HIGH	MAXIMUM CURRENT CM/S	MEAN DURA- TION HOURS	MEAN EXCUR- SION KM	MEAN CURRENT CM/S	MEAN TEMP DEG C
90.0	8.6	2.0	5.0	1.6	9.8	1.8	0.3	5.0	3.4		
45.0	33.9	1.6	11.6	20.7	42.3	3.0	1.3	12.3	3.9		
0.0	25.5	2.6	6.9	16.1	46.8	2.5	1.0	10.9	3.7		
315.0	6.2	1.7	3.2	1.2	20.3	1.8	0.3	5.1	3.3		
270.0	11.0	2.3	5.2	3.5	20.3	1.7	0.4	6.3	3.4		
225.0	8.7	1.3	3.9	3.5	24.0	1.5	0.4	6.9	3.4		
180.0	3.4	0.9	1.3	1.1	15.7	1.2	0.3	5.7	3.8		
135.0	2.7	1.1	1.2	0.4	16.1	1.2	0.2	4.6	3.7		

MEAN SCALAR SPEED = 9.3 CM/S MEAN SQUARE SPEED = 155.9 CM2/S2
MEAN SQUARE E-W SPEED = 41.2 CM2/S2 MEAN SQUARE N-S SPEED = 114.6 CM2/S2
MEAN VELOCITY = 6.1 CM/S, 20 DEG TRUE MEAN TEMPERATURE = 3.7 C
VARIANCE (U,V) = 59.5 CM2/S2 TOTAL HOURS = 744.

PERCENT OBSERVED

LIGHT (0.0 - 3.0) 13.6% MEDIUM (3.0 - 7.0) 38.3% HIGH (GE 7.0) 48.1%

MOORING IS 97-05C-005A014 DEPTH IS 14 METERS THERE ARE 744 VALUES

FIRST DAY 1998/01/01/0000
FINAL DAY 1998/01/31/2300

SHORELINE ORIENTATION IN DEGREES TRUE SPECIFIED AS 90

DIRECTION DEG TRUE	PERCENT OBSERVED	TOWARD	TOTAL	LIGHT	MEDIUM	HIGH	MAXIMUM CURRENT CM/S	MEAN DURA- TION HOURS	MEAN EXCUR- SION KM	MEAN CURRENT CM/S	MEAN TEMP DEG C
90.0	6.3	0.8	4.2	1.3	9.0	1.8	0.3	5.1	3.6		
45.0	37.0	2.7	12.1	22.2	42.0	3.2	1.3	11.0	3.8		
0.0	25.3	3.2	5.4	16.7	46.7	2.6	1.1	11.8	3.7		
315.0	8.1	2.4	4.4	1.2	19.9	1.8	0.3	5.0	3.4		
270.0	9.9	1.7	3.9	4.3	18.2	1.9	0.4	6.6	3.4		
225.0	8.1	0.8	4.6	2.7	23.4	1.8	0.5	6.9	3.6		
180.0	2.8	0.9	1.2	0.7	11.1	1.3	0.2	4.5	3.5		
135.0	2.6	0.8	1.3	0.4	14.1	1.2	0.2	4.4	3.8		

MEAN SCALAR SPEED = 9.2 CM/S MEAN SQUARE SPEED = 153.4 CM2/S2
MEAN SQUARE E-W SPEED = 39.8 CM2/S2 MEAN SQUARE N-S SPEED = 113.6 CM2/S2
MEAN VELOCITY = 6.2 CM/S, 20 DEG TRUE MEAN TEMPERATURE = 3.7 C
VARIANCE (U,V) = 57.7 CM2/S2 TOTAL HOURS = 744.

PERCENT OBSERVED

LIGHT (0.0 - 3.0) 13.4% MEDIUM (3.0 - 7.0) 37.1% HIGH (GE 7.0) 49.5%

DATE: 1998/02/01 TO 1998/02/28
ROSE SUMMARY: WIND AND CURRENT

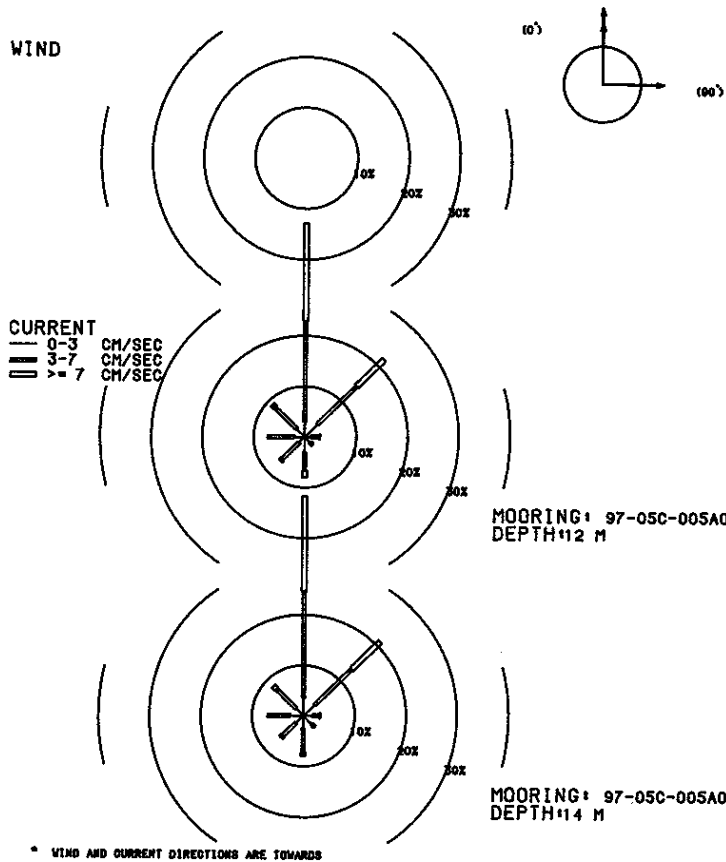

MOORING IS 97-05C-005A012 DEPTH IS 12 METERS THERE ARE 672 VALUES

FIRST DAY 1998/02/01/0000
FINAL DAY 1998/02/28/2300

SHORELINE ORIENTATION IN DEGREES TRUE SPECIFIED AS 90

DIRECTION DEG TRUE	PERCENT OBSERVED	TOWARD	TOTAL	LIGHT	MEDIUM	HIGH	MAXIMUM CURRENT CM/S	MEAN DURA- TION HOURS	MEAN EXCUR- SION KM	MEAN CURRENT CM/S	MEAN TEMP DEG C
90.0	3.0	1.2	1.6	0.1	7.7	1.2	0.2	3.5	2.6		
45.0	21.7	3.4	10.9	7.4	15.5	1.8	0.4	6.3	2.5		
0.0	42.1	3.0	19.9	19.2	16.6	3.2	0.8	7.3	2.5		
315.0	8.9	2.1	6.2	0.6	9.0	1.5	0.2	4.4	2.7		
270.0	7.3	2.1	5.2	0.0	6.6	1.4	0.2	3.8	2.7		
225.0	6.7	1.5	4.8	0.4	8.9	1.3	0.2	4.4	2.6		
180.0	8.0	3.0	3.7	1.3	9.3	2.0	0.3	4.4	2.6		
135.0	2.2	1.5	0.7	0.0	6.1	1.2	0.1	2.7	2.6		
MEAN SCALAR SPEED = 5.9 CM/S		MEAN SQUARE SPEED = 46.0 CM2/S2									
MEAN SQUARE E-W SPEED = 8.2 CM2/S2		MEAN SQUARE N-S SPEED = 37.8 CM2/S2									
MEAN VELOCITY = 3.9 CM/S,		7 DEG TRUE MEAN TEMPERATURE = 2.6 C									
VARIANCE (U,V) = 15.6 CM2/S2		TOTAL HOURS = 672.									

PERCENT OBSERVED
LIGHT (0.0 - 3.0) 17.7% MEDIUM (3.0 - 7.0) 53.1% HIGH (GE 7.0) 29.2%

MOORING IS 97-05C-005A014 DEPTH IS 14 METERS THERE ARE 672 VALUES

FIRST DAY 1998/02/01/0000
FINAL DAY 1998/02/28/2300

SHORELINE ORIENTATION IN DEGREES TRUE SPECIFIED AS 90

DIRECTION DEG TRUE	PERCENT OBSERVED	TOWARD	TOTAL	LIGHT	MEDIUM	HIGH	MAXIMUM CURRENT CM/S	MEAN DURA- TION HOURS	MEAN EXCUR- SION KM	MEAN CURRENT CM/S	MEAN TEMP DEG C
90.0	3.3	1.8	1.3	0.1	9.0	1.1	0.1	3.2	2.5		
45.0	21.0	3.0	10.1	7.9	16.7	1.9	0.5	6.7	2.5		
0.0	43.3	3.6	21.0	18.8	16.1	3.3	0.8	7.0	2.5		
315.0	8.3	1.9	5.5	0.9	10.1	1.5	0.2	4.5	2.7		
270.0	7.0	2.5	4.5	0.0	6.7	1.8	0.2	3.7	2.7		
225.0	6.1	1.9	3.7	0.4	10.1	1.6	0.2	4.2	2.7		
180.0	7.9	2.5	4.8	0.6	9.2	1.6	0.2	4.3	2.6		
135.0	3.1	2.4	0.7	0.0	5.2	1.1	0.1	2.3	2.7		
MEAN SCALAR SPEED = 5.8 CM/S		MEAN SQUARE SPEED = 44.7 CM2/S2									
MEAN SQUARE E-W SPEED = 8.0 CM2/S2		MEAN SQUARE N-S SPEED = 36.6 CM2/S2									
MEAN VELOCITY = 3.8 CM/S,		9 DEG TRUE MEAN TEMPERATURE = 2.6 C									
VARIANCE (U,V) = 15.1 CM2/S2		TOTAL HOURS = 672.									

PERCENT OBSERVED
LIGHT (0.0 - 3.0) 19.6% MEDIUM (3.0 - 7.0) 51.6% HIGH (GE 7.0) 28.7%

DATE: 1998/03/01 TO 1998/03/31
ROSE SUMMARY: WIND AND CURRENT

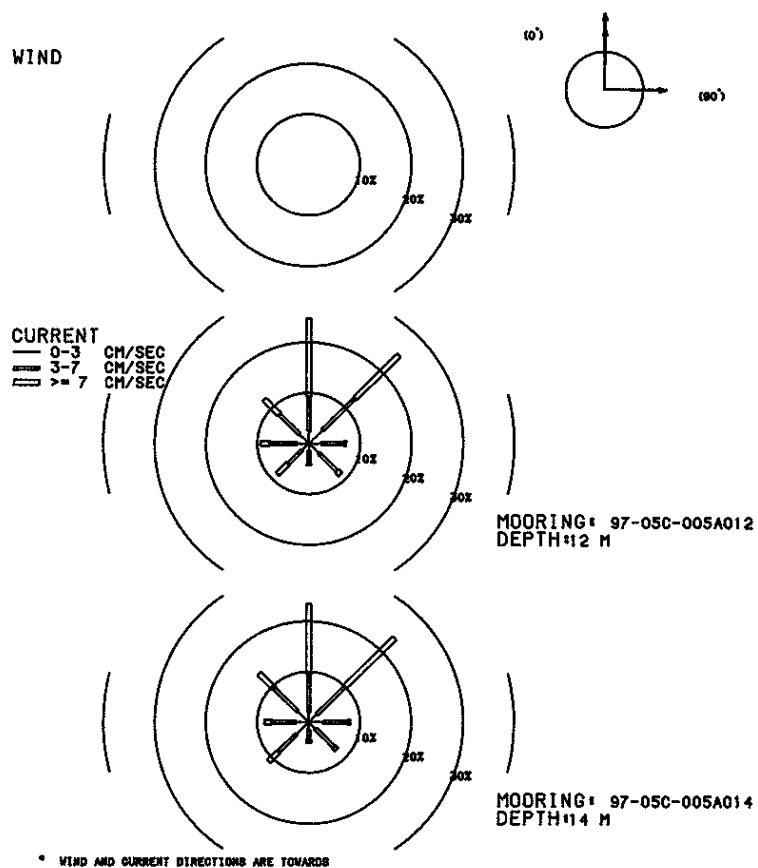

MOORING IS 97-05C-005A012 DEPTH IS 12 METERS THERE ARE 744 VALUES

FIRST DAY 1998/03/01/0000
FINAL DAY 1998/03/31/2300

SHORELINE ORIENTATION IN DEGREES TRUE SPECIFIED AS 90

DIRECTION DEG TRUE	PERCENT OBSERVED	MAXIMUM CURRENT	MEAN DURATION HOURS	MEAN EXCURSION KM	MEAN CURRENT CM/S	MEAN TEMP DEG C
TOWARD	TOTAL	LIGHT	MEDIUM	HIGH	CM/S	
90.0	7.3	2.4	4.3	0.5	12.4	1.8
45.0	24.7	3.6	9.0	12.1	60.2	3.3
0.0	24.7	2.4	6.9	15.5	34.3	3.2
315.0	12.2	2.4	5.6	4.2	51.9	1.8
270.0	9.4	2.3	5.4	1.7	30.6	1.8
225.0	8.6	1.9	3.8	3.0	33.4	2.1
180.0	4.3	1.5	2.7	0.1	10.0	1.5
135.0	8.7	2.8	4.8	1.1	16.4	1.9
MEAN SCALAR SPEED = 8.9 CM/S		MEAN SQUARE SPEED = 165.6 CM2/S2				
MEAN SQUARE E-W SPEED = 58.0 CM2/S2		MEAN SQUARE N-S SPEED = 107.6 CM2/S2				
MEAN VELOCITY = 5.0 CM/S,		12 DEG TRUE		MEAN TEMPERATURE = 2.7 C		
VARIANCE (U,V) = 70.2 CM2/S2		TOTAL HOURS = 744.				

PERCENT OBSERVED
LIGHT (0.0 - 3.0) 19.4% MEDIUM (3.0 - 7.0) 42.5% HIGH (GE 7.0) 38.2%

MOORING IS 97-05C-005A014 DEPTH IS 14 METERS THERE ARE 744 VALUES

FIRST DAY 1998/03/01/0000
FINAL DAY 1998/03/31/2300

SHORELINE ORIENTATION IN DEGREES TRUE SPECIFIED AS 90

DIRECTION DEG TRUE	PERCENT OBSERVED	MAXIMUM CURRENT	MEAN DURATION HOURS	MEAN EXCURSION KM	MEAN CURRENT CM/S	MEAN TEMP DEG C
TOWARD	TOTAL	LIGHT	MEDIUM	HIGH	CM/S	
90.0	8.1	2.8	4.7	0.5	8.0	1.5
45.0	23.7	2.2	7.7	13.8	61.5	3.0
0.0	23.4	2.0	7.5	13.8	37.4	3.0
315.0	13.6	3.0	6.5	4.2	47.9	1.9
270.0	8.6	2.4	4.8	1.3	28.4	1.6
225.0	11.0	3.4	5.0	2.7	33.7	2.6
180.0	4.0	1.5	2.0	0.5	10.8	1.2
135.0	7.7	1.9	5.1	0.7	14.3	1.5
MEAN SCALAR SPEED = 8.9 CM/S		MEAN SQUARE SPEED = 165.0 CM2/S2				
MEAN SQUARE E-W SPEED = 57.9 CM2/S2		MEAN SQUARE N-S SPEED = 107.1 CM2/S2				
MEAN VELOCITY = 5.0 CM/S,		11 DEG TRUE		MEAN TEMPERATURE = 2.7 C		
VARIANCE (U,V) = 70.2 CM2/S2		TOTAL HOURS = 744.				

PERCENT OBSERVED
LIGHT (0.0 - 3.0) 19.1% MEDIUM (3.0 - 7.0) 43.3% HIGH (GE 7.0) 37.6%

DATE: 1998/04/01 TO 1998/04/30
ROSE SUMMARY: WIND AND CURRENT

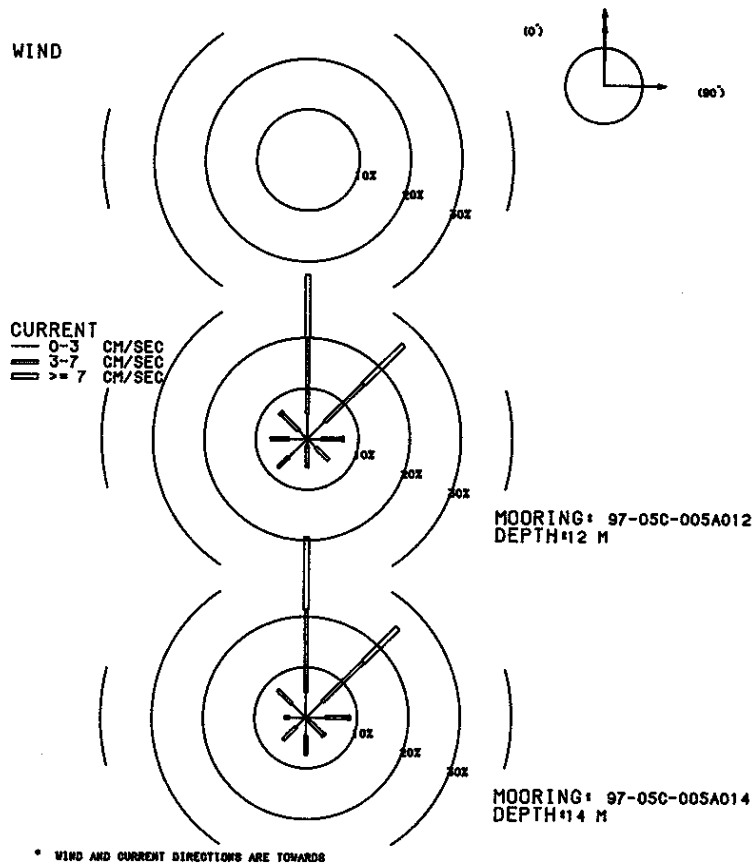

MOORING IS 97-05C-005A012 DEPTH IS 12 METERS THERE ARE 337 VALUES

FIRST DAY 1998/04/01/0000
FINAL DAY 1998/04/15/0000

SHORELINE ORIENTATION IN DEGREES TRUE SPECIFIED AS 90

DIRECTION DEG TRUE	PERCENT OBSERVED	TOWARD	TOTAL	LIGHT	MEDIUM	HIGH	MAXIMUM CURRENT CM/S	MEAN DURA- TION HOURS	MEAN EXCUR- SION KM	MEAN CURRENT CM/S	MEAN TEMP DEG C
90.0	7.1	2.7	4.2	0.3	7.5	1.7	0.2	3.7	3.9		
45.0	26.4	4.7	10.7	11.0	24.1	2.7	0.8	8.6	3.9		
0.0	32.3	5.0	14.8	12.5	21.0	2.6	0.7	7.5	3.9		
315.0	7.4	2.4	4.5	0.6	9.0	1.2	0.2	3.7	3.9		
270.0	7.1	3.6	3.6	0.0	5.1	1.3	0.1	2.8	3.9		
225.0	8.0	5.0	3.0	0.0	5.9	1.4	0.1	3.0	3.7		
180.0	5.6	1.2	4.5	0.0	6.1	1.2	0.2	4.2	3.8		
135.0	5.9	2.4	3.6	0.0	6.5	1.7	0.2	3.5	3.8		

MEAN SCALAR SPEED = 6.1 CM/S MEAN SQUARE SPEED = 63.1 CM²/S²
 MEAN SQUARE E-W SPEED = 14.1 CM²/S² MEAN SQUARE N-S SPEED = 49.0 CM²/S²
 MEAN VELOCITY = 4.1 CM/S, 21 DEG TRUE MEAN TEMPERATURE = 3.9 C
 VARIANCE (U,V) = 23.1 CM²/S² TOTAL HOURS = 337.

PERCENT OBSERVED
 LIGHT (0.0 - 3.0) 27.0% MEDIUM (3.0 - 7.0) 48.7% HIGH (GE 7.0) 24.3%

MOORING IS 97-05C-005A014 DEPTH IS 14 METERS THERE ARE 337 VALUES

FIRST DAY 1998/04/01/0000
FINAL DAY 1998/04/15/0000

SHORELINE ORIENTATION IN DEGREES TRUE SPECIFIED AS 90

DIRECTION DEG TRUE	PERCENT OBSERVED	TOWARD	TOTAL	LIGHT	MEDIUM	HIGH	MAXIMUM CURRENT CM/S	MEAN DURA- TION HOURS	MEAN EXCUR- SION KM	MEAN CURRENT CM/S	MEAN TEMP DEG C
90.0	8.6	3.9	4.5	0.3	8.4	1.7	0.2	3.7	3.9		
45.0	25.2	4.5	11.3	9.5	23.2	2.1	0.6	8.0	3.9		
0.0	35.6	5.0	16.3	14.2	23.3	3.2	0.9	7.8	3.9		
315.0	7.7	3.9	3.9	0.0	6.4	1.4	0.2	3.3	3.9		
270.0	4.2	3.3	0.9	0.0	6.5	1.3	0.1	2.5	3.8		
225.0	6.2	2.7	3.6	0.0	6.5	1.2	0.1	3.1	3.8		
180.0	7.4	3.6	3.9	0.0	5.7	1.6	0.2	3.3	3.8		
135.0	5.0	0.9	3.9	0.3	8.8	1.5	0.2	3.9	3.9		

MEAN SCALAR SPEED = 6.1 CM/S MEAN SQUARE SPEED = 62.9 CM²/S²
 MEAN SQUARE E-W SPEED = 12.4 CM²/S² MEAN SQUARE N-S SPEED = 50.5 CM²/S²
 MEAN VELOCITY = 4.3 CM/S, 21 DEG TRUE MEAN TEMPERATURE = 3.9 C
 VARIANCE (U,V) = 22.3 CM²/S² TOTAL HOURS = 337.

PERCENT OBSERVED
 LIGHT (0.0 - 3.0) 27.6% MEDIUM (3.0 - 7.0) 48.1% HIGH (GE 7.0) 24.3%

DATE: 1997/11/02 TO 1997/11/30
ROSE SUMMARY: WIND AND CURRENT

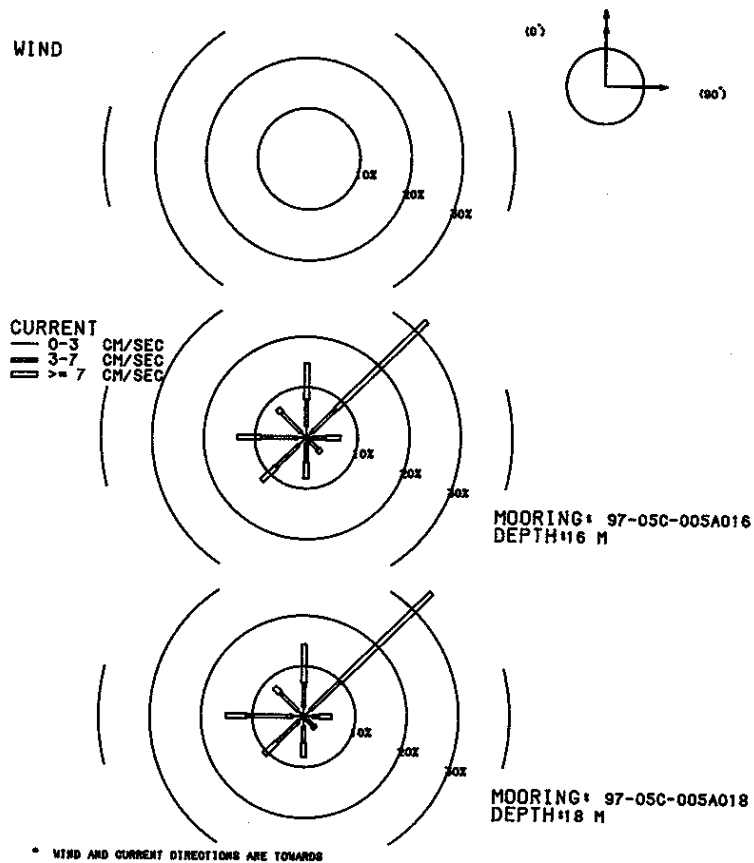

MOORING IS 97-05C-005A016 DEPTH IS 16 METERS THERE ARE 691 VALUES

FIRST DAY 1997/11/02/0500
FINAL DAY 1997/11/30/2300

SHORELINE ORIENTATION IN DEGREES TRUE SPECIFIED AS 90

DIRECTION DEG TRUE	PERCENT OBSERVED	MAXIMUM CURRENT	MEAN DURATION HOURS	MEAN EXCURSION KM	MEAN CURRENT CM/S	MEAN TEMP DEG C
TOWARD	TOTAL	LIGHT	MEDIUM	HIGH	CM/S	
90.0	6.7	1.2	2.6	2.9	12.5	1.9
45.0	32.9	1.4	6.7	24.7	28.8	4.1
0.0	14.8	2.3	5.2	7.2	23.1	1.9
315.0	8.0	1.4	5.4	1.2	11.4	1.7
270.0	13.5	1.7	7.1	4.6	12.0	2.3
225.0	12.2	2.0	6.2	3.9	16.5	2.1
180.0	8.1	1.2	3.6	3.3	18.2	1.9
135.0	4.1	1.0	2.2	0.9	16.9	1.6

MEAN SCALAR SPEED = 7.9 CM/S MEAN SQUARE SPEED = 87.1 CM²/S²
 MEAN SQUARE E-W SPEED = 32.5 CM²/S² MEAN SQUARE N-S SPEED = 54.6 CM²/S²
 MEAN VELOCITY = 3.4 CM/S, 23 DEG TRUE MEAN TEMPERATURE = 8.6 C
 VARIANCE (U,V) = 37.8 CM²/S² TOTAL HOURS = 691.

PERCENT OBSERVED
 LIGHT (0.0 - 3.0) 12.3% MEDIUM (3.0 - 7.0) 38.9% HIGH (GE 7.0) 48.8%

MOORING IS 97-05C-005A018 DEPTH IS 18 METERS THERE ARE 691 VALUES

FIRST DAY 1997/11/02/0500
FINAL DAY 1997/11/30/2300

SHORELINE ORIENTATION IN DEGREES TRUE SPECIFIED AS 90

DIRECTION DEG TRUE	PERCENT OBSERVED	MAXIMUM CURRENT	MEAN DURATION HOURS	MEAN EXCURSION KM	MEAN CURRENT CM/S	MEAN TEMP DEG C
TOWARD	TOTAL	LIGHT	MEDIUM	HIGH	CM/S	
90.0	5.5	1.7	1.3	2.5	11.9	1.7
45.0	34.9	1.7	8.0	25.2	27.4	3.9
0.0	14.3	1.9	4.8	7.7	25.7	1.8
315.0	8.1	1.6	4.9	1.6	11.1	1.8
270.0	15.2	2.2	9.0	4.1	12.1	2.4
225.0	10.7	1.3	5.9	3.5	12.4	1.9
180.0	8.1	1.9	3.3	2.9	16.9	1.9
135.0	3.2	1.0	1.6	0.6	10.2	1.6

MEAN SCALAR SPEED = 7.8 CM/S MEAN SQUARE SPEED = 86.4 CM²/S²
 MEAN SQUARE E-W SPEED = 32.1 CM²/S² MEAN SQUARE N-S SPEED = 54.3 CM²/S²
 MEAN VELOCITY = 3.5 CM/S, 22 DEG TRUE MEAN TEMPERATURE = 8.6 C
 VARIANCE (U,V) = 37.0 CM²/S² TOTAL HOURS = 691.

PERCENT OBSERVED
 LIGHT (0.0 - 3.0) 13.3% MEDIUM (3.0 - 7.0) 38.8% HIGH (GE 7.0) 47.9%

DATE: 1997/12/01 TO 1997/12/31
ROSE SUMMARY: WIND AND CURRENT

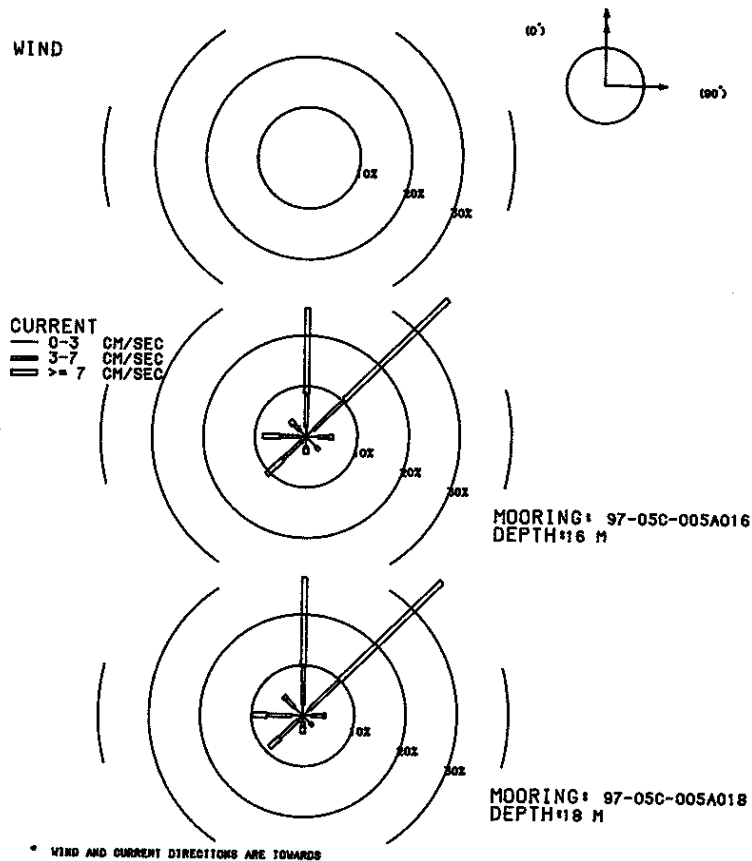

MOORING IS 97-05C-005A016 DEPTH IS 16 METERS THERE ARE 744 VALUES

FIRST DAY 1997/12/01/0000
FINAL DAY 1997/12/31/2300

SHORELINE ORIENTATION IN DEGREES TRUE SPECIFIED AS 90

DIRECTION DEG TRUE	PERCENT OBSERVED	MAXIMUM CURRENT	MEAN DURATION HOURS	MEAN EXCURSION KM	MEAN CURRENT CM/S	MEAN TEMP DEG C
TOWARD	TOTAL	LIGHT	MEDIUM	HIGH	CM/S	
90.0	5.2	2.3	2.2	0.8	9.3	1.4
45.0	38.7	2.0	8.3	28.4	28.4	3.6
0.0	25.4	1.9	6.7	16.8	30.1	2.5
315.0	4.4	1.7	1.6	1.1	9.3	1.3
270.0	8.5	1.3	3.8	3.4	10.9	1.7
225.0	10.8	1.1	5.4	4.3	12.6	2.2
180.0	3.4	1.9	0.4	1.1	17.7	1.2
135.0	3.6	2.7	0.9	0.0	6.0	1.7

MEAN SCALAR SPEED = 8.9 CM/S MEAN SQUARE SPEED = 117.0 CM²/S²
 MEAN SQUARE E-W SPEED = 28.9 CM²/S² MEAN SQUARE N-S SPEED = 88.1 CM²/S²
 MEAN VELOCITY = 5.9 CM/S, 21 DEG TRUE MEAN TEMPERATURE = 6.0 C
 VARIANCE (U,V) = 40.9 CM²/S² TOTAL HOURS = 744.

PERCENT OBSERVED
 LIGHT (0.0 - 3.0) 14.9% MEDIUM (3.0 - 7.0) 29.3% HIGH (GE 7.0) 55.8%

MOORING IS 97-05C-005A018 DEPTH IS 18 METERS THERE ARE 744 VALUES

FIRST DAY 1997/12/01/0000
FINAL DAY 1997/12/31/2300

SHORELINE ORIENTATION IN DEGREES TRUE SPECIFIED AS 90

DIRECTION DEG TRUE	PERCENT OBSERVED	MAXIMUM CURRENT	MEAN DURATION HOURS	MEAN EXCURSION KM	MEAN CURRENT CM/S	MEAN TEMP DEG C
TOWARD	TOTAL	LIGHT	MEDIUM	HIGH	CM/S	
90.0	4.4	1.7	2.2	0.5	11.4	1.3
45.0	37.8	1.7	8.2	27.8	28.6	3.2
0.0	27.3	2.3	7.4	17.6	29.5	2.4
315.0	5.4	2.3	2.4	0.7	8.5	1.3
270.0	9.8	2.2	4.8	2.8	11.3	1.8
225.0	9.0	1.2	5.1	2.7	12.8	2.0
180.0	3.5	1.2	1.1	1.2	18.4	1.7
135.0	2.8	2.0	0.8	0.0	5.9	1.5

MEAN SCALAR SPEED = 8.8 CM/S MEAN SQUARE SPEED = 115.9 CM²/S²
 MEAN SQUARE E-W SPEED = 27.5 CM²/S² MEAN SQUARE N-S SPEED = 88.4 CM²/S²
 MEAN VELOCITY = 6.0 CM/S, 20 DEG TRUE MEAN TEMPERATURE = 6.0 C
 VARIANCE (U,V) = 39.8 CM²/S² TOTAL HOURS = 744.

PERCENT OBSERVED
 LIGHT (0.0 - 3.0) 14.7% MEDIUM (3.0 - 7.0) 32.0% HIGH (GE 7.0) 53.4%

DATE: 1998/01/01 TO 1998/01/31
 ROSE SUMMARY: WIND AND CURRENT

WIND

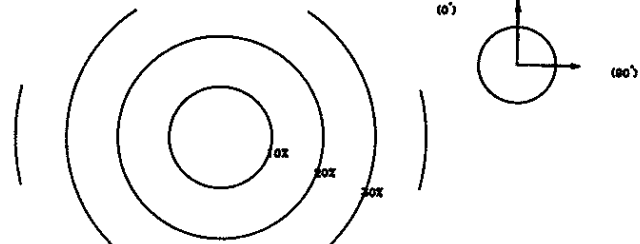

CURRENT
 0-3 CM/SEC
 3-7 CM/SEC
 >= 7 CM/SEC

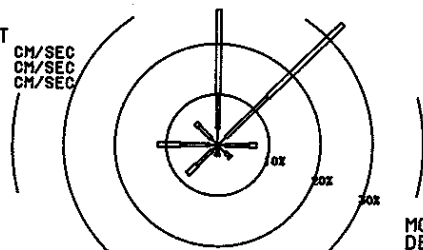

MOORING: 97-05C-005A016
 DEPTH: 16 M

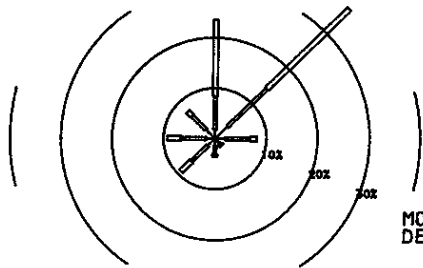

MOORING: 97-05C-005A018
 DEPTH: 18 M

* WIND AND CURRENT DIRECTIONS ARE TOWARDS

MOORING IS 97-05C-005A016 DEPTH IS 16 METERS THERE ARE 744 VALUES

FIRST DAY 1998/01/01/0000
 FINAL DAY 1998/01/31/2300

SHORELINE ORIENTATION IN DEGREES TRUE SPECIFIED AS 90

DIRECTION DEG TRUE	PERCENT OBSERVED	MAXIMUM CURRENT	MEAN DURA- TION HOURS	MEAN EXCUR- SION KM	MEAN CURRENT CM/S	MEAN TEMP DEG C
TOWARD	TOTAL	LIGHT	MEDIUM	HIGH	CM/S	
90.0	7.5	1.5	4.6	1.5	10.0	1.8
45.0	34.1	2.2	11.4	20.6	43.3	3.4
0.0	26.7	3.2	7.0	16.5	45.3	2.9
315.0	6.0	1.7	3.5	0.8	13.5	1.6
270.0	11.7	1.6	5.6	4.4	18.9	2.0
225.0	8.2	1.5	4.2	2.6	18.3	1.9
180.0	2.2	0.5	1.2	0.4	13.3	1.3
135.0	3.5	2.2	1.1	0.3	9.9	1.3

0 MEAN SCALAR SPEED = 9.2 CM/S MEAN SQUARE SPEED = 152.0 CM2/S2
 MEAN SQUARE E-W SPEED = 40.0 CM2/S2 MEAN SQUARE N-S SPEED = 112.0 CM2/S2
 MEAN VELOCITY = 6.1 CM/S, 19 DEG TRUE MEAN TEMPERATURE = 3.7 C
 VARIANCE (U,V) = 57.5 CM2/S2 TOTAL HOURS = 744.

PERCENT OBSERVED
 LIGHT (0.0 - 3.0) 14.4% MEDIUM (3.0 - 7.0) 38.6% HIGH (GE 7.0) 47.0%

MOORING IS 97-05C-005A018 DEPTH IS 18 METERS THERE ARE 744 VALUES

FIRST DAY 1998/01/01/0000
 FINAL DAY 1998/01/31/2300

SHORELINE ORIENTATION IN DEGREES TRUE SPECIFIED AS 90

DIRECTION DEG TRUE	PERCENT OBSERVED	MAXIMUM CURRENT	MEAN DURA- TION HOURS	MEAN EXCUR- SION KM	MEAN CURRENT CM/S	MEAN TEMP DEG C
TOWARD	TOTAL	LIGHT	MEDIUM	HIGH	CM/S	
90.0	8.2	1.9	5.0	1.3	8.7	1.7
45.0	36.7	3.4	10.8	22.6	43.1	3.1
0.0	23.5	1.7	6.7	15.1	44.6	2.4
315.0	7.5	2.4	3.9	1.2	17.6	1.6
270.0	9.3	1.6	5.0	2.7	16.8	1.5
225.0	9.3	1.9	4.4	3.0	20.1	2.0
180.0	3.6	1.5	1.6	0.5	12.9	1.2
135.0	1.9	1.2	0.4	0.3	8.8	1.3

0 MEAN SCALAR SPEED = 9.1 CM/S MEAN SQUARE SPEED = 151.0 CM2/S2
 MEAN SQUARE E-W SPEED = 39.0 CM2/S2 MEAN SQUARE N-S SPEED = 112.0 CM2/S2
 MEAN VELOCITY = 6.1 CM/S, 19 DEG TRUE MEAN TEMPERATURE = 3.7 C
 VARIANCE (U,V) = 56.8 CM2/S2 TOTAL HOURS = 744.

PERCENT OBSERVED
 LIGHT (0.0 - 3.0) 15.6% MEDIUM (3.0 - 7.0) 37.8% HIGH (GE 7.0) 46.6%

DATE: 1998/02/01 TO 1998/02/28
 ROSE SUMMARY: WIND AND CURRENT

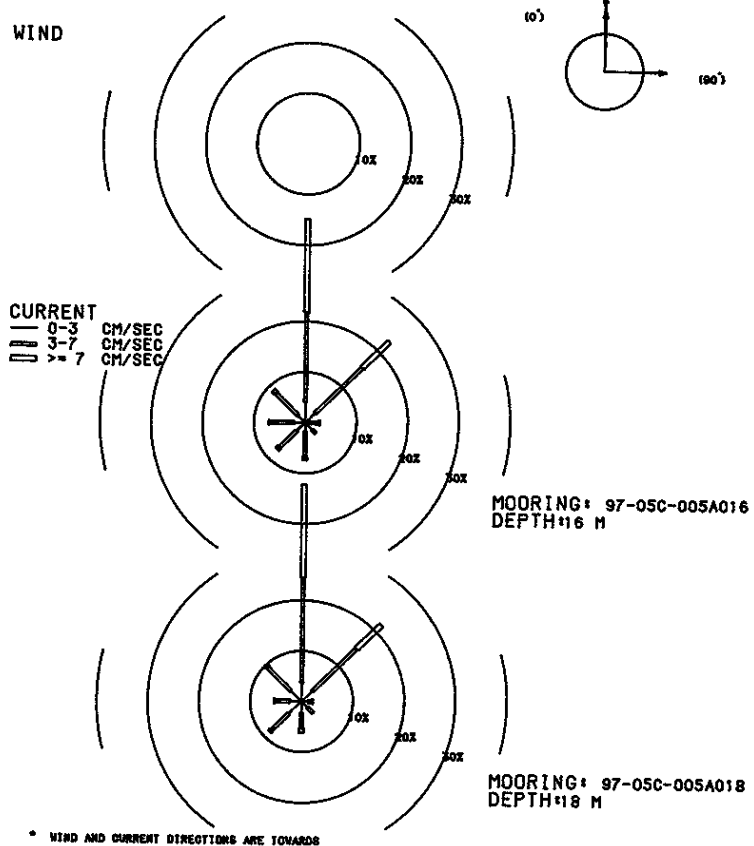

MOORING IS 97-05C-005A016 DEPTH IS 16 METERS THERE ARE 672 VALUES

FIRST DAY 1998/02/01/0000
 FINAL DAY 1998/02/28/2300

SHORELINE ORIENTATION IN DEGREES TRUE SPECIFIED AS 90

DIRECTION DEG TRUE	PERCENT OBSERVED	MAXIMUM CURRENT	MEAN DURA- TION HOURS	MEAN EXCUR- SION KM	MEAN CURRENT CM/S	MEAN TEMP DEG C
TOWARD	TOTAL	LIGHT	MEDIUM	HIGH	CM/S	
90.0	2.8	0.9	1.6	0.3	8.1	2.6
45.0	22.9	2.5	12.9	7.4	15.4	2.5
0.0	40.2	4.0	17.7	18.5	15.9	2.5
315.0	8.9	1.8	6.4	0.7	9.8	2.6
270.0	7.1	2.1	4.9	0.1	8.1	2.8
225.0	7.6	2.2	4.8	0.6	9.6	2.7
180.0	7.4	1.8	5.1	0.6	8.9	2.5
135.0	3.0	1.9	1.0	0.0	4.3	2.6
0	MEAN SCALAR SPEED = 5.8 CM/S		MEAN SQUARE SPEED = 44.5 CM2/S2			
	MEAN SQUARE E-W SPEED = 8.4 CM2/S2		MEAN SQUARE N-S SPEED = 36.1 CM2/S2			
	MEAN VELOCITY = 3.7 CM/S,		8 DEG TRUE MEAN TEMPERATURE = 2.6 C			
	VARIANCE (U,V) = 15.4 CM2/S2		TOTAL HOURS = 672.			

PERCENT OBSERVED
 LIGHT (0.0 - 3.0) 17.3% MEDIUM (3.0 - 7.0) 54.5% HIGH (GE 7.0) 28.3%

MOORING IS 97-05C-005A018 DEPTH IS 18 METERS THERE ARE 672 VALUES

FIRST DAY 1998/02/01/0000
 FINAL DAY 1998/02/28/2300

SHORELINE ORIENTATION IN DEGREES TRUE SPECIFIED AS 90

DIRECTION DEG TRUE	PERCENT OBSERVED	MAXIMUM CURRENT	MEAN DURA- TION HOURS	MEAN EXCUR- SION KM	MEAN CURRENT CM/S	MEAN TEMP DEG C
TOWARD	TOTAL	LIGHT	MEDIUM	HIGH	CM/S	
90.0	2.2	1.2	0.9	0.1	9.7	2.6
45.0	21.7	2.8	12.1	6.8	14.8	2.5
0.0	42.9	3.6	20.8	18.5	14.6	2.6
315.0	9.7	3.0	6.5	0.1	8.8	2.7
270.0	5.4	2.2	3.0	0.1	7.3	2.8
225.0	8.6	3.4	4.8	0.4	8.5	2.6
180.0	6.2	2.2	3.1	0.9	8.3	2.6
135.0	3.3	1.8	1.5	0.0	4.9	2.6
0	MEAN SCALAR SPEED = 5.7 CM/S		MEAN SQUARE SPEED = 42.3 CM2/S2			
	MEAN SQUARE E-W SPEED = 7.4 CM2/S2		MEAN SQUARE N-S SPEED = 34.9 CM2/S2			
	MEAN VELOCITY = 3.7 CM/S,		9 DEG TRUE MEAN TEMPERATURE = 2.6 C			
	VARIANCE (U,V) = 14.1 CM2/S2		TOTAL HOURS = 672.			

PERCENT OBSERVED
 LIGHT (0.0 - 3.0) 20.2% MEDIUM (3.0 - 7.0) 52.7% HIGH (GE 7.0) 27.1%

DATE: 1998/03/01 TO 1998/03/31
 ROSE SUMMARY: WIND AND CURRENT

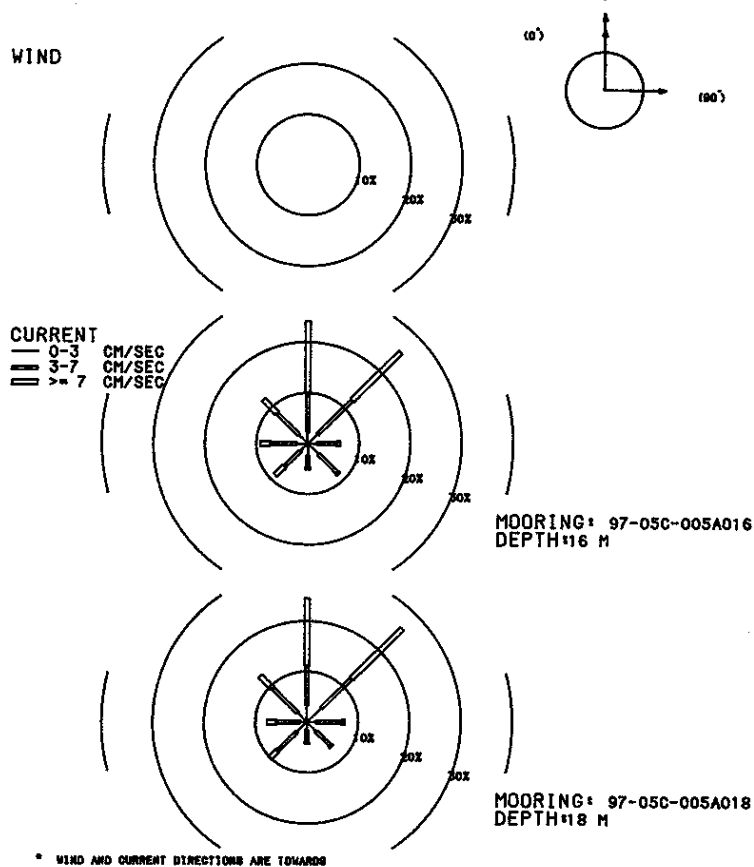

MOORING IS 97-05C-005A016 DEPTH IS 16 METERS THERE ARE 744 VALUES

FIRST DAY 1998/03/01/0000
 FINAL DAY 1998/03/31/2300

SHORELINE ORIENTATION IN DEGREES TRUE SPECIFIED AS 90

DIRECTION DEG TRUE	PERCENT OBSERVED			MAXIMUM CURRENT CM/S	MEAN DURATION HOURS	MEAN EXCURSION KM	MEAN CURRENT CM/S	MEAN TEMP DEG C	
TOWARD	TOTAL	LIGHT	MEDIUM	HIGH	CM/S				
90.0	6.3	1.7	3.9	0.7	11.7	1.4	0.2	4.3	
45.0	25.5	2.6	9.5	13.4	62.1	3.3	1.6	13.3	
0.0	24.2	2.3	7.8	14.1	37.7	2.8	1.0	10.0	
315.0	12.2	2.4	6.0	3.8	49.4	1.9	0.6	8.5	
270.0	9.3	2.3	5.0	2.0	27.8	1.7	0.4	6.5	
225.0	8.9	2.0	4.3	2.6	33.3	1.9	0.5	7.2	
180.0	5.1	2.4	2.3	0.4	10.4	1.7	0.2	3.6	
135.0	8.5	3.0	5.1	0.4	13.7	1.9	0.3	3.9	
0	MEAN SCALAR SPEED = 8.9 CM/S		MEAN SQUARE SPEED = 163.6 CM2/S2						
	MEAN SQUARE E-W SPEED = 58.2 CM2/S2		MEAN SQUARE N-S SPEED = 105.4 CM2/S2						
	MEAN VELOCITY = 5.1 CM/S,		11 DEG TRUE		MEAN TEMPERATURE = 2.7 C				
	VARIANCE (U,V) = 69.1 CM2/S2		TOTAL HOURS = 744.						

PERCENT OBSERVED
 LIGHT (0.0 - 3.0) 18.7% MEDIUM (3.0 - 7.0) 44.0% HIGH (GE 7.0) 37.4%

MOORING IS 97-05C-005A018 DEPTH IS 18 METERS THERE ARE 744 VALUES

FIRST DAY 1998/03/01/0000
 FINAL DAY 1998/03/31/2300

SHORELINE ORIENTATION IN DEGREES TRUE SPECIFIED AS 90

DIRECTION DEG TRUE	PERCENT OBSERVED			MAXIMUM CURRENT CM/S	MEAN DURATION HOURS	MEAN EXCURSION KM	MEAN CURRENT CM/S	MEAN TEMP DEG C	
TOWARD	TOTAL	LIGHT	MEDIUM	HIGH	CM/S				
90.0	7.4	1.7	5.0	0.7	10.3	1.4	0.2	4.3	
45.0	26.2	3.9	8.3	14.0	59.0	2.9	1.4	13.3	
0.0	24.5	3.4	7.8	13.3	36.2	2.5	0.8	9.3	
315.0	12.9	2.6	6.9	3.5	49.1	1.9	0.5	7.7	
270.0	7.8	1.3	4.6	1.9	34.9	1.6	0.4	7.5	
225.0	10.1	2.7	5.4	2.0	32.9	2.0	0.5	6.4	
180.0	4.3	1.6	2.4	0.3	7.7	1.2	0.2	3.4	
135.0	6.9	2.6	3.9	0.4	12.2	1.5	0.2	3.9	
0	MEAN SCALAR SPEED = 8.7 CM/S		MEAN SQUARE SPEED = 160.6 CM2/S2						
	MEAN SQUARE E-W SPEED = 56.7 CM2/S2		MEAN SQUARE N-S SPEED = 103.9 CM2/S2						
	MEAN VELOCITY = 5.1 CM/S,		11 DEG TRUE		MEAN TEMPERATURE = 2.7 C				
	VARIANCE (U,V) = 67.3 CM2/S2		TOTAL HOURS = 744.						

PERCENT OBSERVED
 LIGHT (0.0 - 3.0) 19.8% MEDIUM (3.0 - 7.0) 44.2% HIGH (GE 7.0) 36.0%

DATE: 1998/04/01 TO 1998/04/30
 ROSE SUMMARY: WIND AND CURRENT

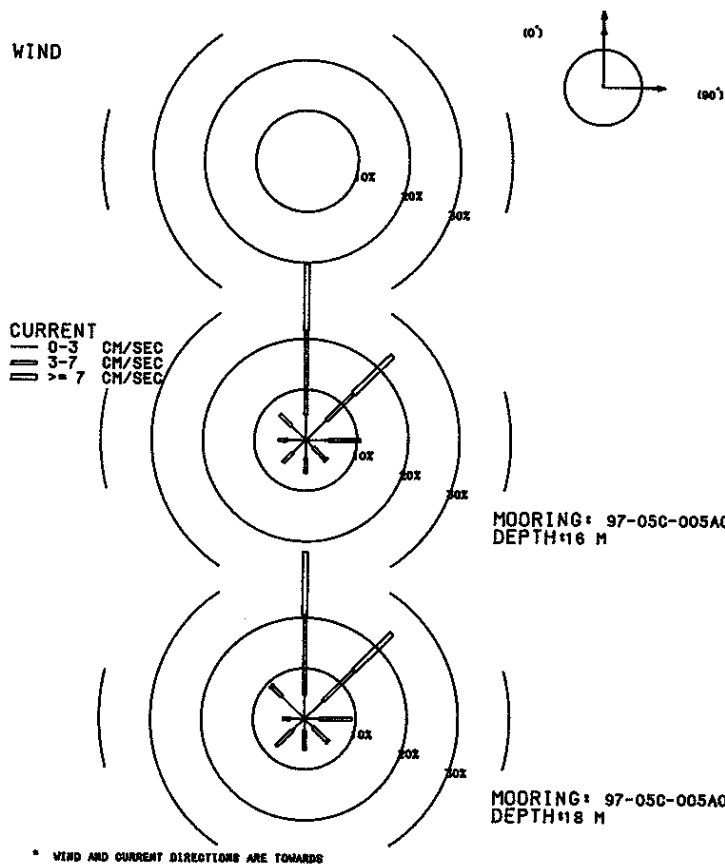

MOORING IS 97-05C-005A016 DEPTH IS 16 METERS THERE ARE 337 VALUES

FIRST DAY 1998/04/01/0000
 FINAL DAY 1998/04/15/0000

SHORELINE ORIENTATION IN DEGREES TRUE SPECIFIED AS 90

DIRECTION DEG TRUE	PERCENT OBSERVED	TOWARD	TOTAL	LIGHT	MEDIUM	HIGH	MAXIMUM CURRENT CM/S	MEAN DURA- TION HOURS	MEAN EXCUR- SION KM	MEAN CURRENT CM/S	MEAN TEMP DEG C
90.0	10.7	4.5	6.2	0.0	6.6	2.0	0.3	3.6	3.9		
45.0	23.7	5.6	7.4	10.7	23.0	2.1	0.7	8.9	3.9		
0.0	34.7	5.0	16.6	13.1	22.7	2.5	0.7	7.2	3.9		
315.0	7.1	3.9	3.3	0.0	6.5	1.3	0.1	2.9	3.9		
270.0	5.3	3.6	1.8	0.0	6.5	1.3	0.1	2.6	3.9		
225.0	6.2	3.6	2.7	0.0	6.8	1.3	0.1	2.9	3.7		
180.0	6.5	3.6	3.0	0.0	6.7	1.4	0.2	3.3	3.7		
135.0	5.6	2.1	3.3	0.3	7.4	1.3	0.2	3.6	3.8		
0	MEAN SCALAR SPEED = 5.9 CM/S		MEAN SQUARE SPEED = 61.9 CM2/S2								
	MEAN SQUARE E-W SPEED = 12.3 CM2/S2		MEAN SQUARE N-S SPEED = 49.6 CM2/S2								
	MEAN VELOCITY = 4.2 CM/S,		23 DEG TRUE		MEAN TEMPERATURE = 3.9 C						
	VARIANCE (U,V) = 22.3 CM2/S2		TOTAL HOURS = 337.								

PERCENT OBSERVED
 LIGHT (0.0 - 3.0) 31.8% MEDIUM (3.0 - 7.0) 44.2% HIGH (GE 7.0) 24.0%

MOORING IS 97-05C-005A018 DEPTH IS 18 METERS THERE ARE 337 VALUES

FIRST DAY 1998/04/01/0000
 FINAL DAY 1998/04/15/0000

SHORELINE ORIENTATION IN DEGREES TRUE SPECIFIED AS 90

DIRECTION DEG TRUE	PERCENT OBSERVED	TOWARD	TOTAL	LIGHT	MEDIUM	HIGH	MAXIMUM CURRENT CM/S	MEAN DURA- TION HOURS	MEAN EXCUR- SION KM	MEAN CURRENT CM/S	MEAN TEMP DEG C
90.0	9.2	3.0	6.2	0.0	6.2	1.6	0.2	3.6	4.0		
45.0	24.0	5.0	8.6	10.4	22.6	2.5	0.8	8.3	3.9		
0.0	32.9	4.7	15.7	12.5	23.3	3.0	0.8	7.7	3.9		
315.0	9.2	6.2	2.7	0.3	7.1	1.3	0.2	3.2	3.9		
270.0	4.2	2.7	1.5	0.0	4.5	1.1	0.1	2.8	3.8		
225.0	7.7	3.3	4.5	0.0	5.6	1.2	0.1	3.3	3.8		
180.0	6.2	2.4	3.9	0.0	6.2	1.2	0.2	3.6	3.8		
135.0	6.5	2.4	3.9	0.3	8.2	1.4	0.2	3.6	3.8		
0	MEAN SCALAR SPEED = 6.0 CM/S		MEAN SQUARE SPEED = 62.0 CM2/S2								
	MEAN SQUARE E-W SPEED = 12.5 CM2/S2		MEAN SQUARE N-S SPEED = 49.5 CM2/S2								
	MEAN VELOCITY = 4.0 CM/S,		22 DEG TRUE		MEAN TEMPERATURE = 3.9 C						
	VARIANCE (U,V) = 22.9 CM2/S2		TOTAL HOURS = 337.								

PERCENT OBSERVED
 LIGHT (0.0 - 3.0) 29.7% MEDIUM (3.0 - 7.0) 46.9% HIGH (GE 7.0) 23.4%

DATE: 1997/11/02 TO 1997/11/30
 ROSE SUMMARY: WIND AND CURRENT

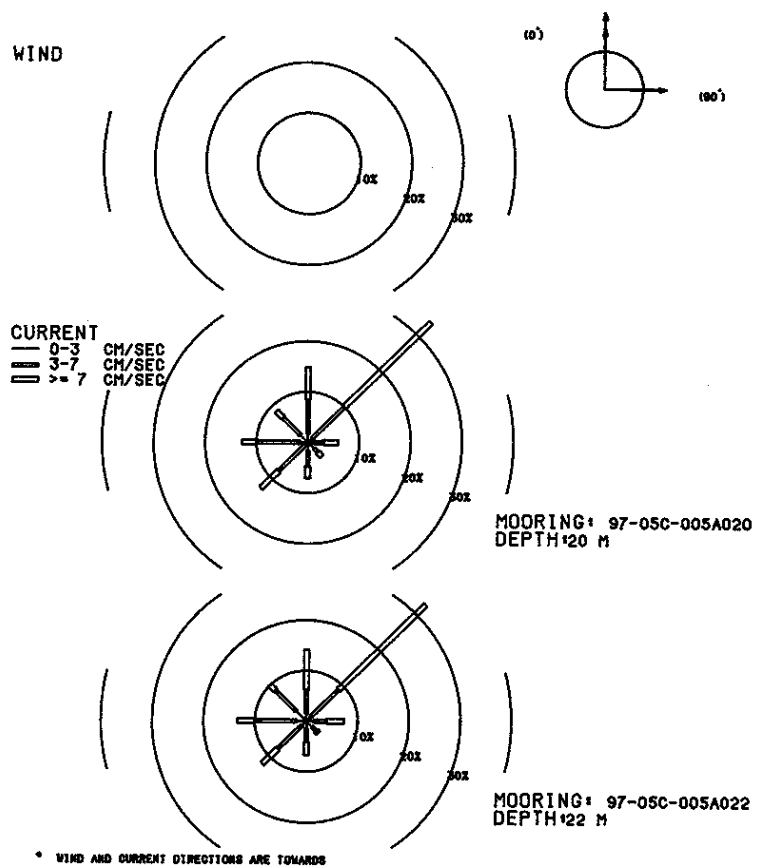

MOORING IS 97-05C-005A020 DEPTH IS 20 METERS THERE ARE 691 VALUES

FIRST DAY 1997/11/02/0500
 FINAL DAY 1997/11/30/2300

SHORELINE ORIENTATION IN DEGREES TRUE SPECIFIED AS 90

DIRECTION DEG TRUE	PERCENT OBSERVED	TOWARD	TOTAL	LIGHT	MEDIUM	HIGH	MAXIMUM CURRENT CM/S	MEAN DURA- TION HOURS	MEAN EXCUR- SION KM	MEAN CURRENT CM/S	MEAN TEMP DEG C
90.0	5.9	1.0	2.0	2.9	12.2	1.5	0.4	6.8	8.8		
45.0	33.7	1.2	8.8	23.7	27.9	4.0	1.5	10.6	8.9		
0.0	14.9	1.7	6.8	6.4	24.9	1.8	0.5	8.1	8.7		
315.0	8.7	2.0	4.8	1.9	12.7	2.0	0.4	5.4	8.2		
270.0	12.9	1.4	8.4	3.0	13.7	2.1	0.4	5.6	8.0		
225.0	12.9	0.6	7.4	4.9	13.1	2.3	0.5	6.3	8.2		
180.0	7.1	1.6	3.2	2.3	18.2	1.8	0.4	6.2	8.4		
135.0	3.9	1.6	1.2	1.2	17.0	1.7	0.3	5.3	8.6		
MEAN SCALAR SPEED = 7.8 CM/S		MEAN SQUARE SPEED = 85.8 CM2/S2									
MEAN SQUARE E-W SPEED = 31.6 CM2/S2		MEAN SQUARE N-S SPEED = 54.3 CM2/S2									
MEAN VELOCITY = 3.4 CM/S,		21 DEG TRUE MEAN TEMPERATURE = 8.6 C									
VARIANCE (U,V) = 37.1 CM2/S2		TOTAL HOURS = 691.									

PERCENT OBSERVED

LIGHT (0.0 - 3.0) 11.1% MEDIUM (3.0 - 7.0) 42.5% HIGH (GE 7.0) 46.3%

MOORING IS 97-05C-005A022 DEPTH IS 22 METERS THERE ARE 691 VALUES

FIRST DAY 1997/11/02/0500
 FINAL DAY 1997/11/30/2300

SHORELINE ORIENTATION IN DEGREES TRUE SPECIFIED AS 90

DIRECTION DEG TRUE	PERCENT OBSERVED	TOWARD	TOTAL	LIGHT	MEDIUM	HIGH	MAXIMUM CURRENT CM/S	MEAN DURA- TION HOURS	MEAN EXCUR- SION KM	MEAN CURRENT CM/S	MEAN TEMP DEG C
90.0	7.4	1.4	2.5	3.5	12.1	1.8	0.4	6.1	8.8		
45.0	32.7	1.0	7.8	23.9	28.4	3.7	1.4	10.8	9.0		
0.0	14.2	1.4	4.8	8.0	23.2	1.8	0.6	8.8	8.7		
315.0	10.1	2.7	5.8	1.6	12.5	1.9	0.3	4.9	8.2		
270.0	13.5	1.9	8.1	3.5	9.9	2.5	0.5	5.6	8.0		
225.0	12.0	1.0	6.7	4.3	12.9	2.8	0.6	6.1	8.1		
180.0	6.8	1.4	2.7	2.6	17.8	1.7	0.4	6.4	8.4		
135.0	3.3	1.6	1.2	0.6	12.0	1.4	0.2	4.3	8.8		
MEAN SCALAR SPEED = 7.8 CM/S		MEAN SQUARE SPEED = 84.9 CM2/S2									
MEAN SQUARE E-W SPEED = 30.8 CM2/S2		MEAN SQUARE N-S SPEED = 54.1 CM2/S2									
MEAN VELOCITY = 3.5 CM/S,		20 DEG TRUE MEAN TEMPERATURE = 8.6 C									
VARIANCE (U,V) = 36.4 CM2/S2		TOTAL HOURS = 691.									

PERCENT OBSERVED

LIGHT (0.0 - 3.0) 12.6% MEDIUM (3.0 - 7.0) 39.5% HIGH (GE 7.0) 47.9%

DATE: 1997/12/01 TO 1997/12/31
ROSE SUMMARY: WIND AND CURRENT

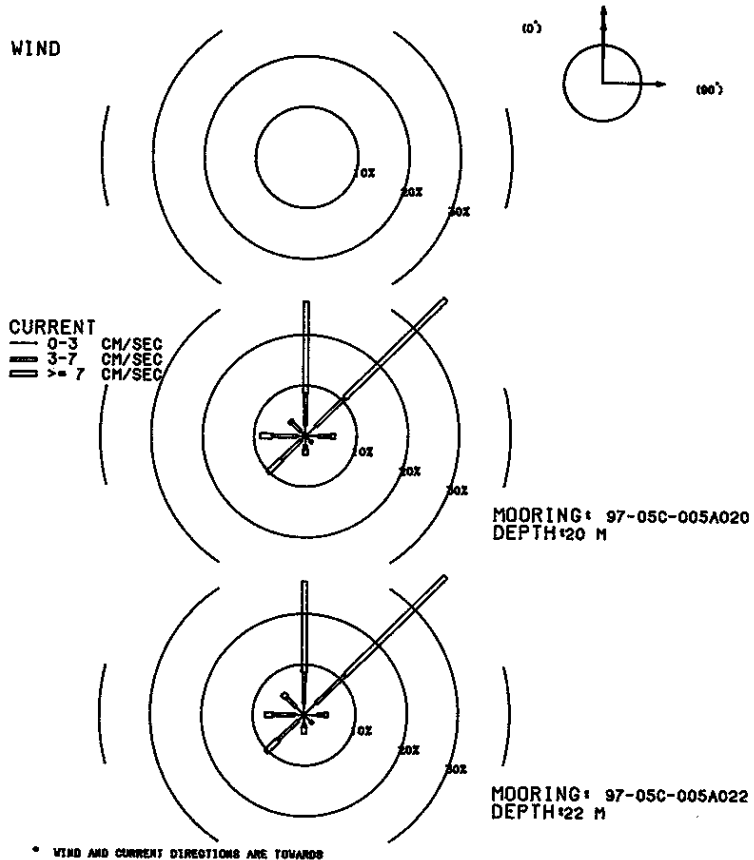

MOORING IS 97-05C-005A020 DEPTH IS 20 METERS THERE ARE 744 VALUES

FIRST DAY 1997/12/01/0000
FINAL DAY 1997/12/31/2300

SHORELINE ORIENTATION IN DEGREES TRUE SPECIFIED AS 90

DIRECTION DEG TRUE	PERCENT OBSERVED	MAXIMUM CURRENT	MEAN DURA- TION HOURS	MEAN EXCUR- SION KM	MEAN CURRENT CM/S	MEAN TEMP DEG C
TOWARD	TOTAL	LIGHT	MEDIUM	HIGH	CM/S	
90.0	5.8	2.6	2.3	0.9	12.5	1.5
45.0	38.4	2.7	8.1	27.7	28.9	3.3
0.0	26.6	2.2	6.3	18.1	29.2	2.6
315.0	4.3	1.2	2.6	0.5	11.1	1.7
270.0	8.9	1.6	4.8	2.4	10.1	1.6
225.0	10.3	1.1	5.5	3.8	12.8	1.9
180.0	3.8	1.9	0.8	1.1	17.7	1.4
135.0	1.9	1.3	0.5	0.0	4.8	1.3

MEAN SCALAR SPEED = 8.8 CM/S MEAN SQUARE SPEED = 115.2 CM2/S2
 MEAN SQUARE E-W SPEED = 26.3 CM2/S2 MEAN SQUARE N-S SPEED = 88.9 CM2/S2
 MEAN VELOCITY = 6.0 CM/S, 20 DEG TRUE MEAN TEMPERATURE = 6.0 C
 VARIANCE (U,V) = 39.5 CM2/S2 TOTAL HOURS = 744.

PERCENT OBSERVED
 LIGHT (0.0 - 3.0) 14.5% MEDIUM (3.0 - 7.0) 30.9% HIGH (GE 7.0) 54.6%

MOORING IS 97-05C-005A022 DEPTH IS 22 METERS THERE ARE 744 VALUES

FIRST DAY 1997/12/01/0000
FINAL DAY 1997/12/31/2300

SHORELINE ORIENTATION IN DEGREES TRUE SPECIFIED AS 90

DIRECTION DEG TRUE	PERCENT OBSERVED	MAXIMUM CURRENT	MEAN DURA- TION HOURS	MEAN EXCUR- SION KM	MEAN CURRENT CM/S	MEAN TEMP DEG C
TOWARD	TOTAL	LIGHT	MEDIUM	HIGH	CM/S	
90.0	4.6	2.6	1.3	0.7	9.9	1.3
45.0	38.8	3.2	8.1	27.6	27.6	3.3
0.0	26.3	2.3	6.2	17.9	28.9	2.3
315.0	5.9	2.2	2.7	1.1	11.1	1.7
270.0	7.7	1.9	4.2	1.6	10.8	1.6
225.0	10.5	1.6	5.5	3.4	13.3	1.9
180.0	3.8	1.7	0.7	1.3	16.2	1.2
135.0	2.4	1.7	0.7	0.0	5.3	1.3

MEAN SCALAR SPEED = 8.7 CM/S MEAN SQUARE SPEED = 114.2 CM2/S2
 MEAN SQUARE E-W SPEED = 25.4 CM2/S2 MEAN SQUARE N-S SPEED = 88.8 CM2/S2
 MEAN VELOCITY = 6.0 CM/S, 20 DEG TRUE MEAN TEMPERATURE = 6.0 C
 VARIANCE (U,V) = 39.1 CM2/S2 TOTAL HOURS = 744.

PERCENT OBSERVED
 LIGHT (0.0 - 3.0) 17.2% MEDIUM (3.0 - 7.0) 29.3% HIGH (GE 7.0) 53.5%

DATE: 1998/01/01 TO 1998/01/31
 ROSE SUMMARY: WIND AND CURRENT

WIND

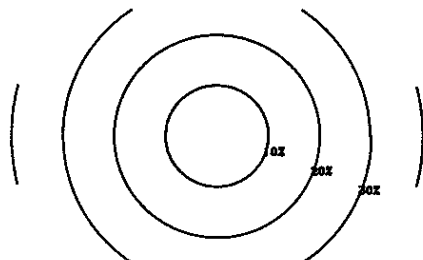

CURRENT
 0-3 CM/SEC
 3-7 CM/SEC
 >= 7 CM/SEC

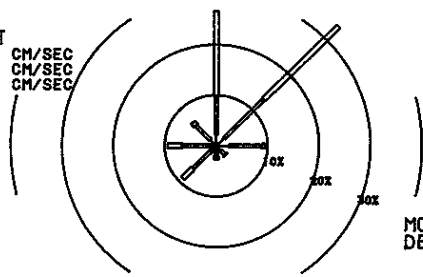

MOORING: 97-05C-005A020
 DEPTH: 20 M

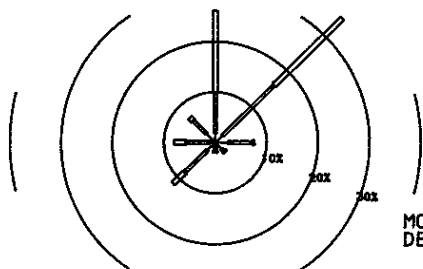

MOORING: 97-05C-005A022
 DEPTH: 22 M

* WIND AND CURRENT DIRECTIONS ARE TOWARDS

MOORING IS 97-05C-005A020 DEPTH IS 20 METERS THERE ARE 744 VALUES

FIRST DAY 1998/01/01/0000
 FINAL DAY 1998/01/31/2300

SHORELINE ORIENTATION IN DEGREES TRUE SPECIFIED AS 90

DIRECTION DEG TRUE	PERCENT OBSERVED	TOWARD	TOTAL	LIGHT	MEDIUM	HIGH	MAXIMUM CURRENT CM/S	MEAN DURATION HOURS	MEAN EXCURSION KM	MEAN CURRENT CM/S	MEAN TEMP DEG C
90.0	9.5	2.4	6.5	0.7	9.1	1.8	0.3	4.4	3.5		
45.0	33.6	2.0	11.0	20.6	45.4	2.8	1.2	11.8	3.8		
0.0	26.6	2.3	7.7	16.7	45.4	2.6	1.1	11.2	3.8		
315.0	6.5	1.6	4.0	0.8	17.4	1.7	0.3	5.0	3.4		
270.0	9.4	0.8	5.8	2.8	17.3	1.6	0.4	6.3	3.4		
225.0	9.1	1.2	5.1	2.8	18.2	1.9	0.5	6.5	3.5		
180.0	2.7	0.8	1.3	0.5	11.3	1.2	0.2	5.0	3.5		
135.0	2.6	1.3	1.1	0.1	7.0	1.0	0.1	2.9	3.5		

MEAN SCALAR SPEED = 9.1 CM/S MEAN SQUARE SPEED = 150.3 CM2/S2
 MEAN SQUARE E-W SPEED = 37.7 CM2/S2 MEAN SQUARE N-S SPEED = 112.6 CM2/S2
 MEAN VELOCITY = 6.2 CM/S, 19 DEG TRUE MEAN TEMPERATURE = 3.7 C
 VARIANCE (U,V) = 56.3 CM2/S2 TOTAL HOURS = 744.

PERCENT OBSERVED
 LIGHT (0.0 - 3.0) 12.5% MEDIUM (3.0 - 7.0) 42.5% HIGH (GE 7.0) 45.0%

MOORING IS 97-05C-005A022 DEPTH IS 22 METERS THERE ARE 744 VALUES

FIRST DAY 1998/01/01/0000
 FINAL DAY 1998/01/31/2300

SHORELINE ORIENTATION IN DEGREES TRUE SPECIFIED AS 90

DIRECTION DEG TRUE	PERCENT OBSERVED	TOWARD	TOTAL	LIGHT	MEDIUM	HIGH	MAXIMUM CURRENT CM/S	MEAN DURATION HOURS	MEAN EXCURSION KM	MEAN CURRENT CM/S	MEAN TEMP DEG C
90.0	7.7	2.4	4.8	0.4	10.6	1.8	0.3	4.1	3.4		
45.0	34.9	2.0	14.1	18.8	44.3	3.0	1.2	11.5	3.8		
0.0	26.1	1.9	8.1	16.1	46.2	2.7	1.1	11.1	3.7		
315.0	7.0	2.4	3.6	0.9	12.5	1.7	0.3	4.3	3.4		
270.0	8.1	1.1	4.6	2.4	19.6	1.7	0.4	6.5	3.5		
225.0	11.6	2.2	6.2	3.2	18.8	2.3	0.5	5.8	3.4		
180.0	2.0	0.8	0.9	0.3	10.1	1.1	0.1	3.8	3.8		
135.0	2.7	1.9	0.5	0.3	8.0	1.1	0.1	3.1	3.7		

MEAN SCALAR SPEED = 8.9 CM/S MEAN SQUARE SPEED = 146.1 CM2/S2
 MEAN SQUARE E-W SPEED = 35.8 CM2/S2 MEAN SQUARE N-S SPEED = 110.4 CM2/S2
 MEAN VELOCITY = 6.0 CM/S, 19 DEG TRUE MEAN TEMPERATURE = 3.7 C
 VARIANCE (U,V) = 55.1 CM2/S2 TOTAL HOURS = 744.

PERCENT OBSERVED
 LIGHT (0.0 - 3.0) 14.7% MEDIUM (3.0 - 7.0) 42.9% HIGH (GE 7.0) 42.5%

DATE: 1998/02/01 TO 1998/02/28
ROSE SUMMARY: WIND AND CURRENT

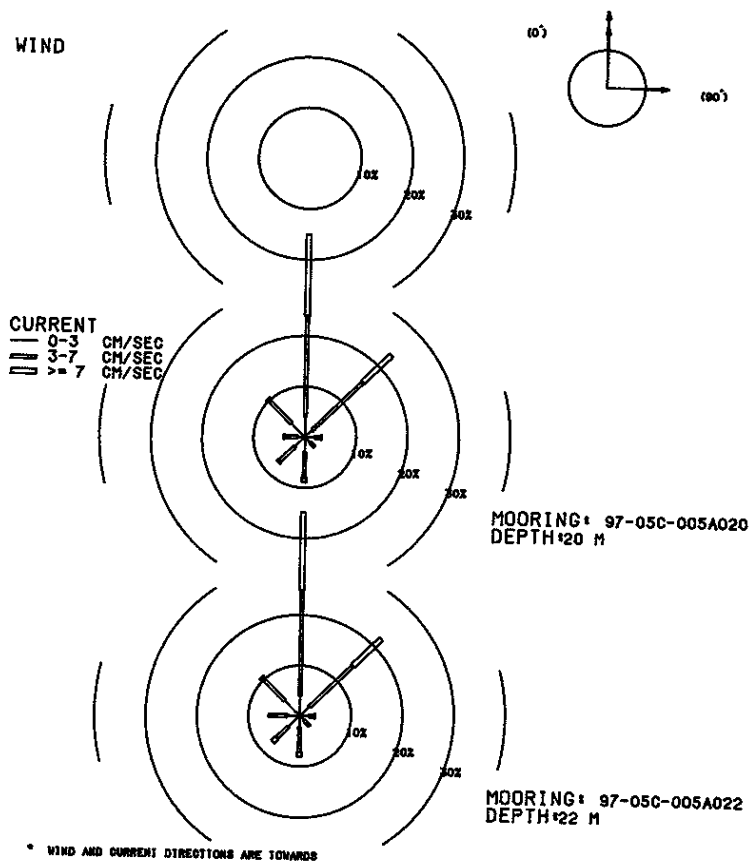

MOORING IS 97-05C-005A020 DEPTH IS 20 METERS THERE ARE 672 VALUES

FIRST DAY 1998/02/01/0000
FINAL DAY 1998/02/28/2300

SHORELINE ORIENTATION IN DEGREES TRUE SPECIFIED AS 90

DIRECTION DEG TRUE	PERCENT OBSERVED	MAXIMUM CURRENT	MEAN DURA- TION HOURS	MEAN EXCUR- SION KM	MEAN CURRENT CM/S	MEAN TEMP DEG C
TOWARD	TOTAL	LIGHT	MEDIUM	HIGH	CM/S	
90.0	3.3	1.8	1.3	0.1	8.4	1.2
45.0	23.4	1.9	13.7	7.7	16.5	2.0
0.0	40.0	4.0	19.9	16.1	15.4	3.2
315.0	10.4	3.9	6.4	0.1	7.5	1.5
270.0	4.2	1.3	2.7	0.1	7.1	1.2
225.0	7.1	2.5	4.3	0.3	7.5	1.5
180.0	8.9	3.0	5.1	0.9	8.1	2.1
135.0	2.7	1.5	1.2	0.0	5.5	1.2
0	MEAN SCALAR SPEED = 5.7 CM/S		MEAN SQUARE SPEED = 42.6 CM ² /S ²			
	MEAN SQUARE E-W SPEED = 7.3 CM ² /S ²		MEAN SQUARE N-S SPEED = 35.3 CM ² /S ²			
	MEAN VELOCITY = 3.7 CM/S,		11 DEG TRUE MEAN TEMPERATURE = 2.6 C			
	VARIANCE (U,V) = 14.5 CM ² /S ²		TOTAL HOURS = 672.			

PERCENT OBSERVED

LIGHT (0.0 - 3.0) 19.9% MEDIUM (3.0 - 7.0) 54.6% HIGH (GE 7.0) 25.4%

MOORING IS 97-05C-005A022 DEPTH IS 22 METERS THERE ARE 672 VALUES

FIRST DAY 1998/02/01/0000
FINAL DAY 1998/02/28/2300

SHORELINE ORIENTATION IN DEGREES TRUE SPECIFIED AS 90

DIRECTION DEG TRUE	PERCENT OBSERVED	MAXIMUM CURRENT	MEAN DURA- TION HOURS	MEAN EXCUR- SION KM	MEAN CURRENT CM/S	MEAN TEMP DEG C
TOWARD	TOTAL	LIGHT	MEDIUM	HIGH	CM/S	
90.0	3.0	1.8	1.0	0.1	7.5	1.2
45.0	22.0	2.5	11.8	7.7	16.2	1.9
0.0	40.2	4.0	20.8	15.3	17.2	2.7
315.0	10.6	4.2	6.2	0.1	7.0	1.5
270.0	6.1	2.4	3.7	0.0	6.5	1.7
225.0	7.3	3.1	3.1	1.0	9.0	1.8
180.0	8.0	2.2	4.9	0.9	9.8	1.8
135.0	2.8	1.2	1.6	0.0	5.4	1.2
0	MEAN SCALAR SPEED = 5.5 CM/S		MEAN SQUARE SPEED = 40.2 CM ² /S ²			
	MEAN SQUARE E-W SPEED = 7.1 CM ² /S ²		MEAN SQUARE N-S SPEED = 33.2 CM ² /S ²			
	MEAN VELOCITY = 3.5 CM/S,		10 DEG TRUE MEAN TEMPERATURE = 2.6 C			
	VARIANCE (U,V) = 14.0 CM ² /S ²		TOTAL HOURS = 672.			

PERCENT OBSERVED

LIGHT (0.0 - 3.0) 21.4% MEDIUM (3.0 - 7.0) 53.3% HIGH (GE 7.0) 25.3%

DATE: 1998/03/01 TO 1998/03/31
 ROSE SUMMARY: WIND AND CURRENT

WIND

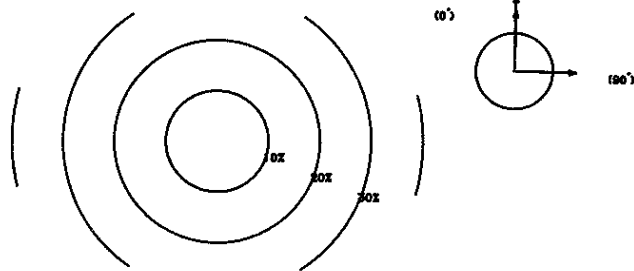

CURRENT

0-3 CM/SEC
 3-7 CM/SEC
 >= 7 CM/SEC

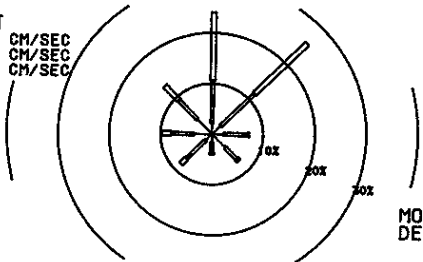

MOORING: 97-05C-005A020
 DEPTH: 20 M

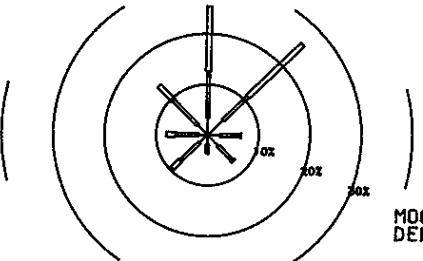

MOORING: 97-05C-005A022
 DEPTH: 22 M

* WIND AND CURRENT DIRECTIONS ARE TOWARDS

MOORING IS 97-05C-005A020 DEPTH IS 20 METERS THERE ARE 744 VALUES

FIRST DAY 1998/03/01/0000
 FINAL DAY 1998/03/31/2300

SHORELINE ORIENTATION IN DEGREES TRUE SPECIFIED AS 90

DIRECTION DEG TRUE	PERCENT OBSERVED	TOWARD	TOTAL	LIGHT	MEDIUM	HIGH	MAXIMUM CURRENT CM/S	MEAN DURA- TION HOURS	MEAN EXCUR- SION KM	MEAN CURRENT CM/S	MEAN TEMP DEG C
90.0	7.3	2.2	4.8	0.3	9.3	1.5	0.2	3.9	2.9		
45.0	25.8	2.3	9.1	14.4	61.0	3.0	1.5	13.7	2.6		
0.0	24.1	2.2	8.5	13.4	34.7	2.6	0.9	9.3	2.6		
315.0	13.2	4.0	5.2	3.9	45.7	2.0	0.6	7.7	2.6		
270.0	9.8	3.5	4.4	1.9	28.6	1.7	0.4	6.3	2.7		
225.0	8.5	1.7	5.2	1.5	32.6	1.9	0.5	6.9	2.7		
180.0	4.0	1.6	2.2	0.3	7.9	1.2	0.2	3.6	2.9		
135.0	7.4	3.5	3.4	0.5	13.7	1.5	0.2	3.5	2.9		
0	MEAN SCALAR SPEED = 8.7 CM/S		MEAN SQUARE SPEED = 159.2 CM2/S2								
	MEAN SQUARE E-W SPEED = 56.4 CM2/S2		MEAN SQUARE N-S SPEED = 102.8 CM2/S2								
	MEAN VELOCITY = 5.1 CM/S,		11 DEG TRUE		MEAN TEMPERATURE = 2.7 C						
	VARIANCE (U,V) = 66.6 CM2/S2		TOTAL HOURS = 744.								

PERCENT OBSERVED
 LIGHT (0.0 - 3.0) 21.0% MEDIUM (3.0 - 7.0) 42.9% HIGH (GE 7.0) 36.2%

MOORING IS 97-05C-005A022 DEPTH IS 22 METERS THERE ARE 744 VALUES

FIRST DAY 1998/03/01/0000
 FINAL DAY 1998/03/31/2300

SHORELINE ORIENTATION IN DEGREES TRUE SPECIFIED AS 90

DIRECTION DEG TRUE	PERCENT OBSERVED	TOWARD	TOTAL	LIGHT	MEDIUM	HIGH	MAXIMUM CURRENT CM/S	MEAN DURA- TION HOURS	MEAN EXCUR- SION KM	MEAN CURRENT CM/S	MEAN TEMP DEG C
90.0	6.6	2.4	4.0	0.1	7.7	1.3	0.2	3.8	2.9		
45.0	25.8	4.2	6.7	14.9	60.5	2.9	1.4	13.5	2.6		
0.0	25.4	3.4	9.3	12.8	37.7	2.7	0.8	8.8	2.6		
315.0	13.6	2.7	6.9	4.0	50.3	2.2	0.6	8.0	2.7		
270.0	8.1	1.7	4.4	1.9	26.7	1.8	0.4	6.9	2.8		
225.0	9.5	2.2	5.1	2.3	30.9	2.4	0.6	7.2	2.7		
180.0	3.8	1.9	1.9	0.0	6.1	1.0	0.1	3.3	2.9		
135.0	7.3	3.1	3.8	0.4	9.2	1.5	0.2	3.7	2.9		
0	MEAN SCALAR SPEED = 8.7 CM/S		MEAN SQUARE SPEED = 159.6 CM2/S2								
	MEAN SQUARE E-W SPEED = 55.9 CM2/S2		MEAN SQUARE N-S SPEED = 103.7 CM2/S2								
	MEAN VELOCITY = 5.1 CM/S,		10 DEG TRUE		MEAN TEMPERATURE = 2.7 C						
	VARIANCE (U,V) = 66.9 CM2/S2		TOTAL HOURS = 744.								

PERCENT OBSERVED
 LIGHT (0.0 - 3.0) 21.5% MEDIUM (3.0 - 7.0) 42.1% HIGH (GE 7.0) 36.4%

DATE: 1998/04/01 TO 1998/04/30
ROSE SUMMARY: WIND AND CURRENT

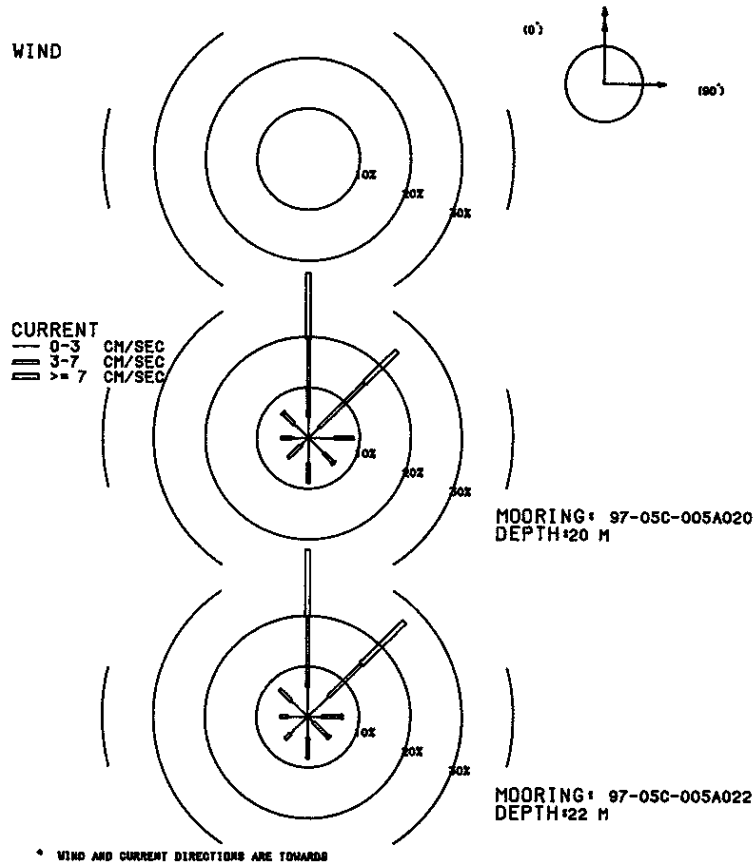

MOORING IS 97-05C-005A020 DEPTH IS 20 METERS THERE ARE 337 VALUES

FIRST DAY 1998/04/01/0000
FINAL DAY 1998/04/15/0000

SHORELINE ORIENTATION IN DEGREES TRUE SPECIFIED AS 90

DIRECTION DEG TRUE	PERCENT OBSERVED				MAXIMUM CURRENT CM/S	MEAN DURA- TION HOURS	MEAN EXCUR- SION KM	MEAN CURRENT CM/S	MEAN TEMP DEG C
TOWARD	TOTAL	LIGHT	MEDIUM	HIGH	CM/S	HOURS	KM	CM/S	DEG C
90.0	8.9	5.0	3.9	0.0	6.7	1.4	0.1	2.9	3.9
45.0	24.3	3.0	12.5	8.9	22.5	2.1	0.6	8.0	3.9
0.0	32.6	4.2	15.4	13.1	22.9	2.9	0.8	8.0	3.9
315.0	7.1	3.9	3.0	0.3	8.1	1.2	0.1	3.2	3.9
270.0	5.3	3.3	2.1	0.0	4.9	1.2	0.1	2.8	3.8
225.0	5.6	2.1	3.6	0.0	6.2	1.1	0.1	3.3	3.7
180.0	8.9	5.0	3.9	0.0	5.3	1.4	0.1	2.8	3.8
135.0	7.1	4.2	2.7	0.3	8.8	1.3	0.2	3.2	3.9
0	MEAN SCALAR SPEED = 5.9 CM/S				MEAN SQUARE SPEED = 61.0 CM2/S2				
	MEAN SQUARE E-W SPEED = 12.0 CM2/S2				MEAN SQUARE N-S SPEED = 49.0 CM2/S2				
	MEAN VELOCITY = 4.1 CM/S,				23 DEG TRUE MEAN TEMPERATURE = 3.9 C				
	VARIANCE (U,V) = 22.3 CM2/S2				TOTAL HOURS = 337.				

PERCENT OBSERVED
LIGHT (0.0 - 3.0) 30.6% MEDIUM (3.0 - 7.0) 46.9% HIGH (GE 7.0) 22.6%

MOORING IS 97-05C-005A022 DEPTH IS 22 METERS THERE ARE 337 VALUES

FIRST DAY 1998/04/01/0000
FINAL DAY 1998/04/15/0000

SHORELINE ORIENTATION IN DEGREES TRUE SPECIFIED AS 90

DIRECTION DEG TRUE	PERCENT OBSERVED				MAXIMUM CURRENT CM/S	MEAN DURA- TION HOURS	MEAN EXCUR- SION KM	MEAN CURRENT CM/S	MEAN TEMP DEG C
TOWARD	TOTAL	LIGHT	MEDIUM	HIGH	CM/S	HOURS	KM	CM/S	DEG C
90.0	6.8	2.7	3.9	0.3	7.1	1.8	0.2	3.8	4.0
45.0	26.7	5.6	9.2	11.9	24.2	2.3	0.7	8.1	3.9
0.0	32.9	5.9	13.9	13.1	23.0	2.6	0.7	7.5	3.9
315.0	7.7	4.5	3.3	0.0	6.2	1.4	0.1	2.9	3.9
270.0	5.3	3.9	1.5	0.0	5.2	1.2	0.1	2.4	3.8
225.0	6.2	4.7	1.5	0.0	5.4	1.2	0.1	2.4	3.8
180.0	8.3	4.2	4.2	0.0	6.9	1.3	0.2	3.2	3.8
135.0	5.9	1.5	4.2	0.3	7.8	1.3	0.2	3.8	3.9
0	MEAN SCALAR SPEED = 5.9 CM/S				MEAN SQUARE SPEED = 62.3 CM2/S2				
	MEAN SQUARE E-W SPEED = 12.0 CM2/S2				MEAN SQUARE N-S SPEED = 50.4 CM2/S2				
	MEAN VELOCITY = 4.2 CM/S,				23 DEG TRUE MEAN TEMPERATURE = 3.9 C				
	VARIANCE (U,V) = 22.5 CM2/S2				TOTAL HOURS = 337.				

PERCENT OBSERVED
LIGHT (0.0 - 3.0) 32.9% MEDIUM (3.0 - 7.0) 41.5% HIGH (GE 7.0) 25.5%

DATE: 1997/11/02 TO 1997/11/30
ROSE SUMMARY: WIND AND CURRENT

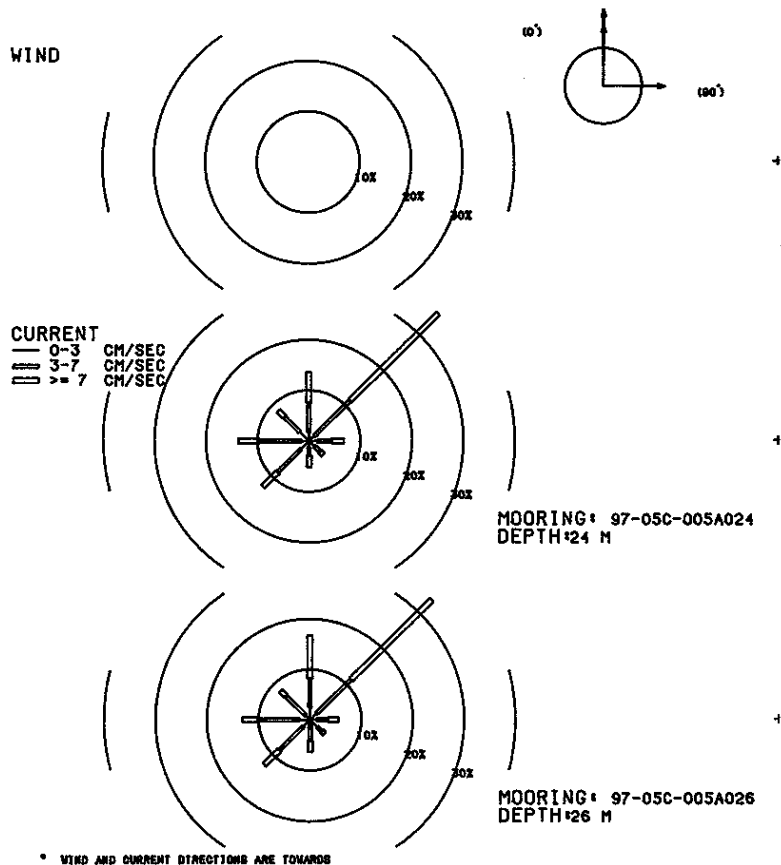

MOORING IS 97-05C-005A024 DEPTH IS 24 METERS THERE ARE 691 VALUES

FIRST DAY 1997/11/02/0500
FINAL DAY 1997/11/30/2300

SHORELINE ORIENTATION IN DEGREES TRUE SPECIFIED AS 90

DIRECTION DEG TRUE	PERCENT OBSERVED	TOWARD	TOTAL	LIGHT	MEDIUM	HIGH	MAXIMUM CURRENT CM/S	MEAN DURATION HOURS	MEAN EXCURSION KM	MEAN CURRENT CM/S	MEAN TEMP DEG C
90.0	6.8	1.6	2.7	2.5	11.6	1.9	0.4	5.5	8.9		
45.0	35.6	1.3	10.0	24.3	27.3	4.5	1.7	10.5	8.9		
0.0	13.6	1.7	5.8	6.1	25.3	1.8	0.5	8.0	8.8		
315.0	8.4	2.5	4.2	1.7	12.8	1.9	0.4	5.0	8.2		
270.0	13.7	1.4	8.2	4.1	13.3	2.4	0.5	5.7	8.0		
225.0	12.7	2.3	6.4	4.1	14.5	2.3	0.5	5.7	8.1		
180.0	5.2	1.3	1.6	2.3	16.5	1.6	0.4	6.4	8.3		
135.0	3.9	1.4	1.6	0.9	16.2	1.8	0.3	4.6	8.8		

MEAN SCALAR SPEED = 7.6 CM/S MEAN SQUARE SPEED = 83.0 CM2/S2
 MEAN SQUARE E-W SPEED = 29.9 CM2/S2 MEAN SQUARE N-S SPEED = 53.1 CM2/S2
 MEAN VELOCITY = 3.5 CM/S, 21 DEG TRUE MEAN TEMPERATURE = 8.6 C
 VARIANCE (U,V) = 35.3 CM2/S2 TOTAL HOURS = 691.

PERCENT OBSERVED
 LIGHT (0.0 - 3.0) 13.6% MEDIUM (3.0 - 7.0) 40.5% HIGH (GE 7.0) 45.9%

MOORING IS 97-05C-005A026 DEPTH IS 26 METERS THERE ARE 691 VALUES

FIRST DAY 1997/11/02/0500
FINAL DAY 1997/11/30/2300

SHORELINE ORIENTATION IN DEGREES TRUE SPECIFIED AS 90

DIRECTION DEG TRUE	PERCENT OBSERVED	TOWARD	TOTAL	LIGHT	MEDIUM	HIGH	MAXIMUM CURRENT CM/S	MEAN DURATION HOURS	MEAN EXCURSION KM	MEAN CURRENT CM/S	MEAN TEMP DEG C
90.0	5.5	1.3	2.2	2.0	11.3	1.2	0.2	5.6	8.7		
45.0	33.6	1.7	9.6	22.3	28.8	3.6	1.3	10.0	9.0		
0.0	16.8	2.5	5.8	8.5	28.5	2.1	0.6	8.6	8.7		
315.0	8.1	1.2	5.5	1.4	12.2	1.7	0.3	5.3	8.0		
270.0	13.2	2.2	8.0	3.0	12.1	2.0	0.4	5.3	8.0		
225.0	12.6	1.7	6.7	4.2	11.6	2.4	0.5	5.9	8.2		
180.0	6.4	0.9	3.3	2.2	13.8	1.7	0.4	5.9	8.3		
135.0	3.9	2.0	1.2	0.7	16.2	1.9	0.3	4.6	8.9		

MEAN SCALAR SPEED = 7.5 CM/S MEAN SQUARE SPEED = 81.4 CM2/S2
 MEAN SQUARE E-W SPEED = 28.1 CM2/S2 MEAN SQUARE N-S SPEED = 53.3 CM2/S2
 MEAN VELOCITY = 3.5 CM/S, 19 DEG TRUE MEAN TEMPERATURE = 8.6 C
 VARIANCE (U,V) = 34.5 CM2/S2 TOTAL HOURS = 691.

PERCENT OBSERVED
 LIGHT (0.0 - 3.0) 13.5% MEDIUM (3.0 - 7.0) 42.1% HIGH (GE 7.0) 44.4%

DATE: 1997/12/01 TO 1997/12/31
 ROSE SUMMARY: WIND AND CURRENT

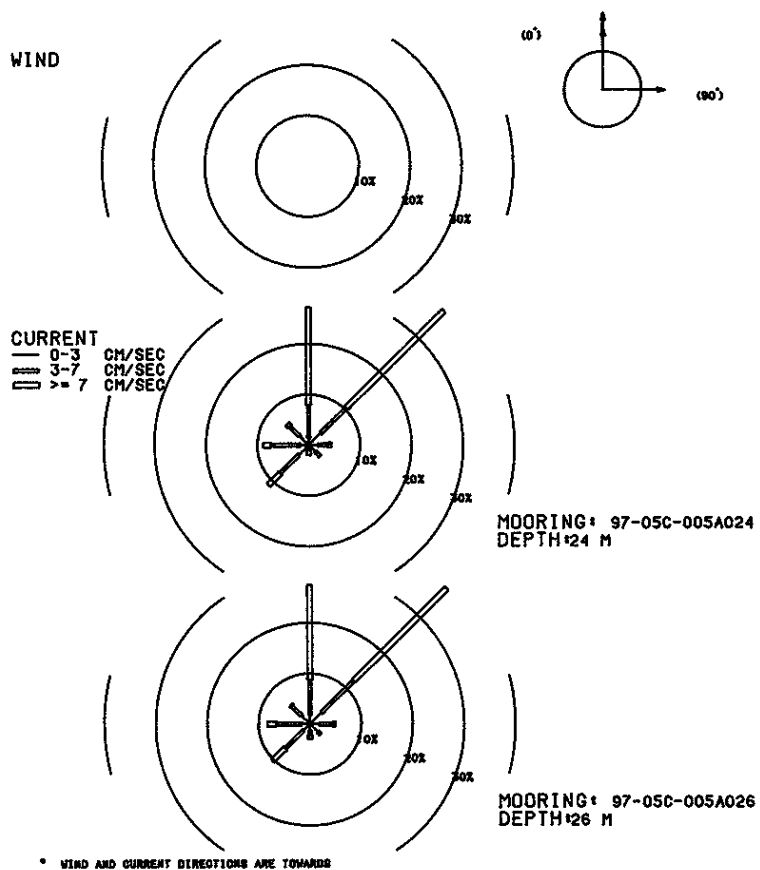

MOORING IS 97-05C-005A024 DEPTH IS 24 METERS THERE ARE 744 VALUES

FIRST DAY 1997/12/01/0000
 FINAL DAY 1997/12/31/2300

SHORELINE ORIENTATION IN DEGREES TRUE SPECIFIED AS 90

DIRECTION DEG TRUE	PERCENT OBSERVED			MAXIMUM CURRENT CM/S	MEAN DURA- TION HOURS	MEAN EXCUR- SION KM	MEAN CURRENT CM/S	MEAN TEMP DEG C
TOWARD	TOTAL	LIGHT	MEDIUM	HIGH	CM/S			
90.0	4.4	1.7	2.0	0.7	11.0	1.3	0.2	5.6
45.0	37.4	3.2	7.1	27.0	28.0	3.5	1.3	5.8
0.0	27.2	1.3	6.6	19.2	29.0	2.8	1.2	6.0
315.0	5.9	2.4	2.8	0.7	11.5	1.8	0.3	6.5
270.0	8.9	1.6	5.8	1.5	10.9	1.9	0.3	6.0
225.0	11.2	2.7	5.1	3.4	14.8	2.1	0.4	6.0
180.0	2.0	0.7	0.3	1.1	15.5	1.2	0.3	6.7
135.0	3.1	1.9	1.2	0.0	5.2	1.3	0.1	5.4
0	MEAN SCALAR SPEED = 8.7 CM/S				MEAN SQUARE SPEED = 113.6 CM2/S2			
	MEAN SQUARE E-W SPEED = 24.7 CM2/S2				MEAN SQUARE N-S SPEED = 88.9 CM2/S2			
	MEAN VELOCITY = 6.0 CM/S,				19 DEG TRUE MEAN TEMPERATURE = 6.0 C			
	VARIANCE (U,V) = 38.8 CM2/S2				TOTAL HOURS = 744.			

PERCENT OBSERVED
 LIGHT (0.0 - 3.0) 15.6% MEDIUM (3.0 - 7.0) 30.9% HIGH (GE 7.0) 53.5%

MOORING IS 97-05C-005A026 DEPTH IS 26 METERS THERE ARE 744 VALUES

FIRST DAY 1997/12/01/0000
 FINAL DAY 1997/12/31/2300

SHORELINE ORIENTATION IN DEGREES TRUE SPECIFIED AS 90

DIRECTION DEG TRUE	PERCENT OBSERVED			MAXIMUM CURRENT CM/S	MEAN DURA- TION HOURS	MEAN EXCUR- SION KM	MEAN CURRENT CM/S	MEAN TEMP DEG C
TOWARD	TOTAL	LIGHT	MEDIUM	HIGH	CM/S			
90.0	5.0	1.7	2.7	0.5	10.9	1.2	0.2	5.5
45.0	37.8	3.1	9.0	25.7	26.9	3.2	1.1	5.9
0.0	27.4	1.7	7.0	18.7	29.1	2.7	1.2	6.0
315.0	5.2	2.3	2.8	0.1	10.0	1.5	0.2	6.5
270.0	8.3	1.6	4.8	1.9	10.1	1.9	0.3	6.0
225.0	10.3	1.7	5.0	3.6	14.4	2.1	0.5	6.1
180.0	3.0	1.2	1.1	0.7	16.3	1.2	0.2	6.2
135.0	3.0	2.2	0.8	0.0	5.1	1.3	0.1	5.3
0	MEAN SCALAR SPEED = 8.6 CM/S				MEAN SQUARE SPEED = 113.2 CM2/S2			
	MEAN SQUARE E-W SPEED = 24.6 CM2/S2				MEAN SQUARE N-S SPEED = 88.5 CM2/S2			
	MEAN VELOCITY = 6.0 CM/S,				19 DEG TRUE MEAN TEMPERATURE = 6.0 C			
	VARIANCE (U,V) = 38.6 CM2/S2				TOTAL HOURS = 744.			

PERCENT OBSERVED
 LIGHT (0.0 - 3.0) 15.6% MEDIUM (3.0 - 7.0) 33.2% HIGH (GE 7.0) 51.2%

DATE: 1998/01/01 TO 1998/01/31
ROSE SUMMARY: WIND AND CURRENT

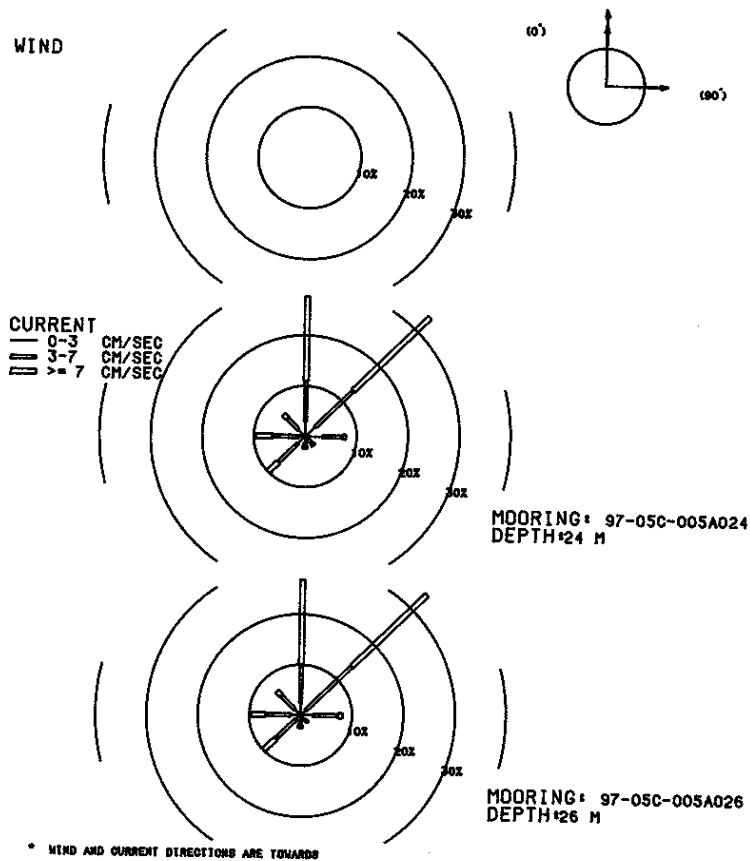

MOORING IS 97-05C-005A024 DEPTH IS 24 METERS THERE ARE 744 VALUES

FIRST DAY 1998/01/01/0000
FINAL DAY 1998/01/31/2300

SHORELINE ORIENTATION IN DEGREES TRUE SPECIFIED AS 90

DIRECTION DEG TRUE	PERCENT OBSERVED	MAXIMUM CURRENT	MEAN DURA- TION HOURS	MEAN EXCUR- SION KM	MEAN CURRENT CM/S	MEAN TEMP DEG C
TOWARD	TOTAL	LIGHT	MEDIUM	HIGH	CM/S	
90.0	7.9	3.4	3.9	0.7	8.0	1.7
45.0	33.9	2.7	10.3	20.8	43.2	3.1
0.0	27.7	3.0	8.1	16.7	44.4	2.5
315.0	6.0	1.9	3.1	1.1	18.9	1.4
270.0	9.5	1.1	5.2	3.2	15.9	1.7
225.0	10.1	2.0	5.2	2.8	17.4	1.9
180.0	2.4	1.3	0.5	0.5	10.9	1.3
135.0	2.4	0.8	1.3	0.3	9.0	1.3
0	MEAN SCALAR SPEED = 9.0 CM/S		MEAN SQUARE SPEED = 148.0 CM2/S2			
	MEAN SQUARE E-W SPEED = 36.8 CM2/S2		MEAN SQUARE N-S SPEED = 111.1 CM2/S2			
	MEAN VELOCITY = 6.1 CM/S,		19 DEG TRUE		MEAN TEMPERATURE = 3.7 C	
	VARIANCE (U,V) = 55.3 CM2/S2		TOTAL HOURS = 744.			

PERCENT OBSERVED

LIGHT (0.0 - 3.0) 16.1% MEDIUM (3.0 - 7.0) 37.8% HIGH (GE 7.0) 46.1%

MOORING IS 97-05C-005A026 DEPTH IS 26 METERS THERE ARE 744 VALUES

FIRST DAY 1998/01/01/0000
FINAL DAY 1998/01/31/2300

SHORELINE ORIENTATION IN DEGREES TRUE SPECIFIED AS 90

DIRECTION DEG TRUE	PERCENT OBSERVED	MAXIMUM CURRENT	MEAN DURA- TION HOURS	MEAN EXCUR- SION KM	MEAN CURRENT CM/S	MEAN TEMP DEG C
TOWARD	TOTAL	LIGHT	MEDIUM	HIGH	CM/S	
90.0	8.2	2.4	4.8	0.9	9.5	1.7
45.0	34.3	1.3	12.5	20.4	42.2	3.5
0.0	26.7	2.4	7.7	16.7	45.6	3.0
315.0	6.6	1.5	3.9	1.2	10.3	1.6
270.0	9.7	1.9	5.0	2.8	20.0	1.8
225.0	9.9	1.2	5.5	3.2	17.2	2.2
180.0	2.6	1.1	0.9	0.5	8.3	1.2
135.0	2.0	1.2	0.8	0.0	4.7	1.2
0	MEAN SCALAR SPEED = 9.0 CM/S		MEAN SQUARE SPEED = 145.9 CM2/S2			
	MEAN SQUARE E-W SPEED = 35.9 CM2/S2		MEAN SQUARE N-S SPEED = 110.0 CM2/S2			
	MEAN VELOCITY = 6.1 CM/S,		18 DEG TRUE		MEAN TEMPERATURE = 3.7 C	
	VARIANCE (U,V) = 54.7 CM2/S2		TOTAL HOURS = 744.			

PERCENT OBSERVED

LIGHT (0.0 - 3.0) 13.0% MEDIUM (3.0 - 7.0) 41.1% HIGH (GE 7.0) 45.8%

DATE: 1998/02/01 TO 1998/02/28
 ROSE SUMMARY: WIND AND CURRENT

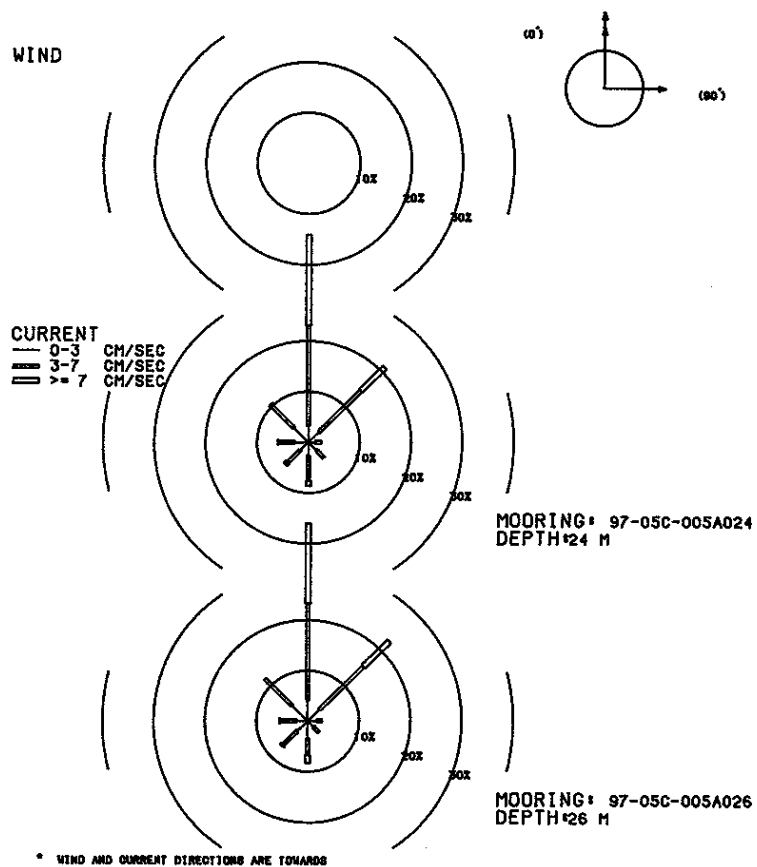

MOORING IS 97-05C-005A024 DEPTH IS 24 METERS THERE ARE 672 VALUES

FIRST DAY 1998/02/01/0000
 FINAL DAY 1998/02/28/2300

SHORELINE ORIENTATION IN DEGREES TRUE SPECIFIED AS 90

DIRECTION DEG TRUE	PERCENT OBSERVED	TOWARD	TOTAL	LIGHT	MEDIUM	HIGH	MAXIMUM CURRENT CM/S	MEAN DURA- TION HOURS	MEAN EXCUR- SION KM	MEAN CURRENT CM/S	MEAN TEMP DEG C
90.0	2.5	1.3	1.2	0.0	4.9	1.1	0.1	3.0	2.6		
45.0	21.0	2.8	11.6	6.5	16.2	1.8	0.4	6.2	2.6		
0.0	40.9	3.3	19.8	17.9	15.8	3.1	0.8	6.9	2.5		
315.0	10.4	4.0	6.2	0.1	7.6	1.7	0.2	3.4	2.7		
270.0	6.0	2.7	3.1	0.1	7.0	1.6	0.2	3.6	2.7		
225.0	6.3	2.2	3.4	0.6	8.7	1.5	0.2	4.0	2.7		
180.0	8.6	2.7	4.9	1.0	8.7	1.9	0.3	4.0	2.5		
135.0	4.3	2.2	2.1	0.0	5.6	1.1	0.1	2.8	2.6		
0 MEAN SCALAR SPEED = 5.5 CM/S MEAN SQUARE SPEED = 39.9 CM2/S2											
MEAN SQUARE E-W SPEED = 6.9 CM2/S2 MEAN SQUARE N-S SPEED = 33.1 CM2/S2											
MEAN VELOCITY = 3.5 CM/S, 11 DEG TRUE MEAN TEMPERATURE = 2.6 C											
VARIANCE (U,V) = 13.8 CM2/S2 TOTAL HOURS = 672.											

PERCENT OBSERVED
 LIGHT (0.0 - 3.0) 21.3% MEDIUM (3.0 - 7.0) 52.4% HIGH (GE 7.0) 26.3%

MOORING IS 97-05C-005A026 DEPTH IS 26 METERS THERE ARE 672 VALUES

FIRST DAY 1998/02/01/0000
 FINAL DAY 1998/02/28/2300

SHORELINE ORIENTATION IN DEGREES TRUE SPECIFIED AS 90

DIRECTION DEG TRUE	PERCENT OBSERVED	TOWARD	TOTAL	LIGHT	MEDIUM	HIGH	MAXIMUM CURRENT CM/S	MEAN DURA- TION HOURS	MEAN EXCUR- SION KM	MEAN CURRENT CM/S	MEAN TEMP DEG C
90.0	2.8	1.8	1.0	0.0	6.4	1.1	0.1	3.0	2.5		
45.0	22.5	3.3	12.1	7.1	16.2	1.9	0.4	6.2	2.5		
0.0	39.0	4.2	19.0	15.8	16.6	2.9	0.7	6.9	2.5		
315.0	11.8	4.3	7.4	0.0	7.0	2.0	0.3	3.7	2.7		
270.0	5.5	2.2	3.1	0.1	7.2	1.6	0.2	3.4	2.7		
225.0	7.0	2.8	3.9	0.3	8.1	1.7	0.2	3.6	2.7		
180.0	8.3	3.4	3.3	1.6	8.7	2.1	0.3	4.2	2.5		
135.0	3.1	1.6	1.5	0.0	5.1	1.3	0.1	3.0	2.7		
0 MEAN SCALAR SPEED = 5.5 CM/S MEAN SQUARE SPEED = 40.9 CM2/S2											
MEAN SQUARE E-W SPEED = 7.0 CM2/S2 MEAN SQUARE N-S SPEED = 33.8 CM2/S2											
MEAN VELOCITY = 3.5 CM/S, 10 DEG TRUE MEAN TEMPERATURE = 2.6 C											
VARIANCE (U,V) = 14.2 CM2/S2 TOTAL HOURS = 672.											

PERCENT OBSERVED
 LIGHT (0.0 - 3.0) 23.7% MEDIUM (3.0 - 7.0) 51.3% HIGH (GE 7.0) 25.0%

DATE: 1998/03/01 TO 1998/03/31
ROSE SUMMARY: WIND AND CURRENT

WIND

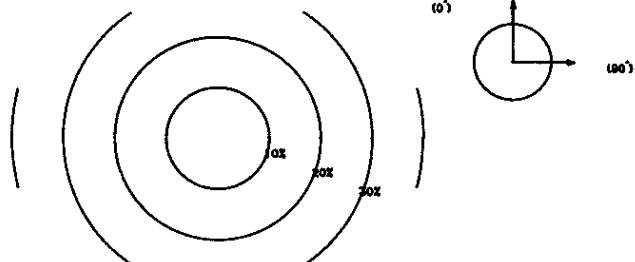

CURRENT
 — 0-3 CM/SEC
 = 3-7 CM/SEC
 ≡ > 7 CM/SEC

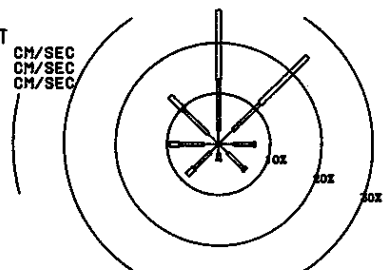

MOORING: 97-05C-005A024
DEPTH: 24 M

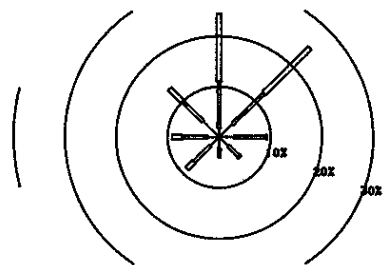

MOORING: 97-05C-005A026
DEPTH: 26 M

* WIND AND CURRENT DIRECTIONS ARE TOWARDS

MOORING IS 97-05C-005A024 DEPTH IS 24 METERS THERE ARE 744 VALUES

FIRST DAY 1998/03/01/0000
FINAL DAY 1998/03/31/2300

SHORELINE ORIENTATION IN DEGREES TRUE SPECIFIED AS 90

DIRECTION DEG TRUE	PERCENT OBSERVED	MAXIMUM CURRENT			MEAN DURA- TION HOURS	MEAN EXCUR- SION KM	MEAN CURRENT CM/S	MEAN TEMP DEG C	
TOWARD	TOTAL	LIGHT	MEDIUM	HIGH	CM/S				
90.0	7.1	3.0	3.8	0.4	8.6	1.6	0.2	3.6	2.8
45.0	24.5	3.9	7.4	13.2	60.3	2.8	1.4	13.5	2.6
0.0	26.5	2.7	10.1	13.7	36.5	2.6	0.9	9.0	2.6
315.0	13.3	2.8	6.7	3.8	47.2	1.9	0.5	7.6	2.7
270.0	9.5	2.8	4.8	1.9	37.0	1.9	0.5	6.6	2.7
225.0	8.6	2.3	4.4	1.9	30.1	2.5	0.6	7.3	2.8
180.0	3.2	1.9	1.2	0.1	7.1	1.3	0.1	3.0	2.8
135.0	7.3	2.6	4.2	0.5	12.1	1.6	0.2	3.9	3.0

MEAN SCALAR SPEED = 8.6 CM/S MEAN SQUARE SPEED = 158.3 CM²/S²
 MEAN SQUARE E-W SPEED = 55.8 CM²/S² MEAN SQUARE N-S SPEED = 102.5 CM²/S²
 MEAN VELOCITY = 5.1 CM/S, 10 DEG TRUE MEAN TEMPERATURE = 2.7 C
 VARIANCE (U,V) = 66.2 CM²/S² TOTAL HOURS = 744.

PERCENT OBSERVED

LIGHT (0.0 - 3.0) 21.9% MEDIUM (3.0 - 7.0) 42.6% HIGH (GE 7.0) 35.5%

MOORING IS 97-05C-005A026 DEPTH IS 26 METERS THERE ARE 744 VALUES

FIRST DAY 1998/03/01/0000
FINAL DAY 1998/03/31/2300

SHORELINE ORIENTATION IN DEGREES TRUE SPECIFIED AS 90

DIRECTION DEG TRUE	PERCENT OBSERVED	MAXIMUM CURRENT			MEAN DURA- TION HOURS	MEAN EXCUR- SION KM	MEAN CURRENT CM/S	MEAN TEMP DEG C	
TOWARD	TOTAL	LIGHT	MEDIUM	HIGH	CM/S				
90.0	9.3	2.8	6.3	0.1	7.8	1.5	0.2	3.6	2.9
45.0	25.0	3.6	8.6	12.8	60.6	3.0	1.5	13.4	2.6
0.0	24.5	1.7	9.3	13.4	38.9	2.5	0.9	9.6	2.6
315.0	13.6	4.4	5.5	3.6	46.7	2.0	0.5	6.9	2.7
270.0	9.1	2.3	4.8	2.0	37.9	2.1	0.5	7.1	2.8
225.0	8.9	2.4	4.4	2.0	29.9	2.4	0.6	7.0	2.7
180.0	4.0	2.2	1.9	0.0	5.4	1.4	0.1	2.7	2.9
135.0	5.6	2.4	3.0	0.3	10.4	1.4	0.2	3.7	2.9

MEAN SCALAR SPEED = 8.5 CM/S MEAN SQUARE SPEED = 159.4 CM²/S²
 MEAN SQUARE E-W SPEED = 56.2 CM²/S² MEAN SQUARE N-S SPEED = 103.1 CM²/S²
 MEAN VELOCITY = 5.1 CM/S, 10 DEG TRUE MEAN TEMPERATURE = 2.7 C
 VARIANCE (U,V) = 66.9 CM²/S² TOTAL HOURS = 744.

PERCENT OBSERVED

LIGHT (0.0 - 3.0) 21.9% MEDIUM (3.0 - 7.0) 43.8% HIGH (GE 7.0) 34.3%

DATE: 1998/04/01 TO 1998/04/30
 ROSE SUMMARY: WIND AND CURRENT

WIND

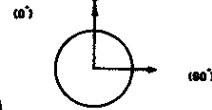
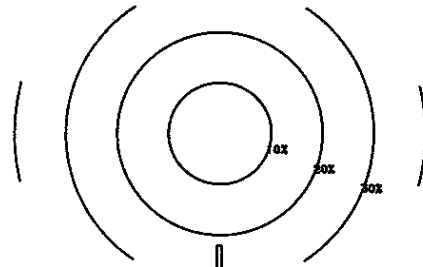

CURRENT
 — 0-3 CM/SEC
 = 3-7 CM/SEC
 = >= 7 CM/SEC

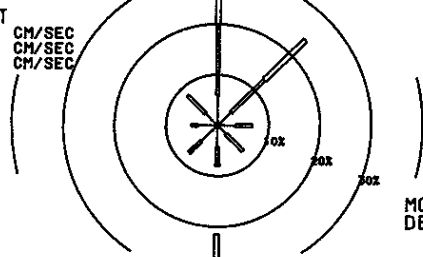

MOORING: 97-05C-005A024
 DEPTH: 24 M

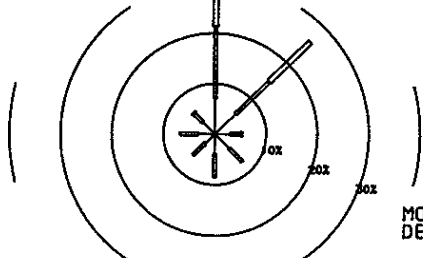

MOORING: 97-05C-005A026
 DEPTH: 26 M

* WIND AND CURRENT DIRECTIONS ARE TOWARDS

MOORING IS 97-05C-005A024 DEPTH IS 24 METERS THERE ARE 337 VALUES

FIRST DAY 1998/04/01/0000
 FINAL DAY 1998/04/15/0000

SHORELINE ORIENTATION IN DEGREES TRUE SPECIFIED AS 90

DIRECTION DEG TRUE	PERCENT OBSERVED	TOWARD	TOTAL	LIGHT	MEDIUM	HIGH	MAXIMUM CURRENT CM/S	MEAN DURA- TION HOURS	MEAN EXCUR- SION KM	MEAN CURRENT CM/S	MEAN TEMP DEG C
90.0	6.8	3.6	3.3	0.0	5.3	1.6	0.2	3.1	3.9		
45.0	24.0	3.6	9.2	11.3	24.2	2.5	0.8	8.5	3.9		
0.0	32.9	5.9	13.9	13.1	25.1	2.8	0.8	7.6	3.9		
315.0	8.3	3.3	5.0	0.0	5.8	1.6	0.2	3.4	3.9		
270.0	5.0	3.9	1.2	0.0	5.2	1.2	0.1	2.2	3.7		
225.0	7.7	4.5	3.3	0.0	4.9	1.6	0.1	2.6	3.8		
180.0	8.0	4.2	3.6	0.3	7.0	1.5	0.2	3.0	3.8		
135.0	7.1	2.4	4.7	0.0	6.1	1.7	0.2	3.4	3.8		

MEAN SCALAR SPEED = 5.9 CM/S MEAN SQUARE SPEED = 62.5 CM2/S2
 MEAN SQUARE E-W SPEED = 12.1 CM2/S2 MEAN SQUARE N-S SPEED = 50.4 CM2/S2
 MEAN VELOCITY = 4.1 CM/S, 22 DEG TRUE MEAN TEMPERATURE = 3.9 C
 VARIANCE (U,V) = 23.0 CM2/S2 TOTAL HOURS = 337.

PERCENT OBSERVED
 LIGHT (0.0 - 3.0) 31.2% MEDIUM (3.0 - 7.0) 44.2% HIGH (GE 7.0) 24.6%

MOORING IS 97-05C-005A026 DEPTH IS 26 METERS THERE ARE 337 VALUES

FIRST DAY 1998/04/01/0000
 FINAL DAY 1998/04/15/0000

SHORELINE ORIENTATION IN DEGREES TRUE SPECIFIED AS 90

DIRECTION DEG TRUE	PERCENT OBSERVED	TOWARD	TOTAL	LIGHT	MEDIUM	HIGH	MAXIMUM CURRENT CM/S	MEAN DURA- TION HOURS	MEAN EXCUR- SION KM	MEAN CURRENT CM/S	MEAN TEMP DEG C
90.0	5.3	3.0	2.1	0.3	7.1	1.6	0.2	3.2	4.0		
45.0	26.1	5.6	9.2	11.3	25.5	2.1	0.6	8.2	3.9		
0.0	33.5	7.1	14.2	12.2	23.3	2.8	0.8	7.4	3.9		
315.0	5.9	3.3	2.4	0.3	7.2	1.4	0.1	2.9	3.9		
270.0	6.8	3.3	3.6	0.0	5.5	1.3	0.1	2.8	3.8		
225.0	5.9	2.7	3.3	0.0	5.4	1.4	0.2	3.1	3.8		
180.0	8.6	3.9	4.7	0.0	6.8	1.6	0.2	3.3	3.7		
135.0	7.7	3.9	3.9	0.0	6.0	1.4	0.2	3.1	4.0		

MEAN SCALAR SPEED = 5.9 CM/S MEAN SQUARE SPEED = 61.6 CM2/S2
 MEAN SQUARE E-W SPEED = 11.5 CM2/S2 MEAN SQUARE N-S SPEED = 50.1 CM2/S2
 MEAN VELOCITY = 4.1 CM/S, 21 DEG TRUE MEAN TEMPERATURE = 3.9 C
 VARIANCE (U,V) = 22.6 CM2/S2 TOTAL HOURS = 337.

PERCENT OBSERVED
 LIGHT (0.0 - 3.0) 32.6% MEDIUM (3.0 - 7.0) 43.3% HIGH (GE 7.0) 24.0%

DATE: 1997/11/02 TO 1997/11/30
ROSE SUMMARY: WIND AND CURRENT

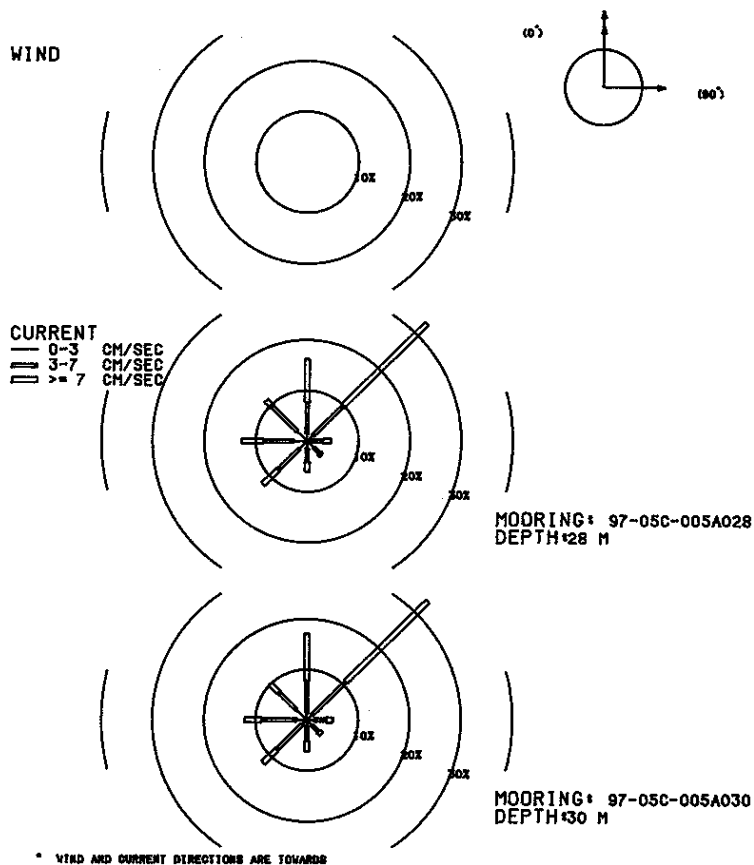

MOORING IS 97-05C-005A028 DEPTH IS 28 METERS THERE ARE 691 VALUES

FIRST DAY 1997/11/02/0500
FINAL DAY 1997/11/30/2300

SHORELINE ORIENTATION IN DEGREES TRUE SPECIFIED AS 90

DIRECTION DEG TRUE	PERCENT OBSERVED	TOWARD	TOTAL	LIGHT	MEDIUM	HIGH	MAXIMUM CURRENT CM/S	MEAN DURA- TION HOURS	MEAN EXCUR- SION KM	MEAN CURRENT CM/S	MEAN TEMP DEG C
90.0	4.6	0.9	2.2	1.6	10.8	1.8	0.4	5.7	8.8		
45.0	33.0	1.4	8.2	23.3	27.8	3.9	1.5	10.5	9.0		
0.0	16.2	1.4	6.2	8.5	23.8	1.8	0.6	8.6	8.8		
315.0	11.3	2.6	6.9	1.7	12.0	2.0	0.4	5.2	8.2		
270.0	12.7	2.6	5.9	4.2	10.1	2.0	0.4	5.7	7.9		
225.0	12.2	2.2	5.8	4.2	12.8	2.3	0.5	5.8	8.1		
180.0	6.1	1.4	2.6	2.0	16.2	2.1	0.5	6.0	8.3		
135.0	3.9	1.9	1.4	0.6	9.9	1.7	0.2	4.0	8.7		
MEAN SCALAR SPEED = 7.7 CM/S		MEAN SQUARE SPEED = 82.6 CM2/S2									
MEAN SQUARE E-W SPEED = 29.1 CM2/S2		MEAN SQUARE N-S SPEED = 53.5 CM2/S2									
MEAN VELOCITY = 3.6 CM/S,		17 DEG TRUE MEAN TEMPERATURE = 8.6 C									
VARIANCE (U,V) = 34.7 CM2/S2		TOTAL HOURS = 691.									

PERCENT OBSERVED

LIGHT (0.0 - 3.0) 14.5% MEDIUM (3.0 - 7.0) 39.4% HIGH (GE 7.0) 46.2%

MOORING IS 97-05C-005A030 DEPTH IS 30 METERS THERE ARE 691 VALUES

FIRST DAY 1997/11/02/0500
FINAL DAY 1997/11/30/2300

SHORELINE ORIENTATION IN DEGREES TRUE SPECIFIED AS 90

DIRECTION DEG TRUE	PERCENT OBSERVED	TOWARD	TOTAL	LIGHT	MEDIUM	HIGH	MAXIMUM CURRENT CM/S	MEAN DURA- TION HOURS	MEAN EXCUR- SION KM	MEAN CURRENT CM/S	MEAN TEMP DEG C
90.0	5.1	1.4	2.3	1.3	11.2	1.5	0.3	4.9	8.6		
45.0	33.3	1.3	9.4	22.6	28.0	3.7	1.3	10.0	9.0		
0.0	17.1	1.4	6.4	9.3	25.6	2.0	0.6	8.8	8.7		
315.0	10.1	2.7	4.9	2.5	11.4	2.0	0.4	5.1	8.2		
270.0	12.2	2.0	6.8	3.3	10.9	2.0	0.4	5.4	7.9		
225.0	12.0	1.2	7.1	3.8	11.9	2.4	0.5	6.1	8.1		
180.0	6.2	1.2	3.0	2.0	13.9	2.0	0.4	5.7	8.4		
135.0	4.1	1.4	1.7	0.9	11.3	1.6	0.3	4.6	8.7		
MEAN SCALAR SPEED = 7.6 CM/S		MEAN SQUARE SPEED = 80.2 CM2/S2									
MEAN SQUARE E-W SPEED = 27.4 CM2/S2		MEAN SQUARE N-S SPEED = 52.8 CM2/S2									
MEAN VELOCITY = 3.6 CM/S,		18 DEG TRUE MEAN TEMPERATURE = 8.6 C									
VARIANCE (U,V) = 33.9 CM2/S2		TOTAL HOURS = 691.									

PERCENT OBSERVED

LIGHT (0.0 - 3.0) 12.7% MEDIUM (3.0 - 7.0) 41.7% HIGH (GE 7.0) 45.6%

DATE: 1997/12/01 TO 1997/12/31
 ROSE SUMMARY: WIND AND CURRENT

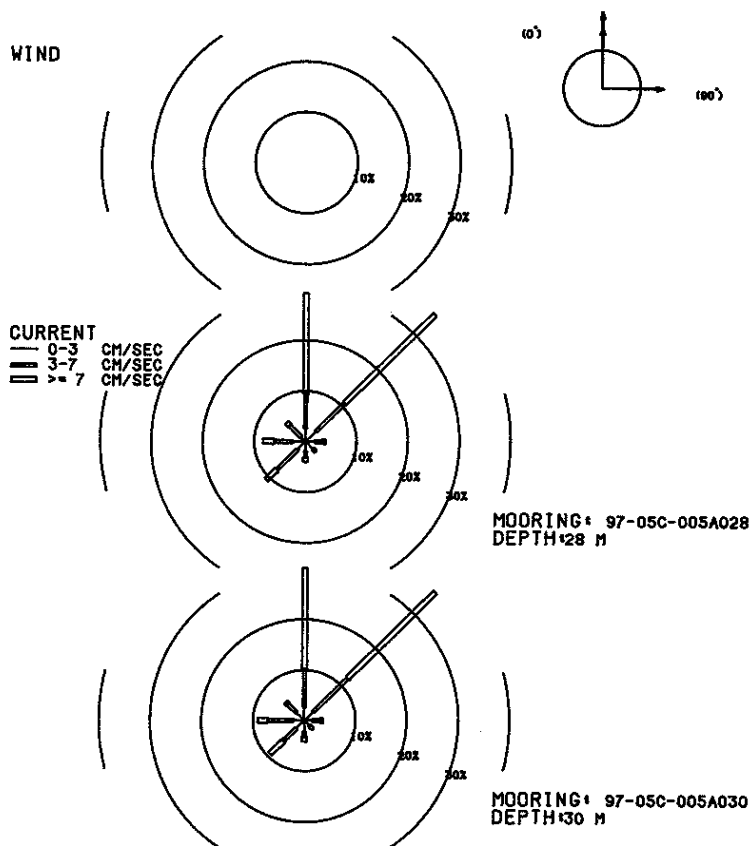

MOORING IS 97-05C-005A028 DEPTH IS 28 METERS THERE ARE 744 VALUES

FIRST DAY 1997/12/01/0000
 FINAL DAY 1997/12/31/2300

SHORELINE ORIENTATION IN DEGREES TRUE SPECIFIED AS 90

DIRECTION DEG TRUE	PERCENT OBSERVED	TOWARD	TOTAL	LIGHT	MEDIUM	HIGH	MAXIMUM CURRENT CM/S	MEAN DURA- TION HOURS	MEAN EXCUR- SION KM	MEAN CURRENT CM/S	MEAN TEMP DEG C
90.0	3.9	1.7	1.6	0.5	9.0	1.1	0.1	3.5	5.6		
45.0	35.6	2.8	7.9	24.9	27.6	3.3	1.2	10.1	5.8		
0.0	29.3	2.6	6.9	19.9	29.4	2.8	1.2	11.7	6.0		
315.0	5.2	1.1	3.4	0.8	10.2	1.6	0.3	4.8	6.6		
270.0	8.3	2.4	3.6	2.3	9.9	1.6	0.3	4.9	6.1		
225.0	10.8	2.2	5.6	3.0	11.9	2.0	0.4	5.7	6.0		
180.0	4.0	1.9	1.2	0.9	15.2	1.5	0.3	4.9	6.3		
135.0	2.8	2.0	0.8	0.0	4.4	1.4	0.1	2.4	5.3		

MEAN SCALAR SPEED = 8.7 CM/S MEAN SQUARE SPEED = 114.7 CM2/S2
 MEAN SQUARE E-W SPEED = 24.3 CM2/S2 MEAN SQUARE N-S SPEED = 90.4 CM2/S2
 MEAN VELOCITY = 6.0 CM/S, 18 DEG TRUE MEAN TEMPERATURE = 6.0 C
 VARIANCE (U,V) = 39.1 CM2/S2 TOTAL HOURS = 744.

PERCENT OBSERVED
 LIGHT (0.0 - 3.0) 16.7% MEDIUM (3.0 - 7.0) 31.0% HIGH (GE 7.0) 52.3%

MOORING IS 97-05C-005A030 DEPTH IS 30 METERS THERE ARE 744 VALUES

FIRST DAY 1997/12/01/0000
 FINAL DAY 1997/12/31/2300

SHORELINE ORIENTATION IN DEGREES TRUE SPECIFIED AS 90

DIRECTION DEG TRUE	PERCENT OBSERVED	TOWARD	TOTAL	LIGHT	MEDIUM	HIGH	MAXIMUM CURRENT CM/S	MEAN DURA- TION HOURS	MEAN EXCUR- SION KM	MEAN CURRENT CM/S	MEAN TEMP DEG C
90.0	3.6	1.6	1.5	0.5	9.4	1.4	0.2	4.2	5.6		
45.0	36.0	2.4	9.4	24.2	29.3	3.0	1.0	9.6	5.8		
0.0	30.1	2.7	7.5	19.9	28.8	2.8	1.2	11.8	6.0		
315.0	5.1	2.2	2.4	0.5	8.9	1.7	0.2	3.9	6.6		
270.0	9.1	2.2	5.0	2.0	12.3	1.8	0.3	5.0	5.9		
225.0	9.4	2.2	3.5	3.8	11.8	1.8	0.4	5.8	6.1		
180.0	4.2	2.2	1.1	0.9	16.6	1.3	0.2	4.7	6.2		
135.0	2.4	1.5	0.9	0.0	4.8	1.4	0.1	2.8	5.5		

MEAN SCALAR SPEED = 8.6 CM/S MEAN SQUARE SPEED = 113.3 CM2/S2
 MEAN SQUARE E-W SPEED = 23.4 CM2/S2 MEAN SQUARE N-S SPEED = 89.8 CM2/S2
 MEAN VELOCITY = 6.0 CM/S, 18 DEG TRUE MEAN TEMPERATURE = 6.0 C
 VARIANCE (U,V) = 38.5 CM2/S2 TOTAL HOURS = 744.

PERCENT OBSERVED
 LIGHT (0.0 - 3.0) 16.8% MEDIUM (3.0 - 7.0) 31.3% HIGH (GE 7.0) 51.9%

DATE: 1998/01/01 TO 1998/01/31
ROSE SUMMARY: WIND AND CURRENT

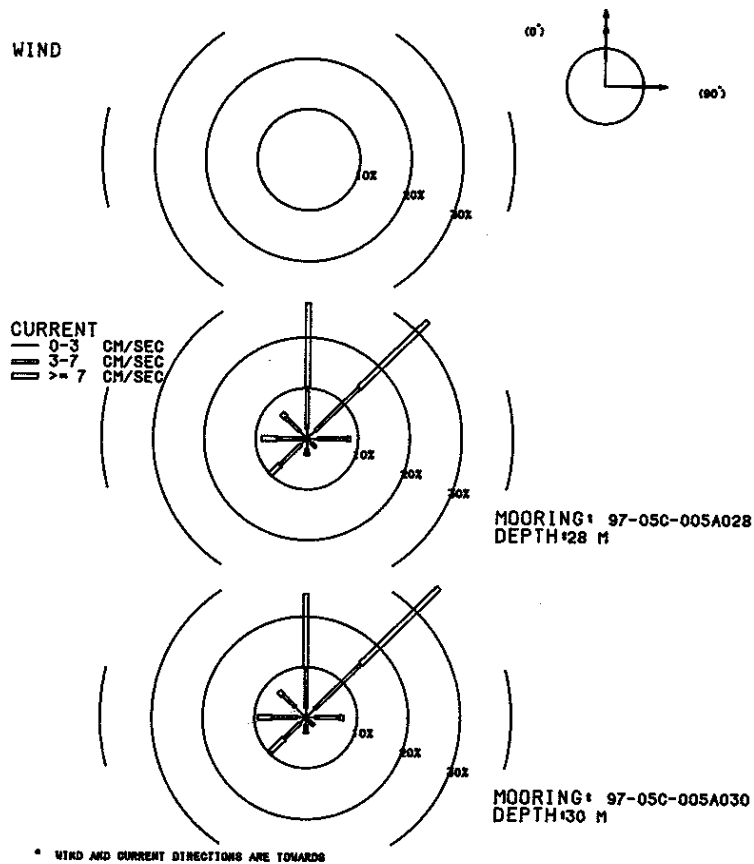

MOORING IS 97-05C-005A028 DEPTH IS 28 METERS THERE ARE 744 VALUES

FIRST DAY 1998/01/01/0000
FINAL DAY 1998/01/31/2300

SHORELINE ORIENTATION IN DEGREES TRUE SPECIFIED AS 90

DIRECTION DEG TRUE	PERCENT OBSERVED	TOWARD	TOTAL	LIGHT	MEDIUM	HIGH	MAXIMUM CURRENT CM/S	MEAN DURA- TION HOURS	MEAN EXCUR- SION KM	MEAN CURRENT CM/S	MEAN TEMP DEG C
90.0	8.5	2.0	5.8	0.7	7.7	1.6	0.2	4.1	3.4		
45.0	33.1	2.3	12.0	18.8	42.6	2.9	1.2	11.2	3.9		
0.0	26.7	2.0	8.2	16.5	43.6	2.6	1.1	11.3	3.8		
315.0	7.0	2.0	3.9	1.1	12.4	2.3	0.4	4.8	3.2		
270.0	8.9	0.9	5.0	3.0	18.0	1.7	0.4	6.3	3.4		
225.0	10.2	1.6	5.8	2.8	15.6	2.1	0.4	5.9	3.5		
180.0	3.2	2.0	0.8	0.4	10.8	1.3	0.2	3.5	3.4		
135.0	2.4	1.2	1.2	0.0	6.7	1.1	0.1	3.5	3.3		

MEAN SCALAR SPEED = 8.8 CM/S MEAN SQUARE SPEED = 141.0 CM²/S²
 MEAN SQUARE E-W SPEED = 34.1 CM²/S² MEAN SQUARE N-S SPEED = 106.9 CM²/S²
 MEAN VELOCITY = 5.9 CM/S, 19 DEG TRUE MEAN TEMPERATURE = 3.7 C
 VARIANCE (U,V) = 53.1 CM²/S² TOTAL HOURS = 744.

PERCENT OBSERVED
 LIGHT (0.0 - 3.0) 14.1% MEDIUM (3.0 - 7.0) 42.6% HIGH (GE 7.0) 43.3%

MOORING IS 97-05C-005A030 DEPTH IS 30 METERS THERE ARE 744 VALUES

FIRST DAY 1998/01/01/0000
FINAL DAY 1998/01/31/2300

SHORELINE ORIENTATION IN DEGREES TRUE SPECIFIED AS 90

DIRECTION DEG TRUE	PERCENT OBSERVED	TOWARD	TOTAL	LIGHT	MEDIUM	HIGH	MAXIMUM CURRENT CM/S	MEAN DURA- TION HOURS	MEAN EXCUR- SION KM	MEAN CURRENT CM/S	MEAN TEMP DEG C
90.0	7.4	1.7	4.8	0.8	9.1	1.5	0.3	4.6	3.6		
45.0	36.6	2.4	12.6	21.5	44.2	3.1	1.3	11.3	3.8		
0.0	24.5	2.0	7.8	14.7	45.4	2.6	1.0	10.9	3.8		
315.0	7.3	3.0	3.2	1.1	12.3	1.9	0.3	4.3	3.2		
270.0	9.3	1.7	4.7	2.8	17.3	1.7	0.4	6.3	3.4		
225.0	9.7	1.5	4.4	3.8	16.6	1.9	0.4	6.3	3.5		
180.0	3.1	1.5	1.5	0.1	9.8	1.2	0.2	3.5	3.2		
135.0	2.3	1.1	1.2	0.0	6.7	1.2	0.1	3.1	3.6		

MEAN SCALAR SPEED = 8.8 CM/S MEAN SQUARE SPEED = 142.3 CM²/S²
 MEAN SQUARE E-W SPEED = 34.6 CM²/S² MEAN SQUARE N-S SPEED = 107.7 CM²/S²
 MEAN VELOCITY = 5.9 CM/S, 19 DEG TRUE MEAN TEMPERATURE = 3.7 C
 VARIANCE (U,V) = 53.5 CM²/S² TOTAL HOURS = 744.

PERCENT OBSERVED
 LIGHT (0.0 - 3.0) 14.9% MEDIUM (3.0 - 7.0) 40.3% HIGH (GE 7.0) 44.8%

DATE: 1998/02/01 TO 1998/02/28
ROSE SUMMARY: WIND AND CURRENT

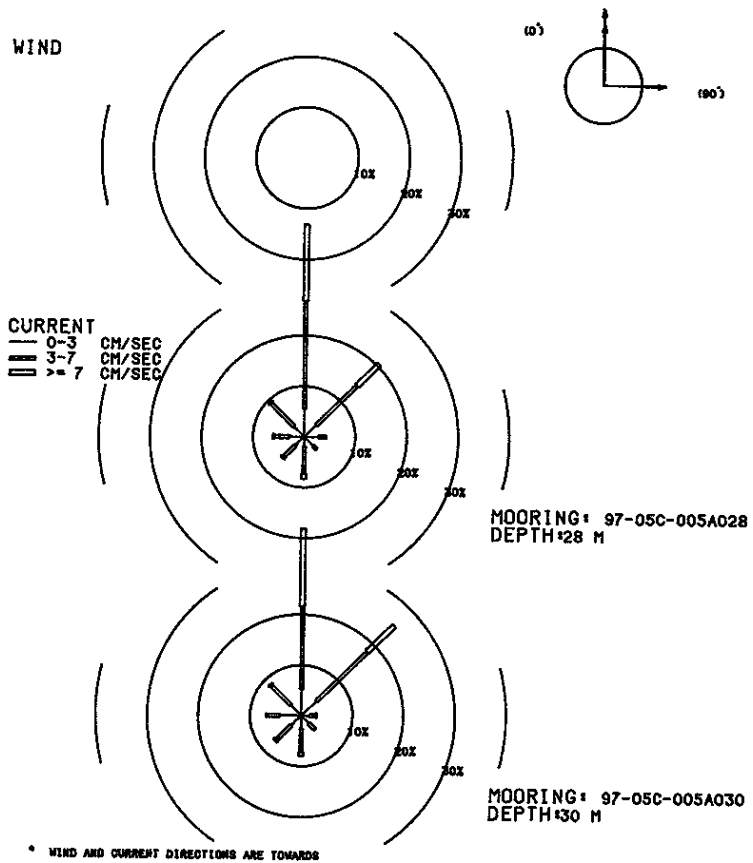

MOORING IS 97-05C-005A028 DEPTH IS 28 METERS THERE ARE 672 VALUES

FIRST DAY 1998/02/01/0000
FINAL DAY 1998/02/28/2300

SHORELINE ORIENTATION IN DEGREES TRUE SPECIFIED AS 90

DIRECTION DEG TRUE	PERCENT OBSERVED	TOWARD	TOTAL	LIGHT	MEDIUM	HIGH	MAXIMUM CURRENT CM/S	MEAN DURA- TION HOURS	MEAN EXCUR- SION KM	MEAN CURRENT CM/S	MEAN TEMP DEG C
90.0	4.3	2.8	1.5	0.0	6.6	1.2	0.1	2.8	2.5		
45.0	20.5	3.3	11.2	6.1	15.4	1.8	0.4	6.2	2.5		
0.0	41.8	5.5	21.3	15.0	16.0	3.1	0.7	6.6	2.5		
315.0	9.5	2.7	6.5	0.3	9.1	1.6	0.2	3.7	2.7		
270.0	6.1	2.8	3.1	0.1	7.7	1.5	0.2	3.4	2.8		
225.0	6.0	2.4	3.3	0.3	8.4	1.7	0.2	3.8	2.6		
180.0	8.3	1.9	5.4	1.0	10.1	2.0	0.3	4.6	2.6		
135.0	3.4	2.5	0.9	0.0	6.6	1.2	0.1	2.6	2.6		
MEAN SCALAR SPEED = 5.4 CM/S		MEAN SQUARE SPEED = 39.3 CM2/S2									
MEAN SQUARE E-W SPEED = 6.8 CM2/S2		MEAN SQUARE N-S SPEED = 32.6 CM2/S2									
MEAN VELOCITY = 3.4 CM/S,		11 DEG TRUE MEAN TEMPERATURE = 2.6 C									
VARIANCE (U,V) = 13.7 CM2/S2		TOTAL HOURS = 672.									

PERCENT OBSERVED
LIGHT (0.0 - 3.0) 24.0% MEDIUM (3.0 - 7.0) 53.1% HIGH (GE 7.0) 22.9%

MOORING IS 97-05C-005A030 DEPTH IS 30 METERS THERE ARE 672 VALUES

FIRST DAY 1998/02/01/0000
FINAL DAY 1998/02/28/2300

SHORELINE ORIENTATION IN DEGREES TRUE SPECIFIED AS 90

DIRECTION DEG TRUE	PERCENT OBSERVED	TOWARD	TOTAL	LIGHT	MEDIUM	HIGH	MAXIMUM CURRENT CM/S	MEAN DURA- TION HOURS	MEAN EXCUR- SION KM	MEAN CURRENT CM/S	MEAN TEMP DEG C
90.0	3.0	1.6	1.2	0.1	7.1	1.0	0.1	3.2	2.5		
45.0	25.4	4.0	14.0	7.4	15.5	1.9	0.4	6.0	2.5		
0.0	36.9	5.2	16.4	15.3	14.8	2.6	0.6	6.5	2.5		
315.0	8.6	2.8	5.5	0.3	7.8	1.7	0.2	3.7	2.7		
270.0	7.0	4.2	2.8	0.0	6.4	1.5	0.2	2.9	2.7		
225.0	7.1	2.7	4.0	0.4	8.8	1.7	0.2	4.0	2.6		
180.0	8.0	2.5	4.8	0.7	8.8	2.1	0.3	4.2	2.6		
135.0	3.9	2.1	1.8	0.0	5.5	1.5	0.2	2.8	2.6		
MEAN SCALAR SPEED = 5.3 CM/S		MEAN SQUARE SPEED = 37.6 CM2/S2									
MEAN SQUARE E-W SPEED = 6.9 CM2/S2		MEAN SQUARE N-S SPEED = 30.8 CM2/S2									
MEAN VELOCITY = 3.3 CM/S,		13 DEG TRUE MEAN TEMPERATURE = 2.6 C									
VARIANCE (U,V) = 13.4 CM2/S2		TOTAL HOURS = 672.									

PERCENT OBSERVED
LIGHT (0.0 - 3.0) 25.1% MEDIUM (3.0 - 7.0) 50.4% HIGH (GE 7.0) 24.4%

DATE: 1998/03/01 TO 1998/03/31
ROSE SUMMARY: WIND AND CURRENT

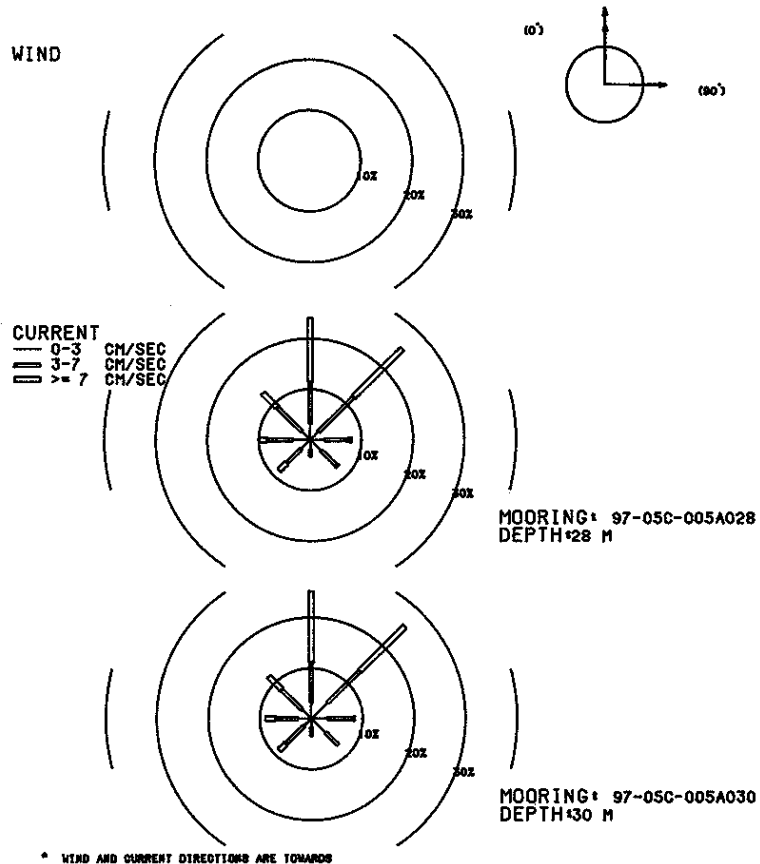

MOORING IS 97-05C-005A028 DEPTH IS 28 METERS THERE ARE 744 VALUES

FIRST DAY 1998/03/01/0000
FINAL DAY 1998/03/31/2300

SHORELINE ORIENTATION IN DEGREES TRUE SPECIFIED AS 90

DIRECTION DEG TRUE	PERCENT OBSERVED	TOWARD	TOTAL	LIGHT	MEDIUM	HIGH	MAXIMUM CURRENT CM/S	MEAN DURATION HOURS	MEAN EXCURSION KM	MEAN CURRENT CM/S	MEAN TEMP DEG C
90.0	8.1	2.7	4.7	0.7	8.5	1.6	0.2	3.9	2.9		
45.0	25.4	2.2	9.8	13.4	60.0	3.4	1.6	13.6	2.6		
0.0	24.1	3.2	8.2	12.6	39.6	2.7	0.9	9.2	2.6		
315.0	13.0	2.3	6.7	4.0	46.4	2.3	0.7	8.3	2.7		
270.0	9.9	3.4	5.0	1.6	27.1	1.8	0.4	6.0	2.7		
225.0	8.6	2.4	4.0	2.2	30.6	2.0	0.5	7.0	2.8		
180.0	3.4	2.0	1.3	0.0	7.0	1.2	0.1	3.2	2.8		
135.0	7.5	3.1	4.0	0.4	11.0	1.6	0.2	3.6	3.0		

MEAN SCALAR SPEED = 8.6 CM/S MEAN SQUARE SPEED = 160.1 CM2/S2
 MEAN SQUARE E-W SPEED = 56.3 CM2/S2 MEAN SQUARE N-S SPEED = 103.8 CM2/S2
 MEAN VELOCITY = 5.1 CM/S, 12 DEG TRUE MEAN TEMPERATURE = 2.7 C
 VARIANCE (U,V) = 66.9 CM2/S2 TOTAL HOURS = 744.

PERCENT OBSERVED
 LIGHT (0.0 - 3.0) 21.2% MEDIUM (3.0 - 7.0) 43.8% HIGH (GE 7.0) 34.9%

MOORING IS 97-05C-005A030 DEPTH IS 30 METERS THERE ARE 744 VALUES

FIRST DAY 1998/03/01/0000
FINAL DAY 1998/03/31/2300

SHORELINE ORIENTATION IN DEGREES TRUE SPECIFIED AS 90

DIRECTION DEG TRUE	PERCENT OBSERVED	TOWARD	TOTAL	LIGHT	MEDIUM	HIGH	MAXIMUM CURRENT CM/S	MEAN DURATION HOURS	MEAN EXCURSION KM	MEAN CURRENT CM/S	MEAN TEMP DEG C
90.0	8.5	3.1	5.1	0.3	9.4	1.3	0.2	3.8	2.9		
45.0	25.8	4.4	8.9	12.5	60.5	3.2	1.5	13.0	2.6		
0.0	25.1	3.2	7.9	14.0	41.7	2.9	1.0	9.4	2.6		
315.0	11.8	2.6	5.6	3.6	45.4	1.9	0.5	7.7	2.7		
270.0	9.0	2.6	4.4	2.0	35.3	1.9	0.5	7.1	2.7		
225.0	8.9	2.0	5.0	1.9	29.8	1.9	0.5	7.1	2.7		
180.0	3.5	1.7	1.7	0.0	6.5	1.2	0.1	3.2	3.0		
135.0	7.4	3.9	3.5	0.0	6.4	1.6	0.2	2.8	2.9		

MEAN SCALAR SPEED = 8.5 CM/S MEAN SQUARE SPEED = 160.9 CM2/S2
 MEAN SQUARE E-W SPEED = 56.5 CM2/S2 MEAN SQUARE N-S SPEED = 104.4 CM2/S2
 MEAN VELOCITY = 5.1 CM/S, 11 DEG TRUE MEAN TEMPERATURE = 2.7 C
 VARIANCE (U,V) = 67.7 CM2/S2 TOTAL HOURS = 744.

PERCENT OBSERVED
 LIGHT (0.0 - 3.0) 23.5% MEDIUM (3.0 - 7.0) 42.2% HIGH (GE 7.0) 34.3%

DATE: 1998/04/01 TO 1998/04/30
ROSE SUMMARY: WIND AND CURRENT

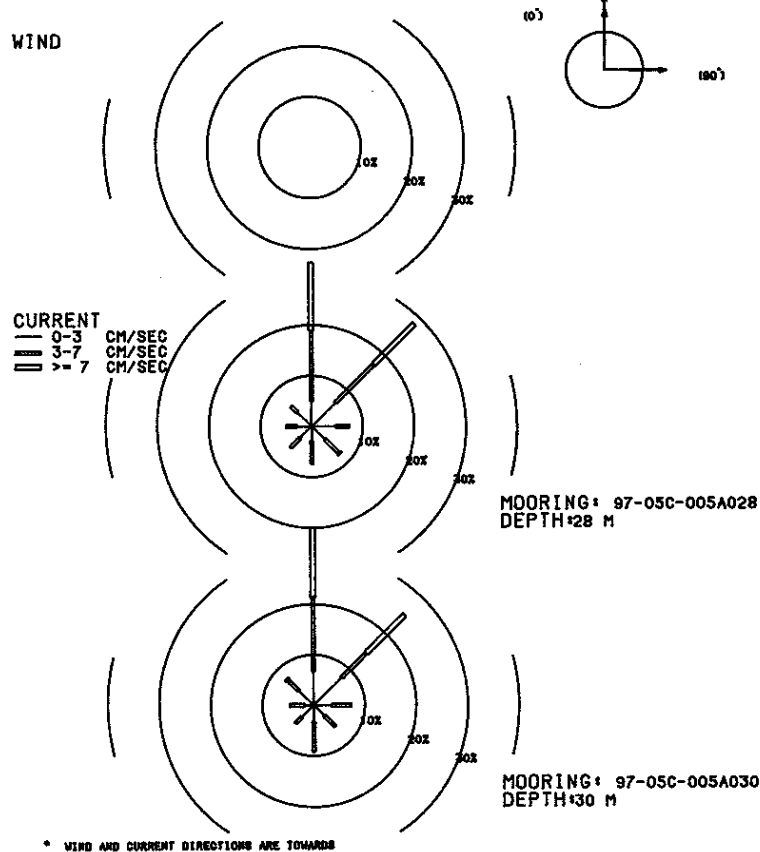

MOORING IS 97-05C-005A028 DEPTH IS 28 METERS THERE ARE 337 VALUES

FIRST DAY 1998/04/01/0000
FINAL DAY 1998/04/15/0000

SHORELINE ORIENTATION IN DEGREES TRUE SPECIFIED AS 90

DIRECTION DEG TRUE	PERCENT OBSERVED	MAXIMUM CURRENT			MEAN DURA- TION HOURS	MEAN EXCUR- SION KM	MEAN CURRENT CM/S	MEAN TEMP DEG C
TOWARD	TOTAL	LIGHT	MEDIUM	HIGH	CM/S			
90.0	7.4	4.7	2.7	0.0	5.9	1.3	0.1	2.9
45.0	28.5	6.5	10.7	11.3	24.4	2.3	0.7	3.9
0.0	32.3	5.0	13.9	13.4	23.1	2.8	0.8	3.9
315.0	5.6	3.9	1.8	0.0	5.3	1.1	0.1	3.9
270.0	5.0	3.0	2.1	0.0	5.3	1.2	0.1	3.8
225.0	5.9	3.3	2.7	0.0	5.7	1.3	0.1	3.8
180.0	7.4	3.0	4.5	0.0	6.7	1.8	0.2	3.8
135.0	7.7	3.6	3.9	0.3	7.3	1.4	0.2	3.9

MEAN SCALAR SPEED = 5.9 CM/S MEAN SQUARE SPEED = 63.1 CM²/S²
 MEAN SQUARE E-W SPEED = 12.1 CM²/S² MEAN SQUARE N-S SPEED = 51.0 CM²/S²
 MEAN VELOCITY = 4.2 CM/S, 24 DEG TRUE MEAN TEMPERATURE = 3.9 C
 VARIANCE (U,V) = 22.6 CM²/S² TOTAL HOURS = 337.

PERCENT OBSERVED
 LIGHT (0.0 - 3.0) 32.9% MEDIUM (3.0 - 7.0) 42.1% HIGH (GE 7.0) 24.9%

MOORING IS 97-05C-005A030 DEPTH IS 30 METERS THERE ARE 337 VALUES

FIRST DAY 1998/04/01/0000
FINAL DAY 1998/04/15/0000

SHORELINE ORIENTATION IN DEGREES TRUE SPECIFIED AS 90

DIRECTION DEG TRUE	PERCENT OBSERVED	MAXIMUM CURRENT			MEAN DURA- TION HOURS	MEAN EXCUR- SION KM	MEAN CURRENT CM/S	MEAN TEMP DEG C
TOWARD	TOTAL	LIGHT	MEDIUM	HIGH	CM/S			
90.0	7.4	3.6	3.9	0.0	6.9	1.5	0.2	4.1
45.0	25.2	7.7	6.8	10.7	23.6	2.4	0.7	3.9
0.0	35.0	6.8	14.5	13.6	22.7	3.1	0.8	3.9
315.0	7.4	4.2	3.0	0.3	7.5	1.3	0.1	3.9
270.0	4.7	1.8	3.0	0.0	4.8	1.1	0.1	3.8
225.0	5.0	3.3	1.8	0.0	4.6	1.2	0.1	3.7
180.0	9.2	3.3	5.9	0.0	6.9	1.8	0.2	3.8
135.0	5.9	3.0	3.0	0.0	6.5	1.2	0.1	3.8

MEAN SCALAR SPEED = 5.9 CM/S MEAN SQUARE SPEED = 61.4 CM²/S²
 MEAN SQUARE E-W SPEED = 10.7 CM²/S² MEAN SQUARE N-S SPEED = 50.7 CM²/S²
 MEAN VELOCITY = 4.2 CM/S, 21 DEG TRUE MEAN TEMPERATURE = 3.9 C
 VARIANCE (U,V) = 22.2 CM²/S² TOTAL HOURS = 337.

PERCENT OBSERVED
 LIGHT (0.0 - 3.0) 33.5% MEDIUM (3.0 - 7.0) 41.8% HIGH (GE 7.0) 24.6%

DATE: 1997/11/02 TO 1997/11/30
ROSE SUMMARY: WIND AND CURRENT

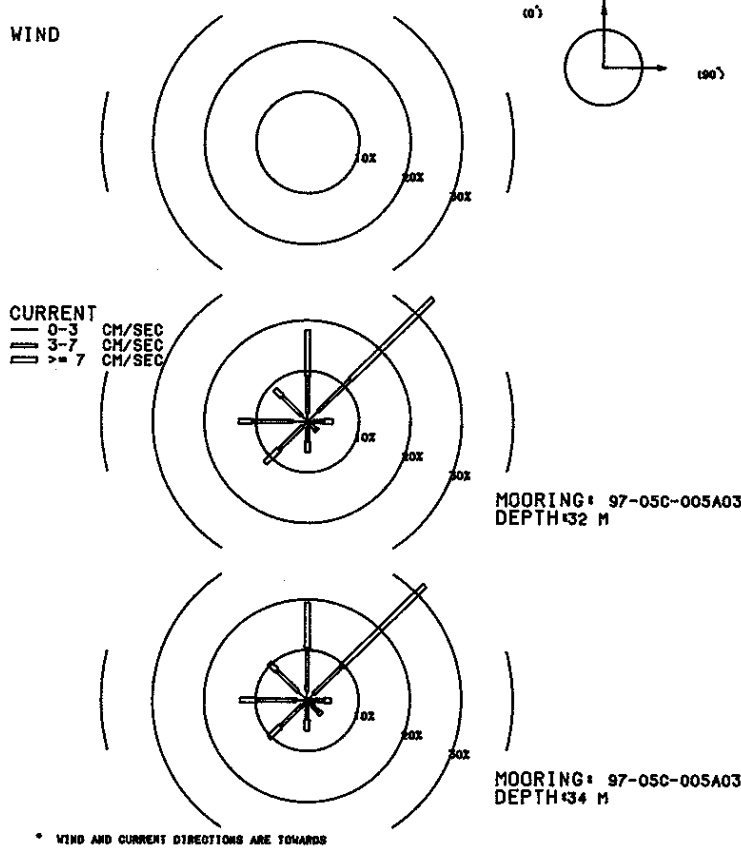

MOORING IS 97-05C-005A032 DEPTH IS 32 METERS THERE ARE 691 VALUES

FIRST DAY 1997/11/02/0500
FINAL DAY 1997/11/30/2300

SHORELINE ORIENTATION IN DEGREES TRUE SPECIFIED AS 90

DIRECTION DEG TRUE	PERCENT OBSERVED	MAXIMUM CURRENT	MEAN DURATION HOURS	MEAN EXCURSION KM	MEAN CURRENT CM/S	MEAN TEMP DEG C
TOWARD	TOTAL	LIGHT	MEDIUM	HIGH	CM/S	
90.0	4.9	1.0	2.2	1.7	11.3	1.7
45.0	34.4	2.9	8.8	22.7	27.2	3.6
0.0	18.1	1.7	7.2	9.1	23.8	2.0
315.0	9.0	1.6	5.4	2.0	12.7	2.0
270.0	13.3	2.9	7.8	2.6	11.8	2.1
225.0	11.6	1.3	6.5	3.8	12.4	2.4
180.0	6.1	1.2	2.7	2.2	12.9	1.7
135.0	2.6	0.6	1.4	0.6	9.4	1.8
0		MEAN SCALAR SPEED = 7.5 CM/S		MEAN SQUARE SPEED = 80.1 CM2/S2		
		MEAN SQUARE E-W SPEED = 27.4 CM2/S2		MEAN SQUARE N-S SPEED = 52.8 CM2/S2		
		MEAN VELOCITY = 3.7 CM/S,		17 DEG TRUE		MEAN TEMPERATURE = 8.6 C
		VARIANCE (U,V) = 33.4 CM2/S2		TOTAL HOURS = 691.		

PERCENT OBSERVED
LIGHT (0.0 - 3.0) 13.2% MEDIUM (3.0 - 7.0) 42.1% HIGH (GE 7.0) 44.7%

MOORING IS 97-05C-005A034 DEPTH IS 34 METERS THERE ARE 691 VALUES

FIRST DAY 1997/11/02/0500
FINAL DAY 1997/11/30/2300

SHORELINE ORIENTATION IN DEGREES TRUE SPECIFIED AS 90

DIRECTION DEG TRUE	PERCENT OBSERVED	MAXIMUM CURRENT	MEAN DURATION HOURS	MEAN EXCURSION KM	MEAN CURRENT CM/S	MEAN TEMP DEG C
TOWARD	TOTAL	LIGHT	MEDIUM	HIGH	CM/S	
90.0	4.6	0.9	2.5	1.3	9.5	1.6
45.0	32.3	1.7	7.8	22.7	26.4	4.1
0.0	19.4	1.9	8.5	9.0	26.2	1.9
315.0	10.4	2.3	6.1	2.0	12.2	1.7
270.0	13.0	2.0	7.7	3.3	11.1	2.2
225.0	10.4	1.3	5.9	3.2	12.9	2.1
180.0	5.9	0.9	2.9	2.2	12.7	2.0
135.0	3.9	1.4	1.7	0.7	10.2	1.9
0		MEAN SCALAR SPEED = 7.5 CM/S		MEAN SQUARE SPEED = 78.4 CM2/S2		
		MEAN SQUARE E-W SPEED = 26.2 CM2/S2		MEAN SQUARE N-S SPEED = 52.2 CM2/S2		
		MEAN VELOCITY = 3.7 CM/S,		15 DEG TRUE		MEAN TEMPERATURE = 8.6 C
		VARIANCE (U,V) = 32.4 CM2/S2		TOTAL HOURS = 691.		

PERCENT OBSERVED
LIGHT (0.0 - 3.0) 12.4% MEDIUM (3.0 - 7.0) 43.1% HIGH (GE 7.0) 44.4%

DATE: 1997/12/01 TO 1997/12/31
ROSE SUMMARY: WIND AND CURRENT

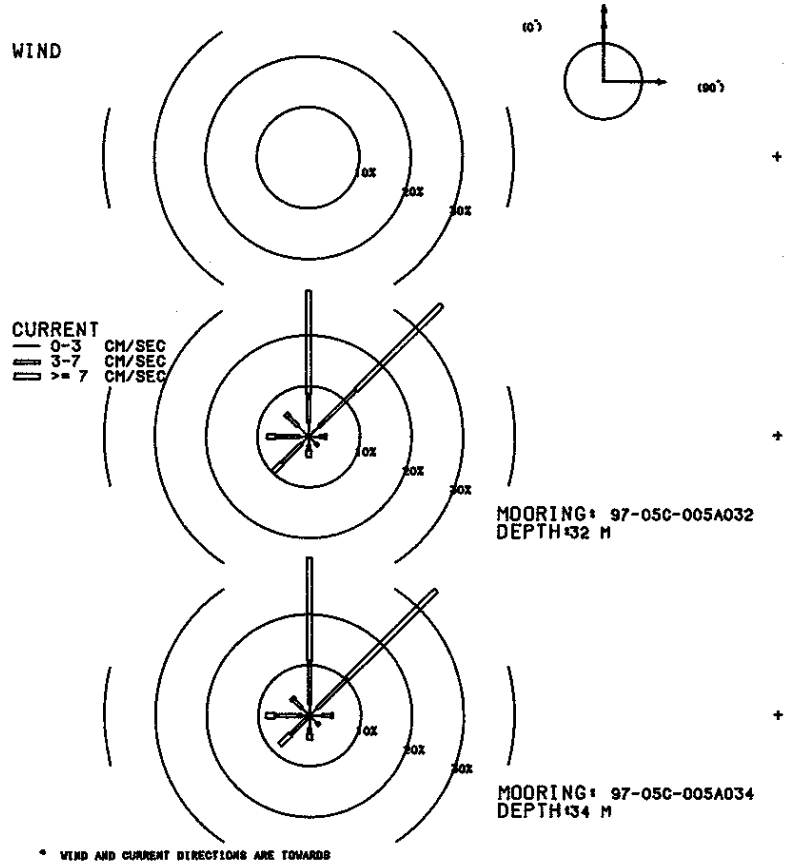

MOORING IS 97-05C-005A032 DEPTH IS 32 METERS THERE ARE 744 VALUES

FIRST DAY 1997/12/01/0000
FINAL DAY 1997/12/31/2300

SHORELINE ORIENTATION IN DEGREES TRUE SPECIFIED AS 90

DIRECTION DEG TRUE	PERCENT OBSERVED	TOWARD	TOTAL	LIGHT	MEDIUM	HIGH	MAXIMUM CURRENT CM/S	MEAN DURA- TION HOURS	MEAN EXCUR- SION KM	MEAN CURRENT CM/S	MEAN TEMP DEG C
90.0	3.5	2.2	0.9	0.4	9.0	1.4	0.2	3.2	5.5		
45.0	36.7	2.8	10.2	23.7	29.6	3.6	1.2	9.4	5.9		
0.0	28.8	2.7	5.8	20.3	28.8	2.9	1.3	12.0	6.0		
315.0	6.3	3.0	2.7	0.7	9.7	2.0	0.3	3.6	6.4		
270.0	8.2	1.9	4.6	1.7	10.5	1.6	0.3	5.2	6.0		
225.0	9.9	2.0	5.4	2.6	11.0	2.1	0.4	5.4	6.0		
180.0	4.0	1.7	0.9	1.3	12.8	1.5	0.3	4.9	6.4		
135.0	2.6	1.9	0.7	0.0	5.5	1.6	0.2	2.7	5.4		
0		MEAN SCALAR SPEED = 8.5 CM/S		MEAN SQUARE SPEED = 111.0 CM2/S2							
		MEAN SQUARE E-W SPEED = 22.7 CM2/S2		MEAN SQUARE N-S SPEED = 88.4 CM2/S2							
		MEAN VELOCITY = 6.0 CM/S,		17 DEG TRUE		MEAN TEMPERATURE = 6.0 C					
		VARIANCE (U,V) = 37.9 CM2/S2		TOTAL HOURS = 744.							

PERCENT OBSERVED
LIGHT (0.0 - 3.0) 18.1% MEDIUM (3.0 - 7.0) 31.2% HIGH (GE 7.0) 50.7%

MOORING IS 97-05C-005A034 DEPTH IS 34 METERS THERE ARE 744 VALUES

FIRST DAY 1997/12/01/0000
FINAL DAY 1997/12/31/2300

SHORELINE ORIENTATION IN DEGREES TRUE SPECIFIED AS 90

DIRECTION DEG TRUE	PERCENT OBSERVED	TOWARD	TOTAL	LIGHT	MEDIUM	HIGH	MAXIMUM CURRENT CM/S	MEAN DURA- TION HOURS	MEAN EXCUR- SION KM	MEAN CURRENT CM/S	MEAN TEMP DEG C
90.0	4.6	2.4	1.7	0.4	9.2	1.4	0.2	3.3	5.7		
45.0	34.9	2.0	8.3	24.6	29.1	3.3	1.2	9.7	5.8		
0.0	31.2	2.2	8.7	20.3	28.4	2.9	1.2	11.5	6.0		
315.0	5.0	2.0	2.4	0.5	8.7	1.6	0.2	4.1	6.5		
270.0	8.6	1.6	5.1	1.9	11.1	2.0	0.4	5.2	6.1		
225.0	8.2	0.8	4.4	3.0	11.3	1.8	0.4	6.3	6.0		
180.0	4.8	2.6	1.1	1.2	14.3	1.4	0.2	4.8	6.1		
135.0	2.7	2.0	0.7	0.0	6.2	1.1	0.1	2.7	5.4		
0		MEAN SCALAR SPEED = 8.6 CM/S		MEAN SQUARE SPEED = 112.3 CM2/S2							
		MEAN SQUARE E-W SPEED = 22.7 CM2/S2		MEAN SQUARE N-S SPEED = 89.6 CM2/S2							
		MEAN VELOCITY = 6.0 CM/S,		18 DEG TRUE		MEAN TEMPERATURE = 6.0 C					
		VARIANCE (U,V) = 38.0 CM2/S2		TOTAL HOURS = 744.							

PERCENT OBSERVED
LIGHT (0.0 - 3.0) 15.6% MEDIUM (3.0 - 7.0) 32.5% HIGH (GE 7.0) 51.9%

DATE: 1998/01/01 TO 1998/01/31
 ROSE SUMMARY: WIND AND CURRENT

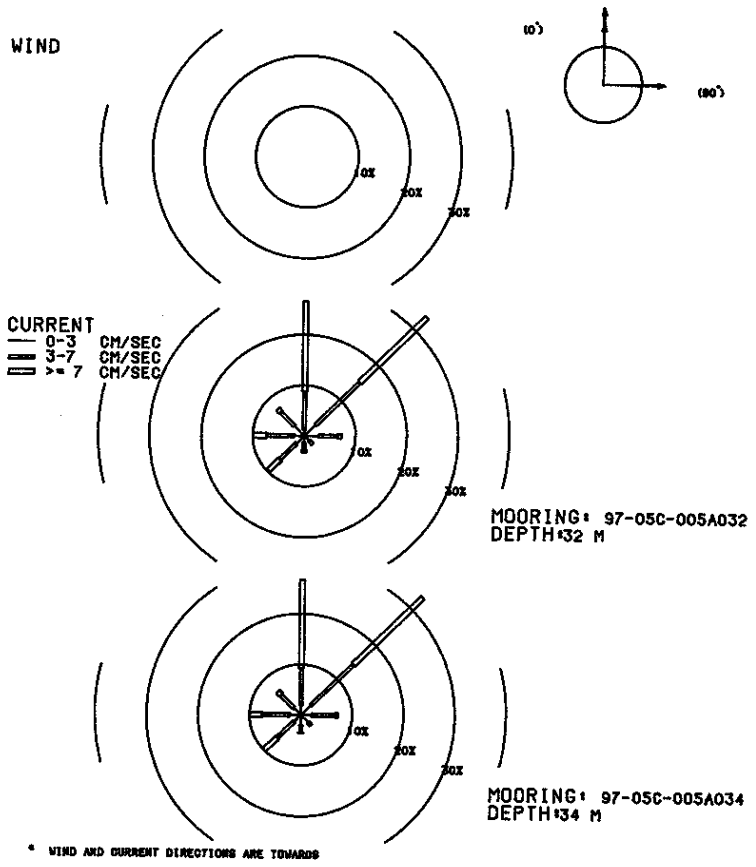

MOORING IS 97-05C-005A032 DEPTH IS 32 METERS THERE ARE 744 VALUES

FIRST DAY 1998/01/01/0000
 FINAL DAY 1998/01/31/2300

SHORELINE ORIENTATION IN DEGREES TRUE SPECIFIED AS 90

DIRECTION DEG TRUE	PERCENT OBSERVED	TOWARD	TOTAL	LIGHT	MEDIUM	HIGH	MAXIMUM CURRENT CM/S	MEAN DURA- TION HOURS	MEAN EXCUR- SION KM	MEAN CURRENT CM/S	MEAN TEMP DEG C
90.0	7.3	2.8	3.8	0.7	8.5	1.8	0.3	4.0	3.6		
45.0	33.5	3.1	12.0	18.4	43.9	3.3	1.3	11.0	3.8		
0.0	26.6	1.1	7.7	17.9	44.8	2.9	1.2	11.8	3.8		
315.0	7.4	2.7	3.9	0.8	10.3	1.8	0.3	4.3	3.3		
270.0	9.9	1.9	5.4	2.7	17.6	1.9	0.4	5.9	3.4		
225.0	9.8	2.2	4.4	3.2	19.3	1.9	0.4	6.2	3.6		
180.0	3.2	1.3	1.5	0.4	9.1	1.3	0.2	3.7	3.2		
135.0	2.3	1.3	0.9	0.0	4.4	1.2	0.1	2.7	3.3		
0		MEAN SCALAR SPEED = 8.8 CM/S		MEAN SQUARE SPEED = 143.3 CM2/S2							
		MEAN SQUARE E-W SPEED = 34.0 CM2/S2		MEAN SQUARE N-S SPEED = 109.3 CM2/S2							
		MEAN VELOCITY = 6.0 CM/S,		18 DEG TRUE		MEAN TEMPERATURE = 3.7 C					
		VARIANCE (U,V) = 53.9 CM2/S2		TOTAL HOURS = 744.							

PERCENT OBSERVED
 LIGHT (0.0 - 3.0) 16.4% MEDIUM (3.0 - 7.0) 39.5% HIGH (GE 7.0) 44.1%

MOORING IS 97-05C-005A034 DEPTH IS 34 METERS THERE ARE 744 VALUES

FIRST DAY 1998/01/01/0000
 FINAL DAY 1998/01/31/2300

SHORELINE ORIENTATION IN DEGREES TRUE SPECIFIED AS 90

DIRECTION DEG TRUE	PERCENT OBSERVED	TOWARD	TOTAL	LIGHT	MEDIUM	HIGH	MAXIMUM CURRENT CM/S	MEAN DURA- TION HOURS	MEAN EXCUR- SION KM	MEAN CURRENT CM/S	MEAN TEMP DEG C
90.0	7.3	2.0	4.7	0.5	8.6	1.9	0.3	4.2	3.4		
45.0	33.2	2.7	11.6	19.0	43.1	3.4	1.3	10.8	3.9		
0.0	26.7	1.9	7.4	17.5	44.2	2.8	1.2	11.8	3.8		
315.0	6.5	1.9	3.6	0.9	11.7	1.8	0.3	4.5	3.3		
270.0	9.9	2.2	5.4	2.4	16.5	1.8	0.4	5.5	3.5		
225.0	9.9	1.7	4.7	3.5	17.7	2.1	0.5	6.4	3.5		
180.0	3.6	2.0	1.5	0.1	9.6	1.4	0.2	3.6	3.3		
135.0	2.8	2.0	0.8	0.0	5.5	1.4	0.1	2.6	3.4		
0		MEAN SCALAR SPEED = 8.7 CM/S		MEAN SQUARE SPEED = 140.1 CM2/S2							
		MEAN SQUARE E-W SPEED = 32.8 CM2/S2		MEAN SQUARE N-S SPEED = 107.3 CM2/S2							
		MEAN VELOCITY = 5.8 CM/S,		18 DEG TRUE		MEAN TEMPERATURE = 3.7 C					
		VARIANCE (U,V) = 53.1 CM2/S2		TOTAL HOURS = 744.							

PERCENT OBSERVED
 LIGHT (0.0 - 3.0) 16.4% MEDIUM (3.0 - 7.0) 39.7% HIGH (GE 7.0) 44.0%

DATE: 1998/02/01 TO 1998/02/28
 ROSE SUMMARY: WIND AND CURRENT

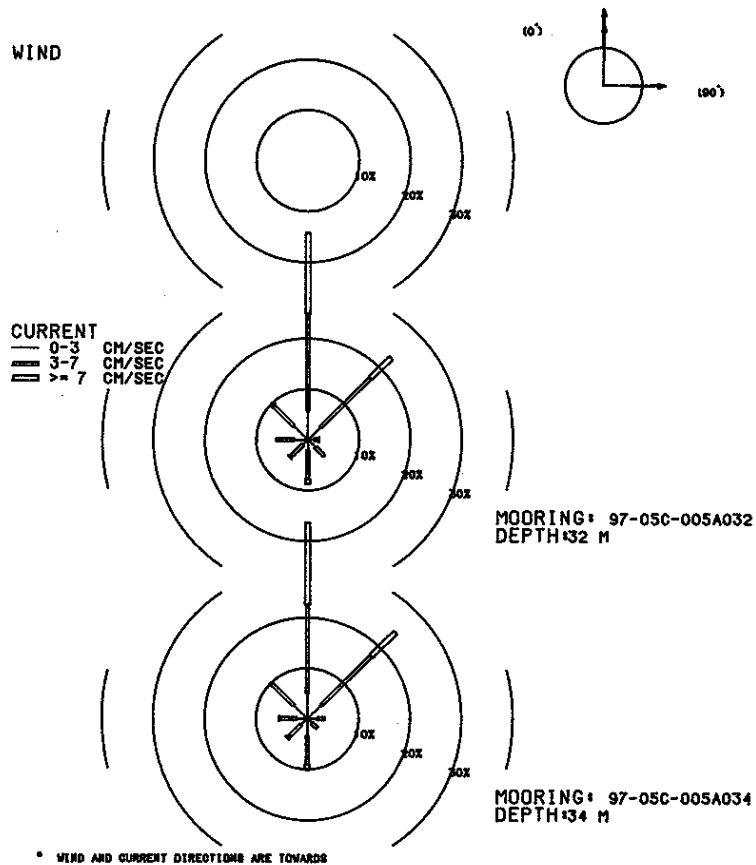

MOORING IS 97-05C-005A032 DEPTH IS 32 METERS THERE ARE 672 VALUES

FIRST DAY 1998/02/01/0000
 FINAL DAY 1998/02/28/2300

SHORELINE ORIENTATION IN DEGREES TRUE SPECIFIED AS 90

DIRECTION DEG TRUE	PERCENT OBSERVED	TOWARD	TOTAL	LIGHT	MEDIUM	HIGH	MAXIMUM CURRENT CM/S	MEAN DURA- TION HOURS	MEAN EXCUR- SION KM	MEAN CURRENT CM/S	MEAN TEMP DEG C
90.0	2.2	1.3	0.7	0.1	9.7	1.0	0.1	3.3	2.6		
45.0	22.9	3.4	13.8	5.7	13.3	1.9	0.4	5.6	2.5		
0.0	40.8	5.7	19.2	15.9	15.4	3.2	0.8	6.6	2.5		
315.0	9.5	3.7	5.7	0.1	8.9	1.7	0.2	3.6	2.7		
270.0	6.2	2.7	3.6	0.0	6.7	1.6	0.2	3.3	2.8		
225.0	4.9	1.3	3.4	0.1	7.7	1.4	0.2	4.1	2.6		
180.0	8.8	2.1	5.7	1.0	8.9	2.3	0.4	4.6	2.6		
135.0	4.6	2.1	2.5	0.0	6.7	1.6	0.2	3.5	2.6		
MEAN SCALAR SPEED = 5.4 CM/S		MEAN SQUARE SPEED = 38.1 CM2/S2									
MEAN SQUARE E-W SPEED = 6.6 CM2/S2		MEAN SQUARE N-S SPEED = 31.5 CM2/S2									
MEAN VELOCITY = 3.3 CM/S,		13 DEG TRUE		MEAN TEMPERATURE = 2.6 C							
VARIANCE (U,V) = 13.5 CM2/S2		TOTAL HOURS = 672.									

PERCENT OBSERVED
 LIGHT (0.0 - 3.0) 22.3% MEDIUM (3.0 - 7.0) 54.6% HIGH (GE 7.0) 23.1%

MOORING IS 97-05C-005A034 DEPTH IS 34 METERS THERE ARE 672 VALUES

FIRST DAY 1998/02/01/0000
 FINAL DAY 1998/02/28/2300

SHORELINE ORIENTATION IN DEGREES TRUE SPECIFIED AS 90

DIRECTION DEG TRUE	PERCENT OBSERVED	TOWARD	TOTAL	LIGHT	MEDIUM	HIGH	MAXIMUM CURRENT CM/S	MEAN DURA- TION HOURS	MEAN EXCUR- SION KM	MEAN CURRENT CM/S	MEAN TEMP DEG C
90.0	3.4	1.9	1.5	0.0	6.8	1.1	0.1	2.8	2.5		
45.0	24.3	3.7	13.8	6.7	16.1	1.7	0.4	5.9	2.6		
0.0	38.7	5.1	17.6	16.1	16.2	2.6	0.6	6.6	2.5		
315.0	9.8	3.7	6.1	0.0	6.2	1.6	0.2	3.4	2.7		
270.0	5.5	2.1	3.3	0.1	8.7	1.5	0.2	3.5	2.8		
225.0	5.5	1.6	3.6	0.3	8.3	1.7	0.3	4.1	2.6		
180.0	10.1	3.4	5.7	1.0	7.9	2.2	0.3	4.1	2.5		
135.0	2.7	1.3	1.3	0.0	5.9	1.2	0.1	3.2	2.5		
MEAN SCALAR SPEED = 5.3 CM/S		MEAN SQUARE SPEED = 38.5 CM2/S2									
MEAN SQUARE E-W SPEED = 7.0 CM2/S2		MEAN SQUARE N-S SPEED = 31.5 CM2/S2									
MEAN VELOCITY = 3.4 CM/S,		14 DEG TRUE		MEAN TEMPERATURE = 2.6 C							
VARIANCE (U,V) = 13.6 CM2/S2		TOTAL HOURS = 672.									

PERCENT OBSERVED
 LIGHT (0.0 - 3.0) 22.9% MEDIUM (3.0 - 7.0) 52.8% HIGH (GE 7.0) 24.3%

DATE: 1998/03/01 TO 1998/03/31
ROSE SUMMARY: WIND AND CURRENT

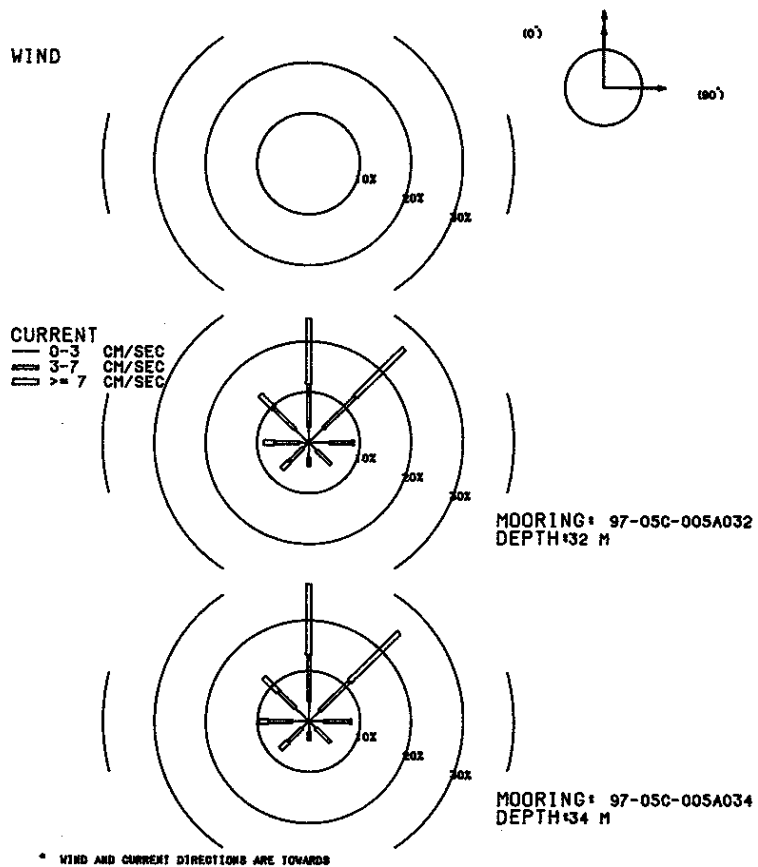

MOORING IS 97-05C-005A032 DEPTH IS 32 METERS THERE ARE 744 VALUES

FIRST DAY 1998/03/01/0000
FINAL DAY 1998/03/31/2300

SHORELINE ORIENTATION IN DEGREES TRUE SPECIFIED AS 90

DIRECTION DEG TRUE	PERCENT OBSERVED	TOWARD	TOTAL	LIGHT	MEDIUM	HIGH	MAXIMUM CURRENT CM/S	MEAN DURA- TION HOURS	MEAN EXCUR- SION KM	MEAN CURRENT CM/S	MEAN TEMP DEG C
90.0	8.9	4.0	4.3	0.5	11.3	1.8	0.2	3.6	2.9		
45.0	26.3	3.9	9.0	13.4	61.2	2.8	1.3	12.9	2.6		
0.0	24.5	3.1	8.5	12.9	38.1	2.7	0.9	9.4	2.6		
315.0	13.3	3.8	5.9	3.6	45.5	2.2	0.6	7.2	2.7		
270.0	8.7	1.9	4.8	2.0	36.0	1.9	0.5	7.3	2.7		
225.0	7.4	1.5	3.9	2.0	28.6	1.9	0.5	7.8	2.8		
180.0	4.7	3.0	1.7	0.0	6.3	1.1	0.1	2.9	2.9		
135.0	6.2	2.2	4.0	0.0	6.9	1.5	0.2	3.7	2.9		

MEAN SCALAR SPEED = 8.5 CM/S MEAN SQUARE SPEED = 160.1 CM²/S²
 MEAN SQUARE E-W SPEED = 56.0 CM²/S² MEAN SQUARE N-S SPEED = 104.0 CM²/S²
 MEAN VELOCITY = 5.1 CM/S, 12 DEG TRUE MEAN TEMPERATURE = 2.7 C
 VARIANCE (U,V) = 66.9 CM²/S² TOTAL HOURS = 744.

PERCENT OBSERVED
 LIGHT (0.0 - 3.0) 23.3% MEDIUM (3.0 - 7.0) 42.2% HIGH (GE 7.0) 34.5%

MOORING IS 97-05C-005A034 DEPTH IS 34 METERS THERE ARE 744 VALUES

FIRST DAY 1998/03/01/0000
FINAL DAY 1998/03/31/2300

SHORELINE ORIENTATION IN DEGREES TRUE SPECIFIED AS 90

DIRECTION DEG TRUE	PERCENT OBSERVED	TOWARD	TOTAL	LIGHT	MEDIUM	HIGH	MAXIMUM CURRENT CM/S	MEAN DURA- TION HOURS	MEAN EXCUR- SION KM	MEAN CURRENT CM/S	MEAN TEMP DEG C
90.0	8.3	2.8	5.2	0.3	7.9	1.3	0.2	3.7	2.8		
45.0	25.0	3.0	8.3	13.7	62.1	3.0	1.5	13.6	2.6		
0.0	27.2	3.9	9.3	14.0	38.9	2.8	0.9	8.8	2.6		
315.0	12.4	3.6	4.7	4.0	47.3	2.1	0.6	7.7	2.7		
270.0	9.7	3.2	4.6	1.9	29.4	1.9	0.5	6.5	2.7		
225.0	7.8	1.9	3.9	2.0	29.1	1.9	0.5	7.6	2.7		
180.0	3.8	2.2	1.6	0.0	5.5	1.2	0.1	2.9	2.9		
135.0	5.9	1.9	4.0	0.0	6.4	1.7	0.2	3.8	3.0		

MEAN SCALAR SPEED = 8.6 CM/S MEAN SQUARE SPEED = 162.4 CM²/S²
 MEAN SQUARE E-W SPEED = 56.5 CM²/S² MEAN SQUARE N-S SPEED = 105.9 CM²/S²
 MEAN VELOCITY = 5.2 CM/S, 11 DEG TRUE MEAN TEMPERATURE = 2.7 C
 VARIANCE (U,V) = 67.9 CM²/S² TOTAL HOURS = 744.

PERCENT OBSERVED
 LIGHT (0.0 - 3.0) 22.4% MEDIUM (3.0 - 7.0) 41.7% HIGH (GE 7.0) 35.9%

DATE: 1998/04/01 TO 1998/04/30
ROSE SUMMARY: WIND AND CURRENT

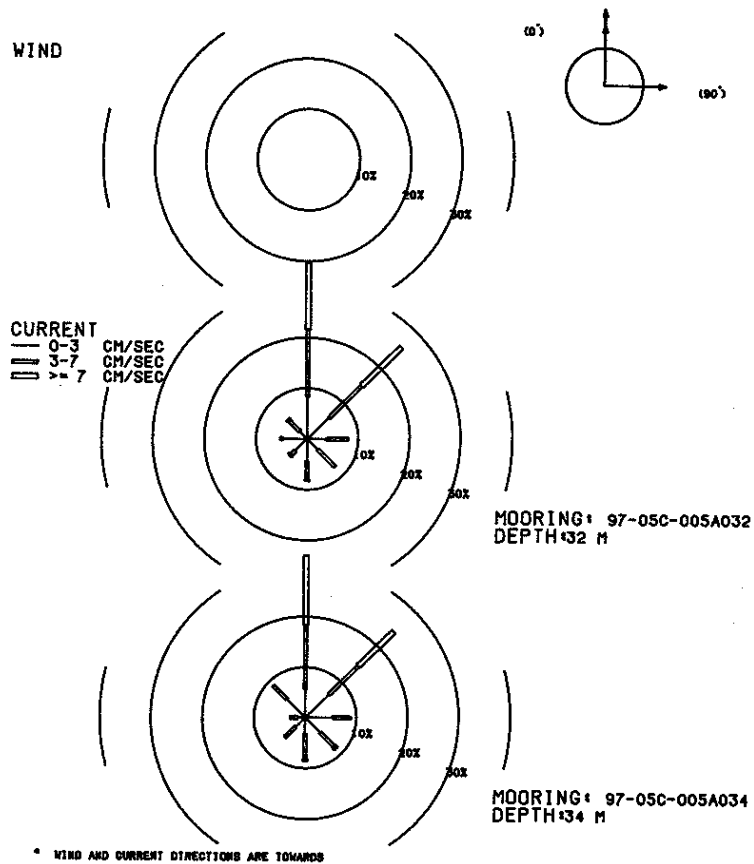

MOORING IS 97-05C-005A032 DEPTH IS 32 METERS THERE ARE 337 VALUES

FIRST DAY 1998/04/01/0000
FINAL DAY 1998/04/15/0000

SHORELINE ORIENTATION IN DEGREES TRUE SPECIFIED AS 90

DIRECTION DEG TRUE	PERCENT OBSERVED	MAXIMUM CURRENT CM/S	MEAN DURA- TION HOURS	MEAN EXCUR- SION KM	MEAN CURRENT CM/S	MEAN TEMP DEG C
TOWARD	TOTAL	LIGHT	MEDIUM	HIGH		
90.0	8.0	3.9	4.2	0.0	5.6	1.4
45.0	25.8	5.9	8.9	11.0	22.5	2.1
0.0	34.7	8.3	13.4	13.1	23.5	3.0
315.0	5.3	2.1	3.0	0.3	7.4	1.3
270.0	5.3	4.7	0.6	0.0	4.5	1.1
225.0	4.7	3.3	1.2	0.3	7.2	1.1
180.0	8.3	4.5	3.6	0.3	7.1	1.5
135.0	7.7	3.0	4.7	0.0	6.7	1.4
MEAN SCALAR SPEED = 5.8 CM/S		MEAN SQUARE SPEED = 60.8 CM ² /S ²				
MEAN SQUARE E-W SPEED = 10.6 CM ² /S ²		MEAN SQUARE N-S SPEED = 50.2 CM ² /S ²				
MEAN VELOCITY = 4.1 CM/S,		23 DEG TRUE		MEAN TEMPERATURE = 3.9 C		
VARIANCE (U,V) = 22.0 CM ² /S ²		TOTAL HOURS = 337.				

PERCENT OBSERVED

LIGHT (0.0 - 3.0) 35.6% MEDIUM (3.0 - 7.0) 39.5% HIGH (GE 7.0) 24.9%

MOORING IS 97-05C-005A034 DEPTH IS 34 METERS THERE ARE 337 VALUES

FIRST DAY 1998/04/01/0000
FINAL DAY 1998/04/15/0000

SHORELINE ORIENTATION IN DEGREES TRUE SPECIFIED AS 90

DIRECTION DEG TRUE	PERCENT OBSERVED	MAXIMUM CURRENT CM/S	MEAN DURA- TION HOURS	MEAN EXCUR- SION KM	MEAN CURRENT CM/S	MEAN TEMP DEG C
TOWARD	TOTAL	LIGHT	MEDIUM	HIGH		
90.0	8.9	5.3	3.6	0.0	5.6	1.6
45.0	24.3	6.5	8.0	9.8	23.5	2.0
0.0	32.0	5.6	12.8	13.6	23.6	2.8
315.0	8.9	5.0	3.9	0.0	5.0	1.5
270.0	3.0	1.5	1.5	0.0	5.0	1.0
225.0	5.6	2.7	3.0	0.0	5.0	1.4
180.0	8.6	3.3	5.0	0.3	7.3	1.6
135.0	8.6	4.2	3.9	0.6	8.3	1.7
MEAN SCALAR SPEED = 5.8 CM/S		MEAN SQUARE SPEED = 62.6 CM ² /S ²				
MEAN SQUARE E-W SPEED = 10.7 CM ² /S ²		MEAN SQUARE N-S SPEED = 51.9 CM ² /S ²				
MEAN VELOCITY = 4.0 CM/S,		24 DEG TRUE		MEAN TEMPERATURE = 3.9 C		
VARIANCE (U,V) = 23.2 CM ² /S ²		TOTAL HOURS = 337.				

PERCENT OBSERVED

LIGHT (0.0 - 3.0) 34.1% MEDIUM (3.0 - 7.0) 41.5% HIGH (GE 7.0) 24.3%

Appendix I - Mooring_CM_1-97. Overall Summary Statistics and Rose Histogram Plots

DATE: 1997/05/21 TO 1998/04/29
ROSE SUMMARY: WIND AND CURRENT

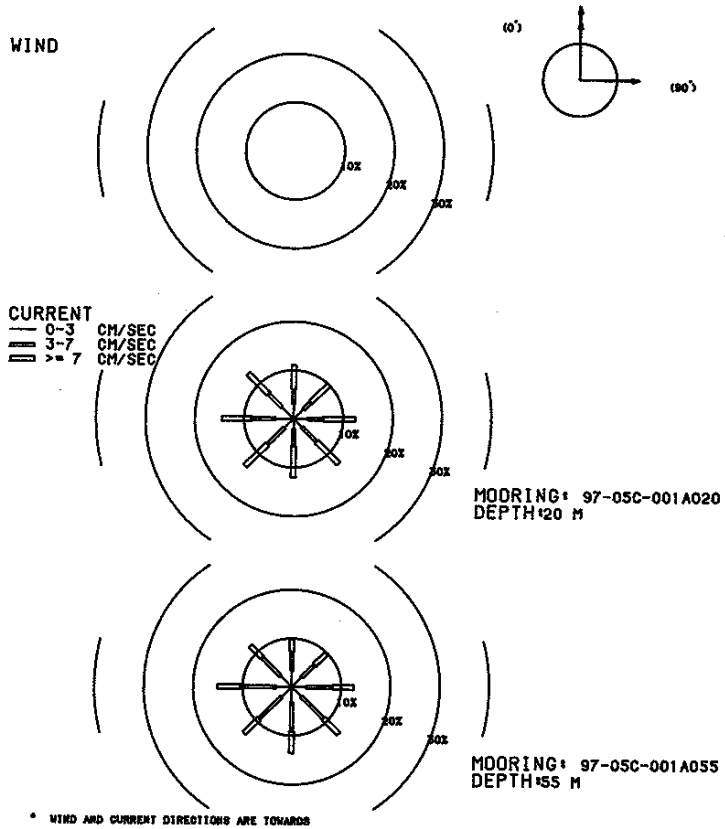

MOORING IS 97-05C-001A020 DEPTH IS 20 METERS THERE ARE 8232 VALUES

FIRST DAY 1997/05/22/0000
FINAL DAY 1998/04/29/2300

SHORELINE ORIENTATION IN DEGREES TRUE SPECIFIED AS 90

DIRECTION DEG TRUE	PERCENT OBSERVED	MAXIMUM CURRENT CM/S	MEAN DURA- TION HOURS	MEAN EXCUR- SION KM	MEAN CURRENT CM/S	MEAN TEMP DEG C
TOWARD	TOTAL	LIGHT	MEDIUM	HIGH	CM/S	DEG C
90.0	12.5	2.8	3.1	6.6	45.3	2.5
45.0	10.0	2.8	2.0	5.2	44.2	2.0
0.0	11.1	3.1	3.0	5.0	41.8	2.0
315.0	13.1	3.4	3.7	6.0	38.8	2.2
270.0	14.5	3.7	4.8	6.0	35.8	2.3
225.0	13.8	2.5	4.7	6.5	39.4	2.4
180.0	12.1	2.1	3.5	6.5	39.9	2.3
135.0	12.9	2.4	4.1	6.4	45.5	2.4
MEAN SCALAR SPEED = 9.4 CM/S		MEAN SQUARE SPEED = 156.8 CM2/S2				
MEAN SQUARE E-W SPEED = 80.3 CM2/S2		MEAN SQUARE N-S SPEED = 76.5 CM2/S2				
MEAN VELOCITY = 0.5 CM/S,		150 DEG TRUE		MEAN TEMPERATURE = 8.2 C		
VARIANCE (U,V) = 78.3 CM2/S2		TOTAL HOURS = 8232.				

PERCENT OBSERVED
LIGHT (0.0 - 3.0) 22.9% MEDIUM (3.0 - 7.0) 28.9% HIGH (GE 7.0) 48.3%

MOORING IS 97-05C-001A055 DEPTH IS 55 METERS THERE ARE 6732 VALUES

FIRST DAY 1997/05/21/2300
FINAL DAY 1998/02/26/1100

SHORELINE ORIENTATION IN DEGREES TRUE SPECIFIED AS 90

DIRECTION DEG TRUE	PERCENT OBSERVED	MAXIMUM CURRENT CM/S	MEAN DURA- TION HOURS	MEAN EXCUR- SION KM	MEAN CURRENT CM/S	MEAN TEMP DEG C
TOWARD	TOTAL	LIGHT	MEDIUM	HIGH	CM/S	DEG C
90.0	12.6	2.9	5.4	4.4	19.6	2.7
45.0	9.9	2.8	3.7	3.4	18.5	2.3
0.0	9.8	3.4	3.9	2.4	14.7	2.1
315.0	12.0	3.2	5.3	3.5	14.8	2.4
270.0	15.1	3.1	7.2	4.7	16.6	2.9
225.0	13.6	2.9	6.4	4.3	23.1	2.6
180.0	13.6	3.1	5.9	4.5	22.3	2.5
135.0	13.5	2.8	6.3	4.5	20.1	2.6
MEAN SCALAR SPEED = 5.6 CM/S		MEAN SQUARE SPEED = 41.0 CM2/S2				
MEAN SQUARE E-W SPEED = 21.2 CM2/S2		MEAN SQUARE N-S SPEED = 19.8 CM2/S2				
MEAN VELOCITY = 0.7 CM/S,		194 DEG TRUE		MEAN TEMPERATURE = 4.5 C		
VARIANCE (U,V) = 20.3 CM2/S2		TOTAL HOURS = 6732.				

PERCENT OBSERVED
LIGHT (0.0 - 3.0) 24.2% MEDIUM (3.0 - 7.0) 44.2% HIGH (GE 7.0) 31.6%

DATE: 1997/05/21 TO 1998/04/29
ROSE SUMMARY: WIND AND CURRENT

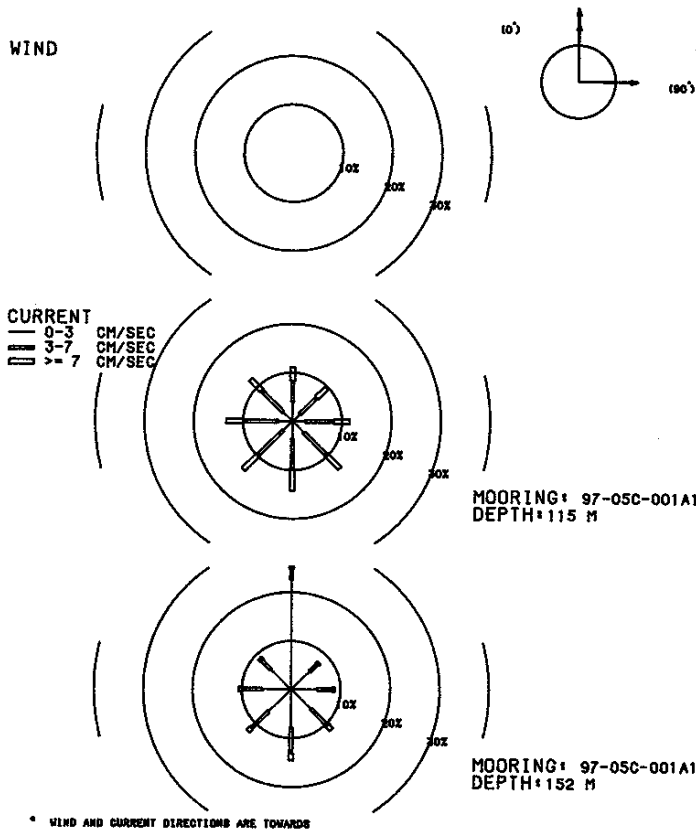

MOORING IS 97-05C-001A115 DEPTH IS 115 METERS THERE ARE 8231 VALUES

FIRST DAY 1997/05/22/0000
FINAL DAY 1998/04/29/2300

SHORELINE ORIENTATION IN DEGREES TRUE SPECIFIED AS 90

DIRECTION DEG TRUE	PERCENT OBSERVED	TOWARD	TOTAL	LIGHT	MEDIUM	HIGH	MAXIMUM CURRENT CM/S	MEAN DURA- TION HOURS	MEAN EXCUR- SION KM	MEAN CURRENT CM/S	MEAN TEMP DEG C
90.0	11.6	2.5	5.9	3.2	19.2	2.8	0.6	5.6	3.8		
45.0	9.8	2.0	4.9	3.0	16.8	2.5	0.5	5.6	3.8		
0.0	11.2	4.0	4.3	2.9	22.0	2.4	0.4	4.8	3.8		
315.0	12.1	2.6	6.2	3.3	23.1	2.7	0.6	5.8	3.8		
270.0	13.4	2.9	6.9	3.7	20.4	3.2	0.6	5.6	3.8		
225.0	14.0	2.6	7.2	4.2	26.8	3.4	0.7	6.0	3.8		
180.0	14.3	3.5	6.2	4.5	20.8	3.3	0.7	5.9	3.8		
135.0	13.6	3.2	6.3	4.1	19.7	3.2	0.7	5.7	3.8		

MEAN SCALAR SPEED = 5.6 CM/S MEAN SQUARE SPEED = 42.8 CM2/S2
MEAN SQUARE E-W SPEED = 20.9 CM2/S2 MEAN SQUARE N-S SPEED = 21.9 CM2/S2
MEAN VELOCITY = 0.6 CM/S, 205 DEG TRUE MEAN TEMPERATURE = 3.8 C
VARIANCE (U,V) = 21.2 CM2/S2 TOTAL HOURS = 8231.

PERCENT OBSERVED
LIGHT (0.0 - 3.0) 23.4% MEDIUM (3.0 - 7.0) 47.8% HIGH (GE 7.0) 28.9%

MOORING IS 97-05C-001A152 DEPTH IS 152 METERS THERE ARE 8233 VALUES

FIRST DAY 1997/05/21/2300
FINAL DAY 1998/04/29/2300

SHORELINE ORIENTATION IN DEGREES TRUE SPECIFIED AS 90

DIRECTION DEG TRUE	PERCENT OBSERVED	TOWARD	TOTAL	LIGHT	MEDIUM	HIGH	MAXIMUM CURRENT CM/S	MEAN DURA- TION HOURS	MEAN EXCUR- SION KM	MEAN CURRENT CM/S	MEAN TEMP DEG C
90.0	8.8	5.3	3.0	0.6	12.5	3.1	0.4	3.4	3.7		
45.0	7.8	5.2	2.2	0.4	12.9	2.7	0.3	3.2	3.7		
0.0	25.2	22.5	2.4	0.3	19.6	3.8	0.2	1.1	3.7		
315.0	9.1	5.7	2.8	0.5	20.2	3.0	0.4	3.5	3.7		
270.0	10.7	5.8	4.0	0.8	15.8	3.6	0.5	3.6	3.7		
225.0	12.3	6.5	4.8	1.0	21.3	3.5	0.5	3.9	3.7		
180.0	14.6	7.8	5.3	1.4	20.0	3.6	0.5	3.9	3.7		
135.0	11.6	5.6	4.7	1.3	15.3	3.5	0.5	4.0	3.7		

MEAN SCALAR SPEED = 3.0 CM/S MEAN SQUARE SPEED = 15.9 CM2/S2
MEAN SQUARE E-W SPEED = 7.0 CM2/S2 MEAN SQUARE N-S SPEED = 8.9 CM2/S2
MEAN VELOCITY = 0.6 CM/S, 196 DEG TRUE MEAN TEMPERATURE = 3.7 C
VARIANCE (U,V) = 7.8 CM2/S2 TOTAL HOURS = 8233.

PERCENT OBSERVED
LIGHT (0.0 - 3.0) 64.4% MEDIUM (3.0 - 7.0) 29.2% HIGH (GE 7.0) 6.4%

Appendix J - Mooring_CM_1-97. Monthly Summary Statistics and Rose Histogram Plots

DATE: 1997/05/01 TO 1997/05/31
ROSE SUMMARY: WIND AND CURRENT

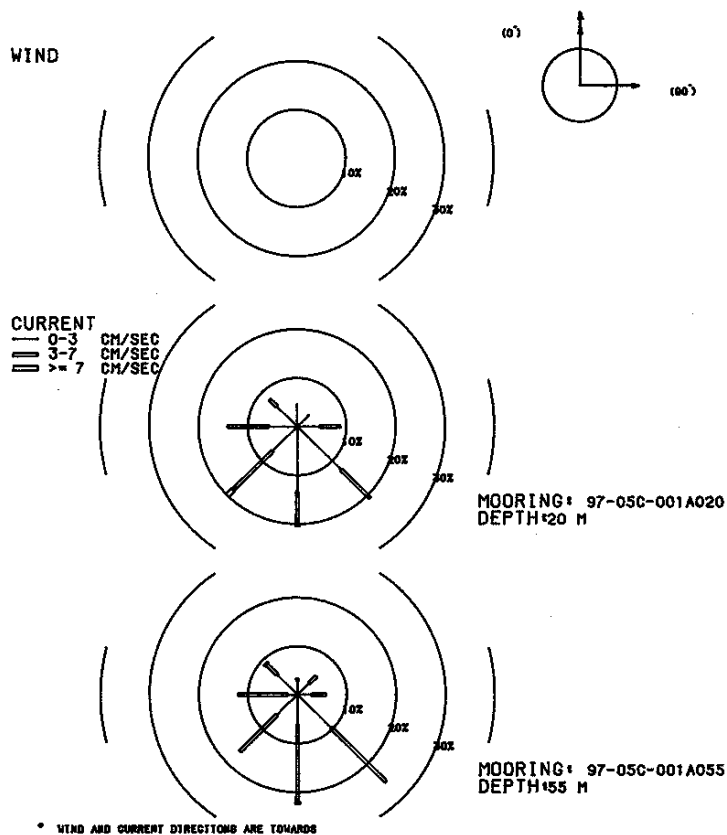

MOORING IS 97-05C-001A020 DEPTH IS 20 METERS THERE ARE 240 VALUES

FIRST DAY 1997/05/22/0000
FINAL DAY 1997/05/31/2300

SHORELINE ORIENTATION IN DEGREES TRUE SPECIFIED AS 90

DIRECTION DEG TRUE	PERCENT OBSERVED				MAXIMUM CURRENT CM/S	MEAN DURA- TION HOURS	MEAN EXCUR- SION KM	MEAN CURRENT CM/S	MEAN TEMP DEG C
TOWARD	TOTAL	LIGHT	MEDIUM	HIGH	CM/S	HOURS	KM	CM/S	DEG C
90.0	8.8	4.6	4.2	0.0	5.4	1.6	0.2	2.9	3.7
45.0	3.3	3.3	0.0	0.0	2.8	1.6	0.1	1.5	3.6
0.0	4.6	4.6	0.0	0.0	2.4	1.4	0.1	1.5	3.6
315.0	7.9	5.8	2.1	0.0	3.7	1.9	0.2	2.3	3.6
270.0	14.2	5.8	8.3	0.0	6.3	2.0	0.2	3.4	3.6
225.0	20.0	7.1	11.2	1.7	8.0	2.7	0.4	4.0	3.6
180.0	20.4	13.3	6.7	0.4	7.0	2.3	0.3	3.2	3.7
135.0	20.8	12.5	8.3	0.0	6.5	2.5	0.3	3.0	3.7
0	MEAN SCALAR SPEED = 3.1 CM/S		MEAN SQUARE SPEED = 12.4 CM2/S2						
	MEAN SQUARE E-W SPEED = 6.8 CM2/S2		MEAN SQUARE N-S SPEED = 5.6 CM2/S2						
	MEAN VELOCITY = 1.5 CM/S,		197 DEG TRUE		MEAN TEMPERATURE = 3.6 C				
	VARIANCE (U,V) = 5.1 CM2/S2		TOTAL HOURS = 240.						

PERCENT OBSERVED
LIGHT (0.0 - 3.0) 57.1% MEDIUM (3.0 - 7.0) 40.8% HIGH (GE 7.0) 2.1%

MOORING IS 97-05C-001A055 DEPTH IS 55 METERS THERE ARE 241 VALUES

FIRST DAY 1997/05/21/2300
FINAL DAY 1997/05/31/2300

SHORELINE ORIENTATION IN DEGREES TRUE SPECIFIED AS 90

DIRECTION DEG TRUE	PERCENT OBSERVED				MAXIMUM CURRENT CM/S	MEAN DURA- TION HOURS	MEAN EXCUR- SION KM	MEAN CURRENT CM/S	MEAN TEMP DEG C
TOWARD	TOTAL	LIGHT	MEDIUM	HIGH	CM/S	HOURS	KM	CM/S	DEG C
90.0	5.8	2.9	2.9	0.0	4.8	1.6	0.2	3.1	3.7
45.0	5.4	3.3	2.1	0.0	5.0	2.2	0.2	2.9	3.6
0.0	3.3	2.9	0.4	0.0	3.2	1.6	0.1	2.4	3.7
315.0	9.1	5.8	2.9	0.4	12.4	4.4	0.5	3.2	3.6
270.0	12.0	2.1	10.0	0.0	6.8	2.9	0.5	4.6	3.7
225.0	16.6	5.8	10.8	0.0	6.5	2.2	0.3	4.1	3.7
180.0	22.4	6.2	15.8	0.4	7.1	2.8	0.4	3.9	3.7
135.0	25.3	9.5	15.8	0.0	6.1	3.0	0.4	3.5	3.7
0	MEAN SCALAR SPEED = 3.7 CM/S		MEAN SQUARE SPEED = 16.0 CM2/S2						
	MEAN SQUARE E-W SPEED = 7.7 CM2/S2		MEAN SQUARE N-S SPEED = 8.4 CM2/S2						
	MEAN VELOCITY = 1.7 CM/S,		194 DEG TRUE		MEAN TEMPERATURE = 3.7 C				
	VARIANCE (U,V) = 6.7 CM2/S2		TOTAL HOURS = 241.						

PERCENT OBSERVED
LIGHT (0.0 - 3.0) 38.6% MEDIUM (3.0 - 7.0) 60.6% HIGH (GE 7.0) 0.8%

DATE: 1997/06/01 TO 1997/06/30
ROSE SUMMARY: WIND AND CURRENT

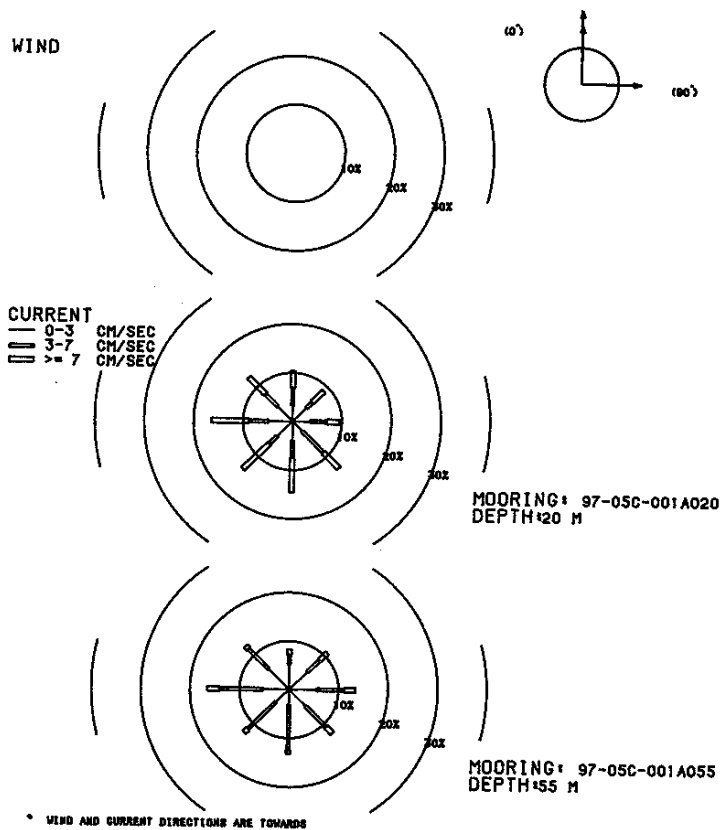

MOORING IS 97-05C-001A020 DEPTH IS 20 METERS THERE ARE 720 VALUES

FIRST DAY 1997/06/01/0000
FINAL DAY 1997/06/30/2300

SHORELINE ORIENTATION IN DEGREES TRUE SPECIFIED AS 90

DIRECTION DEG TRUE	PERCENT OBSERVED	TOWARD	TOTAL	LIGHT	MEDIUM	HIGH	MAXIMUM CURRENT CM/S	MEAN DURA- TION HOURS	MEAN EXCUR- SION KM	MEAN CURRENT CM/S	MEAN TEMP DEG C
90.0	9.6	3.6	3.2	2.8	20.6	1.9	0.4	5.9	5.7		
45.0	8.9	3.9	1.7	3.3	24.4	1.9	0.5	6.8	5.7		
0.0	10.4	3.2	3.8	3.5	22.5	2.0	0.5	6.5	5.9		
315.0	12.6	4.2	3.6	4.9	22.2	1.9	0.5	7.1	5.6		
270.0	16.4	4.9	3.9	7.6	24.3	2.1	0.6	7.5	5.7		
225.0	14.0	4.3	2.2	7.5	28.3	2.0	0.6	8.5	6.2		
180.0	14.6	3.9	3.6	7.1	28.6	2.1	0.7	8.8	6.2		
135.0	13.5	2.8	6.1	4.6	23.5	2.4	0.6	7.3	6.1		
0	MEAN SCALAR SPEED = 7.4 CM/S		MEAN SQUARE SPEED = 91.5 CM2/S2								
	MEAN SQUARE E-W SPEED = 42.5 CM2/S2		MEAN SQUARE N-S SPEED = 49.0 CM2/S2								
	MEAN VELOCITY = 1.5 CM/S,		226 DEG TRUE		MEAN TEMPERATURE = 5.9 C						
	VARIANCE (U,V) = 44.6 CM2/S2		TOTAL HOURS = 720.								

PERCENT OBSERVED
LIGHT (0.0 - 3.0) 30.7% MEDIUM (3.0 - 7.0) 28.1% HIGH (GE 7.0) 41.2%

MOORING IS 97-05C-001A055 DEPTH IS 55 METERS THERE ARE 720 VALUES

FIRST DAY 1997/06/01/0000
FINAL DAY 1997/06/30/2300

SHORELINE ORIENTATION IN DEGREES TRUE SPECIFIED AS 90

DIRECTION DEG TRUE	PERCENT OBSERVED	TOWARD	TOTAL	LIGHT	MEDIUM	HIGH	MAXIMUM CURRENT CM/S	MEAN DURA- TION HOURS	MEAN EXCUR- SION KM	MEAN CURRENT CM/S	MEAN TEMP DEG C
90.0	13.5	5.6	5.6	2.4	12.3	2.1	0.3	4.3	4.0		
45.0	10.8	5.1	3.5	2.2	11.7	2.1	0.3	4.3	4.1		
0.0	8.3	5.1	2.1	1.1	10.8	1.7	0.2	3.7	4.0		
315.0	12.5	6.0	5.7	0.8	8.1	2.1	0.3	3.8	3.9		
270.0	16.5	5.3	8.8	2.5	9.1	2.6	0.4	4.4	4.0		
225.0	12.6	3.6	7.9	1.1	9.2	2.4	0.3	4.1	3.9		
180.0	13.2	3.2	9.3	0.7	8.8	2.4	0.4	4.1	4.0		
135.0	12.5	4.9	5.8	1.8	11.9	2.1	0.3	4.3	4.0		
0	MEAN SCALAR SPEED = 4.1 CM/S		MEAN SQUARE SPEED = 21.9 CM2/S2								
	MEAN SQUARE E-W SPEED = 12.6 CM2/S2		MEAN SQUARE N-S SPEED = 9.3 CM2/S2								
	MEAN VELOCITY = 0.4 CM/S,		202 DEG TRUE		MEAN TEMPERATURE = 4.0 C						
	VARIANCE (U,V) = 10.9 CM2/S2		TOTAL HOURS = 720.								

PERCENT OBSERVED
LIGHT (0.0 - 3.0) 38.8% MEDIUM (3.0 - 7.0) 48.6% HIGH (GE 7.0) 12.6%

DATE: 1997/07/01 TO 1997/07/31
ROSE SUMMARY: WIND AND CURRENT

WIND

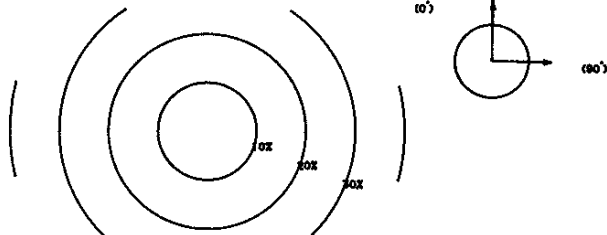

CURRENT

0-3 CM/SEC
3-7 CM/SEC
>7 CM/SEC

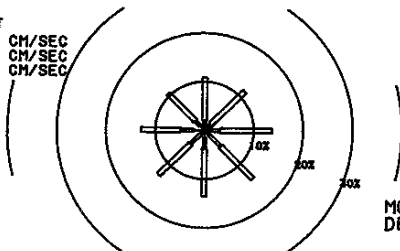

MOORING: 97-05C-001A020
DEPTH: 20 M

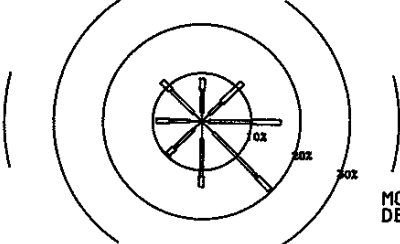

MOORING: 97-05C-001A055
DEPTH: 55 M

* WIND AND CURRENT DIRECTIONS ARE TOWARDS

MOORING IS 97-05C-001A020 DEPTH IS 20 METERS THERE ARE 744 VALUES

FIRST DAY 1997/07/01/0000
FINAL DAY 1997/07/31/2300

SHORELINE ORIENTATION IN DEGREES TRUE SPECIFIED AS 90

DIRECTION DEG TRUE	PERCENT OBSERVED	MAXIMUM CURRENT	MEAN DURA- TION HOURS	MEAN EXCUR- SION KM	MEAN CURRENT CM/S	MEAN TEMP DEG C
TOWARD	TOTAL	LIGHT	MEDIUM	HIGH	CM/S	
90.0	13.7	0.7	2.4	10.6	24.1	2.3
45.0	11.4	0.8	0.8	9.8	24.8	2.0
0.0	10.9	0.5	1.5	8.9	24.5	2.0
315.0	10.5	1.3	1.2	7.9	18.1	2.0
270.0	12.9	2.2	2.7	8.1	24.5	2.1
225.0	13.0	0.8	3.1	9.1	21.9	2.2
180.0	13.6	1.5	2.3	9.8	30.4	2.1
135.0	14.0	1.1	3.5	9.4	29.7	2.3

MEAN SCALAR SPEED = 10.9 CM/S MEAN SQUARE SPEED = 149.7 CM²/S²
MEAN SQUARE E-W SPEED = 72.1 CM²/S² MEAN SQUARE N-S SPEED = 77.6 CM²/S²
MEAN VELOCITY = 1.3 CM/S, 127 DEG TRUE MEAN TEMPERATURE = 9.3 C
VARIANCE (U,V) = 74.2 CM²/S² TOTAL HOURS = 744.

PERCENT OBSERVED

LIGHT (0.0 - 3.0) 8.9% MEDIUM (3.0 - 7.0) 17.5% HIGH (GE 7.0) 73.7%

MOORING IS 97-05C-001A055 DEPTH IS 55 METERS THERE ARE 744 VALUES

FIRST DAY 1997/07/01/0000
FINAL DAY 1997/07/31/2300

SHORELINE ORIENTATION IN DEGREES TRUE SPECIFIED AS 90

DIRECTION DEG TRUE	PERCENT OBSERVED	MAXIMUM CURRENT	MEAN DURA- TION HOURS	MEAN EXCUR- SION KM	MEAN CURRENT CM/S	MEAN TEMP DEG C
TOWARD	TOTAL	LIGHT	MEDIUM	HIGH	CM/S	
90.0	16.0	1.5	8.5	6.0	11.1	3.1
45.0	11.4	2.2	3.4	5.9	10.5	2.7
0.0	8.9	1.9	4.6	2.4	8.9	2.1
315.0	11.6	2.4	6.5	2.7	9.2	2.8
270.0	9.3	2.6	4.0	2.7	9.7	1.9
225.0	9.7	2.3	5.5	1.9	10.9	1.9
180.0	13.4	3.6	7.7	2.2	9.9	2.6
135.0	19.8	3.4	12.6	3.8	11.0	3.1

MEAN SCALAR SPEED = 5.4 CM/S MEAN SQUARE SPEED = 35.1 CM²/S²
MEAN SQUARE E-W SPEED = 19.4 CM²/S² MEAN SQUARE N-S SPEED = 15.6 CM²/S²
MEAN VELOCITY = 1.1 CM/S, 103 DEG TRUE MEAN TEMPERATURE = 4.7 C
VARIANCE (U,V) = 16.9 CM²/S² TOTAL HOURS = 744.

PERCENT OBSERVED

LIGHT (0.0 - 3.0) 19.8% MEDIUM (3.0 - 7.0) 52.7% HIGH (GE 7.0) 27.6%

DATE: 1997/08/01 TO 1997/08/31
ROSE SUMMARY: WIND AND CURRENT

WIND

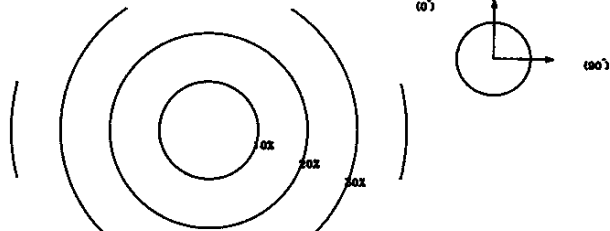

CURRENT
0-3 CM/SEC
3-7 CM/SEC
>= 7 CM/SEC

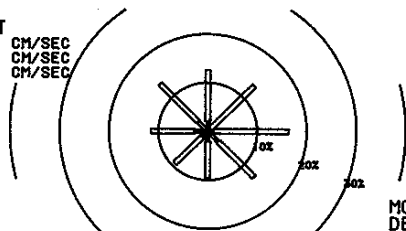

MOORING: 97-05C-001A020
DEPTH: 20 M

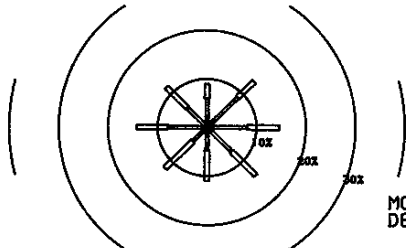

MOORING: 97-05C-001A055
DEPTH: 55 M

* WIND AND CURRENT DIRECTIONS ARE TOWARDS

MOORING IS 97-05C-001A020 DEPTH IS 20 METERS THERE ARE 744 VALUES

FIRST DAY 1997/08/01/0000
FINAL DAY 1997/08/31/2300

SHORELINE ORIENTATION IN DEGREES TRUE SPECIFIED AS 90

DIRECTION DEG TRUE	PERCENT OBSERVED	TOWARD	TOTAL	LIGHT	MEDIUM	HIGH	MAXIMUM CURRENT CM/S	MEAN DURA- TION HOURS	MEAN EXCUR- SION KM	MEAN CURRENT CM/S	MEAN TEMP DEG C
90.0	16.4	0.3	0.8	15.3	38.8	2.7	1.6	16.9	13.7		
45.0	13.3	0.0	0.7	12.6	38.9	2.2	1.5	18.4	14.2		
0.0	12.6	0.4	1.6	10.6	30.8	2.1	1.0	13.4	12.8		
315.0	13.7	0.5	2.2	11.0	35.0	2.3	0.9	11.0	11.8		
270.0	11.6	0.5	2.2	8.9	29.8	1.9	0.7	10.5	11.5		
225.0	9.4	0.8	0.7	7.9	26.2	1.8	0.7	11.3	11.8		
180.0	9.7	0.3	1.7	7.7	25.9	1.8	0.8	12.6	11.8		
135.0	13.3	0.8	2.2	10.3	29.6	2.2	1.1	13.5	12.2		

MEAN SCALAR SPEED = 13.7 CM/S MEAN SQUARE SPEED = 236.4 CM2/S2
MEAN SQUARE E-W SPEED = 132.9 CM2/S2 MEAN SQUARE N-S SPEED = 103.4 CM2/S2
MEAN VELOCITY = 3.2 CM/S, 67 DEG TRUE MEAN TEMPERATURE = 12.6 C
VARIANCE (U,V) = 113.4 CM2/S2 TOTAL HOURS = 744.

PERCENT OBSERVED

LIGHT (0.0 - 3.0) 3.6% MEDIUM (3.0 - 7.0) 12.0% HIGH (GE 7.0) 84.4%

MOORING IS 97-05C-001A055 DEPTH IS 55 METERS THERE ARE 744 VALUES

FIRST DAY 1997/08/01/0000
FINAL DAY 1997/08/31/2300

SHORELINE ORIENTATION IN DEGREES TRUE SPECIFIED AS 90

DIRECTION DEG TRUE	PERCENT OBSERVED	TOWARD	TOTAL	LIGHT	MEDIUM	HIGH	MAXIMUM CURRENT CM/S	MEAN DURA- TION HOURS	MEAN EXCUR- SION KM	MEAN CURRENT CM/S	MEAN TEMP DEG C
90.0	14.7	1.1	7.0	6.6	11.8	2.8	0.7	6.7	4.1		
45.0	13.4	0.9	7.8	4.7	10.3	2.5	0.5	6.1	4.1		
0.0	9.0	1.1	4.8	3.1	10.5	1.8	0.4	5.7	4.2		
315.0	11.7	0.4	5.2	6.0	10.1	2.2	0.5	6.7	4.1		
270.0	14.2	0.9	7.0	6.3	11.5	2.6	0.6	6.5	4.1		
225.0	12.0	0.9	3.1	7.9	12.1	2.3	0.6	7.4	4.1		
180.0	11.0	0.9	3.8	6.3	13.6	2.1	0.6	7.4	4.1		
135.0	14.0	1.1	5.9	7.0	13.2	2.5	0.6	6.9	4.1		

MEAN SCALAR SPEED = 6.7 CM/S MEAN SQUARE SPEED = 50.7 CM2/S2
MEAN SQUARE E-W SPEED = 27.3 CM2/S2 MEAN SQUARE N-S SPEED = 23.4 CM2/S2
MEAN VELOCITY = 0.5 CM/S, 168 DEG TRUE MEAN TEMPERATURE = 4.1 C
VARIANCE (U,V) = 25.3 CM2/S2 TOTAL HOURS = 744.

PERCENT OBSERVED

LIGHT (0.0 - 3.0) 7.4% MEDIUM (3.0 - 7.0) 44.6% HIGH (GE 7.0) 48.0%

DATE: 1997/09/01 TO 1997/09/30
 ROSE SUMMARY: WIND AND CURRENT

WIND

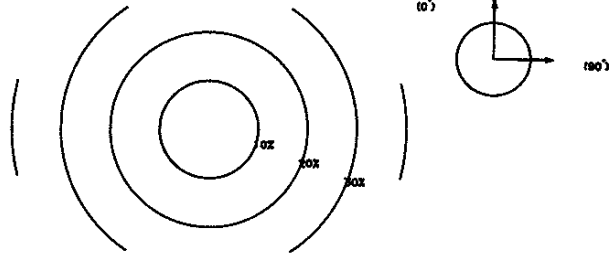

CURRENT
 — 0-3 CM/SEC
 = 3-7 CM/SEC
 = >= 7 CM/SEC

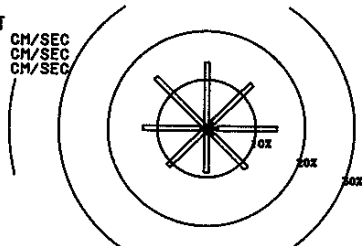

MOORING: 97-05C-001A020
 DEPTH: 20 M

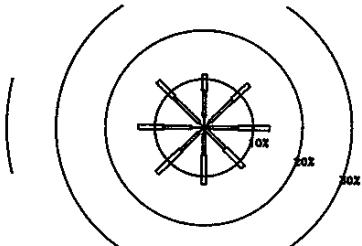

MOORING: 97-05C-001A055
 DEPTH: 55 M

* WIND AND CURRENT DIRECTIONS ARE TOWARDS

MOORING IS 97-05C-001A020 DEPTH IS 20 METERS THERE ARE 720 VALUES

FIRST DAY 1997/09/01/0000
 FINAL DAY 1997/09/30/2300

SHORELINE ORIENTATION IN DEGREES TRUE SPECIFIED AS 90

DIRECTION DEG TRUE	PERCENT OBSERVED	TOWARD	TOTAL	LIGHT	MEDIUM	HIGH	MAXIMUM CURRENT CM/S	MEAN DURA- TION HOURS	MEAN EXCUR- SION KM	MEAN CURRENT CM/S	MEAN TEMP DEG C
90.0	14.3	0.4	1.8	12.1	42.4	2.6	1.7	18.3	18.2		
45.0	12.9	0.1	1.5	11.3	40.3	2.3	1.6	19.0	18.2		
0.0	13.6	0.1	0.1	13.3	38.4	2.4	1.7	20.0	18.1		
315.0	14.7	0.1	0.6	14.0	35.0	2.4	1.6	18.2	18.0		
270.0	12.9	0.0	1.2	11.7	35.8	2.3	1.4	17.2	17.6		
225.0	11.0	0.1	0.7	10.1	39.4	2.3	1.4	17.4	17.4		
180.0	9.0	0.3	0.8	7.9	39.9	1.9	1.2	18.1	17.7		
135.0	11.5	0.7	1.1	9.7	39.0	2.2	1.5	18.3	18.0		

MEAN SCALAR SPEED = 18.3 CM/S MEAN SQUARE SPEED = 421.7 CM2/S2
 MEAN SQUARE E-W SPEED = 216.7 CM2/S2 MEAN SQUARE N-S SPEED = 204.9 CM2/S2
 MEAN VELOCITY = 1.9 CM/S, 9 DEG TRUE MEAN TEMPERATURE = 17.9 C
 VARIANCE (U,V) = 209.4 CM2/S2 TOTAL HOURS = 720.

PERCENT OBSERVED

LIGHT (0.0 - 3.0) 1.9% MEDIUM (3.0 - 7.0) 7.9% HIGH (GE 7.0) 90.1%

MOORING IS 97-05C-001A055 DEPTH IS 55 METERS THERE ARE 720 VALUES

FIRST DAY 1997/09/01/0000
 FINAL DAY 1997/09/30/2300

SHORELINE ORIENTATION IN DEGREES TRUE SPECIFIED AS 90

DIRECTION DEG TRUE	PERCENT OBSERVED	TOWARD	TOTAL	LIGHT	MEDIUM	HIGH	MAXIMUM CURRENT CM/S	MEAN DURA- TION HOURS	MEAN EXCUR- SION KM	MEAN CURRENT CM/S	MEAN TEMP DEG C
90.0	13.3	0.8	6.1	6.4	11.8	3.6	0.9	6.8	4.2		
45.0	12.6	1.7	6.4	4.6	10.5	2.8	0.6	6.0	4.2		
0.0	11.0	2.2	5.4	3.3	9.8	2.5	0.5	5.4	4.2		
315.0	13.3	1.4	7.4	4.6	11.4	2.9	0.6	6.0	4.2		
270.0	13.3	2.5	5.7	5.1	11.1	2.8	0.6	5.8	4.2		
225.0	13.3	1.5	5.1	6.7	12.0	3.4	0.8	6.7	4.2		
180.0	11.7	1.2	4.3	6.1	12.3	3.0	0.8	7.0	4.2		
135.0	11.4	0.4	5.6	5.4	11.9	2.9	0.7	7.0	4.1		

MEAN SCALAR SPEED = 6.3 CM/S MEAN SQUARE SPEED = 46.7 CM2/S2
 MEAN SQUARE E-W SPEED = 25.0 CM2/S2 MEAN SQUARE N-S SPEED = 21.8 CM2/S2
 MEAN VELOCITY = 0.3 CM/S, 178 DEG TRUE MEAN TEMPERATURE = 4.2 C
 VARIANCE (U,V) = 23.4 CM2/S2 TOTAL HOURS = 720.

PERCENT OBSERVED

LIGHT (0.0 - 3.0) 11.8% MEDIUM (3.0 - 7.0) 46.0% HIGH (GE 7.0) 42.2%

DATE: 1997/10/01 TO 1997/10/31
ROSE SUMMARY: WIND AND CURRENT

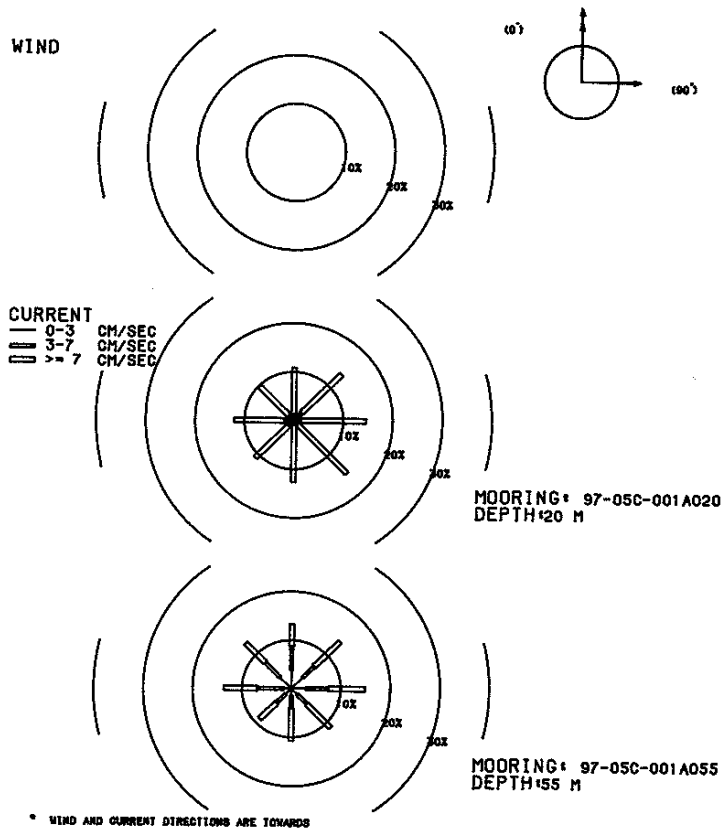

MOORING IS 97-05C-001A020 DEPTH IS 20 METERS THERE ARE 744 VALUES

FIRST DAY 1997/10/01/0000
FINAL DAY 1997/10/31/2300

SHORELINE ORIENTATION IN DEGREES TRUE SPECIFIED AS 90

DIRECTION DEG TRUE	PERCENT OBSERVED	TOWARD	TOTAL	LIGHT	MEDIUM	HIGH	MAXIMUM CURRENT CM/S	MEAN DURA- TION HOURS	MEAN EXCUR- SION KM	MEAN CURRENT CM/S	MEAN TEMP DEG C
90.0	14.7	0.4	0.9	13.3	45.3	2.7	2.2	21.9	14.5		
45.0	13.6	0.4	1.7	11.4	44.2	2.5	2.0	21.6	14.6		
0.0	10.9	0.5	0.8	9.5	41.8	2.2	1.8	22.9	14.9		
315.0	9.9	0.3	1.1	8.6	38.8	1.9	1.4	20.5	14.7		
270.0	12.1	0.4	1.5	10.2	34.8	2.2	1.4	17.6	14.7		
225.0	10.9	0.7	0.8	9.4	34.8	2.1	1.3	17.6	14.7		
180.0	12.6	0.5	0.3	11.8	39.4	2.4	1.7	19.9	14.9		
135.0	15.3	0.5	0.5	14.2	45.5	2.9	2.1	20.6	14.9		
0		MEAN SCALAR SPEED = 20.4 CM/S		MEAN SQUARE SPEED = 540.7 CM2/S2							
		MEAN SQUARE E-W SPEED = 274.9 CM2/S2		MEAN SQUARE N-S SPEED = 265.8 CM2/S2							
		MEAN VELOCITY = 2.6 CM/S,		96 DEG TRUE		MEAN TEMPERATURE = 14.7 C					
		VARIANCE (U,V) = 267.4 CM2/S2		TOTAL HOURS = 744.							

PERCENT OBSERVED
LIGHT (0.0 - 3.0) 3.8% MEDIUM (3.0 - 7.0) 7.7% HIGH (GE 7.0) 88.6%

MOORING IS 97-05C-001A055 DEPTH IS 55 METERS THERE ARE 744 VALUES

FIRST DAY 1997/10/01/0000
FINAL DAY 1997/10/31/2300

SHORELINE ORIENTATION IN DEGREES TRUE SPECIFIED AS 90

DIRECTION DEG TRUE	PERCENT OBSERVED	TOWARD	TOTAL	LIGHT	MEDIUM	HIGH	MAXIMUM CURRENT CM/S	MEAN DURA- TION HOURS	MEAN EXCUR- SION KM	MEAN CURRENT CM/S	MEAN TEMP DEG C
90.0	14.9	3.0	4.4	7.5	19.6	2.7	0.7	7.0	4.4		
45.0	13.8	3.1	3.4	7.4	18.5	2.7	0.7	7.2	4.4		
0.0	13.3	3.8	5.0	4.6	14.7	2.4	0.5	5.7	4.4		
315.0	13.2	3.2	4.2	5.8	14.8	2.5	0.5	6.1	4.4		
270.0	13.7	1.5	5.4	6.9	16.6	3.1	0.8	7.2	4.5		
225.0	9.0	1.6	2.6	4.8	23.1	2.0	0.6	8.0	4.4		
180.0	10.8	1.5	2.6	6.7	22.3	2.4	0.7	8.4	4.4		
135.0	11.3	1.7	2.7	6.9	20.1	2.4	0.7	7.6	4.4		
0		MEAN SCALAR SPEED = 7.1 CM/S		MEAN SQUARE SPEED = 68.2 CM2/S2							
		MEAN SQUARE E-W SPEED = 35.7 CM2/S2		MEAN SQUARE N-S SPEED = 32.5 CM2/S2							
		MEAN VELOCITY = 0.3 CM/S,		76 DEG TRUE		MEAN TEMPERATURE = 4.4 C					
		VARIANCE (U,V) = 34.1 CM2/S2		TOTAL HOURS = 744.							

PERCENT OBSERVED
LIGHT (0.0 - 3.0) 19.4% MEDIUM (3.0 - 7.0) 30.1% HIGH (GE 7.0) 50.5%

DATE: 1997/11/01 TO 1997/11/30
 ROSE SUMMARY: WIND AND CURRENT

WIND

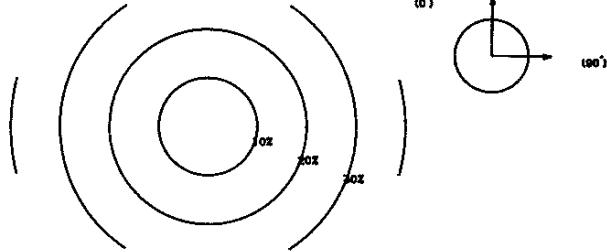

CURRENT
 — 0-3 CM/SEC
 = 3-7 CM/SEC
 ≡ >= 7 CM/SEC

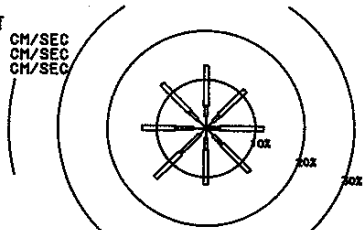

MOORING: 97-05C-001A020
 DEPTH: 20 M

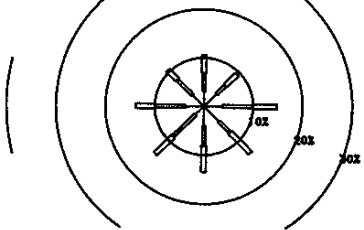

MOORING: 97-05C-001A055
 DEPTH: 55 M

* WIND AND CURRENT DIRECTIONS ARE TOWARDS

MOORING IS 97-05C-001A020 DEPTH IS 20 METERS THERE ARE 720 VALUES

FIRST DAY 1997/11/01/0000
 FINAL DAY 1997/11/30/2300

SHORELINE ORIENTATION IN DEGREES TRUE SPECIFIED AS 90

DIRECTION DEG TRUE	PERCENT OBSERVED	TOWARD	LIGHT	MEDIUM	HIGH	MAXIMUM CURRENT CM/S	MEAN DURA- TION HOURS	MEAN EXCUR- SION KM	MEAN CURRENT CM/S	MEAN TEMP DEG C
90.0	11.7	0.8	1.9	8.9	21.0	2.8	1.1	10.7	9.6	
45.0	11.1	1.9	1.8	7.4	19.2	2.3	0.8	9.2	9.9	
0.0	12.9	2.5	2.1	8.3	19.7	2.4	0.8	9.1	9.7	
315.0	12.8	2.5	2.2	8.1	17.3	2.2	0.6	8.1	9.7	
270.0	13.1	2.6	3.6	6.8	16.0	2.2	0.6	7.0	9.4	
225.0	14.4	1.8	5.4	7.2	16.3	2.3	0.6	7.3	9.8	
180.0	11.5	1.9	2.5	7.1	19.4	2.1	0.6	8.5	9.4	
135.0	12.5	2.1	2.5	7.9	23.5	2.1	0.7	9.1	9.6	

MEAN SCALAR SPEED = 8.6 CM/S MEAN SQUARE SPEED = 96.8 CM2/S2
 MEAN SQUARE E-W SPEED = 47.9 CM2/S2 MEAN SQUARE N-S SPEED = 48.9 CM2/S2
 MEAN VELOCITY = 0.4 CM/S, 70 DEG TRUE MEAN TEMPERATURE = 9.6 C
 VARIANCE (U,V) = 48.4 CM2/S2 TOTAL HOURS = 720.

PERCENT OBSERVED

LIGHT (0.0 - 3.0) 16.2% MEDIUM (3.0 - 7.0) 22.1% HIGH (GE 7.0) 61.7%

MOORING IS 97-05C-001A055 DEPTH IS 55 METERS THERE ARE 720 VALUES

FIRST DAY 1997/11/01/0000
 FINAL DAY 1997/11/30/2300

SHORELINE ORIENTATION IN DEGREES TRUE SPECIFIED AS 90

DIRECTION DEG TRUE	PERCENT OBSERVED	TOWARD	LIGHT	MEDIUM	HIGH	MAXIMUM CURRENT CM/S	MEAN DURA- TION HOURS	MEAN EXCUR- SION KM	MEAN CURRENT CM/S	MEAN TEMP DEG C
90.0	14.9	3.8	6.3	4.9	14.0	2.7	0.5	5.6	5.3	
45.0	9.4	3.6	2.5	3.3	12.0	1.8	0.3	5.2	5.1	
0.0	10.6	3.1	3.8	3.8	13.2	2.5	0.5	5.5	5.3	
315.0	10.4	3.2	4.4	2.8	11.9	2.7	0.5	4.9	4.9	
270.0	13.9	3.8	6.1	4.0	10.2	2.7	0.5	4.9	5.1	
225.0	13.9	2.4	6.4	5.1	12.7	2.9	0.6	5.8	5.3	
180.0	13.5	4.0	4.0	5.4	15.5	2.2	0.4	5.7	5.4	
135.0	13.5	4.3	3.2	6.0	15.1	2.1	0.4	6.0	5.5	

MEAN SCALAR SPEED = 5.5 CM/S MEAN SQUARE SPEED = 41.0 CM2/S2
 MEAN SQUARE E-W SPEED = 20.7 CM2/S2 MEAN SQUARE N-S SPEED = 20.3 CM2/S2
 MEAN VELOCITY = 0.6 CM/S, 166 DEG TRUE MEAN TEMPERATURE = 5.2 C
 VARIANCE (U,V) = 20.3 CM2/S2 TOTAL HOURS = 720.

PERCENT OBSERVED

LIGHT (0.0 - 3.0) 28.1% MEDIUM (3.0 - 7.0) 36.7% HIGH (GE 7.0) 35.3%

DATE: 1997/12/01 TO 1997/12/31
ROSE SUMMARY: WIND AND CURRENT

WIND

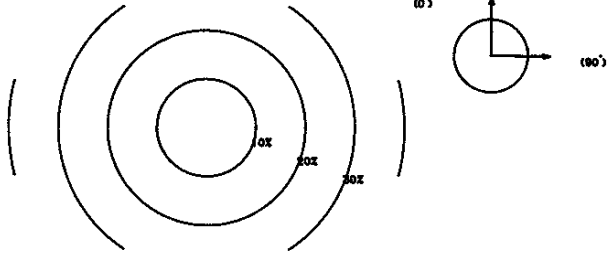

CURRENT

0-3 CM/SEC
3-7 CM/SEC
>= 7 CM/SEC

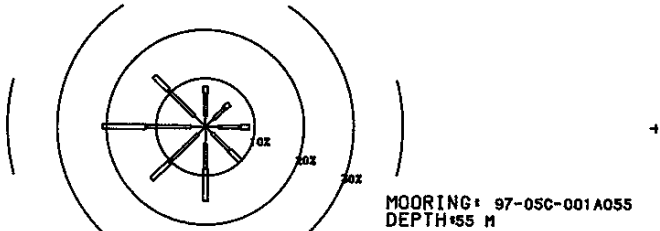
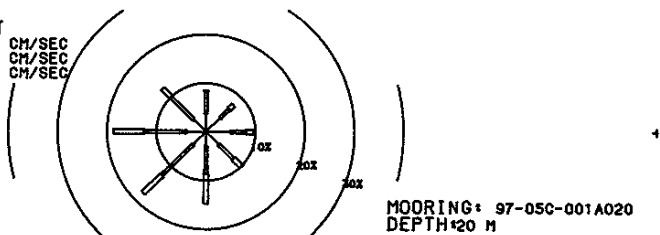

* WIND AND CURRENT DIRECTIONS ARE TOWARDS

MOORING IS 97-05C-001A020 DEPTH IS 20 METERS THERE ARE 744 VALUES

FIRST DAY 1997/12/01/0000
FINAL DAY 1997/12/31/2300

SHORELINE ORIENTATION IN DEGREES TRUE SPECIFIED AS 90

DIRECTION DEG TRUE	PERCENT OBSERVED				MAXIMUM CURRENT CM/S	MEAN DURATION HOURS	MEAN EXCURSION KM	MEAN CURRENT CM/S	MEAN TEMP DEG C
TOWARD	TOTAL	LIGHT	MEDIUM	HIGH	CM/S	HOURS	KM	CM/S	DEG C
90.0	9.5	4.8	3.2	1.5	12.9	1.8	0.3	3.9	5.7
45.0	7.8	4.0	2.6	1.2	12.4	1.7	0.2	3.9	5.7
0.0	8.5	3.6	4.7	0.1	7.0	1.9	0.2	3.4	5.7
315.0	12.5	3.5	6.6	2.4	10.1	2.8	0.5	4.8	5.9
270.0	18.8	3.9	8.6	6.3	12.2	2.9	0.6	5.8	5.8
225.0	17.9	3.6	9.0	5.2	11.6	2.4	0.5	5.6	5.9
180.0	14.8	2.8	5.8	6.2	15.8	2.5	0.6	6.5	5.9
135.0	10.2	3.6	4.2	2.4	13.9	1.9	0.3	4.9	5.8
MEAN SCALAR SPEED = 5.1 CM/S					MEAN SQUARE SPEED = 35.4 CM2/S2				
MEAN SQUARE E-W SPEED = 18.5 CM2/S2					MEAN SQUARE N-S SPEED = 16.9 CM2/S2				
MEAN VELOCITY = 1.7 CM/S,					227 DEG TRUE		MEAN TEMPERATURE = 5.8 C		
VARIANCE (U,V) = 16.2 CM2/S2					TOTAL HOURS = 744.				

PERCENT OBSERVED
LIGHT (0.0 - 3.0) 30.0% MEDIUM (3.0 - 7.0) 44.6% HIGH (GE 7.0) 25.4%

MOORING IS 97-05C-001A055 DEPTH IS 55 METERS THERE ARE 744 VALUES

FIRST DAY 1997/12/01/0000
FINAL DAY 1997/12/31/2300

SHORELINE ORIENTATION IN DEGREES TRUE SPECIFIED AS 90

DIRECTION DEG TRUE	PERCENT OBSERVED				MAXIMUM CURRENT CM/S	MEAN DURATION HOURS	MEAN EXCURSION KM	MEAN CURRENT CM/S	MEAN TEMP DEG C
TOWARD	TOTAL	LIGHT	MEDIUM	HIGH	CM/S	HOURS	KM	CM/S	DEG C
90.0	8.9	2.6	4.6	1.7	10.9	2.4	0.4	4.9	5.6
45.0	6.7	2.4	3.1	1.2	11.0	2.0	0.3	4.5	5.8
0.0	8.3	2.3	4.6	1.5	9.9	1.9	0.3	4.4	5.6
315.0	14.7	3.1	7.5	4.0	10.1	2.9	0.5	5.1	5.7
270.0	20.8	3.0	9.1	8.7	11.9	3.5	0.8	6.1	5.8
225.0	15.3	2.2	8.2	5.0	14.1	2.4	0.5	6.0	5.8
180.0	15.2	3.5	5.1	6.6	16.0	2.5	0.6	6.3	5.9
135.0	10.1	1.9	5.0	3.2	10.7	2.4	0.5	5.8	5.9
MEAN SCALAR SPEED = 5.6 CM/S					MEAN SQUARE SPEED = 39.1 CM2/S2				
MEAN SQUARE E-W SPEED = 21.0 CM2/S2					MEAN SQUARE N-S SPEED = 18.2 CM2/S2				
MEAN VELOCITY = 1.7 CM/S,					237 DEG TRUE		MEAN TEMPERATURE = 5.8 C		
VARIANCE (U,V) = 18.1 CM2/S2					TOTAL HOURS = 744.				

PERCENT OBSERVED
LIGHT (0.0 - 3.0) 20.8% MEDIUM (3.0 - 7.0) 47.2% HIGH (GE 7.0) 32.0%

DATE: 1998/01/01 TO 1998/01/31
 ROSE SUMMARY: WIND AND CURRENT

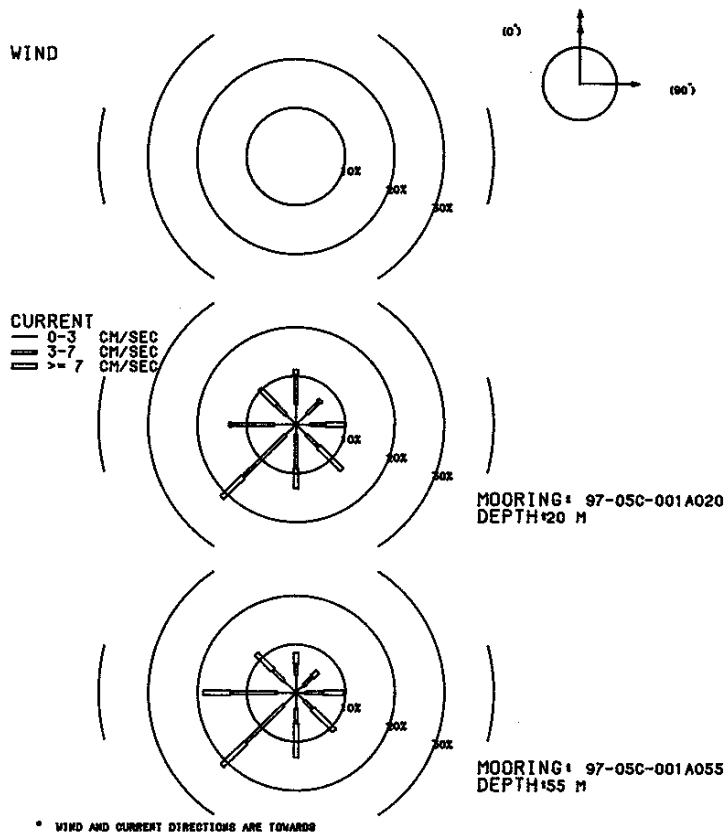

MOORING IS 97-05C-001A020 DEPTH IS 20 METERS THERE ARE 744 VALUES

FIRST DAY 1998/01/01/0000
 FINAL DAY 1998/01/31/2300

SHORELINE ORIENTATION IN DEGREES TRUE SPECIFIED AS 90

DIRECTION DEG TRUE	PERCENT OBSERVED	TOWARD	TOTAL	LIGHT	MEDIUM	HIGH	MAXIMUM CURRENT CM/S	MEAN DURA- TION HOURS	MEAN EXCUR- SION KM	MEAN CURRENT CM/S	MEAN TEMP DEG C
90.0	10.1	3.0	3.1	4.0	13.5	3.4	0.7	5.8	4.3		
45.0	7.1	3.1	3.4	0.7	7.8	1.9	0.2	3.7	4.2		
0.0	11.3	4.2	6.0	1.1	9.5	2.5	0.4	4.0	4.2		
315.0	10.3	2.7	3.0	4.7	14.4	2.3	0.5	6.1	4.3		
270.0	13.6	4.4	8.6	0.5	9.2	2.3	0.3	3.7	4.1		
225.0	21.2	3.0	12.1	6.2	13.8	3.3	0.7	5.8	4.2		
180.0	13.2	2.0	7.0	4.2	21.1	2.3	0.6	7.7	4.3		
135.0	13.2	3.0	3.5	6.7	19.3	3.3	0.9	7.3	4.3		
MEAN SCALAR SPEED = 5.6 CM/S		MEAN SQUARE SPEED = 46.2 CM2/S2									
MEAN SQUARE E-W SPEED = 19.2 CM2/S2		MEAN SQUARE N-S SPEED = 27.1 CM2/S2									
MEAN VELOCITY = 1.5 CM/S,		193 DEG TRUE		MEAN TEMPERATURE = 4.2 C							
VARIANCE (U,V) = 22.0 CM2/S2		TOTAL HOURS = 744.									

PERCENT OBSERVED
 LIGHT (0.0 - 3.0) 25.3% MEDIUM (3.0 - 7.0) 46.6% HIGH (GE 7.0) 28.1%

MOORING IS 97-05C-001A055 DEPTH IS 55 METERS THERE ARE 744 VALUES

FIRST DAY 1998/01/01/0000
 FINAL DAY 1998/01/31/2300

SHORELINE ORIENTATION IN DEGREES TRUE SPECIFIED AS 90

DIRECTION DEG TRUE	PERCENT OBSERVED	TOWARD	TOTAL	LIGHT	MEDIUM	HIGH	MAXIMUM CURRENT CM/S	MEAN DURA- TION HOURS	MEAN EXCUR- SION KM	MEAN CURRENT CM/S	MEAN TEMP DEG C
90.0	9.7	1.9	3.6	4.2	13.1	2.9	0.6	6.0	4.3		
45.0	6.2	2.2	2.6	1.5	9.7	2.0	0.3	4.4	4.3		
0.0	8.3	3.6	2.3	2.4	11.1	2.0	0.3	4.5	4.3		
315.0	11.4	3.4	3.2	4.8	12.7	2.0	0.4	5.7	4.3		
270.0	18.8	3.9	9.4	5.5	15.8	3.4	0.7	5.5	4.2		
225.0	21.2	3.6	10.8	6.9	18.0	3.8	0.8	5.9	4.3		
180.0	13.3	3.1	3.2	7.0	18.9	2.6	0.8	8.7	4.3		
135.0	11.0	2.4	2.2	6.5	15.6	2.6	0.7	7.6	4.4		
MEAN SCALAR SPEED = 6.2 CM/S		MEAN SQUARE SPEED = 54.4 CM2/S2									
MEAN SQUARE E-W SPEED = 23.7 CM2/S2		MEAN SQUARE N-S SPEED = 30.7 CM2/S2									
MEAN VELOCITY = 1.9 CM/S,		212 DEG TRUE		MEAN TEMPERATURE = 4.3 C							
VARIANCE (U,V) = 25.4 CM2/S2		TOTAL HOURS = 744.									

PERCENT OBSERVED
 LIGHT (0.0 - 3.0) 24.1% MEDIUM (3.0 - 7.0) 37.2% HIGH (GE 7.0) 38.7%

DATE: 1998/02/01 TO 1998/02/28
 ROSE SUMMARY: WIND AND CURRENT

WIND

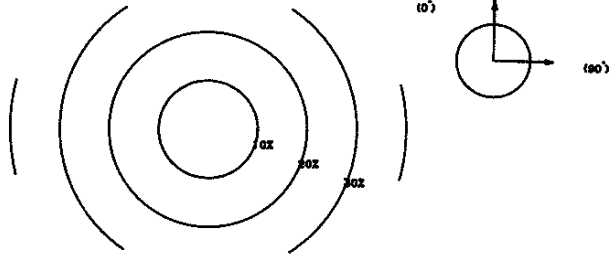

CURRENT

0-3 CM/SEC
 3-7 CM/SEC
 >= 7 CM/SEC

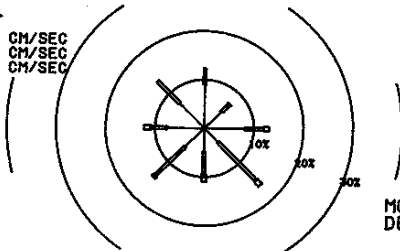

MOORING: 97-05C-001A020
 DEPTH: 20 M

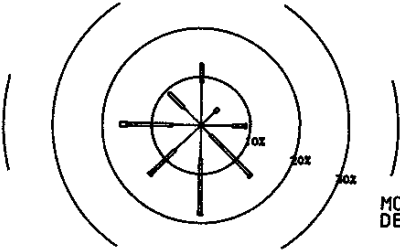

MOORING: 97-05C-001A055
 DEPTH: 55 M

* WIND AND CURRENT DIRECTIONS ARE TOWARDS

MOORING IS 97-05C-001A020 DEPTH IS 20 METERS THERE ARE 672 VALUES

FIRST DAY 1998/02/01/0000
 FINAL DAY 1998/02/28/2300

SHORELINE ORIENTATION IN DEGREES TRUE SPECIFIED AS 90

DIRECTION DEG TRUE	TOWARD	TOTAL	LIGHT	MEDIUM	HIGH	MAXIMUM CURRENT CM/S	MEAN DURATION HOURS	MEAN EXCURSION KM	MEAN CURRENT CM/S	MEAN TEMP DEG C
90.0	13.1	8.2	3.9	1.0	12.3	2.3	0.3	3.2	3.8	
45.0	7.1	4.8	2.2	0.1	9.2	1.5	0.2	2.8	3.8	
0.0	12.4	8.9	3.4	0.0	5.4	1.5	0.1	2.3	3.8	
315.0	13.5	7.0	6.5	0.0	6.7	1.9	0.2	3.0	3.8	
270.0	12.2	7.4	3.4	1.3	7.9	1.9	0.2	3.2	3.8	
225.0	14.4	5.4	8.5	0.6	7.2	2.6	0.4	4.0	3.8	
180.0	11.0	4.9	4.5	1.6	9.1	1.9	0.3	4.0	3.8	
135.0	16.2	3.9	11.0	1.3	10.6	2.8	0.5	4.5	3.8	

MEAN SCALAR SPEED = 3.4 CM/S MEAN SQUARE SPEED = 16.2 CM2/S2
 MEAN SQUARE E-W SPEED = 8.4 CM2/S2 MEAN SQUARE N-S SPEED = 7.7 CM2/S2
 MEAN VELOCITY = 0.7 CM/S, 184 DEG TRUE MEAN TEMPERATURE = 3.8 C
 VARIANCE(U,V) = 7.8 CM2/S2 TOTAL HOURS = 672.

PERCENT OBSERVED

LIGHT (0.0 - 3.0) 50.4% MEDIUM (3.0 - 7.0) 43.5% HIGH (GE 7.0) 6.1%

MOORING IS 97-05C-001A055 DEPTH IS 55 METERS THERE ARE 611 VALUES

FIRST DAY 1998/02/01/0000
 FINAL DAY 1998/02/26/1100

SHORELINE ORIENTATION IN DEGREES TRUE SPECIFIED AS 90

DIRECTION DEG TRUE	TOWARD	TOTAL	LIGHT	MEDIUM	HIGH	MAXIMUM CURRENT CM/S	MEAN DURATION HOURS	MEAN EXCURSION KM	MEAN CURRENT CM/S	MEAN TEMP DEG C
90.0	9.2	6.4	2.6	0.2	7.2	2.4	0.2	2.7	3.9	
45.0	4.9	3.9	1.0	0.0	4.5	1.2	0.1	2.2	3.9	
0.0	12.8	8.8	3.9	0.0	6.3	2.2	0.2	1.9	3.9	
315.0	9.3	4.9	4.4	0.0	6.5	1.9	0.2	2.9	3.9	
270.0	16.4	5.7	9.2	1.5	7.8	3.6	0.5	4.1	3.9	
225.0	14.6	7.4	6.9	0.3	7.6	3.1	0.4	3.6	3.9	
180.0	18.3	6.9	11.3	0.2	8.4	3.1	0.5	4.0	3.9	
135.0	14.6	2.9	11.3	0.3	8.3	3.0	0.4	4.1	3.9	

MEAN SCALAR SPEED = 3.4 CM/S MEAN SQUARE SPEED = 15.1 CM2/S2
 MEAN SQUARE E-W SPEED = 7.4 CM2/S2 MEAN SQUARE N-S SPEED = 7.7 CM2/S2
 MEAN VELOCITY = 1.2 CM/S, 204 DEG TRUE MEAN TEMPERATURE = 3.9 C
 VARIANCE(U,V) = 6.9 CM2/S2 TOTAL HOURS = 611.

PERCENT OBSERVED

LIGHT (0.0 - 3.0) 47.0% MEDIUM (3.0 - 7.0) 50.6% HIGH (GE 7.0) 2.5%

DATE: 1998/03/01 TO 1998/03/31
 ROSE SUMMARY: WIND AND CURRENT

WIND

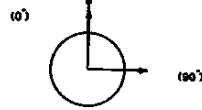
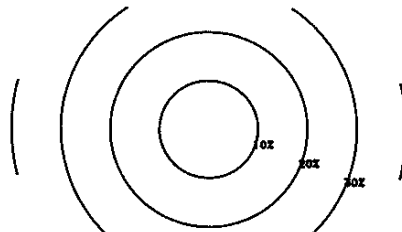

CURRENT

— 0-3 CM/SEC
 = 3-7 CM/SEC
 = >= 7 CM/SEC

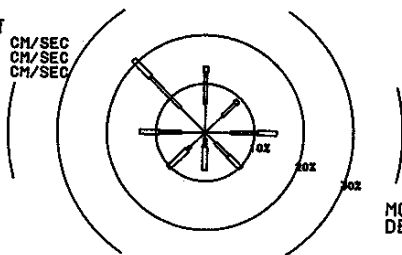

MOORING: 97-05C-001A020
 DEPTH: 20 M

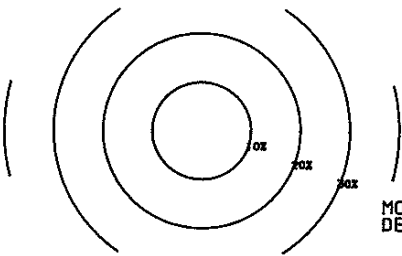

MOORING: 97-05C-001A055
 DEPTH: 20 M

* WIND AND CURRENT DIRECTIONS ARE TOWARDS

MOORING IS 97-05C-001A020 DEPTH IS 20 METERS THERE ARE 744 VALUES

FIRST DAY 1998/03/01/0000
 FINAL DAY 1998/03/31/2300

SHORELINE ORIENTATION IN DEGREES TRUE SPECIFIED AS 90

DIRECTION DEG TRUE	PERCENT OBSERVED	MAXIMUM CURRENT			MEAN DURA- TION HOURS	MEAN EXCUR- SION KM	MEAN CURRENT CM/S	MEAN TEMP DEG C
TOWARD	TOTAL	LIGHT	MEDIUM	HIGH	CM/S			
90.0	14.5	5.2	5.4	3.9	23.3	2.9	0.7	7.0
45.0	9.3	4.8	3.8	0.7	7.8	1.7	0.2	3.3
0.0	13.6	5.9	6.5	1.2	13.0	1.9	0.3	3.8
315.0	20.8	7.1	8.7	5.0	22.7	2.8	0.6	5.8
270.0	13.3	4.8	4.4	4.0	22.9	2.5	0.6	6.7
225.0	10.3	4.2	0.9	5.2	32.4	2.3	1.0	11.6
180.0	7.8	1.2	1.6	5.0	31.3	3.2	1.3	11.6
135.0	10.3	3.0	3.8	3.6	22.6	2.8	0.8	7.8

MEAN SCALAR SPEED = 6.8 CM/S MEAN SQUARE SPEED = 97.4 CM²/S²
 MEAN SQUARE E-W SPEED = 52.9 CM²/S² MEAN SQUARE N-S SPEED = 44.5 CM²/S²
 MEAN VELOCITY = 1.3 CM/S, 228 DEG TRUE MEAN TEMPERATURE = 3.7 C
 VARIANCE (U,V) = 48.0 CM²/S² TOTAL HOURS = 744.

PERCENT OBSERVED
 LIGHT (0.0 - 3.0) 36.3% MEDIUM (3.0 - 7.0) 35.1% HIGH (GE 7.0) 28.6%

DATE: 1998/04/01 TO 1998/04/30
 ROSE SUMMARY: WIND AND CURRENT

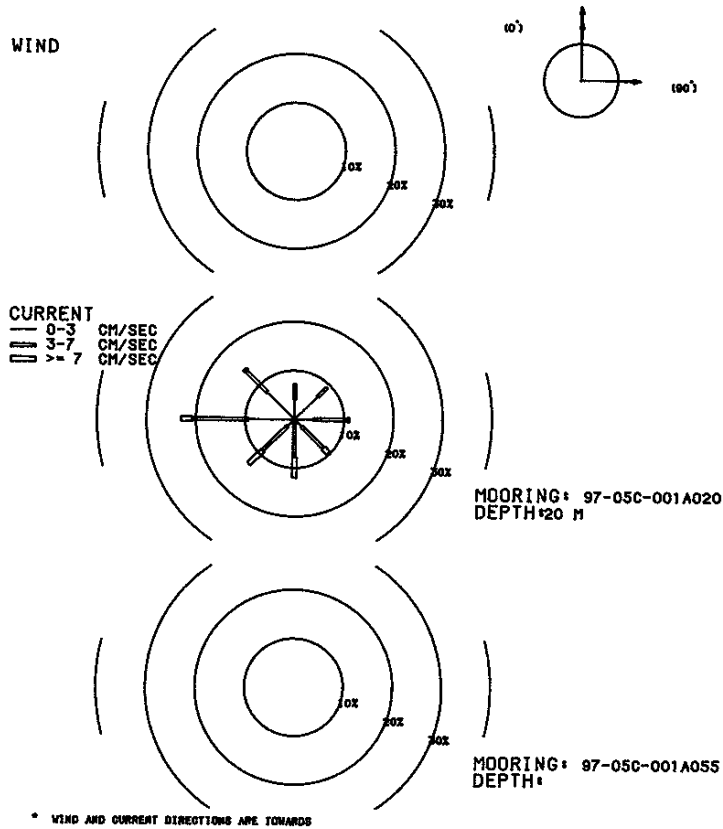

MOORING IS 97-05C-001A020 DEPTH IS 20 METERS THERE ARE 696 VALUES

FIRST DAY 1998/04/01/0000
 FINAL DAY 1998/04/29/2300

SHORELINE ORIENTATION IN DEGREES TRUE SPECIFIED AS 90

DIRECTION DEG TRUE	PERCENT OBSERVED	MAXIMUM CURRENT CM/S	MEAN DURA- TION HOURS	MEAN EXCUR- SION KM	MEAN CURRENT CM/S	MEAN TEMP DEG C
TOWARD	TOTAL	LIGHT	MEDIUM	HIGH		
90.0	11.1	3.7	7.0	0.3	8.0	2.8
45.0	9.3	6.6	2.7	0.0	5.5	1.9
0.0	7.3	4.2	3.2	0.0	6.9	1.6
315.0	14.4	7.9	6.0	0.4	8.1	2.0
270.0	23.0	9.3	11.4	2.3	9.3	3.1
225.0	13.1	2.0	7.0	4.0	9.3	3.0
180.0	12.1	0.6	7.2	4.3	9.3	4.0
135.0	9.8	2.2	6.0	1.6	7.9	2.5

MEAN SCALAR SPEED = 4.1 CM/S MEAN SQUARE SPEED = 21.2 CM²/S²
 MEAN SQUARE E-W SPEED = 11.2 CM²/S² MEAN SQUARE N-S SPEED = 10.0 CM²/S²
 MEAN VELOCITY = 1.2 CM/S, 223 DEG TRUE MEAN TEMPERATURE = 4.0 C
 VARIANCE (U,V) = 9.9 CM²/S² TOTAL HOURS = 696.

PERCENT OBSERVED
 LIGHT (0.0 - 3.0) 36.5% MEDIUM (3.0 - 7.0) 50.6% HIGH (GE 7.0) 12.9%

DATE: 1997/05/01 TO 1997/05/31
ROSE SUMMARY: WIND AND CURRENT

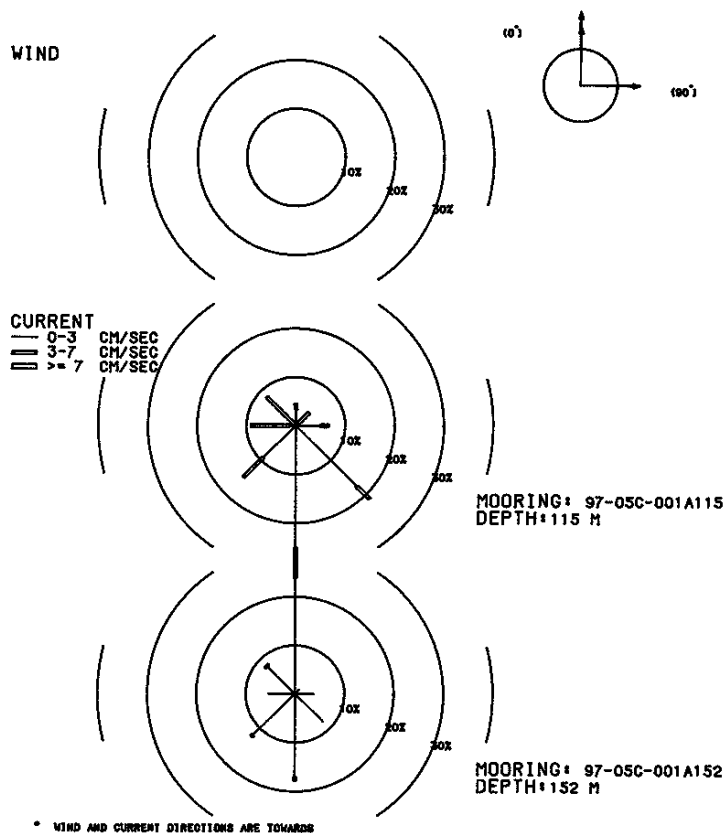

MOORING IS 97-05C-001A115 DEPTH IS 115 METERS THERE ARE 240 VALUES

FIRST DAY 1997/05/22/0000
FINAL DAY 1997/05/31/2300

SHORELINE ORIENTATION IN DEGREES TRUE SPECIFIED AS 90

DIRECTION DEG TRUE	PERCENT OBSERVED	TOWARD	TOTAL	LIGHT	MEDIUM	HIGH	MAXIMUM CURRENT CM/S	MEAN DURA- TION HOURS	MEAN EXCUR- SION KM	MEAN CURRENT CM/S	MEAN TEMP DEG C
90.0	6.7	5.0	1.7	0.0	3.7	3.2	0.3	2.6	3.6		
45.0	3.8	0.4	3.3	0.0	6.0	3.0	0.5	4.3	3.6		
0.0	4.6	3.3	1.2	0.0	3.5	1.6	0.1	2.2	3.6		
315.0	8.3	0.0	8.3	0.0	5.8	10.0	1.7	4.8	3.6		
270.0	9.2	1.2	7.9	0.0	6.8	7.3	1.3	5.1	3.6		
225.0	15.0	9.2	5.8	0.0	4.8	3.6	0.4	3.0	3.6		
180.0	31.2	25.0	6.2	0.0	5.0	4.2	0.4	2.7	3.6		
135.0	21.2	17.5	3.8	0.0	3.5	3.4	0.3	2.4	3.6		
MEAN SCALAR SPEED = 3.1 CM/S		MEAN SQUARE SPEED = 11.2 CM2/S2									
MEAN SQUARE E-W SPEED = 5.5 CM2/S2		MEAN SQUARE N-S SPEED = 5.8 CM2/S2									
MEAN VELOCITY = 1.2 CM/S,		201 DEG TRUE		MEAN TEMPERATURE = 3.6 C							
VARIANCE (U,V) = 4.9 CM2/S2		TOTAL HOURS = 240.									

PERCENT OBSERVED

LIGHT (0.0 - 3.0) 61.7% MEDIUM (3.0 - 7.0) 38.3% HIGH (GE 7.0) 0.0%

MOORING IS 97-05C-001A152 DEPTH IS 152 METERS THERE ARE 241 VALUES

FIRST DAY 1997/05/21/2300
FINAL DAY 1997/05/31/2300

SHORELINE ORIENTATION IN DEGREES TRUE SPECIFIED AS 90

DIRECTION DEG TRUE	PERCENT OBSERVED	TOWARD	TOTAL	LIGHT	MEDIUM	HIGH	MAXIMUM CURRENT CM/S	MEAN DURA- TION HOURS	MEAN EXCUR- SION KM	MEAN CURRENT CM/S	MEAN TEMP DEG C
90.0	3.7	3.7	0.0	0.0	2.2	4.5	0.3	2.1	3.5		
45.0	1.2	1.2	0.0	0.0	2.1	1.5	0.1	2.0	3.5		
0.0	42.7	42.7	0.0	0.0	2.4	4.3	0.1	0.3	3.5		
315.0	8.3	7.9	0.0	0.4	9.6	10.0	1.0	2.7	3.5		
270.0	5.4	5.4	0.0	0.0	2.4	3.2	0.3	2.2	3.5		
225.0	12.4	12.0	0.4	0.0	3.4	2.7	0.2	2.3	3.5		
180.0	17.8	17.0	0.8	0.0	3.5	2.4	0.2	2.3	3.5		
135.0	8.3	8.3	0.0	0.0	2.3	2.5	0.2	2.1	3.5		
MEAN SCALAR SPEED = 1.5 CM/S		MEAN SQUARE SPEED = 3.6 CM2/S2									
MEAN SQUARE E-W SPEED = 1.4 CM2/S2		MEAN SQUARE N-S SPEED = 2.2 CM2/S2									
MEAN VELOCITY = 0.5 CM/S,		209 DEG TRUE		MEAN TEMPERATURE = 3.5 C							
VARIANCE (U,V) = 1.7 CM2/S2		TOTAL HOURS = 241.									

PERCENT OBSERVED

LIGHT (0.0 - 3.0) 98.3% MEDIUM (3.0 - 7.0) 1.2% HIGH (GE 7.0) 0.4%

DATE: 1997/06/01 TO 1997/06/30
ROSE SUMMARY: WIND AND CURRENT

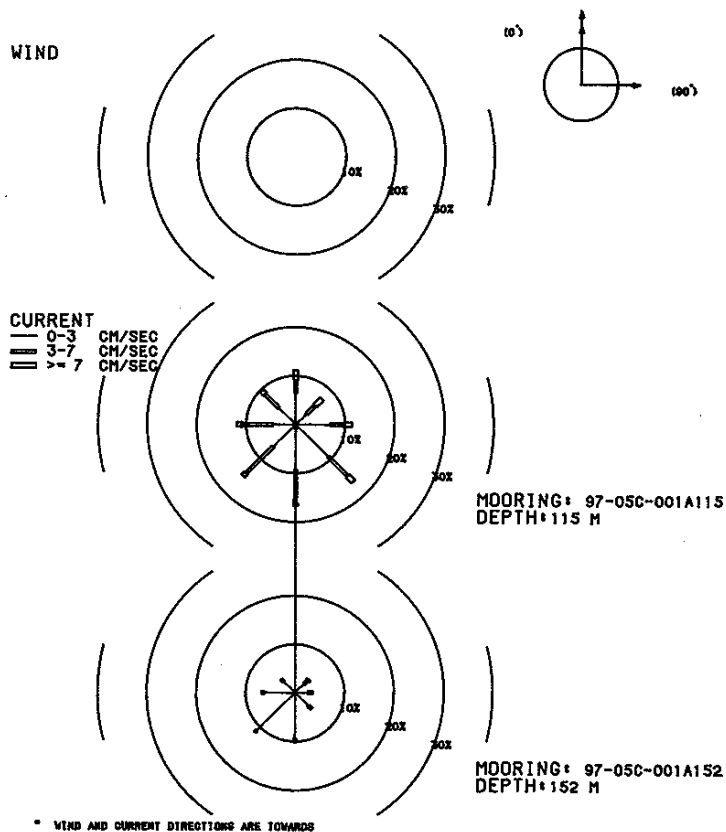

MOORING IS 97-05C-001A115 DEPTH IS 115 METERS THERE ARE 720 VALUES

FIRST DAY 1997/06/01/0000
FINAL DAY 1997/06/30/2300

SHORELINE ORIENTATION IN DEGREES TRUE SPECIFIED AS 90

DIRECTION DEG TRUE	PERCENT OBSERVED	MAXIMUM CURRENT	MEAN DURA- TION HOURS	MEAN EXCUR- SION KM	MEAN CURRENT CM/S	MEAN TEMP DEG C
TOWARD	TOTAL	LIGHT	MEDIUM	HIGH	CM/S	
90.0	11.4	6.9	2.8	1.7	10.7	2.1
45.0	7.5	3.1	2.5	1.9	11.7	1.8
0.0	11.2	6.5	2.6	2.1	11.0	2.0
315.0	9.7	4.7	4.0	1.0	8.4	1.9
270.0	11.9	4.6	6.3	1.1	8.7	2.7
225.0	15.0	6.4	7.8	0.8	7.7	3.0
180.0	16.7	9.3	6.8	0.6	7.7	2.8
135.0	16.5	9.3	5.6	1.7	10.2	2.6
MEAN SCALAR SPEED = 3.8 CM/S		MEAN SQUARE SPEED = 19.2 CM2/S2				
MEAN SQUARE E-W SPEED = 9.7 CM2/S2		MEAN SQUARE N-S SPEED = 9.5 CM2/S2				
MEAN VELOCITY = 0.5 CM/S,		185 DEG TRUE		MEAN TEMPERATURE = 3.7 C		
VARIANCE (U,V) = 9.5 CM2/S2		TOTAL HOURS = 720.				

PERCENT OBSERVED
LIGHT (0.0 - 3.0) 50.8% MEDIUM (3.0 - 7.0) 38.3% HIGH (GE 7.0) 10.8%

MOORING IS 97-05C-001A152 DEPTH IS 152 METERS THERE ARE 720 VALUES

FIRST DAY 1997/06/01/0000
FINAL DAY 1997/06/30/2300

SHORELINE ORIENTATION IN DEGREES TRUE SPECIFIED AS 90

DIRECTION DEG TRUE	PERCENT OBSERVED	MAXIMUM CURRENT	MEAN DURA- TION HOURS	MEAN EXCUR- SION KM	MEAN CURRENT CM/S	MEAN TEMP DEG C
TOWARD	TOTAL	LIGHT	MEDIUM	HIGH	CM/S	
90.0	3.6	2.5	1.1	0.0	4.5	1.7
45.0	3.9	2.6	1.0	0.3	7.9	1.9
0.0	55.3	54.2	0.8	0.3	8.8	5.6
315.0	3.9	3.3	0.6	0.0	5.0	2.0
270.0	6.8	6.3	0.6	0.0	3.6	2.9
225.0	11.5	11.0	0.6	0.0	4.4	3.0
180.0	10.3	9.4	0.8	0.0	4.6	2.4
135.0	4.7	3.9	0.8	0.0	6.4	1.4
MEAN SCALAR SPEED = 1.2 CM/S		MEAN SQUARE SPEED = 3.5 CM2/S2				
MEAN SQUARE E-W SPEED = 1.4 CM2/S2		MEAN SQUARE N-S SPEED = 2.1 CM2/S2				
MEAN VELOCITY = 0.3 CM/S,		209 DEG TRUE		MEAN TEMPERATURE = 3.6 C		
VARIANCE (U,V) = 1.7 CM2/S2		TOTAL HOURS = 720.				

PERCENT OBSERVED
LIGHT (0.0 - 3.0) 93.2% MEDIUM (3.0 - 7.0) 6.3% HIGH (GE 7.0) 0.6%

DATE: 1997/07/01 TO 1997/07/31
ROSE SUMMARY: WIND AND CURRENT

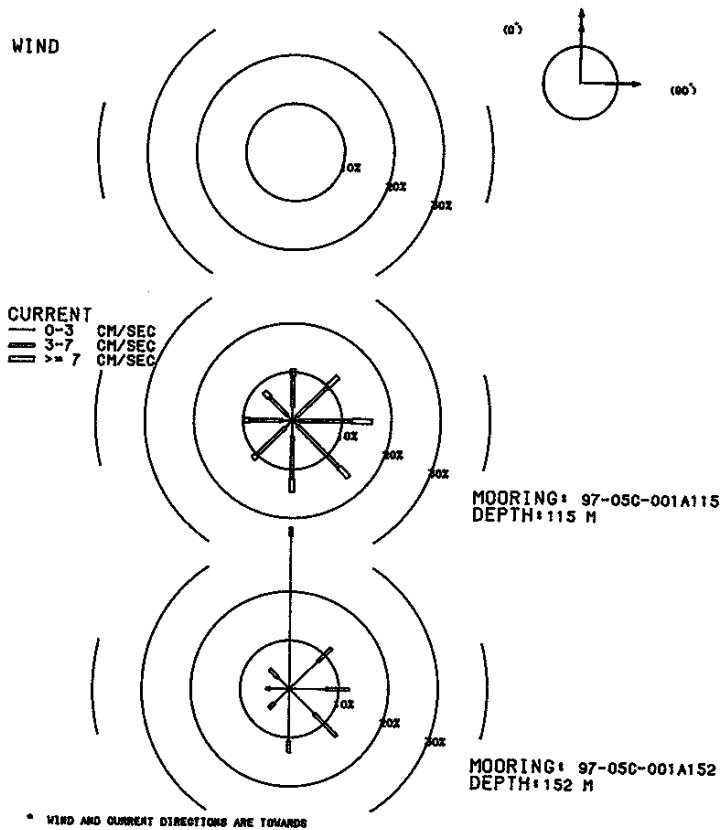

MOORING IS 97-05C-001A115 DEPTH IS 115 METERS THERE ARE 743 VALUES

FIRST DAY 1997/07/01/0000
FINAL DAY 1997/07/31/2300

SHORELINE ORIENTATION IN DEGREES TRUE SPECIFIED AS 90

DIRECTION DEG TRUE	PERCENT OBSERVED	TOWARD	TOTAL	LIGHT	MEDIUM	HIGH	MAXIMUM CURRENT CM/S	MEAN DURA- TION HOURS	MEAN EXCUR- SION KM	MEAN CURRENT CM/S	MEAN TEMP DEG C
90.0	16.2	1.3	10.6	4.2	10.2	2.8	0.6	5.6	3.8		
45.0	12.9	1.1	8.6	3.2	9.5	2.5	0.5	5.6	3.8		
0.0	10.6	2.8	6.5	1.3	8.5	2.2	0.4	4.6	3.8		
315.0	8.2	1.5	5.1	1.6	8.1	1.9	0.3	5.0	3.8		
270.0	10.0	2.0	6.6	1.3	7.8	2.3	0.4	4.7	3.8		
225.0	11.2	2.0	8.1	1.1	8.1	2.0	0.3	4.7	3.8		
180.0	14.7	3.2	8.7	2.7	8.9	2.5	0.4	4.9	3.8		
135.0	16.3	1.5	11.8	3.0	10.2	2.8	0.5	5.5	3.8		
0		MEAN SCALAR SPEED = 5.1 CM/S		MEAN SQUARE SPEED = 30.1 CM2/S2							
		MEAN SQUARE E-W SPEED = 15.7 CM2/S2		MEAN SQUARE N-S SPEED = 14.4 CM2/S2							
		MEAN VELOCITY = 1.1 CM/S,		119 DEG TRUE		MEAN TEMPERATURE = 3.8 C					
		VARIANCE (U,V) = 14.5 CM2/S2		TOTAL HOURS = 743.							

PERCENT OBSERVED
LIGHT (0.0 - 3.0) 15.5% MEDIUM (3.0 - 7.0) 66.1% HIGH (GE 7.0) 18.4%

MOORING IS 97-05C-001A152 DEPTH IS 152 METERS THERE ARE 744 VALUES

FIRST DAY 1997/07/01/0000
FINAL DAY 1997/07/31/2300

SHORELINE ORIENTATION IN DEGREES TRUE SPECIFIED AS 90

DIRECTION DEG TRUE	PERCENT OBSERVED	TOWARD	TOTAL	LIGHT	MEDIUM	HIGH	MAXIMUM CURRENT CM/S	MEAN DURA- TION HOURS	MEAN EXCUR- SION KM	MEAN CURRENT CM/S	MEAN TEMP DEG C
90.0	12.1	7.4	4.7	0.0	5.6	3.0	0.3	2.9	3.7		
45.0	12.0	8.1	3.9	0.0	5.1	2.9	0.3	2.7	3.7		
0.0	33.1	31.3	1.7	0.0	4.6	3.4	0.1	0.6	3.7		
315.0	5.6	3.2	2.4	0.0	4.5	1.9	0.2	2.8	3.7		
270.0	4.7	3.9	0.8	0.0	3.3	2.3	0.2	2.5	3.7		
225.0	5.8	4.3	1.5	0.0	4.5	1.9	0.2	2.5	3.7		
180.0	13.0	10.6	2.4	0.0	5.3	3.2	0.3	2.5	3.7		
135.0	13.7	7.3	6.5	0.0	6.0	3.0	0.3	3.1	3.7		
0		MEAN SCALAR SPEED = 2.0 CM/S		MEAN SQUARE SPEED = 6.2 CM2/S2							
		MEAN SQUARE E-W SPEED = 3.1 CM2/S2		MEAN SQUARE N-S SPEED = 3.1 CM2/S2							
		MEAN VELOCITY = 0.6 CM/S,		110 DEG TRUE		MEAN TEMPERATURE = 3.7 C					
		VARIANCE (U,V) = 2.9 CM2/S2		TOTAL HOURS = 744.							

PERCENT OBSERVED
LIGHT (0.0 - 3.0) 76.1% MEDIUM (3.0 - 7.0) 23.9% HIGH (GE 7.0) 0.0%

DATE: 1997/08/01 TO 1997/08/31
ROSE SUMMARY: WIND AND CURRENT

WIND

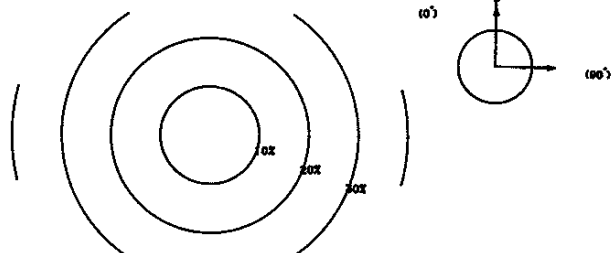

CURRENT
— 0-3 CM/SEC
= 3-7 CM/SEC
≡ 7-11 CM/SEC

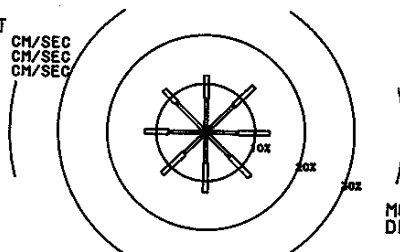

MOORING: 97-05C-001A115
DEPTH: 115 M

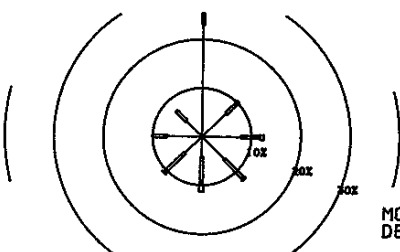

MOORING: 97-05C-001A152
DEPTH: 152 M

* WIND AND CURRENT DIRECTIONS ARE TOWARDS

MOORING IS 97-05C-001A115 DEPTH IS 115 METERS THERE ARE 744 VALUES

FIRST DAY 1997/08/01/0000
FINAL DAY 1997/08/31/2300

SHORELINE ORIENTATION IN DEGREES TRUE SPECIFIED AS 90

DIRECTION DEG TRUE	PERCENT OBSERVED	TOWARD	LIGHT	MEDIUM	HIGH	MAXIMUM CURRENT CM/S	MEAN DURA- TION HOURS	MEAN EXCUR- SION KM	MEAN CURRENT CM/S	MEAN TEMP DEG C
90.0	12.9	0.8	5.8	6.3	12.7	2.5	0.6	6.9	3.7	
45.0	13.6	1.1	6.9	5.6	10.6	2.6	0.6	6.2	3.7	
0.0	11.7	1.3	5.6	4.7	10.0	2.0	0.4	5.8	3.7	
315.0	12.1	0.5	7.9	3.6	9.2	2.2	0.5	5.9	3.7	
270.0	12.4	0.8	6.7	4.8	11.2	2.3	0.5	6.3	3.7	
225.0	12.2	1.1	5.0	6.2	13.7	2.3	0.6	6.9	3.7	
180.0	12.4	1.1	5.2	6.0	14.2	2.3	0.6	7.3	3.7	
135.0	12.8	0.7	6.3	5.8	12.3	2.3	0.6	6.7	3.7	

MEAN SCALAR SPEED = 6.5 CM/S MEAN SQUARE SPEED = 47.7 CM2/S2
MEAN SQUARE E-W SPEED = 23.9 CM2/S2 MEAN SQUARE N-S SPEED = 23.8 CM2/S2
MEAN VELOCITY = 0.5 CM/S, 151 DEG TRUE MEAN TEMPERATURE = 3.7 C
VARIANCE (U,V) = 23.8 CM2/S2 TOTAL HOURS = 744.

PERCENT OBSERVED
LIGHT (0.0 - 3.0) 7.4% MEDIUM (3.0 - 7.0) 49.5% HIGH (GE 7.0) 43.1%

MOORING IS 97-05C-001A152 DEPTH IS 152 METERS THERE ARE 744 VALUES

FIRST DAY 1997/08/01/0000
FINAL DAY 1997/08/31/2300

SHORELINE ORIENTATION IN DEGREES TRUE SPECIFIED AS 90

DIRECTION DEG TRUE	PERCENT OBSERVED	TOWARD	LIGHT	MEDIUM	HIGH	MAXIMUM CURRENT CM/S	MEAN DURA- TION HOURS	MEAN EXCUR- SION KM	MEAN CURRENT CM/S	MEAN TEMP DEG C
90.0	12.5	7.9	3.8	0.8	9.0	3.2	0.4	3.3	3.6	
45.0	10.3	6.9	3.5	0.0	6.2	2.9	0.3	3.0	3.6	
0.0	25.4	23.0	2.4	0.0	5.7	3.6	0.1	0.9	3.6	
315.0	7.4	4.4	3.0	0.0	6.7	2.5	0.3	2.8	3.6	
270.0	10.1	7.1	3.0	0.0	5.9	3.1	0.3	2.7	3.6	
225.0	10.8	4.8	5.8	0.1	7.5	3.3	0.4	3.4	3.6	
180.0	11.3	4.2	5.6	1.5	8.8	3.7	0.5	4.0	3.6	
135.0	12.2	6.6	5.2	0.4	8.8	3.6	0.4	3.4	3.6	

MEAN SCALAR SPEED = 2.7 CM/S MEAN SQUARE SPEED = 10.3 CM2/S2
MEAN SQUARE E-W SPEED = 4.8 CM2/S2 MEAN SQUARE N-S SPEED = 5.4 CM2/S2
MEAN VELOCITY = 0.5 CM/S, 152 DEG TRUE MEAN TEMPERATURE = 3.6 C
VARIANCE (U,V) = 5.0 CM2/S2 TOTAL HOURS = 744.

PERCENT OBSERVED
LIGHT (0.0 - 3.0) 64.9% MEDIUM (3.0 - 7.0) 32.3% HIGH (GE 7.0) 2.8%

DATE: 1997/09/01 TO 1997/09/30
ROSE SUMMARY: WIND AND CURRENT

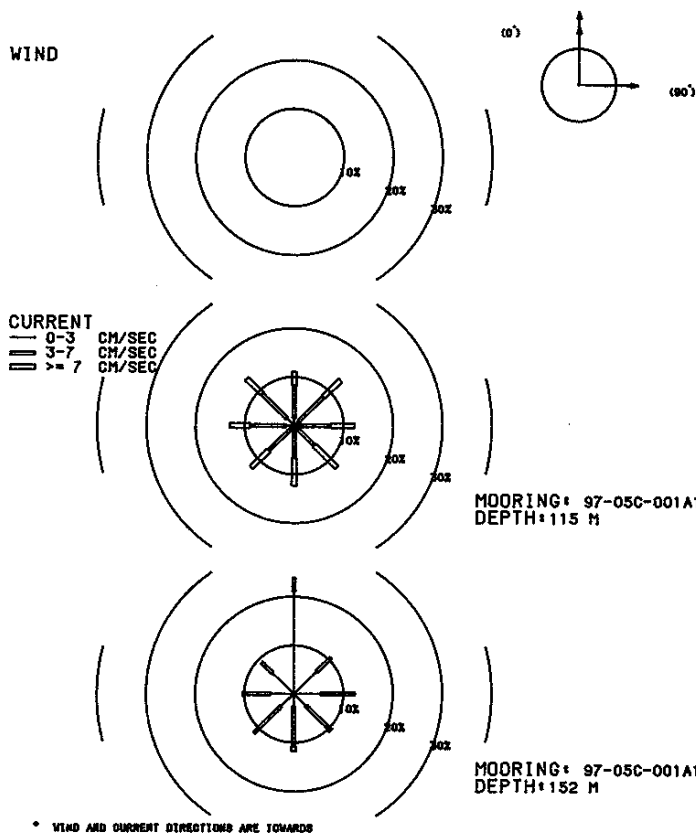

MOORING IS 97-05C-001A115 DEPTH IS 115 METERS THERE ARE 720 VALUES

FIRST DAY 1997/09/01/0000
FINAL DAY 1997/09/30/2300

SHORELINE ORIENTATION IN DEGREES TRUE SPECIFIED AS 90

DIRECTION DEG TRUE	PERCENT OBSERVED	MAXIMUM CURRENT CM/S	MEAN DURA- TION HOURS	MEAN EXCUR- SION KM	MEAN CURRENT CM/S	MEAN TEMP DEG C
TOWARD	TOTAL	LIGHT	MEDIUM	HIGH		
90.0	12.2	0.7	6.7	4.9	11.2	3.1
45.0	13.2	1.2	7.1	4.9	10.4	3.2
0.0	11.1	1.5	6.7	2.9	10.2	2.7
315.0	13.6	1.9	7.2	4.4	10.3	3.4
270.0	13.1	1.7	7.2	4.2	10.2	3.1
225.0	12.2	1.0	6.3	5.0	10.8	3.0
180.0	12.4	0.7	6.0	5.7	10.8	3.2
135.0	12.2	0.7	5.0	6.5	11.0	3.8
MEAN SCALAR SPEED =		6.2 CM/S	MEAN SQUARE SPEED =		43.0 CM2/S2	
MEAN SQUARE E-W SPEED =		21.6 CM2/S2	MEAN SQUARE N-S SPEED =		21.4 CM2/S2	
MEAN VELOCITY =		0.2 CM/S,	155 DEG TRUE		MEAN TEMPERATURE = 3.7 C	
VARIANCE (U,V) =		21.5 CM2/S2	TOTAL HOURS =		720.	

PERCENT OBSERVED

LIGHT (0.0 - 3.0) 9.4% MEDIUM (3.0 - 7.0) 52.1% HIGH (GE 7.0) 38.5%

MOORING IS 97-05C-001A152 DEPTH IS 152 METERS THERE ARE 720 VALUES

FIRST DAY 1997/09/01/0000
FINAL DAY 1997/09/30/2300

SHORELINE ORIENTATION IN DEGREES TRUE SPECIFIED AS 90

DIRECTION DEG TRUE	PERCENT OBSERVED	MAXIMUM CURRENT CM/S	MEAN DURA- TION HOURS	MEAN EXCUR- SION KM	MEAN CURRENT CM/S	MEAN TEMP DEG C
TOWARD	TOTAL	LIGHT	MEDIUM	HIGH		
90.0	12.4	5.4	6.9	0.0	6.8	4.5
45.0	10.6	6.5	4.0	0.0	6.7	3.3
0.0	23.9	21.1	2.8	0.0	5.4	4.0
315.0	9.2	6.0	3.2	0.0	6.7	3.3
270.0	10.3	4.7	5.4	0.1	7.0	4.1
225.0	11.4	3.6	7.8	0.0	6.8	4.1
180.0	11.8	2.6	8.2	1.0	8.0	5.3
135.0	10.6	3.5	6.9	0.1	7.2	4.2
MEAN SCALAR SPEED =		3.1 CM/S	MEAN SQUARE SPEED =		12.7 CM2/S2	
MEAN SQUARE E-W SPEED =		5.9 CM2/S2	MEAN SQUARE N-S SPEED =		6.8 CM2/S2	
MEAN VELOCITY =		0.5 CM/S,	168 DEG TRUE		MEAN TEMPERATURE = 3.6 C	
VARIANCE (U,V) =		6.3 CM2/S2	TOTAL HOURS =		720.	

PERCENT OBSERVED

LIGHT (0.0 - 3.0) 53.5% MEDIUM (3.0 - 7.0) 45.3% HIGH (GE 7.0) 1.2%

DATE: 1997/10/01 TO 1997/10/31
ROSE SUMMARY: WIND AND CURRENT

WIND

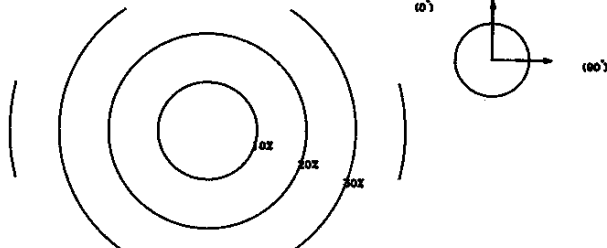

CURRENT
 0-3 CM/SEC
 3-7 CM/SEC
 >= 7 CM/SEC

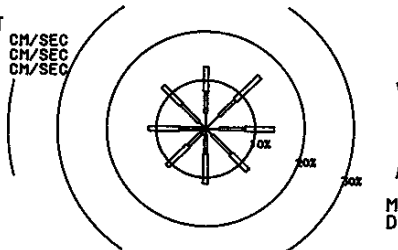

MOORING: 97-05C-001A115
DEPTH: 115 M

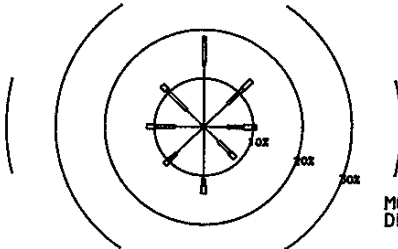

MOORING: 97-05C-001A152
DEPTH: 152 M

* WIND AND CURRENT DIRECTIONS ARE TOWARDS

MOORING IS 97-05C-001A115 DEPTH IS 115 METERS THERE ARE 744 VALUES

FIRST DAY 1997/10/01/0000
FINAL DAY 1997/10/31/2300

SHORELINE ORIENTATION IN DEGREES TRUE SPECIFIED AS 90

DIRECTION DEG TRUE	PERCENT OBSERVED	TOWARD	TOTAL	LIGHT	MEDIUM	HIGH	MAXIMUM CURRENT CM/S	MEAN DURA- TION HOURS	MEAN EXCUR- SION KM	MEAN CURRENT CM/S	MEAN TEMP DEG C
90.0	13.8	2.7	5.2	5.9	19.2	2.8	0.7	6.9	3.7		
45.0	15.3	3.9	4.4	7.0	16.8	2.9	0.7	6.5	3.7		
0.0	12.8	3.2	4.4	5.1	15.4	2.6	0.6	6.0	3.7		
315.0	12.2	1.9	5.0	5.4	15.6	2.5	0.6	6.6	3.7		
270.0	11.6	1.1	4.2	6.3	16.1	2.5	0.7	7.4	3.8		
225.0	10.9	1.1	3.9	5.9	20.7	2.5	0.7	7.9	3.8		
180.0	11.3	1.2	3.9	6.2	20.7	2.5	0.7	7.7	3.8		
135.0	12.1	1.7	5.5	4.8	19.7	2.7	0.7	6.9	3.7		
0	MEAN SCALAR SPEED = 6.9 CM/S		MEAN SQUARE SPEED = 63.1 CM2/S2								
	MEAN SQUARE E-W SPEED = 31.7 CM2/S2		MEAN SQUARE N-S SPEED = 31.3 CM2/S2								
	MEAN VELOCITY = 0.2 CM/S,		91 DEG TRUE		MEAN TEMPERATURE = 3.7 C						
	VARIANCE (U,V) = 31.5 CM2/S2		TOTAL HOURS = 744.								

PERCENT OBSERVED

LIGHT (0.0 - 3.0) 16.8% MEDIUM (3.0 - 7.0) 36.6% HIGH (GE 7.0) 46.6%

MOORING IS 97-05C-001A152 DEPTH IS 152 METERS THERE ARE 744 VALUES

FIRST DAY 1997/10/01/0000
FINAL DAY 1997/10/31/2300

SHORELINE ORIENTATION IN DEGREES TRUE SPECIFIED AS 90

DIRECTION DEG TRUE	PERCENT OBSERVED	TOWARD	TOTAL	LIGHT	MEDIUM	HIGH	MAXIMUM CURRENT CM/S	MEAN DURA- TION HOURS	MEAN EXCUR- SION KM	MEAN CURRENT CM/S	MEAN TEMP DEG C
90.0	10.6	4.8	3.2	2.6	12.5	2.5	0.4	4.5	3.7		
45.0	13.6	6.9	4.3	2.4	9.8	3.1	0.5	4.1	3.7		
0.0	18.5	12.6	5.9	0.0	6.3	3.1	0.2	2.1	3.7		
315.0	12.0	4.8	5.8	1.3	10.1	3.2	0.5	4.1	3.7		
270.0	11.6	5.8	4.2	1.6	10.6	3.1	0.4	4.0	3.7		
225.0	11.0	7.8	1.7	1.5	13.7	3.0	0.4	3.9	3.7		
180.0	13.7	10.8	1.3	1.6	14.2	3.3	0.4	3.6	3.7		
135.0	9.0	4.3	3.4	1.3	14.8	2.5	0.4	4.2	3.7		
0	MEAN SCALAR SPEED = 3.7 CM/S		MEAN SQUARE SPEED = 20.9 CM2/S2								
	MEAN SQUARE E-W SPEED = 9.8 CM2/S2		MEAN SQUARE N-S SPEED = 11.1 CM2/S2								
	MEAN VELOCITY = 0.1 CM/S,		61 DEG TRUE		MEAN TEMPERATURE = 3.7 C						
	VARIANCE (U,V) = 10.5 CM2/S2		TOTAL HOURS = 744.								

PERCENT OBSERVED

LIGHT (0.0 - 3.0) 57.8% MEDIUM (3.0 - 7.0) 29.8% HIGH (GE 7.0) 12.4%

DATE: 1997/11/01 TO 1997/11/30
ROSE SUMMARY: WIND AND CURRENT

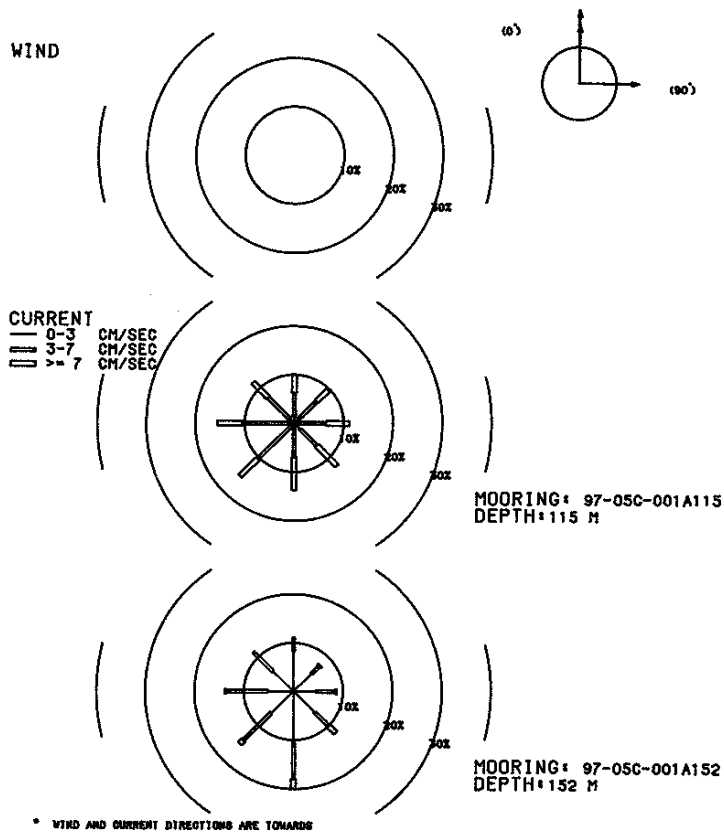

MOORING IS 97-05C-001A115 DEPTH IS 115 METERS THERE ARE 720 VALUES

FIRST DAY 1997/11/01/0000
FINAL DAY 1997/11/30/2300

SHORELINE ORIENTATION IN DEGREES TRUE SPECIFIED AS 90

DIRECTION DEG TRUE	PERCENT OBSERVED	MAXIMUM CURRENT	MEAN DURA- TION HOURS	MEAN EXCUR- SION KM	MEAN CURRENT CM/S	MEAN TEMP DEG C
TOWARD	TOTAL	LIGHT	MEDIUM	HIGH	CM/S	
90.0	11.2	1.0	5.4	4.9	15.0	2.9
45.0	9.7	1.2	5.1	3.3	12.7	2.4
0.0	10.1	1.2	5.0	3.9	11.6	2.4
315.0	11.8	1.4	6.0	4.4	11.6	2.6
270.0	15.6	0.8	9.6	5.1	11.5	3.5
225.0	15.4	0.7	9.6	5.1	12.8	3.7
180.0	13.8	0.7	6.3	6.8	15.1	3.5
135.0	12.4	1.7	4.7	6.0	14.2	2.9

MEAN SCALAR SPEED = 6.5 CM/S MEAN SQUARE SPEED = 49.0 CM2/S2
 MEAN SQUARE E-W SPEED = 24.5 CM2/S2 MEAN SQUARE N-S SPEED = 24.5 CM2/S2
 MEAN VELOCITY = 0.9 CM/S, 215 DEG TRUE MEAN TEMPERATURE = 3.8 C
 VARIANCE (U,V) = 24.2 CM2/S2 TOTAL HOURS = 720.

PERCENT OBSERVED
 LIGHT (0.0 - 3.0) 8.8% MEDIUM (3.0 - 7.0) 51.7% HIGH (GE 7.0) 39.6%

MOORING IS 97-05C-001A152 DEPTH IS 152 METERS THERE ARE 720 VALUES

FIRST DAY 1997/11/01/0000
FINAL DAY 1997/11/30/2300

SHORELINE ORIENTATION IN DEGREES TRUE SPECIFIED AS 90

DIRECTION DEG TRUE	PERCENT OBSERVED	MAXIMUM CURRENT	MEAN DURA- TION HOURS	MEAN EXCUR- SION KM	MEAN CURRENT CM/S	MEAN TEMP DEG C
TOWARD	TOTAL	LIGHT	MEDIUM	HIGH	CM/S	
90.0	8.8	4.6	3.9	0.3	8.4	3.3
45.0	7.6	5.1	2.1	0.4	8.8	2.5
0.0	11.1	8.3	2.8	0.0	6.6	2.8
315.0	11.4	5.7	5.7	0.0	6.7	3.7
270.0	13.9	5.1	8.5	0.3	7.5	4.8
225.0	15.1	6.3	7.9	1.0	8.9	5.0
180.0	20.0	10.4	7.5	2.1	10.9	4.6
135.0	12.1	6.1	3.9	2.1	11.4	3.5

MEAN SCALAR SPEED = 3.6 CM/S MEAN SQUARE SPEED = 16.3 CM2/S2
 MEAN SQUARE E-W SPEED = 7.3 CM2/S2 MEAN SQUARE N-S SPEED = 9.0 CM2/S2
 MEAN VELOCITY = 0.9 CM/S, 206 DEG TRUE MEAN TEMPERATURE = 3.7 C
 VARIANCE (U,V) = 7.8 CM2/S2 TOTAL HOURS = 720.

PERCENT OBSERVED
 LIGHT (0.0 - 3.0) 51.7% MEDIUM (3.0 - 7.0) 42.2% HIGH (GE 7.0) 6.1%

DATE: 1997/12/01 TO 1997/12/31
ROSE SUMMARY: WIND AND CURRENT

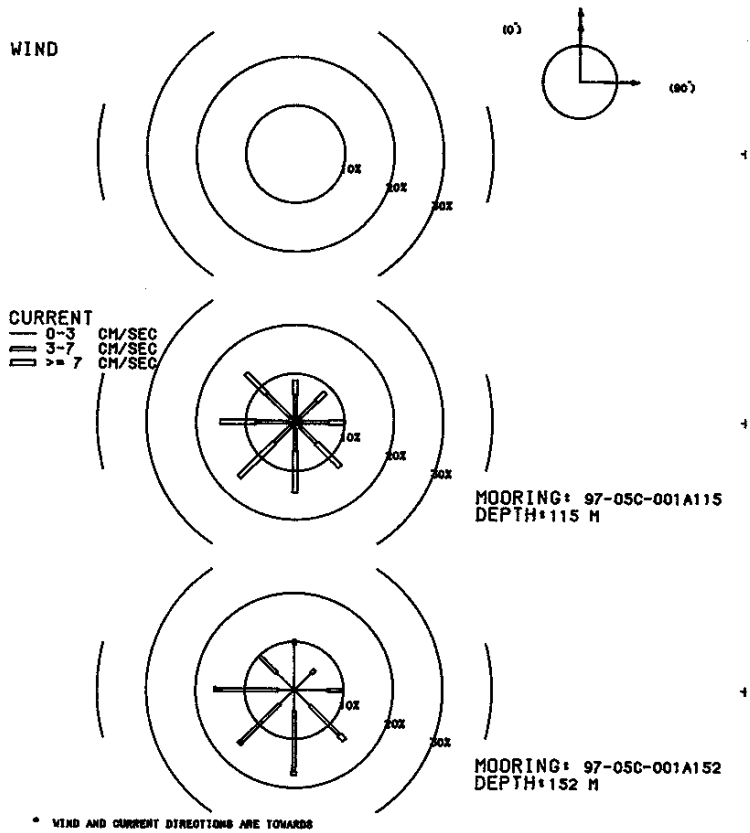

MOORING IS 97-05C-001A115 DEPTH IS 115 METERS THERE ARE 744 VALUES

FIRST DAY 1997/12/01/0000
FINAL DAY 1997/12/31/2300

SHORELINE ORIENTATION IN DEGREES TRUE SPECIFIED AS 90

DIRECTION DEG TRUE	PERCENT OBSERVED	TOWARD	TOTAL	LIGHT	MEDIUM	HIGH	MAXIMUM CURRENT CM/S	MEAN DURA- TION HOURS	MEAN EXCUR- SION KM	MEAN CURRENT CM/S	MEAN TEMP DEG C
90.0	10.1	0.3	6.5	3.4	10.9	3.0	0.7	6.3	3.8		
45.0	8.6	1.1	5.0	2.6	11.6	2.5	0.5	5.7	3.8		
0.0	8.6	0.9	4.7	3.0	10.0	2.1	0.4	5.9	3.8		
315.0	14.1	1.2	7.0	5.9	10.8	2.9	0.7	6.3	3.8		
270.0	15.2	1.3	6.6	7.3	10.4	3.2	0.8	6.5	3.8		
225.0	16.0	0.7	5.2	10.1	10.6	3.8	1.0	7.3	3.8		
180.0	14.5	1.3	4.6	8.6	13.2	3.4	0.9	7.3	3.8		
135.0	12.9	1.3	4.7	6.9	13.5	3.1	0.8	6.8	3.8		
0	MEAN SCALAR SPEED = 6.6 CM/S		MEAN SQUARE SPEED = 49.5 CM2/S2								
	MEAN SQUARE E-W SPEED = 24.6 CM2/S2		MEAN SQUARE N-S SPEED = 24.9 CM2/S2								
	MEAN VELOCITY = 1.3 CM/S,		222 DEG TRUE		MEAN TEMPERATURE = 3.8 C						
	VARIANCE (U,V) = 23.9 CM2/S2		TOTAL HOURS = 744.								

PERCENT OBSERVED
 LIGHT (0.0 - 3.0) 8.2% MEDIUM (3.0 - 7.0) 44.2% HIGH (GE 7.0) 47.6%

MOORING IS 97-05C-001A152 DEPTH IS 152 METERS THERE ARE 744 VALUES

FIRST DAY 1997/12/01/0000
FINAL DAY 1997/12/31/2300

SHORELINE ORIENTATION IN DEGREES TRUE SPECIFIED AS 90

DIRECTION DEG TRUE	PERCENT OBSERVED	TOWARD	TOTAL	LIGHT	MEDIUM	HIGH	MAXIMUM CURRENT CM/S	MEAN DURA- TION HOURS	MEAN EXCUR- SION KM	MEAN CURRENT CM/S	MEAN TEMP DEG C
90.0	9.7	6.6	3.1	0.0	6.6	3.3	0.4	3.1	3.7		
45.0	5.9	4.8	1.1	0.0	6.1	2.6	0.3	2.7	3.7		
0.0	10.3	9.4	0.9	0.0	4.5	3.0	0.2	2.3	3.7		
315.0	9.9	5.0	5.0	0.0	6.7	3.5	0.4	3.4	3.7		
270.0	16.3	3.2	12.8	0.3	7.7	4.7	0.7	4.2	3.7		
225.0	15.9	4.0	11.2	0.7	8.0	3.7	0.6	4.4	3.7		
180.0	17.5	4.3	12.4	0.8	9.4	4.3	0.7	4.3	3.7		
135.0	14.5	4.4	8.5	1.6	10.3	4.5	0.7	4.5	3.7		
0	MEAN SCALAR SPEED = 3.8 CM/S		MEAN SQUARE SPEED = 17.1 CM2/S2								
	MEAN SQUARE E-W SPEED = 8.0 CM2/S2		MEAN SQUARE N-S SPEED = 9.2 CM2/S2								
	MEAN VELOCITY = 1.2 CM/S,		206 DEG TRUE		MEAN TEMPERATURE = 3.7 C						
	VARIANCE (U,V) = 7.8 CM2/S2		TOTAL HOURS = 744.								

PERCENT OBSERVED
 LIGHT (0.0 - 3.0) 41.8% MEDIUM (3.0 - 7.0) 54.8% HIGH (GE 7.0) 3.4%

DATE: 1998/01/01 TO 1998/01/31
ROSE SUMMARY: WIND AND CURRENT

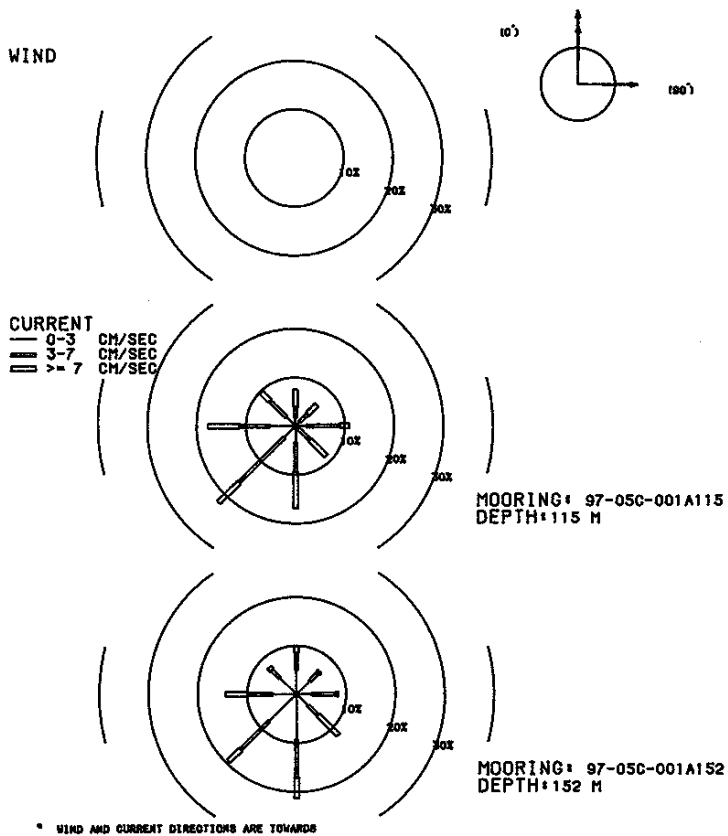

MOORING IS 97-05C-001A115 DEPTH IS 115 METERS THERE ARE 744 VALUES

FIRST DAY 1998/01/01/0000
FINAL DAY 1998/01/31/2300

SHORELINE ORIENTATION IN DEGREES TRUE SPECIFIED AS 90

DIRECTION DEG TRUE	PERCENT OBSERVED	MAXIMUM CURRENT	MEAN DURA- TION HOURS	MEAN EXCUR- SION KM	MEAN CURRENT CM/S	MEAN TEMP DEG C
TOWARD	TOTAL	LIGHT	MEDIUM	HIGH	CM/S	
90.0	10.9	2.2	6.9	1.9	10.3	3.9
45.0	6.2	1.2	2.3	2.7	10.3	2.9
0.0	7.5	1.7	2.2	3.6	15.3	2.7
315.0	9.8	2.6	4.7	2.6	14.0	2.8
270.0	17.7	5.2	6.0	6.5	13.9	4.1
225.0	22.2	3.2	13.0	5.9	17.4	5.0
180.0	16.9	3.4	6.0	7.5	15.9	6.0
135.0	8.7	0.7	3.4	4.7	14.5	4.1

0 MEAN SCALAR SPEED = 6.3 CM/S MEAN SQUARE SPEED = 53.6 CM2/S2
MEAN SQUARE E-W SPEED = 24.0 CM2/S2 MEAN SQUARE N-S SPEED = 29.6 CM2/S2
MEAN VELOCITY = 1.9 CM/S, 218 DEG TRUE MEAN TEMPERATURE = 4.2 C
VARIANCE (U,V) = 25.1 CM2/S2 TOTAL HOURS = 744.

PERCENT OBSERVED
LIGHT (0.0 - 3.0) 20.2% MEDIUM (3.0 - 7.0) 44.5% HIGH (GE 7.0) 35.3%

MOORING IS 97-05C-001A152 DEPTH IS 152 METERS THERE ARE 744 VALUES

FIRST DAY 1998/01/01/0000
FINAL DAY 1998/01/31/2300

SHORELINE ORIENTATION IN DEGREES TRUE SPECIFIED AS 90

DIRECTION DEG TRUE	PERCENT OBSERVED	MAXIMUM CURRENT	MEAN DURA- TION HOURS	MEAN EXCUR- SION KM	MEAN CURRENT CM/S	MEAN TEMP DEG C
TOWARD	TOTAL	LIGHT	MEDIUM	HIGH	CM/S	
90.0	8.5	3.1	5.0	0.4	7.2	5.7
45.0	6.6	3.8	2.4	0.4	7.5	3.3
0.0	9.9	5.0	3.6	1.3	11.4	3.2
315.0	7.8	4.7	2.3	0.8	9.8	3.2
270.0	14.4	4.8	4.8	4.7	11.9	4.7
225.0	19.5	7.8	8.2	3.5	13.5	4.1
180.0	21.4	9.4	7.7	4.3	13.4	4.0
135.0	12.0	3.4	2.8	5.8	11.2	5.2

0 MEAN SCALAR SPEED = 4.7 CM/S MEAN SQUARE SPEED = 30.1 CM2/S2
MEAN SQUARE E-W SPEED = 13.5 CM2/S2 MEAN SQUARE N-S SPEED = 16.6 CM2/S2
MEAN VELOCITY = 1.6 CM/S, 205 DEG TRUE MEAN TEMPERATURE = 4.1 C
VARIANCE (U,V) = 13.8 CM2/S2 TOTAL HOURS = 744.

PERCENT OBSERVED
LIGHT (0.0 - 3.0) 41.9% MEDIUM (3.0 - 7.0) 36.8% HIGH (GE 7.0) 21.2%

DATE: 1998/02/01 TO 1998/02/28
ROSE SUMMARY: WIND AND CURRENT

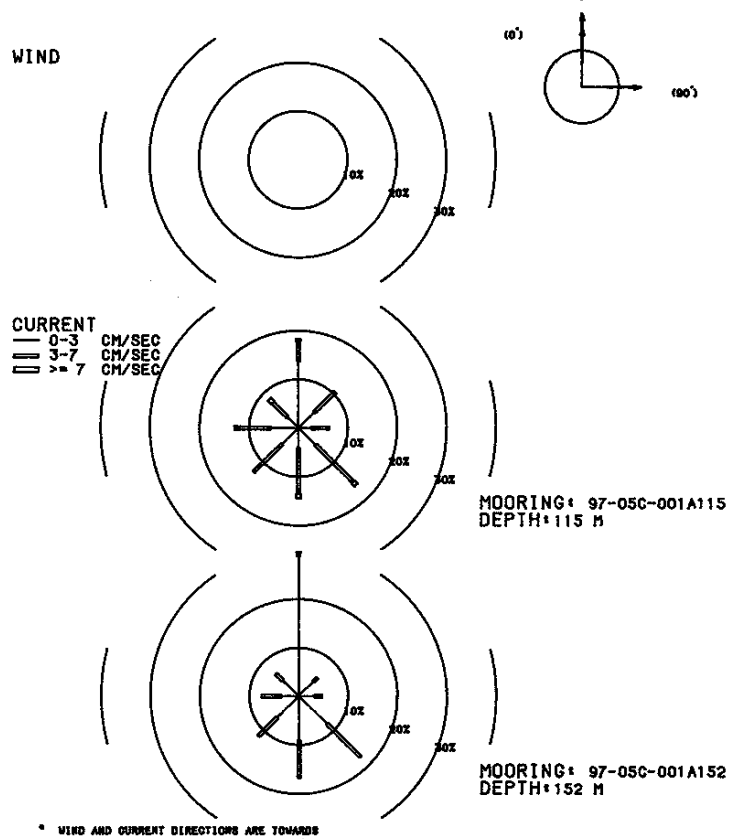

MOORING IS 97-05C-001A115 DEPTH IS 115 METERS THERE ARE 672 VALUES

FIRST DAY 1998/02/01/0000
FINAL DAY 1998/02/28/2300

SHORELINE ORIENTATION IN DEGREES TRUE SPECIFIED AS 90

DIRECTION DEG TRUE	PERCENT OBSERVED	TOWARD	TOTAL	LIGHT	MEDIUM	HIGH	MAXIMUM CURRENT CM/S	MEAN DURA- TION HOURS	MEAN EXCUR- SION KM	MEAN CURRENT CM/S	MEAN TEMP DEG C
90.0	6.2	2.5	3.7	0.0	6.6	1.7	0.2	3.7	3.8		
45.0	10.4	4.5	5.8	0.1	8.4	2.6	0.3	3.5	3.9		
0.0	18.3	13.7	4.2	0.4	9.3	4.2	0.3	1.7	3.8		
315.0	8.3	3.1	4.2	1.0	8.3	2.4	0.4	4.2	3.8		
270.0	12.9	5.7	6.7	0.6	7.7	4.3	0.6	3.9	3.8		
225.0	12.8	4.6	8.2	0.0	6.1	3.9	0.5	3.6	3.8		
180.0	14.4	4.2	9.4	0.9	8.2	3.6	0.5	4.0	3.8		
135.0	16.5	4.9	10.7	0.9	7.4	4.0	0.6	4.3	3.8		
0	MEAN SCALAR SPEED = 3.5 CM/S		MEAN SQUARE SPEED = 16.4 CM2/S2								
	MEAN SQUARE E-W SPEED = 7.8 CM2/S2		MEAN SQUARE N-S SPEED = 8.6 CM2/S2								
	MEAN VELOCITY = 0.6 CM/S,		182 DEG TRUE		MEAN TEMPERATURE = 3.8 C						
	VARIANCE (U,V) = 8.1 CM2/S2		TOTAL HOURS = 672.								

PERCENT OBSERVED
LIGHT (0.0 - 3.0) 43.2% MEDIUM (3.0 - 7.0) 52.8% HIGH (GE 7.0) 4.0%

MOORING IS 97-05C-001A152 DEPTH IS 152 METERS THERE ARE 672 VALUES

FIRST DAY 1998/02/01/0000
FINAL DAY 1998/02/28/2300

SHORELINE ORIENTATION IN DEGREES TRUE SPECIFIED AS 90

DIRECTION DEG TRUE	PERCENT OBSERVED	TOWARD	TOTAL	LIGHT	MEDIUM	HIGH	MAXIMUM CURRENT CM/S	MEAN DURA- TION HOURS	MEAN EXCUR- SION KM	MEAN CURRENT CM/S	MEAN TEMP DEG C
90.0	4.8	3.1	1.6	0.0	3.8	1.9	0.2	2.7	3.8		
45.0	5.4	4.2	1.2	0.0	6.8	2.2	0.2	2.6	3.8		
0.0	29.6	28.7	0.7	0.1	7.4	5.0	0.2	1.1	3.8		
315.0	6.5	4.5	2.1	0.0	5.0	2.8	0.3	2.7	3.8		
270.0	7.6	3.6	4.0	0.0	5.0	3.0	0.3	3.2	3.8		
225.0	11.6	6.1	5.5	0.0	5.1	2.9	0.3	3.1	3.8		
180.0	16.8	9.1	7.7	0.0	6.0	3.2	0.4	3.0	3.8		
135.0	17.7	8.0	9.7	0.0	5.6	5.2	0.6	3.2	3.8		
0	MEAN SCALAR SPEED = 2.4 CM/S		MEAN SQUARE SPEED = 7.8 CM2/S2								
	MEAN SQUARE E-W SPEED = 3.0 CM2/S2		MEAN SQUARE N-S SPEED = 4.8 CM2/S2								
	MEAN VELOCITY = 0.6 CM/S,		181 DEG TRUE		MEAN TEMPERATURE = 3.8 C						
	VARIANCE (U,V) = 3.7 CM2/S2		TOTAL HOURS = 672.								

PERCENT OBSERVED
LIGHT (0.0 - 3.0) 67.3% MEDIUM (3.0 - 7.0) 32.6% HIGH (GE 7.0) 0.1%

DATE: 1998/03/01 TO 1998/03/31
ROSE SUMMARY: WIND AND CURRENT

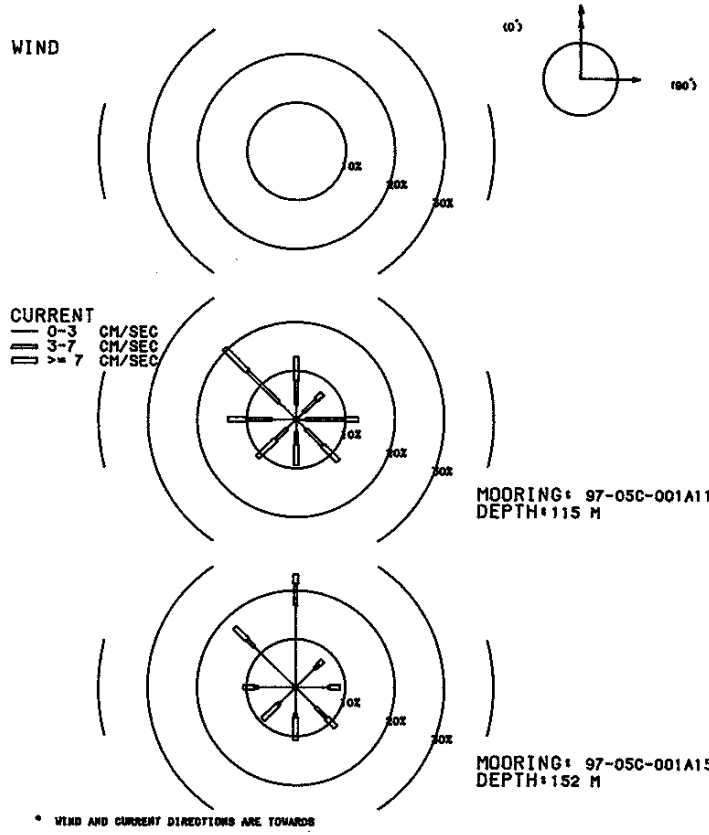

MOORING IS 97-05C-001A115 DEPTH IS 115 METERS THERE ARE 744 VALUES

FIRST DAY 1998/03/01/0000
FINAL DAY 1998/03/31/2300

SHORELINE ORIENTATION IN DEGREES TRUE SPECIFIED AS 90

DIRECTION DEG TRUE	PERCENT OBSERVED	MAXIMUM CURRENT CM/S	MEAN DURA- TION HOURS	MEAN EXCUR- SION KM	MEAN CURRENT CM/S	MEAN TEMP DEG C
TOWARD	TOTAL	LIGHT	MEDIUM	HIGH		
90.0	12.6	1.9	8.1	2.7	14.1	4.3
45.0	7.5	2.0	3.8	1.7	16.4	2.1
0.0	12.9	3.1	4.8	5.0	22.0	2.2
315.0	20.6	4.8	9.1	6.6	23.1	3.5
270.0	13.8	5.0	5.0	3.9	20.4	3.6
225.0	11.0	2.7	3.1	5.2	26.8	4.6
180.0	9.4	2.6	2.7	4.2	20.8	4.1
135.0	12.1	2.8	4.7	4.6	17.0	3.6
MEAN SCALAR SPEED = 7.3 CM/S		MEAN SQUARE SPEED = 87.3 CM ² /S ²				
MEAN SQUARE E-W SPEED = 39.6 CM ² /S ²		MEAN SQUARE N-S SPEED = 47.7 CM ² /S ²				
MEAN VELOCITY = 1.2 CM/S,		266 DEG TRUE		MEAN TEMPERATURE = 3.7 C		
VARIANCE (U,V) = 43.0 CM ² /S ²		TOTAL HOURS = 744.				

PERCENT OBSERVED
LIGHT (0.0 - 3.0) 24.9% MEDIUM (3.0 - 7.0) 41.3% HIGH (GE 7.0) 33.9%

MOORING IS 97-05C-001A152 DEPTH IS 152 METERS THERE ARE 744 VALUES

FIRST DAY 1998/03/01/0000
FINAL DAY 1998/03/31/2300

SHORELINE ORIENTATION IN DEGREES TRUE SPECIFIED AS 90

DIRECTION DEG TRUE	PERCENT OBSERVED	MAXIMUM CURRENT CM/S	MEAN DURA- TION HOURS	MEAN EXCUR- SION KM	MEAN CURRENT CM/S	MEAN TEMP DEG C
TOWARD	TOTAL	LIGHT	MEDIUM	HIGH		
90.0	9.0	6.6	0.3	2.2	10.4	3.2
45.0	7.8	5.5	1.1	1.2	12.9	2.4
0.0	23.3	16.8	4.6	1.9	19.6	3.0
315.0	17.5	11.8	2.0	3.6	20.2	3.4
270.0	10.6	7.5	0.8	2.3	15.8	3.8
225.0	9.4	4.6	0.5	4.3	21.3	4.7
180.0	10.9	5.4	0.8	4.7	20.0	3.7
135.0	11.6	5.8	3.1	2.7	15.3	4.5
MEAN SCALAR SPEED = 4.7 CM/S		MEAN SQUARE SPEED = 46.2 CM ² /S ²				
MEAN SQUARE E-W SPEED = 18.4 CM ² /S ²		MEAN SQUARE N-S SPEED = 27.8 CM ² /S ²				
MEAN VELOCITY = 0.7 CM/S,		250 DEG TRUE		MEAN TEMPERATURE = 3.6 C		
VARIANCE (U,V) = 22.9 CM ² /S ²		TOTAL HOURS = 744.				

PERCENT OBSERVED
LIGHT (0.0 - 3.0) 64.0% MEDIUM (3.0 - 7.0) 13.2% HIGH (GE 7.0) 22.8%

DATE: 1998/04/01 TO 1998/04/30
ROSE SUMMARY: WIND AND CURRENT

WIND

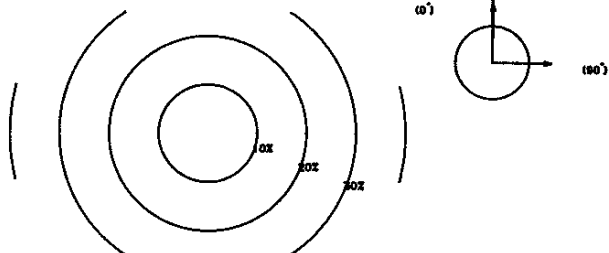

CURRENT
— 0-3 CM/SEC
= 3-7 CM/SEC
≡ > 7 CM/SEC

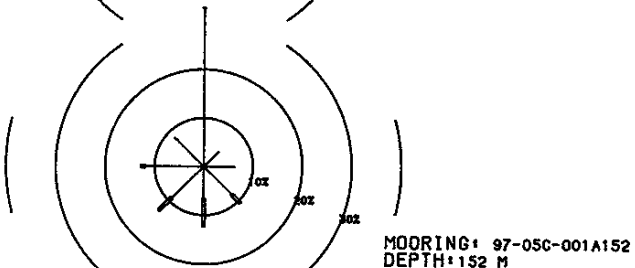
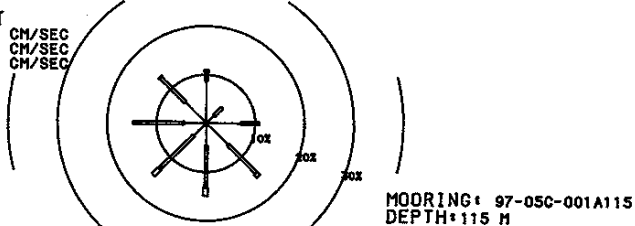

* WIND AND CURRENT DIRECTIONS ARE TOWARDS

MOORING IS 97-05C-001A115 DEPTH IS 115 METERS THERE ARE 696 VALUES

FIRST DAY 1998/04/01/0000
FINAL DAY 1998/04/29/2300

SHORELINE ORIENTATION IN DEGREES TRUE SPECIFIED AS 90

DIRECTION DEG TRUE	PERCENT OBSERVED	TOWARD	TOTAL	LIGHT	MEDIUM	HIGH	MAXIMUM CURRENT CM/S	MEAN DURA- TION HOURS	MEAN EXCUR- SION KM	MEAN CURRENT CM/S	MEAN TEMP DEG C
90.0	10.8	7.0	3.7	0.0	6.6	3.1	0.4	3.1	3.9		
45.0	4.6	2.2	2.4	0.0	7.0	1.9	0.2	3.4	3.8		
0.0	10.9	8.8	1.7	0.4	7.5	2.5	0.2	2.0	3.9		
315.0	13.4	6.0	7.2	0.1	7.8	2.7	0.4	3.7	3.8		
270.0	14.9	4.5	10.5	0.0	6.9	3.9	0.6	4.5	3.8		
225.0	15.2	3.6	9.8	1.9	8.2	4.4	0.7	4.3	3.8		
180.0	14.9	4.6	8.6	1.7	8.0	4.7	0.7	4.2	3.9		
135.0	15.2	6.2	8.2	0.9	7.4	5.0	0.7	4.0	3.9		

MEAN SCALAR SPEED = 3.8 CM/S MEAN SQUARE SPEED = 17.6 CM2/S2
MEAN SQUARE E-W SPEED = 9.3 CM2/S2 MEAN SQUARE N-S SPEED = 8.3 CM2/S2
MEAN VELOCITY = 1.1 CM/S, 218 DEG TRUE MEAN TEMPERATURE = 3.9 C
VARIANCE (U,V) = 8.2 CM2/S2 TOTAL HOURS = 696.

PERCENT OBSERVED
LIGHT (0.0 - 3.0) 42.8% MEDIUM (3.0 - 7.0) 52.2% HIGH (GE 7.0) 5.0%

MOORING IS 97-05C-001A152 DEPTH IS 152 METERS THERE ARE 696 VALUES

FIRST DAY 1998/04/01/0000
FINAL DAY 1998/04/29/2300

SHORELINE ORIENTATION IN DEGREES TRUE SPECIFIED AS 90

DIRECTION DEG TRUE	PERCENT OBSERVED	TOWARD	TOTAL	LIGHT	MEDIUM	HIGH	MAXIMUM CURRENT CM/S	MEAN DURA- TION HOURS	MEAN EXCUR- SION KM	MEAN CURRENT CM/S	MEAN TEMP DEG C
90.0	6.2	6.2	0.0	0.0	2.8	2.5	0.2	2.4	3.7		
45.0	4.2	4.2	0.0	0.0	2.9	2.2	0.2	2.4	3.7		
0.0	32.6	32.5	0.1	0.0	3.0	3.6	0.1	0.4	3.7		
315.0	8.3	8.3	0.0	0.0	2.6	2.1	0.2	2.2	3.7		
270.0	12.8	11.9	0.9	0.0	3.8	3.3	0.3	2.4	3.7		
225.0	12.9	9.2	3.7	0.0	5.2	3.0	0.3	2.9	3.7		
180.0	12.4	6.6	5.7	0.0	6.5	3.4	0.4	3.3	3.7		
135.0	10.6	8.2	2.4	0.0	5.3	2.5	0.2	2.7	3.7		

MEAN SCALAR SPEED = 1.9 CM/S MEAN SQUARE SPEED = 5.6 CM2/S2
MEAN SQUARE E-W SPEED = 2.3 CM2/S2 MEAN SQUARE N-S SPEED = 3.2 CM2/S2
MEAN VELOCITY = 0.6 CM/S, 208 DEG TRUE MEAN TEMPERATURE = 3.7 C
VARIANCE (U,V) = 2.6 CM2/S2 TOTAL HOURS = 696.

PERCENT OBSERVED
LIGHT (0.0 - 3.0) 87.1% MEDIUM (3.0 - 7.0) 12.9% HIGH (GE 7.0) 0.0%

Appendix K - Mooring_V01-97. Overall Summary Statistics and Rose Histogram Plots

DATE: 1997/10/01 TO 1998/06/13
ROSE SUMMARY: WIND AND CURRENT

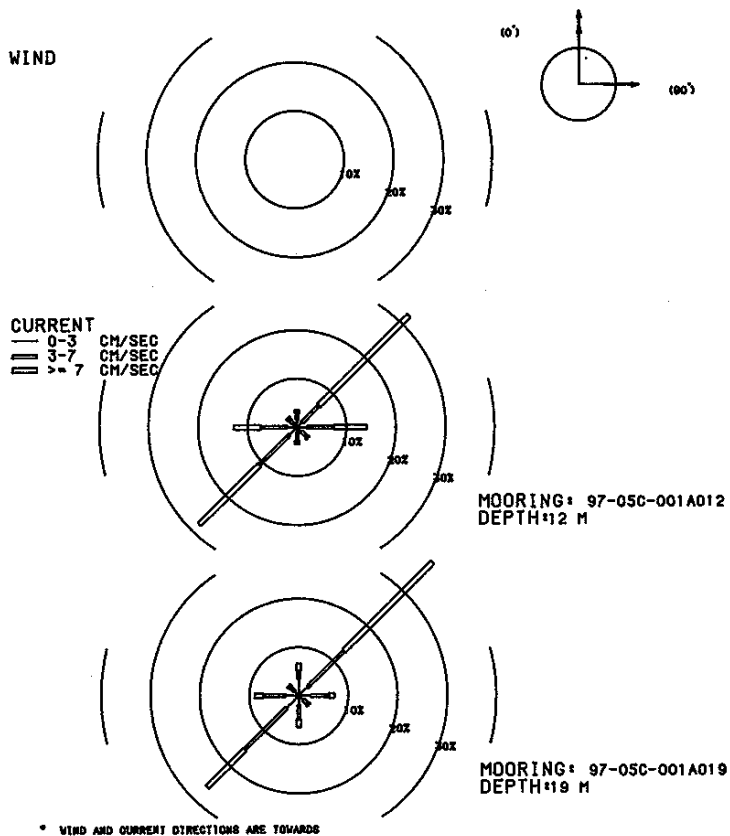

MOORING IS 97-05C-001A012 DEPTH IS 12 METERS THERE ARE 5967 VALUES

FIRST DAY 1997/10/07/1500
FINAL DAY 1998/06/13/0500

SHORELINE ORIENTATION IN DEGREES TRUE SPECIFIED AS 90

DIRECTION DEG TRUE	PERCENT OBSERVED	MAXIMUM CURRENT CM/S	MEAN DURA- TION HOURS	MEAN EXCUR- SION KM	MEAN CURRENT CM/S	MEAN TEMP DEG C
TOWARD	TOTAL	LIGHT	MEDIUM	HIGH	CM/S	
90.0	14.1	1.9	5.6	6.6	23.6	3.1
45.0	32.3	1.3	4.9	26.1	47.9	7.1
0.0	3.5	1.6	1.3	0.6	22.3	2.0
315.0	2.6	0.9	1.4	0.3	10.8	1.7
270.0	12.8	2.0	5.4	5.5	30.2	2.8
225.0	28.1	2.3	8.5	17.2	38.0	5.8
180.0	3.5	1.2	1.7	0.6	15.3	1.9
135.0	3.1	1.1	1.7	0.2	15.8	1.8
0		MEAN SCALAR SPEED = 9.9 CM/S	MEAN SQUARE SPEED = 147.8 CM2/S2			
		MEAN SQUARE E-W SPEED = 107.6 CM2/S2	MEAN SQUARE N-S SPEED = 40.2 CM2/S2			
		MEAN VELOCITY = 1.8 CM/S,	65 DEG TRUE		MEAN TEMPERATURE = 6.5 C	
		VARIANCE (U,V) = 72.3 CM2/S2	TOTAL HOURS = 5967.			

PERCENT OBSERVED
LIGHT (0.0 - 3.0) 12.3% MEDIUM (3.0 - 7.0) 30.6% HIGH (GE 7.0) 57.1%

MOORING IS 97-05C-001A019 DEPTH IS 19 METERS THERE ARE 5961 VALUES

FIRST DAY 1997/10/07/1400
FINAL DAY 1998/06/13/0500

SHORELINE ORIENTATION IN DEGREES TRUE SPECIFIED AS 90

DIRECTION DEG TRUE	PERCENT OBSERVED	MAXIMUM CURRENT CM/S	MEAN DURA- TION HOURS	MEAN EXCUR- SION KM	MEAN CURRENT CM/S	MEAN TEMP DEG C
TOWARD	TOTAL	LIGHT	MEDIUM	HIGH	CM/S	
90.0	7.2	2.3	3.8	1.1	21.2	2.2
45.0	38.6	2.5	10.5	25.6	40.0	10.5
0.0	6.6	3.4	1.7	1.5	26.0	2.3
315.0	2.9	1.2	1.3	0.5	13.6	1.8
270.0	9.0	2.7	4.5	1.8	25.1	2.3
225.0	26.3	3.5	12.0	10.8	36.4	5.3
180.0	6.5	1.9	3.0	1.6	16.0	2.3
135.0	2.8	1.3	1.2	0.3	10.5	1.6
0		MEAN SCALAR SPEED = 7.3 CM/S	MEAN SQUARE SPEED = 78.2 CM2/S2			
		MEAN SQUARE E-W SPEED = 42.8 CM2/S2	MEAN SQUARE N-S SPEED = 35.4 CM2/S2			
		MEAN VELOCITY = 1.8 CM/S,	45 DEG TRUE		MEAN TEMPERATURE = 5.5 C	
		VARIANCE (U,V) = 37.5 CM2/S2	TOTAL HOURS = 5961.			

PERCENT OBSERVED
LIGHT (0.0 - 3.0) 18.8% MEDIUM (3.0 - 7.0) 38.0% HIGH (GE 7.0) 43.2%

Appendix L - Mooring_V01-97. Monthly Summary Statistics and Rose Histogram Plots

DATE: 1997/10/01 TO 1997/10/31
 ROSE SUMMARY: WIND AND CURRENT

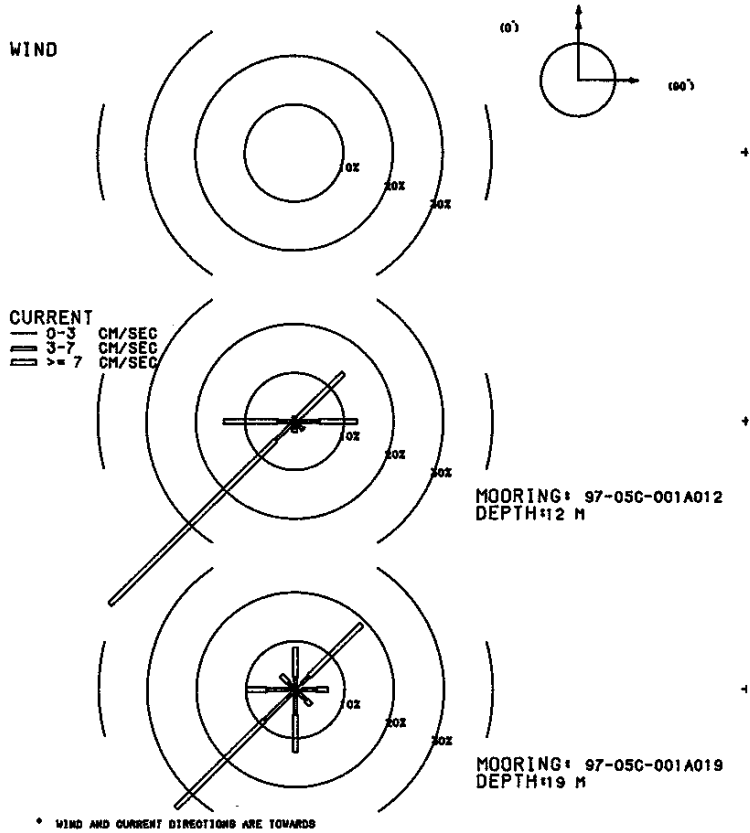

MOORING IS 97-05C-001A012 DEPTH IS 12 METERS THERE ARE 585 VALUES

FIRST DAY 1997/10/07/1500
 FINAL DAY 1997/10/31/2300

SHORELINE ORIENTATION IN DEGREES TRUE SPECIFIED AS 90

DIRECTION DEG TRUE	PERCENT OBSERVED	MAXIMUM CURRENT	MEAN DURATION HOURS	MEAN EXCURSION KM	MEAN CURRENT CM/S	MEAN TEMP DEG C
TOWARD	TOTAL	LIGHT	MEDIUM	HIGH	CM/S	
90.0	12.6	0.5	4.4	7.7	20.4	13.3
45.0	14.0	0.0	0.5	13.5	40.4	13.1
0.0	1.0	0.0	0.9	0.2	11.3	12.1
315.0	0.3	0.0	0.3	0.0	4.3	14.3
270.0	14.4	0.7	2.7	10.9	30.2	13.8
225.0	53.0	0.5	5.0	47.5	38.0	15.3
180.0	2.2	0.2	1.2	0.9	13.1	14.1
135.0	2.4	0.5	1.7	0.2	7.6	12.3
0		MEAN SCALAR SPEED = 15.6 CM/S		MEAN SQUARE SPEED = 315.5 CM2/S2		
		MEAN SQUARE E-W SPEED = 234.4 CM2/S2		MEAN SQUARE N-S SPEED = 81.1 CM2/S2		
		MEAN VELOCITY = 7.7 CM/S,		237 DEG TRUE		MEAN TEMPERATURE = 14.4 C
		VARIANCE (U,V) = 128.7 CM2/S2		TOTAL HOURS = 585.		

PERCENT OBSERVED
 LIGHT (0.0 - 3.0) 2.4% MEDIUM (3.0 - 7.0) 16.8% HIGH (GE 7.0) 80.9%

MOORING IS 97-05C-001A019 DEPTH IS 19 METERS THERE ARE 584 VALUES

FIRST DAY 1997/10/07/1400
 FINAL DAY 1997/10/31/2300

SHORELINE ORIENTATION IN DEGREES TRUE SPECIFIED AS 90

DIRECTION DEG TRUE	PERCENT OBSERVED	MAXIMUM CURRENT	MEAN DURATION HOURS	MEAN EXCURSION KM	MEAN CURRENT CM/S	MEAN TEMP DEG C
TOWARD	TOTAL	LIGHT	MEDIUM	HIGH	CM/S	
90.0	6.7	1.2	3.1	2.4	15.2	11.9
45.0	19.0	1.7	2.2	15.1	27.0	13.0
0.0	8.7	0.7	1.9	6.2	19.1	11.5
315.0	4.1	0.9	1.2	2.1	13.5	9.9
270.0	9.9	1.4	4.5	4.1	25.1	9.3
225.0	34.2	0.2	8.7	25.3	36.4	10.3
180.0	12.8	0.9	4.3	7.7	16.0	9.9
135.0	4.5	1.0	2.1	1.4	10.1	10.1
0		MEAN SCALAR SPEED = 9.6 CM/S		MEAN SQUARE SPEED = 122.9 CM2/S2		
		MEAN SQUARE E-W SPEED = 61.3 CM2/S2		MEAN SQUARE N-S SPEED = 61.6 CM2/S2		
		MEAN VELOCITY = 1.8 CM/S,		228 DEG TRUE		MEAN TEMPERATURE = 10.8 C
		VARIANCE (U,V) = 59.9 CM2/S2		TOTAL HOURS = 584.		

PERCENT OBSERVED
 LIGHT (0.0 - 3.0) 7.9% MEDIUM (3.0 - 7.0) 27.9% HIGH (GE 7.0) 64.2%

DATE: 1997/11/01 TO 1997/11/30
ROSE SUMMARY: WIND AND CURRENT

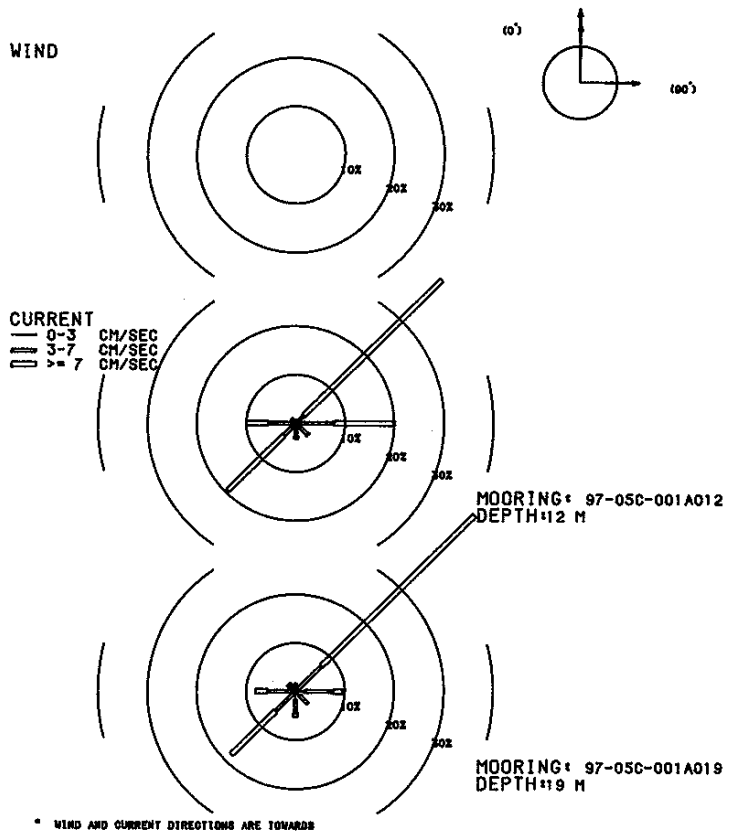

MOORING IS 97-05C-001A012 DEPTH IS 12 METERS THERE ARE 720 VALUES

FIRST DAY 1997/11/01/0000
FINAL DAY 1997/11/30/2300

SHORELINE ORIENTATION IN DEGREES TRUE SPECIFIED AS 90

DIRECTION DEG TRUE	PERCENT OBSERVED	TOWARD	TOTAL	LIGHT	MEDIUM	HIGH	MAXIMUM CURRENT CM/S	MEAN DURATION HOURS	MEAN EXCURSION KM	MEAN CURRENT CM/S	MEAN TEMP DEG C
90.0	20.1	0.7	7.1	12.4	22.5	3.0	1.0	9.0	8.6		
45.0	41.7	0.4	1.8	39.4	32.1	7.3	4.1	15.6	9.1		
0.0	0.7	0.1	0.6	0.0	5.7	1.2	0.2	4.3	9.4		
315.0	1.2	0.1	1.1	0.0	6.2	1.1	0.2	4.8	8.1		
270.0	10.0	0.6	5.0	4.4	12.7	3.1	0.7	6.6	8.5		
225.0	19.6	1.0	2.5	16.1	27.8	6.7	2.9	11.8	9.1		
180.0	3.2	1.1	1.5	0.6	9.4	2.1	0.3	4.5	8.9		
135.0	3.5	0.8	2.5	0.1	7.0	1.7	0.2	4.1	8.6		

MEAN SCALAR SPEED = 11.7 CM/S MEAN SQUARE SPEED = 180.6 CM2/S2
 MEAN SQUARE E-W SPEED = 136.0 CM2/S2 MEAN SQUARE N-S SPEED = 44.6 CM2/S2
 MEAN VELOCITY = 5.3 CM/S, 67 DEG TRUE MEAN TEMPERATURE = 8.9 C
 VARIANCE (U,V) = 76.2 CM2/S2 TOTAL HOURS = 720.

PERCENT OBSERVED
 LIGHT (0.0 - 3.0) 4.9% MEDIUM (3.0 - 7.0) 22.1% HIGH (GE 7.0) 73.1%

MOORING IS 97-05C-001A019 DEPTH IS 19 METERS THERE ARE 719 VALUES

FIRST DAY 1997/11/01/0000
FINAL DAY 1997/11/30/2300

SHORELINE ORIENTATION IN DEGREES TRUE SPECIFIED AS 90

DIRECTION DEG TRUE	PERCENT OBSERVED	TOWARD	TOTAL	LIGHT	MEDIUM	HIGH	MAXIMUM CURRENT CM/S	MEAN DURATION HOURS	MEAN EXCURSION KM	MEAN CURRENT CM/S	MEAN TEMP DEG C
90.0	9.6	1.8	5.8	1.9	21.2	2.6	0.5	5.6	8.5		
45.0	51.2	0.7	6.7	43.8	25.1	13.6	5.6	11.5	9.0		
0.0	1.7	0.7	1.0	0.0	6.4	1.0	0.1	3.8	7.8		
315.0	2.1	0.6	1.0	0.6	9.6	2.1	0.4	5.6	7.7		
270.0	8.2	0.7	5.0	2.5	14.8	2.8	0.6	6.1	8.3		
225.0	18.4	0.6	5.1	12.7	25.7	6.0	2.0	9.5	9.0		
180.0	5.3	1.7	2.8	0.8	7.7	2.2	0.4	4.5	9.3		
135.0	3.6	1.3	2.4	0.0	5.1	1.7	0.2	3.6	9.2		

MEAN SCALAR SPEED = 9.2 CM/S MEAN SQUARE SPEED = 110.1 CM2/S2
 MEAN SQUARE E-W SPEED = 70.0 CM2/S2 MEAN SQUARE N-S SPEED = 40.1 CM2/S2
 MEAN VELOCITY = 4.0 CM/S, 53 DEG TRUE MEAN TEMPERATURE = 8.9 C
 VARIANCE (U,V) = 47.0 CM2/S2 TOTAL HOURS = 719.

PERCENT OBSERVED
 LIGHT (0.0 - 3.0) 7.9% MEDIUM (3.0 - 7.0) 29.8% HIGH (GE 7.0) 62.3%

DATE: 1997/12/01 TO 1997/12/31
 ROSE SUMMARY: WIND AND CURRENT

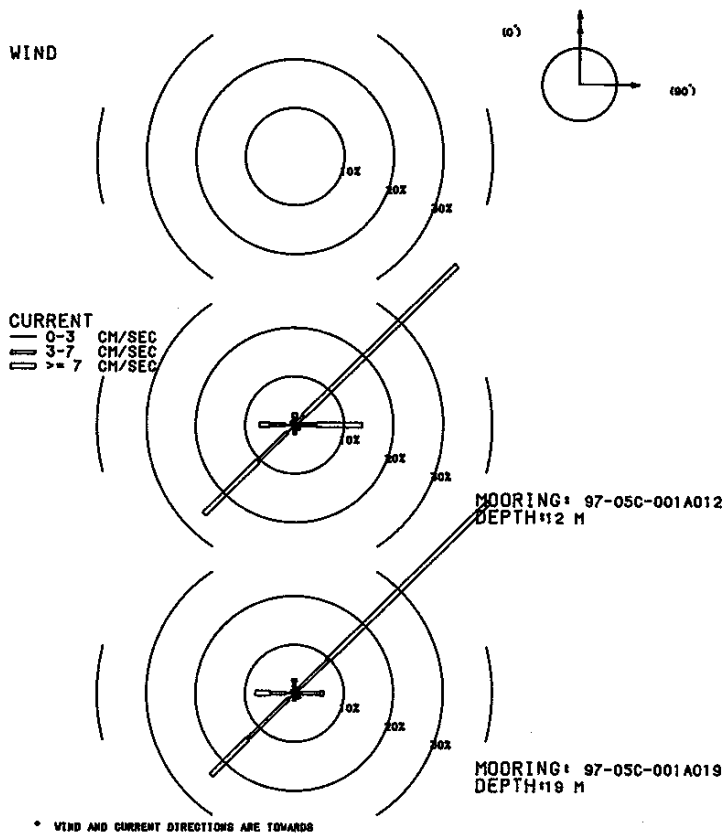

MOORING IS 97-05C-001A012 DEPTH IS 12 METERS THERE ARE 744 VALUES

FIRST DAY 1997/12/01/0000
 FINAL DAY 1997/12/31/2300

SHORELINE ORIENTATION IN DEGREES TRUE SPECIFIED AS 90

DIRECTION DEG TRUE	PERCENT OBSERVED	MAXIMUM CURRENT	MEAN DURA- TION HOURS	MEAN EXCUR- SION KM	MEAN CURRENT CM/S	MEAN TEMP DEG C
TOWARD	TOTAL	LIGHT	MEDIUM	HIGH	CM/S	
90.0	13.7	0.7	3.8	9.3	23.6	3.0
45.0	46.4	0.1	2.4	43.8	28.1	10.5
0.0	2.4	0.5	0.9	0.9	8.7	2.6
315.0	1.1	0.3	0.8	0.0	6.8	1.0
270.0	7.1	1.9	3.2	2.0	16.3	1.7
225.0	25.9	2.2	8.3	15.5	20.8	5.4
180.0	2.0	0.7	1.3	0.0	5.2	1.7
135.0	1.3	0.8	0.5	0.0	4.3	1.4

MEAN SCALAR SPEED = 12.3 CM/S MEAN SQUARE SPEED = 203.0 CM2/S2
 MEAN SQUARE E-W SPEED = 151.0 CM2/S2 MEAN SQUARE N-S SPEED = 52.0 CM2/S2
 MEAN VELOCITY = 6.4 CM/S, 62 DEG TRUE MEAN TEMPERATURE = 4.8 C
 VARIANCE (U,V) = 81.4 CM2/S2 TOTAL HOURS = 744.

PERCENT OBSERVED
 LIGHT (0.0 - 3.0) 7.1% MEDIUM (3.0 - 7.0) 21.4% HIGH (GE 7.0) 71.5%

MOORING IS 97-05C-001A019 DEPTH IS 19 METERS THERE ARE 744 VALUES

FIRST DAY 1997/12/01/0000
 FINAL DAY 1997/12/31/2300

SHORELINE ORIENTATION IN DEGREES TRUE SPECIFIED AS 90

DIRECTION DEG TRUE	PERCENT OBSERVED	MAXIMUM CURRENT	MEAN DURA- TION HOURS	MEAN EXCUR- SION KM	MEAN CURRENT CM/S	MEAN TEMP DEG C
TOWARD	TOTAL	LIGHT	MEDIUM	HIGH	CM/S	
90.0	5.9	0.8	4.4	0.7	9.0	2.4
45.0	55.5	0.8	8.7	46.0	24.6	17.2
0.0	3.0	0.8	1.6	0.5	11.7	1.7
315.0	0.8	0.3	0.5	0.0	5.0	1.2
270.0	7.9	1.7	3.1	3.1	15.4	2.6
225.0	23.8	1.6	11.7	10.5	17.1	7.1
180.0	1.6	0.9	0.7	0.0	6.3	1.3
135.0	1.5	0.9	0.5	0.0	3.5	1.6

MEAN SCALAR SPEED = 9.6 CM/S MEAN SQUARE SPEED = 120.5 CM2/S2
 MEAN SQUARE E-W SPEED = 74.4 CM2/S2 MEAN SQUARE N-S SPEED = 46.1 CM2/S2
 MEAN VELOCITY = 4.8 CM/S, 47 DEG TRUE MEAN TEMPERATURE = 4.8 C
 VARIANCE (U,V) = 48.6 CM2/S2 TOTAL HOURS = 744.

PERCENT OBSERVED
 LIGHT (0.0 - 3.0) 7.9% MEDIUM (3.0 - 7.0) 31.3% HIGH (GE 7.0) 60.8%

DATE: 1998/01/01 TO 1998/01/31
ROSE SUMMARY: WIND AND CURRENT

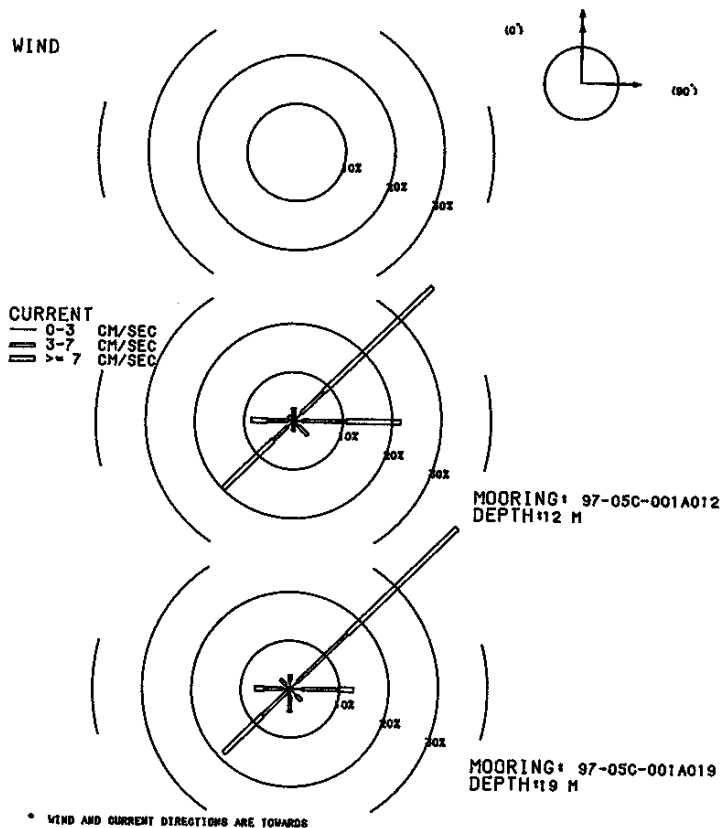

MOORING IS 97-05C-001A012 DEPTH IS 12 METERS THERE ARE 744 VALUES

FIRST DAY 1998/01/01/0000
FINAL DAY 1998/01/31/2300

SHORELINE ORIENTATION IN DEGREES TRUE SPECIFIED AS 90

DIRECTION DEG TRUE	PERCENT OBSERVED	MAXIMUM CURRENT	MEAN DURA- TION HOURS	MEAN EXCUR- SION KM	MEAN CURRENT CM/S	MEAN TEMP DEG C
TOWARD	TOTAL	LIGHT	MEDIUM	HIGH	CM/S	
90.0	21.8	1.9	8.9	11.0	20.4	2.5
45.0	39.4	2.2	6.3	30.9	33.0	2.4
0.0	2.6	0.7	1.7	0.1	7.5	2.8
315.0	1.5	0.3	1.2	0.0	5.3	2.8
270.0	8.6	1.1	4.2	3.4	11.9	2.8
225.0	19.9	1.7	3.9	14.2	19.0	2.4
180.0	2.2	0.7	1.5	0.0	6.1	2.7
135.0	4.2	1.5	2.7	0.0	5.5	3.1
MEAN SCALAR SPEED = 9.9 CM/S		MEAN SQUARE SPEED = 141.3 CM2/S2				
MEAN SQUARE E-W SPEED = 106.3 CM2/S2		MEAN SQUARE N-S SPEED = 35.0 CM2/S2				
MEAN VELOCITY = 4.4 CM/S,		68 DEG TRUE		MEAN TEMPERATURE = 2.5 C		
VARIANCE (U,V) = 61.1 CM2/S2		TOTAL HOURS = 744.				

PERCENT OBSERVED
LIGHT (0.0 - 3.0) 9.9% MEDIUM (3.0 - 7.0) 30.4% HIGH (GE 7.0) 59.7%

MOORING IS 97-05C-001A019 DEPTH IS 19 METERS THERE ARE 743 VALUES

FIRST DAY 1998/01/01/0000
FINAL DAY 1998/01/31/2300

SHORELINE ORIENTATION IN DEGREES TRUE SPECIFIED AS 90

DIRECTION DEG TRUE	PERCENT OBSERVED	MAXIMUM CURRENT	MEAN DURA- TION HOURS	MEAN EXCUR- SION KM	MEAN CURRENT CM/S	MEAN TEMP DEG C
TOWARD	TOTAL	LIGHT	MEDIUM	HIGH	CM/S	
90.0	12.9	2.4	7.4	3.1	11.9	2.7
45.0	47.4	2.0	14.3	31.1	27.1	2.4
0.0	3.0	1.6	1.3	0.0	6.9	2.4
315.0	2.7	1.2	1.5	0.0	6.0	3.0
270.0	7.1	1.5	3.8	1.9	10.5	2.8
225.0	18.8	0.4	7.4	11.0	15.9	2.3
180.0	4.7	1.5	3.1	0.1	7.5	2.8
135.0	3.4	1.9	1.5	0.0	4.5	2.9
MEAN SCALAR SPEED = 7.7 CM/S		MEAN SQUARE SPEED = 81.6 CM2/S2				
MEAN SQUARE E-W SPEED = 53.2 CM2/S2		MEAN SQUARE N-S SPEED = 28.4 CM2/S2				
MEAN VELOCITY = 3.2 CM/S,		56 DEG TRUE		MEAN TEMPERATURE = 2.5 C		
VARIANCE (U,V) = 35.7 CM2/S2		TOTAL HOURS = 743.				

PERCENT OBSERVED
LIGHT (0.0 - 3.0) 12.5% MEDIUM (3.0 - 7.0) 40.2% HIGH (GE 7.0) 47.2%

DATE: 1998/02/01 TO 1998/02/28
ROSE SUMMARY: WIND AND CURRENT

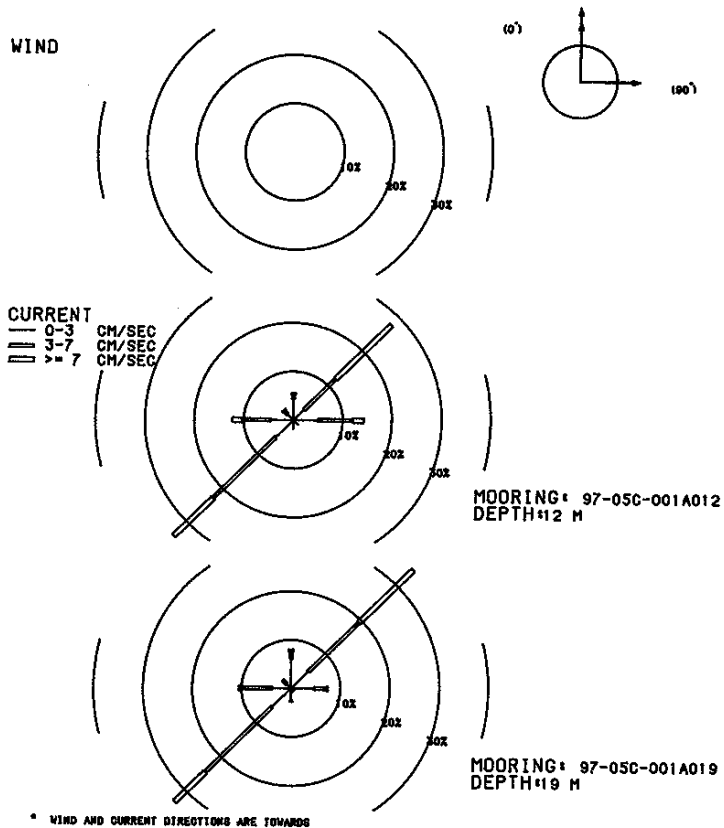

MOORING IS 97-05C-001A012 DEPTH IS 12 METERS THERE ARE 672 VALUES

FIRST DAY 1998/02/01/0000
FINAL DAY 1998/02/28/2300

SHORELINE ORIENTATION IN DEGREES TRUE SPECIFIED AS 90

DIRECTION DEG TRUE	PERCENT OBSERVED	TOWARD	TOTAL	LIGHT	MEDIUM	HIGH	MAXIMUM CURRENT CM/S	MEAN DURA- TION HOURS	MEAN EXCUR- SION KM	MEAN CURRENT CM/S	MEAN TEMP DEG C
90.0	14.3	4.9	7.1	2.2	10.7	4.2	0.7	4.7	1.8		
45.0	27.8	3.0	8.9	15.9	19.9	6.9	2.3	9.1	1.6		
0.0	5.5	4.3	1.0	0.1	7.2	2.8	0.2	1.7	1.6		
315.0	2.8	1.6	1.0	0.1	7.3	2.1	0.2	3.1	1.6		
270.0	12.4	4.6	5.7	2.1	8.7	2.4	0.4	4.5	1.8		
225.0	33.9	5.1	17.7	11.2	20.2	7.1	1.8	6.9	1.9		
180.0	1.9	1.9	0.0	0.0	2.7	1.6	0.1	2.2	1.8		
135.0	1.3	1.3	0.0	0.0	2.6	1.8	0.1	2.2	1.9		
MEAN SCALAR SPEED =		6.3 CM/S	MEAN SQUARE SPEED =		59.8 CM2/S2						
MEAN SQUARE E-W SPEED =		42.8 CM2/S2	MEAN SQUARE N-S SPEED =		17.0 CM2/S2						
MEAN VELOCITY =		0.3 CM/S,	48 DEG TRUE		MEAN TEMPERATURE =		1.7 C				
VARIANCE (U,V) =		29.9 CM2/S2	TOTAL HOURS =		672.						

PERCENT OBSERVED
LIGHT (0.0 - 3.0) 26.8% MEDIUM (3.0 - 7.0) 41.5% HIGH (GE 7.0) 31.7%

MOORING IS 97-05C-001A019 DEPTH IS 19 METERS THERE ARE 672 VALUES

FIRST DAY 1998/02/01/0000
FINAL DAY 1998/02/28/2300

SHORELINE ORIENTATION IN DEGREES TRUE SPECIFIED AS 90

DIRECTION DEG TRUE	PERCENT OBSERVED	TOWARD	TOTAL	LIGHT	MEDIUM	HIGH	MAXIMUM CURRENT CM/S	MEAN DURA- TION HOURS	MEAN EXCUR- SION KM	MEAN CURRENT CM/S	MEAN TEMP DEG C
90.0	7.4	4.6	2.7	0.1	7.8	2.5	0.3	3.1	1.8		
45.0	34.8	4.9	14.4	15.5	13.0	10.6	2.5	6.4	1.6		
0.0	8.0	6.1	1.5	0.4	8.3	2.6	0.2	1.7	1.7		
315.0	2.4	1.2	1.2	0.0	5.7	1.3	0.2	3.3	1.6		
270.0	10.6	3.9	6.0	0.7	7.6	2.4	0.4	4.4	1.8		
225.0	33.2	5.4	19.0	8.8	16.6	7.2	1.5	6.0	1.9		
180.0	2.8	2.5	0.3	0.0	3.2	1.6	0.1	2.4	1.7		
135.0	0.7	0.6	0.1	0.0	3.7	1.0	0.1	2.5	1.9		
MEAN SCALAR SPEED =		5.2 CM/S	MEAN SQUARE SPEED =		37.6 CM2/S2						
MEAN SQUARE E-W SPEED =		21.2 CM2/S2	MEAN SQUARE N-S SPEED =		16.4 CM2/S2						
MEAN VELOCITY =		0.4 CM/S,	331 DEG TRUE		MEAN TEMPERATURE =		1.8 C				
VARIANCE (U,V) =		18.8 CM2/S2	TOTAL HOURS =		672.						

PERCENT OBSERVED
LIGHT (0.0 - 3.0) 29.2% MEDIUM (3.0 - 7.0) 45.2% HIGH (GE 7.0) 25.6%

DATE: 1998/03/01 TO 1998/03/31
ROSE SUMMARY: WIND AND CURRENT

WIND

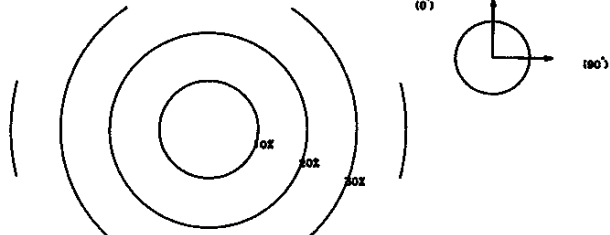

CURRENT

— 0-3 CM/SEC
= 3-7 CM/SEC
≡ >= 7 CM/SEC

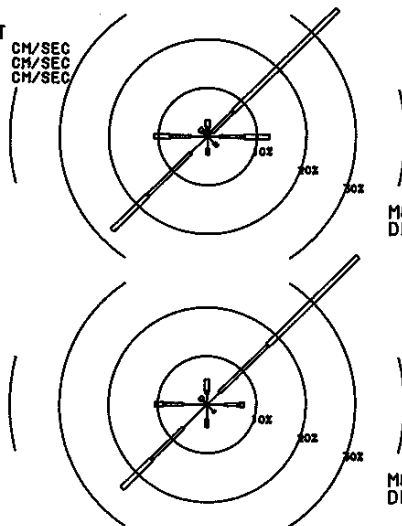

MOORING: 97-05C-001A012
DEPTH 12 M

MOORING: 97-05C-001A019
DEPTH 19 M

* WIND AND CURRENT DIRECTIONS ARE TOWARDS

MOORING IS 97-05C-001A012 DEPTH IS 12 METERS THERE ARE 744 VALUES

FIRST DAY 1998/03/01/0000
FINAL DAY 1998/03/31/2300

SHORELINE ORIENTATION IN DEGREES TRUE SPECIFIED AS 90

DIRECTION DEG TRUE	PERCENT OBSERVED	MAXIMUM CURRENT			MEAN DURA- TION HOURS	MEAN EXCUR- SION KM	MEAN CURRENT CM/S	MEAN TEMP DEG C
TOWARD	TOTAL	LIGHT	MEDIUM	HIGH	CM/S			
90.0	12.5	2.4	5.0	5.1	18.3	2.4	0.6	2.3
45.0	37.1	1.2	6.2	29.7	47.9	7.9	4.7	2.3
0.0	3.4	0.9	0.9	1.5	22.3	2.3	0.7	2.7
315.0	2.3	1.1	0.4	0.8	10.6	1.7	0.3	2.5
270.0	10.9	3.5	4.2	3.2	14.2	3.1	0.6	2.4
225.0	27.3	4.7	12.5	10.1	16.3	5.2	1.3	2.6
180.0	3.8	2.4	1.3	0.0	5.1	1.5	0.1	2.7
135.0	2.8	1.9	0.9	0.0	5.4	1.4	0.1	2.7

MEAN SCALAR SPEED = 10.0 CM/S MEAN SQUARE SPEED = 182.5 CM2/S2
MEAN SQUARE E-W SPEED = 124.9 CM2/S2 MEAN SQUARE N-S SPEED = 57.6 CM2/S2
MEAN VELOCITY = 4.7 CM/S, 57 DEG TRUE MEAN TEMPERATURE = 2.4 C
VARIANCE (U,V) = 80.5 CM2/S2 TOTAL HOURS = 744.

PERCENT OBSERVED

LIGHT (0.0 - 3.0) 18.1% MEDIUM (3.0 - 7.0) 31.5% HIGH (GE 7.0) 50.4%

MOORING IS 97-05C-001A019 DEPTH IS 19 METERS THERE ARE 742 VALUES

FIRST DAY 1998/03/01/0000
FINAL DAY 1998/03/31/2300

SHORELINE ORIENTATION IN DEGREES TRUE SPECIFIED AS 90

DIRECTION DEG TRUE	PERCENT OBSERVED	MAXIMUM CURRENT			MEAN DURA- TION HOURS	MEAN EXCUR- SION KM	MEAN CURRENT CM/S	MEAN TEMP DEG C
TOWARD	TOTAL	LIGHT	MEDIUM	HIGH	CM/S			
90.0	7.5	3.6	3.1	0.8	8.2	2.5	0.3	2.3
45.0	43.1	3.5	13.9	25.7	40.0	14.5	5.7	2.3
0.0	5.3	2.3	0.5	2.4	26.0	2.1	0.6	2.6
315.0	2.0	1.2	0.1	0.7	10.4	1.7	0.3	2.2
270.0	10.6	4.9	4.0	1.8	11.9	2.5	0.4	2.5
225.0	24.4	6.7	9.3	8.4	13.6	3.9	0.8	2.6
180.0	4.7	3.1	1.6	0.0	5.5	1.5	0.2	2.8
135.0	2.3	1.9	0.4	0.0	5.0	1.2	0.1	2.4

MEAN SCALAR SPEED = 7.6 CM/S MEAN SQUARE SPEED = 100.3 CM2/S2
MEAN SQUARE E-W SPEED = 42.0 CM2/S2 MEAN SQUARE N-S SPEED = 58.3 CM2/S2
MEAN VELOCITY = 3.5 CM/S, 31 DEG TRUE MEAN TEMPERATURE = 2.4 C
VARIANCE (U,V) = 44.3 CM2/S2 TOTAL HOURS = 742.

PERCENT OBSERVED

LIGHT (0.0 - 3.0) 27.2% MEDIUM (3.0 - 7.0) 33.0% HIGH (GE 7.0) 39.8%

DATE: 1998/04/01 TO 1998/04/30
 ROSE SUMMARY: WIND AND CURRENT

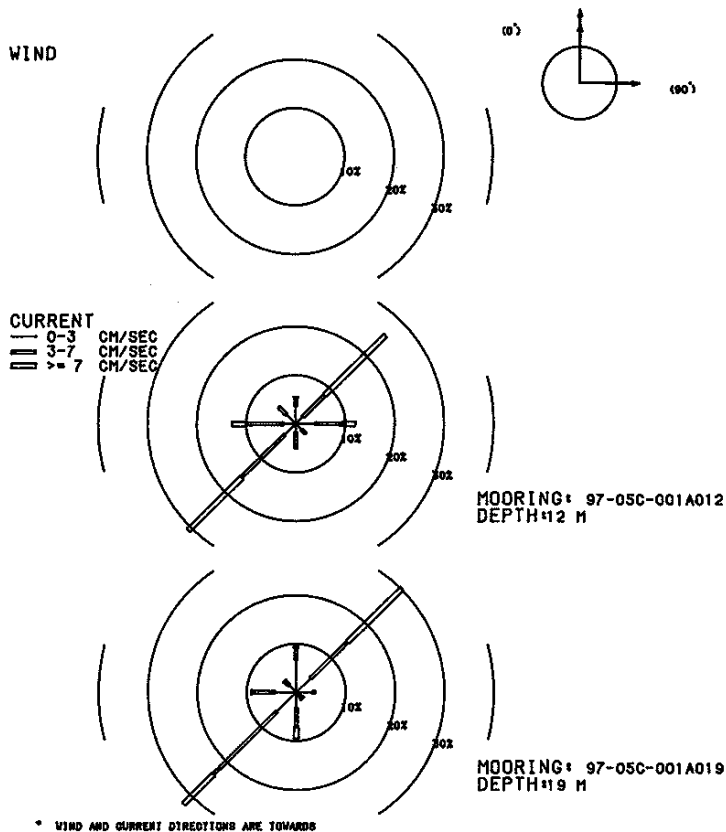

MOORING IS 97-05C-001A012 DEPTH IS 12 METERS THERE ARE 720 VALUES

FIRST DAY 1998/04/01/0000
 FINAL DAY 1998/04/30/2300

SHORELINE ORIENTATION IN DEGREES TRUE SPECIFIED AS 90

DIRECTION DEG TRUE	PERCENT OBSERVED	TOWARD	TOTAL	LIGHT	MEDIUM	HIGH	MAXIMUM CURRENT CM/S	MEAN DURA- TION HOURS	MEAN EXCUR- SION KM	MEAN CURRENT CM/S	MEAN TEMP DEG C
90.0	12.1	3.9	5.6	2.6	16.6	2.4	0.5	5.5	5.7		
45.0	25.7	1.9	6.3	17.5	26.5	5.4	2.2	11.2	5.4		
0.0	5.6	3.6	1.8	0.1	7.8	1.7	0.1	2.3	5.7		
315.0	4.9	2.6	2.2	0.0	6.7	1.8	0.2	3.3	5.9		
270.0	12.9	2.5	7.5	2.9	16.2	2.5	0.5	5.2	6.3		
225.0	30.8	3.2	12.2	15.4	15.4	5.4	1.4	7.2	5.7		
180.0	5.1	1.8	3.3	0.0	6.0	1.9	0.2	3.4	6.4		
135.0	2.9	1.8	1.1	0.0	5.3	1.6	0.2	2.9	6.3		
0		MEAN SCALAR SPEED = 7.0 CM/S		MEAN SQUARE SPEED = 73.3 CM2/S2							
		MEAN SQUARE E-W SPEED = 51.6 CM2/S2		MEAN SQUARE N-S SPEED = 21.7 CM2/S2							
		MEAN VELOCITY = 0.6 CM/S,		64 DEG TRUE		MEAN TEMPERATURE = 5.8 C					
		VARIANCE (U,V) = 36.5 CM2/S2		TOTAL HOURS = 720.							

PERCENT OBSERVED

LIGHT (0.0 - 3.0) 21.4% MEDIUM (3.0 - 7.0) 40.0% HIGH (GE 7.0) 38.6%

MOORING IS 97-05C-001A019 DEPTH IS 19 METERS THERE ARE 720 VALUES

FIRST DAY 1998/04/01/0000
 FINAL DAY 1998/04/30/2300

SHORELINE ORIENTATION IN DEGREES TRUE SPECIFIED AS 90

DIRECTION DEG TRUE	PERCENT OBSERVED	TOWARD	TOTAL	LIGHT	MEDIUM	HIGH	MAXIMUM CURRENT CM/S	MEAN DURA- TION HOURS	MEAN EXCUR- SION KM	MEAN CURRENT CM/S	MEAN TEMP DEG C
90.0	3.9	3.2	0.7	0.0	6.8	1.8	0.2	2.8	5.1		
45.0	30.3	4.0	10.6	15.7	21.7	10.9	2.9	7.5	5.1		
0.0	9.6	6.7	2.5	0.4	9.2	2.7	0.2	2.1	5.5		
315.0	3.3	1.9	1.2	0.1	7.4	1.5	0.2	3.3	4.9		
270.0	9.2	4.3	4.6	0.3	11.0	2.2	0.3	3.5	5.5		
225.0	32.4	5.6	18.2	8.6	12.3	5.7	1.1	5.2	5.2		
180.0	9.6	3.2	4.0	2.4	9.4	3.1	0.5	4.6	5.5		
135.0	1.8	0.8	0.8	0.1	9.0	1.9	0.3	3.8	5.5		
0		MEAN SCALAR SPEED = 5.2 CM/S		MEAN SQUARE SPEED = 38.7 CM2/S2							
		MEAN SQUARE E-W SPEED = 17.7 CM2/S2		MEAN SQUARE N-S SPEED = 21.0 CM2/S2							
		MEAN VELOCITY = 0.2 CM/S,		39 DEG TRUE		MEAN TEMPERATURE = 5.3 C					
		VARIANCE (U,V) = 19.4 CM2/S2		TOTAL HOURS = 720.							

PERCENT OBSERVED

LIGHT (0.0 - 3.0) 29.7% MEDIUM (3.0 - 7.0) 42.6% HIGH (GE 7.0) 27.6%

DATE: 1998/05/01 TO 1998/05/31
 ROSE SUMMARY: WIND AND CURRENT

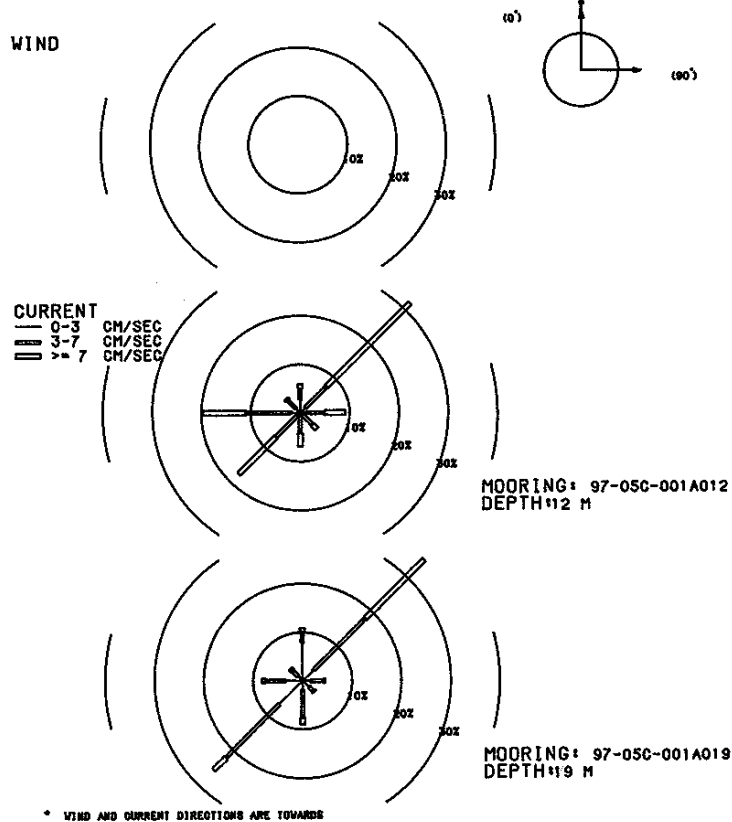

MOORING IS 97-05C-001A012 DEPTH IS 12 METERS THERE ARE 744 VALUES

FIRST DAY 1998/05/01/0000
 FINAL DAY 1998/05/31/2300

SHORELINE ORIENTATION IN DEGREES TRUE SPECIFIED AS 90

DIRECTION DEG TRUE	PERCENT OBSERVED	TOWARD	TOTAL	LIGHT	MEDIUM	HIGH	MAXIMUM CURRENT CM/S	MEAN DURA- TION HOURS	MEAN EXCUR- SION KM	MEAN CURRENT CM/S	MEAN TEMP DEG C
90.0	9.1	1.1	3.8	4.3	14.7	3.0	0.7	6.7	9.0		
45.0	31.7	1.3	6.2	24.2	22.5	8.4	3.1	10.1	8.8		
0.0	5.9	2.7	2.3	0.9	11.3	2.0	0.3	3.9	10.0		
315.0	4.0	1.2	2.3	0.5	8.8	1.4	0.2	4.5	10.3		
270.0	19.8	1.9	9.1	8.7	18.4	3.2	0.8	6.9	10.6		
225.0	17.7	0.5	6.5	10.8	17.8	3.1	0.9	8.0	10.3		
180.0	7.0	0.7	3.5	2.8	12.1	2.4	0.5	6.3	10.1		
135.0	4.7	0.7	2.8	1.2	15.8	1.8	0.4	5.6	10.3		
0	MEAN SCALAR SPEED = 7.7 CM/S		MEAN SQUARE SPEED = 75.0 CM2/S2								
	MEAN SQUARE E-W SPEED = 51.3 CM2/S2		MEAN SQUARE N-S SPEED = 23.7 CM2/S2								
	MEAN VELOCITY = 1.0 CM/S,		57 DEG TRUE		MEAN TEMPERATURE = 9.7 C						
	VARIANCE (U,V) = 37.0 CM2/S2		TOTAL HOURS = 744.								

PERCENT OBSERVED
 LIGHT (0.0 - 3.0) 10.1% MEDIUM (3.0 - 7.0) 36.4% HIGH (GE 7.0) 53.5%

MOORING IS 97-05C-001A019 DEPTH IS 19 METERS THERE ARE 743 VALUES

FIRST DAY 1998/05/01/0000
 FINAL DAY 1998/05/31/2300

SHORELINE ORIENTATION IN DEGREES TRUE SPECIFIED AS 90

DIRECTION DEG TRUE	PERCENT OBSERVED	TOWARD	TOTAL	LIGHT	MEDIUM	HIGH	MAXIMUM CURRENT CM/S	MEAN DURA- TION HOURS	MEAN EXCUR- SION KM	MEAN CURRENT CM/S	MEAN TEMP DEG C
90.0	4.6	1.6	2.7	0.3	9.9	1.8	0.2	3.8	7.5		
45.0	35.0	3.0	15.1	17.0	14.4	10.4	2.6	6.8	8.0		
0.0	10.9	7.8	2.3	0.8	14.9	2.1	0.1	1.9	6.9		
315.0	3.5	1.2	1.6	0.7	13.6	1.5	0.2	4.4	6.8		
270.0	8.2	3.4	4.2	0.7	17.0	1.7	0.2	4.0	7.3		
225.0	25.6	6.7	15.2	3.6	11.0	3.6	0.6	4.7	7.5		
180.0	9.0	1.9	5.7	1.5	11.1	2.0	0.3	4.7	6.7		
135.0	3.2	1.7	1.3	0.1	7.8	1.5	0.2	3.3	6.7		
0	MEAN SCALAR SPEED = 5.0 CM/S		MEAN SQUARE SPEED = 33.5 CM2/S2								
	MEAN SQUARE E-W SPEED = 15.5 CM2/S2		MEAN SQUARE N-S SPEED = 18.0 CM2/S2								
	MEAN VELOCITY = 0.9 CM/S,		49 DEG TRUE		MEAN TEMPERATURE = 7.5 C						
	VARIANCE (U,V) = 16.4 CM2/S2		TOTAL HOURS = 743.								

PERCENT OBSERVED
 LIGHT (0.0 - 3.0) 27.3% MEDIUM (3.0 - 7.0) 48.0% HIGH (GE 7.0) 24.6%

DATE: 1998/06/01 TO 1998/06/30
ROSE SUMMARY: WIND AND CURRENT

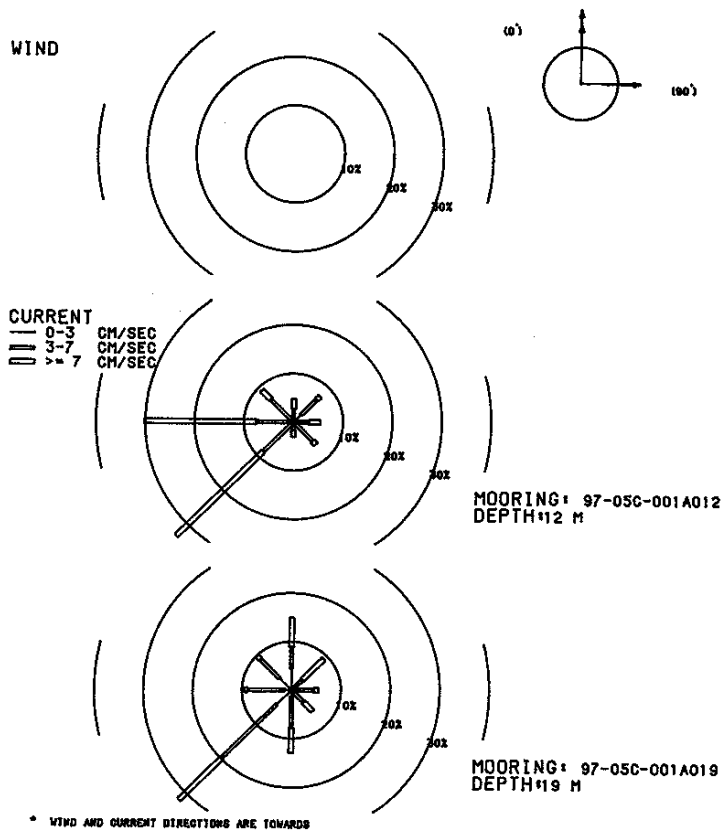

MOORING IS 97-05C-001A012 DEPTH IS 12 METERS THERE ARE 294 VALUES

FIRST DAY 1998/06/01/0000
FINAL DAY 1998/06/13/0500

SHORELINE ORIENTATION IN DEGREES TRUE SPECIFIED AS 90

DIRECTION DEG TRUE	PERCENT OBSERVED	MAXIMUM CURRENT CM/S	MEAN DURA- TION HOURS	MEAN EXCUR- SION KM	MEAN CURRENT CM/S	MEAN TEMP DEG C
TOWARD	TOTAL	LIGHT	MEDIUM	HIGH	CM/S	DEG C
90.0	5.4	0.3	2.7	2.4	9.0	14.8
45.0	7.5	2.0	4.4	1.0	9.5	14.9
0.0	4.8	0.3	2.4	2.0	13.4	15.0
315.0	9.2	0.3	6.1	2.7	10.8	14.2
270.0	30.3	0.0	7.5	22.8	21.9	14.2
225.0	33.3	0.3	8.2	24.8	20.6	14.2
180.0	3.1	0.3	1.4	1.4	15.3	13.2
135.0	6.5	0.3	5.1	1.0	8.7	14.3
0		MEAN SCALAR SPEED = 8.5 CM/S	MEAN SQUARE SPEED = 90.1 CM2/S2			
		MEAN SQUARE E-W SPEED = 63.5 CM2/S2	MEAN SQUARE N-S SPEED = 26.6 CM2/S2			
		MEAN VELOCITY = 5.5 CM/S,	247 DEG TRUE		MEAN TEMPERATURE = 14.3 C	
		VARIANCE(U,V) = 29.9 CM2/S2	TOTAL HOURS = 294.			

PERCENT OBSERVED
LIGHT (0.0 - 3.0) 4.1% MEDIUM (3.0 - 7.0) 37.8% HIGH (GE 7.0) 58.2%

MOORING IS 97-05C-001A019 DEPTH IS 19 METERS THERE ARE 294 VALUES

FIRST DAY 1998/06/01/0000
FINAL DAY 1998/06/13/0500

SHORELINE ORIENTATION IN DEGREES TRUE SPECIFIED AS 90

DIRECTION DEG TRUE	PERCENT OBSERVED	MAXIMUM CURRENT CM/S	MEAN DURA- TION HOURS	MEAN EXCUR- SION KM	MEAN CURRENT CM/S	MEAN TEMP DEG C
TOWARD	TOTAL	LIGHT	MEDIUM	HIGH	CM/S	DEG C
90.0	5.4	1.0	3.4	1.0	8.8	8.6
45.0	9.2	0.3	2.7	6.1	9.9	9.1
0.0	15.0	4.4	4.4	6.1	13.8	8.5
315.0	9.9	3.4	5.4	1.0	10.2	7.6
270.0	9.5	1.4	7.5	0.7	7.6	7.8
225.0	32.0	4.1	15.6	12.2	12.2	7.8
180.0	12.9	1.4	6.5	5.1	11.4	7.9
135.0	6.1	0.7	2.7	2.7	10.5	8.6
0		MEAN SCALAR SPEED = 5.8 CM/S	MEAN SQUARE SPEED = 41.9 CM2/S2			
		MEAN SQUARE E-W SPEED = 14.4 CM2/S2	MEAN SQUARE N-S SPEED = 27.5 CM2/S2			
		MEAN VELOCITY = 1.3 CM/S,	230 DEG TRUE		MEAN TEMPERATURE = 8.1 C	
		VARIANCE(U,V) = 20.1 CM2/S2	TOTAL HOURS = 294.			

PERCENT OBSERVED
LIGHT (0.0 - 3.0) 16.7% MEDIUM (3.0 - 7.0) 48.3% HIGH (GE 7.0) 35.0%

Appendix M - Mooring_V03-97. Overall Summary Statistics and Rose Histogram Plots

DATE: 1997/11/01 TO 1997/11/30
ROSE SUMMARY: WIND AND CURRENT

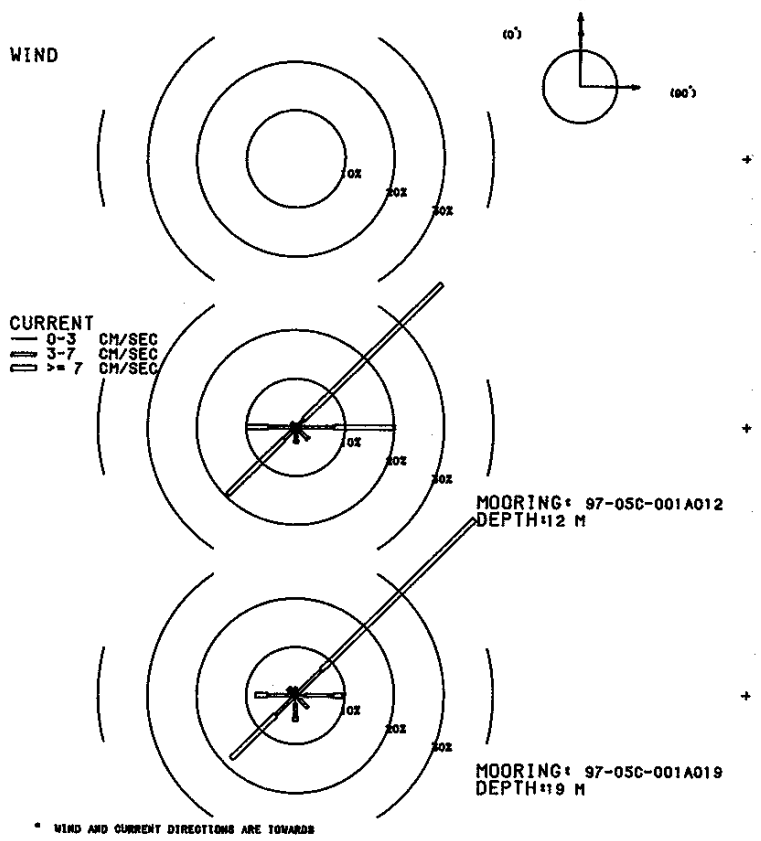

MOORING IS 97-05C-001A012 DEPTH IS 12 METERS THERE ARE 720 VALUES

FIRST DAY 1997/11/01/0000
FINAL DAY 1997/11/30/2300

SHORELINE ORIENTATION IN DEGREES TRUE SPECIFIED AS 90

DIRECTION DEG TRUE	PERCENT OBSERVED	TOWARD	TOTAL	LIGHT	MEDIUM	HIGH	MAXIMUM CURRENT CM/S	MEAN DURATION HOURS	MEAN EXCURSION KM	MEAN CURRENT CM/S	MEAN TEMP DEG C
90.0	20.1	0.7	7.1	12.4	22.5	3.0	1.0	9.0	8.6		
45.0	41.7	0.4	1.8	39.4	32.1	7.3	4.1	15.6	9.1		
0.0	0.7	0.1	0.6	0.0	5.7	1.2	0.2	4.3	9.4		
315.0	1.2	0.1	1.1	0.0	6.2	1.1	0.2	4.8	8.1		
270.0	10.0	0.6	5.0	4.4	12.7	3.1	0.7	6.6	8.5		
225.0	19.6	1.0	2.5	16.1	27.8	6.7	2.9	11.8	9.1		
180.0	3.2	1.1	1.5	0.6	9.4	2.1	0.3	4.5	8.9		
135.0	3.5	0.8	2.5	0.1	7.0	1.7	0.2	4.1	8.6		

MEAN SCALAR SPEED = 11.7 CM/S MEAN SQUARE SPEED = 180.6 CM2/S2
 MEAN SQUARE E-W SPEED = 136.0 CM2/S2 MEAN SQUARE N-S SPEED = 44.6 CM2/S2
 MEAN VELOCITY = 5.3 CM/S, 67 DEG TRUE MEAN TEMPERATURE = 8.9 C
 VARIANCE (U,V) = 76.2 CM2/S2 TOTAL HOURS = 720.

PERCENT OBSERVED
LIGHT (0.0 - 3.0) 4.9% MEDIUM (3.0 - 7.0) 22.1% HIGH (GE 7.0) 73.1%

MOORING IS 97-05C-001A019 DEPTH IS 19 METERS THERE ARE 719 VALUES

FIRST DAY 1997/11/01/0000
FINAL DAY 1997/11/30/2300

SHORELINE ORIENTATION IN DEGREES TRUE SPECIFIED AS 90

DIRECTION DEG TRUE	PERCENT OBSERVED	TOWARD	TOTAL	LIGHT	MEDIUM	HIGH	MAXIMUM CURRENT CM/S	MEAN DURATION HOURS	MEAN EXCURSION KM	MEAN CURRENT CM/S	MEAN TEMP DEG C
90.0	9.6	1.8	5.8	1.9	21.2	2.6	0.5	5.6	8.5		
45.0	51.2	0.7	6.7	43.8	25.1	13.6	5.6	11.5	9.0		
0.0	1.7	0.7	1.0	0.0	6.4	1.0	0.1	3.8	7.8		
315.0	2.1	0.6	1.0	0.6	9.6	2.1	0.4	5.6	7.7		
270.0	8.2	0.7	5.0	2.5	14.8	2.8	0.6	6.1	8.3		
225.0	18.4	0.6	5.1	12.7	25.7	6.0	2.0	9.5	9.0		
180.0	5.3	1.7	2.8	0.8	7.7	2.2	0.4	4.5	9.3		
135.0	3.6	1.3	2.4	0.0	5.1	1.7	0.2	3.6	9.2		

MEAN SCALAR SPEED = 9.2 CM/S MEAN SQUARE SPEED = 110.1 CM2/S2
 MEAN SQUARE E-W SPEED = 70.0 CM2/S2 MEAN SQUARE N-S SPEED = 40.1 CM2/S2
 MEAN VELOCITY = 4.0 CM/S, 53 DEG TRUE MEAN TEMPERATURE = 8.9 C
 VARIANCE (U,V) = 47.0 CM2/S2 TOTAL HOURS = 719.

PERCENT OBSERVED
LIGHT (0.0 - 3.0) 7.9% MEDIUM (3.0 - 7.0) 29.8% HIGH (GE 7.0) 62.3%

Appendix N - Mooring_V03-97. Monthly Summary Statistics and Rose Histogram Plots

DATE: 1997/10/01 TO 1997/10/31
ROSE SUMMARY: WIND AND CURRENT

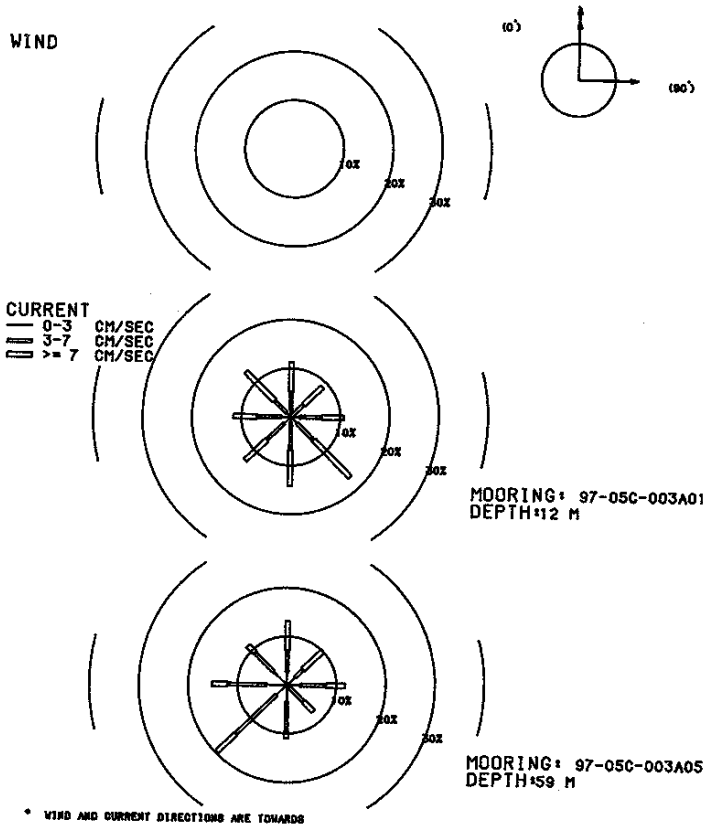

MOORING IS 97-05C-003A012 DEPTH IS 12 METERS THERE ARE 584 VALUES

FIRST DAY 1997/10/07/1600
FINAL DAY 1997/10/31/2300

SHORELINE ORIENTATION IN DEGREES TRUE SPECIFIED AS 90

DIRECTION DEG TRUE	PERCENT OBSERVED	TOWARD	TOTAL	LIGHT	MEDIUM	HIGH	MAXIMUM CURRENT CM/S	MEAN DURA- TION HOURS	MEAN EXCUR- SION KM	MEAN CURRENT CM/S	MEAN TEMP DEG C
90.0	10.8	1.7	4.5	4.6	19.0	2.3	0.6	7.4	16.0		
45.0	8.9	0.2	3.4	5.3	16.2	2.2	0.6	8.2	15.6		
0.0	11.3	1.4	3.8	6.2	15.9	2.3	0.7	8.0	14.9		
315.0	13.0	1.2	3.4	8.4	18.3	2.6	0.8	8.6	14.5		
270.0	11.6	1.9	5.0	4.8	18.7	2.2	0.5	6.8	14.9		
225.0	12.8	1.9	4.8	6.2	22.9	2.6	0.7	7.6	15.6		
180.0	14.2	1.0	5.8	7.4	23.9	3.0	0.9	8.4	15.6		
135.0	17.3	1.7	4.8	10.8	23.1	3.2	1.1	9.9	14.7		

MEAN SCALAR SPEED = 8.2 CM/S MEAN SQUARE SPEED = 88.7 CM2/S2
 MEAN SQUARE E-W SPEED = 40.6 CM2/S2 MEAN SQUARE N-S SPEED = 48.1 CM2/S2
 MEAN VELOCITY = 1.0 CM/S, 165 DEG TRUE MEAN TEMPERATURE = 15.2 C
 VARIANCE (U,V) = 44.0 CM2/S2 TOTAL HOURS = 584.

PERCENT OBSERVED
 LIGHT (0.0 - 3.0) 11.0% MEDIUM (3.0 - 7.0) 35.4% HIGH (GE 7.0) 53.6%

MOORING IS 97-05C-003A059 DEPTH IS 59 METERS THERE ARE 584 VALUES

FIRST DAY 1997/10/07/1600
FINAL DAY 1997/10/31/2300

SHORELINE ORIENTATION IN DEGREES TRUE SPECIFIED AS 90

DIRECTION DEG TRUE	PERCENT OBSERVED	TOWARD	TOTAL	LIGHT	MEDIUM	HIGH	MAXIMUM CURRENT CM/S	MEAN DURA- TION HOURS	MEAN EXCUR- SION KM	MEAN CURRENT CM/S	MEAN TEMP DEG C
90.0	11.8	2.6	5.3	3.9	14.6	2.8	0.6	6.1	5.3		
45.0	10.1	2.2	2.2	5.7	19.1	2.3	0.7	8.2	5.3		
0.0	13.2	2.6	4.6	6.0	19.8	2.8	0.8	8.0	5.1		
315.0	11.3	3.6	5.7	2.1	15.6	2.8	0.5	4.8	4.9		
270.0	15.2	4.1	7.9	3.3	15.4	2.7	0.5	5.3	4.9		
225.0	19.7	2.9	11.5	5.3	14.5	3.6	0.8	5.9	4.8		
180.0	11.0	3.4	6.2	1.4	10.2	2.7	0.4	4.5	4.9		
135.0	7.7	0.7	4.1	2.9	18.8	2.4	0.7	8.0	5.3		

MEAN SCALAR SPEED = 6.2 CM/S MEAN SQUARE SPEED = 54.7 CM2/S2
 MEAN SQUARE E-W SPEED = 27.4 CM2/S2 MEAN SQUARE N-S SPEED = 27.3 CM2/S2
 MEAN VELOCITY = 0.3 CM/S, 337 DEG TRUE MEAN TEMPERATURE = 5.0 C
 VARIANCE (U,V) = 27.4 CM2/S2 TOTAL HOURS = 584.

PERCENT OBSERVED
 LIGHT (0.0 - 3.0) 22.1% MEDIUM (3.0 - 7.0) 47.4% HIGH (GE 7.0) 30.5%

DATE: 1997/11/01 TO 1997/11/30
 ROSE SUMMARY: WIND AND CURRENT

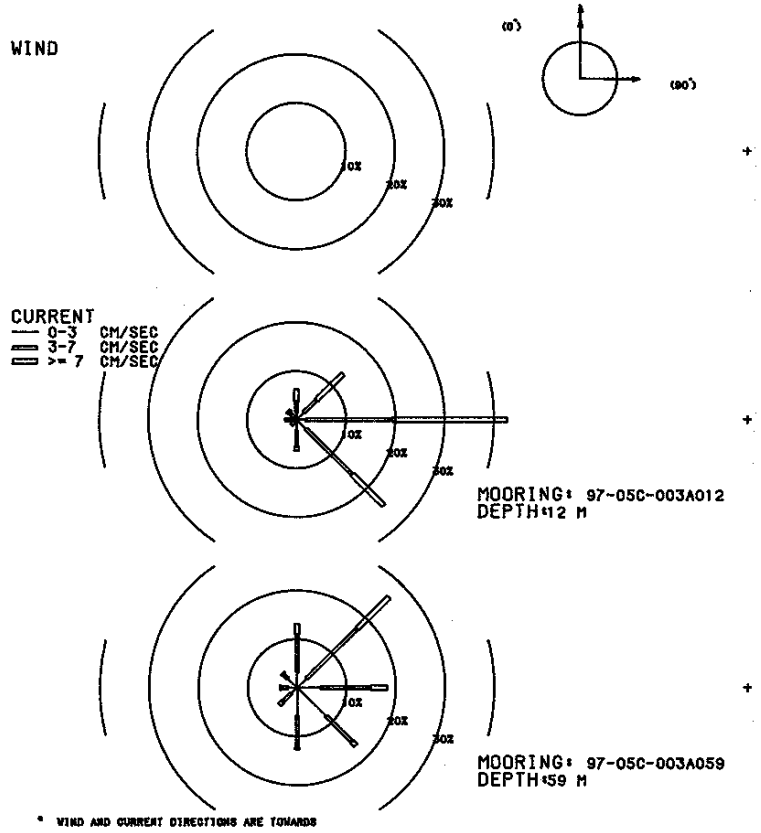

MOORING IS 97-05C-003A012 DEPTH IS 12 METERS THERE ARE 720 VALUES

FIRST DAY 1997/11/01/0000
 FINAL DAY 1997/11/30/2300

SHORELINE ORIENTATION IN DEGREES TRUE SPECIFIED AS 90

DIRECTION DEG TRUE	PERCENT OBSERVED	TOWARD	TOTAL	LIGHT	MEDIUM	HIGH	MAXIMUM CURRENT CM/S	MEAN DURATION HOURS	MEAN EXCURSION KM	MEAN CURRENT CM/S	MEAN TEMP DEG C
90.0	42.6	1.8	17.5	23.3	17.5	5.8	1.6	7.8	9.2		
45.0	13.3	2.1	3.6	7.6	14.4	4.4	1.2	7.7	9.5		
0.0	6.2	1.5	2.2	2.5	9.1	2.5	0.5	5.9	10.0		
315.0	2.5	0.6	1.5	0.4	7.7	1.8	0.3	4.6	9.6		
270.0	2.4	0.8	1.5	0.0	6.6	1.7	0.2	3.7	9.4		
225.0	1.5	0.6	1.0	0.0	5.0	1.2	0.2	3.5	9.8		
180.0	6.4	2.2	3.3	0.8	8.3	3.5	0.6	4.4	9.2		
135.0	25.0	2.6	13.2	9.2	16.5	3.3	0.8	6.7	9.1		
0		MEAN SCALAR SPEED = 6.9 CM/S		MEAN SQUARE SPEED = 57.9 CM2/S2							
		MEAN SQUARE E-W SPEED = 44.3 CM2/S2		MEAN SQUARE N-S SPEED = 13.6 CM2/S2							
		MEAN VELOCITY = 5.2 CM/S,		94 DEG TRUE		MEAN TEMPERATURE = 9.3 C					
		VARIANCE (U,V) = 15.5 CM2/S2		TOTAL HOURS = 720.							

PERCENT OBSERVED
 LIGHT (0.0 - 3.0) 12.2% MEDIUM (3.0 - 7.0) 43.9% HIGH (GE 7.0) 43.9%

MOORING IS 97-05C-003A059 DEPTH IS 59 METERS THERE ARE 720 VALUES

FIRST DAY 1997/11/01/0000
 FINAL DAY 1997/11/30/2300

SHORELINE ORIENTATION IN DEGREES TRUE SPECIFIED AS 90

DIRECTION DEG TRUE	PERCENT OBSERVED	TOWARD	TOTAL	LIGHT	MEDIUM	HIGH	MAXIMUM CURRENT CM/S	MEAN DURATION HOURS	MEAN EXCURSION KM	MEAN CURRENT CM/S	MEAN TEMP DEG C
90.0	18.3	4.7	10.1	3.5	10.1	2.4	0.4	4.8	6.5		
45.0	26.4	2.6	14.6	9.2	13.9	4.3	1.0	6.3	6.4		
0.0	13.2	3.2	7.8	2.2	9.7	2.8	0.5	4.5	6.0		
315.0	4.2	2.6	1.4	0.1	8.3	2.3	0.2	3.0	5.7		
270.0	3.5	1.8	1.5	0.1	9.2	1.8	0.2	3.6	5.8		
225.0	5.0	1.7	2.5	0.8	10.1	2.6	0.4	4.4	6.3		
180.0	12.6	5.8	6.5	0.3	8.3	3.1	0.4	3.5	5.7		
135.0	16.8	8.2	7.5	1.1	8.8	2.5	0.3	3.7	6.1		
0		MEAN SCALAR SPEED = 4.7 CM/S		MEAN SQUARE SPEED = 28.1 CM2/S2							
		MEAN SQUARE E-W SPEED = 13.5 CM2/S2		MEAN SQUARE N-S SPEED = 14.6 CM2/S2							
		MEAN VELOCITY = 2.3 CM/S,		67 DEG TRUE		MEAN TEMPERATURE = 6.2 C					
		VARIANCE (U,V) = 11.4 CM2/S2		TOTAL HOURS = 720.							

PERCENT OBSERVED
 LIGHT (0.0 - 3.0) 30.7% MEDIUM (3.0 - 7.0) 51.9% HIGH (GE 7.0) 17.4%

DATE: 1997/12/01 TO 1997/12/31
ROSE SUMMARY: WIND AND CURRENT

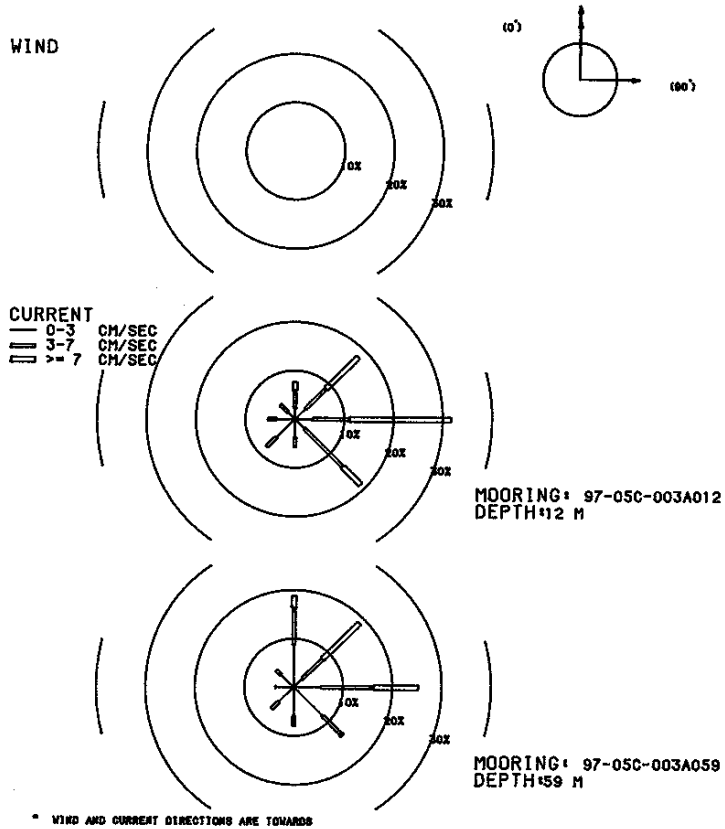

MOORING IS 97-05C-003A012 DEPTH IS 12 METERS THERE ARE 744 VALUES

FIRST DAY 1997/12/01/0000
FINAL DAY 1997/12/31/2300

SHORELINE ORIENTATION IN DEGREES TRUE SPECIFIED AS 90

DIRECTION DEG TRUE	PERCENT OBSERVED	TOWARD	TOTAL	LIGHT	MEDIUM	HIGH	MAXIMUM CURRENT CM/S	MEAN DURA- TION HOURS	MEAN EXCUR- SION KM	MEAN CURRENT CM/S	MEAN TEMP DEG C
90.0	31.7	3.5	7.5	20.7	17.7	4.3	17.7	4.3	1.4	9.0	5.9
45.0	18.1	3.0	5.9	9.3	17.1	2.7	17.1	2.7	0.8	8.6	5.9
0.0	7.7	2.3	3.6	1.7	15.8	1.6	15.8	1.6	0.3	5.0	5.7
315.0	4.2	2.0	2.2	0.0	6.0	1.5	6.0	1.5	0.2	3.4	5.7
270.0	5.5	3.8	1.7	0.0	6.2	1.6	6.2	1.6	0.2	2.9	5.7
225.0	8.1	5.2	2.8	0.0	6.5	1.9	6.5	1.9	0.2	3.2	5.6
180.0	5.8	3.8	2.0	0.0	6.9	1.5	6.9	1.5	0.2	3.0	5.5
135.0	19.0	2.7	11.0	5.2	15.6	3.1	15.6	3.1	0.6	5.7	5.8
0 MEAN SCALAR SPEED = 6.6 CM/S MEAN SQUARE SPEED = 62.1 CM2/S2											
MEAN SQUARE E-W SPEED = 44.6 CM2/S2 MEAN SQUARE N-S SPEED = 17.5 CM2/S2											
MEAN VELOCITY = 4.3 CM/S, 86 DEG TRUE MEAN TEMPERATURE = 5.8 C											
VARIANCE (U,V) = 21.9 CM2/S2 TOTAL HOURS = 744.											

PERCENT OBSERVED
LIGHT (0.0 - 3.0) 26.2% MEDIUM (3.0 - 7.0) 36.8% HIGH (GE 7.0) 37.0%

MOORING IS 97-05C-003A059 DEPTH IS 59 METERS THERE ARE 744 VALUES

FIRST DAY 1997/12/01/0000
FINAL DAY 1997/12/31/2300

SHORELINE ORIENTATION IN DEGREES TRUE SPECIFIED AS 90

DIRECTION DEG TRUE	PERCENT OBSERVED	TOWARD	TOTAL	LIGHT	MEDIUM	HIGH	MAXIMUM CURRENT CM/S	MEAN DURA- TION HOURS	MEAN EXCUR- SION KM	MEAN CURRENT CM/S	MEAN TEMP DEG C
90.0	25.3	5.5	10.6	9.1	13.7	3.1	13.7	3.1	0.7	6.0	5.8
45.0	18.8	2.4	5.8	10.6	14.4	2.5	14.4	2.5	0.7	7.7	6.0
0.0	18.8	8.7	7.7	2.4	13.5	2.3	13.5	2.3	0.3	3.6	5.8
315.0	5.0	3.6	1.3	0.0	4.9	1.4	4.9	1.4	0.1	2.6	5.5
270.0	3.8	3.6	0.1	0.0	3.3	1.9	3.3	1.9	0.1	2.2	5.7
225.0	6.3	4.3	2.0	0.0	6.8	1.6	6.8	1.6	0.2	2.7	5.4
180.0	8.1	5.9	2.2	0.0	6.2	1.7	6.2	1.7	0.2	2.7	5.6
135.0	14.0	8.3	5.2	0.4	8.7	2.0	8.7	2.0	0.2	3.3	5.9
0 MEAN SCALAR SPEED = 4.7 CM/S MEAN SQUARE SPEED = 33.3 CM2/S2											
MEAN SQUARE E-W SPEED = 19.6 CM2/S2 MEAN SQUARE N-S SPEED = 13.7 CM2/S2											
MEAN VELOCITY = 2.8 CM/S, 65 DEG TRUE MEAN TEMPERATURE = 5.8 C											
VARIANCE (U,V) = 12.7 CM2/S2 TOTAL HOURS = 744.											

PERCENT OBSERVED
LIGHT (0.0 - 3.0) 42.5% MEDIUM (3.0 - 7.0) 34.9% HIGH (GE 7.0) 22.6%

DATE: 1998/01/01 TO 1998/01/31
ROSE SUMMARY: WIND AND CURRENT

WIND

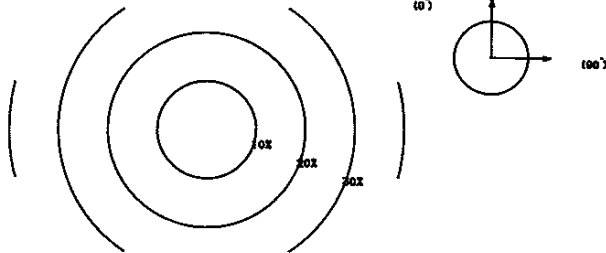

CURRENT

0-3 CM/SEC
3-7 CM/SEC
>= 7 CM/SEC

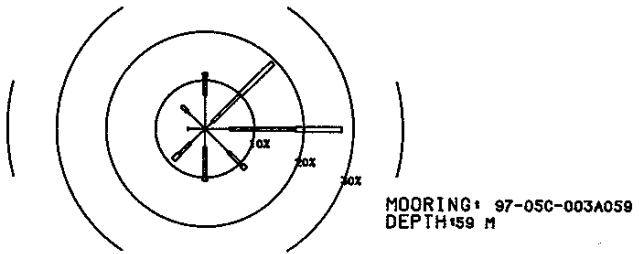
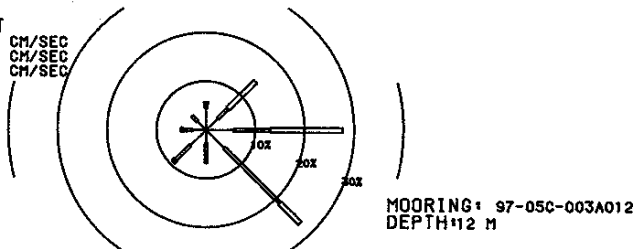

* WIND AND CURRENT DIRECTIONS ARE TOWARDS

MOORING IS 97-05C-003A012 DEPTH IS 12 METERS THERE ARE 744 VALUES

FIRST DAY 1998/01/01/0000
FINAL DAY 1998/01/31/2300

SHORELINE ORIENTATION IN DEGREES TRUE SPECIFIED AS 90

DIRECTION DEG TRUE	PERCENT OBSERVED	TOWARD	TOTAL	LIGHT	MEDIUM	HIGH	MAXIMUM CURRENT CM/S	MEAN DURA- TION HOURS	MEAN EXCUR- SION KM	MEAN CURRENT CM/S	MEAN TEMP DEG C
90.0	27.7	5.5	7.5	14.7	26.9	3.8	1.3	9.3	3.9		
45.0	14.1	3.2	3.0	7.9	20.4	3.2	1.0	8.6	4.1		
0.0	5.8	4.4	1.1	0.3	14.1	2.0	0.2	3.1	3.6		
315.0	4.0	2.4	1.6	0.0	4.0	3.3	0.4	3.0	3.6		
270.0	5.1	2.7	2.2	0.3	7.3	3.5	0.4	3.6	3.5		
225.0	9.4	4.4	4.3	0.7	8.2	3.3	0.5	4.0	4.0		
180.0	6.9	2.7	4.2	0.0	6.7	2.2	0.3	4.0	4.0		
135.0	27.0	5.1	16.0	5.9	13.4	4.8	0.9	5.2	3.8		
0	MEAN SCALAR SPEED = 6.3 CM/S		MEAN SQUARE SPEED = 64.5 CM2/S2								
	MEAN SQUARE E-W SPEED = 50.9 CM2/S2		MEAN SQUARE N-S SPEED = 13.6 CM2/S2								
	MEAN VELOCITY = 4.0 CM/S,		96 DEG TRUE		MEAN TEMPERATURE = 3.8 C						
	VARIANCE (U,V) = 24.2 CM2/S2		TOTAL HOURS = 744.								

PERCENT OBSERVED
LIGHT (0.0 - 3.0) 30.5% MEDIUM (3.0 - 7.0) 39.8% HIGH (GE 7.0) 29.7%

MOORING IS 97-05C-003A059 DEPTH IS 59 METERS THERE ARE 744 VALUES

FIRST DAY 1998/01/01/0000
FINAL DAY 1998/01/31/2300

SHORELINE ORIENTATION IN DEGREES TRUE SPECIFIED AS 90

DIRECTION DEG TRUE	PERCENT OBSERVED	TOWARD	TOTAL	LIGHT	MEDIUM	HIGH	MAXIMUM CURRENT CM/S	MEAN DURA- TION HOURS	MEAN EXCUR- SION KM	MEAN CURRENT CM/S	MEAN TEMP DEG C
90.0	27.7	5.0	13.3	9.4	16.9	5.2	1.2	6.3	3.9		
45.0	19.4	2.2	7.8	9.4	18.9	5.5	1.5	7.5	4.0		
0.0	11.6	7.0	4.0	0.5	13.3	2.9	0.3	3.0	3.6		
315.0	6.7	5.0	1.7	0.0	4.6	3.3	0.3	2.5	3.6		
270.0	3.5	3.4	0.1	0.0	3.8	2.2	0.2	2.3	3.6		
225.0	9.0	4.2	3.2	1.6	8.4	3.4	0.5	4.3	4.1		
180.0	10.6	3.8	6.0	0.8	8.0	3.4	0.5	3.9	3.9		
135.0	11.6	6.7	3.9	0.9	9.7	2.8	0.3	3.5	3.7		
0	MEAN SCALAR SPEED = 5.0 CM/S		MEAN SQUARE SPEED = 37.3 CM2/S2								
	MEAN SQUARE E-W SPEED = 23.5 CM2/S2		MEAN SQUARE N-S SPEED = 13.8 CM2/S2								
	MEAN VELOCITY = 2.7 CM/S,		76 DEG TRUE		MEAN TEMPERATURE = 3.9 C						
	VARIANCE (U,V) = 15.1 CM2/S2		TOTAL HOURS = 744.								

PERCENT OBSERVED
LIGHT (0.0 - 3.0) 37.1% MEDIUM (3.0 - 7.0) 40.2% HIGH (GE 7.0) 22.7%

DATE: 1998/02/01 TO 1998/02/28
 ROSE SUMMARY: WIND AND CURRENT

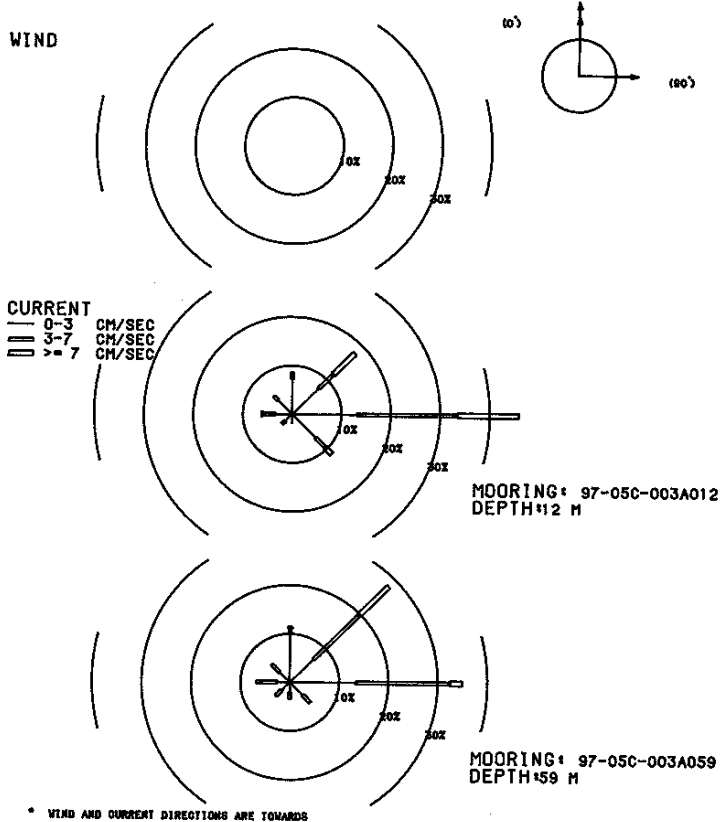

MOORING IS 97-05C-003A012 DEPTH IS 12 METERS THERE ARE 672 VALUES

FIRST DAY 1998/02/01/0000
 FINAL DAY 1998/02/28/2300

SHORELINE ORIENTATION IN DEGREES TRUE SPECIFIED AS 90

DIRECTION DEG TRUE	PERCENT OBSERVED	TOWARD	TOTAL	LIGHT	MEDIUM	HIGH	MAXIMUM CURRENT CM/S	MEAN DURA- TION HOURS	MEAN EXCUR- SION KM	MEAN CURRENT CM/S	MEAN TEMP DEG C
90.0	46.0	13.1	20.4	12.5	12.6	5.8	1.1	5.2	3.0		
45.0	17.9	7.4	4.3	6.1	13.1	2.7	0.5	5.5	3.0		
0.0	8.6	7.3	1.3	0.0	6.0	2.1	0.1	1.6	2.9		
315.0	5.2	4.0	1.2	0.0	5.9	2.3	0.2	2.8	3.1		
270.0	6.2	3.4	2.5	0.3	8.2	2.6	0.3	3.4	3.2		
225.0	2.8	1.9	0.9	0.0	5.1	1.7	0.2	2.7	3.2		
180.0	1.8	1.8	0.0	0.0	2.7	1.5	0.1	2.2	3.2		
135.0	11.5	6.8	2.7	1.9	10.0	2.6	0.4	4.0	2.9		
0		MEAN SCALAR SPEED = 4.5 CM/S		MEAN SQUARE SPEED = 28.1 CM2/S2							
		MEAN SQUARE E-W SPEED = 23.2 CM2/S2		MEAN SQUARE N-S SPEED = 4.9 CM2/S2							
		MEAN VELOCITY = 3.2 CM/S,		81 DEG TRUE		MEAN TEMPERATURE = 3.0 C					
		VARIANCE (U,V) = 9.1 CM2/S2		TOTAL HOURS = 672.							

PERCENT OBSERVED
 LIGHT (0.0 - 3.0) 45.8% MEDIUM (3.0 - 7.0) 33.3% HIGH (GE 7.0) 20.8%

MOORING IS 97-05C-003A059 DEPTH IS 59 METERS THERE ARE 672 VALUES

FIRST DAY 1998/02/01/0000
 FINAL DAY 1998/02/28/2300

SHORELINE ORIENTATION IN DEGREES TRUE SPECIFIED AS 90

DIRECTION DEG TRUE	PERCENT OBSERVED	TOWARD	TOTAL	LIGHT	MEDIUM	HIGH	MAXIMUM CURRENT CM/S	MEAN DURA- TION HOURS	MEAN EXCUR- SION KM	MEAN CURRENT CM/S	MEAN TEMP DEG C
90.0	35.0	13.4	19.0	2.5	9.6	6.2	0.9	4.0	3.0		
45.0	28.1	6.7	12.9	8.5	11.0	4.4	0.8	5.2	3.0		
0.0	11.5	10.3	0.9	0.3	8.2	2.2	0.1	0.9	3.0		
315.0	5.2	2.8	2.4	0.0	5.4	1.8	0.2	2.8	3.2		
270.0	6.8	2.5	4.3	0.0	5.9	2.1	0.3	3.4	3.2		
225.0	4.0	2.2	1.8	0.0	5.0	2.5	0.3	3.1	3.2		
180.0	3.4	2.1	1.3	0.0	4.1	5.8	0.6	2.8	3.2		
135.0	6.0	3.7	2.2	0.0	4.7	2.7	0.3	2.9	2.9		
0		MEAN SCALAR SPEED = 3.7 CM/S		MEAN SQUARE SPEED = 19.5 CM2/S2							
		MEAN SQUARE E-W SPEED = 13.7 CM2/S2		MEAN SQUARE N-S SPEED = 5.8 CM2/S2							
		MEAN VELOCITY = 2.4 CM/S,		65 DEG TRUE		MEAN TEMPERATURE = 3.0 C					
		VARIANCE (U,V) = 6.9 CM2/S2		TOTAL HOURS = 672.							

PERCENT OBSERVED
 LIGHT (0.0 - 3.0) 43.7% MEDIUM (3.0 - 7.0) 44.9% HIGH (GE 7.0) 11.3%

DATE: 1998/03/01 TO 1998/03/31
 ROSE SUMMARY: WIND AND CURRENT

WIND

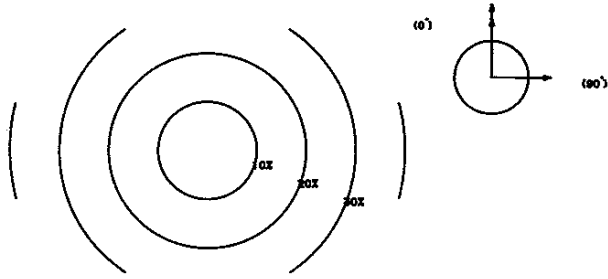

CURRENT
 — 0-3 CM/SEC
 = 3-7 CM/SEC
 ▬ >= 7 CM/SEC

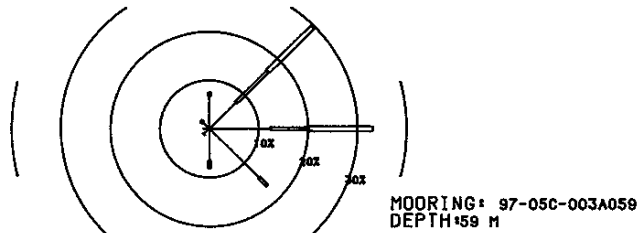
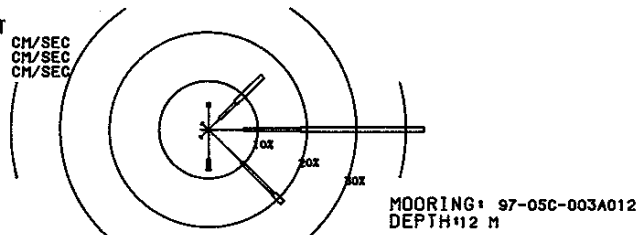

* WIND AND CURRENT DIRECTIONS ARE TOWARDS

MOORING IS 97-05C-003A012 DEPTH IS 12 METERS THERE ARE 744 VALUES

FIRST DAY 1998/03/01/0000
 FINAL DAY 1998/03/31/2300

SHORELINE ORIENTATION IN DEGREES TRUE SPECIFIED AS 90

DIRECTION DEG TRUE	PERCENT OBSERVED				MAXIMUM CURRENT CM/S	MEAN DURA- TION HOURS	MEAN EXCUR- SION KM	MEAN CURRENT CM/S	MEAN TEMP DEG C
	TOWARD	TOTAL	LIGHT	MEDIUM					
90.0	43.7	7.1	11.6	25.0	32.1	5.0	1.6	9.1	2.9
45.0	15.6	3.2	4.6	7.8	29.3	3.4	1.2	10.1	3.0
0.0	5.5	4.7	0.8	0.0	5.1	2.0	0.1	1.2	3.2
315.0	1.9	1.7	0.1	0.0	4.0	1.4	0.1	2.4	3.3
270.0	1.5	1.5	0.0	0.0	2.6	1.2	0.1	2.2	3.3
225.0	2.3	2.2	0.1	0.0	3.4	1.1	0.1	1.9	3.2
180.0	8.3	6.0	2.2	0.1	7.6	1.8	0.2	2.7	3.2
135.0	21.2	9.5	9.1	2.6	10.6	2.5	0.3	3.8	3.0
0	MEAN SCALAR SPEED = 6.8 CM/S		MEAN SQUARE SPEED = 85.7 CM2/S2						
	MEAN SQUARE E-W SPEED = 71.3 CM2/S2		MEAN SQUARE N-S SPEED = 14.4 CM2/S2						
	MEAN VELOCITY = 5.7 CM/S,		87 DEG TRUE		MEAN TEMPERATURE = 3.0 C				
	VARIANCE (U,V) = 26.7 CM2/S2		TOTAL HOURS = 744.						

PERCENT OBSERVED

LIGHT (0.0 - 3.0) 36.0% MEDIUM (3.0 - 7.0) 28.5% HIGH (GE 7.0) 35.5%

MOORING IS 97-05C-003A059 DEPTH IS 59 METERS THERE ARE 744 VALUES

FIRST DAY 1998/03/01/0000
 FINAL DAY 1998/03/31/2300

SHORELINE ORIENTATION IN DEGREES TRUE SPECIFIED AS 90

DIRECTION DEG TRUE	PERCENT OBSERVED				MAXIMUM CURRENT CM/S	MEAN DURA- TION HOURS	MEAN EXCUR- SION KM	MEAN CURRENT CM/S	MEAN TEMP DEG C
	TOWARD	TOTAL	LIGHT	MEDIUM					
90.0	33.1	12.4	7.8	12.9	24.7	3.6	0.8	6.1	3.0
45.0	29.6	7.7	9.1	12.8	29.9	4.9	1.4	7.9	3.0
0.0	7.5	6.9	0.7	0.0	6.4	2.5	0.1	0.9	3.2
315.0	2.4	1.7	0.7	0.0	3.1	2.2	0.2	2.5	3.3
270.0	1.1	1.1	0.0	0.0	2.2	1.3	0.1	1.9	3.3
225.0	1.6	1.5	0.1	0.0	3.5	1.3	0.1	2.2	3.2
180.0	8.2	6.6	1.6	0.0	5.2	2.0	0.2	2.6	3.2
135.0	16.5	14.2	2.3	0.0	6.3	2.8	0.2	2.4	3.0
0	MEAN SCALAR SPEED = 5.2 CM/S		MEAN SQUARE SPEED = 53.1 CM2/S2						
	MEAN SQUARE E-W SPEED = 33.2 CM2/S2		MEAN SQUARE N-S SPEED = 19.9 CM2/S2						
	MEAN VELOCITY = 4.1 CM/S,		69 DEG TRUE		MEAN TEMPERATURE = 3.0 C				
	VARIANCE (U,V) = 18.2 CM2/S2		TOTAL HOURS = 744.						

PERCENT OBSERVED

LIGHT (0.0 - 3.0) 52.0% MEDIUM (3.0 - 7.0) 22.3% HIGH (GE 7.0) 25.7%

DATE: 1998/04/01 TO 1998/04/30
ROSE SUMMARY: WIND AND CURRENT

WIND

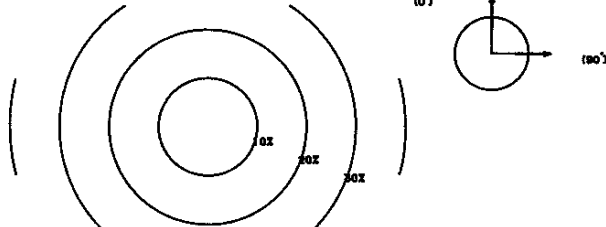

CURRENT
 0-3 CM/SEC
 3-7 CM/SEC
 >= 7 CM/SEC

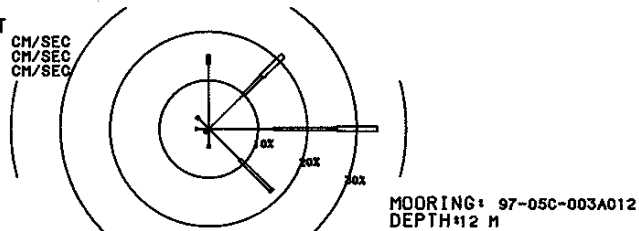

MOORING: 97-05C-003A012
DEPTH: 12 M

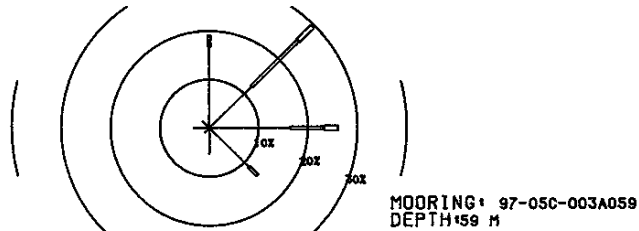

MOORING: 97-05C-003A059
DEPTH: 59 M

* WIND AND CURRENT DIRECTIONS ARE TOWARDS

MOORING IS 97-05C-003A012 DEPTH IS 12 METERS THERE ARE 720 VALUES

FIRST DAY 1998/04/01/0000
FINAL DAY 1998/04/30/2300

SHORELINE ORIENTATION IN DEGREES TRUE SPECIFIED AS 90

DIRECTION DEG TRUE	PERCENT OBSERVED	TOWARD	TOTAL	LIGHT	MEDIUM	HIGH	MAXIMUM CURRENT CM/S	MEAN DURA- TION HOURS	MEAN EXCUR- SION KM	MEAN CURRENT CM/S	MEAN TEMP DEG C
90.0	34.2	13.2	12.8	8.2	16.7	4.4	0.8	5.2	3.7		
45.0	21.4	10.1	5.1	6.1	16.3	3.1	0.6	5.1	3.9		
0.0	15.3	13.3	1.9	0.0	5.9	2.3	0.1	1.2	3.8		
315.0	3.5	2.9	0.6	0.0	4.8	2.5	0.2	2.6	3.9		
270.0	2.6	2.5	0.1	0.0	3.2	2.4	0.2	2.5	3.9		
225.0	1.1	1.0	0.1	0.0	3.6	1.1	0.1	2.2	3.7		
180.0	3.9	3.3	0.6	0.0	3.4	2.3	0.2	2.4	3.8		
135.0	18.1	8.9	8.8	0.4	7.6	3.4	0.4	3.5	3.7		

0 MEAN SCALAR SPEED = 4.0 CM/S MEAN SQUARE SPEED = 25.3 CM2/S2
 MEAN SQUARE E-W SPEED = 19.5 CM2/S2 MEAN SQUARE N-S SPEED = 5.8 CM2/S2
 MEAN VELOCITY = 2.9 CM/S, 83 DEG TRUE MEAN TEMPERATURE = 3.8 C
 VARIANCE (U,V) = 8.3 CM2/S2 TOTAL HOURS = 720.

PERCENT OBSERVED
 LIGHT (0.0 - 3.0) 55.3% MEDIUM (3.0 - 7.0) 30.0% HIGH (GE 7.0) 14.7%

MOORING IS 97-05C-003A059 DEPTH IS 59 METERS THERE ARE 720 VALUES

FIRST DAY 1998/04/01/0000
FINAL DAY 1998/04/30/2300

SHORELINE ORIENTATION IN DEGREES TRUE SPECIFIED AS 90

DIRECTION DEG TRUE	PERCENT OBSERVED	TOWARD	TOTAL	LIGHT	MEDIUM	HIGH	MAXIMUM CURRENT CM/S	MEAN DURA- TION HOURS	MEAN EXCUR- SION KM	MEAN CURRENT CM/S	MEAN TEMP DEG C
90.0	26.1	16.4	6.9	2.8	10.7	3.6	0.5	3.5	3.7		
45.0	29.6	12.1	13.5	4.0	12.0	4.8	0.8	4.4	3.8		
0.0	19.2	16.8	2.4	0.0	5.0	2.6	0.1	1.1	3.7		
315.0	1.8	1.8	0.0	0.0	2.8	1.3	0.1	2.2	3.7		
270.0	3.1	3.1	0.0	0.0	3.0	2.4	0.2	2.2	3.8		
225.0	1.2	1.2	0.0	0.0	2.7	1.5	0.1	2.2	3.8		
180.0	5.3	5.3	0.0	0.0	2.8	2.4	0.2	2.2	3.7		
135.0	13.8	11.4	2.4	0.0	4.6	3.2	0.3	2.5	3.7		

0 MEAN SCALAR SPEED = 3.0 CM/S MEAN SQUARE SPEED = 14.4 CM2/S2
 MEAN SQUARE E-W SPEED = 9.1 CM2/S2 MEAN SQUARE N-S SPEED = 5.2 CM2/S2
 MEAN VELOCITY = 2.2 CM/S, 67 DEG TRUE MEAN TEMPERATURE = 3.8 C
 VARIANCE (U,V) = 4.8 CM2/S2 TOTAL HOURS = 720.

PERCENT OBSERVED
 LIGHT (0.0 - 3.0) 68.1% MEDIUM (3.0 - 7.0) 25.1% HIGH (GE 7.0) 6.8%

DATE: 1998/05/01 TO 1998/05/31

ROSE SUMMARY: WIND AND CURRENT

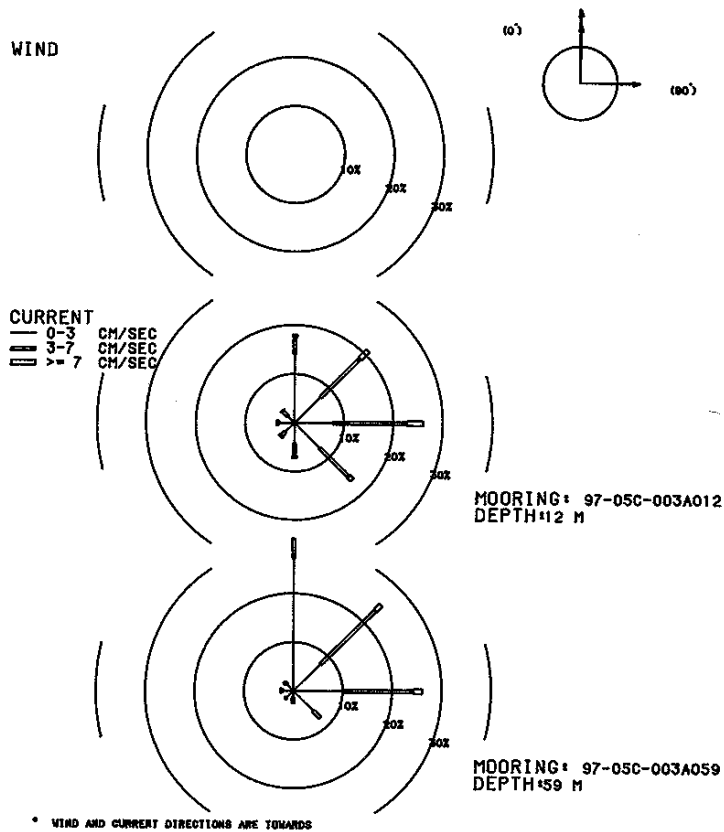

MOORING IS 97-05C-003A012 DEPTH IS 12 METERS THERE ARE 744 VALUES

FIRST DAY 1998/05/01/0000
FINAL DAY 1998/05/31/2300

SHORELINE ORIENTATION IN DEGREES TRUE SPECIFIED AS 90

DIRECTION DEG TRUE	PERCENT OBSERVED	TOWARD	TOTAL	LIGHT	MEDIUM	HIGH	MAXIMUM CURRENT CM/S	MEAN DURATION HOURS	MEAN EXCURSION KM	MEAN CURRENT CM/S	MEAN TEMP DEG C
90.0	26.1	7.8	14.9	3.4	14.4	2.8	0.5	4.7	6.9		
45.0	21.0	7.4	11.3	2.3	14.2	2.7	0.4	4.6	6.6		
0.0	18.0	14.1	3.5	0.4	13.7	2.2	0.1	1.5	6.8		
315.0	3.5	1.9	1.5	0.1	13.0	1.7	0.2	3.6	6.2		
270.0	3.6	3.1	0.3	0.3	11.4	1.6	0.2	3.0	7.4		
225.0	4.0	2.7	0.9	0.4	13.7	1.4	0.2	3.9	8.0		
180.0	7.3	4.2	2.7	0.4	17.6	1.9	0.2	3.6	7.6		
135.0	16.5	7.3	8.3	0.9	11.5	2.5	0.3	3.7	7.1		
MEAN SCALAR SPEED = 3.7 CM/S		MEAN SQUARE SPEED = 20.5 CM2/S2									
MEAN SQUARE E-W SPEED = 13.0 CM2/S2		MEAN SQUARE N-S SPEED = 7.5 CM2/S2									
MEAN VELOCITY = 2.1 CM/S,		84 DEG TRUE		MEAN TEMPERATURE = 7.0 C							
VARIANCE (U,V) = 8.0 CM2/S2		TOTAL HOURS = 744.									

PERCENT OBSERVED
LIGHT (0.0 - 3.0) 48.4% MEDIUM (3.0 - 7.0) 43.4% HIGH (GE 7.0) 8.2%

MOORING IS 97-05C-003A059 DEPTH IS 59 METERS THERE ARE 744 VALUES

FIRST DAY 1998/05/01/0000
FINAL DAY 1998/05/31/2300

SHORELINE ORIENTATION IN DEGREES TRUE SPECIFIED AS 90

DIRECTION DEG TRUE	PERCENT OBSERVED	TOWARD	TOTAL	LIGHT	MEDIUM	HIGH	MAXIMUM CURRENT CM/S	MEAN DURATION HOURS	MEAN EXCURSION KM	MEAN CURRENT CM/S	MEAN TEMP DEG C
90.0	26.1	10.3	14.0	1.7	10.1	3.1	0.4	3.8	4.5		
45.0	25.0	7.7	15.7	1.6	10.5	2.9	0.4	3.9	4.4		
0.0	31.2	27.2	4.0	0.0	5.7	3.1	0.1	0.9	4.4		
315.0	2.6	1.9	0.7	0.0	3.5	1.1	0.1	2.6	4.4		
270.0	2.6	2.0	0.4	0.1	9.2	1.2	0.1	2.9	4.4		
225.0	2.3	2.0	0.3	0.0	5.1	1.4	0.1	2.4	4.4		
180.0	2.6	1.3	1.2	0.0	5.2	1.6	0.2	3.0	4.4		
135.0	7.8	5.6	2.2	0.0	5.6	2.2	0.2	2.8	4.4		
MEAN SCALAR SPEED = 2.8 CM/S		MEAN SQUARE SPEED = 11.6 CM2/S2									
MEAN SQUARE E-W SPEED = 7.9 CM2/S2		MEAN SQUARE N-S SPEED = 3.7 CM2/S2									
MEAN VELOCITY = 1.9 CM/S,		66 DEG TRUE		MEAN TEMPERATURE = 4.4 C							
VARIANCE (U,V) = 4.0 CM2/S2		TOTAL HOURS = 744.									

PERCENT OBSERVED
LIGHT (0.0 - 3.0) 58.1% MEDIUM (3.0 - 7.0) 38.4% HIGH (GE 7.0) 3.5%

DATE: 1998/06/01 TO 1998/06/30
 ROSE SUMMARY: WIND AND CURRENT

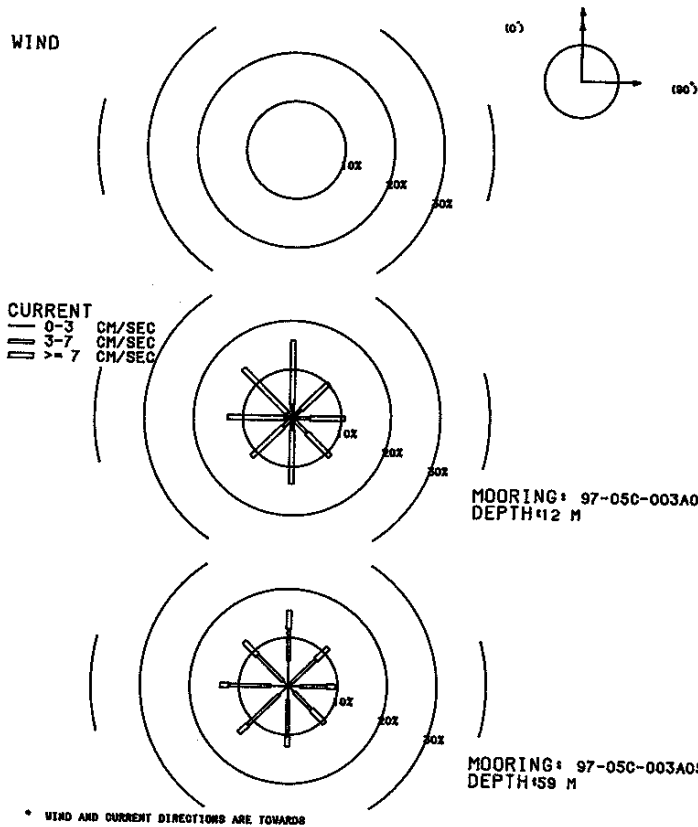

MOORING IS 97-05C-003A012 DEPTH IS 12 METERS THERE ARE 282 VALUES

FIRST DAY 1998/06/01/0000
 FINAL DAY 1998/06/12/1700

SHORELINE ORIENTATION IN DEGREES TRUE SPECIFIED AS 90

DIRECTION DEG TRUE	PERCENT OBSERVED	MAXIMUM CURRENT	MEAN DURA- TION HOURS	MEAN EXCUR- SION KM	MEAN CURRENT CM/S	MEAN TEMP DEG C
TOWARD	TOTAL	LIGHT	MEDIUM	HIGH	CM/S	
90.0	10.6	0.7	2.8	7.1	20.5	1.9
45.0	10.3	0.7	1.8	7.8	22.1	1.9
0.0	16.0	1.4	1.4	13.1	27.0	2.6
315.0	14.2	0.0	1.4	12.8	29.3	2.7
270.0	13.1	0.0	1.4	11.7	29.3	2.3
225.0	11.3	0.4	2.1	8.9	31.3	2.0
180.0	13.5	0.7	1.8	11.0	23.6	2.7
135.0	11.0	0.7	3.5	6.7	21.7	1.8
0		MEAN SCALAR SPEED = 12.4 CM/S		MEAN SQUARE SPEED = 192.8 CM2/S2		
		MEAN SQUARE E-W SPEED = 96.6 CM2/S2		MEAN SQUARE N-S SPEED = 96.3 CM2/S2		
		MEAN VELOCITY = 2.0 CM/S,		283 DEG TRUE		MEAN TEMPERATURE = 12.7 C
		VARIANCE (U,V) = 94.7 CM2/S2		TOTAL HOURS = 282.		

PERCENT OBSERVED
 LIGHT (0.0 - 3.0) 4.6% MEDIUM (3.0 - 7.0) 16.3% HIGH (GE 7.0) 79.1%

MOORING IS 97-05C-003A059 DEPTH IS 59 METERS THERE ARE 282 VALUES

FIRST DAY 1998/06/01/0000
 FINAL DAY 1998/06/12/1700

SHORELINE ORIENTATION IN DEGREES TRUE SPECIFIED AS 90

DIRECTION DEG TRUE	PERCENT OBSERVED	MAXIMUM CURRENT	MEAN DURA- TION HOURS	MEAN EXCUR- SION KM	MEAN CURRENT CM/S	MEAN TEMP DEG C
TOWARD	TOTAL	LIGHT	MEDIUM	HIGH	CM/S	
90.0	9.6	2.5	5.3	1.8	11.9	1.9
45.0	11.3	0.7	7.1	3.5	13.8	2.1
0.0	15.6	5.3	6.4	3.9	11.5	2.2
315.0	12.8	1.4	7.4	3.9	12.9	2.8
270.0	13.8	3.5	8.5	1.8	11.6	2.2
225.0	13.8	2.5	8.9	2.5	10.7	2.8
180.0	12.4	2.8	7.4	2.1	13.4	2.9
135.0	10.6	1.8	5.0	3.9	14.5	2.3
0		MEAN SCALAR SPEED = 5.3 CM/S		MEAN SQUARE SPEED = 35.9 CM2/S2		
		MEAN SQUARE E-W SPEED = 17.0 CM2/S2		MEAN SQUARE N-S SPEED = 18.9 CM2/S2		
		MEAN VELOCITY = 0.3 CM/S,		277 DEG TRUE		MEAN TEMPERATURE = 4.7 C
		VARIANCE (U,V) = 18.0 CM2/S2		TOTAL HOURS = 282.		

PERCENT OBSERVED
 LIGHT (0.0 - 3.0) 20.6% MEDIUM (3.0 - 7.0) 56.0% HIGH (GE 7.0) 23.4%

Appendix O - Mooring_V04-97. Overall Summary Statistics and Rose Histogram Plots

DATE: 1997/10/01 TO 1998/06/13
 ROSE SUMMARY: WIND AND CURRENT

WIND

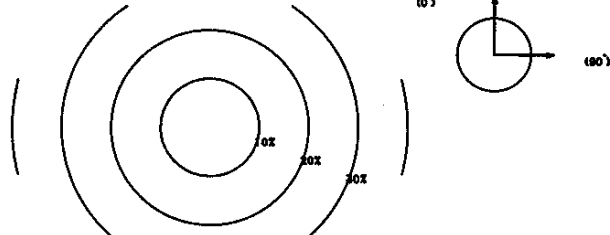

CURRENT

0-3 CM/SEC
 3-7 CM/SEC
 > 7 CM/SEC

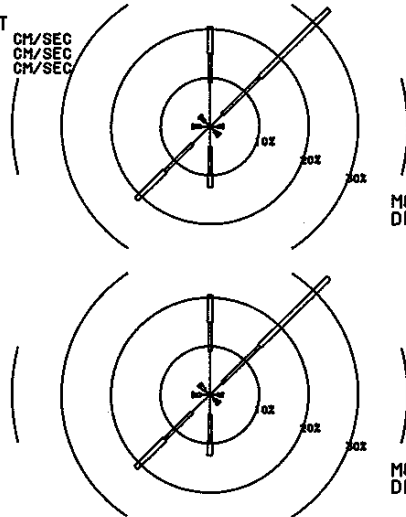

MOORING: 97-05C-004A019
 DEPTH: 19 M

MOORING: 97-05C-004A019
 DEPTH: 19 M

* WIND AND CURRENT DIRECTIONS ARE TOWARDS

MOORING IS 97-05C-004A019 DEPTH IS 19 METERS THERE ARE 5971 VALUES

FIRST DAY 1997/10/07/0300
 FINAL DAY 1998/06/12/2200

SHORELINE ORIENTATION IN DEGREES TRUE SPECIFIED AS 90

DIRECTION DEG TRUE	PERCENT OBSERVED	TOWARD	TOTAL	LIGHT	MEDIUM	HIGH	MAXIMUM CURRENT CM/S	MEAN DURATION HOURS	MEAN EXCURSION KM	MEAN CURRENT CM/S	MEAN TEMP DEG C
90.0	2.7	1.6	1.0	0.1	7.9	1.7	0.2	3.1	5.3		
45.0	34.1	3.6	10.7	19.8	31.7	7.9	2.6	9.1	5.1		
0.0	20.5	9.0	5.9	5.6	24.8	3.7	0.6	4.8	5.4		
315.0	3.0	1.4	1.3	0.4	15.7	2.0	0.3	4.2	7.0		
270.0	3.6	1.9	1.5	0.3	25.8	1.8	0.3	3.8	5.5		
225.0	21.1	5.0	7.9	8.2	33.2	5.0	1.2	6.5	5.5		
180.0	12.5	4.1	5.5	2.9	16.2	3.2	0.6	4.9	6.0		
135.0	2.6	1.4	0.9	0.3	14.7	1.8	0.3	4.0	6.3		
0		MEAN SCALAR SPEED = 6.5 CM/S		MEAN SQUARE SPEED = 67.6 CM2/S2							
		MEAN SQUARE E-W SPEED = 20.3 CM2/S2		MEAN SQUARE N-S SPEED = 47.4 CM2/S2							
		MEAN VELOCITY = 2.1 CM/S,		27 DEG TRUE		MEAN TEMPERATURE = 5.5 C					
		VARIANCE (U,V) = 31.7 CM2/S2		TOTAL HOURS = 5971.							

PERCENT OBSERVED
 LIGHT (0.0 - 3.0) 28.0% MEDIUM (3.0 - 7.0) 34.6% HIGH (GE 7.0) 37.4%

MOORING IS 97-05C-004A019 DEPTH IS 19 METERS THERE ARE 5971 VALUES

FIRST DAY 1997/10/07/0300
 FINAL DAY 1998/06/12/2200

SHORELINE ORIENTATION IN DEGREES TRUE SPECIFIED AS 90

DIRECTION DEG TRUE	PERCENT OBSERVED	TOWARD	TOTAL	LIGHT	MEDIUM	HIGH	MAXIMUM CURRENT CM/S	MEAN DURATION HOURS	MEAN EXCURSION KM	MEAN CURRENT CM/S	MEAN TEMP DEG C
90.0	2.7	1.6	1.0	0.1	7.9	1.7	0.2	3.1	5.3		
45.0	34.1	3.6	10.7	19.8	31.7	7.9	2.6	9.1	5.1		
0.0	20.5	9.0	5.9	5.6	24.8	3.7	0.6	4.8	5.4		
315.0	3.0	1.4	1.3	0.4	15.7	2.0	0.3	4.2	7.0		
270.0	3.6	1.9	1.5	0.3	25.8	1.8	0.3	3.8	5.5		
225.0	21.1	5.0	7.9	8.2	33.2	5.0	1.2	6.5	5.5		
180.0	12.5	4.1	5.5	2.9	16.2	3.2	0.6	4.9	6.0		
135.0	2.6	1.4	0.9	0.3	14.7	1.8	0.3	4.0	6.3		
0		MEAN SCALAR SPEED = 6.5 CM/S		MEAN SQUARE SPEED = 67.6 CM2/S2							
		MEAN SQUARE E-W SPEED = 20.3 CM2/S2		MEAN SQUARE N-S SPEED = 47.4 CM2/S2							
		MEAN VELOCITY = 2.1 CM/S,		27 DEG TRUE		MEAN TEMPERATURE = 5.5 C					
		VARIANCE (U,V) = 31.7 CM2/S2		TOTAL HOURS = 5971.							

PERCENT OBSERVED
 LIGHT (0.0 - 3.0) 28.0% MEDIUM (3.0 - 7.0) 34.6% HIGH (GE 7.0) 37.4%

Appendix P - Mooring_V04-97. Monthly Summary Statistics and Rose Histogram Plots

DATE: 1997/10/01 TO 1997/10/31
ROSE SUMMARY: WIND AND CURRENT

WIND

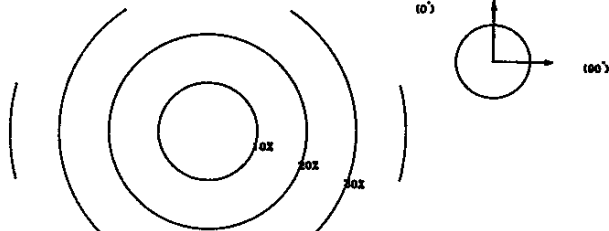

CURRENT

— 0-3 CM/SEC
= 3-7 CM/SEC
≡ > 7 CM/SEC

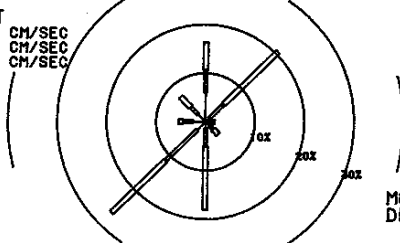

MOORING: 97-05C-004A019
DEPTH: 19 M

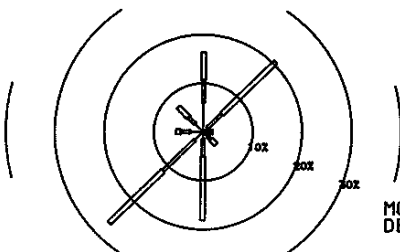

MOORING: 97-05C-004A019
DEPTH: 19 M

* WIND AND CURRENT DIRECTIONS ARE TOWARDS

MOORING IS 97-05C-004A019 DEPTH IS 19 METERS THERE ARE 597 VALUES

FIRST DAY 1997/10/07/0300
FINAL DAY 1997/10/31/2300

SHORELINE ORIENTATION IN DEGREES TRUE SPECIFIED AS 90

DIRECTION DEG TRUE	PERCENT OBSERVED	TOWARD	TOTAL	LIGHT	MEDIUM	HIGH	MAXIMUM CURRENT CM/S	MEAN DURA- TION HOURS	MEAN EXCUR- SION KM	MEAN CURRENT CM/S	MEAN TEMP DEG C
90.0	1.8	0.3	1.0	0.5	7.9	1.8	0.4	5.4	10.2		
45.0	20.6	1.0	4.2	15.4	31.7	6.8	2.8	11.6	12.5		
0.0	16.4	6.0	4.7	5.7	22.4	3.4	0.7	5.7	11.2		
315.0	7.2	2.2	2.0	3.0	12.4	3.3	0.8	6.4	10.1		
270.0	5.5	2.5	2.0	1.0	17.5	2.2	0.4	5.0	8.8		
225.0	26.6	2.3	9.0	15.2	26.4	6.1	2.0	9.2	11.4		
180.0	18.1	1.3	3.7	13.1	16.2	4.3	1.3	8.4	10.0		
135.0	3.7	1.2	1.0	1.5	14.7	2.4	0.6	6.4	8.4		

0 MEAN SCALAR SPEED = 8.4 CM/S MEAN SQUARE SPEED = 99.6 CM2/S2
MEAN SQUARE E-W SPEED = 29.8 CM2/S2 MEAN SQUARE N-S SPEED = 69.7 CM2/S2
MEAN VELOCITY = 0.6 CM/S, 227 DEG TRUE MEAN TEMPERATURE = 11.0 C
VARIANCE (U,V) = 49.7 CM2/S2 TOTAL HOURS = 597.

PERCENT OBSERVED

LIGHT (0.0 - 3.0) 16.9% MEDIUM (3.0 - 7.0) 27.6% HIGH (GE 7.0) 55.4%

MOORING IS 97-05C-004A019 DEPTH IS 19 METERS THERE ARE 597 VALUES

FIRST DAY 1997/10/07/0300
FINAL DAY 1997/10/31/2300

SHORELINE ORIENTATION IN DEGREES TRUE SPECIFIED AS 90

DIRECTION DEG TRUE	PERCENT OBSERVED	TOWARD	TOTAL	LIGHT	MEDIUM	HIGH	MAXIMUM CURRENT CM/S	MEAN DURA- TION HOURS	MEAN EXCUR- SION KM	MEAN CURRENT CM/S	MEAN TEMP DEG C
90.0	1.8	0.3	1.0	0.5	7.9	1.8	0.4	5.4	10.2		
45.0	20.6	1.0	4.2	15.4	31.7	6.8	2.8	11.6	12.5		
0.0	16.4	6.0	4.7	5.7	22.4	3.4	0.7	5.7	11.2		
315.0	7.2	2.2	2.0	3.0	12.4	3.3	0.8	6.4	10.1		
270.0	5.5	2.5	2.0	1.0	17.5	2.2	0.4	5.0	8.8		
225.0	26.6	2.3	9.0	15.2	26.4	6.1	2.0	9.2	11.4		
180.0	18.1	1.3	3.7	13.1	16.2	4.3	1.3	8.4	10.0		
135.0	3.7	1.2	1.0	1.5	14.7	2.4	0.6	6.4	8.4		

0 MEAN SCALAR SPEED = 8.4 CM/S MEAN SQUARE SPEED = 99.6 CM2/S2
MEAN SQUARE E-W SPEED = 29.8 CM2/S2 MEAN SQUARE N-S SPEED = 69.7 CM2/S2
MEAN VELOCITY = 0.6 CM/S, 227 DEG TRUE MEAN TEMPERATURE = 11.0 C
VARIANCE (U,V) = 49.7 CM2/S2 TOTAL HOURS = 597.

PERCENT OBSERVED

LIGHT (0.0 - 3.0) 16.9% MEDIUM (3.0 - 7.0) 27.6% HIGH (GE 7.0) 55.4%

DATE: 1997/11/01 TO 1997/11/30
 ROSE SUMMARY: WIND AND CURRENT

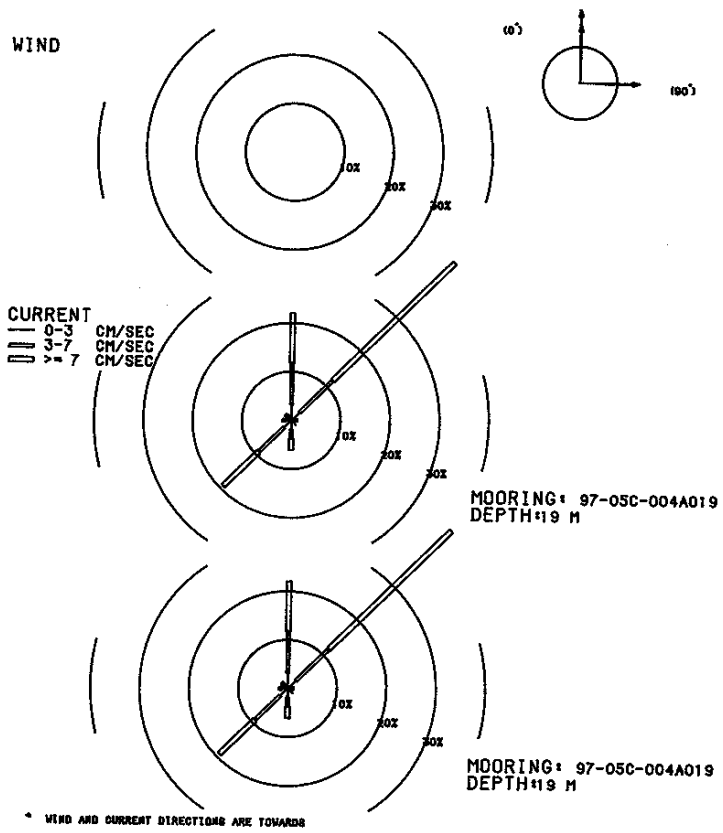

MOORING IS 97-05C-004A019 DEPTH IS 19 METERS THERE ARE 720 VALUES

FIRST DAY 1997/11/01/0000
 FINAL DAY 1997/11/30/2300

SHORELINE ORIENTATION IN DEGREES TRUE SPECIFIED AS 90

DIRECTION DEG TRUE	PERCENT OBSERVED	MAXIMUM CURRENT	MEAN DURATION HOURS	MEAN EXCURSION KM	MEAN CURRENT CM/S	MEAN TEMP DEG C
TOWARD	TOTAL	LIGHT	MEDIUM	HIGH	CM/S	
90.0	1.2	1.0	0.3	0.0	3.2	1.5
45.0	46.4	2.2	9.4	34.7	27.3	7.4
0.0	22.1	3.2	8.6	10.3	16.0	3.1
315.0	1.7	0.6	1.1	0.0	6.4	1.5
270.0	1.8	1.1	0.7	0.0	4.2	1.9
225.0	19.3	2.1	7.1	10.1	18.7	8.7
180.0	6.1	1.8	1.9	2.4	12.0	2.9
135.0	1.4	1.4	0.0	0.0	2.4	1.7
MEAN SCALAR SPEED = 8.9 CM/S		MEAN SQUARE SPEED = 108.6 CM2/S2				
MEAN SQUARE E-W SPEED = 29.8 CM2/S2		MEAN SQUARE N-S SPEED = 78.8 CM2/S2				
MEAN VELOCITY = 5.0 CM/S,		26 DEG TRUE		MEAN TEMPERATURE = 8.4 C		
VARIANCE (U,V) = 42.0 CM2/S2		TOTAL HOURS = 720.				

PERCENT OBSERVED
 LIGHT (0.0 - 3.0) 13.3% MEDIUM (3.0 - 7.0) 29.2% HIGH (GE 7.0) 57.5%

MOORING IS 97-05C-004A019 DEPTH IS 19 METERS THERE ARE 720 VALUES

FIRST DAY 1997/11/01/0000
 FINAL DAY 1997/11/30/2300

SHORELINE ORIENTATION IN DEGREES TRUE SPECIFIED AS 90

DIRECTION DEG TRUE	PERCENT OBSERVED	MAXIMUM CURRENT	MEAN DURATION HOURS	MEAN EXCURSION KM	MEAN CURRENT CM/S	MEAN TEMP DEG C
TOWARD	TOTAL	LIGHT	MEDIUM	HIGH	CM/S	
90.0	1.2	1.0	0.3	0.0	3.2	1.5
45.0	46.4	2.2	9.4	34.7	27.3	7.4
0.0	22.1	3.2	8.6	10.3	16.0	3.1
315.0	1.7	0.6	1.1	0.0	6.4	1.5
270.0	1.8	1.1	0.7	0.0	4.2	1.9
225.0	19.3	2.1	7.1	10.1	18.7	8.7
180.0	6.1	1.8	1.9	2.4	12.0	2.9
135.0	1.4	1.4	0.0	0.0	2.4	1.7
MEAN SCALAR SPEED = 8.9 CM/S		MEAN SQUARE SPEED = 108.6 CM2/S2				
MEAN SQUARE E-W SPEED = 29.8 CM2/S2		MEAN SQUARE N-S SPEED = 78.8 CM2/S2				
MEAN VELOCITY = 5.0 CM/S,		26 DEG TRUE		MEAN TEMPERATURE = 8.4 C		
VARIANCE (U,V) = 42.0 CM2/S2		TOTAL HOURS = 720.				

PERCENT OBSERVED
 LIGHT (0.0 - 3.0) 13.3% MEDIUM (3.0 - 7.0) 29.2% HIGH (GE 7.0) 57.5%

DATE: 1997/12/01 TO 1997/12/31
 ROSE SUMMARY: WIND AND CURRENT

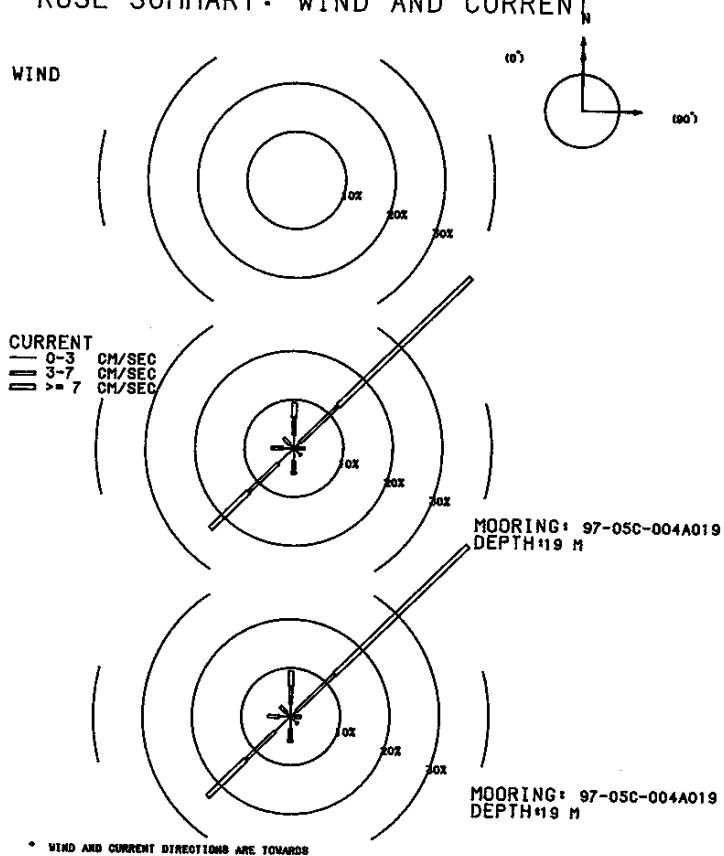

MOORING IS 97-05C-004A019 DEPTH IS 19 METERS THERE ARE 744 VALUES

FIRST DAY 1997/12/01/0000
 FINAL DAY 1997/12/31/2300

SHORELINE ORIENTATION IN DEGREES TRUE SPECIFIED AS 90

DIRECTION DEG TRUE	PERCENT OBSERVED	TOWARD	TOTAL	LIGHT	MEDIUM	HIGH	MAXIMUM CURRENT CM/S	MEAN DURA- TION HOURS	MEAN EXCUR- SION KM	MEAN CURRENT CM/S	MEAN TEMP DEG C
90.0	2.2	0.9	1.2	0.0	6.0	2.0	0.3	3.6	4.0		
45.0	50.1	1.6	10.9	37.6	26.8	18.6	7.9	11.7	4.1		
0.0	9.4	2.7	3.6	3.1	16.0	2.9	0.6	5.5	4.6		
315.0	3.0	1.1	1.9	0.0	5.5	2.0	0.3	3.6	4.5		
270.0	4.6	2.3	2.3	0.0	6.7	2.0	0.2	3.3	4.7		
225.0	23.5	4.4	8.2	10.9	16.8	7.3	1.7	6.5	5.0		
180.0	5.2	2.6	2.3	0.4	9.3	2.6	0.4	3.8	4.2		
135.0	2.0	1.9	0.1	0.0	3.6	1.7	0.1	2.4	3.6		

MEAN SCALAR SPEED = 8.5 CM/S MEAN SQUARE SPEED = 104.4 CM2/S2
 MEAN SQUARE E-W SPEED = 32.5 CM2/S2 MEAN SQUARE N-S SPEED = 71.9 CM2/S2
 MEAN VELOCITY = 4.6 CM/S, 29 DEG TRUE MEAN TEMPERATURE = 4.4 C
 VARIANCE (U,V) = 41.6 CM2/S2 TOTAL HOURS = 744.

PERCENT OBSERVED
 LIGHT (0.0 - 3.0) 17.5% MEDIUM (3.0 - 7.0) 30.5% HIGH (GE 7.0) 52.0%

MOORING IS 97-05C-004A019 DEPTH IS 19 METERS THERE ARE 744 VALUES

FIRST DAY 1997/12/01/0000
 FINAL DAY 1997/12/31/2300

SHORELINE ORIENTATION IN DEGREES TRUE SPECIFIED AS 90

DIRECTION DEG TRUE	PERCENT OBSERVED	TOWARD	TOTAL	LIGHT	MEDIUM	HIGH	MAXIMUM CURRENT CM/S	MEAN DURA- TION HOURS	MEAN EXCUR- SION KM	MEAN CURRENT CM/S	MEAN TEMP DEG C
90.0	2.2	0.9	1.2	0.0	6.0	2.0	0.3	3.6	4.0		
45.0	50.1	1.6	10.9	37.6	26.8	18.6	7.9	11.7	4.1		
0.0	9.4	2.7	3.6	3.1	16.0	2.9	0.6	5.5	4.6		
315.0	3.0	1.1	1.9	0.0	5.5	2.0	0.3	3.6	4.5		
270.0	4.6	2.3	2.3	0.0	6.7	2.0	0.2	3.3	4.7		
225.0	23.5	4.4	8.2	10.9	16.8	7.3	1.7	6.5	5.0		
180.0	5.2	2.6	2.3	0.4	9.3	2.6	0.4	3.8	4.2		
135.0	2.0	1.9	0.1	0.0	3.6	1.7	0.1	2.4	3.6		

MEAN SCALAR SPEED = 8.5 CM/S MEAN SQUARE SPEED = 104.4 CM2/S2
 MEAN SQUARE E-W SPEED = 32.5 CM2/S2 MEAN SQUARE N-S SPEED = 71.9 CM2/S2
 MEAN VELOCITY = 4.6 CM/S, 29 DEG TRUE MEAN TEMPERATURE = 4.4 C
 VARIANCE (U,V) = 41.6 CM2/S2 TOTAL HOURS = 744.

PERCENT OBSERVED
 LIGHT (0.0 - 3.0) 17.5% MEDIUM (3.0 - 7.0) 30.5% HIGH (GE 7.0) 52.0%

DATE: 1998/01/01 TO 1998/01/31
ROSE SUMMARY: WIND AND CURRENT

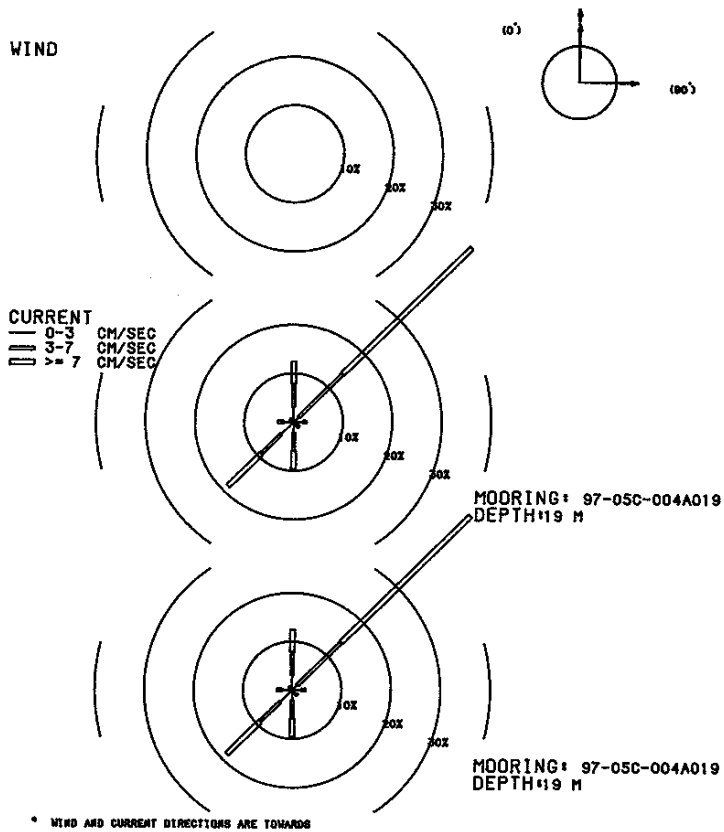

MOORING IS 97-05C-004A019 DEPTH IS 19 METERS THERE ARE 744 VALUES

FIRST DAY 1998/01/01/0000
FINAL DAY 1998/01/31/2300

SHORELINE ORIENTATION IN DEGREES TRUE SPECIFIED AS 90

DIRECTION DEG TRUE	PERCENT OBSERVED	TOWARD	TOTAL	LIGHT	MEDIUM	HIGH	MAXIMUM CURRENT CM/S	MEAN DURA- TION HOURS	MEAN EXCUR- SION KM	MEAN CURRENT CM/S	MEAN TEMP DEG C
90.0	2.7	1.9	0.8	0.0	4.3	2.2	0.2	2.8	2.0		
45.0	50.8	1.3	12.6	36.8	29.7	13.0	4.9	10.5	2.1		
0.0	12.5	3.1	4.8	4.6	14.5	3.0	0.6	6.0	1.8		
315.0	0.9	0.5	0.4	0.0	4.1	1.4	0.1	2.8	1.6		
270.0	3.2	2.0	1.2	0.0	6.2	2.0	0.2	3.0	2.4		
225.0	18.7	3.5	5.6	9.5	12.6	4.6	1.1	6.9	2.3		
180.0	9.7	2.2	3.8	3.8	11.8	3.4	0.7	5.9	2.1		
135.0	1.5	1.1	0.4	0.0	7.0	1.6	0.2	3.3	2.1		

0 MEAN SCALAR SPEED = 8.2 CM/S MEAN SQUARE SPEED = 95.1 CM2/S2
MEAN SQUARE E-W SPEED = 29.6 CM2/S2 MEAN SQUARE N-S SPEED = 65.5 CM2/S2
MEAN VELOCITY = 4.2 CM/S, 37 DEG TRUE MEAN TEMPERATURE = 2.1 C
VARIANCE (U,V) = 38.7 CM2/S2 TOTAL HOURS = 744.

PERCENT OBSERVED

LIGHT (0.0 - 3.0) 15.6% MEDIUM (3.0 - 7.0) 29.7% HIGH (GE 7.0) 54.7%

MOORING IS 97-05C-004A019 DEPTH IS 19 METERS THERE ARE 744 VALUES

FIRST DAY 1998/01/01/0000
FINAL DAY 1998/01/31/2300

SHORELINE ORIENTATION IN DEGREES TRUE SPECIFIED AS 90

DIRECTION DEG TRUE	PERCENT OBSERVED	TOWARD	TOTAL	LIGHT	MEDIUM	HIGH	MAXIMUM CURRENT CM/S	MEAN DURA- TION HOURS	MEAN EXCUR- SION KM	MEAN CURRENT CM/S	MEAN TEMP DEG C
90.0	2.7	1.9	0.8	0.0	4.3	2.2	0.2	2.8	2.0		
45.0	50.8	1.3	12.6	36.8	29.7	13.0	4.9	10.5	2.1		
0.0	12.5	3.1	4.8	4.6	14.5	3.0	0.6	6.0	1.8		
315.0	0.9	0.5	0.4	0.0	4.1	1.4	0.1	2.8	1.6		
270.0	3.2	2.0	1.2	0.0	6.2	2.0	0.2	3.0	2.4		
225.0	18.7	3.5	5.6	9.5	12.6	4.6	1.1	6.9	2.3		
180.0	9.7	2.2	3.8	3.8	11.8	3.4	0.7	5.9	2.1		
135.0	1.5	1.1	0.4	0.0	7.0	1.6	0.2	3.3	2.1		

0 MEAN SCALAR SPEED = 8.2 CM/S MEAN SQUARE SPEED = 95.1 CM2/S2
MEAN SQUARE E-W SPEED = 29.6 CM2/S2 MEAN SQUARE N-S SPEED = 65.5 CM2/S2
MEAN VELOCITY = 4.2 CM/S, 37 DEG TRUE MEAN TEMPERATURE = 2.1 C
VARIANCE (U,V) = 38.7 CM2/S2 TOTAL HOURS = 744.

PERCENT OBSERVED

LIGHT (0.0 - 3.0) 15.6% MEDIUM (3.0 - 7.0) 29.7% HIGH (GE 7.0) 54.7%

DATE: 1998/02/01 TO 1998/02/28
ROSE SUMMARY: WIND AND CURRENT

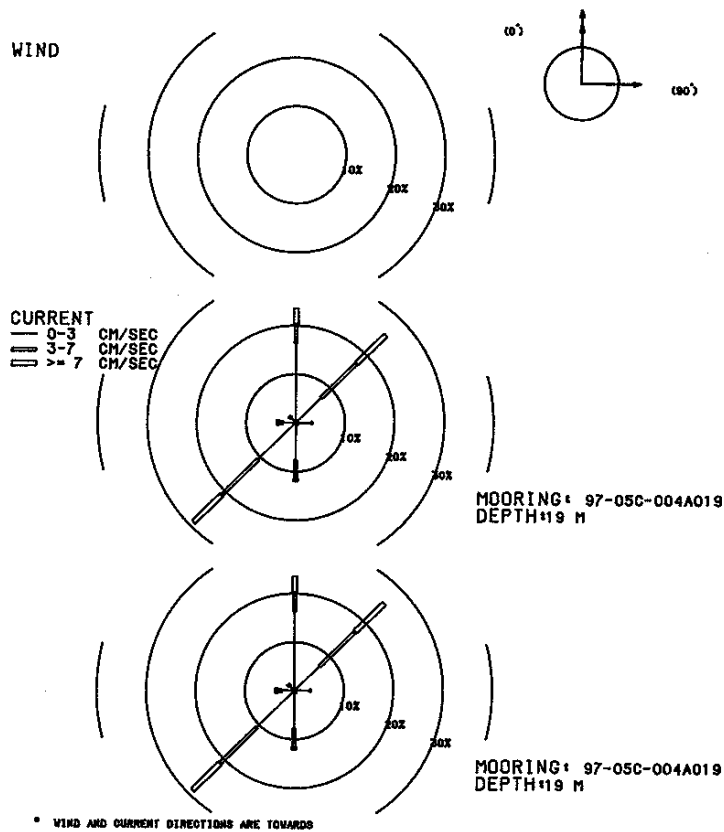

MOORING IS 97-05C-004A019 DEPTH IS 19 METERS THERE ARE 672 VALUES

FIRST DAY 1998/02/01/0000
FINAL DAY 1998/02/28/2300

SHORELINE ORIENTATION IN DEGREES TRUE SPECIFIED AS 90

DIRECTION DEG TRUE	PERCENT OBSERVED	TOWARD	TOTAL	LIGHT	MEDIUM	HIGH	MAXIMUM CURRENT CM/S	MEAN DURA- TION HOURS	MEAN EXCUR- SION KM	MEAN CURRENT CM/S	MEAN TEMP DEG C
90.0	3.4	3.1	0.3	0.0	3.9	1.4	0.1	2.3	1.8		
45.0	25.6	7.1	10.1	8.3	13.5	5.7	1.1	5.5	1.7		
0.0	23.5	16.4	3.9	3.3	11.8	4.8	0.4	2.3	1.8		
315.0	1.8	1.3	0.4	0.0	6.6	1.7	0.2	3.0	1.8		
270.0	3.9	2.5	0.9	0.4	8.9	1.9	0.3	3.8	1.8		
225.0	29.0	10.7	10.4	7.9	13.2	4.4	0.8	5.1	1.8		
180.0	12.1	7.7	3.9	0.4	14.4	2.1	0.2	3.2	1.8		
135.0	0.7	0.7	0.0	0.0	2.5	1.0	0.1	2.2	1.9		

0 MEAN SCALAR SPEED = 4.1 CM/S MEAN SQUARE SPEED = 27.2 CM2/S2
MEAN SQUARE E-W SPEED = 8.7 CM2/S2 MEAN SQUARE N-S SPEED = 18.5 CM2/S2
MEAN VELOCITY = 0.2 CM/S, 326 DEG TRUE MEAN TEMPERATURE = 1.8 C
VARIANCE (U,V) = 13.6 CM2/S2 TOTAL HOURS = 672.

PERCENT OBSERVED
LIGHT (0.0 - 3.0) 49.7% MEDIUM (3.0 - 7.0) 29.9% HIGH (GE 7.0) 20.4%

MOORING IS 97-05C-004A019 DEPTH IS 19 METERS THERE ARE 672 VALUES

FIRST DAY 1998/02/01/0000
FINAL DAY 1998/02/28/2300

SHORELINE ORIENTATION IN DEGREES TRUE SPECIFIED AS 90

DIRECTION DEG TRUE	PERCENT OBSERVED	TOWARD	TOTAL	LIGHT	MEDIUM	HIGH	MAXIMUM CURRENT CM/S	MEAN DURA- TION HOURS	MEAN EXCUR- SION KM	MEAN CURRENT CM/S	MEAN TEMP DEG C
90.0	3.4	3.1	0.3	0.0	3.9	1.4	0.1	2.3	1.8		
45.0	25.6	7.1	10.1	8.3	13.5	5.7	1.1	5.5	1.7		
0.0	23.5	16.4	3.9	3.3	11.8	4.8	0.4	2.3	1.8		
315.0	1.8	1.3	0.4	0.0	6.6	1.7	0.2	3.0	1.8		
270.0	3.9	2.5	0.9	0.4	8.9	1.9	0.3	3.8	1.8		
225.0	29.0	10.7	10.4	7.9	13.2	4.4	0.8	5.1	1.8		
180.0	12.1	7.7	3.9	0.4	14.4	2.1	0.2	3.2	1.8		
135.0	0.7	0.7	0.0	0.0	2.5	1.0	0.1	2.2	1.9		

0 MEAN SCALAR SPEED = 4.1 CM/S MEAN SQUARE SPEED = 27.2 CM2/S2
MEAN SQUARE E-W SPEED = 8.7 CM2/S2 MEAN SQUARE N-S SPEED = 18.5 CM2/S2
MEAN VELOCITY = 0.2 CM/S, 326 DEG TRUE MEAN TEMPERATURE = 1.8 C
VARIANCE (U,V) = 13.6 CM2/S2 TOTAL HOURS = 672.

PERCENT OBSERVED
LIGHT (0.0 - 3.0) 49.7% MEDIUM (3.0 - 7.0) 29.9% HIGH (GE 7.0) 20.4%

DATE: 1998/03/01 TO 1998/03/31
 ROSE SUMMARY: WIND AND CURRENT

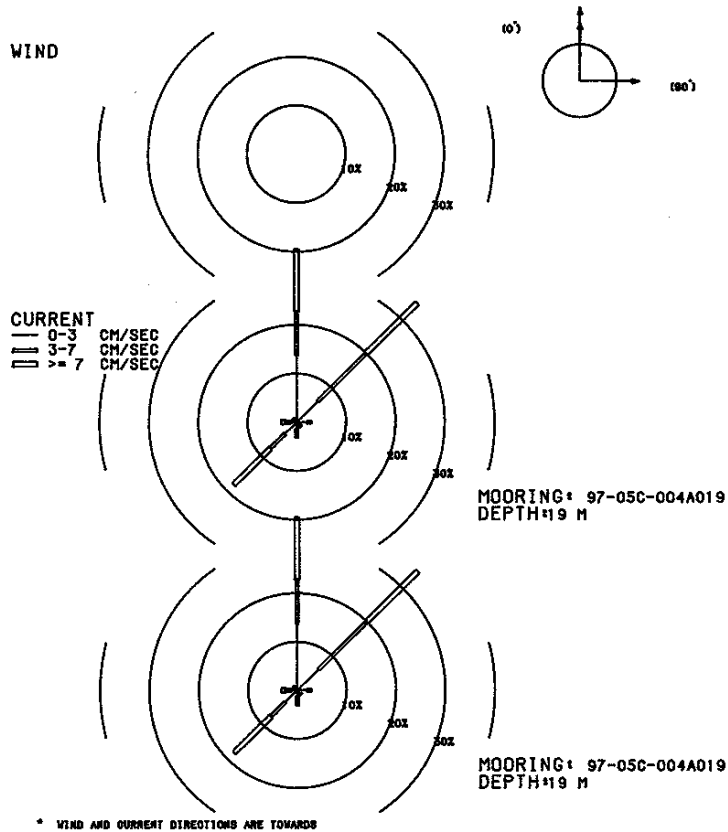

MOORING IS 97-05C-004A019 DEPTH IS 19 METERS THERE ARE 743 VALUES

FIRST DAY 1998/03/01/0000
 FINAL DAY 1998/03/31/2300

SHORELINE ORIENTATION IN DEGREES TRUE SPECIFIED AS 90

DIRECTION DEG TRUE	PERCENT OBSERVED	TOWARD	TOTAL	LIGHT	MEDIUM	HIGH	MAXIMUM CURRENT CM/S	MEAN DURA- TION HOURS	MEAN EXCUR- SION KM	MEAN CURRENT CM/S	MEAN TEMP DEG C
90.0	3.0	2.0	0.9	0.0	0.0	4.9	1.6	0.2	2.8	3.0	
45.0	34.6	6.1	13.9	14.7	19.8	5.4	1.3	6.6	2.6		
0.0	35.5	13.7	9.0	12.8	24.8	5.4	1.3	6.6	2.5		
315.0	1.1	0.8	0.3	0.0	4.9	1.1	0.1	2.6	2.5		
270.0	3.2	1.2	1.2	0.8	25.8	1.6	0.3	5.2	2.5		
225.0	18.2	3.4	4.2	10.6	33.2	7.5	2.4	8.9	2.1		
180.0	3.2	1.3	1.9	0.0	6.7	2.4	0.3	3.9	2.4		
135.0	1.2	0.9	0.3	0.0	3.8	1.8	0.2	2.6	2.6		
0 MEAN SCALAR SPEED = 6.7 CM/S MEAN SQUARE SPEED = 74.1 CM2/S2											
MEAN SQUARE E-W SPEED = 24.3 CM2/S2 MEAN SQUARE N-S SPEED = 49.9 CM2/S2											
MEAN VELOCITY = 2.9 CM/S, 13 DEG TRUE MEAN TEMPERATURE = 2.5 C											
VARIANCE (U,V) = 32.8 CM2/S2 TOTAL HOURS = 743.											

PERCENT OBSERVED
 LIGHT (0.0 - 3.0) 29.5% MEDIUM (3.0 - 7.0) 31.6% HIGH (GE 7.0) 38.9%

MOORING IS 97-05C-004A019 DEPTH IS 19 METERS THERE ARE 743 VALUES

FIRST DAY 1998/03/01/0000
 FINAL DAY 1998/03/31/2300

SHORELINE ORIENTATION IN DEGREES TRUE SPECIFIED AS 90

DIRECTION DEG TRUE	PERCENT OBSERVED	TOWARD	TOTAL	LIGHT	MEDIUM	HIGH	MAXIMUM CURRENT CM/S	MEAN DURA- TION HOURS	MEAN EXCUR- SION KM	MEAN CURRENT CM/S	MEAN TEMP DEG C
90.0	3.0	2.0	0.9	0.0	0.0	4.9	1.6	0.2	2.8	3.0	
45.0	34.6	6.1	13.9	14.7	19.8	5.4	1.3	6.6	2.6		
0.0	35.5	13.7	9.0	12.8	24.8	5.4	1.3	6.6	2.5		
315.0	1.1	0.8	0.3	0.0	4.9	1.1	0.1	2.6	2.5		
270.0	3.2	1.2	1.2	0.8	25.8	1.6	0.3	5.2	2.5		
225.0	18.2	3.4	4.2	10.6	33.2	7.5	2.4	8.9	2.1		
180.0	3.2	1.3	1.9	0.0	6.7	2.4	0.3	3.9	2.4		
135.0	1.2	0.9	0.3	0.0	3.8	1.8	0.2	2.6	2.6		
0 MEAN SCALAR SPEED = 6.7 CM/S MEAN SQUARE SPEED = 74.1 CM2/S2											
MEAN SQUARE E-W SPEED = 24.3 CM2/S2 MEAN SQUARE N-S SPEED = 49.9 CM2/S2											
MEAN VELOCITY = 2.9 CM/S, 13 DEG TRUE MEAN TEMPERATURE = 2.5 C											
VARIANCE (U,V) = 32.8 CM2/S2 TOTAL HOURS = 743.											

PERCENT OBSERVED
 LIGHT (0.0 - 3.0) 29.5% MEDIUM (3.0 - 7.0) 31.6% HIGH (GE 7.0) 38.9%

DATE: 1998/04/01 TO 1998/04/30
 ROSE SUMMARY: WIND AND CURRENT

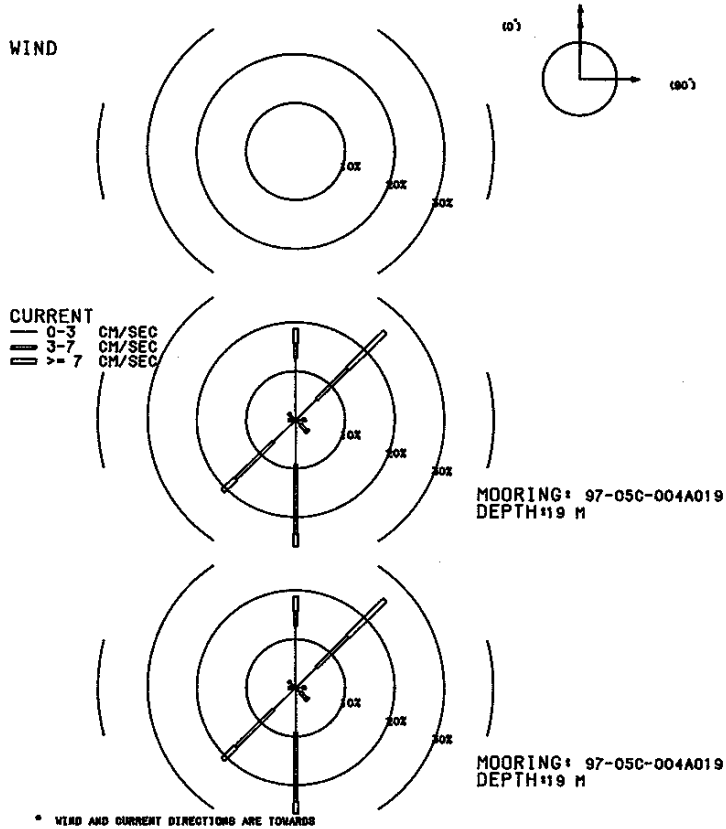

MOORING IS 97-05C-004A019 DEPTH IS 19 METERS THERE ARE 720 VALUES

FIRST DAY 1998/04/01/0000
 FINAL DAY 1998/04/30/2300

SHORELINE ORIENTATION IN DEGREES TRUE SPECIFIED AS 90

DIRECTION DEG TRUE	PERCENT OBSERVED	MAXIMUM CURRENT CM/S	MEAN DURA- TION HOURS	MEAN EXCUR- SION KM	MEAN CURRENT CM/S	MEAN TEMP DEG C
TOWARD	TOTAL	LIGHT	MEDIUM	HIGH		
90.0	2.1	1.4	0.7	0.0	3.4	1.4
45.0	25.6	6.0	8.9	10.7	16.4	6.6
0.0	18.8	12.8	2.9	3.1	15.6	3.3
315.0	1.9	1.5	0.4	0.0	3.8	1.8
270.0	1.4	0.8	0.6	0.0	3.7	1.7
225.0	20.8	6.4	10.8	3.6	9.8	4.8
180.0	26.0	9.2	14.3	2.5	8.5	4.8
135.0	3.5	1.2	1.8	0.4	9.2	2.1

MEAN SCALAR SPEED = 4.4 CM/S MEAN SQUARE SPEED = 28.2 CM2/S2
 MEAN SQUARE E-W SPEED = 7.1 CM2/S2 MEAN SQUARE N-S SPEED = 21.1 CM2/S2
 MEAN VELOCITY = 0.4 CM/S, 83 DEG TRUE MEAN TEMPERATURE = 5.4 C
 VARIANCE (U,V) = 14.1 CM2/S2 TOTAL HOURS = 720.

PERCENT OBSERVED
 LIGHT (0.0 - 3.0) 39.3% MEDIUM (3.0 - 7.0) 40.4% HIGH (GE 7.0) 20.3%

MOORING IS 97-05C-004A019 DEPTH IS 19 METERS THERE ARE 720 VALUES

FIRST DAY 1998/04/01/0000
 FINAL DAY 1998/04/30/2300

SHORELINE ORIENTATION IN DEGREES TRUE SPECIFIED AS 90

DIRECTION DEG TRUE	PERCENT OBSERVED	MAXIMUM CURRENT CM/S	MEAN DURA- TION HOURS	MEAN EXCUR- SION KM	MEAN CURRENT CM/S	MEAN TEMP DEG C
TOWARD	TOTAL	LIGHT	MEDIUM	HIGH		
90.0	2.1	1.4	0.7	0.0	3.4	1.4
45.0	25.6	6.0	8.9	10.7	16.4	6.6
0.0	18.8	12.8	2.9	3.1	15.6	3.3
315.0	1.9	1.5	0.4	0.0	3.8	1.8
270.0	1.4	0.8	0.6	0.0	3.7	1.7
225.0	20.8	6.4	10.8	3.6	9.8	4.8
180.0	26.0	9.2	14.3	2.5	8.5	4.8
135.0	3.5	1.2	1.8	0.4	9.2	2.1

MEAN SCALAR SPEED = 4.4 CM/S MEAN SQUARE SPEED = 28.2 CM2/S2
 MEAN SQUARE E-W SPEED = 7.1 CM2/S2 MEAN SQUARE N-S SPEED = 21.1 CM2/S2
 MEAN VELOCITY = 0.4 CM/S, 83 DEG TRUE MEAN TEMPERATURE = 5.4 C
 VARIANCE (U,V) = 14.1 CM2/S2 TOTAL HOURS = 720.

PERCENT OBSERVED
 LIGHT (0.0 - 3.0) 39.3% MEDIUM (3.0 - 7.0) 40.4% HIGH (GE 7.0) 20.3%

DATE: 1998/05/01 TO 1998/05/31
ROSE SUMMARY: WIND AND CURRENT

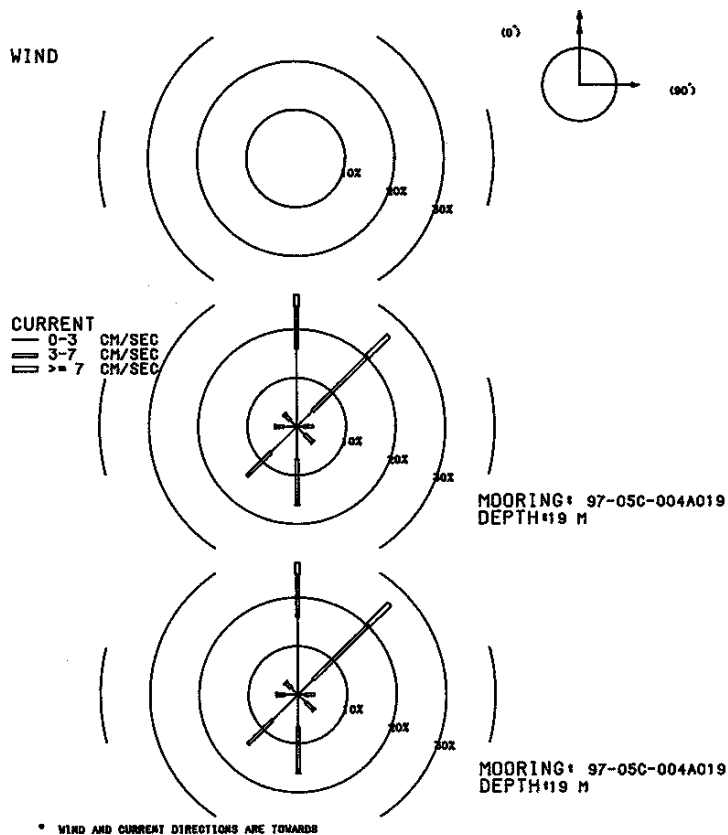

MOORING IS 97-05C-004A019 DEPTH IS 19 METERS THERE ARE 744 VALUES

FIRST DAY 1998/05/01/0000
FINAL DAY 1998/05/31/2300

SHORELINE ORIENTATION IN DEGREES TRUE SPECIFIED AS 90

DIRECTION DEG TRUE	PERCENT OBSERVED	MAXIMUM CURRENT	MEAN DURA- TION HOURS	MEAN EXCUR- SION KM	MEAN CURRENT CM/S	MEAN TEMP DEG C
TOWARD	TOTAL	LIGHT	MEDIUM	HIGH	CM/S	
90.0	3.4	1.5	1.9	0.0	5.9	2.1
45.0	26.3	4.4	15.9	6.0	17.9	6.3
0.0	27.2	16.0	8.7	2.4	22.7	3.6
315.0	3.6	1.9	1.6	0.1	15.7	1.7
270.0	4.4	2.7	1.6	0.1	9.4	1.6
225.0	14.4	7.4	7.0	0.0	6.4	2.5
180.0	16.1	6.6	9.4	0.1	7.0	2.7
135.0	4.6	2.3	2.2	0.1	10.9	1.9

MEAN SCALAR SPEED = 3.7 CM/S MEAN SQUARE SPEED = 20.9 CM2/S2
MEAN SQUARE E-W SPEED = 5.8 CM2/S2 MEAN SQUARE N-S SPEED = 15.0 CM2/S2
MEAN VELOCITY = 1.1 CM/S, 34 DEG TRUE MEAN TEMPERATURE = 7.8 C
VARIANCE (U,V) = 9.9 CM2/S2 TOTAL HOURS = 744.

PERCENT OBSERVED
LIGHT (0.0 - 3.0) 42.7% MEDIUM (3.0 - 7.0) 48.3% HIGH (GE 7.0) 9.0%

MOORING IS 97-05C-004A019 DEPTH IS 19 METERS THERE ARE 744 VALUES

FIRST DAY 1998/05/01/0000
FINAL DAY 1998/05/31/2300

SHORELINE ORIENTATION IN DEGREES TRUE SPECIFIED AS 90

DIRECTION DEG TRUE	PERCENT OBSERVED	MAXIMUM CURRENT	MEAN DURA- TION HOURS	MEAN EXCUR- SION KM	MEAN CURRENT CM/S	MEAN TEMP DEG C
TOWARD	TOTAL	LIGHT	MEDIUM	HIGH	CM/S	
90.0	3.4	1.5	1.9	0.0	5.9	2.1
45.0	26.3	4.4	15.9	6.0	17.9	6.3
0.0	27.2	16.0	8.7	2.4	22.7	3.6
315.0	3.6	1.9	1.6	0.1	15.7	1.7
270.0	4.4	2.7	1.6	0.1	9.4	1.6
225.0	14.4	7.4	7.0	0.0	6.4	2.5
180.0	16.1	6.6	9.4	0.1	7.0	2.7
135.0	4.6	2.3	2.2	0.1	10.9	1.9

MEAN SCALAR SPEED = 3.7 CM/S MEAN SQUARE SPEED = 20.9 CM2/S2
MEAN SQUARE E-W SPEED = 5.8 CM2/S2 MEAN SQUARE N-S SPEED = 15.0 CM2/S2
MEAN VELOCITY = 1.1 CM/S, 34 DEG TRUE MEAN TEMPERATURE = 7.8 C
VARIANCE (U,V) = 9.9 CM2/S2 TOTAL HOURS = 744.

PERCENT OBSERVED
LIGHT (0.0 - 3.0) 42.7% MEDIUM (3.0 - 7.0) 48.3% HIGH (GE 7.0) 9.0%

DATE: 1998/06/01 TO 1998/06/30
ROSE SUMMARY: WIND AND CURRENT

WIND

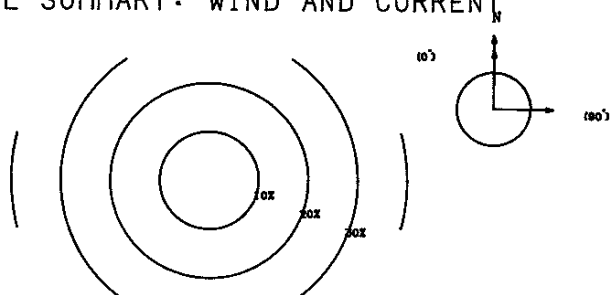

CURRENT
 0-3 CM/SEC
 3-7 CM/SEC
 >= 7 CM/SEC

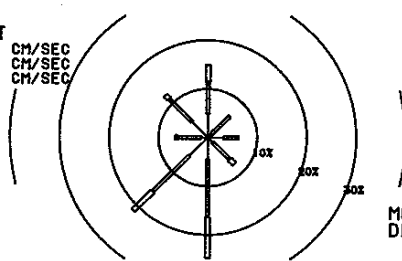

MOORING: 97-05C-004A019
DEPTH: 19 M

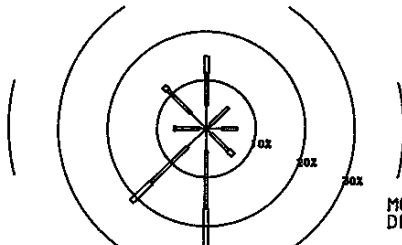

MOORING: 97-05C-004A019
DEPTH: 19 M

* WIND AND CURRENT DIRECTIONS ARE TOWARDS

MOORING IS 97-05C-004A019 DEPTH IS 19 METERS THERE ARE 287 VALUES

FIRST DAY 1998/06/01/0000
FINAL DAY 1998/06/12/2200

SHORELINE ORIENTATION IN DEGREES TRUE SPECIFIED AS 90

DIRECTION DEG TRUE	PERCENT OBSERVED	TOWARD	TOTAL	LIGHT	MEDIUM	HIGH	MAXIMUM CURRENT CM/S	MEAN DURA- TION HOURS	MEAN EXCUR- SION KM	MEAN CURRENT CM/S	MEAN TEMP DEG C
90.0	6.3	3.1	3.1	0.0	0.0	5.9	1.6	0.2	3.4	9.3	
45.0	6.3	1.0	5.2	0.0	6.8	2.0	0.3	4.4	9.4		
0.0	15.0	4.9	6.6	3.5	11.1	2.7	0.4	4.5	9.2		
315.0	12.2	4.5	6.6	1.0	8.2	2.5	0.4	4.0	8.4		
270.0	6.6	1.4	4.9	0.3	7.2	1.7	0.3	4.1	8.2		
225.0	21.3	5.2	10.5	5.6	10.5	3.0	0.6	5.4	8.4		
180.0	24.7	4.5	11.8	8.4	11.1	2.8	0.6	5.8	8.4		
135.0	7.7	1.4	4.9	1.4	10.8	1.8	0.3	5.1	9.4		

MEAN SCALAR SPEED = 4.9 CM/S MEAN SQUARE SPEED = 30.1 CM2/S2
 MEAN SQUARE E-W SPEED = 7.9 CM2/S2 MEAN SQUARE N-S SPEED = 22.2 CM2/S2
 MEAN VELOCITY = 1.6 CM/S, 211 DEG TRUE MEAN TEMPERATURE = 8.7 C
 VARIANCE (U,V) = 13.9 CM2/S2 TOTAL HOURS = 287.

PERCENT OBSERVED

LIGHT (0.0 - 3.0) 26.1% MEDIUM (3.0 - 7.0) 53.7% HIGH (GE 7.0) 20.2%

MOORING IS 97-05C-004A019 DEPTH IS 19 METERS THERE ARE 287 VALUES

FIRST DAY 1998/06/01/0000
FINAL DAY 1998/06/12/2200

SHORELINE ORIENTATION IN DEGREES TRUE SPECIFIED AS 90

DIRECTION DEG TRUE	PERCENT OBSERVED	TOWARD	TOTAL	LIGHT	MEDIUM	HIGH	MAXIMUM CURRENT CM/S	MEAN DURA- TION HOURS	MEAN EXCUR- SION KM	MEAN CURRENT CM/S	MEAN TEMP DEG C
90.0	6.3	3.1	3.1	0.0	5.9	1.6	0.2	3.4	9.3		
45.0	6.3	1.0	5.2	0.0	6.8	2.0	0.3	4.4	9.4		
0.0	15.0	4.9	6.6	3.5	11.1	2.7	0.4	4.5	9.2		
315.0	12.2	4.5	6.6	1.0	8.2	2.5	0.4	4.0	8.4		
270.0	6.6	1.4	4.9	0.3	7.2	1.7	0.3	4.1	8.2		
225.0	21.3	5.2	10.5	5.6	10.5	3.0	0.6	5.4	8.4		
180.0	24.7	4.5	11.8	8.4	11.1	2.8	0.6	5.8	8.4		
135.0	7.7	1.4	4.9	1.4	10.8	1.8	0.3	5.1	9.4		

MEAN SCALAR SPEED = 4.9 CM/S MEAN SQUARE SPEED = 30.1 CM2/S2
 MEAN SQUARE E-W SPEED = 7.9 CM2/S2 MEAN SQUARE N-S SPEED = 22.2 CM2/S2
 MEAN VELOCITY = 1.6 CM/S, 211 DEG TRUE MEAN TEMPERATURE = 8.7 C
 VARIANCE (U,V) = 13.9 CM2/S2 TOTAL HOURS = 287.

PERCENT OBSERVED

LIGHT (0.0 - 3.0) 26.1% MEDIUM (3.0 - 7.0) 53.7% HIGH (GE 7.0) 20.2%

Appendix Q - Mooring_V06-97. Overall Summary Statistics and Rose Histogram Plots

DATE: 1997/10/01 TO 1998/06/13
 ROSE SUMMARY: WIND AND CURRENT

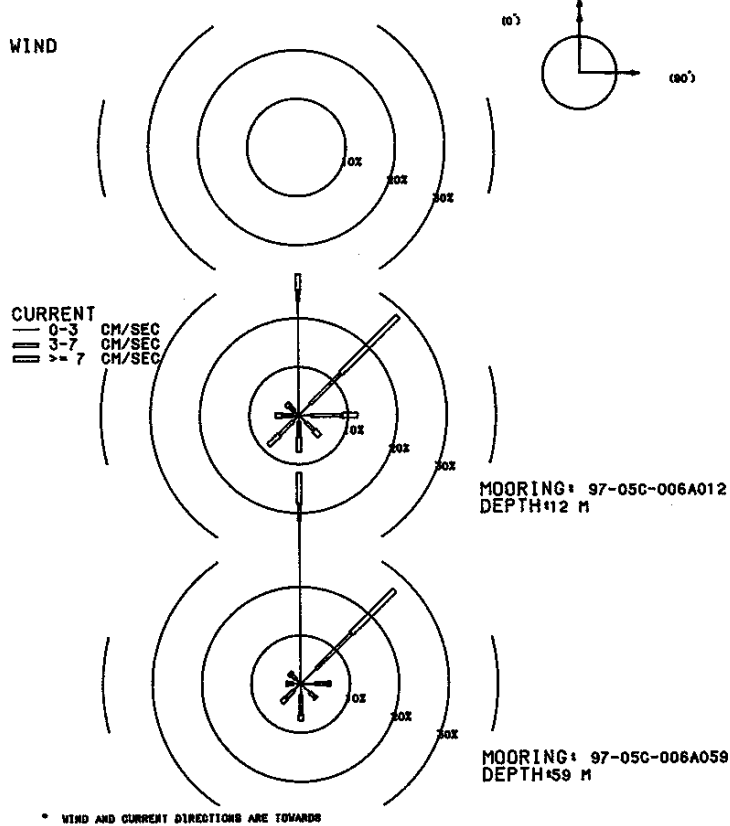

MOORING IS 97-05C-006A012 DEPTH IS 12 METERS THERE ARE 5963 VALUES

FIRST DAY 1997/10/07/0100
 FINAL DAY 1998/06/12/1900

SHORELINE ORIENTATION IN DEGREES TRUE SPECIFIED AS 90

DIRECTION DEG TRUE	PERCENT OBSERVED	MAXIMUM CURRENT	MEAN DURA- TION HOURS	MEAN EXCUR- SION KM	MEAN CURRENT CM/S	MEAN TEMP DEG C
TOWARD	TOTAL	LIGHT	MEDIUM	HIGH	CM/S	
90.0	12.0	2.5	6.4	3.1	22.6	3.0
45.0	28.6	3.3	8.8	16.6	49.3	6.0
0.0	29.0	23.5	2.1	3.4	61.7	7.9
315.0	3.4	1.2	1.3	0.9	33.7	1.9
270.0	4.7	1.1	2.2	1.4	36.8	2.1
225.0	8.6	1.5	4.0	3.1	28.6	3.2
180.0	7.5	1.3	3.1	3.1	25.9	3.0
135.0	6.1	2.1	2.3	1.7	29.0	2.2

MEAN SCALAR SPEED = 6.1 CM/S MEAN SQUARE SPEED = 79.8 CM2/S2
 MEAN SQUARE E-W SPEED = 35.0 CM2/S2 MEAN SQUARE N-S SPEED = 44.8 CM2/S2
 MEAN VELOCITY = 2.6 CM/S, 54 DEG TRUE MEAN TEMPERATURE = 6.7 C
 VARIANCE (U,V) = 36.4 CM2/S2 TOTAL HOURS = 5963.

PERCENT OBSERVED
 LIGHT (0.0 - 3.0) 36.6% MEDIUM (3.0 - 7.0) 30.3% HIGH (GE 7.0) 33.1%

MOORING IS 97-05C-006A059 DEPTH IS 59 METERS THERE ARE 5971 VALUES

FIRST DAY 1997/10/07/0200
 FINAL DAY 1998/06/12/2000

SHORELINE ORIENTATION IN DEGREES TRUE SPECIFIED AS 90

DIRECTION DEG TRUE	PERCENT OBSERVED	MAXIMUM CURRENT	MEAN DURA- TION HOURS	MEAN EXCUR- SION KM	MEAN CURRENT CM/S	MEAN TEMP DEG C
TOWARD	TOTAL	LIGHT	MEDIUM	HIGH	CM/S	
90.0	6.0	2.9	2.5	0.6	14.1	2.1
45.0	27.2	4.5	10.2	12.5	34.8	6.1
0.0	43.3	33.3	3.6	6.4	50.0	7.2
315.0	3.2	1.3	1.3	0.6	13.7	2.2
270.0	2.9	1.6	1.0	0.4	17.7	2.3
225.0	5.4	1.9	2.3	1.2	19.3	2.8
180.0	7.6	2.4	4.0	1.2	14.1	3.1
135.0	4.3	2.6	1.4	0.3	18.4	2.0

MEAN SCALAR SPEED = 4.4 CM/S MEAN SQUARE SPEED = 45.9 CM2/S2
 MEAN SQUARE E-W SPEED = 12.5 CM2/S2 MEAN SQUARE N-S SPEED = 33.4 CM2/S2
 MEAN VELOCITY = 2.5 CM/S, 34 DEG TRUE MEAN TEMPERATURE = 4.4 C
 VARIANCE (U,V) = 19.8 CM2/S2 TOTAL HOURS = 5971.

PERCENT OBSERVED
 LIGHT (0.0 - 3.0) 50.6% MEDIUM (3.0 - 7.0) 26.2% HIGH (GE 7.0) 23.2%

Appendix R - Mooring_V06-97. Monthly Summary Statistics and Rose Histogram Plots

DATE: 1997/10/01 TO 1997/10/31
ROSE SUMMARY: WIND AND CURRENT

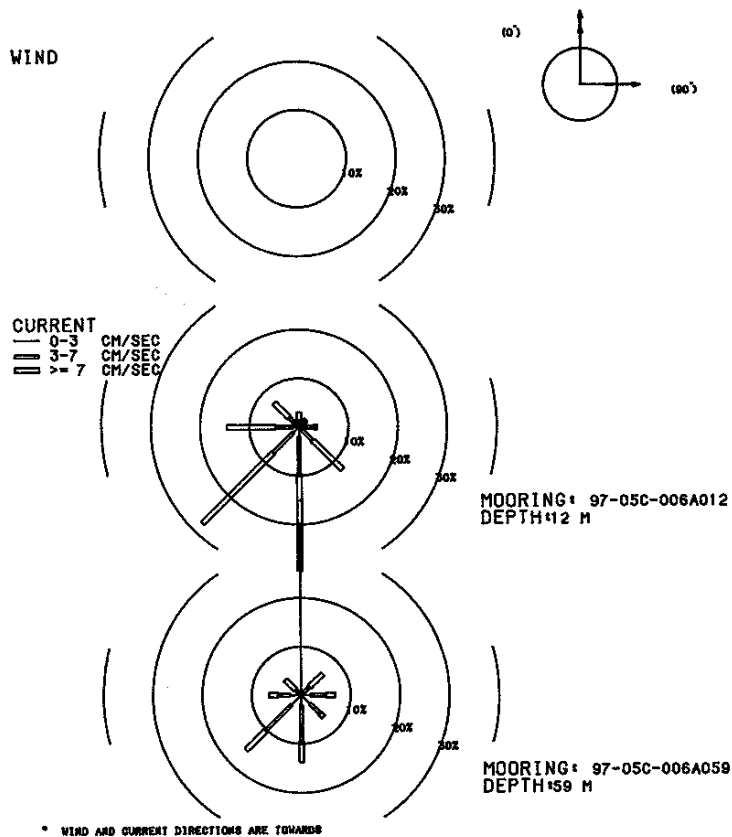

MOORING IS 97-05C-006A012 DEPTH IS 12 METERS THERE ARE 597 VALUES

FIRST DAY 1997/10/07/0100
FINAL DAY 1997/10/31/2300

SHORELINE ORIENTATION IN DEGREES TRUE SPECIFIED AS 90

DIRECTION DEG TRUE	PERCENT OBSERVED	MAXIMUM CURRENT	MEAN DURA- TION	MEAN EXCUR- SION	MEAN CURRENT	MEAN TEMP			
TOWARD	TOTAL	LIGHT	MEDIUM	HIGH	CM/S	HOURS	KM	CM/S	DEG C
90.0	3.7	1.0	2.0	0.7	9.9	1.8	0.3	5.1	13.6
45.0	2.0	0.3	1.2	0.5	11.4	1.5	0.3	5.9	13.8
0.0	3.0	0.7	0.7	1.7	19.7	1.8	0.5	8.0	13.6
315.0	7.0	0.8	1.8	4.4	23.2	2.8	0.9	8.9	14.3
270.0	14.6	1.2	3.5	9.9	36.8	3.0	1.1	10.6	14.7
225.0	27.8	1.7	5.7	20.4	25.6	4.4	1.6	10.1	15.3
180.0	29.5	2.0	7.5	19.9	25.9	5.2	1.7	9.3	15.4
135.0	12.4	0.7	3.2	8.5	29.0	3.5	1.5	11.7	14.0
0	MEAN SCALAR SPEED = 9.7 CM/S		MEAN SQUARE SPEED = 126.0 CM2/S2						
	MEAN SQUARE E-W SPEED = 57.7 CM2/S2		MEAN SQUARE N-S SPEED = 68.3 CM2/S2						
	MEAN VELOCITY = 5.8 CM/S,		207 DEG TRUE		MEAN TEMPERATURE = 14.9 C				
	VARIANCE (U,V) = 46.3 CM2/S2		TOTAL HOURS = 597.						

PERCENT OBSERVED
LIGHT (0.0 - 3.0) 8.4% MEDIUM (3.0 - 7.0) 25.6% HIGH (GE 7.0) 66.0%

MOORING IS 97-05C-006A059 DEPTH IS 59 METERS THERE ARE 598 VALUES

FIRST DAY 1997/10/07/0200
FINAL DAY 1997/10/31/2300

SHORELINE ORIENTATION IN DEGREES TRUE SPECIFIED AS 90

DIRECTION DEG TRUE	PERCENT OBSERVED	MAXIMUM CURRENT	MEAN DURA- TION	MEAN EXCUR- SION	MEAN CURRENT	MEAN TEMP			
TOWARD	TOTAL	LIGHT	MEDIUM	HIGH	CM/S	HOURS	KM	CM/S	DEG C
90.0	6.9	1.8	3.2	1.8	14.1	2.9	0.6	5.7	5.4
45.0	6.2	0.3	2.0	3.8	16.3	3.1	1.0	9.1	6.0
0.0	40.0	32.6	2.5	4.8	18.0	6.6	0.5	1.9	5.0
315.0	4.5	0.2	1.3	3.0	13.0	2.5	0.7	8.2	5.1
270.0	6.5	2.2	2.5	1.8	17.7	2.2	0.5	6.0	4.9
225.0	15.9	2.8	7.4	5.7	19.3	3.8	0.9	6.5	4.9
180.0	13.7	2.0	7.5	4.2	14.1	3.9	0.8	5.7	5.0
135.0	6.4	2.5	2.8	1.0	18.4	2.1	0.4	5.0	5.0
0	MEAN SCALAR SPEED = 4.6 CM/S		MEAN SQUARE SPEED = 41.9 CM2/S2						
	MEAN SQUARE E-W SPEED = 16.9 CM2/S2		MEAN SQUARE N-S SPEED = 25.0 CM2/S2						
	MEAN VELOCITY = 0.5 CM/S,		234 DEG TRUE		MEAN TEMPERATURE = 5.1 C				
	VARIANCE (U,V) = 20.9 CM2/S2		TOTAL HOURS = 598.						

PERCENT OBSERVED
LIGHT (0.0 - 3.0) 44.5% MEDIUM (3.0 - 7.0) 29.3% HIGH (GE 7.0) 26.3%

DATE: 1997/11/01 TO 1997/11/30
 ROSE SUMMARY: WIND AND CURRENT

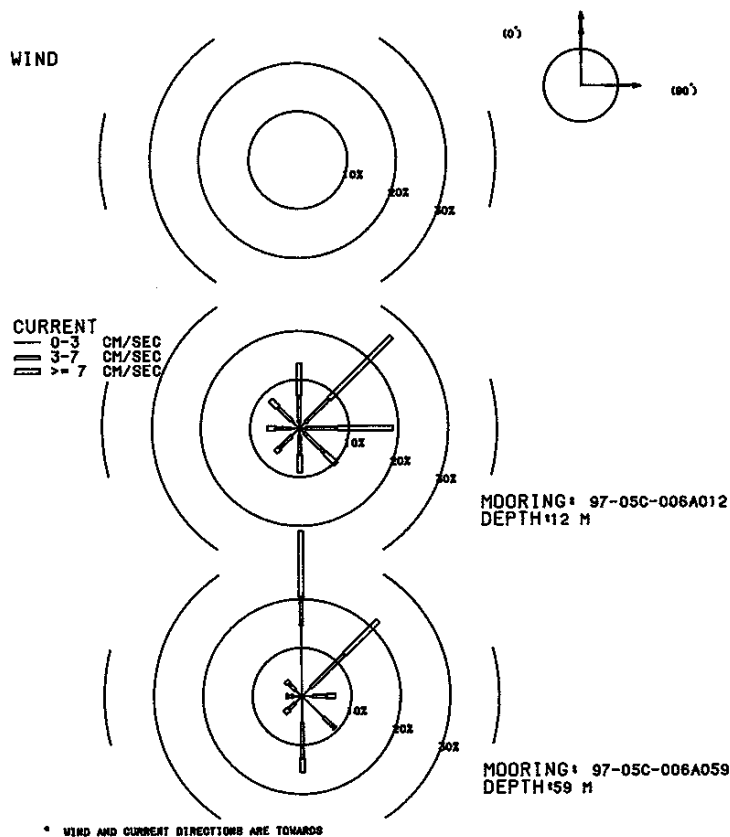

MOORING IS 97-05C-006A012 DEPTH IS 12 METERS THERE ARE 717 VALUES

FIRST DAY 1997/11/01/0000
 FINAL DAY 1997/11/30/2300

SHORELINE ORIENTATION IN DEGREES TRUE SPECIFIED AS 90

DIRECTION DEG TRUE	PERCENT OBSERVED	MAXIMUM CURRENT	MEAN DURA- TION HOURS	MEAN EXCUR- SION KM	MEAN CURRENT CM/S	MEAN TEMP DEG C
TOWARD	TOTAL	LIGHT	MEDIUM	HIGH	CM/S	
90.0	19.0	1.1	6.6	11.3	19.9	3.9
45.0	26.5	1.7	6.8	18.0	19.7	4.6
0.0	13.4	1.1	5.6	6.7	14.8	2.7
315.0	8.2	2.1	3.9	2.2	9.8	2.4
270.0	6.6	1.8	3.1	1.7	10.9	2.0
225.0	6.8	2.2	3.5	1.1	13.1	2.0
180.0	9.1	1.5	3.9	3.6	16.8	3.6
135.0	10.5	1.3	5.9	3.3	14.0	3.0
MEAN SCALAR SPEED = 7.5 CM/S		MEAN SQUARE SPEED = 72.1 CM2/S2				
MEAN SQUARE E-W SPEED = 40.7 CM2/S2		MEAN SQUARE N-S SPEED = 31.5 CM2/S2				
MEAN VELOCITY = 3.7 CM/S,		61 DEG TRUE		MEAN TEMPERATURE = 9.5 C		
VARIANCE (U,V) = 29.3 CM2/S2		TOTAL HOURS = 717.				

PERCENT OBSERVED
 LIGHT (0.0 - 3.0) 12.8% MEDIUM (3.0 - 7.0) 39.2% HIGH (GE 7.0) 48.0%

MOORING IS 97-05C-006A059 DEPTH IS 59 METERS THERE ARE 720 VALUES

FIRST DAY 1997/11/01/0000
 FINAL DAY 1997/11/30/2300

SHORELINE ORIENTATION IN DEGREES TRUE SPECIFIED AS 90

DIRECTION DEG TRUE	PERCENT OBSERVED	MAXIMUM CURRENT	MEAN DURA- TION HOURS	MEAN EXCUR- SION KM	MEAN CURRENT CM/S	MEAN TEMP DEG C
TOWARD	TOTAL	LIGHT	MEDIUM	HIGH	CM/S	
90.0	6.8	2.2	2.8	1.8	13.1	2.6
45.0	21.9	2.5	9.7	9.7	15.6	5.1
0.0	33.9	14.6	5.8	13.5	18.6	5.4
315.0	4.4	1.8	1.9	0.7	13.7	4.0
270.0	3.2	1.8	1.1	0.3	7.2	2.6
225.0	4.9	1.9	1.8	1.1	10.8	2.7
180.0	15.6	5.4	7.4	2.8	9.3	4.0
135.0	9.3	6.1	3.1	0.1	7.6	2.9
MEAN SCALAR SPEED = 5.1 CM/S		MEAN SQUARE SPEED = 40.3 CM2/S2				
MEAN SQUARE E-W SPEED = 10.6 CM2/S2		MEAN SQUARE N-S SPEED = 29.7 CM2/S2				
MEAN VELOCITY = 2.4 CM/S,		34 DEG TRUE		MEAN TEMPERATURE = 6.5 C		
VARIANCE (U,V) = 17.3 CM2/S2		TOTAL HOURS = 720.				

PERCENT OBSERVED
 LIGHT (0.0 - 3.0) 36.4% MEDIUM (3.0 - 7.0) 33.6% HIGH (GE 7.0) 30.0%

DATE: 1997/12/01 TO 1997/12/31
 ROSE SUMMARY: WIND AND CURRENT

WIND

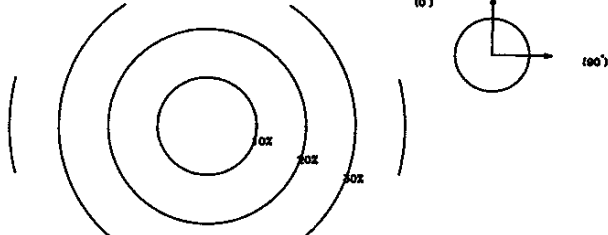

CURRENT
 0-3 CM/SEC
 3-7 CM/SEC
 >= 7 CM/SEC

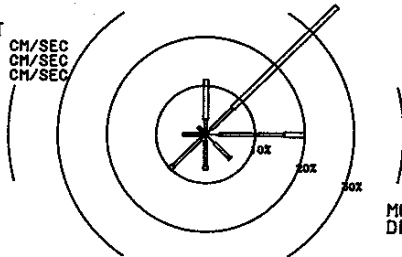

MOORING: 97-05C-006A012
 DEPTH 12 M

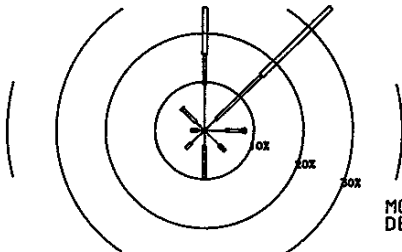

MOORING: 97-05C-006A059
 DEPTH 59 M

* WIND AND CURRENT DIRECTIONS ARE TOWARDS

MOORING IS 97-05C-006A012 DEPTH IS 12 METERS THERE ARE 744 VALUES

FIRST DAY 1997/12/01/0000
 FINAL DAY 1997/12/31/2300

SHORELINE ORIENTATION IN DEGREES TRUE SPECIFIED AS 90

DIRECTION DEG TRUE	PERCENT OBSERVED	TOWARD	TOTAL	LIGHT	MEDIUM	HIGH	MAXIMUM CURRENT CM/S	MEAN DURA- TION HOURS	MEAN EXCUR- SION KM	MEAN CURRENT CM/S	MEAN TEMP DEG C
90.0	20.0	2.7	13.2	4.2	15.4	3.1	0.6	5.8	5.7		
45.0	37.4	1.5	6.2	29.7	24.2	5.2	2.4	12.6	5.8		
0.0	11.3	1.1	2.0	8.2	21.4	3.8	1.5	10.8	6.2		
315.0	2.2	0.3	1.9	0.0	5.7	1.2	0.2	4.2	5.7		
270.0	4.7	0.4	4.3	0.0	6.9	1.9	0.3	4.5	5.5		
225.0	10.2	1.3	7.8	1.1	8.5	2.7	0.5	4.8	5.7		
180.0	7.3	1.3	5.2	0.7	7.9	2.0	0.3	4.7	5.6		
135.0	7.0	2.6	4.3	0.1	7.2	1.9	0.3	3.7	5.8		

MEAN SCALAR SPEED = 8.5 CM/S MEAN SQUARE SPEED = 104.3 CM2/S2
 MEAN SQUARE E-W SPEED = 50.8 CM2/S2 MEAN SQUARE N-S SPEED = 53.5 CM2/S2
 MEAN VELOCITY = 5.6 CM/S, 50 DEG TRUE MEAN TEMPERATURE = 5.8 C
 VARIANCE (U,V) = 36.3 CM2/S2 TOTAL HOURS = 744.

PERCENT OBSERVED

LIGHT (0.0 - 3.0) 11.2% MEDIUM (3.0 - 7.0) 44.9% HIGH (GE 7.0) 44.0%

MOORING IS 97-05C-006A059 DEPTH IS 59 METERS THERE ARE 744 VALUES

FIRST DAY 1997/12/01/0000
 FINAL DAY 1997/12/31/2300

SHORELINE ORIENTATION IN DEGREES TRUE SPECIFIED AS 90

DIRECTION DEG TRUE	PERCENT OBSERVED	TOWARD	TOTAL	LIGHT	MEDIUM	HIGH	MAXIMUM CURRENT CM/S	MEAN DURA- TION HOURS	MEAN EXCUR- SION KM	MEAN CURRENT CM/S	MEAN TEMP DEG C
90.0	8.3	4.3	3.5	0.5	8.9	1.8	0.2	3.2	5.9		
45.0	36.0	3.2	12.9	19.9	18.3	5.8	1.9	8.9	5.8		
0.0	25.3	9.5	6.2	9.5	16.7	3.7	0.7	5.5	6.0		
315.0	6.5	2.4	3.9	0.1	7.5	2.1	0.3	3.9	5.8		
270.0	2.7	1.3	1.3	0.0	4.6	1.4	0.2	3.0	5.6		
225.0	5.2	3.8	1.5	0.0	5.0	1.4	0.1	2.7	5.5		
180.0	10.1	3.2	6.9	0.0	6.8	2.3	0.3	4.0	5.6		
135.0	5.9	4.3	1.6	0.0	5.5	1.6	0.2	2.8	5.8		

MEAN SCALAR SPEED = 5.9 CM/S MEAN SQUARE SPEED = 55.7 CM2/S2
 MEAN SQUARE E-W SPEED = 17.2 CM2/S2 MEAN SQUARE N-S SPEED = 38.5 CM2/S2
 MEAN VELOCITY = 4.0 CM/S, 34 DEG TRUE MEAN TEMPERATURE = 5.8 C
 VARIANCE (U,V) = 19.7 CM2/S2 TOTAL HOURS = 744.

PERCENT OBSERVED

LIGHT (0.0 - 3.0) 32.1% MEDIUM (3.0 - 7.0) 37.8% HIGH (GE 7.0) 30.1%

DATE: 1998/01/01 TO 1998/01/31
 ROSE SUMMARY: WIND AND CURRENT

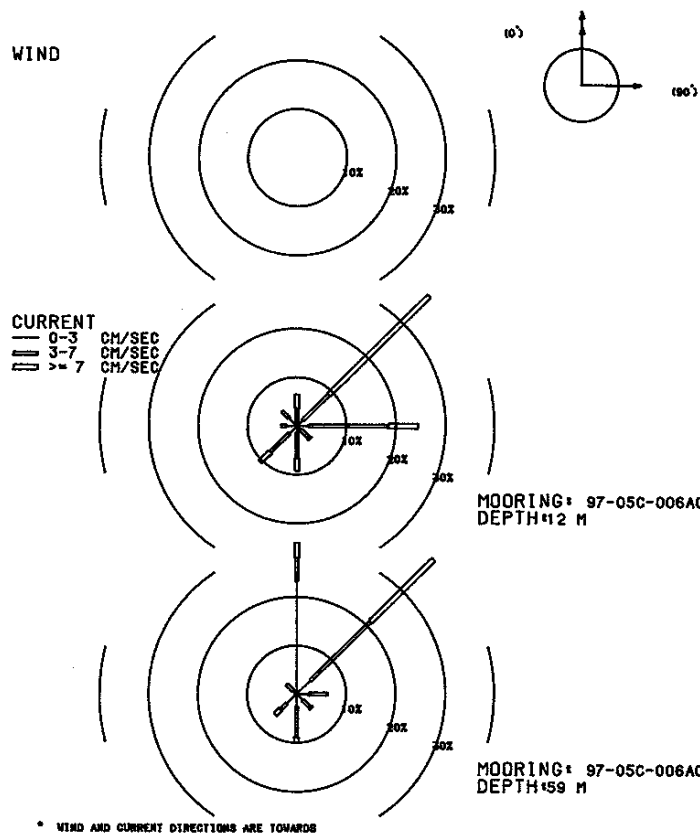

MOORING IS 97-05C-006A012 DEPTH IS 12 METERS THERE ARE 743 VALUES

FIRST DAY 1998/01/01/0000
 FINAL DAY 1998/01/31/2300

SHORELINE ORIENTATION IN DEGREES TRUE SPECIFIED AS 90

DIRECTION DEG TRUE	PERCENT OBSERVED	TOWARD	TOTAL	LIGHT	MEDIUM	HIGH	MAXIMUM CURRENT CM/S	MEAN DURATION HOURS	MEAN EXCURSION KM	MEAN CURRENT CM/S	MEAN TEMP DEG C
90.0	24.6	2.3	16.2	6.2	14.3	5.5	1.2	5.9	3.7		
45.0	37.8	1.6	7.4	28.8	34.9	5.9	2.5	11.9	4.0		
0.0	6.5	0.9	2.7	2.8	29.5	1.8	0.6	9.3	3.9		
315.0	4.3	2.3	2.0	0.0	4.9	1.6	0.2	3.0	3.6		
270.0	3.2	2.2	1.1	0.0	4.4	1.5	0.2	2.9	3.7		
225.0	10.5	2.2	5.4	3.0	9.4	4.3	0.8	5.3	3.6		
180.0	9.3	1.3	5.4	2.6	10.4	4.1	0.8	5.4	4.0		
135.0	3.8	1.1	2.4	0.3	7.0	1.8	0.3	4.1	3.9		
MEAN SCALAR SPEED = 8.0 CM/S		MEAN SQUARE SPEED = 105.6 CM2/S2									
MEAN SQUARE E-W SPEED = 52.5 CM2/S2		MEAN SQUARE N-S SPEED = 53.1 CM2/S2									
MEAN VELOCITY = 5.2 CM/S,		56 DEG TRUE		MEAN TEMPERATURE = 3.8 C							
VARIANCE (U,V) = 39.4 CM2/S2		TOTAL HOURS = 743.									

PERCENT OBSERVED
 LIGHT (0.0 - 3.0) 13.9% MEDIUM (3.0 - 7.0) 42.5% HIGH (GE 7.0) 43.6%

MOORING IS 97-05C-006A059 DEPTH IS 59 METERS THERE ARE 744 VALUES

FIRST DAY 1998/01/01/0000
 FINAL DAY 1998/01/31/2300

SHORELINE ORIENTATION IN DEGREES TRUE SPECIFIED AS 90

DIRECTION DEG TRUE	PERCENT OBSERVED	TOWARD	TOTAL	LIGHT	MEDIUM	HIGH	MAXIMUM CURRENT CM/S	MEAN DURATION HOURS	MEAN EXCURSION KM	MEAN CURRENT CM/S	MEAN TEMP DEG C
90.0	6.3	2.4	3.9	0.0	7.0	2.5	0.4	4.0	4.0		
45.0	39.2	3.9	17.2	18.1	25.6	10.1	2.9	8.1	4.0		
0.0	31.0	23.1	4.8	3.1	23.2	5.4	0.4	2.2	3.6		
315.0	2.8	0.8	2.0	0.0	5.2	3.5	0.5	3.6	3.5		
270.0	0.4	0.4	0.0	0.0	2.2	1.5	0.1	1.7	4.0		
225.0	6.0	2.7	1.9	1.5	9.2	2.6	0.4	4.7	4.2		
180.0	9.9	2.6	6.3	1.1	9.0	3.5	0.6	4.6	3.8		
135.0	4.2	1.7	2.2	0.3	8.7	1.9	0.3	3.6	4.0		
MEAN SCALAR SPEED = 5.1 CM/S		MEAN SQUARE SPEED = 49.9 CM2/S2									
MEAN SQUARE E-W SPEED = 15.8 CM2/S2		MEAN SQUARE N-S SPEED = 34.1 CM2/S2									
MEAN VELOCITY = 3.2 CM/S,		42 DEG TRUE		MEAN TEMPERATURE = 3.8 C							
VARIANCE (U,V) = 19.8 CM2/S2		TOTAL HOURS = 744.									

PERCENT OBSERVED
 LIGHT (0.0 - 3.0) 37.6% MEDIUM (3.0 - 7.0) 38.3% HIGH (GE 7.0) 24.1%

DATE: 1998/02/01 TO 1998/02/28
ROSE SUMMARY: WIND AND CURRENT

WIND

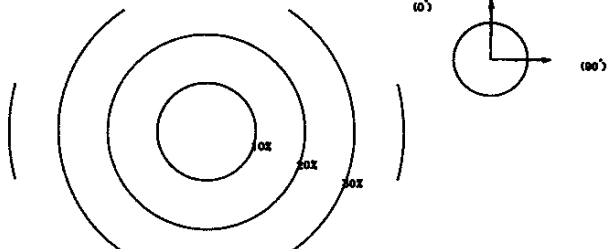

CURRENT

0-3 CM/SEC
3-7 CM/SEC
>= 7 CM/SEC

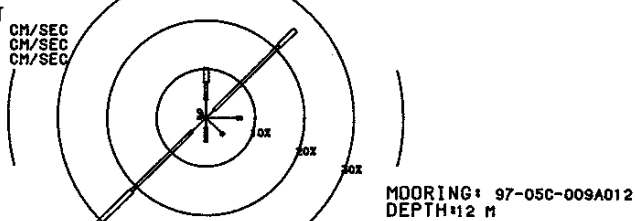

MOORING: 97-05C-009A012
DEPTH: 12 M

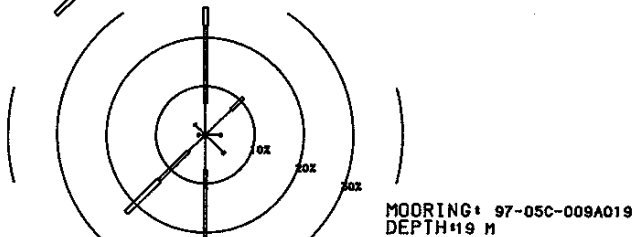

MOORING: 97-05C-009A019
DEPTH: 19 M

* WIND AND CURRENT DIRECTIONS ARE TOWARDS

MOORING IS 97-05C-006A012 DEPTH IS 12 METERS THERE ARE 672 VALUES

FIRST DAY 1998/02/01/0000
FINAL DAY 1998/02/28/2300

SHORELINE ORIENTATION IN DEGREES TRUE SPECIFIED AS 90

DIRECTION DEG TRUE	PERCENT OBSERVED	TOWARD	TOTAL	LIGHT	MEDIUM	HIGH	MAXIMUM CURRENT CM/S	MEAN DURA- TION HOURS	MEAN EXCUR- SION KM	MEAN CURRENT CM/S	MEAN TEMP DEG C
90.0	10.9	2.5	7.1	1.2	8.9	1.8	0.3	4.6	2.9		
45.0	52.8	3.7	26.8	22.3	20.7	7.6	2.2	8.2	2.8		
0.0	7.4	2.2	2.5	2.7	15.7	2.6	0.5	5.7	2.9		
315.0	1.8	0.7	1.0	0.0	6.9	2.0	0.3	3.6	2.8		
270.0	4.5	2.4	1.9	0.1	8.0	1.5	0.2	3.3	3.1		
225.0	13.4	2.7	8.6	2.1	8.5	3.1	0.6	5.0	3.3		
180.0	4.5	1.0	3.4	0.0	7.0	1.6	0.2	4.3	3.2		
135.0	4.8	3.0	1.8	0.0	6.9	1.8	0.2	3.2	3.0		
0		MEAN SCALAR SPEED = 6.5 CM/S		MEAN SQUARE SPEED = 59.8 CM2/S2							
		MEAN SQUARE E-W SPEED = 25.4 CM2/S2		MEAN SQUARE N-S SPEED = 34.4 CM2/S2							
		MEAN VELOCITY = 4.0 CM/S,		45 DEG TRUE		MEAN TEMPERATURE = 2.9 C					
		VARIANCE (U,V) = 21.8 CM2/S2		TOTAL HOURS = 672.							

PERCENT OBSERVED

LIGHT (0.0 - 3.0) 18.3% MEDIUM (3.0 - 7.0) 53.3% HIGH (GE 7.0) 28.4%

MOORING IS 97-05C-006A059 DEPTH IS 59 METERS THERE ARE 672 VALUES

FIRST DAY 1998/02/01/0000
FINAL DAY 1998/02/28/2300

SHORELINE ORIENTATION IN DEGREES TRUE SPECIFIED AS 90

DIRECTION DEG TRUE	PERCENT OBSERVED	TOWARD	TOTAL	LIGHT	MEDIUM	HIGH	MAXIMUM CURRENT CM/S	MEAN DURA- TION HOURS	MEAN EXCUR- SION KM	MEAN CURRENT CM/S	MEAN TEMP DEG C
90.0	5.8	4.2	1.6	0.0	6.8	2.3	0.2	2.8	3.0		
45.0	40.2	10.3	14.1	15.8	15.7	6.8	1.5	6.3	2.8		
0.0	33.9	29.2	1.2	3.6	11.7	6.2	0.3	1.1	2.9		
315.0	0.6	0.4	0.1	0.0	3.6	1.3	0.1	2.5	3.2		
270.0	2.2	1.2	1.0	0.0	5.1	2.5	0.3	3.2	3.3		
225.0	8.6	1.5	6.7	0.4	8.1	5.3	0.9	4.8	3.3		
180.0	6.8	2.1	4.3	0.4	9.4	3.8	0.6	4.4	3.1		
135.0	1.8	1.8	0.0	0.0	2.6	1.3	0.1	2.0	3.0		
0		MEAN SCALAR SPEED = 3.9 CM/S		MEAN SQUARE SPEED = 29.5 CM2/S2							
		MEAN SQUARE E-W SPEED = 9.5 CM2/S2		MEAN SQUARE N-S SPEED = 19.9 CM2/S2							
		MEAN VELOCITY = 2.2 CM/S,		40 DEG TRUE		MEAN TEMPERATURE = 2.9 C					
		VARIANCE (U,V) = 12.3 CM2/S2		TOTAL HOURS = 672.							

PERCENT OBSERVED

LIGHT (0.0 - 3.0) 50.6% MEDIUM (3.0 - 7.0) 29.2% HIGH (GE 7.0) 20.2%

DATE: 1998/03/01 TO 1998/03/31
ROSE SUMMARY: WIND AND CURRENT

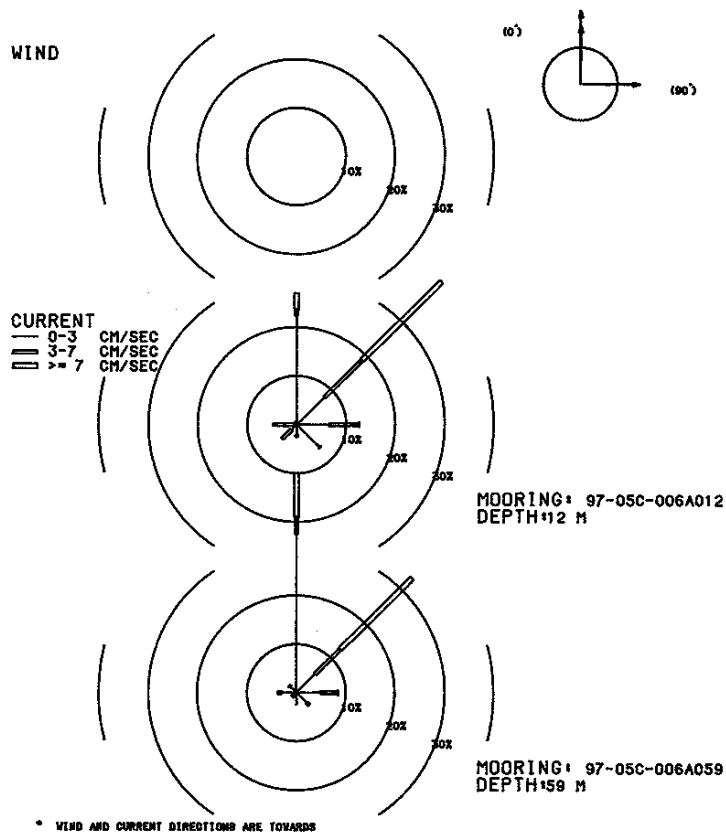

MOORING IS 97-05C-006A012 DEPTH IS 12 METERS THERE ARE 744 VALUES

FIRST DAY 1998/03/01/0000
FINAL DAY 1998/03/31/2300

SHORELINE ORIENTATION IN DEGREES TRUE SPECIFIED AS 90

DIRECTION DEG TRUE	PERCENT OBSERVED	TOWARD	TOTAL	LIGHT	MEDIUM	HIGH	MAXIMUM CURRENT CM/S	MEAN DURA- TION HOURS	MEAN EXCUR- SION KM	MEAN CURRENT CM/S	MEAN TEMP DEG C
90.0	12.6	6.5	6.0	0.1	8.8	2.2	0.3	3.3	3.0		
45.0	41.5	7.9	10.8	22.8	49.3	7.9	2.8	9.8	2.9		
0.0	27.0	22.4	1.2	3.4	61.7	6.3	1.2	5.3	3.0		
315.0	0.5	0.4	0.1	0.0	4.9	1.0	0.1	2.5	3.3		
270.0	4.8	0.3	4.6	0.0	5.5	2.8	0.4	3.8	3.4		
225.0	4.2	1.5	2.7	0.0	5.9	2.8	0.4	3.5	3.5		
180.0	2.6	2.2	0.4	0.0	3.6	1.6	0.1	2.1	3.1		
135.0	6.7	6.5	0.3	0.0	3.7	1.5	0.1	2.0	3.1		

MEAN SCALAR SPEED = 6.5 CM/S MEAN SQUARE SPEED = 141.1 CM2/S2
MEAN SQUARE E-W SPEED = 38.1 CM2/S2 MEAN SQUARE N-S SPEED = 103.0 CM2/S2
MEAN VELOCITY = 5.3 CM/S, 38 DEG TRUE MEAN TEMPERATURE = 3.0 C
VARIANCE (U,V) = 56.8 CM2/S2 TOTAL HOURS = 744.

PERCENT OBSERVED
LIGHT (0.0 - 3.0) 47.6% MEDIUM (3.0 - 7.0) 26.1% HIGH (GE 7.0) 26.3%

MOORING IS 97-05C-006A059 DEPTH IS 59 METERS THERE ARE 744 VALUES

FIRST DAY 1998/03/01/0000
FINAL DAY 1998/03/31/2300

SHORELINE ORIENTATION IN DEGREES TRUE SPECIFIED AS 90

DIRECTION DEG TRUE	PERCENT OBSERVED	TOWARD	TOTAL	LIGHT	MEDIUM	HIGH	MAXIMUM CURRENT CM/S	MEAN DURA- TION HOURS	MEAN EXCUR- SION KM	MEAN CURRENT CM/S	MEAN TEMP DEG C
90.0	8.5	4.8	3.5	0.1	7.0	2.2	0.3	3.4	3.2		
45.0	33.3	5.4	7.3	20.7	34.8	5.5	1.9	9.6	2.9		
0.0	45.0	32.5	3.5	9.0	50.0	5.8	1.1	5.4	3.0		
315.0	2.0	1.7	0.3	0.0	5.7	1.5	0.1	2.5	3.3		
270.0	3.8	3.0	0.8	0.0	4.3	3.5	0.3	2.5	3.4		
225.0	1.2	0.5	0.7	0.0	4.0	2.2	0.2	2.9	3.3		
180.0	2.6	2.6	0.0	0.0	2.4	1.7	0.1	2.1	3.0		
135.0	3.6	3.0	0.7	0.0	4.2	1.8	0.2	2.4	3.0		

MEAN SCALAR SPEED = 6.2 CM/S MEAN SQUARE SPEED = 118.7 CM2/S2
MEAN SQUARE E-W SPEED = 19.2 CM2/S2 MEAN SQUARE N-S SPEED = 99.5 CM2/S2
MEAN VELOCITY = 5.4 CM/S, 28 DEG TRUE MEAN TEMPERATURE = 3.0 C
VARIANCE (U,V) = 45.0 CM2/S2 TOTAL HOURS = 744.

PERCENT OBSERVED
LIGHT (0.0 - 3.0) 53.5% MEDIUM (3.0 - 7.0) 16.7% HIGH (GE 7.0) 29.8%

DATE: 1998/04/01 TO 1998/04/30
ROSE SUMMARY: WIND AND CURRENT

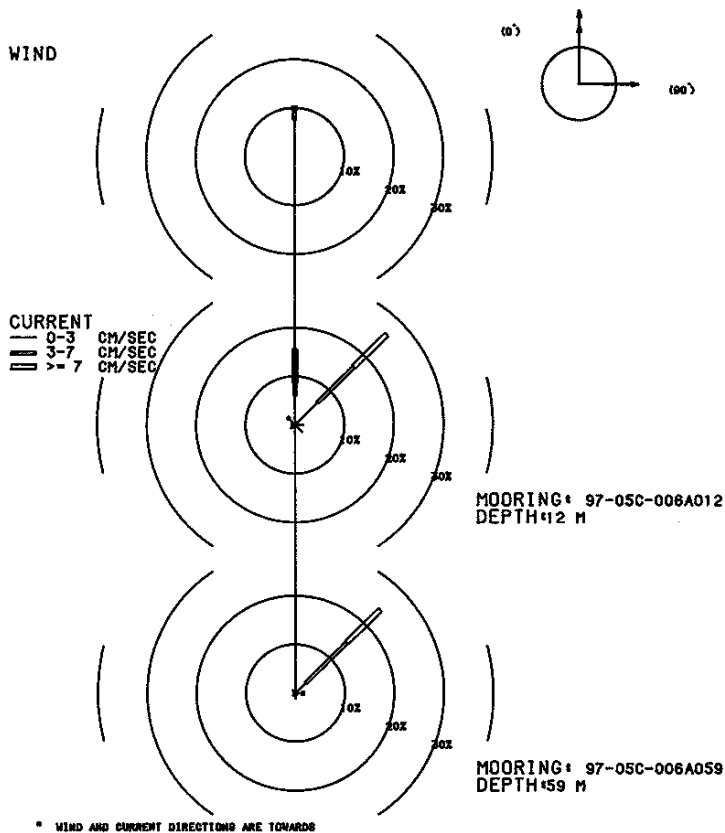

MOORING IS 97-05C-006A012 DEPTH IS 12 METERS THERE ARE 719 VALUES

FIRST DAY 1998/04/01/0000
FINAL DAY 1998/04/30/2300

SHORELINE ORIENTATION IN DEGREES TRUE SPECIFIED AS 90

DIRECTION DEG TRUE	PERCENT OBSERVED	TOWARD	TOTAL	LIGHT	MEDIUM	HIGH	MAXIMUM CURRENT CM/S	MEAN DURA- TION HOURS	MEAN EXCUR- SION KM	MEAN CURRENT CM/S	MEAN TEMP DEG C
90.0	1.7	1.7	0.0	0.0	0.0	0.0	2.4	1.7	0.1	2.1	3.5
45.0	26.3	6.4	10.4	9.5	18.2	8.2	18.2	8.2	2.0	6.8	3.9
0.0	65.4	62.6	2.1	0.7	8.3	14.2	8.3	14.2	0.2	0.3	4.1
315.0	2.1	1.8	0.3	0.0	5.3	1.7	5.3	1.7	0.1	2.2	4.1
270.0	0.7	0.6	0.1	0.0	4.1	1.2	4.1	1.2	0.1	1.7	3.6
225.0	1.1	1.1	0.0	0.0	1.9	1.6	1.9	1.6	0.1	1.4	3.3
180.0	0.7	0.7	0.0	0.0	2.2	1.0	2.2	1.0	0.1	1.6	3.4
135.0	2.1	2.1	0.0	0.0	2.3	1.5	2.3	1.5	0.1	1.8	3.6
0 MEAN SCALAR SPEED = 2.1 CM/S MEAN SQUARE SPEED = 18.6 CM2/S2											
MEAN SQUARE E-W SPEED = 7.3 CM2/S2 MEAN SQUARE N-S SPEED = 11.3 CM2/S2											
MEAN VELOCITY = 1.9 CM/S, 37 DEG TRUE MEAN TEMPERATURE = 4.0 C											
VARIANCE (U,V) = 7.5 CM2/S2 TOTAL HOURS = 719.											

PERCENT OBSERVED
LIGHT (0.0 - 3.0) 76.9% MEDIUM (3.0 - 7.0) 12.9% HIGH (GE 7.0) 10.2%

MOORING IS 97-05C-006A059 DEPTH IS 59 METERS THERE ARE 720 VALUES

FIRST DAY 1998/04/01/0000
FINAL DAY 1998/04/30/2300

SHORELINE ORIENTATION IN DEGREES TRUE SPECIFIED AS 90

DIRECTION DEG TRUE	PERCENT OBSERVED	TOWARD	TOTAL	LIGHT	MEDIUM	HIGH	MAXIMUM CURRENT CM/S	MEAN DURA- TION HOURS	MEAN EXCUR- SION KM	MEAN CURRENT CM/S	MEAN TEMP DEG C
90.0	1.8	1.2	0.6	0.0	5.0	2.2	5.0	2.2	0.2	2.6	4.0
45.0	24.3	2.9	11.8	9.6	16.2	7.0	16.2	7.0	1.8	7.1	3.9
0.0	70.6	61.0	2.6	6.9	14.1	15.4	14.1	15.4	0.6	1.2	3.8
315.0	0.7	0.7	0.0	0.0	2.4	1.0	2.4	1.0	0.1	2.2	3.4
270.0	0.3	0.3	0.0	0.0	2.2	1.0	2.2	1.0	0.1	2.2	3.6
225.0	0.7	0.7	0.0	0.0	2.1	1.2	2.1	1.2	0.1	1.7	3.6
180.0	1.2	1.2	0.0	0.0	2.6	1.8	2.6	1.8	0.2	2.3	3.8
135.0	0.4	0.3	0.1	0.0	3.4	1.5	3.4	1.5	0.1	2.6	3.8
0 MEAN SCALAR SPEED = 2.7 CM/S MEAN SQUARE SPEED = 22.7 CM2/S2											
MEAN SQUARE E-W SPEED = 6.3 CM2/S2 MEAN SQUARE N-S SPEED = 16.3 CM2/S2											
MEAN VELOCITY = 2.4 CM/S, 32 DEG TRUE MEAN TEMPERATURE = 3.8 C											
VARIANCE (U,V) = 8.4 CM2/S2 TOTAL HOURS = 720.											

PERCENT OBSERVED
LIGHT (0.0 - 3.0) 68.3% MEDIUM (3.0 - 7.0) 15.1% HIGH (GE 7.0) 16.5%

DATE: 1998/05/01 TO 1998/05/31
ROSE SUMMARY: WIND AND CURRENT

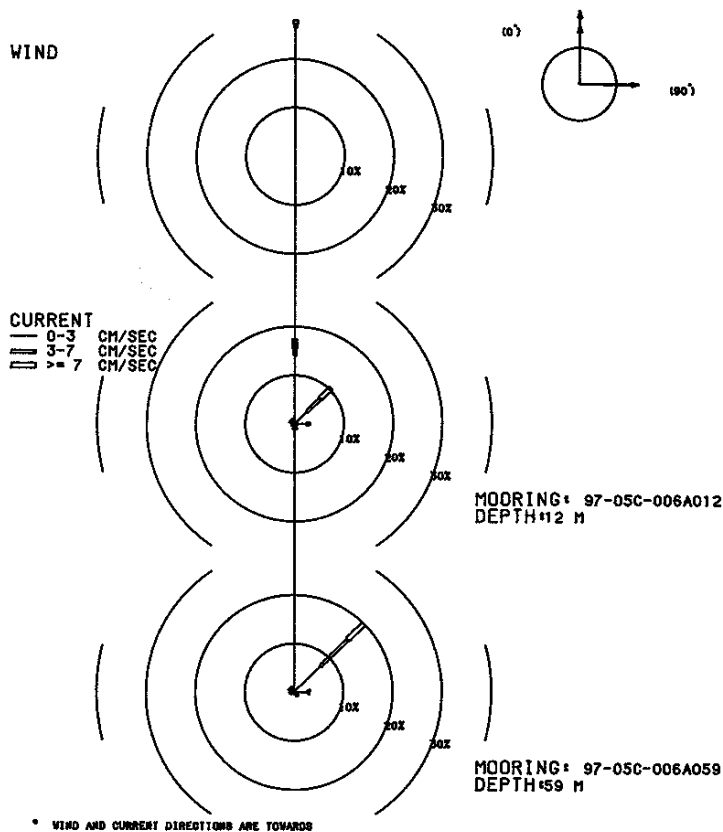

MOORING IS 97-05C-006A012 DEPTH IS 12 METERS THERE ARE 743 VALUES

FIRST DAY 1998/05/01/0000
FINAL DAY 1998/05/31/2300

SHORELINE ORIENTATION IN DEGREES TRUE SPECIFIED AS 90

DIRECTION DEG TRUE	PERCENT OBSERVED	TOWARD	TOTAL	LIGHT	MEDIUM	HIGH	MAXIMUM CURRENT CM/S	MEAN DURA- TION HOURS	MEAN EXCUR- SION KM	MEAN CURRENT CM/S	MEAN TEMP DEG C
90.0	3.1	2.4	0.7	0.0	0.0	6.1	1.9	0.2	2.5	8.5	
45.0	10.4	3.5	3.9	3.0	18.6	4.3	0.9	5.8	7.6		
0.0	82.8	81.3	0.8	0.7	17.1	28.0	0.2	0.2	8.3		
315.0	1.1	0.8	0.0	0.3	8.0	2.0	0.3	3.6	12.4		
270.0	0.7	0.5	0.1	0.0	6.4	1.2	0.1	2.2	11.0		
225.0	0.4	0.3	0.0	0.1	10.6	1.5	0.3	4.8	13.4		
180.0	1.1	0.7	0.3	0.1	10.3	1.3	0.2	3.5	11.0		
135.0	0.5	0.3	0.1	0.1	17.4	1.0	0.2	6.6	11.4		
MEAN SCALAR SPEED = 1.0 CM/S		MEAN SQUARE SPEED = 8.5 CM2/S2									
MEAN SQUARE E-W SPEED = 3.1 CM2/S2		MEAN SQUARE N-S SPEED = 5.4 CM2/S2									
MEAN VELOCITY = 0.7 CM/S,		38 DEG TRUE		MEAN TEMPERATURE = 8.4 C							
VARIANCE (U,V) = 4.0 CM2/S2		TOTAL HOURS = 743.									

PERCENT OBSERVED

LIGHT (0.0 - 3.0) 89.8% MEDIUM (3.0 - 7.0) 5.9% HIGH (GE 7.0) 4.3%

MOORING IS 97-05C-006A059 DEPTH IS 59 METERS THERE ARE 744 VALUES

FIRST DAY 1998/05/01/0000
FINAL DAY 1998/05/31/2300

SHORELINE ORIENTATION IN DEGREES TRUE SPECIFIED AS 90

DIRECTION DEG TRUE	PERCENT OBSERVED	TOWARD	TOTAL	LIGHT	MEDIUM	HIGH	MAXIMUM CURRENT CM/S	MEAN DURA- TION HOURS	MEAN EXCUR- SION KM	MEAN CURRENT CM/S	MEAN TEMP DEG C
90.0	3.2	2.7	0.3	0.3	9.5	1.5	0.1	2.7	4.4		
45.0	20.0	7.7	7.7	4.7	14.6	5.5	1.0	5.0	4.5		
0.0	72.4	69.1	1.5	1.9	13.8	13.8	0.2	0.4	4.4		
315.0	1.2	0.9	0.1	0.1	9.7	1.3	0.1	3.1	4.5		
270.0	0.9	0.8	0.1	0.0	4.4	1.8	0.1	2.1	4.4		
225.0	0.7	0.7	0.0	0.0	2.3	1.0	0.1	1.9	4.4		
180.0	0.4	0.3	0.1	0.0	3.4	1.0	0.1	2.4	4.5		
135.0	1.1	0.9	0.1	0.0	5.1	1.3	0.1	2.5	4.4		
MEAN SCALAR SPEED = 1.5 CM/S		MEAN SQUARE SPEED = 10.3 CM2/S2									
MEAN SQUARE E-W SPEED = 3.8 CM2/S2		MEAN SQUARE N-S SPEED = 6.5 CM2/S2									
MEAN VELOCITY = 1.3 CM/S,		37 DEG TRUE		MEAN TEMPERATURE = 4.4 C							
VARIANCE (U,V) = 4.3 CM2/S2		TOTAL HOURS = 744.									

PERCENT OBSERVED

LIGHT (0.0 - 3.0) 83.1% MEDIUM (3.0 - 7.0) 9.9% HIGH (GE 7.0) 7.0%

DATE: 1998/06/01 TO 1998/06/30
ROSE SUMMARY: WIND AND CURRENT

WIND

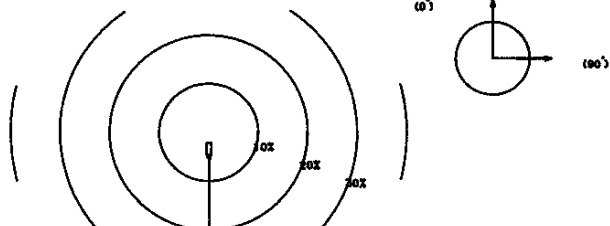

CURRENT
0-3 CM/SEC
3-7 CM/SEC
>= 7 CM/SEC

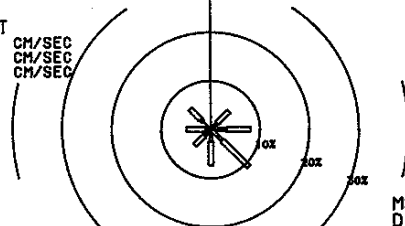

MOORING: 97-05C-006A012
DEPTH: 12 M

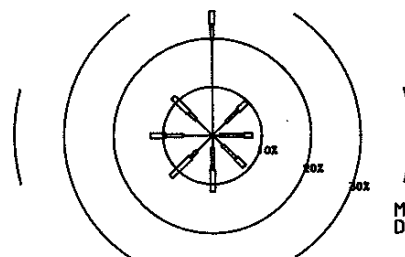

MOORING: 97-05C-006A059
DEPTH: 59 M

* WIND AND CURRENT DIRECTIONS ARE TOWARDS

MOORING IS 97-05C-006A012 DEPTH IS 12 METERS THERE ARE 284 VALUES

FIRST DAY 1998/06/01/0000
FINAL DAY 1998/06/12/1900

SHORELINE ORIENTATION IN DEGREES TRUE SPECIFIED AS 90

DIRECTION DEG TRUE	PERCENT OBSERVED	TOWARD	TOTAL	LIGHT	MEDIUM	HIGH	MAXIMUM CURRENT CM/S	MEAN DURA- TION HOURS	MEAN EXCUR- SION KM	MEAN CURRENT CM/S	MEAN TEMP DEG C
90.0	8.1	1.4	1.8	4.9	22.6	2.3	0.8	10.0	12.3		
45.0	5.3	0.7	1.1	3.5	16.9	2.1	0.7	9.4	11.8		
0.0	52.8	49.6	0.7	2.5	17.1	7.9	0.2	0.8	12.8		
315.0	6.0	2.1	0.7	3.2	33.7	1.7	0.6	10.3	11.9		
270.0	4.9	0.7	0.4	3.9	34.7	2.0	1.1	15.7	11.4		
225.0	4.6	0.4	1.4	2.8	28.6	1.6	0.8	14.1	11.4		
180.0	7.4	0.7	1.8	4.9	23.9	2.1	0.9	12.3	12.0		
135.0	10.9	0.0	3.2	7.7	25.4	2.6	1.1	11.9	12.4		

MEAN SCALAR SPEED = 6.0 CM/S MEAN SQUARE SPEED = 98.7 CM²/S²
MEAN SQUARE E-W SPEED = 54.0 CM²/S² MEAN SQUARE N-S SPEED = 44.7 CM²/S²
MEAN VELOCITY = 1.2 CM/S, 162 DEG TRUE MEAN TEMPERATURE = 12.4 C
VARIANCE (U,V) = 48.8 CM²/S² TOTAL HOURS = 284.

PERCENT OBSERVED

LIGHT (0.0 - 3.0) 55.6% MEDIUM (3.0 - 7.0) 10.9% HIGH (GE 7.0) 33.5%

MOORING IS 97-05C-006A059 DEPTH IS 59 METERS THERE ARE 285 VALUES

FIRST DAY 1998/06/01/0000
FINAL DAY 1998/06/12/2000

SHORELINE ORIENTATION IN DEGREES TRUE SPECIFIED AS 90

DIRECTION DEG TRUE	PERCENT OBSERVED	TOWARD	TOTAL	LIGHT	MEDIUM	HIGH	MAXIMUM CURRENT CM/S	MEAN DURA- TION HOURS	MEAN EXCUR- SION KM	MEAN CURRENT CM/S	MEAN TEMP DEG C
90.0	8.1	1.4	4.9	1.8	13.6	1.6	0.4	6.0	4.9		
45.0	9.8	3.9	3.5	2.5	13.7	2.2	0.4	5.3	4.8		
0.0	25.6	19.6	3.2	2.8	10.2	3.2	0.2	1.7	4.7		
315.0	11.2	4.6	2.1	4.6	12.0	2.5	0.5	5.8	4.7		
270.0	12.6	6.0	3.5	3.2	9.8	2.6	0.4	4.5	4.7		
225.0	11.9	4.6	1.8	5.6	11.1	2.8	0.6	5.6	4.7		
180.0	11.6	2.5	4.6	4.6	11.8	2.4	0.5	6.1	4.8		
135.0	9.1	2.8	3.9	2.5	11.5	2.2	0.4	5.6	4.9		

MEAN SCALAR SPEED = 4.5 CM/S MEAN SQUARE SPEED = 32.5 CM²/S²
MEAN SQUARE E-W SPEED = 15.7 CM²/S² MEAN SQUARE N-S SPEED = 16.8 CM²/S²
MEAN VELOCITY = 0.4 CM/S, 229 DEG TRUE MEAN TEMPERATURE = 4.8 C
VARIANCE (U,V) = 16.2 CM²/S² TOTAL HOURS = 285.

PERCENT OBSERVED

LIGHT (0.0 - 3.0) 45.3% MEDIUM (3.0 - 7.0) 27.4% HIGH (GE 7.0) 27.4%

Appendix S - Mooring_V09-97. Overall Summary Statistics and Rose Histogram Plots

DATE: 1997/10/01 TO 1998/06/13
ROSE SUMMARY: WIND AND CURRENT

WIND

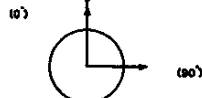
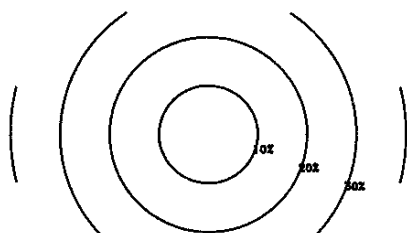

CURRENT
0-3 CM/SEC
3-7 CM/SEC
>= 7 CM/SEC

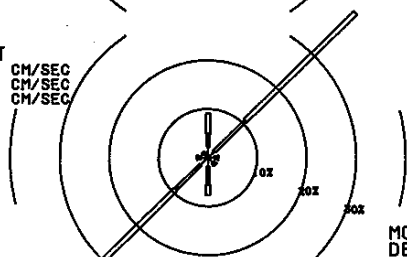

MOORING: 97-05C-009A012
DEPTH: 12 M

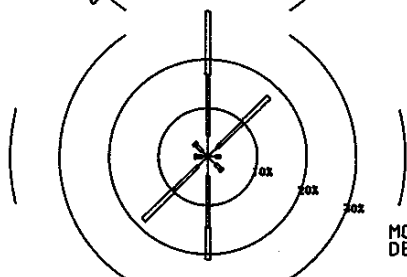

MOORING: 97-05C-009A019
DEPTH: 19 M

* WIND AND CURRENT DIRECTIONS ARE TOWARDS

MOORING IS 97-05C-009A012 DEPTH IS 12 METERS THERE ARE 4163 VALUES

FIRST DAY 1997/10/06/2200
FINAL DAY 1998/04/26/0400

SHORELINE ORIENTATION IN DEGREES TRUE SPECIFIED AS 90

DIRECTION DEG TRUE	PERCENT OBSERVED				MAXIMUM CURRENT CM/S	MEAN DURA- TION HOURS	MEAN EXCUR- SION KM	MEAN CURRENT CM/S	MEAN TEMP DEG C
TOWARD	TOTAL	LIGHT	MEDIUM	HIGH	CM/S	HOURS	KM	CM/S	DEG C
90.0	2.0	1.3	0.7	0.0	7.7	1.5	0.2	2.9	4.4
45.0	42.2	1.6	9.1	31.4	31.6	10.1	4.2	11.4	4.9
0.0	9.2	2.2	2.6	4.3	30.8	2.2	0.6	7.8	4.9
315.0	1.5	1.1	0.4	0.0	6.8	1.4	0.1	2.7	3.9
270.0	2.2	1.4	0.8	0.0	7.4	1.8	0.2	3.0	3.9
225.0	33.1	2.1	7.1	24.0	52.3	10.8	4.4	11.4	6.4
180.0	7.7	1.9	3.7	2.1	19.9	2.5	0.5	5.7	7.0
135.0	2.0	1.3	0.7	0.0	7.9	1.5	0.2	2.9	5.9

0 MEAN SCALAR SPEED = 10.0 CM/S MEAN SQUARE SPEED = 143.5 CM2/S2
MEAN SQUARE E-W SPEED = 38.0 CM2/S2 MEAN SQUARE N-S SPEED = 105.4 CM2/S2
MEAN VELOCITY = 1.3 CM/S, 20 DEG TRUE MEAN TEMPERATURE = 5.5 C
VARIANCE (U,V) = 70.9 CM2/S2 TOTAL HOURS = 4163.

PERCENT OBSERVED
LIGHT (0.0 - 3.0) 12.9% MEDIUM (3.0 - 7.0) 25.2% HIGH (GE 7.0) 61.9%

MOORING IS 97-05C-009A019 DEPTH IS 19 METERS THERE ARE 5984 VALUES

FIRST DAY 1997/10/06/2200
FINAL DAY 1998/06/13/0500

SHORELINE ORIENTATION IN DEGREES TRUE SPECIFIED AS 90

DIRECTION DEG TRUE	PERCENT OBSERVED				MAXIMUM CURRENT CM/S	MEAN DURA- TION HOURS	MEAN EXCUR- SION KM	MEAN CURRENT CM/S	MEAN TEMP DEG C
TOWARD	TOTAL	LIGHT	MEDIUM	HIGH	CM/S	HOURS	KM	CM/S	DEG C
90.0	2.5	1.7	0.8	0.0	5.9	1.8	0.2	2.8	5.5
45.0	17.4	2.7	7.4	7.4	25.6	3.2	0.8	7.4	5.1
0.0	29.9	4.3	12.6	13.0	25.1	4.7	1.2	7.2	5.4
315.0	3.9	1.6	1.7	0.6	14.5	2.2	0.4	4.5	6.0
270.0	2.6	1.2	1.2	0.2	10.2	1.7	0.2	3.7	5.7
225.0	18.4	2.8	6.9	8.7	42.6	4.3	1.2	8.0	5.8
180.0	21.0	4.0	10.5	6.6	27.1	4.2	0.9	5.7	6.1
135.0	4.1	2.3	1.5	0.4	13.8	1.8	0.2	3.7	6.1

0 MEAN SCALAR SPEED = 6.6 CM/S MEAN SQUARE SPEED = 64.2 CM2/S2
MEAN SQUARE E-W SPEED = 12.3 CM2/S2 MEAN SQUARE N-S SPEED = 52.0 CM2/S2
MEAN VELOCITY = 0.8 CM/S, 5 DEG TRUE MEAN TEMPERATURE = 5.6 C
VARIANCE (U,V) = 31.8 CM2/S2 TOTAL HOURS = 5984.

PERCENT OBSERVED
LIGHT (0.0 - 3.0) 20.6% MEDIUM (3.0 - 7.0) 42.6% HIGH (GE 7.0) 36.8%

Appendix T - Mooring_V09-97. Monthly Summary Statistics and Rose Histogram Plots

DATE: 1997/10/01 TO 1997/10/31
ROSE SUMMARY: WIND AND CURRENT

WIND

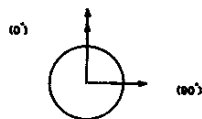
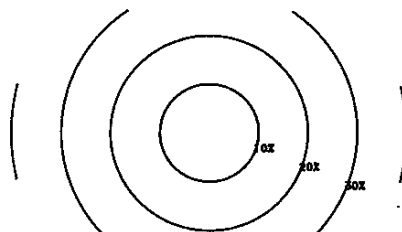

CURRENT
 0-3 CM/SEC
 3-7 CM/SEC
 >= 7 CM/SEC

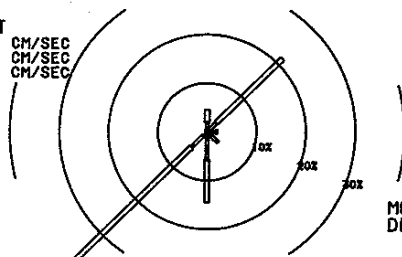

MOORING: 97-05C-009A012
DEPTH: 12 M

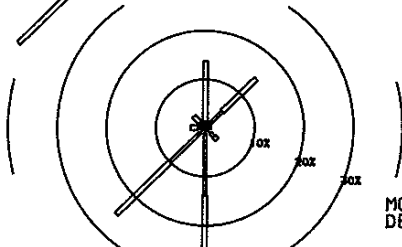

MOORING: 97-05C-009A019
DEPTH: 19 M

* WIND AND CURRENT DIRECTIONS ARE TOWARDS

MOORING IS 97-05C-009A012 DEPTH IS 12 METERS THERE ARE 504 VALUES

FIRST DAY 1997/10/06/2200
FINAL DAY 1997/10/31/0700

SHORELINE ORIENTATION IN DEGREES TRUE SPECIFIED AS 90

DIRECTION DEG TRUE	PERCENT OBSERVED	TOWARD	TOTAL	LIGHT	MEDIUM	HIGH	MAXIMUM CURRENT CM/S	MEAN DURA- TION HOURS	MEAN EXCUR- SION KM	MEAN CURRENT CM/S	MEAN TEMP DEG C
90.0	2.0	0.6	1.2	0.2	7.7	1.2	0.2	4.0	13.7		
45.0	21.4	0.4	2.2	18.8	30.0	8.3	4.3	14.2	13.3		
0.0	4.6	0.0	2.0	2.6	25.3	1.9	0.9	12.7	15.7		
315.0	0.4	0.0	0.4	0.0	6.8	1.0	0.2	5.8	12.6		
270.0	0.4	0.2	0.0	0.2	7.4	1.0	0.2	4.8	12.4		
225.0	53.6	1.0	3.4	49.2	36.6	12.9	6.8	14.6	15.0		
180.0	14.5	1.2	4.6	8.7	19.9	3.0	0.9	8.3	16.3		
135.0	3.2	1.0	2.2	0.0	5.9	2.3	0.3	3.8	12.7		

0 MEAN SCALAR SPEED = 12.9 CM/S MEAN SQUARE SPEED = 211.8 CM2/S2
 MEAN SQUARE E-W SPEED = 58.6 CM2/S2 MEAN SQUARE N-S SPEED = 153.3 CM2/S2
 MEAN VELOCITY = 5.3 CM/S, 212 DEG TRUE MEAN TEMPERATURE = 14.7 C
 VARIANCE (U,V) = 92.1 CM2/S2 TOTAL HOURS = 504.

PERCENT OBSERVED
 LIGHT (0.0 - 3.0) 4.4% MEDIUM (3.0 - 7.0) 15.9% HIGH (GE 7.0) 79.8%

MOORING IS 97-05C-009A019 DEPTH IS 19 METERS THERE ARE 602 VALUES

FIRST DAY 1997/10/06/2200
FINAL DAY 1997/10/31/2300

SHORELINE ORIENTATION IN DEGREES TRUE SPECIFIED AS 90

DIRECTION DEG TRUE	PERCENT OBSERVED	TOWARD	TOTAL	LIGHT	MEDIUM	HIGH	MAXIMUM CURRENT CM/S	MEAN DURA- TION HOURS	MEAN EXCUR- SION KM	MEAN CURRENT CM/S	MEAN TEMP DEG C
90.0	1.2	0.8	0.3	0.0	4.4	1.2	0.1	2.8	14.1		
45.0	14.5	0.8	4.0	9.6	25.2	3.5	1.3	10.4	12.1		
0.0	13.8	0.2	1.2	12.5	23.0	3.6	1.5	11.9	13.2		
315.0	3.3	0.2	1.3	1.8	13.1	3.3	1.0	7.9	10.6		
270.0	3.0	0.3	1.2	1.5	10.2	2.2	0.5	6.6	13.6		
225.0	25.2	1.3	8.5	15.4	30.2	4.2	1.5	9.6	13.6		
180.0	35.5	1.2	12.6	21.8	19.8	5.5	1.5	7.7	13.1		
135.0	3.5	1.5	1.0	1.0	13.8	1.4	0.3	5.1	12.5		

0 MEAN SCALAR SPEED = 9.0 CM/S MEAN SQUARE SPEED = 105.0 CM2/S2
 MEAN SQUARE E-W SPEED = 19.6 CM2/S2 MEAN SQUARE N-S SPEED = 85.3 CM2/S2
 MEAN VELOCITY = 1.9 CM/S, 202 DEG TRUE MEAN TEMPERATURE = 13.0 C
 VARIANCE (U,V) = 50.7 CM2/S2 TOTAL HOURS = 602.

PERCENT OBSERVED
 LIGHT (0.0 - 3.0) 6.3% MEDIUM (3.0 - 7.0) 30.1% HIGH (GE 7.0) 63.6%

DATE: 1997/11/01 TO 1997/11/30
ROSE SUMMARY: WIND AND CURRENT

WIND

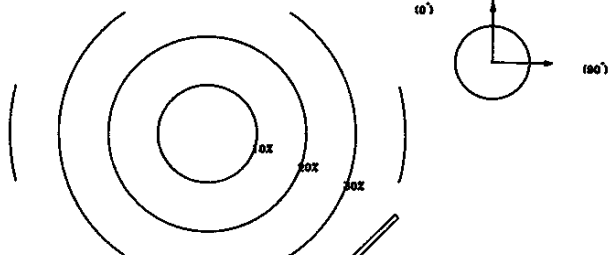

CURRENT
 0-3 CM/SEC
 3-7 CM/SEC
 >= 7 CM/SEC

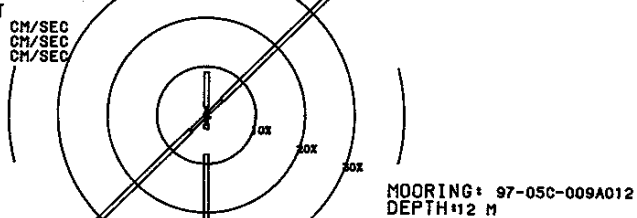

MOORING: 97-05C-009A012
DEPTH: 12 M

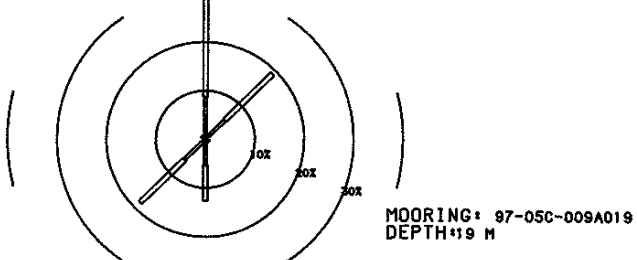

MOORING: 97-05C-009A019
DEPTH: 19 M

* WIND AND CURRENT DIRECTIONS ARE TOWARDS

MOORING IS 97-05C-009A012 DEPTH IS 12 METERS THERE ARE 666 VALUES

FIRST DAY 1997/11/01/0100
FINAL DAY 1997/11/30/2300

SHORELINE ORIENTATION IN DEGREES TRUE SPECIFIED AS 90

DIRECTION DEG TRUE	PERCENT OBSERVED	MAXIMUM CURRENT	MEAN DURATION HOURS	MEAN EXCURSION KM	MEAN CURRENT CM/S	MEAN TEMP DEG C
TOWARD	TOTAL	LIGHT	MEDIUM	HIGH	CM/S	
90.0	0.5	0.3	0.2	0.0	5.4	1.0
45.0	54.2	0.8	3.6	49.8	31.6	11.3
0.0	8.9	0.3	1.4	7.2	30.8	2.0
315.0	0.3	0.3	0.0	0.0	2.7	1.0
270.0	0.6	0.2	0.5	0.0	3.6	1.3
225.0	31.8	0.5	4.1	27.3	23.4	21.2
180.0	2.9	1.2	0.8	0.9	16.6	1.5
135.0	0.9	0.8	0.2	0.0	3.6	1.5

MEAN SCALAR SPEED = 12.7 CM/S MEAN SQUARE SPEED = 195.8 CM2/S2
 MEAN SQUARE E-W SPEED = 49.9 CM2/S2 MEAN SQUARE N-S SPEED = 145.9 CM2/S2
 MEAN VELOCITY = 4.5 CM/S, 26 DEG TRUE MEAN TEMPERATURE = 8.4 C
 VARIANCE (U,V) = 87.8 CM2/S2 TOTAL HOURS = 666.

PERCENT OBSERVED

LIGHT (0.0 - 3.0) 4.2% MEDIUM (3.0 - 7.0) 10.5% HIGH (GE 7.0) 85.3%

MOORING IS 97-05C-009A019 DEPTH IS 19 METERS THERE ARE 720 VALUES

FIRST DAY 1997/11/01/0000
FINAL DAY 1997/11/30/2300

SHORELINE ORIENTATION IN DEGREES TRUE SPECIFIED AS 90

DIRECTION DEG TRUE	PERCENT OBSERVED	MAXIMUM CURRENT	MEAN DURATION HOURS	MEAN EXCURSION KM	MEAN CURRENT CM/S	MEAN TEMP DEG C
TOWARD	TOTAL	LIGHT	MEDIUM	HIGH	CM/S	
90.0	0.6	0.3	0.3	0.0	5.6	1.3
45.0	19.2	1.0	4.6	13.6	23.5	2.8
0.0	46.9	0.3	8.5	38.2	24.6	6.8
315.0	1.0	0.4	0.6	0.0	6.1	1.4
270.0	0.4	0.0	0.4	0.0	4.5	1.0
225.0	18.5	0.7	5.3	12.5	19.8	4.6
180.0	12.6	0.7	4.7	7.2	15.4	3.1
135.0	0.8	0.6	0.1	0.1	8.4	1.0

MEAN SCALAR SPEED = 9.5 CM/S MEAN SQUARE SPEED = 109.8 CM2/S2
 MEAN SQUARE E-W SPEED = 15.6 CM2/S2 MEAN SQUARE N-S SPEED = 94.2 CM2/S2
 MEAN VELOCITY = 4.0 CM/S, 12 DEG TRUE MEAN TEMPERATURE = 8.3 C
 VARIANCE (U,V) = 47.1 CM2/S2 TOTAL HOURS = 720.

PERCENT OBSERVED

LIGHT (0.0 - 3.0) 3.9% MEDIUM (3.0 - 7.0) 24.4% HIGH (GE 7.0) 71.7%

DATE: 1997/12/01 TO 1997/12/31
 ROSE SUMMARY: WIND AND CURRENT

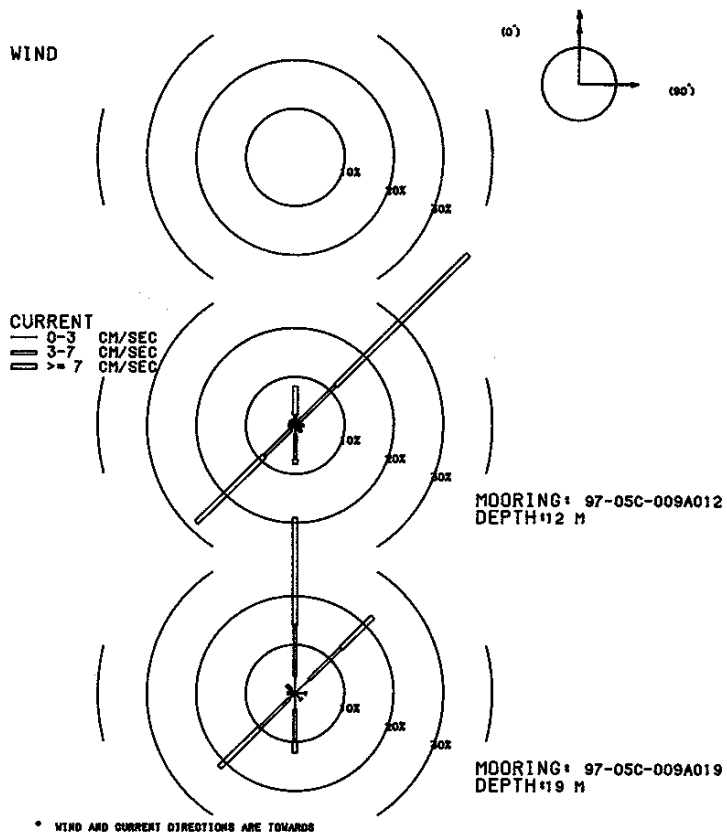

MOORING IS 97-05C-009A012 DEPTH IS 12 METERS THERE ARE 743 VALUES

FIRST DAY 1997/12/01/0000
 FINAL DAY 1997/12/31/2300

SHORELINE ORIENTATION IN DEGREES TRUE SPECIFIED AS 90

DIRECTION DEG TRUE	PERCENT OBSERVED	TOWARD	TOTAL	LIGHT	MEDIUM	HIGH	MAXIMUM CURRENT CM/S	MEAN DURA- TION HOURS	MEAN EXCUR- SION KM	MEAN CURRENT CM/S	MEAN TEMP DEG C
90.0	1.6	0.9	0.7	0.0	0.0	0.0	4.5	1.2	0.1	3.0	4.4
45.0	49.7	1.1	10.5	38.1	31.0	10.0	31.0	10.0	4.0	11.3	4.5
0.0	8.1	0.4	1.7	5.9	22.8	1.8	22.8	1.8	0.7	10.1	4.8
315.0	1.3	1.1	0.3	0.0	0.0	0.0	3.9	1.2	0.1	2.1	4.9
270.0	1.3	0.9	0.4	0.0	0.0	0.0	4.0	1.1	0.1	2.1	4.2
225.0	28.3	1.2	7.7	19.4	27.4	8.1	27.4	8.1	2.9	10.1	4.8
180.0	7.9	1.7	5.2	0.9	14.1	2.2	14.1	2.2	0.3	4.3	4.5
135.0	1.7	0.9	0.8	0.0	0.0	0.0	4.5	1.3	0.1	2.5	4.4

MEAN SCALAR SPEED = 9.7 CM/S MEAN SQUARE SPEED = 129.5 CM2/S2
 MEAN SQUARE E-W SPEED = 31.8 CM2/S2 MEAN SQUARE N-S SPEED = 97.7 CM2/S2
 MEAN VELOCITY = 3.2 CM/S, 27 DEG TRUE MEAN TEMPERATURE = 4.6 C
 VARIANCE (U,V) = 59.7 CM2/S2 TOTAL HOURS = 743.

PERCENT OBSERVED
 LIGHT (0.0 - 3.0) 8.3% MEDIUM (3.0 - 7.0) 27.3% HIGH (GE 7.0) 64.3%

MOORING IS 97-05C-009A019 DEPTH IS 19 METERS THERE ARE 744 VALUES

FIRST DAY 1997/12/01/0000
 FINAL DAY 1997/12/31/2300

SHORELINE ORIENTATION IN DEGREES TRUE SPECIFIED AS 90

DIRECTION DEG TRUE	PERCENT OBSERVED	TOWARD	TOTAL	LIGHT	MEDIUM	HIGH	MAXIMUM CURRENT CM/S	MEAN DURA- TION HOURS	MEAN EXCUR- SION KM	MEAN CURRENT CM/S	MEAN TEMP DEG C
90.0	2.3	2.0	0.3	0.0	0.0	0.0	3.5	1.7	0.1	2.4	4.6
45.0	22.3	4.0	9.1	9.1	23.0	3.0	23.0	3.0	0.8	7.1	3.9
0.0	36.0	3.5	10.6	21.9	25.1	4.5	25.1	4.5	1.4	8.7	4.8
315.0	2.3	1.1	1.2	0.0	0.0	0.0	6.1	1.5	0.2	3.3	5.6
270.0	1.5	0.8	0.7	0.0	0.0	0.0	4.7	1.8	0.2	3.1	4.5
225.0	21.5	1.6	8.5	11.4	21.3	5.9	21.3	5.9	1.8	8.4	4.9
180.0	12.2	3.4	6.6	2.3	18.2	2.9	18.2	2.9	0.5	4.7	4.3
135.0	1.9	1.6	0.3	0.0	0.0	0.0	3.1	1.6	0.1	2.4	4.6

MEAN SCALAR SPEED = 7.3 CM/S MEAN SQUARE SPEED = 72.9 CM2/S2
 MEAN SQUARE E-W SPEED = 12.5 CM2/S2 MEAN SQUARE N-S SPEED = 60.4 CM2/S2
 MEAN VELOCITY = 2.4 CM/S, 12 DEG TRUE MEAN TEMPERATURE = 4.5 C
 VARIANCE (U,V) = 33.6 CM2/S2 TOTAL HOURS = 744.

PERCENT OBSERVED
 LIGHT (0.0 - 3.0) 18.0% MEDIUM (3.0 - 7.0) 37.2% HIGH (GE 7.0) 44.8%

DATE: 1998/01/01 TO 1998/01/31
ROSE SUMMARY: WIND AND CURRENT

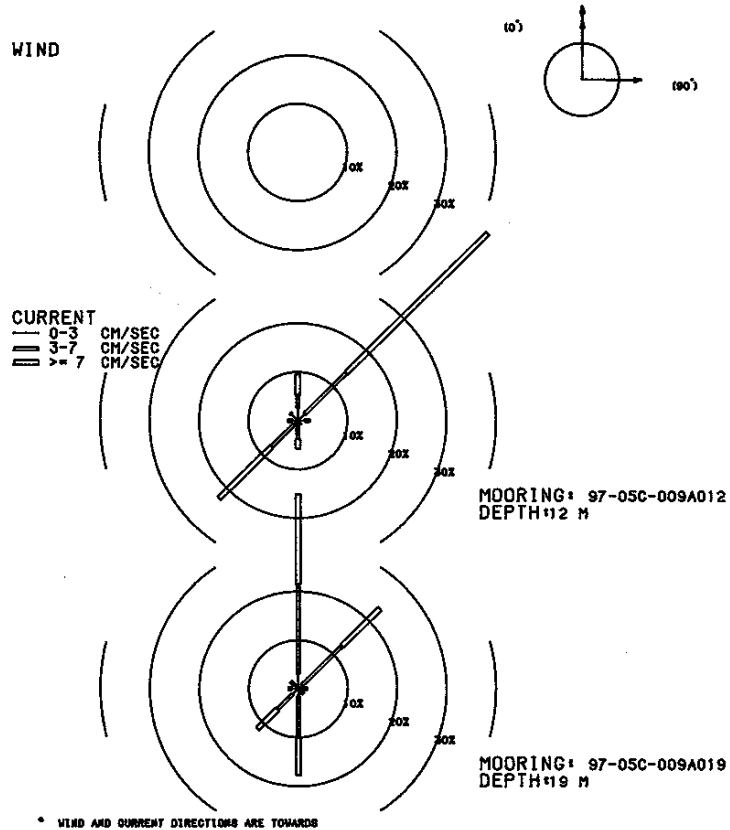

MOORING IS 97-05C-009A012 DEPTH IS 12 METERS THERE ARE 743 VALUES

FIRST DAY 1998/01/01/0000
FINAL DAY 1998/01/31/2300

SHORELINE ORIENTATION IN DEGREES TRUE SPECIFIED AS 90

DIRECTION DEG TRUE	PERCENT OBSERVED	MAXIMUM CURRENT CM/S	MEAN DURA- TION HOURS	MEAN EXCUR- SION KM	MEAN CURRENT CM/S	MEAN TEMP DEG C
TOWARD	TOTAL	LIGHT	MEDIUM	HIGH		
90.0	2.4	1.5	0.9	0.0	5.3	1.8
45.0	54.4	1.9	12.0	40.5	31.1	11.5
0.0	9.6	2.6	2.7	4.3	18.0	2.2
315.0	2.2	1.9	0.3	0.0	5.0	1.8
270.0	2.0	1.2	0.8	0.0	5.3	2.1
225.0	22.6	1.1	6.5	15.1	25.1	7.0
180.0	5.8	0.9	2.8	2.0	15.7	2.0
135.0	1.1	1.1	0.0	0.0	2.5	1.6
0		MEAN SCALAR SPEED = 9.7 CM/S		MEAN SQUARE SPEED = 131.4 CM2/S2		
		MEAN SQUARE E-W SPEED = 30.7 CM2/S2		MEAN SQUARE N-S SPEED = 100.7 CM2/S2		
		MEAN VELOCITY = 4.1 CM/S,		29 DEG TRUE		MEAN TEMPERATURE = 1.8 C
		VARIANCE (U,V) = 57.2 CM2/S2		TOTAL HOURS = 743.		

PERCENT OBSERVED
 LIGHT (0.0 - 3.0) 12.1% MEDIUM (3.0 - 7.0) 26.0% HIGH (GE 7.0) 61.9%

MOORING IS 97-05C-009A019 DEPTH IS 19 METERS THERE ARE 744 VALUES

FIRST DAY 1998/01/01/0000
FINAL DAY 1998/01/31/2300

SHORELINE ORIENTATION IN DEGREES TRUE SPECIFIED AS 90

DIRECTION DEG TRUE	PERCENT OBSERVED	MAXIMUM CURRENT CM/S	MEAN DURA- TION HOURS	MEAN EXCUR- SION KM	MEAN CURRENT CM/S	MEAN TEMP DEG C
TOWARD	TOTAL	LIGHT	MEDIUM	HIGH		
90.0	1.7	1.2	0.5	0.0	3.7	1.6
45.0	23.4	0.9	11.6	10.9	25.6	3.1
0.0	39.9	3.1	18.4	18.4	24.4	4.8
315.0	2.0	1.1	0.9	0.0	6.8	1.7
270.0	2.0	1.3	0.7	0.0	5.2	2.1
225.0	11.7	1.6	4.3	5.8	20.0	4.3
180.0	17.7	1.6	8.2	7.9	19.5	6.6
135.0	1.5	0.4	1.1	0.0	4.8	1.8
0		MEAN SCALAR SPEED = 7.4 CM/S		MEAN SQUARE SPEED = 74.7 CM2/S2		
		MEAN SQUARE E-W SPEED = 11.3 CM2/S2		MEAN SQUARE N-S SPEED = 63.4 CM2/S2		
		MEAN VELOCITY = 3.0 CM/S,		20 DEG TRUE		MEAN TEMPERATURE = 1.8 C
		VARIANCE (U,V) = 32.9 CM2/S2		TOTAL HOURS = 744.		

PERCENT OBSERVED
 LIGHT (0.0 - 3.0) 11.3% MEDIUM (3.0 - 7.0) 45.7% HIGH (GE 7.0) 43.0%

DATE: 1998/02/01 TO 1998/02/28
ROSE SUMMARY: WIND AND CURRENT

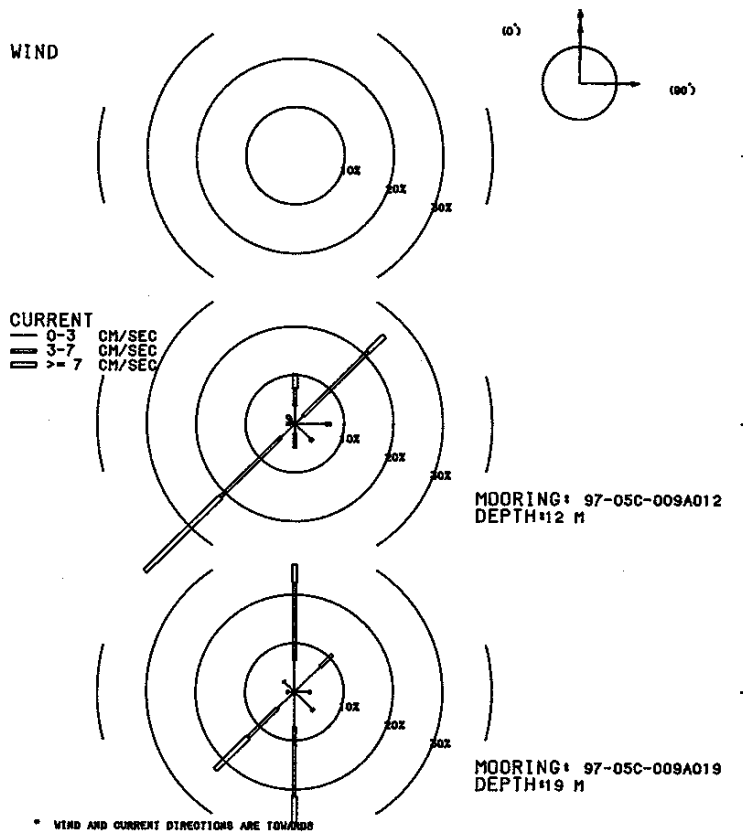

MOORING IS 97-05C-009A012 DEPTH IS 12 METERS THERE ARE 301 VALUES

FIRST DAY 1998/02/01/0000
FINAL DAY 1998/02/28/1800

SHORELINE ORIENTATION IN DEGREES TRUE SPECIFIED AS 90

DIRECTION DEG TRUE	PERCENT OBSERVED	TOWARD	TOTAL	LIGHT	MEDIUM	HIGH	MAXIMUM CURRENT CM/S	MEAN DURATION HOURS	MEAN EXCURSION KM	MEAN CURRENT CM/S	MEAN TEMP DEG C
90.0	7.3	6.3	1.0	0.0	0.0	3.8	1.7	0.1	2.4	1.2	
45.0	25.6	2.3	18.6	4.7	15.3	5.5	1.1	5.5	1.3		
0.0	10.3	3.7	3.7	3.0	14.8	1.9	0.4	5.7	1.2		
315.0	2.3	1.3	1.0	0.0	3.9	1.4	0.1	2.7	1.3		
270.0	1.7	1.0	0.7	0.0	4.0	1.2	0.1	2.9	1.3		
225.0	42.9	4.0	17.3	21.6	18.2	21.5	6.6	8.5	1.3		
180.0	5.0	2.0	3.0	0.0	6.5	5.0	0.7	3.8	1.2		
135.0	5.0	4.3	0.7	0.0	4.1	1.2	0.1	2.5	1.2		
0		MEAN SCALAR SPEED = 6.3 CM/S		MEAN SQUARE SPEED = 57.5 CM2/S2							
		MEAN SQUARE E-W SPEED = 18.3 CM2/S2		MEAN SQUARE N-S SPEED = 39.3 CM2/S2							
		MEAN VELOCITY = 1.8 CM/S,		214 DEG TRUE		MEAN TEMPERATURE = 1.3 C					
		VARIANCE (U,V) = 27.3 CM2/S2		TOTAL HOURS = 301.							

PERCENT OBSERVED
LIGHT (0.0 - 3.0) 24.9% MEDIUM (3.0 - 7.0) 45.8% HIGH (GE 7.0) 29.2%

MOORING IS 97-05C-009A019 DEPTH IS 19 METERS THERE ARE 672 VALUES

FIRST DAY 1998/02/01/0000
FINAL DAY 1998/02/28/2300

SHORELINE ORIENTATION IN DEGREES TRUE SPECIFIED AS 90

DIRECTION DEG TRUE	PERCENT OBSERVED	TOWARD	TOTAL	LIGHT	MEDIUM	HIGH	MAXIMUM CURRENT CM/S	MEAN DURATION HOURS	MEAN EXCURSION KM	MEAN CURRENT CM/S	MEAN TEMP DEG C
90.0	3.3	3.0	0.3	0.0	3.2	1.7	0.2	2.5	1.7		
45.0	10.9	7.3	3.6	0.0	5.6	2.1	0.2	2.9	2.0		
0.0	26.2	6.5	15.9	3.7	12.4	5.2	0.9	4.6	1.9		
315.0	3.1	2.8	0.3	0.0	3.3	2.6	0.2	2.5	2.2		
270.0	1.5	1.2	0.3	0.0	3.5	1.1	0.1	2.6	2.2		
225.0	22.6	4.8	8.5	9.4	14.6	4.8	1.1	6.4	1.8		
180.0	26.9	7.3	14.1	5.5	12.4	4.2	0.7	4.8	2.0		
135.0	5.5	5.1	0.4	0.0	3.7	1.9	0.2	2.4	1.8		
0		MEAN SCALAR SPEED = 4.6 CM/S		MEAN SQUARE SPEED = 28.1 CM2/S2							
		MEAN SQUARE E-W SPEED = 5.4 CM2/S2		MEAN SQUARE N-S SPEED = 22.7 CM2/S2							
		MEAN VELOCITY = 1.2 CM/S,		208 DEG TRUE		MEAN TEMPERATURE = 1.9 C					
		VARIANCE (U,V) = 13.4 CM2/S2		TOTAL HOURS = 672.							

PERCENT OBSERVED
LIGHT (0.0 - 3.0) 37.9% MEDIUM (3.0 - 7.0) 43.5% HIGH (GE 7.0) 18.6%

DATE: 1998/03/01 TO 1998/03/31
ROSE SUMMARY: WIND AND CURRENT

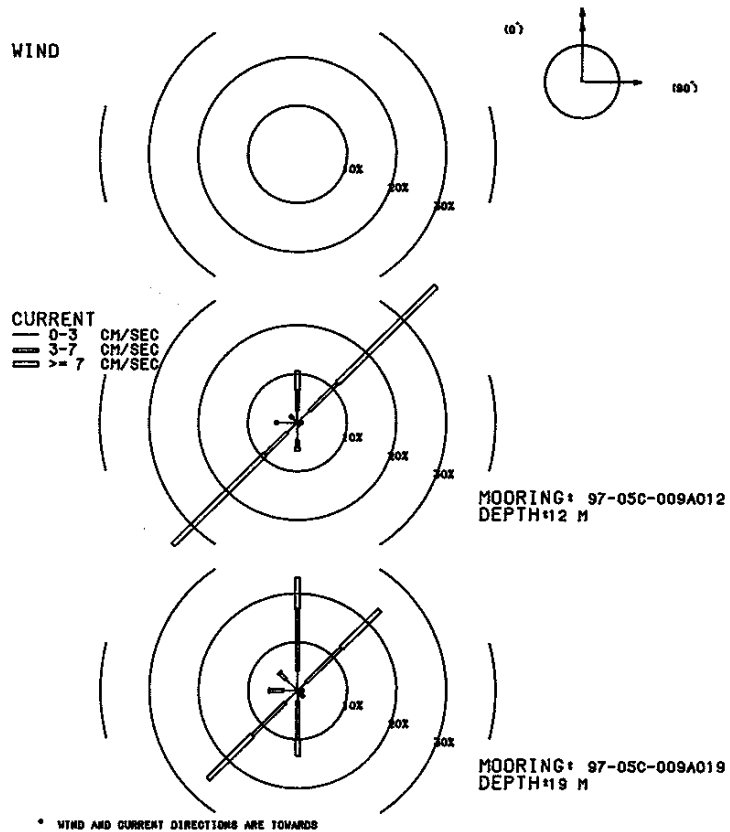

MOORING IS 97-05C-009A012 DEPTH IS 12 METERS THERE ARE 602 VALUES

FIRST DAY 1998/03/06/2200
FINAL DAY 1998/03/31/2300

SHORELINE ORIENTATION IN DEGREES TRUE SPECIFIED AS 90

DIRECTION DEG TRUE	PERCENT OBSERVED	MAXIMUM CURRENT	MEAN DURA- TION HOURS	MEAN EXCUR- SION KM	MEAN CURRENT CM/S	MEAN TEMP DEG C
TOWARD	TOTAL	LIGHT	MEDIUM	HIGH	CM/S	
90.0	1.0	0.5	0.5	0.0	4.6	1.5
45.0	39.7	3.5	8.0	28.2	28.9	9.2
0.0	10.6	2.5	4.2	4.0	24.5	2.8
315.0	2.0	1.3	0.7	0.0	4.6	1.3
270.0	4.5	4.0	0.5	0.0	5.5	2.7
225.0	35.5	2.8	6.5	26.2	52.3	11.9
180.0	5.8	3.7	1.5	0.7	10.0	2.1
135.0	0.8	0.7	0.2	0.0	3.2	1.2
0	MEAN SCALAR SPEED = 10.5 CM/S		MEAN SQUARE SPEED = 190.8 CM2/S2			
	MEAN SQUARE E-W SPEED = 55.9 CM2/S2		MEAN SQUARE N-S SPEED = 134.9 CM2/S2			
	MEAN VELOCITY = 0.6 CM/S,		282 DEG TRUE		MEAN TEMPERATURE = 2.2 C	
	VARIANCE (U,V) = 95.4 CM2/S2		TOTAL HOURS = 602.			

PERCENT OBSERVED
LIGHT (0.0 - 3.0) 18.9% MEDIUM (3.0 - 7.0) 21.9% HIGH (GE 7.0) 59.1%

MOORING IS 97-05C-009A019 DEPTH IS 19 METERS THERE ARE 744 VALUES

FIRST DAY 1998/03/01/0000
FINAL DAY 1998/03/31/2300

SHORELINE ORIENTATION IN DEGREES TRUE SPECIFIED AS 90

DIRECTION DEG TRUE	PERCENT OBSERVED	MAXIMUM CURRENT	MEAN DURA- TION HOURS	MEAN EXCUR- SION KM	MEAN CURRENT CM/S	MEAN TEMP DEG C
TOWARD	TOTAL	LIGHT	MEDIUM	HIGH	CM/S	
90.0	1.2	0.8	0.4	0.0	3.8	1.5
45.0	23.5	2.4	10.1	11.0	22.5	4.3
0.0	23.3	4.2	12.6	6.5	20.4	3.8
315.0	5.2	3.2	1.9	0.1	7.9	2.1
270.0	5.8	2.8	2.8	0.1	10.0	2.4
225.0	25.7	3.5	9.4	12.8	42.6	6.6
180.0	13.4	2.2	7.8	3.5	27.1	3.6
135.0	1.9	0.9	0.9	0.0	4.3	2.0
0	MEAN SCALAR SPEED = 7.0 CM/S		MEAN SQUARE SPEED = 86.2 CM2/S2			
	MEAN SQUARE E-W SPEED = 25.1 CM2/S2		MEAN SQUARE N-S SPEED = 61.1 CM2/S2			
	MEAN VELOCITY = 0.9 CM/S,		294 DEG TRUE		MEAN TEMPERATURE = 2.6 C	
	VARIANCE (U,V) = 42.8 CM2/S2		TOTAL HOURS = 744.			

PERCENT OBSERVED
LIGHT (0.0 - 3.0) 20.0% MEDIUM (3.0 - 7.0) 46.0% HIGH (GE 7.0) 34.0%

DATE: 1998/04/01 TO 1998/04/30
ROSE SUMMARY: WIND AND CURRENT

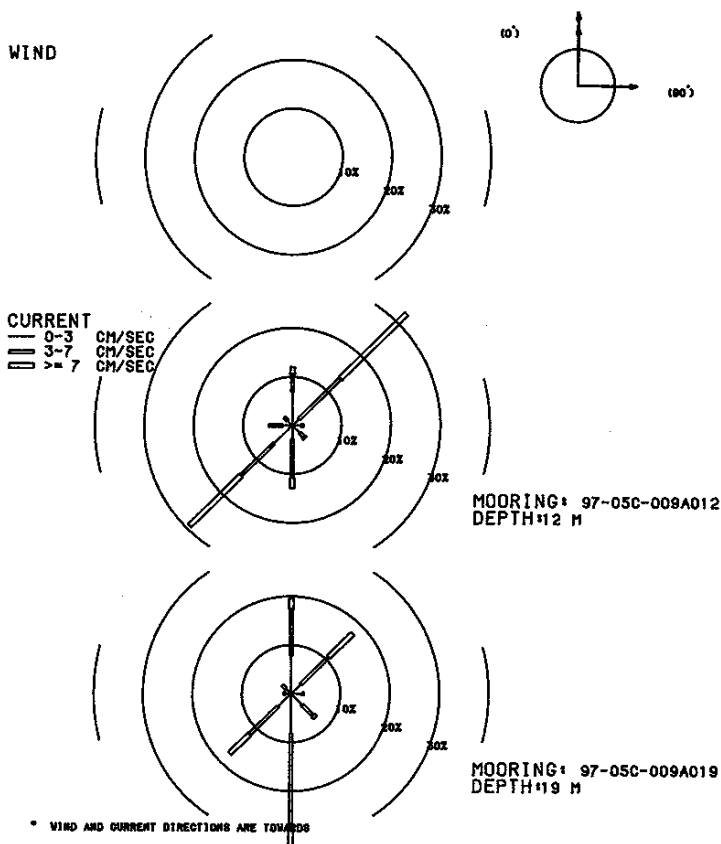

MOORING IS 97-05C-009A012 DEPTH IS 12 METERS THERE ARE 604 VALUES

FIRST DAY 1998/04/01/0000
FINAL DAY 1998/04/26/0400

SHORELINE ORIENTATION IN DEGREES TRUE SPECIFIED AS 90

DIRECTION DEG TRUE	PERCENT OBSERVED	TOWARD	TOTAL	LIGHT	MEDIUM	HIGH	MAXIMUM CURRENT CM/S	MEAN DURA- TION HOURS	MEAN EXCUR- SION KM	MEAN CURRENT CM/S	MEAN TEMP DEG C
90.0	2.3	1.8	0.5	0.0	5.2	1.4	0.1	2.5	6.1		
45.0	32.6	1.8	11.9	18.9	18.0	9.9	3.1	8.7	5.4		
0.0	12.1	7.0	3.6	1.5	15.2	2.6	0.3	3.0	6.6		
315.0	2.3	1.5	0.8	0.0	5.9	1.4	0.2	3.2	7.1		
270.0	4.8	2.0	2.8	0.0	6.9	1.8	0.2	3.7	6.6		
225.0	29.3	5.3	9.3	14.7	17.3	7.4	1.9	7.2	5.6		
180.0	12.9	2.8	7.9	2.2	12.0	3.4	0.6	5.0	6.0		
135.0	3.6	2.2	1.3	0.2	7.9	1.7	0.2	3.2	6.5		
0 MEAN SCALAR SPEED = 6.4 CM/S MEAN SQUARE SPEED = 56.3 CM2/S2											
MEAN SQUARE E-W SPEED = 16.4 CM2/S2 MEAN SQUARE N-S SPEED = 39.9 CM2/S2											
MEAN VELOCITY = 0.4 CM/S, 17 DEG TRUE MEAN TEMPERATURE = 5.8 C											
VARIANCE (U,V) = 28.1 CM2/S2 TOTAL HOURS = 604.											

PERCENT OBSERVED

LIGHT (0.0 - 3.0) 24.3% MEDIUM (3.0 - 7.0) 38.2% HIGH (GE 7.0) 37.4%

MOORING IS 97-05C-009A019 DEPTH IS 19 METERS THERE ARE 720 VALUES

FIRST DAY 1998/04/01/0000
FINAL DAY 1998/04/30/2300

SHORELINE ORIENTATION IN DEGREES TRUE SPECIFIED AS 90

DIRECTION DEG TRUE	PERCENT OBSERVED	TOWARD	TOTAL	LIGHT	MEDIUM	HIGH	MAXIMUM CURRENT CM/S	MEAN DURA- TION HOURS	MEAN EXCUR- SION KM	MEAN CURRENT CM/S	MEAN TEMP DEG C
90.0	2.6	2.2	0.4	0.0	4.0	1.7	0.2	2.5	5.6		
45.0	17.6	2.8	7.9	6.9	14.2	4.5	1.0	6.2	5.7		
0.0	19.6	7.9	9.4	2.2	14.3	3.6	0.5	3.6	5.9		
315.0	2.5	1.4	1.1	0.0	6.2	2.0	0.2	3.3	6.3		
270.0	1.5	1.1	0.4	0.0	4.6	1.4	0.1	2.8	6.3		
225.0	17.5	3.8	8.1	5.7	15.2	3.8	0.8	6.0	5.7		
180.0	31.7	8.2	19.0	4.4	9.1	5.4	0.9	4.6	5.8		
135.0	6.9	3.2	3.1	0.7	8.3	2.4	0.3	3.6	5.9		
0 MEAN SCALAR SPEED = 4.8 CM/S MEAN SQUARE SPEED = 30.9 CM2/S2											
MEAN SQUARE E-W SPEED = 6.4 CM2/S2 MEAN SQUARE N-S SPEED = 24.5 CM2/S2											
MEAN VELOCITY = 0.8 CM/S, 168 DEG TRUE MEAN TEMPERATURE = 5.8 C											
VARIANCE (U,V) = 15.1 CM2/S2 TOTAL HOURS = 720.											

PERCENT OBSERVED

LIGHT (0.0 - 3.0) 30.6% MEDIUM (3.0 - 7.0) 49.4% HIGH (GE 7.0) 20.0%

DATE: 1998/05/01 TO 1998/05/31
 ROSE SUMMARY: WIND AND CURRENT

WIND

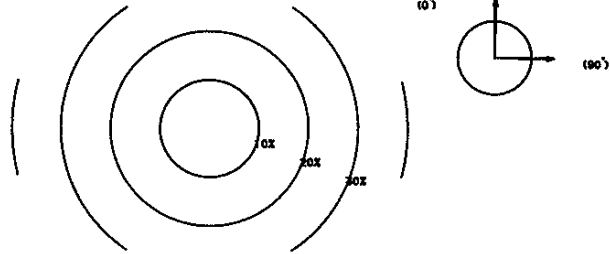

CURRENT

0-3 CM/SEC
 3-7 CM/SEC
 >= 7 CM/SEC

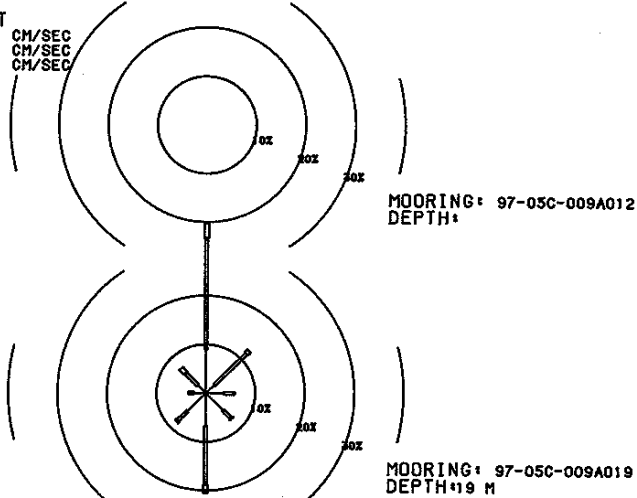

* WIND AND CURRENT DIRECTIONS ARE TOWARDS

MOORING IS 97-05C-009A019 DEPTH IS 19 METERS THERE ARE 744 VALUES

FIRST DAY 1998/05/01/0000
 FINAL DAY 1998/05/31/2300

SHORELINE ORIENTATION IN DEGREES TRUE SPECIFIED AS 90

DIRECTION DEG TRUE	PERCENT OBSERVED	MAXIMUM CURRENT CM/S	MEAN DURA- TION HOURS	MEAN EXCUR- SION KM	MEAN CURRENT CM/S	MEAN TEMP DEG C
TOWARD TOTAL LIGHT MEDIUM HIGH						
90.0	5.9	3.6	2.3	0.0	5.1	2.4
45.0	12.4	2.4	9.1	0.8	11.4	2.7
0.0	34.8	9.0	22.7	3.1	20.8	5.3
315.0	7.1	2.2	3.6	1.3	14.5	2.3
270.0	3.5	2.4	1.1	0.0	5.0	1.4
225.0	8.3	5.2	2.8	0.3	9.1	1.9
180.0	20.6	6.7	12.1	1.7	13.4	3.1
135.0	7.4	5.0	2.3	0.1	11.7	1.6

MEAN SCALAR SPEED = 3.9 CM/S MEAN SQUARE SPEED = 20.5 CM²/S²
 MEAN SQUARE E-W SPEED = 3.8 CM²/S² MEAN SQUARE N-S SPEED = 16.7 CM²/S²
 MEAN VELOCITY = 0.9 CM/S, 16 DEG TRUE MEAN TEMPERATURE = 7.3 C
 VARIANCE (U,V) = 9.9 CM²/S² TOTAL HOURS = 744.

PERCENT OBSERVED
 LIGHT (0.0 - 3.0) 36.6% MEDIUM (3.0 - 7.0) 56.0% HIGH (GE 7.0) 7.4%

DATE: 1998/06/01 TO 1998/06/30
 ROSE SUMMARY: WIND AND CURRENT

WIND

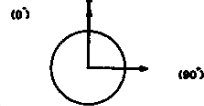
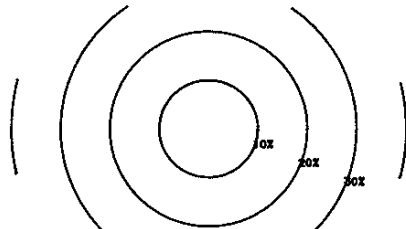

CURRENT
 — 0-3 CM/SEC
 = 3-7 CM/SEC
 = > 7 CM/SEC

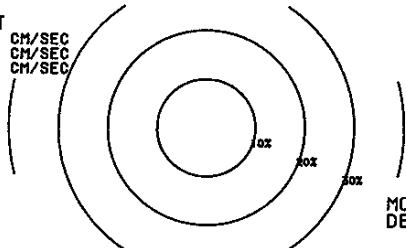

MOORING: 97-05C-009A012
 DEPTH:

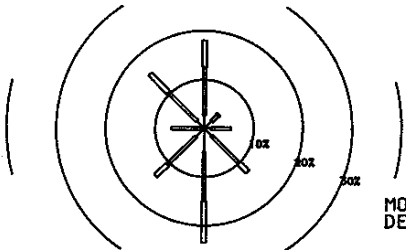

MOORING: 97-05C-009A019
 DEPTH: 19 M

* WIND AND CURRENT DIRECTIONS ARE TOWARDS

MOORING IS 97-05C-009A019 DEPTH IS 19 METERS THERE ARE 294 VALUES

FIRST DAY 1998/06/01/0000
 FINAL DAY 1998/06/13/0500

SHORELINE ORIENTATION IN DEGREES TRUE SPECIFIED AS 90

DIRECTION DEG TRUE	PERCENT OBSERVED	MAXIMUM CURRENT CM/S	MEAN DURA- TION HOURS	MEAN EXCUR- SION KM	MEAN CURRENT CM/S	MEAN TEMP DEG C
TOWARD TOTAL	LIGHT MEDIUM HIGH					
90.0	5.4	1.4	4.1	0.0	5.9	1.6
45.0	4.1	2.0	1.7	0.3	7.5	1.5
0.0	18.0	2.7	9.9	5.4	12.6	2.8
315.0	15.6	2.0	8.2	5.4	13.7	2.4
270.0	6.8	0.3	6.5	0.0	7.0	1.5
225.0	13.9	2.4	8.2	3.4	10.3	2.3
180.0	23.5	4.8	10.2	8.5	13.3	3.6
135.0	12.6	2.0	7.8	2.7	13.5	2.2

0 MEAN SCALAR SPEED = 5.6 CM/S MEAN SQUARE SPEED = 40.3 CM²/S²
 MEAN SQUARE E-W SPEED = 9.7 CM²/S² MEAN SQUARE N-S SPEED = 30.5 CM²/S²
 MEAN VELOCITY = 0.9 CM/S, 225 DEG TRUE MEAN TEMPERATURE = 8.2 C
 VARIANCE (U,V) = 19.7 CM²/S² TOTAL HOURS = 294.

PERCENT OBSERVED
 LIGHT (0.0 - 3.0) 17.7% MEDIUM (3.0 - 7.0) 56.5% HIGH (GE 7.0) 25.9%

Appendix U - Mooring_V12-97. Overall Summary Statistics and Rose Histogram Plots

DATE: 1997/10/01 TO 1998/06/13
ROSE SUMMARY: WIND AND CURRENT

WIND

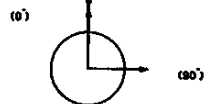
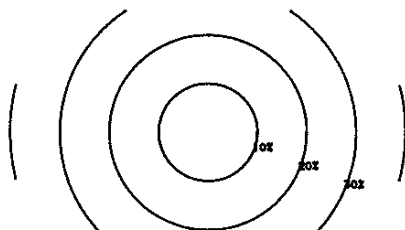

CURRENT
 0-3 CM/SEC
 3-7 CM/SEC
 >=7 CM/SEC

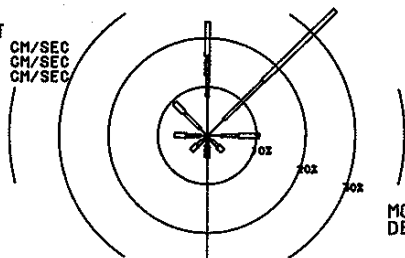

MOORING: 97-05C-012A012
DEPTH: 12 M

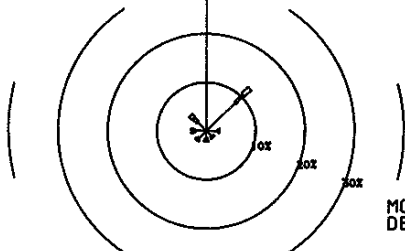

MOORING: 97-05C-012A059
DEPTH: 59 M

* WIND AND CURRENT DIRECTIONS ARE TOWARDS

MOORING IS 97-05C-012A012 DEPTH IS 12 METERS THERE ARE 4320 VALUES

FIRST DAY 1997/10/06/2100
FINAL DAY 1998/04/05/1900

SHORELINE ORIENTATION IN DEGREES TRUE SPECIFIED AS 90

DIRECTION DEG TRUE	PERCENT OBSERVED	MAXIMUM CURRENT	MEAN DURA- TION	MEAN EXCUR- SION	MEAN CURRENT	MEAN TEMP			
TOWARD	TOTAL	LIGHT	MEDIUM	HIGH	CM/S	HOURS	KM	CM/S	DEG C
90.0	10.6	2.9	3.5	4.2	30.5	2.8	0.7	7.2	6.8
45.0	36.6	4.7	11.2	20.7	50.0	5.7	1.9	9.4	5.3
0.0	23.3	7.9	8.3	7.1	35.0	3.5	0.7	5.4	4.9
315.0	9.4	2.0	4.5	3.0	38.4	2.3	0.5	6.3	6.5
270.0	6.6	1.3	2.8	2.4	38.6	2.3	0.7	8.1	8.3
225.0	4.4	1.4	1.5	1.6	37.7	2.2	0.5	7.0	10.2
180.0	4.5	0.9	1.1	2.5	38.2	2.4	0.9	10.3	11.8
135.0	4.6	1.5	1.7	1.4	38.0	2.4	0.7	7.8	8.3

0 MEAN SCALAR SPEED = 7.7 CM/S MEAN SQUARE SPEED = 101.1 CM2/S2
 MEAN SQUARE E-W SPEED = 45.2 CM2/S2 MEAN SQUARE N-S SPEED = 55.8 CM2/S2
 MEAN VELOCITY = 4.0 CM/S, 33 DEG TRUE MEAN TEMPERATURE = 6.3 C
 VARIANCE (U,V) = 42.5 CM2/S2 TOTAL HOURS = 4320.

PERCENT OBSERVED
 LIGHT (0.0 - 3.0) 22.6% MEDIUM (3.0 - 7.0) 34.6% HIGH (GE 7.0) 42.8%

MOORING IS 97-05C-012A059 DEPTH IS 59 METERS THERE ARE 5985 VALUES

FIRST DAY 1997/10/06/2100
FINAL DAY 1998/06/13/0500

SHORELINE ORIENTATION IN DEGREES TRUE SPECIFIED AS 90

DIRECTION DEG TRUE	PERCENT OBSERVED	MAXIMUM CURRENT	MEAN DURA- TION	MEAN EXCUR- SION	MEAN CURRENT	MEAN TEMP			
TOWARD	TOTAL	LIGHT	MEDIUM	HIGH	CM/S	HOURS	KM	CM/S	DEG C
90.0	2.7	2.4	0.3	0.1	10.1	1.8	0.2	2.5	5.1
45.0	12.4	8.2	2.3	1.9	29.3	2.7	0.4	4.3	4.7
0.0	70.6	64.2	3.2	3.2	28.1	8.6	0.3	1.1	4.3
315.0	4.5	2.5	1.2	0.8	23.8	2.1	0.4	4.8	4.9
270.0	3.1	2.2	0.5	0.4	16.0	1.7	0.2	3.6	5.1
225.0	2.7	2.1	0.3	0.3	12.5	1.8	0.2	3.2	5.0
180.0	2.2	1.5	0.5	0.2	11.8	1.8	0.2	3.3	4.9
135.0	1.8	1.5	0.2	0.2	11.7	1.7	0.2	3.0	4.8

0 MEAN SCALAR SPEED = 1.9 CM/S MEAN SQUARE SPEED = 15.5 CM2/S2
 MEAN SQUARE E-W SPEED = 4.1 CM2/S2 MEAN SQUARE N-S SPEED = 11.4 CM2/S2
 MEAN VELOCITY = 1.2 CM/S, 11 DEG TRUE MEAN TEMPERATURE = 4.5 C
 VARIANCE (U,V) = 7.1 CM2/S2 TOTAL HOURS = 5985.

PERCENT OBSERVED
 LIGHT (0.0 - 3.0) 84.6% MEDIUM (3.0 - 7.0) 8.4% HIGH (GE 7.0) 7.1%

Appendix V - Mooring_V12-97. Monthly Summary Statistics and Rose Histogram Plots

DATE: 1997/10/01 TO 1997/10/31
ROSE SUMMARY: WIND AND CURRENT

WIND

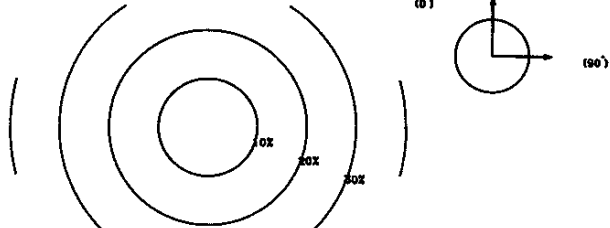

CURRENT
 0-3 CM/SEC
 3-7 CM/SEC
 >= 7 CM/SEC

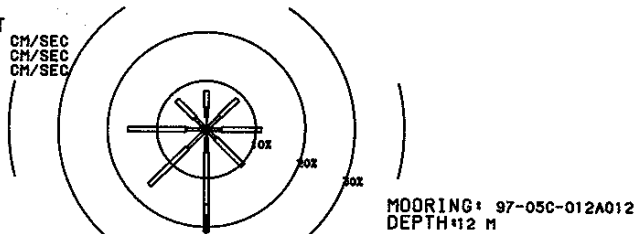

MOORING: 97-05C-012A012
DEPTH: 12 M

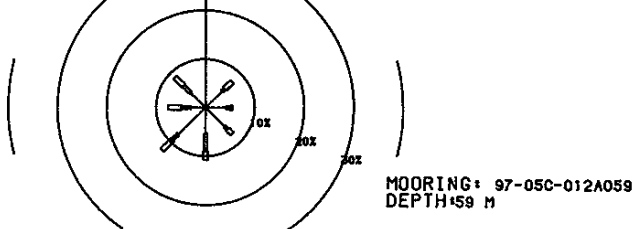

MOORING: 97-05C-012A059
DEPTH: 59 M

* WIND AND CURRENT DIRECTIONS ARE TOWARDS

MOORING IS 97-05C-012A012 DEPTH IS 12 METERS THERE ARE 603 VALUES

FIRST DAY 1997/10/06/2100
FINAL DAY 1997/10/31/2300

SHORELINE ORIENTATION IN DEGREES TRUE SPECIFIED AS 90

DIRECTION DEG TRUE	PERCENT OBSERVED	MAXIMUM CURRENT	MEAN DURA- TION	MEAN EXCUR- SION	MEAN CURRENT	MEAN TEMP			
TOWARD	TOTAL	LIGHT	MEDIUM	HIGH	CM/S	HOURS	KM	CM/S	DEG C
90.0	11.1	0.7	2.3	8.1	30.5	2.9	1.3	12.3	14.3
45.0	8.8	0.7	3.2	5.0	21.0	2.3	0.8	9.4	14.6
0.0	8.0	2.5	2.0	3.5	22.2	1.8	0.5	8.1	14.6
315.0	8.5	1.0	2.3	5.1	24.8	2.1	0.8	9.9	14.2
270.0	15.9	0.3	3.8	11.8	38.6	3.3	1.8	14.9	13.6
225.0	16.3	0.7	4.8	10.8	37.7	2.7	1.0	10.6	14.9
180.0	21.1	1.7	3.0	16.4	38.2	3.4	1.7	13.6	15.1
135.0	10.4	0.7	2.0	7.8	38.0	2.4	1.3	15.3	14.8

0 MEAN SCALAR SPEED = 12.2 CM/S MEAN SQUARE SPEED = 214.2 CM2/S2
 MEAN SQUARE E-W SPEED = 111.6 CM2/S2 MEAN SQUARE N-S SPEED = 102.6 CM2/S2
 MEAN VELOCITY = 3.6 CM/S, 197 DEG TRUE MEAN TEMPERATURE = 14.6 C
 VARIANCE (U,V) = 100.8 CM2/S2 TOTAL HOURS = 603.

PERCENT OBSERVED
 LIGHT (0.0 - 3.0) 8.1% MEDIUM (3.0 - 7.0) 23.4% HIGH (GE 7.0) 68.5%

MOORING IS 97-05C-012A059 DEPTH IS 59 METERS THERE ARE 603 VALUES

FIRST DAY 1997/10/06/2100
FINAL DAY 1997/10/31/2300

SHORELINE ORIENTATION IN DEGREES TRUE SPECIFIED AS 90

DIRECTION DEG TRUE	PERCENT OBSERVED	MAXIMUM CURRENT	MEAN DURA- TION	MEAN EXCUR- SION	MEAN CURRENT	MEAN TEMP			
TOWARD	TOTAL	LIGHT	MEDIUM	HIGH	CM/S	HOURS	KM	CM/S	DEG C
90.0	5.5	4.1	0.8	0.5	9.9	2.8	0.3	3.1	5.1
45.0	7.6	4.8	0.7	2.2	19.9	2.9	0.6	5.7	5.1
0.0	39.6	35.7	1.7	2.3	20.0	3.9	0.2	1.2	5.1
315.0	8.8	4.3	2.0	2.5	17.2	2.4	0.5	5.6	4.9
270.0	7.6	3.0	1.8	2.8	16.0	2.3	0.5	6.2	5.1
225.0	12.4	7.8	1.7	3.0	12.5	2.0	0.3	4.3	5.1
180.0	10.8	5.3	3.6	1.8	11.8	2.6	0.4	4.3	5.1
135.0	7.6	5.5	0.8	1.3	11.7	2.3	0.3	3.8	5.1

0 MEAN SCALAR SPEED = 3.3 CM/S MEAN SQUARE SPEED = 28.0 CM2/S2
 MEAN SQUARE E-W SPEED = 12.5 CM2/S2 MEAN SQUARE N-S SPEED = 15.5 CM2/S2
 MEAN VELOCITY = 0.5 CM/S, 277 DEG TRUE MEAN TEMPERATURE = 5.1 C
 VARIANCE (U,V) = 13.9 CM2/S2 TOTAL HOURS = 603.

PERCENT OBSERVED
 LIGHT (0.0 - 3.0) 70.5% MEDIUM (3.0 - 7.0) 13.1% HIGH (GE 7.0) 16.4%

DATE: 1997/11/01 TO 1997/11/30
ROSE SUMMARY: WIND AND CURRENT

WIND

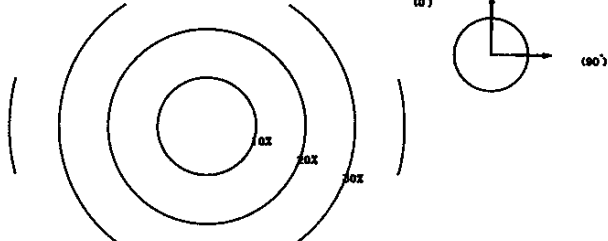

CURRENT
0-3 CM/SEC
3-7 CM/SEC
>7 CM/SEC

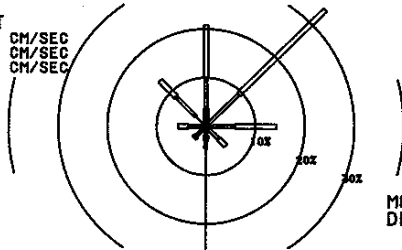

MOORING: 97-05C-012A012
DEPTH: 12 M

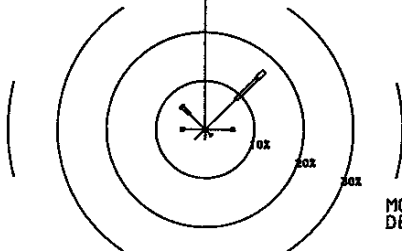

MOORING: 97-05C-012A059
DEPTH: 59 M

* WIND AND CURRENT DIRECTIONS ARE TOWARDS

MOORING IS 97-05C-012A012 DEPTH IS 12 METERS THERE ARE 720 VALUES

FIRST DAY 1997/11/01/0000
FINAL DAY 1997/11/30/2300

SHORELINE ORIENTATION IN DEGREES TRUE SPECIFIED AS 90

DIRECTION DEG TRUE	PERCENT OBSERVED	TOWARD	TOTAL	LIGHT	MEDIUM	HIGH	MAXIMUM CURRENT CM/S	MEAN DURA- TION HOURS	MEAN EXCUR- SION KM	MEAN CURRENT CM/S	MEAN TEMP DEG C
90.0	14.3	1.4	4.4	8.5	22.1	3.7	1.2	9.0	9.3		
45.0	34.0	0.7	8.6	24.7	22.6	6.6	2.5	10.4	9.4		
0.0	20.8	2.5	7.4	11.0	12.9	4.5	1.1	6.6	9.0		
315.0	13.2	2.9	5.7	4.6	11.2	2.5	0.5	5.7	9.6		
270.0	5.7	0.7	2.9	2.1	11.4	2.3	0.5	6.0	9.6		
225.0	3.3	1.2	1.5	0.6	11.9	2.7	0.5	4.8	9.5		
180.0	2.9	0.6	1.4	1.0	14.3	2.6	0.6	6.4	9.8		
135.0	5.7	0.8	2.8	2.1	20.0	4.1	1.1	7.3	9.0		

MEAN SCALAR SPEED = 8.1 CM/S MEAN SQUARE SPEED = 84.1 CM2/S2
MEAN SQUARE E-W SPEED = 45.0 CM2/S2 MEAN SQUARE N-S SPEED = 39.2 CM2/S2
MEAN VELOCITY = 5.0 CM/S, 40 DEG TRUE MEAN TEMPERATURE = 9.3 C
VARIANCE (U,V) = 29.5 CM2/S2 TOTAL HOURS = 720.

PERCENT OBSERVED

LIGHT (0.0 - 3.0) 10.8% MEDIUM (3.0 - 7.0) 34.7% HIGH (GE 7.0) 54.4%

MOORING IS 97-05C-012A059 DEPTH IS 59 METERS THERE ARE 720 VALUES

FIRST DAY 1997/11/01/0000
FINAL DAY 1997/11/30/2300

SHORELINE ORIENTATION IN DEGREES TRUE SPECIFIED AS 90

DIRECTION DEG TRUE	PERCENT OBSERVED	TOWARD	TOTAL	LIGHT	MEDIUM	HIGH	MAXIMUM CURRENT CM/S	MEAN DURA- TION HOURS	MEAN EXCUR- SION KM	MEAN CURRENT CM/S	MEAN TEMP DEG C
90.0	6.0	5.3	0.7	0.0	4.7	2.3	0.2	2.3	6.8		
45.0	16.9	8.8	6.3	1.9	10.1	3.5	0.5	3.9	7.0		
0.0	58.6	50.4	5.3	2.9	13.0	5.4	0.2	1.3	6.6		
315.0	6.8	4.4	2.1	0.3	10.2	1.9	0.2	3.2	6.5		
270.0	5.0	4.3	0.7	0.0	5.5	1.9	0.2	2.3	6.4		
225.0	2.8	2.8	0.0	0.0	2.4	2.0	0.2	2.1	5.9		
180.0	2.1	2.1	0.0	0.0	2.3	1.7	0.1	2.0	5.7		
135.0	1.8	1.7	0.1	0.0	4.6	1.6	0.1	2.2	5.9		

MEAN SCALAR SPEED = 2.0 CM/S MEAN SQUARE SPEED = 9.7 CM2/S2
MEAN SQUARE E-W SPEED = 2.9 CM2/S2 MEAN SQUARE N-S SPEED = 6.8 CM2/S2
MEAN VELOCITY = 1.3 CM/S, 14 DEG TRUE MEAN TEMPERATURE = 6.6 C
VARIANCE (U,V) = 4.0 CM2/S2 TOTAL HOURS = 720.

PERCENT OBSERVED

LIGHT (0.0 - 3.0) 79.7% MEDIUM (3.0 - 7.0) 15.1% HIGH (GE 7.0) 5.1%

DATE: 1997/12/01 TO 1997/12/31
ROSE SUMMARY: WIND AND CURRENT

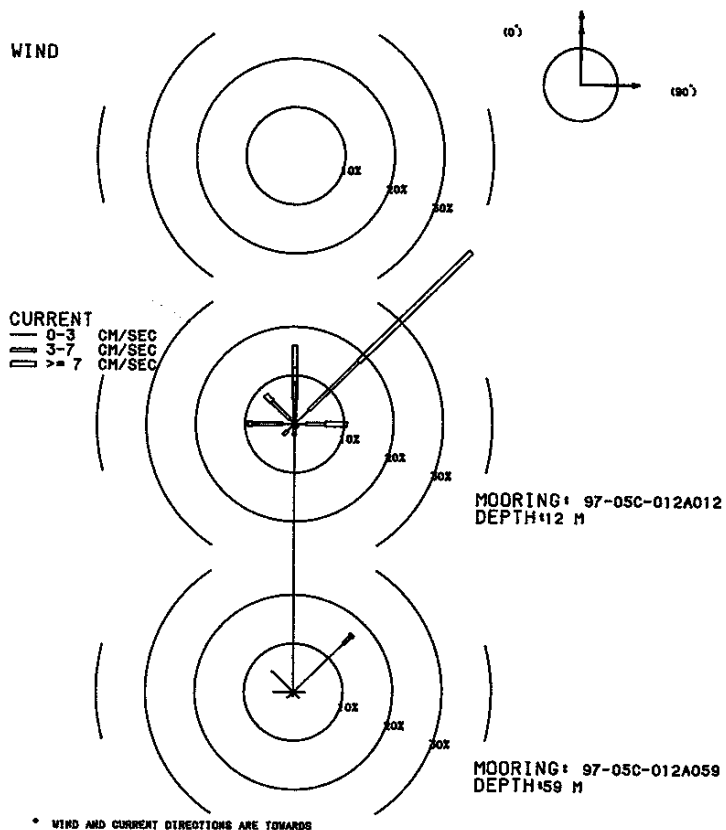

MOORING IS 97-05C-012A012 DEPTH IS 12 METERS THERE ARE 744 VALUES

FIRST DAY 1997/12/01/0000
FINAL DAY 1997/12/31/2300

SHORELINE ORIENTATION IN DEGREES TRUE SPECIFIED AS 90

DIRECTION DEG TRUE	PERCENT OBSERVED	TOWARD	TOTAL	LIGHT	MEDIUM	HIGH	MAXIMUM CURRENT CM/S	MEAN DURA- TION HOURS	MEAN EXCUR- SION KM	MEAN CURRENT CM/S	MEAN TEMP DEG C
90.0	10.6	2.3	3.9	4.4	11.4	2.3	0.5	6.1	6.1		
45.0	50.3	4.0	14.1	32.1	22.5	8.3	2.8	9.3	6.1		
0.0	16.1	3.0	5.6	7.5	17.6	3.3	0.8	6.7	6.3		
315.0	8.3	1.3	5.1	1.9	9.5	2.3	0.4	5.1	6.2		
270.0	9.5	2.6	6.0	0.9	10.8	2.2	0.3	4.3	5.9		
225.0	3.2	2.0	1.2	0.0	5.3	1.6	0.2	2.9	5.8		
180.0	0.9	0.3	0.7	0.0	5.5	1.0	0.1	4.0	5.6		
135.0	0.9	0.5	0.4	0.0	4.6	1.2	0.1	2.7	6.9		

MEAN SCALAR SPEED = 7.4 CM/S MEAN SQUARE SPEED = 74.3 CM2/S2
MEAN SQUARE E-W SPEED = 30.0 CM2/S2 MEAN SQUARE N-S SPEED = 44.4 CM2/S2
MEAN VELOCITY = 5.7 CM/S, 31 DEG TRUE MEAN TEMPERATURE = 6.1 C
VARIANCE (U,V) = 20.8 CM2/S2 TOTAL HOURS = 744.

PERCENT OBSERVED

LIGHT (0.0 - 3.0) 16.0% MEDIUM (3.0 - 7.0) 37.1% HIGH (GE 7.0) 46.9%

MOORING IS 97-05C-012A059 DEPTH IS 59 METERS THERE ARE 744 VALUES

FIRST DAY 1997/12/01/0000
FINAL DAY 1997/12/31/2300

SHORELINE ORIENTATION IN DEGREES TRUE SPECIFIED AS 90

DIRECTION DEG TRUE	PERCENT OBSERVED	TOWARD	TOTAL	LIGHT	MEDIUM	HIGH	MAXIMUM CURRENT CM/S	MEAN DURA- TION HOURS	MEAN EXCUR- SION KM	MEAN CURRENT CM/S	MEAN TEMP DEG C
90.0	2.3	2.3	0.0	0.0	2.8	1.2	0.1	2.1	5.8		
45.0	16.8	14.2	2.0	0.5	11.8	1.9	0.2	2.7	5.9		
0.0	66.7	52.7	7.4	6.6	13.9	5.0	0.3	1.9	6.0		
315.0	6.0	6.0	0.0	0.0	2.6	1.5	0.1	2.0	6.4		
270.0	3.9	3.9	0.0	0.0	2.5	1.4	0.1	2.0	6.2		
225.0	1.6	1.6	0.0	0.0	2.4	1.5	0.1	2.0	6.3		
180.0	0.9	0.9	0.0	0.0	2.2	1.2	0.1	1.8	5.8		
135.0	1.7	1.7	0.0	0.0	2.4	1.3	0.1	2.1	5.7		

MEAN SCALAR SPEED = 2.0 CM/S MEAN SQUARE SPEED = 11.0 CM2/S2
MEAN SQUARE E-W SPEED = 1.7 CM2/S2 MEAN SQUARE N-S SPEED = 9.3 CM2/S2
MEAN VELOCITY = 1.7 CM/S, 16 DEG TRUE MEAN TEMPERATURE = 6.0 C
VARIANCE (U,V) = 4.1 CM2/S2 TOTAL HOURS = 744.

PERCENT OBSERVED

LIGHT (0.0 - 3.0) 83.5% MEDIUM (3.0 - 7.0) 9.4% HIGH (GE 7.0) 7.1%

DATE: 1998/01/01 TO 1998/01/31
ROSE SUMMARY: WIND AND CURRENT

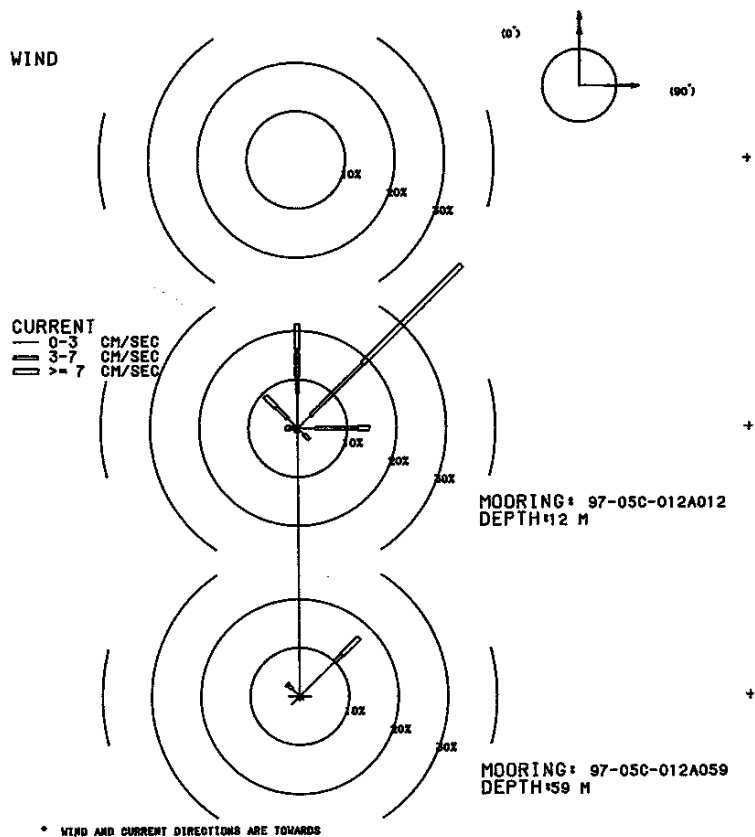

MOORING IS 97-05C-012A012 DEPTH IS 12 METERS THERE ARE 744 VALUES

FIRST DAY 1998/01/01/0000
FINAL DAY 1998/01/31/2300

SHORELINE ORIENTATION IN DEGREES TRUE SPECIFIED AS 90

DIRECTION DEG TRUE	PERCENT OBSERVED	MAXIMUM CURRENT CM/S	MEAN DURA- TION HOURS	MEAN EXCUR- SION KM	MEAN CURRENT CM/S	MEAN TEMP DEG C
TOWARD	TOTAL	LIGHT	MEDIUM	HIGH		
90.0	14.5	3.5	8.6	2.4	16.5	2.9
45.0	47.2	3.6	15.1	28.5	38.6	5.9
0.0	21.4	7.1	9.1	5.1	27.7	2.8
315.0	9.3	2.8	3.4	3.1	18.5	2.2
270.0	2.4	0.5	1.1	0.8	10.3	1.6
225.0	0.9	0.7	0.3	0.0	4.6	1.2
180.0	0.9	0.1	0.8	0.0	5.3	1.0
135.0	3.4	1.7	1.6	0.0	6.0	1.5
0	MEAN SCALAR SPEED = 8.0 CM/S		MEAN SQUARE SPEED = 119.6 CM2/S2			
	MEAN SQUARE E-W SPEED = 48.5 CM2/S2		MEAN SQUARE N-S SPEED = 71.1 CM2/S2			
	MEAN VELOCITY = 6.6 CM/S,		35 DEG TRUE		MEAN TEMPERATURE = 4.0 C	
	VARIANCE (U,V) = 38.0 CM2/S2		TOTAL HOURS = 744.			

PERCENT OBSERVED

LIGHT (0.0 - 3.0) 20.2% MEDIUM (3.0 - 7.0) 39.9% HIGH (GE 7.0) 39.9%

MOORING IS 97-05C-012A059 DEPTH IS 59 METERS THERE ARE 744 VALUES

FIRST DAY 1998/01/01/0000
FINAL DAY 1998/01/31/2300

SHORELINE ORIENTATION IN DEGREES TRUE SPECIFIED AS 90

DIRECTION DEG TRUE	PERCENT OBSERVED	MAXIMUM CURRENT CM/S	MEAN DURA- TION HOURS	MEAN EXCUR- SION KM	MEAN CURRENT CM/S	MEAN TEMP DEG C
TOWARD	TOTAL	LIGHT	MEDIUM	HIGH		
90.0	2.3	2.3	0.0	0.0	2.2	1.9
45.0	17.1	9.9	2.2	5.0	23.0	3.2
0.0	70.4	64.8	0.9	4.7	25.7	9.4
315.0	3.6	2.2	1.2	0.3	8.2	1.9
270.0	2.2	2.2	0.0	0.0	2.2	1.2
225.0	2.4	2.4	0.0	0.0	2.5	2.2
180.0	0.9	0.9	0.0	0.0	2.3	1.0
135.0	1.1	1.1	0.0	0.0	2.1	1.6
0	MEAN SCALAR SPEED = 2.5 CM/S		MEAN SQUARE SPEED = 29.7 CM2/S2			
	MEAN SQUARE E-W SPEED = 4.9 CM2/S2		MEAN SQUARE N-S SPEED = 24.7 CM2/S2			
	MEAN VELOCITY = 2.1 CM/S,		19 DEG TRUE		MEAN TEMPERATURE = 3.9 C	
	VARIANCE (U,V) = 12.7 CM2/S2		TOTAL HOURS = 744.			

PERCENT OBSERVED

LIGHT (0.0 - 3.0) 85.8% MEDIUM (3.0 - 7.0) 4.3% HIGH (GE 7.0) 9.9%

DATE: 1998/02/01 TO 1998/02/28
 ROSE SUMMARY: WIND AND CURRENT

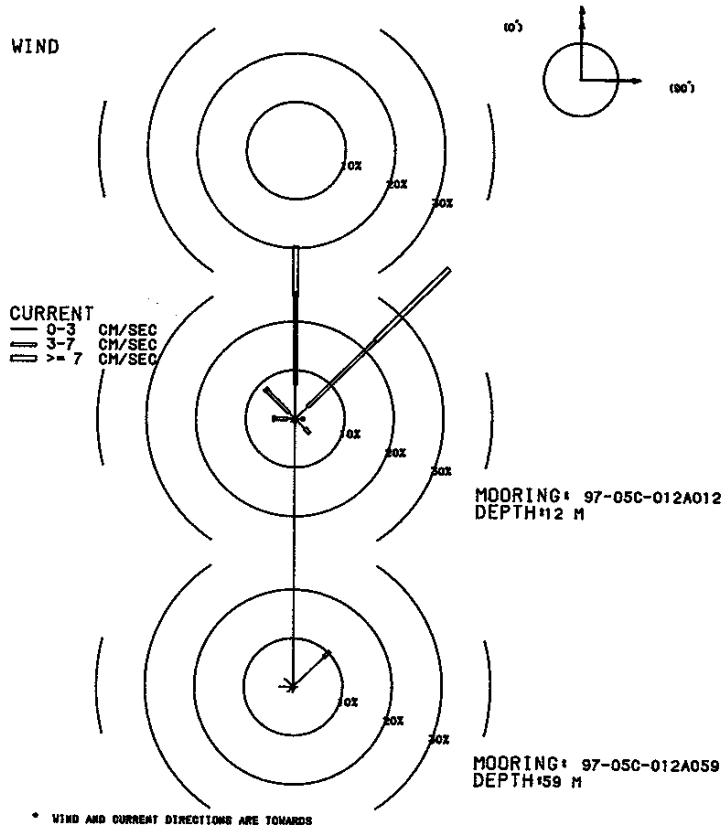

MOORING IS 97-05C-012A012 DEPTH IS 12 METERS THERE ARE 672 VALUES

FIRST DAY 1998/02/01/0000
 FINAL DAY 1998/02/28/2300

SHORELINE ORIENTATION IN DEGREES TRUE SPECIFIED AS 90

DIRECTION DEG TRUE	PERCENT OBSERVED				MAXIMUM CURRENT CM/S	MEAN DURA- TION HOURS	MEAN EXCUR- SION KM	MEAN CURRENT CM/S	MEAN TEMP DEG C
TOWARD	TOTAL	LIGHT	MEDIUM	HIGH	CM/S	HOURS	KM	CM/S	DEG C
90.0	1.8	1.2	0.6	0.0	4.6	1.5	0.2	2.9	3.1
45.0	43.9	3.6	19.3	21.0	15.3	5.9	1.6	7.4	2.8
0.0	35.4	7.0	18.2	10.3	15.0	3.7	0.7	5.7	2.8
315.0	8.6	1.8	6.2	0.6	7.8	2.3	0.4	5.0	2.9
270.0	4.5	1.6	2.5	0.3	7.5	2.0	0.3	4.1	3.2
225.0	0.9	0.9	0.0	0.0	2.5	1.0	0.1	1.9	3.1
180.0	0.7	0.6	0.1	0.0	4.0	1.0	0.1	2.2	3.2
135.0	4.2	2.8	1.3	0.0	4.3	4.0	0.4	2.7	3.3
0	MEAN SCALAR SPEED = 6.1 CM/S				MEAN SQUARE SPEED = 50.2 CM ² /S ²				
	MEAN SQUARE E-W SPEED = 12.1 CM ² /S ²				MEAN SQUARE N-S SPEED = 38.1 CM ² /S ²				
	MEAN VELOCITY = 5.2 CM/S,				20 DEG TRUE MEAN TEMPERATURE = 2.9 C				
	VARIANCE (U,V) = 11.6 CM ² /S ²				TOTAL HOURS = 672.				

PERCENT OBSERVED
 LIGHT (0.0 - 3.0) 19.5% MEDIUM (3.0 - 7.0) 48.4% HIGH (GE 7.0) 32.1%

MOORING IS 97-05C-012A059 DEPTH IS 59 METERS THERE ARE 672 VALUES

FIRST DAY 1998/02/01/0000
 FINAL DAY 1998/02/28/2300

SHORELINE ORIENTATION IN DEGREES TRUE SPECIFIED AS 90

DIRECTION DEG TRUE	PERCENT OBSERVED				MAXIMUM CURRENT CM/S	MEAN DURA- TION HOURS	MEAN EXCUR- SION KM	MEAN CURRENT CM/S	MEAN TEMP DEG C
TOWARD	TOTAL	LIGHT	MEDIUM	HIGH	CM/S	HOURS	KM	CM/S	DEG C
90.0	0.7	0.7	0.0	0.0	2.4	1.2	0.1	2.0	3.1
45.0	10.4	8.8	1.6	0.0	4.2	2.3	0.2	2.4	2.8
0.0	81.0	75.1	5.8	0.0	5.6	10.3	0.3	0.7	2.9
315.0	2.2	2.2	0.0	0.0	2.3	1.2	0.1	2.1	3.2
270.0	2.7	2.7	0.0	0.0	2.4	1.6	0.1	2.0	3.2
225.0	1.3	1.3	0.0	0.0	2.4	1.1	0.1	2.3	2.9
180.0	1.0	1.0	0.0	0.0	2.1	1.0	0.1	1.9	2.9
135.0	0.6	0.6	0.0	0.0	2.2	1.0	0.1	2.0	2.9
0	MEAN SCALAR SPEED = 1.0 CM/S				MEAN SQUARE SPEED = 2.8 CM ² /S ²				
	MEAN SQUARE E-W SPEED = 0.5 CM ² /S ²				MEAN SQUARE N-S SPEED = 2.3 CM ² /S ²				
	MEAN VELOCITY = 0.8 CM/S,				11 DEG TRUE MEAN TEMPERATURE = 2.9 C				
	VARIANCE (U,V) = 1.1 CM ² /S ²				TOTAL HOURS = 672.				

PERCENT OBSERVED
 LIGHT (0.0 - 3.0) 92.6% MEDIUM (3.0 - 7.0) 7.4% HIGH (GE 7.0) 0.0%

DATE: 1998/03/01 TO 1998/03/31
ROSE SUMMARY: WIND AND CURRENT

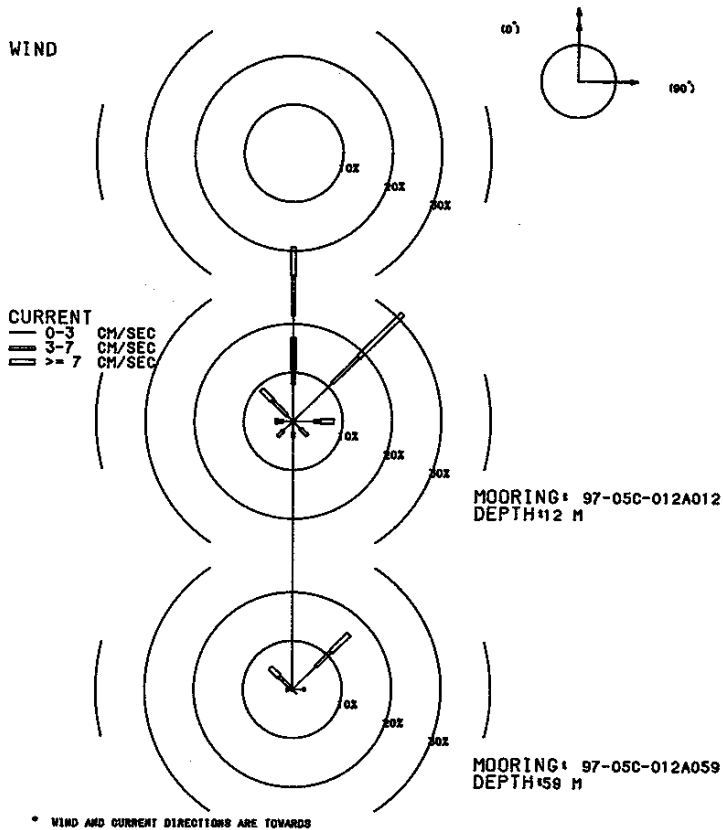

MOORING IS 97-05C-012A012 DEPTH IS 12 METERS THERE ARE 744 VALUES

FIRST DAY 1998/03/01/0000
FINAL DAY 1998/03/31/2300

SHORELINE ORIENTATION IN DEGREES TRUE SPECIFIED AS 90

DIRECTION DEG TRUE	PERCENT OBSERVED	TOWARD	TOTAL	LIGHT	MEDIUM	HIGH	MAXIMUM CURRENT CM/S	MEAN DURA- TION HOURS	MEAN EXCUR- SION KM	MEAN CURRENT CM/S	MEAN TEMP DEG C
90.0	8.2	4.2	1.3	2.7	23.2	2.7	0.6	6.7	2.9		
45.0	31.3	11.2	7.5	12.6	50.0	4.7	1.5	8.9	2.9		
0.0	35.8	21.6	8.3	5.8	35.0	4.4	0.6	4.0	2.9		
315.0	9.1	1.6	4.4	3.1	38.4	2.6	0.7	7.2	2.8		
270.0	3.6	2.0	1.1	0.5	11.0	1.5	0.2	3.8	2.8		
225.0	4.4	2.8	1.6	0.0	4.5	1.9	0.2	2.8	2.8		
180.0	3.4	2.3	1.1	0.0	5.3	1.5	0.1	2.7	2.8		
135.0	4.2	2.0	2.2	0.0	6.0	2.1	0.2	3.0	2.9		
0		MEAN SCALAR SPEED = 5.9 CM/S		MEAN SQUARE SPEED = 92.1 CM2/S2							
		MEAN SQUARE E-W SPEED = 39.1 CM2/S2		MEAN SQUARE N-S SPEED = 53.1 CM2/S2							
		MEAN VELOCITY = 4.2 CM/S,		27 DEG TRUE		MEAN TEMPERATURE = 2.9 C					
		VARIANCE (U,V) = 37.3 CM2/S2		TOTAL HOURS = 744.							

PERCENT OBSERVED

LIGHT (0.0 - 3.0) 47.7% MEDIUM (3.0 - 7.0) 27.6% HIGH (GE 7.0) 24.7%

MOORING IS 97-05C-012A059 DEPTH IS 59 METERS THERE ARE 744 VALUES

FIRST DAY 1998/03/01/0000
FINAL DAY 1998/03/31/2300

SHORELINE ORIENTATION IN DEGREES TRUE SPECIFIED AS 90

DIRECTION DEG TRUE	PERCENT OBSERVED	TOWARD	TOTAL	LIGHT	MEDIUM	HIGH	MAXIMUM CURRENT CM/S	MEAN DURA- TION HOURS	MEAN EXCUR- SION KM	MEAN CURRENT CM/S	MEAN TEMP DEG C
90.0	2.6	2.3	0.3	0.0	5.4	1.1	0.1	2.5	2.9		
45.0	16.1	6.7	4.3	5.1	29.3	4.0	1.0	6.9	2.8		
0.0	72.2	62.6	3.1	6.5	28.1	9.8	0.6	1.8	2.9		
315.0	6.3	0.7	3.1	2.6	23.8	6.7	2.2	9.0	2.6		
270.0	1.1	0.7	0.3	0.1	10.2	1.0	0.1	4.1	2.8		
225.0	0.3	0.3	0.0	0.0	2.2	1.0	0.1	2.1	2.7		
180.0	0.3	0.3	0.0	0.0	2.2	1.0	0.1	2.2	2.8		
135.0	1.2	1.2	0.0	0.0	2.4	1.1	0.1	2.0	2.8		
0		MEAN SCALAR SPEED = 3.1 CM/S		MEAN SQUARE SPEED = 37.7 CM2/S2							
		MEAN SQUARE E-W SPEED = 8.5 CM2/S2		MEAN SQUARE N-S SPEED = 29.2 CM2/S2							
		MEAN VELOCITY = 2.6 CM/S,		12 DEG TRUE		MEAN TEMPERATURE = 2.8 C					
		VARIANCE (U,V) = 15.5 CM2/S2		TOTAL HOURS = 744.							

PERCENT OBSERVED

LIGHT (0.0 - 3.0) 74.7% MEDIUM (3.0 - 7.0) 11.0% HIGH (GE 7.0) 14.2%

DATE: 1998/04/01 TO 1998/04/30
 ROSE SUMMARY: WIND AND CURRENT

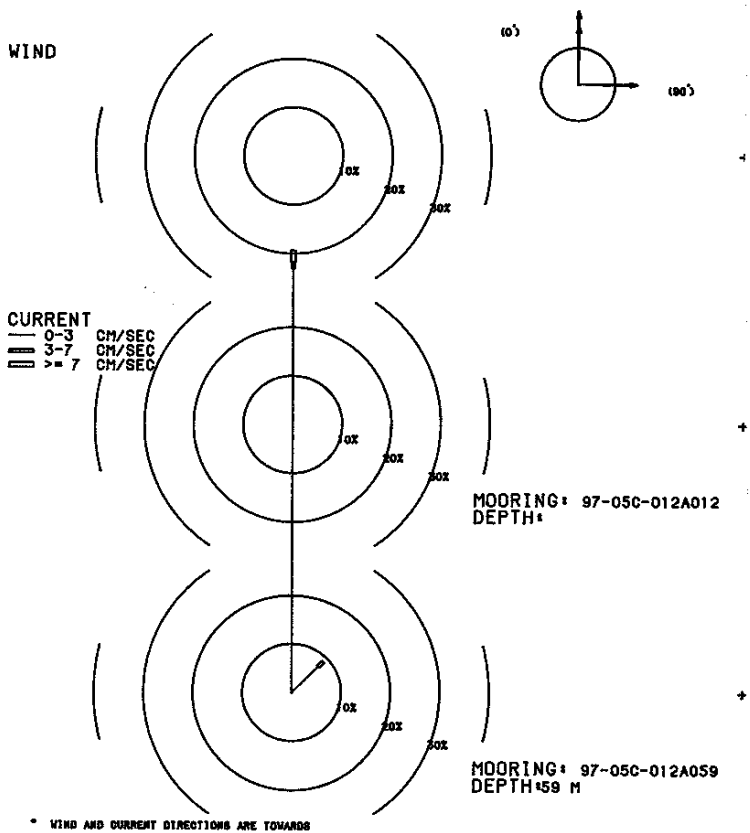

MOORING IS 97-05C-012A012 DEPTH IS 12 METERS THERE ARE 93 VALUES

FIRST DAY 1998/04/01/0000
 FINAL DAY 1998/04/05/1900

SHORELINE ORIENTATION IN DEGREES TRUE SPECIFIED AS 90

DIRECTION DEG TRUE	PERCENT OBSERVED	TOWARD	TOTAL	LIGHT	MEDIUM	HIGH	MAXIMUM CURRENT CM/S	MEAN DURATION HOURS	MEAN EXCURSION KM	MEAN CURRENT CM/S	MEAN TEMP DEG C
90.0	30.1	30.1	0.0	0.0	2.5	2.3	0.2	2.0	3.6		
45.0	32.3	32.3	0.0	0.0	2.5	2.1	0.2	2.1	3.6		
0.0	28.0	28.0	0.0	0.0	2.2	2.2	0.1	1.8	3.7		
315.0	4.3	4.3	0.0	0.0	2.2	1.0	0.1	1.8	3.8		
270.0	2.2	2.2	0.0	0.0	2.0	1.0	0.1	2.0	3.8		
225.0	0.0	0.0	0.0	0.0	0.0	0.0	0.0	0.0	0.0		
180.0	1.1	1.1	0.0	0.0	1.2	1.0	0.0	1.2	3.7		
135.0	2.2	2.2	0.0	0.0	1.9	1.0	0.1	1.5	3.6		
MEAN SCALAR SPEED = 1.9 CM/S		MEAN SQUARE SPEED = 4.0 CM2/S2									
MEAN SQUARE E-W SPEED = 2.3 CM2/S2		MEAN SQUARE N-S SPEED = 1.7 CM2/S2									
MEAN VELOCITY = 1.4 CM/S,		48 DEG TRUE		MEAN TEMPERATURE = 3.7 C							
VARIANCE (U,V) = 1.0 CM2/S2		TOTAL HOURS = 93.									

PERCENT OBSERVED
 LIGHT (0.0 - 3.0) 100.0% MEDIUM (3.0 - 7.0) 0.0% HIGH (GE 7.0) 0.0%

MOORING IS 97-05C-012A059 DEPTH IS 59 METERS THERE ARE 720 VALUES

FIRST DAY 1998/04/01/0000
 FINAL DAY 1998/04/30/2300

SHORELINE ORIENTATION IN DEGREES TRUE SPECIFIED AS 90

DIRECTION DEG TRUE	PERCENT OBSERVED	TOWARD	TOTAL	LIGHT	MEDIUM	HIGH	MAXIMUM CURRENT CM/S	MEAN DURATION HOURS	MEAN EXCURSION KM	MEAN CURRENT CM/S	MEAN TEMP DEG C
90.0	0.1	0.1	0.0	0.0	2.2	1.0	0.1	2.2	3.8		
45.0	9.0	7.5	1.5	0.0	6.9	2.7	0.2	2.5	3.8		
0.0	90.7	86.9	1.4	2.4	10.3	24.2	0.4	0.5	3.8		
315.0	0.0	0.0	0.0	0.0	0.0	0.0	0.0	0.0	0.0		
270.0	0.0	0.0	0.0	0.0	0.0	0.0	0.0	0.0	0.0		
225.0	0.0	0.0	0.0	0.0	0.0	0.0	0.0	0.0	0.0		
180.0	0.0	0.0	0.0	0.0	0.0	0.0	0.0	0.0	0.0		
135.0	0.1	0.1	0.0	0.0	1.9	1.0	0.1	1.9	4.2		
MEAN SCALAR SPEED = 0.7 CM/S		MEAN SQUARE SPEED = 3.2 CM2/S2									
MEAN SQUARE E-W SPEED = 0.3 CM2/S2		MEAN SQUARE N-S SPEED = 2.9 CM2/S2									
MEAN VELOCITY = 0.7 CM/S,		19 DEG TRUE		MEAN TEMPERATURE = 3.8 C							
VARIANCE (U,V) = 1.4 CM2/S2		TOTAL HOURS = 720.									

PERCENT OBSERVED
 LIGHT (0.0 - 3.0) 94.7% MEDIUM (3.0 - 7.0) 2.9% HIGH (GE 7.0) 2.4%

DATE: 1998/05/01 TO 1998/05/31
 ROSE SUMMARY: WIND AND CURRENT

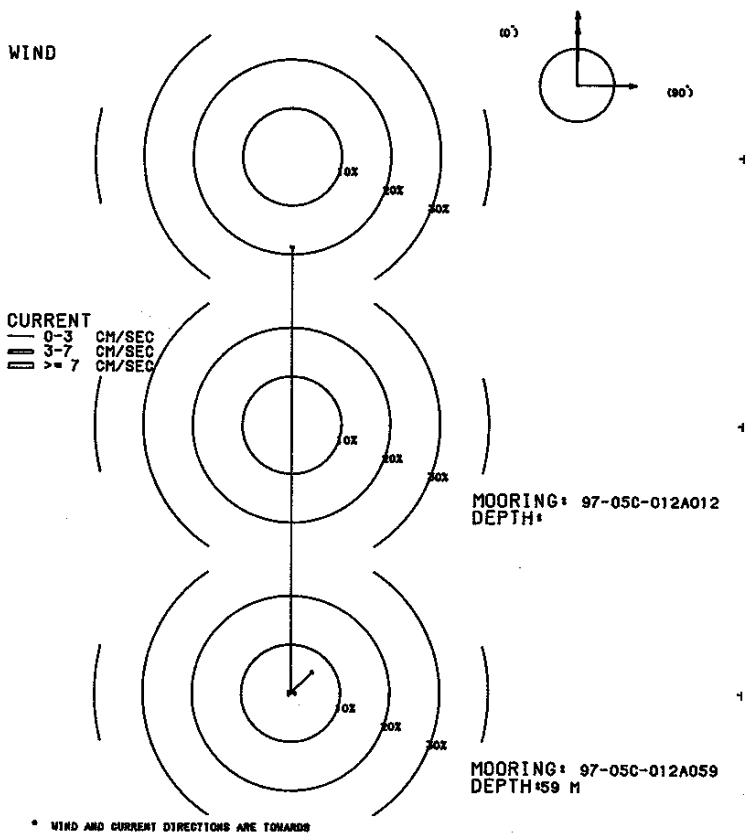

MOORING IS 97-05C-012A059 DEPTH IS 59 METERS THERE ARE 744 VALUES

FIRST DAY 1998/05/01/0000
 FINAL DAY 1998/05/31/2300

SHORELINE ORIENTATION IN DEGREES TRUE SPECIFIED AS 90

DIRECTION DEG TRUE	PERCENT OBSERVED				MAXIMUM CURRENT CM/S	MEAN DURA- TION HOURS	MEAN EXCUR- SION KM	MEAN CURRENT CM/S	MEAN TEMP DEG C
TOWARD	TOTAL	LIGHT	MEDIUM	HIGH	CM/S	HOURS	KM	CM/S	DEG C
90.0	0.9	0.8	0.1	0.0	6.6	1.8	0.2	2.8	4.4
45.0	6.3	6.0	0.3	0.0	5.5	1.7	0.1	2.1	4.6
0.0	91.7	91.3	0.4	0.0	4.5	18.4	0.2	0.2	4.5
315.0	0.3	0.1	0.1	0.0	4.8	1.0	0.1	3.5	4.6
270.0	0.5	0.4	0.0	0.1	7.3	2.0	0.2	3.4	4.6
225.0	0.1	0.1	0.0	0.0	2.1	1.0	0.1	2.1	4.4
180.0	0.1	0.1	0.0	0.0	2.1	1.0	0.1	2.1	4.4
135.0	0.0	0.0	0.0	0.0	0.0	0.0	0.0	0.0	0.0

MEAN SCALAR SPEED = 0.4 CM/S MEAN SQUARE SPEED = 1.0 CM2/S2
 MEAN SQUARE E-W SPEED = 0.3 CM2/S2 MEAN SQUARE N-S SPEED = 0.7 CM2/S2
 MEAN VELOCITY = 0.3 CM/S, 16 DEG TRUE MEAN TEMPERATURE = 4.5 C
 VARIANCE (U,V) = 0.4 CM2/S2 TOTAL HOURS = 744.

PERCENT OBSERVED
 LIGHT (0.0 - 3.0) 98.9% MEDIUM (3.0 - 7.0) 0.9% HIGH (GE 7.0) 0.1%

DATE: 1998/06/01 TO 1998/06/30
 ROSE SUMMARY: WIND AND CURRENT

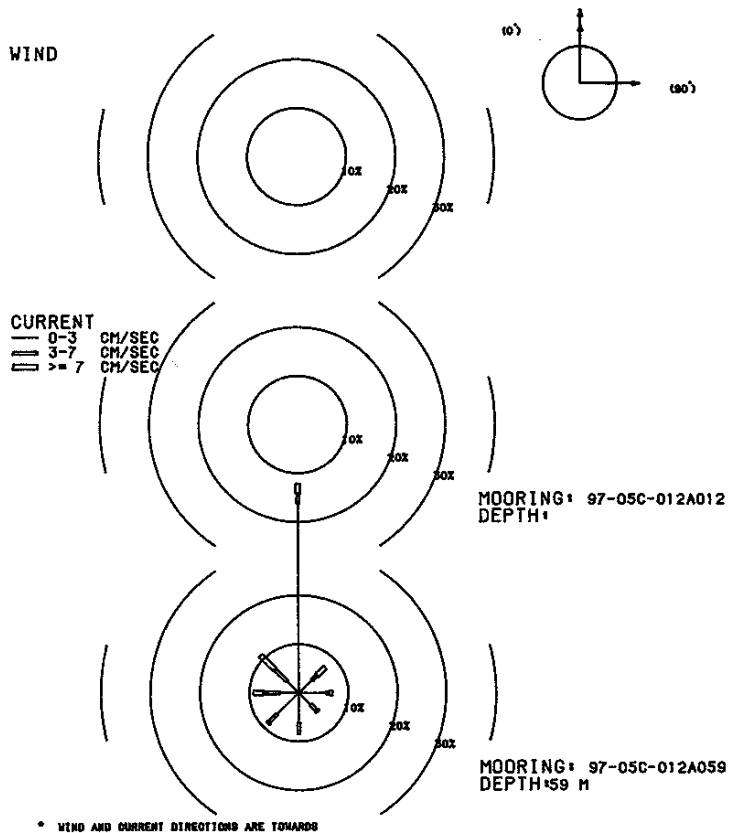

MOORING IS 97-05C-012A059 DEPTH IS 59 METERS THERE ARE 294 VALUES

FIRST DAY 1998/06/01/0000
 FINAL DAY 1998/06/13/0500

SHORELINE ORIENTATION IN DEGREES TRUE SPECIFIED AS 90

DIRECTION DEG TRUE	PERCENT OBSERVED	MAXIMUM CURRENT CM/S	MEAN DURA- TION HOURS	MEAN EXCUR- SION KM	MEAN CURRENT CM/S	MEAN TEMP DEG C
TOWARD	TOTAL	LIGHT	MEDIUM	HIGH		
90.0	6.8	5.4	0.7	0.7	10.1	2.0
45.0	7.5	3.7	1.4	2.4	14.7	2.0
0.0	42.9	38.8	2.0	2.0	15.9	4.1
315.0	10.9	3.4	3.4	4.1	17.0	2.3
270.0	9.2	3.7	3.4	2.0	14.8	2.1
225.0	8.8	6.1	2.4	0.3	8.4	1.6
180.0	8.5	6.1	2.4	0.0	6.6	1.8
135.0	5.4	3.4	1.7	0.3	8.6	1.8

0 MEAN SCALAR SPEED = 2.8 CM/S MEAN SQUARE SPEED = 20.0 CM2/S2
 MEAN SQUARE E-W SPEED = 10.0 CM2/S2 MEAN SQUARE N-S SPEED = 10.0 CM2/S2
 MEAN VELOCITY = 0.8 CM/S, 315 DEG TRUE MEAN TEMPERATURE = 4.9 C
 VARIANCE(U,V) = 9.7 CM2/S2 TOTAL HOURS = 294.

PERCENT OBSERVED
 LIGHT (0.0 - 3.0) 70.7% MEDIUM (3.0 - 7.0) 17.3% HIGH (GE 7.0) 11.9%