



UNITED STATES  
 CONSUMER PRODUCT SAFETY COMMISSION  
 WASHINGTON, DC 20207 CPSC/OFFICE OF  
 THE SECRETARY

Memorandum

2000 MAY 18 P 2:36 Date: MAY 15 2000

TO : The Commission  
 Sadye E. Dunn, Secretary

THROUGH: Pamela Gilbert, Executive Director *PG*

FROM : Michael S Solender, General Counsel *MS*  
 Stephen Lemberg, Assistant General Counsel *SL*  
 Patricia M. Pollitzer, Attorney *MP*

SUBJECT : Revision of Garage Door Operator Standard

BALLOT VOTE due: MAY 26 2000

Attached is a draft proposed rule that would revise the Commission's garage door operator standard to reflect changes UL has made to its standard upon which the Commission standard was based.

Please indicate your vote on the following options

- I. Approve the draft Federal Register notice without change.

\_\_\_\_\_  
 Signature Date

- II Approve the draft Federal Register notice with the following changes (please specify):

\_\_\_\_\_  
 \_\_\_\_\_  
 \_\_\_\_\_

\_\_\_\_\_  
 Signature Date

NOTE: This document has not been reviewed or accepted by the Commission.  
 Initial *rh* Date *5/15/00* CPSC Hotline 1-800-638-CPSC(2772) ★ CPSC's Web Site <http://www.cpsc.gov>

CPSA 6 (b)(1) Cleared  
*5/15/00*  
 No Mis/Priv/Librs or  
 Products Identified  
 Excepted *RP*

III. Do not approve the draft Federal Register notice.

\_\_\_\_\_  
Signature

\_\_\_\_\_  
Date



## Briefing Package to Amend the Standard for Garage Door Operators (16 CFR Part 1211)

April 2000

**For Further Information, Contact:**  
**John R. Murphy**  
**Directorate for Engineering Sciences**  
**301-504-0494, Extension 1311**

NOTE: This document has not been  
reviewed or accepted by the Commission.  
Initial rh Date 5/15/00

CPSA 6 (b)(1) Cleared  
5/12/00  
No Mfrs/Prohibitors of  
Products Identified  
Excepted Products



UNITED STATES  
 CONSUMER PRODUCT SAFETY COMMISSION  
 WASHINGTON, DC 20207

Memorandum

Date: MAY 15 2000

TO The Commission  
 Sadye E. Dunn, Secretary

THROUGH Michael Solender, General Counsel *MS*  
 Pamela Gilbert, Executive Director *PG*

FROM : Ronald L. Medford, Assistant Executive Director, *RLM*  
 Office of Hazard Identification and Reduction  
 John R. Murphy, Mechanical Engineer, *John R. Murphy*  
 Directorate for Engineering Sciences

SUBJECT · Revision of Garage Door Operator Standard, 16 (CFR) Part 1211

I. Introduction

This briefing package provides background on the Commission's mandatory standard for garage door operators (16 CFR Part 1211) and recommends the publication of a notice of proposed rulemaking to revise the standard.

II. Background

In the Consumer Product Safety Improvement Act of 1990 (the Improvement Act), Congress mandated that automatic residential garage door operators (GDOs) manufactured on or after January 1, 1991 conform to the entrapment protection requirements of the 1988 version of Underwriters Laboratories, Inc (UL) Standard for Safety—UL 325. A copy of the Improvement Act is provided at Tab A. On June 19, 1991, the Commission issued the garage door operator standard (16 CFR Part 1211). The Improvement Act also required that the Commission revise the GDO standard to include additional entrapment protection provisions adopted by UL. The Commission did so on December 21, 1992 (57 Fed. Reg 60449).

The Improvement Act provides that when UL makes changes to the entrapment protection provisions of UL 325, UL must notify the Commission of proposed revisions. Those changes must be incorporated into the Commission rule unless the Commission notifies UL within 30 days that the Commission has determined the revisions do not carry out the purposes of the Improvement Act.

NOTE: This document has not been reviewed or accepted by the Commission  
 Initial RL Date 5/15/00  
 1-800-638-CPSC(2772) \* CPSC's Web Site <http://www.cpsc.gov>

CPSA 6 (b)(1) Cleared  
 5/15/00  
 No Miss/Priv/Dir or  
 Products Identified  
 Excepted by *[Signature]*

### **III. Discussion**

#### **A. The Current Mandatory Standard**

The primary provision of the Commission's standard requires that all residential garage door operators sold in the United States have an inherent reversing mechanism capable of reversing the motion of a downward moving garage door within 2 seconds. This system is referred to as an inherent system because it is physically located within the housing of the garage door operator. In addition, the operator shall be provided with a "means" for connection of an external entrapment-sensing device. Most garage door operators on the market today use an electric eye as the external entrapment-sensing device. The purpose of this device is to monitor the area under the garage door for people who might become entrapped by the garage door. The standard also allows a device known as a door edge sensor, similar to the sensors used on elevator doors, or any other device that provides equivalent protection. These devices are known as external entrapment sensing devices because they are located outside the housing of the garage door operator.

In addition, the standard requires all garage door operators to have a device referred to as a 30-second clock. The 30-second clock is a back-up device that reopens the door if the door can not close completely within 30 seconds, as would be the case when a person becomes entrapped under the door. The 30-second clock is a back up to the primary inherent entrapment system that must reverse the door within 2 seconds should a person become entrapped under the door.

The standard also requires that every garage door operator be equipped with a "means to manually detach the door operator from the door." The reason for this requirement is to enable a person to quickly detach the operator from the door in the event a person becomes entrapped under the door. For most garage doors, the means of detachment is actuated by pulling on a red handle that hangs below the garage door operator.

#### **B. Recent Revisions to UL 325**

UL revised its standard on September 18, 1998. A memo from the Directorate for Engineering Sciences outlines the changes to the standard (Tab B). A copy of UL 325 that only contains the entrapment protection requirements that apply to automatic garage door operators is provided at Tab C. Three substantive changes were made. These changes allow for new technological advances and do not modify the requirements for conventional garage door operators.

The first of the three substantive changes allows for a new type of entrapment protection system that monitors the actual position of the door. This type of system is not required to have a 30-second clock. A system that monitors the position of the door instantly detects when the door has stopped moving as would be the case in an entrapment and can reverse the door without waiting 30 seconds. Systems that do not measure the actual position of the door would still be required to have a 30-second clock.

The second substantive change allows for a secondary inherent entrapment protection device that takes the place of the secondary external entrapment protection device, such as the electric eye and door edge sensor. It is referred to as inherent, because the actual mechanism is enclosed within the casing of the garage door operator. It is referred to as secondary because it provides back-up entrapment protection to the primary device. This device is only allowed if it is completely independent of the primary entrapment protection device.

The third substantive change applies to garage door operators that are not directly connected to the garage door. Some newer garage door operators that are mounted to the header of the door and are not directly connected to the door do not need a means to detach, since the door can easily be raised while still connected to the operator. All requirements for operating instructions and field installed labels have been modified to allow a system that is not directly connected to the door. All garage door operators that are directly connected to the garage door must continue to have a means to detach the garage door operator from the door.

In addition, UL has made editorial changes to provide better descriptions of the appropriate requirements and to insert mandatory code language where needed. Other standards that have been incorporated into the garage door operator standard by reference have been updated to the most recent version.

### **C. Economic Impact**

The Commission is required by the Regulatory Flexibility Act of 1980 (RFA) to address and give particular attention to the economic effects on small entities. The staff believes that due to the nature of the revisions, they are unlikely to have any adverse impact on small businesses or other entities. The Directorate for Economic Analysis indicates (Tab D) that according to industry sources, there are 22 manufacturers or importers of GDOs, only one of these uses the new mechanisms that would be permitted under the revised standard. With over 1,000 employees, this firm would not be considered a small business under Small Business Administration guidelines. The substantive changes affect only the companies that either use the new designs or may adapt them to future production. No firm would be required to make changes to its products in order to conform to the standard. Any firms that currently comply with UL 325 would continue to comply after the technical amendments. The revisions will not render other models obsolete, and are not expected to affect consumer demand.

### **IV. Recommendations**

The staff recommends that the Commission issue a notice of proposed rulemaking to amend the Commission's standard for automatic residential garage door operators. A draft proposed rule is attached at Tab E. The proposed rule revises the standard to reflect changes Underwriters Laboratories, Inc (UL) has made to UL 325.

TAB A

Public Law 101-608

SEC. 203 AUTOMATIC GARAGE DOOR OPENERS

(a) **CONSUMER PRODUCT SAFETY RULE.**—The provisions of subsection (b) shall be considered to be a consumer product safety rule issued by the Consumer Product Safety Commission under section 9 of the Consumer Product Safety Act

(b) **REQUIREMENTS** —

(1) Effective on and after January 1, 1991, each automatic residential garage door opener manufactured on or after that date for sale in the United States shall conform to the entrapment protection requirements of the American National Standards Institute Underwriters Laboratories, Inc. Standards for Safety—UL 325, third edition, as revised May 4, 1988.

(2)(A) Effective on and after January 1, 1993, all residential automatic garage door openers manufactured on and after such date for sale in the United States shall conform to any additional entrapment protection requirements of the American National Standards Institute Underwriters Laboratories, Inc. Standards for Safety—UL 325, third edition, which were issued after the date of the enactment of this Act to become effective on or before January 1, 1993

(B) If, by June 1, 1992, the Underwriters Laboratories, Inc., has not issued a revision to the May 4, 1988, Standards for Safety—UL 325, third edition, to require an entrapment protection feature or device in addition to that required by the May 4, 1988, Standard, the Consumer Product Safety Commission shall begin a rulemaking proceeding, to be completed no later than October 31, 1992, to require an additional such feature or device on all automatic residential garage door openers manufactured on or after January 1, 1993, for sale in the United States. If such a revision is issued by the Underwriters Laboratories, Inc. after the rulemaking has commenced, the rulemaking shall be terminated and the revision shall be incorporated in the consumer product safety rule under subsection (a) unless the Commission has determined under subsection (c) that such revision does not carry out the purposes of subsection (b).

(c) **REVISION OF RULE.**—If, after June 1, 1992, or the date of a revision described in subsection (b)(2)(B) if later, the Underwriters Laboratories, Inc. proposes to further revise the entrapment protection requirements of the American National Standards Institute Underwriters Laboratories, Inc. Standards for Safety—UL 325, third edition, the Laboratories shall notify the Consumer Product Safety Commission of the proposed revision and the proposed revision shall be incorporated in the consumer product safety rule under subsection (a) unless, within 30 days of such notice, the Commission notifies the Laboratories that the Commission has determined that such revision does not carry out the purposes of subsection (b)

(d) **LABELING.**—On and after January 1, 1991, a manufacturer selling or offering for sale in the United States an automatic residential garage door opener manufactured on or after January 1, 1991, shall clearly identify on any container of the system and on the system the month or week and year the system was manufactured and its conformance with the requirements of subsection (b). The display of the UL logo or listing mark, and compliance with the date marking requirements of UL 325, on both the container and the system, shall satisfy the requirements of this subsection.



Public Law 101-608

(e) **NOTIFICATION** —Effective on and after July 1, 1991, all manufacturers of automatic residential garage door openers shall, in consultation with the Consumer Product Safety Commission, notify the public of the potential for entrapment by garage doors equipped with automatic garage door openers and advise the public to test their openers for the entrapment protection feature or device required by subsection (b).

(f) **PREEMPTION** —In applying section 26(a) of the Consumer Product Safety Act (15 U.S.C. 2075) with respect to the consumer product safety rule of the Consumer Product Safety Commission under subsection (a), only those provisions of laws of States or political subdivisions which relate to the labeling of automatic residential garage door openers and those provisions which do not provide at least the equivalent degree of protection from the risk of injury associated with automatic residential garage door openers as the consumer product safety rule provides shall be subject to such section.

(g) **REGULATIONS**.—Section 553 of title 5, United States Code, shall apply with respect to the issuance of any regulations by the Consumer Product Safety Commission to implement the requirements of this section and sections 7 and 9 of the Consumer Product Safety Act do not apply to such issuance. Any additional or revised requirement issued by the Commission shall provide an adequate degree of protection to the public.

(h) **CONSTRUCTION** —Nothing in this section shall affect or modify in any way the obligations or liabilities of any person under the common law or any Federal or State law.

TAB B



UNITED STATES  
CONSUMER PRODUCT SAFETY COMMISSION  
WASHINGTON, DC 20207

Memorandum

Date: March 17, 2000

TO : David A. Walden, Acting Associate Executive Director,  
Directorate for Engineering Sciences

THROUGH: Nicholas V. Marchica, Division Director, Division of Mechanical Engineering

FROM : John R. Murphy, Mechanical Engineer, Division of Mechanical Engineering

SUBJECT: Revision to 16 CFR part 1211

*P. V. Marchica*  
*JRM*

The Consumer Product Safety Improvement Act of 1990 (CPSIA) provided that, as of January 1, 1991, each residential garage door operator manufactured for sale in the United States shall conform to the entrapment protection requirements of the Underwriters Laboratories, Inc (UL) Standard for Safety – UL 325. Congress stated that these requirements are to “be considered a consumer product safety rule issued by the Consumer Product Safety Commission (CPSC) under Section 9 of the Consumer Product Safety Act”. In addition, Congress provided that UL notify the Commission of any future changes to UL 325 and that those changes be incorporated into the safety rule unless the Commission determines that the changes do not carry out the purposes of the CPSIA.

UL revised the voluntary standard, UL 325 on September 18, 1998. There are three substantive changes to the entrapment protection provisions of the standard that will require changes to the mandatory standard for garage door operators. In addition, there are other revisions to the entrapment protection provisions that are editorial in nature.

The first of the three substantive changes allows for a new type of entrapment protection system to monitor the actual position of the door. This type of system is not required to have a 30-second clock. The 30-second clock is a back-up device that reopens the door if the door can not close completely within 30 seconds, as would be the case when a person becomes entrapped under the door. The 30-second clock is a back up to the primary inherent entrapment system that must reverse the door within two seconds should a person become entrapped under the door. A system that monitors the position of the door instantly knows when the door has stopped moving as would be the case in an entrapment and can reverse without waiting 30 seconds. Systems that do not measure the actual position of the door would still be required to have a 30-second clock.

The second substantive change allows for a secondary inherent entrapment protection device that takes the place of the secondary external entrapment protection device, such as the electric eye and door edge sensor. It is referred to as inherent, because the actual mechanism is enclosed within the casing of the garage door operator. It is referred to as secondary because it provides back-up entrapment protection to the primary device. This device is only allowed if it is completely independent of the primary entrapment protection device.

The third substantive change applies to garage door operators that are not directly connected to the garage door. Currently the standard requires that all garage door operators have a means to disconnect the garage door operator from the garage door. The reason for this is to enable a person to quickly detach the operator from the door in the event a person becomes entrapped under the door. The current mandatory standard requires that the means be colored red and be capable of being adjusted to a height of six feet above the floor to maintain uniformity between garage door operator brands. The means of detachment is usually a red handle that hangs below the garage door operator. The door can be released from the operator by pulling on this handle. Some newer garage door operators that are mounted to the header of the door and are not directly connected to the door do not need a means to detach since the door can easily be raised while still connected to the operator. All requirements for operating instructions and field installed labels have been modified to allow a system that is not directly connected to the door. All garage door operators that are directly connected to the garage door must still have a means to detach the garage door operator from the door.

In addition, UL has made editorial changes to provide better descriptions of the appropriate requirements and to insert mandatory code language where needed. One example of the use of mandatory code language involves restating the requirements without using the words "if" or "may". These mandatory code language changes would allow the adoption of some provisions of UL 325 into the International Building Code. Another example of the editorial changes is that other standards that have been incorporated into the garage door operator standard by reference have been updated to the most recent version.

Engineering Sciences believes that these changes improve the level of safety provided by the mandatory standard by updating the standard to the latest developments in garage door operator technology.

TAB C

# UL 325

Door, Drapery, Gate, Louver,  
and Window Operators and  
Systems

This document only contains the  
entrapment provisions of UL 325 that  
apply to Automatic Residential Garage  
Door Openers

These provisions were extracted from  
the February 25, 2000 version of the  
standard

### **3 Glossary**

**3 5 RESIDENTIAL GARAGE-DOOR OPERATOR** – A vehicular door operator serving a residential building of one to four single family units

**3 22 INHERENT ENTRAPMENT SENSOR SYSTEM** – An automatic sensor system, examples being a photoelectric sensor, an edge sensor, or similar entrapment protection device, which senses entrapment of a solid object and is incorporated as a permanent and integral part of an operator

3 22 revised February 25, 2000

**3 23 ENTRAPMENT** – The condition when an object is caught or held in a position that increases the risk of injury

Added 3 23 effective September 18, 1998

### **5 Units of Measurement**

**5 1** If a value for measurement is followed by a value in other units in parentheses, the second value may be only approximate. The first stated value is the requirement.

5 1 revised February 25, 2000

**17 3** The functioning of a motor-protective device, whether such device is required or not, shall not result in a risk of fire, electric shock, or injury to persons.

## **PROTECTION AGAINST RISK OF INJURY TO PERSONS**

### **25 General**

**25 1** If an automatically-reset protective device is employed, automatic restarting of a motor shall not result in a risk of injury to persons.

**25 2** An appliance is considered to comply with the requirement in 25 1 if some means is provided to prevent the motor from restarting when the protector closes.

**25 3** Parts supported or actuated hydraulically shall not develop a risk of injury to persons due to pressure loss.

**25 4** An enclosure, an opening, a frame, a guard, a knob, a handle, or the like shall not be sufficiently sharp to cause a risk of injury to persons in normal maintenance or use.

25.5 An electronic or solid-state circuit that performs a back-up, limiting, or other function intended to reduce the risk of fire, electric shock, or injury to persons, including entrapment protection circuits, shall comply with the requirements in the Standard for Tests for Safety-Related Controls Employing Solid-State Devices, UL 991, including environmental and stress tests appropriate to the intended usage of the end-product.

25.6 The following test parameters are to be used in the investigation of the circuit covered by 25.5 for compliance with the Standard for Tests for Safety-Related Controls Employing Solid-State Devices, UL 991:

- a) With regard to electrical supervision of critical components, an operator being inoperative with respect to downward movement of the door meets the criteria for trouble indication
- b) A field strength of 3 volts per meter is to be used for the Radiated EMI Test.
- c) The Composite Operational and Cycling Test is to be conducted for 14 days at temperature extremes of minus 35°C (minus 31°F) and 70°C (158°F)
- d) Exposure Class H5 is to be used for the Humidity Test.
- e) A vibration level of 5g is to be used for the Vibration Test
- f) When a Computational Investigation is conducted,  $\lambda_p$  shall not be greater than 6 failures/ $10^6$  hours for the entire system. For external secondary entrapment protection devices that are sold separately,  $\lambda_p$  shall not be greater than 0 failures/ $10^6$  hours. For internal secondary entrapment protection devices whether or not they are sold separately,  $\lambda_p$  shall not be greater than 0 failures/ $10^6$  hours. The Operational Test is to be conducted for 14 days.

*Exception: An external secondary entrapment protection device that is sold separately, and that has a  $\lambda_p$  greater than 0 failures/ $10^6$  hours meets the intent of the requirement when for the combination of the operator and the specified external secondary entrapment protection device  $\lambda_p$  does not exceed 6 failures/ $10^6$  hours. See 53.3.3 – 53.3.5.*

- g) When the Demonstrated Method Test is conducted, the multiplier is to be based on the continuous usage level, and a minimum of 24 units for a minimum of 24 hours per unit are to be tested
- h) The Endurance Test is to be conducted concurrently with the Operational Test. The control shall perform its intended function while being conditioned for 14 days in an ambient air temperature of 60°C (140°F), or 10°C (18°F) greater than the operating temperature of the control, whichever is higher. During the test, the control is to be operated in a manner representing the opening and closing of the door at a rate of one open-close operation per minute
- i) For the Electrical Fast Transient Burst Test, test level 3 is to be used for residential garage door operators and all other indoor use operators. For all other operators, test level 4 is to be used

Revised 25.6 effective March 1, 2000

25.7 In the evaluation of entrapment protection circuits used in residential garage door operators, the critical condition flow chart shown in Figure 25.1 shall be used to

- a) Conduct a failure-mode and effect analysis (FMEA),
- b) In investigating the performance during the Environmental Stress Tests, and
- c) During the Power Cycling Tests in accordance with the Standard for Tests for Safety-Related Controls Employing Solid-State Devices, UL 991



**Figure 25.1**  
**Critical condition flow chart for residential garage door operator entrapment protection devices and functions**

Figure 25.1 revised September 18, 1998

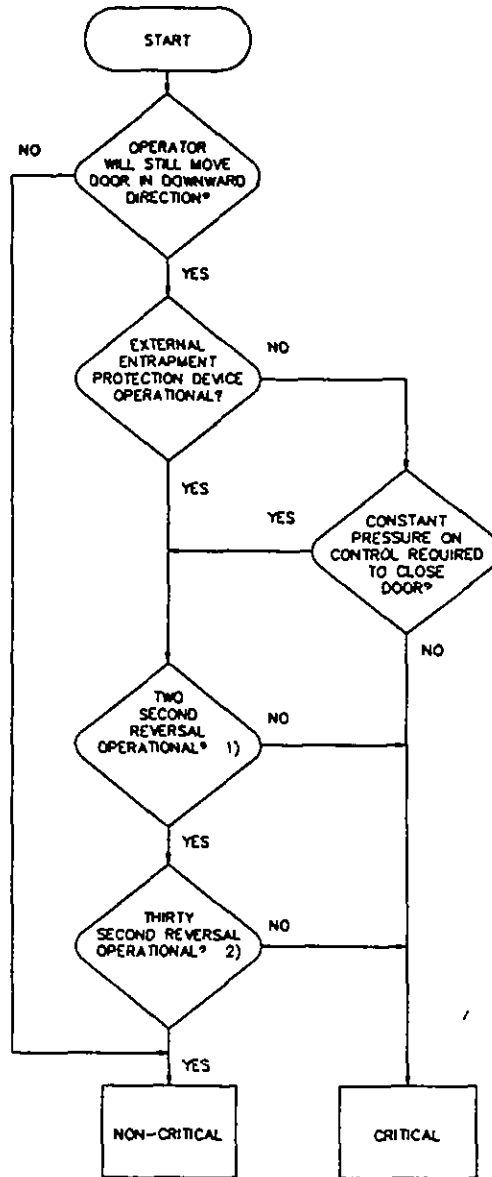

SM395

NOTES -

1) See 31.2.1

2) See 31.2.6

## 31 Residential Garage Door Operator and Door Operator Systems

### 31.1 General

31.1.1 A residential garage door operator system shall be supplied with primary inherent entrapment protection that complies with the requirements as specified in 31.2.1–31.2.8.

31.1.1 revised September 18, 1998

31.1.2 In addition to the primary inherent entrapment protection as required by 31.1.1, a residential garage door operator shall comply with one of the following

a) Shall be constructed to:

- 1) Require constant pressure on a control to lower the door,
- 2) Reverse direction and open the door to the upmost position when constant pressure on a control is removed prior to operator reaching its lower limit, and
- 3) Limit a portable transmitter, when supplied, to functioning only to cause the operator to open the door;

b) Shall be provided with a means for connection of an external secondary entrapment protection device as described in 31.3.1 – 31.3.3, or

c) Shall be provided with an inherent secondary entrapment protection device as described in 31.3.1, 31.3.2, and 31.3.4

31.1.2 revised September 18, 1998

*31.1.3 Revised and relocated as 45.5 effective March 1, 2000*

*31.1.4 Revised and relocated as 45.6 effective March 1, 2000*

*31.1.5 Revised and relocated as 31.2.8 September 18, 1998*

31.1.6 In the case of a door operator system that relies on the operator mounted to the header of the door for compliance with the requirements in this Standard, the door shall comply with the requirements in Specifications for Sectional Overhead Type Doors, ANSI/DASMA 102-1996. A pinch point shall not be contacted by the probe illustrated in Figure 9.1 using the procedures described in paragraphs 9.3, 9.4, 9.5, and 9.7. In addition, a section joint of a residential sectional garage door, that admits a 0.35 inch (9 mm) diameter rod that is 3.9 inches (100 mm) long, shall also admit a 1.0 inch (25 mm) diameter rod that is 3.9 inches (100 mm) long, at all positions of the door. Rubber or textile coverings or shields, when used to cover the joint, shall pass the same test. Evaluation of pinch points shall be made with the door installed on all track configurations supplied with the door.

31.1.6 added September 18, 1998

### 31.2 Inherent entrapment protection

31.2.1 Other than for the first 1 foot (305 mm) of travel as measured over the path of the moving door, both with and without any external entrapment protection device functional, the operator of a downward moving residential garage door shall initiate reversal of the door within 2 seconds of contact with the obstruction as specified in 31.2.2. After reversing the door, the operator shall return the door to, and stop the door at, the full upmost position. Compliance shall be determined in accordance with 31.2.2 – 31.2.8.

*Exception* The door operator is not required to return the door to, and stop the door at, the full upmost position when an inherent entrapment circuit senses a second obstruction or a control is actuated to stop the door during the upward travel

31 2 1 revised February 25, 2000

31 2 2 A solid object is to be placed on the floor of the test installation and at various heights under the edge of the door and located in line with the driving point of the operator. When tested on the floor, the object shall be 1 inch (25.4 mm) high. In the test installation, the bottom edge of the door under the driving force of the operator is to be against the floor when the door is fully closed.

*Exception.* For operators other than those attached to the door, a solid object is not required to be located in line with the driving point of the operator. The solid object is to be located at points at the center and within 1 foot of each end of the door.

31 2 2 revised September 18, 1998

31 2 3 An operator is to be tested for compliance with 31 2.1 for 50 open-and-close cycles of operation while the operator is connected to the type of residential garage door with which it is intended to be used or with the doors specified in 31 2.5. For an operator having a force adjustment on the operator, the force is to be adjusted to the maximum setting or at the setting that represents the most severe operating condition. Any accessories having an effect on the intended operation of entrapment protection functions that are intended for use with the operator, are to be attached and the test is to be repeated for one additional cycle.

31 2 3 revised September 18, 1998

31 2 4 For an operator that is to be adjusted (limit and force) according to instructions supplied with the operator, the operator is to be tested for 10 additional obstruction cycles using the solid object described in 31 2.2 at the maximum setting or at the setting that represents the most severe operating condition.

31 2 4 revised September 18, 1998

31 2 5 For an operator that is intended to be used with more than one type of door, one sample of the operator is to be tested on a sectional door with a curved track and one sample is to be tested on a one-piece door with jamb hardware and no track. For an operator that is not intended for use on either or both of these types of doors, a one-piece door with track hardware or a one-piece door with pivot hardware shall be used for the tests. For an operator that is intended for use with a specifically dedicated door or doors, a representative door or doors shall be used for the tests. See the marking requirements in 53 3 1.

31 2 5 revised September 18, 1998

31 2 5A An operator, using an inherent entrapment protection system that monitors the actual position of the door, shall initiate reversal of the door and shall return the door to, and stop the door at, the full upmost position in the event the inherent door operation "profile" of the door differs from the originally set parameters. The entrapment protection system shall monitor the position of the door at increments not greater than 1 inch (25.4 mm).

*Exception* The door operator is not required to return the door to, and stop the door at, the full upmost position when an inherent entrapment circuit senses an obstruction or a control is actuated to stop the door during the upward travel.

31 2 5A added September 18, 1998

31 2 6 An operator, using an inherent entrapment protection system that does not monitor the actual position of the door, shall initiate reversal of the door and shall return the door to, and stop the door at, the full upmost position, when the lower limiting device is not actuated within 30 seconds or less following the initiation of the close cycle

*Exception The door operator is not required to return the door to, and stop the door at, the full upmost position when an inherent entrapment circuit senses an obstruction or a control is actuated to stop the door during the upward travel. When the door is stopped manually during its descent, the 30 seconds shall be measured from the resumption of the close cycle*

31 2 6 revised September 18, 1998

31 2 7 To determine compliance with 31 2 5A or 31 2 6, an operator is to be subjected to 10 open-and-close cycles of operation while connected to the door or doors specified in 31 2 3 and 31 2 5. The cycles are not required to be consecutive. Motor cooling-off periods during the test meet the intent of the requirement. The means supplied to comply with 31 2 1 and 31 3 1 are to be inoperative or defeated during the test. An obstructing object is to be used so that the door is not capable of activating a lower limiting device

31 2 7 revised September 18, 1998

31 2 8 During the closing cycle, the system providing compliance with 31 2 1 and 31.2 5A or 31 2 1 and 31 2 6 shall function regardless of a short- or open-circuit anywhere in any low-voltage external wiring, any external entrapment devices, or any other external component.

31 1 5 revised and relocated as 31 2 8 September 18, 1998

### 31.3 Secondary entrapment protection

31 3 1 A secondary entrapment protection device supplied with, or as an accessory to, an operator shall consist of,

- a) An external photoelectric sensor that, when activated, results in an operator that is closing a door to reverse direction of the door and the sensor prevents an operator from closing an open door,
- b) An external edge sensor installed on the edge of the door that, when activated, results in an operator that is closing a door to reverse direction of the door and the sensor prevents an operator from closing an open door,
- c) An inherent door sensor independent of the system used to comply with Section 31 2 that, when activated, results in an operator that is closing a door to reverse direction of the door and the sensor prevents an operator from closing an open door, or
- d) Any other external or internal device that provides entrapment protection equivalent to (a), (b), or (c)

31 3 1 revised September 18, 1998

31 3 2 With respect to 31 3 1, the operator shall monitor for the presence and correct operation of the device, including the wiring to it, at least once during each close cycle. In the event the device is not present or a fault condition occurs which precludes the sensing of an obstruction, including an open- or short-circuit in the wiring that connects an external entrapment protection device to the operator and the device's supply source, the operator shall be constructed such that:

- a) A closing door shall open and an open door shall not close more than 1 foot (305 mm) below the upmost position, or
- b) The operator shall function as required by 31 1 2(a)

31 3 2 revised February 25, 2000

31 3 3 An external entrapment protection device shall comply with the applicable requirements in Sections 32– 34 of this Standard.

31 3 3 revised September 18, 1998

31 3 4 An inherent secondary entrapment protection device shall comply with the applicable requirements in Door Sensors, Section 42A Software used in an inherent entrapment protection device shall comply with the Standard for Safety Related Software, UL 1998

31 3 4 added September 18, 1998

#### 31.4 Additional features

31 4 1 A means to manually detach the door operator from the door shall be supplied The gripping surface (handle) shall be colored red and shall be easily distinguishable from the rest of the operator It shall be capable of being adjusted to a height of 6 feet (1 8 m) above the garage floor when the operator is installed according to the instructions specified in 51 3 1 and 51 4 1(4) The means shall be constructed so that a hand firmly gripping it and applying a maximum of 50 pounds (223 N) of force shall detach the operator with the door obstructed in the down position The obstructing object, as described in 31 2 2, is to be located in several different positions A marking with instructions for detaching the operator shall be supplied The marking shall comply with 52 1 – 52 8

*Exception A means to manually detach the door operator from the door is not required for a door operator that is not directly attached to the door and that controls movement of the door so that*

- a) The door is capable of being moved open from any position other than the last (closing) 2 inches (50 8 mm) of travel, and*
- b) The door is capable of being moved to the 2-inch point from any position between closed and the 2-inch point*

31 4 1 revised September 18, 1998

31 4 2 Actuation of a control that initiates movement of a door shall stop and may reverse the door on the down cycle On the up cycle, actuation of a control shall stop the door but not reverse it.

31 4 3 A residential garage door operator when tested as described in 39 1 shall have a maximum appliance current draw, excluding lamps or external devices, of not more than 5 amperes

31 4 3 revised November 24, 1997

31.4.4 An operator shall be constructed so that adjustment of limit, force or other user controls and connection of external entrapment protection devices can be accomplished without exposing normally enclosed live parts or wiring. See 9.7.

## EXTERNAL ENTRAPMENT PROTECTION DEVICES

### 32 All Devices

#### 32.1 General

32.1.1 An external entrapment protection device shall perform its intended function when tested in accordance with 32.1.2 – 32.1.4.

32.1.2 The device is to be installed in the intended manner and its terminals connected to circuits of the operator as indicated by the installation instructions.

Effective date of 32.1.2 changed from July 16, 1999 to March 1, 2000

32.1.3 The device is to be installed and tested at minimum and maximum heights and widths representative of recommended ranges specified in the installation instructions. For doors, if not specified, devices are to be tested on a minimum 7-foot (2.1-m) wide door and maximum 20-foot (6.1-m) wide door.

Effective date of 32.1.3 changed from July 16, 1999 to March 1, 2000

32.1.4 If powered by a separate source of power, the power-input supply terminals are to be connected to supply circuits of rated voltage and frequency.

32.1.5 An external entrapment protection device requiring alignment, such as a photoelectric sensor, shall be provided with a means, such as a visual indicator, to show proper alignment and operation of the device.

#### 32.2 Current protection test

32.2.1 There shall be no damage to the entrapment protection circuitry if low voltage field-wiring terminals or leads are shorted or miswired to adjacent terminals.

32.2.2 To determine compliance with 32.2.1, an external entrapment protection device is to be connected to an operator or other source of power in the intended manner, after which all connections to low-voltage terminals or leads are to be reversed as pairs, reversed individually, or connected to any low-voltage lead or adjacent terminal.

Effective date of 32.2.2 changed from July 16, 1999 to March 1, 2000

#### 32.3 Water exposure tests

32.3.1 *Revised and relocated as 32.3.1.1 effective March 1, 2000*

##### 32.3.1 Splash test

32.3.1.1 An external entrapment protection device intended to be installed inside a garage 3 feet (914 mm) or less above the floor shall withstand indirect water spray as described in 32.3.1.2 without resulting in a risk of electric shock and shall function as intended. After exposure to the water spray, the external surface of the device is to be dried before determining its functionality.

32.3.1 revised and relocated as 32.3.1.1 effective March 1, 2000

32.3.1.2 External entrapment protection devices are to be indirectly sprayed using a hose having the free end fitted with a nozzle as illustrated in Figure 32.1 and connected to a water supply capable of maintaining a flow rate of 5 gallons (19 liters) per minute as measured at the outlet orifice of the nozzle. The water from the hose is to be sprayed, from all sides and at any angle, against the floor under the device in a manner that results in water spray on the enclosure of electrical components. The nozzle is not to be brought closer than 10 feet (3.05 m) horizontally to the device. The water is to be sprayed for 1 minute.

32.3.2 revised and relocated as 32.3.1.2 effective March 1, 2000

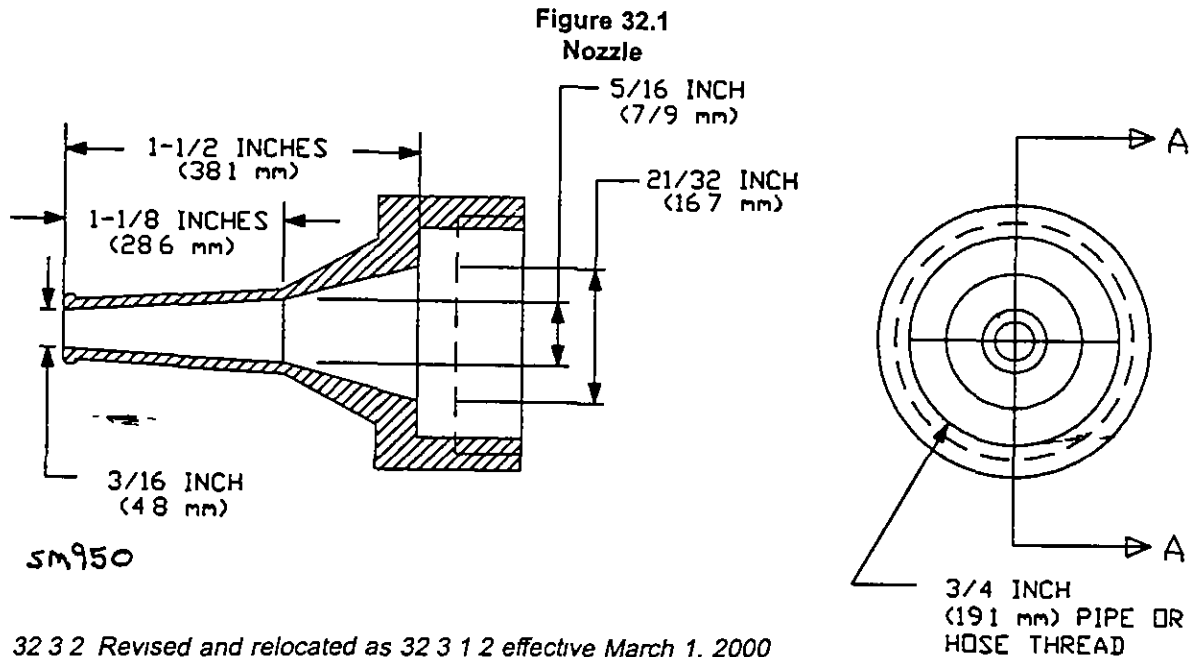

32.3.2 Revised and relocated as 32.3.1.2 effective March 1, 2000

### 33 Photoelectric Sensors

#### 33.1 Normal operation test (doors, vertical lift gates, and vertical pivot gates)

33.1.1 When installed as described in 32.1.1 – 32.1.4, a photoelectric sensor shall sense an obstruction as described in 33.1.2 that is to be placed on a level surface below the door or gate. The sensor is to be tested with the obstruction at a total of five different locations over the width of the door or gate opening. The locations shall include distances 1 inch (25.4 mm) from each end, 1 foot (305 mm) from each end, and the midpoint.

Revised 33.1.1 effective March 1, 2000

### 32.5 Resistance to impact test

32.5.1 An external entrapment protection device employing a polymeric or elastomeric material as a functional part shall be subjected to the impact test specified in 32.5.2. As a result of the test:

- a) There shall not be cracking or breaking of the part, and
- b) The part shall operate as intended.

A part that is dislodged, is not cracked or broken, and is capable of being restored to its original condition meets the intent of the requirement.

32.5.1 revised September 18, 1998

32.5.2 Samples of the external entrapment protection device are to be subjected to the Impact Test described in the Standard for Polymeric Materials – Use in Electrical Equipment Evaluations, UL 746C. The external entrapment protection device is to be subjected to 5 foot-pound (6.8 J) impacts. Three samples are to be tested, each sample being subjected to three impacts at different points.

33.1.2 The obstruction noted in 33.1.1 shall consist of a white vertical surface, 6 inches (152 mm) high by 12 inches (305 mm) long. The obstruction is to be centered under the door or gate perpendicular to the plane of the door or gate when in the closed position. See Figure 33.1.

Revised 33.1.2 effective March 1, 2000

**Figure 33.1**  
**Stationary obstruction**

Effective date of Figure 33.1 changed from July 1, 1999 to March 1, 2000

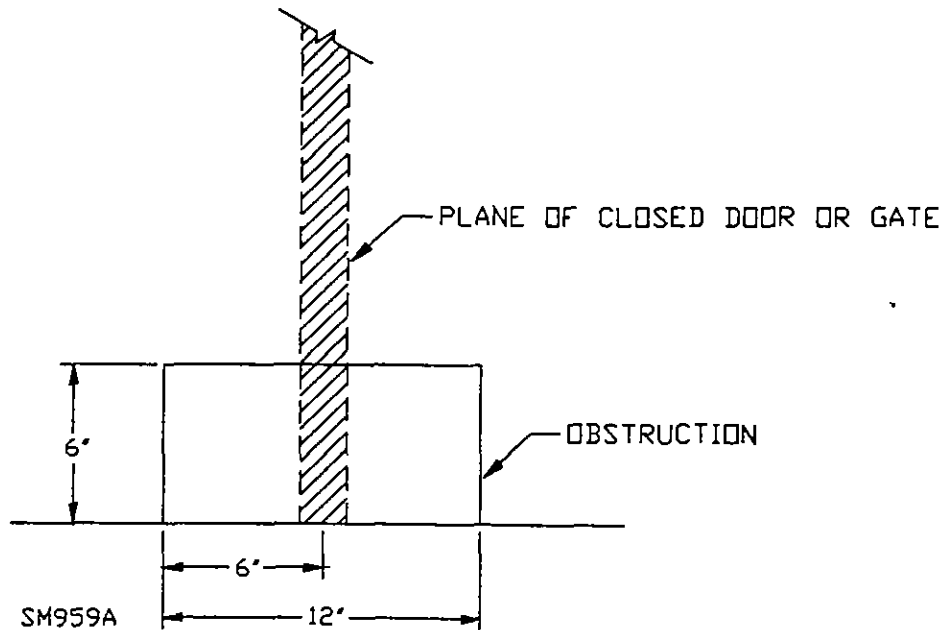

**33.2 Sensitivity test**

33.2.1 When installed as described in 32.1.1 – 32.1.4, a photoelectric sensor shall sense the presence of a moving object when tested according to 32.2.2.

33.2.2 The moving object is to consist of a 1-7/8 inch (47.6 mm) diameter cylindrical rod, 34-1/2 inches (876 mm) long, with the axis point being 34 inches (864 mm) from the end. The axis point is to be fixed at a point centered directly above the beam of the photoelectric sensor 36 inches (914 mm) above the level surface below the door or gate. The photoelectric sensor is to be mounted at the highest position as recommended by the manufacturer. The rod is to be swung as a pendulum through the photoelectric sensor's beam from a position 45 degrees from the plane of the door or gate when in the closed position. See Figure 33.2.

Effective date of 33.2.2 changed from July 1, 1999 to March 1, 2000



**Figure 33.2**  
**Moving obstruction**

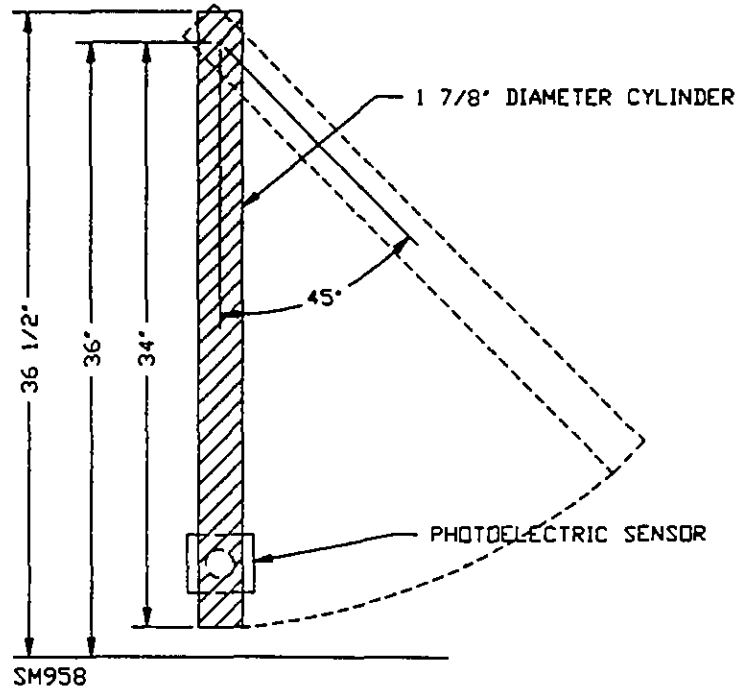

33 2 3 The test described in 33 2 2 is to be conducted at three points over the width of the door or gate opening, at distances of 1 foot (305 mm) from each end and the midpoint

Effective date of 33 2 3 changed from July 16, 1999 to March 1, 2000

**33.3 Ambient light test**

33 3 1 A photoelectric sensor shall operate as specified in 31 3 1 and 31 3 2 when subjected to ambient light impinging at an angle of 15 to 20 degrees from the axis of the beam when tested according to 33 3 2 and, if appropriate, 33 3 3

33 3 2 To determine compliance with 33.3 1, a 500 watt, 3600K Photo Floodlamp, type DXC RFL-2, is to be energized from a 120-volt, 60-hertz source. The lamp is to be positioned 5 feet from the front of the receiver and aimed directly at the sensor at an angle of 15 to 20 degrees from the axis of the beam. See Figure 33 3

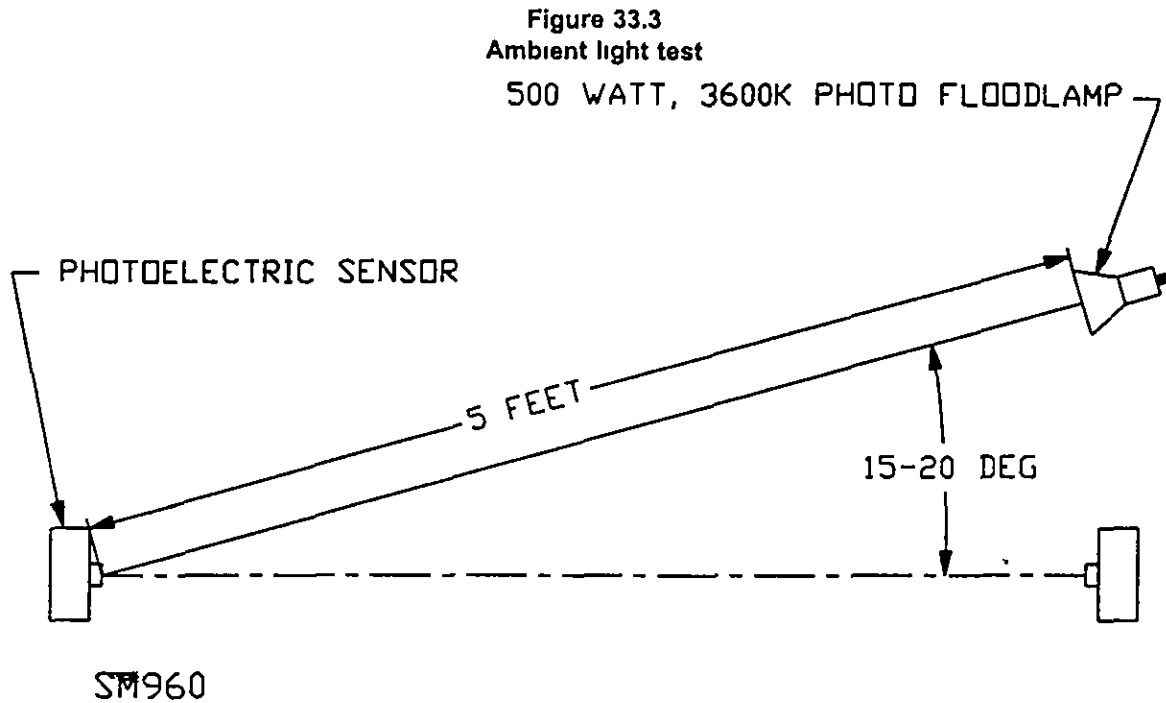

33.3.3 If the photoelectric sensor uses a reflector, this test is to be repeated with the lamp aimed at the reflector.

#### 34 Edge Sensors

##### 34.1 Normal operation test

34.1.1 When installed on a representative door edge, an edge sensor shall actuate upon the application of a 15 pound (66.7 N) or less force in the direction of the application. For an edge sensor intended to be used on a sectional door, the force is to be applied by the longitudinal edge of a 1-7/8 inch (47.6 mm) diameter cylinder placed across the sensor so that the axis is perpendicular to plane of the door. For an edge sensor intended to be used on a one piece door, the force is to be applied so that the axis is at an angle 30 degrees from the direction perpendicular to the plane of the door. See Figure 34.1.

**Figure 34.1**  
Edge sensor normal operation test

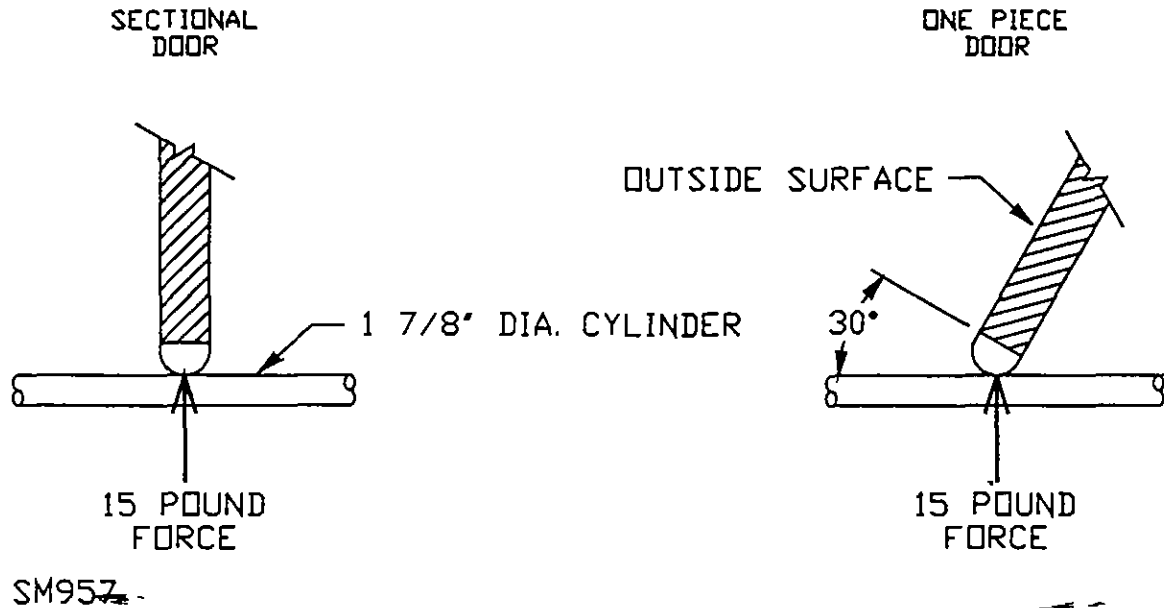

34.1.2 With respect to the test of 34.1.1, the test is to be repeated at various representative points of the edge sensor across the width of the door

*Exception* The edge sensor need not be sensitive to actuation 2 inches (50.4 mm) or less from each end of the intended width of the door opening

### 34.2 Endurance test

34.2.1 An edge sensor system and associated components shall withstand 30,000 cycles of mechanical operation without failure. For this test, the edge sensor is to be cycled by the repetitive application of the force as described in 34.1.1. The force is to be applied to the same location for the entire test. For an edge sensor system employing integral electric contact strips, this test shall be conducted with the contacts connected to a load no less severe than it controls in the operator. For the last 50 cycles of operation, the sensor shall function as intended when connected to an operator.

### 34.3 Elastomeric material conditioning test

34.3.1 An elastomeric material used as a functional part of an edge sensor shall function as intended when subjected to

- a) Accelerated Aging Test of Gaskets, Section 44, and
- b) Puncture Resistance Test, Section 47

34.3.2 An elastomeric material used for a functional part that is exposed to outdoor weather conditions when the door is in the closed position shall have physical properties as specified in Table 44.1 after being conditioned in accordance with the Ultraviolet Light Exposure Test described in the Standard for Polymeric Materials – Use in Electrical Equipment Evaluations, UL 746C

### 35 Trial Installation

35.1 To determine whether the installation instructions in the instruction manual comply with the requirements in 51.1.1– 51.1.3, 51.3.1, and 51.3.2, a trial installation is to be made using the instruction manual

Effective date of 35.1 changed from July 16, 1999 to March 1, 2000

## 42A Inherent Secondary Force Activated Door Sensors

### 42A.1 Normal operation test

42A.1.1 A force activated door sensor of a door system installed according to the installation instructions shall actuate when the door applies a force of 15 pound (66.7 N) or less in the down or closing direction and when the door applies a force of 25 pound (111.2 N) or less in the up or opening direction. For a force activated door sensor intended to be used in an operator intended for use only on a sectional door, the force is to be applied by the door against the longitudinal edge of a 1-7/8 inch (47.6 mm) diameter cylinder placed across the door so that the axis is perpendicular to the plane of the door. See Figure 34.1. The weight of the door is to be equal to the maximum weight rating of the operator.

42A.1.1 added September 18, 1998

42A.1.2 The test described in 42A.1.1 is to be repeated and measurements made at various representative points across the width and height of the door. For this test, a force activated door sensor system and associated components shall withstand a total of 9 cycles of mechanical operation without failure with the force applied as follows:

- a) At the center at points one, three, and five feet (304.8 mm, 914.4 mm and 1.5 m) from the floor,
- b) Within 1 foot (304.8 mm) of the end of the door, at points one, three, and five feet from the floor,
- c) Within 1 foot of the other end of the door at points one, three, and five feet from the floor.

The cycles are not required to be consecutive. Continuous operation of the motor without cooling is not required.

42A.1.2 added September 18, 1998

### 42A.2 Adjustment of door weight

42A.2.1 With the door at the point and at the weight determined by the tests of 42A.1.2 and 42A.2.2 to be most severe, the door sensor and associated components shall function as intended after 50 cycles of operation.

42A.2.1 added September 18, 1998

42A.2.2 At the point determined by the test in 42A.1.1 and 42A.1.2 to be the most severe, weight is to be added to the door in 5.0-pound (2.26-Kg) increments and the test repeated until a total of 15.0 pounds (6.78 kg) has been added to the door. Before performing each test cycle, the door is to be cycled 2 times to update the profile. Similarly, starting from normal weight plus 15.0 pounds, the test is to be repeated by subtracting weight in 5.0-pound increments until a total of 15.0 pounds has been subtracted from the door.

42A.2.2 added September 18, 1998

45 5 A mechanical switch or a relay used in an entrapment protection circuit of an operator shall withstand 100,000 cycles of operation controlling a load no less severe (voltage, current, power factor, inrush, and similar ratings) than it controls in the operator, and shall function normally upon completion of the test

31 1 3 revised and relocated as 45 5 effective March 1, 2000

45 6 In the event malfunction of a switch or a relay (open or short) described in 45 5 results in loss of any entrapment protection required by 30A 1 1, 31 2 1, 31 2 5A, 31 2 6, or 31 3 1, the door or gate operator shall become inoperative at the end of the opening or closing operation, or for a door operator only, the door operator shall move the door to, and stay within, 1 foot (305 mm) of the uppermost position.

31 1 4 revised and relocated as 45 6 effective March 1, 2000

#### 47 Puncture Resistance Test

47 1 After being subjected to the test described in 47 2, an elastomeric material that is a functional part of an edge sensor shall

- a) Not be damaged in a manner that would adversely affect the intended operation of the edge sensor, and
- b) Maintain enclosure integrity if it serves to reduce the likelihood of contamination of electrical contacts

47 2 A sample of the edge sensor is to be installed in the intended manner on a representative door edge. The probe described in Figure 47 1 is to be applied with a 20 pound-force (89N) to any point on the sensor that is 3 inches or less above the floor when the door is fully closed. For each type of door, the force is to be applied in the direction specified in the Edge Sensor Normal Operation Test, Figure 34 1. The test is to be repeated on three locations on each surface of the sensor being tested.

**Figure 47.1**  
**Puncture probe**

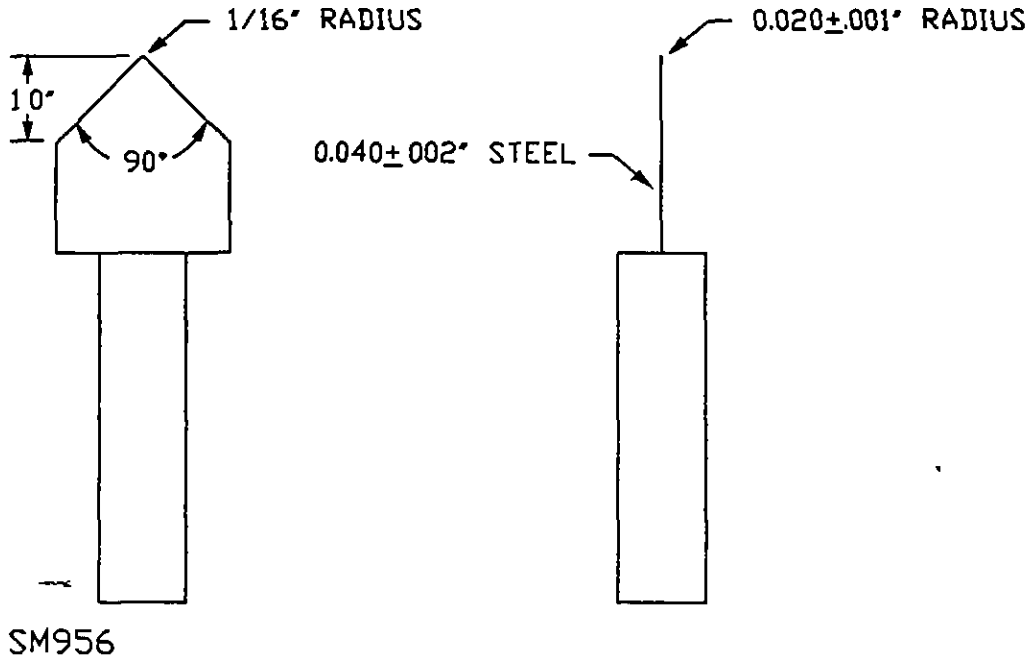

47.3 The test is to be repeated on an additional sample cooled to a temperature of 0 0°C (32 0°F) and maintained at this temperature for 3 hours. While the sample is still cold, it is to be subjected to the puncture resistance tests described in 47.1 and 47.2.

#### 48 Permanence of Marking Tests

48.1 A marking that is required to be permanent shall be molded, die-stamped, paint-stenciled, stamped or etched metal that is permanently secured, or indelibly stamped lettering on a pressure-sensitive label secured by adhesive that, upon investigation, is found to be acceptable for the application. Ordinary usage, handling, storage, and the like of a product are considered in the determination of the permanence of a marking.

48.2 Unless rated for the application, a pressure-sensitive label or a label that is secured by cement or adhesive and that is required to be permanent shall comply with the applicable requirements in the Standard for Marking and Labeling Systems, UL 969. The label shall be evaluated for exposure to

- a) High humidity,
- b) Occasional exposure to water, and
- c) Minimum temperature of minus 40°C (minus 40°F)

A label used on a product or device anticipated to be exposed to the weather shall be evaluated for outdoor use.

## **INSTRUCTION MANUAL**

### **51 Details**

#### **51.1 General**

51 1 1 An appliance shall be provided with an instruction manual. The instruction manual shall give instructions for the installation, operation, and user maintenance of the appliance

51 1 7 Where a minimum letter height is specified, the height of the largest letter shall be used to determine letter height, unless stated otherwise. Numbers and all other letters shall be proportional.

51 1 7 added September 18, 1998

#### **51 3 Residential garage doors and door operators**

51 3 1 Instructions that clearly detail installation and adjustment procedures required to effect proper operation of the safety means included shall be provided with each door operator

51 3 2 A residential garage door or door operator shall be provided with complete and specific instructions for the correct adjustment of the control mechanism and the need for periodic checking and, if needed, adjustment of the control mechanism so as to maintain satisfactory operation of the door

51 3 3 The instruction manual shall include the important instructions specified in 51 4 1 and 51 5 1. All required text shall be legible and contrast with the background. Upper case letters of required text shall be no less than 5/64 inch (2 0 mm) high and Lower case letters shall be no less than 1/16 inch (1 6 mm) high. Headings such as "IMPORTANT INSTALLATION INSTRUCTIONS", "IMPORTANT SAFETY INSTRUCTIONS", "SAVE THESE INSTRUCTIONS" and the words "WARNING - To reduce the risk of severe injury or death to persons" shall be in letters no less than 3/16 inch (4 8 mm) high

51 3 4 The instructions listed in 51 4 1 and 51 5 1 shall be in the exact words specified or shall be in equally definitive terminology to those specified. No substitutes shall be used for the word "WARNING". The items may be numbered. The first and last items specified in 51 5 1 shall be first and last respectively. Other important and precautionary items considered appropriate by the manufacturer may be inserted

51 3 5 The instructions listed in 51 4 1 shall be located immediately prior to the installation instructions. The instructions listed in 51 5 1 shall be located immediately prior to user operation and maintenance instructions. In each case, the instructions shall be separate in format from other detailed instructions related to installation, operation and maintenance of the appliance. All instructions, except installation instructions, shall be a permanent part of the manual(s)

## 51.4 Installation instructions

51 4 1 The installation instructions shall include the following or equivalent text

### IMPORTANT INSTALLATION INSTRUCTIONS

**WARNING** – To reduce the risk of severe injury or death.

1 **READ AND FOLLOW ALL INSTALLATION INSTRUCTIONS.**

2 Install only on a properly balanced garage door. An improperly balanced door has the potential to inflict severe injury. Have a qualified service person make repairs to cables, spring assemblies, and other hardware before installing the opener.

3 Remove all ropes and remove or make inoperative all locks connected to the garage door before installing opener.

4 Where possible, install the door opener 7 feet or more above the floor. For products having an emergency release, mount the emergency release 6 feet above the floor.

5 Do not connect the opener to source of power until instructed to do so.

6 Locate the control button (a) within sight of door, (b) at a minimum height of 5 feet so small children are not able to reach it, and (c) away from all moving parts of the door.

7. Install the Entrapment Warning Label next to the control button in a prominent location. Install the Emergency Release Marking. Attach the marking on or next to the emergency release.

8 After installing the opener, the door must reverse when it contacts a 1-1/2 inch high object (or a 2 by 4 board laid flat) on the floor.

51 4 1 revised September 18, 1998

## 51.5 User instructions

51 5 1 The user instructions shall include the following or equivalent text

### IMPORTANT SAFETY INSTRUCTIONS

**WARNING** – To reduce the risk of severe injury or death.

1 **READ AND FOLLOW ALL INSTRUCTIONS.**

2 Never let children operate or play with door controls. Keep the remote control away from children.

3 Always keep the moving door in sight and away from people and objects until it is completely closed. **NO ONE SHOULD CROSS THE PATH OF THE MOVING DOOR.**

4 Test door opener monthly. The garage door **MUST** reverse on contact with a 1-1/2 inch high object (or a 2 by 4 board laid flat) on the floor. After adjusting either the force or the limit of travel, retest the door opener. Failure to adjust the opener properly increases the risk of severe injury or death.



5 For products having an emergency release, when possible, use the emergency release only when the door is closed. Use caution when using this release with the door open. Weak or broken springs are capable of increasing the rate of door closure and increasing the risk of severe injury or death.

6 **KEEP GARAGE DOORS PROPERLY BALANCED** See owner's manual. An improperly balanced door increases the risk of severe injury or death. Have a qualified service person make repairs to cables, spring assemblies, and other hardware.

7 **SAVE THESE INSTRUCTIONS**

51 5 1 revised September 18, 1998

## 52 Field Installed Labels

52.1 A residential garage door operator shall be provided with labels for field installation and constructed as specified in 52.3 – 52.9. The labels shall be acceptable for permanent installation. The instruction manual shall specify where the labels are to be located.

52.2 If labels secured by adhesive are used, the instructions shall specify that an additional mechanical means shall be used to secure the labels to surfaces to which the adhesive will not adhere.

52.3 A residential garage door operator shall be provided with a cautionary label intended for permanent installation to identify the possible risk of entrapment. The instruction manual shall direct that the label be affixed near the wall-mounted control button.

52.4 The label required in accordance with 52.3 shall be in a vertical layout with three panels:

- a) A signal word panel,
- b) A pictorial panel, and
- c) A message panel.

Adjacent panels shall be delineated from each other by a bold black line. The entire label shall be surrounded by a black border and shall not be less than 5 inches (127 mm) wide by 6-1/4 inches (159 mm) long overall.

52.4 revised September 18, 1998

52.5 The signal word panel as specified in 52.4 shall contain the word "WARNING," in upper case letters, preceded by a safety alert symbol consisting of an orange exclamation mark on a black solid equilateral triangle background with the point of the triangle oriented upward. The word "WARNING" and the safety alert symbol shall be centered on one line and shall be in black letters at least 7/16 inch (11.1 mm) high on an orange background.

52.6 The pictorial panel as specified in 52.4 shall be positioned between the signal word panel and the message panel. The pictorial shall be black on a white background and shall clearly depict a child running toward or under a garage door. A red prohibition symbol (slash, oriented from the upper left to the lower right, through a circle) shall be superimposed over, and totally surround, the pictorial. The pictorial shall have an overall diameter of 1-7/8 inch (47.6 mm) minimum.

52.7 The message panel specified in 52.4 shall include the following statements and instructions or an equivalent wording:

- a) **POSSIBLE RISK AND CONSEQUENCE STATEMENT** – "There is a risk of a child becoming trapped under an automatic garage door resulting in severe injury or death."

## b) AVOIDANCE STATEMENTS

- 1) "Do not let children walk or run under a closing door "
- 2) "Do not let children operate door operator controls "
- 3) "Always keep a closing door within sight "
- 4) "In the event a person is trapped under the door, push the control button or use the emergency release."

*Exception For products not having an emergency release, the instructions shall omit "or use the emergency release"*

## c) INSTRUCTIONS

- 1) "Test Door Operator Monthly Use a 1-1/2-inch high object (or a 2 by 4 board laid flat) on the floor under the closing door In the event the door does not reverse upon contact, adjust, repair, or replace the operator "
- 2) Additional instructions on not removing or painting over the label, mounting the label adjacent to the wall control, and mounting the wall control out of children's reach shall be supplied. These additional instructions shall be in less prominent lettering than the lettering for item 1

52 7 revised September 18, 1998

52 8 The lettering of the message panel described in 52 7 shall be black on a white background and shall be in sans serif letters in combinations of upper case and lower case letters The upper case letters of the Possible Risk and Consequence Statements and Avoidance Statements shall be 1/8 inch (3 18 mm) high minimum The lettering of the Possible Risk and Consequence Statement shall be in italics, underlined, bold, or the like, and shall be double spaced from the Avoidance Statements so that it is more prominent than the Avoidance Statements All other instructions shall be in letters less prominent than the Possible Risk and Consequence Statements and shall be separated with at least a single space between individual instructions

52.9 A residential garage door operator shall be supplied with a cautionary marking attached to, or adjacent at all times to, the means supplied to detach the operator from the garage door. The marking shall include the following statement or the equivalent: "In the event the door becomes obstructed, detach door from operator as follows. (The method to detach the operator shall be shown on the marking)."

*Exception:* For a product complying with the Exception to 31.4.1, a cautionary marking is not required.

52.9 revised September 18, 1998

## MARKING

### 53 Details

#### 53.1 General

53.1.1 Unless specifically indicated otherwise, markings required in 53.1.2 – 53.4.8 and elsewhere in this standard shall be permanent in accordance with Permanence of Marking Tests, Section 48.

Revised 53.1.1 effective July 16, 1998

53.1.2 An appliance shall be plainly marked, at a location where the marking shall be readily visible – after installation, in the case of a permanently connected appliance – with

- a) The manufacturer's name, trademark, or other descriptive marking by which the organization responsible for the product is identified – hereinafter referred to as the manufacturer's name,
- b) The catalog number or the equivalent,
- c) The voltage, frequency, and input in amperes or watts, and
- d) The date or other dating period of manufacture not exceeding any three consecutive months. The ampere rating shall be included unless the full-load power factor is 80 percent or more, or, for a cord-connected appliance, unless the rating is 50 watts or less. The number of phases shall be indicated when an appliance is for use on a polyphase circuit. The date code repetition cycle shall not be less than 20 years.

*Exception No. 1:* The manufacturer's identification is not restricted from being in a traceable code when the appliance is identified by the brand or trademark owned by a private labeler.

*Exception No. 2:* The date of manufacture is not restricted from being abbreviated or in an established or otherwise accepted code.

53.1.2 revised September 18, 1998

53.1.3 If a manufacturer produces or assembles appliances at more than one factory, each finished appliance shall have a distinctive marking, which may be in code, to identify it as the product of a particular factory.

### 53.3 Specific appliances

53 3 1 The carton and the instruction manual for an operator shall be marked with the word "WARNING" and the following or the equivalent "To reduce the risk of injury to persons – Use this operator only with (a) \_\_\_ door(s) "

53 3 2 For products with user adjustments, a residential garage door operator shall be marked with the word "WARNING" and the following or equivalent "Risk of entrapment After adjusting either the force or limits of travel adjustments, confirm that the door reverses on a 1-1/2 inch (or a 2 by 4 board laid flat) high obstruction on the floor "

53 3 2 revised September 18, 1998

53 3 3 A separately supplied accessory, including an external entrapment protection device, intended for installation with an appliance or appliances shall be marked with the manufacturer's name and catalog or model number and the type of appliance or appliances (such as a residential garage door operator) with which it is intended to be used

53 3 3 revised September 18, 1998

53 3 4 An appliance provided with terminals or connectors for connection of a separately supplied accessory, such as an external entrapment protection device, shall be marked to identify the accessory intended to be connected to the terminals or connectors The accessory identification shall be by manufacturer's name and catalog or model number or other means to allow for the identification of accessories intended for use with the appliance

53 3 5 With reference to 53 3 3, instructions for installing a separately supplied accessory shall be provided A statement shall be included in the instructions warning the user that the appliance must be disconnected from the source of supply before attempting the installation of the accessory

53 3 12 A door or door operator as described in 30 1 1(c) shall be provided with a placard that is marked in letters at least 1/4 inch (6.4 mm) high with the word "WARNING" and the following statement or the equivalent "To Prevent Entrapment – Do not start door downward unless doorway is clear " The placard shall be made of substantially rigid material such as vulcanized fiber, or the equivalent, to provide mechanical strength, and provided with at least two holes for wall mounting

**TAB D**



UNITED STATES  
CONSUMER PRODUCT SAFETY COMMISSION  
WASHINGTON, DC 20207

**Memorandum**

Date: April 20, 2000

TO : John R. Murphy, Mechanical Engineer, ES  
THROUGH: Warren J. Prunella, AED, EC *WJP*  
FROM : Terrance R. Karels, EC *TRK*  
SUBJECT Revision of Garage Door Operator Standard

The Commission staff is recommending that the standard for automatic residential garage door operators (GDOs) be revised to conform to revisions in the UL standard for these products. The revisions would accommodate technical advances and newer designs in GDOs. The Commission is required by the Regulatory Flexibility Act of 1980 (RFA) to address and give particular attention to the economic effects of the revisions on small entities. Due to the nature of the revisions, they are unlikely to have any adverse impact on small businesses or other entities.

There are three changes addressing new types of mechanisms to prevent entrapment. One change allows for a system that continuously monitors the position of the door, while another allows for the incorporation of an additional, secondary door sensor to prevent entrapment. The third change exempts GDOs from having a manual release mechanism if they are not directly connected to the door and the door can be easily raised manually. The amendment also includes a revision of the standard's labeling provisions.

The changes are not expected to have a significant impact on a substantial number of small businesses. According to industry sources, there are 22 manufacturers or importers of GDOs; only one of these uses the new mechanisms that would be permitted under the revised standard. With over 1,000 employees, this firm would not be considered a small business under Small Business Administration guidelines. The substantive changes affect only the companies that either use the new designs or may adapt them to future production. No firms would be required to make changes to its products in order to conform to the standard. Any firms that currently comply with UL325 would continue to comply after the technical amendments. The revisions will not render other models obsolete, and are not expected to affect consumer demand.

**TAB E**

[Billing Code 6335-01]

DRAFT 5/9/00

CONSUMER PRODUCT SAFETY COMMISSION

Safety Standard for Automatic Residential Garage Door  
Operators

16 CFR Part 1211

**AGENCY:** Consumer Product Safety Commission.

**ACTION:** Notice of proposed rulemaking.

**SUMMARY:** The Consumer Product Safety Commission is proposing to amend 16 CFR part 1211, Safety Standard for Automatic Residential Garage Door Operators, to reflect changes made by Underwriters Laboratories, Inc. in its standard UL 325.

**DATE:** The Office of the Secretary must receive comments by [Insert date 75 days from date of publication in the FEDERAL REGISTER].

**ADDRESSES:** Comments may be mailed to the Office of the Secretary, Consumer Product Safety Commission, Washington, DC 20207 or delivered to the Office of the Secretary, Consumer Product Safety Commission, Room 502, 4330 East-West Highway, Bethesda, Maryland 20814-4408, telephone (301) 504-0800. Comments may also be filed by telefacsimile to (301) 504-0127 or e-mailed to [cpsc-os@cpsc.gov](mailto:cpsc-os@cpsc.gov).

**FOR FURTHER INFORMATION CONTACT:** John Murphy, Directorate for Engineering Sciences, Consumer Product Safety Commission, Washington, DC 20207, telephone 301-504-0494.

**SUPPLEMENTARY INFORMATION:** The Commission issued part 1211 on December 21, 1992 to minimize the risk of entrapment by



residential garage door openers. As mandated by section 203 of Public Law 101-608, subpart A of part 1211 codifies garage door operator entrapment provisions of Underwriter Laboratories, Inc. ("UL") standard UL 325, third edition, "Door, Drapery, Louver and Window Operators and Systems." Subparagraph (c) of section 203 of Pub. L. 101-608 also required the Commission to incorporate into part 1211 any revisions that UL proposed to the entrapment protection requirements of UL 325, unless the Commission notified UL that the revision does not carry out the purposes of Pub. L. 101-608.

UL proposed revisions to UL 325 on June 30, 1998 and made them final on September 18, 1998. The Commission determined that the entrapment related revisions do carry out the purposes of Public Law 101-608. This proposed rule would incorporate into subpart A of part 1211 those revisions that relate to entrapment by residential automatic garage door operators. It would also correct a few typographical errors in part 1211.

The changes to the UL standard allow for advances in the state of the art in garage door safety. Some new garage door operators have an inherent entrapment protection system that can continuously monitor the position of the door. The UL revisions add requirements for this type of system. Some new garage door operators have an inherent secondary door sensor that is independent of the primary entrapment

protection system. The UL revisions add requirements for this type of new system. Finally, the UL standard adds some new and revised provisions concerning instructions and field installed labels. The proposed rule would incorporate these changes into the CPSC mandatory standard.

Pursuant to section 605(b) of the Regulatory Flexibility Act, 5 U.S.C. 605(b), the Commission certifies that this rule will not have a significant impact on a substantial number of small entities. Most of the changes are editorial and minor. The substantive changes only affect the few companies that are developing the new type of garage door operators discussed above. Moreover, UL has already made these changes to its UL 325 standard which is widely followed by the industry. The Commission also certifies that this rule will have no environmental impact. The Commission's regulations state that safety standards for products normally have little or no potential for affecting the human environment. 16 CFR 1021.5(c)(1). Nothing in this proposed rule alters that expectation.

Public Law 101-608 contains a preemption provision. It states: "those provisions of laws of States or political subdivisions which relate to the labeling of automatic residential garage door openers and those provisions which do not provide at least the equivalent degree of protection from the risk of injury associated with automatic residential garage door openers as the consumer product

safety rule" are subject to preemption under 15 U.S.C. 2075. Pub. L. 101-608, section 203(f).

**List of Subjects in 16 CFR Part 1211**

Consumer protection, imports, labeling, reporting and recordkeeping requirements

Accordingly, 16 CFR part 1211 is proposed to be amended as follows:

**PART 1211--SAFETY STANDARDS FOR AUTOMATIC RESIDENTIAL GARAGE DOOR OPENERS**

1. The authority citation for part 1211 is revised to read as follows:

**Authority:** Sec. 203 of Pub. L. 101-608, 104 Stat. 3110; 15 U.S.C. 2063 and 2065.

2. In § 1211.2(c) remove the word "1993" and add, in its place "1999".

3. In the first sentence of § 1211.3 remove the words "as given in these requirements" and "an equivalent" and add the word "a" between the words "by" and "value".

4. Section 1211.4 is amended as follows:

a. In § 1211.4(c) remove the words "1st ed., dated July 19, 1991" and add, in their place "second edition, dated June 23, 1995".

b. In § 1211.4(c) add "5" before "U.S.C.".

5. Section 1211.5 is amended as follows:

a. In § 1211.5(a) and (b)(3) remove the words "1st ed., dated July 19, 1991" and add, in their place "second edition, dated June 23, 1995".

b. Revise paragraphs (a)(1), (a)(6), and (a)(7); and add a new paragraph (a)(9) to read as follows:

§ 1211.5 General testing parameters.

(a) \* \* \*

(1) With regard to electrical supervision of critical components, an operator being inoperative with respect to downward movement of the door meets the criteria for trouble indication.

\* \* \* \* \*

(6) When a Computational Investigation is conducted,  $\lambda_p$  shall not be greater than 6 failures/ $10^6$  hours for the entire system. For external secondary entrapment protection devices that are sold separately,  $\lambda_p$  shall not be greater than 0 failures/ $10^6$  hours. For internal secondary entrapment protection devices whether or not they are sold separately,  $\lambda_p$  shall not be greater than 0 failures/ $10^6$  hours. The operational test is conducted for 14 days. An external secondary entrapment protection device that is sold separately, and that has a  $\lambda_p$  greater than 0 failures/ $10^6$  hours meets the intent of the requirement when for the combination of the operator and the specified external secondary entrapment protection device  $\lambda_p$  does not exceed 6

failures/10<sup>6</sup> hours. See § 1211.15(i) and (k).

(7) When the Demonstrated Method Test is conducted, the multiplier is to be based on the continuous usage level, and a minimum of 24 units for a minimum of 24 hours per unit are to be tested.

(8) \* \* \*

(9) For the Electrical Fast Transient Burst Test, test level 3 is to be used for residential garage door operators.

\* \* \* \* \*

6. Section 1211.6 is amended by revising paragraphs (a), (b), (b)(ii), (b)(iii), (b)(2), adding a new paragraph (b)(3), revising paragraphs (c) and (d), and removing paragraph (e) to read as follows:

§ 1211.6 General entrapment protection requirements.

(a) A residential garage door operator system shall be provided with primary inherent entrapment protection that complies with the requirements as specified in § 1211.7.

(b) In addition to the primary inherent entrapment protection as required by paragraph (a) of this section, a residential garage door operator shall comply with one of the following:

(1) \* \* \*

(i) \* \* \*

(ii) Reverse direction and open the door to the upmost position when constant pressure on a control is removed prior to operator reaching its lower limit, and

(iii) Limit a portable transmitter, when supplied, to function only to cause the operator to open the door;

(2) Shall be provided with a means for connection of an external secondary entrapment protection device as described in § 1211.8, 1211.10, and 1211.11; or

(3) Shall be provided with an inherent secondary entrapment protection device as described in § 1211.8, 1211.10, and 1211.12.

(c) A mechanical switch or a relay used in an entrapment protection circuit of an operator shall withstand 100,000 cycles of operation controlling a load no less severe (voltage, current, power factor, inrush and similar ratings) than it controls in the operator, and shall function normally upon completion of the test.

(d) In the event malfunction of a switch or relay (open or short) described in paragraph (c) of this section results in loss of any entrapment protection required by §§ 1211.7(a), 1211.7(f), or 1211.8(a), the door operator shall become inoperative at the end of the opening or closing operation, the door operator shall move the door to, and stay within, 1 foot (305 mm) of the uppermost position.

7. Section 1211.7 is amended as follows:

a. Revise paragraph (a) to read as follows:

§ 1211.7 Inherent entrapment protection requirements.

(a) Other than the first 1 foot (305mm) of travel as measured over the path of the moving door, both with and

without any external entrapment protection device functional, the operator of a downward moving residential garage door shall initiate reversal of the door within 2 seconds of contact with the obstruction as specified in paragraph (b) of this section. After reversing the door, the operator shall return the door to, and stop at, the full upmost position, unless an inherent entrapment circuit senses a second obstruction or a control is actuated to stop the door during the upward travel. Compliance shall be determined in accordance with paragraphs (b) through (1) of this section.

b. In the first sentence of paragraph (b) remove the words "For the tests described in paragraph (a) of this section," and change the succeeding word "a" to "A"; at the end of paragraph (b) add the sentence "For operators other than those attached to the door, the solid object is to be located at points at the center, and within 1 foot of each end of the door."

c. In paragraph (c), remove the second sentence and add, in its place "For an operator having a force adjustment on the operator, the force is to be adjusted to the maximum setting or at the setting that represents the most severe operating condition."; in the last sentence, remove the words "that could have" and add, in their place "having".

d. Revise paragraphs (d) and (e), add a new paragraph (f), revise and redesignate paragraphs (f) and (g) as (g)

and (h) respectively, and add a new paragraph (i) to read as follows:

§ 1211.7 Inherent entrapment protection requirements.

\* \* \* \* \*

(d) For an operator that is to be adjusted (limit and force) according to instructions supplied with the operator, the operator is to be tested for 10 additional obstruction cycles using the solid object described in paragraph (b) of this section at the maximum setting or at the setting that represents the most severe operating condition.

(e) For an operator that is intended to be used with more than one type of door, one sample of the operator is to be tested on a sectional door with a curved track and one sample is to be tested on a one-piece door with jamb hardware and no track. For an operator that is not intended for use on either or both types of doors, a one-piece door with track hardware or a one-piece door with pivot hardware shall be used for the tests. For an operator that is intended for use with a specifically dedicated door or doors, a representative door or doors shall be used for the tests. See the marking requirements at § 1211.16 of this subpart.

(f) An operator, using an inherent entrapment protection system that monitors the actual position of the door, shall initiate reversal of the door and shall return the door to, and stop the door at, the full upmost position



in the event the inherent door operating "profile" of the door differs from the originally set parameters. The entrapment protection system shall monitor the position of the door at increments not greater than 1 inch (25.4 mm). The door operator is not required to return the door to, and stop the door at, the full upmost position when an inherent entrapment circuit senses an obstruction or a control is actuated to stop the door during the upward travel.

(g) An operator, using an inherent entrapment protection system that does not monitor the actual position of the door, shall initiate reversal of the door and shall return the door to and stop the door at the full upmost position, when the lower limiting device is not actuated in 30 seconds or less following the initiation of the close cycle. The door operator is not required to return the door to and stop at the full upmost position when an inherent entrapment circuit senses an obstruction or a control is actuated to stop the door during the upward travel. When the door is stopped manually during its descent, the 30 seconds shall be measured from the resumption of the close cycle.

(h) To determine compliance with paragraph (f) or (g) of this section, an operator is to be subjected to 10 open-and-close cycles of operation while connected to the door or doors specified in paragraphs (c) and (e) of this section. The cycles are not required to be consecutive. Motor

cooling-off periods during the test meet the intent of the requirement. The means supplied to comply with the requirement in paragraph (a) of this section and § 1211.8(a) are to be defeated during the test. An obstructing object is to be used so that the door is not capable of activating a lower limiting device.

(i) During the closing cycle, the system providing compliance with §§ 1211.7(a) and 1211.7(f) or 1211.7 (a) and 1211.7(g) shall function regardless of a short- or open-circuit anywhere in any low-voltage external wiring, any external entrapment devices, or any other external component.

8. Section 1211.8 is amended by revising the title of § 1211.8, paragraphs (a), (b) and (c), and adding paragraph (d) to read as follows:

§ 1211.8 Secondary entrapment protection requirements.

(a) A secondary entrapment protection device supplied with, or as an accessory to, an operator shall consist of:

(1) An external photoelectric sensor that when activated results in an operator that is closing a door to reverse direction of the door and the sensor prevents an operator from closing an open door,

(2) An external edge sensor installed on the edge of the door that, when activated results in an operator that is closing a door to reverse direction of the door and the sensor prevents an operator from closing an open door,

(3) An inherent door sensor independent of the system used to comply with § 1211.7 that, when activated, results in an operator that is closing a door to reverse direction of the door and the sensor prevents an operator from closing an open door, or

(4) Any other external or internal device that provides entrapment protection equivalent to subparagraphs (a) (1), (a) (2), or (a) (3) of this section.

(b) With respect to paragraph (a) of this section, the operator shall monitor for the presence and correct operation of the device, including the wiring to it, at least once during each close cycle. In the event the device is not present or a fault condition occurs which precludes the sensing of an obstruction, including an open or short circuit in the wiring that connects an external entrapment protection device to the operator and device's supply source, the operator shall be constructed such that:

(1) A closing door shall open and an open door shall not close more than 1 foot (305 mm) below the upmost position, or

(2) The operator shall function as required by § 1211.6(b) (1).

(c) An external entrapment protection device shall comply with the applicable requirements in §§ 1211.10, 1211.11 and 1211.12 of this subpart.

(d) An inherent secondary entrapment protection device

shall comply with the applicable requirements in § 1211.13. Software used in an inherent entrapment protection device shall comply with UL 1998 Standard for Safety-Related Software, First Edition, January 4, 1994. This incorporation by reference was approved by the Director of the Federal Register in accordance with 5 U.S.C. 552(a) and 1 CFR part 51. Copies may be obtained from Underwriters Laboratories, Inc., 333 Pfingsten Road, Northbrook, IL 60062-2096. Copies may be inspected at the Consumer Product Safety Commission, Office of the Secretary, 4330 East West Highway, Bethesda, Maryland or at the Office of the Federal Register, 800 North Capitol Street, N.W. suite 700, Washington, D.C.

9. Section 1211.9 is amended by revising paragraph (a), redesignating paragraphs (b) and (c) as paragraphs (c) and (d) respectively, and adding a new paragraph (b) to read as follows:

§ 1211.9 Additional entrapment protection.

(a) A means to manually detach the door operator from the door shall be supplied. The gripping surface (handle) shall be colored red and shall be easily distinguishable from the rest of the operator. It shall be capable of being adjusted to a height of 6 feet (1.8 m) above the garage floor when the operator is installed according to the instructions specified in § 1211.14(a)(2). The means shall be constructed so that a hand firmly gripping it and

applying a maximum of 50 pounds (223 N) of force shall detach the operator with the door obstructed in the down position. The obstructing object, as described in § 1211.7(b), is to be located in several different positions. A marking with instructions for detaching the operator shall be provided as required by § 1211.15(1).

(b) A means to manually detach the door operator from the door is not required for a door operator that is not directly attached to the door and that controls movement of the door so that:

(1) The door is capable of being moved open from any position other than the last (closing) 2 inches (50.8 mm) of travel, and

(2) The door is capable of being moved to the 2-inch point from any position between closed and the 2-inch point.

\* \* \* \* \*

10. Section 1211.10 is amended as follows:

a. In the first sentence of paragraph (a)(3), after the word "minimum" add the words "and maximum"; at the beginning of the second sentence add the words "For doors," and change the word "If" to "if".

b. In the first sentence of paragraph (c)(2) remove the initial word "An" and change the succeeding word "external" to "External"; remove the word "device" and add, in its place the word "devices"; remove the word "is" and add, in its place the word "are".

c. In paragraphs (d) and (e) (2), remove the words "3rd ed., dated July 1, 1991" and add, in their place "4th ed., dated December 27, 1995".

d. In paragraph (d), second sentence, insert "5 " before "U.S.C"

e. In paragraph (e) (1), second sentence, remove the words "After being subjected to this" and add, in their place the words "As a result of the".

f. In paragraph (e) (1) (ii), add at the end thereof and before the period the words "or, if dislodged after the test, is capable of being restored to its original condition".

11. Section 1211.12 is amended as follows:

a. In paragraph 1211.12(c) (2), first sentence, remove the words "3rd ed., dated July 1, 1991" and add in their place "4th ed., dated December 27, 1995".

b. In paragraph 1211.12(c) (2), second sentence, insert "5" before "U.S.C."

12. Redesignate sections 1211.13 through 1211.16 as sections 1211.14 through 1211.17, respectively, and add a new section 1211.13 to read as follows:

§ 1211.13 Inherent force activated secondary door sensors.

(a) Normal operation test. (1) A force activated door sensor of a door system installed according to the installation instructions shall actuate when the door applies a 15 pound (66.7 N) or less force in the down or

closing direction and when the door applies a 25 pound (111.2 N) or less force in the up or opening direction. For a force activated door sensor intended to be used in an operator intended for use only on a sectional door, the force is to be applied by the door against the longitudinal edge of a 1-7/8 (47.6 mm) diameter cylinder placed across the door so that the axis is perpendicular to the plane of the door. See Figure 6. The weight of the door is to be equal to the maximum weight rating of the operator.

(2) The test described in section 1211.13(a)(1) is to be repeated and measurements made at various representative points across the width and height of the door. For this test, a door sensor system and associated components shall withstand a total of 9 cycles of mechanical operation without failure with the force applied as follows:

- (1) At the center at points one, three, and five feet from the floor,
  - (11) Within 1 foot of the end of the door, at points one, three, and five feet from the floor,
  - (11i) Within 1 foot of the other end of the door at points one, three, and five feet from the floor.

The cycles are not required to be consecutive. Continuous operation of the motor without cooling is not required.

(b) Adjustment of door weight. (1) With the door at the point and at the weight determined by the tests of paragraphs (a)(2) and (b)(2) of this section to be the most

severe, the door sensor and associated components shall withstand 50 cycles of operation without failure.

(2) At the point determined by the test in paragraphs (a) (1) and (a) (2) of this section to be the most severe, weight is to be added to the door in 5.0 pound (2.26 Kg) increments and the test repeated until a total of 15.0 pounds (66.72 N) has been added to the door. Before performing each test cycle, the door is to be cycled 2 times to update the profile. Similarly, starting from normal weight plus 15.0 pounds, the test is to be repeated by subtracting weight in 5.0 pound increments until a total of 15.0 pounds has been subtracted from the door.

13. Redesignated section 1211.14 is amended as follows:

a. In paragraph (a) (4), third sentence, remove the word "that" and add in its place "than".

b. In paragraph (b) (1) remove the initial word "If" (in paragraph 4 of the installation instructions) and add, in its place "Where"; remove the word "Mount" and add, in its place "For products requiring an emergency release, mount".

c. In paragraph (b) (2), in the second sentence of paragraph 4 of the safety instructions, remove the number "1" and add in its place the number "1 ½".

d. In paragraph (b) (2) before the initial word "If" (in paragraph 5 of the safety instructions), add "For products requiring an emergency release," and change the word "If" to



"if".

14. Redesignated section 1211.15 is amended as follows:

a. In paragraph (g) (1) remove the words "A child may become" and add, in their place "There is a risk of a child becoming".

b. In paragraph (g) (2) (iv) remove the first word "If" and add, in its place "In the event".

c. In paragraph (g) (2) (iv) add a second sentence to read "For products not having an emergency release use instead 'In the event a person is trapped under the door, push the control button'".

d. In paragraph (g) (3) (1) in the second sentence, remove the word "If" and add in its place "In the event".

e. In paragraph (1) remove the initial word "A" and add, in its place "Except for door operators complying with § 1211.9(b) of this part, a".

Dated: \_\_\_\_\_

---

Sadye E. Dunn, Secretary  
Consumer Product Safety Commission