

U.S. CONSUMER PRODUCT SAFETY COMMISSION
W276 N878 Woodridge Lane
Waukesha, WI. 53188
tel (414) 650-1216
fax (414) 650-1217



fax t r a n s m i t t a l

to: Kmart, Att: Charlene Haines

fax #: 248-643-1054

from: Dennis R. Blasius

date: January 19, 1998

re: Attached

pages: 24, including this cover sheet

REMAINDER OF photos!

NOTES: Charlene, I've attached a copy of the consumer complaint from the gas grill incident. Sounds like you've already accumulated much of the documentation I'm interested in. I don't have anything more on the doll stroller except what I gave you.

I look forward to meeting with you Tuesday 1/27 at 9:00AM. Hopefully you will be able to provide much of the information I've requested at that time and I can collect samples of the products involved. Thank you very much for your help!

Dennis

SS

970528CWE5012

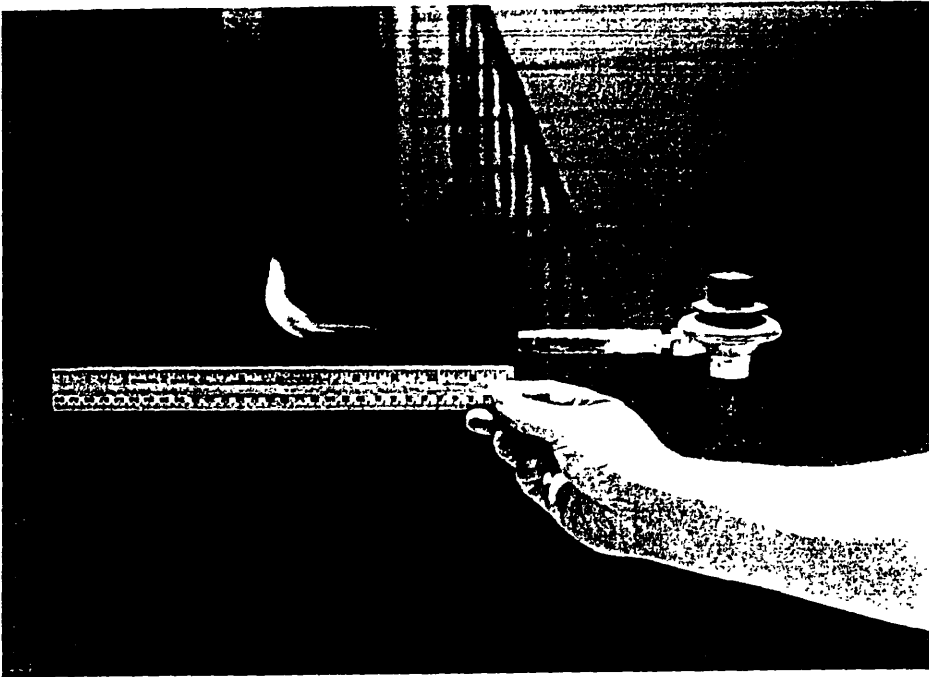

PHOTOGRAPH 5:
Reenactment of flame intensity, another view. The flame,
representative of the one at the time of the event, is about 6-
1/2 inches long.

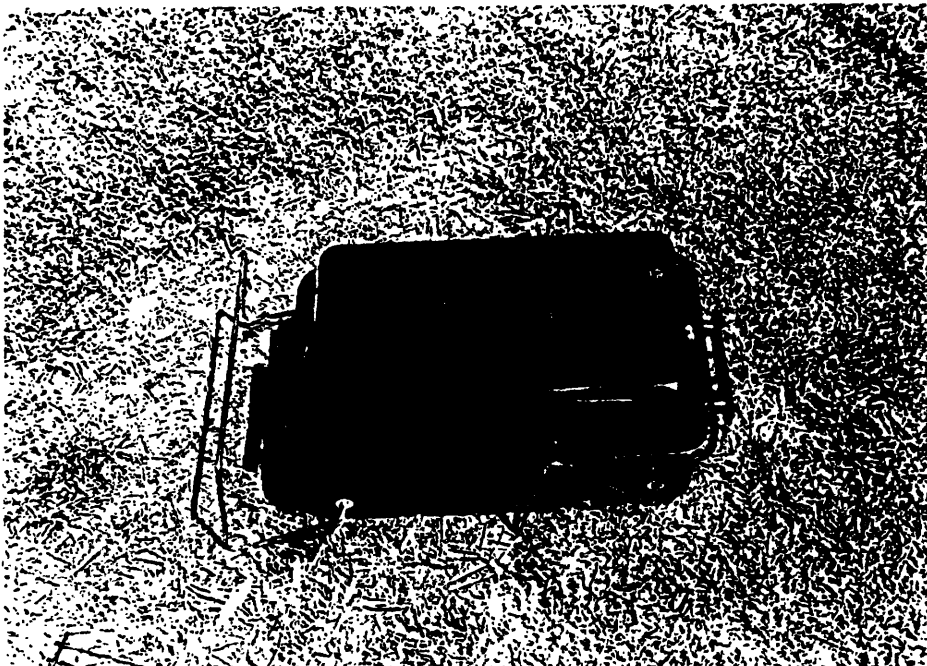

PHOTOGRAPH 6:
The subject LP gas grill, another view.

56



PHOTOGRAPH 7:
The subject gas grill. Seen here is the entire grill minus its cover.

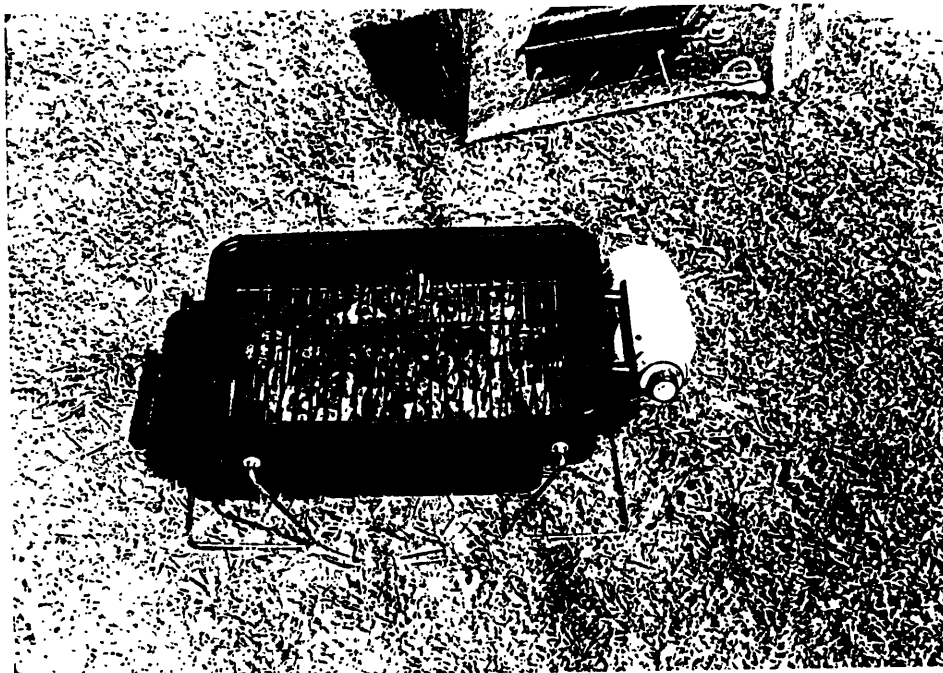

PHOTOGRAPH 8:
The gas grill, another view.

57

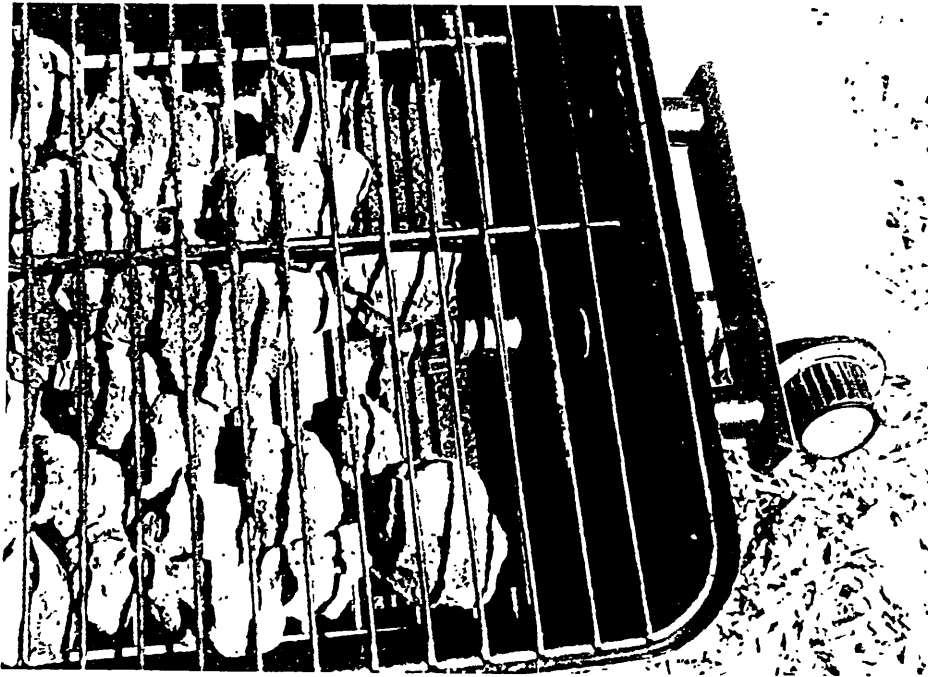

PHOTOGRAPH 9:
Looking through the top grill and the lava rock grill, one can see the burner tube.

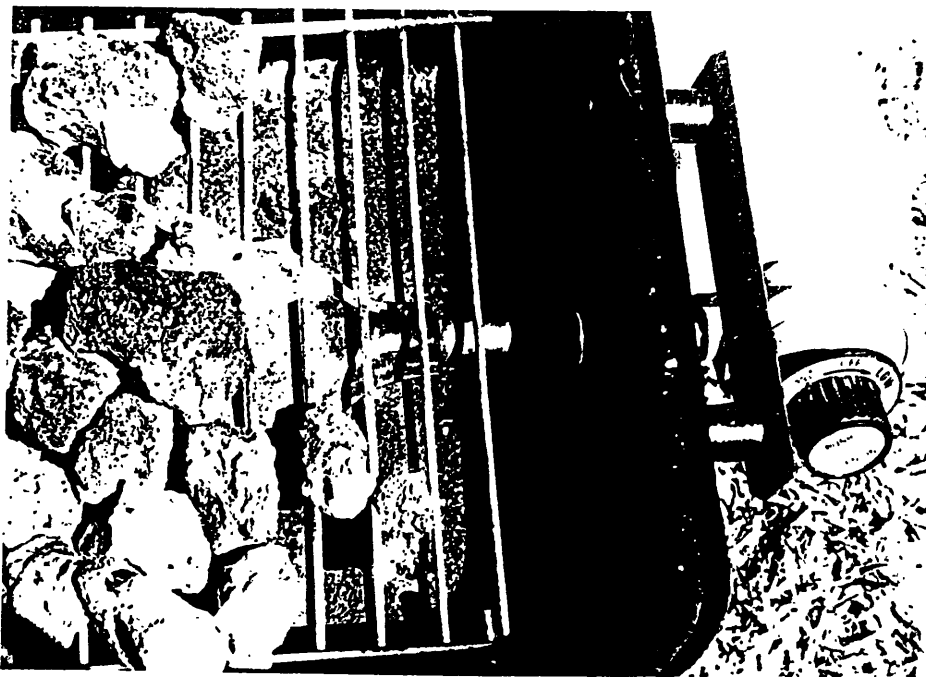

PHOTOGRAPH 10:
Same view as the previous photograph, but with the top grill removed.

58

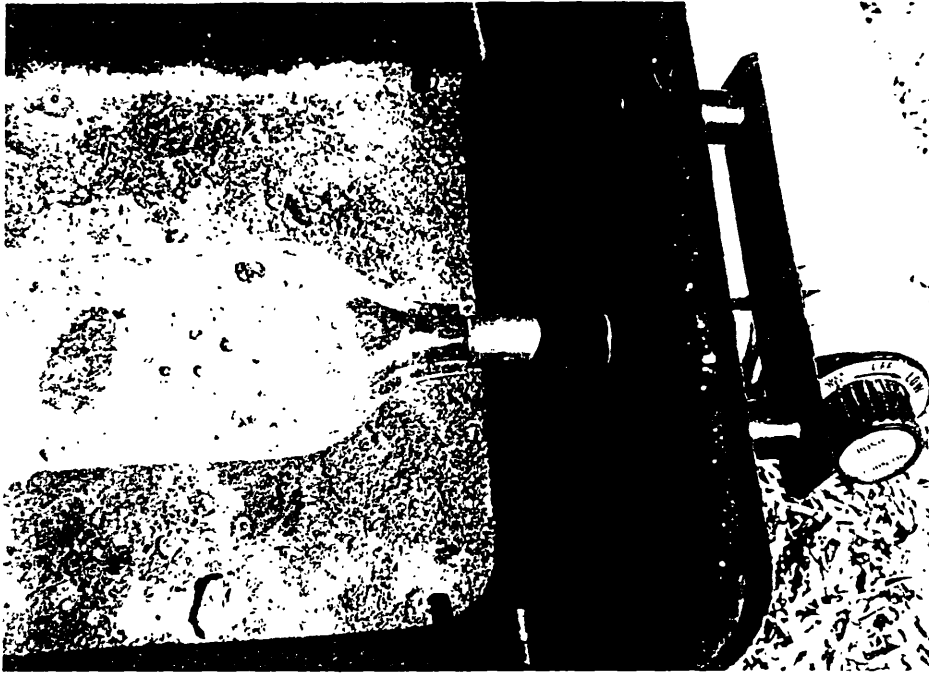

PHOTOGRAPH 11:
Same view as the previous photograph, but with the lava rock grill removed.

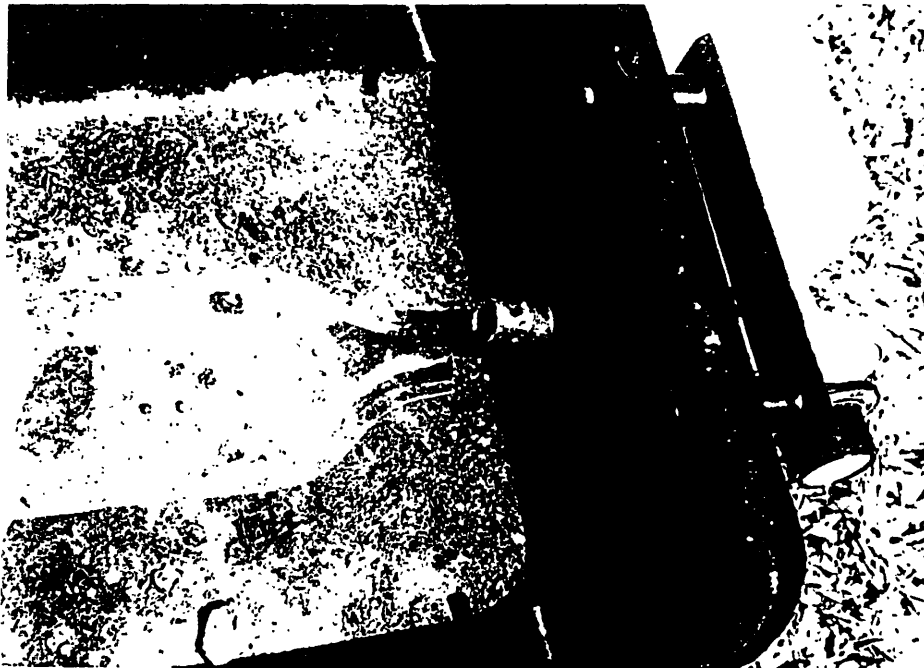

PHOTOGRAPH 12:
Same view as the previous photograph, but with the burner tube displaced.

59



PHOTOGRAPH 13:
Overall view of the grill burner.

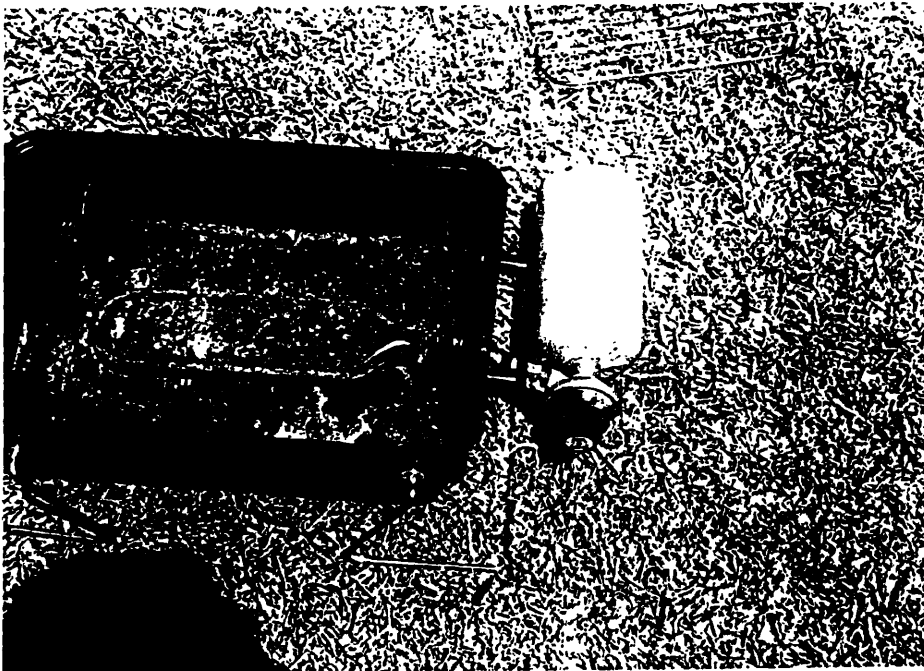

PHOTOGRAPH 14:
Sequence of events: When the burner tube fell out of the grill burner and slid to the position seen here (and in Photograph 12), the burner tube hit the side of the hole in the metal housing and stayed there for a moment before falling completely out.

60

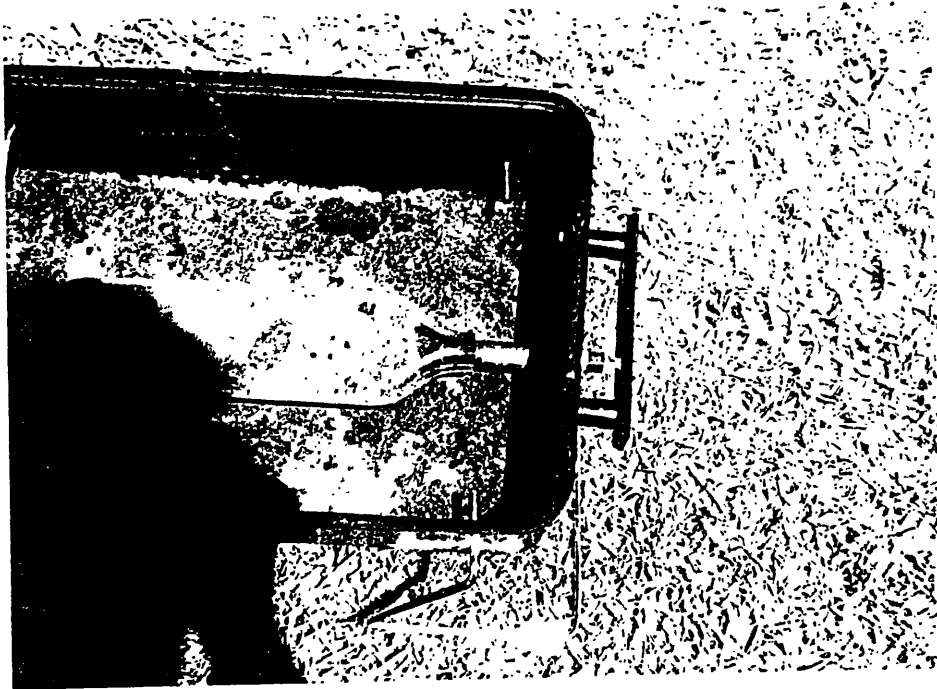

PHOTOGRAPH 14A:

This is how the respondent found the burner and burner pipe when he opened the cardboard container. The gas control was elsewhere in the box.

61

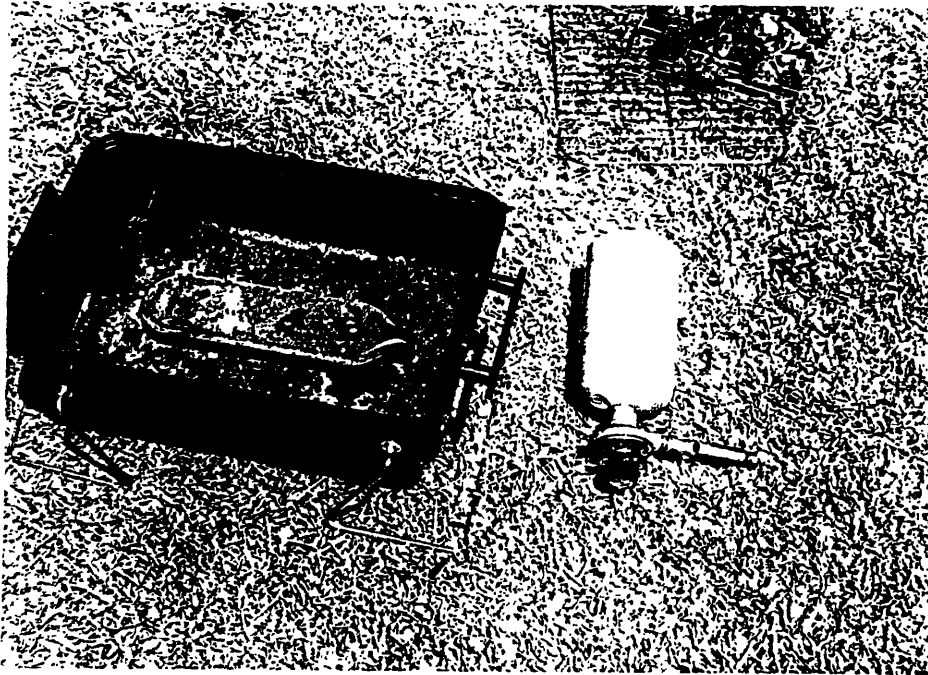

PHOTOGRAPH 15:

Sequence of events: After a moment in the position shown in the previous photograph, the bottle and assembly fell completely out of the housing.

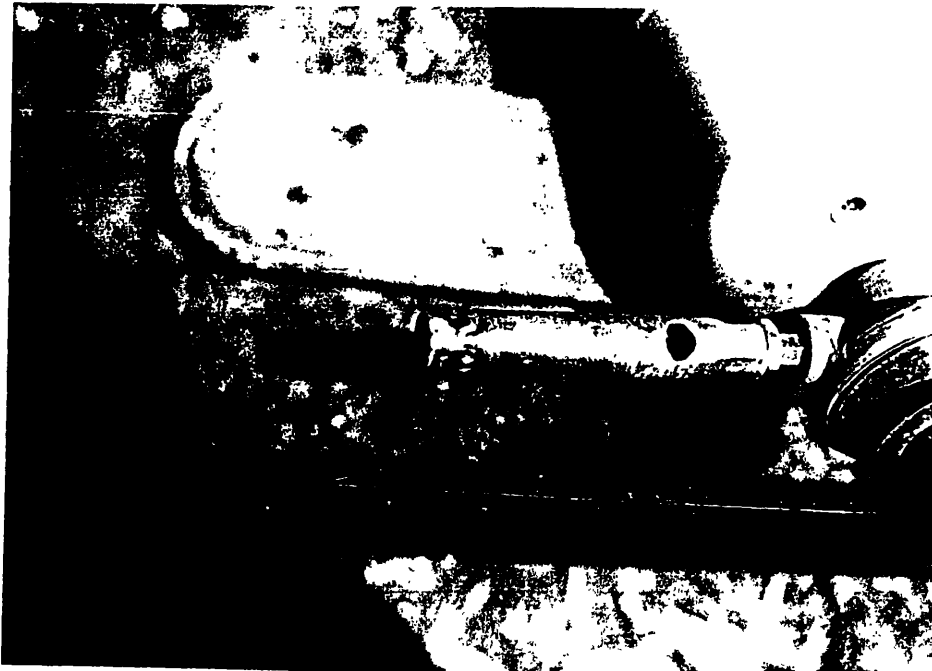

PHOTOGRAPH 16:

Close-up of the burner tube end. The end is fluted with six ridges (and six more or less flat sides), and it fits into corresponding flutes in the grill burner; friction holds the tube in place. The small circular spots on the end are not holes; they are reflections of deflections in the metal.

62

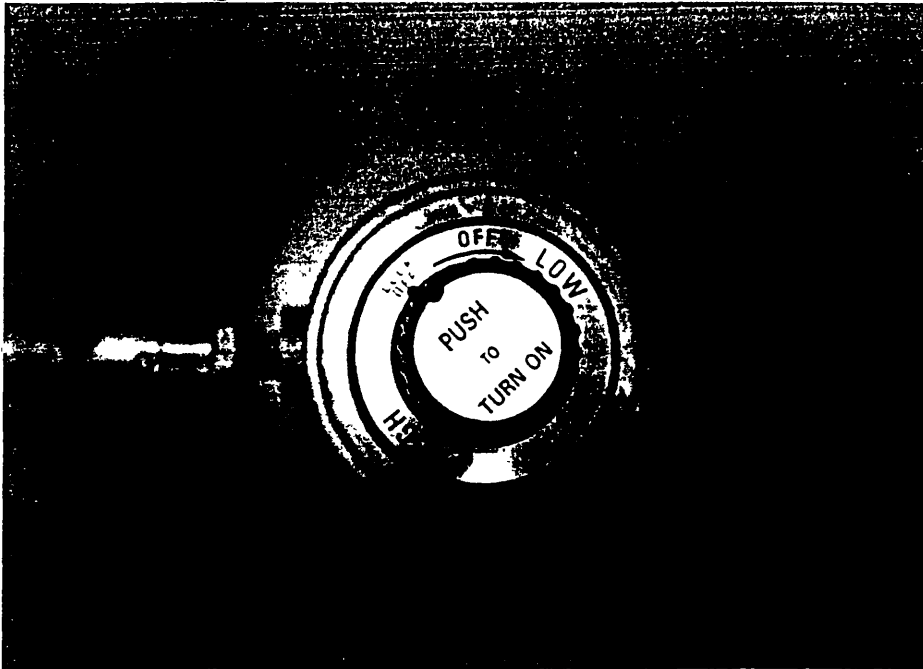

PHOTOGRAPH 17:
The gas control. The top reads "push to turn on"; the positions are "lock off off low med high".

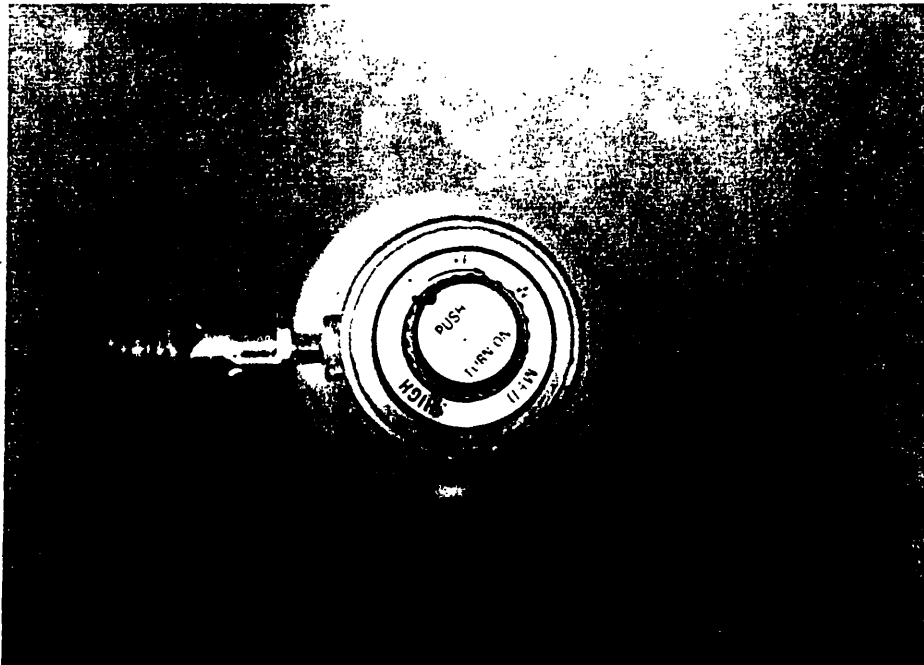

PHOTOGRAPH 18:
Another view of the gas control.

69

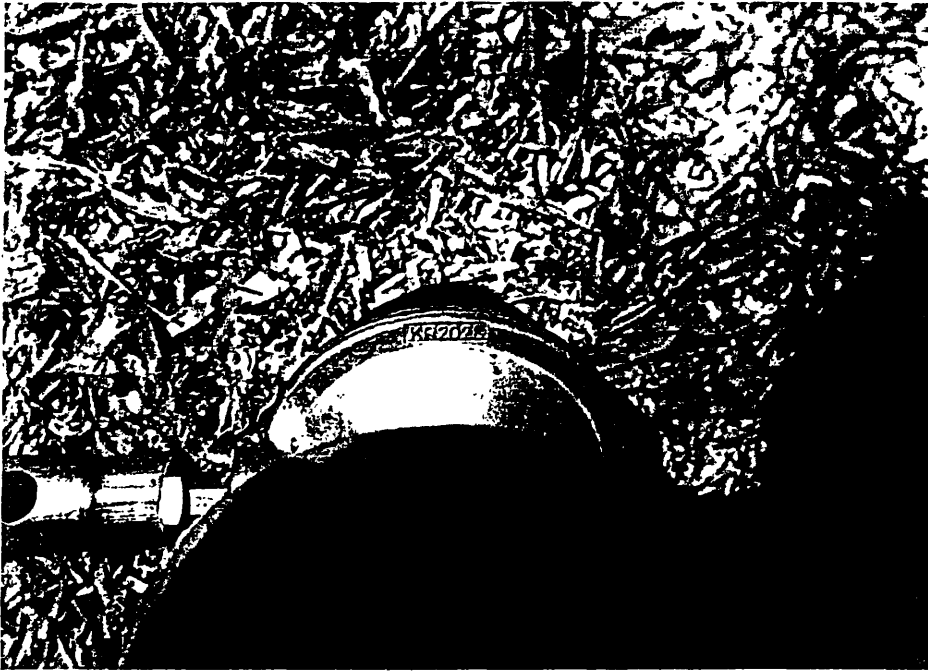

PHOTOGRAPH 19:
Labeling on the gas control; it reads "KR202L".



PHOTOGRAPH 20:
Additional labeling on the gas control; it reads "11 96".

64

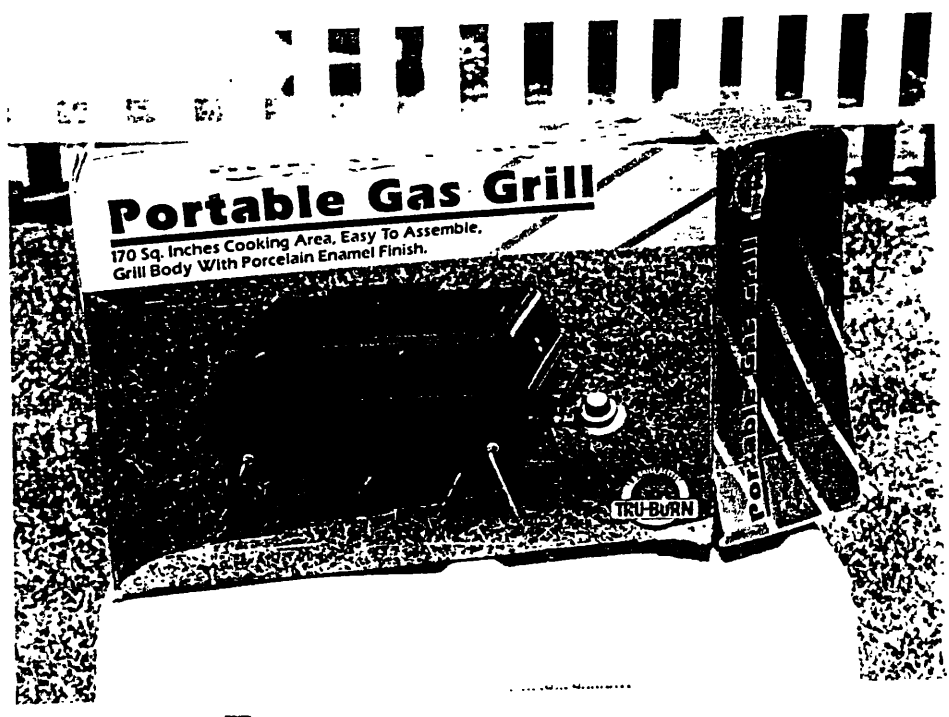

PHOTOGRAPH 21:
The container, front panel.



PHOTOGRAPH 22:
Container end panel.

65



PHOTOGRAPH 23:
Close-up of the brand name seen in Photograph 22; it reads in part "Grill and Grill accessories TRU-BURN ***".

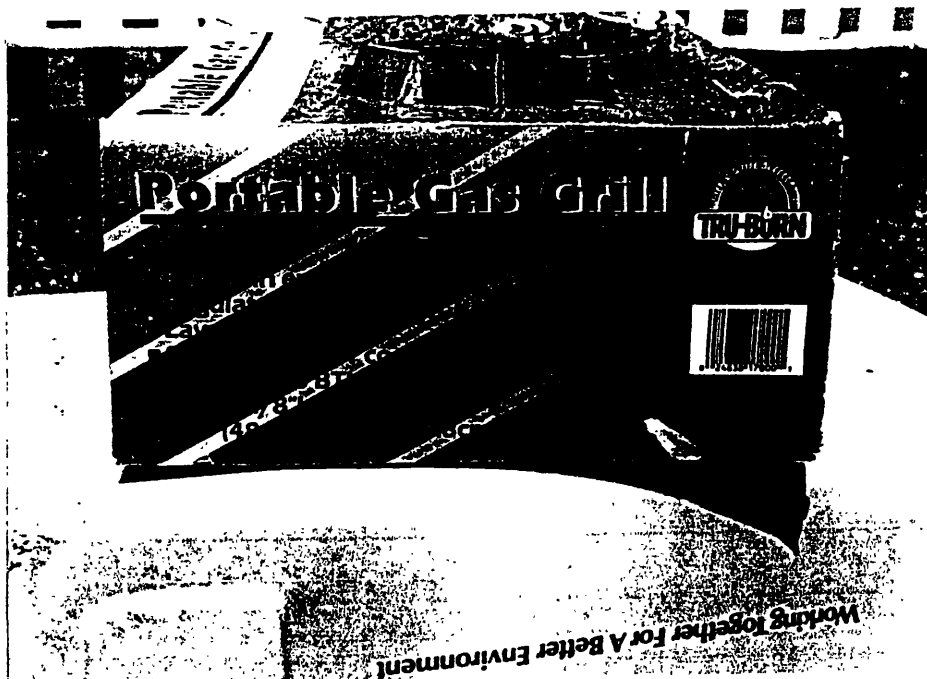

PHOTOGRAPH 24:
The other end panel.

6/6



PHOTOGRAPH 25:
Close-up of the manufacturer's identification; it reads in part
"Made in China for Kmart Corporation Troy, Michigan 48084 Code:
0-118731-116 ***". The product code reads "0 24838 17000 1".

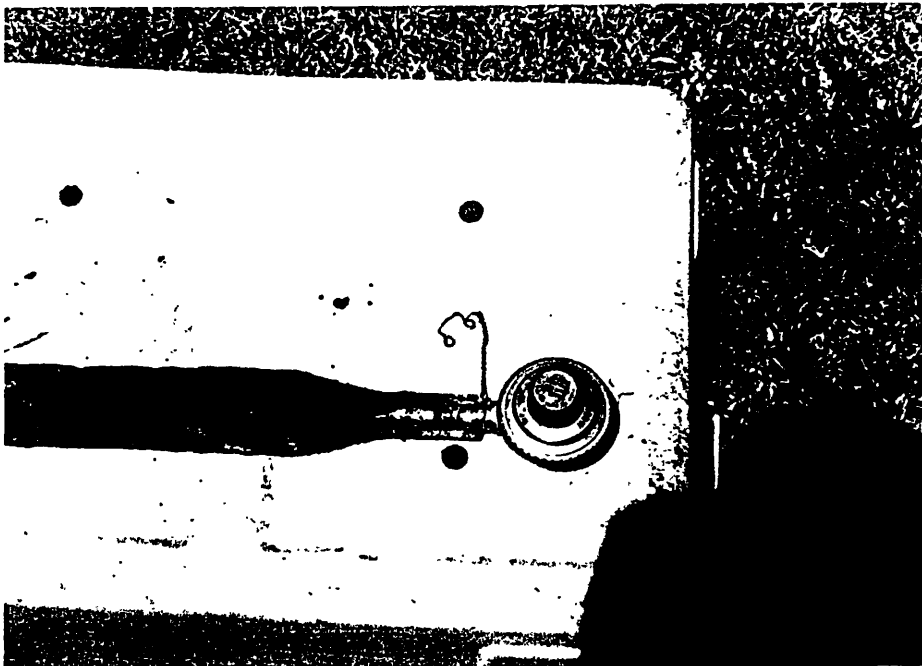

PHOTOGRAPH 26:
One solution to the detachment problem: Seen here is a
domestically made competitor's model. There are two differences
between this unit and the subject grill: (1): The gas control
connects directly to the burner without first going through a
tube. (2): The assembly is provided with a locking device.

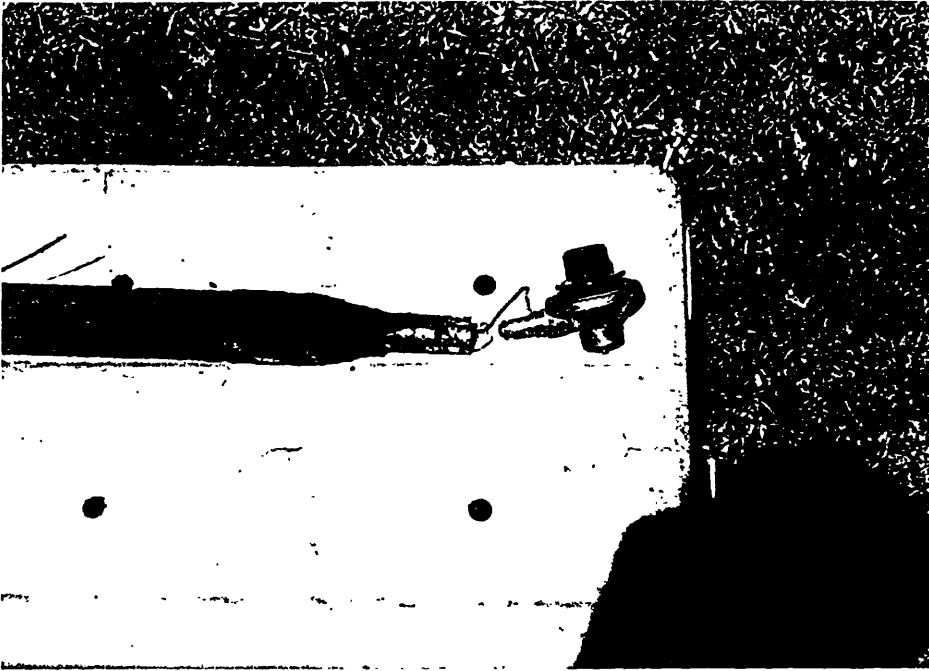

PHOTOGRAPH 27:
Another view of the competitor's model.



PHOTOGRAPH 28:
The clip, identified by the arrow, secures the connection.

CS

FOR OFFICIAL USE ONLY

| | | |
|---|--------------------------------------|------------------------|
| CONSUMER PRODUCT SAFETY COMMISSION ENGINEERING REPORT FOR SECTION 15 | PSA 0954.97 | FOCR |
| | FILE# | |
| | SAMPLE NO: 97-860-6276 | |
| | CPSC SEAL: intact | |
| | REF Incident report 970528CWE5012 | |
| TO: L. George Gayman, FOCR | DATE: October 27, 1997 | |
| THROUGH: signed by George F. Sushinsky, Team Leader | | |
| FIRM: K mart Corporation, | Troy MI | |
| PRODUCT: Table top LP gas grill - TRU BURN | | |
| POTENTIAL HAZARD: LP gas leak; Fire/explosion | | |
| EVALUATION REQUESTED: Examine the grill. Can attachment of the gas cylinder separate while the grill is in use? What circumstances could result in separation of the cylinder from the grill? Is there need for a retention mechanism on the cylinder or burner tube to keep the cylinder assembly properly connected to the burner during use? | | |
| Laboratory Analyst: signed by John Griffith 301-413-0181 | | Date: October 27, 1997 |

Background:

The sample (97-860-6276) is a portable gas grill. This grill was involved in the incident covered in the referenced incident report. The grill measures 480 mm, by 303 mm by 308 mm (18.1 by 12.0 by 12.0 in). As received, the grill consists of a porcelain enamelled base and cover, a cooking grill, an 11,000 BTU burner, a regulator, and a burner tube connecting the regulator to the burner. The grill is supported on legs made of bent metal rods that also serve to secure the cover of the grill to the base for storage. (See photographs 1, 2, 6, 7, and 8 of the incident report.) A propane tank connects to the regulator during use. The product's instructions were not included with the sample.

The burner tube is approximately 100 mm (4 in) long. It has one six-sided faceted end that fits into a mating, six-sided receptacle of the burner manifold. The tube is held in position by friction.

In the incident report, The respondent reported that the "4"

69

long metal gas pipe (gas pipe connects gas valve to grill) detached from grill ... 8" high flames were shooting out of the gas pipe ..."

The incident report includes 28 photographs documenting the incident including a solution to the described problem.

Tests:

LSE staff performed tests intended to measure the forces to dislodge the burner tube from the burner manifold. These tests included the application of either vertical or horizontal forces at the gas regulator. The horizontal forces measured either the force to fully insert the tube into the manifold or to separate the tube from the manifold. The vertical forces were applied to note the effect on tube/manifold separation.

Results:

The results of tests show:

1. Compressive forces between 22 and 40 N (5 and 9 lbf) is needed to fully seat the burner tube into the burner.
2. Tensile forces between 18 and 31 N (4 and 7 lbf) is needed to fully remove the burner tube from the burner.
3. Purely vertical forces up to approximately 62 N (14 lbf) produce little observable movement of the burner tube when it is attached to the burner.

Discussion:

The press fit friction between the burner tube and burner is the only means for keeping the tube attached to the burner on this sample. This friction, with the burner tube fully seated in the burner, can be overcome with forces as low as 18 N (4 lbf). At this force level, the tube could separate from the burner and result in the incident as portrayed in the incident report. The force levels for separation could be even lower if the tube is not fully seated in the burner

How this separation force was produced in the reported incident is unknown. Photographs 1 and 3 of the incident report may provide some clues to the answer. Photograph 1 reportedly shows the grill as it was positioned on a wire rack just before the incident. Photograph 3 reportedly shows the grill after separation of the burner tube occurred. In Photograph 3, the right leg of the grill is shown to be rotated from its initial position and the propane bottle, regulator and burner tube are on the deck separated from the grill. This rotation, if accurately portrayed, appears to be the result of a gross reaction to an unknown event. In order for the leg to move from the position shown in Photograph 1 to that shown in Photograph 3, the whole

70

grill would have shifted to the left by about 80 mm (3.1 in). With this amount shift it would be possible for the propane bottle to pull with enough force to separate the tube from the burner.

Upon examination of the sample, it was noted that the legs to the grill allowed a gentle rocking to the grill. as it sat on a flat base. This rocking may have initiated the movement of the grill on the wire rack and loosened the tube connection to further exacerbate the conditions leading to the incident.

Conclusions:

The PSA request asks questions about the possibility of the tube separating during use, and the need for positive retention of the burner tube to the burner. With a relatively small amount of force (18 N [4 lbf]), the tube can separate from the burner. A retention device would prevent accidental separation.

71

****FOR OFFICIAL USE ONLY****

PRODUCT SAFETY ASSESSMENT (PSA) TECHNICAL EVALUATION REQ

Requested by: L. George Gayman Or OK to proceed! : FOCR

Date Submitted: 3/17/98 Prio B

PRODUCT INFORMATION

Manufacturer: Kmart Corporation City: Troy State: MI

Product: Table-top, portable LP Gas Grill. NEISS Code: 3248

Brand name, model, etc. "TRU-BURN" brand; UPC Code 0-24838-17000-1; Kmart item #043-11-87-31-116.

Sample number: 97-860-6276 (collected during IDI 970528CWES012); 98-830-3415 (New Unit) & 98-830-3416 (Char-Broil unit)

Sample Disposition Return to Requestor Store at Whse Other:

IDI Number: IDI 970528CWES012.

EVALUATION REQUESTED: Please have Engineering Sciences examine the new Kmart grill sampled under 98-830-3415 and the assembly instructions attached to the EIR dated 1/27/98. The concern is with the two-piece burner system and the connection of the burner manifold to the burner tube. Please refer to PSA #0954.97 done on sample 97-860-6276. Please measure the diameter of the connecting components for the manifold and the burner tube, and perform force measurements on the assembly and detachment of these components as was done on 97-860-6276 under PSA #0954.97. Is this connection mechanism for attachment of the burner tube to the manifold adequate to prevent accidental loosening and separation of these two components during use of the grill? Is the concept of a two-piece burner system a safe idea? Sample 98-830-3416 is a Char-Broil portable LP gas grill that has a one piece burner system. Please compare these two systems and offer your comments and observations.

EPI ASSESSMENT: Dates: From: _____ To: _____ Sort by Mfg. Yes _____ No _____

IDI _____ IPII _____ NEISS Comments _____ NEISS Estimates _____ Deaths _____ NFIRS _____

Hazard: LP gas could leak from grill due to loose connection. Hazard Code: 32103

Requested Completion Date: 04/24/98

Locations of: Samples: Off. of Comp. _____ Files: Carlos Perez

PSA ACTION (FOR PSA USE ONLY)

Request number: 0463.98

Date Processed: 3/18/98

Date Requested: 4/24/98

Due Date: _____

Assigned to: _____

Organization: _____

Technical Off. _____

Request Summary: _____

Comments: _____

Exhibit "A"
 Kmart Corporation
 1/27/98 Inspection

(Handwritten initials)

U.S. CONSUMER PRODUCT SAFETY COMMISSION
 NOTICE OF INSPECTION

| | |
|--------------------------------|--|
| 1. DATE <i>1/27/98</i> | 3. FROM (Area Office and Address) <i>10000 Kmart Blvd Detroit, MI 48215 Contact: 313 253188</i> |
| 2. TIME ____ A.M. ____ P.M. | |

| | |
|-------|---|
| 4. TO | A. NAME AND TITLE OF INDIVIDUAL <i>Charles J. Holmes</i> |
| | B. FIRM NAME <i>Kmart Corporation</i> |
| | C. NUMBER AND STREET ADDRESS <i>10000 Kmart Blvd</i> |
| | D. CITY, STATE AND ZIP CODE <i>Detroit, MI 48215</i> |



Charles J. Holmes
 Trade Regulation
 Division
 Kmart Corporation
 10000 Kmart Blvd
 Detroit, MI 48215
 Telephone: 313-253-1888

Notice of Inspection is hereby given pursuant to:

- Flammable Fabrics Act (15 U.S.C. 1191 *et seq.*);
- Federal Trade Commission Act (15 U.S.C. 41 *et seq.*);
- Sections 16, 19 and 27 of the Consumer Product Safety Act (15 U.S.C. 2065, 2068 and 2076)
- Section 704(a) of the Federal Food, Drug, and Cosmetic Act (21 U.S.C. 374(a)) [Authority for inspections in connection with the Poison Prevention Packaging Act of 1970 (15 U.S.C. 1471 *et seq.*)] and/or
- Section 11(b) of the Federal Hazardous Substances Act as Amended (15 U.S.C. 1270(b)).

6. FREEDOM OF INFORMATION REQUIREMENTS

Those from whom information is requested should state whether any of the information submitted is believed to contain or relate to a trade secret or other matter which should be considered by the Commission to be confidential and whether any of the information is believed to be entitled to exemption from disclosure by the Commission under the provisions of the Freedom of Information Act (15 U.S.C. 552). Any statement asserting this claim of confidentiality must be in writing, and any request for exemption of the information from disclosure must be made in accordance with the Commission's Freedom of Information Act regulations. 16 CFR Part 1015.

7. SIGNATURE (Authorized CPSC Official): *William A. Adams*
William A. Adams

75

Exhibit "B"
Kmart Inspection
1/27/98 Ins. ction

Q13

U.S. Consumer Product Safety Commission

W276 N878 Woodridge Lane • Waukesha, WI. 53188 • (414) 650-1216 • (414) 650-1217 fax

January 19, 1998

Charlene J. Haines
Kmart Corporation
3100 W. Big Beaver Road
Troy, MI. 48084



Re: 1/26/98 Inspection Visit

Dear Atty. Haines:

As we discussed by telephone this morning, I will be visiting your firm in person on 1/26/98 to obtain information regarding two different products distributed by Kmart. The first is a "Tru-Burn" table top LP gas grill, the second is a "Loving Wonders" plastic single stroller with accessories.

Regarding the gas grill, the CPSC has received a complaint from a consumer who reported that the gas cylinder/regulator assembly separated from its connection with the burner tube while the grill was lighted. I hope to address the following questions during our meeting:

- 1) Please list all table top gas grill models sold by Kmart and the manufacturer of each. Provide dates of first/last distribution and number of units sold for each model grill. If any/all of the grill models are imported, is Kmart the actual importer? If so, please provide a copy of the import documentation for each model grill. If not, from whom does Kmart purchase the grills? Provide a copy of a purchase invoice and bill of lading documenting Kmart's purchase of each model LP gas grill from the supplier.
- 2) Provide any instructional literature, assembly instructions or brochures that come with each model grill. If several models are depicted in a single publication that will suffice.
- 3) Provide copies of any and all complaints regarding these LP gas table top grills. This information to include a copy of the consumer's complaint letter, any Kmart complaint form documenting the complaint, any Kmart adjuster claims, and any correspondence between the consumer and your firm. What was the resolution of each complaint. Provide copies of documentation pertaining to any lawsuits or other civil actions brought against Kmart by consumers. What is the status of each suit? If settlement was reached, provide terms.
- 4) Provide documentation regarding the total number of returns for each model table top LP gas grill, broken down by year and reason for return. Does Kmart do any examination or testing of such returned products, or arrange for such testing to be done? Please provide copies of any such records. What is the disposition of returned products and are they available for CPSC examination?

76

5) Is any initial product testing done on these grills, either by the supplier/manufacturer or at Kmart's direction? Provide copies. Does such testing cover the integrity of the connection of the gas cylinder/regulator assembly tubing and the burner tube? Do the products claim certification with any voluntary standards for such products?

6) Attached is a copy of the consumer complaint received by the CPSC. What is Kmart's assessment of this incident?

Regarding the "**Loving Wonders**" plastic single stroller, CPSC has become aware of several such products that have plastic end caps of the tubing that may detach easily and pose a choking hazard for young children.

1) Provide dates of first and last distribution, and number of units sold. Is this product imported, and if so is Kmart the actual importer? Please provide a copy of the import documentation. If purchased from a domestic vendor, please provide a copy of a purchase invoice and bill of lading documenting Kmart's purchase of the product from that supplier.

2) Provide any instructional literature, assembly instructions or brochures that come with this toy stroller. Are there any age labeling recommendations or warnings of potential small part choking hazards on the packaging or the literature?

3) Provide copies of any and all complaints. This information to include a copy of the consumer's complaint letter, any Kmart complaint form documenting the complaint, any Kmart adjuster claims, and any correspondence between the consumer and your firm. What was the resolution of each complaint. Provide copies of documentation pertaining to any lawsuits or other civil actions brought against Kmart by consumers. What is the status of each suit? If settlement was reached, provide terms.

4) Provide documentation regarding the total number of returns, broken down by year and reason for return. Does Kmart do any examination or testing of such returned products, or arrange for such testing to be done? Please provide copies of any such records.

As we discussed, it will be necessary for me to collect samples of both the grills and the baby stroller. I will require one unit of each LP gas table top grill model, and 12 units of the baby stroller product. I appreciate your cooperation in these matters, and look forward to your continued assistance.

Sincerely yours,



Dennis R. Blasius
Federal Investigator

77

Exhibit "C"
Kmart Inspection
1/27/98 Inspection

QES



Deborah L. Miela
Trade Regulation Counsel
248 643 1053
dmiela@kmart.com

Charlene J. Haines
248 643 5705
chaines@kmart.com

Kmart Corporation
International Headquarters
3100 West Big Beaver Road
Troy MI 48084-3163
248 643 1054 Facsimile

January 27, 1998

HAND-DELIVERED

Mr. Dennis Blasius, Compliance Officer
U.S. Consumer Product Safety Commission
W276 N878 Woodridge Lane
Waukesha, WI 53188

Dear Mr. Blasius:

We have compiled the following information in response to your January 19, 1998 facsimile.

1. Please list all table top grill models sold by Kmart and the manufacturer of each. Provide dates of first/last distribution and number of units sold for each model grill. If any/all of the grill models are imported, is Kmart the actual importer? If so, please provide a copy of the import documentation for each model grill. If not, from whom does Kmart purchase the grills? Provide a copy of a purchase invoice and bill of lading documenting Kmart's purchase of each model LP gas grill from the supplier.

- 1a. Tru Burn table top gas grill - 17"
UPC Code: 0-24838-17000-1
Kmart Code: 043-11-87-31-116
Purchased from Lien Mou Industrial Factory Co. Ltd. - Manufacturer;
Kmart Corporation - Importer
Date of first distribution: Approximately December 1996
Date of last distribution: Current item being sold
1996 Sales: 265
1997 Sales: 43,112

Copies of the import orders for the above Tru Burn grill in question have been attached.

- 1b. Char Broil table top grill
Purchased from Char Broil
200 Brookstone Centre Parkway, Suite 310
Columbus, GA 31904
UPC Code: 0-47362-51230-7
Kmart Code: 043-11-80-29-1100
Date of first distribution: Approximately March 1996
Date of last distribution: Current item being sold
1996 Sales: 29,634
1997 Sales: 37,406

78

Mr. Dennis Blasius
Page 2
January 27, 1998

- 1c. Char Broil table top grill
Purchased from Char Broil
UPC Code: 0-47362-51000-6
Kmart Code: 043-11-17-50-1100
Date of first distribution: Approximately September 1991
Date of last distribution: Last receipt of grills in Shakopee, MN Distribution Center,
March 20, 1996 (Discontinued Item).
1996 Sales: 7,826
1997 Sales: 199

Copies of purchase orders for the Char Broil grills are not available at this time. We believe that the grills are imported by Char Broil.

2. Provide any instructional literature, assembly instructions or brochures that come with each model grill. If several models are depicted in a single publication, that will suffice.

Any instructional literature, assembly instructions or brochures that come with the Tru-Burn grill will be contained in the grill package. We didn't open packages, assuming you may prefer to do so at the time of your visit. We have requested samples of the Char Broil grills. They have not arrived at this time.

3. Provide copies of any and all complaints regarding these LP gas table top grills. This information to include a copy of the consumer's complaint letter, any Kmart complaint form documenting the complaint, any Kmart adjuster claims, and any correspondence between the consumer and your firm. What was the resolution of each complaint? Provide copies of documentation pertaining to any lawsuits or other civil actions brought against Kmart by consumers. What is the status of each suit? If settlement was reached, provide terms.

Kmart is unaware of any additional incidents regarding the any of the LP gas table top grills sold at Kmart stores.

4. Provide documentation regarding the total number of returns for each model table top LP gas grill, broken down by year and reason for return. Does Kmart do any examination or testing of such returned products, or arrange for such testing to be done? Please provide copies of such records. What is the disposition of returned products and are they available for CPSC examination?

Information regarding customer returns are currently kept at the daily level only for the most current 22 days. Information older than 22 days is kept on cartridges. Merchandise return history cartridges would take a minimum of three weeks to load and additional time to run reports. Also, this report would not include information as to why the merchandise was returned.

We are continuing to investigate as to whether information on grills returned to the supplier is available.

5. Is any initial product testing done on these grills, either by the supplier/manufacturer or at Kmart's direction? Provide copies. Does testing cover the integrity of the connection of the gas cylinder/regulator assembly tubing and burner tube? Do the products claim certification with any voluntary standards for such products?

We are checking with our Quality Assurance Lab for this information.

79

Mr. Dennis Blasius
Page 3
January 27, 1998

6. What is Kmart's assessment of this incident?

The Tru Burn grill was evaluated (in response to the Wesley Wong's complaint) by Kmart's Quality Assurance Department. No safety defects were found. A copy of the evaluation report is attached.

"LOVING WONDERS" PLASTIC STROLLER

1. Provide dates of first and last distribution and number of units sold. If this product is imported, and if so, is Kmart the actual importer? Please provide a copy of the import documentation. If purchased from a domestic vendor, please provide a copy of the purchase invoice and bill of lading documenting Kmart's purchase of the product from that supplier.

The stroller in question has not been sold at Kmart locations at this time. Approximately 14,000 have been ordered and the shipment should be arriving in Kmart Distribution Centers in early February. Kmart Corporation is the actual importer of the product.

2. Provide any instructional literature, assembly instructions or brochures that come with this toy stroller. Are there any age labeling recommendations or warnings of potential small part choking hazards on the package or the literature?

We do not have any instructional literature regarding the stroller at this time. Kmart Co-Buyer Rick Schmid has requested a sample of the stroller.

3. Provide copies of any and all complaints. This information to include a copy of the consumer's complaint letter, any Kmart complaint form documenting the complaint, any Kmart adjuster claims, and any correspondence between the consumer and your firm. What was the resolution of each complaint? Provide copies of documentation pertaining to any lawsuits or other civil actions brought against Kmart by consumers. What is the status of each suit? If settlement was reached, provide terms.

N/A. This item is a new item which has not been sold in any Kmart stores at this time.

4. Provide documentation regarding the total number of returns, broken down by year and reason for return. Does Kmart do any examination or testing of such returned products, or arrange for such testing to be done? Please provide copies of such records.

N/A. This item is a new item which has not been sold in any Kmart stores at this time.

If you require additional information, please let me know.

Sincerely,



Charlene J. Haines



ORDER CONTRACT

Exhibit "D"
Kmart Inspection
1/27/98 Inspection
Telephone:
Facsimile:

QES

KI MART CORPORATION
3100 W BIG BEAVER RD
TROY MICHIGAN
48084 USA

ORDER DATE: 09/03/96 CONTRACT NO: K3129 ITEM CODE: 640-118731-116 BUYER: LVW LARRY VANDERWERFF
DIV: 1 DEPT NO: 43 UPC CARTON ID: 10024838170008 FACTORY: 3647

ITEM: TABLETOP GAS GRILL

Manufacturer: LIEN MOU INDUSTRIAL FACTORY CO LTD
556 MIN WOO ROAD,
HSIN-CHU CITY,
TAIWAN, R.O.C.

FOREIGN AGENT: KKTP KMART TAIWAN LTD
FOREIGN OFFICE: RKKTP KMART TAIWAN LTD
PRODUCTION OFFICE: PKKTP KMART TAIWAN LTD
SHIP VIA: (X)SEA ()AIR ()TRUCK/RAIL
VIA LINE:
Payment to be made by (X) CHECK or () Letter of Credit
LC#: BANK: BANKOA
LC Transferable: No

LIFESTYLE: HARDLINES
TRADEMARK: NO TRADEMARK ON THIS ORDER
BRAND NAME: NONE

Each item to be marked: MADE IN CHINA (MAINLAND)
Embark/Go-down: CHINA (MAINLAND)

| Total Cartons | Total SET | per SET | Total Cost of Order | Terms |
|---------------|-----------|---------|---------------------|-------|
| 12,495 | 49,980 | \$9.500 | \$474,810.00 | FOB |

| PER CTN | KGS: | 22.600 | CBM: | .079500 | SET per Inner: | 1 | Packing Instruction: |
|---------|---------|--------|---------|---------|---------------------------------|---|----------------------|
| | LBS: | 49.824 | CUF.FT: | 2.808 | Inners per outer carton: | 4 | CASEPACK |
| | NET WT: | | | | Total SET per outer export ctn: | 4 | |

| | per SET | per CARTON | | per SET | per CARTON | | per SET | per CARTON |
|-----------------|----------|------------|-------------|---------|------------|-------|--------------------------------|----------------|
| F.O.B. PRICE | \$9.500 | \$38.000 | IMPORT CHR | 1.70% | .197 | .787 | DC ALLOWANCE | |
| DUTY | .542 | 2.166 | BANK FEE | % | | | ROYALTY | |
| COUNTER VEILING | | | PIER CHR | | | | COST OUT OF DC | 11.95 |
| USER FEE | .019 | .076 | TICKET DUTY | | | | SELLING PRICE | 21.99 |
| HARBOR FEE | .019 | .076 | ASSIST | | | | GROSS MARGIN | .456353 |
| OCEAN FREIGHT | 51 1.014 | 4.055 | EXCISE TAX | | | | MARKON | 45.6353 |
| TARIFF # KHCH1 | | | ODC TAX | | | | | |
| AGENT FEE | 5% .475 | 1.900 | DEFECT | | .190 | .760 | TOTAL SELLING VALUE FOR ORDER: | |
| BUYER CRDT | % | | SERVICE | | | | | |
| AGENT 2 | % | | DECON FEE | | | | | \$1,099,060.20 |
| WAREHOUSE | % | | LANDED COST | | 11.95 | 47.82 | | |

| HTS # | \$/HTS UNIT | HTS DUTY % | NET NET WGT per HTS UNIT | WT RATE % | SPECIAL QTY / HTS UNIT | #HTS UNITS per PIECE | QUOTA # | CVD RATE |
|-------|-------------|------------|--------------------------|-----------|------------------------|----------------------|---------|----------|
| | | | | | | | | |

BINDING RULE # OR PRECLASS #

| BUYER/DATE | MDSE. MGR-SALES/DATE | OFFICE/DATE | INTERNATIONAL DEPT./DATE |
|------------|----------------------|-------------|--------------------------|
| | | | |

Special Instructions:

() RETURN SHEET # _____
Conveyable : N

() DEFERRED PMT. ___ Days

81

ORDER CONTRACT

KMART CORPORATION
 7100 W BIG BEAVER RD
 TROY MICHIGAN
 48084 USA

(CONTINUED)

Tr phone:
 Facsimile:

ORDER DATE: 09/03/96 CONTRACT NO: K3129 ITEM CODE: 640-118731-116 BUYER: LVW LARRY VANDERWERFF
 DIV: 1 DEPT NO: 43 UPC CARTON ID: 10024838170008 FACTORY: 3647

ITEM: TABLETOP GAS GRILL

UPC NUMBER

 024838170001

SHIPPING SCHEDULE

| Reference (PO) | Discharge Point | Final Dest. (DC) | Ship Date | Cancel Date | Cartons | Quantity (EA) |
|-------------------|--------------------|------------------------|-----------|-------------|---------|------------------|
| 116 | C | CAN | CAN | 12/01/96 | | 1,396 |
| 125 | | COR | COR | 12/01/96 | 735 | 2,940 |
| 121 | | DEN | DEN | 12/01/96 | 735 | 2,940 |
| 123 | | GEO | GEO | 12/01/96 | 735 | 2,940 |
| 119 | | GNB | GNB | 12/01/96 | 735 | 2,940 |
| 115 | | LAW | LAW | 12/01/96 | 735 | 2,940 |
| 120 | C | MAN | MAN | 12/01/96 | | 1,184 |
| 122 | | OCA | OCA | 12/01/96 | 735 | 2,940 |
| 118 | | ONT | ONT | 12/01/96 | 735 | 2,940 |
| 124 | C | SHA | SHA | 12/01/96 | | 868 |
| 114 | C | SPK | SPK | 12/01/96 | | 1,916 |
| 128 | | CAN | CAN | 01/01/97 | 735 | 2,940 |
| 134 | C | COR | COR | 01/01/97 | | 392 |
| 131 | C | DEN | DEN | 01/01/97 | | 864 |
| 133 | C | GEO | GEO | 01/01/97 | | 484 |
| 130 | C | GNB | GNB | 01/01/97 | | 996 |
| 127 | C | LAW | LAW | 01/01/97 | | 508 |
| 110 | | MAN | MAN | 01/01/97 | 735 | 2,940 |
| 109 | | MOR | MOR | 01/01/97 | 735 | 2,940 |
| 111 | | SHA | SHA | 01/01/97 | 735 | 2,940 |
| 108 | | SPK | SPK | 01/01/97 | 735 | 2,940 |
| 135 | | WAR | WAR | 01/01/97 | 735 | 2,940 |
| 117 | | MOR | MOR | 02/15/97 | 735 | 2,940 |
| 126 | | WAR | WAR | 02/15/97 | 735 | 2,940 |
| 132 | | OCA | OCA | 02/28/97 | 735 | 2,940 |
| 129 | | ONT | ONT | 02/28/97 | 735 | 2,940 |
| 137 | C | CAN | CAN | 03/01/97 | | 1,048 |
| 106 | C | COR | COR | 03/01/97 | | 392 |
| 102 | C | DEN | DEN | 03/01/97 | | 864 |
| 104 | C | GEO | GEO | 03/01/97 | | 484 |
| 139 | C | GNB | GNB | 03/01/97 | | 996 |
| 136 | C | LAW | LAW | 03/01/97 | | 508 |
| 101 | C | MAN | MAN | 03/01/97 | | 888 |
| 113 | C | MOR | MOR | 03/01/97 | | 2,972 |
| 103 | C | OCA | OCA | 03/01/97 | | 952 |
| 138 | C | ONT | ONT | 03/01/97 | | 1,920 |
| 105 | C | SHA | SHA | 03/01/97 | | 648 |
| 112 | C | SPK | SPK | 03/01/97 | | 1,440 |
| 107 | C | WAR | WAR | 03/01/97 | | 1,896 |

Summary by Final Destination (DC)

| Discharge Point | Cartons | Quantity |
|--------------------|---------|----------|
| | | |

82 ✓

CAN

735

2,940

83

Summary by Final Destination (DC)

| Discharge Point | Cartons | Quantity |
|-----------------|---------|----------|
| COR | 735 | 2,940 |
| DEN | 735 | 2,940 |
| GEO | 735 | 2,940 |
| GNB | 735 | 2,940 |
| LAW | 735 | 2,940 |
| MAN | 735 | 2,940 |
| MOR | 1,470 | 5,880 |
| OCA | 1,470 | 5,880 |
| ONT | 1,470 | 5,880 |
| SHA | 735 | 2,940 |
| SPK | 735 | 2,940 |
| WAR | 1,470 | 5,880 |

Summary by SHIPPING SCHEDULE DATE

| DATE | Cartons | Quantity |
|----------|---------|----------|
| 12/01/96 | 5,145 | 20,580 |
| 01/01/97 | 4,410 | 17,640 |
| 02/15/97 | 1,470 | 5,880 |
| 02/28/97 | 1,470 | 5,880 |

Fiber Information

Additional Information

84

ORDER CONTRACT
(CONTINUED)

Page: 4

KMART CORPORATION
3100 W BIG BEAVER RD
TROY MICHIGAN
48084 USA

Telephone:
Facsimile:

ORDER DATE: 09/03/96 CONTRACT NO: K3129 ITEM CODE: 640-118731-116 BUYER: LVW LARRY VANDERWERFF
DIV: 1 DEPT NO: 43 UPC CARTON ID: 10024838170008 FACTORY: 3647

ITEM: TABLETOP GAS GRILL

HH1

4404R
SPECIAL PROJECT SPRING

K mart Corporation
I M P O R T O R D E R Page 3

Order: K3129 Code: 11-87-31 Document: 4404 R
ITEM: TABLE TOP GAS GRILL

BASIC
TABLE TOP PORTABLE BBQ GAS GRILL 17"
COLOR: LID & BODY BLACK
MATERIAL: TOP & BOTTOM: STEEL SHEET. SHEET THICKNESS: 0.6MM
WIRE DIA. OF COOKING GRILL 3.5X2.5 MM AND CHARCOAL GRILL
3.3X4.5MM, WIRE DIA. OF LEGS: 6MM BURNER: 1 PC, GAS
REGULATOR WITH FILTER: 1 PC BAKELITE HANDLES: 3 PCS & LAVA
ROCKS : 1 BAG (2.2 LBS)
FINISH: TOP & BOTTOM: PORCELAIN ENAMEL
COOKING GRILL, STEEL LEGS: CHROME-PLATED CHARCOAL GRILL:
ZINC-PLATED
PACKING: EA PACKED INTO TRU-BURN COLOR BOX. 4 SETS/CTN
OUTER CARTON MARKINGS:
REFER TO KMART CORP. "CARTON MARKING INSTRUCTIONS".
NOTE: CARTONS MUST BE PACKED TO INNER AND OUTER PIECE
COUNTS SPECIFIED ON THE ORDER. PARTIAL OR ODD PACKED
CARTONS ARE NOT PERMITTED FOR SHIPMENT.
VENDOR IS TO DEVELOP AND FORWARD PACKAGE PROOFS TO THE
KMART OVERSEAS LOCAL OFFICE 60 DAYS PRIOR TO SHIP DATE

M E R C H A N D I S E I N F O R M A T I O N

Spec No: 640118731116K3129

Spec Type: MDSNAPP MERCHANDISE SPEC FOR HARDLINES

TICKET LABEL INFORMATION

Factory:

Address:

ORDER CONTRACT

KMART CORPORATION
3100 W BIG BEAVER RD
TROY MICHIGAN
48084 USA

Telephone:
Facsimile:

ORDER DATE: 05/21/97 CONTRACT NO: I0757 ITEM CODE: 640-118731-116 BUYER: LVW LARRY VANDERWERFF
DIV: 1 DEPT NO: 43 UPC CARTON ID: 10072000716738 FACTORY: 3647

ITEM: TABLE TOP GAS GRILL - 17"

Manufacturer: LIEN MOU INDUSTRIAL FACTORY CO LTD
556 MIN WOO ROAD,
HSIN-CHU CITY,
TAIWAN,R.O.C.

FOREIGN AGENT: KKTP KMART TAIWAN LTD
FOREIGN OFFICE: RKKTP KMART TAIWAN LTD
PRODUCTION OFFICE: PKKHK KMART HONG KONG OFFICE
SHIP VIA: (X)SEA ()AIR ()TRUCK/RAIL
VIA LINE:
Payment to be made by (X) CHECK or () Letter of Credit
LC#: BANK: BANKOA
LC Transferable: No

Each item to be marked: MADE IN CHINA (MAINLAND)
Embark/Go-down: CHINA (MAINLAND)

LIFESTYLE: HARDLINES
TRADEMARK: NO TRADEMARK ON THIS ORDER
BRAND NAME: NONE

| Total Cartons | Total Piece | per Piece | Total Cost of Order | Terms |
|---------------|-------------|-----------|---------------------|-------|
| 1,470 | 5,880 | \$9.590 | \$56,389.20 | FOB |

| PER CTN | KGS: | CBM: | LBS: | CUF.FT: | Piece per Inner: | Inners per outer carton: | Total Piece per outer export ctn: | Packing Instruction: |
|---------|---------|---------|--------|---------|------------------|--------------------------|-----------------------------------|----------------------|
| | 22.600 | .079500 | 49.824 | 2.808 | 4 | 1 | 4 | CASEPACK |
| | NET WT: | | | | | | | |

| | per Piece | per CARTON | per Piece | per CARTON | per Piece | per CARTON |
|------------------|-----------|------------|------------------|------------|-----------|--------------------------------|
| F.O.B. PRICE | \$9.590 | \$38.360 | IMPORT CHR | 1.70% | .186 | .743 |
| DUTY | .163 | .652 | BANK FEE | | | |
| COUNTER VEILING | | | PIER CHR | | | |
| USER FEE | .020 | .081 | TICKET DUTY | | | |
| HARBOR FEE | .012 | .048 | ASSIST | | | |
| OCEAN FREIGHT 33 | .656 | 2.624 | EXCISE TAX | | | |
| TARIFF # KHCH9 | | | ODC TAX | | | |
| AGENT FEE 5% | .480 | 1.918 | DEFECT | | | |
| BUYER CRDT | | | SERVICE | | | |
| AGENT 2 | | | DECON FEE 24.000 | .477 | 1.908 | \$129,301.20 |
| WAREHOUSE | | | LANDED COST | 11.58 | 46.33 | |
| | | | | | | TOTAL SELLING VALUE FOR ORDER: |

| HTS # | \$/HTS UNIT | HTS DUTY % | NET NET WGT per HTS UNIT | WT RATE % | SPECIAL QTY / HTS UNIT | #HTS UNITS per PIECE | QUOTA # | CVD RATE |
|--------------|-------------|------------|--------------------------|-----------|------------------------|----------------------|---------|----------|
| 7321.1300.40 | 9.59 | 1.7 | | | | | | |

BINDING RULE # OR PRECLASS #

| BUYER/DATE | MDSE. MGR-SALES/DATE | OFFICE/DATE | INTERNATIONAL DEPT./DATE |
|------------|----------------------|-------------|--------------------------|
| | | | |

Special Instructions:

() RETURN SHEET # _____

() DEFERRED PMT. _____ Days

Conveyable : N

ORDER CONTRACT
(CONTINUED)

KMART CORPORATION
3100 W BIG BEAVER RD
TROY MICHIGAN
48084 USA

Telephone:
Facsimile:

ORDER DATE: 05/21/97 CONTRACT NO: I0757 ITEM CODE: 640-118731-116 BUYER: LVW LARRY VANDERWERFF
DIV: 1 DEPT NO: 43 UPC CARTON ID: 10072000716738 FACTORY: 3647

ITEM: TABLE TOP GAS GRILL - 17"

UPC NUMBER

072000716731

SHIPPING SCHEDULE

| Reference (PO) | Discharge Point | Final Dest. (DC) | Ship Date | Cancel Date | Cartons | Quantity (EA) |
|-------------------|--------------------|------------------------|-----------|-------------|---------|------------------|
| 801 | WCD | WCD | 12/19/97 | | | 5,880 |

Summary by Final Destination (DC)

| Discharge Point | Cartons | Quantity |
|--------------------|---------|----------|
| CAN | 120 | 480 |
| DEN | 120 | 480 |
| GEO | 240 | 960 |
| GNB | 90 | 360 |
| LAW | 90 | 360 |
| MAN | 90 | 360 |
| MOR | 75 | 300 |
| OCA | 300 | 1,200 |
| ONT | 90 | 360 |
| SHA | 60 | 240 |
| SPK | 75 | 300 |
| WAR | 120 | 480 |
| WCD | | 5,880 |

Summary by SHIPPING SCHEDULE DATE

| DATE | Cartons | Quantity |
|----------|---------|----------|
| 12/19/97 | | 5,880 |

Fiber Information

Additional Information

COMMERCIAL INVOICE IN DUPLICATE (COPIES OR ORIGINALS ACCEPTABLE.)
PACKING LIST IN DUPLICATE (COPIES OR ORIGINALS ACCEPTABLE.)
COMBINED DRAWINGS ACCEPTABLE.
SEPARATE INVOICES MUST BE ISSUED FOR EACH DESTINATION (COPIES OR ORIGINALS
ACCEPTABLE.)
ON BOARD NON NEGOTIABLE SEAWAY BILL OR ONE ON BOARD OCEAN BILL OF LADING
CONSIGNED TO KMART CORPORATION MARKED FREIGHT COLLECT AND FORWARDERS CARGO
RECEIPT ISSUED BY ACS LOGISTICS LTD. (COPIES OR ORIGINALS ACCEPTABLE)
INSURANCE TO BE AFFECTED BY BUYER KMART CORPORATION
ALL SHIPMENTS TO BE MADE AS SPECIFIED IN BUYER'S ORDER NO. _____
WITH SHIPMENT TO COMMENCE ON _____
BUT IN ANY EVENT NOT LATER THAN _____.
REFERENCE (PO) FROM ORDER CONTRACT SHIPPING SCHEDULE MUST BE SPECIFIED ON THE
COMMERCIAL INVOICE FOR EACH SHIPMENT COVERED ON THE INVOICE
KMART INSPECTION CERTIFICATE (COPIES OR ORIGINALS ACCEPTABLE.)

ORDER CONTRACT

(CONTINUED)

Telephone:
Facsimile:

KMART CORPORATION
3100 W BIG BEAVER RD
TROY MICHIGAN
48084 USA

ORDER DATE: 05/21/97 CONTRACT NO: I0757 ITEM CODE: 640-118731-116 BUYER: LVW LARRY VANDERWERFF
DIV: 1 DEPT NO: 43 UPC CARTON ID: 10072000716738 FACTORY: 3647

ITEM: TABLE TOP GAS GRILL - 17"

TS1

PRODUCT LIABILITY INSURANCE CERTIFICATE REQUIRED COVERING ALL SHIP DATES
7431R
SPECIAL PROJECT SPRING

CARTON UPC #:10072000716738

K mart Corporation
I M P O R T O R D E R Page 3

Order: K3828 Code: 11-87-31 Document: 7431 R
SPECIAL PROJECT SPRING

TABLE TOP PORTABLE GAS GRILL - 17"

SEASONAL ITEM
COLOR: BLACK
MATERIAL: TOP & BOTTOM: STEEL SHEET.
SHEET THICKNESS: 0.6MM
WIRE DIA. OF COOKING GRILL 3.5 X 2.5MM AND CHARCOAL GRILL
3.3 X 4.5MM
WIRE DIA. OF LEGS: 6MM. 3PCS OF BAKELITE HANDLES &
LAVA ROCK: 1 BAG (2.2 LBS)
GAS REGULATOR WITH FILTER. 1PC
FINISH: TOP & BOTTOM: PORCELAIN ENAMEL.
COOKING GRILL, STEEL LEGS: CHROME-PLATED
CHARCOAL GRILL: ZINC PLATED
LOGO "BBO-PRO" WILL BE BURNT ONTO THE TOP LID HANDLE
PACKING: EACH PACKED INTO COLOR BOX, 4 PCS/CTN.
CHINA PORT - HUANG PU, CHINA
UPC SYMBOL IS REQUIRED ON THIS ITEM

OUTER CARTON MARKINGS:

REFER TO KMART CORP. "CARTON MARKING INSTRUCTIONS".
NOTE: CARTONS MUST BE PACKED TO INNER AND OUTER PIECE
COUNTS SPECIFIED ON THE ORDER. PARTIAL OR ODD PACKED
CARTONS ARE NOT PERMITTED FOR SHIPMENT.
VENDOR IS TO DEVELOP AND FORWARD PACKAGE PROOFS TO THE
KMART OVERSEAS LOCAL OFFICE 60 DAYS PRIOR TO SHIP DATE
WHEN NEW PACKAGE DESIGNS ARE REQUIRED.
END OF DOCUMENT.....

M E R C H A N D I S E I N F O R M A T I O N

Spec No: I0757640118731116

Spec Type: MDSNAPP MERCHANDISE SPEC FOR HARDLINES

TICKET LABEL INFORMATION

Factory:

Address:

89

ORDER CONTRACT

KMART CORPORATION
3100 W BIG BEAVER RD
TROY MICHIGAN
48084 USA

Telephone:
Facsimile:

ORDER DATE: 05/21/97 CONTRACT NO: K3821 ITEM CODE: 640-118731-116 BUYER: LVW LARRY VANDERWERFF
DIV: 1 DEPT NO: 43 UPC CARTON ID: 10072000716738 FACTORY: 3647

ITEM: TABLE TOP GAS GRILL - 17"

Manufacturer: LIEN MOU INDUSTRIAL FACTORY CO LTD
556 MIN WOO ROAD,
HSIN-CHU CITY,
TAIWAN, R.O.C.

FOREIGN AGENT: KKTTP KMART TAIWAN LTD
FOREIGN OFFICE: RKKTP KMART TAIWAN LTD
PRODUCTION OFFICE: PKKHK KMART HONG KONG OFFICE
SHIP VIA: (X)SEA ()AIR ()TRUCK/RAIL
VIA LINE:
Payment to be made by (X) CHECK or () Letter of Credit
LC#: BANK: BANKOA
LC Transferable: No

Each item to be marked: MADE IN CHINA (MAINLAND)
Embark/Go-down: CHINA (MAINLAND)

LIFESTYLE: HARDLINES
TRADEMARK: NO TRADEMARK ON THIS ORDER
BRAND NAME: NONE

| Total Cartons | Total Piece | per Piece | Total Cost of Order | Terms |
|---------------|-------------|-----------|---------------------|-------|
| 1,470 | 5,880 | \$9.590 | \$56,389.20 | FOB |

| PER | KGS: | 22.600 | CBM: | .079500 | Piece per Inner: | 4 | Packing Instruction: |
|-----|---------|--------|---------|---------|-----------------------------------|---|----------------------|
| CTN | LBS: | 49.824 | CUF.FT: | 2.808 | Inners per outer carton: | 1 | CASEPACK |
| | NET WT: | | | | Total Piece per outer export ctn: | 4 | |

| | per Piece | per CARTON | per Piece | per CARTON | per Piece | per CARTON |
|------------------|-----------|------------|-------------------|------------|-----------|--------------------------------|
| F.O.B. PRICE | \$9.590 | \$38.360 | IMPORT CHRG 1.70% | .186 | .743 | DC ALLOWANCE |
| DUTY | .163 | .652 | BANK FEE | % | | ROYALTY |
| COUNTER VEILING | | | PIER CHRG | | | COST OUT OF DC 11.58 |
| USER FEE | .020 | .081 | TICKET DUTY | | | SELLING PRICE 21.99 21.99 |
| HARBOR FEE | .012 | .048 | ASSIST | | | GROSS MARGIN .473252 |
| OCEAN FREIGHT 33 | .656 | 2.624 | EXCISE TAX | | | MARKON 47.3252 |
| TARIFF # KHCH9 | | | ODC TAX | | | |
| AGENT FEE 5% | .480 | 1.918 | DEFECT | | | TOTAL SELLING VALUE FOR ORDER: |
| BUYER CRDT | % | | SERVICE | | | |
| AGENT 2 | % | | DECON FEE 24.000 | .477 | 1.908 | \$129,301.20 |
| WAREHOUSE | % | | LANDED COST | 11.58 | 46.33 | |

| HTS # | \$/HTS UNIT | HTS DUTY % | NET NET WGT per HTS UNIT | WT RATE % | SPECIAL QTY / HTS UNIT | #HTS UNITS per PIECE | QUOTA # | CVD RATE |
|--------------|-------------|------------|--------------------------|-----------|------------------------|----------------------|---------|----------|
| 7321.1300.40 | 9.59 | 1.7 | | | | | | |

BINDING RULE # OR PRECLASS #

| BUYER/DATE | MDSE. MGR-SALES/DATE | OFFICE/DATE | INTERNATIONAL DEPT./DATE |
|------------|----------------------|-------------|--------------------------|
| | | | |

Special Instructions:

() RETURN SHEET # _____
Conveyable : N

() DEFERRED PMT. _____ Days

90

ORDER CONTRACT
(CONTINUED)

KMART CORPORATION
3100 W BIG BEAVER RD
TROY MICHIGAN
48084 USA

Telephone:
Facsimile:

ORDER DATE: 05/21/97 CONTRACT NO: K3821 ITEM CODE: 640-118731-116 BUYER: LVW LARRY VANDERWERFF
DIV: 1 DEPT NO: 43 UPC CARTON ID: 10072000716738 FACTORY: 3647

ITEM: TABLE TOP GAS GRILL - 17"

UPC NUMBER

07200716731

SHIPPING SCHEDULE

| Reference (PO) | Discharge Point | Final Dest. (DC) | Ship Date | Cancel Date | Cartons | Quantity (EA) |
|-------------------|--------------------|------------------------|-----------|-------------|---------|------------------|
| 119 | C | COR | 10/10/97 | | | 2,000 |
| 130 | C | DEN | 10/10/97 | | | 2,000 |
| 123 | C | OCA | 10/10/97 | | | 4,000 |
| 101 | C | ONT | 10/10/97 | | | 4,000 |
| 120 | C | COR | 11/05/97 | | | 2,000 |
| 110 | C | GEO | 11/05/97 | | | 4,000 |
| 127 | C | GNB | 11/05/97 | | | 2,000 |
| 106 | C | LAW | 11/05/97 | | | 2,000 |
| 124 | C | OCA | 11/21/97 | | | 4,000 |
| 102 | C | ONT | 11/21/97 | | | 2,000 |
| 104 | C | SPK | 11/21/97 | | | 2,000 |
| 111 | C | GEO | 12/06/97 | | | 2,000 |
| 107 | C | MOR | 12/06/97 | | | 4,000 |
| 114 | C | CAN | 12/21/97 | | | 2,000 |
| 116 | C | MAN | 12/21/97 | | | 2,000 |
| 128 | C | GNB | 01/06/98 | | | 2,000 |
| 121 | C | SHA | 01/06/98 | | | 2,000 |
| 122 | C | WAR | 01/06/98 | | | 2,000 |
| 131 | C | DEN | 01/24/98 | | | 2,000 |
| 112 | C | GEO | 01/24/98 | | | 2,000 |
| 117 | C | MAN | 01/24/98 | | | 2,000 |
| 108 | C | MOR | 01/24/98 | | | 2,000 |
| 105 | C | SPK | 01/24/98 | | | 2,000 |
| 125 | C | OCA | 02/20/98 | | | 2,000 |
| 103 | C | ONT | 02/20/98 | | | 2,000 |
| 115 | C | CAN | 03/16/98 | | | 2,000 |
| 113 | C | GEO | 03/16/98 | | | 2,000 |
| 129 | C | GNB | 03/16/98 | | | 2,000 |
| 109 | C | MOR | 03/16/98 | | | 2,000 |
| 126 | C | OCA | 03/31/98 | | | 2,000 |
| 801 | | WCD | 03/31/98 | | 1,470 | 5,880 |
| 118 | C | MAN | 04/15/98 | | | 2,000 |

Summary by Final Destination (DC)

| Discharge Point | Cartons | Quantity |
|--------------------|---------|----------|
| WCD | 1,470 | 5,880 |

Summary by SHIPPING SCHEDULE DATE

| DATE | Cartons | Quantity |
|------|---------|----------|
|------|---------|----------|

91

03/31/98

1,470

5,880

ar ✓

Summary by SHIPPING SCHEDULE DATE

| DATE | Cartons | Quantity |
|------|---------|----------|
| | | |

Fiber Information

Additional Information

COMMERCIAL INVOICE IN DUPLICATE (COPIES OR ORIGINALS ACCEPTABLE.)
 PACKING LIST IN DUPLICATE (COPIES OR ORIGINALS ACCEPTABLE.)
 COMBINED DRAWINGS ACCEPTABLE.
 SEPARATE INVOICES MUST BE ISSUED FOR EACH DESTINATION (COPIES OR ORIGINALS ACCEPTABLE.)
 ON BOARD NON NEGOTIABLE SEAWAY BILL OR ONE ON BOARD OCEAN BILL OF LADING
 CONSIGNED TO KMART CORPORATION MARKED FREIGHT COLLECT AND FORWARDERS CARGO
 RECEIPT ISSUED BY ACS LOGISTICS LTD. (COPIES OR ORIGINALS ACCEPTABLE)
 INSURANCE TO BE AFFECTED BY BUYER KMART CORPORATION
 ALL SHIPMENTS TO BE MADE AS SPECIFIED IN BUYER'S ORDER NO. _____
 WITH SHIPMENT TO COMMENCE ON _____
 BUT IN ANY EVENT NOT LATER THAN _____.
 REFERENCE (PO) FROM ORDER CONTRACT SHIPPING SCHEDULE MUST BE SPECIFIED ON THE
 COMMERCIAL INVOICE FOR EACH SHIPMENT COVERED ON THE INVOICE
 KMART INSPECTION CERTIFICATE (COPIES OR ORIGINALS ACCEPTABLE.)

93

ORDER CONTRACT
(CONTINUED)

KMART CORPORATION
3100 W BIG BEAVER RD
TROY MICHIGAN
48084 USA

Telephone:
Facsimile:

ORDER DATE: 05/21/97 CONTRACT NO: K3821 ITEM CODE: 640-118731-116 BUYER: LVW LARRY VANDERWERFF
DIV: 1 DEPT NO: 43 UPC CARTON ID: 10072000716738 FACTORY: 3647

ITEM: TABLE TOP GAS GRILL - 17"

TS1

PRODUCT LIABILITY INSURANCE CERTIFICATE REQUIRED COVERING ALL SHIP DATES
7424R
SPECIAL PROJECT SPRING

CARTON UPC NUMBER:10072000716738

K mart Corporation
I M P O R T O R D E R Page 3

Order: K3821 Code: 11-87-31 Document: 7424 R
SPECIAL PROJECT SPRING

TABLE TOP PORTABLE GAS GRILL - 17"

SEASONAL ITEM
COLOR: BLACK
MATERIAL: TOP & BOTTOM: STEEL SHEET.
SHEET THICKNESS: 0.6MM
WIRE DIA. OF COOKING GRILL 3.5 X 2.5MM AND CHARCOAL GRILL
3.3 X 4.5MM
WIRE DIA. OF LEGS: 6MM. 3PCS OF BAKELITE HANDLES &
LAVA ROCK: 1 BAG (2.2 LBS)
GAS REGULATOR WITH FILTER. 1PC
FINISH: TOP & BOTTOM: PORCELAIN ENAMEL.
COOKING GRILL, STEEL LEGS: CHROME-PLATED
CHARCOAL GRILL: ZINC PLATED
LOGO "BBO-PRO" WILL BE BURNT ONTO THE TOP LID HANDLE
PACKING: EACH PACKED INTO COLOR BOX, 4 PCS/CTN.
CHINA PORT - HUANG PU, CHINA
UPC SYMBOL IS REQUIRED ON THIS ITEM

OUTER CARTON MARKINGS:

REFER TO KMART CORP. "CARTON MARKING INSTRUCTIONS".
NOTE: CARTONS MUST BE PACKED TO INNER AND OUTER PIECE
COUNTS SPECIFIED ON THE ORDER. PARTIAL OR ODD PACKED
CARTONS ARE NOT PERMITTED FOR SHIPMENT.
VENDOR IS TO DEVELOP AND FORWARD PACKAGE PROOFS TO THE
KMART OVERSEAS LOCAL OFFICE 60 DAYS PRIOR TO SHIP DATE
WHEN NEW PACKAGE DESIGNS ARE REQUIRED.
END OF DOCUMENT.....

M E R C H A N D I S E I N F O R M A T I O N

Spec No: 640118731116K3821

Spec Type: MDSNAPP MERCHANDISE SPEC FOR HARDLINES

TICKET LABEL INFORMATION

Factory:

Address:

ORDER CONTRACT

KMART CORPORATION
3100 W BIG BEAVER RD
TROY MICHIGAN
48084 USA

Telephone:
Facsimile:

ORDER DATE: 05/21/97 CONTRACT NO: I0756 ITEM CODE: 640-118731-116 BUYER: LVW LARRY VANDERWERFF
DIV: 1 DEPT NO: 43 UPC CARTON ID: 10072000716738 FACTORY: 3647

ITEM: TABLE TOP GAS GRILL - 17"

Manufacturer: LIEN MOU INDUSTRIAL FACTORY CO LTD
556 MIN WOO ROAD,
HSIN-CHU CITY,
TAIWAN, R.O.C.

FOREIGN AGENT: KKTP KMART TAIWAN LTD
FOREIGN OFFICE: RKKTP KMART TAIWAN LTD
PRODUCTION OFFICE: PKKHK KMART HONG KONG OFFICE
SHIP VIA: (X)SEA ()AIR ()TRUCK/RAIL
VIA LINE:
Payment to be made by (X) CHECK or () Letter of Credit
LC#: BANK: BANKOA
LC Transferable: No

Each item to be marked: MADE IN CHINA (MAINLAND)
Embark/Go-down: CHINA (MAINLAND)

LIFESTYLE: HARDLINES
TRADEMARK: NO TRADEMARK ON THIS ORDER
BRAND NAME: NONE

| Total Cartons | Total Piece | per Piece | Total Cost of Order | Terms |
|---------------|-------------|-----------|---------------------|-------|
| | | \$9.590 | \$0.00 | FOB |

| PER | KGS: | 22.600 | CBM: | .079500 | Piece per Inner: | 4 | Packing Instruction: |
|-----|---------|--------|---------|---------|-----------------------------------|---|----------------------|
| CTN | LBS: | 49.824 | CUF.FT: | 2.808 | Inners per outer carton: | 1 | CASEPACK |
| | NET WT: | | | | Total Piece per outer export ctn: | 4 | |

| | per Piece | per CARTON | | per Piece | per CARTON | | per Piece | per CARTON |
|------------------|-----------|------------|-------------|-----------|------------|-------|--------------------------------|-------------|
| F.O.B. PRICE | \$9.590 | \$38.360 | IMPORT CHR | 1.70% | .186 | .743 | DC ALLOWANCE | |
| DUTY | .163 | .652 | BANK FEE | % | | | ROYALTY | |
| COUNTER VEILING | | | PIER CHR | | | | COST OUT OF DC | 11.58 |
| USER FEE | .020 | .081 | TICKET DUTY | | | | SELLING PRICE | 21.99 21.99 |
| HARBOR FEE | .012 | .048 | ASSIST | | | | GROSS MARGIN | .473252 |
| OCEAN FREIGHT 33 | .656 | 2.624 | EXCISE TAX | | | | MARKON | 47.3252 |
| TARIFF # KHCH9 | | | ODC TAX | | | | | |
| AGENT FEE 5% | .480 | 1.918 | DEFECT | | | | TOTAL SELLING VALUE FOR ORDER: | |
| BUYER CRDT % | | | SERVICE | | | | | |
| AGENT 2 % | | | DECON FEE | 24.000 | .477 | 1.908 | | \$.00 |
| WAREHOUSE % | | | LANDED COST | | 11.58 | 46.33 | | |

| HTS # | \$/HTS UNIT | HTS DUTY % | NET NET WGT per HTS UNIT | WT RATE % | SPECIAL QTY / HTS UNIT | #HTS UNITS per PIECE | QUOTA # | CVD RATE |
|--------------|-------------|------------|--------------------------|-----------|------------------------|----------------------|---------|----------|
| 7321.1300.40 | 9.59 | 1.7 | | | | | | |

BINDING RULE # OR PRECLASS #

| BUYER/DATE | MDSE. MGR-SALES/DATE | OFFICE/DATE | INTERNATIONAL DEPT./DATE |
|------------|----------------------|-------------|--------------------------|
| | | | |

Special Instructions:

() RETURN SHEET # _____
Conveyable : N

() DEFERRED PMT. ___ Days

95

ORDER CONTRACT

KMART CORPORATION
 3100 W BIG BEAVER RD
 TROY MICHIGAN
 48084 USA

(CONTINUED)

Telephone:
 Facsimile:

ORDER DATE: 05/21/97 CONTRACT NO: I0756 ITEM CODE: 640-118731-116 BUYER: LVW LARRY VANDERWERFF
 DIV: 1 DEPT NO: 43 UPC CARTON ID: 10072000716738 FACTORY: 3647

ITEM: TABLE TOP GAS GRILL - 17"

UPC NUMBER

072000716731

SHIPPING SCHEDULE

| Reference (PO) | Discharge Point | Final Dest. (DC) | Ship Date | Cancel Date | Cartons | Quantity (EA) |
|-------------------|--------------------|------------------------|-----------|-------------|---------|------------------|
| 801 | C | WCD | 12/25/97 | | | 5,880 |

Summary by Final Destination (DC)

| Discharge Point | Cartons | Quantity |
|--------------------|---------|----------|
| | | |

Summary by SHIPPING SCHEDULE DATE

| DATE | Cartons | Quantity |
|------|---------|----------|
| | | |

Fiber Information

Additional Information

COMMERCIAL INVOICE IN DUPLICATE (COPIES OR ORIGINALS ACCEPTABLE.)
 PACKING LIST IN DUPLICATE (COPIES OR ORIGINALS ACCEPTABLE.)
 COMBINED DRAWINGS ACCEPTABLE.
 SEPARATE INVOICES MUST BE ISSUED FOR EACH DESTINATION (COPIES OR ORIGINALS ACCEPTABLE.)
 ON BOARD NON NEGOTIABLE SEAWAY BILL OR ONE ON BOARD OCEAN BILL OF LADING
 CONSIGNED TO KMART CORPORATION MARKED FREIGHT COLLECT AND FORWARDERS CARGO
 RECEIPT ISSUED BY ACS LOGISTICS LTD. (COPIES OR ORIGINALS ACCEPTABLE)
 INSURANCE TO BE AFFECTED BY BUYER KMART CORPORATION
 ALL SHIPMENTS TO BE MADE AS SPECIFIED IN BUYER'S ORDER NO. _____
 WITH SHIPMENT TO COMMENCE ON _____
 BUT IN ANY EVENT NOT LATER THAN _____
 REFERENCE (PO) FROM ORDER CONTRACT SHIPPING SCHEDULE MUST BE SPECIFIED ON THE
 COMMERCIAL INVOICE FOR EACH SHIPMENT COVERED ON THE INVOICE
 KMART INSPECTION CERTIFICATE (COPIES OR ORIGINALS ACCEPTABLE.)

96

ORDER CONTRACT
(CONTINUED)

Page: 3

KMART CORPORATION
3100 W BIG BEAVER RD
TROY MICHIGAN
48084 USA

Telephone:
Facsimile:

ORDER DATE: 05/21/97 CONTRACT NO: I0756 ITEM CODE: 640-118731-116 BUYER: LVW LARRY VANDERWERFF
DIV: 1 DEPT NO: 43 UPC CARTON ID: 10072000716738 FACTORY: 3647

ITEM: TABLE TOP GAS GRILL - 17"

TS1

PRODUCT LIABILITY INSURANCE CERTIFICATE REQUIRED COVERING ALL SHIP DATES
7431R
SPECIAL PROJECT SPRING

CARTON UPC #:10072000716738

K mart Corporation
I M P O R T O R D E R Page 3

Order: I0756 Code: 11-87-31 Document: 7431 R
SPECIAL PROJECT SPRING

TABLE TOP PORTABLE GAS GRILL - 17"

SEASONAL ITEM

COLOR: BLACK

MATERIAL: TOP & BOTTOM: STEEL SHEET.

SHEET THICKNESS: 0.6MM

WIRE DIA. OF COOKING GRILL 3.5 X 2.5MM AND CHARCOAL GRILL
3.3 X 4.5MM

WIRE DIA. OF LEGS: 6MM. 3PCS OF BAKELITE HANDLES &

LAVA ROCK: 1 BAG (2.2 LBS)

GAS REGULATOR WITH FILTER. 1PC

FINISH: TOP & BOTTOM: PORCELAIN ENAMEL.

COOKING GRILL, STEEL LEGS: CHROME-PLATED

CHARCOAL GRILL: ZINC PLATED

LOGO "BBO-PRO" WILL BE BURNT ONTO THE TOP LID HANDLE

PACKING: EACH PACKED INTO COLOR BOX, 4 PCS/CTN.

CHINA PORT - HUANG PU, CHINA

UPC SYMBOL IS REQUIRED ON THIS ITEM

OUTER CARTON MARKINGS:

REFER TO KMART CORP. "CARTON MARKING INSTRUCTIONS".

NOTE: CARTONS MUST BE PACKED TO INNER AND OUTER PIECE
COUNTS SPECIFIED ON THE ORDER. PARTIAL OR ODD PACKED
CARTONS ARE NOT PERMITTED FOR SHIPMENT.

VENDOR IS TO DEVELOP AND FORWARD PACKAGE PROOFS TO THE
KMART OVERSEAS LOCAL OFFICE 60 DAYS PRIOR TO SHIP DATE
WHEN NEW PACKAGE DESIGNS ARE REQUIRED.

END OF DOCUMENT.....

M E R C H A N D I S E I N F O R M A T I O N

Spec No: I0756640118731116

Spec Type: MDSNAPP MERCHANDISE SPEC FOR HARDLINES

TICKET LABEL INFORMATION

Factory:

Address:

97

ORDER CONTRACT

KMART CORPORATION
3100 W BIG BEAVER RD
TROY MICHIGAN
48084 USA

Telephone:
Facsimile:

ORDER DATE: 05/21/97 CONTRACT NO: K3828 ITEM CODE: 640-118731-116 BUYER: LVW LARRY VANDERWERFF
DIV: 1 DEPT NO: 43 UPC CARTON ID: 10072000716738 FACTORY: 3647

ITEM: TABLE TOP GAS GRILL - 17"

Manufacturer: LIEN MOU INDUSTRIAL FACTORY CO LTD
556 MIN WOO ROAD,
HSIN-CHU CITY,
TAIWAN, R.O.C.

FOREIGN AGENT: KKTP KMART TAIWAN LTD
FOREIGN OFFICE: RKKTP KMART TAIWAN LTD
PRODUCTION OFFICE: PKKHK KMART HONG KONG OFFICE
SHIP VIA: (X)SEA ()AIR ()TRUCK/RAIL
VIA LINE:
Payment to be made by (X) CHECK or () Letter of Credit
LC#: BANK: BANKOA
LC Transferable: No

Each item to be marked: MADE IN CHINA (MAINLAND)
Embark/Go-down: CHINA (MAINLAND)

LIFESTYLE: HARDLINES
TRADEMARK: NO TRADEMARK ON THIS ORDER
BRAND NAME: NONE

| Total Cartons | Total Piece | per Piece | Total Cost of Order | Terms |
|---------------|-------------|-----------|---------------------|-------|
| 17,640 | 70,560 | \$9.590 | \$676,670.40 | FOB |

| PER CTN | KGS: | 22.600 | CBM: | .079500 | Piece per Inner: | 4 | Packing Instruction: |
|---------|---------|--------|---------|---------|-----------------------------------|---|----------------------|
| | LBS: | 49.824 | CUF.FT: | 2.808 | Inners per outer carton: | 1 | CASEPACK |
| | NET WT: | | | | Total Piece per outer export ctn: | 4 | |

| | per Piece | per CARTON | per Piece | per CARTON | per Piece | per CARTON |
|------------------|-----------|------------|-------------------|------------|-----------|--------------------------------|
| F.O.B. PRICE | \$9.590 | \$38.360 | IMPORT CHRG 1.70% | .186 | .743 | DC ALLOWANCE |
| DUTY | .163 | .652 | BANK FEE % | | | ROYALTY |
| COUNTER VEILING | | | PIER CHRG | | | COST OUT OF DC 11.58 |
| USER FEE | .020 | .081 | TICKET DUTY | | | SELLING PRICE 21.99 21.99 |
| HARBOR FEE | .012 | .048 | ASSIST | | | GROSS MARGIN .473252 |
| OCEAN FREIGHT 33 | .656 | 2.624 | EXCISE TAX | | | MARKON 47.3252 |
| TARIFF # KHCH9 | | | ODC TAX | | | |
| AGENT FEE 5% | .480 | 1.918 | DEFECT | | | TOTAL SELLING VALUE FOR ORDER: |
| BUYER CRDT % | | | SERVICE | | | |
| AGENT 2 % | | | DECON FEE 24.000 | .477 | 1.908 | \$1,551,614.40 |
| WAREHOUSE % | | | LANDED COST | 11.58 | 46.33 | |

| HTS # | \$/HTS UNIT | HTS DUTY % | NET NET WGT per HTS UNIT | WT RATE % | SPECIAL QTY / HTS UNIT | #HTS UNITS per PIECE | QUOTA # | CVD RATE |
|--------------|-------------|------------|--------------------------|-----------|------------------------|----------------------|---------|----------|
| 7321.1300.40 | 9.59 | 1.7 | | | | | | |

BINDING RULE # OR PRECLASS #

BUYER/DATE | MDSE. MGR-SALES/DATE | OFFICE/DATE | INTERNATIONAL DEPT./DATE

Special Instructions:

() RETURN SHEET # _____

() DEFERRED PMT. _____ Days

Conveyable : N

98

ORDER CONTRACT
(CONTINUED)

KMART CORPORATION
3100 W BIG BEAVER RD
TROY MICHIGAN
48084 USA

Telephone:
Facsimile:

ORDER DATE: 05/21/97 CONTRACT NO: K3828 ITEM CODE: 640-118731-116 BUYER: LVW LARRY VANDERWERFF
DIV: 1 DEPT NO: 43 UPC CARTON ID: 10072000716738 FACTORY: 3647

ITEM: TABLE TOP GAS GRILL - 17"

UPC NUMBER

072000716731

S H I P P I N G S C H E D U L E

| Reference (PO) | Discharge Point | Final Dest. (DC) | Ship Date | Cancel Date | Cartons | Quantity (EA) |
|-------------------|--------------------|------------------------|-----------|-------------|---------|------------------|
| 801 | WCD | WCD | 12/05/97 | | | 11,760 |
| 802 | WCD | WCD | 12/13/97 | | | 11,760 |
| 807 | C | WCD | 12/17/97 | | | 5,880 |
| 803 | WCD | WCD | 12/27/97 | | 3,675 | 14,700 |
| 804 | WCD | WCD | 01/20/98 | | 3,675 | 14,700 |
| 805 | WCD | WCD | 01/25/98 | | 2,205 | 8,820 |
| 806 | WCD | WCD | 03/16/98 | | 2,205 | 8,820 |

Summary by Final Destination (DC)

| Discharge Point | Cartons | Quantity |
|--------------------|---------|----------|
| COR | 735 | 2,940 |
| DEN | 735 | 2,940 |
| GEO | 735 | 2,940 |
| GNB | 735 | 2,940 |
| MOR | 735 | 2,940 |
| OCA | 735 | 2,940 |
| ONT | 735 | 2,940 |
| SPK | 735 | 2,940 |
| WCD | 11,760 | 70,560 |

Summary by SHIPPING SCHEDULE DATE

| DATE | Cartons | Quantity |
|----------|---------|----------|
| 12/05/97 | | 11,760 |
| 12/13/97 | | 11,760 |
| 12/27/97 | 3,675 | 14,700 |
| 01/20/98 | 3,675 | 14,700 |
| 01/25/98 | 2,205 | 8,820 |
| 03/16/98 | 2,205 | 8,820 |

cm

Fiber Information

Additional Information

COMMERCIAL INVOICE IN DUPLICATE (COPIES OR ORIGINALS ACCEPTABLE.)
PACKING LIST IN DUPLICATE (COPIES OR ORIGINALS ACCEPTABLE.)
COMBINED DRAWINGS ACCEPTABLE.
SEPARATE INVOICES MUST BE ISSUED FOR EACH DESTINATION (COPIES OR ORIGINALS
ACCEPTABLE.)
ON BOARD NON NEGOTIABLE SEAWAY BILL OR ONE ON BOARD OCEAN BILL OF LADING
CONSIGNED TO KMART CORPORATION MARKED FREIGHT COLLECT AND FORWARDERS CARGO
RECEIPT ISSUED BY ACS LOGISTICS LTD. (COPIES OR ORIGINALS ACCEPTABLE)
INSURANCE TO BE AFFECTED BY BUYER KMART CORPORATION
ALL SHIPMENTS TO BE MADE AS SPECIFIED IN BUYER'S ORDER NO. _____
WITH SHIPMENT TO COMMENCE ON _____
BUT IN ANY EVENT NOT LATER THAN _____.
REFERENCE (PO) FROM ORDER CONTRACT SHIPPING SCHEDULE MUST BE SPECIFIED ON THE
COMMERCIAL INVOICE FOR EACH SHIPMENT COVERED ON THE INVOICE
KMART INSPECTION CERTIFICATE (COPIES OR ORIGINALS ACCEPTABLE.)

100

ORDER CONTRACT
(CONTINUED)

KMART CORPORATION
3100 W BIG BEAVER RD
TROY MICHIGAN
48084 USA

Telephone:
Facsimile:

ORDER DATE: 05/21/97 CONTRACT NO: K3828 ITEM CODE: 640-118731-116 BUYER: LVW LARRY VANDERWERFF
DIV: 1 DEPT NO: 43 UPC CARTON ID: 10072000716738 FACTORY: 3647

ITEM: TABLE TOP GAS GRILL - 17"

TS1

PRODUCT LIABILITY INSURANCE CERTIFICATE REQUIRED COVERING ALL SHIP DATES
7431R
SPECIAL PROJECT SPRING

CARTON UPC #:10072000716738

K mart Corporation
I M P O R T O R D E R Page 3

Order: K3828 Code: 11-87-31 Document: 7431 R
SPECIAL PROJECT SPRING

TABLE TOP PORTABLE GAS GRILL - 17"

SEASONAL ITEM
COLOR: BLACK
MATERIAL: TOP & BOTTOM: STEEL SHEET.
SHEET THICKNESS: 0.6MM
WIRE DIA. OF COOKING GRILL 3.5 X 2.5MM AND CHARCOAL GRILL
3.3 X 4.5MM
WIRE DIA. OF LEGS: 6MM. 3PCS OF BAKELITE HANDLES &
LAVA ROCK: 1 BAG (2.2 LBS)
GAS REGULATOR WITH FILTER. 1PC
FINISH: TOP & BOTTOM: PORCELAIN ENAMEL.

COOKING GRILL, STEEL LEGS: CHROME-PLATED
CHARCOAL GRILL: ZINC PLATED

LOGO "BBO-PRO" WILL BE BURNT ONTO THE TOP LID HANDLE
PACKING: EACH PACKED INTO COLOR BOX, 4 PCS/CTN.
CHINA PORT - HUANG PU, CHINA
UPC SYMBOL IS REQUIRED ON THIS ITEM

OUTER CARTON MARKINGS:

REFER TO KMART CORP. "CARTON MARKING INSTRUCTIONS".
NOTE: CARTONS MUST BE PACKED TO INNER AND OUTER PIECE
COUNTS SPECIFIED ON THE ORDER. PARTIAL OR ODD PACKED
CARTONS ARE NOT PERMITTED FOR SHIPMENT.
VENDOR IS TO DEVELOP AND FORWARD PACKAGE PROOFS TO THE
KMART OVERSEAS LOCAL OFFICE 60 DAYS PRIOR TO SHIP DATE
WHEN NEW PACKAGE DESIGNS ARE REQUIRED.
END OF DOCUMENT.....

M E R C H A N D I S E I N F O R M A T I O N

Spec No: 640118731116K3828

Spec Type: MDSENAPP MERCHANDISE SPEC FOR HARDLINES

TICKET LABEL INFORMATION

Factory:

Address:

182

Exhibit "E"
Kmart Corporation
1/27/98 Inspection
DRB

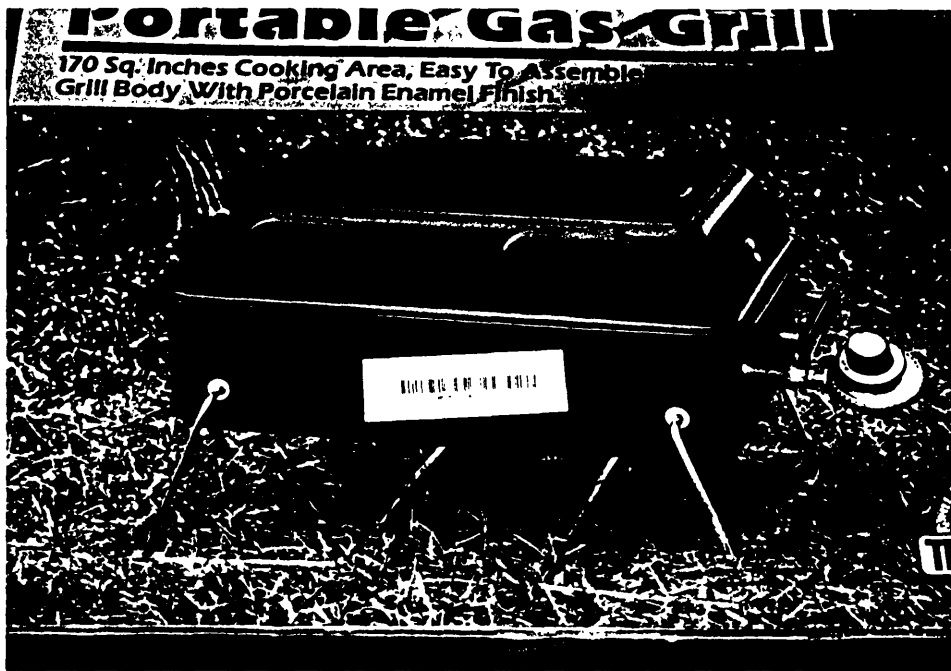

Photos of sample #98-830-3415, the "Tru-Burn" model gas grill.

103

Exhibit "E"
Kmart Corporation
1/27/98 Inspection
DRB

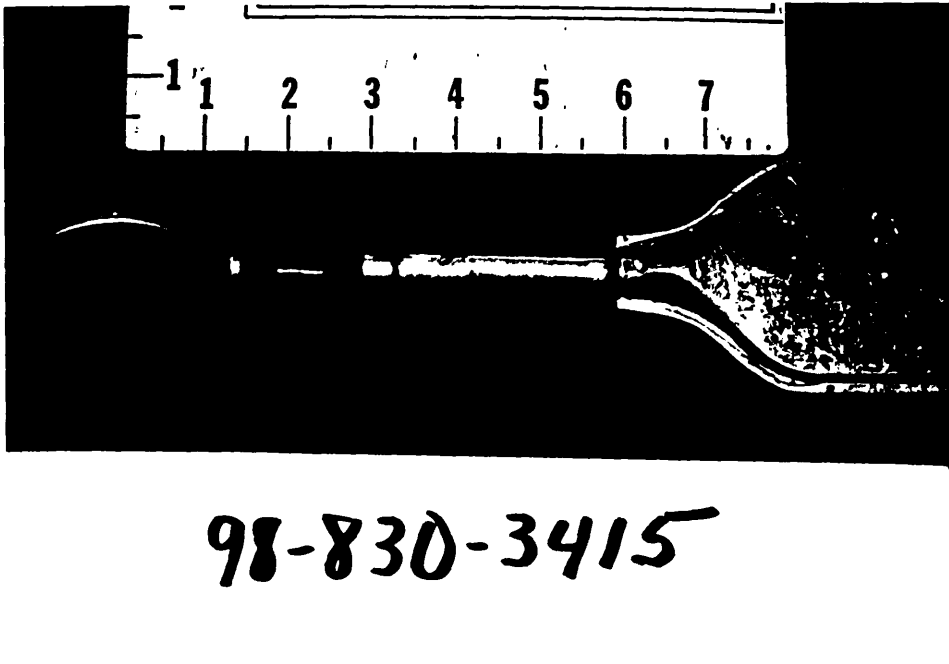

Photos of the gas regulator and burner assembly.

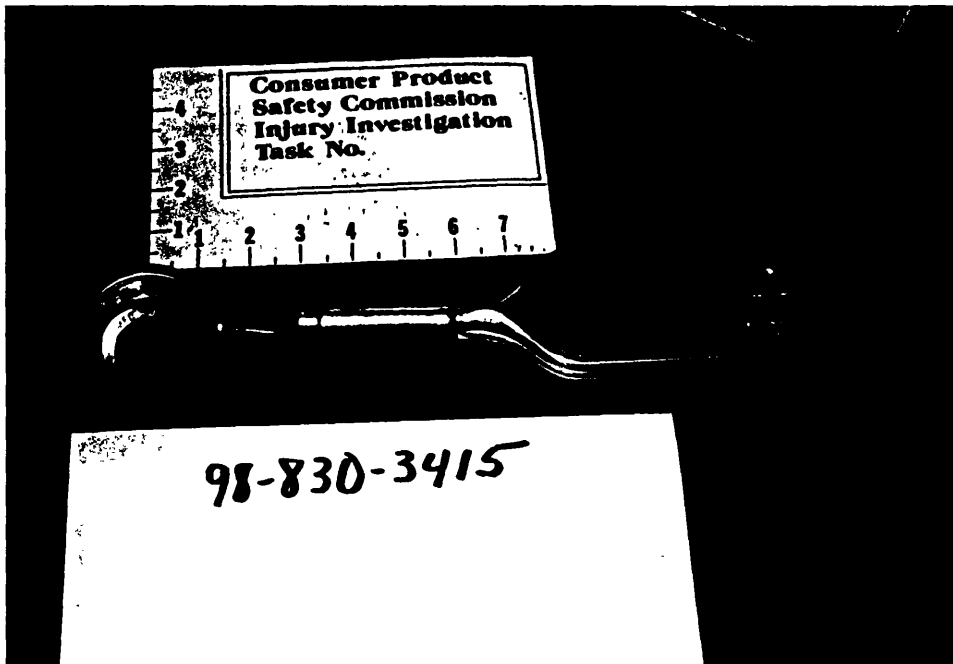

101

Exhibit "E"
Kmart Corporation
1/27/98 Inspection
DRB

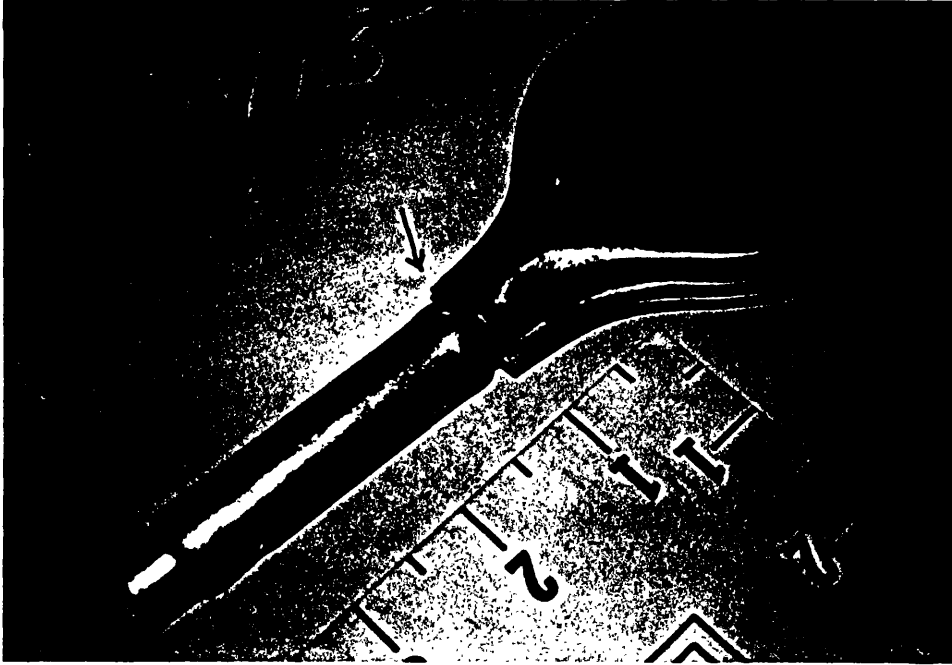

Photos of the gas regulator and burner assembly.

105

Exhibit "F"
Kmet Corp. from
1/27/98 inspection

002



Portable Gas Grill Assembly Instruction

The Other Choice.

Assembly Diagram Bolts and Parts List

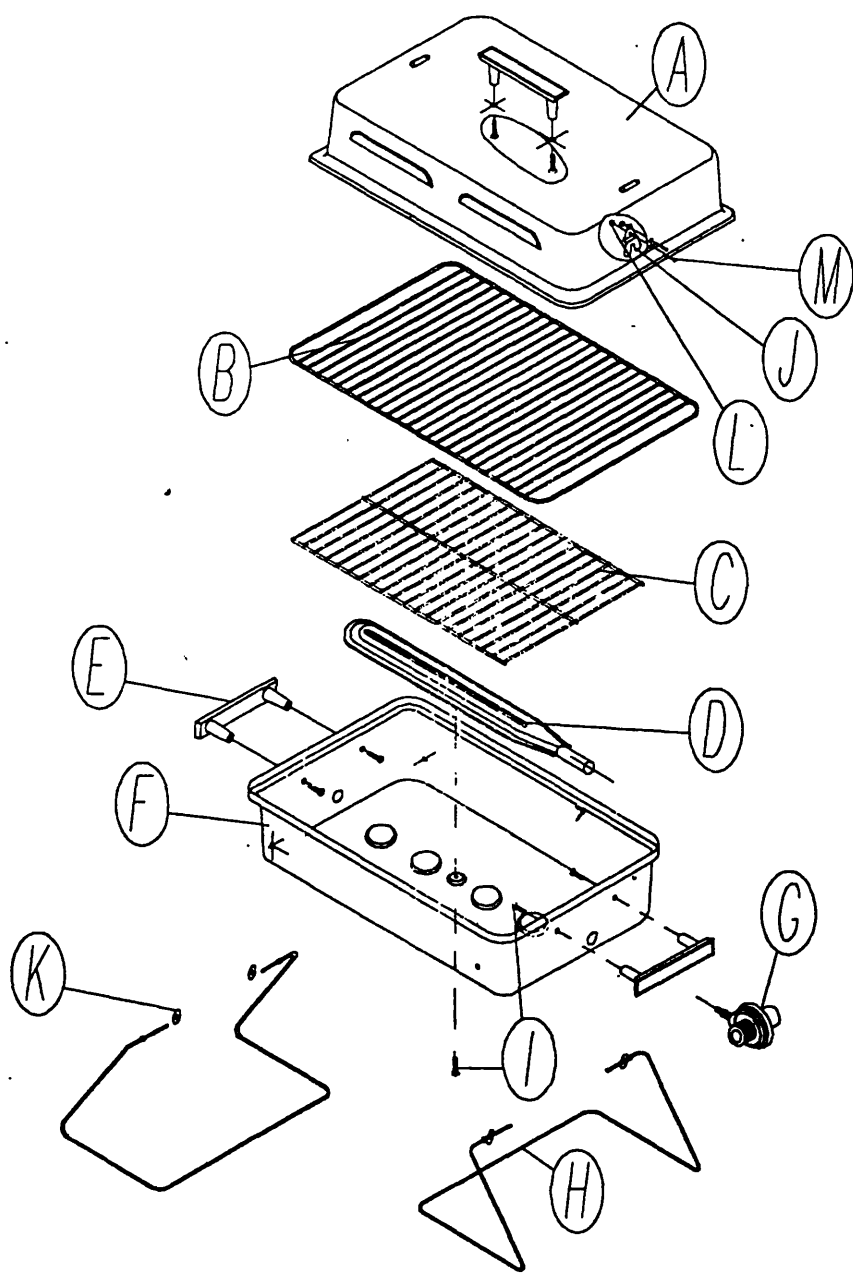

| Part | Description | Q'ty |
|------|-----------------|------|
| A | Grill Top | 1 |
| B | Cooking Grill | 1 |
| C | Lava Rock Grate | 1 |
| D | Burner | 1 |
| E | Bakelite Handle | 3 |
| F | Grill Bottom | 1 |
| G | Regulator | 1 |
| H | Steel Wire Leg | 2 |
| I | 3/4" Bolts | 7 |
| J | Lid Bracket | 2 |
| K | Washers | 4 |
| L | 7/16" Nut | 4 |
| M | 7/16" Bolts | 4 |

106
~~106~~

Kmart Corporation

To: Charlene Haines
Company: KMART
cc: Sal Incalcaterra
Chris Gullen - KIH
Chuck Hajduk - KIH

From: *Jim* JIM DONOHUE
Department: KMART
Phone: (248)637-6501
Fax: (248)643-4245
Date: 9/22/97

Pages Including Cover: 1

RE: TRU-BURN PORTABLE LP GAS GRILL

Dear Charlene,

With reference to your letter of September 17, 1997, and in response to your request, I am enclosing the Hardline Quality Assurance evaluation report # 24096-1CC.

Please note that Romel Mascapac, our mechanical engineer, evaluated the product, and did not find any safety defects. I have also checked with Chuck Hajduk, and he does not have any other complaints on this item.

If you have any pertinent questions, please advise.

Best Regards

107



KMAA - PERFORMANCE STANDARD

**SUMMARY OF TEST RESULTS FOR
GAS GRILL (ANSI Z21.58)**

| | |
|----------------------|---------------------|
| PRODUCT DESCRIPTION: | TABLE TOP GAS GRILL |
| UPC # | |
| MANUFACTURER | LIEN MOU |
| QA CONTROL NO: | 24096-1CC |
| KMART CODE | |
| ITEM # | |
| COUNTRY OF ORIGIN | CHINA |
| DATE OF ANALYSIS: | 15-Sep-97 |
| ANALYSIS BY: | R. MACASPAC |

| TESTED PROPERTY | REQUIREMENT | RESULTS | RATING |
|-----------------|-------------|---------|--------|
|-----------------|-------------|---------|--------|

LABELED INFORMATION

| | | | |
|-------------------|------------|---------|--------------|
| PRODUCER MARKINGS | | BBQ PRO | SATISFACTORY |
| LABELED CONTENT | AS CLAIMED | 1 GRILL | SATISFACTORY |

PHYSICAL PROPERTIES

| | | | |
|-------------------------------|--------------------|---|--------------|
| OVERALL DIMENSIONS (LXWXH) | AS LABELED (+- 5%) | 16 3/4" X 10 7/8" X 6 1/2" (W/LID 9 1/2") | SATISFACTORY |
| AREA OF GRILL (LXW)/(SQ. IN.) | AS LABELED (+- 5%) | 14 1/4" X 10 1/8" | SATISFACTORY |
| TOTAL AREA (SQ. IN.) | AS LABELED (+- 5%) | N/A | |
| SIDE/FRONT SHELF | | " | |
| RIGHT: (LXW)/(SQ. IN.) | AS LABELED (+- 5%) | " | |
| LEFT (LXW)/(SQ. IN.) | AS LABELED (+- 5%) | " | |
| FRONT: (LXW)/(SQ. IN.) | AS LABELED (+- 5%) | " | |
| WARMING RACK | | " | |
| TYPE | AS CLAIMED | " | |
| LXW (SQ. IN.) | AS LABELED (+- 5%) | " | |
| AUTOMATIC LIFT | AS CLAIMED | " | |
| HOUSING (FRAME) | | | |
| TYPE | AS CLAIMED | STEEL | SATISFACTORY |
| THICKNESS(BODY) | AS LABELED (+- 5%) | 0.94mm | SATISFACTORY |
| GRILL | | | |
| TYPE | AS CLAIMED | CHROME PLATED | SATISFACTORY |
| DIAMETER | AS LABELED (+- 5%) | 3.5mm/2.4mm | SATISFACTORY |
| CERAMIC/ LAVA BRIQUETTES | AS CLAIMED | N/A | |

CONSTRUCTION QUALITIES

| | | | |
|------------------|-----------------|-----------------|----------------|
| MATERIAL QUALITY | NO MAJOR DEFECT | NO MAJOR DEFECT | SATISFACTORY |
| WORKMANSHIP | NO MAJOR DEFECT | LEGS* | UNSATISFACTORY |

PERFORMANCE FEATURES

106



Kmart Corporation
 International Headquarters
 Quality Assurance Department
 3100 W. Big Beaver Road
 Troy MI 48084-3163
 Phone (810) 643-1722
 Fax (E10) 643-4245

**Quality Assurance
 Evaluation (Hardlines)**

| | | | |
|---------------|----------------------|------------------|--------------------|
| Buyer: | <u>L VANDERWERFF</u> | Q.A. Control No: | <u>24096 - 1CC</u> |
| Department: | <u>43</u> | Log-In Date: | <u>12-Sep-97</u> |
| Requested By: | <u>L VANDERWERFF</u> | Completion Date: | <u>18-Sep-97</u> |
| Test Type: | <u>COMPLAINT</u> | Assigned to: | <u>R MACASPAC</u> |

Product Information

Brand Name: National Brand Private Label

Detailed Description:
TABLE TOP GAS GRILL

Vendor: LIEN MOU
 Address: _____
 Address: _____
 Kmart Code: _____
 Duns No: IMPORT
 This Product is: COMPLAINT

Analysis Performed

- PERFORMANCE
- PHYSICAL PROPERTIES
- CONSTRUCTION

| | | | |
|----------------|-----------------|--------------------|----------------------------|
| Sample Cost(s) | Test Charge | Priority Surcharge | Total Charge |
| | <u>\$280.00</u> | | to Vendor: <u>\$280.00</u> |

| | | | |
|--------------------|--------------------------|------------------|----------|
| Evaluation: | <u>Approved</u> | <u>Approved*</u> | <u>X</u> |
| | <u>Corrective Action</u> | <u>Rejected</u> | |

Conclusion:

THE PRODUCT WAS EVALUATED DUE TO COMPLAINT/INCIDENT ISSUE. THE CUSTOMER ALLEGES THAT THE LP GAS CANISTER ASSEMBLY OF A BRAND NEW SMALL PORTABLE GRILL DETACHED ITSELF FROM THE BURNER AND ROLLED ONTO A WOODEN FLOOR. (SEE ATTACHED REPORT)

A NEW SAMPLE WAS PROVIDED BY THE MERCHANDISING DEPARTMENT. NO SAFETY DEFECTS WERE FOUND REGARDING THE USE OF THE PRODUCT. THE BURNER PIPE STAYED INTACT AND COULD NOT BE DISLodge EVEN WHEN A TENSILE AND TORQUE FORCE WAS APPLIED.

Q.A. Representative:

Testing of vendor's merchandise is not a substitute for vendor's own testing and other Quality Assurance related obligations in connection with its sale of merchandise to Kmart. Kmart testing shall not limit Kmart's rights, or diminish or remove any of vendor's responsibilities, under Kmart's purchase order terms and conditions including, without limitations, those relating to warranty and indemnification under paragraphs 2 & 3 thereof.

109



KMAK PERFORMANCE STANDARD
SUMMARY OF TEST RESULTS FOR
GAS GRILL (ANSI Z21.58)

| | |
|----------------------|---------------------|
| PRODUCT DESCRIPTION: | TABLE TOP GAS GRILL |
| UPC # | |
| MANUFACTURER | LIEN MOU |
| QA CONTROL NO: | 24096-1CC |
| KMART CODE | |
| ITEM # | |
| COUNTRY OF ORIGIN | CHINA |
| DATE OF ANALYSIS: | 15-Sep-97 |
| ANALYSIS BY: | R. MACASPAC |

| TESTED PROPERTY | REQUIREMENT | RESULTS | RATING |
|---|---|-----------------------|---------------|
| HEAT GENERATION (BTU) | AS RATED (+- 10%) | 10919 BTU/HR | SATISFACTORY |
| EASE OF IGNITION | | | |
| STABILITY | AS CLAIMED | N/A | |
| RIGHT | MIN. 20 LBS. TO TIP-OVER | | |
| LEFT | | N/A | |
| FRONT | | N/A | |
| BODY LOAD- UNIFORMLY APPLY WEIGHT FOR 5 MIN. WITHOUT DEFECT | | 43° | SATISFACTORY |
| < 25 LBS: APPLY 25 LBS | | | |
| 25- 75: APPLY 75 LBS | NO MAJOR DEFECT | SOME DEFLECTION | *SATISFACTORY |
| > 75 LBS: APPLY 150 LBS | NO MAJOR DEFECT | N/A | |
| MOBILITY (WHEELS) | NO MAJOR DEFECT | N/A | |
| TEMPERATURE @ MAX. HIGH SETTING | SHALL NOT HAVE ANY BINDING | N/A | |
| HOOD HANDLE | | N/A | |
| BURNER HANDLE | MAX. 300 DEG. F. | 167°F | SATISFACTORY |
| - METALLIC | | N/A | |
| - NON- METALLIC | MAX. 40° F RISE OVER ROOM TEMP. | | |
| GRILL AREA (RT/LEFT) | MAX. 60° F RISE ABOVE ROOM TEMP. | NO MORE THAN 30° RISE | SATISFACTORY |
| WARMING RACK | | 293°F | |
| TOP HOUSING | | N/A | |
| FRONT VIEWING AREA | | 360°F | SATISFACTORY |
| SIDE HOUSING | | N/A | |
| TEMPERATURE INDICATOR | | 284°F | SATISFACTORY |
| LOW | SHALL PROVIDE PROPER LEVEL OF TEMPERATURE | N/A | |
| MEDIUM | | . | |
| HIGH | | . | |
| COOKING PERFORMANCE CHARACTERISTICS @ HIGH | | . | |
| HOT DOG | SUBJECTIVE | | |
| HAMBURGER (1/4 LBS) | | ACCEPTABLE | SATISFACTORY |
| | | ACCEPTABLE | SATISFACTORY |

KMAR. PERFORMANCE STANDARE

**SUMMARY OF TEST RESULTS FOR
GAS GRILL (ANSI Z21.58)**

| | |
|----------------------|---------------------|
| PRODUCT DESCRIPTION: | TABLE TOP GAS GRILL |
| UPC # | |
| MANUFACTURER | LIEN MOU |
| QA CONTROL NO: | 24096-1CC |
| KMART CODE | |
| ITEM # | |
| COUNTRY OF ORIGIN | CHINA |
| DATE OF ANALYSIS: | 15-Sep-97 |
| ANALYSIS BY: | R. MACASPAC |

| TESTED PROPERTY | REQUIREMENT | RESULTS | RATING |
|------------------|-----------------------------------|------------------|--------------|
| CHICKEN (FILLET) | | ACCEPTABLE | SATISFACTORY |
| CLEANABILITLY | | ACCEPTABLE | SATISFACTORY |
| TIMER | SHALL BE ACCURATE (+- 5%) MIN. | N/A | |
| EASE OF ASSEMBLY | | EASY TO ASSEMBLE | SATISFACTORY |

FUNCTIONAL FEATURES

| | | | |
|-----------------------|------------|---------|--------------|
| FRONT VIEWING GLASS | AS CLAIMED | N/A | |
| TEMPERATURE INDICATOR | AS CLAIMED | N/A | |
| TWO BURNERS | AS CLAIMED | N/A | |
| AUTOMATIC IGNITOR | AS CLAIMED | N/A | |
| FUEL INDICATOR | AS CLAIMED | N/A | |
| TIMER | AS CLAIMED | N/A | |
| HANDLE TYPE | AS CLAIMED | PLASTIC | SATISFACTORY |
| WHEELS (DIAMETER) | AS CLAIMED | N/A | |
| BOTTOM SHELF - TYPE | AS CLAIMED | N/A | |

PRODUCT PACKAGING

| | | | |
|--------------------------|---|----------|--------------|
| FPLA CONFORMANCE | SHALL CONFORM TO FPLA AND ANSI Z21.58. | N/A | |
| TRADEMARKS OR COPYRIGHTS | | N/A | |
| INSTRUCTIONS/DIRECTIONS | SHALL PROVIDE CLEAR AND EASY TO FOLLOW USER/ASSEMBLY INSTRUCTIONS. | INCLUDED | SATISFACTORY |

COMMENTS:

*THE LEGS OF THE GRILL WERE NOT ABLE TO ADEQUATELY SECURE THE COVER.
THE CONSTRUCTION TOLERANCE MUST BE IMPROVED.

Exhibit "H"

823

U.S. CONSUMER PRODUCT SAFETY COMMISSION

1. AREA OF OPERATION: Kmart Corp. Division
1/27/98 IN ACTION
1176 N. W. 20th St
Miami, FL 33138

2. NAME OF INDIVIDUAL: CHARLIE HARRIS
3. TITLE OF INDIVIDUAL: Attorney
4. DATE: 1/27/98

5. FIRM NAME: Kmart Corporation
6. SAMPLE NUMBER: 98-830-3415

7. NUMBER AND STREET: 1176 N. W. 20th St
8. CITY AND STATE (Include Zip Code): MIAMI, FL 33138

9. SAMPLES COLLECTED (Describe fully. List lot, serial, model numbers and other positive identification)

The following samples were collected by the Consumer Product Safety Commission pursuant to Section 27(f) of the Consumer Product Safety Act (15 U.S.C. 2076(f) and/or Section 11(b) of the Federal Hazardous Substances Act (15 U.S.C. 1270(b) and/or Sections 5(c) and (d) of the Flammable Fabrics Act (15 U.S.C. 1194(c) and (d) and/or Section 704(c) of the Federal Food Drug and Cosmetic Act (21 U.S.C. 374(c)) [Authority for sample collections made in connection with the Poison Prevention Packaging Act of 1970 (15 U.S.C. 1471 et seq.)], and receipt for said samples is hereby acknowledged. Sections cited are quoted on the reverse side of this form.

— ONE "Tou-Ban" portable gas grill, UPC # 0-24838-17000-1.
Unit is new, unopened.

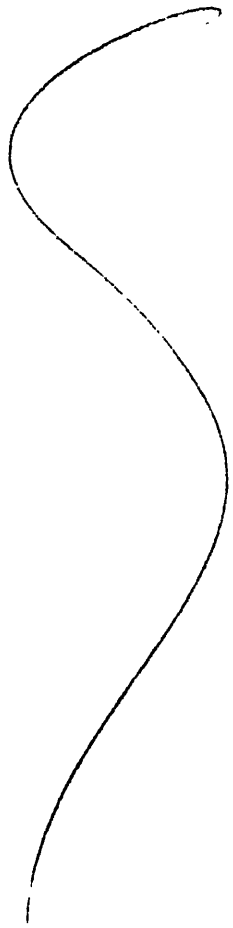

112

| | | | | | |
|--|--|--|--|--|--|
| 10. SAMPLES | | 11. SAMPLES WERE | | 12. COLLECTOR | |
| a. AMOUNT RECEIVED FOR SAMPLE | | <input checked="" type="checkbox"/> PURCHASED | | a. NAME (Print or type) Dennis J. Adams | |
| b. SIGNATURE (Person from whom sample received) [Signature] | | <input type="checkbox"/> BORROWED (To be returned) | | b. SIGNATURE [Signature] | |

Exhibit "I"
Kmart Corporation
1/27/98 inspection

(CR)

| | | |
|-----------------------------|-----------------------------|--------------------------|
| AFFIDAVIT | | SAMPLE NO 78-830-3415 |
| STATE OF <u>MICHIGAN</u> | COUNTY OF <u>OAKLAND</u> | |

Before me, DENNIS R. BLASIUS, a duly authorized employee of the Consumer Product Safety Commission, appropriately designated by the Chairman of said Commission pursuant to provisions of the Consumer Product Safety Act (sec. 27 (b)(2), 86 Stat. 1228; 15 U.S.C. 2076 (b)(2)), to administer or take oaths, affirmations, and affidavits, personally appeared _____ in the county and State aforesaid, who, being first duly sworn, deposes and says:

that I am an attorney for the Kmart Corporation and as such have sufficient knowledge to make this statement. THAT ON 1/27/97 I PROVIDED CASE INVESTIGATOR DENNIS BLASIUS WITH ONE NEW "TRU-BURN" LABEL FOR GAS GRILL, UPC # 0-24838-17000-1; THESE GRILLS ARE IMPORTED BY K MART FROM ^(USA) ~~THE~~ CHINESE MANUFACTURER, UEN MOU INDUSTRIAL FACTORY CO., LTD. NO PURCHASE ORDER, INVOICING, OR OTHER SIMILAR IMPORT DOCUMENTATION IS AVAILABLE.

AFFIANT'S SIGNATURE & TITLE C. J. Haines, Attorney

FIRM (Name and address, include ZIP Code)
Kmart Corporation
3100 W. Big BEAVER RD.
TROY, MI. 48064

Subscribed and sworn to before me at TROY, MI (City and State)
 this 27th day of JANUARY, 1998.

Dennis Blasius
 (Employee's Signature)

EMPLOYEE OF THE CONSUMER PRODUCT SAFETY COMMISSION ACTING IN ACCORDANCE WITH AUTHORITY GRANTED IN THE ABOVE STATED DECLARATION.

117