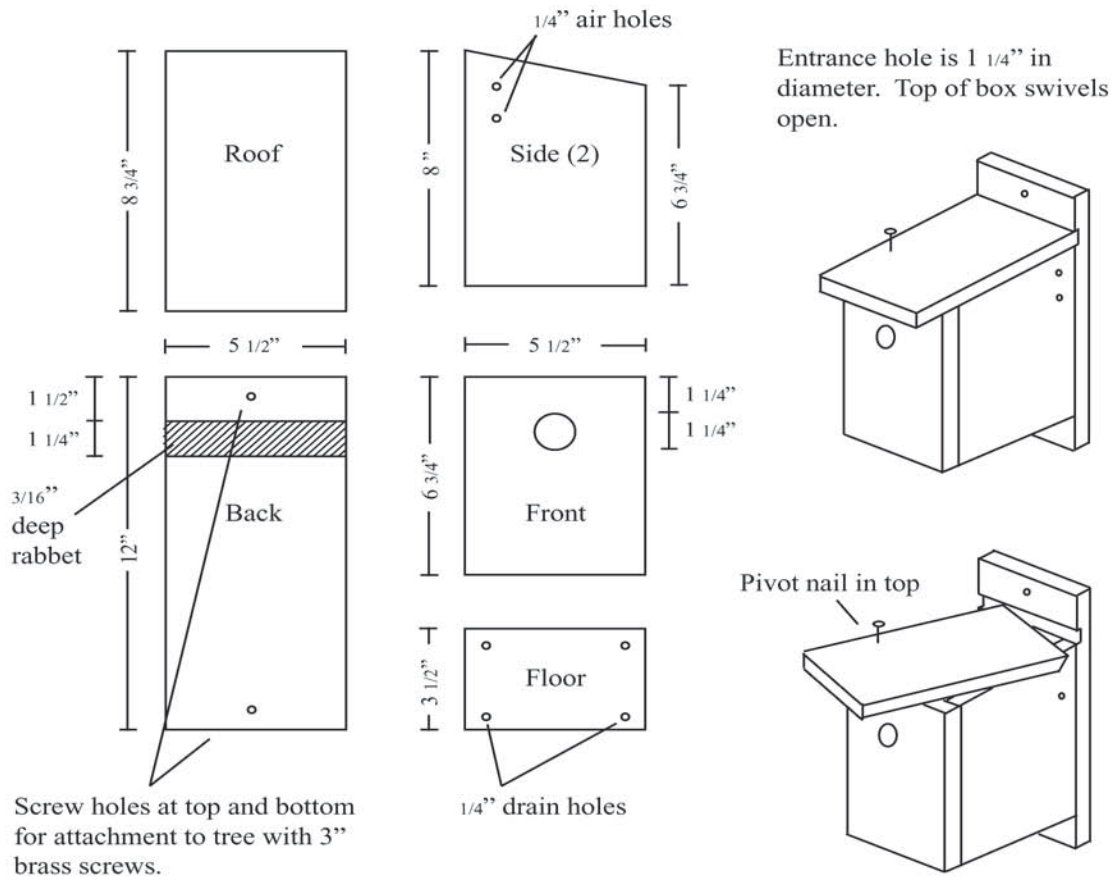
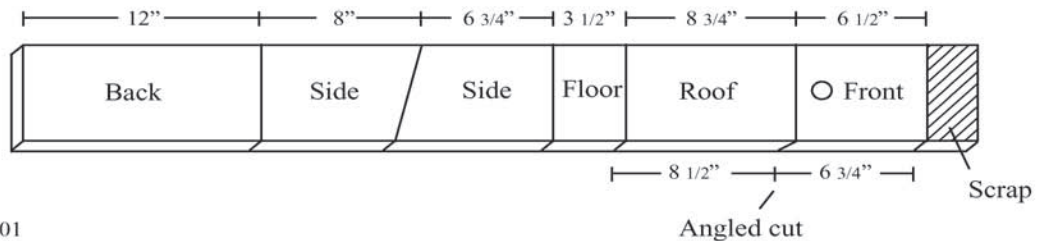

Figure 1. Map of Alaska showing primary sites where deformed birds have been observed or sampled.

**Nest Box for Black-capped Chickadee, Boreal Chickadee,  
and Red-breasted Nuthatch**  
USGS Alaska Biological Research Center



Lumber: One 1" x 6" x 4'0" spruce.



March 2001

Figure 2. Design of nest boxes used in study of Black-capped Chickadees, south-central Alaska, 2000-2004.

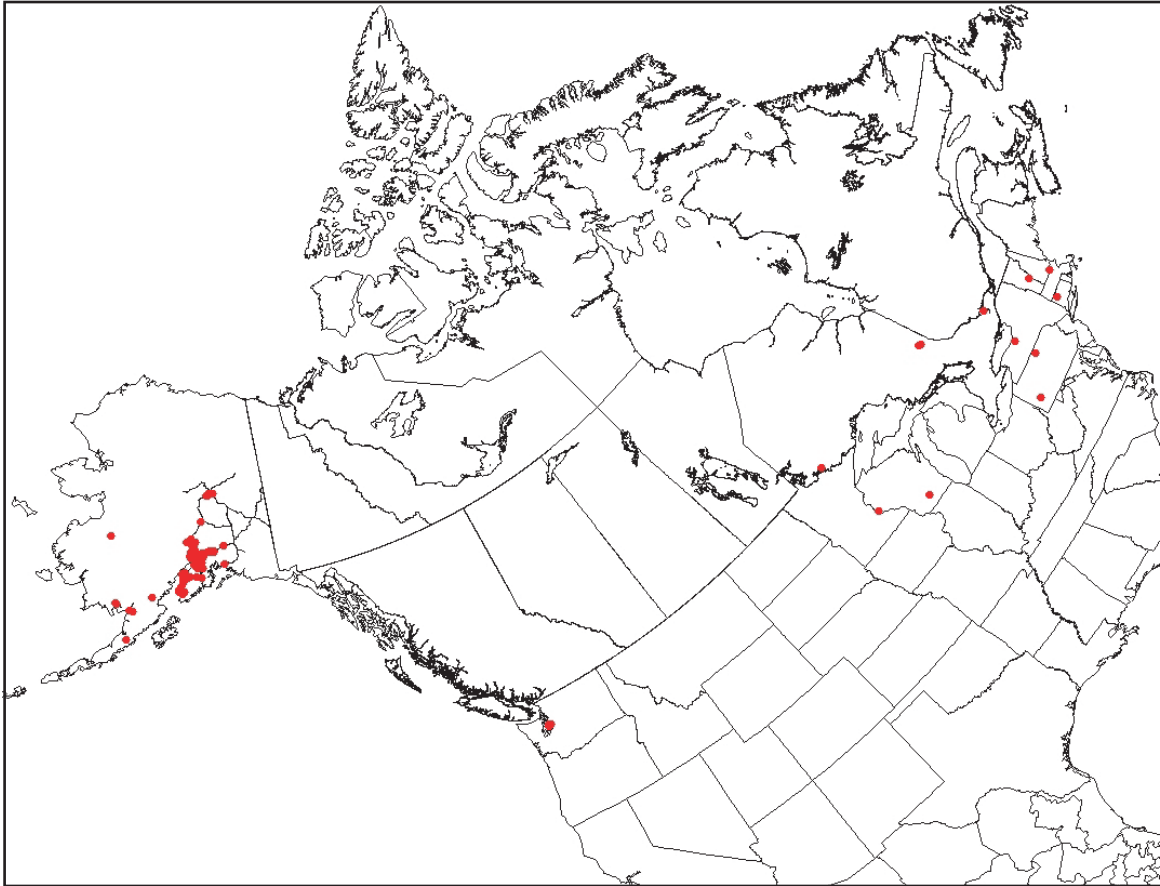

Figure 3. Cumulative distribution of Black-capped Chickadees reported from North America with beak deformities between winter 1991-1992 and winter 2004-2005.

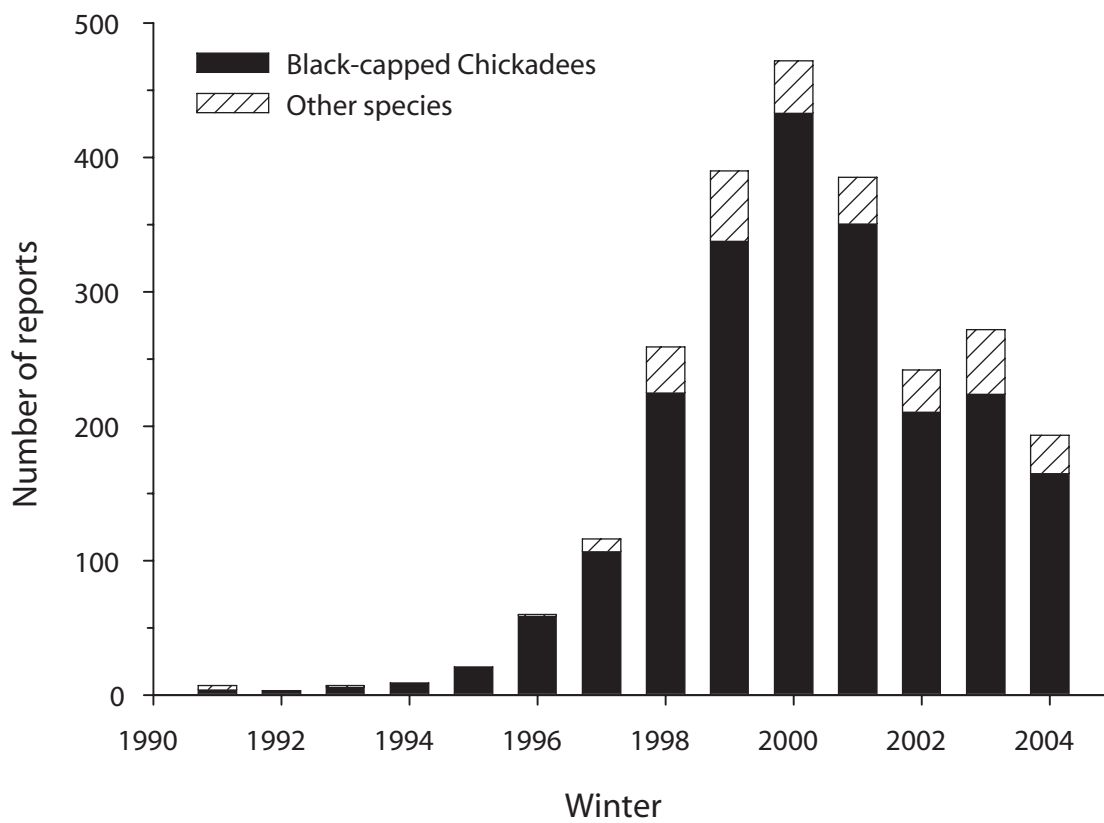

Figure 4. Number of reports received of Black-capped Chickadees and 27 other species of birds with beak deformities in Alaska each year from 1991-2004. Each year brackets a winter, spanning from 1 July to 30 June.

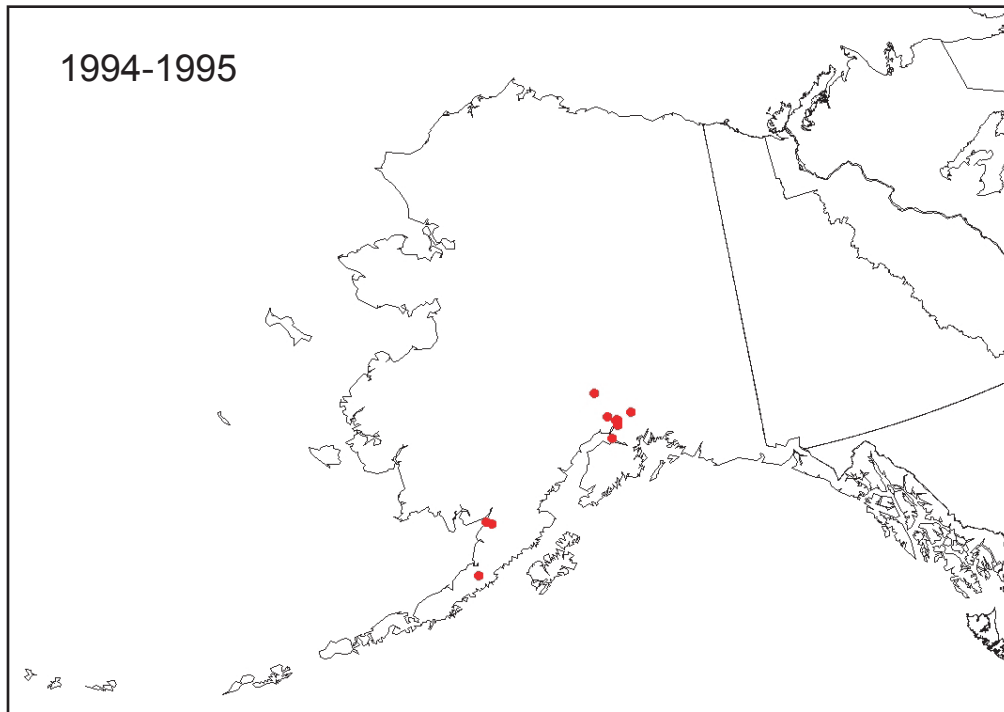
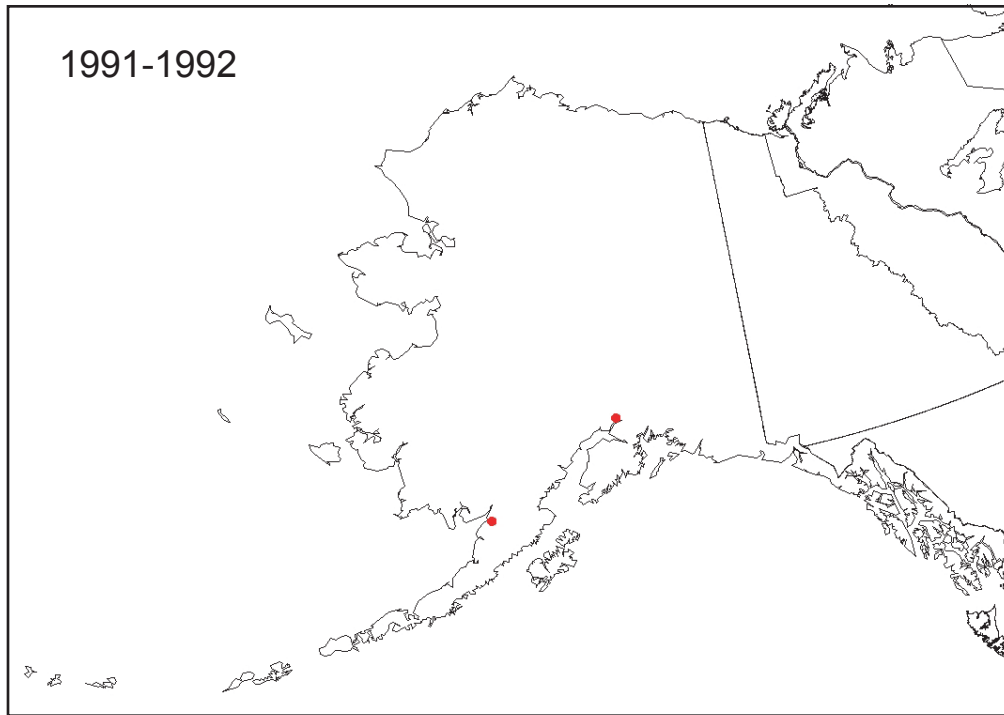

Figure 5. Distribution of Black-capped Chickadees reported from Alaska with beak deformities during winter 1991-1992 (top) and cumulatively through winter 1994-1995 (bottom).

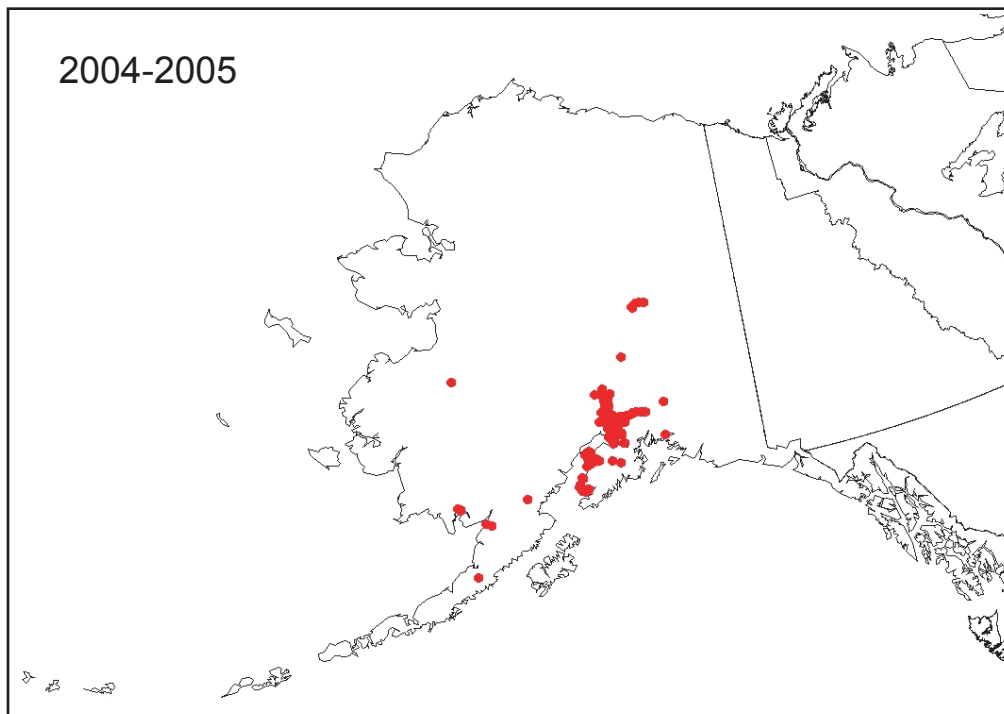
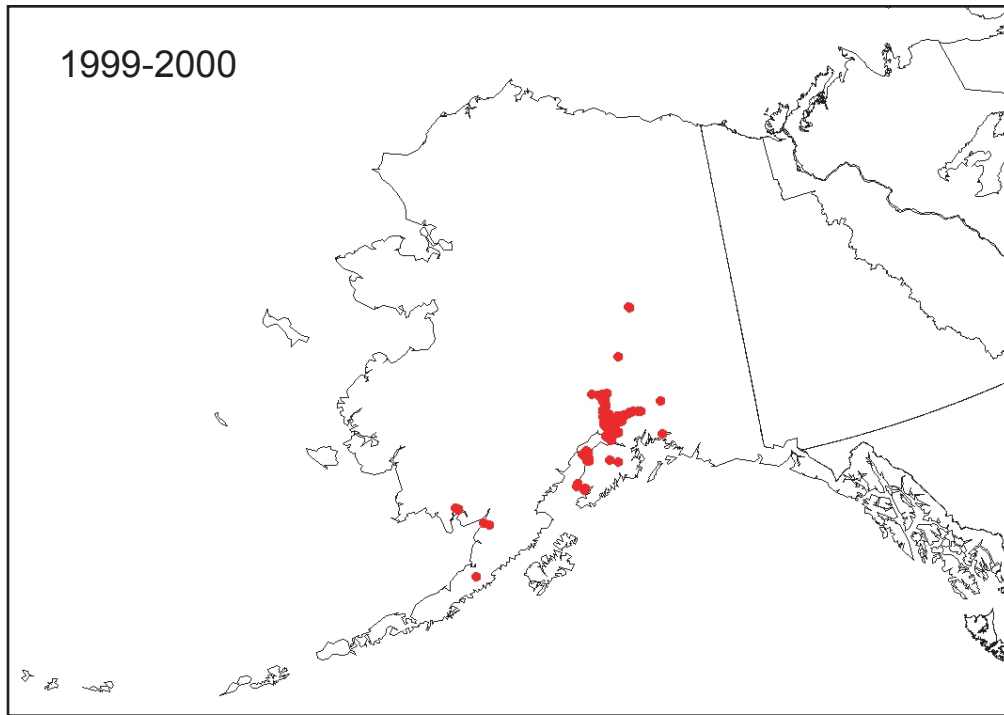

Figure 6. Distribution of Black-capped Chickadees reported from Alaska with beak deformities cumulatively through winter 1999-2000 (top) and winter 2004-2005 (bottom).

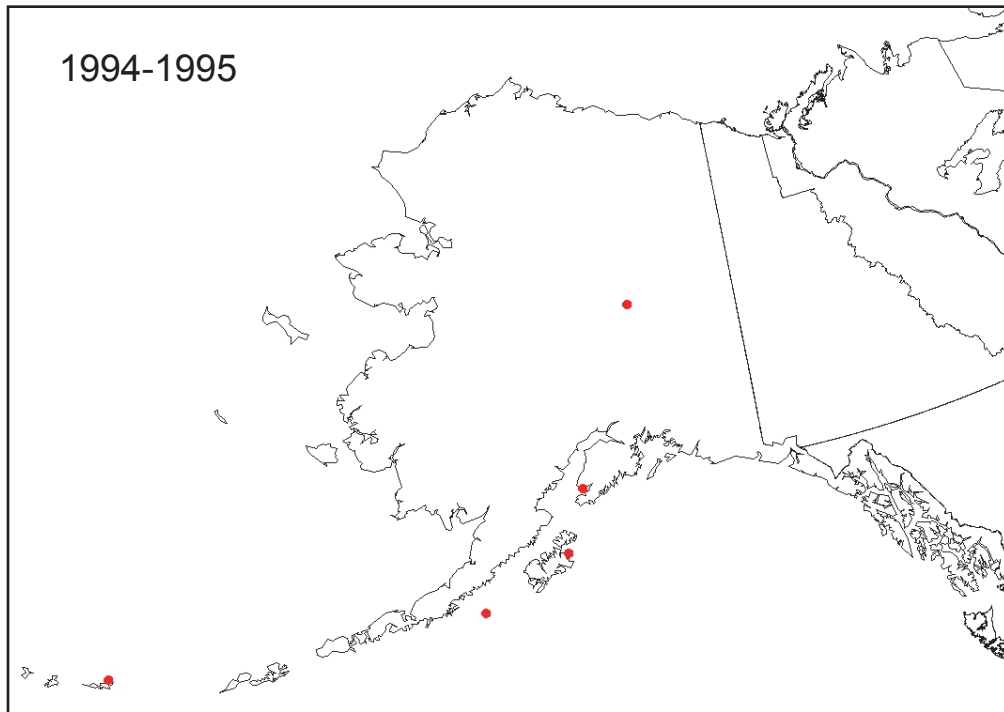
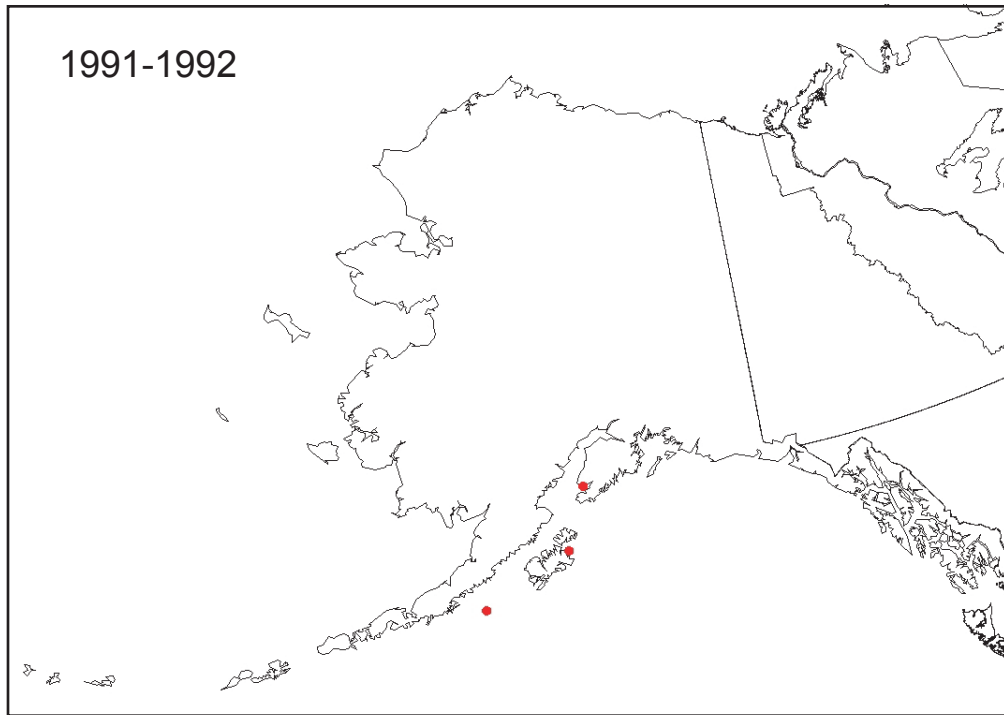

Figure 7. Distribution of birds other than Black-capped Chickadees reported from Alaska with beak deformities cumulatively through winter 1991-1992 (top) and winter 1994-1995 (bottom).

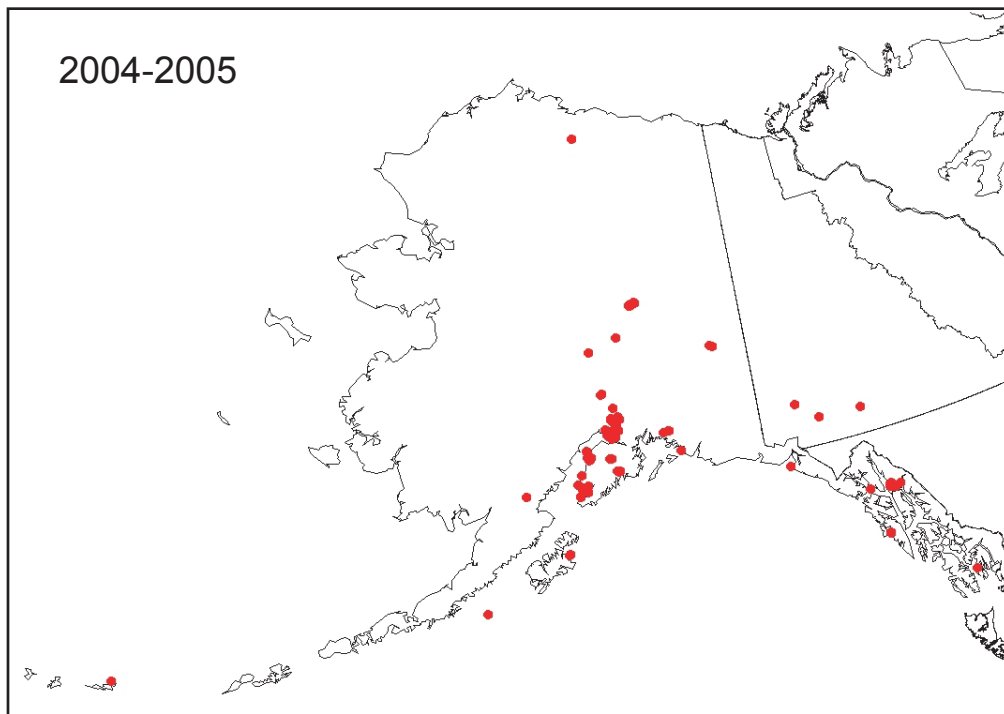
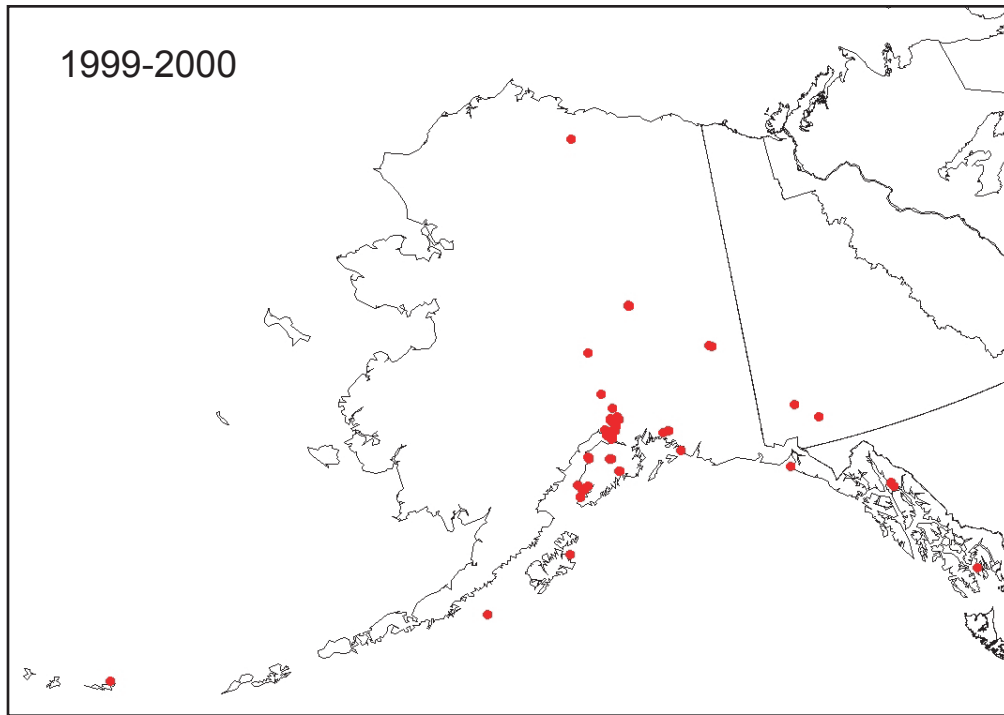

Figure 8. Distribution of birds other than Black-capped Chickadees reported from Alaska and Yukon Territory with beak deformities cumulatively through winter 1999-2000 (top) and winter 2004-2005 (bottom).



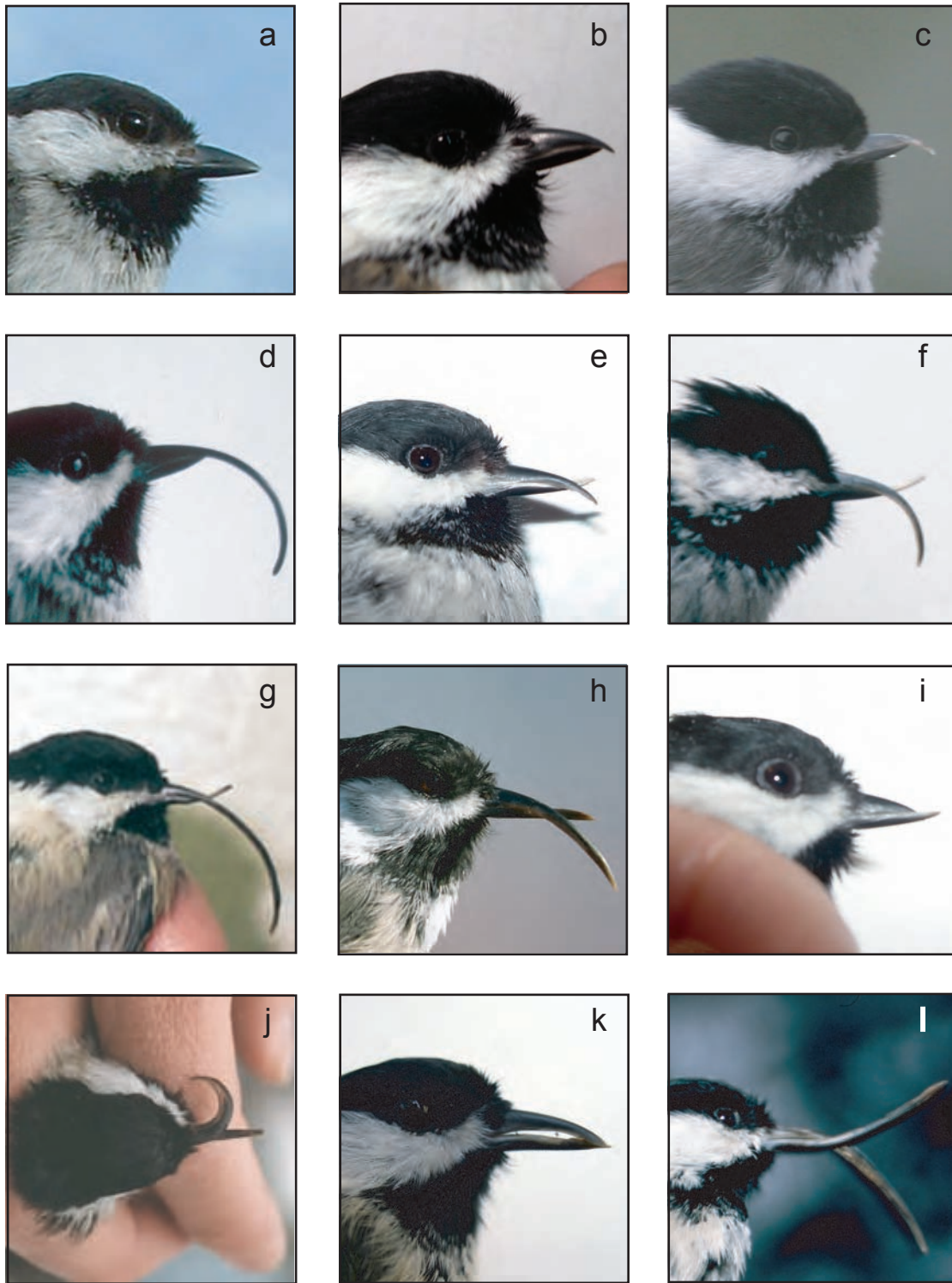

Figure 9. Black-capped Chickadees with normal beak (a), overgrown maxilla (b-d), overgrown and crossed maxilla and mandible (e-h), overgrown mandible (i), laterally curved maxilla (j), overgrown maxilla and mandible with pronounced gap (k), and overgrown, crossed, and greatly thickened maxilla and mandible (l).



Figure 10. Other abnormal conditions associated with beak deformities among Black-capped Chickadees in Alaska. Many chickadees had dry, reddened skin and patches of missing feathers, usually in the head region (a). On others, the keratin sheath on the tarsometarsus was dry and flaky (b). One female chickadee with a grossly overgrown beak (c) also had a large lipoma on the abdomen on the brood patch (d). Several nestlings had a folding fracture of the tibiofibula (e).

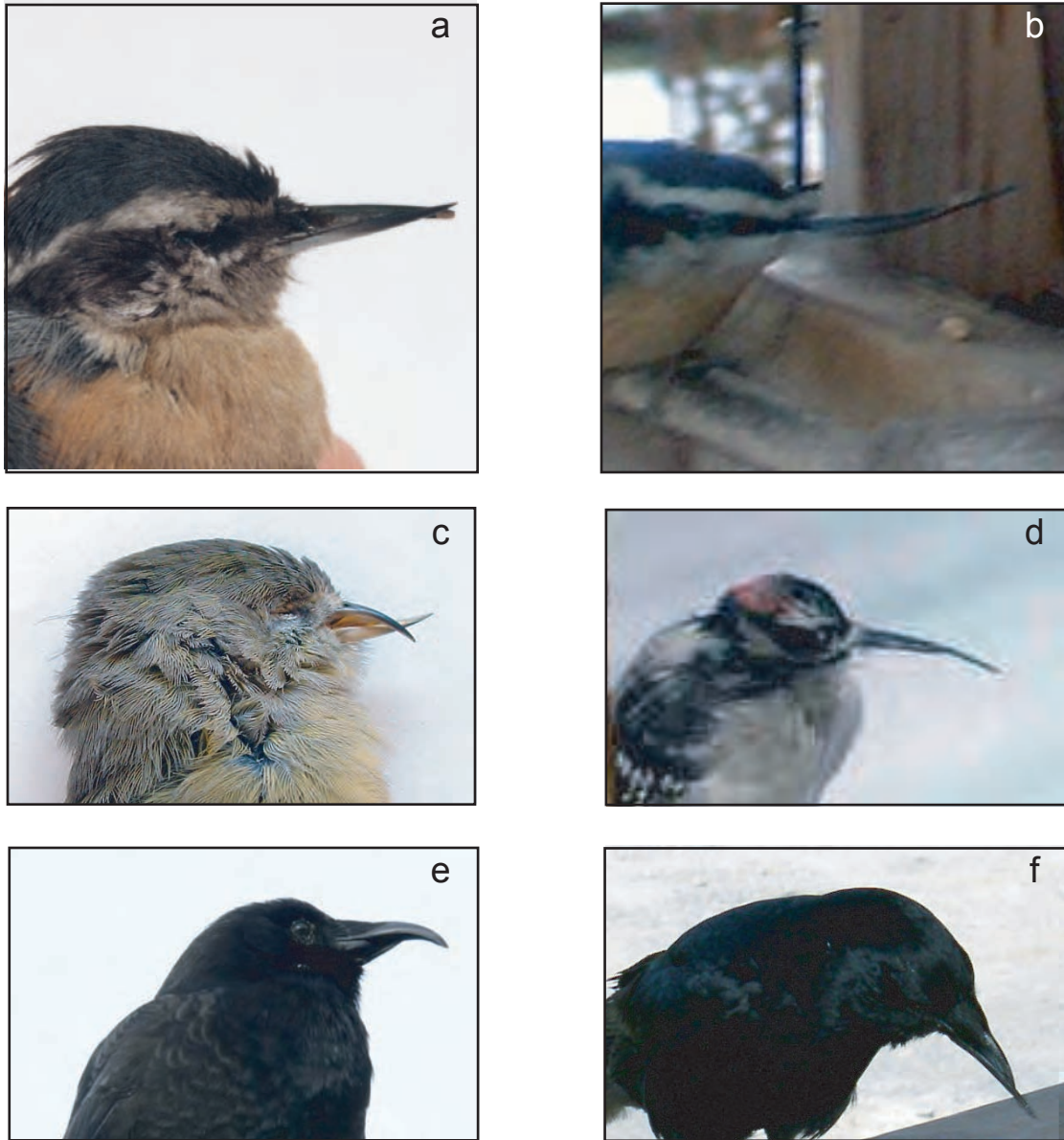

Figure 11. Examples of other species with beak deformities in Alaska. Red-breasted Nuthatch with elongated and crossed maxilla and mandible (a), Red-breasted Nuthatch with elongated, upcurved, and crossed maxilla and mandible (b), Orange-crowned Warbler with decurved and crossed maxilla (c), Downy Woodpecker with elongated maxilla and mandible (d), Northwestern Crow with slightly elongated and decurved maxilla (e), and Northwestern Crow with elongated mandible and slight crossing of maxilla and mandible (f). Photos courtesy of Stephanie Cristal (b), Owen Hughes (d), Paul Suchanek (e), and Donna Dewhurst (f).

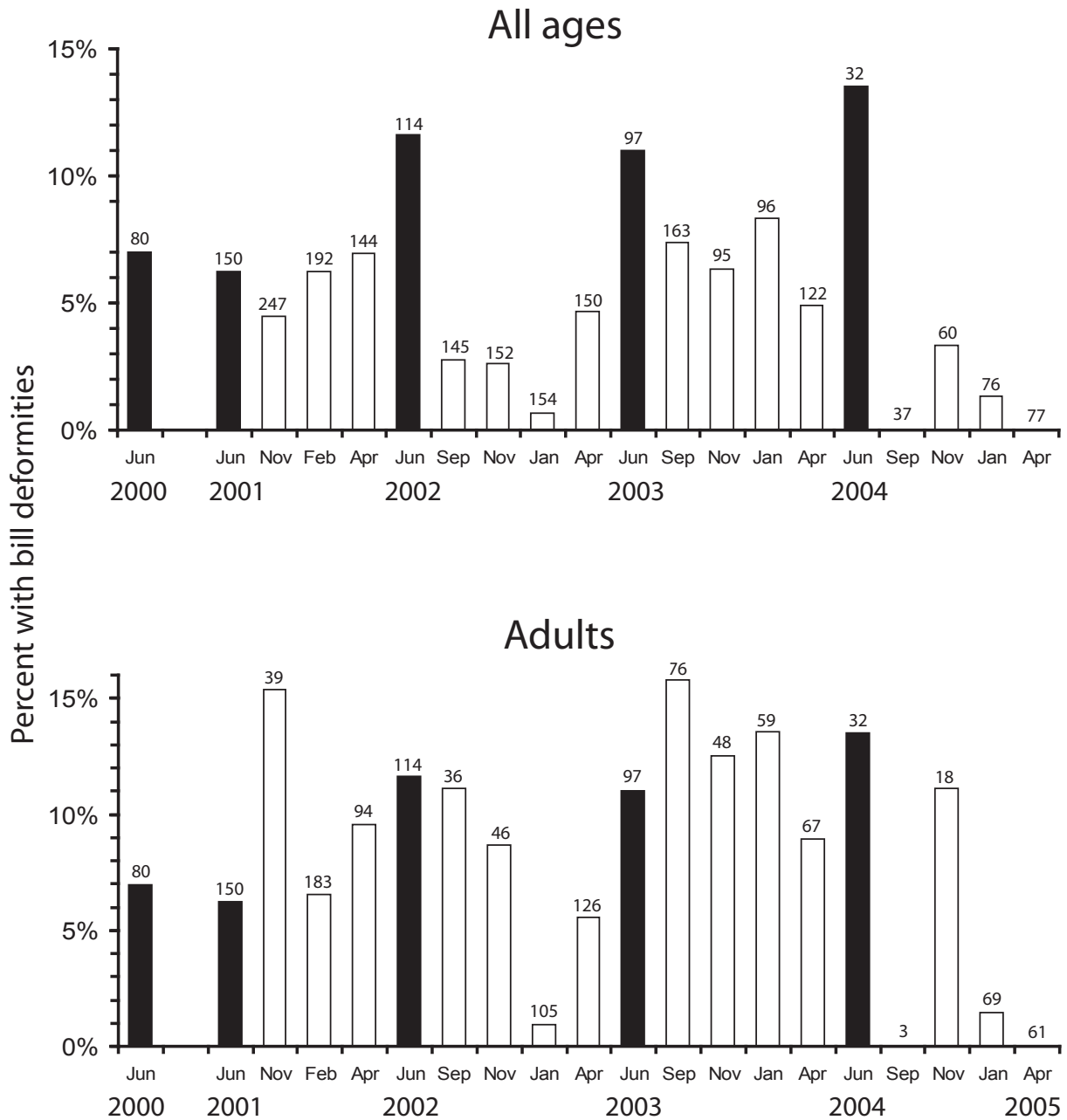

Figure 12. Percent of individual Black-capped Chickadees captured at nest boxes (solid bars) or at winter feeder traps (open bars) each month from 2000-2005 with beak deformities in south-central Alaska. Top graph includes all adults and juveniles captured and lower graph includes only known adults (excludes all hatching-year and second-year birds and birds of uncertain age in November). Number of birds captured is given above each bar.

### Timing of development of beak deformities

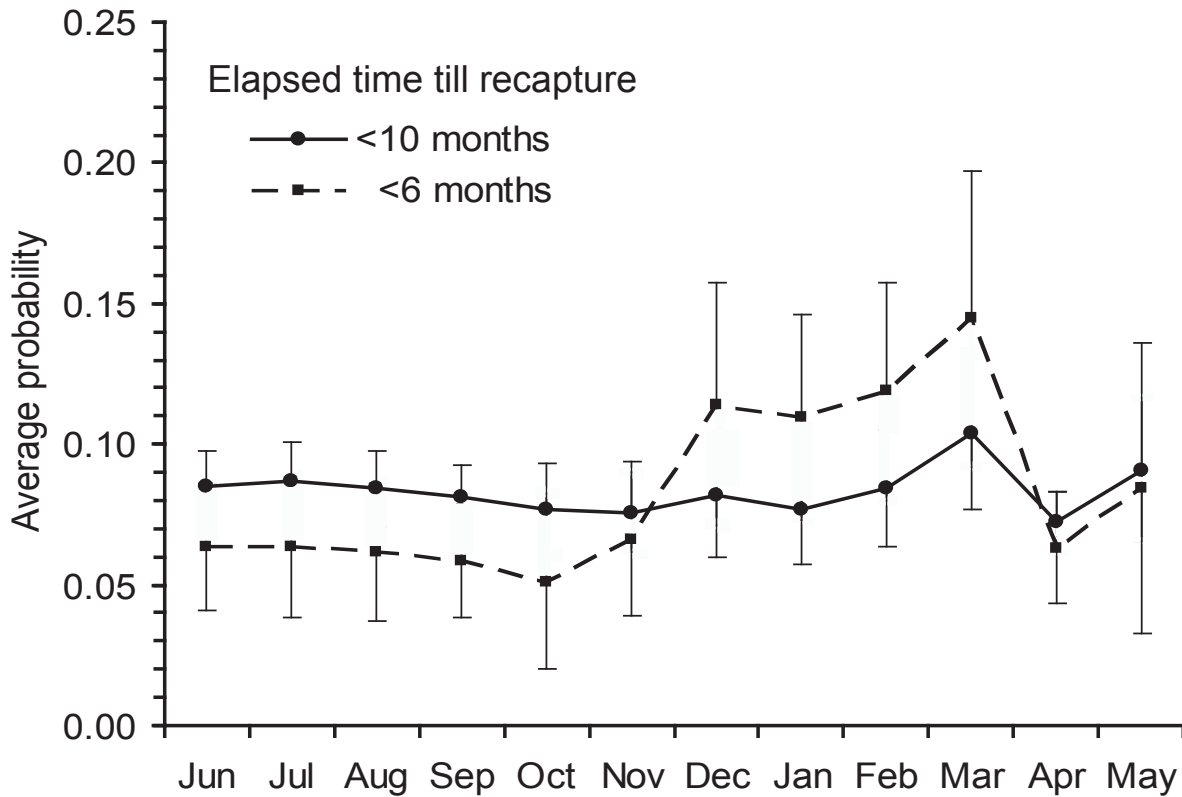

Figure 13. We recaptured 54 individual Black-capped Chickadees that had normal beaks when originally captured but had deformed beaks upon a subsequent recapture. This illustrates the estimated average probability ( $\pm$  SE) that these deformities developed during a given month. Estimates are shown for 35 individuals that were known to have changed sometime within a 10-month period (solid line) and for the subset of 17 individuals that were recaptured within 6 months and for which timing of development of the deformity was more precisely known (dashed line). For each individual, the probability of becoming deformed was allocated evenly to the days between capture and recapture. Monthly probabilities were then averaged across all individuals.

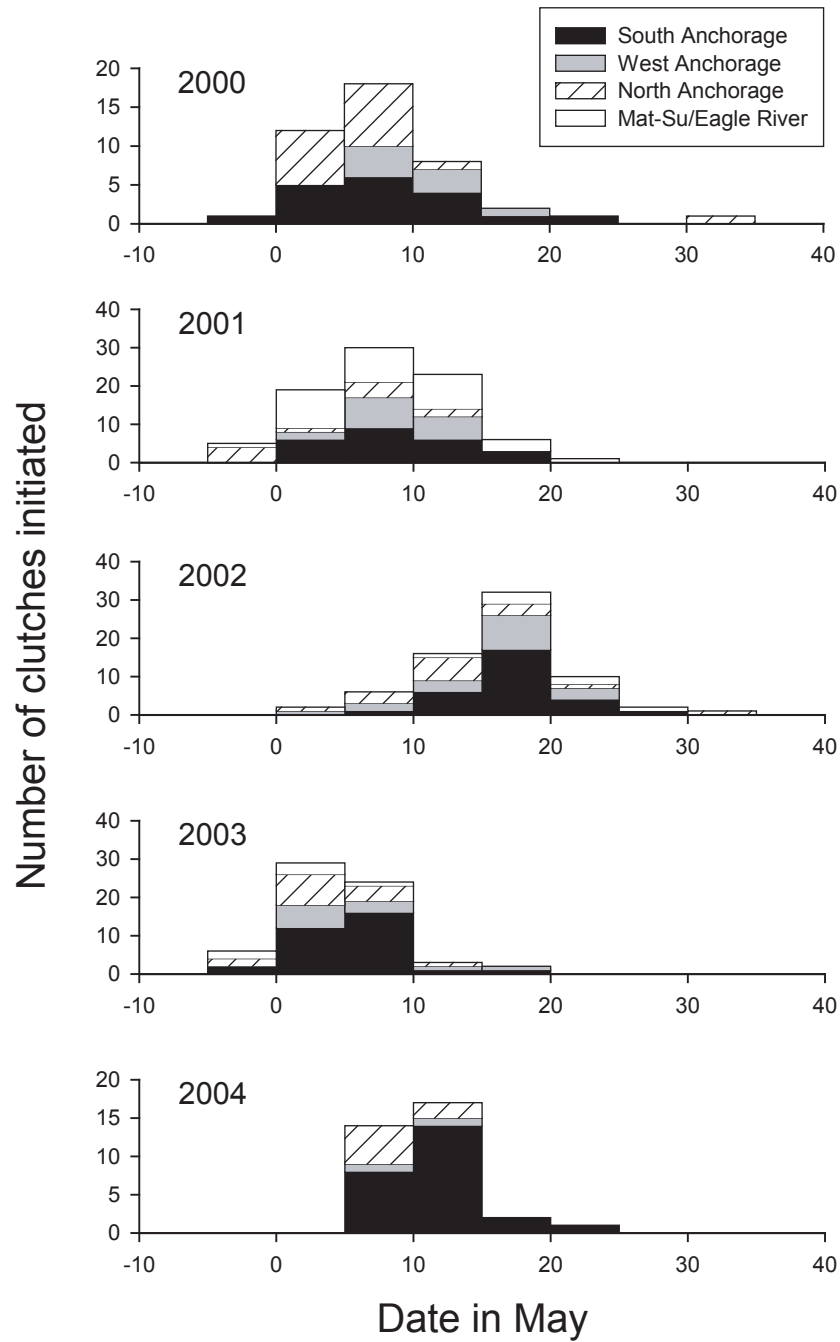

Figure 14. Timing of clutch initiation among Black-capped Chickadees nesting in nest boxes in south-central Alaska from 2000-2004 by geographic area. No nest boxes were monitored in the Mat-Su Valley or Eagle River in 2000 or 2004.

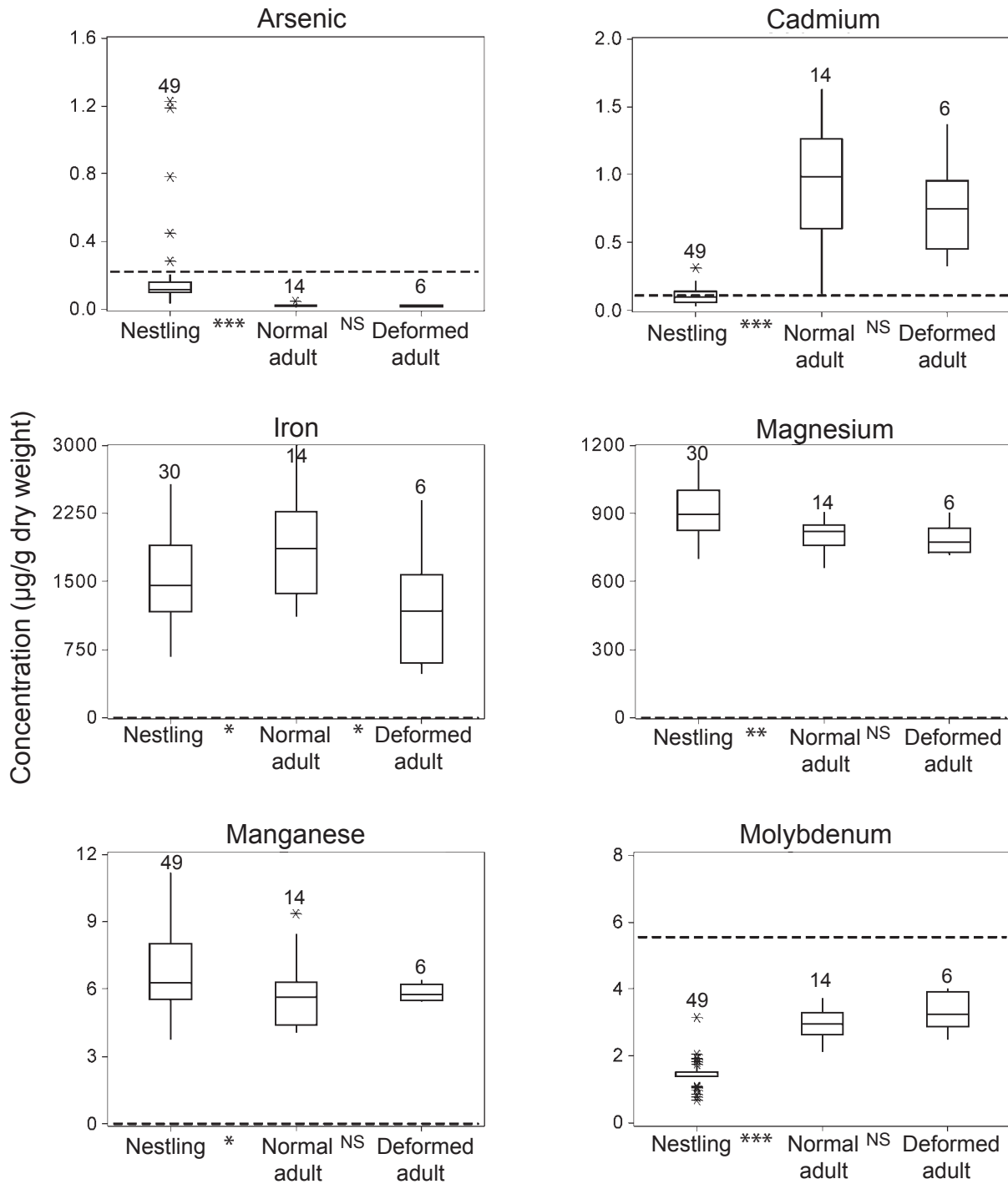

Figure 15. Censored box plots of concentrations (µg/g dry weight) of six elements in livers of nestling Black-capped Chickadees, normal adults, and adults with deformed beaks. Horizontal bar shows median, box shows first and third quartiles, whiskers include 1.5 times IQR beyond first and third quartiles, asterisks indicate outliers, and sample sizes are above plots. Dashed line shows maximum detection limit. Differences between nestlings and normal adults and between normal and deformed adults are shown: \*\*\* $P < 0.001$ , \*\* $P < 0.01$ , \* $P < 0.05$ , NS = not significant.

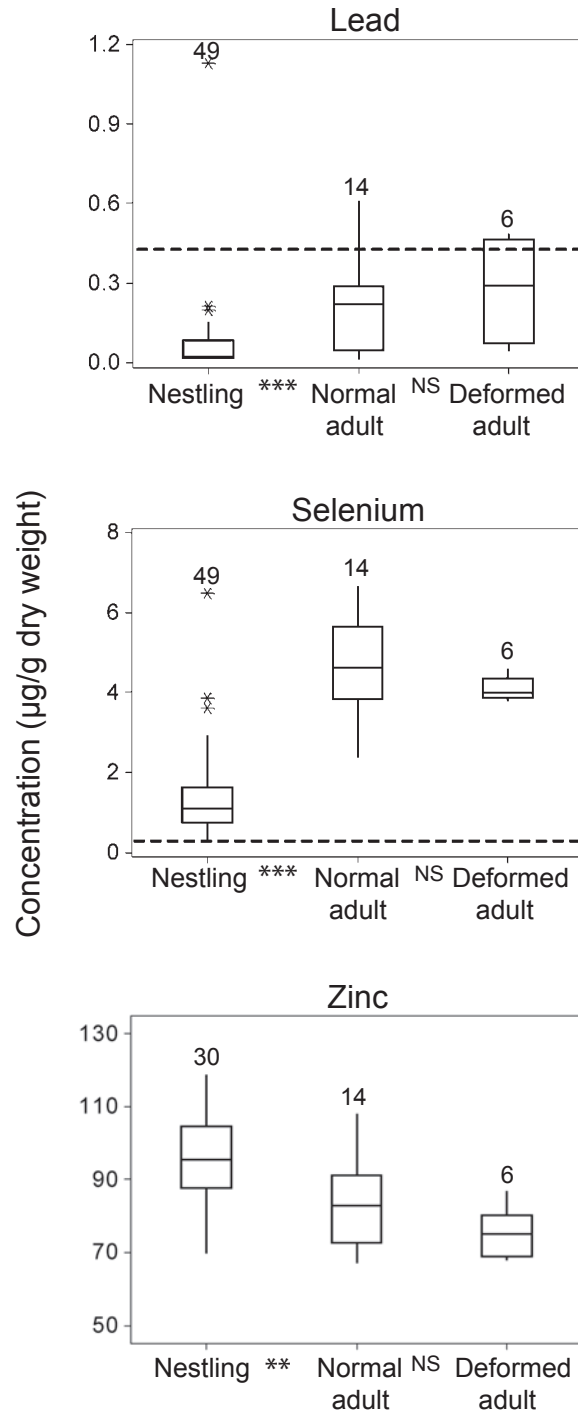

Figure 16. Censored box plots of concentrations ( $\mu\text{g/g}$  dry weight) of three elements in livers of nestling Black-capped Chickadees, normal adults, and adults with deformed beaks. Horizontal bar shows median, box shows first and third quartiles, whiskers include 1.5 times IQR beyond first and third quartiles, asterisks indicate outliers, and sample sizes are above plots. Dashed line shows maximum detection limit. Differences between nestlings and normal adults and between normal and deformed adults are shown: \*\*\* $P < 0.001$ , \*\* $P < 0.01$ , NS = not significant.



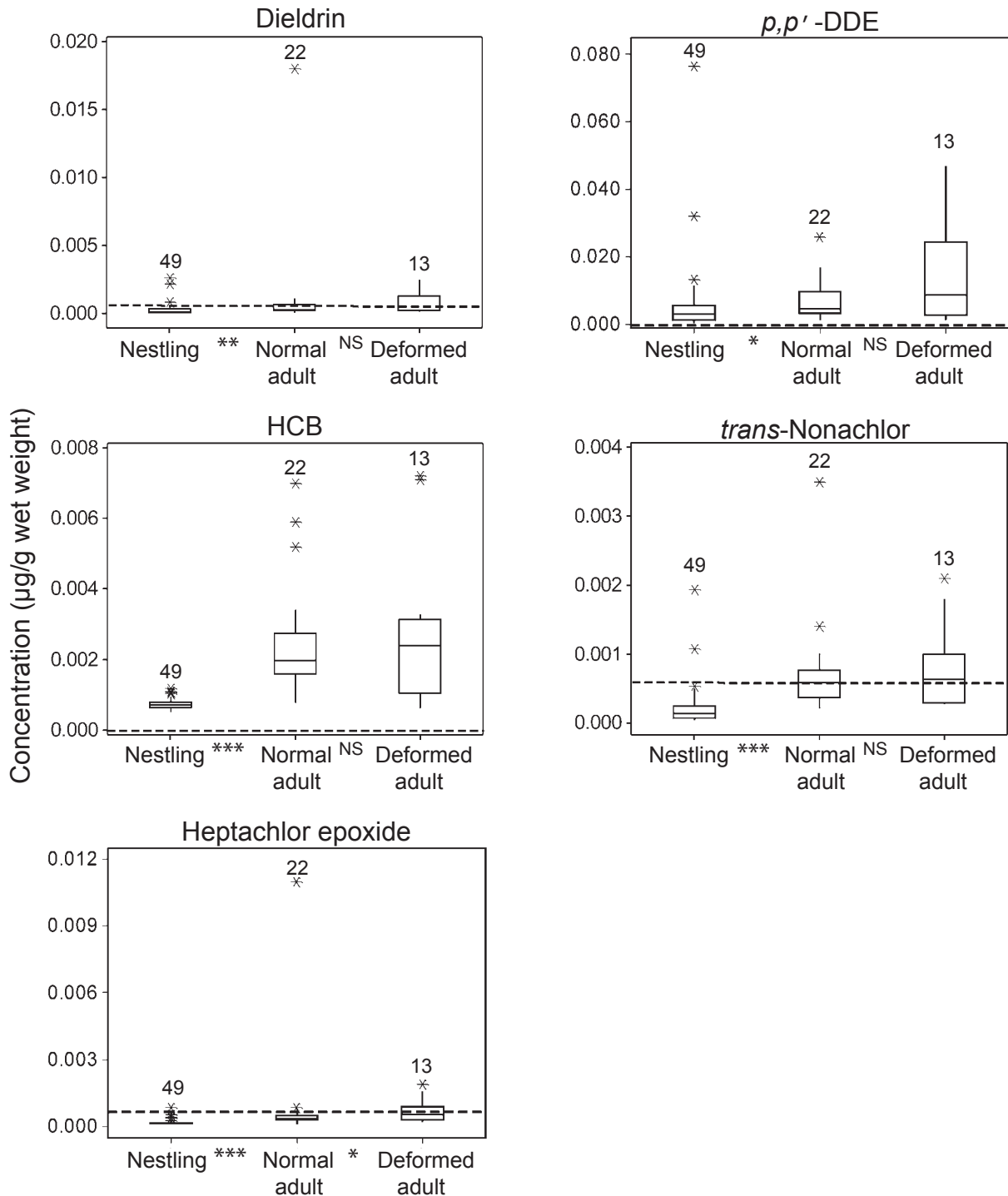

Figure 17. Censored box plots of concentrations ( $\mu\text{g/g}$  wet weight) of organochlorine compounds in tissues of nestling Black-capped Chickadees, normal adults, and adults with deformed beaks. Horizontal bar shows median, box shows first and third quartiles, whiskers include 1.5 times IQR beyond first and third quartiles, asterisks indicate outliers, and sample sizes are above plots. Dashed line shows maximum detection limit. Differences between nestlings and normal adults and between normal and deformed adults are shown: \*\*\* $P < 0.001$ , \*\* $P < 0.01$ , \*  $P < 0.05$ , NS = not significant.

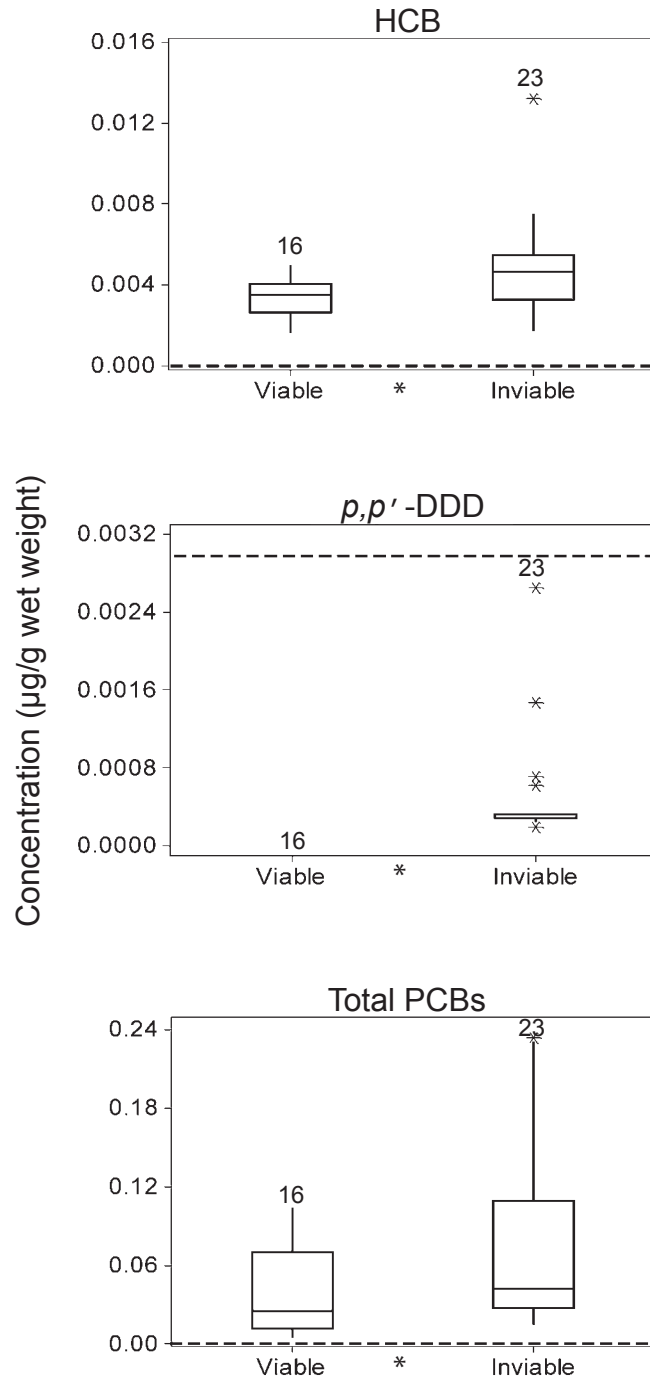

Figure 18. Censored box plots of concentrations ( $\mu\text{g/g}$  wet weight) of three contaminants in Black-capped Chickadee eggs from clutches in which all eggs were viable compared with those in which at least one egg was inviable. Horizontal bar shows median, box shows first and third quartiles, whiskers include 1.5 times IQR beyond first and third quartiles, asterisks indicate outliers, and sample sizes are above plots. Dashed line shows maximum detection limit. Differences between groups are shown: \*  $P < 0.05$ .

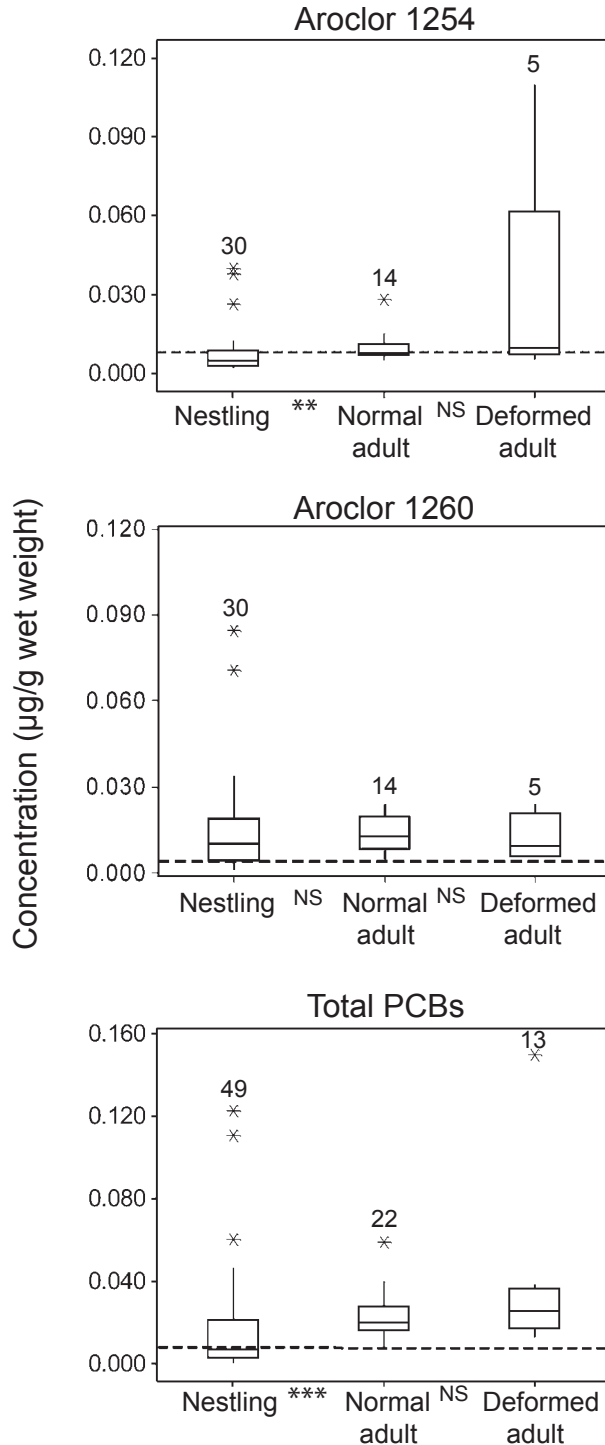

Figure 19. Censored box plots of concentrations ( $\mu\text{g/g}$  wet weight) of two Arochlor mixtures and total PCBs in tissues of nestling Black-capped Chickadees, normal adults, and adults with deformed beaks. Horizontal bar shows median, box shows first and third quartiles, whiskers include 1.5 times IQR beyond first and third quartiles, asterisks indicate outliers, and sample sizes are above plots. Dashed line shows maximum detection limit. Differences between nestlings and normal adults and between normal and deformed adults are shown:  $***P < 0.001$ ,  $**P < 0.01$ ,  $*P < 0.05$ , NS = not significant.

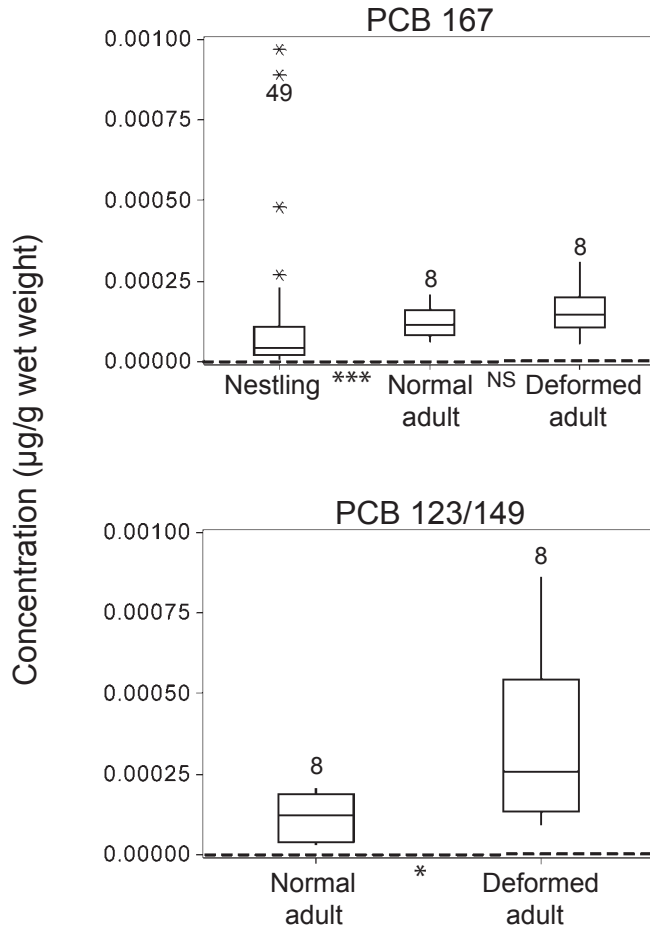

Figure 20. Censored box plots of concentrations ( $\mu\text{g/g}$  wet weight) of PCB congeners in tissues of nestling Black-capped Chickadees, normal adults, and adults with deformed beaks. Horizontal bar shows median, box shows first and third quartiles, whiskers include 1.5 times IQR beyond first and third quartiles, asterisks indicate outliers, and sample sizes are above plots. Dashed line shows maximum detection limit. Differences between groups are shown:  $*P < 0.05$ ,  $***P < 0.001$ , NS = not significant.

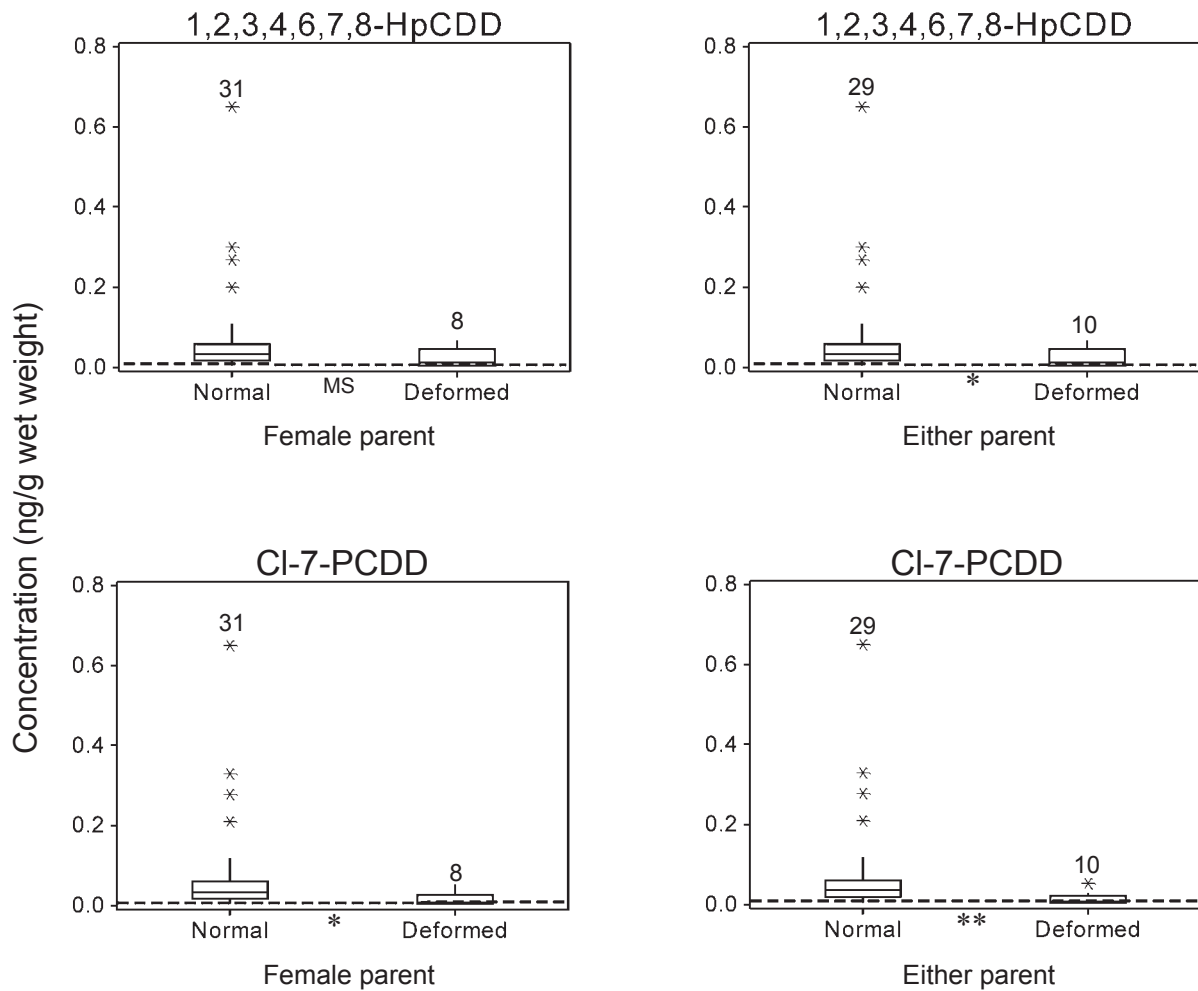

Figure 21. Censored box plots of concentrations (ng/g wet weight) of polychlorinated dibenzo-*p*-dioxins in Black-capped Chickadee eggs from parents (female or either parent) with normal vs. deformed beaks. Horizontal bar shows median, box shows first and third quartiles, whiskers include 1.5 times IQR beyond first and third quartiles, asterisks indicate outliers, and sample sizes are above plots. Dashed line shows maximum detection limit. Differences between groups are shown: \*\* $P < 0.01$ , \* $P < 0.05$ ; MS = marginally significant ( $0.05 < P < 0.10$ ).

