

**NATIONAL WATER-QUALITY ASSESSMENT PROGRAM**

**Estimation of Agricultural Pesticide Use in Drainage Basins  
Using Land Cover Maps and County Pesticide Data**

Open File Report 2005-1188



# **Estimation of Agricultural Pesticide Use in Drainage Basins Using Land Cover Maps and County Pesticide Data**

By Naomi Nakagaki and David M. Wolock

National Water-Quality Assessment Program

Open-File Report 2005-1188

**U.S. Department of the Interior**  
**U.S. Geological Survey**

**U.S. Department of the Interior**  
Gale A. Norton, Secretary

**U.S. Geological Survey**  
Charles G. Groat, Director

**U.S. Geological Survey, Reston, Virginia: 2005**

For sale by U.S. Geological Survey, Information Services

Box 25286, Denver Federal Center  
Denver, CO 80225

For more information about the USGS and its products:  
Telephone: 1-888-ASK-USGS  
World Wide Web: <http://www.usgs.gov/>

Any use of trade, product, or firm names in this publication is for descriptive purposes only and does not imply endorsement by the U.S. Government.

Although this report is in the public domain, permission must be secured from the individual copyright owners to reproduce any copyrighted materials contained within this report.

Suggested reference:

Nakagaki, Naomi, and Wolock, D.M., 2005, Estimation of agricultural pesticide use in drainage basins using land cover maps and county pesticide data: U.S. Geological Survey Open-File Report 2005-1188, 46 p.

## FOREWORD

The U.S. Geological Survey (USGS) is committed to providing the Nation with accurate and timely scientific information that helps enhance and protect the overall quality of life and that facilitates effective management of water, biological, energy, and mineral resources (<http://www.usgs.gov/>). Information on the quality of the Nation's water resources is critical to assuring the long-term availability of water that is safe for drinking and recreation and suitable for industry, irrigation, and habitat for fish and wildlife. Population growth and increasing demands for multiple water uses make water availability, now measured in terms of quantity and quality, even more essential to the long-term sustainability of our communities and ecosystems.

The USGS implemented the National Water-Quality Assessment (NAWQA) Program in 1991 to support national, regional, and local information needs and decisions related to water-quality management and policy (<http://water.usgs.gov/nawqa>). Shaped by and coordinated with ongoing efforts of other Federal, State, and local agencies, the NAWQA Program is designed to answer: What is the condition of our Nation's streams and ground water? How are the conditions changing over time? How do natural features and human activities affect the quality of streams and ground water, and where are those effects most pronounced? By combining information on water chemistry, physical characteristics, stream habitat, and aquatic life, the NAWQA Program aims to provide science-based insights for current and emerging water issues and priorities.

From 1991-2001, the NAWQA Program completed interdisciplinary assessments in 51 of the Nation's major river basins and aquifer systems, referred to as Study Units (<http://water.usgs.gov/nawqa/studyu.html>). Baseline conditions were established for comparison to future assessments, and long-term monitoring was initiated in many of the basins. During the next decade, 42 of the 51 Study Units will be reassessed so that 10 years of comparable monitoring data will be available to determine trends at many of the Nation's streams and aquifers. The next 10 years of study also will fill in critical gaps in characterizing water-quality conditions, enhance understanding of factors that affect water quality, and establish links between sources of contaminants, the transport of those contaminants through the hydrologic system, and the potential effects of contaminants on humans and aquatic ecosystems.

The USGS aims to disseminate credible, timely, and relevant science information to inform practical and effective water-resource management and strategies that protect and restore water quality. We hope this NAWQA publication will provide you with insights and information to meet your needs, and will foster increased citizen awareness and involvement in the protection and restoration of our Nation's waters.

The USGS recognizes that a national assessment by a single program cannot address all water-resource issues of interest. External coordination at all levels is critical for a fully integrated understanding of watersheds and for cost-effective management, regulation, and conservation of our Nation's water resources. The NAWQA Program, therefore, depends on advice and information from other agencies—Federal, State, interstate, Tribal, and local—as well as nongovernmental organizations, industry, academia, and other stakeholder groups. Your assistance and suggestions are greatly appreciated.

Robert M. Hirsch  
Associate Director for Water



# Contents

Abstract.....	1
Introduction.....	1
Background.....	1
Purpose and Scope.....	3
Acknowledgments.....	3
GIS Datasets.....	4
Drainage Basin Boundaries.....	4
Land Cover.....	4
30-Meter Resolution.....	4
1-Kilometer Resolution.....	10
County Agricultural Pesticide Use.....	12
Estimating Agricultural Pesticide Use in Drainage Basins.....	15
Basin Pesticide Use Estimated from the 1-Kilometer Resolution Land Cover Dataset.....	15
Steps to Generate a 1-Kilometer Resolution Pesticide Use Grid.....	17
Steps to Estimate the Basin Pesticide Use Using a 1-Kilometer Resolution Pesticide Use Grid.....	21
Basin Pesticide Use Estimated from the 30-Meter Resolution Land Cover Dataset.....	21
Results.....	23
Which Resolution is the Most Appropriate for Estimating Agricultural Pesticide Use in Drainage Basins?.....	41
Limitations of the Agricultural Pesticide Use Estimates in Drainage Basins.....	42
Other Applications of the Methods.....	43
Future Directions.....	43
Summary.....	43
Endnotes.....	44
References Cited.....	45

## Figures

<b>Figure 1.</b> Geographic distribution of the study units of the National Water-Quality Assessment Program in the conterminous United States that were active during 1991–2001 .....	2
<b>Figure 2.</b> Geographic distribution of the 150 National Water-Quality Assessment drainage basins for which basin atrazine use estimates are presented and analyzed in this report .....	8
<b>Figure 3.</b> The “enhanced” 30-m resolution National Land Cover Data 1992 for the conterminous United States shown with boundaries of the four quadrant grids .....	9
<b>Figure 4.</b> The process of creating 1-km resolution national grids of percentage land cover from the 30-m resolution “enhanced” National Land Cover Data 1992 .....	11
<b>Figure 5.</b> The complete set of 1-km resolution national grids of percentage land cover derived from the 30-m resolution “enhanced” National Land Cover Data 1992 .....	13
<b>Figure 6.</b> The process of creating the 1992 county tabular file of atrazine use estimates by crop class .....	16
<b>Figure 7.</b> Steps to generate a 1-km resolution grid of estimated atrazine use on crops associated with the crop class “row crops, small-grain crops, and fallow land” .....	18
<b>Figure 8.</b> The 1-km resolution national grids of estimated atrazine use on crops associated with the crop classes “row crops, small-grain crops, and fallow land” and “pasture and hay crops” .....	20
<b>Figure 9.</b> The process of estimating basin pesticide use derived from a 1-km resolution pesticide use grid, and a basin boundary grid at the 1-km resolution and 100-m resolution .....	22
<b>Figure 10.</b> Steps to estimate 30-m resolution basin atrazine use on crops associated with the crop class “row crops, small-grain crops, and fallow land” .....	24
<b>Figure 11.</b> Comparison of 30-m basin atrazine estimates in relation to the 1-km basin atrazine estimates .....	33
<b>Figure 12.</b> The 30-m and 1-km resolution drainage basin boundaries, distribution of 30-m resolution “row crops,” “small grains,” and “fallow” from the “enhanced” National Land Cover Data 1992, and selected cell values of the 1-km resolution national grid of percentage “row crops, small grains, and fallow” in the vicinity of the drainage basin for the U.S. Geological Survey’s station U.S. Sugar Outflow Canal near Clewiston, Florida .....	35
<b>Figure 13.</b> The bias between the 1-km basin atrazine estimates and the 30-m basin atrazine estimates in relation to drainage area .....	36
<b>Figure 14.</b> The percentage bias of the 1-km basin atrazine estimates and the 30-m basin atrazine estimates in relation to drainage area.....	36
<b>Figure 15.</b> The 30-m resolution basin atrazine estimates in relation to drainage area.....	37
<b>Figure 16.</b> The 30-m basin atrazine use intensity and the 1-km basin atrazine use intensity in relation to drainage area.....	38
<b>Figure 17.</b> The bias between the 30-m basin atrazine use intensity and the 1-km basin atrazine use intensity, in relation to drainage area .....	39
<b>Figure 18.</b> The mixed resolution basin atrazine estimates in relation to the 30-m basin atrazine estimates .....	40



## Tables

<b>Table 1.</b> The selected 150 drainage basins for which estimates of basin atrazine use are presented and analyzed in this report.....	5
<b>Table 2.</b> The numeric codes and land cover classifications of the “enhanced” version of the National Land Cover Data 1992 .....	10
<b>Table 3.</b> The crop class framework and the associations between the agricultural land cover classifications in the “enhanced” National Land Cover Data 1992.....	14
<b>Table 4.</b> The 30-m, 1-km, and mixed resolution basin atrazine estimates on crops associated with the crop class, “row crops, small-grain crops, and fallow land,” and associated biases .....	27

## Conversion Factors, Datum, Abbreviations and Acronyms, and Editor's Note

Multiply	By	To obtain
kilogram (kg)	2.205	pound avoirdupois (lb)
kilogram per square kilometer (kg/km <sup>2</sup> )	0.00892	pound per acre (lb/acre)
kilogram per square kilometer (kg/km <sup>2</sup> )	5.711	pound per square mile (lb/mi <sup>2</sup> )
kilometer (km)	0.6214	mile (mi)
meter (m)	3.281	foot (ft)
meter (m)	1.094	yard (yd)
square kilometer (km <sup>2</sup> )	247.1	acre
square kilometer (km <sup>2</sup> )	0.3861	square mile (mi <sup>2</sup> )

### DATUM

Vertical coordinate information is referenced to the North American Vertical Datum of 1988 (NAVD 88).

Horizontal coordinate information is referenced to the North American Datum of 1983 (NAD 83).

### Abbreviations and Acronyms (additional information noted in parentheses)

AML	Arc Macro Language (ESRI)
ESRI	Environmental Systems Research Institute, Inc.
FIPS	Federal Information Processing Standards
GIS	geographic information system
ID	identification
LULC	land use and land cover
NASS	National Agricultural Statistics Service
NAWQA	National Water-Quality Assessment Program
NCFAP	National Center for Food and Agricultural Policy
NLCD 92	National Land Cover Data 1992
NLCDe 92	enhanced version of NLCD 92
TIFF	tag interchange file format
TM	thematic mapper
USGS	U.S. Geological Survey

### Editor's Note

Endnotes are denoted by a number in brackets “[n],” and explanations of endnotes are listed in the back of the report. In addition to standard usage, double quotes are used throughout the report for all references to crop classes, land cover classifications, and raster datasets of land cover classifications. Hyphenation of unit modifiers has been reduced where not required to comprehend the meaning of the phrase (Suggestions to Authors, p. 138, Nos. 8 and 12, [http://www.nwrc.usgs.gov/lib/lib\\_sta.htm](http://www.nwrc.usgs.gov/lib/lib_sta.htm)) and to aid in overall readability of text (for example, land cover classification, pesticide use intensity). Phrases that include “water quality” are hyphenated because of common in-house practice. In all other cases, hyphenation in unit modifiers is used where required (for example, small-grain crops).

# Estimation of Agricultural Pesticide Use in Drainage Basins Using Land Cover Maps and County Pesticide Data

By Naomi Nakagaki and David M. Wolock

## Abstract

A geographic information system (GIS) was used to estimate agricultural pesticide use in the drainage basins of streams that are studied as part of the U.S. Geological Survey's National Water-Quality Assessment (NAWQA) Program. Drainage basin pesticide use estimates were computed by intersecting digital maps of drainage basin boundaries with an enhanced version of the National Land Cover Data 1992 combined with estimates of 1992 agricultural pesticide use in each United States county. This report presents the methods used to quantify agricultural pesticide use in drainage basins using a GIS and includes the estimates of atrazine use applied to row crops, small-grain crops, and fallow lands in 150 watersheds in the conterminous United States. Basin atrazine use estimates are presented to compare and analyze the results that were derived from 30-meter and 1-kilometer resolution land cover and county pesticide use data, and drainage basin boundaries at various grid cell resolutions. Comparisons of the basin atrazine use estimates derived from watershed boundaries, county pesticide use, and land cover data sets at different resolutions, indicated that overall differences were minor. The largest potential for differences in basin pesticide use estimates between those derived from the 30-meter and 1-kilometer resolution enhanced National Land Cover Data 1992 exists wherever there are abrupt agricultural land cover changes along the basin divide. Despite the limitations of the drainage basin pesticide use data described in this report, the basin estimates provide consistent and comparable indicators of agricultural pesticide application in surface-water drainage basins studied in the NAWQA Program.

## Introduction

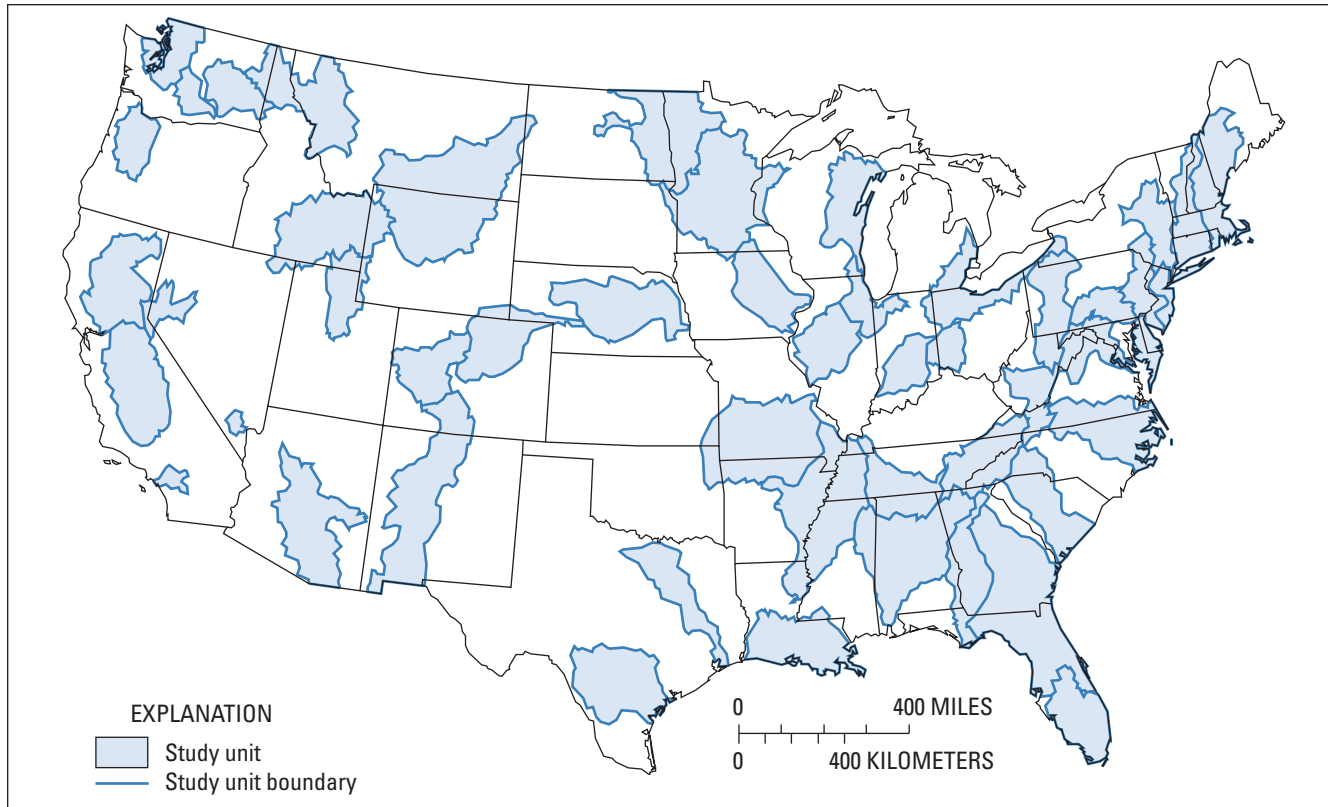
## Background

In 1991, the U.S. Geological Survey (USGS) began the National Water-Quality Assessment (NAWQA) Program. The

goals of this program are to assess the status of, and trends in, the quality of the nation's surface- and ground-water resources and to link the status and trends with an understanding of the natural and human factors that affect the quality of water (Hirsch and others, 1988; Leahy and Thompson, 1994; Gilliom and others, 1995). To meet these goals, water-quality investigations are conducted in major river basins and aquifers referred to as "study units." The first cycle of investigations began in 1991, and a total of 49 study units in the conterminous United States [1] were assessed between 1991 and 2001 (*fig. 1*). The water-quality data collected in these study units have become a primary source for nationwide information on the quality of streams, ground water, and aquatic ecosystems.

To aid in addressing how environmental conditions affect water quality, information on the physical and anthropogenic features in study areas are incorporated into an environmental framework. This framework provides the basis for nationally consistent assessments of environmental characteristics that are analyzed with water-quality findings. Because each assessment of a study area in the NAWQA Program adheres to a national design of consistent sampling and analytical methods, water-quality conditions and environmental characteristics in a specific locality or watershed can be compared with those in other geographic regions (U.S. Geological Survey, 2001a). For example, the chemical and biological findings in a drainage basin in the eastern United States can be compared with the findings in a drainage basin that has similar physical and environmental characteristics located in the western United States.

The drainage basin, or watershed, is the basic geographic unit for analysis of streams within the environmental framework. Because a drainage basin defines the area that is drained by all surface water located upstream of its outlet, the hydrologic and aquatic biological conditions of the stream at the outlet reflect the natural features and human activities present within the watershed. The physical features of a drainage basin, such as slope and soil type, affect how water is transported to the stream and, consequently, how contaminants resulting from human activities (for example, application of pesticides and fertilizers) are transported to, and within, the stream.



**Figure 1.** Geographic distribution of the study units of the National Water-Quality Assessment (NAWQA) Program in the conterminous United States (Hitt, 2002) that were active during 1991–2001 (see endnote [1]).

Pesticide use is one of the important elements of the environmental framework in the NAWQA Program. The amount of chemicals that is applied to agricultural lands and the spatial distribution of these chemicals are key factors that are needed to understand the water quality of streams in drainage basins that include land used for agriculture. The NAWQA national assessment of pesticides in streams, for example, has indicated a correlation between agricultural herbicide use and detection frequencies of herbicides in streams (Larson and Gilliom, 2001; Larson and others, 1998).

Nationally consistent county pesticide use estimates by crop for the conterminous United States have been developed (Thelin and Gianessi, 2000) and used to study the effects of agricultural settings on stream pesticide concentrations (Larson and Gilliom, 2001) and pesticide detection in shallow ground water (Barbash and others, 1999; Barbash and Resek, 1996). The county estimates of pesticide use by crop are useful in quantifying agricultural pesticide use in drainage basins that encompass or intersect a greater part of one or more counties, but may not be as accurate in quantifying chemical application in watersheds that partially extend into limited parts of one or more counties. This limitation results primarily from the spatial variability of agricultural land within a county because agricultural pesticides are applied only to agricultural

areas, and the county pesticide estimates do not indicate where the chemicals are applied within the county. Identification of the agricultural areas within a county is crucial to accurate mapping of the spatial pattern of agricultural pesticide use, and the use of an accurate map of agricultural pesticide use improves the accuracy of agricultural pesticide use estimates in drainage basins.

Agricultural pesticide application within a county can be mapped using a spatial land cover dataset such as the USGS's 30-m resolution National Land Cover Data 1992 (U.S. Geological Survey, 1999), also known as "NLCD 92." The NLCD 92 is a seamless raster [2] dataset of land cover within the conterminous United States and includes five agricultural land cover classifications. These land cover classifications can be used to designate where, within a county, agricultural chemicals are applied to the land surface. The NLCD 92, therefore, can be used to spatially apportion or "disaggregate" the county pesticide use estimates according to the within-county location of agricultural land. (The methods and results presented in this report illustrate the use of an enhanced version of the NLCD 92. More details on the enhanced version of the NLCD 92 are provided in the section "GIS Datasets, Land Cover, 30-Meter Resolution.")

Geoprocessing at the 30-m resolution is difficult for some geographic analyses that require GIS processing of the entire conterminous United States (for example, the extrapolation of water-quality information collected at all streams sampled in the NAWQA Program). A single, national land cover dataset at the 30-m resolution could not be created because of limitations of the GIS software. Consequently, alternative approaches to managing a national 30-m resolution dataset were adopted.

The national 30-m resolution land cover dataset was managed in two ways: first, it was divided into four regional 30-m resolution datasets, and second, it was converted into 1-km resolution land cover datasets. The 1-km representation of the enhanced version of the 30-m resolution NLCD 92 presented in this report is not a generalized version; it preserves the information stored in the 30-m version because each cell value in the 1-km resolution grids is the percentage of the land cover classification at the 30-m resolution within each 1-km resolution grid cell. (The process used to create the 1-km representation of the 30-m resolution NLCD 92 is described in detail in the section “GIS Datasets, Land Cover, 1-Kilometer Resolution”).

Both the 30-m and 1-km resolution versions of the land cover datasets were used to estimate agricultural pesticide use in drainage basins. Estimates of basin atrazine use derived from land cover data at both resolutions are presented and analyzed in this report so that comparative assessments of basin atrazine use estimates could be made. Though conceptually similar, the methods used to compute basin pesticide use from the two versions of the land cover datasets are different. These methods are documented in this report.

## Purpose and Scope

The purpose of this report is to describe the data sources and the two methods used to quantify agricultural pesticide use in drainage basins and to compare the basin atrazine estimates derived from the two methods. The primary difference in the two methods is the use of two resolutions of the land cover dataset: (1) the 30-m resolution dataset and (2) the derivative 1-km resolution dataset of the percentages of each land cover classification within each grid cell. The source for land cover was an enhanced version of the USGS’s NLCD 92. Land cover data at both resolutions were integrated with the 1990 county boundaries linked to the 1992 county tabular file of pesticide use estimates by crop (Thelin and Gianessi, 2000) to estimate agricultural pesticide use in drainage basins. To quantify the differences in estimated basin atrazine use when the 1-km resolution land cover data are used instead of the 30-m resolution, multiple estimates of atrazine applied to row crops, small-grain crops, and fallow land are presented and analyzed for 150 watersheds distributed among 36 NAWQA study units.

In addition to the use of two resolutions of land cover, basin boundaries were rasterized at various cell resolutions: 30, 50, 100, and 1,000 m. The comparison of agricultural pesticide use estimates in drainage basins derived from the 30-m and 1-km resolution land cover datasets and various grid cell resolutions of watershed boundaries can aid in determining the conditions (for example, basin size or particular land cover patterns) when the 1-km resolution dataset would suffice in estimating basin pesticide use.

The application of atrazine was chosen as the example to compare basin estimates of pesticide use because atrazine is one of the most widespread and intensely used agricultural herbicides in the conterminous United States. It is applied primarily on corn and sorghum, but also on other crops including sugarcane, millet, sod, seed crops, and pasture (Gianessi and Anderson, 1995).

The 150 drainage basins selected for comparing basin atrazine use estimates correspond to a subset of the NAWQA Program’s surface-water sites sampled for pesticides [3] between 1991 and 2001. The watersheds that were excluded from the selected set had atrazine use estimates of less than 1 kg.

It is important to note that the quantification of agricultural pesticide use in drainage basins is dependent on the specific GIS datasets used. Datasets such as the NLCD 92 have been enhanced or used in various ways (for example, all agricultural land cover classifications grouped into one category). Delineations of drainage area are also periodically enhanced. Therefore, the basin atrazine use values in this report will not necessarily match the results in other NAWQA reports that were derived from different versions of basin delineations and the NLCD 92 or other land use and land cover datasets, for example, as with the USGS’s Land Use and Land Cover dataset (U.S. Geological Survey, 1990).

Environmental Systems Research Institute’s (ESRI) ArcInfo Workstation Version 8.2 [4] was the software used for all GIS analyses in this report. Although many of the GIS processing steps were combined in computer programs written in ESRI’s Arc Macro Language (AML), the computer code is not presented in this report. Instead, the processing steps are descriptive and supplemented with snapshots of fictitious tabular files and GIS raster datasets.

## Acknowledgments

We would like to express our sincere appreciation to the individuals who provided assistance in the development of this report. We are grateful to Kerie J. Hitt and Steven K. Predmore for providing thorough and timely technical reviews that included a number of helpful suggestions. We also want to thank Robert J. Gilliom for providing guidance, support, and helpful discussions on various aspects of this report.

## GIS Datasets

The GIS datasets that were used to estimate agricultural pesticide use in watersheds were (1) drainage basin boundaries, (2) land cover, and (3) county agricultural pesticide use. This section of the report provides details on how these datasets were acquired and developed.

### Drainage Basin Boundaries

Agricultural pesticide use was estimated for most of the drainage basins from which pesticide samples were collected as part of the NAWQA Program. The selected 150 drainage basins for which atrazine use estimates are presented in this report range in size from 17 to 92,942 km<sup>2</sup> (*table 1*) and are located in the conterminous United States (*fig. 2*). These watersheds represent the contributing drainages, or areas that drain into the main channel network. Noncontributing drainage areas, such as closed drainages and subbasins that seldom or never drain into the main drainage network, were not included.

Each drainage basin was managed as a separate digital map identified by a unique identification number (hereinafter referred to as “basin ID”). For most basins, the basin ID numbers are identical to the respective USGS station identification numbers that represent sites where water-quality samples are collected. (The basin ID numbers for the selected 150 watersheds in this report are the first eight digits of the USGS’s station identification number). The basin ID number, the USGS’s station identification number, and the station name and area corresponding to each drainage basin are shown in *table 1*.

The source for the digital drainage basin boundaries was maps of watershed delineations in vector format, or basin boundary “coverages” [5]. Geographers of the USGS created a coverage for each drainage basin from a variety of data sources. Data sources ranged from 1:24,000- to 1:250,000-scale, depending on the size of the watershed. Coverages for many of the larger drainage basins were based on the 1:250,000-scale national coverage of hydrologic unit boundaries (Steeves and Nebert, 1994). The primary sources for creating coverages for the relatively smaller watersheds were the USGS’s topographic and hydrography digital maps at the 1:24,000-scale. All basin boundary coverages were managed in the Albers Conical Equal-Area projection of the North American Datum 1983, with a longitude of central meridian 96 degrees west of Greenwich [6].

Drainage basin boundary coverages were converted into digital maps in raster format (hereinafter referred to as “grids” [7]). Multiple boundary grids were produced for a drainage

basin as follows: for all 150 drainage basins, boundary grids were generated at the 30- and 1,000-m resolutions; for watersheds less than or equal to 25 km<sup>2</sup>, a 50-m resolution basin boundary grid was also created; and for watersheds with an area greater than 25 km<sup>2</sup> and less than or equal to 1,000 km<sup>2</sup>, a 100-m resolution boundary grid also was created. The basin boundary grid cells at the 30-m resolution were coincident with the grid cells of the enhanced version of the 30-m resolution NLCD 92. The 1,000-m resolution basin boundary grid cells were coincident with the grid cells of the 1-km resolution enhanced NLCD 92, whereas the 50- and 100-m resolution basin boundary grid cells shared common corner coordinates with the grid cells of the 1-km resolution enhanced NLCD 92.

### Land Cover

The selected source for land cover information was USGS’s NLCD 92, a 30-m resolution raster dataset that classifies land cover of the early to mid-1990s in the conterminous U.S. [8]. The NAWQA National Synthesis Project created an enhanced version of the NLCD 92 (hereinafter referred to as the “NLCDe 92”) at the 30-m and 1-km resolution. The following discussions briefly describe the 30-m resolution NLCD 92 and address how they were modified to create the 30-m and 1-km resolution NLCDe 92.

### 30-Meter Resolution

The NLCD 92 is a nationwide land cover dataset with 21 classifications [9]. It is based primarily on Landsat 5 Thematic Mapper (TM) imagery data and from other sources of ancillary spatial data (Vogelmann and others, 2001). The 30-m resolution NLCD 92 was acquired as state files in Geo-TIFF format [10], which were converted into 30-m resolution ArcInfo state grids and merged into four multistate quadrant grids (northeast, northwest, southeast, and southwest), each slightly overlapping one another (Curtis Price, U.S. Geological Survey, written commun., 2002). Four separate quadrant grids, rather than a single national grid, were generated because of the limitations of the ArcInfo GRID data model [11].

The NAWQA National Synthesis Project developed an enhanced version of the 30-m resolution NLCD 92 by combining the NLCD 92 with selected land categories from USGS’s Land Use and Land Cover (LULC) dataset (U.S. Geological Survey, 1990) [12]. Although the LULC (vector) dataset was derived from the interpretation of aerial photography taken in the 1970s to mid-1980s (U.S. Geological Survey, 1990), it is accepted as a better source of information for certain land cover types that are difficult to interpret from satellite imagery alone. The enhanced version of the NLCD 92 included the addition of four new classifications:

**Table 1.** The selected 150 drainage basins for which estimates of basin atrazine use are presented and analyzed in this report.

Basin identification number	U.S. Geological Survey station identification number	Drainage area (km <sup>2</sup> )	U.S. Geological Survey station name
01095220	01095220	79	Stillwater River near Sterling, Massachusetts
01100000	01100000	11,983	Merrimack River below Concord River at Lowell, Massachusetts
01104615	01104615	695	Charles River above Watertown Dam at Watertown, Massachusetts
01170100	01170100	107	Green River near Colrain, Massachusetts
01184000	01184000	25,049	Connecticut River at Thompsonville, Connecticut
01209710	01209710	85	Norwalk River at Winnipauk, Connecticut
01349150	01349150	155	Canajoharie Creek near Canajoharie, New York
01356190	01356190	40	Lisha Kill northwest of Niskayuna, New York
01357500	01357500	9,113	Mohawk River at Cohoes, New York
01362200	01362200	169	Esopus Creek at Allaben, New York
01382000	01382000	936	Passaic River at Two Bridges, New Jersey
01401000	01401000	115	Stony Brook at Princeton, New Jersey
01403300	01403300	2,074	Raritan River at Queens Bridge at Bound Brook, New Jersey
01403900	01403900	126	Bound Brook at Middlesex, New Jersey
01410784	01410784	39	Great Egg Harbor River near Sicklerville, New Jersey
01463500	01463500	17,580	Delaware River at Trenton, New Jersey
01464907	01464907	72	Little Neshaminy Creek at Valley Road near Neshaminy, Pennsylvania
01470779	01470779	185	Tulpehocken Creek near Bernville, Pennsylvania
01472157	01472157	152	French Creek near Phoenixville, Pennsylvania
01474500	01474500	4,896	Schuylkill River at Philadelphia, Pennsylvania
01493112	01493112	17	Chesterville Branch near Crumpton, Maryland
01555400	01555400	116	East Mahantango Creek at Klingerstown, Pennsylvania
01571490	01571490	33	Cedar Run at Eberlys Mill, Pennsylvania
01573095	01573095	20	Bachman Run at Annville, Pennsylvania
01576540	01576540	141	Mill Creek at Eshelman Mill Road near Lyndon, Pennsylvania
01578310	01578310	70,182	Susquehanna River at Conowingo, Maryland
01636500	01636500	7,880	Shenandoah River at Millville, West Virginia
01639000	01639000	457	Monocacy River at Bridgeport, Maryland
02082731	02082731	35	Devils Cradle Creek at Secondary Road 1412 near Alert, North Carolina
02083500	02083500	5,754	Tar River at Tarboro, North Carolina
02083833	02083833	44	Pete Mitchell Swamp at Secondary Road 1409 near Penny Hill, North Carolina
02084557	02084557	56	Van Swamp near Hoke, North Carolina
02084558	02084558	191	Albemarle Canal near Swindell, North Carolina
02087580	02087580	54	Swift Creek near Apex, North Carolina
02089500	02089500	7,022	Neuse River at Kinston, North Carolina
02091500	02091500	1,909	Contentnea Creek at Hookerton, North Carolina
02143500	02143500	181	Indian Creek near Laboratory, North Carolina
02169570	02169570	154	Gills Creek at Columbia, South Carolina
02172300	02172300	40	McTier Creek near Monetta, South Carolina
02174250	02174250	62	Cow Castle Creek near Bowman, South Carolina
02175000	02175000	7,077	Edisto River near Givhans, South Carolina
02215100	02215100	420	Tusawhatchee Creek near Hawkinsville, Georgia
02281200	02281200	806	Hillsboro Canal at Structure 6 near Shawano, Florida
02289034	02289034	73	U.S. Sugar outflow canal near Clewiston, Florida
02296750	02296750	3,436	Peace River at Arcadia, Florida
02317797	02317797	335	Little River at Upper Ty Ty Road near Tifton, Georgia
02318500	02318500	3,864	Withlacoochee River at US Highway 84 near Quitman, Georgia
02326838	02326838	25	Lafayette Creek, Miccosukee Road (No. 28) Tallahassee, Florida
02338000	02338000	6,245	Chattahoochee River near Whitesburg, Georgia
02350080	02350080	161	Lime Creek near Cobb, Georgia

## 6 Estimation of Agricultural Pesticide Use in Drainage Basins Using Land Cover Maps and County Pesticide Data

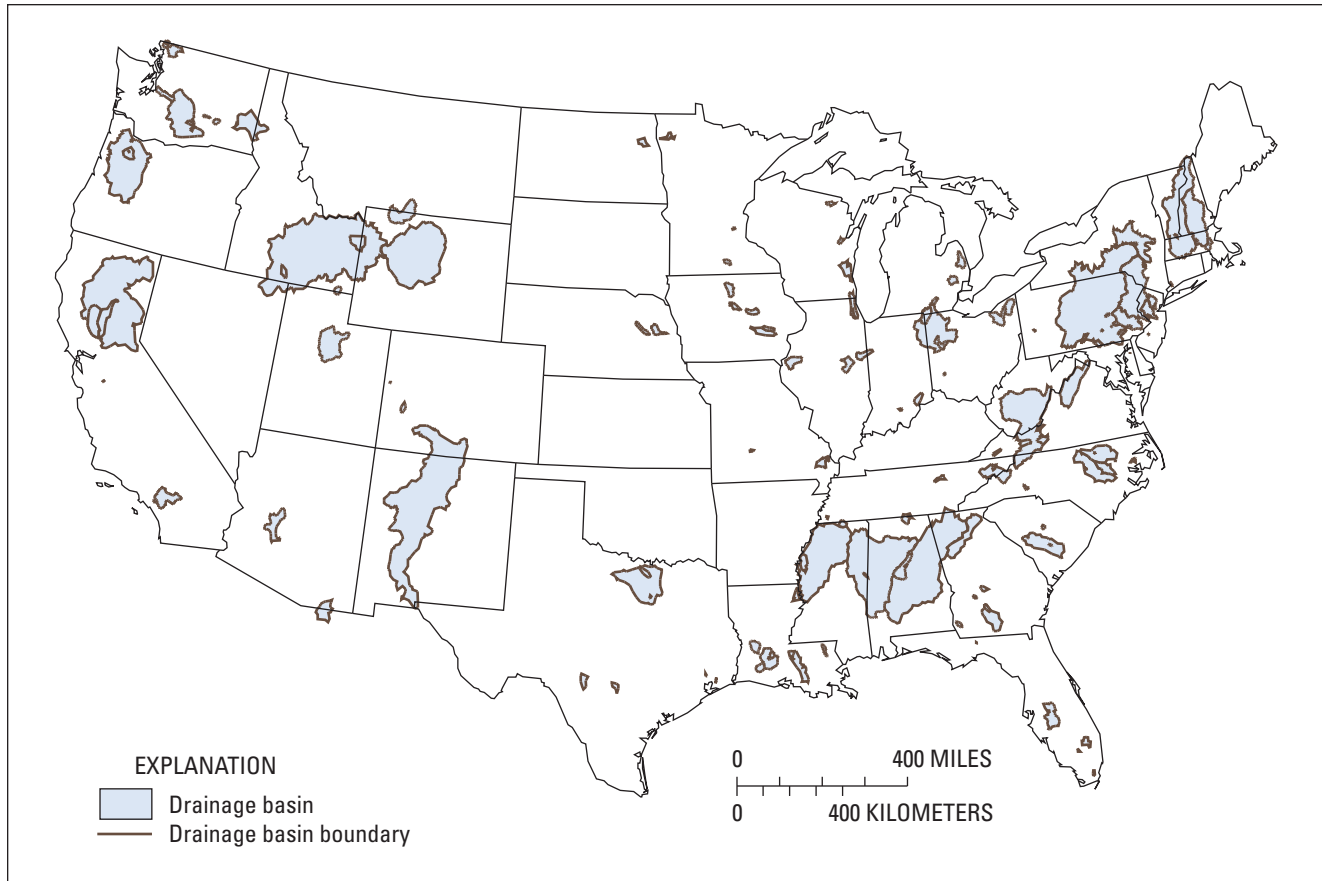
**Table 1.** The selected 150 drainage basins for which estimates of basin atrazine use are presented and analyzed in this report—*Continued.*

Basin identification number	U.S. Geological Survey station identification number	Drainage area (km <sup>2</sup> )	U.S. Geological Survey station name
02356980	02356980	273	Aycocks Creek near Boykin, Georgia
02423547	0242354750	66	Cahaba Valley Creek at Cross Creek Road at Pelham, Alabama
02424000	02424000	2,657	Cahaba River at Centreville, Alabama
02429500	02429500	56,921	Alabama River at Claiborne, Alabama
02444490	02444490	136	Bogue Chitto Creek near Memphis, Alabama
02469762	02469762	47,833	Tombigbee River below Coffeeville Lock and Dam near Coffeeville, Alabama
03049646	03049646	70	Deer Creek near Dorseyville, Pennsylvania
03167000	03167000	669	Reed Creek at Grahams Forge, Virginia
03170000	03170000	795	Little River at Graysontown, Virginia
03201300	03201300	30,628	Kanawha River at Winfield, West Virginia
03366500	03366500	755	Muscatatuck River near Duputy, Indiana
03373530	03373530	90	Lost River near Leipsic, Indiana
03466208	03466208	205	Big Limestone Creek near Limestone, Tennessee
03467609	03467609	4,373	Nolichucky River near Lowland, Tennessee
03526000	03526000	277	Copper Creek near Gate City, Virginia
03539778	03539778	441	Clear Creek at Lilly Bridge near Lancing, Tennessee
03574796	0357479650	76	Hester Creek at Buddy Williamson Road near Plevna, Alabama
03575100	03575100	969	Flint River at Brownsboro, Alabama
04063700	04063700	363	Popple River near Fence, Wisconsin
04072150	04072150	281	Duck Creek near Howard, Wisconsin
04086307	040863075	133	North Branch Milwaukee River near Random Lake, Wisconsin
04087000	04087000	1,804	Milwaukee River at Milwaukee, Wisconsin
04159492	04159492	1,198	Black River near Jeddo, Michigan
04161820	04161820	803	Clinton River at Sterling Heights, Michigan
04175600	04175600	331	River Raisin near Manchester, Michigan
04178000	04178000	1,600	St. Joseph River near Newville, Indiana
04186500	04186500	858	Auglaize River near Fort Jennings, Ohio
04193500	04193500	16,409	Maumee River at Waterville, Ohio
04208504	04208504	2,044	Cuyahoga River at LTV Steel Cleveland, Ohio
04211820	04211820	1,431	Grand River at Harpersfield, Ohio
05082625	05082625	658	Turtle River at Turtle River State Park near Arvilla, North Dakota
05085900	05085900	566	Snake River above Alvarado, Minnesota
05288705	05288705	73	Shingle Creek at Queen Ave in Minneapolis, Minnesota
05320270	05320270	336	Little Cobb River near Beauford, Minnesota
05449500	05449500	1,084	Iowa River near Rowan, Iowa
05451210	05451210	581	South Fork Iowa River northeast of New Providence, Iowa
05455100	05455100	522	Old Mans Creek near Iowa City, Iowa
05455570	05455570	1,622	English River at Riverside, Iowa
05464220	05464220	775	Wolf Creek near Dysart, Iowa
05525500	05525500	1,159	Sugar Creek at Milford, Illinois
05531500	05531500	291	Salt Creek at Western Springs, Illinois
05532500	05532500	1,634	Des Plaines River at Riverside, Illinois
05572000	05572000	1,426	Sangamon River at Monticello, Illinois
05584500	05584500	1,696	La Moine River at Colmar, Illinois
06208500	06208500	5,238	Clarks Fork Yellowstone River at Edgar, Montana
06279500	06279500	40,825	Bighorn River at Kane, Wyoming
06795500	06795500	762	Shell Creek near Columbus, Nebraska
06800000	06800000	955	Maple Creek near Nickerson, Nebraska
06923150	06923150	106	Dousinbury Creek on Highway JJ near Wall Street, Missouri
07030392	07030392	543	Wolf River at Lagrange, Tennessee



**Table 1.** The selected 150 drainage basins for which estimates of basin atrazine use are presented and analyzed in this report—*Continued.*

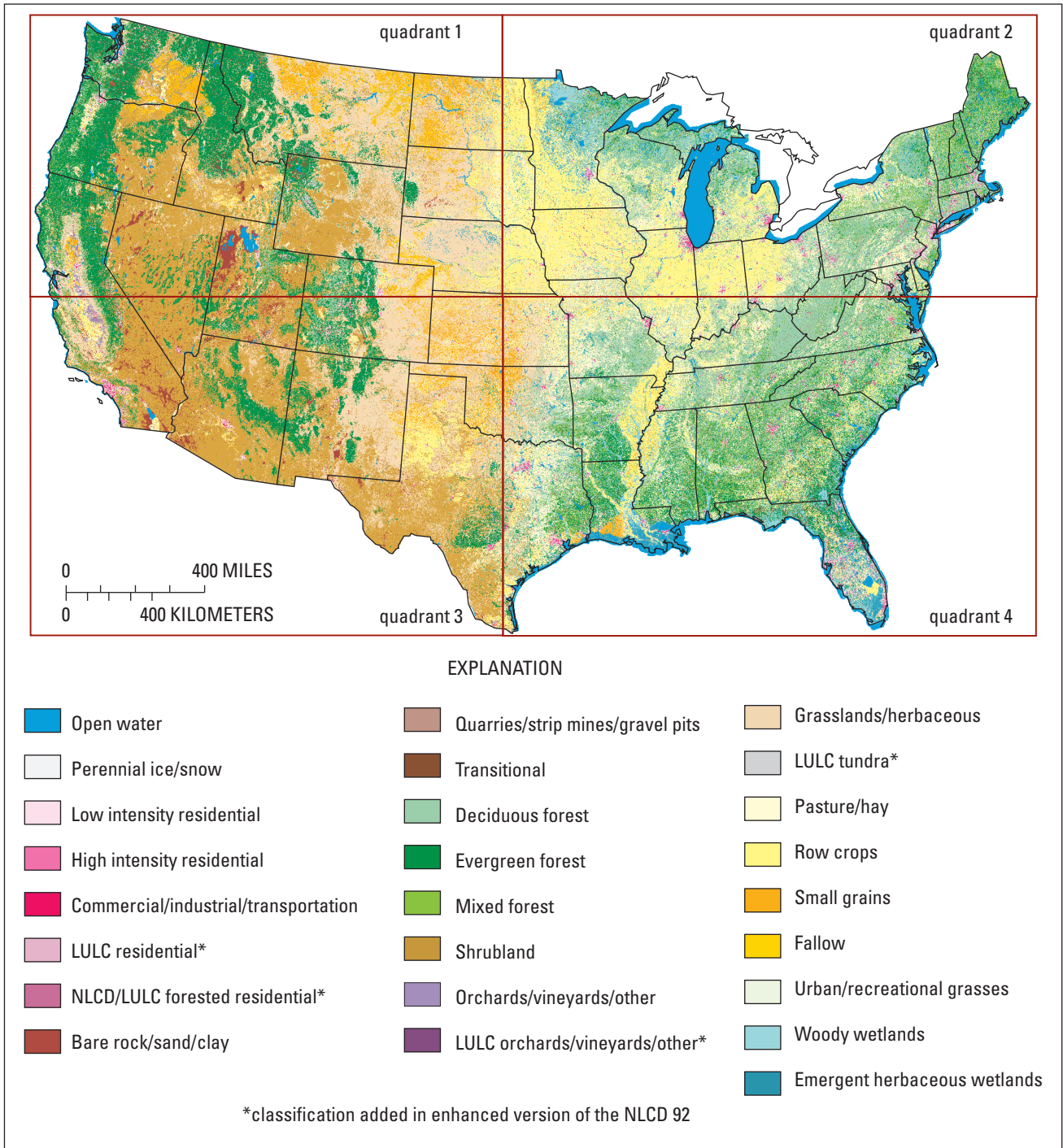
Basin identification number	U.S. Geological Survey station identification number	Drainage area (km <sup>2</sup> )	U.S. Geological Survey station name
07031692	07031692	79	Fletcher Creek at Sycamore View Road at Memphis, Tennessee
07043500	07043500	1,144	Little River Ditch No. 1 near Morehouse, Missouri
07288650	07288650	1,301	Bogue Phalia near Lelend, Mississippi
07288955	07288955	34,850	Yazoo River below Steele Bayou near Long Lake, Mississippi
07369500	07369500	721	Tensas River at Tendal, Louisiana
07375050	07375050	366	Tchefuncte River near Covington, Louisiana
07381440	07381440	305	Bayou Grosse Tete at Rosedale, Louisiana
07381467	073814675	3,171	Bayou Boeuf at Railroad Bridge at Amelia, Louisiana
08010000	08010000	369	Bayou Des Cannes near Eunice, Louisiana
08012150	08012150	3,576	Mermentau River at Mermentau, Louisiana
08012470	08012470	767	Bayou Lacassine near Lake Arthur, Louisiana
08014500	08014500	1,305	Whiskey Chitto Creek near Oberlin, Louisiana
08049240	08049240	69	Rush Creek at Woodland Park Blvd, Arlington, Texas
08051500	08051500	785	Clear Creek near Sanger, Texas
08057410	08057410	16,273	Trinity River below Dallas, Texas
08178800	08178800	506	Salado Creek at Loop 13 at San Antonio, Texas
08195000	08195000	1,028	Frio River at Concan, Texas
08364000	08364000	77,556	Rio Grande at El Paso, Texas
09149480	09149480	448	Dry Creek at Begonia Road, near Delta, Colorado
09153290	09153290	36	Reed Wash near Mack, Colorado
09471000	09471000	3,257	San Pedro River at Charleston, Arizona
09517000	09517000	3,967	Hassayampa River near Arlington, Arizona
10102200	10102200	577	Cub River near Richmond, Utah
10171000	10171000	9,096	Jordan River at Salt Lake City, Utah
11074000	11074000	3,727	Santa Ana River below Prado Dam, California
11075610	11075610	3,868	Santa Ana River upstream spreading diversion below Imperial Highway near Anaheim, California
11274538	11274538	28	Orestimba Creek at River Road near Crows Landing, California
11390890	11390890	4,258	Colusa Basin Drain at Road 99E near Knights Landing, California
11391100	11391100	3,400	Sacramento Slough near Knights Landing, California
11447650	11447650	61,720	Sacramento River at Freeport, California
12113390	12113390	1,194	Duwamish River at golf course at Tukwila, Washington
12212100	12212100	99	Fishtrap Creek at Flynn Road at Lynden, Washington
12213140	12213140	2,024	Nooksack River at Brennan, Washington
12472380	12472380	146	Crab Creek Lateral above Royal Lake near Othello, Washington
12473740	12473740	377	El 68 D Wasteway near Othello, Washington
12500420	12500420	353	Moxee Drain at Birchfield Road near Union Gap, Washington
12505450	12505450	160	Granger Drain at Granger, Washington
12510500	12510500	14,536	Yakima River at Kiona, Washington
13055000	13055000	2,294	Teton River near St. Anthony, Idaho
13092747	13092747	623	Rock Creek above State Highway 30/93 crossing at Twin Falls, Idaho
13154500	13154500	92,942	Snake River at King Hill, Idaho
13351000	13351000	6,380	Palouse River at Hooper, Washington
14201300	14201300	39	Zollner Creek near Mt. Angel, Oregon
14202000	14202000	1,261	Pudding River at Aurora, Oregon
14206950	14206950	80	Fanno Creek at Durham, Oregon
14211720	14211720	28,937	Willamette River at Portland, Oregon
25241408	252414080333200	132	C-111 Canal 100 feet above Structure 177 near Homestead, Florida
29434909	294349094345999	112	East Fork Double Bayou at Sykes Road near Anahuac, Texas
29574009	295740094542399	75	West Prong Old River at State Highway 146, near Dayton, Texas
39394408	393944084120700	52	Holes Creek in Huffman Park at Kettering, Ohio



**Figure 2.** Geographic distribution of the 150 National Water-Quality Assessment (NAWQA) drainage basins for which basin atrazine use estimates are presented and analyzed in this report.

- 1)“LULC tundra”—“Tundra” is not defined in the NLCD 92. For the NLCD 92, a 30-m grid cell in the NLCD 92 that is classified as either “shrubland” or “grasslands/herbaceous” was reclassified as “LULC tundra” if the same 30- by 30-m area in the LULC dataset is classified as “shrub and brush tundra,” “herbaceous tundra,” “bare ground,” “wet tundra,” or “mixed tundra.”
- 2)“NLCD/LULC forested residential”—For the NLCD 92, a 30-m grid cell in the NLCD 92 that is classified as “deciduous forest,” “evergreen forest,” or “mixed forest” was reclassified to “NLCD/LULC forested residential” if the same 30- by 30-m area in the LULC dataset is classified as “residential.”
- 3)“LULC residential”—For the NLCD 92, a 30-m grid cell in the NLCD 92 that is not classified as forest (“deciduous forest,” “evergreen forest,” “mixed forest”), water (“open water,” “woody wetlands,” “emergent herbaceous wetlands”), or urban (“low intensity residential,” “high intensity residential,” “commercial/industrial/transportation,” “urban/recreational grasses”) was changed to “LULC residential” if the same 30- by 30-m area in the LULC dataset is classified as “residential.”
- 4)“LULC orchards/vineyards/other”—This classification was added to ensure that orchards were identified in areas of the nation where they are difficult to distinguish from surrounding deciduous forest using satellite imagery. For the NLCD 92, a 30-m grid cell in the NLCD 92 already not classified as “orchards/vineyards/other,” and not classified as water or urban, was changed to “LULC orchards/vineyards/other” if the same 30- by 30-m area in the LULC dataset is classified as “orchards, groves, vineyards, nurseries, and ornamental horticultural areas.” The reclassification of “LULC orchards/vineyards/other” was not done for California, Florida, Washington, and Oregon because orchards were found to be well represented by the NLCD 92 in these states.

*Figure 3* shows a map of the NLCD 92 for the conterminous United States along with the boundaries of the four quadrant grids, and lists the original 21 and added 4 land cover classifications. *Table 2* shows these 25 classifications with the associated two-digit numeric codes, which are stored in the cell values of the 30-m resolution NLCD 92 quadrant grids.



**Figure 3.** The “enhanced” 30-m resolution National Land Cover Data 1992 (NLCD 92) for the conterminous United States shown with boundaries of the four quadrant grids. Because of limitations of the ArcInfo GRID data model, four separate quadrant grids, rather than a single grid, were generated. LULC, Land Use and Land Cover; NLCD, National Land Cover Data. [9]

**Table 2.** The numeric codes and land cover classifications of the “enhanced” version of the National Land Cover Data 1992 (NLCDe 92)

[LULC, Land Use and Land Cover; NLCD, National Land Cover Data. \*, new classification in the NLCDe 92]

Code	Land cover classification
11	Open water
12	Perennial ice/snow
21	Low intensity residential
22	High intensity residential
23	Commercial/industrial/transportation
25	LULC residential*
26	NLCD/LULC forested residential*
31	Bare rock/sand/clay
32	Quarries/strip mines/gravel pits
33	Transitional
41	Deciduous forest
42	Evergreen forest
43	Mixed forest
51	Shrubland
61	Orchards/vineyards/other
62	LULC orchards/vineyards/other*
71	Grasslands/herbaceous
72	LULC tundra*
81	Pasture/hay
82	Row crops
83	Small grains
84	Fallow
85	Urban/recreational grasses
91	Woody wetlands
92	Emergent herbaceous wetlands

## 1-Kilometer Resolution

After these enhancements were made to the 30-m resolution NLCD 92, they were used to create a set of 1-km resolution national grids of “percentage” land cover. In this process, the NAWQA National Synthesis Project created a separate 1-km resolution grid of percentage land cover for each of the 25 land cover classifications in the 30-m resolution NLCDe 92 (Curtis Price, U.S. Geological Survey, written commun., 2003). In each 1-km resolution grid, the resulting integer value of a grid cell was the percentage of the 1- by 1-km area specific to a land cover classification.

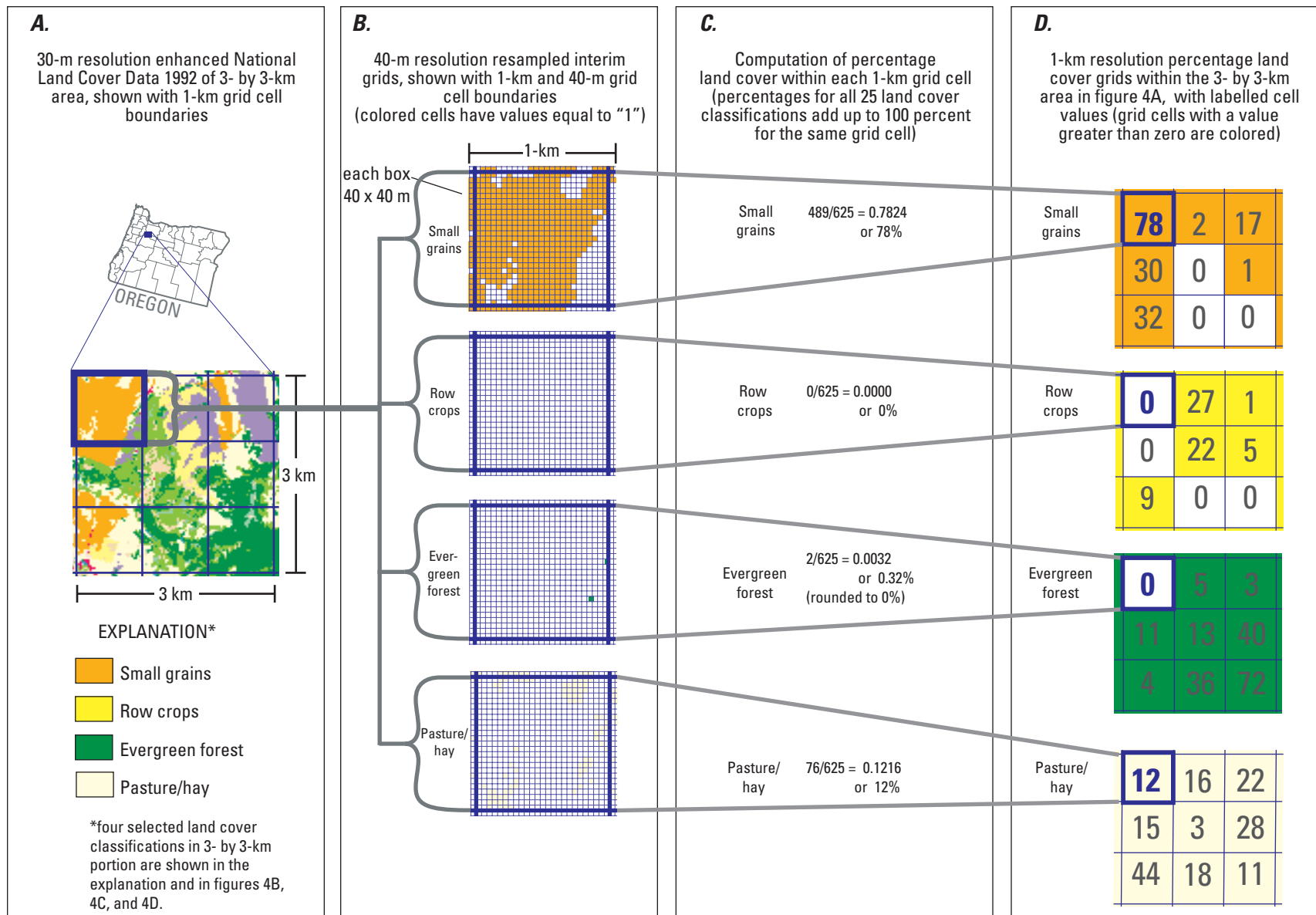
The first step in creating the 1-km representation of the 30-m resolution NLCDe 92 was to resample [13] the 30-m grid cells to a cell size that factors evenly into 1,000 (for example, 25- or 40 m) to ensure that multiple undivided grid cells would fit into each 1-km grid cell. Because resampling the 30-m resolution NLCDe 92 to 25-m resolution would create a raster dataset that contained more detail than that captured in the original data, the 30-m grid cells were resampled to 40-m grid cells.

The resampling process resulted in four 40-m resolution interim quadrant grids for each land classification. The resampling technique that was applied was the “nearest neighbor” algorithm, whereby cell values in the interim 40-m resolution grids were assigned either a value of “1” or a “0”. To describe

this technique, take for example, the determination of the value of a single cell in the 40-m resolution “small grains” grid. The software first determined the geographic center of a 40-m grid cell, then identified the 30-m NLCDe 92 grid cell whose center was closest to this 40-m grid cell. If this 30-m grid cell was coded as “83” (numeric code for “small grains” in the NLCDe 92), the 40-m grid cell was assigned a value of “1”. If this 30-m grid cell was not coded 83, then the 40-m grid cell was assigned a value of “0”.

Finally, the 1-km resolution grids of percentage land cover were generated from the 40-m resolution interim quadrant grids, thereby producing a single 1-km resolution percentage grid for each land cover classification. The percentage of a land cover classification in a 1- by 1-km area was computed by (1) determining the total number of 1-coded 40-m grid cells for a particular land cover classification in a 1- by 1-km area, (2) dividing this total by 625, the number of 40-m grid cells in a 1- by 1-km area [14], then (3) rounding the divisor to an integer. This step was repeated 100 times, as there were four 40-m resolution interim quadrant grids for each of the 25 land classifications. The resulting output was four 1-km resolution quadrant grids, which were then mosaicked into national grids of percentage land cover. For each 1- by 1-km area, the sum of the cell values of the percentage grids for all 25 classifications was 100.

*Figure 4* illustrates the general process of creating 1-km resolution grids of percentage land cover from the 30-m resolution NLCDe 92. *Figure 4A* shows the 30-m resolution NLCDe 92 within a 3- by 3-km area in northwest Oregon; *figure 4B* shows the resampled 40-m resolution “small grains,” “row crops,” “evergreen forest,” and “pasture/hay” interim grids, within the northwestern 1- by 1-km area shown in bold in *figure 4A*; *figure 4C* shows the computation of the percentages within the same northwestern 1-km<sup>2</sup> area for “small grains,” “row crops,” “evergreen forest,” and “pasture/hay”; and *figure 4D* shows the derived percentage grid cell values in the “small grains,” “row crops,” “evergreen forest,” and “pasture/hay” grids within the 3- by 3-km area shown in *figure 4A*. Note that most of the northwestern 1- by 1-km area consists mainly of “small grains” pixels (*figs. 4A* and *4B*). The derived cell value of the 1-km resolution “small grains” percentage grid for this 1-km<sup>2</sup> area indicates that 78 percent of the 1- by 1-km area (489 of the 625 40-m grid cells) is identified as “small grains” (*figs. 4C* and *4D*). The derived zero cell values in the “row crops” percentage grid in the same 1- by 1-km area indicate that row crops were not found in this 1-km<sup>2</sup> area. In the same 1-km<sup>2</sup> area, there are two 40-m grid cells characterized as “evergreen forest” (*fig. 4B*); however, in *figure 4C*, the 1-km<sup>2</sup> percentage calculation for “evergreen forest” ( $2/625 = 0.0032$ , or 0.32 percent) was rounded to zero percentage [15]. The percentage computation for “pasture/hay” (*fig. 4C*) indicates the same 1-km grid cell consists of 12 percent “pasture/hay” ( $76/625 = 0.1216$ , or 12 percent).



**Figure 4.** The process of creating 1-km resolution national grids of percentage land cover from the 30-m resolution "enhanced" National Land Cover Data 1992 (NLCDe 92) [15].

The entire set of the 1-km resolution national grids of “percentage” land cover derived from the 30-m resolution NLCDe 92 is shown in *figure 5*. There are 25 maps, one for each land cover classification, which includes 21 land cover classifications in the original NLCD 92 and the 4 classifications added by the NAWQA National Synthesis Project. These maps, with the exception of the map showing the “commercial/industrial/transportation” classification, were generated by coloring all grid cells where the percentage value of a land cover class (or grid cell value) is greater than or equal to 1. The map for the “commercial/industrial/transportation” classification was generated by coloring all grid cells where the percentage value of a land cover class is greater than or equal to 5. This adjustment was made to reduce highly dense roads in areas of the country where interpretation of roads differed, and thus, eliminating the possibility of misinterpreting these road networks as errors.

## County Agricultural Pesticide Use

County information on agricultural pesticide use in the early 1990s for over 200 chemicals and 87 crops was developed for the conterminous United States using methods developed by Thelin and Gianessi (2000). The county agricultural pesticide use estimates are based on 1992 Census of Agriculture [16] county harvested cropland acreage and state agricultural pesticide use in the early to mid-1990s reported by the National Center for Food and Agricultural Policy (NCFAP) [17, 18, 19]. (“Cropland,” in reference to data collected in the Census of Agriculture, includes land used for row crops, orchard and vineyard crops, pasture, and fallow land). These county estimates of pesticide use by crop are stored in a tabular file, hereinafter referred to as the “1992 county file of pesticide use by crop” [20]. In addition to the amount of pesticides applied to a crop, this county pesticide file includes the area of cropland onto which pesticides are applied as well as the name and numeric code for each crop and county.

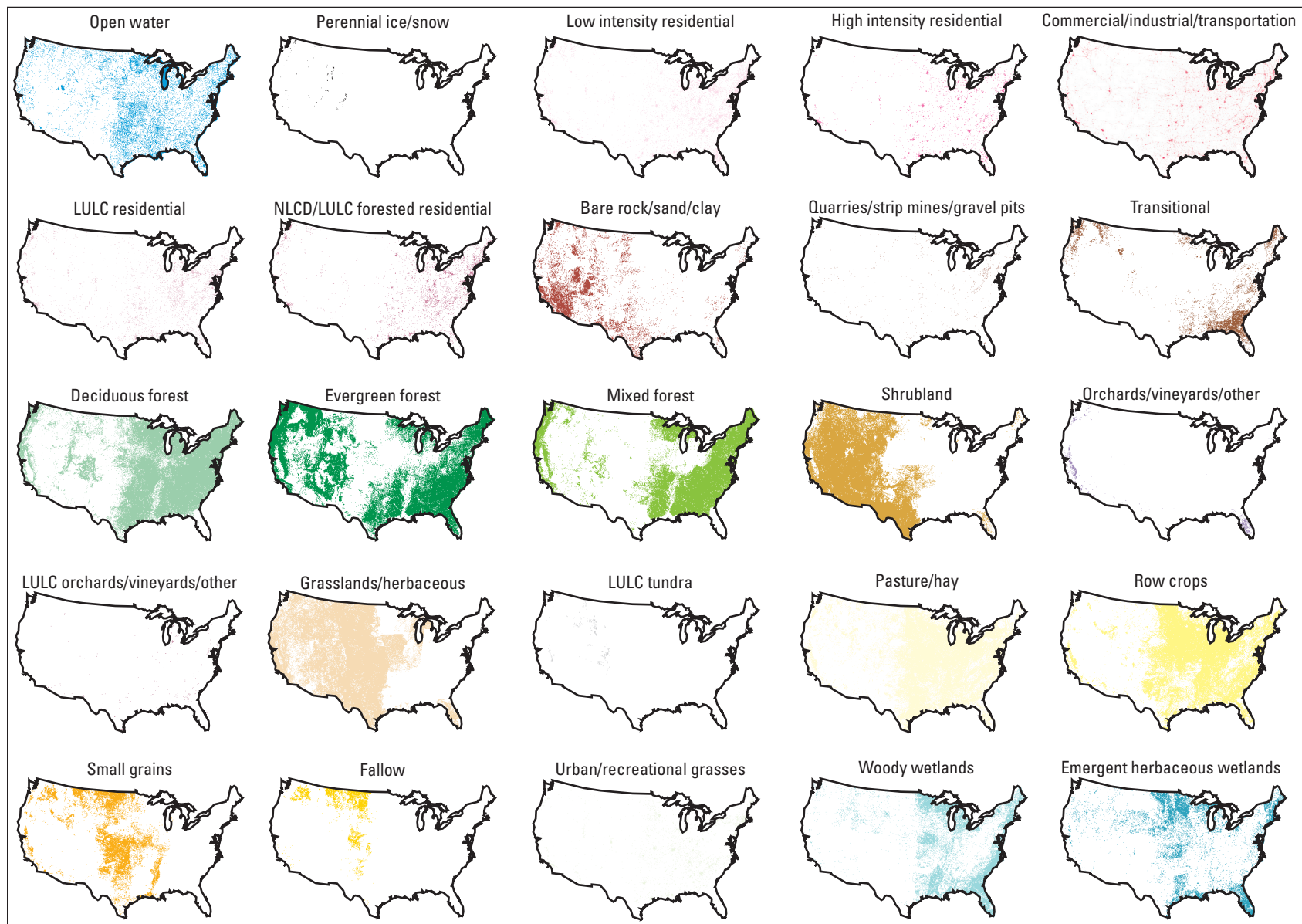
County estimates of agricultural pesticide use were combined with mapped land cover information (NLCDe 92) to refine the geographic areas of pesticide application to groups of crops from countywide to within-county agricultural land. Because the land cover classifications in the NLCDe 92 do not include the mapping of agricultural land by individual crops

however, it was necessary to establish a “crop class” framework that was built on a systematic correspondence between multiple crop types in the 1992 county file of pesticide use by crop and agricultural land classifications in the NLCDe 92.

To obtain a reasonable association between agricultural land classifications in the NLCDe 92 to the 86 crops for which 1992 county pesticide use estimates are available, the following three crop classes were established: (1) “row crops, small-grain crops, and fallow land,” (2) “orchard and vineyard crops,” and (3) “pasture and hay crops.” *Table 3* shows these three crop classes and their association to the individual crops in the 1992 county file of pesticide use by crop. The crop class “row crops, small-grain crops, and fallow land,” which is associated with the NLCDe 92 classifications “row crops,” “small grains,” and “fallow,” corresponds to 55 crops in the 1992 county file of pesticide use by crop; the crop class “orchard and vineyard crops” is associated with the NLCDe 92 classifications “orchards/vineyards/other” and “LULC orchards/vineyards/other” and corresponds to 26 crops in the 1992 county file of pesticide use by crop; and the crop class “pasture and hay crops,” which is associated with the NLCDe 92 classification “pasture/hay,” corresponds to five crops in the 1992 county file of pesticide use by crop.

It was important to consider the spectral signatures of each crop to determine its association with the closest matching land cover classification. Though the association between individual crops and land cover classifications was apparent in most cases, there were a few crops that had less obvious associations. For instance, seed crops were associated with the “pasture/hay” land cover classification because it is more likely they would be spectrally interpreted as pastured lands than the “row crops” classification in the NLCDe 92.

Once these associations were established, estimates of the total amount of a pesticide used on the group of crops associated with each crop class was determined by county. A separate tabular file was created for a pesticide, and the pesticide files contained a single record for each county, with the estimated totals of the county’s (a) pesticide application onto the crops associated with the crop class “row crops, small-grain crops, and fallow land,” (b) pesticide use onto crops associated with the crop class “orchard and vineyard crops,” and (c) pesticide application onto crops associated with the crop class “pasture and hay crops.”



**Figure 5.** The complete set of 1-km resolution national grids of percentage land cover derived from the 30-m resolution “enhanced” National Land Cover Data 1992 (NLCDe 92). LULC, Land Use and Land Cover; NLCD, National Land Cover Data. These maps, with the exception of the map showing the “commercial/industrial/transportation” classification, were generated by coloring all grid cells where the percentage value of a land cover class (or grid cell value) is greater than or equal to 1. The map for the “commercial/industrial/transportation” classification was generated by coloring all grid cells where the percentage value of a land cover class is greater than or equal to 5.

## 14 Estimation of Agricultural Pesticide Use in Drainage Basins Using Land Cover Maps and County Pesticide Data

**Table 3.** The crop class framework and the associations between the agricultural land cover classifications in the “enhanced” National Land Cover Data 1992 (NLCDe 92) and crops from the 1992 county file of pesticide use estimates by crop.

[Each of the three crop classes corresponds to the following agricultural land cover classifications from the NLCDe 92, respectively: first, “row crops,” “small grains,” and “fallow”; second, “orchards/vineyards/other” and “LULC orchards/vineyards/other”; and third, “pasture/hay.” LULC, Land Use and Land Cover]

Crop class	Crops from the 1992 county file of pesticide use estimates by crop	
Row crops, small-grain crops, and fallow land:	Artichokes Asparagus Barley Beets Broccoli Brussel sprouts Cabbage Canola Cantaloupes Carrots Cauliflower Celery Collards Corn Cotton Cucumbers Dry beans Dry peas Eggplant Flax Garlic Green Beans Green Onions Green Peas Hot Peppers Lettuce Melons	Millet Mint Oats Okra Onions Parsley Peanuts Potatoes Sweet Corn Sweet Potatoes Sweet Peppers Pumpkins Radishes Rice Rye Safflower Sorghum Soybeans Spinach Squash Sugarbeets Sugarcane Sunflowers Tobacco Tomatoes Watermelons Wheat Wild rice
Orchard and vineyard crops:	Almonds Apples Apricots Avocados Blackberries Blueberries Cherries Citrus fruits Cranberries Dates Figs Hazelnuts Grapes	Hops Kiwi Nectarines Olives Peaches Pears Pecans Pistachios Plums/Prunes Pomegranates Raspberries Strawberries Walnuts
Pasture and hay crops:	Alfalfa hay Other hay Pasture	Seed Crops Sod



Figure 6 illustrates the process of generating a 1992 county file of atrazine use estimates associated with each of the three crop classes mentioned in the previous paragraph, derived from a fictitious 1992 county file of pesticide use by crop. First it was necessary to create a crops-by-crop class file (fig. 6A), which identified each crop in the 1992 county file of pesticide use by crop by its associated crop class. The crops-by-crop class file was then linked to the 1992 county file of pesticide use by crop (selected fields are shown in the first seven columns in fig. 6B) by the commonly shared field CROP\_CODE. This process allowed the field CROP\_CLASS to be added into the 1992 county file of pesticide use by crop. Next, the records for atrazine in the 1992 county file of pesticide use by crop were used to determine the county sums of atrazine use by crop class. The atrazine totals by crop class were stored in a new tabular file referred to as the “1992 county atrazine use by crop class” file in figure 6C. This file contains the following fields: FIPS, “Federal Information Processing Standards,” which is the unique numeric code for a county; COUNTY, the name of the county; CGF\_KG, the amount of atrazine applied on all crops associated with the crop class “row crops, small-grain crops, and fallow land” (hereinafter shortened to ‘atrazine use on row crops, small-grain crops, and fallow land’); PAST\_KG, the amount of atrazine applied on all crops associated with the crop class “pasture and hay crops” (hereinafter shortened to ‘atrazine use on pasture and hay crops’); and ORCH\_KG, the amount of atrazine applied on all crops associated with the crop class “orchard and vineyard crops” (hereinafter shortened to ‘atrazine use on orchard and vineyard crops’). For county A, a total of 50 kg of atrazine was used on row crops, small-grain crops, and fallow land (the sum of 45 kg applied on corn and 5 kg applied on sorghum); and 20 kg of atrazine was applied on pasture and hay crops (the same amount applied on seed crops). For county B, a total of 100 kg of atrazine was used on row crops, small-grain crops, and fallow land (the sum of 75 kg applied on corn and 25 kg applied on millet). There was no atrazine applied on pasture and hay crops in county B and no atrazine applied on any crops in county D. This summarization process of determining total pesticide use (in kilograms) by crop class was repeated for each pesticide in the 1992 county file of pesticide use by crop, and a new county file was created for each pesticide (figure 6D shows the first record for cyanazine).

It is important to note how the land cover data were managed to accommodate the crop class framework. In regard to the 1-km resolution NLCDe 92 grids, it was necessary to create two 1-km resolution percentage grids of multiple land cover classifications: (1) the “row crops, small grains, and fallow” grid, and (2) the “orchards and vineyards” grid. These new grids were generated by summing the grid cell values of the individual grids of “row crops,” “small grains,” and “fallow” percentages and the grids of “orchards/vineyards/other” and “LULC orchards/vineyards/other” percentages, respectively. For instance, a “row crops” percentage grid cell value of 10, a “small grains” percentage grid cell value of 20, and a

“fallow” percentage grid cell value of 5 within the same 1- by 1-km area would yield a “row crops, small grains, and fallow” grid cell value of  $10 + 20 + 5$ , or 35.

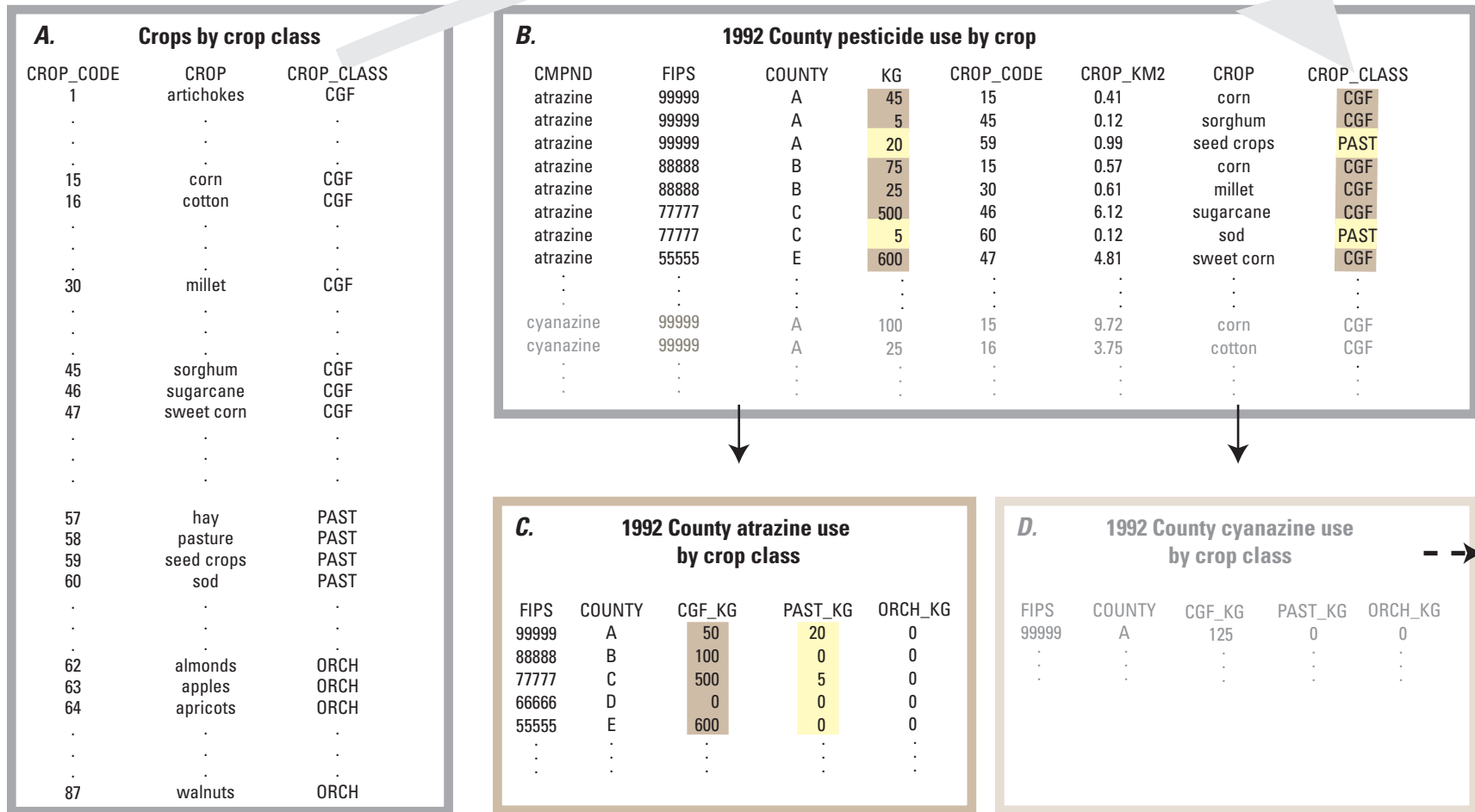
Spatial county boundary datasets were used to geographically link the 1992 county file of pesticide use estimates by crop class to the location of counties. The selected sources for digital maps of county boundaries were the 1990 county boundaries for the conterminous U.S. at the 1:100,000-scale (U.S. Department of Commerce, 1993) [21] and at the 1:2,000,000-scale (U.S. Geological Survey, 2001b) [22]. The county boundaries for 1990 rather than 2000 were used to more closely correspond temporally to the 1992 county pesticide use estimates and the NLCDe 92. Because the method to estimate basin pesticide use requires the overlay of the spatial county boundary datasets with the land cover grids, it was necessary to convert the county boundaries, natively in vector format, to raster format. Hence, the more detailed 1:100,000-scale county boundaries were converted to a 30-m resolution grid, and the 1:2,000,000-scale county boundaries were converted to a 1-km resolution grid. The data files resulting from the overlay of the 1990 county boundaries and the NLCDe 92 were linked to the 1992 county files of pesticide use by the five-digit numeric code for a county, referred to as the “FIPS” code.

## Estimating Agricultural Pesticide Use in Drainage Basins

Two methods for estimating agricultural pesticide use in drainage basins are presented. One method uses the 30-m resolution NLCDe 92, and the other method uses the 1-km resolution representation of the 30-m resolution NLCDe 92. The difference between the two methods is in the technique used to distribute the county pesticide use estimates onto agricultural land.

### Basin Pesticide Use Estimated from the 1-Kilometer Resolution Land Cover Dataset

Estimates of agricultural pesticide use in drainage basins were computed from the 1-km resolution representation of the NLCDe 92 combined with the county pesticide data and drainage basins at various grid cell resolutions. The integration of the 1-km resolution land cover data and the county pesticide data resulted in the creation of a national grid of agricultural pesticide use for each of the three crop classes. This section describes the process to develop a 1-km resolution national pesticide use grid by crop class followed by the procedure to determine basin estimates of agricultural pesticide use derived from the national pesticide use grid and basin boundaries at the 50-, 100-, and 1,000-meter resolution.



**Figure 6.** The process of creating the 1992 county tabular file of atrazine use estimates by crop class (using fictitious data). CROP\_CODE stores the numeric code for a crop; CROP stores the name of the crop; CROP\_CLASS is either “CGF,” “ORCH,” or “PAST,” where “CGF” represents the crop class “row crops, small-grain crops, and fallow land,” “PAST” represents the crop class “pasture and hay crops,” and “ORCH” represents the crop class “orchard and vineyard crops.” CMPND stores the name of the compound or pesticide; FIPS stores the unique 5-digit numeric code for a county; COUNTY stores the name of the county; KG stores atrazine (CMPND) in kilograms per county applied to the CROP. CROP\_KM2 stores the area, in square kilometers, of the crop harvested in the county. CGF\_KG stores kilograms of the pesticide per county applied to crops associated with the crop class “row crops, small-grain crops, and fallow land”; PAST\_KG stores kilograms of the pesticide per county applied to crops associated with the crop class “pasture and hay crops”; ORCH\_KG stores kilograms of the pesticide per county applied to crops associated with the crop class, “orchard and vineyard crops.”

## Steps to Generate a 1-Kilometer Resolution Pesticide Use Grid

The steps to generate a 1-km resolution national grid of a pesticide applied to crops associated with a crop class were to (1) compute the county area of the agricultural land cover classification(s) corresponding to the crop class for the conterminous United States, (2) compute the county pesticide use intensity (or rate) of pesticide application for the crop class for the conterminous United States, and finally, (3) create the national grid of pesticide use for the crop class. The procedure to generate a 1-km resolution national atrazine grid associated with the crop class “row crops, small-grain crops, and fallow land” is illustrated in *figure 7* using a fictitious file of 1992 county atrazine use by crop class with a fictitious portion of the 1-km resolution grid of percentage “row crops, small grains, and fallow.” Though *figure 7* illustrates only the computations for fictitious county A, the procedure was applied once for all counties in the conterminous United States.

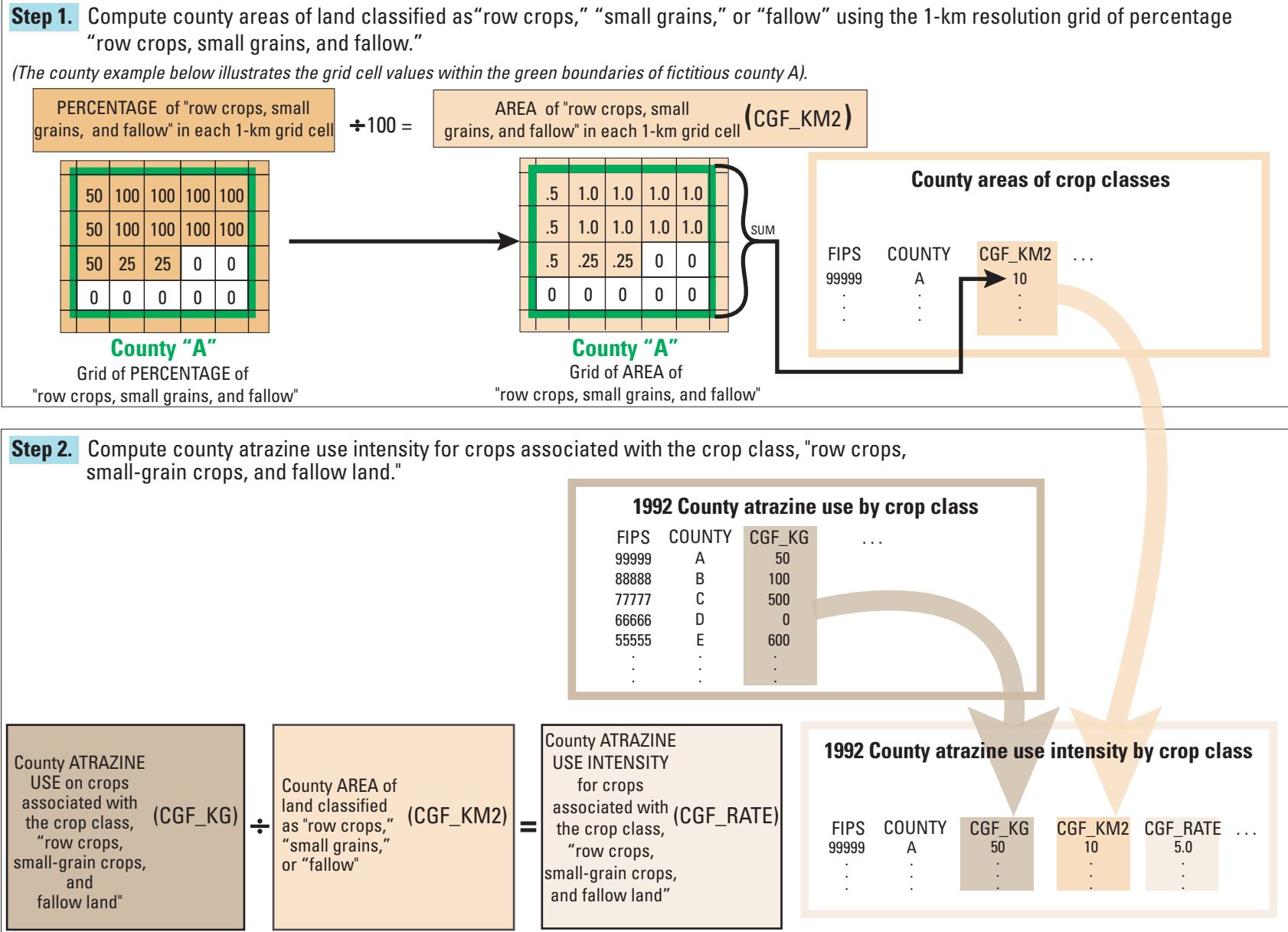
The first step (*fig. 7A*, step 1) was to compute county areas of land classified as “row crops,” “small grains,” or “fallow” at the 1-km resolution. These county areas were calculated by overlaying the 1-km resolution grid of county boundaries onto the 1-km resolution grid of percentage “row crops, small grains, and fallow.” (The boundary of county A is shown as a green rectangular border in *fig. 7A*, step 1, and in *fig. 7B*, step 3). The cell values of the percentage “row crops, small grains, and fallow” grid were converted to units of km<sup>2</sup> by dividing by 100, and stored in the 1-km resolution areal grid of “row crops, small grains, and fallow.” The cell values of this areal grid were then summed by county to calculate the county area of land classified as “row crops,” “small grains,” or “fallow.” At the 1-km resolution, the total area in county A classified as “row crops,” “small grains,” or “fallow” was 10 km<sup>2</sup>.

The second step (*fig. 7A*, step 2) was to compute the county atrazine use intensity (rate) for the crop class “row crops, small-grain crops, and fallow land.” The use intensity, or rate of application, is calculated by dividing the amount of pesticide used, by the area of land to which it was applied.

County A’s atrazine use on row crops, small-grain crops, and fallow land (50 kg, computed in *fig. 6C* and shown again in *fig. 7A*, step 2) was divided by county A’s area of land classified as “row crops,” “small grains,” or “fallow” (10 km<sup>2</sup>, as shown in step 1). The atrazine use intensity for county A was 50 kg/10 km<sup>2</sup>, or 5 kg/km<sup>2</sup>. Though not shown in *figure 7A*, step 2, the county atrazine use intensity data file was then linked to the value attribute table of the 1-km resolution county boundaries grid by the county FIPS code to produce a 1-km resolution grid of county atrazine use intensity.

The final step (*fig. 7B*, step 3) was to create the 1-km resolution national grid of estimated atrazine use on row crops, small-grain crops, and fallow land. In this step, the cell values of the areal grid of “row crops, small grains, and fallow” were multiplied by the cell values of the grid of county atrazine use intensity (rate). The cell values of the final 1-km resolution grid of atrazine use on row crops, small-grain crops, and fallow land represented the mass (kilograms) of atrazine applied to each 1- by 1-km area. In other words, a portion of the county’s total atrazine for crop class “row crops, small-grain crops, and fallow land” was allocated to each 1-km grid cell in the county on the basis of the area of row crops, small-grain crops, and fallow land in that grid cell. Note that the sum of all the cell values in the atrazine use grid for county A (50 kg) is equal to the CGF\_KG value for county A in the 1992 county file of atrazine use by crop class used in step 2 of *figure 7A*. *Figure 8A* shows the actual 1-km resolution national grid of estimated atrazine use on row crops, small-grain crops, and fallow land.

Though not shown in *figures 7A* and *7B*, this method was repeated for the remaining two crop classes, “pasture and hay crops” and “orchard and vineyard crops.” *Figure 8B* shows the actual 1-km resolution national grid of atrazine use on pasture and hay crops. Because atrazine is not applied to any orchard or vineyard crops (according to the 1992 county agricultural pesticide use estimates), the cell values of the 1-km resolution national grid of atrazine use on orchard and vineyard crops are all zero, and thus, this grid is not shown in this report. A national grid of the total amount of a pesticide applied to all crop types was derived by summing the grid cell values of the three individual national pesticide use grids by crop class.



**Figure 7.** Steps to generate a 1-km resolution grid of estimated atrazine use on crops associated with the crop class "row crops, small-grain crops, and fallow land" (using fictitious data). A. Steps 1–2. B. Step 3. FIPS stores the unique 5-digit numeric code for a county; COUNTY stores the name of the county; CGF\_KM2 stores the county area in square kilometers of land classified as "row crops," "small grains," or "fallow"; CGF\_KG stores atrazine in kilograms per county applied to crops associated with the crop class "row crops, small-grain crops, and fallow land"; CGF\_RATE contains the county rate of application of atrazine or atrazine use intensity on crops associated with the crop class "row crops, small-grain crops, and fallow land."

**Step 3.** Create the 1-km resolution national grid of estimated atrazine use on crops associated with the crop class, "row crops, small-grain crops, and fallow land."

On a cell-by-cell basis, the 1-km resolution areal grid of "row crops, small grains, and fallow" (created in step 1) is multiplied by the 1-km resolution grid of county atrazine use intensity. The grid of county atrazine use intensity was created by merging the 1-km resolution grid of county boundaries with the tabular file of 1992 county atrazine use intensity generated in Step 2. The final 1-km resolution grid of estimated atrazine use contains the apportioned amount of atrazine applied on crops associated with the crop class, "row crops, small-grain crops, and fallow land" in each 1-by-1 square kilometer area.

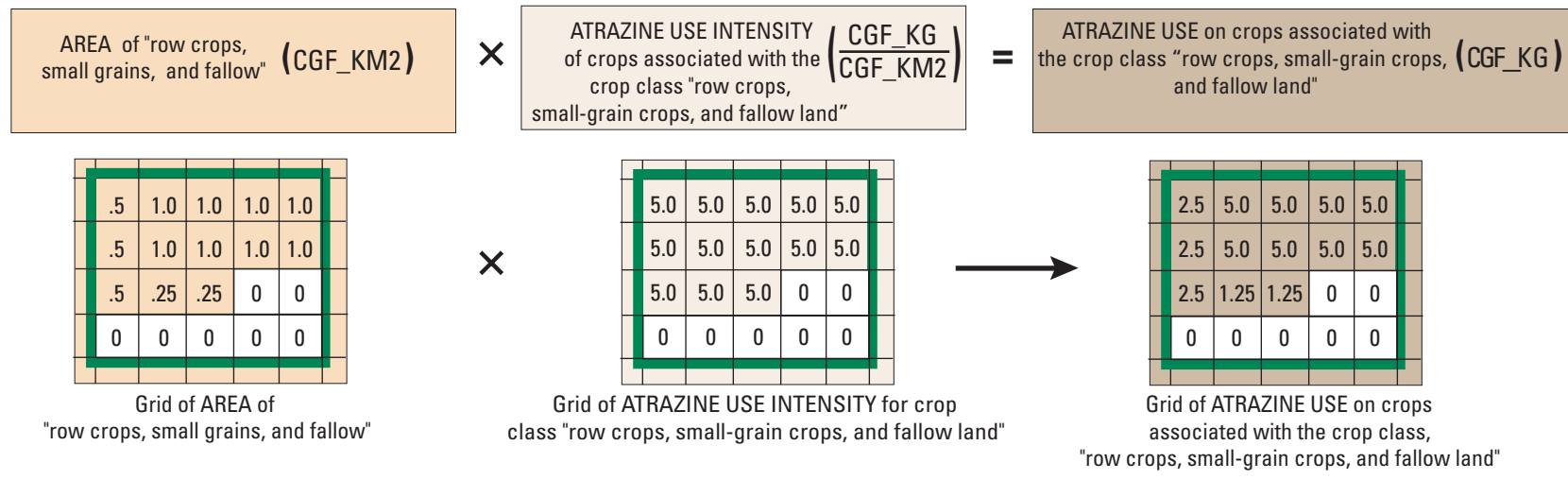
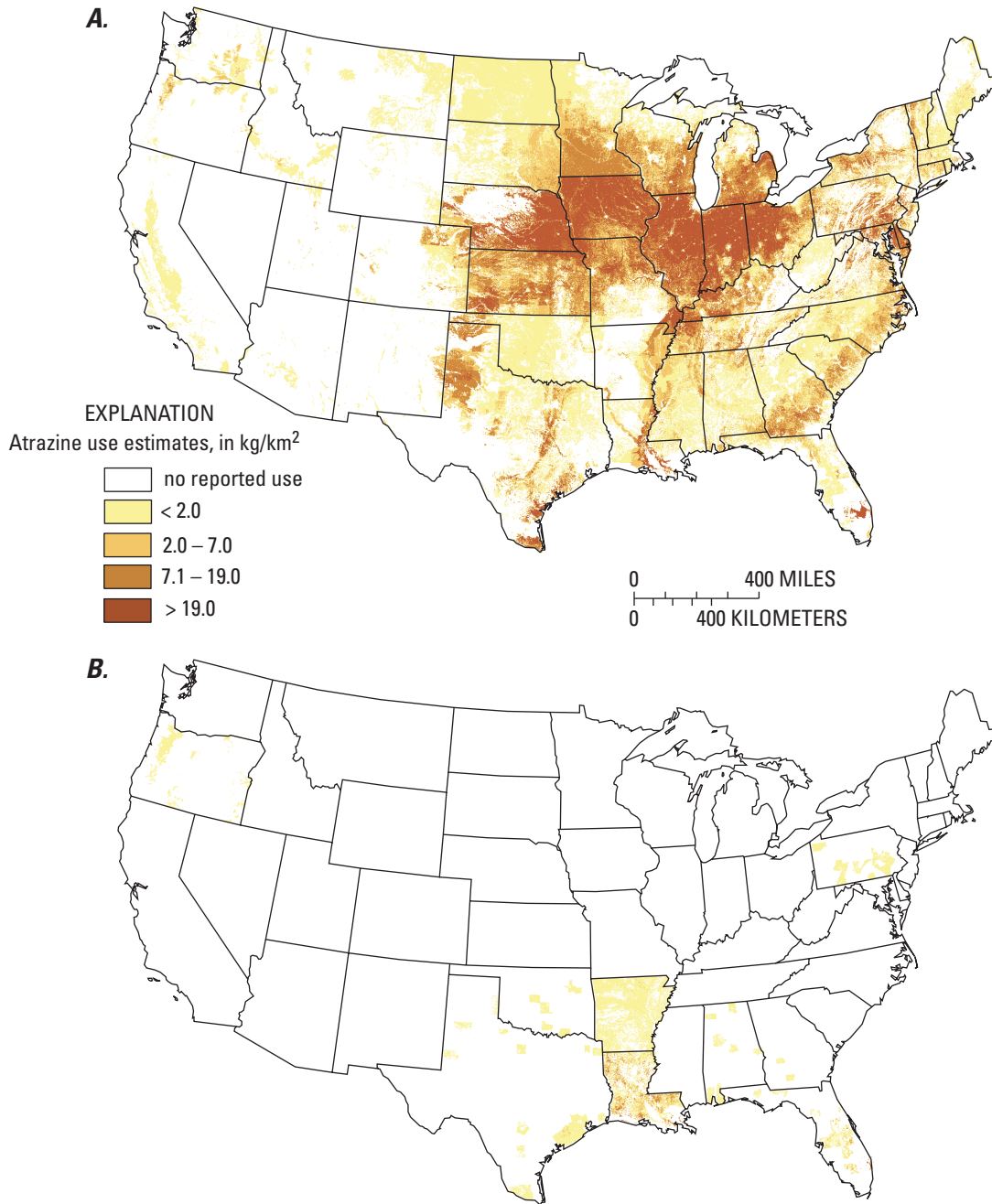


Figure 7. Continued.



**Figure 8.** The 1-km resolution national grids of estimated atrazine use on crops associated with the crop classes “row crops, small-grain crops, and fallow land” and “pasture and hay crops.” *A.* On crops associated with the crop class “row crops, small-grain crops, and fallow land.” *B.* On crops associated with the crop class “pasture and hay crops.”

## Steps to Estimate the Basin Pesticide Use Using a 1-Kilometer Resolution Pesticide Use Grid

To estimate atrazine use in a drainage basin using data at the 1-km resolution, a 1-km resolution grid of the basin boundary was created to identify and sum the 1-km resolution atrazine use grid cell values within the basin boundary. *Figure 9A* illustrates the general process using a portion of a fictitious 1-km resolution pesticide use grid overlaid by a fictitious 1-km resolution basin boundary grid. The estimated pesticide use in this watershed adds up to 16.25 kg ( $[3 \text{ cells} \times 5 \text{ kg}] + [1 \text{ cell} \times 1.25 \text{ kg}]$ ).

The grid cell resolution of the drainage basin was evaluated as a factor that may affect basin pesticide use estimates. When a drainage basin boundary coverage was converted to a grid, the level of spatial detail and precision in the rasterized watershed boundary was determined by the grid cell resolution. Applying a grid cell size that is too large with respect to the size of a watershed produced an overly generalized (blocky) rasterized basin boundary, and a generalized basin boundary grid erroneously includes and (or) excludes pesticide use grid cells in the summation process, which may result in either an over or underestimation of basin pesticide use. For this reason, it is important to note that basin pesticide use estimates for relatively small drainage basins have a higher potential to be affected by such boundary discretization errors to a greater degree than relatively large drainage basins; furthermore, the amount of pesticide application is generally lower in smaller drainage basins, so there is a higher potential bias as a percentage of basin pesticide use. (This observation is further examined in the “Results” section.)

Consequently, to minimize errors introduced from an overly generalized basin boundary, watersheds less than or equal to 1,000 km<sup>2</sup> were rasterized at different resolutions prior to their overlay with the 1-km resolution pesticide use grids. Drainage basins less than or equal to 25 km<sup>2</sup> were rasterized at the 50-m resolution, and drainage basins larger than 25 km<sup>2</sup> and smaller than or equal to 1,000 km<sup>2</sup> were rasterized at the 100-m resolution (The comparisons of the basin atrazine estimates derived from drainage basins rasterized at various grid cell resolutions are discussed in the “Results” section.)

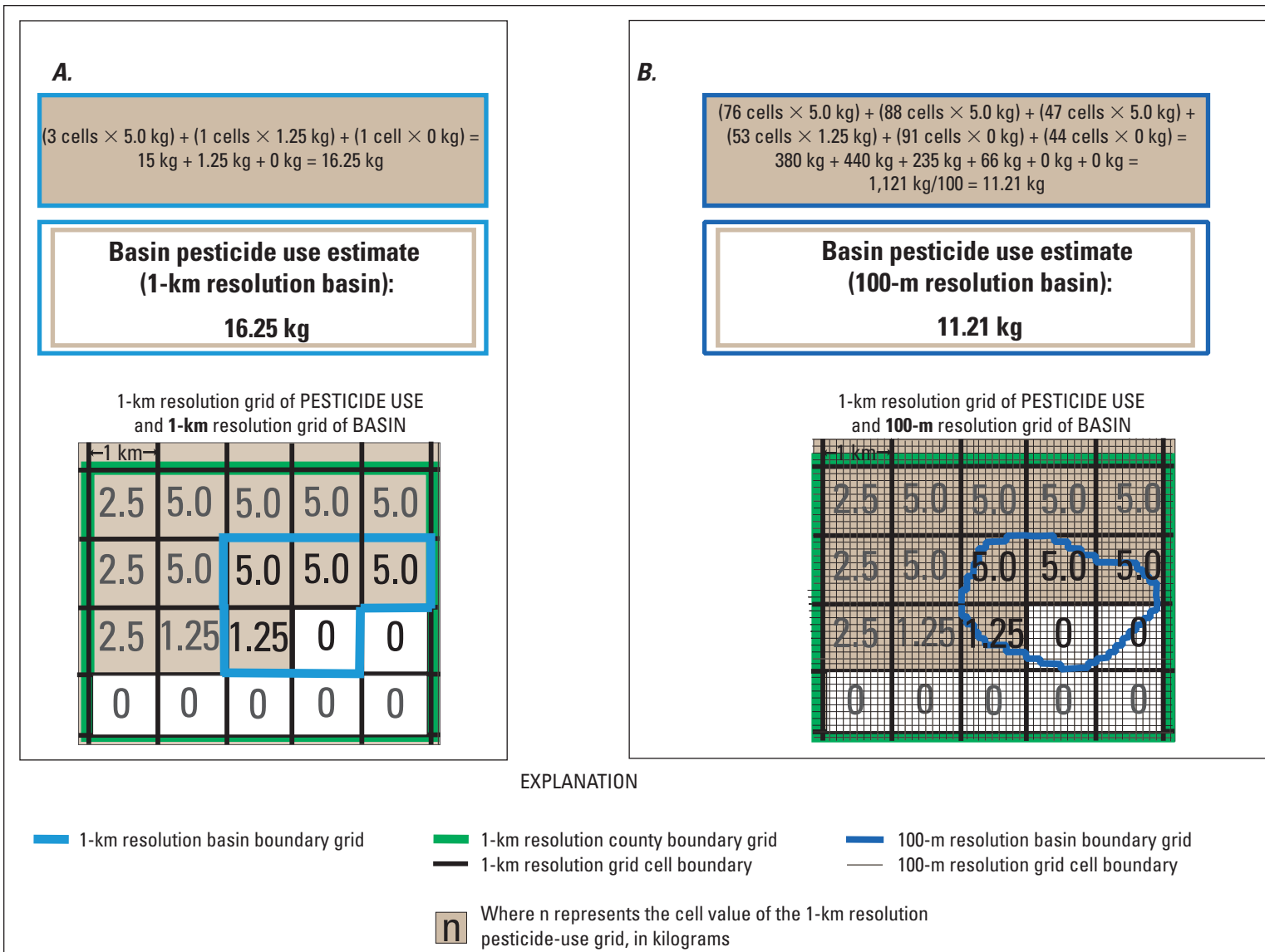
*Figure 9B* shows the computation of pesticide use for the same fictitious drainage basin shown in *figure 9A*, but this time overlaying a 100-m resolution version of the basin boundary with the same 1-km resolution pesticide grid. The basin pesticide use estimate derived from the 100-m resolution basin boundary overlaid with 1-km resolution pesticide use grid was 11.21 kg. The use value derived from applying the 100-m resolution basin boundary was lower because the drainage basin boundary was better defined and in this case, overlaps less area of 1-km cells of the pesticide use grid with values greater than zero. In this process, the geoprocessing resolution also was set to 100 m, which results in each 1-km pesticide use grid cell split into one hundred 100-m grid cells. Because each 100-m pesticide use grid cell inherited the value of the 1-km pesticide use grid cell, the sum of the 100-m pesticide grid

cell values within the watershed was divided by 100 to adjust to the correct basin pesticide use estimate (When a 50-m resolution basin boundary was used with the 1-km resolution pesticide use grid to estimate basin pesticide use, the sum of the 50-m pesticide grid cell values within the watershed was divided by 400 to adjust to the correct basin pesticide estimate.). The basin estimate in *figure 9B* is considered more precise than the basin estimate computed in *figure 9A* because of the refined spatial overlap of the drainage basin to the pesticide use grid.

## Basin Pesticide Use Estimated from the 30-Meter Resolution Land Cover Dataset

The overall method to estimate basin pesticide use derived from 30-m resolution land cover grids is conceptually similar to the technique used to estimate basin pesticide use derived from the 1-km resolution land cover grids; however, there are some distinct differences. Both methods were based on using the same (1) crop class framework, (2) land cover classifications, and (3) county data of pesticide use estimates by crop class. However, when basin pesticide estimates were derived from the 30-m resolution land cover grids, basin boundary polygon coverages were rasterized at the 30-m resolution, and the manner in which the county pesticide use was apportioned onto agricultural land differed. If the approach of apportioning county pesticide use onto agricultural land at the 1-km resolution was applied to agricultural land at the 30-m resolution, it would result in approximately 2,400 30-m resolution pesticide grids: 4 (number of quadrant grids per pesticide) multiplied by 3 (number of crop classes) multiplied by 200 (number of pesticides). The computer processing time and storage required to produce and manage such a large number of 30-m resolution grids would be prohibitive. Consequently, the apportionment of county pesticide use onto agricultural lands in the 30-m resolution NLCDe 92 was achieved, for the most part, outside the raster processing environment.

The only process that took place within the raster environment was the compilation of data necessary to compute the basin’s county “weighting factors,” or ratios that quantified the basin’s areal extent of agricultural land in each intersecting county. For example, a drainage basin that was classified 100 percent as “pasture/hay,” and had an area of 50 km<sup>2</sup> located within a single county of 5,000 km<sup>2</sup> consisting entirely of “pasture/hay,” had a county weighting factor for “pasture/hay” of 50/5,000, or 0.01. The basin’s county weighting factors were derived such that the basin pesticide use (for a crop class) could be computed by multiplying the basin’s county weighting factors by the county pesticide use estimates (by crop class) and summing the county apportioned pesticide use results. The NLCDe 92 quadrant grids, national county boundaries grid, and the basin boundary grids, all at the 30-m resolution, were used to produce the basin’s county weighting factors.



**Figure 9.** The process of estimating basin pesticide use derived from a 1-km resolution pesticide use grid, and a basin boundary grid at the 1-km resolution and 100-m resolution (using fictitious data). *A.* At the 1-km resolution. *B.* At the 100-km resolution.



The steps to estimate basin atrazine use on row crops, small-grain crops, and fallow land derived from the drainage basin boundaries, land cover, and county boundaries, all at the 30-m resolution with the county file of atrazine use by crop class, are illustrated in *figures 10A, 10B, and 10C* using fictitious data. This procedure can be summarized as follows: (1) determine the countywide number of 30-m resolution grid cells coded as “row crops,” “small grains,” or “fallow,” (2) determine the county number of 30-m grid cells coded as “row crops,” “small grains,” or “fallow” within the basin boundary, (3) compute the basin’s county weighting factors for the crop class “row crops, small-grain crops, and fallow land,” (4) calculate the within-basin apportioned amount of county atrazine use for this crop class and, if the basin falls in multiple counties, (5) sum the within-basin apportioned atrazine estimates computed for each intersecting county.

The first step was to determine the countywide number of 30-m grid cells coded as “row crops,” “small grains,” or “fallow” (*fig. 10A*, step 1). This step required the overlay of the 30-m resolution county boundary grid on the 30-m resolution land cover quadrant grids, resulting in a tabular file of counties and corresponding grid cell counts of each crop class (“row crops, small-grain crops, and fallow land,” “pasture and hay crops,” and “orchard and vineyard crops”) [23]. In the fictitious example shown in *figure 10*, county A (western county outlined by a bold green line) has 15 cells classified as “row crops,” “small grains,” or “fallow,” and county B (eastern county outlined by a bold green line) has 8 cells classified as “row crops,” “small grains,” or “fallow.”

The second step (*fig. 10A*, step 2) was to determine the county number of 30-m grid cells classified as “row crops,” “small grains,” or “fallow” within the basin boundary (outlined in a blue line in *fig. 10A*, step 1). First, the 30-m resolution land cover grid was overlaid with the 30-m resolution basin boundary grid to produce a 30-m resolution land cover grid of the basin [24]. Next, this basin land cover grid was overlaid with the 30-m resolution county boundary grid to determine the within-basin counts of grid cells coded as “row crops,” “small grains,” or “fallow” in each county. The map in *figure 10A*, step 1, shows that the basin has three grid cells classified as “row crops,” “small grains,” or “fallow” in county A and two grid cells classified as “row crops,” “small grains,” or “fallow” in county B.

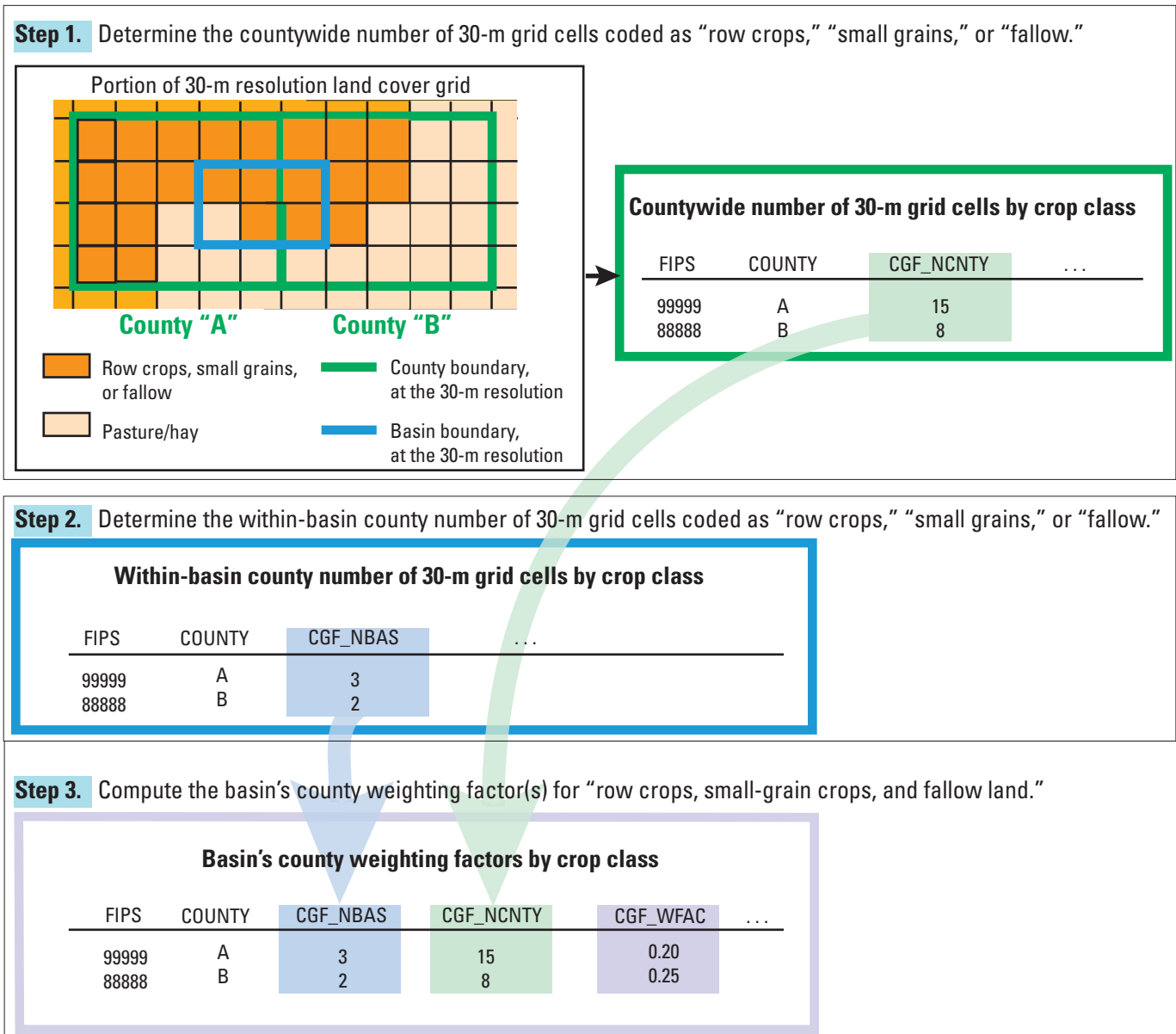
The third step was to compute the basin’s county weighting factors for the crop class “row crops, small-grain crops, and fallow land” (*fig. 10A*, step 3). A weighting factor for this crop class was computed for each county that intersected the basin. This weighting factor was calculated by dividing the within-basin number of grid cells coded as “row crops,” “small grains,” or “fallow” (as determined in step 2) by the countywide number of grid cells coded as “row crops,” “small grains,” or “fallow” (as determined in step 1). The county weighting factors for this basin corresponding to the crop class “row crops, small-grain crops, and fallow land” are  $3/15 = 0.20$  for county A and  $2/8 = 0.25$  for county B [25].

In step 4 (*fig. 10B*), the county-apportioned (within-basin) atrazine use applied on row crops, small-grain crops, and fallow land was calculated for each county that intersected the basin. The amount of atrazine applied to row crops, small-grain crops, and fallow land in county A was calculated by multiplying its weighting factor (0.20 from step 3) by countywide atrazine use by crop class (50 kg) to get the result (10 kg). Similarly, for county B, the amount of atrazine applied to row crops, small-grain crops, and fallow land was estimated as  $0.25 \times 100 \text{ kg} = 25 \text{ kg}$ . The basin estimate of atrazine use was the sum of all county-apportioned atrazine estimates determined in step 4. In the example (*fig. 10C*, step 5), the estimate of basin atrazine use on row crops, small-grain crops, and fallow land was calculated to be 35 kg (10 kg + 25 kg).

## Results

Estimates of atrazine use on row crops, small-grain crops, and fallow land for 150 watersheds derived from the 30-m resolution land cover data were compared with basin atrazine estimates derived from the 1-km resolution land cover data. Estimates of basin atrazine use applied on row crops, small-grain crops, and fallow land are hereinafter referred to as the “basin atrazine estimates.” Basin atrazine estimates that were derived from the 1992 county tabular file of atrazine use by crop class and the 1-km resolution grids of (1) drainage basin boundaries, (2) percentage of “row crops, small grains, and fallow,” and (3) 1990 county boundaries are referred to as “1-km basin atrazine estimates”; basin atrazine estimates that were derived from 50-m or 100-m resolution basin boundaries (depending on drainage area), the 1992 county tabular file of atrazine use by crop class, and the 1-km resolution grids of the percentage “row crops, small grains, and fallow” and 1990 county boundaries are referred to as “mixed resolution basin atrazine estimates”; and basin atrazine estimates that were derived from the 1992 county tabular file of atrazine use by crop class and the 30-m resolution grids of NLCD 92, 1990 county boundaries, and drainage basin boundaries are referred to as “30-m basin atrazine estimates.”

The 30-m and 1-km basin atrazine estimates are comparable (columns 4 and 5 of *table 4*, *fig. 11*). Scatter is not evident in the data when the results for all 150 drainage basins are plotted (*fig. 11A*). However, when the maximum values of the x- and y-axes are adjusted to show only drainage basins with basin atrazine estimates less than 1,000 kg (*fig. 11B*), a small amount of scatter can be observed. More scatter can be observed when the maximum values of the x- and y-axes are further reduced to show only basin atrazine estimates less than 100 kg (*fig. 11C*). Basin ID 02289034 in particular appears as an outlier.



**Figure 10.** Steps to estimate 30-m resolution basin atrazine use on crops associated with the crop class “row crops, small-grain crops, and fallow land” (using fictitious data). A. Steps 1–3. B. Step 4, and C. Step 5. The 30-m basin atrazine estimates were derived from the 1992 county tabular file of atrazine use estimates by crop class and the 30-m resolution grids of the (1) “enhanced” National Land Cover Data 1992 (NLCDe 92), (2) 1990 county boundaries, and (3) drainage basin boundaries. FIPS stores the unique 5-digit numeric code for a county; COUNTY stores the name of the county; CGF\_NCNTY stores the countywide number of 30-m grid cells classified as “row crops,” “small grains,” or “fallow”; CGF\_NBAS stores the within-basin county number of 30-m grid cells that are classified as “row crops,” “small grains,” or “fallow”; CGF\_WFAC stores the basin’s county weighting factor for the crop class, “row crops, small-grain crops, and fallow land”; CGF\_KG in step 4 stores the estimated amount of atrazine in kilograms per county applied to crops associated with the crop class “row crops, small-grain crops, and fallow land”; CGF\_APPKG stores the basin’s county apportioned atrazine use estimate on crops associated with the crop class “row crops, small-grain crops, and fallow land”; BASINID stores the basin’s unique identification number; BAS\_CGFKG in step 5 is the basin’s estimate of atrazine use on crops associated with the crop class “row crops, small-grain crops, and fallow land.”

**Step 4.** Calculate the within-basin county-apportioned amount of the atrazine use on crops associated with the crop class “row crops, small-grain crops, and fallow land.”

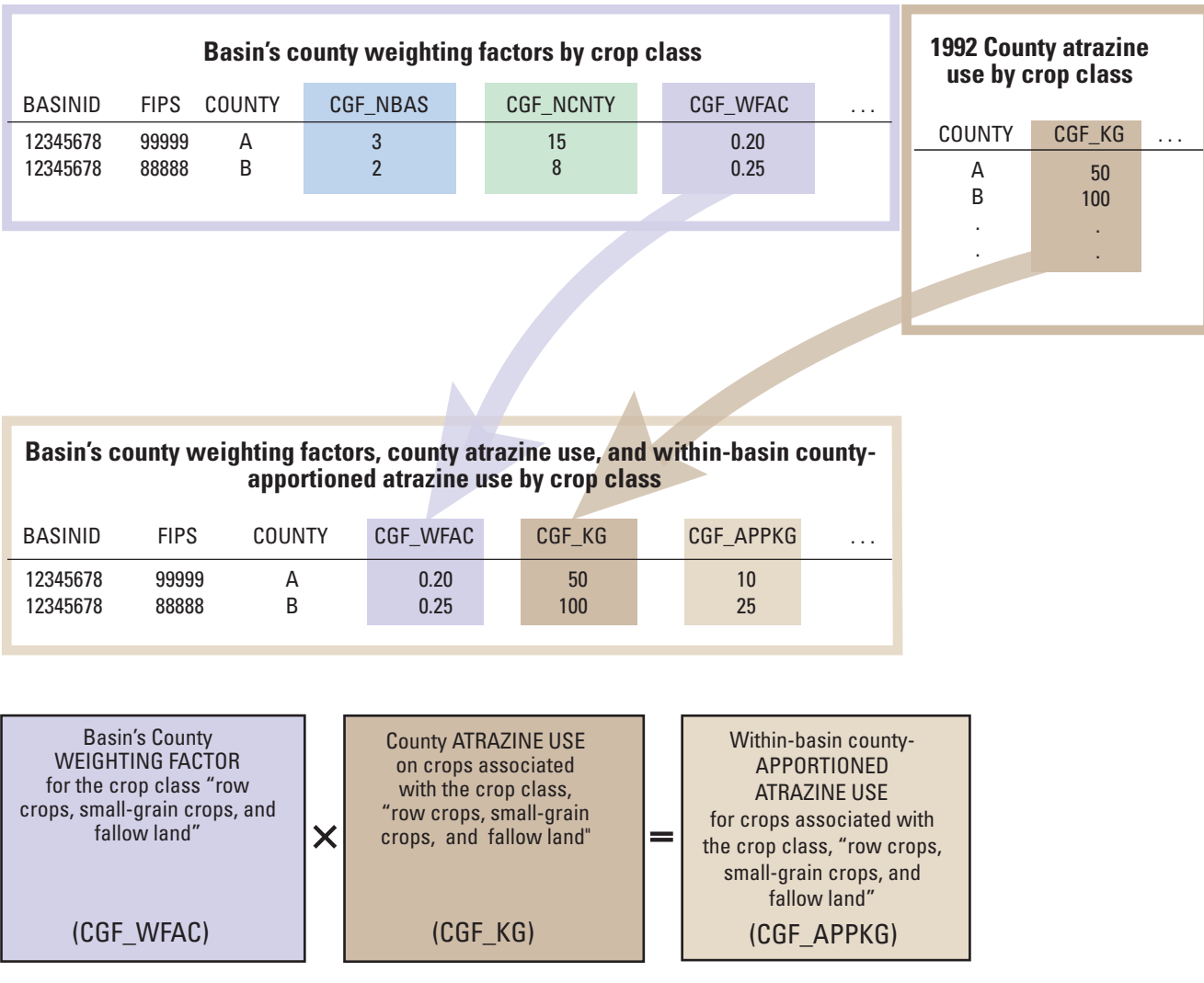
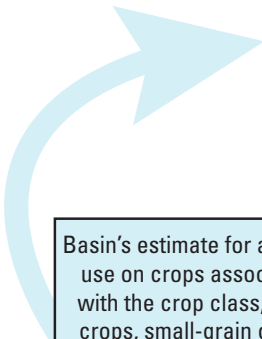


Figure 10. Continued.

**Step 5.** Sum the within-basin apportioned atrazine use estimates for “row crops, small grains, and fallow” to determine the estimate of basin atrazine use applied on “row crops, small grains, and fallow.”

Basin estimate of atrazine by crop class		
BASINID	BAS_CGFKG	...
12345678	35	



Basin’s estimate for atrazine use on crops associated with the crop class, “row crops, small-grain crops, and fallow land”  (BAS_CGFKG)	=	$\sum_{i=1}^n$	Within-basin county APPORTIONED ATRAZINE USE for crops associated with the crop class “row crops, small-grain crops, and fallow land”  (CGF_APPKG) FOR COUNTY # <i>i</i>	+	Within-basin county APPORTIONED ATRAZINE USE for crops associated with the crop class “row crops, small-grain crops, and fallow land”  (CGF_APPKG) FOR COUNTY # <i>i</i> +1	...	Within-basin county APPORTIONED ATRAZINE USE for crops associated with the crop class “row crops, small-grain crops, and fallow land”  (CGF_APPKG) FOR COUNTY # <i>n</i>
---	---	----------------	---	---	--	-----	---

*n* = number of counties the basin intersects

Figure 10. Continued.

**Table 4.** The 30-m, 1-km, and mixed resolution basin atrazine estimates on crops associated with the crop class, “row crops, small-grain crops, and fallow land,” and associated biases.

[The table shows the bias of 30-m and 1-km basin atrazine estimates, the bias of 30-m and mixed resolution basin atrazine estimates, the percentage bias of the 1-km and 30-m basin atrazine estimates, the use intensities of the 30-m and 1-km basin atrazine estimates, and the bias of the use intensities of the 30-m and 1-km basin atrazine estimates. The 30-m basin atrazine estimates were derived from the 1992 county tabular file of atrazine use estimates by crop class and 30-m resolution grids of the (1) “enhanced” National Land Cover Data 1992 (NLCD 92), (2) 1990 county boundaries, and (3) drainage basin boundaries; the 1-km basin atrazine estimates were derived from the 1992 county tabular file of atrazine use estimates by crop class and the 1-km resolution grids of the (1) percentage “row crops, small grains, and fallow,” (2) 1990 county boundaries, and (3) drainage basin boundaries; and the mixed resolution basin atrazine estimates were derived from 50-m or 100-m resolution drainage basin boundaries, the 1992 county tabular file of atrazine use estimates by crop class, and the 1-km resolution grids of percentage “row crops, small grains, and fallow” and 1990 county boundaries. Drainage area was calculated from the polygon coverage of the drainage basin. The mixed resolution basin atrazine estimates were computed only for drainage basins that were less than or equal to 1,000 km<sup>2</sup>. For basins larger than 1,000 km<sup>2</sup>, “n/a” is populated as the mixed resolution basin atrazine estimate. Basin boundary cell resolutions are shown in column 2 as a: the 30-m, 1-km, and 50-m resolutions; b: the 30-m, 1-km, and 100-m resolutions; and c: the 30-m and 1-km resolutions. km<sup>2</sup>, square kilometer; kg, kilogram; kg/km<sup>2</sup>, kilogram per square kilometer; m, meter; n/a, not applicable; NLCD 92, enhanced National Land Cover Data 1992]

1	2	3	4	5	6	7	8	9	10	11	12
Basin identification number	Basin boundary cell resolutions that were applied	Drainage area (km <sup>2</sup> )	30-m basin atrazine estimates (kg)	1-km basin atrazine estimates (kg)	Mixed-resolution basin atrazine estimates (kg)	Bias of 1-km and 30-m basin atrazine estimates (kg)	Bias of mixed and 30-m basin atrazine estimates (kg)	Percentage bias of 1-km and 30-m basin atrazine estimates	Use intensity of 30-m basin atrazine estimates (kg/km <sup>2</sup> )	Use intensity of 1-km basin atrazine estimates (kg/km <sup>2</sup> )	Bias of use intensity of 1-km and 30-m basin atrazine estimates (kg/km <sup>2</sup> )
01493112	a	17	860	859	894	-1	34	-0.12	50.59	50.53	-0.06
01573095	a	20	496	448	475	-48	-21	-9.68	24.80	22.40	-2.40
02326838	a	25	3	4	3	1	0	33.33	0.12	0.16	0.04
11274538	b	28	38	38	38	0	0	0.00	1.36	1.36	0.00
01571490	b	33	268	257	240	-11	-28	-4.10	8.12	7.79	-0.33
02082731	b	35	25	27	26	2	1	8.00	0.71	0.77	0.06
09153290	b	36	259	254	258	-5	-1	-1.93	7.19	7.06	-0.14
01410784	b	39	42	40	42	-2	0	-4.76	1.08	1.03	-0.05
14201300	b	39	339	330	328	-9	-11	-2.65	8.69	8.46	-0.23
01356190	b	40	42	32	38	-10	-4	-23.81	1.05	0.80	-0.25
02172300	b	40	33	29	35	-4	2	-12.12	0.83	0.73	-0.10
02083833	b	44	266	271	283	5	17	1.88	6.05	6.16	0.11
39394408	b	52	307	297	317	-10	10	-3.26	5.90	5.71	-0.19
02087580	b	54	7	7	7	0	0	0.00	0.13	0.13	0.00
02084557	b	56	49	50	58	1	9	2.04	0.88	0.89	0.02
02174250	b	62	590	596	592	6	2	1.02	9.52	9.61	0.10
02423547	b	66	11	11	11	0	0	0.00	0.17	0.17	0.00
08049240	b	69	11	12	12	1	1	9.09	0.16	0.17	0.01
03049646	b	70	92	96	93	4	1	4.35	1.31	1.37	0.06
01464907	b	72	443	434	437	-9	-6	-2.03	6.15	6.03	-0.13
02289034	b	73	102	144	287	42	185	41.18	1.40	1.97	0.58
05288705	b	73	10	14	13	4	3	40.00	0.14	0.19	0.05
29574009	b	75	125	121	124	-4	-1	-3.20	1.67	1.61	-0.05
03574796	b	76	878	872	892	-6	14	-0.68	11.55	11.47	-0.08
01095220	b	79	80	71	77	-9	-3	-11.25	1.01	0.90	-0.11
07031692	b	79	42	37	38	-5	-4	-11.90	0.53	0.47	-0.06

**Table 4.** The 30-m, 1-km, and mixed resolution basin atrazine estimates on crops associated with the crop class, “row crops, small-grain crops, and fallow land,” and associated biases—*Continued*.

[The table shows the bias of 30-m and 1-km basin atrazine estimates, the bias of 30-m and mixed resolution basin atrazine estimates, the percentage bias of the 1-km and 30-m basin atrazine estimates, the use intensities of the 30-m and 1-km basin atrazine estimates, and the bias of the use intensities of the 30-m and 1-km basin atrazine estimates. The 30-m basin atrazine estimates were derived from the 1992 county tabular file of atrazine use estimates by crop class and 30-m resolution grids of the (1) “enhanced” National Land Cover Data 1992 (NLCD 92), (2) 1990 county boundaries, and (3) drainage basin boundaries; the 1-km basin atrazine estimates were derived from the 1992 county tabular file of atrazine use estimates by crop class and the 1-km resolution grids of the (1) percentage “row crops, small grains, and fallow,” (2) 1990 county boundaries, and (3) drainage basin boundaries; and the mixed resolution basin atrazine estimates were derived from 50-m or 100-m resolution drainage basin boundaries, the 1992 county tabular file of atrazine use estimates by crop class, and the 1-km resolution grids of percentage “row crops, small grains, and fallow” and 1990 county boundaries. Drainage area was calculated from the polygon coverage of the drainage basin. The mixed resolution basin atrazine estimates were computed only for drainage basins that were less than or equal to 1,000 km<sup>2</sup>.

For basins larger than 1,000 km<sup>2</sup>, “n/a” is populated as the mixed resolution basin atrazine estimate. Basin boundary cell resolutions are shown in column 2 as a: the 30-m, 1-km, and 50-m resolutions; b: the 30-m, 1-km, and 100-m resolutions; and c: the 30-m and 1-km resolutions. km<sup>2</sup>, square kilometer; kg, kilogram; kg/km<sup>2</sup>, kilogram per square kilometer; m, meter; n/a, not applicable; NLCD 92, enhanced National Land Cover Data 1992]

1	2	3	4	5	6	7	8	9	10	11	12
Basin identification number	Basin boundary cell resolutions that were applied	Drainage area (km <sup>2</sup> )	30-m basin atrazine estimates (kg)	1-km basin atrazine estimates (kg)	Mixed-resolution basin atrazine estimates (kg)	Bias of 1-km and 30-m basin atrazine estimates (kg)	Bias of mixed and 30-m basin atrazine estimates (kg)	Percentage bias of 1-km and 30-m basin atrazine estimates	Use intensity of 30-m basin atrazine estimates (kg/km <sup>2</sup> )	Use intensity of 1-km basin atrazine estimates (kg/km <sup>2</sup> )	Bias of use intensity of 1-km and 30-m basin atrazine estimates (kg/km <sup>2</sup> )
14206950	b	80	12	9	10	-3	-2	-25.00	0.15	0.11	-0.04
01209710	b	85	10	10	10	0	0	0.00	0.12	0.12	0.00
03373530	b	90	2,572	2,570	2,549	-2	-23	-0.08	28.58	28.56	-0.02
12212100	b	99	87	86	91	-1	4	-1.15	0.88	0.87	-0.01
06923150	b	106	71	69	70	-2	-1	-2.82	0.67	0.65	-0.02
01170100	b	107	64	71	69	7	5	10.94	0.60	0.66	0.07
29434909	b	112	18	14	17	-4	-1	-22.22	0.16	0.13	-0.04
01401000	b	115	220	210	211	-10	-9	-4.55	1.91	1.83	-0.09
01555400	b	116	2,211	2,248	2,205	37	-6	1.67	19.06	19.38	0.32
01403900	b	126	14	11	11	-3	-3	-21.43	0.11	0.09	-0.02
25241408	b	132	407	390	405	-17	-2	-4.18	3.08	2.95	-0.13
04086307	b	133	1,184	1,182	1,188	-2	4	-0.17	8.90	8.89	-0.02
02444490	b	136	1,474	1,476	1,470	2	-4	0.14	10.84	10.85	0.01
01576540	b	141	4,117	4,034	4,088	-83	-29	-2.02	29.20	28.61	-0.59
12472380	b	146	277	282	271	5	-6	1.81	1.90	1.93	0.03
01472157	b	152	884	908	908	24	24	2.71	5.82	5.97	0.16
02169570	b	154	104	103	106	-1	2	-0.96	0.68	0.67	-0.01
01349150	b	155	682	671	674	-11	-8	-1.61	4.40	4.33	-0.07
12505450	b	160	140	135	140	-5	0	-3.57	0.88	0.84	-0.03
02350080	b	161	1,792	1,819	1,807	27	15	1.51	11.13	11.30	0.17
01362200	b	169	32	27	27	-5	-5	-15.63	0.19	0.16	-0.03
02143500	b	181	277	275	276	-2	-1	-0.72	1.53	1.52	-0.01
01470779	b	185	5,531	5,482	5,513	-49	-18	-0.89	29.90	29.63	-0.26
02084558	b	191	1,774	1,775	1,797	1	23	0.06	9.29	9.29	0.01
03466208	b	205	1,345	1,376	1,338	31	-7	2.30	6.56	6.71	0.15
02356980	b	273	2,603	2,583	2,591	-20	-12	-0.77	9.53	9.46	-0.07

**Table 4.** The 30-m, 1-km, and mixed resolution basin atrazine estimates on crops associated with the crop class, “row crops, small-grain crops, and fallow land,” and associated biases—*Continued*.

[The table shows the bias of 30-m and 1-km basin atrazine estimates, the bias of 30-m and mixed resolution basin atrazine estimates, the percentage bias of the 1-km and 30-m basin atrazine estimates, the use intensities of the 30-m and 1-km basin atrazine estimates, and the bias of the use intensities of the 30-m and 1-km basin atrazine estimates. The 30-m basin atrazine estimates were derived from the 1992 county tabular file of atrazine use estimates by crop class and 30-m resolution grids of the (1) “enhanced” National Land Cover Data 1992 (NLCDe 92), (2) 1990 county boundaries, and (3) drainage basin boundaries; the 1-km basin atrazine estimates were derived from the 1992 county tabular file of atrazine use estimates by crop class and the 1-km resolution grids of the (1) percentage “row crops, small grains, and fallow,” (2) 1990 county boundaries, and (3) drainage basin boundaries; and the mixed resolution basin atrazine estimates were derived from 50-m or 100-m resolution drainage basin boundaries, the 1992 county tabular file of atrazine use estimates by crop class, and the 1-km resolution grids of percentage “row crops, small grains, and fallow” and 1990 county boundaries. Drainage area was calculated from the polygon coverage of the drainage basin. The mixed resolution basin atrazine estimates were computed only for drainage basins that were less than or equal to 1,000 km<sup>2</sup>. For basins larger than 1,000 km<sup>2</sup>, “n/a” is populated as the mixed resolution basin atrazine estimate. Basin boundary cell resolutions are shown in column 2 as a: the 30-m, 1-km, and 50-m resolutions; b: the 30-m, 1-km, and 100-m resolutions; and c: the 30-m and 1-km resolutions. km<sup>2</sup>, square kilometer; kg, kilogram; kg/km<sup>2</sup>, kilogram per square kilometer; m, meter; n/a, not applicable; NLCDe 92, enhanced National Land Cover Data 1992]

1	2	3	4	5	6	7	8	9	10	11	12
Basin identification number	Basin boundary cell resolutions that were applied	Drainage area (km <sup>2</sup> )	30-m basin atrazine estimates (kg)	1-km basin atrazine estimates (kg)	Mixed-resolution basin atrazine estimates (kg)	Bias of 1-km and 30-m basin atrazine estimates (kg)	Bias of mixed and 30-m basin atrazine estimates (kg)	Percentage bias of 1-km and 30-m basin atrazine estimates	Use intensity of 30-m basin atrazine estimates (kg/km <sup>2</sup> )	Use intensity of 1-km basin atrazine estimates (kg/km <sup>2</sup> )	Bias of use intensity of 1-km and 30-m basin atrazine estimates (kg/km <sup>2</sup> )
03526000	b	277	108	116	115	8	7	7.41	0.39	0.42	0.03
04072150	b	281	3,822	3,854	3,843	32	21	0.84	13.60	13.72	0.11
05531500	b	291	86	78	86	-8	0	-9.30	0.30	0.27	-0.03
07381440	b	305	5,736	5,766	5,698	30	-38	0.52	18.81	18.90	0.10
04175600	b	331	4,758	4,764	4,750	6	-8	0.13	14.37	14.39	0.02
02317797	b	335	2,236	2,240	2,211	4	-25	0.18	6.67	6.69	0.01
05320270	b	336	5,065	5,110	5,059	45	-6	0.89	15.07	15.21	0.13
12500420	b	353	146	142	145	-4	-1	-2.74	0.41	0.40	-0.01
04063700	b	363	18	16	16	-2	-2	-11.11	0.05	0.04	-0.01
07375050	b	366	451	477	466	26	15	5.76	1.23	1.30	0.07
08010000	b	369	1,716	1,740	1,742	24	26	1.40	4.65	4.72	0.07
12473740	b	377	36	38	39	2	3	5.56	0.10	0.10	0.01
02215100	b	420	1,040	1,036	1,035	-4	-5	-0.38	2.48	2.47	-0.01
03539778	b	441	621	608	648	-13	27	-2.09	1.41	1.38	-0.03
09149480	b	448	331	317	329	-14	-2	-4.23	0.74	0.71	-0.03
01639000	b	457	2,956	2,930	2,934	-26	-22	-0.88	6.47	6.41	-0.06
08178800	b	506	52	50	49	-2	-3	-3.85	0.10	0.10	-0.00
05455100	b	522	11,917	11,815	11,846	-102	-71	-0.86	22.83	22.63	-0.20
07030392	b	543	2,562	2,562	2,550	0	-12	0.00	4.72	4.72	0.00
05085900	b	566	204	218	215	14	11	6.86	0.36	0.39	0.02
10102200	b	577	122	123	123	1	1	0.82	0.21	0.21	0.00
05451210	b	581	17,210	17,212	17,184	2	-26	0.01	29.62	29.62	0.00
13092747	b	623	107	108	107	1	0	0.93	0.17	0.17	0.00
05082625	b	658	44	44	44	0	0	0.00	0.07	0.07	0.00
03167000	b	669	1,428	1,446	1,451	18	23	1.26	2.13	2.16	0.03
01104615	b	695	224	225	225	1	1	0.45	0.32	0.32	0.00

**Table 4.** The 30-m, 1-km, and mixed resolution basin atrazine estimates on crops associated with the crop class, “row crops, small-grain crops, and fallow land,” and associated biases—*Continued.*

[The table shows the bias of 30-m and 1-km basin atrazine estimates, the bias of 30-m and mixed resolution basin atrazine estimates, the percentage bias of the 1-km and 30-m basin atrazine estimates, the use intensities of the 30-m and 1-km basin atrazine estimates, and the bias of the use intensities of the 30-m and 1-km basin atrazine estimates. The 30-m basin atrazine estimates were derived from the 1992 county tabular file of atrazine use estimates by crop class and 30-m resolution grids of the (1) “enhanced” National Land Cover Data 1992 (NLCDe 92), (2) 1990 county boundaries, and (3) drainage basin boundaries; the 1-km basin atrazine estimates were derived from the 1992 county tabular file of atrazine use estimates by crop class and the 1-km resolution grids of the (1) percentage “row crops, small grains, and fallow,” (2) 1990 county boundaries, and (3) drainage basin boundaries; and the mixed resolution basin atrazine estimates were derived from 50-m or 100-m resolution drainage basin boundaries, the 1992 county tabular file of atrazine use estimates by crop class, and the 1-km resolution grids of percentage “row crops, small grains, and fallow” and 1990 county boundaries. Drainage area was calculated from the polygon coverage of the drainage basin. The mixed resolution basin atrazine estimates were computed only for drainage basins that were less than or equal to 1,000 km<sup>2</sup>. For basins larger than 1,000 km<sup>2</sup>, “n/a” is populated as the mixed resolution basin atrazine estimate. Basin boundary cell resolutions are shown in column 2 as a: the 30-m, 1-km, and 50-m resolutions; b: the 30-m, 1-km, and 100-m resolutions; and c: the 30-m and 1-km resolutions. km<sup>2</sup>, square kilometer; kg, kilogram; kg/km<sup>2</sup>, kilogram per square kilometer; m, meter; n/a, not applicable; NLCDe 92, enhanced National Land Cover Data 1992]

1	2	3	4	5	6	7	8	9	10	11	12
Basin identification number	Basin boundary cell resolutions that were applied	Drainage area (km <sup>2</sup> )	30-m basin atrazine estimates (kg)	1-km basin atrazine estimates (kg)	Mixed-resolution basin atrazine estimates (kg)	Bias of 1-km and 30-m basin atrazine estimates (kg)	Bias of mixed and 30-m basin atrazine estimates (kg)	Percentage bias of 1-km and 30-m basin atrazine estimates	Use intensity of 30-m basin atrazine estimates (kg/km <sup>2</sup> )	Use intensity of 1-km basin atrazine estimates (kg/km <sup>2</sup> )	Bias of use intensity of 1-km and 30-m basin atrazine estimates (kg/km <sup>2</sup> )
07369500	b	721	8,553	8,427	8,492	-126	-61	-1.47	11.86	11.69	-0.17
03366500	b	755	12,336	12,441	12,328	105	-8	0.85	16.34	16.48	0.14
06795500	b	762	38,710	38,921	38,758	211	48	0.55	50.80	51.08	0.28
08012470	b	767	956	972	963	16	7	1.67	1.25	1.27	0.02
05464220	b	775	23,119	22,941	23,079	-178	-40	-0.77	29.83	29.60	-0.23
08051500	b	785	951	959	964	8	13	0.84	1.21	1.22	0.01
03170000	b	795	1,434	1,441	1,433	7	-1	0.49	1.80	1.81	0.01
04161820	b	803	1,673	1,656	1,666	-17	-7	-1.02	2.08	2.06	-0.02
02281200	b	806	175,559	174,952	175,020	-607	-539	-0.35	217.82	217.06	-0.75
04186500	b	858	23,005	22,907	22,999	-98	-6	-0.43	26.81	26.70	-0.11
01382000	b	936	412	420	413	8	1	1.94	0.44	0.45	0.01
06800000	b	955	38,049	38,052	37,854	3	-195	0.01	39.84	39.84	0.00
03575100	b	969	8,315	8,303	8,232	-12	-83	-0.14	8.58	8.57	-0.01
08195000	c	1,028	125	124	n/a	-1	n/a	-0.80	0.12	0.12	-0.00
05449500	c	1,084	31,134	30,972	n/a	-162	n/a	-0.52	28.72	28.57	-0.15
07043500	c	1,144	37,842	37,538	n/a	-304	n/a	-0.80	33.08	32.81	-0.27
05525500	c	1,159	52,262	52,101	n/a	-161	n/a	-0.31	45.09	44.95	-0.14
12113390	c	1,194	20	21	n/a	1	n/a	5.00	0.02	0.02	0.00
04159492	c	1,198	20,321	20,400	n/a	79	n/a	0.39	16.96	17.03	0.07
14202000	c	1,261	3,990	4,025	n/a	35	n/a	0.88	3.16	3.19	0.03
07288650	c	1,301	1,224	1,221	n/a	-3	n/a	-0.25	0.94	0.94	-0.00
08014500	c	1,305	55	54	n/a	-1	n/a	-1.82	0.04	0.04	-0.00
05572000	c	1,426	53,487	53,237	n/a	-250	n/a	-0.47	37.51	37.33	-0.18
04211820	c	1,431	8,912	8,944	n/a	32	n/a	0.36	6.23	6.25	0.02
04178000	c	1,600	29,379	29,530	n/a	151	n/a	0.51	18.36	18.46	0.09
05455570	c	1,622	34,717	34,583	n/a	-134	n/a	-0.39	21.40	21.32	-0.08



**Table 4.** The 30-m, 1-km, and mixed resolution basin atrazine estimates on crops associated with the crop class, “row crops, small-grain crops, and fallow land,” and associated biases—*Continued*.

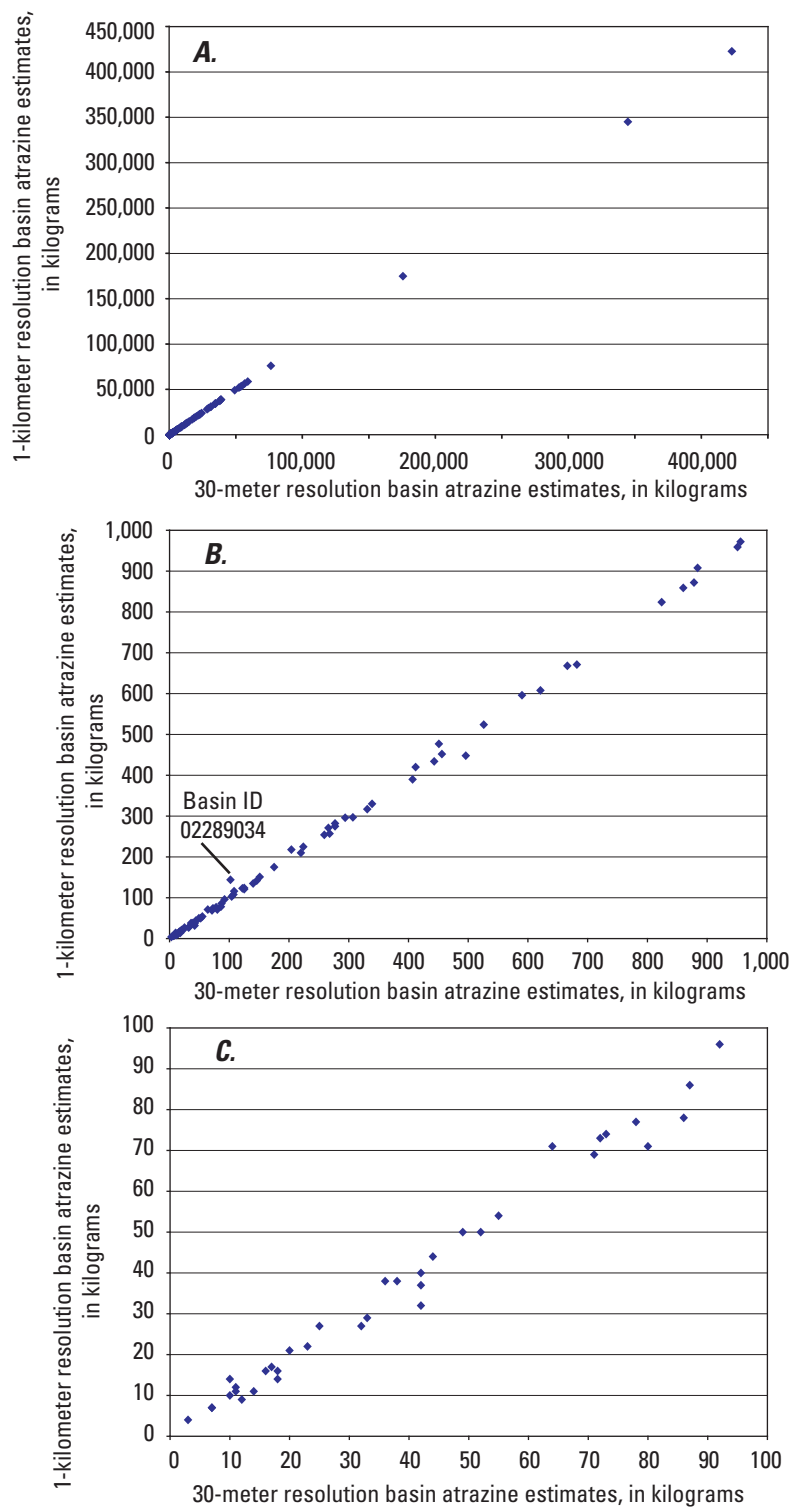
[The table shows the bias of 30-m and 1-km basin atrazine estimates, the bias of 30-m and mixed resolution basin atrazine estimates, the percentage bias of the 1-km and 30-m basin atrazine estimates, the use intensities of the 30-m and 1-km basin atrazine estimates, and the bias of the use intensities of the 30-m and 1-km basin atrazine estimates. The 30-m basin atrazine estimates were derived from the 1992 county tabular file of atrazine use estimates by crop class and 30-m resolution grids of the (1) “enhanced” National Land Cover Data 1992 (NLCDe 92), (2) 1990 county boundaries, and (3) drainage basin boundaries; the 1-km basin atrazine estimates were derived from the 1992 county tabular file of atrazine use estimates by crop class and the 1-km resolution grids of the (1) percentage “row crops, small grains, and fallow,” (2) 1990 county boundaries, and (3) drainage basin boundaries; and the mixed resolution basin atrazine estimates were derived from 50-m or 100-m resolution drainage basin boundaries, the 1992 county tabular file of atrazine use estimates by crop class, and the 1-km resolution grids of percentage “row crops, small grains, and fallow” and 1990 county boundaries. Drainage area was calculated from the polygon coverage of the drainage basin. The mixed resolution basin atrazine estimates were computed only for drainage basins that were less than or equal to 1,000 km<sup>2</sup>. For basins larger than 1,000 km<sup>2</sup>, “n/a” is populated as the mixed resolution basin atrazine estimate. Basin boundary cell resolutions are shown in column 2 as a: the 30-m, 1-km, and 50-m resolutions; b: the 30-m, 1-km, and 100-m resolutions; and c: the 30-m and 1-km resolutions. km<sup>2</sup>, square kilometer; kg, kilogram; kg/km<sup>2</sup>, kilogram per square kilometer; m, meter; n/a, not applicable; NLCDe 92, enhanced National Land Cover Data 1992]

1	2	3	4	5	6	7	8	9	10	11	12
Basin identification number	Basin boundary cell resolutions that were applied	Drainage area (km <sup>2</sup> )	30-m basin atrazine estimates (kg)	1-km basin atrazine estimates (kg)	Mixed-resolution basin atrazine estimates (kg)	Bias of 1-km and 30-m basin atrazine estimates (kg)	Bias of mixed and 30-m basin atrazine estimates (kg)	Percentage bias of 1-km and 30-m basin atrazine estimates	Use intensity of 30-m basin atrazine estimates (kg/km <sup>2</sup> )	Use intensity of 1-km basin atrazine estimates (kg/km <sup>2</sup> )	Bias of use intensity of 1-km and 30-m basin atrazine estimates (kg/km <sup>2</sup> )
05532500	c	1,634	8,615	8,642	n/a	27	n/a	0.31	5.27	5.29	0.02
05584500	c	1,696	49,122	49,195	n/a	73	n/a	0.15	28.96	29.01	0.04
04087000	c	1,804	14,895	14,885	n/a	-10	n/a	-0.07	8.26	8.25	-0.01
02091500	c	1,909	9,084	9,054	n/a	-30	n/a	-0.33	4.76	4.74	-0.02
12213140	c	2,024	456	452	n/a	-4	n/a	-0.88	0.23	0.22	-0.00
04208504	c	2,044	5,392	5,381	n/a	-11	n/a	-0.20	2.64	2.63	-0.01
01403300	c	2,074	11,243	11,126	n/a	-117	n/a	-1.04	5.42	5.36	-0.06
13055000	c	2,294	23	22	n/a	-1	n/a	-4.35	0.01	0.01	-0.00
02424000	c	2,657	294	296	n/a	2	n/a	0.68	0.11	0.11	0.00
07381467	c	3,171	54,413	53,911	n/a	-502	n/a	-0.92	17.16	17.00	-0.16
09471000	c	3,257	7	7	n/a	0	n/a	0.00	0.00	0.00	0.00
11391100	c	3,400	175	175	n/a	0	n/a	0.00	0.05	0.05	0.00
02296750	c	3,436	17	17	n/a	0	n/a	0.00	0.00	0.00	0.00
08012150	c	3,576	13,053	13,015	n/a	-38	n/a	-0.29	3.65	3.64	-0.01
11074000	c	3,727	72	73	n/a	1	n/a	1.39	0.02	0.02	0.00
02318500	c	3,864	28,353	28,354	n/a	1	n/a	0.00	7.34	7.34	0.00
11075610	c	3,868	73	74	n/a	1	n/a	1.37	0.02	0.02	0.00
09517000	c	3,967	78	77	n/a	-1	n/a	-1.28	0.02	0.02	-0.00
11390890	c	4,258	526	524	n/a	-2	n/a	-0.38	0.12	0.12	-0.00
03467609	c	4,373	9,257	9,270	n/a	13	n/a	0.14	2.12	2.12	0.00
01474500	c	4,896	38,805	38,820	n/a	15	n/a	0.04	7.93	7.93	0.00
06208500	c	5,238	151	151	n/a	0	n/a	0.00	0.03	0.03	0.00
02083500	c	5,754	6,840	6,874	n/a	34	n/a	0.50	1.19	1.19	0.01
02338000	c	6,245	1,982	1,973	n/a	-9	n/a	-0.45	0.32	0.32	-0.00
13351000	c	6,380	16	16	n/a	0	n/a	0.00	0.00	0.00	0.00

**Table 4.** The 30-m, 1-km, and mixed resolution basin atrazine estimates on crops associated with the crop class, “row crops, small-grain crops, and fallow land,” and associated biases—*Continued*.

[The table shows the bias of 30-m and 1-km basin atrazine estimates, the bias of 30-m and mixed resolution basin atrazine estimates, the percentage bias of the 1-km and 30-m basin atrazine estimates, the use intensities of the 30-m and 1-km basin atrazine estimates, and the bias of the use intensities of the 30-m and 1-km basin atrazine estimates. The 30-m basin atrazine estimates were derived from the 1992 county tabular file of atrazine use estimates by crop class and 30-m resolution grids of the (1) “enhanced” National Land Cover Data 1992 (NLCDe 92), (2) 1990 county boundaries, and (3) drainage basin boundaries; the 1-km basin atrazine estimates were derived from the 1992 county tabular file of atrazine use estimates by crop class and the 1-km resolution grids of the (1) percentage “row crops, small grains, and fallow,” (2) 1990 county boundaries, and (3) drainage basin boundaries; and the mixed resolution basin atrazine estimates were derived from 50-m or 100-m resolution drainage basin boundaries, the 1992 county tabular file of atrazine use estimates by crop class, and the 1-km resolution grids of percentage “row crops, small grains, and fallow” and 1990 county boundaries. Drainage area was calculated from the polygon coverage of the drainage basin. The mixed resolution basin atrazine estimates were computed only for drainage basins that were less than or equal to 1,000 km<sup>2</sup>. For basins larger than 1,000 km<sup>2</sup>, “n/a” is populated as the mixed resolution basin atrazine estimate. Basin boundary cell resolutions are shown in column 2 as a: the 30-m, 1-km, and 50-m resolutions; b: the 30-m, 1-km, and 100-m resolutions; and c: the 30-m and 1-km resolutions. km<sup>2</sup>, square kilometer; kg, kilogram; kg/km<sup>2</sup>, kilogram per square kilometer; m, meter; n/a, not applicable; NLCDe 92, enhanced National Land Cover Data 1992]

1	2	3	4	5	6	7	8	9	10	11	12
Basin identification number	Basin boundary cell resolutions that were applied	Drainage area (km <sup>2</sup> )	30-m basin atrazine estimates (kg)	1-km basin atrazine estimates (kg)	Mixed-resolution basin atrazine estimates (kg)	Bias of 1-km and 30-m basin atrazine estimates (kg)	Bias of mixed and 30-m basin atrazine estimates (kg)	Percentage bias of 1-km and 30-m basin atrazine estimates	Use intensity of 30-m basin atrazine estimates (kg/km <sup>2</sup> )	Use intensity of 1-km basin atrazine estimates (kg/km <sup>2</sup> )	Bias of use intensity of 1-km and 30-m basin atrazine estimates (kg/km <sup>2</sup> )
02089500	c	7,022	13,456	13,428	n/a	-28	n/a	-0.21	1.92	1.91	-0.00
02175000	c	7,077	34,616	34,634	n/a	18	n/a	0.05	4.89	4.89	0.00
01636500	c	7,880	34,280	34,296	n/a	16	n/a	0.05	4.35	4.35	0.00
10171000	c	9,096	1,445	1,418	n/a	-27	n/a	-1.87	0.16	0.16	-0.00
01357500	c	9,113	24,174	24,098	n/a	-76	n/a	-0.31	2.65	2.64	-0.01
01100000	c	11,983	6,204	6,199	n/a	-5	n/a	-0.08	0.52	0.52	-0.00
12510500	c	14,536	3,733	3,728	n/a	-5	n/a	-0.13	0.26	0.26	-0.00
08057410	c	16,273	18,816	18,956	n/a	140	n/a	0.74	1.16	1.16	0.01
04193500	c	16,409	422,780	422,739	n/a	-41	n/a	-0.01	25.77	25.76	-0.00
01463500	c	17,580	56,578	56,593	n/a	15	n/a	0.03	3.22	3.22	0.00
01184000	c	25,049	21,774	21,776	n/a	2	n/a	0.01	0.87	0.87	0.00
14211720	c	28,937	22,462	22,470	n/a	8	n/a	0.04	0.78	0.78	0.00
03201300	c	30,628	18,418	18,437	n/a	19	n/a	0.10	0.60	0.60	0.00
07288955	c	34,850	76,281	76,124	n/a	-157	n/a	-0.21	2.19	2.18	-0.00
06279500	c	40,825	666	668	n/a	2	n/a	0.30	0.02	0.02	0.00
02469762	c	47,833	58,911	58,878	n/a	-33	n/a	-0.06	1.23	1.23	-0.00
02429500	c	56,921	31,140	31,094	n/a	-46	n/a	-0.15	0.55	0.55	-0.00
11447650	c	61,720	1,060	1,063	n/a	3	n/a	0.28	0.02	0.02	0.00
01578310	c	70,182	344,691	345,050	n/a	359	n/a	0.10	4.91	4.92	0.01
08364000	c	77,556	824	824	n/a	0	n/a	0.00	0.01	0.01	0.00
13154500	c	92,942	4,889	4,888	n/a	-1	n/a	-0.02	0.05	0.05	0.00



**Figure 11.** Comparison of 30-m basin atrazine estimates in relation to the 1-km basin atrazine estimates. *A.* For the entire set of 150 drainage basins. *B.* For drainage basins with use estimates less than 1,000 kg. *C.* For drainage basins with use estimates less than 100 kg. The 30-m basin atrazine estimates were derived from the 1992 county tabular file of atrazine use estimates by crop class and the 30-m resolution grids of the (1) “enhanced” National Land Cover Data 1992 (NLCDe 92), (2) 1990 county boundaries, and (3) drainage basin boundaries; the 1-km basin atrazine estimates were derived from the 1992 county tabular file of atrazine use estimates by crop class and the 1-km resolution grids of (1) percentage “row crops, small grains, and fallow,” (2) 1990 county boundaries, (3) and drainage basin boundaries.

The outlier shown in *figure 11B*, basin ID 02289034, is a drainage basin in southern Florida [26]. The 30-m and 1-km basin atrazine estimates for this site are 102 and 144 kg, respectively. A map of this watershed (*fig. 12*) illustrates the conditions that lead to the outlier. *Figure 12* shows the basin boundary drawn at the 30-m and 1-km resolutions, the “row crops,” “small grains,” and “fallow” areas colored at the 30-m resolution, and cell values of the 1-km resolution percentage “row crops, small grains, and fallow” grid. The northeastern boundary of this drainage basin lies at an abrupt land use transition from very low to very high percentages of “row crops, small grains, and fallow.” The 30-m basin atrazine estimate (102 kg), which is derived from the application of county weighting factors (computed from the basin boundary grid, NLCDe 92 southeastern quadrant grid, and county boundaries grid, all at the 30-m grid cell resolution), is the most precise estimate. The 30-m resolution basin boundary grid, which closely follows the vector-based basin boundary, depicts that the northeastern boundary separates an area with very few row crops, small-grain crops, and fallow land within the basin from an area of widespread cropland outside the basin. The 1-km resolution basin boundary, in contrast, includes several nonzero 1-km resolution “row crops, small grains, and fallow” grid cells with values of 21, 14, 9, 5, and 3 (percent) along the northeastern border. These nonzero grid cell values in turn, produce pesticide use grid cell values of 27, 18, 12, 6, and 4 kg, respectively. Including these 1-km resolution pesticide grid cell values in the drainage basin inflates the 1-km basin estimate when compared with the more precise 30-m basin estimate. This example indicates that abrupt transitions of agricultural land along the borders of a drainage basin can lead to significant pesticide use differences between the 30-m and 1-km basin estimates.

It is worth noting that the mixed resolution basin atrazine estimate for basin ID 02289034 is higher than the 1-km basin atrazine estimate, and therefore, deviates further from the 30-m basin atrazine estimate. By using a 100-m resolution basin boundary with the 1-km resolution atrazine use grid, the mixed resolution atrazine estimate for this basin is 287 kg, nearly double the 1-km basin atrazine estimate (144 kg) and approximately triple the most precise 30-m basin atrazine estimate (102 kg). Furthermore, using an even more detailed basin boundary grid (30-m resolution) with the 1-km resolution atrazine use grid, does not significantly improve the basin’s estimate; the basin estimate derived from these two data sources is 256 kg. Though the 30-m resolution basin boundary is much better defined than the 1-km resolution basin boundary, the basin pesticide estimates remain overestimated because these 30-m grid cells overlap additional 1-km resolution “row crops, small grains, and fallow” percentage grid cells that have relatively high cell values (90, 76, 59, 88, 84, 74, 66, 50, and 30, in addition to the above mentioned 21, 14, 9, 5, and 3). Another reason to avoid using a 30-m resolution basin boundary with the 1-km resolution percentage land cover grid to estimate basin pesticide use is that most of the processing time is invested in generating a 30-m resolution basin boundary

grid. The time it takes to compute county weighting factors, county-apportioned pesticide use, and total basin pesticide use at the 30-m resolution is approximately the same as the time it takes to determine basin pesticide use estimates derived from a 30-m resolution basin boundary grid and 1-km resolution percentage land cover grid.

Another approach that is used to compare the 30-m and 1-km basin atrazine estimates is to analyze the bias, or difference between the 1-km basin estimate and 30-m basin estimate (column 7 of *table 4*). The bias is computed by subtracting the 30-m basin estimate from the 1-km basin estimate; thus, a positive bias means the 1-km basin estimate was greater than the 30-m basin estimate, and a negative bias indicates that the 1-km basin estimate was less than the 30-m basin estimate. The median bias is only  $-1$  kg, and the median of the 30-m basin estimates for all 150 drainage basins is 951 kg. The most negative bias value is  $-607$  kg (basin ID 02281200, with a 30-m basin estimate of 175,559 kg), and the most positive bias value is 359 kg (basin ID 01578310, with a 30-m basin estimate of 344,691 kg). Although these extreme bias values are large numbers, they represent only a small fraction of the basin atrazine estimate.

The bias between the 1-km and 30-m basin atrazine estimates does not show a clear relation to basin area (*fig. 13*). Bias values about 300 kg occur for drainage basins ranging in size from 1,144 km<sup>2</sup> (basin ID 07043500) to 70,182 km<sup>2</sup> (basin ID 01578310). The two drainage basins with the largest bias have areas of 806 km<sup>2</sup> (basin ID 02281200) and 3,171 km<sup>2</sup> (basin ID 07381467).

The difference between the 30-m and 1-km basin atrazine estimates can be expressed as a percentage of the 30-m basin estimate of atrazine use. This “percentage bias” is calculated as

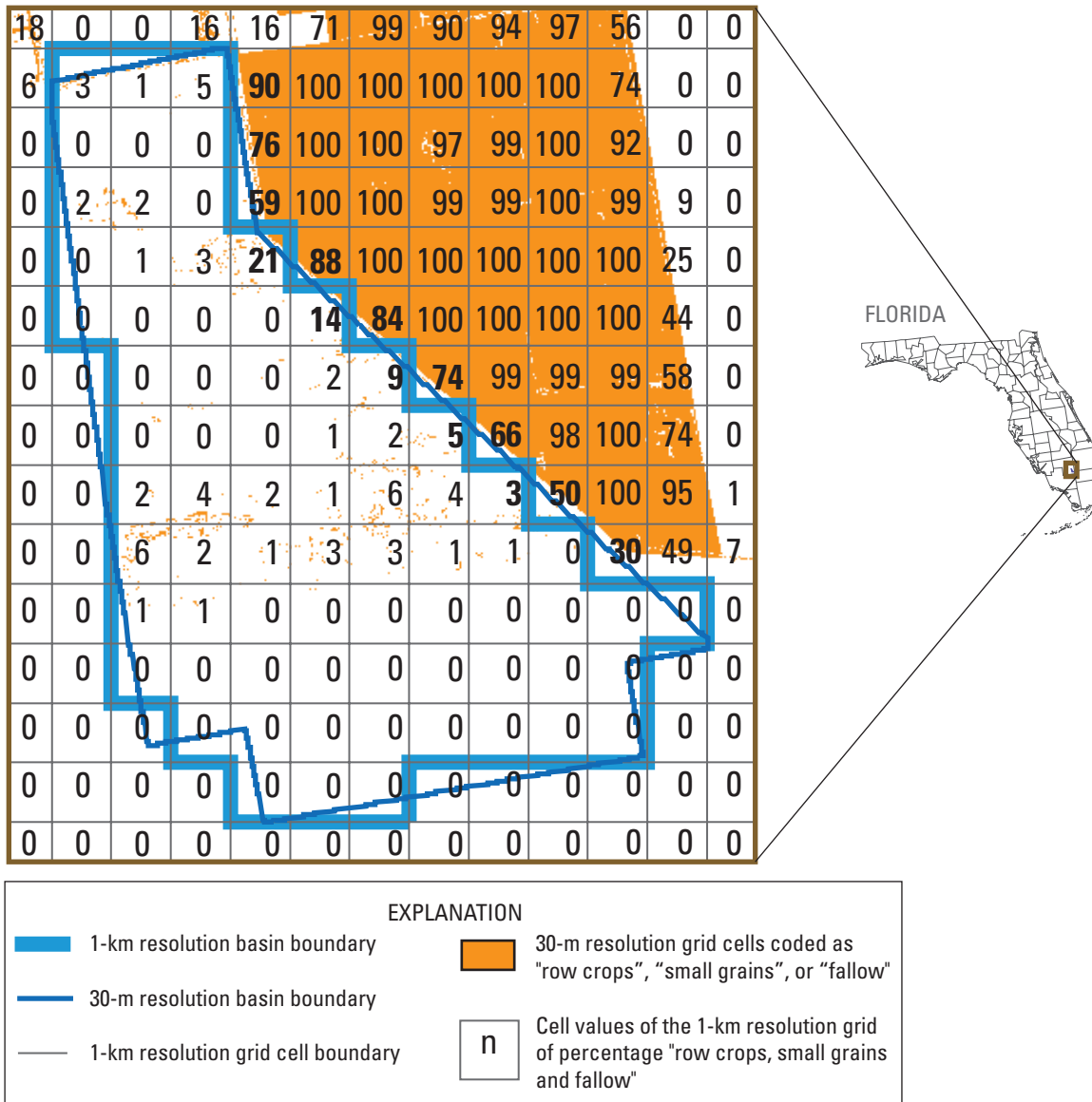
$$\text{Percentage bias} = (\text{Bias}/\text{Use}_{30}) \times 100$$

where

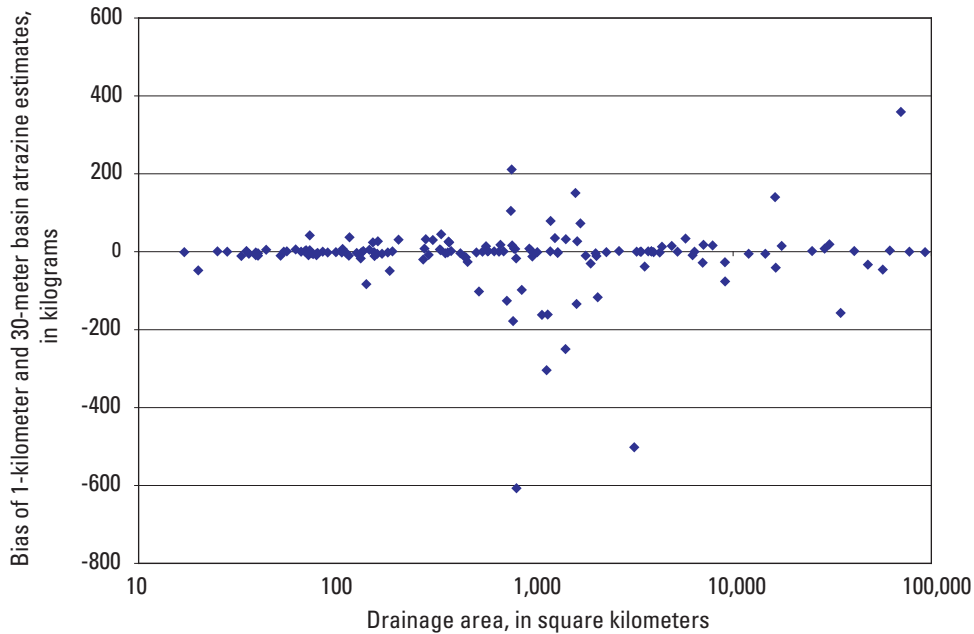
*Bias* is the 1-km basin estimate minus the 30-m basin estimate

*Use*<sub>30</sub> is the 30-m basin estimate

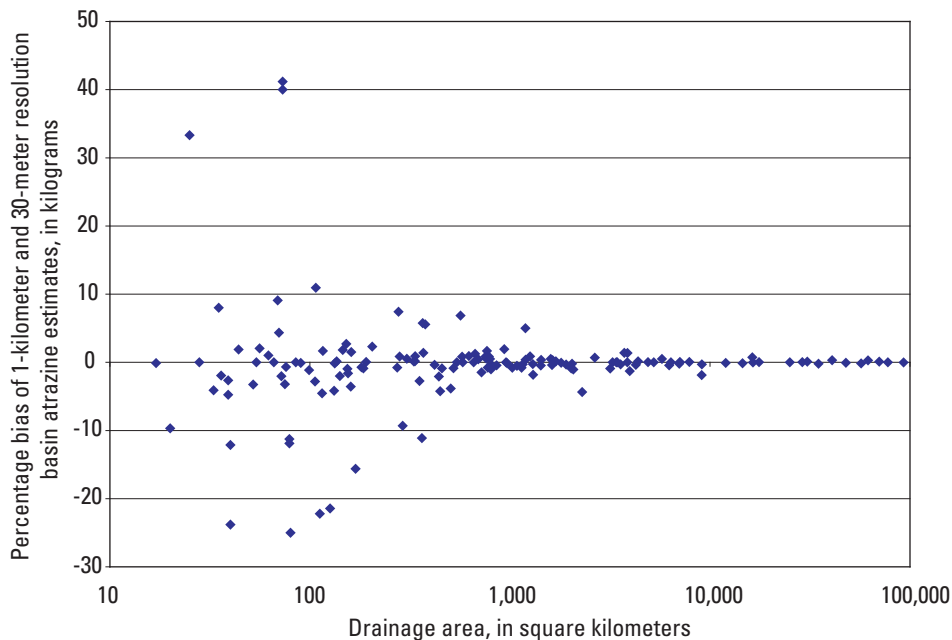
The percentage bias is an indicator that reflects the difference in 30-m and 1-km basin estimates in relation to the basin’s most precise estimate (30-m basin estimate). For instance, a bias of 50 kg is insignificant if the 30-m basin estimate is 10,000 kg, but the same bias is significant if the 30-m basin estimate is only 100 kg. The largest percentage bias occurs for drainage basins smaller than approximately 1,000 km<sup>2</sup> (column 9 of *table 4*, *fig. 14*); overall, the percentage bias ranges from  $-25$  to 41 with a median value of  $-0.01$ . The highest magnitude percentage bias occurs for drainage basins with relatively low 30-m basin estimates (the denominator in the equation above). Generally, the drainage basins with the lowest 30-m basin atrazine estimates are among the relatively small basins (*fig. 15*).



**Figure 12.** The 30-m and 1-km resolution drainage basin boundaries, distribution of 30-m resolution "row crops," "small grains," and "fallow" from the "enhanced" National Land Cover Data 1992 (NLCDe 92), and selected cell values of the 1-km resolution national grid of percentage "row crops, small grains, and fallow" in the vicinity of the drainage basin (Basin ID 02289034) for the U.S. Geological Survey's station U.S. Sugar Outflow Canal near Clewiston, Florida.



**Figure 13.** The bias between the 1-km basin atrazine estimates and the 30-m basin atrazine estimates in relation to drainage area. The bias was determined by subtracting the 30-m basin atrazine estimate from the 1-km basin atrazine estimate. The 30-m basin atrazine estimates were derived from the 1992 county tabular file of atrazine use estimates by crop class and the 30-m resolution grids of the (1) “enhanced” National Land Cover Data 1992 (NLCDe 92), (2) 1990 county boundaries, and (3) drainage basin boundaries; the 1-km basin atrazine estimates were derived from the 1992 county tabular file of atrazine use estimates by crop class and the 1-km resolution grids of (1) percentage “row crops, small grains, and fallow,” (2) 1990 county boundaries, and (3) drainage basin boundaries. Drainage area was computed from the polygon coverage of the drainage basin.

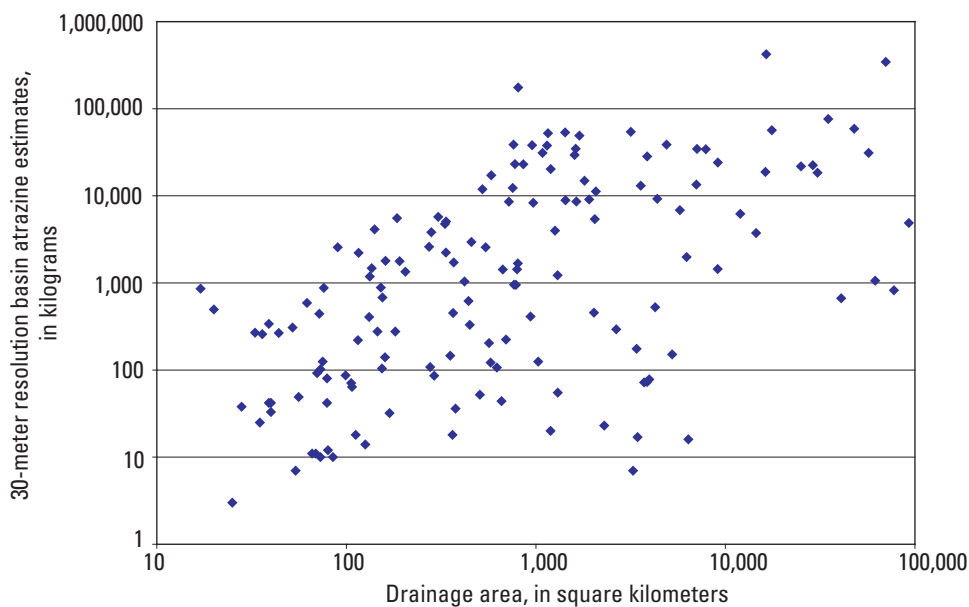


**Figure 14.** The percentage bias of the 1-km basin atrazine estimates and the 30-m basin atrazine estimates in relation to drainage area. The percentage bias was computed by subtracting the 30-m basin atrazine estimate from the 1-km basin atrazine estimate, dividing the difference by the 30-m basin atrazine estimate, then multiplying the quotient by 100. The 30-m basin atrazine estimates were derived from the 1992 county tabular file of atrazine use estimates by crop class and the 30-m resolution grids of the (1) “enhanced” National Land Cover Data 1992 (NLCDe 92), (2) 1990 county boundaries, and (3) drainage basin boundaries; the 1-km basin atrazine estimates were derived from the 1992 county tabular file of atrazine use estimates by crop class and the 1-km resolution grids of (1) percentage “row crops, small grains, and fallow,” (2) 1990 county boundaries, and (3) drainage basin boundaries. Drainage area was computed from the polygon coverage of the drainage basin.

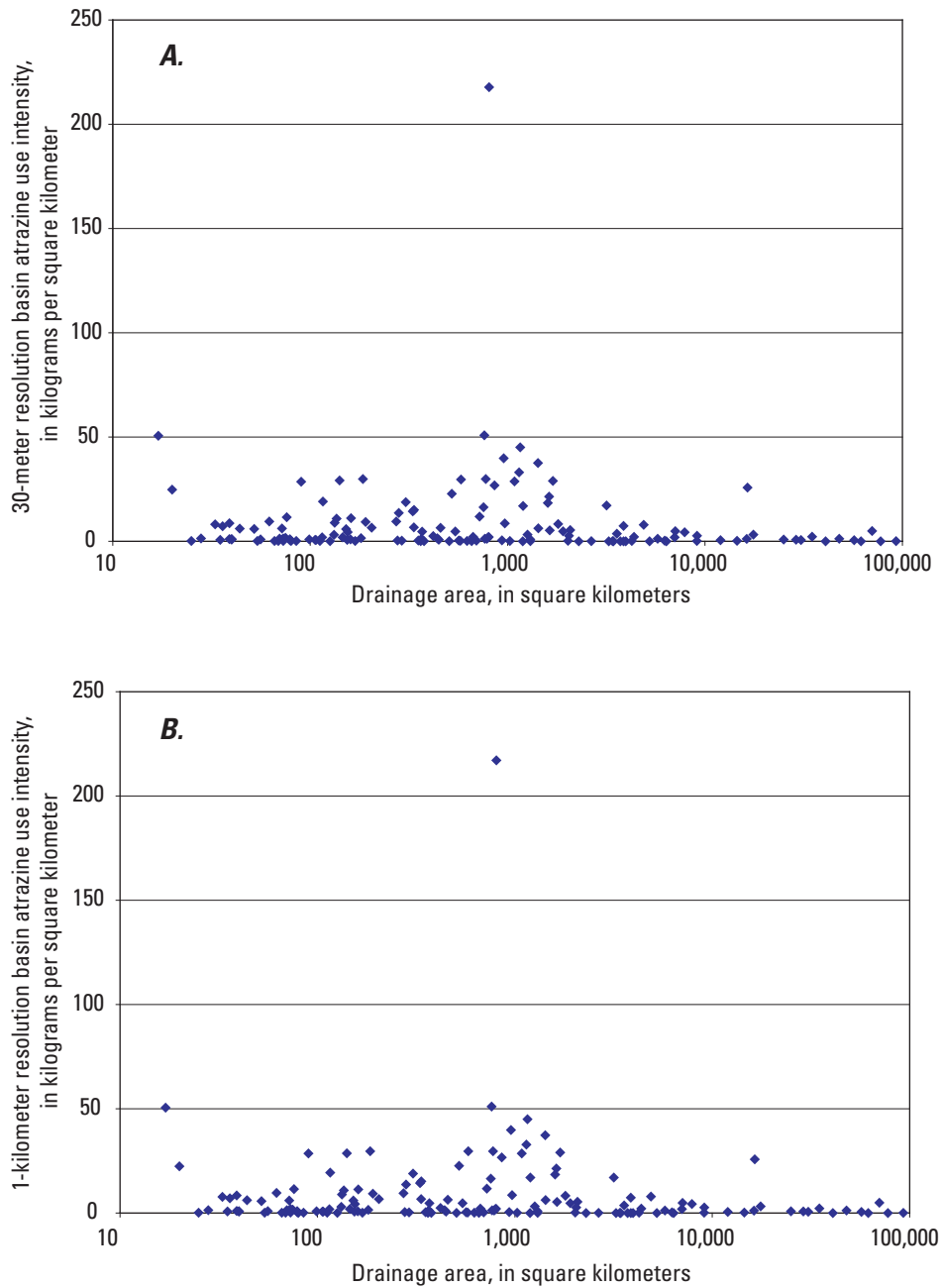
Another approach used in comparing the 1-km and 30-m basin atrazine estimates is to compare basin use intensity (rate) values: the estimated use (mass) divided by the drainage area. Columns 10 and 11 of *table 4* show that the 30-m and 1-km basin use intensity values for atrazine are very close for most drainage basins. The median 30-m basin use intensity value is also very close in comparison with the median 1-km basin use intensity value (1.67 kg/km<sup>2</sup> and 1.81 kg/km<sup>2</sup>, respectively). The 1-km and 30-m basin atrazine use intensity values do not show a relation to basin area (*fig. 16*). However, the bias or difference in basin use intensities (column 12 of *table 4*, *fig. 17*) does exhibit a pattern related to basin size. The magnitude of the bias is greatest in drainage basins smaller than approximately 1,200 km<sup>2</sup>. The bias in basin use intensity exceeds a magnitude of 0.25 kg/km<sup>2</sup> for only 9 of the 150 drainage basins.

The mixed resolution basin atrazine estimates (column 6 of *table 4*) appear highly correlated with the 30-m atrazine estimates (column 4 of *table 4*, *fig. 18*). The mixed resolution basin atrazine estimates were calculated only for the 91 of the 150 drainage basins with an area less than or equal to 1,000 km<sup>2</sup> (these drainage basins are identified with either an “a” or a “b” in column 2 of *table 4*). The correlation pattern between the mixed resolution basin estimates and the 30-m

basin estimates (*fig. 18*) is very similar to the pattern between the 1-km and 30-m basin estimates (*fig. 11*). There is some scatter in the relation between the two sets of basin estimates, and one drainage basin in particular (basin ID 02289034) stands out again as an outlier. As previously discussed, the large bias for basin ID 02289034 is caused by an abrupt change in land cover and, hence, in the 1-km grid cell values of pesticide use along the basin boundary (*fig. 12*). The median bias between the mixed resolution basin estimates and the 30-m basin estimates is -1 kg (column 8 of *table 4*), the same median bias between the 1-km basin estimates and the 30-m basin estimates. When the mixed resolution basin atrazine estimates are evaluated according to whether they were closer to the 30-m basin atrazine estimate when compared with the 1-km basin atrazine estimate, 55 percent (50 of the 91 basins) of the basins had a closer mixed resolution basin estimate to the more precise 30-m estimate; 14 percent (13 of the 91 basins) had the same absolute value difference; and 31 percent (28 of the 91 basins) of the mixed resolution basin estimates had a larger bias. Therefore, using a 50- or 100-m resolution basin boundary grid with the 1-km resolution grids of percentage land cover to gain more precise basin pesticide estimates was successful only about half the time.

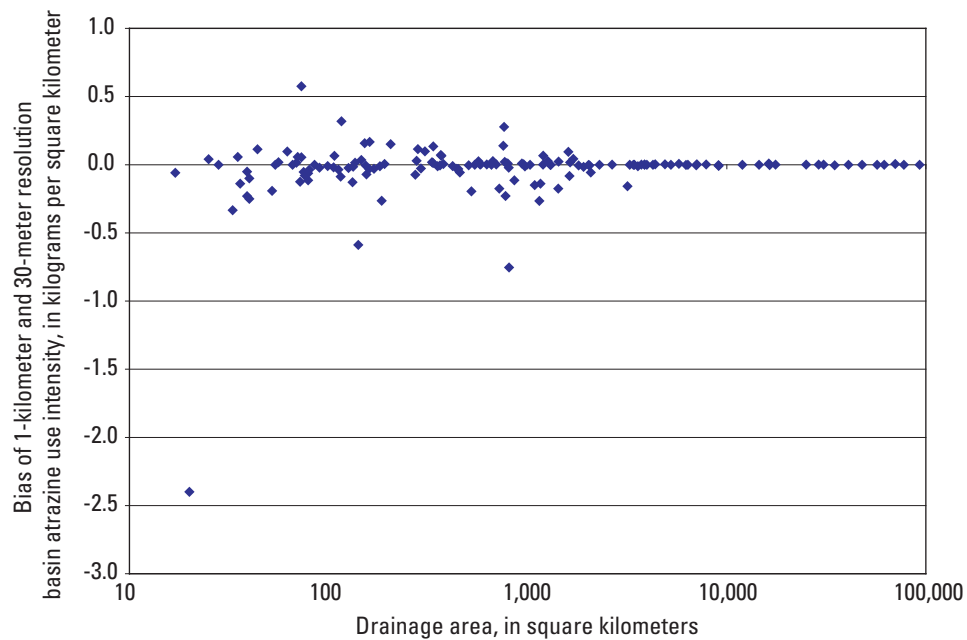


**Figure 15.** The 30-m resolution basin atrazine estimates in relation to drainage area. The 30-m basin atrazine estimates were derived from the 1992 county tabular file of atrazine use estimates by crop class and the 30-m resolution grids of the (1) “enhanced” National Land Cover Data 1992 (NLCDe 92), (2) 1990 county boundaries, and (3) drainage basin boundaries. Drainage area was computed from the polygon coverage of the drainage basin.

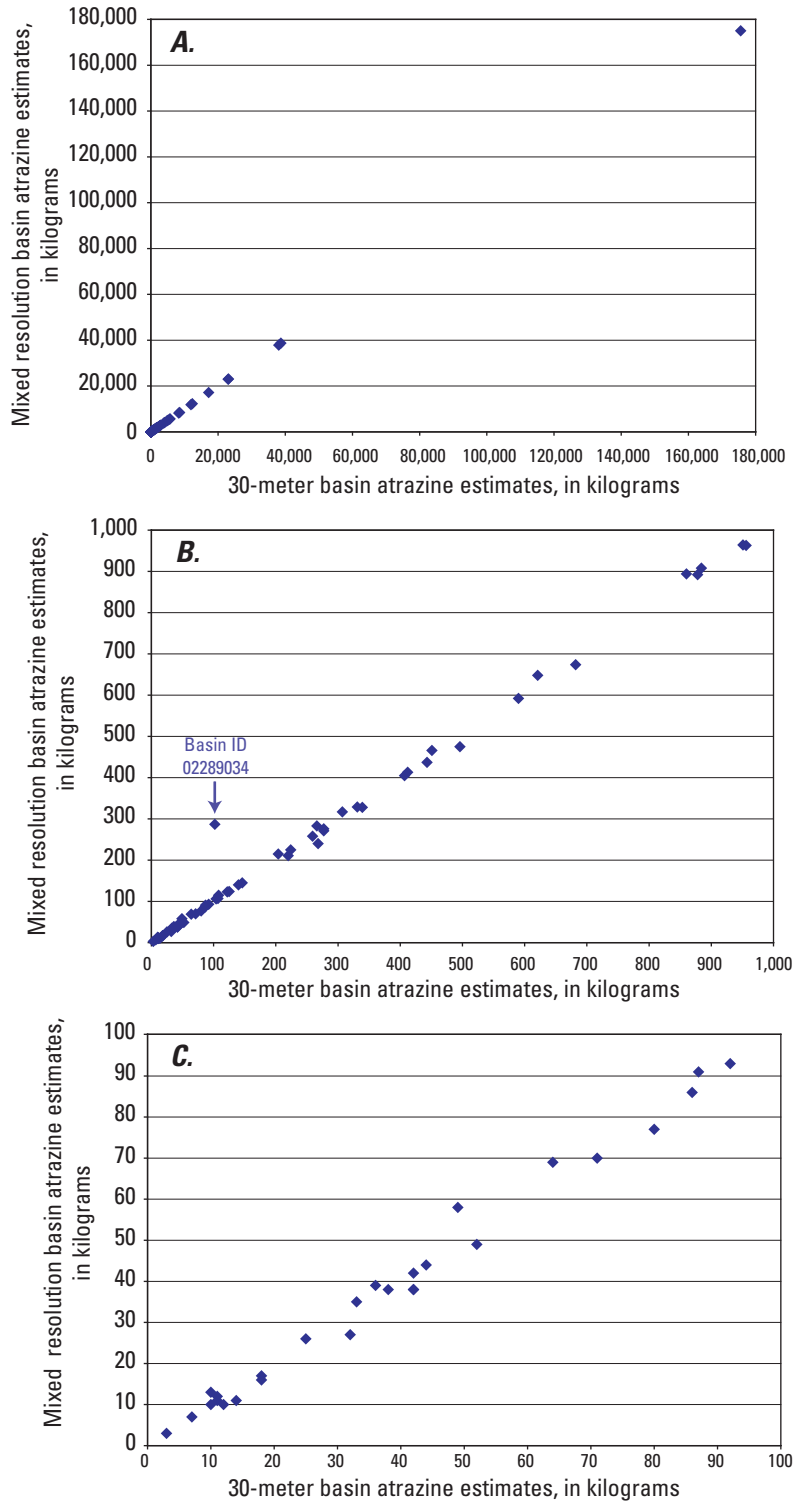


**Figure 16.** The 30-m basin atrazine use intensity and the 1-km basin atrazine use intensity in relation to drainage area. *A.* 30-m resolution basin atrazine use intensity. *B.* 1-km resolution basin atrazine use intensity. The 30-m basin atrazine use intensity was derived by dividing the 30-m basin atrazine estimate by drainage area, and the 1-km basin atrazine use intensity was derived by dividing the 1-km basin atrazine estimate by drainage area. The 30-m basin atrazine estimates were derived from the 1992 county tabular file of atrazine use estimates by crop class and the 30-m resolution grids of the (1) “enhanced” National Land Cover Data 1992 (NLCDe 92), (2) 1990 county boundaries, and (3) drainage basin boundaries; the 1-km basin atrazine estimates were derived from the 1992 county tabular file of atrazine use estimates by crop class and the 1-km resolution grids of (1) percentage “row crops, small grains, and fallow,” (2) 1990 county boundaries, and (3) drainage basin boundaries. Drainage area was computed from the polygon coverage of the drainage basin.





**Figure 17.** The bias between the 30-m basin atrazine use intensity and the 1-km basin atrazine use intensity, in relation to drainage area. The 30-m basin atrazine use intensity was derived by dividing the 30-m basin atrazine estimate by drainage area; the 1-km resolution basin atrazine use intensity was derived by dividing the 1-km basin atrazine estimate by drainage area; and the bias was computed by subtracting the 30-m basin atrazine use intensity from the 1-km basin atrazine use intensity. The 30-m basin atrazine estimates were derived from the 1992 county tabular file of atrazine use estimates by crop class and the 30-m resolution grids of the (1) “enhanced” National Land Cover Data 1992 (NLCD 92), (2) 1990 county boundaries, and (3) drainage basin boundaries; the 1-km basin atrazine estimates were derived from the 1992 county tabular file of atrazine use estimates by crop class and the 1-km resolution grids of (1) percentage “row crops, small grains, and fallow,” (2) 1990 county boundaries, and (3) drainage basin boundaries. Drainage area was computed from the polygon coverage of the drainage basin.



**Figure 18.** The mixed resolution basin atrazine estimates in relation to the 30-m basin atrazine estimates. *A.* For the entire set of 150 drainage basins. *B.* For drainage basins with use estimates less than 1,000 kg. *C.* For drainage basins with use estimates less than 100 kg. The mixed resolution basin atrazine estimates were derived from the grids of percentage “row crops, small grains, and fallow” and 1990 county boundaries, both at the 1-km grid cell resolution, the 50-m or 100-m resolution drainage basin boundaries, and the 1992 county tabular file of atrazine use estimates by crop class. The 30-m basin atrazine estimates were derived from the 1992 county tabular file of atrazine use estimates by crop class and the 30-m resolution grids of the (1) “enhanced” National Land Cover Data 1992 (NLCDe 92), (2) 1990 county boundaries, and (3) drainage basin boundaries.

## Which Resolution is the Most Appropriate for Estimating Agricultural Pesticide Use in Drainage Basins?

A common question when geoprocessing data in raster format is “What cell resolution is most appropriate for my application”? The answer to this question depends, in part, on the resolution of the information contained in the data sources. Raster processing at a much larger grid cell size than the resolution of the data source will cause a loss of spatial information in the generalization process. On the other hand, geoprocessing at a finer grid cell resolution than the cell resolution of the data source will increase processing time while not gaining precision or accuracy. The ideal cell resolution is one that efficiently preserves the spatial information contained in the data sources.

For quantifying agricultural pesticide use in drainage basins that is derived from the data sources selected in this report, one might assume that the appropriate cell resolution for geoprocessing is determined by the cell resolution of the land cover dataset because it is stored at a smaller spatial unit than the county pesticide use information. The agricultural pesticide use data are georeferenced by counties, which range in size from less than 10 km<sup>2</sup> to over 100,000 km<sup>2</sup>, whereas the NLCDe 92 contains information georeferenced by grid cells with an area of 0.0009 km<sup>2</sup>. Geoprocessing at the 30-m resolution is justified if it is important to obtain the highest precision possible and if time and computer resources are not restraints.

Another issue is the number of drainage basins to characterize. Estimating chemical application for a couple hundred pesticides in a few thousand watersheds at the 30-m resolution in a few weeks may be feasible; however, estimating application for several hundred chemicals for tens of thousands of drainage basins within the same time period may be prohibitive without multiple high-powered computer resources. (In regard to the NAWQA drainage basins, the grids of drainage basin boundaries, 1990 county boundaries, and NLCDe 92, all at the 30-m resolution, continue to be used with the county files of pesticide use by crop class to estimate agricultural pesticide use in drainage basins.)

The 1-km resolution approach may be appropriate for studies in which all drainage basins of interest are “large” (perhaps greater than 10,000 km<sup>2</sup>), but would not be ideal for a set of “small” watersheds (perhaps less than 1,200 km<sup>2</sup>). The overall comparisons of the 30-m and 1-km resolution basin atrazine use estimates for drainages ranging in area from 17 to over 90,000 km<sup>2</sup> showed that percentage biases in particular are relatively small for most of the drainage basins. The decision regarding appropriate cell resolution for geoprocessing depends on the acceptable margin of error.

If the watersheds of interest have a broad range in size, then another approach may be to geoprocess basin pesticide

use estimates at the 30-m resolution for the small basins, at the 1-km resolution for the large basins, and at a grid cell resolution between 30-m and 1-km for the medium-sized basins. This approach would require the determination of drainage basins considered small, medium, and large, and the acceptable bias or percentage bias of basin estimates of pesticide use. However, the comparisons of the mixed resolution basin estimates with the 30-m basin estimates showed that only about half of the mixed basin estimates are closer to the 30-m estimate than the 1-km basin estimate. Even if the basin boundary grids were all rasterized to a grid cell size of 30-m, the potential for misleading results remains when they are used with the 1-km resolution pesticide grids, as was found with the drainage basin in southern Florida (basin ID 02289034).

The most significant factor related to biases in pesticide use estimates was found to be the agricultural land cover changes within a 1-km buffered area of the watershed boundary. The abrupt agricultural land cover change within a 1-km buffer around the drainage basin in southern Florida (basin ID 02289034), which is located within the bounds of a single county, was shown to be the cause for the major differences among the 30-m, 1-km, and the mixed resolution atrazine estimates for this watershed. The other two drainage basins that showed biases over 500 kg (basin IDs 02281200 and 07381467) also exhibited analogous land cover changes along a portion of the basin boundary. However, the impact of land cover changes was not consistently evident: large biases can also arise from scattered areas along the basin boundary where land cover changes do not have well-defined divisions. This was the case for the remaining two drainage basins that showed biases over 300 kg (basin IDs 07043500 and 01578310). The four basins with biases over 300 kg range in size from 806 to 70,182 km<sup>2</sup>, and the drainage identified as basin ID 02289034 is only 73 km<sup>2</sup>; therefore, drainage size alone is not a reliable indicator for determining the appropriate grid cell resolution at which estimates of basin pesticide use should be computed.

In summary, it is difficult to predict whether the use of the 1-km resolution land cover data will produce satisfactory results without assessing land cover change along the drainage boundary at the 30-m resolution. However, such an assessment would be impractical because it would require the same amount of geoprocessing to derive basin pesticide use estimates from 30-m resolution land cover data. The basin estimates of pesticide use should be derived from land cover, basin, and county boundaries, all at the 30-m resolution if it is important to obtain the most precise estimates and if time and computer resources allow for geoprocessing at this detailed resolution. Otherwise, the decision may ultimately rely on the uses of the estimates of pesticide use in watersheds, and thus acceptable margin of error.

## Limitations of the Agricultural Pesticide Use Estimates in Drainage Basins

There are two primary factors that contribute to the limitations of agricultural pesticide use estimates in drainage basins. These factors are: (1) the temporal differences between land cover and county pesticide use estimates and (2) the areal differences between land cover and county pesticide data for agricultural land.

The pesticide use and land cover data sources used to estimate agricultural pesticide use in drainage basins do not completely coincide temporally. Though the 1992 county agricultural pesticide dataset and the NLCDe 92 are referenced to the year 1992, these datasets represent information covering the years from early to mid-1990s. The county agricultural pesticide use estimates are multiyear averages derived from (1) state average annual agricultural pesticide use numbers pertaining to early to mid-1990s and (2) county crop areas that are based on the census of agriculture of 1992 (Thelin and Gianessi, 2000). The NLCD 92 are compiled from a large number of Landsat TM scenes acquired from the early to mid-1990s (Vogelmann and others, 2001). The NLCDe 92 incorporates the spatial distribution of tundra, residential urban, and orchards/vineyards from the 1970s to the mid-1980s. Hence, counties that are characterized by dramatic changes in agricultural land (for example resulting from urbanization) within the early to mid-1990s timeframe have the potential of affecting pesticide use estimates in drainage basins. Accuracy of basin estimates of pesticide use could be greatly improved if information on land cover and agricultural pesticide application were collected for the same time period, for instance, during the same season in a given year.

Though temporal differences contribute to the limitations of agricultural pesticide use estimates in basins, the differences in areas identified as agricultural land in the two data sources have a much greater potential to skew basin pesticide estimates. Despite extensive use of ancillary information, there remains some potential for misclassification of agricultural land in the NLCD 92 because it is based on primarily spectral signatures. In addition, revisions to orchard and vineyard areas incorporated into the NLCDe 92 may not be accurate in some areas. Consequently, the county areas of agricultural land classifications derived from the NLCDe 92 may be over or underestimated. The pesticide estimate for a given crop in a county in the 1992 county pesticide use file has an associated area of cropland, which is based on cropland information from the 1992 Census of Agriculture. When the county areas of land

between the 1992 county agricultural pesticide use data and NLCDe 92 are substantially different, the amount of county pesticide use either has a “diluting” or “concentrating” effect when it is distributed or apportioned onto the agricultural land.

When the geospatial land cover data depicts a smaller county area of agricultural land than the agricultural land reflected in the county pesticide tabular data, the concentration of pesticide application in these counties becomes higher than the concentration depicted in the county pesticide data. Take, for example, county “A,” in which the land cover dataset depicts a much smaller pastured area (for example, 1 km<sup>2</sup>) than the pastured area according to the county pesticide data (say, 100 km<sup>2</sup>). According to the county pesticide data, 1,000 kg of atrazine is applied to the 100 km<sup>2</sup> of pasture in county A, but since the land cover data depicted only 1 km<sup>2</sup> of land classified as “pasture/hay,” the atrazine use intensity that is based on land cover information is computed to be 1,000 kg/km<sup>2</sup>, whereas it is 10 kg/km<sup>2</sup> when based on the county pesticide data. The difference in use intensity is 100-fold. Another problematic case occurs when the land cover dataset depicts the absence of agricultural land while the county pesticide data estimates some amount of pesticide use on crops. Under these rare conditions, the amount of pesticide estimated in this county is lost because there is no agricultural land (in the NLCDe 92) on which to apply it.

On the other hand, when the source for land cover information depicts a much larger county area of agricultural land than that reflected in the county pesticide data, the estimated amount of county pesticide use is distributed over a much larger area than expected. This condition leads to the “diluting” effect of pesticides in these counties.

Consequently, the highest potential for error in estimating agricultural pesticide in drainage basins arise from the “diluting” and “concentrating” effects of pesticide application within counties and is intensified when basins partially intersect counties in which the spatial distribution of agricultural land is significantly in error. For counties that are located entirely within the basin boundary, the total amount of pesticide use estimated for the county is accounted for, and thus, are not affected by the diluting or concentrating effects. Because most drainage basins partially overlap multiple counties, however, the pesticide estimates for most watersheds are subject to a combination of diluting and concentration effects. To assess the net result of error in estimating pesticide use in drainage basins, the “diluting” and “concentrating” effects would need to be assessed on a county-by-county basis.

To reduce the potential for errors in basin pesticide use estimates, one approach is to aggregate all agricultural land cover classifications into a single crop class and distribute the estimates of county pesticide use applied to all crops onto the all-inclusive (aggregated) agricultural land category [27]. The aggregation of agriculturally related land classes lessens the chance for error because it has been observed that an agricultural area is sometimes misclassified as a different type of agricultural land. For instance, an area that is classified as “pasture/hay” may have been misclassified as “fallow.” In addition, by using this approach, it is rare for county pesticide use estimates to be entirely unaccounted for when it is distributed onto agricultural land because there is some type of agricultural land in most counties (on the basis of NLCD 92). This approach also reduces the likelihood for extremely high pesticide use intensities for a county because the total amount of pesticides applied to all crops in a county is distributed over all types of agricultural land. The drawback of combining all agricultural land cover classes together is that true differences in pesticide use on different types of agricultural land are lost.

In summary, the estimates of agricultural pesticide use in drainage basins are affected by the temporal and areal differences in agricultural land between the county pesticide use and land cover datasets. It is difficult, however, to correct for these errors without intensive research of pesticide application by county and season. Consequently, it is important for users of the basin pesticide use estimates to be aware of the limitations when they are used in any scientific analyses.

## Other Applications of the Methods

The 30-m basin processing method and 30-m resolution NLCD 92 described in this report are also applied to compute fertilizer and manure applications for NAWQA drainage basins. The land cover classifications “row crops,” “small grains,” “fallow,” and “orchards/vineyards/other” combined with the “LULC orchards/vineyards/other” are used to apportion county nitrogen in farm fertilizers to quantify basin estimates of farm fertilizer use, and the classifications “low intensity residential,” “LULC residential,” “NLCD/LULC forested residential,” and “urban recreational grasses” are used to apportion county nonfarm fertilizer use in urbanized areas (Barbara C. Ruddy, U.S. Geological Survey, written commun., 2003). In addition, county total nitrogen and phosphorus input from manure are integrated with land cover classifications “row crops,” “small grains,” “fallow,” “pasture/hay,” and, in some cases, also “grasslands/herbaceous” [28] to estimate application of nitrogen and phosphorus from manure in drainage basins.

The 30-m basin processing methods also are applied to characterize pesticide and fertilizer use in ground-water study areas to support ground water-quality analyses in the NAWQA Program. Polygon coverages representing ground-water study

areas defined by a combination of geological and physiographic settings, replace the drainage basin boundary coverages as the areas over which chemical use is estimated.

## Future Directions

Understanding how pesticide use affects stream-water quality can be enhanced by integrating additional drainage basin characteristics. Soil drainage characteristics and stream-flow generation processes, for example, have been shown to affect the transport efficiency of pesticides into streams (Larson and Gilliom, 2001). While previous research has shown how basin-average soil characteristics affect stream chemistry (as in Larson and Gilliom, 2001), the spatial interaction of these drainage basin characteristics (including land cover, soil properties, terrain characteristics, and climate) within the basin landscape has not been demonstrated. For example, a pesticide applied in the riparian zone probably is transported more readily into the stream compared with its application far from the stream. Furthermore, a pesticide applied on impermeable soils is more likely to appear in the stream than a pesticide applied on very permeable soils. A GIS provides the appropriate analysis framework to consider how the spatial pattern of interacting drainage basin characteristics affects water quality in streams. Future work in quantifying basin pesticide use should incorporate spatial datasets of factors that affect important transport mechanisms.

## Summary

This report presents the geographic information system (GIS) methods used to estimate agricultural pesticide use in drainage basins that combined national land cover maps with county agricultural pesticide use data. Two versions of the selected source for land cover were used: the 30-m resolution enhanced National Land Cover Data (NLCD) 1992 and a 1-km resolution representation of the 30-m resolution enhanced NLCD 1992. The basin atrazine use estimates that were applied to row crops, small-grain crops, and fallow land were presented for 150 drainage basins in the conterminous United States. The overall comparative assessment of basin agricultural pesticides estimates derived from land cover data at these two resolutions indicated that the differences were minor. However, the most significant factor related to the differences in basin pesticide estimates was found to be agricultural land cover changes along the basin divide. Despite limitations of the basin estimates of agricultural pesticide use, they continue to be nationally consistent and comparable indicators of pesticide application in watersheds in the conterminous United States.

## Endnotes

- [1]. The map in *figure 1* displays 49 of the 51 study units that were active in the first decade of water-quality assessments that took place between 1991 and 2001. The two study units that are not shown are located outside the conterminous United States: the Oahu study unit in Hawaii, and the Cook Inlet Basin study unit, in Alaska. These study units are excluded from this map because agricultural pesticide use was not estimated for any drainage basins within these study units due to the unavailability of county crop pesticide data outside the conterminous United States. For more information on the NAWQA program and study-unit investigations, please refer to the NAWQA Program's main Web site at <http://water.usgs.gov/nawqa> (accessed Feb. 29, 2004).
- [2]. "Raster" is a method for storing, processing, and displaying spatial data managed as a matrix of cells or pixels.
- [3]. Most of these sites have associated stream pesticide data that were collected on a monthly basis for 1 to 3 years.
- [4]. Environmental Systems Research Institute, Inc., distributes the GIS software ArcInfo. For more information on the Environmental Systems Research Institute, please refer to <http://www.esri.com> (accessed August 21, 2003). Use of this product name in this report does not constitute endorsement by the U.S. Geological Survey.
- [5]. "Coverage" is the term used by Environmental Systems Research Institute, Inc., (2003b) for a vector-based digital map stored in ArcInfo. Coverages and vector data in general consist of geographic features stored as points, lines or polygons, attribute tables accessible to the user, and internal tables that are used strictly by the software.
- [6]. The Albers Conical Equal-Area projection referenced to the North American Datum of 1983 (NAD83) was used with the following parameters: 1st standard parallel: 29 degrees, 30 minutes; 2nd standard parallel: 45 degrees, 30 minutes; longitude of central meridian: -96 degrees; latitude of projection's origin: 23 degrees; false easting: 0 meters; false northing: 0 meters.
- [7]. "Grid" is the term used by the Environmental Systems Research Institute, Inc., (2003b) for a raster-based digital map stored in ArcInfo. A grid is organized as rows and columns of uniform cells, and each cell is referenced by its geographic x- and y-coordinate. Integer grids, or grids with grid cell values stored as integers, have an associated attribute table that includes cell counts by unique grid cell values, in addition to any user-defined attributes. Attribute tables are associated only with integer grids; grids that store grid cell values as floating numbers do not have attribute tables (for more information, please refer to the software documentation by Environmental Systems Research Institute, Inc., 2003a).
- [8]. The National Land Cover Data 1992 is available from <http://edc.usgs.gov/products/landcover/nlcd.html> (accessed June 16, 2005).
- [9]. Information regarding the land cover classifications in the NLCD 92 is available at <http://landcover.usgs.gov/classes.asp> (accessed January 27, 2004).
- [10]. TIFF is an acronym for Tag Interchange (Image) File Format, which is an industry standard raster data format. Instructions for converting the NLCD 92 in its native data format to ArcInfo format are available at <http://edcwww.cr.usgs.gov/pub/data/landcover/states/flat2grid.txt> (accessed August 21, 2003).
- [11]. In ArcInfo Workstation Version 8.2, the file size limit for a grid is 2.1 gigabytes (Environmental Systems Research Institute, Inc., 2003a).
- [12]. The NAWQA National Synthesis Project actually used an enhanced version of USGS's Land Use and Land Cover (LULC) dataset, which was created to fill in missing land use codes and to close gaps between quadrangle boundaries (Price and others, 2003). The enhanced version of the LULC dataset was converted from vector to raster format, at the 30-m resolution, prior to its integration with the 30-m resolution NLCD 92.
- [13]. "Resample" is a term used by Environmental Systems Research Institute, Inc., (2003b), which is the process of reducing image dataset size by representing a group of grid cells with a lower number of grid cells. Thus, pixel count is lowered, individual pixel size is increased, and overall image geographic extent is retained (Environmental Systems Research Institute, Inc., 2003b).
- [14]. In most cases, the percentage of a land classification in each 1- by 1-km area was computed by dividing the number of 1-coded 40-m grid cells by 625 (the number of 40-m grid cells within a 1- by 1-km area). However, along the shoreline, the divisor was not always 625 because many of the grid cells representing the oceans do not have grid cell values (are coded "no data"). In these cases, the divisor was set to the actual number of 40-m grid cells within the 1- by 1-km area that had a data value.
- [15]. There are two 40-m grid cells coded as "1" in the "evergreen forest" grid (*fig. 4B*) but six 30-m grid cells classified as "evergreen forest" (*fig. 4A*). This difference is a result of the resampling process from 30 to 40-m resolution. Though these types of differences do arise, they are insignificant when percentages (of 1-km grid cells) are rounded to an integer.

- [16]. The Census of Agriculture is a comprehensive national source for information on agricultural production by county. The Census of Agriculture data are available online at <http://www.usda.gov/census> (accessed March 1, 2004). Prior to 1997, the U.S. Census Bureau conducted the agricultural census. However, as of 1997, it became the responsibility of the United States Department of Agriculture's National Agricultural Statistics Service (NASS).
- [17]. The National Center for Food and Agricultural Policy (NCFAP) is a private non-profit organization located in Washington, D.C. For more information about the NCFAP, please refer to their main Web site at <http://www.ncfap.org> (accessed January 6, 2004).
- [18]. Pesticide use in the NCFAP database, reported in pounds, and harvested acreages of crops acquired from the Census of Agriculture were converted to kilograms and square kilometers, respectively.
- [19]. The state pesticide use database managed by the National Center for Food and Agricultural Policy is accessible at <http://www.ncfap.org/database/default.htm> (accessed August 21, 2003). Pesticide use is expressed as "percent of a crop treated with an individual active ingredient" and "average annual application rate of active ingredient per treated acre" (Gianessi and Anderson, 1995). Of the 200 or so pesticides managed in NCFAP's database, nearly half are herbicides, approximately one-third are insecticides, and the rest are fungicides, fumigants, growth regulators, and defoliant.
- [20]. Though the data are referenced to the year 1992, the use numbers represent average annual estimates derived from data sources that span multiple years. For instance, the state pesticide data from NCFAP is representative of pesticide usage patterns for the years 1990–93 and 1995 (Gianessi and Anderson, 1995), and these data are keyed to county harvested cropland acreages on the basis of the 1992 Census of Agriculture (U.S. Department of Commerce, 1995).
- [21]. The 1:100,000 scale digital maps of the 1990 county boundaries were downloaded from <http://water.usgs.gov/lookup/getspatial?county100> (accessed August 21, 2003).
- [22]. The 1:2,000,000-scale digital maps of the 1990 county boundaries were downloaded from National Atlas of the United States, at <http://nationalatlas.gov/atlasftp.html> (accessed March 26, 2001).
- [23]. The overlay step was repeated four times, once for each 30-m resolution quadrant NLCD grid, and the numbers of 30-m grid cells associated with each of the three crop classes for all counties in the conterminous United States were stored in a single county tabular file of grid cell counts.
- [24]. If the basin overlaid multiple quadrant grids, the software determined the basin portions of the intersecting quadrant grids, which were then merged together to generate a single basin land cover grid.
- [25]. The county weighting factors were actually defined as floating numbers, but *figures 10A* and *10B* only show up to two digits to the right of the decimal. Because the third and fourth digits to the right of the decimal in both computations of the example weighting factors (2/8 and 3/15) are zero, these digits are not shown.
- [26]. This drainage basin is among a small group of watersheds that are affected by water management decisions. In this case, the corresponding sampling site is located at the outflow of a canal.
- [27]. Users of the NLCD 92 are encouraged to apply aggregates of land cover classifications. For more information, see "Accuracy Assessment of the 1992 National Land Cover Data: Methods and Results," posted at <http://landcover.usgs.gov/accuracy> (accessed August 21, 2003).
- [28]. Basin estimates of nitrogen and phosphorus input that are based on manure from unconfined animals include the integration of the land classification "grasslands/herbaceous" along with "row crops," "small grains," "fallow," and "pasture/hay," whereas basin estimates of nitrogen and phosphorus input that are based on manure from confined animals excludes the "grassland/herbaceous" classification (Barbara C. Ruddy, U.S. Geological Survey, written commun., 2004). The number of confined and unconfined animals is based on data from the census of agriculture.

## References Cited

- Barbash, J.E., and Resek, E.R., 1996, Pesticides in ground water: Distribution, trends, and governing factors: Ann Arbor Press, Chelsea, Mich. [available from CRC Press], Pesticides in the Hydrologic System series, v. 2, 590 p.
- Barbash, J.E., Thelin, G.P., Kolpin, D.W., and Gilliom, R.J., 1999, Distribution of major herbicides in ground water of the United States: U.S. Geological Survey Water-Resources Investigations Report 98-4245, 57 p.
- Environmental Systems Research Institute, Inc., 2003a, Online Help, ArcDoc Version 8.2: Redlands, Calif., ESRI.
- Environmental Systems Research Institute, Inc., 2003b, The Glossary of GIS Terms: ESRI, accessed August 21, 2003, at <http://www.esri.com/library/glossary/glossary.html>
- Gianessi, L.P., and Anderson, J.E., 1995, Pesticide use in U.S. crop production— national data report: Washington, D.C., National Center for Food and Agricultural Policy [variously paged; interim update April 1996].

- Gilliom, R.J., Alley, W.M., and Gurtz, M.E., 1995, Design of the National Water-Quality Assessment Program—occurrence and distribution of water-quality conditions: U.S. Geological Survey Circular 1112, 33 p., accessed August 21, 2003, at <http://water.usgs.gov/pubs/circ/circ1112>
- Hirsch, R.M., Alley, W.M., and Wilber, W.G., 1988, Concepts for a National Water-Quality Assessment Program: U.S. Geological Survey Circular 1021, 42 p.
- Hitt, K.J., 2002, Generalized boundaries of the National Water-Quality Assessment (NAWQA) study-unit investigations in the conterminous United States (1991–2001), ver.1.1: U.S. Geological Survey digital map data, accessed December 23, 2003, at <http://water.usgs.gov/lookup/getspatial?nawqagencyc1>
- Larson, S.J., and Gilliom, R.J., 2001, Regression models for estimating herbicide concentrations in U.S. streams from watershed characteristics: *Journal of the American Water Resources Association*, v. 37, no. 5, p. 1349–1367.
- Larson S.J., Gilliom R.J., and Capel, P.D., 1998, Pesticides in streams of the United States—initial results from the National Water-Quality Assessment Program: U.S. Geological Survey Water-Resources Investigations Report 98-4222, 92 p., accessed August 21, 2003, at <http://ca.water.usgs.gov/pnsp/rep/wrir984222/>
- Leahy, P.P., and Thompson, T.H., 1994, The National Water-Quality Assessment Program: U.S. Geological Survey Open-File Report 94-70, 4 p.
- National Center for Food and Agricultural Policy, National Pesticide Use Database, NCFAP, accessed January 6, 2004, at <http://www.ncfap.org/database/>
- Price, C.V., Nakagaki, Naomi; Hitt, K.J., and Clawges, R.M., 2003, Mining GIRAS: Improving on a national treasure of land use data, in *Proceedings of the 23rd ESRI International Users Conference*, July 7–11, 2003: Redlands, Calif., 11 p., accessed March 22, 2005, at <http://gis.esri.com/library/userconf/proc03/p0904.pdf>
- Steeves, P.A., and Nebert, D.D., 1994, Hydrologic unit maps of the conterminous United States: U.S. Geological Survey digital map data, accessed August 21, 2003, at <http://water.usgs.gov/lookup/getspatial?huc250k>
- Theilin, G.P., and Gianessi, L.P., 2000, Method for estimating pesticide use for county areas of the United States: U.S. Geological Survey Open-File Report 00-250, accessed August 21, 2003, at <http://ca.water.usgs.gov/pnsp/rep/ofr00250>
- U.S. Department of Commerce, 1993, Bureau of Census, County boundaries extracted from TIGER/line Precensus files, 1990: digital map, accessed August 21, 2003, at <http://water.usgs.gov/lookup/getspatial?county100>
- U.S. Department of Commerce, 1995, 1992 Census of agriculture, geographic area series 1A., U.S. summary state data file and cross-tab data file: U.S. Department of Commerce, Bureau of the Census, Data User Services Division, CD-AG-92-IC [CD-ROM, dBase format].
- U.S. Geological Survey, 1990, Land use and land cover digital data from 1:250,000- and 1:100,000-scale maps: U.S. Geological Survey Data User Guide, no. 4, 25 p.
- U.S. Geological Survey, 1999, National land cover data, digital files, accessed June 16, 2005, at <http://edc.usgs.gov/products/landcover/nlcd.html>
- U.S. Geological Survey, 2001a, The National Water-Quality Assessment Program—entering a new decade of investigations: U.S. Geological Survey Fact Sheet 071-01, accessed August 21, 2003, at <http://water.usgs.gov/pubs/FS/fs-071-01/pdf/fs07101.pdf>
- U.S. Geological Survey, 2001b, 1990 county boundaries of the United States (February 2001 version), digital map, accessed March 26, 2001, at <http://nationalatlas.gov/atlasftp.html>
- Vogelmann, J.E., Howard, S.M., Yang, Limin; Larson, C.R., Wylie, B.K., and Van Driel, Nick, 2001, Completion of the 1990's national land cover dataset for the conterminous United States from Landsat Thematic Mapper data and ancillary data sources: *Photogrammetric Engineering and Remote Sensing*, v. 67, p. 650–662.