

BRIEFING BOOK

PREPARED FOR
NEW ENGLAND STEERING COMMITTEE

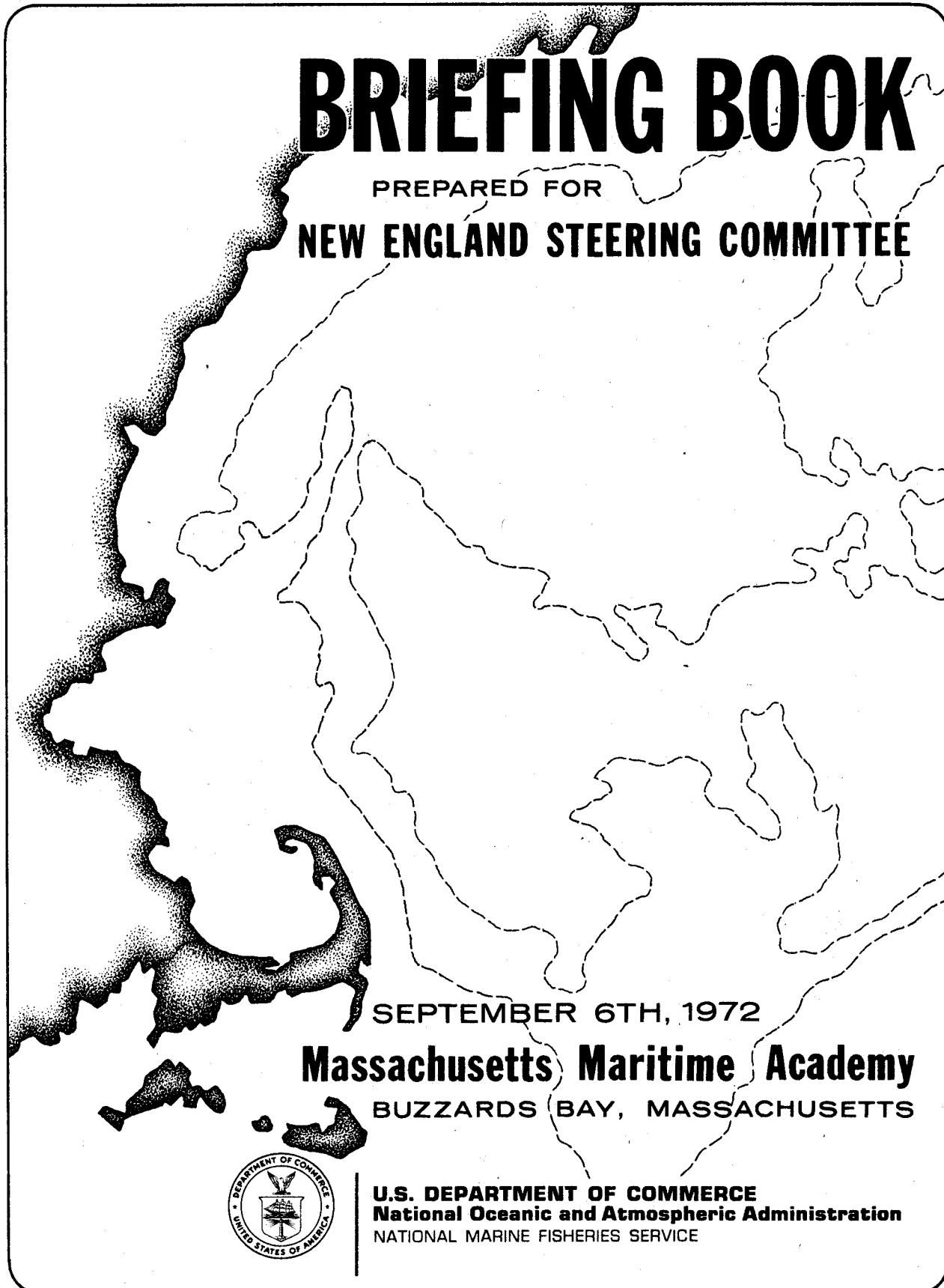

SEPTEMBER 6TH, 1972

Massachusetts Maritime Academy

BUZZARDS BAY, MASSACHUSETTS



U.S. DEPARTMENT OF COMMERCE
National Oceanic and Atmospheric Administration
NATIONAL MARINE FISHERIES SERVICE

NORTHEAST FISHERIES CENTER
NATIONAL MARINE FISHERIES SERVICE
NATIONAL OCEANIC AND ATMOSPHERIC ADMINISTRATION
U. S. DEPARTMENT OF COMMERCE

September 6, 1972

NORTHEAST FISHERIES CENTER

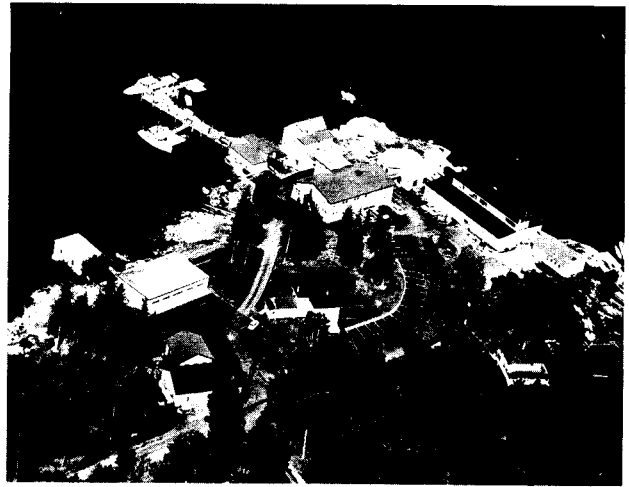
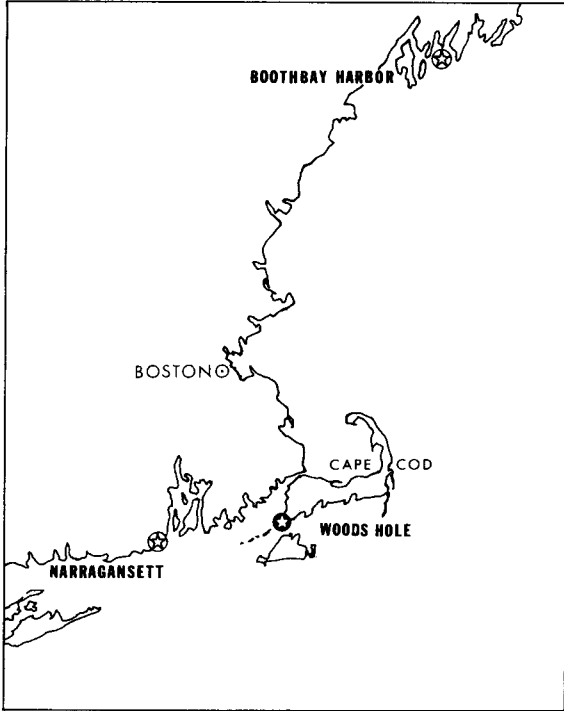

Boothbay Harbor Biological Laboratory



Narragansett Biological Laboratory



Woods Hole Biological Laboratory

TABLE OF CONTENTS

- 1.0. Area of Responsibility
- 2.0. Mission and Objectives
- 3.0. Organization
- 4.0. Research Program
 - 4.1. Integrated Activities
 - 4.1.1. Total Effort Management
 - 4.1.2. Biome Studies
 - 4.1.3. Alternate Resources
 - 4.2. Investigations
 - 4.2.1. Fishery Management Biology
 - 4.2.2. Resource Ecology
 - 4.2.3. Fishery Technology and Engineering
 - 4.2.4. Experimental Biology I - Physiology
 - 4.2.5. Experimental Biology II - Biochemistry
 - 4.2.6. Ichthyoplankton
 - 4.2.7. Invertebrate Resources
 - 4.2.8. Manned Undersea Technology
 - 4.3. Additional Studies
- 5.0. Staff
- 6.0. Funding

1.0. Area of Responsibility

1.0. The Problem

The Northwest Atlantic, from Greenland to Cape Hatteras, supports a resource capable of sustaining an annual harvest of 3 to 4 million metric tons of finfish. There are now more than 2,000 fishing vessels from 18 different nations (15%-U.S.) attempting to get their share of the harvest. In 1971 the total catch was about 3.5 million metric tons. In 1960, there were approximately 1,000 vessels, 28% of which were American, and the total catch was 2.3 million metric tons.

In 1960, the grounds south of Nova Scotia were fished almost entirely by U.S. vessels, with the exception of a few Canadian scallopers. In 1970, 80% of the total effort was generated by countries other than the U.S., the latter having decreased by about 30% since 1960. Total fishing effort tripled during this period.

There are over 200 different species of fish inhabiting the area, 37 of which are now of major importance in terms of harvest. In the waters off New England and mid-Atlantic states, 200 species of fish exist of which 36 are now of some importance in the harvest. There are not many more, perhaps only four or five species, which provide a fishable biomass.

The harvest of fish seems now to be beyond the total potential sustainable production and yet, demand and fishing fleets are increasing. Significant increases in invertebrates (squid, shellfish) catch is possible; most of the alternate resource is included in this group.

Some of the fluctuations in abundance are caused by natural changes in the marine environment. At times these natural changes will be the predominant influence on catches. However, man's fishing activity is now the pervasive and only controllable factor affecting abundance, and will seemingly persist as such for the foreseeable future. In addition, man's use of the marine environment for waste disposal, mining, oil extraction is potentially significant; the ocean is also a receptacle for synthetic substances used on land which persist in runoff and wind-borne deposits reaching the ocean.

Our mission and objectives are rather clearly defined by this state of affairs. It will take at least five years, but more probably ten, before we obtain an adequate understanding of the causes and consequences of all these factors. Within the constraints imposed upon the Center, we have designed the research program to provide advice related to detecting or solving immediate problems, and to initiate longer range studies related to solution of the more general but increasingly serious problems.

ATLANTIC COAST

CAPE SABLE TO CAPE HATTERAS

For other information see
the following publications:
Sailing Directions for the
Atlantic Coast of North America
from Cape Sable to Cape Hatteras
and from Cape Hatteras to Cape
Cod, 1973 Edition, Volume 1, Part 1,
Chapter 1, Section 1.

Scale
1:50,000
Scale of the Chart
1:50,000
Scale of the Coast
1:50,000

For other information see
the following publications:
Sailing Directions for the
Atlantic Coast of North America
from Cape Sable to Cape Hatteras
and from Cape Hatteras to Cape
Cod, 1973 Edition, Volume 1, Part 1,
Chapter 1, Section 1.

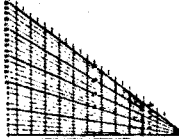

For other information see
the following publications:
Sailing Directions for the
Atlantic Coast of North America
from Cape Sable to Cape Hatteras
and from Cape Hatteras to Cape
Cod, 1973 Edition, Volume 1, Part 1,
Chapter 1, Section 1.

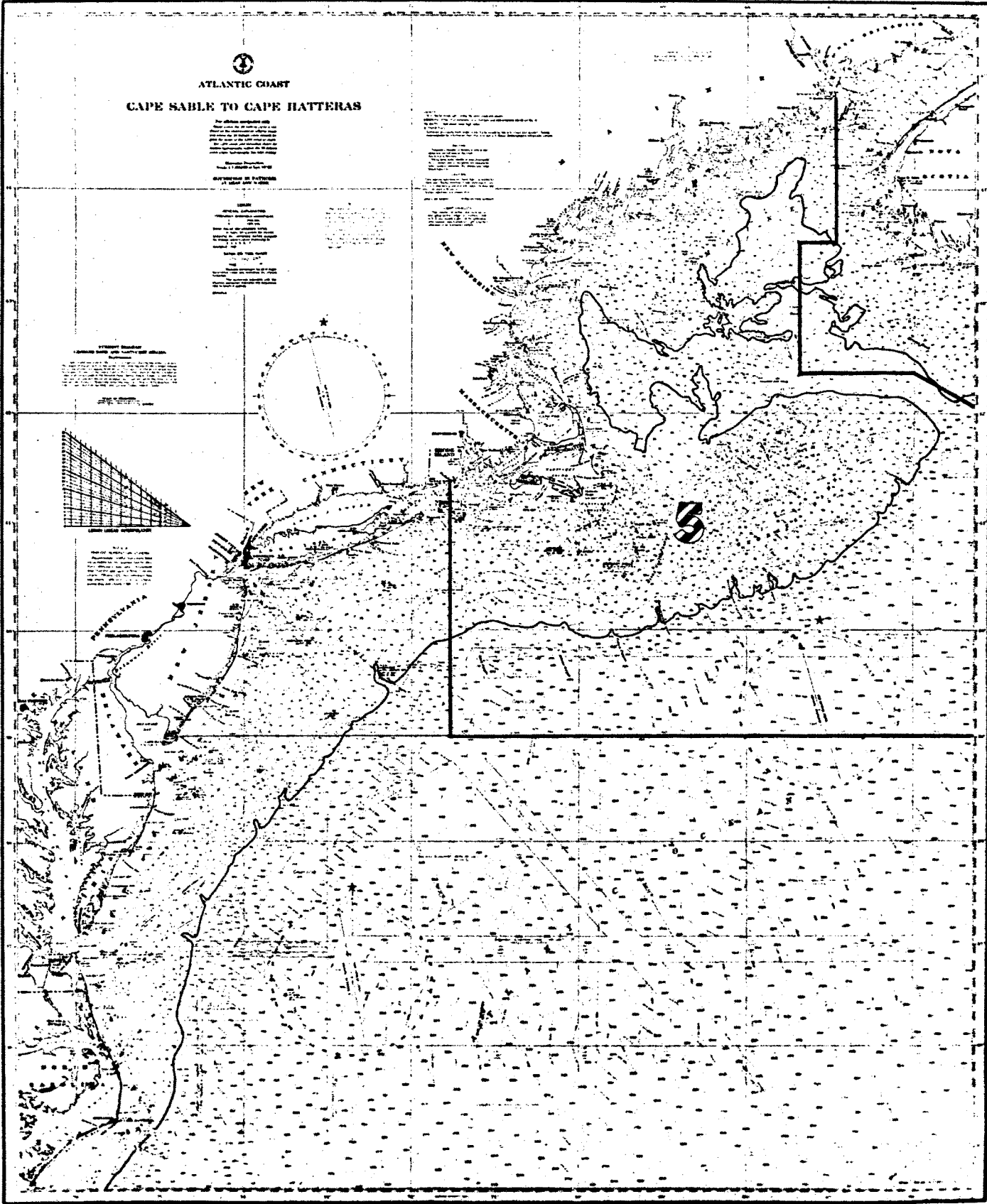

2.0. Mission and Objectives

2.0. MISSION, OBJECTIVES AND GENERAL PLAN OF ACTIVITIES

Mission: Conservation of the living marine resources of the Northwest Atlantic.

Note: Conservation is interpreted as utilization in a manner which provides for maintenance of the resource and yields at levels which will provide for the needs of society.

Objectives:

1. Determine potential yields and availability of various components of the total biomass.
2. Develop management systems which will maintain biomass and yield therefrom at levels providing for needs for food and recreational fisheries.
3. Develop the technology required to promote conservation and maximize benefits therefrom.

Note: Technology refers to both hardware and software.

4. Promote public knowledge of the resource, marine environment and effects of utilization.

The required phasing of major accomplishments is about as follows:

One year - Establish status of major fisheries sufficient to form the basis of an interim management (conservation) program.

We hope with this to complete assessments required to achieve the objective of establishing (through ICNAF at present) control of fishing effort on major stocks of immediate interest to U. S. This should provide a reasonable basis for government-industry planning of fishery development.

Stocks. Cod, haddock, yellowtail flounder, redfish, silver and red hake, herring, scallops, lobsters.

An interim management capability is defined as knowing (1) the current exploitation rate relative to the rate which maximizes yield-per-recruit and/or (2) the yield which corresponds to the harvestable surplus production in the next year or (3) the long term maximum equilibrium yield.

(2.0. - Mission)

Two years - Establish first approximation to total biomass yield (productivity) in N. E. waters which will permit consideration of total effort (harvest) control.

It will be difficult to establish viable control on a species-by-species basis. We are attempting here to provide for the option of managing certain components as a whole, so that we do not just shift effort from one component to another. A given species which has been over-exploited may never recover if the effort on other species catches the former incidentally or if the redirected effort severely exploits food species of the former.

Five years - Operational management capability, the basis for which includes effects of stock density on recruitment and production, other biotic factors affecting reproduction and survival, and effects of abiotic factors.

We probably will not yet have an adequate understanding of the production processes, but we will be more certain of the efficiency of regulatory measures in achieving the objectives. We will also be able to predict the reasonable precision the transitory state of the stocks.

By this time our major activities will have shifted from assessment of effects of fishing to study of ecosystem dynamics.

Ten Years - The previous work has related mostly to accruing knowledge. At this stage we should understand the process involved and the inter-relations of components of the biomass.

It implies rather accurate and precise prediction of events before the fact, as opposed to monitoring and predicting impact after the event.

The time table could be met with adequate (and reasonable) resources. It would require at least a doubling of the current level by the next two years. We would, throughout the mid-third of the period, be reassigning activity from assessment activities to ecosystem studies.

We probably will become increasingly involved in environmentally-related problems, effects of dumping, other pollution, mining, etc. In ten years, our work may be more related to the quality of human survival than fish survival.

(2.0. - Mission)

If this is in fact true, we must, of course, start the required research now. In effect, we are - by providing advice, data, and information to other studies (Sea Grant, etc.). We should program increasing participation of this kind over the next two years. The next phase will be increasing direct studies based on the knowledge acquired in the ecosystem studies.

General comments on problem areas:

The foregoing activities are based primarily on the application of our research to management problems. Our research will be directed in 5 years to a large extent on rather basic biological and ecological problems. However, it will still be directed towards solving the problems as they exist or can be predicted. We are taking the approach that our mission requires research based on society's needs rather than that based on producing knowledge per se.

Some specific problem areas will require special attention:

1. Calibration of our sampling gear. This is especially important in the MARMAP concept. It includes studies of behavior and availability, i.e., life history studies.

2. Environmental factors related to survival of fishes (extrinsic or abiotic factors). Our approach here is to determine the interactions of these intrinsic factors.

3. Physiology. Reproduction, survival and growth must be understood, not just observed.

4. Logistics. To meet rudimentary needs and provide the minimum of flexibility (necessary for external credibility), we need the equivalent of one additional Albatross IV.

5. Statistical needs are severe - both sport and commercial. Probably, the only way out is mandatory log books for commercial vessels and greatly improved estimates of the sports catch. Our approach to studies of the entire biomass does not, in our view, require any special approach for species associated with commercial fisheries or recreational fisheries.

A crucial, but unanswered question:

What is the degree of national commitment to establishment of a management regime in Northwest Atlantic? There is a need for an explicit policy statement concerning responsibility for renewable resources.

3.0. Organization

Northeast Fisheries Center Organization

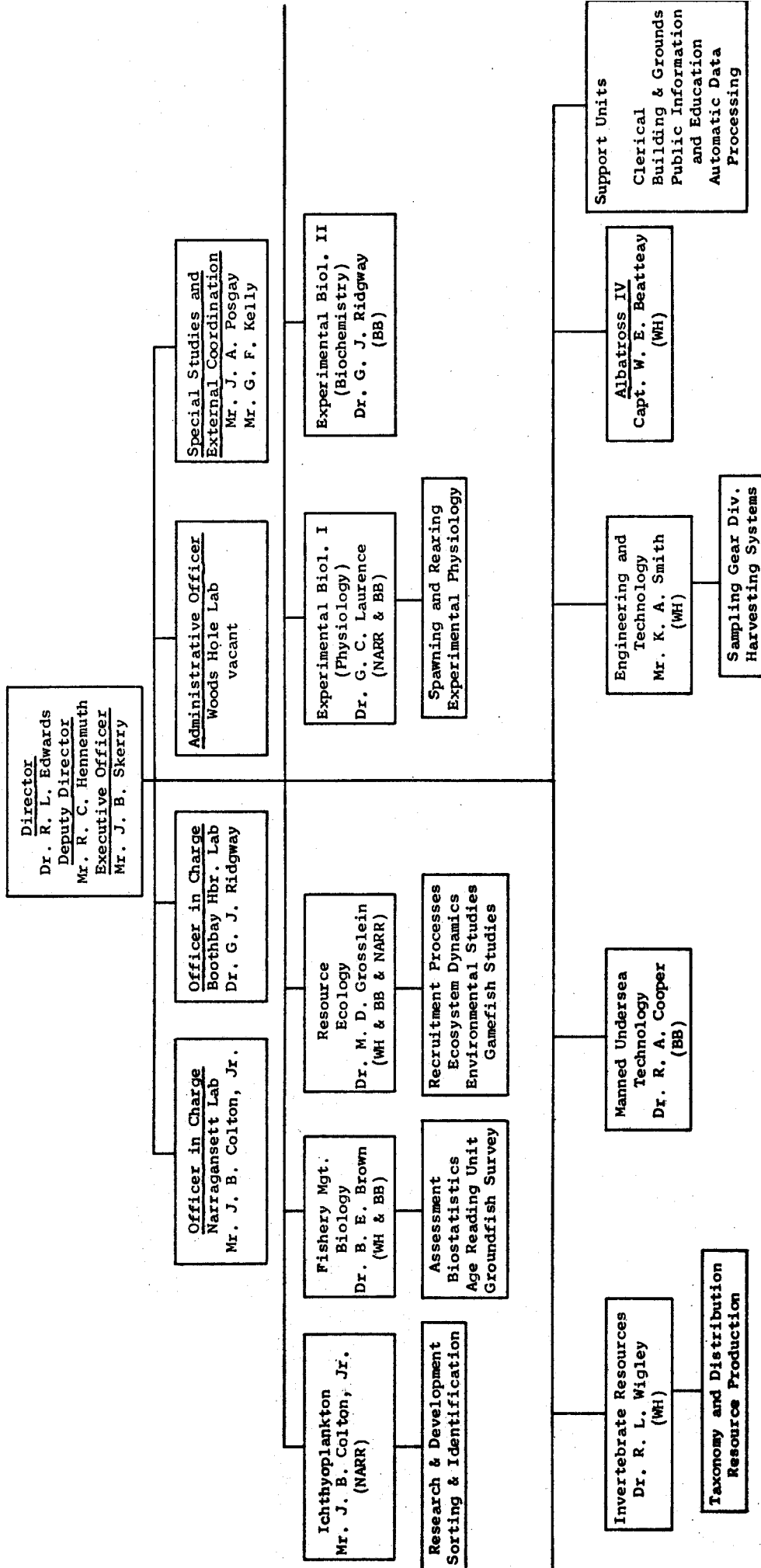

4.0. Research Program

4.1. Integrated Activities

4.1.1. Total Effort Management

4.1.2. Biome Studies

4.1.3. Alternate Resources

4.1.1. Total Effort Management

The objective of this activity is to provide the scientific basis for an interim total effort management scheme. It represents the first step in achieving one of the major objectives of the Center - establishing options for management of the fisheries which allow for planning and development within the framework of an adequate conservation program. By interim we mean that explicit interspecific relations are not taken into account. Also, it will apply only to the finfish biomass.

As indicated in the event diagram, the solution of this problem requires the integration of four major Center activities - Fishery Management Biology, Resource Ecology, Fishery Technology and Engineering, and Ichthyoplankton. Most of the work outlined is of the nature of synthesis of information supplied by the related activities which are indicated on the diagram by the term prior related activities (PRA's) and circled in green.

There are seven such PRA's which lead to achieving the following events:

1. Surveillance data base
2. Major species assessment
3. Foreign catch/effort data base
4. U. S. catch/effort data base
5. Groundfish survey data base
6. Pelagic sampling protocol
7. Plankton data base

Of the seven PRA's, #1, #6 and #7 are not currently advanced enough to provide the requisite information, and will require special emphasis if the objective is to be achieved.

The three events indicated in red represent studies which require significant further development of technology and methodology before we can accomplish them. Calibration means relating what we catch on our surveys to the total available population. We have no existing basis for sampling pelagics. Both of these aspects require considerable work at sea and careful studies of fish behavior.

PRA - PRIOR RELATED ACTIVITY

— TOTAL EFFORT MANAGEMENT —

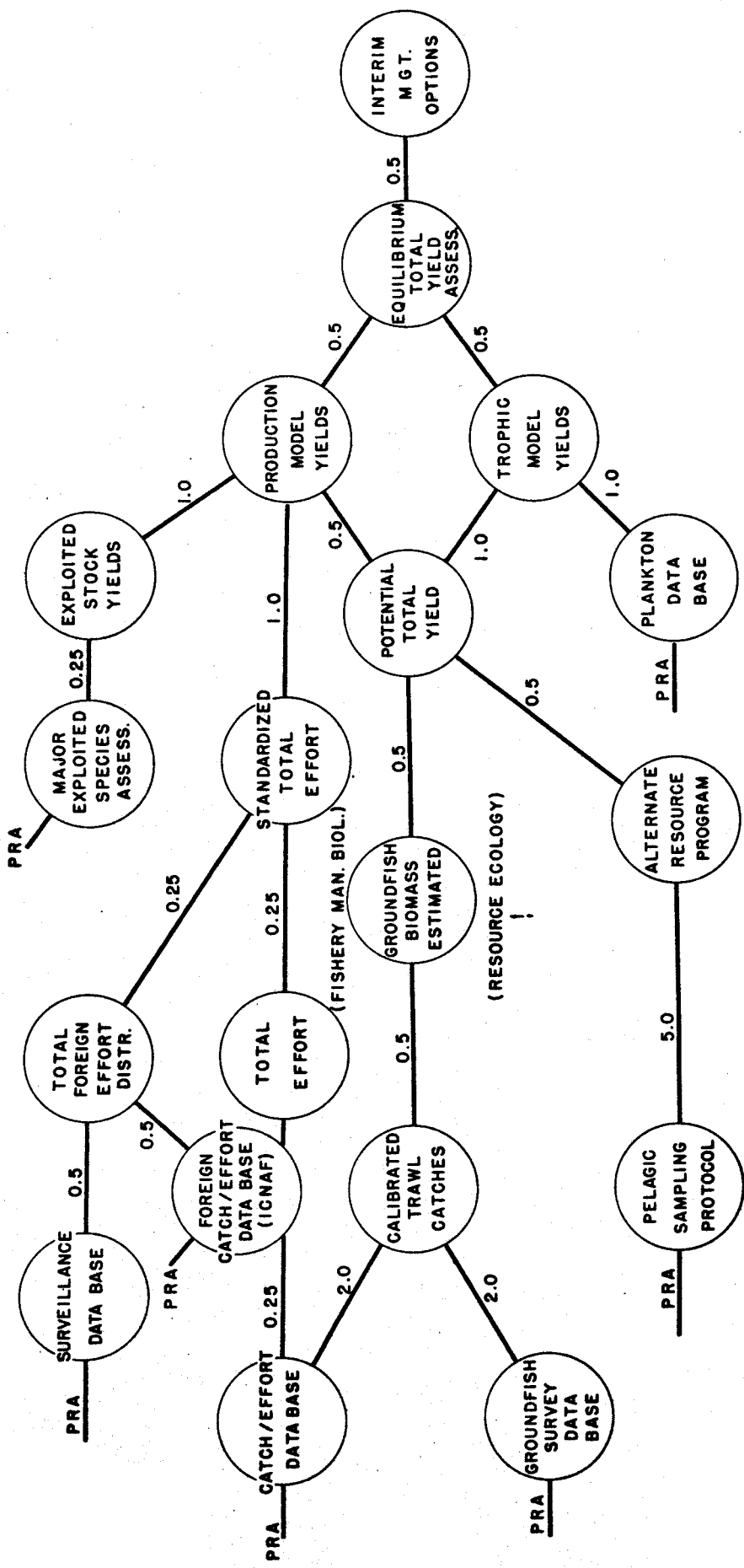

(FISHERY ENG. & TECH.)

(ICHTHYOPLANKTON)

JULY 72

JULY 73

JAN. 74

APR. 74

4.1.2. Massachusetts Bay - Stellwagen Bank Biome Study*

The purpose of this study is to survey and evaluate the living marine resources of Massachusetts Bay and vicinity (see map) and to develop a prototype of methods to study the ecosystem as a whole. Baseline data resulting from this work will be used to assess the effect of man-made influences on this environment and these resources. Procedures will be established and tested here which may be applied elsewhere to evaluate multiple use of the marine environment.

The history of Massachusetts Bay since the arrival of the Pilgrims is a chronicle in miniature of the impact of man on the environment. The question of how the waters and shores of this bay will be used in the future is a timely one and should be addressed now so that traditional oceanic activities, such as fishing, are not smothered or lost under the impact of increasing pressures for more extensive utilization.

The scientific literature will be searched to establish the prior patterns of change in hydrography, water quality, abundance of marine plants and animals and other environmental factors. These data will aid in determining present sampling requirements. Sampling will be done from surface vessels, aircraft, moored buoys, and submersibles using photography, underwater television and SCUBA divers in addition to conventional trawls, plankton nets, dredges, water samplers, and other collecting equipment.

At a network of stations from ten meters seaward, salinity, temperature, benthic organisms, groundfish and pelagic species will be sampled regularly. Inshore of ten meters will be sampled from small boats working from the shore at selected locations. Records of the quantities of commercial and sport species removed from the area will be obtained from cooperative commercial and sport fishermen recording accurate data on their catches. Records of sightings, and regular aerial surveys of the whole area, will provide a means of estimating the quantities of marine mammals and birds present.

These studies will be integrated with others already in progress conducted by universities, private research groups, state or other federal agencies. We are also trying to make arrangements with the International Institutes of Mathematical Ecology at Pennsylvania State University to participate in the study.

Successful completion of this biome study will result in improved management of the fish resource. This type of study is necessary to gain better understanding of how to deal with conflicts generated by man's activities.

*Biome is an ecological term which denotes a complex community of organisms within a defined environment.

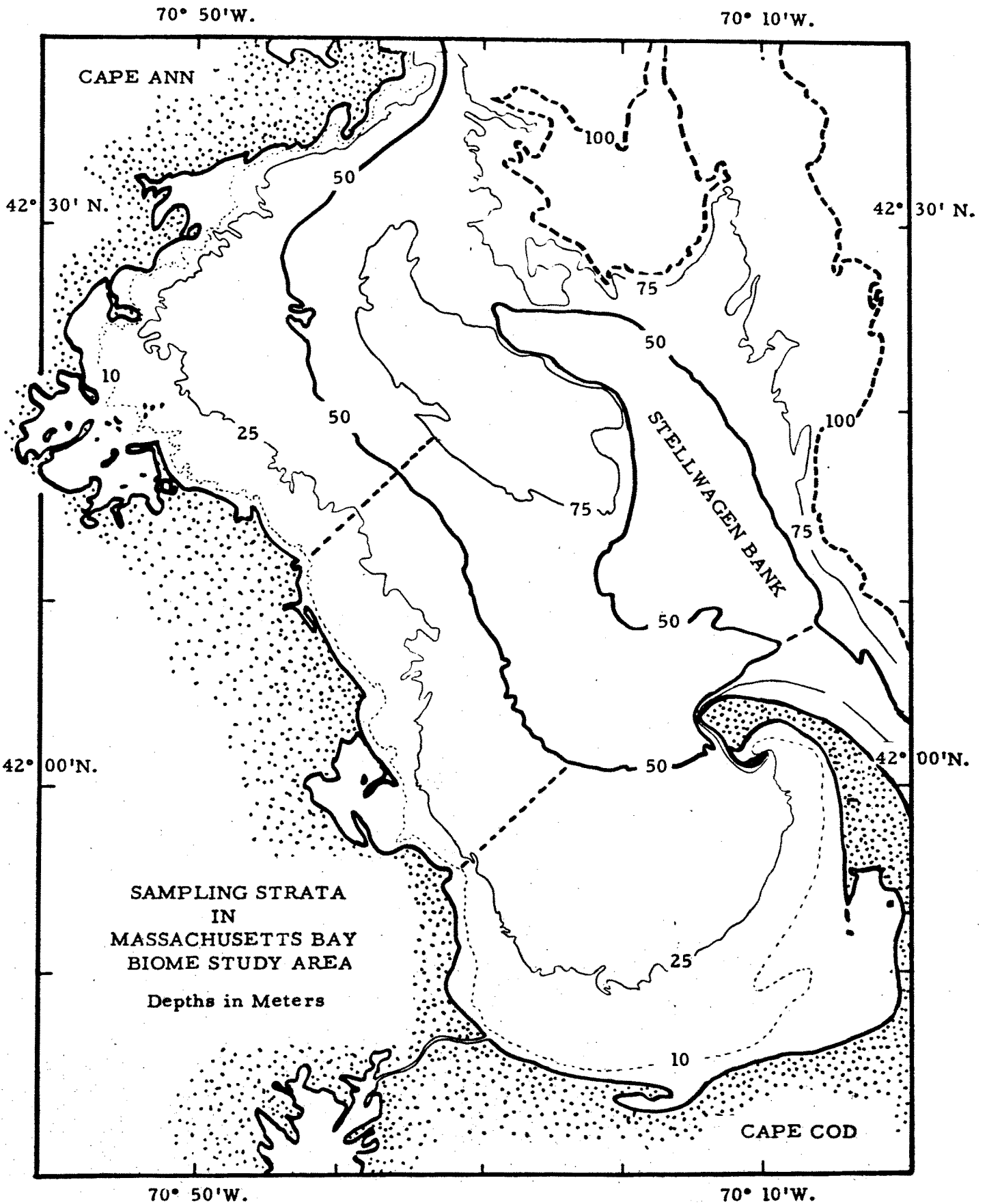

ANALYTICAL

MASSACHUSETTS BAY BIOME STUDY

FIELD ACTIVITY

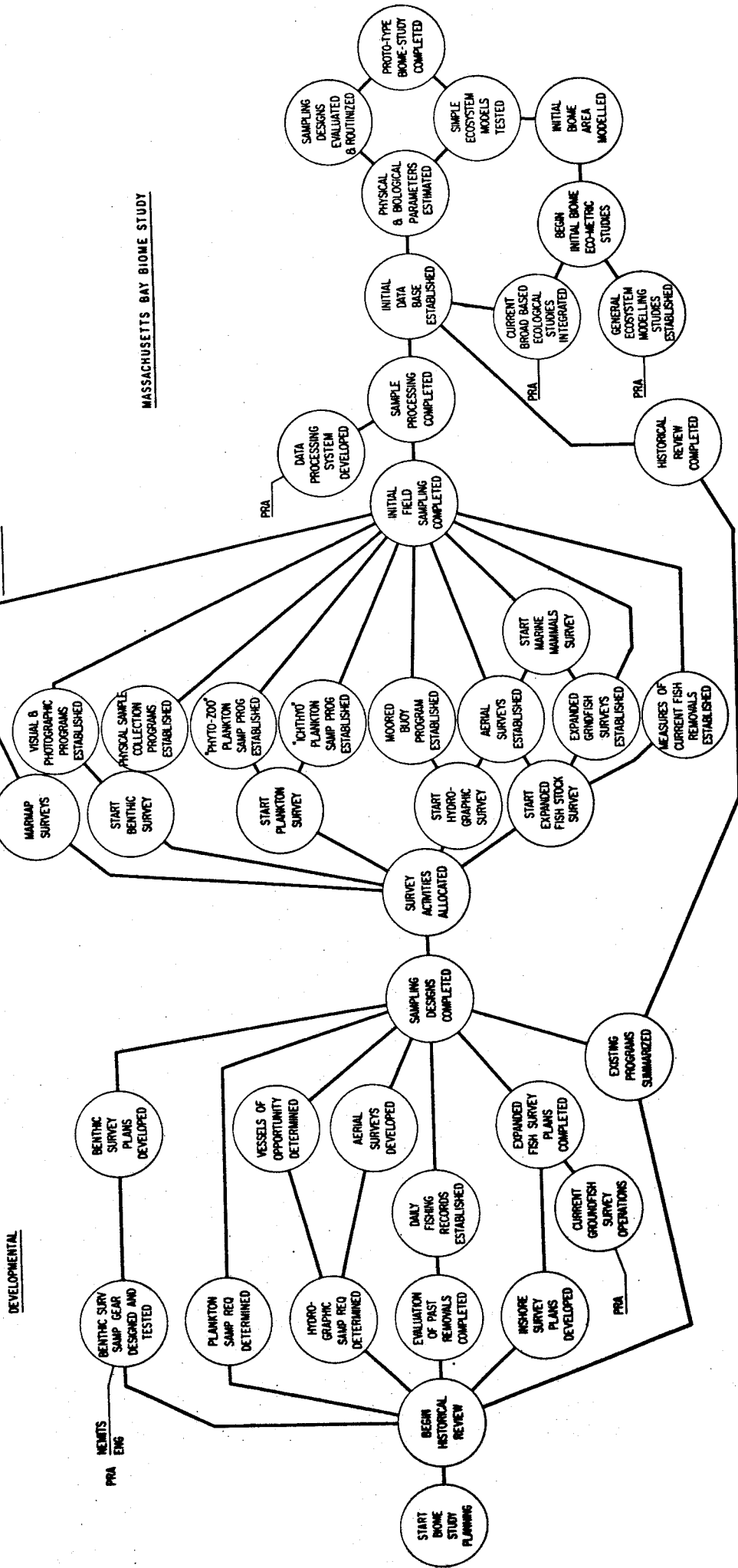

DEVELOPMENTAL

PRA ENG

PRA

PRA

PRA

PRA

4.1.3 Alternate Resources

Northeast Fisheries Center has proposed an intensive Alternate Resources Development Program. This is designed to assess the availability and potential yield of certain shellfish and groundfish populations which require further development of survey techniques. Such species as mackerel, butterfish, scup, squid, deep-water shrimp, crab (rock and red), pollock and shark are included in this group. The study is designed to extend our survey activities to increase assessment of these species and to provide a basis for fishery development.

Some work is scheduled for this fiscal year by Center investigations, using funds and facilities we anticipate will be available. Pelagic survey cruises aboard the Delaware II are planned in cooperation with the NMFS Center at Sandy Hook for three weeks during the winter of 1973 and up to 30 days in mid-summer. These periods are to be devoted to survey and technique development work using echo-sounding and pelagic-trawl sampling system currently on hand. Areas of operation will be the mid-Atlantic Bight during the winter period and Georges Bank-Gulf of Maine in July.

A two-week period aboard the Albatross IV is scheduled in June 1973 for a survey of large shellfish (crabs and lobster). The 1973 work will be devoted to development of techniques for rapid conduct of resource inventories and for environmental studies. More intensive inventory work and technique comparison involving observation by submersible and underwater photography is proposed for fiscal year 1974.

A two-week survey for deep-water shrimp (royal red and scarlet prawn) is scheduled aboard the Albatross IV in August, 1973. This survey using commercial-type shrimp trawls will be expanded as we are able, using a chartered vessel to conduct a reconnaissance survey of shrimp resources of the Georges Bank area between Hydrographer Canyon and the Fundian Channel in depths of 25 to 500 fathoms.

As indicated above, we are endeavoring to initiate alternate resource development using available facilities, equipment and funding in FY 1973. However, an adequate program will require additional gear development and survey work at sea using chartered vessels.

The program represents an integration of activities within several of the Center's investigations - Fishery Engineering & Technology, Invertebrate Resources, Manner Undersea Technology, and Fishery Management Biology.

ALTERNATE RESOURCES PROGRAM

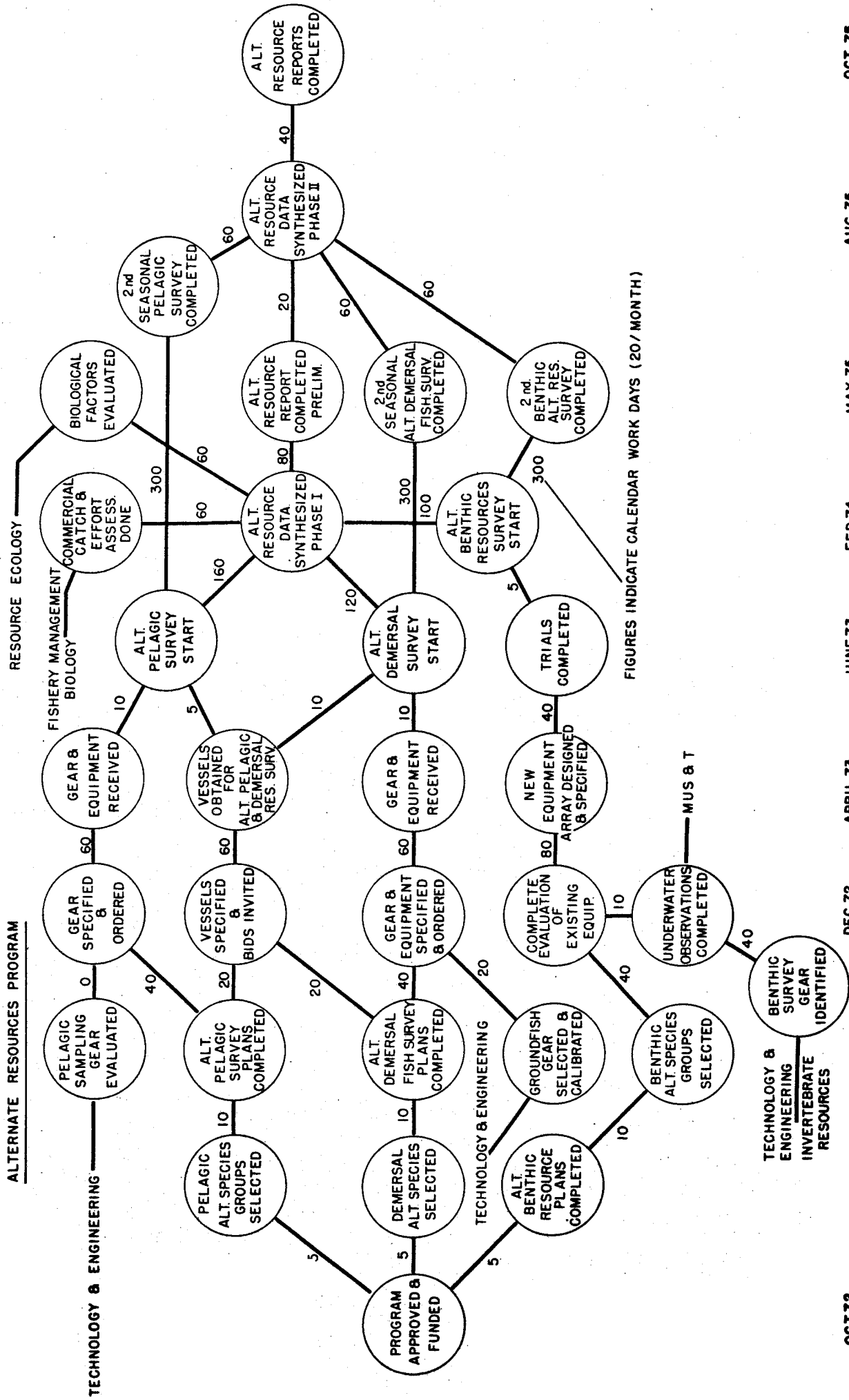

FIGURES INDICATE CALENDAR WORK DAYS (20/MONTH)

OCT.72 APRIL 73 JUNE 73 FEB.74 MAY 75 AUG 75 OCT 75

4.2. Investigations

- 4.2.1. Fishery Management Biology
- 4.2.2. Resource Ecology
- 4.2.3. Fishery Technology and Engineering
- 4.2.4. Experimental Biology I - Physiology
- 4.2.5. Experimental Biology II - Biochemistry
- 4.2.6. Ichthyoplankton
- 4.2.7. Invertebrate Resources
- 4.2.8. Manned Undersea Technology

4.2. Investigations

Research activities of the Center have been organized into eight investigations which are illustrated in the detail on the ensuing pages. They are structured as both functional and problem-solving activities.

The Associate for Resource Research has defined areas of Resource Investigation.

Resource survey: Involves monitoring and assessment of the resources exploited and unexploited to provide biological baseline data of their distribution and abundance, and to detect changes in the resource bases. Routine.

Examples: MARMAP, exploratory fishing, distribution and abundance studies, monitoring and prediction, etc.

Ecology: Investigations to provide information on the interaction between the living resources within their physical and biological environment - especially those interactions that determine their distribution and abundance.

Examples: Trophic dynamics, larval and adult fish physiology and behavior, contaminant research, pathology, oceanography, pollution studies.

Fishing management biology: Activity directed toward providing information necessary to maintain the optimum yield of exploited resources.

Examples: Population dynamics, stock assessment, ICATT, etc.

Technology: Investigations and services to improve the efficiency of resource use and the quality of the products, and to provide engineering support for sampling and assessment work and aquaculture.

Examples: Gear research, instrumentation, vessels, etc.

Aquaculture: Activities related to the culture of aquatic organisms for public utilization.

Examples: Food culture, hatchery engineering, etc.

The relation of the Center's investigation to these areas is shown on the chart following.

NEFC Areas of Resource Investigations

Center Investigations	Resource Survey	Ecology	Fishery Man. Biology	Technol.	Aqua-culture
Fish. Man. Biol.	**		***		
Resource Ecology	*	***	**		
Fishery Tech. & Eng.	**		*	***	
Exp. Biol. I (Phys.)		***			*
Exp. Biol. II (Biochem.)		*	***		
Ichthyoplankton	***	*			
Invert. Resource	***	*	*		
MUS&T	*	*		***	

* Less than 25% of Activity

** 25 to 50% of Activity

*** 50 to 100% of Activity

4.2.1. Fishery Management Biology Investigation

The Fishery Management Biology Investigation is responsible for 1) assessing the status of the stocks of fish and shellfish in the offshore areas of the Northwest Atlantic and 2) making recommendations concerning the effects of different management regimes from a conservation standpoint. This means determining the effect of fishing on these stocks and the yields that they can sustain, and a continuous monitoring of the fishery.

Several separate tasks have been organized within the Investigation. Biostatistics is concerned with measuring the rates of catch, fishing intensity, and mortality, and with monitoring the effects of regulatory measures. This group works primarily with the information collected by agents of the Fisheries Service's Port Pool and by sea samplers. The Groundfish Survey Cruise Unit is responsible for the conduct of twice yearly groundfish surveys from Cape Hatteras to the Scotian shelf. These surveys provide baseline measurements of the magnitude and age composition of the populations. A third unit is Age Reading, which has the responsibility of aging fish collected from landings and research cruises, so that the age composition of both the removals and the population can be estimated. The above tasks are largely routine but they are essential. A historical time series of data is needed to make an initial assessment of a fishery, but also continual current information is required to monitor changes and update the assessments. These tasks are shown in the PERT Diagram in the upper and lower left hand corners. Efforts are being made to automate some of the age reading through the use of optical scanners and computers, and to improve the measurement of fishing effort by determining the time and depth a net actually fished with fishnet bathykymographs (commonly called "the Black Ball") tied to trawl headropes.

Assessments of effects of fishing are done at various levels of sophistication as indicated in the PERT chart by the terms "first run assessment", "steady state management regime", and "dynamic state management regime". The first utilizes models based on survey cruise standing crop estimates and catch/effort relationships from the commercial fishery; the second involves biological parameters such as growth and mortality rates; while the third requires more complex understanding of ecological factors and population processes.

Current plans involve working over the next year on the assessments of cod, haddock, herring, lobster, mackerel, silver and red hake, redfish, and yellowtail flounder.

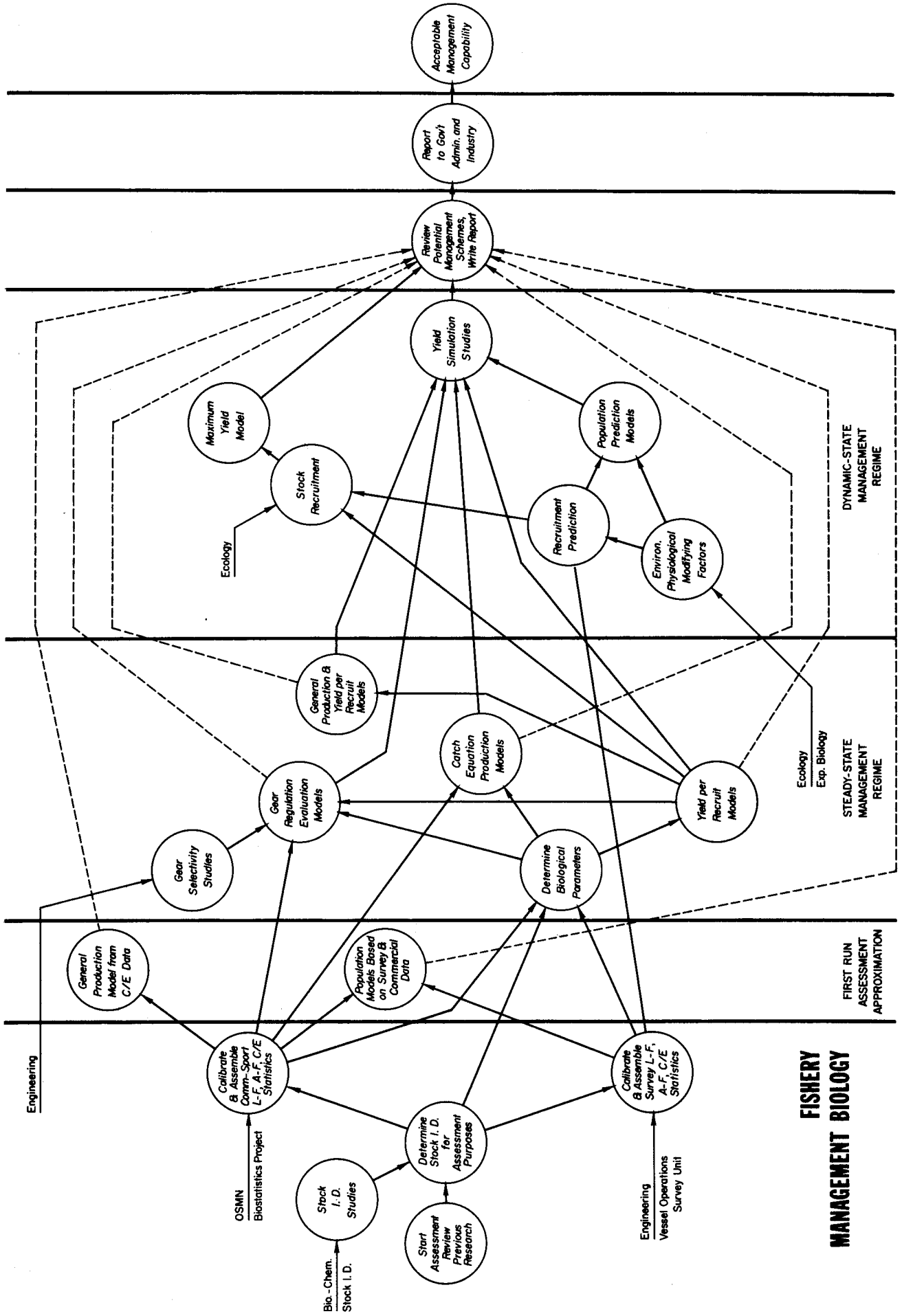

STATUS OF KNOWLEDGE FOR FISHERY MANAGEMENT

	I	II	III	IV	V	VI	VII	VIII	IX	X	XI	XII	XIII	XIV	XV	XVI	XVII	XVIII	XIX	XX	XXI	XXII	XXIII	
	Review Literature	Stock Identification	C/E Data Assembly	Catch Sampling Program	Analysis of Effort	Commercial C/E Analysis	L. F. Evaluation of Removals	Pop. Size & Abund. Index Survey	L. F. Evaluation of Population	General Production Model	Prod. Model from Survey Estimates	Growth Curve	A. F. Evaluation of Population	Yield/Recruit Model	Mesh Studies	Catch Equation Prod. Model	Virtual Pop. Analysis	Prediction Model						
1) Lobster	■	■	■	■	■	■	■	■	■	■	■	■	■	■	■	■	■	■	■	■	■	■	■	
2) Herring	■	■	■	■	■	■	■	■	■	■	■	■	■	■	■	■	■	■	■	■	■	■	■	
3) Silver Hake	■	■	■	■	■	■	■	■	■	■	■	■	■	■	■	■	■	■	■	■	■	■	■	
4) Red Hake	■	■	■	■	■	■	■	■	■	■	■	■	■	■	■	■	■	■	■	■	■	■	■	
5) Mackerel	■	■	■	■	■	■	■	■	■	■	■	■	■	■	■	■	■	■	■	■	■	■	■	
6) Yellowtail	■	■	■	■	■	■	■	■	■	■	■	■	■	■	■	■	■	■	■	■	■	■	■	
7) Cod	■	■	■	■	■	■	■	■	■	■	■	■	■	■	■	■	■	■	■	■	■	■	■	
8) Squid	■	■	■	■	■	■	■	■	■	■	■	■	■	■	■	■	■	■	■	■	■	■	■	
9) Haddock	■	■	■	■	■	■	■	■	■	■	■	■	■	■	■	■	■	■	■	■	■	■	■	
10) Scallops	■	■	■	■	■	■	■	■	■	■	■	■	■	■	■	■	■	■	■	■	■	■	■	
11) River Herring	■	■	■	■	■	■	■	■	■	■	■	■	■	■	■	■	■	■	■	■	■	■	■	
12) Surf Clams	■	■	■	■	■	■	■	■	■	■	■	■	■	■	■	■	■	■	■	■	■	■	■	
13) Shrimp	■	■	■	■	■	■	■	■	■	■	■	■	■	■	■	■	■	■	■	■	■	■	■	
14) Redfish	■	■	■	■	■	■	■	■	■	■	■	■	■	■	■	■	■	■	■	■	■	■	■	
15) Flounder Species	■	■	■	■	■	■	■	■	■	■	■	■	■	■	■	■	■	■	■	■	■	■	■	
16) Pollack	■	■	■	■	■	■	■	■	■	■	■	■	■	■	■	■	■	■	■	■	■	■	■	
17) Argentines	■	■	■	■	■	■	■	■	■	■	■	■	■	■	■	■	■	■	■	■	■	■	■	
18) Dogfish	■	■	■	■	■	■	■	■	■	■	■	■	■	■	■	■	■	■	■	■	■	■	■	
19) Total Biomass	■	■	■	■	■	■	■	■	■	■	■	■	■	■	■	■	■	■	■	■	■	■	■	

■ Acceptable State of Knowledge (to meet current needs)
 ▤ Preliminary Analysis, complete, refin., necs.
 ▥ Data Available - no analysis
 □ No Data

4.2.2. Resource Ecology Investigation

The goal of this investigation is to acquire a basic understanding of the manner in which natural biotic and abiotic factors control the distribution and abundance of marine organisms. Such an understanding is essential in order to have any reasonable chance of distinguishing between the usually more subtle long term natural changes and those caused by fishing or pollution, and to improve both short- and long-term predictions of potential yield. The investigation involves the study of interrelationships among all the major biological communities and the environment in New England waters.

Our research strategy has two primary phases. The first involves rather intensive studies of critical biological processes controlling production of marine fishes - recruitment, growth, and natural mortality. Attempts will be made to identify the controlling mechanisms and how they interact with the species composition and biomass of all biological communities as well as abiotic factors. Particular emphasis will be placed on factors affecting survival of early life stages of a few selected, representative species, and on energy requirements and feeding interactions among key species in the pelagic and demersal communities. Environmental studies will be closely integrated with the above and special emphasis will be given to understanding water circulation controlling dispersion of eggs and larvae. Results of these studies will be used to formulate mathematical models of processes, e.g., recruitment, which may be applicable to a wider range of species.

The second phase of research involves analysis of long-term changes in such processes as spawning, growth, and natural mortality in relation to changes in total biomass and structure of fish communities as well as other major biological communities and the environment.

These studies are critical to the assessment of total biomass yields and to the assessments of individual fisheries, particularly in relation to the dynamic phase of assessments.

4.2.3. Fisheries Technology and Engineering Investigation

This investigation is currently staffed primarily by personnel of the Gloucester Exploratory Fishing and Gear Research Base, which was transferred to Woods Hole in September 1970 and included as part of the Northeast Fisheries Center. Work projects are assigned in two major areas: sampling gear development and harvesting system development.

An Alternate Resources Development project has been planned by this group and the Invertebrate Resources Investigation (see Section 4.1.3.).

A Lobster Conservation project is underway to devise methods of eliminating the threat posed by the so-called "Ghost Pot" problem. Standard and experimental lobster pots are to be tested with the assistance of the Center diving team at Boothbay Harbor.

Projects related to separator trawls, savings gear-mesh selection studies, and the design of effectively selective scallop fishery gear will be developed in order to assure efficient use of the resource and to promote compatibility with conservation requirements.

Three Modified No. 41 Trawls, designed to fish with up to 16-foot headrope height and yet retain the durability and ease of repair of the standard No. 41, are to be given a second series of sea trials September 12-22. These are candidates for a new standard groundfish survey trawl. If they are as successful as we anticipate, they should also be superior fishing trawls.

A juvenile fish trawl to sample fishes too large and active to take in plankton nets but too small for conventional bottom or midwater trawls is also under development.

The Fishnet Bathykymograph, a device that fits in a headrope float-type steel ball and automatically measures the time and depth of trawl tows on commercial fishing vessels, is almost completely developed and in service. An Automatic Data Logger that records (on magnetic tape) course, speed, and position of the vessel, plus 23 other meteorological, hydrographic, and biological measurements was developed to aid in survey cruise data processing.

Fishery Engineering and Electronic Support to the various programs of the Northeast Fisheries Center are the responsibility of this investigation.

FISHERIES TECHNOLOGY AND ENGINEERING

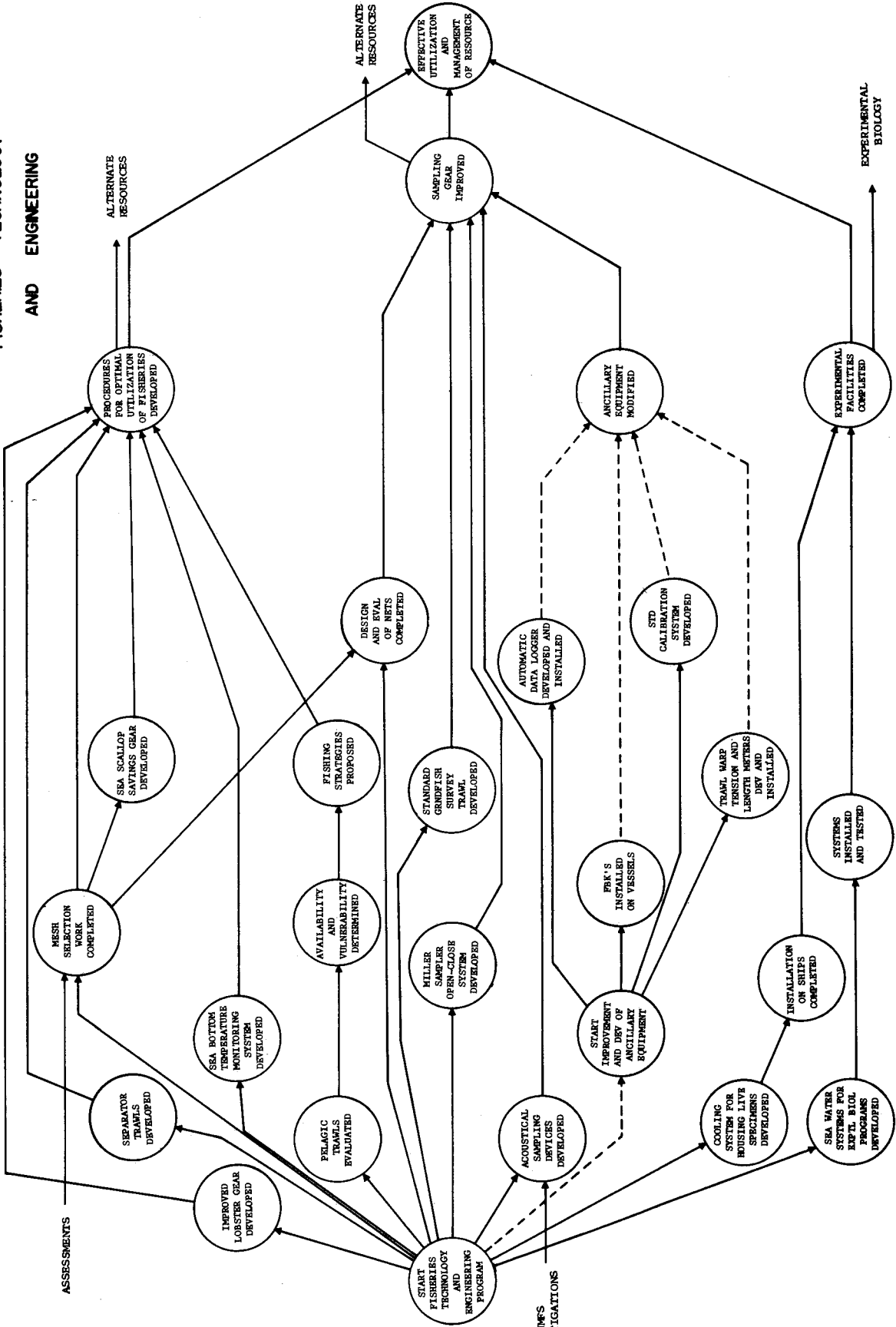

4.2.4. Experimental Biology (Physiology) Investigation

As part of the NEFC's mission of conserving the living marine resources of the Northeast Atlantic, the Experimental Biology (Physiology) unit conducts laboratory studies to aid in the determination of the mechanisms of survival of the early life stages of selected finfishes and invertebrates.

The investigations will need a reliable and constant source of experimental materials to solve the basic problems associated with survival. Consequently, the physical and biological requirements of adult organisms, especially as it applies to reproductive capacity and spawning in the laboratory, must be determined. Suitable systems for rearing and maintaining the resultant early life stages must also be developed.

Survival processes will be determined by studying growth, metabolism, feeding relationships and behavior as influenced by a variety of biotic and abiotic factors.

Ultimately, the results of these laboratory studies will be coordinated with other field-oriented Center investigations to gain a basic and broad knowledge of the biology of young life stages. This, in turn, will lead to an understanding of recruitment processes and the relationship to exploitable biomass as well as the impact of natural and man-induced environmental changes on the productivity of living marine resources.

This investigation furnishes one of the prime sources of information that is required to understand the life processes that affect abundance. It deals with knowledge we must have, to achieve our objectives. The impact of these studies will be evident 5 years from now.

BASIC SUPPORT STUDIES
REGIME

EXPERIMENTAL STUDIES
REGIME

ANALYTICAL STUDIES
REGIME

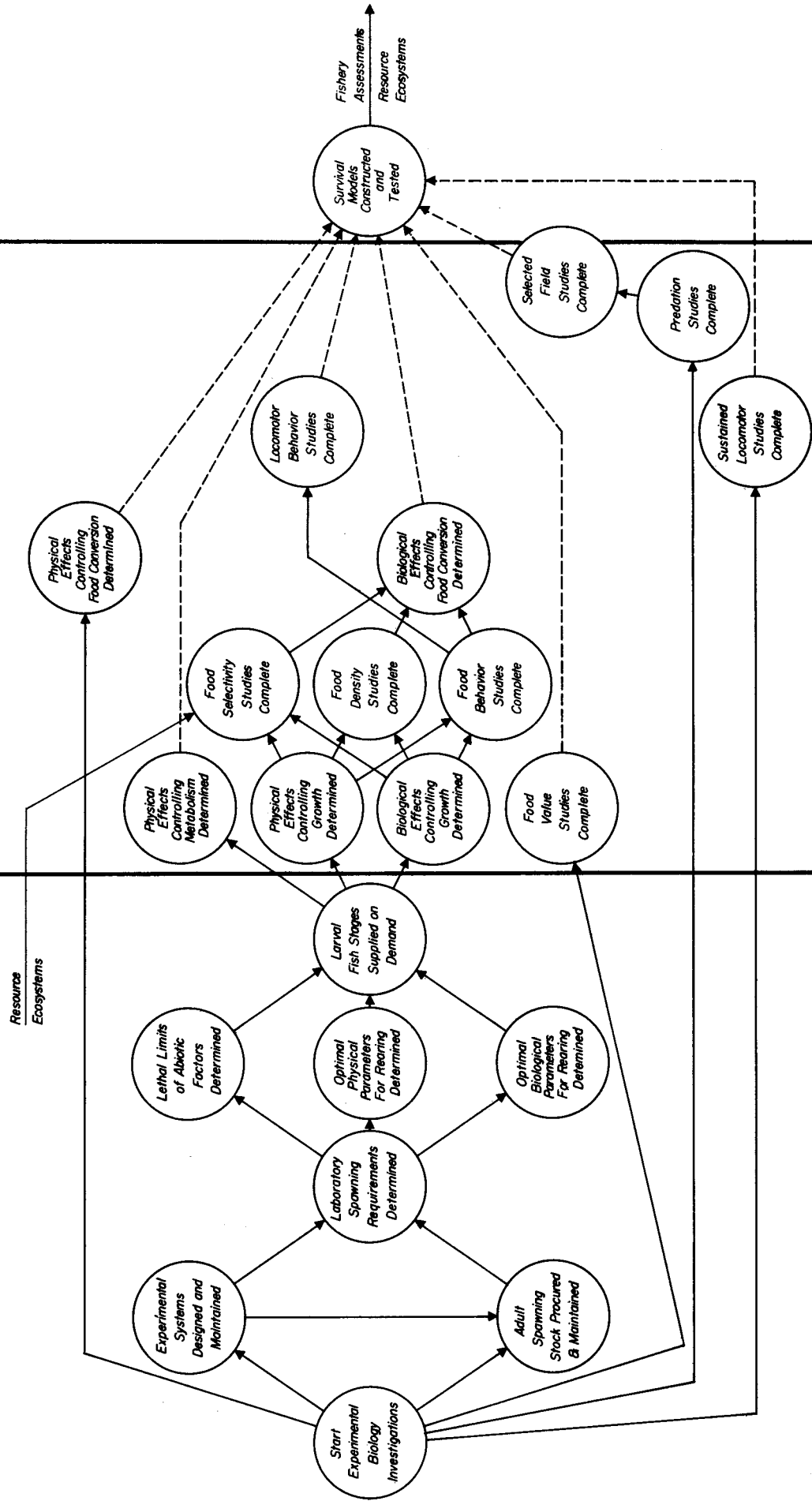

EXPERIMENTAL BIOLOGY I
PHYSIOLOGY

4.2.5. Experimental Biology (Biochemistry) Investigation

All species of fish are separated into a number of discrete geographic races or unit stocks. These stocks spawn in separate places and in some cases at different times or seasons. Nevertheless, several stocks may intermingle during juvenile stages or while undertaking feeding or overwintering migrations. Such unit stocks may differ not only in their distribution patterns but in growth rate, fecundity, year class abundance, and mortality rates. Thus, accurate assessment and management of resource species must be based on a knowledge of their stock structure.

The objective of the Center's biochemistry investigation is to use biochemical and population genetic methods to delineate the unit stock structure of important resource species in the Northwest Atlantic. Work accomplished so far indicates that important resource species have numerous genetically controlled systems of biochemical characteristics that occur in several forms or types. Similar characters are well known in man, e.g., skin color, eye color, and blood types. Stocks of marine animals vary in their biochemical characteristics and this variation can be used to distinguish among them.

Currently, biochemical studies are being made on the stock structure of herring, lobsters, yellowtail flounder, and salmon. Research is also underway to apply biochemical methods to identification of egg and larval forms taken on ichthyoplankton surveys. The biochemical studies on lobsters are virtually complete. The studies on herring are relatively far advanced but the stock structure of herring is complex and an additional two years work will be required to clarify detailed aspects. Biochemical research on yellowtail flounder has only recently been started but excellent progress has been made in finding useable genetic characters. The West Greenland salmon fishery has created a serious problem of international management, and research has been initiated to determine the relative contribution to Greenland of salmon stocks from Europe and America.

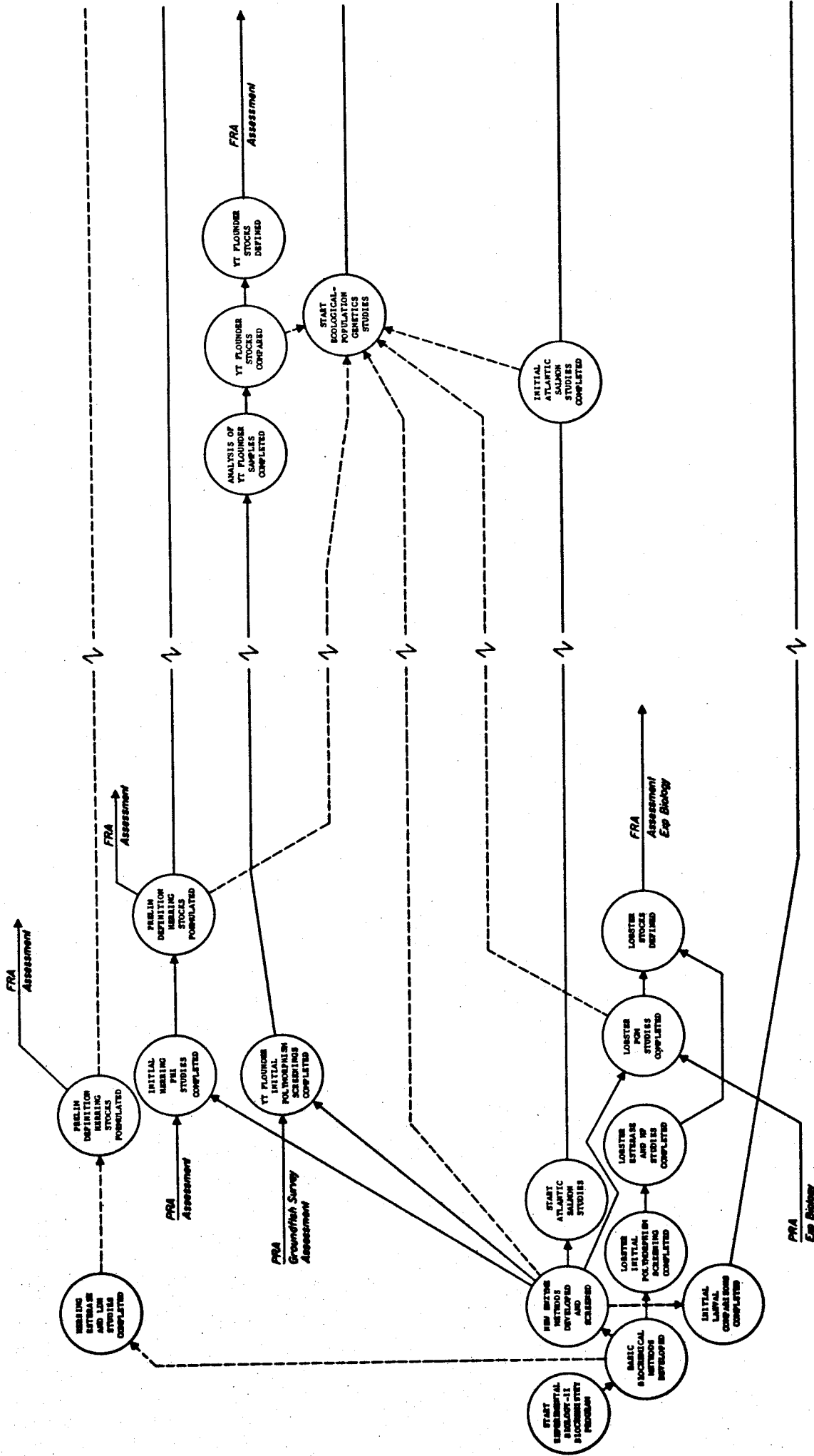

EXPERIMENTAL BIOLOGY II BIOCHEMISTRY

JUL 72 1 OCT 1 JAN 1
 APR JUL 73 1 1 1
 OCT 1 JAN 1

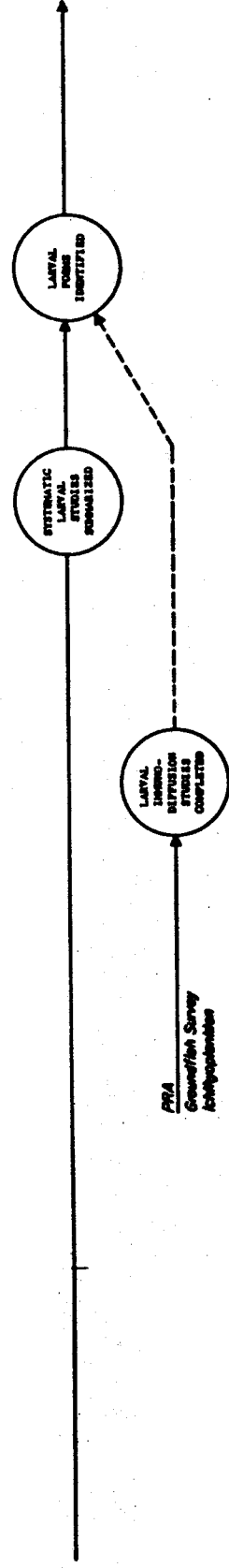
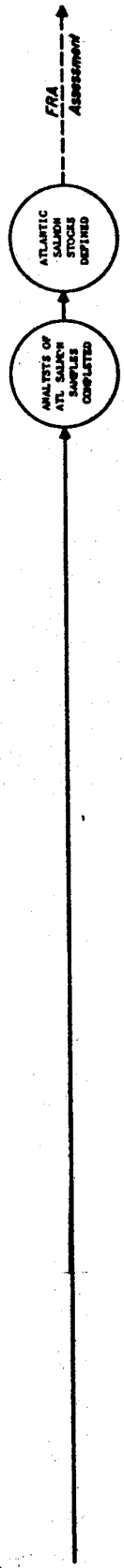
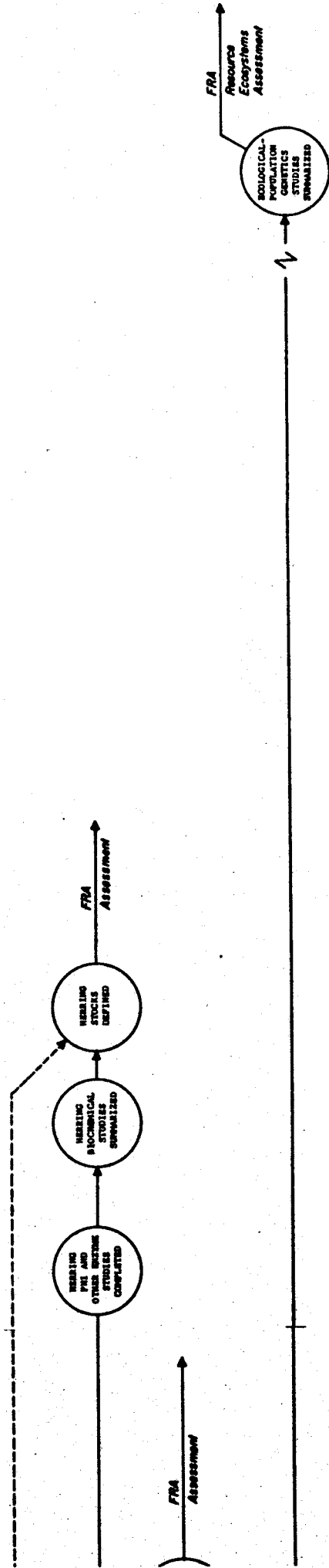

MAY |
 APR |
 APR |
 OCT |
 JAN |
 APR |
 JUL 76 |

4.2.6. Ichthyoplankton Investigation

This program is responsible for the shoreside handling of plankton samples collected on MARMAP and Northeast Fisheries Center cruises in coastal and offshore waters between Nova Scotia and Cape Hatteras. The immediate program objectives are: (1) Receive, catalog, process, store, and disseminate ichthyoplankton samples and data; (2) Sort, identify, measure, and enumerate fish eggs and larvae, and determine zooplankton biomass; (3) Conduct studies of the systematics of previously undescribed Northwest Atlantic larvae fishes; (4) Develop new techniques to more effectively and efficiently sort, measure, and enumerate fish eggs and larvae; and (5) Prepare and publish tabular, graphic, and descriptive summaries of the distribution abundance, taxonomy, and early life history stages of fish eggs and larvae.

These objectives relate primarily to the functional aspect of the investigation. They result in providing the data base which is required for completing the objectives in Management Biology and Resource Ecology Investigations. The initial activities will be concentrated on fish eggs and larvae to furnish the basis for estimating future recruits and adults. However, a measure of the total plankton biomass will ultimately be obtained to permit an independent assessment of yield potential of the fish biomass.

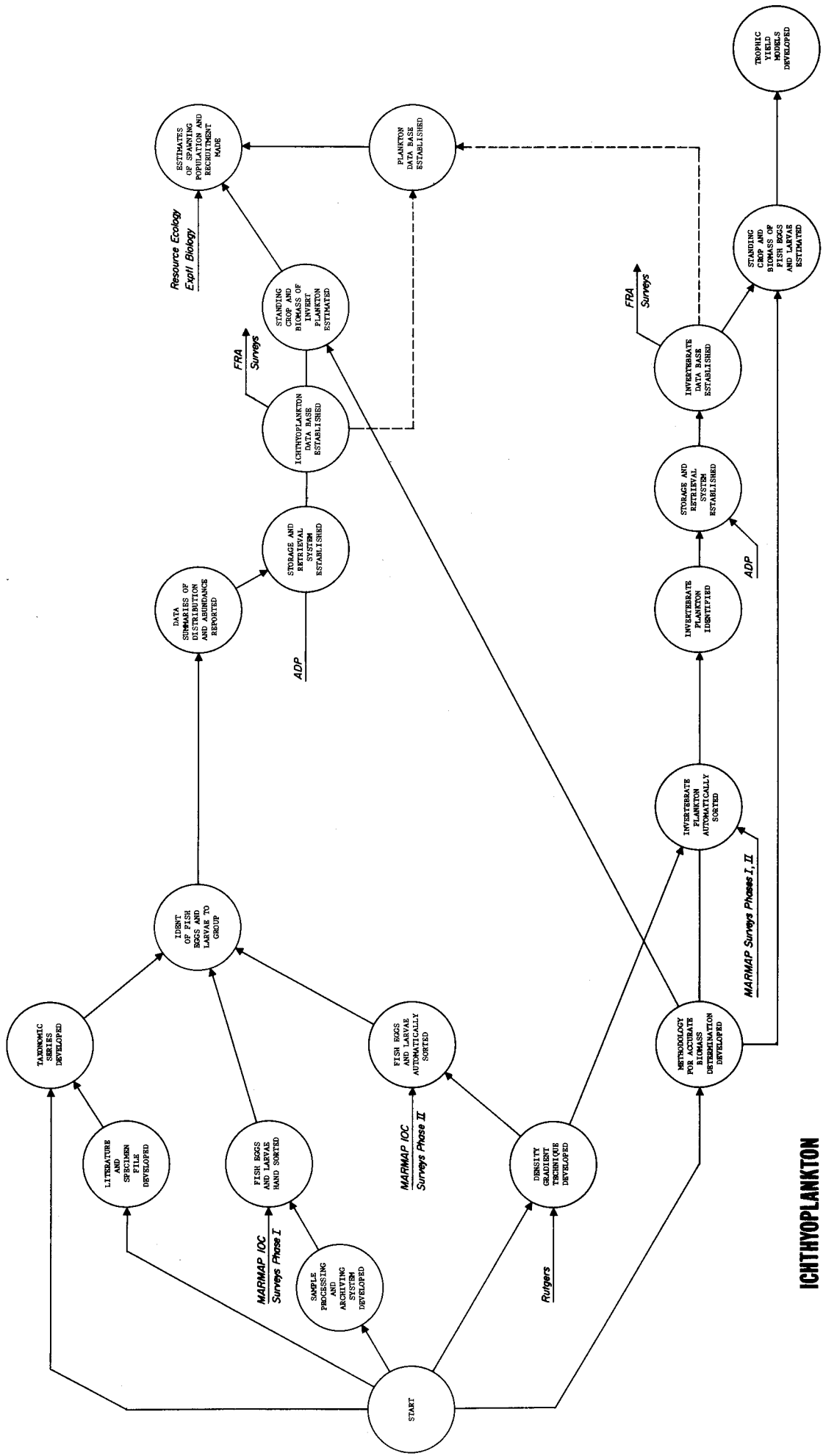

ICHTHYOPLANKTON

4.2.7. Invertebrate Resources Investigation

The principal goals of this investigation are to determine the distribution, abundance, and -- for selected species -- life history of bottom-living invertebrate animals. This includes large and abundant species, such as the northern shrimp, rock crab, sea scallop, as well as the multitude of small organisms that serve as food for other invertebrates and fishes. (Part of the alternate resource task is included in this activity.)

Knowledge of the different kinds of invertebrates that inhabit our offshore waters, their interrelationships with one another, and their dependence upon the various environmental characteristics are necessary to understand the productive potential of the area. Because of the prime importance of food supplies in the production of fish, our objective is to ascertain the kinds of organisms inhabiting the various fishing grounds, particularly the more productive areas, and ultimately to determine the quantities of major fish foods produced each year. This knowledge together with estimates of plankton production provides a basis for estimating fish production.

Invertebrates presently constitute a major share (54 percent of the total value) of all fishery products landed in New England. To allow for expanding utilization of invertebrates, we are emphasizing study of two species of squid -- the long-finned squid and the short-finned squid; both species occur in large quantity of New England. Information about cancer crabs and deepwater shrimp are also being developed. These activities will be coordinated with direct sampling (c.f. fishery technology) to ascertain potentials.

Materials for invertebrate studies are collected on groundfish survey cruises, cooperating institutional cruises (U. S. Geological Survey, Woods Hole Oceanographic Institution, etc.), and special cruises of NMFS vessels. The sampling is coordinated under Phase II of MARMAP. Biological information to supplement and calibrate the surface-collected samples is obtained from photographs and visual observations of the sea bottom from research submarines and SCUBA-equipped divers in the MUS&T activity.

4.2.8. Manned Undersea Technology Investigation

The Northeast Fisheries Research Center initiated a Man-in-the-Sea program in the winter of 1972 to solve certain resource oriented sampling problems that have been difficult or impossible to address using conventional surface oriented techniques. Major goals of the New England Man-in-the-Sea (MITS) program are (1) develop efficient research diving capability to the edge of the continental shelf - 100 fathoms, (2) a description of the early life history of the sea herring, Clupea harengus, and knowledge of the ecological factors that effect their survival, (3) survey of the macro-benthos of the outer continental shelf with special reference to the seasonal distribution and abundance of the lobster.

Within the first year of operations, Center team personnel have been trained in research submarine operations and diver lock-out to depths of 300 feet. Saturation diving and bounce diving techniques have been developed, working from fixed habitats on the ocean bottom and stationary platforms at the surface. By 1976 this investigation calls for scientists to be conducting in-situ research at any desired depth of the continental shelf. Scientist/divers from the Fisheries Research Board of Canada, several coastal states of the New England area and other NOAA research activities are also involved.

The first major field study to define the early life history of the sea herring and the ecological factors affecting their survival will take place during September and October, 1972 in the vicinity of Jeffreys Ledge, western Gulf of Maine. This mission will be a prelude to similar studies of herring on Georges Bank in 1973 through 1975.

Seasonal cruises with surface support ship and research submarine will be continued in the offshore fishing grounds between Veatch and Hydrographer Canyons beginning in the spring of 1973. Major emphasis will be placed on defining, calibrating towed optical sampling gear to determine the seasonal distribution, abundance and ecology of the lobster and other commercially important shellfish.

Beginning in mid-fiscal 1973 a one-year study will commence in inshore Gulf of Maine waters to define trap related lobster behavior, escapement re vent size, cannibalism and catchability re trap design on a cost-effective basis. A major part of these data will be gathered by diver/scientists working in cooperation with personnel of the Fisheries Engineering Program.

MANNED UNDERSEA TECHNOLOGY

NON-NAFES DIVERS; R & D DIVING EQUIPMENT

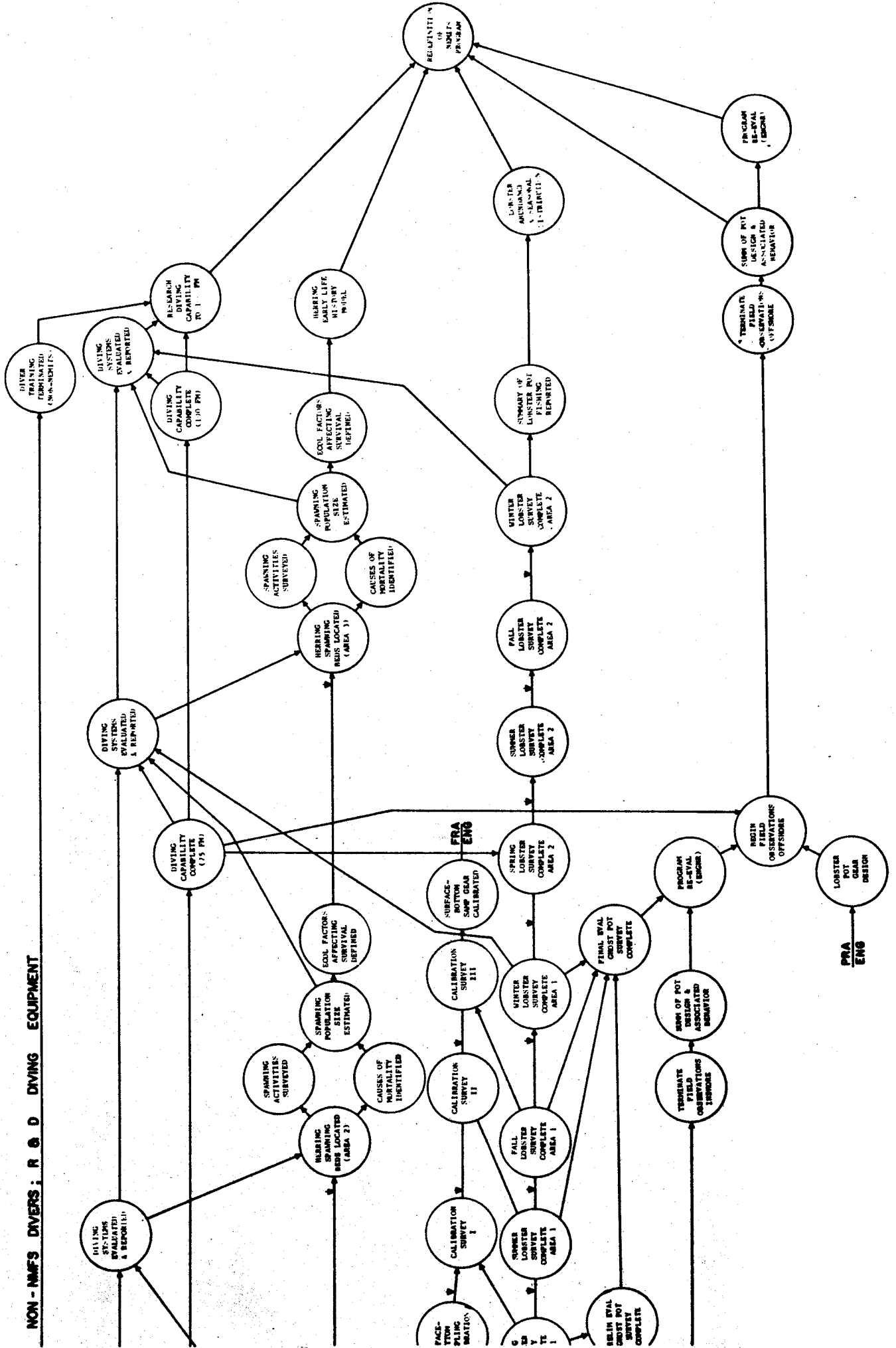

4.3. Additional Studies

4.3 Additional Activities

The increased use of the ocean for mining, oil extraction, dumping, cooling water, etc. has caused great public concern for the future state of the marine environment. As a consequence, there has been an increasing need for evaluation of the effects of such use, both before and after the event. The Center provides a focal point of knowledge and expertise that is frequently called upon for data, advice and assistance in these evaluations which are the administrative responsibility of other agencies. We accept this as an important function of the Center. However, the increasing workload imposed by this activity generally not planned in advance tends to interfere with planned investigations that provide the very basis of the knowledge which is required.

New England Offshore Mining Evaluation Study (NOMES)

Project NOMES has been designed by NOAA to evaluate the biological, chemical, and physical effects of dredging sand and gravel from marine deposits. It is to be directed by the Environmental Research Laboratories and managed by the Marine Minerals Technology Center. All operations will be conducted by State, university, and private groups through contracts from Sea Grant and NOAA and with some matching funds.

The NEFC has been directed, by NOAA through NMFS, to provide scientific and technical guidance to NOMES on the biological aspects of the project. This consists of reviewing contract proposals, suggesting changes or additions, monitoring progress, reviewing results, and assisting in the final interpretation of the environmental impact of the dredging. Mr. J. A. Posgay and Dr. R. L. Wigley have been detailed to provide these services. Other staff members will assist as a need for their particular expertise develops.

In order to provide a more rational basis for evaluation of this and other uses of the marine area, we have developed and proposed a more comprehensive study - the Biome Study (see Section 4.1.2).

Effects of Oil Extraction

At least 2 months of one of our high level scientists time has been expended to review and advise on the effects of possible oil pollution. We can expect increased demands on the Center for information and evaluation studies.

Water Pollution

We have over the last year provided nearly one full man-year to aid in the evaluation of proposals for power plants, dredging, dumping, etc.,

Northern Lobster Management

There has been a good deal of pressure lately to come up with a

(4.3 Additional Activities)

management plan for the northern lobster based on State and Federal cooperation. Biologists of the NEFC have participated in several planning sessions and meetings with State biologists and administrators. The latest meeting resulted in the formation of a technical and a policy committee to consider the matters raised at the meeting, and we are providing a biologist to participate in the former.

Direct Aid to Industry (Extension)

The industry is becoming more sophisticated in its planning and development of fisheries. We are frequently requested to supply data and information for a variety of needs. We are trying (and planning) to routinely provide more useful information to the public and private sectors. We do now provide a full man-year to extension activities.

However, we cannot predict all the demands for information, and thus we must many times devote unplanned time and money, to be responsive.

We are involved in many other activities related to our scientific position in the community. We are providing staff to teach courses at the Massachusetts Maritime Academy. We continually evaluate proposals and review results of contract work done by states (P. L. 88-309), universities (Sea Grants), and other national agencies (NSF, EPA, etc.). We also provide facilities and staff time to training of students from the U. S. and other countries.

The accumulated effect of these activities probably accounts for 5-10% of our present activities. It is difficult to get direct support for this - we must develop some slack in the Center program to be properly responsive.

5.0. Staff

5.0. Staff

The pages following list by investigations and administrative units the present staff and what we consider the optimum staff. The latter is our best judgement of the personnel required to achieve all objectives within the required time span.

The Center currently employes 129 full-time, permanent people, of which 79 are in the research investigations and 50 in technical support and administration. We are presently allocated 130 full-time, permanent positions. We will propose an increase of 77 over the next two years.

These numbers do not include the Port Captain and his Assistant nor the vessel crew of 22. These positions are due for transfer to the NMFS Office of Fleet Operations in January 1974. In addition, there are 13 temporary or intermittent employees, and 35 students in the cooperative training program and summer assistants' category.

**NORTHEAST FISHERIES CENTER
TABLE OF ORGANIZATION**

<u>Title</u>	<u>Proposed Staff</u>		<u>No.</u>	<u>Present Staff</u>	
	<u>No.</u>	<u>Grade</u>		<u>Name</u>	<u>(Grade)</u>
<u>Fishery Management Biology</u>					
Investigation Chief	1	GS 13-15	1	Brown	(13)
<u>Assessment</u>					
Task Leader	1	GS 12-14			
Research Biologists	6	GS 5-13	4	Anderson	(12)
				Heyerdahl	(12)
				Anthony	(12)
				Vacant	(5)
Math. Statistician	1	GS 9-11	1	Brennen	(9)
Technicians	2	GS 4-6	2	Callahan	(7)
				Lewis	(5)
<u>Biostatistics</u>					
Task Leader	1	GS 12-14	1	Stern	(12)
Research Biologists	2	GS 9-11	1	Parrack	(9)
Statistician	1	GS 9-11			
Technicians	3	GS 4-9	4	Dryer	(9)
				Lozier*	(7)
				Morgan	(2)
				Wentworth*	(7)
<u>Groundfish Survey Unit</u>					
Survey Unit Leader	1	GS 9-11	1	Jensen	(9)
Research Biologist	1	GS 9	1	Flescher	(9)
Chief Data Technician	1	GS 7-9			
Sea-going Technicians	7	GS 4-7	2	Mantzaris	(5)
				Poskus	(4)
<u>Age Unit</u>					
Unit Leader	1	GS 11-13	1	Nichy	(11)
Research Biologists	2	GS 5-7	1	Pentilla	(5)
Technicians	3	GS 3-5	2	Gifford	(3)
				Vacant	(4)
<u>NUMBER</u>		<u>TOTAL</u>		<u>NUMBER</u>	
34	<u>AVERAGE GS</u>			22	<u>AVERAGE GS</u>
	8.0				7.8

*Samples ports in Maine for sardines, and does other work elsewhere performed by OSS.

<u>Title</u>	<u>Proposed Staff</u>		<u>No.</u>	<u>Present Staff</u>		
	<u>No.</u>	<u>Grade</u>		<u>Name</u>	<u>(Grade)</u>	
	<u>Resource Ecology</u>					
Investigation Chief	1	GS 13-15	1	Grosslein (14)		
	<u>Recruitment Processes</u>					
Leader	1	GS 12-14	5	Au (11)		
FRB	6	GS 9-13		Graham (13)		
						Livingstone (11)
Technician						4
						Dohrmann (4)
						<u>Ecosystem Dynamics</u>
Leader	1	GS 12-14	3	Griswold (11)		
FRB	5	GS 7-12		Lux (12)		
						Morris (7)
Technician						3
						Hersey (7)
						<u>Environmental Studies</u>
Leader	1	GS 12-14	1	Nickerson (8)		
FRB	1	9-11				
Technician	1	7-9				
	<u>Gamefish Studies*</u>					
Leader	1	GS 12-14	1	Casey (12)		
FRB	1	GS 9-11	1	Stillwell (9)		
Technician	2	GS 5-9	1	Pratt (5)		

TOTALS

<u>NUMBER</u>	<u>AVERAGE GS</u>	<u>NUMBER</u>	<u>AVERAGE GS</u>
28	9.7	17	9.2

	<u>Engineering & Technology</u>				
Chief	1	GS 13-15	1	Smith (14)	
	<u>Sampling Gear Development</u>				
Leader	1	GS 12-14	2	Corbett (11)	
FRB	1	GS 9-12		Blott (9)	
Mechanical Engineer	2	GS 9-12		Twohig (12)	
Electrical Technician	1	GS 5-12	2	Carter (9) (to Alb. IV OFO)**	
Engineer Draftsman	1	GS 4-7			

*Mather (WHOI Cooperator)

**This position will be assigned to OFO when Albatross IV management is transferred to NOAA.

<u>Title</u>	<u>Proposed Staff</u>		<u>No.</u>	<u>Name (Grade)</u>
	<u>No.</u>	<u>Grade</u>		
	<u>Harvesting Systems</u>			
Leader	1	GS 12-14	1	McRae (13)
FRB	2	GS 7-12	1	Bowman (12)
FMES (Incl. Trawl Master)	3	GS 7-11	1	Handwork (11)
Electrical Technician	1	GS 9-11	1	Crossen (11)
Technicians	2	GS 4-7		

TOTALS

<u>NUMBER</u>	<u>AVERAGE GS</u>	<u>NUMBER</u>	<u>AVERAGE GS</u>
18	9.3	10	10.7

	<u>Experimental Biology I (Physiology)</u>			
Chief	1	GS 13-15	1	Laurence (12)
	<u>Spawning & Rearing</u>			
Leader	1	GS 12-14		
FRB	2	GS 7-12	1	Rogers (7)
Technicians	3	GS 4-9	1	Halarik (4)
	<u>Experimental Physiology</u>			
Leader	1	GS 12-14		
FRB	3	GS 9-12	2	Stickney (13)
Technicians	3	GS 4-9	2	Chenowith (11)
				Perkins (9)
				Smigielsky (7)

TOTALS

<u>NUMBER</u>	<u>AVERAGE GS</u>	<u>NUMBER</u>	<u>AVERAGE GS</u>
14	9.6	7	9.0

	<u>Experimental Biology II (Biochemistry)</u>			
Chief	1	GS 13-15	1	Ridgway (14)
Population Geneticist	1	GS 12-14		
FRB	3	GS 9-12	3	Watson (12)
				Lewis (11)
Technicians	4	GS 4-9	3	Perkins (11)
				Sherburne (9)
				Dogget (3)
				Marston (3)

TOTALS

<u>NUMBER</u>	<u>AVERAGE GS</u>	<u>NUMBER</u>	<u>AVERAGE GS</u>
9	9.3	7	9.0

<u>Title</u>	<u>Proposed Staff</u>		<u>No.</u>	<u>Present Staff</u>	
	<u>No.</u>	<u>Grade</u>		<u>Name (Grade)</u>	
	<u>Ichthyoplankton</u>				
Chief	1	GS 13-15	1	Colton (13)	
	<u>Research & Development</u>				
Leader	1	GS 12-14			
FRB	1	GS 9-12			
Technician	1	GS 4-7			
	<u>Sorting & Identification</u>				
Leader	1	GS 12-14			
FRB	4	GS 7-12	2	Burns (7) Kinnear (9)	
Technicians	2	GS 5-9	1	Stoddard (7)	
Sorters	6	GS 2-4	2	Munroe (2) Vacant (2)	

<u>TOTALS</u>			
<u>NUMBER</u>	<u>AVERAGE GS</u>	<u>NUMBER</u>	<u>AVERAGE GS</u>
17	7.5	6	6.7

	<u>Invertebrate Resources</u>				
Chief	1	GS 13-15	1	Wigley (14)	
	<u>Taxonomy & Distribution</u>				
Leader	1	GS 12-14			
FRB	2	GS 7-11	1	Theroux (9)	
Technicians	3	GS 4-7	1	Murray (7)	
	<u>Resource Production</u>				
Leader	1	GS 12-14	1	Rathjen (13)	
FRB	2	GS 9-12			
Technicians	2	GS 4-7			

<u>TOTALS</u>			
<u>NUMBER</u>	<u>AVERAGE GS</u>	<u>NUMBER</u>	<u>AVERAGE GS</u>
12	9.0	4	10.0

	<u>Manned Undersea Technology</u>				
Chief	1	GS 13-15	1	Cooper (12)	
FRB	3	GS 9-13	3	Uzmann (13) Boyer (12) Pecci (5)	
Technicians	4	GS 5-9	3	Clifford (7) Newell (7) Orne (5)	

<u>TOTALS</u>			
<u>NUMBER</u>	<u>AVERAGE GS</u>	<u>NUMBER</u>	<u>AVERAGE GS</u>
7	9.3	7	8.9

<u>Title</u>	<u>Proposed Staff</u>		<u>Present Staff</u>	
	<u>No.</u>	<u>Grade</u>	<u>No.</u>	<u>Name (Grade)</u>
<u>Administration</u>				
<u>Directorate</u>				
Director	1	GS 16	1	Edwards (16)
Deputy Director	1	GS 15	1	Hennemuth (15)
Executive Officer	1	GS 13-14	1	Skerry (13)
Secretary	3	GS 3-6	2	Crook (4) Vacant (3)
Special Staff Assts	4	GS 5-14	2	Posgay (14) Kelly (13)
<u>Support</u>				
Administrative Officer	1	GS 7-11		
Administrative Assts.	3	GS 4-9	3	Swafford (3) Perrigo (7) Cowley (4)
Secretary, Clerk/Typist	9	GS 3-5	7	Addams (5) Foss (4) Wilde (3) Lynch (3) Cristy (2) Kelly (4) Rinaldo (3)
Purchasing, Accounting, Personnel	4	GS 4-9	4	Kiernan (6) Howe (5) Harkins (4) Burke (3)
<u>Building & Grounds</u>				
Foreman	3	WB 7-10	3	Macaulay (9) Ally (8) Pratt (7)
Maintenance	13	WB 2-9	8	Reese (9) Costa (9) Sandlin (5) Blevins (2) Dolloff (8) Campbell (8) Leeman (2) Larkin (2)
Motorboat Operator	1	WB 5-9	1	Trask (9)

<u>Title</u>	<u>Proposed Staff</u>		<u>No.</u>	<u>Present Staff</u>	
	<u>No.</u>	<u>Grade</u>		<u>No.</u>	<u>Name (Grade)</u>
<u>Public Information & Editing</u>					
Task Leader	1	GS 9-11			
Writer/Editor	1	GS 9-11	1		Eddy (9)
Aquarium Director	2	GS 9-12	2		Wheeler (11) Welch (12)
Aquarium Operator	2	GS 7-11	1		Ruschky (9)
Graphic Arts	6	GS 4-11	5		Brigham (9) Bailey (9) Coffin (9) Rollins (6) Lamont (7) Gerrior (5)
Librarian	1	GS 5-9	1		
<u>Automatic Data Processing</u>					
Unit Manager	1	GS 11-12	1		Handy (11)
Systems Program	1	GS 9-11			
Computer Technicians	4	GS 3-9	3		Laird (9) Chase (7) Thompson (5)
Card Punch Supervisor	1	GS 4-6	1		Cory (4)
Card Punch Operator	2	GS 3-5	1		Kingsley (3)
<u>TOTALS</u>					
<u>NUMBER</u>	<u>AVERAGE GS</u>		<u>NUMBER</u>	<u>AVERAGE GS</u>	
65	7.0		48	6.8	

	<u>PROPOSED</u>		<u>CURRENT</u>		<u>INCREASE</u>
	<u>No.</u>	<u>Avg. GS</u>	<u>No.</u>	<u>Avg. GS</u>	
Chief GS 13-15	8		8		0
Task Leaders GS 12-14	16		4		12
FRB GS 5-12	48		29		19
Math Statisticians GS 9-12	2		1		1
Engineers (ME) GS 9-12	2		2		0
Technicians GS 2-11	64		35		29
Totals	140	8.9	79	9.0	61

ADMINISTRATIVE TOTAL

	<u>PROPOSED</u>		<u>CURRENT</u>		<u>INCREASE</u>
	<u>No.</u>	<u>Avg. GS</u>	<u>No.</u>	<u>Avg. GS</u>	
Directors GS 13-26	3		3		0
Special Staff GS 5-14	4		2		2
Task Leaders GS 7-12	3		1		2
Administrative Specialist GS 3-9	19		16		3
Technical Specialist GS 3-12	20		16		4
O & M Specialist WB 2-10	<u>16</u>		<u>11</u>		<u>5</u>
Totals	<u>65</u>	<u>7.0</u>	<u>49</u>	<u>6.7</u>	<u>16</u>

CENTER TOTAL

Proposed Number 206
Current Number 129
Increase 77

Proposed Average GS 8.3
Current Average GS 8.1

6.0. Funding

6.9. Funds

The table on the next page gives a five-year history of funding, and a breakdown of fiscal 1973 funds. The funding of the Center has not increased over the last five years. (To obtain a figure in 1968 equivalent to the Center's in 1973, we added to the funds and the Gear Base in 1971). The funds available for direct costs of the research investigations in 1973 (\$191,200) is small in relation to immediate program needs. The 1973 allotment does not include funds required to support the three integrated programs (see Section 4. L.).

In terms of achieving our objectives over the next five years, we estimate that funds must be about doubled.

Allotments FY 1968 Through FY 1973

FY 1968	Woods Hole Laboratory	\$1,162,000.00
	Boothbay Harbor Laboratory	630,100.00
	Narragansett Laboratory	*
	Total	\$1,792,100.00
FY 1969	Woods Hole Laboratory	\$1,138,300.00
	Boothbay Harbor Laboratory	549,400.00
	Narragansett Laboratory	*
	Total	\$1,687,700.00
FY 1970	Woods Hole Laboratory	\$1,216,300.00
	Boothbay Harbor Laboratory	561,200.00
	Narragansett Laboratory	*
	Total	\$1,777,500.00
FY 1971	Woods Hole Laboratory	\$1,030,600.00
		898,100.00
		(transfer with Gear Base)
	Boothbay Harbor Laboratory	599,900.00
	Narragansett Laboratory	222,000.00
	Total	\$2,750,600.00
FY 1972	Northeast Fisheries Center	\$2,912,300.00
FY 1973	Northeast Fisheries Center	\$2,960,700.00
Total Personnel		\$2,176,900.00
Permanent Laboratory Personnel		1,586,200.00
ALBATROSS IV		248,000.00
Other Personnel Costs		342,200.00
Other Direct Fixed Costs		592,600.00
Fixed Facility Costs		423,200.00
ALBATROSS IV Operation		169,400.00
Available for Research Costs		191,400.00

*Under Bureau of Sportsfish & Wildlife

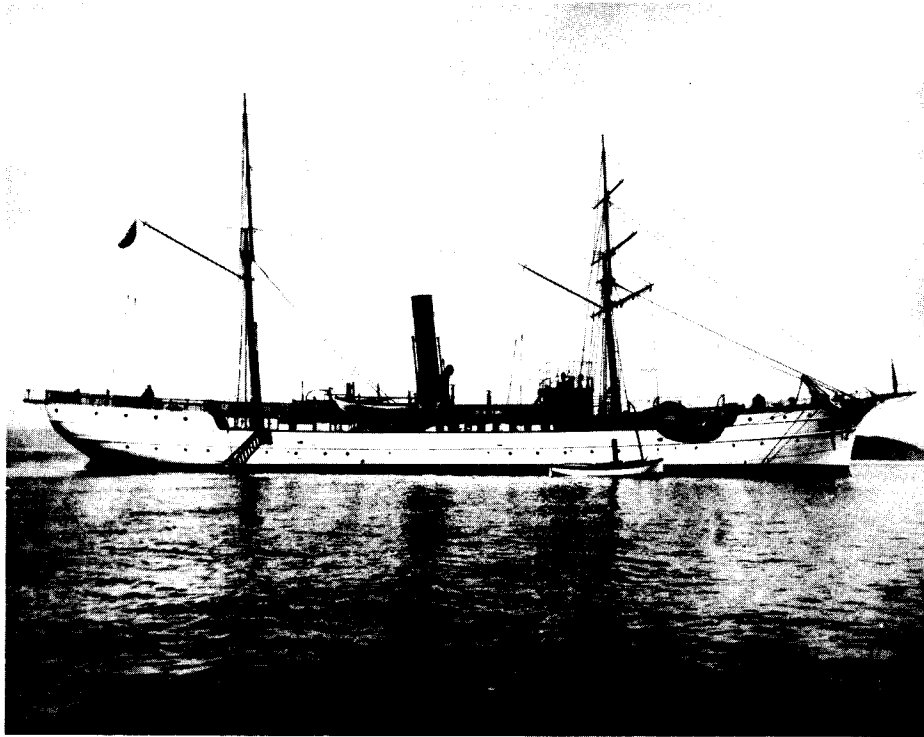

The first Albatross, used by Woods Hole Laboratory from 1882-1921.



Albatross IV, present Fisheries research vessel, commissioned in 1962.