

Fall Protection

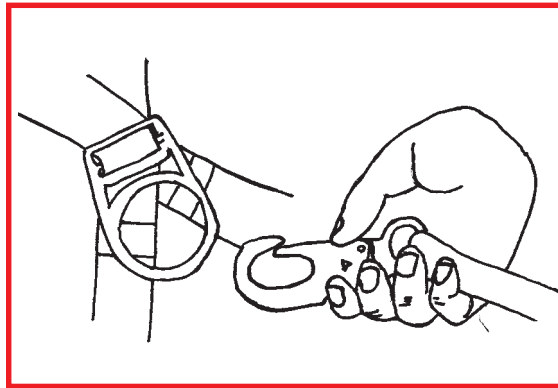

It 's A Snap!

U.S. Department of Labor
Occupational Safety & Health Administration
Region VII

(Revised 02/02)

Dear Employees:

Falls are the leading cause of fatalities and catastrophes investigated by OSHA in Region 7.

- *44% of the fatal and catastrophic incidents in OSHA-Region 7 from October 1994 through September 1999 occurred in the construction industry;*
- *36% of those involved a fall.*

OSHA-Region 7 is seeking to facilitate employee awareness and involvement in the prevention of fatal and injurious falls in construction. This document was prepared for YOU, the construction worker, exposed to fall hazards. This document is designed to be an easy reference tool for your daily use. Yes, it is a tool! Please place it in your tool box; take it to work with you; and use it daily. . .at every work site. The life you save may be your own!!!

*Sincerely,
OSHA Region 7*

Table of Contents

Fall Facts 1

Fatal/Catastrophic Construction Falls 2

Fall Protection 9

Open Holes & Unprotected Sides and Edges 18

Ladders 20

Scaffolding 27

Steel Erection 34

How to Report a Hazard 35

For information on items contained in this pocket guide, as well as other Safety and Health issues, please contact your nearest OSHA office (see last page).

*FATAL/CATASTROPHIC INCIDENTS
Comparison by SIC Code
FY 95 - FY 99*

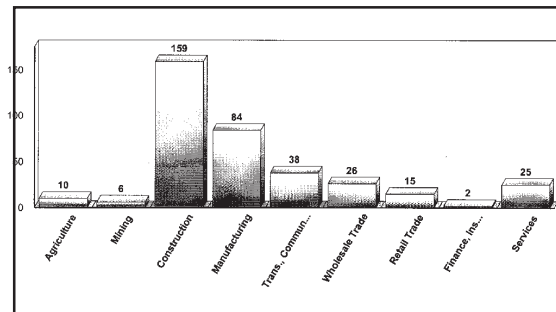

*FATAL/CATASTROPHIC INCIDENTS
Comparison by Type of Accident
Division C - Construction
FY 95 - FY 99*

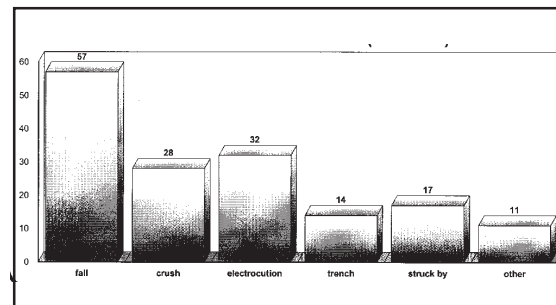

Source: OSHA Integrated Management Information System (IMIS)

Fall Facts

Fatal/Catastrophic Construction Falls

- *Twenty-two employees performing roofing work (i.e., laying shingles, installing metal decking, etc.) fell to their death. Fall heights were from 13' to 120'.*

In most instances no personal protection equipment was being used. In at least two cases, however, the victim was wearing the equipment but did not have it tied off.

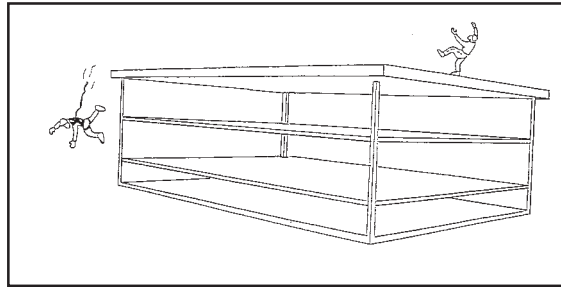

Fatal/Catastrophic Construction Falls

- *In two separate instances, employees were working on a roof and fell through a skylight to their death. One fell 22'; and the other fell 27'.*

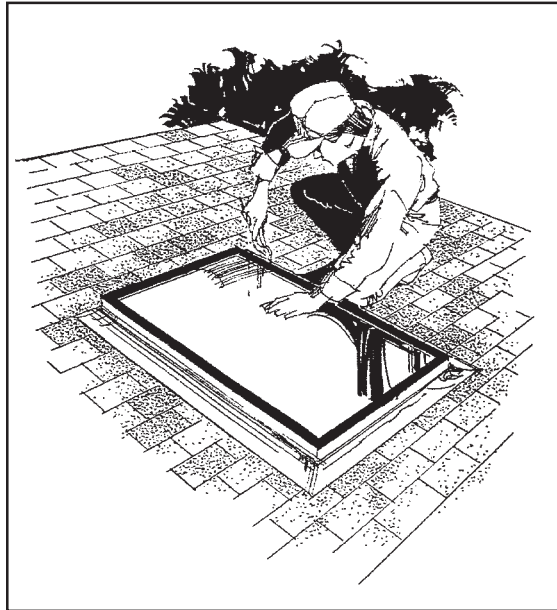

Fatal/Catastrophic Construction Falls

- *Two employees have died while working from platforms performing bridge work. One victim fell 45' into a river, the other fell 31' and landed on rocks.*

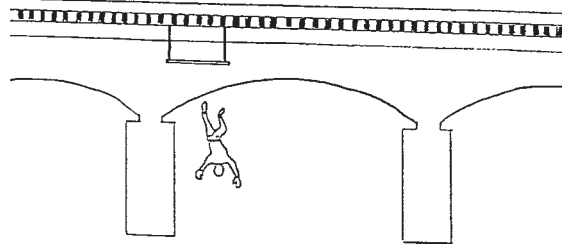

Sixteen employees have been killed or seriously injured from scaffolds.

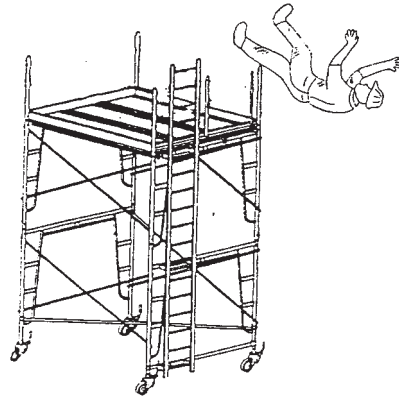

Fatal/Catastrophic Construction Falls

- Three employees fell to their death as a result of improperly guarded floor holes. In two cases the victims removed the hole covering and fell through the opening; in the third case the victim was using a pole extension to paint a lower floor and walked into the unguarded basement entrance floor opening.

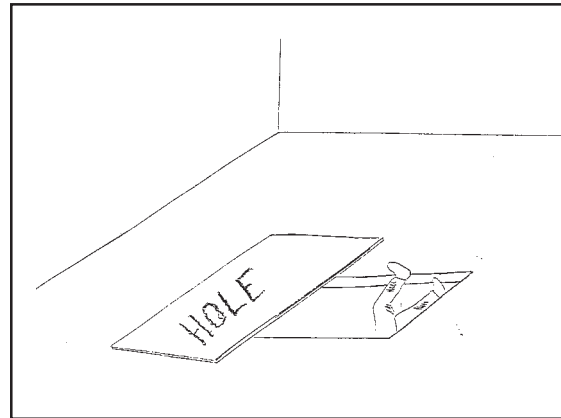

Fatal/Catastrophic Construction Falls

- Two employees were using a 2-point suspended scaffold when one side of the scaffold fell. One employee was wearing a body harness hooked to a lifeline with a lanyard, and was restrained from falling. The other employee, wearing the same equipment, but not hooked to his lifeline, fell over 100' to his death.

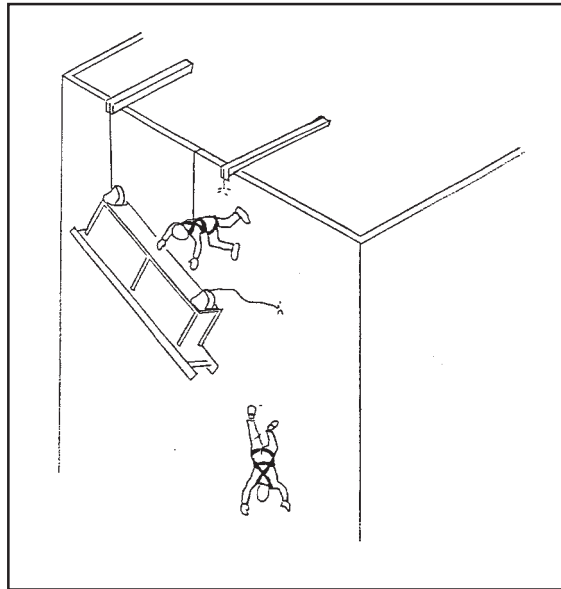

Fatal/Catastrophic Construction Falls

- In three separate incidents, employees have fallen to their death while working on a tower. In all cases, the fall height was greater than 200’.
- In addition to the incidents previously mentioned in this section, 21 more employees either died or suffered serious injuries in Kansas, Missouri and Nebraska between October 1, 1994 and September 30, 1999 as a result of fall hazards not depicted.

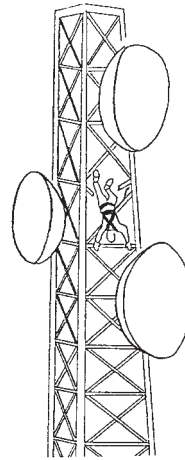

Fatal/Catastrophic Construction Falls

*HELLO! I'm Lenny the Lanyard!!
Fall Protection is my Life...AND YOURS!
Follow me and I'll show you... It's a Snap!*

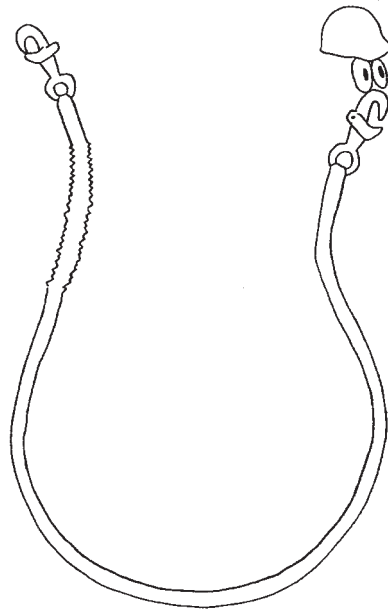

Fall Protection

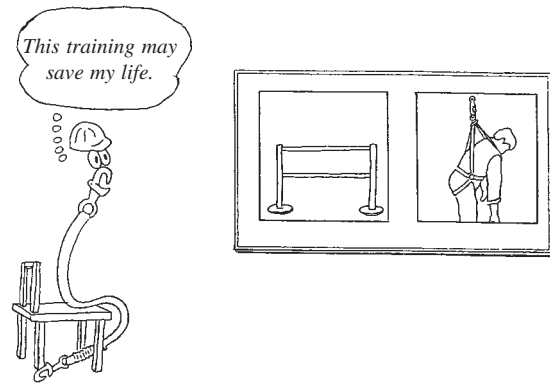

The employer must:

1. Select the most appropriate method of fall protection to protect the employee.
2. Acquire the necessary equipment.
3. Train the employee in proper equipment use.
4. Insure that the program is followed and employees accept their obligation to follow the rules to protect themselves.

Fall Protection

- Any employee who might be exposed to fall hazards must be trained.
- Walking/working surfaces must be inspected before work begins.
- Employees can only work on surfaces strong enough to support them.
- Each employee on a walking/working surface (horizontal and vertical surface) with an unprotected side or edge which is 6' (1.8m) or more above a lower level shall be protected from falling by use of:
 - guardrail system
 - safety net systems or
 - personal fall arrest systems.
- Refer to manufacturer's specifications for proper installation.
- Employers engaged in leading edge work, precast concrete construction work and residential construction work who can demonstrate that it is infeasible or creates a greater hazard to use conventional fall protection systems must develop and follow a fall protection plan.

Fall Protection

Full Body Harnesses:

- Full body harnesses should be snug fitting and worn with all hardware and straps intact and properly fastened and maintained according to manufacturer's specifications. (Body belts are not accepted by OSHA as a fall arrest device, but can be worn as a positioning device if the employee cannot free fall more than 2").

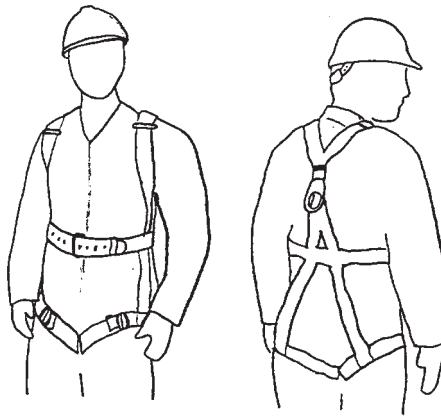

Fall Protection

How to Wear a Full-Body Harness

1. Hold the harness by the back D-ring. Shake the harness to allow all straps to fall in place.
2. With waist and/or leg straps unbuckled, release snaps and unbuckle at this time.
3. Slip straps over your shoulder so the D-ring is located in middle of the back.
4. Connect the waist strap. The waist strap should be tight, but not binding.
5. Pull the buckle portion of the leg strap between your legs and connect to opposite end of the leg strap. Repeat the procedure with second leg strap.
6. After all straps have been buckled, tighten all friction buckles so harness fits snug but allows free range of motion.
7. If the harness contains a chest strap, pull it around the shoulder strap and fasten it in middle chest area. Tightening will keep the straps taut.
8. To remove the harness reverse the procedure.
9. Reconnect the waist strap after removing the harness. This will give you a starting point when next attempting to put harness on.
10. Manufacturer's recommend hanging the harness by the D-ring to help keep its shape when not in use.

Fall Protection

Roof Sheathing in Residential Construction:

- Only those workers trained in the roof sheathing process will be allowed to perform this work.
- The bottom row of sheathing may be installed by workers standing in truss webs.

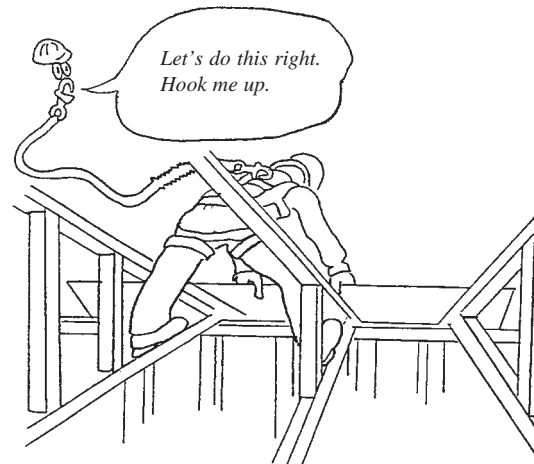

Fall Protection

Roofs - Residential Construction

- Slide guards shall be installed extending the width of the eave and securely attached to the roof.
- On slopes greater than 6/12, up to and including 8/12, additional slide guards shall be installed below the work area at intervals not to exceed 8'.
- At a pitch of 8/12 or greater, and on roofs with a slope greater than 4/12 where eave to lower level is more than 25', conventional methods of fall protection must be used.

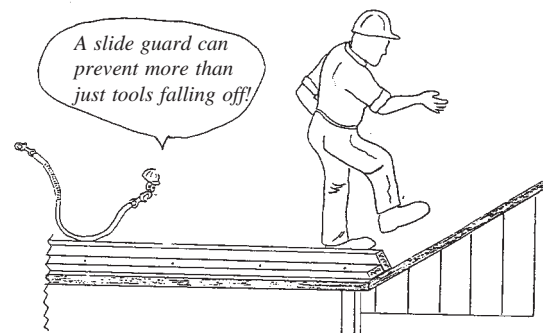

Fall Protection

- Slide guards are to be constructed of 2”x 4” flat and 2” x 6” on edge. Workers should install the slide guard while standing in truss webs and leaning over the sheathing.
- Metal brackets for slide guards are recommended.

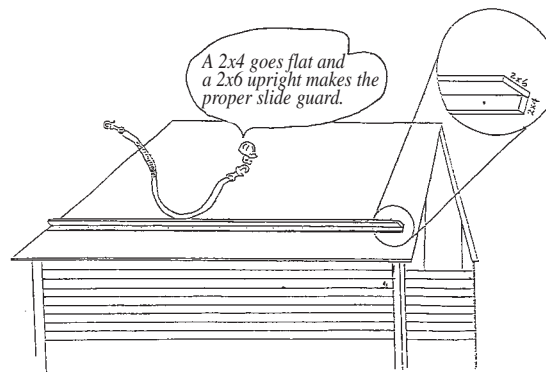

Fall Protection

Warning Line System

- Erected all around sides of the roof work area.
- With no mechanical equipment - the warning lines shall be erected not less the 6' from the edge of the roof.
- When using mechanical equipment - lines erected not less than 6' from the edge which is parallel to the direction of mechanical equipment operation, and not less than 10' from the edge which is perpendicular to the direction of mechanical equipment operation.
- Warning lines shall consist of ropes, wires, or chains with a minimum tensile strength of 500 pounds, and supporting stanchions capable of resisting, without tipping over, 16 pounds applied horizontally.

(continued on next page)

<i>Fall Protection</i>

- Rope, wire, or chain shall be rigged so that its lowest point (including sag) is 34 inches and its highest point is 39 inches from walking/working surface and shall be flagged with high visibility material at not more than 6' intervals.

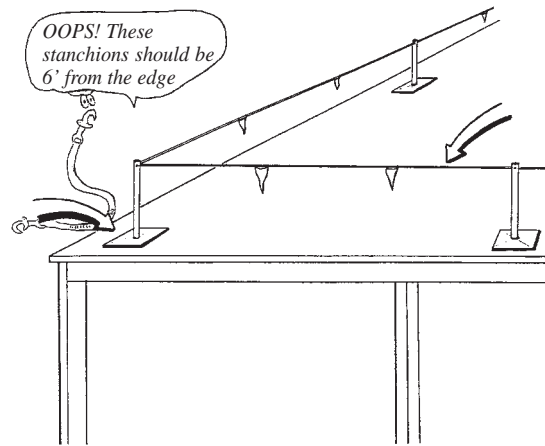

Fall Protection

- Open-side floors and holes, such as stairwells, door and window openings, and skylights (that have a fall distance of more than 6') must be protected by use of a guardrail system or covers.
- If the inside bottom edge of the wall opening is less than 39" above the walking/working surface, a guardrail system or personal fall arrest system shall be used.

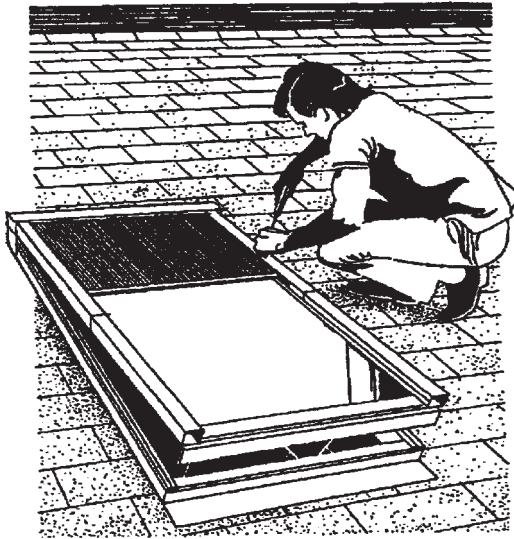

Open Holes & Unprotected Sides and Edges

- A guardrail system shall be constructed of at least 2" x 4" wood posts and top rail, or equivalent material, and consist of a top rail at 39-45", a midrail at 21", upright a 8' intervals and a toeboard when someone is working below.
- Steel banding or plastic shall not be used as top rails or midrails.
- Guardrail systems shall be capable of withstanding 200 pounds of force in an outward or downward direction.
- Ends or top rails and midrails shall not overhang terminal posts, unless such overhang does not constitute a hazard.

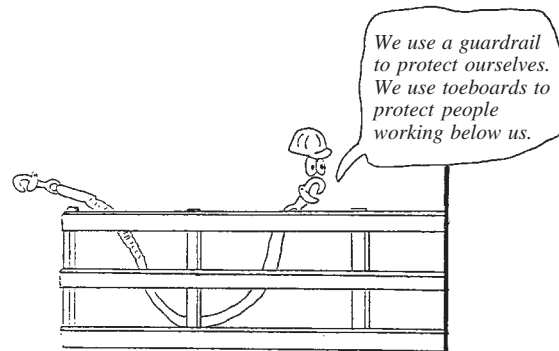

Open Holes & Unprotected Sides and Edges

Any employee using ladders must be trained.

Ladders must be adequate for the job and properly maintained (i.e., the right ladder for the job).

A stairway or ladder must be provided at all worker points of access where there is a break in elevation of 19" (48cm) or more and no ramp, runway, embankment or personnel hoist is provided.

Guidelines for use:

- Clear scrap and material away from the base and top of the ladder, since getting on and off the ladder is relatively hazardous.
- Always face the ladder when climbing up or down and while working from it.



*A ladder climbing
no-no*

Ladders

- Each worker must use at least one hand to grasp the ladder when climbing.
- A worker on a ladder must not carry any object or load that could cause him/her to lose balance and fall.
- Keep your center of gravity between the side rails. Your belt buckle should never be outside the side rails.
- Keep boots clean of mud, grease, or any slippery materials which could cause loss of footing.



Don't let this happen to you!

Ladders

- Straight or extension ladders shall be set 1' out for every 4' up.
- When portable ladders are used for access to an upper landing surface, the side rails must extend at least 3' (.9m) above the upper landing surface or the ladder must be secured from slipping.

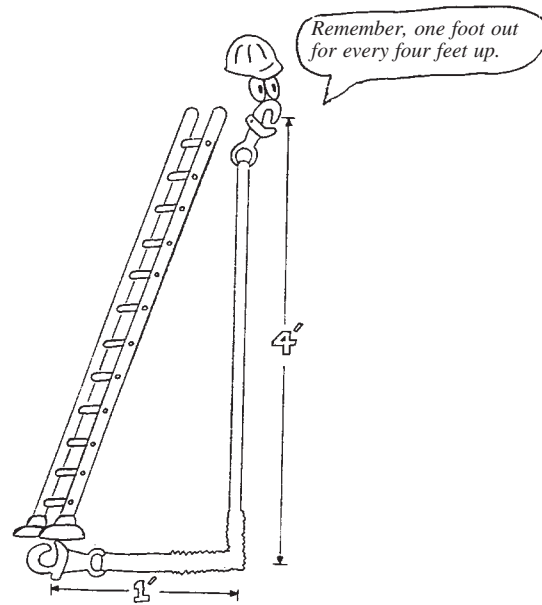

Ladders

- Do not splice short ladders together to make a long ladder. The side rails will not be strong enough for the extra loads.
- Never use ladders horizontally as scaffold planks, runways, or any other service for which they have not been designed.

Horizontal ladders are NOT scaffold planks.

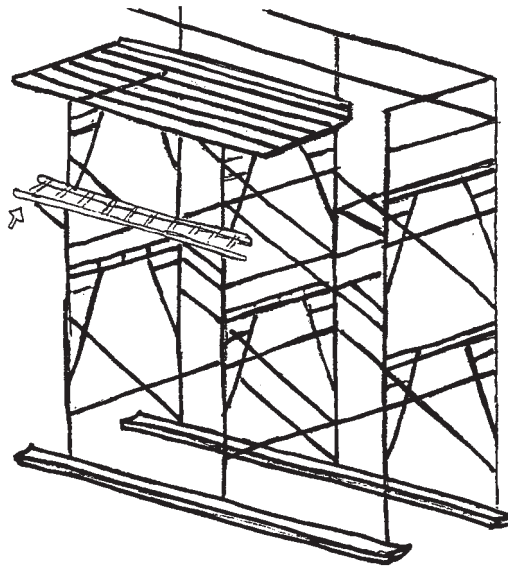

Ladders

- Never rest a ladder on its rungs. Ladders must rest on the side rails.
- To erect long, awkward, or heavy ladders, get help to avoid injury from overexertion.
- Avoid setting up ladders in doorways, passageways, driveways, or any other location where they can be struck or knocked over.

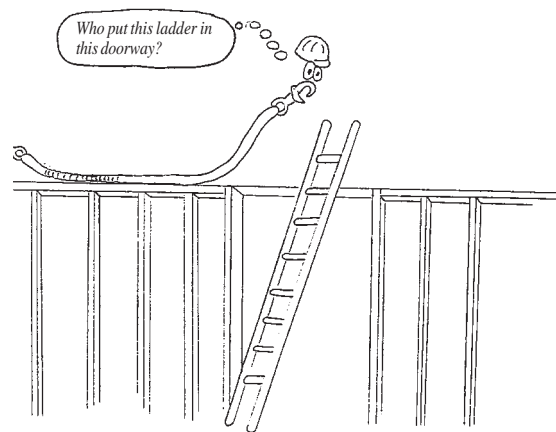

Ladders

Ladders used to access working platforms must be securely placed.

- Set the ladder on a firm, level surface.
- Never erect ladders on boxes, carts, tables, or other unstable surfaces.

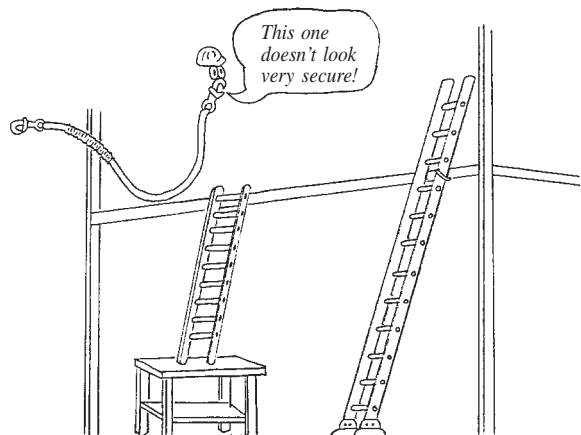

Ladders

- The top or top step of a stepladder must not be used as a step.
- Crossbracing on the rear section of step ladders must not be used for climbing unless the ladders are designed and provided with steps for climbing on both front and rear sections.
- Ladders must be inspected by a competent person for visual defects on a periodic basis and after any incident that could affect their safe use.



Ladders

- Any employee who performs work while on a scaffold must be trained.
- Fall protection is required at height of 10' or greater.
- When used, scaffolding must be suitable for the job and adequate for the load.
- No scaffold shall be erected, moved, dismantled, or altered except under the supervision of a competent person.
- Workers must be provided a safe access on or off the walks planks, work platforms, and/or scaffolding. Such access shall be provided by a ladder or equivalent safe access.

Scaffolding

Types of Scaffolds:

- **Job - Built Wood**

This type may be used for erection of trusses and for drywall where conventional scaffold cannot be used.

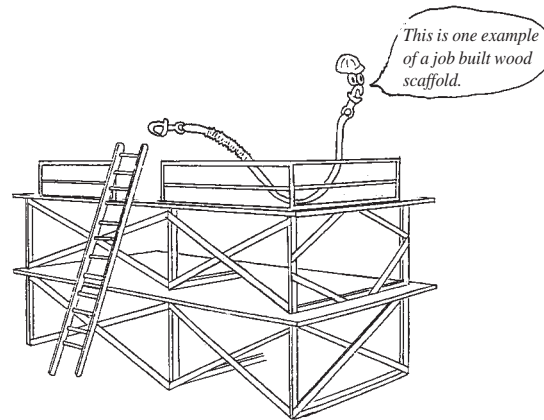

Scaffolding

- **Tubular Welded Frame Scaffold**

Planks must be adequate for the load.

Scaffold-grade plank, microlam, or aluminum only.

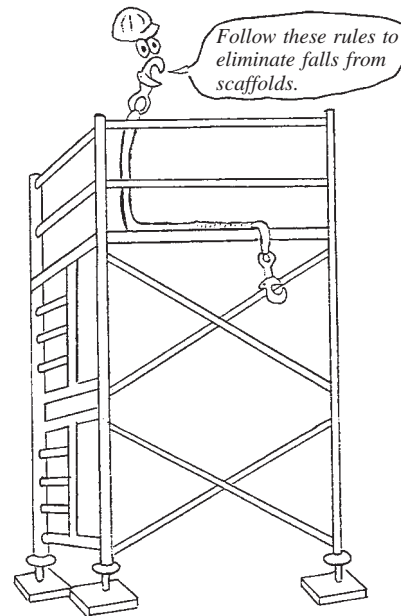

- *Erected plumb*
- *Guardrails when above 10'*
- *Properly Braced*
- *Fully Planked*

Scaffolding

Erected Tubular Steel Platform Scaffolding:

- According to manufacturer's recommendations only.
- Properly maintained.
- Poles, legs, posts, frames and uprights must be on base plates, mud sills or other adequate firm foundations.

Scaffolding

Erecting Pump Jack Scaffolding:

(Wood or Aluminum)

- According to manufacturer's recommendations only.
- Properly maintained.
- The poles, legs or uprights of the scaffolding shall be plumb and securely braced to prevent swaying and/or displacement.
- Intermediate bracing is to be used on wood poles at 10' intervals.
- Pump Jack brackets, braces and accessories shall be fabricated from metal plates and angles.
- All poles shall bear on mud sills or other adequate firm foundations.

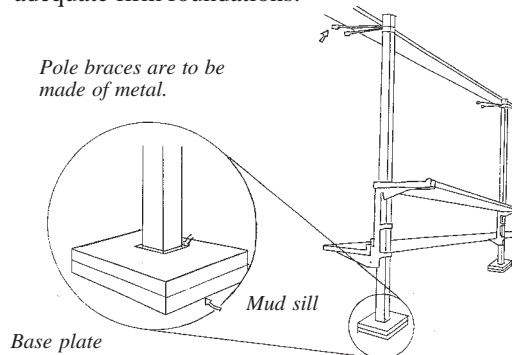

Scaffolding

Erecting Pump Jack Scaffolding:
(For Wood Only)

- Poles made of straight grain wood must be free of shakes, large loose or dead knots and other defects, and should be nailed 12" on center on both sides, 30' maximum height.

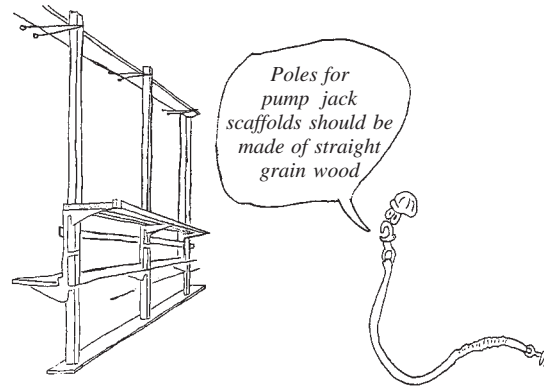

Scaffolding

Ladder Jack:

- Need additional ladder for access.
- Plank bracket must be at least 10” wide on each rung.
- Platform shall not exceed 20’ in height.
- A personal fall protection system required above 10’.

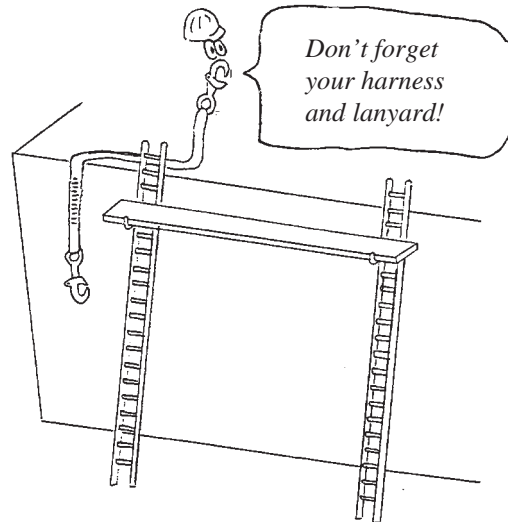

Scaffolding



- Fall protection is required on a walking surface with an unprotected side or edge more than 15 feet above the next level.
- There are exceptions for connectors and deckers in a controlled decking zone; this exception is limited to 30 feet or two stories, whichever is less.

Steel Erection

YOU CAN HELP your community prevent unnecessary workplace accidents. If you observe any of the fall hazards depicted in this guide, or any other situation where an employee could fall, please contact the **Occupational Safety and Health Administration (OSHA):**

Kansas

271 W. 3rd Street North
Room 400
Wichita, KS 67202
(316) 269-6644
1-800-362-2896 (KS only)

Nebraska

Overland-Wolf Building
Rm 100
6910 Pacific Street
Omaha, NE 68106
(402) 221-3182
1-800-642-8963 (NE Only)

Missouri

6200 Connecticut Suite 100
Kansas City, MO 64120
(816) 483-9531
1-800-892-2674 (MO only)
or
911 Washington Avenue
Room 420
St Louis, MO 63101
(314) 425-4249
1-800-392-7743 (MO only)

**FALL PROTECTION
IT'S A SNAP!**

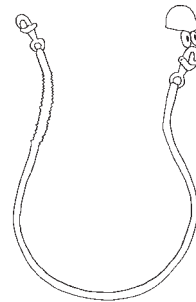

Scaffolding