



**United States
Department of
Agriculture**

Rural
Utilities
Service

RUS Bulletin 1753F-150
RUS Form 515a

September 2001

Specifications and Drawings for Construction of Direct Buried Plant

This page intentionally left blank

UNITED STATES DEPARTMENT OF AGRICULTURE
Rural Utilities Service

BULLETIN 1753F-150

SUBJECT: Specifications and Drawings for Construction of Direct Buried Plant, RUS Form 515a

TO: All Telecommunications Borrowers
RUS Telecommunications Staff

EFFECTIVE DATE: September 17, 2001

OFFICE OF PRIMARY INTEREST: Outside Plant Branch,
Telecommunications Standards Division.

AVAILABILITY: This bulletin supersedes RUS Bulletin 345-150, Specifications and Drawings for Construction of Direct Buried Plant, RUS Form 515a, issued May 25, 1989. This bulletin can be accessed via the Internet at <http://www.usda.gov/rus/telecom/publications/bulletins.htm>

PURPOSE: This specification provides Contractors, Engineers, and RUS Borrowers with assembly unit descriptions, materials, construction and installation, and drawings for direct buried plant associated with RUS Form 515, Telecommunications System Construction Contract.

Roberta D. Purcell
Roberta D. Purcell
Assistant Administrator
Telecommunications Program

8/21/01
Date

**RUS Bulletin 1753F-150
Specifications and Drawings for Construction of
Direct Buried Plant, RUS Form 515a**

TABLE OF CONTENTS

	<u>Page</u>
List of Changes.....	i
Part I - Description of Assembly Units and Proposal and Contract Sections.....	1
Part II - Specification for Materials.....	22
1. Scope	22
2. General	22
3. Stub Poles	22
4. Miscellaneous	22
Part III - Specification for Construction and Installations...	22
1. General	22
2. Buried Plant Housing Stub Poles	23
3. Cable Splicing	23
4. Buried Cable or Wire	23
5. Buried Handholes	28
6. Miscellaneous - Buried Plant	28
7. Special Requirements for Installation of Serving Area Interface Cabinets (SAIC)	30
List of Construction Drawings and Plans.....	31

INDEX

CONSTRUCTION:

Buried Cable Plant
Fiber Optic Cable Plant

SPECIFICATIONS AND STANDARDS:

Outside Plant

LIST OF CHANGES

1. Elimination of Section BC. Cross-connecting modules and blocks are now included as part of Section BDS, Serving Area Interface Cabinet (SAIC) Assembly Units.
2. Modification of Section BD as follows:
 - (a) Redefined unit to indicate stake mounted as default unit type;
 - (b) Requires that the grounding connector for terminating the external ground wire is included with the unit;
 - (c) Added units for Large Pair Count Housings;
 - (d) Added suffixes "A" for poled mounted, "F" for concrete pad mounted, and "R" for crushed stone or gravel bed;
 - (e) Eliminated suffixes "B" for internal offset bracket for load coil mounting, "C" grounding connector, and "G" for additional guard.
3. Addition of Section BDO, Buried Plant Fiber Optic Housing Assembly Units.
4. Modification of Section BDS, as follows:
 - (a) Redefined unit to indicate stake mounted as default unit type;
 - (b) Requires that the grounding connector for terminating the external ground wire is included with the unit;
 - (c) Redefined unit to included cross-connect modules and blocks;
 - (d) Eliminated suffixes "M" framed for cross-connect modules, "B" framed for screw blocks, and "S" for stake mount.
5. Modification of the BFC and BFO units as follows:
 - (a) Compensation will be on a per foot basis;
 - (b) Ripping is now included as part of the unit;
 - (c) Provided suffixes "I" for installation of cable inside a duct, and "V" for installation of vacant duct or ducts simultaneously in the same plow slot or trench.
6. Elimination of Section BG.
7. Addition of Section BH, Buried Handhole Assembly Unit.
8. Elimination the BM76 unit. Ripping is now included as part of the buried cable units (BFC and BFO).

9. Modification of the BM2A unit to comply with the National Electrical Code.
10. Modification of the BM2C unit to include provisions for bonding existing cables in an existing facility.
11. Addition of BM2D, New Facility Re-Bonding Assembly Unit.
12. Modification of BM6M to provide compensation on a per foot basis.
13. Addition of miscellaneous assembly units BM21, Cable Entrance; BM22, Grounding System; BM50, Buried Service Wire or Cable Installation to Pole-Mounted Wire Terminal Assembly Unit; BM52 Re-numbering Assembly Unit; BM65, Guard Assembly Unit; and BM91, Pedestal Restricted Access Insert Assembly Unit.
14. Provision of suffix "D" to the BM60 and BM61 units to indicate directional boring.
15. Provision of suffix "P" to the BM60 and BM66 units to indicate plastic pipe.
16. Modification of the BM61 unit by allowing the Engineer to specify the maximum bore diameter in parentheses.
17. Provision of suffix "E" to the BM71 unit to indicate extra depth in rock.
18. Modification of the BM80, 81, and 82 assembly unit drawing to indicate a 12 inch placement of the brackets from the top and bottom of the guard.
19. Elimination of the BM90 unit.
20. Modification of Section HBF as follows:
 - (a) Redefined unit to include compensation for installing closure in a housing or handhole;
 - (b) Eliminated suffixes "B", "C", "H", and "J".
21. Modification of Section HC as follows:
 - (a) Redefined unit to provide compensation on a single pair basis;
 - (b) Created HC2 unit in order to provide compensation for terminating cable pairs on cross-connect modules or blocks.
22. Modification of Section HO to provide compensation for testing a fiber.

23. Elimination of Section PM. The PM21 and PM22 have been redesignated under the miscellaneous units as BM21 and BM22. In addition the units were changed to be more generalized.
24. In part III, section 4, the determination for when a rock excavating unit (BM71) is applied was redefined.
25. In part III, section 4, when a BM71 unit is applied, trench width and depth requirements were added.
26. In part III, an additional section was added for buried handholes.

For editorial or other minor technical changes, refer to the body of the document.

This page intentionally left blank

**Part I - DESCRIPTION OF ASSEMBLY UNITS AND PROPOSAL AND
CONTRACT SECTIONS**

The Contractor's Proposal form is divided into sections and the sections approved for construction shall be listed in the Construction Agreement by the Owner. The sections are as follows:

Section BA	-	Buried Plant Housing Stub Pole Units
Section BD	-	Buried Plant Housing Assembly Units
Section BDO	-	Buried Plant Fiber Optic Housing Assembly Units
Section BDS	-	Serving Area Interface Cabinet (SAIC) Assembly Units
Section BFC	-	Buried Filled Copper Cable Assembly Units
Section BFO	-	Buried Filled Fiber Optic Cable Assembly Units
Section BH	-	Buried Handhole Assembly Units
Section BM	-	Miscellaneous Assembly Units
Section HBF	-	Buried Filled Splice Closure Assembly Units
Section HC	-	Copper Splicing Assembly Units
Section HO	-	Fiber Optic Splicing Assembly Units
Section W	-	Rearrangement Units
Section XX	-	Nonreusable Materials Removal Units
Section XZ	-	Reusable Materials Removal Units

Each assembly unit includes only the materials listed on the corresponding Installation and Construction Guide Drawings or description of unit where no drawing exists. The various installation and construction units, which are included in this Proposal and upon which quotations are required, are defined by the following descriptions:

Section BA - BURIED PLANT HOUSING STUB POLE UNITS

Consists of all labor and material for a stub pole in place. Stub poles shall be of the length and type designated by the Engineer as follows:

BA2	6.5 Feet [1.98 meters (m)],	Round Wood Stub Pole
BA3	8.0 Feet (2.44 m),	Round Wood Stub Pole
BA4	10.0 Feet (3.05 m),	Round Wood Stub Pole
BA5	13.5 Feet (4.12 m),	Round Wood Stub Pole
BA21	6.5 Feet (1.98 m),	Sawn Wood Stub Pole
BA22	8.0 Feet (2.44 m),	Sawn Wood Stub Pole
BA23	10.0 Feet (3.05 m),	Sawn Wood Stub Pole

The stub pole plan, kind of preservative, and method of treatment are designated in the Proposal.

Section BD - BURIED PLANT HOUSING ASSEMBLY UNITS

Consists of a buried plant housing stake mounted in place. These units include all labor and material to install pea gravel, housing numbers, route letters, load point numbers, directional and other markings of buried filled copper cable. Includes all labor and material to install bonding connectors, harnesses, and grounding connector for terminating external ground wire, in accordance with RUS Splicing Standard Bulletin 1753F-401 (PC-2).

The assembly units are defined as follows:

BD3	Buried Plant Housing, Type H	Stake-Mounted
BD4	Buried Plant Housing, Type H	Stake-Mounted
BD5	Buried Plant Housing, Type H	Stake-Mounted
BD7	Buried Plant Housing, Type H	Stake-Mounted
BD14	Buried Plant Housing, Type M	Stake-Mounted
BD15	Buried Plant Housing, Type M	Stake-Mounted
BD16	Buried Plant Housing, Type M	Stake-Mounted
BD6000	Buried Plant Housing, Large Count	Stake-Mounted
BD8000	Buried Plant Housing, Large Count	Stake-Mounted
BD10000	Buried Plant Housing, Large Count	Stake-Mounted

Note: The splicing capacity shall be in accordance with RUS Splicing Standard Bulletin 1753F-401(PC-2).

Options designated by the following suffixes apply:

<u>Suffix</u>	<u>Description</u>
A	Pole mounted (see guide drawing 905 when increased height is required).
F	Concrete pad mounted.
H	Good-housekeeping panel.
P	Plastic pad mounted.
R	Crushed stone or gravel bed.

Examples:

BD3	BD3 housing stake mounted.
BD4AH	BD4 housing pole mounted and good-housekeeping panel.

BD14R BD14 housing with crushed stone or gravel bed.

BD8000F BD8000 housing, concrete pad mounted.

Section BDO - BURIED PLANT FIBER OPTIC HOUSING ASSEMBLY UNITS

Consists of a buried plant fiber optic splice case housing stake mounted in place. These units include all the labor and material to install pea gravel, housing numbers, route letters, and directional and other markings of buried filled fiber optic cable. Includes all labor and material to install mounting hardware for fiber optic splice case, bonding connectors, harnesses, and grounding connector for terminating external ground wire in accordance with RUS Splicing Standard Bulletin 1753F-401(PC-2).

The assembly unit is defined as follows:

BDO Buried Plant Fiber Optic Housing, Stake-Mounted

Note: Type of mounting hardware shall be dependent upon the type of fiber optic splice case utilized.

Options designated by the following suffixes apply:

<u>Suffix</u>	<u>Description</u>
A	Pole mounted.
F	Concrete pad mounted.
P	Plastic pad mounted.
R	Crushed stone or gravel bed.

Examples:

BDOA BDO Housing pole mounted.

BDOP BDO Housing plastic pad mounted.

Section BDS - SERVING AREA INTERFACE CABINET (SAIC)
ASSEMBLY UNITS

Consists of an SAIC stake mounted in place. Includes all labor and materials to complete the installation. Included in this unit shall be the cabinet; cross-connect modules or blocks; cabinet mounting accessories; internal mounting hardware such as frames, mounting brackets, splicing ladders and talk block; grounding connector for terminating external ground wire, bonding

connectors and harnesses in accordance with RUS Splicing Standard Bulletin 1753F-401(PC-2); pea gravel; interface number and direction markings and placement of conduit(s) and such other labor and materials necessary to complete the installation. Detailed plans and specifications further defining these units and establishing specific requirements including size of the housing for each SAIC location are attached hereto and are identified by the name and location of each SAIC.

The assembly units are defined as follows:

- BDSM()()() - SAIC equipped with modules.
- BDSB()()() - SAIC equipped with blocks.

The number of feeder pairs to be terminated shall be indicated in the first parentheses; the number of distribution pairs to be terminated shall be indicated in the second parentheses; and the number of electronic pairs to be terminated shall be indicated in the third parentheses.

Options designated by the following suffixes apply:

<u>Suffix</u>	<u>Description</u>
A	Pole mount.
F	Concrete slab mount.
P	Plastic pad mount.
R	Crushed stone or gravel bed.

Examples:

BDSM(25)(25)(0)A	SAIC equipped with modules, 25 feeder pairs terminated, 25 distribution pairs, pole mounted.
BDSB(50)(25)(25)F	SAIC equipped with blocks, 50 feeder pairs terminated, 25 distribution pairs terminated, 25 electronic pairs terminated, concrete pad mounted.

Section BFC - BURIED FILLED COPPER CABLE ASSEMBLY UNITS

Consists of one (1) foot (0.305 m) of buried filled copper cable in place. This unit includes all material and labor for installing, ripping (where necessary as determined by the Engineer), and backfilling, except as specifically provided for

in other units. Where the cable is plowed, ripping may be necessary to provide a ripped path to allow placement at the required depth, and may require more than one ripped pass.

Options designated by the following suffixes apply:

<u>Suffix</u>	<u>Description</u>
D	Two or more cables placed simultaneously in the same plow slot or trench. Specify all cables within parentheses ().
H	Screened cable designated for T1 carrier systems.
H1C	Screened cable designated for T1C carrier systems.
I	Buried filled cable, which will be installed inside a duct.
P	Predesignated buried filled cable which will, in the judgment of the Engineer, be much more difficult to install than normal for this project because of the presence of underground facilities or severe right-of-way restrictions. This suffix will be specified on the Construction Sheets in advance of bidding, and will not be specified later unless changes in the presence of underground utilities, right-of-way easement, or route changes occur that would, in the judgment of the Engineer, greatly increase the difficulty of cable placement. Also, this suffix will be specified during construction when undocumented buried facilities are encountered that, in the judgment of the Engineer, greatly increase the difficulty of cable placement.
T	Buried filled cable which will be placed at the specified depth by trenching only. This unit will be specified by the Engineer on the Construction Sheets in advance of bidding.
V()()	One or more vacant ducts to be placed simultaneously in the same plow slot or trench. The first set of parentheses shall indicate the number of ducts and the second set of parentheses shall indicate the inside diameter of the ducts.

A. This unit also includes:

- (1) Clearing of right-of-way. (The Engineer will be responsible for specifying any special conditions or instructions concerning the right-of-way clearing on the Construction Sheets.)

Note 1: Trees that are felled shall be cut to commercial wood length and placed on the side of the right-of-way for the landowner. Commercial wood length means the length designated by the Engineer, but in no case shall be required to be less than 2 feet (0.61 m).

Note 2: Brush, branches, and refuse from the clearing operations shall, without delay, be disposed of by such of the following methods as the Engineer will direct:

<u>Code</u>	<u>Disposition</u>
A	Chipped and Blown.
B	Removed from the vicinity of the right-of-way.
C	Piled on one side of the right-of-way in such manner as to not obstruct roads, ditches, etc.
D	Other as specified by Engineer.

- (2) All labor and material required for the installation of cable guards installed with the approval of the Engineer for the convenience of the Contractor.
- (3) All labor and material required in the repair and/or replacement of streets, sidewalks, roads, drives, fences, lawns, shrubbery, watermains, pipes, pipelines and contents, underground power and telecommunications facilities, buried sewerage and drainage facilities, and any other property damaged during the installation of the buried cable, except loss or damage to crops, gardens, ornamental flowers or trees in the construction corridor necessarily incident to the construction of the Project and not caused by the negligence of the Contractor.
- (4) The cable installed in place for aerial inserts in buried plant when specified by the Engineer. It includes the miscellaneous accessories such as drive rings, thimbleye nuts, etc., in accordance with the Construction Sheets, not included in other units, needed to secure the buried cable in place. (This unit

does not include poles, anchors, guys, riser guards or suspension strand units which will be separately specified by the Engineer.)

- (5) The spiraling of buried cable at an aerial insert where indicated by the Engineer on the Construction Sheets.
 - (6) All labor and material including housings, splice closures, stub poles, trenching, backfilling, tamping, cable, straight splicing, and other material and labor required for the purpose of joining cable of the same size and gauge in continuous lengths (reel ends). The housings or closures and all other associated materials and equipment shall be of the same type as required at other cable splicing points specified in the construction of the Project unless otherwise approved by the Engineer.
 - (7) The labor and material for buried cable installed in Miscellaneous Assembly Units, such as, pipe crossings, rock excavating, asphalt or concrete. The labor and material required by these miscellaneous assembly units are specified separately.
- B. The length of buried cable for compensation purposes is determined by taking the sum of distances between splice or terminal points specified by the Engineer, paralleling the cable. It includes the cable installed in trenches, pipes and non-pipe underground crossings, in sections of aerial construction of buried cable and in vertical runs on poles and in stake-mounted or pole-mounted housings. It excludes lateral and vertical runs of cable required solely for the purpose of joining cable in continuous lengths (reel ends) of the same size and gauge. The length of buried cable installed shall be determined from the sequential number length markers on the outer jacket of the buried cable except where the markings are illegible, found to be in error or an excessive amount of slack has been provided such as in housings, filled splice closures and aerial inserts. Compensation for multiple cables placed in the same plow slot or trench is determined on the basis of the lengths of the individual cables involved.

Each buried filled copper cable assembly unit is listed in accordance with the number of pairs and gauge of conductors. Each unit is prefixed by the letters BFC. The following illustrations indicate the method of designating the material required.

BFC(50-24 & 25-22)D	Two cables placed simultaneously in the same plow slot or trench; one a 50 pair, 24 gauge and the other a 25 pair, 22 gauge cable. Quantity, labor and material unit prices are to be specified for each cable separately.
BFC100-22H	A 100 pair, 22 gauge buried filled copper cable with a screen designated for T1 carrier systems.
BFC300-24P	A 300 pair, 24 gauge buried filled copper cable which in the judgment of the Engineer will be much more difficult to install than normal because of the presence of underground facilities or severe right-of-way restrictions.
BFC200-24V(2)(1")	A 200 pair, 24 gauge buried filled copper cable with 2 vacant ducts having 1 inch (in.) [25.4 millimeters (mm)] inside diameters placed simultaneously in the same plow slot or trench.
BFC25-24I	A 25 pair, 24 gauge buried filled copper cable to be installed in a duct.

Section BFO - BURIED FILLED FIBER OPTIC CABLE ASSEMBLY UNITS

Consists of one (1) foot (0.305 m) of buried filled fiber optic cable in place. This unit includes all material and labor for installing, ripping (where necessary as determined by the Engineer), and backfilling, except as specifically provided for in other units. Where the cable is plowed, ripping may be necessary to provide a ripped path to allow placement at the required depth, and may require more than one ripped pass.

Options designated by the following suffixes apply:

<u>Suffix</u>	<u>Description</u>
D	Two or more cables placed simultaneously in the same plow slot or trench. Specify all cables within parentheses ().

- I Buried filled cable, which will be installed inside a duct.
- P Predesignated buried filled cable which will, in the judgment of the Engineer, be much more difficult to install than normal for this project because of the presence of underground facilities or severe right-of-way restrictions. This suffix will be specified on the Construction Sheets in advance of bidding, and will not be specified later unless changes in the presence of underground utilities, right-of-way easement, or route changes occur that would, in the judgment of the Engineer, greatly increase the difficulty of cable placement. Also, this suffix will be specified during construction when undocumented buried facilities are encountered that, in the judgment of the Engineer, greatly increase the difficulty of cable placement.
- T Buried filled cable which will be placed at the specified depth by trenching only. This unit will be specified by the Engineer on the Construction Sheets in advance of bidding.
- V()() One or more vacant ducts to be placed simultaneously in the same plow slot or trench. The first set of parentheses shall indicate the number of ducts and the second set of parentheses shall indicate the inside diameter of the ducts.

A. This unit also includes:

- (1) Clearing of right-of-way. (The Engineer will be responsible for specifying any special conditions or instructions concerning the right-of-way clearing on the Construction Sheets).

Note 1: Trees that are felled shall be cut to commercial wood length and left on the side of the right-of-way for the landowner. Commercial wood length means the length designated by the Engineer, but in no case shall be required to be less than 2 feet (0.61 m).

Note 2: Brush, branches, and refuse from the clearing operations shall, without delay, be disposed of by such of the following methods as the Engineer will direct:

<u>Code</u>	<u>Disposition</u>
A	Chipped and Blown.
B	Removed from the vicinity of the right-of-way.
C	Piled on one side of the right-of-way in such manner as to not obstruct roads, ditches, etc.
D	Other as specified by Engineer.
	(2) All labor and material required for the installation of cable guards installed with the approval of the Engineer for the convenience of the Contractor.
	(3) All labor and material required in the repair and/or replacement of streets, sidewalks, roads, drives, fences, lawns, shrubbery, watermains, pipes, pipelines and contents, underground power and telecommunications facilities, buried sewerage and drainage facilities, and any other property damaged during the installation of the buried cable, except loss or damage to crops, gardens, ornamental flowers or trees in the construction corridor necessarily incident to the construction of the Project and not caused by the negligence of the Contractor.
	(4) The cable installed in place for aerial inserts in buried plant when specified by the Engineer. It includes the miscellaneous accessories such as drive rings, thimbleye nuts, etc., in accordance with the Construction Sheets, not included in other units, needed to secure the buried cable in place. (This unit does not include poles, anchors, guys, riser guards or suspension strand units which will be separately specified by the Engineer.)
	(5) The spiraling of buried cable at an aerial insert where indicated by the Engineer on the Construction Sheets.
	(6) The labor and material for buried cable installed in Miscellaneous Assembly Units, such as, pipe crossings, rock excavating, asphalt or concrete. The labor and material required by these miscellaneous assembly units are specified separately.
B.	The Buried Filled Fiber Optic Cable Assembly Unit does not include labor and material for splicing the individual fibers. All splice points, including reel end splices, shall be specified by the Engineer on the Construction

Sheets. All labor and material required for splicing the fibers and for enclosing the splice, such as, fiber organizers, splice closures, housings and stub poles, and miscellaneous hardware items shall be included in other assembly units.

- C. The length of buried cable for compensation purposes is determined by taking the sum of all distances between splice or terminal points specified by the Engineer. It includes the cable installed in trenches, pipes and non-pipe underground crossings, in sections of aerial construction of buried cable and in vertical runs on poles and in stake-mounted or pole-mounted housings. The length of buried cable installed shall be determined from the sequential number length markers on the outer jacket of the buried cable except where the markings are illegible or found to be in error. Compensation for multiple cables placed in the same plow slot or trench is determined on the basis of the lengths of the individual cables involved.

Each buried filled fiber optic cable assembly unit is listed in accordance with the number of optical fibers. Each unit is prefixed by the letters BFO. The following illustrations indicate the method of designating the material required.

- | | |
|-------------------------|--|
| BF024 | A buried filled fiber optic cable with 24 fibers. |
| (BF036 &
BFC100-24)D | Indicates a 36 fiber, buried filled fiber optic cable and a 100 pair, 24 gauge buried filled copper cable, placed in same plow slot or trench. Quantity, labor and material unit prices are to be specified for each cable separately. |
| BFO24V(2)(1") | A buried filled fiber optic cable containing 24 fibers with 2 vacant ducts having 1 in. (25.4 mm) inside diameters placed simultaneously in the same plow slot or trench. |
| BFO36I | A buried filled fiber optic cable containing 36 fibers installed in a duct. |

Section BH - BURIED HANDHOLE ASSEMBLY UNITS

Consists of labor and material for one (1) buried handhole installed in place, including the base, top cover and mounting hardware, and pea gravel. The handhole size, amount of pea gravel and the installation shall be as specified by the Engineer. The handhole assembly unit shall be used only in areas of non-vehicular traffic. When required for use in areas of vehicular traffic, the handhole shall be rated to withstand vehicular traffic. Where specified, vehicular traffic rated handholes shall be suffixed with the letter "T".

The assembly units are defined as follows:

BHC() Buried Handhole for copper systems.
 BHF() Buried Handhole for fiber optic systems.

The dimensions of length, width, and depth of the handhole shall be indicated in the parentheses in inches (millimeters).

Examples:

BHC(13x24X24) Buried handhole for copper systems with dimensions of 13 x 24 x 24 in. (330 x 610 x 610 mm) (approximate).

BHF(17x30x30)T Buried handhole for fiber optic systems with dimensions of 17 x 30 x 30 in. (432 x 762 x 762 mm)(approximate) which is rated for vehicular traffic.

Section BM - MISCELLANEOUS ASSEMBLY UNITS

Consists of all labor and material to construct and install the units defined individually below required for the installation and construction of the buried cable portions of the Project:

BM2()() Housing Ground Assembly Unit - Consists of the necessary labor and material for the installation of a ground rod (installed in undisturbed soil), ground rod clamp and the required length of a bare #6 AWG copper ground wire connected to an auxiliary grounding connector (included in the housing assembly unit) within the housing (see unit drawing BM2). Indicate the desired diameter and length of ground rod. For a sectionalized ground rod and coupling device use the suffix "S".

- Examples: BM2(1/2)(5) A 1/2 in. X 5 foot (13 mm X 1.5 m) ground rod.
- BM2(5/8)(8) A 5/8 in. x 8 foot (16 mm X 2.4 m) ground rod.
- BM2(5/8)(20)S Two 5/8 in. x 10 foot (16 mm X 3.1 m) sectionalized ground rods and a coupling device. Where sectionalized ground rods are required the total length should appear on the Construction Sheets.
- BM2A Housing Auxiliary Ground Assembly Unit - Consists of the necessary labor and material for the installation of a ground rod clamp (if required) and the required length of a bare #6 AWG copper ground wire connected to a pole ground wire using a ground wire connector (see unit drawing BM2A).
- BM2B Housing Ground Assembly Unit - Consists of the necessary labor and materials for the installation of a bonding connector bracket within an existing housing. The bonding connector bracket should be the bracket that is recommended by the housing manufacturer.
- BM2C Existing Facility Bonding Assembly Unit - Consists of the necessary labor and material for bonding new or existing cable in an existing facility, such as a buried plant housing or splice closure. This unit includes a bonding connector, a bonding harness, tie-wraps, replacement of gravel and/or sealer, and rearrangement of an existing cable. Compensation shall be paid on a per bond basis.
- BM2D New Facility Re-Bonding Assembly Unit - Consists of the necessary labor and material for re-bonding an existing cable in a new facility such as a buried plant housing or splice closure. This unit includes a bonding connector, a bonding harness, and tie wraps. Compensation shall be paid on a per bond basis.
- BM6M Suspension Strand Assembly Unit - Consists of one (1) foot (0.305 m) of 6M [6,000 pounds (lbs)--2722 kilograms (kg)] suspension strand, supporting hardware, lashing wire, cable straps, and all other accessories required for aerial insert construction in buried plant, but excludes the buried cable.

This unit will be used for short sections of aerial construction in buried plant. When such aerial inserts are required, the Engineer will specify the pole, riser guard, guy and anchor assembly units required, plus the appropriate quantity of this unit. The Contractor will be compensated for these units at their respective bid prices plus the appropriate cable units including the vertical length on the end poles.

- BM10M Suspension Strand Assembly Unit - This unit is the same as the BM6M unit except that the size of the strand is 10M (10,000 lbs--4536 kg).
- BM16M Suspension Strand Assembly Unit - This unit is the same as the BM6M unit except that the size of the strand is 16M (16,000 lbs--7257 kg).
- BM21 Cable Entrance - Consists of the necessary labor and material to terminate copper and/or fiber optic outside plant cables as shown on the detailed drawings as specified by the Engineer.
- BM22 Grounding System - Consists of the necessary labor and material to construct a grounding system as shown on the detailed drawings as specified by the Engineer. This unit shall include all ground electrodes, trenching, backfilling, bonding the auxiliary ground electrodes to each other and to the primary ground electrodes, and bonding to the master ground bar (MGB).
- BM50() Buried Service Wire or Cable Installation to Pole-Mounted Wire Terminal Assembly Unit - Consists of the necessary labor and material to install a buried wire or cable from a buried plant housing to a pole mounted wire terminal. This unit includes the installation of pole mounted buried wire or cable, a pole mounted wire terminal, and the necessary wire work at the wire terminal (see assembly unit drawing BM50). Pair count of the terminal size shall be indicated in the parentheses. Installation of the buried plant housing and splicing of the pole mounted buried wire or cable inside the buried plant housing shall be compensated under separate units.
- BM52 Re-numbering Assembly Unit - This unit consists of the necessary labor and material to remove existing numbers and clean where necessary, and re-number an existing housing.

- BM53 Warning Sign Assembly Unit - Consists of one (1) staked mounted warning sign, in place as shown on the Construction Sheets. This unit includes all labor and material to install the stake mounted sign (see detail drawing specified by the Engineer).
- BM54 Route Sign Assembly Unit - Consists of one (1) stake mounted route sign, in place, as shown on the Construction Sheets. This unit includes all labor and material to install the stake mounted sign (see detail drawing specified by the Engineer).
- BM55 Splice Location Sign Assembly Unit - Consists of one (1) stake mounted splice location sign, in place, as shown on the Construction Sheets. This unit includes all labor and material to install the stake mounted sign (see detail drawing specified by the Engineer).
- BM55A Buried Splice Location Assembly Unit - Consists of one (1) buried splice location assembly unit installed in or above the buried splice case. The installation of the buried splice location unit shall be in accordance with the manufacturer's instructions. If the owner has standardized on a specific system, the Engineer shall so indicate (see detail drawing specified by the Engineer).
- BM60() Underground Pipe Crossing Assembly Unit - Consists of one (1) lineal foot (0.305 m) of steel pipe, with the inside diameter in inches (meters) specified in parentheses, installed in place. This unit includes the pushing of pipe and any excavation, backfilling and tamping necessary for the installation of the pipe. The pipe shall be installed at the depth specified by the Engineer. The installed pipe shall be free of any sharp projections to avoid damage to the outer jacket of the buried cable or wire during its installation in the pipe. The contractor will be compensated for labor and material for the buried cable or wire under separate units. Options designated by the following suffixes apply:

<u>Suffix</u>	<u>Description</u>
D	Directional boring required.
P	Plastic pipe required.

- BM61() Underground Non-Pipe Crossing Assembly Unit - Consists of the labor in providing a hole in soil one (1) foot (0.305 m) in length and of a diameter in inches (meters) specified in parentheses. The depth of the hole below the surface of the ground shall be specified by the Engineer. This unit includes any excavation, backfilling and tamping necessary for the installation. This unit may be used where the permanent installation of a steel or plastic pipe under the BM60 unit is not required. The contractor will be compensated for labor and material for the buried cable or wire under separate units. Where directional boring is required, the unit shall be suffixed by the letter "D".
- BM65() Guard Assembly Unit - Consists of the necessary labor and material for installing one (1) lineal foot (0.305 m) of split galvanized steel guard. The sections of guard may be straight and or curved. This unit may be used as attachments to bridges, abutments, walls, etc., and any below ground location. All hangers, bolts, and other attachment hardware along with excavation, backfilling, tamping, and restoration are included as part of this unit. The diameter of the guard shall be indicated in the parentheses. The contractor will be compensated for labor and material for the buried cable or wire under separate units. (See detailed drawings as specified by the Engineer). Where a split plastic guard is required, the unit shall be suffixed by the letter "P".
- BM66() Bridge Attachment Assembly Unit - Consists of the necessary labor and material for installing one (1) lineal foot (0.305 m) of galvanized steel pipe, of the inside diameter in inches (meters) specified, attached to a bridge. Details of the method of installation will be in accordance with the Plans and Specifications as determined by the Engineer. The contractor will be compensated for labor and material for the buried cable or wire under separate units. (See detailed drawings as specified by the Engineer). Where a plastic pipe is required, the unit shall be suffixed by the letter "P".

- BM71 Rock Excavating Unit - Consists of one (1) lineal foot (0.305 m) of trenching, blasting, sawing, etc., measured parallel to the surface of the ground, in rock, including excavation, backfilling and tamping to place cable or wire to the depth specified in the Specifications. This unit includes all material and labor required in the repair and/or replacement of streets, roads, sidewalks, drives, fences, lawns, shrubbery, watermains, pipes, pipelines and contents, underground power and telecommunications facilities and any other property damaged by the excavating, except loss or damage to crops, gardens, trees or ornamental flowers in the construction corridor necessarily incident to the construction of the Project and not caused by the negligence of the Contractor. This unit will be specified by the Engineer only when field conditions at the site show the existence of rock to a depth required by the specification, which cannot be trenched, plowed or ripped. If extra depth is required, the unit shall be suffixed by "E()", where the required depth in rock shall be shown inside the parentheses. The contractor will be compensated for labor and material for the buried cable or wire under separate units.
- BM72 Asphalt Assembly Unit - Consists of labor and material necessary to remove and restore one (1) lineal foot (0.305 m) of asphalt pavement (where the removal does not necessitate the breaking up of concrete) measured along the route of the cable or wire. Any trenching which may be necessary for the installation of buried cable or wire is included in this unit. All work shall be performed as required in accordance with federal, state and/or local construction standards in effect at the time of bid date. (Pursuant to these federal, state and/or local standards, restoration may include the use of any base and sub-base materials such as concrete, crushed stone, etc.). The contractor will be compensated for labor and material for the buried cable or wire under the separate units.
- BM73 Concrete Assembly Unit - Consists of the labor and material necessary to remove and restore one (1) lineal foot (0.305 m) of concrete pavement (or any combination of concrete pavement and other surfacing material) where the removal necessitates the breaking up of concrete pavement, measured along the route of cable or wire. Any trenching which may be necessary for the installation of buried cable or wire is

included in this unit. All work shall be performed as required in accordance with federal, state and/or local construction standards in effect at the time of bid date. (Pursuant to these federal, state and/or local standards, restoration may include the use of any base and sub-base materials such as concrete, crushed stone, etc.) The contractor will be compensated for labor and material for the buried cable or wire separate units.

- BM80 Riser Guard, 1 in. inside diameter (ID) x 8 feet (25.4 mm x 2.44 m).
(see assembly unit drawing BM80)
- BM81 Riser Guard, 2 in. ID x 8 feet (50.8 mm x 2.44 m).
(see assembly unit drawing BM81)
- BM82 Riser Guard, 3 in. ID x 8 feet (76.2 mm x 2.44 m).
(see assembly unit drawing BM82)
- BM91 Pedestal Restricted Access Insert Assembly Unit -
Consists of a restricted access insert installed within a housing and the labor and material for setting up in preparation for installing the insert, such as, opening the jacket and bonding of the cable shields. Cable splicing shall be compensated under the appropriate splicing units.

Section HBF - BURIED FILLED SPLICE CLOSURE ASSEMBLY UNITS

Consists of a buried splice closure and the closure manufacturer's provided encapsulating material, installed in place and the labor and material for setting up in preparation for installing the closure, such as, excavating a splicing pit, installing closure in a housing or handhole if necessary, opening the sheath or jacket of the cable, bonding of the cable shields, filling the closure, and closing the closure in accordance with the manufacturer's instructions. Cable splicing shall be compensated under the appropriate splicing units.

The assembly units are defined as follows:

- HBF() Buried Filled Closure - A filled splice closure with pair count and gauge for each cable to be spliced.
- HBFO() Buried Filled Fiber Optic Closure - A fiber optic closure and organizer with the number of fibers to be housed in the organizer.

Note: Suffix "A" shall indicate a treated plank with dimensions as specified by the Engineer, placed 6 in. [15.24 centimeters (cm)] above the closure (see guide drawing 907).

The following illustrations indicate the method of designating the material required.

HBF(100-24)	Buried filled closure enclosing two cable ends same pair count and gauge.
HBF(200-24)(100-24)A	Buried filled closure enclosing two cable ends with different pair counts provided with a treated plank above.
HBFO(24)	Buried filled fiber optic splice closure and organizer capable of accommodating a minimum of 24 fibers.

Section HC - COPPER SPLICING ASSEMBLY UNITS

- HC1 Consists of the labor and material necessary in the wire work and splicing of one (1) cable pair in any cable, including any non-working pair in an existing cable in accordance with RUS Splicing Standard Bulletin 1753F-401 (PC-2) using individual mechanical splicing connectors. The splice may be straight, bridged, or pieced out and bridged. Pairs that are to be tested, capped, or tested and capped, when specified by the Engineer are considered to be part of this unit. Only those pairs on which splicing, testing, and/or capping operations are performed are counted and each pair is counted only once at each location. On aerial inserts, each end of the fuse link is considered as a splice.
- HC2 Consists of the labor and material necessary for terminating one (1) distribution, feeder, and/or electronic pair on a cross-connect block or a cross-connect module, including any non-working pair in an existing cable in accordance with RUS Splicing Standard Bulletin 1753F-401(PC-2). Pairs that are to be tested, when specified by the Engineer are considered to be part of this unit. Only those pairs on which terminating and/or testing operations are performed are counted and each pair is counted only once at each location.
- HC3 Consists of the labor and material necessary in the wire work and splicing of one (1) cable pair in any cable, including any non-working pair in an existing cable in accordance with RUS Splicing Standard Bulletin 1753F-401

(PC-2) using splicing modules. The splice may be straight, bridged or pieced out and bridged. Pairs that are to be tested, capped, or tested and capped, when specified by the Engineer are considered to be part of this unit. Only those pairs on which splicing, testing, and/or capping operations are performed are counted and each pair is counted only once at each location. On aerial inserts, each end of the fuse link is considered as a splice.

HC4 Consists of the labor and material for placing and terminating both ends of one (1) pair of cross-connect jumper wires on cross-connecting blocks and/or modules.

Section HO - FIBER OPTIC SPLICING ASSEMBLY UNITS

Consists of all labor and material necessary to splice and/or test one (1) glass fiber in any cable in accordance with RUS Splicing Standard Bulletin 1753F-401(PC-2). The labor shall include initial measurement, minimizing the attenuation, splicing and stowing the spliced fiber in a fiber organizer. The labor and material for the fiber organizer is part of the appropriate splice closure unit.

<u>Suffix</u>	<u>Description</u>
H01	Fusion Splice
H02	Mechanical Splice
H03	Connector Splice

Section W - REARRANGEMENT UNITS

Specific rearrangement units shall be designated and described by the Engineer on the "List of Special Arrangement Units" table of RUS Form 515. Existing plant assembly units to be rearranged are designated by a prefix "W".

Section XX - NONREUSABLE MATERIALS REMOVAL UNITS

These units cover the furnishing of all labor for the removal of construction assembly units from existing lines, and transportation of the removed materials for proper disposal. The Contractor will be permitted to use the most economical method of removing these units. The removal units are designated by the prefix "XX" followed by the assembly unit designation of the unit to be removed.

Section XZ - REUSABLE MATERIALS REMOVAL UNITS

These units cover the furnishing of all labor for the removal of construction assembly units from existing lines and all labor and transportation of the removed materials to a location designated by the Owner. The Contractor will be charged by the Owner for the materials removed under this section at the unit material values shown in column 2 of the "Value and Disposition of Units to be Removed" table of RUS Form 515. The number of units to be charged to the Contractor and the extended value of these units are shown in columns 3 and 4. Such charges will be placed against the Contractor as assembly units are removed and the unit material values will be deducted from the total value of assembly units constructed on this project for determination of the work accomplished for purposes of the monthly progress payments to the Contractor. Of the assembly units listed in the "Value and Disposition of Units to be Removed" table to be removed from existing lines certain units are to be reused in the construction of the project. The quantity of such units to be reused is listed in the "Value and Disposition of Units to be Removed" table, column 5. These units where installed in the project will be inventoried as new assembly units and compensated for at the unit bid prices. The quantity of assembly units listed in column 6 of the "Value and Disposition of Units to be Removed" table is the maximum quantity of removed assembly units that are to be returned to the Owner for credit which will be allowed at the unit material prices in column 2. Column 7 indicates the extended value of the units to be returned to the Owner. The Contractor will be allowed credit for assembly units listed in column 6 which, in the opinion of the Engineer, have not been damaged by the Contractor in removal and handling. Such credits will be allowed the Contractor as the assembly units are returned to a location designated by the Owner and shall be added to the total value of installed assembly units for determination of work accomplished for the purposes of the monthly progress payments to the Contractor. The removal units are specified by the prefix "XZ" followed by the assembly unit designation of the existing assembly unit to be removed.

Part II - SPECIFICATION FOR MATERIALS**1. SCOPE**

This part of the specification is concerned with the various materials required for the construction of the outside buried cable and wire plant of the rural telecommunications system as shown on the Plans, Specifications, and Construction Sheets.

2. GENERAL

All materials used in the construction of the rural telecommunications system except those listed in Paragraph 4 below shall be listed in RUS Informational Publication (IP) 344-2, "List of Materials Acceptable for Use on Telecommunications Systems of RUS Borrowers," unless specific written approval has been granted by the Administrator.

3. STUB POLES

The stub pole plan, method of treatment, kind of preservative and general procedure applying to all stub poles shall be in accordance with the latest RUS specifications in effect at the time the bids are received.

4. MISCELLANEOUS

Items for which categories do not appear in RUS IP 344-2, "List of Materials Acceptable for Use on Telecommunications Systems of RUS Borrowers," shall be of a quality suitable for the application for which they are intended.

Part III - SPECIFICATION FOR CONSTRUCTION AND INSTALLATION**1. GENERAL**

1.1 All construction and installation work shall be done in a thorough and workmanlike manner in accordance with the Plans, Specifications and Construction Sheets and shall be subject to acceptance by the Owner and the Administrator.

1.2 All material to be used in construction of the Project shall be stored so as to be protected from deteriorating effects of the elements.

1.3 All buried cables or wires, and accessory materials used in the construction of the Project shall be handled with care. Each reel of buried cable or wire shall be inspected for damage. All damage shall be repaired to the satisfaction of the Engineer and

in accordance with the methods or other instructions described in the appropriate paragraphs of Part III. If reel wrap is present, the reel wrap shall remain intact on the reel until the cable or wire is ready to be placed.

1.4 Deviations from the Plans, Specifications and Construction Sheets shall not be permitted except upon written permission of the Engineer.

1.5 The latest revision of the National Electrical Safety Code (NESC) and the National Electrical Code (NEC) shall be followed in every case except where local regulations are more stringent, in which case local regulations shall govern.

1.6 The Contractor shall maintain conductor polarity (tip and ring) identification at the main distributing frame, buried plant housings, splice closures and in the service entrance, all in accordance with the Plans, Specifications, and Construction Sheets (see guide drawing 815-1).

2. BURIED PLANT HOUSING STUB POLES

2.1 The setting depth of stub poles where specified and used as mounting posts in connection with buried plant housings, shall be a minimum of 3.0 feet (0.91 m) in soil and as specified by the Engineer in solid rock. If a greater depth in soil is necessary, the Engineer will indicate the required depth in the Proposal.

2.2 The bottom of the hole shall be thoroughly tamped.

3. CABLE SPLICING

Splicing for fiber optic cable, copper cable and wire shall be in accordance with RUS Splicing Standard Bulletin 1753F-401(PC-2).

4. BURIED CABLE OR WIRE

4.1 General

4.1.1 The construction equipment shall be subject to the approval of the Owner and the public authorities having jurisdiction over highway and road rights-of-way.

4.1.2 The design of the plowshare shall be such that the buried copper cable or wire passing through the plow shall not bind and shall not be bent in a radius less than 10 times the outside diameter of the copper cable or wire. Buried fiber optic cable passing through the plow shall not bind and shall not be bent in a radius less than 20 times the outside diameter of the cable. The plowshare shall have a removable gate for the purpose of inspection, and a hinged fairlead, which shall be equipped with smooth, free wheeling rollers or low friction surfaces to prevent damage to the cable or wire.

4.1.3 The Engineer should periodically inspect the cable or wire as well as the installation equipment and procedures during installation to guard against damage to the cable or wire when it is being placed in the ground, and to see that proper depth is maintained at all times.

4.1.4 The Contractor shall promptly repair any damage to fences, lawns, shrubbery, drives and any other property damaged during construction.

4.1.5 A rock excavating unit (BM71) shall be applied where a plow train cannot maintain specified depth under the buried cable or wire unit (including ripping). To assist in determining the ability of any plowing equipment to place the cable at a specified depth, the table below shall be used only to compare the capability of this equipment with standard minimum drawbar pull ratings unless different characteristics are specified by the Engineer (greater drawbar pull may only be specified at greater depths than shown in the table).

Minimum Drawbar Pull vs. Cable or Wire Depth at
1.2 MPH (1.93 km/hr)

Depth		Minimum Drawbar Pull	
Inches	Meters	Pounds	Newtons
24	0.61	55,000	2.45×10^5
30	0.76	75,000	3.34×10^5
36	0.91	95,000	4.23×10^5

4.1.6 The equipment and construction methods used by the Contractor shall be such as to cause minimum displacement of the soil. The slot made in the soil by the cable plow shall be immediately closed.

4.1.7 Damage to banks, ditches, driveways and roads caused by the equipment shall be immediately repaired to the satisfaction of the Engineer and public authorities having jurisdiction over highway and road rights-of-way where involved.

4.1.8 Where cables or wires are buried near the edge of pavements, the Contractor shall take particular care to avoid damaging the pavement. If such damage does occur repairs shall be made immediately to meet the requirements of state or local authorities having jurisdiction over the pavement involved.

4.1.9 The stub pole or stake portion of stake mounted housings shall be installed in accordance with the Construction Sheets in a manner not to damage the cable or wire placed in the trench.

4.1.10 To avoid possible damage to buried cable or wire from exposure to traffic, livestock and other hazards, trenching of laterals, trenching around culverts, construction of aerial inserts and similar operations shall be completed as soon as practicable behind the plowing operation.

4.1.11 Trenches shall be promptly backfilled with earth and tamped at 6 in. (15.24 cm) lifts so that the earth is restored to original grade to assure no hazard to vehicular, animal or pedestrian traffic. No trenches shall be left open overnight.

4.1.12 When placing cable or wire in a trench in rock, the cable or wire shall be cushioned by a fill of sand or selected soil at least 2 in. (5.08 cm) thick on the floor of the trench. The backfill for at least 4 in. (10.16 cm) above the cable or wire shall be free from stones, rock or other hard or sharp materials, which might damage the cable. Alternate methods are permissible subject to approval of the Engineer.

4.2 Handling of Cable

4.2.1 Cables or wires shall be carefully inspected by the Contractor during the placement operation to be certain that the cables or wires are free from defects.

4.2.2 Bends of small radii and twists that might damage cable or wire shall be avoided. During the placement operation, copper cable or wire shall not be bent in a radius less than 10 times the outside diameter of the cable or wire. Fiber optic cable shall not be bent in a radius less than 20 times the outside diameter of the cable.

4.2.3 Care is to be exercised during the plowing operation, to feed the cable or wire into the ground through the plow loosely and at no tension. Equipment and construction methods shall be such as to assure compliance with this requirement. The Contractor shall furnish competent supervision at all times at the site of plowing operations to assure compliance with this requirement.

4.2.4 If, during the plowing operation, the plow should strike a buried object or rock that stops the equipment which necessitates removal of the plow from the ground, the plow shall be removed from the ground carefully, and if practicable without backing the plow, to avoid damage to the cable or wire. Should it be necessary to back the plow to remove it from the ground, the cable or wire shall be uncovered a sufficient distance back for inspection by the Engineer to determine whether the cable or wire has been damaged.

4.2.5 Every instance of damaged cable or wire observed at any time whether prior to installation, occurring during construction, or discovered by test or observation subsequent to installation in plant, shall be immediately called to the attention of the Engineer. The method of repair or correction of such damage shall be in accordance with the written instructions of the Engineer. The Contractor shall promptly repair such damage or make such corrections in accordance with such written instructions of the Engineer. Minor damage to the outer jacket of the cable or wire observed prior to or occurring during construction shall be repaired in accordance with RUS Splicing Standard Bulletin 1753F-401(PC-2).

4.2.6 Major damage to cable or wire observed prior to or during construction shall be corrected by enclosing the damaged section of cable or wire in (1) a buried plant housing located as specified by the Engineer or (2) a buried filled splice closure if approved by the Engineer, which are buried to the same depth as that required for the cable or wire. If the shield has been broken or the conductor insulation damaged, the cable or wire shall be restored to the equivalent of new condition. This may require cutting out the damaged section of cable or wire if required by the Engineer.

4.2.7 Major damage to cable or wire discovered after placement either through test or observation shall be repaired as approved by the Engineer. This may require cutting out the damaged section and replacing it with a short section of new cable or wire with splices made in (1) buried plant housing or (2) buried

filled splice closures, if approved by the Engineer, which are buried to the same depth as that required for the cable or wire. It may also require the replacement of an entire section between housings already installed.

4.3 Depth of Buried Plant

4.3.1 Unless otherwise specified by the Engineer in the Proposal, or on the Construction Sheets, the depth of buried cable or wire placed, measured from the top of the cable or wire to the surface of ground or rock shall be as listed in the following table:

Minimum depth in soil	24 in. (610 mm)
Minimum depth at ditch crossings (See guide Drawing 975)	36 in. (914 mm)
Minimum depth in rock	6 in. (152 mm)

4.3.2 In the case of a layer of soil over rock, either the minimum depth in rock, measured to the surface of the rock, or the minimum depth in soil, measured to the surface of the soil, may be used at the Contractor's option.

4.3.3 When rock excavating is specified, width and depth requirements of the trench shall be as shown below:

<u>Trench Width</u>	<u>Trench Depth</u>
6 in. (152 mm) or less	6 in. (152 mm)
7 in. (178 mm)	9 in. (229 mm)
8 in. (203 mm)	12 in. (305 mm)
9 in. (229 mm)	15 in. (381 mm)
10 in. (254 mm) or greater	18 in. (457 mm)

Either the minimum depth in rock shall be achieved or some other method may be employed by the Contractor to provide adequate protection to the cable or wire as agreed to by the Engineer.

4.3.4 When directional boring is used, the Contractor shall continually control the horizontal and vertical movements of the bore to a specified route and depth.

4.4 Splicing and Terminations

4.4.1 Buried service wires shall be spliced directly to the appropriate pair of the buried cable, or spliced to the appropriate pair number on a filled terminal block as specified by the Engineer.

4.4.2 For the purpose of joining buried cable or wire at reel ends, the buried cable or wire shall be made continuous by splicing the conductors directly together either in a housing or a filled buried splice closure. The method and location shall be specified by the Engineer.

4.4.3 Splicing and termination of cable or wire pairs shall be in accordance with the cable schematic drawings issued by the Engineer.

4.4.4 All splices and terminations of cable or wire pairs in filled buried splice closures shall be electrically tested to ensure freedom from opens, shorts, crosses and grounds and all defects cleared prior to closing the splice closure. Shield continuity also shall be checked prior to closing the splice closure.

4.4.5 Splicing of copper cable, wire, or fiber optic cable shall be in accordance with RUS Splicing Standard Bulletin 1753F-401(PC-2).

5. BURIED HANDHOLES

5.1 Buried handholes shall be installed in accordance with the instructions given herein unless otherwise specified by the Engineer unless state or local requirements are more stringent in which case the latter requirements will govern.

5.2 The Engineer shall determine the location of the handhole and shall specify type, position and depth of installation.

5.3 A hole shall be dug large enough to accommodate the handhole.

5.4 The handhole shall be positioned and a suitable backfill shall be tamped around the handhole.

5.5 Pea gravel should be placed inside of the handhole to minimize condensation problems.

5.6 The Engineer shall ensure that the dimensions of the handhole shall be large enough to accommodate the splice case installation and when required, cable slack.

6. MISCELLANEOUS - BURIED PLANT

6.1 The separate steel stakes of stake mounted housings shall be driven a minimum of 12 in. (30.48 cm) in undisturbed earth in a vertical position and faced in accordance with the Construction Sheets. Care shall be exercised in the installation of stakes or

housings. Housing covers shall be securely closed at all times except when work is being performed within the housing.

6.2 The shields of all buried copper cable or wire and the armor of all buried fiber optic cable shall be connected together at all splices and termination points, as specified in RUS Splicing Standard Bulletin 1753F-401(PC-2) to ensure a continuous metallic connection throughout the buried plant. Buried cable or wire shields and fiber optic cable armor shall also be connected to the ground connectors in buried plant housings and to other ground installations as shown on the Construction Sheets and in RUS Splicing Standard Bulletin 1753F-401(PC-2).

6.3 Stake mounted warning, route, and splice location signs shall be installed in accordance with the manufacturer's instructions and in locations as specified by the Engineer. As an alternate to the splice location sign, the Engineer may specify the use of a buried splice location device (BM 55A).

6.4 Buried cable and wire, including buried services, terminated or spliced in a housing shall be directionally marked as specified on the Construction Sheets or as specified by the Engineer. The directional markers shall be installed at the time the cable or wire is placed in the housing and before the lateral trench to the housing is backfilled.

6.5 Where aerial inserts in buried plant are specified by the Engineer, the construction shall be accomplished if possible without cutting the cable or wire. Where due to physical conditions, in the opinion of the Contractor, the cutting and splicing of cable or wire are necessary, prior approval to cut the cable or wire shall be obtained from the Engineer. The splicing of cable or wire shall be in accordance with RUS Splicing Standard Bulletin 1753F-401(PC-2).

6.6 Junctions between buried cable and aerial circuits shall be made in accordance with the applicable Construction Sheets.

6.7 All products utilized to control rodents and/or insects should be specifically formulated for the telecommunications industry and applied in accordance with the instructions or directions detailed on the manufacturer's product label.

6.8 Buried cable and wire shall be placed in the same trench to the buried plant housing, unless otherwise specified by the Engineer.

7. SPECIAL REQUIREMENTS FOR INSTALLATION OF SERVING AREA INTERFACE CABINETS (SAIC)

7.1 Specific installation instructions for the pad or slab base preparation and construction, placement of conduit(s), and the assembly and installation cabinet shall be provided by the manufacturer and/or the Engineer.

7.2 A drainage hole shall be drilled at the low point of the radius of bend of the conduit placed between two cabinets.

7.3 All vacant or unused conduit shall be sealed as specified by the Engineer.

7.4 Specific installation instructions for mounting the cabinet assembly will be provided by the manufacturer and/or the Engineer.

7.5 The separate steel stakes of stake mounted housings shall be driven a minimum of 12 in. (30.48 cm) in undisturbed earth in a vertical position and faced in accordance with the Construction Sheets. Care shall be exercised in the installation of the stakes and housings. Housing covers shall be securely closed at all times except when work is being performed within the housing.

7.6 All special installation tools for splicing and placing cross-connect jumper wires shall be used as indicated by the manufacturer.

7.7 here conventional hard-wire splicing is employed at SAIC locations, the splicing and lay-up of conductor pairs shall be in accordance with RUS Splicing Standard Bulletin 1753F-401 (PC-2) and/or special instructions issued by the Engineer.

7.8 Pair counts shall be shown on all splice, feeder and cross-connect modules or blocks identifying feeder, distribution and electronic terminations.

7.9 air count tags shall be used on bundle pair counts where hard-wire splicing is employed. On bundle tags, feeder, feeder/distribution, distribution and electronic cable identification, pair counts shall be shown per cable schematics in accordance with RUS Splicing Standard Bulletin 1753F-401 (PC-2).

LIST OF CONSTRUCTION DRAWINGS AND PLANSAssembly Unit Drawings

BM2, -2A	Ground Wire Assembly, Buried Plant
BM50	Buried Service Wire or Cable Installation to Pole-Mounted Wire Terminal
BM80, BM81, BM82	Riser Guards

Construction Guide Drawings

815-1	Buried Plant Conductor Polarity Diagram
905	Installation of Type "M" or Type "H" Pole-Mounted Housings at Increased Height
907	Splice Closures - Direct Burial
910	Pea Gravel and Sealer Installation Procedures for Buried Plant Housings
951	Aerial Insert in Buried Plant Construction
952	Protection of Buried Cable from Power Contact to Aerial Inserts
965	Placement of Numbers and Letters on Housings
971-1	Wiring Arrangement at Junction of New Aerial Cable with Buried Cable or Wire
971-2	Junction of Aerial Cable with Buried Cable or Wire
975	Buried Plant Under Ditches
976	Housing Installation Details

NOTE: On the Assembly Unit and Construction Guide Drawings an asterisk (*) in the ITEM column indicates items that are no longer listed in RUS IP 344-2, "List of Materials Acceptable for Use on Telecommunications Systems of RUS Borrowers."

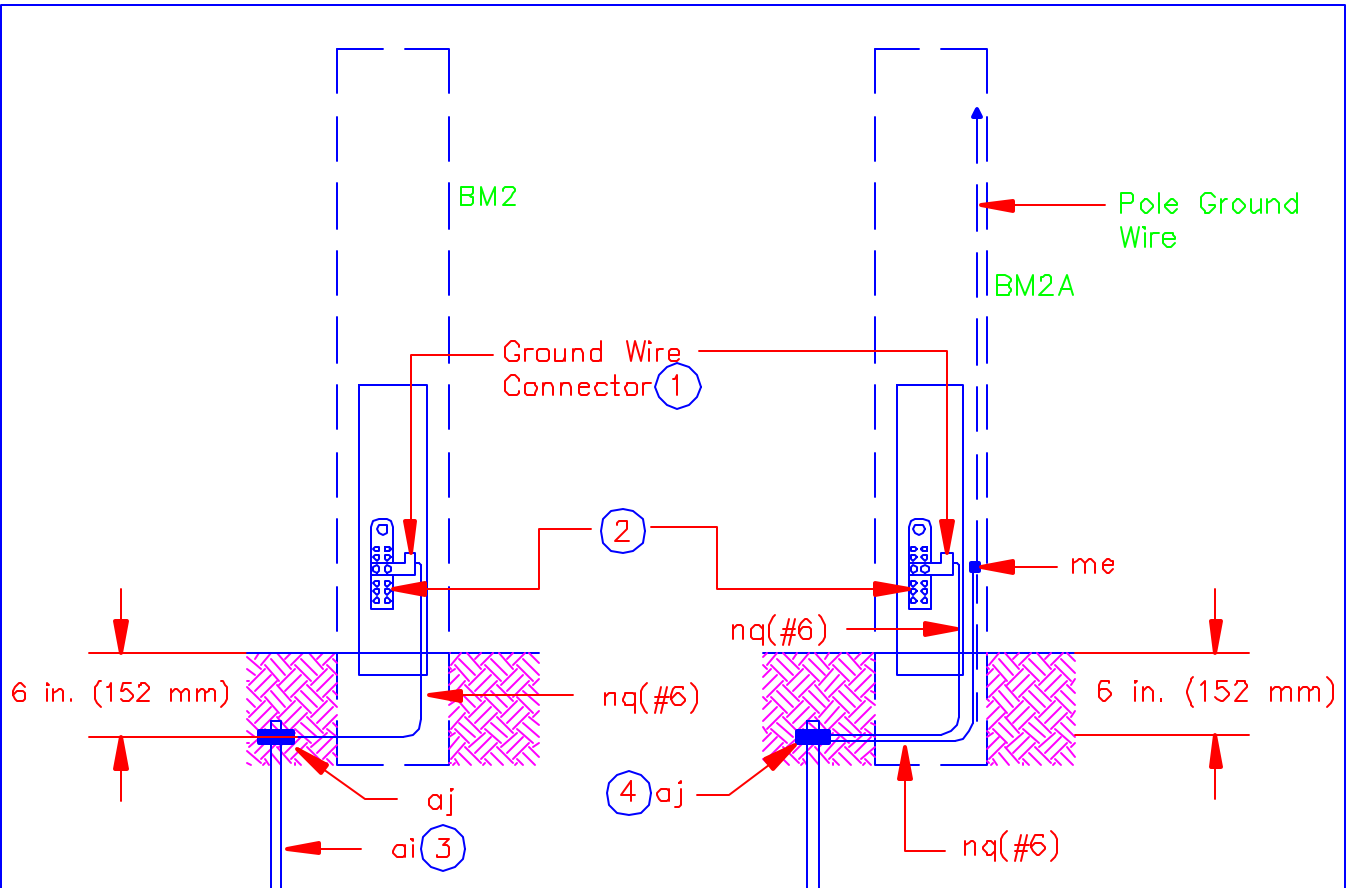

Notes.

1. The ground wire connector is supplied with the buried plant housing, buried plant fiber optic housing, and serving area interface cabinet under the BD, BDO, and BDS Assembly Units, respectively.
2. The bonding bracket is supplied with the buried plant housing, buried plant fiber optic housing, and serving area interface cabinet under the BD, BDO, and BDS Assembly Units, respectively.
3. The ground rod shall be installed in undisturbed soil.
4. One clamp may be used if it is listed by Underwriter's Laboratories (UL) or other acceptable organizations for connecting two wires, otherwise two UL or other acceptable organization listed clamps must be used.

ITEMS	MATERIALS	BM2	BM2A
		NO. REQ'D	NO. REQ'D
*nq	Wire, ground, bare, #6 AWG copper	As required	As required
ai	Rod, ground (size & length as req'd)	1	—
me	Connector, ground wire	—	1
aj	Clamp, ground rod	1	If required

RURAL TELECOMMUNICATIONS CONSTRUCTION PRACTICES
 GROUND WIRE ASSEMBLY, BURIED PLANT

Scale: NTS

March 2001

BM2 — BM2A

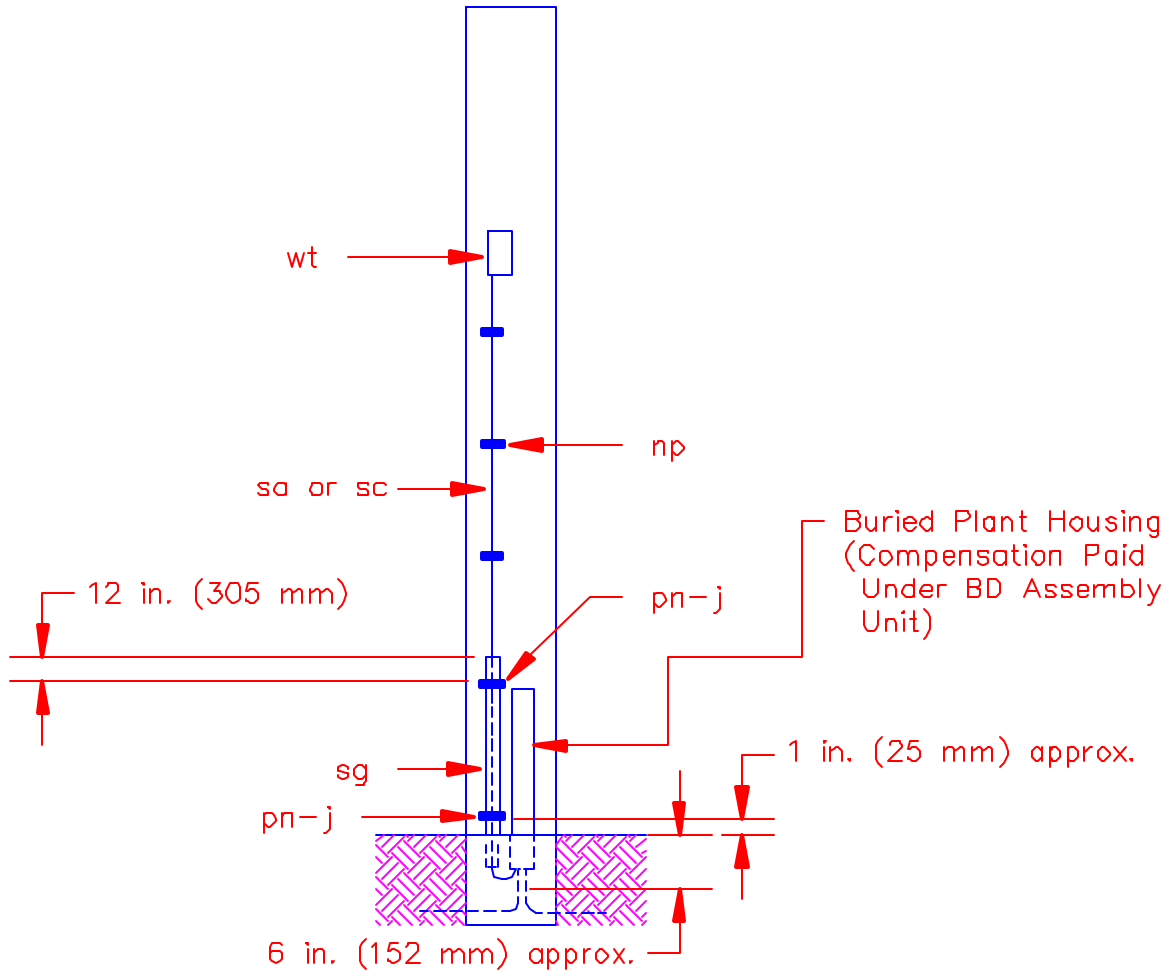

ITEMS	MATERIALS	NO. REQ'D
wt	Terminal, wire, filled, unprotected, pole-mounted (specify pair size)	1
*pn	Strap, riser guard	2
*np	Clamp, one-hole, offset	as req'd
sa or sc	Wire or cable, filled, buried	as req'd
sg	Guard, riser, 1 in. ID by 8 ft (25 mm ID by 2.4 m)	as req'd
j	Screws, lag (size as required)	4
RURAL TELECOMMUNICATIONS CONSTRUCTION PRACTICES BURIED SERVICE WIRE OR CABLE INSTALLATION TO POLE-MOUNTED WIRE TERMINAL		
Scale: NTS		March 2001
		BM50

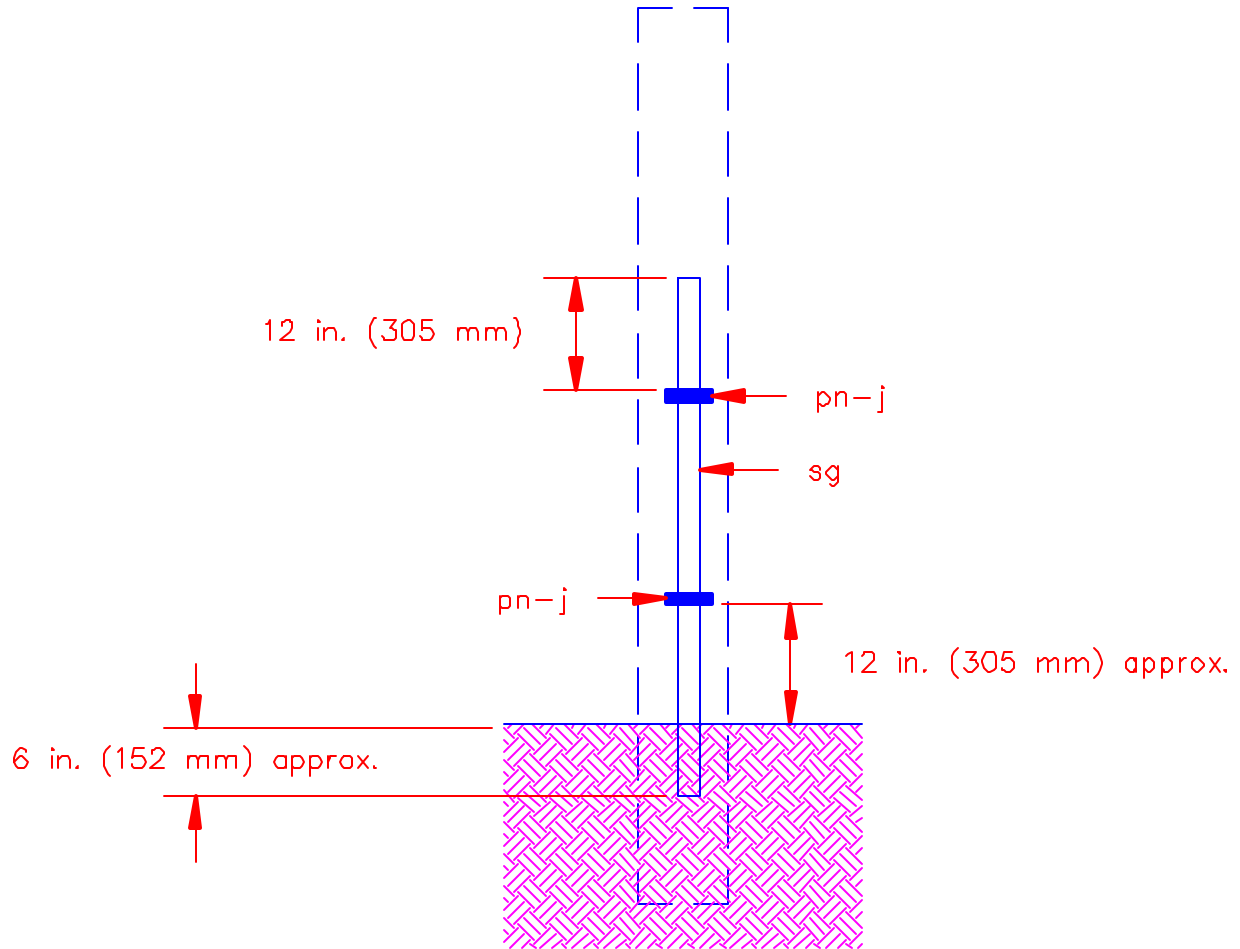

ITEMS	MATERIALS	BM80	BM81	BM82
		NO. REQ'D	NO. REQ'D	NO. REQ'D
sg	Guard, riser 1 in. ID * 8 ft (25 mm ID * 2.4 m)	1	—	—
sg	Guard, riser 2 in. ID * 8 ft (51 mm ID * 2.4 m)	—	1	—
sg	Guard, riser 3 in. ID * 8 ft (76 mm ID * 2.4 m)	—	—	1
*pn	Strap, riser guard	2	2	2
j	Screw, lag (size as required)	4	4	4

RURAL TELECOMMUNICATIONS CONSTRUCTION PRACTICES
 RISER GUARDS

Scale: NTS

March 2001

BM80, 81, 82

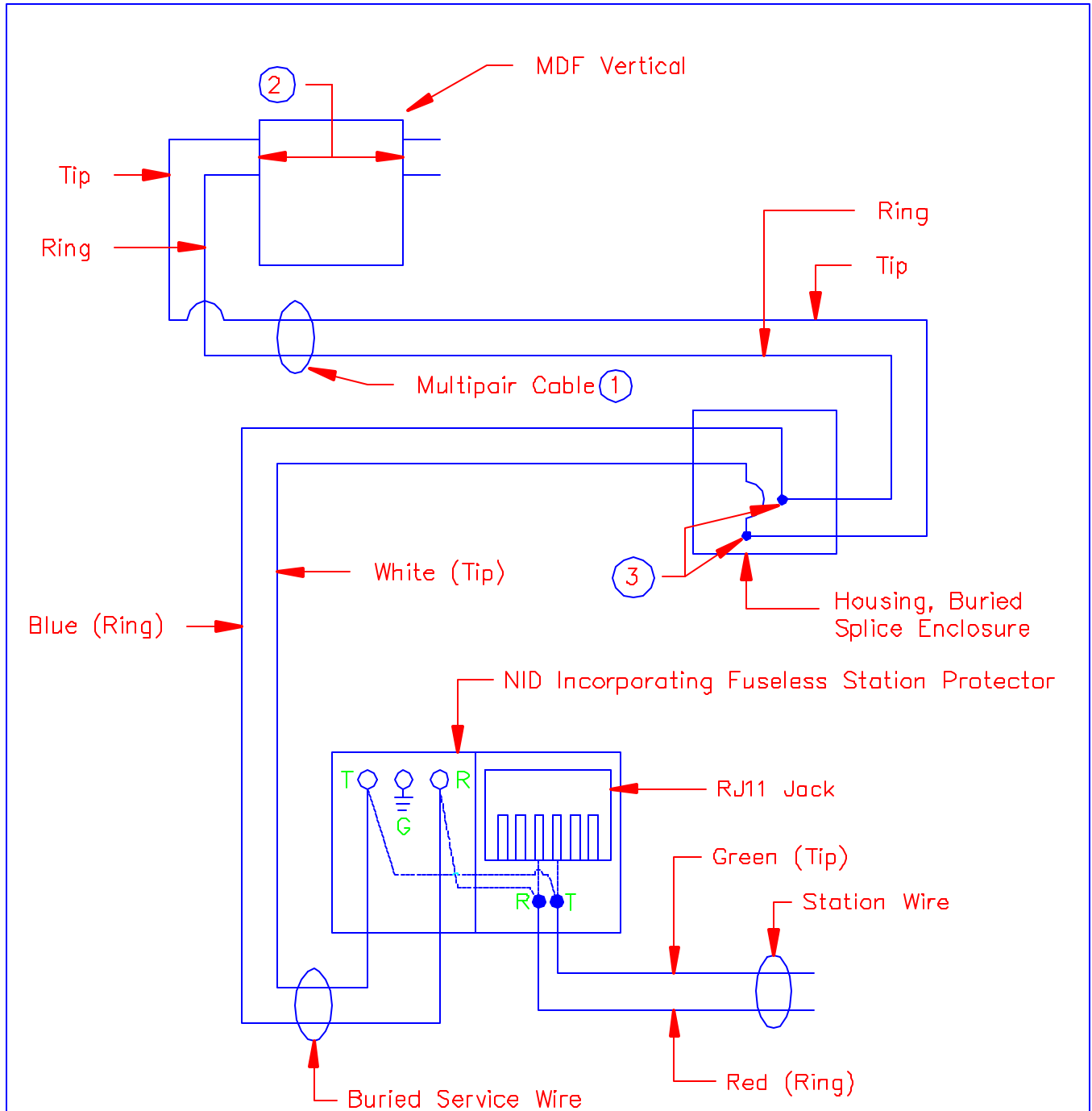

Notes:

- ① Refer to appropriate cable specifications for tip and ring conductor identification.
- ② Connections to be made in accordance with the manufacturer's instructions.
- ③ Connections to be made in accordance with RUS Bulletin 1753F-401(PC-2), "RUS Standard for Splicing Copper and Fiber Optic Cables."

RURAL TELECOMMUNICATIONS CONSTRUCTION PRACTICES
 BURIED PLANT CONDUCTOR POLARITY DIAGRAM

Scale: NTS

March 2001

815-1

TYPE M or H Buried Plant Housing

Notes:

- ① The radius of bend of the copper cable or wire at the base of the housing shall not be less than 10 times the diameter of the cable or wire.
- ② Height to be specified by Engineer.

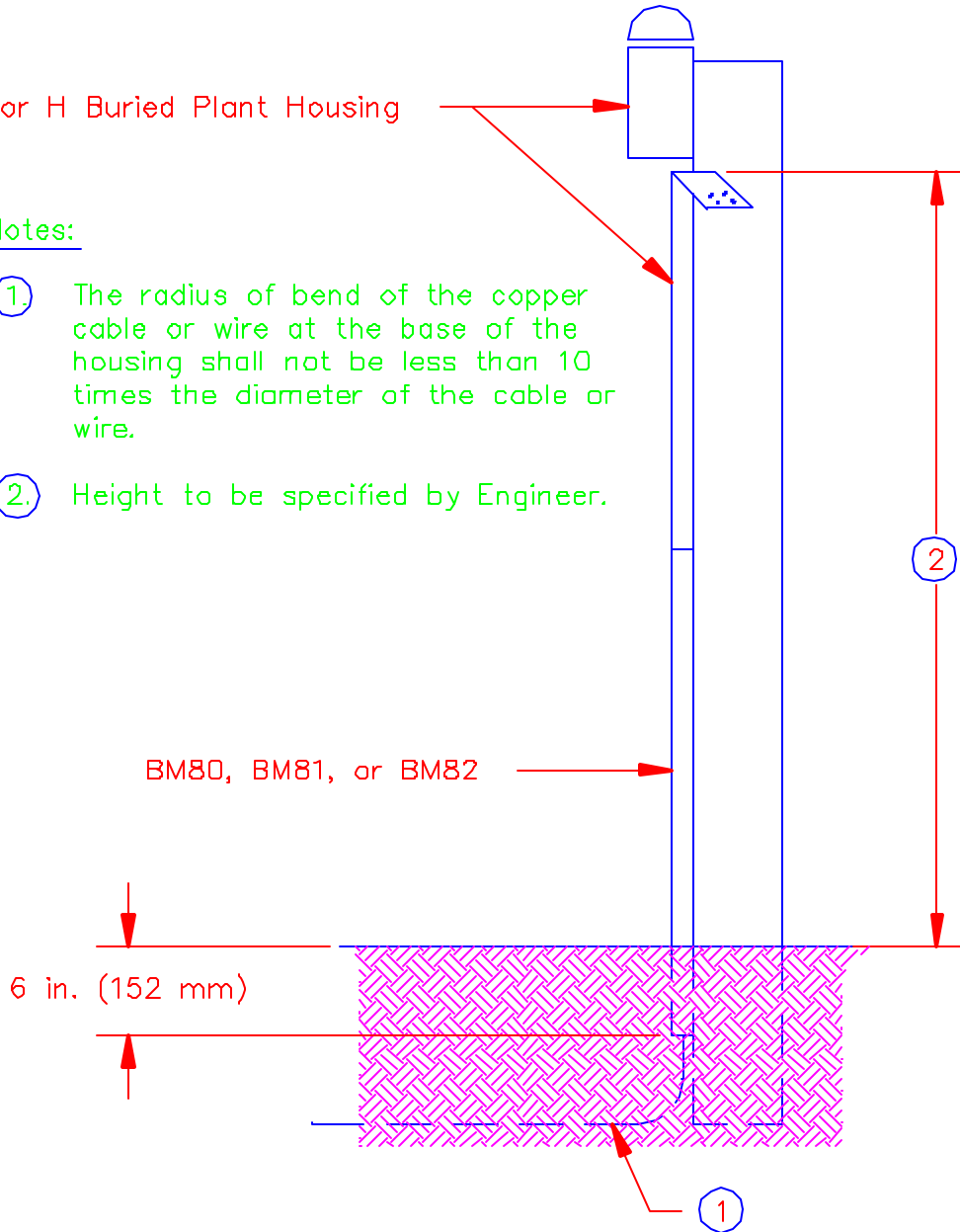

RURAL TELECOMMUNICATIONS CONSTRUCTION PRACTICES
 INSTALLATION OF TYPE M OR H POLE-MOUNTED
 BURIED PLANT HOUSINGS AT INCREASED HEIGHT

Scale: NTS

March 2001

905

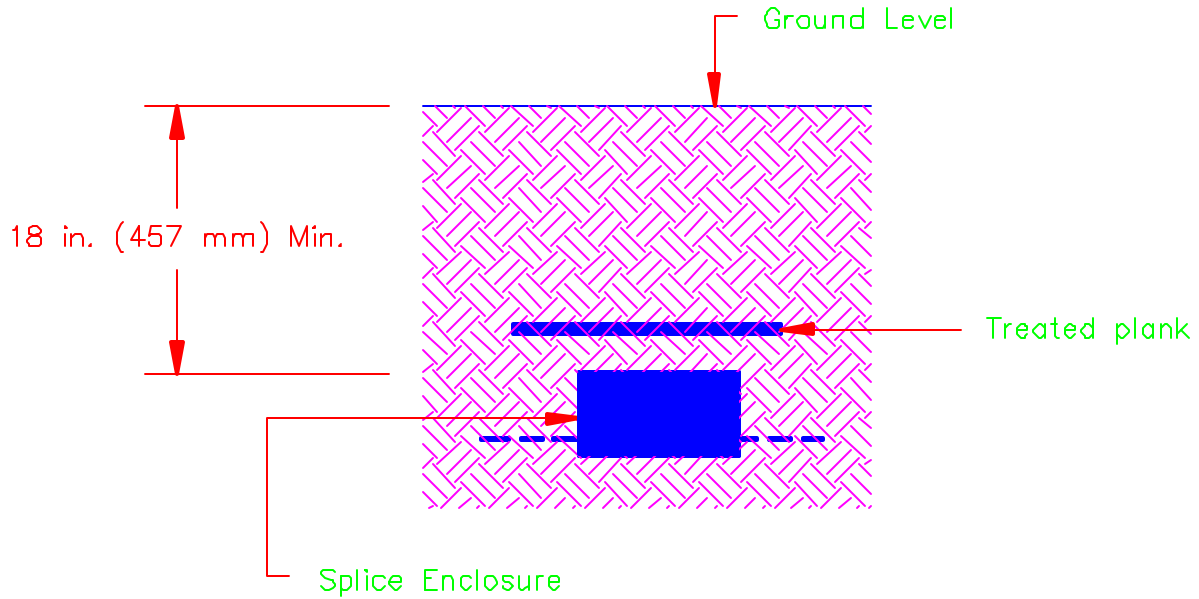

Note:

1. Fill the trench with soil to 6 in. (152 mm) above top surface of the buried splice enclosure and compact soil carefully. Place the treated plank over the top of the installed buried splice enclosure as shown.

RURAL TELECOMMUNICATIONS CONSTRUCTION PRACTICES
 SPLICE CLOSURES – DIRECT BURIAL

Scale: NTS

March 2001

907

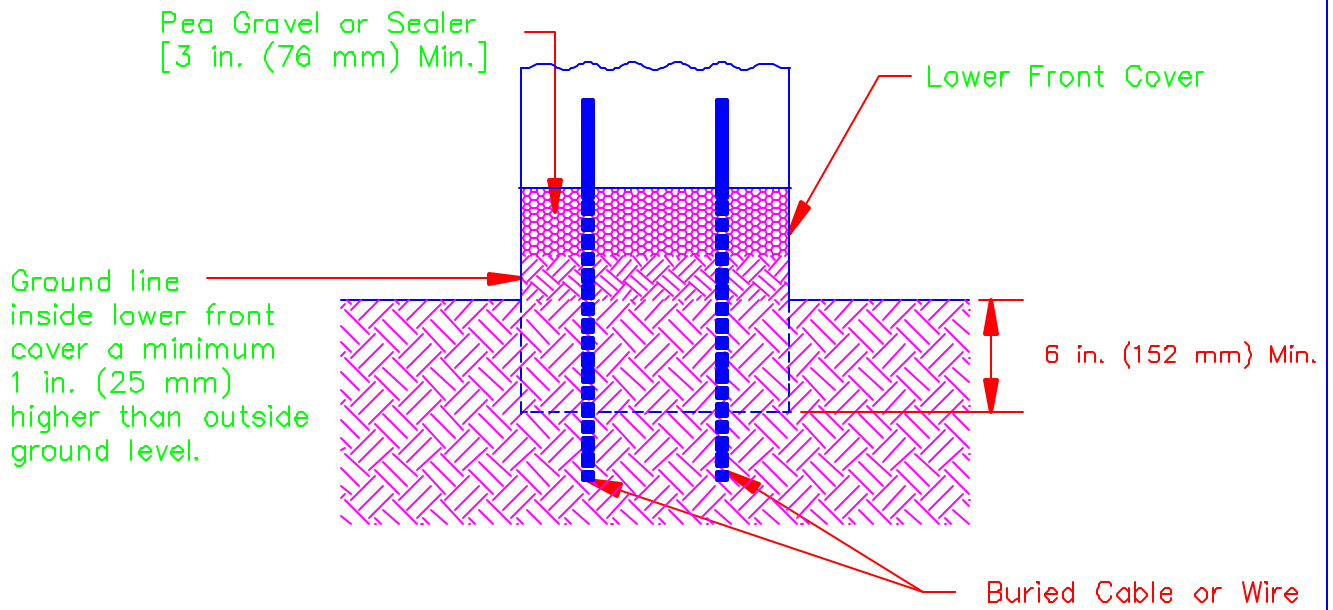

RURAL TELECOMMUNICATIONS CONSTRUCTION PRACTICES
 PEA GRAVEL OR SEALER INSTALLATION
 PROCEDURES FOR BURIED PLANT HOUSINGS

Scale: NTS

March 2001

910

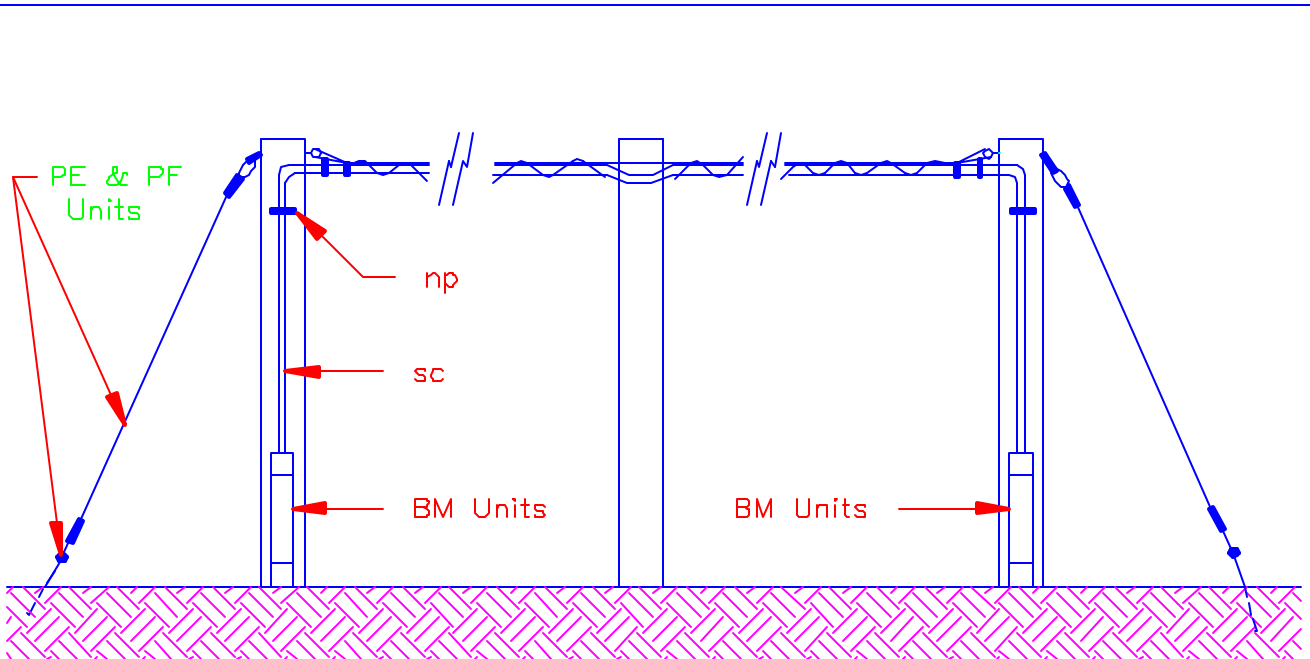

Notes:

- ①. The aerial construction used in this case shall be in accordance with the aerial construction practices described in RUS Form 515c entitled, "Specifications and Drawings for Construction of Aerial Plant."
- ②. The cable clamps shall be installed at approximately 18 in. (457 mm) intervals.
- ③. If it is necessary to cut the cable in making an aerial installation, the use of a ready-access enclosure or filled splice enclosure is acceptable.
- ④. Aerial inserts exposed to power contacts requiring special splicing will be identified by the Engineer and shall be isolated as shown on Guide Drawing 952.
- ⑤. Ground support strand where exposed to power contacts as specified by the Engineer on the Construction Sheets.

ITEMS	MATERIALS	NO. REQ'D
*np	Clamp, one-hole, offset	as req'd
pl	Enclosure, filled splice	if req'd
sc	Cable, filled buried	
er	Enclosure, ready-access	if req'd
RURAL TELECOMMUNICATIONS CONSTRUCTION PRACTICES AERIAL INSERT IN BURIED PLANT CONSTRUCTION		
Scale: NTS		March 2001
		951

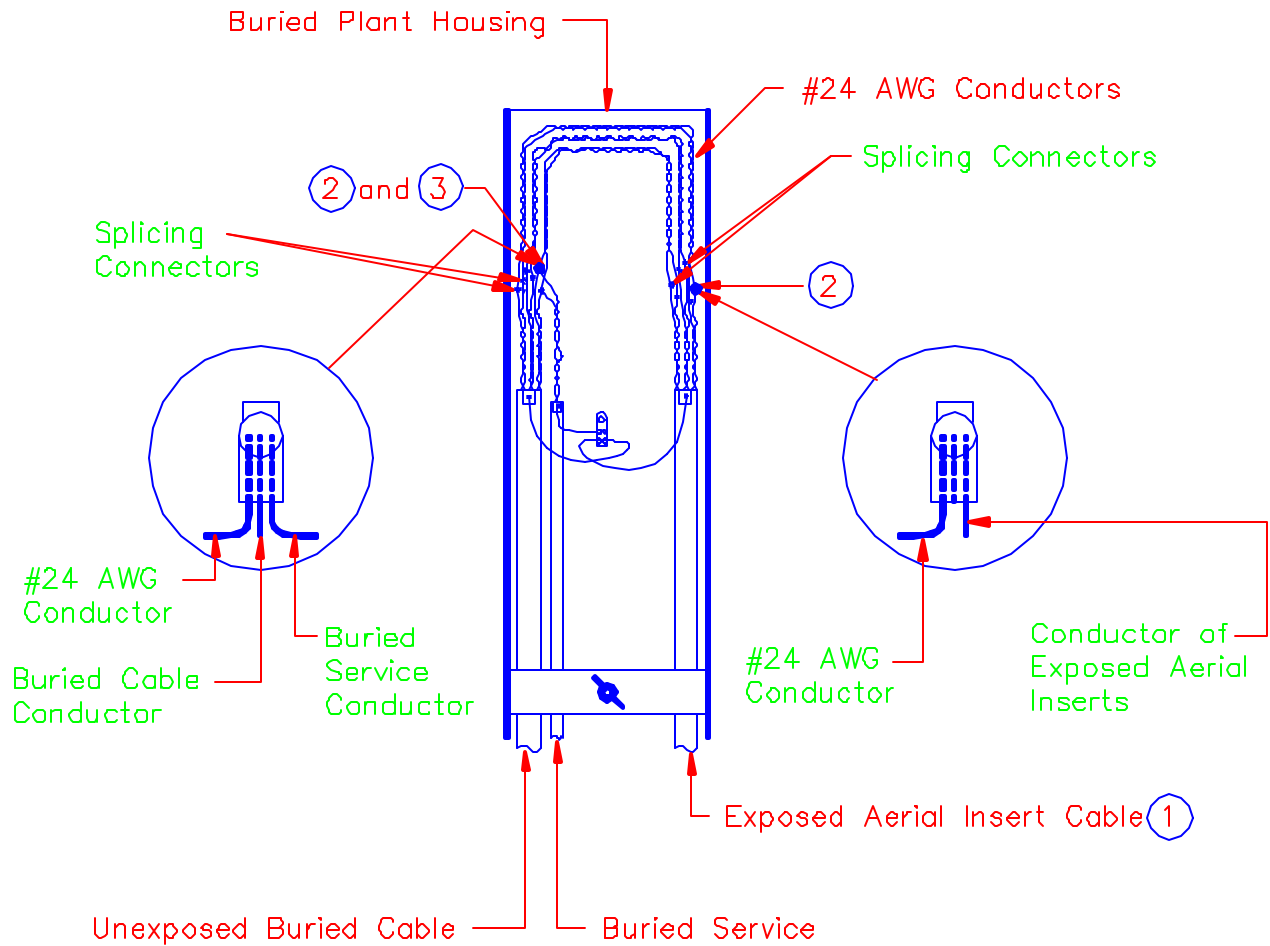

Notes:

- ①. Guide Drawing 952 is applicable if the exposed aerial cable insert is #22 AWG or larger.
- ②. Splice a color coded #24 AWG Conductor [8 in. (203 mm) min. length] in series with each cable conductor appearing in the aerial insert.
- ③. Splice the buried service, if any, to the unexposed buried cable at the same point that the #24 AWG conductor is spliced.

RURAL TELECOMMUNICATIONS CONSTRUCTION PRACTICES
 PROTECTION OF BURIED CABLE FROM POWER
 CONTACT TO AERIAL INSERTS

Scale: NTS

March 2001

952

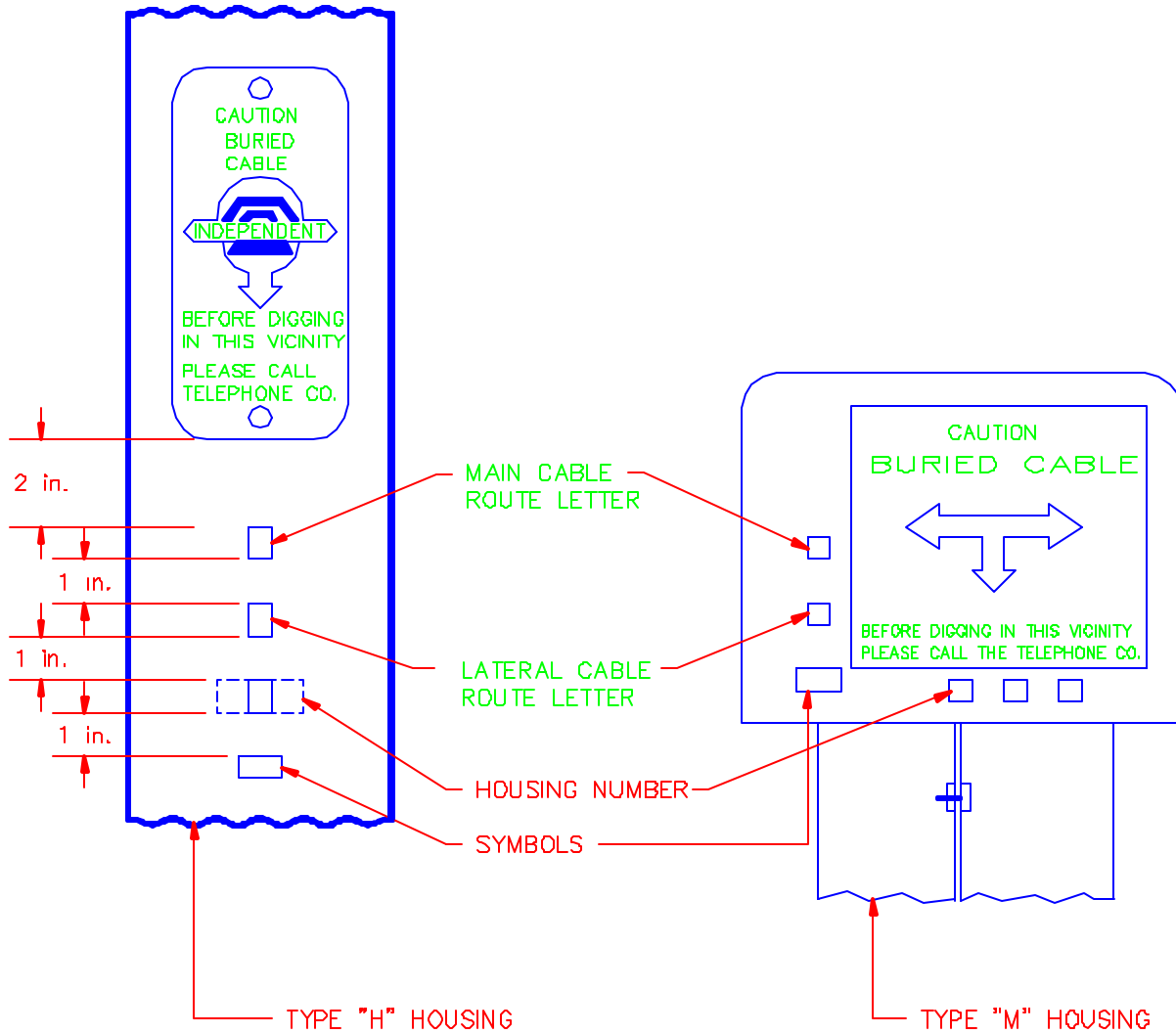

Notes:

1. Field installed warning signs or numbering systems should not penetrate or harm the housing surface.
2. For converting English units to metric units use 1 in. = 25.4 mm.

RURAL TELECOMMUNICATIONS CONSTRUCTION PRACTICES
 PLACEMENT OF NUMBERS AND LETTERS ON
 HOUSINGS

Scale: NTS

March 2001

965

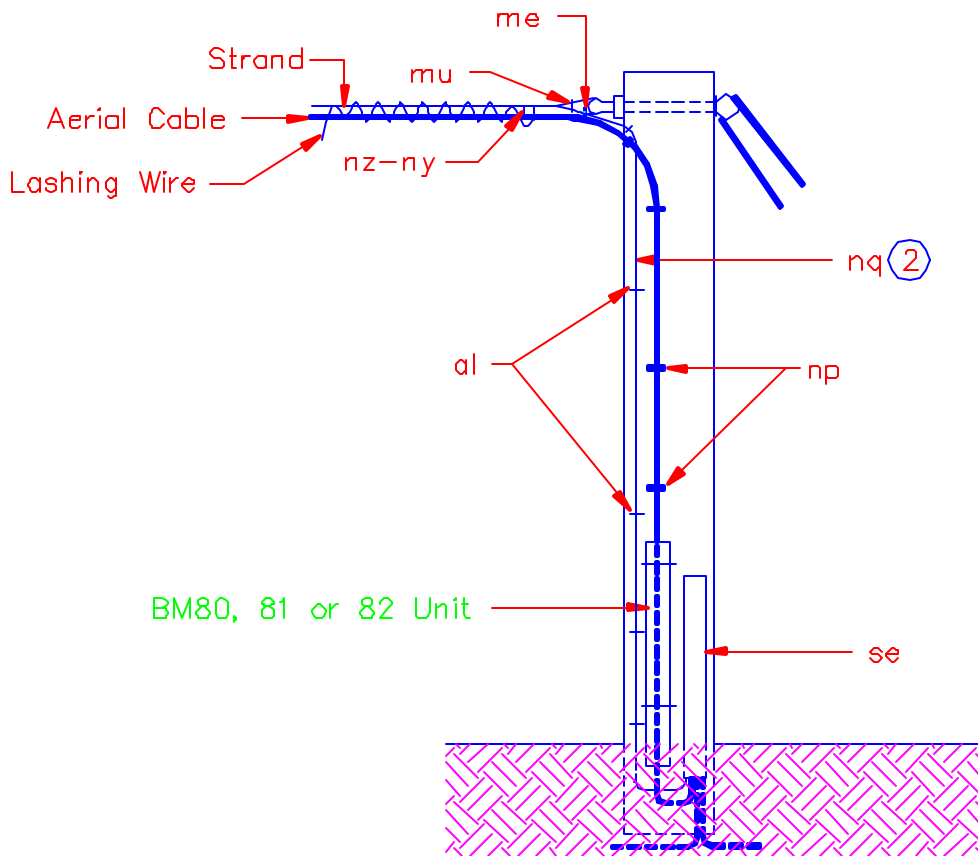

Notes:

- ① If the aerial conductors are smaller than 22 gauge, splice each aerial cable conductor, to be connected, directly to the main buried cable or wire conductor. If the aerial conductors are 22 gauge or larger, splice each aerial conductor to an 8 in. (203 mm) long 24 gauge insulated copper conductor of the same color as the conductor to be spliced. Splice other end of the 24 gauge conductor to the buried cable or wire conductor of the main lead.
- ② Connect the support strand of the cable to the grounding connector in the housing, by means of a #6 AWG ground wire and ground as specified by the Engineer.
- ③ Bond shield of aerial cable to bonding bracket in the housing.

ITEMS	MATERIALS	ITEMS	MATERIALS
*nq	Wire, ground, bare, #6 AWG copper	*mu	Sleeve, deadend, automatic
*al	Staples, ground, wire	*nz	Supports, lashed cable
me	Connector, ground wire	*ny	Spacer, cable
se	Housing, buried plant		
*np	Clamp, one-hole, offset		
		RURAL TELECOMMUNICATIONS CONSTRUCTION PRACTICES WIRING ARRANGEMENT AT JUNCTION OF NEW AERIAL CABLE WITH BURIED CABLE OR WIRE	
		Scale: NTS	March 2001
			971-1

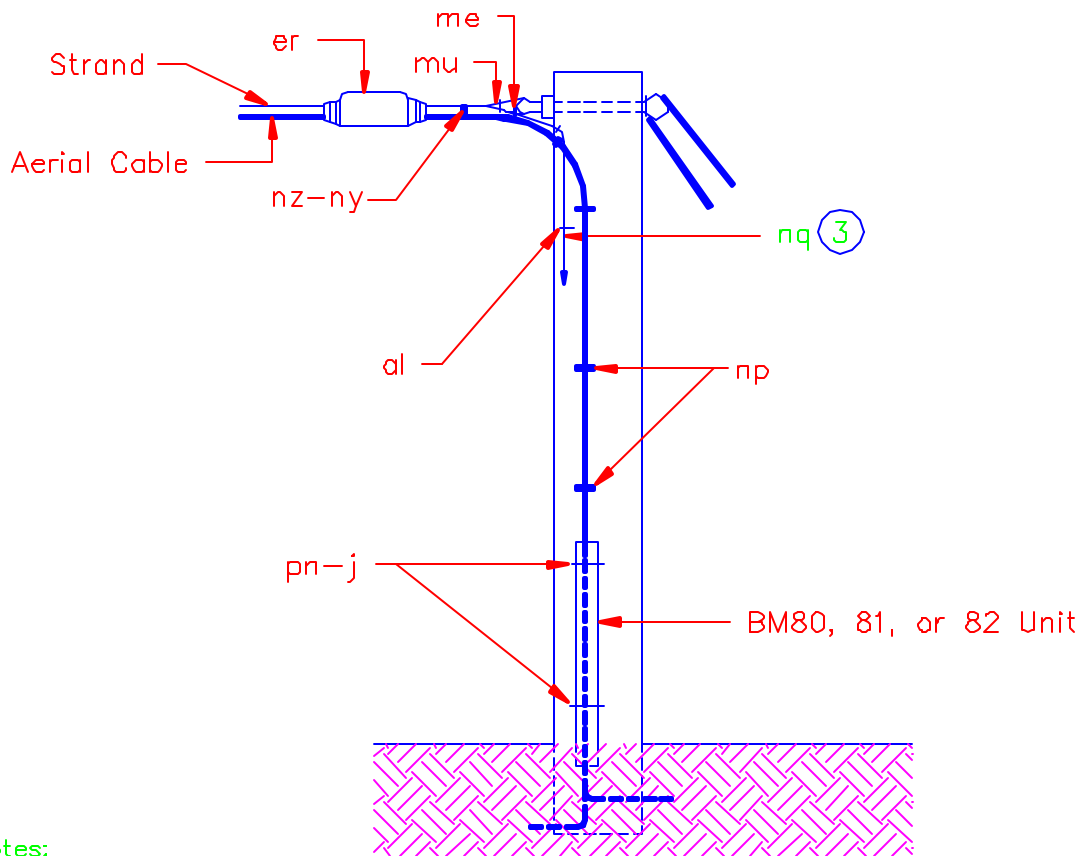

Notes:

- ①. If the aerial conductors are smaller than 22 gauge, splice each aerial cable conductor, to be connected, directly to the main buried cable or wire conductor. If the aerial conductors are 22 gauge or larger, splice each aerial conductor to an 8 in. (203 mm) long 24 gauge insulated copper conductor of the same color as the conductor to be spliced. Splice other end of the 24 gauge conductor to the proper buried cable or wire conductor of the main lead.
- ②. If necessary, remove insulation from under one clamp on support strand to obtain electrical bond between frame of ready-access enclosure and support strand.
- ③. If specified by the Engineer, install a #6 AWG bare ground wire and connect the ground wire to the grounding electrode from the support deadend sleeve to a ground electrode.

ITEMS	MATERIALS	ITEMS	MATERIALS
*nq	Wire, ground, bare, #6 AWG copper	*mu	Sleeve, deadend, automatic
*al	Staples, ground wire	*nz	Supports, lashed cable
me	Connector, ground wire	*ny	Spacer, cable
er	Enclosure, ready-access, cable	*j	Screw, lag
*pn	Strap, riser guard		
*np	Clamp, one-hole, offset		

RURAL TELECOMMUNICATIONS CONSTRUCTION PRACTICES
 JUNCTION OF AERIAL CABLE WITH BURIED
 CABLE OR WIRE

Scale: NTS

March 2001

971-2

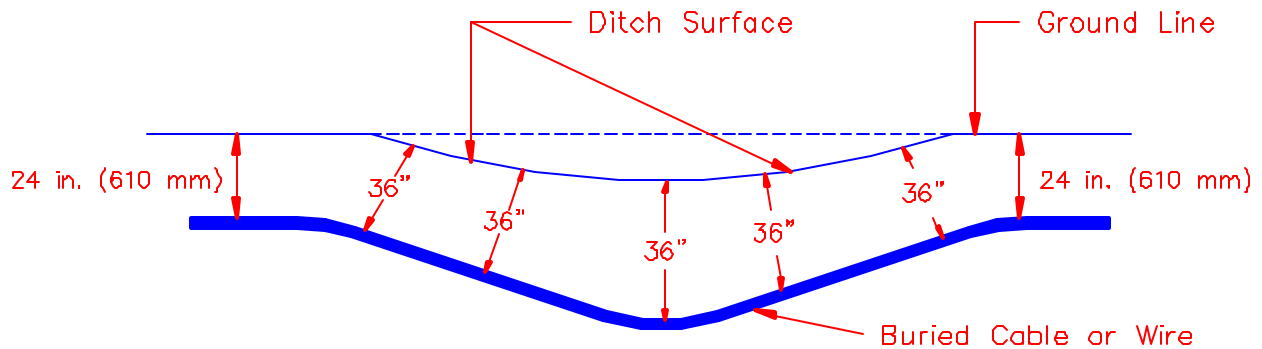
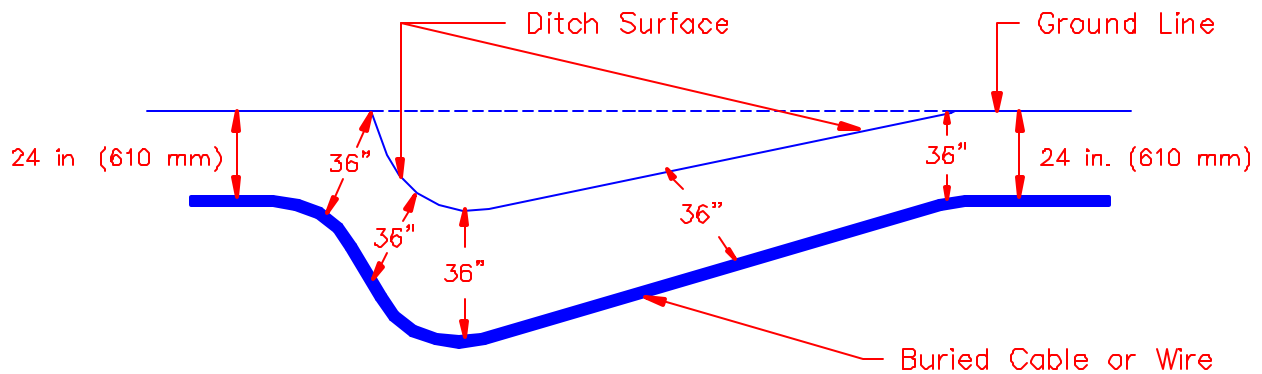
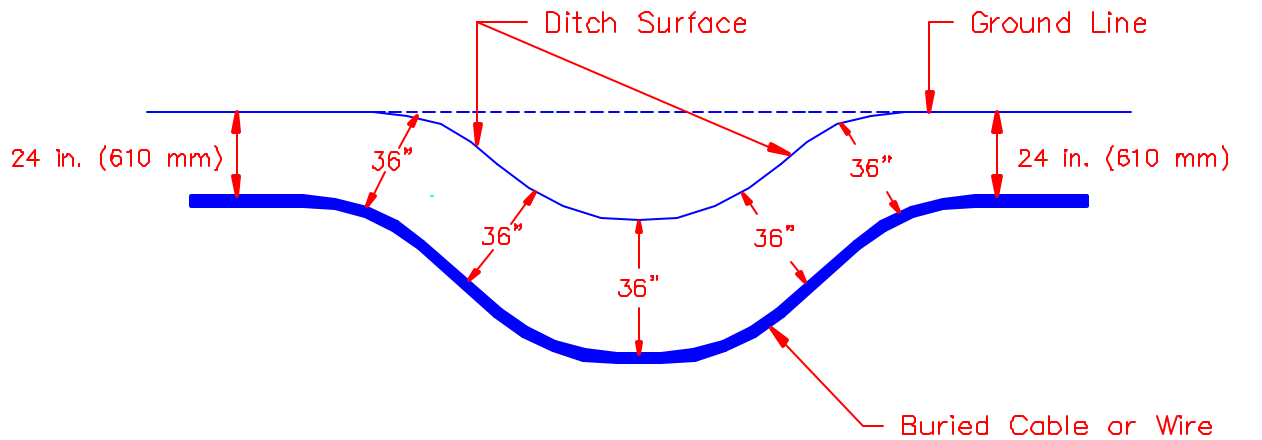

Note: Buried cable, wire, or services shall be placed as shown above. The 36 in. (914 mm) depth shall apply only at locations where the buried plant crosses the ditch, and shall not apply to buried plant installed parallel to and adjacent to the ditch.

RURAL TELECOMMUNICATIONS CONSTRUCTION PRACTICES
 BURIED PLANT UNDER DITCHES

Scale: NTS

March 2001

975

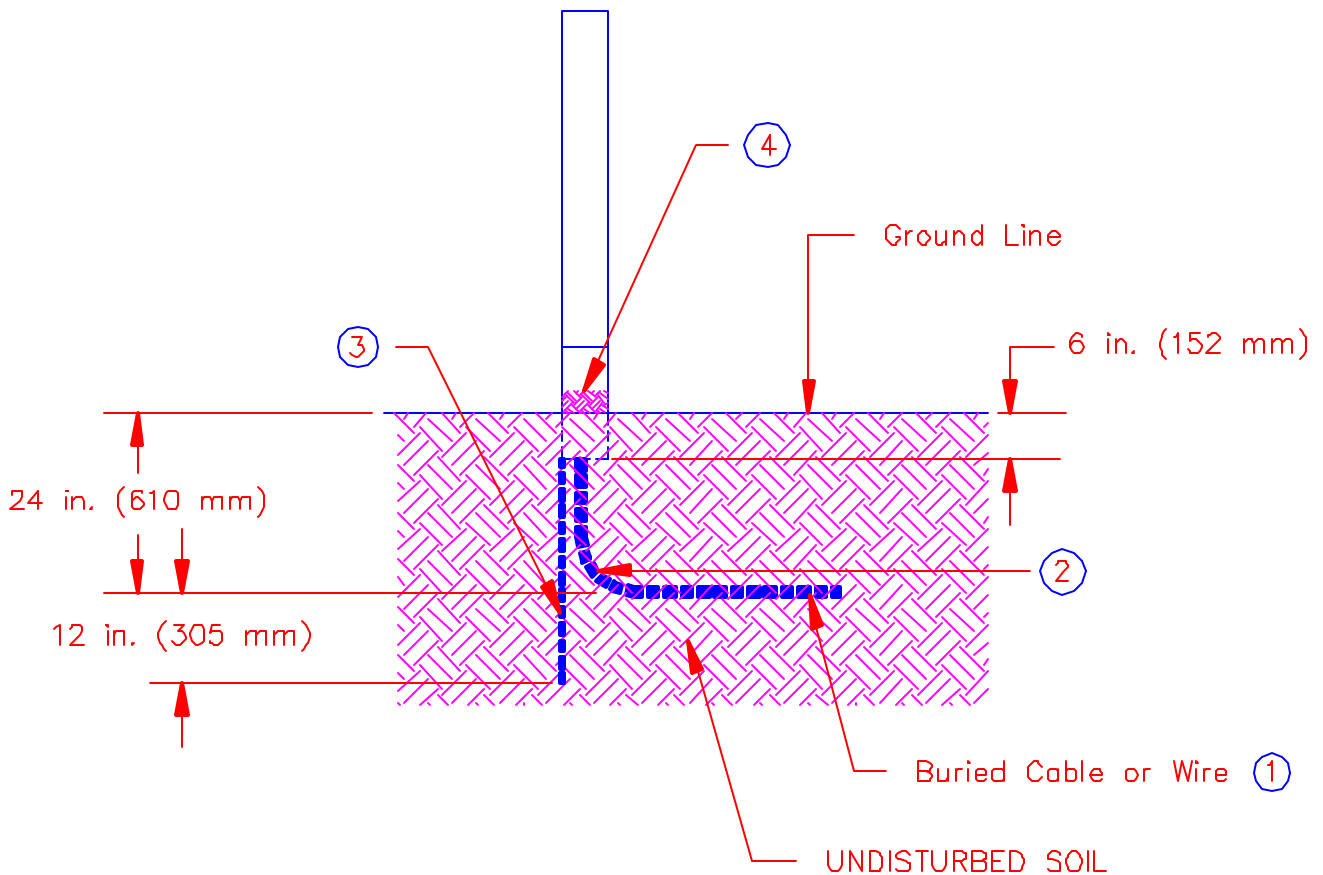

Notes:

- ①. Cable shall be placed on undisturbed soil at the bottom of the trench.
- ②. For copper cable and/or wire, the radius of bend of the cable and/or wire at the base of the housing shall not be less than 10 times the diameter of the cable and/or wire. For fiber optic cable, the radius of bend of the cable at the base of the housing shall not be less than 20 times the diameter of the cable.
- ③. The stake of the housing shall be driven into undisturbed soil to a depth of approximately 12 in. (305 mm).
- ④. The ground level inside the ground line cover plate shall not be less than 1 in. (25 mm) above the outside ground level.

RURAL TELECOMMUNICATIONS CONSTRUCTION PRACTICES
 HOUSING INSTALLATION DETAILS

Scale: NTS

March 2001

976