

UNITED STATES DEPARTMENT OF AGRICULTURE
Rural Utilities Service

BULLETIN 1753F-302(PE-91)

SUBJECT: RUS Specification for Outside Plant Housings and
Serving Area Interface Systems

TO: All Telecommunications Borrowers
RUS Telephone Staff

EFFECTIVE DATE: November 21, 1994.

EXPIRATION DATE: Date of change in 7 CFR 1755.910 by rulemaking.

OFFICE OF PRIMARY INTEREST: Outside Plant Branch,
Telecommunications Standards Division.

PREVIOUS INSTRUCTIONS: This is a new bulletin. This user friendly guide bulletin updates and consolidates information previously located in rescinded RUS Bulletin 345-26, RUS Specification for Buried Plant Housings (PE-35), and RUS Bulletin 345-77, RUS Specification for Serving Area Interface Housings (PE-79).

FILING INSTRUCTIONS: File with 7 CFR 1755. This bulletin is available to the RUS staff on RUSNET (text only) and can be accessed via Internet at <http://www.usda.gov/rus/home/home.htm>

PURPOSE: This specification informs manufacturers and users of outside plant housings and serving area interface systems of the engineering and technical requirements that are considered necessary for satisfactory performance in outside plant environments. This bulletin is a user friendly guide and a reformat of the text codified in 7 CFR 1755.910 published at 59 FR 53043, dated October 21, 1994.

Every effort has been made to ensure the accuracy of this document. However, in case of discrepancies, the regulations at 7 CFR 1755.910 are the authorized sources.

Wally Beyer

Administrator

7/3/96

Date

TABLE OF CONTENTS

CFR to Bulletin Conversion Table 4

Abbreviations 7

1. Scope 8

2. General Information 9

3. General Documentation Requirements 9

 3.1 Installation and Maintenance Instructions 9

 3.2 Quality Assurance 10

 3.3 RUS Acceptance Applications 10

4. Functional Design Criteria for Housings 11

 4.1 General Requirements 11

 4.2 Housing Types and Capacities 11

 4.3 Design and Fabrication Requirements for Housings . 13

 4.4 Warning Sign 17

 4.5 Housing Materials 17

 4.6 Housing Finish Requirements 19

 4.7 Installation Requirements 20

5. Performance Criteria and Test Procedures for Housings .. 20

 5.1 General Information 20

 5.2 Description of Test Housing 20

 5.3 Environmental Requirement for Housings 21

 5.4 Mechanical Requirements for Housings 26

 5.5 Electrical Requirements for Housings 30

 5.6 Finish Requirements 30

6. Functional Design Criteria for Binding Post Terminal
Blocks Used in SAI Cabinets 31

 6.1 General Description 31

 6.2 Design and Fabrication Requirements 31

 6.3 Auxiliary Features 32

7. Performance Criteria and Test Procedures for Binding
Post Terminal Blocks Used in SAI Cabinets 33

 7.1 General 33

 7.2 Environmental Requirements 33

 7.3 Mechanical Requirements 36

 7.4 Dielectric Strength 37

 7.5 Operational Requirements 38

8. Functional Design Criteria for Insulation Displacement
Type Cross-connect Modules Used in SAI Cabinets 38

 8.1 General Description 38

 8.2 Design and Fabrication Requirements 39

 8.3 Auxiliary Features 39

TABLE OF CONTENTS - Continued

9.	Performance Criteria and Test Procedures for Insulation	
	Displacement Type Cross-connect Modules	40
9.1	General	40
9.2	Environmental Requirements	40
9.3	Mechanical Requirements	41
9.4	Electrical Requirements	42
9.5	Operational Requirements	42
10.	Packaging and Identification Requirements	43
10.1	Product Identification	43
10.2	Packaging Requirements	43
10.3	Container Marking Requirements	44

TABLES & FIGURES

Figure 1	Warning Sign	45
Figure 2	Thermal Shock Temperature Cycle	46
Figure 3	Environmental Test Chamber Temperature Cycle	47
Figure 4	Turning Moment - Pole Mounted Housings	48
Figure 5	Overturning Moment, Pad Mounted Housings	49
Figure 6	Measuring Load Deflection	50
Figure 7	Vibration Test for Packaged Housings	51
Figure 8	Vibration Test for Unpackaged Housings	52
Figure 9	Corner Drop Tests for Packaged Housings Weighing More Than 91 Kilograms (200 Pounds)	53
Figure 10	Edge Drop Test for Packaged Housings Weighing More Than 91 Kilograms (200 Pounds)	54
Figure 11	Drop Test for Unpackaged Housings Weighing More Than 23 Kilograms (50 Pounds)	55
Figure 12	Binding Post Arrangement for Insulation Resistance Testing	56
Figure 13	Lateral Loading of Binding Post Terminals	57
Figure 14	Axial Pullout of Binding Post Terminals	58

INDEX:

Housings, Buried Plant, Telecommunications
Cabinets, SAI Systems, Telecommunications

CFR TO BULLETIN CONVERSION TABLE

7 CFR 1755.910	Bulletin 1753F-302	7 CFR 1755.910	Bulletin 1753F-302
(a)	1.	(d)(3)(xiii)	4.3.13
(a)(1)	1.1	(d)(3)(xiv)	4.3.14
(a)(2)	1.2	(d)(3)(xv)	4.3.15
(a)(3)	1.3	(d)(3)(xvi)	4.3.16
(a)(4)	1.4	(d)(3)(xvii)	4.3.17
(a)(5)	1.5	(d)(3)(xviii)	4.3.18
(a)(6)	1.6	(d)(3)(xix)	4.3.19
(a)(7)	1.7	(d)(3)(xx)	4.3.20
(b)	2.	(d)(3)(xxi)	4.3.21
(b)(1)	2.1	(d)(3)(xxii)	4.3.22
(b)(2)	2.2	(d)(3)(xxiii)	4.3.23
(b)(3)	2.3	(d)(3)(xxiv)	4.3.24
(b)(4)	2.4	(d)(3)(xxv)	4.3.25
(c)	3.	(d)(3)(xxvi)	4.3.26
(c)(1)	3.1	(d)(3)(xxvii)	4.3.27
(c)(1)(i)	3.1.1	(d)(3)(xxviii)	4.3.28
(c)(1)(ii)	3.1.2	(d)(3)(xxix)	4.3.29
(c)(1)(iii)	3.1.3	(d)(3)(xxx)	4.3.30
(c)(2)	3.2	(d)(4)	4.4
(c)(3)	3.3	(d)(4)(i)	4.4.1
(c)(3)(i)	3.3.1	(d)(4)(ii)	4.4.2
(c)(3)(ii)	3.3.2	(d)(4)(iii)	4.4.3
(c)(3)(iii)	3.3.3	(d)(4)(iv)	4.4.4
(c)(3)(iv)	3.3.4	(d)(4)(v)	4.4.5
(d)	4.	(d)(5)	4.5
(d)(1)	4.1	(d)(5)(i)	4.5.1
(d)(1)(i)	4.1.1	(d)(5)(ii)	4.5.2
(d)(1)(ii)	4.1.2	(d)(5)(iii)	4.5.3
(d)(2)	4.2	(d)(5)(iv)	4.5.4
(d)(2)(i)	4.2.1	(d)(5)(v)	4.5.5
(d)(2)(ii)	4.2.2	(d)(5)(vi)	4.5.6
(d)(2)(iii)	4.2.3	(d)(5)(vii)	4.5.7
(d)(2)(iv)	4.2.4	(d)(5)(viii)	4.5.8
(d)(2)(v)	4.2.5	(d)(5)(ix)	4.5.9
(d)(2)(vi)	4.2.6	(d)(5)(x)	4.5.10
(d)(3)	4.3	(d)(5)(xi)	4.5.11
(d)(3)(i)	4.3.1	(d)(5)(xii)	4.5.12
(d)(3)(ii)	4.3.2	(d)(5)(xiii)	4.5.13
(d)(3)(iii)	4.3.3	(d)(6)	4.6
(d)(3)(iv)	4.3.4	(d)(6)(i)	4.6.1
(d)(3)(v)	4.3.5	(d)(6)(ii)	4.6.2
(d)(3)(vi)	4.3.6	(d)(6)(iii)	4.6.3
(d)(3)(vii)	4.3.7	(d)(6)(iv)	4.6.4
(d)(3)(viii)	4.3.8	(d)(6)(v)	4.6.5
(d)(3)(ix)	4.3.9	(d)(7)	4.7
(d)(3)(x)	4.3.10	(d)(7)(i)	4.7.1
(d)(3)(xi)	4.3.11	(d)(7)(ii)	4.7.2
(d)(3)(xii)	4.3.12	(d)(7)(iii)	4.7.3

CFR TO BULLETIN CONVERSION TABLE

7 CFR 1755.910	Bulletin 1753F-302	7 CFR 1755.910	Bulletin 1753F-302
(e)	5.	(e)(4)(v)	5.4.5
(e)(1)	5.1	(e)(4)(vi)	5.4.6
(e)(1)(i)	5.1.1	(e)(4)(vii)	5.4.7
(e)(1)(ii)	5.1.2	(e)(4)(viii)	5.4.8
(e)(2)	5.2	(e)(4)(viii)(A)	5.4.8.1
(e)(2)(i)	5.2.1	(e)(4)(viii)(B)	5.4.8.2
(e)(2)(ii)	5.2.2	(e)(4)(ix)	5.4.9
(e)(3)	5.3	(e)(5)	5.5
(e)(3)(i)	5.3.1	(e)(6)	5.6
(e)(3)(ii)	5.3.2	(e)(6)(i)	5.6.1
(e)(3)(iii)	5.3.3	(e)(6)(ii)	5.6.2
(e)(3)(iv)	5.3.4	(e)(6)(iii)	5.6.3
(e)(3)(v)	5.3.5	(e)(6)(iv)	5.6.4
(e)(3)(vi)	5.3.6	(e)(6)(v)	5.6.5
(e)(3)(vii)	5.3.7	(f)	6.
(e)(3)(viii)	5.3.8	(f)(1)	6.1
(e)(3)(ix)	5.3.9	(f)(2)	6.2
(e)(3)(ix)(A)	5.3.9.1	(f)(2)(i)	6.2.1
(e)(3)(ix)(B)	5.3.9.2	(f)(2)(ii)	6.2.2
(e)(3)(x)	5.3.10	(f)(2)(iii)	6.2.3
(e)(3)(xi)	5.3.11	(f)(2)(iv)	6.2.4
(e)(3)(xii)	5.3.12	(f)(2)(v)	6.2.5
(e)(3)(xii)(A)(1)	5.3.12.1	(f)(2)(vi)	6.2.6
(e)(3)(xii)(A)(2)	5.3.12.2	(f)(2)(vii)	6.2.7
(e)(3)(xii)(A)(3)	-----	(f)(2)(viii)	6.2.8
(e)(3)(xii)(B)(1)	5.3.12.3	(f)(2)(ix)	6.2.9
(e)(3)(xii)(B)(2)	5.3.12.4	(f)(3)	6.3
(e)(3)(xii)(B)(3)	-----	(f)(3)(i)	6.3.1
(e)(3)(xiii)	5.3.13	(f)(3)(ii)	6.3.2
(e)(3)(xiii)(A)	5.3.13.1	(f)(3)(iii)	6.3.3
(e)(3)(xiii)(B)	5.3.13.2	(f)(3)(iv)(A)	6.3.4
(e)(4)	5.4	(f)(3)(iv)(B)	6.3.5
(e)(4)(i)	5.4.1	(g)	7.
(e)(4)(i)(A)	5.4.1.1	(g)(1)	7.1
(e)(4)(i)(B)	5.4.1.2	(g)(2)	7.2
(e)(4)(i)(C)	5.4.1.3	(g)(2)(i)	7.2.1
(e)(4)(ii)	5.4.2	(g)(2)(i)(A)	7.2.1.1
(e)(4)(iii)	5.4.3	(g)(2)(i)(B)	7.2.1.2
(e)(4)(iv)	5.4.4	(g)(2)(ii)	7.2.2
(e)(4)(iv)(A)	5.4.4.1	(g)(2)(ii)(A)	7.2.2.1
(e)(4)(iv)(B)	5.4.4.2	(g)(2)(ii)(B)	7.2.2.2
(e)(4)(iv)(B)(1)	5.4.4.2.1	(g)(2)(iii)	7.2.3
(e)(4)(iv)(B)(2)	5.4.4.2.2	(g)(2)(iii)(A)	7.2.3.1
(e)(4)(iv)(B)(3)	5.4.4.2.3	(g)(2)(iii)(B)	7.2.3.2
(e)(4)(iv)(B)(4)	5.4.4.2.4	(g)(2)(iv)	7.2.4
(e)(4)(iv)(C)	5.4.4.3	(g)(2)(v)	7.2.5
(e)(4)(iv)(D)(1)	5.4.4.4	(g)(2)(vi)	7.2.6
(e)(4)(iv)(D)(2)	-----	(g)(3)	7.3

CFR TO BULLETIN CONVERSION TABLE

7 CFR 1755.910	Bulletin 1753F-302	7 CFR 1755.910	Bulletin 1753F-302
(g)(3)(i)	7.3.1	(i)(4)(ii)	9.4.2
(g)(3)(ii)	7.3.2	(i)(5)	9.5
(g)(3)(ii)(A)	7.3.2.1	(i)(5)(i)	9.5.1
(g)(3)(ii)(B)	7.3.2.2	(i)(5)(ii)	9.5.2
(g)(3)(iii)	7.3.3	(i)(5)(iii)	9.5.3
(g)(3)(iv)	7.3.4	(j)	10.
(g)(3)(v)	7.3.5	(j)(1)	10.1
(g)(3)(v)(A)	7.3.5.1	(j)(1)(i)	10.1.1
(g)(3)(v)(B)	7.3.5.2	(j)(1)(ii)	10.1.2
(g)(3)(vi)	7.3.6	(j)(2)	10.2
(g)(4)	7.4	(j)(2)(i)	10.2.1
(g)(5)	7.5	(j)(2)(ii)	10.2.2
(g)(5)(i)	7.5.1	(j)(2)(iii)	10.2.3
(g)(5)(ii)	7.5.2	(j)(2)(iv)	10.2.4
(g)(5)(iii)	7.5.3	(j)(2)(v)	10.2.5
(g)(5)(iv)	7.5.4	(j)(2)(vi)	10.2.6
(h)	8.	(j)(2)(vii)	10.2.7
(h)(1)	8.1	(j)(3)	10.3
(h)(2)	8.2	(j)(3)(i)	10.3.1
(h)(2)(i)	8.2.1	(j)(3)(ii)	10.3.2
(h)(2)(ii)	8.2.2	(j)(3)(iii)	10.3.3
(h)(2)(iii)	8.2.3	(j)(3)(iv)	10.3.4
(h)(2)(iv)	8.2.4	(j)(3)(v)	10.3.5
(h)(2)(v)	8.2.5		
(h)(2)(vi)	8.2.6		
(h)(2)(vii)	8.2.7		
(h)(3)	8.3		
(h)(3)(i)	8.3.1		
(h)(3)(ii)	8.3.2		
(h)(3)(iii)	8.3.3		
(i)	9.		
(i)(1)	9.1		
(i)(2)	9.2		
(i)(2)(i)	9.2.1		
(i)(2)(ii)	9.2.2		
(i)(2)(iii)	9.2.3		
(i)(2)(iv)	9.2.4		
(i)(2)(v)	9.2.5		
(i)(2)(vi)	9.2.6		
(i)(2)(vii)	9.2.7		
(i)(3)	9.3		
(i)(3)(i)	9.3.1		
(i)(3)(ii)	9.3.2		
(i)(3)(iii)	9.3.3		
(i)(3)(iv)	9.3.4		
(i)(3)(v)	9.3.5		
(i)(4)	9.4		
(i)(4)(i)	9.4.1		

ABBREVIATIONS

ac	Alternating current
ASTM	American Society For Testing and Materials
AWG	American Wire Gauge
BD	Buried Plant Pedestal Stake-Mounted Assembly Unit
BDA	Buried Plant Pedestal Pole-Mounted Assembly Unit
BDAG	Buried Plant Pedestal Extra Height Pole-Mounted Assembly Unit
°C	Centigrade temperature scale
CFR	Code of Federal Regulations
cm	Centimeters
cm ²	Square centimeters
cm ³	Cubic centimeters
cm/min	Centimeters per minute
°	Degrees
dc	Direct current
E	East direction
°F	Fahrenheit temperature scale
ft	Feet
Hz	Hertz
in.	Inches
in. ²	Square inches
in. ³	Cubic inches
in./min	Inches per minute
kg	Kilograms
km/h	Kilometers per hour
kV	Kilovolts
lb	Pounds
lb-in.	Pounds-inches
m	Meters
mi/h	Miles per hour
m/s ²	Meters per second squared
N	North direction
N-m	Newton-meters
OSHA	Occupational Safety and Health Administration
%	Percent
ppm	Parts per million
RH	Relative humidity
RUS	Rural Utilities Service
S	South direction
SAI	Service Area Interface
UL	Underwriters' Laboratories, Inc.
V	Volts
W	West direction

1. SCOPE

1.1 The purpose of this specification is to inform manufacturers and users of outside plant housings and serving area interface (SAI) systems of the engineering and technical requirements that are considered necessary for satisfactory performance in outside plant environments. Included are the mechanical, electrical, and environmental requirements, desired design features, and test methods for evaluation of the product.

1.2 The housing and terminal requirements reflect the best engineering judgment available at the present time and may be subject to change due to advances in technology, economic conditions, or other factors.

1.3 The test procedures described in this specification are required by the Rural Utilities Service (RUS) to demonstrate the functional reliability of the product. However, other standard or unique test procedures may serve the same function. In such cases, RUS shall evaluate the test procedures and results on an individual basis.

1.4 The test procedures specified herein satisfy the requirements of housings as well as the requirements of terminals that may be installed within housings. Some of the requirements are interrelated to several tests designed to determine the performance aspects of terminals and are directly affected by testing required for housings. Therefore, the manufacturer should carefully review all the test requirements in order to develop a testing schedule that is comprehensive, efficient in terms of the number of test specimens required and can be accomplished in an orderly and logical sequence.

1.5 The specified tests may require special facilities to comply with Federal, State, or local regulatory requirements. Some test procedures are potentially hazardous to personnel because of the high voltages and mechanical forces involved. Safety precautions are necessary to prevent injury.

1.6 The Underwriters' Laboratories, Inc. (UL) 94, Tests for Flammability of Plastic Materials for Parts in Devices and Appliances, fourth edition, dated June 18, 1991, referenced in this specification can be ordered from UL at the address below:

UL Inc.
333 Pfingsten Road
Northbrook, Illinois 60062-2096
Telephone Number (708) 272-8800

1.7 The American Society for Testing and Materials (ASTM) Specifications referenced in this specification can be ordered from ASTM at the address below:

ASTM
100 Barr Harbor Drive
West Conshohocken, Pennsylvania 19428-2959
Telephone Number (610) 832-9598

2. GENERAL INFORMATION

2.1 Outside plant housings are fabricated of either metallic or nonmetallic materials in different sizes and configurations to suit a variety of applications. The purpose of a housing is to protect its contents from environmental elements, rodents, insects, or vandalism and unauthorized access. Housings are designed with internal brackets for accommodating splicing, bonding and grounding connections, cable terminals, cross-connect facilities, load coils, and optical and electronic equipment.

2.2 Pedestals are housings primarily intended to house, organize, and protect cable terminations incorporating terminal blocks, splice connectors and modules, ground lugs and load coils. Activities typically performed in a pedestal are cable splicing, shield bonding and grounding, inductive loading, and connection of subscriber drops.

2.3 SAI cabinets are housings intended to perform some of the same functions as pedestals but are primarily intended to serve as the connecting terminal between feeder cable and distribution cables.

2.4 Outside plant housings shall be manufactured in accordance with National Electrical Code (NEC) requirements, UL requirements, Department of Labor, Occupational Safety and Health Administration Standards (OSHA), and all other applicable Federal, State, and local requirements including, but not limited to, statutes, rules, regulations, orders, or ordinances otherwise imposed by law.

3. GENERAL DOCUMENTATION REQUIREMENTS

3.1 Installation and Maintenance Instructions:

3.1.1 Each product shall have available a set of instructions designed to provide sufficient information for the successful installation of the housing, cables, auxiliary equipment, and the associated splice preparation. The instructions shall be of sufficient size to be easily read and shall be printed using waterproof ink. Pedestal instruction sheets shall include a list

of miscellaneous replacement parts that may be purchased locally. SAI systems shall be supplied with complete instructions for installation and use.

3.1.2 When requested by RUS, or a RUS borrower, the manufacturer shall prepare a training package for the purpose of training technicians in the use and installation of the product and its auxiliary equipment.

3.1.3 The manufacturer shall provide ordering information for repair parts. Repair parts shall be obtainable through a local distributor or shall be easily obtainable. Information describing equivalent parts and their sources should be provided for those parts that may also be obtained from other sources.

3.2 Quality Assurance: The manufacturer shall demonstrate the existence of an ongoing quality assurance program that includes controls, procedures, and standards used for vendor certification, source inspection, incoming inspection, manufacture, in process testing, calibration and maintenance of tools and test equipment, final product inspection and testing, periodic qualification testing and control of nonconforming materials and products. The manufacturer shall maintain quality assurance records for five years.

3.3 RUS Acceptance Applications:

3.3.1 The tests described in this specification are required for acceptance of product designs and major modifications of accepted designs. All modifications shall be considered major unless otherwise declared by RUS. The tests are intended to show the inherent capability of the manufacturer to produce products which have an expected service life of 30 years.

3.3.2 For initial acceptance the manufacturer shall:

- a. Submit an original signature certification that the product complies with each Paragraph of this specification;
- b. Provide qualification test data;
- c. Provide OSHA Material Safety Data Sheets for the product;
- d. Provide a detailed explanation concerning the intended use and capacity of the product;
- e. Provide a complete set of instructions, recommendations for equipment organization and splicing;
- f. Agree to periodic plant inspections;

- g. Provide certification that the product does or does not comply with the domestic origin manufacturing provisions of the "Buy American" requirement of the Rural Electrification Act of 1938 (52 Stat. 818);
- h. Provide user testimonials concerning field performance of the product;
- i. Provide product samples if requested by RUS; and
- j. Provide any other data required by the Chief, Outside Plant Branch (Telecommunications).

3.3.3 Each requirement of this specification must be addressed in submissions for acceptance. The designation N/A may be entered when the requirements do not apply.

3.3.4 Acceptance requests should be addressed to: Chairman, Technical Standards Committee "A" (Telecommunications), Telecommunications Standards Division, RUS, AG Box 1598, Washington, DC 20250-1598.

4. FUNCTIONAL DESIGN CRITERIA FOR HOUSINGS

4.1 General Requirements:

4.1.1 The functional requirements for housings concern materials, finishes, environmental factors, and design features that are applicable to most above ground housings used in the outside plant.

4.1.2 Housings shall be of sufficient size to permit easily managed installation, operational, testing, and maintenance operations. The general shape of outside plant housings is usually comparable to that of a rectangular column or cylinder, with the shape of any particular housing being left to the manufacturer's discretion. Each design is subject to acceptance by RUS.

4.2 Housing Types and Capacities:

4.2.1 Housings used in outside plant are either the smaller housings generally known as pedestals or larger housings known as equipment or splice cabinets. Both categories may have designs intended for stake mounting, pole mounting, or pad mounting.

4.2.2 The classifications of pedestals are the general purpose channel Type (H) and the dome Type (M). The Type H pedestal has either front only access or back and front access while the Type M pedestal has top only access. Pedestals are further designated as follows:

Stake Mounted	Type	Pole Mounted	Pole Mounted (extra high)
BD3	H	BD3A	-
BD4	H	BD4A	-
BD5	H	BD5A	-
BD7	H	BD7A	-
BD14	M	BD14A	BD14AG
BD15	M	BD15A	BD15AG
BD16	M	BD16A	BD16AG

4.2.3 The minimum volume associated with the pedestal designations shall be as shown in the following table:

Pedestal ⁽¹⁾ Housing Designation	Minimum Volume	
	Cubic Centimeters (cm ³)	(Cubic Inches) (in. ³)
BD3, BD3A ⁽²⁾	9,000	(550)
BD4, BD4A ⁽²⁾	15,000	(900)
BD5, BD5A ⁽²⁾	35,000	(2,100)
BD7 ⁽²⁾	72,000	(4,400)
BD14, BD14A, BD14AG ⁽³⁾	9,000	(550)
BD15, BD15A, BD15AG ⁽³⁾	27,000	(1,600)
BD16, BD16A, BD16AG ⁽³⁾	38,000	(2,300)

Note (1): Housings designed for unique purposes will be evaluated on a case-by-case basis.

Note (2): For Type H pedestals, the minimum volume is that space as measured 5 centimeters (cm) [2 inches (in.)] below the top of the housing to a point 40 cm (16 in.) above the bottom of the lower cover plate.

Note (3): The minimum volume of the Type M pedestals shall be the space within the dome measured from the lower edge of of the dome to a point 5 cm (2 in.) from the top.

4.2.4 Equipment cabinets intended for use as SAI housings shall be assigned size designations according to their maximum pair termination capacities. The capacity will vary depending on the type of terminating equipment used. SAI cabinets shall be suffix designated with an "A" for pole mounting, "X" for pad mounting, and "S" for stake mounting.

4.2.5 Large pair count splice cabinets are classified according to their splice capacity. Approximately 48 cm³ (3.0 in.³) of splice area per pair straight spliced shall be permitted.

4.2.6 The minimum volume associated with large pair count splice cabinets shall be as shown in the following table:

Splice Cabinet ⁽¹⁾ Designation	Minimum Volume		Maximum Splice Capacity (Pairs)
	cm ³	(in. ³)	
BD6000	295,000	(18,000)	6,000
BD8000	393,000	(24,000)	8,000
BD10000	491,000	(30,000)	10,000

Note (1): Additional sizes of splice cabinets shall be considered by RUS on a case-by-case basis.

4.3 Design and Fabrication Requirements for Housings:

4.3.1 Type H pedestal housings may consist of an enclosed channel incorporating an integrally mounted stake that serves as a backplate, or they may be designed for universal mounting on stakes or poles. The body of the housing shall have two major components; an upper cover and a base cover. The upper cover shall have a top, front and back plate with the front cover removable to permit entry and provide increased work space. The base cover shall consist of a front plate and back plate. The base cover back plate may be an extension of the upper back plate cover.

4.3.2 Type M pedestal housings shall consist of a one piece upper sleeve designed to fit over the base cover trapping air to prohibit water from entering the splice area when installed in locations prone to temporary flooding. Pedestals designed to be mounted extra high on poles for locations susceptible to deep snow shall have a bottom close-off option available to prohibit the ingress of birds, rodents and insects.

4.3.3 The external housing components on all outside plant housings shall provide reasonable protection against accidental removal or vandalism. Housings shall be equipped with a cover plate retaining bolt and cup washer that may be opened only with an industry accepted socket type can wrench. Housings may be equipped with provisions to allow the purchaser to install a padlock.

4.3.4 Installed housings shall resist the disassembling force of frost heaving applied to the bottom of ground line cover plates. The base cover must remain stationary to stabilize the contents of the housing cavity.

4.3.5 In an effort to provide protection against dust penetration, blowing snow, rain, and ultraviolet light degradation of internal components, all mechanical gaps shall be restricted. The use of seals, overlaps, gaskets, and dovetailing is required to assure satisfactory protection of housed equipment.

4.3.6 Knockouts, cutouts, or notches designed to accommodate aerial service drops shall not be permitted. A design option for housings intended to accommodate service drops shall include a separate channel or equivalent in the base cover to allow future additions of service drops without the removal of gravel or the moisture barrier in the base of the housing. Service wire channels must be designed to prevent the entry of birds, reptiles, rodents and insects.

4.3.7 Minimal venting of SAI housings may be necessary to relieve internal pressure and condensation.

4.3.8 There shall be no aluminum housing components that will become buried in the soil when the housing is properly installed.

4.3.9 Housing components may be assembled using rivets, welds, glue, bolts and nuts, or other techniques suitable for the materials involved.

4.3.10 Housings and their components that require field assembly must be capable of being assembled with tools normally available to outside plant technicians.

4.3.11 Hinged doors on SAI housings and large pair count splice housings shall be equipped with a device that restrains the doors in the open position.

4.3.12 Outside plant housings shall be free of sharp edges, burrs, etc., that could present a safety hazard to personnel involved in installation and use of the product or to the general public. Surfaces inside housings must not allow pinching of conductors during installation of cover plates or the opening and closing of doors.

4.3.13 A ground line mark shall be provided, approximately 15 cm (6 in.) below the top edge of the housing base cover plate on housings intended for ground level mounting. Base cover plates shall have be a minimum height of 31 cm (12 in.).

4.3.14 Any housing, which weighs in excess of 91 kilograms (kg) [200 pounds (lb)], including its contents, shall be equipped with lifting brackets for attaching hoisting cables or chains.

4.3.15 Housing stakes shall be a minimum of 107 cm (42 in.) in length. If fabricated from steel, they shall have a minimum thickness of No. 13 gauge as measured according to American Society for Testing and Materials (ASTM) A-525-91b. Stakes shall be formed into a "U" channel with a minimum depth of 2 cm (0.75 in.). The stake shall be a single part of suitable design strength for driving 91 cm (36 in.) into the soil with hand tools without damage such as bending or warping. The stake shall have adequate mounting holes having a minimum separation of 15 cm (6 in.) for mounting the housing baseplate. The stake material must resist corrosion and deterioration when exposed to soil and atmospheric conditions.

4.3.16 The housing design must permit a logical progression of installation steps that would normally be encountered in typical field installations.

4.3.17 Provisions for attaching housings to stakes, poles, walls, other housings, or pads shall be provided for each design intended for those purposes. Locations of holes for mounting attachments may be provided by knockouts on above ground components. Mounting hole locations for below ground components may be predrilled.

4.3.18 Pole mounting hardware shall provide at least 1.3 cm (0.5 in.) clearance from the pole to the housing. Pole mounting brackets shall accommodate the wide range of pole sizes used in the telephone industry.

4.3.19 Pad mounted housings shall have hardware available for anchoring the housing base to the pad. A template may be provided to assist in the location of mounting attachment details for pad preparation.

4.3.20 Housings equipped with stub cables shall have strain relief devices to permit shipping and handling of the housing without damage to the housing or stub cables. Only RUS accepted cable shall be used for stub cables. The cable manufacturer's recommendations concerning minimum bend radius shall be observed. The minimum bend radius for most copper cables is 10 times the cable diameter.

4.3.21 Cable supports shall be provided near the top of the ground line cover and other appropriate locations within the housing to provide cable stability consistent with the intended use and capacity of the housing. Cable supports shall be capable of holding a minimum load of 23 kg (50 lb).

4.3.22 An adequate supply of nonmetallic retainer clips or tie wraps capable of supporting a minimum load of 23 kg (50 lb) shall be provided with the housing. Adequate spaces for installation of the clips or tie wraps must be provided on the housing backplate and cable supports.

4.3.23 Housing chambers designed for splicing operations shall be equipped with insulated supporting straps or rods suitable for supporting splice bundles. The insulation on the straps or rods shall extend for the entire length of the device and shall have a dielectric strength of 15 kilovolts (kv) direct current (dc) minimum. Housings having an "H" frame design where both front and rear covers may be removed may incorporate insulated tie bars to be used as cable supports.

4.3.24 Housings designed to contain equipment in addition to splices shall be equipped with a device for physically separating the splice area from the service area of the housing.

4.3.25 A dielectric shield rated at 15 kv dc shall be provided to enclose the cable splice area. The shield shall extend from the lower cable supports to within 2.5 cm (1 in.) of the top of the housing. The shield shall be equipped with Velcro or equivalent fastening devices designed to hold the shield in both the open or closed positions. The fastening devices shall extend along the entire vertical edge of the dielectric shield.

4.3.26 Mounting arrangements for a variety of terminal blocks and other equipment shall be provided by means of good housekeeping panels or other devices that may enhance the service aspect of the housing.

4.3.27 Housings designed for SAI cabinets may be shipped with terminal blocks installed and stub cables attached. If this option is exercised, the stub cables and terminal blocks must be RUS accepted. In all cases, SAI cabinets must be equipped with appropriate mounting devices for installing the peripheral equipment required for a serving area interface.

4.3.28 SAI cabinets shall be designed to provide physical separation between the splicing area and the area provided for running cross-connect jumpers.

4.3.29 SAI cabinets and large splice housings must have an external feature for attaching a padlock to prevent unauthorized entry.

4.3.30 Each housing shall have a tinned or zinc electroplated copper alloy or equivalent connector plate or bar to be used for terminating ground and cable shield bond connections. The device shall be equipped with captive studs and nuts with captive lock washers designed for attaching 6 American Wire Gauge (AWG) copper

bonding harness wire or braid and a 6 AWG copper ground wire. Connector plates shall be equipped with enough studs and nuts to provide individual connections equivalent to the maximum number of cable sheaths recommended for the housing. Housings shall incorporate design features that enable the field installation of at least one additional connector plate for service conditions that require numerous connections. A bonding and grounding system capable of providing support and strain relief for service wires shall be provided for housings intended for use as distribution points. The bonding system shall be designed to provide sheath continuity as cable and service wires are installed, and prior to any other operation being performed. The bonding arrangement shall provide electrical continuity between all bonds and the ground connector plate. The bonding and grounding arrangement shall permit the lifting of individual cable ground connections for testing and cable locating activities without jeopardizing the grounding potential of other cables that may enter the housing. The bonding and grounding system shall be capable of conducting a current of 1000 amperes for at least 20 seconds.

4.4 Warning Sign:

4.4.1 A buried cable warning sign shall be securely attached to the outside of each housing. The lettering information on the sign shall be permanent.

4.4.2 For pedestals, the sign shall be centered horizontally on the front cover and the top of the sign shall be not more than 10 cm (4 in.) from the top of the housing.

4.4.3 For SAI cabinets, the sign shall be centered horizontally and vertically on the door. If there are two doors, the sign shall be mounted on the left door.

4.4.4 Deviations from warning sign location requirements are permitted only for housing design constraints. Alternate sign locations will be considered by RUS.

4.4.5 The RUS standard sign design is shown in Figure 1.

4.5 Housing Materials:

4.5.1 Materials used in housings shall present no environmental or safety hazard as defined by industry standards or Federal, State, or local laws and regulations.

4.5.2 All materials are required to have fire resistance ratings consistent with recognized industry standards. External materials must be flame resistant.

4.5.3 All materials used in the manufacture of housings or component parts must achieve the required strength properties, resist deterioration when exposed to outdoor conditions, and be acceptable to RUS for the specific application. New materials or materials not familiar to the RUS staff shall be supported by test and performance data which demonstrates their suitability for the intended use.

4.5.4 Nonmetallic housing materials shall have a fungus growth rating no greater than one according to ASTM G-21-90.

4.5.5 Metallic components shall be either corrosion resistant or protected against corrosion and must not produce galvanic corrosion in wet or humid conditions on other metals that may be present in the housing environment.

4.5.6 Mill galvanized steel used in the manufacture of housings shall comply with the appropriate requirements of one of the following standards:

- a. ASTM A 109-91;
- b. ASTM A 366/A 366M-91;
- c. ASTM A 525-91b; or
- d. ASTM A 526/A 526M-90.

4.5.7 Hot rolled steel shall comply with the appropriate requirements of one of the following standards:

- a. ASTM A 569/A 569M-91a; or
- b. ASTM A 621/A 621M-92.

4.5.8 Cold rolled steel shall comply with the appropriate requirements of one of the following standards:

- a. ASTM A 109-91; or
- b. ASTM A 366/A 366M-91.

4.5.9 Steel parts used for internal housing brackets shall be hexavalent chromate coated or zinc plated in accordance with ASTM B 633-85.

4.5.10 Hardware items used for assembling or fastening housing components shall be 300 series or passivated 400 series stainless steel or hot dip galvanized in accordance with ASTM A 153-82 (1987). Other materials will be considered by RUS on an individual basis.

4.5.11 Aluminum components shall be fabricated from alloy types 5052 or 6061 or other types that have been recognized as having acceptable corrosion resistance and formability and weldability features.

4.5.12 Nonmetallic parts must be resistant to solvents and stress cracking and shall be compatible with metals and other materials such as conductor insulations and filling compounds used in the manufacture of cable. Plastic materials must be noncorrosive to metals and resist deterioration when exposed to industrial chemical pollutants, ultra-violet rays, road salts, cleaning agents, insecticides, fertilizers, or other detrimental elements normally encountered in the outdoor environment.

4.5.13 Housing door seals and gaskets may be manufactured from rubber or synthetic rubber-like elastomer materials. Seals and gaskets shall exhibit a high degree of weatherability with an effective life of at least 30 years in the outdoor environment. The material shall be tear resistant and have a low compression set.

4.6 Housing Finish Requirements:

4.6.1 All interior and exterior surfaces of housings shall be free from blisters, wrinkles, cracks, scratches, dents, heat marks and other defects.

4.6.2 There shall be inherent design provisions to prevent objectionable deterioration of the housing such as rusting, exposure of fiber or delamination. Secondary protection, such as galvanizing over steel per ASTM A 526/A 526M-90 or anodizing over aluminum, shall be provided to ensure reliability over the projected 30 year design life of the housing.

4.6.3 Painted metal housings shall have a minimum gloss of 60 (60° specular) in accordance with ASTM D 523-89.

4.6.4 All painted surfaces shall have a uniform color and texture in accordance with ASTM D 3928-89. Nonmetallic housings shall meet recognized industry standards concerning optical appearance for gloss and haze as applicable for the material.

4.6.5 The colors of housings that RUS will consider for acceptance shall be as follows:

Color	Standard
Gray-Green	Munsell 6.5GY 6.03/1.6 Munsell 4.4GY 6.74/1.5
Green	Munsell 8.8G 2.65/5.3
Orange	Federal Standard 595A Color Number 12246 Munsell 0.15YR 5.26/13.15
Chocolate	Munsell 5.27YR 2.40/2.60 Color Number 835

4.7 Installation Requirements:

4.7.1 The design of the housing must provide for a logical and normal installation sequence, i.e., excavation, installation of a foundation or base and anchoring devices, addition of hardware, installation and bonding of cables, splicing, addition of service, and final closing.

4.7.2 No special tools or equipment other than that usually carried by outside plant technicians and construction crews must be required for installation of the housing. Security devices are the exception to this requirement.

4.7.3 Installation hardware shall maintain housings in an erect and stable position when subjected to normal storm loads. Pad mounted designs must accommodate precast or cast-in-place reinforced concrete or other suitable prefabricated material. Brackets, inserts for fastening, conduit openings, or other items necessary for a pad mounted installation must be provided. The manufacturer shall provide detailed drawings or a template for locating inserts, conduit openings, or slots for cast-in-place pad construction.

5. PERFORMANCE CRITERIA AND TEST PROCEDURES FOR HOUSINGS

5.1 General Information:

5.1.1 The housing manufacturer shall perform adequate inspections and tests to demonstrate that housings and housing components comply with RUS requirements.

5.1.2 Testing usually shall be performed at a room temperature of $24 \pm 3^{\circ}\text{C}$ ($75 \pm 5^{\circ}\text{F}$). Temperatures for testing performed at other than room temperature shall be determined as near the center of the product under test as practical.

5.2 Description of Test Housing:

5.2.1 Each distinctly designed and configured family of housings intended to perform a particular function shall be tested.

5.2.2 The typical test sample shall consist of the exterior housing components such as covers, backplates, good housekeeping panels, cap assembly, anchor posts, decals, etc. Interior components must include the bonding and grounding hardware for cables and service wires and the dielectric shield. The housing may include terminal blocks or cross-connect modules, cable splices, or the typical outside plant equipment the housing is designed to contain and protect.

5.3 Environmental Requirement for Housings:

5.3.1 Thermal Shock: The test housing shall be placed in a test chamber and exposed to the temperature cycle of Figure 2 for five complete cycles. The step function nature of the temperature changes may be achieved by insertion and removal of the test housing from the chamber. The soak time at each temperature shall be four hours. The housing shall be removed from the test chamber at the conclusion of the five-cycle period. After the test housing temperature has stabilized to room temperature, the housing must be inspected for deterioration of materials and satisfactory operation of mechanical functions.

5.3.2 Thermal Shock and Humidity: The test housing shall be placed in an environmental test chamber at 95 ± 3 percent (%) relative humidity (RH) and temperature cycled per Figure 3 for a period of 30 days. At the end of the test there shall be no rust or corrosion of any closure components. Minor corrosion due to surface scratches, nicks, etc. is permitted. If the closure is made of a nonmetallic material, there shall be no signs of degradation.

5.3.3 Humidity and Condensation: Test panels shall be placed in an environmental chamber and subjected to 1008 hours (42 cycles) of exposure per ASTM D 2247-92. One cycle consists of 24 hours of 100 % humidity (with condensation on the panels) at a cabinet temperature of $38 \pm 1^\circ\text{C}$ ($100 \pm 2^\circ\text{F}$) and an ambient temperature of $25 \pm 1^\circ\text{C}$ ($77 \pm 2^\circ\text{F}$) without heat input. Upon completion of cycling, the test panels shall be subjected to an 11 newton-meter (N-m) [100 pound-inches (lb-in.)] impact test using the Gardner-Impact Tester or equivalent. Test panels shall show no substrate or coating cracking or loss of coating adhesion on either side.

5.3.4 Weatherability: Three test panels shall be tested for weatherability in accordance with the appropriate procedures of either ASTM D 822-89 or ASTM G 23-90. Total exposure time shall be a minimum of 800 hours. Failure is defined as fading, cracking, blistering, or delamination on any of the three test panels.

5.3.5 Low Temperature Durability: Low temperature durability shall be proven by exposing the three test panels from Paragraph 5.3.4 of this specification to at least 25 continuous cycles of the following test sequence:

- a. To insure complete saturation of the three test panels, soak them for 96 hours in a container of distilled water at $22 \pm 2^{\circ}\text{C}$ ($71.6 \pm 4^{\circ}\text{F}$);
- b. Lower the temperature of the water and immerse test panels to $-28 \pm 2^{\circ}\text{C}$ ($-18.4 \pm 4^{\circ}\text{F}$) and stabilize for 24 hours;
- c. Thaw the water with the samples to $22 \pm 2^{\circ}\text{C}$ ($71.6 \pm 4^{\circ}\text{F}$) and stabilize for 24 hours;
- d. Repeat the procedure 24 times. Any cracking, crazing, deforming, or delaminating on any of the three test panels shall be considered a failure; and
- e. Remove the samples from the water and impact test the three panels by delivering a force of 11.3 N-m (100 lb-in.) using a Gardner-Impact Tester to each specimen at 71, 22, and $-28 \pm 2^{\circ}\text{C}$ (159.8, 71.6, and $-18.4 \pm 4^{\circ}\text{F}$), after stabilizing them at those temperatures for at least two hours. Visual inspection shall reveal no deformation or perforation on any of the test panels.

5.3.6 Corrosion Resistance: Corrosivity shall be tested in accordance with the requirements of ASTM B 117-90. Both scribed and unscribed panels shall be evaluated following the procedures of ASTM D 1654-92. Scribed panels shall have a rating of at least six, following 500 hours of exposure to salt fog, and the unscribed panels shall have a rating no lower than 10, after 1,000 hours exposure. Visual rust inspection shall confirm no more than 0.03 % rusting (rust grade 9) of the surface area of the test sample when evaluated in accordance with ASTM D 610-85(1989). The unscribed samples shall be impacted with an 11.3 N-m (100 lb-in.) force, using a Gardner-Impact Tester or equivalent. Visual inspection of the impacted samples shall reveal no loss of adhesion between the base material and the coating or cracking at the finish on the test panels.

5.3.7 Fungi Resistance: Fungi resistance of nonmetallic housing materials shall be tested according to the procedures of ASTM G 21-90. Any rating greater than one shall be considered a failure.

5.3.8 Stress Crack Resistance: The stress cracking resistance of nonmetallic housing materials shall be tested according to the procedures of ASTM D 1693-70(1988). The tests shall be performed at $49 \pm 2^{\circ}\text{C}$ ($120 \pm 4^{\circ}\text{F}$) for 14 days and exposed to the following materials:

- a. Industry recognized filling compounds;
- b. Isopar M;
- c. Industry recognized solvents;
- d. Industry recognized encapsulants; and
- e. Commonly used insect, pest, and weed control products and agricultural fertilizers.

5.3.9 Chemical Resistance:

5.3.9.1 Chemical resistance shall be determined by immersing representative nonmetallic material samples in each of the following solutions for 72 hours at $22 \pm 2^{\circ}\text{C}$ ($71.6 \pm 4^{\circ}\text{F}$):

- a. 3% sulfuric acid;
- b. 100 parts per million (ppm) trichloroethane in water;
- c. 0.2 N sodium hydroxide; and
- d. Unleaded high octane gasoline.

5.3.9.2 There shall be no swelling, deformation, or softening of the material samples or any discoloration of the solution.

5.3.10 Ultraviolet Resistance: Test panels of metallic and nonmetallic outer housing materials shall be subjected to 700 hours exposure per ASTM D 2565-92 using the type BH apparatus. The panels shall not exhibit fading, blistering, checking, or delamination.

5.3.11 Weathertightness: The housing shall be mounted in its typical field installation position and sprayed with water. The temperature of the water shall be adjusted to be equal to or warmer than the temperature of the cabinet interior to avoid the possibility of condensation. A water spray head shall be used to direct water at the housing so that the water stream will strike the assembly at a downward angle of 45 degrees. The flow of the water shall be 3.8 liters per minute (one gallon per minute), with 276 kilopascals (40 pounds per square inch) head of pressure. The spray head shall be held 1.8 meters (m) [6 feet (ft)] from the test cabinet. The spray head shall be adjusted so that water impinges uniformly over the housing surface. The duration of the test shall be five minutes. All

vertical cabinet surfaces shall be tested by this procedure. The exterior of the cabinet shall be thoroughly dried with towels (no heat drying) prior to examination of the housing interior. The interior of the housing shall be checked for presence of water. Wetting of over-lapping surfaces is permitted. There shall be no presence of water inside the housing.

5.3.12 Wind Resistance:

5.3.12.1 Stub pole or wall mounted SAI and large pair count splice housings shall be subjected to a load (F) as shown in Figure 4 and the following table to simulate the turning moment equivalent to a uniform wind load of 161 kilometers per hour (km/h) [100 miles per hour (mi/h)] perpendicular to the largest surface area:

Maximum Area of Largest Surface Square Centimeters (cm ²) [Square Inches (in. ²)]	Load	
	Kg	(lb)
5,200 (800) or less	18	(40)
5,201 to 9,100 (801 to 1.400)	32	(70)
9,101 to 13,000 (1,401 to 2,000)	45	(100)
13,001 to 16,200 (2,001 to 2,500)	57	(125)

Note: The procedure for housings with larger surface areas will be evaluated by RUS on a case-by-case basis.

5.3.12.2 The housing shall remain in its original mounting position throughout the test and exhibit no mechanical deformation.

5.3.12.3 Pad or ground mounted SAI or splice housings shall be subjected to a load (F) as shown in Figure 5 and the following table to simulate the overturning moment equivalent to a uniform wind load of 161 km/h (100 mi/h) perpendicular to the largest surface area:

Height cm (in.)	Maximum Area of Largest Surface cm ² (in. ²)	Load	
		kg	(lb)
122 (48) or less	11,000 (1,700) or less	91	(200)
	11,001 - 13,000 (1,701 - 2,000)	104	(230)
	13,001 - 14,900 (2,001 - 2,300)	118	(260)
123 - 152 (49 - 60)	11,700 (1,800) or less	91	(200)
	11,701 - 14,300 (1,801 - 2,200)	109	(240)
	14,301 - 16,200 (2,201 - 2,500)	127	(280)
	16,201 - 18,800 (2,501 - 2,900)	145	(320)
	18,801 - 20,800 (2,901 - 3,200)	163	(360)
	20,801 - 23,400 (3,201 - 3,600)	181	(400)
153 - 183 (61 - 72)	14,300 (2,200) or less	109	(240)
	14,301 - 16,900 (2,201 - 2,600)	127	(280)
	16,901 - 19,500 (2,601 - 3,000)	150	(330)
	19,501 - 22,700 (3,001 - 3,500)	172	(380)
	22,701 - 25,300 (3,501 - 3,900)	190	(420)
	25,301 - 27,900 (3,901 - 4,300)	213	(470)

Note: The procedure for housings with larger surface areas will be evaluated by RUS on a case-by-case basis.

5.3.12.4 The housing shall remain in its original mounting position throughout the test and exhibit no mechanical deformation.

5.3.13 Fire Resistance:

5.3.13.1 The test housing shall be installed in a manner typical of field installation. U.S. No. 1 wheat straw shall be placed on the ground around the housing base in a one meter (3 ft) radius at an approximate depth of 10 cm (4 in.). The straw shall be ignited and permitted to burn fully. After the housing has

cooled, its contents shall be inspected for evidence of ignition, melting, burning, or structural damage. Damage sufficient to impair service constitutes failure.

5.3.13.2 Polymeric materials shall be tested in accordance with UL Publication 94, dated June 18, 1991. Materials used in housing components shall have a rating of 94V-0 or 94V-1 and shall not sustain combustion when an open flame source is removed.

5.4 Mechanical Requirements for Housings:

5.4.1 Impact Resistance: The test housing shall be subjected to the following impacts according to its minimum volume or minimum width and depth as shown in the following table:

Minimum Volume cm ³ (in. ³)	Minimum Width or Depth cm (in.)	Impact Force	
		N-m	(lb-ft)
Less than 35,000 (2,100)	Less than 13 (5)	68	(50)
35,000 (2,100) or greater	13 (5) or greater	136	(100)

5.4.1.1 The impact force shall be delivered to the front, back, and top surfaces. Circular housings shall be impacted on side surfaces 180° apart and on the top. The device used to deliver the force shall be spherical and approximately 25 to 31 cm (10 to 12 in.) in diameter. A typical test procedure may include the use of a hard rubber bowling ball, weighing 6 to 7 kg (13 to 16 lb), enclosed in a mesh bag, attached to a rope with a metal ring. The load shall be dropped vertically on the top surface and applied to the sides with a pendulum motion using the appropriate height and extension arm to achieve the required impact force. The housing must be impacted at the approximate mid-point of the surface area.

5.4.1.2 Housings shall be conditioned for a minimum of eight hours at -40°C (-40°F) in an environmental chamber prior to testing. If the chamber is insufficient in size to conduct tests within the chamber, the housing may be removed and shall be tested within 10 minutes after removal.

5.4.1.3 After impact testing, the housing shall not exhibit fractured or ruptured surfaces sufficient to allow the ingress of moisture or dust. The housing shall not exhibit mechanical damage that would impair the functioning of hinges, latches, locks, etc.

5.4.2 Load Deflection: Free standing buried plant housings shall be tested for load deflection in accordance with Figure 6. The assembled housing shall be rigidly held in place by a mechanical means to simulate a normal field installation. A length of wire or cable, or other suitable material, shall be placed around the top section of the housing and deadended. The wire or cable shall be initially tensioned to 23 kg (50 lb). A measurement shall then be taken of the deflection of the housing at the top as shown in Figure 6. The deflection shall be recorded at incremental loads of 23 kg (50 lb) until destruction of the housing occurs. The average load for the three directions shall not be less than 136 kg (300 lb) and the minimum load in any direction shall be 113 kg (250 lb). Failure is defined as housing component fracture or crazing of the housing's surface finish.

5.4.3 Vibration Requirements: The test housing and its contents shall be subjected to acceleration at a sine wave frequency sweep rate as shown in Figure 7 for a housing packaged for shipment and Figure 8 for an unpackaged housing. The frequency sweep may be performed continually or sequentially. The test shall be conducted once along each of three mutually perpendicular axes of the housing. There shall be no mechanical or electrical degradation of the housing or its contents. Noticeable damage to the housing constitutes failure.

5.4.4 Drop Test Requirements: Housings shall be subjected to appropriate drop tests according to their weight. The drop tests shall be performed on housings and their contents as normally packaged as well as on unpackaged housings. The tests shall be conducted on a smooth level concrete floor or similar unyielding surface. For corner drops, the packaged housing and its contents shall be oriented at impact such that a straight line drawn through the struck corner and package geometric center is approximately perpendicular to the impact surface.

5.4.4.1 Packaged housings and their contents weighing 91 kg (200 lb) or less shall be capable of enduring a single drop on each face or corner without damage from a height specified as follows:

Packaged Housing Including Contents - Weight kg (lb)	Drop Height cm (in.)
0 to 9 (0 to 20)	76 (30)
10 to 23 (21 to 50)	61 (24)
24 to 45 (51 to 100)	53 (21)
46 to 91 (101 to 200)	46 (18)

5.4.4.2 Packaged housings and their contents weighing more than 91 kg (200 lb) shall be capable of enduring a single drop on each of two diagonally opposite corners of the package without significant damage from a height specified as follows:

Packaged Housing Including Contents - Weight kg (lb)	Drop Height cm (in.)
92 to 453 (201 to 1000)	30 (12)
Over 453	15 (6)

5.4.4.2.1 The packaged housing and contents shall be placed on its normal shipping base with one corner supported 15 cm (6 in.) above the floor and the other corner of the same end supported 30 cm (12 in.) above the floor as shown in Figure 9. The unsupported end of the package shall be raised so that the lowest corner reaches the height listed above and then allowed to fall freely.

5.4.4.2.2 The procedure of Paragraph 5.4.4.2.1 of this specification shall be repeated for the diagonally opposite corner.

5.4.4.2.3 The packaged housing and contents shall be capable of enduring a single drop on each edge of the base of its normal shipping position from the required height without damage and shall remain operational without function impairment. The packaged housing and contents shall be placed on its base with one edge supported on a sill 15 cm (6 in.) high and the unsupported edge raised to the required height as shown in Figure 10 and allowed to fall freely.

5.4.4.2.4 The procedures of Paragraph 5.4.4.2.3 of this specification shall be repeated for all edges of the base.

5.4.4.3 Unpackaged housings and their contents weighing 23 kg (50 lb) or less shall be capable of enduring a single drop on each face and adjacent corners without significant damage from a height specified as follows:

Unpackaged Housing Including Contents - Weight kg (lb)	Drop Height cm (in.)
0 to 9 (0 to 20)	10 (4)
10 to 23 (21 to 50)	8 (3)

5.4.4.4 Unpackaged housings and their contents weighing more than 23 kg (50 lb) shall be capable of enduring a single drop without significant damage when lifted by its normal hoisting supports as shown in Figure 11 and with its lowest point at a height specified as follows:

Unpackaged Housing Including Contents - Weight kg (lb)	Drop Height cm (in.)
23 to 45 (51 to 100)	5 (2)

5.4.5 Firearms Resistance: All housings shall be tested for resistance to penetration by direct impact from a 12 gauge shotgun equipped with a modified choke and the use of a 3-3/4 dram equivalent powder charge and 35 grams #6 lead shot fired from a distance of 15 m (50 ft). The 12 gauge shotgun shall be fired from a normal standing position at the front side of the housing. Penetration through the housing wall by the lead shot shall constitute failure.

5.4.6 Lifting Hardware Requirements: The lifting hardware on housings and their contents that weigh more than 91 kg (200 lb) shall be tested. The housing shall be fastened to a restraining device such as a concrete slab and subjected to loading through the lifting attachments to simulate the lifting load. For the first test a lifting line equipped with a dynamometer shall be attached to the housing lifting hardware and a load applied equal to three times the weight of a fully equipped housing. Deformation or damage to the housing or lifting hardware constitutes failure. A second test shall be conducted with the same arrangements as for the first except that a load shall be applied equal to six times the weight of a fully equipped housing. There shall be no catastrophic failure of the lifting hardware or housing.

5.4.7 Stub Cable Strain Relief Tests: Housings equipped with cable stubs and cable shipping retainer shall be tested by lifting a test housing, with the maximum length and weight of cable orderable, in a manner causing the full weight of the cable to be supported by the cabinet. Examination of the cable sheath after lifting shall reveal no tearing, rupturing, or other damage. The cable conductors and shield shall be tested for shorts and opens. Electrical defects to the stub cable or damage to the housing constitutes failure.

5.4.8 Door Restrainer Evaluation:

5.4.8.1 The housing shall be positioned with the door held in the open position by the door restraining device. A load, determined in accordance with the following table, shall be applied to the center of the door, perpendicular to the door and in each of the opening and closing directions.

Maximum Area of Door Surface cm ² (in. ²)	Load	
	kg	(lb)
5,200 (800) or less	72	(160)
5,201 to 9,100 (801 to 1,400)	127	(280)
9,101 to 13,000 (1,401 to 2,000)	181	(400)

Note: Test procedures for housings with larger doors will be evaluated by RUS on a case-by-case basis.

5.4.8.2 There shall be no functional failure of the restraining device nor mechanical damage to the housing.

5.4.9. Security Evaluation: The security locking device shall be capable of withstanding a maximum torque of 2.8 N-m (25 lb-in.) without incurring physical damage to the closure, thereby resulting in a condition where the closure cannot be either accessed or locked.

5.5 Electrical Requirements for Housings: Each bonding stud and nut location shall be evaluated by attaching one lead from a dc or alternating current (ac) power source to a bonding stud with the nut torqued as specified by its manufacturer and the other power source lead connected to the closure grounding conductor connector. The current path thus established must be capable of sustaining a current of 1,000 amperes root-mean-square for at least 20 seconds without fusing or causing any damage to the closure or its contents.

5.6 Finish Requirements:

5.6.1 Impact Resistance: The finish on painted metal surfaces shall not exhibit radial cracking on the impact surface (intrusion) when indented at 18 N-m (160 lb-in.) with a 1.6 cm (0.6 in.) diameter spherical indenter. This test shall be performed in accordance with ASTM D 2794-94 with the exception that the test panel shall be of the same material, thickness, and finish as the pedestal housing being evaluated.

5.6.2. Finish Adhesion: Painted finishes shall be tested for adhesion of finish in accordance with ASTM D 2197-86(1991), Method A. There shall be no gouging in the top coat when tested with an 8 kg (17.7 lb) load. Gouging is defined as removal or separation of paint particles or breaking of the finish by the scraping loop to the extent of exposing base metal.

5.6.3 Color Evaluation: The color of the housing finish should be compared against the Munsell system of color notation, as described in ASTM D 1535-89 to determine color consistency with that desired.

5.6.4 Gloss Evaluation: The finish on painted housings shall be tested on two approximately 20 cm x 20 cm (8 in. x 8 in.) samples for each color used in accordance with the procedures of ASTM D 523-89. The finish shall have a minimum gloss of 60 (60° Specular).

5.6.5 Secondary Finish Evaluation: Evidence of secondary protection shall be required for RUS acceptance. Typical secondary protection is galvanizing per ASTM A 526/A 526M-90 for steel surfaces.

6. FUNCTIONAL DESIGN CRITERIA FOR BINDING POST TERMINAL BLOCKS USED IN SAI CABINETS

6.1 General Description: A conventional binding post terminal consists of a metallic element or post, one end of which is configured for the permanent connection of 22, 24, or 26 AWG solid copper conductors and the opposite end is configured for recurring connections and disconnections of solid copper cross-connect wire using a threaded screw or stud and nut combination for gripping the wire. The terminal is usually housed in a SAI cabinet. However, the terminal may receive limited use in smaller pedestal-type housings and pole mounted cabinets in the outside plant environment.

6.2 Design and Fabrication Requirements:

6.2.1 Terminal blocks used in outside plant housings are expected to perform satisfactorily for a nominal design life of 30 years.

6.2.2 All individual terminals or terminal fields must be enclosed and the terminal enclosure must be totally filled with an encapsulating grease or gel which prevents connection degradation caused by moisture and corrosion. The encapsulant must provide complete encapsulation of terminal metallic connections and surfaces and totally fill all voids and cavities within individual terminal enclosures or terminal field enclosures to prevent ingress of moisture. The encapsulant must not restrict access to the terminal or restrict craft personnel from making connections. The encapsulant must be compatible with the standard materials used in cross-connect hardware and wiring.

6.2.3 Binding post terminals shall not be susceptible to damage under normal use of standard tools used by outside plant technicians such as screwdrivers and test set clips.

In addition, use of other tools such as scissors, diagonal cutters and long nose pliers for tightening and loosening screws shall not result in damage to the terminal.

6.2.4 Terminals shall be designed so that a typical technician using customary tools shall be able to terminate cross-connect wire on a pair of terminals, or to remove it, without causing an electrical short between any two terminals or any other adjacent terminals.

6.2.5 The terminal count sequence shall be indicated using numerals of at least 0.25 cm (0.10 in.) in height.

6.2.6 A means shall be provided to distinguish feeder terminals from distribution terminals.

6.2.7 A means shall be provided to identify tip terminals and ring terminals in a terminal field. The identification convention shall indicate tip on the left with ring on the right for horizontal spacing and tip on the top with ring on the bottom for vertical spacing.

6.2.8 The preferred height of the highest terminal in the connector field in a ground mounted SAI unit shall be 168 cm (66 in.) or less as measured from the top surface of the mounting pad. The bottom or lowest terminals in the connector field shall be at least 46 cm (18 in.) from the top surface of the pad.

6.2.9 Pole mounted aerial units shall be 84 cm (33 in.) or less in width. The maximum allowable height of the highest terminals in a pole mounted aerial unit is 168 cm (66 in.) as measured from the top surface of the standard balcony seat used with the interface. For computation purposes, 15 cm (6 in.) shall be allowed for the distance between the bottom of the interface and the top of the balcony seat.

6.3 Auxiliary Features:

6.3.1 SAI cabinets with terminal designs which do not permit direct attachment of common test instrument clips to terminal pairs without the occurrence of shorts shall be equipped with single pair auxiliary test contacts. The auxiliary test contacts shall attach to a terminal pair and provide a set of secondary terminals which will accept typical test instrument clips without the occurrence of shorts. Wire used to connect the auxiliary test contacts to the secondary terminals shall be 20 gauge minimum stranded conductor copper wire with a minimum dielectric strength between conductors of 15 kv. The test connector shall be functional on all terminal pairs.

6.3.2 A 25 or 50 pair test connector shall be available which can be used to make reliable electrical contact to terminals associated with discrete 25 pair binder groups. The multi-pair test connector shall be provided with a minimum of 1.8 m (6 ft) of suitable cabling terminated to a connector, for interfacing with test sets common to the industry. The multi-pair test connector shall be functional on all terminal groups.

6.3.3 A special service marker shall be available which must attach to a binding post terminal to identify special circuits and insulate exposed metal parts from accidental shorts from tools and wires. A supply of 25 special service markers shall be provided with each SAI cabinet. The color of special service markers shall be red.

6.3.4 A supply of twisted pair cross-connect wire shall be supplied with housings that are equipped with cross-connect terminals or that have provisions for mounting cross-connect terminals. The minimum length of cross-connect wire supplied is dependent on the SAI cabinet terminal capacity as follows:

Cabinet Termination Capacity (pairs)	Wire Length m (ft)
1 to 600	60 (200)
601 to 1200	120 (400)
Over 1200	180 (600)

6.3.5 The cabinet shall be equipped to store the length of wire in a manner designed for convenient dispensing. The cross-connect wire supply shall be easily replaceable.

7. PERFORMANCE CRITERIA AND TEST PROCEDURES FOR BINDING POST TERMINAL BLOCKS USED IN SAI CABINETS

7.1 General: Many of the tests described in this paragraph require that the terminal block be installed in an appropriate housing in its typical field configuration.

7.2 Environmental Requirements:

7.2.1 Insulation Resistance/High Humidity and Salt Fog Exposure:

A test specimen shall consist of a standard ground or pole mounted housing equipped with a full complement of binding post terminals equipped with 25 special service markers. The minimum number of terminals to be tested shall be 100 pair (100 tips and 100 associated rings). The test terminals shall be selected to form a terminal array of approximate square dimensions. A 91 cm (36 in.) length of cross-connect wire shall be installed on each test terminal. All tips shall be joined together and all rings shall be joined together with a 48 volt dc potential applied as shown in Figure 12 during the high humidity/salt fog and

simulated rain exposures. The 48 volt dc may be temporarily removed from the test samples during the measurement process and the ring terminal being measured shall be isolated from the remaining ring terminals. The terminal insulation resistance shall be measured at a potential of 100 volts dc using suitable instrumentation with a minimum measurement range of 10^4 to 10^{12} ohms.

7.2.1.1 High Humidity: The test housing shall be placed in an environmental test chamber at $95 \pm 3\%$ RH and the temperature cycled as shown in Figure 3 of this specification for a period of 30 days. The cabinet doors shall remain in the fully open position. The insulation resistance between the ring terminal of each sample and all the common tip terminals shall be measured each 24 hours when the temperature is between 38 and 57°C (100 and 135°F) and increasing. The minimum insulation resistance when measured in accordance with Paragraph 7.2.1 of this specification shall not be less than 1×10^6 ohms.

7.2.1.2 Salt Fog: A test housing with its doors closed shall be placed in a salt fog 35°C (95°F) test chamber and exposed to a salt fog spray per ASTM B 117-90 for a period of 30 days. The insulation resistance should be measured every 24 hours as indicated in Paragraph 7.2.1 of this specification and shall not be less than 1×10^6 ohms. The special service markers shall exhibit no sign of fading, corrosion, swelling, warping, running color, or other signs of deterioration.

7.2.2 Insulation Resistance/Simulated Rain Exposure:

7.2.2.1 A test housing as described in Paragraph 7.2.1 of this specification shall be tested for water infiltration. The test shall be conducted using the method described in Paragraph 5.3.11 of this specification. The cabinet doors shall remain closed for the duration of the test. The insulation resistance between the ring terminals and the common tip terminals shall be measured during and immediately following the spray application as indicated in paragraph 7.2.1 of this specification and shall not be less than 1×10^6 ohms.

7.2.2.2 With the cabinet doors open, a spray of tap water at a rate of 3.8 liters per minute (1 gallon per minute) at 276 kilopascals (40 pounds per square inch) shall be directed on the terminal array for a period of 1 minute saturating all of the terminals. Following the spray application the doors shall be closed. The cabinet shall be maintained in a temperature environment of 26 to 28°C (78 to 82°F) at $95 \pm 3\%$ RH for 6 hours. The insulation resistance shall then be measured as specified in Paragraph 7.2.1 of this specification. The minimum insulation resistance shall not be less than 1×10^6 ohms.

7.2.3 Contact Resistance: A minimum of 100 terminals equipped with cross-connect wire that has been installed in a manner typical of that used in the industry shall be temperature cycled.

7.2.3.1 The test shall consist of eight-hour temperature cycles with one-hour dwells at extreme temperatures of -40°C to 60°C (-40°F to $+140^{\circ}\text{F}$), and temperature changes at an average rate of 16°C (60°F) per hour between the extremes. The relative humidity shall be maintained at $95 \pm 3\%$. The eight-hour test shall be conducted for 512 cycles. Millivolt drop measurements shall be made initially and after 2, 8, 16, 32, 64, 256, and 512 cycles with the samples at room temperature. The resistance measurement technique must conform to ASTM B 539-90. The measurement method must have an accuracy of at least ± 30 microohms for resistances less than 50 milliohms. The change in contact resistance shall not exceed 2 milliohms.

7.2.3.2 A minimum of 100 terminals equipped with cross-connect wire installed in a manner typical of the industry shall be maintained at 118°C (245°F) during the test period, except during disturbance measurement periods where each wire connection to the terminals shall have a 0.23 kg (0.5 lb) force momentarily applied in a manner to stress the connection. Initial millivolt measurements shall be made without disturbing the joints in accordance with Paragraph 7.2.3.1 of this specification with the samples at room temperature. After initial measurement each sample shall be disturbed followed by a millivolt drop measurement after 1, 2, 4, 8, 16, and 33 days. The change in contact resistance should be less than 2 milliohms when compared to the initial measurement.

7.2.4 Fire Resistance: A fully equipped cabinet including a full complement of cross-connect jumpers shall be installed in the standard field arrangement and tested for fire resistance in accordance with Paragraphs 5.3.13 through 5.3.13.2 of this specification. After cooling, the cabinet, terminals, and associated wiring shall be inspected for signs of ignition, melting, burning, or structural damage of sufficient consequences such that the results are service affecting.

7.2.5 Encapsulant Material Compatibility: The terminal connection encapsulant compound must be compatible with the standard materials used in cross-connect hardware and wiring when aged in accordance with ASTM D 4568-86 at a temperature of $80 \pm 1^{\circ}\text{C}$ ($176 \pm 2^{\circ}\text{F}$). The conductor insulation shall retain a minimum of 85% of its unaged tensile strength and elongation values. The cross-connect hardware shall exhibit no visible material degradation.

7.2.6 Encapsulant Flow Test: Terminal connection encapsulant must remain stable at $80 \pm 1^{\circ}\text{C}$ ($176 \pm 2^{\circ}\text{F}$) when tested in an environmental chamber. Test specimens shall be suspended in a preheated oven over a glass dish or other drip-catching medium for a period of 24 hours. At the end of the test period, the glass dish shall be examined for evidence of flowing or dripping of encapsulant from the cross-connect terminal. More than 0.5 gram of encapsulant in the dish at the end of the test constitutes failure.

7.3 Mechanical Requirements:

7.3.1 Vibration: A test housing equipped with a full complement of cross-connect terminals and jumper wiring shall be subjected to vibration testing in accordance with Paragraph 5.4.3 of this specification.

7.3.2 Torsional Capacity of Binding Posts: The test specimens shall consist of the complete binding post terminal consisting of the screw or nut, washers if required, and threaded post or stud respectively.

7.3.2.1 Test specimens shall include the terminals along the matrix edge at mid-span locations as well as centrally located terminals. Tests shall be conducted using a torque indicating screwdriver, or wrench, with an accuracy of ± 0.17 N-m (± 1.5 lb-in.) or better. The torque indicating device shall be used to tighten a screw or nut until failure of the screw or nut is achieved. Tests shall be conducted while the test specimen is stabilized at temperatures of -40°C , 20°C , and 71°C (-40°F , $+68^{\circ}\text{F}$, and at $+160^{\circ}\text{F}$.) Record the torques at terminal failure. At least 10 test specimens shall be tested at each temperature. The failure torque shall not be less than 2.8 N-m (25.0 lb-in.) for each temperature.

7.3.2.2 The post or stud of the binding post terminal shall not fail before the screw or nut when increasing torque. The faceplate or receptacle restraining the post or stud shall not fail before the screw or nut when increasing torque.

7.3.3 Lateral Loading Capacity of Binding Posts: A minimum of three sets of 25 terminals shall be tested with the test specimens stabilized at temperatures of -40°C , 20°C and 71°C (-40°F , $+68^{\circ}\text{F}$, and 100°F). The test arrangement shall include the terminals along the matrix edge at mid-span locations as well as centrally located terminals. A force measuring device, such as a dynamometer, shall be attached to the end of a binding post terminal and a 16 kg (35 lb) force applied orthogonally to the terminal axis in 4 perpendicular directions as shown in Figure 13. Permanent deformation in excess of 0.08 cm (0.03 in.) or any structural damage in either the terminal or faceplate constitutes a failure.

7.3.4 Axial Pullout Resistance: A minimum of three sets of 25 terminals shall be tested with the test specimens stabilized at temperatures of -40°C , 20°C and 71°C (-40°F , $+68^{\circ}\text{F}$, and 100°F). The test arrangement shall include the terminals along the matrix edge at mid-span locations as well as centrally located terminals. A force measuring device, such as a dynamometer, shall be attached to a terminal and a force of 16 kg (35 lb) applied on axis as shown in Figure 14. There shall be no permanent deformation in excess of 0.08 cm (0.03 in.), any structural damage, or terminal pull-out in either the terminal or the faceplate.

7.3.5 Test Connector Reliability:

7.3.5.1 A single pair connector shall be capable of making a minimum of 100 successive connections to binding post terminals without the occurrence of an open circuit. The test shall include terminals along the matrix edge, center, top, and bottom.

7.3.5.2 A multi-pair test connector shall be attached to the binding post terminal field and tests for opens between the binding post terminals and the test connector shall be conducted. All circuits must prove good. The test shall be repeated along the terminal matrix edges, center, top, and bottom.

7.3.6 Service Cycle Reliability: A torque indicating device or wrench with an accuracy of ± 0.17 N-m (± 1.5 lb-in.) or better shall be used to tighten the terminal screw or nut as appropriate to 1.7 N-m (15.0 lb-in.). The terminal nut or screw is then loosened and retightened to 1.7 N-m (15 lb-in.). After 50 repeated connections and disconnections, the terminal shall be placed in an environmental chamber at 95% RH where the temperature shall be cycled as indicated in Figure 3 of this specification for a duration of 72 hours. The terminal shall then be momentarily removed from the chamber and the test procedure repeated. After a total of 250 loosening and retightening cycles have accumulated, the terminal must be capable of withstanding a torque of 1.7 N-m (15 lb-in.).

7.4 Dielectric Strength: All housing components in the vicinity of unsheathed field cable conductors, unsheathed housing stub cable or harness conductors, terminals, or cross-connect wire paths shall have a minimum dielectric strength of 500 volts ac to the cabinet grounding and bonding bracket. Dielectric strength is tested by connecting one lead from a 500-volt ac at 0.5 ampere source to the cabinet ground connector and the other lead is passed along the surfaces of all cabinet components in the vicinity of unsheathed cable or harness conductors, cross-connect wire paths, and in the splice area where unsheathed field cable conductors may be located. Sparkover constitutes failure.

7.5 Operational Requirements:

7.5.1 Durability: In order to verify the durability requirements while minimizing the number of test housings required to complete the test program, the binding posts selected for tests shall be separately identified and then checked to establish compliance after the various tests have been conducted.

7.5.2 Twenty-five jumper connections shall be made on each of two binding post connectors chosen at random from a representative sample in an assembled interface unit. After exposure to this test, these and adjacent connectors shall be inspected for damage such as cracks or chips in metal or plastic parts. Failure consists of structural damage, open circuits through the connector, or inability to pass the torsional, lateral loading, or axial pullout tests described in Paragraphs 7.3.2 through 7.3.4 of this specification.

7.5.3 Select six binding posts at random in a representative interface. On each connector, attach any test cord included with the unit and then remove the test cord as follows. On binding post sample 1, remove the cord normally ten times. On binding post sample 2, remove the cord ten times by jerking the test leads straight out. In these and the remaining tests, do this without releasing any manual attachment mechanisms. On sample 3, remove ten times by jerking downward at 45° from horizontal; sample 4, upward at 45° ten times; sample 5, left 45° ten times; sample 6, right 45° ten times. Check for opens and damage in the test cord, clips, and connectors. Failure consists of structural damage, open circuits through the connector, or inability of the terminal blocks to pass the torsional, lateral loading, axial pullout, test connector reliability, or dielectric strength tests described in Paragraphs 7.3.2 through 7.3.5.2, and Paragraph 7.4 of this specification.

7.5.4 Use craft tools such as scissors, diagonal cutters, and long nose pliers to loosen and tighten screws where the binding post design does not prohibit the possibility. Failure consists of severe structural damage.

8. FUNCTIONAL DESIGN CRITERIA FOR INSULATION DISPLACEMENT TYPE CROSS-CONNECT MODULES USED IN SAI CABINETS

8.1 General Description: Cross-connect modules normally consist of multiple metallic contact elements that are retained by nonmetallic fixtures. The contact elements are spliced with permanent wire leads compatible for splicing to 22, 24, or 26 gauge cable on one side and configured for the acceptance of recurring connections and disconnections of plastic insulated cross-connect wire on the other side. Cross-connect modules are

usually housed in a SAI cabinet. However, modules may receive limited usage in smaller pedestal-type housings and cabinets in the outside plant environment.

8.2 Design and Fabrication Requirements:

8.2.1 All individual terminals or terminal fields must be enclosed and the terminal enclosures must be totally filled with an encapsulating grease or gel which prevents connection degradation caused by moisture and corrosion. The encapsulant must provide complete encapsulation of terminal metallic connections and surfaces and totally fill all voids and cavities within individual terminal enclosures or terminal field enclosures to prevent ingress of moisture. The encapsulant must not restrict access to the terminal or restrict craft personnel from making connections. The encapsulant must be compatible with the standard materials used in cross-connect hardware and wiring.

8.2.2 The cross-connect module manufacturer shall make available any nonstandard tools and test apparatus which are required for splicing, placing of jumpers, and the performance of maintenance operations.

8.2.3 The module shall be designed so that a typical outside plant technician using tools shall be able to terminate cross-connect wire on terminals, or to remove them without causing electrical shorts between any other terminals.

8.2.4 The pair count sequence terminated on a module shall be easily visible and shall have numerals of at least 0.25 cm (0.10 in.) in height.

8.2.5 Feeder terminations shall be easily distinguished from distribution terminations.

8.2.6 Tip and ring terminations shall be easily visible and shall be identifiable as described in Paragraph 6.2.6 of this specification.

8.2.7 The preferred locations for cross-connect modules to be mounted inside a housing is the same as those for terminals and are described in Paragraphs 6.2.7 and 6.2.8 of this specification.

8.3 Auxiliary Features:

8.3.1 Housings equipped with cross-connect modules shall be equipped with auxiliary test contacts as described in Paragraphs 6.3.1 and 6.3.2 of this specification.

8.3.2 Special service markers shall be available for cross-connect modules as described in Paragraph 6.3.3 of this specification.

8.3.3 Housings equipped with, or designed for, cross-connect modules shall contain a supply of cross-connect wire as described in Paragraph 6.3.4 of this specification.

**9. PERFORMANCE CRITERIA AND TEST PROCEDURES FOR INSULATION
DISPLACEMENT TYPE CROSS-CONNECT MODULES**

9.1 General: Many of the tests described in this Paragraph require that the cross-connect module be installed in an appropriate housing in its typical field configuration for testing. Resistance measurements should be made with an electrical device which measures changes in resistance for each test parameter measured. The tests specified provide an indication of the stability of the electrical connections under the test conditions encountered.

9.2 Environmental Requirements:

9.2.1 A fully equipped arrangement of cross-connect modules having approximately 25 special service markers shall successfully complete environmental testing in accordance with Paragraphs 5.3 through 5.3.13.2 of this specification.

9.2.2 Insulation Resistance/High Humidity and Salt Fog Exposure: Insulation resistance measurements shall not be less than 1×10^6 ohms when cross-connect modules are tested by a procedure similar to that described in Paragraphs 7.2.1 through 7.2.1.2 of this specification.

9.2.3 Insulation Resistance/Simulated Rain Exposure: Insulation resistance measurements shall not be less than 1×10^6 ohms when cross-connect modules are tested by a procedure similar to that described in Paragraphs 7.2.2 through 7.2.2.2 of this specification.

9.2.4 Contact Resistance: The change in contact resistance should not exceed 2 milliohms when cross-connect modules are tested by a procedure similar to that described in Paragraphs 7.2.3 through 7.2.3.2 of this specification.

9.2.5 Fire Resistance: A housing fully equipped with cross-connect modules and jumper wiring shall be tested for fire resistance by a procedure similar to that described in Paragraph 7.2.4 of this specification.

9.2.6 Encapsulant Material Compatibility: Cross-connect wire insulation and cross-connect hardware shall exhibit no visible material degradation when tested by the procedure described in Paragraph 7.2.5 of this specification.

9.2.7 Encapsulant Flow Test: The cross-connect contact encapsulant shall drip no more than 0.5 gram when tested by the procedure described in Paragraph 7.2.6 of this specification.

9.3 Mechanical Requirements:

9.3.1 Vibration: A housing fully equipped with cross-connect modules shall be vibration tested in accordance with Paragraph 7.3.1 of this specification.

9.3.2 Test Connector Reliability: The test connectors supplied with housings intended for cross-connect modules shall successfully complete 100 successive connections as described in Paragraphs 7.3.5 through 7.3.5.2 of this specification.

9.3.3 Service Cycle Reliability: A combination of multiple insertions of jumper wires, vibration, and temperature cycling shall be performed on cross-connect modules. The multiple insertions on approximately 100 connections shall be accomplished by 300 operations consisting of insertion, removal and reinsertion of new jumper wire. Contact resistance shall be measured and the final insertion of jumper wire shall not be removed from the connectors but must be subjected to vibration testing in accordance with Paragraph 7.3.1 of this specification and temperature cycled as indicated in Figure 3 of this specification for a duration of 72 hours. After vibration and temperature cycling, the average change in contact resistance shall be no greater than 2 milliohms.

9.3.4 Jumper Wire Pull-Out Resistance: Test modules that have received no prior conditioning shall be equipped with 100 38 cm (15 in.) jumper connections of the gauges recommended for use with the module using the insertion tool recommended by the cross-connect module manufacturer. With the test samples suitably supported, wires from each sample shall be pulled, one at a time, by a tensile machine at a cross-head speed of 6 centimeters per minute (cm/min) [2.4 inches per minute (in./min)]. Wires shall be pulled both perpendicular and parallel to the plane of the cross-connect field and shall withstand a load of at least 1.1 kg (2.5 lb) before pulling out.

9.3.5 Cable Conductor Pull-Out Resistance: Test modules that have received no prior conditioning shall be equipped with 100 26, 24 and 22 AWG 38 cm (15 in.) cable conductors using the insertion tool recommended by the cross-connect module manufacturer. With the test samples suitably supported, conductors from each sample shall be pulled, one at a time, by a tensile machine at a cross-head speed of 6 cm/min (2.4 in./min).

Wires shall be pulled both perpendicular and parallel to the plane of the face of the splice module and shall withstand a load of at least 1.1 kg (2.5 lb) before pulling out.

9.4 Electrical Requirements:

9.4.1 Dielectric Strength: A housing fully equipped with cross-connect modules shall be tested for dielectric strength in accordance with Paragraph 7.4 of this specification.

9.4.2 The dielectric strength of a contact within the cross-connect module to contacts on either side shall be tested. The module shall be tested in a dry environment with an ac power source capable of supplying 8 kv at a rate of increase of 500 volts per second, a circuit breaker to open at breakdown, and a voltmeter to record the breakdown potential. Cross-connect modules shall be prepared in accordance with industry accepted splicing techniques with leads trimmed to approximately 38 cm (15 in.). The dielectric strength of each contact to the contacts on either side shall have an average dielectric strength of approximately 5.0 kv.

9.5 Operational Requirements:

9.5.1 Durability: In order to verify the durability requirements while minimizing the number of test housings required to complete the test program, the contacts selected for tests shall be separately identified and then checked to establish compliance after the various tests have been conducted.

9.5.2 Twenty-five jumper connections shall be made on each of two contacts chosen at random from a representative sample in an assembled interface unit. After this test, these and surrounding contacts shall be inspected for damage such as cracks or chips in metal or plastic parts. Failure consists of structural damage, open circuits through the connector, or inability to pass the jumper wire pullout tests described in Paragraph 9.3.4 of this specification.

9.5.3 Select six contacts at random in a representative interface. On each of these contacts attach any test cord included with the unit as specified under normal use of that cord and then remove the test cord as follows. On sample 1, remove the cord normally ten times. On sample 2, remove the clip ten times by jerking the test leads straight out. In these and the remaining tests, do this without releasing any manual attachment mechanisms. On sample 3, remove ten times by jerking downward at 45° from horizontal; sample 4, upward 45° ten times; sample 5, left 45° ten times; sample 6, right 45° ten times. Check for opens and damage in the test cord, clips, and cross-connect modules. Failure consists of structural damage, open circuits through the connector, or inability of module to pass the test

connector reliability, jumper wire pullout, and dielectric strength tests described in Paragraphs 9.3.2, 9.3.4, and 9.4.2 of this specification.

10. PACKAGING AND IDENTIFICATION REQUIREMENTS

10.1 Product Identification:

10.1.1 Each housing, terminal block, or cross-connect module shall be permanently marked with the manufacturer's name or trade mark.

10.1.2 The date of manufacture, model number, serial number and RUS assigned designations shall be placed on a decal inside housings. The product identification nomenclature must correspond with the nomenclature used in the manufacturer's quality assurance program.

10.2 Packaging Requirements:

10.2.1 Buried plant housings shall be packaged securely in an environmentally safe container to prevent either deterioration or physical damage to the unit during shipment, handling and storage.

10.2.2 The product with all the necessary parts shall be shipped in one container unless significant advantages to the user can be obtained otherwise. Packaging of parts in the carton shall be such that the parts become available in the order in which they are needed. The package should be clearly marked as to which end to open. Packages shall be clearly labeled, and correspond to the names given in the instructions.

10.2.3 Products packed in shipping containers shall be cushioned, blocked, braced, and anchored to prevent movement and damage.

10.2.4 All products shall be secured to pallets with non-metallic strapping. The strapping and the manner employed shall be of sufficient quantity, width, and thickness to preclude failure during transit and handling.

10.2.5 The use of shrink or stretch film to secure the load to the pallet is permitted. However, such film must be applied over the required strapping.

10.2.6 Containers that are too large or heavy to be palletized, such as crates, shall be shipped in their own containers. When practical, these containers shall be provided with skids to facilitate fork-lift handling.

10.2.7 When packaged, the outer cartons shall meet the requirements of the Uniform Freight Classification and the National Motor Freight Classification.

10.3 Container Marking Requirements:

10.3.1 The package shall be readily identifiable as to the manufacturer, model number, date of manufacture, and serial number.

10.3.2 The RUS assigned housing designation shall be stamped or marked on the outside of the package container with letter and number sizes large enough for easy identification.

10.3.3 Each package shall be marked with its approximate gross weight.

10.3.4 All containers carrying delicate or fragile items shall be marked to clearly identify this condition.

10.3.5 All marking shall be clear, legible, and as large as space permits.

FIGURE 1
WARNING SIGN

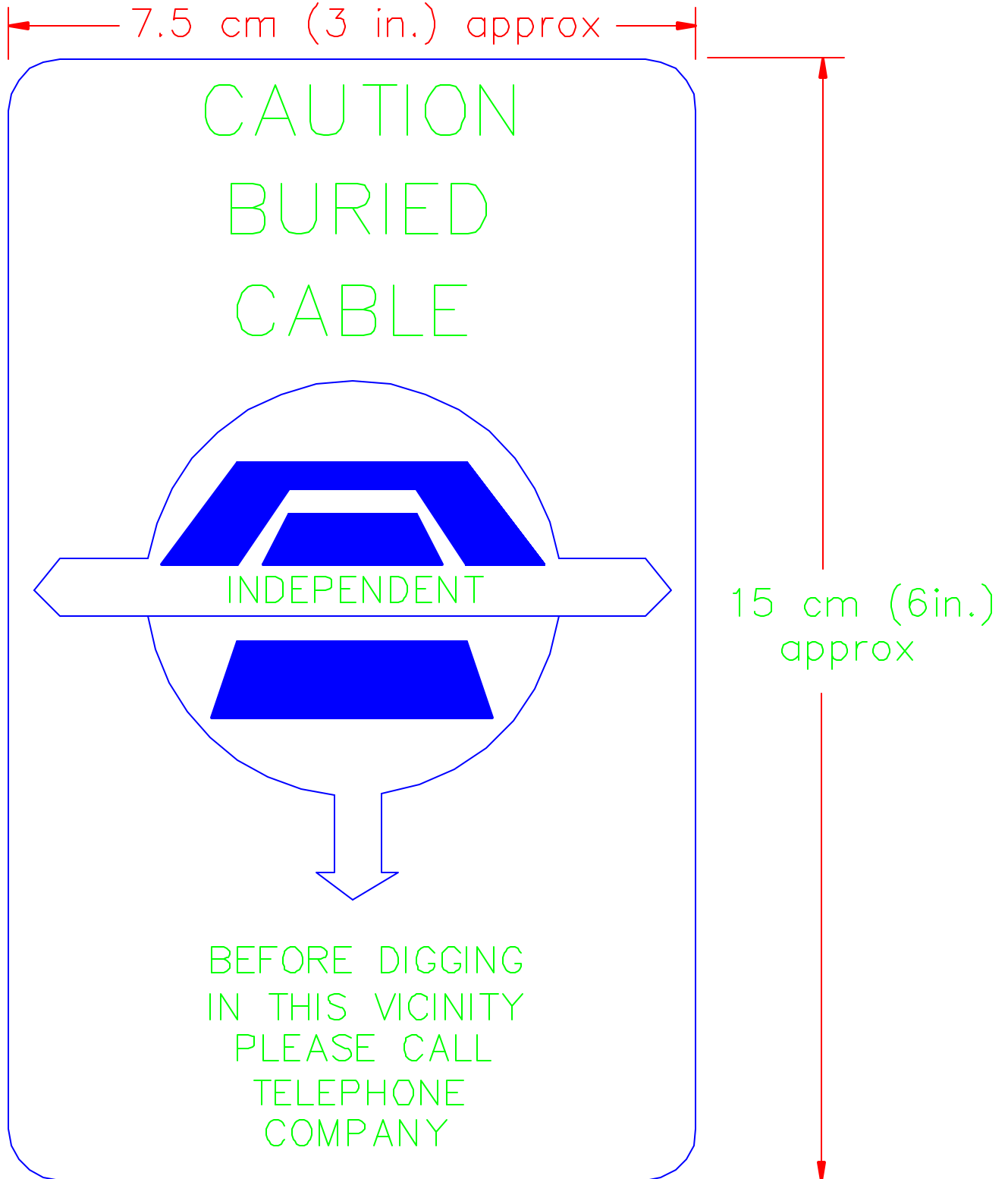

FIGURE 2
THERMAL SHOCK TEMPERATURE CYCLE

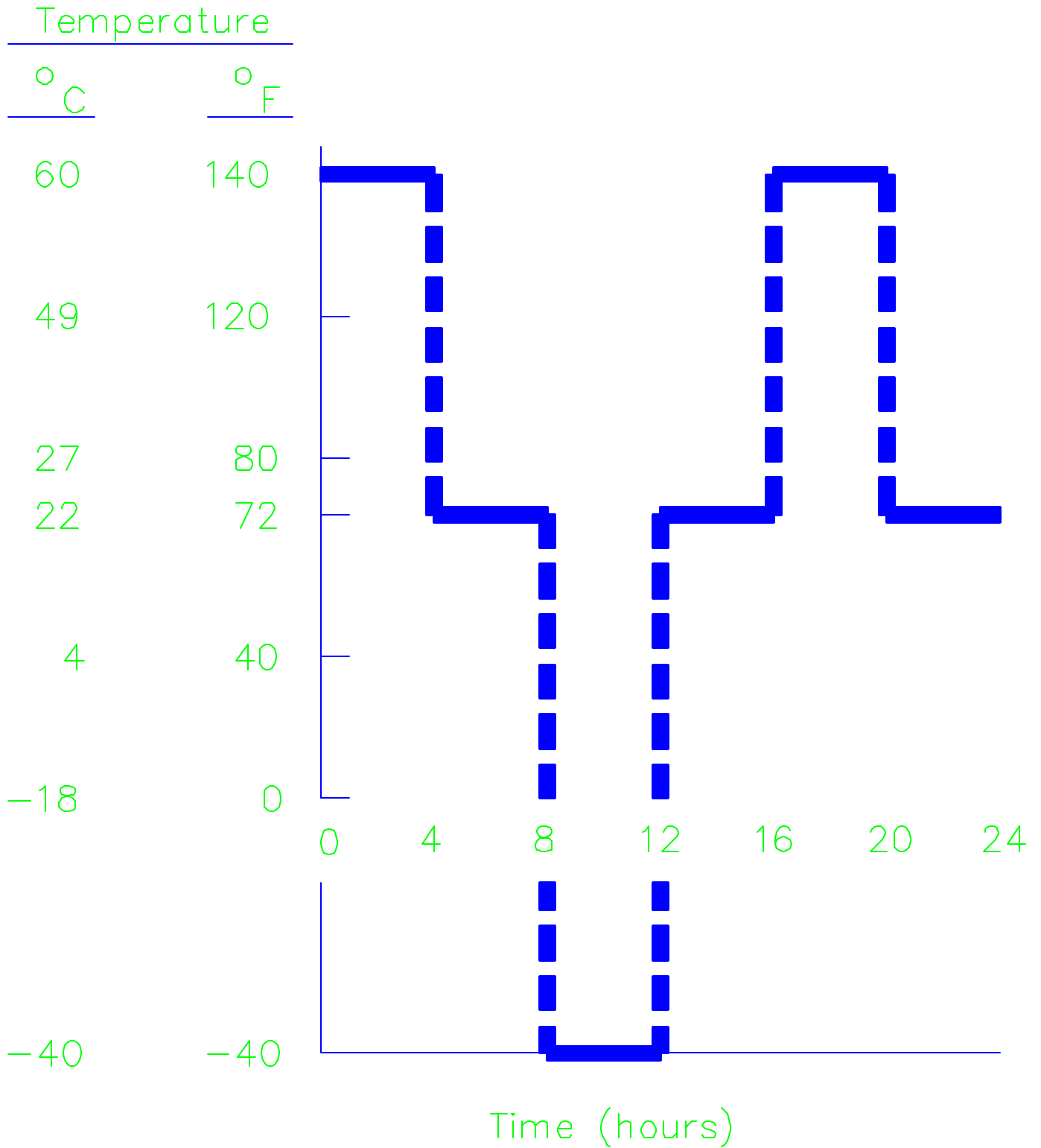
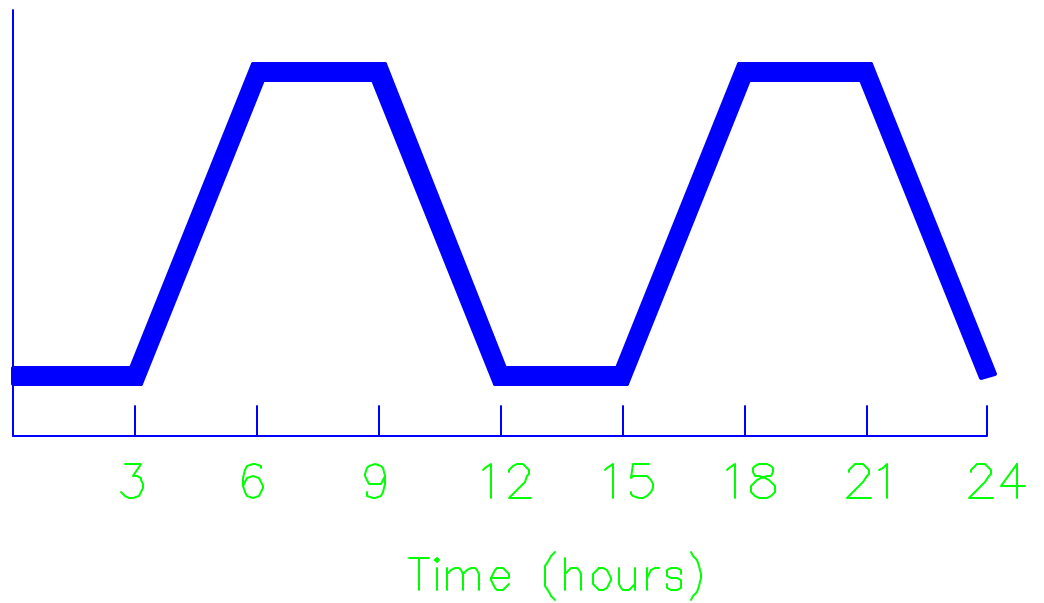

FIGURE 3
ENVIRONMENTAL TEST CHAMBER
TEMPERATURE CYCLE

Temperature

<u>°C</u>	<u>°F</u>
60	140
49	120
38	100
27	80
16	60
4	40
-7	20



Note: Relative Humidity = 95% ± 3%

FIGURE 4
TURNING MOMENT — POLE MOUNTED HOUSINGS

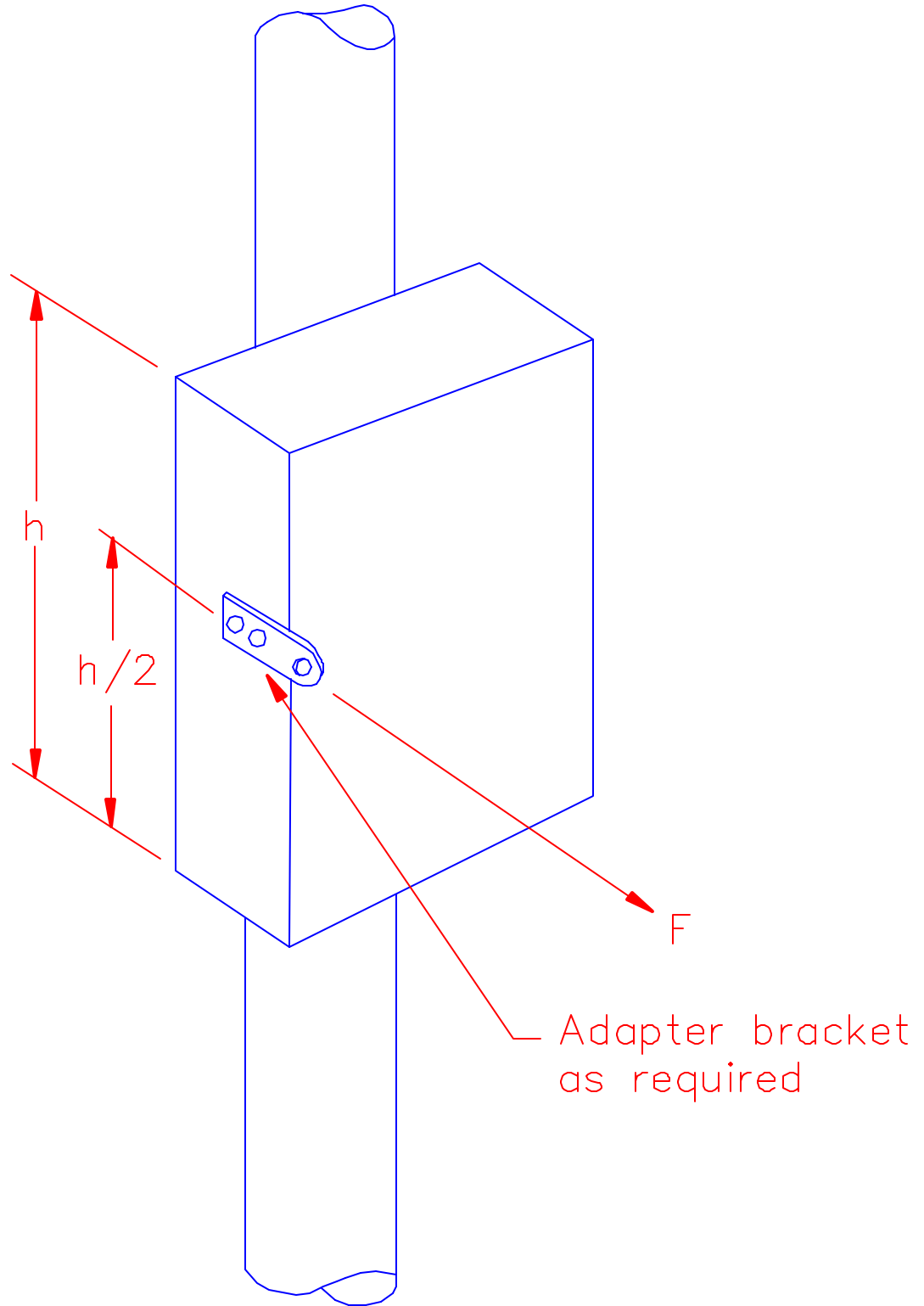
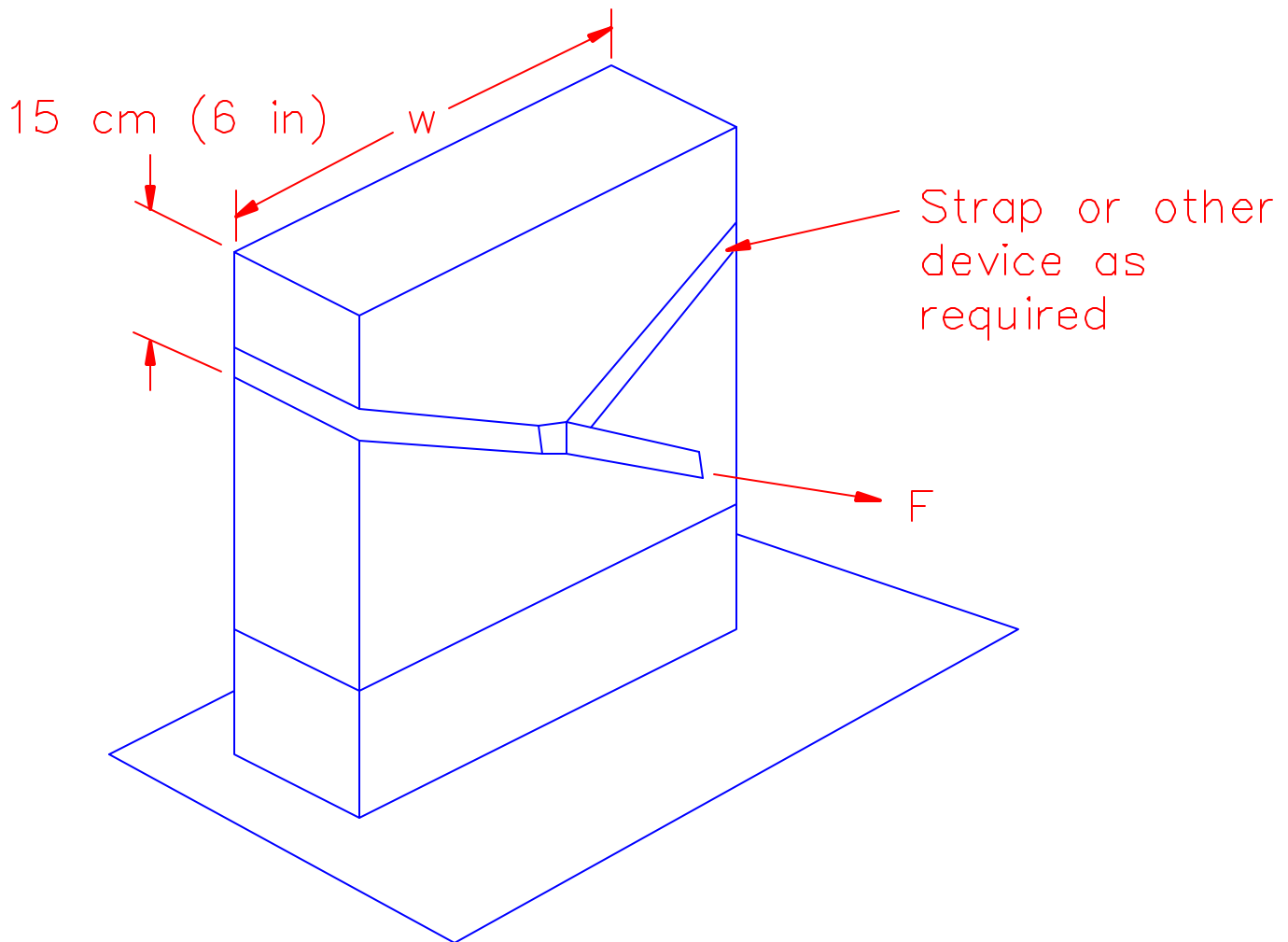

FIGURE 5

OVERTURNING MOMENT, PAD MOUNTED HOUSINGS



Notes:

1. The load "F" shall be applied perpendicular to the cabinet width where the width is greater than the depth.
2. If a foundation is used, the load "F" shall be applied toward the edge nearest to the cabinet.

FIGURE 6
MEASURING LOAD DEFLECTION

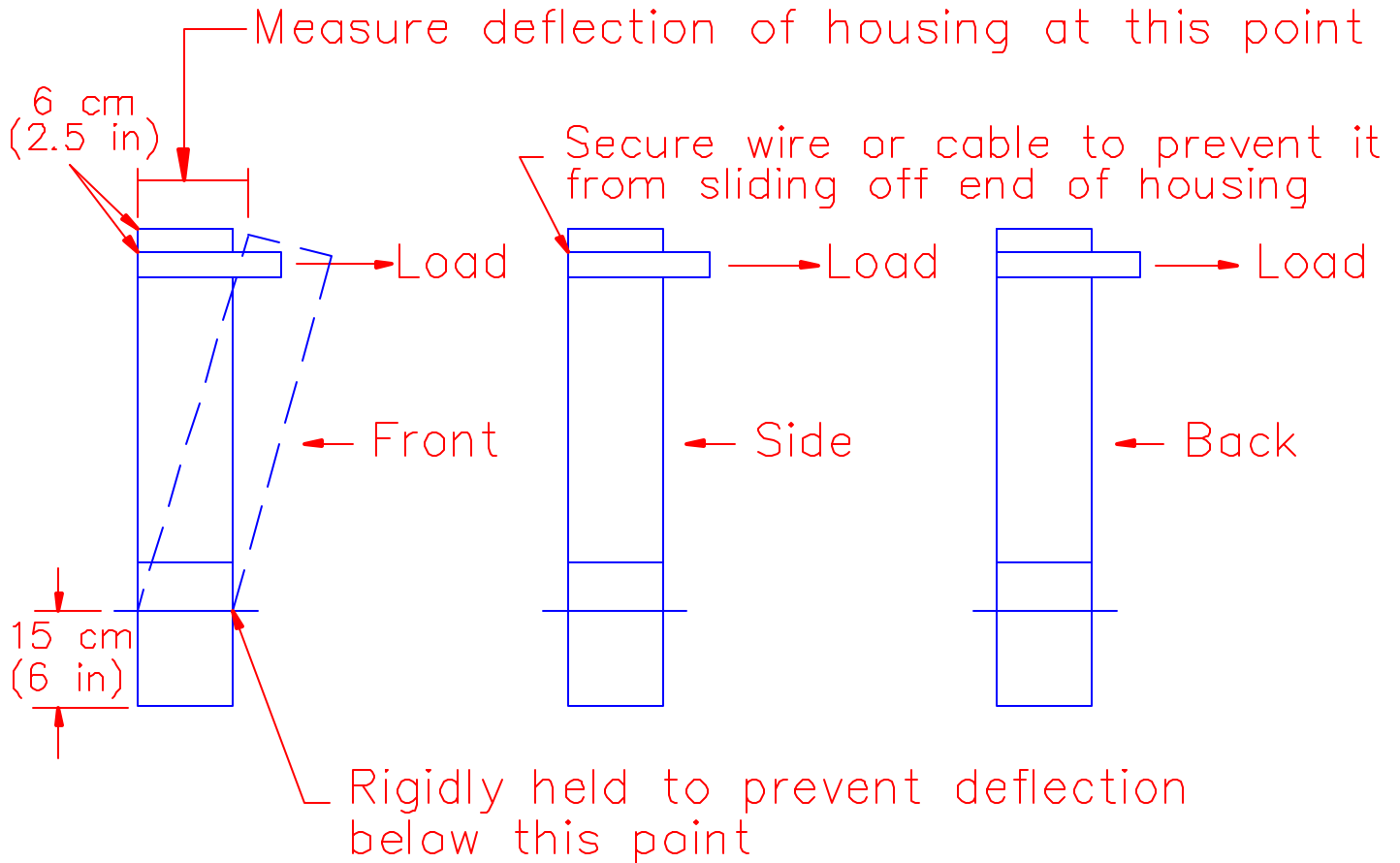

Notes:

1. One pedestal-mounted housing of each BD classification shall be tested to failure in each of the directions shown above.
2. A total of three pedestal-mounted housings of each BD classification shall be subjected to the required loads in each direction.
3. The average load for the three directions shall not be less than 136 kilograms (300 pounds). The minimum load shall be 113 kilograms (250 pounds).
4. Pole mounted housings shall be subjected to the same loading criteria.

FIGURE 7
VIBRATION TEST FOR PACKAGED HOUSINGS

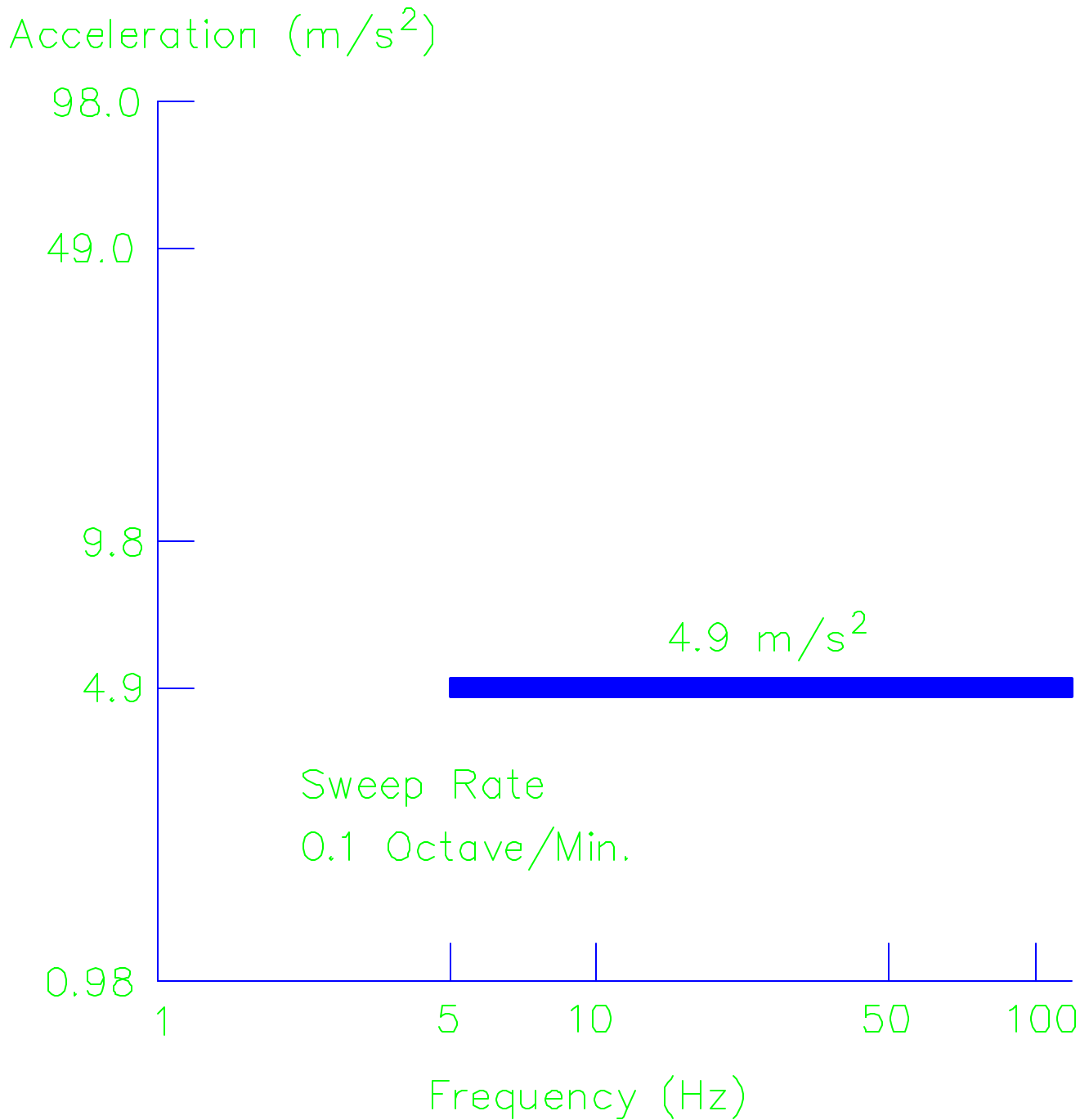

FIGURE 8

VIBRATION TEST FOR UNPACKAGED HOUSINGS

Acceleration (m/s^2)

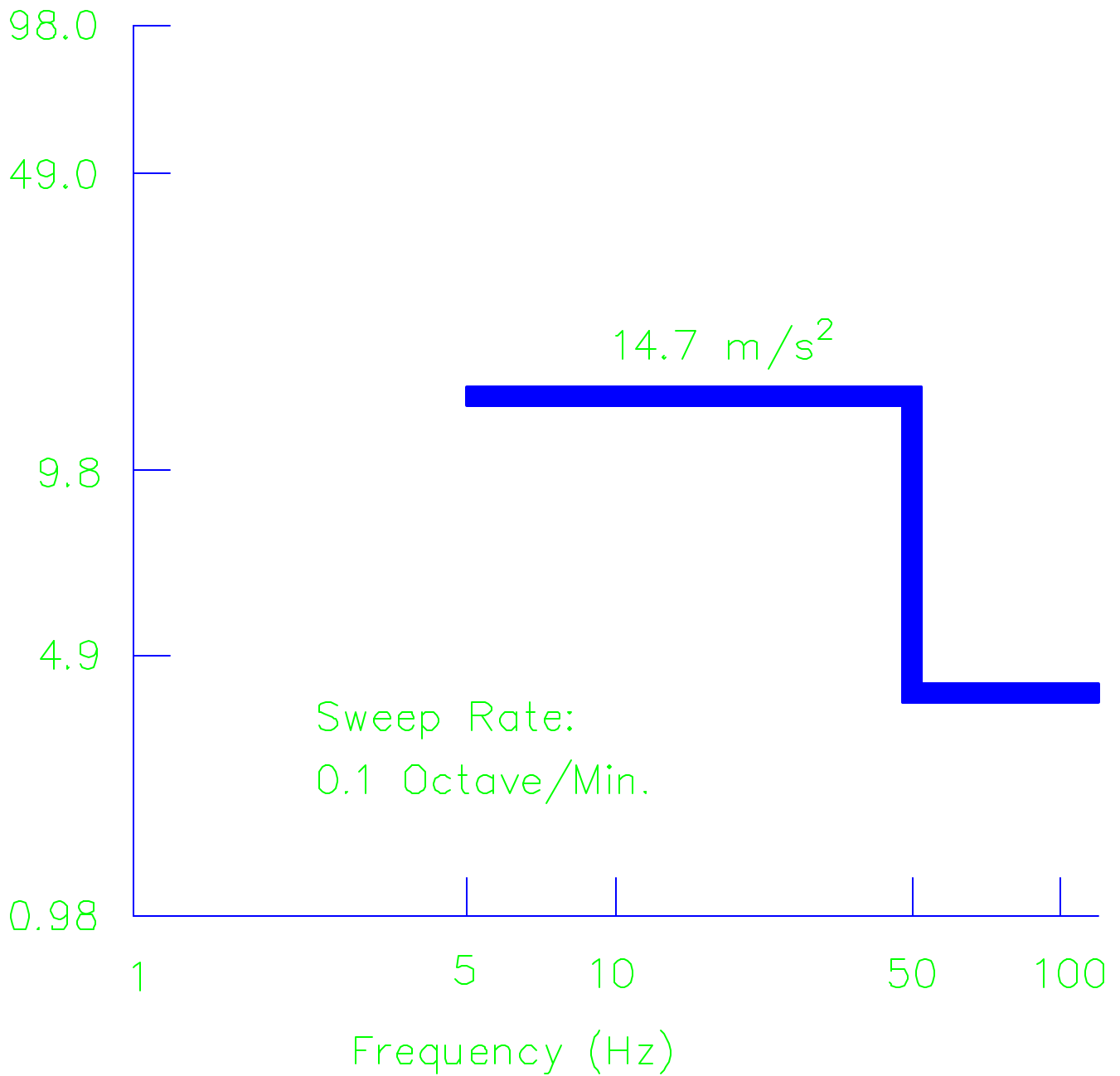

FIGURE 9

CORNER DROP TESTS FOR PACKAGED HOUSINGS
WEIGHING MORE THAN 91 KILOGRAMS (200 POUNDS)

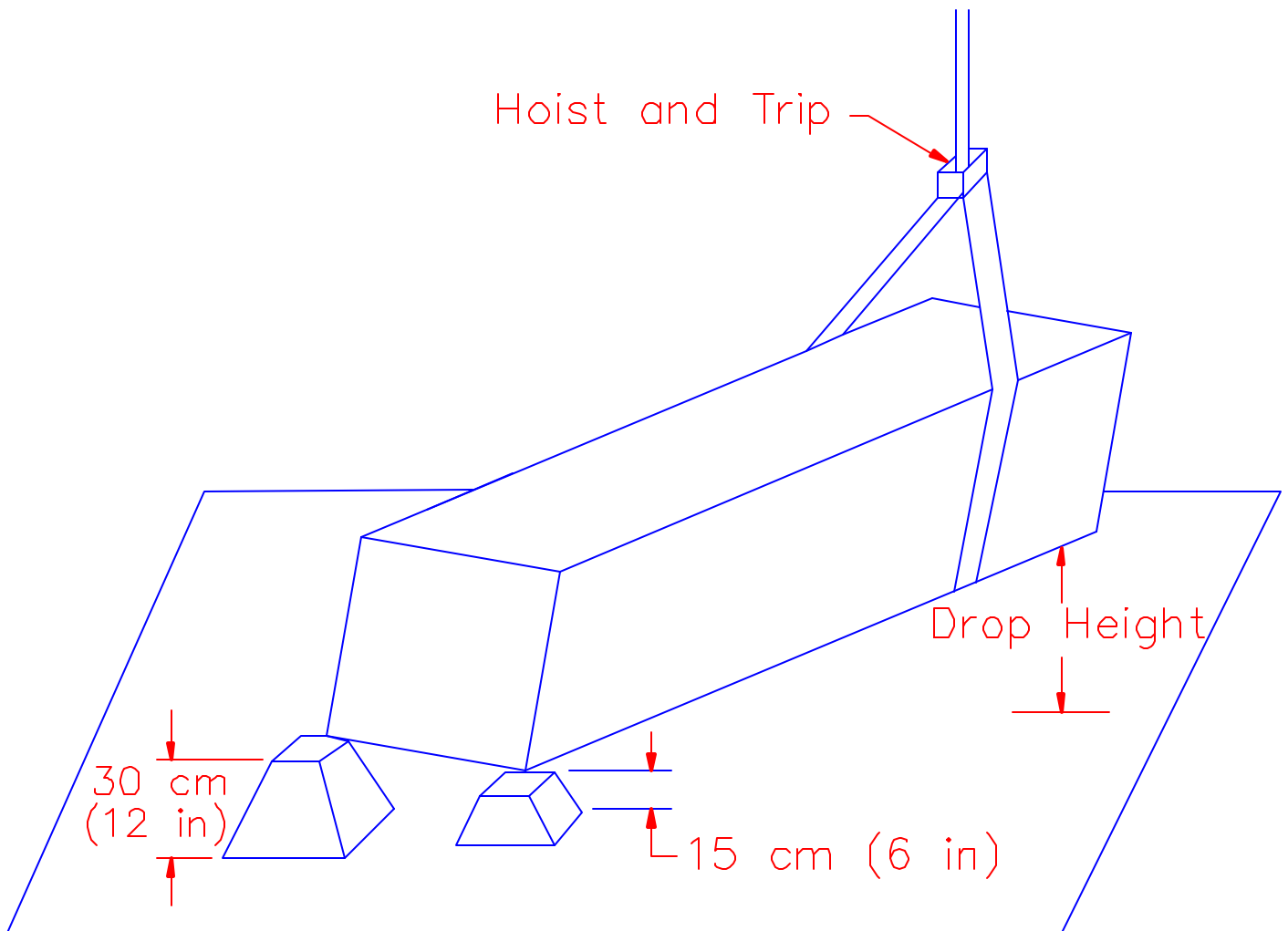

FIGURE 10

EDGE DROP TEST FOR PACKAGED HOUSINGS
WEIGHING MORE THAN 91 KILOGRAMS (200 POUNDS)

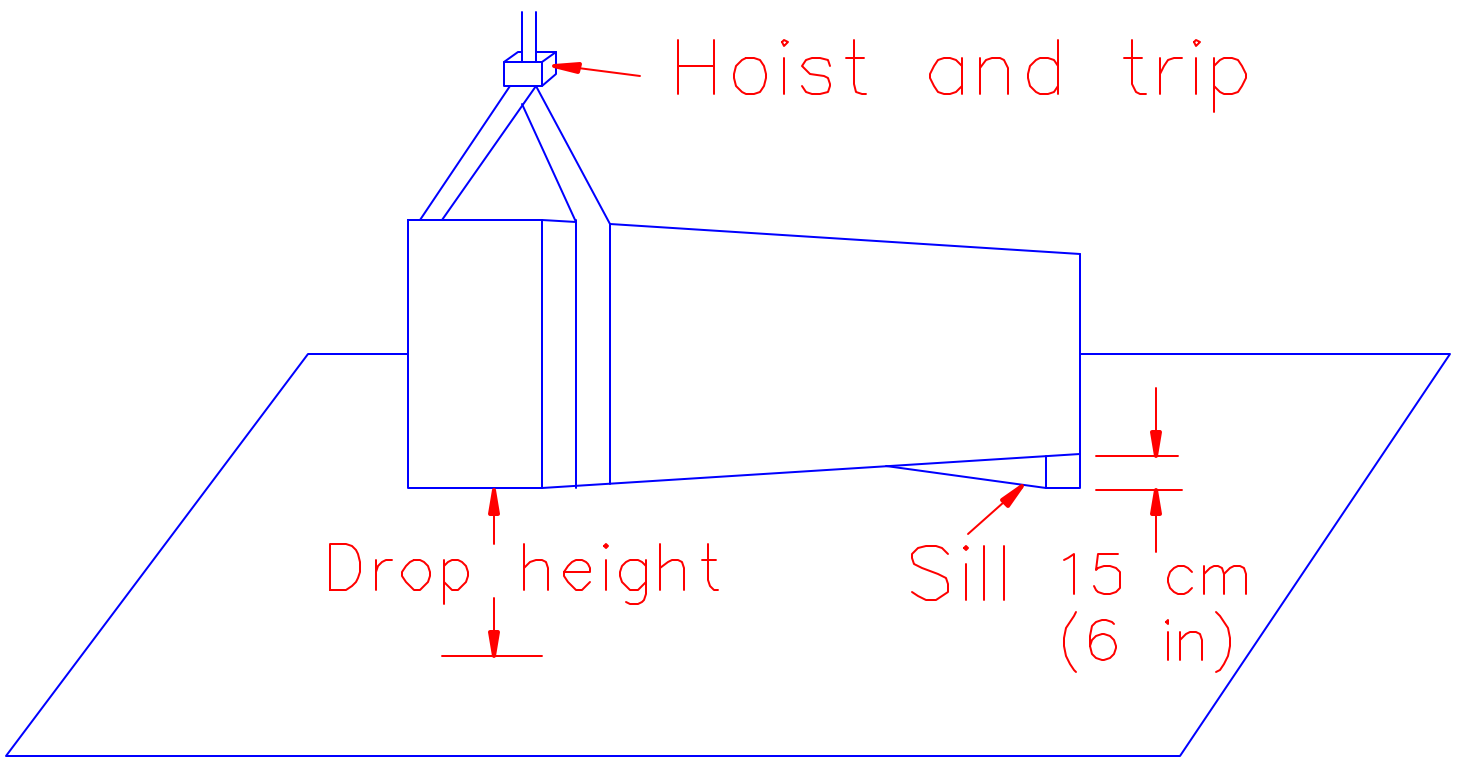
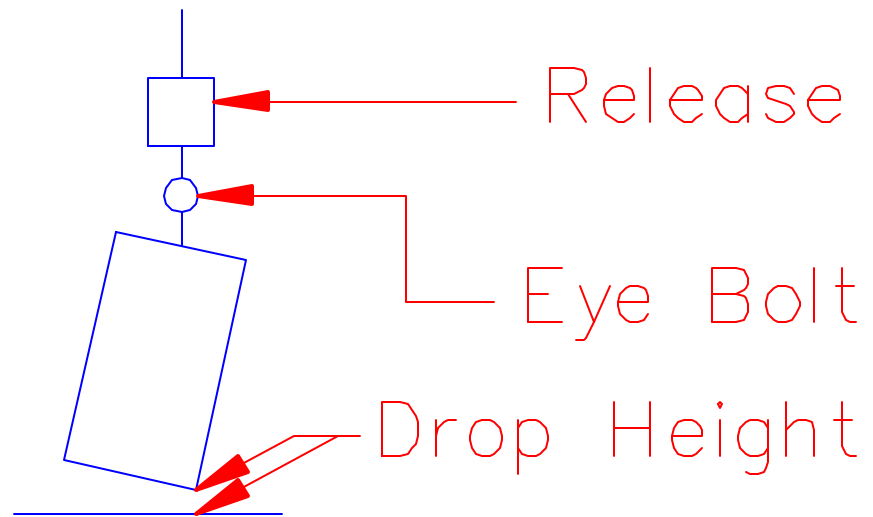
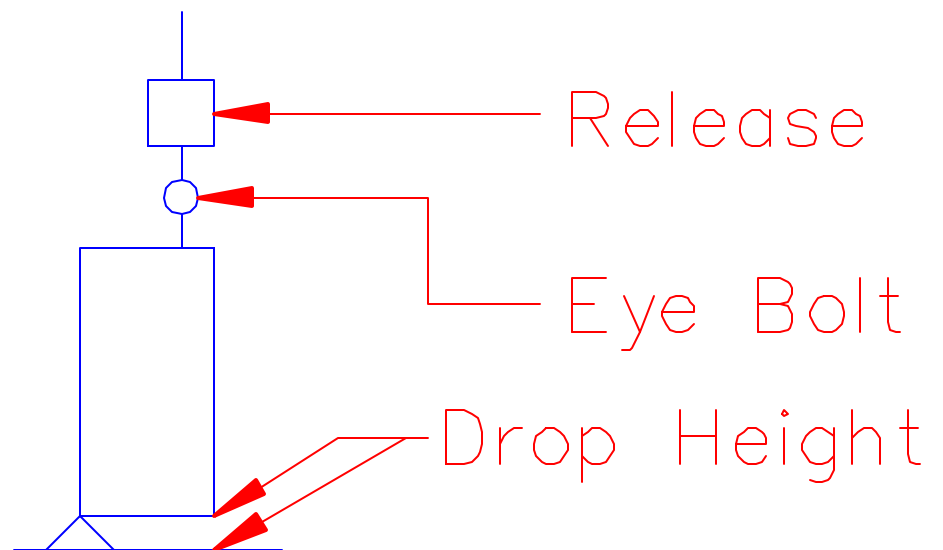

FIGURE 11

DROP TEST FOR UNPACKAGED HOUSINGS
WEIGHING MORE THAN 23 KILOGRAMS (50 POUNDS)



Hoisting Drop Test



Edge and Corner Drop Test

FIGURE 12

BINDING POST ARRANGEMENT FOR
INSULATION RESISTANCE TESTING

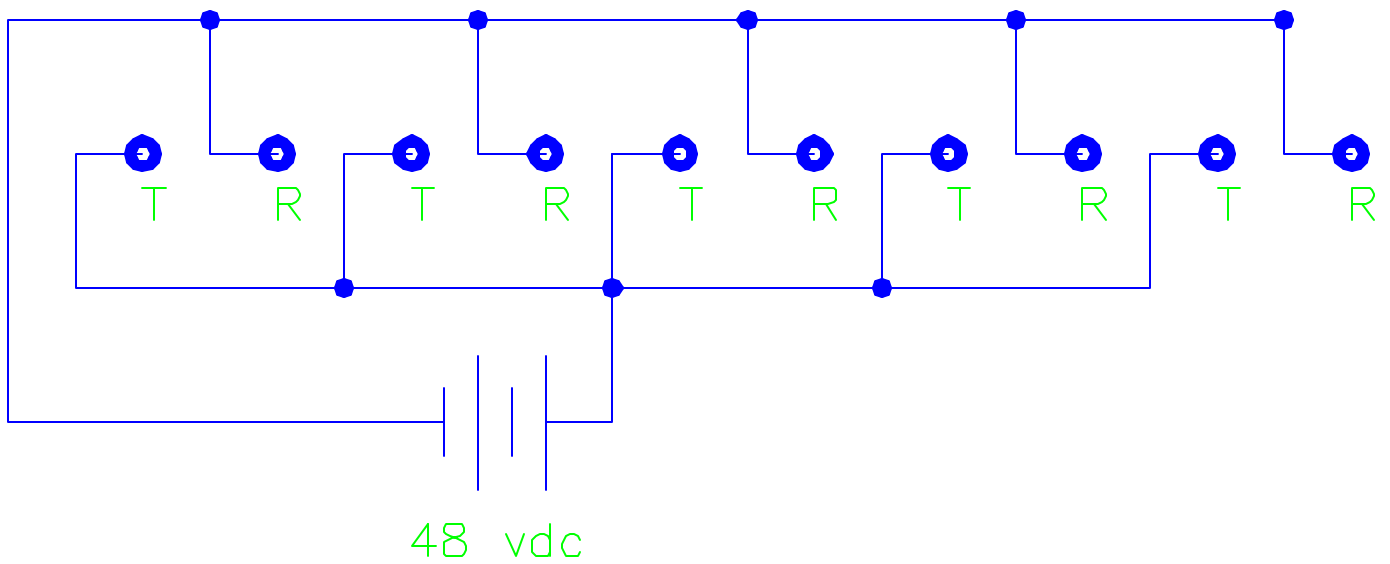

Note: 5 pair specimen arrangement shown is typical for entire (100 pair specimen minimum) test population.

FIGURE 13

LATERAL LOADING OF BINDING POST TERMINALS

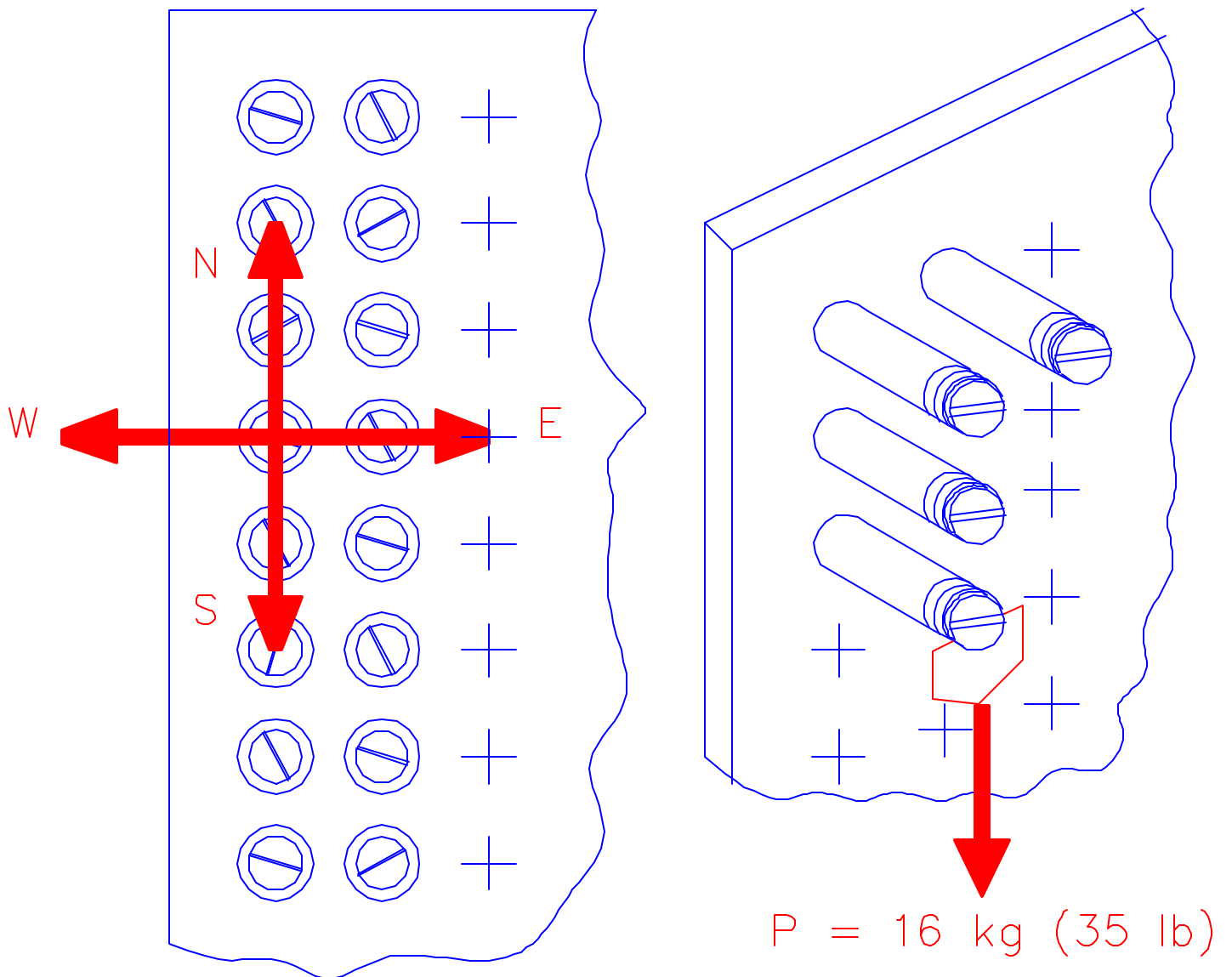

Note: Apply load P in N, E, S, and W directions

FIGURE 14
AXIAL PULLOUT OF BINDING POST TERMINALS

