

Table of Contents

	<i>page</i>	<i>date</i>
601: General Information		
601 A: Principles	601-1	1/94
601 B: Modes of Operation	601-2	1/94
Liquid-Solid Chromatography	601-2	1/94
Liquid-Liquid Chromatography	601-3	1/94
Bonded Phase Chromatography	601-3	1/94
Ion Exchange Chromatography	601-4	1/94
Size Exclusion Chromatography	601-4	1/94
601 C: Instrumentation and Apparatus	601-5	1/94
Basic Components	601-5	1/94
HPLC System Plumbing	601-7	1/94
601 D: Solvents and Reagents	601-10	1/94
Potential Problems	601-10	1/94
Specific Solvents	601-12	1/94

	<i>page</i>	<i>date</i>
	Reagent Blanks	601-14 1/94
	Safety Precautions	601-14 1/94
601 E:	Sample Preparation	601-14 1/94
	Sample Cleanup	601-14 1/94
	Sample Filtration	601-14 1/94
	Sample Solvent Degassing	601-15 1/94
	Choice of Sample Solvent	601-15 1/94
601 F:	Reference Standards	601-15 1/94
	Stock Solutions	601-15 1/94
	Working Standard Solutions	601-16 1/94
	Storage	601-16 1/94
	References	601-16 1/94
602:	Columns	
602 A:	Column Selection	602-1 1/94
602 B:	Analytical Columns	602-1 1/94
	Liquid-Solid Chromatography	602-2 1/94
	Bonded Phases	602-2 1/94
	Ion Exchange	602-3 1/94
	Ion Pair	602-4 1/94
	Size Exclusion	602-4 1/94
602 C:	Column Evaluation	602-5 1/94
602 D:	Column Specifications	602-6 1/94
602 E:	Analytical Column Protection	602-8 1/94
	Filters	602-8 1/94
	Precolumns	602-9 1/94
	Guard Columns	602-9 1/94
602 F:	Column Maintenance and Troubleshooting	602-9 1/94
	Column Care	602-9 1/94
	Column Evaluation by Injection of Test Mixtures	602-10 1/94
	Column Storage	602-11 1/94
	Column Regeneration	602-11 1/94
	References	602-12 1/94
603:	Mobile Phase Selection, Preparation, and Delivery	
603 A:	Mobile Phase Selection	603-1 1/94
	Normal Phase Chromatography	603-1 1/94
	Reverse Phase Chromatography	603-3 1/94
	Ion Exchange Chromatography	603-4 1/94
	Ion Pair Chromatography	603-5 1/94
	Size Exclusion Chromatography	603-5 1/94
	Gradient Elution in HPLC	603-5 1/94
603 B:	Mobile Phase Preparation	603-6 1/94
	Filtering Solvents	603-6 1/94
	Degassing Solvents	603-6 1/94

		<i>page</i>	<i>date</i>
	Preparation of Multisolvent Mobile Phases	603-7	1/94
	Solvent Reservoirs	603-7	1/94
603 C:	Mobile Phase Delivery Systems	603-8	1/94
	Pumps	603-8	1/94
	Gradient Programming Systems	603-10	1/94
603 D:	Maintenance and Troubleshooting	603-10	1/94
	Problems with Pumps	603-10	1/94
	References	603-13	1/94
604:	Injection Systems		
604 A:	Injection Valves	604-1	1/94
604 B:	Automatic Injectors	604-3	1/94
604 C:	Operation, Maintenance, Troubleshooting, and Repair of Injection Valves	604-3	1/94
	References	604-4	1/94
605:	Detectors		
605 A:	UV/VIS Absorbance Detectors	605-2	1/94
	Fixed Wavelength UV Detectors	605-3	1/94
	Variable Wavelength UV Detectors	605-4	1/94
	Solvents	605-4	1/94
	Performance Characteristics	605-4	1/94
	Multichannel or Photodiode Array Detectors	605-5	1/94
	Applications	605-5	1/94
	Problems, Maintenance, and Troubleshooting	605-5	1/94
605 B:	Fluorescence Detectors	605-6	1/94
	Detector Design	605-6	1/94
	Solvents	605-7	1/94
	Performance Characteristics	605-7	1/94
	Parameter Adjustments	605-8	1/94
	Applications	605-8	1/94
	Detector Maintenance	605-8	1/94
605 C:	Electrochemical Detectors	605-8	1/94
	Conductivity Detectors	605-9	1/94
	Amperometric and Coulometric Detectors	605-9	1/94
	Performance Characteristics	605-10	1/94
	Applications	605-11	1/94
605 D:	Photoconductivity Detectors	605-11	1/94
	Apparatus	605-11	1/94
	Performance Characteristics	605-11	1/94
	Applications	605-13	1/94
605 E:	Mass Spectrometric Detectors	605-13	1/94
605 F:	Derivatization for Detection Enhancement	605-14	1/94
	Comparison of Pre- and Post-Column Derivatization	605-14	1/94

	<i>page</i>	<i>date</i>
Post-Column Reactor Design	605-14	1/94
References	605-16	1/94
606: Residue Identification and Quantitation		
606 A: Residue identification	606-1	1/94
Co-chromatography	606-1	1/94
Use of Alternative Columns	606-2	1/94
Spectrometric Confirmation	606-2	1/94
606 B: Quantitation	606-3	1/94
Reference	606-3	1/94
607: Quality Assurance and Troubleshooting		
607 A: Liquid Chromatograph Monitoring and Performance Testing	607-1	1/94
607 B: Troubleshooting from Chromatograms	607-2	1/94
608: Bibliography		
General Texts	608-1	1/94
Columns	608-1	1/94
Detectors	608-2	1/94
Troubleshooting	608-2	1/94
Application to Pesticides	608-2	1/94
Figures		
601-a Chromatographic Separation Techniques	601-1	1/94
601-b HPLC Modes of Operation	601-2	1/94
601-c Guide to Selection of HPLC Mode	601-5	1/94
601-d Block Diagram of HPLC System	601-6	1/94
601-e Column Outlet Fittings	601-7	1/94
601-f Low Dead Volume Fitting	601-7	1/94
601-g Standard Internal Fitting	601-8	1/94
601-h Internal Thread Low Dead Volume Fitting	601-8	1/94
602-a Calculation of Column Performance Parameters	602-5	1/94
603-a Reciprocating Pump	603-8	1/94
603-b Gradient System I	603-9	1/94
603-c Gradient System II	603-9	1/94
603-d Gradient System III	603-10	1/94
604-a External Loop Injector: Six-Port Injection Valve	604-1	1/94
604-b Internal Loop Injector	604-2	1/94
605-a UV/VIS Detector	605-3	1/94
605-b Variable Wavelength UV/VIS Detector	605-4	1/94
605-c Fluorescence HPLC Detector	605-6	9/96
605-d Three Electrode Electrochemical Detector	605-10	1/94
605-e Post-Column Reactors	605-15	1/94

		<i>page</i>	<i>date</i>
	Tables		
602-a:	HPLC Column Specification Elements	602-7	1/94
602-b:	Minimum Efficiency Values	602-8	1/94
603-a:	Properties of Common HPLC Solvents with Alumina Columns	603-2	1/94
603-b:	Classification of Solvent Selectivity	603-2	1/94

601: GENERAL INFORMATION

In recent years, high performance liquid chromatography (HPLC) has grown in popularity as a determinative step for residue analysis, until today it is accepted as complementary to the more traditional gas liquid chromatography (GLC). HPLC provides capabilities not possible with GLC, most importantly the ability to separate and quantitate residues of polar, nonvolatile, and heat-labile chemicals. These characteristics make HPLC the determinative step of choice for many residues previously beyond the applicability of multiresidue methodology.

601 A: PRINCIPLES

Figure 601-a
Chromatographic Separation Techniques

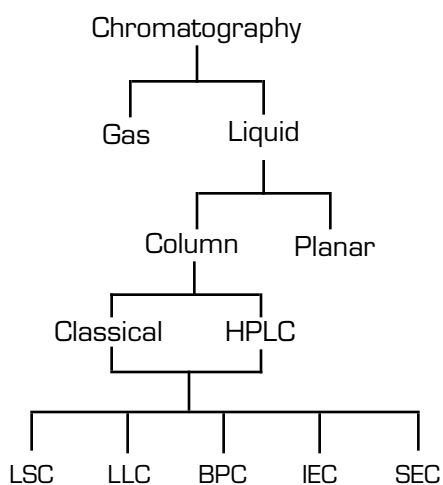

Chromatography comprises a family of separation techniques (Figure 601-a), all of which share common characteristics. A narrow initial zone of mixture is applied to a sorptive stationary phase having a large surface area. Development with mobile phase causes components of a mixture to move through the stationary phase at different rates and to separate from one another. Differential migration occurs because of differences in distribution between the two phases. The mobile phase can be a gas or a liquid. Liquid chromatography is divided into two main types, planar (thin layer and paper chromatography) and column. Column liquid chromatography, both the classical (low pressure) version and the high performance version discussed here, is further subdivided according to the mechanism of separation into five major types: liquid-solid (adsorption) chromatography, LSC; liquid-liquid (partition) chromatography, LLC; bonded phase chromatography, BPC; ion exchange chromatography, IEC; and size exclusion chromatography, SEC.

HPLC developed steadily during the late 1960s as high efficiency, small particle packings and improved instrumentation were produced. In contrast to classical column liquid chromatography, HPLC uses high pressure pumps; short, narrow columns packed with microparticulate phases; and a detector that continuously records the concentration of the sample.

HPLC systems use the principles of classical column chromatography in an analytical instrument. Development of HPLC has been directly related to availability of suitable hardware (columns, pumps, inlet systems, low dead volume fittings, *etc.*) that allows precise flow control under the elevated pressures needed, as well as the ability to manufacture a wide variety of column packing materials in particle sizes of exacting micron (μm) dimensions.

In contrast to GLC, where the gas mobile phase is inert and does not affect separation of analytes from one another, the HPLC mobile phase is critical to this

Chapter 6 is revised from a chapter on HPLC written for FDA in 1989-90 by Joseph Sherma, Ph.D., Lafayette College, Easton, PA.

resolution. Choice of mobile phase is second only to the choice of operating mode in determining the suitability of the system to produce the desired separations.

HPLC had limited use for routine trace multiresidue analysis in the absence of sensitive element-selective detectors. Early development work relied primarily on refractive index (RI) or fixed wavelength UV absorbance detectors. Neither detector demonstrated sufficient sensitivity or selectivity for use in trace residue analysis. In the mid-1970s, the fluorescence detector was shown to provide the needed sensitivity and specificity for pesticides that are naturally fluorescent or can be chemically labeled with a fluorophore. This resulted in the first practical application of HPLC to multiresidue pesticide determination (see method for N-methylcarbamates, Section 401).

More recently, scientists have investigated photoconductivity and electrochemical detectors and certain applications of the newer multiwavelength UV detectors. This research indicates that these detectors can also fulfill the sensitivity and selectivity requirements for determination of certain pesticides at residue levels.

601 B: MODES OF OPERATION

Separations by HPLC are achieved using the five basic operational modes (Figure 601-b). The mode chosen for a particular application will depend on the properties of the analyte(s) to be separated and determined. For residue determination, as for HPLC analyses in general, BPC is the most widely used.

There are two variations within the five operational modes of HPLC operation; these distinctions are based on the relative polarities of stationary and mobile phases:

- 1) **normal phase (NP)** chromatography: stationary phase is more polar than the mobile phase; the least polar analytes elute first; analyte retention is increased by decreasing mobile phase polarity.
- 2) **reverse phase (RP)** chromatography: stationary phase is less polar than the mobile phase; the most polar analytes elute first; analyte retention is increased by increasing mobile phase polarity.

Liquid-Solid Chromatography

LSC, also called adsorption chromatography, uses an adsorbent, usually uncoated silica gel. The basis for separation is the selective adsorption of polar compounds, presumably by hydrogen bonding, to active silanol (SiOH) groups by orientation and on the surface of the silica gel. Analytes that are more polar will be attracted more strongly to the active silica gel sites. The solvent strength of the mobile phase determines the rate at which adsorbed analytes are desorbed and eluted.

Figure 601-b
HPLC Modes of Operation

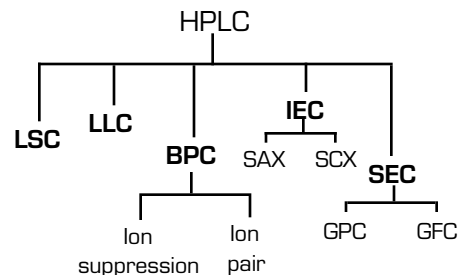

LSC is useful for separation of isomers and classes of compounds differing in polarity and number of functional groups. It works best with compounds that have relatively low or intermediate polarity. Highly polar compounds may irreversibly adsorb on the column. Poor LSC separations are usually obtained for chemicals containing only nonpolar aliphatic substituents.

Liquid-Liquid Chromatography

LLC, also called partition chromatography, involves a solid support, usually silica gel or kieselguhr, mechanically coated with a film of an organic liquid. A typical system for NP LLC is a column coated with β,β' -oxy dipropionitrile and a nonpolar solvent like hexane as the mobile phase. Analytes are separated by partitioning between the two phases as in solvent extraction. Components more soluble in the stationary liquid move more slowly and elute later. LLC has now been replaced by BPC for most applications.

Bonded Phase Chromatography

BPC uses a stationary phase that is chemically bonded to silica gel by reaction of silanol groups with a substituted organosilane. Unlike LLC, the stationary phase is not altered by mobile phase development or temperature change. All solvents can be used, presaturation of the mobile phase with the stationary phase is not required, and gradient elution can be used to improve resolution.

Specialized applications of BPC have been developed for ionized compounds, which are highly water soluble and generally not well retained on RP BPC columns. Retention and separation can be increased by adding an appropriate pH buffer to suppress ionization (ion suppression chromatography) or by forming a lipophilic ion pair (ion pair chromatography) between the analyte and a counter ion of opposite charge. The resultant nonionic species are separated by the same column techniques used for naturally nonionic organic molecules.

Ion suppression is the preferred method for separation of weak acids and bases, for which the pH of the mobile phase can be adjusted to eliminate analyte ionization while remaining within the pH 2-8 stability range of bonded silica phases. The analyte is chromatographed by RP HPLC, usually on a C-18 column, using methanol or acetonitrile plus a buffer as the mobile phase. The technique is often preferred over IEC (see below) because C-18 columns have higher efficiency, equilibrate faster, and are generally easier to use reproducibly compared to ion exchange phases. Strong acids and bases are usually separated on an ion exchange column or by ion pair chromatography.

Ion pair chromatography is used to separate weak or strong acids or bases as well as other types of organic ionic compounds. The method involves use of a C-18 column and a mobile phase buffered to a pH value at which the analyte is completely ionized (acid pH for bases, basic pH for acids) and containing an appropriate ion pairing reagent of opposite charge. Trialkylammonium salts are commonly used for complex acidic analytes and alkylsulfonic acids for basic analytes. The ion pairs separate as if they are neutral polar molecules, but the exact mechanism of ion pair chromatography is unclear. Retention and selectivity are affected by the chain length and concentration of the pairing reagent, the concentration of organic solvent in the mobile phase, and its pH. Retention increases up to a point as the chain length of the pairing reagent or its concentration increases, then decreases or levels off [1].

Compounds not ionized at the operative pH will not pair with the reagent, but they may still be strongly retained by a C-18 column depending on their alkyl structure. In this case, however, retention will not increase with the addition of an ion pairing reagent, and some decrease in retention may occur, probably due to reagent competition for the stationary phase [1].

Ion Exchange Chromatography

IEC is used to separate ionic compounds. Microparticulate insoluble organic polymer resin or silica gel is used as the support. Negatively charged sulfonic acid groups chemically bound to the support produce strong acid cation exchange (SCX) phases. Positively charged quaternary ammonium ions bound to the support produce strong base anion exchange (SAX) phases. The most widely used resin support is cross-linked copolymer prepared from styrene and divinylbenzene. Mobile phases are aqueous buffers.

Separations in IEC result from competition between the analytes and mobile phase ions for sites of opposite charge on the stationary phase. Important factors controlling retention and selectivity include the size and charge of the analyte ions, the type and concentration of other ions in the buffer system, pH, temperature, and the presence of organic solvents.

Ion chromatography, a subcategory of IEC, has been used primarily for separations of inorganic cations or anions. Because a conductivity detector is usually employed, some means is required to reduce the ionic concentration and, hence, the background conductance of the mobile phase. A second ion exchange suppressor column to convert mobile phase ions to a nonconducting compound may be used. Alternatively, a stationary phase with very low exchange capacity may be used with a dilute, low conductance mobile phase containing ions that interact strongly with the column.

Size Exclusion Chromatography

SEC separates molecules based on differences in their size and shape in solution. SEC cannot separate isomers. SEC is carried out on silica gel or polymer packings having open structures with solvent-filled pores of limited size range. Small analyte molecules can enter the pores and spend a longer amount of time passing through the column than large molecules, which are excluded from the pores. Ideally, there should be no interaction between the analytes and the surface of the stationary phase.

Two important subdivisions of SEC are gel permeation chromatography (GPC) and gel filtration chromatography (GFC). GPC uses organic solvents for organic polymers and other analytes in organic solvents. GFC uses aqueous systems to separate and characterize biopolymers such as proteins and nucleic acids.

The chemist developing an HPLC method must first consider the properties of the analytes of interest and choose an HPLC separation method that best takes advantage of those properties. Many of the references in the bibliography (Section 608) offer guidance to making these choices. A general, simplified guide for selecting an HPLC mode according to the properties of the analyte(s) is illustrated in Figure 601-c; the guide is based on the principles of Snyder and Kirkland [2].

Figure 601-c
Guide to Selection of HPLC Mode
 (based on analyte characteristics)

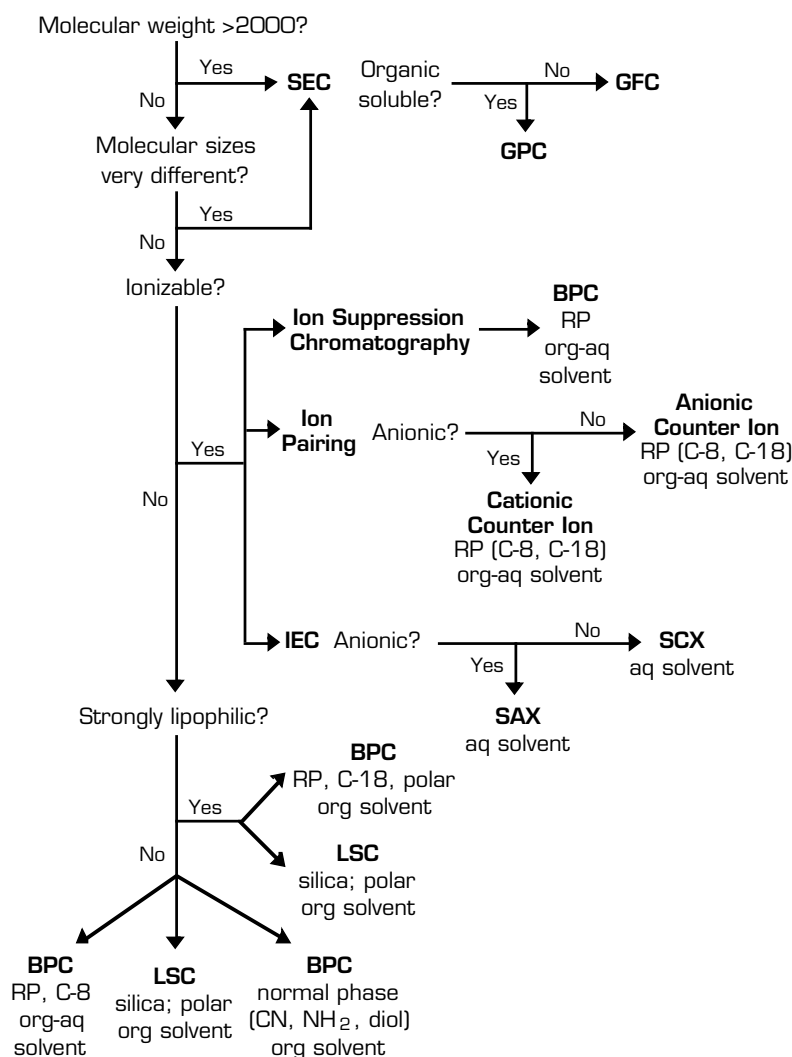

This scheme categorizes analytes as either ionic/ionizable (and therefore water soluble) or nonionic/nonionizable (not water soluble). Based on these distinctions, and on the polarity of the analytes, the diagram provides general rules for choosing an HPLC mode of operation likely to separate the analytes.

601 C: INSTRUMENTATION AND APPARATUS

Basic Components

The following basic components are typically included in an HPLC system (Figure 601-d): solvent reservoir(s); optional gradient-forming device; one or more precision solvent delivery pumps; injector; analytical column and optional precolumn and guard column; column oven; detector; recorder, integrator, or computerized digital signal processing device; and associated plumbing and wiring.

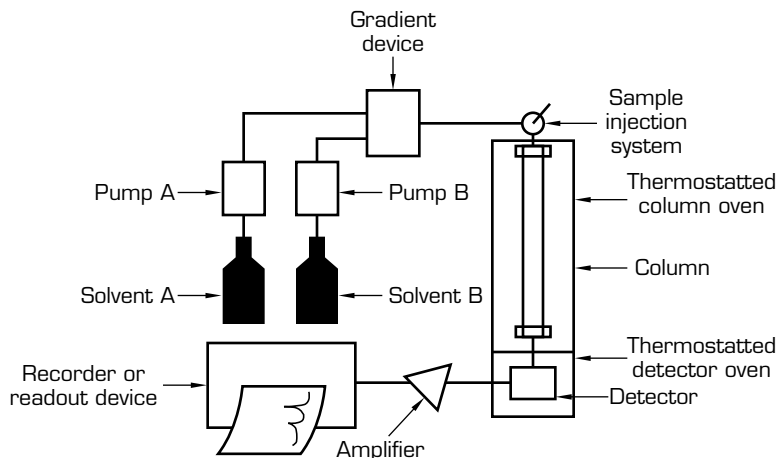

Figure 601-d
Block Diagram of
HPLC System

[Reprinted with permission of McGraw-Hill Book Company, from West, C.D. (1987) *Essentials of Quantitative Analysis*, Figure 14.1, page 346.]

For analytical HPLC, typical flow rates of 0.5-5 mL/min are produced by pumps operating at 300-6000 psi. Although pumps are capable of high pressure operation, state-of-the-art 25 cm × 4 mm id columns with 5 μm packings typically produce 1000-2000 psi at 1 mL/min. High pressures should be avoided because they contribute to limited column life expectancies.

Sample extract is applied to the column from an injector valve containing a loop that has been filled with sample solution from a syringe. After passing through the column, the separated analytes are sensed by visible/UV absorption, fluorescence, electrochemical, photoconductivity, or RI detectors. To minimize extra-column peak spreading, the instrument components must be connected using low dead volume (ldv) fittings and valves and tubing as short and narrow in bore as possible.

Analytical HPLC may use either isocratic or gradient elution methods. Isocratic elution uses a mobile phase of constant composition, whereas the strength of the mobile phase in gradient elution is made to increase continually in some predetermined manner during the separation. Gradient elution, which requires an automatic electronic programmer that pumps solvent from two or more reservoirs, reduces analysis time and increases resolution for complex mixtures in a manner similar to temperature programming in GLC. Gradient elution capability is highly recommended for systems to be used for residue determination. However, it is not always possible to employ gradient elution because some HPLC column/solvent systems and detectors are not amenable to the rapid solvent and pressure changes involved.

Stationary phases are uniform, spherical, or irregular porous particles having nominal diameters of 10, 5, or 3 μm. Bonded phases produced by chemically bonding different functional groups to the surface of silica gel are most widely used, along with unmodified silica gel and size exclusion gels. Columns are usually stainless steel, 3-25 cm long and 4.6 mm id, prepacked by commercial manufacturers. There has been increasing use of microbore columns having diameters ≤2 mm. Although many HPLC separations can be carried out at ambient temperature, column operation in a thermostatted column oven is necessary for reproducible, quantitative results, because distribution coefficients and solubilities are temperature dependent.

Depending on the nature of the analyte(s), certain additional equipment may be required. For example, apparatus and reagents for performing post-column

derivatization, as used in Section 401 for N-methylcarbamates, may be needed to convert analytes to compounds that can be detected with the required sensitivity and/or selectivity.

HPLC System Plumbing

Band broadening can occur not only in the analytical and guard columns, but also in dead volume in the injector, detector, or plumbing connecting the various components of the HPLC system. This effect, called extra-column dispersion, must be minimized for high efficiency. The proper choice and use of tubing and fittings are critical in this regard.

Fittings. Figure 601-e illustrates three types of column outlet fittings. The conventional fitting (i) used in GLC and general laboratory plumbing has excessive dead volume. It has been modified to produce a zero dead volume (zdv) fitting (ii) in which the metal column and the tubing are butted up directly against the stainless steel frit. There is evidence that the nature of the tubing connection in the zdv fitting may lead to some loss in efficiency, especially if the connection is not made carefully. The ldv fitting (iii) improves efficiency by use of a cone-shaped distributor connecting the gauze or frit at the end of the column with the tubing. A typical dead volume for the ldv fitting is 0.1 μ L.

Figure 601-e
Column Outlet Fittings

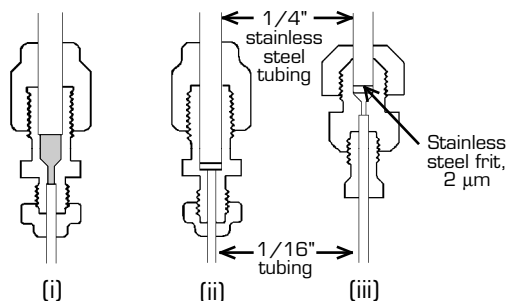

(i) Conventional reducing union (dead volume is shaded); (ii) zdv union; (iii) ldv union.

[Reprinted with permission of John Wiley and Sons, Inc., from Lindsay, S. (1987) *High Performance Liquid Chromatography*, Figure 2.3a, page 28.]

Figure 601-f
Low Dead Volume Fitting

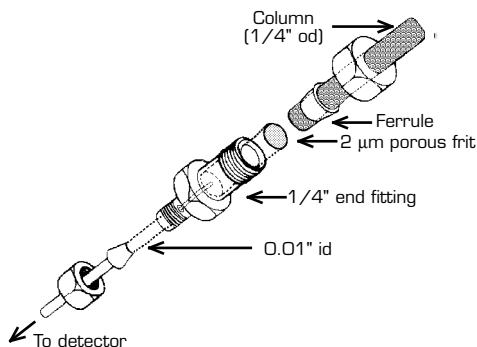

[Reprinted with permission of Howard Sloane, Savant, from LC-102 audiovisual program.]

Columns are usually received from manufacturers with a 1/4–1/16" zdv or ldv outlet fitting and a 1/4" nut and cap or a reducing union at the inlet (*i.e.*, not 1/4" in size, but suitable for 1/4" tubing). Figure 601-f shows a complete ldv fitting connection between a column and a detector. The column fits snugly inside the stainless steel end fitting and is sealed by a high compression ferrule. A 2 μ m porous frit is firmly seated between the column and end fitting. The column and detector are connected by a short length of stainless steel (or polymer) tubing. The column is also connected to the injection valve using a zdv or ldv fitting and a short length of stainless steel tubing.

Figure 601-g
Standard Internal Fitting

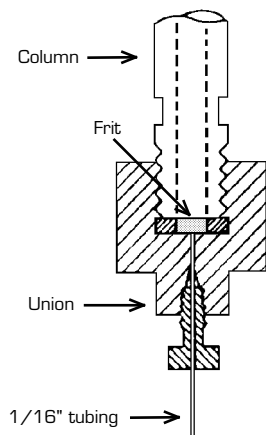

[Reprinted with permission of John Wiley and Sons, Inc., from Meyer, V.R. (1988) *Practical High Performance Liquid Chromatography*, Figure 6.18, page 80.]

ferrule are slid onto the tube end, the tube is pushed all the way into the fitting body and held there securely, the nut is finger-tightened, and then another three-quarter turn is made with a wrench. This procedure should assure that the ferrule is pressed ("swaged") onto the tubing. To replace the ferrule, the tubing must be cut and the fitting remade. When using fittings to connect system components, the nut should be finger-tightened and then tightened a one-half turn more with a wrench. If leaking is observed, slightly more tightening should be sufficient to complete the seal. Over-tightening of nuts can lead to fitting distortion and leaks.

Fitting components from different manufacturers have dissimilar designs, sizes, and thread types and are usually not interchangeable. Ferrules from different manufacturers have unique shapes, but they are usually interchangeable because the front edge is deformed when pressed onto the tubing. However, as a general rule, it is best to purchase all fittings and spare parts from one manufacturer. Even fittings from a given manufacturer differ slightly because of manufacturing tolerances. However, this is of concern only with microbore columns, for which dead volume is a greater consideration. For these columns, it is best to not even interchange fittings from the same manufacturer.

A variety of fittings are available that can be finger-tightened to the degree necessary to seal stainless steel tubing at 2000-6000 psi. All of these are based on the use of polymeric ferrules, but some have a steel nut, whereas others are all plastic.

External column end fittings (Figures 601-e and 601-f), which were formerly popular, are not durable during repeated attachments and removals. Thus, the internal fitting is practically standard today. This uses female threads in the fitting body and a male nut (Figure 601-g).

Unions. Unions are fittings that connect two pieces of tubing. The most commonly used type is the internal thread ldv type (Figure 601-h). The union is not drilled through completely, but a short (0.02") web of metal is left between the two pieces of tubing with a small diameter (approximately 0.02 or 0.01") hole drilled through. Even though the tubing ends do not butt against each other as in early zdv unions, there is essentially no dead volume added to the system through their use. For this reason, they are commonly classified as zdv unions. This type of union has fewer assembly, re-assembly, and tubing interchange problems than the early butt-together zdv type.

Assembly of Fittings. Fittings consist of four parts: the body, tubing, ferrule, and nut. The nut and

Figure 601-h
Internal Thread Low Dead Volume Fitting

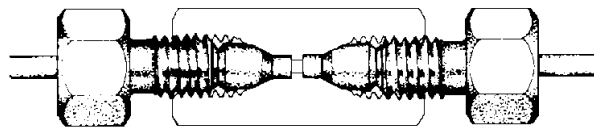

[Reprinted with permission of Aster Publishing Corporation, from Dolan, J.W., and Upchurch, P. (1988) *LC-GC* 6, Figure 3, page 788.]

They are used mostly on frequently attached and detached high pressure connections, such as between the injector and column or column and detector, and for polymer tubing waste lines from the injector or detector.

Fittings must be kept free of silica particles, which may scratch surfaces between the ferrule and union and cause leaks.

Tubing. Stainless steel tubing is available commercially that is supposedly ready for immediate use in HPLC systems. It is machine cut, polished, and deburred to provide perfectly square ends. It is also cleaned by sonication, passivated, washed, and rinsed with a solvent such as isopropanol to eliminate residual dirt or oils. Despite this careful preparation, it is a wise precaution to rinse new tubing with mobile phase under operating pressure before using it as part of the HPLC system.

The most commonly used tubing for connecting components of the chromatograph is 316 stainless steel, 1/16" od, with different inside diameters. Tubing with 0.01" (0.25 mm) id is commonly used in areas where dead volume must be minimized to maximize efficiency, *e.g.*, between the injector and column, precolumn and column, columns in series, and column and detector, and for preparing pulse damping spirals.

Typical lengths of tubing connections are 3-6 cm. Tubing with 0.005 or 0.007" id is used to connect microbore or short 3 μm particle size columns to detectors and injectors. Filtering of samples and solvents is especially critical to prevent clogging of this narrow bore tubing. Tubing with 0.02-0.05" id is available when *ldv* is not important and low resistance to flow and pressure drop is desirable. For example, 1 mm (0.04") tubing is often used between the pump and sample injector.

Tubing can be cut to any required length in the laboratory, but it is important not to distort the interior or exterior during the process. The simplest method is to score the tubing completely around the outside with a file and then bend it back and forth while holding it on either side of the score with two smooth-jawed pliers. The ends are filed smooth and deburred, and the tubing is thoroughly washed with solvent. If the bore should become closed by the bending and filing, the tube can be reamed out with an appropriate drill bit before final smoothing and washing. A number of types of manual and motorized tubing cutters are available from chromatography accessory suppliers. Proper cutting of tubing to make leak-free connections is an art that requires considerable practice.

Although stainless steel tubing and fittings are standard for systems using organic and salt-free aqueous solvents, corrosion becomes a problem with buffers containing salts, particularly halide salts at low pH. HPLC companies have available a variety of accessories that can solve this problem. These include titanium high pressure system components, for use in the flow stream at all points of mobile phase contact, and titanium or polymeric fluorocarbon tubing with id values similar to stainless steel. One such polymer is Tefzel (ethylene-tetrafluoroethylene copolymer), which can withstand pressures of 5000 psi or higher. (Teflon is limited to pressures <1000 psi.) Titanium and polymeric plumbing components are especially valuable for biochemical HPLC and ion chromatography.

Reference 3 is a valuable source of information to help avoid many tubing installation problems.

System Leaks. Leaks are relatively easy to detect in LC instruments because liquid will be visible around a loose fitting. A loss of system pressure when using a constant volume pump is a common sign that a leak may be present. If this occurs, all fittings, especially sample valve and column fittings, should be checked and tightened if necessary with two open-ended wrenches. Care must be taken not to overtighten. If leaking does not stop, the faulty fitting must be replaced.

601 D: SOLVENTS AND REAGENTS

The mobile phase in HPLC is chosen for its ability, in combination with a particular column, to provide the required separation of the analyte(s). The solvents used to prepare the mobile phase must be of high purity, most often HPLC grade, spectrophotometric grade, or distilled from all-glass apparatus. Other factors of importance include cost, viscosity, toxicity, boiling point, compressibility, UV transparency (if a UV detector is used), RI (if an RI detector is used), vapor pressure, flash point, odor, inertness with respect to sample compounds, and ability to cause corrosion. Choices of solvents and reagents cannot be made without careful consideration of the effect their presence can have on the entire HPLC system.

Solvents and reagents used in the HPLC determinative step and in sample preparation procedures preceding HPLC should not:

- 1) cause degradation or unintended reaction of the analyte(s);
- 2) cause the solvent delivery system to malfunction;
- 3) cause damage to the analytical column;
- 4) cause damage to the detector; or
- 5) contribute noise or increased or decreased detector response for the analyte.

Potential Problems

Many of the problems with mobile phases arise because of the presence of impurities, additives, dust or other particulate matter, or dissolved air. Examples of some specific potential problems with solvents and reagents and suggested solutions follow.

Degradation. Analytes can be degraded by solvents and reagents used in the extraction and cleanup steps of the analysis, or in the HPLC step itself. Analyte chemistry is usually known in advance, and reagents likely to cause degradation can be avoided. Unexpected reaction of the analyte(s) will usually be demonstrated by poor or no recovery of the compound(s) through the method, or by detection of additional reaction products in the determinative step.

The presence of impurities in solvents or reagents is often the cause of such unexpected reactions. For example, traces of oxidizing agents in solvents have been found to degrade N-methylcarbamates prior to their determination by HPLC. Purity of all reagents used in trace-level determinations should always be as high as possible.

Dissolved Gases. The presence of dissolved gases in solvents composing the mobile phase is a major cause of practical problems in HPLC. Gas bubbles can collect in pumps, the detector cell, or other locations in the HPLC system. This can affect the reproducibility of the volume delivered by the pump, or large bubbles may completely stop the pump from working. Detection can be affected in various ways. With the UV detector, air in the detector cell can cause seriously increased detector noise or high absorbance. Dissolved oxygen can interfere with detection at short wavelengths, as oxygen absorbs radiation at <200 nm. Solvents must be “degassed,” a topic covered in Section 603 B, Mobile Phase Preparation.

Damage to Columns. HPLC columns are easily damaged and expensive to replace. Bases can remove the functional groups from bonded HPLC phases. Therefore, bases should not be used in analyses involving BPC unless their removal prior to chromatography can be assured. Bonded phases are usually stable in the pH range of approximately 2-8.

Microscopic particles and microorganisms can clog column frits or even the top of the column itself. If this happens, the pressure drop across the column for a given flow will gradually increase, and the column may eventually become completely blocked. Filtration of the sample solution and mobile phase to remove particles ≥ 5 μm , and the use of an appropriate precolumn and guard column, are recommended to protect the analytical column. Particles < 5 μm may be of concern with some columns and detectors.

Any mobile phase, especially one containing water or methanol, can dissolve silica gel in unmodified and bonded silica gel columns. A precolumn containing silica gel can be positioned between pump and injector to saturate the mobile phase with silica gel so that the analytical column is not dissolved.

Both precolumns and guard columns are discussed in Section 602 E, Analytical Column Protection.

The potential for damage to the column by reagents used in post-column derivatization is unlikely but not impossible. If the flow of the mobile phase is stopped, post-column reagents can diffuse back through the column effluent onto the column. This can result in deterioration of the column packing.

Damage to Detectors. The potential for reagent damage varies with each detector. As stated above, the compressibility of dissolved gases in solvents can cause bubbles to appear in the detector cell and interfere with the analysis. Traces of oxygen are incompatible with electrochemical detectors operating in the reductive mode; oxygen can also cause quenching in fluorescence detectors, leading to reduced sensitivity. Degassing of solvents is required. Porous flow-through coulometric detectors can be clogged by the presence of particles ≥ 0.2 μm . Filtration of solvents through a 0.22 μm filter is essential when using this type of detector.

Solvent Impurities. Many reagent grade solvents contain levels of impurities that make them unsuitable for use in HPLC. Sometimes the impurities are added deliberately by manufacturers as antioxidants, stabilizers, or denaturing agents. For example, chloroform usually contains up to 1.0% methanol or ethanol, and tetrahydrofuran may contain butylated hydroxytoluene or hydroquinone. These impurities may cause increased or decreased detector response or change the mobile phase strength and/or selectivity.

In some cases, incompatibility of a solvent or reagent with the HPLC system can be determined in advance and avoided. In the case of unknown impurities, problems will be recognized only during use of the chemical; careful investigation will be needed to determine the cause of the problem. Even microorganisms in inadequately purified water can cause a high background signal in some detectors (see Water, below). Whenever possible, HPLC grade solvents should be used to prepare mobile phases. Spectral or pesticide grade solvents may not be adequately pure for HPLC use. Solvents should be adequately purified and tested before use.

Specific Solvents

Water. Water is probably the most commonly used solvent in HPLC because of its role as the strength-adjusting solvent in RP mobile phases. It is also one of the most difficult solvents to purify and maintain in the pure state. Purity of water is especially critical in the determination of trace residues, when detectors are operated at high sensitivity.

Purification of water by distillation, even triple distillation, is inadequate because volatile and codistilled organics will not be removed. Bonded RP columns will collect these impurities over long term use, which can alter the properties of the column or sometimes produce spurious peaks. Water can be purified by distillation from potassium permanganate, by passage through a coarse grained C-18 bonded phase column that is periodically regenerated with acetonitrile, or by means of a commercial water purification system.

One widely used water purification system (Millipore Milli-Q) pumps distilled water through a prefilter cartridge to eliminate particulates; then through sequential cartridges of charcoal, ion exchange resin, and Organex-Q; and finally through a 0.22 μm filter. The activated charcoal cartridge removes organic impurities that can interfere with spectroscopic detectors. The mixed bed ion exchange resin cartridge(s) removes inorganics and ionized organics, as well as impurities leached from the charcoal; this removal is essential for proper operation of electrochemical detectors. The Organex-Q cartridge eliminates any remaining organics, in addition to traces of material leached from the ion exchange cartridge. The final 0.22 μm filter removes microscopic particles and microorganisms not eliminated by the previous cartridges. This filtration step protects column frits, columns, and porous flow-through detectors from particles that could clog them. It also minimizes the possibility that microorganisms will grow sufficiently to cause a background detector signal. The quality of the feed water is improved and the life of the purification system is extended if a reverse osmosis system is included between the prefilter and carbon cartridges. This system lowers the base level of organics, inorganics, and microorganisms.

Microorganisms such as bacteria and algae multiply rapidly in water. Therefore, even when using water purified in the manner just described, it is wise to discard all remaining water at the end of each week. The HPLC system should be flushed with methanol to destroy any microorganisms that have entered it during the week. At the beginning of a new work week, the water reservoir should be washed with methanol prior to filling with newly purified water. Growth of microorganisms can also be prevented by adding 0.02% sodium azide or acetonitrile (which is present in many RP mobile phases) to the water.

Purified water is best stored in carefully cleaned glass containers. Plasticizers can leach into water stored in plastic containers, interfering with RP systems or

contaminating the column. Leaching of metals from glass containers is also a possibility, but this is usually less of a problem than introduction of organic impurities.

HPLC grade water can be purchased from a number of commercial sources. This water can be used successfully as received for most applications.

The following purity check can be used to test water for applicability in HPLC:

- Pump 100 mL water through C-18 column.
- With a UV detector in-line, run a linear gradient from 0 to 100% methanol at 1 mL/min for 10 min and hold for 15 min.
- If the UV baseline shift at 0.08 AUFS is <10% and very few peaks of <3-5% full scale deflection are observed, the water is pure enough for most applications.

Acetonitrile. Acetonitrile is commonly used in RP HPLC mobile phases. Manufacturers' specifications for HPLC solvent purity are usually based on acceptability for UV detectors. Specifications for fluorescence and electrochemical detectors are very difficult to define because of the complexity of instrumental parameters.

Methanol. Another of the more common solvents employed in RP HPLC is methanol, which suffers from the same inadequacy of specifications as acetonitrile. Methanol has the disadvantage of producing relatively viscous solutions when mixed with water, giving rise to much higher pressures than with other mobile phases.

Chlorinated Solvents. Some chlorinated solvents are stabilized against oxidative breakdown by addition of small amounts of methanol or ethanol. Alcohol will increase polarity of mobile phases and shorten elution times in NP HPLC. Also, reproducibility will be affected because the concentration of stabilizer will vary slightly from batch to batch.

Chlorinated solvents can be purchased without stabilizer, or the stabilizer can be removed by adsorption onto alumina, or by extraction with water followed by drying. Unstabilized chlorinated solvents may slowly decompose, producing hydrochloric acid, which degrades columns and corrodes stainless steel. The rate of decomposition may be accelerated by the presence of other solvents. Hydrochloric acid can be removed by passing the solvent through activated silica or calcium carbonate chips. Solvents can be stabilized with amylene to avoid these problems.

Gillespie *et al.* [4] noted problems such as increased detector response and discoloration of equipment when ethylene dichloride or methylene chloride was used in HPLC mobile phases. The problems described were attributed to a reaction between solvent impurities and stainless steel upon prolonged contact.

Ethers. Ethers contain additives to stabilize them against peroxide formation. For example, tetrahydrofuran is often stabilized by addition of small amounts of hydroquinone. This compound absorbs UV radiation and so interferes with UV absorption detection. It can be removed by distilling the solvent from potassium hydroxide pellets. Inhibitor-free tetrahydrofuran should be stored in a dark bottle and flushed with nitrogen after each use. Any peroxides that form should be periodically removed by adsorption onto alumina.

Reagent Blanks

Blank samples should be analyzed to ascertain that no interferences from reagents (or glassware) occur during analysis. Reagent blanks are especially important when using nonspecific optical detectors such as UV or RI detectors.

Safety Precautions

Beyond the concern over damage to HPLC systems that can be caused by reagents and solvents, it is important to protect the health of the analyst. An awareness of the toxicity of the chemicals in use is essential. Care must be taken to minimize exposure to toxic chemicals. See Reference 5 for more on laboratory safety for HPLC analysis.

601 E: SAMPLE PREPARATION

Sample Cleanup

Extracts to be analyzed by HPLC must be cleaned up (*i.e.*, interfering co-extractives removed) sufficiently to permit identification and quantitation of residues, and to prevent contamination or harm to any part of the HPLC system. The column and/or detector may be impaired by injection of dirty extracts, especially when many samples are analyzed.

Cleanup procedures for trace residue determination by HPLC must be developed to accommodate the selectivity of the detector. Dissolved interferences in the sample solution that appear in the chromatogram as extra peaks must be removed. Any materials that will be strongly adsorbed by the column must also be removed to prevent their affecting chromatographic characteristics of the column, causing baseline drift, or appearing as spurious peaks in later chromatograms.

A recent innovation combines cleanup of the sample extract in-line with the HPLC determinative step [6]. A short column of SCX resin replaces the sample loop in a six-port HPLC injection valve, where it effectively removes the analyte, formetanate hydrochloride, from the extract. Solvent flushing of the column while the short column is still off-line (disconnected from the analytical column) provides cleanup and substitutes for traditional separatory funnel partitionings. Subsequent switching of the valve places the cleanup column in-line with the analytical SCX column for elution and determination. This coupled column application and other multidimensional variations [7] provide simple, rapid analysis with minimum solvent use.

Sample Filtration

Removal of particulate matter in the sample solution is critical for HPLC stability. Both column frits and the top of the column packing can become clogged by particles, leading to increased back pressure and adverse effects on chromatographic results because of decreased column efficiency, production of split peaks, *etc.*

At a minimum, samples should be passed through a commercial clarification apparatus, such as a syringe and a 5 μm filter pad in a Swinny adapter, before injection. In residue determination, passing samples through filters with $<1 \mu\text{m}$

pores is preferred. If the detector in use is of the porous flow-through type, the sample should be filtered to remove particles $>0.2 \mu\text{m}$. In addition, in-line filters placed ahead of the column can be used to prevent clogging of column frits. It is important to ensure that the analyte is not lost on the filter medium, especially for quantitative determination. This should be determined by analysis of samples fortified with known concentrations.

Sample Solvent Degassing

Sample extracts should be prepared for injection using solvents that have been degassed in the same manner as mobile phase solvents (see Section 603 B, Mobile Phase Preparation). This will reduce the possibility of problems when the sample solvent enters the detector cell. The sample solution itself should not be degassed because evaporation will change its concentration.

Choice of Sample Solvent

Ideally, the sample should be dissolved in the mobile phase. This reduces the size of the solvent peak, thereby aiding identification of early eluting sample peaks. It also avoids sample precipitation on or before the column, which can result in the loss of peaks for the analyzed sample and appearance of unknown, randomly eluting peaks in chromatograms from subsequent injections. This could occur, for example, if the mobile phase is methanol/water and the sample is dissolved in neat methanol because of insolubility in the mobile phase. As a precaution after using a different sample solvent, the column should be flushed with a strong solvent that is compatible with the column, followed by equilibration with the mobile phase before injection of the next sample. Ultrasonic mixing may aid in dissolving the sample in the mobile phase or a similar solution.

If the sample must be prepared in a solvent different from the mobile phase, it should be compatible with the column, as close as possible to the mobile phase in composition, and of weaker elution strength if this is consistent with solubility requirements. In addition to possible sample precipitation as described above, injection in a stronger solvent can cause peak tailing. If a stronger solvent must be used, the smallest possible volume should be injected.

601 F: REFERENCE STANDARDS

General procedures for storage, handling, and preparation of solutions of analytical reference standards for pesticide residue analysis are covered in Section 205. Preparation, storage, and stability are described in greater detail in Reference 8. The nature of HPLC makes it the preferred determinative step for many unstable, reactive, or easily degraded pesticides. For this reason, the stability of the pesticide in the solvent used to prepare standard solutions requires particular attention.

Stock Solutions

Considerations for the choice of a solvent for preparing stock standard solutions are the same as for choosing a solvent in which to inject samples (see Section 601 E). If stability permits, standard solutions should be prepared in the mobile phase to be used in the HPLC analysis. However, many pesticides have limited stability in "reactive" solvents, such as methanol or water, often used for mobile phases. For example, the fungicides thiophanate-methyl, captan, folpet, and captafol can be

stored indefinitely in benzene, acetone, or isooctane, but they quickly degrade in methanol/water.

Alternatively, stock standard solutions can be prepared in a less reactive solvent with a fairly high volatility (*e.g.*, acetone). Working standard solutions can then be prepared by evaporation of the volatile solvent from an aliquot and subsequent dissolution in the HPLC mobile phase or other appropriate solvent.

Benzene is a good solvent for most pesticide standards, but its toxicity makes its use inadvisable. Isooctane and hexane dissolve most organochlorine pesticides; isooctane's low volatility minimizes evaporative loss during storage, but also precludes its use in cases where it is desirable to evaporate the original solvent prior to dissolution in the mobile phase. Chloroform is useful for triazines, methylene chloride or methanol for carbamates, acetone for benzimidazole-related fungicides, and methanol for phenylurea herbicides.

Because of possible deterioration due to evaporation and/or instability, it may be necessary to remake stock standard solutions frequently. Because standard reference materials are often supplied in limited quantities (<100 mg), use of a microbalance is preferred for accurate weighing of low mg quantities of standard for preparation of stock solutions. Direct preparation of dilute solutions in this way can also reduce the number of dilutions required to make the working standard solution.

Working Standard Solutions

These solutions are prepared at concentrations suitable to the detector in use and the expected levels of pesticides in sample extracts. Concentrations of working standard solutions should closely match those in sample extracts for the most reliable comparison of peak heights or areas. For general screening purposes or multiresidue analysis, working standard solutions can be made up as mixtures of pesticides resolvable by the method.

Stability of working standard solutions should be confirmed by periodic comparison against newly prepared solutions or fresh dilutions of stock solutions. Solvents used to prepare working standard solutions should be compatible with the sample solvent and the HPLC system (see Section 601 E) and should be checked for contaminants that could possibly interfere with the analysis.

Storage

Stock standard solutions should be stored in an explosion-proof refrigerator at $\leq 4^{\circ}\text{C}$. Benzene solutions can freeze at these temperatures and may crack containers. Organochlorine pesticide stock solutions can be stored for at least 6 months without deterioration. Organophosphorus and carbamate solutions are less stable and should be discarded 3-4 months after preparation. Some standard solutions degrade quickly and must be made fresh at least daily.

References

- [1] Gilvydis, D.M., and Walters, S.M. (1990) *J. Assoc. Off. Anal. Chem.* **73**, 753-761

- [2] Snyder, L.R., and Kirkland, J.J. (1979) *Modern Liquid Chromatography*, 2nd ed., Wiley, New York
- [3] Callahan, F.J. (1985) *Swagelok Tube Fitting and Installation Manual*, Markad Service Co.; available from Supelco, Bellefonte, PA 16823-0048
- [4] Gillespie, A.M., *et al.* (Feb. 1986) "Cautionary Note on Use of Ethylene Dichloride and Methylene Chloride in HPLC Mobile Phases," LIB 3011, FDA, Rockville, MD
- [5] Runser, D.J. (1981) *Maintaining and Troubleshooting HPLC Systems — A User's Guide*, Wiley, New York
- [6] Niemann, R.A. (1993) *J. AOAC Int.* **76**, 1362-1368
- [7] Wojtowicz, E.J. (Feb. 1992) "HPLC Fluorometric Analysis of Benomyl and Thiabendazole in Various Agricultural Commodities," LIB 3650, FDA, Rockville, MD
- [8] *EPA Manual of Quality Control for Pesticides and Related Compounds in Human and Environmental Samples* (2nd rev., 1981) Section 3-O, Environmental Protection Agency, Washington, DC

602: COLUMNS

The nature and dimensions of the column packing, together with the nature of the mobile phase, largely determine the selectivity and efficiency of the separation that is achieved. HPLC columns are packed with small particles (usually 3-10 μm) having a narrow size distribution (approximately $\pm 20\%$). The use of microparticulate materials requires that the mobile phase be pumped through the column at high pressure. Columns can be prepared in the laboratory, but most analysts purchase commercial prepacked, pretested columns.

An HPLC column is a highly efficient filter, and any particulate matter or strongly retained impurity that is injected will remain on the top. To prevent deterioration of the analytical column, a guard column should be installed between it and the injection device. The guard column is discarded or repacked after a certain number of sample injections. A saturation precolumn situated between the pump and injector device may be used to ensure equilibrium between the two phases in a liquid-liquid chromatography system, or to prevent dissolution of silica from an unmodified or bonded silica analytical column. Although columns of different sizes have been used, 25 cm \times 3-5 mm id columns packed with 5 or 10 μm stationary phase material have provided adequate separation in a reasonable time for many applications.

602 A: COLUMN SELECTION

Column selection is not a straightforward process. The best approach is to search the literature for work published on a separation that is the same as, or similar to, the one that needs to be accomplished. Many of the references in Section 608 discuss column selection techniques for different sample types, and most column manufacturers have published guides and technical data sheets that will aid in column selection.

A knowledge of the chemistry of the sample, often determined by some simple wet chemistry experiments, combined with a systematic trial and error approach, is probably the method used most often in column selection. If the molecular weight, range of solubility, and molecular or ionic structure of the analyte are known, a mode of separation can be selected as discussed previously (see Figure 601-c). The most appropriate column for that mode is then chosen, based on the experience of the analyst, column manufacturers' recommendations, or a search of the literature.

602 B: ANALYTICAL COLUMNS

Factors important in producing efficient columns include narrow particle size distribution in the packing and minimal dead volume in the tubing, fittings, cells, and other components of the HPLC instrument.

Most packed columns are made from stainless steel. In addition, glass cartridge columns are common and radial compression columns prepared from heavy wall polyethylene cartridges are available. The latter columns are radially compressed in a hydraulic press during use to minimize void volumes and wall effects and thereby increase column efficiency.

Recent advances in column technology include use of 3-10 cm columns packed with 3-5 μm particles. The major advantages of these shorter columns over conventional 25 cm columns are faster separations and improved sensitivity of detection. Another trend is the use of microbore columns, 0.2-1 mm id columns packed with conventional bonded phases. Microbore columns can be made very long, providing up to one million theoretical plates for difficult separations. They require only small volumes of mobile phases and allow novel detection possibilities, including flame ionization, chemical ionization mass spectrometry, and IR spectrometry.

Normal phase (NP) HPLC is carried out on adsorbent (silica gel, alumina) columns or polar bonded (cyano, amino, diol) columns. Liquid solid chromatography and polar bonded phase chromatography are suitable for separation of nonionic multifunctional compounds and isomers. Silica gel is by far the most used column for NP separations. However, because NP columns have not been used widely for analytical work, most discussion of columns in this section refers to various types of reverse phase (RP) chromatography used for pesticide determination.

Liquid-Solid Chromatography

Until recently, little use had been made of liquid-solid chromatography (LSC) for pesticide analysis. Now, however, a column of porous graphitic carbon, a nonpolar RP adsorbent, has been successfully applied to the determination of ethylenethiourea (ETU) using a strongly acid mobile phase [1]. Such columns offer stability for applications requiring pH extremes and are complementary to silica-based columns.

Bonded Phases

Most analytical HPLC systems use RP chromatography on silica-based C-18 or C-8 bonded phases. Other RP bonded packings include those having C-1, C-2, C-4, C-12, cyano, phenyl, diol, or cyclohexyl groups. In RP mode, the stationary phase is hydrophobic and nonpolar, and mobile phases are relatively polar (usually water with methanol or acetonitrile). Nonpolar sample components are strongly retained, and polar components are less retained. Bonded columns are stable and reproducible compared to nonbonded columns with physically adsorbed coatings, which they have almost completely replaced. The major limitation is the narrow pH range for column stability.

Most commercially available bonded phases are of the siloxane type, Si-O-Si-R. They are prepared by reacting surface silanol groups on silica with an organochlorosilane reagent, the organic portion of which is the moiety to be bonded (octyl, octadecyl, phenyl, aminopropyl, cyanopropyl, *etc.*). Packings can be prepared, for example, by using mono-, di-, or trichloroorganosilanes to produce products having different chromatographic properties. Monochloroorganosilanes react with silica to form a monomolecular layer of bonded organic groups. Di- or trichloroorganosilanes react with silica in the presence of a protic reagent to form a linear or cross-linked polymeric layer, the structures and properties of which are not as well defined as with monomeric phases. Polymer bonded phases have poorer mass transfer characteristics but higher loadability. Some of the accessible unreacted silanols on the silica surface after the primary bonding reaction may be removed by end-capping, which involves reaction with a less bulky reagent such as trimethylchlorosilane.

Most of the current bonded RP columns have 5 μm spherical silica as the base material. Pore size ranges from 60-300 nm, with 80-120 nm most common. To increase the range of pH stability, bonded columns having polystyrene-divinylbenzene (DVB) polymer as the base material have been developed. Another approach is a base material composed of alumina coated with a polybutadiene polymer layer to protect the bonded surface from attack by hydroxide. Stability up to pH 13 is possible for such columns because alumina is stable at this pH.

Short chain phases such as C-2 and C-4 are used to reduce hydrophobic interactions in separating high molecular weight analytes, such as proteins and peptides. Cyanopropyl phases can be used in NP work by selective interactions with the cyano functional group or as a short chain RP material for separation of polar analytes. Diol phases, whose structures involve two hydroxy groups on adjacent carbon atoms in an aliphatic chain, are less polar than silica and are used in both NP and RP chromatography. Phenyl phases are prepared by the reaction of dimethylphenylchlorosilane with silica gel. They are nonpolar and have special affinity for aromatic compounds. Cyclohexyl phases have selectivity for alicyclic compounds compared to straight chain compounds. Some RP columns are base-deactivated to optimize separation of basic compounds without tailing or need for mobile phase modifiers for ion pairing or ion suppression.

The determinative steps of Sections 401, 403, and 404, methods for N-methylcarbamates, substituted ureas, and benzimidazoles, respectively, provide examples of applications of bonded RP HPLC to pesticide residue analysis.

Ion Exchange

Four types of microparticulate packings are available for high performance ion exchange chromatography (IEC). Polystyrene-DVB polymeric gel resin particles of 5-10 μm diameter substituted with ionogenic groups were the earliest of these packings. The amount of DVB added for the polymerization reaction determines the degree of cross-linking and, hence, the pore structure. Resins with <6% DVB are not pressure stable and cannot be considered HPLC packings. Slow diffusion of analytes within the polymer matrix and the resulting poor efficiency led to development of pellicular ion exchange materials, consisting of a glass core, an intermediate coating of silica, and an outer ion exchanger polymer film. These materials suffer from low efficiency due to their relatively large particle size and low sample capacity.

Silica-based ion exchange packings are prepared in a manner similar to other bonded phases. Controlled porosity glass column packings with attached hydrophilic polymeric groups can be used for high speed separations of large ionic molecules such as proteins and nucleic acids.

Virtually all commercial ion exchange materials contain sulfonate (strong cation exchange), carboxylate (weak cation exchange), tetraalkylammonium ion (strong anion exchange), or an amine (weak anion exchange) functional group. The capacity of exchangers is a function of the pH of the mobile phase. Full exchange capacity is exhibited by different exchangers at the following pH values: strong cation, above 3; weak cation, above 8; strong anion, below 9; and weak anion, below 6. The wide exchange range of strong exchangers makes them most useful for general analytical work. The pH of the mobile phase controls retention by its effect on the ionic nature of both the sample and the exchange sites.

IEC has been applied to determination of residues of formetanate hydrochloride [2]. A strong cation exchange mechanism is used for the chromatography of this ionic residue.

Ion Pair

RP ion pair chromatography is an alternative to IEC. It is an extension of ion suppression chromatography, in which weak acids or bases are separated on an RP bonded column by addition of a pH modifier to the mobile phase to ensure that analytes are in their undissociated forms.

In ion pair chromatography, a charged organic compound is added to the mobile phase to form a neutral ion pair with an analyte of opposite charge. For example, an alkylsulfonate can be added to cationic samples and tetrabutylammonium phosphate to anionic substances. Ion pair chromatography is suitable for separating mixtures of anions, cations, and neutral substances; the pH of the mobile phase will suppress the ionic character of one of the types of ions, while the counter ion will react with the other type to form ion pairs. For example, tetrabutylammonium phosphate buffered to pH 7.5 can form ion pairs with strong and weak acids, and the buffering suppresses weak base ions. Amphoteric molecules can be chromatographed with either quaternary amine or sulfonate counter ions at an appropriate pH value.

Selectivity can be affected by the concentration and choice of the ion pair reagent. The k values (see Section 602 C) of analytes are proportional to the counter ion concentration. The longer the alkyl chain length, the greater are k values. Retention times can also be adjusted by changing the composition of the mobile phase, which is usually a mixture of water with either methanol or acetonitrile.

Quaternary ammonium salts in alkaline medium are damaging to silica gel. Columns should never be stored in such solutions. A precolumn placed in front of the injector, to saturate the mobile phase with silica gel, is highly recommended in these systems.

An example of pesticide determination using ion pair chromatography (on a bonded phase) is the determination of benzimidazole residues (Section 404). In addition, two methods for determining residues of paraquat and diquat use the ion pair mechanism, one with a polymeric (PRP-1) column [3], and the second with a silica column using NP mode chromatography [4].

Size Exclusion

Separations in the size exclusion (SEC) mode are based on molecular size and are controlled by the pore size of the packing material. Particle sizes in the 5-20 μm range are used to provide good column efficiency. Packings for SEC include semi-rigid organic gels, porous silica, and controlled pore glasses.

The major use of SEC in pesticide determination is for cleanup of residues from fatty samples by gel permeation chromatography, rather than as a determinative step. The most used packing for this purpose has been styrene-DVB copolymer such as Bio-Beads S-X3 (Section 304 C5, Section 402). The Bio-Beads S-X series offers exclusion limits from 400-14,000 molecular weight; S-X3 has a 2000 exclusion limit. The exclusion limit is determined by the amount of DVB cross-linking

of the gel, as well as by the degree of swelling that can occur in different solvents. Maximum expansion of the gel occurs in relatively nonpolar solvents. Typical solvents used include benzene, toluene, xylene, carbon tetrachloride, methylene chloride, and mixtures such as methylene chloride/hexane. The sample should not interact with the stationary phase in any way, *e.g.*, by adsorption. Stationary phase with a smaller particle size will provide greater peak capacity, and better and faster separations.

602 C: COLUMN EVALUATION

An HPLC column can be evaluated by measuring certain performance characteristics or parameters, many of which can be visualized or measured on the chromatograms produced by the column. Column efficiency and peak symmetry reflect the quality of the column, whereas the capacity factor and selectivity indicate its capability to retain and separate compounds of interest.

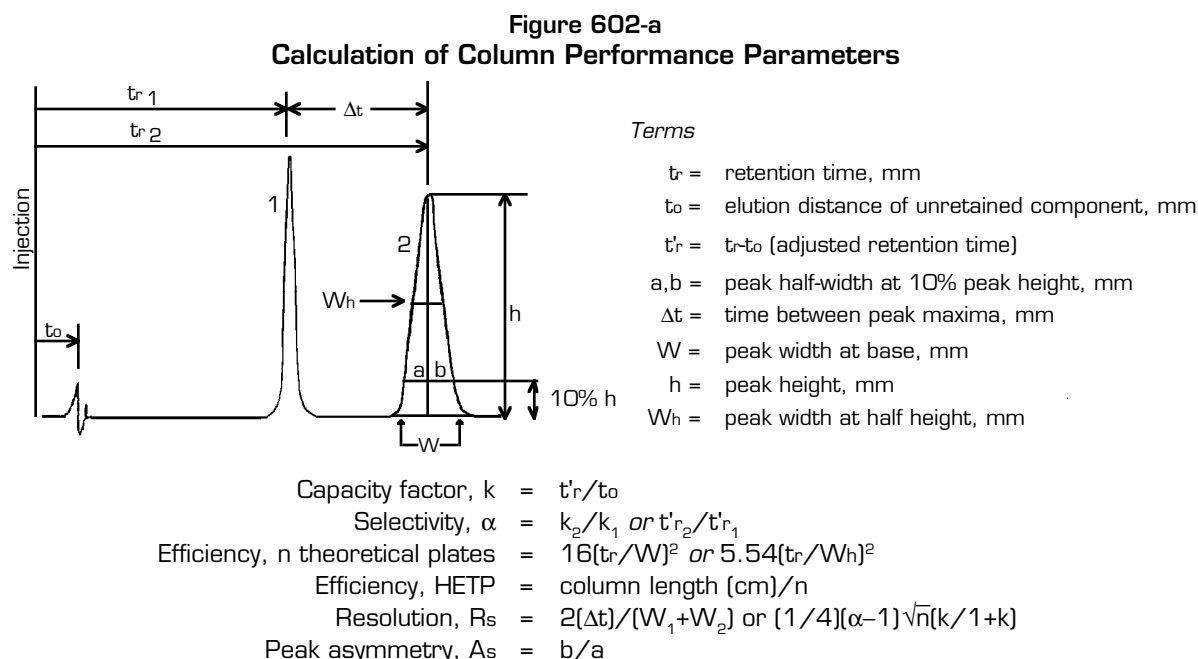

References: Walters, M.J., *et al.* (Nov. 1980) "Recommendations for HPLC Columns," LIB 2447, FDA, Rockville, MD; ASTM Standards on Chromatography (1981) E682.

Several terms must be measured in order to calculate the parameters of a column. Figure 602-a provides a visual representation of these terms:

The time from injection to the peak maximum is known as the retention time, t_r . The retention time consists of two parts, t_o and t'_r . t_o is the time from injection to emergence of the solvent front, which may be noted as a small shift or disturbance in the baseline or a solvent peak if the sample solvent is different from the mobile phase and is sensed by the detector. t'_r , the adjusted retention time, equals t_r minus t_o . t'_r represents the time that the analyte is retained in the stationary phase.

Δt is the time between the maxima of two peaks, and W is the peak width determined between the intersections of tangents drawn on the sides of the peaks with the baseline. All of these time values can be measured in mm directly on the

recorder trace of the chromatogram. These terms are used to calculate the following parameters for evaluation of columns: capacity factor, selectivity, efficiency, resolution, and peak asymmetry.

The capacity factor, k , measures retention of an analyte by the column in terms of column volumes. It is affected by the strength (*e.g.*, polarity) of the mobile phase and the strength (retentivity) of the column packing. A k value of 2-10 for the most retained component is generally optimal for good resolutions but may be higher for difficult separations.

Selectivity is a thermodynamic factor that measures the ability of a particular column/mobile phase combination to provide different distribution constants for two substances, thereby causing a different degree of retention for the two substances, as indicated by the separation of their peak maxima. It is symbolized by α and calculated as the ratio of t'_r values or k values for two peaks, with the largest value placed in the numerator. Selectivity is affected by the chemistry of the entire system, including the functionality of the sample components.

Efficiency is a kinetic factor that indicates the ability of the column/mobile phase combination to produce narrow peaks. Efficiency is dependent on particle size, column dimensions, and packing technique. It is determined by the number of theoretical plates, n , and height equivalent to a theoretical plate, HETP.

Resolution is the ability of the column/mobile phase combination to separate the peaks representing two substances. It is a function of efficiency, selectivity, and retention and is improved by increasing the separation of the peaks (selectivity) and/or by decreasing their width (increasing efficiency). Resolution should be >1 to minimize error in quantitative analysis. A retention, k , of 2-10 is usually assumed.

Peak asymmetry describes the shape of a chromatographic peak. Theory assumes a symmetrical, Gaussian shape for peaks, but asymmetry can be caused by extra-column effects, poorly packed columns, deterioration of packing, incompatibility between analyte and packing, *etc.* The peak asymmetry factor is the ratio, at 10% peak height, of the distance between the peak apex and the back side of the chromatographic curve to the distance between the peak apex and the front side of the chromatographic curve. A value of 1 indicates a symmetrical peak, a value >1 is a tailing peak, and a value <1 is a fronting peak.

Higher efficiency, which leads to sharper peaks, is achieved by using columns with small, uniform, tightly packed particles and optimized column flow rates. High selectivity, which is manifested by well separated peak maxima, is influenced mostly by the nature of the stationary and mobile phases.

602 D: COLUMN SPECIFICATIONS

The parameters described above can be used to evaluate column quality. Columns that produce the desired separation should be defined for future reference by the measured parameters. A "system suitability test" that specifies acceptable operation of the HPLC determinative step should be included with any method description; this may require the use of specific compounds involved in the procedure. System suitability test elements that relate to column specifications are listed in Table 602-a.

*Table 602-a: HPLC Column Specification Elements***Physical Description**

Packing material

- particle type: size, shape, pore size
- bonded surface type: functionality, mono or polymeric
- surface coverage: (% concentration or $\mu\text{moles}/\text{m}^2$)
- additional silylation

Column dimensions

Performance Characteristics

[Requires that the test system be defined by specifying mobile phase solvent and flow rate, test solution compounds, and solvent. Characteristics must be related to peak(s) that were used to measure each.]

- Minimum theoretical plates, n
- Resolution, R_s
- Selectivity, α
- Capacity factor, k
- Asymmetry, A_s

At a minimum, a new analytical column should be checked for efficiency by calculating and recording the number of theoretical plates using an appropriate test solution. This value is compared with the manufacturer's specifications and used in later column quality control evaluations.

Expected minimum efficiency values are shown in Table 602-b. In general, efficiency (plates per meter) decreases with larger or less uniform size column packing, lower temperature, increased extra-column volume in the system, and larger samples. Efficiency improves when $k = <2$ unless extra-column effects are dominant.

Specifications and test systems for six satisfactory HPLC bonded phase silica columns were recommended at an early stage of HPLC application [5]. These recommendations are useful as a guideline for comparing and defining columns, but the specifications themselves are no longer applicable because of subsequent improvements in HPLC column technology. Other protocols for column testing and evaluation have been suggested. For example, Poole and Schuette [6] described test conditions and specifications for a 10 μm C-18 RP column using a mixture of resorcinol, naphthalene, and anthracene and a UV detector.

Commercial bonded silica RP columns from different manufacturers are not equivalent, and information on the degree of hydrocarbon coverage in a column is not usually provided. In addition, the free (unreacted) silanol sites vary among

*Table 602-b: Minimum Efficiency Values
(in thousands of theoretical plates per meter)*

Column Type	Particle Size		
	10 μm	5 μm	3 μm
porous RP bonded	12-20	35-40	80-100
porous silica gel adsorbent	24	40	
porous ion exchangers	10-15		
semirigid organic size exclusion gels	9-12		

columns and manufacturers, and these can have significant effects on the chromatography of polar analytes. A test scheme developed for classifying and selecting C-18 bonded columns was used to classify 12 brands of columns into three major groups based on a hydrophobicity index, free silanol index, and column efficiency [7].

602 E: ANALYTICAL COLUMN PROTECTION

HPLC analytical columns are expensive and subject to damage during use. The following items must be used to protect the column and prolong its useful life:

Filters

A major cause of column deterioration and damage is the buildup of particulate and chemical contamination at the head of the column. This can lead to increased back pressure and anomalous chromatographic results. Particle buildup is minimized by proper filtering of mobile phase solvents (see Section 603 B) and by choosing a sample solvent that will not cause precipitation (Section 601 E). In addition, in-line column filters help to eliminate particulate impurities.

Columns normally contain stainless steel inlet and outlet filters or frits to retain the column packing. The pore size of the frit must be smaller than the particle diameter of the packing, *e.g.*, a 2 μm frit for 5 μm packing. Frits are either incorporated into the ends of the column itself or made an integral part of the column end fittings.

Periodic cleaning of end fittings and frits in an ultrasonic bath in a solution such as 6 M nitric acid is recommended, especially when column back pressure increases. Before removing column end fittings, the manufacturer's literature should be read carefully for procedural instructions or notification of any loss of warranty if the column is taken apart. Some companies seal end fittings onto the column with epoxy and do not guarantee the column if the seal is broken.

Precolumns

The terms “precolumn” and “guard column” are often used interchangeably, but the two types of columns are different and serve separate primary functions. Precolumns are positioned in the HPLC system prior to the sample injector. Their purpose is to saturate the mobile phase with silica so that the silica or bonded silica analytical column packing is not dissolved during use. Precolumns packed with inexpensive, coarse silica are suitable for this mobile phase conditioning function.

Guard Columns

A guard column is inserted between the injector and analytical column to protect the latter from damage or loss of efficiency due to the presence of particulate matter or strongly adsorbed impurities from analytical samples. It can also serve as a saturator column to prevent dissolution of the stationary phase, in addition to, or instead of, a precolumn as described above. The use of a guard column is especially important when injecting relatively crude sample extracts or biological fluids.

Guard columns are short (2-6 cm) disposable columns containing the same packing as the analytical column. The guard column must be changed frequently, as dictated by the contamination level of the samples, to ensure that the lifetime of the analytical column, which should be several hundred hours running time, is not shortened.

The use of a commercial guard column having the same particle diameter packing as the analytical column, in combination with low dead volume fittings and short lengths of connection tubing, should cause essentially no loss in efficiency. Guard columns containing 5 or 10 μm particles can be purchased in the form of prepacked disposable cartridges (often 2 cm). They must be slurry packed if prepared in the laboratory. When a greater loss of efficiency is not critical, guard columns containing larger particle (20-40 μm) microporous or pellicular packings can be dry-packed in the laboratory using the tap and fill method, but the pellicular packings do not provide as much protection because of their lower surface area.

602 F: COLUMN MAINTENANCE AND TROUBLESHOOTING

Column Care

Chromatography companies usually supply a booklet describing recommended care and use of their columns. Topics covered typically include column description; directions for initial inspection, connection, equilibration, operation, regeneration, repair, and storage; mobile phase requirements; and information about solvent purification, protector columns, and replacement of frits. Any such literature should be read carefully and the suggestions followed as closely as possible. The following items describe routine handling and maintenance:

- Do not jar, drop, or vibrate columns.
- Pass solvent through the column in the direction specified by the manufacturer. If a flow direction is indicated, operation in the opposite direction may disturb the packing and reduce column efficiency.

- When starting up the HPLC system, gradually increase column flow rate and pressure to avoid pressure shock and formation of voids in the packing.
- Operate the column at a constant temperature using a column oven. If temperature significantly above ambient is used, raise the temperature slowly with solvent flowing. Elevated temperature improves column efficiency and reduces operating pressure by lowering solvent viscosity. However, thermal expansion of the column wall can lead to sinking or channeling of the column packing and loss of efficiency. Do not operate analytical columns at $>60^{\circ}\text{C}$.
- Allow the column to equilibrate with the mobile phase, as indicated by a stable detector baseline, before injecting samples. Be sure that back pressure is acceptable for the required flow rate.
- Check fittings visually and by feel to be sure there are no mobile phase leaks. Leaks too small to see may be detected by the coolness of fittings to the touch.
- Particulate matter can become caught in the inlet frit, causing high back pressure. Replace the frit to return the column to the lowest possible operating pressure. Alternatively, clean the frit by washing with dilute nitric acid in an ultrasonic bath, dry, and replace. Never remove the bottom frit from the column. Use a precolumn filter to avoid the need to change the inlet frit and possibly disturb the column packing. Filter samples that may contain particulate matter to prevent contamination of the sample valve or column inlet frit. A commercial clarification kit that attaches to a syringe is a convenient way to filter samples.
- Do not overtighten column end fittings, or threads may be stripped, causing a leak.
- Flush the column with a solvent stronger than the mobile phase at the end of the day if dirty samples were injected.
- Handle columns gently to avoid shock and the formation of voids.
- Label columns with complete information on their source, identity, history and conditions of use, and regeneration and storage solvents. Keep a log notebook for each column from time of installation.
- Do not subject columns to operating conditions that may destroy their structure; be aware of the appropriate solvents and conditions that are compatible with the particular column.

Column Evaluation by Injection of Test Mixtures

Inject a test mixture to evaluate efficiency, selectivity, k, peak shape, *etc.*, according to the laboratory's instrument quality assurance requirements (see Section 602 C). Choose the test mixture according to the purpose of the test:

- To compare a chromatogram to the one supplied with a prepacked column by the manufacturer, use the same compounds and conditions specified by the manufacturer for comparable results.
- If an in-house test mixture for column assessment is needed, prepare it to contain the following types of components:
 - 1) an unretained (but not excluded) component for assessment of the volume between the particles and in the pores;
 - 2) a minimally retained component ($k = \text{about } 0.2$) to assess zone broadening caused mainly by the injector, column, and detector. Because the peak volume of this component will be small, it will be a critical test of the effect of these system components on performance;
 - 3) a moderately retained component ($k = 1-3$);
 - 4) a well retained component ($k = 7-20$). This component is optional because zone broadening will not be obvious because of the large peak volume; and
 - 5) a totally excluded component for determination of column void volume.

Column Storage

When no longer in use, columns should be equilibrated with an appropriate storage solvent, disconnected from the HPLC system, and the ends capped securely for storage.

Buffer solutions and halogen salts can easily damage column packings and stainless steel columns. Columns should be flushed with water after the use of buffers and should never be stored in such a solution. LSC columns are best stored in a dry organic solvent; RP columns in methanol, acetonitrile, or a water/acetonitrile or water/methanol mixture (use of water-free organic solvent reduces silica dissolution); IEC columns in a compatible solvent with the same ion as the form of the exchanger; and SEC columns in a solvent compatible with the swelling properties of the packing. Columns are not normally stored under pressure. The temperature and humidity of the storage area should be moderate and consistent.

Column Regeneration

Columns should not be operated with excessive pressure as this can create a void at the column head, resulting in a significant loss of efficiency. The cause of increased back pressure should be determined and steps taken to remedy the situation. Pressure buildup due to particulates can sometimes be relieved by back flushing the column or changing the frit at the head of the column. The simplest method of removing strongly retained material is washing with a solvent stronger than the mobile phase. If an appropriate guard column is in use, rejuvenation of the system should be possible in most cases by merely replacing the guard column.

A void at the head of the column can be observed after removing the inlet fitting. Voids can be filled with either glass beads or the same or similar packing as originally in the column.

Flushing with pure organic solvents such as methanol, tetrahydrofuran, chloroform, or acetonitrile is useful for regenerating bonded polar phase columns. When using any series of washes, the order of solvents should be weak to strong (nonpolar to polar for NP, and polar to nonpolar for RP), with consideration of mutual solubility at each stage. Basic impurities may be washed out with 1-5% aqueous phosphoric or acetic acid and acidic impurities with 1-5% aqueous pyridine. Biological materials and fats are removed from RP columns by washing with methylene chloride and making several 0.2-1 mL injections of dimethylsulfoxide during elution. Typically, 75 mL of each wash solvent is used at a flow rate of 0.5-3 mL/min. If washing does not remove adsorbed impurities from the top of the column bed, the upper, contaminated layers of packing must be removed with a spatula (exercising great care to avoid scratching the internal column wall), and the column repacked as described above for the case of a void.

In all cases, the last wash in the regeneration process should be with a solvent that is miscible with the mobile phase, and the column should be finally re-equilibrated with the mobile phase. After regeneration (or between washing stages to check progress), a test mixture should be chromatographed to evaluate plate number, *k*, and peak shape. Regeneration and return to equilibrium with the mobile phase can also be monitored by keeping the column connected to the detector and observing baseline drift. This should not be done if eluted impurities might contaminate the detector cell.

References

- [1] Krause, R.T. (1989) *J. Liq. Chromatogr.* **12**, 1635-1644
- [2] Niemann, R.A. (1993) *J. AOAC Int.* **76**, 1362-1368
- [3] Worobey, B.L. (1987) *Pestic. Sci.* **18**, 245-257
- [4] Chichila, T.M., and Walters, S.M. (1991) *J. Assoc. Off. Anal. Chem.* **74**, 961-967
- [5] Walters, M.J., *et al.* (Nov. 1980) "Recommendations for HPLC Columns," LIB 2447, FDA, Rockville, MD
- [6] Poole, C.F., and Schuette, S.A. (1984) *Contemporary Practice of Chromatography*, pp. 241-252, Elsevier, New York
- [7] Walters, M.J. (1987) *J. Assoc. Off. Anal. Chem.* **70**, 465-469

603: MOBILE PHASE SELECTION, PREPARATION, AND DELIVERY

Mobile phases for different HPLC modes were described briefly under Modes of Operation (Section 601 B). Solvents used to prepare mobile phases were discussed under Solvents and Reagents (Section 601 D). This section presents additional considerations related to the preparation and delivery of mobile phases.

603 A: MOBILE PHASE SELECTION

Mobile phases in HPLC are usually mixtures of two or more individual solvents with or without additional additives or modifiers. The mobile phase is an active partner with the column in obtaining the required separation. The usual approach is to choose what appears to be the most appropriate column, and then to design a mobile phase that will optimize the retention and selectivity of the system.

The two most critical parameters for nonionic mobile phases are strength and selectivity. Mobile phase strength is related directly to polarity and ability to dissolve polar analytes in normal phase (NP) chromatography, while the opposite relationship exists for reverse phase (RP) chromatography. The general strategy for choosing a mobile phase is to find a solvent or solvent mixture with the correct strength to give k values in the optimum 2-10 range, and then to alter the phase to give the needed selectivity while maintaining the same strength. Solvents have been classified according to strength and selectivity to allow the selection process to be at least somewhat systematic.

Solvent strength for any solvent is dependent on the stationary phase adsorbent. An eluotropic series is a ranking of solvent strengths on a given adsorbent. Table 603-a lists solvent strengths for common solvents when used with different stationary phases.

Table 603-b shows solvents that are members of the different selectivity groups; the solvents most preferred for HPLC are underlined. Compounds in different groups interact in different ways with the analytes to be separated, *e.g.*, dispersion interactions, dipole forces, and hydrogen bonding. To optimize selectivity and improve separations, mobile phases are prepared from solvents in different selectivity groups.

Normal Phase Chromatography

The eight groups of solvents shown in Table 603-b emerged from Snyder's plot of solvents within a triangle of selectivity coordinates representing relative proton donor, proton acceptor, and dipole parameters [1, 2]. Maximum selectivity is obtained if one solvent is chosen from each group closest to the corners of the triangle. Based on other factors, such as viscosity and UV absorption properties, the three solvents chosen are usually diethyl ether or methyl tert-butyl ether (MTBE), chloroform, and methylene chloride. Hexane is used as the base solvent to adjust polarity (solvent strength). A binary mixture of hexane with one of these three solvents can be used to determine the appropriate solvent strength, and other binary, tertiary, and quaternary mixtures with the same strength can be tested in a systematic trial and error fashion for the required selectivity. The overall strength (P') of a mixture is the sum of the product of the individual P' values times the volume fraction for each component solvent. Other useful combinations of

Table 603-a: Properties of Common HPLC Solvents with Alumina Columns

Solvent	UV Cut-off, nm	Refractive Index	Boiling Point, °C	Viscosity cP, 25°C	Solvent Polarity Parameter, P'	Solvent Strength Parameter, ε°	Group
isooctane	197	1.389	99	0.47	0.1	0.01	—
n-hexane	190	1.372	69	0.30	0.1	0.01	—
methyl t-butyl ether	210	1.369	56	0.27	2.5	0.35	—
benzene	278	1.501	81	0.65	2.7	0.32	VII
methylene chloride	233	1.421	40	0.41	3.1	0.42	V
n-propanol	240	1.385	97	1.9	4.0	0.82	II
tetrahydrofuran	212	1.405	66	0.46	4.0	0.82	II
ethyl acetate	256	1.370	77	0.43	4.4	0.58	VIa
chloroform	245	1.443	61	0.53	4.1	0.40	VIII
dioxane	215	1.420	101	1.2	4.8	0.56	VIa
acetone	330	1.356	56	0.3	5.1	0.56	VIa
ethanol	210	1.359	78	1.08	4.3	0.88	II
acetic acid		1.370	118	1.1	6.0	Large	IV
acetonitrile	190	1.341	82	0.34	5.8	0.65	VIb
methanol	205	1.326	65	0.54	5.1	0.95	II
water		1.333	100	0.89	10.2	Very Large	VIII

Table 603-b: Classification of Solvent Selectivity

Group	Solvents
I	aliphatic ethers, <u>methyl t-butyl ether</u> ¹ , tetramethylguanidine, hexamethylphosphoric acid amide, alkyl amines
II	aliphatic alcohols, <u>methanol</u>
III	pyridine derivatives, <u>tetrahydrofuran</u> , amides (except formamide), glycol ethers, sulfoxides
IV	glycols, benzyl alcohol, <u>acetic acid</u> , <u>formamide</u>
V	<u>methylene chloride</u> , ethylene chloride
VI	a) tricresyl phosphate, aliphatic ketones and esters, polyesters, <u>dioxane</u> b) sulfones, nitriles, <u>acetonitrile</u> , propylene carbonate
VII	aromatic hydrocarbons, <u>toluene</u> , halosubstituted aromatic hydrocarbons, nitro compounds, aromatic ethers
VIII	fluoroalcohols, m-cresol, water, <u>chloroform</u>

¹Underlined solvents are those generally preferred.

[Both tables reprinted with permission of Elsevier Science Publishers, from Poole, C.F., and Schuette, S.A. (1984) *Contemporary Practice of Chromatography*, Table 4.16, page 260.]

solvents with different selectivity characteristics plus miscibility over the entire range of mixture composition include methylene chloride, MTBE, and acetonitrile in Freon FC-113 (1,1,2-trifluoro,1,2,2-trichloroethane), and methylene chloride, MTBE, and ethyl acetate in hexane.

Solvents for liquid-solid chromatography (LSC) HPLC should contain at least a small concentration (*e.g.*, 0.01-1%) of a polar modifier (water, alcohol, acetonitrile) to de-activate highly adsorptive sites that can cause tailing of chromatographic peaks. Water is the most important de-activator, and it can have a profound effect on chromatographic results. It is very difficult to control exactly the amount of water dissolved in nonpolar solvents such as pentane, hexane, heptane, and methylene chloride; this is one of the major causes of slow column equilibration with mobile phases and poor reproducibility in LSC. The following are useful precautions when using alumina and silica columns:

- Use 50% water-saturated solvents for silica gel and 25% water-saturated solvents for alumina, except for pentane, hexane, and heptane, which should contain 0.05% acetonitrile. (50% water-saturated means that the solvent has 50% of the water it would have if it were totally saturated. 50% water-saturated solvents are prepared by mixing equal volumes of dry solvent and saturated solvent or by passing dry solvents through a special moisture control column for specified time periods.)
- Change from one solvent to another in small steps along the eluotropic series. Do not attempt to follow a very polar solvent with a very nonpolar one directly, or *vice versa*.
- Chromatograph a test mixture repeatedly to test column equilibrium each time a column is used after being shut down or when changing mobile phases.
- If possible, use a separate column for each mobile phase to avoid problems associated with slow equilibrium. Avoid gradient elution with silica gel or alumina columns.

Reverse Phase Chromatography

This section will only consider mobile phases for bonded polar phase columns such as C-8 and C-18, which predominate in pesticide determinations. Classical liquid-liquid chromatography (LLC) will not be covered because it has been almost completely superseded by bonded phase chromatography.

In RP chromatography, the mobile phase is more polar than the stationary phase, and the most polar compounds elute first from the column. Mobile phases generally consist of mixtures of water, the weakest solvent for RP HPLC, or aqueous buffers with water-soluble organic solvents. Typically used solvents include, in order of decreasing polarity and increasing elution strength: methanol, acetonitrile, ethanol, isopropanol, 1-propanol, dioxane, and tetrahydrofuran (THF). Acid and basic buffers are used in the ion suppression mode to convert, respectively, weak acid and weak base analytes to their nonionic, hydrophobic forms, which are selectively retained on RP phases. Totally nonaqueous mobile phases are being increasingly used for the “nonaqueous RP” HPLC of polar substances.

The selectivity triangle approach described above for NP HPLC is applied equally well to RP HPLC. The solvents nearest to the corners of the triangle and having the requisite water solubility are acetonitrile (dipole interactions), methanol (proton acceptor), and THF (proton donor properties). It is most common to start with a water/methanol mixture to find the optimum solvent strength (P'), and then add one or both of the other solvents to maintain the strength but increase selectivity for the required separation. Each mobile phase modifier imparts a special selectivity by causing lower k values (faster elution) for compounds with a particular type of functional group.

A systematic four-solvent, seven-mixture mobile phase optimization strategy based on the approach described above is widely used for isocratic NP and RP HPLC [3]. In the case of acids or bases, an additional modifier to adjust pH may be necessary, *e.g.*, 1% acetic acid in water for the chromatography of phenols. One of the seven mixtures tested by this protocol should provide the required separation. If not, a different column, temperature, pH, or solvent modifier is required. An HPLC system with four solvent reservoirs and computerized solvent mixing capability makes this optimization routine a simple matter.

Ion Exchange Chromatography

Solvents for the separation of ionic compounds (*e.g.*, pesticides with acidic or basic groups) by ion exchange chromatography (IEC) include aqueous acids, bases, or buffers that allow the analytes to possess full or partial electronic charges and to be more or less attracted to the ionic groups of the stationary phase.

Ion exchange separations usually depend on several equilibria, the positions of which are a function of the following factors: the relative affinities of the analyte and the mobile phase counter ions, the ionic strengths of the analyte and counter ions, the acid or base strengths of the analyte and the stationary phase functional groups, and the mobile phase pH.

The general approach to designing a mobile phase is to first adjust the ionic strength to give analyte k values between 2 and 10, and then adjust the pH to control selectivity. Low ionic strength facilitates retention and high ionic strength elution. A change in pH affects both the character of the functional groups of the stationary phase and the ionization of the analyte. Retention is favored by a mobile phase/exchanger pH between the pK_a values of the exchanger and the analyte (both must be charged). Elution is facilitated by mobile phase/exchanger pH above the pK_a of a cation or below the pK_a of an anion. Efficiency is improved by elevated temperatures and lower flow rates. An increase in counter ion concentration increases mobile phase strength. The proper choice of counter ion can improve selectivity. In general, exchangers prefer ions with higher charge, smaller hydrated diameter, and greater polarizability. Retention of analytes is favored if the exchanger is equilibrated with counter ions that are weakly held, and elution if the mobile phase/exchanger contain strongly held counter ions. Addition of an organic modifier generally increases solvent strength (especially if analytes are interacting with the mobile phase by a hydrophobic mechanism) and increases efficiency by lowering viscosity.

Ion Pair Chromatography

The mobile phase for ion pair chromatography is at a pH where the analyte is in its ionic form, and it also contains a pairing agent that conjugates with the analyte to form a hydrophobic, uncharged species that is selectively retained by a C-18 or C-8 bonded column. Typical pairing agents are a quaternary amine for weak acids and an alkyl sulfate or sulfonate for weak bases.

The choice of a mobile phase is aided by the following guidelines:

- 1) Methanol/water mixtures are preferred as the mobile phase to minimize counter ion solubility problems.
- 2) Short chain counter ions are recommended for analytes with little difference in molecular structure, and longer chain, hydrophobic counter ions for greater retention.
- 3) If silica-based bonded columns are used, the pH of the mobile phase must be maintained within the column's stability range. Use of porous polymer packings avoids this concern.
- 4) The mobile phase should be degassed before adding the counter ion to prevent possible foaming.
- 5) Typical concentrations for counter ions are 0.005-0.01 M, and 0.0005-0.001 M for buffer components.
- 6) Counter ions should not absorb UV light if a UV detector is in use.
- 7) To prevent salt precipitation, the pump should not be turned off until mobile phase is washed out of the system. Alternatively, a slow flow of mobile phase can be maintained overnight. It is best to have a dedicated column only for ion pair HPLC.

Size Exclusion Chromatography

Because of the nature of size exclusion chromatography, there are only two basic requirements for a mobile phase: it must readily dissolve the analyte and not damage the stationary phase. Solvents that are not compatible with polystyrene-divinylbenzene (DVB) phases include water, alcohols, acetone, methyl ethyl ketone, and dimethylsulfoxide. If the analyte does not dissolve well in the mobile phase, tailing and/or delayed elution due to interaction of the analyte with the stationary phase can occur. Adsorption effects are reduced by using a mobile phase chemically related to the stationary phase, *e.g.*, toluene for polystyrene-DVB columns.

Gradient Elution in HPLC

The preceding discussions relate principally to mobile phases for isocratic HPLC. Isocratic elution is widely used because of its convenience and reproducibility. It is not adequate, however, for separation of analytes containing components with greatly different retention times. Gradient elution improves resolution of early

eluting peaks while causing later eluting peaks to elute sooner and in a narrower band. Alternative approaches to the general elution problem include column coupling and flow and temperature gradient, but these will not be discussed here.

Solvent gradients are usually composed of a binary mixture of a weak solvent to which continuously increasing amounts of stronger solvent are added in a linear, convex, or concave relationship over time. Isocratic elution periods are often included at the beginning and/or end of the gradient sequence. Important considerations include the solvents chosen, the initial and final composition, and the gradient shape and steepness. Stepwise gradients are also possible. Methods are available for predicting and optimizing gradients for the different HPLC modes [4, 5], but the most suitable gradient for a particular separation is usually determined empirically.

Gradient elution is used widely in NP and RP bonded phase and IEC. It is not recommended for LSC and cannot be used with LLC or with refractive index (RI) or conductivity detectors. Regeneration at the end of the gradient must return the column to equilibrium with the initial solvent. Solubility considerations may require purging the system with an intermediate strength solvent, or it may be possible to simply pass 5-10 column volumes of the first solvent through the column.

pH and ionic strength gradients are common in IEC to control mobile phase strength and selectivity. Gradients for ion pair chromatography must be checked to be sure that the counter ion and buffer components are soluble in all solvent compositions used. Ion pair gradients may involve a solvent gradient with constant pH and counter ion concentration, or these may be changed along with, or instead of, the methanol/water (or other solvent) composition.

603 B: MOBILE PHASE PREPARATION

Mobile phases must be prepared from high purity solvents, including water that must be highly purified (see Section 601 D). Mobile phases must be filtered through $\leq 1 \mu\text{m}$ pore size filters and be degassed before use.

Filtering Solvents

Particulate matter in solvents can damage pumps, block flow in tubing, and degrade column performance. Filtering of all HPLC solvents should be a routine laboratory procedure. Filtering is especially important for removal of particles when solvents are stored over molecular sieves. Commercial units that attach to any vacuum line are available for simultaneous filtration and degassing of solvents, or similar apparatus can be assembled in the laboratory. Commercial nylon membrane filters with 0.22-1.2 μm pore size are compatible with all solvents commonly used in HPLC. Most commercial HPLC grade solvents are prefiltered through a 0.2 μm filter and should not require additional filtration.

Degassing Solvents

Degassing of solvents is necessary to avoid problems with columns, pumps, and detectors caused by gas bubbles in the system. The filtering step, if carried out with an aspirator or vacuum pump, can also provide degassing. Degassing of volatile

solvent mixtures with a vacuum can change the composition of the solvent; vacuum degassing should never be used for such mixtures.

Other degassing methods include boiling, use of an in-line degassing unit with a gas-permeable membrane, or by agitation in an ultrasonic bath. However, the most effective and convenient degassing method is helium sparging. A commercial unit can be used, or a setup can be made in the laboratory from Teflon tubing and an inlet line frit attached to a helium supply. The frit is immersed in the solvent reservoir, and helium is bubbled for a few minutes with about 3-4 psi pressure at the tank. The helium flow is reduced to a trickle during operation of the system. If solvent mixtures are made manually, individual solvents are degassed prior to preparation, and the mixture is kept under helium during use.

Preparation of Multisolvent Mobile Phases

Mobile phase mixtures can be prepared either by manual blending or by in-line mixing using the HPLC solvent blending and delivery apparatus. Laboratory glassware used for preparing mobile phases should be exceptionally clean so it does not introduce particles or impurities.

Two different approaches to manual preparation of solvents are possible. Either is valid, as long as the preparation method is clearly recorded so others can reproduce the results. In the first method, volumes of solvents A and B measured in graduated cylinders or pipets are mixed together in the mobile phase reservoir. In the second method, a measured volume of solvent A is placed in a volumetric flask, and the solution is diluted to the line with solvent B and transferred to the mobile phase reservoir. Solutions prepared by these methods will be slightly different, especially for water/alcohol mixtures, because of the nonexact additivity of volumes upon mixing. It is good practice to prepare the mobile phase fresh each day, especially if a volatile solvent is involved. If the mobile phase will be used for longer periods, it should be definitely proven, *e.g.*, by measuring RI or chromatographing a test mixture, that there is no change in composition with time.

If an error in composition is suspected for a mobile phase prepared in-line, a new batch of the mobile phase should be carefully prepared manually and the separation repeated.

Solvent Reservoirs

The solvent container should be made of a material from which the solvent cannot leach significant impurities, and should have a cover with a small opening through which the Teflon or stainless steel delivery tubing fits snugly but without constriction. The reservoir is placed away from sunlight or drafts to avoid temperature gradients, and above the solvent delivery system to provide siphon feed to the pump. The reservoir should be labeled with the composition and date of preparation of the mobile phase, and a solvent reservoir filter (sinker frit) should be attached to the end of the delivery tube.

603 C: MOBILE PHASE DELIVERY SYSTEMS

Pumps

The function of the pump in HPLC is to deliver the mobile phase through the column at high pressure with a controlled flow rate. Two major categories of pumps are constant flow or volume and constant pressure. Constant pressure pumps apply a constant pressure to the mobile phase; flow through the column is determined by the flow resistance of the column and any other restrictions in the system. Constant flow pumps generate a certain flow rate of mobile phase; the pressure depends on the flow resistance.

Constant flow pumps are recommended for HPLC because flow resistance may change with time due to swelling or settling of the column, small temperature variations, or buildup of particulate matter. These effects will cause flow rate changes with a constant pressure pump and result in nonreproducible retention data and erratic baselines.

A suitable pump should have the following characteristics:

- 1) The interior of the pump should be made of inert materials that resist corrosion by any solvents being used.
- 2) Pressures up to 6000 psi and a wide range of flow rates (0.1–10 mL/min) should be available, and the flow rate should be easy to change. High flow rate capability is especially important for preparative work.
- 3) The flow should be constant, reproducible within at least 1%, and pulseless or have a damping system to minimize detector noise generated by the pulses. It should be easy to set, measure, and change the flow rate.
- 4) It should be easy to change from one mobile phase to another.
- 5) The internal volume of the pump and all of the plumbing between the pump and the injector should be as small as possible.
- 6) The pump should be useful for isocratic or gradient operation.
- 7) The pump should be adaptable to the use of small volumes of mobile phase, a high volume mobile phase reservoir, or a heated reservoir.
- 8) The pump should be easy to maintain and repair. Even with the best of care, seals, rings, and gaskets will require occasional replacement, and it will help if these are easy to access.

Figure 603-a
Reciprocating Pump

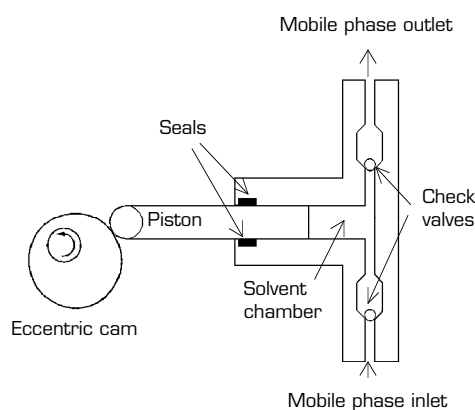

[Reprinted with permission of John Wiley and Sons, Inc., from Lindsay, S. (1987) *High Performance Liquid Chromatography*, Figure 2.2d, page 21.]

Neither constant pressure pumps nor screw-driven syringe constant flow pumps are described here because the reciprocating pump (Figure 603-a) is used in most HPLC instruments. In this pump, a small piston is driven in and out of a solvent chamber by a motor-driven eccentric cam and gear arrangement. On the forward stroke, the inlet check valve closes, the outlet valve opens, and the mobile phase is pumped to the column. On the return stroke, the outlet valve closes and the chamber is refilled.

Because the displaced volume is small, the pump must cycle frequently. Abrasion is minimized by using hard, smooth piston material such as borosilicate glass, sapphire, or chrome-plated steel. Solvent capacity of a reciprocating pump is unlimited if the external reservoir is filled as required. The internal chamber volume can be very small (*e.g.*, 10-100 μL), allowing rapid change of mobile phases. The flow rate, 0.01-50 mL/min, is changed by varying the length of the piston stroke or the speed of the motor. Piston seals and check valves must remain leak free. This requires regular maintenance and periodic replacement of parts. Access to valves and seals for maintenance is usually quite easy.

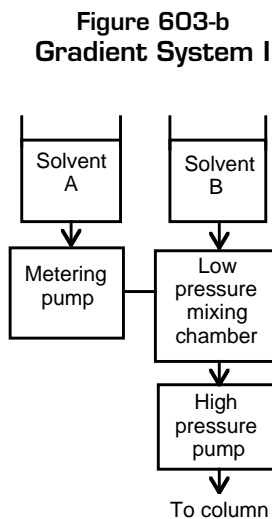

[Reprinted with permission of John Wiley and Sons, Inc., adapted from Lindsay, S. (1987) *High Performance Liquid Chromatography*, Figure 2.2f, page 24.]

Figure 603-a shows a single-head reciprocating pump, in which solvent is delivered to the column for only one-half of the pumping cycle. Flow pulsations arise from the piston action, which may produce noise with some detectors during high sensitivity analyses. Flow noise is reduced if the pump is designed with a rapid stroke rate so the detector cannot respond rapidly enough to sense the flow changes. Other ways to obtain constant flow rate are the incorporation of dampeners or a feedback control system.

Twin- or dual-piston reciprocating pumps have two heads operated 180 degrees out of phase by the action of a single cam so that one pumps while the others refills, producing a constant, pulseless flow and reduced noise.

The diaphragm or membrane reciprocating pump is a variation of the piston pumps described above. A piston is driven back and forth by an eccentric disc. The movement is conveyed hydraulically to a flexible steel membrane, which flexes and displaces the solvent out to the column, and then pulls in mobile phase from the reservoir when the diaphragm returns. Check valves at the inlet and outlet ensure flow in the proper direction. The piston does not contact the solvent directly, so seals are not needed. Pulsations caused by discontinuous pumping and suction cycles are stabilized by incorporation of a damping system or two pistons synchronized to minimize pulse lag. Back pressure changes in the column and the elasticity of the diaphragm can cause flow rate

**Figure 603-c
Gradient System II**

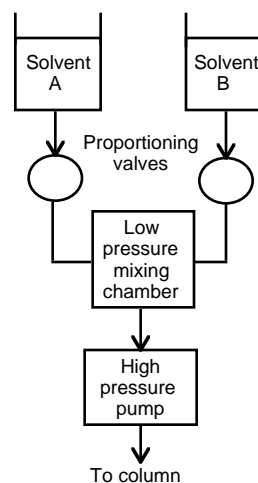

[Reprinted with permission of John Wiley and Sons, Inc., adapted from Lindsay, S. (1987) *High Performance Liquid Chromatography*, Figure 2.2f, page 24.]

**Figure 603-d
Gradient System III**

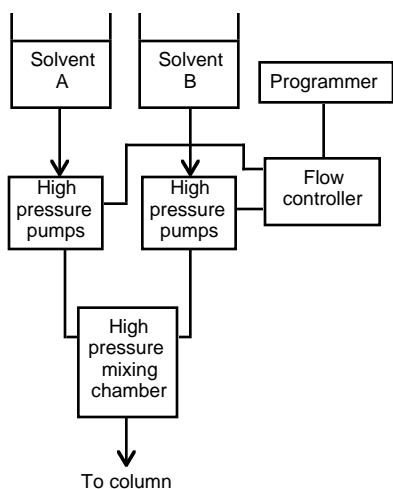

[Reprinted with permission of John Wiley and Sons, Inc., adapted from Lindsay, S. (1987) *High Performance Liquid Chromatography*, Figure 2.2f, page 24.]

deviations. A feedback flow controller should be incorporated to ensure constant flow rate.

Gradient Programming Systems

Figures 603-b, -c, and -d show the arrangements for gradient-forming systems involving two solvents.

In Figure 603-b, the gradient is formed at low pressure by metering controlled amounts of solvents A and B from low pressure pumps into a mixing chamber (volume <1 mL) fitted with a magnetic stirrer, from which it is drawn into a high pressure pump for delivery to the column.

The arrangement in Figure 603-c is similar, but composition of solvent in the low pressure mixing chamber is regulated using microprocessor-controlled, solenoid-operated time-proportioning valves. Low pressure systems with no mixing chamber are also available. Such systems, which

ensure that the gradient is not retarded, involve highly precise valve control and a great deal of mechanical and electronic equipment to mix extreme volume ratios.

In Figure 603-d, the separate solvents are pumped with two high pressure pumps into a high pressure mixing chamber. The type of gradient formed is controlled by programming the delivery rate of each pump. Electronic control must ensure that the total volume is always constant and that compensation is made for changes in viscosity. The post-pump chamber must provide rapid and complete mixing and have a small volume and no "dead" areas. This method is more expensive than low pressure mixing because a separate pump is required for each solvent and thus is decreasingly favored.

Technically sophisticated systems, usually involving low pressure, controlled mixing and delivery to the column with a high pressure pump, are now available for gradients involving three and four different solvents, which are becoming more widely used for separation of complex mixtures.

Errors in gradient formation can be caused by restricted lines and loose tubing connections, which can be corrected by the operator. Problems with valve controllers or software usually must be handled by a manufacturer's service technician.

603 D: MAINTENANCE AND TROUBLESHOOTING

Problems with Pumps

The following considerations are important in the maintenance and troubleshooting of all types of HPLC pumps:

- Have pumps set up by a manufacturer's service technician, who should explain proper operation, maintenance, troubleshooting procedures, and precautions to all users and in-house service personnel.

- Obtain all available operation manuals and require that they are read carefully by users. Many manufacturers provide extensive maintenance and troubleshooting information with their pumps.
- Stock an adequate supply of parts that require routine replacement or may be damaged or broken during routine maintenance, such as seals, plungers, fittings, cams, O-rings, heads, check valves, springs, clamps, *etc.*
- Maintain a log notebook for each pump. List maintenance and repair dates and procedures, and use and storage history.
- Do not store corrosive solvents or buffers in the pump overnight.
- Periodically lubricate pump motors with the proper grade of oil.
- Do not attempt to replace one solvent with another unless both are completely miscible.
- Degas solvents to avoid bubbles in the pump head(s) and filter all solvents. These are the two primary precautions for preventing pump problems.
- If possible, avoid highly volatile solvents (*e.g.*, pentane), which with the pumping action can cause volatilization and bubbles.
- Avoid pump overheating by working in a well-ventilated area.
- Confirm that the pressure limit switch, if available, is set properly.
- Inspect pump heads and fittings for leaks on a daily basis. Leaks can be caused by dirty pistons and worn piston seals. Gentle tightening of fittings usually eliminates leaks. Overtightening of fittings can cause leaks and permanently damage the part. This can be an expensive matter if the affected fitting threads into a pump check valve or head.
- Dirty, sticking, or malfunctioning check valves can cause irregular or inaccurate flow and drifting baselines, or stop flow altogether. Check valves can be replaced or cleaned. In either case, follow the manufacturer's instructions.
- Determine the useful lifetime of pump seals under the operating conditions in each laboratory. Replace the seals on a regular basis before the useful lifetime is over, or at least on a yearly basis. At the same time, inspect the piston for scratches.
- Verify the flow rate of pumps on a periodic basis, to an accuracy of 10%, by delivery into a graduated cylinder while timing with a stop watch. When an accuracy of $\pm 1\%$ is desired, use a stop watch and buret. Measure the time interval as the meniscus passes two marks on the buret a known volume apart. At least a 2 min period is desirable for this degree of accuracy. If the delivered flow rate is not within specifications, check for leaks and/or make adjustments or repairs as outlined in the operating manual.

- If the pump starts up but does not move the solvent, it is probably in need of priming. Pump-priming procedures vary from one instrument to another; check the correct procedure in the manufacturer's instrument manual.

Problems Caused by Air. Most problems with HPLC pumps are caused by air bubbles. These arise when air is drawn into the pump when the solvent reservoir runs dry or the solvent inlet line is lifted out of the reservoir; from leaks at the fittings that connect the inlet tubing to the pump; from bubbles generated when the mobile phase components are mixed; or from cavitation of the mobile phase in the inlet line or pump head. The symptom in each case is stoppage of flow or fluctuating pressure.

A sinker frit on the end of the inlet tubing or tight connection through a cap at the mouth of the reservoir will keep the tubing submerged in the bottom of the reservoir and prevent air in the reservoir from reaching the pump.

If an air leak on the inlet side of the pump is suspected, carefully tighten each of the fittings, including the check valve. Do not overtighten plastic fittings to the point of distortion. If the leak persists, disassemble the fittings and examine them for damage.

Recut suspect tube ends and re-assemble or replace suspect low pressure or compression fittings until the problem is solved. If buffers have been used, flush the fitting with nonbuffered solvent before re-assembly.

When RP solvents (*e.g.*, water and methanol) are mixed, the mixture has a lower capacity for dissolved gases than the pure component solvents. This is why bubbles often are seen evolving from freshly mixed mobile phase. With manual mixing, excess gas bubbles from the solution, but the mixture remains saturated with air. Therefore, when the pump begins to fill, pressure is reduced and gas bubbles form in the pump head. With low pressure mixing, solvents are combined just prior to the pump. Mobile phase entering the pump is supersaturated with air, which bubbles out in the pump. With high pressure mixing, solvents are mixed after the pump, so bubble problems should not occur in the pump. Proper degassing of solvents (Section 603 B) is essential.

Cavitation occurs when the pump draws solvent through a line with restricted flow and creates a partial vacuum in the line. This vacuum can cause dissolved air to expel, forming bubbles in the inlet line or pump head. Blockage of the inlet filter in the mobile phase reservoir is a common cause of cavitation that can be corrected by replacing the restricted filter. Another cause is a tightly fitting reservoir cap that is not properly vented. Drilling a very small (<1 mm) hole in the cap or loosening it can remedy this problem.

Problems Caused by Dirt. The most damaging pumping system problems are caused by dirt, a term that encompasses particulate matter introduced by the mobile phase, buffer evaporation, or wearing of seals. The main problems caused by the presence of dirt are malfunctioning check valves and premature pump seal wear.

Particulate matter can prevent proper sealing of check valves, resulting in pressure fluctuations and poor pump delivery. With high pressure mixing, a dirty check valve can cause proportioning problems. If simple flushing does not cure a

suspected check valve problem, the valve should be replaced. If the problem is eliminated, the dirty check valve should be cleaned, if possible, and later re-used. If it cannot be cleaned, it can be returned to the manufacturer for rebuilding. A dirty check valve is cleaned by rinsing with HPLC grade solvent or sonicating in 10% nitric acid followed by rinsing with HPLC grade water.

If a pump containing buffered mobile phase is shut off and allowed to sit overnight or longer without washing out the buffer, mobile phase behind the pump seal will evaporate and abrasive solid crystals will form. When the pump is restarted, these crystals will abrade the seal and cause accelerated wear. Abraded seal particles can also cause check valve problems and block the top column frit. Flushing with 10-20 column volumes of nonbuffered solvent at the end of each day is recommended. Some pumps are designed to allow direct flushing of buffer from behind the seal. The pump operation manual should be consulted.

Proportioning Problems. To prevent proportioning problems, solvents must flow freely with no restrictions. Change inlet (sinker) frits in solvent reservoirs before they become blocked. Make buffers fresh daily to extend frit lifetime by retarding microbial contamination. Make sure that low pressure fittings are sealed properly so that air cannot leak in and solvent out. Thoroughly degas solvents to prevent bubble problems. Elevate solvent reservoirs above the proportioning manifold to apply slight head pressure and improve the reliability of solvent delivery.

Run reference tests routinely to recognize mechanical problems with the proportioning valves and problems with the controlling software. For example, set the programmer so the solvent does not flow through the column. Use any convenient (miscible) solvents of HPLC quality in the pumps. Attach a recorder to the program monitor terminal jacks so the pen traces the gradient. Operate the programmer as outlined in the instrument operating manual. Compare the trace on the recorder to determine whether the correct programs are actually being produced. Test each program that is regularly used for actual analyses.

Another test may involve a series of 10% isocratic steps from 0 to 100% of solvent B (containing a UV absorber to allow detection), changed every 5 min. The resulting trace of absorption *vs* time should yield rising steps that have the same height and are fairly square. A third test is a 20 min blank gradient run at 4 mL/min using the same spiked B solvent. This trace should be essentially straight (especially between 5 and 95% B), with angular intersections at the 0% baseline and 100% plateau.

Bubble problems can be caused by air leaks, which can occur when a proportioning valve diaphragm becomes perforated or other damage to the solvent proportioning manifold occurs. The proportioning manifold can be tested by connecting the manifold inlet and outlet tubing with a union. If the bubble problem disappears, the manifold is bad and must be replaced.

References

- [1] Snyder, L.R. (1974) *J. Chromatogr.* **92**, 223-230
- [2] Snyder, L.R. (1978) *J. Chromatogr. Sci.* **16**, 223-234
- [3] Glajch, J.L., *et al.* (1980) *J. Chromatogr.* **199**, 57-79

- [4] Snyder, L.R., *et al.* (1988) Chapter 6, *Practical HPLC Method Development*, Wiley-Interscience, New York
- [5] Poole, C.F., and Schuette, S.A. (1984) *Contemporary Practice of Chromatography*, pp. 265-271, Elsevier, New York

604: INJECTION SYSTEMS

The purpose of the injection system is to apply the sample extract onto the column in a narrow band. Three techniques are available: direct syringe injection, stop-flow syringe injection, and use of an injection valve.

In direct syringe injection, the extract is injected into the flowing mobile phase through a septum using a high pressure syringe in a manner similar to GLC. A septumless injector is also available for direct syringe injection without interrupting mobile phase flow. In stop-flow injection, injection is made at ambient pressure after depressurizing the injection port by use of a sliding seal and shut-off valve, or by turning off the solvent delivery pump. The direct syringe injection and stop-flow injection techniques are now obsolete and rarely used.

604 A: INJECTION VALVES

The injection valve is at present the most widely used injection device for reproducibly introducing sample extracts into pressurized columns without flow interruption. Valves can be made with external or internal loops. Virtually all commercial external loop valves are variations of the six-port design shown in Figure 604-a. A fixed volume loop is connected across two of the ports. The extract is introduced through the injection port, and excess extract flows out through the waste port. The other two ports provide a path for the mobile phase as it is pumped into the column. External loops are available in sizes ranging from 5 μL to 2 mL. The 10 and 20 μL sizes are probably most widely used. Loops are usually made from standard 1/16" stainless steel, but other materials are used in biocompatible injectors.

When the valve is rotated to the load position on the left in Figure 604-a, mobile phase flows directly from the pump to the column and the loop connects the injection and waste ports. The loop is at ambient pressure and is filled with extract from a regular

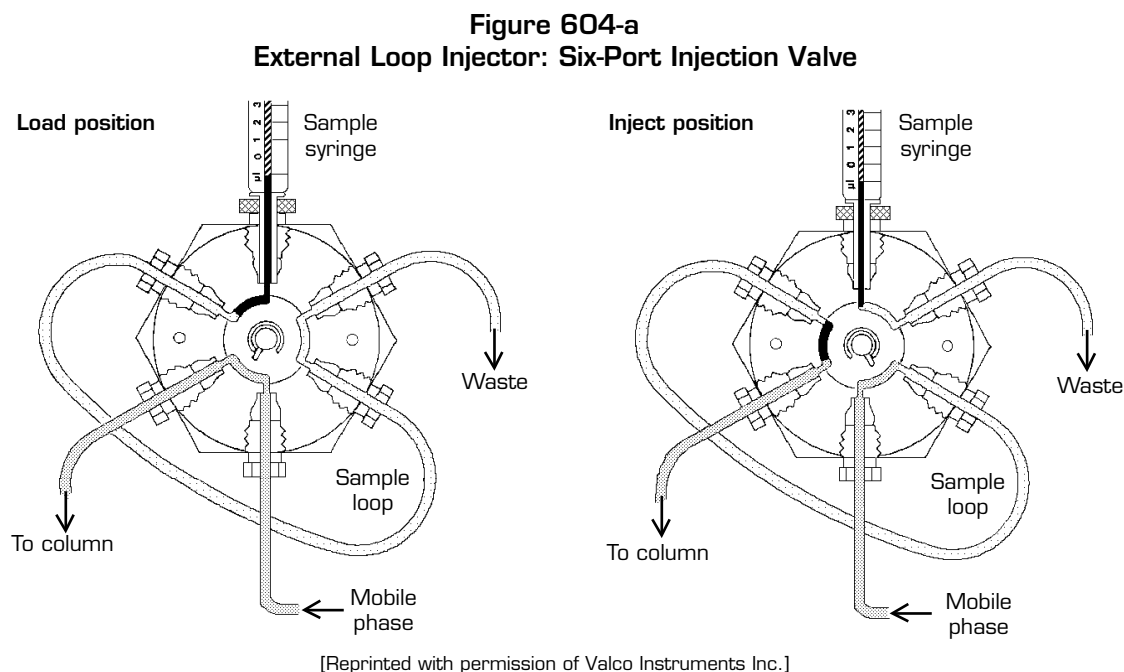

microliter syringe. When the valve is rotated to the inject position, shown on the right, mobile phase flows through the loop, sweeping the extract rapidly onto the column.

One common technique is to fill the loop completely with extract (the “filled loop” technique). In this case, the loop volume fixes the injection volume, and the loop must be changed to vary the extract volume. To achieve good reproducibility, an extract volume equal to twice the loop volume should be used to flush and fill the loop. If a Teflon waste tube is used, air and excess solvent will be seen going to waste. All air should be expelled when filling the loop. For applications in which limited extract is available, some valves have a special loop-filler port that permits loading of the loop with minimal waste.

Other methods for varying the volume of extract injected include filling a fixed volume loop completely with a combination of extract and solvent; partially filling the loop (the “partial loop” technique), following the manufacturer’s procedural guidelines; or using special variable volume valves. For best results with the partial loop technique, the volume of extract injected should be <50% of the nominal loop volume, *e.g.*, 10 μL extract in a 25 μL loop. If a tiny air bubble is injected just before the extract to isolate it from previous solution in the loop, >50% of the nominal loop volume can be injected. The partial loop technique allows flexibility of injection volume, but precision is dependent on the analyst’s skill in reproducibly injecting specific extract aliquots from a syringe.

Recently, the six-port valve has been adapted to place cleanup and analyte concentration steps in-line with the determinative step. A short cleanup column chosen for its ability to retain the analyte replaces the loop shown in Figure 604-a [1]. While the valve is in the load position, sample extract is injected onto the cleanup column; subsequent injection of solvent removes co-extractives to waste without removing the analyte. When the valve is rotated to the inject position, mobile phase flows through the cleanup column and elutes the analyte onto and through the analytical column to the detector. Variations of this technique can involve cleanup and analytical columns of the same or different HPLC modes [2]. When the injection valve is used this way, no loop is available, so the extract volume injected must be measured accurately in a syringe.

Figure 604-b
Internal Loop Injector

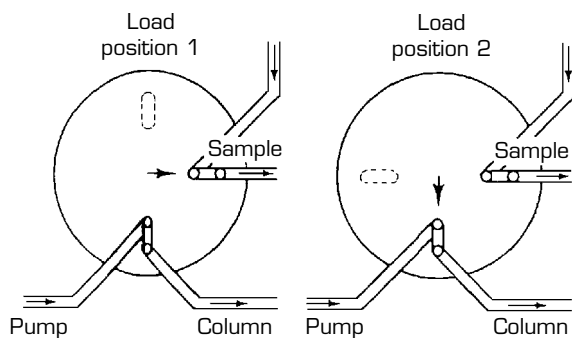

[Reprinted with permission of John Wiley and Sons, Inc., adapted from Lindsay, S. (1987) *High Performance Liquid Chromatography*, Figure 2.2g, page 26.]

Internal loop injectors are valves with four ports, with the loop in the form of an engraved groove or slot in the body of the valve. These are used for injecting extracts in the 0.05-5 μL range. Figure 604-b illustrates the internal loop injector. These injection valves are also available for microbore HPLC. This type of valve, which is designed for narrow bore (1-2 mm) columns, has a 0.2-1 μL interchangeable chamber and built-in needle port with 0.3 μL holdup volume to reduce extract loss.

Ten-port multifunctional valves are now available for HPLC. These can perform as a standard six-port injection valve and in addition allow extract injection followed by back flush, injection into two columns simultaneously, injection into either of two columns (random access), extract injection followed by precolumn back flush, trace enrichment, alternate extract injection from two streams, two-column selection with flow maintained in both, heart-cutting operations, and fast, sequential injections of a single extract.

Injection valves used with the filled loop technique are easy to use, provide the best precision for quantitative HPLC, typically <1% relative standard deviation, are easily adapted for automatic injection, and allow high pressure operation (up to 7000 psi). The partial loop injection technique is not as reproducible as the filled loop technique for manual injections. It is best used only for preliminary experiments when determining the optimum injection volume, or with automatic injectors that provide high precision automatic syringe delivery. To maximize column efficiency, the smallest convenient extract volume should be injected using an extract solvent that is weaker (*i.e.*, more polar for reverse phase HPLC) than the mobile phase.

The method used to insert the valve in the HPLC system is critical for minimizing loss of efficiency. A 5 cm length of 0.15 or 0.50 mm id tubing between the valve and column with connection via a low or zero dead volume fitting is recommended. When using the partial fill technique, the valve should be connected as shown in Figure 604-a. This plumbing arrangement delivers the extract to the column before the solution previously in the loop, preventing band spreading due to dilution of the extract.

604 B: AUTOMATIC INJECTORS

Automatic injectors are valve injectors whose rotation is controlled by pneumatic or electric actuators. Most use a mechanized syringe to dispense the extract into the loop. Systems with both fixed and adjustable volumes are available for unattended operation. A typical adjustable volume model allows injection of 1-100 μL , accurate measurement by a motor-driven microsyringe, a positive displacement mechanism to minimize extract waste, microprocessor-controlled injection sequencing, and a multivial sample turntable. The microprocessor controls movement of the turntable, sampling needle, microsyringe, and injection valve. All injection parameters, including sampling interval, sample number, and injections per sample, are entered from a keyboard. Injection precisions are typically quoted as 0.5-1%.

604 C: OPERATION, MAINTENANCE, TROUBLESHOOTING, AND REPAIR OF INJECTION VALVES

The following considerations are important for trouble-free operation, maintenance, and repair of injection valves:

- Read carefully the literature packed with the valve for information on installation, use, maintenance, and repair.
- The major cause of injector problems is particulate matter entering the valve. Particles can lodge in moving parts, scratch the rotor surface, and cause leakage. They can also block the connecting tubing or sample loop. To avoid formation of particles, dissolve the sample extract in the

mobile phase itself. If a solvent is used in which the analyte is more soluble, components of the extract may precipitate when contact is made with the mobile phase. To eliminate particulate matter, install an in-line 5 μm filter between the pump and the valve, and filter any extracts that have visible particulate material or are cloudy or opalescent.

- If blockage occurs, locate it and back flush the blocked passage; disassemble the valve and sonicate the blocked part in soapy water, rinse in clear water, and blow the passage clear with compressed air; or replace the blocked tubing. Return blocked valves that cannot be cleared in the laboratory for reconditioning by the manufacturer.
- To minimize rotor seal wear, prevent abrasive particles from entering the valve as described above, and do not allow buffered or corrosive mobile phases to remain in the valve for extended periods of time without flushing.
- Do not operate above the pressure limit of the valve (usually 1500-7000 psi) or leakage may occur. Operate at the lowest possible pressure to reduce rotor seal wear.
- Use valves that are constructed of materials compatible with extract and mobile phase components. In addition to the usual valves constructed from stainless steel with a polymeric rotor, specialty valves made from more inert materials are commercially available.
- Maintain a good supply of spare parts, *e.g.*, dead volume fittings, ferrules, and rotors. It is best to stock backup valves in case repair cannot be done in the laboratory and return of a malfunctioning valve to the manufacturer is necessary.
- Engrave an identification number on each valve, and keep a log notebook to monitor the history of use and repairs.
- Do not overtighten valve fittings. Overtightening can cause leaks or damage to the valve body.
- To minimize dead volume and peak broadening, use connecting tubing between the injection valve and the column, and the column and the detector, that is as short as possible and has a small id. See that valve tubing is straight and has a perpendicularly flat end that is sealed tightly inside the port in the valve body. Do not allow metal pieces formed in the tube-cutting process to enter the valve body.
- Identify crossport leaks by observing mobile phase emerging from a Teflon exit line when the valve is in the load or run position.

References

- [1] Niemann, R.A. (1993) *J. AOAC Int*, **76**, 1362-1368
- [2] Wojtowicz, E.J. (Feb. 1992) "HPLC Fluorometric Analysis of Benomyl and Thiabendazole in Various Agricultural Commodities," LIB 3650, FDA, Rockville, MD

605: DETECTORS

The function of an HPLC detector is to continuously and instantaneously monitor the mobile phase emerging from the column. The output of the detector is an electrical signal that results from measuring some property of the mobile phase and/or the analytes. Application of HPLC to trace residue determination is dependent on the availability of sufficiently specific and sensitive detectors. The common HPLC refractive index (RI) detectors are nonselective and require microgram quantities of analyte, so were never adequate.

The UV/VIS absorbance and fluorescence detectors are now commonly applied to pesticide residue determination, because methods research has resulted in schemes that utilize their capabilities while overcoming their limitations. Other detectors available for HPLC include photoconductivity, electrochemical, and mass spectrometric; published applications to residue determination increase each year. Use of combined detection systems is also increasing, *e.g.*, the combination of UV absorbance and electrochemical detection.

The following are important characteristics of HPLC detectors:

Sensitivity. Detector sensitivity is a gauge of the detector's response (signal) to the presence of an analyte. In HPLC applications, the usual quantitative measurement is called minimum detectability, defined as concentration of analyte that causes the detector to produce a response twice that of instrument noise.

Minimum detectability refers to detector response to an analyte in pure solution. "Limit of detection" or "limit of determination," however, takes into account the amount of sample extract that can be introduced to the detector and is partially dependent on the degree of cleanup provided by the analytical method (see Section 105). Injection volume is an important parameter in determining the limit of detection of an HPLC analysis, because aqueous extracts prepared for HPLC determination are not easily concentrated. However, HPLC can tolerate large volumes of solvent without loss of column performance, thus improving detection. Injection volumes up to 100 μL are not unusual for analytical HPLC.

Linearity. The linear range is the concentration range over which response is directly related to analyte concentration (*i.e.*, a plot of response *vs* concentration has a constant slope). Linearity is commonly expressed in units such as 1:10,000 or 10^4 , which might indicate a range of 10^{-10} (the minimum detectable quantity) to 10^{-6} g/mL for the UV detector.

Selectivity of Response. Universal detectors respond to all components in the extract, while specific (selective) detectors respond to only certain compounds depending on their structure. Selective detectors are usually more sensitive and less affected by variations in the mobile phase.

Effect of Changing Conditions. Ideally, the detector should not be affected by changes in temperature or mobile phase composition.

Time Response. The detector-recorder combination should react rapidly so that quickly eluting, narrow peaks can be measured accurately. The time constant of the detector-recorder, which is defined as the time required to reach 63 or 98% of full

scale deflection, should be at least in the 0.1-0.3 sec range for high speed HPLC and narrow peaks. Modern instruments are capable of response in the millisecond range.

Cell Volume. Detector cell volume should be minimized to limit peak broadening and maximize efficiency. A cell volume of 8 μL is typical, with smaller values for micro-HPLC. The volume of associated tubing should also be minimized. However, as the volume of the detector cell decreases, sensitivity of detection is poorer. Detector design should eliminate dead corners in the cell from which the analyte is not quickly washed by the mobile phase.

Noise and Drift. Baseline noise, as indicated by variations in the recorder signal with no sample in the detector cell, is caused mostly by the electronics of the detector, recorder, or amplifier. Additional sources include the mobile phase (bubbles, changes in flow rate or pressure, leaks, impurities) and temperature fluctuations. To reduce the chance for bubble formation from depressurized mobile phase in the detector cell, modern detectors include a back pressure restrictor.

Baseline drift may occur when the HPLC system is first turned on. If drift persists after warmup, it is most likely due to changes in mobile phase composition, leaks, temperature variations, column bleed, or a gas bubble in the detector cell. Baseline drift can also be caused by slow elution of highly retained components left on the column from previous samples.

Nondestructiveness. An analyte can be collected for further characterization if its chemical form is not changed by the detector. UV and fluorescence detectors are examples of nondestructive detectors, while the electrochemical and photoconductivity detectors are destructive.

Ruggedness, reliability, and ease of use, maintenance, and repair are also important qualities to seek in HPLC detectors.

605 A: UV/VIS ABSORBANCE DETECTORS

The most popular HPLC detectors are the fixed and variable wavelength UV/VIS types. Fixed wavelength UV detectors most often operate at 254 nm, which is useful for molecules with aromatic rings, carbonyl, conjugated double bonds, and other suitable chromophores. Variable wavelength detectors usually operate in the 190-380 nm range with a deuterium source or 190-900 nm with a supplemental tungsten source. Other supplementary lamps that have been used are the 229 nm cadmium lamp and 214 nm zinc lamp.

Variable wavelength detectors provide several advantages. A wider applicability and significant increase in sensitivity often result from operating at wavelengths in the 190-230 nm range. This is due to the large molar absorptivities of many pesticides in this region. Typically, aromatic systems have a 10-50 times greater absorbance at 214 and 229 nm than at 254 nm. Different peaks in the chromatogram can be detected at different optimum wavelengths.

Very pure solvents, including water, must be used to avoid noise and unstable baselines at the lower wavelengths. Increased selectivity for pesticides with aromatic and certain other functional groups can be obtained by measuring at longer wavelengths such as 280 or 295 nm. This gives the analyst the ability to "edit out"

unwanted peaks. This approach, however, may lead to some loss in sensitivity if measurement of the analyte cannot be made at its wavelength of maximum absorbance. An additional advantage of a spectrophotometric-type detector is that unknown components can be identified by stopping the mobile phase flow and scanning the full UV/VIS spectrum of the component trapped in the sample cell (stop-flow scanning).

Fixed Wavelength UV Detectors

There are several types of fixed wavelength UV detectors that differ mainly in the output of the source. One type has a low pressure mercury lamp source that emits a sharp line spectrum. A filter passes the principal 254 nm line and removes other weaker lines. A second type has a modified mercury lamp with a phosphor and provides output at 254 or 280 nm. A third type employs a medium pressure mercury lamp and band pass filters to isolate emission lines at 220, 254, 280, 313, 334, or 365 nm.

Figure 605-a shows a diagram of the light path and liquid flow path for a double-beam fixed wavelength UV/VIS detector. Light from the source is focused by a quartz lens onto sample and reference cells. Column effluent flows continuously through the sample side (top), while the reference side (bottom) is filled with pure mobile phase or air. A wavelength of absorption is chosen by the filter. After passing through the filter, the radiation is chopped by a rotating sector so that alternating pulses fall on the detector (double beam in time). The presence of absorbing analyte in the sample cell decreases the intensity of the sample beam relative to the reference beam. The difference in signal between the two beams, which represents the absorbance of the analyte, is amplified and recorded.

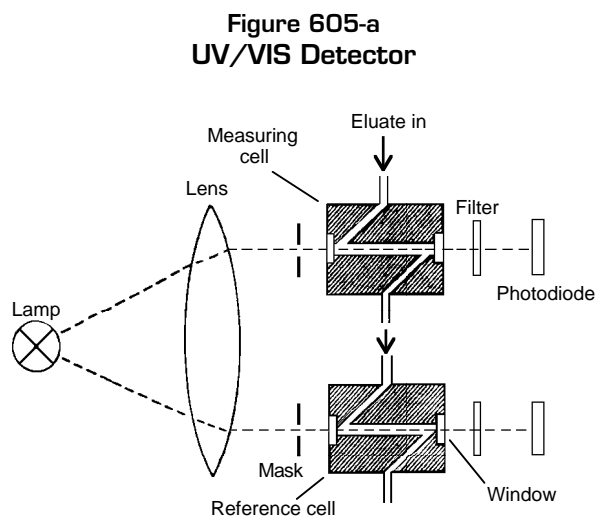

[Reprinted with permission of John Wiley and Sons, Inc., from Meyer, V.R. (1988) *Practical High Performance Liquid Chromatography*, Figure 5.5, page 69.]

In an alternative detector design, the sample and reference radiation fall on two photodetectors whose outputs pass through pre-amplifiers to a log comparator, which produces the absorbance signal. Double-beam design compensates for changes in source output and photomultiplier tube response.

Detector cells are typically 1 mm id with a 10 mm optical path, or approximately 8 μ L volume. The most common designs are the H-cell, Z-cell, and the tapered cell. The latter design minimizes the effects of changing mobile phase RI, as can occur during gradient elution.

Figure 605-b
Variable Wavelength UV/VIS Detector

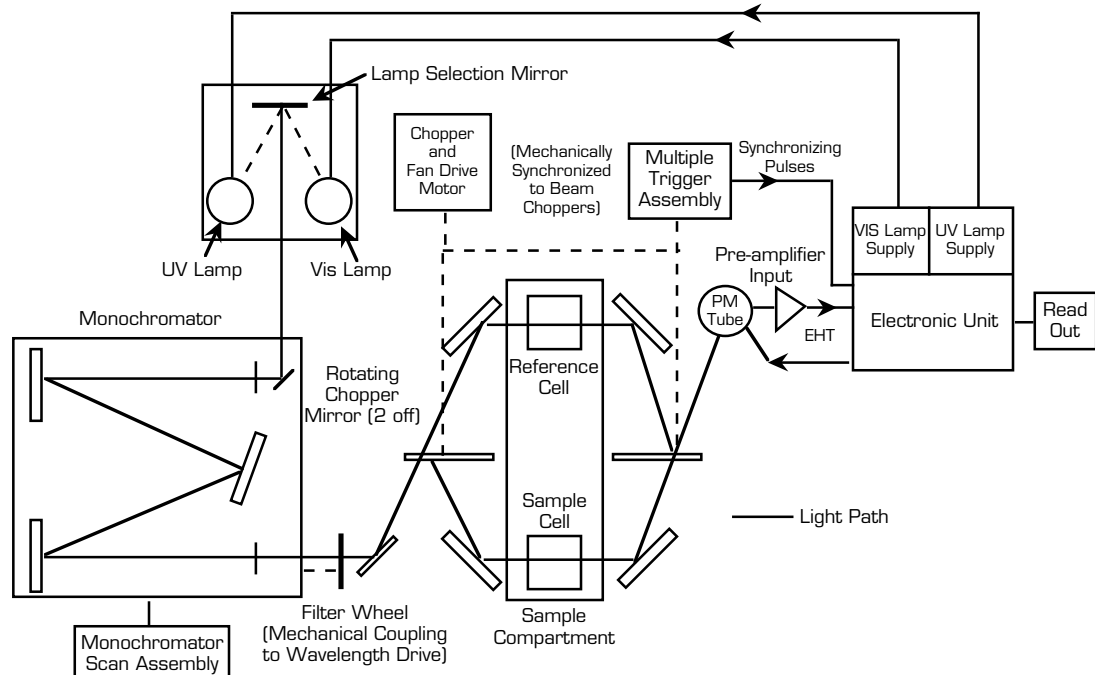

[Reprinted with permission of Elsevier Science Publishers, from Poole, C.F., and Schuette, S.A. (1984) *Contemporary Practice of Chromatography*, Figure 5.6A, page 377.]

Variable Wavelength UV Detectors

The second major UV/VIS detector is the continuously variable wavelength type (Figure 605-b). Light from a continuous deuterium source (or tungsten source for the visible region) is focused on the entrance slit of a grating monochromator, which disperses it into its component wavelengths. The monochromatic light emerging through the exit slit is divided into sample and reference beams by a beam splitter or chopper. The detector measures the difference in absorbance between the sample and reference.

Solvents

Many solvents absorb strongly in the UV and cannot be used in certain spectral regions. It is important to choose solvents that are transparent at the wavelength(s) being used. For example, carbon tetrachloride, benzene, and acetone cannot be used at 254 nm because they absorb too strongly. Hexane, chloroform, methanol, and water are transparent at 254 nm and provide a wide range of solvent strength for preparing mobile phases. The choice of solvents with UV cutoffs <220 nm is quite limited.

Performance Characteristics

The UV detector is sensitive to 10^{-6} to 10^{-10} g/mL of many compounds. It has a wide linear range and is relatively insensitive to small changes in flow or back pressure, although at the detection limit the detector is very sensitive to changes in temperature. Detection is limited to compounds that absorb at the chosen wavelength.

Gradient elution is possible provided the solvents do not absorb. At very sensitive settings, changes in RI, as caused by gradient elution or pressure and flow changes, can produce baseline shifts with some types of detector cells.

The fixed wavelength detector is less versatile but is much less expensive and often gives less noise than the continuously variable wavelength spectrophotometric detector. As mentioned above, the great advantage of the variable wavelength detector is the ability to optimize sensitivity and/or selectivity for each analyte by detection at the most favorable wavelength.

Multichannel or Photodiode Array Detectors

In a photodiode array detector, polychromatic radiation is passed through the detector flow cell, and emerging radiation is diffracted by a grating so that it falls on an array of photodiodes. Each diode receives a different narrow wavelength band. The complete array of diodes is scanned by a microprocessor many times a second. The resulting spectra may be displayed on a cathode ray tube monitor and/or stored in the instrument for transfer to a recorder or printer. The detector is best used in conjunction with a computerized data station, which allows various post-run manipulations, such as identity confirmation by comparison of spectra with a library of standard spectra recalled from disk storage. Detection can be made at a single wavelength or at a number of wavelengths simultaneously, or wavelength changes can be programmed to occur at specified points during the run. Absorbance ratios at selected wavelengths (*e.g.*, 254 and 280 nm) can be displayed for each peak, which aids in determining identity and the presence of unresolved components.

Applications

The UV detector has been the most widely used for pesticide residue determination. Section 404 uses UV and fluorescence detectors to determine benzimidazole residues, whereas other references describe combinations of UV and photoconductivity [1-3]; the photodiode array is applicable to determining paraquat and diquat [4].

Problems, Maintenance, and Troubleshooting

Air bubbles in UV flow cells can produce a series of very fast noise spikes on the chromatogram, or pronounced baseline drift. Falsely high absorbance readings can be caused by impure or improperly prepared mobile phase, large air bubbles in the flow cell, a misaligned flow cell, or dirty end windows. Gas bubbles develop in the detector cell because they are pumped through the system or the solvent is degassed in the detector. Prevent bubbles from being pumped through the system by eliminating system leaks, expelling air from the pumping system, avoiding very volatile solvents, and not stirring the mobile phase reservoir too vigorously. Prevent solvent degassing in the sample cell by degassing the mobile phase prior to use. If the cell has no back pressure valve, raise cell pressure above atmospheric by attaching $\geq 10'$ spiral steel or Teflon tubing to the detector outlet to act as a flow restrictor, and placing the tubing outlet above the detector. The tubing must not shut off flow completely, as too great a pressure increase could shatter the cell windows.

To dissolve gas bubbles lodged in the cell, briefly increase cell back pressure by holding a piece of rubber septum over the detector outlet or by connecting a syringe to the outlet. With aqueous systems, it may be necessary to fill the cell with methanol and repeat application of back pressure.

Protect the detector from temperature fluctuations by placing the system away from direct sunlight and drafts, and regularly monitor flow rate and pressure for change.

Detector response can drop because dirt in the cell or a bad source lamp reduces the level of radiation reaching the photocell. Some detectors have a meter that allows easy determination of light level. If it is low, clean the detector or change the source lamp. (Avoid eye damage by not viewing the light directly.) Consult the detector manual for the proper procedure for changing the lamp and cleaning the cell. The average life of a 254 nm lamp is approximately 5000 hr, but it should be replaced as soon as aging begins to cause significant intensity changes. Some cells can be taken apart, the optical components cleaned with a suitable solvent and dried, and the cell re-assembled. Others cannot be taken apart and are cleaned by flushing the cells with a series of solvents delivered from a 50 mL glass syringe, *e.g.*, acetone, 6 M nitric acid, distilled water, and acetone, then drying with a flow of clean, dry nitrogen before reconnection to the column. If necessary, allow 6 M nitric acid to stand in the cell overnight. To remove particles most effectively, draw nitric acid through the cell with a syringe in a direction opposite to the normal flow.

605 B: FLUORESCENCE DETECTORS

Fluorescence detectors provide two to three orders of magnitude more sensitivity than UV detection. Selectivity is also excellent because of the choice of excitation and emission wavelengths and the fact that only a small fraction of all compounds naturally fluoresce.

▶ The simplest type of instrumentation is a fixed wavelength fluorometer with bandpass filters for both excitation and emission. More convenient and versatile fluorometric detectors can operate at variable wavelengths. These are equipped with monochromators to select excitation and emission wavelengths. Most compounds that fluoresce naturally have a rigid, planar conjugated cyclic structure. Nonfluorescent compounds can be detected if they are first converted to fluorescent compounds by pre- and post-column derivatization.

Detector Design

Figure 605-c is a schematic diagram of a simple filter fluorometer detector. Light from a mercury lamp passes through a filter that selects the excitation wavelength. An interference filter providing a 10-20 nm

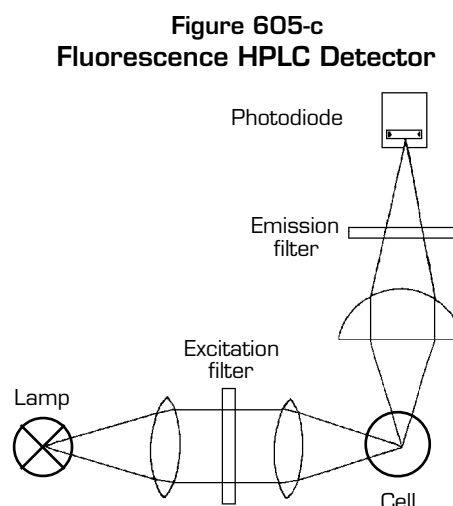

[Reprinted with permission of John Wiley and Sons, Inc., from Meyer, V.R. (1988) *Practical High Performance Liquid Chromatography*, Figure 5.10, page 74.]

bandpass is commonly used. Lenses focus the radiation on the sample cell, which contains the flowing column effluent. If fluorescent compounds are present, they absorb the incident radiation and re-emit at a longer wavelength.

Although it is emitted in all directions, the re-emitted or fluorescent light is usually measured at a right angle to the direction of the incident light. A second filter isolates a suitable wavelength from the fluorescence spectrum and rejects any scattered exciting radiation from the source. A lens focuses the emitted light on a photomultiplier tube.

The second filter can be a bandpass filter for selectivity, or a cutoff filter for greater sensitivity.

The right angle measurement design allows monitoring of the incident beam as well as the emitted light, so that dual UV absorption and fluorescence detection is possible with some commercial detectors. A more common arrangement is to place a separate UV detector in tandem with a fluorescence detector to check the reliability of the fluorescence measurements, especially at low levels of quantitation.

Other more sophisticated fluorescence detectors use grating monochromators instead of filters and are termed continuous wavelength spectrofluorometric detectors. These usually have either a deuterium (190-400 nm) or xenon (200-850 nm) arc source. Because these sources are more unstable than a mercury discharge source, detector design is often modified to correct for fluctuations in source intensity by splitting off a portion of the exciting light to a reference detector. Variable wavelength detectors have the advantage of allowing low wavelength excitation, which is necessary for some naturally fluorescent compounds such as indoles and catecholamines.

Fluorescence detectors that use a laser as the excitation source are being studied. The intensity of lasers is about 10^4 higher than that of conventional sources, providing a 10-100 fold improvement in detection sensitivity. The use of lasers can reduce stray light, because their radiation is entirely monochromatic and coherent and the beam has a small cross section and is nondiverging. At present, the use of lasers as detector sources is limited by their high cost and relatively narrow range of available excitation wavelengths.

Solvents

The intensity of fluorescence is affected by the composition of the mobile phase and the presence of impurities. Quenching can occur with halide ions, water and other strong hydrogen-bonding solvents, and buffers. High temperature and oxygen in the mobile phase can also induce quenching. Compounds that fluoresce in organic solvents may show a shift in intensity and fluorescence maximum wavelength with change in solvent polarity.

Performance Characteristics

Sensitivity is greater for fluorescence because the signal is measured directly against a dark background, and signal intensity can be increased by an increase in source intensity. The sensitivity of fluorescence detectors is in the range of 1-100 pg/mL for favorable compounds. Because both the excitation and detected wavelengths can be varied, selectivity is high for fluorescence detection. The linear range is

generally two or three orders of magnitude at low concentrations where absorbance is <0.05 . At higher concentration levels, the linear range can be very small.

Parameter Adjustments

Optimum wavelengths for fluorescence detection are chosen by scanning analyte excitation and emission spectra with a fluorescence spectrofluorometer. For most compounds, excitation and emission spectra are mirror images that more or less overlap at longer excitation and shorter emission wavelengths. When excitation and emission maxima are close together, optimization of fluorescence detector monochromator settings is critical for achieving maximal emission output while avoiding light-scattering effects due to the overlap. Careful choice of emission wavelength and slit width based on spectral characteristics is necessary for maximum sensitivity, as well as for controlling background noise if fluorescent impurities are present in the injected extract [5].

Applications

Section 401, method for N-methylcarbamates, uses post-column hydrolysis and derivatization to produce a chemical detectable by a fluorescence detector; a variation of that determinative step detects naturally fluorescent residues without the post-column reactions. Section 403 uses photolysis to degrade substituted ureas for subsequent fluorometric labeling and determination. Section 404 uses UV and fluorescence detectors for benzimidazole residues.

Detector Maintenance

Clean the cell compartment with chromic acid (or equivalent) cleaning solution, followed by thorough rinsing with dilute nitric acid and water. An overnight soaking in chromic acid cleaning solution may be necessary to remove stubborn impurities.

605 C: ELECTROCHEMICAL DETECTORS

Electrochemical (ECh) detectors include the conductivity detector for the determination of ionic analytes and amperometric, coulometric, and polarographic detectors for analytes with oxidizable or reducible functional groups. The first ECh detector for HPLC used polarography, but because use of this mode today is infrequent, it will not be discussed in this chapter. The most widely used type is the thin layer amperometric detector using a glassy carbon electrode, or, less frequently, a gold amalgam or carbon paste electrode, which can provide sensitive and selective determination of compounds with appropriate structures.

ECh detection can be used with reverse phase (RP) columns because of the high polarity of RP mobile phases. For the detector to function properly, the mobile phase must possess good electrical conductivity. Salt or buffer at a concentration of 0.05 M is often used to provide the required ionic strength. The detector is impractical for normal phase (NP) HPLC, and RP systems with high modifier concentrations may also cause problems.

ECh detection has been applied to the HPLC determination of phenols, amines, mercaptans, halogen compounds, ketones, aldehydes, and nitroaromatics. It is suitable for quantitation of various pesticide classes, such as dinitroaniline,

bipyridinium, triazine, and phenylurea herbicides; nitrophenyl, dinitrophenol, carbamate, and organophosphorus insecticides; and azomethine insecticides and fungicides. Any pesticide that produces an electroactive compound (phenol, aromatic amine, aromatic nitro compounds) on metabolism or decomposition, such as carbamates, ureas, anilides, *etc.*, can potentially be determined using the ECh detector.

Conductivity Detectors

Conductivity detectors measure the conductance (reciprocal of resistance) of the effluent, which is proportional to ionic analyte concentration if the cell is suitably designed. They are usually used to detect inorganic or organic ions after separation by ion exchange or ion chromatography. Since these modes of HPLC employ mobile phases with high conductances, it is necessary to incorporate a chemical or electronic means of eliminating the conductance of the mobile phase before the analyte can be measured sensitively and accurately with a conductivity detector. Typical detectors have a cell with a small (2 μL) active volume, composed of insulating material, into which graphite or noble metal electrodes are implanted.

A constant alternating voltage is applied to the electrodes, and conductance is measured with an appropriate circuit, such as a Wheatstone bridge. Since conductivity is highly temperature dependent, a means for automatic temperature compensation is usually included.

Amperometric and Coulometric Detectors

ECh detectors are most often amperometric or coulometric detectors that measure current associated with the oxidation or reduction of analytes. Oxidation is carried out at an anode bearing a positive potential, and reduction at a cathode having a negative potential. Different compounds require unique potentials for these electrochemical reactions to occur. The current produced by the electrode reaction is measured in a flow cell at the column outlet. Detector selectivity and sensitivity are changed by varying the potential of the electrode.

The use of electrochemical reduction as an HPLC detection method is impractical because oxygen is easily reduced, and it is difficult to remove oxygen completely from the mobile phase. Most ECh detector applications are, therefore, based on oxidation. Mobile phases that work best are aqueous/organic mixtures with added salts or buffers.

The coulometric type of ECh detector reacts all of the electroactive analyte passing through it, yielding a higher current for the electroactive species than the amperometric detector. However, background noise is also greater, so it is not more sensitive. The coulometric detector is insensitive to flow rate and temperature changes, and, like the GLC microcoulometric detector, it responds in an absolute manner, eliminating the need for calibration. However, it is more prone to electrode contamination and must be designed to provide strict potential control over the entire electrode area. The coulometric type of ECh detector is much less popular than the amperometric type.

The amperometric ECh detector uses a smaller electrode surface and reacts only about 1-10% of the electroactive analyte, so that most of the analyte leaves the detector cell unchanged. Small currents in the nanoampere range are produced.

Figure 605-d
Three Electrode Electrochemical
Detector

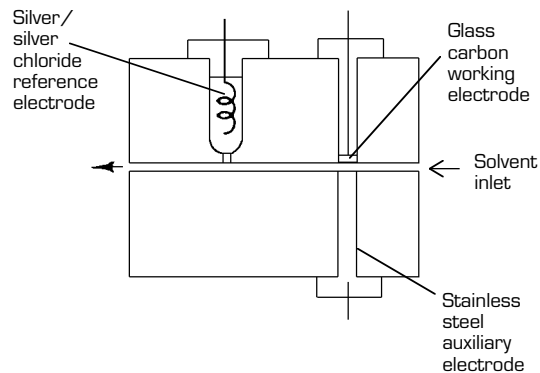

[Reprinted with permission of John Wiley and Sons, Inc., from Lindsay, S. (1987) *High Performance Liquid Chromatography*, Figure 2.4j(i), page 68.]

These currents can be amplified and measured accurately, leading to sensitivities as low as 0.1 pmol in favorable cases. Amperometric ECh detectors are also simple in design and relatively inexpensive and can be made with a very small internal volume (0.1-5 μL), thereby minimizing band broadening, but they are difficult to use.

Figure 605-d is a simplified schematic diagram of an amperometric ECh detector. Three electrodes are used: the working electrode at which the current due to the analyte is measured, a silver/silver chloride reference electrode against which the potential at the working electrode is selected, and a stainless steel auxiliary electrode to carry the current arising from the electrochemical reaction.

The working electrode is most commonly glassy carbon, which is a highly polished, inert, and electrically conducting form of carbon. To maintain reproducibility, the solid carbon electrode requires regular maintenance in the form of polishing and cleaning, so detectors must be relatively simple to take apart and re-assemble.

The chromatogram is obtained by measuring the current at the working electrode, which is maintained at a fixed potential relative to the reference electrode, as the electroactive analyte elutes from the column. The working electrode potential is usually at or near the limiting current plateau of the analyte. The background current, which is constant for a given mobile phase flow rate and composition, is subtracted from the analytical signal to give a detector current that is proportional to the concentration of the analyte according to Faraday's law. Cyclic voltammetry is often used to obtain preliminary electrochemical data that determine the optimum applied potential and the effect of variables such as solution pH, mobile phase composition and concentration, and analyte structure.

Performance Characteristics

In general, ECh detection offers better sensitivity and selectivity than the UV detector for pesticide residue determination. Detection limits are generally at picogram levels, whereas for the UV detector, detection limits are, at best, low nanogram levels. On the other hand, the UV detector has greater long term stability and is easier to use on an everyday basis.

Detector operation and sensitivity are critically dependent on flow rate constancy, solution pH, ionic strength, temperature, cell geometry, condition of the electrode surface, and the presence of electroactive impurities (*e.g.*, dissolved oxygen, halides, trace metals). The detector cannot be used with flow or solvent programming if these changes affect the baseline, and waiting periods of ≥ 10 min are required for variations in conditions such as flow rate, applied voltage, or mobile phase, or for initial startup each day. Both increased flow rate and an increase in the volume of injected extract decrease detection sensitivity.

Applications

An ECh detector was used for oxidative detection of coulometrically reduced organonitro pesticides separated by RP HPLC [6]. Pesticides were separated on a C-8 bonded column and monitored indirectly by means of a porous graphite coulometric detector. The organonitro functional groups were reduced in the guard cell of the detector, and the reduction products were then detected by electrochemical oxidation. A 20-90% acetonitrile/water gradient with constant electrolyte concentration could be used without occurrence of a significant baseline change. The cell required periodic cleaning with dilute nitric acid and sodium hydroxide solutions to eliminate negative peaks.

HPLC with ECh detection was also used to determine 0.01-0.02 ppm ethylene-thiourea (ETU) in foods by a revised official AOAC method [7, 8]. The prepared extract was chromatographed on a graphitized carbon column with acetonitrile/aqueous 0.1 M phosphoric acid/water (5:25:70) mobile phase, and the eluted ETU was detected by using an amperometric ECh detector having a gold/mercury working electrode.

605 D: PHOTOCODUCTIVITY DETECTORS

The photoconductivity detector (PCD) is sensitive and selective for organic halogen, sulfur, and nitrogen compounds that form strong, stable ions upon photolysis. The effluent is split as it leaves the column; one-half is passed through the reference cell of a conductivity detector and the other half is irradiated with 214 or 254 nm UV light. Suitable analytes become ionized, and the resulting conductance is measured by the detector. Operation of the PCD requires an ion exchange resin to purify the mobile phase and lower background conductivity. Both RP and NP (nonaqueous) systems have been used with the PCD, but the former are more commonly used for pesticide determination and will be emphasized in this section.

Apparatus

Publications [9, 10] describing applications of a PCD to pesticide residue determination employed a system with a reciprocating pump, loop injector or autosampler, forced draft column oven, variable wavelength UV detector in tandem ahead of the PCD, dual recorders, a data system for peak integration, and C-18 and cyano bonded columns. A flow splitter was adjusted to give equal flow rate of column effluent through the analytical and reference cells of the detector. Balance of flows through the reference and analytical loops is facilitated by a metering valve in the solvent line exiting from the reference compartment of the conductivity cell. This apparatus, or an equivalent system, will be assumed in this section.

Performance Characteristics

The following performance characteristics have been determined by studies of a PCD-UV detector system for residue determination.

Mobile Phase Preparation. Optimum sensitivity and stable baselines are achieved when the mobile phase has a minimal ionic background concentration. De-ionization of the mobile phase solvents, either individually or as a mixture, is carried out

by circulation through a mixed bed cartridge (1:1 mixture of anion and cation exchange resins). Ion exchange treatment of aqueous mobile phases shortly before use with the PCD is recommended. A 24 hr period of resin circulation at 2.5 mL/min was chosen arbitrarily for "complete purification" of the solvent. Resin-treated acetonitrile was found to be incompatible with the PCD-UV detector system, and the use of resin-treated methanol rather than treated or untreated acetonitrile is recommended.

Temperature Control. More sensitive and consistent detection was obtained when the column, photolysis reaction chamber, conductivity cells, and associated plumbing were all maintained at a constant, elevated temperature (35-40° C) within a column oven.

Mobile Phase Flow Rate. The use of low flow rates improves detector response and reduces the expenditure of purified mobile phase. However, lower flow rates lead to longer analysis time unless the strength of the mobile phase can be increased without losing the required resolution. A compromise among speed, resolution, and detection sensitivity is necessary, depending on the requirements of a particular analysis.

Pressure. The PCD is very sensitive to pressure fluctuations. Thorough mobile phase degassing and subsequent gentle sparging with helium help maintain stable pumping pressure. Use of gradient elution is limited by pressure variations that occur as the mobile phase composition changes, leading to excessive baseline shift, especially in high sensitivity applications.

Reproducibility of Response. Improved reproducibility was shown to result from complete purification of the mobile phase by ion exchange resin treatment and, to a lesser degree, temperature control.

NP (Nonaqueous) Solvent Operation. The practical application of the PCD to NP HPLC is limited by the low polarity of the mobile phases used. This results in poor ion mobility and poor charge transfer in the conductivity cell and thus adversely affects peak shape and response. Some workers have attained adequate polarity for good response by adding acetic acid or other polar or ionic modifiers to nonaqueous mobile phases, but this approach is limited by the increase in background noise the added compounds can cause. Reduced background conductivity and diminished need for purification by de-ionization are advantages of the use of certain nonaqueous solvents.

Choice of Irradiation Wavelength. In general, the 254 nm mercury lamp provides greater detection sensitivity than the 214 nm zinc lamp. However, response can be improved for certain compounds if the zinc lamp is substituted for the mercury lamp. Greater stability is ensured if the detector, including the lamp, is left on at all times.

Sensitivity, Selectivity, and Linearity. The PCD can detect low ng levels of many pesticides and was found to be linear from 1-100 ng injected. Injection aliquots are typically 5 µL containing 1-20 ng pesticide. UV detection typically shows more background interferences from crop extracts than the PCD, indicating superior selectivity for the PCD. Because the PCD is more complex and sensitive to variations in system conditions (*e.g.*, de-ionization and degassing of mobile phases, temperature, pumping fluctuations), it should be operated with a tandem UV

detector to monitor the chromatographic system and aid in the diagnosis of anomalies.

Applications

The PCD has been included in several methods for pesticide residues [1-3, 10].

605 E: MASS SPECTROMETRIC DETECTORS

Mass spectrometric (MS) determination can be definitive, providing information on analyte retention and concentration while simultaneously confirming its identity. Interpretation of mass spectra permits determination of molecular mass, empirical formula, arrangement of molecular constituents, and, ultimately, molecular identity.

Successful use of MS as a chromatographic detector requires introduction of column effluent to the MS without breaking the vacuum in which the detector operates. This task is now easily accomplished for GLC-MS, but systems for vaporizing or otherwise eliminating the HPLC mobile phase before introduction to the MS are still being developed. Numerous interfaces and ionization techniques for HPLC-MS have been made available, but so far no one system serves all needs.

An HPLC-MS interface involves two stages: effluent introduction and analyte ionization. Available effluent introduction techniques include spray techniques, in which the analyte is introduced as an aerosol; direct liquid introduction, and mechanical transfer, such as the moving belt interface. Spray techniques are most common; the aerosol may be produced through nebulization of the effluent using thermal (*e.g.*, Thermospray), pneumatic (heated nebulizer, particle beam, Thermabeam), or electrostatic (electrospray, Ion Spray) processes.

The particle beam interface actually combines several processes to remove solvent from the effluent. After nebulization, the resulting aerosol loses its more volatile components in a desolvation chamber. Subsequently, the remaining aerosol is pumped through a momentum separator, a series of skimmers and pumps that divert most of the solvent vapors. The heavier analyte molecules then pass into the MS.

Several approaches to analyte ionization exist; the combination of effluent introduction and ionization must be compatible. Direct ionization of the effluent occurs in Thermospray or electrospray interfaces; vaporization and ionization occur simultaneously. Another direct ionization technique, called fast atom bombardment, ionizes the analyte by bombarding the effluent with fast moving argon atoms. Electron impact ionization can be achieved if the solvent is removed first, such as with the particle beam interface. Chemical ionization (CI) can be used without removal of solvent, using "filament-on" Thermospray, direct liquid introduction, or one of several atmospheric pressure chemical ionization (APCI) systems that now exist.

APCI is a recent and significant improvement in HPLC-MS interfacing technology. APCI is a process of ion formation that occurs at atmospheric pressure outside the MS. APCI ion sources are unique and versatile because they can be utilized with most of the interfaces described above. One unique advantage of APCI systems is that interfaces (*e.g.*, electrospray, heated nebulizer) can be readily interchanged

without venting the MS. APCI most commonly provides CI spectra, but with tandem MS instruments (MS/MS), more complex spectral information is obtainable.

Selection of an interface for a particular HPLC-MS application requires consideration of many factors. Among these, HPLC mobile phase flow rate may limit the choice of interface to those capable of handling the volume; *e.g.*, Ion Spray interface is limited to 200 $\mu\text{L}/\text{min}$, while Thermospray can accept 1 mL/min. Thermal stability of the analyte(s) may also restrict choice of interface. The interface must also be compatible with mobile phase composition; *e.g.*, nonvolatile salts or buffers may clog some interfaces, flammable solvents are generally unsuitable, and high aqueous content may inhibit volatilization.

Numerous applications of HPLC-MS have been published, and reviews of the applications are available [11, 12]. References to the use of particle beam interface [13-15] and to APCI [16, 17] provide information about application to pesticide residue determination.

605 F: DERIVATIZATION FOR DETECTION ENHANCEMENT

The detection properties of an analyte can in many cases be enhanced by pre- or post-column derivatization. Pre-column derivatization is usually carried out independent of the instrument and post-column derivatization is usually performed in-line. Derivatization reactions have been carried out mostly in conjunction with fluorescence detectors, but visible absorption and ECh detectors are also widely applied.

Comparison of Pre- and Post-Column Derivatization

Pre-column derivatization procedures have the advantages that long reaction times and extreme reaction conditions can be used, and reagents can be employed that have the same detection properties as the derivatives. This is not possible with post-column reactions, because excess reagent is fed with the effluent to the detector. Pre-column derivatization may serve as a purification step, and the derivatives may chromatograph more favorably than the parent compounds. However, the derivatives are usually more similar structurally than the parent compounds, reducing the chromatographic selectivity. Pre-column derivatization requires a quantitative reaction resulting in a stable and well defined product; by-products formed in the reaction may interfere with the analyte in the chromatogram, necessitating extensive cleanup after the derivatization reaction. No instrumental modifications are required for pre-column derivatization, unless it is carried out in-line. In general, post-column procedures allow for a higher degree of automation. Reactions for post-column derivatization should be rapid to avoid extra-column band broadening. An upper practical limit for high efficiency HPLC is about 20 min.

Post-Column Reactor Design

Post-column in-line derivatization is carried out in a reactor located between the column and detector. The mobile phase flow is not interrupted, although it may be augmented by addition of a secondary solvent to aid the reaction or meet detector requirements. This is especially important for ECh detectors, for which the mobile phase and derivatization reagent are seldom fully compatible. Since the reactor is located after the column, products of derivatization will not interfere

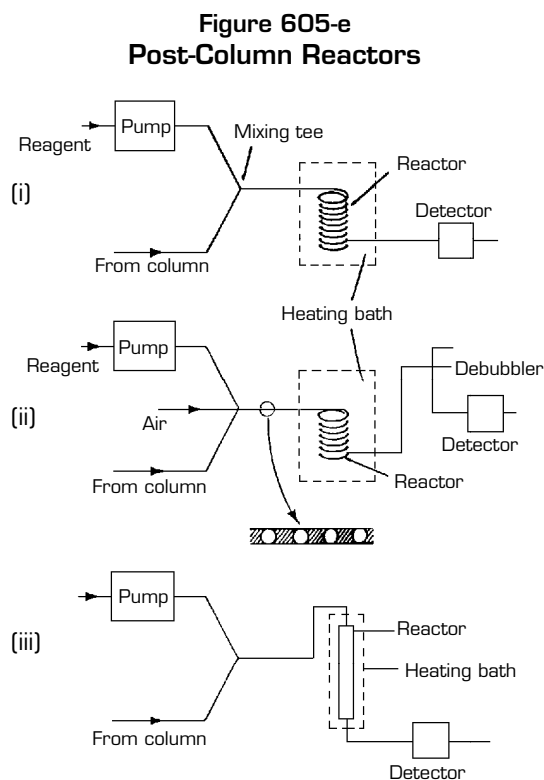

(i) Open tubular reactor; (ii) Segmented reactor; (iii) Packed bed reactor

[Reprinted with permission of John Wiley and Sons, Inc., from Lindsay, S. (1987) *High Performance Liquid Chromatography*, Figure 2.4p, page 79.]

0.3 mm id, 150-600 μL volume), provides the necessary time for the reaction without significantly contributing to band broadening. The combined streams are finally passed on to the detector. This type of reactor is suitable for fast (\leq about 1 min) derivatization reactions, *e.g.*, for determination of amines with *o*-phthalaldehyde reagent.

The segmented stream tubular reactor (ii) is used for slower reactions (5-30 min). Bubbles of air or a nonmiscible liquid are introduced into the stream at fixed time intervals. This segments the column effluent into a series of reaction volumes whose size is governed by the dimensions of the reaction tube and the frequency of the bubble introduction. Optimal conditions include small liquid segments introduced at high frequency; short, small id reaction tubes; and a high flow rate. This type of reactor reduces analyte diffusion and band broadening. The segmentation agent is generally removed by a phase separator prior to the detector, but noise can also be suppressed electronically.

For intermediate speed reactions (0.3-5 min), packed bed reactors (iii) consisting of a column containing a nonporous material such as glass beads have been used. Reagent is pumped into the flowing effluent stream, and the mixture enters the reactor column. Improper packing of the reaction column can lead to band broadening in the same way as for the analytical column.

with chromatography. The derivatization reaction does not have to go to completion or be well defined if it is reproducible. The reaction should take place in a reasonable time, and the reagent should not be detectable under the same conditions as the derivative. A high concentration of reagent is usually used to minimize dilution effects, and a moderately elevated temperature to speed the reaction.

Figure 605-e shows schematic representations of three types of post-column reactors, the designs of which are strongly influenced by the time required for the reaction. In all of these designs, controlled volumes of one or more reagents are added to the column effluent, followed by mixing and incubation for a certain time period with controlled temperature. Reagents are added at low pressure using pulse-free peristaltic pumps.

In the open tubular or open capillary reactor (i), reagent is pumped via a mixing tee into the column effluent containing the separated analytes. The reactor, which is a coil of stainless steel or Teflon capillary tubing (typically

A second detector can be placed ahead of the reaction detector to gather additional information about the analyte. For example, a UV detector can be utilized prior to a derivatization/fluorescence detector.

Post-column derivatization techniques can involve simple modification of solution pH. For example, post-column conversion from slightly acid to a pH above 8 increases the fluorescence of coumarin anticoagulant rodenticides and allows their sensitive determination with a fluorescence detector. More commonly, reagents are used that produce fluorescent, UV-absorbing, colored, or electroactive derivatives. Formation of a UV-absorbing derivative is difficult because most suitable reagents are also strongly absorbing. Reagents can be directly reacted with the analyte, or an initial hydrolysis or oxidation reaction is sometimes carried out, followed by derivatization of the product. Fluorescamine, dansyl chloride, and o-phthalaldehyde are examples of fluorogenic reagents, and ninhydrin is a common chromogenic reagent for amino acids. Derivatives containing nitroaromatic chromophores can be used for UV or ECh detection based on reduction. p-Aminophenol derivatives of carboxylic acids and p-dimethylaminophenyl isocyanate derivatives of arylhydroxyamines are also suitable for ECh detection.

The most important applications of post-column derivatization to pesticide determination have involved detection of amines. One example is the detection of N-methylcarbamate insecticides and metabolites as described in Section 401.

Photochemical reactors have been employed to convert compounds to a more readily detectable fluorescent species, or to a fragment that can be coupled with a detection-enhancing reagent. The reactor often consists of a Teflon or quartz coil wrapped around a high power UV lamp in a reflective housing. The length of the coil is optimized in relation to the desired irradiation time. An example of this technique applied to residue determination is the method for substituted urea herbicides, Section 403.

References

- [1] Gilvydis, D.M., and Walters, S.M. (1988) *J. Agric. Food Chem.* **36**, 957-961
- [2] Walters, S.M., and Gilvydis, D.M. (1983) *LC Mag.* **1**, 302-304
- [3] Walters, S.M., *et al.* (1984) *J. Chromatogr.* **317**, 533-544
- [4] Chichila, T.M., and Walters, S.M. (1991) *J. Assoc. Off. Anal. Chem.* **74**, 961-967
- [5] Walters, S.M., and Gilvydis, D.M. (May 1987) "HPLC-UV-Fluorescence Determination of Benomyl as its Hydrolysis Product MBC in Bananas," LIB 3143, FDA, Rockville, MD
- [6] Krause, R.T., and Wang, Y. (1988) *J. Chromatogr.* **459**, 151-162
- [7] Krause, R.T. (1989) *J. Assoc. Off. Anal. Chem.* **72**, 975-979
- [8] Krause, R.T., and Wang, Y. (1988) *J. Liq. Chromatogr.* **11**, 349-362
- [9] Walters, S.M., and Gilvydis, D.M. (June 1986) "Studies on the Operation of Photolysis-Conductivity Detection with HPLC," LIB 3054, FDA, Rockville, MD

- [10] Walters, S.M. (1983) *J. Chromatogr.* **259**, 227-242
- [11] Voyksner, R.D., and Cairns, T. (1989) in *Analytical Methods for Pesticides and Plant Growth Regulators*, Volume XVII, Academic Press, NY
- [12] Sherma, J. (1993) *Anal. Chem.* **65**, 40R-54R, and previous biennial reviews
- [13] Behymer, T.D., *et al.* (1990) *Anal. Chem.* **62**, 1686-1690
- [14] Doerge, D.R., and Miles, C.J. (1991) *Anal. Chem.* **63**, 1999-2001
- [15] Kim, I.S., *et al.* (1991) *Anal. Chem.* **63**, 819-823
- [16] Kawasaki, S., *et al.* (1992) *J. Chromatogr.* **595**, 193-202
- [17] Pleasance, S., *et al.* (1992) *J. Am. Soc. Mass Spectrom.* **3**, 378-397

606: RESIDUE IDENTIFICATION AND QUANTITATION

606 A: RESIDUE IDENTIFICATION

The first step in determining residues in a cleaned up, concentrated extract is to run a preliminary chromatogram. Tentative peak identification is made by comparing retention data with data for standards measured under identical conditions. If these data indicate the presence of one or more probable pesticide peaks, proper standard solutions are prepared for qualitative confirmation and quantitation.

Identical retention characteristics of an analyte and reference substance in a single determination do not assure accurate identification, because several compounds may have the same retention time under any given set of conditions. Confirmation of peak identity must be obtained by use of additional determinations (Section 103). Co-chromatography and HPLC using alternative (dissimilar) columns and/or selective detectors are most appropriate for residues determined with HPLC. Other chromatographic methods such as GLC or thin layer chromatography (TLC), or UV, IR, nuclear magnetic resonance (NMR), or mass spectrometry (MS) may also be useful for confirming residue identity.

Relative retention time, the ratio of the absolute retention of the compound of interest to that of a selected reference standard ("marker compound"), is more reproducible than the absolute retention time, so it is used to compare residue and standard peaks. Only the composition of the mobile phase influences the relative retention time, whereas absolute retentions can vary slightly from day to day or even from hour to hour if instrumental parameters, such as mobile phase flow rate, recorder chart speed, or injection technique vary. The marker compound may be chromatographed just before or after the sample, but it is best to include a portion of the marker compound in the injection of the sample extract; in this way, both residue and marker peaks are chromatographed at the same conditions and appear in the same chromatogram.

In addition to relative retention time, peak shape is often another useful aid in comparing sample and standard chromatograms. Residue identity can be confirmed by observing changes in absolute or relative retention time upon derivatization of both the analyte and the appropriate reference standard.

Co-chromatography

Co-chromatography provides an alternative means of qualitative analysis based on retention times. An amount of pure standard compound, thought to be the analyte, is added to a portion of the sample extract at approximately double the amount present, and an aliquot is re-injected. If the tentative identification of the residue was correct, only the peak due to the analyte will be intensified, and peak shape will not be distorted (*i.e.*, no shoulders or broadening will be produced). This method has the same limitation as comparison of retention times, in that it is possible that another compound with chromatographic characteristics corresponding to the added compound might be present. Compound identification using this technique is enhanced by high column efficiency and resolution and optimized operating parameters; when pesticides are well resolved from one another and from nonpesticide artifacts co-extracted from the sample substrate, there will be the greatest chance for the analyte and the co-injected standard to separate if they

are not the same compound. If the HPLC system has recycling capability, the co-injected mixture can be recycled several times to try to separate the analyte from the added standard.

Use of Alternative Columns

Concurrence of retention times between analyte and standard peaks, or absence of separation of peaks in a co-injected sample plus standard, on two or more different HPLC columns (each with a suitable mobile phase) gives greater assurance that the two peaks represent the same compound. However, the columns must be judiciously chosen so that their separations are governed by distinctly different mechanisms that produce different elution patterns. Reverse phase (RP) and normal phase (NP) partition columns and silica gel adsorption columns have been shown to be independent, complementary columns for confirmation of peak identity for many compound types.

Spectrometric Confirmation

It is possible to confirm identification spectrometrically by collecting the analyte as it elutes from the HPLC instrument, either manually or with an automatic fraction collector, and analyzing it with UV, MS, IR, or NMR. However, the practical application of this approach for trace pesticide determination is limited. Because the sensitivity of such instruments is limited, eluates from HPLC are often difficult to concentrate, and buffers and salts from RP mobile phases can interfere.

Spectrometric confirmation can be performed in-line. The absorbance (peak height) ratio at two different UV wavelengths, *e.g.*, 254 and 280 nm, can be characteristic for a particular compound, and comparison of the ratio for the analyte and a standard can be helpful for peak confirmation. The presence or absence of peaks or the signal ratio when using different selective detectors provides additional confirmational information. Combinations that have been employed for pesticide determination include the UV detector followed by a photoconductivity, fluorescence, or electrochemical detector. Specificity is obtained by the position of the absorption wavelength with the UV detector, the excitation and emission wavelengths with the fluorescence detector, and the reduction or oxidation potential with the electrochemical detector.

Identification can be made by use of a scanning UV/VIS detector. The spectrometer is initially set to a wavelength that produces a strong signal for the chromatographic peak to be identified. When the absorbance signal is at its maximum, the flow of mobile phase is stopped by means of a stop-flow valve and the full spectrum of the trapped component is scanned. The flow of mobile phase is then restarted and the analysis continued. A limitation of this approach is that UV and visible absorption spectra are not as characteristic as IR, NMR, and MS for compound identification.

Scanning of fluorescence spectra provides somewhat better characterization. If full spectrum detection is used for identification confirmation, the following criteria have been suggested [1]: the maximum absorption wavelength in the spectrum of the analyte should be the same as that of the standard material to which it is compared within a margin determined by the resolution of the detection system. For diode array detectors, this is typically ± 2 nm. The spectrum of the analyte should not be visually different from the spectrum of the standard material

for the parts of the two spectra with a relative absorbance >10%. This criterion is met when the same maxima are present and when the difference between the two spectra is never >10% of the absorbance of the standard material at any point.

606 B: QUANTITATION

Techniques for quantitating detector response by measurement of chromatographic peaks are the same for HPLC as for GLC. Section 504 provides directions for both manual peak measurement and use of electronic integrators; these directions should be followed in HPLC quantitation.

Pesticide residues are quantitated by comparing the size (height or area) of the peak for each analyte and the size of a peak from a similar, known amount of each reference standard injected under the same HPLC conditions just before and/or after the sample injection. Only one standard concentration is required for each analyte if injections are made at concentration levels providing linear detector response. This procedure, which is the most widely used, is known as the external standardization method. Other quantitation methods, such as internal standardization and standard additions, have not been widely used for pesticide residue determination.

The exploratory chromatogram of the sample extract used to obtain qualitative analysis will indicate to the analyst the proper standard solution to be used. The solution should contain the pesticides to be quantitated at proper concentration levels to fall within the linearity range of the detector and also to produce peaks comparable in size (usually $\pm 25\%$) to those obtained from the chromatogram of the sample extract. Injection of the standard mixture may show that additional dilution of the sample extract is required to produce peaks of the higher concentration pesticides that are within the linear detector range and similar in size to those from the standard mixture. If several standard mixtures are available at different concentration levels, selection of one closely approximating the unknown will facilitate the analysis. It cannot be emphasized too strongly that accurate quantitation is not possible unless standards are prepared and maintained properly and replaced on schedule.

Peak height linearity in HPLC can be lost due to band spreading when the sample solvent is significantly stronger than the mobile phase, *e.g.*, the sample is dissolved in methanol and injected into methanol/water (1:1) mobile phase in an RP column. If possible, the sample should be dissolved in the mobile phase to minimize this problem. Otherwise, the injection volumes must be carefully considered; the amounts of sample and standard injected should be equal, or the sample volume must be kept small and the volume causing the onset of band spreading determined and not exceeded.

Reference

- [1] de Ruig, W., *et al.* (1989) *J. Assoc. Off. Anal. Chem.* **72**, 487-490

607: QUALITY ASSURANCE AND TROUBLESHOOTING

Previous sections of this chapter included troubleshooting advice related to the specific system components (Sections 601 D, 601 E, 602 F, 603 B, 603 D, 604 C, 605 A, and 605 B). This section provides testing, maintenance, and troubleshooting procedures for the HPLC system as a whole. These procedures are recommended to minimize poor performance, damage, and downtime of the HPLC system and to help ensure that results of HPLC analyses are accurate and precise.

607 A: LIQUID CHROMATOGRAPH MONITORING AND PERFORMANCE TESTING

Consult the instruction manual supplied with each instrument component for specific installation, operation, maintenance, and performance check procedures. The following tests are general in nature and should be appropriate for most HPLC systems and analyses.

Time of use:

- Check visually for solvent leaks at all fittings.
- Operate pump(s) at 1 mL/min, at the detector sensitivity anticipated, and note baseline noise. If noise problems exist, consult the instrument manual.
- Check detector sensitivity by chromatographing a reference standard (or mixture) appropriate for the particular detector being used; note detector response.
- Pretested columns, with which a test chromatogram is supplied by the manufacturer, are preferred. Verify the adequacy of new columns by repeating the manufacturer's test. At time of use, test the column by repeating the performance test specified when the column was purchased, or use an alternative in-house test. Verify the performance of columns packed in the laboratory in the same way and with the same reference material as for commercially packed columns.
- With the column in place and pumps, detector, and recorder or integrator in operation, inject several identical amounts of standard to check that reproducibility is within laboratory specifications (typically $\pm 3\%$).
- Before using the system for a new application, determine that the detector response is linear and reproducible by construction of a standard curve. Using standards of different concentrations, occasionally spot-check that linearity and response factors are within laboratory specifications.
- Check that the mobile phase components (solvents, salts) are of adequate purity grade and are properly filtered and degassed. If there is indication of contamination or significant concentration change, prepare new mobile phase.

- Do not leave water or aqueous solutions of salts, acids, or bases in the pump(s). Flush the system with an appropriate pure organic or aqueous/organic solvent. Methanol is preferred for long term shutdown.

607 B: TROUBLESHOOTING FROM CHROMATOGRAMS

Efficiency is a measure of the ability of the column to produce narrow peaks (Section 602 C). It is expressed by the plate number (number of theoretical plates) of the column. The ability of the column to separate two components is termed resolution. Resolution is a function of the peak widths (efficiency), the separation between peak centers (selectivity), and the degree of retention for the components by the column (capacity). This section reviews some problems that can be detected by inspection of chromatograms and offers possible causes and solutions for them. Specific procedures for solving most of the problems will be found in the individual sections covering various instrument components.

- Peaks that elute too quickly with poor resolution are usually caused by a flow rate that is too high or a capacity factor that is too low. Increase the capacity factor (and affinity for the column) by using a mobile phase that is weaker, *i.e.*, less polar for adsorption chromatography and more polar for reverse phase (RP) chromatography.
- If peaks of a mixture are not well separated but capacity and efficiency are adequate (*i.e.*, $k' = 2-10$ and narrow peaks), selectivity is too low. Vary selectivity by changing to a second column operating with a completely different mechanism (*e.g.*, adsorption rather than RP), or try a different mobile phase with both of the columns. If the column is old, its resolution may have deteriorated; try a new column of the same type with the original mobile phase.
- Poor resolution can also be due to low column efficiency. Improve efficiency by lowering the flow rate to increase the number of theoretical plates and improve resolution. Alternatively, improve efficiency by increasing the column length (the analysis will take longer), by using a column with smaller diameter packing, or by increasing the operating temperature (mass transfer is improved). A void at the top of the column can also cause poor efficiency and resolution.
- Loss of retention from one chromatogram to the next can be caused by incomplete column equilibration after gradient elution, adsorption of sample impurities, or loss of column activity. Solve the first problem by proper column regeneration after each gradient elution. Remove adsorbed impurities by washing the column or replacing the top 2-3 mm column packing. Maintain constant column activity by using properly dried solvents (for adsorption chromatography). Use a guard column to help prevent adsorption of high molecular weight and polar impurities by the analytical column. Replace the guard column as required.
- An increase in retention times can be caused by too low flow rate, incorrectly prepared mobile phase mixture, the wrong solvent in one of the pump reservoirs, or too slow rate of change of gradient. If silica gel is being used, the activity of the column may have increased because of the use of more completely dried solvents.

- Additional causes of drifting retention times include differences among solvent batches, changes in the composition of a batch of mobile phase upon standing, changes in temperature, a nonconstant recorder drive or slipping chart paper, or changing mobile phase flow rate caused by nonreproducible pump delivery or a leak in the system.
- Tailing peaks in adsorption chromatography can result from column sites with too much activity. To solve this problem, add an optimum amount of a deactivator (*e.g.*, water) to the mobile phase.
- In RP HPLC, tailing can result if the sample is nearly insoluble in the mobile phase or if the sample is partly or completely ionic. Bonded RP columns have a high proportion of unreacted silanol groups (SiOH) available for secondary reaction with analytes. Some of these silanol groups cause bases to tail, and others affect acidic compounds. Different commercial columns are better or worse in terms of their ability to produce peaks with good peak shapes, but none will be completely free from tailing problems.
- Add appropriate mobile phase additives to ensure neutrality of analytes, thereby minimizing unwanted silanol interactions and the resultant peak tailing. The best additives are usually 10-50 mM triethylamine or dimethylhexylamine for suppressing base tailing, and approximately 1% acetic acid for eliminating the tailing of acids. If both acidic and basic sample components are present, combine the additives to give a cumulative effect.
- In ion exchange chromatography, the cause of tailing peaks can be mobile phase with too low an ionic strength or the wrong pH, or adsorption on the resin. Optimum buffer concentrations are sample dependent, generally ranging from 10-100 mM. Ideally, the pH of the mobile phase should ensure that the solute is completely ionized. Adsorption to the resin can often be eliminated by an increase in temperature or addition of a small percentage of organic modifier to the mobile phase.
- For all types of packings, tailing can be caused by a void at the top of the column or excessively long or wide connection tubing between the injection valve and column or between the column and detector. The latter type of cause is indicated if the tailing of early peaks is greater than that of later peaks, and if tailing is greater for faster flow rates.
- A peak exhibiting fronting (a slowly rising leading edge) is usually caused by overloading. Remedy this by injecting less sample.
- A peak exhibiting a doublet or a shoulder (or tailing) results from a dirty, channeled, or defective column. Regenerate dirty columns by washing or repacking the top of the bed. If the inlet frit rather than the packing is dirty, clean or replace the frit.
- Peaks with a staircase shape that never reach true maximum height result from an incorrect recorder damping control setting.
- A noisy recorder baseline can be caused by incorrect recorder damping control setting, or by incorrect grounding of the recorder or the HPLC

instrument, a defective source lamp or dirty cell windows (UV detector), or contaminated solvent. Baseline noise in the form of successive sharp spikes is most likely due to formation of bubbles in the detector cell. Baseline drift is caused by contamination of the detector cell or column, elution of adsorbed impurities, or a change in detector temperature.

- A negative recorder trace is usually caused by a leak between the sample and reference cell compartments; locate and repair.

608: BIBLIOGRAPHY*GENERAL TEXTS*

Brown, P.R., and Hartwick, R. A. (1989) *High Performance Liquid Chromatography*, Wiley, New York

Engelhardt, H., ed. (1989) *Practice of High Performance Liquid Chromatography*, Springer-Verlag, New York

Engelhardt, H., and Hupe, K.P. (1985) *Coupling Methods in HPLC*, GIT Verlag GMBH, Darmstadt, Germany

Katz, E., ed. (1987) *Quantitative Analysis Using Chromatographic Techniques*, Wiley, New York

Lawrence, J.F. (1981) *Organic Trace Analysis by Liquid Chromatography*, Academic Press, New York

Lindsay, S. (1987) *High Performance Liquid Chromatography (Analytical Chemistry by Open Learning)*, Wiley, New York

Meyer, V.R. (1988) *Practical High Performance Liquid Chromatography*, Wiley, New York

Miller, J.M. (1988) *Chromatography: Concepts and Contrasts*, Wiley, New York

Parris, N.A. (1984) *Journal of Chromatography Library, Volume 27: Instrumental Liquid Chromatography. A Practical Manual on High Performance Liquid Chromatography Methods*, 2nd ed, Elsevier, New York

Poole, C.F., and Poole, S.K. (1991) *Chromatography Today*, Elsevier, New York

Poole, C.F., and Schuette, S.A. (1984) *Contemporary Practice of Chromatography*, Elsevier, New York

Schoenmakers, P. (1986) *Journal of Chromatography Library, Volume 35: Optimization of Chromatographic Selectivity. A Guide to Method Development*, Elsevier, New York

Snyder, L.R., et al. (1988) *Practical HPLC Method Development*, Wiley-Interscience, New York

Snyder, L.R., and Dolan, J.W. LC Video Course: *Getting Started in HPLC*, LC Resources, Inc., San Jose, CA (consists of five 45-60 min videotapes for beginners in HPLC)

Yau, W.W., et al. (1979) *Modern Size-Exclusion Liquid Chromatography*, Wiley-Interscience, New York

COLUMNS

Ishii, D., ed. (1988) *Introduction to Microscale High Performance Liquid Chromatography*, VCH, Weinheim, Germany

Kucera, P. (1984) *Journal of Chromatography Library, Volume 28: Microcolumn High Performance Liquid Chromatography*, Elsevier, New York

Scott, R.P.W., ed. (1984) *Small Bore Liquid Chromatography Columns: Their Properties and Uses*, Wiley, New York

DETECTORS

Krull, I.S., ed. (1987) *Chromatographic Science Series, Volume 34: Reaction Detection in High Performance Liquid Chromatography; Part A*, Elsevier, New York

Ryan, T.H., ed. (1984) *Electrochemical Detectors: Fundamental Aspects and Analytical Applications*, Plenum Press, New York

Scott, R.P.W. (1986) *Journal of Chromatography Library, Volume 33: Liquid Chromatography Detectors*, 2nd ed, Elsevier, New York

Yang, E.S., ed. (1986) *Detectors for Liquid Chromatography*, Wiley, New York

TROUBLESHOOTING

Dolan, J.W., and Snyder, L.R. (1989) *Troubleshooting LC Systems: A Practical Approach to Troubleshooting LC Equipment and Separations*, Humana Press, Clifton, NJ

Dolan, J.W., and Snyder, L.R. *Trouble Shooting HPLC Systems*, Elsevier Science Publishers, New York (consists of three 55 min training tapes)

Runser, D.J. (1981) *Maintaining and Troubleshooting HPLC Systems — A User's Guide*, Wiley, New York

Walker, J.Q., ed. (1984) *Chromatographic Systems: Problems and Solutions*, Preston Publishers, Niles, IL

APPLICATION TO PESTICIDES

Follweiler, J.M., and Sherma, J. (1984) *CRC Handbook of Chromatography: Pesticides and Related Organic Compounds*, Volume 1, CRC Press, Boca Raton, FL

Lawrence, J.F. (1982) *High Performance Liquid Chromatography of Pesticides, Volume XII of Analytical Methods for Pesticides and Plant Growth Regulators*, Zweig, G. and Sherma, J., eds., Academic Press, New York

Lawrence, J.F., ed. (1984) *Food Constituents and Food Residues: Their Chromatographic Determination*, Marcel Dekker, New York

Lawrence, J.F., ed. (1984) *Liquid Chromatography in Environmental Analysis*, Humana Press, Clifton, NJ