

Energy Design and Performance Analysis of the BigHorn Home Improvement Center

M. Deru, P. Torcellini, and S. Pless



NREL

National Renewable Energy Laboratory
1617 Cole Boulevard, Golden, Colorado 80401-3393
303-275-3000 • www.nrel.gov

Operated for the U.S. Department of Energy
Office of Energy Efficiency and Renewable Energy
by Midwest Research Institute • Battelle

Contract No. DE-AC36-99-GO10337

Energy Design and Performance Analysis of the BigHorn Home Improvement Center

M. Deru, P. Torcellini, and S. Pless

Prepared under Task No. BEC3.4001 and BEC3.1001



NREL

National Renewable Energy Laboratory
1617 Cole Boulevard, Golden, Colorado 80401-3393
303-275-3000 • www.nrel.gov

Operated for the U.S. Department of Energy
Office of Energy Efficiency and Renewable Energy
by Midwest Research Institute • Battelle

Contract No. DE-AC36-99-GO10337

NOTICE

This report was prepared as an account of work sponsored by an agency of the United States government. Neither the United States government nor any agency thereof, nor any of their employees, makes any warranty, express or implied, or assumes any legal liability or responsibility for the accuracy, completeness, or usefulness of any information, apparatus, product, or process disclosed, or represents that its use would not infringe privately owned rights. Reference herein to any specific commercial product, process, or service by trade name, trademark, manufacturer, or otherwise does not necessarily constitute or imply its endorsement, recommendation, or favoring by the United States government or any agency thereof. The views and opinions of authors expressed herein do not necessarily state or reflect those of the United States government or any agency thereof.

Available electronically at <http://www.osti.gov/bridge>

Available for a processing fee to U.S. Department of Energy and its contractors, in paper, from:

U.S. Department of Energy
Office of Scientific and Technical Information
P.O. Box 62
Oak Ridge, TN 37831-0062
phone: 865.576.8401
fax: 865.576.5728
email: <mailto:reports@adonis.osti.gov>

Available for sale to the public, in paper, from:

U.S. Department of Commerce
National Technical Information Service
5285 Port Royal Road
Springfield, VA 22161
phone: 800.553.6847
fax: 703.605.6900
email: orders@ntis.fedworld.gov
online ordering: <http://www.ntis.gov/ordering.htm>



Acknowledgments

The U.S. Department of Energy's Office of Energy Efficiency and Renewable Energy's Building Program funded this research effort through the High-Performance Building initiative (HPBi). We appreciate the support and guidance of Dru Crawley, program manager of the HPBi who reviewed this document prior to publication. The authors would also like to thank others who reviewed this document: Ron Judkoff, NREL; John Ryan, DOE; Ed Hancock and Greg Barker, Mountain Energy Partnership; and Thomas Wood, Montana State University. Mark Eastment, NREL, conducted additional analysis for this work along with the following NREL student interns: Brandon Gleeson, Agata Miodonski, and Sara Hastings. The authors would also like to thank Don and Betsy Sather, the building owners, for their gracious assistance provided to the researchers.

Contents

ACKNOWLEDGMENTS	III
FIGURES	VII
TABLES	IX
EXECUTIVE SUMMARY	X
1 INTRODUCTION	1
2 BACKGROUND	2
2.1 ENERGY USE IN U.S. COMMERCIAL BUILDINGS	2
2.2 HIGH-PERFORMANCE BUILDINGS RESEARCH OBJECTIVES	3
2.3 PROJECT OBJECTIVES.....	3
3 ENERGY DESIGN PROCESS	5
3.1 ENERGY DESIGN TEAM.....	5
3.2 DESIGN CONSTRAINTS	5
3.3 ENERGY DESIGN ANALYSIS	5
3.3.1 <i>Design Baseline Model</i>	7
3.3.2 <i>Parametric Analysis of Baseline</i>	9
3.3.3 <i>Original Model</i>	12
3.3.4 <i>Optimized Energy Design</i>	15
3.3.5 <i>Economic Analysis</i>	22
3.3.6 <i>Recommendations from the Energy Design Process</i>	23
4 CONSTRUCTION AND COMMISSIONING	25
4.1 CONSTRUCTION DETAILS THAT AFFECTED ENERGY PERFORMANCE	25
4.2 COMMISSIONING	26
5 BUILDING DESCRIPTION	28
5.1 BUILDING ENVELOPE	30
5.2 SPACE CONDITIONING.....	31
5.3 LIGHTING SYSTEMS AND DAYLIGHTING	34
5.4 LIGHTING DISPLAY AND MISCELLANEOUS ELECTRICAL LOADS	37
5.5 PHOTOVOLTAIC SYSTEM.....	38
5.6 TRANSPIRED SOLAR COLLECTOR.....	40
5.7 ENERGY MANAGEMENT SYSTEM.....	40
6 WHOLE-BUILDING ENERGY EVALUATION	42
6.1 PERFORMANCE MONITORING PLAN	42
6.2 MEASURED BUILDING ENERGY USE	45
6.2.1 <i>Total Building Energy Use</i>	45
6.2.2 <i>Energy Cost Analysis</i>	51
6.3 WHOLE-BUILDING ENERGY SIMULATION ANALYSIS	57
6.3.1 <i>Development of As-Built Simulation Models</i>	57

6.3.2	<i>Performance from Simulation Models</i>	59
6.3.3	<i>Measured Performance versus Preconstruction Predicted Performance</i>	65
7	SUBSYSTEM ENERGY EVALUATIONS	67
7.1	ANALYSIS OF THE SPACE CONDITIONING SYSTEMS	67
7.2	ANALYSIS OF THE LIGHTING SYSTEMS AND DAYLIGHTING	68
7.2.1	<i>Illuminance Distribution</i>	68
7.2.2	<i>Lighting System Energy Consumption</i>	79
7.2.3	<i>Lighting System Daily Load Profiles</i>	82
7.2.4	<i>Comments on the Lighting Design</i>	84
7.3	PHOTOVOLTAIC SYSTEM ANALYSIS.....	85
7.3.1	<i>Photovoltaic System Measured Energy Production</i>	85
7.3.2	<i>Photovoltaic System Performance Analysis</i>	87
7.3.3	<i>Predicted Photovoltaic System Performance</i>	91
8	CONCLUSIONS	93
8.1	LESSONS LEARNED	93
8.2	RECOMMENDATIONS.....	97
	REFERENCES	98
APPENDIX A	UTILITY RATE STRUCTURE	100
APPENDIX B	SITE TO SOURCE ENERGY CONVERSIONS	102
APPENDIX C	WEATHER FILE CREATION	105

Figures

Figure ES-1	Annual source energy consumption for the As-Built Baseline Model and As-Built Model	xi
Figure 1-1	Main entrance of the BigHorn Home Improvement Center (east elevation)	1
Figure 2-1	Typical site EUIs by end use for retail buildings (kBtu/ft ² ·yr) (DOE 2003)	2
Figure 2-2	Typical site EUIs by end use for warehouse buildings (kBtu/ft ² ·yr) (DOE 2003)	3
Figure 3-1	Design Baseline Model annual site energy consumption (MMBtu)	9
Figure 3-2	Baseline parametric study results for total energy consumption	12
Figure 3-3	Total energy consumption versus wall and roof insulation values	13
Figure 3-4	Original Model annual site energy consumption (MMBtu)	15
Figure 3-5	Total energy consumption for the Design Baseline, Original, design variations, and Optimized Models	20
Figure 3-6	Optimized Model annual site energy consumption (MMBtu) (savings relative to the Design Baseline Model)	21
Figure 5-1	Illustration of the layout and some of the energy features of the BigHorn Center: (1) photovoltaic panels, (2) radiant floor heating, (3) natural ventilation, and (4) daylighting	28
Figure 5-2	Floor plan of the retail/office area	29
Figure 5-3	Floor plan of the warehouse	30
Figure 5-4	Radiant-floor heating zones in the retail/office area	32
Figure 5-5	Schematic of the BigHorn Center hot water system	33
Figure 5-6	Seasonal daylighting and natural ventilation through the clerestory windows in the retail/office space	34
Figure 5-7	Pendant luminaire with eight 42-Watt CFL bulbs used in the retail and warehouse areas	35
Figure 5-8	Translucent skylights in the warehouse	37
Figure 5-9	Installation of the roof-integrated PV panels	39
Figure 5-10	Schematic of the 3-phase PV system	39
Figure 5-11	Schematic of a transpired solar collector (solar wall)	40
Figure 5-12	Transpired solar collector on the south wall of the warehouse	41
Figure 6-1	BigHorn Center electrical diagram and data monitoring points	44
Figure 6-2	Measured source energy use from September 1, 2002 to August 31, 2003 (MMBtu)	48
Figure 6-3	Daily average source energy consumption by end use for the BigHorn Center (monitoring of the lighting display began in July 2001)	50
Figure 6-4	Average daily electrical energy load profiles by season	51
Figure 6-5	BigHorn Center monthly utility costs	53
Figure 6-6	Estimated monthly electrical energy costs by end use	54
Figure 6-7	Electrical power profile on the peak demand day in July 2003	55
Figure 6-8	Electrical power profile on the peak demand day in December 2002	55
Figure 6-9	Calibration of simulated gas consumption with utility bills	59
Figure 6-10	Simulated annual site energy consumption for the As-Built Baseline Model and As-Built Model with an average year weather file	60
Figure 6-11	Simulated annual site energy consumption for the retail/office space using an average year weather file	62
Figure 6-12	Simulated annual site energy consumption for the warehouse using an average year weather file	64
Figure 7-1	Warehouse lighting with daylight only for clear sky conditions on June 5, 2000	69
Figure 7-2	Retail area lighting with daylight only for clear sky conditions on June 5, 2000	70
Figure 7-3	Illuminance levels in lux from daylight only on June 5, 2000, at 11:00 MDT	71
Figure 7-4	Photometer placement in the retail area for illuminance measurements	72
Figure 7-5	Exterior illuminance for June 23, 2001	73

Figure 7-6	Exterior illuminance for December 31, 2000.....	73
Figure 7-7	Daylight levels on the south side of the retail area for a clear winter day (December 31, 2000)	74
Figure 7-8	Daylight levels on the north side of the retail area for a clear winter day (December 31, 2000)	74
Figure 7-9	Daylight levels on the south side of the retail area for a partly cloudy summer day (June 23, 2001)	75
Figure 7-10	Daylight levels on the north side of the retail area for a partly cloudy summer day (June 23, 2001)	75
Figure 7-11	Exterior illuminance for September 16 and 17, 2000	76
Figure 7-12	Daylight levels on the south side of the retail area for clear and partly cloudy autumn days (September 16 and 17, 2000).....	77
Figure 7-13	Daylight levels on the north side of the retail area for clear and partly cloudy autumn days (September 16 and 17, 2000)	77
Figure 7-14	Light levels from daylight and electric lights on the south side of the retail area on September 16, 2000.....	78
Figure 7-15	Light levels from daylight and electric lights on the north side of the retail area on September 16, 2000.....	79
Figure 7-16	Seasonal average daily profile for the retail lighting power	83
Figure 7-17	Seasonal average daily profile for the warehouse lighting power.....	83
Figure 7-18	Seasonal average daily profile for the exterior lighting power	84
Figure 7-19	PV system energy production and percentage of the total electrical load met by the PV system	86
Figure 7-20	Power-voltage (P-V) curves for different combinations of panels with the incident solar radiation for each curve.....	88
Figure 7-21	Monthly PV system conversion efficiency with outdoor temperature and snowfall amounts	89
Figure 7-22	AC Generation Effectiveness for June 2003 with 1, 2, or 3 inverters operating.....	90
Figure 7-23	AC Generation Effectiveness and PV cell temperature for July 2002	91
Figure 7-24	Estimated and measured PV system production	92
Figure A-1	Total utility natural gas charges for the BigHorn Center.....	101
Figure A-2	Total utility electricity rate charges for the BigHorn Center	101
Figure B-1	Gas use statistics 1998-2002 (EIA 2004).....	103
Figure B-2	Energy flow diagram for electricity generation for 2002 (EIA 2003)	104

Tables

Table ES-1	Net Source Energy and Energy Cost Performance Metrics	xii
Table 3-1	Energy Simulation Models.....	7
Table 3-2	Design Baseline Model Thermal Parameters.....	8
Table 3-3	Parametric Study Results for Heating Energy	10
Table 3-4	Parametric Study Results for Total Energy Consumption	11
Table 3-5	Original Model Thermal Parameters.....	13
Table 3-6	Heating Energy for Design Variations.....	18
Table 3-7	Lighting Energy for Design Variations.....	19
Table 3-8	Total Energy Consumption for Design Variations.....	20
Table 3-9	Optimized Building Parameters	22
Table 3-10	Annual Energy Cost Comparison for the Design Phase Simulation Models	23
Table 3-11	Design Recommendations and Implementation in the Actual Building	24
Table 5-1	Building Functional Areas	29
Table 5-2	Envelope Parameters for the Baseline Models, Design Recommendations, and As-Built Building.....	31
Table 5-3	Lighting Parameters for the Baseline Models, Design Recommendations, and As-Built Building.....	35
Table 5-4	BigHorn Installed Lighting Fixtures	36
Table 6-1	Data Monitored for Energy Performance Evaluation	43
Table 6-2	Measurement Accuracies	45
Table 6-3	Electrical End-Use Load Descriptions.....	45
Table 6-4	Comparison of DAS Measurements with Utility Bills.....	46
Table 6-5	Annual Energy Totals from Utility Bills.....	47
Table 6-6	Measured Annual Energy Totals by End Use	49
Table 6-7	Summary of Utility Charges	52
Table 6-8	Total and Effective Electrical Energy Charges by End Use	56
Table 6-9	Thermal Parameters of the As-Built Baseline and As-Built Models	57
Table 6-10	Annual Facility Energy Use from the As-Built Simulations (end use numbers are for site energy use)	61
Table 6-11	Annual Energy Use for the Retail/Office from the As-Built Simulations	63
Table 6-12	Annual Warehouse Energy from the As-Built Simulations	65
Table 6-13	Comparison of the As-Built and the Predicted Performance	66
Table 7-1	Energy Consumption and Energy Cost for Interior Lighting Systems	80
Table 7-2	Lighting Power Densities for the Interior Lighting Systems for September 2002 to August 2003.....	80
Table 7-3	Lighting Design Energy Savings	81
Table 7-4	Interior Lighting Energy Savings.....	82
Table 7-5	Annual Energy Totals for the PV System	86
Table 7-6	Estimated Energy Cost Savings from the PV System.....	87
Table 7-7	Measured PV system Performance Compared to Estimated Performance	92
Table 8-1	Cost, Site, and Source Energy Savings Summary.....	93
Table A-1	Utility Charges	100
Table B-1	Site to Source Energy Conversions.....	102
Table C-1	Weather Files Created for Simulations	105

Executive Summary

Introduction

The BigHorn Development Project, located in Silverthorne, Colorado, is one of the nation's first commercial building projects to integrate extensive high-performance design into retail spaces. The project, which includes a department store, an open retail space, and a hardware store/lumberyard, was completed in three phases. Phase I is a department store and was completed in February 1998. Phase II added smaller retail stores and was completed in 1999. Phase III is a 42,366-ft² (3,936 m²) hardware store, warehouse, and lumberyard called the BigHorn Home Improvement Center. This final building was completed in the spring of 2000 and builds on lessons learned from the first two phases. This report focuses on the Phase III efforts.

The climatic conditions in Silverthorne, Colorado, are different from most commercial building locations in the United States. Silverthorne is a mountain community at an elevation of 8,720 ft (2,658 m) with long winters and short summers. It is a heating dominated climate with over 10,000 (base 65°F) (6,000 base 18°C) heating degree-days. The average annual temperature is 35°F (2°C), and the average annual snowfall is 129 in (328 cm).

The BigHorn Center features numerous energy-saving innovations. The extensive use of natural light, combined with energy-efficient electrical lighting design, provides good illumination and excellent energy savings. The reduced lighting loads, management of solar gains, and cool climate allow natural ventilation to meet the cooling loads. A hydronic radiant floor system, gas-fired radiant heaters, and a transpired solar collector deliver heat. An 8.9-kW roof-integrated photovoltaic system offsets electrical energy consumption. In addition, on-site wetland areas were expanded and used in the development of the storm water management plan. The environmental design is in keeping with the developer's commitment to green buildings.

Researchers from the National Renewable Energy Laboratory (NREL) were brought in at the design stage of the project to provide research-level guidance. After construction, they installed monitoring equipment to collect energy performance data and analyzed the building's energy performance for 2½ years. NREL researchers also helped program the building controls and provided recommendations for improving operating efficiency. This report documents the design process and the energy performance analysis of the BigHorn Center.

Approach

NREL established the following goals for working with the BigHorn Center:

- Assist in the design process to create a building that is predicted to achieve a 60% energy cost saving compared to a baseline building built to the requirements of ASHRAE 90.1.
- Monitor and analyze the performance of the building and its subsystems for at least two years.
- Implement improvements to the building operation based on monitoring and analysis.
- Document lessons learned to improve future low-energy buildings.

NREL followed an integrated building design process developed from experience on previous projects. This process relies heavily on whole-building energy simulations to characterize the energy requirements, explore energy-efficient design alternatives, and analyze the as-built performance. NREL installed an extensive data acquisition system to monitor the energy consumption of the as-built building. Information from this system and from the utility bills was used to analyze the building energy

performance over 2½ years. Changes to the building’s operation and control sequences were made during this period to improve the energy performance. Performance metrics for site energy, source energy, and energy cost savings were determined with the energy consumption data.

Results

With assistance from NREL, the design team produced a building that is very energy efficient. The building shows an estimated 53% energy cost saving and a 54% source energy saving. These savings were determined with whole-building energy simulations that were calibrated with measured data. The baseline model was compliant with ASHRAE 90.1-2001. The annual energy consumption for the As-Built Baseline Model and As-Built Model is shown in the Figure ES-1. Most of the energy savings are from an 80% reduction in the lighting energy and the elimination of the fans. The heating energy is 30% higher in the As-Built Model than in the As-Built Baseline Model because of the large reduction in the heat gain from the fans and lights. Table ES-1 shows the energy performance of the retail/office space and the warehouse space. The retail/office space has a 45% source energy saving and the warehouse has a 69% source energy saving. In addition, the annual peak electrical demand in the As-Built Model was nearly 60% lower than in the As-Built Baseline Model.

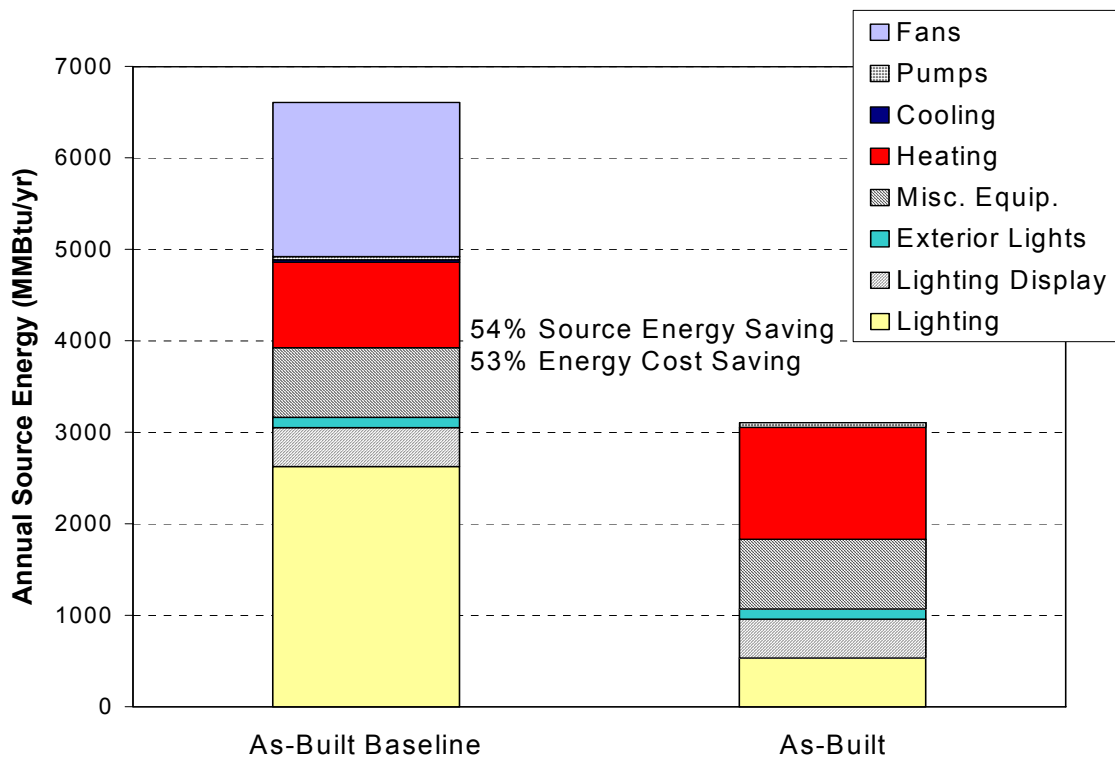

Figure ES-1 Annual source energy consumption for the As-Built Baseline Model and As-Built Model

Table ES-1 Net Source Energy and Energy Cost Performance Metrics

Model	Site Energy Use Intensity		Source Energy Use Intensity		Energy Costs	
	kBtu/ft ² ·yr (MJ/m ² ·yr)	% Savings	kBtu/ft ² ·yr (MJ/m ² ·yr)	% Savings	\$/ft ² ·yr (\$/m ² ·yr)	% Savings
Retail/Office Space						
Baseline	80 (909)		212 (2,410)			
As-Built	60 (680)	25%	117 (1,330)	45%		
Warehouse Space						
Baseline	48 (550)		108 (1,230)			
As-Built	24 (273)	50%	33 (380)	69%		
Facility						
Baseline	63 (720)		156 (1,770)			
As-Built	40 (450)	36%	72 (820)	54%		
Facility						
Baseline					\$1.08 (\$11.63)	
As-Built					\$0.51 (\$5.43)	53%

NREL’s involvement in this project has provided valuable lessons that inform research on other energy-efficient buildings. NREL has applied this knowledge to other research projects and added to the larger body of knowledge in the building community.

Setting specific performance goals that are important to the design team is critical. These goals focus the efforts of the design team and provide benchmarks for measuring the success of the project. Whole-building energy simulations are invaluable in optimizing the design of energy-efficient buildings, as they provide detailed analysis of design variations. After the design, the energy-efficient features must be monitored during construction to ensure the proper equipment is installed correctly.

Daylighting works very well in this building. It reduces electrical energy consumption to the point that demand charges are 59%–80% of the monthly electricity bill. Analysis has shown that charging the electric forklift and light control during cleaning remain significant contributions to the peak demand. By controlling these items, another \$600 and \$1000 per year in electricity costs can be saved. The PV system was one of the first grid-tied systems in Colorado, and numerous faults reduced its performance. Replacing the inverters with ones designed to be grid-tied would solve many problems. Maintaining the energy-efficient performance of the building is not difficult, but it requires a continual effort by a motivated and trained staff. Additional loads and changes in the control schemes can cause energy use to increase.

1 Introduction

The BigHorn Development Project in Silverthorne, Colorado, is a retail complex that consists of two buildings developed in three phases. The owners had been involved with the solar industry for many years and maintained their interest in building energy efficiency and renewable energy technology as their business expanded. They improved on the energy design in each phase of the project.

Phase I was completed in February 1998 with the construction of a department store that included clerestory windows that bring daylight into the retail space, insulation levels higher than typical values, and radiant-floor heating. Construction on Phase II began in the spring of 1998 and was an expansion of the first building to add more retail space. The addition included an improved daylighting design and two, 1-kW photovoltaic (PV) systems. Construction on Phase III started in the spring of 1999 and was completed in April 2000. Phase III is a separate building that houses a hardware store and warehouse/lumberyard. It is called the BigHorn Home Improvement Center (BigHorn Center). Figure 1-1 shows the main entrance to the BigHorn Center.

In this final phase, a multidisciplinary design team was established to investigate available innovative technologies and design strategies to produce an energy-efficient building. High-Performance Buildings staff at the National Renewable Energy Laboratory (NREL) participated in the design process. NREL assisted in the energy design of the building and monitored the performance of the building for 2½ years.

This report focuses on the energy aspects of the Phase III building from the design phase through the first 2½ years of occupancy. The energy design process, including the energy simulation results and how they guided decision making, is described in detail. The energy monitoring system and the data recorded are described along with the performance analysis. A comprehensive set of lessons learned and recommendations is included at the end of the report.



Figure 1-1 Main entrance of the BigHorn Home Improvement Center (east elevation)

2 Background

2.1 Energy Use in U.S. Commercial Buildings

The operation of commercial buildings accounts for approximately 18% of the total primary energy consumption in the United States. The total for all buildings is more than one-third of the primary energy consumption and approximately 70% of the electricity consumption. The operation of buildings in the United States results in 38% of U.S. and 9% of global carbon dioxide (CO₂) emissions. Electricity consumption in the commercial building sector doubled between 1980 and 2000, and is expected to increase another 50% by 2025 (DOE 2003).

Average site energy consumption by end use for mercantile and service (retail) buildings in the U.S. is shown in Figure 2-1 and for warehouse and storage buildings in Figure 2-2 (DOE 2003). The building site energy use intensity (EUI) is 76.4 kBtu/ft²·yr and 38.3 kBtu/ft²·yr for the two building types. These numbers are based on 1995 data collected by the Energy Information Administration. Most of the space heating, water heating, and cooking are by natural gas; the rest of the energy consumption is electricity. The primary energy consumed to generate and distribute the electricity is approximately three times the energy used on site. Lighting is the largest primary energy end use for both building types; therefore, reduction in the lighting of loads is a primary objective in this project.

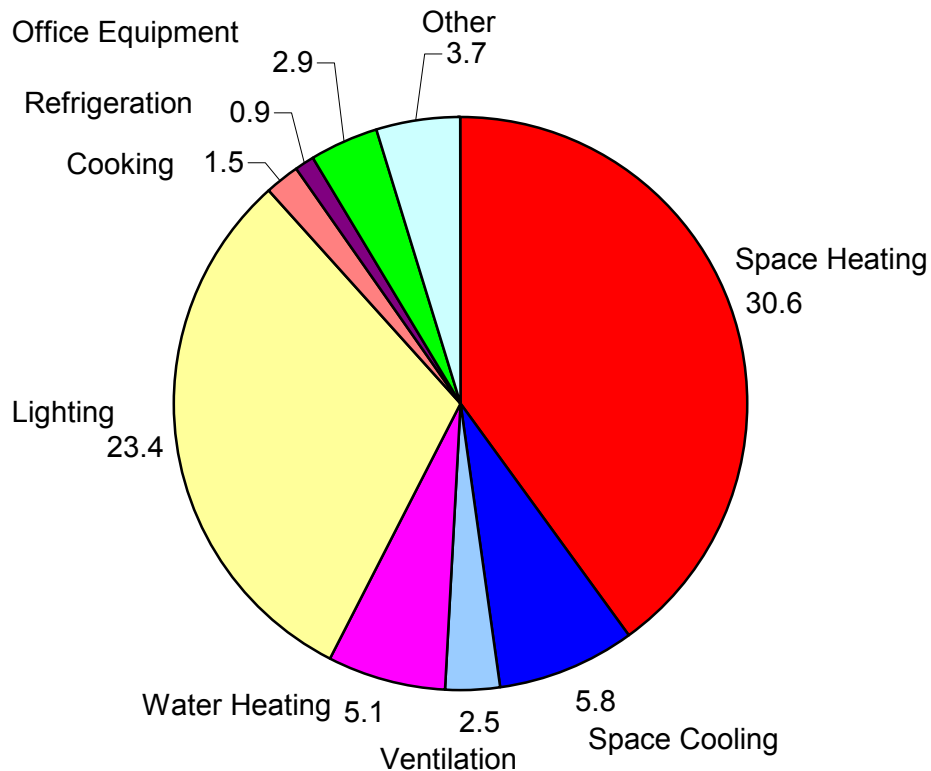

Figure 2-1 Typical site EUIs by end use for retail buildings (kBtu/ft²·yr) (DOE 2003)

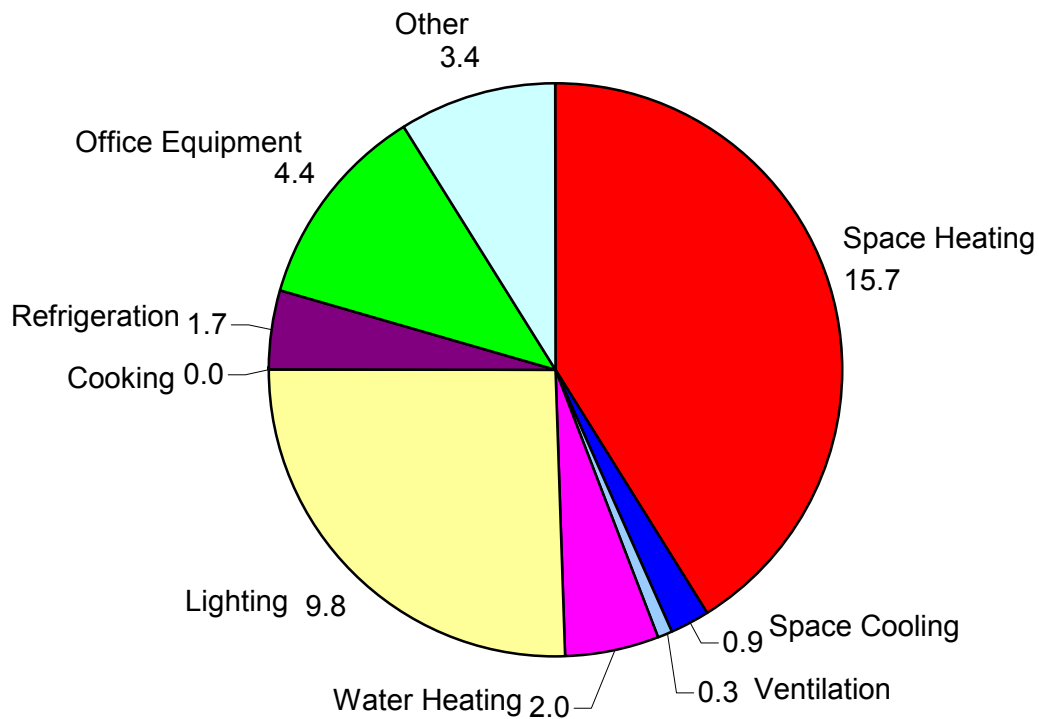

Figure 2-2 Typical site EUIs by end use for warehouse buildings (kBtu/ft²·yr) (DOE 2003)

2.2 High-Performance Buildings Research Objectives

NREL conducts research for the U.S. Department of Energy’s High-Performance Buildings initiative (HPBi). NREL evaluates commercial buildings from a whole-building perspective to understand the impact of integrated design issues on energy use and costs in commercial buildings. NREL provides direct assistance to industry by documenting analysis methodologies and results on new commercial design. NREL’s research objectives are to:

- Develop processes for high-performance building design, construction, and operation.
- Provide the tools needed to replicate the processes.
- Research new technologies used in high-performance buildings.
- Develop standardized metrics and procedures for measuring building energy performance.
- Measure and document building performance in high-profile examples.

2.3 Project Objectives

In general, NREL’s goal is to use passive solar design and demand-side strategies to reduce building energy requirements by 50%–70% compared to buildings that meet standard energy codes. The overall energy goal for this project was to design the building and its systems to save at least 60% in energy costs compared to a similar building built and operated according to the energy standards in 10 CFR 435 (FERC 1995) for lighting power densities and ANSI/ASHRAE/IESNA Standard 90.1-1989 (ASHRAE

1989) for all other parameters. To achieve this, a major objective was to maximize the use of daylighting and achieve 100% daylighting under bright sky conditions. Additional objectives included minimizing heating loads and peak electrical demand.

An important part of NREL's building research is to understand the operation of real buildings and verify energy-efficient design strategies and technologies. This project offered a great opportunity to closely monitor an energy-efficient building for multiple years. Lessons learned from this effort will then be applied to improve the performance of this building, and will be available to future projects.

NREL set the following goals for working with the BigHorn Center:

- Provide design assistance to save 60% in energy costs compared to a baseline building built to the requirements of 10 CFR 435 (1995) for lighting and ASHRAE 90.1-1989 for all other requirements (this project was initiated before ASHRAE 90.1-1999 was released).
- Monitor and analyze the performance of the building and its subsystems for at least 2 years.
- Implement improvements to the building operation based on the monitoring and analysis.
- Document lessons learned to improve future low-energy buildings.

3 Energy Design Process

NREL approaches building design from a whole-building perspective. In this approach, all members of the design team (architect, engineer, building owner, landscape architect, facility manager, building occupants, etc.) work together from the early stages of building design to ensure the greatest project efficiency and to foster communication within the team. When NREL researchers were contacted for this project, they proposed a whole-building approach for the design of Phase III.

3.1 Energy Design Team

The design team for the Phase III building consisted of the owner/developer, building users, architect, mechanical engineer, electrical engineer, and NREL researchers. When NREL was approached about participating in the BigHorn project, building design was already underway. Although being involved from the beginning is preferable, this project represented an opportunity to work on a retail project. Also, the design team was willing to work with NREL to maximize the energy saving potential. NREL provided research level design assistance to integrate energy-efficient design solutions and technologies into the building architecture and into the mechanical and electrical systems.

3.2 Design Constraints

The constraints on the design process included the building program document, site restrictions, and climate variables. The building program called for a 36,980-ft² (3,436 m²) building to house a hardware store and a warehouse/lumberyard building. The site dictated that the building be built with a long north-south axis, which required special consideration for solar load control and daylighting. The general look and feel of the building had to match the building that was built in the first two phases of the project and the rustic mountain character of the community. In addition, the Army Corps of Engineers restricted site development to preserve wetlands.

The climatic conditions in Silverthorne, Colorado, are different from most commercial building locations in the United States. Silverthorne is a mountain community at an elevation of 8,720 ft (2,658 m) with long winters and short summers. Based on long-term average weather data, there are 10,869 base 65°F (6,038 base 18°C) heating degree-days (HDD) and 0 base 65°F cooling degree-days (CDD). The average annual temperature is 35°F (2°C), and the average annual snowfall is 129 in (328 cm).

3.3 Energy Design Analysis

NREL developed an energy design process as a guideline for designing, constructing, and commissioning low-energy buildings (Hayter and Torcellini 2000). This process relies heavily on whole-building energy simulations to investigate the effectiveness of design alternatives. The energy design process is divided into three categories with nine steps. This is a recommended process—every building design evolves in different ways, so completing the process as presented may be unnecessary or impractical in some cases.

Pre-Design Steps

1. Simulate a baseline-building model and establish energy use targets.
2. Complete a parametric analysis of the baseline building.
3. Brainstorm energy-efficient solutions with all design team members.
4. Perform simulations on baseline variants and consider economic criteria.

Design Steps

5. Prepare preliminary architectural drawings.

6. Design the heating, ventilating, and air conditioning (HVAC) and lighting systems with the use of simulations.
7. Finalize plans and specifications, and perform simulations to ensure design targets are being met.

Construction/Occupation Steps

8. Rerun simulations of proposed construction design changes.
9. Commission all equipment and controls.
10. Educate building operators to ensure they operate the building as intended.

This process was developed during the course of working on the BigHorn Center and other projects. The steps were refined after the design was completed, so the design process used in the BigHorn project did not follow these steps exactly. For example, the simulations in step 4 were evaluated based on energy performance rather than economic criteria. Only the final version of each building model was evaluated on economic criteria. In addition, the building and the systems designs were continually refined even during construction, which is common in small building projects. Energy simulations must be run during the design steps (5–7) to ensure optimal building design and to size the HVAC and Lighting (HVAC&L) systems.

All daylighting and thermal analyses in the design phase were performed with the building energy analysis program DOE-2.1E-W54 (LBNL 2003). DOE-2.1E is an hourly simulation tool designed to evaluate building system and envelope performance. The program requires detailed descriptions of the thermal and optical properties of the envelope, HVAC systems, lighting systems, internal loads, operating schedules, utility rate schedules, and hourly weather data. The outputs from the simulation include a long list of hourly, monthly, and annual reports for energy consumption and energy cost.

There is no Typical Meteorological Year (TMY) weather file for Silverthorne (NREL 2004a). The closest station is Eagle, Colorado, which is about 45 miles (72 km) away and 2,200 ft (670 m) lower in elevation. The temperature is the main difference between the two sites. Five weather files were created by modifying the Eagle, Colorado, TMY2 file for the building simulations. Appendix C contains a description of the weather files and provides details on their creation. All of the files were used during the design and analysis of the building, but only the results from using two of the files are reported here. Weather file A was created to represent the long-term average conditions by adjusting the dry-bulb and dew-point temperatures in the Eagle TMY2 weather file. The file was based on the 30-year average, daily high and low temperatures measured at a weather station near Silverthorne. This weather file was used for all the design simulations and the comparison of the as-built simulation models. Weather file E was created to represent the local weather conditions for the year from September 2002 through August 2003. The dry-bulb and dew-point temperature data were modified with the monthly average temperatures from the utility bills, and the solar radiation data were modified with five-minute solar data measured at a local weather station maintained by NREL.

Three main simulation models were created during the design process, with many variations of each model. In addition, two simulation models were created based on the as-built building. Table 3-1 lists these five models along with a description of each.

Table 3-1 Energy Simulation Models

Model	Description
Design Baseline	Building model based on the size and functionality of the Original Model and compliant with ASHRAE 90.1-1989 for the envelope and equipment and Federal Energy Code 10 CFR 435 for lighting
Original	This model was based on the original building design developed by the design team at the time NREL joined the project
Optimized	Final building model from the design phase, including the most energy-efficient features from the design process
As-Built-Baseline	ASHRAE 90.1-2001 compliant model based on the size and functionality of the as-built building
As-Built	Calibrated model of the as-built building based on actual schedules and plug loads

3.3.1 Design Baseline Model

The first step in the energy design process is to create a simulation model of the theoretical baseline building. The baseline simulation is extremely important to the design process. It establishes a fixed reference point to start the energy design process and allows the design team to investigate the effectiveness of many design alternatives, which may include changes in shape, orientation, envelope, lighting, and HVAC systems. As long as the overall size and function of the building during the design process do not change, the baseline model should not change.

The Design Baseline Model represents a hypothetical building with the same size and function as the proposed design building. It is designed to meet the minimum requirements of the energy codes, and represents a baseline of energy performance to measure the effectiveness of the final design. It is a square building with windows distributed equally on all four sides. For this case, the energy standards were taken from ASHRAE Standard 90.1-1989 for the envelope and equipment requirements and from the Federal Energy Code 10 CFR 435 for the allowable lighting power densities. The lighting power densities in 10 CFR 435 are more restrictive than ASHRAE Standard 90.1-1989. Table 3-2 shows the thermal performance parameters used for this model.

Table 3-2 Design Baseline Model Thermal Parameters

Component	Value
Wall R-Value – $\text{ft}^2 \cdot \text{°F} \cdot \text{hr} / \text{Btu}$ ($\text{m}^2 \cdot \text{K} / \text{W}$)	19 (3.3)
Roof R-Value – $\text{ft}^2 \cdot \text{°F} \cdot \text{hr} / \text{Btu}$ ($\text{m}^2 \cdot \text{K} / \text{W}$)	30 (5.3)
Floor Perimeter Insulation R-Value – $\text{ft}^2 \cdot \text{°F} \cdot \text{hr} / \text{Btu}$ ($\text{m}^2 \cdot \text{K} / \text{W}$)	13 (2.3)
Window Area/Gross Wall Area	16%
Window U-Value – $\text{Btu} / \text{ft}^2 \cdot \text{°F} \cdot \text{hr}$ ($\text{W} / \text{m}^2 \cdot \text{K}$)	0.51 (2.9)
Window Solar Heat Gain Coefficient	0.21
Outside Air – $\text{cfm} / \text{person}$ ($\text{l/s} \cdot \text{person}$)	15 (8)
Retail/office Infiltration – occ/unocc (ACH)	0.5 / 0.3
Warehouse Infiltration – occ/unocc (ACH)	1.0 / 0.6
Retail/office Lighting Power Density – W / ft^2 (W / m^2)	2.32 (25.0)
Warehouse Lighting Power Density – W / ft^2 (W / m^2)	0.42 (4.5)
Retail/office Plug Load Power (kW)	5.25
Warehouse Plug Load Power (kW)	2.2

The Design Baseline Model has two-zones, with one zone for the retail/office space and one zone for the warehouse. Equal window areas were used on all wall orientations. Occupancy schedules were estimated with typical operation hours from a similar hardware store and expected customer density data provided by the owner. The HVAC system was simulated as two packaged single-zone systems with economizers. Hourly annual simulations were performed with weather file A, which represents an average weather year for Silverthorne.

Figure 3-1 shows a breakdown of the Design Baseline Model annual energy consumption by category. The building is obviously dominated by the heating load, which is almost half the total building energy. The cooling load for this building can be almost entirely met by outside air economizers, which suggests that natural ventilation may meet the cooling loads. For this building with this system, the fans use a significant amount of energy to meet the ventilation needs. The high light levels in the retail area make the lighting almost one-quarter of the total. This analysis shows that reductions in the heating, fan, and lighting loads have the most energy saving potential.

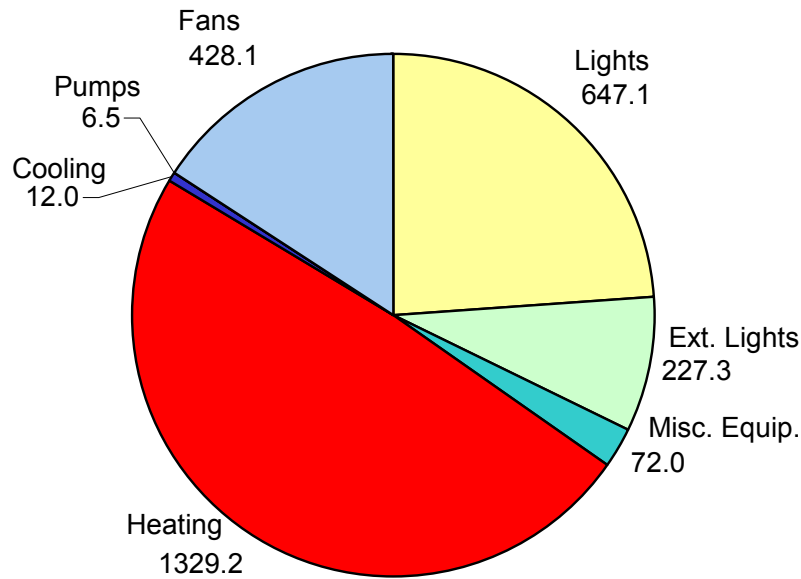

Figure 3-1 Design Baseline Model annual site energy consumption (MMBtu)

3.3.2 Parametric Analysis of Baseline

The second step in the energy design process is to perform a series of parametric variations on the Design Baseline Model to determine which variables have the greatest impact on the building energy consumption. The parametric cases are formed by effectively removing each thermal energy path or energy source from the simulation one at a time. For example, thermal conduction through the walls is virtually eliminated by increasing the R-value to 99 ft²·°F·hr/Btu (17 m²·K/W). Results of alternative simulations are listed in Tables 3-3 and 3-4 and illustrated in Figure 3-2. A summary of each parametric simulation follows.

- **R-99 Walls, Roof, Floor, and Windows:** The insulation value was increased to R-99 ft²·°F·hr/Btu (17 m²·K/W) separately for each building component. The parametric runs showed that heat loss through the windows had the greatest impact on heating energy consumption and that additional insulation to the walls and roof should be considered.
- **No Solar Gain:** Solar gain through the fenestration was eliminated. This alternative increased the heating energy, which indicates that passive solar heating helps meet the building heating loads. However, because of the building orientation and the need to avoid glare in the retail area, passive solar heating will be limited.
- **No Outside Air or Infiltration:** The outside air intake and infiltration were set to zero. This setting had the greatest impact on the building loads. Steps to minimize the infiltration and alternative controls for the outside air intake should be considered.

- **No Occupants:** An unoccupied building was simulated, which eliminated this source of heat gain and the outside air intake per person. This variation had little effect on the overall energy use.
- **No Lights:** A building with no lights was simulated. This alternative had a negative impact on the building heating energy, but reduced the overall building energy use. Therefore, the lighting energy could be reduced with daylighting and controls, and the building could be heated more efficiently by the heating system. More discussion of the building daylighting opportunities used for this building is presented later in this report.
- **No Plug Loads:** All the plug load equipment was eliminated. The internal equipment in a hardware store was assumed to be minimal; therefore, removing these loads had little impact on building energy requirements.

Table 3-3 Parametric Study Results for Heating Energy

Model	Heating Energy MMBtu/yr (GJ/yr)	Heating Intensity kBtu/ft²·yr (MJ/m²·yr)	% Improvement over Baseline
Design Baseline	1,329 (1,402)	35.9 (408)	0%
R-99 Walls	1,165 (1,229)	31.5 (358)	12%
R-99 Roof	1,115 (1,176)	30.1 (342)	16%
R-99 Floor	1,253 (1,322)	33.9 (385)	6%
R-99 Windows	1,017 (1,073)	27.5 (312)	24%
No Solar Gain	1,429 (1,508)	38.6 (438)	-7%
No Outside Air or Infiltration	493 (520)	13.3 (151)	63%
No Occupants	1,156 (1,220)	31.3 (355)	13%
No Lights	1,819 (1,919)	49.2 (559)	-37%
No Plug Loads	1,363 (1,438)	36.9 (419)	-3%

Table 3-4 Parametric Study Results for Total Energy Consumption

Model	Total Energy MMBtu/yr (GJ/yr)	Energy Use Intensity kBtu/ft²·yr (MJ/m²·yr)	% Improvement over Design Baseline Model
Design Baseline	2,722 (2,872)	73,614 (836,000)	0%
R-99 Walls	2,535 (2,674)	68,544 (778,420)	7%
R-99 Roof	2,479 (2,615)	67,023 (761,150)	9%
R-99 Floor	2,639 (2,784)	71,352 (810,310)	3%
R-99 Windows	2,369 (2,499)	64,064 (727,540)	13%
No Solar Gain	2,819 (2,974)	76,225 (865,650)	-4%
No Outside Air or Infiltration	1,631 (1,721)	44,093 (500,740)	40%
No Occupants	2,557 (2,698)	69,132 (785,100)	6%
No Lights	2,616 (2,760)	70,744 (803,400)	4%
No Plug Loads	2,692 (2,840)	72,799 (826,740)	1%

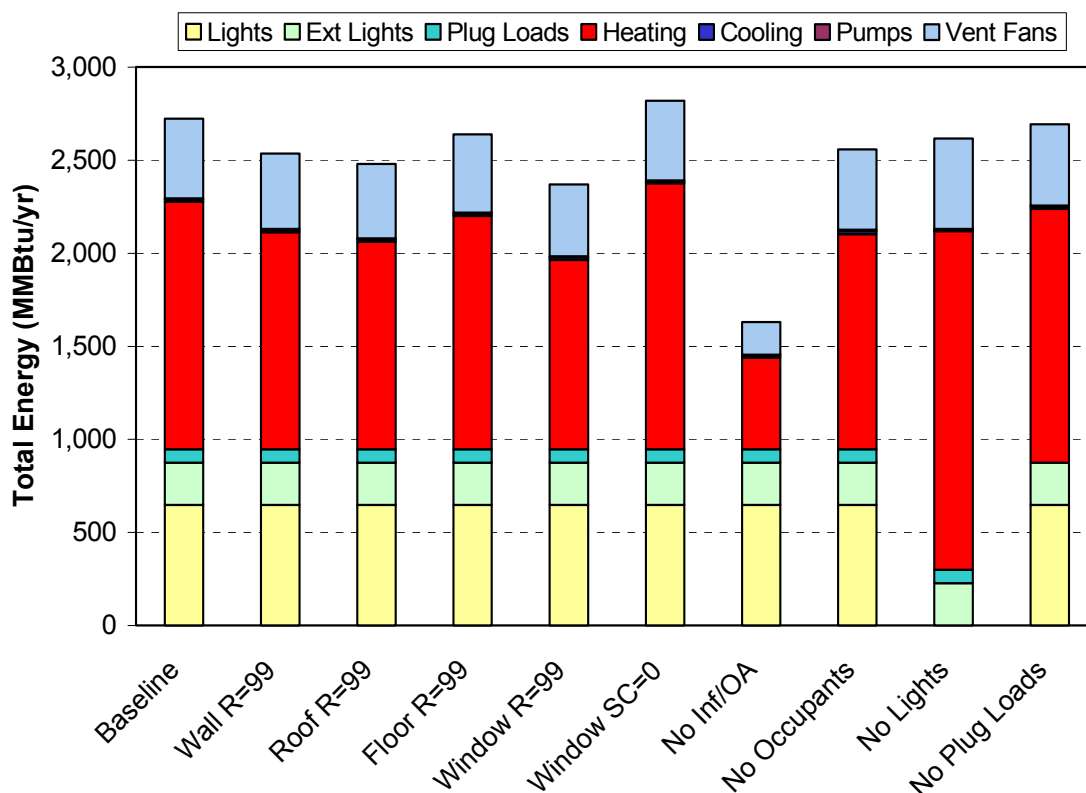

Figure 3-2 Baseline parametric study results for total energy consumption

Additional parametric simulations were completed with the Design Baseline Model to investigate the effects of wall and roof insulation on heating energy. The insulation levels in the wall and the roof were varied in separate runs from R-1 to R-50 $\text{ft}^2 \cdot \text{°F} \cdot \text{hr} / \text{Btu}$ (RSI-0.2 to $8.8 \text{ m}^2 \cdot \text{K} / \text{W}$). The effect on the total energy consumption in the building is shown in Figure 3-3. From these runs, it was recommended that the wall insulation should be at least R-20 (RSI-3.5) and the roof insulation should be at least R-30 (RSI-5.3), which is the same as the Design Baseline Model.

3.3.3 Original Model

At the time the building owner approached NREL with this project, a preliminary concept for the hardware store and warehouse/lumberyard building had been developed based on the Phase I and II building. This meant that the energy analysis was brought into the design process later than is optimal, but the owner and architect were willing to work on design alternatives to improve the energy performance. This building design has a rectangular warehouse/lumberyard section along a north-south axis and a rectangular retail/office section along an east-west axis. The building included steel stud construction, high clerestory windows in the retail/office area, hydronic radiant floor heating in the retail/office area, gas-fired radiant heaters in the warehouse, and a transpired solar collector on the south wall of the warehouse. A simulation model based on the preliminary conceptual drawings was created and called the Original Model. The thermal parameters used in this model are shown in Table 3-5.

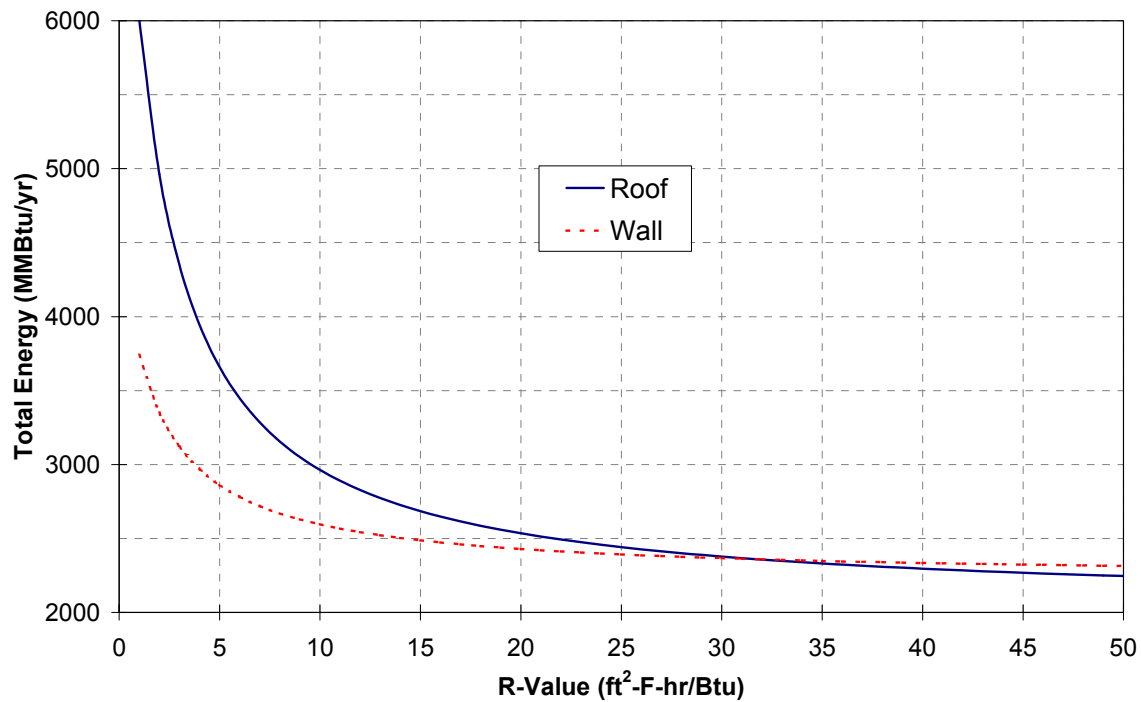

Figure 3-3 Total energy consumption versus wall and roof insulation values

Table 3-5 Original Model Thermal Parameters

Component	Value
Wall R-Value – R-19 batt between metal studs with R-11 continuous insulation on outside – ft ² ·°F·hr/Btu (<i>m</i> ² ·K/W)	20 (3.5)
Clerestory wall R-Value – R-19 batt between metal studs – ft ² ·°F·hr/Btu (<i>m</i> ² ·K/W)	9 (1.6)
Roof R-Value – ft ² ·°F·hr/Btu (<i>m</i> ² ·K/W)	38 (6.7)
Floor Perimeter Insulation R-Value – ft ² ·°F·hr/Btu (<i>m</i> ² ·K/W)	11 (1.9)
Window Area/Gross Wall Area	10.2%
Window U-Value – Btu/ft ² ·°F·hr (<i>W/m</i> ² ·K)	0.32 (1.8)
Window Solar Heat Gain Coefficient	0.60
Outside Air (cfm/person)	0.0
Retail/Office Infiltration – occ/unocc (ACH)	0.5 / 0.3
Warehouse Infiltration – occ/unocc (ACH)	1.0 / 0.6
Retail Lighting Power Density – W/ft ² (<i>W/m</i> ²)	1.75 (18.8)
Office Lighting Power Density – W/ft ² (<i>W/m</i> ²)	1.5 (16.1)
Warehouse Lighting Power Density – W/ft ² (<i>W/m</i> ²)	1.5 (16.1)
Retail Plug Load Power (kW)	3.0
Office Plug Load Power (kW)	2.25
Warehouse Plug Load Power (kW)	2.2

Several assumptions were made to accurately reflect the energy design. The Original Model assumed that there were no daylighting controls, and the electric lighting was turned on during all occupied hours. The heating in the office/retail area was designed as a hydronic radiant floor system, which was simulated in DOE-2 with the floor panel heating (FPH) system. A natural gas boiler with an overall efficiency of 80% was used as the heating supply. The FPH system does not include ventilation; therefore, the outside air for ventilation was not included in the model. However, the infiltration for this space is more than adequate to provide fresh air. When the store is fully occupied (only 2 hours on weekend days), the modeled infiltration rate of 0.5 air changes per hour (ACH) equals the outside air requirement of ASHRAE Standard 62-1999 of 20 cfm/person (10 l/s-person) for offices and 0.2 cfm/ft² (1 l/s·m²) (ASHRAE 1999). Most of the time in the retail/office area, the occupancy schedule is less than half the maximum occupancy, which means that the modeled infiltration provides more than double the required amount of outside air. The infiltration rate is high because a large amount of traffic is expected in and out of the exterior doors and there are no vestibules in the design.

Another issue with using the FPH system is that there is no cooling in this model and DOE-2 does not allow more than one HVAC system per zone. The Design Baseline Model showed that the cooling load was small and could probably be met by natural ventilation; therefore, no cooling was modeled in the building for most simulations. However, simulations with no cooling system showed that there were some periods of uncomfortably high temperatures during the summer. When a model was created with a cooling system, a separate simulation for the summer months was completed with a different system that allowed cooling and heating. Additional runs were completed to investigate the use of natural ventilation to meet the cooling loads. The cooling load is limited mostly to the mezzanine area; however, the temperature in the mezzanine is not simulated well in DOE-2 because of the assumption that zones are well mixed. Temperature stratification in tall zones can be significant and attempts to simulate this were conducted by modeling the mezzanine as a separate zone.

The heating system in the warehouse was designed as ceiling-mounted, gas-fired radiant heaters, which were modeled as fan-powered unit heaters. Note that DOE-2 does not simulate the comfort conditions created by the radiant heaters, but it does simulate the conditions seen by the thermostat controlling the heaters, which is more important from an energy point of view. In addition, the fan energy from the fan-powered unit heaters will show up as heat added to the space. The total heat input to the space from the fan-powered unit heaters should be a fair representation of the gas-fired radiant heaters. The south wall of the warehouse area included a transpired solar collector or solar wall (see Section 5.6), which was modeled as a sunspace with a fan to move warm air from the sunspace into the warehouse.

An annual energy simulation was completed with weather file A, which represents the “average” weather year based on long-term weather data. The energy consumption of the Original Model is illustrated in Figure 3-4. The energy loads in this building are dominated by the heating and lighting loads. The heating energy use is lower than that of the Design Baseline Model because of improved insulation levels, less outside air intake in the retail/office area, and increased heat gain from the lights. The lighting energy has increased because the Original Model assumes a lighting power density (LPD) of 1.5 W/ft² (16 W/m²) in the warehouse and the Design Baseline Model is limited to 0.42 W/ft² (4.5 W/m²) by the 10 CFR 435 energy code. These lighting levels are high for this space because it is a retail lumberyard that requires more lighting than a warehouse devoted strictly to storage.

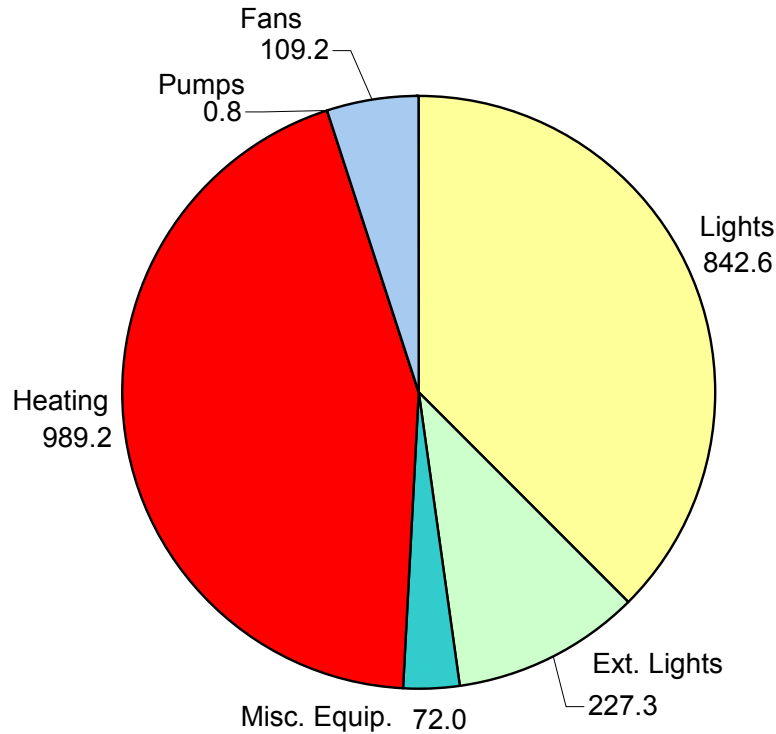

Figure 3-4 Original Model annual site energy consumption (MMBtu)

3.3.4 Optimized Energy Design

The third and fourth steps in the design process are to brainstorm solutions to improve the energy performance (based on the results of the parametric analysis) and to analyze the solutions with energy simulations. The design team used the Original Model as the starting point and worked to find energy-efficient solutions that fit within the physical and aesthetic design constraints described in Section 3.2. At this point in the design process, the focus was on energy efficiency. The cost implications of the variations were not explicitly part of the evaluation process; however, changes that carried a high price tag were not considered. In the end, the process of selecting the features for the final building design was based on economic, environmental, aesthetic, marketing image, and other values. There was no scientific method of evaluating the relative importance of each variable. Ultimately, the owner evaluated all the information then made the final decisions. Several design iterations were completed in this process. The highlights are presented in this report.

From the parametric analysis of the Design Baseline Model, the variation that had the greatest effect was the elimination of the infiltration and ventilation air. As discussed in the Original Model, the outside air intake for ventilation was eliminated, as infiltration was more than adequate to provide the ventilation requirements. This also eliminated the fan power, which was the third-largest load in the Design Baseline Model. Most of the infiltration was assumed to come from traffic in and out of the exterior doors and the doors between the retail and warehouse areas. This was a fixed assumption, and no changes to the design were considered to change the infiltration values.

Natural ventilation using open doors on the first floor and the clerestory windows was also added. The natural ventilation variations were only run to determine the effect on comfort. There is no energy savings because there is no cooling in the models.

In the Design Baseline Model and the Original Model, the two largest loads are heating and lighting. The lighting loads in the Original Model are very high and were seen as the best place to improve the energy performance. One goal of this project was to be able to light the store with 100% daylighting under bright sky conditions, which are common for this location. To achieve this, the first change was to include dimmable luminaires and daylighting controls. Then three dormer windows were added to the north side of the retail area and ridgeline skylights were added to the warehouse because there was not enough light in the retail area and the warehouse. In addition, the wall insulation values in the design were changed to work with the exterior finish systems. All these changes are summarized as Design Variation #1:

Design Variation #1 – Daylighting (starting with the Original Model)

- All walls have R-19 ft²·°F·hr/Btu (RSI-3.3 m²·K/W) batt insulation between metal studs for an effective insulation value of R-9 (RSI-1.6). The bottom 5 ft (1.5 m) of wall includes 2.5 in (6.4 cm) of rigid insulation for a total of R-20 (RSI-3.5). The remaining upper parts of the walls had 1 in (2.5 cm) of rigid insulation for a total of R-14 (RSI-2.5). Clerestory walls remained at R-9 (RSI-1.6).
- Continuous dimmable lighting controls were added to the retail and warehouse areas.
- Dimmable metal halide luminaires replaced conventional metal halide luminaires.
- Three north-facing dormers were added to the north-sloping roof of the retail area.
- Ridgeline skylights were added to the warehouse/lumber yard [clear double pane low-e, U = 0.24 Btu/ft²·°F·hr (1.36 W/m²·K), solar heat gain coefficient (SHGC) = 0.43, and visible transmittance (T_{vis}) = 0.70].
- The lighting power density in the warehouse was changed to 0.42 W/ft² (4.52 W/m²) to match the energy code requirements for a storage space.

Additional variations were explored to investigate other energy efficiency opportunities. The remaining variations included the changes made in Design Variation #1. The design changes focused on increasing the natural lighting in the spaces, investigating the use of natural ventilation, and reducing envelope loads. Variations 2 and 3 were mini-studies that consisted of numerous runs with different HVAC systems and simulation periods to optimize the overhang length and natural ventilation. The energy totals cannot be directly compared to the other variations; however, the building design changes can be carried over to the final design. Description of the main design variations and the results of each follow:

Design Variation #2 – Optimal clerestory overhangs

- Design Variation #1 plus changes to the length of the overhang over the south-facing clerestory windows in the retail and office spaces from 0 to 2.5 ft (0.76 m) (coplanar with roof pitch). The simulations showed that the case with no overhang had the lowest total energy use; however, this was only 2% lower than the case with a 2.5-ft (0.76 m) overhang. The optimal overhang length was determined by the lowest cooling load, which was the best combination of controlling the direct solar gain and optimizing the daylighting to reduce heat gain from the lights. The optimal overhang length for the lowest cooling load is recommended to be 9.5 in (24 cm) (normal to exterior wall roughly 8 in [20 cm] above the top of the window). The cooling load had to be minimized so natural ventilation could meet all the cooling loads. These runs were completed with a packaged multizone direct expansion (DX) cooling system to measure the cooling load.

Design Variation #3 – Natural ventilation

- Design Variation #1 plus natural ventilation were simulated in the office and retail areas to assess the ability to maintain comfortable thermal conditions during the summer. To simulate the natural ventilation in DOE-2, a summer simulation (May–September) was completed with the residential system (with air conditioning) and a winter (October–April) simulation was completed with the FPH system. The recommended minimum operable opening area (windows and doors)

for effective natural ventilation was determined to be 330 ft² (31 m²) for the ground floor and clerestory areas.

Design Variation #4 – Daylighting in first floor office space

- Design Variation #1 plus windows were included along the west side to improve the daylighting in the first floor offices.

Design Variation #5 – Dimmable fluorescent lamps

- Design Variation #1 plus continuously dimmable fluorescent lamps were used throughout the building. The metal halide lamps in the Original Model only reduce to 50% power consumption and 40% light output. In addition, they require a warm-up period of several minutes.

Design Variation #6 – Improved low-e warehouse skylights

- Design Variation #1 plus the skylights at the ridgeline of the warehouse were changed to clear double-glazed low-e glazing units with $U = 0.26 \text{ Btu/ft}^2 \cdot \text{°F} \cdot \text{hr}$ ($1.48 \text{ W/m}^2 \cdot \text{K}$), $\text{SHGC} = 0.65$, and $T_{\text{vis}} = 0.77$.

Design Variation #7 – Insulated translucent warehouse skylights

- Design Variation #1 plus the skylights at the ridgeline of the warehouse were changed to 0.625 in (0.25 cm) thick insulated translucent flat panels with $U = 0.53 \text{ Btu/ft}^2 \cdot \text{°F} \cdot \text{hr}$ ($3.0 \text{ W/m}^2 \cdot \text{K}$), $\text{SHGC} = 0.55$, and $T_{\text{vis}} = 0.50$.

Design Variation #8 – 2.5-in wall insulation

- Design Variation #1 plus 2.5-in (6.4-cm) rigid insulation were included on all exterior walls; therefore, all walls were insulated to $R\text{-}20 \text{ ft}^2 \cdot \text{°F} \cdot \text{hr/Btu}$ ($\text{RSI}\text{-}3.5 \text{ m}^2 \cdot \text{K/W}$).

Design Variation #9 – Optimized building

- This design included the best performers of the all design variations, which are Design Variations 1, 2, 3, 4, 5, 6, and 8.

The heating requirements associated with Design Variations 1 and 4–9 are shown in Table 3-6. Design Variations 2 and 3 cannot be compared directly to the others because they used different systems and simulation periods to optimize building design features. The most effective reduction in heating requirement came from increasing the thickness of the exterior rigid insulation on all exterior walls to 2.5 in (6.4 cm) (Variation #8). Variations that reduce lighting energy requirements have a negative impact on the heating energy required (i.e., the heating load is increased); however, the total building energy use is reduced for these cases (see Table 3-8). The impact of the lighting energy on the heating can also be seen in the Original Model, which has the lowest heating loads, but the highest lighting loads.

Table 3-6 Heating Energy for Design Variations

Variation	Model Description	Heating Energy MMBtu/yr (GJ/yr)	Improvement Over Design Baseline Model	Improvement Over Original Model
	Design Baseline	1,329 (1,402)		-34%
	Original	989 (1,043)	26%	
1	Daylighting	1,093 (1,153)	18%	-11%
4	Daylighting in First Floor Office Space	1,100 (1,161)	17%	-11%
5	Dimmable Fluorescent Lamps	1,199 (1,265)	10%	-21%
6	Improved Low-E Warehouse Skylights	1,082 (1,142)	19%	-9%
7	Insulated Translucent Warehouse Skylights	1,125 (1,187)	15%	-14%
8	Added 2.5-in Wall Insulation	1,024 (1,080)	23%	-4%
9	Optimized	1,085 (1,145)	18%	-10%

Table 3-7 shows the interior lighting system energy consumption for the Design Baseline Model, Original Model, and the design variations. These simulations show the potential for large energy savings with aggressive daylighting designs. The Optimized Model uses 77% less energy for lighting than the Design Baseline Model and 82% less lighting energy than the Original Model. Also, the Original Model used more lighting energy than the Baseline Mode; that is, the default design had a greater LPD than code would allow.

Table 3-7 Lighting Energy for Design Variations

Variation	Model Description	Lighting Energy MMBtu/yr (GJ/yr)	Improvement Over Design Baseline Model	Improvement Over Original Model
	Design Baseline	647 (683)		23%
	Original	842 (888)	-30%	
1	Daylighting	310 (327)	52%	63%
4	Daylighting in First Floor Office Space	300 (317)	54%	64%
5	Dimmable Fluorescent Lamps	158 (167)	76%	81%
6	Improved Low-E Warehouse Skylights	251 (265)	61%	70%
7	Insulated Translucent Warehouse Skylights	310 (327)	52%	63%
8	Added 2.5-in Wall Insulation	310 (327)	52%	63%
9	Optimized	148 (156)	77%	82%

The predicted total energy consumption of all the simulations is listed in Table 3-8 and shown graphically in Figure 3-5. The most effective reduction in total energy comes from the Optimized Model, which shows a 42% energy saving compared to the Design Baseline Model and a 29% energy saving over the Original Model. Figure 3-6 presents a breakdown of the Optimized Model energy consumption by category. Savings in Figure 3-6 refer to the Design Baseline Model. The characteristics of the Optimized Model are shown in Table 3-9.

Table 3-8 Total Energy Consumption for Design Variations

Variation	Model Description	Total Energy MMBtu/yr (GJ/yr)	EUI kBtu/ft ² ·yr (MJ/m ² ·yr)	Improvement Over Design Baseline Model	Improvement Over Original Model
	Design Baseline	2,722 (2,872)	73.5 (835)		-21%
	Original	2,241 (2,364)	60.6 (688)	18%	
1	Daylighting	1,791 (1,890)	48.4 (550)	34%	20%
4	Daylighting in First Floor Office Space	1,789 (1,887)	48.4 (550)	34%	20%
5	Dimmable Fluorescent Lamps	1,747 (1,843)	47.2 (536)	36%	22%
6	Low-E Warehouse Skylights	1,722 (1,817)	46.6 (529)	37%	23%
7	Insulated Translucent Warehouse Skylights	1,826 (1,926)	49.4 (561)	33%	19%
8	Added 2.5-in Wall Insulation	1,721 (1,816)	46.5 (528)	37%	23%
9	Optimized	1,586 (1,673)	42.9 (487)	42%	29%

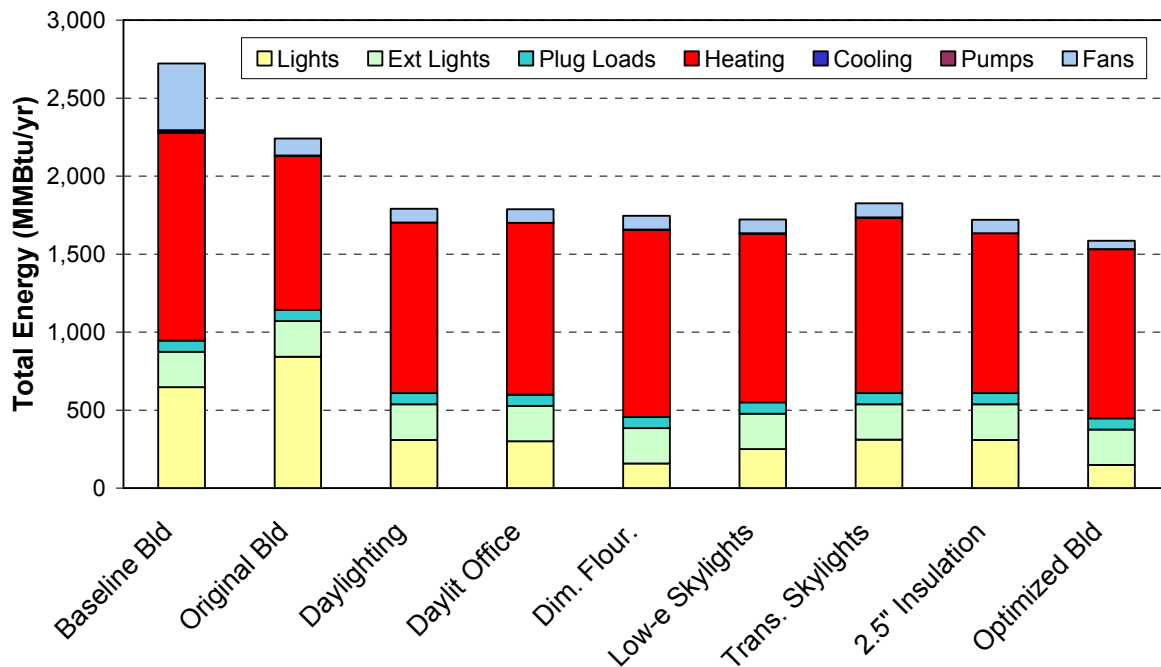

Figure 3-5 Total energy consumption for the Design Baseline, Original, design variations, and Optimized Models

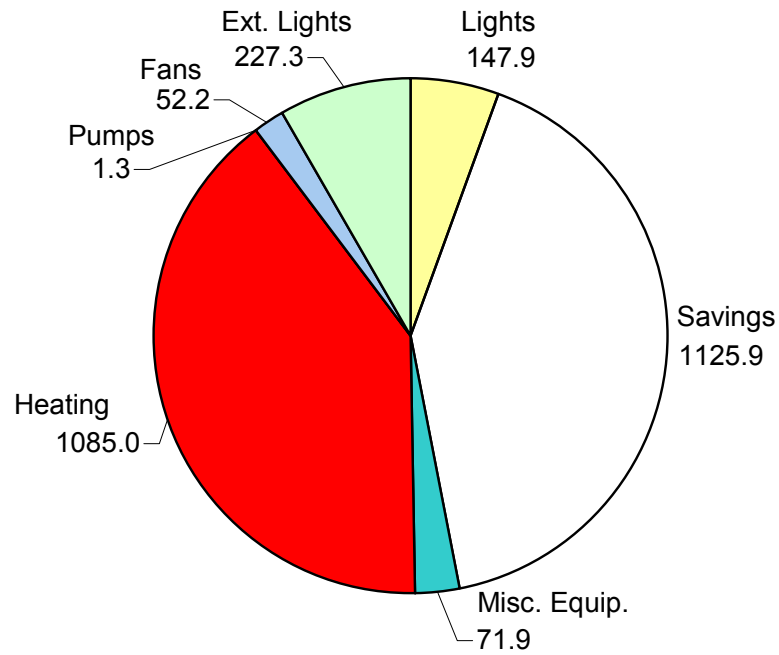

Figure 3-6 Optimized Model annual site energy consumption (MMBtu) (savings relative to the Design Baseline Model)

Table 3-9 Optimized Building Parameters

Component/Feature	Value as Modeled
Wall R-Value – Insulated Cavity between Metal Studs – $\text{ft}^2 \cdot \text{°F} \cdot \text{h} / \text{Btu}$ ($\text{m}^2 \cdot \text{K} / \text{W}$)	19 (3.3)
Exterior Wall Insulation Thickness – in (cm)	2.5 (6.35) (all walls)
Roof R-Value – $\text{ft}^2 \cdot \text{°F} \cdot \text{h} / \text{Btu}$ ($\text{m}^2 \cdot \text{K} / \text{W}$)	38 (6.7)
Floor Perimeter Insulation R-value – $\text{ft}^2 \cdot \text{°F} \cdot \text{hr} / \text{Btu}$ ($\text{m}^2 \cdot \text{K} / \text{W}$)	13 (2.3)
Window Area/Gross Wall Area	9.75%
N/S Clerestory Window U-Value – $\text{Btu} / \text{ft}^2 \cdot \text{°F} \cdot \text{hr}$ ($\text{W} / \text{m}^2 \cdot \text{K}$)	0.30 (1.7)
N/S Clerestory Window Solar Heat Gain Coefficient	0.75
Window U-Value – $\text{Btu} / \text{ft}^2 \cdot \text{°F} \cdot \text{hr}$ ($\text{W} / \text{m}^2 \cdot \text{K}$)	0.24 (1.4)
Window Solar Heat Gain Coefficient	0.57
Skylight U-Value – $\text{Btu} / \text{ft}^2 \cdot \text{°F} \cdot \text{hr}$ ($\text{W} / \text{m}^2 \cdot \text{K}$)	0.26 (1.5)
Skylight Solar Heat Gain Coefficient	0.86
Retail Infiltration – occ/unocc (ACH)	0.5 / 0.3
Warehouse Infiltration – occ/unocc (ACH)	1.0 / 0.6
Retail Lighting Power Density – W / ft^2 (W / m^2)	1.75 (18.8)
Office Lighting Power Density – W / ft^2 (W / m^2)	1.34 (14.4)
Warehouse Lighting Power Density – W / ft^2 (W / m^2)	0.42 (4.5)
Lighting Controls	100% dimmable, continuous
Lighting Type	Fluorescent
Lighting Control Set Points – fc (lux) retail/office/warehouse	70/50/30 (750/540/320)
Retail/office Plug Load Power (kW)	5.25
Warehouse Plug Load Power (kW)	2.2
Heating Type	Hydronic radiant floor with gas fired boiler for retail/office area; gas fired unit heaters for warehouse
Cooling Type	Natural ventilation via automatically operable windows in clerestory and manually operated windows and doors on the ground floor
Operable Window Area – ground floor/clerestory – ft^2 (m^2)	330/330 (31/31)
Passive Solar Features	Optimized south overhang length above clerestory windows; transpired solar collector on warehouse south wall

3.3.5 Economic Analysis

The annual energy costs for several models are compared in Table 3-10. Utility rates used in the simulations are summarized in Table A-1 in Appendix A. The Optimized Model produced a 41% energy cost saving compared to the code compliant Design Baseline Model. This fell short of NREL’s goal of a 60% energy cost saving. However, this building represents a huge step for changing retail construction.

Table 3-10 Annual Energy Cost Comparison for the Design Phase Simulation Models

Model	Annual Energy Cost \$/yr	Improvement over Design Baseline Model	Improvement over Original Model
Design Baseline	\$29,960		-15%
Original	\$25,957	13%	
Optimized	\$17,652	41%	32%

3.3.6 Recommendations from the Energy Design Process

Several recommendations from the energy design process were made to improve the energy efficiency and operability of the building. Some of these items, like the thermal and lighting parameters listed in Table 3-9, resulted directly from the energy simulations. Other recommendations could not be simulated in DOE-2 and were based on engineering judgment and experience. Economics or other design changes prevented some recommendations from being included in the building. The recommendations and their implementation are listed in Table 3-11.

Table 3-11 Design Recommendations and Implementation in the Actual Building

No	Recommendation	Implementation
1	Energy-efficient lighting, including T-8 fluorescent fixtures with electronic ballasts and compact fluorescent fixtures, should be used throughout the buildings. All lighting systems should be on photo sensor/motion controls to make maximum use of the available daylighting. Motion sensors should be in spaces that will receive no natural daylight, such as enclosed offices and restrooms.	Compact fluorescent lamps (CFL) with some T-8 fluorescents. Photo sensors in large areas and motion sensors in restrooms
2	Continuous (dimnable) ballasts and controls should be used for the interior electric lighting.	Stepped lighting control
3	The entire heated slab area should be insulated to R13 ft ² ·°F·h/Btu (RSI-2.3 m ² ·K/W) to reduce the heat loss to the ground. Thermal breaks should be placed in the slab between areas of the building with radiant floor heating and those areas without it. A thermal break should also be placed between the interior slab and the exterior environment. The zoning should be carefully considered for energy and comfort control.	Slab and foundation insulated with R-10 ft ² ·°F·h/Btu (RSI-1.8 m ² ·K/W) and thermal breaks installed. Nine radiant heating zones.
4	Natural ventilation should be implemented to increase the comfort level in the building during the summer months. Thermostatically controlled actuators should be installed on the clerestory windows. Opening the clerestory windows in conjunction with manually operable windows and opened doors on the ground level will induce natural ventilation through the building. The DOE-2 simulations indicate that a minimum of 330 ft ² (31 m ²) of operable glass at the clerestory level and 330 ft ² (31 m ²) of operable glass/doors at the ground level are needed to provide adequate natural ventilation cooling.	Natural ventilation via thermostatically controlled clerestory windows and manually operated doors. Effective opening areas on clerestory and ground levels are 170 ft ² (16 m ²) and 200 ft ² (19 m ²), respectively.
5	A provision for evaporative cooling should be designed before the building is occupied in case natural ventilation does not provide adequate cooling. Store operation will be minimally disrupted by doing this initially if evaporative cooling installation becomes necessary.	Not installed
6	The building envelope should be tightened to reduced infiltration. The buildings should be designed to not exceed an infiltration rate of 0.25 air changes per hour. Careful attention to construction detail can achieve this goal.	Tight building construction, but the infiltration was not measured
7	Thermostatically controlled ceiling fans should be installed to prevent thermal stratification in the high ceiling areas of the building.	On/off ceiling fans installed
8	A transpired solar collector should be installed on the south wall of the warehouse with as large an area as possible to minimize the load on other heating systems in the warehouse space.	Installed
9	Alternative technologies for domestic hot water should be considered. One option is active solar batch heaters, which store a quantity of hot water in the collector until needed. A second option is on-demand water heaters, which are especially effective where hot water loads are small, such as in a retail space.	Not installed
10	Low-flow toilets, faucets, and showerheads should be installed where appropriate. Toilets should have a flush of 1.6 gal/flush (6 l/flush) or less. Motion activated water fixtures should be installed.	Only low flow toilets installed
11	Carbon monoxide (CO) sensors that were added to ventilation fans in the warehouse should cycle on only when ventilation from exhaust was needed. The original plan had fans operating during occupied hours.	Ventilation fans controlled by CO sensors

4 Construction and Commissioning

Construction on the Phase III building of the BigHorn Center began on June 9, 1999 and was completed on April 15, 2000. The total project cost, excluding the land, was \$5.2 million (\$116/ft² or \$1250/m²) and included the main building, storage sheds for lumber, and parking lots. The energy-efficient features and PV system added approximately 10% to the total cost.

There was no definite separation between design and construction phases of the BigHorn Center. Modifications were made to the building and systems throughout the construction process, which is common for small buildings. The major advantage of this process is the ability to improve the design as the building comes together with new ideas or new technologies. There are two main potential disadvantages. First, the changes are often not documented properly, which can lead to incomplete building plans and disagreements between the owner and contractors about what was decided. Second, the impact on the overall building performance of the changes is often not fully analyzed.

Many changes that arise during construction can have a direct impact on energy performance. Other changes may affect occupant comfort, which can lead to higher energy consumption as occupants change their environment. The project should be monitored throughout construction for potential impacts to energy performance and occupant comfort. Even a building with a great energy design can become a poor performer if the details of the energy-efficient design are not implemented properly.

After building construction is complete, the proper operation of all the systems must be verified through a detailed commissioning. Commissioning entails verifying equipment installation and performance, system operation sequences, set points, and proper operation manuals. Commissioning can be done by either a third party agent or someone on the design team—the key is to make sure the building is operating according to the design.

4.1 Construction Details that Affected Energy Performance

NREL made several site visits during construction and stayed in close contact with the owner, architect, and general contractor to ensure that energy performance was not compromised. The building owner also took a special interest in energy performance and made several design changes to improve it. Issues that arose during construction included:

- The original lighting design had too many fixtures. The owner reduced the design lighting power density by 30% and still met the minimum illumination requirements.
- Some lighting fixtures were relocated to avoid producing bright spots and shadows. Poor light quality can adversely affect the perception of the lighting design, which can have a negative impact on the energy performance if the lights are used more or if more fixtures are added.
- The quality of the lighting from the pendant light fixtures was a potential problem in the mezzanine, where they were close to the working surface. An alternative was to use strip T-8 fixtures, which were not incorporated.
- The private offices on the mezzanine would be dark. The suggestion was made to add windows as high as possible to the office wall to use shared light from the clerestory windows. These windows would also allow ventilation air to circulate by natural convection. This suggestion was not incorporated and the offices required additional lights and fans during the summer to move the stuffy air.
- The lamps used in the pendant light fixtures were changed from high intensity discharge (HID) lamps to CFLs so they could be switched on/off with the daylighting controls.

- The yard foreman's office may be dark and glare from the windows may be a problem. To help this situation, NREL recommended that the walls and ceiling be painted white and the ceiling sloped to help distribute the light to the space. In addition, small light shelves would help direct some of the light to the back of the space. The space was painted white, which improves the light distribution; however, there are still glare problems during the afternoons.
- Many options for zoning the radiant floor heating system were discussed before the design team agreed on the final plan. The energy implications of each design had to be evaluated to produce the most effective control strategies for comfort and energy performance. The final plan included nine control zones instead of the original six, which provided better control of heat flow and temperature.
- NREL recommended that the thermostat in the yard foreman's office have a programmable timer or be attached to the energy management system (EMS). This was not incorporated; however, there are other problems with this space, which are discussed in Section 7.
- Demand control options were discussed for the forklift recharging station. Recharging the forklifts during high electrical demand periods significantly increases the electrical utility costs, and demand control for the recharging station could help avoid this increase. This was not implemented, and the impacts on demand are discussed in Section 6.2.2.
- Fire safety concerns about the automatically controlled clerestory windows were identified by the Fire Marshall. If the windows were left open during a fire, the air would fuel the fire and help it spread quickly. Another issue was that if a fire started with the windows open, the fuses in the fire sprinklers may not become hot enough to trigger. The solution was to automatically close all the windows when the fire detection system is triggered (either manually or through sensors).
- It was requested that provisions be made in the electrical circuiting for monitoring equipment. The electrical loads should have been grouped by type, which allows them to be properly disaggregated and makes long-term maintenance much easier. This request was not fulfilled, and the EMS could not be implemented as planned.
- The control circuits for the electric lighting required rewiring for proper operation. Control of the lights is very important for daylighting performance.
- An additional section of sidewalk, north of the main entrance, was added to the snowmelt system.

4.2 Commissioning

There was no formal commissioning process for this building. The owner had the subcontractors commission their own work, which resulted in a few minor modifications to the building. These changes included:

- The boiler and pump sequencing was reprogrammed in the EMS and the operators for the clerestory windows had to be rewired to work with the EMS.
- Programming the EMS was an ongoing process to fine-tune the performance of the building.

The owner had to work out other issues with the subcontractors about systems that did not work properly or were not installed as requested. Some took more than a year to resolve and some were never completely resolved. These problems included:

- A misunderstanding about whether the fire protection system in the warehouse should have been a wet system or a dry-head system (a dry system allows the space to drop below freezing)
- The sidewalk snowmelt system, which has never worked properly because of system leaks and inadequate flows

- Roof leaks caused by ice damming.

The commissioning approach used for BigHorn had the advantage that the subcontractors were familiar with their work and could easily check it without having to hire another company. However, full commissioning was hindered because many changes made during design and construction were not fully documented. This lack of documentation led to disagreements about the intended design and the responsible parties. Another option for commissioning is a third-party commissioning agent who can establish a formal process and provide an independent review of the work. The third-party agent can also provide a central point of contact between the owner and subcontractors to resolve issues, which can offer greater protection to the owner. However, this additional party comes at a higher cost that must be justified by the owner. For small projects it is often not economical to include a third party in the commissioning process.

5 Building Description

This section describes the building as it was built, including all design and construction modifications. It also summarizes results of the processes that were highlighted in the previous chapters of this report.

The BigHorn Center building is divided into two distinct sections: a retail/office area and a warehouse. The building layout is illustrated in Figure 5-1 with the warehouse on the left (south end) and the retail/office space on the right. The floor plans for the retail/office space and the warehouse are shown in Figures 5-2 and 5-3. The retail/office space is on an east-west axis, which allows north- and south-facing clerestory windows to be used for daylighting and natural ventilation. The warehouse area is on a north-south axis with an insulated translucent skylight along the ridge of the roof and a transpired solar collector on the south wall. Both the retail/office space and warehouse are single-story open interior floor plans, with small mezzanines and an approximately 18° sloped roof. The retail/office space mezzanine is located along the centerline of the building at the west end of the building and is used primarily as office space. The warehouse mezzanine is located along the north wall of the warehouse and is used for storage and as a pathway to the retail/office space. The Functional Areas, as defined in *Standard Definitions of Building Geometry for Energy Evaluation Purposes* (NREL 2004c), were measured from the inside surface of exterior walls and from the centerline of walls that connect adjoining spaces. These are summarized in Table 5-1. The break room and Yard Foreman's office are along the north wall of the warehouse, but they are on the same heating system as the retail/office space.

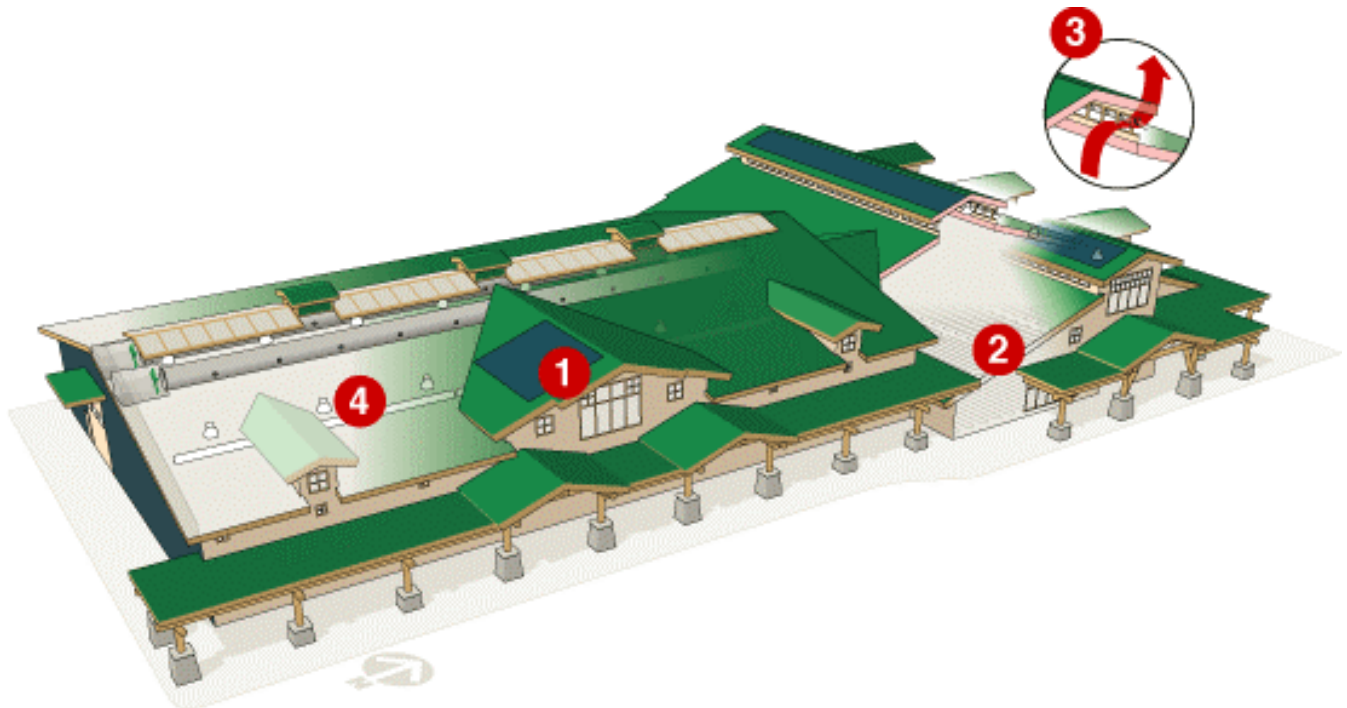

Figure 5-1 Illustration of the layout and some of the energy features of the BigHorn Center: (1) photovoltaic panels, (2) radiant floor heating, (3) natural ventilation, and (4) daylighting

Table 5-1 Building Functional Areas

Space	Area, ft2 (m2)
Retail/Office Main Floor	14,944 (1,388)
Retail Mezzanine	2,731 (254)
Break Room/Yard Foreman's Office	721 (67)
Total Retail/Office	18,396 (1,709)
Warehouse	23,258 (2,161)
Warehouse Mezzanine	1,433 (133)
Break Room/Yard Foreman's Office	-721 (-67)
Total Warehouse	23,970 (2,227)
Total Building	42,366 (3,936)

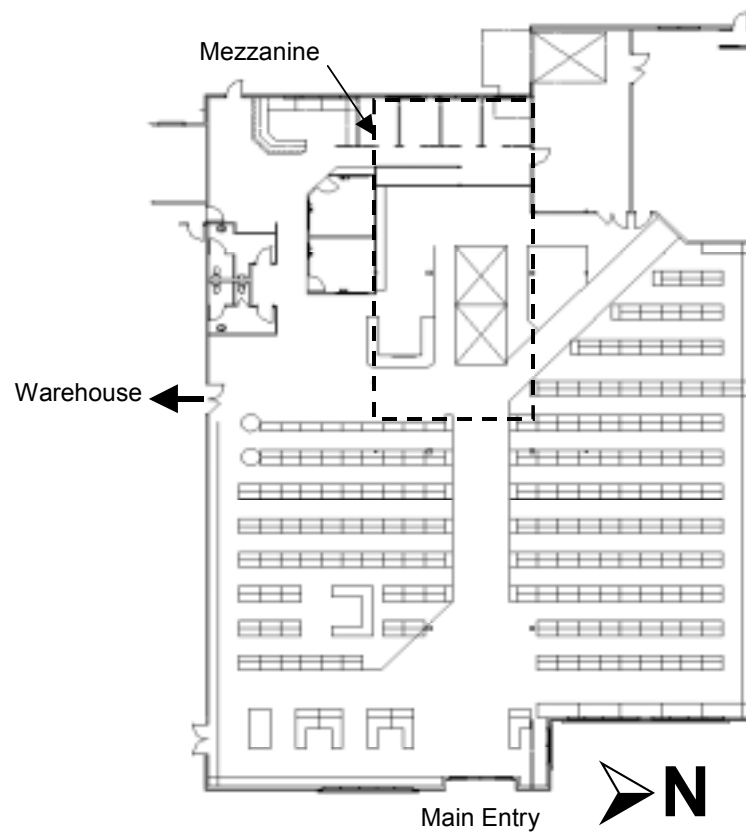

Figure 5-2 Floor plan of the retail/office area

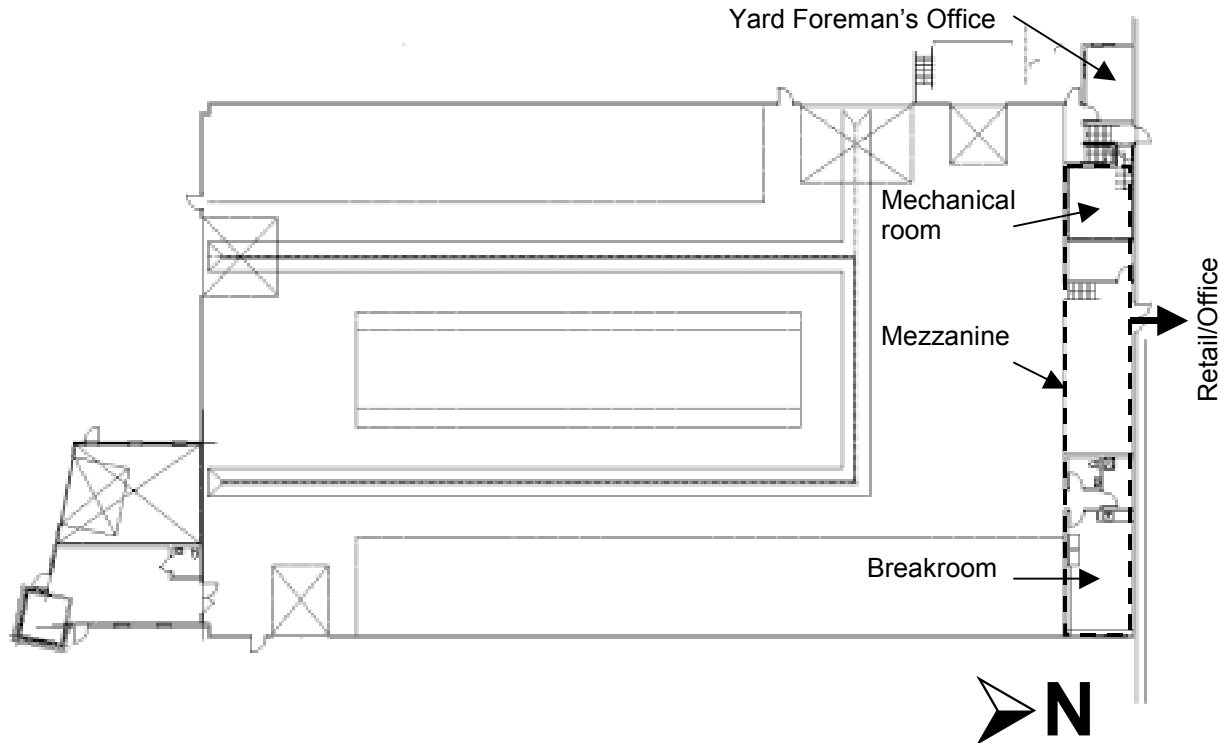

Figure 5-3 Floor plan of the warehouse

5.1 Building Envelope

The construction parameters for the as-built building are shown in Table 5-2 along with those used for the Design Baseline Model, the As-Built Baseline Model, and the recommendations from the design process. The parameters used for the baseline buildings are from ASHRAE 90.1-1989 for the Design Baseline Model and 90.1-2001 for the As-Built Baseline Model. The building envelope is well insulated with the bottom 4 ft (1.22 m) of the walls insulated to R-23 (ft²·h·°F/Btu) or RSI-4.1 (m²·K/W) and the upper part at R-16 (RSI-2.8); the roof has R-38 (RSI-6.7) insulation, and the entire retail/office floor area is insulated with R-10 (RSI-1.8) insulation. The wall insulation has different values for the lower and upper parts because of architectural finish reasons, not for energy performance.

Table 5-2 Envelope Parameters for the Baseline Models, Design Recommendations, and As-Built Building

Component/Feature	Design Baseline Model	As-Built Baseline Model	Design Recommendation	As-Built Building
Wall R-Value – insulated cavity between metal studs at 24 in – $\text{ft}^2 \cdot \text{°F} \cdot \text{h} / \text{Btu}$ ($\text{m}^2 \cdot \text{K} / \text{W}$)	19 (3.3) (total)	16 (2.8) (total)	19 (3.3) [eff. R-10.6 (1.9)]	19 (3.3) (eff. R-10.6)
Exterior Insulation R-Value – $\text{ft}^2 \cdot \text{°F} \cdot \text{hr} / \text{Btu}$ ($\text{m}^2 \cdot \text{K} / \text{W}$)	19 (3.3) (total)	16 (2.8) (total)	12.5 (2.2) (all walls)	12.5 / 5.0 / 0.0 (2.2 / 0.9 / 0.0) (bottom 5 ft / upper wall / clerestory wall)
Roof R-Value – $\text{ft}^2 \cdot \text{°F} \cdot \text{hr} / \text{Btu}$ ($\text{m}^2 \cdot \text{K} / \text{W}$)	30 (5.3)	16 (2.8)	38 (6.7)	38 (6.7)
Floor Insulation R-Value for Retail/Sales Area – $\text{ft}^2 \cdot \text{°F} \cdot \text{hr} / \text{Btu}$ ($\text{m}^2 \cdot \text{K} / \text{W}$)	13 (2.3) (first 36" in around perimeter)	10 (1.8) (first 36" in around perimeter)	10 (1.8) (entire floor)	10 (1.8) (vertical on foundation and entire floor)
Window Area/Gross Wall Area	< 16%	< 40%	9.75%	9.2%
N/S Clerestory Window U-Value – $\text{Btu} / \text{ft}^2 \cdot \text{°F} \cdot \text{hr}$ ($\text{W} / \text{m}^2 \cdot \text{K}$)	0.51 (2.9)	0.46 (2.6) (fixed) 0.47 (2.7) (open)	0.30 (1.7)	0.30 (1.7)
N/S Clerestory Window Solar Heat Gain Coefficient	0.21	0.36 (all) 0.46 (north)	0.75	0.75
Window U-Value – $\text{Btu} / \text{ft}^2 \cdot \text{°F} \cdot \text{hr}$ ($\text{W} / \text{m}^2 \cdot \text{K}$)	0.51 (2.9)	0.46 (2.6) (fixed) 0.47 (2.7) (open)	0.24 (1.4)	0.24 (1.4)
Window Solar Heat Gain Coefficient	0.21	0.36 (all) 0.46 (north)	0.44	0.44
Skylight U-Value – $\text{Btu} / \text{ft}^2 \cdot \text{°F} \cdot \text{hr}$ ($\text{W} / \text{m}^2 \cdot \text{K}$)	N/A	0.58 (3.3)	0.26 (1.5)	0.1 (0.6)
Skylight Solar Heat Gain Coefficient	N/A	0.49	0.57	0.22
Operable Window Area Ground Floor/Clerestory ft^2 (m^2)	N/A	N/A	330/330 (31/31)	170/200 (16/19)
Retail/Office Infiltration (ACH)	N/A	N/A	0.25	Not measured
Warehouse Infiltration (ACH)	N/A	N/A	0.25	Not measured

5.2 Space Conditioning

Heating loads dominate the building's energy use because of the cold winters and cool summers. The heating in the retail/office area and employee break room is provided by a hydronic radiant floor heating system. The nine heating zones shown in Figure 5-4 allow hot water to be delivered to the parts of the floor where it is most needed. For example, the perimeter zones require more heat than the interior zones. The zone heating valves are regulated by the EMS with wall- and slab-mounted temperature sensors. No heat is directly supplied to the mezzanine area by the HVAC system. All the heat comes from the first floor heating system and from internal gains. Ceiling fans along the center ridge in the retail/office area move heat down from the high ceilings.

The hot water is provided by four natural gas boilers that are sequenced by the EMS to meet the heating demand. The boilers have an overall efficiency of 85% and are rated at 442 kBtu/hr (130 kW) output. The boilers also supply hot water to a baseboard heater in the Yard Foreman’s office and to the sidewalk snowmelt system along the east side of the building. A schematic of the hot water system is shown in Figure 5-5.

The warehouse is designed to be a drive-through loading area for lumber and building materials; therefore, at least one of the overhead doors is open during business hours. This means that the warehouse is usually quite cold in the winter, which makes it difficult to keep the space warm. Radiant gas heaters are used to maintain the space temperatures higher than 37°F (2.8°C). A transpired solar collector on the south wall provides warm ventilation air when there is sufficient solar heat gain in the wall. More details of the transpired solar collector are given in Section 5.6.

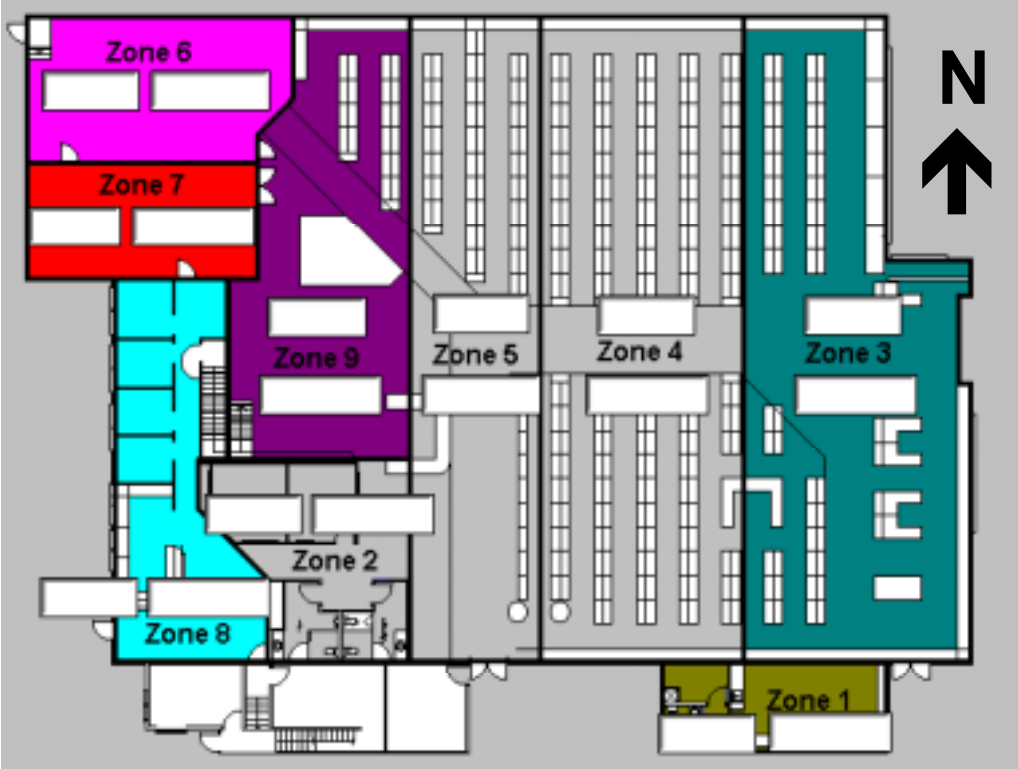

Figure 5-4 Radiant-floor heating zones in the retail/office area

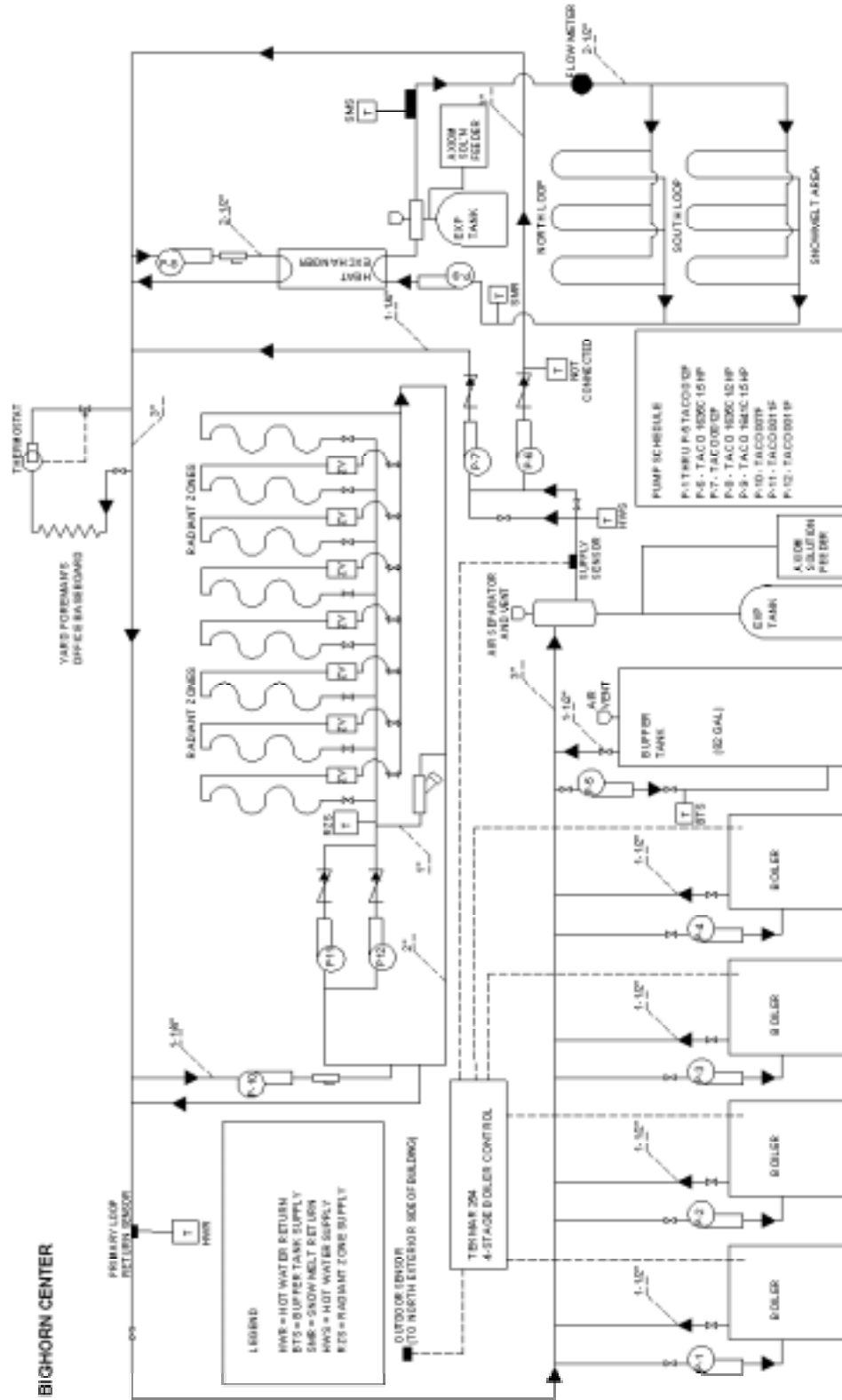

Figure 5-5 Schematic of the Big Horn Center hot water system

During the summer, the retail area and offices are cooled by minimizing solar heat gain and by using natural ventilation. Overhangs on south-facing clerestory windows block unwanted summertime solar heat gain. Natural ventilation is provided through EMS-operated, north-facing clerestory windows and manually opened doors on the ground level. Figure 5-6 illustrates the passive cooling strategies, which are feasible because of low internal gains and Silverthorne’s cool climate. The actual opening areas for natural ventilation are smaller than the design recommendations as shown in Table 5-2. The reduction in opening area reduces the effectiveness of the natural ventilation and portable fans are used in the mezzanine on hot days to improve comfort.

In the warehouse, the open overhead doors provide adequate ventilation for cooling and for vehicle exhaust fumes. An electric forklift is used in the warehouse to limit exhaust fumes. Carbon monoxide (CO) sensors activate roof-mounted exhaust fans when pollutants from vehicles accumulate near the ceiling. The original design called for continuous operation of the roof-mounted exhaust fans, and the CO sensors were installed to provide ventilation based on pollutants, thereby minimizing energy consumption.

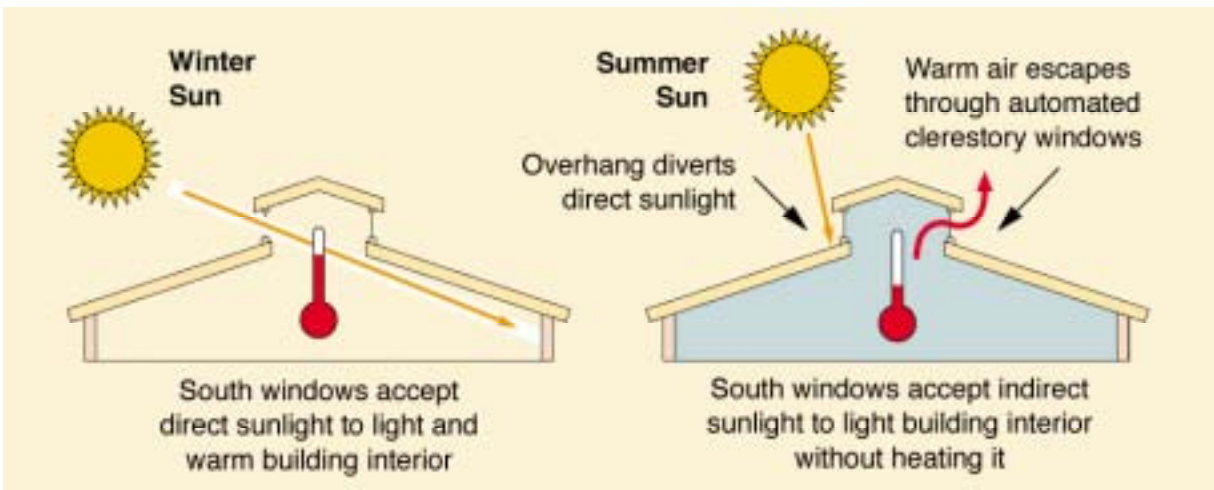

Figure 5-6 Seasonal daylighting and natural ventilation through the clerestory windows in the retail/office space

5.3 Lighting Systems and Daylighting

One design objective was to minimize lighting energy use with extensive use of daylighting and energy-efficient lighting systems. Reducing the lighting energy was also an important factor in being able to meet the cooling loads with natural ventilation. The lighting system parameters in the as-built building are presented in Table 5-3, which also lists the lighting system parameters for the Design Baseline Model, the As-Built Baseline Model, and the recommendations from the design process.

The installed LPDs in the retail and office areas are considerably lower than the design recommendations. The warehouse LPD is higher because this space is a lumberyard and not just a storage space; therefore, it requires higher lighting levels. It was recommended from the design process that the luminaires in the retail and warehouse areas use linear T-8 fluorescent lamps and that CFLs be used in other areas that could not use the linear fixtures. However, there was concern that the T-8 luminaires would not provide enough light when mounted near the high ceilings in the retail and warehouse areas. Therefore, pendant-type, high-output, high-bay fixtures designed for sports lighting were used with eight 42-W CFL bulbs (see Figure 5-7). The installed fixture types and LPDs are shown by space in Table 5-4. The lighting display area is located in the center of the retail area and is dedicated to the display of lighting fixtures.

The energy used in this area is treated as a separate plug load and is not included in the lighting energy totals.

Table 5-3 Lighting Parameters for the Baseline Models, Design Recommendations, and As-Built Building

Component/Feature	Design Baseline Model	As-Built Baseline Model	Design Recommendation	As-Built Building
Retail Lighting Power Density – W/ft^2 (W/m^2)	2.32 (25.0)	1.9 (20.4)	1.75 (18.8)	1.1 (11.8)
Office Lighting Power Density – W/ft^2 (W/m^2)	1.34 (14.4)	1.3 (14.0)	1.34 (14.4)	1.0 (10.8)
Warehouse Lighting Power Density – W/ft^2 (W/m^2)	0.42 (4.5)	1.2 (12.9)	0.42 (4.5)	0.6 (6.5)
Lighting Type	N/A	N/A	Mostly T-8 fluorescents & some CFLs	Mostly CFLs & some T-8 fluorescents
Lighting Controls	- Schedule - No occupancy or daylighting controls	- Schedule - No occupancy or daylighting controls	- Daylighting with continuous 100% dimmable control - Occupancy sensors for nondaylit areas	- Daylighting with five-level stepped control - Occupancy sensors in restrooms
Lighting Control Set Points Retail/Office/Warehouse – fc (lux)	N/A	N/A	70/50/30 (700/500/300)	50 (500) – rtl/off 30 (300) – whs



Figure 5-7 Pendant luminaire with eight 42-Watt CFL bulbs used in the retail and warehouse areas

Table 5-4 BigHorn Installed Lighting Fixtures

Space	Occupancy Control	Daylighting Control	Qty	Fixture Type	Number of Lamps (W)	Total (W)
Retail/Shop/Mezzanine	No	Yes	60	Pendant - CFL	8 (42)	20,160
Open Office Area	No	No	6	T-8	4 (32)	768
Enclosed Offices	No	No	8	T-8	4 (32)	1,024
Retail	No	No	2	T-8	4 (32)	256
Retail	No	No	2	T-12	2 (40)	160
Restroom	Yes	No	2	T-8	2 (32)	128
Restroom	Yes	No	4	T-8	2 (25)	200
Break Room	No	No	4	T-8	2 (32)	256
Total Retail/Office						22,952
Warehouse	No	Yes	54	Pendant - CFL	8 (42)	18,144
Warehouse	No	No	4	T-8	4 (32)	512
Mechanical/ Electrical Room	No	No	4	T-8	2 (32)	256
Total Warehouse						18,912
Total Building						27,272

Daylighting is provided in the warehouse primarily through skylights along the ridgeline (Figures 5-1 and 5-8). The skylights are insulated translucent glazing panels with the thermal and optical properties listed in Table 5-2. One large dormer, two smaller dormers, and small windows on the south and east walls provide additional natural lighting. The bright white interior ceiling and wall surfaces improve daylight distribution. An analysis of the lighting systems, including illuminance measurements, is presented in Section 7.2.



Figure 5-8 Translucent skylights in the warehouse

Daylighting strategies in the retail area include north- and south-facing clerestory windows that run the length of the store; three dormer windows on the north side; high windows on the east and west ends; and a borrow window from the warehouse. The walls, floor, and vaulted ceiling of the retail area were painted white to distribute the daylight and make the space look brighter. The retail products on the shelves and the signs that hang from the ceiling provide contrast for the space. A schematic of the daylighting and natural ventilation with the clerestory windows is shown in Figure 5-6.

Some parts of the design reduce the amount of light from the clerestory windows. The large wood frames reduce the glass area. The dark wood underside of the overhangs reduces the amount of incoming light. The north clerestory windows are operable for natural ventilation and have bug screens on them, which also reduce incoming light.

Daylighting controls provided by the EMS use three light sensors (exterior, retail, and warehouse). The luminaires in the retail/office area and the warehouse use eight 42-W CFLs (Figure 5-7). The lamps can be controlled two at a time to provide five lighting level steps for each fixture as an energy-efficient way of matching the available daylighting. Sixteen circuits are available to control the lights: four are used for the exterior lights, four for the warehouse lights, seven for the retail/office lights, and one is reserved for future use. The lighting control circuits in the retail/office area are wired to provide even illuminance levels throughout the store. The lighting controls are configured to turn on lights in the darker areas first (contractor sales and outside edges of the retail space), then more lights are turned on toward the center of the store as the natural light levels decrease.

5.4 Lighting Display and Miscellaneous Electrical Loads

A major electrical end use is the lighting display area. This is an area to display all the lighting fixtures and other interior decorating items. The displays are often changed to show new fixtures and new light

bulbs. Even with efforts to control the energy consumption of this area with CFLs, the energy consumption is about the same as the lighting for the entire retail and office spaces.

There are considerable plug and other electrical loads in this building, which are labeled miscellaneous loads. These loads change continually as new equipment and plug-in lighting are added or removed. A detailed survey of the loads was completed on December 17, 2002. The accent lighting load comprises display lights and other plug-in lights that are used to accent products or features. Electric ice melt is required on some parts of the roof and roof drain structures to avoid ice damming, which can damage the roof and prevent proper drainage. During the monitoring period, there was 500 W of roof ice melt; however, this number increased to approximately 6 kW in December 2003 because of persistent ice damming problems.

5.5 Photovoltaic System

The building receives some electrical power from a roof-integrated photovoltaic (PV) system. The PV system consists of amorphous silicon panels that are laminated onto the conventional standing-seam metal roofing above the clerestory in the retail/office area and on the larger dormer in the warehouse (Figures 5-1 and 5-9). The roof-integrated PV system and the standing-seam metal roof is a durable and practical solution for buildings in this alpine climate because the snow can easily slide off the roof without damaging the PV panels. The system consists of 18, 120-W modules and 105, 64-W modules for a total 8.9-kW peak supply. This system was the first of its kind in Colorado and the first to have a net-metering agreement with the local utility company.

Strings of three modules in series are wired in parallel to form three arrays, which were originally configured to have similar power outputs. To accomplish this, two arrays (the Phase-B and Phase-C arrays) each consisted of 48 64-W modules and the third array (the Phase-A array) was configured with 18 120-W modules and nine 64-W modules. Each array is connected to its own inverter, and each inverter is tied to a separate phase of the three-phase electrical system (see Figure 5-10). The inverters were designed to work with a standalone PV system and have no internal battery backup, so an external circuit with four 12-V batteries is used to maintain the inverter memories at night. The battery backup system is tied to the Phase-A inverter to maintain the battery charge. Problems with the PV system resulted in reconfiguring the system, which is discussed in Section 7.3.



Figure 5-9 Installation of the roof-integrated PV panels

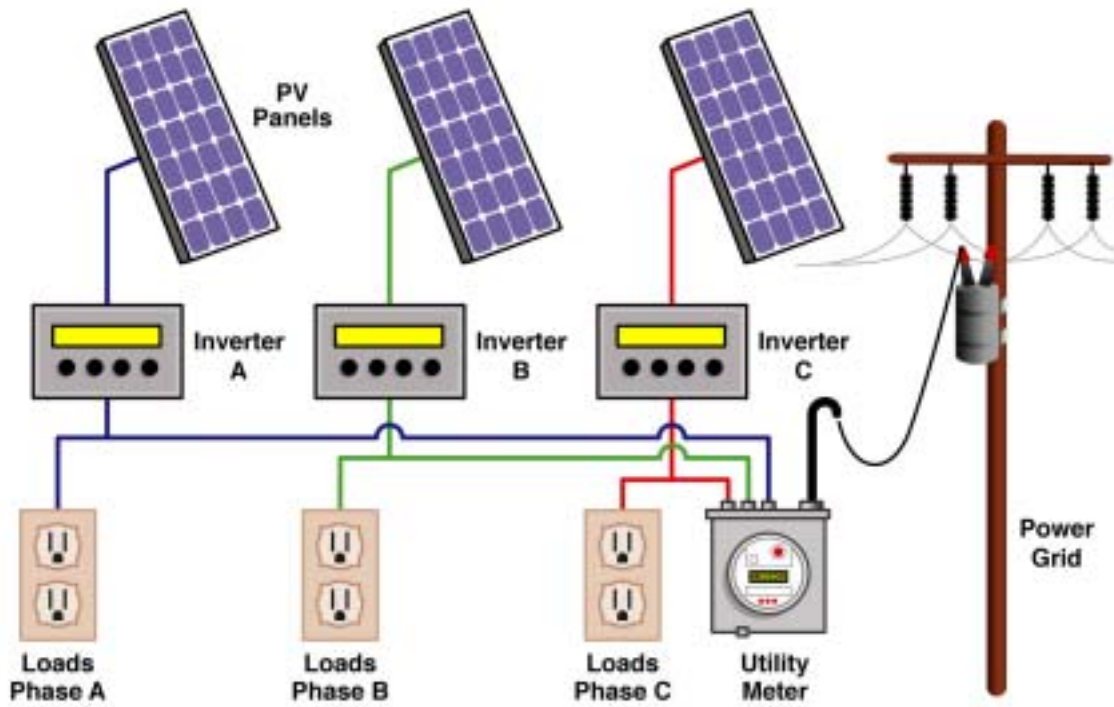

Figure 5-10 Schematic of the 3-phase PV system

5.6 Transpired Solar Collector

Warm air is provided to the warehouse during the heating season with a transpired solar collector that covers most of the south wall. This system includes a 2,250 ft² (209 m²) perforated, dark metal absorber panel with an air space behind it. A schematic of the system is shown in Figure 5-11. The heated air is drawn into a plenum at the top of the warehouse with two fans and distributed the length of the building via fabric ducts. The collector, fans, and ducts can be seen in Figures 5-1 and 5-12. The high distribution of the warm air reduces the effectiveness of the system because the warm air tends to stay near the ceiling.

5.7 Energy Management System

An EMS was installed to control the operation of the energy systems in the building. This system controls the heating, snowmelt, clerestory windows, lighting in the retail and warehouse buildings, and exterior lighting. The system has limited capability for data monitoring, so an additional performance monitoring system was installed (see Section 6.1).

The EMS uses a modified C programming language with custom defined objects and functions to simplify the programming. The initial control programs were written and tested by the vendor. These programs were simple and did not take advantage of the flexibility of the system to minimize energy consumption. Changes to the system were made for better scheduling and control of the lighting and heating systems.

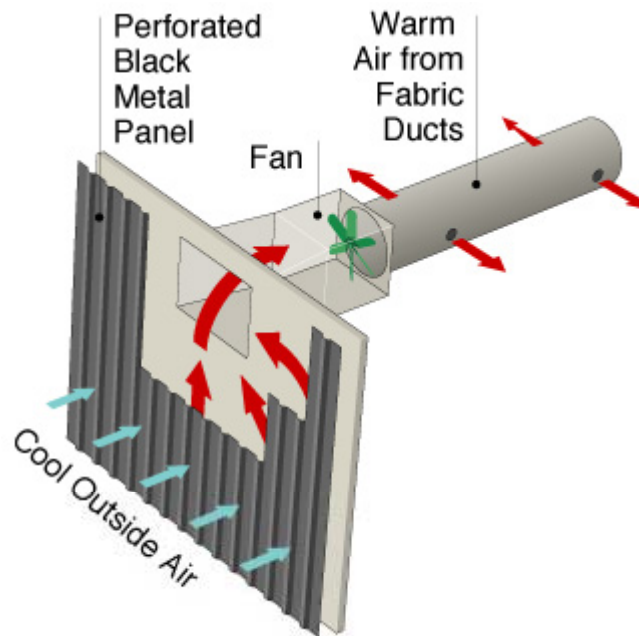

Figure 5-11 Schematic of a transpired solar collector (solar wall)



Figure 5-12 Transpired solar collector on the south wall of the warehouse

6 Whole-Building Energy Evaluation

The energy performance of the BigHorn Center was evaluated by continuous detailed end-use monitoring, utility bill analysis, walk-through inspections of the building, spot measurements, and computer simulations. This section describes the monitoring plan and equipment, results, and comparison to simulated baseline predictions. Guidance for monitoring and reporting the energy performance of commercial buildings can be found in the *Procedure for Measuring and Reporting Commercial Building Energy Performance* (NREL 2004d).

6.1 Performance Monitoring Plan

The overall goal of the energy monitoring analysis was to measure and evaluate the building energy use patterns. This goal was broken down into the following objectives for the energy-monitoring plan:

1. Evaluate the whole-building energy performance and compare this with the design expectations.
2. Analyze the monthly electrical demand and cost profiles.
3. Evaluate the lighting system performance, including the effects of daylighting.
4. Evaluate the PV system performance.
5. Compare the building energy performance to a building that meets the minimum standards of the energy code.
6. Generate a list of lessons learned to apply to other buildings.

To satisfy these objectives, a data-monitoring plan was developed and the following measurements were taken:

1. Surveys of electrical equipment in the building, including spot measurements of power or current
2. Monthly building utility bills for natural gas and electricity
3. Total electrical energy at 15-minute increments
4. Electrical energy use of major end uses at 15-minute increments
5. Electrical energy delivered to the building by the PV system in 15-minute increments
6. Temperature and flow of the radiant floor water loop
7. Solar radiation incident on the PV system and temperature of the PV cells.

A data acquisition system (DAS), which consists of a data logger and sensors, was designed to monitor all the data points. The time-series data points (numbers 3–7), monitoring frequencies, and monitoring equipment are listed in Table 6-1. A schematic diagram of the electrical system with the location of the monitoring points is shown in Figure 6-1. The monitoring equipment for the electrical measurements consisted of current transformers (CTs) and watt-hour transducers (Table 6-1). The CTs were sized based on the expected load on the circuits from the building electrical drawings. The watt-hour transducers have a pulse output relative to the energy consumed by the circuit. The virtual wattmeters in Figure 6-1 represent one calculated value, which is the miscellaneous loads or point number 10 in Table 6-1.

Initially, the watt-hour transducers were connected to the building EMS for data logging purposes. However, using the EMS to log data caused many difficulties. First, the format of the data was difficult to process. Second, downloading and archiving the data were difficult. Finally, the system has limited memory dedicated to data storage, which resulted in lost data. For these reasons, a dedicated data logger was used for all the instrumentation installed by NREL. It was connected to a cellular phone for remote access and the all the data storage and retrieval operations were automated.

Five additional measurements were recorded through the data logger. They are listed as data points 11–15 in Table 6-1. The sensors for the PV cell temperature and the PV solar radiation were mounted on one of the PV panels above the clerestory and were taken to verify the performance of the PV system. The

temperature and flow of the hot water for the radiant floor heating system were measured to estimate the amount of heat that goes into the floor.

Table 6-1 Data Monitored for Energy Performance Evaluation

No	Data	Measurement Point	Monitoring Equipment	Frequency	Recording Channel
1	Building Total Electrical Energy	MDP (WM1)	9-100 amp CT 1-Wh trans.	15 minute	SDM-SW8A ch-8
2	Exterior Lighting	PP-A (WM2)	3-50 amp CT 1-Wh trans.	15 minute	SDM-SW8A ch-7
3	Pumps	PP-A (WM3)	3-50 amp CT 1-Wh trans	15 minute	SDM-SW8A ch-4
4	PV System Supply	PP-A (WM4)	3-30 amp CT 1-Wh trans	15 minute	CR10X P1
5	Retail Lighting	PP-B (WM5)	6-100 amp CT 1-Wh trans	15 minute	SDM-SW8A ch-5
6	Lighting Display	PP-B (WM6)	6-30 amp CT 1-Wh trans	15 minute	SDM-SW8A ch-1
7	Warehouse Lighting	PP-C (WM7)	6-100 amp CT 1-Wh trans	15 minute	SDM-SW8A ch-6
8	Solar Wall Fans	PP-C (WM8)	3-50 amp CT 1-Wh trans	15 minute	SDM-SW8A ch-2
9	Forklift Charging Station	PP-C (WM9)	3-100 amp CT 1-Wh trans	15 minute	SDM-SW8A ch-3
10	Miscellaneous Electrical Loads	Inferred from other data (VM)	N/A	15 minute	N/A
11	Temperature PV Cell	Clerestory PV panel	Type-T thermocouple	15 minute	AM25T ch1
12	PV Plane Solar Radiation	Clerestory PV panel	Pyranometer	15 minute	CR10X Diff Ch 2
13	Floor Loop Supply Temperature	Floor supply header	Type-T thermocouple	15 minute	AM25T ch2
14	Floor Loop Return Temperature	Floor return header	Type-T thermocouple	15 minute	AM25T ch3
15	Floor Flow	Floor return pipe	Ultrasonic flow meter	15 minute	CR10X Diff Ch 3

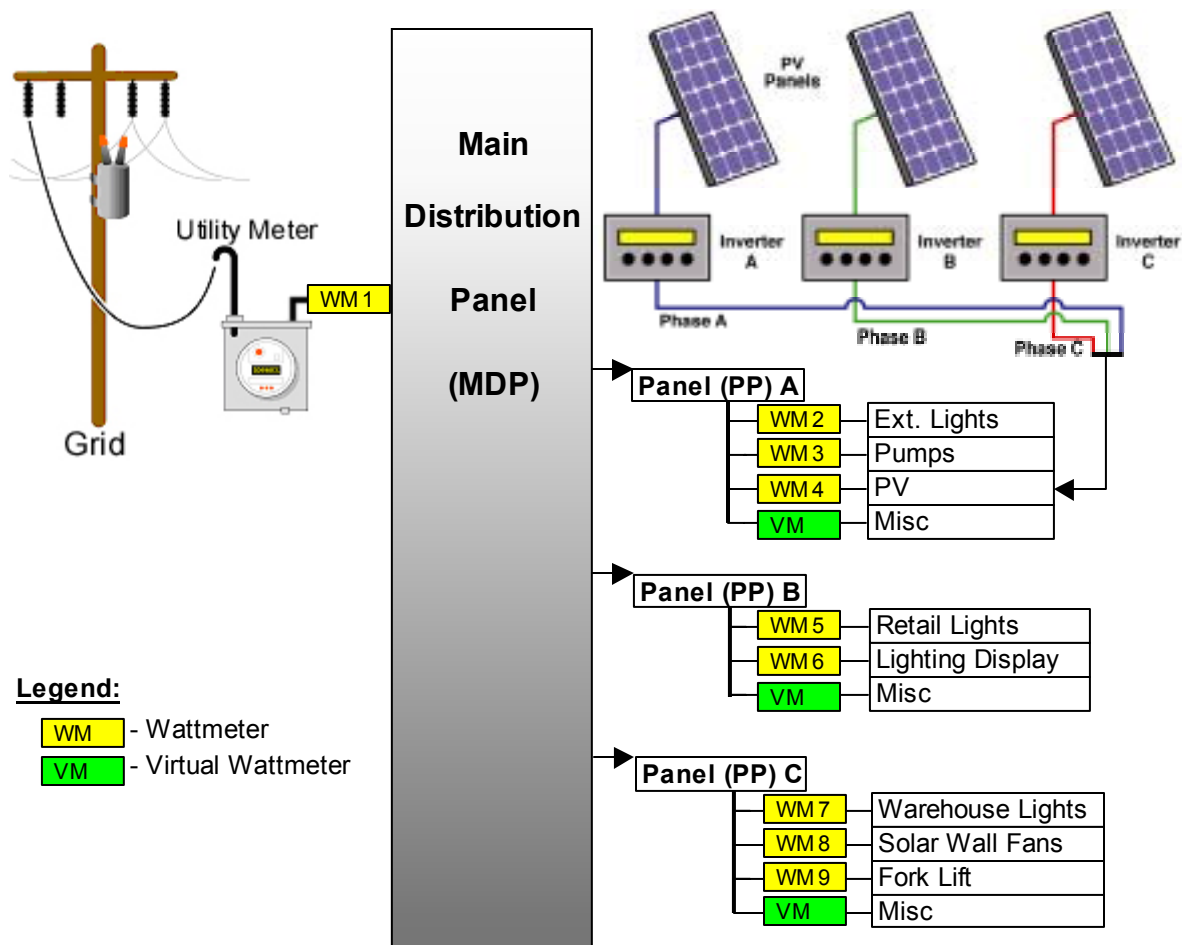

Figure 6-1 BigHorn Center electrical diagram and data monitoring points

The monitoring of the electrical loads started in February 2001. A dedicated data logger was installed in August 2001 because of EMS data logging problems discussed above. The PV solar radiation and temperature sensors were installed and connected in mid-August 2001. The floor supply and return loop temperatures were monitored starting in November 2001. Finally, the floor loop flow monitoring began in October 2002 because of problems with the flow meter that could not be resolved earlier.

Additional data were collected through the building EMS; however, because of the difficulties in collecting those data, they were not continuous. The data consisted of outdoor and space temperatures, equipment on/off times, and indoor and outdoor illuminance. Because the data were sporadic and difficult to process, they were used only as spot checks on performance.

The expected accuracy of the sensors used in the monitoring system is determined from product specifications (see Table 6-2). Individual electricity measurements are $\pm 0.5\%$ based on manufacturer's data. Some of the values are summations or subtractions of individual measurements, but the errors are assumed to be independent and do not increase the level of uncertainty. Based on the expected uncertainty of the energy use measurements and the long-term reliability of the DAS, NREL expected the uncertainty of the annual performance metrics based on measured energy use to be $\pm 1\%$.

Table 6-2 Measurement Accuracies

Measurement Type	Sensor Accuracy
WattNode watt-hour meter for electrical end use measurements	± 0.5%
Standard type T thermocouple for PV cell and floor loop temperatures	± 0.5°C
LiCor solar radiation pyranometer for outdoor horizontal and vertical insolation	± 5.0%

The layout of the electrical loads in the power panels was not well organized, which made submetering all the loads difficult. Some loads were divided between two panels and some were labeled incorrectly. The miscellaneous loads account for all the loads that could not be monitored separately. Table 6-3 provides a description of each electrical end-use load.

The miscellaneous loads were calculated as the total building load [purchased energy plus the PV supplied energy (WM1+WM4)] minus the sum of the submetered loads (all other WMs). However, this includes some loads that belong in the retail lights, lighting display, and exterior lights. The miscellaneous loads were adjusted to account for these other loads to more accurately reflect the distribution of energy. The adjustments were estimated from analyzing plots of the time-series data and noting the change in the miscellaneous loads with changes in the other loads.

Table 6-3 Electrical End-Use Load Descriptions

Meter	Load	Description
1	Building Purchased	Purchased electrical energy
2	Exterior Lights	All exterior lights including façade lights
3	Pumps	Hydronic heating system pumps
4	PV	Energy supplied by the photovoltaic system
5	Retail Lights	Retail area, office, receiving area, and workshop lights
6	Lighting Display	Lights and other loads in the lighting display area
7	Warehouse Lights	Warehouse lights
8	Solar Wall Fans	Two fans for the transpired solar collector
9	Forklift	Electric forklift charging
	Miscellaneous loads (equipment recorded on 12/17/02)	37 computers, 22 CRT monitors, 8 LCD monitors, 7 printers, 17 9-pin printers, 2 copiers, 3 cash registers, accent lighting, two 10-gal domestic hot-water heaters, one 500-W air conditioner in the server room, ceiling fans, 500-W roof ice melt, two electric space heaters, two refrigerators, three vending machines, two microwave ovens, and other plug loads.

6.2 Measured Building Energy Use

6.2.1 Total Building Energy Use

Gas energy consumption at the BigHorn Center was monitored through the monthly utility bills. Electrical energy consumption was recorded monthly by the utility company and every 15 minutes by the NREL-installed DAS. Table 6-4 shows a comparison of electrical energy consumption as measured by

the NREL instrumentation and by the utility company for two consecutive years starting with September 2001. The NREL instrumentation was within 0.2% of the utility bills for annual electrical energy for both years. Electrical energy consumption as measured by the NREL instrumentation is used in the remainder of this report. The utility bills do not cover exactly 1 year of data and do not start and end on the dates shown in Table 6-4. The energy numbers in Table 6-4 were adjusted to approximate 1 full year of data by adding or subtracting the appropriate number of daily average values for the first and last months of the billing periods. The daily average values used for the adjustments were taken as the average daily values for the 2 months around the start and end dates of the billing periods.

Table 6-4 Comparison of DAS Measurements with Utility Bills

Performance Metric	9/1/2001–8/31/2002	9/1/2002–8/31/2003
NREL Measurements		
PV Energy Production – MMBtu (GJ)	19 (1.8)	13 (1.2)
Total Facility Site Electrical Energy – MMBtu (GJ)	525 (48.8)	599 (55.6)
Net Facility Site Electrical Energy – MMBtu (GJ)	506 (47.0)	586 (54.4)
Utility Bills		
Net Facility Site Electrical Energy – MMBtu (GJ)	507 (47.1)	585 (54.3)
% Difference	< 0.2%	< 0.2%

The net and total annual energy use for the facility are shown in Table 6-5 for site and source energy. The *net* energy use refers to the energy purchased from the utility company, and the *total* energy refers to the entire energy consumed at the site (including the PV energy production). *Site* refers to the energy consumed at the location, which is equivalent to the energy measured by the utility meters. The *source* energy refers to the energy used to generate and deliver the energy to the building. The conversion factors for energy measured at the site to source energy are 1.084 for natural gas and 3.167 for electricity. The details of how these factors were calculated are included in Appendix B.

Table 6-5 Annual Energy Totals from Utility Bills

Performance Metric	9/1/2001-8/31/2002		9/1/2002-8/31/2003	
Annual HDD – 65°F (18 °C)	10,444 (5,802)		9,873 (5,485)	
Average Monthly Peak Demand (kW)	47.3		52.2	
Maximum Peak Demand (kW)	(Jan-02) 59.2		(Dec-02) 65.6	
Facility Purchased Energy Cost	\$18,024		\$18,379	
Facility Energy Cost EUI – \$/ft ² ·yr (\$/m ² ·yr)	\$0.43 (\$4.63)		\$0.43 (\$4.63)	
	Site Energy	Source Energy	Site Energy	Source Energy
PV Energy Production – MMBtu (GJ)	19 (1.8)	41 (3.8)	13 (1.2)	60 (5.6)
Net Facility Electrical Energy – MMBtu (GJ)	506 (47.0)	1,856 (172.4)	586 (54.4)	1,603 (148.9)
Net Facility Natural Gas – MMBtu (GJ)	1,410 (131.0)	1,166 (108.3)	1,075 (99.9)	1,529 (142.0)
Net Facility Energy - MMBtu (GJ)	1,916 (178.0)	3,022 (280.8)	1,661 (154.3)	3,132 (291.0)
Total Facility Energy – MMBtu (GJ)	1,935 (179.8)	3,062 (284.5)	1,674 (155.5)	3,192 (296.5)
Net Facility EUI – kBtu/ft²·yr (MJ/m²·yr)	45.2 (513)	71.3 (810)	39.2 (445)	73.9 (839)
Total Facility EUI – kBtu/ft²·yr (MJ/m²·yr)	45.7 (519)	72.3 (821)	39.5 (449)	75.3 (855)

Total electrical energy consumption increased by 16% from the first year to the second, and gas consumption decreased by 24%. The reasons for these changes are discussed below. Overall, site energy consumption decreased by 14%, but energy costs increased slightly because of higher gas and electricity costs. Higher electricity costs are due to increased consumption, higher monthly peak demands, and higher rate charges.

Measured source energy consumption by end use for the September 1, 2002 to August 31, 2003 period is shown in Figure 6-2. The electrical data are from the NREL-installed DAS and the gas data are from the utility bills. The electrical data are the total consumption and do not reflect the energy supplied by the PV system. The same information for site and source energy is listed in Table 6-6 along with the facility and building total values. *Facility* refers to the energy consumed in the building and the exterior lights, and *Building* refers to the energy consumed in the building, including the roof ice melt but not the exterior lights. The building and facility EUIs are listed at the bottom of Table 6-6 for site and source energies.

A monthly view of the data is presented in Figure 6-3, which shows the daily average source energy consumption by major end use from February 2001 to August 2003. The energy produced by the PV system is also shown as a line graph. The PV energy production was adjusted to reflect the amount of source energy that was offset by producing and using the PV energy onsite.

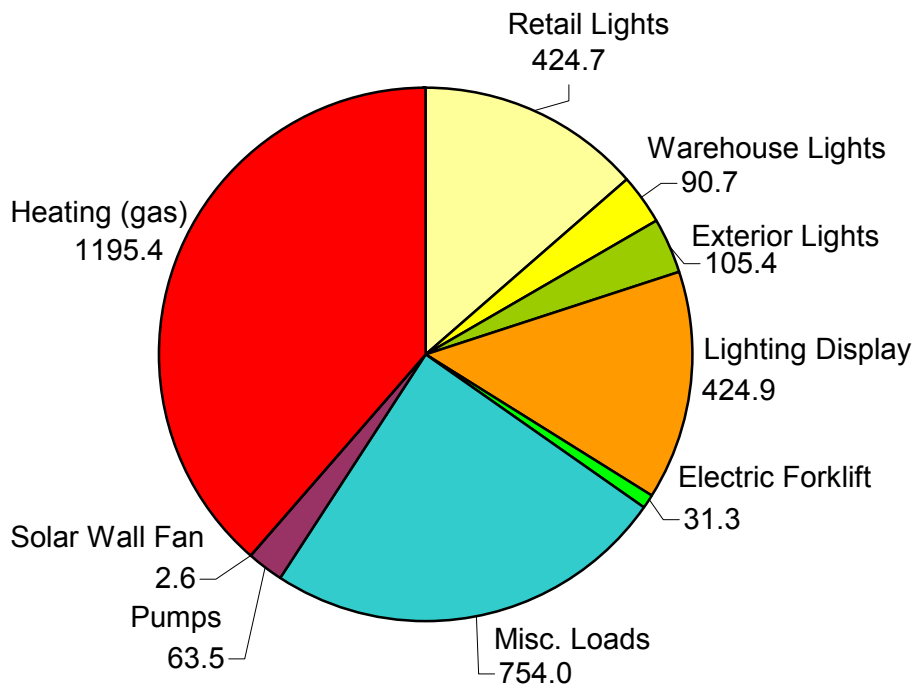

Figure 6-2 Measured source energy use from September 1, 2002 to August 31, 2003 (MMBtu)

Table 6-6 Measured Annual Energy Totals by End Use

End Use*			Site Energy		Source Energy	
			9/1/2001– 8/31/2002	9/1/2002– 8/31/2003	9/1/2001– 8/31/2002	9/1/2002– 8/31/2003
	B	F	(MMBtu) (GJ)	(MMBtu) (GJ)	(MMBtu) (GJ)	(MMBtu) (GJ)
Heating (gas)	x	x	1,410.0 (1,488)	1,075.0 (1,134.1)	1,528.5 (1,612.6)	1,165.7 (1,229.8)
Pumps	x	x	19.9 (21.0)	20.1 (21.2)	63.0 (66.5)	63.6 (67.1)
Solar Wall Fan	x	x	1.2 (1.3)	0.8 (0.8)	3.7 (3.9)	2.6 (2.7)
Retail Lights	x	x	150.6 (158.9)	134.1 (141.5)	477.0 (503)	424.7 (448.1)
Warehouse Lights	x	x	12.6 (13.3)	28.6 (30.2)	39.8 (42.0)	90.6 (95.6)
Lighting Display	x	x	88.7 (93.6)	134.2 (141.6)	267.5 (282.2)	424.8 (448.2)
Forklift	x	x	10.9 (11.5)	9.9 (10.4)	34.6 (36.5)	31.39 (33.1)
Miscellaneous Loads	x	x	218.6 (230.6)	238.1 (251.2)	692.25 (730.3)	754.1 (795.6)
Exterior Lights		x	22.8 (24.1)	33.3 (35.1)	72.2 (76.2)	105.4 (111.2)
Total Electric Energy			525.2 (554.1)	599.0 (631.9)	1,663.0 (1,754.5)	1,896.1 (2,000.4)
Total Building Energy Use			1,912.4 (2,017.6)	1,640.7 (1,730.9)	3,119.3 (3,290.9)	2,956.4 (3,119.0)
Total Facility Energy Use			1,935.2 (2,041.6)	1,674.0 (1,766.1)	3,191.5 (,3367.0)	3,061.8 (3,230.2)
PV Energy Production			19.0 (20.0)	12.8 (13.5)	60.1 (63.4)	40.5 (42.7)
Total Building EUI – kBtu/ft²·yr (MJ/m²·yr)			45.1 (512)	38.7 (439)	73.6 (836)	69.8 (793)
Total Facility EUI – kBtu/ft²·yr (MJ/m²·yr)			45.7 (519)	39.5 (449)	75.3 (855)	72.3 (821)
Net Building EUI – kBtu/ft²·yr (MJ/m²·yr)			44.7 (508)	38.4 (436)	72.2 (820)	68.8 (781)
Net Facility EUI – kBtu/ft²·yr (MJ/m²·yr)			45.2 (513)	39.2 (445)	73.9 (839)	71.3 (810)

* Breakdown of the building (B) and facility (F) end-use energy totals.

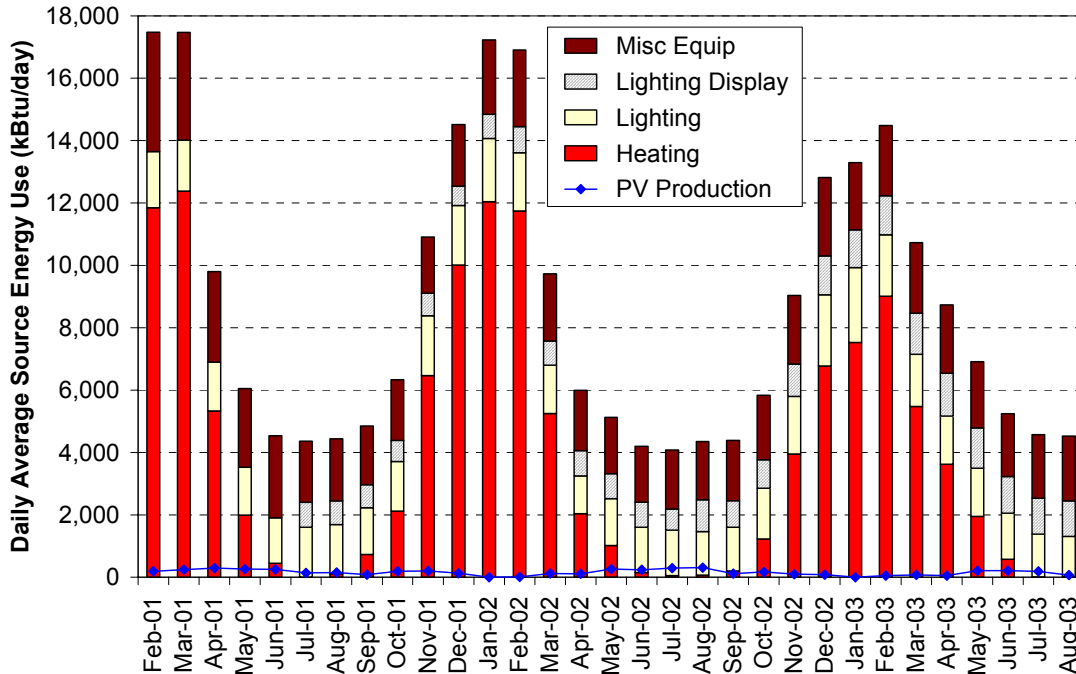

Figure 6-3 Daily average source energy consumption by end use for the BigHorn Center (monitoring of the lighting display began in July 2001)

The total energy consumption in Figure 6-3 shows a strong seasonal correlation. The increase in the winter is caused by the high heating loads, higher lighting loads due to the reduced number of daylight hours, and the use of snow and ice melt systems.

The heating energy consumption is a combination of the gas use taken from the utility bills plus pump energy for the hydronic heating system and fan energy for the transpired solar collector. The heating load approaches zero in summer months and has shown a general decrease over the monitoring period. Table 6-6 shows a 24% decrease in the gas energy use from the 2001–2002 winter to the 2002–2003 winter. This decrease is mostly due to the introduction of a dry fire-protection system in the warehouse in March 2002. Before this change, the warehouse was kept warmer than 40°F (4.4°C) to ensure that all pipes remained above freezing. A second reason for the reduced gas use was the reduced use of the sidewalk snowmelt system, which was not effective and was phased out during the 2001–2002 winter. Finally, the 2002–2003 winter was slightly warmer than the 2001–2002 winter, with 5% fewer heating degree days.

The lighting loads in Figure 6-3 consist of all the interior ambient lights and exterior lights. The lighting display is monitored separately, and the limited accent lighting loads are monitored with the miscellaneous loads. There is a slight increase in the total lighting load from the first year to the second year. Table 6-6 shows that the retail/office area lighting energy decreased by 16.5 MMBtu because the daylighting controls were fine tuned, and a higher number of the light bulbs burned out after the first year of operation. The warehouse lighting energy increased by 16 MMBtu and the exterior lighting energy increased by 11.5 MMBtu. These increases are mainly due to the changes in the cleaning process that left more lights on for longer periods. The lighting display load increased by more than 50% from the first monitoring year to the second as more lighting fixtures were added to the display.

The miscellaneous loads include items noted in Table 6-3. The display lighting load was included in the miscellaneous loads from February 2001 to June 2001. The miscellaneous loads increased during the winter by approximately 20%, which is mainly due to the roof ice melt and the two electric space heaters.

There has been a slight increase in the miscellaneous loads during the monitoring period because more plug loads and accent lighting were added.

Another useful method of viewing the electrical energy consumption data is to look at the average daily energy use profiles by season (see Figure 6-4). The winter profile is the largest because the shorter days require more lighting and the cold weather requires increased use of the heating system pumps and the roof ice melt. The relative magnitude of the load profile between the other seasons varies with the operation of the building. The lighting display area is altered every few months to add or remove lights. The operation of the warehouse and retail/office lights varies slightly with the personnel working in these spaces and how much light they desire for working conditions. The evening profile reflects the effects of the cleaning crew, who work two to three nights a week and turn on most of the interior and exterior lights while they clean.

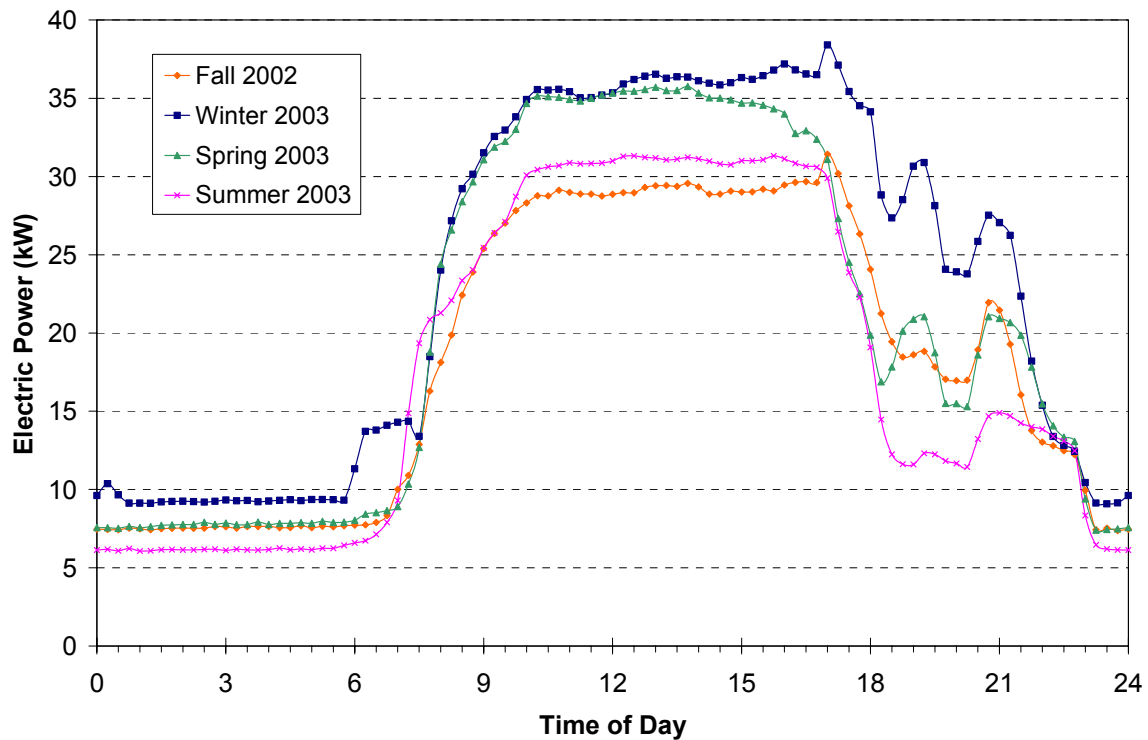

Figure 6-4 Average daily electrical energy load profiles by season

6.2.2 Energy Cost Analysis

The utility company for gas and electric service is Xcel Energy. Its rate structures are summarized in Table 6-7 and presented in detail in Appendix A. The charges for electricity consist of a fixed charge, an energy rate charge, a demand charge, two to four energy rate charge adjustments, a franchise fee, and sales tax. All the charges remained fixed during the monitoring period except for the energy rate charge adjustments, which varied from month to month. Energy rate adjustments doubled the total electrical energy rate charge from the beginning to the end of the monitoring period; however, the electrical demand charge did not change. The energy rate adjustment charges are included to account for such things as changes in primary fuel costs and air quality improvement costs.

Table 6-7 Summary of Utility Charges

Category	Actual Costs Throughout Monitoring	Costs Used in As-Built Simulations
Natural Gas		
Total Rate Charge (\$/therm) (\$/GJ)	\$0.34546 to \$0.85546 (\$3.27 to \$8.11)	\$0.59 (\$5.59)
Metering and Billing	\$15.35 to \$17.29	\$15.35
Franchise Fee (% of subtotal)	3.0%	
Sales Tax (% of total)	7.65%	
Electricity		
Service and Facility Charge	\$15.30	\$15.30
Total Rate Charge (\$/kWh)	\$0.01455 to \$0.03004	\$0.01645
Demand Charge (\$/kW)	\$12.55	\$12.55
Franchise Fee (% of subtotal)	3.0%	
Sales Tax (% of total)	7.65%	

The monthly energy costs from the utility bills from November 2000 to August 2003 are shown in Figure 6-5. This graph shows the breakout of the energy charges and the average monthly outdoor temperature. The gas costs were very high during the first winter because consumption and prices were high. The cost of electricity was dominated by the demand charge, which was more than half the electrical utility bill. The “Other Electrical” category includes the fixed monthly charge, energy rate adjustments, fees, and taxes. The increase in this value over the last nine months was due to increases in the energy rate adjustments.

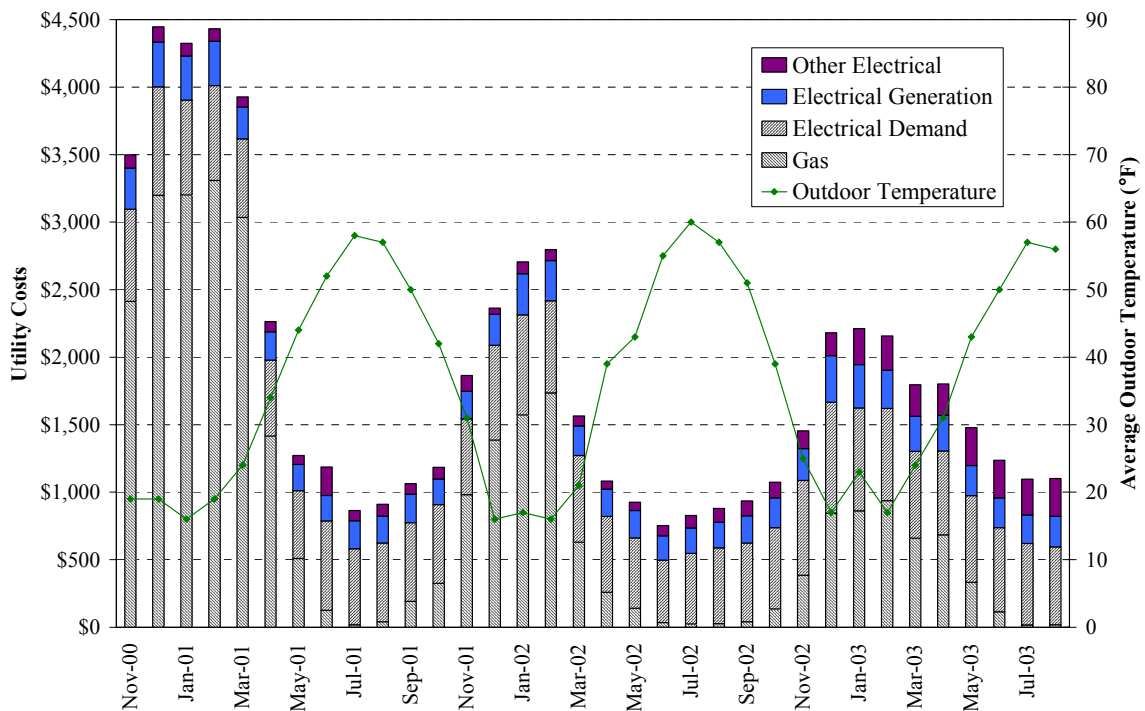

Figure 6-5 BigHorn Center monthly utility costs

A detailed analysis of the electricity costs was undertaken to determine the relative energy costs, understand the impacts of the demand charges, and determine potential cost saving measures. The electrical demand charges and associated taxes constitute a significant part (59%-80%) of the monthly electricity bills. The demand charge, including taxes, is \$13.92/kW based on the maximum 15-minute integrated kilowatt demand used during the billing month.

The impact of demand charges on electricity costs was examined by estimating the electrical energy cost by end use from the 15-minute data measured by NREL. The demand charges were divided among the end uses by determining their fraction of the total load at the time of the monthly peak demand. This approach allows an estimation of the energy costs of actual operation, and allows an estimation of changes to reduce the demand charges. The electrical loads at the BigHorn Center are mostly independent of each other; changing one load does not significantly affect the other loads. However, removing the power draw of one load does not reduce the monthly peak demand by that load's power draw. The new monthly peak demand will shift to the next largest peak demand value with a different mixture of loads. The new peak demand value can be estimated by ranking the top peak demand periods in each month and selecting the highest value after removing the loads being investigated.

The monthly electricity costs by end use were estimated for the two-year monitoring period (see Figure 6-6). The energy costs are estimated by calendar month, and do not align with the utility bills. The utility bills are not billed on the same day every month, but typically run from the 25th to the 25th of each month. For most months, the measured peak demand was within 2% of the billed demand value. For some months, the time of the measured peak demand did not align with the billing periods, which resulted in a difference in the billed and measured demand values. For two months, there was an unexplained larger measured demand value than the billed value.

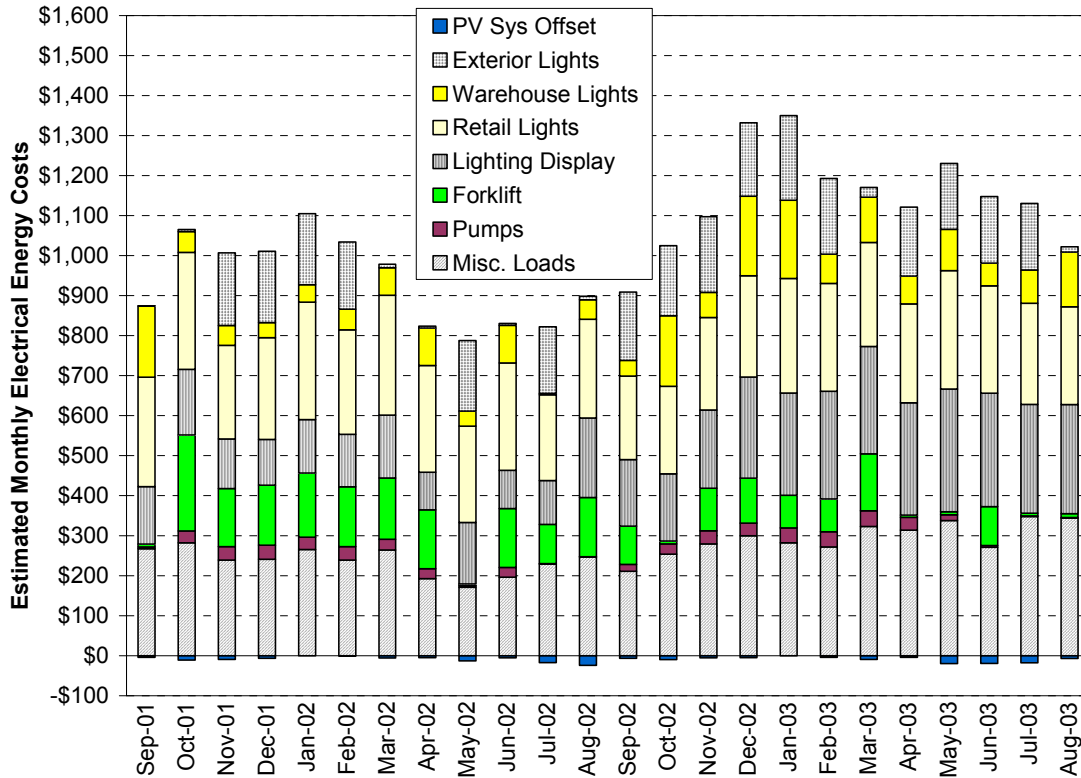

Figure 6-6 Estimated monthly electrical energy costs by end use

Some loads have high costs relative to their energy consumption because the loads coincide with the monthly peak demand period. Highly variable loads can have large costs if the peak use period coincides with the building peak demand for the month. An examination of the peak demand days revealed that the peak demand typically occurs under one of four scenarios:

1. During normal business hours in the winter after the sun sets and most of the interior and some exterior lights automatically come on
2. During normal business hours when dark clouds cover the sun and more interior lights come on
3. After store hours when the cleaning crew turns on most of the interior and exterior lights
4. The electric forklift is plugged in for charging when the power draw is already high, which sometimes occurs at the same time as one of the first two scenarios.

In the first two scenarios, little can be done to reduce the demand because the lights are required for normal business operation. Fortunately, these have the smallest peak demand. The third scenario is preventable with some training of the cleaning crew to avoid turning on all the lights at the same time; however, this requires retraining with each new crew. The fourth scenario is preventable by charging the forklift at night. However, this would require a timer on the charging station circuit or someone to come in late at night after the exterior lights are turned off.

The electrical power profiles for typical peak demand days during the summer and winter are shown in Figures 6-7 and 6-8. These figures show the average power drawn every 15 minutes. The heavy black line is the purchased electrical power. When this line is below the top of the graph, the PV system provided some of the building electrical load. In Figure 6-7, the PV system provides some power during the day; however, the PV system was only operating on one of three inverters on this day. In Figure 6-8, the PV system was down and did not produce any power.

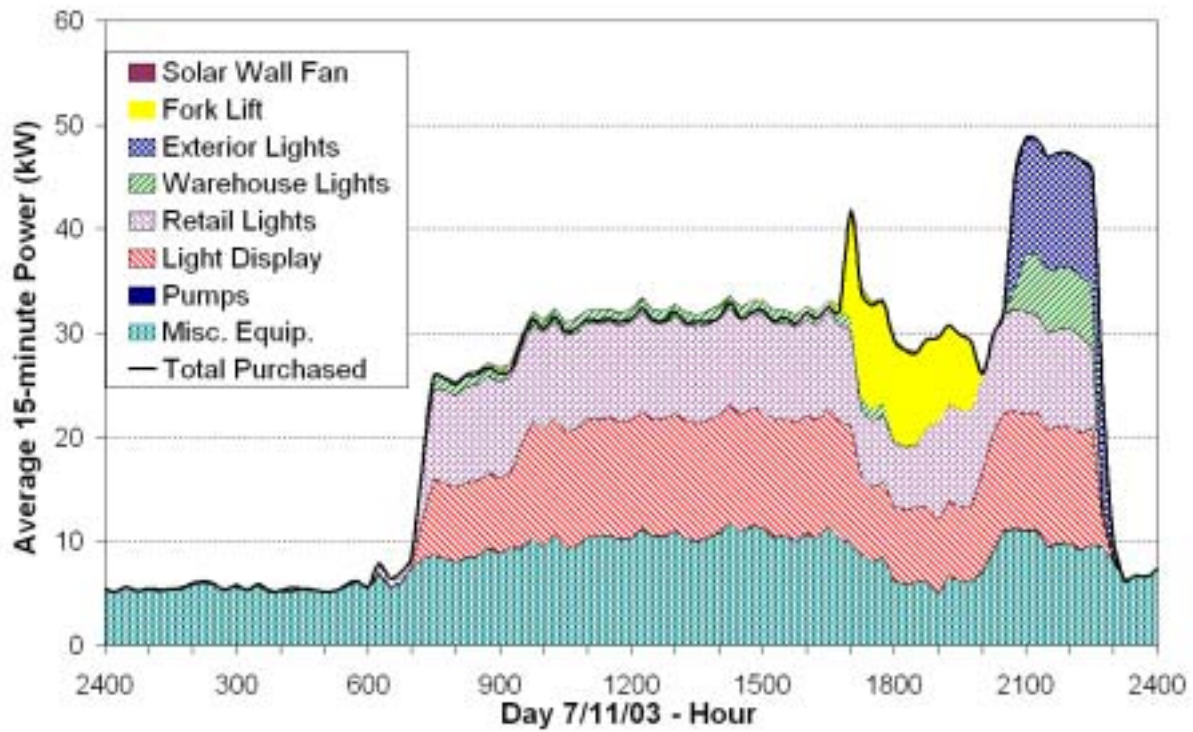

Figure 6-7 Electrical power profile on the peak demand day in July 2003

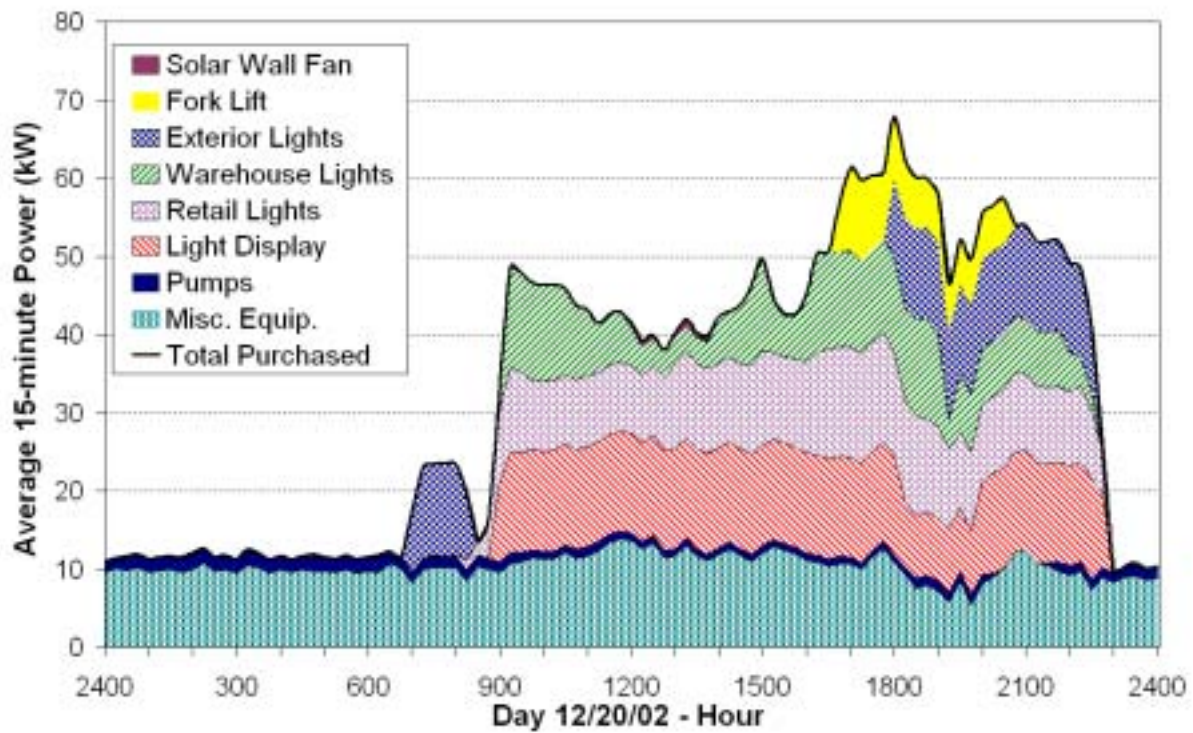

Figure 6-8 Electrical power profile on the peak demand day in December 2002

The peak demand in Figure 6-7 occurred after the store was closed when the cleaning crew came in and turned on most of the lights on, including the entire lighting display. Earlier in the day, the forklift was plugged in for charging right before closing time, which raised the power draw by nearly 10 kW but still allowed it to remain below peak. The peak demand in Figure 6-8 occurred when the exterior lights came on at the end of the day while the interior lights were still on and the forklift was charging.

Figure 6-8 also shows the effect of the daylighting controls on the warehouse lighting load, which was lower in the middle of the day when more daylight was available. The retail lights show a small bump in the morning and an increase in the early evening as it became darker outside.

One way to compare the cost of operating loads is to look at the effective energy charge, which is the total energy cost divided by the total energy use. This comparison was done annually for each load and is tabulated in Table 6-8. The miscellaneous loads, pumps, and retail lights have low effective energy charges; the forklift, exterior lights, and warehouse lights have very high effective energy charges. For comparison, the base electrical energy charge, including taxes, varied each month from a low of \$0.01613/kWh to a high of \$0.0333/kWh during the two-year monitoring period.

Table 6-8 Total and Effective Electrical Energy Charges by End Use

Load	Total Energy Cost		Effective Charge (\$/kWh)	
	9/1/2001– 8/31/2002	9/1/2002– 8/31/2003	9/1/2001– 8/31/2002	9/1/2002– 8/31/2003
Retail Lights	\$3,145.41	\$3,036.65	\$0.0713	\$0.0773
Warehouse Lights	\$757.34	\$1,307.10	\$0.2055	\$0.1559
Exterior Lights	\$1,081.49	\$1,828.04	\$0.1620	\$0.1875
Lighting Display	\$1,619.70	\$2,992.26	\$0.0623	\$0.0761
Forklift	\$1,549.74	\$753.65	\$0.4841	\$0.2598
Miscellaneous Loads	\$2,833.93	\$3,535.63	\$0.0442	\$0.0507
Pumps	\$248.80	\$274.63	\$0.0427	\$0.0467
Total	\$11,243.14	\$13,734.53	\$0.0721	\$0.0785

The electric forklift had the highest effective energy charge. It cost more than \$0.48/kWh from September 1, 2001 to August 31, 2002 and almost \$0.26/kWh from September 1, 2002 to August 31, 2003. This cost is high because charging the forklift contributed to the monthly peak demand in 10 of 12 months for the first monitoring period and 7 of 12 months in the second monitoring period. If the forklift had been charged at night and had not incurred demand charges, the annual energy costs would have been \$57 and \$76 for the 2 monitoring periods. One method of estimating the savings is to subtract these energy costs from those listed in Table 6-8 for the forklift. This method results in a total saving of \$2170.31 for the two-year period. However, this is not the correct method of calculating the saving, because the new monthly peak demand would not simply be the measured demand minus the forklift power. The new monthly peak demand would shift to the next lowest peak demand with a different mixture of loads. Because charging the forklift does not affect other loads in the building, all the data can be reexamined without the forklift load and the new peak demands determined. We performed this analysis and demonstrated an estimated saving of \$1600 for the two-year period by charging the forklift during off-peak hours.

The third scenario that caused the peak demand was due to the number of lights turned on by the cleaning crew. If only half the display lights and half the retail lights had been turned on during cleaning, an additional \$360 would have been saved.

6.3 Whole-Building Energy Simulation Analysis

Whole-building energy simulations formed a significant part of the design process for this building. They were also instrumental in evaluating the energy performance of the building after construction. Energy simulations of the as-built building were completed to better understand the energy performance and compare it to the design predictions. The simulations of the as-built building were conducted with the same simulation program and version as used in the design process (DOE-2.1E - W54).

6.3.1 Development of As-Built Simulation Models

Two simulation models of the as-built building were created (see Table 3-1 for a summary of the main simulation models used in this project):

- An As-Built Baseline Model was developed that reflects the size and functionality of the as-built building, but it was created to just match the thermal efficiency requirements of ASHRAE Standard 90.1-2001 (ASHRAE 2001). This model was created according to the guidelines of Addendum e to ASHRAE 90.1-2001.
- An As-Built Model was created to accurately reflect the building and was calibrated against the measured building energy data with measured weather data.

The thermal and system parameters for the two models are listed in Table 6-9.

Table 6-9 Thermal Parameters of the As-Built Baseline and As-Built Models

Component	As-Built Baseline	As-Built
Wall R-Value (ft ² ·°F·hr/Btu) (<i>m²·K/W</i>)	16.0 (2.8)	23 (4.0) (lower) 16 (2.8) (upper)
Window U-Value (Btu/ft ² ·°F·hr) (<i>W/m²·K</i>)	0.51 (2.9)	0.30 / 0.24* (1.7 / 1.4)
Window Solar Heat Gain Coefficient	0.21	0.75 / 0.44
Floor Perimeter Insulation (ft ² ·°F·hr/Btu) (<i>m²·K/W</i>)	13.0 (2.3)	13.0 (2.3)
Floor Center Insulation for the Retail/Office Space (ft ² ·°F·hr/Btu) (<i>m²·K/W</i>)	0.0	10.0 (1.8)
Roof R-Value (ft ² ·°F·hr/Btu) (<i>m²·K/W</i>)	23.0 (4.0)	38.0 (6.7)
Retail/Office Infiltration – occ/unocc (ACH)	0.5 / 0.3	0.5 / 0.3
Warehouse Infiltration – occ/unocc (ACH)	5.25 / 1.0	5.25 / 1.0
Retail/office LPD (W/ft ²) (<i>W/m²</i>)	1.62 (0.15)	1.13 (0.10)
Lighting Display (kW)	12.0	12.0
Warehouse LPD (W/ft ²) (<i>W/m²</i>)	1.2 (0.11)	0.638 (0.06)
Retail/office Plug Load Power (kW)	9.0	9.0
Warehouse Plug Load Power (kW)	15.0	15.0
Daylighting Controls	No	Yes
Retail HVAC System **	PSZ w/ Econ	FPH
Mezzanine ***	-	RESYS
Warehouse HVAC System **	PSZ w/ Econ	UVT

* Window properties in the As-Built Model are listed for the view windows/clerestory and dormer windows

** PSZ = Packaged Single Zone system, FPH = Floor Panel Heating system, UVT = Unit Ventilator

*** RESYS = Residential System (split air conditioning/heating system with a natural ventilation option) modeled in the mezzanine to simulate natural ventilation

To improve the validity of the simulation results, the two models were carefully examined to verify the input details against the construction and operation of the as-built building. The first step in this verification process was to perform a walkthrough of the building to ensure the plans reflected actual conditions. The plug loads, lighting display, and exterior lights were scheduled to match the measured energy consumption data as closely as possible for the calibration period. The lighting power densities of interior lighting systems were set to match the peak-measured values. The operating schedules were set to match the measured energy data as closely as possible. The store operation is consistent from day to day; therefore, matching the simulation schedule to the store schedule is relatively easy. The cleaning schedule is not the same every week; therefore, an average schedule was created that best matched the annual totals for the interior and exterior lights.

The heating and ventilating systems in the As-Built Model were designed to match the real building as closely as possible. The boiler capacities and efficiencies for the retail/office heating system were matched to the existing system. The Panel Loss Ratio in the Floor Panel Heating system is the ratio of the panel heat losses to the panel heat output and was assumed to be 0.3 for the retail space, 0.25 for the office space, and 0.5 for the break room. The warehouse heating system was approximated as a Unit Ventilator system. The heat input to the unit ventilator in the warehouse was modeled as electricity and then converted to gas consumption and assumes a burner efficiency of 90%. This approach was taken to separate the gas consumption in the warehouse from the gas consumption in the retail area. The maximum infiltration for the retail/office area was set to 0.5 ACH and the maximum for the warehouse was set to 4.0 ACH to simulate one overhead door open.

Next, the As-Built Model was calibrated against the measured energy consumption with a TMY2 weather file for Eagle, Colorado, modified to match weather conditions from September 2002 to August 2003 (weather file E). The modifications were made with monthly temperature data from the utility bills and hourly solar radiation data from an NREL weather station at a similar altitude as Silverthorne but on the other side of the continental divide. Details of the weather file creation are included in Appendix C.

First, the electric loads were calibrated against the measured electricity data. The three largest electrical loads are the ambient lighting, lighting display, and miscellaneous equipment. The schedules were adjusted to closely match the monthly totals. The annual totals from the simulation for these loads were 1.3% lower, 0.3% higher, and 2.1% lower than the measured loads. The total electricity consumption of the As-Built Model was 1.8% lower than measured total energy consumption.

Next, the gas consumption was calibrated with the monthly totals from the utility bills. This was difficult because only the monthly total natural gas for the building is known, and the split between the warehouse and the retail/office area is not known. In addition, the operating conditions and thermostat schedules change occasionally depending on the needs and desires of the building occupants. The warehouse is operated as a drive-in loading space, and at least one overhead door is always open during store operating hours. The radiant gas heaters are operated to keep the space warmer than 37°F (3°C). This operation is difficult to model because the air exchange with the outdoors is unknown. However, the low temperature set point in the warehouse makes it possible to find months where the heating load in the warehouse is small. The largest unknown in the model of the retail/office space heating system is the Panel Loss Ratio; therefore, this value was altered to best match the measured data. The Panel Loss Ratios that best matched the monthly data were 0.05 for the retail and office space and 0.1 for the break room. Next, the maximum infiltration for the warehouse was changed to find the best match for every month of the year. The best fit of the data was found with the maximum warehouse infiltration set to 5.25 ACH. Because of the high flow rates from open doors, it was not feasible to measure the ACH. The annual total gas use from the As-Built Model was 4.8% lower than the total from the utility bills. A look at the month-by-month comparison in Figure 6-9 shows a good match for most months. Excluding January, the simulated results are only 0.03% lower than the utility bills. January had some operational differences that were unknown and we were unable to account for them in the model.

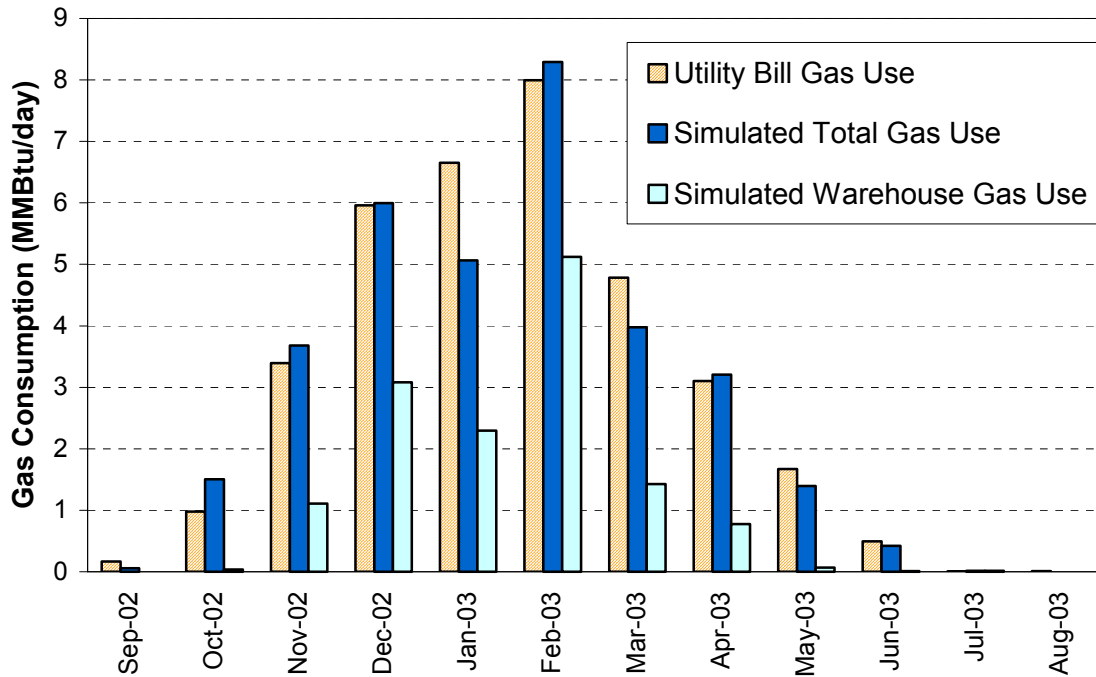

Figure 6-9 Calibration of simulated gas consumption with utility bills

6.3.2 Performance from Simulation Models

After the two simulation models were calibrated, they were run with a weather file based on the long-term average weather conditions to show the performance and savings for an average weather year. The annual site energy consumption by end use for the two building models is shown in Figure 6-10 and Table 6-10. The net site energy saving was 36% and the net source energy saving was 54%, which includes the measured energy production from the PV system for September 2002 to August 2003. The energy cost saving was 53%, which does not include the PV system because this cannot be modeled in DOE-2. The energy cost must be included in the simulation to properly account for the effect of the PV system on the demand. The simulation predicted that the average monthly peak electrical demand would be reduced by 59% from 124 kW for the As-Built Baseline Model to 50 kW for the As-Built Model. The reduction in annual peak demand is mainly due to the elimination of the HVAC fans and the reduction in the lighting power. The energy cost data were calculated with the utility rate structure as of August 2003, which is summarized in Table 6-7 and presented in detail in Appendix A.

The source energy savings are much greater than the site energy savings because the mix of electrical and gas energy consumption is different in the two building models. The As-Built Baseline Model has much higher energy consumption due to the lights and fans than the As-Built Model, and the As-Built Model has much higher gas consumption. In the As-Built Baseline Model, 68% of the site energy consumption is electricity; in the As-Built Model, the electricity consumption is only 34% of the total.

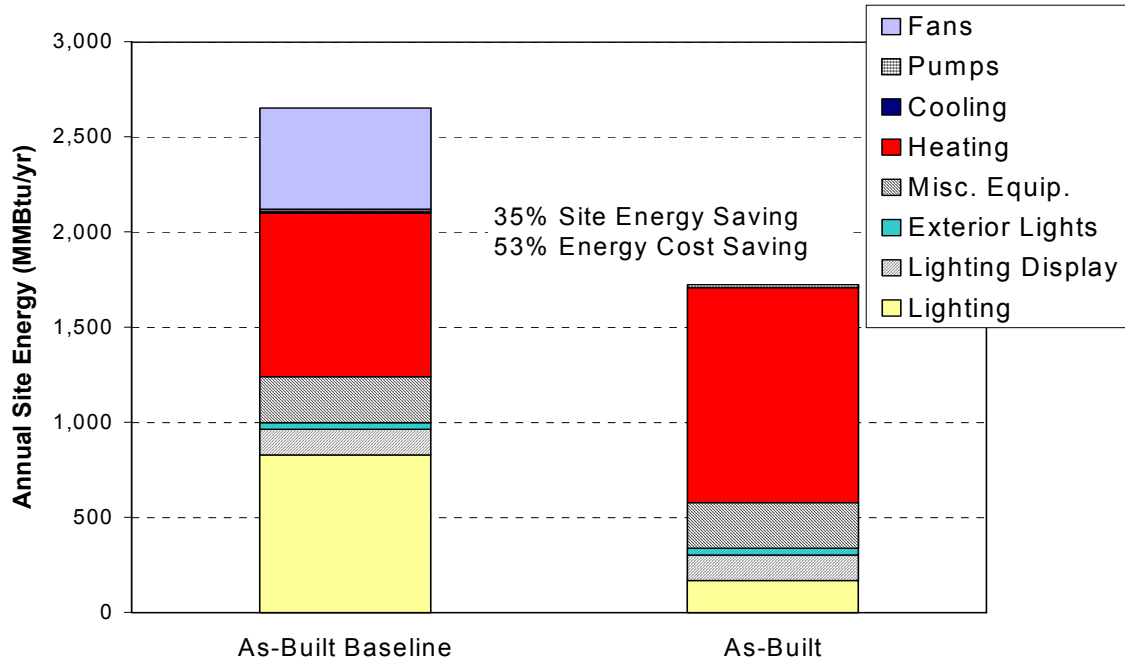

Figure 6-10 Simulated annual site energy consumption for the As-Built Baseline Model and As-Built Model with an average year weather file

**Table 6-10 Annual Facility Energy Use from the As-Built Simulations
(end use numbers are for site energy use)**

Performance Metric	As-Built Baseline	As-Built	% Saving
Lighting – MMBtu (GJ)	830 (876)	168 (177)	80%
Lighting Display – MMBtu (GJ)	135 (142)	135 (142)	0%
Exterior Lights – MMBtu (GJ)	35 (37)	35 (37)	0%
Miscellaneous Equipment – MMBtu (GJ)	241 (254)	241 (254)	0%
Heating – MMBtu (GJ)	861 (908)	1,130 (1,192)	-31%
Cooling – MMBtu (GJ)	9 (9)	0 (0)	100%
Pumps – MMBtu (GJ)	11 (12)	15 (16)	-41%
Fans – MMBtu (GJ)	532 (541)	0 (0)	100%
HVAC Total – MMBtu (GJ)	1,413 (1,491)	1,145 (1,208)	19%
Average Monthly Peak Demand (kW)	124	50	59%
Total Site EUI – kBtu/ft²·yr (MJ/m²·yr)	62.6 (711)	40.7 (462)	35%
Net Site EUI – kBtu/ft²·yr (MJ/m²·yr)	62.6 (711)	40.3 (458)	36%
Total Source EUI – kBtu/ft²·yr (MJ/m²·yr)	155.9 (1,770)	73.3 (832)	53%
Net Source EUI – kBtu/ft²·yr (MJ/m²·yr)	155.9 (1,770)	72.1 (819)	54%
Total Energy Cost Intensity – \$/ft²·yr (\$/m²·yr)	\$1.08 (\$11.63)	\$0.51 (\$5.49)	53%

The energy use patterns for the retail/office and warehouse spaces are very different, and the simulation models allow us to look at the spaces separately. The annual site energy consumption by end use for both spaces as predicted by the two models is shown in Figures 6-11 and 6-12 and in Tables 6-11 and 6-12. These tables also show the site and source energy totals for total and net energy consumption. The energy supplied by the PV system was divided between the two spaces based on their percentage of the facility electrical energy total. The energy consumption for typical retail and warehouse buildings from the *2003 Buildings Energy Databook* are also shown in the tables for comparison (DOE 2003).

The retail/office space shows an annual site energy saving of 24% and a source energy saving of 44%. The energy saving comes from a reduction in the lights and from the elimination of the fans and cooling load. The heating energy in the As-Built Model is more than double the value for the As-Built Baseline Model. The increased heating load is mainly due to lower heat gains from the lights and fans. The source

energy saving in the retail/office space is much larger than the site energy saving because gas is used more efficiently than electric lights and fans to heat the building.

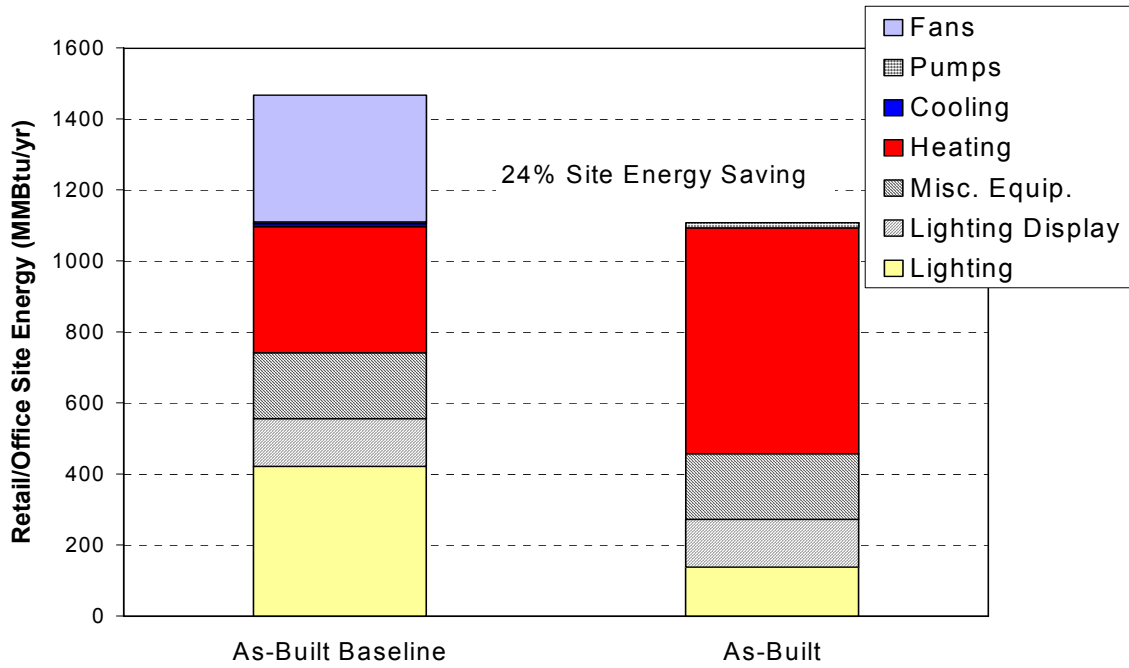

Figure 6-11 Simulated annual site energy consumption for the retail/office space using an average year weather file

Table 6-11 Annual Energy Use for the Retail/Office from the As-Built Simulations

Performance Metric	Typical Retail Building	As-Built Baseline	As-Built	% Saving Over Baseline
Lighting – kBtu/ft ² ·yr (<i>MJ/m²·yr</i>)	23.4 (266)	23.0 (261)	7.5 (85)	67%
Lighting Display – kBtu/ft ² ·yr (<i>MJ/m²·yr</i>)	N/A	7.3 (83)	7.3 (83)	0%
Miscellaneous Equipment – kBtu/ft ² ·yr (<i>MJ/m²·yr</i>)	14.1 (160)	10.0 (114)	10.0 (114)	0%
Heating – kBtu/ft ² ·yr (<i>MJ/m²·yr</i>)	30.6 (348)	19.3 (219)	34.6 (393)	-79%
Cooling – kBtu/ft ² ·yr (<i>MJ/m²·yr</i>)	5.8 (66)	0.5 (6)	0.0 (0)	100%
Pumps – kBtu/ft ² ·yr (<i>MJ/m²·yr</i>)	N/A	0.2 (2)	0.8 (9)	-243%
Fans – kBtu/ft ² ·yr (<i>MJ/m²·yr</i>)	2.5 (28)	19.4 (220)	0.0 (0)	100%
HVAC Total – kBtu/ft ² ·yr (<i>MJ/m²·yr</i>)	38.9 (442)	39.4 (448)	35.4 (402)	10%
Total Site EUI – kBtu/ft²·yr (<i>MJ/m²·yr</i>)	76.4 (868)	79.7 (905)	60.2 (684)	24%
Net Site EUI – kBtu/ft²·yr (<i>MJ/m²·yr</i>)	76.4 (868)	79.7 (905)	59.6 (677)	25%
Total Source EUI – kBtu/ft²·yr (<i>MJ/m²·yr</i>)	164.5 (1868)	212.3 (2,411)	118.8 (1,349)	44%
Net Source EUI – kBtu/ft²·yr (<i>MJ/m²·yr</i>)	164.5 (1868)	212.3 (2,411)	116.6 (1,324)	45%

The warehouse has a 50% site energy saving and a 79% source energy saving. The energy saving comes mainly from the reduction in the lighting loads and the elimination of the fans. The warehouse heating energy in the As-Built Model is approximately the same as the As-Built Baseline Model. This result may seem counterintuitive to the results from the retail/office space. There are two main reasons for the difference: (1) Because of the low heating set point, the required heating load is very small and much of the heat gain from the additional lights and fans in the baseline building warms the space above the heating set point; and (2) the transpired solar collector adds a small amount of useful heat to the space through the warm air delivered to the space and by conducting heat from the hot air space through the wall into the warehouse.

Another potentially large energy saving can be attributed to the addition of the CO sensor controls on the roof-mounted exhaust fans. The original building design called for continuous operation of these fans during occupied periods; however, the CO sensors were installed and these fans have only come on once.

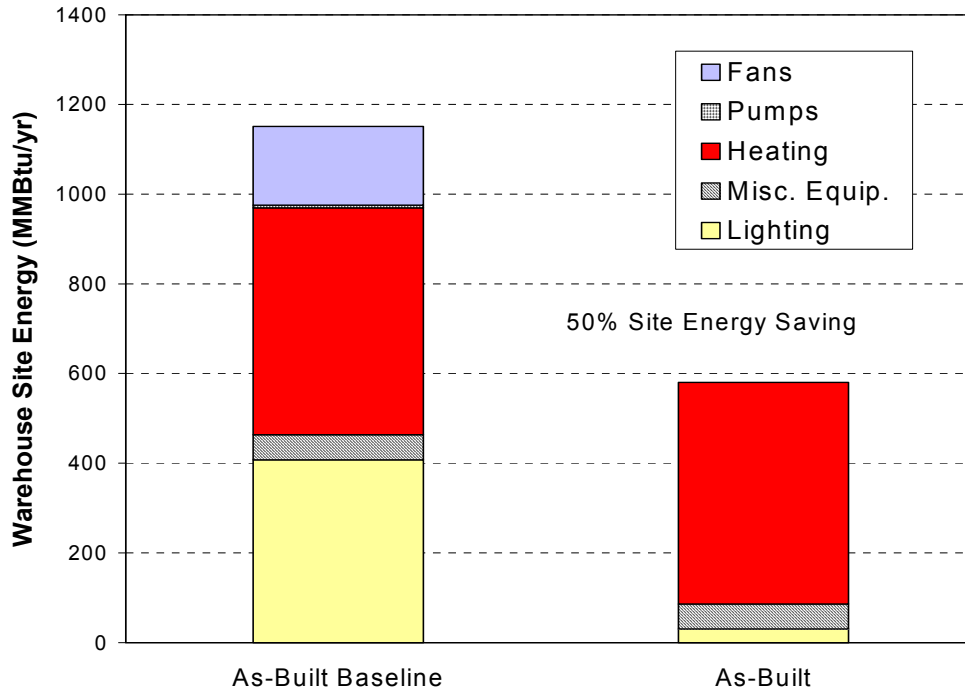

Figure 6-12 Simulated annual site energy consumption for the warehouse using an average year weather file

Table 6-12 Annual Warehouse Energy from the As-Built Simulations

Performance Metric	Typical Warehouse Building	As-Built Baseline	As-Built	% Saving Over Baseline
Lighting – kBtu/ft ² ·yr (<i>MJ/m²·yr</i>)	9.8 (111)	17 (193)	1.3 (15)	93%
Miscellaneous Equipment – kBtu/ft ² ·yr (<i>MJ/m²·yr</i>)	12.4 (141)	2.3 (26)	2.3 (26)	0%
Heating – kBtu/ft ² ·yr (<i>MJ/m²·yr</i>)	15.7 (178)	21.1 (240)	20.6 (234)	2%
Pumps – kBtu/ft ² ·yr (<i>MJ/m²·yr</i>)	N/A	0.3 (3)	0 (0)	100%
Fans – kBtu/ft ² ·yr (<i>MJ/m²·yr</i>)	0.3 (3)	7.3 (83)	0 (0)	100%
HVAC total – kBtu/ft ² ·yr (<i>MJ/m²·yr</i>)	16.0 (182)	28.7 (326)	20.6 (234)	28%
Total Site EUI – kBtu/ft²·yr (<i>MJ/m²·yr</i>)	38.3 (435)	48.0 (545)	24.2 (275)	50%
Net Site EUI – kBtu/ft²·yr (<i>MJ/m²·yr</i>)	38.3 (435)	48.0 (545)	24.1 (274)	50%
Total Source EUI – kBtu/ft²·yr (<i>MJ/m²·yr</i>)	84.1 (955)	108.1 (1,228)	33.7 (383)	69%
Net Source EUI – kBtu/ft²·yr (<i>MJ/m²·yr</i>)	84.1 (955)	108.1 (1,228)	33.4 (379)	69%

6.3.3 Measured Performance versus Preconstruction Predicted Performance

Comparing the measured performance to the design phase predicted performance is useful to the designers and energy researchers. The designers want to know how well the energy-efficient design features perform so they can design better buildings in the future. The energy researchers are interested in how well the energy-efficient features perform; additionally, they want to know how well the energy simulations can predict performance. Two issues in the accuracy of the energy simulations can cause the simulations to be inaccurate: the assumptions used to define the inputs and the accuracy of the mathematical models.

The energy results predicted by the Optimized Model and the calibrated As-Built Model with the same long-term average weather file are shown in Table 6-13. The Optimized Model has an area and volume of 36,980 ft² (3435 m²) and 974,914 ft³ (27,610 m³) versus 42,366 ft² (3936 m²) and 933,00 ft³ (26,423 m³) in the as-built building. Most of the difference in floor area is due to the inclusion of the office and warehouse mezzanines in the As-Built Model. The difference in the volume is due to a higher warehouse ceiling in the Optimized Model. Because of the differences in the models, The results are compared on a per unit area basis.

The largest difference in the models is the energy for the exterior lights. The Optimized Model assumed that the exterior lighting load was 36.5 kW and that the lights would be on for 5 hours every night. The exterior lighting load is only 10.5 kW and they are only on for 2–4 hours per day depending on the season and the requirements of the cleaning crew. One major omission in the Optimized Model was the lighting display area. This load was lumped in with the total lighting load. The lighting display area was not

expected to be a large load during the design; however, the installed display lights increased as light fixtures became a large sale item for the store. The installed lighting display area has a very high lighting power density and is not controlled by the daylighting controls.

In addition, the “Miscellaneous Equipment” load was underestimated by a factor of three in the Optimized Model. Underestimating the plug load energy use is a common mistake in design energy simulations. The predicted heating total is 14% higher than the measured value; however, the as-built building has higher internal gains. When the internal gains are included in the heating of the building, the predicted heating energy is very close to the measured heating energy.

The predicted Building Site EUI (excluding the exterior lights) is only 7.5% lower than the measured, but the Building Source EUI is 26% lower. This difference is due to the larger than anticipated electrical energy load in the as-built building. The energy cost was not compared because the two models used different utility rate data. The utility rates changed dramatically from the time the design simulations were completed to the time the final as-built simulations were completed; a period of approximately 4 years. Additionally, comparing the energy and energy cost savings from the design simulations and the as-built simulations is not meaningful, because the baseline building requirements changed. The design savings predictions use a baseline building based on ASHRAE 90.1-1989 and 10 CFR 435, and the as-built simulation savings predictions used ASHRAE 90.1-2001 as the baseline building. The most significant difference is in the lighting power densities, which are lower for the retail area and higher for the warehouse area in ASHRAE 90.1-2001.

Table 6-13 Comparison of the As-Built and the Predicted Performance

Performance Metric	Predicted	As-Built
Lighting – kBtu/ft ² ·yr (<i>MJ/m²·yr</i>)	4.0 (45)	4.0 (45)
Lighting Display – kBtu/ft ² ·yr (<i>MJ/m²·yr</i>)	0 (0)	3.2 (36)
Miscellaneous Equipment – kBtu/ft ² ·yr (<i>MJ/m²·yr</i>)	1.9 (22)	5.7 (65)
Heating – kBtu/ft ² ·yr (<i>MJ/m²·yr</i>)	30.9 (351)	27.1 (308)
Exterior Lights – MMBtu/yr (<i>GJ/yr</i>)	227 (239)	35 (37)
Building Site EUI – kBtu/ft²·yr (<i>MJ/m²·yr</i>)	37 (420)	40 (454)
Building Source EUI – kBtu/ft²·yr (<i>MJ/m²·yr</i>)	52 (591)	70 (795)

7 Subsystem Energy Evaluations

7.1 Analysis of the Space Conditioning Systems

The space conditioning systems at BigHorn are not typical of commercial buildings because there is no cooling system, no ventilation system, and the heating systems are radiant. The cooling loads are met by natural ventilation, and the ventilation for indoor air quality requirements is easily satisfied by infiltration when the windows are closed. Because there is no cooling system and no need for ventilation air, there was no need for a duct system in the retail/office area. Eliminating the ductwork freed up the interior space for improved daylighting and provided a cleaner looking interior. The heating system for the warehouse and retail/office areas is the largest energy end use. It consumes 40% of the annual building source energy; in the winter, it can exceed 60% of the monthly source energy.

Even though there are zero CDD base 65°F (18°C), there is still a cooling load on days when the afternoon outdoor temperature exceeds 80°F (27°C). The CDD calculation is based on the daily average temperature (not the hourly temperature), so a large diurnal temperature swing can be misleading. Energy simulations of the Design Baseline Model showed that the building needed mechanical cooling for 160 hours over the year. The remaining cooling load was met by economizer operation. The Optimized Model has lower internal gains from the lights, which allowed all the cooling loads to be met by natural ventilation.

Natural ventilation is initiated by the EMS, which opens the north-facing clerestory windows based on the internal and external temperature (see Figure 5-6). In addition, doors are manually opened in the front, back, and side connections to the warehouse. For most days, this system works well; however, there are some exceptions. On the few very warm days per year [5–10 days near 90°F (32°C)], the mezzanine temperature approaches 80°F (27°C), and portable fans are used to improve the comfort. An opposite problem in this mountain location is that the outside air can cool off quickly. The cold outdoor air can produce drafts of cold air on the mezzanine occupants who sit directly below the clerestory windows. The thermostat, which is at the same level as the window openings and controls the windows, does not immediately sense this cold air. In this case, the windows must be closed by overriding the EMS control scheme.

The designers decided on the hydronic radiant floor system for the retail/office area because of (1) the reduced noise from the elimination of the fans, (2) the improved comfort from the warm floor, and (3) the ability to have multiple zones within one large open space for better heating control. The main disadvantage of this type of system is that it has a slow response time and nighttime setbacks are often not used. The hot water is provided by four natural gas boilers with a 442 kBtu/hr (130 kW) output and an overall rated efficiency of 85%. This system was designed to provide hot water for the retail/office area and the sidewalk snowmelt system. Using boilers with an efficiency of 92% would save approximately \$250 per year for heating the retail/office area, which is a little more than 1% of the total annual utility costs.

The conventional wisdom is that the hydronic radiant floor system would be more energy efficient than a Packed-Single-Zone (PSZ) system because the same comfort conditions can be maintained with a lower temperature set point and less energy is required to move the working fluid (pumping water requires less energy than blowing air for the same amount of energy delivered to the zone). An annual energy simulation was completed with a PSZ system in the As-Built Model in place of the radiant floor heating system to test this hypothesis. The temperature set point with the radiant floor system was 68°F (20°C) and a temperature schedule of 65°F (18.3°C) and night and 72°F (22.2°C) during the day was used with the PSZ system. The simulation predicted that the PSZ system would use 17% less site energy, but about the same amount of source energy. This difference between site and source energy consumption is due to

the lower gas consumption by the heating coils and higher electricity consumption by the fans in the PSZ system. The annual energy costs for the two systems are approximately the same. This analysis predicts that the two systems are similar from an energy consumption and energy cost points of view. However, the approximations used in the mathematical models of the two systems and the building responses to the systems are very different, which makes a direct comparison with simulations difficult. Measured data from two similar buildings with different HVAC systems would have to be made to more definitely answer this question. Two items that are difficult to model in the current energy simulation software are thermal comfort and the amount of heat transfer from the radiant floor system to the ground. Therefore, we are unable to draw any conclusions about the relative energy efficiency of the two systems.

The Yard Foreman's office has a hydronic finned-tube baseboard heater that is connected to the main hot water loop. The water temperature in this loop is typically 130°F (54°C), which is too low for effective baseboard heating. Therefore, a portable electric radiant heater is used in this office. Water temperatures for baseboard heaters should be maintained above 180°F (82°C). The simulations used in this project are not detailed enough to determine the penalty for maintaining the primary hot water loop above 180°F (82°C). A gas-fired, wall-mounted heater may have been a better choice for this space.

The primary heating system for the warehouse is comprised of gas-fired radiant heaters. The warehouse is used as a drive-through lumberyard with at least one overhead door open during business hours. Because of this, the space has minimal space conditioning. The temperature is maintained just above freezing in the winter and there is no need for cooling in the summer. Some heat is supplied to the space by the transpired solar collector when there is adequate solar gain on the collector. This system provides warm air through fabric ducts mounted high in the space. Transpired solar collectors are most effective in spaces that need large amounts of ventilation. However, the BigHorn warehouse does not need ventilation because an overhead door is usually open. The low temperature warm air delivered by the transpired solar collector does not effectively heat this space when the door is open. For the September 2002–August 2003 monitoring year, the transpired solar collector fans ran only about one-third of the days in the heating season for 2 to 3 hours in the middle of the day.

7.2 Analysis of the Lighting Systems and Daylighting

The lighting systems at BigHorn were evaluated to determine the energy savings and to evaluate the quality of the light delivered by the lighting design. The *Procedure to Measure Indoor Lighting Energy Performance* provides performance metrics for evaluating lighting design, including daylighting (NREL 2004e). In addition, illuminance measurements were taken in the retail area following a modification of the International Energy Agency protocol established under Daylight in Buildings Task 21 (Atif et al. 1997). The goals of the monitoring plan were to:

1. Measure the energy consumption by the lighting systems.
2. Determine the energy savings that result from the lighting design without daylighting controls.
3. Determine the amount of electric lighting offset by daylighting and the energy saved in lighting.
4. Analyze the operation of the lighting design and optimize its performance.
5. Quantitatively assess the quality of the lighting and daylighting designs.
6. Document the successes and weakness of the lighting design.

7.2.1 Illuminance Distribution

According to the IESNA (2000), the recommended minimum illuminance levels for a retail area are 50 fc (500 lux). Several illuminance measurements were taken to verify that these levels were obtained and to determine the contribution of daylight to these levels. One-time, handheld illuminance measurements were taken in the warehouse and in the retail area. Short-term continuous illuminance measurements were recorded in the retail area three times during the year.

The handheld illuminance measurements were taken on June 5, 2000 between 10:30 a.m. and 11:30 a.m. MDT with all the electric lights off. The sky conditions were clear during the measurement period. The measurements were taken at a height of 4 ft (1.2 m), with a Li-Cor Model LI-250 Light Meter. Figures 7-1 and 7-2 show the light conditions with no electric lights at the time of the illuminance measurements in the warehouse and the retail area. The warehouse is very well lit with a bright diffuse light. The retail area has good lighting in the center aisle, but there are some dark areas near the edge.



Figure 7-1 Warehouse lighting with daylight only for clear sky conditions on June 5, 2000



Figure 7-2 Retail area lighting with daylight only for clear sky conditions on June 5, 2000

Handheld illuminance measurements were taken throughout the working areas of the warehouse to quantify the darkest and brightest conditions. The illuminance levels ranged from 60 to 438 fc (600 to 4380 lux), which is well above the recommended minimum levels with no overly bright areas.

The handheld illuminance measurements in the retail area were taken on a grid that covers the entire sales area except the lighting display section. A sample of the measurements is shown in Figure 7-3. The illuminance levels along the center and at the east end of the store are adequate and should require very little supplemental light from the electric lights. The north-facing dormer windows and the borrow window from the warehouse effectively raise the light levels in their adjacent spaces. The areas with illuminance levels near or below 100 lux (10 fc) are problem areas that will always require supplementary electric lights. Additional lights were added to the northwest corner [30 lux (3 fc) reading] as part of a lighting display. Two two-bulb linear fluorescent fixtures were added in the back aisle on the southwest side [76 lux (8 fc) reading]. The light levels in the other two areas with illuminance readings lower than 100 lux [52 and 61 lux (5 and 6 fc) readings] are adequately lit by the installed ambient electric lighting. For conditions during measurement, the illuminance levels with natural light only are enough to function, but they are below the desired levels of 500 lux (50 fc) and always require input from the electric lights. Wintertime illuminance measurements show that natural light can provide adequate lighting in much of the retail area during bright sky conditions, which are typical for Colorado during the winter.

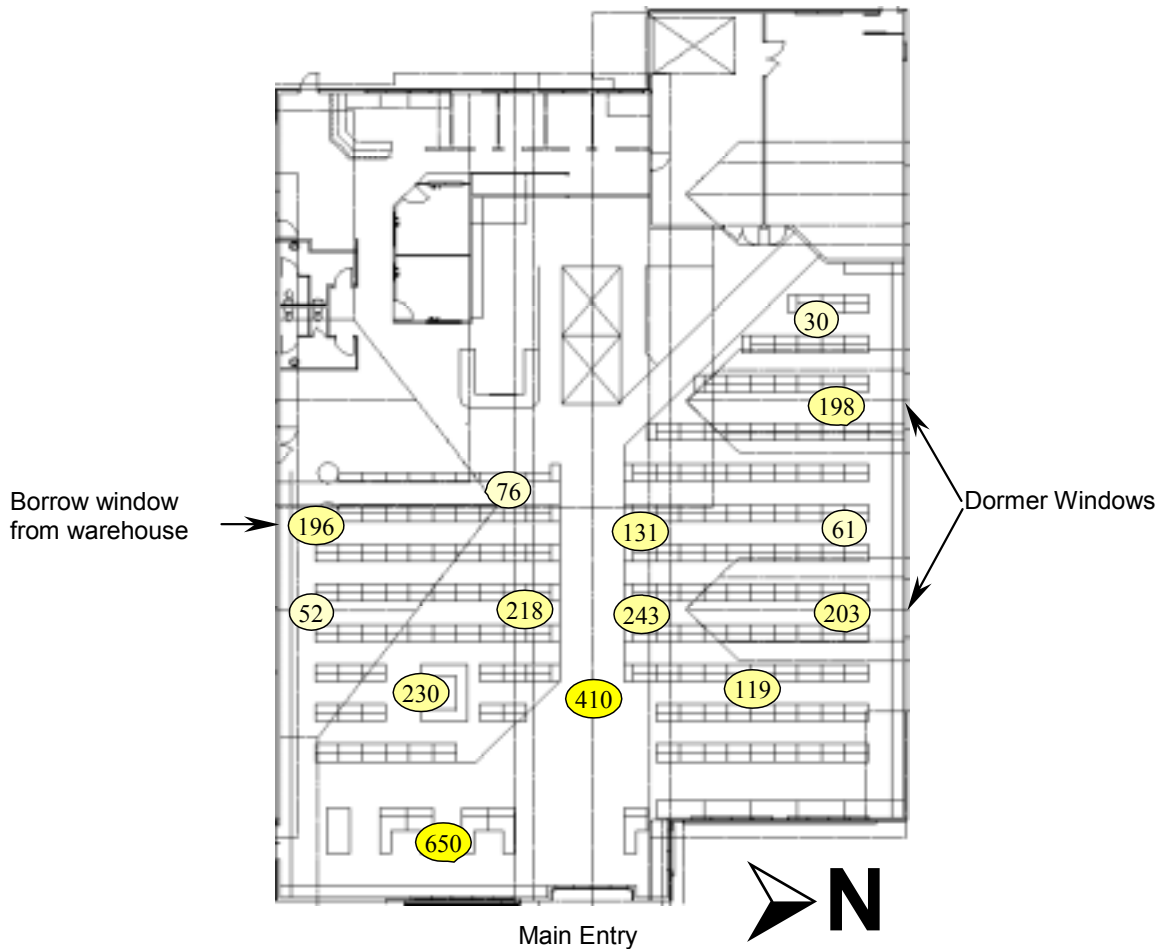

Figure 7-3 Illuminance levels in lux from daylight only on June 5, 2000, at 11:00 MDT

Short-term continuous illuminance measurements were taken in the retail area during three periods near the summer solstice, autumnal equinox, and winter solstice: June 22–28, 2000; September 15–19, 2000; and December 31, 2000, to January 2, 2001. Monitoring periods of 3 to 7 days were used to capture various building use patterns and sky conditions. The same measurement equipment was used for each monitoring session to maintain consistency. The horizontal illuminance was measured by 12 photometers placed on top of the shelving in the retail area [approximately 5.5 ft (1.7 m) high] to create a grid of the light distribution (see Figure 7-4). An additional photometer was placed on the roof to measure ambient light levels. This outside photometer was shaded for approximately 1 hour in the morning for the autumn and winter measurements because of the low sun angle. A data logger scanned the photometers every 5 seconds and recorded averages every 15 minutes for the summer measurements and every 5 minutes for the autumn and winter measurements.

The lights were manually controlled and their status was not changed during store operation hours in all illuminance studies. On January 1, 2001, the store was closed and no electric lights were turned on; no electric lights were used on September 17, 2000. The electric lighting illuminance levels were measured on the evening of June 26 after the sun had set and no natural light entered the building. Each lighting circuit was energized and the light levels recorded by the 12 photometers.

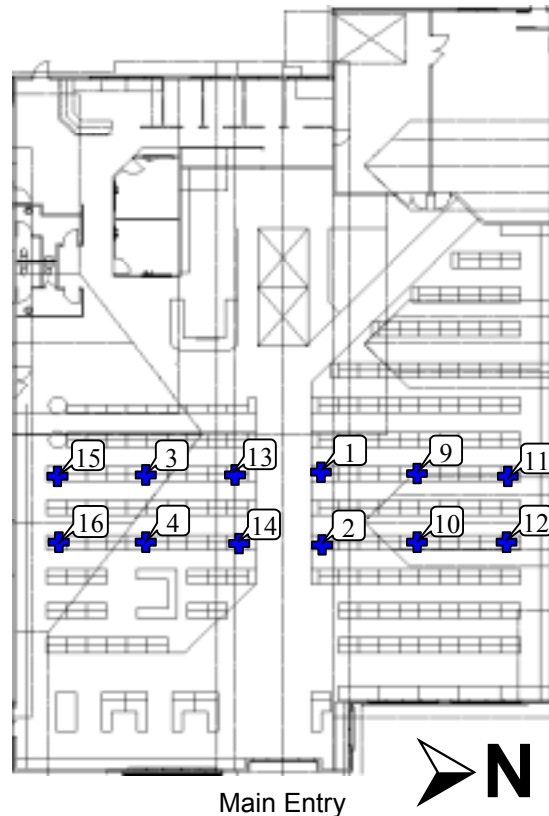

Figure 7-4 Photometer placement in the retail area for illuminance measurements

The exterior illuminance levels for a summer test day and a winter test day are shown in Figures 7-5 and 7-6, respectively. The winter day is very clear with some light clouds near midday. The photometer is shaded by the building in the morning with the low sun angle in the winter. In the afternoon, the sharp drop in illuminance is caused by the sun going behind a nearby mountain. The summer data in Figure 7-5 are not complete because some sensor readings were out of range. This summer session was the first data-monitoring period, and this problem was corrected for the autumn and winter monitoring sessions.

The daylight levels in the retail area for the winter day are shown in Figures 7-7 and 7-8, and for the summer day in Figures 7-9 and 7-10. In general, the lighting in the winter is higher because the lower sun angle allows better daylight penetration through the clerestory windows. The winter daylight levels can provide most of the lighting needs. The measurements show that summer periods require more electric lighting. The north side has slightly higher light levels than the south side because of the north-facing dormer windows, and more light enters the south-facing clerestory windows than the north-facing clerestory windows. The layout of the store is such that the north side of the building views the south-facing clerestory windows and visa-versa.

There are some glare problems in the space at certain times of the day. The morning sun through the large east window produces high illuminance levels, which can cause glare problems in the center of the store. There are also short periods of direct sun through the clerestory windows on the north side during the winter. This direct beam can also cause minor glare problems for customers when they look at products.

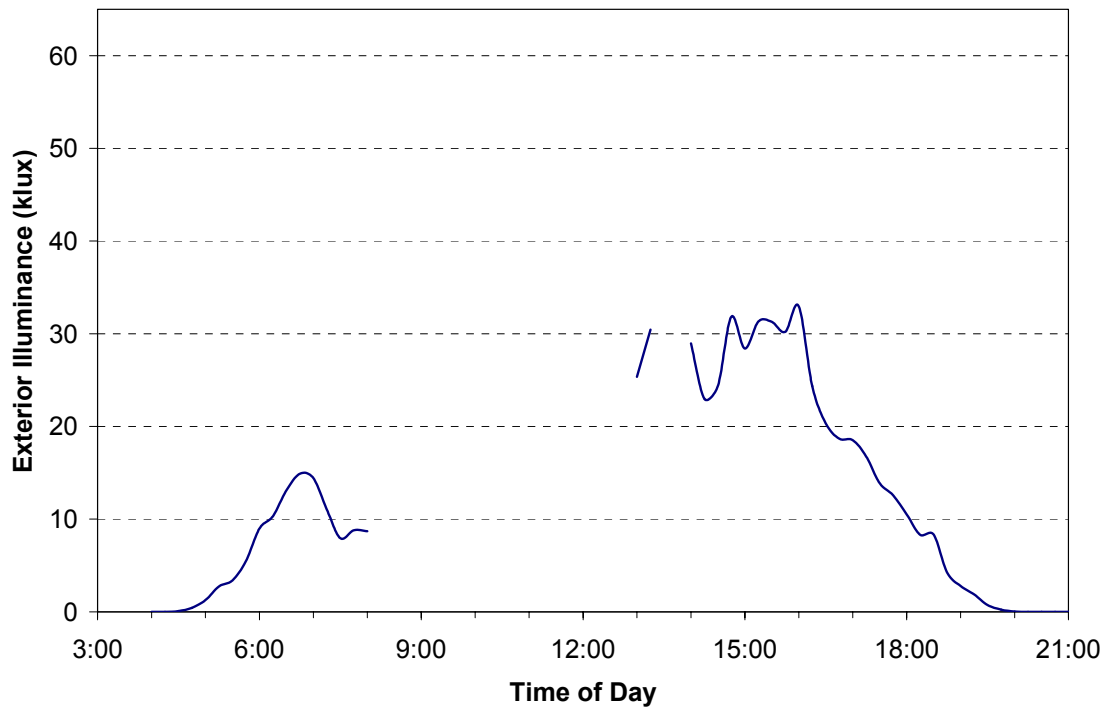

Figure 7-5 Exterior illuminance for June 23, 2001

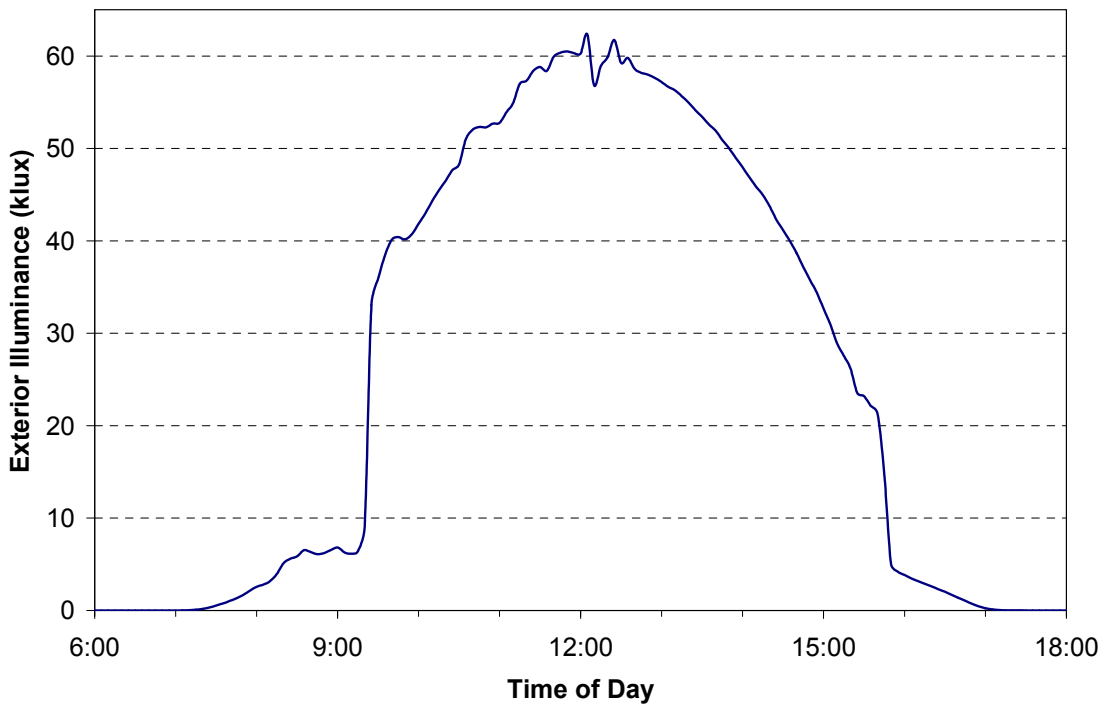

Figure 7-6 Exterior illuminance for December 31, 2000

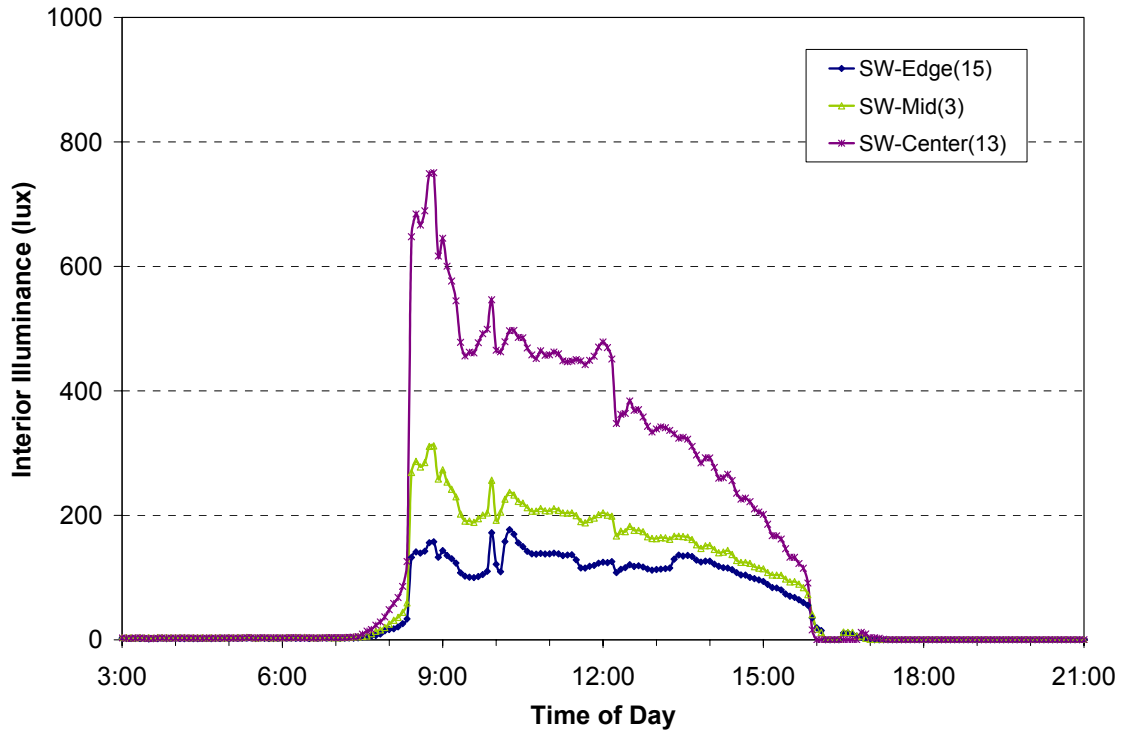

Figure 7-7 Daylight levels on the south side of the retail area for a clear winter day (December 31, 2000)

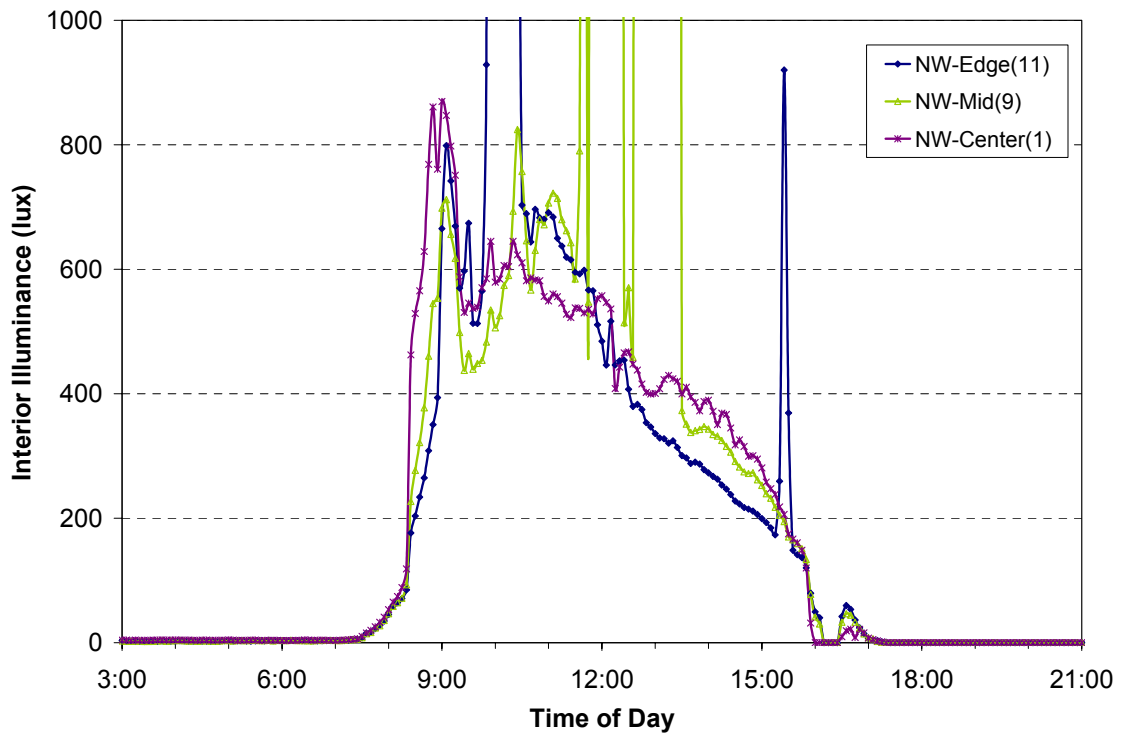

Figure 7-8 Daylight levels on the north side of the retail area for a clear winter day (December 31, 2000)

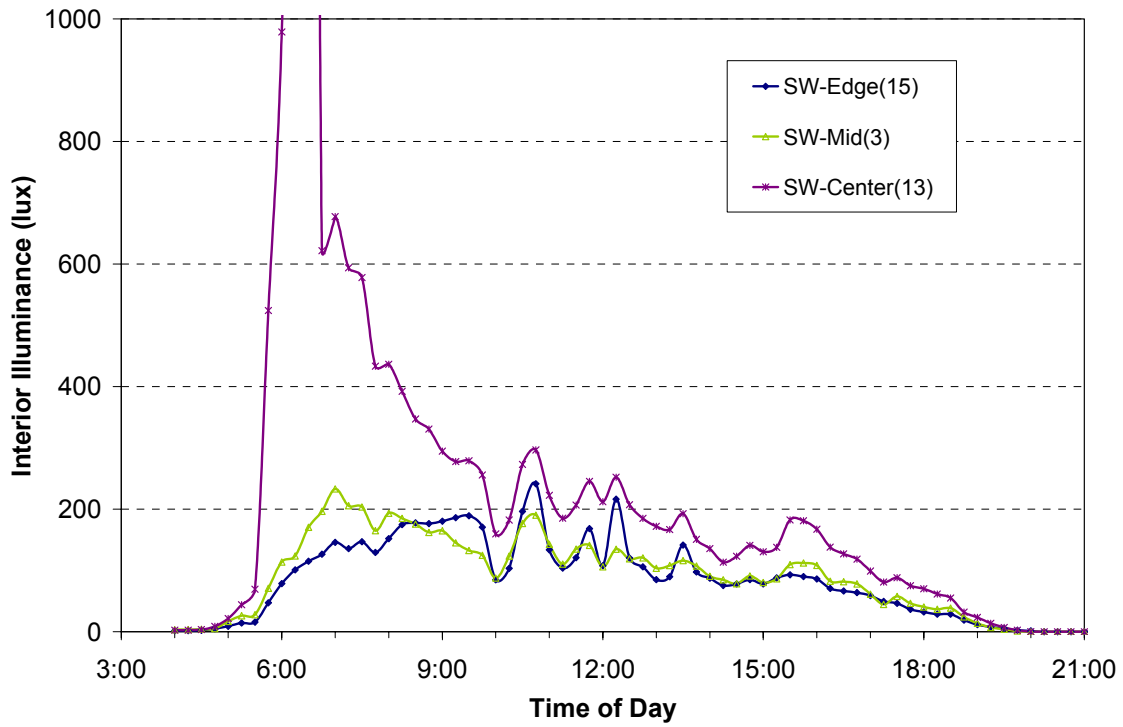

Figure 7-9 Daylight levels on the south side of the retail area for a partly cloudy summer day (June 23, 2001)

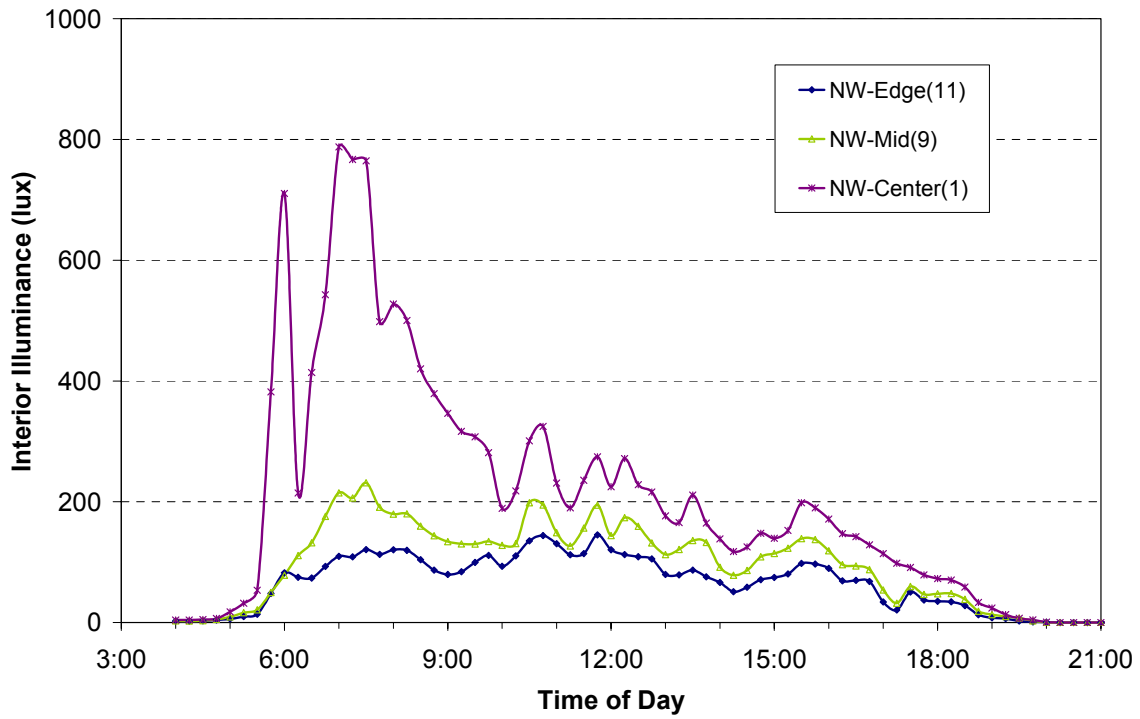

Figure 7-10 Daylight levels on the north side of the retail area for a partly cloudy summer day (June 23, 2001)

The same graphs for September 16 and 17, 2000, are shown in Figures 7-11 to 7-13. These graphs show a comparison of a clear day with a partly cloudy day. The measured illuminance levels for September 16 were adjusted to subtract out the electric light contribution. The electric light levels were determined from the data measured after sunset. The daylighting controls were disabled during the measurement periods. The electric lights were not used on September 17; therefore, no adjustments were made to the measured values. The exterior photometer was again shaded early in the morning, which is evident on the clear day. The morning of the partly cloudy day was mostly diffuse light, so the shading by the building is not as evident in the measurements.

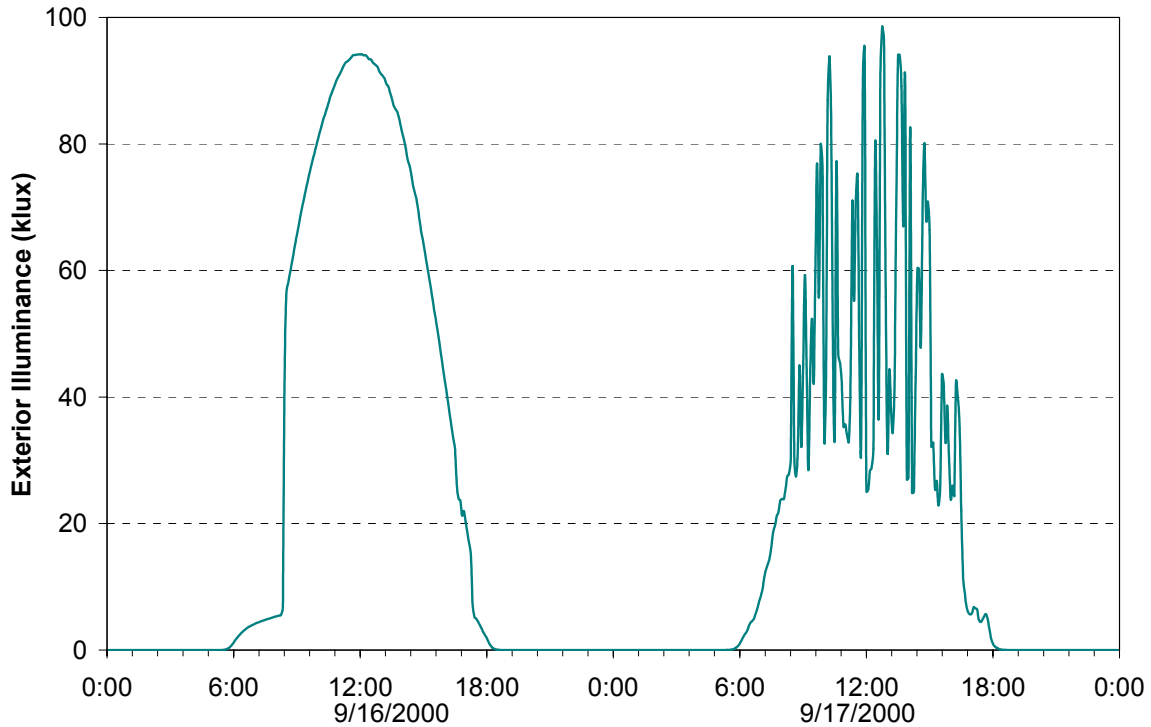

Figure 7-11 Exterior illuminance for September 16 and 17, 2000

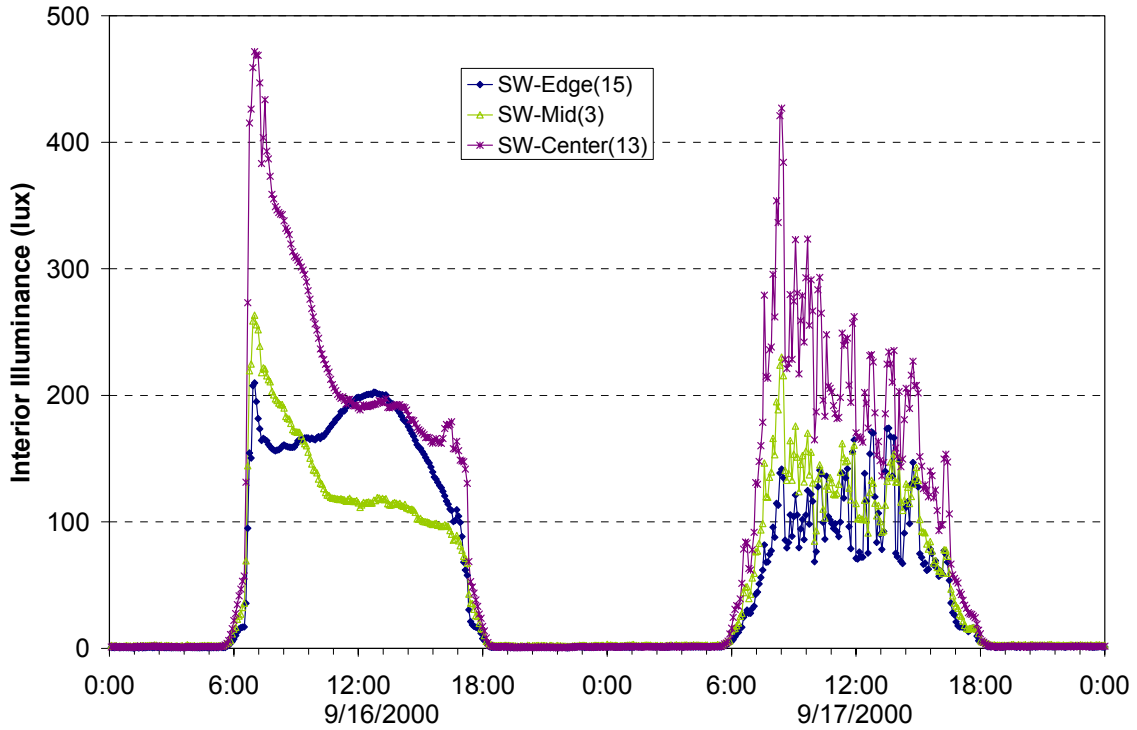

Figure 7-12 Daylight levels on the south side of the retail area for clear and partly cloudy autumn days (September 16 and 17, 2000)

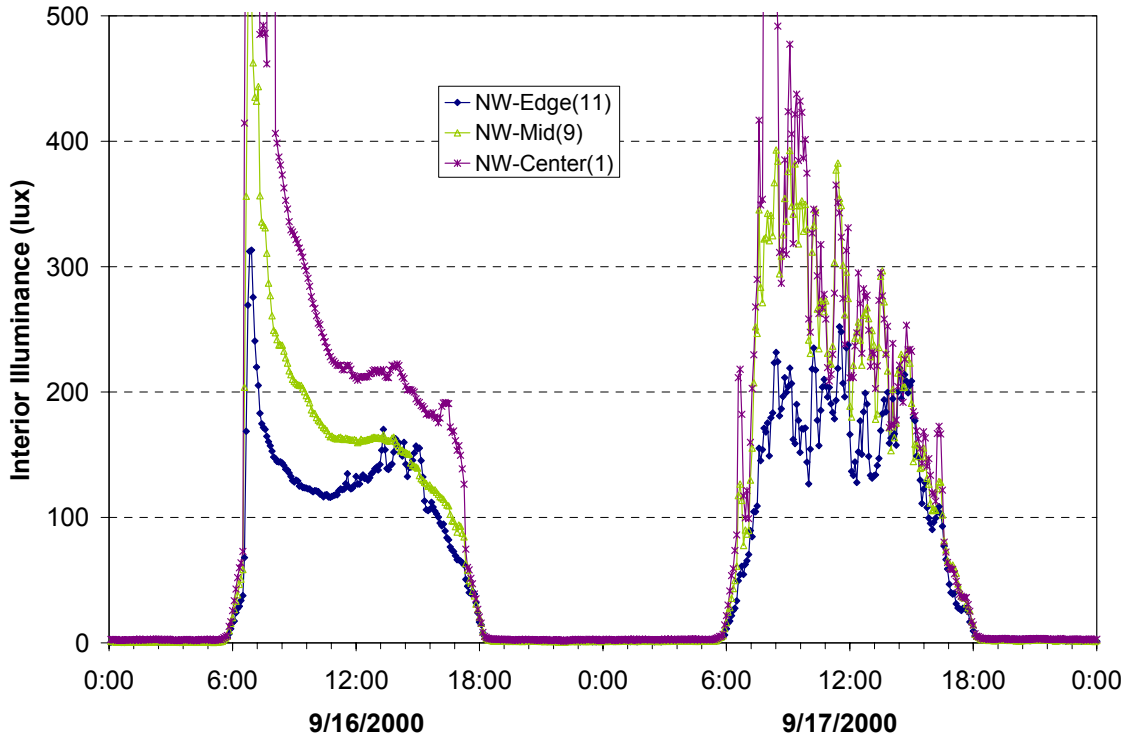

Figure 7-13 Daylight levels on the north side of the retail area for clear and partly cloudy autumn days (September 16 and 17, 2000)

The general illuminance values are similar for September 16 and 17. The values on the partly cloudy day are slightly higher because of the higher levels of diffuse light. The variations in illuminance levels on the partly cloudy day with the changes in cloud cover do not cause problems for the human eye because the human eye is not very sensitive to changes in light level at these values. However, the human eye is sensitive to changes in illuminance at very low light levels. The high illuminance values in the morning in the winter and summer measurements are due to the morning sun coming through the east window. There is no direct beam radiation in the afternoon.

An evaluation of the light levels provided by the daylighting and the electric lights was also completed. Figures 7-14 and 7-15 show the light levels on September 16, 2000, as measured by the same photometers as used in Figures 7-12 and 7-13. The light distribution over space and time is very good. The light levels are nearly flat remaining near or above 500 lux (50 fc) through out the day and only exceeding 1000 lux (100 fc) on sensor 1 in the morning. The reading at 8:00 a.m. that is off the scale was 8000 lux (800 fc). Sensor 1 was located in the center aisle and received direct sunlight in the morning through the east window, which causes some glare problems in the mornings. The light levels measured by sensor 11 are higher because this sensor was located near a light fixture along the edge where the ceiling is low.

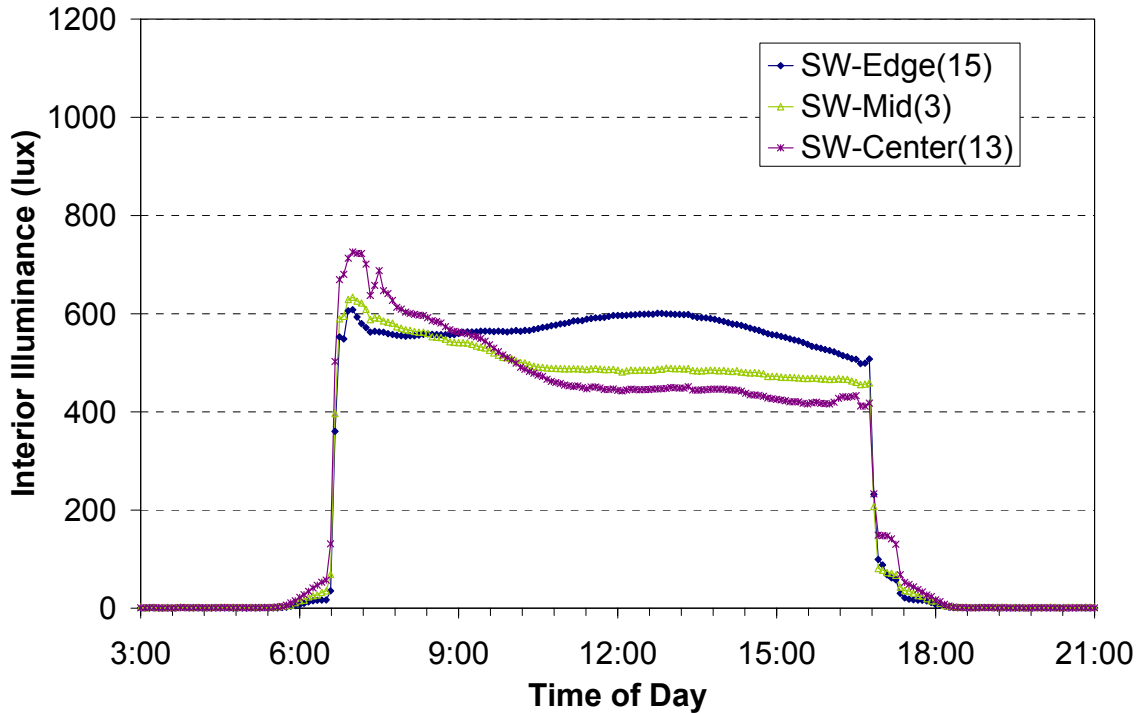

Figure 7-14 Light levels from daylight and electric lights on the south side of the retail area on September 16, 2000

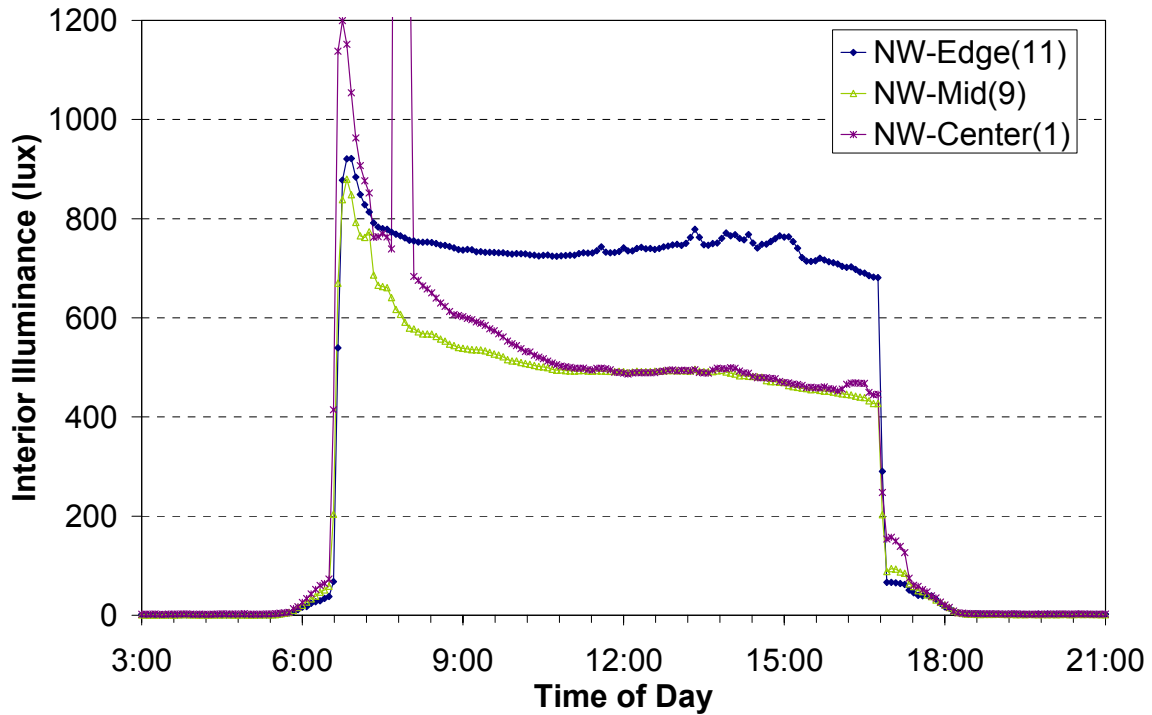

Figure 7-15 Light levels from daylight and electric lights on the north side of the retail area on September 16, 2000

7.2.2 Lighting System Energy Consumption

The lighting systems represent a significant fraction of the energy use in the BigHorn Center and even a greater percentage of the energy costs. The annual energy use and estimated energy cost for the interior lighting systems and the total building (excluding the exterior lights) are listed in Table 7-1. For the September 2002 to August 2003 period, the lighting systems accounted for 29% of the electrical energy use, 36% of the electrical energy cost, and 26% of the total energy cost. These numbers do not include the lighting display energy use, which is treated as a plug load in this analysis.

Table 7-1 Energy Consumption and Energy Cost for Interior Lighting Systems

Load	Energy Use MWh (GJ)		Estimated Energy Cost	
	9/1/2001– 8/31/2002	9/1/2002– 8/31/2003	9/1/2001– 8/31/2002	9/1/2002– 8/31/2003
Retail Lights	44.1 (159)	39.3 (141)	\$3,145	\$3,037
Warehouse Lights	3.7 (13)	8.4 (30)	\$757	\$1,307
Total Interior Lights	47.8 (172)	47.7 (172)	\$3,872	\$4,344
Total Building Site Electrical Energy	147 (529)	166 (598)	\$10,162	\$11,907
Total Building Source Energy	914 (3,290)	866 (3,118)	\$16,932	\$16,661
Percentage of Total Building Electrical Energy	33%	29%	38%	36%
Percentage of Total Building Source Energy	15%	14%	23%	26%

The measured LPDs provide another view of the energy use patterns in the building. The installed and measured LPDs for the retail and warehouse spaces for the period between September 2002 to August 2003 is shown in Table 7-2. The normal operation of the retail area uses less than half the installed capacity and measured peak is 16% less than the installed capacity. The warehouse uses less than 10% of the installed capacity most of the time. The measured peak in both spaces is lower than the installed capacity because not all of the lights are turned on at once and there are always a number of light bulbs that are burned out. Burned out bulbs have been a significant problem in the retail area, where an estimated 10% of the bulbs can be not functioning at any given time.

Table 7-2 Lighting Power Densities for the Interior Lighting Systems for September 2002 to August 2003

Load	Installed	Average (during normal operation)	Average Summer Peak	Average Winter Peak	Measured Peak
Retail Lights	1.25	0.51	0.53	0.64	1.05
Warehouse Lights	0.79	0.08	0.07	0.16	0.55

Although the lighting systems represent a significant fraction of the building energy consumption, they do exhibit considerable savings compared to the energy code. The *Procedure to Measure Indoor Lighting Energy Performance* (NREL 2004e) defines two performance metrics to assess the overall lighting system energy savings. The Lighting Design Energy Saving results from the design of the lighting design only with no occupancy or daylighting controls. They compare the maximum LPD allowed by code to the installed LPD. For this case, ASHRAE Standard 90.1-2001 was used to determine the maximum allowable LPDs. Table 7-3 presents the LPDs and savings for the retail/office area and warehouse. The retail/office area LPD for ASHRAE 90.1 was calculated as the area weighted average of the LPDs of each

space in the retail and office areas. The installed LPD includes two sets of luminaires added to the retail area after construction, but it does not include the area or the lights in the lighting display area.

Table 7-3 Lighting Design Energy Savings

Space	ASHRAE 90.1 W/ft² (W/m²)	Installed W/ft² (W/m²)	Saving
Retail/Office Area	1.63 (17.5)	1.25 (13.5)	23%
Warehouse	1.20 (12.9)	0.79 (8.5)	34%
Whole Building	1.39 (15.0)	1.00 (10.8)	28%

The Lighting Design Energy Saving is not the actual energy savings; it is only a measure of the effectiveness of the lighting design. Some of this saving is from the daylighting design that allows for less electrical lighting to be incorporated into the design. Some of the human perception of light is based on the contrast between inside and outside. During the day, additional lighting levels are needed. In the case of BigHorn, some of this can be met with lighting fixtures and some with daylighting. The lighting system can be based on the lighting requirements at night, which are often lower than during the day.

The Lighting Energy Saving represents the actual energy saving and includes the savings that result from the occupancy controls and the daylighting controls. It can be calculated by two methods. The first method compares the measured lighting energy use to what would be expected by using the allowable LPDs according to the energy code and the operating schedule. This approach has the advantage that it uses measured data, but the disadvantage is that the accuracy of the expected energy use is based on an approximation of the annual operating schedule. The second method of calculating the energy savings is from the calibrated whole-building energy simulations of the As-Built Baseline Model and the As-Built Model. This approach has the advantage of using the same operating schedule, but the simulation may not represent the as-built conditions exactly. The Interior Lighting Energy Saving from both methods are shown in Table 7-4. The measured energy use is from September 1, 2003 to August 31, 2003. The savings predicted by both methods are similar, because the simulations were closely aligned with the energy code and the as-built building. Using the measured energy data, the Lighting Energy Saving for the retail area was 69%, the Lighting Energy Saving for the warehouse was 93%, and the whole-building Lighting Energy Saving was 81%.

Table 7-4 Interior Lighting Energy Savings

Space	ASHRAE 90.1 MWh (GJ)	As-Built MWh (GJ)	Savings
Method #1: Code vs. Measured Data			
Retail/Office Area	125.2 (451)	39.3 (141)	69%
Warehouse	120.1 (432)	8.4 (30)	93%
Whole Building	245.3 (883)	47.7 (172)	81%
Method #2: Simulated Comparison			
Retail/Office Area	123.7 (445)	41.1 (148)	67%
Warehouse	119.4 (430)	7.9 (28)	93%
Whole Building	243.1 (875)	49.0 (176)	80%

7.2.3 Lighting System Daily Load Profiles

One method used to understand how the lights are used in the building and determine possible areas for reducing energy consumption, is to look at the daily electrical load profiles. The average daily electrical load profiles by season for the retail/office lighting are shown in Figure 7-16. The profiles are similar in shape from season to season. The winter profile shows the need for additional light in the mornings and late afternoons because of the limited daylight. The fall profile shows a slight increase in the late afternoons caused by the change from daylight saving time in late October. The light use in the evening (after 18:00) is from the cleaning crew, who typically turn on most of the lights. This represents a higher light use than during normal operating hours. The average profile is lower than the total because the crew is only in the store two or three days per week.

The average daily load profiles by season for the warehouse lighting are shown in Figure 7-17. Unlike the retail lighting profiles, the warehouse lighting profiles show significant variations by season that are caused by varying daylighting conditions. The effect of the daylighting controls is apparent with less light use during the middle of the day. The pattern of high light use by the cleaning crew is evident, especially in the winter.

Figure 7-18 shows the same lighting profiles for the exterior lights. The winter profile shows the lights were used early in the morning before sunrise when the workers first arrived to the building. The small bump just after midnight is due to all the lights turning on at this time for 10 days in December for an unknown reason. The first bump in the evening is the lighting energy used for daily operations, and the second bump in the evening is from the cleaning crew.

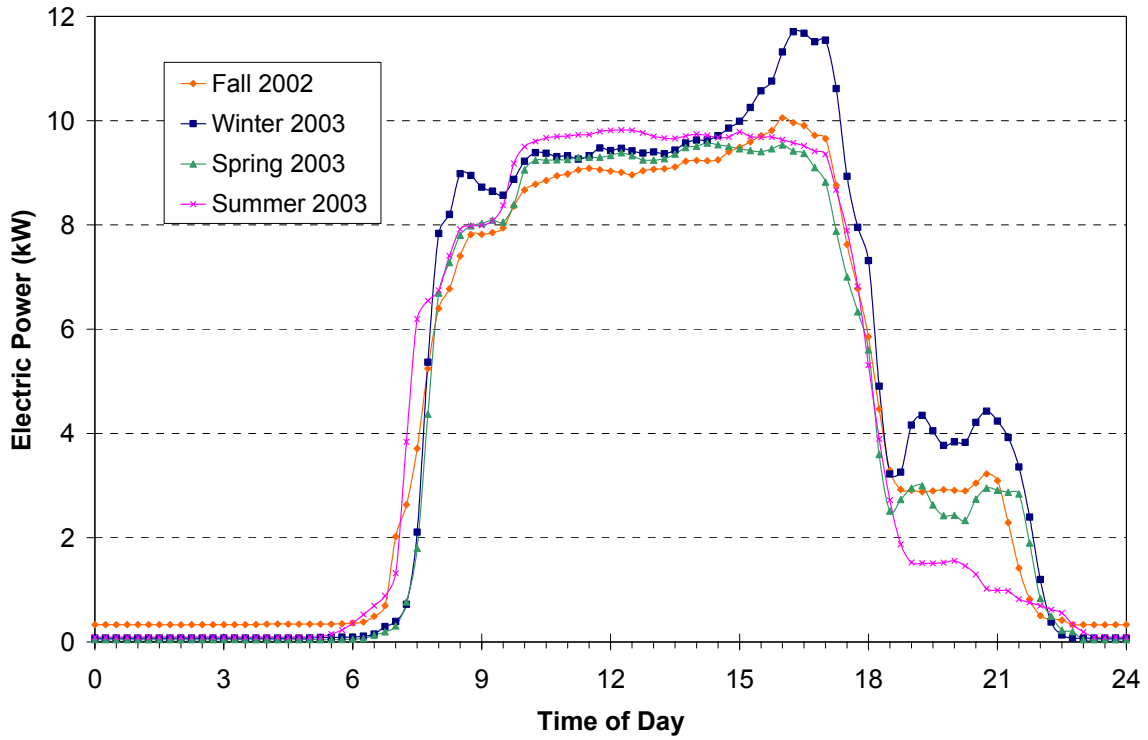

Figure 7-16 Seasonal average daily profile for the retail lighting power

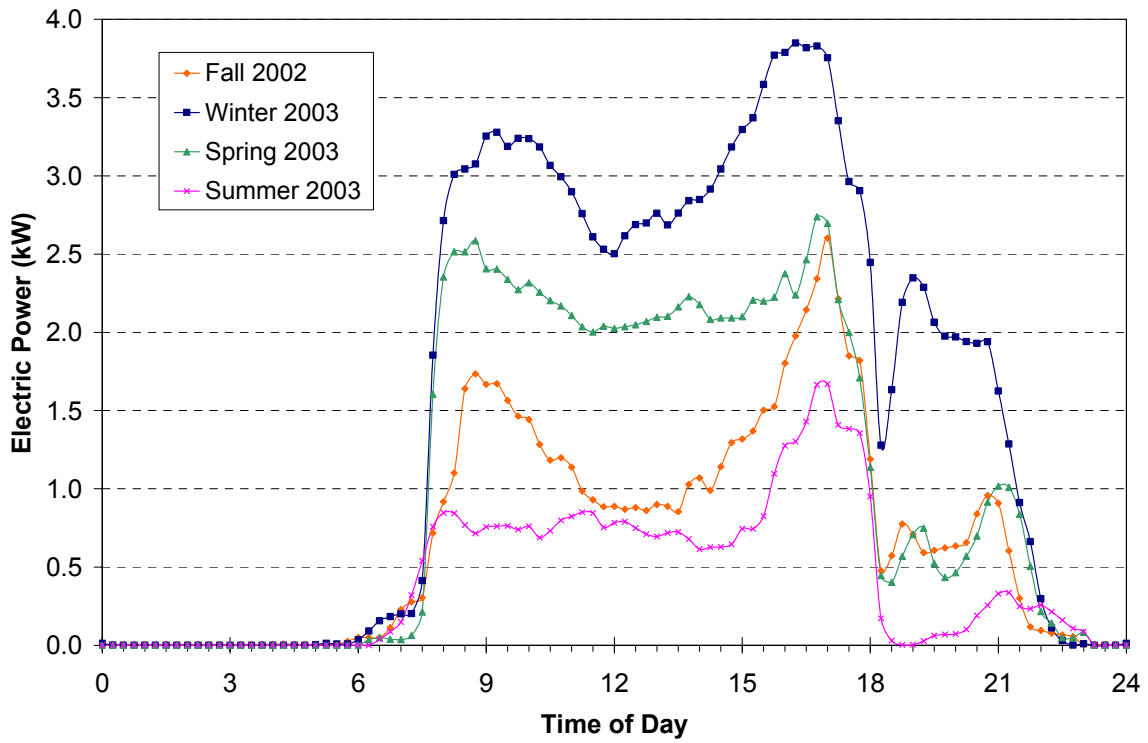

Figure 7-17 Seasonal average daily profile for the warehouse lighting power

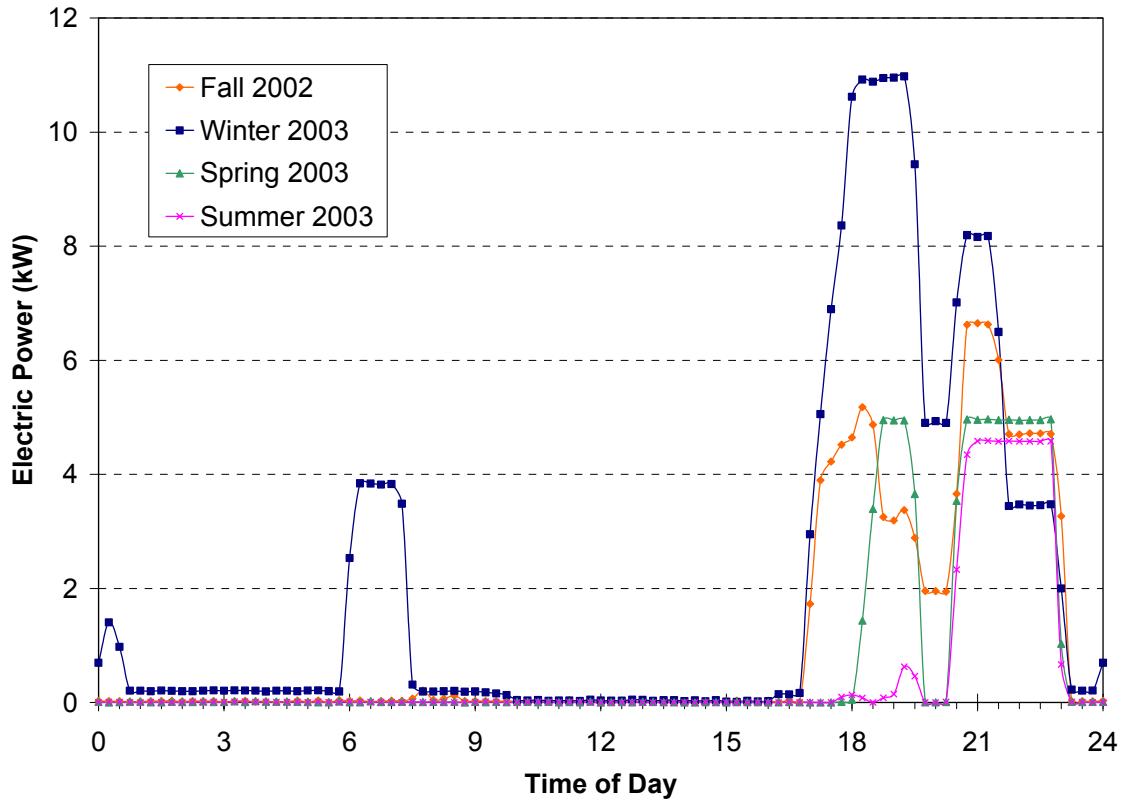

Figure 7-18 Seasonal average daily profile for the exterior lighting power

7.2.4 Comments on the Lighting Design

In general, the lighting design at the BigHorn Center works very well. The system provides the required light levels and produces good energy savings; however, a few issues remain. A summary of what works well and what could be improved follows.

- The retail/office lighting design produces nearly 70% energy savings and provides good light for most of the space; however, some areas near the outside edges have low light levels and required additional lights. The important features of the daylighting design are the north and south clerestory windows along the length of the space; the north-facing dormer windows; the borrow window to the warehouse; and the high-reflective ceiling, walls, and floor. Features that adversely affect the amount of available daylight are the dark roof and dark soffits under and over the clerestory windows and the bug screens on the north-facing clerestory windows. In addition, direct-beam radiation through the south-facing clerestory windows is a problem during the winter, especially in the mezzanine offices. Potential solutions to these problems are a lighter color for the roof and soffits and larger clerestory windows. The direct-beam problem through the south clerestory windows could be solved by a louver system to direct the light up, or pattern glass in the windows to diffuse the light. A longer overhang is not recommended.
- The warehouse daylighting design is very effective, as it requires no electric lights during most of the daylight hours. The translucent skylights work well in this application where lighting is more important than the thermal issues of overheating in the summer and heat loss in the winter. The climate and operating conditions keep the warehouse cool in the summer and the space is maintained at a low temperature in the winter so heat loss through the skylights is a small concern. During the design stage, there was a concern that snow cover on the skylights would

reduce the daylighting. However, snow buildup on the roof has had little impact on the amount of daylight that enters the space. Small amounts of snow still allow adequate light transmission, and large snowfalls slide off the metal roof within a few days.

- The CFLs in the pendant fixtures provide adequate light, and the step lighting control provided by switching sets of two lamps works well for the daylighting control. However, the operating life of the bulbs has only been 4,000–5,000 hours instead of the expected 10,000 hours. In addition, the high placement of the fixtures in the store makes lamp replacement time consuming. Standard T-8 fluorescent lamps would have been more energy efficient (efficacies are typically above 80 lumens/Watt for T-8 lamps and around 60 lumens/Watt for CFLs) and lamp life is longer. In addition, the pendant fixtures did not work well because they produced uneven lighting in the lower ceiling heights. Again, T-8 fixtures would have worked better.
- The lighting control in the building is awkward. The manual switches and the EMS have to be in the on position for the lights to be on. If the EMS has the lights off, there is no way to manually override the system without going into the EMS control panel. Therefore, some of the lighting circuits are always on in the EMS and are controlled by the manual switches. Typically, all the manual switches in the retail/office area are turned on in the morning and off in the evening, and the EMS is allowed to control the lights based on the schedule and light level. This system would have been improved if the manual switches were signals to the EMS such that overrides and time delays could be programmed in. Demand limiting during cleaning schedules could also be implemented.
- The stepped controls worked well. The lighting circuits were carefully designed to provide more light in the darker spaces with the first few control steps. This reduced the cost of the controls implementation. At the time of design, dimming technology was not practical. It should be considered in the future as fixtures are replaced.

7.3 Photovoltaic System Analysis

The PV system at BigHorn was evaluated to determine the energy produced by the system, the effect on the building purchased electrical energy, and the performance of the system. The *Procedure for Measuring and Reporting the Performance of Photovoltaic Systems in Buildings* (NREL 2004f) provides guidance on evaluating the performance of PV systems in the built environment. Additional measurements were taken for a more detailed evaluation of the system performance. The goals of the monitoring plan were to:

1. Measure the delivered AC energy production by the PV system.
2. Determine the percentage of the building electrical energy consumption offset by the PV system.
3. Determine building electrical demand offset by the PV system and the energy cost savings.
4. Determine the performance of the PV system compared to the expected performance.

7.3.1 Photovoltaic System Measured Energy Production

The average daily purchased (net) electrical energy and PV system energy production per month are summarized in Figure 7-19. The total electricity consumption is the purchased electricity plus the PV energy production. The percentage of the total monthly building electrical load met by the PV system is also shown in this figure. A number of problems, which are discussed in a detailed analysis in Section 7.3.2, have caused the performance of the PV system to be sporadic. The seasonal variation in the output of the PV system is apparent in the figure. The winter production is generally poor because of the shorter days, the lower incidence angle of the solar radiation, occasional snow cover on the PV arrays, and problems with system operation. The highest percentage of the monthly facility electrical load met was

7.3% in July 2002, and the lowest was 0.0% in January 2002 and 2003. The annual energy production from the PV system and the percentage of the facility electrical energy consumed and the total energy consumed are shown in Table 7-5. This table lists the numbers for site energy production and source energy offset by the PV system.

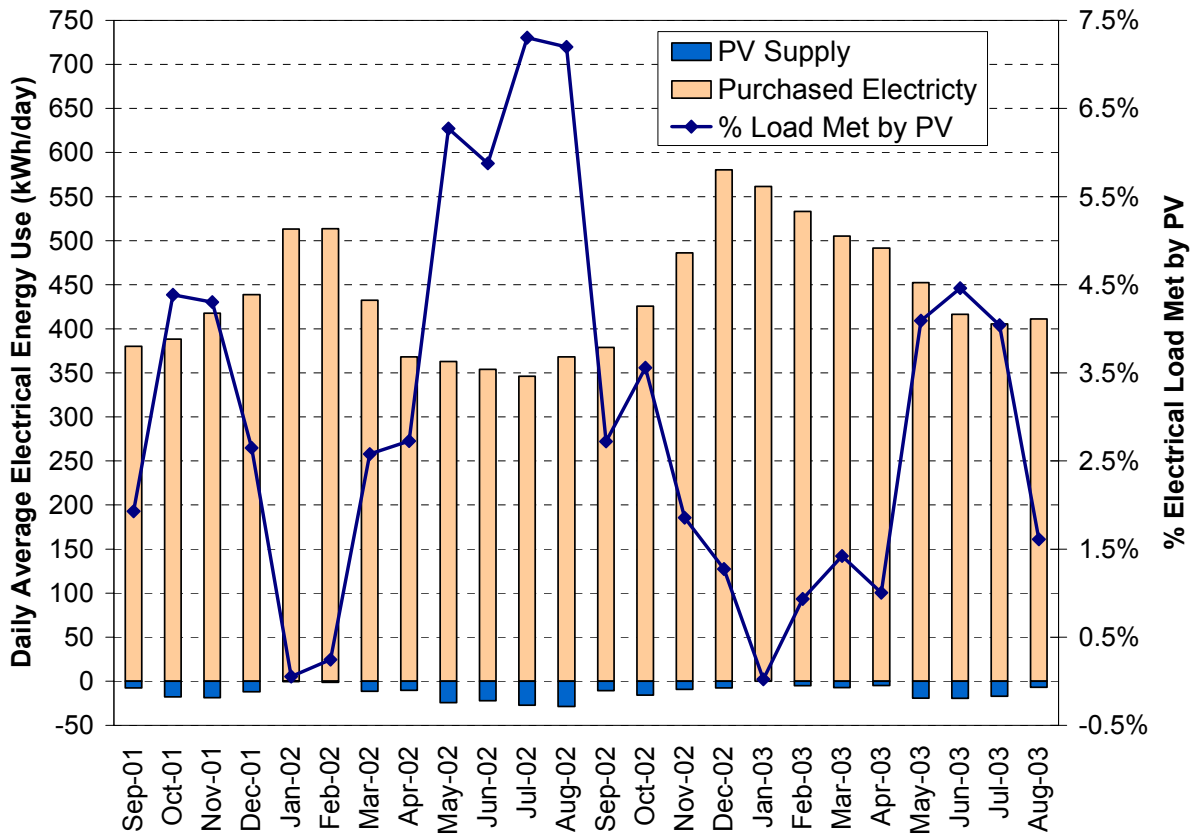

Figure 7-19 PV system energy production and percentage of the total electrical load met by the PV system

Table 7-5 Annual Energy Totals for the PV System

	Site Energy Production		Source Energy Offset	
	9/1/2001– 8/31/2002	9/1/2002– 8/31/2003	9/1/2001– 8/31/2002	9/1/2002– 8/31/2003
	MWh (GJ)	MWh (GJ)	MWh (GJ)	MWh (GJ)
PV Supply	5.6 (20)	3.8 (14)	16.8 (60)	11.3 (41)
% PV of Electrical Energy	3.6%	2.1%	3.6%	2.1%
% PV of Total Energy	1.0%	0.8%	1.8%	1.3%

The energy cost saving from the PV system operation is very small (see Table 7-6). This is mainly due to the utility rate structure and the operation of the building. During the two monitoring years, our

measurements show that the PV system only reduced the monthly peak demand in two of the months and only for a total of 3 kW. Most of the energy from the PV system is produced when the building's incremental energy cost is \$0.02–\$0.03/kWh. The building peak demands usually occur in the late afternoons and early evenings when the PV system is at low production or off. The PV system was not fully functional during the monitoring period, and the output of the system would have been about 2–3 times the measured value if the system had operated correctly. If the system were fully operational, the energy cost savings would probably be 3–4 times more, assuming slightly more peak demand would be offset by the PV system.

Table 7-6 Estimated Energy Cost Savings from the PV System

	Energy Costs		% Saving	
	9/1/2001– 8/31/2002	9/1/2002– 8/31/2003	9/1/2001– 8/31/2002	9/1/2002– 8/31/2003
PV Energy Cost Savings	\$101	\$108		
Electrical Energy Costs	\$10,737	13,489	0.9%	0.8%
Total Energy Costs	\$18,024	\$18,379	0.6%	0.6%

7.3.2 Photovoltaic System Performance Analysis

From the initial operation of the PV system, energy production was lower than expected. The poor performance was believed to be caused by two issues with the inverters. First, the inverters were not designed to operate in a grid-tied system; therefore, circuitry was included to couple the inverters to the grid. This circuitry includes four 12-V batteries used to maintain the inverter memories at night. The battery backup system is tied to the Phase-A inverter to maintain the battery charge. Charging the external battery backup requires the Phase-A inverter float voltage to be set at 50 VDC. The Phase-B and Phase-C inverters were also set at 50 VDC to match the Phase-A setting.

In addition, the inverters do not have maximum power point (MPP) tracking ability. Cell temperature affects the output of the amorphous-silicon PV modules only slightly; however, the peak power-point voltage drops as the cell temperature rises. Because the modules are integrated into the insulated roof of the BigHorn Center, there is little heat loss through the backs of the modules and cell temperatures can exceed 170°F (77°C).

A detailed investigation of PV system operation was performed on April 17, 2001, which was a very clear and relatively warm day for April. This investigation started with a verification of the system wiring and a check of all fuses. The Phase-A inverter was tied to all 18, 120-W PV panels and 9, 64-W panels. To understand the effect of fixing the float voltage at 50 VDC and the effect of mixing the different panels on one inverter, current-voltage (I-V) curve trace measurements were performed. These measurements allow the power-voltage (P-V) curves to be generated, which show the MPP voltage of the PV panels. The outdoor dry-bulb and PV cell temperatures were measured at that same time as the I-V curve trace measurements to be 70°F (21°C) and 142°F (61°C).

P-V curves were generated for the combination of the 120-W and 64-W panels, the 64-W panels alone, and the 120-W panels alone (see Figure 7-20) with the incident solar radiation for each curve. The behavior of the two panel types is very different. The approximate MPP voltages for the panels under these conditions are 38 V for the 64-W panels, 53 V for the 120-W panels, and 46 V for the combination of the two panel types. Operating at a fixed 50 VDC is close to the MPP voltage for the 120-W panels, but reduces the power output of the 64-W panels significantly.

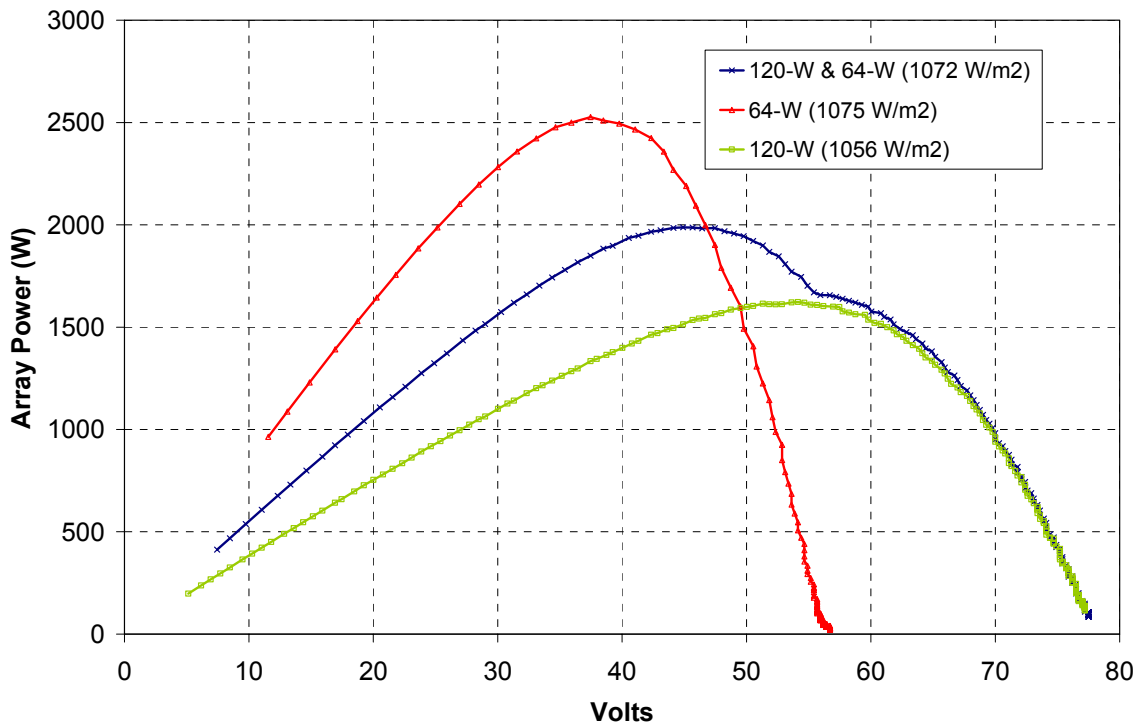

Figure 7-20 Power-voltage (P-V) curves for different combinations of panels with the incident solar radiation for each curve

The easiest solution to these problems was to rewire the arrays, which was completed by the system installer on July 7, 2001. The Phase-A array was rewired to consist of only 120-W panels and the 64-W panels were divided between the Phase-B and Phase-C arrays. The Phase-A inverter was kept at 50 VDC to match the battery circuit charging requirement. The Phase-B and Phase-C inverters were set to 44 VDC to more closely correspond to the MPP of these arrays on clear sunny days. The expected output of the rewired system was investigated through simulations (see Section 7.3.3). The simulations showed that fixing the DC voltage does not significantly affect annual performance unless the voltage is more than 4 volts (+ or -) from the maximum power point. Separating the 64-W panels from the 120-W panels and changing the operating DC voltage were predicted to improve the annual performance by approximately 10% if the system maintained proper functionality.

However, lowering the voltage on the Phase-B and Phase-C inverters increases the DC current, which can produce another problem. During periods of high output by the PV panels, the DC current exceeds the breaker limit (60 A) and trips the inverters offline. An additional intermittent problem, which became worse after the arrays were rewired, is that the battery circuitry occasionally fails to provide the proper power to the inverters when they are not producing power. This causes them to lose their memory and shut down. Because of the over current and the battery circuit problems, one or both inverters shut down frequently. Because there is no automated means of alerting the building operators when an inverter failure has occurred, they must be manually checked. Relying on manual checking and resetting the inverters have led to long periods when the system is not fully operational.

The better solution to improve the PV system performance is to replace the inverters with some that are designed to be grid-tied with MPP tracking capability. This change has been investigated and planned for the future.

Additional analysis was performed to quantify the magnitude of the degraded performance with performance metrics from the *Procedure for Measuring and Reporting the Performance of Photovoltaic*

Systems in Buildings NREL (2004f). One measure of the PV system performance is how effectively the system converts available solar energy into usable electrical energy. The AC Generation Effectiveness is the ratio of usable AC electricity delivered by the PV system to incident solar energy on the panels. Both data points were measured directly by the DAS (data points 4 and 12 in Table 6-1).

Figure 7-21 shows monthly AC Generation Effectiveness for the 2-year analysis period. The generation effectiveness is inconsistent from month to month. The winter performance is especially poor. One explanation for the poor winter performance is persistent snow cover on the PV panels but not on the pyranometer. An investigation into the monthly snowfall amounts and average monthly outdoor temperatures showed little correlation between these variables and the system effectiveness. However, snow cover can be a problem for the 120-W panels, which are tied to the Phase-A inverter and provide power to charge the backup batteries. These panels are located on the large dormer in the warehouse. A valley is formed by the junction of the main roof and the dormer that traps the snow that partially covers the PV panels (Figure 5-1). Covering a small segment of the PV panels can reduce the voltage below the minimum required to operate the system. When the Phase-A inverter is not operating, the other two inverters go down because the batteries are not charged. Because the inverters rely on manual resets, the system can go 3 to 4 weeks during the winter with only the partially operational Phase-A inverter.

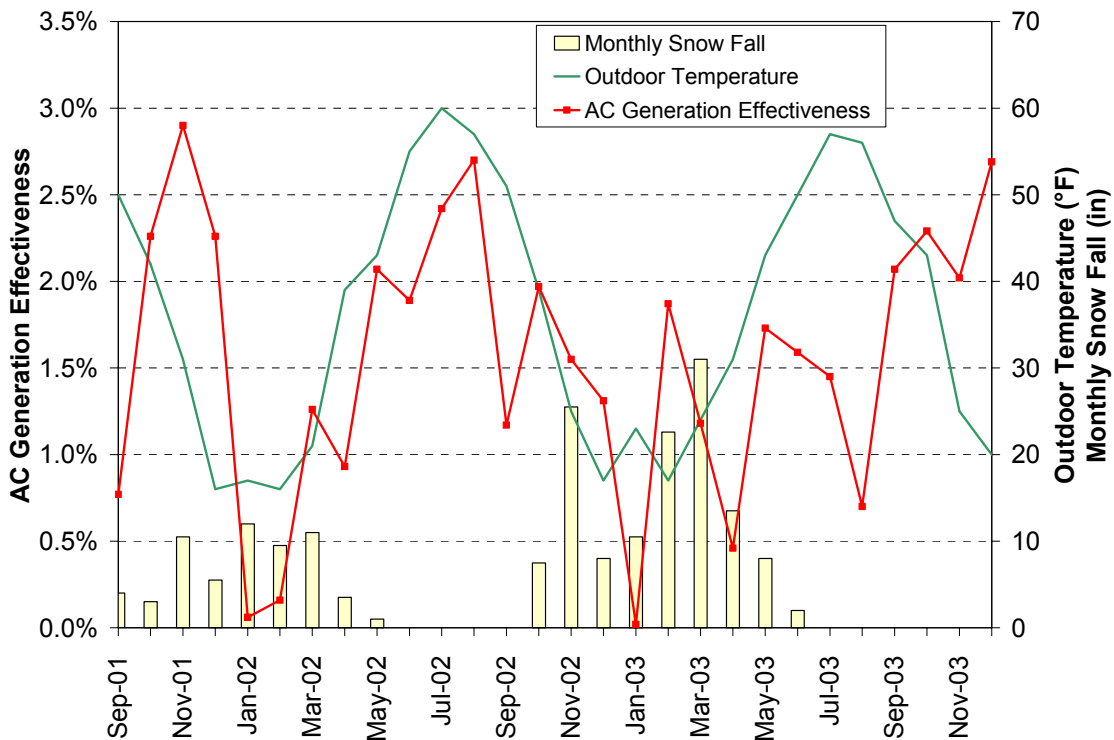

Figure 7-21 Monthly PV system conversion efficiency with outdoor temperature and snowfall amounts

The effect on system performance of operating with one, two, or three inverters is seen in Figure 7-22. This figure shows a graph of the AC Generation Effectiveness versus the incident solar radiation for every 15 minutes during June 2003. Most of the month, the system was operating with two inverters, and all three inverters were functional for only 3½ days. When the system is fully functional, the efficiency is higher than 3%, but it drops to lower than 2% with two inverters and near 0.5% with only one inverter. The PV system was estimated to be fully functional for only about one-third of the days during the 2-year monitoring period and operated with only one inverter for half the time.

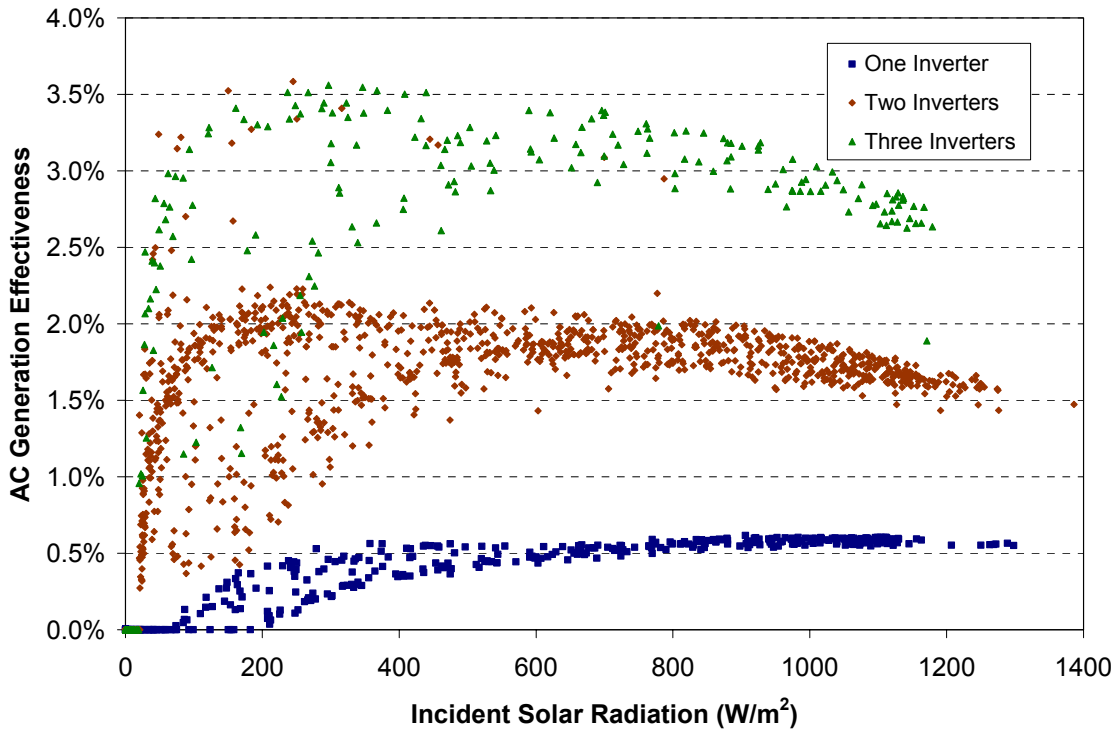

Figure 7-22 AC Generation Effectiveness for June 2003 with 1, 2, or 3 inverters operating

The drop in efficiency at higher solar radiation values is caused by an increase in PV cell temperature. An extreme example of temperature dependence is shown in Figure 7-23, where the PV cell temperatures were very high and the effectiveness drops from greater than 3% to 1.5%. As the temperature rises, the maximum power point voltage drops, but the inverters operate at a fixed voltage, so the system efficiency drops. This effect is smaller when only one inverter is operational, which indicates that temperature has a lesser effect on the 120-W panels. The 120-W panels have a much flatter P-V curve than the 64-W panels (see Figure 7-20).

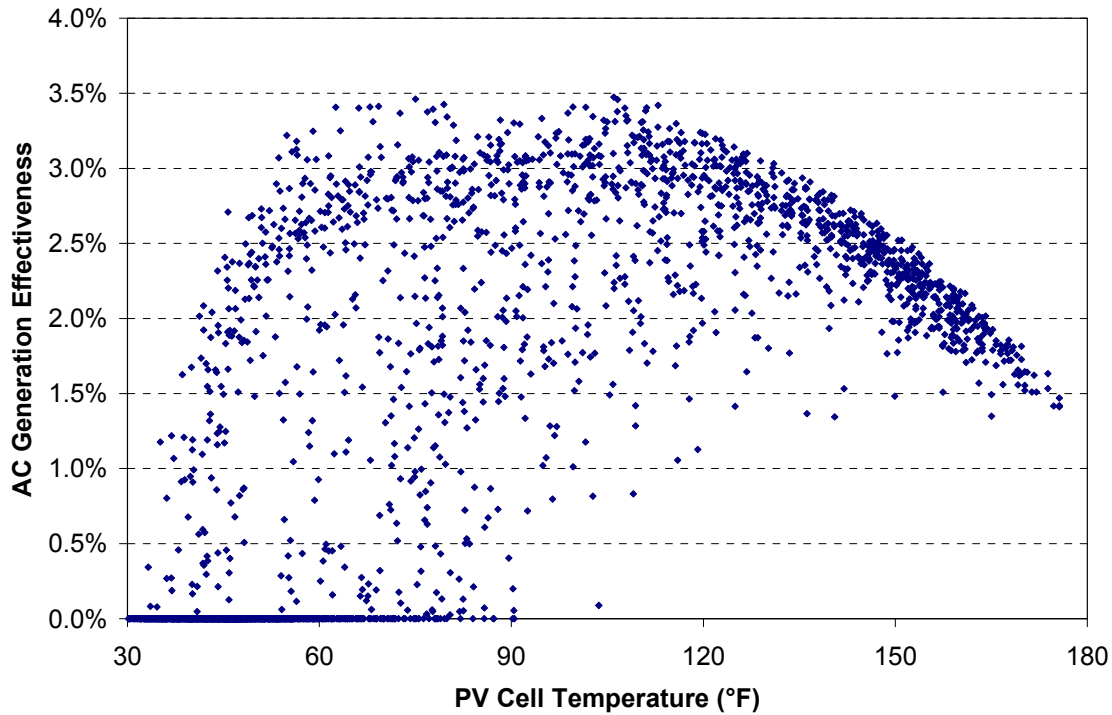

Figure 7-23 AC Generation Effectiveness and PV cell temperature for July 2002

7.3.3 Predicted Photovoltaic System Performance

We compared measured system performance to predicted performance to better understand the effects of the system failures. The predicted system performance was estimated by two methods. First, the energy production was estimated by projecting the measured energy production from the current configuration, assuming no system failures. The second method was based on annual hourly simulations of the current system configuration and the same system with grid-tied, maximum-power-point-tracking (MPPT) inverters. The annual hourly simulations were completed with PVSYST v3.2 (Mermoud 1996) with TMY2 weather for Eagle, Colorado, because the program requires global horizontal solar radiation and outdoor air temperature inputs, which were not measured on site. Eagle is 2,200 ft (671 m) lower in elevation and is further from the mountains than Silverthorne, so it has warmer temperatures and less snowfall. The simulations were calibrated by adjusting the heat loss from the PV panels to match the simulated cell temperatures with the measured cell temperatures. Despite the weather differences, the relative performance of the two systems should be the same for both locations. This similarity allows the results from the Eagle simulations to be translated to Silverthorne.

The measured and estimated PV system energy production for the two-year analysis period is shown in Figure 7-24. The estimated production values were generated by multiplying the measured monthly solar radiation in the plane of the PV system and monthly AC Generation Effectiveness values from the PVSYST simulations. The onsite measured solar radiation accounts for most of the snow cover effects because the pyranometer is located near the 64-W PV panels. When the 64-W panels are covered with snow, the pyranometer is also likely to be covered with snow. The annual average AC Generation Effectiveness values from the PVSYST simulation were 3.27% for the current system and 3.92% for the same panels and an MPPT inverter, which is a 20% annual improvement with the MPPT inverters over the use of fixed voltage inverters.

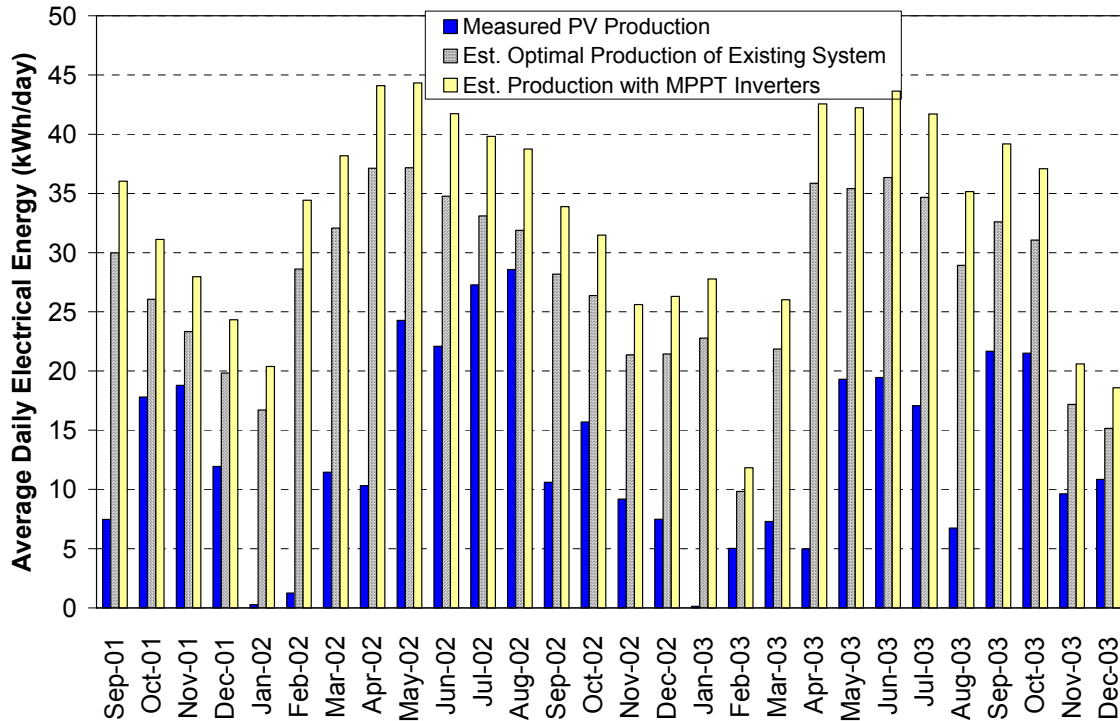

Figure 7-24 Estimated and measured PV system production

Annual energy production for the three scenarios in Figure 7-24 are listed in Table 7-7. If the current system had performed with no system failures, it would have produced 160% more energy than it actually did for September 2002 to August 2003. The poorer performance in the second monitoring year was due to more system faults, which resulted in having only one or two inverters operate for longer periods.

Table 7-7 Measured PV system Performance Compared to Estimated Performance

	Annual Energy MWh (GJ)		% Increase Over Measured	
	9/1/2001– 8/31/2002	9/1/2002– 8/31/2003	9/1/2001– 8/31/2002	9/1/2002– 8/31/2003
Measured Performance	5.6 (20)	3.8 (14)		
Estimated Optimal Performance of Current System	10.7 (38)	9.9 (35)	92%	163%
Estimated Performance with MPPT Inverters	12.8 (46)	11.9 (43)	130%	216%

8 Conclusions

The owners of the BigHorn Center worked with NREL to improve the design of their facility by using a whole-building approach that uses energy performance simulation to look at the way the building's site, walls, floors, electrical, and mechanical systems work together most efficiently. The operation of the building systems was verified to ensure that they were operating as designed; however, occupant behavior and operating conditions could not always be anticipated. Careful monitoring of operating performance led to fine-tuning system operations to improve the performance. Maintaining a high level of performance has required a consistent effort by the operating staff, who have been alerted to specific issues with the lighting and heating systems.

The estimated performance of the BigHorn Home Improvement Center from calibrated simulations is shown in Table 8-1. The detailed monitoring and analysis have shown that the BigHorn Center uses 36% less site energy, 54% less source energy, and has 53% lower energy costs than typical, minimally code-compliant retail buildings of similar size. The source energy savings are much better than the site energy savings because the energy efficiency features in the as-built building had a large impact on the electrical load and increased the gas consumption compared to the baseline building. The lighting design and the extensive use of daylighting reduced the lighting energy requirements by 80%, which contributes significantly to the reduced energy loads in the building. Approximately half the lighting energy savings can be attributed to lower lighting power densities and half to daylighting controls. Reducing the lighting and control of solar gains has lowered the internal gains enough to meet the cooling load with natural ventilation. The 8.9-kW PV system provides 2.5% of the electricity needed to operate the building. Improvements to the PV system and building operation should improve the performance to almost 8%.

Table 8-1 Cost, Site, and Source Energy Savings Summary

	Cost		Net Site Energy		Net Source Energy	
	$\$/\text{ft}^2\cdot\text{yr}$ $(\$/\text{m}^2\cdot\text{yr})$	Percent Savings	$\text{kBtu}/\text{ft}^2\cdot\text{yr}$ $(\text{MJ}/\text{m}^2\cdot\text{yr})$	Percent Savings	$\text{kBtu}/\text{ft}^2\cdot\text{yr}$ $(\text{MJ}/\text{m}^2\cdot\text{yr})$	Percent Savings
Baseline	\$1.08 (\$11.63)	53%	63 (720)	36%	156 (1,770)	54%
As-Built	\$0.51 (\$5.49)		40 (450)		72 (820)	

8.1 Lessons Learned

Involvement in this project has provided real-world examples of how advanced building technologies work together. Lessons learned have already been applied to other research projects and will continue to be valuable for future projects. The lessons learned can be divided into four categories: 1) design, construction, and commissioning; 2) technical; 3) building operation; and 4) energy monitoring and analysis.

Design, Construction, and Commissioning

1. Setting specific performance goals that the whole design team believes in is a critical first step toward producing a building that operates efficiently. The estimated energy cost saving compared to ASHRAE Standard 90.1-2001 is 53%. This very good performance was achieved through a concerted effort by the owner and entire design team.
2. Energy simulations played an important part in understanding the forces that drive energy performance and allowed many design alternatives to be investigated. Energy simulations had

the greatest impact on the daylighting design. Because of the energy simulations, windows were added that vastly improved daylighting in the building.

3. DOE-2 is limited in the flexibility of HVAC systems that can be modeled. DOE-2 cannot include cooling or natural ventilation in the same model with a radiant floor heating system.
4. It is difficult to compare the effectiveness of the radiant systems versus forced air systems in DOE-2. For the radiant heated floor, there is no physical model for the heat loss to the ground. The panel heat loss factor is a crude proxy for this important heat transfer path. There is no model for the gas-fired radiant heaters in the warehouse; therefore, the system was approximated with electric unit heaters. Finally, the systems cannot be controlled based on comfort conditions. The radiant and forced air systems create different comfort conditions that cannot be simulated, which makes it difficult to make direct comparisons between the models.
5. The electrical panels should be modular to group like loads. The electrical panels at BigHorn are not organized well, which makes it difficult to operate and maintain the building and difficult to monitor energy performance by end use.
6. There should be close communication between the energy engineer, mechanical engineer, and electrical engineer throughout the design and implementation of the building control systems. New systems are often difficult to get right the first time, and upfront communication can help identify potential problems. The lighting control circuits and the natural ventilation control circuits had to be rewired after construction to achieve the desired operation.
7. Building construction should be monitored for issues that could affect energy use. This includes ensuring the proper materials and equipment are used and that they are installed correctly. Designers should watch for unwanted thermal bridging.
8. Systems that affect occupant comfort should be monitored during construction. An uncomfortable environment can lead to higher energy consumption if the occupants change their working environment to maintain comfort. Examples include lighting quality and thermal comfort.
9. The daylighting design resulted in less light than anticipated. The operable windows had less glass area than assumed in the simulations, dark overhangs reduced the light reflected through the clerestories, and the impact of the window screens was not taken into account. In addition, the tall rows of merchandise create dark areas in the aisles. Additional lights were added in some areas to improve the lighting. Careful attention should be paid to design details in lighting simulations and these details cannot be captured in the simple daylighting models contained in whole building energy simulation models. Separate simulations should be run with detailed lighting design software.
10. The translucent roof panels in the warehouse provided excellent daylighting. As cooling loads were not of concern for this location and building type, this technology was effective for this application.
11. The quality of the lighting from the pendant CFL light fixtures is poor in the mezzanine, where they are relatively close to the working surface. Linear T-8 fluorescent fixtures would have been better for lighting quality, control, and maintenance.
12. Operable high windows should have been added to the private offices on the mezzanine. These windows would allow more light from the clerestory and allow ventilation air to circulate by natural convection.
13. The design of the hydronic systems (radiant floor and snowmelt) should be considered carefully for head loss and heat transfer issues. The snowmelt system was disabled because of a poor design, which resulted in low flows and ineffective snow melting capabilities.
14. Changes to the design during construction should be documented carefully, and responsibility for implementing the changes should be noted. This will provide clear records to avoid disagreements later in the construction process and for building operation and maintenance.
15. The roof and roof drains should be designed to avoid ice buildup, which can damage the roof and prevent proper drainage of the melting snow and ice. Poor roof design can lead to higher energy

use because electric roof ice melt is required. Control of roof ice-melt systems is difficult and is often left on continuously, which results in excessive energy use.

16. Commissioning should follow a formal process with complete documentation. The documentation will provide records for the culpability of the performance and will provide valuable information for the building operation and maintenance.
17. Commissioning can be completed by an independent commissioning agent or by the contractor and subcontractors. An independent agent provides an objective review of the building and systems and acts as an owner's representative, but this comes at an added cost. The contractor and subcontractors are very familiar with their work, but they usually do not follow a formal process and they may not provide an objective review of the work.
18. Passive barometric dampers are installed in the warehouse that are supposed to open when the ceiling exhaust fans turn on; however, they also open when the wind is blowing directly on the dampers allowing cold air to enter directly into the warehouse. These dampers are inexpensive, but they should not be used in this application.

Technical

19. Light sensor locations must be carefully planned to measure the intended light levels and avoid extraneous light sources. The exterior light sensor had a full view of the exterior lights, which caused the lights to cycle on and off until the sensor was shielded from these lights. The light sensor in the retail area received direct sunlight for a few hours on a few winter days, which caused the control system to turn off too many lights.
20. Lighting systems should be controlled by the EMS with easily accessible manual overrides to turn lights on after hours. The manual overrides should have timers or the EMS should sweep the systems to ensure that the lights do not stay on excessively. The current system at BigHorn has manual switches in series with the EMS controlled relays; therefore, both must be on for the lights to turn on. The lights can be manually turned off, but there is no way to manually turn the lights on if the EMS has them turned off except to override the control program. The human-computer interface and easily accessible manual overrides are critical for success.
21. Grid-tied PV systems and inverters should be carefully designed as an integrated system. Numerous problems with the original PV system design have limited its useful output.
22. An automatic monitoring system for PV system operation should be installed. There is no way to know whether a grid-tied PV system is operating correctly without manually checking the inverter output on its display terminal. Continual manual monitoring is not practical, and a simple automated system should be put in place that alerts the building operators when the system is down.
23. The transpired solar collector is not effective in this building. Transpired solar collectors can provide large amounts of preheated ventilation air. However, the warehouse always has at least one large overhead door open during business hours, there is no need to provide ventilation air. Most of the heat from the transpired solar collector is lost through the open door. Also, the low temperature and low velocity air is delivered near the ceiling, which does not affect the occupied part of the space.
24. Some PV panels showed signs of deteriorating after 3 years. The plastic laminate separated from the PV material in small areas spread over the PV panels. This problem occurred only on the 120-W panels in the area that has the most snow and ice coverage.

Building Operation

25. The CFL pendant fixtures are not the best options for this application. Strip fluorescent fixtures are more energy efficient, easier to control, and cheaper to maintain. The CFLs installed have a real operating life of approximately 4,000 hours—much less than the 10,000 hours advertised.
26. The timing of recharging the electric forklift can make a large difference in the operating cost. The forklift should be charged at night to avoid coinciding with the monthly peak demand. By

- charging the forklift at night, the annual energy cost would be approximately \$75. Under the current mode of recharging during the day, the annual energy cost is \$600–\$800.
27. Lights used during cleaning should be turned on only in the parts of the store the cleaners are working. The monthly peak electrical demand is often incurred during cleaning and after store operation hours. Approximately \$200 a year could be saved by turning on only half the retail and lighting display area lights during cleaning. Staging the cleaning by zone would effectively address this issue.
 28. The automated natural ventilation system works well most of the time. However, the system required extra effort in the beginning because the automated windows did not operate properly. In addition, control has been difficult under some circumstances. The natural ventilation window control should include outside temperature so the windows can be closed before the weather becomes too cold and produces cold drafts.
 29. If the outdoor temperature remains higher than 80°F (27°C) for extended periods, the natural ventilation does not provide adequate cooling. Predictive controls could allow the building to precool on days that are going to be hot. This strategy is usually effective, but it would not always work because it is difficult to cool and maintain temperature in such a large volume for long periods. Also, predicting the high temperature of the day is difficult.
 30. The PV system contributes very little to reducing building peak electrical demands. The largest variable electric loads in this building are the lights, which are needed most when the sun is down. The peak building electric load is typically in the late afternoon to early evening; the PV peak output is in the middle of the day. This means that the PV system output does not correspond well with the building load profile. Therefore, the payback for the PV system is poor because it offsets electricity energy charges of only \$0.02–\$0.03/kWh.
 31. The building energy performance benefited from post occupancy fine-tuning of the system operations. Achieving and maintaining high performance requires a constant effort, which is absent in most buildings. Continually tracking building performance can be expensive and requires motivated and trained staff.
 32. The ceiling fans in the retail area should operate at lower speed to avoid drafts in the mezzanine and thermostatically controlled for better control. During natural ventilation operation, the fans above the retail area should turn off or be reversible to aid the upward airflow. The fans over the mezzanine should remain blowing down at all times to help comfort.
 33. The CO sensors on the warehouse exhaust fans have been successful for demand-controlled ventilation. The exhaust fans were originally designed to run continuously during occupied periods, but they have operated only once with the CO sensor control.
 34. Computers are often left on overnight, which adds significantly to the building nighttime load. Leaving all of the computers and monitors in the building on, but in standby mode, is about 2 kW or about one third of the nighttime load in the summer.

Energy Monitoring and Analysis

35. The EMS should be investigated to ensure that it is suitable for data logging and reporting. The data logging capabilities of the BigHorn Center EMS were not compatible with the requirements of a rigorous, long-term monitoring project. The data formatting and collection options were difficult to work with and resulted in unreliable data collection. A separate data logger had to be installed.
36. Space temperatures should be measured and recorded on a system separate from the EMS for detailed energy monitoring projects.
37. Weather information is important for high-performance building projects that are often more weather dependent. Preferably, weather data should be measured on site, but a nearby reliable weather station with the required data can also be used.

38. The monitoring plan should be carefully laid out early, beginning with a list of specific questions. The most suitable performance metrics are then chosen, which leads to the data and analysis techniques required.
39. Creating energy cost goals during design, and verifying the costs are difficult because energy prices change. Natural gas prices varied by 40% during the 3-year monitoring period and electrical prices varied widely, mainly because of new pollution regulations and a partial shift from coal to natural gas for electricity production.

8.2 Recommendations

Several actions could further improve and maintain the energy performance of the building. Our top recommendations are presented here. Most of these issues have been discussed previously, but they are presented here with more specific information.

1. Charge the electric forklift during off-peak hours. The BigHorn Center pays \$0.02–\$0.03/kWh for electricity, which makes operating the electric forklift inexpensive if it does not incur demand charges. During the 2 years of monitoring, demand charges have increased the effective energy charge for the forklift to \$0.26–\$0.48/kWh. By charging the forklift at night, the annual energy costs for the forklift are expected to be less than \$100. This recommendation does not save energy, but reduces costs by shifting the energy consumption to off-peak periods.
2. Work with the cleaning crew to control the number of lights turned on during cleaning. Currently, most of the interior and exterior lights are turned on during cleaning, which often results in setting the peak monthly electrical demand. If only half the retail and half the lighting display are turned on at a time, this will probably save \$150–\$200 annually.
3. Continue to monitor the energy performance of the building each month. This should include comparing monthly total energy by end use to past and expected performance. Things to look for here are sudden changes in energy consumption and gradual upward trends in energy consumption. In addition, track the monthly peak electrical demand to control utility costs. This will require staff to be trained and graphs to be generated automatically from the monthly data.
4. Consider the energy demand and use implications of adding loads to the building. Over the monitoring period, there was a trend of adding lights and appliances to the building, all of which increase energy consumption and possibly peak demand.
5. Replace the PV system inverters with ones that are designed to be grid-tied to significantly improve system reliability and performance. New inverters will be difficult to justify economically if only the energy costs are considered. The building peak demand usually occurs in the afternoons and evenings, which is when the PV system has a very low to zero output. However, the current system requires continual staff effort to maintain system operation, which is a large cost that should be included in any analysis.
6. Install power control devices on the vending machines to reduce the energy consumption of the vending machines in the breakroom and the retail area. These products have been shown to save nearly 50% of the energy and typically have a payback period of two to three years.

References

- ASHRAE. (1989). *Energy Efficient Design of New Buildings Except Low-Rise Residential Buildings*. ANSI/ASHRAE/IESNA Standard 90.1-1989. Atlanta, GA: American Society of Heating, Refrigerating, and Air Conditioning Engineers.
- ASHRAE. (1999). *Ventilation for Acceptable Indoor Air Quality*. ASHRAE Standard 62-1999. Atlanta, GA: American Society of Heating, Refrigerating, and Air Conditioning Engineers.
- ASHRAE. (2001). *Energy Standard for Buildings Except Low-Rise Residential Buildings*. ANSI/ASHRAE/IESNA Standard 90.1-2001. Atlanta, GA: American Society of Heating, Refrigerating, and Air Conditioning Engineers.
- Atif, M. R., J. A. Love, and P. Littlefair. (1997). *Daylighting Monitoring Protocols and Procedures for Buildings*. A Report of IEA Task 21 / Annex 29 Daylight in Buildings. T21/D2.1/97-01. Ottawa, Ontario, Canada: Institute for Research in Construction.
- Deru, M. (2004). DataReader – computer program. Golden, CO: National Renewable Energy Laboratory.
- DOE. (2003). *2003 Buildings Energy Databook*. Washington, D.C.: U.S. Department of Energy. <http://buildingsdatabook.eren.doe.gov/>. Accessed July 2004.
- EIA. (2003). *Annual Energy Review 2002*. <http://www.eia.doe.gov/emeu/aer/contents.html>. Washington, D.C.: U.S. Department of Energy/Energy Information Administration. Accessed March 3, 2004.
- EIA. (2004). *Natural Gas Annual 2002*. http://www.eia.doe.gov/oil_gas/natural_gas/data_publications/natural_gas_annual/nga.html. Washington, D.C.: U.S. Department of Energy/Energy Information Administration. Accessed March 3, 2004.
- FERC. (1995). *Code of Federal Regulations 10CFR435 – Energy*. Washington, D.C.: Office of the Federal Register National Archives and Records Administration.
- Hayter, S. and P. Torcellini. (2000). “A Case Study of the Energy Design Process Used for a Retail Application.” Presented at the American Solar Energy Society Conference. June 2000. NREL/CP-550-28129. Golden, CO: National Renewable Energy Laboratory.
- IESNA. (2000). *The IESNA Lighting Handbook: Reference & Application*, ninth edition. New York: Illuminating Engineering Society of North America.
- LBL. (2003). Simulation Research Group. <http://simulationresearch.lbl.gov/>. Berkeley, CA: Lawrence Berkeley National Laboratory. Accessed December 29, 2003.
- Mermoud, A. (1996). *PVSYST Version 3.2. User's Manual*. <http://www.pvsyst.com/>. Geneva, Switzerland: University of Geneva, University Center for the Study of Energy Problems. Accessed December 2002.
- NREL. (2001). *Mastering Energy-10, A User Manual for Version 1.3*. Golden, CO: National Renewable Energy Laboratory.
- NREL. (2004a). *Typical Meteorological Year 2 data*. Renewable Resource Data Center <http://rredc.nrel.gov/>. Golden, CO: National Renewable Energy Laboratory. Accessed May 2004.
- NREL. (2004b). Weather from the South Park Mountain Data station. <http://www.nrel.gov/midc/spmd/>. Golden, CO: National Renewable Energy Laboratory. Accessed May 2004.
- NREL. (2004c). *Standard Definitions of Building Geometry for Energy Evaluation Purposes*. Publication expected July 2005. Golden, CO: National Renewable Energy Laboratory.

NREL. (2004d). *Procedure for Measuring and Reporting Commercial Building Energy Performance*. Publication expected July 2005. Golden, CO: National Renewable Energy Laboratory.

NREL. (2004e). *Procedure to Measure Indoor Lighting Energy Performance*. Publication expected July 2005. Golden, CO: National Renewable Energy Laboratory.

NREL. (2004f). *Procedure for Measuring and Reporting the Performance of Photovoltaic Systems in Buildings*. Publication expected July 2005. Golden, CO: National Renewable Energy Laboratory.

WRCC. (2003). <http://www.wrcc.dri.edu/summary/climsmco.html>. Reno, NV: Western Regional Climate Center. Accessed May 2004.

Appendix A Utility Rate Structure

The utility company for gas and electric service for the BigHorn Home Improvement Center is Xcel Energy. The gas rate structure is Commercial Gas Service Schedule CG, and the electric rate structure is Commercial and Industrial Secondary Service Schedule SG. The utility charges are summarized in the second column of Table A-1. Charges listed as single numbers in column two did not change from January 2001 through August 2003. Other charges varied monthly. The total energy charges (\$/therm and \$/kWh) are shown in Figures A-1 and A-2. The electricity energy charge adjustments vary monthly and the values in Figure A-2 are approximate. The charges used in all the design simulations are listed in the third column and exclude Franchise Fee and Sales Tax. The last column contains the utility charges used in the as-built simulations. The gas rate charge in the final column includes all three gas rate charges from the utility bill.

Table A-1 Utility Charges

Category	Actual Costs Throughout Monitoring	Costs Used in Design Simulations	Costs Used in As-Built Simulations
Natural Gas			
Distribution (\$/therm) (\$/MJ)	varies	\$0.3695 (\$0.0035)	\$0.59 (\$0.00559)
Natural Gas (\$/therm) (\$/MJ)	varies		
Interstate Pipe Line (\$/therm) (\$/MJ)	varies		
Metering and Billing	\$15.35 to \$17.29	\$11	\$15.35
Franchise Fee (% of subtotal)	3.0%		3.0%
Sales Tax (% of total)	7.65%		7.65%
Electricity			
Service & Facility Charge	\$15.30	\$15.30	\$15.30
Secondary Generation (SG) (\$/kWh)	\$0.01645	\$0.01645	\$0.01645
GRSA (% SG Charge)	-8% to 2%		-1.0%
Incentive Cost Adjustment (\$/kWh)	-\$0.00089 to \$0.00210		\$0.00210
Interim Adjustment Clause (\$/kWh)	\$0.0 to \$0.01015		\$0.01015
Air Quality Improvement (\$/kWh)	\$0.0 to \$0.00150		\$0.00150
Demand Charge (\$/kW)	\$12.55	\$12.55	\$12.55
Franchise Fee (% Total)	3.0%		3.0%
Sales Tax (% Total)	7.65%		7.65%

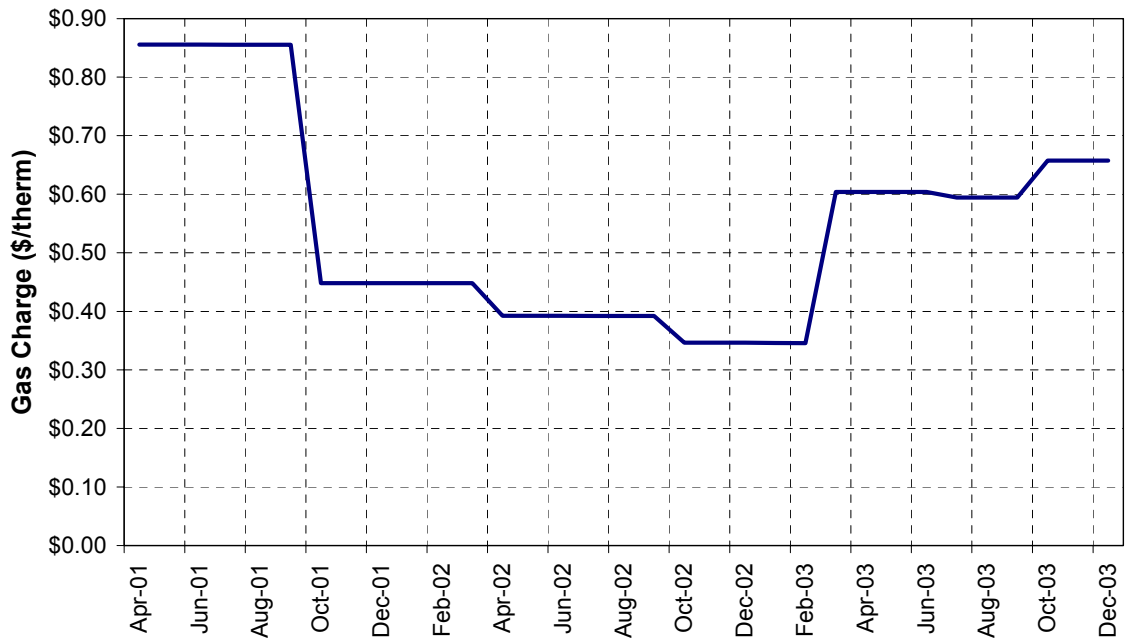

Figure A-1 Total utility natural gas charges for the BigHorn Center

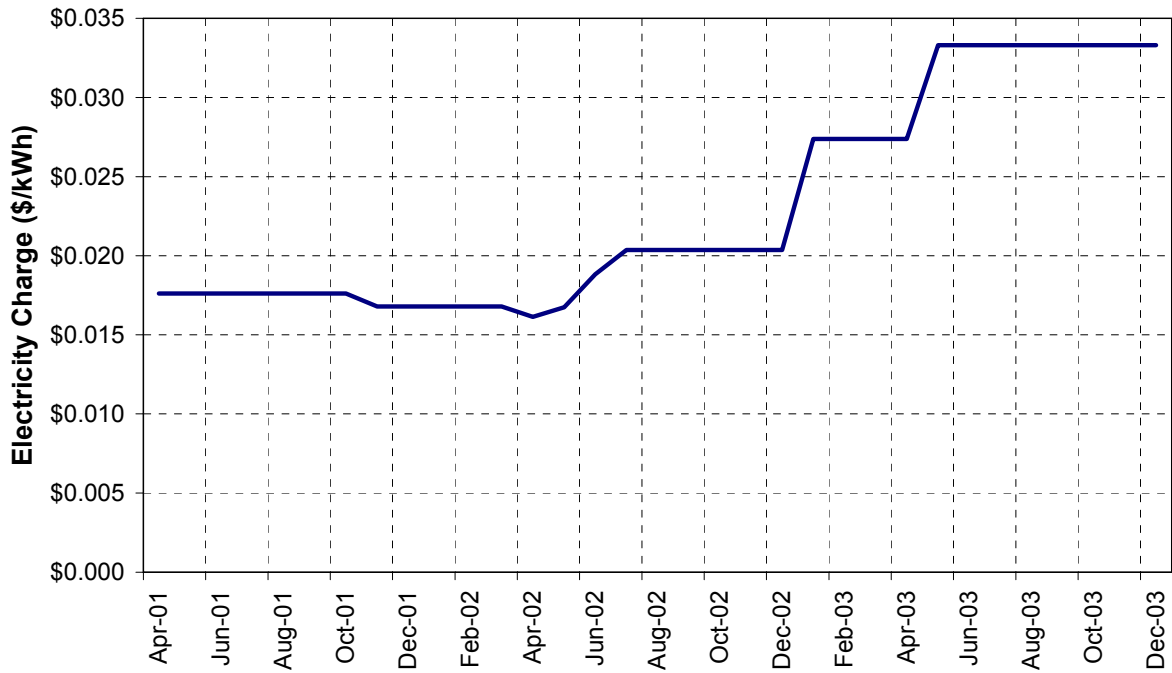

Figure A-2 Total utility electricity rate charges for the BigHorn Center

Appendix B Site to Source Energy Conversions

It is difficult to compare the consumption of different forms of energy at the building site. For example, heating with gas, electricity, or district heat cannot be compared, because electricity and district heat are nearly 100% efficient. However, this comparison does not account for the energy used to generate and deliver the electricity or district heat. A better comparison is to calculate the source (or primary) energy used to generate and deliver the energy to the site. But many of the important issues necessary to calculate source energy are often unknown at the local utility level, including energy source mix, generation efficiencies, and distribution and transmission efficiencies. A solution is to use primary energy based on total energy generation and consumption data for the United States. Using national average data is a good approach because the energy distribution network in the United States is highly interconnected. National energy data are compiled by the Energy Information Administration (EIA) and can be accessed through its Web site (<http://www.eia.doe.gov/>). The site-to-source conversion efficiencies for natural gas and electricity are shown in Table B-1.

The delivery efficiency of natural gas for 2002 was approximately 92.2%, or the source energy is 1.084 times the site energy consumption. This number represents the total natural gas delivered to the consumers divided by the total consumption of natural gas (shown in Figure B-1). The inefficiency in delivery represents natural gas consumed at the well, in processing plants, and in distribution. This does not account for other energy consumed in extracting, processing, and distributing products such as gasoline, diesel, and electricity. The magnitude of these other energy forms is not easily obtainable and would require a full life-cycle assessment of the natural gas extraction-to-delivery process. The information used here comes from Table 1 of the EIA *Natural Gas Annual 2002* (see Figure B-1) (EIA 2004).

The average generation and delivery efficiency of electricity for 2002 was approximately 31.57%, or source energy is 3.167 times site energy consumption. The national energy flow associated with the production of electricity is shown in Figure B-2. Electricity efficiency is calculated by dividing end use electricity by energy consumed to generate electricity and accounts for conversion, transmission, and distribution losses. It is based on the average of all sources of electricity generation and distribution in the nation, as reported by EIA in the *2002 Annual Energy Review* (EIA 2003). This does not account for precombustion energy—energy to extract, transport, and process fuels used to generate electricity.

Table B-1 Site to Source Energy Conversions

Energy	Source-to-Site Efficiency	Site-to-Source Conversion
Natural Gas	92.2%	1.084
Electricity	31.6%	3.167

Table 1. Summary Statistics for Natural Gas in the United States, 1998-2002

	1998	1999	2000	2001	2002
Number of Gas and Gas Condensate Wells Producing at End of Year	316,929	302,421	341,678	*373,304	360,626
Production (million cubic feet)					
Gross Withdrawals					
From Gas Wells.....	17,728,520	17,590,187	17,726,056	*18,129,408	17,727,880
From Oil Wells.....	6,379,808	6,232,524	6,447,820	*6,371,371	6,248,404
Total.....	24,108,328	23,822,711	24,173,875	*24,500,779	23,977,284
Repressuring.....	-3,427,045	-3,292,564	-3,379,661	*-3,379,832	-3,455,145
Vented and Flared.....	-103,019	-110,285	-91,232	*-95,913	-98,173
Wet After Lease Separation.....	20,578,064	20,419,863	20,792,983	*21,033,033	20,422,965
Nonhydrocarbon Gases Removed.....	-616,715	-615,014	-695,472	*-462,738	-502,176
Marketed Production.....	19,961,348	19,804,848	20,197,511	*20,579,295	19,929,789
Extraction Loss.....	-937,798	-972,614	-1,015,542	-953,984	-956,952
Total Dry Production.....	19,023,550	18,832,234	19,181,969	*19,616,311	18,963,797
Supply (million cubic feet)					
Dry Production.....	19,023,550	18,832,234	19,181,969	*19,616,311	18,963,797
Receipts at U.S. Borders					
Imports.....	3,152,058	3,585,505	3,781,603	3,976,939	4,015,463
Intransit Receipts.....	481,581	486,488	451,374	539,156	588,702
Withdrawals from Storage					
Underground Storage.....	2,377,344	2,771,535	3,496,205	2,308,667	3,137,666
LNG Storage.....	54,365	36,179	51,513	35,470	42,796
Supplemental Gas Supplies.....	102,169	98,249	90,235	86,312	67,980
Balancing Item.....	*634,809	*-108,642	*-240,343	*134,347	-36,942
Total Supply.....	*25,625,896	*25,698,952	*26,814,556	*26,697,222	26,776,463
Disposition (million cubic feet)					
Consumption.....	*22,245,956	*22,405,151	*23,333,121	*22,238,624	23,017,983
Deliveries at U.S. Borders					
Exports.....	159,007	163,415	243,716	373,276	516,233
Intransit Deliveries.....	459,461	494,544	516,586	574,871	530,464
Additions to Storage					
Underground Storage.....	2,903,595	2,597,509	2,684,285	*3,465,239	2,669,844
LNG Storage.....	57,867	36,333	36,869	45,210	41,939
Total Disposition.....	*25,625,896	*25,698,952	*26,814,556	*26,697,222	26,776,463
Consumption (million cubic feet)					
Lease Fuel.....	771,366	679,480	746,889	*747,411	731,991
Pipeline and Distribution Use.....	635,477	645,319	642,210	*624,964	667,027
Plant Fuel.....	401,314	399,509	404,059	371,141	382,503
Delivered to Consumers					
Residential.....	4,520,276	4,725,672	4,996,179	*4,771,340	4,869,732
Commercial.....	2,999,491	3,044,658	3,182,489	*3,022,712	3,103,277
Industrial.....	8,320,407	8,079,359	8,142,240	*7,344,219	7,556,607
Vehicle Fuel.....	*9,341	*11,622	*12,752	*14,536	14,950
Electric Power.....	4,568,264	4,819,531	5,206,324	*5,342,301	5,671,897
Total Delivered to Consumers.....	*20,437,768	*20,680,843	*21,538,964	*20,495,108	21,236,462
Total Consumption.....	*22,245,956	*22,405,151	*23,333,121	*22,238,624	23,017,983
Delivered for the Account of Others (million cubic feet)					
Residential.....	105,128	225,186	371,972	*361,903	421,513
Commercial.....	990,265	1,031,794	1,147,565	*1,026,557	1,101,876
Industrial.....	6,984,012	6,584,492	6,529,240	*6,813,726	6,854,657
Number of Consumers					
Residential.....	57,321,746	58,223,229	59,252,728	*60,286,363	61,140,021
Commercial.....	5,044,497	5,010,189	5,010,817	*4,986,446	5,059,734
Industrial.....	226,191	228,331	220,251	*217,026	210,006
Average Annual Consumption per Consumer (thousand cubic feet)					
Commercial.....	595	608	635	*605	613
Industrial.....	36,785	36,384	36,968	*33,840	35,880
Average Prices for Natural Gas (dollars per thousand cubic feet)					
Wellhead (Marketed Production).....	1.96	2.19	3.68	*4.00	2.95
Imports.....	1.97	2.24	3.95	4.43	3.14
Exports.....	2.45	2.61	4.10	4.19	3.41
Pipeline and Distribution Use.....	2.01	1.88	2.97	3.55	—
City Gate.....	3.07	3.10	4.62	5.72	4.15
Delivered to Consumers					
Residential.....	6.82	6.69	7.76	*9.63	7.91
Commercial.....	5.48	5.33	6.59	8.43	6.64
Industrial.....	3.14	3.12	4.45	*5.24	4.02
Vehicle Fuel.....	4.59	4.34	5.54	6.60	4.74
Electric Utilities.....	2.40	2.62	4.38	*4.61	3.77

— = Not applicable.
 * = Revised data.
 Notes: The United States includes the 50 states and the District of Columbia. Totals may not equal sum of components due to independent rounding.
 Sources: Energy Information Administration (EIA), Form EIA-176, "Annual Report of Natural and Supplemental Gas Supply and Disposition"; Form EIA-895, "Monthly Quantity and Value of Natural Gas Report"; Form EIA-857, "Monthly Report of Natural Gas Purchases and Deliveries to Consumers"; Form EIA-910, "Monthly Natural Gas Marketer Survey"; Form EIA-816, "Monthly Natural Gas Liquids Report"; Form EIA-61A, "Annual Report of the Origin of Natural Gas Liquids Production"; Form FERC-423, "Monthly Report of Cost and Quality of Fuels for Electric Plants"; Form EIA-191, "Underground Gas Storage Report"; Office of Fossil Energy, U.S. Department of Energy, "Natural Gas Imports and Exports"; the U.S. Minerals Management Service; EIA-905, "Power Plant Report"; EIA-866, "Annual Survey of Alternative Fueled Vehicle Suppliers and Users"; and EIA estimates.

Figure B-1 Gas use statistics 1998-2002 (EIA 2004)

Diagram 5. Electricity Flow, 2002
(Quadrillion Btu)

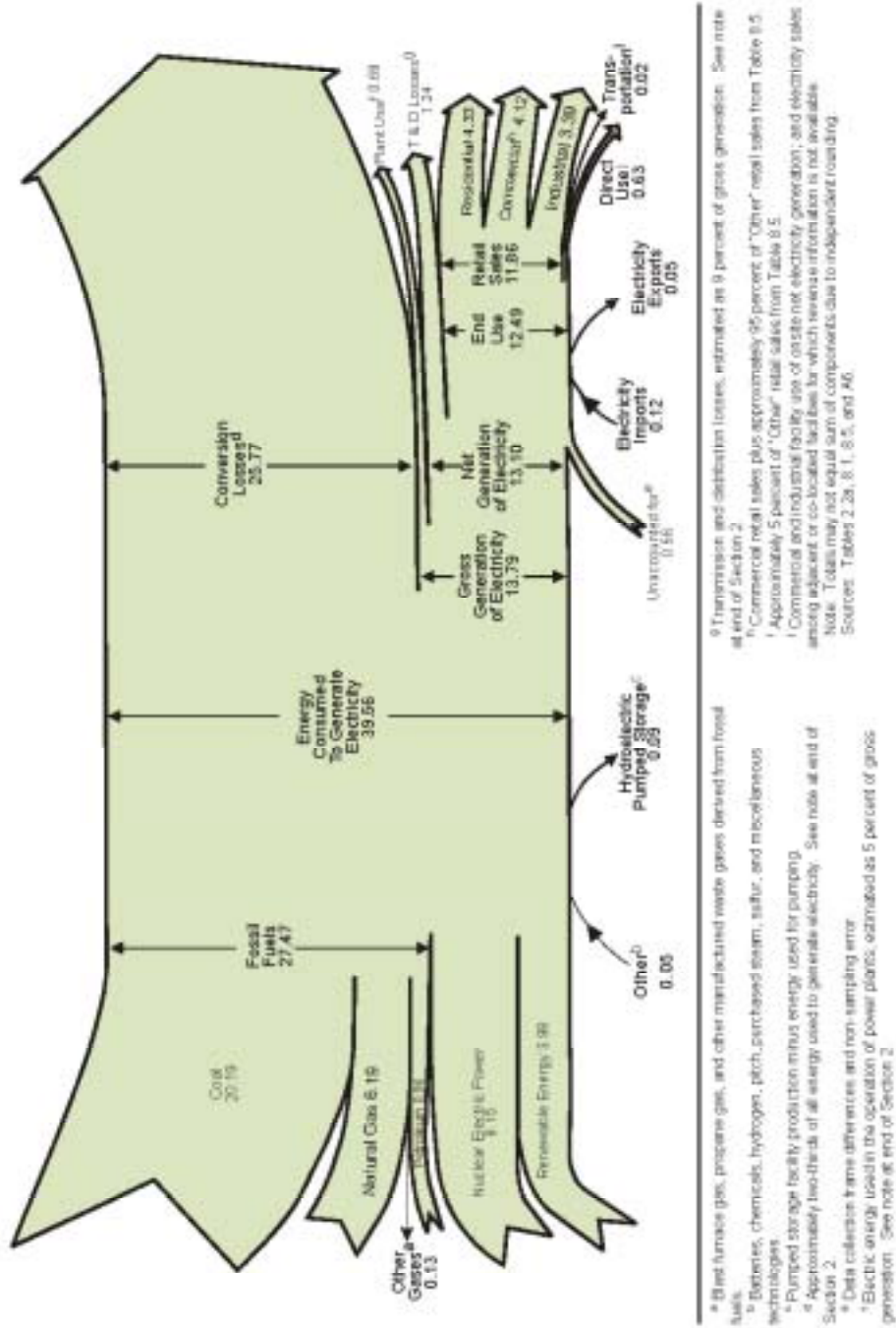

Figure B-2 Energy flow diagram for electricity generation for 2002 (EIA 2003)

Appendix C Weather File Creation

We created several weather files for use in the whole-building energy simulations and PV system simulations by altering the Typical Meteorological Year 2 (TMY2) file for Eagle, Colorado (NREL 2004a). Although Eagle is approximately 45 miles (72 km) away, at a lower elevation (6,500 ft or 1,981 m), and has slightly different weather patterns than Silverthorne because it is further from the mountains, it is the closest location with typical year data. The main difference between the two sites is dry bulb temperature, which is the main environmental driving factor for this building. Solar radiation has a lesser effect, and humidity and wind have very little effect on the thermal energy performance of this building.

The only weather data recorded on site were outdoor dry bulb temperatures. These data were collected through the energy management system, which was unreliable as a data collection device. The result was an incomplete data set that could not be used to create a weather file. Therefore, we used temperature data from other sources to adjust the Eagle TMY2 file. Daily temperature data were obtained from a nearby Western Regional Climate Center (WRCC) weather station in Dillon, Colorado (WRCC 2003), and monthly temperature data were obtained from the utility bills. The adjustments to the temperature were made using WeatherMaker, which is included with the Energy-10 energy simulation program (NREL 2001). WeatherMaker can adjust hourly dry-bulb and dew point temperatures based on monthly daily average minimum and maximum dry-bulb temperatures. We used temperature data from the Dillon WRCC weather station to create three files: a file based on the long-term (1971–2000) averages, a file for the period from September 1, 2001 to August 31, 2002, and a file for the period from September 1, 2002 to August 31, 2003. An additional file for September 1, 2002 to August 31, 2003 was created with monthly average temperature data from the utility bills. We created the monthly daily average minimum and maximum temperatures by matching the diurnal temperature swings of the WRCC data around the average temperatures from the utility bills. The monthly average temperatures from the utility bills differed slightly from the WRCC data, but the simulation results followed the gas use patterns of the building better than the simulations using the WRCC data.

We used the utility bill weather file for September 1, 2002 to August 31, 2003 to calibrate the As-Built Model. During the calibration process, we found heating load differences that could not be accounted for. The solar data were the likely source of the difference. A search for other sources of weather data revealed that NREL maintained a weather station in the mountains near Silverthorne. The South Park Mountain Data (SPMD) weather station is approximately 35 miles (56 km) away and at an elevation of 9,660 ft (2,944 m) (NREL 2004b). This station records 5 minute global horizontal solar radiation data, which we used to estimate direct normal and diffuse solar radiation to replace the typical values in the Eagle TMY2 file. DataReader (Deru 2004) was used to calculate solar radiation and perform other data manipulations. We used this modified weather file to further calibrate the As-Built Model and produced very close heating energy values.

Table C-1 Weather Files Created for Simulations

Designation	Base File	Temperature Data Modification	Solar Data Modification
A	Eagle, CO TMY2	WRCC 1971-2000 (average)	none
B	Eagle, CO TMY2	WRCC 09/2001 – 08/2002	none
C	Eagle, CO TMY2	WRCC 09/2002 – 08/2003	none
D	Eagle, CO TMY2	Utility Bills 09/2002 – 08/2003	none
E	Eagle, CO TMY2	Utility Bills 09/2002 – 08/2003	NREL SPMD 09/2002 – 08/2003

During the design and construction analysis of this building, we created five weather files based on the Eagle, Colorado, TMY2 file, but used only two of them for the final results. The first file represents weather conditions for the period of September 1, 2002 to August 31, 2003 and was used to calibrate the As-Built Model and the As-Built Baseline Model against measured energy consumption data. The dry bulb and dew point temperatures were modified with monthly average temperatures from the utility bills and monthly diurnal temperature ranges from the WRCC data. Global horizontal solar radiation data in this file were from the solar data measured at the SPMD weather station. We created the second weather file to represent long-term weather conditions at the site that were used to estimate the energy performance for an average year. In this file, only the temperature data were modified based on the long-term (1971–2000) average temperatures from the WRCC weather station in Dillon, Colorado.

REPORT DOCUMENTATION PAGE

Form Approved
OMB No. 0704-0188

The public reporting burden for this collection of information is estimated to average 1 hour per response, including the time for reviewing instructions, searching existing data sources, gathering and maintaining the data needed, and completing and reviewing the collection of information. Send comments regarding this burden estimate or any other aspect of this collection of information, including suggestions for reducing the burden, to Department of Defense, Executive Services and Communications Directorate (0704-0188). Respondents should be aware that notwithstanding any other provision of law, no person shall be subject to any penalty for failing to comply with a collection of information if it does not display a currently valid OMB control number.

PLEASE DO NOT RETURN YOUR FORM TO THE ABOVE ORGANIZATION.

1. REPORT DATE (DD-MM-YYYY) January 2005		2. REPORT TYPE Technical Report		3. DATES COVERED (From - To)	
4. TITLE AND SUBTITLE Energy Design and Performance Analysis of the BigHorn Home Improvement Center				5a. CONTRACT NUMBER DE-AC36-99-GO10337	
				5b. GRANT NUMBER	
				5c. PROGRAM ELEMENT NUMBER	
6. AUTHOR(S) M. Deru, P. Torcellini, and S. Pless				5d. PROJECT NUMBER NREL/TP-550-34930	
				5e. TASK NUMBER BEC3.1001	
				5f. WORK UNIT NUMBER	
7. PERFORMING ORGANIZATION NAME(S) AND ADDRESS(ES) National Renewable Energy Laboratory 1617 Cole Blvd. Golden, CO 80401-3393				8. PERFORMING ORGANIZATION REPORT NUMBER NREL/TP-550-34930	
9. SPONSORING/MONITORING AGENCY NAME(S) AND ADDRESS(ES)				10. SPONSOR/MONITOR'S ACRONYM(S) NREL	
				11. SPONSORING/MONITORING AGENCY REPORT NUMBER	
12. DISTRIBUTION AVAILABILITY STATEMENT National Technical Information Service U.S. Department of Commerce 5285 Port Royal Road Springfield, VA 22161					
13. SUPPLEMENTARY NOTES					
14. ABSTRACT (Maximum 200 Words) Final report of energy performance analysis and design process for the BigHorn Home Improvement Center in Silverthorne, Colorado					
15. SUBJECT TERMS DOE; High Performance Buildings; BigHorn; energy analysis; energy performance analysis; design analysis					
16. SECURITY CLASSIFICATION OF:			17. LIMITATION OF ABSTRACT UL	18. NUMBER OF PAGES	19a. NAME OF RESPONSIBLE PERSON
a. REPORT Unclassified	b. ABSTRACT Unclassified	c. THIS PAGE Unclassified			19b. TELEPHONE NUMBER (Include area code)