

Tropical Island Climates

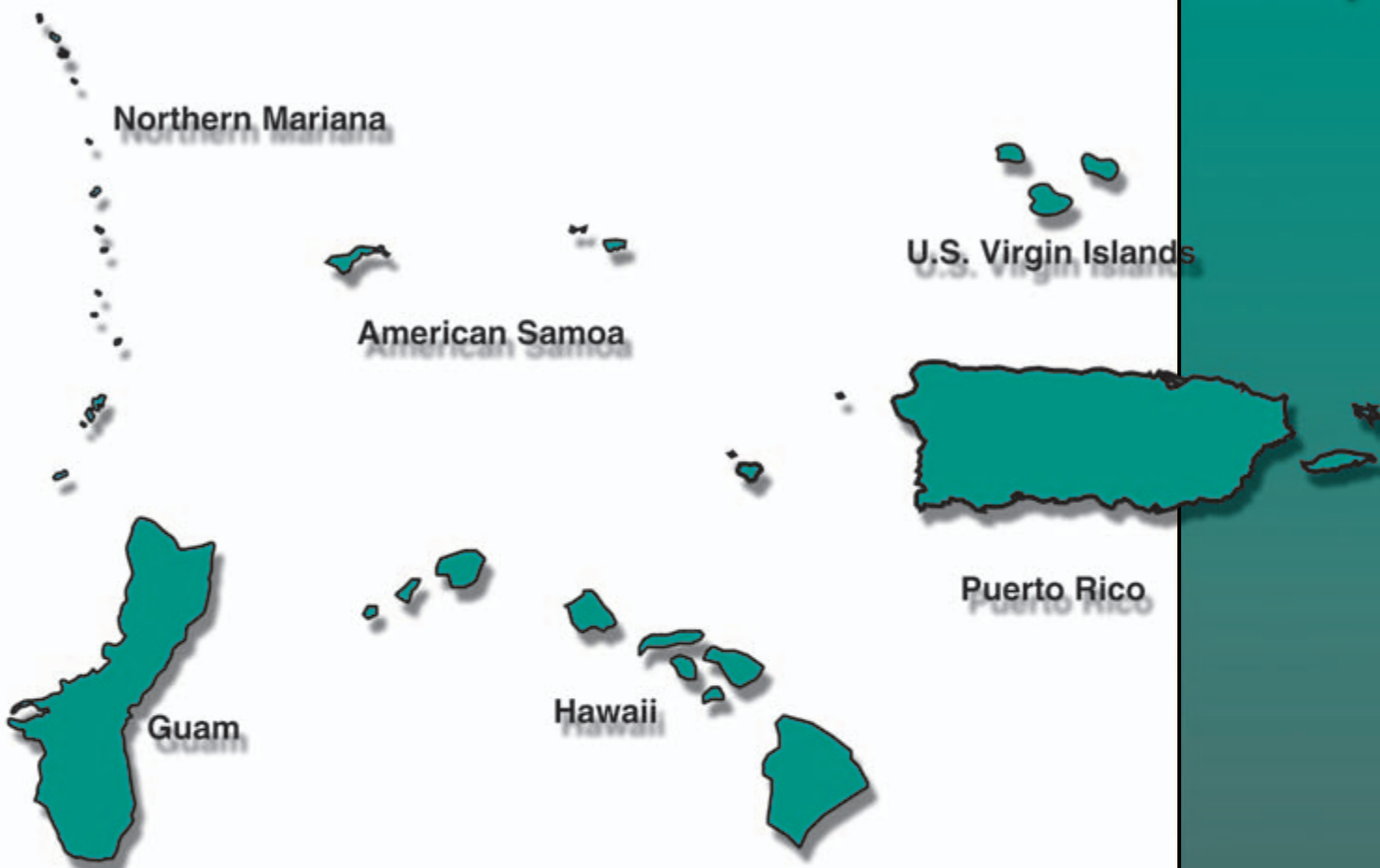

Energy Design Guidelines for High Performance Schools

Bringing you a prosperous future
where energy is clean, abundant,
reliable, and affordable



This document was developed by the National Renewable Energy Laboratory with subcontractors Architectural Energy Corporation and Innovative Design. Technical Assistance came from Padia Consulting, BuildingGreen, and the Sustainable Buildings Industry Council. Appreciation is also extended to the following groups for their assistance in developing this manual: Mitsunaga & Associates, Inc., and the energy offices of American Samoa and Guam.

This report was prepared as an account of work sponsored by an agency of the United States government. Neither the United States government nor any agency thereof, nor any of their employees or subcontractors makes any warranty, express or implied, or assumes any legal liability or responsibility for the accuracy, completeness, or usefulness of any information, apparatus, product, or process disclosed, or represents that its use would not infringe privately owned rights. Reference herein to any specific commercial product, process, or service by trade name, trademark, manufacturer, or otherwise does not necessarily constitute or imply its endorsement, recommendation, or favoring by the United States government or any agency thereof. The views and opinions of authors expressed herein do not necessarily state or reflect those of the United States government or any agency thereof.

Acknowledgements

The U.S. Department of Energy would like to acknowledge the help and assistance of the EnergySmart Schools team and the many reviewers who provided input and feedback during the process of developing this document as well as the other design guidelines in this series. Those include:

U.S. Department of Energy

Rebuild America National Program Manager, Daniel Sze and **EnergySmart Schools National Federal Coordinator**, Margo Appel. **Office of Building Technology**, David Hansen, George James, Arun Vohra; **Chicago Regional Office**: John Devine, Peter Dreyfuss; **Seattle Regional Office**: Richard Putnam; **Office of Policy and Management**: John Ruckes; **EnergySmart Schools Team**: Dennis Clough, Pat Courtney, Scott Igoe, Jennifer May, Larry Schoff, Blanche Sheinkopf; **Rebuild America Products and Services**: Greg Andrews, Ken Baker, Chip Larson, Bill Mixon, Sue Seifert; **U.S. Environmental Protection Agency**: Elisabeth Freed, Marti Otto, Melissa Payne; **Lawrence Berkeley National Laboratory**: Dariush Arasteh, Doug Avery, Rick Diamond; **National Renewable Energy Laboratory**: Kimberly Adams, Ren Anderson, John Brown, Victoria Healey, Molly Miller, Patricia Plympton, Susan Szczepanski, Roya Stanley, Kara Stevens; **Oak Ridge National Laboratory**: Sherry Livengood, Ron Shelton; **Pacific Northwest National Laboratory**: Michael Baechler, Kim Fowler, Eric Richman, David Winiarski

The following reviewed this Tropical Islands document: **Architectural Energy Corporation**: Charles Eley, Erik Kolderup, Kimberly Gott, Zelaikha Akram; **D & R International**: Bill Zwack; **Group 70 International**: George Att, Charles Kaneshiro; **Hawaii Department of Business, Economic Development & Tourism**: Maurice Kaya, Dean K. Masai, Howard C. Wiig; Ken Kajiwara, AIA; **Stringer Tusher Architects**: David Ayer; **U.S. Department of Energy**: Eileen Yoshinaka; **Velux America**: Stephen Moyon

The following reviewed the other documents in this series: **Advance Transformer Co.**: Gary Sanders; **AndersonMasonDale Architects**: Peggy Kinsey; **Ashley McGraw Architects, PC**: David Ashley; **Atelier/Jilk**: Bruce Jilk, AIA; **Austin Independent School District**: Dan Robertson; **Building America**: Mark Halverson; **Building Science Corporation**: Joseph Lstiburek, Betsy Pettit; **Cutler-Hammer**: David DePirro; **Donald Aitken Assoc.**: Donald Aitken; **Energy Design & Consulting**: Ed Mangan; **Environmental Support Solutions**: Dana Johnson; **Facility Improvement Corp.**: John Phillips, PE; **Hickory Consortium**: Mark Kelley; **Horst, Terrill & Karst Architects, P.A.**: Mark E. Franzen, AIA; **IBACOS Inc.**: Brad Oberg; **Innovative Design**: Mike Nicklas, Pascale Rosemain; **John Portman & Associates**: Jeff Floyd, AIA; **Kansas State University**: Bruce Snead; **Kinsey Shane and Assoc.**: William T. Traylor, AIA; **Lithonia Lighting Co.**: Richard Heinisch; **Margo Jones Architects**: Margo Jones; **Maryland Energy Administration**: Fred Hoover; **National Institute of Building Sciences**: Bill Brenner; **Noack Little Architects**: Chris Noack; **NORESCO**: John Rizzo, PE; **Northeast Energy Efficiency Partnerships Inc.**: Jim Rutherford; **Oregon Office of Energy**: Greg Churchill; **Poudre School District**: Mike Spearnak; **Power Correction Systems**: Brahm Segal; **SAFE-BIDCO**: Mary Jo Dutra; **Sarnafil Inc.**: Peter D'Antonio; **Sherber Assoc. Inc.**: Michael S. Sherber; **SHW Group**: Gary Keep; **Stanley Architects**: Lars Stanley; **TechBrite**: Michael Boyd; **Texas State Energy Office**: Robin Bailey; **TRACO**: Tony Bartorillo, Scott Roy; **University of Wisconsin-Madison**: Jeffrey Lackney; **U.S. Department of Education**: Jack Lyons, Sylvia Wright; **WaterLess Co. LLC**: Klaus Reichardt; **WattStopper**: Dorene Maniccia; **Weller and Michal Architects Inc.**: Charles J. Michal, AIA

In addition to the reviewers, many participated in the roundtable discussions leading to the publication of this document:

Association of School Business Officials, International: Don Tharpe; **Burr Lawrence Rising + Bates Architects**: Tom Bates; **California Energy Commission**: Darryl Mills; **Charles Michal AIA PE LC**: Charles Michal; **CMD Group**: Michelle Hesler; **Council on Educational Facility Planners International**: Elisa Warner; **Dry Creek Elementary Schools**: Kelvin Lee; **Energy Center of Wisconsin**: Abby Vogen; **Estes McClure & Assoc. Inc.**: James McClure; **Florida Solar Energy Center**: Danny Parker; **Hanson Design Group LTD**: Henry Hanson; **Heschong Mahone Group**: Lisa Heschong; **HL Turner Group Inc.**: Harold Turner; **Loudon County Public Schools**: Evan Mohler; **Manheim Township School District**: David Arnstrad; **National Association of State Energy Officials**: David Terry; **New York State Energy Research and Development Authority**: Don LaVada; **Padia Consulting Inc**: Harshad Padia; **Portland Public Schools Environmental Services**: Patrick Wolfe; **Public School Construction Program**: Yale Stenzler; **Simon and Assoc.**: Lynn Simon; **Southern California Edison**: Gregg Ander; **Sustainable Buildings Industry Council**: Deane Evans, Ellen Larson; **U.S. Department of Energy**: Mark Bailey; **U.S. Department of Education**: Tom Corwin; **U.S. Environmental Protection Agency**: Bob Thompson; **Washington State University Energy Program**: Michael McSorley

This document was produced by the U.S. Department of Energy's Energy Efficiency and Renewable Energy under the direction of the Office of Weatherization and Intergovernmental Program.

Available electronically at www.osti.gov/bridge

Creating High Performance Schools

School districts around the country are finding that smart energy choices can help them save money and provide healthier, more effective learning environments. By incorporating energy improvements into their construction or renovation plans, schools can significantly reduce energy consumption and costs. These savings can then be redirected to educational needs such as additional teachers, instructional materials, or new computers.

The U.S. Department of Energy's (DOE) EnergySmart Schools Program provides school boards, administrators, and design staff with guidance to help them make informed decisions about energy and environmental issues important to school systems and communities. These design guidelines outline high performance principles for the new or retrofit design of your K-12 school. By incorporating these principles, you can create an exemplary building that is both energy- and resource-efficient—a school that is a teaching tool.

The Importance of Connecting Energy and Environmental Issues

Throughout the tropical island climates, energy demands are on the rise. Energy costs—already higher in these climates due to geographic limitations and transportation issues than in other parts of the U.S.—continue to increase as demand outpaces supply. While building decisions on the islands in this climate have always been influenced by energy and water availability, these factors will only become more critical as development and population growth continues. There is growing concern about the environmental and societal implications of energy. Today, energy costs over the life of a school will far exceed the initial cost of the building. As prices continue to rise, comprehensively addressing this issue will become even more critical.

This guide was developed to promote long-term thinking and to build our schools in ways that reflect values that support our planet. Our schools can make a strong statement that saving energy and resources protects our environment, and benefits students. The message we give to future generations should be embodied in the buildings we use to teach them.



Photo: Architectural Energy Corporation

Shading strategies, such as these building overhangs, are vital for schools in this climate to reduce cooling costs.

"Good teachers never teach anything. What they do is create conditions under which learning takes place."

— S.I. Hayakawa

By implementing the high performance practices included within these guidelines, you will be taking a significant step forward in creating the physical conditions in which the learning process can thrive.

For more information, visit the EnergySmart Schools Web site:

www.energysmartschools.gov



The LEED (Leadership in Energy and Environmental Design) Green Building Rating System™ is a voluntary, consensus-based national standard for developing high-performance, sustainable buildings.



Help Your School Meet National Energy Criteria: ENERGY STAR®, LEED, ASHRAE

Many national and regional programs exist that provide standards and criteria for building high performance schools. The information in this document is intended to work collaboratively with these programs to achieve a common goal: high performance schools.

One prominent national program is ENERGY STAR. The ENERGY STAR label on a school building wall tells an important story. The label not only identifies a school building whose energy performance is in the nation's top 25%—but it also lets taxpayers know you're using money wisely, spending the resources on education instead of high energy bills. The label tells students that their school cares about the environment, that you're doing your part to reduce energy-related pollution. And it indicates that your school has the great lighting, comfortable temperatures, and high-quality air that go hand in hand with smart energy use.

ENERGY STAR, a registered trademark of DOE and the U.S. Environmental Protection Agency (EPA), is the mark of excellence in energy performance. It is a trusted national brand that symbolizes superior energy performance in more than 30 categories of consumer electronics and appliances, as well as office buildings, schools, supermarkets, hospitals, and homes. The ENERGY STAR benchmarking tool is a powerful way to manage building energy performance and to earn recognition for excellence in building energy performance. The rating system measures the energy performance of each building on a scale of 1 to 100 and shows how a building compares with other buildings in your portfolio or nationwide. The rating system provides useful baseline information to help organizations set energy performance targets and plan energy efficiency improvements. Buildings whose energy performance places them in the top 25% among similar buildings nationwide, and that meet industry standards for indoor environment, are eligible to apply for the ENERGY STAR label, a large bronze plaque that can be displayed on the building.

Determining whether your buildings qualify for this label is easy. You need data about your school's energy use over the past 12 months, the square footage of your buildings, and the number of students enrolled. You can then establish an account for your school district and enter your energy data into the ENERGY STAR computer analysis tool available on the Internet. Each school building that scores 75 or higher, while maintaining indoor air quality that meets industry standards, can apply for the ENERGY STAR label.

By incorporating the energy design guidelines detailed in this document into your school's construction or renovation plans, you can take the first essential steps toward earning the ENERGY STAR label for your school.

The U.S. Green Building Council's Leadership in Energy and Environmental Design (LEED) program is a voluntary, consensus-based national standard for developing high-performance, sustainable buildings. The LEED criteria address strategies for site development, water conservation, energy efficiency, materials selection and indoor environmental quality. To earn LEED certification, the building must satisfy all of the prerequisites and a minimum number of points to attain a LEED rating level – silver, gold, or platinum.

The American Society of Heating, Refrigerating and Air-Conditioning Engineers (ASHRAE) publish mechanical systems standards for the industry. These guidelines also serve as the foundation for many state and local energy codes. In addition to the standards, ASHRAE also produces the ASHRAE GreenGuide, a manual that provides information to design teams on incorporating sustainable and efficient mechanical and ventilation strategies into buildings.

An Introduction to the Energy Design Guidelines

This document presents recommended design elements in 10 sections, each representing a key interrelated component of high performance school design. To effectively integrate energy-saving strategies, these options must be evaluated together from a whole building perspective early in the design process. A “high performance checklist” for designers is located at the end of the document. The checklist is a quick reference for key architectural and engineering considerations. Case studies can also be found at the end of the document, as well as Web sites with additional information.

Site Design	5
Daylighting and Windows	11
Energy-Efficient Building Shell	19
Lighting and Electrical Systems	25
Mechanical and Ventilation Systems	31
Renewable Energy Systems	39
Water Conservation	47
Recycling Systems and Waste Management	51
Transportation	55
Resource-Efficient Building Products	59
Checklist of Key Design Issues	63
Case Studies	77
Web Resources	82

Climate Zones for Energy Design Guidelines

These guidelines contain general recommendations for tropical island climates, which includes Hawaii, Guam, American Samoa, Puerto Rico, the Northern Mariana Islands, and the U.S. Virgin Islands. Although there are many similar design challenges on these islands, island-specific strategies are noted where applicable.

Guidelines have been developed for the other climate zones, shown on the map below. A companion document, “National Best Practices Manual for Building High Performance Schools” contains detailed design information for the seven climate zones on the mainland and much of the information is applicable for tropical island climates.

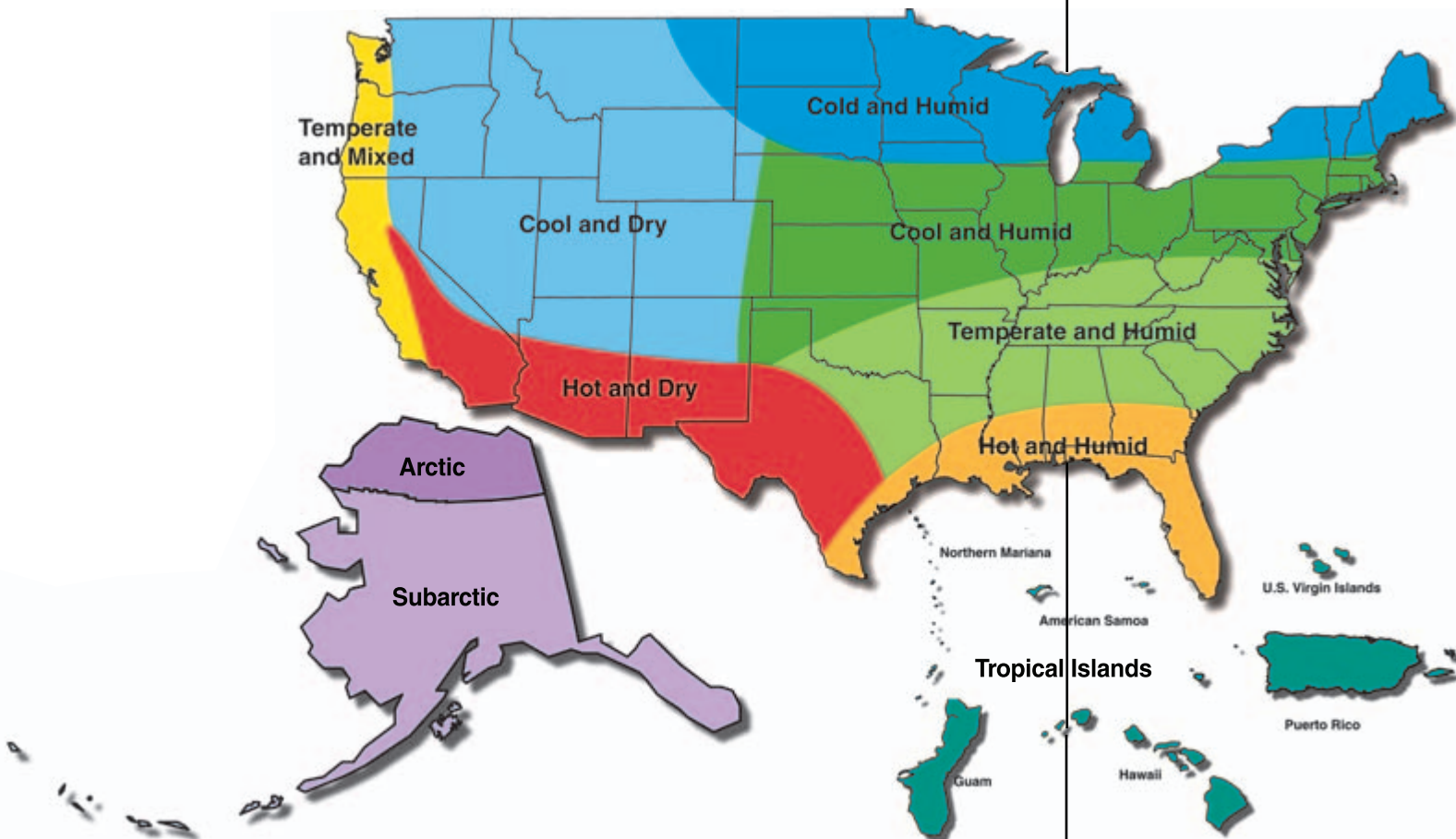



Photo: Clarence Lee

Energy efficiency measures at Iolani School's new classroom complex in Honolulu saves 28% annually on energy costs.



A 1999 study conducted by the Hescong Mahone Group shows that students with the best daylighting in their classrooms progressed 20% faster on math tests and 26% faster on reading tests in one year than those with the worst daylighting.

Establishing High Performance Goals

Cost-effective energy- and resource-efficient schools start with good planning, especially in the tropical island climates, where school construction costs are significantly higher than on the mainland. Working closely with the school's design and planning staff, the architects and engineers should develop objectives that reflect local conditions and priorities, balance short-term needs and long-term savings, and address environmental issues.

Goals can include:

- Reduce operating costs
- Design buildings that teach
- Improve academic performance
- Protect the environment
- Design for health, safety, and comfort
- Support community values
- Consider emerging solutions.

Reduce Operating Costs

To ensure that your school is water- and energy-efficient, you must first work with the school system to establish clear consumption goals. Given your climactic region and building type, this "energy budget" must be realistic, and you must base it on the potential of current, proven energy-saving technologies.

Design Buildings That Teach

When designing the school, consider high performance features that can be used for educational purposes. Some may be harder to rationalize financially, but from an educational standpoint are still important. Solar electric systems (photovoltaics), for example, may have a longer return on investment but, if installed properly, can be very powerful educational tools, teaching students about the science behind solar energy.

Improve Academic Performance

During the past decade, remarkable studies have indicated a correlation between school design and student performance. You can maximize student performance by setting air quality objectives that:

- Define a level of indoor air quality desired during occupied times
- Limit the use of materials, products, or systems that create indoor air quality problems
- Require monitoring equipment.

Establishing daylighting objectives will also improve classroom conditions and can help improve performance if you:

- Include controlled daylighting in all classrooms, administrative areas, the gymnasium, cafeterias, libraries, and other significantly occupied spaces
- Develop intentional visual connections between the indoor and outdoor environments.

Protect Our Environment

High performance school design considers the economic, academic, and environmental impacts of design. Environmentally sound design elements:

- Use renewable energy systems and energy-efficient technologies
- Incorporate resource-efficient building products and systems
- Promote water-conserving strategies
- Use less polluting transportation alternatives
- Establish recycling systems
- Incorporate environmentally sound site design
- Use an effective construction and demolition waste management plan.

Design for Health, Safety, and Comfort

You cannot design a high performance school without including design strategies that address health, safety, and comfort issues. Goals should include:

- Implement daylighting and indoor air quality solutions to make the school a healthier place to teach and learn
- Address acoustical and thermal comfort.

Support Community Values

Incorporating high performance strategies in your school's design results in a win-win situation for the community and the school. Implementing energy-saving strategies saves money. Additionally, the energy dollars saved stay in the community and help build a stronger local economy.

Building to high performance standards implies the purchase of locally manufactured products and the use of local services albeit a challenge for tropical island climates. Where feasible, this approach is effective because much of the environmental impact associated with materials, products, and equipment purchased for construction involves transportation. The more transportation, the more pollution. The approach, however, poses interesting challenges for the tropical island climates, where most materials will need to be imported. Combined with the additional transportation costs, selecting building materials becomes a fine balance between cost and efficiency.



Integrating daylighting into classrooms can improve the health and comfort of students and staff, while also reducing electricity consumption.

To help offset the higher cost, specify local products whenever possible. This benefits the community by strengthening the local economy. Implementing energy-efficient, environmentally sound practices also has a direct impact on the local air and water quality. By establishing goals to positively address these issues, you are taking the first step toward creating a better community.

Consider Emerging Solutions

The recommendations in this document reflect proven technologies that have been successfully incorporated into school applications in this climate zone and other climate zones in the U.S. However, every year, new solutions are developed that can make your facilities more energy-efficient and environmentally sound. As these new systems, materials, and products become commercially available, designers should exercise care in selecting those that are viable, but should not be discouraged from implementing technologies just because they are not commonplace.

Because of their dynamic nature, these emerging solutions will be addressed and updated on the EnergySmart Schools Web site, which provides cost information and examples of projects where the solutions are already in use.

“Whole Building” Energy Analysis

Determining the relative merits of one energy strategy versus another can only be accurately determined by analyzing the specific measure in the context of the “whole building.” Each component or system is continually affected by climatic conditions and occupancy demands. Each component has an effect on another.

When evaluating energy options, the design team must use computer energy analysis programs that can simulate the impact the specific measure has on the overall energy consumption and peak load. The program must provide hourly, daily, monthly, and yearly energy profiles and accurately account for the benefits associated with daylighting. DOE has two programs to assist with this analysis: DOE-2 and Energy Plus. More information can be found on these programs in the Web resources section on page 82.

And of course, commissioning is important for ensuring that the school’s energy saving strategies actually perform as designed. A commissioning plan should be included as part of the school design and construction process.



Photo: Architectural Energy Corporation

Many innovations are being made in landscaping design and maintenance that can make schools' athletic fields more environmentally sound and water efficient.

“We will insist on protecting and enhancing the environment, showing consideration for air and natural lands and watersheds of our country.”

National Energy Policy, 2001

Site Design

By orienting your school building effectively, you can maximize solar access and boost the effectiveness of daylighting strategies to reduce the need for electrical lighting and cooling loads. Designing the site to reduce or eliminate vehicular travel to the school helps to reduce fuel use and emissions, which improve the air quality in and around the school. And water requirements can be reduced by incorporating vegetation native to the local ecosystem in the site design.

Decisions made early in the design have a significant impact on many other aspects of the design. Orienting the building linearly on an east-west axis is one important example. By maximizing north-facing and well-controlled, south-facing glass (Samoa excepted) and minimizing east- and west-facing glass, energy performance is greatly enhanced, comfort and learning conditions are improved, and initial costs associated with cooling are reduced.

The educational potential of high performance design can also be greatly emphasized by integrating effective indoor-outdoor relationships between the building, the site, and the design of outdoor spaces as educational resources and venues.

When considering the location for a school, you must consider initial cost and evaluate environmental implications, how health and safety are influenced, and how well the school design is integrated into the fabric of the community.



Photo: Roy Beaty

Retaining ecosystems and wildlife habitat surrounding schools and incorporating them into outdoor learning activities enhances student interest in the environment.



Photo: Clarence Lee

The courtyard at Iolani School in Honolulu, Hawaii is often used as an educational venue. Teachers can use outdoor areas as teaching space or for larger student programs and assemblies.



Many of the practices outlined in these guidelines are applicable to LEED standards.

Guidelines for Site Design

Selecting a Site

Since the construction costs are much higher on tropical islands, give the highest priority to selecting locations that enable the school to be built cost effectively and resource efficiently.

- **Cost**
 - Consider rehabilitating an established site before choosing an undeveloped site. This also helps preserve undisturbed spaces.
 - Select a site that can maximize solar access for daylighting and other solar systems and minimize east and west glass.
 - Consider the availability and cost of utilities.
 - Consider wind and solar resources and the potential for implementing renewable energy systems.
 - Analyze mass transit, bicycle routes, and other pedestrian options.
- **Environment**
 - Avoid sensitive ecosystems such as wildlife habitats and greenfields.
 - Consider geological, micro-ecological, and micro-climatic conditions.
 - Evaluate the potential implications of erosion control and rainwater management.
 - Determine the presence of historic landmarks or archeological features on the site.
 - Conduct an assessment of the impact the school will have on the local environment.
 - Consider the ability to protect and retain landscaping.
- **Health/Safety**
 - Determine the current and projected air, soil, and water quality.
 - Evaluate the physical relationships to industries or utilities that may pollute the air.
 - Evaluate typical noise levels.
- **Community**
 - Work with community leaders to determine multiuse needs for the school buildings, since schools often serve as the center of the community for smaller towns.
 - Determine how the site will connect to the surrounding community through bike and pedestrian paths.
 - Evaluate the potential for recycling programs in the area.
 - Consider sites where local developers are interested in working together to integrate the school into the overall community design.



Photo: Architectural Energy Corporation
In tropical island climates, water needs for irrigation can be minimized by protecting the existing natural vegetation and using native planting.



Protecting Local Ecosystems

Protecting local ecosystems is critical to an environmentally sensitive site design.

- Integrate the school into the surrounding landscape. For instance, if the site has trees, consider designs that will minimize tree removal. Not only will this preserve the natural landscape, but mature trees will help with shading.
- Develop a landscaping design that uses native plants.
- Protect and restore ecosystems and wildlife habitats.
- Develop nature trails through preserved wildlife habitats and ecosystems.
- Use explanatory signage for plants and trees.
- Develop a construction/demolition waste management plan.
- Consult with local universities and master gardeners about the surrounding ecosystems, how to protect them, and strategies for maximizing their educational value.

Water-Conserving Strategies

Implementating these ideas will help reduce school water use and conserve water in the community.

- Use native planting materials and xeriscape principles to minimize site irrigation. With xeriscaping, some island locations require no irrigation systems.
- Explore the feasibility of rainwater catchment systems for irrigation and toilet flushing. Rainwater catchment is feasible in many locations in this climate, and has been the traditional water supply for many remote areas in Hawaii and the Caribbean. An alternative strategy is to divert rain falling on roofs onto the landscaping. Use permeable asphalt and concrete whenever possible.
- Consider employing graywater from sinks and water fountains for site irrigation. Be sure to check local regulations.
- Use soaker hoses and drip irrigation techniques that minimize evaporative losses and concentrate water on plants' roots.
- Use timers on irrigation systems to water at night.

Photo: Warren Gretz, NREL/PIX00311

Employing native xeriscape principles minimizes the need for irrigation.

Photo: Mitsunaga & Associates

Situating the school buildings along an east-west axis greatly enhanced the daylighting effectiveness at Chiefess Kamakaha Middle School on Kauai.



Erosion Control and Off-Site Impacts

Developing on-site erosion control and stormwater management strategies will help minimized off-site impacts.

- Employ site contours and natural drainage strategies.
- Divert rainwater to landscaping.
- Use porous paving materials that allow rainwater to drain into the soil.
- Determine the key pollutants that affect your aquifers, and develop strategies to reduce their effects.

Building Orientation

Orient the building optimally for solar potential and the prevailing winds.

- Analyze seasonal variations in wind speed and variation. High winds and other severe weather patterns may make a site unsuitable for a school, especially in areas prone to hurricanes or typhoons.
- Establish the school buildings on an east-west axis to maximize north-south daylighting and shading opportunities.
- Develop a floor plan that minimizes east- and west-facing glass to reduce impact on cooling needs.
- Single-story designs will optimize daylighting potential. The trade-off is that a larger building footprint increases site impact and consumes scarce buildable land.
- In multi-story schools, minimize room depth to maximize daylighting.
- Take into account the differences in daytime wind patterns on the windward and leeward sides of the island and the impact of cool air flowing down mountain slopes at night on larger islands.

Renewable Energy

When evaluating site design issues, investigate renewable energy systems early in the process. You need to evaluate the specific climate conditions to determine feasibility.

- Consider building-integrated photovoltaic (PV) systems for electricity production.

- Ensure that solar (PV) systems are not shaded and are positioned to be visible to the students, teachers, and parents.
- Consider non-grid-connected photovoltaic systems for:
 - crossing and caution lights
 - lighting at walkways and parking areas
 - telephone call boxes for emergencies.
- Consider installing building-integrated solar thermal systems for domestic hot water and absorption cooling.
- Evaluate the potential for using wind energy systems to generate electricity.
- Consider geothermal heat pumps.

Maximize the Potential of the Site

Understanding and using the ground conditions at the site will determine, to a great degree, the economic and environmental success of the design.

- Shading is important throughout the year in the tropical island climates. Consider the shading potential of landscaping and other site features. Shading east and west facing walls is particularly important for decreasing thermal load.
- Consider incorporating covered exterior spaces for study and social activities, which can occur year round in tropical climates.
- Establish floor grades that least affect site grading.
- Stockpile rock from site development for later use as ground cover.



Photo: Clarence Lee

These bleachers at Iolani School in Honolulu are partially covered for year-round activity.



Safe walkways connect the school to the surrounding neighborhoods and help reduce air pollution from cars and buses, avoid traffic congestion, and decrease the cost of operating buses.



Photo: Senior Airman Lesley Waters

Andersen Elementary School, Guam. Consider community multi-use opportunities when making a site selection. Many communities in the tropical island climate zones use school facilities for meetings, parties, and other gatherings.

- Consider alternate design solutions for parking lots, roads and walkways. Paved areas become heat sinks by absorbing solar energy and raising the surrounding ambient temperature. Using grass or grass-crete surfaces in parking areas with only the high traffic areas paved will decrease the absorbed heat and leaving a larger part of the site as a pervious surface. Walkways of crushed stone, sand, or wood chips can also be appropriate for this climate. However, access according to the Americans with Disabilities Act must also be considered when designing these areas.

Connecting the School to the Community

One measure of school success is the degree to which it is a vital part of the community. In many communities in the tropical island climates, the school is the cornerstone. It is used for meetings, parties, weddings, and more when class is not in session. If these needs are addressed early in the site selection and design phases, the school can easily meet all these needs.

- Provide optimum access to public transit.
- Link the school to surrounding communities through safe bicycle routes and pedestrian walkways.
- Incorporate convenient bicycle parking at the school site.
- Consider requirements related to multiuse of kitchen facilities, libraries, media centers, athletic fields, etc.

Daylighting and Windows

Of all the high performance design features typically considered, none will have a greater impact on your school than daylighting. Optimum daylighting design can drastically reduce energy consumption and creates healthier learning environments that may result in increased attendance and improved grades. When properly designed, windows, clerestories, skylights, and roof monitors can meet many lighting needs without undesirable heat gain or glare.

Electric lights produce more waste heat energy than daylighting for the equivalent lighting effect. This heat must be removed through ventilation or air conditioning. However, properly designed daylighting is cooler. Reductions in cooling loads from daylighting often enable designers to downsize air conditioning systems which reduces the initial cost of equipment. High performance windows also help to minimize heat gain. Although improperly designed windows can create glare and skylights may cause overheating, daylighting strategies reduce lighting and cooling energy as well as control glare.

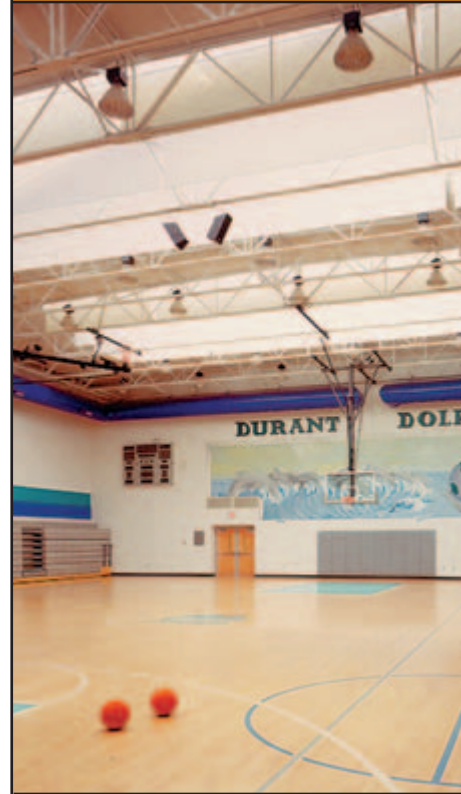
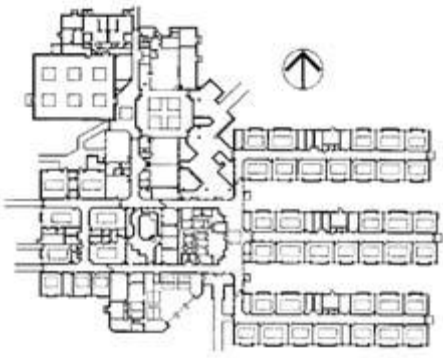

Photo: Robert Flynn

Implement effective daylighting strategies to create significant cost and energy savings by reducing lighting and cooling loads.



This classroom is daylit two-thirds of the time the school is occupied. The daylighting strategy selected consists of roof monitors, light shelves, and light-colored interior finishes.



To optimize solar access, develop a floor plan along an east-west axis.

Design Guidelines for Daylighting and Windows

Building Orientation and Solar Access

- When looking at building orientation and solar access, consider the island’s proximity to the Equator. Location, and resulting variations in day length over the course of the year, will affect solar access.
- Elongate the school design on an east-west axis to maximize the potential for cost-effective daylighting.
- For islands in the northern hemisphere, emphasize daylighting strategies that use north-facing glass. Shield south-facing glass with overhangs. In the southern hemisphere, emphasize south-facing glass. Avoid exposed east- and west-facing glass because it can increase heat gain.
- Pay particular attention to shading strategies. For the tropical island climates, overhangs are important for all sides of the building. For instance, in tropical zones near the equator, the sun is at high elevation angles during much of the year, making building overhangs a vital requirement.
- Verify that other exterior design elements or exterior site features do not negatively affect the lighting design.
- Consider the reflectance of materials in front of the glazing areas. Light roofing colors can reduce the glass area needed for roof monitors; a light-colored walkway in front of a lower window may cause unwanted reflections and glare inside the classroom.

Lighting Efficacy

Lighting Source	Efficacy (lumens/watt)
Beam Sunlight/ Diffuse Skylight	110–130
High-Intensity Discharge (high pressure sodium, metal halide)	32–124
Fluorescent	55–90
Compact Fluorescent	50–60
Incandescent	10–20

Source: Lawrence Berkeley National Laboratory Lighting Market Source Book for the United States

Sunlight provides more lumens per watt than electrical lamps.

Daylighting Strategies

Because electric lighting can account for 35% to 50% of a school’s electrical energy consumption, daylighting can dramatically offset electricity needs. Properly designed windows also help to create a more pleasant environment.

- Properly designed daylighting can reduce the electricity needed to light and cool a school. The reason is simple: daylight provides a higher ratio of light to heat than electrical sources. This ratio, known as lighting efficacy, means that daylight provides more light and less heat, which can greatly reduce cooling loads. The chart to the left compares the efficacy (measured in lumens per watt) of various light sources.
- Since the tropical island climates are cooling-dominated, you can incorporate either north- or south-facing roof monitors. If facing the glass south, provide overhangs to eliminate most direct solar gain. Because of cooling loads, size the glass area to minimize solar gain during times of peak cooling. If designed correctly, this sunlight will generate less heat for the same amount of light. This means that in addition to the lights being off, the peak cooling mechanical load will be reduced.

- Consider daylighting apertures to limit the amount of beam radiation that enters during the hottest part of the day. Minimize east- and west-facing glass. In tropical island climates, you can incorporate south-facing vertical glazing (north-facing in the southern hemisphere) if roof overhangs are designed to effectively admit low-angle winter radiation for daylighting and exclude excessive higher-angle sunlight in the warmer months. North glazing (or south glazing in the southern hemisphere) is best because it does not create overheating problems during the hottest part of the warmest months. For example, the charts below indicate seasonal sun angles for Honolulu, Hawaii; San Juan, Puerto Rico; and Luma, American Samoa.

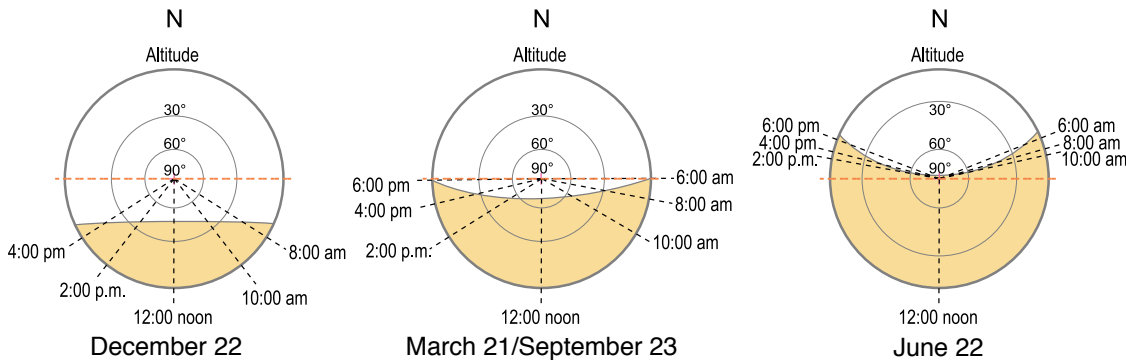

Sun angles for Hawaii, Puerto Rico*

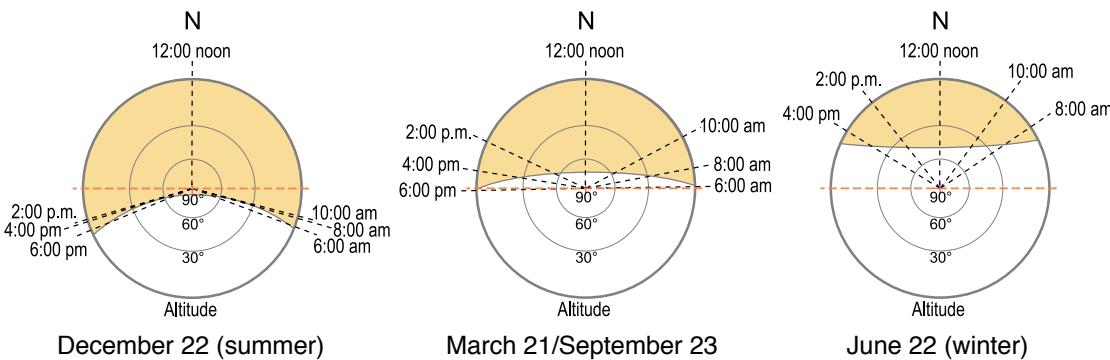

Sun angles for American Samoa**

*For illustration purposes, a latitude of N20 was used. Honolulu, Hawaii has a latitude of N21. San Juan, Puerto Rico's latitude is N18."

**For illustration purposes, a latitude of S16 was used. The latitude of Luma, American Samoa is S14."

Graphics courtesy of Architectural Energy Corporation

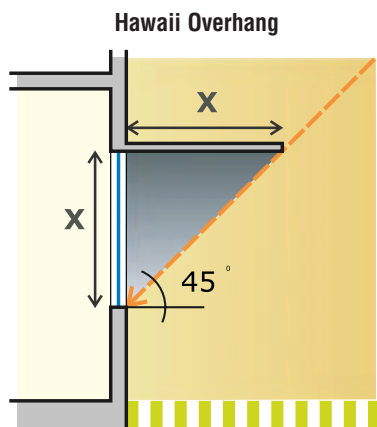

To shade south-facing windows at tropical island schools in the northern hemisphere during school hours (9am-3pm), the overhang should have a cutoff angle of approximately 45°.

Graphics courtesy of Architectural Energy Corporation

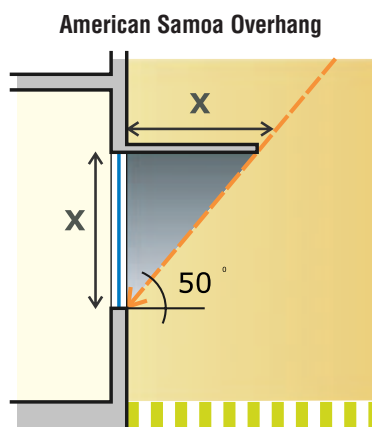

To shade north-facing windows at tropical island schools in the southern hemisphere during school hours (9am-3pm), the overhang should have a cutoff angle of approximately 50°.



Room monitors and windows provide natural light in the classrooms.



Properly designed daylighting can provide superior light in classrooms up to 100 percent of the time.



Overhangs or other shading strategies should be used on all fenestration in the tropical island climates.

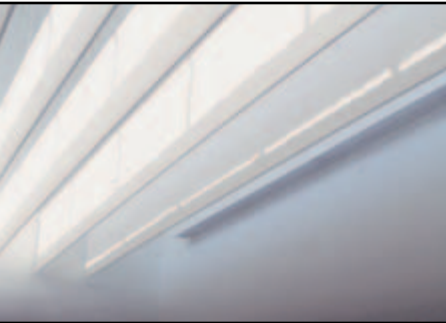

Translucent baffles block direct beam radiation and diffuse the sunlight throughout the space.

For more information on sun angles, see the Web Resource section.

- Develop a daylighting design with south- or north-facing roof monitors and a secondary emphasis on lightshelves. Lightshelves can significantly enhance natural lighting uniformity and provide good lighting in narrow rooms (less than 16 feet to 20 feet). Lightshelves may also be the only option on multiple-story schools.

Roof Monitors and Clerestories

Roof monitors (skylights with vertical glazing) and clerestories provide uniform light in the room and eliminate glare. In this climate zone, overhangs on roof monitors and clerestories make them more effective for daylighting.

- Design daylighting strategies to meet the lighting needs of each major space, accounting for:
 - differing lighting level requirements by time of day
 - the ability to darken particular spaces for limited periods.
- While north-facing is generally preferred, if you use south-facing roof monitors, they should:
 - Employ baffles within the light wells to totally block direct beam radiation from entering the spaces
 - Block high summer sun with exterior overhangs
 - Reduce contrast between very bright surfaces and less bright areas.
- Optimize the design of roof monitors to enhance their benefits.
 - Minimize the size and maximize the transmission of glass to reduce conductive losses and gains.
 - Develop an overall building structural design that integrates the daylighting strategies and minimizes redundant structural elements.
 - For roof monitor glass, select clear double glazing. Avoid using glass with low visible light transmittance, such as gray or bronze tinted glass, for windows that are used to provide daylight. Consider low light transmission glass only where a view is desired but glare needs to be controlled.
 - Choose light-colored roofing materials in front of roof monitors to reflect additional light into the glazing.
 - In roof monitor/lightwell assemblies, incorporate white (or very light-colored) translucent baffles that run parallel to the glass and are spaced to ensure that no direct beams can enter into the space. These baffles should be fire-retardant and UV-resistant. In addition to reflecting the sunlight into the space, baffles eliminate contrast from one side to the other.
 - At the bottom of the lightwell, provide a transition between the vertical and horizontal plane surfaces by either introducing a 45° transition or, if possible, a curved section. This will decrease the contrast between the higher light level inside the lightwell and the horizontal ceiling.

- Ensure that the walls and ceiling of the roof monitor are well insulated and incorporate infiltration and moisture barriers.
- Be aware that windward facing roof monitors may allow moisture to intrude. This is important to address during design.

Lightshelves

You can easily transform a south-facing (in northern hemisphere) or north-facing (in southern hemisphere) window into a well-controlled lighting source by adding a lightshelf a couple of feet below the top of the window. The lightshelf, made of a highly reflective material, will bounce the sunlight that strikes the top of the surface deep into the building. The reflected sunlight will hit the ceiling and, in turn, provide light for the room. This is an effective strategy for rooms as deep as 20 feet and works well in multistory schools or where roof monitors are not possible. The lightshelf also shades the window below. In the tropical island climates, shade the window above the lightshelf to help minimize glare and heat gain.

- Select durable materials for interior and exterior lightshelves, and design them to carry the weight of a person.
- Aluminum exterior lightshelves should be a good compromise between good reflectance, little or no maintenance, and cost.
- Incorporate white painted gypsum board on top of interior lightshelves. However, aluminized acrylic sheets applied to the top of a shelf allow light to bounce farther back into spaces and can improve performance in deeper rooms without top lighting.
- Use blinds to enhance performance. Even with a combination of interior and exterior lightshelves, direct beam light can, at times, enter into the space and create unwanted glare. If the lightshelves are located close to perpendicular interior walls and are not deep enough to eliminate this problem (which is the typical case), vertical blinds can provide an excellent option. Vertical blinds on the window section above the lightshelf, can direct the light toward the walls eliminate glare, and enhance the bouncing of light deep into the space. White blinds are better for increasing reflectance. If the lightshelf windows are located near the middle of the space and farther away from perpendicular walls, horizontal blinds (flat or curved but turned upside-down) would allow the light to be reflected toward the ceiling and deep into the space.
- Control the windows above and below the lightshelves independently. Daylighting can be enhanced by:
 - incorporating vertical blinds that can focus radiation to the perimeter walls within a space and away from people within the space
 - using horizontal blinds that can be installed to reflect the light toward the ceiling, thus reflecting it back farther into the space.
- Don't use lightshelves on northern exposures (in northern hemisphere) or southern exposures (in southern hemisphere). They are not cost-effective or necessary. However, using clear double glass or clear double glass with argon (if possible) is still advisable on high non-view windows in these cases.

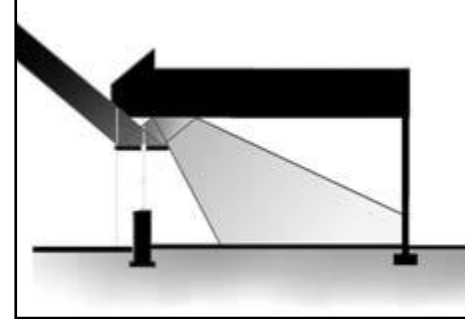

Lightshelves on south-facing (north-facing in southern-hemisphere schools) allow natural light to bounce deep into the room.



Lightshelves can also shade the lower window glass. However, a small overhang is appropriate in lower latitudes to help shade windows from direct glare during summer months.

- When calculating daylighting contribution, don't consider the low height windows (view glass) in your calculation, as these windows are often closed or covered.
- Since exterior lightshelves can be favored nesting sites for birds in this climate, consider using bird repellent spikes or netting.

Lighting Controls

Lighting controls can ensure that students and teachers always have adequate light and that energy efficiency is maintained. Control systems must be simple for ease of use and maintenance, particularly in more remote areas where transport costs are high and resources are limited. Be sure to train staff on the system operation. Locate controls where students cannot access them. Systems that are too complex or difficult to maintain will likely be disabled.

- Consider incorporating occupancy sensors.
- Enhance the economic benefits and provide for smoother transition between varying light conditions by using multi-staged or dimmable lighting controls. The success of these controls relies on:
 - having the sensors mounted in a location that closely simulates the light level (or can be set by being proportional to the light level) at the work plane
 - implementing a fixture layout and control wiring plan that complements the daylighting strategy
 - providing means to override daylighting controls in spaces that are intentionally darkened to use overhead projectors or slides.
- Consider photosensors for outdoor lighting to shut off or dim fixtures when daylight levels are sufficient.

Interior Finishes

The color of interior finishes will have a dramatic impact on the lighting requirements of each space.

- Use white (or very light-colored) paint inside the lightwell area. Colors inside the room can be slightly darker, but the lighter colors will help the light to reflect deeper into the space. Accent colors (with most still white) and beige colors are acceptable inside typical rooms. The tables included within the Energy-Efficient Building Shell section of this document provide additional information on the recommended reflectance ranges for different interior finishes.
- Apply floor coverings that are as light as practical for maintenance. This will greatly enhance reflectance and require less glazing to produce the same light levels. If the floor finish is dark, more glass is required to effectively daylight the space.
- If there are television monitors, computers, or whiteboards in the classrooms, locate them to minimize glare.
- Enhance the daylighting by placing south-facing windows with lightshelves close to perpendicular interior north-south walls. The color of the walls immediately inside the window should be light to enhance this reflectance. See page 23 for reflectance values of interior paint and wood.



Light-colored interior finishes help the uniform distribution of natural light in the classroom.

Skylights

Carefully designed skylights can provide daylighting for schools in the tropical islands, but heat and moisture intrusion are key concerns. Pay careful attention to climate and weather patterns when designing skylights.

- Use diffuse glazing or a means to diffuse the radiation before it enters the space
- Consider skylights that incorporate motorized, louvered systems that seasonally and hourly adjust to allow the optimum amount of radiation to enter the glazing
- Consider tubular skylights.

Windows—Appropriate Choice

Windows will have a significant impact on energy consumption. Their characteristics, locations, designs, and purposes will determine, to a great degree, the level of energy efficiency.

Energy efficiency, cost, and availability are major considerations when selecting windows for schools in these climates. The distance required for transport will add cost to any window selection. If a window is too specialized and expensive, maintenance and replacement costs will be prohibitive.

In all cases, windows should be made of high-quality construction and include the correct glazing for the application. Windows should be designed to meet the overall objective and not be oversized. To determine the optimum glazing for each application, the designer should conduct computer simulations that compare options. The DOE-2 program is one of the better analytical tools available for this purpose. You'll find more information on the DOE-2 program in the Web Resource section.

- Identify weather patterns that may affect window design and selection. For instance, islands that experience extreme weather, such as hurricanes and typhoons, have historically used smaller view windows than other locations.
- Analyze and select the right glazing for each orientation, location, and purpose. For example, if windows are:
 - oriented east and west and not externally shaded, the best choice is to use a tinted glazing with low solar low-e

Solar (Heat) Transmission Values for Typical Glass Types

Glazing Type	Solar Transmission	Equivalent U-Value
Clear, Single	75%–89%	1.11
Clear, Double	68%–75%	0.49
Low-e, Double, Clear	35%–55%	0.38
Low-e, Tinted, Gray	30%–45%	0.38
Low-e, Argon	45%–55%	0.3

Considering the transmission values of glass by orientation can greatly reduce cooling loads. Low-e glass reduces the amount of heat gain through the window, which can lower cooling needs.

Window Selection Considerations

(Note: The exposures in this table are for schools in the northern hemisphere. For schools in the southern hemisphere, north and south would be switched in this table.)

Application	Exposure	Type	
		Shaded	Unshaded
View Glass (Non-Daylighting Apertures)	North	Single or Double Clear	Double Low Solar Low-e
	South	Single or Double Clear	Double Low Solar Low-e
	East/West	Double Low Solar Low-e	Tinted Double Low Solar Low-e
Windows above Lightshelves	South	Single or Double Clear	Double Low Solar Low-e
High Windows above View Glass	North	Single or Double Clear	Single or Double Clear
Roof Monitors	South	Single or Double Clear	Double Low Solar Low-e

The intended application and exposure determines appropriate window selection.

Light Transmission Values

0.9	Standard Double Glazing
0.5–0.9	Internal Venetian Blinds — Drawn
0.4–0.8	Internal Curtains — Drawn
0.4–0.8	Internal Roller Blinds — Drawn
0.7	Heat-Absorbing Glass
0.6	Tree Providing Light Shade
0.5	Internal Blind — Reflective Backing
0.4	Solar Control Glass
0.2	External Blinds — Drawn
0.2	External Shutters — Closed

Transmission of light is greatly affected by the type of window treatments used.



Photo: Architectural Energy Corporation
At Iolani School in Honolulu, Hawaii, window overhangs provide effective shading for view windows.

- well-shaded by building elements (e.g., overhangs) or north-facing in the northern hemisphere, tinting would not be advised since it restricts the transmission of visible light
- located close to the floor, comfort becomes a more critical issue, and low-e windows are appropriate
- designed as daylighting components above lightselves or in roof monitors, the best option is typically clear single or double glazing.
- Select spectrally selective, low solar gain, low-e glazing for non-daylighting apertures.
- If noise is an issue, consider double glazed windows.
- Consider operable view windows on opposite classroom walls to allow for natural cross-ventilation.

Exterior Window Treatments

The most efficient means of restricting unwanted solar gain from entering glass areas is to block the radiation before it reaches the glazing. In the tropical island climates, overhangs or other shading strategies are necessary on all glazing orientations.

- Properly size fixed overhangs
- Consider the advantages of awnings, solar screens, shutters, or vertical louvers when fixed overhangs are impossible or impractical
- In areas prone to hurricanes and typhoons, explore the cost-effectiveness of windows with external opaque louvers that can be closed to prevent damage.

Interior Window Treatments

If exterior window treatments cannot effectively control the seasonal and daily variations in radiation (and resulting glare), or if it is desirable to be able to darken the space needs to be darkened, blinds or shades provide better control.

If blinds or rolling type dark-out shades are employed, install types that are either motorized or easily accessible and made of durable construction materials and components.

Energy-Efficient Building Shell

Because heat flowing through the building shell is typically responsible for 10%–20% of the total energy consumed in a school, focusing on this area of design can help reduce energy consumption. Increased insulation in the walls and ceiling helps to reduce heat gain and improve comfort. Light-colored exterior walls and white roofs help to reduce cooling loads. These factors also contribute to reducing the size and cost of the mechanical and ventilation systems. The useful life of building materials, systems, and equipment incorporated in schools can vary considerably, so the building shell decisions you make will affect the first cost of the school as well as the long-term costs associated with operation, maintenance, and replacement.

Wall insulation is necessary even if the school is not air conditioned, especially for non-shaded east- and west-facing walls, and should be selected based on the assumption that it will never be replaced. When selecting your wall and roof systems, you need to choose what is best for the life of the facility. Specify interior and exterior finishes that are durable and as maintenance-free as possible, and integrate insulation levels that are appropriate for the life of the facility. Also, incorporate durable strategies that address air infiltration.

If specified correctly, energy-efficient building shell elements can effectively reduce our impact on the environment, and they will never need to be replaced.



Photo: Architectural Energy Corporation
Energy-efficient exterior walls, light-colored roof finishes, and window shading overhangs are among the high performance building shell elements used at Pearl Ridge Elementary School on Oahu.

Design Guidelines for an Energy-Efficient Building Shell

Insulation Strategies

Energy-efficient building design starts with implementing optimum insulation levels. You can maximize long-term benefits by evaluating the cost-effectiveness of varying insulation R-values.

- When selecting insulation levels, consider American Society of Heating, Refrigerating and Air Conditioning Engineers (ASHRAE) Standard 90.1 R-values as the minimum (typically R-19 in the ceiling and R-11 in the walls).
- When determining the choice of insulation, you should consider energy efficiency, initial cost, and long-term performance. Carefully research insulation products for stability of R-value over time, as well as moisture resistance, and make comparisons based on the average performance over the service life.
- Properly insulated roofs prevent heat gain. Roof insulation is recommended for all roofs in this climate.
- If the school is not air conditioned, wall insulation is still recommended unless the wall is shaded.
- Use computer analysis to help optimize the placement and installation of insulation throughout the structure.

Stopping Radiant Heat Gains

In the tropical island climates, radiant barriers and cool roofs are an excellent strategy for reducing heat gains. As much as 90% of the cooling load coming from the roof area can be attributed to radiant heat gain. You can decrease your cooling load significantly by addressing this problem through radiant barriers, cool roofs, and shading strategies.

- Incorporate radiant barriers in the roof assemblies to reduce as much as 95% of radiant heat gain. When solar radiation strikes a roof, some radiation is reflected away, and the balance is absorbed. When this occurs, it heats that material, and the material reradiates downward. The low-emissivity properties of the aluminum in the radiant barrier stop this radiant process, allowing only 5% of the radiation to pass through. Radiant barriers that have coatings to protect against oxidation help ensure long-term performance. These types of radiant barriers are superior to reflective roofing strategies that tend to lose their reflective qualities over time. However, dust accumulation on radiant barriers reduces their performance. When possible, suspend them from the joists or rafters to reduce dust accumulation.
- Incorporate highly reflective roofing systems (cool roofs) to reflect solar gain away before it can create negative radiant impacts in the spaces below. This strategy is particularly important, in areas where you cannot practically install radiant barriers.



High-mass construction techniques lag the heat gain experienced during the daytime well into the evening.



Light-colored roofing materials reflect solar radiation and can complement daylighting strategies.

Reflectance Values for Exterior Surfaces

		% Reflected	% Absorbed
Roofing Material (1)			
Single-Ply Roof Membrane	Black EPDM	6%	94%
	Gray EPDM	23%	77%
	White EPDM	69%	31%
Asphalt Shingles	Black	5%	95%
	Medium Brown	12%	88%
	Green	19%	81%
	Gray	22%	78%
	White	25%	75%
Metal Roof	Aluminum	61%	39%
	Metal White	67%	33%
Exterior Wall Material (2)			
Brick	Light Buff	45%	55%
	Dark Buff	40%	60%
	Dark Red	30%	70%
Concrete	Light	55%	45%
	Medium	20%	80%
	Dark	15%	85%

(1) Source: Berdahl 2000. "Cool Roofing Material Database," LBNL

(2) Source: 1981 IES Lighting Handbook

- Select a light color for the exterior wall finish to reflect solar radiation.
- Shade exterior walls with architectural elements (or landscaping) to enhance performance. Insulation or a radiant barrier is necessary in walls exposed to the sun.
- Ventilate spaces with radiant barriers to remove heat.

Moisture and Infiltration Strategies

Controlling air flow and moisture penetration are critical elements in reducing energy consumption, maintaining structural integrity, and ensuring a healthy indoor environment.

- Use eaves and overhangs to keep moisture off building walls.
- Prevent moisture infiltration from outside air by caulking and sealing any building shell penetrations.
- If the school is air conditioned, consider using a vapor barrier on the outside of the wall.
- If faced insulation is used, install so the facing is placed on the exterior side.
- Avoid interior wall coverings that are not permeable to moisture to help prevent mold growth inside the wall cavity or behind the wall covering.



Radiant heat gain can be responsible for 90% of the heat entering through the roof. The use of a radiant barrier can block as much as 95% of this gain.

The chart on the left indicates the reflectance of various typical roofing materials when first installed. Materials that maintain their reflective characteristics should be preferred.



Photo: Architectural Energy Corporation

An energy-efficient building shell requires that the designer view the wall assembly as a system within the "whole building."

Massive Wall Construction

In tropical island climates, high-mass construction techniques have been historically employed to moderate the heat gain during the hot days. This delays and reduces the impact until the nighttime when ventilation strategies during the swing months can cool the interior spaces. Though not as effective as in climates with greater daily temperature variation, thermal mass can provide cooling benefits in tropical climates, particularly for schools that are not occupied during evening hours. Thermal mass is most useful in maintaining comfort in naturally ventilated schools. Massive walls have also been traditionally used for their strength against strong winds and storms.

- Combining high-mass wall construction techniques to lag the heat gains combined with wall insulation can delay thermal gains as long as 12 hours.
- Consider newer wall systems that use insulated concrete forms or tilt-up insulated concrete panels which are also effective.
- Provide a way for the mass to cool passively at night, typically through natural ventilation. Be careful in air conditioned buildings not to create an undesirable dehumidification load.
- Other construction types including metal-framed and slab-on grade construction are also gaining prominence in this climate. Evaluate the specific feasibility for your project.
- Wood-framed buildings are also found in this climate, but are less preferable than other materials because of cost, durability, moisture, and termite issues.

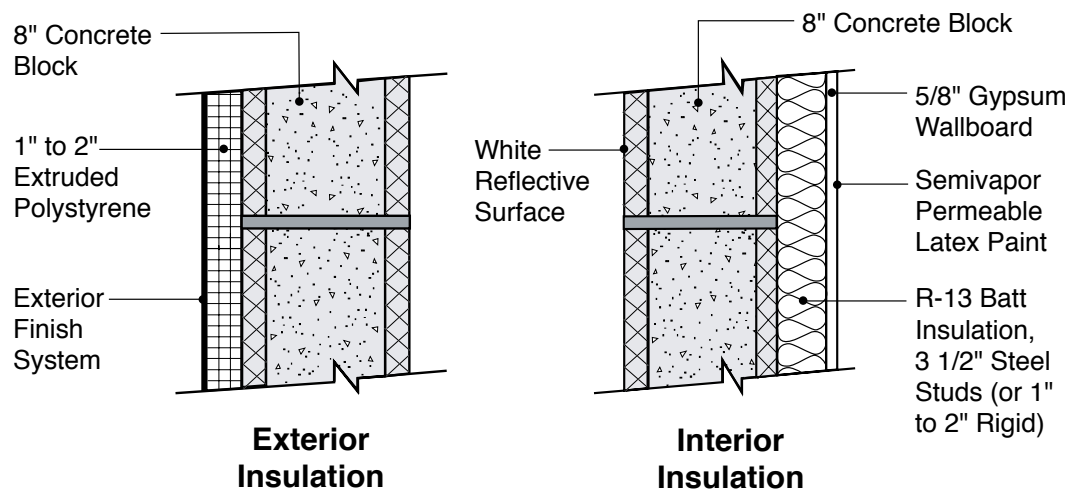

Wall Sections

By incorporating high-mass construction, cooling loads can be reduced and air conditioning equipment can be downsized.



Light-colored finishes will significantly reduce lighting demands in interior spaces.

Interior Finishes

By properly selecting interior finishes, lighting energy demands can be reduced and visual comfort can be improved for no additional cost.

- Select light colors for interior walls and ceilings to increase light reflectance and reduce lighting and daylighting requirements.
- Consider the color and finish of interior walls and ceilings. When placed incorrectly, light-colored, glossy finishes can create glare problems that negatively affect visual comfort.

Reflectance Table: Paints

Color	Reflectance
Semi-Gloss White	70%
Light Green*	53%
Kelly Green*	49%
Medium Blue*	49%
Medium Yellow*	47%
Medium Orange*	42%
Medium Green*	41%
Medium Red*	20%
Medium Brown*	16%
Dark Blue-Gray*	16%
Dark Brown*	12%

Reflectance Table: Woods

Type	Reflectance
Maple	54%
Poplar	52%
White Pine	51%
Red Pine	49%
Oregon Pine	38%
Birch	35%
Beech	26%
Oak	23%
Cherry	20%

* These values are estimated for flat paints. For gloss paints, add 5%–10%. Source: SBIC, Passive Solar Design Strategies

Careful consideration of interior finishes based on reflectance values can reduce lighting demands.

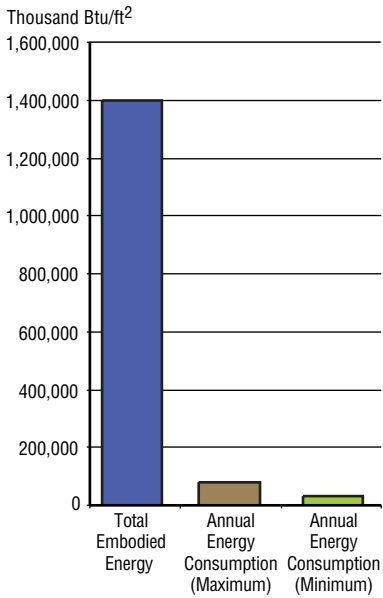

Total embodied energy per square foot for educational buildings

The embodied energy of a school building exceeds the annual energy consumption of the school.

Embodied Energy

When selecting the building materials, consider that in many cases, the amount of energy embodied in constructing the school is equal to more than two decades of a school’s energy consumption. This is especially true in the tropical island climates, where distance and weather can add time and cost constraints to the school construction process. To seriously address the overall impacts of energy consumption, consider the energy involved in making each product, transporting the product to the site, and implementing the component into the school.

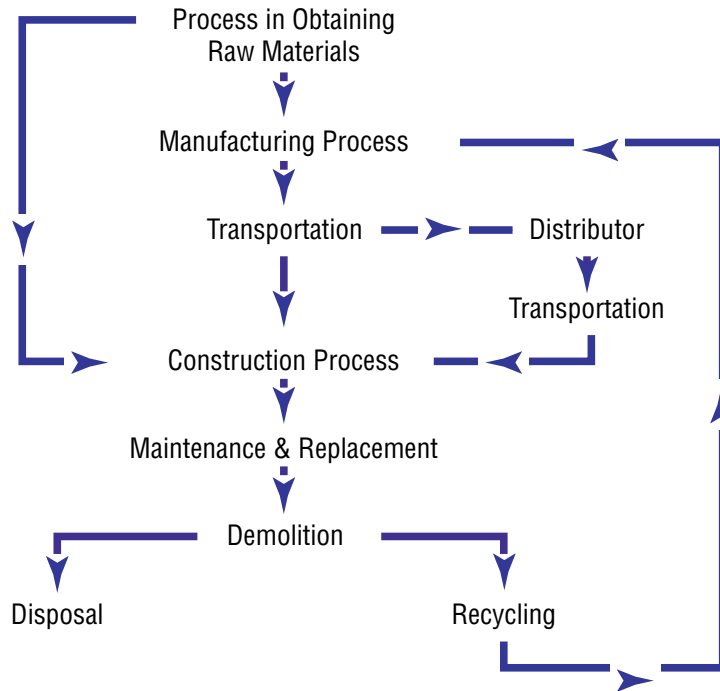

Source: Padia Consulting

Total Embodied Energy Diagram

Products, materials, equipment, and processes incorporated into construction.

- Although locally produced building products are limited on most islands in this climate, specify local products and materials when possible.
- Consider the energy intensity of the manufacturing process involved in making materials and products incorporated in the school.
- Encourage the use of recycled products.
- Evaluate the recyclability of products once the building has passed its useful life.
- If structures on the school site are to be demolished, consider how the typically wasted materials could be used in the new construction or salvaged for reuse. Work with demolition or salvage companies to evaluate materials for salvage and reuse.

Lighting and Electrical Systems

The design of your school's lighting system has direct bearing on the performance of students and teachers. The ability to read comfortably and perform visual tasks is strongly affected by the type and quality of the lighting systems. Lighting strategies that reduce glare and produce the required lumen levels are essential components of a high performance school.

Lighting represents 25%–40% of a typical school's energy costs. An energy-efficient lighting system in one school can save thousands of dollars annually because lighting efficiency reduces the energy requirements for both lighting and air conditioning. Controls in daylit spaces can automatically reduce or increase light levels as needed, and occupancy sensors can automatically turn off lights in unoccupied spaces.

Your design team can create an energy-efficient, high-quality lighting system by following three key strategies:

- Select efficient lamps, ballasts, lenses, and fixtures that address the needs of each space and achieve the highest output of lumens per input of energy.
- Provide occupancy sensors, time clocks, and other controls that limit the time the lights are on to hours when the space is occupied and the light is needed.
- Consider automated daylighting controls that dim or switch off the electrical lighting when sufficient natural light is present.

Finally, because of the high cost to transport equipment to the tropical island locations, balance efficiency goals with cost and availability of lighting system equipment.



Photo: NREL/PIX03045

Indirect lighting can provide excellent uniform artificial lighting in a classroom, eliminating glare and contrast between bright and dark areas.

Design Guidelines for Lighting and Electrical Systems

Lighting Strategies

In naturally lit spaces, the artificial lighting design should be compatible with the objectives of the daylighting. In non-daylit spaces, the objective should be to implement the most energy-efficient system possible that minimizes glare and provide the proper level and quality of light.

- Consider the geometry and reflectance of finishes in each space to maximize the illumination.
- Implement indirect lighting strategies.
- Select fixtures that are designed to minimize glare, particularly in rooms with computers.
- Verify the lighting requirements for each space function.
- Consider providing low-level ambient lighting supplemented by task lighting in administrative and library areas as well as rooms with computers.
- Prefer photovoltaic lighting systems for remote exterior applications such as parking areas or walkways. Using a localized photovoltaic system with its own battery storage is often more cost effective than providing underground electrical service.
- Incorporate lamps with high color rendering in non-daylit spaces.
- Design switching circuits to allow little-used spaces to be switched off.



Photo: NREL/PIX03047

Indirect lighting systems provide high-quality lighting in classrooms.

High-Efficacy Lamps and Ballasts

Efficacy is an important measure for energy efficiency in light output per unit of energy used. High-efficacy lamps can provide similar illumination and color rendition as incandescent lamps but at two to six times the efficiency.

Source: The Collaborative for High Performance Schools

The table to the right outlining comparative lamp efficacies shows that T-8 Super tubes are rated best.

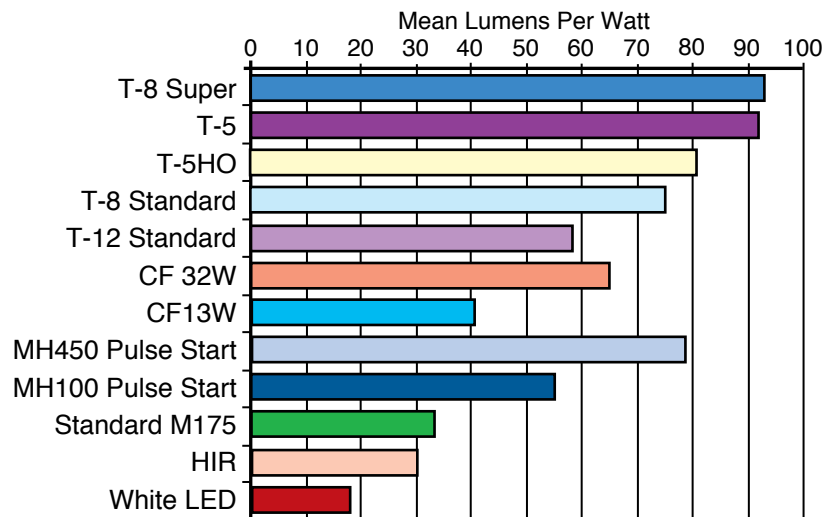

- When selecting lamps, consider the maintenance and lamp replacement costs. Highly specialized lighting systems and lamps may not be cost effective, particularly for schools in the more remote areas, because of the added transportation and labor costs.
- Minimize the use of incandescent fixtures.
- Select the lamp ballast system with the highest lumens of output per watt of input that address the specific need.

Fluorescent Lamp Technologies—Efficacy Comparisons

Lamp Type	Lamp Life (hours)	Lumen/Watt	C.R.I.*	Lumen Maint.**	Ballast Factor	Description and Comments
T-5 Fluorescent (28 W/4 Ft)	20,000	104	85	0.95	1	5/8" dia. tube, high lamp and ballast efficiency, high CRI, similar output to second generation T-8
T-5 HO Fluorescent (54 W/4 Ft)	20,000	93	85	0.93	1	5/8" dia. tube, high lumen output, high CRI, 61% higher lumens than second generation 4 ft T-8
T-8 Fluorescent (32 W/4 Ft)	24,000	97	85	0.95	0.88	1" dia., standard for efficient fluorescent lamps, 24% efficiency improvement over second generation T-12
T-12 Fluorescent (34 W/4 Ft)	20,000	78	62	0.86	0.87	1 1/2" dia. tube, still used on ballasts where efficiency is not considered

Developed by Padia Consulting from manufacturers' literature (Philips, Osram Sylvania, General Electric)

* Color Rendering Index

** The lumen maintenance percentage of a lamp is based on measured light output at 40% of that lamp's rated average life. For T-5, after 8,000 hours of lifetime, the lumens/watt will be 98.8 lumen/watt (104x0.95).

Fluorescent lamp selection should be based on the illumination needs of the area and lamp replacement frequency and cost.

Compact Fluorescent Lamps

- Consider compact fluorescent lamps that are energy efficient and long lasting. A 13-watt compact fluorescent lamp (about 15 watts with an electronic ballast) provides the same illumination as a 60-watt incandescent lamp and lasts up to 13 times longer. Additionally, they have excellent color rendering.
- In larger daylit spaces like gymnasias, provide multiple light level capacity through fluorescent systems using T5HO or T-8 lamps, or multiple compact fluorescent lamps.
- Select fixtures with effective reflector design.



Photo: NREL/PIX07071

LED exit signs last 10-50 times longer than fluorescents and can use up to 50% less energy than incandescent fixtures.

Fluorescent Lamps

- Choose higher efficacy T-8 and T-5 fluorescent tubes over the traditional T-12s. The T-8 system produces 97 lumens per watt, compared with 79 lumens per watt for the T-12 system. The T-5 system produces 25% more lumens per watt than the T-12 system.
- Specify fixtures that are designed to enhance the efficacy of the T-8 and T-5 lamps by incorporating better optics in the luminaire design.
- In gymnasiums, multi-purpose, and other high ceiling spaces, consider T-5 or T-8 luminaires instead of metal halide.

Metal Halide and High-Pressure Sodium Lamps

- Consider metal halide and high-pressure sodium lamps for exterior lighting applications.
- Use metal halide and high-pressure sodium lamps only in areas where the long warmup and restrike time after a power outage will not affect the safety of students, visitors, and staff.

LED Exit Lights

- Select light-emitting diodes (LEDs) exit signs that operate 24 hours a day, 365 days a year. LED exit signs offer energy savings of 80–330 kilowatt-hours/year per fixture with little maintenance. LED exit lights have a projected life of 700,000 hours to more than 5 million hours, and the standby battery requires replacement about every 80,000 hours. Typical fluorescent lamps will last only 15,000 hours.

High-Efficiency Reflectors

High-efficiency fixtures employ two main strategies to minimize the blockage or trapping of light within the housing: high-efficiency lensed troffers and fixtures with parabolic reflectors.

- With troffers, select the shape and finish of the inner housing to minimize inter-reflections and maximize the lumens per watt. A high-efficiency troffer with two or three lamps can produce the same illumination as a standard four-lamp fixture.
- Select fixtures with parabolic reflectors for administrative areas to improve the optics and increase the performance of the light fixtures.

Ballasts

Solid-state electronic ballasts are available in rapid- and instant-start models. The instant-start ballasts have a very high efficiency but should be avoided in applications that use occupant sensors. Electronic ballasts are identical in shape, size, and external wiring to magnetic ballasts, but electronic ballasts can operate as many as four lamps each.

When selecting a dimmable ballast, consider that magnetic ballasts will dim to only about 40% of full power before the flicker becomes problematic, whereas electronic ballasts may be dimmed to near zero output with no perceptible flicker. Electronic ballasts also have a higher lumen output than magnetic ballasts at reduced power levels.

- Select high-efficiency electronic ballasts because they save energy, have a low propensity to attract dust, incorporate a minimum of hazardous materials, and operate at a cooler temperature.
- Select electronic ballasts because they minimize the characteristic humming from fluorescent lamps.
- Electronic ballasts can serve up to four lamps, while magnetic ballasts can serve only two.
- Consider that conventional ballasts cycle at 60 hertz and create a perceptible flicker, whereas electronic ballasts cycle faster and reduce eye strain.
- In areas where daylighting strategies are being implemented, employ electronic ballasts designed specifically for dimming and controlled by photosensors.

Lighting Controls

Because of changing use patterns in schools, occupancy sensors and photosensors can save considerable energy by simply turning off unneeded lights. There are two commonly used occupancy sensors: infrared and ultrasonic. Infrared sensors detect occupants by sensing changes in heat as occupants move; ultrasonic sensors detect movement of solid objects. Sensors that combine both technologies are recommended for classrooms. Photosensor controls should be used for outdoor lights to ensure that the lights are on only at night.

- In daylit spaces, incorporate staged or dimmable (preferred) lighting controls tied to photocells in each space that can read light levels at the work surface.
- Incorporate override switches for automatic daylight dimming controls only where manually controlled lighting levels are necessary to the function of the space. Make sure controls are not accessible to students.
- Provide photocells on outdoor lights to ensure that they are off during daytime hours.

Electrical Systems

An inefficient electrical distribution system can result in degraded power quality, the introduction of wasteful harmonics, and line losses as high as 3% or 4%.

- Evaluate the merits of a high-voltage distribution system. Consider the initial cost and operational savings that result from reduced line losses. Analyze the costs of delivering power at 208/120 volts versus 480/277 volts.
- Correctly size transformers to fit the load, keep losses to a minimum, and optimize transformer efficiency. The correct sizing of a transformer depends on the economic value and size of load losses versus no-load losses and consideration of expected transformer life.



Daylight sensors combined with occupancy sensors are used as an energy-saving measure to turn the lights off if the natural light level is sufficient or if the space is unoccupied.



ESTABLISH ENERGY PERFORMANCE GOALS

For new school design (K-12), the U.S. EPA recommends setting a design target and monitoring progress throughout the design process.

The ENERGY STAR label can be used to identify energy-efficient office equipment, exit signs, water coolers, and other products. By choosing these products, your school can save energy and money.

- Consider more efficient transformers that operate at lower temperatures. Most transformers are 93%–98% efficient. Transformer efficiency is improved by reducing the losses in the transformer. Some states have transformer efficiency standards; others, including Hawaii, require them by code. Check with your state energy office.
- Consider using K-rated transformers to serve nonlinear equipment. K factor is a constant developed to take into account the effect of harmonics on transformer loading and losses. A K-rated transformer may initially cost more, and may be less efficient, but it should result in a longer transformer life.
- Evaluate the distribution system to determine whether power factor correction is justified. Utilities usually charge users for operating at power factors below a specified level. In addition to causing unnecessary line losses, low power factors create the need for a larger energy source. If power factor correction is necessary, a common method is to place power-factor-corrective capacitors or three-phase synchronous capacitors (motors) in the system, close to the load.
- In some situations, disconnecting the primary side of transformers not serving active loads can save energy. Disconnecting the primary sides of transformers is safe provided that critical equipment such as fire alarms and heating control circuits are not affected.
- Where possible, minimize long runs of wire from power distribution panels to electrical equipment. Where equipment would be likely to operate at a low voltage because of distance from the distribution panel, install larger wire to reduce voltage drop.

Because appliances, motors, fans, and other electrical equipment are responsible for a high percentage of building electrical consumption, select equipment that is properly sized, energy-efficient, and environmentally sound.

- Don't oversize the equipment. It will add to the peak electrical loads and often does not operate as well at part-load conditions.
- Use high-efficiency motors and, where appropriate, variable frequency drives. Compare motors using No. 112, Method B, developed by the Institute of Electrical and Electronic Engineers, <http://www.ieee.org>
- Select fans and pumps for the highest operating efficiency at the predominant operating conditions.
- Set temperatures on electric water heaters based on use requirements. Switch off water heaters during vacation periods.
- Use timers to limit the duty cycle of heaters when they are not in full use.
- Select energy-efficient food service appliances.
- Specify ENERGY STAR-rated appliances when applicable.

Mechanical and Ventilation Systems

In the tropical island climates, ventilation and air conditioning systems are typically responsible for 55%–65% of the energy consumed in schools. However, for some areas in these climates, mechanical cooling is not necessary. The fundamental question for designers of tropical island schools is: Will the school have an air conditioning system? Although the trend is to use air conditioning, these systems can often be avoided through careful design practices. Since electricity costs are significantly higher in the tropical islands, designing without air conditioning will greatly reduce costs loads.

By using the “whole-building” approach—looking at how all of the building’s design elements work together—your design team can factor in energy-saving choices

that can downsize the mechanical system you will need, and perhaps eliminate the mechanical cooling. By properly sizing the system, you can reduce initial equipment costs as well as long-term operating costs. Overdesigning or oversizing the equipment can also result in loss of humidity control and mold problems.

More importantly, mechanical and ventilation systems have a significant effect on the health, comfort, productivity, and academic performance of students and teachers. A study by the U.S. General Accounting Office found that half of the more than 90,000 public schools in the country are facing noise-control problems, lack of adequate ventilation, physical security issues, poor indoor air quality and comfort issues. A 1999 U.S. Department of Education study found that 26% of the country’s schools had unsatisfactory levels of outside air. Most of these issues are directly or indirectly linked to system design and operation and can be corrected by improved mechanical and ventilation systems.

The best mechanical system design considers all the interrelated building systems and addresses indoor air quality, energy consumption, and environmental benefit. Optimizing the design and benefits requires that the mechanical system designer and architect address these issues early in the schematic design phase and continually revise decisions throughout the design process. You must also implement thorough commissioning processes and routine preventative maintenance programs.



An exposed energy-efficient mechanical system can serve as an educational tool for energy conservation.



EnergyPlus is a new-generation building energy simulation program designed for modeling buildings with associated heating, cooling, lighting, and ventilation flows. EnergyPlus builds on the most popular features and capabilities of BLAST and DOE-2 and includes many advanced and innovative simulation capabilities.

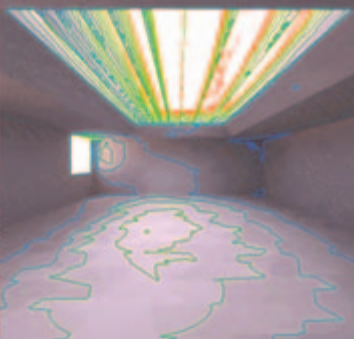

Computer simulations of daylighting are essential to achieving a clear understanding of how this energy strategy affects mechanical loads and the “whole building” performance.

Communication among members of the school system, architects, and engineers early in the predesign process is critical for establishing the most energy-efficient “whole-building” strategy.

Design Guidelines for Mechanical and Ventilation Systems

Energy Analysis

Perform an energy analysis during the schematic design phase to select the most efficient, cost-effective mechanical and ventilation systems. System optimization (which may include smaller mechanical and electrical systems) also improves indoor air quality, allows humidity control, and may lower construction costs. Several available computer programs provide hourly building simulations to predict the energy behavior of the school’s structure, air conditioning system, and central equipment plant.

An energy analysis considers the school’s key components—the building walls and roof, insulation, glazing, the lighting and daylighting systems, as well as the mechanical systems and equipment. Proper roof, wall, and window insulation can dramatically reduce the size of the cooling system. The analysis program can simultaneously assess and predict the results of choices associated with each component. For buildings in the design phase, computer models are generally useful for comparing alternatives and predicting trends.

Energy analysis computer programs that simulate hourly performance should include a companion economic simulation to calculate energy costs based on computed energy use. This model can estimate monthly and annual energy use and costs. Some models allow the user to input estimated capital equipment and operating costs so that the life-cycle economics of the design can be evaluated and compared.

- Before starting work on the design, establish an “energy budget” that exceeds the minimum building code standards. One consideration is to set an energy budget that would potentially qualify the school for an ENERGY STAR buildings label. An ENERGY STAR designation places the school in the top 25% of energy performance.
- Learn how the school system wants to balance initial cost versus life-cycle cost, and point out the long-term advantages of investing in more energy-efficient and environmentally friendly approaches.
- When evaluating life-cycle costs, take into account:



- the initial cost of equipment
 - anticipated maintenance expenses
 - projected annual energy costs
 - projected energy and labor cost escalation rates
 - replacement costs.
- Optimize the mechanical system as a complete entity to allow for interactions between system components.
 - In the schematic design phase, determine the mechanical system implications of all related site, building shell, daylighting, and lighting elements.

When energy use and operating expenditures are considered at the outset of the design process, energy- and resource-efficient strategies can be integrated at the lowest possible cost.

Cooling Systems

Consider cooling systems for the climate that match the building loads and are not over designed.

- Evaluate various cooling equipment sizes and models to select the unit that best matches the demand requirements. To accomplish this, use an hourly computer simulation tool to generate energy consumption profiles and the incidence of coincidental peak cooling loads. Select equipment that achieves a high efficiency at the predominant load but also remains efficient over the range of operating conditions.
- Avoid oversizing air condition (AC) equipment. AC equipment that is oversized for demand not only wastes energy, but can degrade the dehumidification performance. Consider a dedicated outside air system or dual-path air handler design to improve dehumidification performance.
- Consider the use of desiccant dehumidification (enthalpy exchangers) cooling, which can reduce the need for mechanical cooling, and evaluate the requirements for proper maintenance of these systems.
- Avoid system designs where equipment will be exposed. In the tropical climates, the air contains a large amount of salt, which corrode mechanical equipment.
- Consider solar-driven absorption cooling to reduce peak electricity consumption.
- To reduce upper atmospheric ozone depletion, reduce the use of chlorofluorocarbon (CFC) and hydrochlorofluorocarbon (HCFC) refrigerants.
- Consider thermal (ice or water) storage where peak load avoidance is critical. Thermal storage that takes advantage of off-peak utility rate schedules where applicable. Some electric utilities promote thermal storage by offering an incentive for power use that can be displaced from peak to off-peak time.
- Consider opportunities for heat recovery. Although heating is not needed in most areas in this climate, the generated heat can be used for other applications. For instance, heat generated from chillers can be used to warm swimming pool water or pre-heat kitchen and shower water.



The energy budget and goals should be established prior to the start of the schematic design phase.

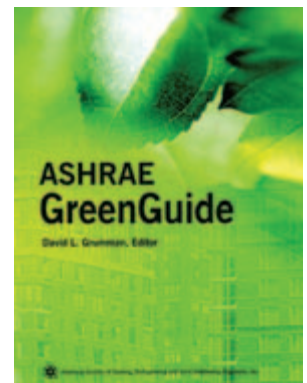

ASHRAE sets the industry standards for mechanical and ventilation systems, as well as providing continuing education for design professionals on the latest strategies and techniques for mechanical system design.



The LEED Criteria for developing sustainable, high-performing buildings features several credits dealing with mechanical and ventilation systems, including thermal comfort, ventilation effectiveness, and system controls.

Ventilation and Indoor Air Quality Strategies

ASHRAE Standard 62 addresses the criteria for ventilation and indoor air quality. The outside air requirements for ventilating an occupied school are considerable and can greatly affect energy load and system operating costs. Carefully consider the strategy you employ to achieve proper ventilation.

- Implement ventilation strategies that will ensure outside air by complying with ASHRAE Standard 62-1999.
- Consider a dedicated ventilation system that can regulate and measure the quantity of air. This will provide a greater certainty that proper ventilation is maintained. Such a system can also improve overall energy efficiency.
- Separate and ventilate highly polluting spaces. Provide separate exhaust from kitchens, toilets, custodial closets, chemical storage rooms, and dedicated copy rooms to the outdoors, with no recirculation through the mechanical system.
- Consider an enthalpy recovery system.
- Locate outdoor air intakes at least 7 feet vertically and 25 feet horizontally from polluted and/or overheated exhaust (e.g., cooling towers, loading docks, fume hoods, and chemical storage areas). Consider other potential sources of contaminants, such as lawn maintenance. Separate vehicle traffic and parking at least 50 feet from outdoor air inlets or spaces that use natural ventilation strategies. Create landscaping buffers between high traffic areas and building intakes or natural ventilation openings.
- Locate exhaust outlets at least 10 feet above ground level and away from doors, occupied areas, and operable windows. The preferred location for exhaust outlets is at roof level projecting upward or horizontally away from outdoor intakes.
- Provide filters capable of 60% or greater dust spot efficiency, and install them where all makeup and return air can be intercepted. In dusty areas, use a higher efficiency filtration system (80%–85% by ASHRAE standards with 30% efficient pre-filters).

Natural Ventilation

If the tradewinds are adequate at your site and dust and noise are not problems, consider natural ventilation strategies to either eliminate the need for mechanical cooling or to reduce the number of hours a mechanical cooling system is needed.

- Orient buildings to maximize cooling from prevailing winds and minimize afternoon heat gain.
- Design floor plans and window/door openings to provide adequate cross-ventilation and air circulation.
- Provide screens for windows and other openings and ensure they are well protected from rain and other elements.
- Consider high ceilings to allow warm air to rise out of occupied zones.
- Use ceiling fans to enhance air circulation and thermal comfort.



Photo: Architectural Energy Corporation
Pearl Ridge Elementary School in Honolulu has no mechanical cooling system. It uses natural ventilation strategies. Ceiling fans and operable windows help keep the front office thermally comfortable.

- Consider elements such as vents and casement windows to improve air circulation.
- Use landscaping and airflow strategies to enhance the effectiveness of cross-ventilation at the site.
- Consider using thermal chimney, ventilating skylights, or solar powered roof fans.

Distribution Systems

Design an energy-efficient air distribution system that protects against poor indoor air quality.

- Where individual room control is desired or diverse loads are present, employ variable air volume (VAV) systems (versus constant air systems) to capitalize on reduced fan loads during times of reduced demand.
- Use constant volume systems when the load is uniform and predictable (e.g., kitchen).
- If a particular mechanical system serves more than one space, ensure that each space has the same orientation and fulfills a similar function. Consider independent mechanical rooms and systems on separate floors to reduce ductwork and enhance the balance of air delivered.
- Consider a design that supplies air at lower temperatures to reduce airflow requirements and fan energy.
- Specify ductwork that has smooth interior surfaces and transitions to minimize the collection of microbial growth. Design ductwork and plenums to minimize the accumulation of dirt and moisture and to provide access areas in key locations for inspection, maintenance, and cleaning. Use mastic to seal metal ductwork. Pre-fabricated low leakage ductwork systems that snugly snap together are also available. Where possible, locate ductwork in conditioned or semiconditioned spaces.
- Specify duct leakage tests.
- Make sure that air handling units and filters are easy to access and maintain.
- Insulate supply ducts and provide an external vapor barrier.

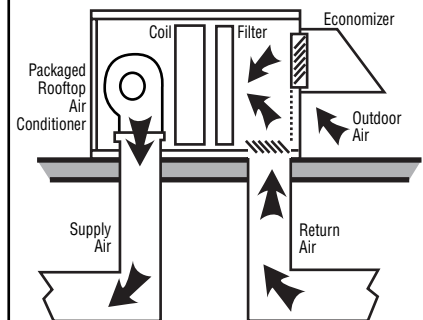

Economizer Cycle Diagram

An air economizer cycle based on enthalpy control can lower energy consumption by using as much as 100% outside air.

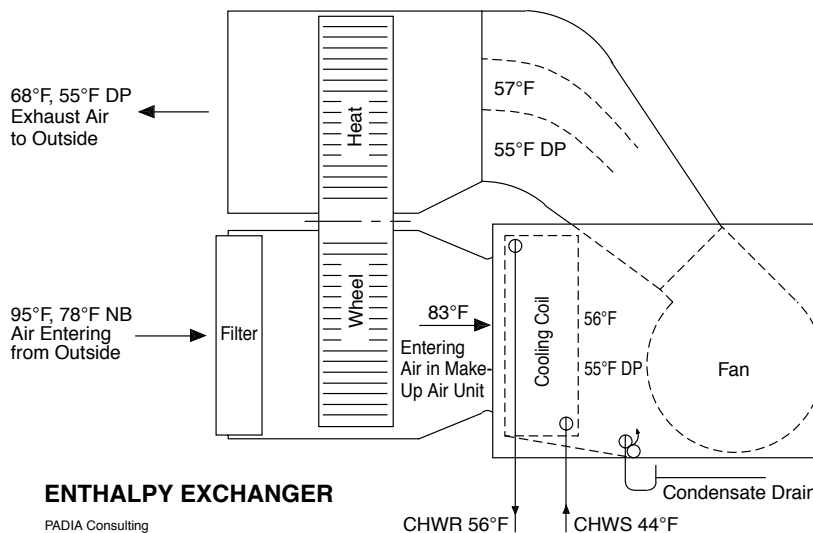

Enthalpy Recovery System

An enthalpy recovery system reduces energy consumption by capturing the energy that would normally be lost in the exhaust airstream.

Tropical Island Climates

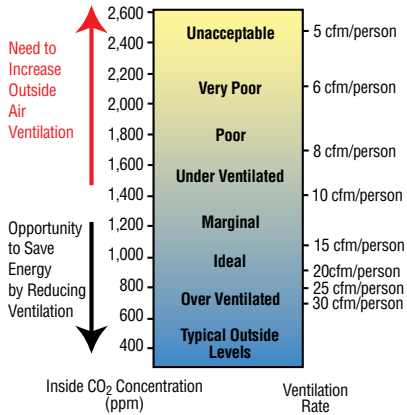
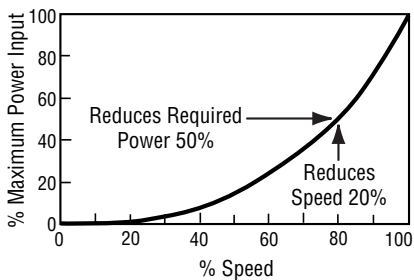

Diagram: TelAir, Goleta, CA

Conditions of Indoor Air Quality

Carbon dioxide concentration is a factor in determining adequate indoor air quality.



Graphic: Padia Consulting

Variable Air Volume Fan Speed Versus Input Power

Controlling motor speed to control air flow is the more energy-efficient strategy. Variable frequency drive control offers a distinct advantage over other forms of air volume control in VAV systems.

- Reduce duct pressures to minimize the amount of fan energy used to distribute the air. Use low-velocity coils and filters.
- To minimize energy consumption, select fans for the highest operating efficiency at predominant operating conditions, and use lower fan speeds to reduce noise levels. Consider direct-drive fans for their improved efficiency.
- Use filters that meet a minimum of 60% ASHRAE Dust Spot Method Standards.

Controls

To ensure proper, energy-efficient operation, implement a control strategy that is tied to key energy systems. Include system optimization, dynamic system control, integrated lighting, and mechanical system control.

- Analyze the applicability for direct digital control (DDC) for the specific site. These systems generally have the greatest benefit in larger schools. DDC systems will result in greater accuracy, performance, and energy savings. However, these systems are not necessarily feasible in smaller or remote schools with smaller maintenance staffs and limited phone capacities. Be sure to weigh these factors when specifying a DDC system.
- Set up the control system to operate according to need. Limit electrical demand during peak hours by turning off (or rotating) nonessential equipment.
- Establish temperature and humidity set points based on occupancy patterns, scheduling, and outside climatic conditions.
- Install occupancy sensors to reduce ventilation air requirements for unoccupied spaces.

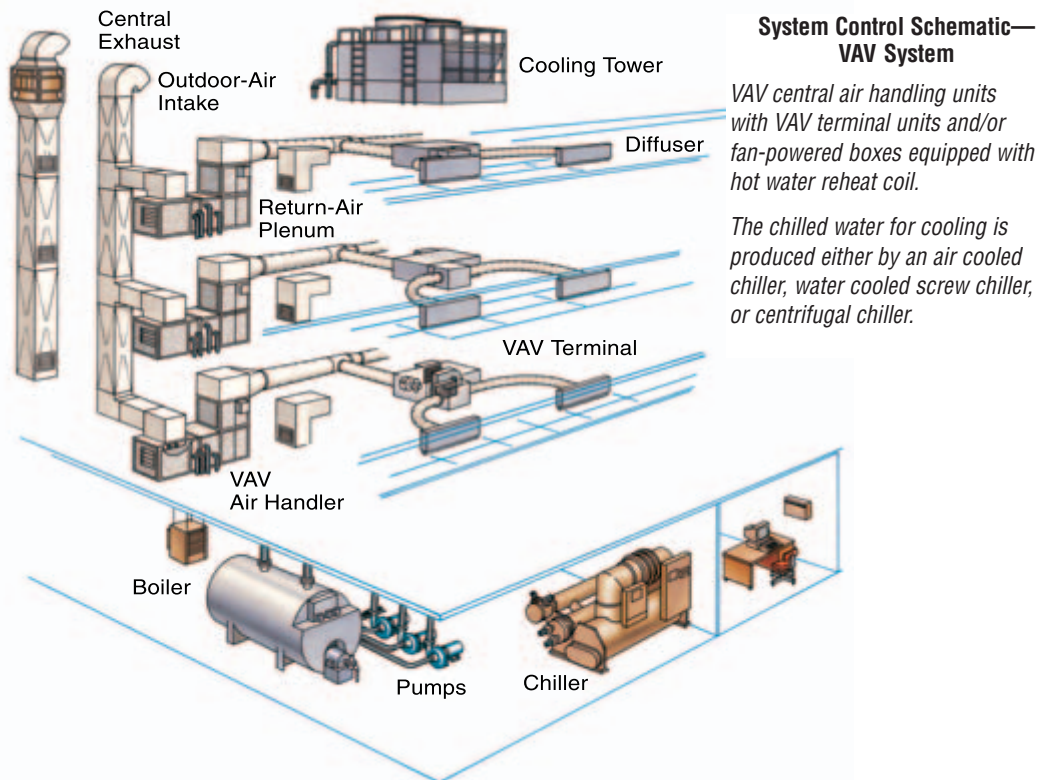

System Control Schematic—VAV System

VAV central air handling units with VAV terminal units and/or fan-powered boxes equipped with hot water reheat coil.

The chilled water for cooling is produced either by an air cooled chiller, water cooled screw chiller, or centrifugal chiller.

- Periodically verify the accuracy of the sensors and control functions and calibrate if necessary.
- Periodically audit all computer-controlled mechanical and ventilation systems to verify performance and calibration.
- Install sensors for relative humidity and temperature as close to occupants as possible. Carbon dioxide concentration sensors may enhance a properly designed and maintained ventilation system.
- Supply air temperature reset controls for VAV systems are not applicable in these climates since supply air temperatures need to be as low as possible for better dehumidification.
- Control strategies for chilled water plant operation should address:
 - variable speed drives
 - modular chillers or chillers with multiple compressors
 - a chilled water reset
 - variable flow through the chillers
 - a condenser water reset
 - chiller sequencing
 - the soft-starting of chiller motors
 - demand control.
- Consider time clocks with night and weekend setbacks.
- Work with the school system to establish a means to monitor and document the performance of the energy management control system and train maintenance staff.

Hot and Chilled Water Distribution

- Carefully select heat exchangers with a low approach temperature and reduced pressure drops.
- In large systems with multiple heat exchangers, designate a separate pump for each heat exchanger to maintain high efficiency at part-load operating conditions.
- Consider primary pumping systems with variable-speed drives because of their effects on a part-load energy use.



Indoor Air Quality: Tools for Schools

This program is designed to give schools the information and skills they need to manage air quality in a low-cost, practical manner. The kit is published by the EPA and co-sponsored by the American Lung Association.



Control strategies like occupancy and pollutant sensors are essential to improve efficiency in the school's energy system management.



ASHRAE sets the industry standards for mechanical and ventilation systems, as well as providing continuing education for design professionals on the latest strategies and techniques for mechanical system design. ASHRAE also produces the ASHRAE GreenGuide, a manual that provides information to design teams on incorporating sustainable and efficient HVAC strategies into buildings.



Photo: NREL/PIX09214

An energy management system optimizes mechanical and lighting system operation.

Water Heating

- Consider a solar water heating system, especially in year-round schools. Such systems are excellent applications for this climate, where gas and electric power is expensive and solar power is available year round.
- Heat pump water heaters or tankless (instantaneous) water heaters are also good applications for this climate. Use tankless water heaters in remote areas that require small amounts of hot water. On some islands, hot water systems are not needed at all.
- For larger schools, consider heat recovery options that are available for larger packaged air conditioning systems.
- Consider localized versus centralized hot water equipment by evaluating the types of loads served. A remote location may be best served by localized equipment.
- Minimize the standby heat losses from hot water distribution piping and hot water storage tanks by increasing insulation levels, using anti-convection valves, and using heat traps.

Renewable Energy Systems

Renewable energy is abundant and can contribute to reduced energy costs and reduced air pollution. More importantly, the renewable energy systems that you incorporate into your school design will demonstrate to the students the technologies that will fuel the 21st century.

Over the past two decades, the costs of renewable energy systems have dropped dramatically. According to the Department of Energy's Office of Power Technologies, wind turbines can now produce electricity at less than 4 cents per kilowatt-hour—a sevenfold reduction in energy cost. Concentrating solar technologies and photovoltaic costs have dropped more than threefold during the past 20 years. And, with improvements in analytical tools, passive solar and daylighting technologies can be implemented into schools with less than a two-year return on investment.

Incorporating renewable energy options into your school design helps students learn firsthand about these cost-effective and energy-efficient options. Input from teachers early in the design process helps to ensure that energy features are incorporated in a way that optimizes the learning experience. “Buildings that teach” offer students an intriguing, interactive way to learn about relevant topics like energy and the environment.



Photo: Glen Bair, by State of Texas
Energy Conservation Office

*Photovoltaic-powered school
zone warning signals can be used
instead of traditional electric traffic
signals.*



Photo: Warren Gretz, NREL/PIX08845

*Solar resources are highly viable
in the tropical island climates.
This children's park in the
U.S. Virgin Islands uses
photovoltaic panels.*



Photo: American Wind Energy Association

Schools on tropical island sites with suitable wind resources can implement wind turbines to save thousands of dollars annually on energy costs, and, in some cases, even make money by selling the generated power.

Design Guidelines for Renewable Energy Systems

Available Renewable Energy Resources

When evaluating potential renewable systems, use the best available historic climatic data, closest to the school site.

- Solar radiation levels are high all year in most of these climate zones, making solar systems an excellent renewable energy strategy. Additional island-specific information can be obtained from the State Energy Alternatives Web site (www.eere.energy.gov/state_energy/).

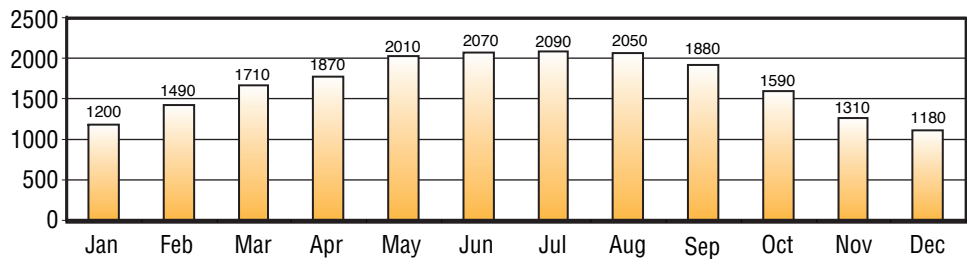

Average incident solar radiation data for Honolulu, Hawaii (Btus/square foot/day)

NOTE: Watts/square meter x .317 = Btus/square foot

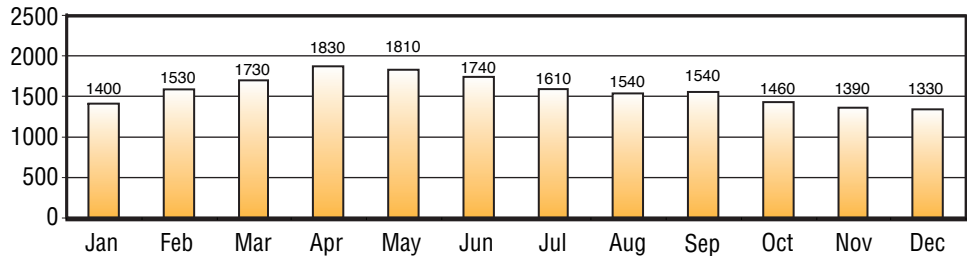

Average incident solar radiation data for Guam (Btus/square foot/day)

NOTE: Watts/square meter x .317 = Btus/square foot

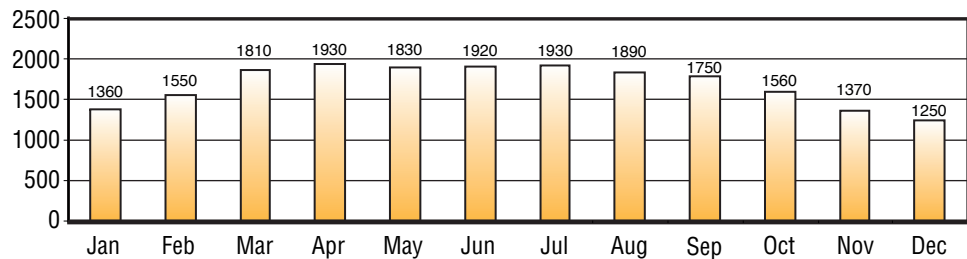

Average incident solar radiation data for San Juan, Puerto Rico (Btus/square foot/day)

NOTE: Watts/square meter x .317 = Btus/square foot

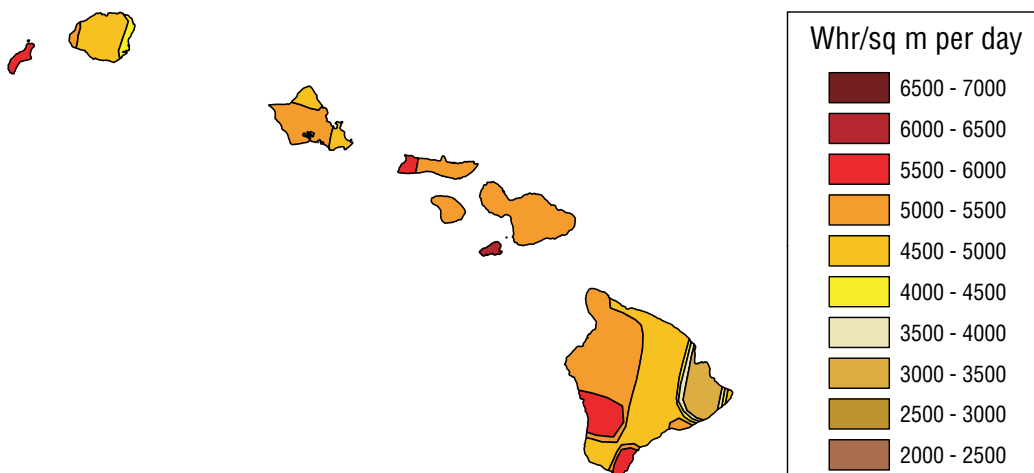

Average direct normal radiation (kWh/square meter/day)

- Wind generation becomes cost effective in most areas when the average wind speed exceeds 10 miles per hour. In locations where the wind is marginally below this amount, you should still consider wind systems for their educational value.

Wind resources are substantial in much of the tropical island climate. According to the National Renewable Energy Laboratory, Puerto Rico has class 3 and 4 annual wind power, as do the U.S. Virgin Islands. Guam experiences class 2 wind power. Data from American Samoa indicates low wind, but ship winds indicate class 3 to class 4 power in the surrounding waters. The Northern Mariana Islands also have lower wind power measurement on land (class 2 and 3), but ship measurement from the surrounding sea indicate power in the range of class 5 to class 6.

Check DOE's State Energy Alternatives Web site (see Web Resources section) to determine the wind resources in your location.

Building Orientation and Solar Access

Employing renewable energy strategies cost effectively requires the school to be sited to maximize the locally available natural resources.

- Establish the building on an east-west axis that maximizes southern exposure in the northern hemisphere and northern exposure in the southern hemisphere for solar systems.
- Employ the necessary shading strategies.



Photo: NREL/PIX08884

This building-integrated photovoltaic system covers the roof of this school's cafeteria.



The view from this ancient dwelling demonstrates that massive walls have long been used to minimize the impact of midday sun. Combining massive walls with wall insulation can delay thermal heat gains in the school — and reduce the need for mechanical cooling — by as long as 12 hours. Massive walls have long been used to minimize the impact of midday sun.

Building-Integrated Approaches

To maximize cost effectiveness and improve aesthetics, consider integrating solar thermal and photovoltaic systems into the building shell.

- Integrate solar systems into the overall design to allow the system to serve multiple purposes (e.g, a photovoltaic array that can also serve as a covered walkway).
- Eliminate the additional costs associated with a typical solar system’s structure by designing the building’s roof assembly to also support the solar components.
- Minimize redundant materials by using the glazing of the solar collector as the waterproofing skin of the building.
- Incorporate building-integrated approaches to save valuable land.
- Consider designs where the solar panels shade or provide extra insulation for the roof to help reduce solar heat gain through the roof.

Renewable Energy Applications for Schools

Several renewable energy systems are fully or partially applicable in the tropical island climates. Consider daylighting, solar water heating, wind, geothermal, and photovoltaics as energy-saving strategies that also teach students about energy technologies.

Daylighting

Because of the unique potential of this renewable energy option to provide multiple benefits, daylighting is discussed in a separate section within these guidelines. See the Daylighting and Windows section.

Solar Hot Water

When water heating is required, solar water heating systems are excellent for this climate.

Several types of systems could be used in this region. Two of the more common are “drainback” and “closed-loop” systems.

Drainback Systems

- Use “drainback” solar systems in small applications where the piping can be sloped back toward a collection tank.

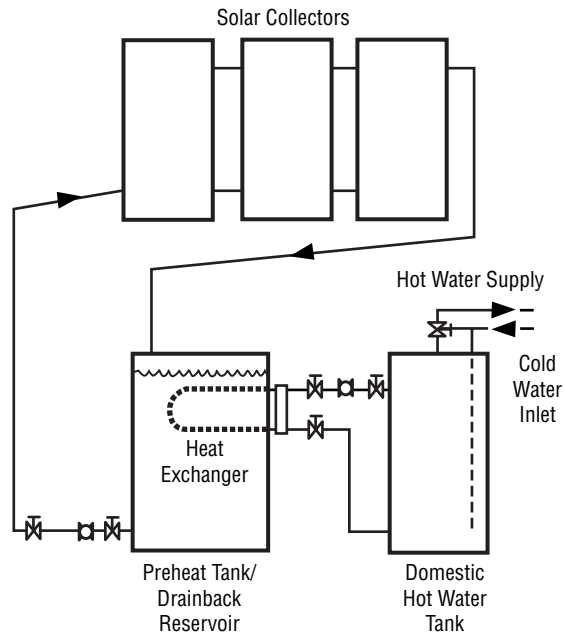

Drainback Solar Hot Water System Diagram

A drainback system pumps water from a storage tank when adequate solar radiation is available.

Closed-Loop Systems

- Select a closed-loop solar system if piping layouts make drainback options impractical.

In closed-loop systems, a small pump circulates fluids through the collection loop when there is adequate solar radiation and the differential between the collector fluid temperature and the tank temperature justifies the collection mode continuing.

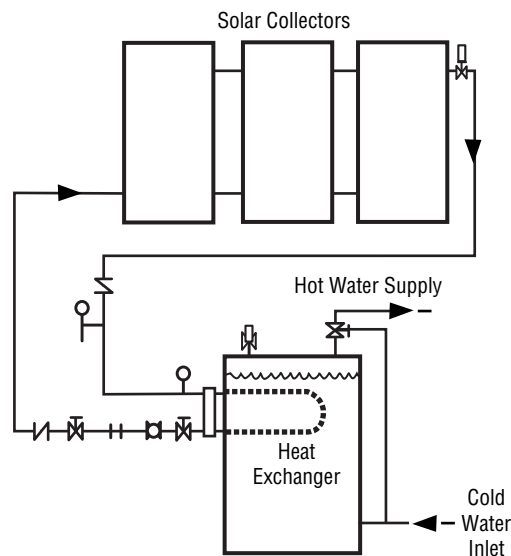

Closed-Loop Solar Hot Water System Diagram

Closed-loop systems use a controller to shut the system down when the temperature differential becomes too small or when the tank reaches a set peak temperature.



This drainback solar domestic water system was added to the school's kitchen roof area and provides most of the hot water required by the cafeteria.

Wind

Wind turbines convert the kinetic energy in the wind into mechanical power that can either be used directly (e.g., water pumping) or converted into electricity.

- Consider wind electric generators in areas where the sustained wind speed exceeds 10 miles per hour. Many areas of the tropical island climates have feasible wind power.
- Consider wind systems for well water pumping.
- Address potential noise problems by properly siting wind installations.
- Consider the educational benefits of installing a windmill or a wind generator on the school site.

Photovoltaics

Photovoltaic modules, which convert sunlight into electricity, are highly applicable in most of the tropical island climates. Photovoltaics have numerous school applications and can be designed as “stand-alone” applications or for utility “grid-connected” applications. They are particularly effective in powering roof fans.

Photo: Applied Power Corporation/
PIX08804

This stand-alone photovoltaic system in Puerto Rico not only saves on electricity costs, but also can serve as an excellent teaching tool for science classes on solar energy.



Stand-Alone Systems

- Select stand-alone photovoltaic systems to address small, remotely located loads. They tend to be more cost effective than the conventional approach that requires extensive underground wiring. Applications include parking and walkway lighting, caution lights at street crossings, security lights, emergency telephone call boxes, and remote signage.

Because these systems are not connected to the utility grid, battery storage is typically required. Depending on the device being powered, a DC to AC inverter may or may not be installed.

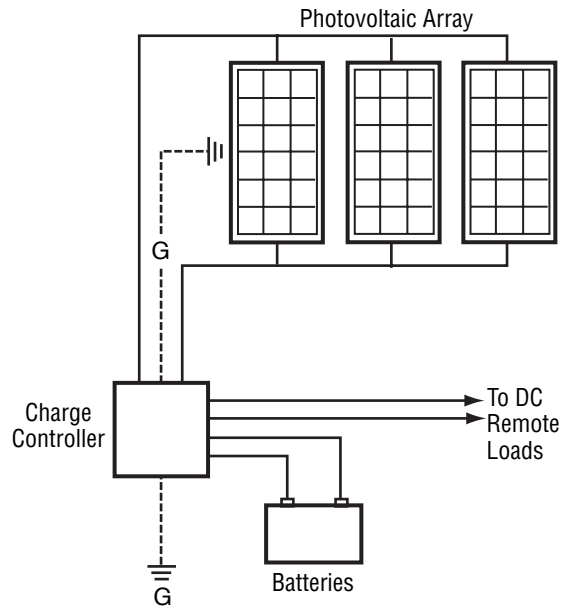

Stand-Alone Photovoltaic System

Stand-alone systems are ideal for remote loads located away from electrical lines.



Photo: Byron Stafford, NREL/PIX7403

Photovoltaics are excellent for powering warning systems, like this hurricane warning system in St. Croix, U.S. Virgin Islands.



Photo: Bluffsview Middle School

Photovoltaic systems can serve as excellent science teaching tools about how energy works. Their impact on energy and related cost savings can also be a great lesson in conservation and economics.



Photovoltaic systems in schools provide substantial energy savings and are educational tools for sustainability.

Grid-Connected Systems

- Choose grid-connected systems in large applications where peak load pricing is high or where first cost is an issue. Because these systems typically rely on the utility to provide power when the sun isn't shining, battery cost is eliminated and long-term maintenance is reduced greatly. This strategy, particularly in hot and humid climates, is advantageous to the utility and the school because peak demand will occur when the sun is shining.

In these applications, a DC to AC inverter is required. Additionally, protection must be provided to ensure that the system does not feed back into the utility grid in the event of a utility power failure.

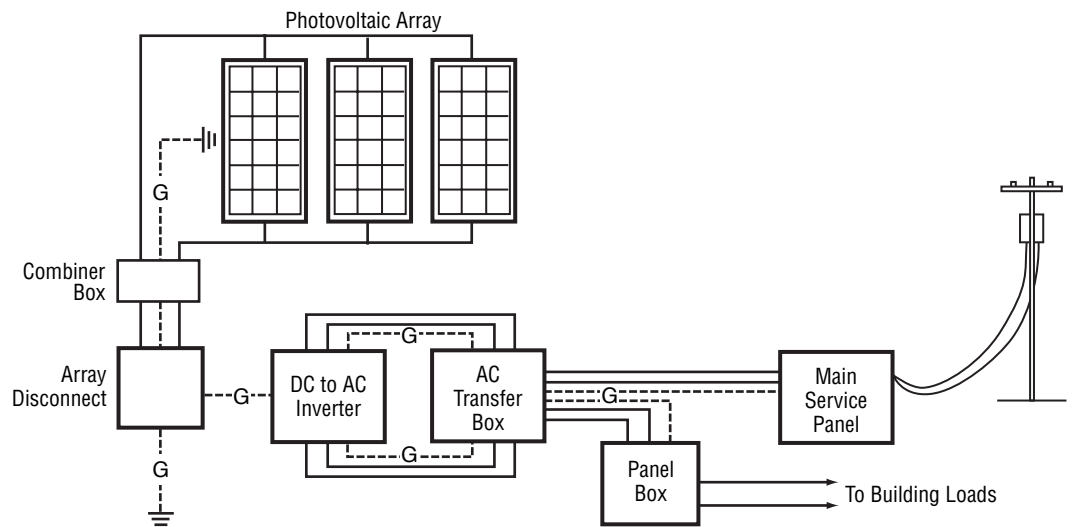

Grid-Connected Photovoltaic System Diagram

Grid-connected systems work well for large loads located near electrical grids.

Water Conservation

Fresh water conservation is a vital issue in the tropical island climate. With continued development and population growth on the tropical islands, surface and groundwater sources of potable water are further taxed. And unlike in many regions on the mainland, these islands do not have the option to pipe in water from other locations. For these reasons, strategies to reduce the amount of potable water used at school facilities are critical for any new project.

Water rationing is becoming commonplace in thousands of communities across the country, and the price of water is escalating at unprecedented rates. You can make a considerable difference at your school by reducing community water use. By using water-conserving fixtures, implementing graywater or rainwater catchment systems, and using xeriscape practices, schools can easily reduce their municipal water consumption 25%–75%.



Photo: NREL/PIX00653

This water-conserving sink uses infrared sensors to cut down on water consumption, creating significant cost-related reductions.



A water gauge that measures the rainwater collection tank level helps demonstrate the value of water to students.

Water needs for irrigation can be minimized by using native planting.



Design Guidelines for Conserving Water

Water-Conserving Landscaping Strategies

The demand for water will be largely determined by the amount of site irrigation required. Limiting new landscaped areas and consider the types of plants and vegetation installed to reduce water needs. Some areas—like the windward side of an island—may require no irrigation systems.

- Minimize disruption to the site conditions, and retain as much native vegetation as practical. Maximize trees as cooling agents to minimize ground evaporation.
- Incorporate native and drought-resistant plants and xeriscape principles to minimize irrigation requirements.
- Ensure that rainwater from roofs drains into landscaping.
- Use porous paving surfaces to allow rainwater to drain into soil.
- In-ground, automatic irrigation systems are generally not recommended. Consider service sprinklers to efficiently meet irrigation needs.

Conserving Water during Construction

You can save a considerable amount of water during your construction projects by including specifications that address water during construction.

- Include disincentives in specifications to the general contractor for excessive water use and incentives for reducing consumption during construction.
- Specify that the general contractor is responsible for water cost during construction.
- Minimize watering requirements by specifying times of year when new landscaping should be done.
- At pre-bid meetings, stress to the general contractor and subcontractors the importance of water conservation.

Water-Conserving Fixtures

One of the most effective means to limit demand for water is to reduce the requirements associated with necessary plumbing fixtures. Depending upon your site’s location and transport requirements, consider cost and availability when specifying low-flow fixtures.

- Consider the standards of the 1992 Energy Policy Act as a minimum. Specify low-flow toilets that use less than 1.6 gallons per flush.
- Consider showerheads that require less than 2.5 gallons per minute and incorporate levers for reducing flow 2.1–1.5 gallons per minute.
- Use aerators to reduce flow in lavatory faucets to as low as 1 gallon per minute.
- Specify self-closing, slow-closing, or electronic faucets in student bathrooms where faucets may be left running.
- Consider waterless urinals or 1-gallon-per-flush urinals.

Projected Water Savings by Installing Waterless Urinals in Schools

	School with Regular Urinals	School with Waterless Urinals
Number of Males	300	300
Number of Urinals	10	10
Use/Day/Male	2	2
Gallon/Flush	3	0
School Days/Year	185	185
Water Saved/Year		222,000 Gallons

Waterless urinals are one way to reduce water usage in your school.

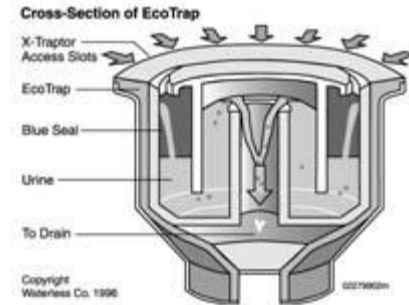

Waterless Urinals

With waterless urinals, the traditional water-filled trap drain is eliminated, and the unit does not need to be flushed.



Photo: Darrow School

Biological wastewater treatment systems, like this living machine, can transform “waste” into a resource that can be used to improve soil conditions, save water, reduce the need for municipal treatment infrastructure, and address problems directly associated with septic system technologies.

Rainwater Management

Rainwater, captured from the roof of your school, can be harvested and stored in cisterns for nonpotable use. Rainwater catchment is very common on many islands in this climate, but look at the island’s microclimates to ensure that enough annual rainfall will occur at the school site to make such a system feasible.

In most rainwater catchment systems, the water runs off the roof into gutters and downspouts, which carry the water to a storage device for future use.

- Consider the savings made possible by a reduced need for retention ponds.
- When cost effective, implement a rainwater collection system to provide water for toilet flushing and irrigation through separate plumbing lines.
- Use a durable storage container, and locate it away from direct sunlight and septic tanks.
- Design the system so that potable water can be safely added to the storage tank, and guarantee an uninterrupted supply to toilets and the irrigation system.
- Determine the necessary water treatment and filters for your area. If water catchment is not feasible, divert rainwater from roofs onto landscaping. Maximize use of permeable asphalt and concrete.

Rainwater Catchment Diagram

The initial water collected off the roof is intentionally “dumped” to reduce filtration of large particles. A low flow pump and chlorinator are used to stop algae growth. Makeup water from a typical potable supply is added to the tank when rainfall is insufficient.

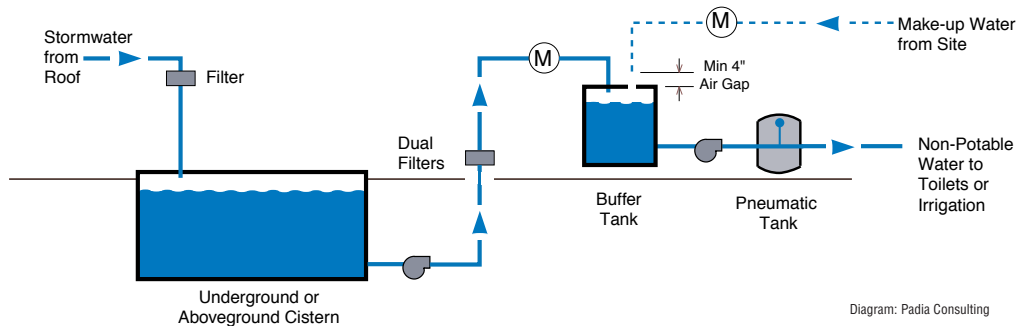

Graywater Systems

Relatively uncontaminated waste can be easily captured, stored, and used to fulfill nonpotable needs.

- Use graywater from lavatories and water fountains for underground site irrigation. Design the system, according to local regulations, to:
 - move the graywater into the soil as soon as possible instead of storing it
 - irrigate below the surface of the ground only
 - deliver the graywater to biologically activate the soil where organic matter will quickly be broken down.
- Consider recycled, brackish, or ocean water for nonpotable uses.

Graywater System Diagram

Graywater collects through a separate plumbing system and is treated and stored in an underground tank. The graywater is then pumped into a second hydropneumatic tank that maintains the proper system pressure. When necessary, additional fresh water is brought into the graywater storage tank to maintain the minimum level needed for the circulation pumps.

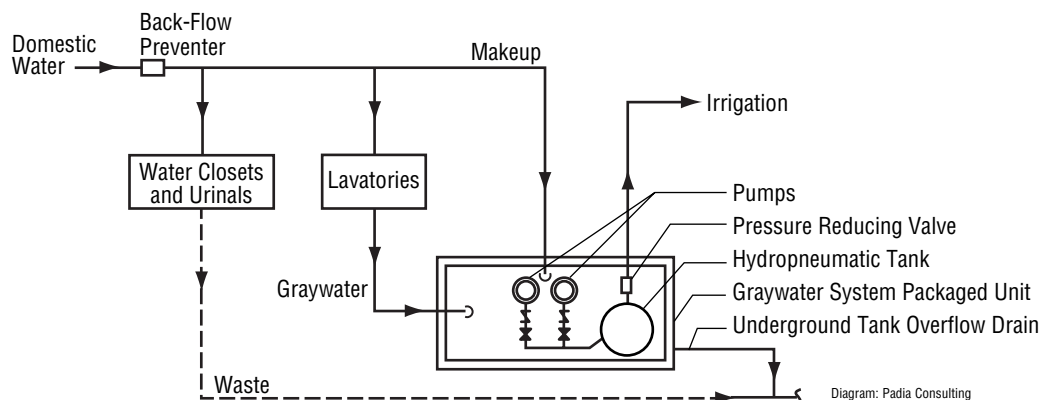

Recycling Systems and Waste Management

Schools produce billions of pounds of municipal solid waste each year in the United States. Waste management is a growing problem for all communities, but poses an extra challenge for islands in this tropical climate, where landfill space is limited.

You can help reduce much of this waste by recycling or composting at your schools. In a compilation of studies of waste generation in Washington State and New York City schools reported by the EPA, paper was found to account for as much as half of the waste in schools, organic (compostable) materials as much as one-third, plastic about 10%, and glass and metals about 7%. To the extent that school buildings can be made more recycling and composting friendly, very high percentages of this waste material can be kept out of the waste stream. In fact, if every school system implemented aggressive recycling efforts, landfills would have 1.5 billion pounds less solid waste each year.

Recycling programs are becoming commonplace in tropical island climates, but costs may still be higher than in other areas of the United States, since some of this recyclable material is shipped to the mainland for processing. However, by creating schools in which comprehensive waste recycling can be carried out, your design team has an opportunity to instill the practice of recycling. Hundreds of schools throughout the country have embarked on exciting and highly successful hands-on programs to encourage recycling. Often, the students design and manage these programs—and see the fruits of their labors as they quantify waste reduction or recycling. The most successful recycling and waste management programs are integrated into classes, where students make use of mathematical, investigative, and communication skills to implement these programs.



For efficient recycling collection, the recycling bins must be labeled and located in easily accessible areas.



Photo: Chittenden Solid Waste District
Teaching students the benefits of recycling improves the overall success rate of a school's waste reduction program by reinforcing the importance of minimizing waste.



Photo: Huntsville High School East, Huntsville, Alabama

Signage can encourage students and staff to actively recycle major waste materials in the school.

Design Guidelines for Implementing Recycling Systems and Waste Management

Paper, Plastics, Glass, and Aluminum Recycling

Students are able and eager to participate in recycling programs. Successful recycling programs teach students recycling skills and save money by reusing materials and avoiding disposal fees.

Paper represents one of the largest components of a school's waste stream. Glass, aluminum, plastic bottles, cans, and even styrofoam can now be recycled.

- Allocate space within each classroom, the main administrative areas, and the cafeteria for white and mixed paper waste.
- Provide central collection points for paper and cardboard that are convenient to custodial staff as well as collection agencies or companies.
- Place the receptacles for all recyclables where the waste is generated. The best places are in the cafeteria and administrative areas. Receptacles should be made available in public spaces, gymnasiums, and hallways for plastic and aluminum in schools with soda machines.
- Locate convenient bins for other materials being recycled.

In implementing a comprehensive approach to recycling, consider all the aspects needed to make recycling easier and more educational.

- Integrate containers into cabinetry, or provide free-standing stations that do not disrupt other functions in the spaces.
- Design bins to be easily dumped into a cart that will be taken by custodial staff to a central collection point.
- Incorporate chutes to accommodate recycling in multistory facilities.
- Establish a color coding system, and use clearly labeled dispersed containers and centralized bins to distinguish the recycled material.
- Use dispersed receptacles and centralized bins that are easy to clean and maintain.
- Coordinate with a local recycling agency or waste hauler to obtain important information regarding its trucks and how it prefers to access the recycling bins.

Safe Disposal of Hazardous Waste

Provide a secure space within the school to temporarily store hazardous materials (e.g., batteries, fluorescent lights, medical waste) until they can be taken to a recycling center or safe disposal site.

Composting

About one-third of the average school's waste stream is food and other organic materials. Composting is one environmentally friendly way of handling this waste.

- Design a conveniently located composting bin.
- Ensure excess moisture does not affect the compost bin. Keep extra “dry” compost material, such as mixed shredded paper, cardboard egg cartons, and macadamia nut shells, handy to maintain the correct wet-dry balance in the compost bin.
- Use vermicompost bins in classrooms as educational tools. The bins use worms to dramatically accelerate decomposition.
- Green waste recycling should also be considered for the school's plant trimmings, tree prunings, grass clippings, and other landscaping waste. These waste products are turned into mulch and compost. Removing these items from the waste stream conserves landfill space. Check with local recycling and/or waste management agencies to see if green waste recycling is available.



Composted kitchen scraps can be used to fertilize gardens at the school.



*Photo: Chittenden Solid Waste District
Michael Kellogg, waste reduction specialist for the Chittenden Solid Waste District, Vermont, teaches students from Calliope House of Allen Brook School in Williston how worms can compost their food scraps.*



Photo: NREL/PIX05289

Recycling by the contractor during construction should be encouraged to decrease the amount of waste sent to landfills.

Construction Waste Recycling and Waste Management

Recycling efforts should begin during the construction of the school and engage the general contractor and all subcontractors.

- Specify the specific jobsite wastes (corrugated cardboard, all metals, clean wood waste, gypsum board, beverage containers, and clean fill material) to be recycled during construction.
- Require the contractor to have a waste management plan that involves everyone on the site.
- Stockpile topsoil and rock for future ground cover.
- Monitor the contractors and subcontractor's recycling efforts during construction.

To minimize the impacts from any hazardous materials or waste used in construction, require that the contractor use safe handling, storage, and control procedures, and specify that the procedures minimize waste.

Photo: Craig Miller Productions and DOE/PIX03494

Construction waste materials, including corrugated cardboard, metals, clean wood waste, gypsum board, and clean fill material like concrete or brick can be recycled or reused.



Transportation

In many school districts across the country, more energy dollars are spent transporting students to and from school than in meeting the energy needs of their school buildings. As much as 40% of morning traffic congestion at schools is a result of parents driving children to school.

Incorporating a network of safe walkways and bike paths that connect into the community’s sidewalks and greenways can reduce local traffic congestion, minimize busing costs, and reduce air pollution. And, by incorporating natural gas, biodiesel, methanol, or solar electric buses into a district’s vehicle fleet, you can help to reduce fuel costs and harmful emissions—lowering fuel costs and contributing to reduced operating and maintenance costs.

Today, nearly 60% of all school buses run on diesel. Alternative fuel buses and school fleet vehicles can be used to provide environmentally friendly alternatives to high-polluting vehicles. Options for alternative fuel buses include electric, hybrid electric, compressed natural gas (CNG), ethanol, and biodiesel—all of which are available today. Although all these alternative fuels may not yet be available on every island in this climate, current options for alternative fuel buses include electric, hybrid electric, propane, ethanol, and biodiesel. In addition to long-term energy savings, these vehicles serve as great educational tools for the students and the community. DOE’s Clean Cities Program can help you determine the best alternative fuel vehicles (AFVs) for your fleet.



Driving students individually to school each day creates 0.5–3.3 tons of carbon dioxide per student being emitted into the air each year. Providing safe pedestrian walkways throughout the neighborhood allows students who attend a school in their community to walk.



Photo: Senior Airman Lesley Waters
Andersen Elementary School, Guam, provides good access to buses and other types of alternative transportation that will reduce the amount of traffic and air pollution near the school.

Design Guidelines for Integrating Transportation Considerations into School Design

Connecting the School to the Community

One measure of success is the degree to which the school is a vital part of the community. If addressed early in the site selection and design phase, a school can be planned to serve the students and the entire community.

- Design the school so that the athletic fields, gymnasium, media center, and classrooms are accessible and can be shared with the community.
- Provide good access to any public transit.
- Link the school to the surrounding communities through safe bicycle routes, pedestrian pathways, and greenways.
- Incorporate convenient bicycle parking at the school to discourage single car traffic.

In growing areas, more schools are being built in conjunction with large subdivisions. This situation offers the school system and the community an excellent opportunity to coordinate with developers to make the school a more integral part of the community.

- Work with the developer to implement new, safe walkways and bike paths that link the neighborhood to the school.
- Develop a master plan with the community so that the main pedestrian ways to the site do not cross over busy roads. Or, if that cannot be avoided, provide safe and handicap-accessible pedestrian overpasses or underpasses.
- Develop recreational facilities that can be shared with the community.

Photo: Northwest Landing

With the tremendous amount of fuel currently consumed in transporting students, and the resulting pollution, schools must be located to minimize vehicular transportation and maximize the potential for pedestrian access. This master plan encourages walking instead of driving. Homes are, on average, a 10–15 minute walk from schools. Connecting school sites into the community's walkway system greatly decreases busing and car drop-offs and, in turn, reduces localized air pollution.



Walkways and Bike Paths

Safe walkways and bike paths that link the school to the sidewalks and greenways of the surrounding communities offer an easy solution to many of the school's budgetary problems and the community's air pollution and traffic problems. During the early planning of the school, the design team should work with the adjacent developers and local planning officials to implement strategies that enhance safe pedestrian paths connecting the school and the community.

- If sidewalks provide the main pedestrian access to the school, encourage the developer and/or local planning department to separate them a safe distance from the road.
- Use walkway surfacing materials that are appropriate for handicap access.
- Provide separate bike paths.
- Incorporate caution lights throughout the community to warn drivers of student pedestrian travel.
- Provide controllable crossing lights at the intersections of student pedestrian paths and roadways.
- Provide underpasses or overpasses at the intersections of high-traffic roads and main pedestrian paths.
- On school property, minimize potential conflicts by separating students from vehicular pathways.

High-Efficiency and Low-Emission Vehicles

High-efficiency vehicles and AFVs are encouraged in these climates, particularly since these communities must import 100% of their petroleum. In addition to the economic cost, relying entirely on imported oil creates a greater potential for catastrophic oil spills. Electric vehicles, hybrid electric vehicles (HEVs), and vehicles that use alternative fuels like propane, and ethanol are proven options and may be applicable and even cost effective.

Electric Vehicles

Although a school bus can be powered by pure electricity, only a few electric school bus options are available today. However, small maintenance carts and other vehicles that are used by school officials and staff can easily use electricity as a fuel. Electric vehicles typically have limited ranges, so they are great for short trips and stop-and-go driving. Electric vehicles reduce local pollution, but unless they are charged with renewable energy, they are still sources of regional pollution.

These charging areas can be viewable by students to assist with teaching about renewable energy and can include displays to indicate to students the contribution that the station is providing.

- To ensure availability, the school or school system should provide a charging station for electric vehicles.



CLEAN CITIES PROGRAM

The Clean Cities Program, sponsored by DOE, supports public-private partnerships that help put AFVs into the market and build supporting infrastructure.

Unlike traditional command and control programs, the Clean Cities Program takes a unique, voluntary approach to AFV development, working with coalitions of local stakeholders to help develop the industry and integrate this development into larger planning processes.

Currently Clean Cities coalitions are dedicated to putting AFVs on the road. The Clean Cities Program helps educate fleets across the country on which AFVs and fuel types are right for each fleet. Coalitions also help fleets understand incentives and legislation related to AFVs. More information on the Clean Cities Program can be found in the Web Resources section.



Photo: Medford Township Board of Education

Medford Township Schools, Medford, New Jersey, converted 22 school buses to run on a fuel consisting of 20% soybean-derived biodiesel. According to Joe Biluck, director of operations for the school system, their goal of reducing pollution has been achieved. Particulate emissions have been reduced by 35%–40%.



Photo: NREL/PIX04152

This school bus looks and operates like a standard diesel bus but runs on alternative fuel.

Hybrid Electric Vehicles

HEVs have the same power as conventional vehicles and do not have the reduced driving range that electric vehicles have. There are several options for HEV buses available today, and there are two HEV automobile models that can be used as school fleet vehicles. HEVs can be produced in a variety of ways, but typically the battery pack helps supplement the vehicle's power when accelerating and hill climbing. During stop-and-go driving, the traditional gasoline engine and batteries work together. For extended highway driving, the engine does most of the work because that is when it is operating most efficiently.

Propane

Propane has been used as a vehicle fuel on islands in tropical island climates, such as Hawaii, for more than 25 years, so the distribution infrastructure is well established. This fuel has helped reduce carbon monoxide emissions. However, it is nonrenewable, as it is produced from fossil fuel refinery by-products and natural gas reserves.

Ethanol

Ethanol is typically produced from domestically grown, plant-based materials such as corn or other grains. Ethanol is a promising alternative fuel for this climate because it can be produced locally from materials such as sugarcane molasses and agricultural wastes, once production facilities are established. Ethanol buses and vehicles are good options for school districts because several vehicle choices are available.

Vehicles that use ethanol as a fuel perform as well as typical conventional vehicles. Under current conditions, the use of ethanol-blended fuels such as E85 (85% ethanol and 15% gasoline) can reduce the net emissions of greenhouse gases by as much as 37%.

- To ensure availability, the school or school system should provide a storage tank for ethanol fuel.

Resource-Efficient Building Products

A school, like any building, is only as good as the sum of the materials and products from which it is made. To create a high performance school, your design team must choose the most appropriate materials and components and combine these components effectively through good design and construction practices.

Typically, architects and engineers primarily consider the performance of materials and components in terms of how they serve their intended functions in the building. Material function may be a top consideration, but your design team should also consider the materials from a broader environmental perspective. For instance, in the tropical island climates, durability is a vital consideration. Also, you should evaluate embodied energy costs. Because of the additional transport energy and cost required, materials that may be efficient for other locales would be less so in this area. Specify local materials such as basalt and tropical woods when practical.

Indoor air quality can also be greatly affected by indoor materials. For example, eliminating or minimizing volatile organic compounds (VOC) in paints, carpet, and adhesives in addition to minimizing formaldehyde in plywood, particleboard, composite doors, and cabinets will help to improve the air quality of the classroom.

Moisture resistance is also a key consideration in materials selection for this humid climate. Materials should be mold resistant and easy to clean. Also, materials with high pest resistance should be selected.

The best resource-efficient products and systems help improve the indoor air quality, energy efficiency, and durability of a school, protect the natural environment by minimizing use of limited resources and promoting reuse and recycling.



Photo: NREL/PIX03049

Choosing durable, low-maintenance flooring will significantly reduce labor and replacement costs, and are especially recommended in high-traffic areas.

Photo: NREL/PIX03050

True linoleum is made from wood flour, cork, and linseed oil. It gets harder over time and makes for an attractive, durable surface.



Photo: NREL/PIX02213

These ceiling beams are made from recycled wood products.

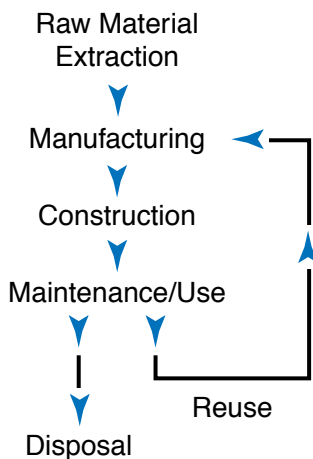

Life-Cycle Analysis

The life cycle of a building product can have significant environmental implications.

Design Guidelines for Resource-Efficient Building Products

The Life-Cycle Approach

To select environmentally preferable products, consider environmental impacts from all phases in the product’s life cycle. This approach is called life-cycle analysis. A product’s life cycle can be divided into the following phases:

- Raw material extraction
- Manufacturing
- Construction
- Maintenance and use
- Reuse or disposal.

Environmentally important impacts associated with the transportation of raw materials and finished products are included with each phase.

Unlike many consumer products, in which the “use” phase is very short (a soft-drink bottle, for example), building materials are typically in place for a relatively long time. As a result, if ongoing environmental impacts are associated with the use phase, these often outweigh those from other phases.

Following are descriptions of key issues to consider at each phase of the life cycle and some examples of products that have environmental advantages.

Phase 1: Raw Material Extraction

Building materials are all made from resources that are either mined from the Earth or harvested from its surface. The most common are sand and stone to make concrete, clay for bricks, trees for wood products, and petroleum for plastics and other petrochemical-based products.

- Eliminate component materials from rare or endangered resources.
- Determine whether there are significant ecological impacts from mining or harvesting the raw materials.
- Specify that wood products must be harvested from well-managed forests. Require that suppliers show credible third-party verification of environmentally sound harvesting methods.
- Determine the origin of the primary raw materials, and select options close to the site.



Photo: NREL/PIX03048

Cork is harvested from the cork oak. The bark can be removed from the tree about every 9 years without adversely affecting the tree. Cork is used to make cork and linoleum flooring.

Phase 2: Manufacturing

Manufacturing operations can vary considerably in their environmental impact. The manufacturer of one product may rely on numerous outsourcing operations at separate locations or obtain raw materials from another country. Another, less energy-intensive product may be produced in a single, well-integrated operation at one site with raw materials and components from nearby locations. Likewise, one manufacturer may use a process that relies on toxic chemicals; a competing manufacturer may incorporate environmentally friendly technologies to accomplish the same end.

- Determine whether the manufacturing process results in significant toxic or hazardous intermediaries or by-products. Most petrochemical-based processes involve some hazardous ingredients, so plastics should be used only when they offer significant performance advantages.
- Specify products that are made from recycled materials.
- Select products that are made from low-intensity energy processes. The manufacture of some materials, such as aluminum and plastics, requires a lot of energy while the “embodied energy” to make other materials is considerably less.
- Select products manufactured at facilities that use renewable energy.
- Consider the quantity of waste generated in the manufacturing process and the amount that is not readily usable for other purposes.

Phase 3: Construction

To a great degree, the energy and environmental impacts of products and materials are determined by the way they are implemented.

- Avoid products that contain pollutants by:
 - excluding high VOC paints, carpets, and adhesives
 - avoiding products with excessive formaldehyde
 - using the least toxic termite and insect control.
- When pesticide treatments are required, prefer bait-type systems over widespread chemical spraying and soil treatments.
- Separate materials that out-gas toxins (e.g., plywood with formaldehyde) or emit particulates (e.g., fiberglass insulation) with careful placement, encapsulation, or barriers.



Photo: NREL/PIX03041

This environmentally sound, no-VOC carpet tile line is leased and maintained by the manufacturer, which reduces waste by recycling and reusing the carpet tiles. The up-front and maintenance costs are lower, and the environmental and health benefits are substantial.



Photo: NREL/PIX03051

Choose carpet backings with low or no formaldehyde to avoid indoor air contamination.



Photo: BuildingGreen Inc.

Cement manufacturing is very energy intensive. The cement kiln is the largest piece of moving industrial machinery in common use, and temperatures inside it reach 2,700°F.



Photo: Barry Halkin Photography

Recycled tiles in school hallways and cafeterias require very low maintenance.

- Require the contractor to recycle construction materials.
- Ensure that unconventional products are installed properly.
- Require proper handling and storage of toxic materials at the job site.
- Require that the packaging of products, materials, and equipment delivered to the site be made of recyclable or reusable materials, and discourage unnecessary packaging.
- Ensure that product and material substitutions during construction contain the same energy and environmental benefits.
- Avoid materials that are likely to adversely affect occupant health. Interior furnishings and finishes and mechanical systems all have the potential to affect the indoor air quality. Material Safety Data Sheets can be good sources of information on the contents of various products.

Phase 4: Maintenance/Use

How easily building components can be maintained—as well as their impact on long-term energy, environmental, and health issues—is directly linked to the quality of the materials, products, and installation.

- Select materials, products, and equipment for their durability and maintenance characteristics. Pay particular attention to roofing systems, wall surfaces, flooring, and sealants—components that will be subject to high wear and tear or exposure to the elements.
- Avoid products with short expected life spans (unless they are made from low-impact, renewable materials and are easily recycled) or products that require frequent maintenance.
- Provide detailed guidance on any special maintenance or inspection requirements for unconventional materials or products.

Phase 5: Disposal or Reuse

Some surfaces in the school, such as carpets, may need to be replaced regularly. The building as a whole will eventually be replaced or require a total renovation. To minimize the environmental impacts of these activities, designers have to choose the right materials and use them wisely.

- Select materials that can be easily separated out for reuse or recycling after their useful life in the structure. Products that should be avoided include those that combine different materials (e.g., composites) or undergo fundamental chemical change during the manufacturing process.
- Avoid materials that become toxic or hazardous at the end of their useful lives. Preservative-treated wood, for example, contains highly toxic heavy metals that are contained within the wood for a time but will eventually be released when the wood decays or burns.

Checklist of Key Design Issues

The following checklist can be used by school designers, planners, and administrators when considering comprehensive high performance strategies for new and renovated schools.

The format follows each of the 10 design components and cross-references critical issues for the school decision makers.

Legend

- Critical Design Element
- Suggested Design Element



Photo: Kent Hwang
Since many schools serve as a cultural center for communities, it is important to design school facilities, like this stadium at Iolani School in Honolulu, Hawaii, to allow for shared recreational use.

Checklist of Key Issues for Site Design

Site Design

- Take advantage of your site’s natural resources by:
 - orienting the building to optimize solar access and daylighting
 - using vegetation and earth formations to your advantage.
- Incorporate rainwater catchment systems and xeriscape landscaping to save water.
- Retain and add site features that could become educational resources for teachers to incorporate into their instructional programs.
- Include outdoor teaching and interpretive areas.
- Provide diverse natural environments for exploration.
- Showcase local natural features.
- Maximize the educational opportunities of the pedestrian pathways from residential areas to the school.
- Provide the school with information on environmental design features.
- Develop the site in a manner that protects landscaping, ecosystems, and wildlife habitat.
- Employ energy-saving strategies, and use renewable energy to reduce air pollution.
- Develop on-site erosion control and stormwater management strategies.
- Connect the school’s walkways and bike paths directly into greenways and sidewalks around residential areas.
- Design the school as a part of the community by:
 - providing easy, safe pedestrian access to surrounding communities and mass transit
 - allowing for shared recreational facilities.

Reducing Operating Costs	Designing Buildings That Teach	Improving Academic Performances	Protecting Our Environment	Designing for Health, Safety, and Comfort	Supporting Community Values
<input checked="" type="checkbox"/>	<input checked="" type="checkbox"/>	<input type="checkbox"/>	<input checked="" type="checkbox"/>	<input type="checkbox"/>	
<input checked="" type="checkbox"/>	<input checked="" type="checkbox"/>		<input checked="" type="checkbox"/>	<input type="checkbox"/>	
<input checked="" type="checkbox"/>	<input checked="" type="checkbox"/>		<input checked="" type="checkbox"/>		<input checked="" type="checkbox"/>
	<input checked="" type="checkbox"/>	<input checked="" type="checkbox"/>	<input checked="" type="checkbox"/>		
	<input checked="" type="checkbox"/>	<input checked="" type="checkbox"/>	<input type="checkbox"/>		
	<input checked="" type="checkbox"/>	<input checked="" type="checkbox"/>	<input type="checkbox"/>		
	<input checked="" type="checkbox"/>	<input checked="" type="checkbox"/>	<input type="checkbox"/>		
	<input checked="" type="checkbox"/>	<input checked="" type="checkbox"/>	<input type="checkbox"/>		<input type="checkbox"/>
<input checked="" type="checkbox"/>	<input checked="" type="checkbox"/>	<input checked="" type="checkbox"/>	<input checked="" type="checkbox"/>		<input checked="" type="checkbox"/>
	<input checked="" type="checkbox"/>		<input checked="" type="checkbox"/>		<input checked="" type="checkbox"/>
<input checked="" type="checkbox"/>	<input checked="" type="checkbox"/>		<input checked="" type="checkbox"/>	<input checked="" type="checkbox"/>	<input checked="" type="checkbox"/>
<input checked="" type="checkbox"/>	<input checked="" type="checkbox"/>		<input checked="" type="checkbox"/>		<input checked="" type="checkbox"/>
			<input checked="" type="checkbox"/>		<input checked="" type="checkbox"/>

Checklist of Key Issues for Daylighting and Windows

Daylighting and Windows

- Account for all the financial and environmental benefits associated with daylighting, including:
 - reduced electrical lighting and cooling
 - decreased electrical service to the site
 - less mechanical system maintenance
 - fewer lamp replacements.
- Evaluate and avoid negative impacts associated with window treatments, placement, and types, including:
 - glare and direct beam radiation entering teaching and work spaces
 - excessive radiation
 - comfort problems
 - maintenance.
- Make daylighting strategies obvious to the students.
- Create deliberate connections to the outside environment so that changes in weather conditions are apparent as well as stimulating to students.
- Incorporate daylighting strategies that could be enhanced through student participation and understanding.
- Recognize the importance of daylighting as a strategy to create superior learning environments that:
 - have a positive physiological impact on the students and teachers
 - provide better quality light
 - increase the performance of students and teachers.
- Reduce building materials and cost by integrating daylighting into the overall structural design and roofing system.
- Incorporate controlled daylighting strategies.
- When climatic conditions allow, install operable windows to improve indoor air quality.
- Use daylighting and high performance windows to reduce long-term energy costs, shift more financial resources to critical educational needs, and keep more energy dollars in the community.

	Reducing Operating Costs	Designing Buildings That Teach	Improving Academic Performances	Protecting Our Environment	Designing for Health, Safety, and Comfort	Supporting Community Values
– reduced electrical lighting and cooling	■	■		■	□	■
– decreased electrical service to the site	■	■		■		□
– less mechanical system maintenance	■	■		■		■
– fewer lamp replacements.	■	■		■		■
– glare and direct beam radiation entering teaching and work spaces	□	■	■		■	
– excessive radiation	■	■	■		■	
– comfort problems	■	■	■		■	
– maintenance.	■	■				
Make daylighting strategies obvious to the students.		■		□		
Create deliberate connections to the outside environment so that changes in weather conditions are apparent as well as stimulating to students.		■		□		
Incorporate daylighting strategies that could be enhanced through student participation and understanding.	□	■	□	□		
Recognize the importance of daylighting as a strategy to create superior learning environments that:						
– have a positive physiological impact on the students and teachers	■	■	■		■	■
– provide better quality light	■	■	■		■	
– increase the performance of students and teachers.	■	■	■			■
Reduce building materials and cost by integrating daylighting into the overall structural design and roofing system.				■		
Incorporate controlled daylighting strategies.			■		■	
When climatic conditions allow, install operable windows to improve indoor air quality.			■		■	
Use daylighting and high performance windows to reduce long-term energy costs, shift more financial resources to critical educational needs, and keep more energy dollars in the community.	■	■	■			■

Checklist of Key Issues for Energy-Efficient Building Shell

Energy-Efficient Building Shell

- Carefully evaluate building shell issues. Many of these components are likely to go unchanged during the life of the facility.
- Consider the wide range of building systems that can improve energy consumption, reduce maintenance requirements, and improve comfort. These include:
 - light-colored exterior walls and high-reflectance roofing (cool roof) systems
 - radiant barriers (in addition to or in place of insulation) in the roof/ceiling assemblies and exposed walls
 - shading strategies, including building overhang
 - optimum wall and roofing insulation/radiant barriers with ventilation
 - infiltration and weather-resistive barriers
 - light-colored interior walls and ceilings.
- Incorporate artwork and graphics in the building that will help to educate students about energy and environmental issues.
- Design energy-efficient building components to make their purposes and functions obvious to the students.
- Highlight different wall and glass treatments on each facade to emphasize the appropriateness of different design responses.
- Consider building shell issues that directly affect comfort and health and indirectly affect the performance of students in the classroom.
- Consider the embodied energy of optional building components and implementation strategies.
- Consider the colors and finishes of interior surfaces in controlling glare and improving visual comfort.
- Employ energy-saving strategies that will keep more energy dollars in the community.

	Reducing Operating Costs	Designing Buildings That Teach	Improving Academic Performances	Protecting Our Environment	Designing for Health, Safety, and Comfort	Supporting Community Values
• Carefully evaluate building shell issues. Many of these components are likely to go unchanged during the life of the facility.	■	■				
• Consider the wide range of building systems that can improve energy consumption, reduce maintenance requirements, and improve comfort. These include:						
– light-colored exterior walls and high-reflectance roofing (cool roof) systems	■	■	□	■	□	■
– radiant barriers (in addition to or in place of insulation) in the roof/ceiling assemblies and exposed walls	■	■	□	■	□	■
– shading strategies, including building overhang	■	■	□	■	■	■
– optimum wall and roofing insulation/radiant barriers with ventilation	■	■	□	■	□	■
– infiltration and weather-resistive barriers	■	■	□	□	■	■
– light-colored interior walls and ceilings.	■	■	□	■	■	□
• Incorporate artwork and graphics in the building that will help to educate students about energy and environmental issues.		■	■			
• Design energy-efficient building components to make their purposes and functions obvious to the students.		■	■			
• Highlight different wall and glass treatments on each facade to emphasize the appropriateness of different design responses.		■				
• Consider building shell issues that directly affect comfort and health and indirectly affect the performance of students in the classroom.		■	■		■	
• Consider the embodied energy of optional building components and implementation strategies.				■		
• Consider the colors and finishes of interior surfaces in controlling glare and improving visual comfort.		■	■		■	
• Employ energy-saving strategies that will keep more energy dollars in the community.	■	■				■

Checklist of Key Issues for Lighting and Electrical Systems

Lighting and Electrical Systems

- Select high-efficiency lamps, ballasts, lenses, and lighting fixtures that address the specific task requirements.
- Specify high-efficiency appliances and equipment.
- Use long-life lamps to reduce maintenance.
- Develop the primary lighting strategy around a daylighting approach.
- Incorporate controls, occupancy sensors, and dimmable or staged lights to automatically reduce electric lighting during times of adequate daylighting.
- Provide photocell controls on exterior lights to ensure lights are not operating during the day. Provide control access for teachers only.
- Consider LED exit lights.
- Minimize electrical line losses by installing a high-voltage distribution system.
- Conduct a commissioning process that verifies the proper operation of equipment and systems.
- Implement a regular maintenance schedule to ensure proper operation.
- Incorporate photovoltaic and solar thermal-electric systems where appropriate.
- Monitor total building energy use and renewable energy system contribution.
- Design lighting to uniformly light each space, minimize glare, and reduce overheating from light fixtures.
- Select low-mercury lamps.
- Design site lighting in a manner that will minimize “light pollution” by:
 - using fixtures with cutoff angles that prevent light from going beyond the specific area to be lighted
 - optimizing the height of luminaries for pathways to improve illumination and prevent light from straying onto adjacent properties
 - limiting exterior lighting to critical areas only.
- Select ballasts that do not contain PCBs.

	Reducing Operating Costs	Designing Buildings That Teach	Improving Academic Performances	Protecting Our Environment	Designing for Health, Safety, and Comfort	Supporting Community Values
• Select high-efficiency lamps, ballasts, lenses, and lighting fixtures that address the specific task requirements.	■	■	■	■	■	■
• Specify high-efficiency appliances and equipment.	■	■		■		■
• Use long-life lamps to reduce maintenance.	■	■		■		■
• Develop the primary lighting strategy around a daylighting approach.	■	■	■	■	■	■
• Incorporate controls, occupancy sensors, and dimmable or staged lights to automatically reduce electric lighting during times of adequate daylighting.	■	■	□	■	■	
• Provide photocell controls on exterior lights to ensure lights are not operating during the day. Provide control access for teachers only.	■	■		■		■
• Consider LED exit lights.	■	■		■		■
• Minimize electrical line losses by installing a high-voltage distribution system.	■	■		■		■
• Conduct a commissioning process that verifies the proper operation of equipment and systems.	■	■		■		■
• Implement a regular maintenance schedule to ensure proper operation.	■	■		■		■
• Incorporate photovoltaic and solar thermal-electric systems where appropriate.	■	■		■	■	■
• Monitor total building energy use and renewable energy system contribution.	■	■	□	■		
• Design lighting to uniformly light each space, minimize glare, and reduce overheating from light fixtures.	■	■	■		■	
• Select low-mercury lamps.		■		■	■	■
• Design site lighting in a manner that will minimize “light pollution” by:						
– using fixtures with cutoff angles that prevent light from going beyond the specific area to be lighted		■	■		■	■
– optimizing the height of luminaries for pathways to improve illumination and prevent light from straying onto adjacent properties	□	■		■	■	■
– limiting exterior lighting to critical areas only.	■	■		■	■	■
• Select ballasts that do not contain PCBs.		■		■	■	■

Checklist of Key Issues for Lighting and Electrical Systems

- Minimize glare and eye strain by:
 - incorporating indirect lighting, particularly in computer areas
 - using lenses that shield the lamp from direct view and help disperse light more evenly
 - evaluating the location of the lighting sources in relationship to the occupants and what the occupants will be viewing
 - avoiding reflected glare commonly experienced when viewing a computer screen and seeing the light fixtures
 - minimizing situations of “transient adaptation” in which the eye cannot properly adjust when going from one space to another with drastically different light levels.
- Consider energy-efficient lighting and electrical systems that will keep more energy dollars in the community.
- Employ life-cycle costs to ensure that the best long-term solutions are implemented.

	Reducing Operating Costs	Designing Buildings That Teach	Improving Academic Performances	Protecting Our Environment	Designing for Health, Safety, and Comfort	Supporting Community Values
		■	■		■	
		■	■		■	
		■	■		■	
		■	■		■	
		■	■		■	
	■	■				■
	■	■				■

Checklist of Key Issues for Mechanical and Ventilation Systems

Mechanical and Ventilation Systems

- Evaluate if natural ventilation strategies are feasible.
- Implement the most energy-efficient mechanical and ventilation strategies to save energy.
- Consider the initial cost of equipment, anticipated maintenance expenses, and projected operating costs when evaluating the life-cycle benefits of system options.
- Use a computer energy analysis program that simulates hourly, daily, monthly, and yearly energy consumption and effectively accounts for daylighting benefits (i.e., reduced cooling).
- Optimize the mechanical system as a complete entity to allow for the interaction of various building system components.
- Employ the most energy-efficient mechanical systems by:
 - not oversizing equipment
 - matching the air supply to the load, without adding a reheat penalty
 - considering thermal storage systems
 - zoning air handling units so that each unit serves spaces with similar orientation and use patterns.
- Implement strategy that energy efficiently ensures adequate outside air by incorporating economizer cycles and heat recovery systems.
- Provide safe visual access to mechanical systems to explain how they work.
- Use energy monitoring stations as teaching aids.
- Improve student and teacher performance by ensuring adequate fresh air is provided by:
 - complying with ASHRAE ventilation standards
 - incorporating pollutant sensors
 - installing ductwork that has smooth internal surfaces and transitions to minimize the collection of microbial growth
 - designing ductwork and plenums to minimize the accumulation of dirt and moisture and providing access areas in key locations for inspection, maintenance, and cleaning
 - locating outdoor-air intakes a safe distance from polluted and/or overheated exhaust grilles and away from parking or traffic.

	Reducing Operating Costs	Designing Buildings That Teach	Improving Academic Performances	Protecting Our Environment	Designing for Health, Safety, and Comfort	Supporting Community Values
Evaluate if natural ventilation strategies are feasible.	■	■		■	■	■
Implement the most energy-efficient mechanical and ventilation strategies to save energy.	■	■	□	■	■	■
Consider the initial cost of equipment, anticipated maintenance expenses, and projected operating costs when evaluating the life-cycle benefits of system options.	■	■		■		■
Use a computer energy analysis program that simulates hourly, daily, monthly, and yearly energy consumption and effectively accounts for daylighting benefits (i.e., reduced cooling).	■	■				
Optimize the mechanical system as a complete entity to allow for the interaction of various building system components.	■	■				
Employ the most energy-efficient mechanical systems by:						
– not oversizing equipment	■	□		■	□	■
– matching the air supply to the load, without adding a reheat penalty	■	□		■		■
– considering thermal storage systems	■	□		□		■
– zoning air handling units so that each unit serves spaces with similar orientation and use patterns.	■	□		■		■
Implement strategy that energy efficiently ensures adequate outside air by incorporating economizer cycles and heat recovery systems.	■	■	■		■	■
Provide safe visual access to mechanical systems to explain how they work.		■	□		■	
Use energy monitoring stations as teaching aids.		■	□			
Improve student and teacher performance by ensuring adequate fresh air is provided by:						
– complying with ASHRAE ventilation standards	■	□	■		■	
– incorporating pollutant sensors	■	□	■		■	
– installing ductwork that has smooth internal surfaces and transitions to minimize the collection of microbial growth	■	□	■		■	
– designing ductwork and plenums to minimize the accumulation of dirt and moisture and providing access areas in key locations for inspection, maintenance, and cleaning	■	□	■		■	
– locating outdoor-air intakes a safe distance from polluted and/or overheated exhaust grilles and away from parking or traffic.		■	■		■	

Checklist of Key Issues for Mechanical and Ventilation Systems

- Implement mechanical and ventilation strategies that control humidity and address all physical, biological, and chemical pollutants. Test duct work for air leakage.
- Incorporate renewable energy systems to provide for hot water, and electricity.
- Address the impacts of CFCs and HCFCs when selecting refrigerants for cooling systems.
- Implement indoor air quality strategies that can provide for healthier learning environments.
- Design the mechanical and ventilation systems to maximize the comfort of the students and teachers.
- Employ energy-efficient mechanical and ventilation systems that will result in more energy dollars staying within the community.
- Use heat recovery from the air conditioning system for water heating.

	Reducing Operating Costs	Designing Buildings That Teach	Improving Academic Performances	Protecting Our Environment	Designing for Health, Safety, and Comfort	Supporting Community Values
• Implement mechanical and ventilation strategies that control humidity and address all physical, biological, and chemical pollutants. Test duct work for air leakage.		■	■		■	
• Incorporate renewable energy systems to provide for hot water, and electricity.	■	■		■		■
• Address the impacts of CFCs and HCFCs when selecting refrigerants for cooling systems.		■		■		■
• Implement indoor air quality strategies that can provide for healthier learning environments.	■	■	■		■	
• Design the mechanical and ventilation systems to maximize the comfort of the students and teachers.		■	■		■	
• Employ energy-efficient mechanical and ventilation systems that will result in more energy dollars staying within the community.	■	■				■
• Use heat recovery from the air conditioning system for water heating.	■	□				

Checklist of Key Issues for Renewable Energy Systems

Renewable Energy Systems

- Consider the wide range of renewable options, including:
 - daylighting
 - passive cooling
 - solar hot water
 - photovoltaics
 - wind.
- Consider daylighting your highest priority.
- Incorporate PV systems.
- Employ photovoltaic and wind systems as educational tools that demonstrate the opportunities for converting sunlight and wind into electricity.
- Incorporate solar hot water, and provide a view that will illustrate how sunlight can be converted into thermal energy.
- Use daylighting and passive ventilation strategies to show students the importance of working with, instead of against, nature.
- Integrate displays showing total energy use at the school and the percentage of energy being provided by renewable energy sources.
- Use renewable energy systems as stimulating, educational tools involving multiple subject areas.
- Use on-site, renewable energy systems to help make the link between saving energy and helping our environment.
- Use renewable energy systems in conjunction with battery storage to provide for emergency power.
- Use PV systems to reliably power:
 - parking and walkway lighting
 - caution lights at street crossings and remote signage
 - security lights
 - emergency telephone call boxes
 - electric charging stations
 - emergency warning systems for hurricanes.
- Employ renewable energy and energy-saving strategies that will result in more energy dollars staying within the community.
- Install renewable energy systems at schools to serve the community in times of natural disasters and utility outages.

	Reducing Operating Costs	Designing Buildings That Teach	Improving Academic Performances	Protecting Our Environment	Designing for Health, Safety, and Comfort	Supporting Community Values
• Consider the wide range of renewable options, including:	■	■	■	■	■	■
– daylighting	■	■		■		■
– passive cooling	■	■		■		■
– solar hot water	■	■		■		■
– photovoltaics	■	■		■		■
– wind.	■	■		■		■
• Consider daylighting your highest priority.	■	■	■	■	■	■
• Incorporate PV systems.	■	■		■		■
• Employ photovoltaic and wind systems as educational tools that demonstrate the opportunities for converting sunlight and wind into electricity.	■	■				
• Incorporate solar hot water, and provide a view that will illustrate how sunlight can be converted into thermal energy.	■	■				
• Use daylighting and passive ventilation strategies to show students the importance of working with, instead of against, nature.	■	■	□	■	■	
• Integrate displays showing total energy use at the school and the percentage of energy being provided by renewable energy sources.	■	■	■			
• Use renewable energy systems as stimulating, educational tools involving multiple subject areas.	■	■	■			
• Use on-site, renewable energy systems to help make the link between saving energy and helping our environment.	■	■	■	■		
• Use renewable energy systems in conjunction with battery storage to provide for emergency power.	■	■		□	■	■
• Use PV systems to reliably power:						
– parking and walkway lighting	■	■		■	■	■
– caution lights at street crossings and remote signage	■	■		□	■	■
– security lights	■	■		□	■	■
– emergency telephone call boxes	■	■		□	■	■
– electric charging stations	■	■		■	■	■
– emergency warning systems for hurricanes.	■	■		■	■	■
• Employ renewable energy and energy-saving strategies that will result in more energy dollars staying within the community.	■	■				■
• Install renewable energy systems at schools to serve the community in times of natural disasters and utility outages.	■	■				■

Checklist of Key Issues for Water Conservation

Water Conservation

- Encourage the general contractor to conserve water during construction.
- Incorporate indigenous vegetation to minimize irrigation requirements.
- Install water-conserving fixtures.
- Consider rainwater collection systems.
- Provide more localized water heaters, closer to the loads in the school, to avoid wasting water and energy.
- Use educational signage and graphics to help inform students and staff about the need to conserve water and instruct them on what they can personally do to save water.
- Install monitoring devices, sight glasses in storage tanks, and energy management systems that can be used by students to monitor school usage and see the benefits of using graywater.
- Adequately insulate hot water supply piping.
- Ensure that the water is clean and lead-free.
- Implement water-conserving strategies that will reduce the need to provide water from nonsustainable aquifers and water sources not within the immediate region.
- Consider installing an on-site biological wastewater treatment system.
- Check the condition of all plumbing lines and fixtures for sources of potential contamination, particularly lead.
- Use only lead-free materials in the potable plumbing system to avoid lead-related impacts such as lower IQ levels, impaired hearing, reduced attention span, and poor student performance.
- Verify the condition of the potable water supply.
- Install separate plumbing lines that will allow the school to irrigate by using reclaimed water, avoiding the costs, chemicals, and energy associated with treating water to potable levels but still achieving health standards for discharging into streams.
- Use porous paving surfaces.
- Drain rainwater into landscaping.
- Water landscaping during appropriate times of day to reduce evaporation and evapotranspiration.

	Reducing Operating Costs	Designing Buildings That Teach	Improving Academic Performances	Protecting Our Environment	Designing for Health, Safety, and Comfort	Supporting Community Values
• Encourage the general contractor to conserve water during construction.	■			■		■
• Incorporate indigenous vegetation to minimize irrigation requirements.	■	■		■		■
• Install water-conserving fixtures.	■	■		■		■
• Consider rainwater collection systems.	■	■		■		■
• Provide more localized water heaters, closer to the loads in the school, to avoid wasting water and energy.	■	■		■		■
• Use educational signage and graphics to help inform students and staff about the need to conserve water and instruct them on what they can personally do to save water.	□	■	■	□		
• Install monitoring devices, sight glasses in storage tanks, and energy management systems that can be used by students to monitor school usage and see the benefits of using graywater.		■	■	□		
• Adequately insulate hot water supply piping.	■	■		■		■
• Ensure that the water is clean and lead-free.		■	■		■	
• Implement water-conserving strategies that will reduce the need to provide water from nonsustainable aquifers and water sources not within the immediate region.		■		■		■
• Consider installing an on-site biological wastewater treatment system.	■	■	□	■		■
• Check the condition of all plumbing lines and fixtures for sources of potential contamination, particularly lead.		■		□	■	
• Use only lead-free materials in the potable plumbing system to avoid lead-related impacts such as lower IQ levels, impaired hearing, reduced attention span, and poor student performance.		■	■	□	■	
• Verify the condition of the potable water supply.					■	
• Install separate plumbing lines that will allow the school to irrigate by using reclaimed water, avoiding the costs, chemicals, and energy associated with treating water to potable levels but still achieving health standards for discharging into streams.	■	■		■		■
• Use porous paving surfaces.		■		■		
• Drain rainwater into landscaping.	■	■		■		
• Water landscaping during appropriate times of day to reduce evaporation and evapotranspiration.	■	■		■		

Checklist of Key Issues for Recycling Systems and Waste Management

Recycling Systems and Waste Management

- Implement a comprehensive recycling strategy that involves all major recyclable waste materials in the school.
- Allocate space throughout the building for recycling receptacles to reduce waste hauling and disposal costs.
- Provide outdoor recycling bins accessible to collection agencies or companies.
- Allocate space for yard waste composting to further reduce landfill tipping costs.
- Ensure that recycling receptacles are designed and labeled so as not to be confused with trash receptacles.
- Design recycling receptacles as attractive components, well-integrated into the overall design but still obvious to the students.
- Incorporate recycling receptacles that are easily accessible to students and custodial staff and designed to be used by students.
- Develop a recycling system that allows students to monitor their waste stream and that teaches them about waste reduction.
- Require a detailed waste management plan from the contractor to minimize the disposal of recyclable or reusable construction waste.
- Monitor construction waste management throughout the construction process to minimize the landfilling, incineration, or improper disposal of recyclable materials.
- Design recycling systems that will enable the school to recycle as much daily waste as possible.
- Consider incorporating a compost center that allows food waste to be used in gardens or landscaping.
- Select recycling containers that are made of recycled materials.
- Ensure that recycling receptacles are designed and installed so as not to create a physical hazard.
- Design recycling receptacles for easy cleaning.
- Provide documentation on cleaning procedures and maintenance requirements associated with the recycling receptacles.
- Locate local companies or services that can benefit from the use of recycled materials or construction waste.

	Reducing Operating Costs	Designing Buildings That Teach	Improving Academic Performances	Protecting Our Environment	Designing for Health, Safety, and Comfort	Supporting Community Values
• Implement a comprehensive recycling strategy that involves all major recyclable waste materials in the school.	■	■		■		■
• Allocate space throughout the building for recycling receptacles to reduce waste hauling and disposal costs.	■	■		■		■
• Provide outdoor recycling bins accessible to collection agencies or companies.	■	■		■		□
• Allocate space for yard waste composting to further reduce landfill tipping costs.	■	■		■		■
• Ensure that recycling receptacles are designed and labeled so as not to be confused with trash receptacles.	■	■				
• Design recycling receptacles as attractive components, well-integrated into the overall design but still obvious to the students.		■				
• Incorporate recycling receptacles that are easily accessible to students and custodial staff and designed to be used by students.	■	■		■		
• Develop a recycling system that allows students to monitor their waste stream and that teaches them about waste reduction.		■	■	□		■
• Require a detailed waste management plan from the contractor to minimize the disposal of recyclable or reusable construction waste.	■			■		■
• Monitor construction waste management throughout the construction process to minimize the landfilling, incineration, or improper disposal of recyclable materials.				■		■
• Design recycling systems that will enable the school to recycle as much daily waste as possible.	■	■		■		■
• Consider incorporating a compost center that allows food waste to be used in gardens or landscaping.		■		■		
• Select recycling containers that are made of recycled materials.	■	■		■		
• Ensure that recycling receptacles are designed and installed so as not to create a physical hazard.		■			■	
• Design recycling receptacles for easy cleaning.		■			■	
• Provide documentation on cleaning procedures and maintenance requirements associated with the recycling receptacles.					■	
• Locate local companies or services that can benefit from the use of recycled materials or construction waste.		■		■		■

Checklist of Key Issues for Transportation

Transportation

- Work with developers and local planning departments to design easy, safe pedestrian access throughout the community to the school site.
- Use high-efficiency buses and service vehicles.
- Use graphics and signage to help educate students and the community about the environmental benefits of the energy-efficient and low-emission approaches to transportation implemented by the school.
- Give high priority to the placement of bicycle racks and use personalized nameplates for regular bikers.
- Incorporate a highly visible solar electric and/or wind-powered charging station for electric buses and service vehicles.
- Design sidewalks and bike paths throughout the community and school site to help reduce air pollution associated with busing and single car drop-offs.
- Use low-emission methanol, biodiesel, natural gas, and solar electric buses and service vehicles to reduce air pollution.
- Stress safety when designing walkways and bike paths.
- Use photovoltaic systems to reliably power:
 - parking and walkway lights
 - caution lights and street crossings
 - electric charging stations.
- Allow for handicap access.
- Encourage recreational activities by providing access to athletic facilities that can be shared with residents of the local community.
- Provide pedestrian ways to and a mass transit stop at the school site so that the school is more easily accessible to the community.
- Implement energy-efficient transportation options that keep energy dollars in the community, strengthening the local economy.
- Choose high-efficiency and low-emission vehicles as the best long-term solution to protect against future energy cost escalation.

	Reducing Operating Costs	Designing Buildings That Teach	Improving Academic Performances	Protecting Our Environment	Designing for Health, Safety, and Comfort	Supporting Community Values
• Work with developers and local planning departments to design easy, safe pedestrian access throughout the community to the school site.	■	■		■	■	■
• Use high-efficiency buses and service vehicles.	■			■		■
• Use graphics and signage to help educate students and the community about the environmental benefits of the energy-efficient and low-emission approaches to transportation implemented by the school.		■	■			
• Give high priority to the placement of bicycle racks and use personalized nameplates for regular bikers.		■				
• Incorporate a highly visible solar electric and/or wind-powered charging station for electric buses and service vehicles.	■	■		■		■
• Design sidewalks and bike paths throughout the community and school site to help reduce air pollution associated with busing and single car drop-offs.	■	■		■	■	■
• Use low-emission methanol, biodiesel, natural gas, and solar electric buses and service vehicles to reduce air pollution.	■	■		■	■	■
• Stress safety when designing walkways and bike paths.		■			■	
• Use photovoltaic systems to reliably power:						
– parking and walkway lights	■	■		■	■	■
– caution lights and street crossings	■	■		□	■	■
– electric charging stations.	■	■		□	■	■
• Allow for handicap access.		■			■	■
• Encourage recreational activities by providing access to athletic facilities that can be shared with residents of the local community.		■				■
• Provide pedestrian ways to and a mass transit stop at the school site so that the school is more easily accessible to the community.	■	■				■
• Implement energy-efficient transportation options that keep energy dollars in the community, strengthening the local economy.	■	■				■
• Choose high-efficiency and low-emission vehicles as the best long-term solution to protect against future energy cost escalation.	■	■				■

Checklist of Key Issues for Resource-Efficient Building Products

Resource-Efficient Building Materials

- Use products that are energy-efficient.
- Choose fixtures and equipment that conserve water.
- Specify building systems, components, and materials with low maintenance requirements.
- Incorporate less-polluting materials to reduce the need for mechanically induced fresh air and increase energy efficiency.
- Incorporate pollutant sensors to reduce ventilation air exchange during non-occupied times.
- Design environmentally sound building components to make their purpose and function obvious to students.
- Use products and systems that save water in explicit, visible ways.
- Incorporate locally harvested or mined materials as prominent design elements.
- Avoid materials containing toxic or irritating compounds that negatively affect the indoor air quality.
- Select materials that are moisture and pest resistant, and easy to clean.
- Specify products, materials, and equipment that can be maintained in an environmentally friendly way.
- Select products made from renewable energy and low-polluting processes.
- Specify products harvested from well-managed forests.
- Avoid products harvested or mined from environmentally sensitive areas.
- Select products that are made from recycled materials and/or are recyclable.
- Specify products made with a minimum of process (embodied) energy.
- Evaluate the environmental life-cycle impacts to minimize the environmental impact of the building's operation.
- Incorporate energy-efficiency and renewable energy systems.
- Avoid products that produce indoor air pollution.

	Reducing Operating Costs	Designing Buildings That Teach	Improving Academic Performances	Protecting Our Environment	Designing for Health, Safety, and Comfort	Supporting Community Values
• Use products that are energy-efficient.	<input checked="" type="checkbox"/>	<input checked="" type="checkbox"/>		<input checked="" type="checkbox"/>		<input checked="" type="checkbox"/>
• Choose fixtures and equipment that conserve water.	<input checked="" type="checkbox"/>	<input checked="" type="checkbox"/>		<input checked="" type="checkbox"/>		<input checked="" type="checkbox"/>
• Specify building systems, components, and materials with low maintenance requirements.	<input checked="" type="checkbox"/>	<input checked="" type="checkbox"/>		<input checked="" type="checkbox"/>		<input checked="" type="checkbox"/>
• Incorporate less-polluting materials to reduce the need for mechanically induced fresh air and increase energy efficiency.	<input checked="" type="checkbox"/>	<input checked="" type="checkbox"/>	<input type="checkbox"/>	<input type="checkbox"/>	<input checked="" type="checkbox"/>	
• Incorporate pollutant sensors to reduce ventilation air exchange during non-occupied times.	<input checked="" type="checkbox"/>	<input type="checkbox"/>		<input checked="" type="checkbox"/>	<input checked="" type="checkbox"/>	<input checked="" type="checkbox"/>
• Design environmentally sound building components to make their purpose and function obvious to students.		<input checked="" type="checkbox"/>				
• Use products and systems that save water in explicit, visible ways.		<input checked="" type="checkbox"/>				
• Incorporate locally harvested or mined materials as prominent design elements.	<input checked="" type="checkbox"/>	<input checked="" type="checkbox"/>		<input checked="" type="checkbox"/>		<input checked="" type="checkbox"/>
• Avoid materials containing toxic or irritating compounds that negatively affect the indoor air quality.	<input type="checkbox"/>	<input checked="" type="checkbox"/>	<input checked="" type="checkbox"/>	<input checked="" type="checkbox"/>	<input checked="" type="checkbox"/>	
• Select materials that are moisture and pest resistant, and easy to clean.	<input checked="" type="checkbox"/>	<input checked="" type="checkbox"/>	<input checked="" type="checkbox"/>	<input checked="" type="checkbox"/>	<input checked="" type="checkbox"/>	
• Specify products, materials, and equipment that can be maintained in an environmentally friendly way.		<input checked="" type="checkbox"/>		<input checked="" type="checkbox"/>	<input checked="" type="checkbox"/>	
• Select products made from renewable energy and low-polluting processes.		<input checked="" type="checkbox"/>	<input checked="" type="checkbox"/>	<input checked="" type="checkbox"/>		<input checked="" type="checkbox"/>
• Specify products harvested from well-managed forests.		<input checked="" type="checkbox"/>		<input checked="" type="checkbox"/>		<input type="checkbox"/>
• Avoid products harvested or mined from environmentally sensitive areas.		<input checked="" type="checkbox"/>		<input checked="" type="checkbox"/>		<input type="checkbox"/>
• Select products that are made from recycled materials and/or are recyclable.		<input checked="" type="checkbox"/>		<input checked="" type="checkbox"/>		
• Specify products made with a minimum of process (embodied) energy.		<input checked="" type="checkbox"/>		<input checked="" type="checkbox"/>		
• Evaluate the environmental life-cycle impacts to minimize the environmental impact of the building's operation.				<input checked="" type="checkbox"/>	<input type="checkbox"/>	<input checked="" type="checkbox"/>
• Incorporate energy-efficiency and renewable energy systems.	<input checked="" type="checkbox"/>	<input checked="" type="checkbox"/>		<input checked="" type="checkbox"/>		<input checked="" type="checkbox"/>
• Avoid products that produce indoor air pollution.	<input checked="" type="checkbox"/>	<input checked="" type="checkbox"/>	<input checked="" type="checkbox"/>	<input checked="" type="checkbox"/>	<input checked="" type="checkbox"/>	

Checklist of Key Issues for Resource-Efficient Building Products

- Separate polluting materials from exposed surfaces.
- Incorporate indoor planting strategies.
- Avoid equipment that requires toxic or irritating maintenance procedures.
- Provide detailed guidance on preferable maintenance procedures to minimize exposure of staff and students to toxic and irritating chemicals.
- Work with the school system to develop an indoor pollutant source assessment and control plan.
- Choose products and materials that are locally produced or made from readily available materials.
- Choose products and building procedures that maximize local labor.
- Select indigenous materials, and implement designs that enhance the connection to “place.”
- Select materials that can be reused or recycled to minimize impacts on landfills.

	Reducing Operating Costs	Designing Buildings That Teach	Improving Academic Performances	Protecting Our Environment	Designing for Health, Safety, and Comfort	Supporting Community Values
		■	■		■	
		■	■		■	
		■	■		■	
		■	■		■	
		■	■		■	■
	■	■		■		■
	■	■				■
		■				■
		■		■		■

Case Studies

The following case studies demonstrate successful applications of high performance solutions for tropical island climates. Contact information is provided to allow you to gain firsthand knowledge from schools that have successfully implemented many of the high performance design strategies included in this guideline.

To find additional case studies around the country, visit the EnergySmart Schools Web site:

www.energysmartschools.gov

or call the EERE Information Center:

1 (877) 337-3463



Properly designed daylighting can lower utility bills by reducing the need for electric lighting in classrooms during portions of the school day.



Daylighting strategies using diffuse systems are highly applicable to spaces with high ceilings and open spaces, like gymnasiums. Prevent direct sun penetration into gym space, which can create unpleasant glare and bright spots.

Chiefess Kamakahahelei Middle School, Lihue, Kauai, Hawaii

Contact:

*Steven Wong
Mitsunaga & Associates
747 Amana Street, Suite 216
Honolulu, HI 96814
(808) 945-7882*

Benefits:

- ✓ *Natural ventilation*
- ✓ *Daylighting in classrooms*
- ✓ *66.7% reduction in energy use*

In October 1997, Kauai school representatives, teachers, and students joined forces with architects, staff, and personnel from DOE in an effort to provide a school that meets student needs and demonstrates resource and energy efficiency. As a result, the Chiefess Kamakahahelei Middle School was designed as one of DOE's 21st Century Schools with the following design themes:

- Energy efficient
- Dynamically flexible
- Safe
- Nurturing
- Instilling an unprecedented sense of ownership and pride in the school and the surrounding neighborhood.

The administration, faculty, students, parents, and community teamed together and shared in decisions to achieve visions and goals, to provide a self-sufficient and secure learning environment for the students and community. In addition, the intense design research included a survey of area students, as to what they desired from a learning environment.

Sustainable design was an important requirement for all involved in the project, and the school (which opened in June 2000) reflects that commitment. This 134,000 ft² school was oriented on an east-west axis to maximize daylight exposure and to capture the northeast tradewinds. The site examination addressed flood and site water issues and studied for traces of historic landmarks and archeological features before proceeding to construction.

Photo: Mitsunaga & Associates

The Chiefess Kamakahahelei Middle School is orientated along an east-west axis, which allows the school to use tradewinds for natural ventilation.

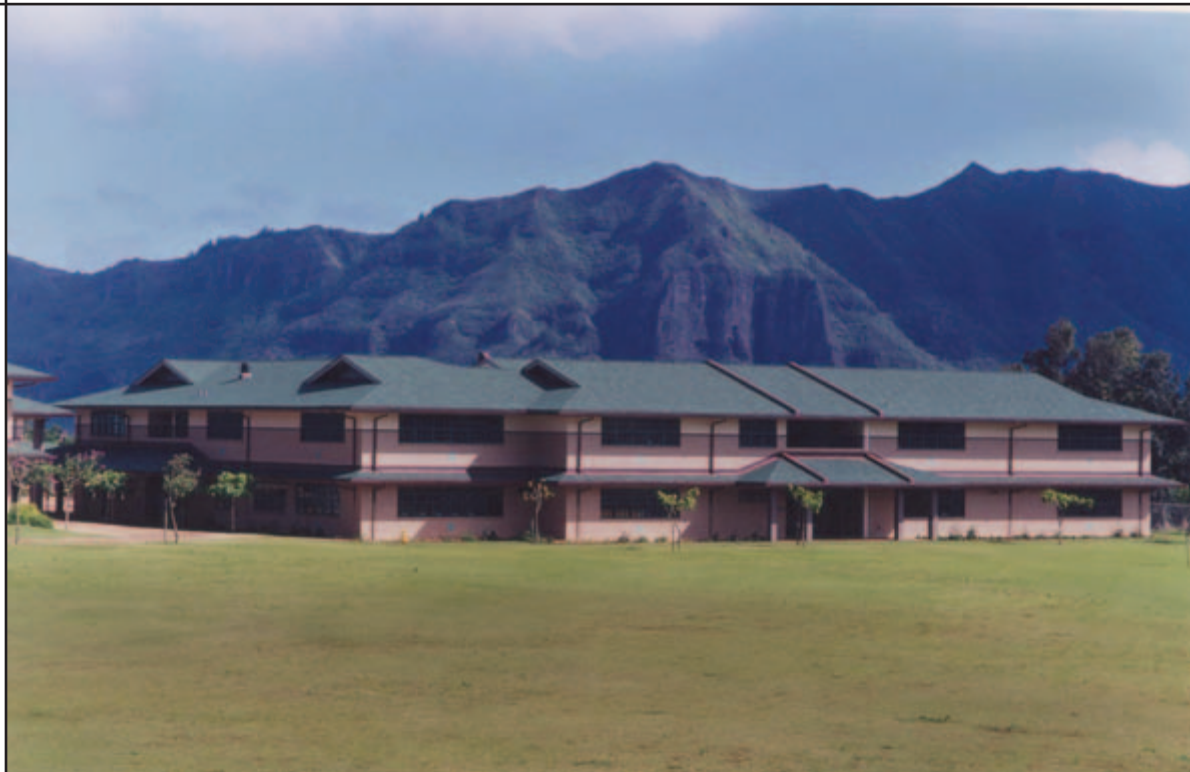



Photo: Mitsunaga & Associates

The open courtyard design at the school helps enhance the daylighting and natural ventilation, as well as provides an outdoor area that can be used as a teaching space.

Taking advantage of the tradewinds, all buildings at the school—except for the library and music buildings—are naturally ventilated. VAV systems were used with variable speed drives to efficiently air condition the library and music buildings. A heat recovery unit was used to supplement the hot water system by converting the heat of the refrigerant to help further reduce energy use. The building shell is also high performance, with tinted, low-e windows and R-19 roof insulation.

Daylighting strategies were used in the design of most rooms, combined with an efficient electric lighting system. The lighting design employs 32-watt T-8 fluorescent lamps and electronic ballasts, in sharp contrast to the older technology that was based on 4- and 34-watt T-12 fluorescent lamps with magnetic ballasts. Previous energy codes allowed an energy budget of 3-watts per square foot for interior lighting systems. Newer codes reduce this amount to 1-watt per square foot, resulting in a 66.7% reduction in energy consumption in new and retrofitted lighting systems.

Water conservation strategies included installing low-flow plumbing fixtures, including water closets and urinals that are rated at 1.6 gallons per flush. Lavatories and sinks are provided with flow restrictors that limit water flow to 2.0 gpm and 2.5 gpm, respectively.



Photo: Senior Airman Lesley Waters

Contact:

Joe Masters, Principal
 Unit 14057
 APO AP 96543-4057
 (671) 366-1511

Benefits:

- ✓ Collaborative design process with the community
- ✓ Daylighting

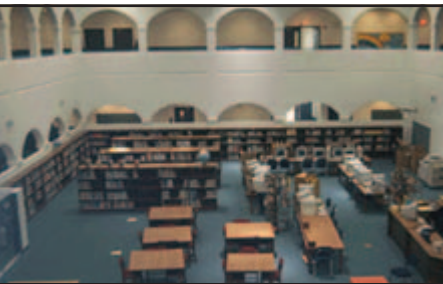

Photo: Senior Airman Lesley Waters

Andersen Air Force Base Elementary and Middle School, Guam

This middle school is one of the largest facilities on Anderson Air Force Base. The design process began collaboratively with an eleven-day design charrette for administrators, base representatives, design managers, and construction agencies to explore goals and requirements for the school.

A key feature of the resulting design involves using open interior space to connect the major areas of the campus. Classrooms are located in “pods” around multipurpose areas that allow for team teaching. These interior courtyards can be used for assemblies, displays of student work, and other activities. These courtyards are climate controlled with respect to Guam’s high humidity and other weather considerations. The gymnasium and courtyards maximize natural light. Covered walkways between buildings protect students and staff from rain.

With its opening in 2001, this school soon became a focal point for the Andersen Air Force Base community.



Photo: Harper Partners

Contact:

Kurt Vialet, Principal
 Rural Route No. 2
 Kingshill St. Croix, VI 00850
 (340) 778-2036

Benefits:

- ✓ Natural ventilation
- ✓ Joint-use of facility for community activities

St. Croix Educational Complex, St. Croix, U.S. Virgin Islands

As with most school facilities on the smaller islands in this climate zone, the St. Croix Educational Complex had to meet many needs for the surrounding community. Completed in 1992, this 31,200 ft² school is a high school and houses a vocational center that serves the students and adult residents. The high school and vocational center share the gymnasium, auditorium, cafeteria, and kitchen.

The complex’s building orientation takes advantage of natural winds. The building is organized along a diagonal circulation spine with large courtyards at each end, which serve as focal points for the facilities. This orientation allows for the island breeze to reach the adjacent building areas.



Photo: Kent Hwang

The Iolani School features the first multistory daylighted classrooms in Hawaii.

Weinberg Classroom/Kozuki Stadium/Multipurpose Complex, Iolani School, Honolulu, Hawaii

With the completion of the Weinberg Classroom/Kozuki Stadium/Multipurpose Complex in September 2003, Iolani School finished the first phase in a 20-year master plan to enhance facilities on this 20-acre campus. Iolani School serves more than 1,800 K-12 students in Honolulu, Hawaii.

One of the oldest schools in Hawaii, the project design aimed to marry sustainable design strategies and technology with an aesthetic design that reflects the school's roots as an Anglican school founded during Hawaii's monarchy period by English clergy.

Energy efficiency was a key goal in the design of the new complex, which is made up of the 74,000 ft² Weinberg Classroom building and the 174,000 ft² Kozuki Stadium/Multipurpose Complex. The Weinberg Classroom building uses high performance daylighting principles and features the first multistory daylighted classrooms in Hawaii. More than 75% of the occupied space in this complex incorporates daylighting. The daylighting system combines aluminum lightshelves, light pipes, low-e glass, VAV, and DDC controls to enhance energy performance.

The Kozuki Stadium/Multipurpose structure contains parking for 350 cars, bleacher seating for approximately 1,200, and a central ice storage plant. The ice storage plant uses high-flux cavity refrigerant that does not deplete the ozone. Furthermore, the plant was designed to expand in phases to eventually accommodate the entire campus.

Finally, large asphalt areas were replaced by concrete or landscaping to reduce heat islands. Designers also planted creeping fig around the building exteriors to reduce heat islands. Combined, these energy efficiency measures save the school 28% annually on electricity costs, which translates into nearly \$32,000 per year.

Energy is not the only area where efficiency measures were used. The Iolani School also incorporated many other sustainable strategies. Fifty-eight percent of the construction materials (including 90% of the structural steel) used to build the Weinberg Classroom/Kozuki Stadium/Multipurpose Complex were made of post-consumer or post-industrial content. Local materials were also widely used, with 31% of the construction materials Hawaii-manufactured and 29% percent of these materials harvested from Hawaii.

Indoor environmental quality has also been improved at the complex since low VOC products were installed throughout the buildings. Low VOC sealants, carpets, sheet vinyl, vinyl tiles, and paints were used in areas and corridors frequented by students, faculty, and staff.



Photo: Kent Hwang

Contact:

Charles Kaneshiro, AIA
Group 70 International, Inc.
 925 Bethel Street
 Fifth Floor
 Honolulu, HI 96813
 (808) 523-5866

Benefits:

- ✓ 28% energy savings annually
- ✓ Daylighting in 75% of occupied spaces
- ✓ Locally manufactured construction materials



EnergySmart Schools is part of the Rebuild America program, a national DOE initiative to improve energy use in buildings. This means that if your school is part of a Rebuild America community partnership, you're ready to benefit from EnergySmart Schools.

Be sure to ask about energy improvements and educational materials for your bus fleet as well as your buildings. Rebuild America focuses on buildings, but its representatives can also direct you to resources for buses. After all, the goal of EnergySmart Schools is a comprehensive one: a nation of schools that are smart about energy in every way.

Web Resources for More Information

EnergySmart Schools Web Site: www.energysmartschools.gov

Comprehensive Sources

www.ase.org/greenschools/newconstruction.htm — Alliance to Save Energy's Green Schools Program

www.eere.energy.gov/EE/buildings.html — DOE's Energy Efficiency and Renewable Energy Network buildings site

www.advancedbuildings.org/ — Advanced Buildings Technologies and Practices

www.edfacilities.org/rl/ — National Clearinghouse for Educational Facilities

http://208.254.22.7/index.cfm?c=k12_schools.bus_schoolsk12 — EPA's ENERGY STAR for Schools K-12

www.usgbc.org/leed/leed_main.asp

www.ashrae.org

www.nyserda.org/schools/schoolprograms.html

www.chps.net/

Introductory Section

www.rebuild.gov — DOE's Rebuild America program, with energy-efficient solutions for communities

www.eere.energy.gov/buildings/energy_tools/doe_tools.html — DOE energy simulation software

www.usgbc.org — U.S. Green Building Council

Site Design

www.epa.gov/glnpo/greenacres/ — EPA's site on native landscaping

www.water.az.gov — Arizona Department of Water Resources

Daylighting and Windows

windows.lbl.gov/daylighting/designguide/designguide.html — Lawrence Berkeley National Laboratory's "Tips for Daylighting with Windows"

www.eere.energy.gov/erec/factsheets/windows.html — DOE's "Advances in Glazing Materials for Windows"

www.nfrc.org — National Fenestration Rating Council

www.daylighting.org — Daylighting Collaborative

aa.usno.navy.mil/data/docs/AltAz.html — U.S. Naval Observatory's sun or moon altitude/azimuth table

Energy Efficient Building Shell

www.nrel.gov/buildings_thermal/ — National Renewable Energy Laboratory's Center for Buildings and Thermal Systems

www.ornl.gov/roofs+walls/index.html — Oak Ridge National Laboratory's Building Envelopes Program

gundog.lbl.gov/dirsoft/d2whatis.html — Lawrence Berkeley National Laboratory's DOE-2 energy simulation software

Renewable Energy Systems

www.eere.energy.gov/state_energy/ — DOE's State Energy Alternatives
www.eere.energy.gov/greenpower/ — DOE's Green Power Network
www.nrel.gov — National Renewable Energy Laboratory
www.schoolsgoingsolar.org — The Interstate Renewable Energy Council Schools Going Solar program

Lighting and Electrical Systems

www.iaeel.org — International Association for Energy-Efficient Lighting
eetd.lbl.gov/btp/lst/ — Lawrence Berkeley National Laboratory's Lighting Systems Research Group

Mechanical and Ventilation Systems

www.epa.gov/iaq/schools/ — EPA's Indoor Air Quality Design Tools for Schools
www.eere.energy.gov/buildings/energyplus/ — DOE's EnergyPlus Building Energy Simulation software
epb.lbl.gov/thermal/ — Lawrence Berkeley National Laboratory's information on Resource Efficient Building Conditioning

Resource-Efficient Building Products

www.sustainable.doe.gov/buildings/rescon.shtml — DOE's Smart Communities Network site
www.ciwmb.ca.gov/GreenBuilding/Materials — California Integrated Waste Management Board's Green Building Materials site
www.ciwmb.ca.gov/RCP/ — California Integrated Waste Management Board's Recycled-Content Building Product Directory

Water Conservation

www.epa.gov/ow/ — EPA's Office of Water
www.water.az.gov/adwr/ — Arizona Department of Water Resources
www.amwua.org/conservation-school.htm — Arizona Municipal Water User Association's "Water in Our Desert Community," an instructional resource for middle school students

Recycling and Waste Management

<http://yosemite.epa.gov/oar/globalwarming.nsf/content/ResourceCenterToolsGHGCalculator.html> — EPA's Waste Reduction Model to calculate greenhouse gas emissions
www.p2pays.org/ref/01/00626.htm — North Carolina Division of Pollution Prevention and Environmental Assistance's "Solid Waste Management in North Carolina—A Curriculum Resource Guide for Teachers"

Transportation

www.cities.doe.gov — DOE's Clean Cities Program
www.nrel.gov/vehiclesandfuels/ — National Renewable Energy Laboratory's Advanced Vehicles and Fuels Web site

This publication and additional information are available online at:

www.energysmartschools.gov

Photo Credits: All photographs not specifically credited were taken by Innovative Design.

Graphics Credits: All graphics not specifically credited were supplied by NREL.

For helpful resources or more information:

Call the EERE Information Center:
1-877-337-3463

Ask a question about saving energy in your school or request information about the EnergySmart Schools program. You may want to inquire about the availability of the following EnergySmart Schools resources:

Publications and Videotapes

- National Best Practice Manual for Building High Performance Schools
- Energy Design Guidelines for High Performance Schools
- Portable Classroom Guidelines
- Decisionmaker Brochures
- Designing Smarter Schools, a 30-minute videotape that originally aired on the CNBC television network
- Educational CD-ROM featuring teaching and learning materials
- The High Performance School 30-minute video is also available by calling one of these three numbers: (303) 443-3130 Ext. 106, (202) 628-7400, or (202) 857-0666

Services

- Technical assistance
- Regional peer exchange forums
- State-based forums for school decisionmakers
- Financing workshops
- Technology workshops

A Strong Energy Portfolio for a Strong America

Energy efficiency and clean, renewable energy will mean a stronger economy, a cleaner environment, and greater energy independence for America. By investing in technology breakthroughs today, our nation can look forward to a more resilient economy and secure future.

Far-reaching technology changes will be essential to America's energy future. Working with a wide array of state, community, industry, and university partners, the U.S. Department of Energy's Office of Energy Efficiency and Renewable Energy invests in a portfolio of energy technologies that will:

- Conserve energy in the residential, commercial, industrial, government, and transportation sectors
- Increase and diversify energy supply, with a focus on renewable domestic sources
- Upgrade our national energy infrastructure
- Facilitate the emergence of hydrogen technologies as vital new "energy carriers."

The Opportunities

Biomass Program

Using domestic, plant-derived resources to meet our fuel, power, and chemical needs

Building Technologies Program

Homes, schools, and businesses that use less energy, cost less to operate, and ultimately, generate as much power as they use

Distributed Energy & Electric Reliability Program

A more reliable energy infrastructure and reduced need for new power plants

Federal Energy Management Program

Leading by example, saving energy and taxpayer dollars in federal facilities

FreedomCAR & Vehicle Technologies Program

Less dependence on foreign oil, and eventual transition to an emissions-free, petroleum-free vehicle

Geothermal Technologies Program

Tapping the Earth's energy to meet our heat and power needs

Hydrogen, Fuel Cells & Infrastructure Technologies Program

Paving the way toward a hydrogen economy and net-zero carbon energy future

Industrial Technologies Program

Boosting the productivity and competitiveness of U.S. industry through improvements in energy and environmental performance

Solar Energy Technology Program

Utilizing the sun's natural energy to generate electricity and provide water and space heating

Weatherization & Intergovernmental Program

Accelerating the use of today's best energy-efficient and renewable technologies in homes, communities, and businesses

Wind & Hydropower Technologies Program

Harnessing America's abundant natural resources for clean power generation

For more information contact:

EERE Information Center
1-877-EERE-INF (1-877-337-3463)
www.eere.energy.gov



U.S. Department of Energy

Energy Efficiency and
Renewable Energy

Office of Weatherization and
Intergovernmental Programs

