

# INTERSTATE INTERCHANGES AND REST AREAS

Siskiyou Summit – Exit 1

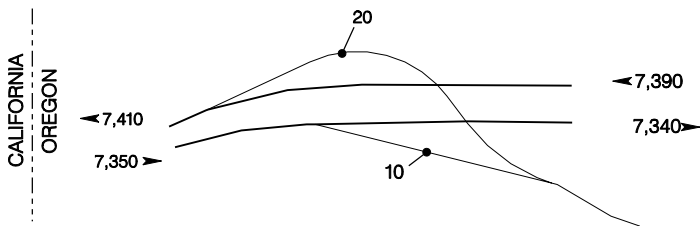

Siskiyou Hwy. – Exit 5

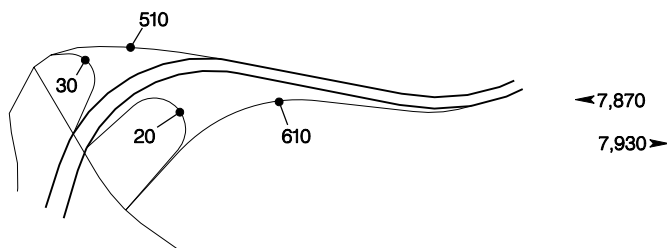

Siskiyou Rest Area – Exit 9

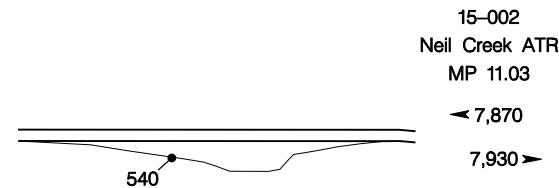

South Ashland – Exit 11

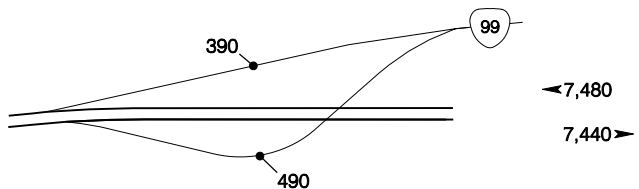

Green Springs – Exit 14

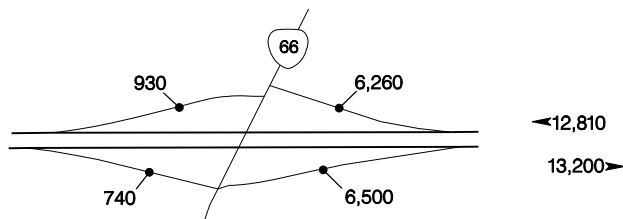

North Ashland – Exit 19

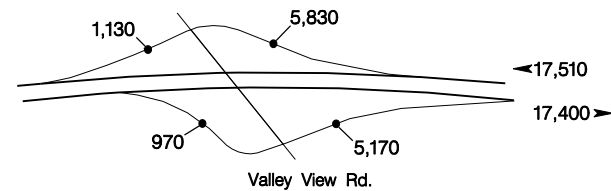

West Valley View – Exit 21

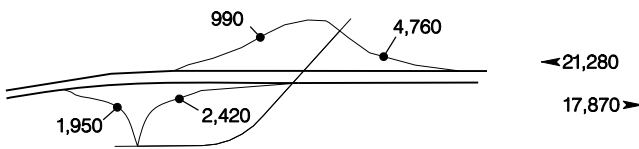

Suncrest Rest Area – Exit 22

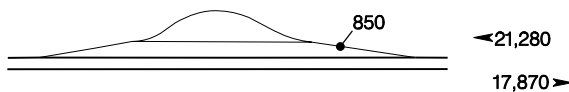

Phoenix – Exit 24

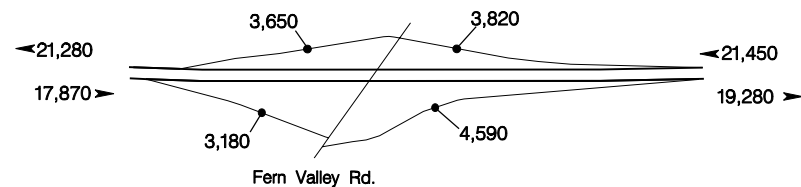

# INTERSTATE INTERCHANGES AND REST AREAS

Barnett Road – Exit 27

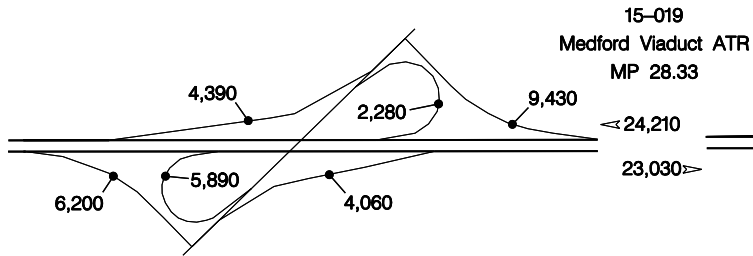

Crater Lake Hwy. – Exit 30

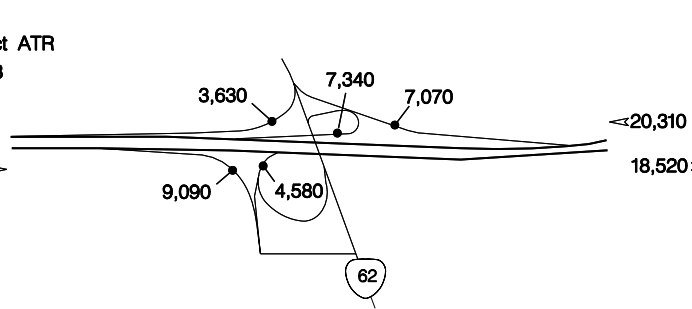

Central Point – Exit 32

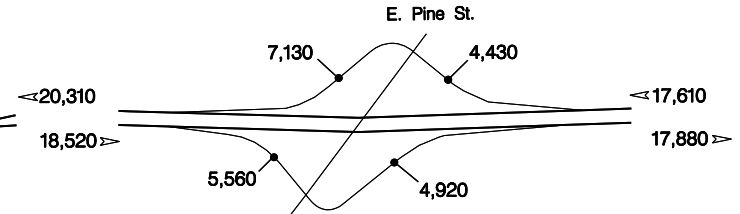

Seven Oaks – Exit 35

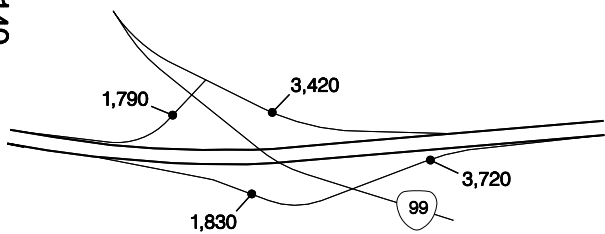

Kane Creek – Exit 40

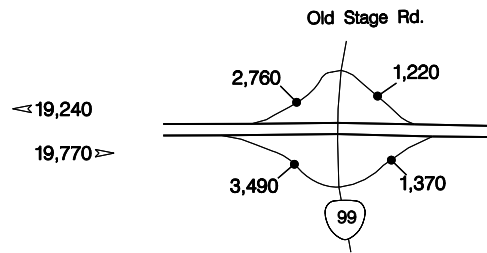

Rock Point – Exit 44

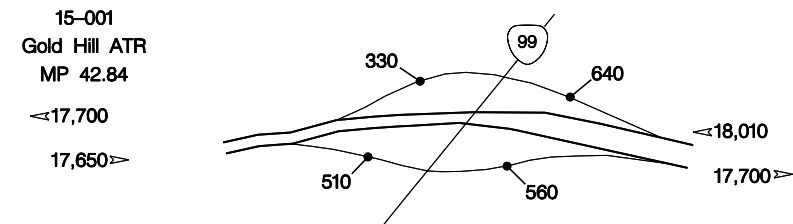

Homestead – Exit 45A

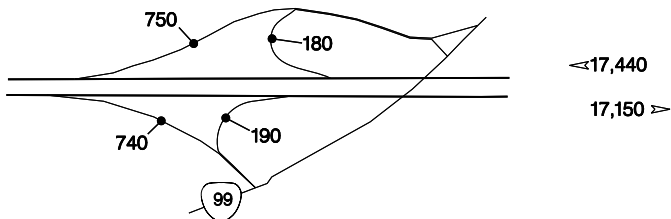

Valley Of The Rogue Rest Area – Exit 45B

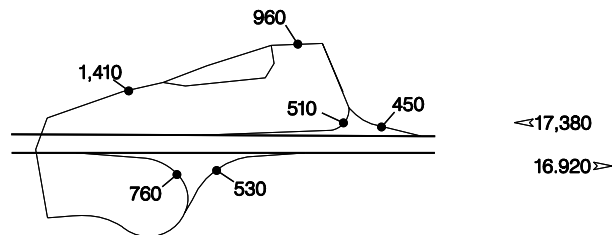

# INTERSTATE 5 INTERCHANGES AND REST AREAS

Roque River – Exit 48

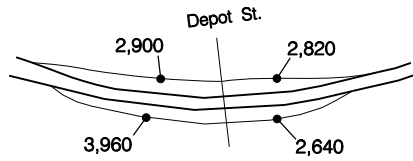

East Grants Pass – Exit 55

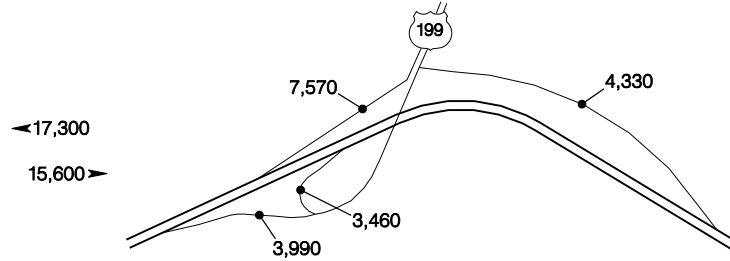

North Grants Pass – Exit 57

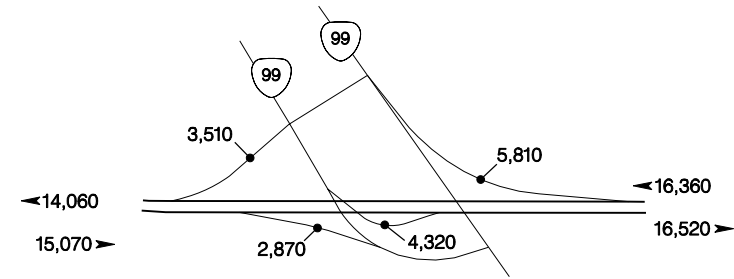

Louse Creek – Exit 61

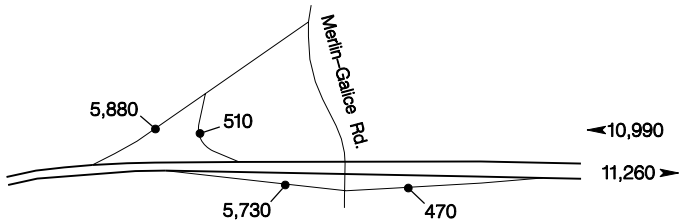

Manzanita Rest Area – Exit 62A, 62B

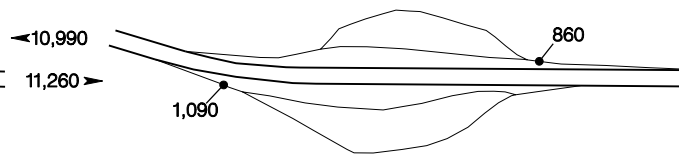

Jumpoff Joe – Exit 66

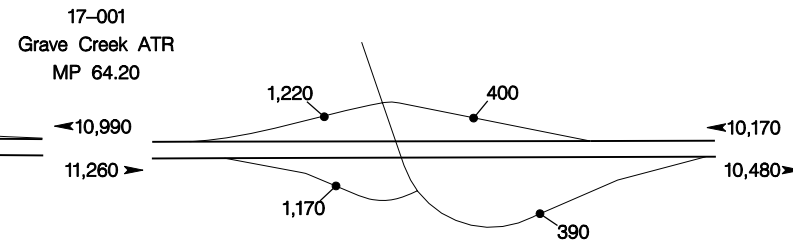

Sunny Valley – Exit 71

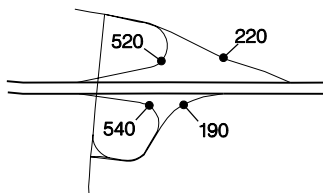

South Wolf Creek – Exit 76A



North Wolf Creek – Exit 76B

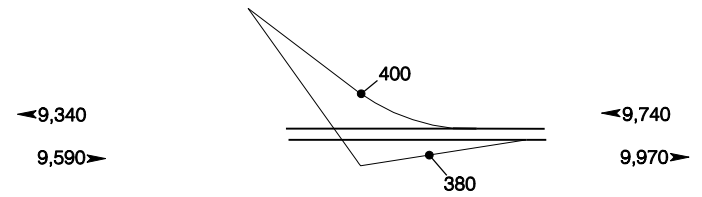

# INTERSTATE INTERCHANGES AND REST AREAS

Speaker Road – Exit 78

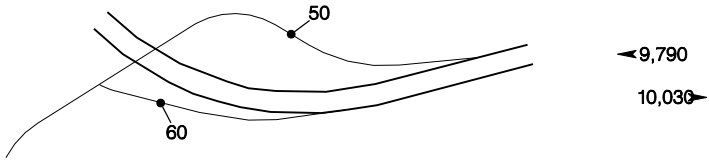

Glendale – Exit 80

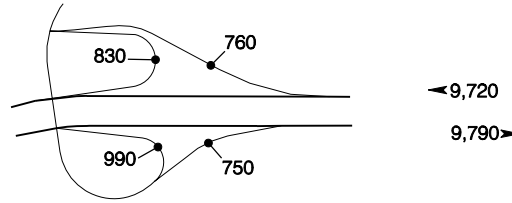

Cow Creek Rest Area – Exit 81

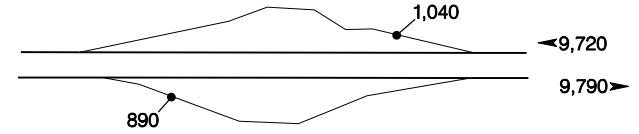

Barton Road – Exit 83

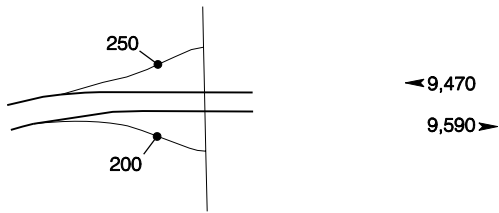

Quines Creek – Exit 86

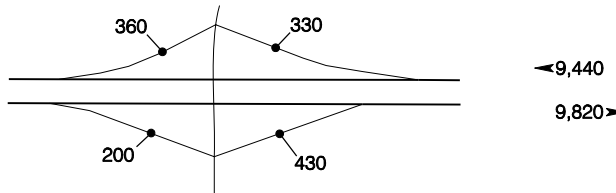

Azalea – Exit 88

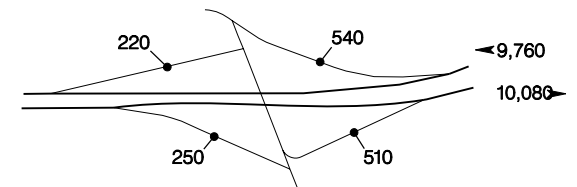

West Fork – Exit 95

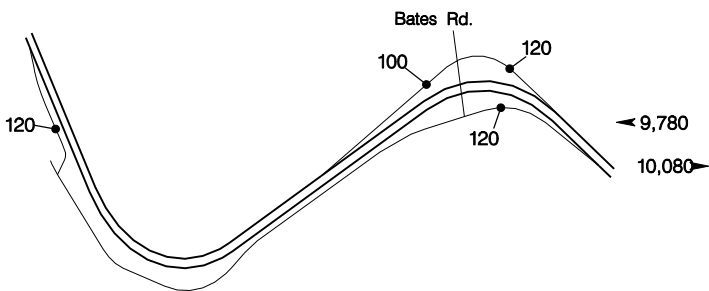

Canyonville – Exit 98

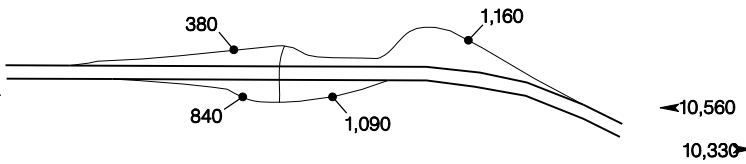

# INTERSTATE INTERCHANGES AND REST AREAS

North Canyonville – Exit 99

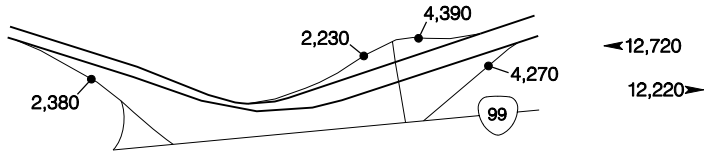

Yokum Road – Exit 101A

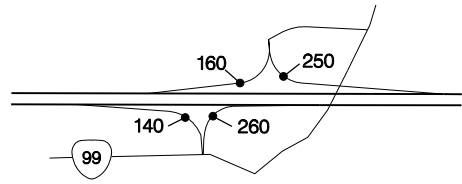

Gazely Road – Exit 101B

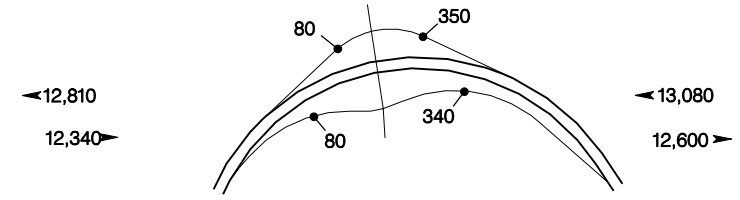

Riddle Road – Exit 103

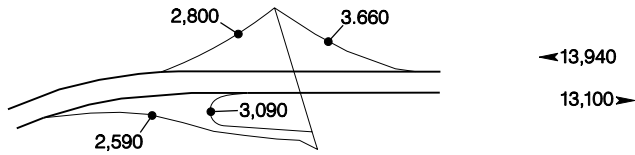

Weaver Road – Exit 106

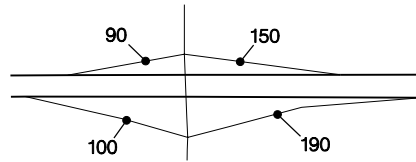

Myrtle Creek – Exit 108

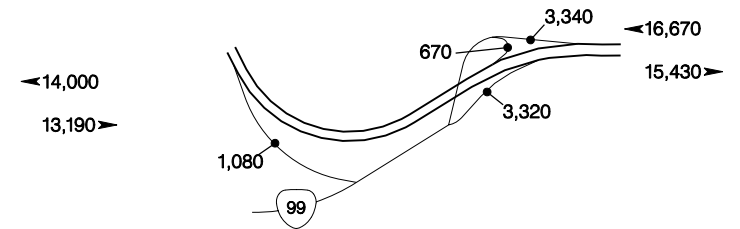

Boomer Hill Road – Exit 110

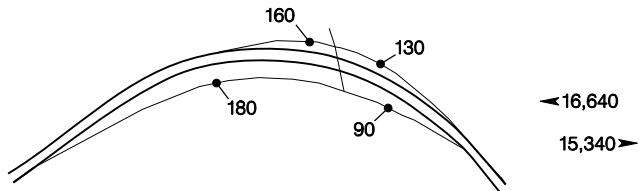

South Umpqua Rest Area – Exit 111B

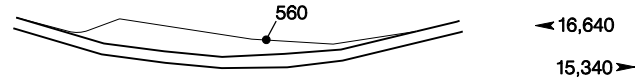

Dillard Hwy. – Exit 112

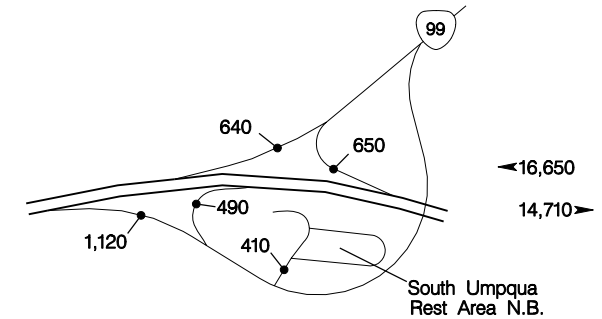

# INTERSTATE INTERCHANGES AND REST AREAS

Clarks Branch – Exit 113

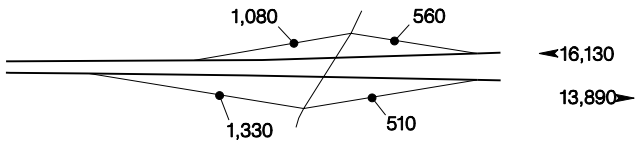

Coos Bay – Roseburg Hwy. – Exit 119

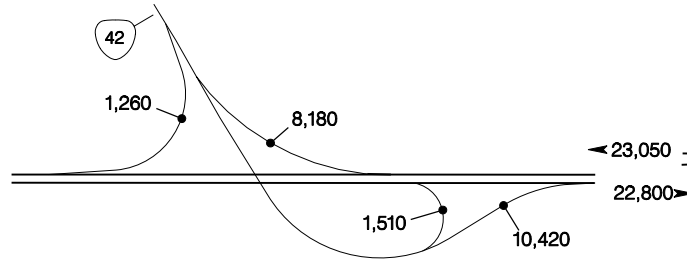

Oakland – Shady Hwy. – Exit 120

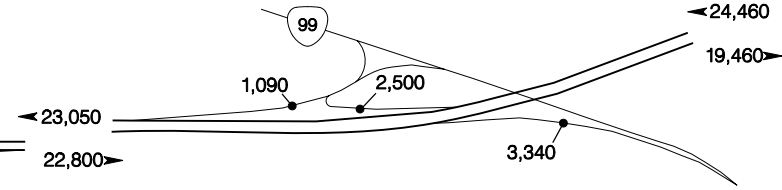

McLain Ave. – Exit 121

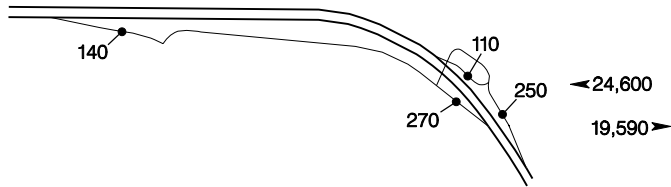

Fairgrounds – Exit 123

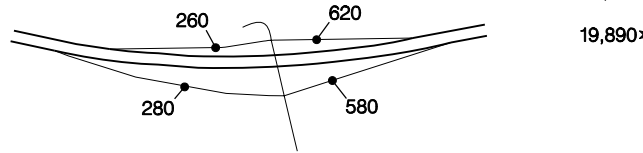

Harvard – Exit 124

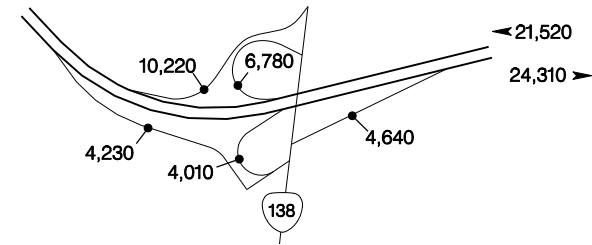

Garden Valley – Exit 125

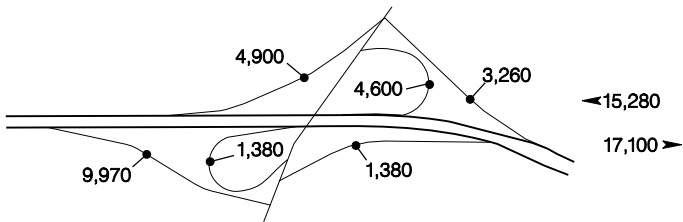

North Roseburg – Exit 127

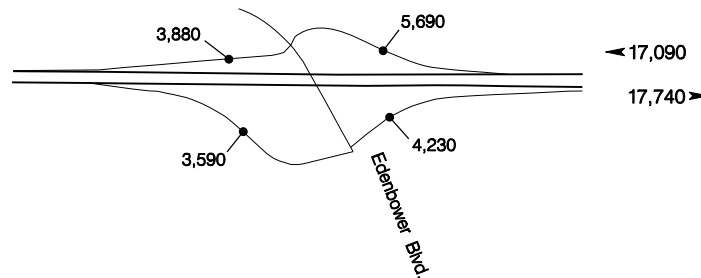

153

# INTERSTATE 5 INTERCHANGES AND REST AREAS

Winchester – Exit 129

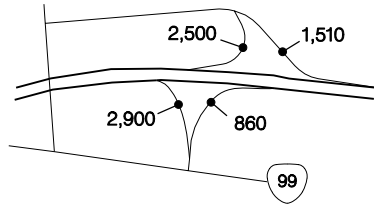

Deady – Exit 135

10-005  
Roseburg ATR  
MP 129.75

◀16,100  
15,700▶

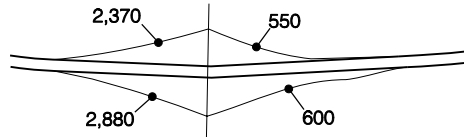

Sutherlin – Exit 136

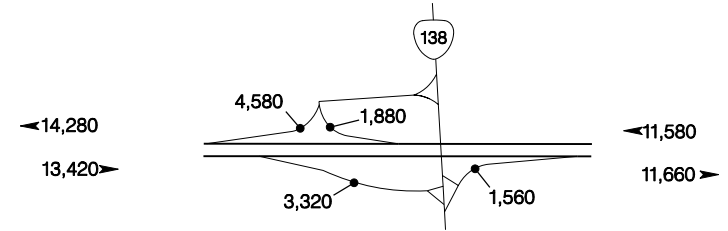

South Oakland – Exit 138

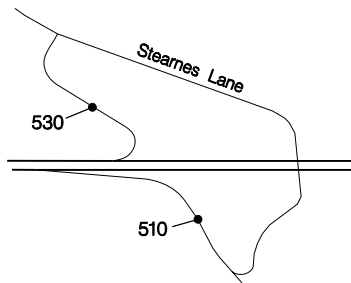

North Oakland – Exit 140

◀11,050  
11,150▶

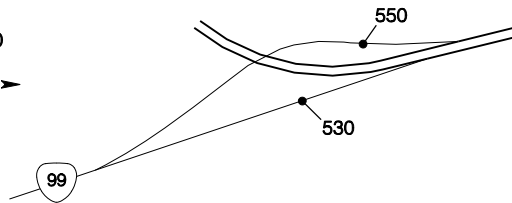

Metz Hill – Exit 142A

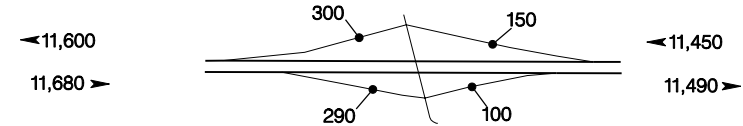

Cabin Creek Rest Area NB – Exit 142B



Cabin Creek Rest Area SB – Exit 143

◀11,450  
11,490▶



South Rice Hill – Exit 146

10-007  
Oakland ATR  
MP 145.39

◀11,450  
11,490▶

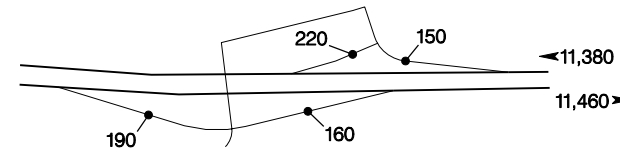

# INTERSTATE INTERCHANGES AND REST AREAS

Rice Hill – Exit 148

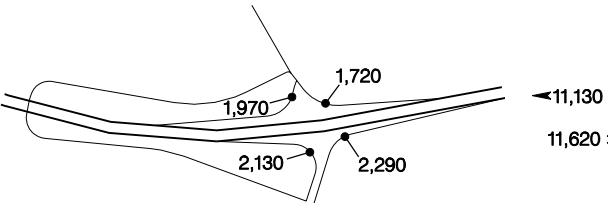

Yoncalla – Exit 150

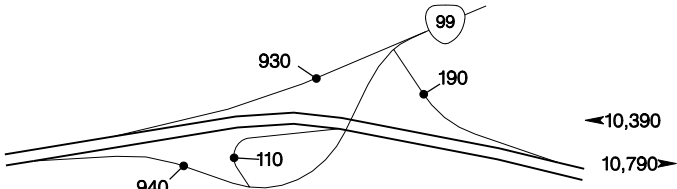

Elkhead Road – Exit 154

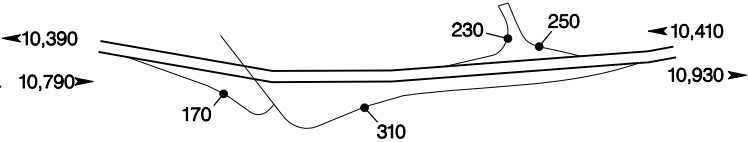

Elk Creek / Cox Road – Exit 159

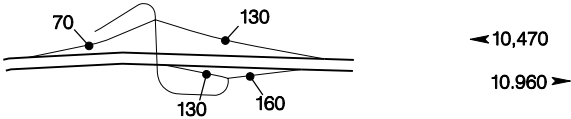

Salt Springs Road – Exit 160

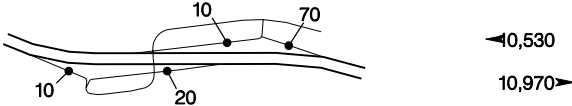

Buck Creek – Exit 161

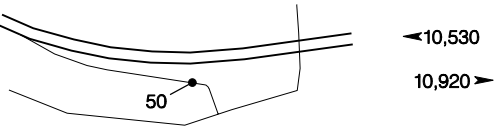

Umpqua Hwy. – Exit 162

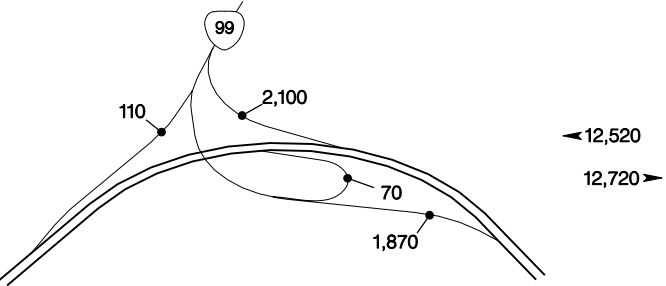

Curtin – Exit 163

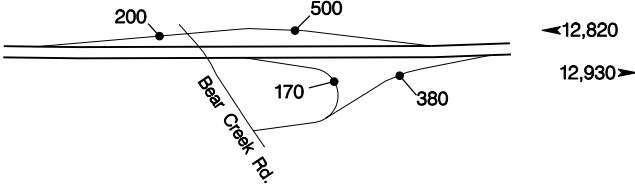

155



# INTERSTATE 5 INTERCHANGES AND REST AREAS

Goshen – Divide Highway – Exit 168

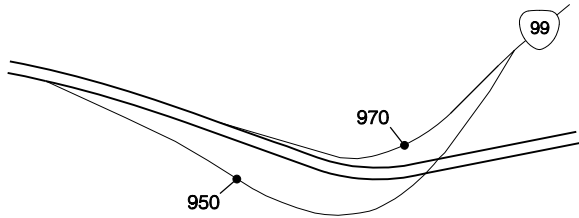

20-020  
Martins Creek ATR  
MP 169.20

←11,850  
11,980→

London Road – Exit 172

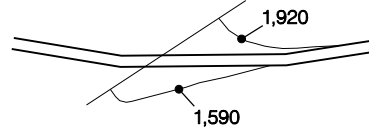

←13,770  
13,570→

Cottage Grove – Exit 174

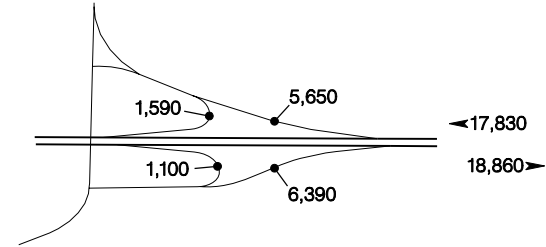

←17,830  
18,860→

Saginaw – Exit 176

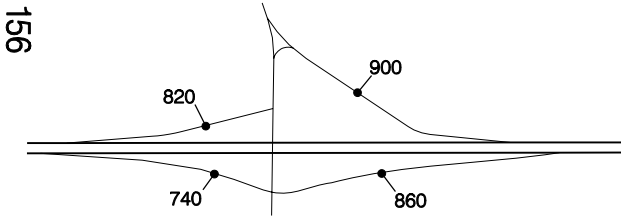

156

←17,910  
18,980→

Gettings Creek Rest Area – Exit 177, 178

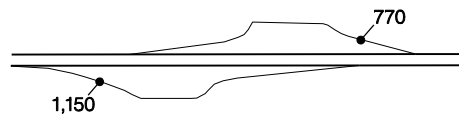

←17,910  
18,980→

Creswell – Exit 182

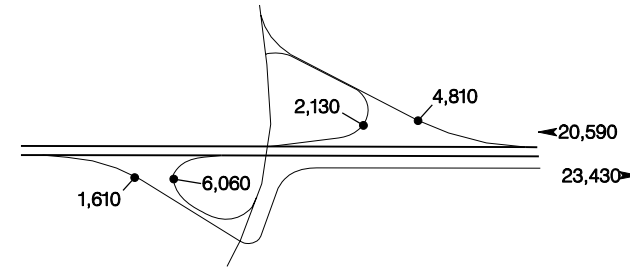

←20,590  
23,430→

Dillard Road – Exit 186

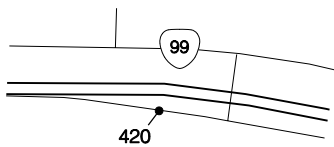

←20,590  
23,010→

Goshen – Exit 188

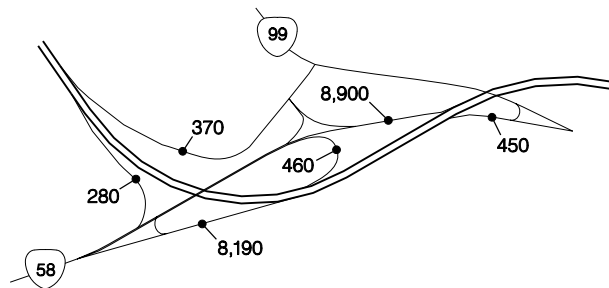

←28,660  
30,470→

Bonneville Power – Exit 189

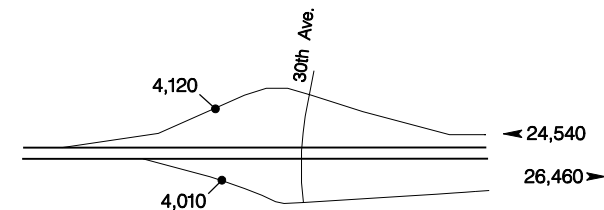

←24,540  
26,460→

# INTERSTATE INTERCHANGES AND REST AREAS

McVay Hwy. – Exit 190

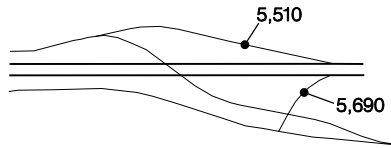

← 30,050  
32,150 →

Judkins Point – Exit 191

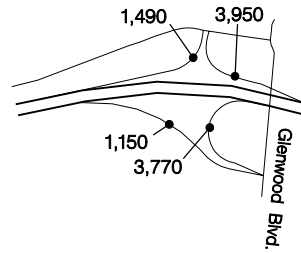

← 32,510  
34,770 →

Pacific Hwy. West – Exit 192

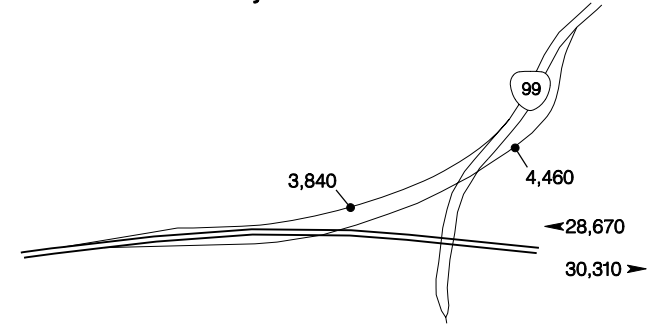

← 28,670  
30,310 →

"Q" Street – Exit 194

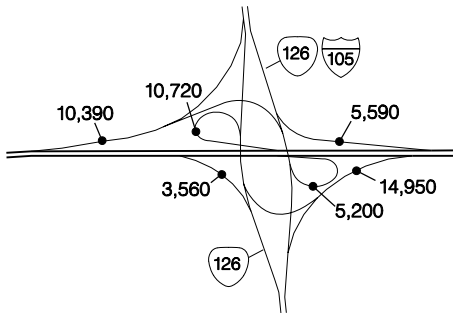

← 34,590  
36,500 →

Belt Line Hwy. – Exit 195

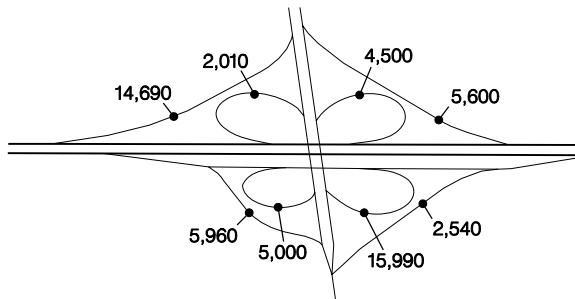

← 23,010  
22,090 →

Van Duyn Road – Exit 199

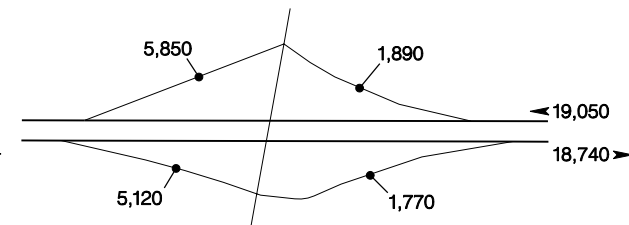

← 19,050  
18,740 →

Oak Grove Rest Area – Exit 206B

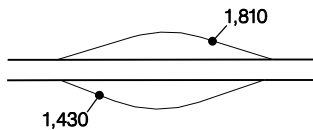

← 19,050  
18,740 →

Diamond Hill – Exit 209

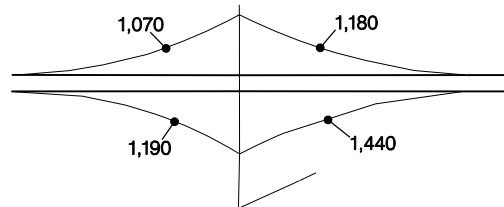

← 19,160  
18,990 →  
22-016  
Lake Creek ATR  
MP 214.56

# INTERSTATE 5 INTERCHANGES AND REST AREAS

Halsey – Sweethome – Exit 216

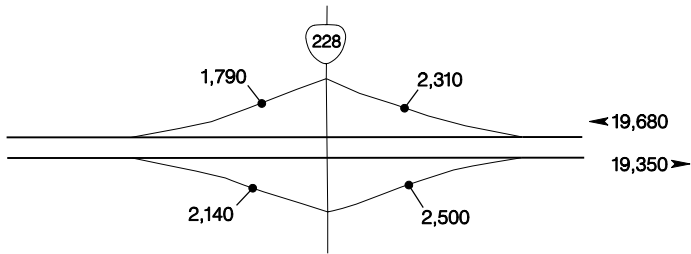

Corvallis – Lebanon Hwy. – Exit 228

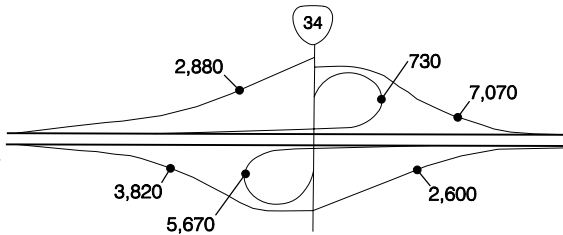

Santiam Hwy. – Exit 233

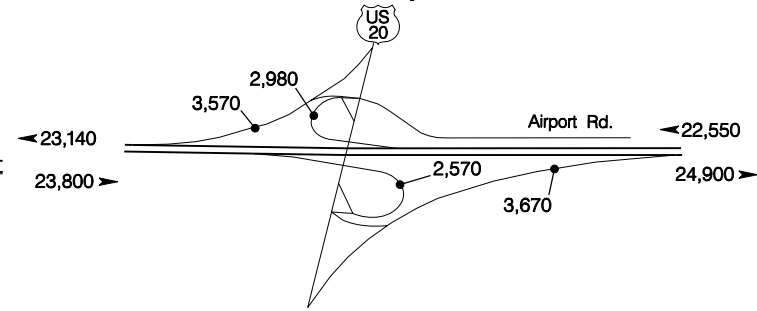

North Albany – Exit 234

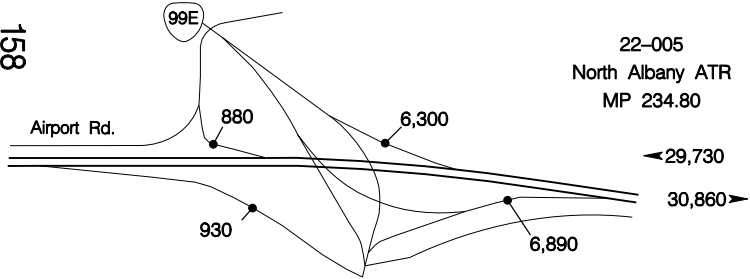

Murder Creek – Exit 235

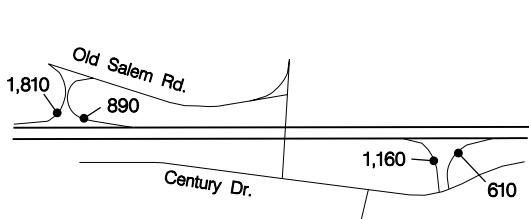

Viewcrest – Exit 237

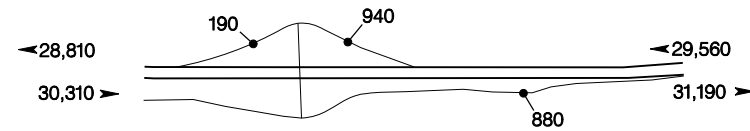

South Jefferson – Exit 238

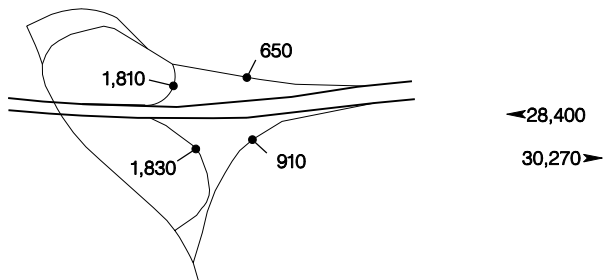

Dever Road – Exit 239

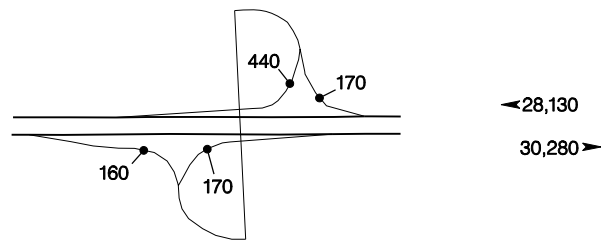

158

INTERSTATE  INTERCHANGES AND REST AREAS

Santiam Rest Area – Exit 241

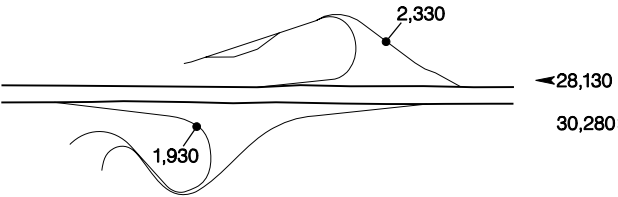

Talbot Road – Exit 242

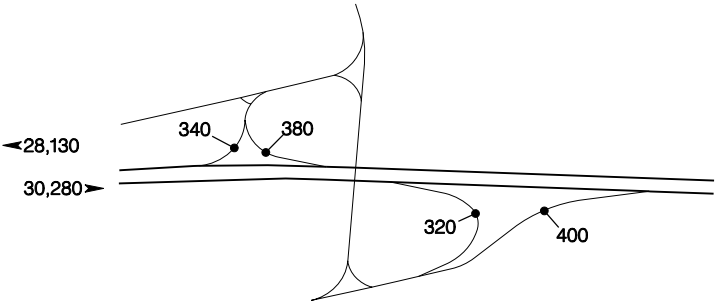

Ankeny Hill – Exit 243

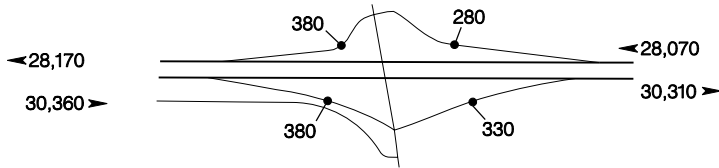

Jefferson Hwy. – Exit 244

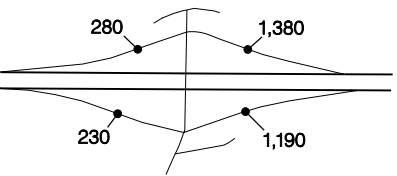

Battle Creek – Exit 248



Commerical Street – Exit 249

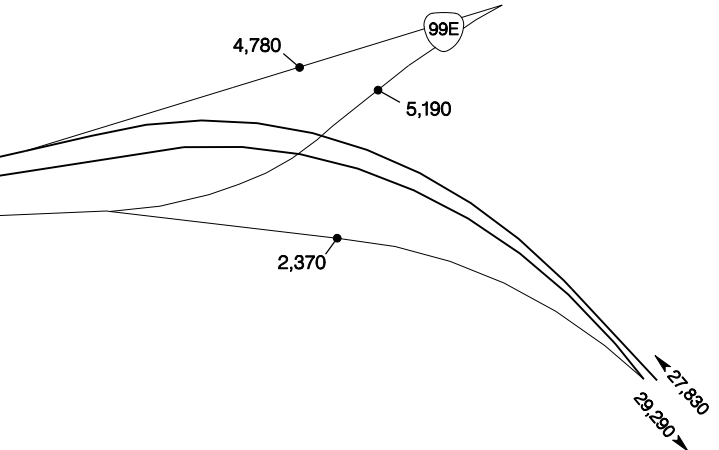

Kuebler – Exit 252

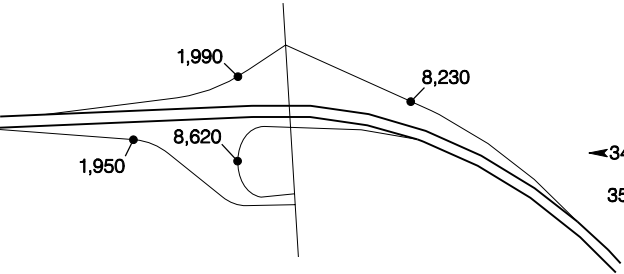

North Santiam – Exit 253

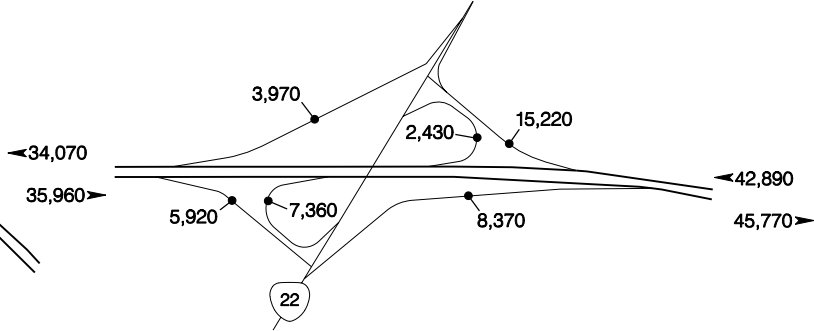

# INTERSTATE INTERCHANGES AND REST AREAS

Market Street – Exit 256

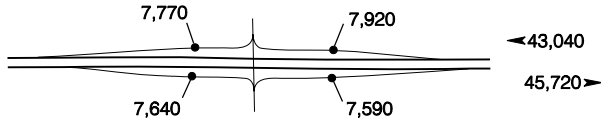

Hayesville – Exit 258

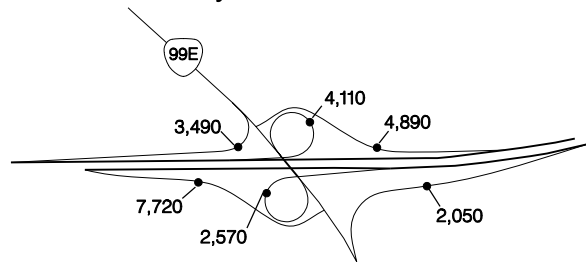

Chemawa Road – Exit 260

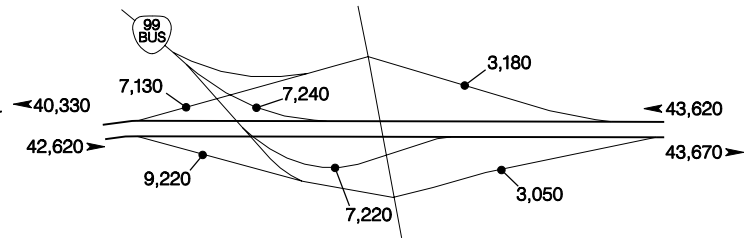

Brooks – Exit 263

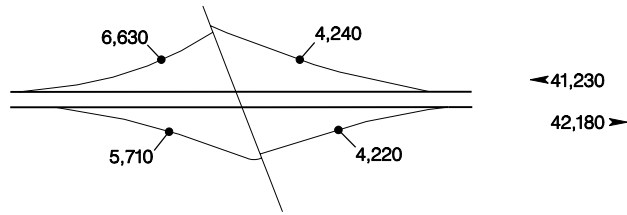

Woodburn – Exit 271

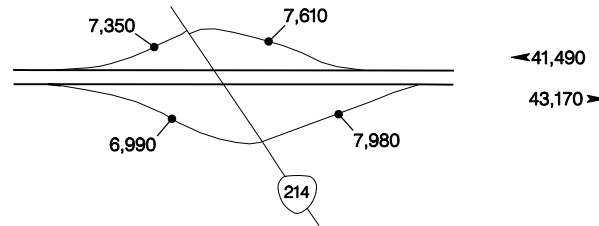

Fargo Road – Exit 278

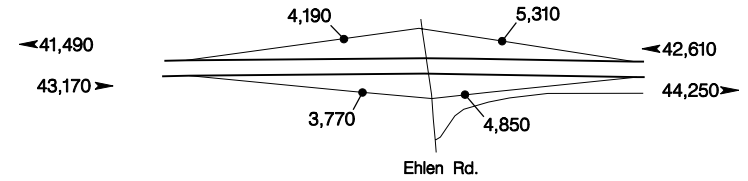

Baldock Rest Area – Exit 281B

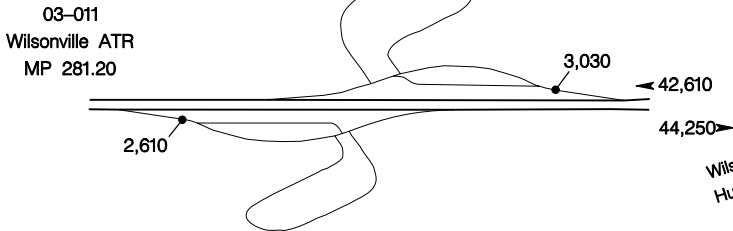

Hubbard – Exit 282

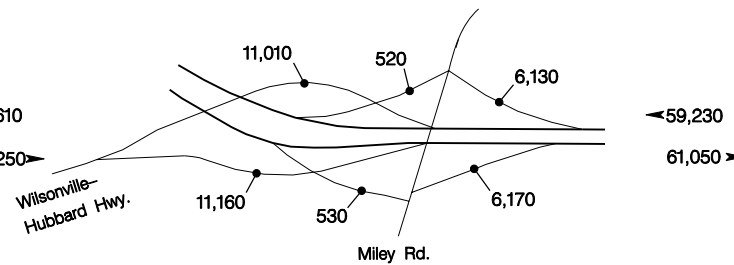

Willsonville – Exit 283

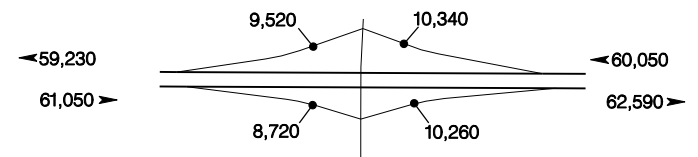

160

# INTERSTATE INTERCHANGES AND REST AREAS

Stafford Road – Exit 286

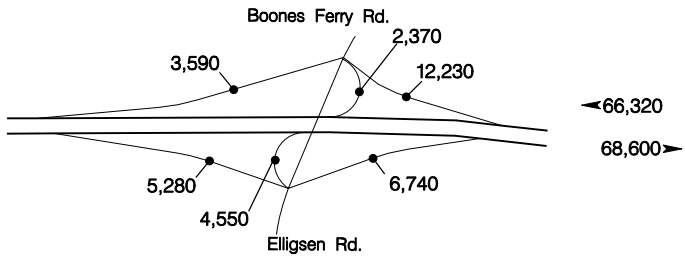

East Portland Freeway – Exit 288

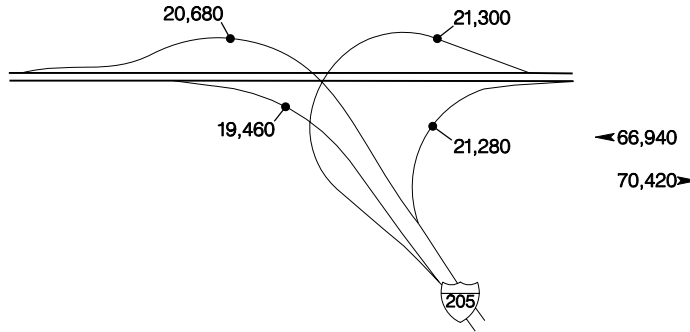

Nyberg Road – Exit 289

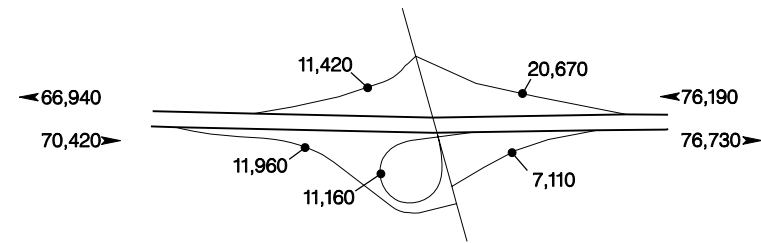

Lower Boones Ferry Road – Exit 290

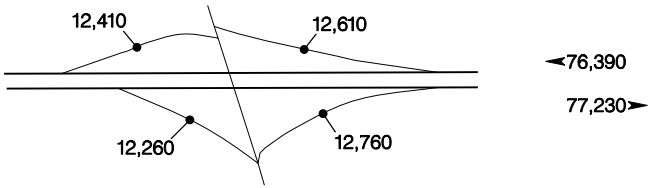

Upper Boones Ferry Road – Exit 291

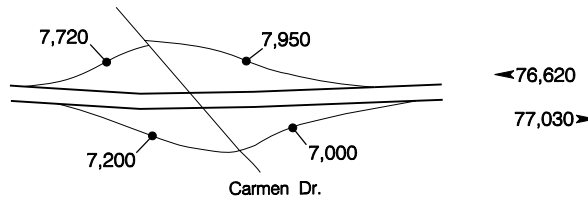

South Tigard – Exit 292

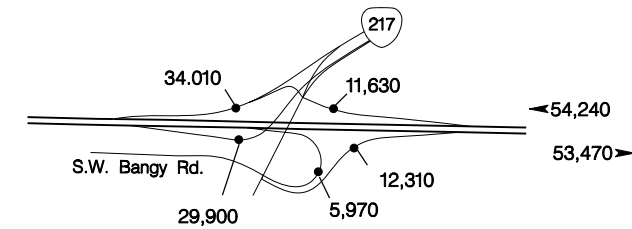

Haines Road – Exit 293

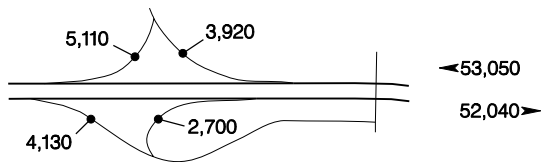

North Tigard – Exit 294

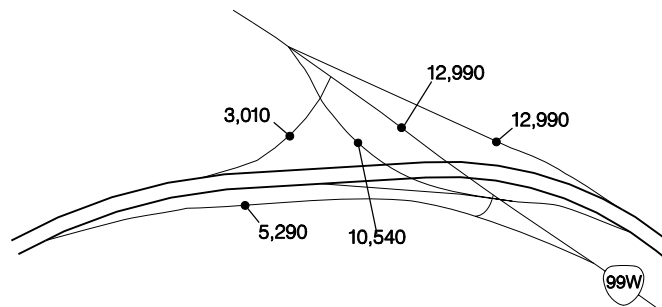

Capitol Highway – Exit 295A

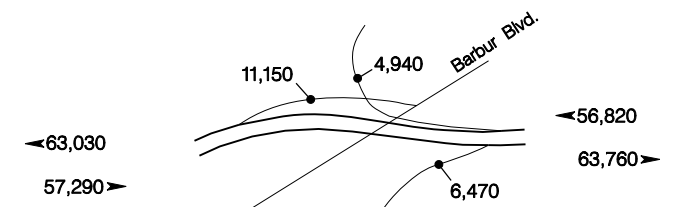

# INTERSTATE INTERCHANGES AND REST AREAS

Taylors Ferry Road – Exit 295B

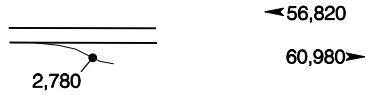

Spring Garden

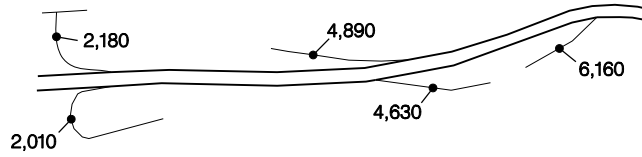

Multnomah Blvd. – Exit 296

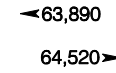

Terwilliger Blvd. – Exit 297

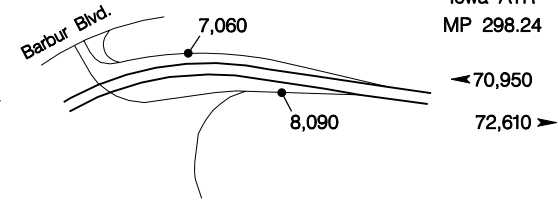

26-016  
Iowa ATR  
MP 298.24

70,950  
72,610

Corbett Avenue – Exit 298

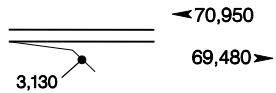

West Marquam – Exit 300

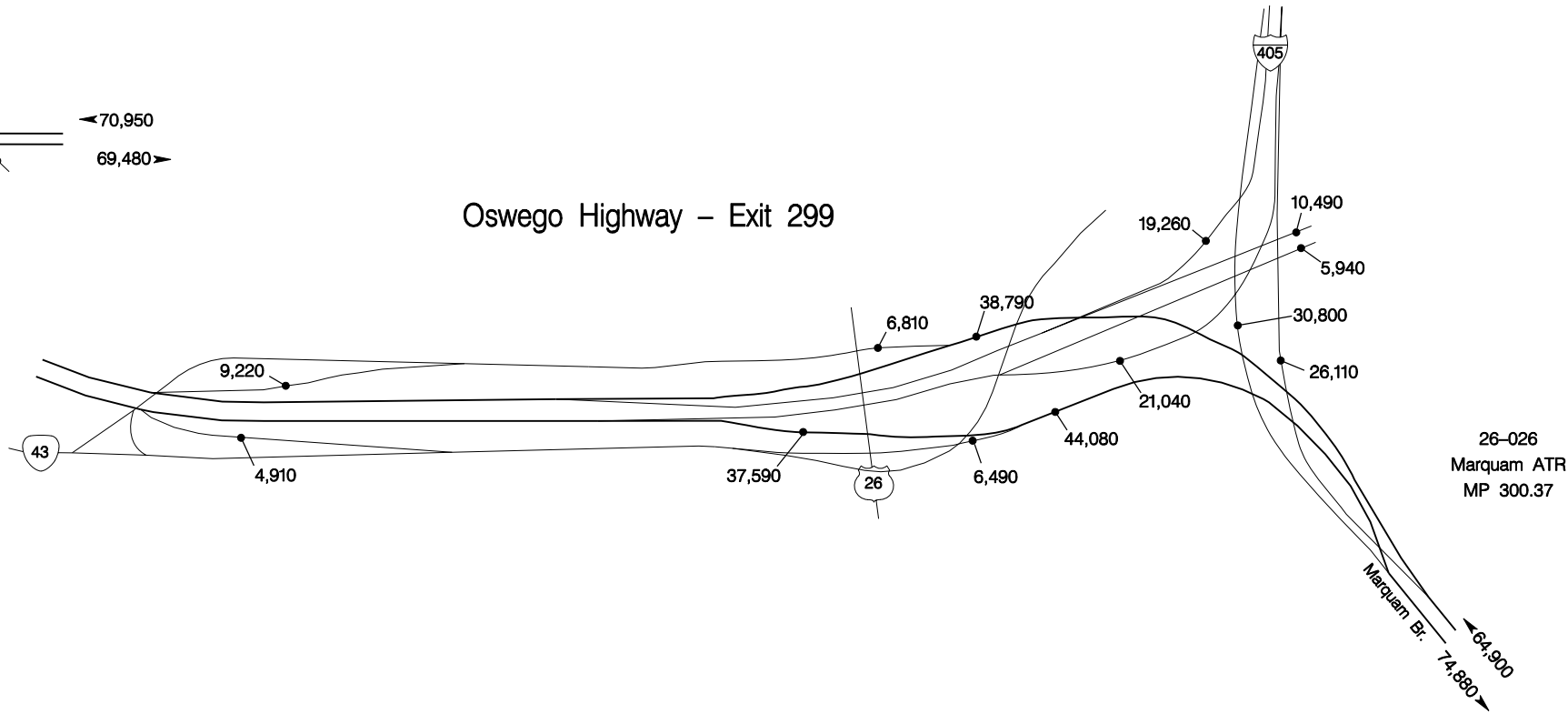

26-026  
Marquam ATR  
MP 300.37

64,900  
74,880

# INTERSTATE 5 INTERCHANGES AND REST AREAS

## Columbia River Highway – Exit 301

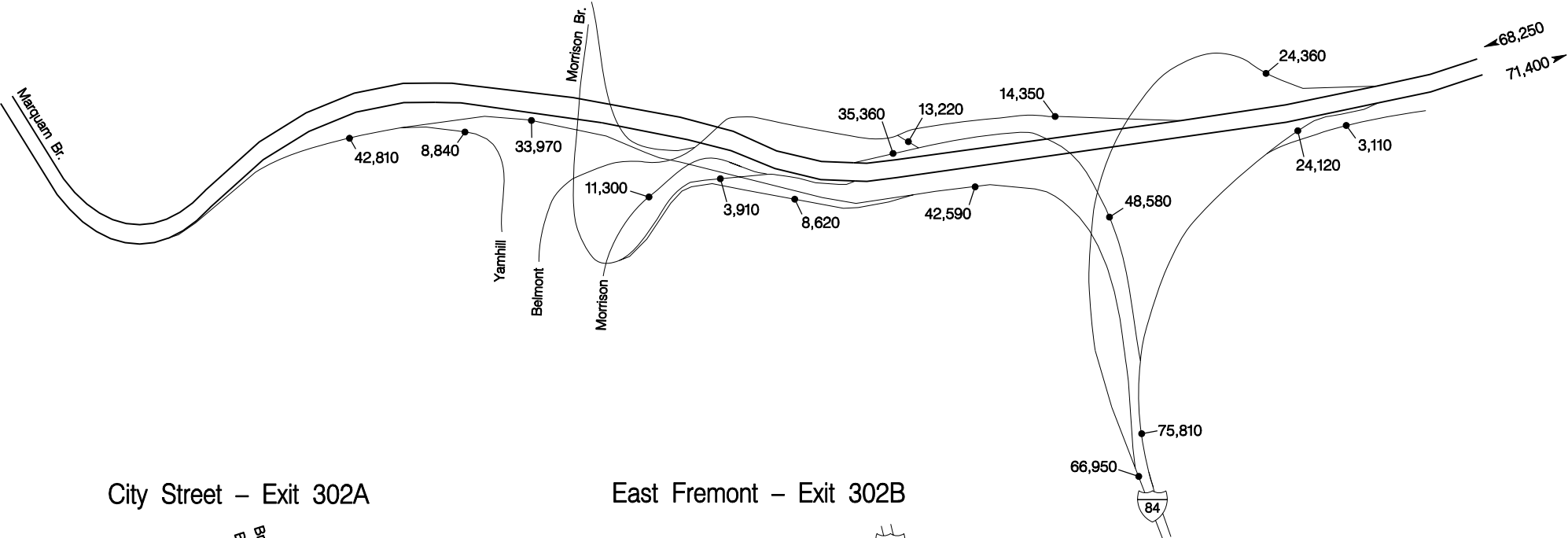

## City Street – Exit 302A

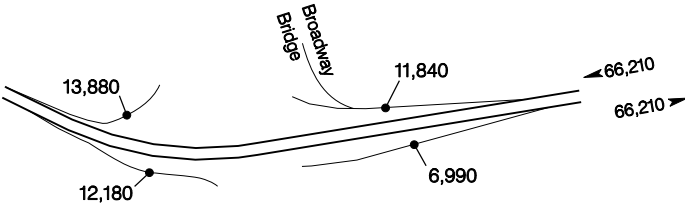

## East Fremont – Exit 302B

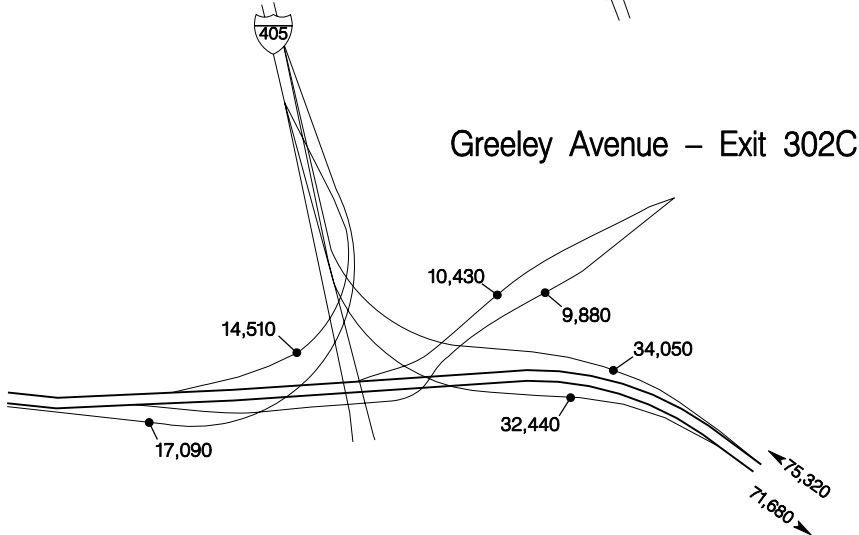



# INTERSTATE INTERCHANGES AND REST AREAS

Going Street – Exit 303

Minnesota Avenue – Exit 304A

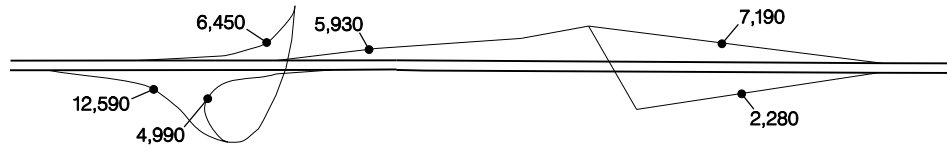

26-019  
Minnesota ATR  
MP 304.66

← 70,130  
66,360 →

Portland Blvd. – Exit 304B

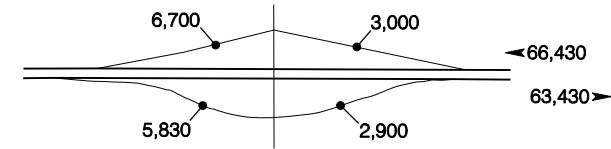

N.E. Portland – Exit 305A

Columbia Blvd. – Exit 305B

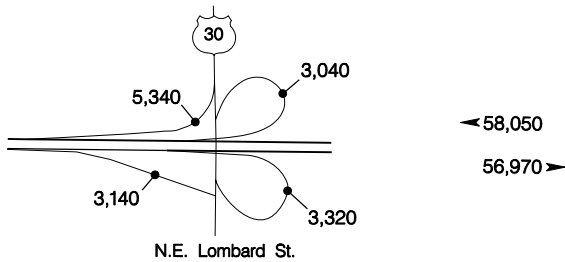

← 58,050  
56,970 →

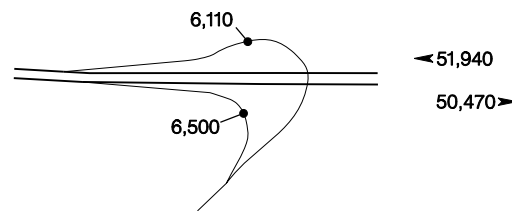

← 51,940  
50,470 →

Delta Park – Exit 306

Swift-Union – Exit 307

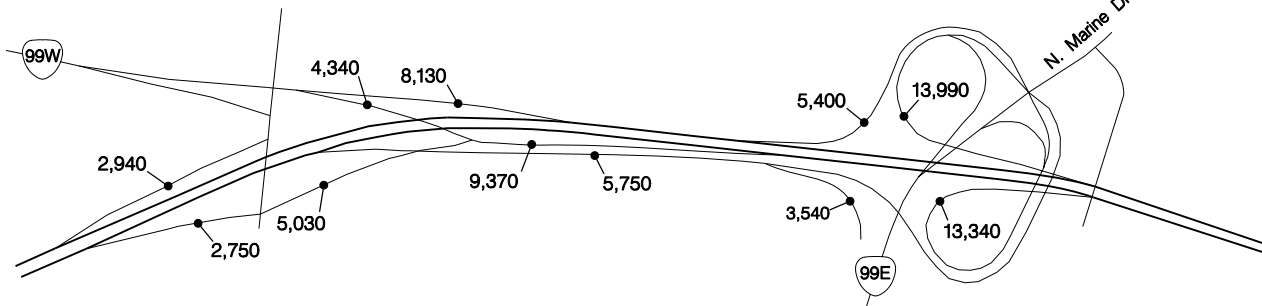

Jantzen Beach – Exit 308

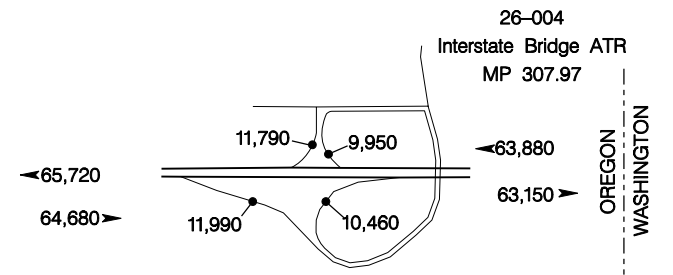

26-004  
Interstate Bridge ATR  
MP 307.97

OREGON  
WASHINGTON

# INTERSTATE INTERCHANGES AND REST AREAS

Pacific Hwy. Exit 0

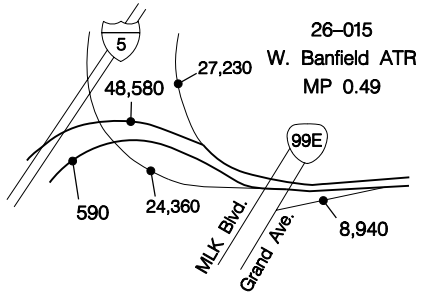

NE Holladay St. – Exit 1A

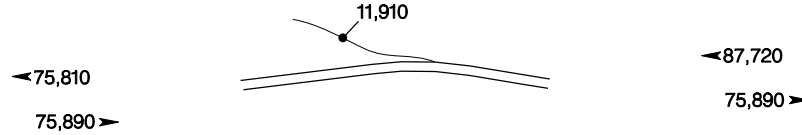

NE 16th Ave. – Exit 1B

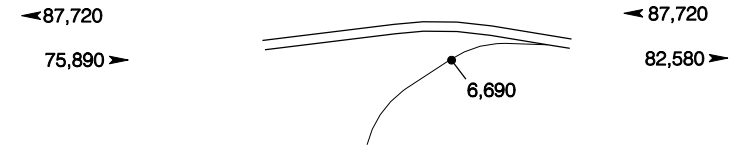

NE 33rd Ave. – Exit 2A

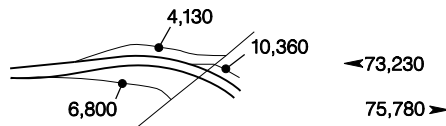

NE 39th Ave. – Exit 2B

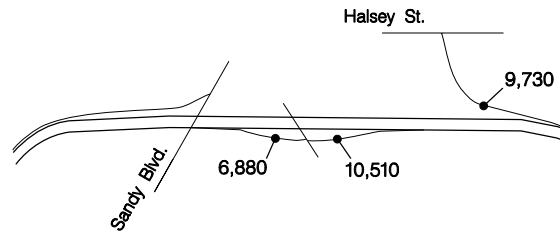

NE Glisan St. – Exit 3

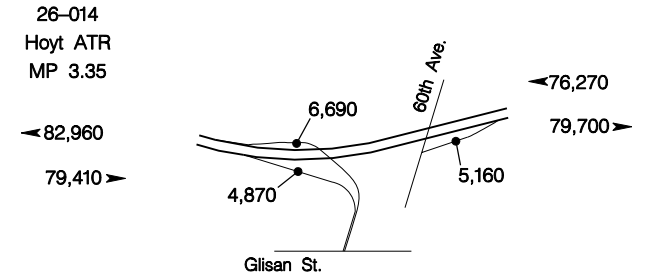

NE 68th Ave. – Exit 4

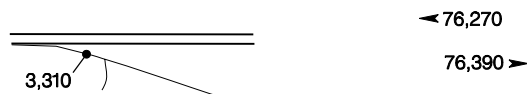

Cascade Hwy. – Exit 5A



# INTERSTATE INTERCHANGES AND REST AREAS

Hwy. 64 – Exit 5B

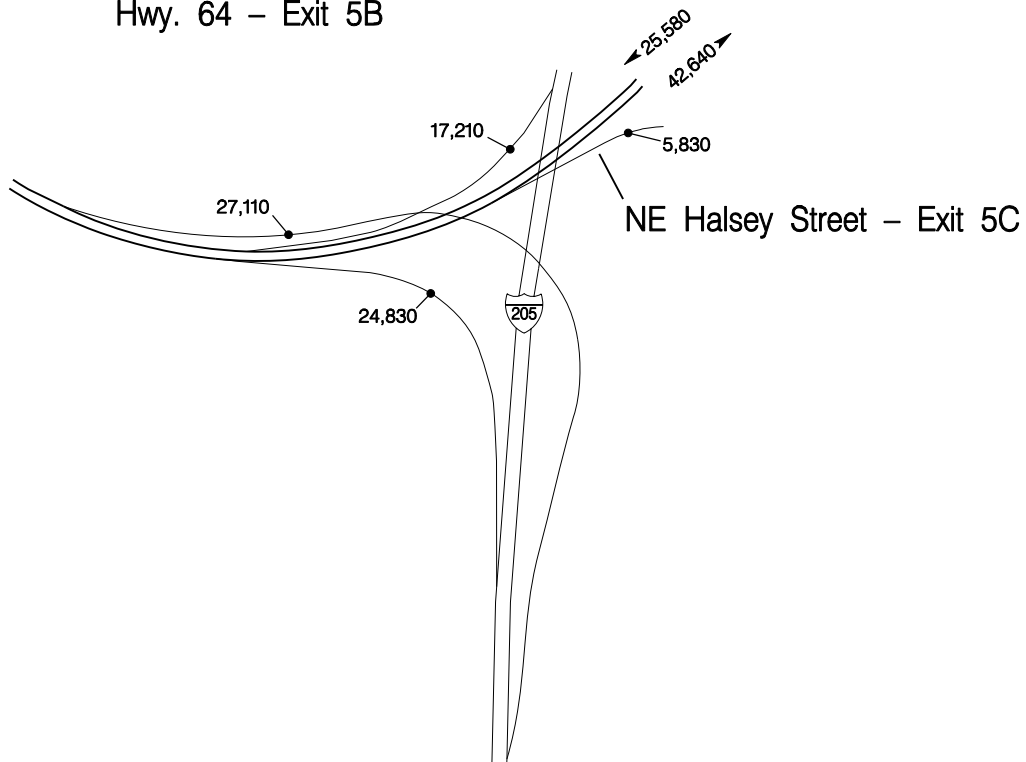

North Banfield – Exit 6A

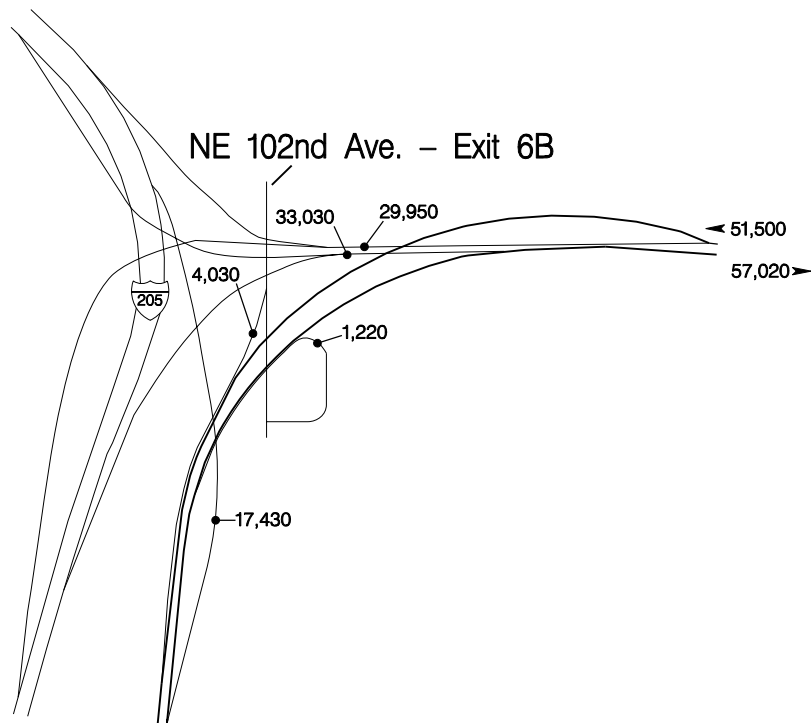

NE 122nd Ave. – Exit 10

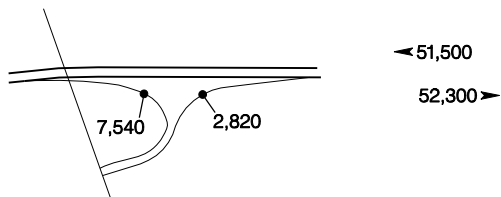

NE 181st Ave. – Exit 13

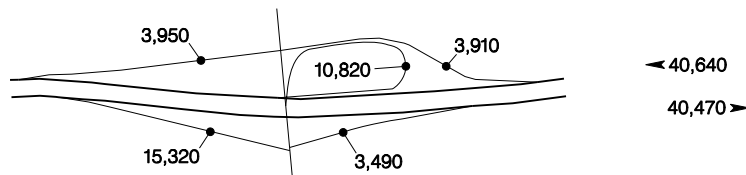

INTERSTATE  INTERCHANGES AND REST AREAS

NE 207th Ave. – Exit 14

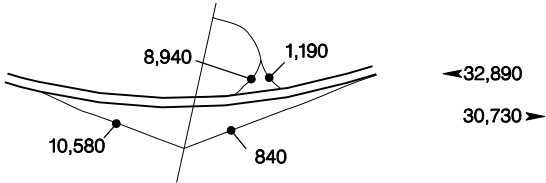

NE 238th Ave. – Exit 16A

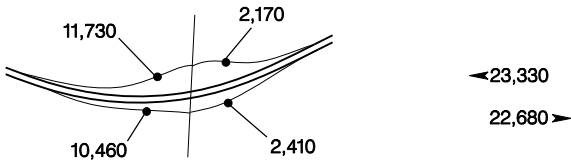

NE Marine Drive – Exit 17

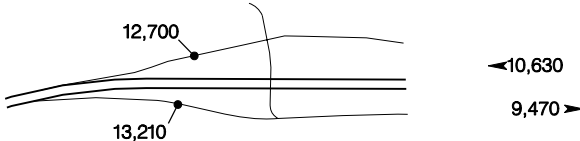

Troutdale – Exit 17

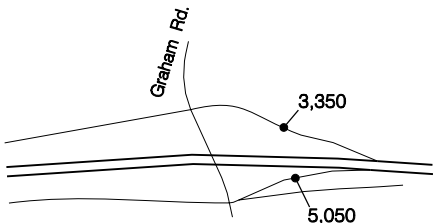

26-001  
Troutdale ATR  
MP 17.71

Jordan – Exit 18

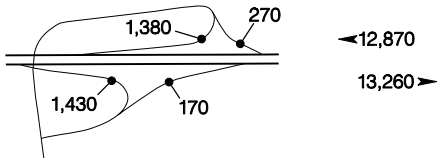

Corbett – Exit 22

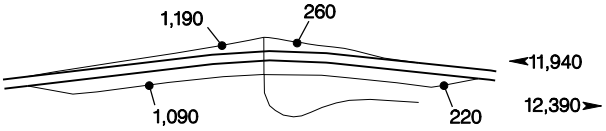

Rooster Rock – Exit 24

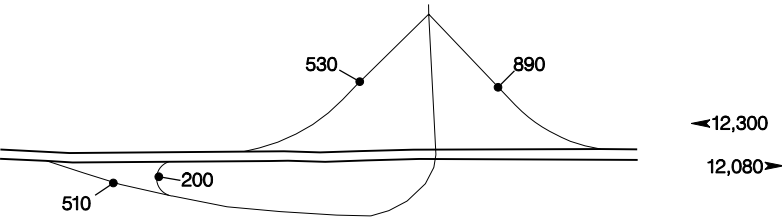

Bridal Veil – Exit 28

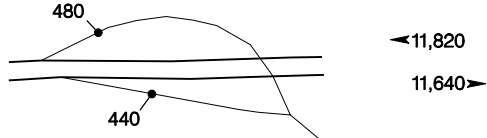

INTERSTATE  INTERCHANGES AND REST AREAS

Multnomah Falls – Exit 31

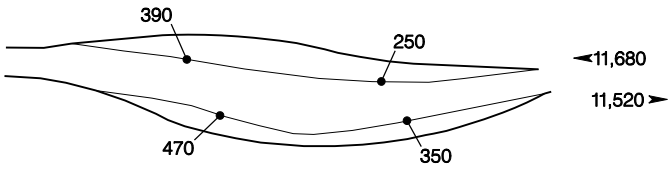

Historic Col. River Hwy. – Exit 35A

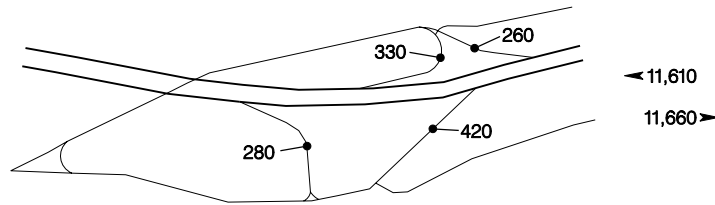

Warrendale O'King – Exit 37

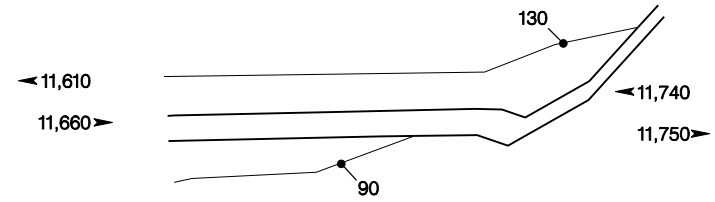

Bonneville Dam – Exit 40

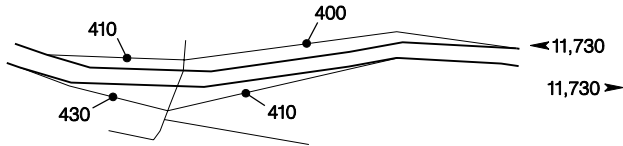

West Cascade Locks – Exit 43

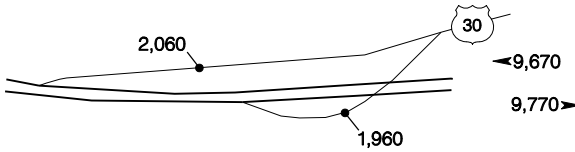

East Cascade Locks – Exit 45

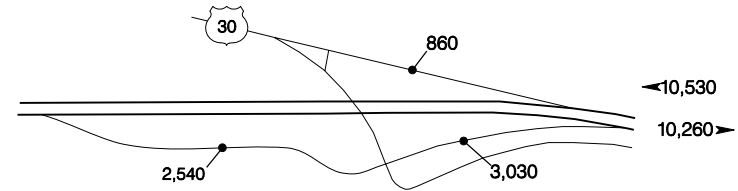

Herman Creek – Exit 47

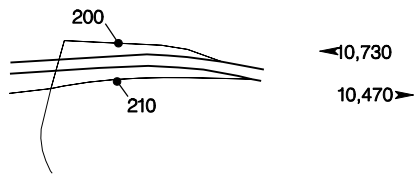

Wyeth – Exit 50

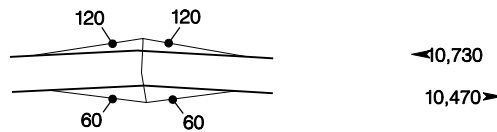

Starvation Creek State Park – Exit 54

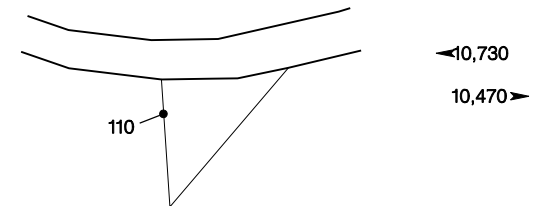

INTERSTATE  INTERCHANGES AND REST AREAS

Viento State Park – Exit 56

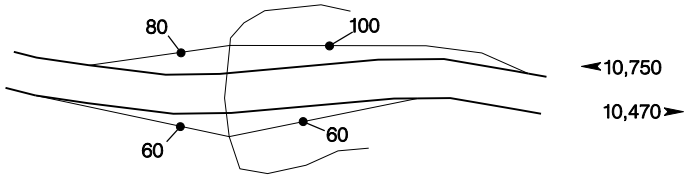

Mitchell Point – Exit 58

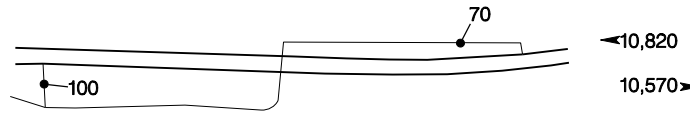

West Hood River – Exit 62

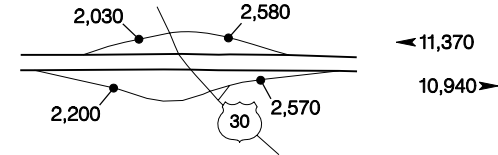

2nd Street – Exit 63

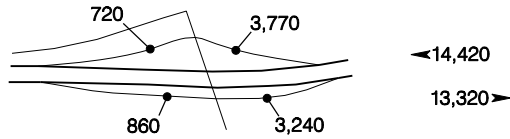

East Hood River – Exit 64

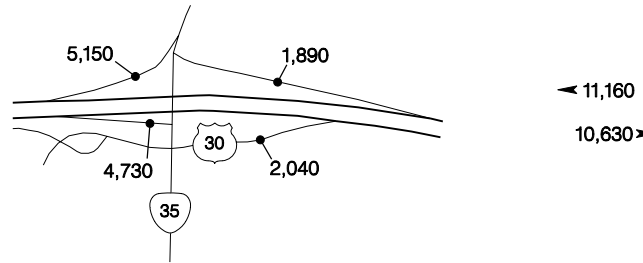

Mosier – Exit 69

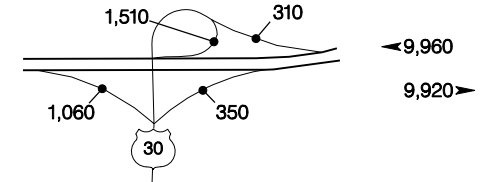

Memaloose Rest Area – Exit 72, 73

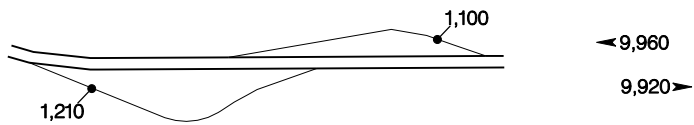

33-001  
Rowena ATR  
MP 75.93

Rowena – Exit 76

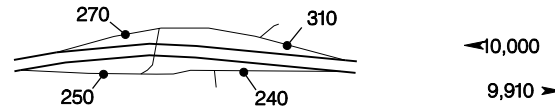

Chenoweth – Exit 82

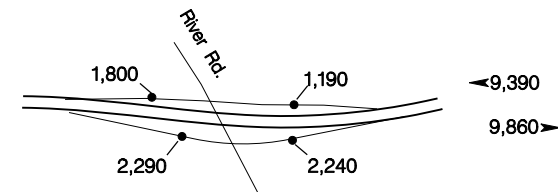

170

# INTERSTATE INTERCHANGES AND REST AREAS

West The Dalles – Exit 83

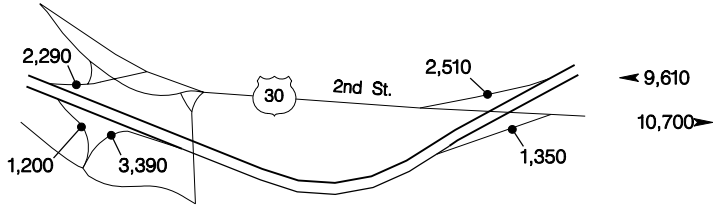

Brewery Grade – Exit 85

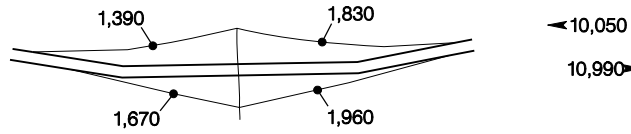

The Dalles Bridge – Exit 87

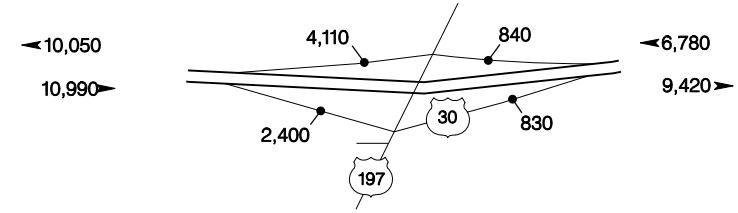

The Dalles Dam – Exit 88

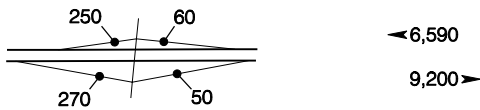

Celilo–Wasco Hwy. – Exit 97

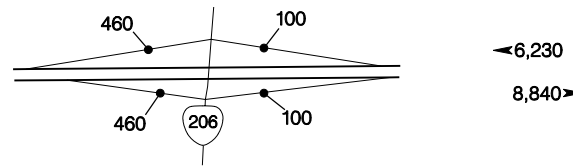

Biggs Jct. – Exit 104

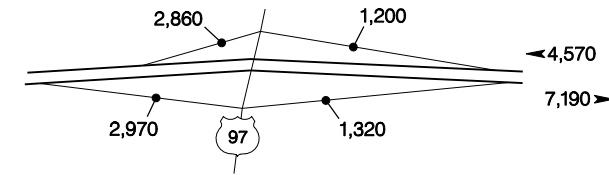

Rufus – Exit 109

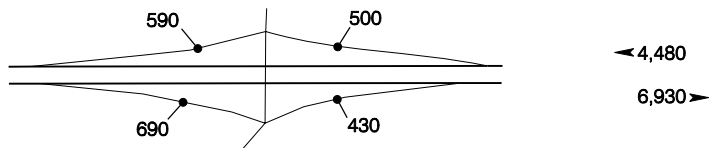

West John Day – Exit 114

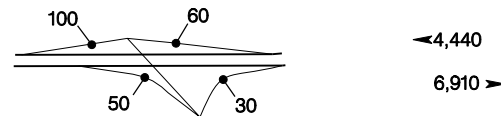

INTERSTATE  INTERCHANGES AND REST AREAS

Philippi Canyon – Exit 123

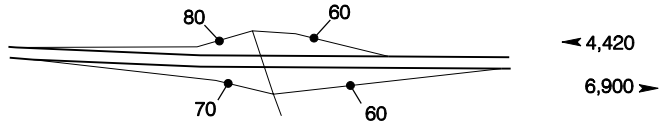

Blalock – Exit 129

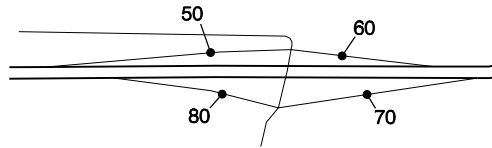

Woelpern – Exit 131

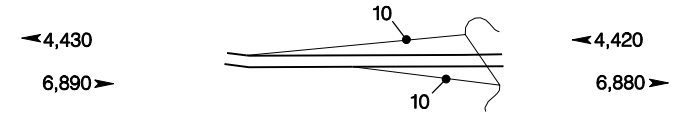

Arlington – Exit 137

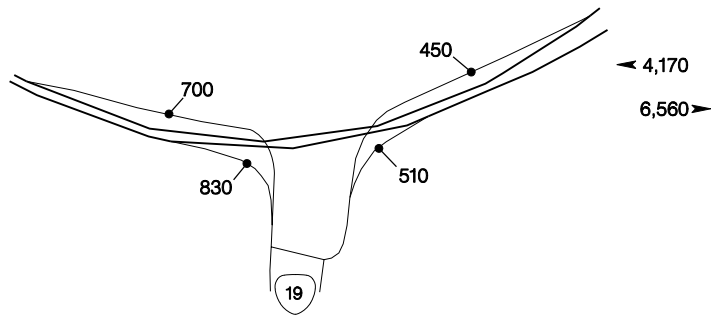

Heppner Jct. – Exit 147

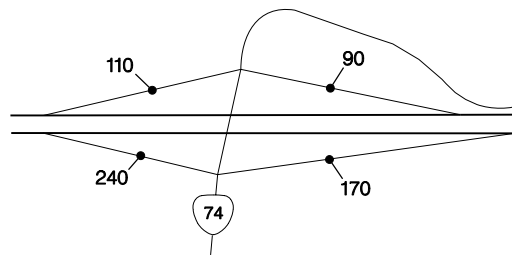

Threemile Canyon – Exit 151

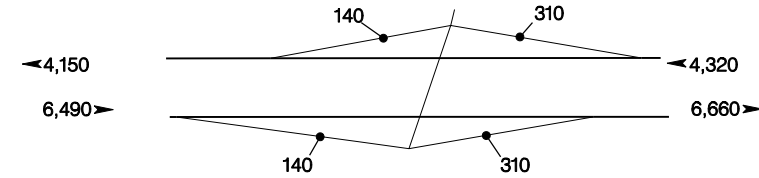

Tower Road – Exit 159

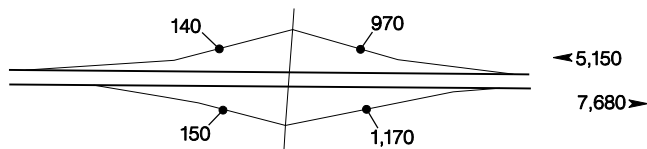

Boardman Rest Area – Exit 160

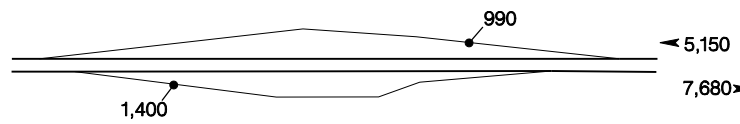

Boardman – Exit 164

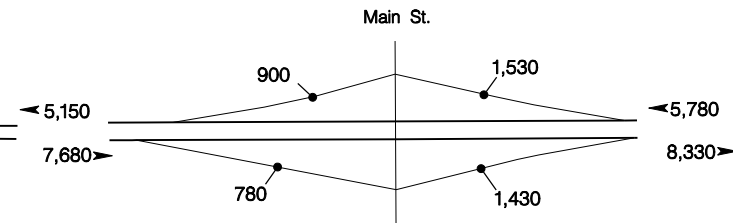



# INTERSTATE INTERCHANGES AND REST AREAS

Port Of Morrow – Exit 165

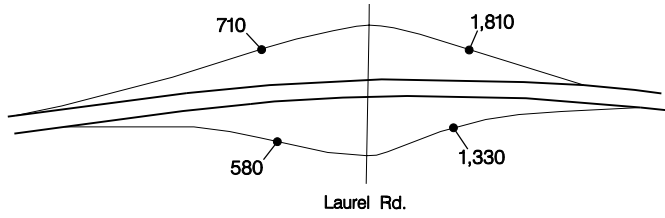

Boardman Jct. – Exit 168

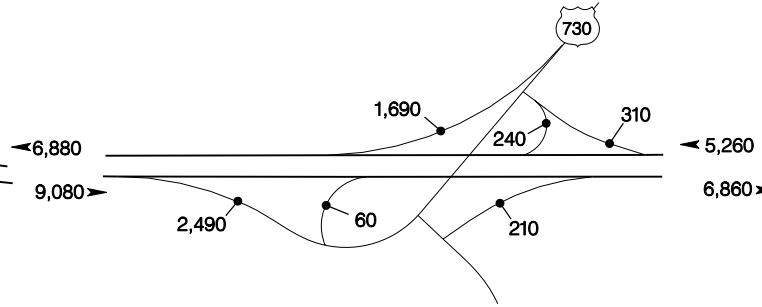

Paterson Ferry Road – Exit 171

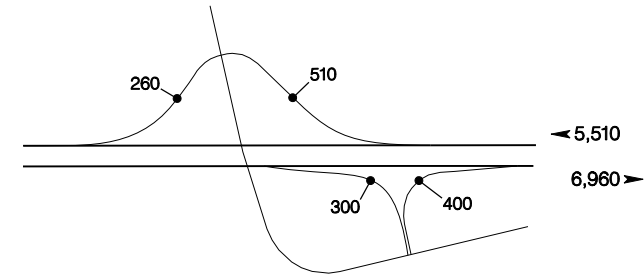

Ordnance – Exit 177

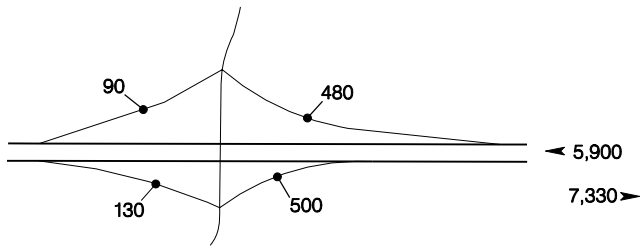

McNary Highway – Exit 179

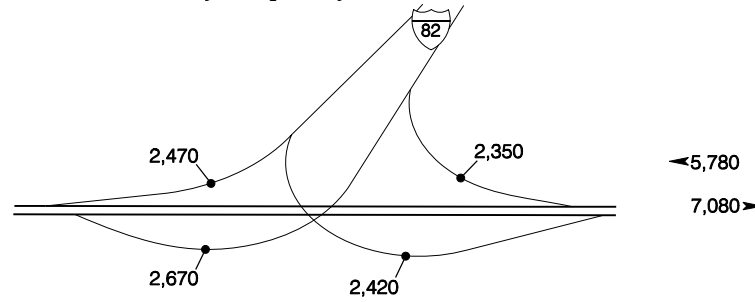

Westland Road – Exit 180

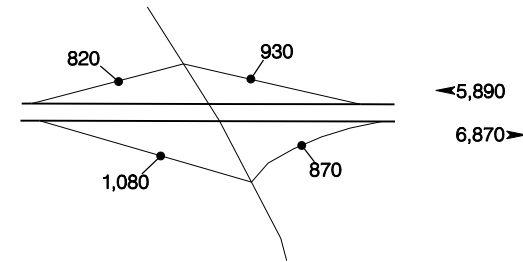

Hermiston – Exit 182

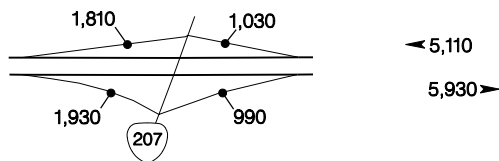

Stanfield Rest Area – Exit 186A, 186B

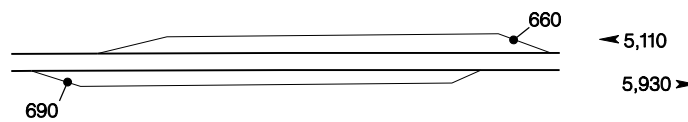

# INTERSTATE INTERCHANGES AND REST AREAS

Stanfield Jct. – Exit 188

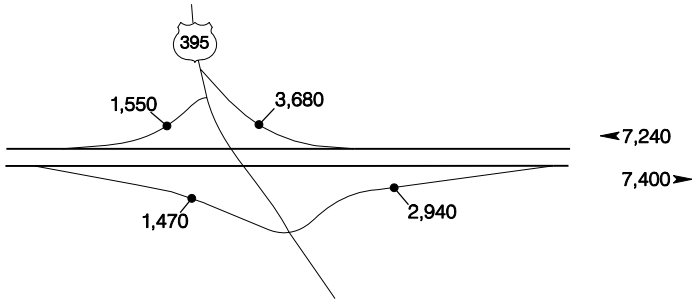

Echo Jct. – Exit 193

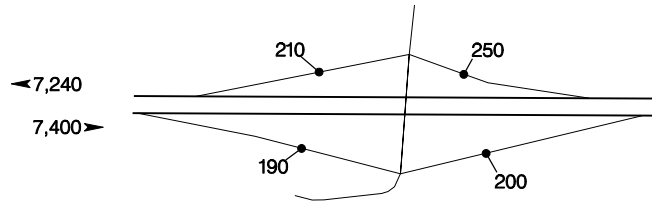

Rew Elevator – Exit 198

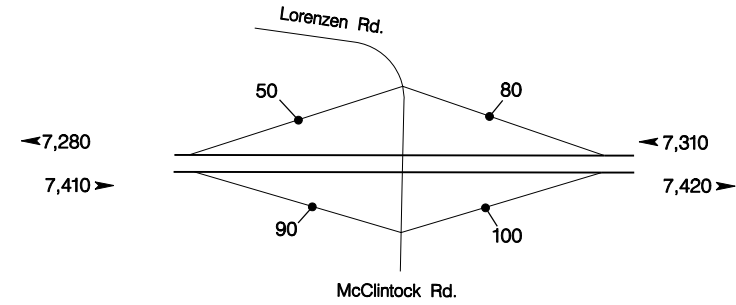

Yoakum Road – Exit 199

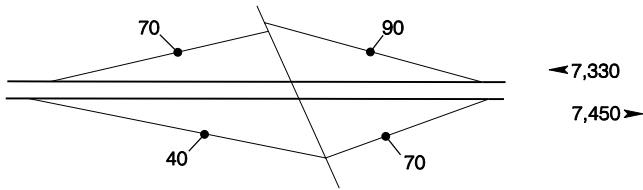

Barnhart – Exit 202

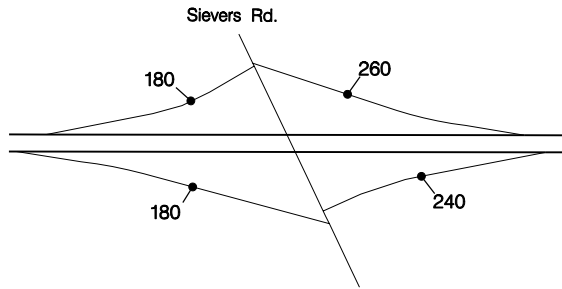

West Pendleton – Exit 207

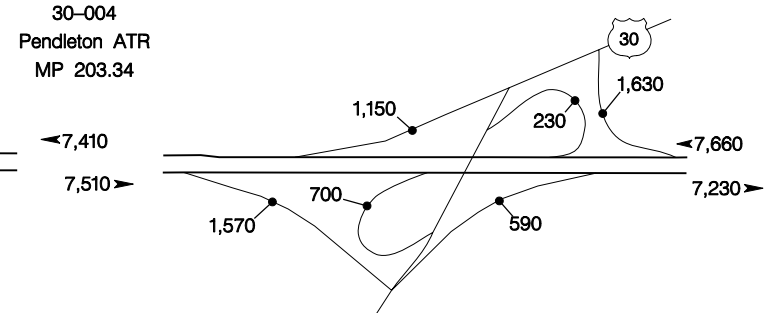

Emigrant Avenue – Exit 209

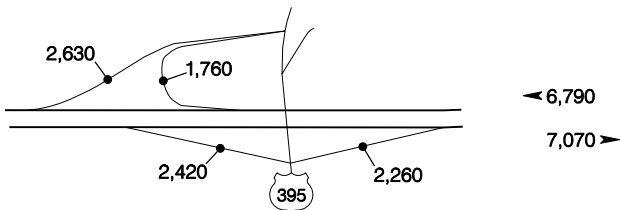

South Pendleton – Exit 211

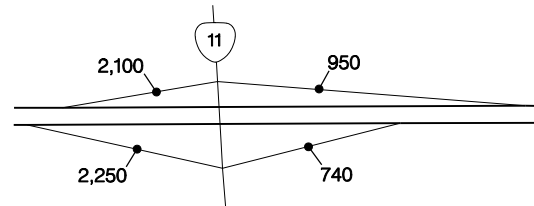

East Pendleton – Exit 213

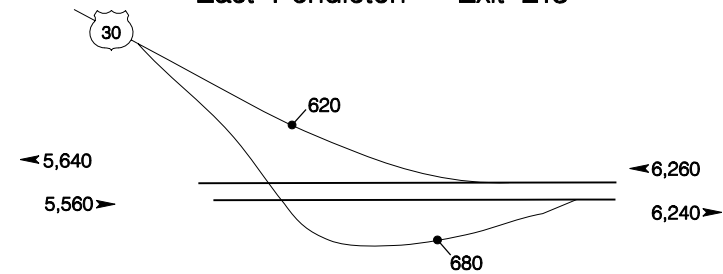

174

# INTERSTATE INTERCHANGES AND REST AREAS

Mission Jct. – Exit 215

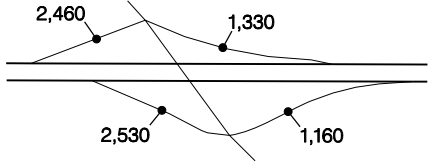

Emigrant Hill – Exit 224

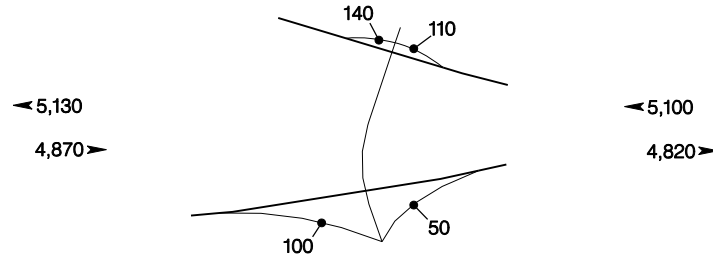

Deadman's Pass – Exit 228

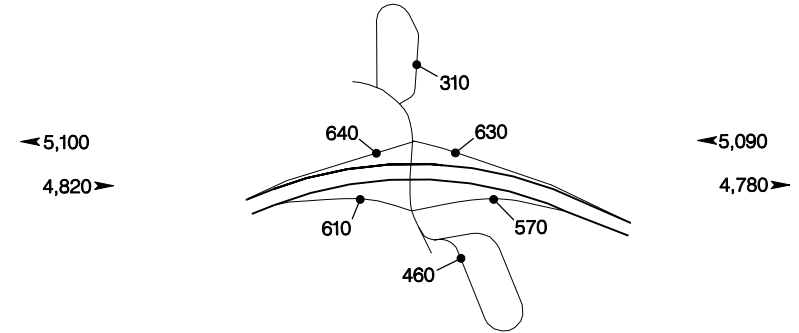

West Emigrant Park – Exit 233

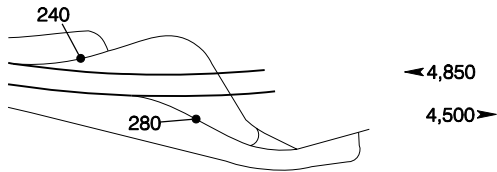

East Emigrant Park – Exit 235

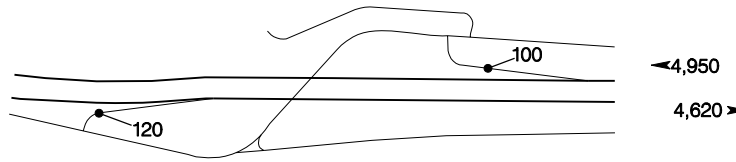

Meacham – Exit 238

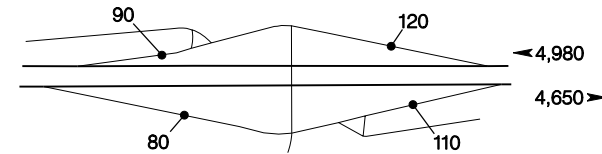

Kamela – Exit 243

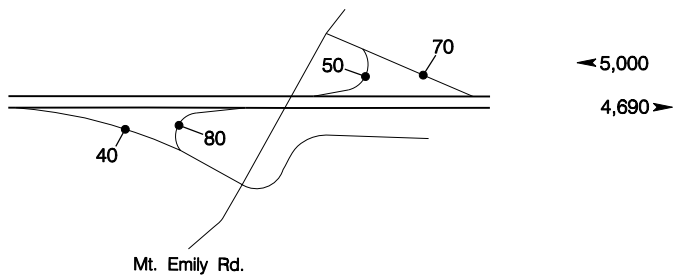

Glover – Exit 248

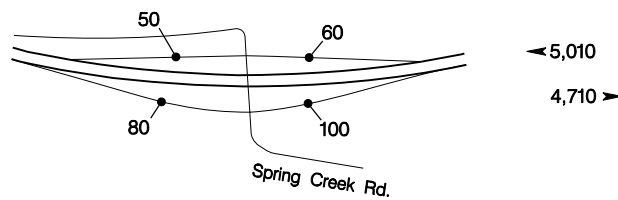

# INTERSTATE 84 INTERCHANGES AND REST AREAS

Ukiah-Hilgard – Exit 252

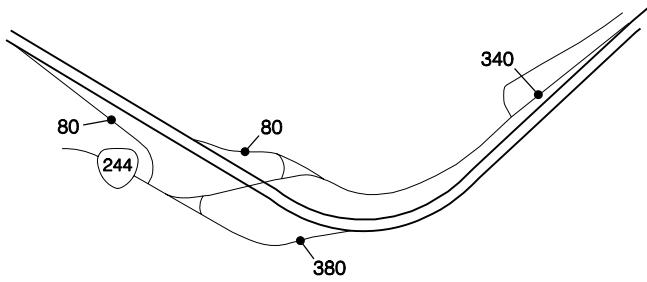

Upper Perry – Exit 256

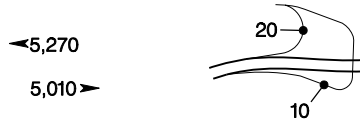

Lower Perry – Exit 257

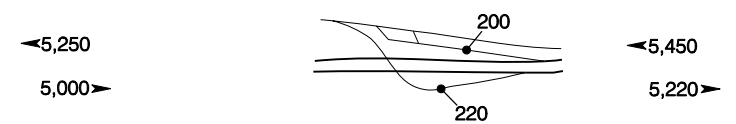

North LaGrande – Exit 259

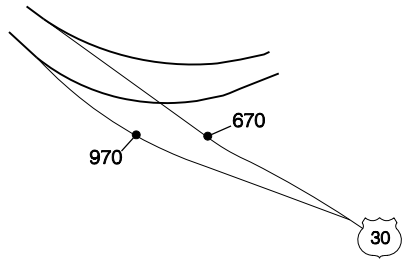

Wallowa Lake – Exit 261

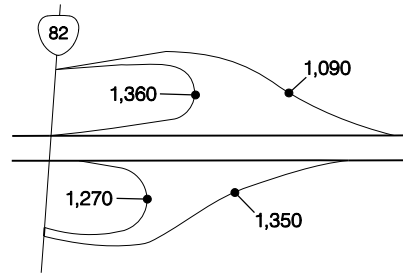

South LaGrande – Exit 264

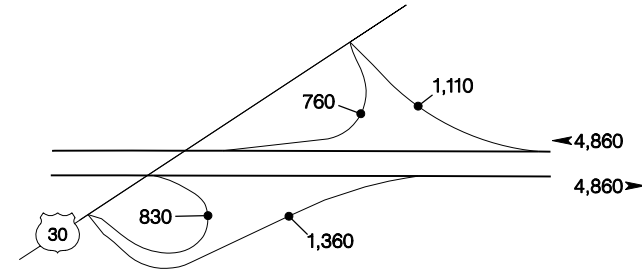

Foothill Road – Exit 268A

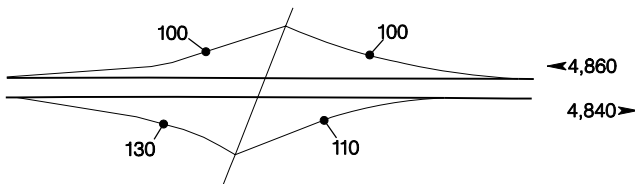

Ladd Canyon Rest Area – Exit 268B

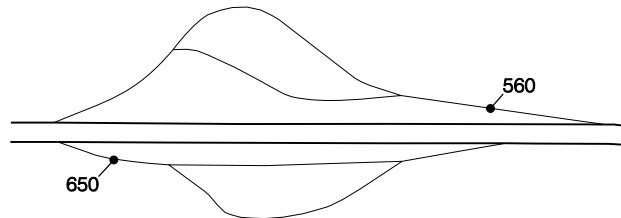

Ladd Creek – Exit 270

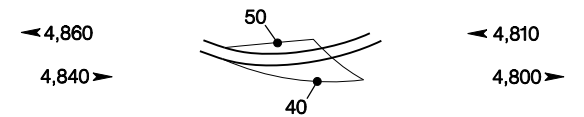

176

# INTERSTATE INTERCHANGES AND REST AREAS

Ladd Canyon – Exit 273

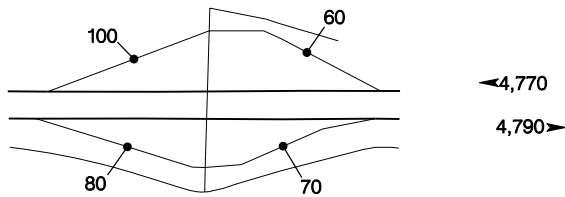

Clover Creek – Exit 278

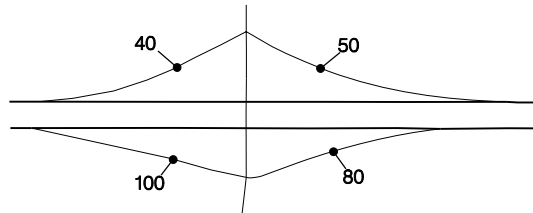

Wolf Creek – Exit 283

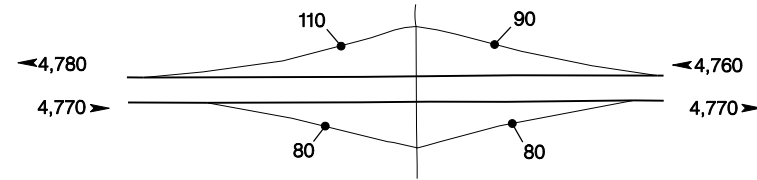

North Powder – Exit 285

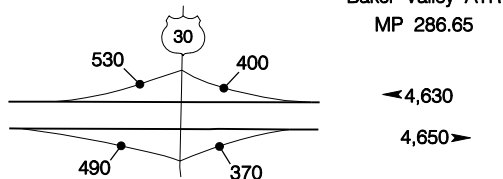

01-011  
Baker Valley ATR  
MP 286.65

Baker Valley Rest Area – Exit 294

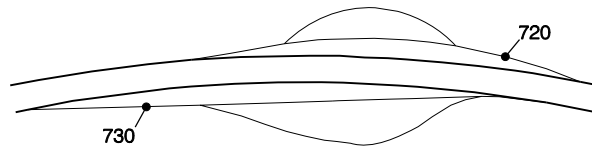

Chandler Lane – Exit 298

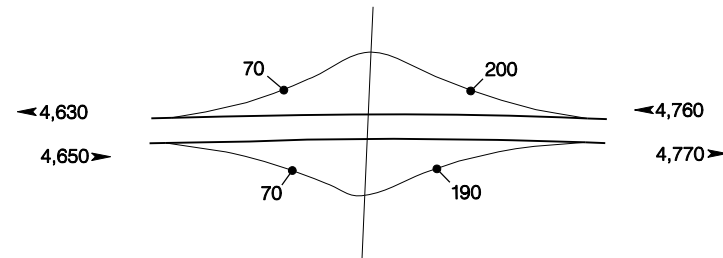

Richland – Exit 302

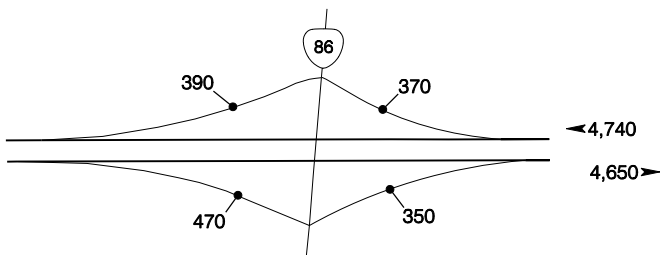

Campbell Street – Exit 304

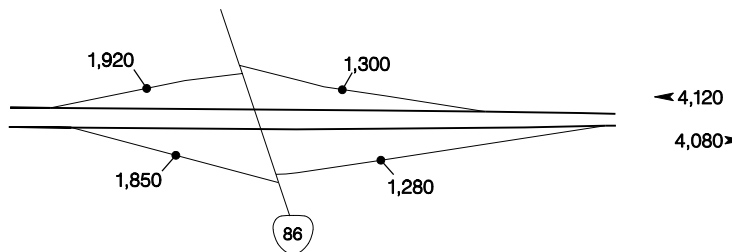

# INTERSTATE INTERCHANGES AND REST AREAS

South Baker – Exit 306

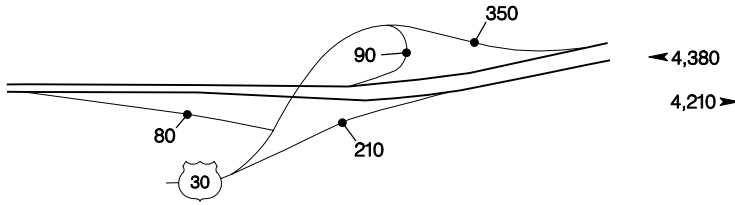

Encina – Exit 313

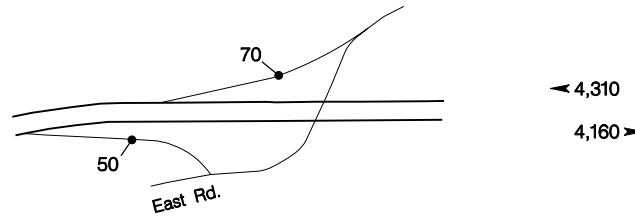

Pleasant Valley – Exit 317



Durkee – Exit 327

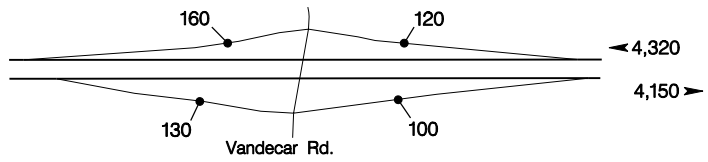

Nelson – Exit 330

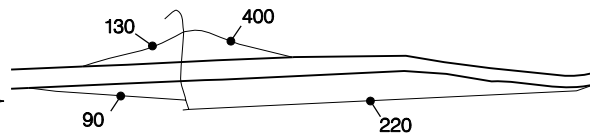

Weatherby – Exit 335

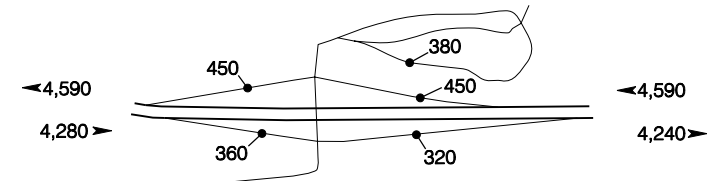

Jordan Creek – Exit 338

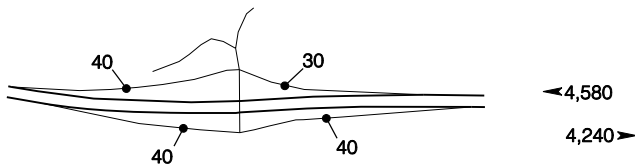

Dixie – Exit 340

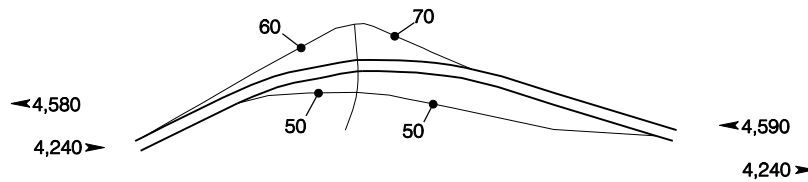

Lime – Exit 343

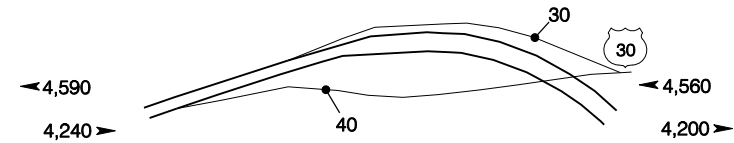

178

# INTERSTATE 84 INTERCHANGES AND REST AREAS

North Huntington – Exit 345

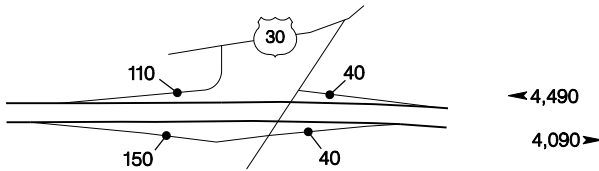

Benson – Exit 352

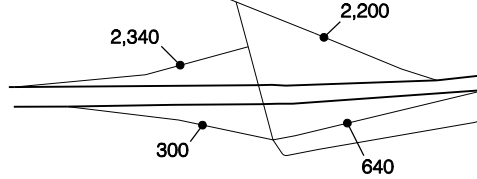

Olds Ferry – Exit 356

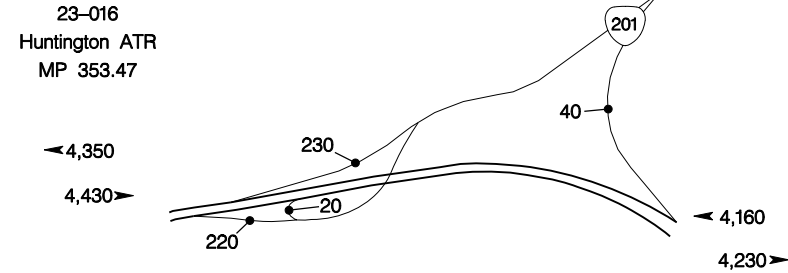

Moore's Hollow – Exit 362

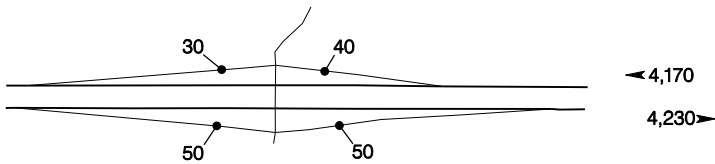

Stanton Blvd. – Exit 371

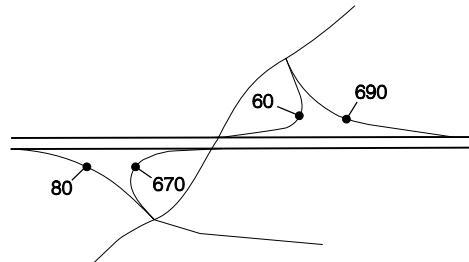

North Ontario – Exit 374

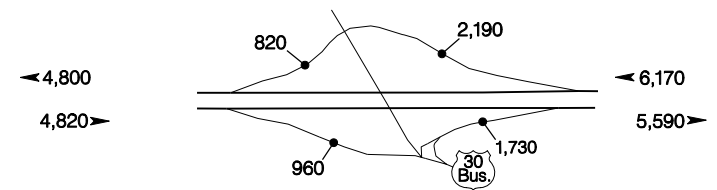

Idaho Avenue – Exit 376

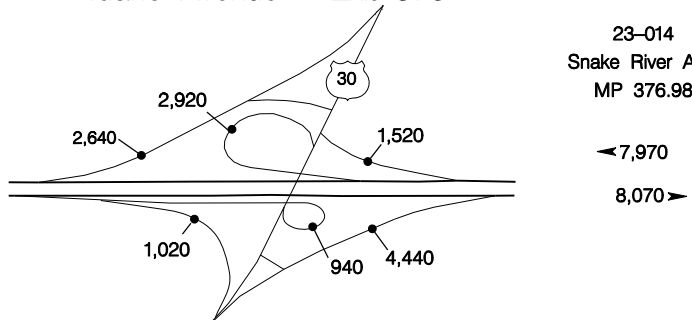

Ontario Rest Area – Exit 377

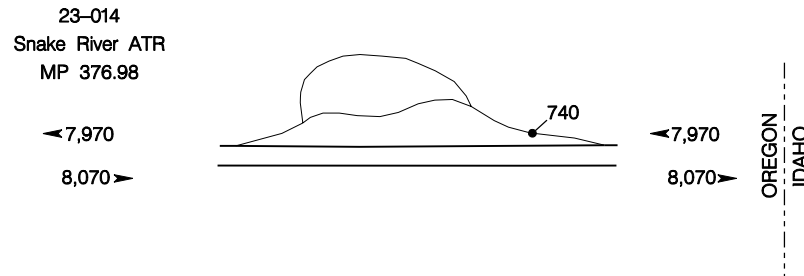

179

# US 97 INTERCHANGES

McKenzie-Bend Hwy. – Exit 135A

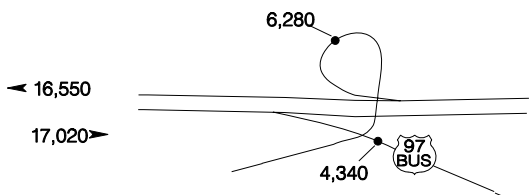

Empire Blvd. – Exit 135B

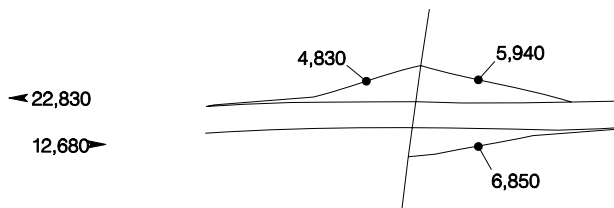

Butler Market Rd. – Exit 136

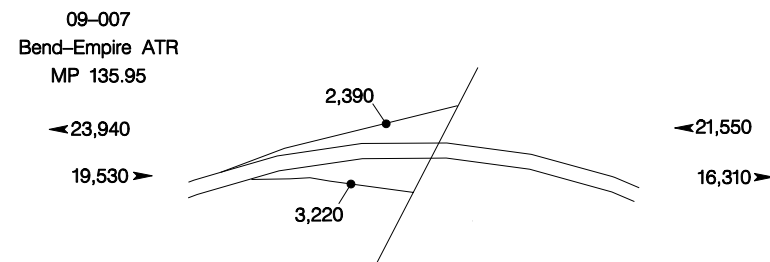

US20 – 3rd St

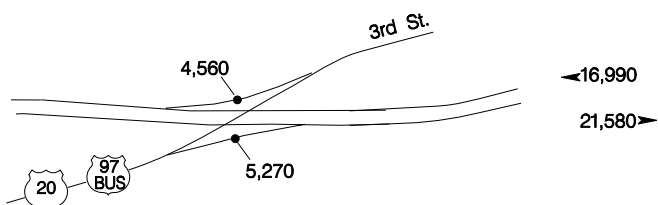

Revere Ave. – Exit 137



Lafayette Ave.

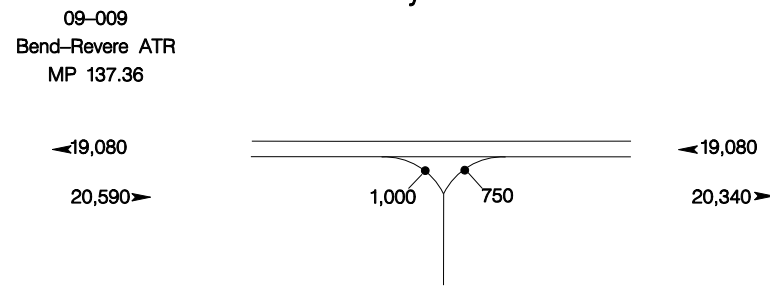

Hawthorne Ave.

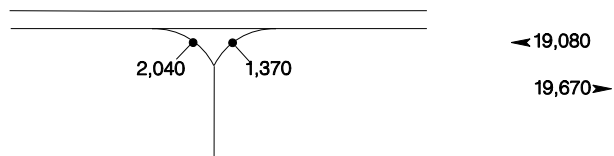

Colorado Ave. – Exit 138

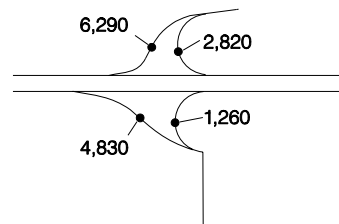

Truman Ave.

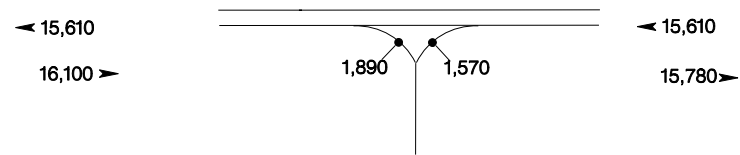



US  INTERCHANGES

Reed Market Rd. – Exit 139

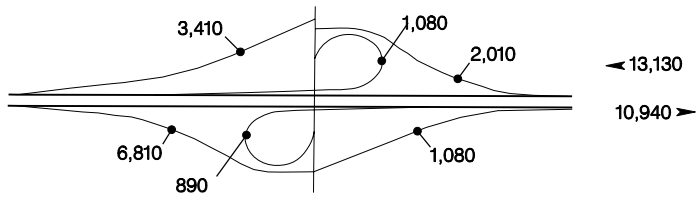

Reed Rd.

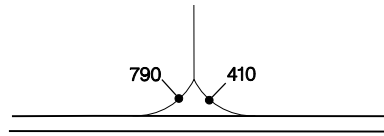

Powers Rd. – Exit 140

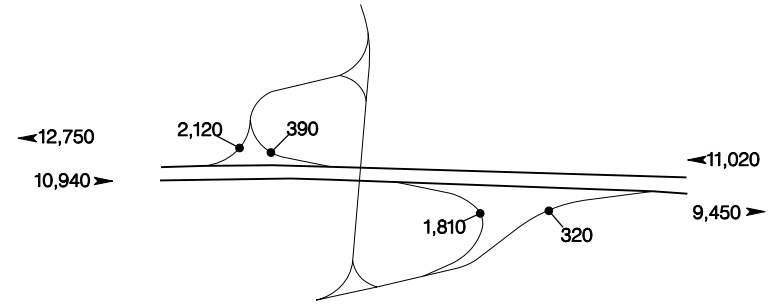

Badger Rd.

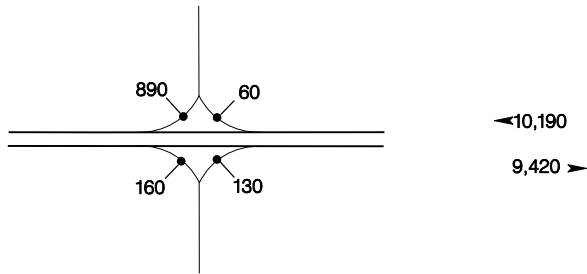

Pinebrook Blvd.

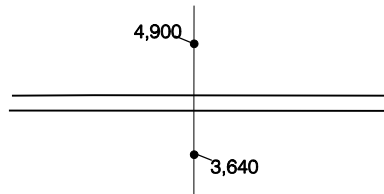

South End of Parkway

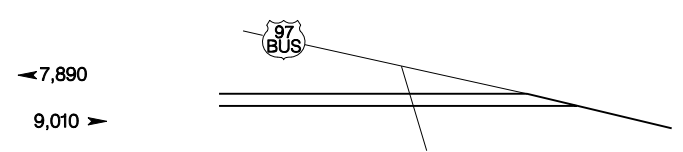

# US INTERCHANGES

Wilson River Hwy. – Exit 53A

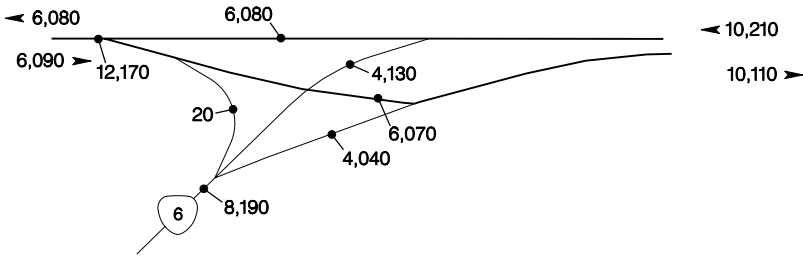

Dersham Road – Exit 55

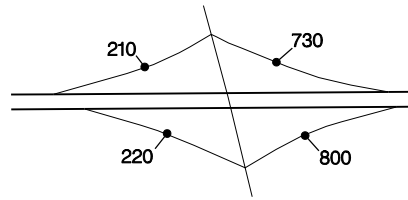

North Plains – Exit 57

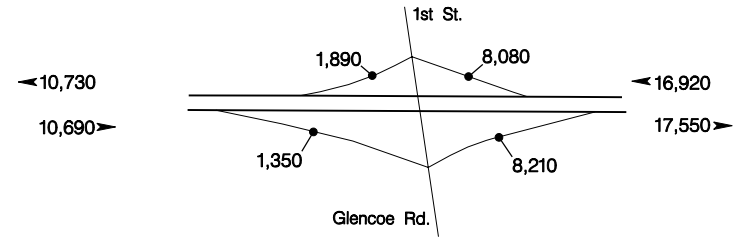

Jackson Road – Exit 58

186

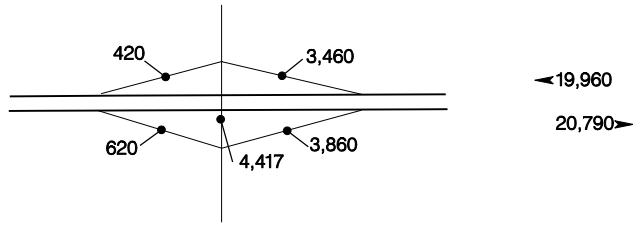

Helvetia Road – Exit 61

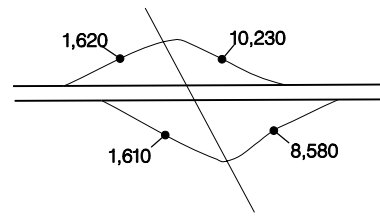

Cornelius Pass Rd. – Exit 62

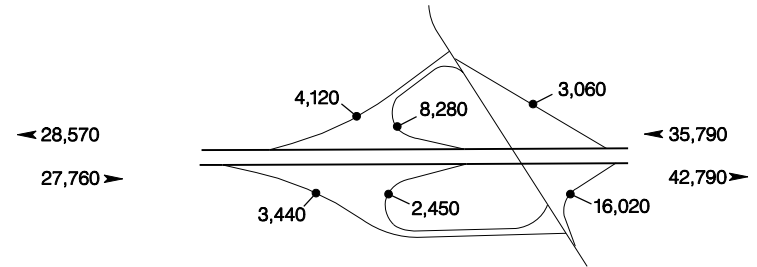

185th Ave. – Exit 64B

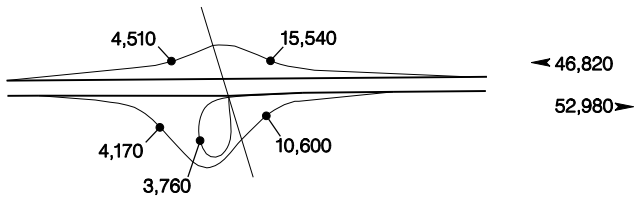

Cornell Road – Exit 65

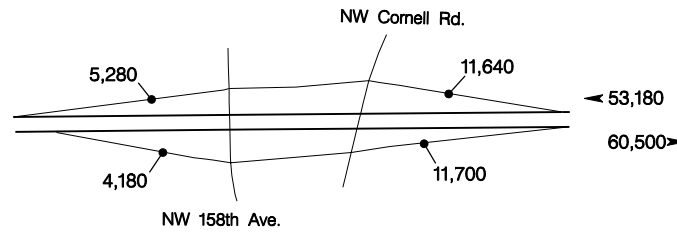

Murray Blvd. – Exit 67

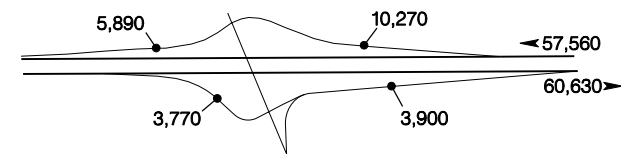

# US 26 INTERCHANGES

Cedar Hills Blvd. – Exit 68

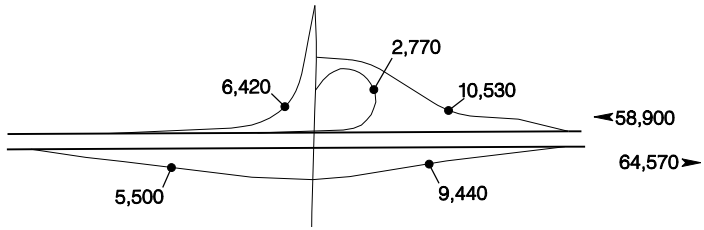

Beaverton – Tigard – Exit 69

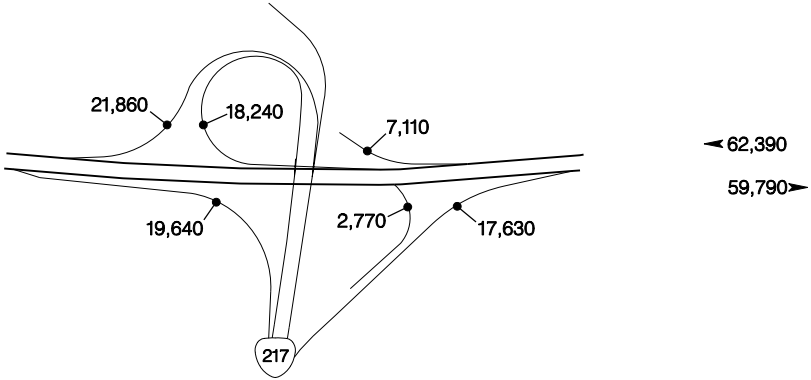

Sunset Hills – Exit 70B

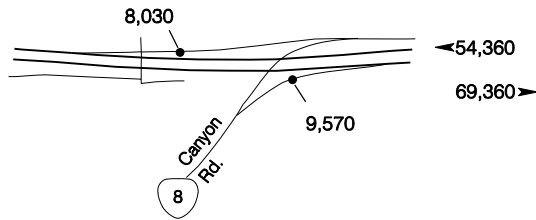

Sylvan – Exit 71

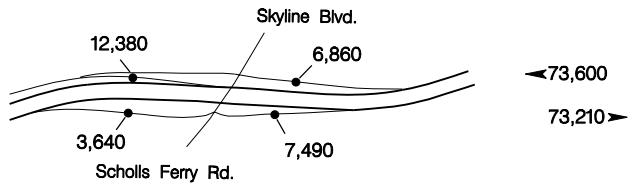

Highlands – Exit 72

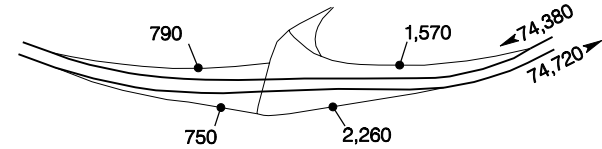

Jefferson St. – Exit 73B

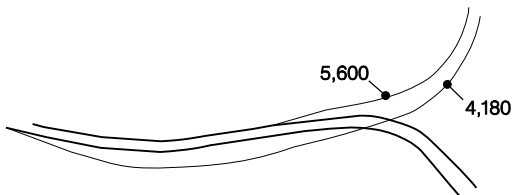

Stadium Freeway. – Exit 73C

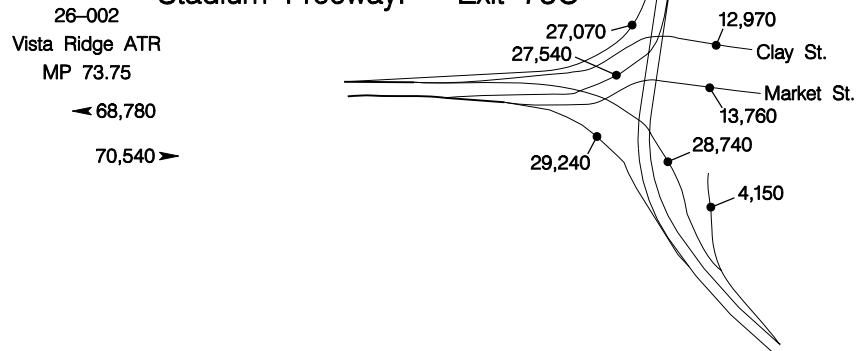

# INTERSTATE INTERCHANGES

W. Marquam – Exit 0A

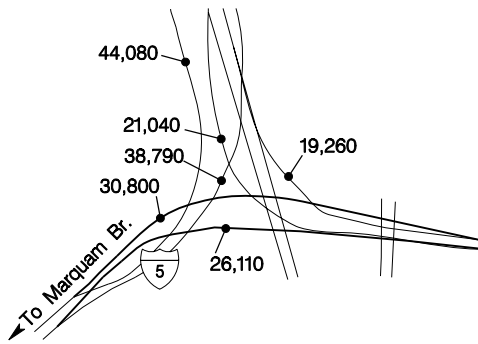

Broadway – Exit 0B

26-005  
Stadium Freeway ATR  
MP 0.60

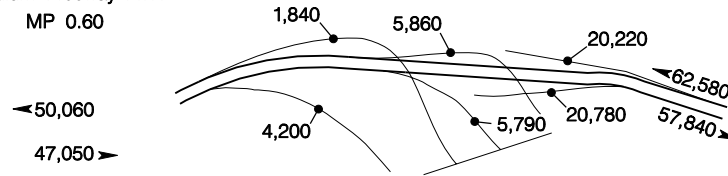

Sunset – Exit 1

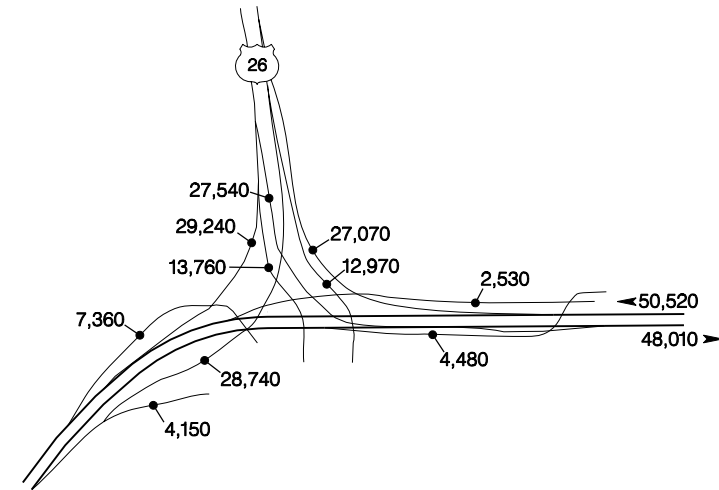

Burnside – Exit 2

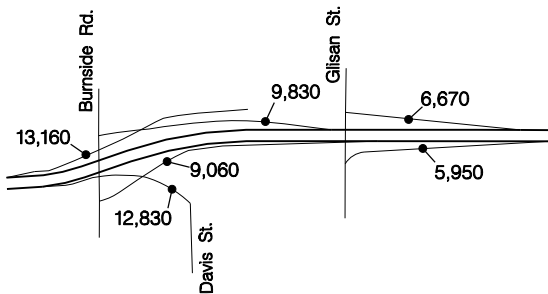

W. Fremont – Exit 3A

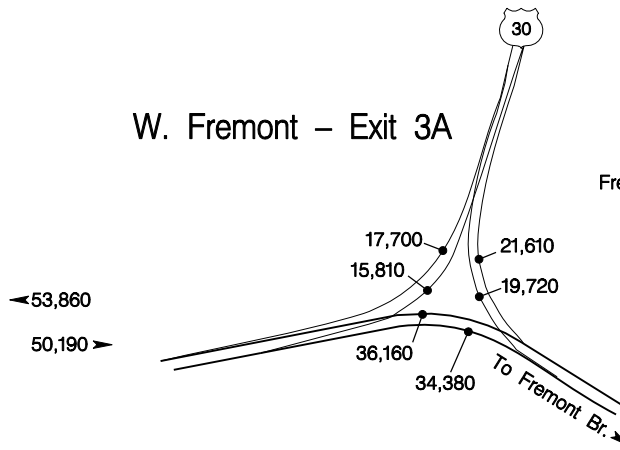

E. Fremont – Exit 3B

26-027  
Fremont Bridge ATR  
MP 3.05

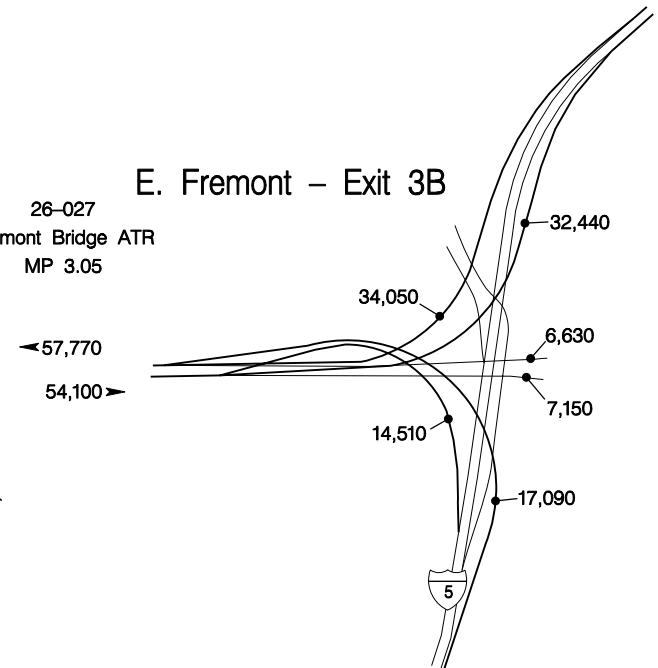

INTERSTATE  INTERCHANGES AND REST AREAS

Pacific Hwy. Exit 1

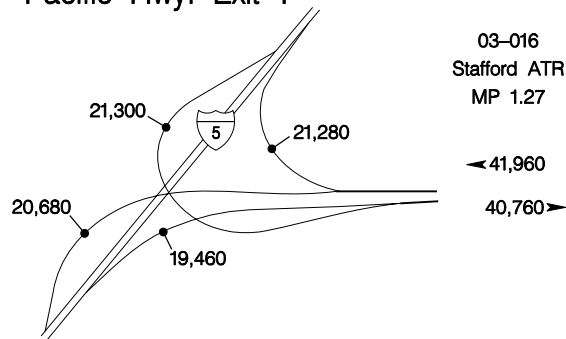

Wankers Corner – Exit 3

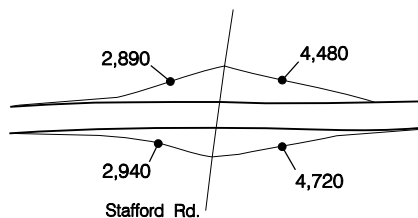

S. West Linn – Exit 6

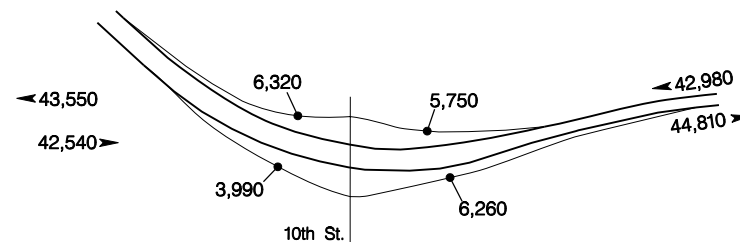

Willamette Falls Viewpoint – Exit 8A



West Linn – Exit 8B

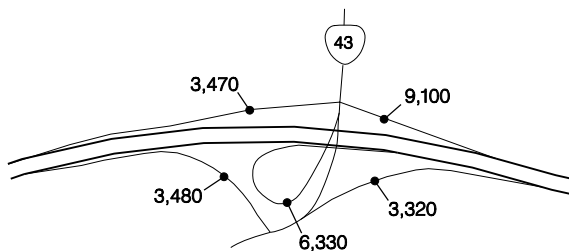

Oregon City – Exit 9

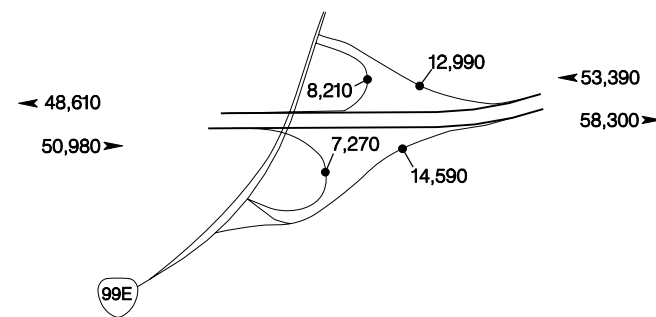

Park Place – Exit 10

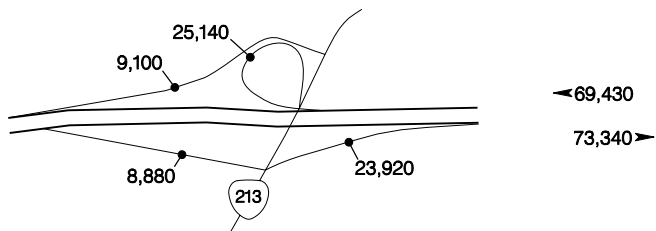

Gladstone – Exit 11

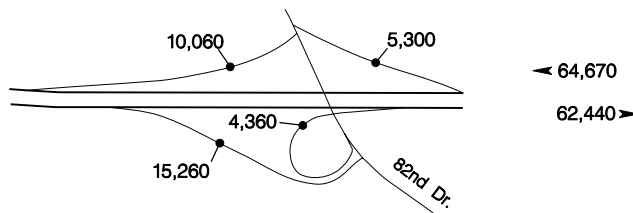

Clackamas – Exit 12

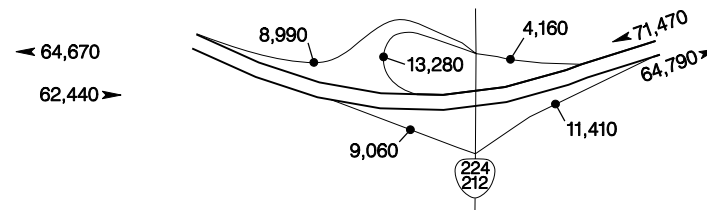

# INTERSTATE 205 INTERCHANGES AND REST AREAS

Lake Road – Exit 13

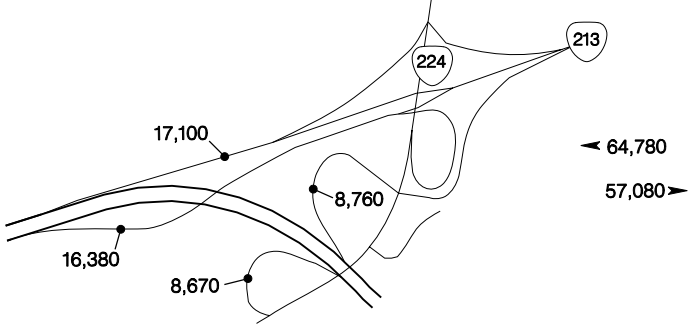

Sunnyside Rd. – Exit 14

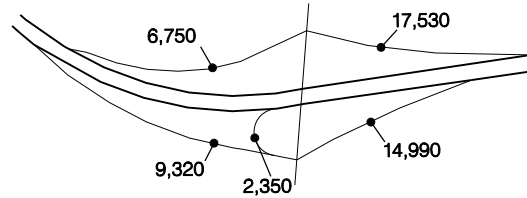

Johnson Cr. Blvd. – Exit 16

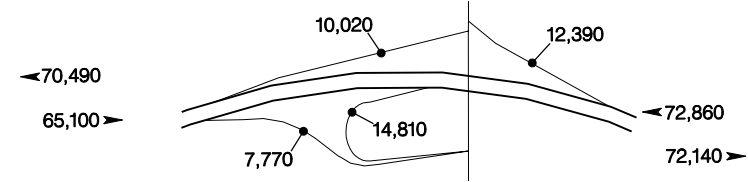

Foster & Woodstock – Exit 17

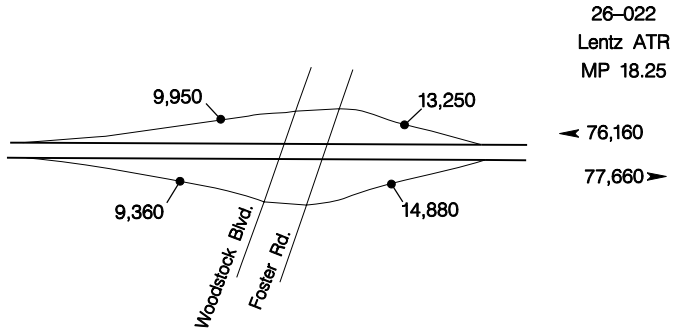

Division & Powell – Exit 19

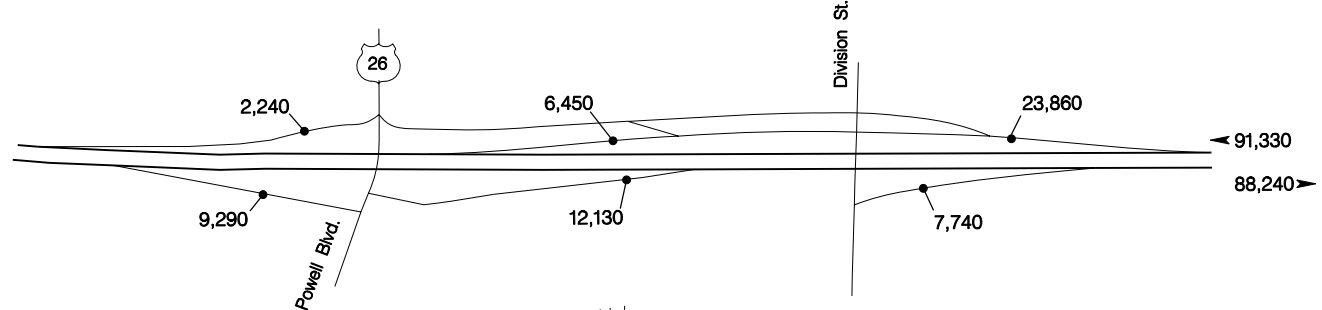

Stark-Washington St. – Exit 20B

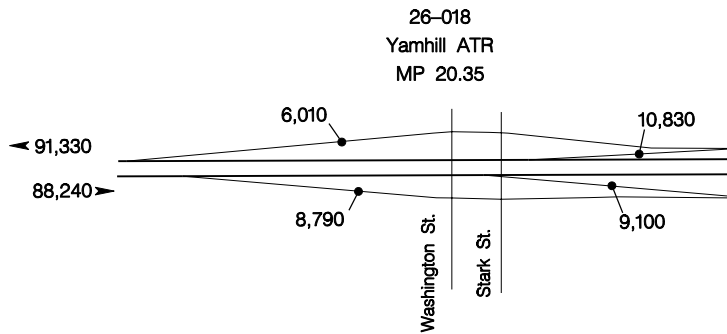

N.E. Glisan St. – Exit 20C

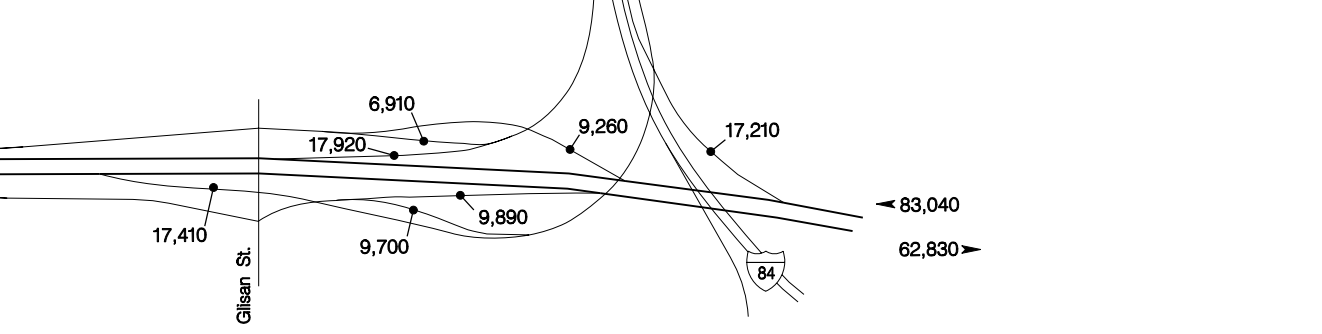

S. Banfield – Exit 20D

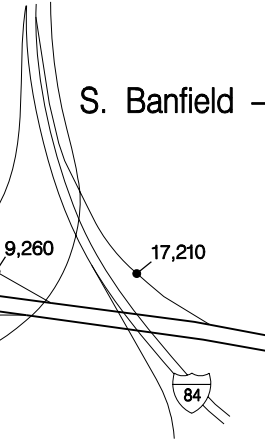

193

# INTERSTATE 205 INTERCHANGES AND REST AREAS

N. Banfield – Exit 22

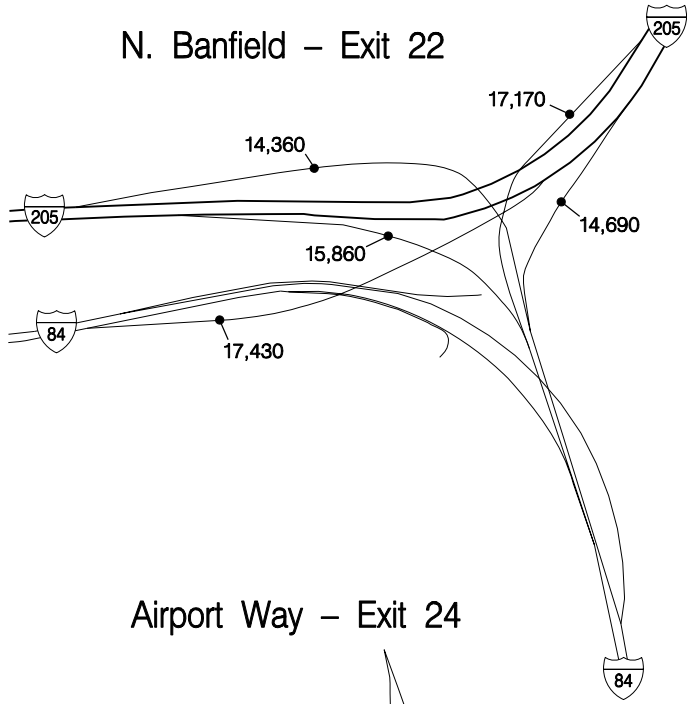

Sandy Blvd. – Exit 23A

Columbia Blvd. – Exit 23B

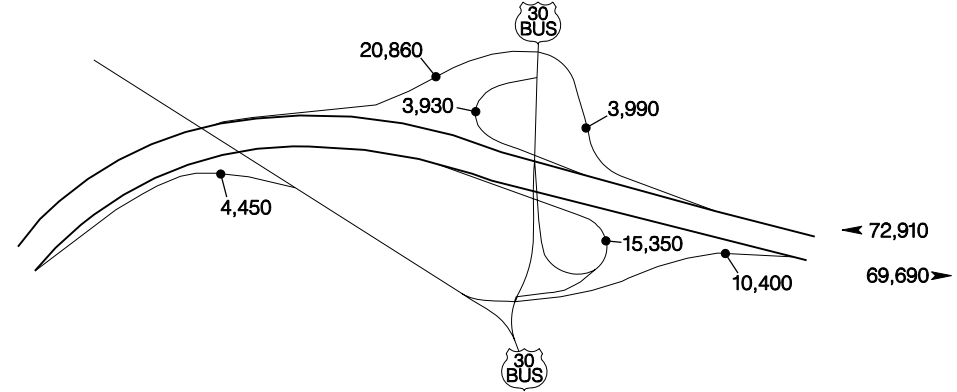

Airport Way – Exit 24

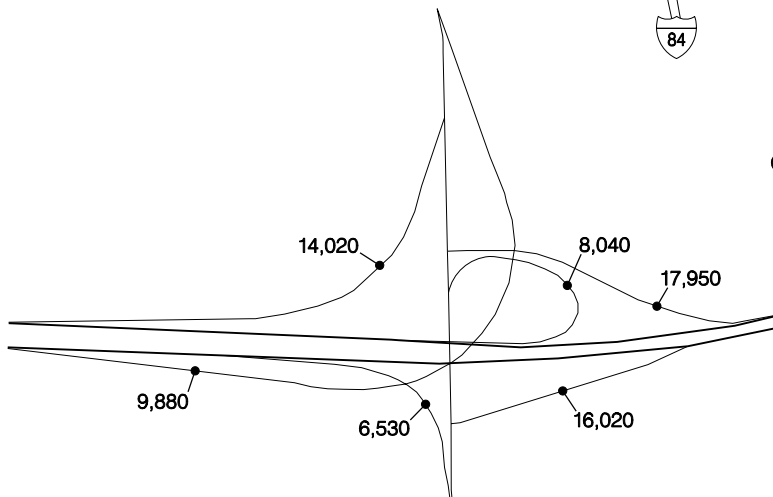

26-024  
Glenn Jackson ATR  
MP 25.50

68,800  
69,300

OREGON  
WASHINGTON

# BELTLINE HIGHWAY NO. 69 INTERCHANGES

Barger Dr. – Exit 5

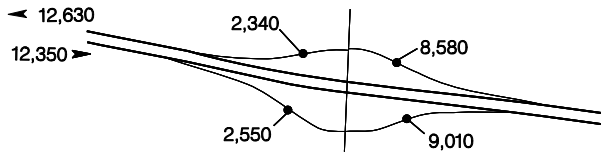

Pacific Hwy. West – Exit 6A

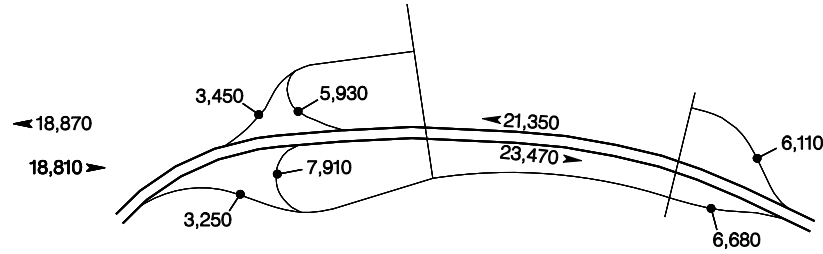

Prairie Road – Exit 6B

N. W. Expressway – Exit 7

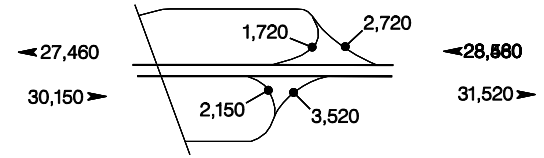

River Road – Exit 8

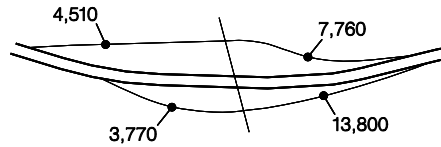

River Ave. – Exit 9

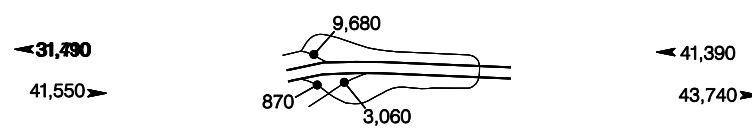

Delta Hwy. – Exit 9A

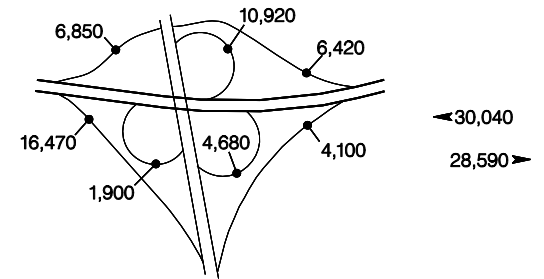

Coburg Road – Exit 11

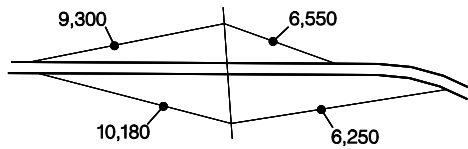

Pacific Hwy. – Exit 12

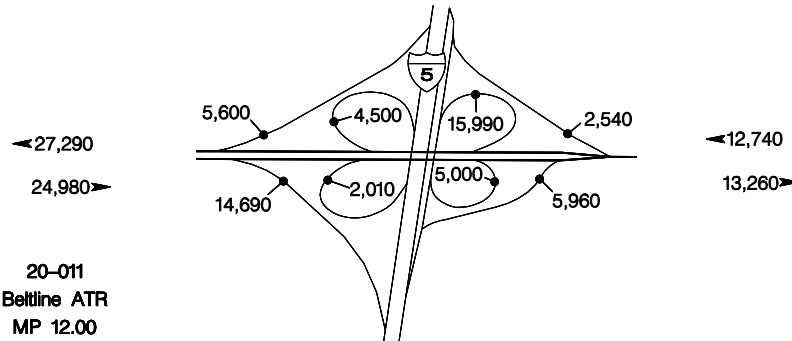

196

20-011  
Beltline ATR  
MP 12.00



# INTERSTATE 82 INTERCHANGES

## Umatilla City – Exit 1

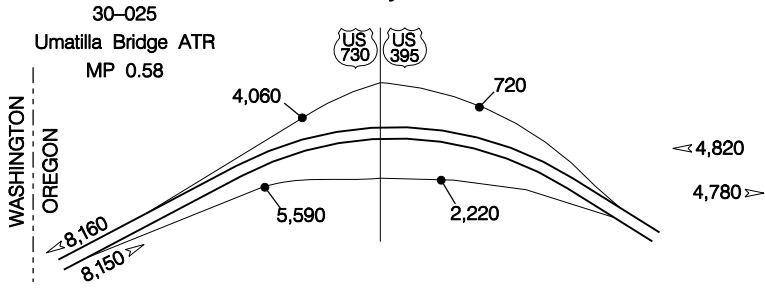

## Power Line Road – Exit 5

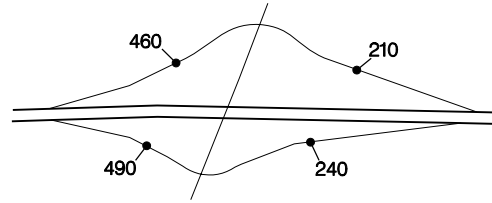

## Westland – Ordnance Road – Exit 10

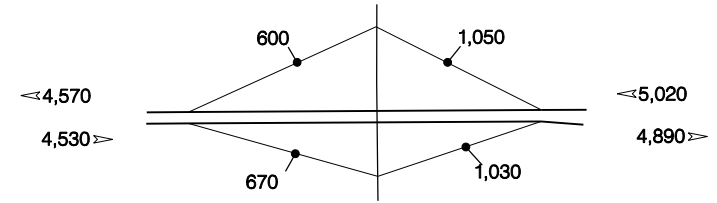

## McNary Highway – Exit 11

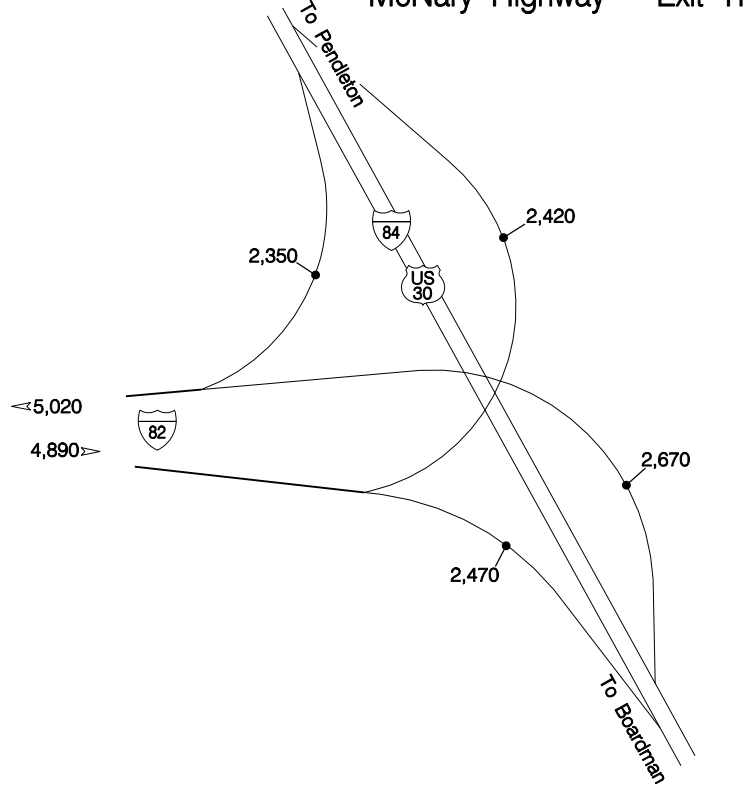

# OR 217 INTERCHANGES

Sunset Hwy. – Exit 0A

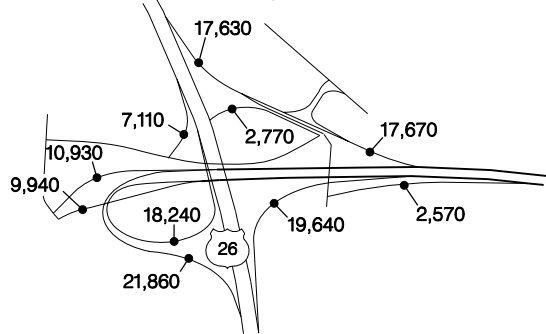

Walker Road – Exit 0B

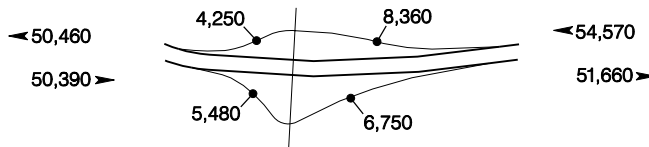

East Beaverton – Exit 1

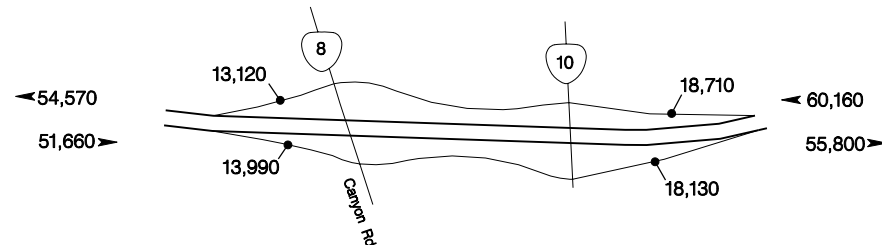

Allen Blvd. – Exit 2

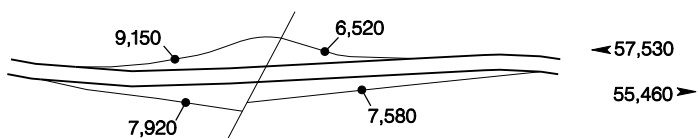

Denney Road – Exit 3A

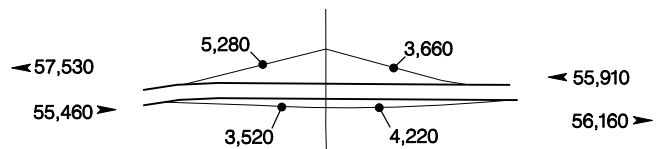

Beaverton–Tualatin Hwy. – Exit 3B

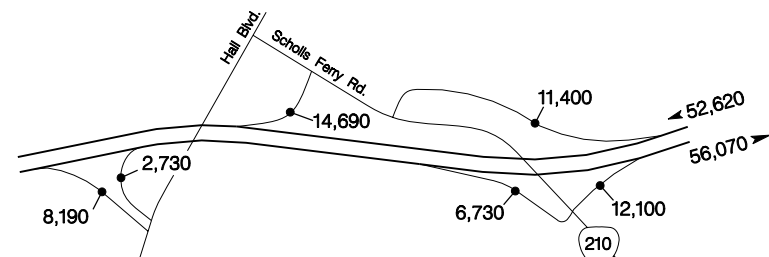

Progress – Exit 4A

Greenburg Road – Exit 4B

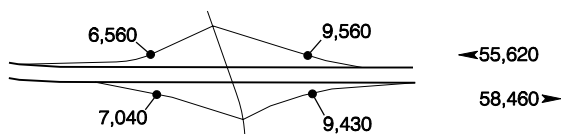

Tigard – Exit 5

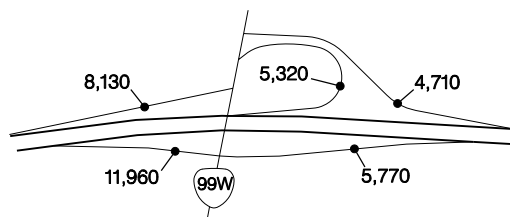

SW 72nd Ave. – Exit 6

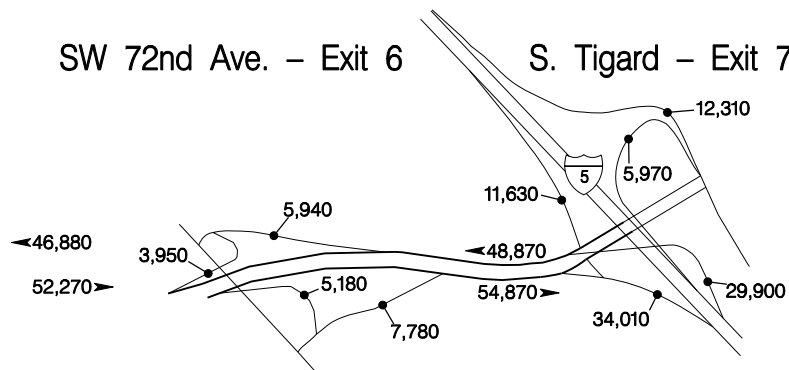

S. Tigard – Exit 7

200

# OR 22 INTERCHANGES

North Santiam – Exit 1

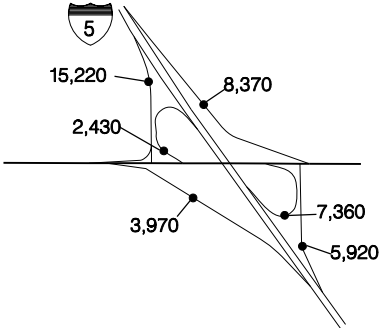

Lancaster Dr. – Exit 2

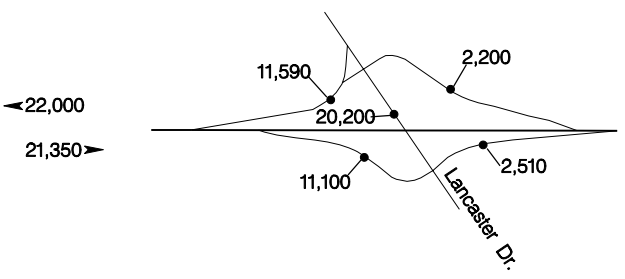

Deer Park Dr. – Exit 4

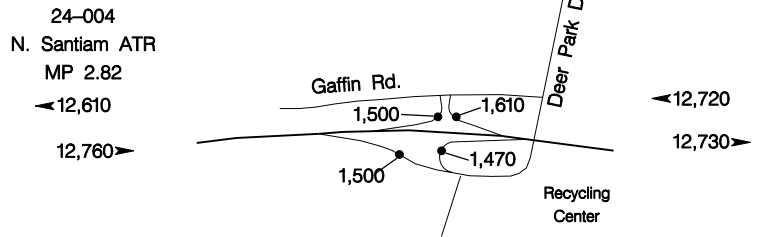

Joseph St. – Exit 5

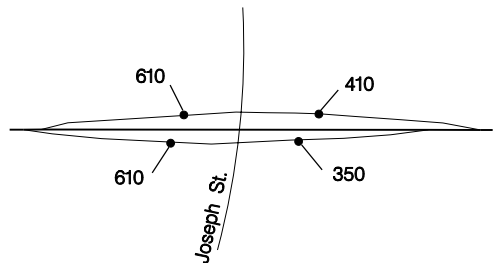

Silver Cr. Falls Hwy. – Exit 7

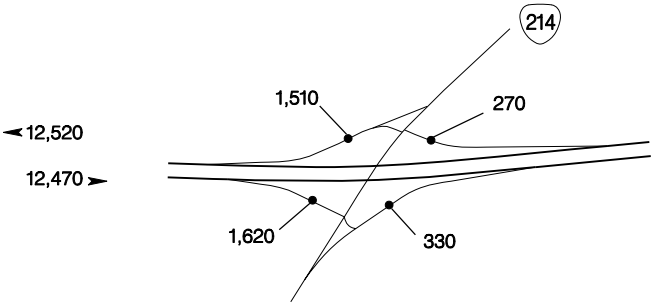

Shaw – Aumsville – Exit 9

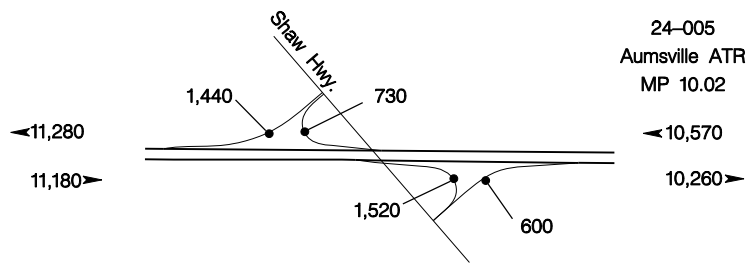

Golf Club Rd. – Exit 12

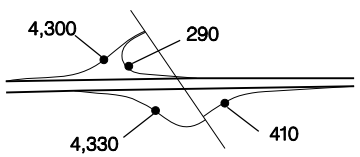

Stayton – Sublimity

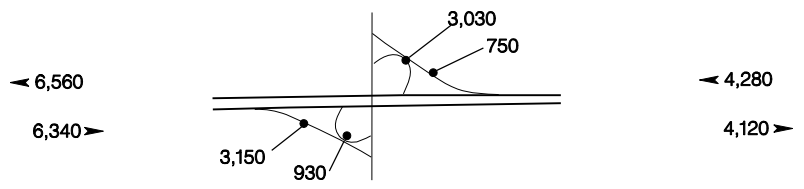

# INTERSTATE INTERCHANGES

6th & 7th Ave. – Exit 0A

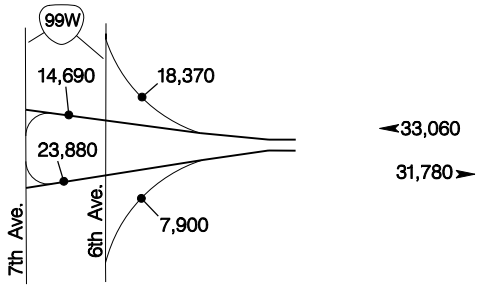

Delta Highway – Exit 0B

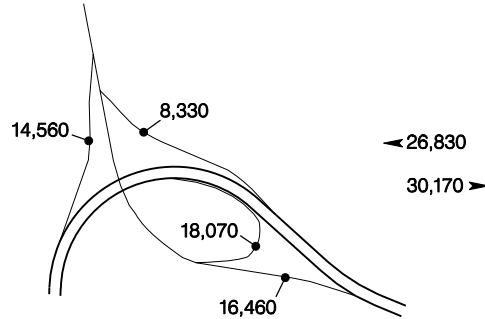

Country Club Rd. – Exit 1A

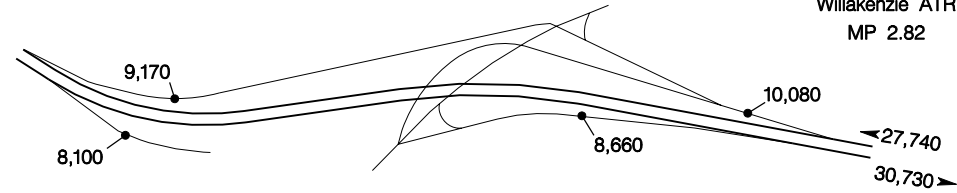

Coburg Road – Exit 1B

20-008  
Willakenzie ATR  
MP 2.82

"Q" Street – Exit 3

204

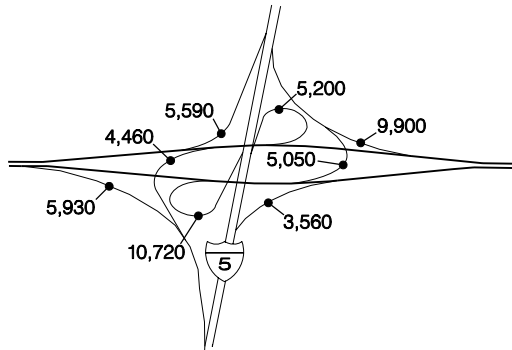

Springfield Hwy. – Exit 4

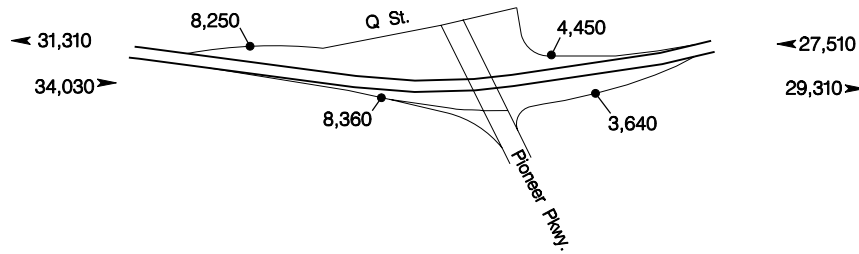

Mohawk Blvd. – Exit 6

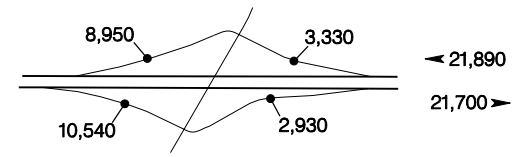

42nd Street – Exit 7

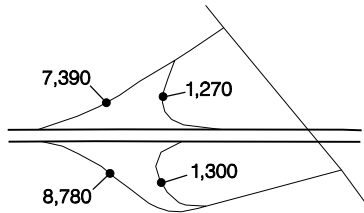

52nd Street – Exit 8

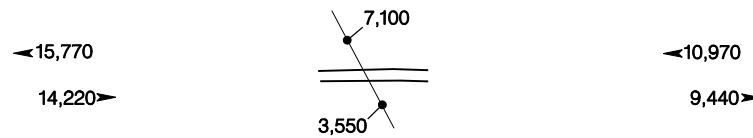

McKenzie Hwy. – Exit 10

