

TOPIC: 191006
KNOWLEDGE: K1.07 [2.4/2.6]
QID: P104 (B231)

Refer to the drawing of an operating water cleanup system. All valves are identical and are initially 50% open (see figure below).

To lower the temperature at point 7, the operator should adjust valve _____ in the open direction.

- A. A
- B. B
- C. C
- D. D

ANSWER: D.

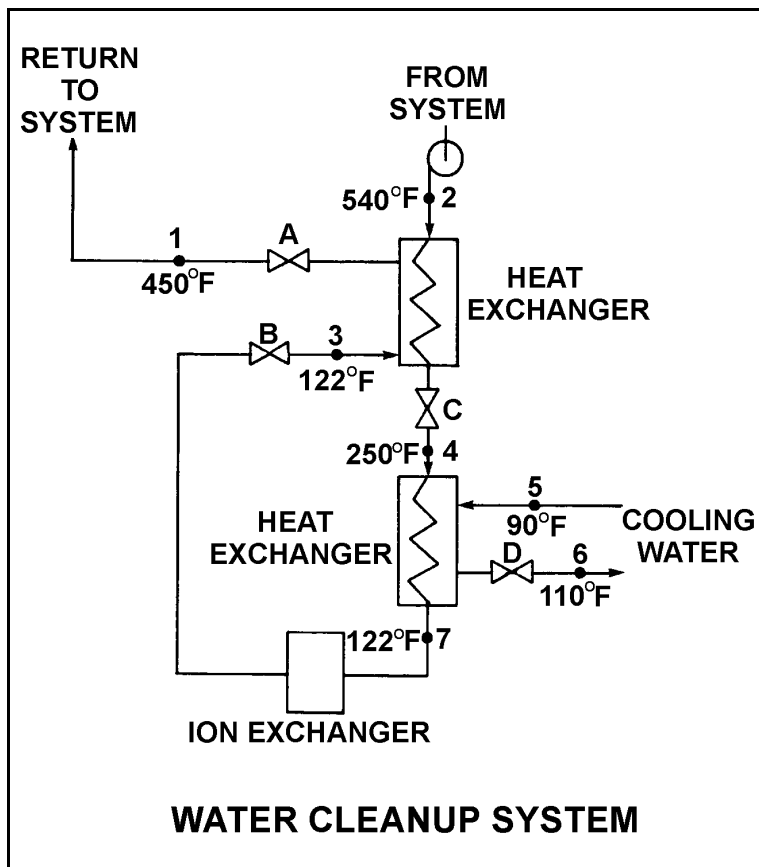

TOPIC: 191006
KNOWLEDGE: K1.07 [2.4/2.6]
QID: P534 (B331)

Refer to the drawing of an operating lube oil heat exchanger (see figure below).

Increasing the oil flow rate through the heat exchanger will cause the oil outlet temperature to _____ and the cooling water outlet temperature to _____. (Assume cooling water flow rate remains the same.)

- A. decrease; decrease
- B. decrease; increase
- C. increase; decrease
- D. increase; increase

ANSWER: D.

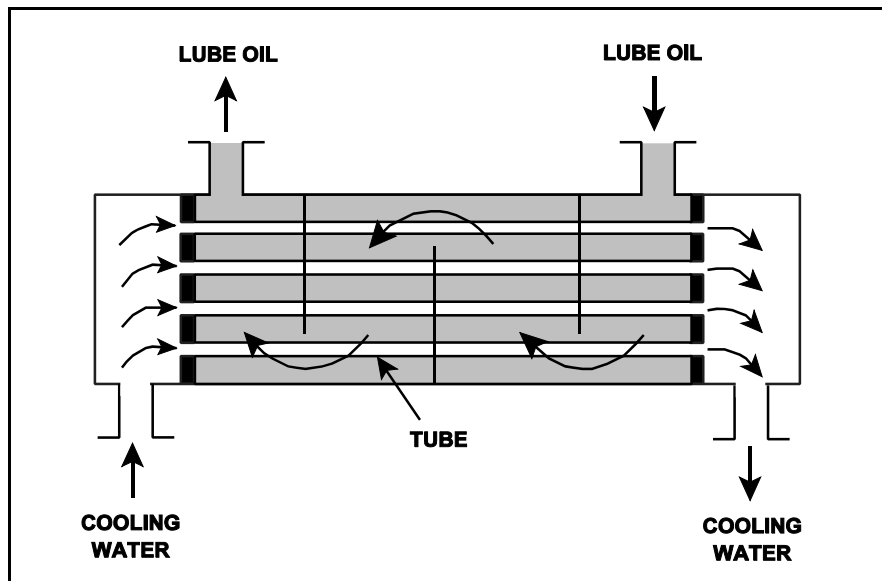

TOPIC: 191006
KNOWLEDGE: K1.07 [2.4/2.6]
QID: P632 (B431)

Refer to the drawing of an operating lube oil heat exchanger (see figure below).

Assume that the inlet lube oil and inlet cooling water temperatures are constant and cooling water flow rate remains the same. Decreasing the oil flow rate through the heat exchanger will cause the oil outlet temperature to _____ and the cooling water outlet temperature to _____.

- A. increase, increase
- B. increase, decrease
- C. decrease, increase
- D. decrease, decrease

ANSWER: D.

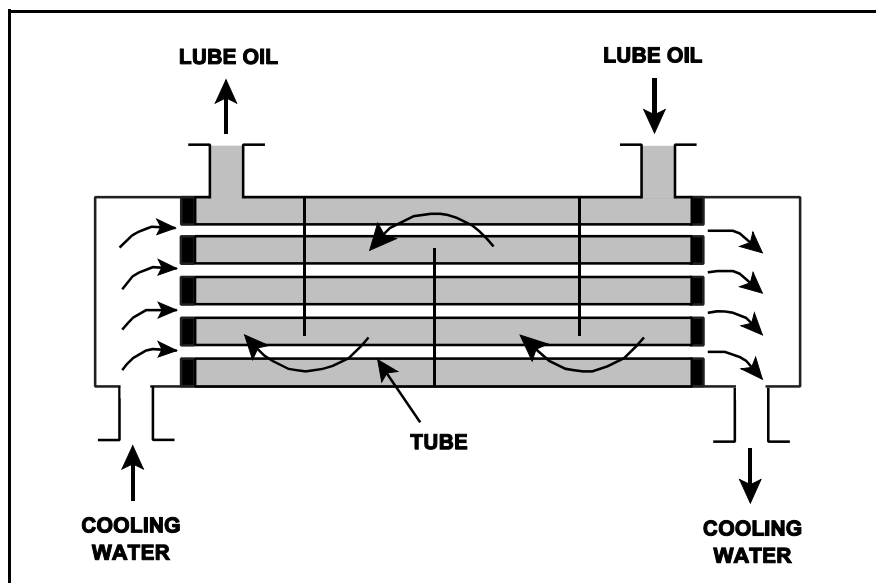

TOPIC: 191006
KNOWLEDGE: K1.07 [2.4/2.6]
QID: P732 (B1834)

Refer to the drawing of an operating water cleanup system (see figure below).

Valves A, B, and C are fully open. Valve D is 80% open. All temperatures are as shown. If valve D is then throttled to 50%, the temperature at point...

- A. 3 will decrease.
- B. 4 will increase.
- C. 5 will increase.
- D. 6 will decrease.

ANSWER: B.

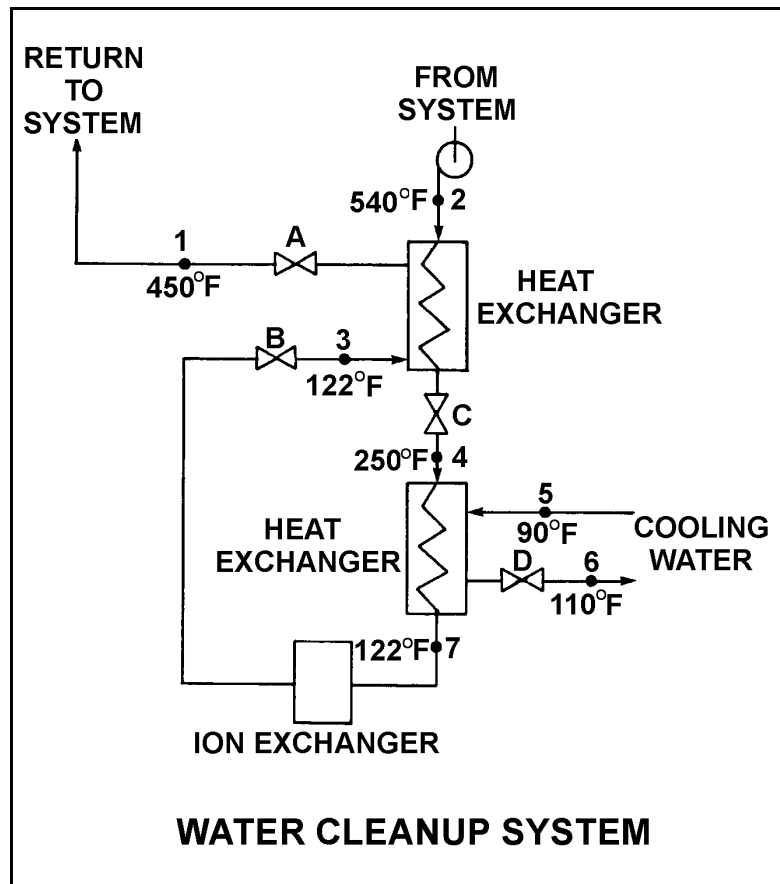

TOPIC: 191006
KNOWLEDGE: K1.07 [2.4/2.6]
QID: P1032 (B1031)

Refer to the drawing of an operating water cleanup system (see figure below).

Valves A, B, and C are fully open. Valve D is 20% open. All temperatures are as shown. Valve D is then quickly opened to 100%.

The temperature at point...

- A. 3 will increase.
- B. 4 will decrease.
- C. 5 will decrease.
- D. 7 will increase.

ANSWER: B.

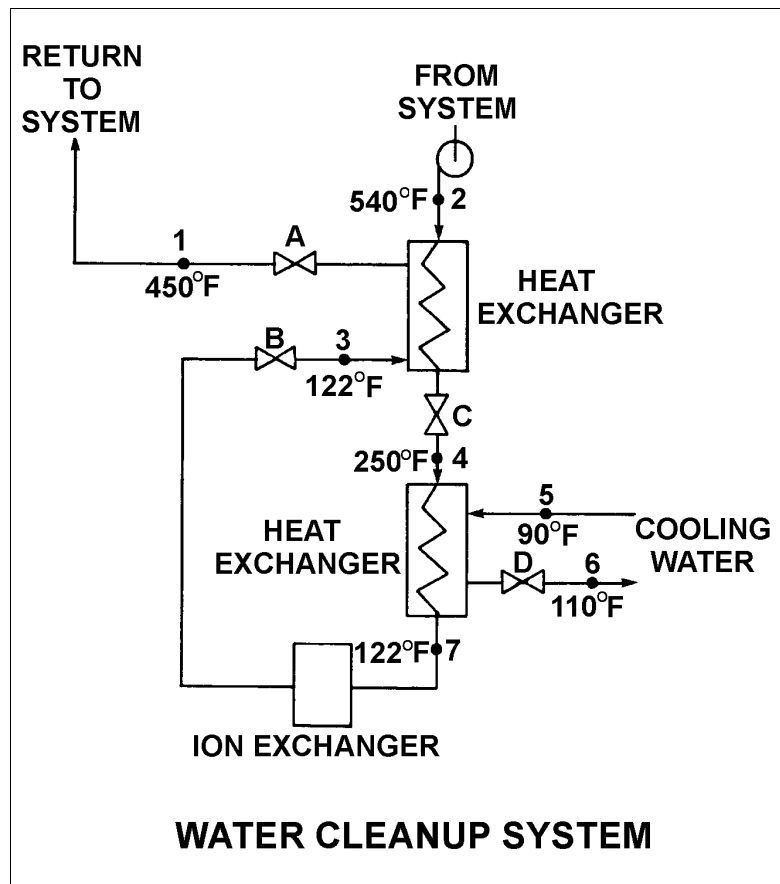

TOPIC: 191006
KNOWLEDGE: K1.07 [2.4/2.6]
QID: P1231 (B1231)

Refer to the drawing of an operating water cleanup system (see figure below).

All valves are identical and are initially 50% open. To lower the temperature at point 4, the operator can adjust valve _____ in the _____ direction.

- A. A; open
- B. B; shut
- C. C; open
- D. D; shut

ANSWER: B.

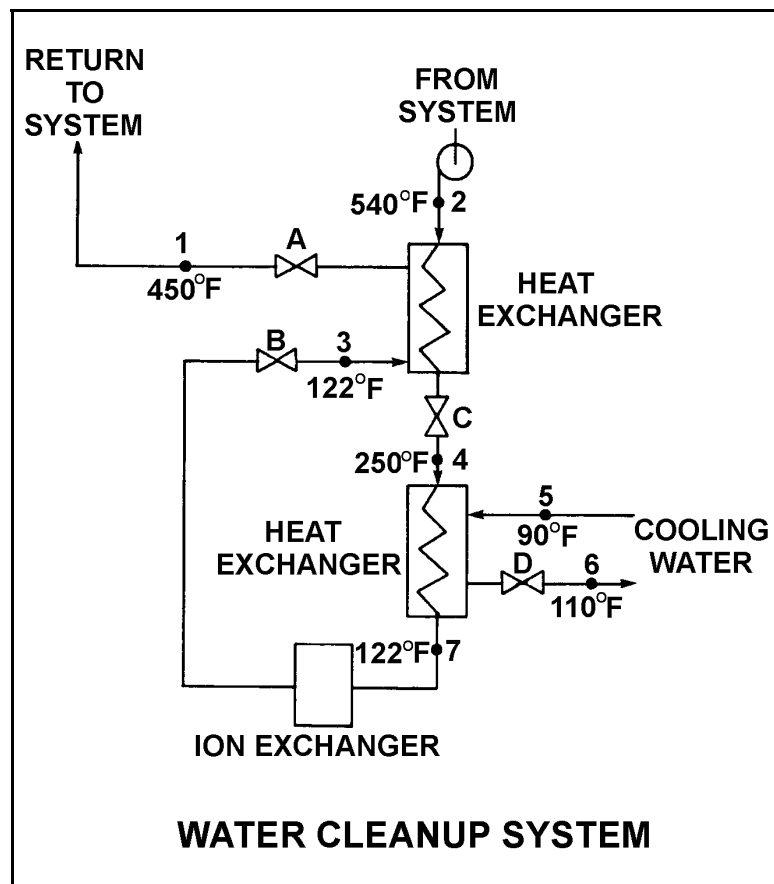

TOPIC: 191006
KNOWLEDGE: K1.07 [2.4/2.6]
QID: P1432 (B1432)

The rate of heat transfer between two liquids in a heat exchanger will be increased if the: (Assume single-phase conditions and a constant specific heat.)

- A. temperature of the hotter liquid is decreased by 20°F.
- B. temperature of the colder liquid is increased by 20°F.
- C. flow rates of both liquids are decreased by 10%.
- D. flow rates of both liquids are increased by 10%.

ANSWER: D.

TOPIC: 191006
KNOWLEDGE: K1.07 [2.4/2.6]
QID: P1533 (B1531)

Refer to the drawing of a lube oil heat exchanger (see figure below).

The heat exchanger is operating with the following parameters:

$T_{\text{oil in}} = 174^{\circ}\text{F}$
 $T_{\text{oil out}} = 114^{\circ}\text{F}$
 $c_{p\text{-oil}} = 1.1 \text{ Btu/lbm-}^{\circ}\text{F}$
 $\dot{m}_{\text{oil}} = 4.0 \times 10^4 \text{ lbm/hr}$
 $T_{\text{water in}} = 85^{\circ}\text{F}$
 $T_{\text{water out}} = 115^{\circ}\text{F}$
 $c_{p\text{-water}} = 1.0 \text{ Btu/lbm-}^{\circ}\text{F}$
 $\dot{m}_{\text{water}} = ?$

What is the mass flow rate of the cooling water?

- A. $8.8 \times 10^4 \text{ lbm/hr}$
- B. $7.3 \times 10^4 \text{ lbm/hr}$
- C. $2.2 \times 10^4 \text{ lbm/hr}$
- D. $1.8 \times 10^4 \text{ lbm/hr}$

ANSWER: A.

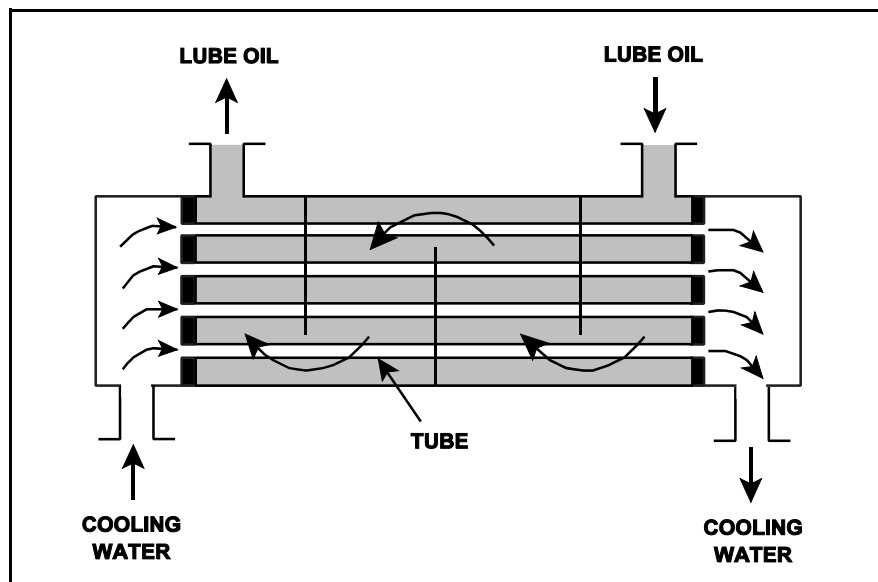

TOPIC: 191006
KNOWLEDGE: K1.07 [2.4/2.6]
QID: P1632 (B832)

A liquid-to-liquid counterflow heat exchanger is operating with single-phase conditions and a constant specific heat for each liquid. Which one of the following will decrease the heat transfer between the two liquids?

- A. The temperature of both liquids is increased by 20°F.
- B. The temperature of both liquids is decreased by 20°F.
- C. The flow rate of the hotter liquid is increased by 10%.
- D. The flow rate of the colder liquid is decreased by 10%.

ANSWER: D.

TOPIC: 191006
KNOWLEDGE: K1.07 [2.4/2.6]
QID: P1634 (B1631)

Refer to the drawing of an operating lube oil heat exchanger (see figure below).

Given the following information, which one of the following is the temperature of the oil exiting the heat exchanger ($T_{\text{oil-out}}$)?

$$\begin{aligned}\dot{m}_{\text{oil}} &= 2.0 \times 10^4 \text{ lbm/hr} \\ \dot{m}_{\text{water}} &= 3.0 \times 10^4 \text{ lbm/hr} \\ c_{p\text{-oil}} &= 1.1 \text{ Btu/lbm-}^\circ\text{F} \\ c_{p\text{-water}} &= 1.0 \text{ Btu/lbm-}^\circ\text{F} \\ T_{\text{cw-in}} &= 92^\circ\text{F} \\ T_{\text{cw-out}} &= 125^\circ\text{F} \\ T_{\text{oil-in}} &= 180^\circ\text{F} \\ T_{\text{oil-out}} &= ?\end{aligned}$$

- A. 135°F
- B. 140°F
- C. 145°F
- D. 150°F

ANSWER: A.

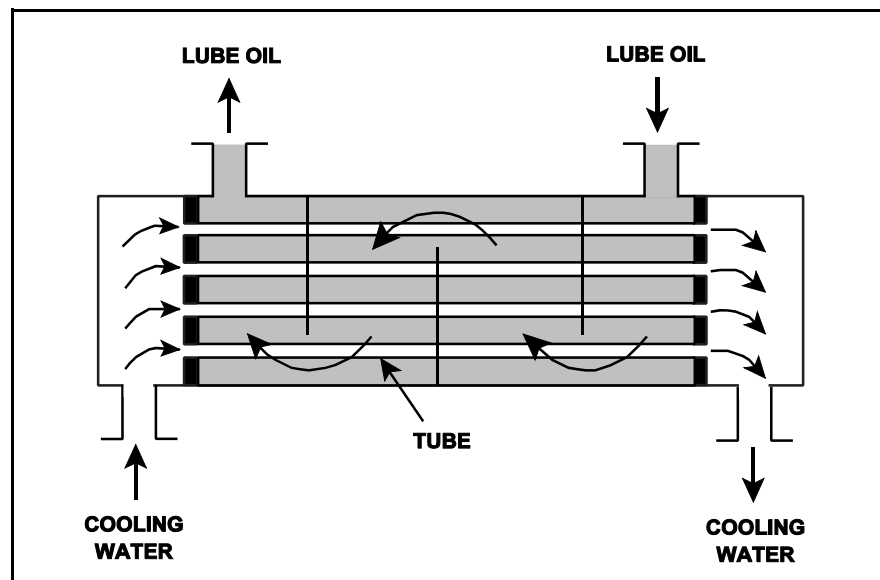

TOPIC: 191006
KNOWLEDGE: K1.07 [2.4/2.6]
QID: P1732 (B1732)

Which one of the following will reduce the rate of heat transfer between two liquids in a heat exchanger? (Assume single-phase conditions and a constant specific heat for both liquids.)

- A. The inlet temperatures of both liquids are decreased by 20°F.
- B. The inlet temperatures of both liquids are increased by 20°F.
- C. The inlet temperature of the hotter liquid is increased by 20°F.
- D. The inlet temperature of the colder liquid is increased by 20°F.

ANSWER: D.

TOPIC: 191006
KNOWLEDGE: K1.07 [2.4/2.6]
QID: P1832 (B631)

The rate of heat transfer between two liquids in a heat exchanger will be increased if the: (Assume single-phase conditions and a constant specific heat capacity.)

- A. temperature of both liquids is decreased by 20°F.
- B. temperature of both liquids is increased by 20°F.
- C. flow rate of the colder liquid is decreased by 10%.
- D. flow rate of the hotter liquid is increased by 10%.

ANSWER: D.

TOPIC: 191006
KNOWLEDGE: K1.07 [2.4/2.6]
QID: P1934 (B1933)

Refer to the drawing of an operating lube oil heat exchanger (see figure below).

Given the following information, which one of the following is the temperature of the oil exiting the heat exchanger ($T_{\text{oil-out}}$)?

$$\begin{aligned}\dot{m}_{\text{oil}} &= 1.5 \times 10^4 \text{ lbm/hr} \\ \dot{m}_{\text{water}} &= 2.5 \times 10^4 \text{ lbm/hr} \\ c_{p\text{-oil}} &= 1.1 \text{ Btu/lbm-}^\circ\text{F} \\ c_{p\text{-water}} &= 1.0 \text{ Btu/lbm-}^\circ\text{F} \\ T_{\text{cw-in}} &= 92^\circ\text{F} \\ T_{\text{cw-out}} &= 125^\circ\text{F} \\ T_{\text{oil-in}} &= 160^\circ\text{F} \\ T_{\text{oil-out}} &= ?\end{aligned}$$

- A. 110°F
- B. 127°F
- C. 135°F
- D. 147°F

ANSWER: A.

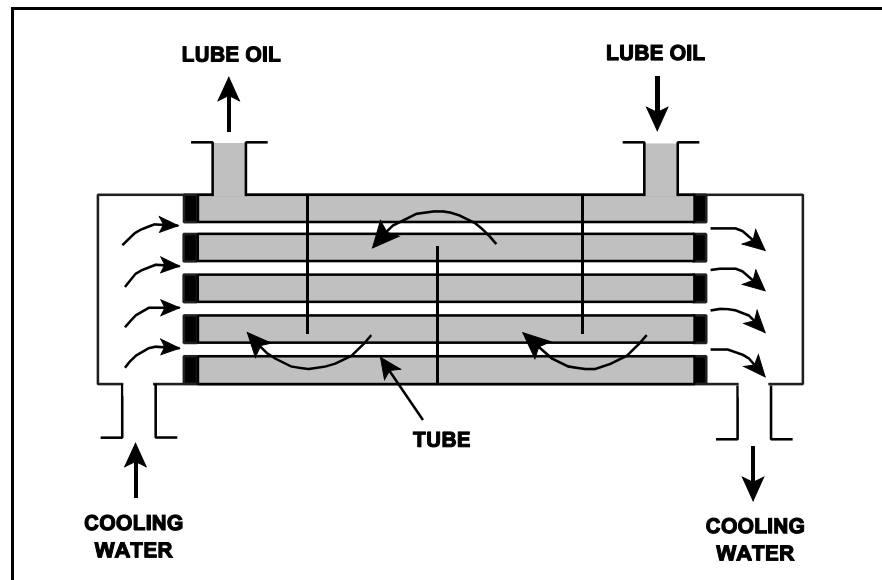

TOPIC: 191006
KNOWLEDGE: K1.07 [2.4/2.6]
QID: P2034 (B834)

Refer to the drawing of an operating lube oil heat exchanger (see figure below).

Given the following existing conditions:

$c_{p\text{-oil}} = 1.1 \text{ Btu/lbm-}^\circ\text{F}$
 $c_{p\text{-water}} = 1.0 \text{ Btu/lbm-}^\circ\text{F}$
 $\dot{m}_{\text{oil}} = 1.2 \times 10^4 \text{ lbm/hr}$
 $\dot{m}_{\text{water}} = 1.61 \times 10^4 \text{ lbm/hr}$
 $T_{\text{oil in}} = 170^\circ\text{F}$
 $T_{\text{oil out}} = 120^\circ\text{F}$
 $T_{\text{water out}} = 110^\circ\text{F}$
 $T_{\text{water in}} = ?$

Which one of the following is the approximate cooling water inlet temperature ($T_{\text{water in}}$) in this heat exchanger?

- A. 65°F
- B. 69°F
- C. 73°F
- D. 77°F

ANSWER: B.

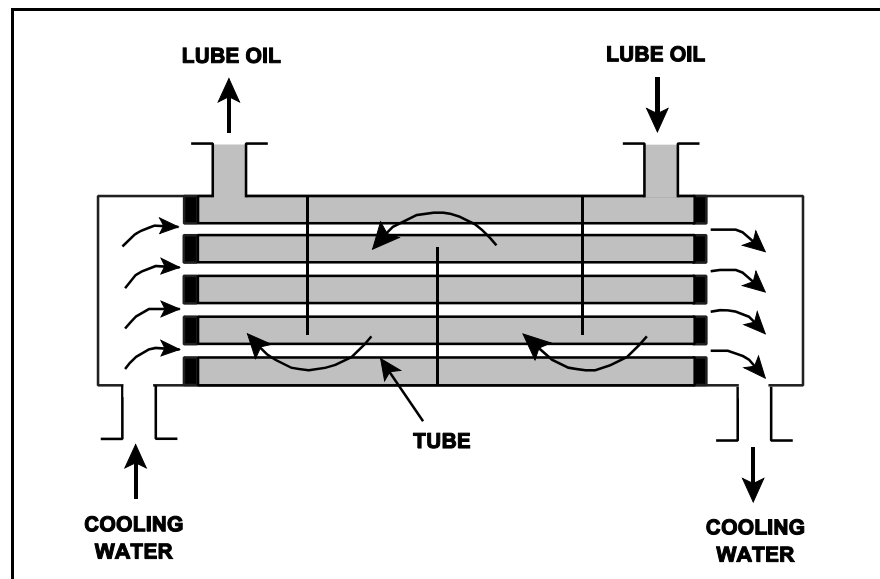

TOPIC: 191006
KNOWLEDGE: K1.07 [2.4/2.6]
QID: P2133 (B2132)

Refer to the drawing of a lube oil heat exchanger (see figure below).

The lube oil heat exchanger is in service with the following inlet temperatures:

Lube oil inlet temperature: 120°F
Cooling water inlet temperature: 60°F

Assuming cooling water flow rate is greater than lube oil flow rate, which one of the following pairs of heat exchanger outlet temperatures is possible? (Assume both fluids have the same c_p .)

	<u>Lube Oil Outlet Temp</u>	<u>Cooling Water Outlet Temp</u>
A.	100°F	100°F
B.	90°F	90°F
C.	80°F	80°F
D.	80°F	100°F

ANSWER: C.

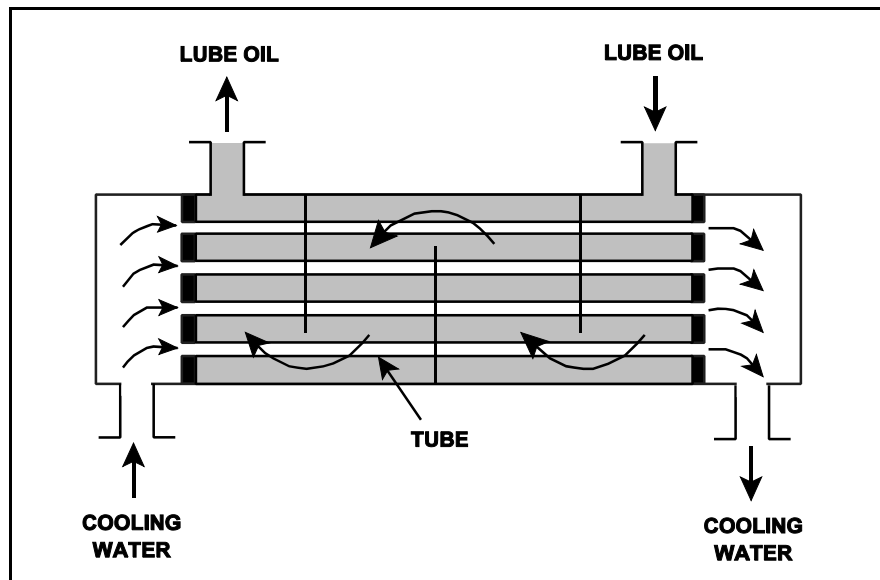

TOPIC: 191006
KNOWLEDGE: K1.07 [2.4/2.6]
QID: P2232 (B1435)

Refer to the drawing of an operating lube oil heat exchanger (see figure below).

Given the following existing conditions:

$$\begin{aligned}\dot{m}_{\text{oil}} &= 1.8 \times 10^4 \text{ lbm/hr} \\ \dot{m}_{\text{water}} &= 3.3 \times 10^4 \text{ lbm/hr} \\ c_{p\text{-oil}} &= 1.1 \text{ Btu/lbm-}^\circ\text{F} \\ c_{p\text{-water}} &= 1.0 \text{ Btu/lbm-}^\circ\text{F} \\ T_{\text{cw-in}} &= 90^\circ\text{F} \\ T_{\text{cw-out}} &= 120^\circ\text{F} \\ T_{\text{oil-in}} &= 190^\circ\text{F} \\ T_{\text{oil-out}} &= ?\end{aligned}$$

Which one of the following is the temperature of the oil exiting the heat exchanger ($T_{\text{oil-out}}$)?

- A. 110°F
- B. 120°F
- C. 130°F
- D. 140°F

ANSWER: D.

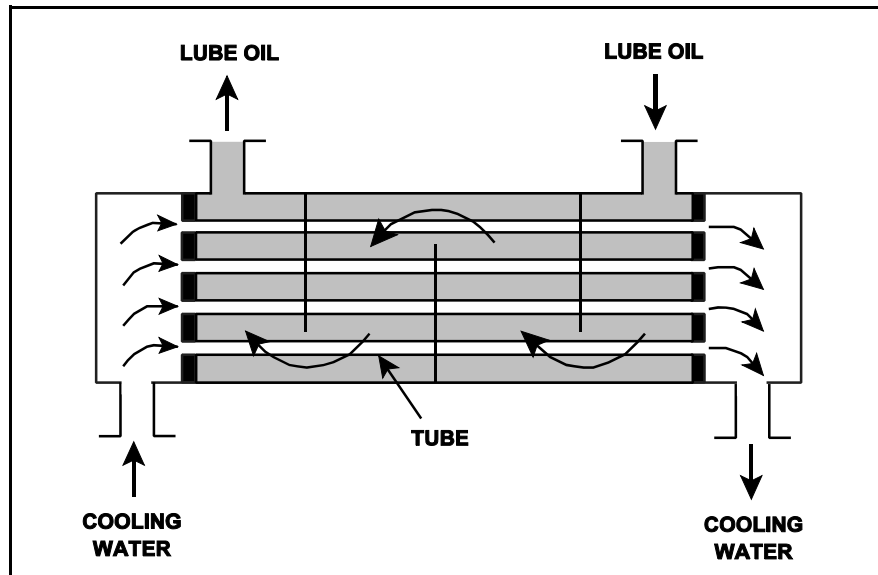

TOPIC: 191006
KNOWLEDGE: K1.07 [2.4/2.6]
QID: P2434 (B2233)

Refer to the drawing of a lube oil heat exchanger (see figure below).

The lube oil heat exchanger is in service with the following inlet temperatures:

Lube oil inlet temperature: 130°F
Cooling water inlet temperature: 70°F

Assuming cooling water flow rate is greater than lube oil flow rate, which one of the following pairs of heat exchanger outlet temperatures is possible? (Neglect any difference between fluid specific heat.)

- | | <u>Lube Oil
Outlet Temp</u> | <u>Cooling Water
Outlet Temp</u> |
|----|---------------------------------|--------------------------------------|
| A. | 90°F | 100°F |
| B. | 90°F | 110°F |
| C. | 100°F | 100°F |
| D. | 100°F | 110°F |

ANSWER: A.

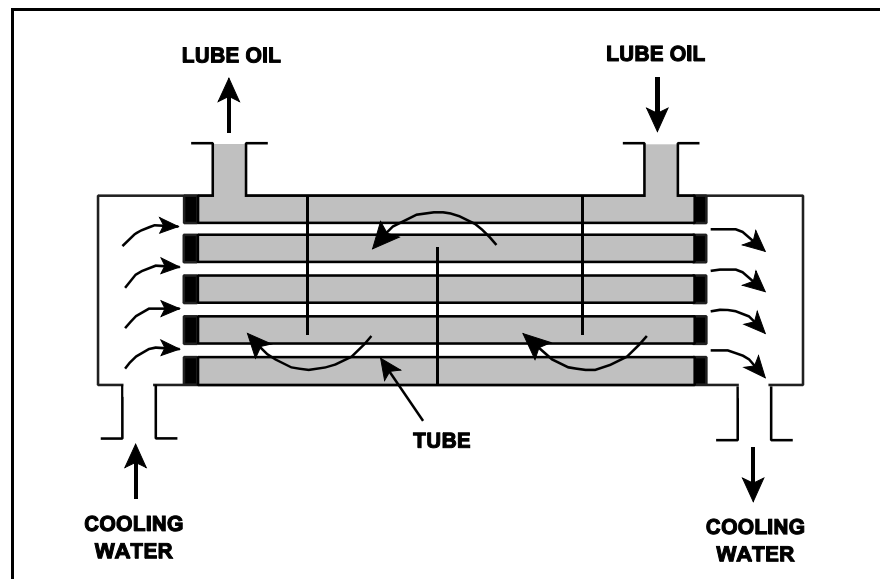

TOPIC: 191006
KNOWLEDGE: K1.07 [2.4/2.6]
QID: P2532 (B2534)

Refer to the drawing of an operating lube oil heat exchanger (see figure below).

Given the following information, which one of the following is the temperature of the cooling water exiting the heat exchanger (T_{cw-out})?

$$\begin{aligned}\dot{m}_{oil} &= 1.5 \times 10^4 \text{ lbm/hr} \\ \dot{m}_{water} &= 2.5 \times 10^4 \text{ lbm/hr} \\ c_{p-oil} &= 1.1 \text{ Btu/lbm-}^\circ\text{F} \\ c_{p-water} &= 1.0 \text{ Btu/lbm-}^\circ\text{F} \\ T_{oil-in} &= 160^\circ\text{F} \\ T_{oil-out} &= 110^\circ\text{F} \\ T_{cw-in} &= 92^\circ\text{F} \\ T_{cw-out} &= ?\end{aligned}$$

- A. 110°F
- B. 115°F
- C. 120°F
- D. 125°F

ANSWER: D.

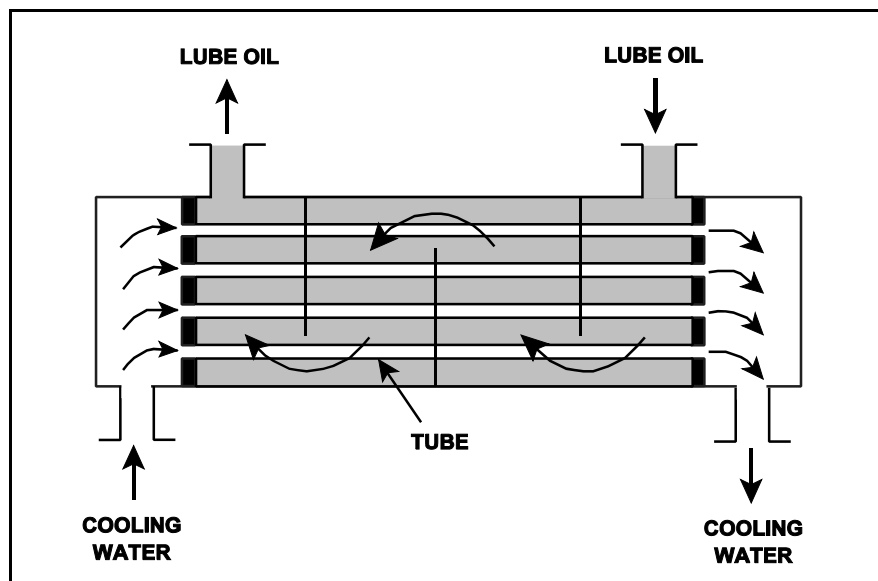

TOPIC: 191006
KNOWLEDGE: K1.07 [2.4/2.6]
QID: P2632 (B2531)

The rate of heat transfer between two liquids in a heat exchanger will be decreased if the: (Assume single-phase conditions and a constant specific heat for both liquids.)

- A. inlet temperature of the hotter liquid is increased by 20°F.
- B. inlet temperature of the colder liquid is decreased by 20°F.
- C. flow rates of both liquids are decreased by 10%.
- D. flow rates of both liquids are increased by 10%.

ANSWER: C.

TOPIC: 191006
KNOWLEDGE: K1.07 [2.4/2.6]
QID: P2633 (B2632)

Refer to the drawing of a lube oil heat exchanger (see figure below).

The lube oil heat exchanger is in service with the following inlet temperatures:

Lube oil inlet temperature: 110°F
Cooling water inlet temperature: 75°F

Assuming cooling water flow rate is greater than lube oil flow rate, which one of the following pairs of heat exchanger outlet temperatures is possible? (Neglect any difference between fluid specific heats.)

- | Lube Oil
Outlet Temp | Cooling Water
Outlet Temp |
|-------------------------|------------------------------|
| A. 100°F | 100°F |
| B. 100°F | 90°F |
| C. 90°F | 100°F |
| D. 90°F | 90°F |

ANSWER: D.

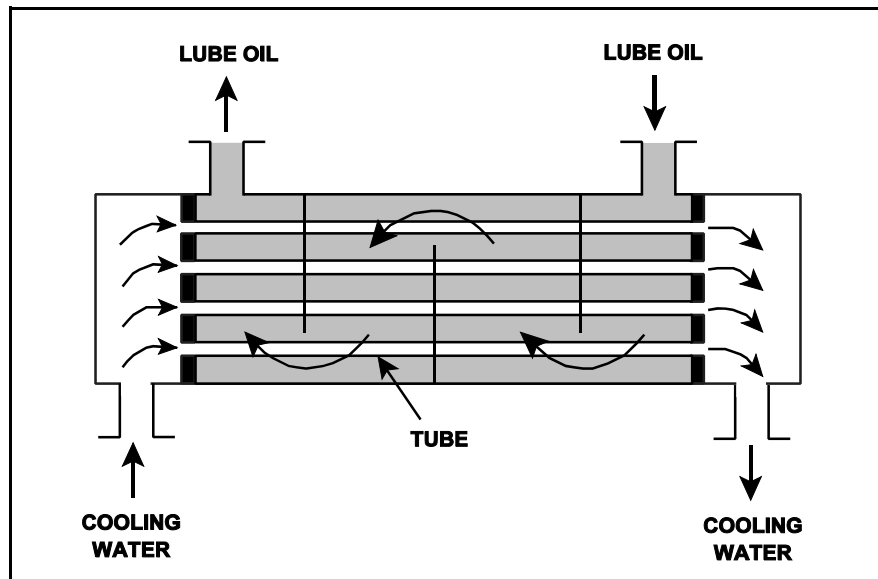

TOPIC: 191006
KNOWLEDGE: K1.07 [2.4/2.6]
QID: P2732 (B2732)

Refer to the drawing of an operating water cleanup system (see figure below).

All valves are identical and are initially 50% open. To raise the temperature at point 4, the operator can adjust valve _____ in the _____ direction.

- A. A; shut
- B. B; shut
- C. C; open
- D. D; open

ANSWER: C.

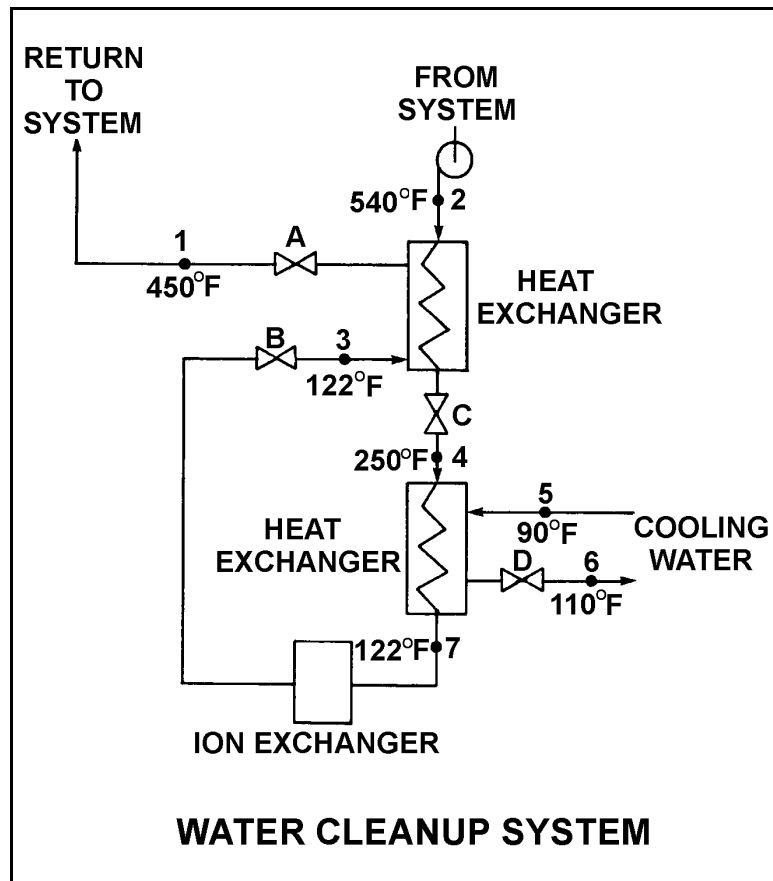

TOPIC: 191006
KNOWLEDGE: K1.07 [2.4/2.6]
QID: P2733 (B2733)

Refer to the drawing of a lube oil heat exchanger (see figure below).

The lube oil heat exchanger is in service with the following inlet temperatures:

Lube oil inlet temperature: 130°F
Cooling water inlet temperature: 70°F

Assuming cooling water flow rate is greater than lube oil flow rate, which one of the following pairs of heat exchanger outlet temperatures is not possible? (Assume both fluids have the same specific heat.)

- | | <u>Lube Oil</u>
<u>Outlet Temp</u> | <u>Cooling Water</u>
<u>Outlet Temp</u> |
|----|---------------------------------------|--|
| A. | 90°F | 86°F |
| B. | 100°F | 85°F |
| C. | 110°F | 84°F |
| D. | 120°F | 83°F |

ANSWER: D.

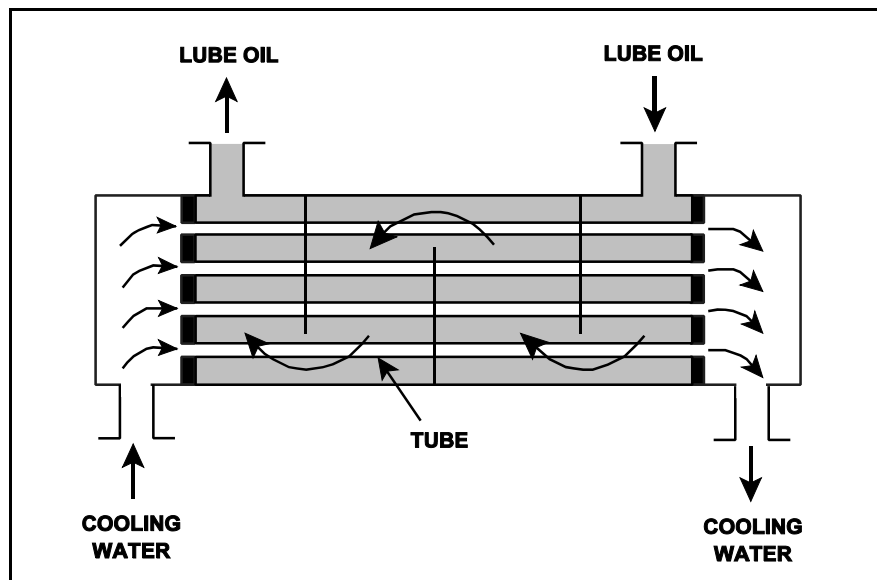

TOPIC: 191006
KNOWLEDGE: K1.07 [2.4/2.6]
QID: P2934 (B2933)

Refer to the drawing of a lube oil heat exchanger (see figure below).

The lube oil heat exchanger is in service with the following inlet temperatures:

Lube oil inlet temperature: 130°F
Cooling water inlet temperature: 70°F

Assuming that cooling water flow rate is significantly larger than lube oil flow rate, which one of the following pairs of heat exchanger outlet temperatures is possible? (Assume both fluids have the same specific heat.)

- | | <u>Lube Oil
Outlet Temp</u> | <u>Cooling Water
Outlet Temp</u> |
|----|---------------------------------|--------------------------------------|
| A. | 100°F | 90°F |
| B. | 100°F | 100°F |
| C. | 110°F | 90°F |
| D. | 110°F | 100°F |

ANSWER: A.

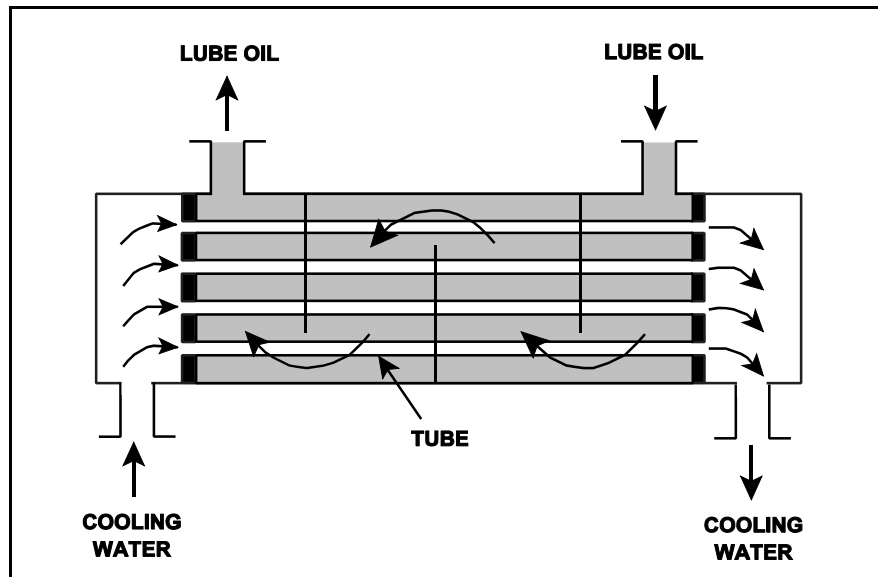

TOPIC: 191006
KNOWLEDGE: K1.07 [2.4/2.6]
QID: P3034 (B3082)

Refer to the drawing of an operating lube oil heat exchanger (see figure below).

Given the following lube oil cooling system conditions:

The lube oil flow rate in the lube oil heat exchanger is 200 lbm/min.

The lube oil enters the heat exchanger at 140°F.

The lube oil leaves the heat exchanger at 100°F.

The specific heat of the lube oil is 0.8 Btu/lbm-°F.

The cooling water flow rate is 400 lbm/min.

The cooling water enters the lube oil heat exchanger at 60°F.

The specific heat of the cooling water is 1.0 Btu/lbm-°F.

What is the approximate temperature of the cooling water leaving the lube oil heat exchanger?

- A. 76°F
- B. 85°F
- C. 92°F
- D. 124°F

ANSWER: A.

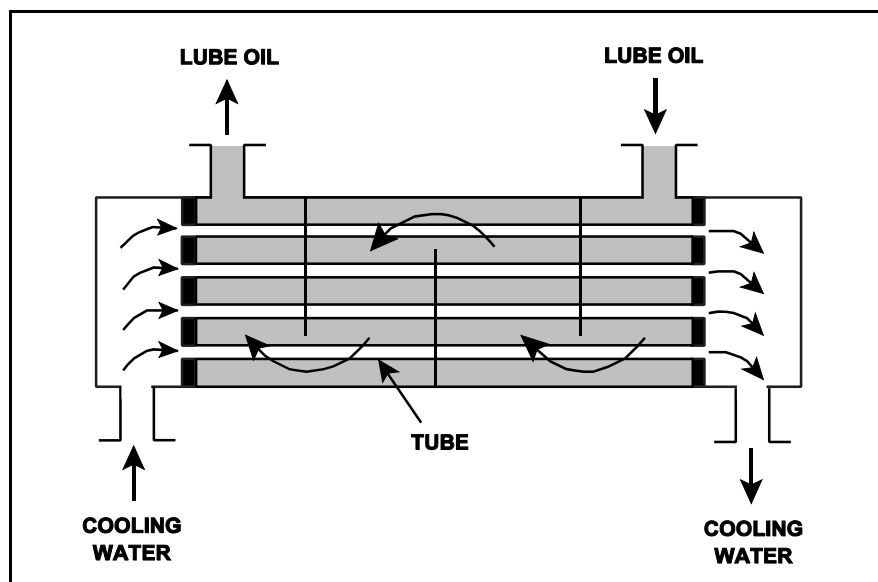

TOPIC: 191006
KNOWLEDGE: K1.07 [2.4/2.6]
QID: P3132 (B934)

Refer to the drawing of a lube oil heat exchanger (see figure below).

The heat exchanger is operating with the following parameters:

$$\begin{aligned}\dot{Q}_{\text{oil}} &= 1.0 \times 10^7 \text{ Btu/hr} \\ T_{\text{oil in}} &= 170^\circ\text{F} \\ T_{\text{oil out}} &= 134^\circ\text{F} \\ T_{\text{water in}} &= 85^\circ\text{F} \\ T_{\text{water out}} &= 112^\circ\text{F} \\ c_{p\text{-oil}} &= 1.1 \text{ Btu/lbm-}^\circ\text{F} \\ c_{p\text{-water}} &= 1.0 \text{ Btu/lbm-}^\circ\text{F} \\ \dot{m}_{\text{water}} &= ?\end{aligned}$$

Which one of the following is the mass flow rate of the cooling water?

- A. 4.5×10^5 lbm/hr
- B. 3.7×10^5 lbm/hr
- C. 2.5×10^5 lbm/hr
- D. 1.2×10^5 lbm/hr

ANSWER: B.

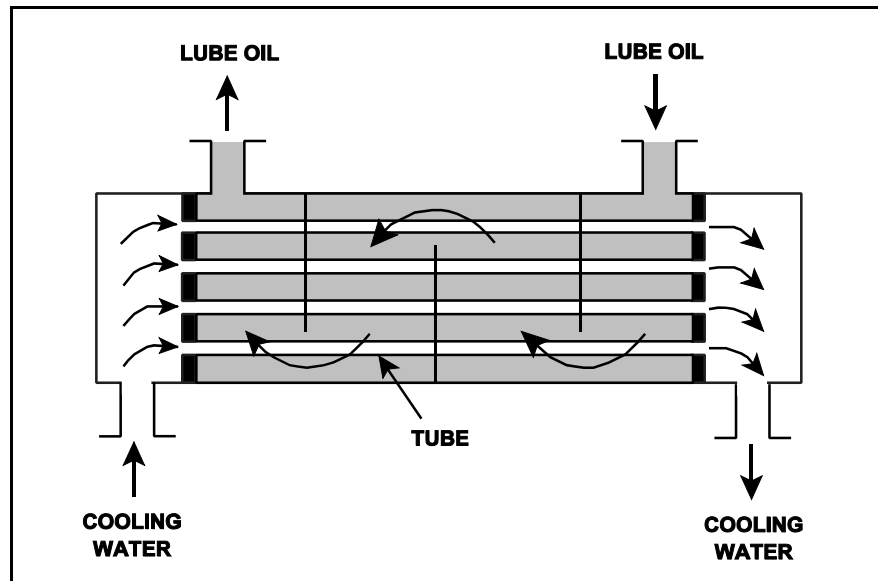

TOPIC: 191006
KNOWLEDGE: K1.07 [2.4/2.6]
QID: P3232 (B632)

Refer to the drawing of an operating water cleanup system (see figure below). Valves A, B, and D are fully open and valve C is 50% open.

If valve C is opened to 100%, how will the temperatures at points 3 and 6 be affected?

- | <u>Point 3</u> | <u>Point 6</u> |
|----------------|----------------|
| A. Decrease | Decrease |
| B. Decrease | Increase |
| C. Increase | Decrease |
| D. Increase | Increase |

ANSWER: D.

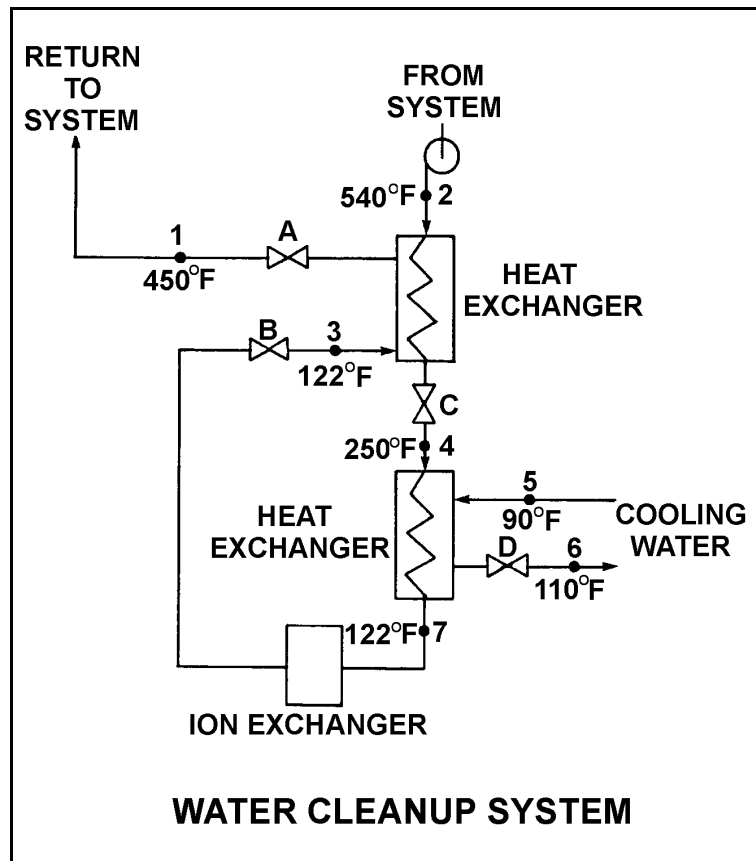

TOPIC: 191006
KNOWLEDGE: K1.07 [2.4/2.6]
QID: P3332 (B1930)

Refer to the drawing of an operating water cleanup system (see figure below). All valves are identical and are initially 50% open.

To raise the temperature at point 7, the operator should adjust valve _____ in the close direction.

- A. A
- B. B
- C. C
- D. D

ANSWER: D.

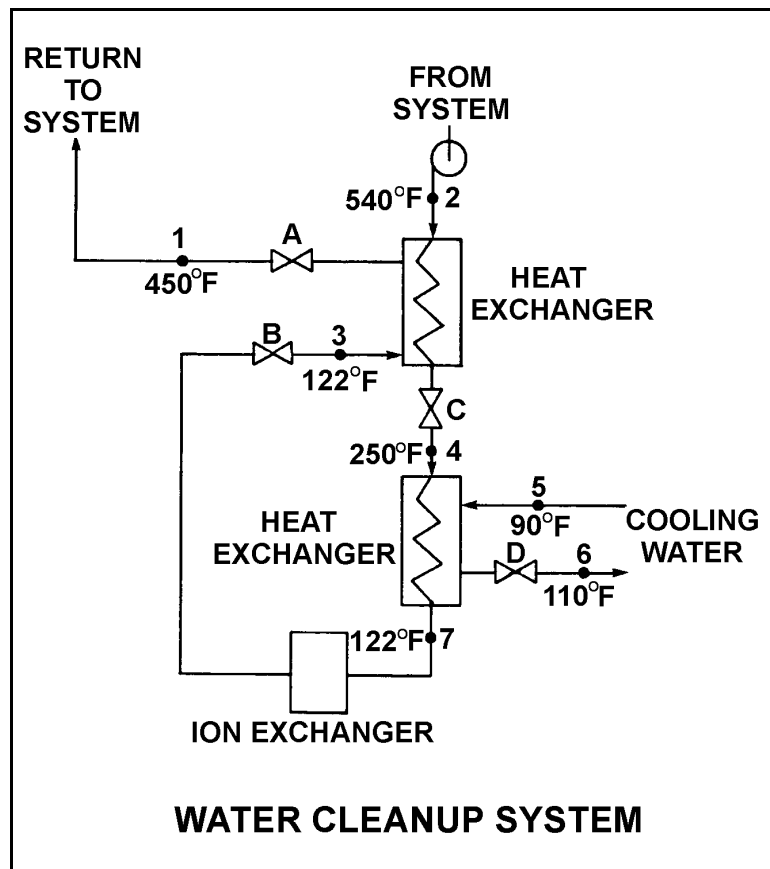

TOPIC: 191006
KNOWLEDGE: K1.07 [2.4/2.6]
QID: P3432 (B1435)

Refer to the drawing of an operating lube oil heat exchanger (see figure below).

Given the following existing conditions:

$$\begin{aligned}\dot{m}_{\text{oil}} &= 1.8 \times 10^4 \text{ lbm/hr} \\ \dot{m}_{\text{water}} &= 3.3 \times 10^4 \text{ lbm/hr} \\ c_{p\text{-oil}} &= 1.1 \text{ Btu/lbm-}^\circ\text{F} \\ c_{p\text{-water}} &= 1.0 \text{ Btu/lbm-}^\circ\text{F} \\ T_{\text{cw-in}} &= 90^\circ\text{F} \\ T_{\text{cw-out}} &= 120^\circ\text{F} \\ T_{\text{oil-in}} &= 170^\circ\text{F} \\ T_{\text{oil-out}} &= ?\end{aligned}$$

What is the approximate temperature of the oil exiting the heat exchanger ($T_{\text{oil-out}}$)?

- A. 110°F
- B. 120°F
- C. 130°F
- D. 140°F

ANSWER: B.

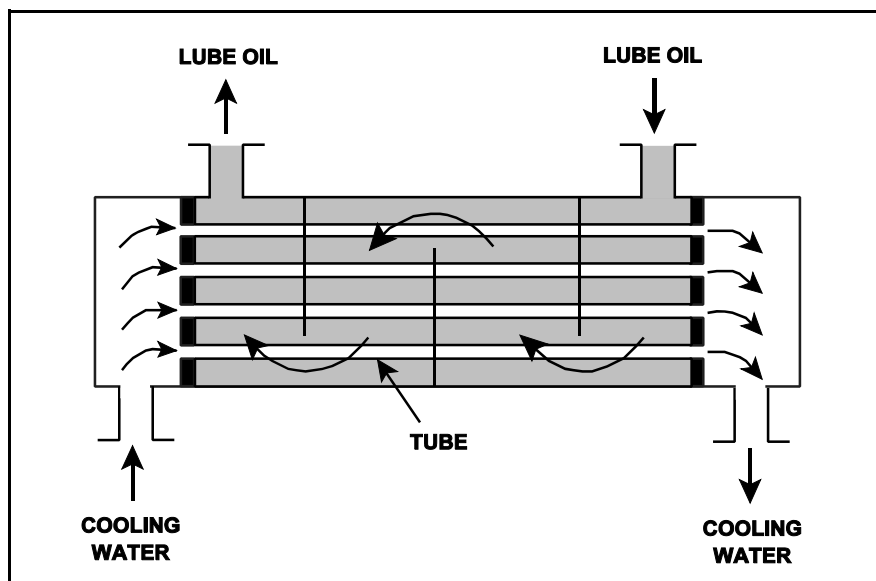

TOPIC: 191006
KNOWLEDGE: K1.07 [2.4/2.6]
QID: P3632 (B3631)

Refer to the drawing of an operating water cleanup system (see figure below).

If cooling water flow rate is 1.0×10^6 lbm/hr, what is the approximate water flow rate in the cleanup system?

- A. 1.6×10^5 lbm/hr
- B. 3.2×10^5 lbm/hr
- C. 1.6×10^6 lbm/hr
- D. 3.2×10^6 lbm/hr

ANSWER: A.

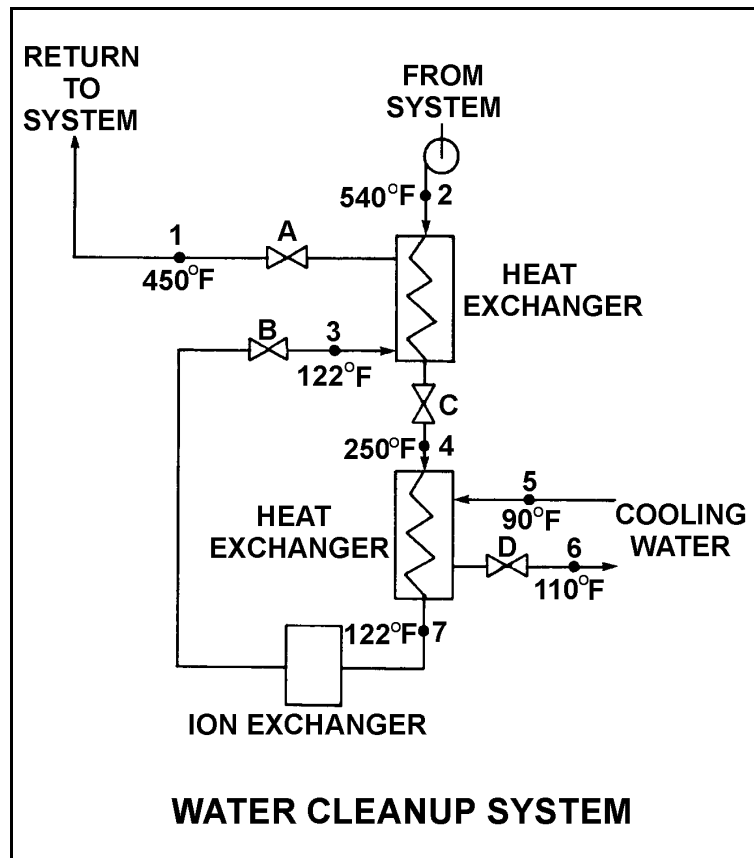

TOPIC: 191006
KNOWLEDGE: K1.07 [2.4/2.6]
QID: P3732 (B3732)

Refer to the drawing of a lube oil heat exchanger (see figure below).

The lube oil heat exchanger is in service with the following inlet temperatures:

Lube oil inlet temperature: 130°F
Cooling water inlet temperature: 70°F

Assume that cooling water mass flow rate is less than lube oil mass flow rate, and that both fluids have the same specific heat. Which one of the following pairs of heat exchanger outlet temperatures is not possible?

- | Lube Oil
Outlet Temp | Cooling Water
Outlet Temp |
|-------------------------|------------------------------|
| A. 100°F | 105°F |
| B. 105°F | 105°F |
| C. 110°F | 90°F |
| D. 115°F | 90°F |

ANSWER: C.

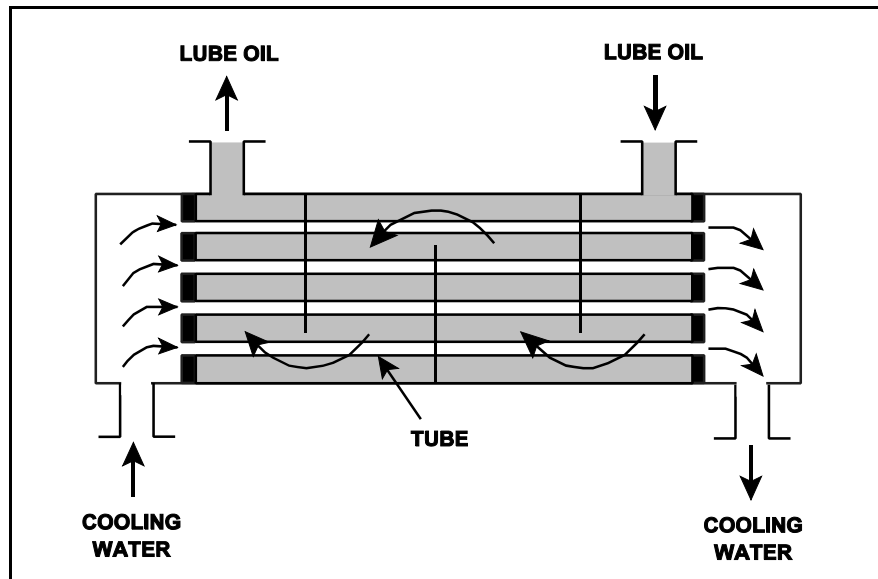

TOPIC: 191006
KNOWLEDGE: K1.07 [2.5/2.7]
QID: P3833 (B3832)

A main turbine-generator was operating at 80% load with the following initial steady-state lube oil and cooling water temperatures for the main turbine lube oil heat exchanger:

$$\begin{aligned}T_{\text{oil in}} &= 174^{\circ}\text{F} \\T_{\text{oil out}} &= 114^{\circ}\text{F} \\T_{\text{water in}} &= 85^{\circ}\text{F} \\T_{\text{water out}} &= 115^{\circ}\text{F}\end{aligned}$$

Six months later, the following current steady-state heat exchanger temperatures are observed:

$$\begin{aligned}T_{\text{oil in}} &= 177^{\circ}\text{F} \\T_{\text{oil out}} &= 111^{\circ}\text{F} \\T_{\text{water in}} &= 85^{\circ}\text{F} \\T_{\text{water out}} &= 115^{\circ}\text{F}\end{aligned}$$

Assume that the total heat exchanger heat transfer coefficient and the cooling water mass flow rate do not change, and that the specific heat values for the cooling water and lube oil do not change. Also, assume that the lube oil system is a closed system.

Which one of the following could be responsible for the differences between the initial and current steady-state heat exchanger temperatures?

- A. The current main turbine-generator load is lower than the initial load.
- B. The current main turbine-generator load is higher than the initial load.
- C. The current main turbine lube oil mass flow rate is less than the initial flow rate.
- D. The current main turbine lube oil mass flow rate is greater than the initial flow rate.

ANSWER: C.

TOPIC: 191006
KNOWLEDGE: K1.07 [2.4/2.6]
QID: P4416 (B4416)

Refer to the drawing of a lube oil heat exchanger (see figure below).

The lube oil heat exchanger is in service with the following inlet temperatures:

Lube oil inlet temperature: 120°F
Cooling water inlet temperature: 60°F

Assuming cooling water flow rate is greater than lube oil flow rate, which one of the following sets of heat exchanger outlet temperatures is possible? (Neglect any difference between fluid specific heats.)

- | | <u>Lube Oil
Outlet Temp</u> | <u>Cooling Water
Outlet Temp</u> |
|----|---------------------------------|--------------------------------------|
| A. | 90°F | 100°F |
| B. | 90°F | 85°F |
| C. | 95°F | 100°F |
| D. | 95°F | 85°F |

ANSWER: B.

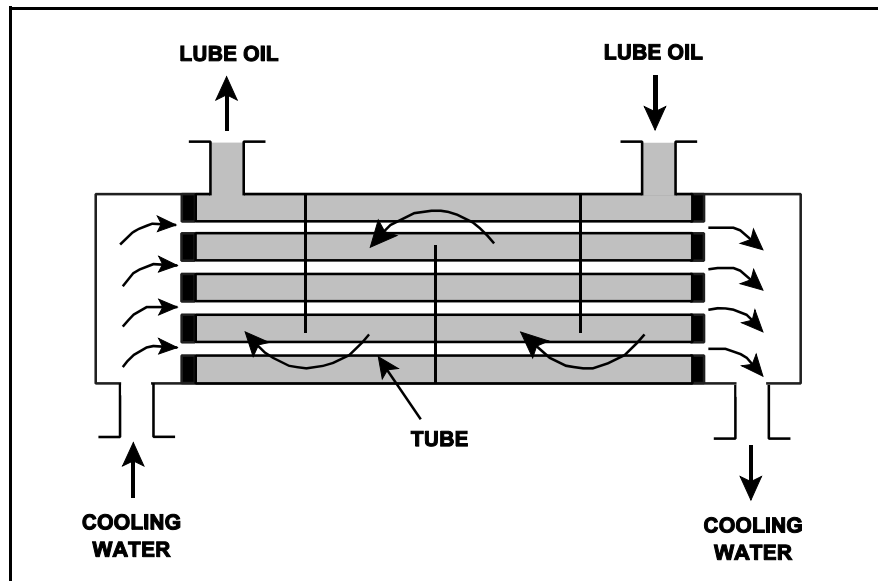

TOPIC: 191006
KNOWLEDGE: K1.07 [2.5/2.7]
QID: P5316 (B5317)

A main turbine-generator was operating at 80% load with the following initial steady-state lube oil and cooling water temperatures for the main turbine lube oil heat exchanger:

$$\begin{aligned}T_{\text{oil in}} &= 174^{\circ}\text{F} \\T_{\text{oil out}} &= 114^{\circ}\text{F} \\T_{\text{water in}} &= 85^{\circ}\text{F} \\T_{\text{water out}} &= 115^{\circ}\text{F}\end{aligned}$$

Six months later, the current steady-state heat exchanger temperatures are:

$$\begin{aligned}T_{\text{oil in}} &= 174^{\circ}\text{F} \\T_{\text{oil out}} &= 120^{\circ}\text{F} \\T_{\text{water in}} &= 85^{\circ}\text{F} \\T_{\text{water out}} &= 120^{\circ}\text{F}\end{aligned}$$

Assume that the lube oil mass flow rate does not change, and that the specific heat values for the cooling water and lube oil do not change. Also, assume that the main turbine lube oil system is a closed system.

The differences between the initial and current steady-state heat exchanger temperatures could be caused by the current main turbine-generator load being _____ with the current heat exchanger cooling water mass flow rate being _____.

- A. higher; lower
- B. higher; higher
- C. lower; lower
- D. lower; higher

ANSWER: C.

TOPIC: 191006
KNOWLEDGE: K1.07 [2.4/2.6]
QID: P5516 (B5517)

Refer to the drawing of a lube oil heat exchanger (see figure below).

The lube oil heat exchanger is in service with the following inlet temperatures:

Lube oil inlet temperature: 130°F
Cooling water inlet temperature: 70°F

Given that cooling water mass flow rate is greater than lube oil mass flow rate, which one of the following pairs of heat exchanger outlet temperatures is not possible? (Neglect any difference between the fluid specific heat capacities.)

- | | <u>Lube Oil
Outlet Temp</u> | <u>Cooling Water
Outlet Temp</u> |
|----|---------------------------------|--------------------------------------|
| A. | 90°F | 105°F |
| B. | 90°F | 100°F |
| C. | 110°F | 95°F |
| D. | 110°F | 85°F |

ANSWER: C.

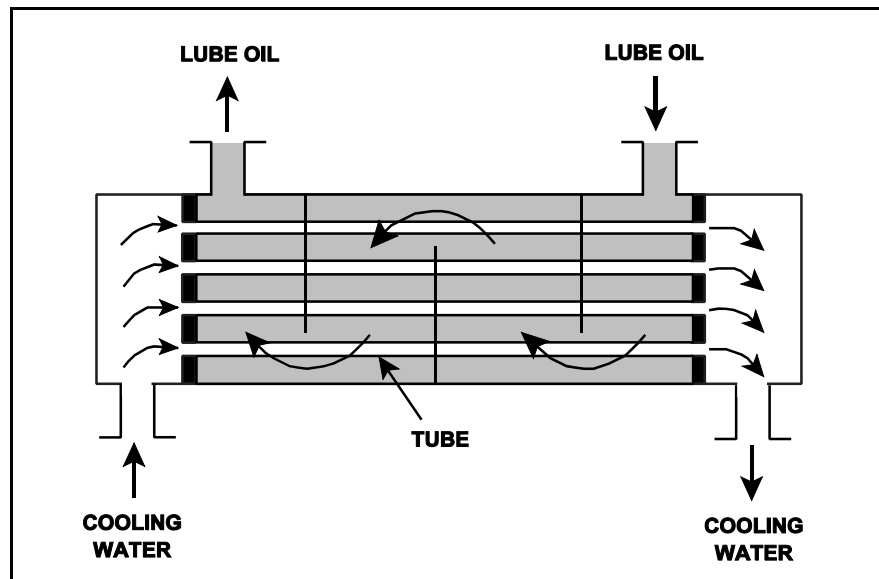

TOPIC: 191006
KNOWLEDGE: K1.07 [2.4/2.6]
QID: P5616 (B5617)

Refer to the drawing of an operating lube oil heat exchanger (see figure below).

Assume that the inlet lube oil and inlet cooling water temperatures are constant and the lube oil flow rate remains the same. If the cooling water flow rate increases, the lube oil outlet temperature will _____ and the cooling water outlet temperature will _____.

- A. increase, increase
- B. increase, decrease
- C. decrease, increase
- D. decrease, decrease

ANSWER: D.

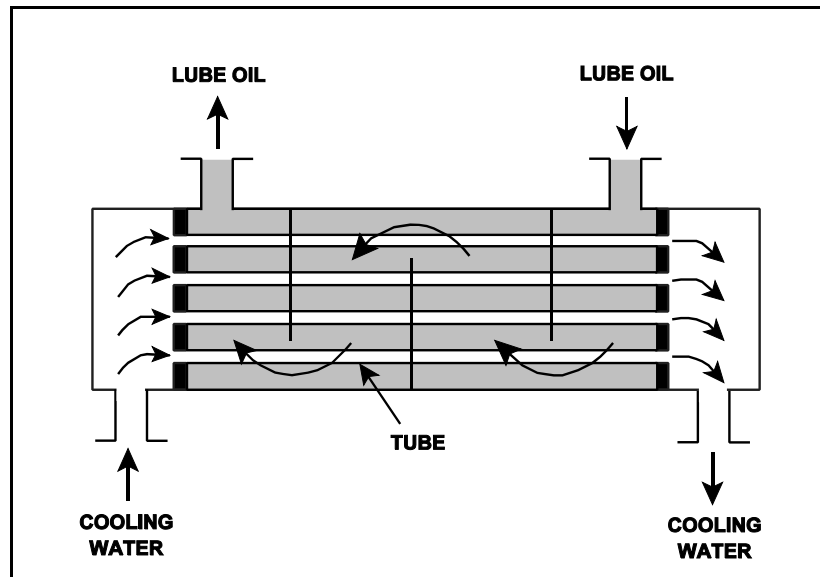

TOPIC: 191006
KNOWLEDGE: K1.09 [2.8/2.8]
QID: P31

Severe stress in a mechanical component, induced by a sudden, unequally distributed temperature reduction is a description of...

- A. fracture stress.
- B. brittle fracture.
- C. thermal shock.
- D. pressurized thermal shock.

ANSWER: C.

TOPIC: 191006
KNOWLEDGE: K1.09 [2.8/2.8]
QID: P233

The major thermodynamic concern resulting from rapidly cooling a reactor vessel is...

- A. thermal shock.
- B. stress corrosion.
- C. loss of shutdown margin.
- D. loss of subcooling margin.

ANSWER: A.

TOPIC: 191006
KNOWLEDGE: K1.09 [2.8/2.8]
QID: P2832 (B633)

Steam has been admitted to a main condenser for 25 minutes with no cooling water. Initiating full cooling water flow rate at this time will...

- A. reduce the stress on the condenser shell by rapidly cooling the shell.
- B. reduce the stress on the condenser tubes by rapidly cooling the tubes.
- C. induce large thermal stresses on the condenser shell.
- D. induce large thermal stresses on the junctions between the condenser tubes and the tubesheet.

ANSWER: D.

TOPIC: 191006
KNOWLEDGE: K1.12 [2.5/2.7]
QID: P32 (B1234)

Refer to the drawing of an operating lube oil heat exchanger (see figure below).

If scaling occurs inside the cooling water tubes, cooling water outlet temperature will _____ and lube oil outlet temperature will _____. (Assume oil and cooling water flow rates remain the same.)

- A. decrease; decrease
- B. decrease; increase
- C. increase; decrease
- D. increase; increase

ANSWER: B.

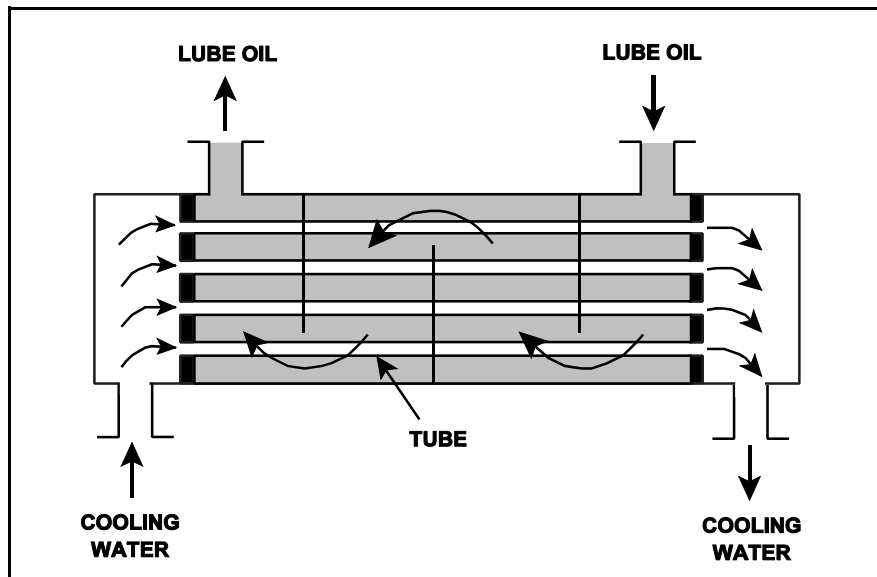

TOPIC: 191006
KNOWLEDGE: K1.12 [2.5/2.7]
QID: P105

Which one of the following will occur to reduce the heat transfer rate in a parallel-flow heat exchanger as scaling increases on the exterior surface of the tubes? (Assume no operator actions.)

- A. Flow through the heat exchanger tubes will decrease.
- B. Surface area of the tubes will decrease.
- C. Thermal conductivity of the tubes will decrease.
- D. Delta-T across the tubes will decrease.

ANSWER: C.

TOPIC: 191006
KNOWLEDGE: K1.12 [2.5/2.7]
QID: P331 (B332)

A nuclear power plant is operating at steady-state conditions with the main generator supplying 1,000 MW to the power grid. Assume main generator load remains constant.

If 1% of the tubes in the main condenser become plugged, condenser absolute pressure will _____; and condenser hotwell temperature will _____.

- A. increase; increase
- B. decrease; increase
- C. increase; decrease
- D. decrease; decrease

ANSWER: A.

TOPIC: 191006
KNOWLEDGE: K1.12 [2.5/2.7]
QID: P2233 (B1833)

Refer to the drawing of an operating lube oil heat exchanger (see figure below).

If deposits accumulate on the outside of the cooling water tubes, cooling water outlet temperature will _____ and oil outlet temperature will _____. (Assume oil and cooling water inlet temperatures and flow rates remain the same.)

- A. increase; decrease
- B. increase; increase
- C. decrease; decrease
- D. decrease; increase

ANSWER: D.

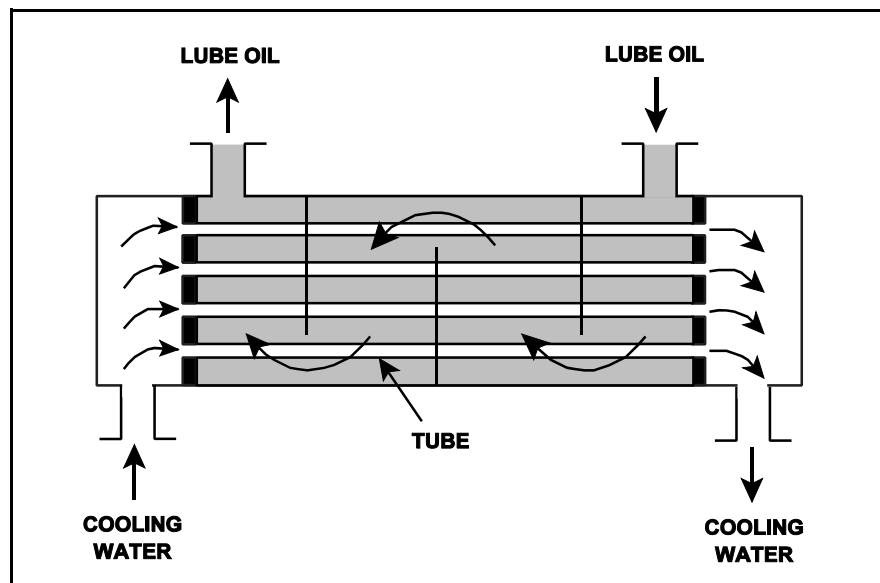

TOPIC: 191006
KNOWLEDGE: K1.12 [2.5/2.7]
QID: P3633 (B3635)

A main turbine-generator is operating at 80% load with the following initial steady-state temperatures for the main turbine lube oil heat exchanger:

$$\begin{aligned}T_{\text{oil in}} &= 174^{\circ}\text{F} \\T_{\text{oil out}} &= 114^{\circ}\text{F} \\T_{\text{water in}} &= 85^{\circ}\text{F} \\T_{\text{water out}} &= 115^{\circ}\text{F}\end{aligned}$$

After six months of main turbine operation, the following final steady-state lube oil heat exchanger temperatures are observed:

$$\begin{aligned}T_{\text{oil in}} &= 179^{\circ}\text{F} \\T_{\text{oil out}} &= 119^{\circ}\text{F} \\T_{\text{water in}} &= 85^{\circ}\text{F} \\T_{\text{water out}} &= 115^{\circ}\text{F}\end{aligned}$$

Assume that the final cooling water and lube oil flow rates are the same as the initial flow rates, and that the specific heat values for the cooling water and lube oil do not change.

Which one of the following could be responsible for the differences between the initial and final heat exchanger steady-state temperatures?

- A. The heat exchanger tubes have become fouled with scale.
- B. The temperature of the cooling water source has increased.
- C. The final main turbine-generator load is higher than the initial load.
- D. The final main turbine-generator load is lower than the initial load.

ANSWER: A.

TOPIC: 191006
KNOWLEDGE: K1.12 [2.5/2.7]
QID: P4617 (B4616)

Refer to the drawing of two system curves for a typical main condenser cooling water system (see figure below).

Which one of the following will cause the system curve to shift from the solid curve toward the dashed curve?

- A. The main condenser tubes are cleaned.
- B. The main condenser tubes become increasingly fouled.
- C. Cooling water flow rate is increased by 25% by starting an additional cooling water pump.
- D. Cooling water flow rate is decreased by 25% by stopping one of the operating cooling water pumps.

ANSWER: A.

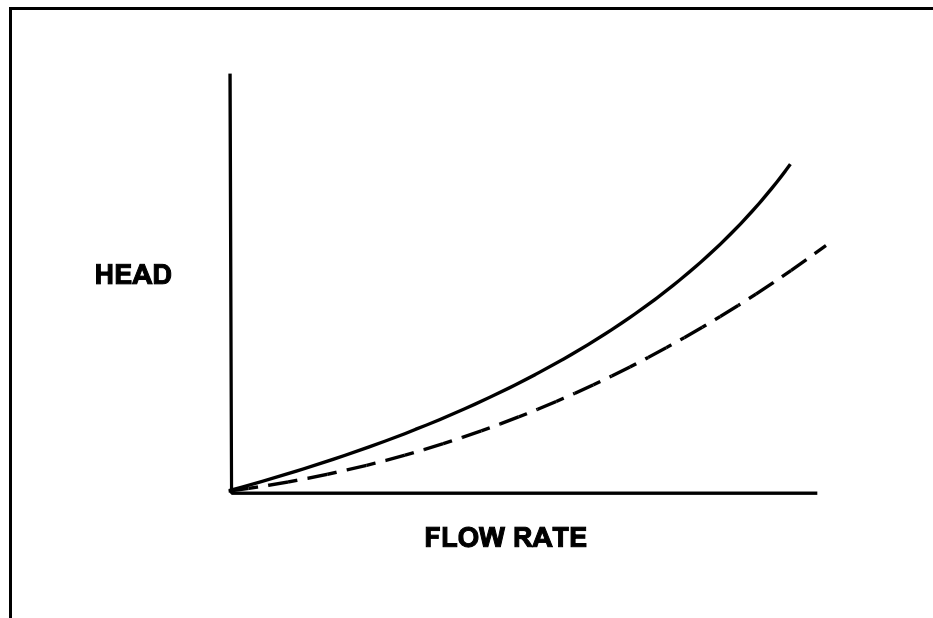

TOPIC: 191006
KNOWLEDGE: K1.12 [2.5/2.7]
QID: P5116 (B5117)

Refer to the drawing of two system curves for a typical main condenser cooling water system (see figure below).

Which one of the following will result in the system curve shifting from the solid curve toward the dashed curve?

- A. The main condenser tubes are cleaned.
- B. The main condenser tubes become increasingly fouled.
- C. Cooling water system flow rate is increased by 25% by starting an additional cooling water pump.
- D. Cooling water system flow rate is decreased by 25% by stopping one of the operating cooling water pumps.

ANSWER: B.

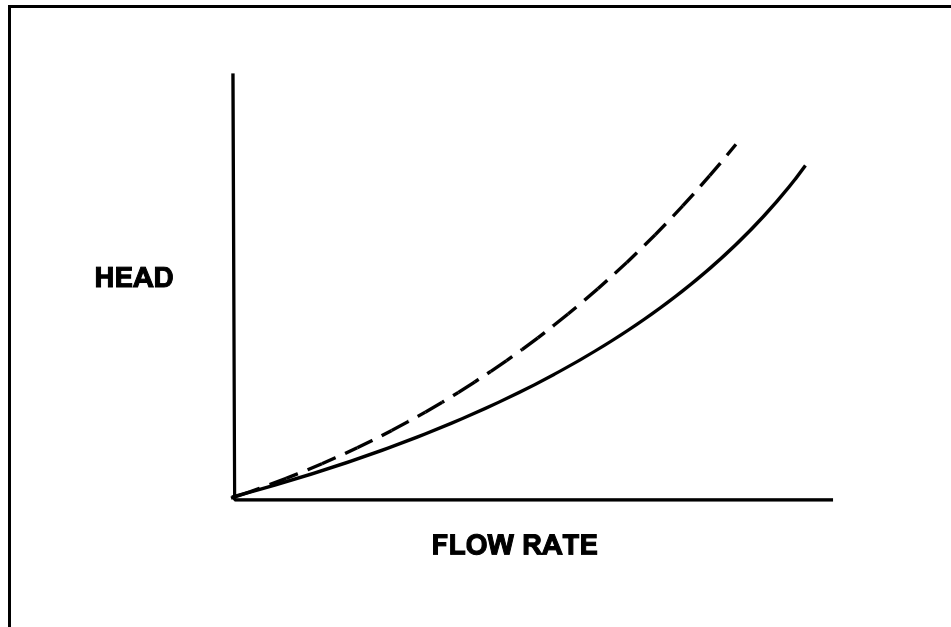

TOPIC: 191006
KNOWLEDGE: K1.13 [2.8/2.9]
QID: P33

Borated water is flowing through the tubes of a heat exchanger being cooled by fresh water. The shell side pressure is less than tube side pressure. What will occur as a result of a tube failure?

- A. Shell side pressure will increase and the borated water system will be diluted.
- B. Shell side pressure will decrease and the borated water inventory will be depleted.
- C. Shell side pressure will increase and the borated water inventory will be depleted.
- D. Shell side pressure will decrease and the borated water system will be diluted.

ANSWER: C.

TOPIC: 191006
KNOWLEDGE: K1.13 [2.8/2.9]
QID: P234 (B3535)

Refer to the drawing of an operating cooling water system (see figure below).

Which one of the following effects would occur as a result of the failed tube in the heat exchanger?

- A. Level in the surge tank increases.
- B. Flow in the low pressure system reverses.
- C. Pressure in the low pressure system decreases.
- D. Low pressure fluid heat exchanger outlet temperature decreases.

ANSWER: D.

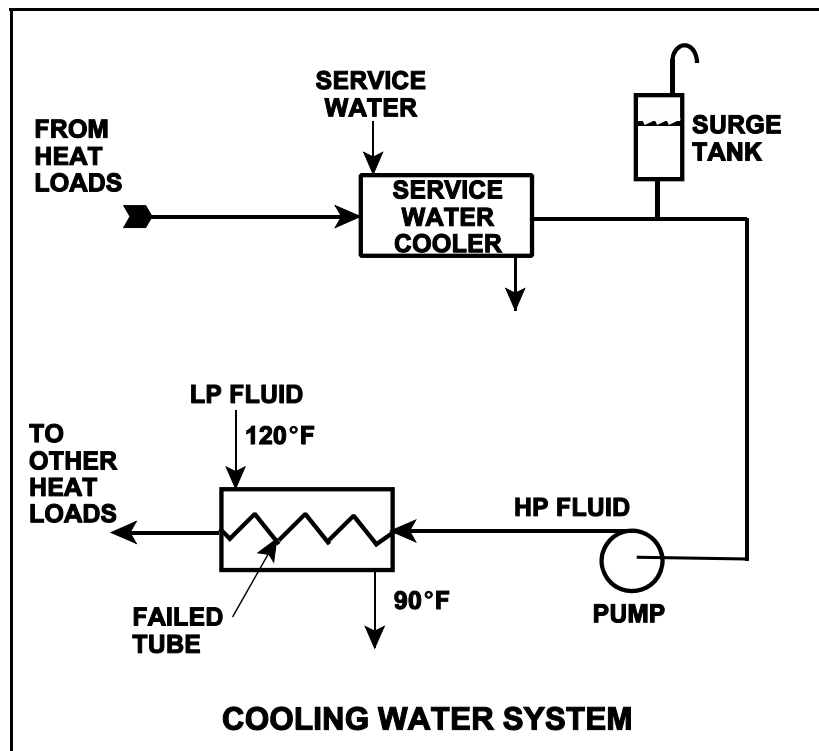

TOPIC: 191006
KNOWLEDGE: K1.13 [2.8/2.9]
QID: P333 (B333)

A nuclear power plant is operating normally at 50% power. Which one of the following will result from a cooling water tube rupture in the main condenser?

- A. Increased condenser vacuum
- B. Increased conductivity of the condensate
- C. Decreased condensate pump net positive suction head
- D. Decreased condensate pump flow rate

ANSWER: B.

TOPIC: 191006
KNOWLEDGE: K1.13 [2.8/2.9]
QID: P1134 (B1931)

Which one of the following effects will occur as a result of multiple tube failures (leaks) in the main condenser of a nuclear power plant at 50% power?

- A. Condensate depression will decrease.
- B. Condensate conductivity will increase.
- C. Condensate oxygen concentration will decrease.
- D. Condenser inlet cooling water flow rate will decrease.

ANSWER: B.

TOPIC: 191006
KNOWLEDGE: K1.13 [2.8/2.9]
QID: P1234 (B1535)

Refer to the drawing of an operating cooling water system (see figure below).

Which one of the following will occur as a result of the indicated tube failure in the heat exchanger?

- A. High pressure (HP) fluid inventory increases.
- B. Pressure in the low pressure (LP) system decreases.
- C. Temperature in the low pressure (LP) system increases.
- D. Level in the surge tank decreases.

ANSWER: D.

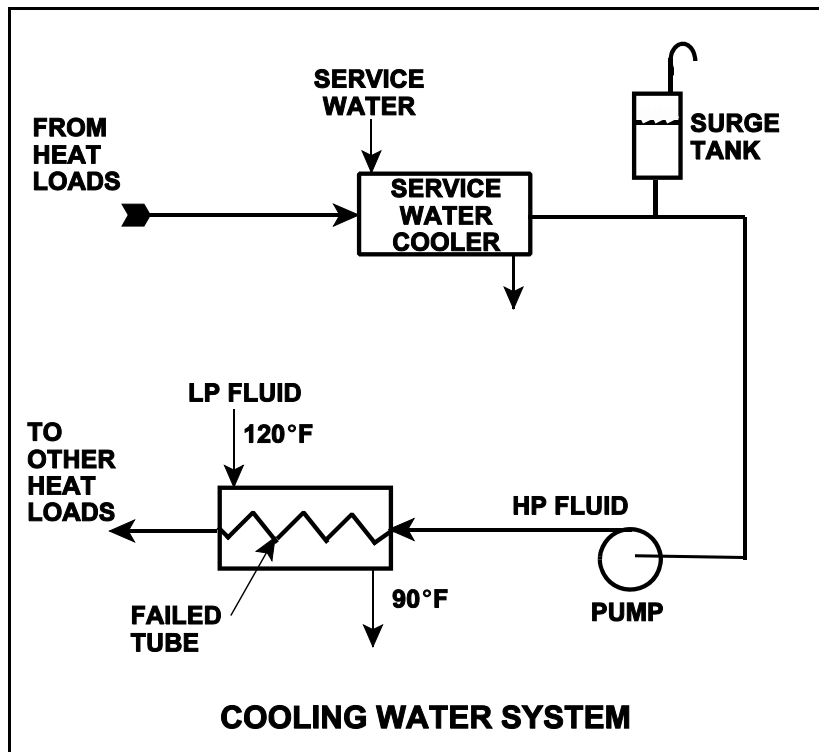

TOPIC: 191006
KNOWLEDGE: K1.13 [2.8/2.9]
QID: P2984 (B2084)

The following 100% rated power conditions existed before a nuclear power plant outage:

Main condenser pressure: 1.20 psia
Cooling water inlet temperature: 60°F
Cooling water outlet temperature: 92°F

During the outage, 6% of the main condenser tubes were plugged. After the outage, the following 100% rated power conditions exist:

Main condenser pressure: 1.31 psia
Cooling water inlet temperature: 60°F
Cooling water outlet temperature: ?

Which one of the following is the approximate cooling water outlet temperature after the outage?

- A. 92°F
- B. 94°F
- C. 96°F
- D. 98°F

ANSWER: B.

TOPIC: 191006
KNOWLEDGE: K1.13 [2.8/2.9]
QID: P4917 (B4918)

A nuclear power plant was initially operating at steady-state 50% thermal power with 50 gpm of main condenser cooling water inleakage through a cooling water tube rupture. Thermal power was then increased and is currently stable at 60%.

Assume that the size of the cooling water tube rupture does not change, and that the main condenser cooling water inlet pressure and inlet temperature do not change.

When compared to the flow rate of main condenser cooling water inleakage at 50% power, the flow rate of main condenser cooling water inleakage at 60% power is _____ because the main condenser pressure at 60% power is _____.

- A. lower; lower
- B. lower; higher
- C. higher; lower
- D. higher; higher

ANSWER: B.

TOPIC: 191006
KNOWLEDGE: K1.14 [2.4/2.6]
QID: P1834 (B111)

During normal nuclear power plant operation, a main condenser develops an air leak which decreases vacuum at a rate of 1 inch Hg/min. Which one of the following will increase because of this condition?

- A. Extraction steam flow rate
- B. Condenser hotwell temperature
- C. Low pressure turbine exhaust steam moisture content
- D. Steam cycle efficiency

ANSWER: B.

TOPIC: 191006
KNOWLEDGE: K1.14 [2.4/2.6]
QID: P1912 (B936)

During normal nuclear power plant operation, why does air entry into the main condenser reduce the thermodynamic efficiency of the steam cycle?

- A. The rate of steam flow through the main turbine increases.
- B. The condensate subcooling in the main condenser increases.
- C. The enthalpy of the low pressure turbine exhaust increases.
- D. The air mixes with the steam and enters the condensate.

ANSWER: C.

TOPIC: 191006
KNOWLEDGE: K1.14 [2.4/2.6]
QID: P2634 (B2633)

A nuclear power plant is operating at steady-state 100% power. Assuming that condenser cooling water inlet temperature and flow rate do not change, if condenser vacuum decreases, condensate temperature will...

- A. increase because condensate subcooling has decreased.
- B. increase because condenser saturation pressure has increased.
- C. decrease because condensate subcooling has increased.
- D. decrease because condenser saturation pressure has decreased.

ANSWER: B.

TOPIC: 191006
KNOWLEDGE: K1.14 [2.4/2.6]
QID: P3534 (B2736)

A nuclear power plant is operating at steady-state 100% power when air inleakage causes main condenser vacuum to decrease from 28 inches Hg to 27 inches Hg. Assume the steam inlet quality and mass flow rate of steam through the main turbine remain unchanged, and that condenser cooling water inlet temperature and flow rate do not change.

When the plant stabilizes, turbine exhaust quality will be _____ and turbine exhaust temperature will be _____.

- A. higher; higher
- B. higher; lower
- C. lower; higher
- D. lower; lower

ANSWER: A.

TOPIC: 191006
KNOWLEDGE: K1.14 [2.4/2.6]
QID: P3734 (B3777)

A nuclear power plant is operating near rated power with the following initial conditions:

Main steam pressure: 900 psia
Main steam quality: 100%, saturated vapor
Main condenser pressure: 1.0 psia

Air leakage into the main condenser results in the main condenser pressure increasing and stabilizing at 2.0 psia. Assume that all main steam parameters (e.g., pressure, quality, and mass flow rate) remain the same and that the main turbine efficiency remains at 100%.

Which one of the following is the approximate percent by which the main generator output will decrease as a result of the main condenser pressure increase?

- A. 5.0%
- B. 6.3%
- C. 7.5%
- D. 8.8%

ANSWER: C.

TOPIC: 191006
KNOWLEDGE: K1.14 [2.4/2.6]
QID: P4016 (B4018)

Refer to the drawing of an operating lube oil heat exchanger (see figure below).

Given the following initial parameters:

Cooling water inlet temperature (T_{cw-in}) = 75°F
Cooling water outlet temperature (T_{cw-out}) = 95°F
Oil inlet temperature (T_{oil-in}) = 150°F
Oil outlet temperature ($T_{oil-out}$) = 120°F

Air introduction to the heat exchanger results in some of the heat exchanger tubes becoming uncovered. As a result, T_{cw-out} decreases to 91°F. Assume the inlet temperatures, mass flow rates, and specific heats of both fluids remain the same.

Which one of the following will be the resulting temperature of the oil exiting the heat exchanger ($T_{oil-out}$)?

- A. 126°F
- B. 130°F
- C. 134°F
- D. 138°F

ANSWER: A.

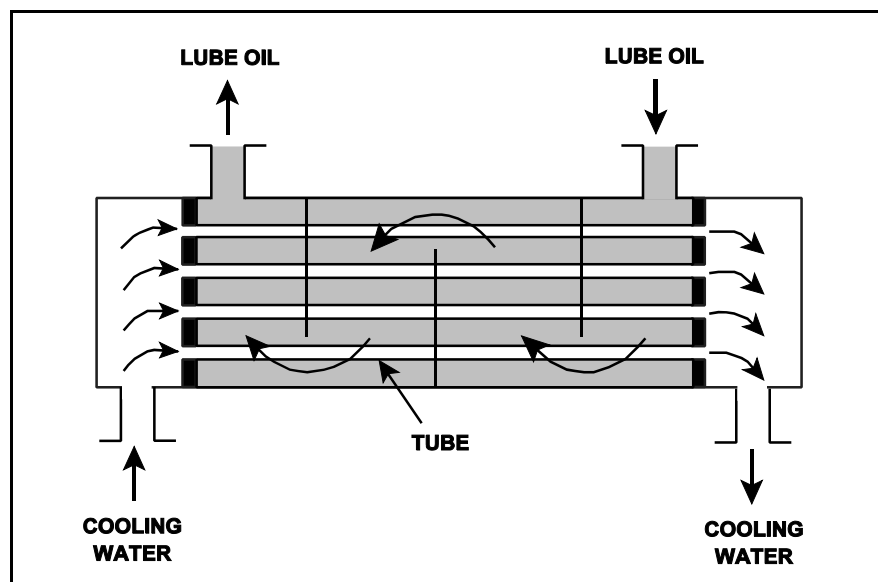

TOPIC: 191006
KNOWLEDGE: K1.14 [2.4/2.6]
QID: P4517 (B2832)

Refer to the drawing of an operating lube oil heat exchanger (see figure below).

Given the following initial parameters:

Cooling water inlet temperature (T_{cw-in}) = 75°F
Cooling water outlet temperature (T_{cw-out}) = 105°F
Oil inlet temperature (T_{oil-in}) = 140°F
Oil outlet temperature ($T_{oil-out}$) = 100°F

Air introduction to the heat exchanger results in some of the heat exchanger tubes becoming uncovered. As a result, T_{cw-out} decreases to 99°F. Assume that the mass flow rate and specific heat of both fluids remain the same, and that T_{oil-in} does not change. Which one of the following will be the approximate temperature of the oil exiting the heat exchanger ($T_{oil-out}$)?

- A. 99°F
- B. 108°F
- C. 116°F
- D. 122°F

ANSWER: B.

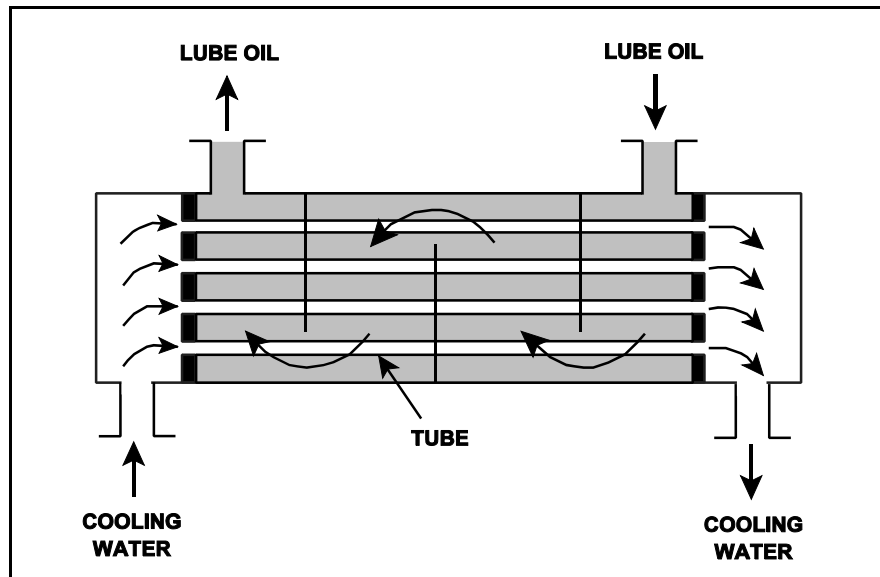

TOPIC: 191006
KNOWLEDGE: K1.14 [2.4/2.6]
QID: P4816 (B4817)

Refer to the drawing of an operating lube oil heat exchanger (see figure below).

Given the following initial parameters:

Cooling water inlet temperature (T_{cw-in}) = 75°F
Cooling water outlet temperature (T_{cw-out}) = 95°F
Oil inlet temperature (T_{oil-in}) = 150°F
Oil outlet temperature ($T_{oil-out}$) = 110°F

Air leakage into the heat exchanger causes some of the heat exchanger tubes to become uncovered. As a result, T_{cw-out} decreases to 89°F. Assume the inlet temperatures, mass flow rates, and specific heats of both fluids remain the same.

Which one of the following will be the new approximate temperature of the oil exiting the heat exchanger ($T_{oil-out}$)?

- A. 116°F
- B. 122°F
- C. 130°F
- D. 138°F

ANSWER: B.

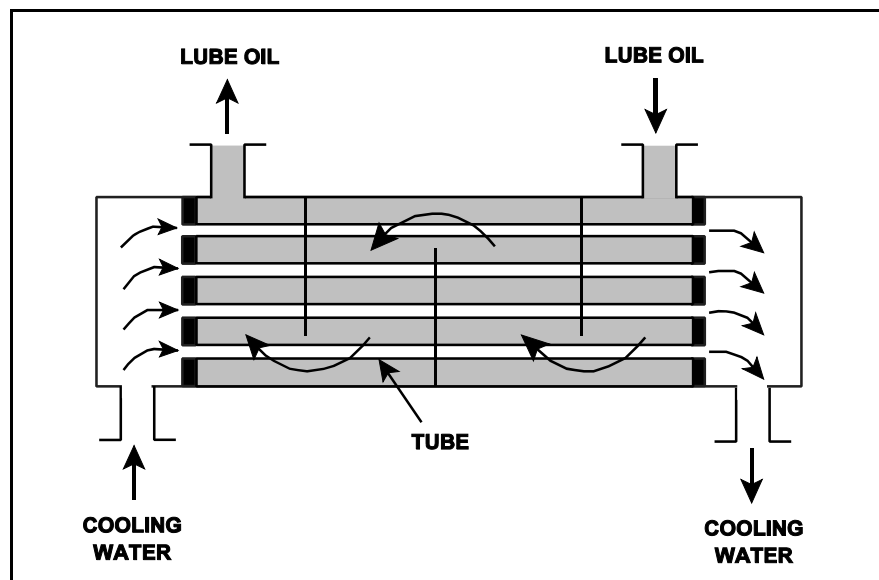

TOPIC: 191006
KNOWLEDGE: K1.14 [2.4/2.6]
QID: P5417 (B5418)

Refer to the drawing of an operating lube oil heat exchanger (see figure below).

The heat exchanger was operating with the following initial parameters:

Cooling water inlet temperature (T_{cw-in}) = 71 °F
Cooling water outlet temperature (T_{cw-out}) = 91 °F
Oil inlet temperature (T_{oil-in}) = 175 °F
Oil outlet temperature ($T_{oil-out}$) = 125 °F

The heat exchanger was vented, resulting in the following current parameters:

Cooling water inlet temperature (T_{cw-in}) = 71 °F
Cooling water outlet temperature (T_{cw-out}) = 95 °F
Oil inlet temperature (T_{oil-in}) = 175 °F
Oil outlet temperature ($T_{oil-out}$) = ?

Assume that the mass flow rates and specific heats of both fluids were unchanged.

Which one of the following is the current lube oil outlet temperature ($T_{oil-out}$)?

- A. 115 °F
- B. 120 °F
- C. 130 °F
- D. 135 °F

ANSWER: A.

