

**UNITED STATES NUCLEAR REGULATORY COMMISSION  
PRESSURIZED WATER REACTOR GENERIC FUNDAMENTALS EXAMINATION  
OCTOBER 2001--FORM A**

**Please Print**

Name: \_\_\_\_\_

Facility: \_\_\_\_\_

Docket No.: \_\_\_\_\_

Start Time: \_\_\_\_\_ Stop Time: \_\_\_\_\_

**INSTRUCTIONS TO APPLICANT**

Answer all the test items using the answer sheet provided. Each item has equal point value. A score of at least 80% is required to pass this portion of the written licensing examination. All examination papers will be collected 4.0 hours after the examination starts. This examination applies to a typical pressurized water reactor (PWR) power plant.

SECTION	QUESTIONS	% OF TOTAL	SCORE
COMPONENTS	1 - 44		
REACTOR THEORY	45 - 72		
THERMODYNAMICS	73 - 100		
TOTALS	100		

All work done on this examination is my own. I have neither given nor received aid.

\_\_\_\_\_  
Applicant's Signature

**RULES AND GUIDELINES FOR THE  
GENERIC FUNDAMENTALS EXAMINATION**

During the administration of this examination the following rules apply:

NOTE: The generic term "control rod" refers to the length of neutron absorber material that can be positioned by the operator to change core reactivity.

1. Print your name in the blank provided on the cover sheet of the examination.
2. Fill in the name of your facility.
3. Fill in your individual docket number.
4. Fill in your start and stop times at the appropriate time.
5. Two aids are provided for your use during the examination:
  - (1) An equations and conversions sheet contained within the examination copy, and
  - (2) Steam tables provided by your proctor.
6. Place your answers on the answer sheet provided. Credit will only be given for answers properly marked on this sheet. Follow the instructions for filling out the answer sheet.
7. Scrap paper will be provided for calculations.
8. Cheating on the examination will result in the automatic forfeiture of this examination. Cheating could also result in severe penalties.
9. Restroom trips are limited. Only **ONE** examinee may leave the room at a time. In order to avoid the appearance or possibility of cheating, avoid all contact with anyone outside of the examination room.
10. After you have completed the examination, sign the statement on the cover sheet indicating that the work is your own and you have neither given nor received any assistance in completing the examination.
11. Turn in your examination materials, answer sheet on top, followed by the examination booklet, then examination aids - steam table booklets, handouts, and scrap paper used during the examination.
12. After turning in your examination materials, leave the examination area, as defined by the proctor. If after leaving you are found in the examination area while the examination is in progress, your examination may be forfeited.

**GENERIC FUNDAMENTALS EXAMINATION**  
**EQUATIONS AND CONVERSIONS HANDOUT SHEET**

**EQUATIONS**

---

$$\dot{Q} = \dot{m}c_p\Delta T$$

$$\dot{Q} = \dot{m}\Delta h$$

$$\dot{Q} = UA\Delta T$$

$$\dot{Q} \propto \dot{m}_{\text{Nat Circ}}^3$$

$$\Delta T \propto \dot{m}_{\text{Nat Circ}}^2$$

$$K_{\text{eff}} = 1/(1 - \rho)$$

$$\rho = (K_{\text{eff}} - 1)/K_{\text{eff}}$$

$$\text{SUR} = 26.06/\tau$$

$$\tau = \frac{\bar{\beta} - \rho}{\lambda_{\text{eff}} \rho}$$

$$\rho = \frac{\ell^*}{\tau} + \frac{\bar{\beta}}{1 + \lambda_{\text{eff}}\tau}$$

$$\ell^* = 1 \times 10^{-4} \text{ seconds}$$

$$\lambda_{\text{eff}} = 0.1 \text{ seconds}^{-1}$$

$$\text{DRW} \propto \phi_{\text{tip}}^2 / \phi_{\text{avg}}^2$$

$$P = P_o 10^{\text{SUR}(t)}$$

$$P = P_o e^{(t/\tau)}$$

$$A = A_o e^{-\lambda t}$$

$$\text{CR}_{\text{S/D}} = S/(1 - K_{\text{eff}})$$

$$\text{CR}_1(1 - K_{\text{eff}1}) = \text{CR}_2(1 - K_{\text{eff}2})$$

$$1/M = \text{CR}_1/\text{CR}_X$$

$$A = \pi r^2$$

$$F = PA$$

$$\dot{m} = \rho A \bar{v}$$

$$\dot{W}_{\text{Pump}} = \dot{m}\Delta P v$$

$$E = IR$$

$$\text{Eff.} = \text{Net Work Out/Energy In}$$

$$v(P_2 - P_1) + \frac{(\bar{v}_2^2 - \bar{v}_1^2)}{2g_c} + \frac{g(z_2 - z_1)}{g_c} = 0$$

$$g_c = 32.2 \text{ lbm-ft/lbf-sec}^2$$

**CONVERSIONS**

---

$$1 \text{ Mw} = 3.41 \times 10^6 \text{ Btu/hr}$$

$$1 \text{ hp} = 2.54 \times 10^3 \text{ Btu/hr}$$

$$1 \text{ Btu} = 778 \text{ ft-lbf}$$

$$^\circ\text{C} = (5/9)(^\circ\text{F} - 32)$$

$$^\circ\text{F} = (9/5)(^\circ\text{C}) + 32$$

$$1 \text{ Curie} = 3.7 \times 10^{10} \text{ dps}$$

$$1 \text{ kg} = 2.21 \text{ lbm}$$

$$1 \text{ gal}_{\text{water}} = 8.35 \text{ lbm}$$

$$1 \text{ ft}^3_{\text{water}} = 7.48 \text{ gal}$$

**USNRC GENERIC FUNDAMENTALS EXAMINATION  
OCTOBER 2001 PWR--FORM A**

QUESTION: 1

A control valve is most likely to experience cavitation when the valve is almost fully \_\_\_\_\_ because of a relatively \_\_\_\_\_ pressure drop across the valve seat.

- A. open; large
- B. open; small
- C. closed; large
- D. closed; small

**USNRC GENERIC FUNDAMENTALS EXAMINATION  
OCTOBER 2001 PWR--FORM A**

QUESTION: 2

Refer to the drawing of a hydraulically-operated valve that is shown in a throttled position (see figure below).

Select the position of this valve following a loss of hydraulic system pressure.

- A. Fully open
- B. As is
- C. Fully closed
- D. Midposition

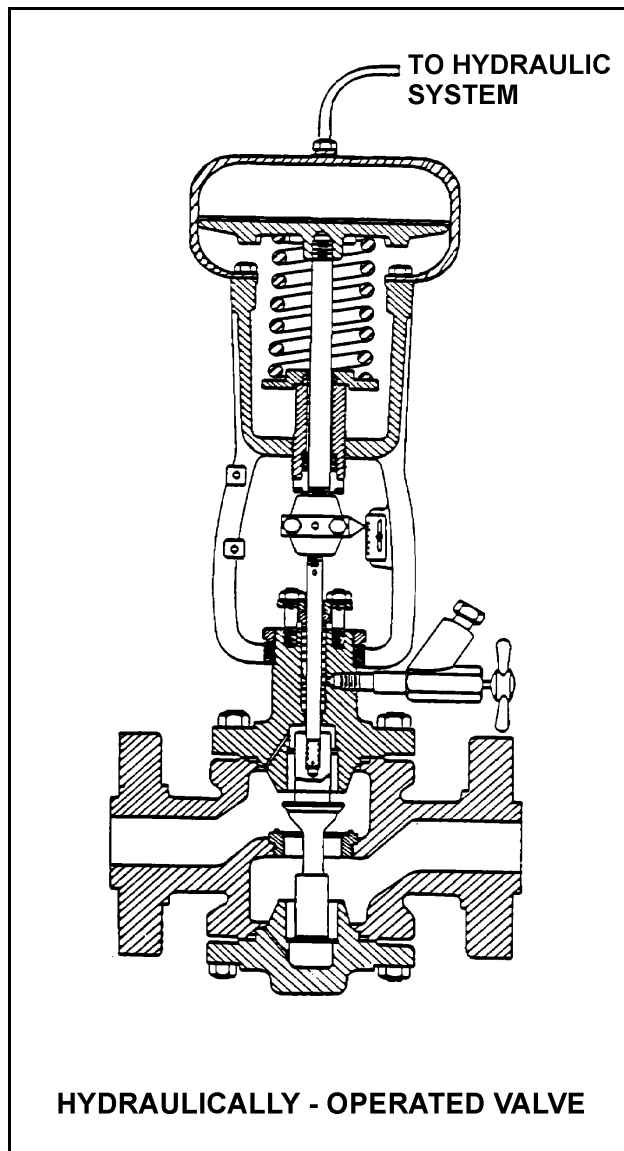

**USNRC GENERIC FUNDAMENTALS EXAMINATION  
OCTOBER 2001 PWR--FORM A**

QUESTION: 3

Which one of the following describes the function and use of the backseat on a manual valve?

- A. Removes pressure from the packing/stuffing box and is normally used to isolate the stuffing box for valve repacking.
- B. Removes pressure from the packing/stuffing box and is normally used to prevent packing leakage.
- C. Acts as a backup in case the primary seat leaks and is normally used during system isolation for personnel protection.
- D. Acts as a backup in case the primary seat leaks and is only used when needed to prevent the primary seat from leaking excessively.

QUESTION: 4

Check valves are normally used to prevent:

- A. overpressurization of nonoperating system piping and components.
- B. backflow through nonoperating components or flowpaths.
- C. pump runout by providing a constant backpressure.
- D. pump cavitation by keeping nonoperating systems filled.

**USNRC GENERIC FUNDAMENTALS EXAMINATION  
OCTOBER 2001 PWR--FORM A**

QUESTION: 5

Density input is normally used in steam flow instruments to convert \_\_\_\_\_ into \_\_\_\_\_.

- A. mass flow rate; volumetric flow rate
- B. volumetric flow rate; mass flow rate
- C. mass flow rate; differential pressure
- D. differential pressure; volumetric flow rate

QUESTION: 6

Flow rate is being measured using a differential pressure flow detector and a calibrated orifice. If actual flow rate remains constant, which one of the following will cause indicated flow rate to be higher than actual flow rate?

- A. The flow detector equalizing valve is inadvertently opened.
- B. A leak develops in the high pressure sensing line.
- C. Debris becomes lodged in the orifice.
- D. The orifice erodes over time.

**USNRC GENERIC FUNDAMENTALS EXAMINATION  
OCTOBER 2001 PWR--FORM A**

QUESTION: 7

A cooling water system uses a horizontal venturi with a flow detector to provide cooling water flow rate indication. Water enters and leaves the venturi at 70°F, 120 psig and 20 ft/sec. Water velocity at the throat of the venturi is 45 ft/sec. Assume water is incompressible and the venturi experiences no unrecoverable head loss.

What is the approximate pressure of the water at the throat of the venturi?

- A. 109 psig
- B. 98 psig
- C. 86 psig
- D. 71 psig

QUESTION: 8

A reactor is currently shut down at 140°F and 150 psig. Pressurizer level is being monitored using a normal at-power pressurizer level instrument that was calibrated at normal plant operating conditions.

The pressurizer level instrument indicates \_\_\_\_\_ than actual pressurizer level because, compared to the calibration conditions, there has been a significant change in the density of the fluid in the \_\_\_\_\_.

- A. lower; reference leg
- B. lower; pressurizer
- C. higher; reference leg
- D. higher; pressurizer



**USNRC GENERIC FUNDAMENTALS EXAMINATION  
OCTOBER 2001 PWR--FORM A**

QUESTION: 9

Refer to the drawing of a steam generator (S/G) with a differential pressure (D/P) level detector (see figure below).

Which one of the following events will result in a steam generator level indication that is greater than actual level?

- A. The S/G pressure increases by 50 psia.
- B. The variable leg breaks and completely drains.
- C. A portion of the reference leg water flashes to steam.
- D. The temperature surrounding the S/G and reference leg decreases by 30°F.

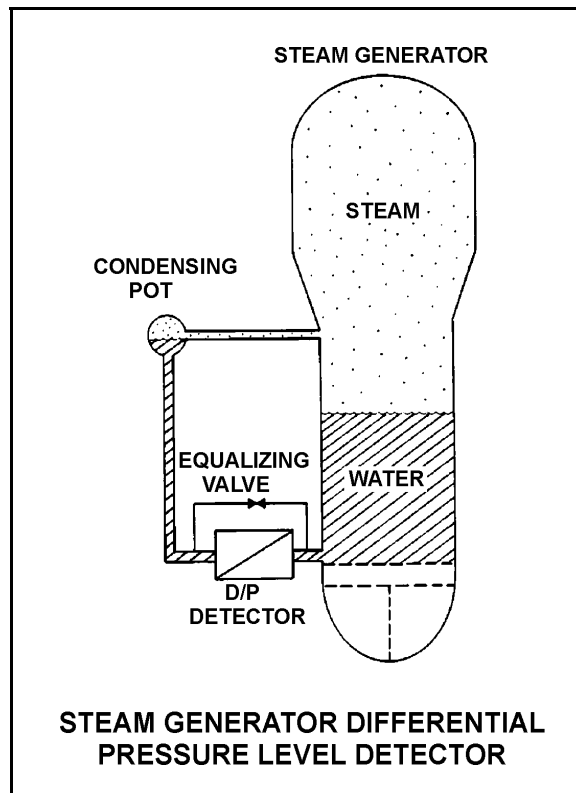

**USNRC GENERIC FUNDAMENTALS EXAMINATION  
OCTOBER 2001 PWR--FORM A**

QUESTION: 10

Semiconductor strain gages are often used in transmitters for:

- A. reactor coolant pressure instruments.
- B. reactor coolant temperature instruments.
- C. control rod position instruments.
- D. steam generator level instruments.

QUESTION: 11

A simple bellows pressure detector is connected to a cooling water system. The detector is located in the reactor containment and has its low pressure side vented to the containment atmosphere. Current system pressure indication is 100 psig.

If a main steam line break raises containment pressure by 40 psig, the system pressure indication will: (Disregard any temperature effect on the pressure detector.)

- A. increase by 40 psig.
- B. increase by the square root of 40 psig.
- C. decrease by 40 psig.
- D. decrease by the square root of 40 psig.

**USNRC GENERIC FUNDAMENTALS EXAMINATION  
OCTOBER 2001 PWR--FORM A**

QUESTION: 12

A thermocouple operates on the principle that a measurable voltage will be produced when two:

- A. similar metals form two junctions at the same temperature.
- B. similar metals form two junctions at different temperatures.
- C. dissimilar metals form two junctions at the same temperature.
- D. dissimilar metals form two junctions at different temperatures.

QUESTION: 13

Reed switches are being used in an electrical measuring circuit to monitor the position of a control rod in a reactor. The reed switches are mounted in a column above the reactor vessel such that the control rod drive shaft passes by individual reed switches as the control rod is withdrawn.

Which one of the following describes the action that causes the electrical output of the reed switch circuit to change as the control rod is withdrawn?

- A. An ac coil on the control rod drive shaft induces a voltage into each reed switch as the drive shaft passes by.
- B. A metal tab on the control rod drive shaft mechanically closes each reed switch as the drive shaft passes by.
- C. The primary and secondary coils of each reed switch attain maximum magnetic coupling as the drive shaft passes by.
- D. A permanent magnet on the control rod drive shaft attracts the movable contact arm of each reed switch as the drive shaft passes by.

**USNRC GENERIC FUNDAMENTALS EXAMINATION  
OCTOBER 2001 PWR--FORM A**

QUESTION: 14

A reactor plant has experienced a loss of coolant accident combined with a loss of emergency coolant injection flow. Homogeneous core voiding has occurred, with the void fraction currently nearing 100%. Now, emergency coolant injection flow is restored, which causes a steady reduction in the core void fraction as the core is refilled.

Which one of the following describes the expected trend in excore source/startup range neutron level indication as the homogeneous core void fraction decreases from 100% to 20% in the core and downcomer? (Assume the source/startup range neutron detectors are located adjacent to the bottom third of the core.)

- A. Increases, then decreases
- B. Increases continuously
- C. Decreases, then increases
- D. Decreases continuously

**USNRC GENERIC FUNDAMENTALS EXAMINATION  
OCTOBER 2001 PWR--FORM A**

QUESTION: 15

Refer to the drawing of a pressure bistable in an alarm circuit (see figure below).

Assume the orientation of the bistable symbol indicates the characteristics of the bistable. The bistable turns on to actuate an alarm at a system pressure of 100 psig. The bistable has a 5 psig dead band, or neutral zone.

If current system pressure is 90 psig, which one of the following describes the alarm response as system pressure is slowly increased to 110 psig?

- A. The alarm is currently actuated and will turn off at 95 psig.
- B. The alarm is currently actuated and will turn off at 105 psig.
- C. The alarm will actuate at 100 psig and will NOT turn off.
- D. The alarm will actuate at 100 psig and will turn off at 105 psig.

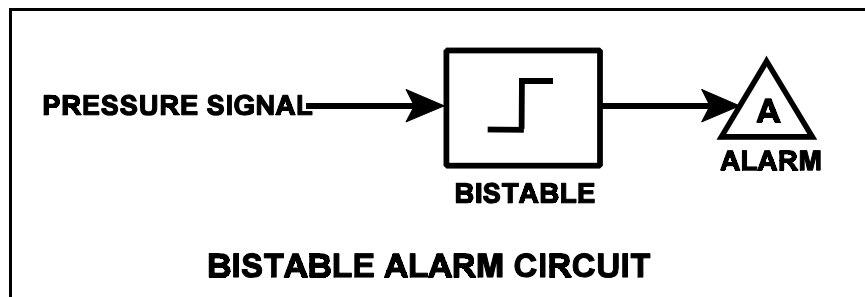

**USNRC GENERIC FUNDAMENTALS EXAMINATION  
OCTOBER 2001 PWR--FORM A**

QUESTION: 16

Which one of the following describes the operation of a typical pneumatic valve positioner?

- A. Compares the valve controller demand signal with actual valve position and sends an error signal to the valve controller for adjustment of the demand signal.
- B. Compares the valve controller automatic and manual set points and sends an error signal to the valve controller to ensure the manual demand signal is tracking the automatic demand signal.
- C. Receives a valve position error signal from the valve controller and positions the valve as necessary to null the valve position error signal.
- D. Receives a demand signal from the valve controller and supplies the appropriate air pressure to the valve actuator to move the valve to the demanded position.

QUESTION: 17

Given the following diesel generator design ratings:

Overspeed trip setpoint:	2000 rpm
Operating speed, no load:	1800 rpm
Operating speed, full load:	1720 rpm

Which one of the following is the speed droop for the diesel generator?

- A. 3.6%
- B. 3.8%
- C. 4.4%
- D. 4.6%

**USNRC GENERIC FUNDAMENTALS EXAMINATION  
OCTOBER 2001 PWR--FORM A**

QUESTION: 18

The level in a drain collection tank is being controlled by an automatic level controller and is initially at the controller set point. Flow rate into the tank increases, slowly at first, and then faster until a stable high flow rate is attained.

As tank level increases, the controller slowly opens a tank drain valve. The level controller output signal increases both as the tank level increases and as the rate of tank level change quickens. After a few minutes, a new, steady-state tank level at the original level is established, with the drain flow rate equal to the supply flow rate.

The controller in this system uses \_\_\_\_\_ control.

- A. proportional only
- B. proportional plus derivative only
- C. proportional plus integral only
- D. proportional plus integral plus derivative

QUESTION: 19

What precaution must be observed when transferring a valve controller from the automatic mode to the manual mode of control?

- A. Ensure that the automatic and manual valve controller outputs are matched.
- B. Ensure that a substantial deviation is established between the automatic and manual valve controller outputs.
- C. Ensure that the automatic valve controller output is increasing before transferring to the manual mode of control.
- D. Ensure that the automatic valve controller output is decreasing before transferring to the manual mode of control.

**USNRC GENERIC FUNDAMENTALS EXAMINATION  
OCTOBER 2001 PWR--FORM A**

QUESTION: 20

Which one of the following would result from operating a motor-driven centrifugal pump for extended periods of time with the discharge valve shut and no recirculation flow?

- A. No motor damage, but the pump will overheat and may be damaged.
- B. No motor damage, but the pump will overspeed and may be damaged.
- C. No pump damage, but the motor will overspeed and the motor bearings may fail.
- D. No pump damage, but the motor windings will draw excessive current and may fail.

QUESTION: 21

A centrifugal pump is taking suction on an open storage tank that is filled to a level of 40 feet with 10,000 gallons of 60°F water. The pump is located at the base of the tank, takes a suction from the bottom of the tank, and discharges through a fire hose.

Given:

- The pump is currently operating at its design flow rate of 200 gpm and a total developed head of 150 feet.
- The pump requires 4 feet of net positive suction head (NPSH).

How will the centrifugal pump flow rate be affected as the water storage tank level decreases?

- A. Flow rate will remain constant until the pump begins to cavitate at a tank level of about 4 feet.
- B. Flow rate will remain constant until the pump becomes air bound when the tank empties.
- C. Flow rate will gradually decrease until the pump begins to cavitate at a tank level of about 4 feet.
- D. Flow rate will gradually decrease until the pump becomes air bound when the tank empties.



**USNRC GENERIC FUNDAMENTALS EXAMINATION  
OCTOBER 2001 PWR--FORM A**

QUESTION: 22

A centrifugal pump is operating in parallel with a positive displacement pump in an open water system. Each pump has the same maximum design pressure.

If pump discharge pressure increases to the maximum design pressure of each pump, the centrifugal pump will be operating at \_\_\_\_\_ flow and the positive displacement pump will be operating near \_\_\_\_\_ flow.

- A. minimum; minimum
- B. minimum; maximum rated
- C. maximum rated; minimum
- D. maximum rated; maximum rated

QUESTION: 23

Some large motor-driven centrifugal pumps are interlocked so that the pump will not start unless its discharge valve is at least 90% fully closed. This interlock is provided to minimize:

- A. pump discharge pressure.
- B. heating of the pumped fluid.
- C. cavitation at the pump suction.
- D. duration of the pump motor starting current.

**USNRC GENERIC FUNDAMENTALS EXAMINATION  
OCTOBER 2001 PWR--FORM A**

QUESTION: 24

Which one of the following is an indication of pump runout?

- A. Low pump flow rate
- B. High pump vibration
- C. Low pump motor current
- D. High pump discharge pressure

**USNRC GENERIC FUNDAMENTALS EXAMINATION  
OCTOBER 2001 PWR--FORM A**

QUESTION: 25

Refer to the drawing of a lube oil temperature control system and the associated centrifugal pump operating curve (see figure below).

If the pump is operating at point B on the operating curve, how will the operating point change if the temperature controller setpoint is decreased by 10°F?

- A. Operating point B will be located on curve 1 closer to point E.
- B. Operating point B will be located on curve 1 closer to point D.
- C. Operating point B will be located on curve 2 closer to point A.
- D. Operating point B will be located on curve 2 closer to point C.

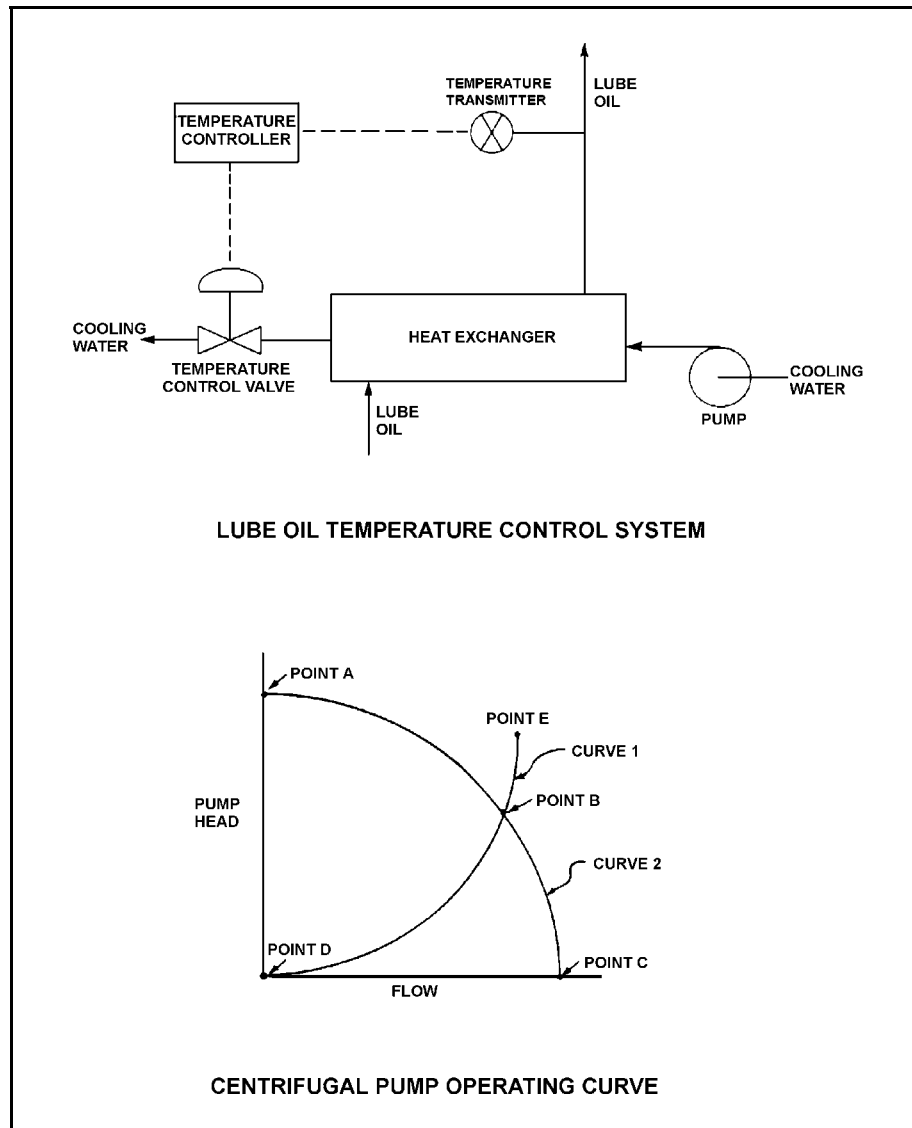

**USNRC GENERIC FUNDAMENTALS EXAMINATION  
OCTOBER 2001 PWR--FORM A**

QUESTION: 26

If the fully-open discharge valve of a reciprocating positive displacement pump is throttled closed approximately 10%, pump flow rate will \_\_\_\_\_ and pump head will \_\_\_\_\_. (Assume "ideal" pump response.)

- A. decrease; increase
- B. remain constant; increase
- C. decrease; remain constant
- D. remain constant; remain constant

QUESTION: 27

A reactor plant is operating normally at 80% power. Which one of the following is not an indication of a locked reactor coolant pump (RCP) rotor?

- A. Reactor coolant system pressure transient
- B. Reactor trip on low reactor coolant system flow
- C. Decreased flow rate in remaining reactor coolant loop(s)
- D. Increased current to the affected RCP with possible breaker trip

**USNRC GENERIC FUNDAMENTALS EXAMINATION  
OCTOBER 2001 PWR--FORM A**

QUESTION: 28

If the generator bearings on a motor-generator begin to overheat from excessive friction, which one of the following will occur next?

- A. Generator current will begin to increase.
- B. Generator windings will begin to heat up.
- C. Motor current will begin to decrease.
- D. Motor windings will begin to heat up.

QUESTION: 29

A cooling water system is being returned to service following maintenance on the two identical centrifugal cooling water pumps. The two pumps take suction from a common suction header and discharge to a common discharge header. Each pump is driven by a three phase ac induction motor.

Cooling water pump A was started five minutes ago to initiate flow in the cooling water system. Cooling water pump B is about to be started in parallel alignment with pump A.

When pump B is started, which one of the following would cause the ammeter for pump B to remain off-scale high for several seconds longer than usual before returning to normal running current indication?

- A. The pump packing was removed and not reinstalled.
- B. The pump was initially rotating in the reverse direction.
- C. Two phases of the motor windings were electrically switched.
- D. The coupling between the motor and the pump was removed and not reinstalled.

**USNRC GENERIC FUNDAMENTALS EXAMINATION  
OCTOBER 2001 PWR--FORM A**

QUESTION: 30

An ac motor-driven centrifugal pump is operating with a flow rate of 3,000 gpm and a motor current of 150 amps. If the pump speed is reduced such that the flow rate is 2,000 gpm, what is the approximate final motor current at the new lower speed? (Assume a constant motor voltage.)

- A. 44 amperes
- B. 59 amperes
- C. 67 amperes
- D. 100 amperes

QUESTION: 31

What is the primary reason for limiting the number of starts for an electric motor in a given period of time?

- A. Prevent overheating of the windings due to high starting currents.
- B. Prevent overheating of the windings due to shorting within the stator.
- C. Prevent rotor damage due to excessive cyclic stresses on the shaft.
- D. Prevent rotor damage due to excessive axial displacement of the shaft.

**USNRC GENERIC FUNDAMENTALS EXAMINATION  
OCTOBER 2001 PWR--FORM A**

QUESTION: 32

Refer to the drawing of a water cleanup system (see figure below). Valves A, B, and D are fully open and valve C is 20% open.

If valve C is opened to 50%, how will the temperatures at points 3 and 6 be affected?

- | <u>Point 3</u> | <u>Point 6</u> |
|----------------|----------------|
| A. Decrease    | Decrease       |
| B. Decrease    | Increase       |
| C. Increase    | Decrease       |
| D. Increase    | Increase       |

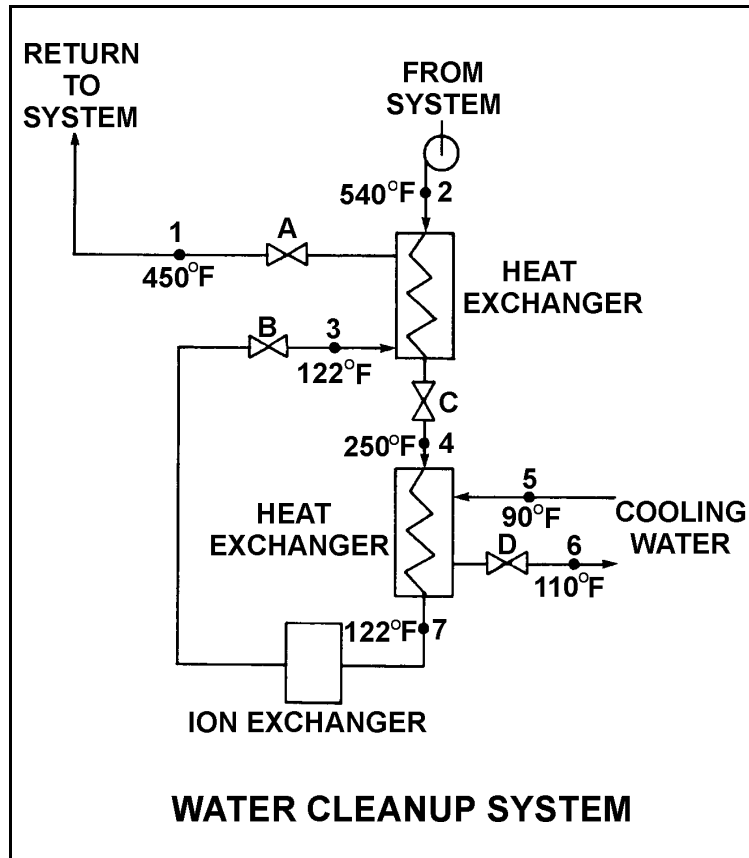

**USNRC GENERIC FUNDAMENTALS EXAMINATION  
OCTOBER 2001 PWR--FORM A**

QUESTION: 33

Steam has been admitted to a condenser for 25 minutes with no cooling water during a condenser startup. Initiating cooling water at this time will:

- A. reduce the stress on the condenser shell because the shell has been pre-warmed.
- B. reduce the stress on the condenser tubes by gradually cooling the tubes.
- C. induce large thermal stresses on the junctions between the condenser tubes and the tubesheet.
- D. induce large thermal stresses on the condenser shell.

QUESTION: 34

A reactor plant is operating normally at 50% power. Which one of the following will result from a cooling water tube rupture in the main condenser?

- A. Increased condenser vacuum
- B. Increased conductivity of the condensate
- C. Decreased condensate pump net positive suction head
- D. Decreased condensate pump flow rate



**USNRC GENERIC FUNDAMENTALS EXAMINATION  
OCTOBER 2001 PWR--FORM A**

QUESTION: 35

What percentage of ionic impurities is being removed from the water passing through an ion exchanger if the ion exchanger has a decontamination factor of 50?

- A. 98%
- B. 96%
- C. 75%
- D. 50%

QUESTION: 36

How does demineralizer differential pressure indicate the condition of a demineralizer resin bed?

- A. Low differential pressure indicates flow blockage in the demineralizer.
- B. Low differential pressure indicates that the demineralizer resin bed is exhausted.
- C. High differential pressure indicates flow blockage in the demineralizer.
- D. High differential pressure indicates that the demineralizer resin bed is exhausted.

**USNRC GENERIC FUNDAMENTALS EXAMINATION  
OCTOBER 2001 PWR--FORM A**

QUESTION: 37

A reactor plant is operating at 70% steady-state power level when the temperature of the reactor coolant letdown passing through a boron-saturated mixed bed ion exchanger is decreased by 20°F.

As a result, the boron concentration in the effluent of the ion exchanger will \_\_\_\_\_ because the affinity of the ion exchanger for boron atoms has \_\_\_\_\_.

- A. decrease; increased
- B. decrease; decreased
- C. increase; increased
- D. increase; decreased

QUESTION: 38

Which one of the following would cause a loss of ability to remotely trip a circuit breaker and a loss of remote breaker position indication?

- A. Failure of the breaker control switch
- B. Racking the breaker to the "test" position
- C. Mechanical binding of the breaker tripping bar
- D. Loss of control power for the breaker

**USNRC GENERIC FUNDAMENTALS EXAMINATION  
OCTOBER 2001 PWR--FORM A**

QUESTION: 39

Refer to the drawing of a motor controller circuit for a three-phase ac motor (see figure below).

Select the combination below that completes the following statement:

The two overload (OL) relays protect the motor from overload current on \_\_\_\_\_ motor phases, and \_\_\_\_\_ OL relay(s) must actuate to deenergize the main coil.

- A. only two; only one
- B. only two; both
- C. all three; only one
- D. all three; both

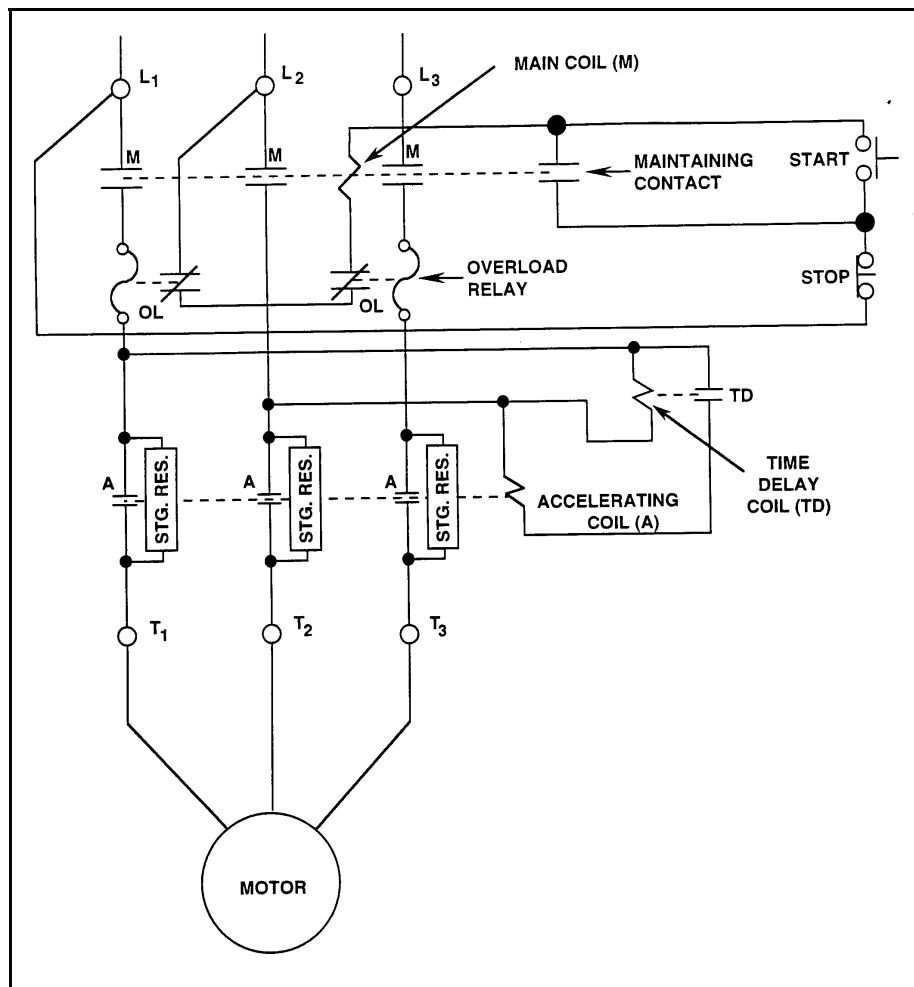

**USNRC GENERIC FUNDAMENTALS EXAMINATION  
OCTOBER 2001 PWR--FORM A**

QUESTION: 40

Which one of the following is an unsafe practice if performed when working on or near energized electrical equipment?

- A. Cover exposed energized circuits with insulating material to prevent inadvertent contact.
- B. Have a person standing by to deenergize the equipment in the event of an emergency.
- C. Use two hands for balance and to prevent dropping tools onto energized equipment.
- D. Stand on insulating rubber material to prevent yourself from being grounded.

QUESTION: 41

A three-phase ac generator is being paralleled to the grid with the following conditions:

Generator frequency:	59.5 Hz
Grid frequency:	59.8 Hz
Generator voltage:	115.1 KV
Grid voltage:	114.8 KV

When the generator output breaker is closed the generator will:

- A. acquire real load and reactive load.
- B. acquire real load but become a reactive load to the grid.
- C. become a real load to the grid but acquire reactive load.
- D. become a real load and a reactive load to the grid.

**USNRC GENERIC FUNDAMENTALS EXAMINATION  
OCTOBER 2001 PWR--FORM A**

QUESTION: 42

High voltage electrical disconnects are used to:

- A. adjust the output voltage range from a main power transformer.
- B. protect bus feeder breakers by opening upon bus short-circuit faults.
- C. provide equipment isolation under no-load conditions.
- D. bypass and isolate an electrical bus while maintaining the downstream buses energized.

QUESTION: 43

The following indications are observed in the control room for a normally-open motor control center (MCC) breaker that directly starts/stops a 480 Vac motor:

Red position indicating light is on.  
Green position indicating light is off.  
Motor load current indicates 0 amps.  
MCC voltage indicates 480 volts.

What is the condition of the breaker?

- A. Open and racked in
- B. Closed and racked in
- C. Open and racked to "test" position
- D. Closed and racked to "test" position

**USNRC GENERIC FUNDAMENTALS EXAMINATION  
OCTOBER 2001 PWR--FORM A**

QUESTION: 44

Thermal overload devices will provide the first electrical protection for a pump motor in the event of:

- A. a locked rotor upon starting.
- B. an electrical short circuit.
- C. gradual motor bearing damage.
- D. a sheared shaft during operation.

QUESTION: 45

A neutron that is born  $10^{-10}$  seconds after the associated fission event is classified as a \_\_\_\_\_ fission neutron.

- A. delayed
- B. prompt
- C. thermal
- D. spontaneous

**USNRC GENERIC FUNDAMENTALS EXAMINATION  
OCTOBER 2001 PWR--FORM A**

QUESTION: 46

A reactor plant is currently operating at equilibrium 80% power near the end of its fuel cycle. During the next 3 days of equilibrium power operation no operator action is taken.

How will core  $K_{\text{eff}}$  be affected during the 3-day period?

- A. Core  $K_{\text{eff}}$  will gradually increase during the entire period.
- B. Core  $K_{\text{eff}}$  will gradually decrease during the entire period.
- C. Core  $K_{\text{eff}}$  will tend to increase, but inherent reactivity feedback will maintain  $K_{\text{eff}}$  at 1.0.
- D. Core  $K_{\text{eff}}$  will tend to decrease, but inherent reactivity feedback will maintain  $K_{\text{eff}}$  at 1.0.

QUESTION: 47

During each refueling, burnable poisons are installed in the core to help control  $K_{\text{excess}}$ . Why are more burnable poison rods installed during fuel load for the first fuel cycle than subsequent fuel cycles?

- A. More fission product poisons are present at the beginning of subsequent fuel cycles.
- B. More fuel reactivity is present at the beginning of subsequent fuel cycles.
- C. Reactor coolant boron concentration is higher at the beginning of subsequent fuel cycles.
- D. Control rod worth is lower at the beginning of subsequent fuel cycles.

**USNRC GENERIC FUNDAMENTALS EXAMINATION  
OCTOBER 2001 PWR--FORM A**

QUESTION: 48

Two reactors are identical in every way except that reactor A is at the end of core life and reactor B is at the beginning of core life. Both reactors are operating at 100% power when a reactor trip occurs at the same time on each reactor. The reactor systems for each reactor respond identically to the trip and no operator action is taken.

Ten minutes after the trip, the higher fission rate will exist in reactor \_\_\_\_\_ because it has a \_\_\_\_\_ delayed neutron fraction.

- A. A; larger
- B. B; larger
- C. A; smaller
- D. B; smaller



**USNRC GENERIC FUNDAMENTALS EXAMINATION  
OCTOBER 2001 PWR--FORM A**

QUESTION: 49

Refer to the unlabeled reactor response curve shown below for a reactor that was initially stable in the source range. A momentary control rod withdrawal occurred at time = 0 sec.

The response curve shows \_\_\_\_\_ versus time for a reactor that was initially \_\_\_\_\_.

- A. startup rate; subcritical
- B. startup rate; critical
- C. reactor fission rate; subcritical
- D. reactor fission rate; critical

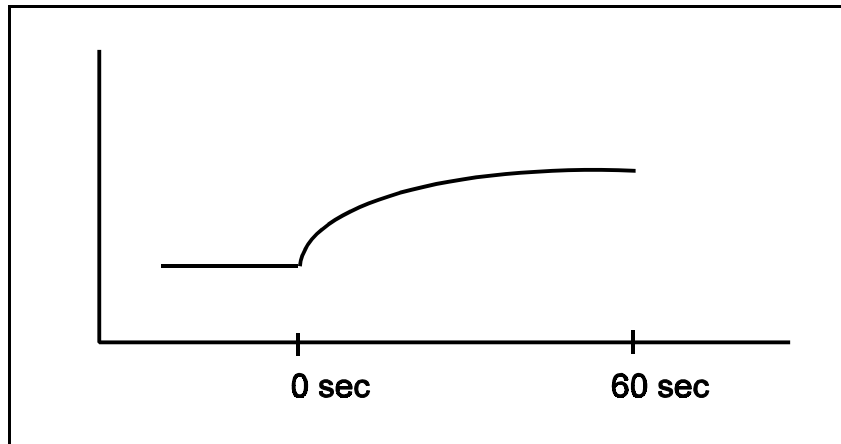

**USNRC GENERIC FUNDAMENTALS EXAMINATION  
OCTOBER 2001 PWR--FORM A**

QUESTION: 50

Which one of the following isotopes is the most significant contributor to resonance capture of fission neutrons in the reactor core at the end of core life?

- A. U-235
- B. U-238
- C. Pu-239
- D. Pu-240

QUESTION: 51

How does a moderator temperature increase affect the moderator temperature coefficient (MTC) in an overmoderated reactor core?

- A. The initially negative MTC becomes more negative.
- B. The initially negative MTC becomes less negative.
- C. The initially positive MTC becomes more positive.
- D. The initially positive MTC becomes less positive.

**USNRC GENERIC FUNDAMENTALS EXAMINATION  
OCTOBER 2001 PWR--FORM A**

QUESTION: 52

With higher concentrations of boron in the reactor coolant, the core neutron flux distribution shifts to \_\_\_\_\_ energies where the absorption cross-section of boron is \_\_\_\_\_.

- A. higher; lower
- B. higher; higher
- C. lower; lower
- D. lower; higher

QUESTION: 53

Neglecting the effects of core Xe-135, which one of the following power changes requires the greatest amount of positive reactivity addition?

- A. 3% power to 10% power
- B. 10% power to 25% power
- C. 25% power to 65% power
- D. 65% power to 100% power

**USNRC GENERIC FUNDAMENTALS EXAMINATION  
OCTOBER 2001 PWR--FORM A**

QUESTION: 54

A control rod is positioned in a reactor with the following neutron flux parameters:

Core average thermal neutron flux =  $1 \times 10^{12}$  n/cm<sup>2</sup>-sec

Control rod tip thermal neutron flux =  $5 \times 10^{12}$  n/cm<sup>2</sup>-sec

If the control rod is slightly withdrawn such that the control rod tip is located in a thermal neutron flux of  $1 \times 10^{13}$  n/cm<sup>2</sup>-sec, then the differential control rod worth will increase by a factor of \_\_\_\_\_. (Assume the core average thermal neutron flux is constant.)

- A. 2
- B. 4
- C. 10
- D. 100

QUESTION: 55

One purpose of using control rod bank/group overlap is to:

- A. provide adequate shutdown margin.
- B. provide a more uniform differential rod worth.
- C. allow dampening of xenon-induced flux oscillation.
- D. ensure rod insertion limits are not exceeded.

**USNRC GENERIC FUNDAMENTALS EXAMINATION  
OCTOBER 2001 PWR--FORM A**

QUESTION: 56

A reactor is operating at equilibrium full power when a single control rod fully inserts (from the fully withdrawn position). Reactor power is returned to full power with the control rod still fully inserted.

Compared to the initial axial neutron flux shape, the current flux shape will have a:

- A. minor distortion, because a fully inserted control rod has zero reactivity worth.
- B. minor distortion, because the fully inserted control rod is an axially uniform poison.
- C. major distortion, because the upper and lower core halves are loosely coupled.
- D. major distortion, because power production along the length of the rod drastically decreases.

QUESTION: 57

Control rod insertion limits ensure that control rods will be more withdrawn as reactor power \_\_\_\_\_ to compensate for the change in \_\_\_\_\_.

- A. increases; xenon reactivity
- B. decreases; xenon reactivity
- C. increases; power defect
- D. decreases; power defect

**USNRC GENERIC FUNDAMENTALS EXAMINATION  
OCTOBER 2001 PWR--FORM A**

QUESTION: 58

Compared to other poisons in the core, the two characteristics that cause Xe-135 to be a major reactor poison are its relatively \_\_\_\_\_ absorption cross section and its relatively \_\_\_\_\_ variation in concentration for large reactor power changes.

- A. small; large
- B. small; small
- C. large; small
- D. large; large

QUESTION: 59

Immediately after a reactor trip from sustained high power operation, xenon-135 concentration in the reactor will:

- A. increase due to the decay of iodine already in the core.
- B. decrease because xenon is produced directly from fission.
- C. remain the same because the decay of iodine and xenon balance each other out.
- D. decrease initially, then slowly increase due to the differences in the half-lives of iodine and xenon.

**USNRC GENERIC FUNDAMENTALS EXAMINATION  
OCTOBER 2001 PWR--FORM A**

QUESTION: 60

A reactor has been shut down for seven days to perform maintenance. A reactor startup is performed and power is ramped to 50% over a 5-hour period.

When power reaches 50%, the magnitude of core xenon negative reactivity will be:

- A. increasing toward a peak.
- B. increasing toward equilibrium.
- C. decreasing toward equilibrium.
- D. decreasing toward a valley.

QUESTION: 61

A reactor plant is initially operating at equilibrium 100% power in the middle of a fuel cycle. The operators decrease main generator load while adding boric acid to the RCS over a period of 30 minutes. At the end of this time period, reactor power is 70% and average reactor coolant temperature is 575°F. All control rods remain fully withdrawn and in manual control.

Given:

$$\begin{aligned} \text{Total reactivity added by operator} &= -3.3 \times 10^{-3} \Delta K/K \\ \text{Total power coefficient} &= -1.1 \times 10^{-4} \Delta K/K/\% \text{ power} \end{aligned}$$

Assuming no additional RCS boration occurs and no other operator actions are taken, what will average reactor coolant temperature be after an additional 60 minutes?

- A. 575°F and stable
- B. Less than 575°F and increasing
- C. Less than 575°F and decreasing
- D. Less than 575°F and stable

**USNRC GENERIC FUNDAMENTALS EXAMINATION  
OCTOBER 2001 PWR--FORM A**

QUESTION: 62

Which one of the following reactor prescram conditions requires the least amount of control rod withdrawal to attain reactor criticality during peak core xenon conditions after a reactor scram from equilibrium core xenon conditions? (Assume equilibrium core xenon reactivity at 20% power and 100% power does not change over core life.)

- A. Beginning of core life (BOL) and 100% power
- B. End of core life (EOL) and 100% power
- C. BOL and 20% power
- D. EOL and 20% power

QUESTION: 63

A reactor plant is initially operating at 100% power with equilibrium core xenon-135. Power is decreased to 75% over a 1-hour period and then stabilized. The operator then adjusts control rod height as necessary to maintain average reactor coolant temperature constant.

What will be the rod position and directional trend 30 hours after the power change?

- A. Above the initial 75% power position and inserting slowly
- B. Above the initial 75% power position and withdrawing slowly
- C. Below the initial 75% power position and inserting slowly
- D. Below the initial 75% power position and withdrawing slowly



**USNRC GENERIC FUNDAMENTALS EXAMINATION  
OCTOBER 2001 PWR--FORM A**

QUESTION: 64

Which one of the following describes whether reactor power can be increased from 50% to 100% in a controlled manner faster at the beginning of core life (BOL) or at the end of core life (EOL)? (Assume all control rods are fully withdrawn just prior to beginning the power increase.)

- A. Faster at EOL due to faster changes in boron concentration
- B. Faster at EOL due to greater control rod worth
- C. Faster at BOL due to faster changes in boron concentration
- D. Faster at BOL due to greater control rod worth

QUESTION: 65

During a reactor startup, the first reactivity addition caused the source range count rate to increase from 20 to 40 cps. The second reactivity addition caused the count rate to increase from 40 to 160 cps.

Which one of the following statements accurately compares the two reactivity additions?

- A. The first reactivity addition was larger.
- B. The second reactivity addition was larger.
- C. The first and second reactivity additions were equal.
- D. There is not enough data given to determine the relationship of reactivity values.

**USNRC GENERIC FUNDAMENTALS EXAMINATION  
OCTOBER 2001 PWR--FORM A**

QUESTION: 66

Refer to the drawing of three 1/M plots labeled A, B, and C (see figure below).

A core refueling is in progress with an installed neutron source. During the early stages of the refueling, reactor criticality would be predicted earliest by plot \_\_\_\_\_ and could possibly be the result of using nuclear instrumentation that is located too \_\_\_\_\_ the neutron source.

- A. A; far from
- B. A; close to
- C. C; far from
- D. C; close to

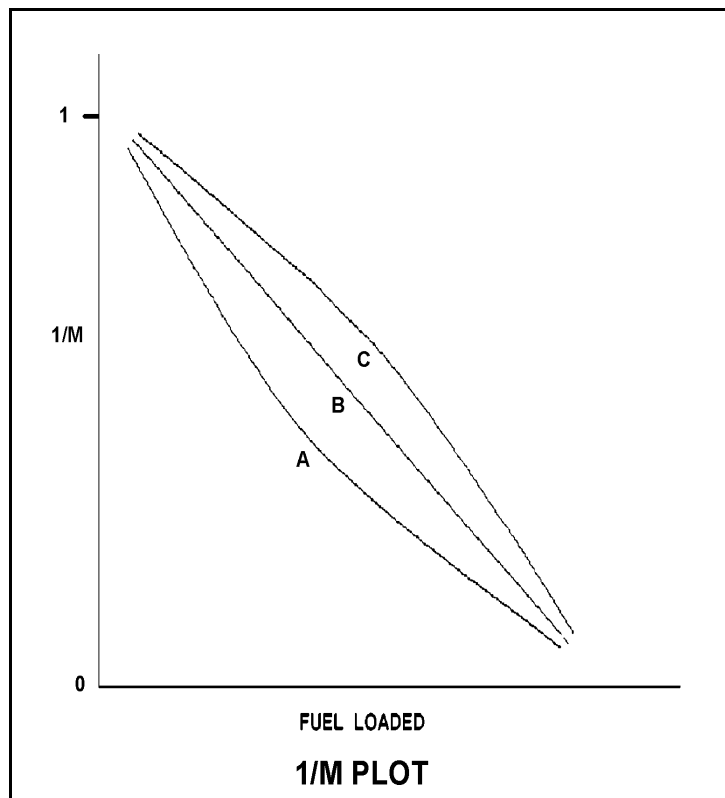

**USNRC GENERIC FUNDAMENTALS EXAMINATION  
OCTOBER 2001 PWR--FORM A**

QUESTION: 67

Which one of the following is not required to determine the estimated critical boron concentration for a reactor startup to be performed 48 hours following an inadvertent reactor trip?

- A. Reactor power level just prior to the trip
- B. Steam generator levels just prior to the trip
- C. Xenon reactivity in the core just prior to the trip
- D. Samarium reactivity in the core just prior to the trip

QUESTION: 68

During a reactor startup from a xenon-free condition, and after recording critical data, the operator establishes a positive startup rate to continue increasing power. Within a few minutes, reactor power stops increasing and begins to slowly decrease.

Which one of the following changes could have caused this behavior?

- A. Inadvertent boration of the RCS
- B. Xenon buildup in the core
- C. Gradual cooling of the RCS
- D. Fission-induced heating of the fuel

**USNRC GENERIC FUNDAMENTALS EXAMINATION  
OCTOBER 2001 PWR--FORM A**

QUESTION: 69

One week after a refueling outage, a reactor is operating at 80% power with control rods fully withdrawn. During the outage, the entire core was replaced by new fuel assemblies and new burnable poison assemblies were installed at various locations in the core.

Assume reactor power and control rod position do not change. If no operator action is taken, how and why will reactor coolant average temperature change during the next week?

- A. Decrease slowly due to fuel burnup only.
- B. Decrease slowly due to fuel burnup and fission product poison buildup.
- C. Increase slowly due to burnable poison burnout only.
- D. Increase slowly due to burnable poison burnout and fission product poison decay.

QUESTION: 70

A reactor plant is operating at 100% power at the end of core life when the main turbine trips. If the reactor does not immediately scram, which one of the following will act first to change reactor power?

- A. Positive reactivity addition from the Doppler coefficient will cause reactor power to initially increase.
- B. Positive reactivity addition from the moderator temperature coefficient will cause reactor power to initially increase.
- C. Negative reactivity addition from the Doppler coefficient will cause reactor power to initially decrease.
- D. Negative reactivity addition from the moderator temperature coefficient will cause reactor power to initially decrease.

**USNRC GENERIC FUNDAMENTALS EXAMINATION  
OCTOBER 2001 PWR--FORM A**

QUESTION: 71

Reactors A and B are identical and have been operated at 100% power for six months when a reactor scram occurs simultaneously on both reactors. All reactor A control rods fully insert. One reactor B control rod sticks fully withdrawn.

After five minutes, when compared to reactor B, the core fission rate in reactor A will be \_\_\_\_\_, and the reactor period in reactor A will be \_\_\_\_\_.

- A. the same; shorter
- B. the same; the same
- C. lower; shorter
- D. lower; the same

QUESTION: 72

After one month of operation at 100% reactor power, the fraction of thermal power being produced from the decay of fission products in the operating reactor is:

- A. greater than 10%.
- B. greater than 5% but less than 10%.
- C. greater than 1% but less than 5%.
- D. less than 1%.

**USNRC GENERIC FUNDAMENTALS EXAMINATION  
OCTOBER 2001 PWR--FORM A**

QUESTION: 73

Subcooled water is flowing through each of the following devices. Which one of the devices will produce an outlet pressure that is greater than the inlet pressure?

- A. Convergent nozzle
- B. Divergent nozzle
- C. Orifice
- D. Flow restrictor

QUESTION: 74

A reactor is shut down with reactor coolant system (RCS) pressure at 1500 psig and decay heat is being removed by the steam generators (S/Gs). What pressure must be maintained in the S/Gs to obtain a 110°F subcooling margin in the RCS loops? (Assume a negligible temperature difference between the RCS and the S/Gs.)

- A. 577 psig
- B. 592 psig
- C. 607 psig
- D. 622 psig

**USNRC GENERIC FUNDAMENTALS EXAMINATION  
OCTOBER 2001 PWR--FORM A**

QUESTION: 75

An ideal main turbine generator (MTG) is producing 1000 MW of electrical power while being supplied with 100% quality steam at 920 psig. Steam supply pressure is then gradually increased to 980 psig at the same quality. Assume turbine control valve position and condenser vacuum remain the same.

Which one of the following describes why the MTG output increases as steam pressure increases?

- A. Each lbm of steam entering the turbine has a higher specific heat.
- B. Each lbm of steam entering the turbine has a higher specific enthalpy.
- C. Each lbm of steam passing through the turbine expands to fill a greater volume.
- D. Each lbm of steam passing through the turbine performs increased work in the turbine.

QUESTION: 76

A plant is operating at 80% power with 5°F of condensate depression in the main condenser. If the condensate depression decreases to 2°F, plant efficiency will \_\_\_\_\_ and the probability of condensate pump cavitation will \_\_\_\_\_.

- A. increase; increase
- B. increase; decrease
- C. decrease; increase
- D. decrease; decrease

**USNRC GENERIC FUNDAMENTALS EXAMINATION  
OCTOBER 2001 PWR--FORM A**

QUESTION: 77

A reactor plant is operating at 100% rated power. Steam is escaping to atmosphere through a flange leak in a steam supply line to the low pressure section of the main turbine.

Given:

- Steam line pressure is 280 psia.
- Steam line temperature is 450°F.

What is the approximate temperature of the steam as it reaches atmospheric pressure?

- A. 212°F
- B. 268°F
- C. 322°F
- D. 378°F

QUESTION: 78

A reactor plant is operating at 85% reactor power when the extraction steam to a high-pressure feedwater heater is isolated. After the transient, the operator returns reactor power to 85% and stabilizes the plant. Compared to conditions just prior to the transient, current main turbine generator output (MWe) is:

- A. higher because increased steam flow is causing the turbine to operate at a higher speed.
- B. lower because decreased steam flow is causing the turbine to operate at a lower speed.
- C. higher because plant efficiency has increased.
- D. lower because plant efficiency has decreased.



**USNRC GENERIC FUNDAMENTALS EXAMINATION  
OCTOBER 2001 PWR--FORM A**

QUESTION: 79

A 60 gpm leak to atmosphere has developed from a cooling water system that is operating at 150 psig. Which one of the following will be the approximate leak rate when system pressure has decreased to 75 psig?

- A. 15.0 gpm
- B. 30.0 gpm
- C. 42.4 gpm
- D. 53.1 gpm

QUESTION: 80

Reactor coolant system (RCS) hot leg temperature is 520°F and RCS pressure is decreasing due to a small leak. Which one of the following pressure ranges includes the pressure at which two-phase flow will first occur in the hot leg?

- A. 950 to 901 psig
- B. 900 to 851 psig
- C. 850 to 801 psig
- D. 800 to 751 psig

**USNRC GENERIC FUNDAMENTALS EXAMINATION  
OCTOBER 2001 PWR--FORM A**

QUESTION: 81

A reactor plant is recovering from a loss of offsite power that caused all reactor coolant pumps (RCPs) to be lost. Pressurizer level indication is off-scale high.

Prior to restarting an RCP, the steam generator (S/G) temperatures should be equal to or less than the associated reactor coolant system (RCS) loop temperature to avoid:

- A. localized water hammer in the RCS.
- B. inadvertently lifting a S/G atmospheric relief valve.
- C. pressurized thermal shock to the S/Gs.
- D. a large pressure spike throughout the RCS.

QUESTION: 82

The major concern with starting a feed water pump with downstream fluid in a saturated condition is:

- A. cavitation.
- B. water hammer.
- C. thermal shock.
- D. positive reactivity addition.

**USNRC GENERIC FUNDAMENTALS EXAMINATION  
OCTOBER 2001 PWR--FORM A**

QUESTION: 83

Two identical centrifugal pumps (CPs) and two identical positive displacement pumps (PDPs) are able to take suction on a vented water storage tank and provide makeup water flow to a cooling water system. The pumps are capable of being cross-connected to provide multiple configurations. In single pump alignment, each pump will supply 100 gpm at a system pressure of 1000 psig.

Given the following information:

Centrifugal Pumps

Shutoff head:	1500 psig
Maximum design pressure:	2000 psig

Positive Displacement Pumps

Maximum design pressure:	2000 psig
--------------------------	-----------

Which one of the following pump configurations will supply the lowest makeup flow rate to the system if system pressure is at 1700 psig?

- A. One PDP and one CP in series (CP supplying PDP)
- B. One PDP and one CP in parallel
- C. Two CPs in series
- D. Two CPs in parallel

**USNRC GENERIC FUNDAMENTALS EXAMINATION  
OCTOBER 2001 PWR--FORM A**

QUESTION: 84

Which one of the following describes a heat transfer process in which convection is the most significant heat transfer mechanism?

- A. From the reactor fuel to the core barrel during core uncover
- B. Through the tube walls in a steam generator during normal operation at 100% power
- C. From the reactor fuel to the steam generators following a loss of all RCPs
- D. From the fuel pellet centerline to the fuel clad during normal operation at 100% power

QUESTION: 85

A reactor is producing 200 MW of core thermal power. Reactor coolant pumps are adding 10 MW of additional thermal power into the coolant system based on heat balance calculations. The core is rated at 1,330 MW thermal power.

Which one of the following is core thermal power in percent?

- A. 14.0%
- B. 14.3%
- C. 15.0%
- D. 15.8%

USNRC GENERIC FUNDAMENTALS EXAMINATION  
OCTOBER 2001 PWR--FORM A

QUESTION: 86

Refer to the drawing of a pool boiling curve (see figure below).

Which region of the curve contains the operating point at which the hottest locations of a reactor operate to transfer heat from the cladding to the coolant at 100% power?

- A. Region I
- B. Region II
- C. Region III
- D. Region IV

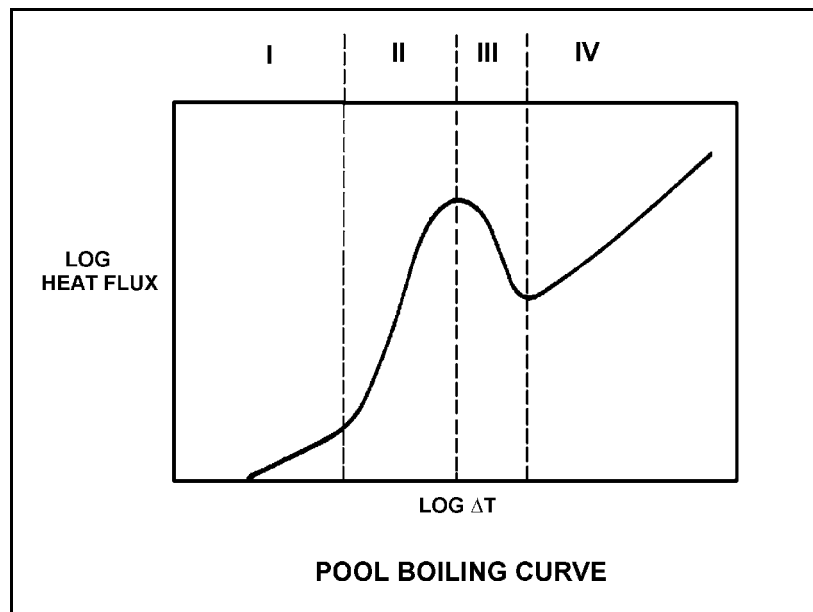

**USNRC GENERIC FUNDAMENTALS EXAMINATION  
OCTOBER 2001 PWR--FORM A**

QUESTION: 87

Why does nucleate boiling improve heat transfer in a reactor core?

- A. The formation of steam bubbles at nucleation sites on the fuel clad allows more heat to be transferred by conduction.
- B. The formation of steam bubbles at nucleation sites on the fuel clad promotes local radiative heat transfer and allows more heat to be transferred by convection.
- C. Heat is removed from the fuel rod as both sensible heat and latent heat of condensation, and the heat is transferred directly to the coolant by radiative heat transfer.
- D. Heat is removed from the fuel rod as both sensible heat and latent heat of vaporization, and the motion of the steam bubbles causes rapid mixing of the coolant.

QUESTION: 88

The heat transfer rate that causes departure from nucleate boiling is the:

- A. critical heat flux.
- B. nucleate heat flux.
- C. transition heat flux.
- D. departure heat flux.

**USNRC GENERIC FUNDAMENTALS EXAMINATION  
OCTOBER 2001 PWR--FORM A**

QUESTION: 89

Select the statement that describes the effect of transition (partial film) boiling at the fuel clad surface-to-coolant interface.

- A. A small increase in heat flux requires a large increase in fuel clad temperature because of increased fuel rod steam blanketing.
- B. The temperature of the fuel clad surface is so high that thermal radiation heat transfer becomes significant, which causes heat flux to rapidly increase.
- C. A small increase in heat flux increases the formation of steam bubbles causing increased turbulence in the liquid boundary layer, consequently decreasing clad temperature.
- D. As the heat flux increases, a few vapor bubbles are formed but collapse when they enter into the bulk of the fluid, which decreases clad temperature.

QUESTION: 90

During a plant cooldown and depressurization with forced circulation, reactor coolant system (RCS) loop flow and reactor coolant pump (RCP) current indications become erratic. This is most likely caused by:

- A. RCP cavitation.
- B. RCP runout.
- C. RCS loop water hammer.
- D. RCS hot leg saturation.

**USNRC GENERIC FUNDAMENTALS EXAMINATION  
OCTOBER 2001 PWR--FORM A**

QUESTION: 91

Which one of the following describes a function of core bypass flow?

- A. Prevents excessive reactor vessel wall differential temperature
- B. Prevents elevated boron concentration in the bottom of the reactor vessel
- C. Provides an alternate means of measuring core flow
- D. Provides cooling to various reactor vessel internal components

QUESTION: 92

A few minutes ago, a reactor plant experienced a loss of offsite power that caused a reactor trip and a loss of all reactor coolant pumps. Natural circulation flow is currently developing in the reactor coolant system (RCS).

Which one of the following operator actions will enhance RCS natural circulation flow rate?

- A. Establish and maintain saturation conditions in the RCS.
- B. Establish and maintain a steam bubble in the reactor vessel.
- C. Establish and maintain steam generator pressure above RCS pressure.
- D. Establish and maintain steam generator water level high in the normal operating range.



**USNRC GENERIC FUNDAMENTALS EXAMINATION  
OCTOBER 2001 PWR--FORM A**

QUESTION: 93

Which one of the following describes the mechanism for core heat removal during reflux cooling?

- A. Forced coolant flow
- B. Natural circulation coolant flow
- C. Conduction with stagnant coolant flow
- D. Radiation with total core voiding

QUESTION: 94

A reactor is operating at 75% power at the middle of a fuel cycle with radial power distribution peaked in the center of the core. All control rods are fully withdrawn and in manual control.

Assuming all control rods remain fully withdrawn, except as noted, which one of the following will cause the maximum steady-state radial peaking (or hot channel) factor to increase?

- A. A center control rod fully inserts into the core.
- B. Turbine load/reactor power is reduced by 20%.
- C. Reactor coolant system boron concentration is reduced by 10 ppm.
- D. The reactor is operated continuously at 75% power for three months.

**USNRC GENERIC FUNDAMENTALS EXAMINATION  
OCTOBER 2001 PWR--FORM A**

QUESTION: 95

A PWR core consists of 50,000 fuel rods; each fuel rod has an active length of 12 feet. The core is producing 1,800 MW of thermal energy. If the nuclear heat flux hot channel factor,  $F_Q(z)$ , (also called the total core peaking factor) is 2.0, what is the maximum local linear power density being produced in the core?

- A. 4.5 kW/ft
- B. 6.0 kW/ft
- C. 9.0 kW/ft
- D. 12.0 kW/ft

QUESTION: 96

A pressure stress applied to the reactor vessel is:

- A. compressive at the inner wall, tensile at the outer wall.
- B. tensile at the inner wall, compressive at the outer wall.
- C. tensile across the entire wall.
- D. compressive across the entire wall.

**USNRC GENERIC FUNDAMENTALS EXAMINATION  
OCTOBER 2001 PWR--FORM A**

QUESTION: 97

A reactor is shut down for refueling following 18 months of operation at an average power level of 85%. During the shutdown, a reactor vessel metal specimen is removed from the reactor vessel for testing. The testing determines that the nil-ductility transition (NDT) temperature of the specimen has increased from 42°F to 44°F since the last refueling.

Which one of the following conclusions is warranted?

- A. The test results are credible and the reactor vessel is more susceptible to brittle fracture now than after the last refueling.
- B. The test results are credible and the reactor vessel is less susceptible to brittle fracture now than after the last refueling.
- C. The test results are questionable because the vessel NDT temperature would not increase during the described 18-month period of operation.
- D. The test results are questionable because the vessel NDT temperature would increase by at least 10°F during the described 18-month period of operation.

QUESTION: 98

Why are reactor coolant system cooldown rate limitations established?

- A. Prevent excessive reactivity additions.
- B. Prevent brittle fracture of the reactor vessel.
- C. Prevent excessive reactor coolant system subcooling.
- D. Prevent impurities from precipitating out of solution in the reactor vessel.

**USNRC GENERIC FUNDAMENTALS EXAMINATION  
OCTOBER 2001 PWR--FORM A**

QUESTION: 99

A reactor plant is operating at full power when a small reactor coolant leak occurs, which results in a reactor scram and initiation of emergency coolant injection. Reactor coolant system (RCS) pressure decreases to 300 psia and then begins to slowly increase as the pressurizer fills. All injection pumps are operating with their pump recirculation (or miniflow) valves operable. The shutoff heads for the pumps are as follows:

High pressure injection (HPI) pumps: 2500 psia  
Low pressure injection (LPI) pumps: 200 psia

Which pumps must be stopped before the pressurizer fills completely and why?

- A. Only the HPI pumps to prevent pressurized thermal shock to the RCS.
- B. All LPI and HPI pumps to prevent pressurized thermal shock to the RCS.
- C. Only the LPI pumps to prevent pump overheating caused by low flow.
- D. All LPI and HPI pumps to prevent pump overheating caused by low flow.

QUESTION: 100

Which one of the following describes the thermal stress placed on the reactor vessel during a cooldown of the reactor coolant system?

- A. Compressive at the inner wall, tensile at the outer wall
- B. Tensile at the inner wall, compressive at the outer wall
- C. Compressive across the entire wall
- D. Tensile across the entire wall

**\*\*\* FINAL ANSWER KEY \*\*\***

**OCTOBER 2001 NRC GENERIC FUNDAMENTALS EXAMINATION  
PRESSURIZED WATER REACTOR - ANSWER KEY**

FORM		ANS	FORM		ANS	FORM		ANS	FORM		ANS
A	B		A	B		A	B		A	B	
1	29	C	26	54	B	51	79	C/D	76	4	A
2	30	A	27	55	C	52	80	A	77	5	D
3	31	B	28	56	D	53	81	C	78	6	D
4	32	B	29	57	B	54	82	B	79	7	C
5	33	B	30	58	A	55	83	B	80	8	D
6	34	C	31	59	A	56	84	B	81	9	D
7	35	A	32	60	D	57	85	C	82	10	B
8	36	D	33	61	C	58	86	D	83	11	D
9	37	C	34	62	B	59	87	A	84	12	C
10	38	A	35	63	A	60	88	B	85	13	C
11	39	C	36	64	C	61	89	C	86	14	B
12	40	D	37	65	A	62	90	C	87	15	D
13	41	D	38	66	D	63	91	C	88	16	A
14	42	A	39	67	A/C	64	92	C	89	17	A
15	43	C	40	68	C	65	93	A	90	18	A
16	44	D	41	69	C	66	94	A/B	91	19	D
17	45	C	42	70	C	67	95	B	92	20	D
18	46	D	43	71	D	68	96	A	93	21	B
19	47	A	44	72	C	69	97	B	94	22	A/B
20	48	A	45	73	A	70	98	D	95	23	B
21	49	D	46	74	D	71	99	D	96	24	C
22	50	B	47	75	A	72	100	B	97	25	A
23	51	D	48	76	B	73	1	B	98	26	B
24	52	B	49	77	C	74	2	B	99	27	Deleted
25	53	D	50	78	B	75	3	D	100	28	B