

**UNITED STATES NUCLEAR REGULATORY COMMISSION  
PRESSURIZED WATER REACTOR GENERIC FUNDAMENTALS EXAMINATION  
MARCH 2006--FORM A**

**Please Print**

Name: \_\_\_\_\_

Docket No.: \_\_\_\_\_

Facility: \_\_\_\_\_

Start Time: \_\_\_\_\_ Stop Time: \_\_\_\_\_

**INSTRUCTIONS TO APPLICANT**

Answer all the test items using the answer sheet provided, ensuring a single answer is marked for each test item. Each test item has equal point value. A score of at least 80% is required to pass this portion of the NRC operator licensing written examination. All examination papers will be collected 3.0 hours after the examination starts. This examination applies to a typical pressurized water reactor (PWR) nuclear power plant.

SECTION	QUESTIONS	% OF TOTAL	SCORE
COMPONENTS	1 - 22		
REACTOR THEORY	23 - 36		
THERMODYNAMICS	37 - 50		
TOTALS	50		

All work performed on this examination is my own. I have neither given nor received aid.

\_\_\_\_\_  
Applicant's Signature

**RULES AND GUIDELINES FOR THE NRC  
GENERIC FUNDAMENTALS EXAMINATION**

During the administration of this examination the following rules apply:

NOTE: The generic term "control rod" refers to the length of neutron absorber material that can be positioned by the operator to change core reactivity.

1. Print your name in the blank provided on the cover sheet of the examination.
2. Fill in your individual docket number.
3. Fill in the name of your facility.
4. Fill in your start and stop times at the appropriate time.
5. Two aids are provided for your use during the examination:
  - (1) An equations and conversions sheet contained within the examination copy, and
  - (2) Steam tables and Mollier Diagram provided by your proctor.
6. Place your answers on the answer sheet provided. Credit will only be given for answers properly marked on this sheet. Follow the instructions for filling out the answer sheet.
7. Scrap paper will be provided for calculations.
8. Cheating on the examination will result in the automatic forfeiture of this examination. Cheating could also result in severe penalties.
9. Restroom trips are limited. Only **ONE** examinee may leave the room at a time. In order to avoid the appearance or possibility of cheating, avoid all contact with anyone outside of the examination room.
10. After you have completed the examination, sign the statement on the cover sheet indicating that the work is your own and you have neither given nor received any assistance in completing the examination.
11. Turn in your examination materials, answer sheet on top, followed by the examination booklet, then examination aids - steam table booklets, handouts, and scrap paper used during the examination.
12. After turning in your examination materials, leave the examination area, as defined by the proctor. If after leaving you are found in the examination area while the examination is in progress, your examination may be forfeited.

**GENERIC FUNDAMENTALS EXAMINATION**  
**EQUATIONS AND CONVERSIONS HANDOUT SHEET**

**EQUATIONS**

---

$$\dot{Q} = \dot{m}c_p\Delta T$$

$$\dot{Q} = \dot{m}\Delta h$$

$$\dot{Q} = UA\Delta T$$

$$\dot{Q} \propto \dot{m}_{\text{Nat Circ}}^3$$

$$\Delta T \propto \dot{m}_{\text{Nat Circ}}^2$$

$$K_{\text{eff}} = 1/(1 - \rho)$$

$$\rho = (K_{\text{eff}} - 1)/K_{\text{eff}}$$

$$\text{SUR} = 26.06/\tau$$

$$\tau = \frac{\bar{\beta} - \rho}{\lambda_{\text{eff}} \rho}$$

$$\rho = \frac{\ell^*}{\tau} + \frac{\bar{\beta}}{1 + \lambda_{\text{eff}}\tau}$$

$$\ell^* = 1 \times 10^{-4} \text{ sec}$$

$$\lambda_{\text{eff}} = 0.1 \text{ sec}^{-1} \text{ (for small positive } \rho)$$

$$\text{DRW} \propto \phi_{\text{tip}}^2 / \phi_{\text{avg}}^2$$

$$P = P_o 10^{\text{SUR}(t)}$$

$$P = P_o e^{(t/\tau)}$$

$$A = A_o e^{-\lambda t}$$

$$\text{CR}_{\text{S/D}} = S/(1 - K_{\text{eff}})$$

$$\text{CR}_1(1 - K_{\text{eff}1}) = \text{CR}_2(1 - K_{\text{eff}2})$$

$$1/M = \text{CR}_1/\text{CR}_x$$

$$A = \pi r^2$$

$$F = PA$$

$$\dot{m} = \rho A \bar{v}$$

$$\dot{W}_{\text{Pump}} = \dot{m}\Delta P v$$

$$E = IR$$

$$\text{Eff.} = \text{Net Work Out/Energy In}$$

$$\frac{g(z_2 - z_1)}{g_c} + \frac{(\bar{v}_2^2 - \bar{v}_1^2)}{2g_c} + v(P_2 - P_1) + (u_2 - u_1) + (q - w) = 0$$

$$g_c = 32.2 \text{ lbf-ft/lbf-sec}^2$$

**CONVERSIONS**

---

$$1 \text{ Mw} = 3.41 \times 10^6 \text{ Btu/hr}$$

$$1 \text{ hp} = 2.54 \times 10^3 \text{ Btu/hr}$$

$$1 \text{ Btu} = 778 \text{ ft-lbf}$$

$$^\circ\text{C} = (5/9)(^\circ\text{F} - 32)$$

$$^\circ\text{F} = (9/5)(^\circ\text{C}) + 32$$

$$1 \text{ Curie} = 3.7 \times 10^{10} \text{ dps}$$

$$1 \text{ kg} = 2.21 \text{ lbf}$$

$$1 \text{ gal}_{\text{water}} = 8.35 \text{ lbf}$$

$$1 \text{ ft}^3_{\text{water}} = 7.48 \text{ gal}$$

**USNRC GENERIC FUNDAMENTALS EXAMINATION  
MARCH 2006 PWR--FORM A**

QUESTION: 1

A completely full water storage tank is being hydrostatically tested to 200 psig using a positive displacement pump (PDP) with a smooth and constant discharge flow rate of 8 gpm. The tank is protected by a relief valve and a safety valve; both valves discharge to the atmosphere. Each valve has an opening setpoint of 205 psig and a maximum rated discharge flow rate of 6 gpm. The PDP is inadvertently left running when tank pressure reaches 200 psig.

With the PDP still running, when conditions stabilize the relief valve will be \_\_\_\_\_ open; and the safety valve will be discharging approximately \_\_\_\_\_ to atmosphere.

- A. partially; 6 gpm
- B. partially; 2 gpm
- C. fully; 6 gpm
- D. fully; 2 gpm

QUESTION: 2

To verify a manual valve in an operating system is closed, the operator should operate the valve handwheel in the...

- A. open direction until the valve is fully open, then close it using normal force.
- B. open direction until flow sounds are heard, then close the valve using normal force.
- C. close direction using normal force and verify there is no substantial handwheel movement.
- D. close direction until it stops, then close it an additional one-half turn using additional force if necessary.

**USNRC GENERIC FUNDAMENTALS EXAMINATION  
MARCH 2006 PWR--FORM A**

QUESTION: 3

A nuclear power plant is initially operating with the following main steam parameter values:

Main steam pressure: 1,000 psia

Main steam flow rate: 500,000 lbm/hr

Main steam pressure decreases and stabilizes at 950 psia.

Assume 100% quality saturated steam and that main steam volumetric flow rate is the same before and after the pressure change.

Which one of the following is the approximate mass flow rate of main steam after the pressure change?

- A. 528,000 lbm/hr
- B. 500,000 lbm/hr
- C. 472,000 lbm/hr
- D. 444,000 lbm/hr

**USNRC GENERIC FUNDAMENTALS EXAMINATION  
MARCH 2006 PWR--FORM A**

QUESTION: 4

Refer to the drawing of a horizontal pipe elbow (top view) in an operating water system (see figure below).

Three separate bellows differential pressure flow detectors are connected to taps A, B, C, and D as follows:

<u>DETECTOR</u>	<u>TAPS</u>
AD	A and D
BD	B and D
CD	C and D

Assuming zero head loss in this section of pipe, how will the detectors be affected if tap D ruptures?

- A. All detectors will fail low.
- B. All detectors will fail high.
- C. Two detectors will fail low and one will fail high.
- D. Two detectors will fail high and one will fail low.

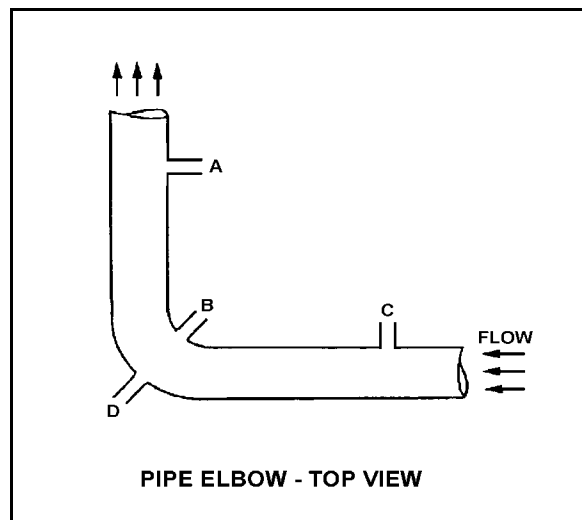

**USNRC GENERIC FUNDAMENTALS EXAMINATION  
MARCH 2006 PWR--FORM A**

QUESTION: 5

The pressure within a cooling water system is 100 psig, as indicated by a bourdon tube pressure detector. The cooling water system and the detector are located inside a reactor containment building. The pressure detector case is vented to the containment building, which is currently at atmospheric pressure.

If a steam line rupture raises the containment building pressure by 20 psi, the cooling water system pressure indication will: (Disregard any temperature effect on the detector.)

- A. increase to 120 psig.
- B. increase by a small, but indeterminate amount.
- C. decrease by a small, but indeterminate amount.
- D. decrease to 80 psig.

QUESTION: 6

Reed switches are being used in an electrical measuring circuit to monitor the position of a control rod in a nuclear reactor. The reed switches are mounted in a column above the reactor vessel such that the control rod drive shaft passes by the reed switches as the control rod is withdrawn.

Which one of the following describes the action that causes the electrical output of the measuring circuit to change as the control rod is withdrawn?

- A. An ac coil on the control rod drive shaft induces a voltage into each reed switch as the drive shaft passes by.
- B. A metal tab on the control rod drive shaft mechanically closes each reed switch as the drive shaft passes by.
- C. The primary and secondary coils of each reed switch attain maximum magnetic coupling as the drive shaft passes by.
- D. A permanent magnet on the control rod drive shaft attracts the movable contact arm of each reed switch as the drive shaft passes by.

**USNRC GENERIC FUNDAMENTALS EXAMINATION  
MARCH 2006 PWR--FORM A**

QUESTION: 7

Refer to the following valve controller logic diagram (see figure below).

Which one of the following combinations of inputs will result in the valve receiving an open signal?

	INPUTS			
	1.	2.	3.	4.
A.	ON	OFF	OFF	ON
B.	OFF	ON	ON	OFF
C.	ON	OFF	ON	OFF
D.	OFF	ON	OFF	ON

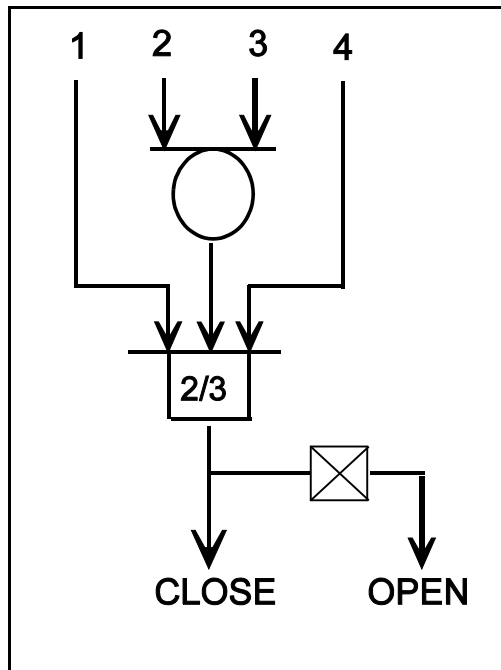



**USNRC GENERIC FUNDAMENTALS EXAMINATION  
MARCH 2006 PWR--FORM A**

QUESTION: 8

Refer to the drawing of a pressure bistable in an alarm circuit (see figure below).

The orientation of the bistable symbol indicates the characteristics of the bistable, as is normal for a control circuit diagram. The bistable turns on to actuate an alarm at a system pressure of 100 psig. The bistable has a 5 psig dead band, or neutral zone.

If current system pressure is 90 psig, which one of the following describes the alarm response as system pressure is slowly increased to 110 psig?

- A. The alarm is currently actuated and will turn off at 95 psig.
- B. The alarm will actuate at 100 psig and will not turn off.
- C. The alarm is currently actuated and will turn off at 105 psig.
- D. The alarm will actuate at 100 psig and will turn off at 105 psig.

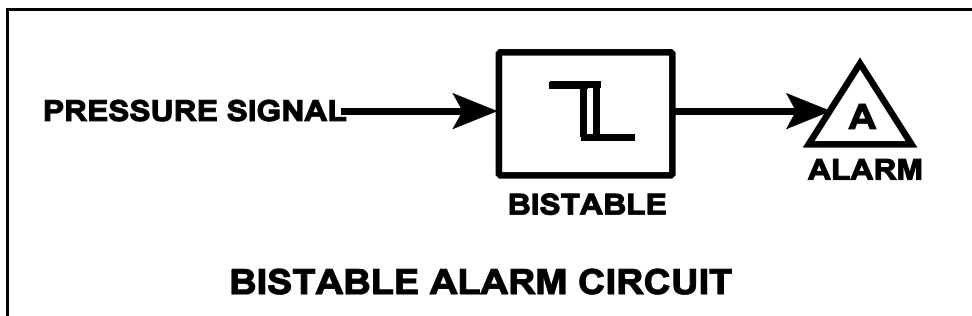

**USNRC GENERIC FUNDAMENTALS EXAMINATION  
MARCH 2006 PWR--FORM A**

QUESTION: 9

The level in a drain collection tank is being controlled by an automatic level controller and is initially at the controller set point. Flow rate into the tank increases, slowly at first, and then faster until a stable higher flow rate is attained.

As tank level increases, the controller slowly opens a tank drain valve. The level controller output signal increases both as the tank level increases and as the rate of tank level change quickens. After a few minutes, a new, steady-state tank level above the original level is established, with the drain flow rate equal to the supply flow rate.

The controller in this system uses \_\_\_\_\_ control.

- A. proportional only
- B. proportional plus derivative
- C. proportional plus integral
- D. proportional plus integral plus derivative

QUESTION: 10

A centrifugal pump is operating at its maximum design flow rate, delivering water through two parallel valves. Valve "A" is half open, and valve "B" is one quarter open.

Which one of the following will occur if both valves are fully opened?

- A. The pump will operate at shutoff head.
- B. The pump available net positive suction head will increase.
- C. The pump required net positive suction head will decrease.
- D. The pump will operate at runout conditions.

**USNRC GENERIC FUNDAMENTALS EXAMINATION  
MARCH 2006 PWR--FORM A**

QUESTION: 11

Refer to the drawing showing two operating points for the same centrifugal pump (see figure below).

Operating point A was generated from pump performance data taken six months ago. Current pump performance data was used to generate operating point B. Which one of the following would cause the observed difference between operating points A and B?

- A. The pump discharge valve was more open when data was collected for operating point A.
- B. The pump discharge valve was more closed when data was collected for operating point A.
- C. The pump internal components have worn since data was collected for operating point A.
- D. The system piping head loss has increased since data was collected for operating point A.

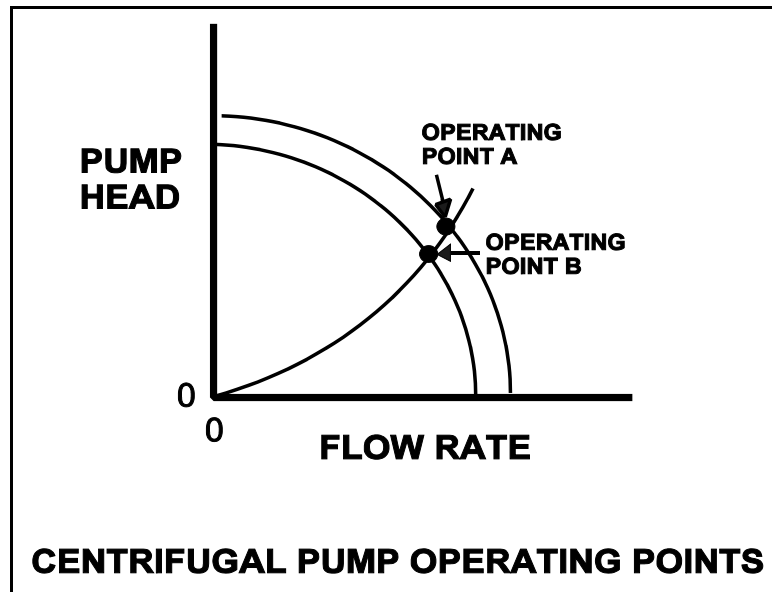

**USNRC GENERIC FUNDAMENTALS EXAMINATION  
MARCH 2006 PWR--FORM A**

QUESTION: 12

A motor-driven centrifugal cooling water pump is operating in an open system with its discharge valve fully open. If the discharge valve is repositioned to 50% open, the pump's available net positive suction head (NPSH) will \_\_\_\_\_ and the pump's required NPSH will \_\_\_\_\_.

- A. remain the same; decrease
- B. remain the same; remain the same
- C. increase; decrease
- D. increase; remain the same

QUESTION: 13

A positive displacement pump should be started with its suction valve \_\_\_\_\_ and its discharge valve \_\_\_\_\_.

- A. fully open; throttled
- B. fully open; fully open
- C. throttled; throttled
- D. throttled; fully open

**USNRC GENERIC FUNDAMENTALS EXAMINATION  
MARCH 2006 PWR--FORM A**

QUESTION: 14

A nuclear power plant startup is in progress. The main generator has just been connected to the power grid with the following generator indications:

10 MW  
0 MVAR  
288 amps  
20,000 volts

The operator suspects that the main generator is operating under reverse power conditions and attempts to increase generator load (MW) normally. If the main generator is operating under reverse power conditions when the operator attempts to increase generator load, generator MW will initially \_\_\_\_\_; and generator amps will initially \_\_\_\_\_.

- A. decrease; decrease
- B. decrease; increase
- C. increase; decrease
- D. increase; increase

QUESTION: 15

A large centrifugal pump is driven by a 200 horsepower 4.16 kV ac motor. The motor breaker control circuit contains the following protection devices: instantaneous overcurrent relay, motor thermal overload relay, control power fuses, and an anti-pumping device.

The pump had been manually started and stopped several times during a 5-minute period when the motor breaker unexpectedly tripped. In this situation, which one of the following is the most likely cause of the breaker trip?

- A. Instantaneous overcurrent
- B. Motor thermal overload
- C. Blown control power fuse
- D. Anti-pumping device actuation

**USNRC GENERIC FUNDAMENTALS EXAMINATION  
MARCH 2006 PWR--FORM A**

QUESTION: 16

Refer to the drawing of an operating water cleanup system (see figure below).

Valves A, B, and C are fully open. Valve D is 20% open. All temperatures are as shown. Valve D is then quickly opened to 100%.

The temperature at point...

- A. 3 will increase.
- B. 4 will decrease.
- C. 5 will decrease.
- D. 7 will increase.

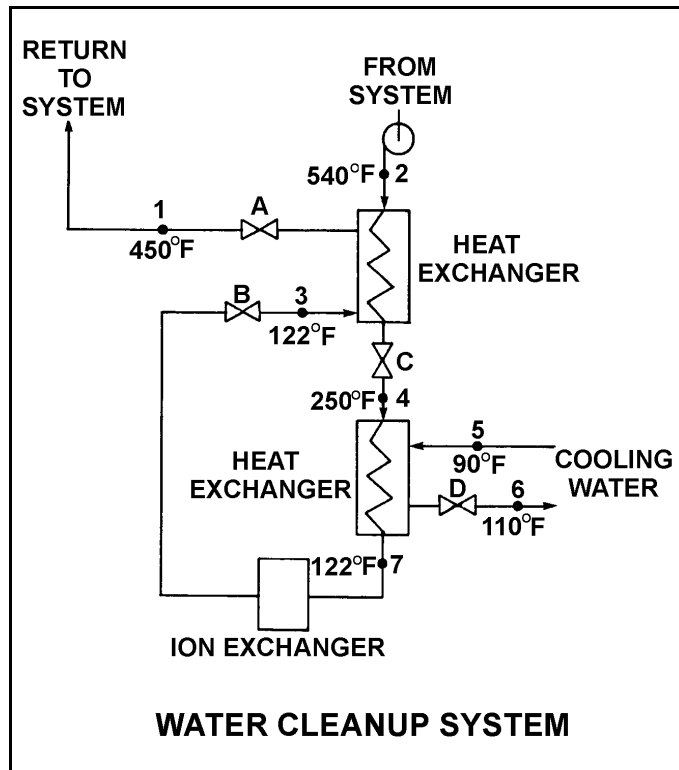

**USNRC GENERIC FUNDAMENTALS EXAMINATION  
MARCH 2006 PWR--FORM A**

QUESTION: 17

A nuclear power plant is operating near rated power with the following initial conditions:

Main steam pressure: 900 psia  
Main steam quality: 100%, saturated vapor  
Main condenser pressure: 1.0 psia

Air leakage into the main condenser results in the main condenser pressure increasing and stabilizing at 2.0 psia. Assume that all main steam parameters (e.g., pressure, quality, and mass flow rate) remain the same and that the main turbine efficiency remains at 100%.

Which one of the following is the approximate percent by which the main generator output will decrease as a result of the main condenser pressure increase?

- A. 5.0%
- B. 6.3%
- C. 7.5%
- D. 8.8%

QUESTION: 18

What percentage of ionic impurities is being removed from the water passing through an ion exchanger if the ion exchanger has a decontamination factor of 1.0?

- A. 100%
- B. 99%
- C. 1%
- D. 0%

**USNRC GENERIC FUNDAMENTALS EXAMINATION  
MARCH 2006 PWR--FORM A**

QUESTION: 19

A PWR nuclear power plant has two identical mixed resin bed reactor coolant ion exchangers, A and B, which were each conditioned and placed in parallel service continuously for about two weeks with the plant at full power after a refueling outage. Then, ion exchanger A was isolated for standby use while ion exchanger B remained in service. After 10 months of continuous operation at full power, it is necessary to place ion exchanger A in service and isolate ion exchanger B.

Which one of the following describes why the effluent from ion exchanger A is initially drained to a collection facility prior to placing the ion exchanger in service?

- A. To avoid an undesired increase in reactor coolant pH.
- B. To avoid an undesired decrease in reactor coolant pH.
- C. To avoid an undesired increase in reactor coolant boron concentration.
- D. To avoid an undesired decrease in reactor coolant boron concentration.



**USNRC GENERIC FUNDAMENTALS EXAMINATION  
MARCH 2006 PWR--FORM A**

QUESTION: 20

Two identical 1,000 MW electrical generators are operating in parallel, supplying the same isolated electrical bus. The generator output breakers also provide identical protection for the generators. Generator A and B output indications are as follows:

<u>Generator A</u>	<u>Generator B</u>
22.5 KV	22.5 KV
60.2 Hertz	60.2 Hertz
750 MW	750 MW
25 MVAR (VARs out)	50 MVAR (VARs out)

A malfunction causes the voltage regulator for generator B to slowly and continuously increase the terminal voltage for generator B. If no operator action is taken, which one of the following describes the electrical current indications for generator A?

- A. Current will decrease continuously until the output breaker for generator A trips on reverse power.
- B. Current will decrease continuously until the output breaker for generator B trips on reverse power.
- C. Current will initially decrease, and then increase until the output breaker for generator A trips on overcurrent.
- D. Current will initially decrease, and then increase until the output breaker for generator B trips on overcurrent.

QUESTION: 21

Which one of the following is an unsafe practice if performed when working on or near energized electrical equipment?

- A. Cover exposed energized circuits with insulating material to prevent inadvertent contact.
- B. Have a person standing by to deenergize the equipment in the event of an emergency.
- C. Use two hands for balance and to prevent dropping tools onto energized equipment.
- D. Stand on insulating rubber material to prevent yourself from being grounded.

**USNRC GENERIC FUNDAMENTALS EXAMINATION  
MARCH 2006 PWR--FORM A**

QUESTION: 22

Given the following indications for an open 4160 Vac breaker:

- The local OPEN/CLOSED mechanical flag indicates open
- A breaker overcurrent trip flag is actuated on one phase
- The line-side voltmeter indicates 4160 Vac
- The load-side voltmeter indicates 0 volts

Assuming no operator actions were taken since the breaker opened, which one of the following could have caused the breaker to open?

- A. A ground fault caused an automatic breaker trip.
- B. A loss of control power caused an automatic breaker trip.
- C. An operator tripped the breaker normally at the breaker.
- D. An operator tripped the breaker normally from a remote location.

QUESTION: 23

As compared to a prompt neutron, a delayed neutron, born from the same fission event, requires \_\_\_\_\_ collisions in the moderator to become thermal and is \_\_\_\_\_ likely to cause fission of a U-238 nucleus. (Neglect the effects of neutron leakage.)

- A. more; more
- B. more; less
- C. fewer; more
- D. fewer; less

**USNRC GENERIC FUNDAMENTALS EXAMINATION  
MARCH 2006 PWR--FORM A**

QUESTION: 24

A nuclear reactor is initially subcritical with the effective multiplication factor ( $K_{\text{eff}}$ ) equal to 0.998. After a brief withdrawal of control rods,  $K_{\text{eff}}$  equals 1.002. The reactor is currently...

- A. prompt critical.
- B. supercritical.
- C. exactly critical.
- D. subcritical.

QUESTION: 25

A nuclear reactor is exactly critical several decades below the point of adding heat (POAH) with a xenon-free core. The operator continuously withdraws control rods until a positive 0.5 decades per minute (dpm) startup rate (SUR) is reached and then stops control rod motion.

When rod motion is stopped, SUR will immediately... (Neglect any reactivity effects of fission products.)

- A. stabilize at 0.5 dpm until power reaches the POAH.
- B. decrease, and then stabilize at a value less than 0.5 dpm until power reaches the POAH.
- C. stabilize at 0.5 dpm, and then slowly and continuously decrease until power reaches the POAH.
- D. decrease, and then continue to slowly decrease until power reaches the POAH.

**USNRC GENERIC FUNDAMENTALS EXAMINATION  
MARCH 2006 PWR--FORM A**

QUESTION: 26

With higher concentrations of boron in the reactor coolant, the core neutron flux distribution shifts to \_\_\_\_\_ energies where the absorption cross-section of boron is \_\_\_\_\_.

- A. higher; lower
- B. higher; higher
- C. lower; lower
- D. lower; higher

QUESTION: 27

Given the following initial parameters:

Total power coefficient	= -0.020% $\Delta K/K/\%$
Boron worth	= -0.010% $\Delta K/K/ppm$
Control rod worth	= -0.025% $\Delta K/K/inch$ inserted
Initial reactor coolant system (RCS) boron concentration	= 600 ppm

Which one of the following is the final RCS boron concentration required to support increasing plant power from 40% to 80% with 40 inches of outward control rod motion? (Ignore any change in fission product poison reactivity.)

- A. 420 ppm
- B. 580 ppm
- C. 620 ppm
- D. 780 ppm

**USNRC GENERIC FUNDAMENTALS EXAMINATION  
MARCH 2006 PWR--FORM A**

QUESTION: 28

A nuclear reactor has been taken critical following a refueling outage and is currently at the point of adding heat during a normal reactor startup. Which one of the following describes the axial power distribution in the core as power is increased to 10% by control rod withdrawal? (Neglect reactivity effects of reactor coolant temperature change.)

- A. Shifts toward the bottom of the core
- B. Shifts toward the top of the core
- C. Shifts away from the center toward the top and bottom of the core
- D. Shifts away from the top and bottom toward the center of the core

QUESTION: 29

Why are the control rod insertion limits power dependent?

- A. Power defect increases as power increases.
- B. Control rod worth decreases as power increases.
- C. Doppler (fuel temperature) coefficient decreases as power increases.
- D. Moderator temperature coefficient increases as power increases.

**USNRC GENERIC FUNDAMENTALS EXAMINATION  
MARCH 2006 PWR--FORM A**

QUESTION: 30

Nuclear reactors A and B are operating at steady-state 100% power with equilibrium core Xe-135. The reactors are identical except that reactor A is operating near the end of core life and reactor B is operating near the beginning of core life.

Which reactor is experiencing the most negative reactivity from equilibrium core Xe-135?

- A. Reactor A due to a greater concentration of equilibrium core Xe-135.
- B. Reactor A due to lower competition from the fuel for thermal neutrons.
- C. Reactor B due to a greater thermal neutron flux in the core.
- D. Reactor B due to a smaller accumulation of stable fission product poisons.

QUESTION: 31

A nuclear reactor has been operating at a steady-state power level for 15 hours following a rapid power reduction from 100% to 50% using boration for reactivity control. Which one of the following describes the current core Xe-135 concentration?

- A. Increasing
- B. Decreasing
- C. At equilibrium
- D. Oscillating

**USNRC GENERIC FUNDAMENTALS EXAMINATION  
MARCH 2006 PWR--FORM A**

QUESTION: 32

A nuclear reactor has been operating at 100% power for three months following a refueling outage. If the reactor is operated at 100% power without making RCS boron additions or dilutions for the next month, RCS boron concentration will...

- A. decrease because boron atoms decompose at normal RCS operating temperatures.
- B. decrease because irradiated boron-10 atoms undergo a neutron-alpha reaction.
- C. remain constant because irradiated boron-10 atoms become stable boron-11 atoms.
- D. remain constant because irradiated boron-10 atoms still have large absorption cross sections for thermal neutrons.

QUESTION: 33

A nuclear power plant was operating at steady-state 100% power near the end of a fuel cycle when a reactor trip occurred. Four hours after the trip, reactor coolant temperature is being maintained at normal no-load temperature in anticipation of commencing a reactor startup.

At this time, which one of the following will cause the fission rate in the reactor core to decrease?

- A. The operator fully withdraws the shutdown control rods.
- B. Reactor coolant temperature is allowed to decrease by 3°F.
- C. Reactor coolant boron concentration is decreased by 10 ppm.
- D. An additional two hours is allowed to pass with no other changes in plant parameters.

**USNRC GENERIC FUNDAMENTALS EXAMINATION  
MARCH 2006 PWR--FORM A**

QUESTION: 34

During a nuclear reactor startup, positive reactivity addition X caused the stable source range count rate to increase from 20 to 40 cps. Later in the startup, after several other additions of positive reactivity, positive reactivity addition Y caused the stable source range count rate to increase from 320 cps to 640 cps.

Which one of the following statements describes how the magnitudes of the two positive reactivity additions (X and Y) compare?

- A. Reactivity addition X was several times greater in magnitude than reactivity addition Y.
- B. Reactivity addition X was several times smaller in magnitude than reactivity addition Y.
- C. Reactivity additions X and Y were about equal in magnitude.
- D. There is not enough information given to determine the relationship between the reactivity additions.

QUESTION: 35

A nuclear power plant is initially operating at steady-state 100% reactor power with the main generator producing 1,100 MW. A power grid disturbance occurs and appropriate operator actions are taken. The plant is stabilized with the following current conditions:

- Main generator output is 385 MW.
- Steam dump/bypass system is discharging 15% of rated steam flow to the main condenser.
- All reactor coolant system parameters are in their normal ranges.

What is the approximate current reactor power level?

- A. 15%
- B. 35%
- C. 50%
- D. 65%



**USNRC GENERIC FUNDAMENTALS EXAMINATION  
MARCH 2006 PWR--FORM A**

QUESTION: 36

A nuclear reactor is exactly critical below the point of adding heat when a single control rod fully inserts into the core. Assuming no operator or automatic action, reactor power will slowly decrease to...

- A. zero.
- B. an equilibrium value equal to the source neutron strength.
- C. an equilibrium value greater than the source neutron strength.
- D. a slightly lower value, then slowly return to the initial value.

**USNRC GENERIC FUNDAMENTALS EXAMINATION  
MARCH 2006 PWR--FORM A**

QUESTION: 37

Refer to the drawing of four differential pressure (D/P) level detectors (see figure below).

The tanks are identical and are being maintained at 17 psia and 70% water level (calibration conditions). They are contained in a building that is open to atmospheric pressure.

Which of the level detectors will provide the lowest level indication if atmospheric pressure decreases?

- A. 1 and 3
- B. 1 and 4
- C. 2 and 3
- D. 2 and 4

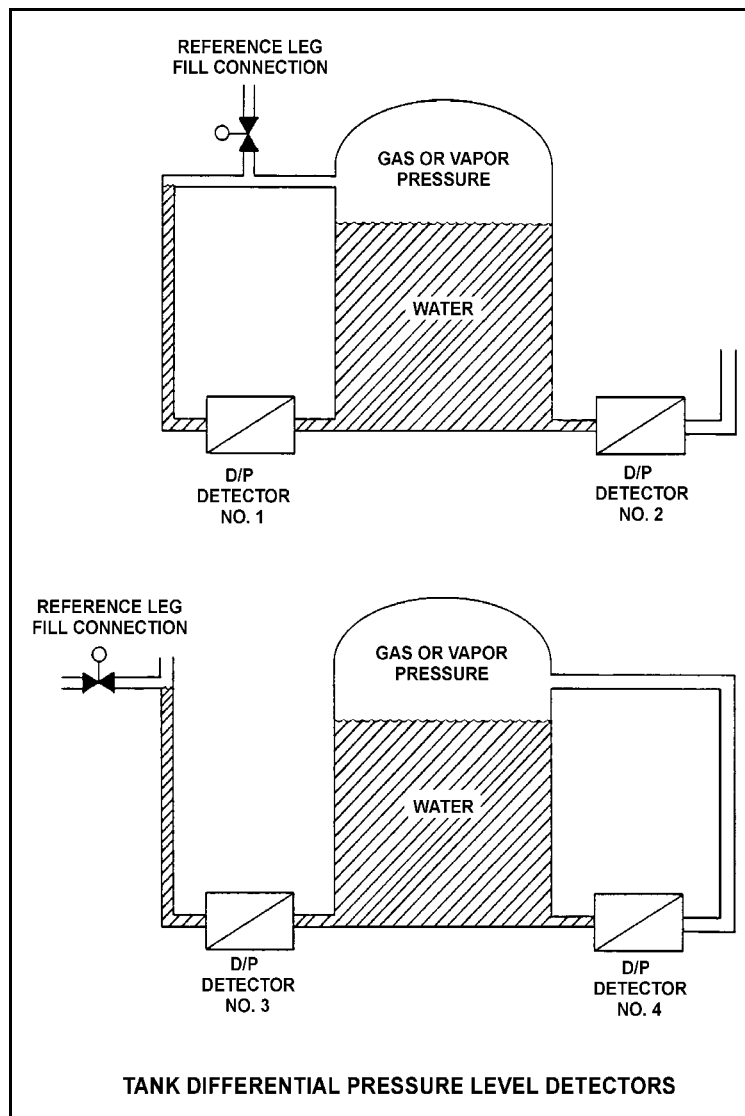

**USNRC GENERIC FUNDAMENTALS EXAMINATION  
MARCH 2006 PWR--FORM A**

QUESTION: 38

Two identical pressurizers are connected to the same location on two identical reactor coolant systems operating at 1,000 psia. Pressurizer A volume contains 50% subcooled water (300°F) and 50% nitrogen. Pressurizer B volume contains 50% saturated water and 50% saturated steam. Which one of the following explains which pressurizer will maintain the highest pressure during a sudden 10% liquid outsurge from each pressurizer?

- A. Pressurizer A due to the subcooled water resulting in a smaller amount of energy being lost during the outsurge.
- B. Pressurizer A due to the expansion characteristics of nitrogen being better than the expansion characteristics of saturated steam.
- C. Pressurizer B due to vaporizing of saturated water as pressure begins to decrease.
- D. Pressurizer B due to the expansion characteristics of saturated steam being better than the expansion characteristics of nitrogen.

QUESTION: 39

Consider a 100 lbm quantity of a steam-water mixture at standard atmospheric pressure. The mixture has a quality of 70 percent. Assume that pressure remains constant and there is no heat loss from the mixture.

Which one of the following is the approximate heat addition needed to increase the quality of the mixture to 100 percent?

- A. 5,400 Btu
- B. 12,600 Btu
- C. 29,100 Btu
- D. 67,900 Btu

**USNRC GENERIC FUNDAMENTALS EXAMINATION  
MARCH 2006 PWR--FORM A**

QUESTION: 40

Condensate depression is the process of...

- A. removing condensate from turbine exhaust steam.
- B. spraying condensate into turbine exhaust steam.
- C. heating turbine exhaust steam above its saturation temperature.
- D. cooling turbine exhaust steam below its saturation temperature.

QUESTION: 41

A nuclear power plant is operating at 90% of rated power. Main condenser pressure is 1.7 psia and hotwell condensate temperature is 120°F.

Which one of the following describes the effect of a 5% decrease in cooling water flow rate through the main condenser?

- A. Overall steam cycle efficiency will increase because the work output of the turbine will increase.
- B. Overall steam cycle efficiency will increase because condensate depression will decrease.
- C. Overall steam cycle efficiency will decrease because the work output of the turbine will decrease.
- D. Overall steam cycle efficiency will decrease because condensate depression will increase.

**USNRC GENERIC FUNDAMENTALS EXAMINATION  
MARCH 2006 PWR--FORM A**

QUESTION: 42

Refer to the drawing of a cooling water system in which only pump A is operating and the pump discharge valve is currently 50% open (see figure below).

If pump A is cavitating, which one of the following will reduce or eliminate cavitation in pump A?

- A. Starting pump B
- B. Positioning the discharge valve to 40% open
- C. Lowering the water level in the surge tank by 2 feet
- D. Decreasing heat exchanger service water flow rate by 10%

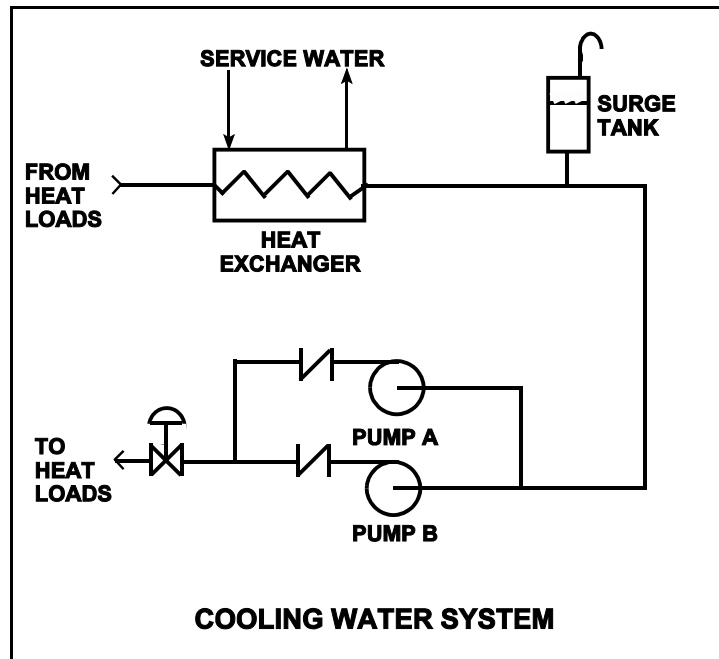

**USNRC GENERIC FUNDAMENTALS EXAMINATION  
MARCH 2006 PWR--FORM A**

QUESTION: 43

A four-loop PWR nuclear power plant uses four identical single-speed reactor coolant pumps (RCPs) to supply reactor coolant flow through the reactor vessel. The plant is currently shut down with one RCP in operation.

Which one of the following describes the stable reactor coolant flow rate through the reactor vessel following the start of a second RCP?

- A. Less than twice the original flow rate.
- B. Exactly twice the original flow rate.
- C. More than twice the original flow rate.
- D. Cannot be determined without additional information.

QUESTION: 44

The power range nuclear instruments have been adjusted to 100% based on a heat balance calculation. Which one of the following will result in indicated reactor power being higher than actual reactor power?

- A. The feedwater temperature used in the heat balance calculation was 20°F higher than actual feedwater temperature.
- B. The reactor coolant pump heat input term was omitted from the heat balance calculation.
- C. The feedwater flow rate used in the heat balance calculation was 10% lower than actual feedwater flow rate.
- D. The ambient heat loss term was omitted from the heat balance calculation.

**USNRC GENERIC FUNDAMENTALS EXAMINATION  
MARCH 2006 PWR--FORM A**

QUESTION: 45

Refer to the drawing of a pool-boiling curve (see figure below).

The point at which heat flux stops increasing and the critical heat flux has been reached (point B), marks the beginning of...

- A. nucleate boiling.
- B. stable film boiling.
- C. partial film boiling.
- D. single-phase convection.

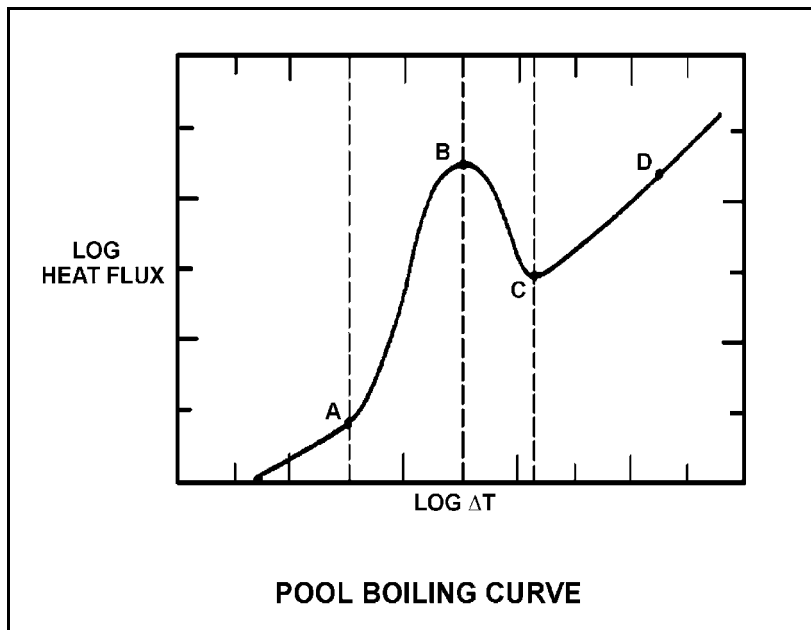

**USNRC GENERIC FUNDAMENTALS EXAMINATION  
MARCH 2006 PWR--FORM A**

QUESTION: 46

A reactor coolant system (RCS) cooldown and depressurization is in progress on natural circulation following a loss of offsite power. The following conditions exist:

RCS T<sub>cold</sub>: 520°F, decreasing  
RCS T<sub>hot</sub>: 538°F, decreasing  
Pressurizer pressure: 2000 psia, decreasing

If the cooldown rate is being maintained at 50°F/hour, which one of the following locations is most likely to experience steam formation?

- A. Reactor vessel head
- B. RCS loop hot leg
- C. Steam generator U-tubes
- D. Reactor core

QUESTION: 47

A nuclear reactor is shut down with natural circulation core cooling. Decay heat generation is equivalent to 1.0% rated thermal power. Core  $\Delta T$  has stabilized at 16°F.

When decay heat generation decreases to 0.333% rated thermal power, core  $\Delta T$  will be approximately...

- A. 2°F.
- B. 4°F.
- C. 8°F.
- D. 10°F.



**USNRC GENERIC FUNDAMENTALS EXAMINATION  
MARCH 2006 PWR--FORM A**

QUESTION: 48

A reactor coolant system natural circulation cooldown is in progress via the steam generator (S/G) atmospheric steam relief valves (operated in manual control).

If high point voiding interrupts natural circulation, which one of the following will occur? (Assume feed flow rate, relief valve position, and decay heat level are constant.)

- A. S/G pressure decreases and core exit thermocouple (CETC) temperature increases.
- B. S/G pressure decreases and CETC temperature remains constant.
- C. S/G pressure increases and CETC temperature increases.
- D. S/G pressure increases and CETC temperature remains constant.

QUESTION: 49

Which one of the following describes the basis for the 2,200°F maximum fuel clad temperature limit?

- A. The material strength of zircaloy decreases rapidly at temperatures above 2,200°F.
- B. At the normal operating pressure of the reactor vessel a clad temperature above 2,200°F indicates that the critical heat flux has been exceeded.
- C. The rate of the zircaloy-water reaction becomes significant at temperatures above 2,200°F.
- D. 2,200°F is approximately 500°F below the fuel clad melting temperature.

**USNRC GENERIC FUNDAMENTALS EXAMINATION  
MARCH 2006 PWR--FORM A**

QUESTION: 50

Operating with which of the following conditions is least effective in preventing brittle fracture in the reactor coolant system (RCS)?

- A. Operating within prescribed heatup and cooldown rate limitations.
- B. Operating with RCS temperature greater than nil-ductility transition temperature.
- C. Operating with RCS pressure low when RCS temperature is low.
- D. Operating with a ramped RCS temperature as power level varies.

**\*\*\* FINAL ANSWER KEY \*\*\***

**MARCH 2006 NRC GENERIC FUNDAMENTALS EXAMINATION  
PRESSURIZED WATER REACTOR - ANSWER KEY**

<u>FORM A</u>	<u>FORM B</u>	<u>ANS.</u>	<u>FORM A</u>	<u>FORM B</u>	<u>ANS.</u>
1	15	A	26	40	A
2	16	C	27	41	C
3	17	C	28	42	B
4	18	A	29	43	A
5	19	D	30	44	B
6	20	D	31	45	B
7	21	B	32	46	B
8	22	C	33	47	D
9	23	B	34	48	A
10	24	D	35	49	C
11	25	C	36	50	C
12	26	C	37	1	B
13	27	B	38	2	C
14	28	A	39	3	C
15	29	B	40	4	D
16	30	B	41	5	C
17	31	C	42	6	B
18	32	D	43	7	A
19	33	C	44	8	B
20	34	D	45	9	C
21	35	C	46	10	A
22	36	A	47	11	C
23	37	D	48	12	A
24	38	B	49	13	C
25	39	B	50	14	D