

**UNITED STATES NUCLEAR REGULATORY COMMISSION
PRESSURIZED WATER REACTOR GENERIC FUNDAMENTALS EXAMINATION
JUNE 2005--FORM A**

Please Print

Name: _____

Facility: _____

Docket No.: _____

Start Time: _____ Stop Time: _____

INSTRUCTIONS TO APPLICANT

Answer all the test items using the answer sheet provided, ensuring a single answer is marked for each test item. Each test item has equal point value. A score of at least 80% is required to pass this portion of the NRC operator licensing written examination. All examination papers will be collected 3.0 hours after the examination starts. This examination applies to a typical pressurized water reactor (PWR) nuclear power plant.

SECTION	QUESTIONS	% OF TOTAL	SCORE
COMPONENTS	1 - 22		
REACTOR THEORY	23 - 36		
THERMODYNAMICS	37 - 50		
TOTALS	50		

All work performed on this examination is my own. I have neither given nor received aid.

Applicant's Signature

**RULES AND GUIDELINES FOR THE NRC
GENERIC FUNDAMENTALS EXAMINATION**

During the administration of this examination the following rules apply:

NOTE: The generic term "control rod" refers to the length of neutron absorber material that can be positioned by the operator to change core reactivity.

1. Print your name in the blank provided on the cover sheet of the examination.
2. Fill in the name of your facility.
3. Fill in your individual docket number.
4. Fill in your start and stop times at the appropriate time.
5. Two aids are provided for your use during the examination:
 - (1) An equations and conversions sheet contained within the examination copy, and
 - (2) Steam tables and Mollier Diagram provided by your proctor.
6. Place your answers on the answer sheet provided. Credit will only be given for answers properly marked on this sheet. Follow the instructions for filling out the answer sheet.
7. Scrap paper will be provided for calculations.
8. Cheating on the examination will result in the automatic forfeiture of this examination. Cheating could also result in severe penalties.
9. Restroom trips are limited. Only **ONE** examinee may leave the room at a time. In order to avoid the appearance or possibility of cheating, avoid all contact with anyone outside of the examination room.
10. After you have completed the examination, sign the statement on the cover sheet indicating that the work is your own and you have neither given nor received any assistance in completing the examination.
11. Turn in your examination materials, answer sheet on top, followed by the examination booklet, then examination aids - steam table booklets, handouts, and scrap paper used during the examination.
12. After turning in your examination materials, leave the examination area, as defined by the proctor. If after leaving you are found in the examination area while the examination is in progress, your examination may be forfeited.

GENERIC FUNDAMENTALS EXAMINATION
EQUATIONS AND CONVERSIONS HANDOUT SHEET

EQUATIONS

$$\dot{Q} = \dot{m}c_p\Delta T$$

$$\dot{Q} = \dot{m}\Delta h$$

$$\dot{Q} = UA\Delta T$$

$$\dot{Q} \propto \dot{m}_{\text{Nat Circ}}^3$$

$$\Delta T \propto \dot{m}_{\text{Nat Circ}}^2$$

$$K_{\text{eff}} = 1/(1 - \rho)$$

$$\rho = (K_{\text{eff}} - 1)/K_{\text{eff}}$$

$$\text{SUR} = 26.06/\tau$$

$$\tau = \frac{\bar{\beta} - \rho}{\lambda_{\text{eff}} \rho}$$

$$\rho = \frac{\ell^*}{\tau} + \frac{\bar{\beta}}{1 + \lambda_{\text{eff}}\tau}$$

$$\ell^* = 1 \times 10^{-4} \text{ sec}$$

$$\lambda_{\text{eff}} = 0.1 \text{ sec}^{-1} \text{ (for small positive } \rho)$$

$$\text{DRW} \propto \phi_{\text{tip}}^2 / \phi_{\text{avg}}^2$$

$$P = P_o 10^{\text{SUR}(t)}$$

$$P = P_o e^{(t/\tau)}$$

$$A = A_o e^{-\lambda t}$$

$$\text{CR}_{\text{S/D}} = S/(1 - K_{\text{eff}})$$

$$\text{CR}_1(1 - K_{\text{eff}1}) = \text{CR}_2(1 - K_{\text{eff}2})$$

$$1/M = \text{CR}_1/\text{CR}_x$$

$$A = \pi r^2$$

$$F = PA$$

$$\dot{m} = \rho A \bar{v}$$

$$\dot{W}_{\text{Pump}} = \dot{m}\Delta P v$$

$$E = IR$$

$$\text{Eff.} = \text{Net Work Out/Energy In}$$

$$v(P_2 - P_1) + \frac{(\bar{v}_2^2 - \bar{v}_1^2)}{2g_c} + \frac{g(z_2 - z_1)}{g_c} = 0$$

$$g_c = 32.2 \text{ lbm-ft/lbf-sec}^2$$

CONVERSIONS

$$1 \text{ Mw} = 3.41 \times 10^6 \text{ Btu/hr}$$

$$1 \text{ hp} = 2.54 \times 10^3 \text{ Btu/hr}$$

$$1 \text{ Btu} = 778 \text{ ft-lbf}$$

$$^\circ\text{C} = (5/9)(^\circ\text{F} - 32)$$

$$^\circ\text{F} = (9/5)(^\circ\text{C}) + 32$$

$$1 \text{ Curie} = 3.7 \times 10^{10} \text{ dps}$$

$$1 \text{ kg} = 2.21 \text{ lbm}$$

$$1 \text{ gal}_{\text{water}} = 8.35 \text{ lbm}$$

$$1 \text{ ft}^3_{\text{water}} = 7.48 \text{ gal}$$

**USNRC GENERIC FUNDAMENTALS EXAMINATION
JUNE 2005 PWR--FORM A**

QUESTION: 1

Given the following pressure specifications for a main steam safety valve (MSSV):

Setpoint pressure (MSSV will start to open): 1,200 psia
Maximum pressure (MSSV will be fully open): 1,242 psia
Reseat pressure (MSSV will be fully closed): 1,152 psia

Which one of the following is the percent accumulation for this MSSV?

- A. 2.5%
- B. 3.0%
- C. 3.5%
- D. 4.0%

**USNRC GENERIC FUNDAMENTALS EXAMINATION
JUNE 2005 PWR--FORM A**

QUESTION: 2

Refer to the drawing of two identical pressure vessels with identical relief valve protection (see figure below).

Both vessels have been pressurized to 50 psig and then isolated. Vessel A is completely filled with water at 150°F. Vessel B is in a saturated condition with one-half steam (100% quality) and one-half water (0% quality) by volume.

If both relief valves fully open simultaneously, the faster pressure reduction will occur in vessel _____; and if both relief valves close at 40 psig, the greater mass loss will have occurred in vessel _____.

- A. A; A
- B. A; B
- C. B; A
- D. B; B

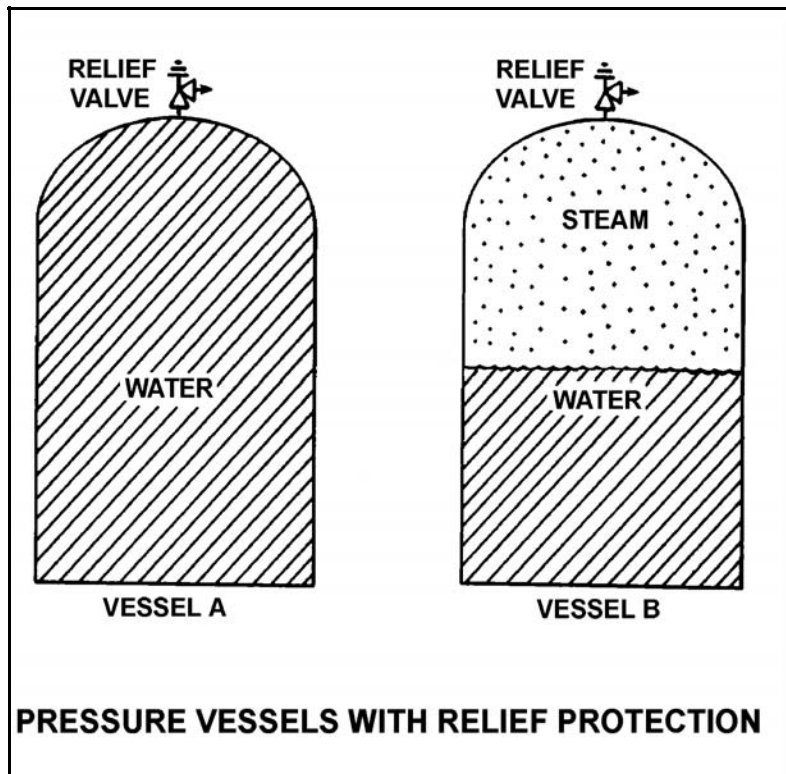

**USNRC GENERIC FUNDAMENTALS EXAMINATION
JUNE 2005 PWR--FORM A**

QUESTION: 3

Refer to the drawing of a horizontal pipe elbow (top view) in an operating water system (see figure below).

Three separate bellows-type differential pressure flow detectors are connected to taps A, B, C, and D as follows:

<u>DETECTOR</u>	<u>TAPS</u>
AD	A and D
BD	B and D
CD	C and D

Assuming zero head loss in this section of pipe, how will the detectors be affected if tap B experiences a significant leak? (Assume water system pressure does not change.)

- A. All detectors will fail low.
- B. All detectors will fail high.
- C. Only one detector will fail, and it will fail low.
- D. Only one detector will fail, and it will fail high.

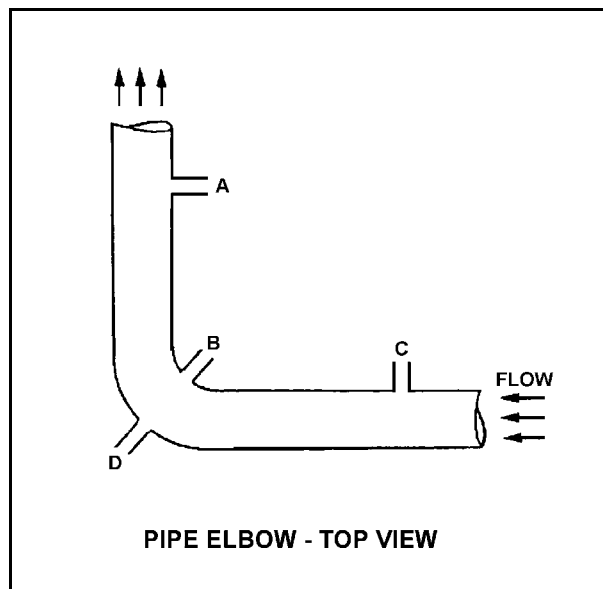

**USNRC GENERIC FUNDAMENTALS EXAMINATION
JUNE 2005 PWR--FORM A**

QUESTION: 4

Refer to the drawing of a pressurizer differential pressure (D/P) level detector (see figure below). The associated pressurizer level instrument was recently calibrated with the nuclear power plant at normal operating conditions. Assume that the level instrument does not use density compensation.

If the plant is currently shut down at reduced reactor coolant system temperatures and pressure, pressurizer water level will currently indicate _____ than actual water level because, for a given pressurizer water level, the D/P sensed by the D/P detector is currently _____.

- A. higher; smaller
- B. higher; larger
- C. lower; smaller
- D. lower; larger

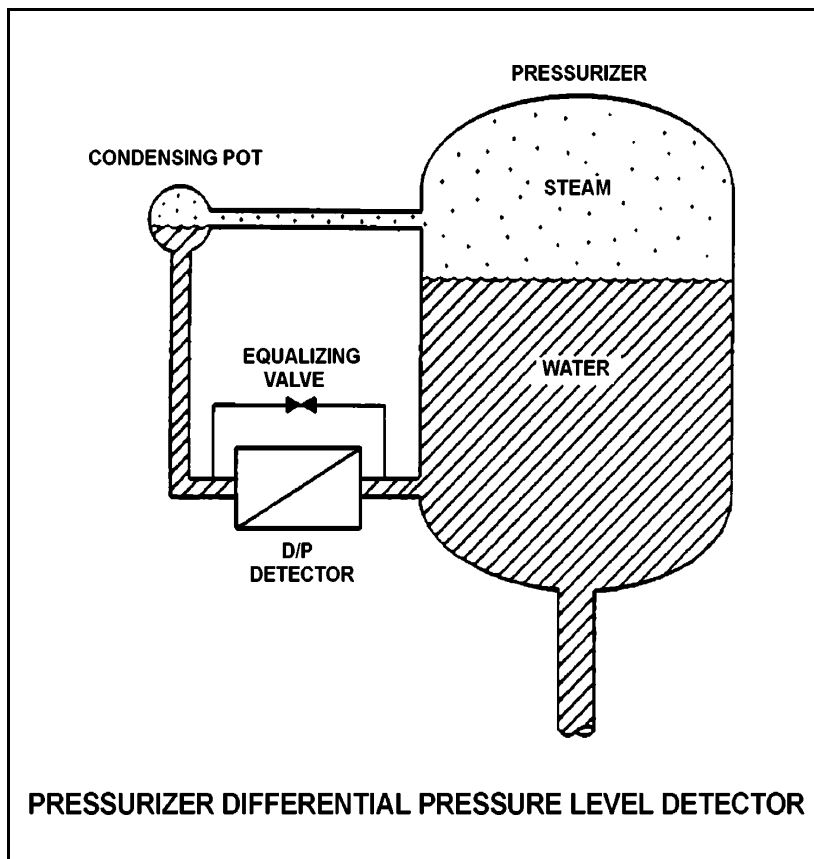

**USNRC GENERIC FUNDAMENTALS EXAMINATION
JUNE 2005 PWR--FORM A**

QUESTION: 5

Refer to the drawing of a simple thermocouple circuit (see figure below).

Given that the temperatures at the measuring and reference junctions remain constant, if a ventilation system malfunction causes the temperature of the temperature indication panel to increase by 10°F , indicated temperature will...

- A. not be affected.
- B. increase by 10°F .
- C. decrease by 10°F .
- D. change in an unpredictable manner.

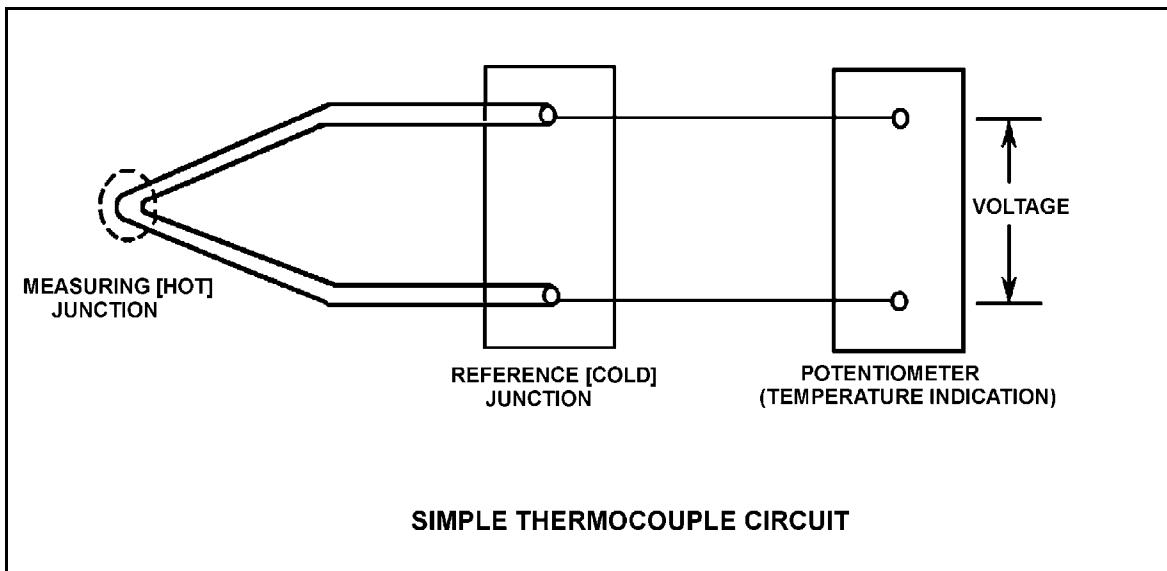

**USNRC GENERIC FUNDAMENTALS EXAMINATION
JUNE 2005 PWR--FORM A**

QUESTION: 6

Refer to the simplified drawing of a control rod position detector circuit (see figure below).

A magnet on the control rod extension (or drive) shaft sequentially closes individual reed switches mounted vertically adjacent to the control rod drive housing. A constant +5 dc volts is supplied to the input of the resistor network at resistor R_1 .

A control rod is initially fully inserted such that all reed switch contacts are open; then the rod is withdrawn until reed switch contact S_1 is closed. Compared to the initial circuit currents, the current through resistor R_5 after the rod withdrawal will be _____, and the output current of the resistor network to the amplifier will be _____.

- A. lower, higher
- B. lower, lower
- C. higher, higher
- D. higher, lower

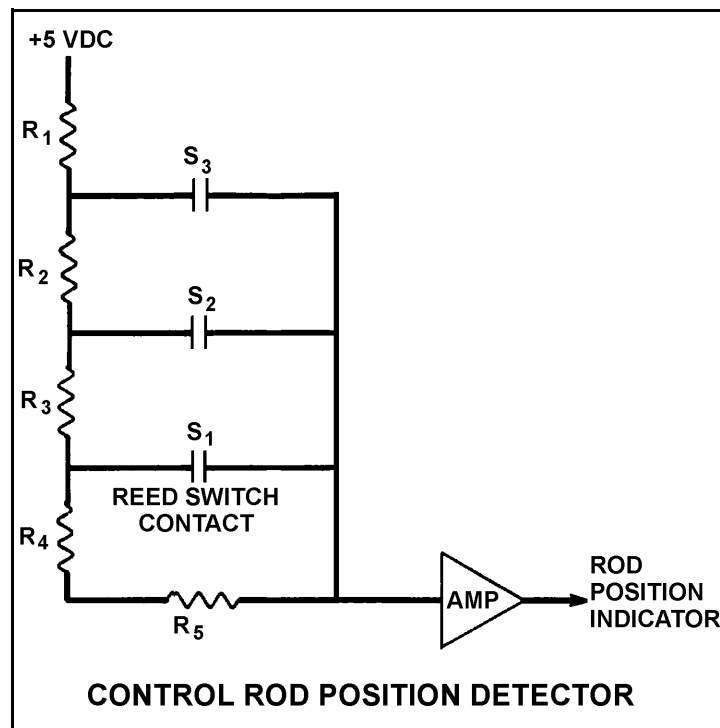

**USNRC GENERIC FUNDAMENTALS EXAMINATION
JUNE 2005 PWR--FORM A**

QUESTION: 7

A typical flow controller uses the _____ method of control.

- A. open-loop
- B. on-off
- C. closed-loop
- D. external regulating

QUESTION: 8

The water level in a drain collection tank is being controlled by an automatic bistable level controller. When tank level increases to 70%, the controller bistable turns on to fully open a tank drain valve. When tank level decreases to 60%, the controller bistable turns off to close the drain valve.

Which one of the following bistable symbols indicates the characteristics of the bistable used in the level controller?

- A. 1.
- B. 2.
- C. 3.
- D. 4.

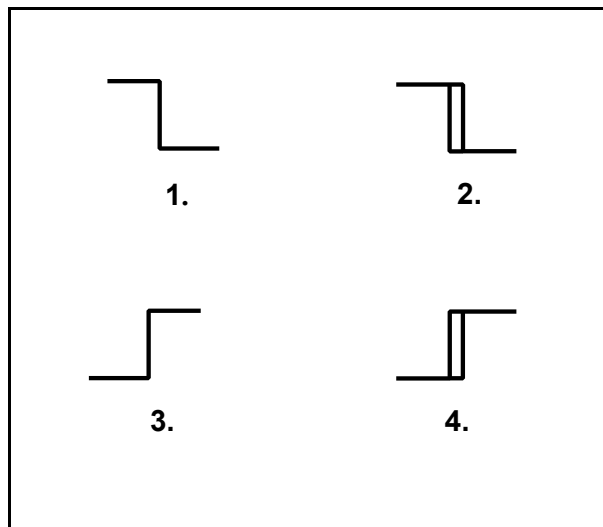

**USNRC GENERIC FUNDAMENTALS EXAMINATION
JUNE 2005 PWR--FORM A**

QUESTION: 9

Which one of the following describes a characteristic of pneumatic valve positioners?

- A. They can provide automatic and manual demand signals to valve controllers and valve actuators.
- B. They can increase or decrease air pressure to valve actuators to obtain the proper valve response.
- C. They can either supply or receive air to/from valve controllers, depending on the direction of valve travel.
- D. They can increase air pressure to valve actuators above existing main air header pressure.

QUESTION: 10

Refer to the drawing below of a centrifugal pump taking suction from the bottom of an open storage tank containing water at 66°F. Pump and water level elevations are indicated in the figure. Assume standard atmospheric pressure.

Assuming that pump suction fluid velocity head loss is negligible, what is the approximate value of net positive suction head available to the pump.

- A. 6 feet
- B. 12 feet
- C. 39 feet
- D. 45 feet

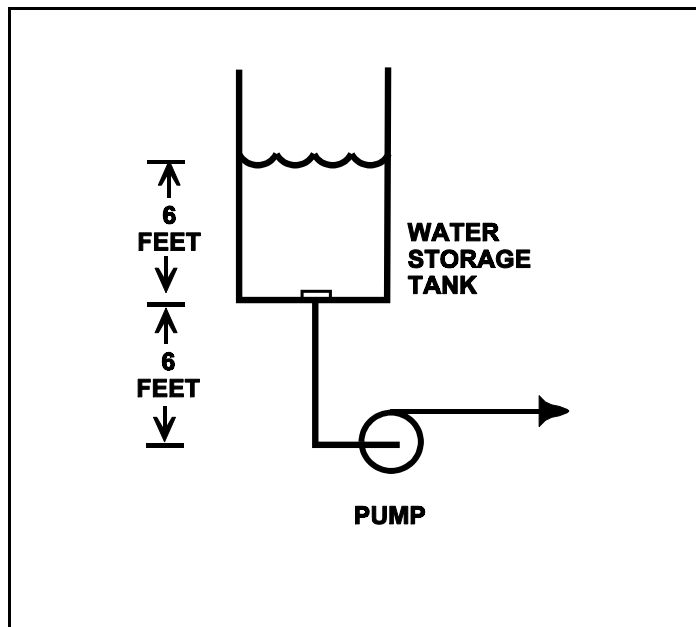

**USNRC GENERIC FUNDAMENTALS EXAMINATION
JUNE 2005 PWR--FORM A**

QUESTION: 11

An ac motor-driven centrifugal pump was just started. During the start, motor current remained peaked for 6 seconds before decreasing to standard running current. Normally, the starting current peak lasts about 4 seconds.

Which one of the following could have caused the extended starting current peak?

- A. The pump shaft was seized and did not turn.
- B. The pump was initially rotating slowly in the reverse direction.
- C. The pump discharge check valve was stuck closed and did not open.
- D. The pump was initially air bound, and then primed itself after 6 seconds of operation.

**USNRC GENERIC FUNDAMENTALS EXAMINATION
JUNE 2005 PWR--FORM A**

QUESTION: 12

Refer to the drawing of an operating cooling water system (see figure below). As depicted in the drawing, only two of the three system heat loads are currently in service.

Which one of the following changes to the cooling water system will result in a higher cooling water pump flow rate and a reduced pump discharge head?

- A. Increase pump speed by 20%.
- B. Decrease pump speed by 20%.
- C. Isolate one of the two in-service heat loads.
- D. Place the third system heat load in service.

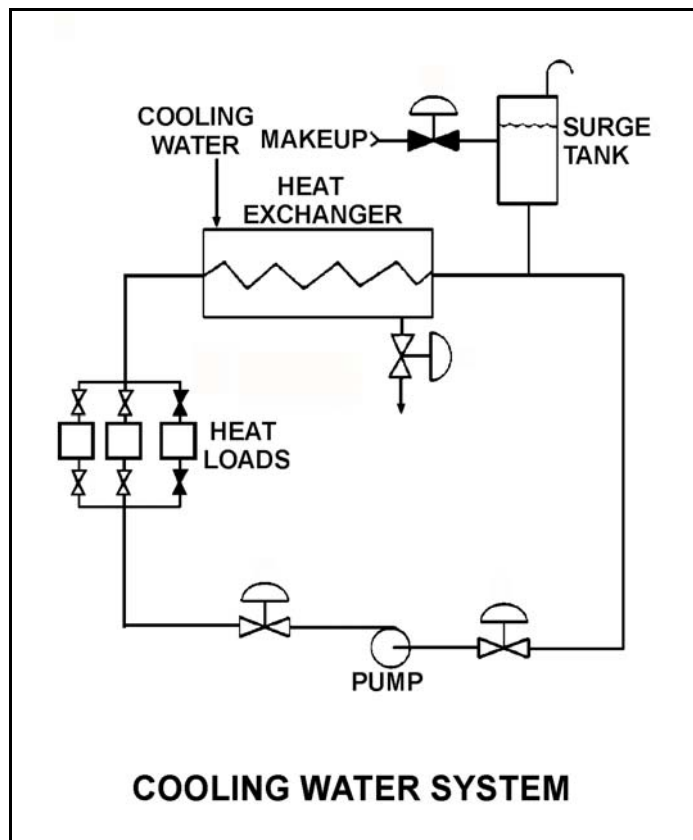

**USNRC GENERIC FUNDAMENTALS EXAMINATION
JUNE 2005 PWR--FORM A**

QUESTION: 13

What is the purpose of the safety/relief valve located between the pump outlet and the discharge isolation valve of most positive displacement pumps?

- A. Protect the pump and suction piping from overpressure if the discharge valve is open during system startup.
- B. Protect the pump and suction piping from overpressure if the suction valve is closed during pump operation.
- C. Protect the pump and discharge piping from overpressure if the discharge valve is closed during pump operation.
- D. Protect the pump and discharge piping from overpressure due to thermal expansion of pump contents when the pump is shutdown with its suction valve closed.

**USNRC GENERIC FUNDAMENTALS EXAMINATION
JUNE 2005 PWR--FORM A**

QUESTION: 14

Two identical 1,000 MW electrical generators are operating in parallel supplying the same isolated electrical bus. The generator output breakers provide identical protection for the generators. Generator A and B output indications are as follows:

<u>Generator A</u>	<u>Generator B</u>
22 KV	22 KV
60.2 Hertz	60.2 Hertz
800 MW	800 MW
50 MVAR (out)	25 MVAR (in)

A malfunction causes the voltage regulator for generator B to slowly and continuously increase the terminal voltage for generator B. If no operator action is taken, generator B output current will...

- A. increase continuously until the output breaker for generator A trips on overcurrent.
- B. increase continuously until the output breaker for generator B trips on overcurrent.
- C. initially decrease, and then increase until the output breaker for generator A trips on overcurrent.
- D. initially decrease, and then increase until the output breaker for generator B trips on overcurrent.

QUESTION: 15

The starting current in an ac motor is significantly higher than the full-load running current because...

- A. little counter electromotive force is induced onto the rotor during motor start.
- B. motor torque production is highest during motor start.
- C. little counter electromotive force is induced onto the stator during motor start.
- D. work performed by the motor is highest during motor start.

**USNRC GENERIC FUNDAMENTALS EXAMINATION
JUNE 2005 PWR--FORM A**

QUESTION: 16

Refer to the drawing of a lube oil heat exchanger (see figure below).

The lube oil heat exchanger is in service with the following inlet temperatures:

Lube oil inlet temperature: 120°F

Cooling water inlet temperature: 60°F

Assuming cooling water flow rate is greater than lube oil flow rate, which one of the following sets of heat exchanger outlet temperatures is possible? (Neglect any difference between fluid specific heats.)

- | | <u>Lube Oil
Outlet Temp</u> | <u>Cooling Water
Outlet Temp</u> |
|----|---------------------------------|--------------------------------------|
| A. | 90°F | 100°F |
| B. | 90°F | 85°F |
| C. | 95°F | 100°F |
| D. | 95°F | 85°F |

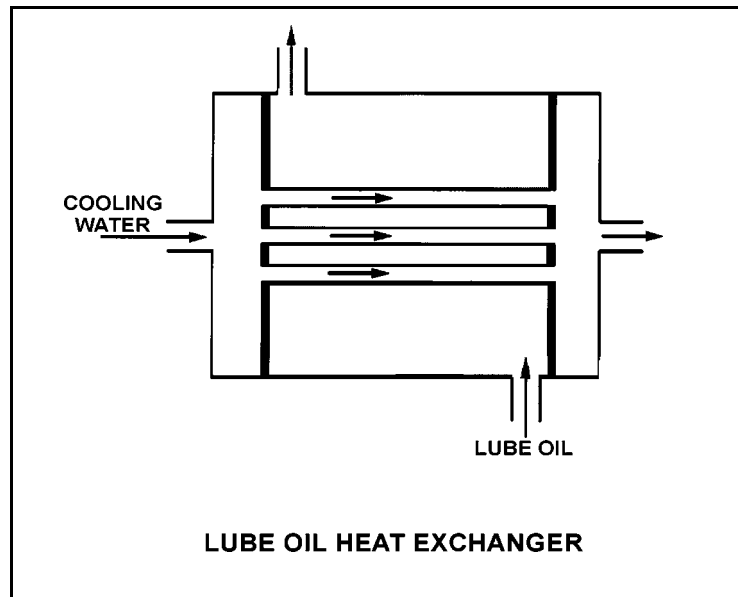

**USNRC GENERIC FUNDAMENTALS EXAMINATION
JUNE 2005 PWR--FORM A**

QUESTION: 17

A main turbine-generator is operating at 80% load with the following initial steady-state temperatures for the main turbine lube oil heat exchanger:

$$\begin{aligned}T_{\text{oil in}} &= 174^{\circ}\text{F} \\T_{\text{oil out}} &= 114^{\circ}\text{F} \\T_{\text{water in}} &= 85^{\circ}\text{F} \\T_{\text{water out}} &= 115^{\circ}\text{F}\end{aligned}$$

After six months of main turbine operation, the following final steady-state lube oil heat exchanger temperatures are observed:

$$\begin{aligned}T_{\text{oil in}} &= 179^{\circ}\text{F} \\T_{\text{oil out}} &= 119^{\circ}\text{F} \\T_{\text{water in}} &= 85^{\circ}\text{F} \\T_{\text{water out}} &= 115^{\circ}\text{F}\end{aligned}$$

Assume that the final cooling water and lube oil flow rates are the same as the initial flow rates, and that the specific heat values for the cooling water and lube oil do not change.

Which one of the following could be responsible for the differences between the initial and final heat exchanger steady-state temperatures?

- A. The heat exchanger tubes have become fouled with scale.
- B. The temperature of the cooling water source has increased.
- C. The final main turbine-generator load is higher than the initial load.
- D. The final main turbine-generator load is lower than the initial load.

**USNRC GENERIC FUNDAMENTALS EXAMINATION
JUNE 2005 PWR--FORM A**

QUESTION: 18

A condensate demineralizer differential pressure (D/P) gauge indicates 4.0 psid at 50% flow rate. Which one of the following combinations of condensate flow and demineralizer D/P observed at various power levels indicates an increase in the accumulation of insoluble corrosion products in the demineralizer?

	<u>CONDENSATE FLOW</u>	<u>DEMINERALIZER D/P (PSID)</u>
A.	25%	0.9
B.	60%	6.3
C.	75%	8.7
D.	100%	15.6

**USNRC GENERIC FUNDAMENTALS EXAMINATION
JUNE 2005 PWR--FORM A**

QUESTION: 19

A demineralizer that has been exposed to _____ should be bypassed because the resin beads may release unwanted ions.

- A. high flow
- B. low flow
- C. high temperature
- D. low temperature

QUESTION: 20

Which one of the following will cause a loss of indication from the remote breaker position indicating lights associated with a typical 480 Vac load supply breaker?

- A. Loss of breaker line voltage
- B. Locally opening the breaker
- C. Burnout of the local breaker position indicating lights
- D. Removing the breaker control power fuses

**USNRC GENERIC FUNDAMENTALS EXAMINATION
JUNE 2005 PWR--FORM A**

QUESTION: 21

Refer to the drawing of a motor and its control circuit (see figure below). (Note: The relay contacts shown follow the standard convention for control circuit drawings.)

The motor has been operating for several hours when it is decided to stop the motor. What is the status of the starting resistors before and after the motor STOP button is depressed?

- A. Initially inserted in the motor circuit; bypassed immediately after the STOP button is depressed.
- B. Initially inserted in the motor circuit; bypassed following a preset time delay after the STOP button is depressed.
- C. Initially bypassed; bypass is removed immediately after the STOP button is depressed.
- D. Initially bypassed; bypass is removed following a preset time delay after the STOP button is depressed.

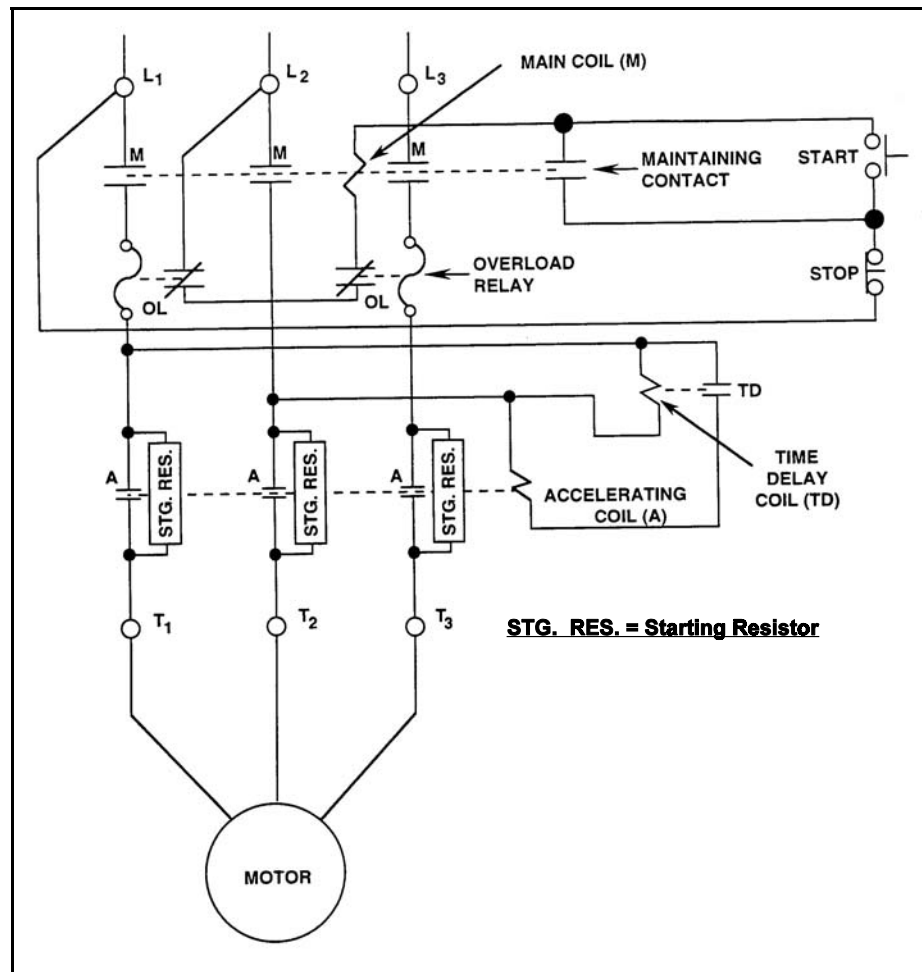

**USNRC GENERIC FUNDAMENTALS EXAMINATION
JUNE 2005 PWR--FORM A**

QUESTION: 22

A 480 Vac motor control center supplies a load through a breaker and a manual disconnect. If both isolation devices are operated to isolate the load, which one of the following sequences will provide the greatest level of personnel safety when deenergizing the load for maintenance and when reenergizing the load after the maintenance?

DEENERGIZING

REENERGIZING

- | | |
|--------------------------|-----------------------|
| A. Open breaker first | Shut breaker first |
| B. Open breaker first | Shut disconnect first |
| C. Open disconnect first | Shut breaker first |
| D. Open disconnect first | Shut disconnect first |

QUESTION: 23

In a comparison between a delayed neutron and a prompt neutron born from the same fission event, the prompt neutron is more likely to...

- A. leak out of the core while slowing down.
- B. be captured by a U-238 nucleus at a resonance energy.
- C. be captured by a Xe-135 nucleus.
- D. cause thermal fission of a U-235 nucleus.

**USNRC GENERIC FUNDAMENTALS EXAMINATION
JUNE 2005 PWR--FORM A**

QUESTION: 24

Select the equation that defines K-excess (excess reactivity).

- A. $K_{\text{eff}} + 1$
- B. $K_{\text{eff}} - 1$
- C. $K_{\text{eff}}(1-\text{SDM})$
- D. $1/(1-K_{\text{eff}})$

QUESTION: 25

The following data is given for the fuel in an operating nuclear reactor core:

<u>Nuclide</u>	<u>Delayed Neutron Fraction</u>	<u>Fraction of Total Fuel Composition</u>	<u>Fraction of Total Fission Rate</u>
U-235	0.0065	0.03	0.73
U-238	0.0148	0.96	0.07
Pu-239	0.0021	0.01	0.20

What is the approximate core average delayed neutron fraction for this reactor?

- A. 0.0052
- B. 0.0054
- C. 0.0062
- D. 0.0068

**USNRC GENERIC FUNDAMENTALS EXAMINATION
JUNE 2005 PWR--FORM A**

QUESTION: 26

Which one of the following exhibits the smallest microscopic cross section for absorption of a thermal neutron in an operating nuclear reactor?

- A. Uranium-235
- B. Uranium-238
- C. Samarium-149
- D. Xenon-135

QUESTION: 27

Which one of the following describes the net reactivity effect of a moderator temperature increase in an overmoderated nuclear reactor core?

- A. Negative reactivity will be added because more neutrons will be absorbed at resonance energies while slowing down.
- B. Negative reactivity will be added because more neutrons will be captured by the moderator.
- C. Positive reactivity will be added because fewer neutrons will be absorbed at resonance energies while slowing down..
- D. Positive reactivity will be added because fewer neutrons will be captured by the moderator.

**USNRC GENERIC FUNDAMENTALS EXAMINATION
JUNE 2005 PWR--FORM A**

QUESTION: 28

A nuclear reactor is operating at 85% power with the controlling group of control rods inserted 10%. Which one of the following will cause the differential rod worth of the controlling group to become more negative? (Assume reactor power and control rod position remain constant for each case.)

- A. Fuel temperature increases as fission product gasses accumulate in a fuel rod.
- B. RCS average temperature drifts from 580°F to 575°F.
- C. Core Xe-135 builds up in the lower half of the core.
- D. RCS boron concentration is increased by 5 ppm.

QUESTION: 29

If core quadrant power distribution (sometimes referred as quadrant power tilt or azimuthal tilt) is maintained within design limits, which one of the following conditions is most likely?

- A. Axial power distribution is within design limits.
- B. Radial power distribution is within design limits.
- C. Nuclear instrumentation is indicating within design accuracy.
- D. Departure from nucleate boiling ratio is within design limits.

**USNRC GENERIC FUNDAMENTALS EXAMINATION
JUNE 2005 PWR--FORM A**

QUESTION: 30

A fission product poison can be differentiated from all other fission products in that a fission product poison...

- A. will be radioactive for thousands of years.
- B. has a relatively high probability of absorbing a fission neutron.
- C. is produced in a relatively large percentage of thermal fissions.
- D. is formed as a gas and is contained within the fuel pellets and fuel rods.

QUESTION: 31

A nuclear reactor startup is being performed 5 hours after a reactor scram from 100% equilibrium power. The nuclear power plant is being returned to rated power at 2.0%/minute instead of the normal rate of 0.5%/minute.

At the faster rate of power increase, the minimum amount of core xenon will occur _____; and the amount of equilibrium core xenon will be _____.

- A. sooner; the same
- B. sooner; smaller
- C. later; the same
- D. later; smaller

**USNRC GENERIC FUNDAMENTALS EXAMINATION
JUNE 2005 PWR--FORM A**

QUESTION: 32

Instead of using a higher concentration of soluble boric acid, burnable poisons are installed in a new nuclear reactor core to...

- A. prevent boron precipitation during normal operation.
- B. establish a more negative moderator temperature coefficient.
- C. allow control rods to be withdrawn farther upon initial criticality.
- D. maintain reactor coolant pH above a minimum acceptable value.

QUESTION: 33

As criticality is approached during a nuclear reactor startup, equal insertions of positive reactivity will result in a _____ absolute change in equilibrium neutron count rate and a _____ time to reach each new equilibrium neutron flux level.

- A. smaller; shorter
- B. smaller; longer
- C. greater; shorter
- D. greater; longer

**USNRC GENERIC FUNDAMENTALS EXAMINATION
JUNE 2005 PWR--FORM A**

QUESTION: 34

Refer to the drawing that shows a graph of startup rate versus time (see figure below). Both axes have linear scales.

Which one of the following events, occurring at time = 0 seconds, would cause the reactor response shown on the graph?

- A. A step addition of positive reactivity to a reactor that is initially stable in the power range and remains in the power range for the duration of the 120-second interval shown.
- B. A constant rate of positive reactivity addition to a reactor that is initially stable in the power range and remains in the power range for the duration of the 120-second interval shown.
- C. A step addition of positive reactivity to a reactor that is initially critical in the source range and remains below the point of adding heat for the duration of the 120-second interval shown.
- D. A constant rate of positive reactivity addition to a reactor that is initially critical in the source range and remains below the point of adding heat for the duration of the 120-second interval shown.

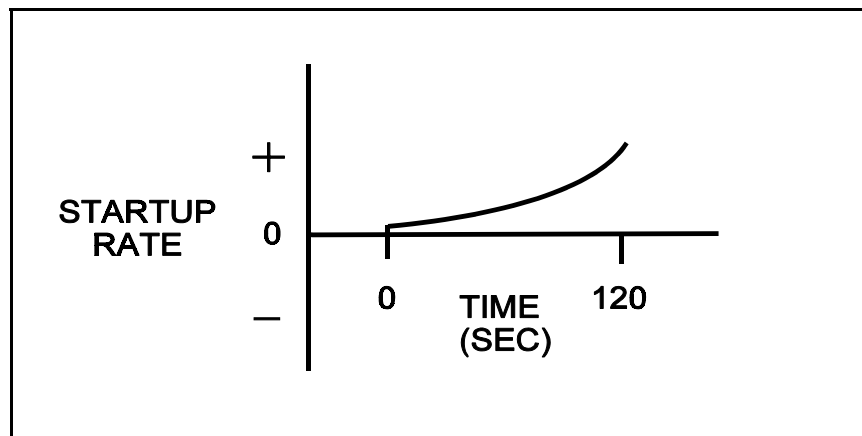

**USNRC GENERIC FUNDAMENTALS EXAMINATION
JUNE 2005 PWR--FORM A**

QUESTION: 35

A nuclear reactor is stable at the point of adding heat (POAH) with the average reactor coolant temperature at 550°F during a startup. Control rods are then withdrawn a few inches to increase steam generator steaming rate.

When the reactor stabilizes, reactor power will be _____ the POAH, and average reactor coolant temperature will be _____ 550°F.

- A. greater than; equal to
- B. greater than; greater than
- C. equal to; equal to
- D. equal to; greater than

QUESTION: 36

A nuclear power plant had been operating at 100% power for six months when a steam line rupture occurred that resulted in a reactor trip and all steam generators (S/Gs) blowing down (emptying) after approximately 1 hour. The S/G blowdown caused reactor coolant system (RCS) temperature to decrease to 400°F at which time an RCS heatup began.

Given the following information, what was the average RCS heatup rate during the 5 minutes immediately after all S/Gs became empty?

Reactor rated thermal power:	3,400 MWt
Decay heat:	1.0% rated thermal power
Reactor coolant pumps heat input to the RCS:	15 MWt
RCS total heat loss:	Negligible
RCS c_p :	1.1 Btu/lbm-°F
RCS inventory (less pressurizer):	475,000 lbm

- A. 8 to 15°F/hour
- B. 50 to 75°F/hour
- C. 100 to 150°F/hour
- D. 300 to 350°F/hour

**USNRC GENERIC FUNDAMENTALS EXAMINATION
JUNE 2005 PWR--FORM A**

QUESTION: 37

Which one of the following is arranged from the lowest pressure to the highest pressure?

- A. 2 psig, 12 inches Hg absolute, 8 psia
- B. 2 psig, 18 inches Hg absolute, 8 psia
- C. 12 psia, 20 inches Hg absolute, 2 psig
- D. 12 psia, 30 inches Hg absolute, 2 psig

QUESTION: 38

A reactor trip occurred 10 minutes ago due to a loss of coolant accident. Emergency coolant injection is in progress and pressurizer level is increasing. Current pressurizer conditions are as follows:

Pressurizer liquid temperature	= 540°F
Pressurizer vapor temperature	= 607°F
Pressurizer pressure	= 1,410 psia
Pressurizer level	= 60%

Given these conditions, the pressurizer liquid is _____ and the pressurizer vapor is _____.

- A. saturated; saturated
- B. saturated; superheated
- C. subcooled; saturated
- D. subcooled; superheated

**USNRC GENERIC FUNDAMENTALS EXAMINATION
JUNE 2005 PWR--FORM A**

QUESTION: 39

An open vessel contains one pound-mass of water at 206°F and atmospheric pressure. Which one of the following will be caused by the addition of 3.0 Btu to the water?

- A. The water temperature will rise by approximately 3°F.
- B. Approximately 3% of the water mass will vaporize.
- C. The water density will decrease by approximately 3%.
- D. The water will become superheated by approximately 3°F.

QUESTION: 40

Which one of the following is essentially a constant-enthalpy process?

- A. Throttling of main steam through main turbine steam inlet valves
- B. Condensation of turbine exhaust in a main condenser
- C. Expansion of main steam through the stages of an ideal turbine
- D. Steam flowing through an ideal convergent nozzle

**USNRC GENERIC FUNDAMENTALS EXAMINATION
JUNE 2005 PWR--FORM A**

QUESTION: 41

Consider the thermal efficiency of a nuclear power plant operating at rated power.

If the pressure at which saturated steam is produced in the steam generators is increased, thermal efficiency will _____; and if the temperature of the feedwater entering the steam generators is increased, thermal efficiency will _____.

- A. increase; increase
- B. increase; decrease
- C. decrease; increase
- D. decrease; decrease

USNRC GENERIC FUNDAMENTALS EXAMINATION
JUNE 2005 PWR--FORM A

QUESTION: 42

Refer to the drawing of two lengths of 6-inch piping, each containing an identical automatic isolation valve. The actual pipe lengths are proportional to their symbols in the drawing

Water at 65°F is flowing at 1,000 gpm through each pipe. If the isolation valves suddenly and simultaneously close, valve A and its associated piping will experience a maximum pressure that is _____ the maximum pressure experienced by valve B and its associated piping. The pressure spike will dissipate quicker in the _____ length of pipe.

- A. equal to; shorter
- B. equal to; longer
- C. less than; shorter
- D. less than; longer

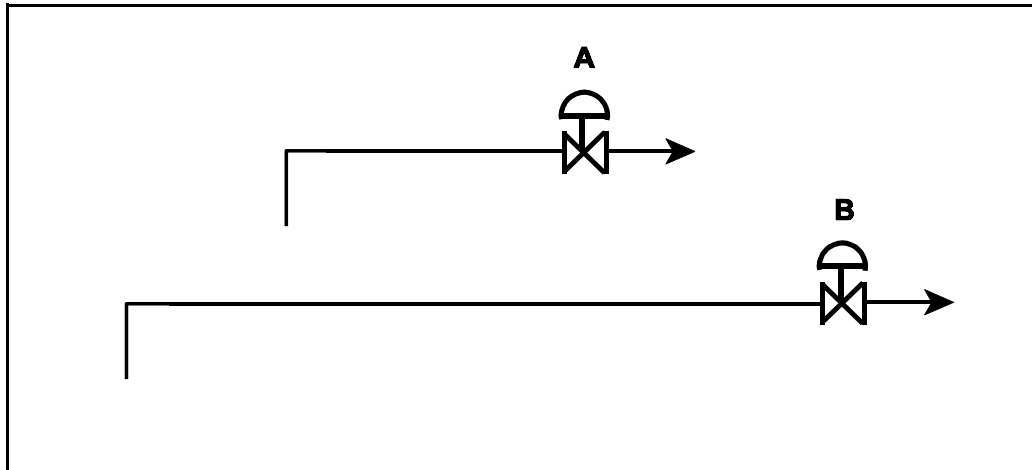

**USNRC GENERIC FUNDAMENTALS EXAMINATION
JUNE 2005 PWR--FORM A**

QUESTION: 43

Refer to the drawing of a venturi in a main steamline (see figure below). The venturi inlet and outlet pipe diameters are equal.

A main steamline break downstream of the venturi causes the main steam mass flow rate through the venturi to increase. Soon, the steam reaches sonic velocity in the throat of the venturi.

How will the main steam mass flow rate through the venturi be affected as the steam pressure downstream of the venturi continues to decrease?

- A. It will continue to increase at a rate that is dependent on the steam velocity in the throat of the venturi.
- B. It will continue to increase at a rate that is dependent on the differential pressure ($P_1 - P_2$) across the venturi.
- C. It will not continue to increase because the steam velocity cannot increase above sonic velocity in the throat of the venturi.
- D. It will not continue to increase because the differential pressure ($P_1 - P_2$) across the venturi cannot increase further once the steam reaches sonic velocity in the throat of the venturi.

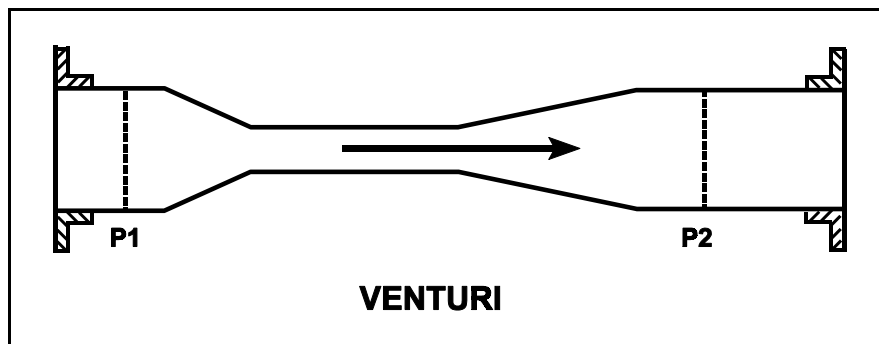

**USNRC GENERIC FUNDAMENTALS EXAMINATION
JUNE 2005 PWR--FORM A**

QUESTION: 44

A nuclear reactor is producing 200 MW of core thermal power. Reactor coolant pumps are adding 10 MW of additional thermal power into the coolant system based on heat balance calculations. The core is rated at 1,330 MW thermal power.

Which one of the following is the core thermal power in percent?

- A. 14.0%
- B. 14.3%
- C. 15.0%
- D. 15.8%

QUESTION: 45

If ΔT is the temperature difference between the fuel rod clad surface and the coolant, which one of the following describes the heat transfer from a fuel rod experiencing departure from nucleate boiling?

- A. Steam bubbles begin to form on the fuel rod clad, causing a rapid decrease in the heat flux from the fuel rod for a given ΔT .
- B. Steam bubbles completely blanket the fuel rod clad, causing a rapid increase in the heat flux from the fuel rod for a given ΔT .
- C. Steam bubbles begin to blanket the fuel rod clad, causing a rapid increase in the ΔT for a given heat flux.
- D. Steam bubbles completely blanket the fuel rod clad, causing a rapid decrease in the ΔT for a given heat flux.

**USNRC GENERIC FUNDAMENTALS EXAMINATION
JUNE 2005 PWR--FORM A**

QUESTION: 46

During a nuclear power plant cooldown and depressurization with forced circulation, reactor coolant system (RCS) loop flow and reactor coolant pump (RCP) motor current indications become erratic. These abnormal indications are most likely caused by...

- A. RCP cavitation.
- B. RCP runout.
- C. RCS loop water hammer.
- D. RCS hot leg saturation.

QUESTION: 47

Single-phase coolant flow resistance (head loss) in a nuclear reactor core is directly proportional to the square of coolant _____ and inversely proportional to _____.

- A. velocity; fuel assembly length
- B. temperature; fuel assembly length
- C. velocity; coolant channel cross-sectional area
- D. temperature; coolant channel cross-sectional area

**USNRC GENERIC FUNDAMENTALS EXAMINATION
JUNE 2005 PWR--FORM A**

QUESTION: 48

Adequate core bypass flow is needed to...

- A. cool the excore nuclear instrument detectors.
- B. provide reactor coolant pump minimum flow requirements.
- C. prevent stratification of reactor coolant inside the reactor vessel.
- D. equalize the temperatures between the reactor vessel and the upper vessel head.

QUESTION: 49

A nuclear reactor is operating at 80% power with all control rods fully withdrawn. Compared to a 50% insertion of one control rod, a 50% insertion of a group (or bank) of control rods will cause a _____ increase in the axial peaking hot channel factor and a _____ increase in the radial peaking hot channel factor. (Assume reactor power remains constant.)

- A. larger; smaller
- B. larger; larger
- C. smaller; smaller
- D. smaller; larger

**USNRC GENERIC FUNDAMENTALS EXAMINATION
JUNE 2005 PWR--FORM A**

QUESTION: 50

A nuclear reactor is shut down for refueling. During the shutdown, a reactor vessel metal specimen is removed from the reactor vessel for testing. The specimen was last tested six years ago. During the subsequent six years, the reactor has completed several 18-month fuel cycles with an average power level of 85%.

The test determines that the nil-ductility transition (NDT) temperature of the specimen has remained unchanged at 44°F since it was last tested. Which one of the following conclusions is warranted?

- A. The test results are credible, however, the reactor vessel is more susceptible to brittle fracture now than six years ago.
- B. The test results are credible, however, the reactor vessel is less susceptible to brittle fracture now than six years ago.
- C. The test results are questionable because the specimen NDT temperature should have increased since it was last tested.
- D. The test results are questionable because the specimen NDT temperature should have decreased since it was last tested.

***** FINAL ANSWER KEY *****

**JUNE 2005 NRC GENERIC FUNDAMENTALS EXAMINATION
PRESSURIZED WATER REACTOR - ANSWER KEY**

<u>FORM A</u>	<u>FORM B</u>	<u>ANS.</u>	<u>FORM A</u>	<u>FORM B</u>	<u>ANS.</u>
1	15	C	26	40	B
2	16	B	27	41	D
3	17	D	28	42	C
4	18	A	29	43	B
5	19	A	30	44	B
6	20	A	31	45	A
7	21	C	32	46	B
8	22	D	33	47	D
9	23	B	34	48	D
10	24	D	35	49	B
11	25	B	36	50	D
12	26	D	37	1	D
13	27	C	38	2	D
14	28	D	39	3	A
15	29	C	40	4	A
16	30	B	41	5	A
17	31	A	42	6	A
18	32	B	43	7	C
19	33	C	44	8	C
20	34	D	45	9	C
21	35	C	46	10	A
22	36	B	47	11	C
23	37	A	48	12	D
24	38	B	49	13	A
25	39	C	50	14	C