

**Questions with Illustrations**  
**as of August 15, 2008**

**ABS 210145 VER 1**

**Illustration:** GS-0158 (Handbook of Instrumentation & Control, Kallen)

The ball float shown in the illustration is 9 inches in diameter and floats in a liquid with a specific gravity of 0.9. If the effective length (EL) is 18 inches and “L” is 3 inches, how many pounds of force will be available at “X” if there is no mechanical loss?

A. 36

**Correct Answer:** (Available Operating Force from Float Ball) x (EL) = (L) x (X)

From Ball Float Data Chart: Float with a 9 inch ball diameter floating in a liquid with a S.G. of 0.9 has an available operating force of 6 pounds.

$$(6 \text{ lbs.})(18 \text{ inches}) = (3 \text{ inches})(X)$$

$$X = \frac{(6 \text{ lbs.})(18 \text{ inches})}{3 \text{ inches}}$$

$$X = \frac{108}{3}$$

$$X = 36 \text{ lbs.}$$

B. 108

Incorrect Answer: Choice “A” is the only correct answer.

C. 162

Incorrect Answer: Choice “A” is the only correct answer.

D. 324

Incorrect Answer: Choice “A” is the only correct answer.

GS-0158

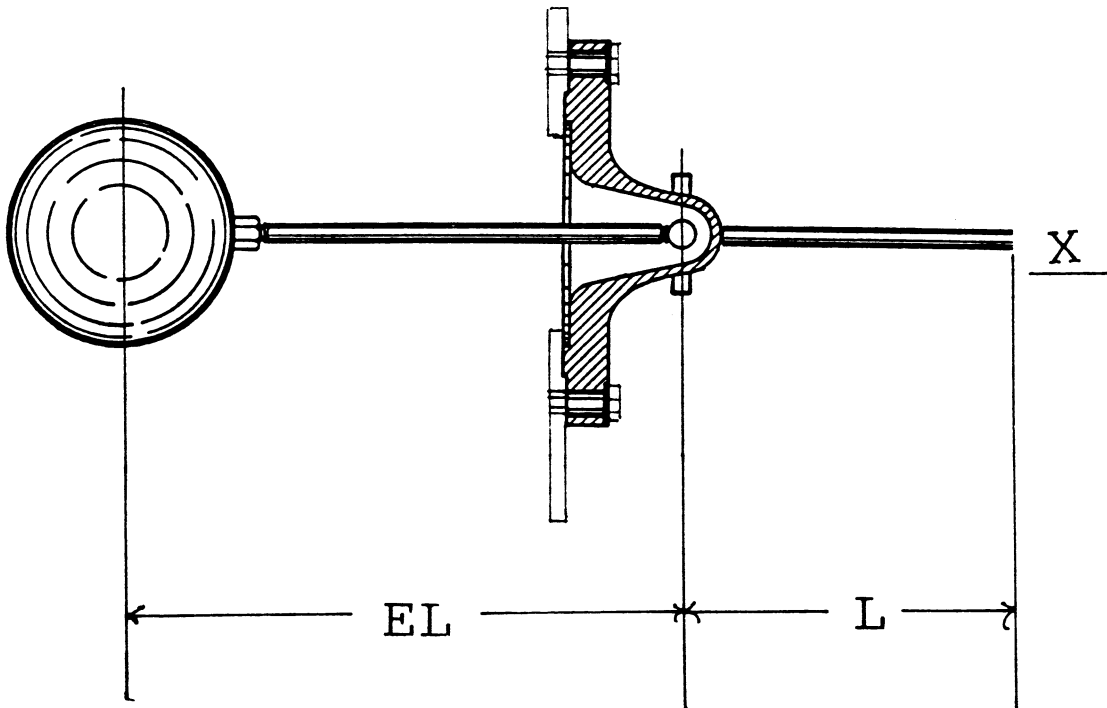
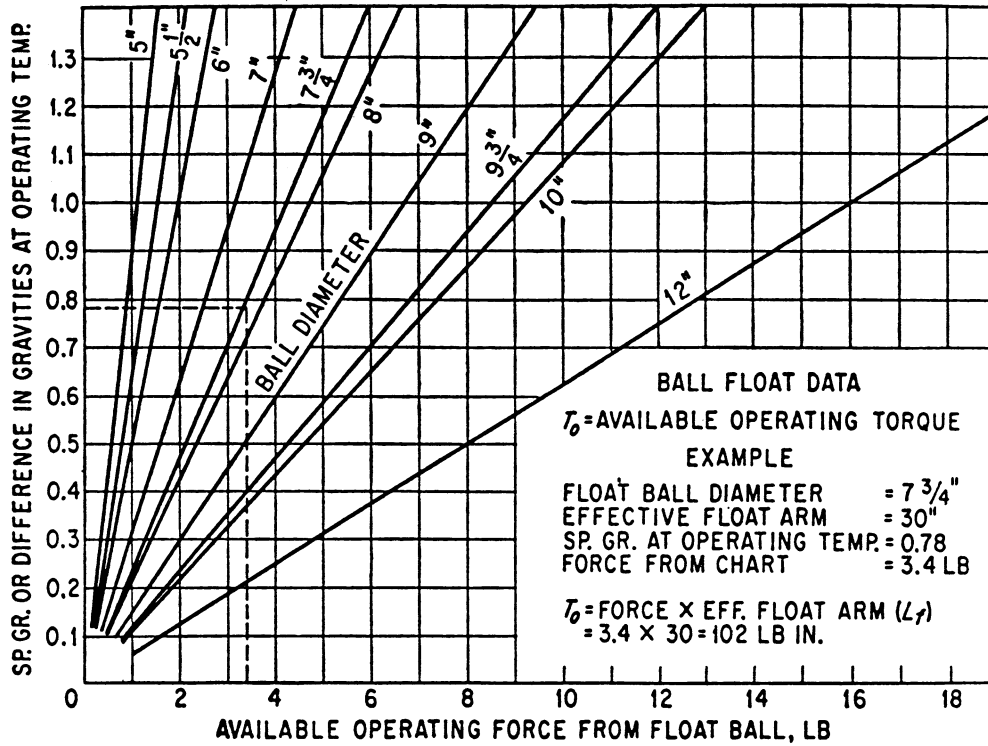

**ABS 280349 VER 1**

**Illustration:** MO-0112 (Westfalia Separator Bowl Assembly)

The device labeled “A”, shown in the illustration, is known as the \_\_\_\_\_.

A. centripetal pump cover

Incorrect Answer: The device labeled “B” is the centripetal pump cover.

B. bowl assembly hood

Incorrect Answer: The device labeled “D” is the bowl assembly hood, or bowl top.

C. regulating ring

**Correct Answer:** The device labeled “A” is known as the regulating ring.

D. kinetic converter

Incorrect Answer: The centripetal pump, or kinetic converter, is not labeled in the illustration.

MO-0112

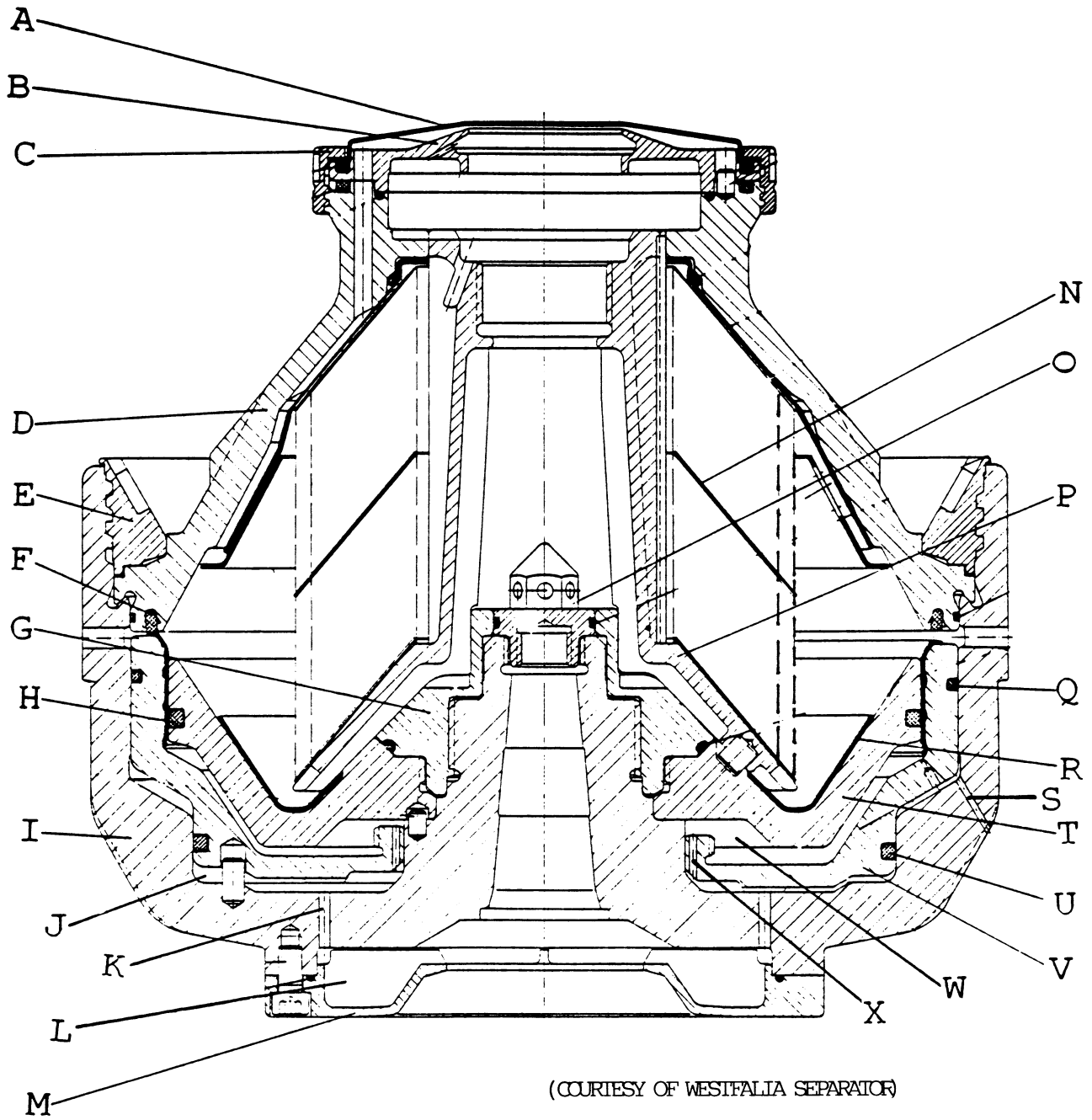

(COURTESY OF WESTFALIA SEPARATOR)

**ABS 231406 VER 4**

**Illustration:** EL-0084 (Preventive Maintenance of Electrical Equipment, Hubert)

Figure “D” of the diagram shown in the illustration has a turns ratio of four to one. If a three-phase 440 volt supply is connected to terminals ‘a-b-c’, what voltage should develop across terminals ‘a-b-c’?

A. 64 volts

**Correct Answer:** Figure “D” is a “Wye-Delta” transformer arrangement.

$$E_{HV} = E_{LV} \times (\text{Turn Ratio} \times 1.73)$$

$$E_{LV} = E_{HV} \div (\text{Turn Ratio} \times 1.73)$$

$$E_{LV} = 440 \text{ V} \div (4 \times 1.73)$$

$$E_{LV} = 440 \text{ V} \div 6.92$$

$$E_{LV} = 63.58 \text{ volts} \approx 64 \text{ volts}$$

B. 110 volts

Incorrect Answer: “A” is the only correct answer.

C. 190 volts

Incorrect Answer: “A” is the only correct answer.

D. 762 volts

Incorrect Answer: “A” is the only correct answer.

EL-0084

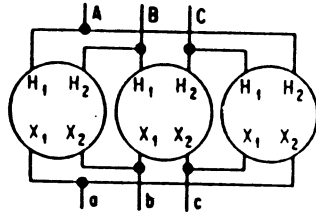

A

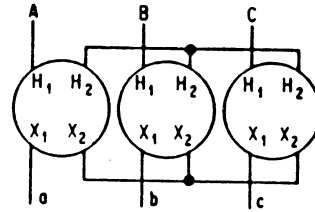

B

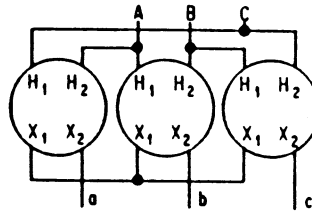

C

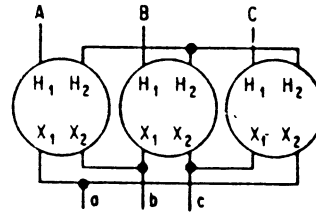

D

**ABS 231204 VER 1**

**Illustration:** EL-0075 (Basic Electricity, NAVPERS)

If the total source voltage of the three-wire distribution system shown in the illustration is 240 volts, what is the voltage across the load L5? ( NOTE: Kirchhoff's voltage and current laws apply).

A. 110.4 volts

Incorrect Answer: Choice "D" is the only correct answer.

B. 112.2 volts

Incorrect Answer: Choice "D" is the only correct answer.

C. 113.0 volts

Incorrect Answer: Choice "D" is the only correct answer.

D. 114.8 volts

**Correct Answer:**

1. To find load voltage  $E_5$ , the algebraic sum of the voltages around loop *nadpmn* is calculated (Kirchhoff's Voltage Law).

Starting at *n*,

$$E_{S2} = I_{mn}(R_{mn}) + E_5 + I_{pd}(R_{pd}) - I_{ad}(R_{ad})$$

2. Calculate currents for  $I_{mn}$ ,  $I_{pd}$ , and  $I_{ad}$  (Kirchhoff's Current Law) :

$$I_{mn} = I_{mk} + I_{mp} = 12a + 6a = 18a$$

$$I_{pd} = I_{mp} + I_{fp}$$

$$I_{pd} = I_{mp} + (I_{hf} - I_{fe}) \quad I_{hf} = I_{kh} - I_{gh} = 12a - 8a = 4a$$

$$I_{pd} = 6a + (4a - 4a) = 6a$$

$$I_{ad} = I_{dc} - I_{pd} = 10a - 6a = 4a$$

3. Utilizing the equation calculated in Step 1, solve for load voltage  $E_5$  :

$$E_{S2} = I_{mn}(R_{mn}) + E_5 + I_{pd}(R_{pd}) - I_{ad}(R_{ad})$$

$$E_5 = E_{S2} + I_{ad}(R_{ad}) - I_{pd}(R_{pd}) - I_{mn}(R_{mn})$$

$$E_5 = 120 \text{ volts} + 4a(0.2 \text{ ohms}) - 6a(0.1 \text{ ohms}) - 18a(0.3 \text{ ohms})$$

$$E_5 = 120 \text{ volts} + 0.8 \text{ volts} - 0.6 \text{ volts} - 5.4 \text{ volts}$$

$$E_5 = 114.8 \text{ volts}$$



EL-0075

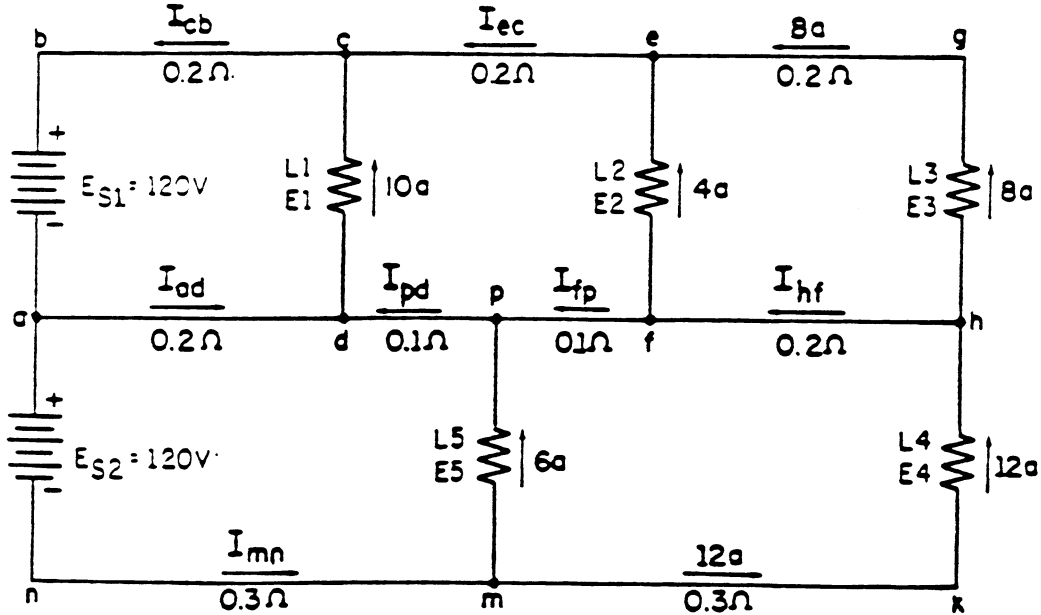

**ABS 246210 VER 3**

**Illustration:** EL-0065 (Basic Electronics, Grob)

The leads of the device in figure “B” shown in the illustration are named \_\_\_\_\_.

A. source, gate and drain

**Correct Answer:** Figure “B” is the symbol for a JFET (Junction Field Effect Transistor) and the leads are named source, gate, and drain.

B. emitter, base and collector

Incorrect Answer: “A” is the only correct answer.

C. emitter, base 1 and base 2

Incorrect Answer: “A” is the only correct answer.

D. anode, cathode and gate

Incorrect Answer: “A” is the only correct answer.

EL-0065

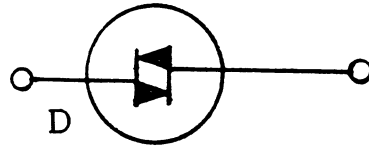
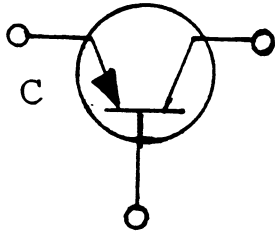
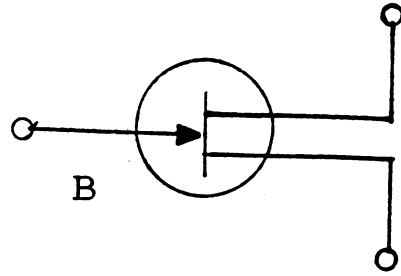
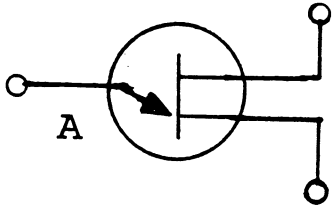

**ABS 246809 VER 3**

**Illustration:** EL-0087 (Basic Electronics, Grob)

If a frequency of 16.8 kHz were measured at the output of 'FF-C' of the circuit shown in the illustration, the clock frequency would be \_\_\_\_\_.

A. 8.4 kHz

Incorrect Answer: "C" is the only correct answer.

B. 50.4 kHz

Incorrect Answer: "C" is the only correct answer.

C. 134.4 kHz

**Correct Answer:** The circuit shown in the illustration is a binary counter and consists of three JK type flip-flops (FF). The input frequency of the clock-pulse (Clk) is divided in multiples of two in three successive steps through the flip-flops, thus the frequency at the output of 'FF-C' is the clock input frequency divided by eight.

$$\text{Output Frequency} = \text{Input Frequency} \div (2) (2) (2)$$

$$\text{Output Frequency} = \text{Input Frequency} \div 8$$

$$\text{Input Frequency} = \text{Output Frequency} (8)$$

$$\text{Input Frequency} = 16.8 \text{ kHz} (8) = 134.4 \text{ kHz.}$$

D. 1680.0 kHz

Incorrect Answer: "C" is the only correct answer.

EL-0087

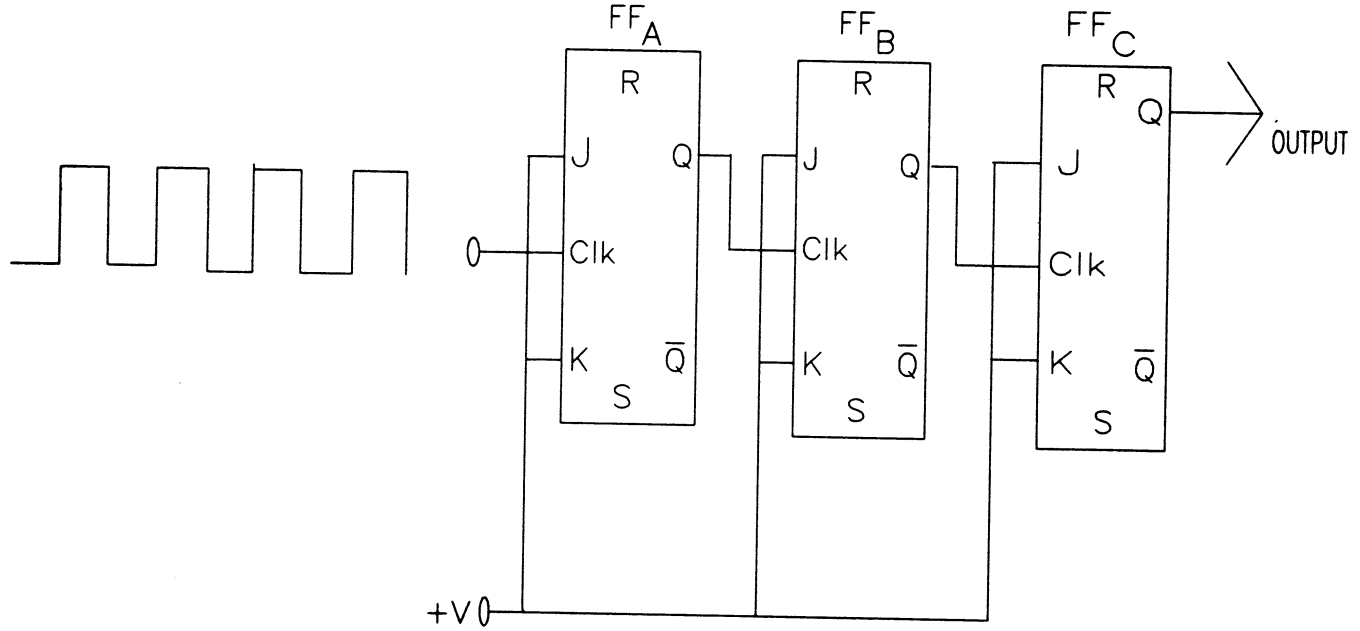

**ABS 210974 VER 1**

**Illustration:** GS-0090 (Machine Tool Metalworking, Feirer & Tatro)

The lathe tool shown as figure “T” in the illustration is commonly known as a/an

\_\_\_\_\_.

A. right-cut roughing tool

**Correct Answer:** The lathe tool shown as figure “T” in the illustration is a right-cut roughing tool.

B. left-cut side-facing tool

**Incorrect Answer:** The lathe tool shown as figure “Q” in the illustration is a left-cut side-facing tool.

C. right-cut side-facing tool

**Incorrect Answer:** The lathe tool shown as figure “R” in the illustration is a right-cut side-facing tool.

D. left-cut knurling tool

**Incorrect Answer:** The lathe tool shown as figure “N” in the illustration is a knurling tool.

GS-0090

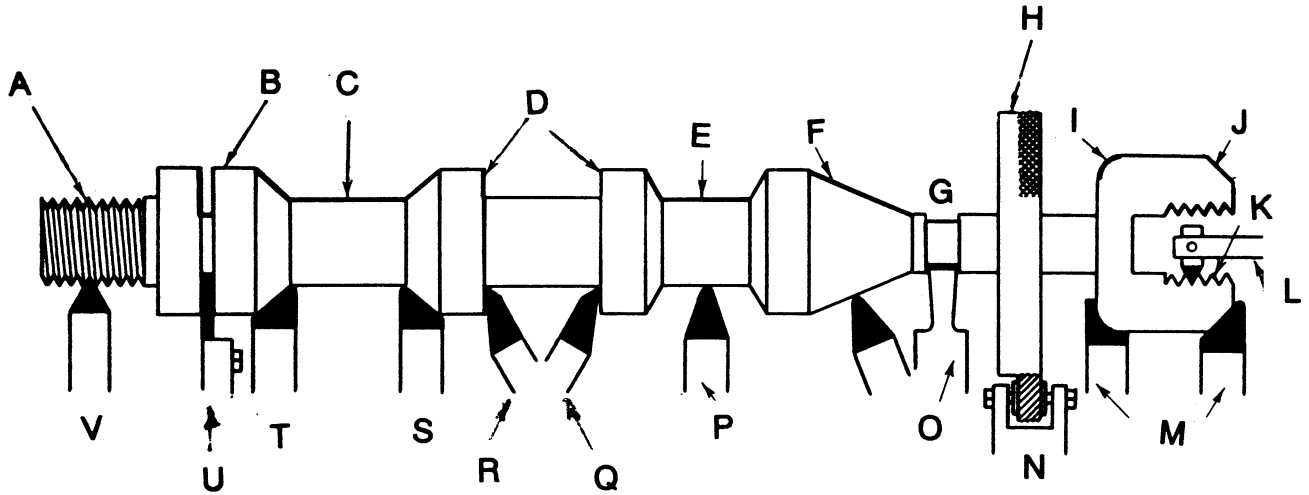

**ABS 268810 VER 1**

**Illustration:** SE-0012 (Marine Engineering, Harrington)

The base ring shown in the illustration is identified by the letter \_\_\_\_\_.

A. A

Incorrect Answer: Item “A” is the thrust collar.

B. C

Incorrect Answer: Items “C” are the leveling plates.

C. D

**Correct Answer:** Item “D” is the base ring.

D. E

Incorrect Answer: Item “E” is the shoe.



SE-0012

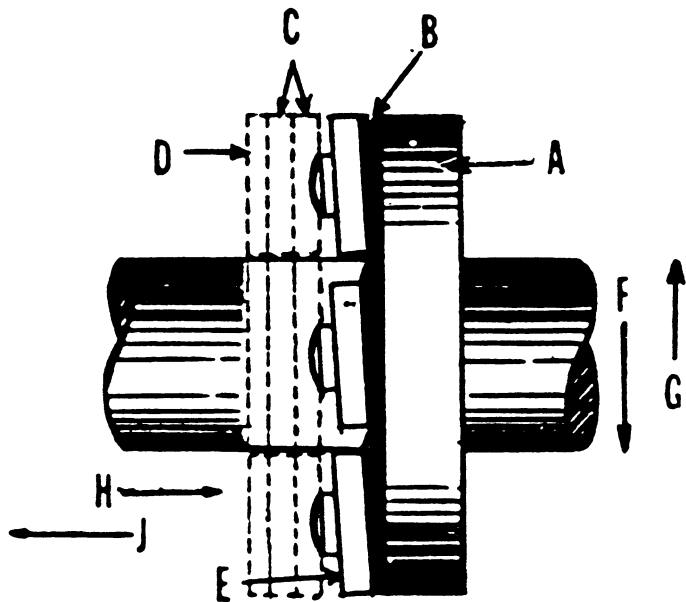

**ABS 265203 VER 3**

**Illustration:** SE-0009 (Modern Marine Engineers Manual, Osbourne)

In the illustration of a typical ship service turbogenerator control system, the device that monitors turbine exhaust pressure is labeled \_\_\_\_\_.

A. K

Incorrect Answer: The item labeled “K” is the main oil pump that is driven by the turbine shaft via a worm gear.

B. J

**Correct Answer:** Item “J” is the back pressure trip, which trips the turbine off the line in the event that the exhaust pressure gets too high.

C. M

Incorrect Answer: Item “M” is the main steam throttle valve through which steam is admitted to the turbine steam chest.

D. F

Incorrect Answer: Item “F” is the pilot valve which controls the flow of oil to the operating cylinder, “O”, which in turn controls the opening or closing of the turbine nozzle valves.

SE-0009

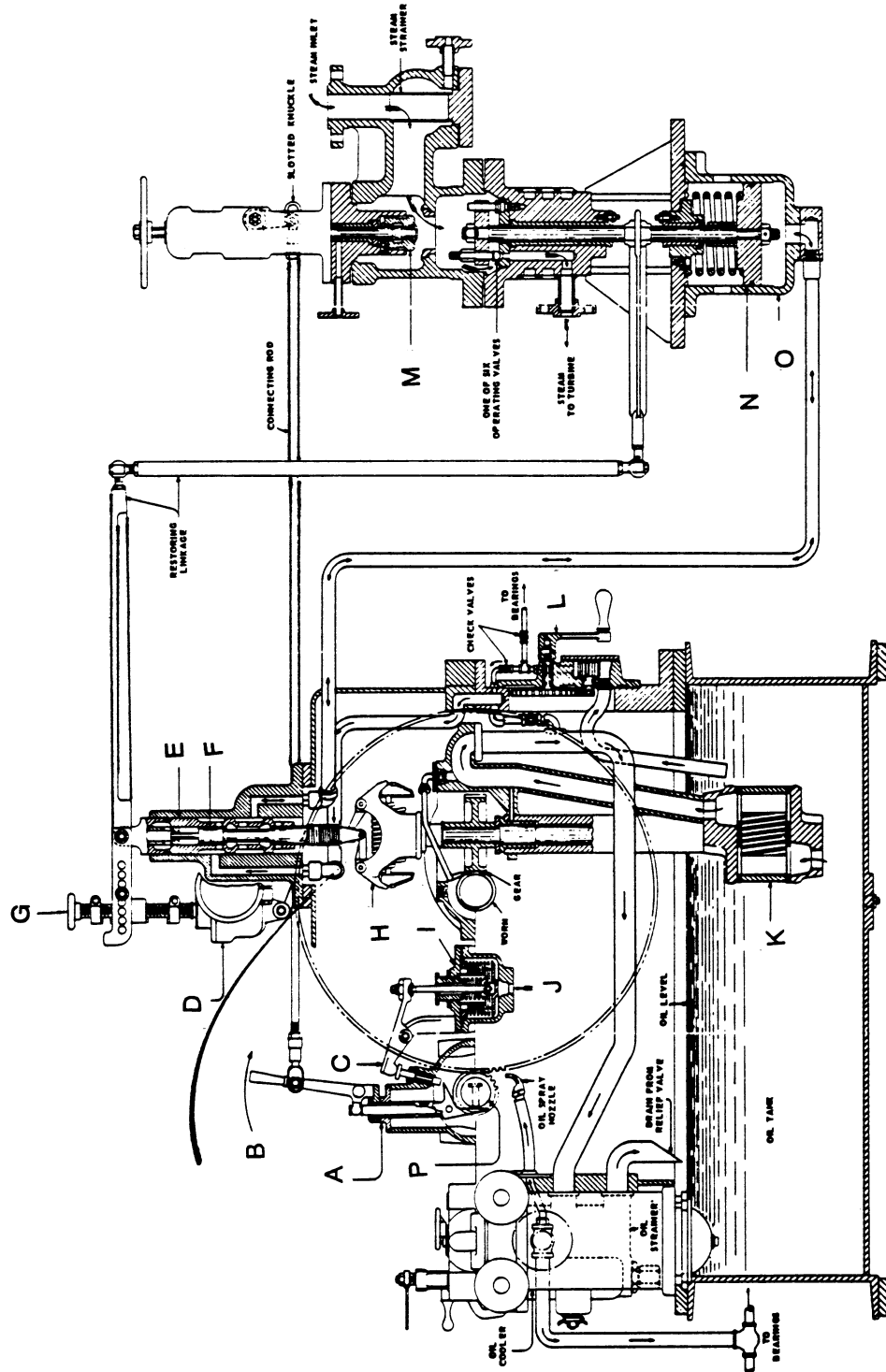

**ABS 250101 VER 6**

**Illustration:** SG-0024 (Marine Engineering, Harrington)

Identify the system shown in the illustration.

A. Bleed steam

**Correct Answer:** Steady-state operation of the main propulsion turbines allows for a constant supply of steam to be extracted from bleed points within the turbines.

Intermediate-pressure (IP) steam is extracted from the high-pressure turbine or from the crossover to the low-pressure turbine. IP bleed steam is typically used for the boiler air heaters and make-up steam for the auxiliary exhaust system. Low-pressure (LP) bleed steam is extracted from the low-pressure turbine, and is typically used for first stage feedwater heating and the distilling plant salt water feed heater.

B. Auxiliary steam

**Incorrect Answer:** The auxiliary steam system supplies steam from the boiler desuperheater directly or by way of reducing stations to all steam driven auxiliaries and ships services not served by the main steam (superheated) system.

C. High pressure drains

**Incorrect Answer:** High-pressure drains, which include low-point drains from the main and auxiliary desuperheated steam piping, are collected in a high pressure drain main and discharged to the deaerating feed tank (DFT).

D. Auxiliary condensate

**Incorrect Answer:** The auxiliary condensate system includes the equipment and piping utilized to collect the condensate from the auxiliary condenser and discharge to the DFT.

SG-0024

FLOWS AND VELOCITIES						
SYM	SIZE IN.	NOM PRESS	VEL. FT. SEC	FLOW LB. HR	CONDITION	SERVICE
A	3	35	78.2	1700	MAX. HEATING REQUIREMENT	STM. TO GALLEY, LAV. & SHIP HEATING
B	6	67	203	22610	MAXIMUM	I.P. TURBINE BLEED
C	4	67	267	13070	MAXIMUM	I.P. BLEED TO EXH. MN.
D	5	67	124	9540	ABS. MAX. POWER	2 BOILER-AIR HEATERS
E	3 1/2	67	125	4770	ABS. MAX. POWER	1 BOILER-AIR HEATER
F	12	13.6 PSIA	190	19420	RATED	L.P. TURBINE BLEED
G	8	13.6 PSIA	160	7220	RATED	L.P. BLEED TO DISTYL. PLANT
H	10	13.6 PSIA	171	12200	RATED	L.P. BLEED TO FIRST STAGE FEED HEATER
J	4	35	418	13070	MAXIMUM	I.P. BLEED TO EXH. MN.
K	6	35	130	11000	RATED	EXH. - 1 MN. FD. PUMP
L	8	35	106	14230	ABS. MAX. POWER	EXH. TO DFT
M	5	33	128	7220	RATED	EXH. TO DISTL. PLANT
N	4	35	105	4309	STAND-BY	EXH. UNLOAD TO DUMP VALVE
P	5	35	130	7297	ASTERN	EMER. EXH. TO BLR. AIR HEATERS
R	3	35	92.2	2000	MAX. HEATING REQUIREMENT	STM. TO H.W. HTR. GALLEY, LAV. & SHIP HEATING
S	3	35	92.2	2000	MAX. HEATING REQUIREMENT	SHORE STM. TO H.W. HTR. GALLEY, LAV. & SHIP HTG.
T	1 1/2	35	67.2	300	RATED	STM. TO H.W. HEATER

\* PSIG EXCEPT AS NOTED

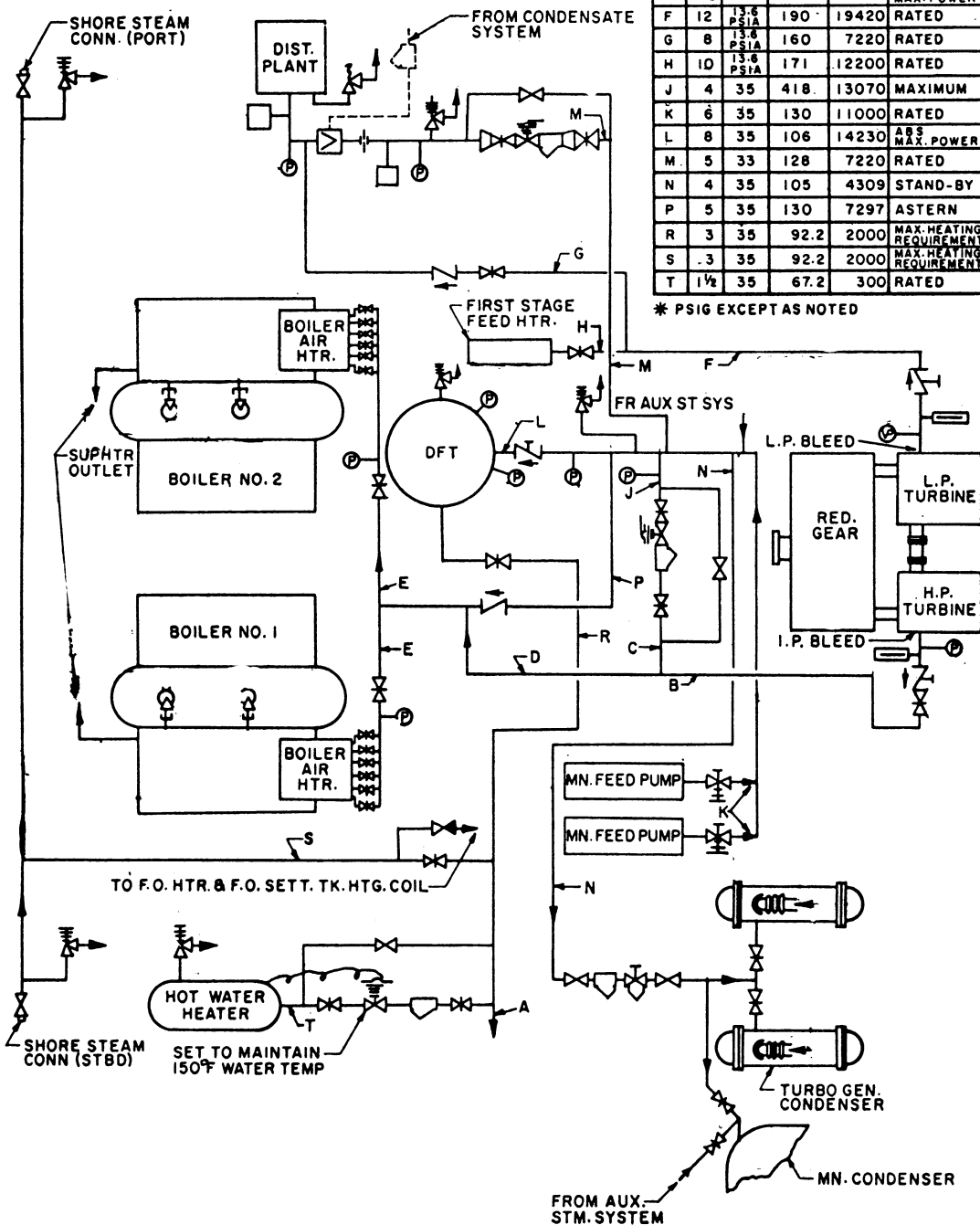

**ABS 223207 VER 1**

**Illustration:** RA-0005 (Machinist's Mate 3 & 2, NAVEDTRA)

Which of the lettered components shown in the illustration indicates the high pressure cutout?

A. E

Incorrect Answer: Component "E" is the low pressure cutout.

B. B

Incorrect Answer: Component "B" is the liquid line solenoid valve.

C. C

**Correct Answer:** Component "C" is the high pressure cutout.

D. F

Incorrect Answer: Component "F" is the evaporator coil back pressure regulating valve.

RA-0005

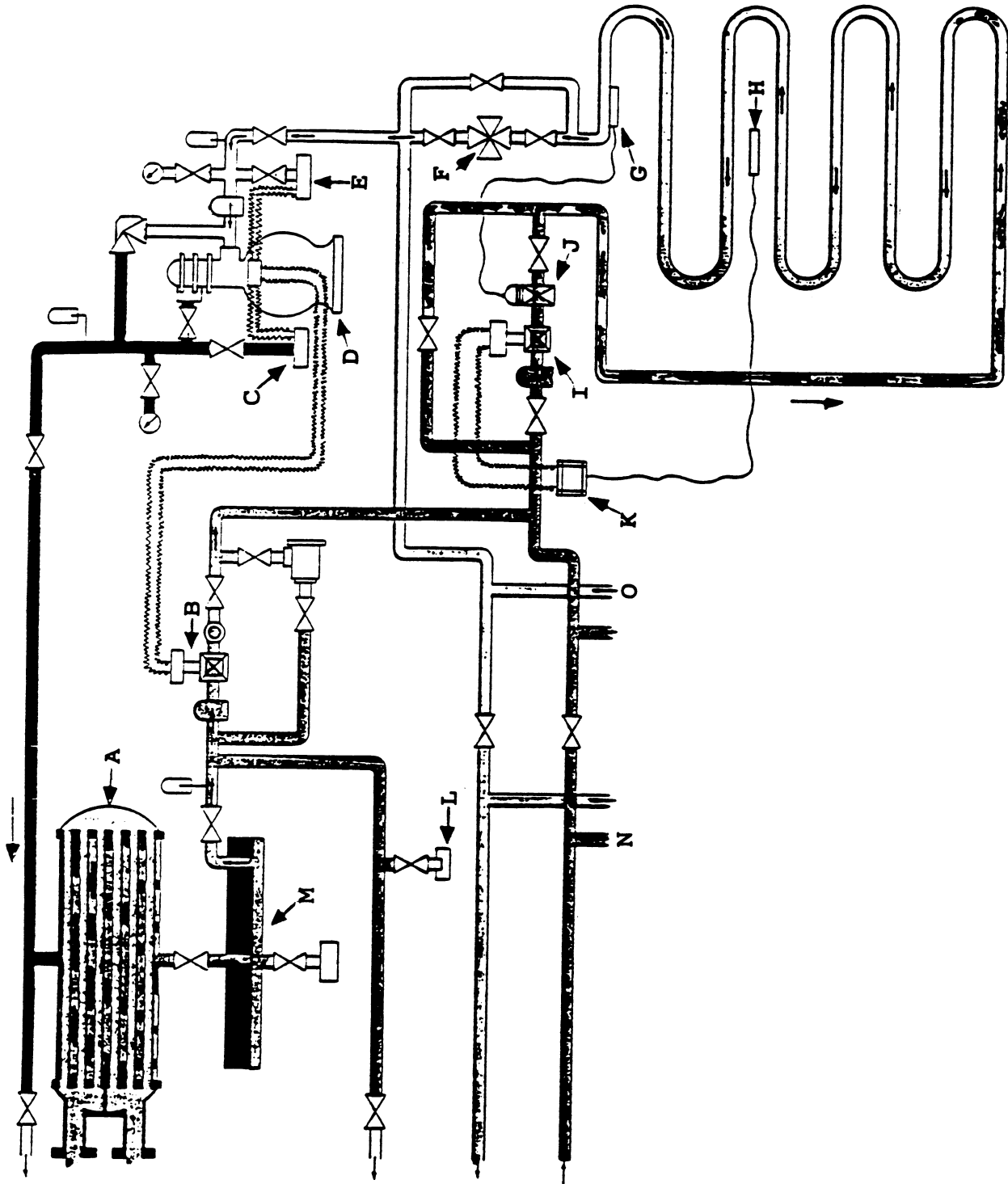

**ABS 248404 VER 1**

**Illustration:** EL-0013 (46 CFR 111.75-5(d))

In the illustration, if BRANCH NO. 1 is a lighting circuit for crew's berthing, 46 CFR requires the maximum fuse rating for that branch to be \_\_\_\_\_.

A. 15 amps

Incorrect Answer: Choice "C" is the only correct answer.

B. 80% of the connected load

Incorrect Answer: Choice "C" is the only correct answer.

C. 20 amps

**Correct Answer:** 46 CFR 111.75-5(d) states "*Overcurrent protection*. Each lighting branch circuit must be protected by an overcurrent device rated at 20 ampere or less, except as allowed under paragraph (e) of this section.

D. 30 amps

Incorrect Answer: Choice "C" is the only correct answer.



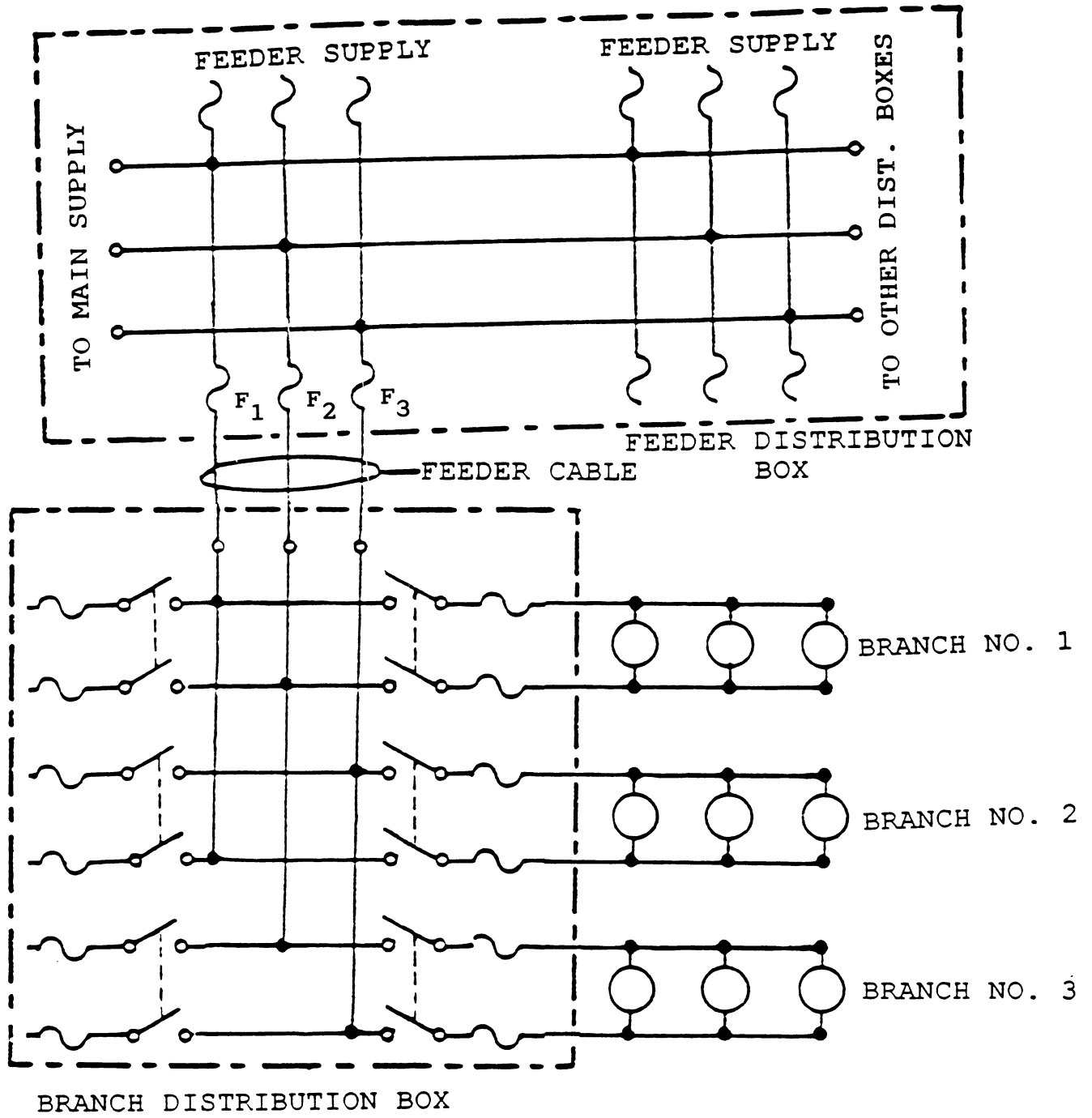

**ABS 212058 VER 4**

**Illustration:** GS-0077 (The Procedure Handbook of Electric Arc Welding)

The weld type illustrated and indicated as '5B' is known as a/an \_\_\_\_\_.

A. X

Incorrect Answer: An "X" weld type does not exist.

B. K

Incorrect Answer: A "K" weld type does not exist.

C. double bevel









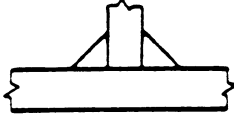

Incorrect Answer: '3B' is a "double bevel groove" weld type.

D. double J

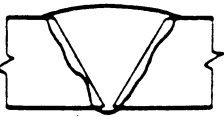
**Correct Answer:** '5B' is a "double J groove" weld type.

GS-0077

TYPES of WELDS

	A	B
1		
2		
3		
4		
5		
6		

**ABS 287912 VER 16**

**Illustration:** MO-0088, (Basic Machines, NAVPERS)

The RPM of gear “D” is 900 and is hobbled with 48 teeth. If gears “A”, “B”, and “C” have 88, 66, and 22 teeth respectively, the RPM of gear ‘A” in the gear train illustration is \_\_\_\_\_.

A. 75.00 RPM

Incorrect Answer: Choice “B” is the only correct answer.

B. 163.64 RPM

**Correct Answer:** The formula for any gear speed reduction problem is:

$$S_2 = S_1 \times (T_1 \div T_2)$$

$S_2$  = speed of last gear in train

$S_1$  = speed of first gear in train

$T_1$  = product of teeth on all drivers

$T_2$  = product of teeth on all driven gears

$$S_1 = 900 \text{ RPM} \quad T_1 = (48)(22) = 1056 \quad T_2 = (66)(88) = 5808$$

$$S_2 = 900 (1056 \div 5808) = 900(.1818) = 163.64 \text{ RPM}$$

C. 100.00 RPM

Incorrect Answer: Choice “B” is the only correct answer.

D. 675.00 RPM

Incorrect Answer: Choice “B” is the only correct answer.

MO-0088

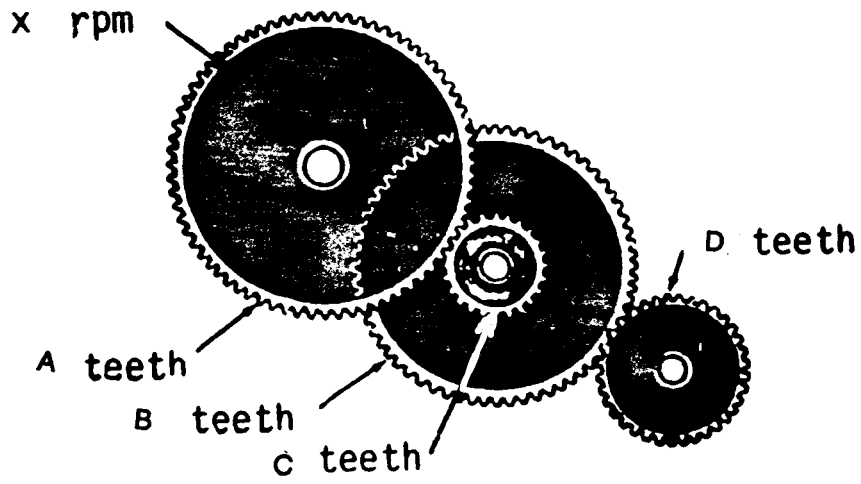

**ABS 280394 VER 1**

**Illustration:** MO-0113

From the graph shown in the illustration, if the separating temperature required is to be 167° F, and the specific gravity of the oil is .98 kg./dm<sup>3</sup> at 59° F, what size regulating ring is required?

A. 86 mm

Incorrect Answer: Choice “C” is the only correct answer.

B. 89 mm

Incorrect Answer: Choice “C” is the only correct answer.

C. 92 mm

**Correct Answer:** For a given separating temperature, the inner diameter of the regulating ring can be determined from the diagram, provided that the specific gravity of the oil at a temperature ranging between 15° and 90° C is known.

Given: Specific Gravity of oil @ 15° C (59° F) = .98 kg/dm<sup>3</sup>

Separating temperature = 167° F = 75° C

Plot of values on the graph indicate that a 92 mm inner diameter regulating ring is required (where solid arrows intersect on graph).

D. 95 mm

Incorrect Answer: Choice “C” is the only correct answer.

MO-0113

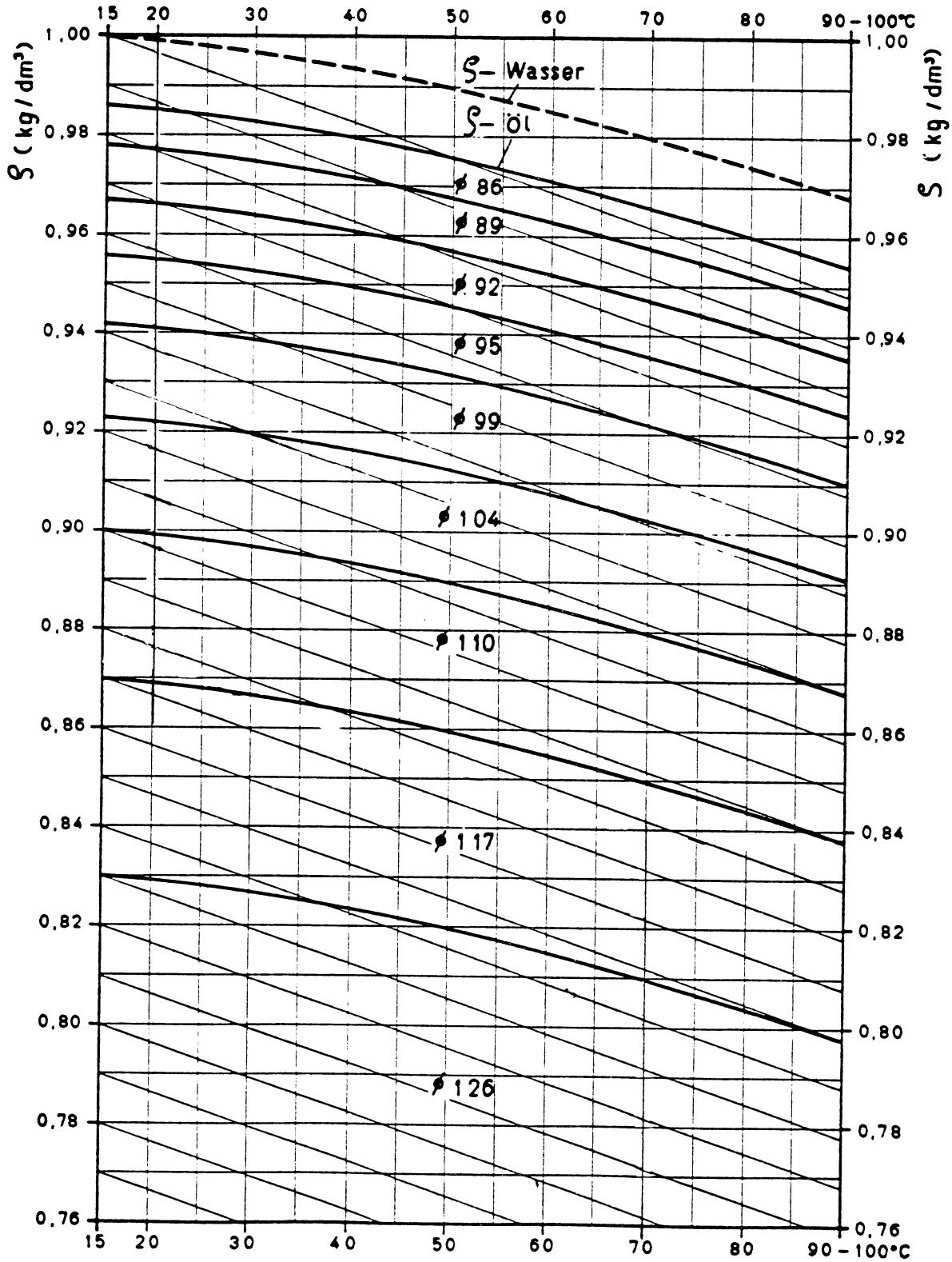

Separating temperature

(COURTESY OF WESTFALIA SEPARATOR)

MO-0113

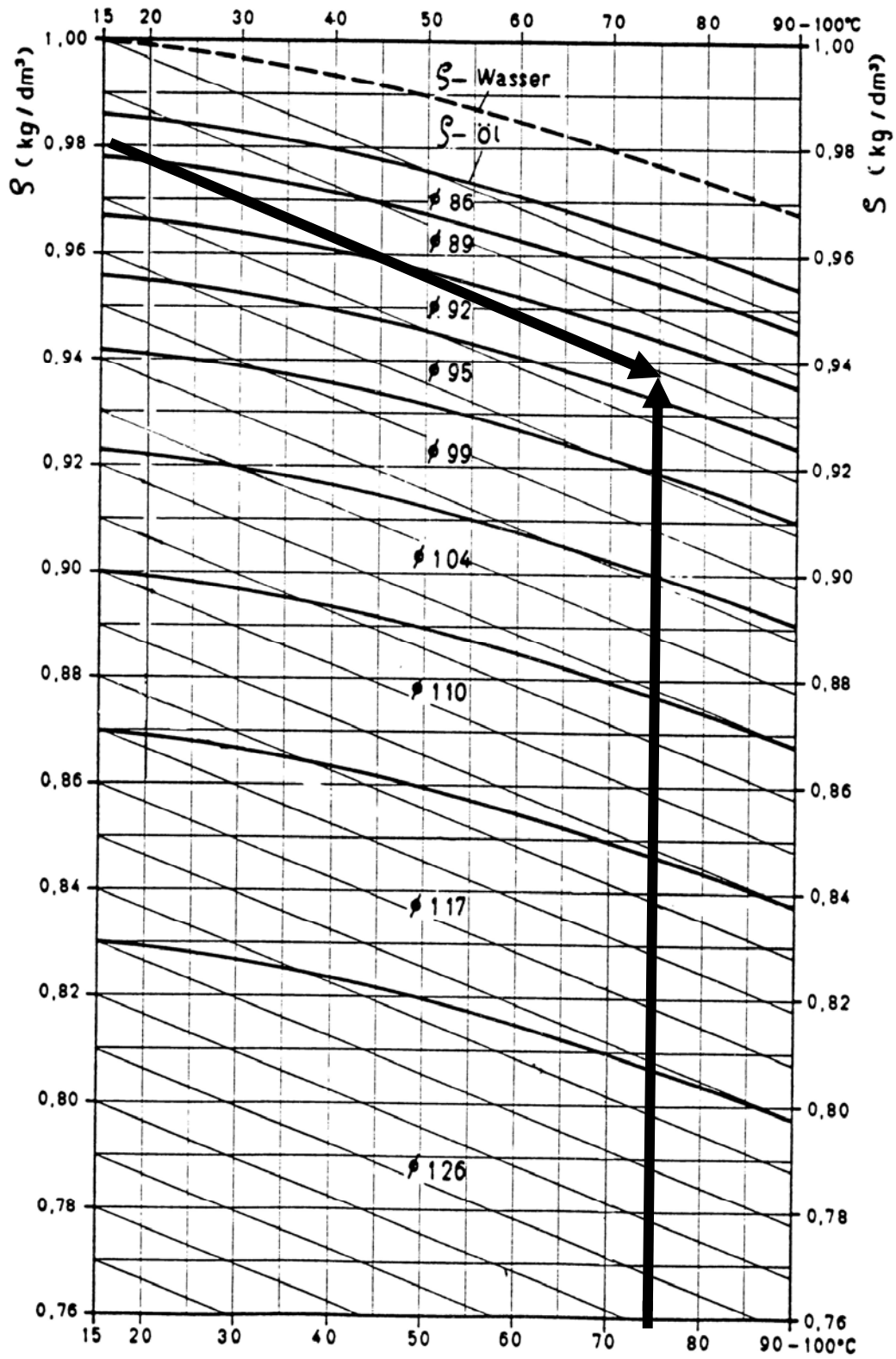

Separating temperature

(COURTESY OF WESTFALIA SEPARATOR)