

GS-0001

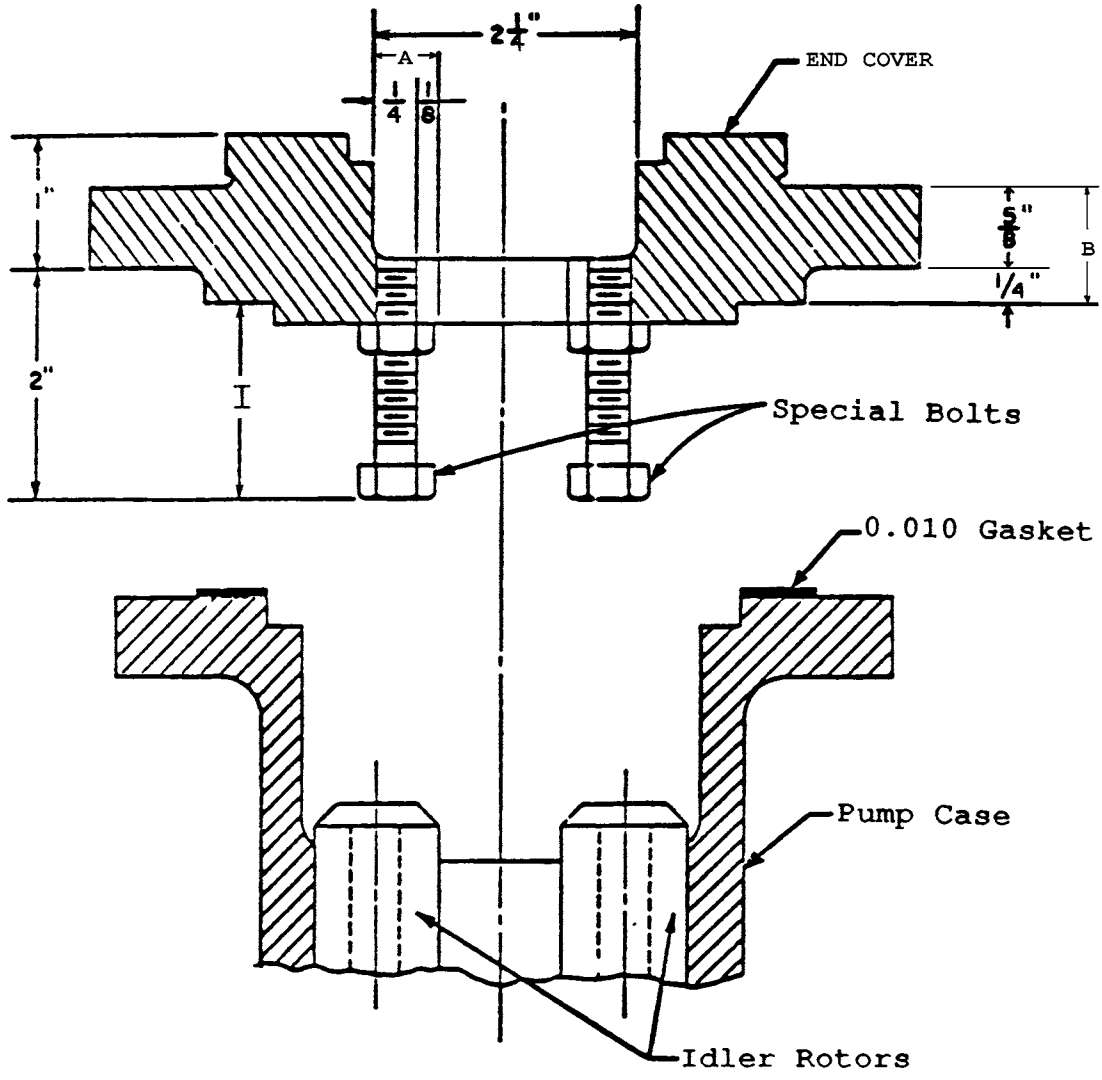

GS-0002

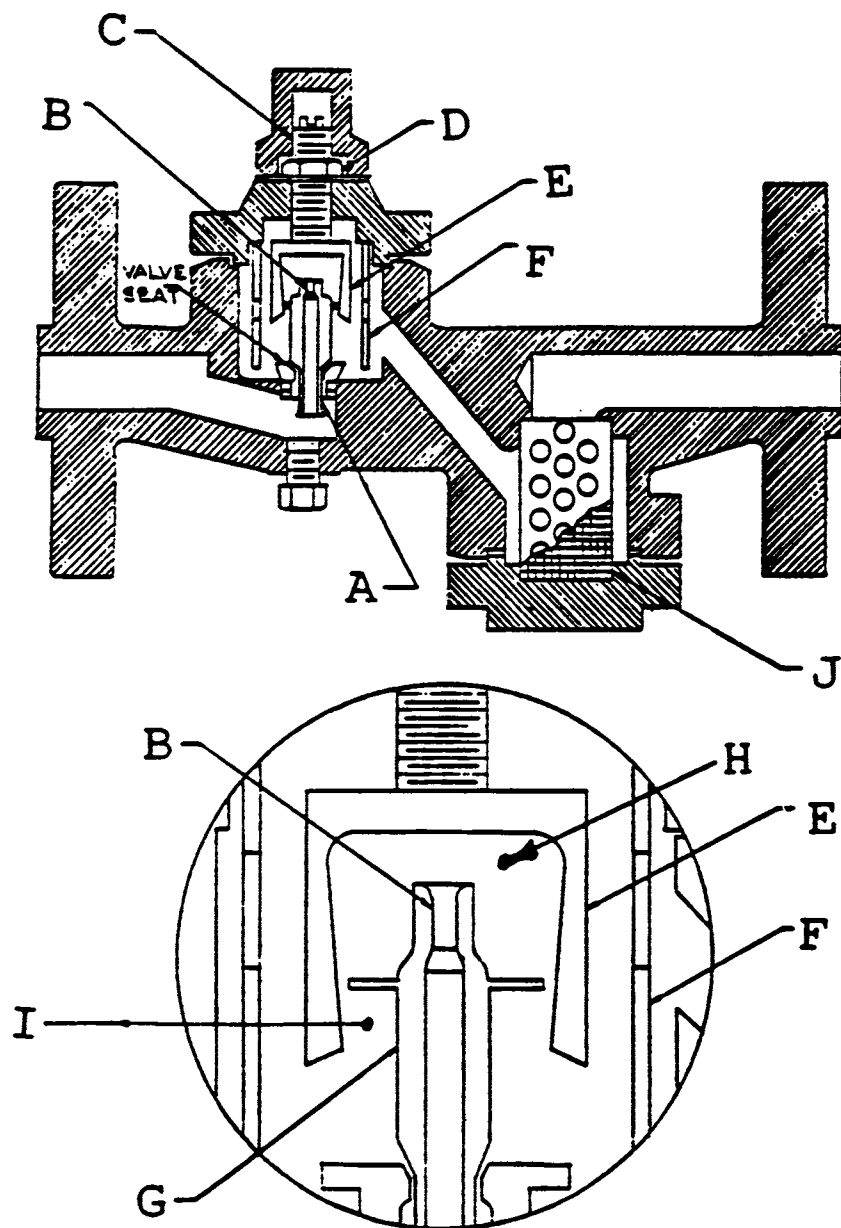

GS-0003

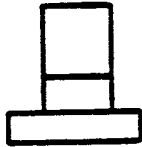
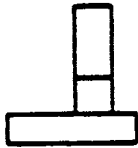
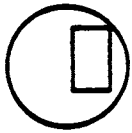

1

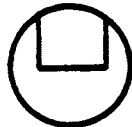

2



3



4

GS-0004



16



21



2

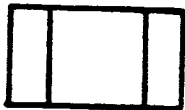

GS-0005

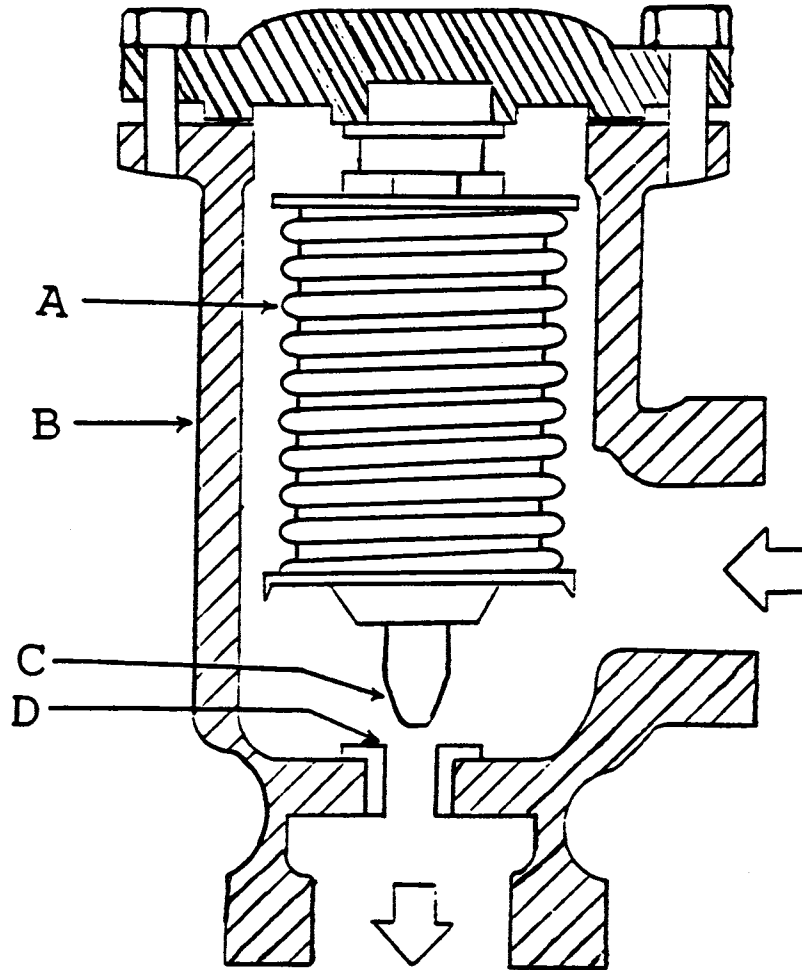

GS-0006

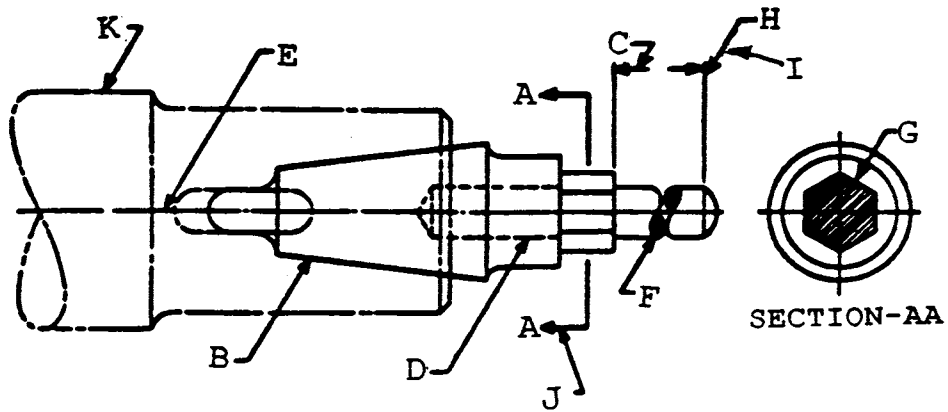

GS-0007

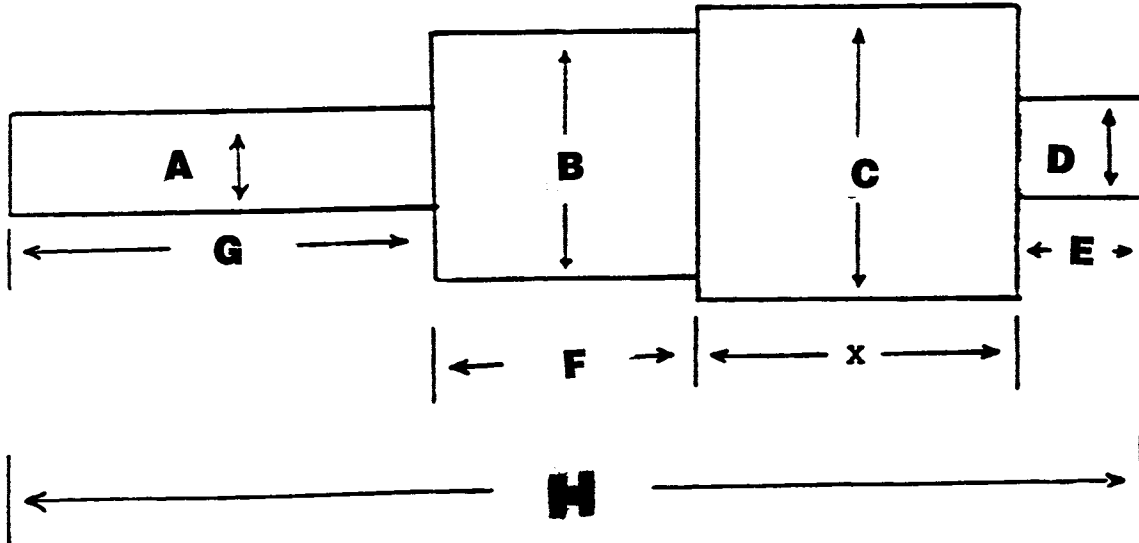

GS-0008

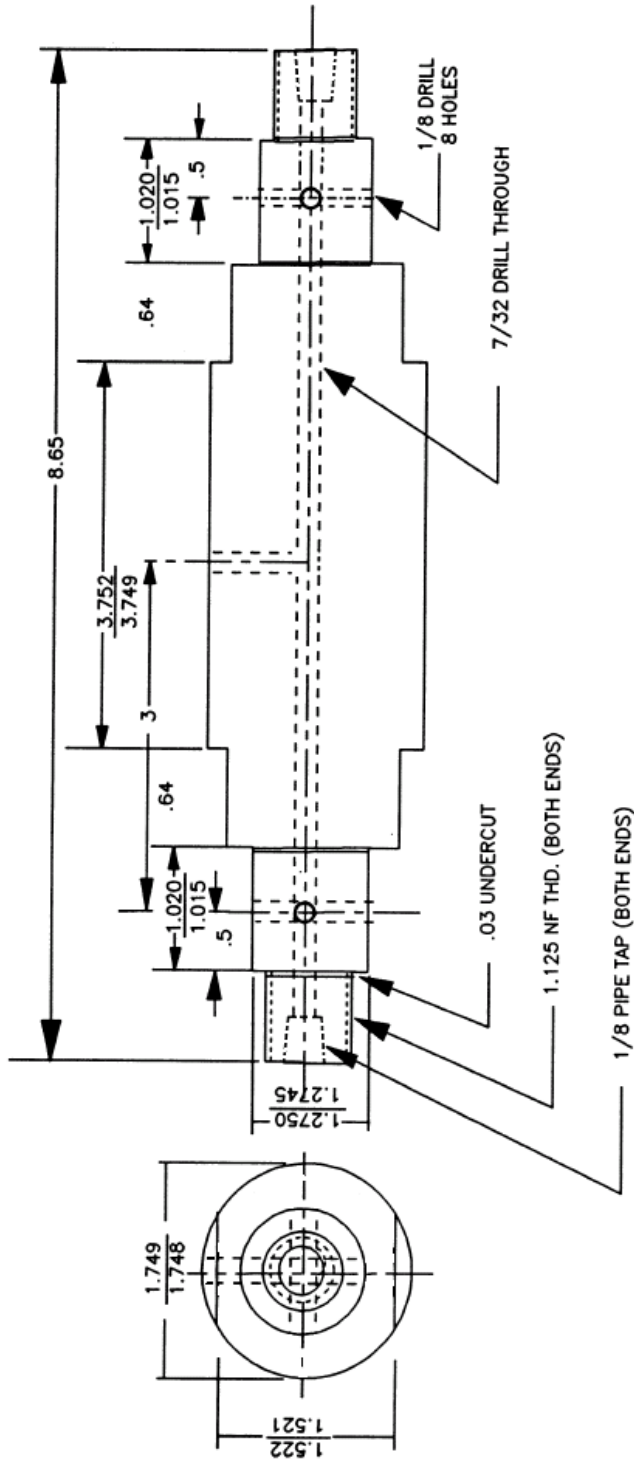

DET --- 56 --- SHAFT
 6 --- TYPE SAE 1095 STEEL
 STK 2 DIA WT 7.92 LBS.
 HARDEN --- ROCKWELL 52-64
 GRIND

GS-0009



A



B



C



D



E



F



G

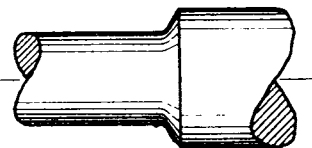

FIG. I

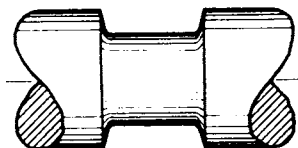

FIG. II

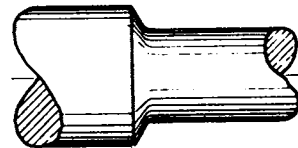

FIG. III

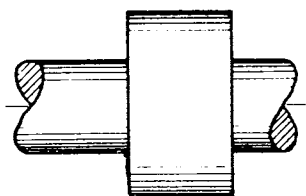

FIG. IV

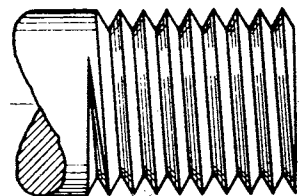

FIG. V

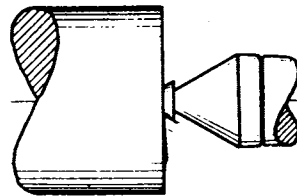
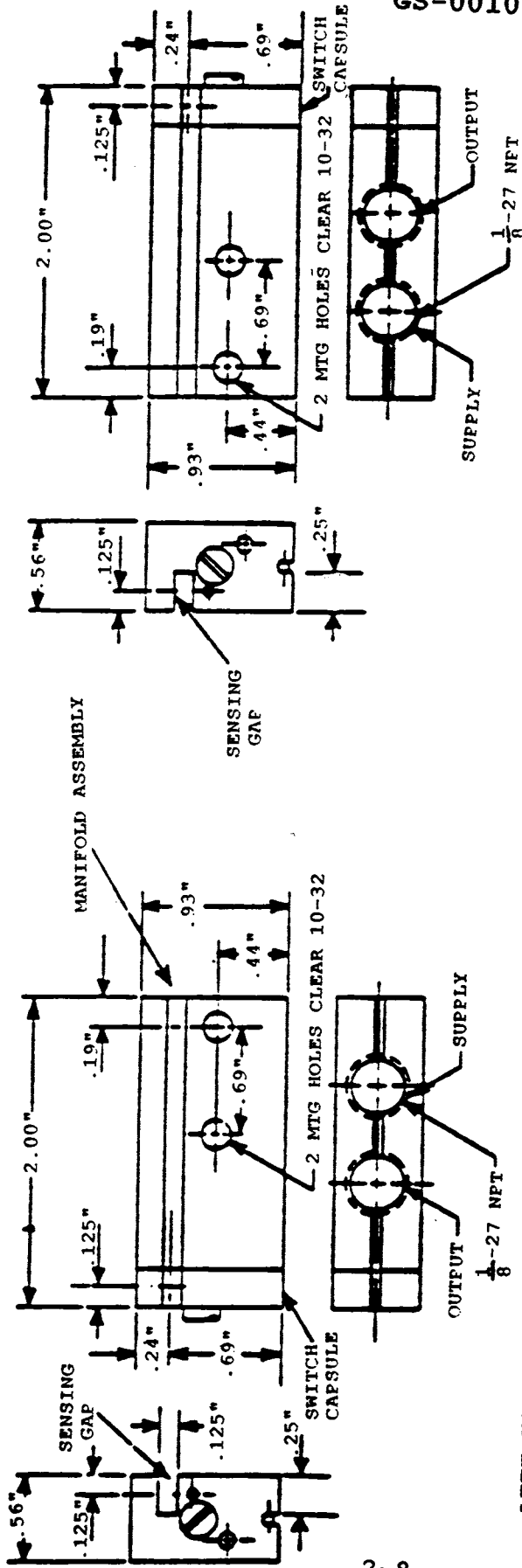

FIG. VI

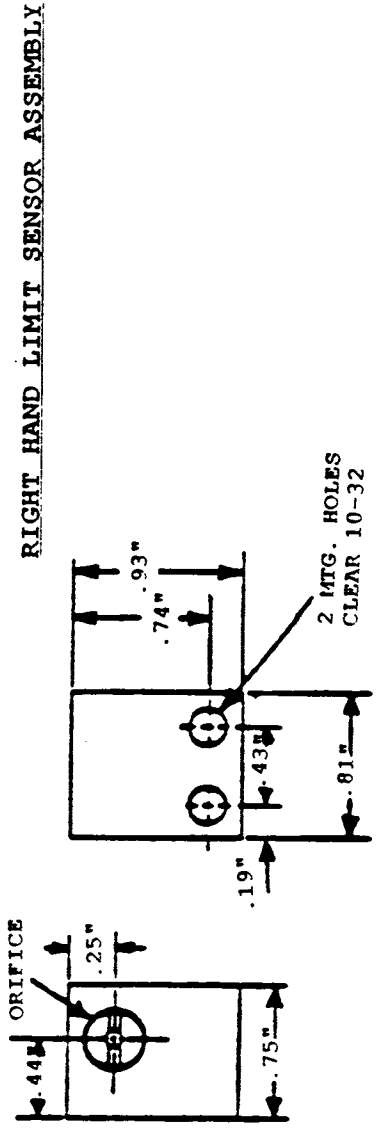

FIG. VII

GS-0010



LEFT HAND LIMIT SENSOR ASSEMBLY



RIGHT HAND LIMIT SENSOR ASSEMBLY

GS-0011

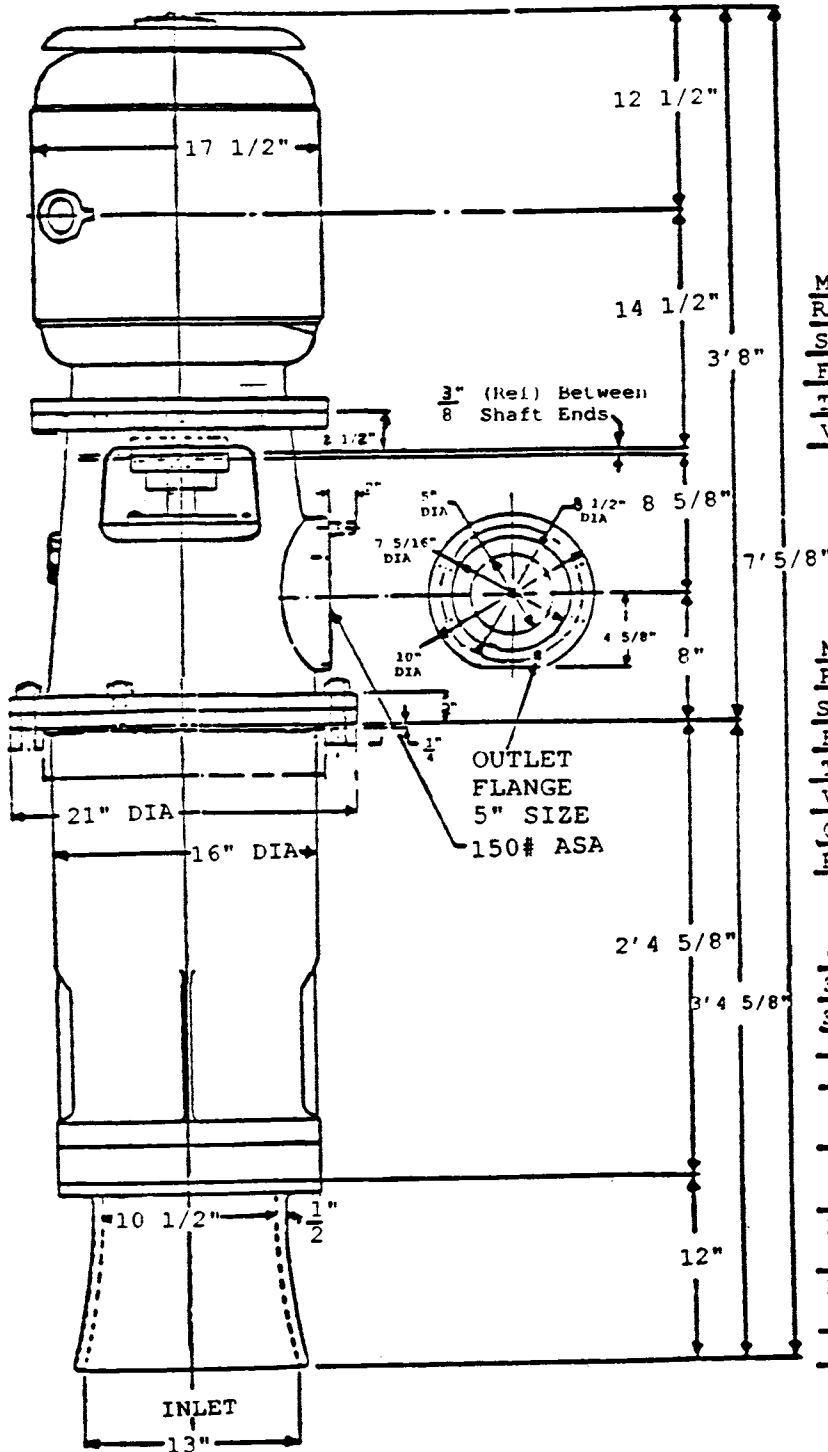

MOTOR CHARACTERISTICS

MOTOR (D.C.)	ELECTRO DYNAMIC
RATING H.P.	25
SPEED R.P.M.	1150
FRAME	405 VY
TYPE	R
VOLTS	250/210-355

MOTOR CHARACTERISTICS

MOTOR (A.C.)	ELECTRO DYNAMIC
RATING H.P.	25
SPEED R.P.M. (SYN.)	1200
FRAME	365 VY
TYPE	TN
VOLTS	440
CYCLES	60
PHASE	3

PUMP CHARACTERISTICS

CAPACITY G.P.M.	400
SPEED R.P.M.	1150
SUCTION LIFT "HG	10
E.H.P @ 1200	
SSU-75°F	24.9
OIL VISCOSITY RANGE, SSU	74-7000
VISCOSITY NORMAL SSU @ 140°F	155
DISCHARGE NORMAL PSIG	55
FLUID HANDLED, LUBE OIL	2190 TEP.
NAVY SPECIFICATION	MIL-L-17331
OIL TEMPERATURE RANGE °F	40-180

GS-0012

NOTE: INSIDE DIA OF WEARING RING, PC NO. (4) IS .020 UNDERSIZE
 OUTSIDE DIA OF WEARING RING, PC NO. (6) IS .020 OVERSIZE
 WHEN FINISHED AS REPAIR PARTS AND ARE DESIGNATED AS
 PART NO. 5 A3H180A-1 U/S AND 3H180-1 O/S

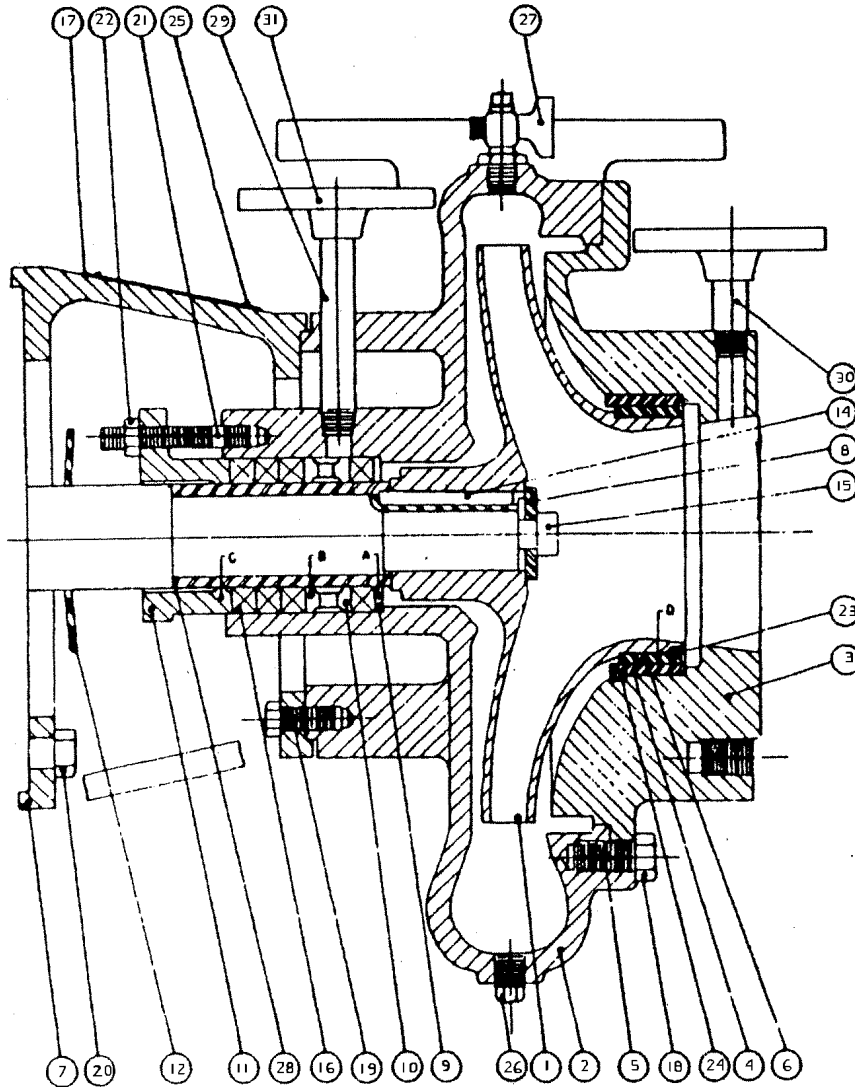

ITEM	QTY	DESCRIPTION	MATERIAL	REMARKS
1	1	IMPELLER	NI-CU ALLOY	3H1A
2	1	VOLUTE	GUNMETAL	3H4C
3	1	SUCTION COVER	GUMMETAL	3H193
4	1	VOLUTE WEAR RING	VALVE BRONZE	A-3H180A
5	1	VOLUTE GASKET	ASBESTOS	P/N 3H37
6	1	IMPELLER WEAR RING	NI-CU ALLOY	3H180
7	1	MOTOR BRACKET	CAST STEEL	2L3C
8	1	SHAFT SLEEVE	NI-CU ALLOY	P/N A-014-20A-0-01
9	1	THROAT BUSHING	NI-CU ALLOY	P/N 4L26-4
10	1	LANTERN RING	NI-CU ALLOY	4L169
11	2	GLAND HALF	BRONZE	B-017-5AH-A
12	1	SLINGER	NEOPRENE	1 47/64 X 3 3/4 X 1/8 TH
13	1	IMPELLER WASHER	NI-CU ALLOY	17/32 X 9/16 X 3/16 TH
14	1	IMPELLER KEY	NI-CU ALLOY	1/4 SQ X 2 5/16 TH
15	1	SKT HD CAPSCREW	SST	1/2-13 NC X 1 1/4 LG NYLOCK
16	5	PACKING RINGS	PLASTIC MTL	1 3/4 X 2 5/8 X 7/16 SQ
17	1	NAME PLATE	BPASS	P/N A-226-00N-0-03
18	8	HEX HEAD CAPSCREWS	NI-CU ALLOY	1/2-13 NC X 1 LG
19	4	HEX HEAD CAPSCREWS	NI-CU ALLOY	3/8-16 x 1 LG
20	4	HEX HEAD CAPSCREWS	NI-CU ALLOY	1/2-13 NC X 1 1/4 LG
21	2	STUD	SST	3/8-16 NC X 2 1/2 LG
22	2	HEX NUT	BRONZE	3/16-16 2
23	3	SETSCREW	NI-CU ALLOY	10-24 NC X 1/4 LG CUP POINT
24	3	SETSCREW	NI-CU ALLOY	10-24 NC X 1/4 LG CUP POINT
25	4	DRIVE SCREW	BRASS	6-24 X 3/4 LG
26	3	PIPE PLUG	BRONZE	1/4 NPT
27	1	VENT VALVE	BRONZE	1/4 NPT
28	1	O RING	BUNH "N"	1 5/16 ID 1/16 WIDE
29	1	PIPE	70-30 CU-NI	4 11/16 LG 1/4 NPT
30	1	PIPE	70-30 CU-NI	3 3/16 LG 1/4 NPT
31	2	FLANGE	VALVE BRONZE	1/4 INCH 150#

GS-0013

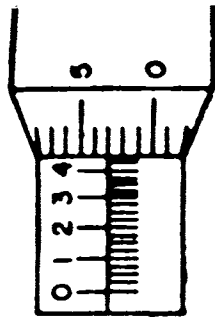

FIG. A

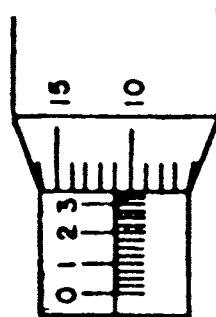

FIG. B

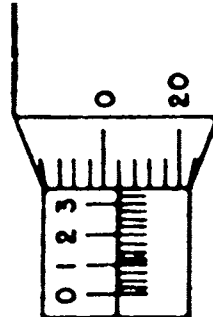

FIG. C

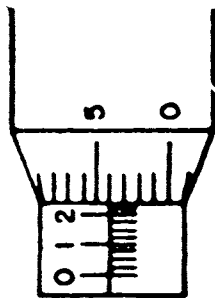

FIG. D

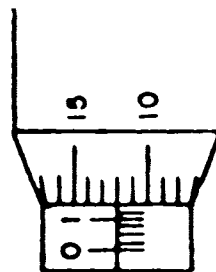

FIG. E

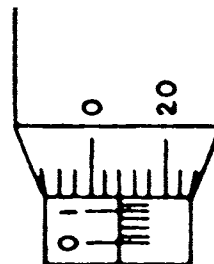

FIG. F

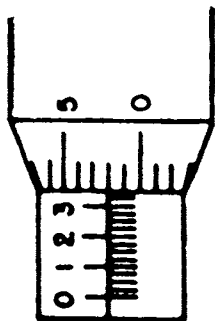

FIG. G

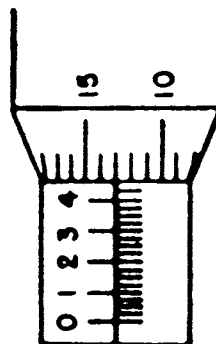

FIG. H

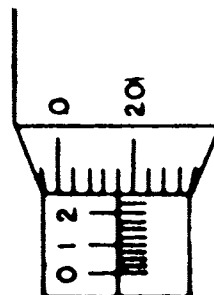
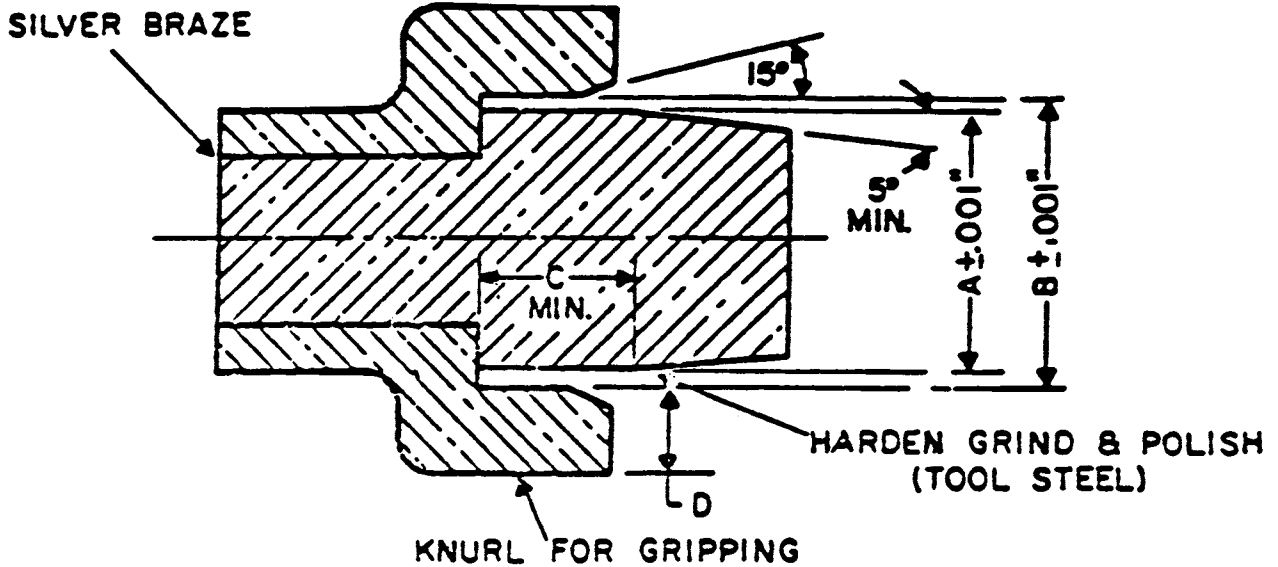

FIG. I

GS-0014



FITTING SIZE (INCH)	A	B	C	D
1/4	.400	.500	33/64	1/4
3/8	.535	.675	9/16	1/4
1/2	.700	.840	5/8	1/4
3/4	.910	1.050	21/32	1/4
1	1.175	1.315	11/16	3/8
1 1/4	1.520	1.660	3/4	3/8
1 1/2	1.760	1.900	7/8	7/16
2	2.235	2.375	27/32	1/2

GS-0015

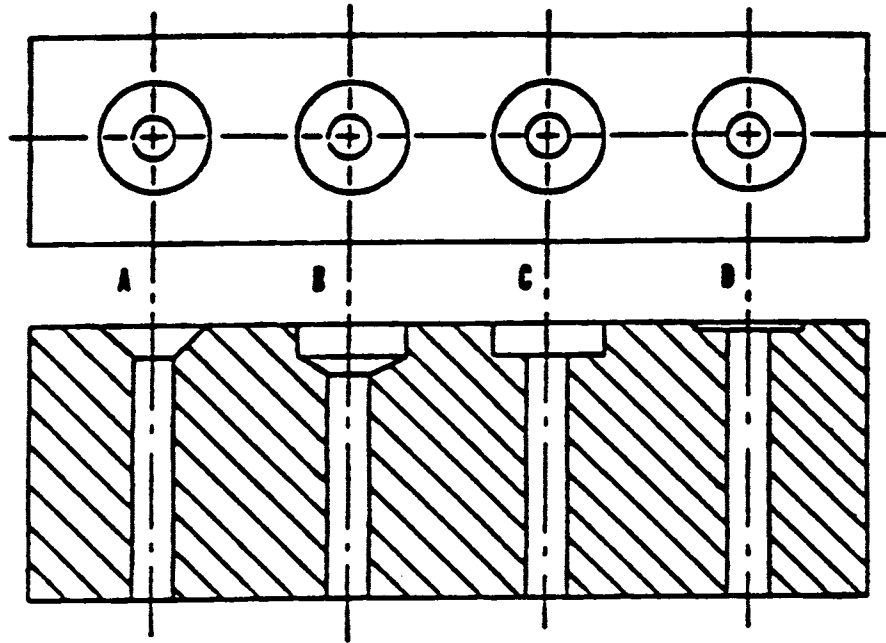

GS-0016

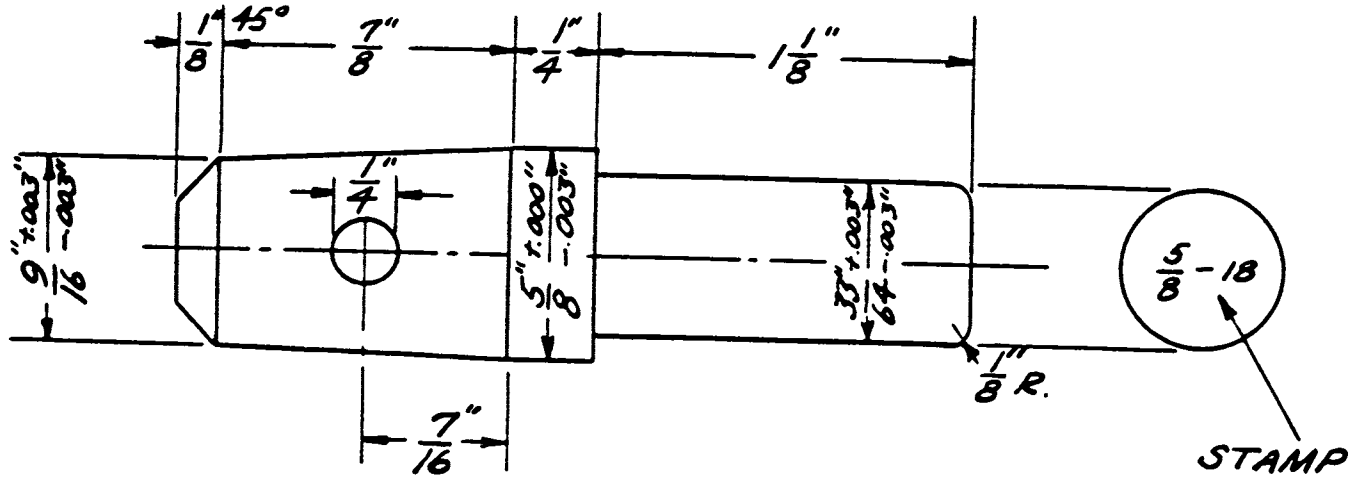

GS-0017

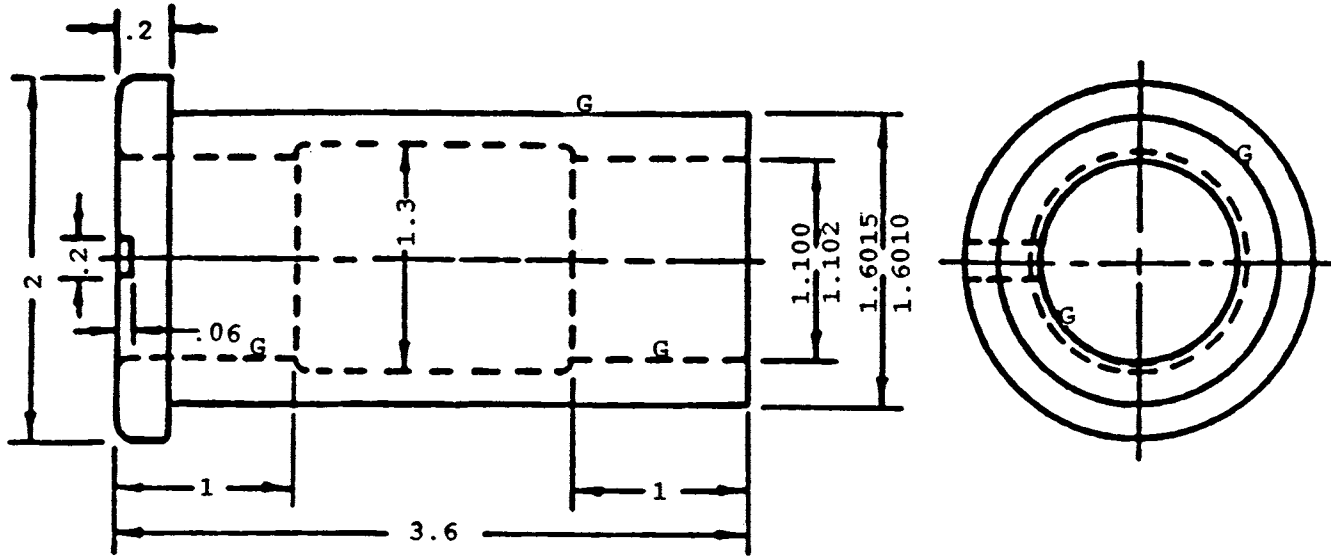

DET. 7--- BUSHING
1 --- SAE 1095 STEEL
STK. 2 1/8 DIA.
HARDEN & GRIND

GS-0018

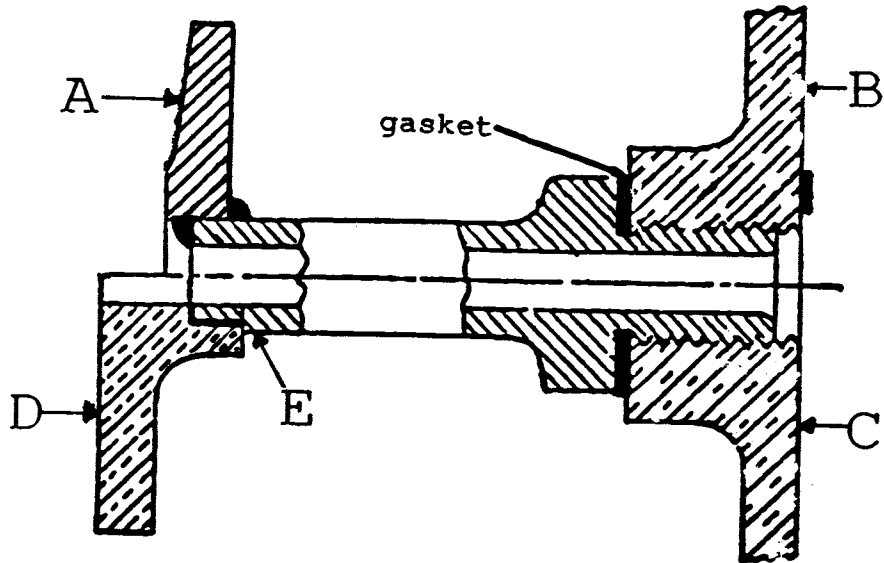

GS-0019

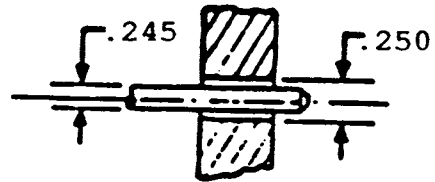

CLEARANCE $+ .005$

(a)

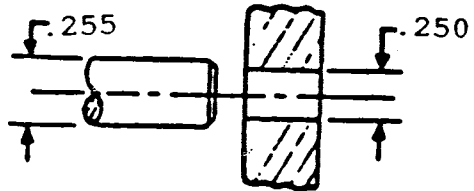

(b)

GS-0020

Cylinder Test Valve
All 8,12,16 and 20-645 Engines

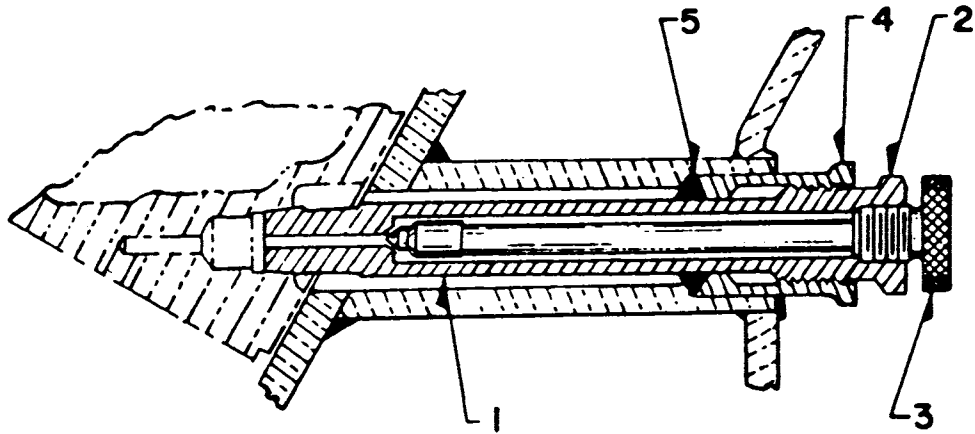

GS-0021

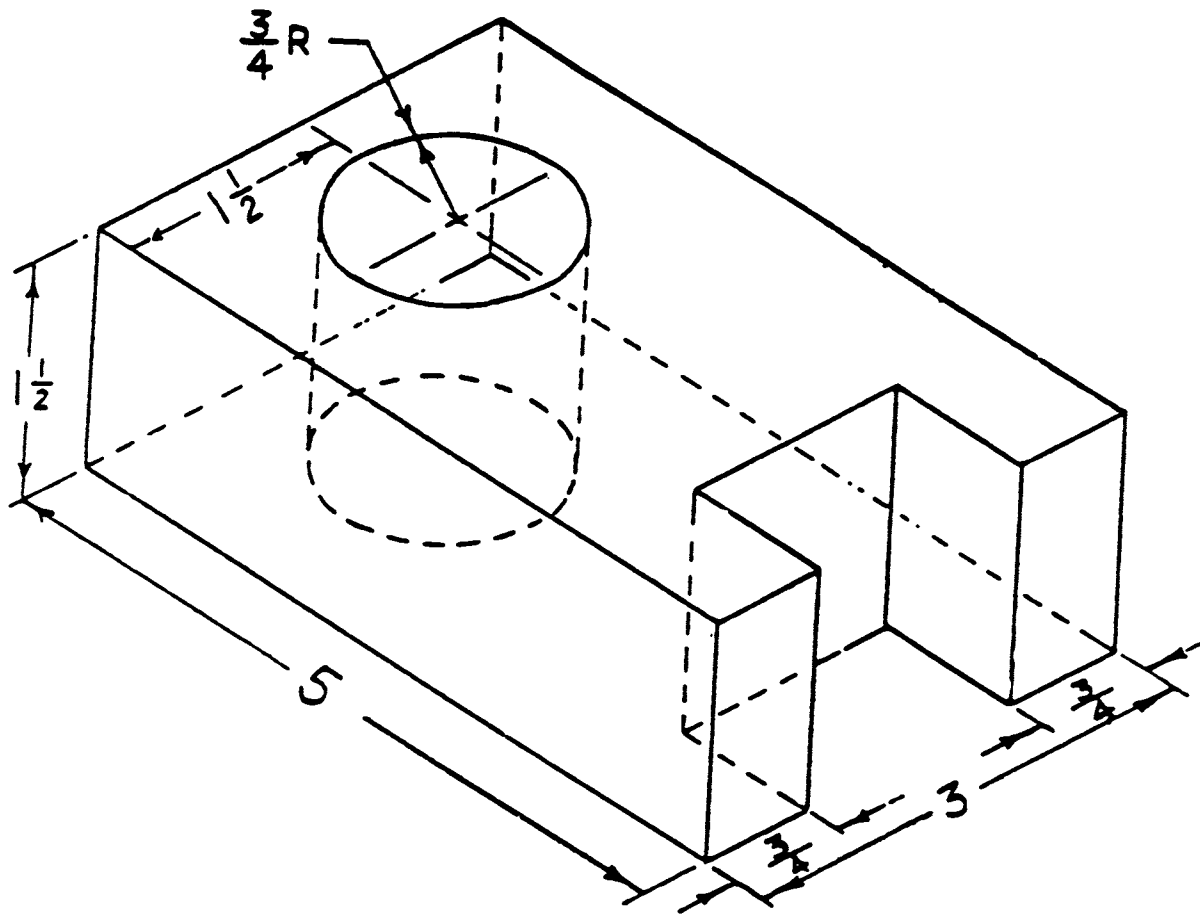

GS-0022

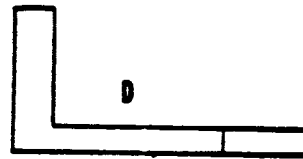
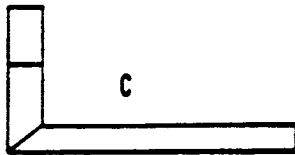
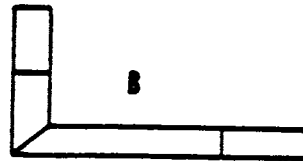
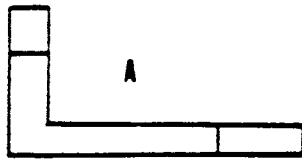
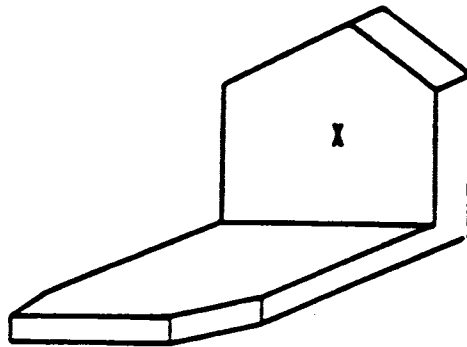

GS-0023

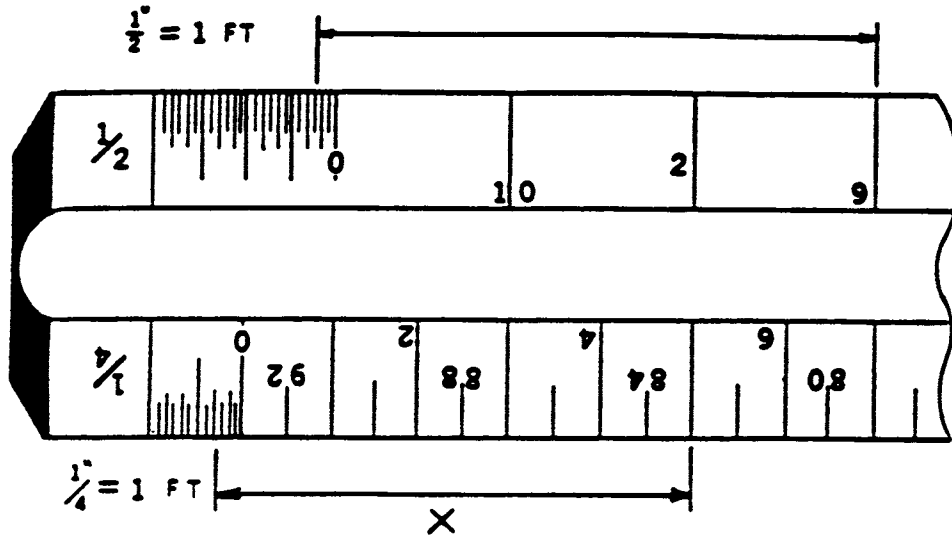

GS-0024

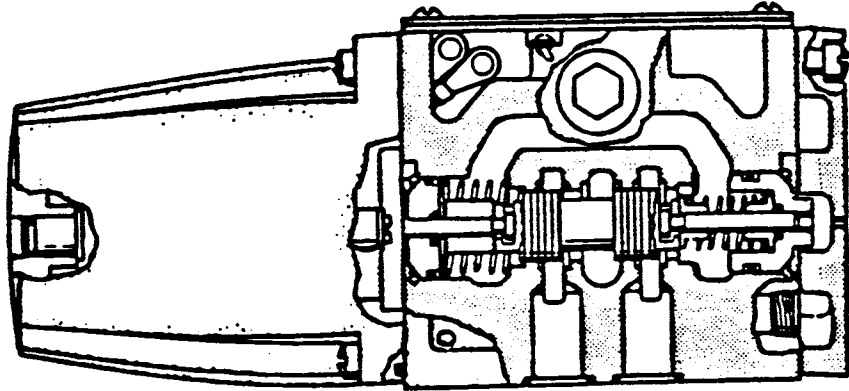

GS-0025

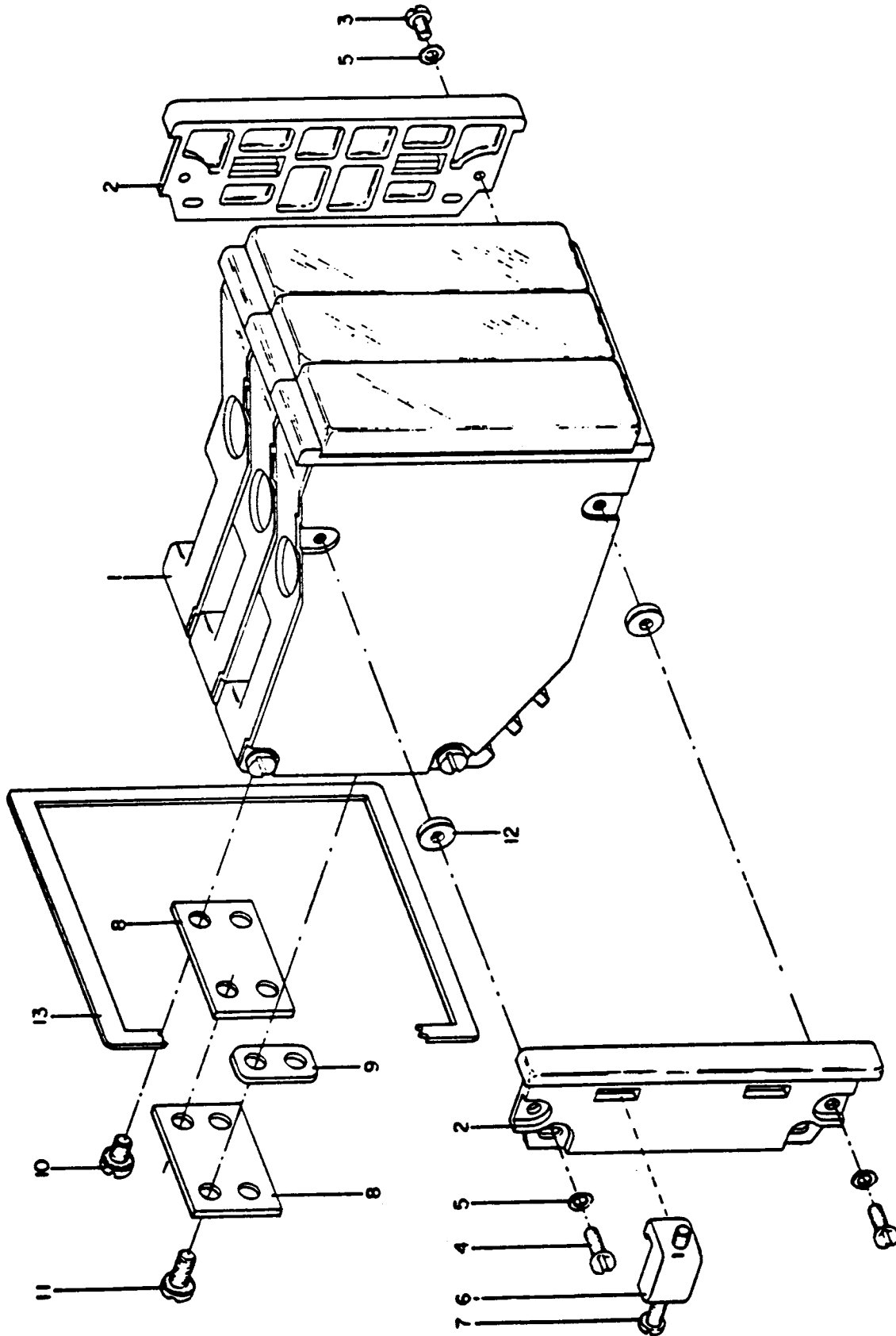

GS-0026

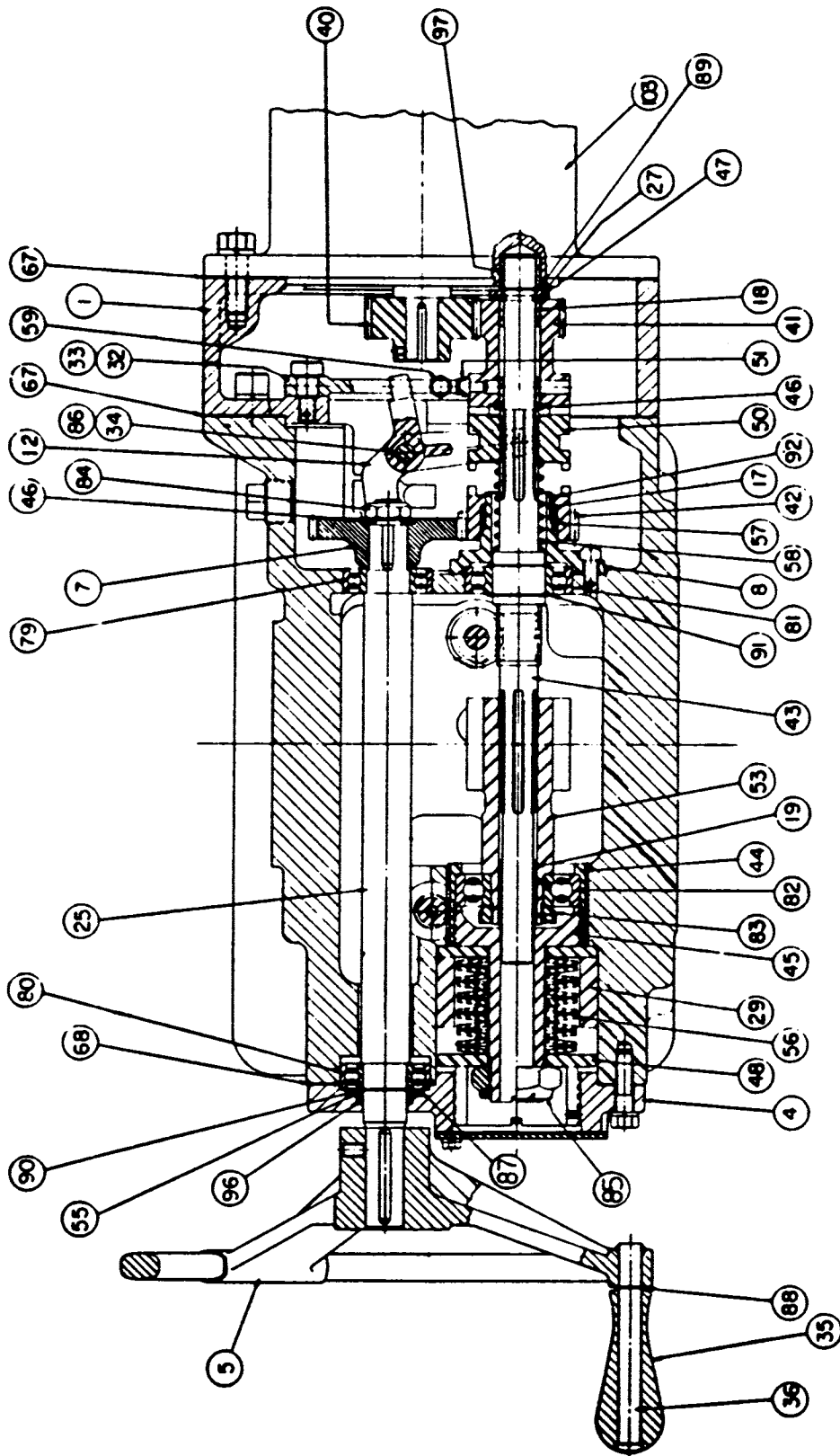

(COURTESY OF LIMBORQUE CORP.)

GS-0027

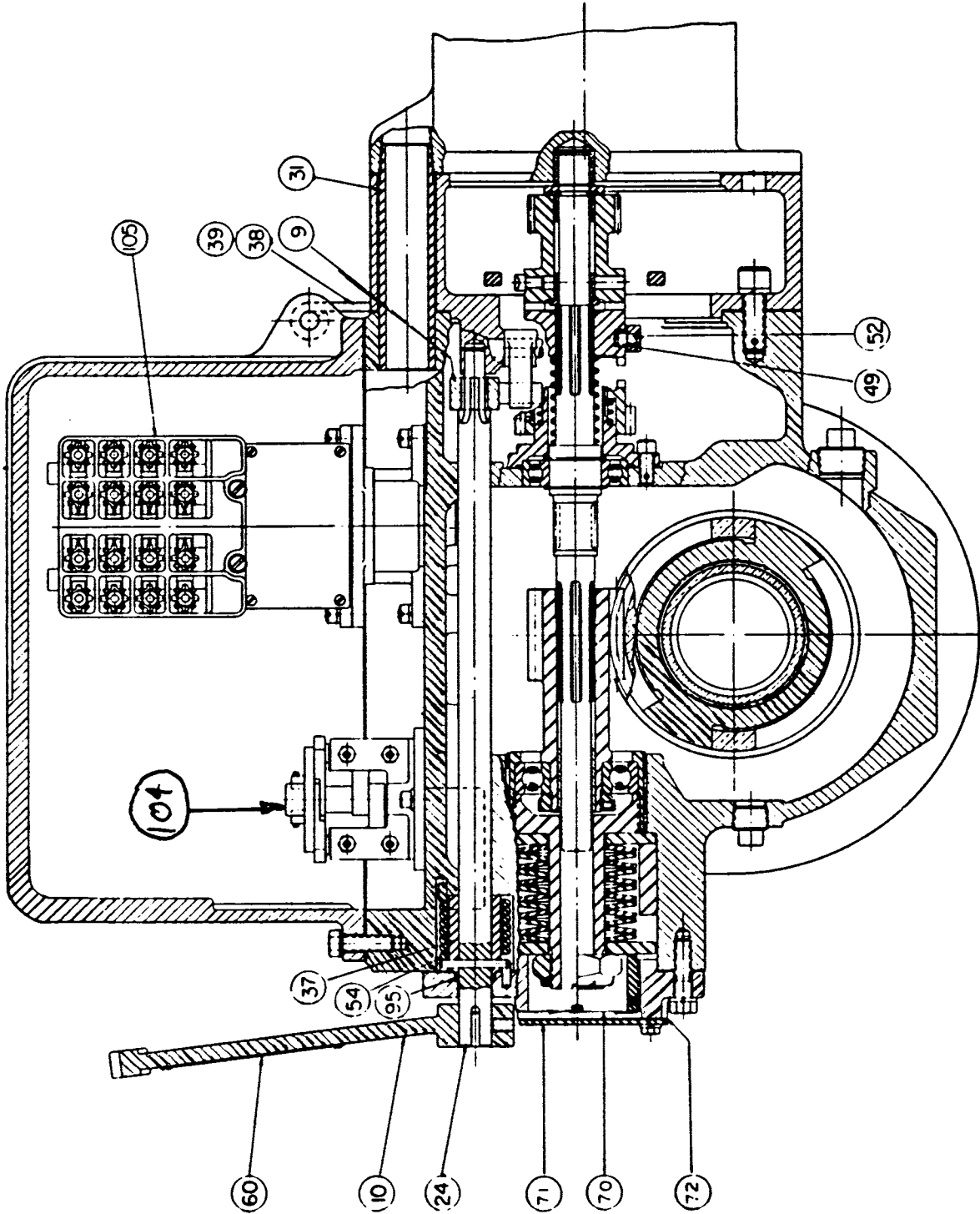

(COURTESY OF LIMITORQUE CORP.)

GS-0028

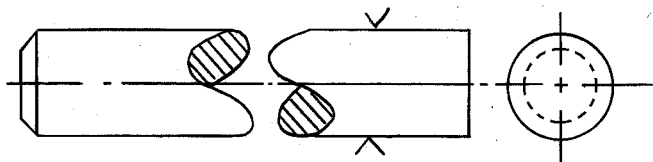

GS-0029

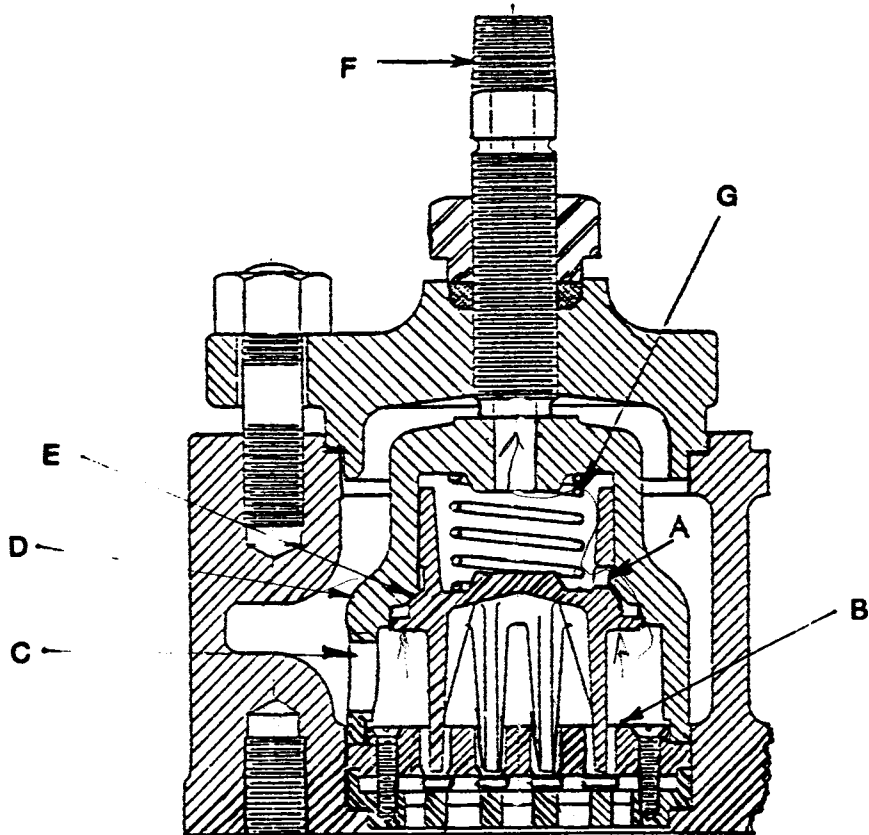

GS-0030



GS-0031

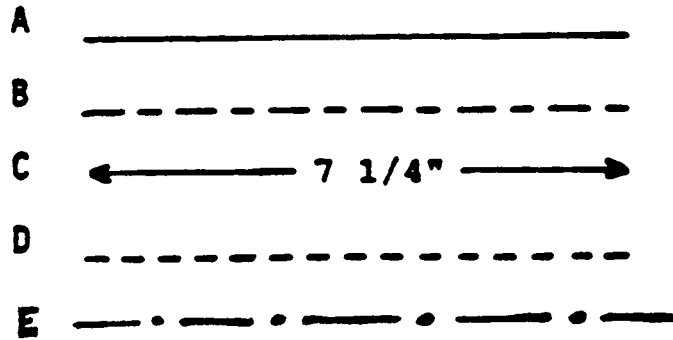

GS-0032

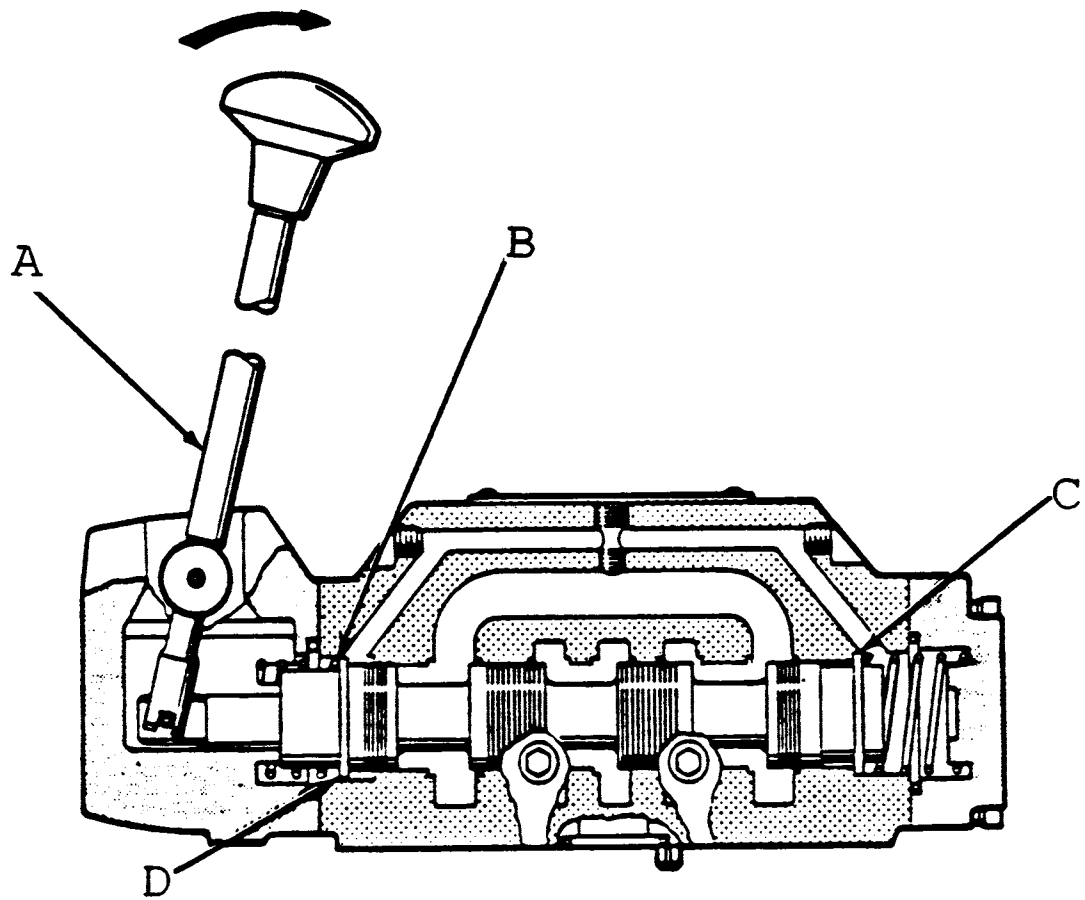

GS-0033

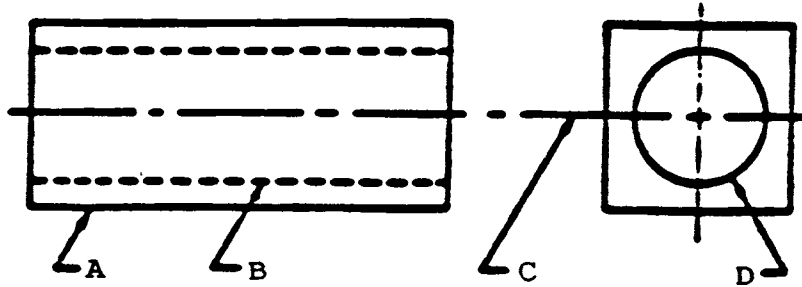

GS-0034

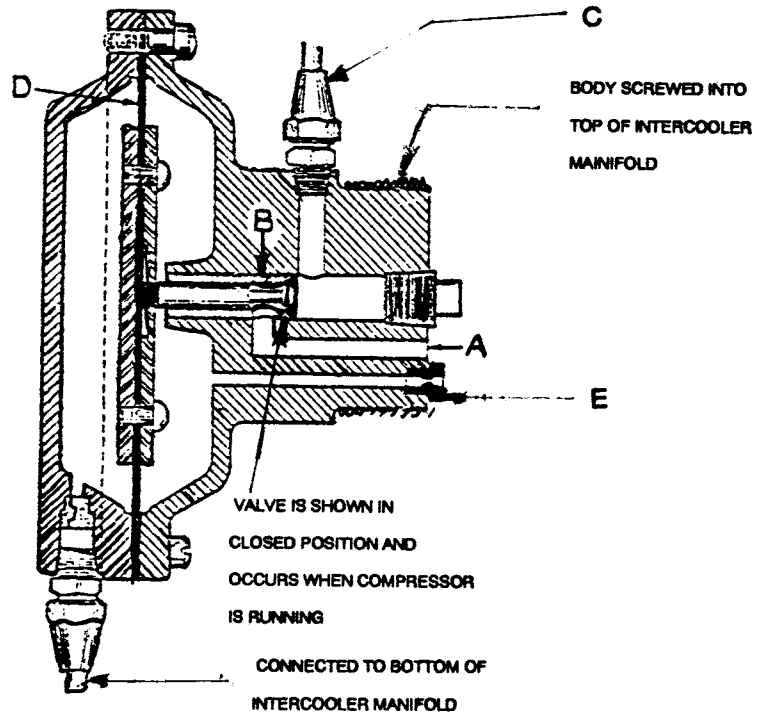

GS-0035

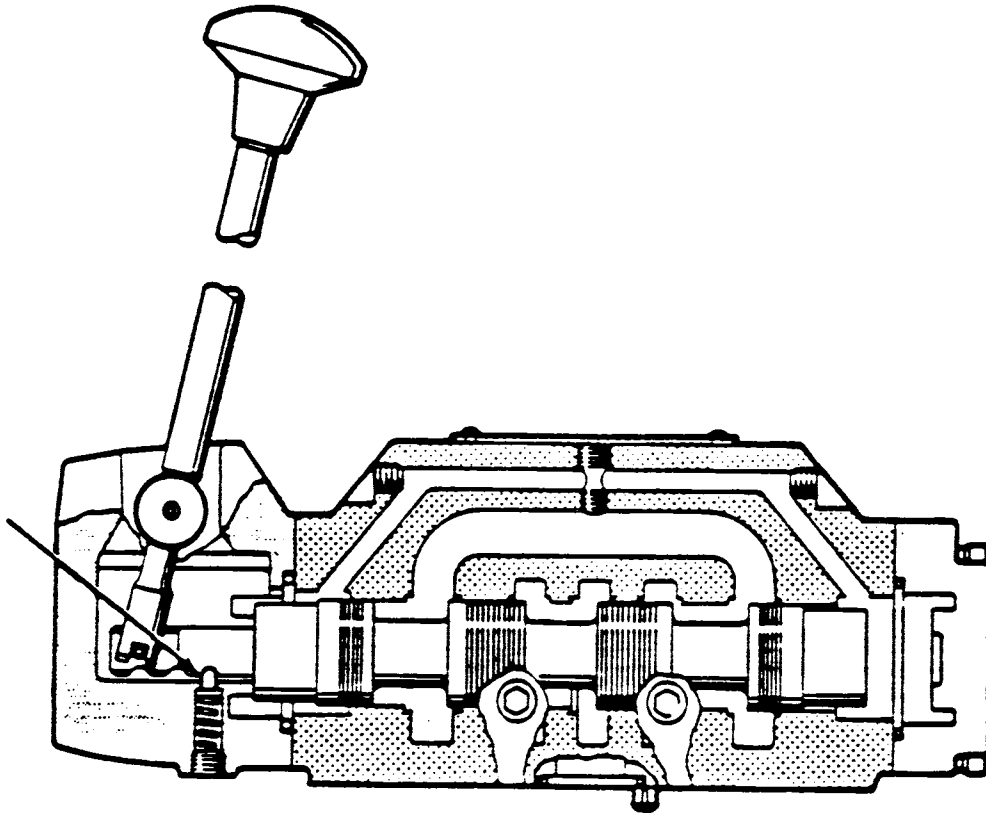

GS-0036

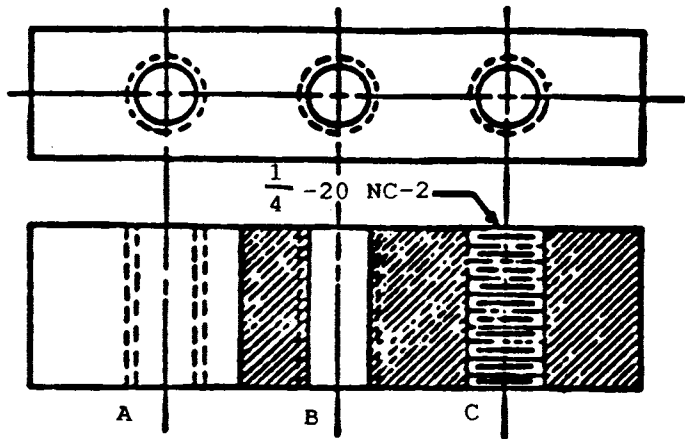

GS-0037

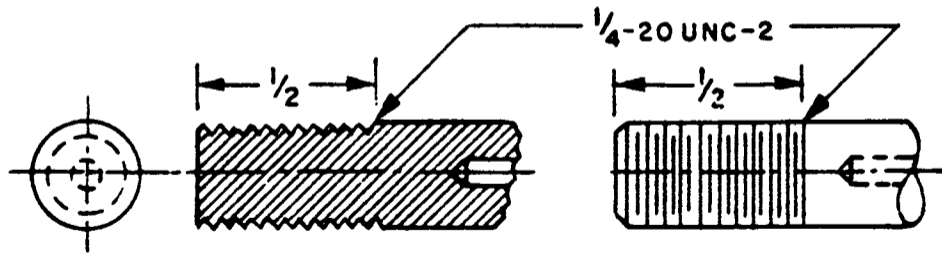

GS-0038

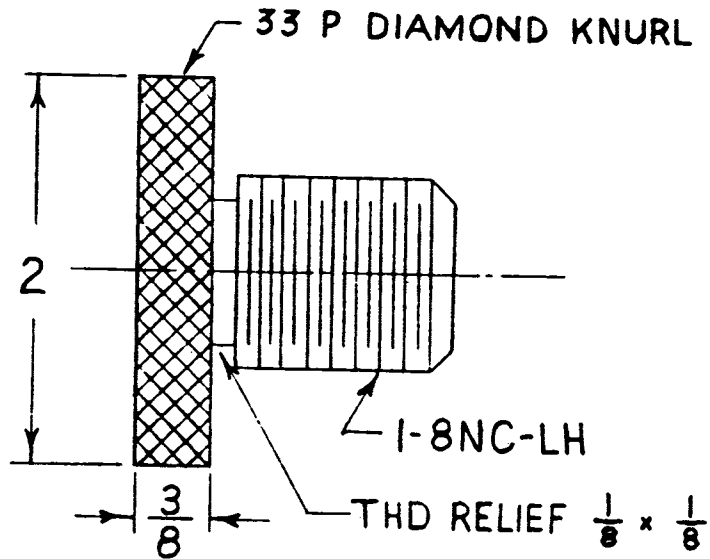

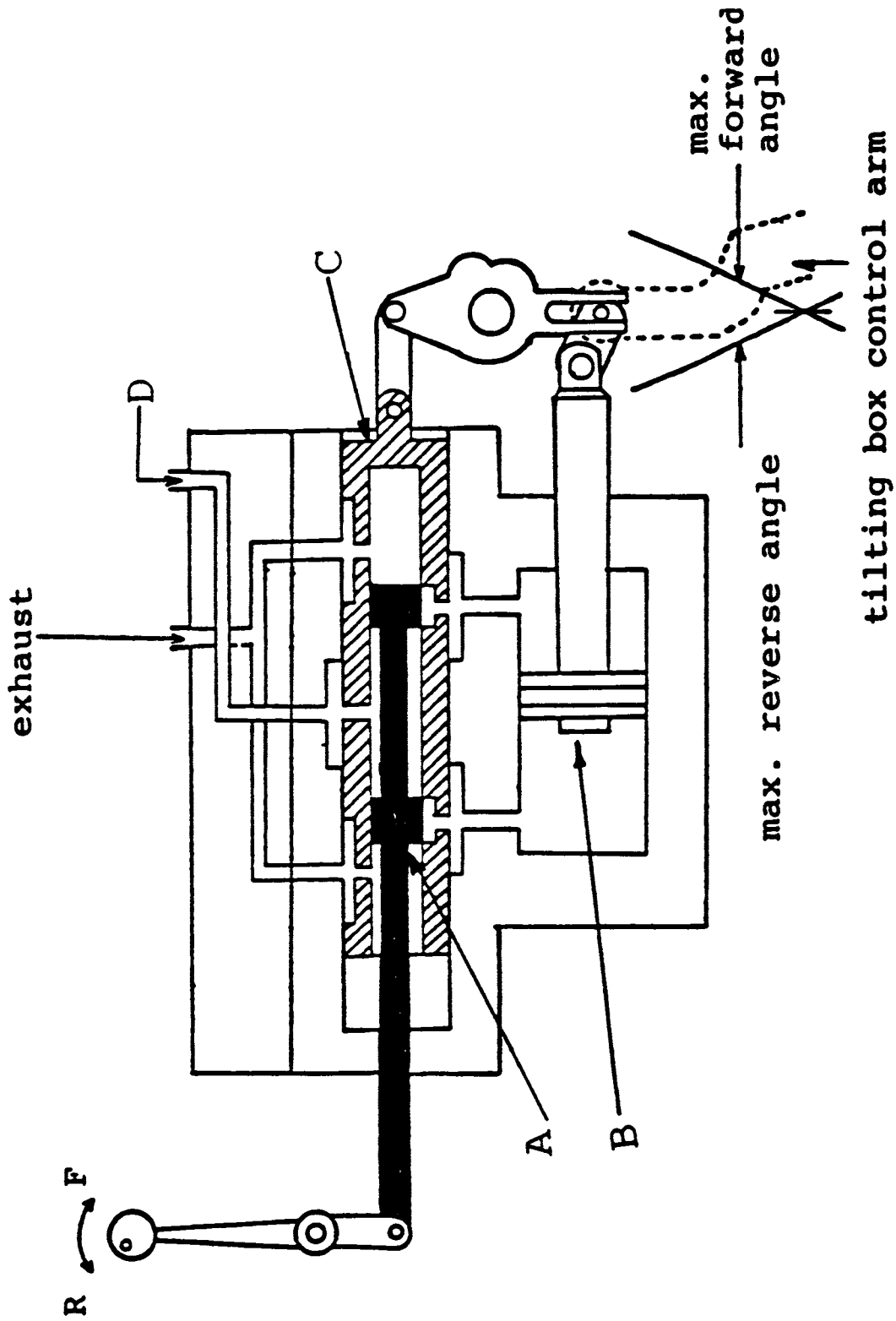

tilting box control arm

GS-0040

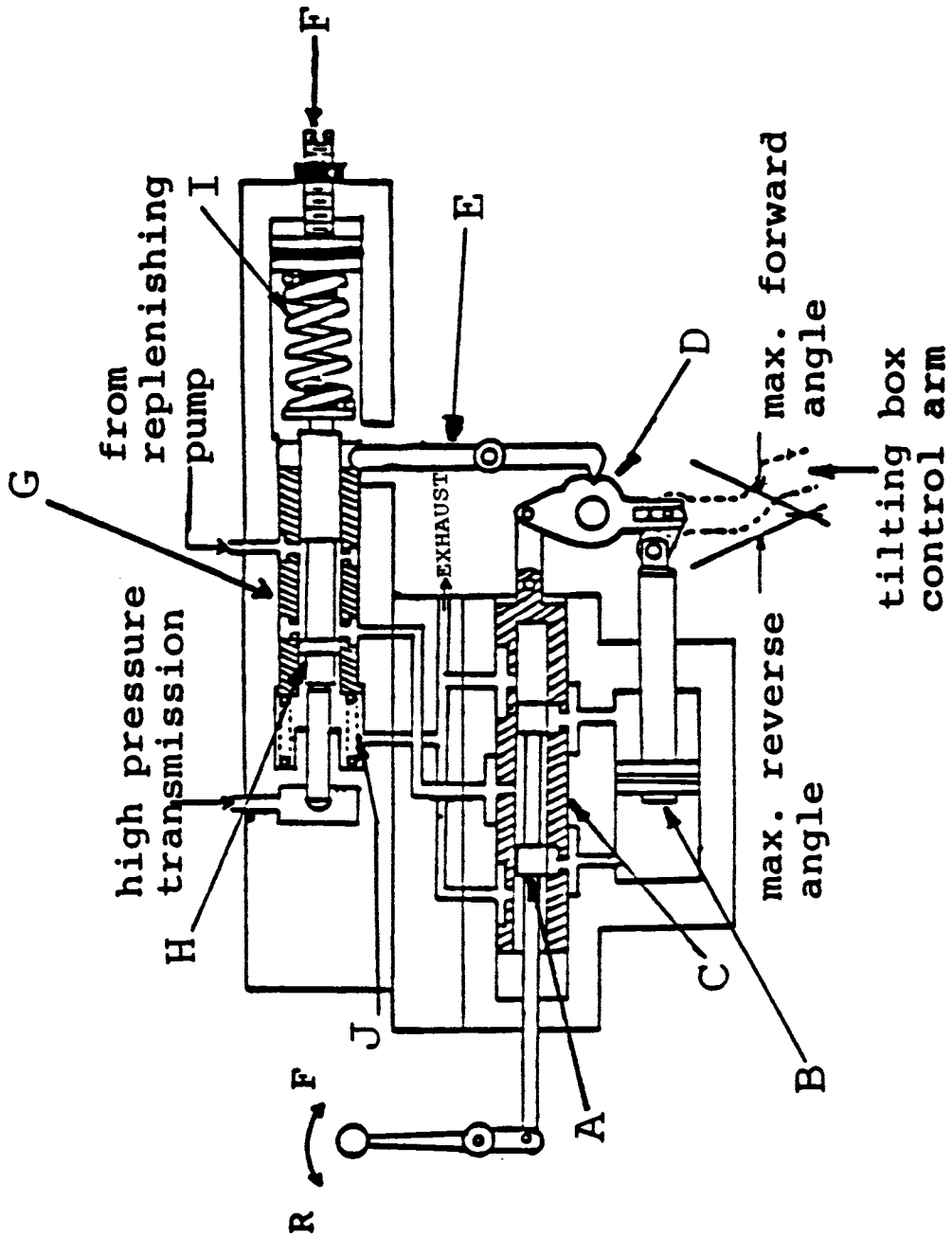

GS-0041

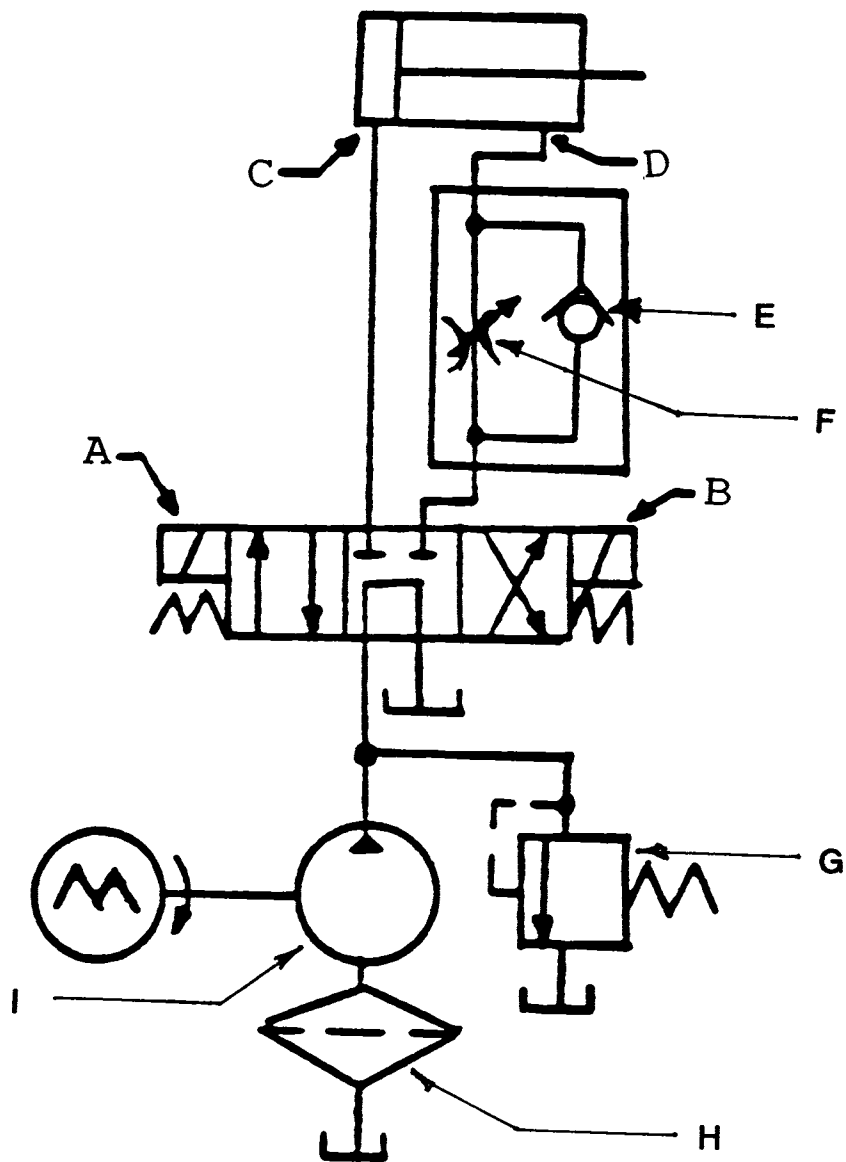

GS-0042

Symbols

- | | | | |
|--|--|---|---|
| <ul style="list-style-type: none"> ⊗ Stop Check Valve ⊙ Stop Check Lift Valve } Operated from above Bulkhead Deck ⊗ Stop Valve ⊗ Gate Valve ⊗ Globe Valve | <ul style="list-style-type: none"> ⊖ Spectacle Flange ⊙ Combination Gage ⊙ Pressure Gage ⊙ Macomb Strainer | <ul style="list-style-type: none"> ↔ Reversible Fittings ⊖ Thermometer ⊖ Air Chamber ⊖ Relief Valve | <ul style="list-style-type: none"> ⊙ Bell Mouth ⊖ Manifold, Stop Valves ⊖ Manifold, Stop Check Valves ⊖ Open End Bilge Suction Strainer |
|--|--|---|---|

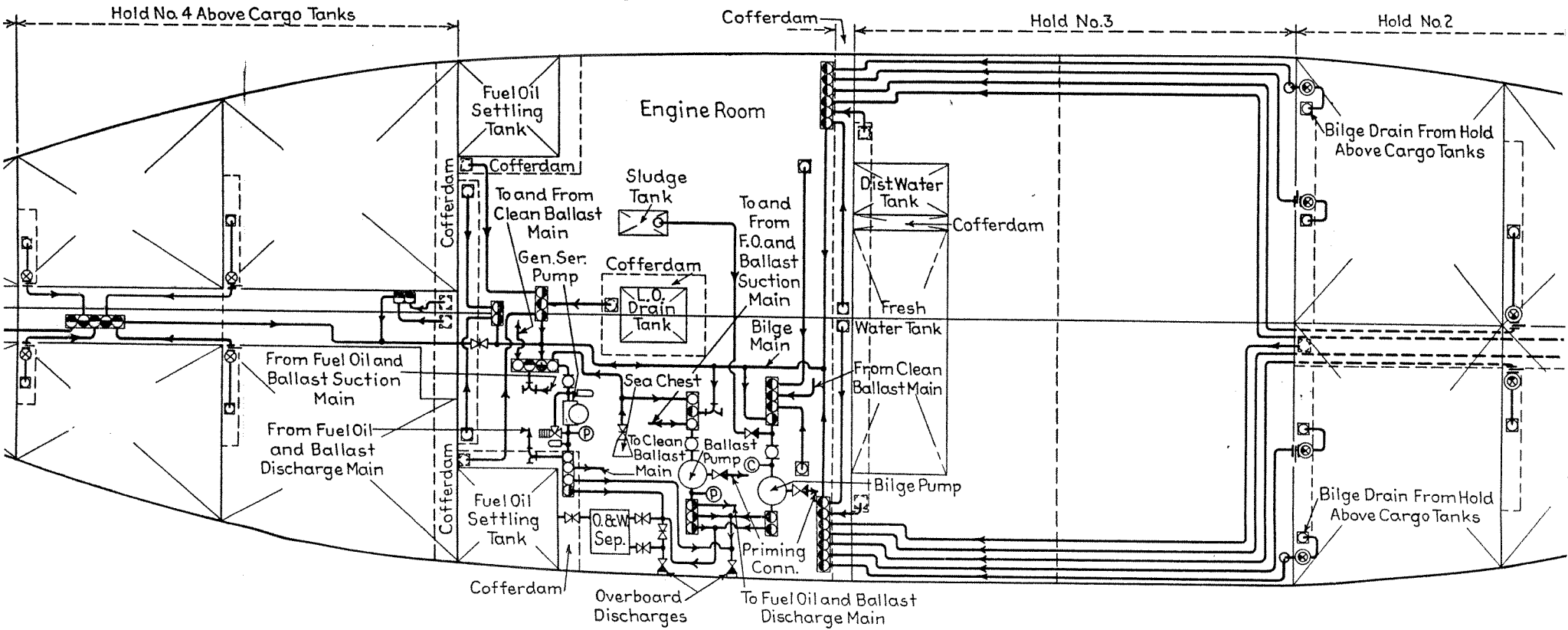

DIAGRAMMATIC ARRANGEMENT OF BILGE SYSTEM ON C-2 CARGO SHIP

GS-0043

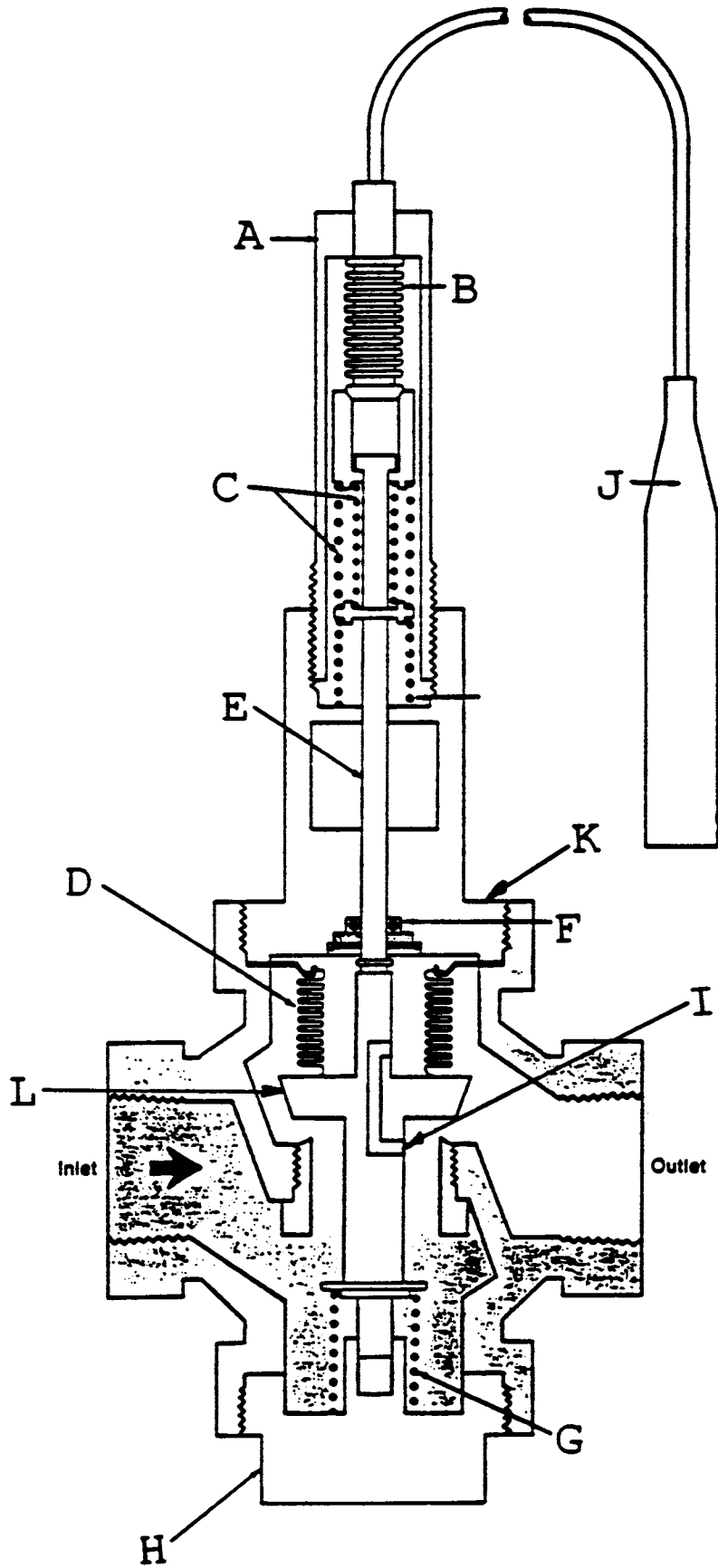

GS-0044

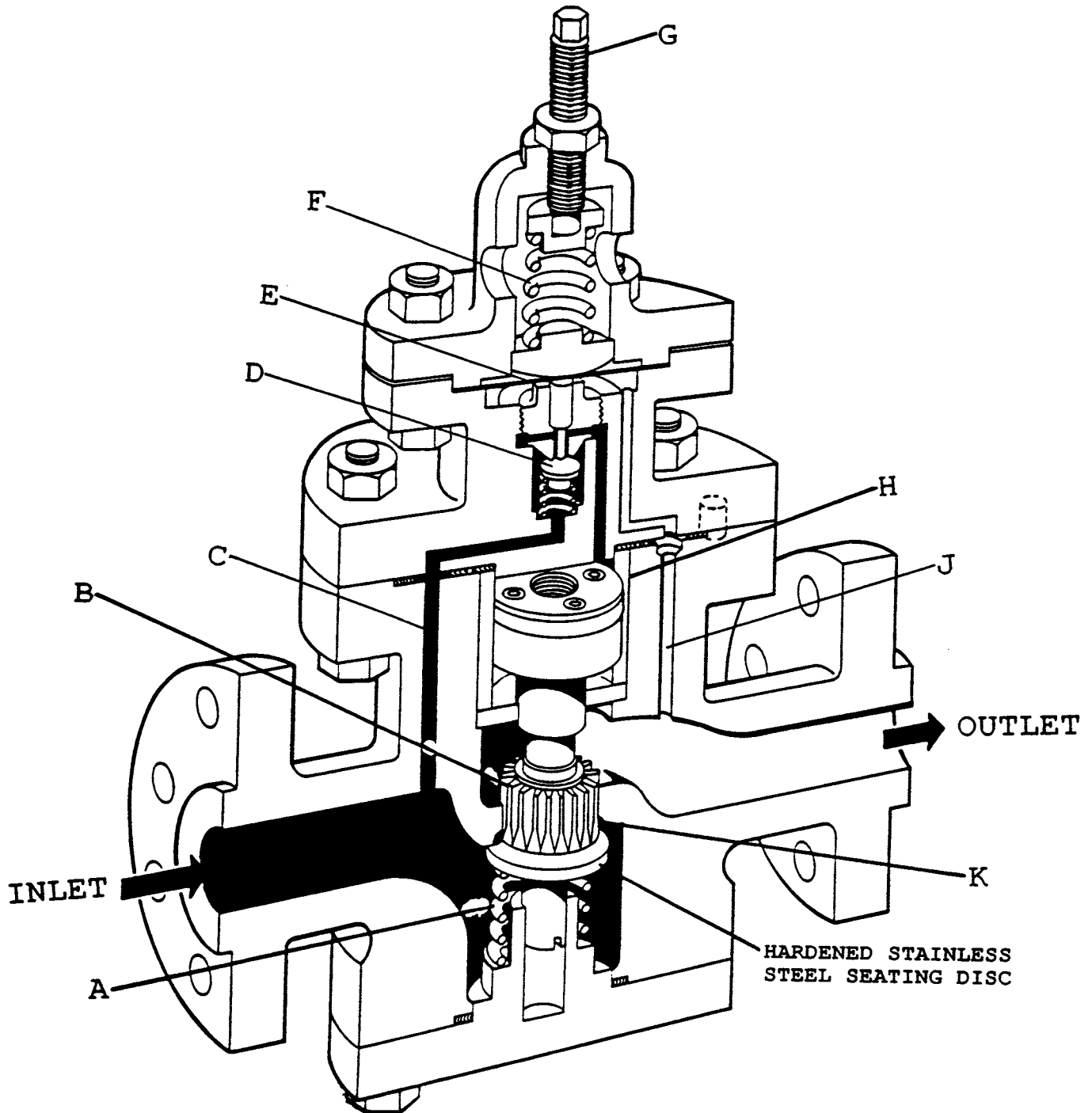

GS-0045

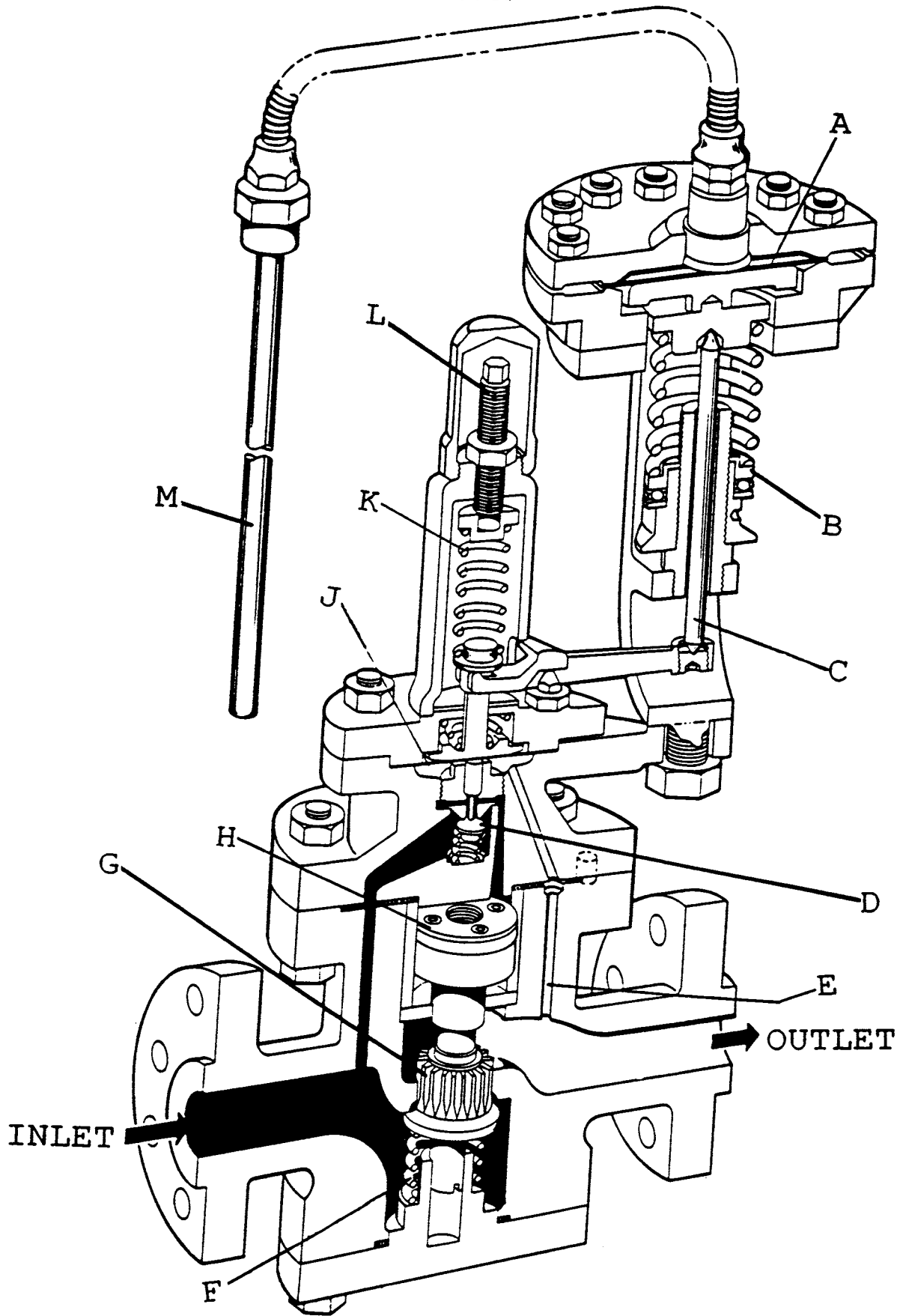

GS-0046



A



B



C



D

GS-0047

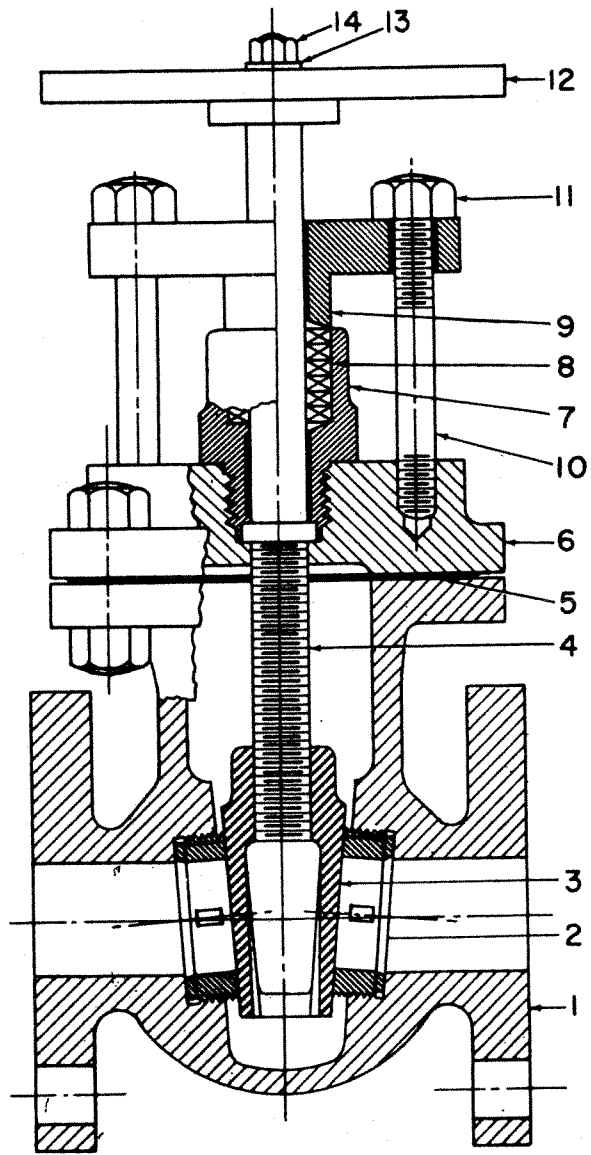

GS-0048

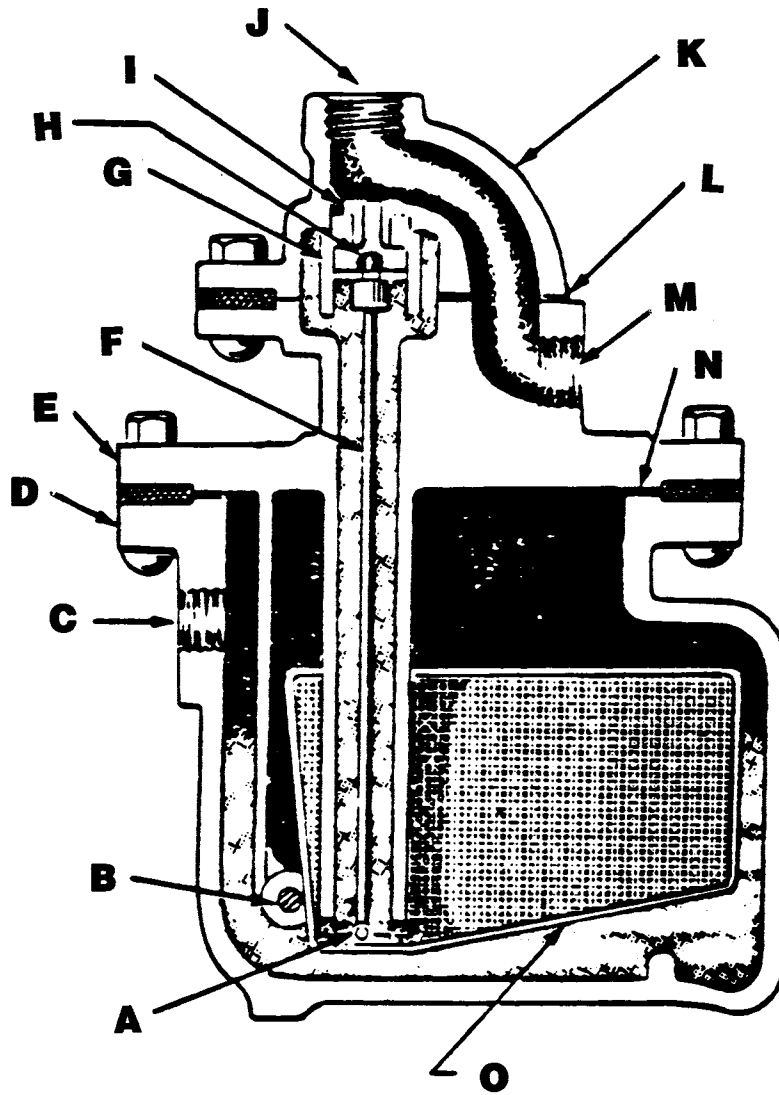

GS-0049

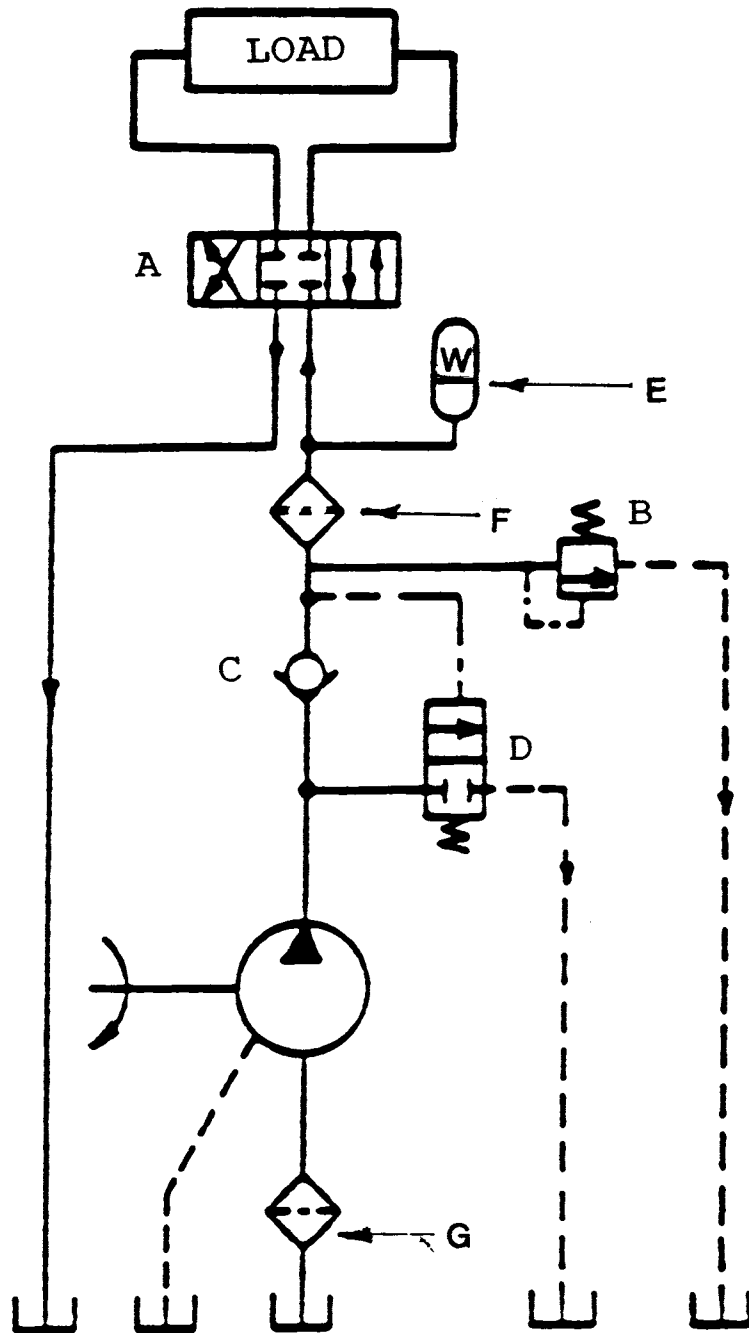

GS-0050

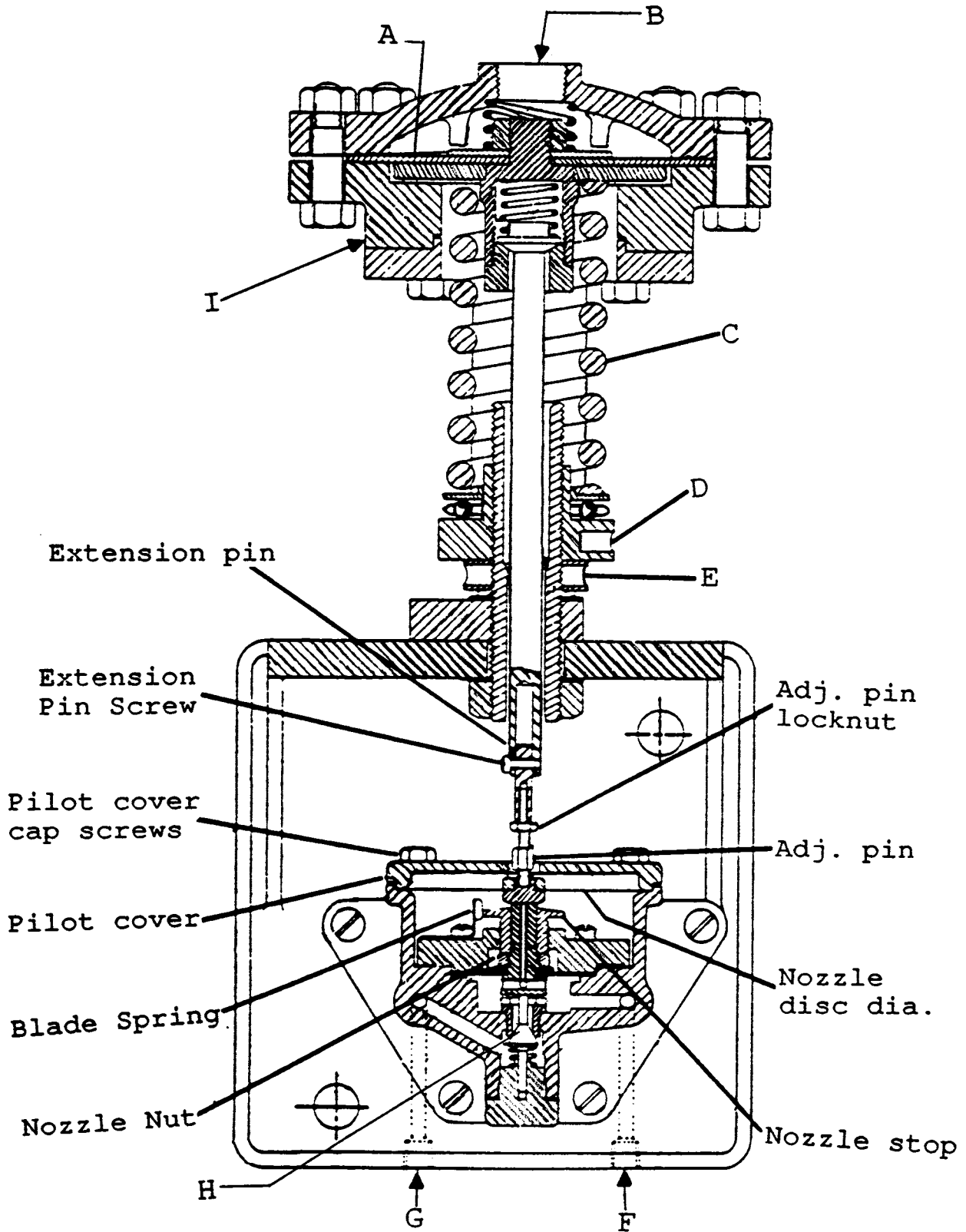

GS-0051

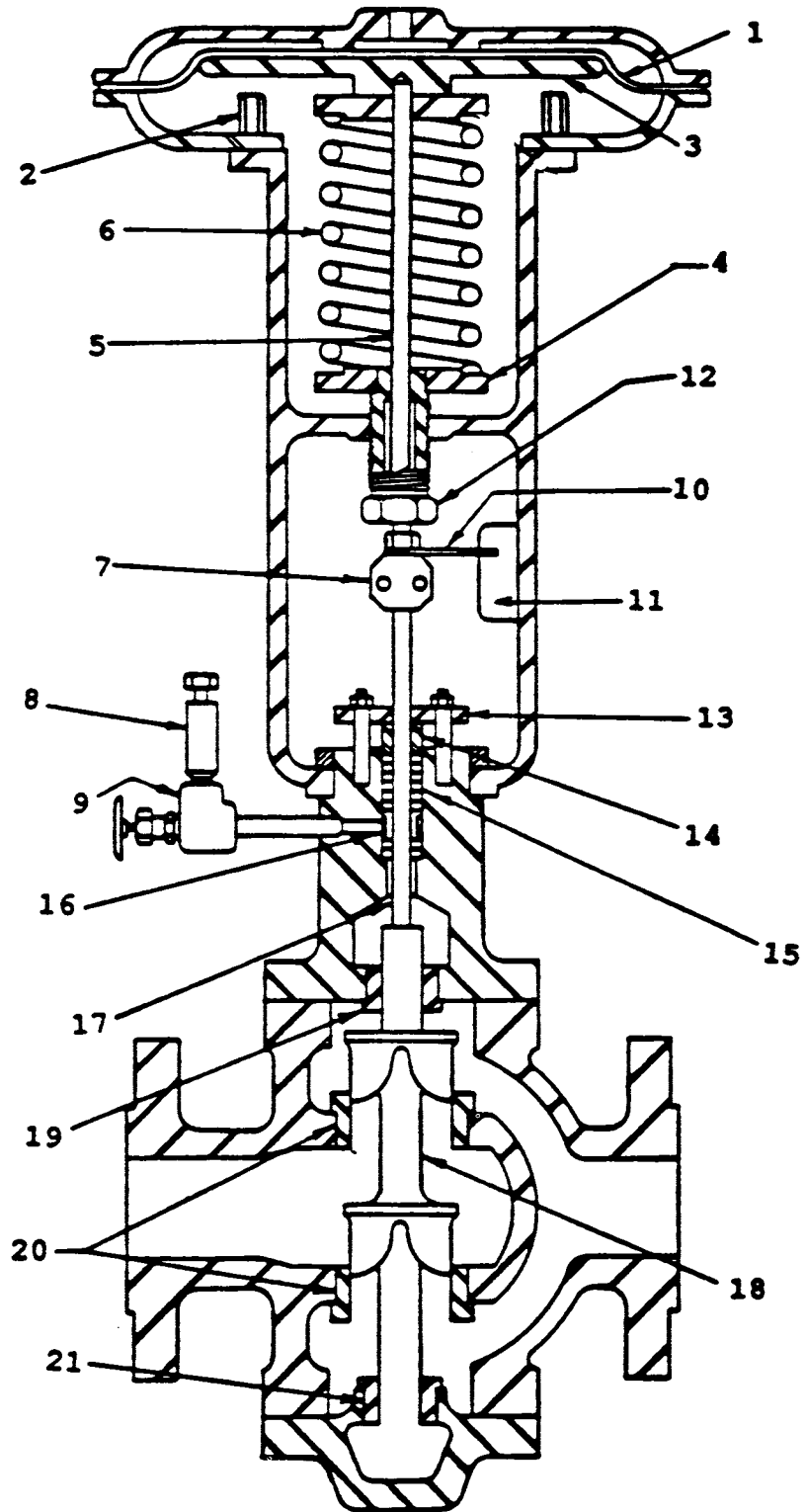

GS-0052

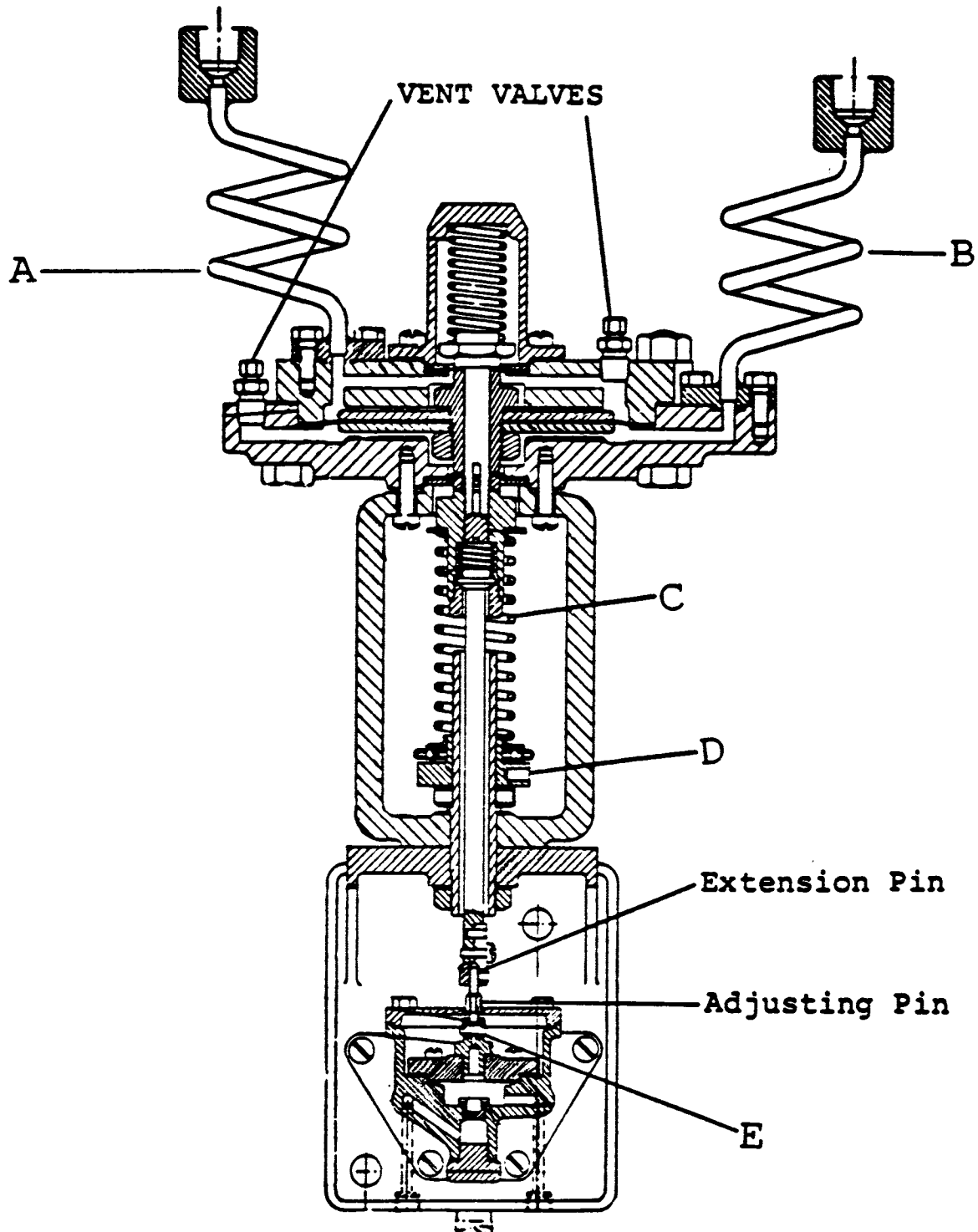

GS-0053

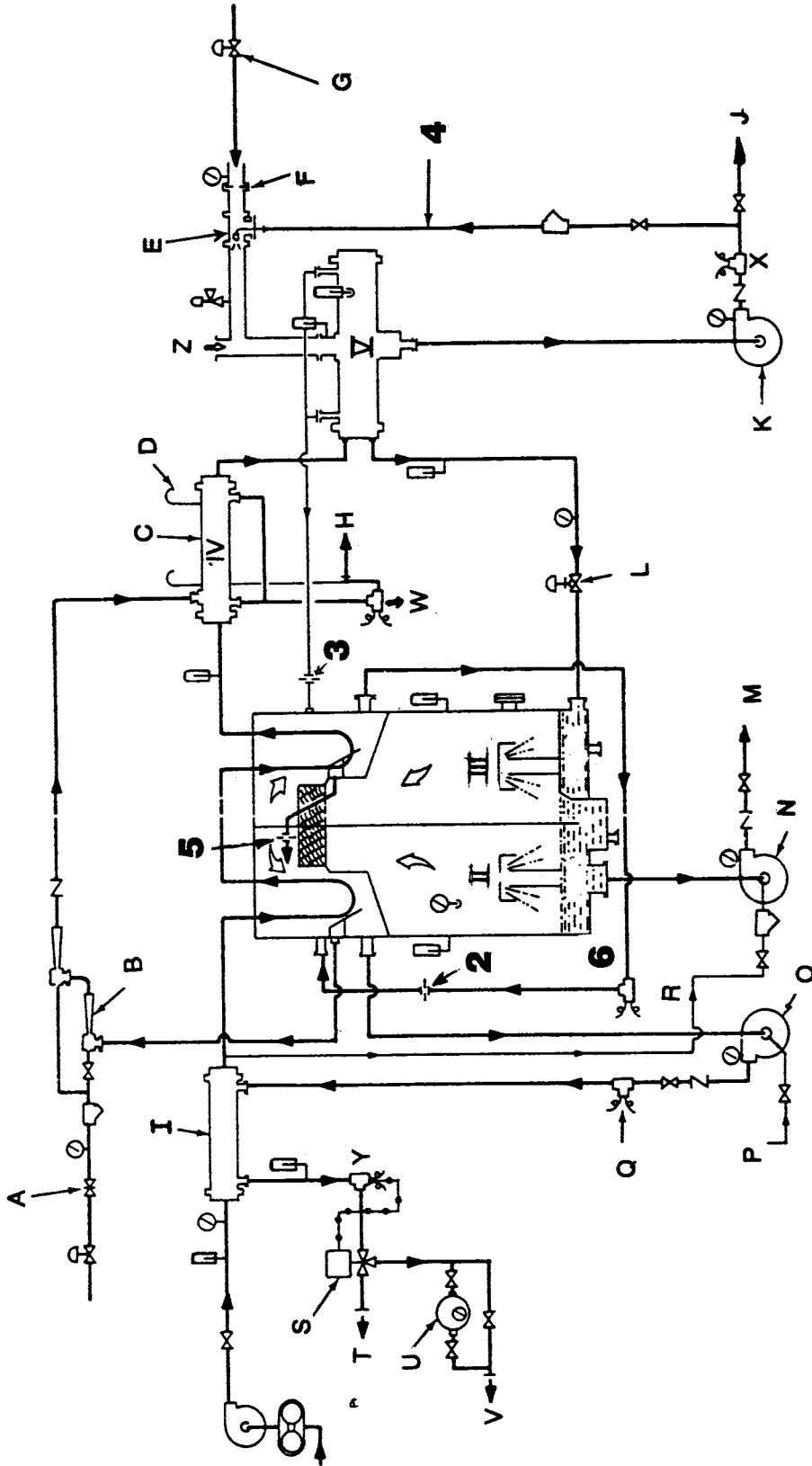

GS-0054

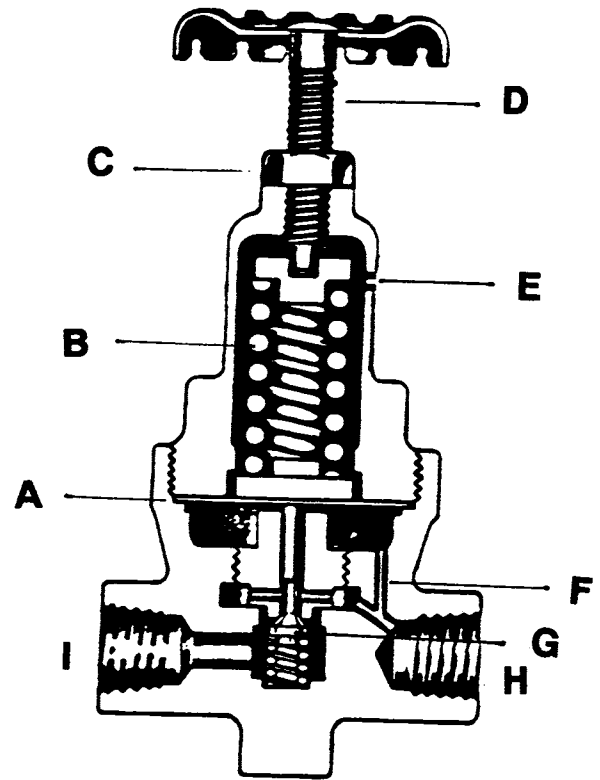

GS-0055

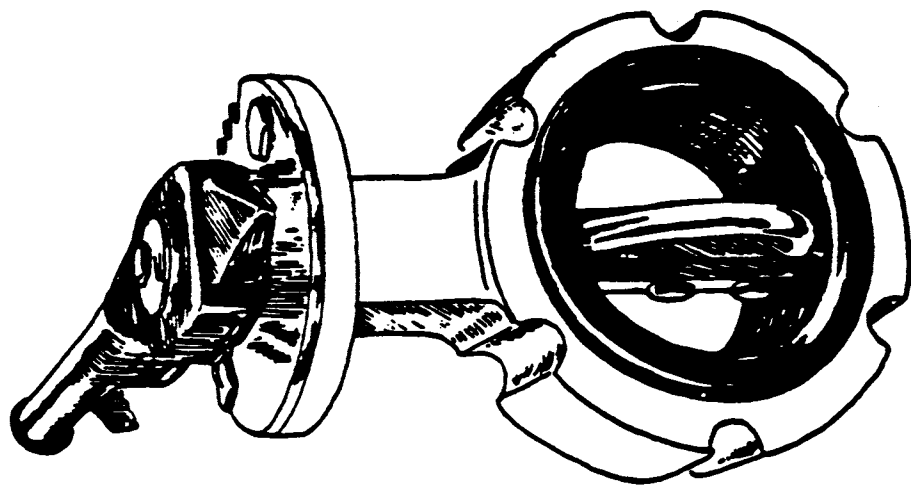

GS-0056

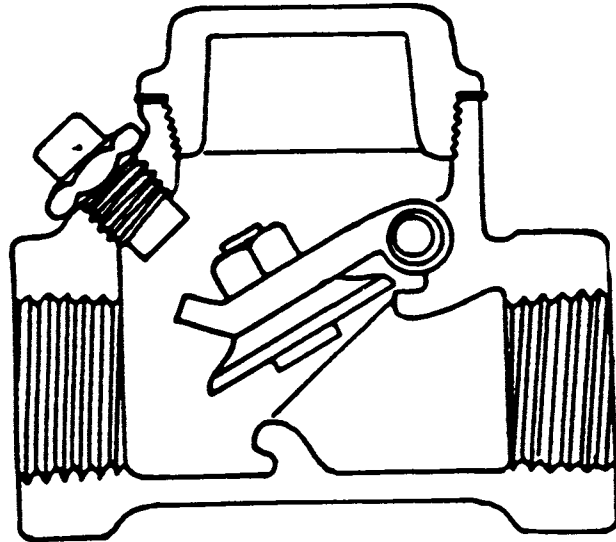

GS-0057

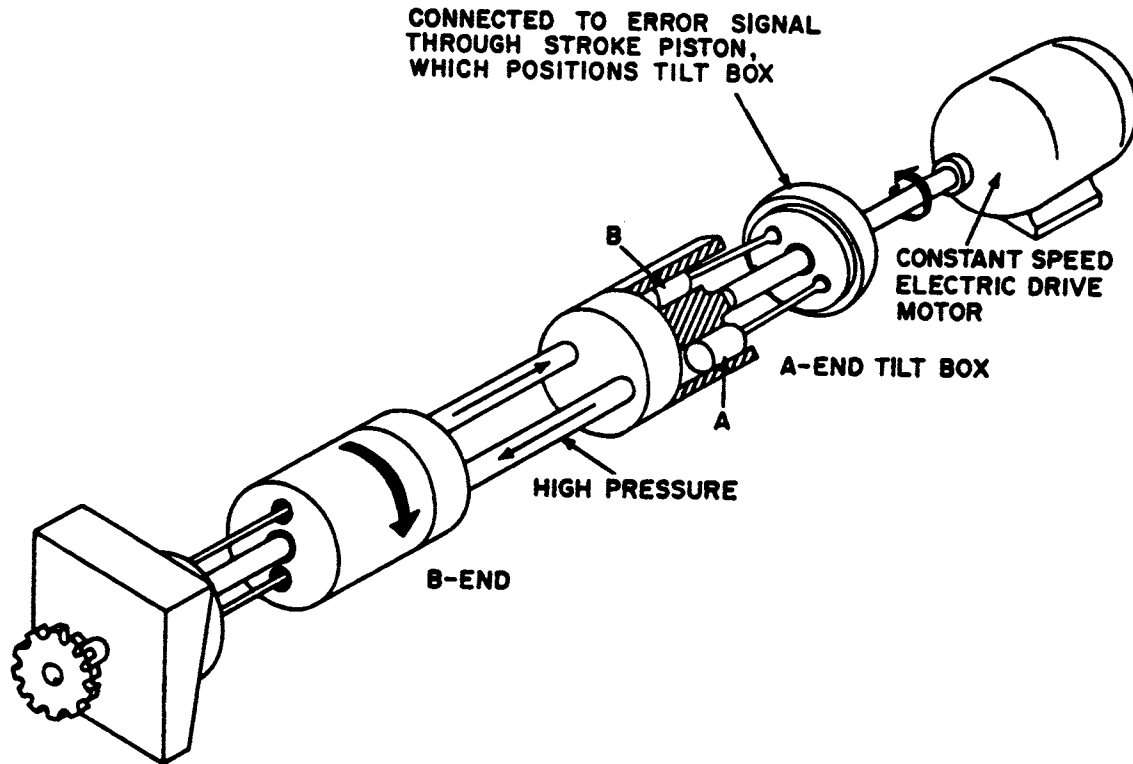

GS-0058

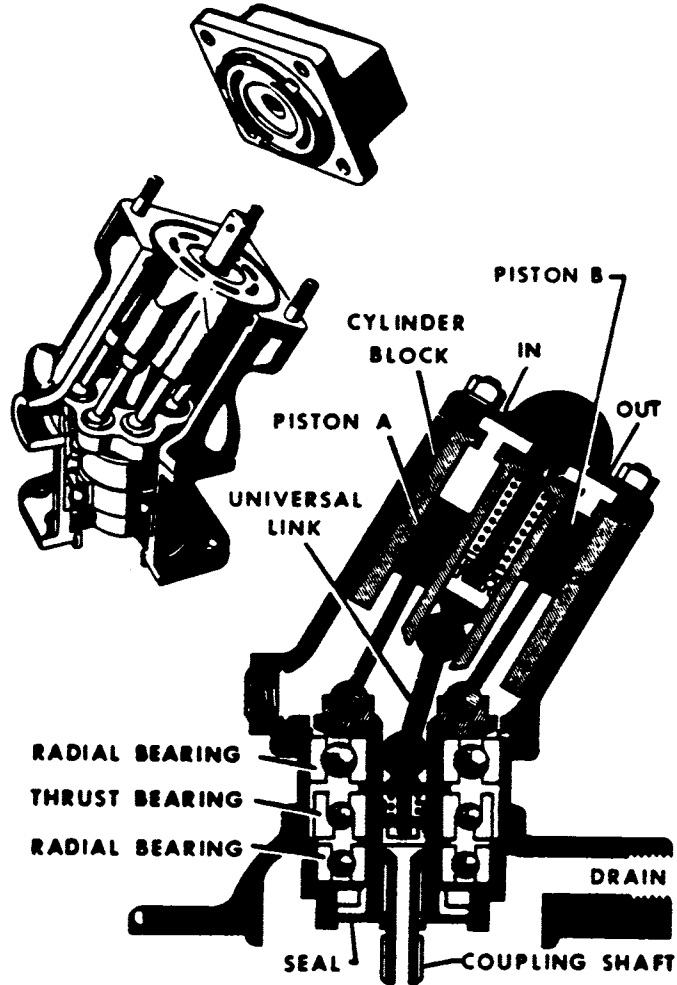

GS-0059

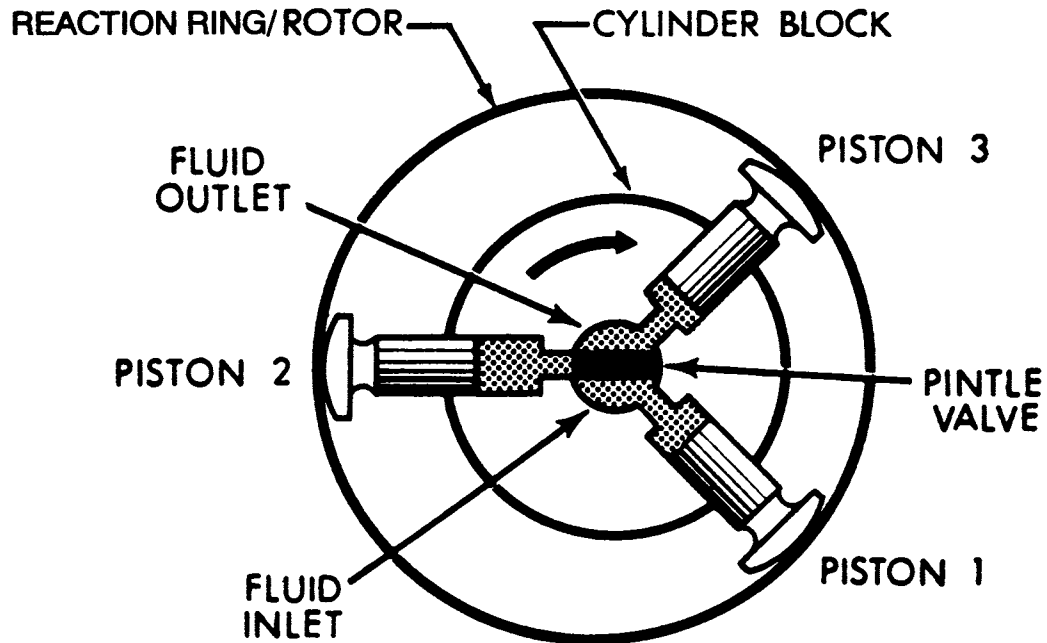

GS-0060

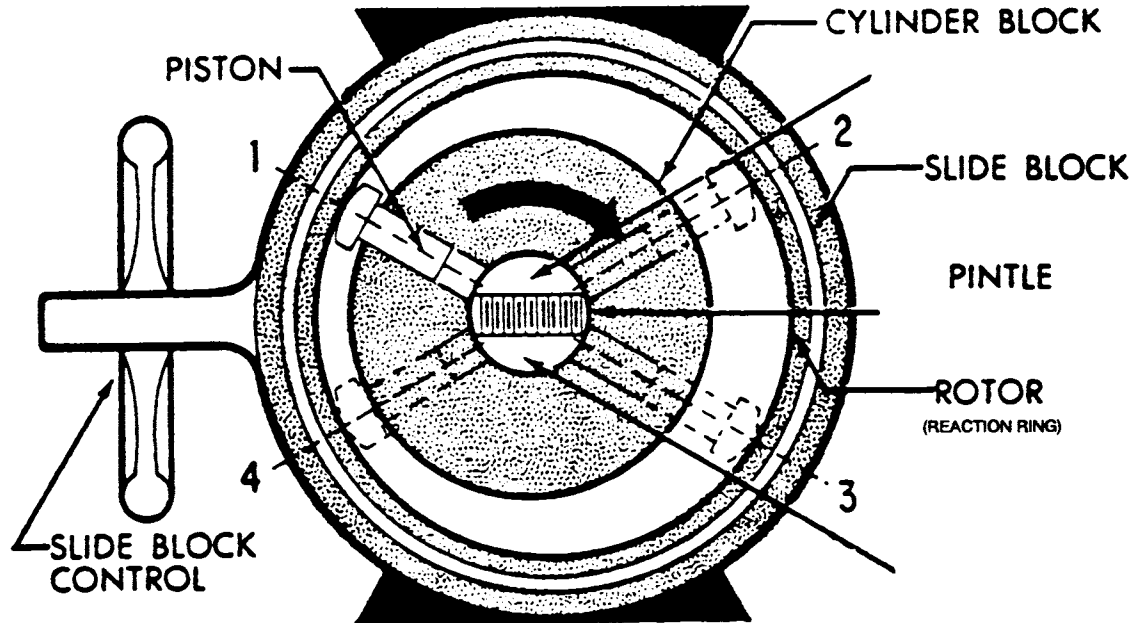

GS-0061

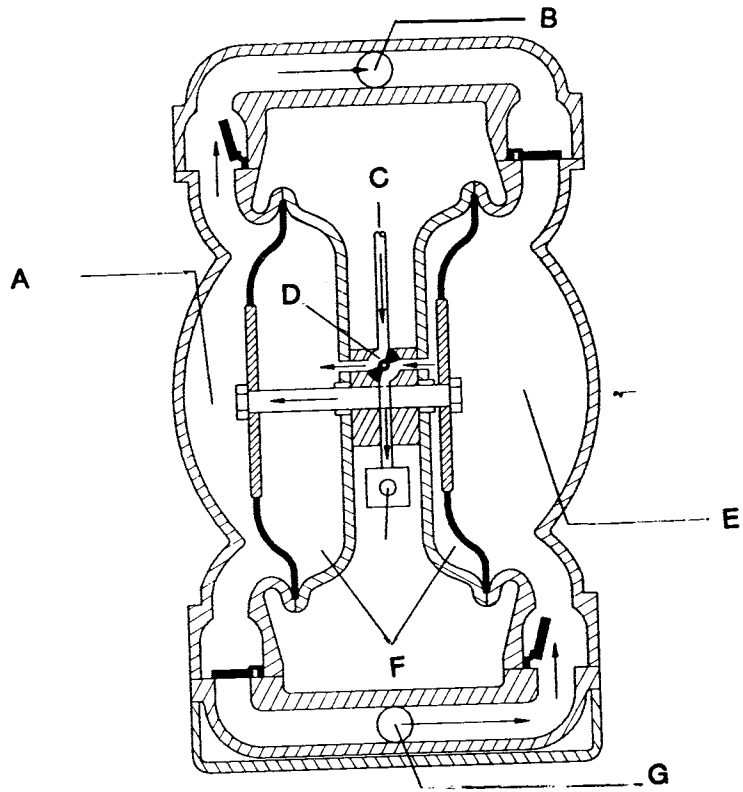

GS-0062

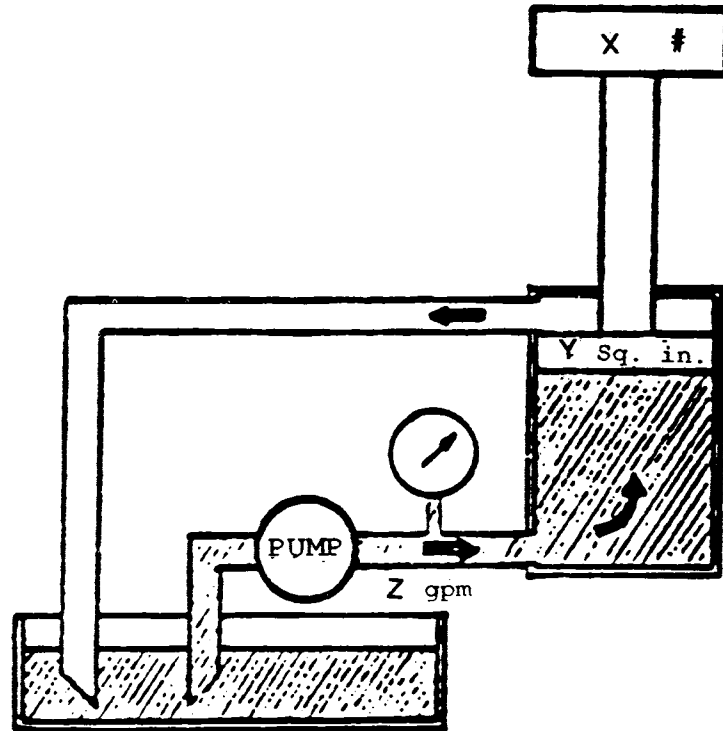

GS-0063

A



B



C



D

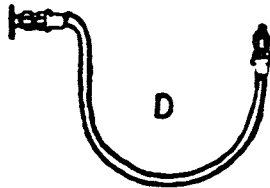

GS-0064

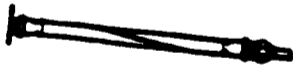

GS-0065

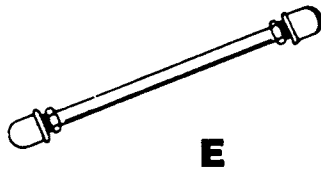
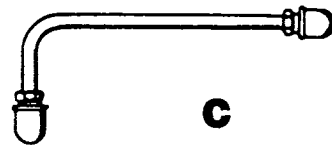
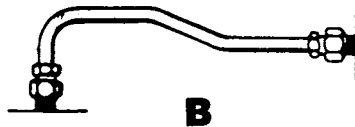
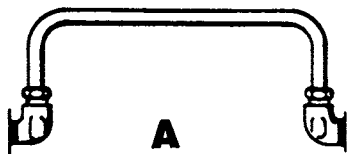

GS-0066

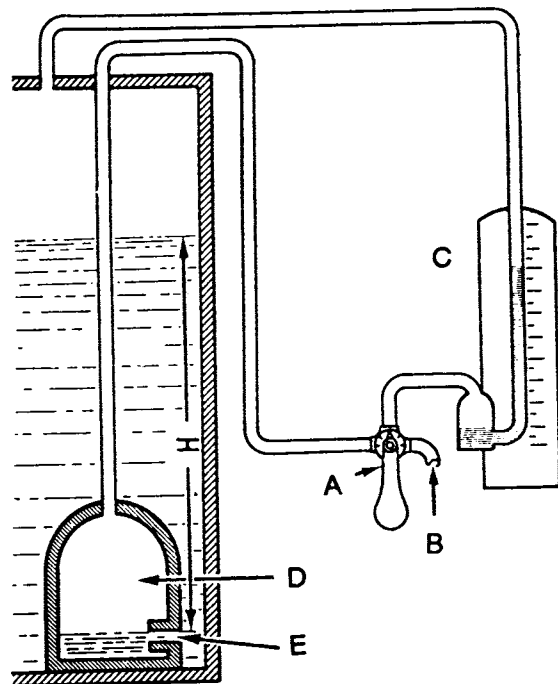

GS-0067

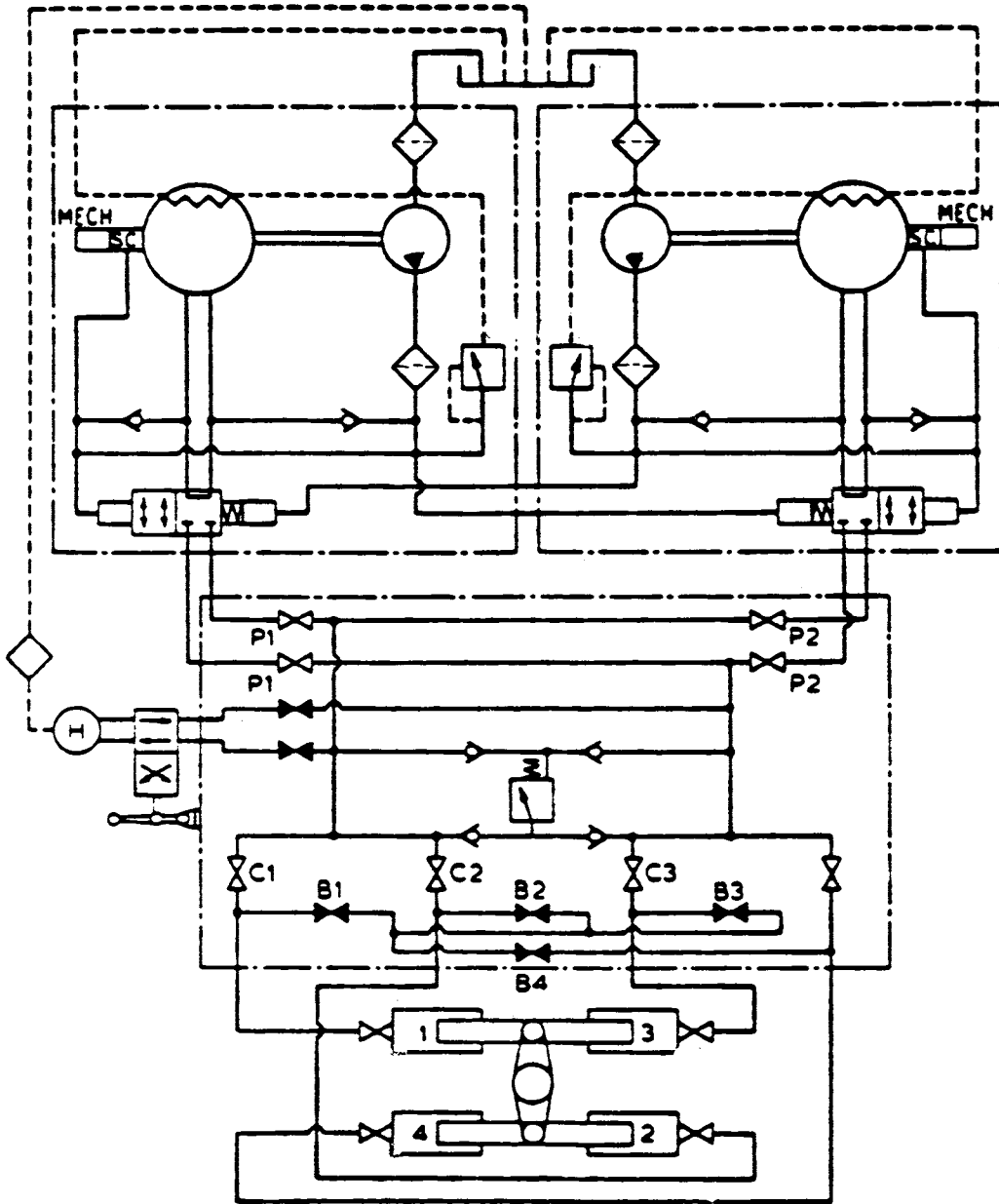

GS-0068



Fig. A



Fig. B

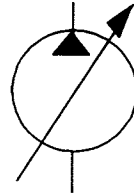

Fig. C

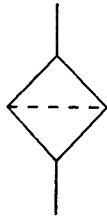

Fig. D

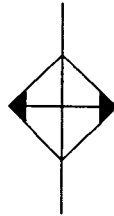

Fig. E

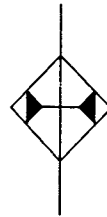
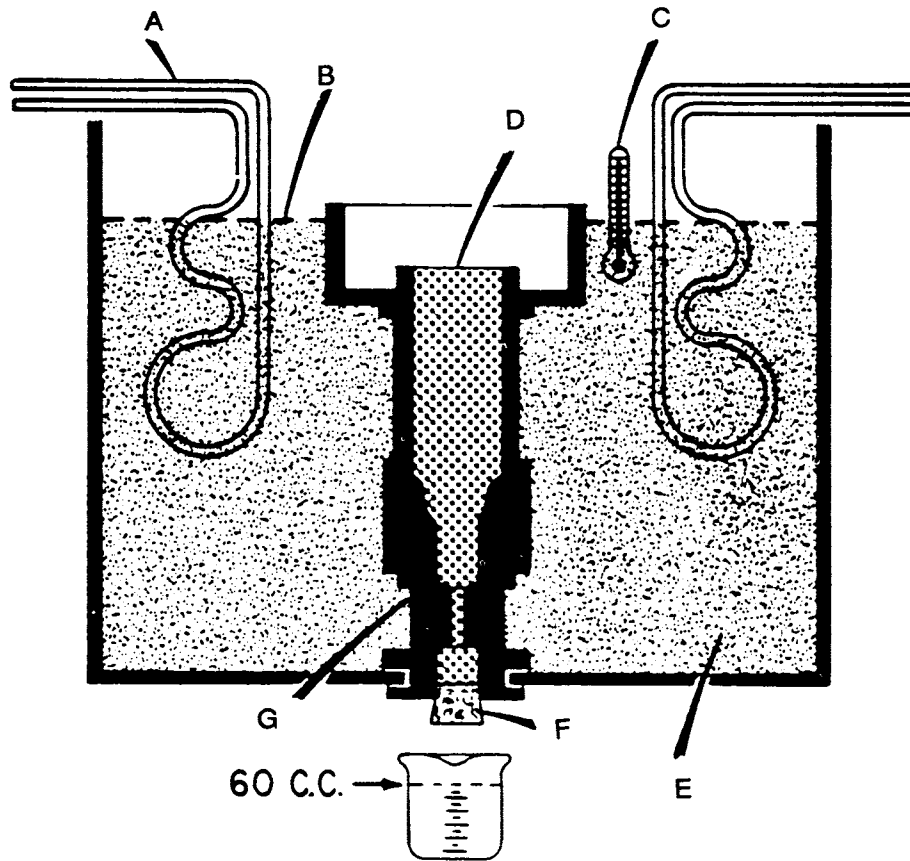
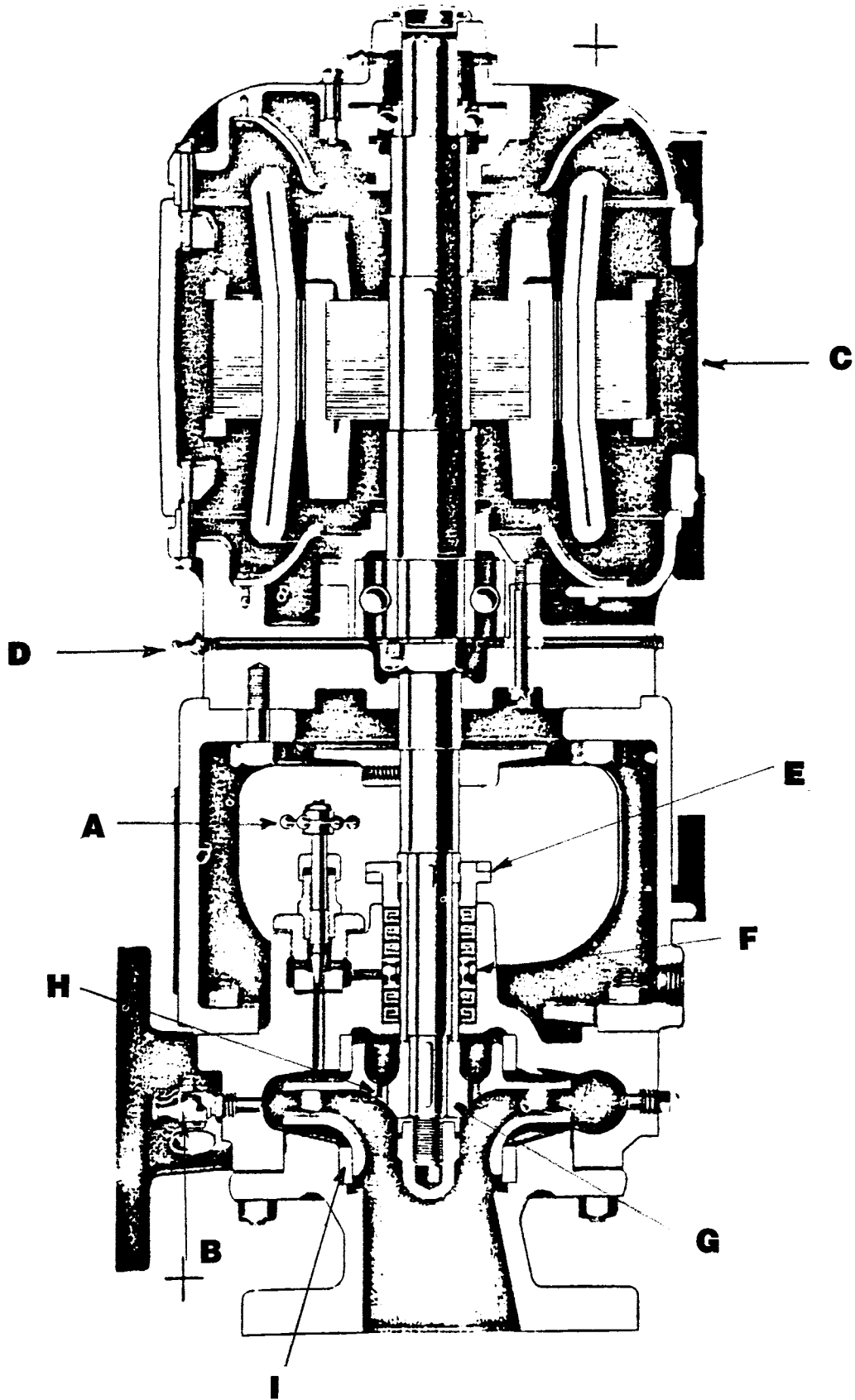

Fig. F

GS-0069



GS-0070



GS-0071

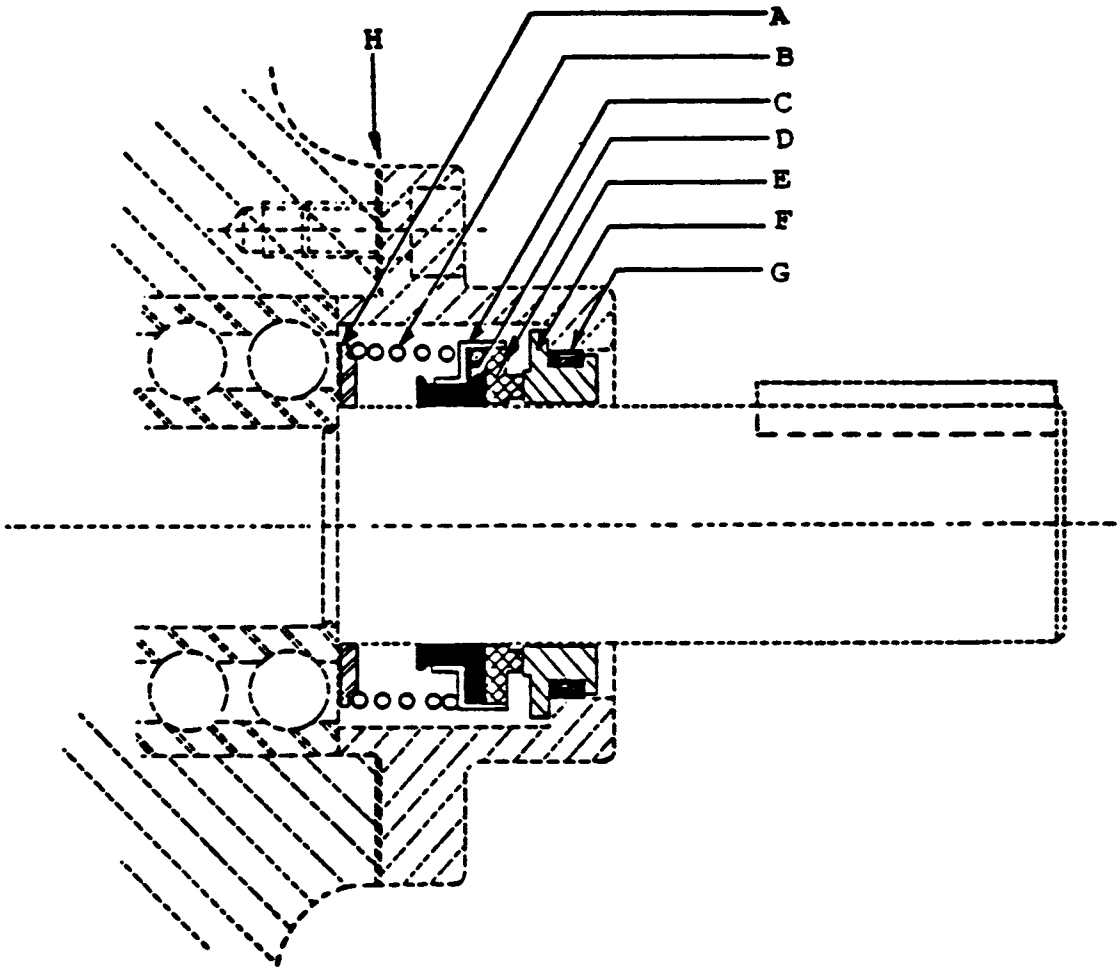

(COURTESY OF CORNELL MARITIME PRESS)

GS-0072

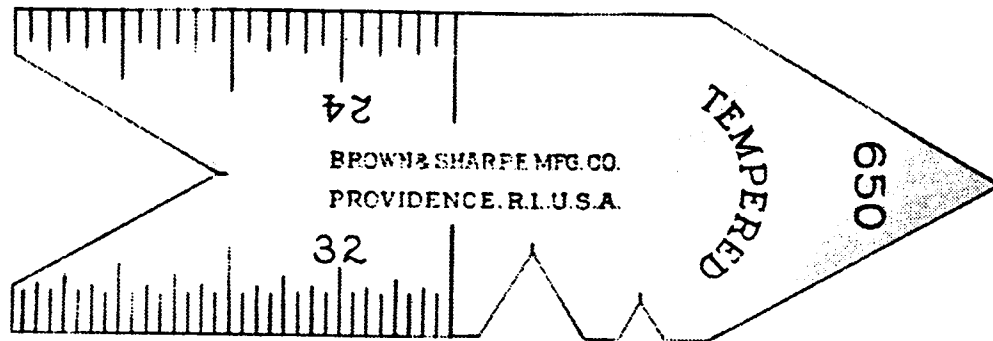

GS-0073

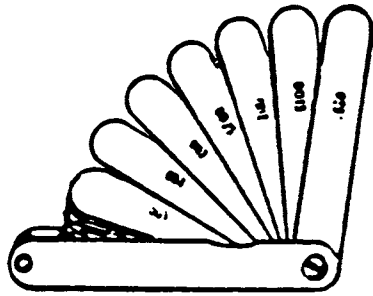

A

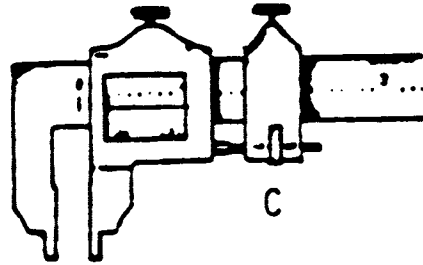

C

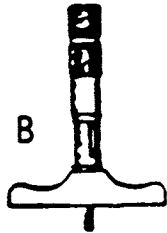

B

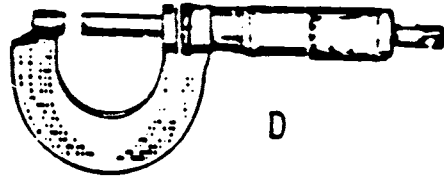

D

GS-0074

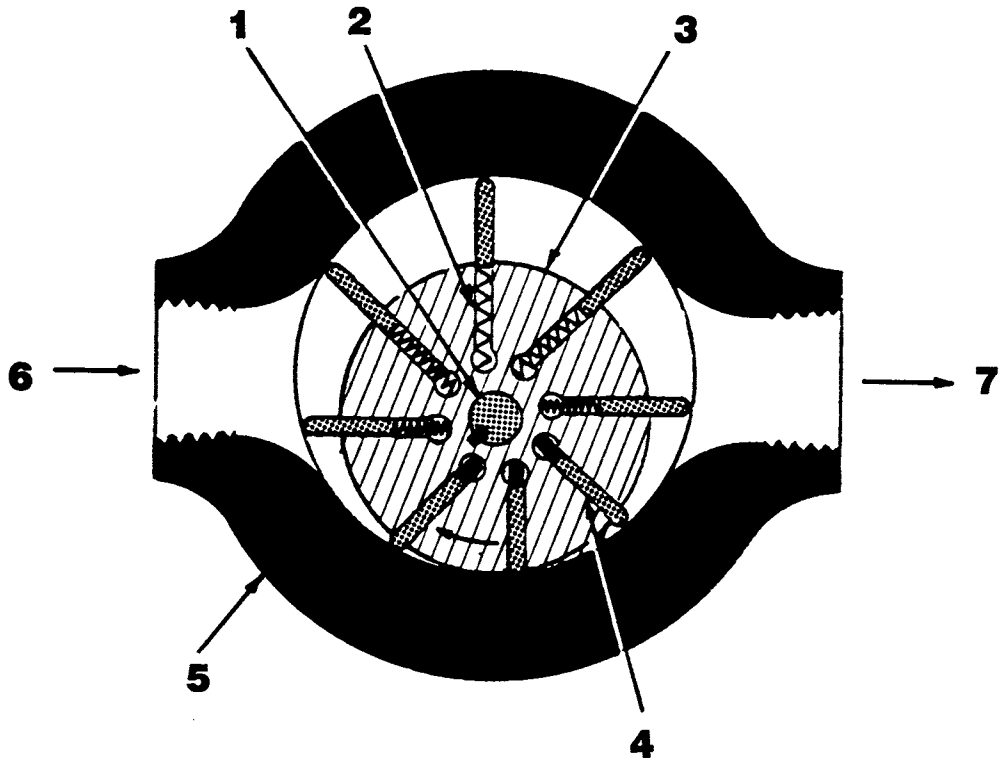

GS-0075

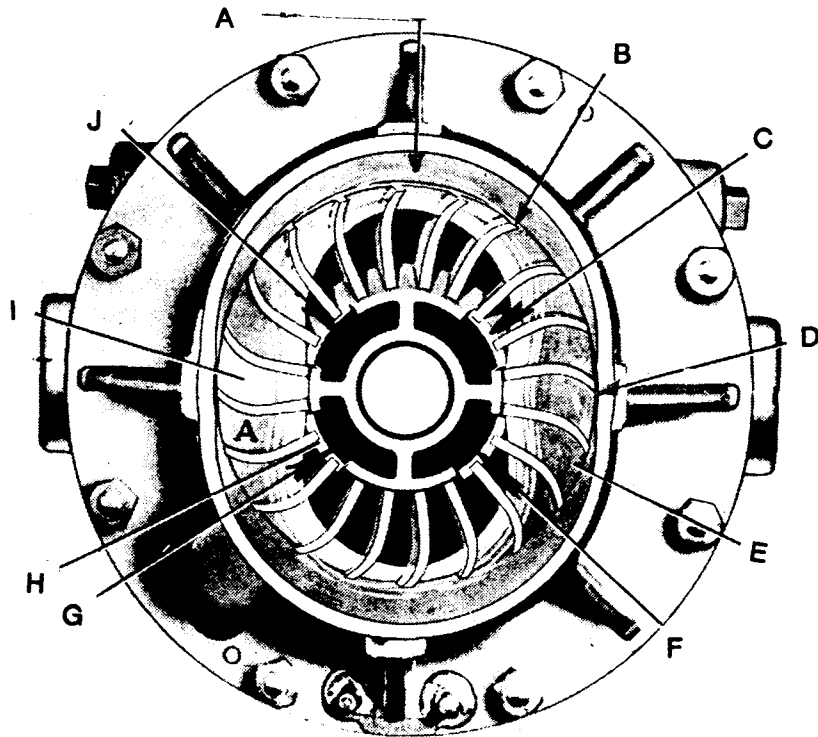



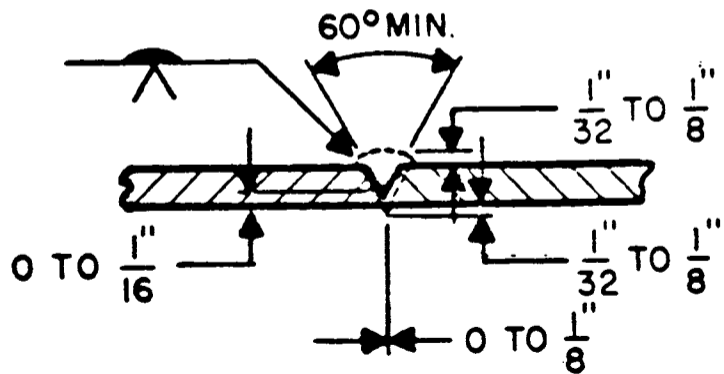





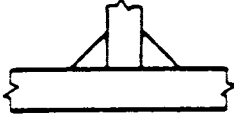

GS-0076

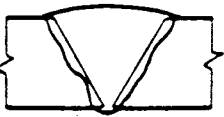

GS-0077

TYPES of WELDS

	A	B
1		
2		
3		
4		
5		
6		

GS-0078

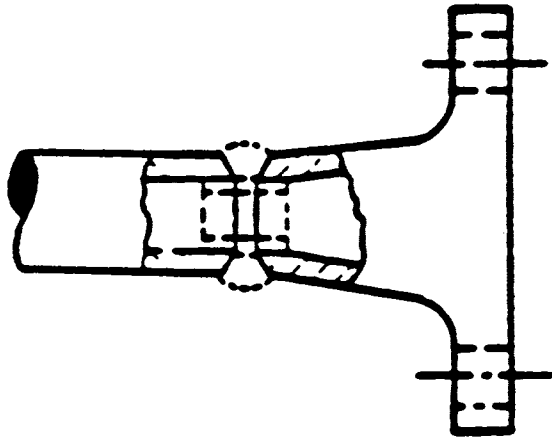

GS-0079

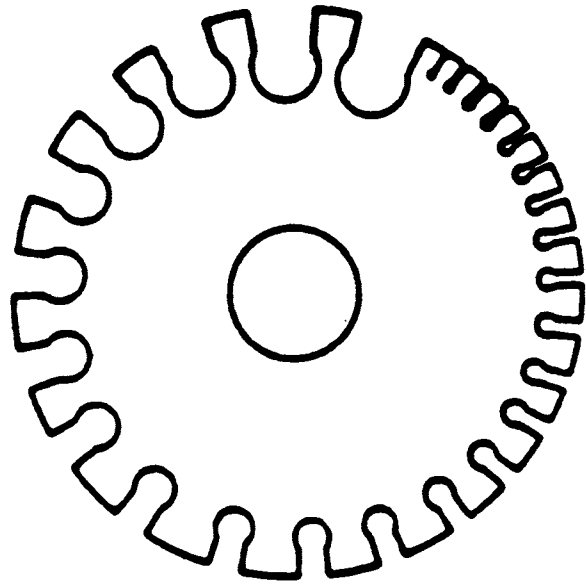

GS-0080



A



E



I

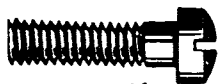

K

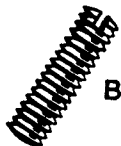

B

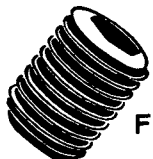

F

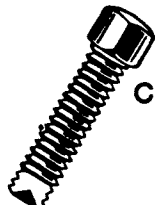

C

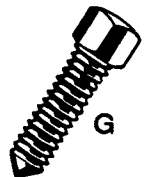

G

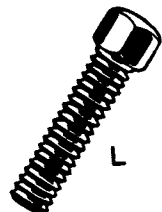

L



D

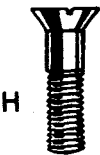

H



J



M

GS-0081

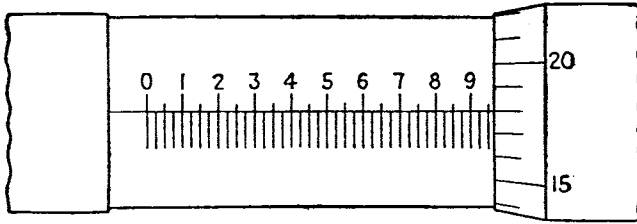

A

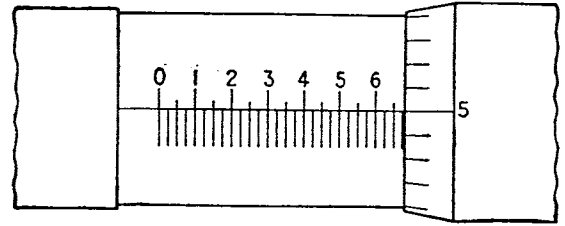

B

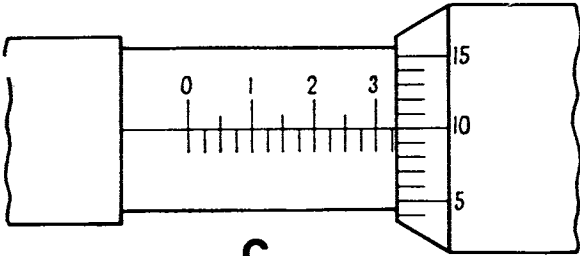

C

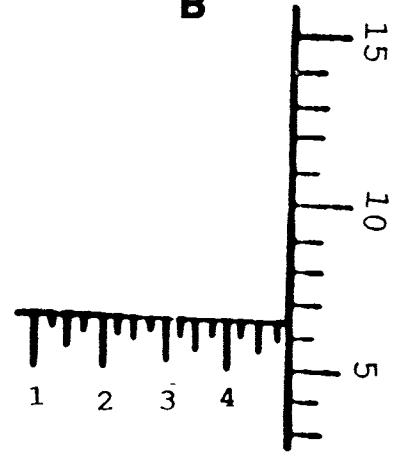

D

GS-0082

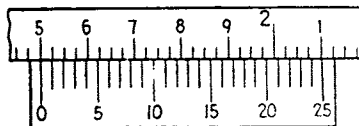

A

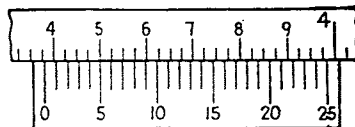

B

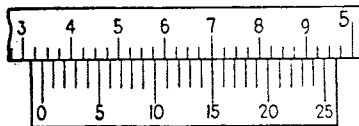

C

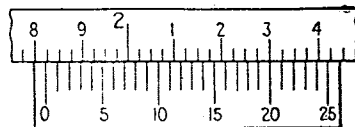

D

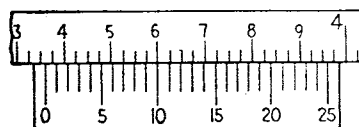

E

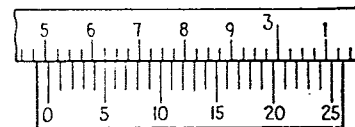

F

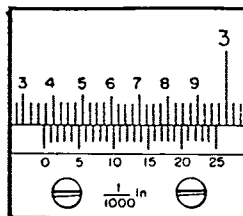

G

GS-0083

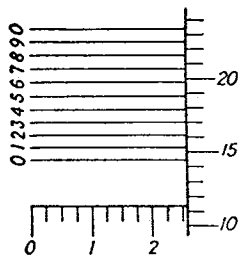

A

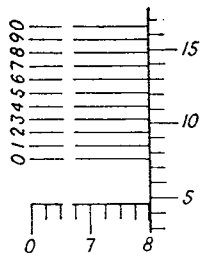

B

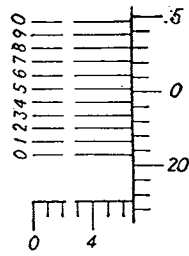

C

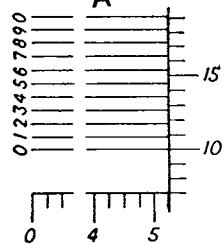

D

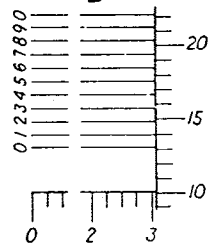

E

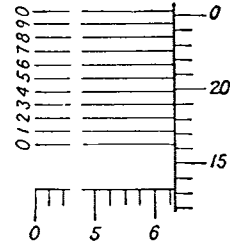

F

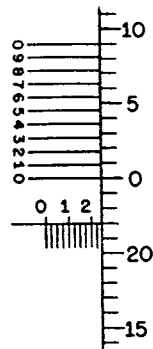

G

GS-0084

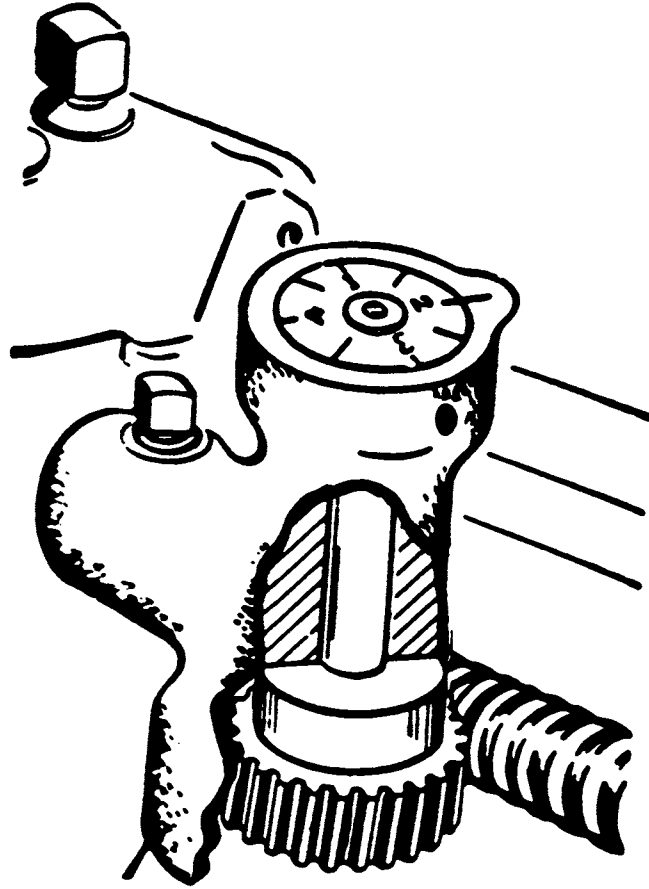

GS-0085

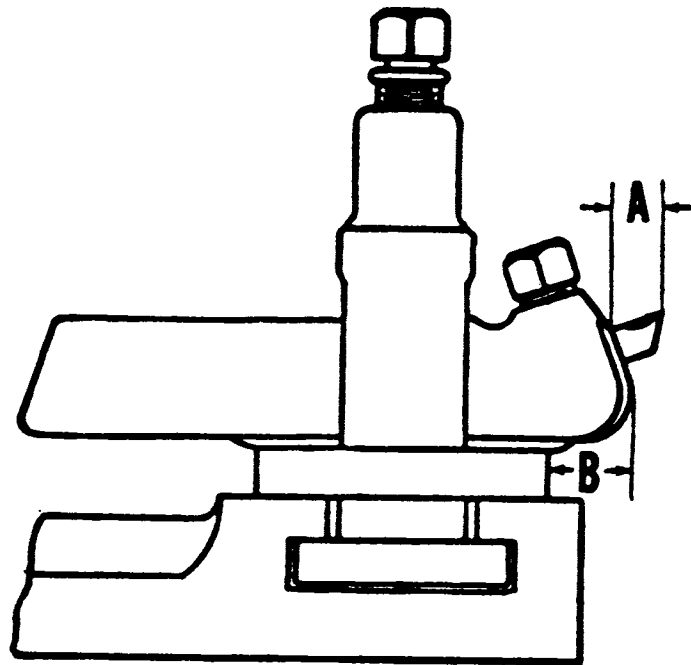

GS-0086

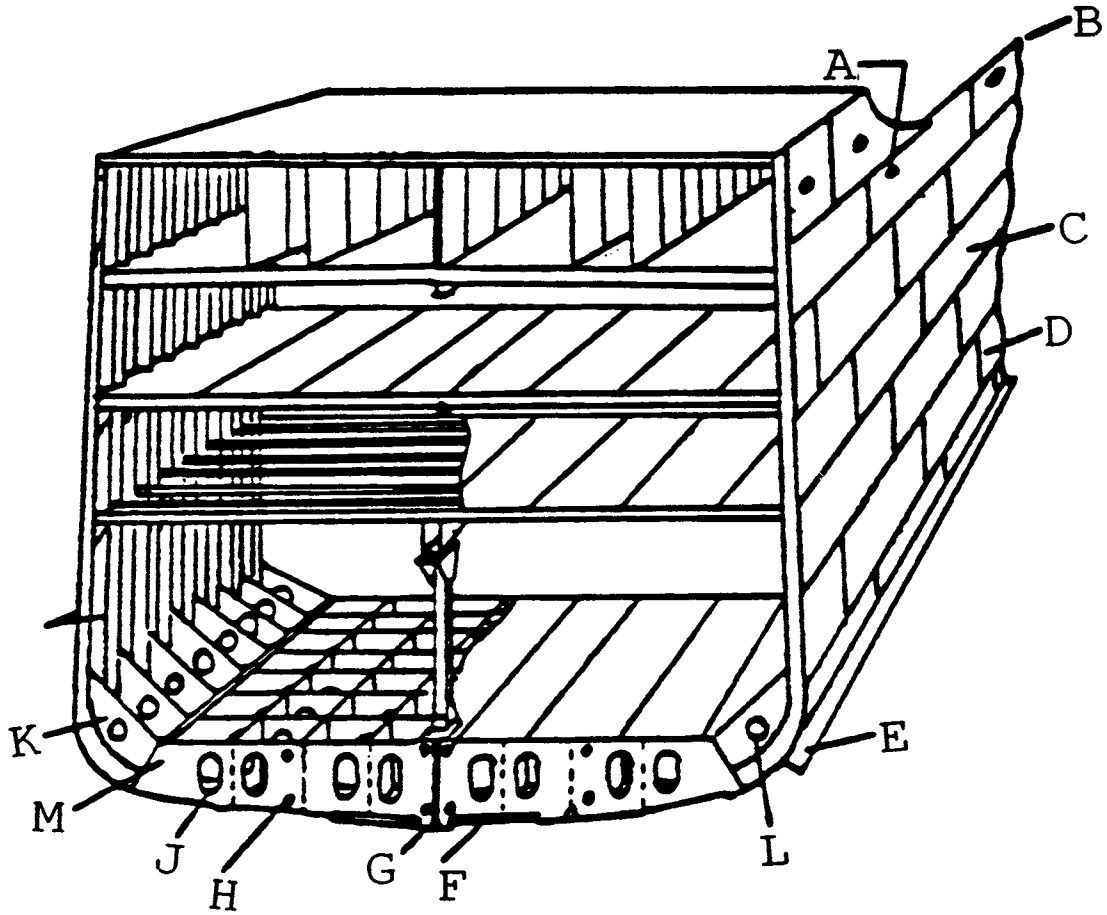

GS-0087

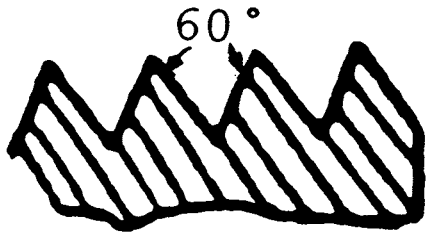

GS-0088

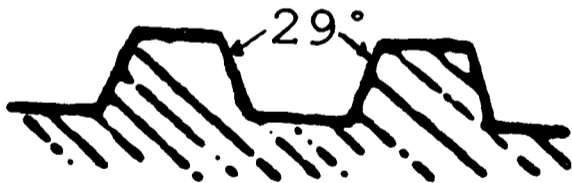

GS-0089

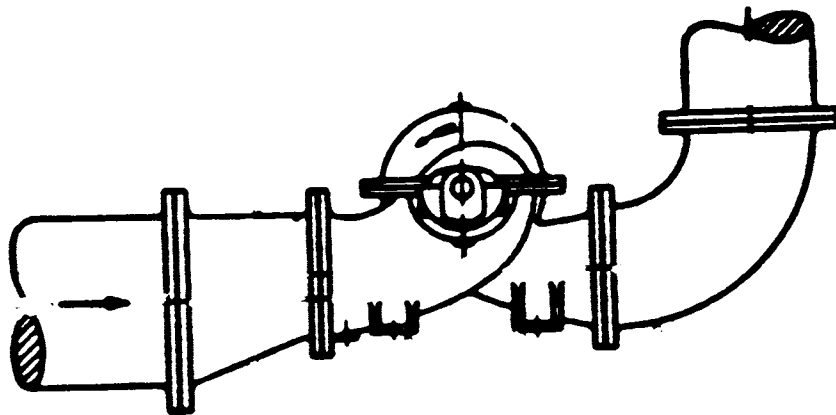

GS-0090

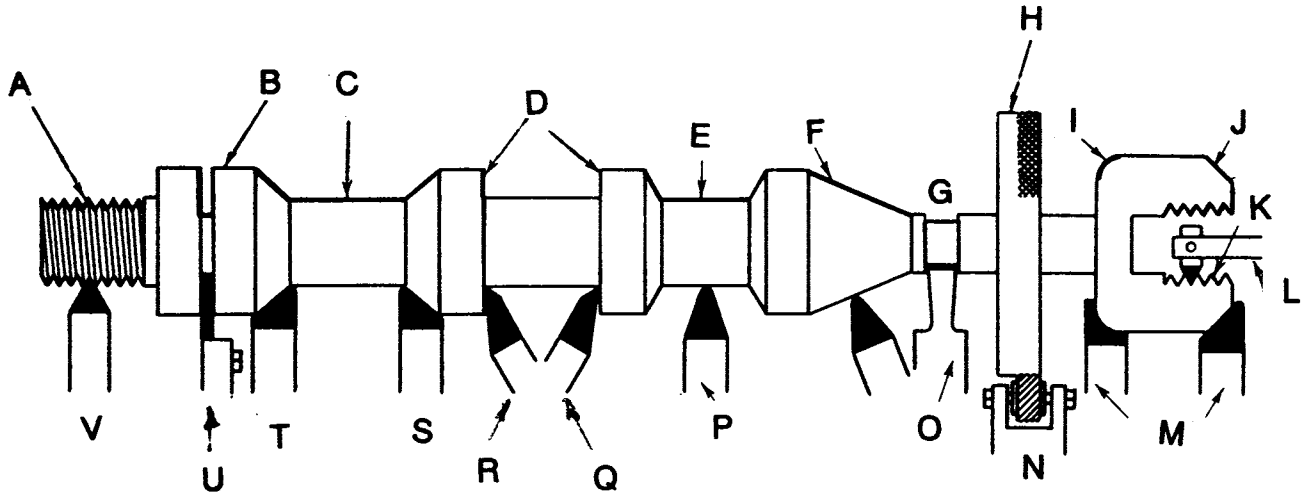

GS-0091

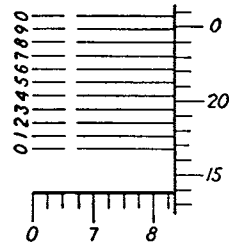

A

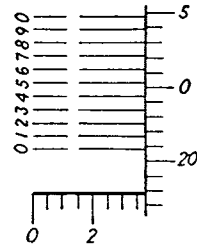

B

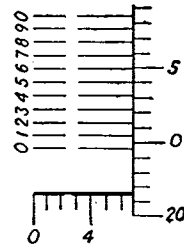

C

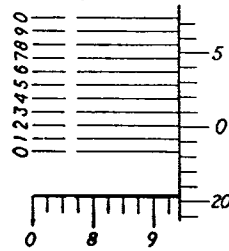

D

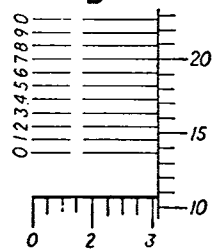

E

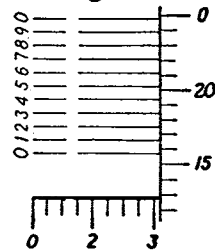

F

GS-0092

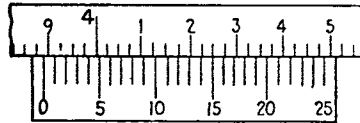

A

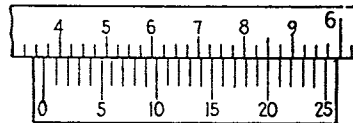

B

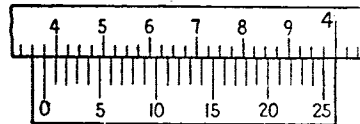

C

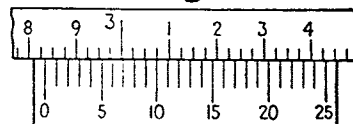

D

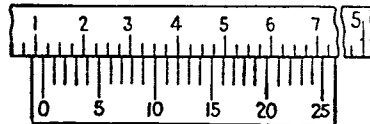

E

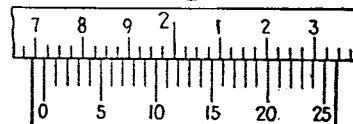

F

GS-0093

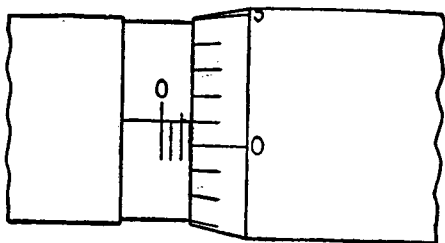

A

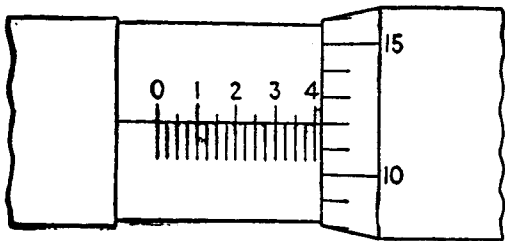

B

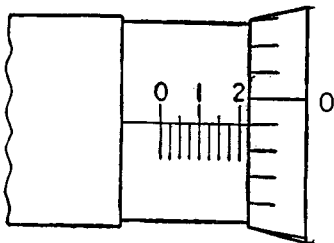

C

GS-0094

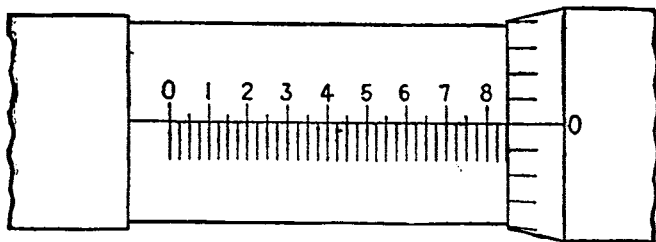

1

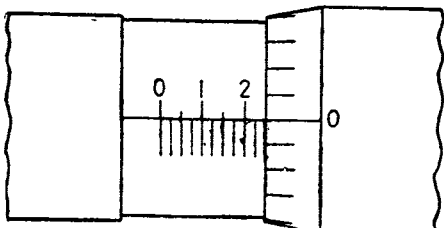

2

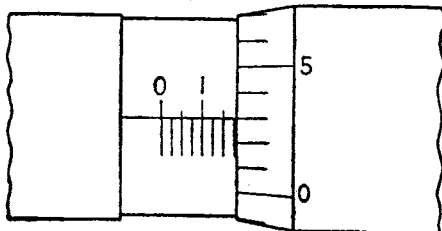

3

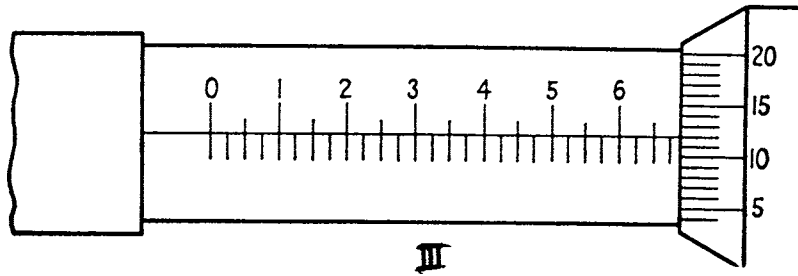
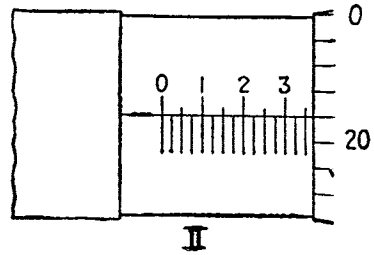
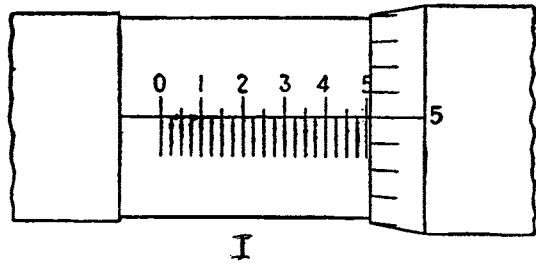

GS-0096

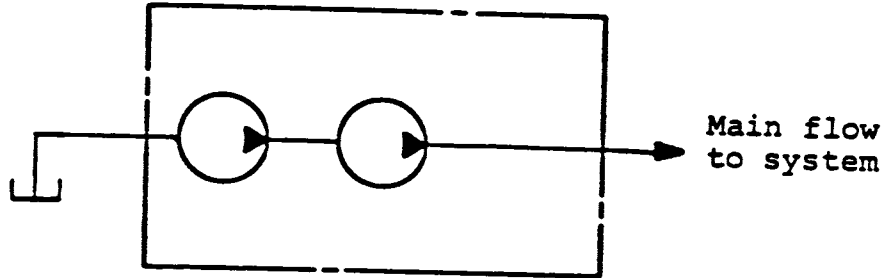

(COURTESY OF CORNELL MARITIME PRESS)

GS-0097

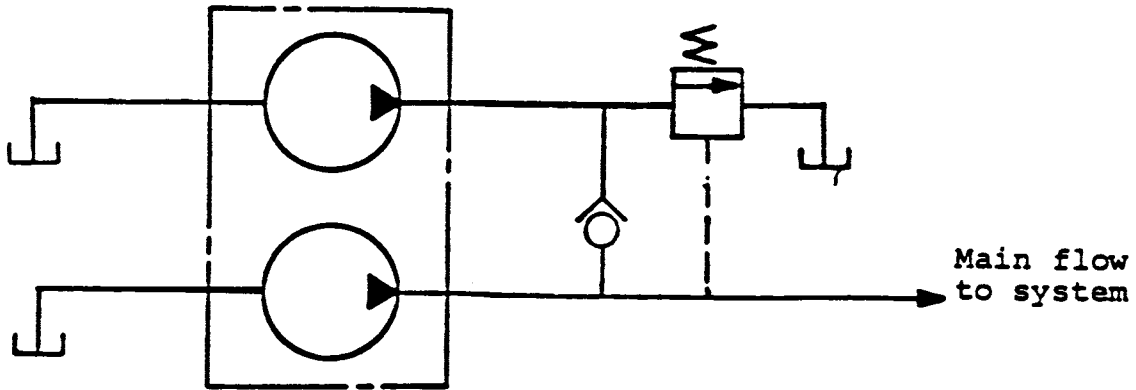

(COURTESY OF CORNELL MARITIME PRESS)

GS-0098

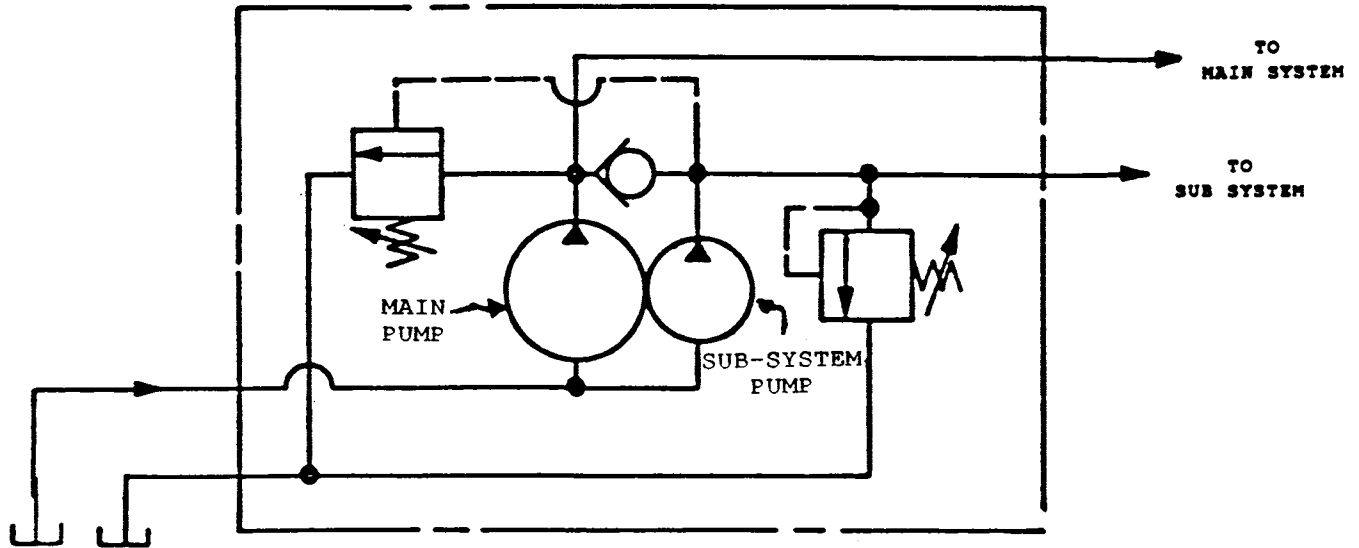

(COURTESY OF CORNELL MARITIME PRESS)

GS-0099

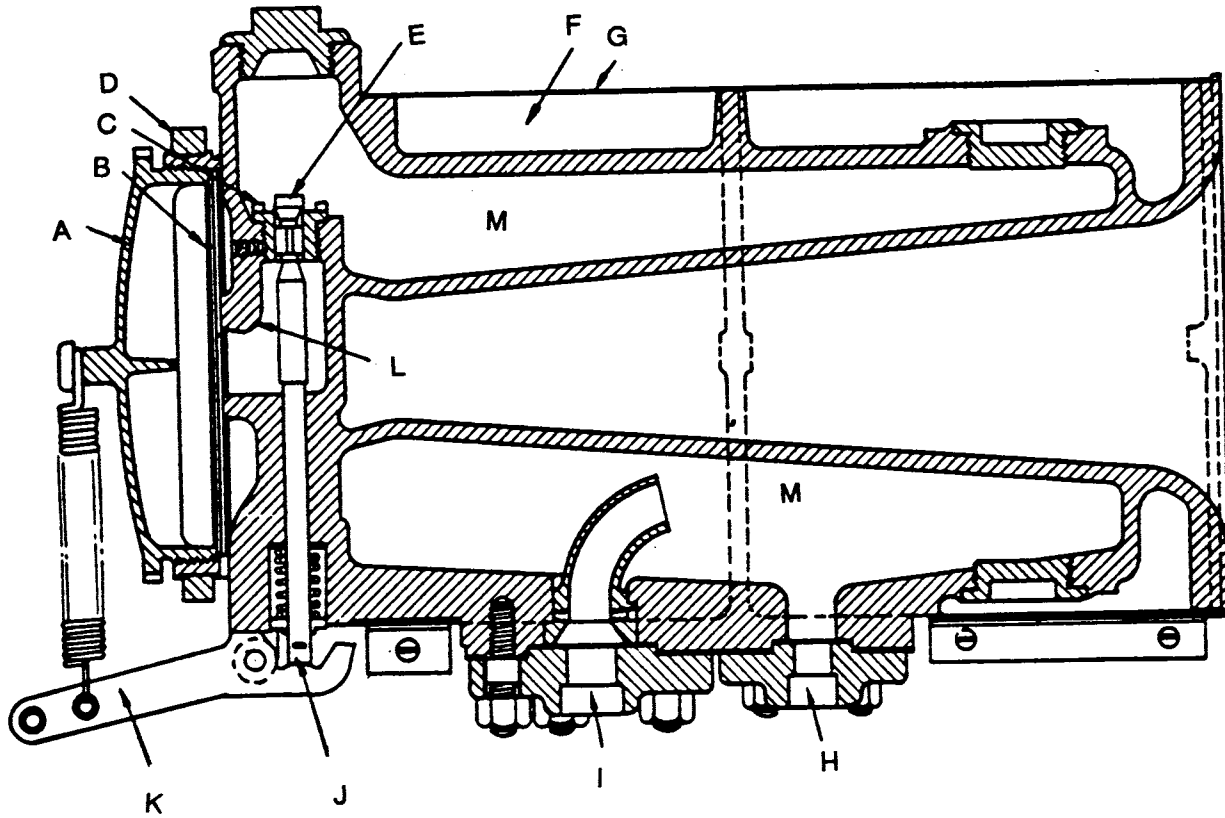

GS-0100

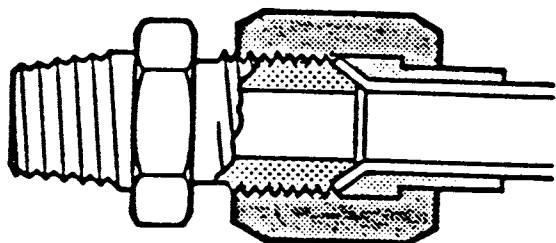

A

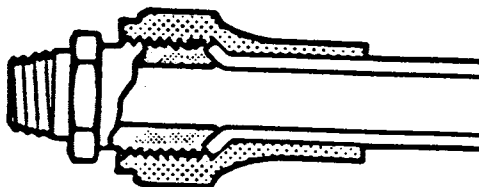

STANDARD

INVERTED

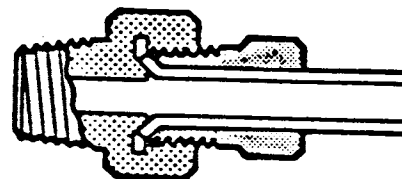

B

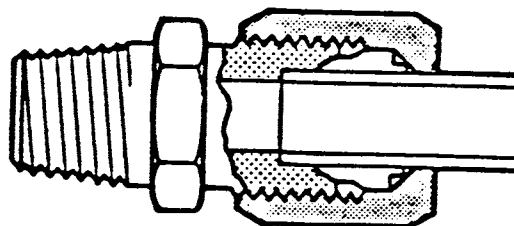
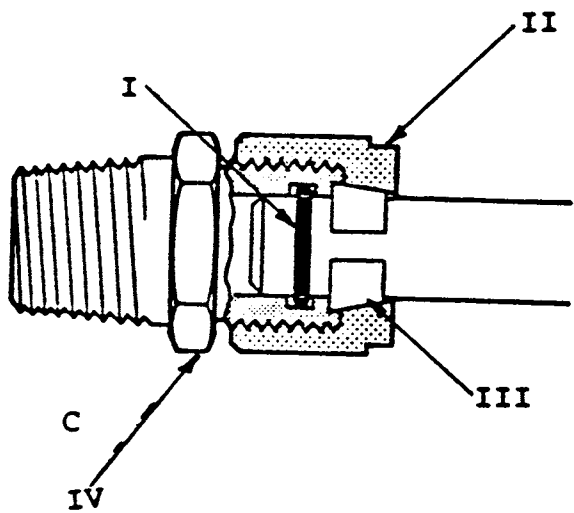

D

(COURTESY OF CORNELL MARITIME PRESS)

GS-0101

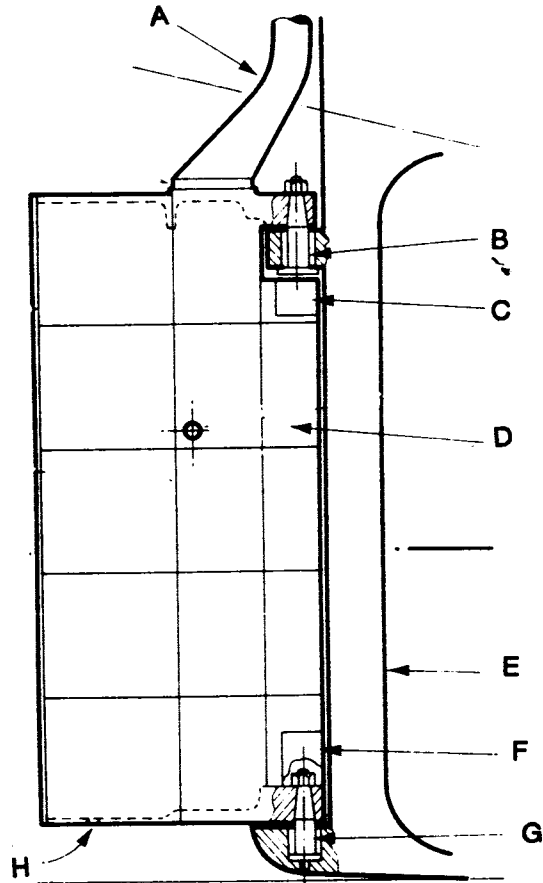

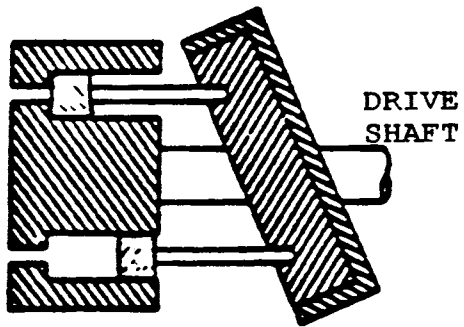

I

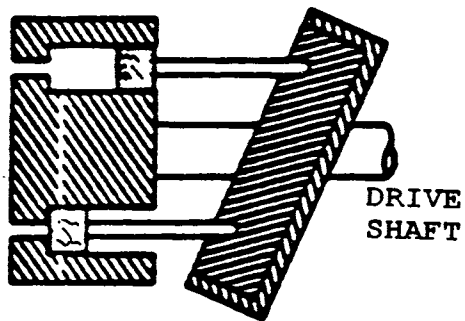

II

GS-0103

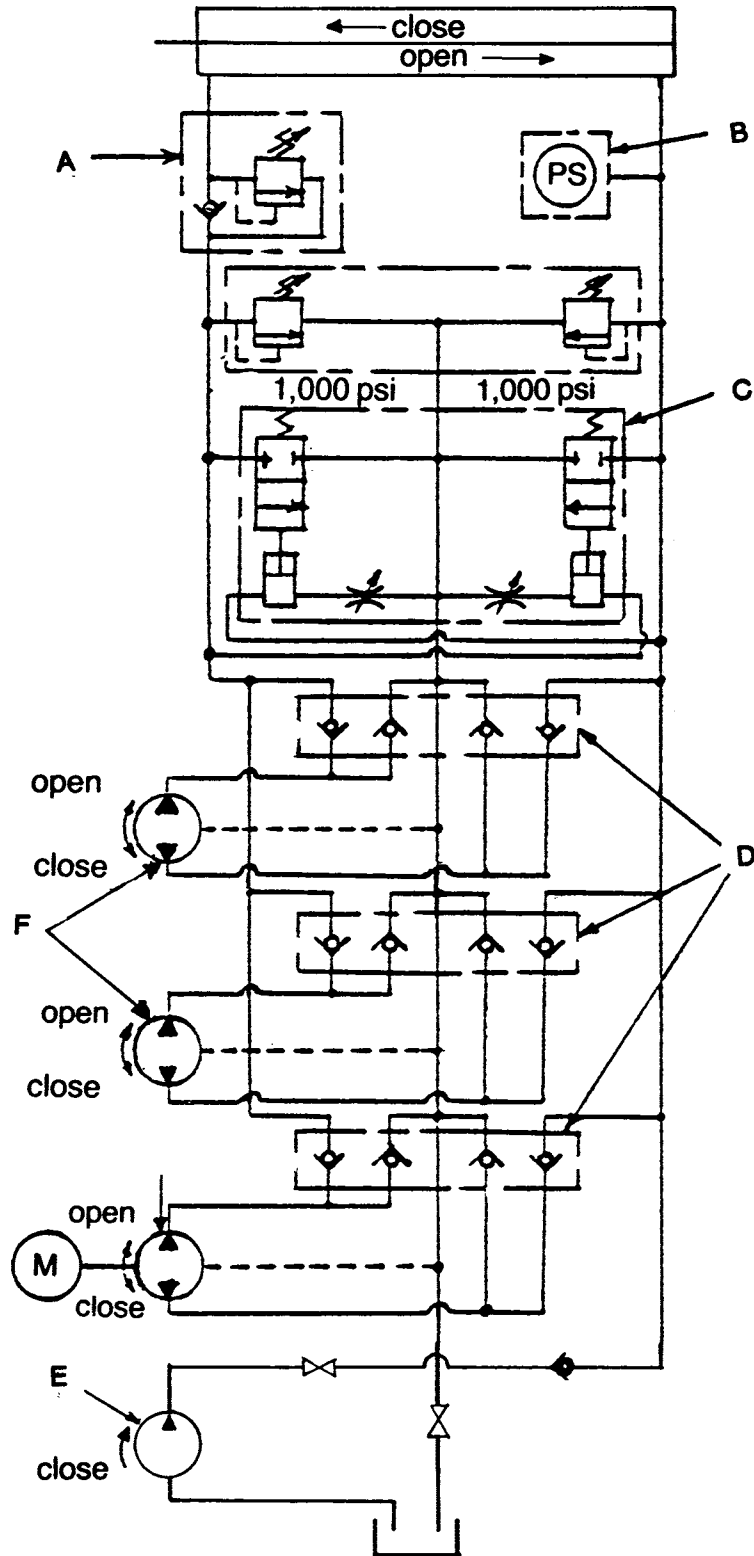

GS-0104

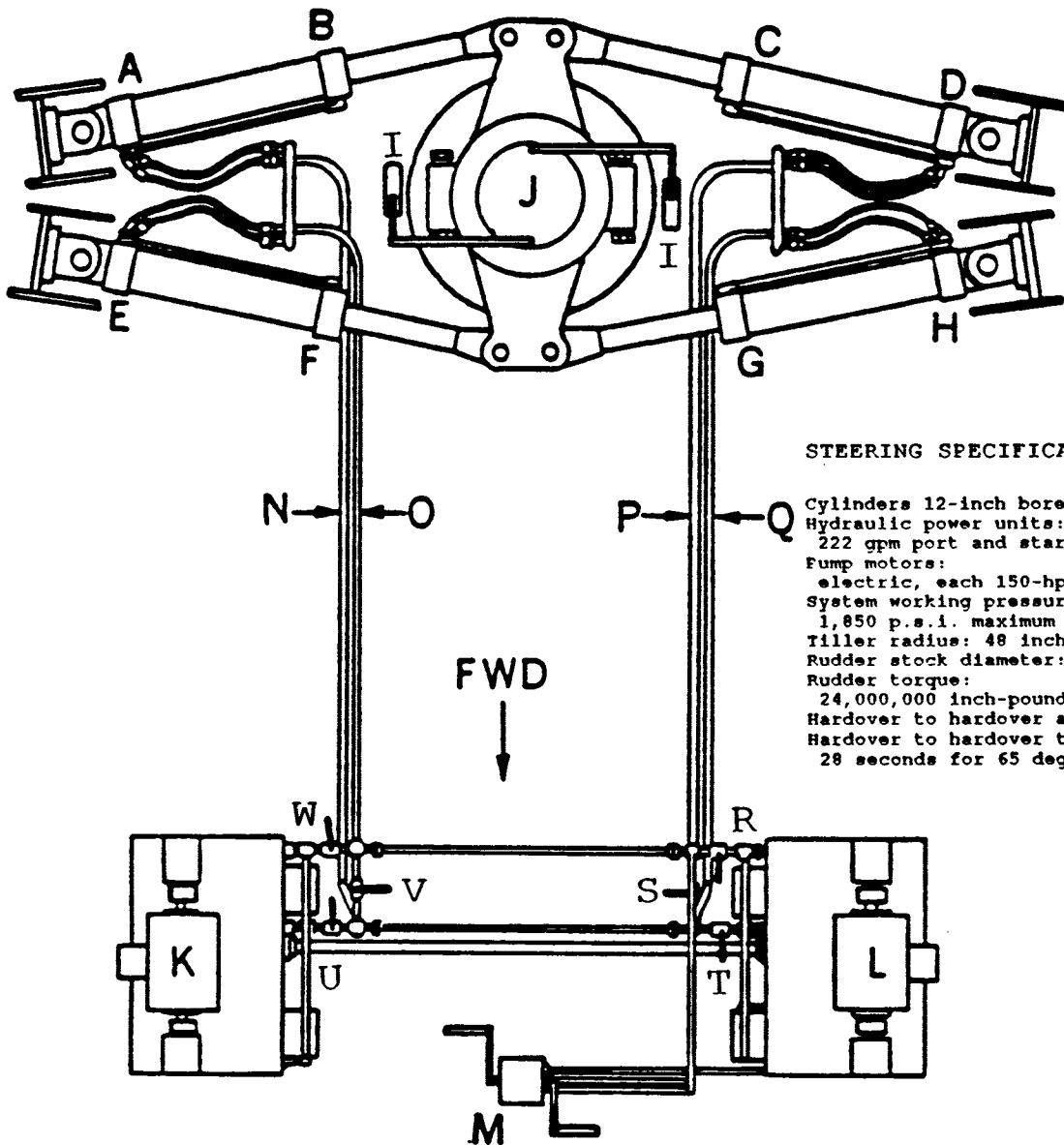

STEERING SPECIFICATION

Cylinders 12-inch bore, 65-inch stroke
Hydraulic power units:
222 gpm port and starboard units
Pump motors:
electric, each 150-hp., 1,800 r.p.m.
System working pressure:
1,850 p.s.i. maximum
Tiller radius: 48 inches
Rudder stock diameter: 30.2 inches
Rudder torque:
24,000,000 inch-pounds maximum
Hardover to hardover angle: 70 degrees
Hardover to hardover time:
28 seconds for 65 degrees

GS-0105

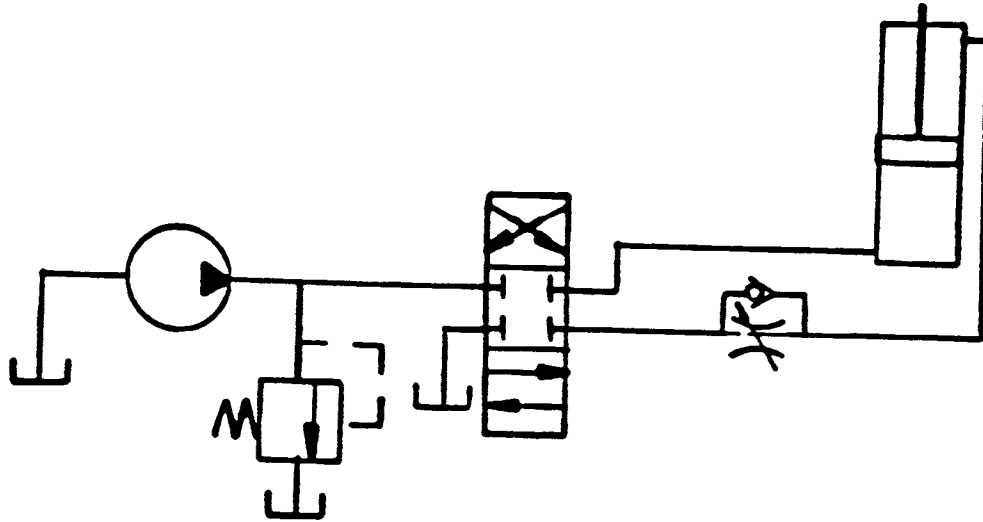

GS-0106

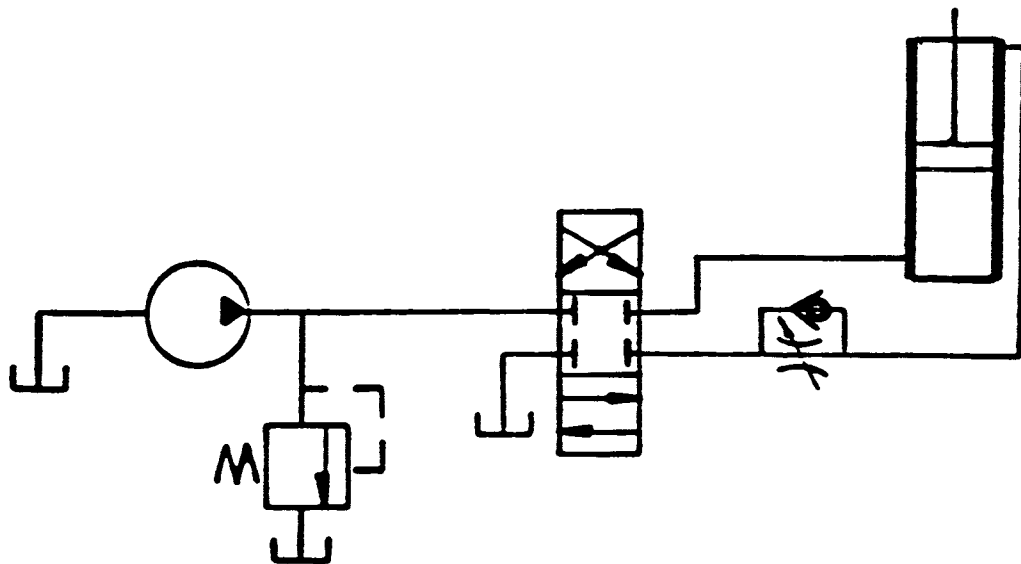

GS-0107

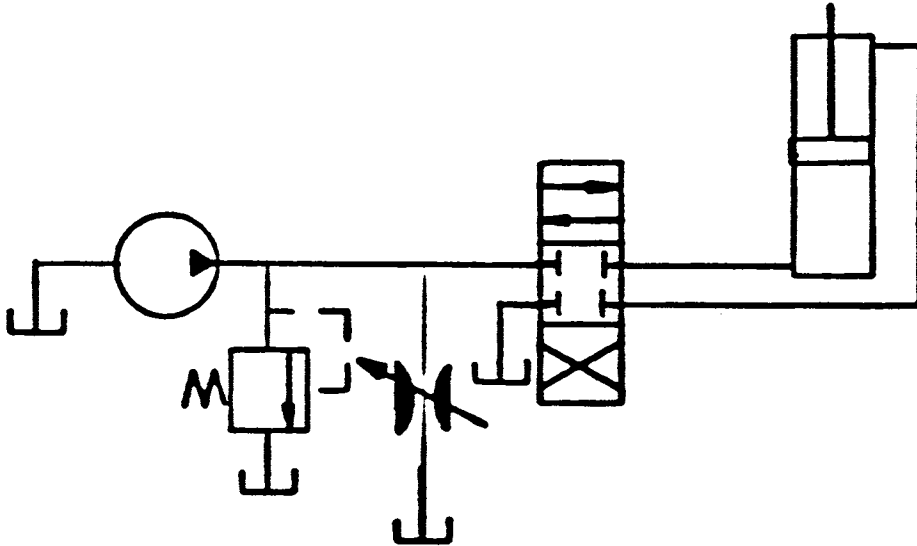

GS-0108

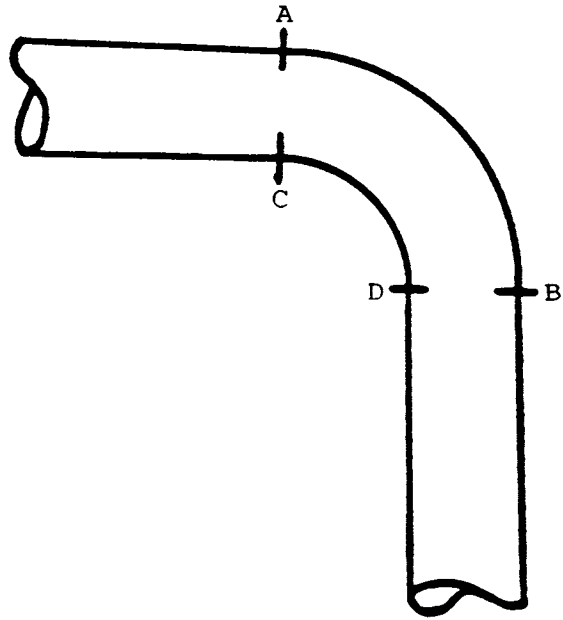

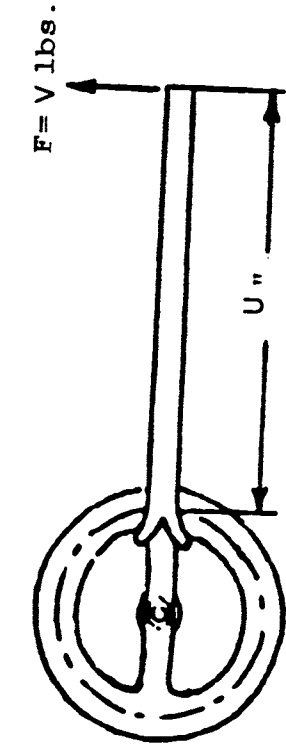

Figure II

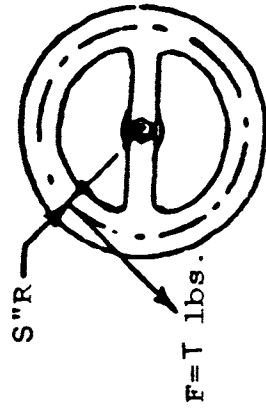
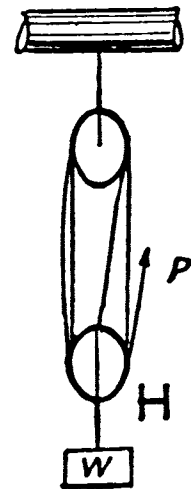
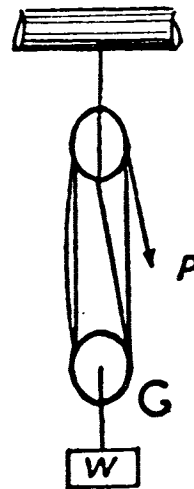
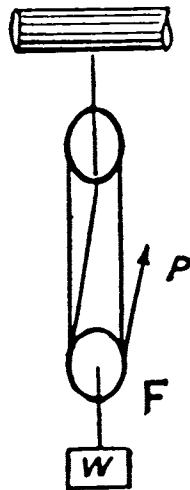
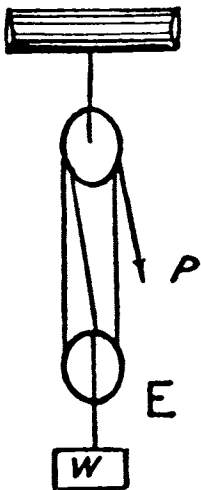
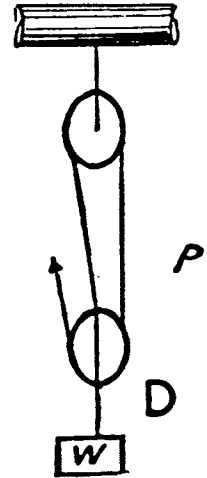
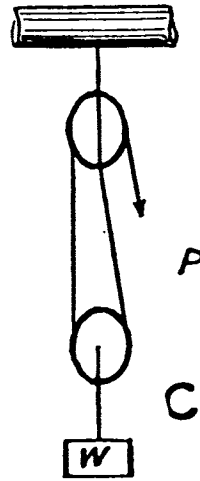
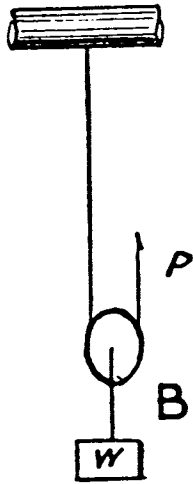
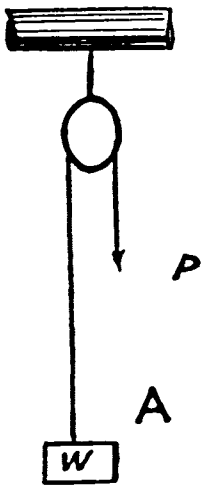
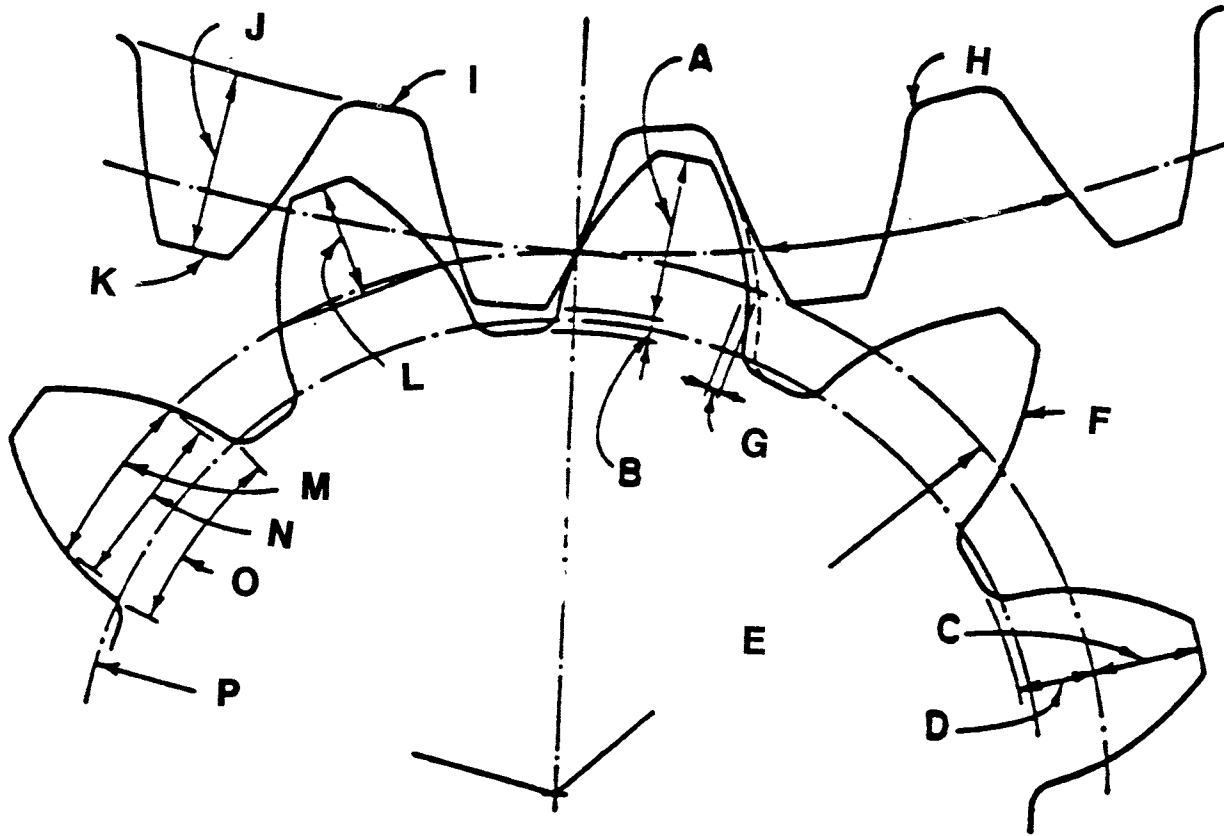

Figure I

GS-0110



GS-0111



GS-0112

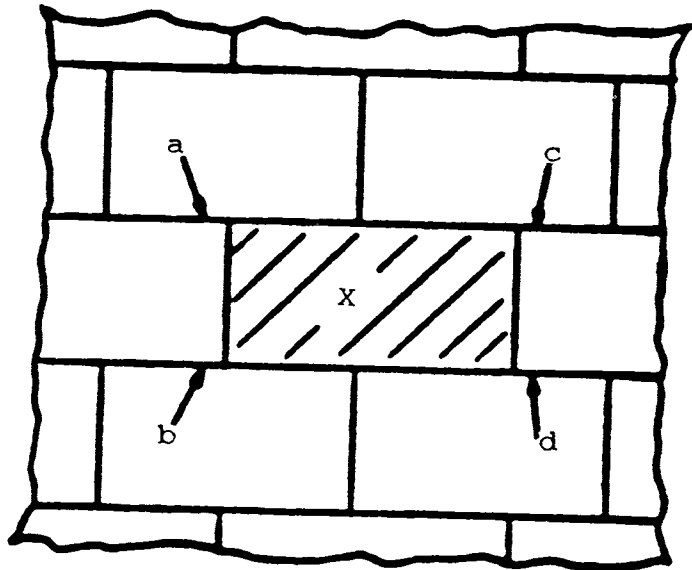

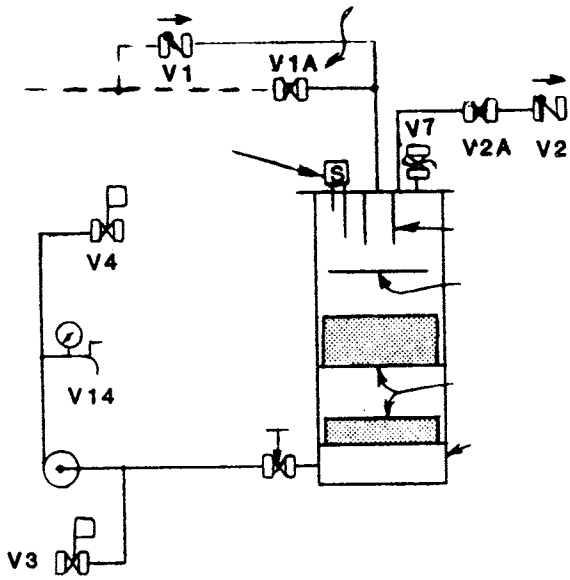

FIG. A

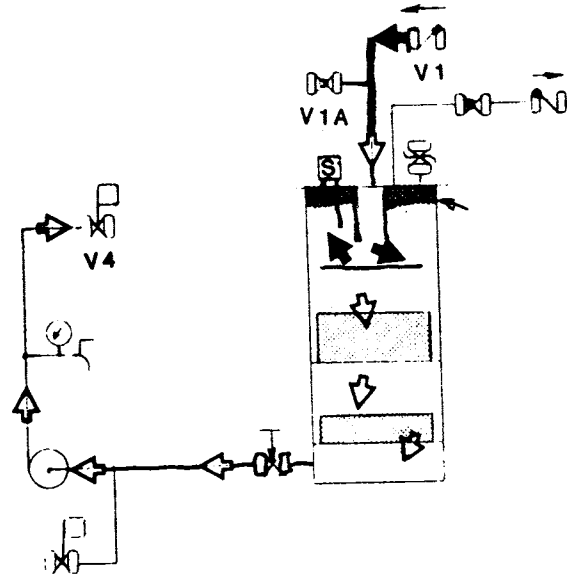

FIG. B

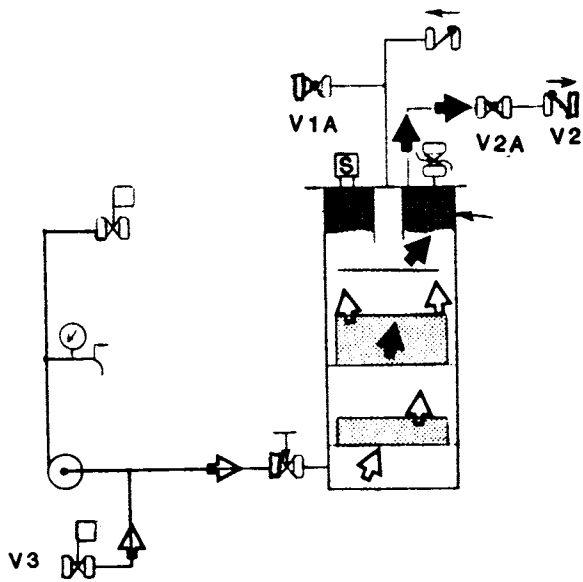

FIG. C

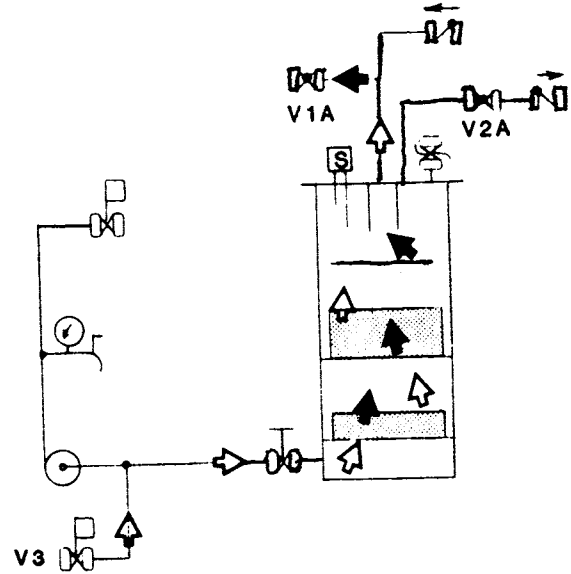
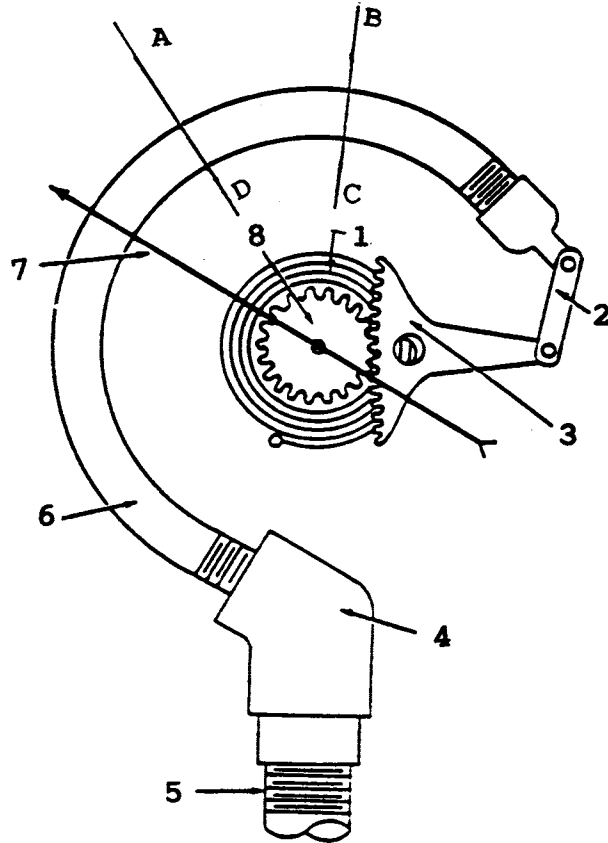

FIG. D

 OIL
 WATER

GS-0114



GS-0115

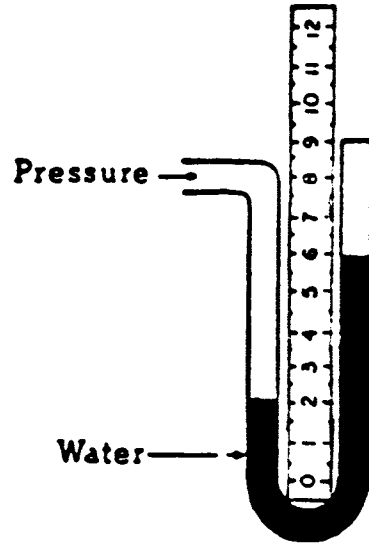

GS-0116

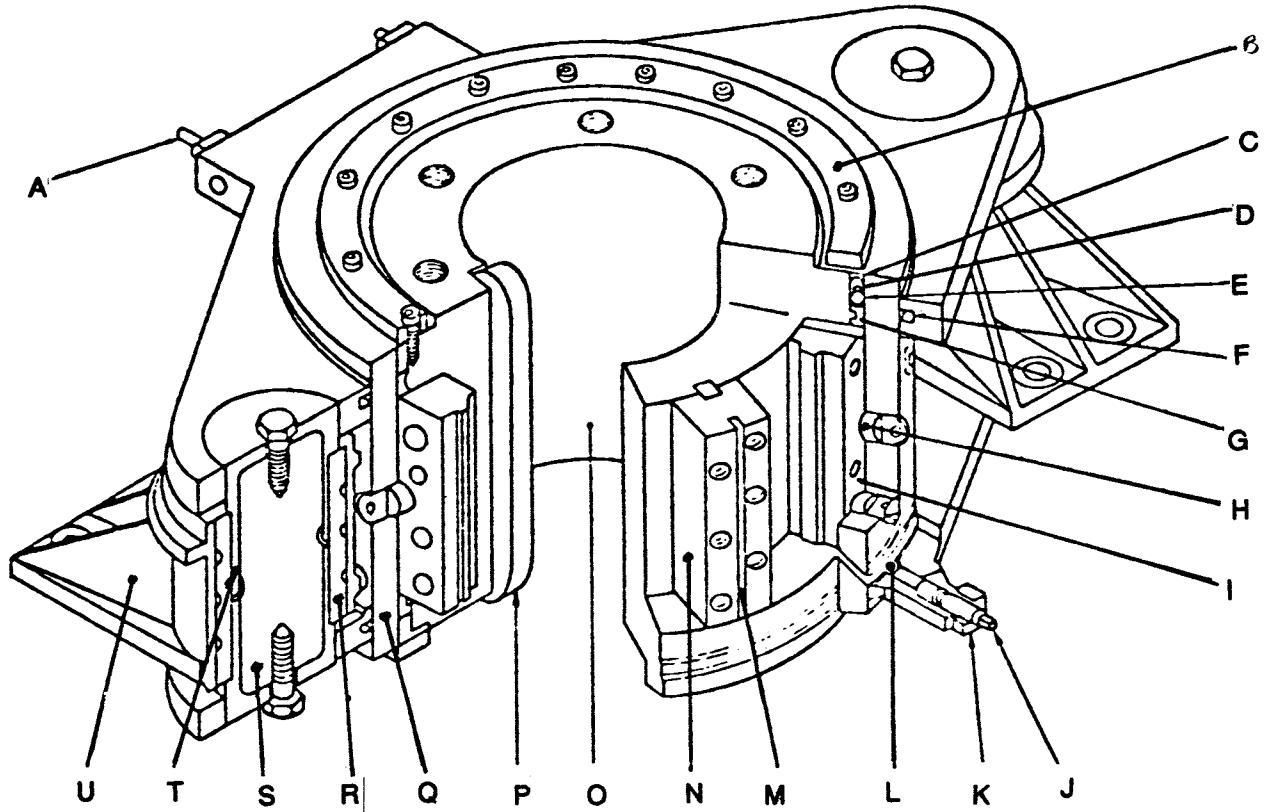

GS-0117

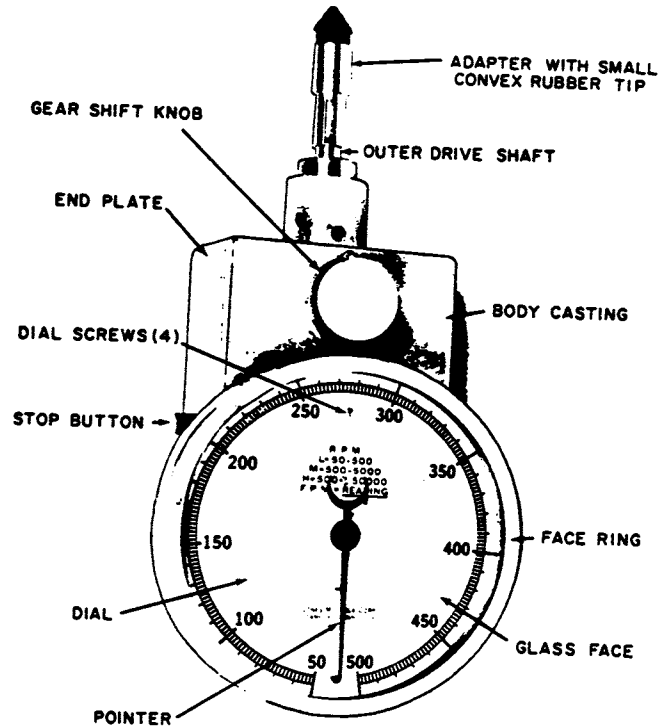

GS-0118

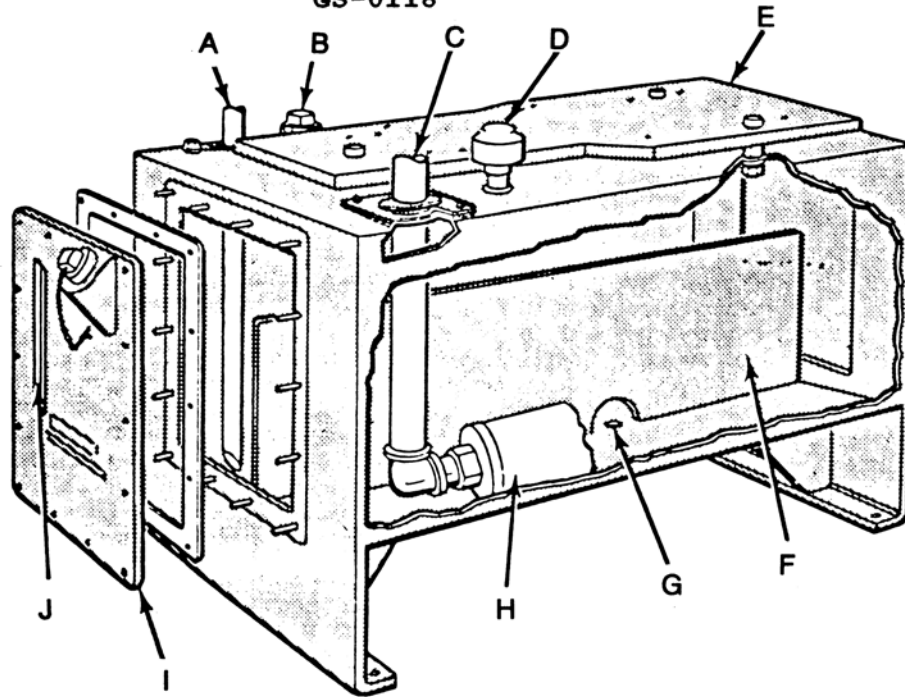

GS-0119

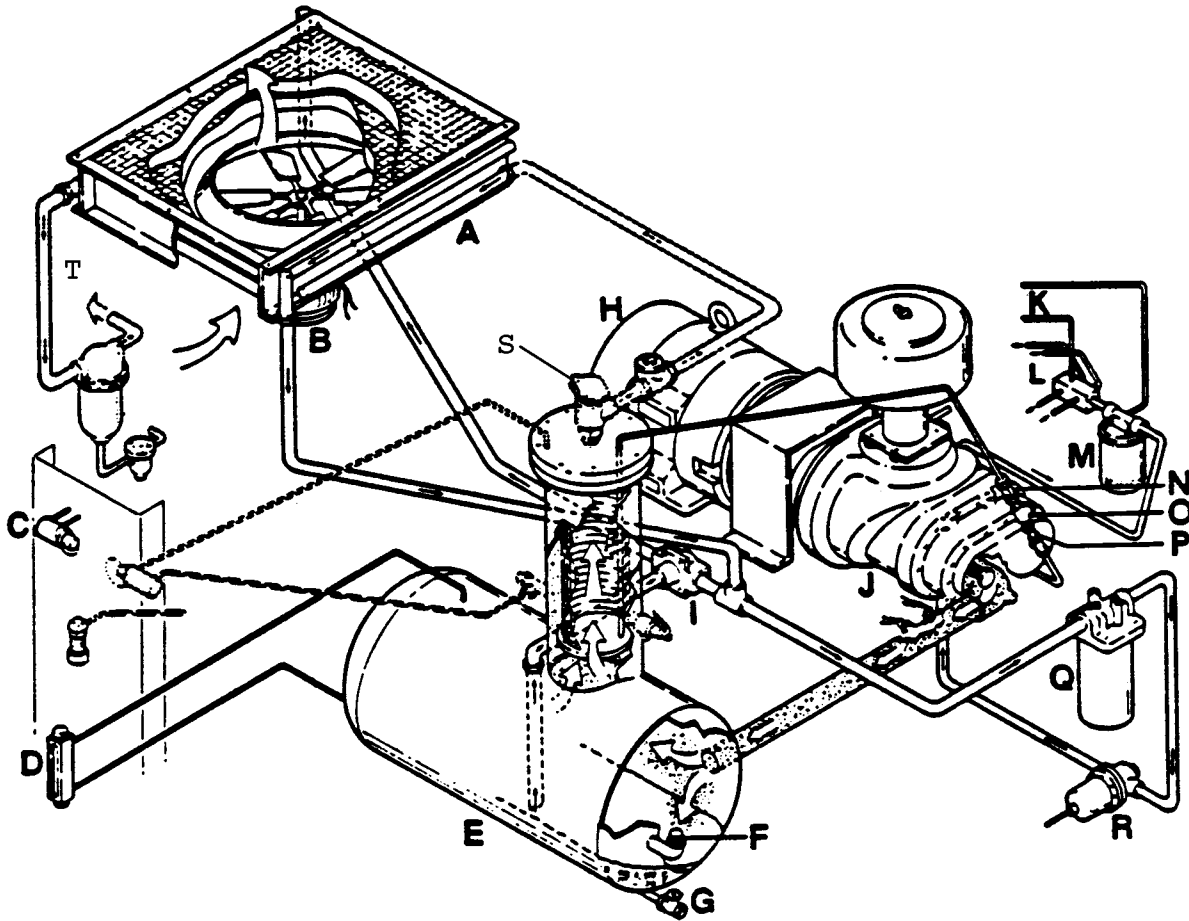

- A - FLUID COOLER (TOP)
- B - FAN MOTOR
- C - BEARING FILTER MAINTENANCE INDICATOR
- D - FLUID LEVEL SIGHT GLASS
- E - RECEIVER SUMP
- F - FLUID FILL CAP
- G - FLUID DRAIN
- H - MOTOR
- I - THERMAL VALVE

- J - COMPRESSOR UNIT
- K - TO BEARING FILTER MAINTENANCE INDICATOR
- L - FLUID MANIFOLD TO COMPRESSOR BEARINGS
- M - BEARING FLUID FILTER
- N - FLUID RETURN LINE SIGHT GLASS
- O - RETURN LINE STRAINER
- P - ORIFICE
- Q - MAIN FLUID FILTER
- R - FLUID STOP VALVE

(COURTESY OF SULLAIR CORPORATION)

GS-0120

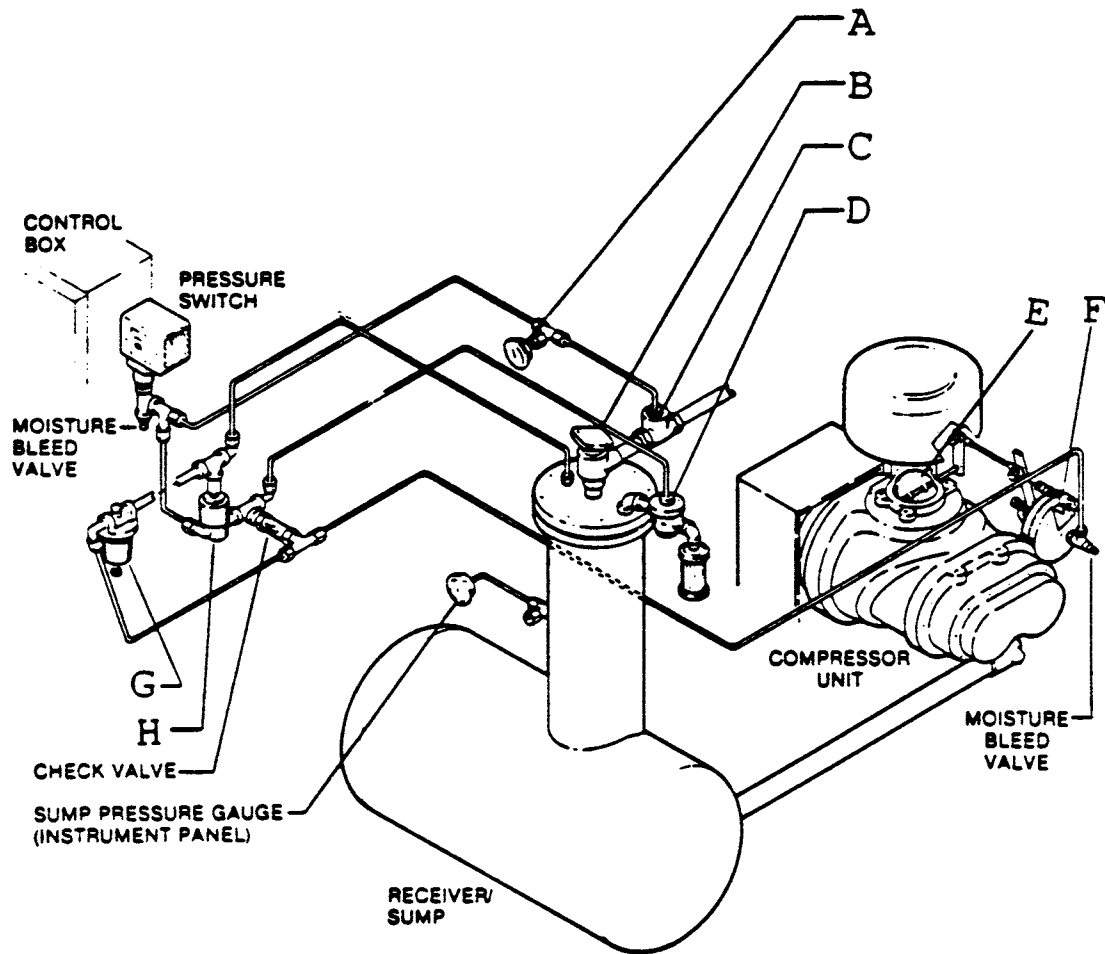

(COURTESY OF SULLAIR CORP.)

GS-0121

A

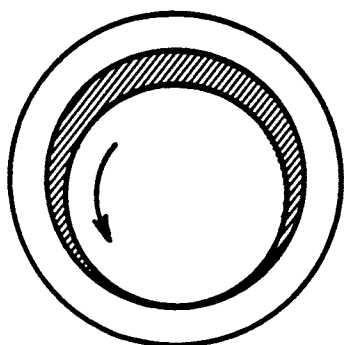

B

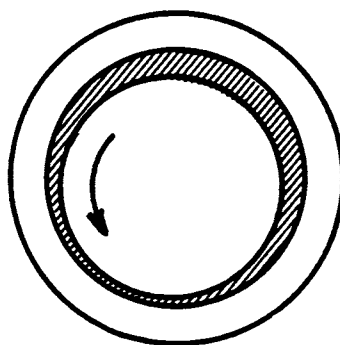

C

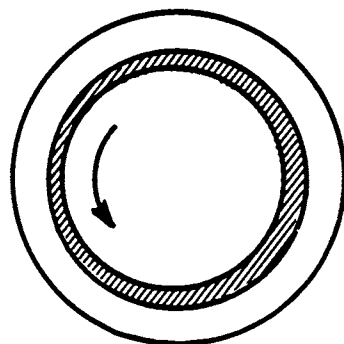

D

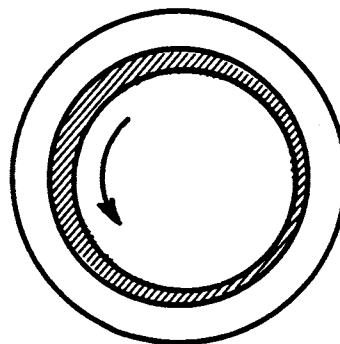

GS-0122

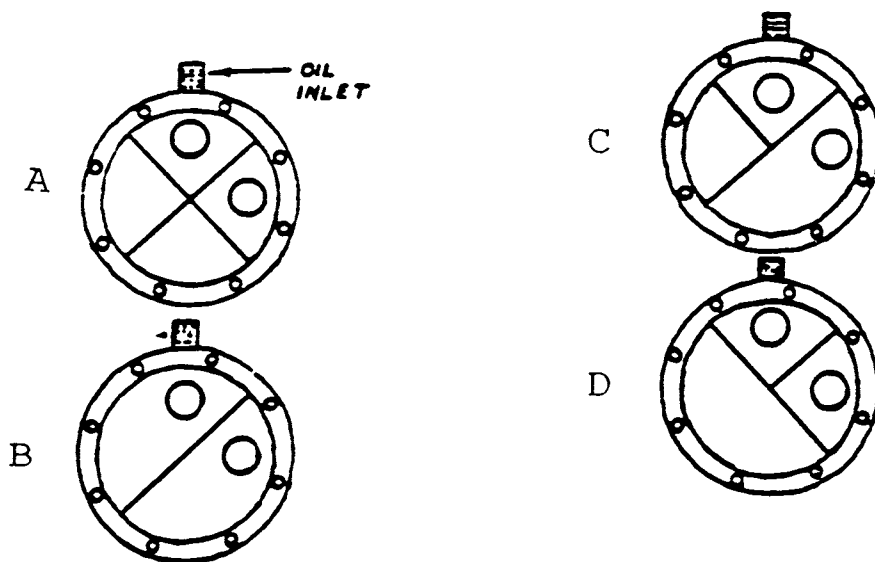
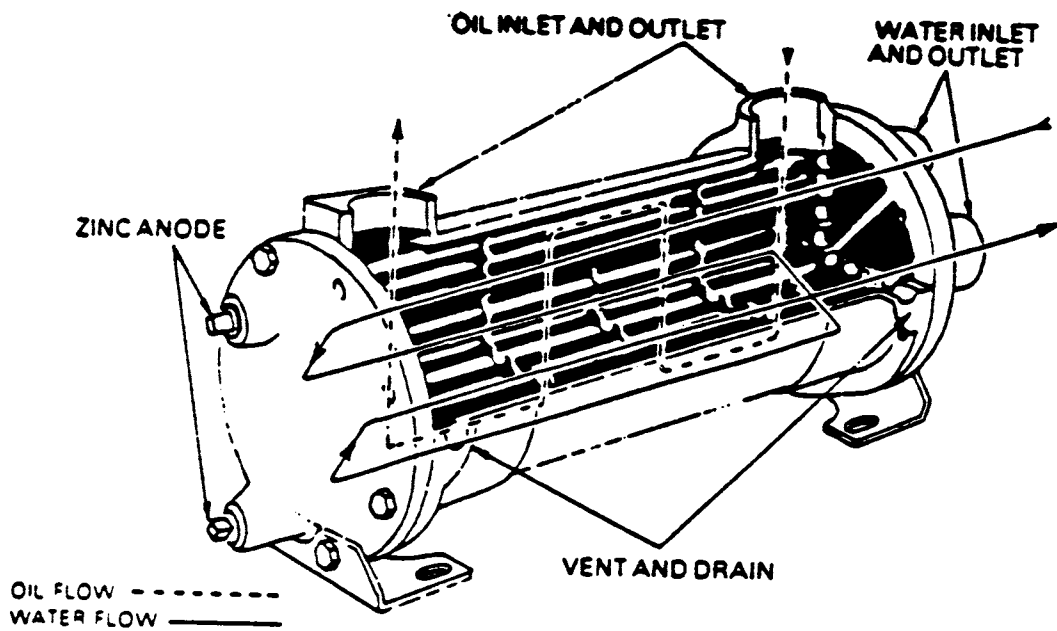

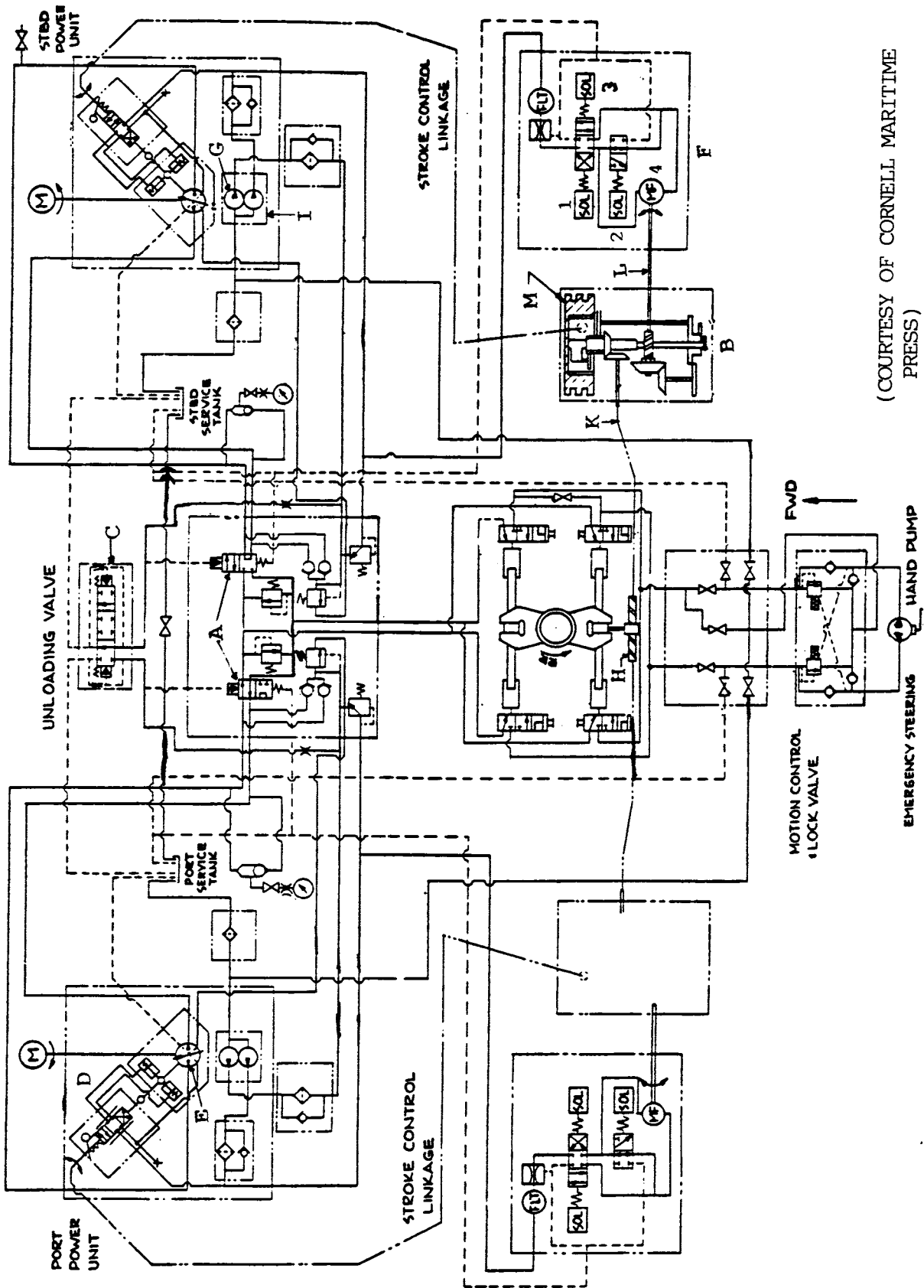

(COURTESY OF CORNELL MARITIME PRESS)

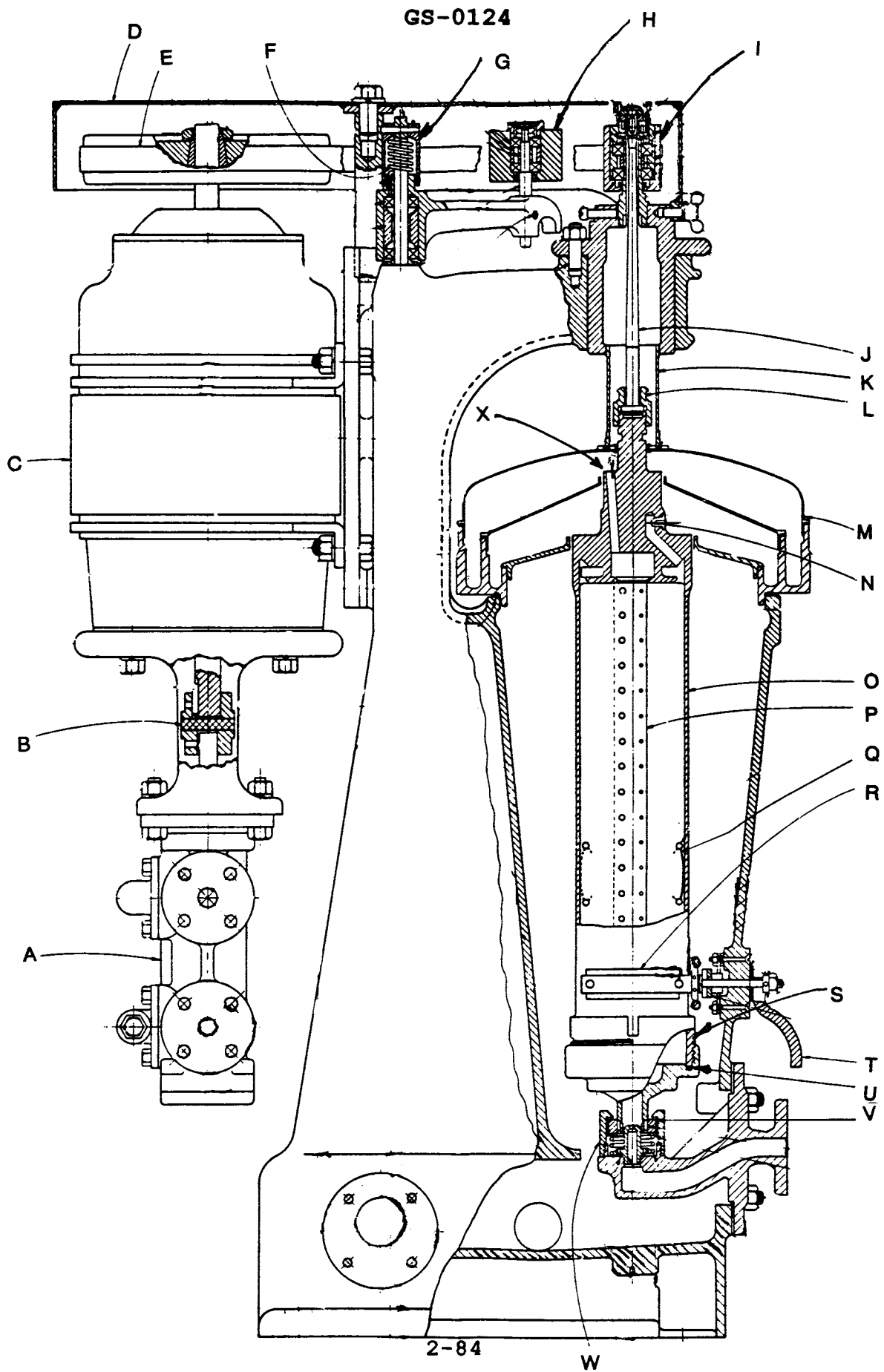

GS-0125

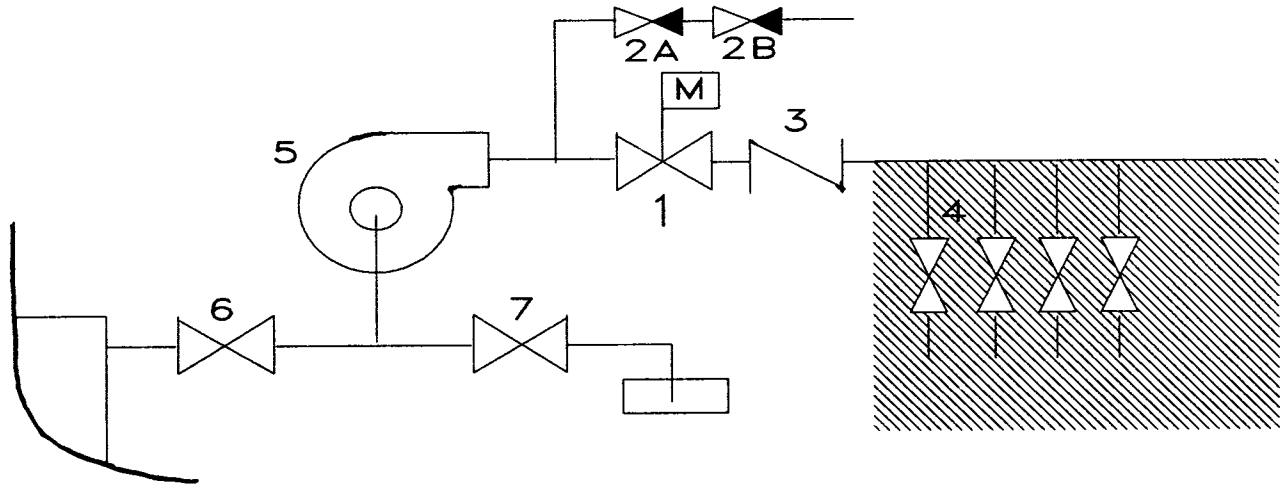

GS-0126

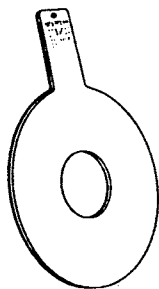

FIG. A

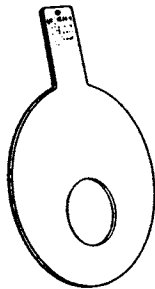

FIG. B

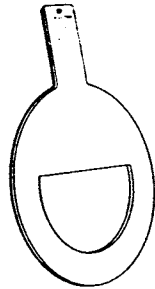

FIG. C

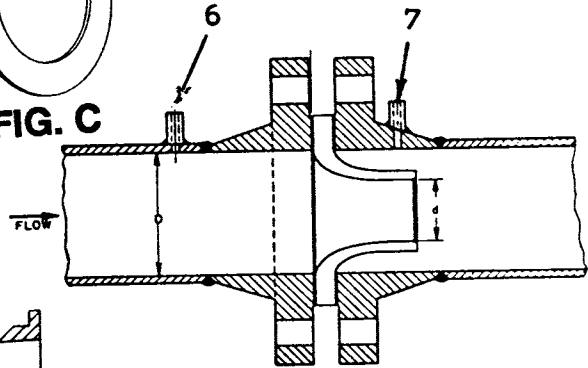

FIG. D

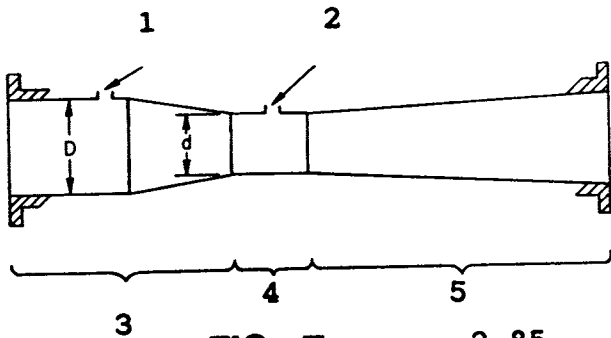
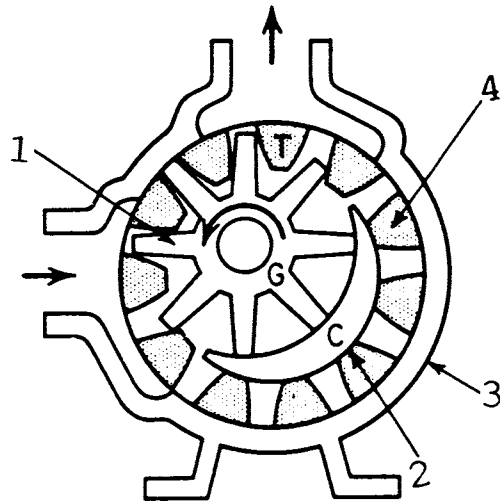

FIG. E

2-85

GS-0127



GS-0128

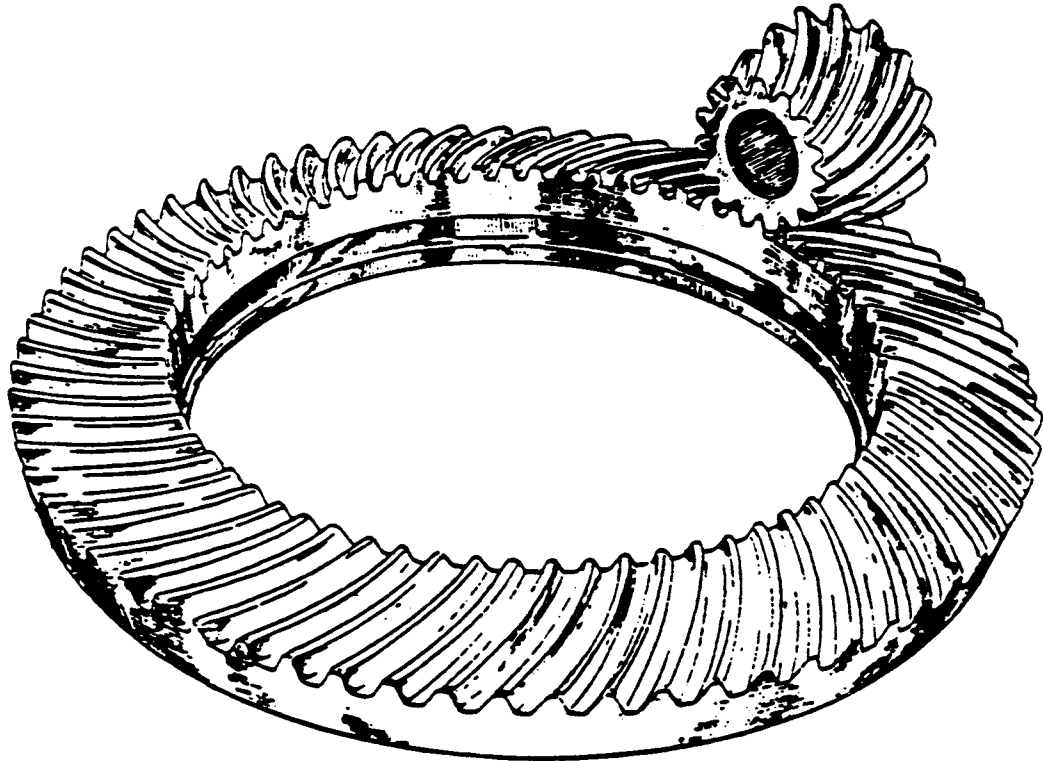

GS-0129

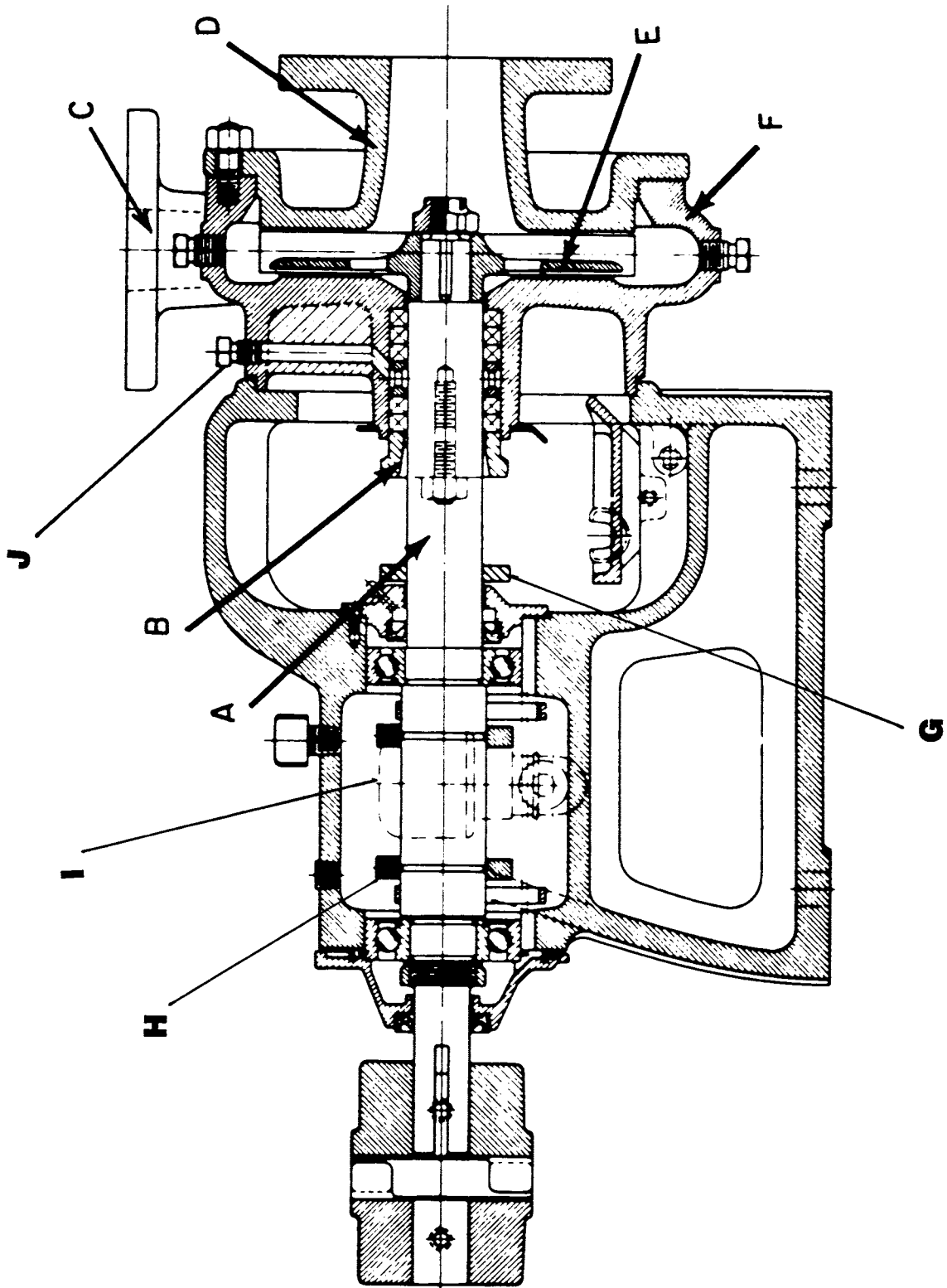

GS-0130

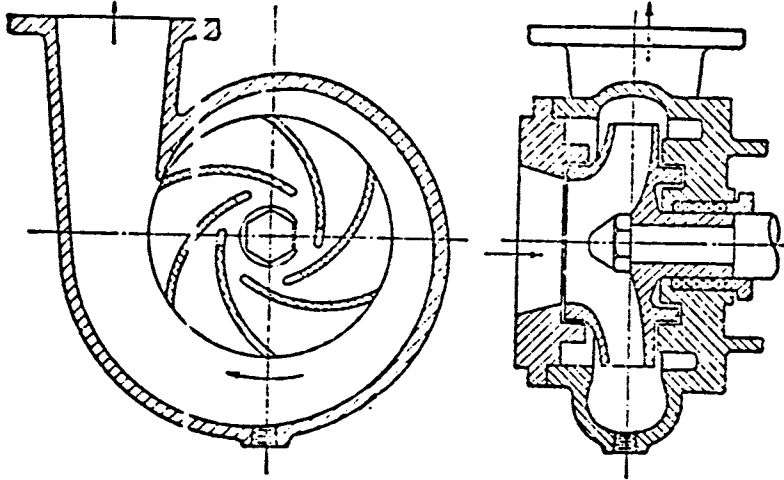

GS-0131

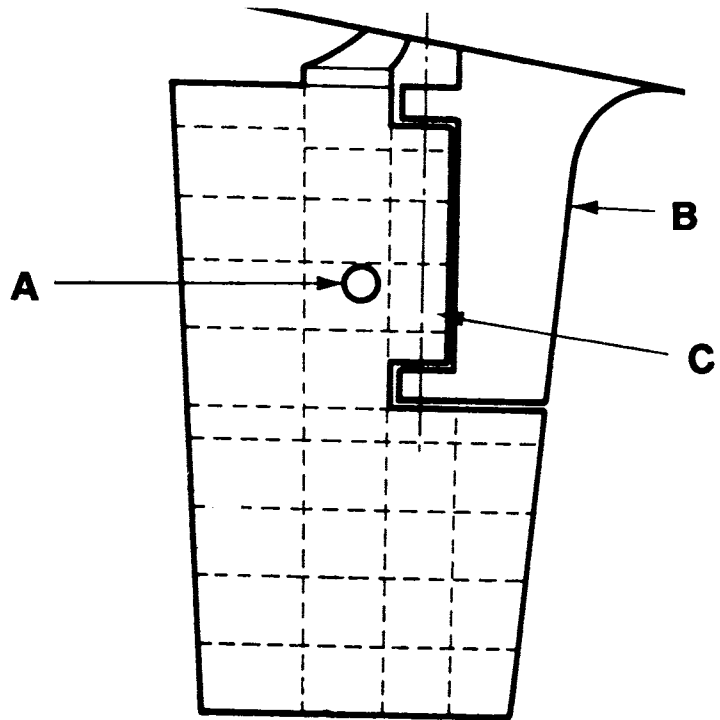

GS-0132

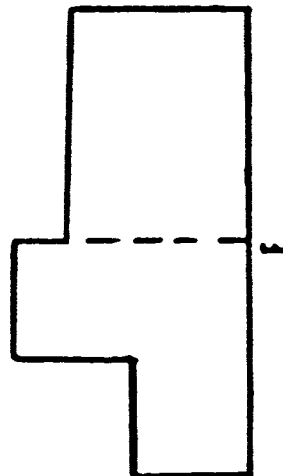
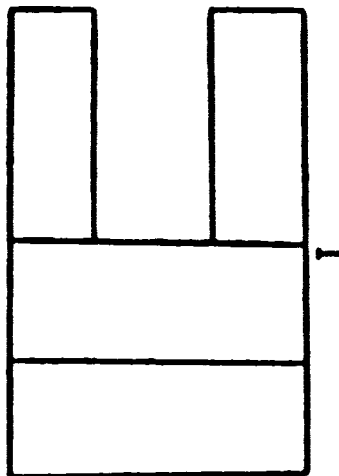
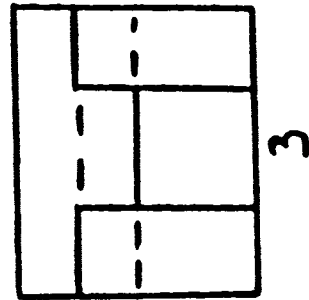
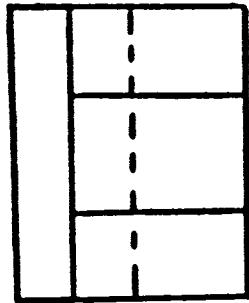
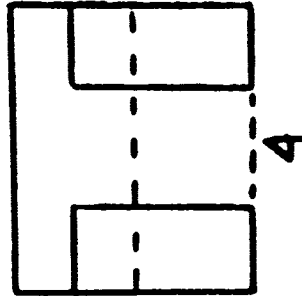
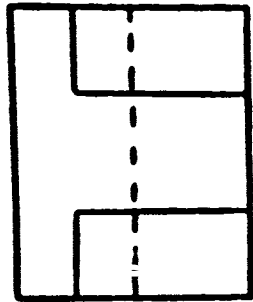

GS-0133

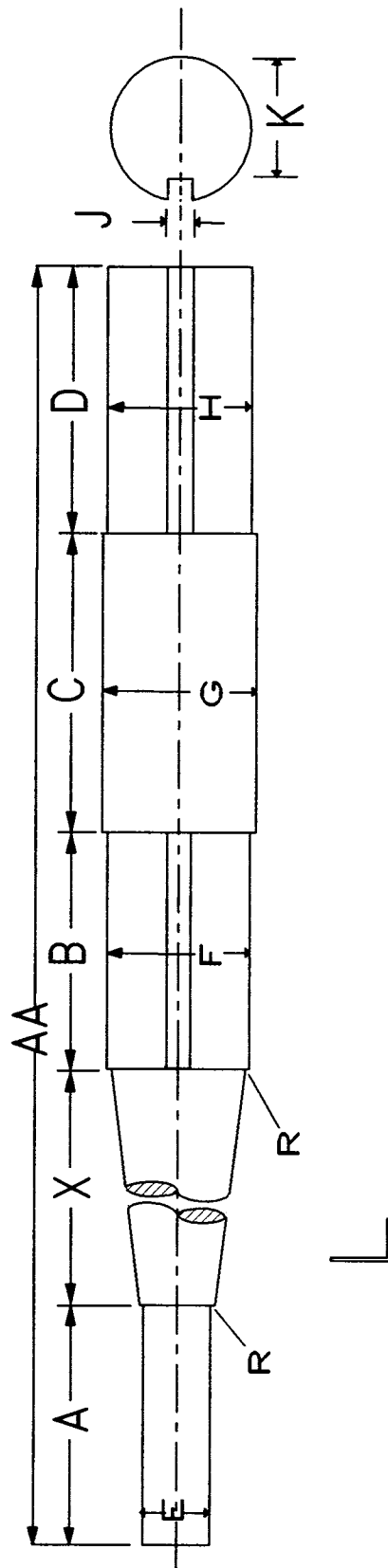

TAPER PER FOOT

GS-0134

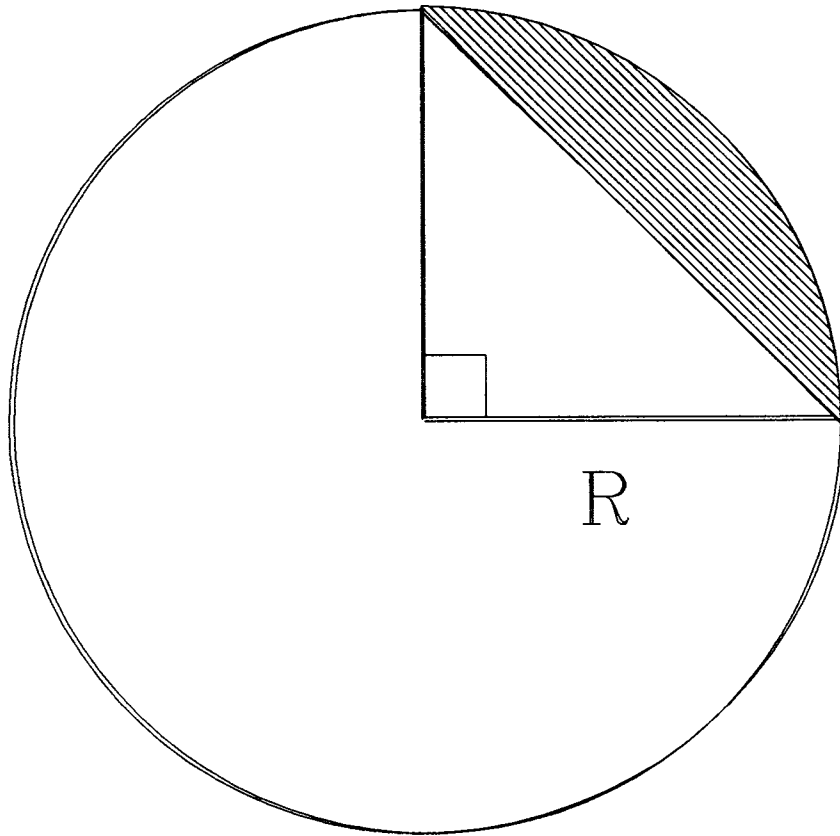

GS-0135

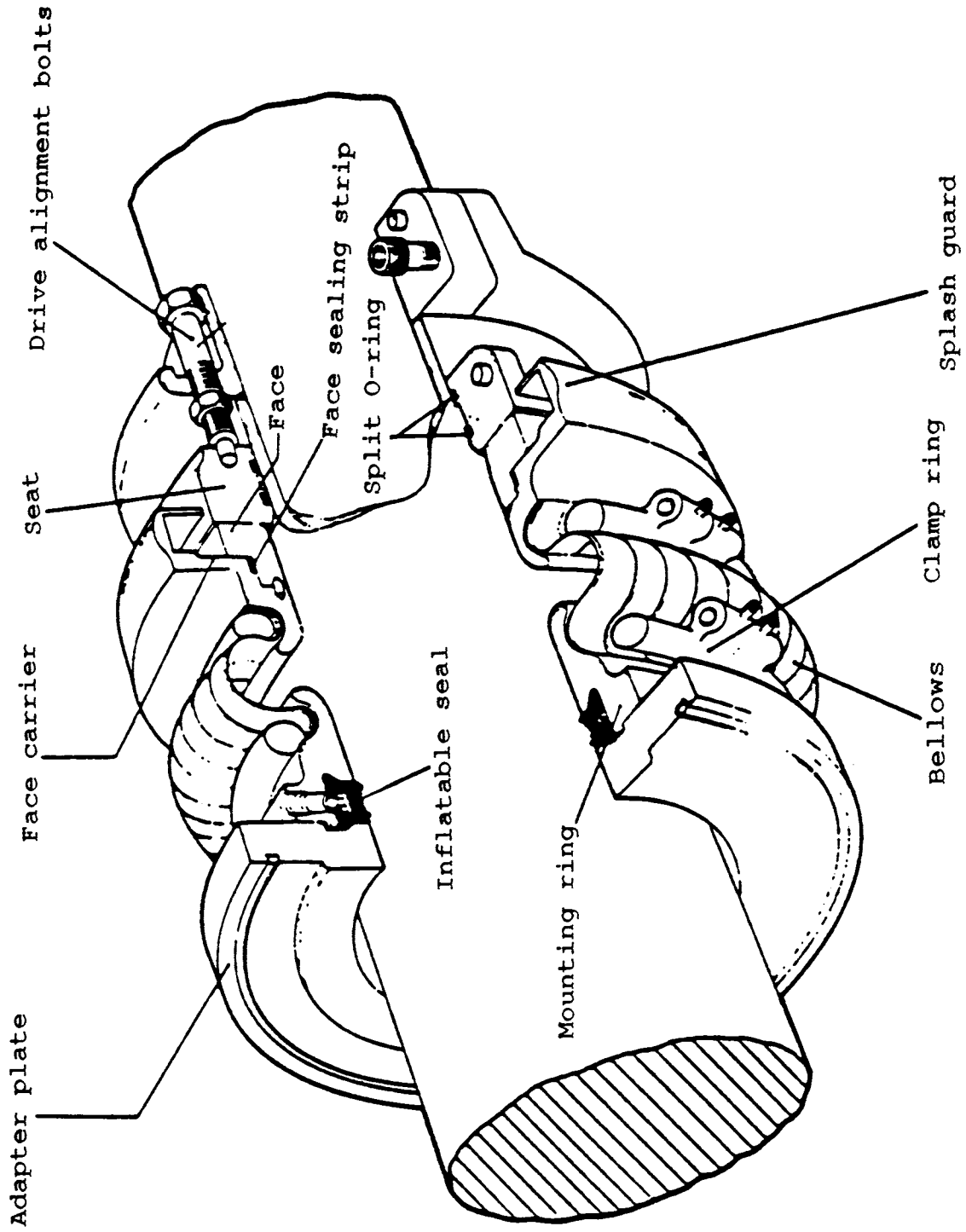

GS-0136

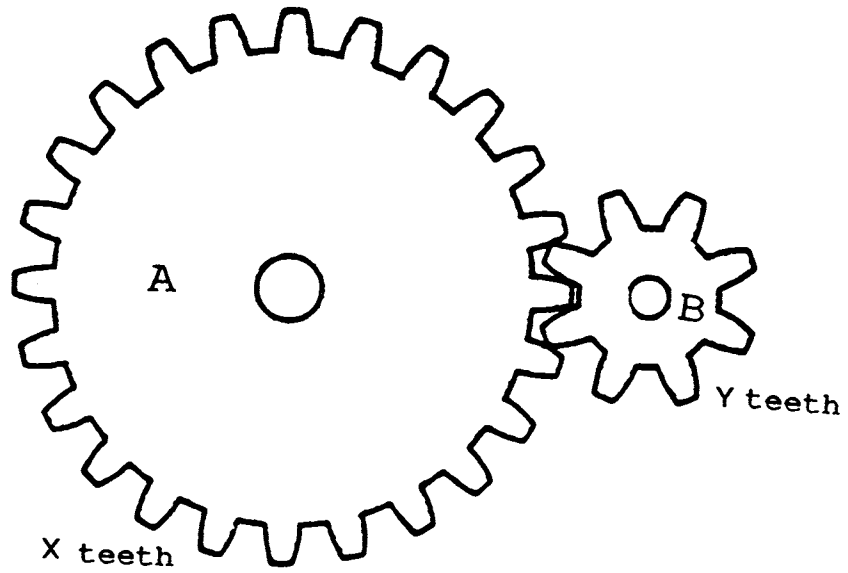

GS-0137

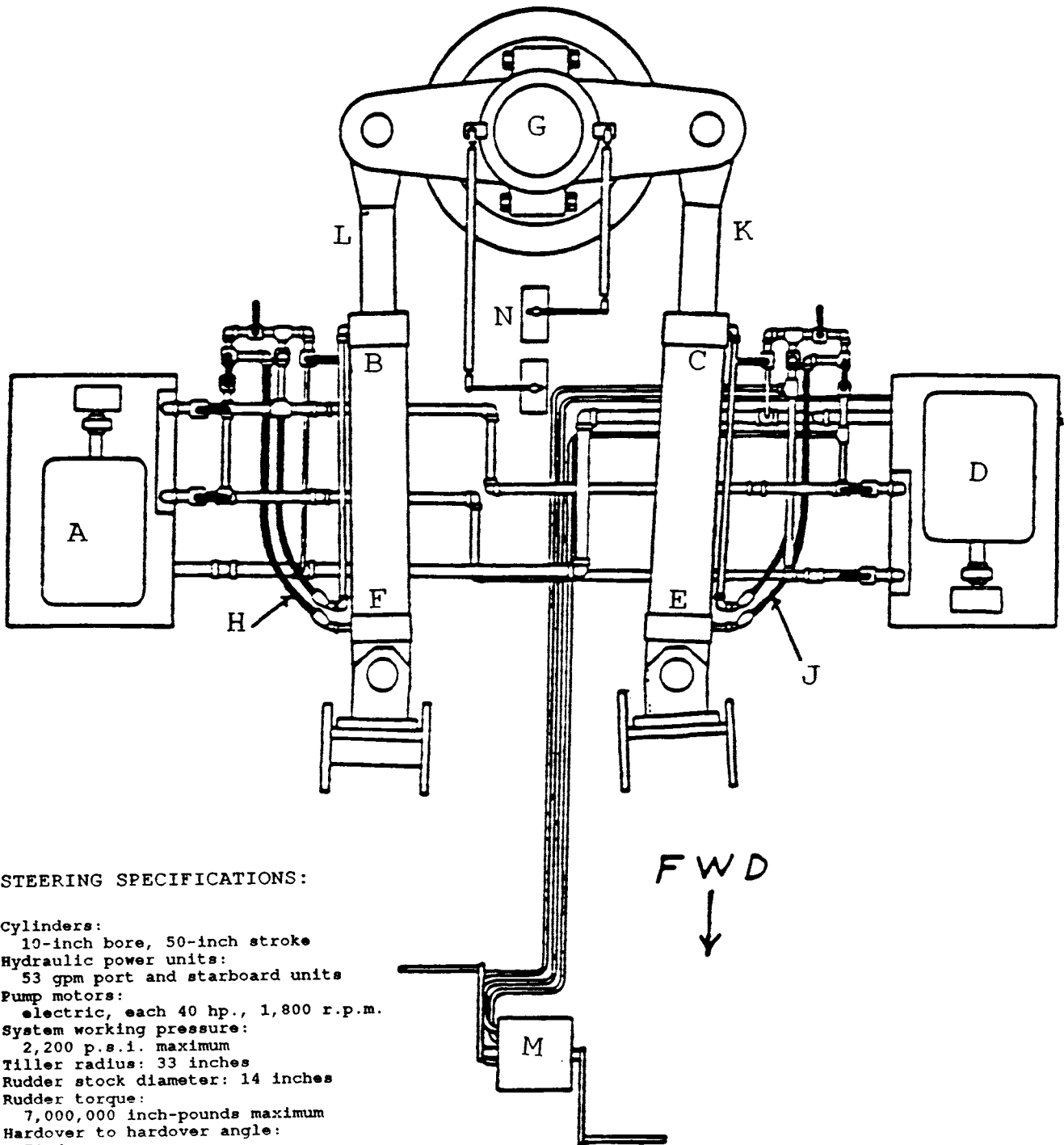

STEERING SPECIFICATIONS:

Cylinders:

10-inch bore, 50-inch stroke

Hydraulic power units:

53 gpm port and starboard units

Pump motors:

electric, each 40 hp., 1,800 r.p.m.

System working pressure:

2,200 p.s.i. maximum

Tiller radius: 33 inches

Rudder stock diameter: 14 inches

Rudder torque:

7,000,000 inch-pounds maximum

Hardover to hardover angle:

70 degrees

Hardover to hardover time:

28 seconds for 65 degrees

GS-0138

Typical constant-speed characteristic curves for a high-specific-speed pump

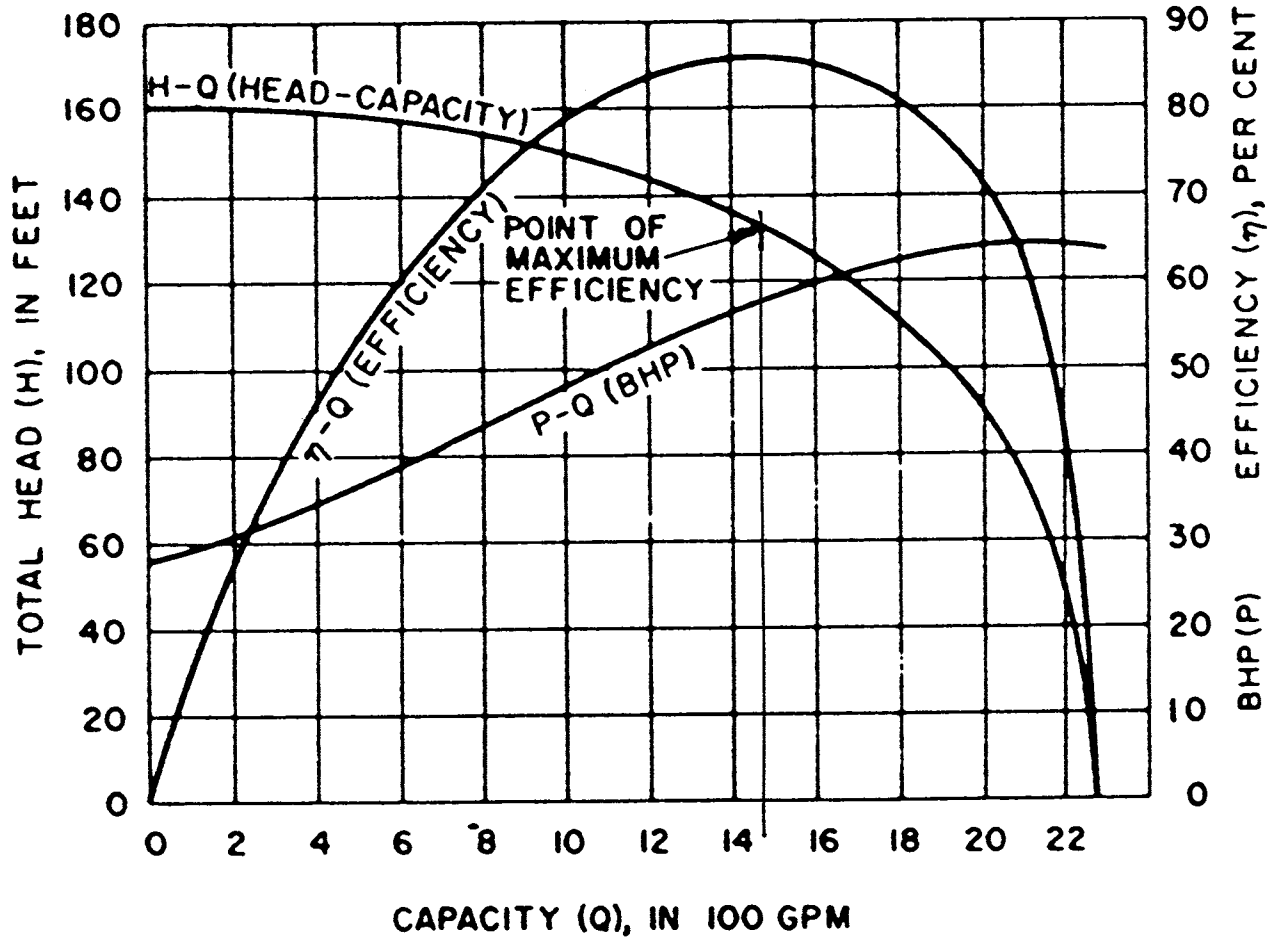

GS-0139

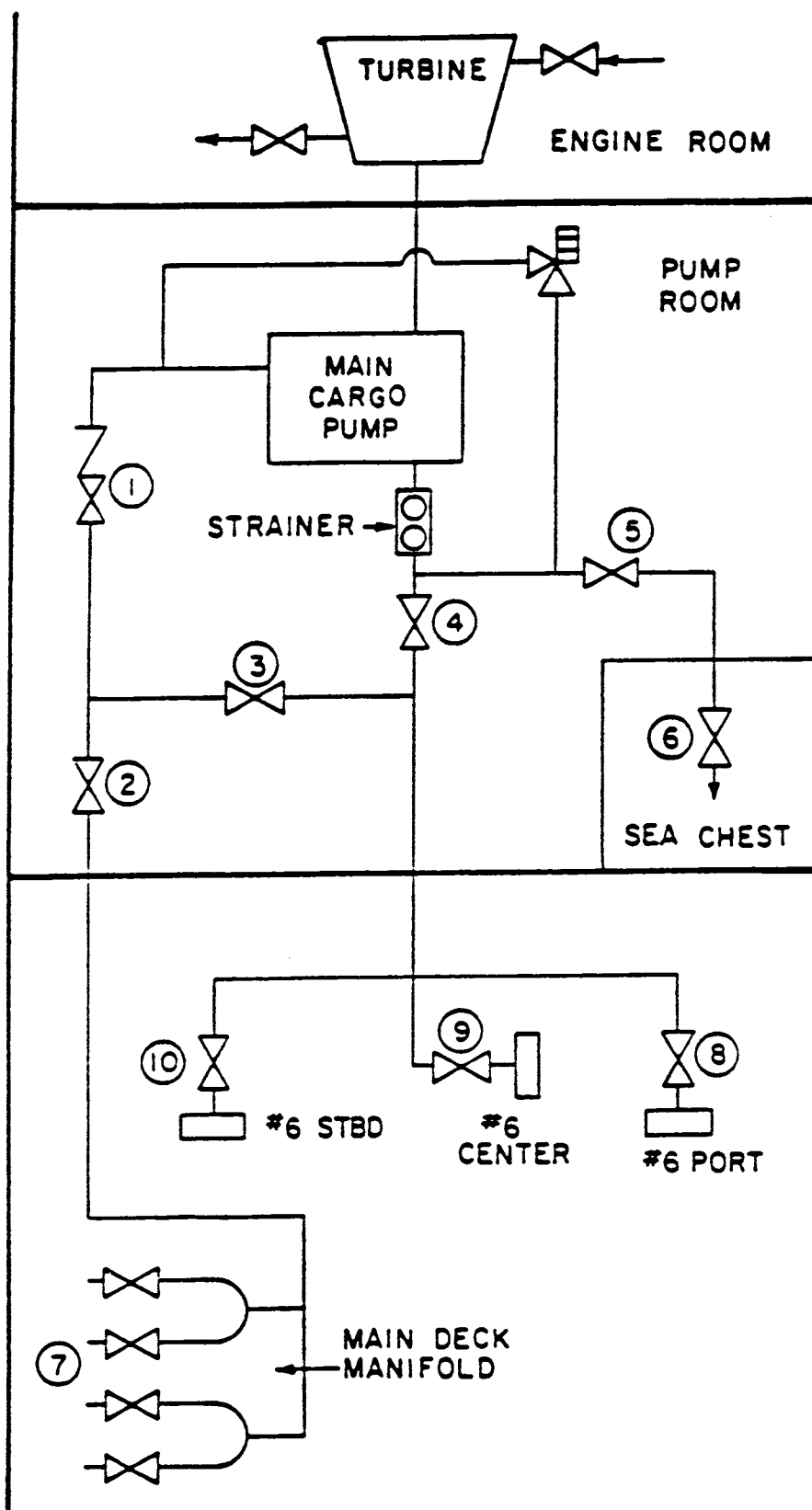

GS-0140

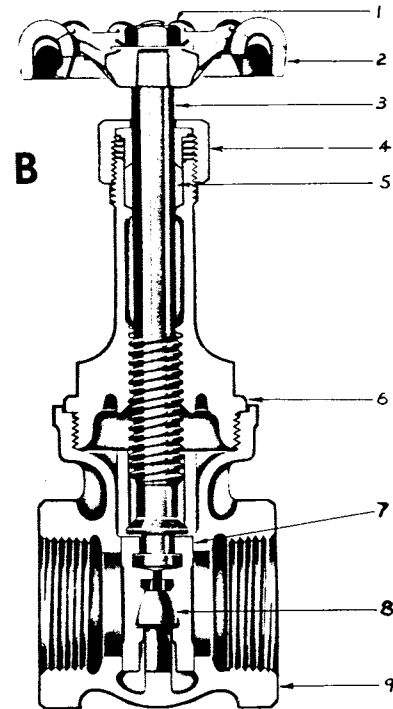
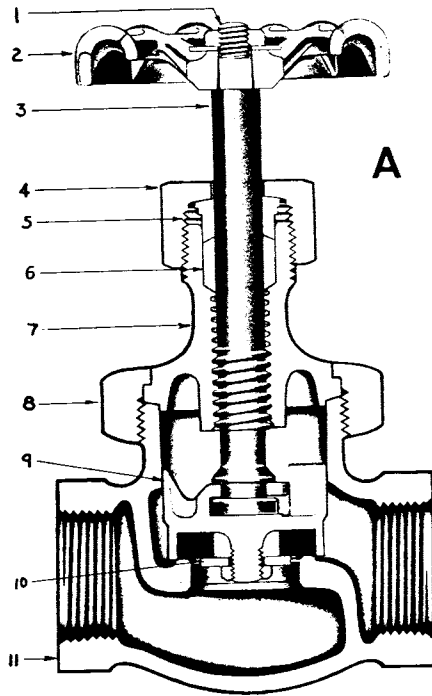

GS-0141

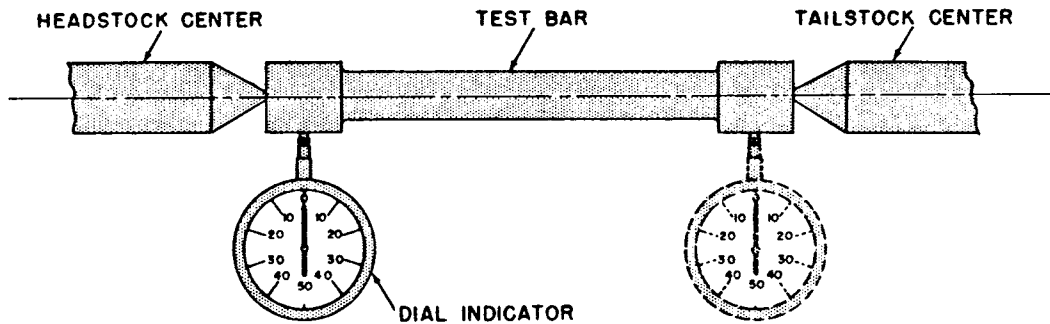

Alignment of lathe centers with a dial indicator.

GS-0142

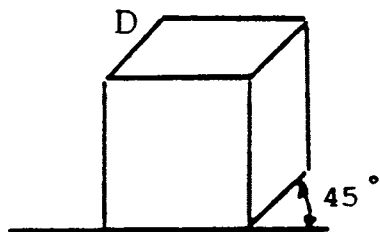
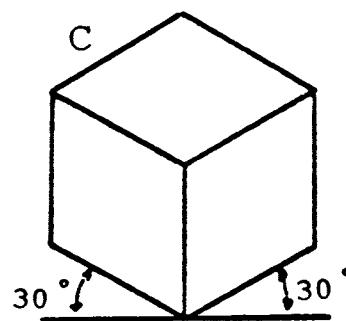
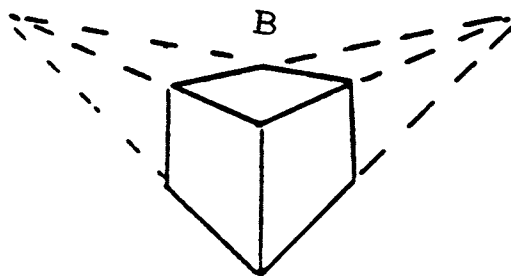
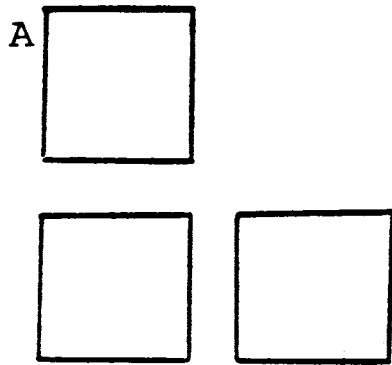

GS-0143

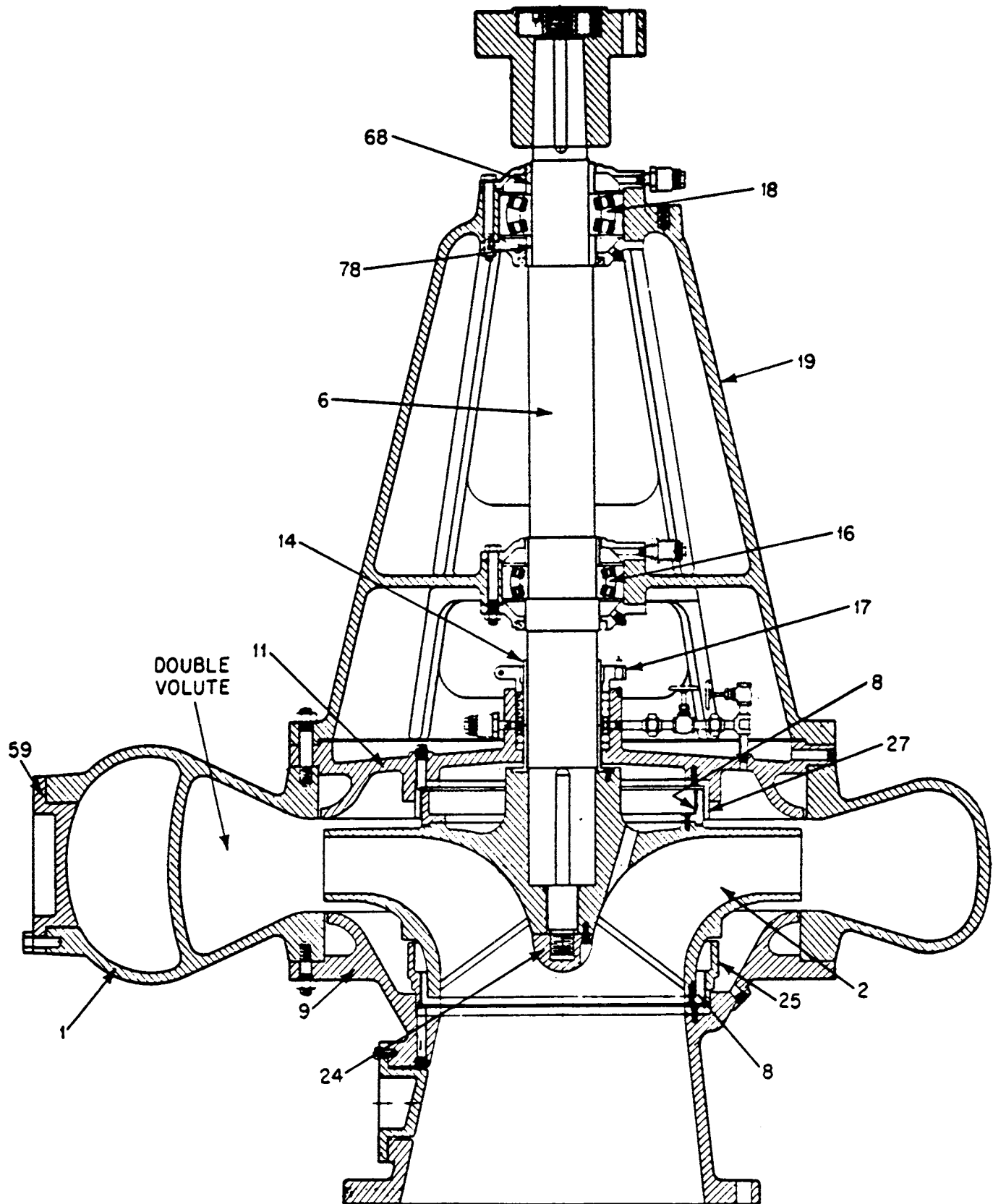

GS-0144

LIST OF MATERIAL FOR ONE UNIT

PC NO	NAME	MATERIAL
1	PUMP CASE	CAST STEEL
2	INLET BELL	CAST STEEL
3	SEAL HOUSING	CAST STEEL
4	PACKING GLAND	GUN METAL
5	BEARING RETAINER	BEARING BRONZE
6	BALANCE ROTOR HOUSING	BEARING BRONZE
7	GASKET	PLANT FIBRE
8	MECHANICAL SEAL FOR 2, 3, 8" DIA SHAFT	STEEL & SYN RUBBER
9	SPACER	BEARING BRONZE
10	ROTOR HOUSING	BEARING BRONZE
11	CHECK NUT	STEEL
12	BALANCE PISTON	STEEL
13	POWER ROTOR	STEEL
14	CLER ROTOR	STEEL
15	SOC HD SET SCREW 1/4 - 20 x 7/16" LONG	STEEL
16	KEY	STEEL
17	BOLT 3/8" - 16 x 1" LONG	STEEL
18	BOLT 3/8" - 16 x 1 1/4" LONG	STEEL
19	EXTERNAL TOOTH LOCKWASHER	STEEL
20	EXTERNAL TOOTH LOCKWASHER	STEEL
21	BOLT 1/4" - 13 x 1 1/4" LONG	STEEL
22	SOC. HD PIPE PLUG - 1/8" SIZE	BRASS
23	INLET BELL	CAST STEEL
24	BOLT 1/4" - 13 x 1 1/4" LONG	STEEL
25	SPACER	STEEL PIPE
26	THRUST PLATE	STEEL
27	GASKET	PLANT FIBRE
28	OIL BALANCE TUBE	STEEL
29	O RING	SYNTHETIC RUBBER
30	STUD 5/8" - 11 x 3 1/4" LONG	STEEL
31	NUT 5/8" - 11" THDS.	STEEL
32	BOLT 1/4" - 13 x 4 1/4" LONG	STEEL
33	THRUST SHOE	BEARING BRONZE
34	LACING WIRE 1/16" DIA. x 16 FT. LG. (CUT TO SUIT)	MONEL
35	PKG RING FOR 2 3/8" DIA SHAFT 1/4" SQ	SYMBOL 430
36	BOLT 3/8" - 16" x 1 3/4" LONG	STEEL
37	STUD 3/4" - 10 x 3" LONG	STEEL
38	EXTERNAL TOOTH LOCKWASHER	STEEL
39	SPRING PIN 3/32" x 3/8" LONG	STEEL
40	NAME PLATE (SERIAL)	BRASS SHEET
41	NAME PLATE (CAUTION)	BRASS SHEET
42	NAME PLATE (ROTATION)	BRASS SHEET

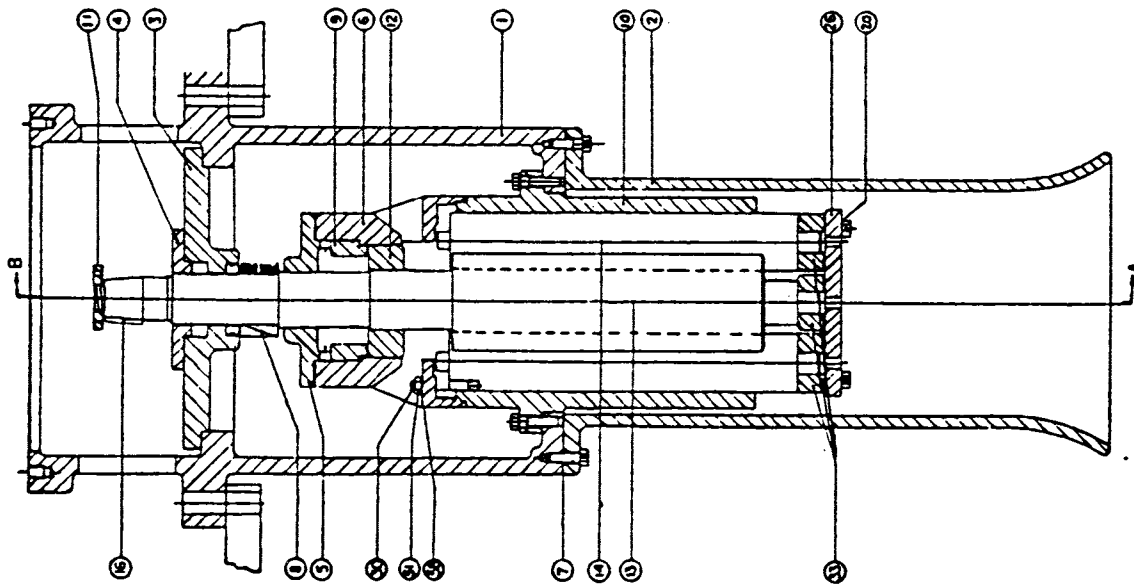

GS-0145

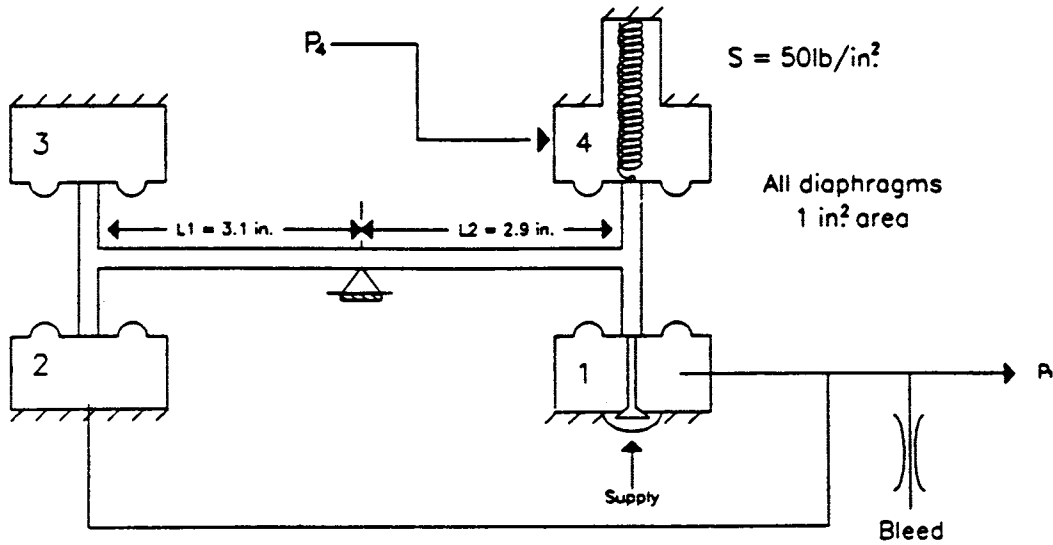

GS-0146

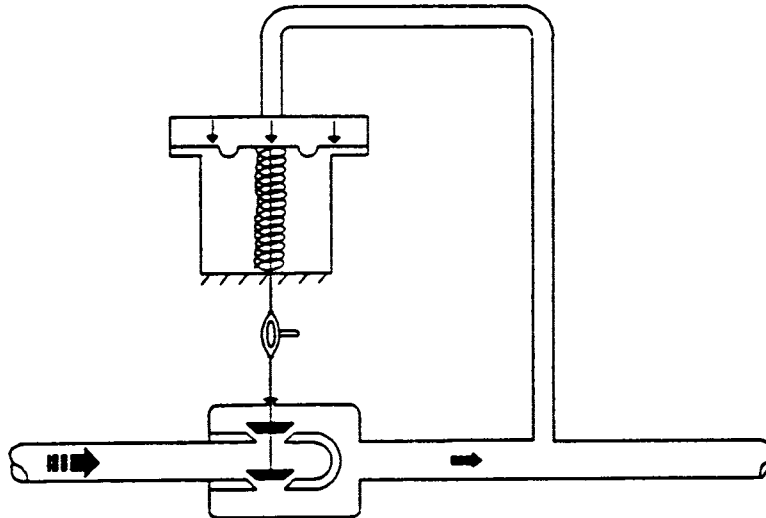

GS-0147

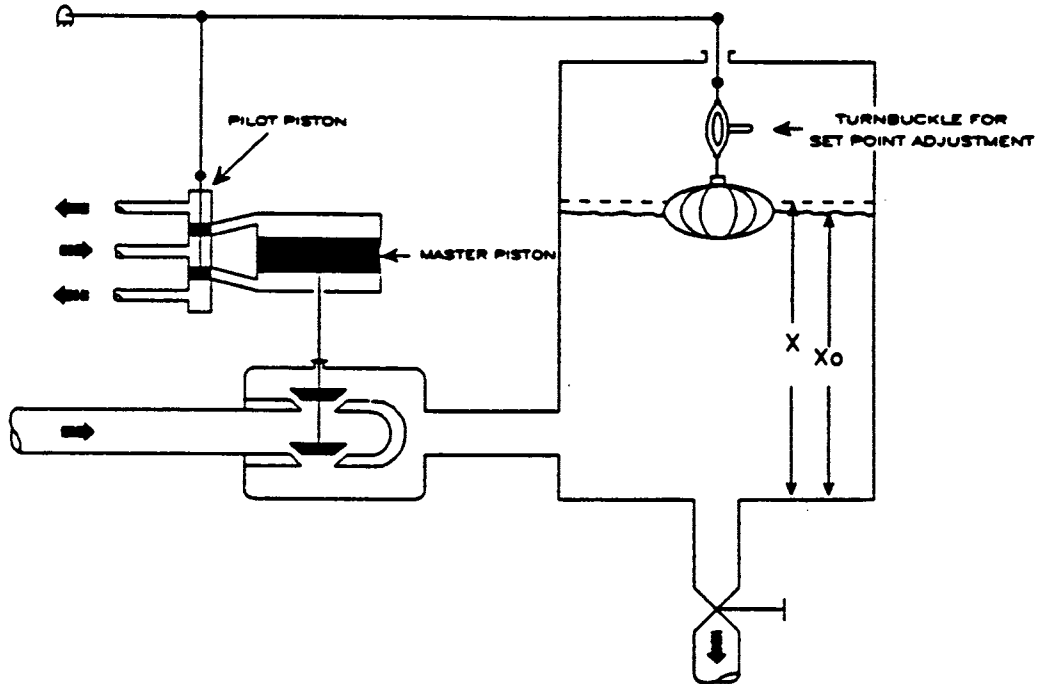

GS-0148

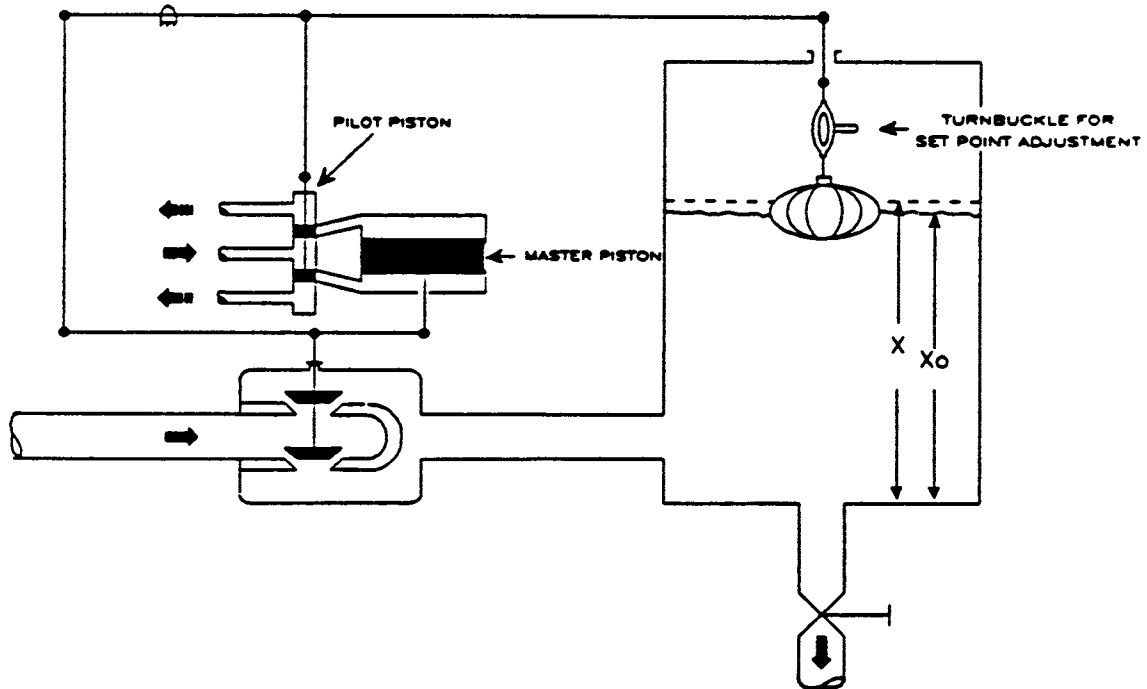

ASTM-IP		Table 8 Pounds per U.S. Gallon and U.S. Gallons per Pound					30-45° API	
API Gravity 60° F.	Pounds per U.S. Gallon at 60° F.	U.S. Gallons at 60° F. per Pound	API Gravity 60° F.	Pounds per U.S. Gallon at 60° F.	U.S. Gallons at 60° F. per Pound	API Gravity 60° F.	Pounds Per U.S. Gallon at 60° F.	U.S. Gallons at 60° F. per Pound
30.0	7.296	0.13707	35.0	7.076	0.14132	40.0	6.870	0.14557
30.1	7.291	0.13715	35.1	7.072	0.14140	40.1	6.866	0.14565
30.2	7.287	0.13724	35.2	7.068	0.14149	40.2	6.862	0.14574
30.3	7.282	0.13732	35.3	7.064	0.14157	40.3	6.858	0.14582
30.4	7.278	0.13741	35.4	7.059	0.14166	40.4	6.854	0.14591
30.5	7.273	0.13749	35.5	7.055	0.14174	40.5	6.850	0.14599
30.6	7.269	0.13758	35.6	7.051	0.14183	40.6	6.846	0.14608
30.7	7.264	0.13768	35.7	7.047	0.14191	40.7	6.842	0.14616
30.8	7.260	0.13775	35.8	7.042	0.14200	40.8	6.838	0.14625
30.9	7.255	0.13783	35.9	7.038	0.14208	40.9	6.834	0.14633
31.0	7.251	0.13792	36.0	7.034	0.14217	41.0	6.830	0.14642
31.1	7.246	0.13800	36.1	7.030	0.14225	41.1	6.826	0.14650
31.2	7.242	0.13809	36.2	7.026	0.14234	41.2	6.822	0.14659
31.3	7.237	0.13817	36.3	7.021	0.14242	41.3	6.818	0.14667
31.4		0.13826	36.4	7.017		41.4	6.814	0.14675
							6.810	

NOTES

1. WHEN TWO OR MORE HEATING COILS ARE REQUIRED, PROVIDE DRAINS FOR EACH COIL AS INDICATED.
2. PIPE STRAINER TO OPEN DRAIN WITHIN SIGHT OF THE VALVE.
3. PROVIDE BLOWOFF COCKS IN EQUIPMENT SPACES ONLY.
4. PROVIDE BARE PIPE COOLING LEG BETWEEN COIL AND TRAP AT LEAST 24" LONG.
5. PROVIDE STRAINER AHEAD OF TRAP ON UNIT HEATERS.
6. PROVIDE CHECK VALVE IN RETURN ONLY WHERE CONDENSATE MUST BE LIFTED.
7. PROVIDE STUFFING TUBES IN WET SPACES ONLY, DESIGNED TO THERMALLY ISOLATE PIPE FROM STRUCTURE. AT ALL OTHER PENETRATIONS, PROVIDE OVERSIZED CUTS WITH SUITABLE SLEEVES LARGE ENOUGH TO PASS THE FULL THICKNESS OF STANDARD PIPE INSULATION.
8. ALL STRAINERS SHALL BE OF THE SELF-CLEANING TYPE.
9. MOUNT THE CONVECTOR ON THE EXPOSED (COLD) BULKHEAD OR BULKHEAD LINING, WITH A 0.5-IN. AIR SPACE.
10. PROVIDE ONE PRESSURE GAGE IN EACH FAN EQUIPMENT ROOM.

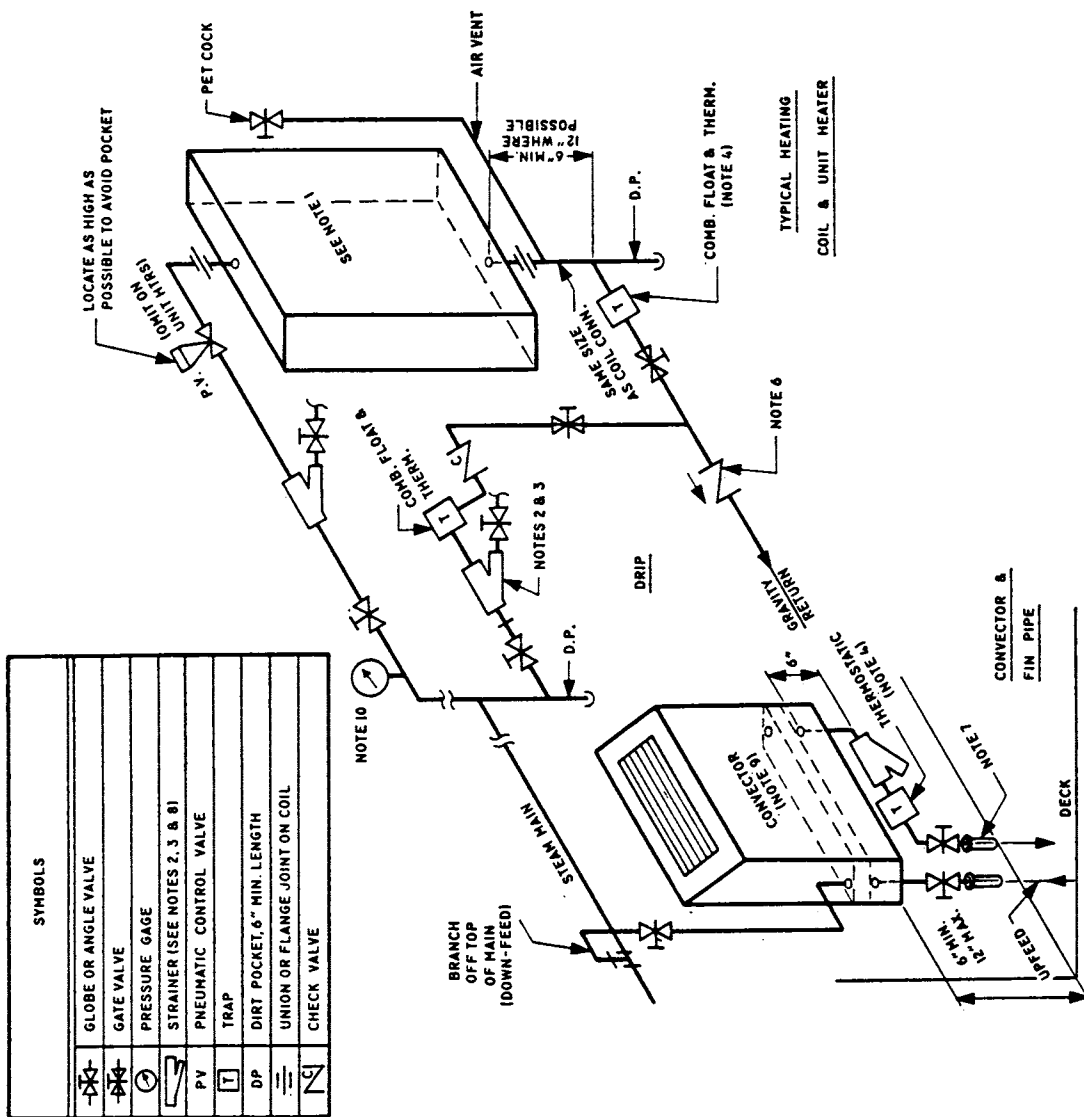

TYPICAL HEATING COIL & UNIT HEATER

GS-0151

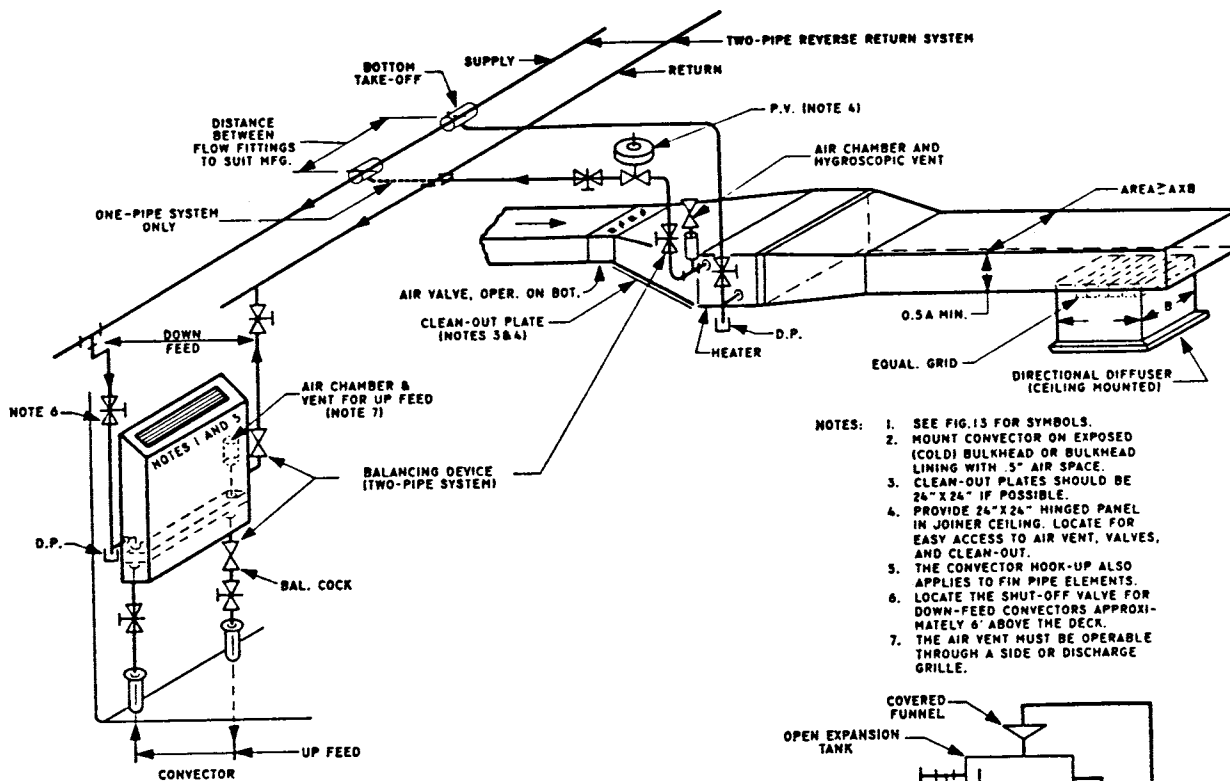

- NOTES:
1. SEE FIG. 13 FOR SYMBOLS.
 2. MOUNT CONVECTOR ON EXPOSED (COLD) BULKHEAD OR BULKHEAD LINING WITH .5" AIR SPACE.
 3. CLEAN-OUT PLATES SHOULD BE 24" X 24" IF POSSIBLE.
 4. PROVIDE 24" X 24" HINGED PANEL IN JOINDER CEILING. LOCATE FOR EASY ACCESS TO AIR VENT, VALVES, AND CLEAN-OUT.
 5. THE CONVECTOR HOOK-UP ALSO APPLIES TO FIN PIPE ELEMENTS.
 6. LOCATE THE SHUT-OFF VALVE FOR DOWN-FEED CONVECTORS APPROXIMATELY 6' ABOVE THE DECK.
 7. THE AIR VENT MUST BE OPERABLE THROUGH A SIDE OR DISCHARGE GRILLE.

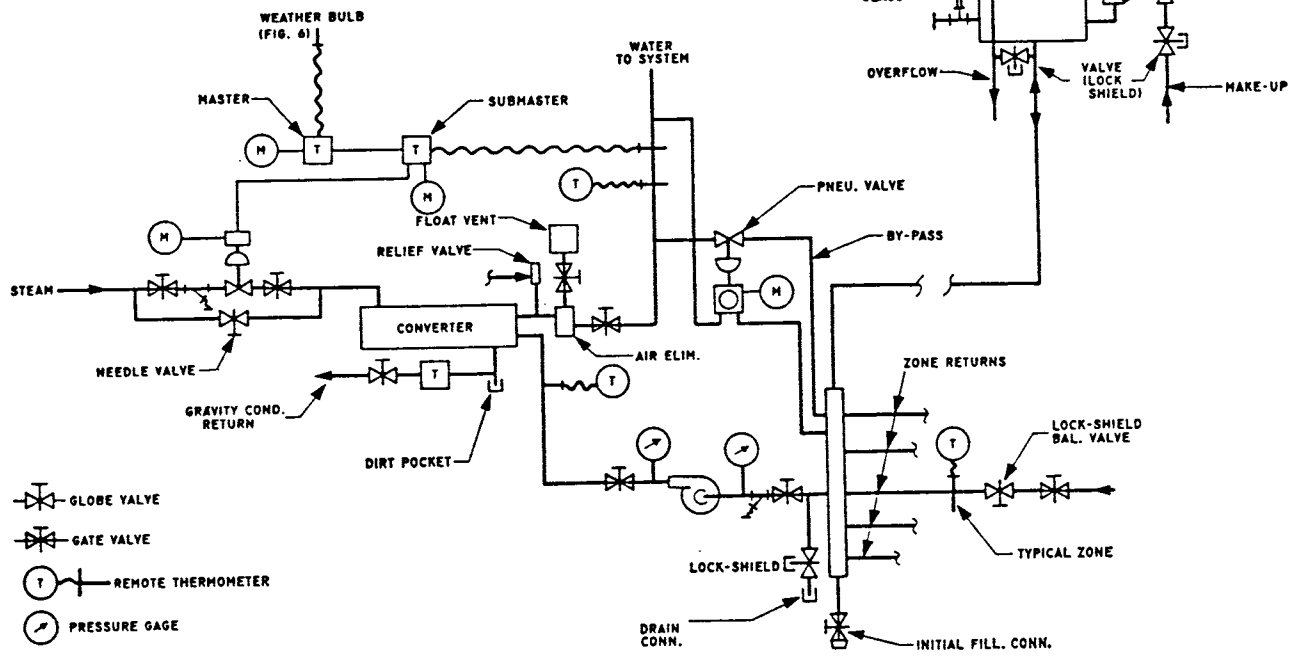

- GLOBE VALVE
- GATE VALVE
- REMOTE THERMOMETER
- PRESSURE GAGE
- INDICATING CONSTANT PRES. REGULATOR
- CONTROL AIR MAIN
- "Y" STRAINER WITH BLOW-OFF DRAIN CONN.
- PNEUMATIC CONTROL VALVE WITH POSITIVE POSITIONER
- COMBINATION FLOAT AND THERMOSTATIC TRAP

NOTE: ALL REGULATORS, GAGES, THERMOSTATS, THERMOMETERS, AND CONTROLS SHOULD BE PANEL MOUNTED.

GS-0152

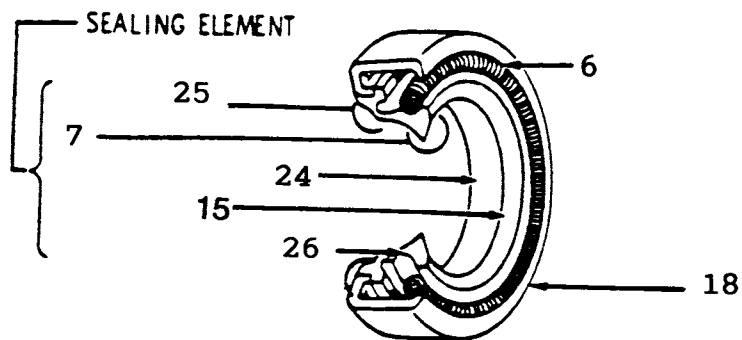
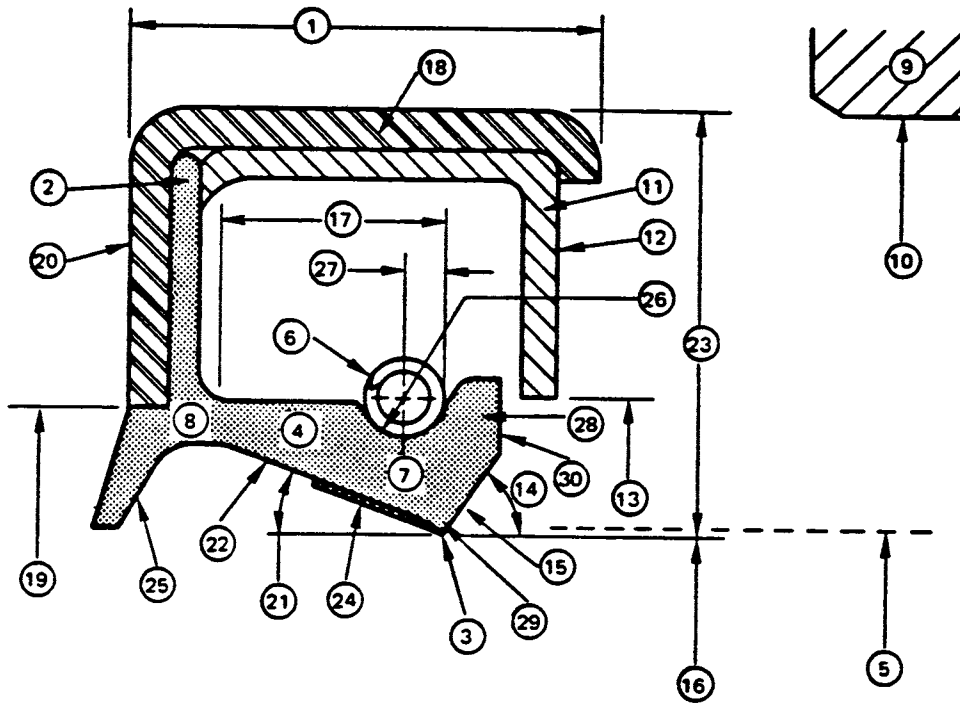

GS-0153

CONTROL PANEL ASSY.

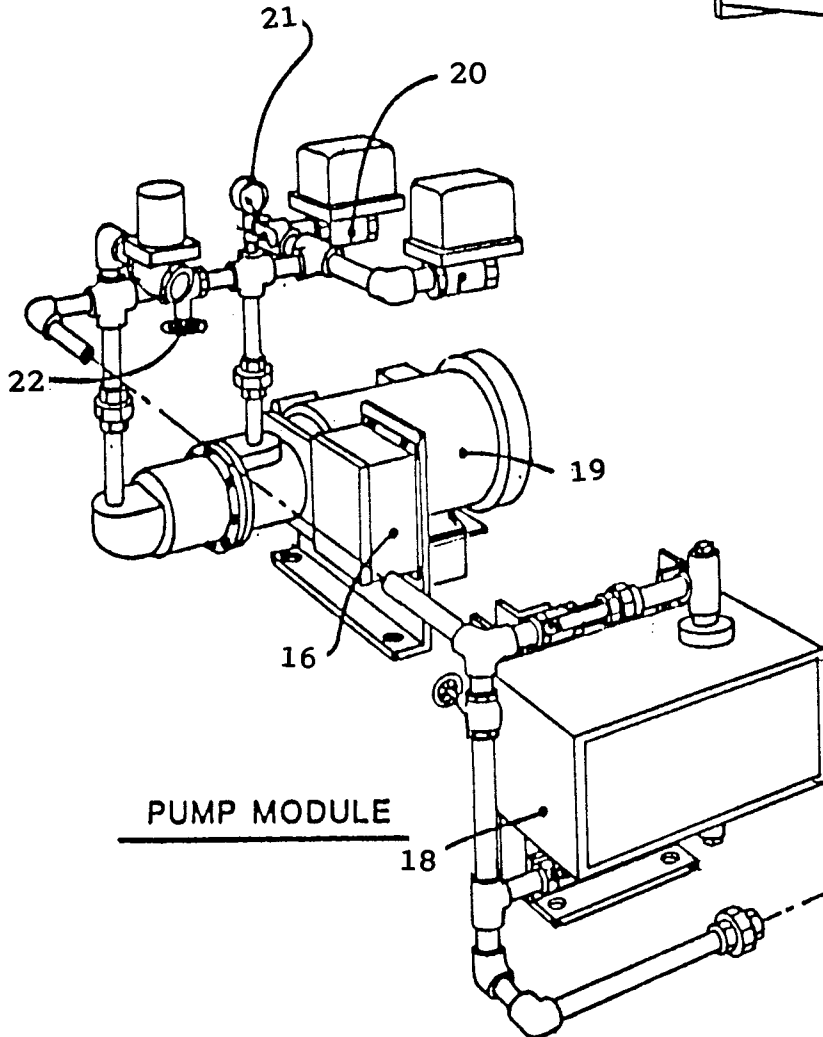
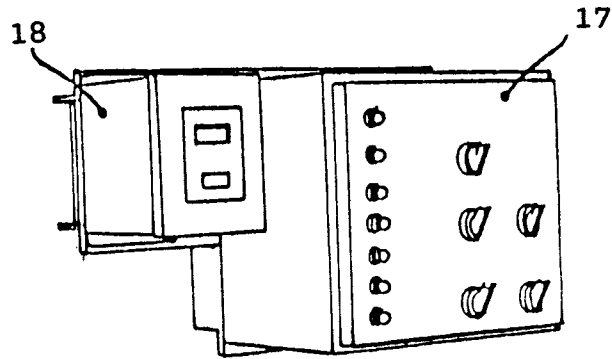

PUMP MODULE

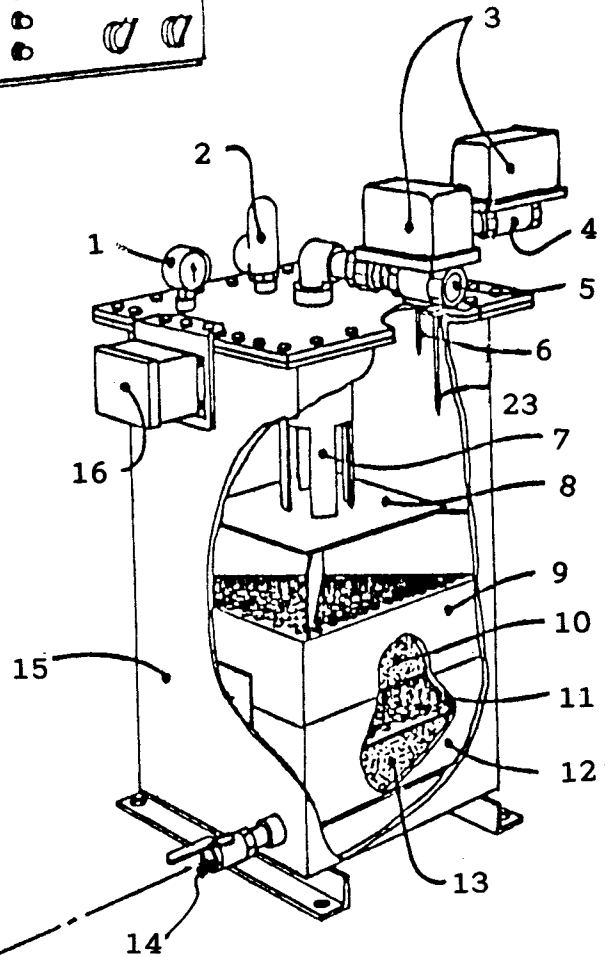

SEPARATOR TANK MODULE

(COURTESY OF PARMATIC POLLUTION CONTROL CORP.)

GS-0154

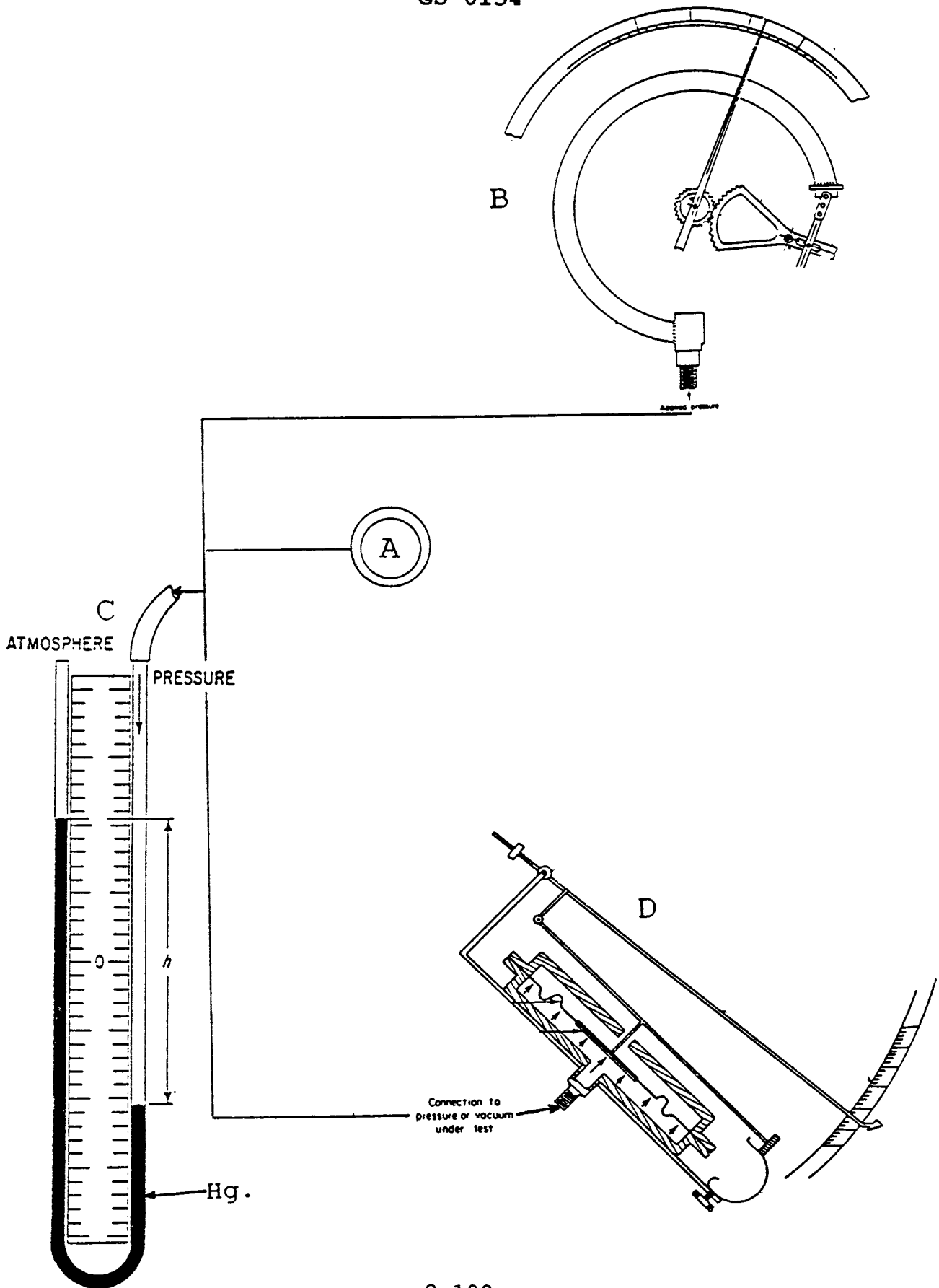

GS-0155

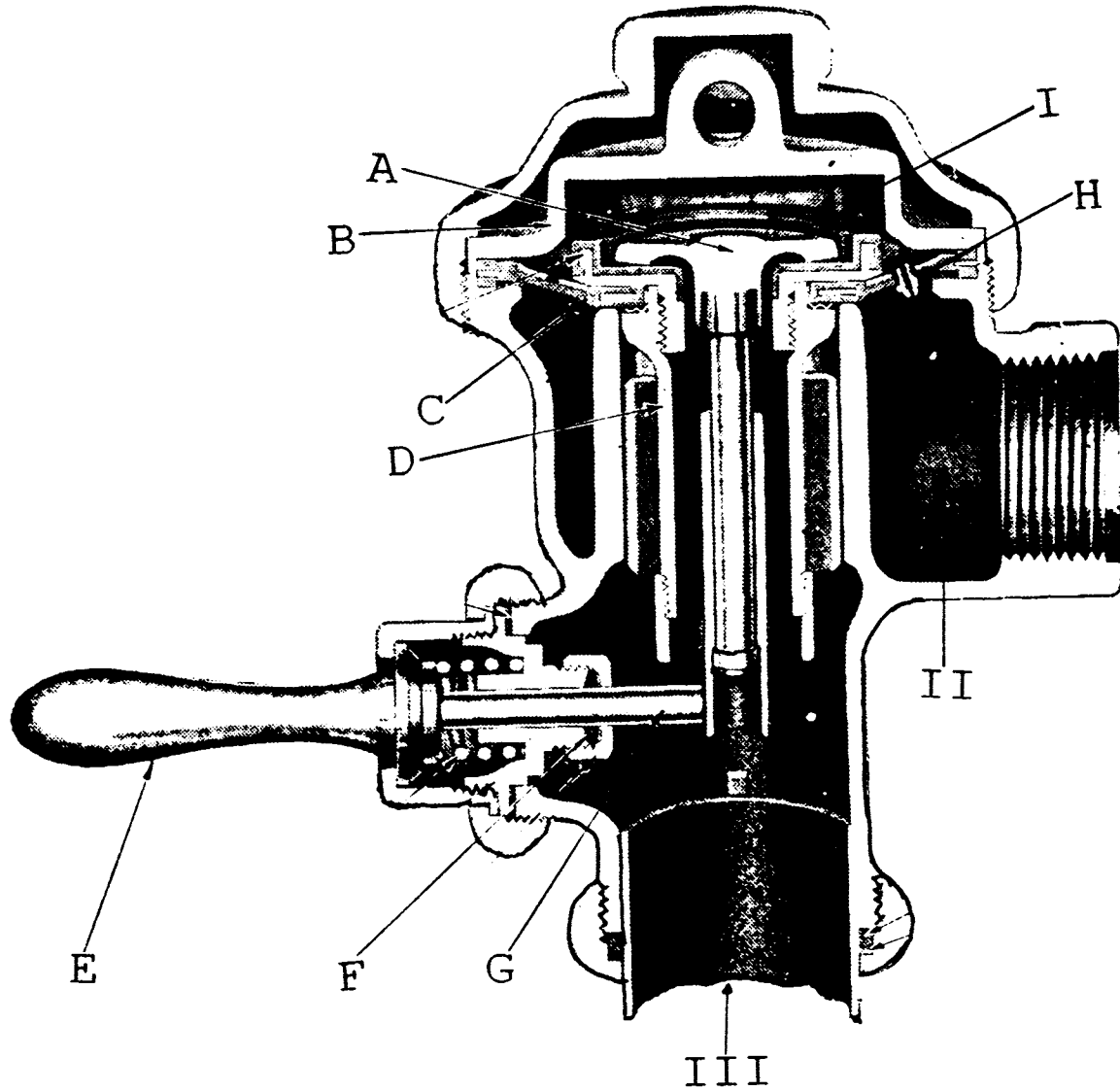

(COURTESY OF SLOAN VALVE COMPANY)

GS-0156

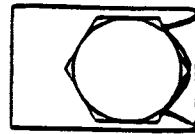
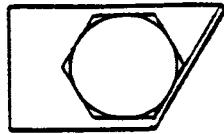
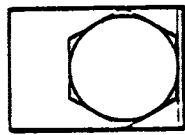

A

B

C

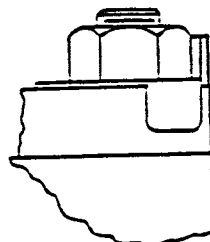
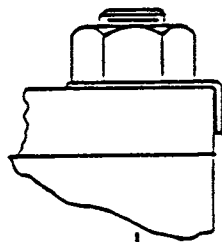
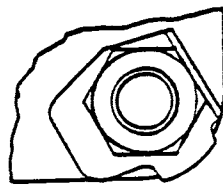
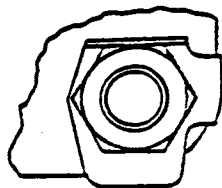

D

E

GS-0157

COMMON BARGE

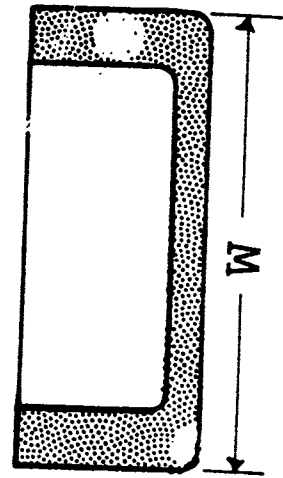
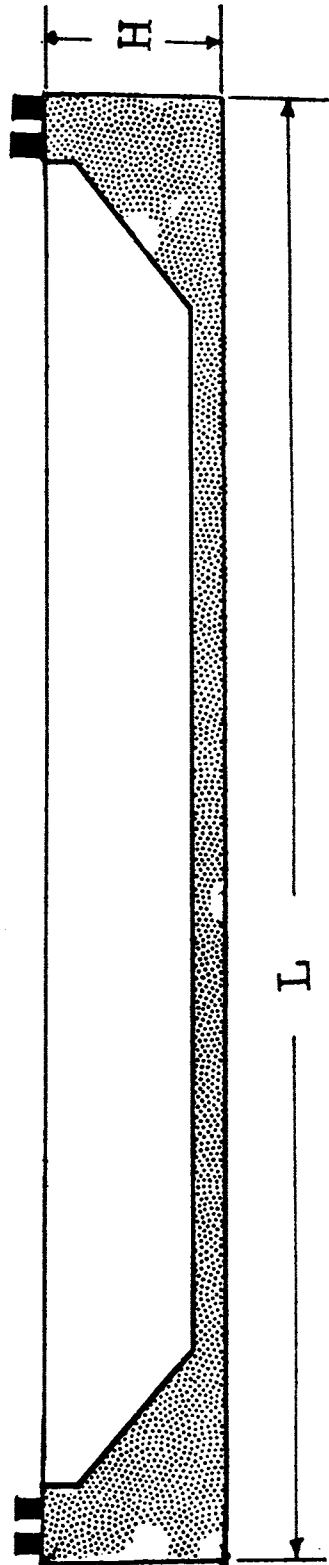

GS-0158

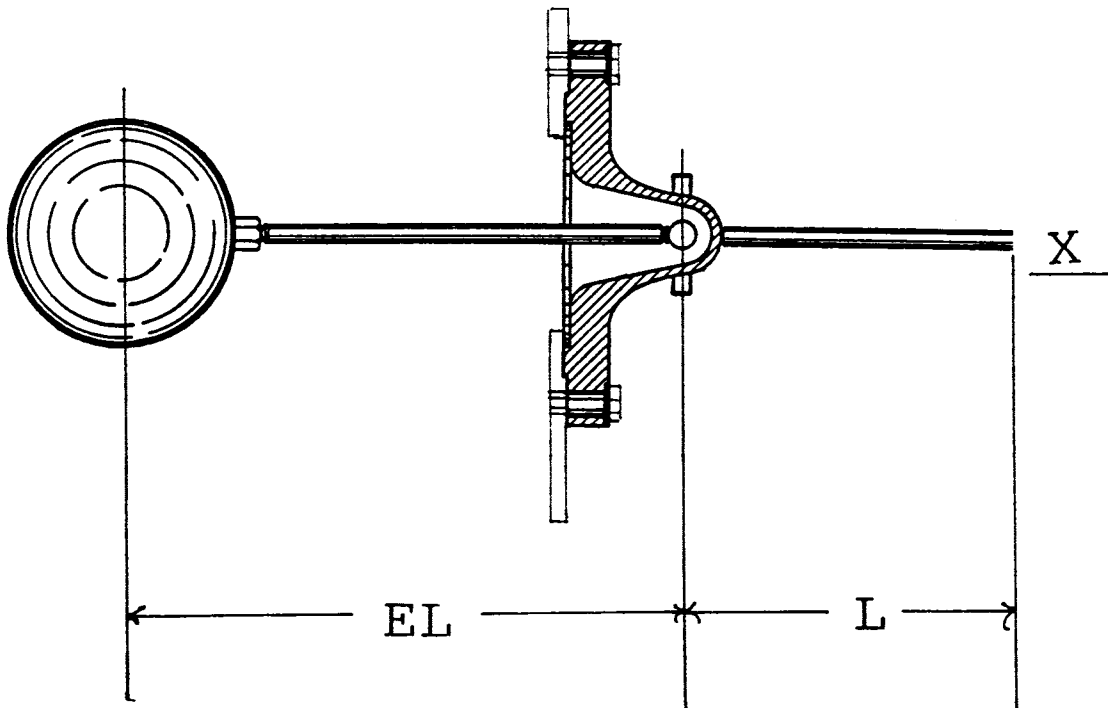
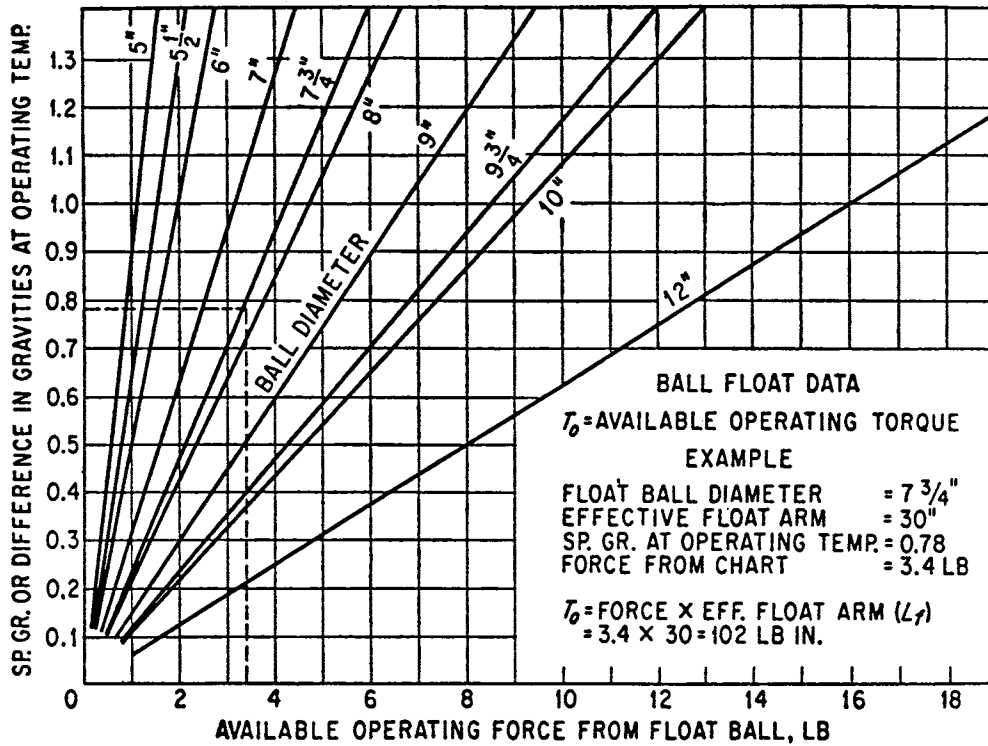

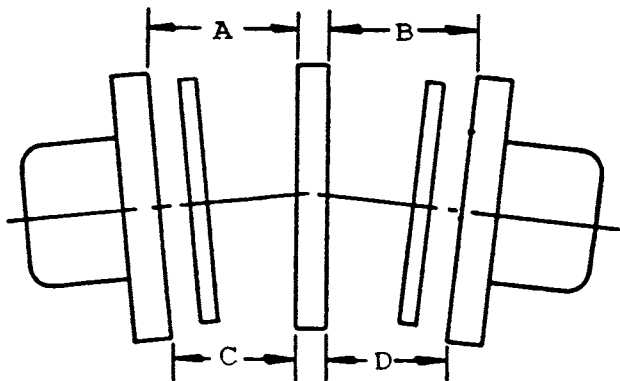

Figure 1

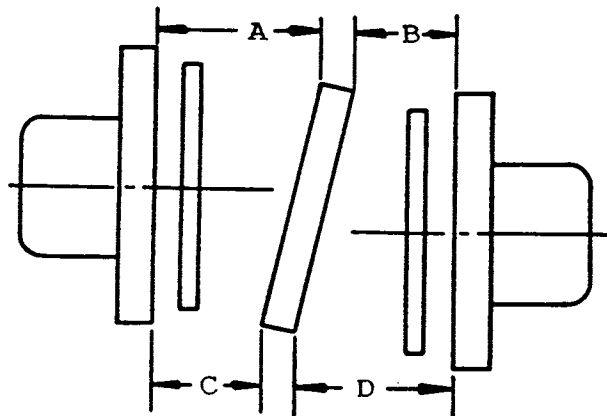

Figure 2

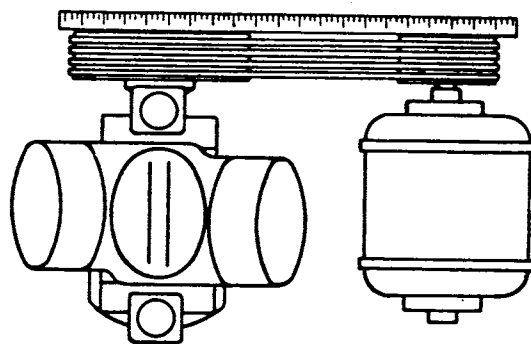

Figure 3

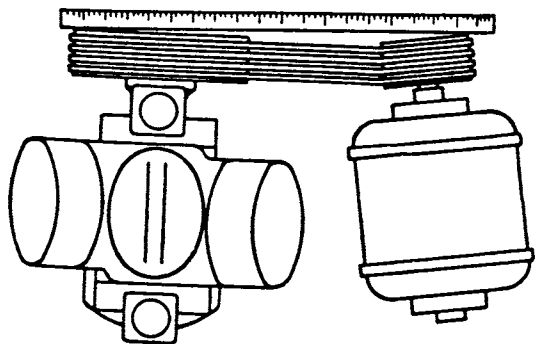

Figure 4

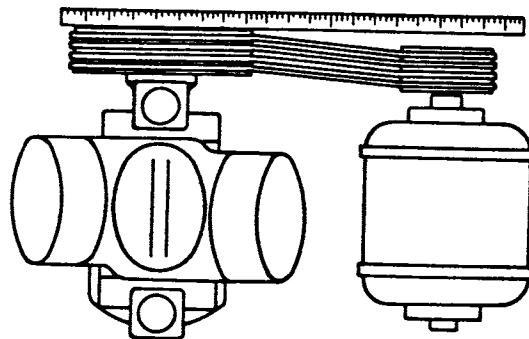
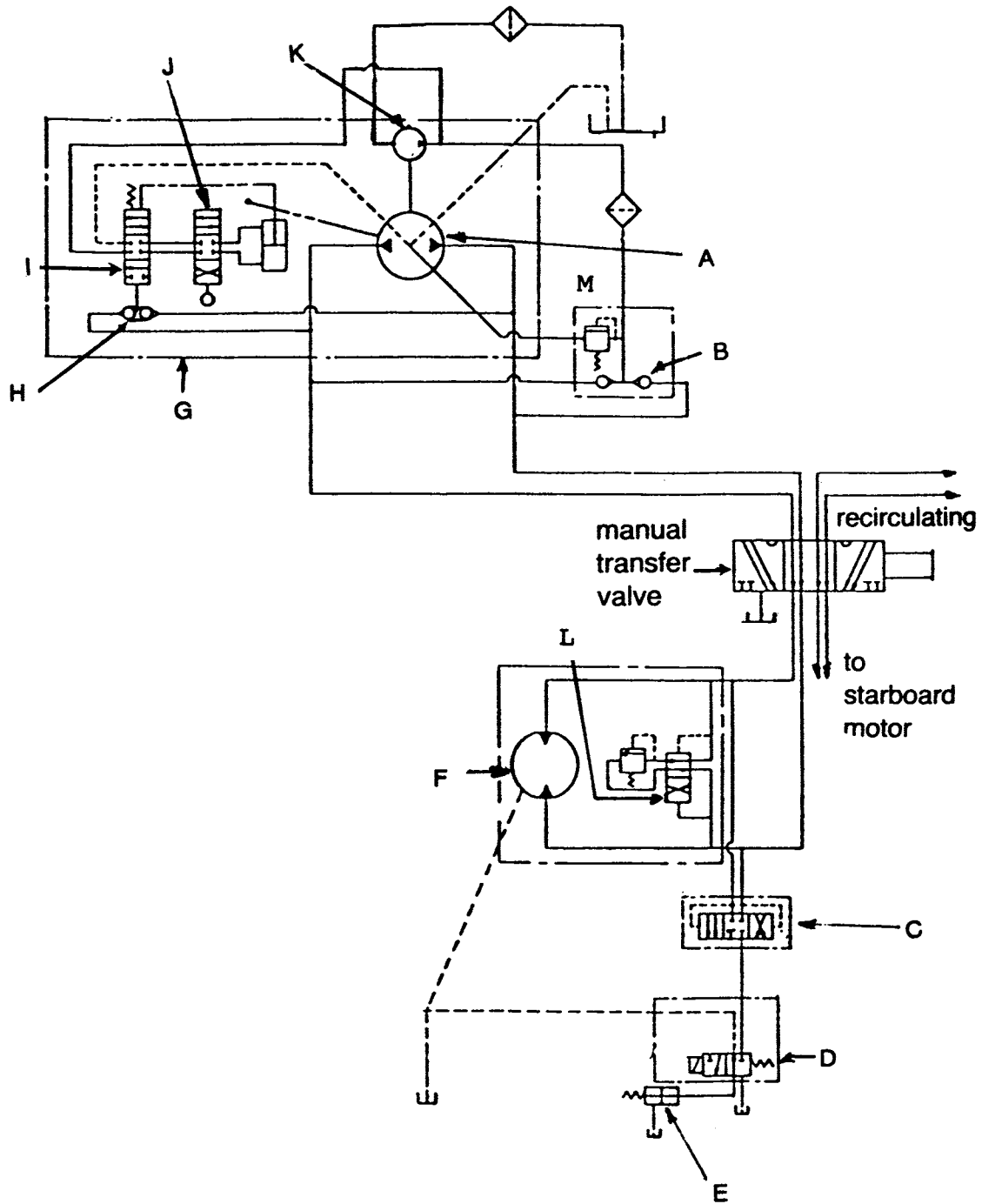
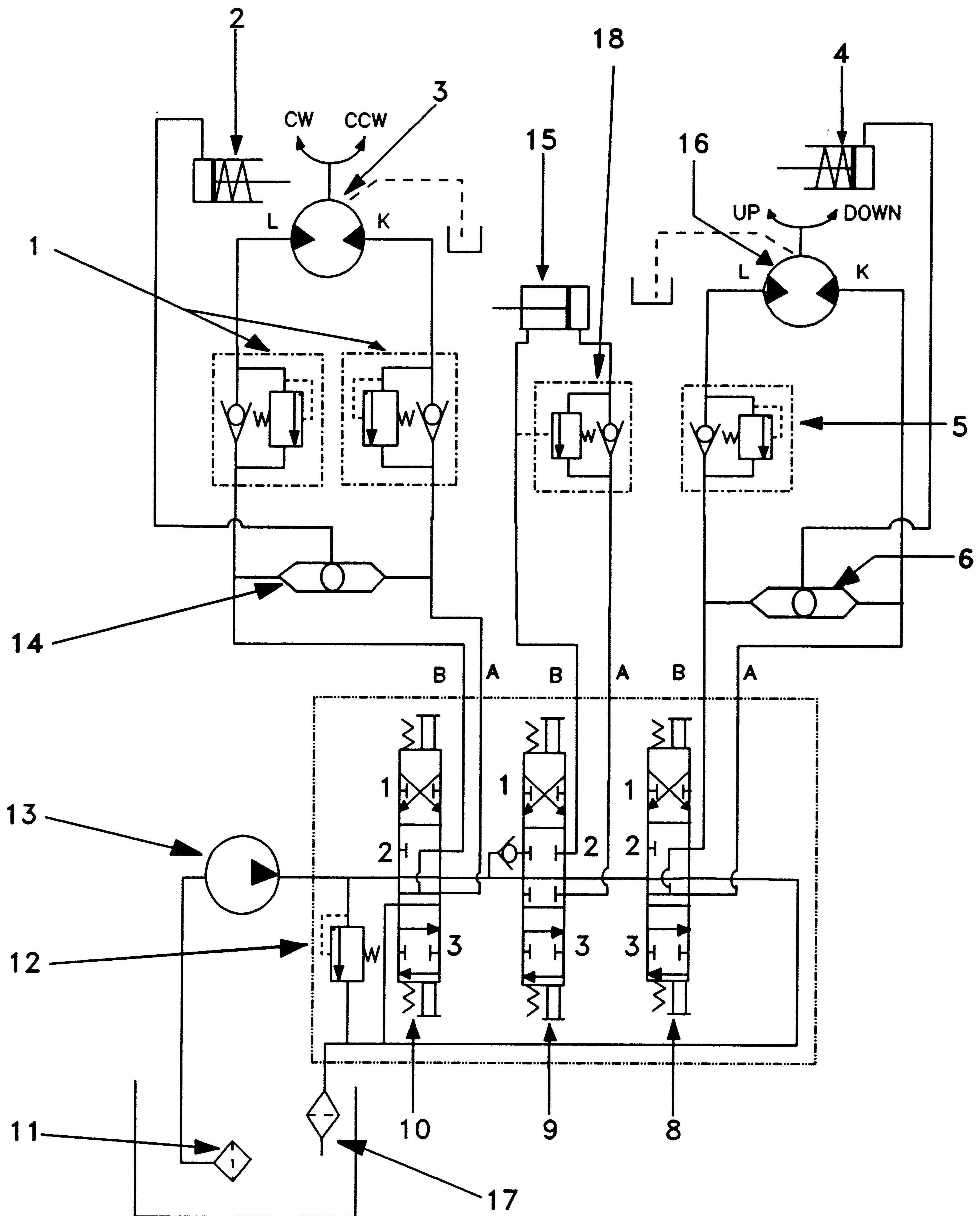

Figure 5

GS-0160



GS-0161



GS-0162

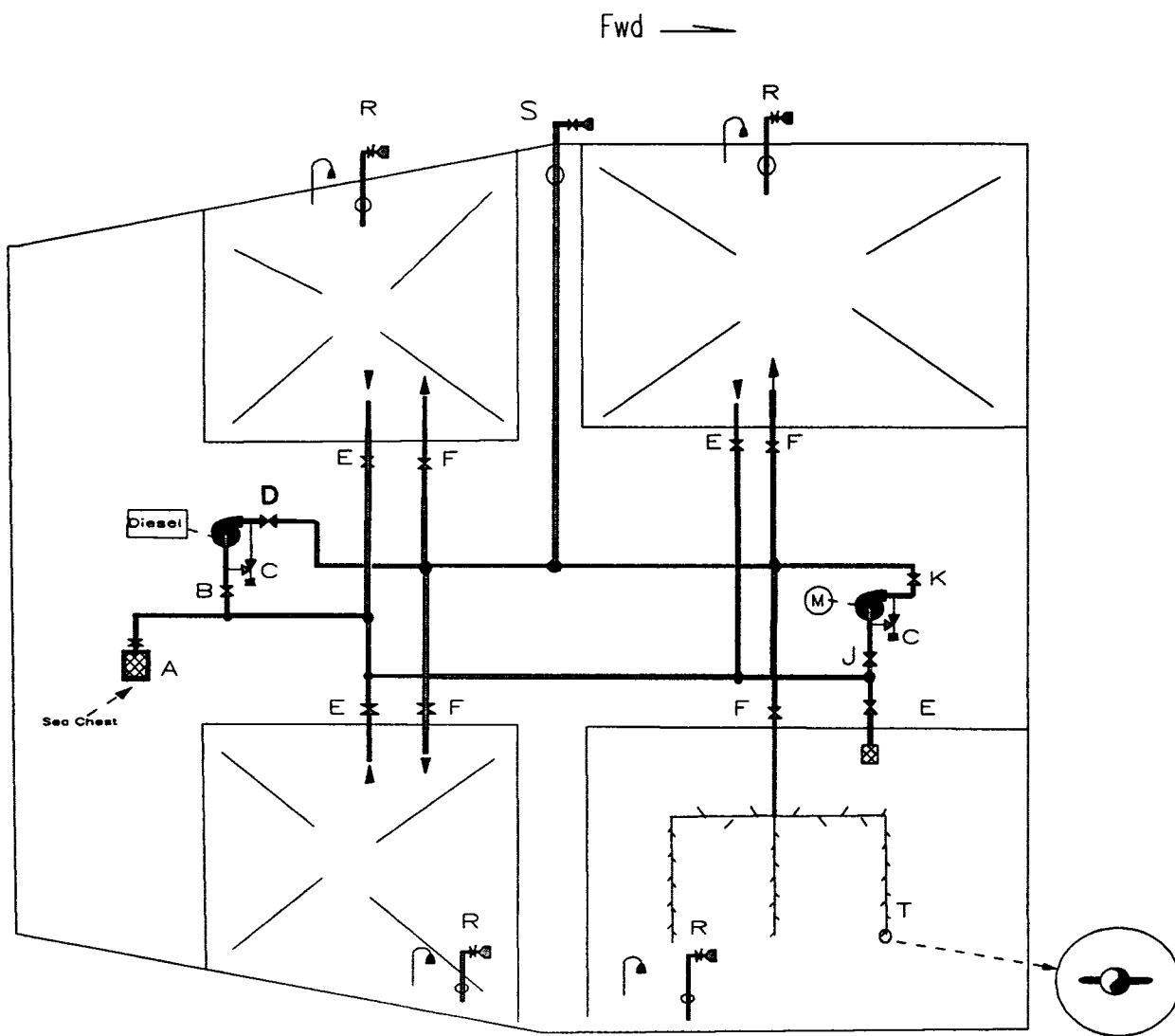

GS-0163

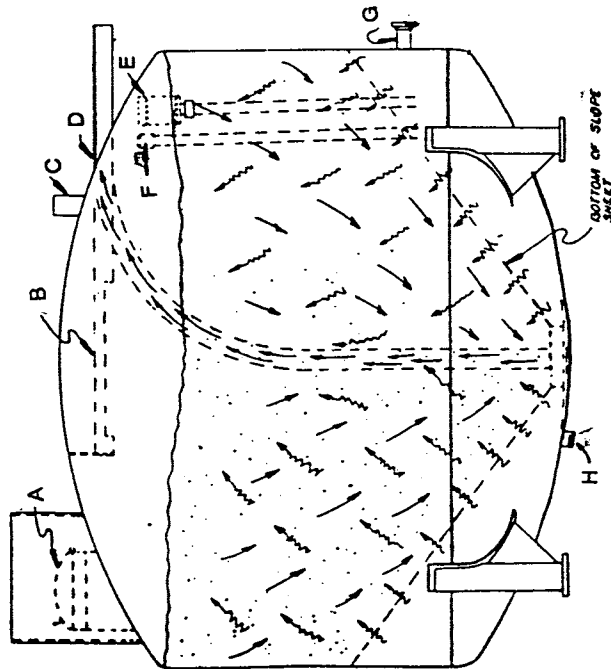
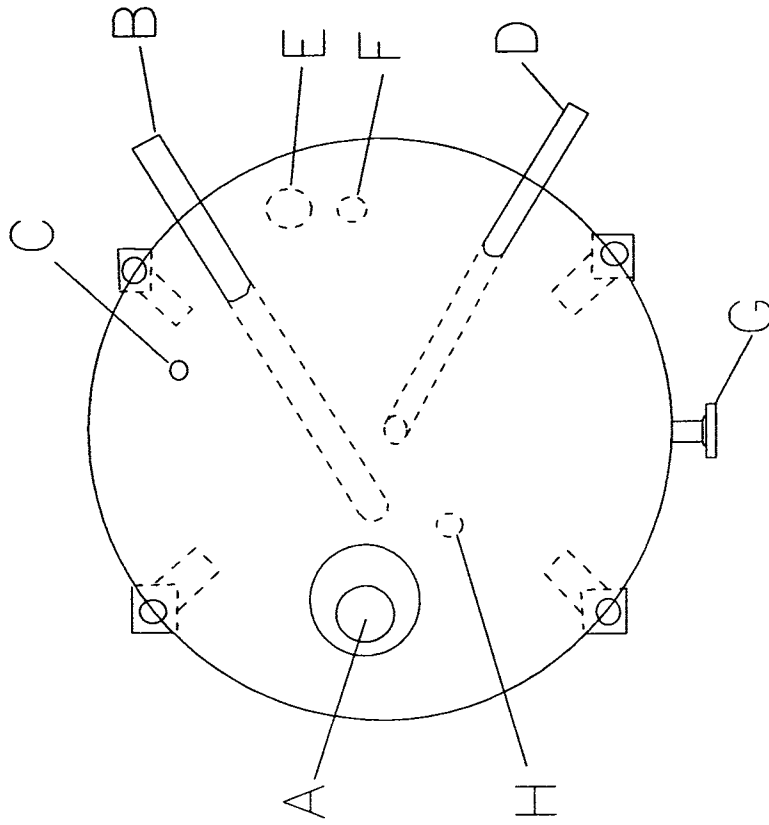

GS-0164

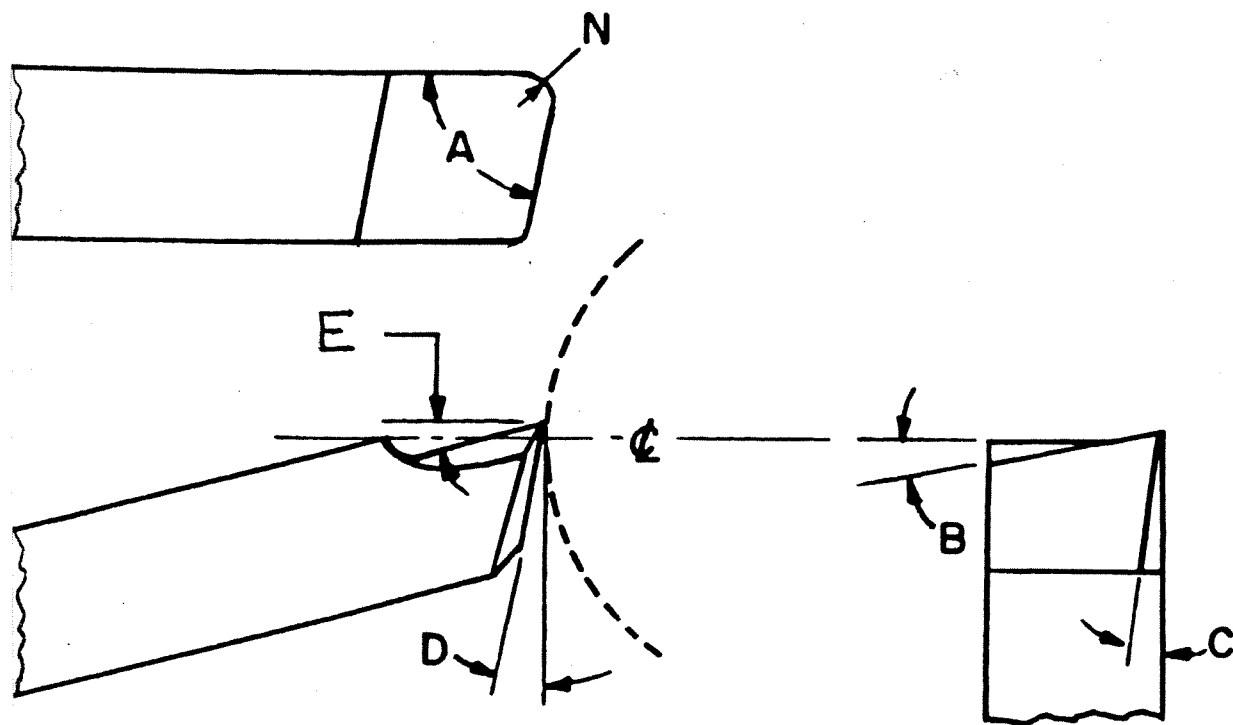

GS-0165

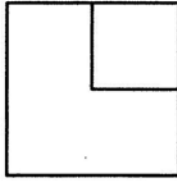

1.

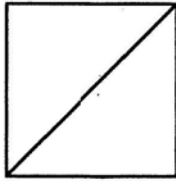

2.

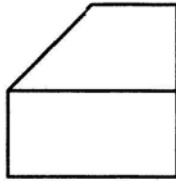

3.

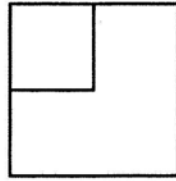

4.

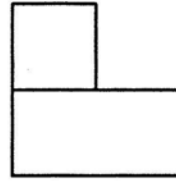

5.

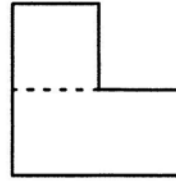

6.

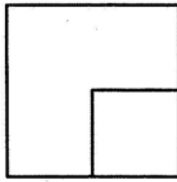

7.

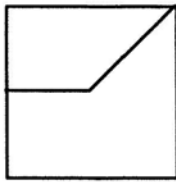

8.

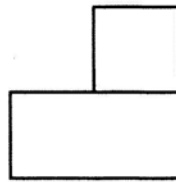

9.

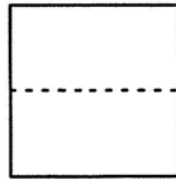

10.

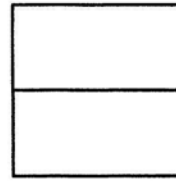

11.

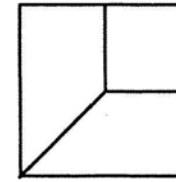

12.

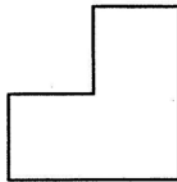

13.

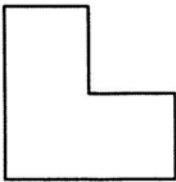

14.

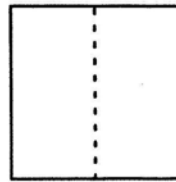

15.

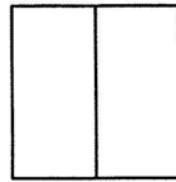

16.

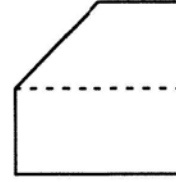

17.

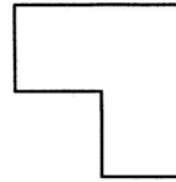

18.

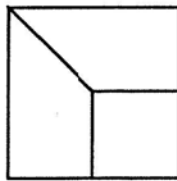

19.

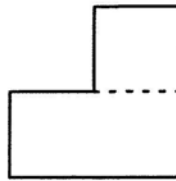

20.

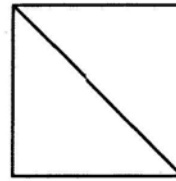

21.

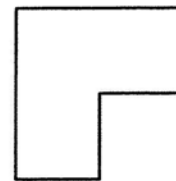

22.

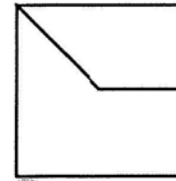

23.

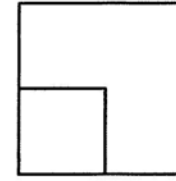

24.

GS-0166

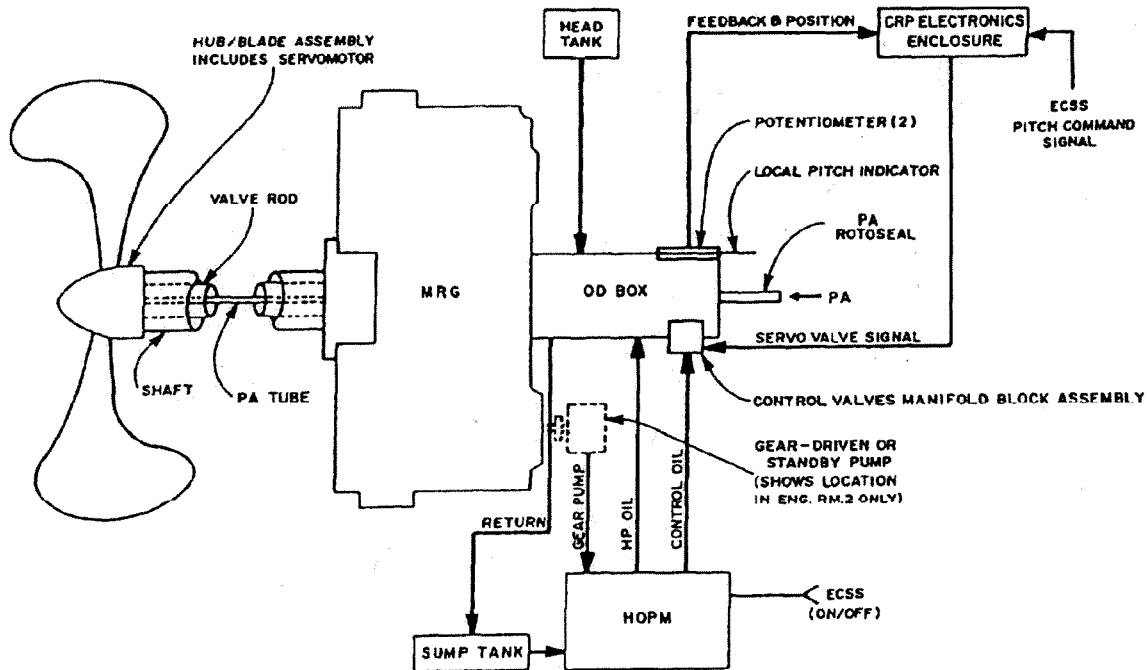

GS-0167

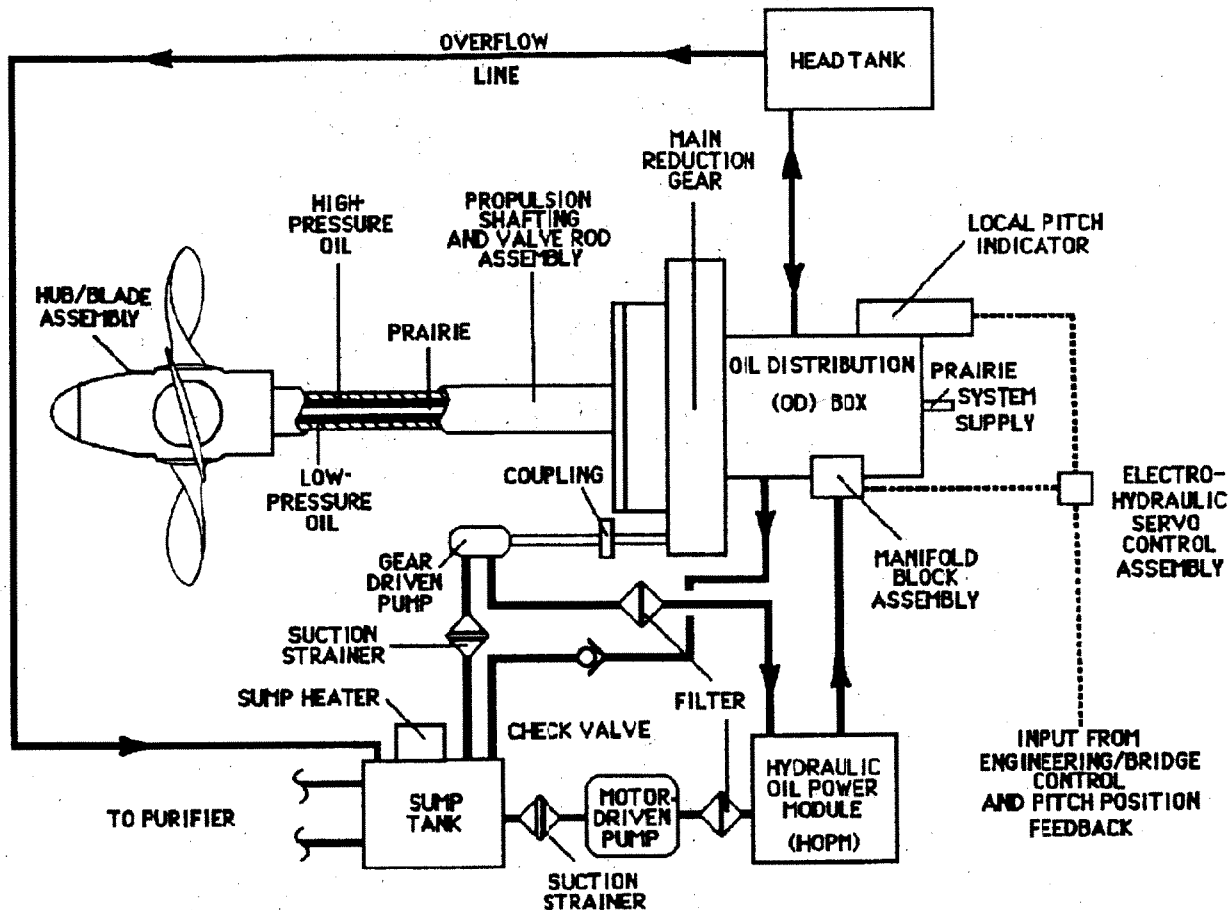

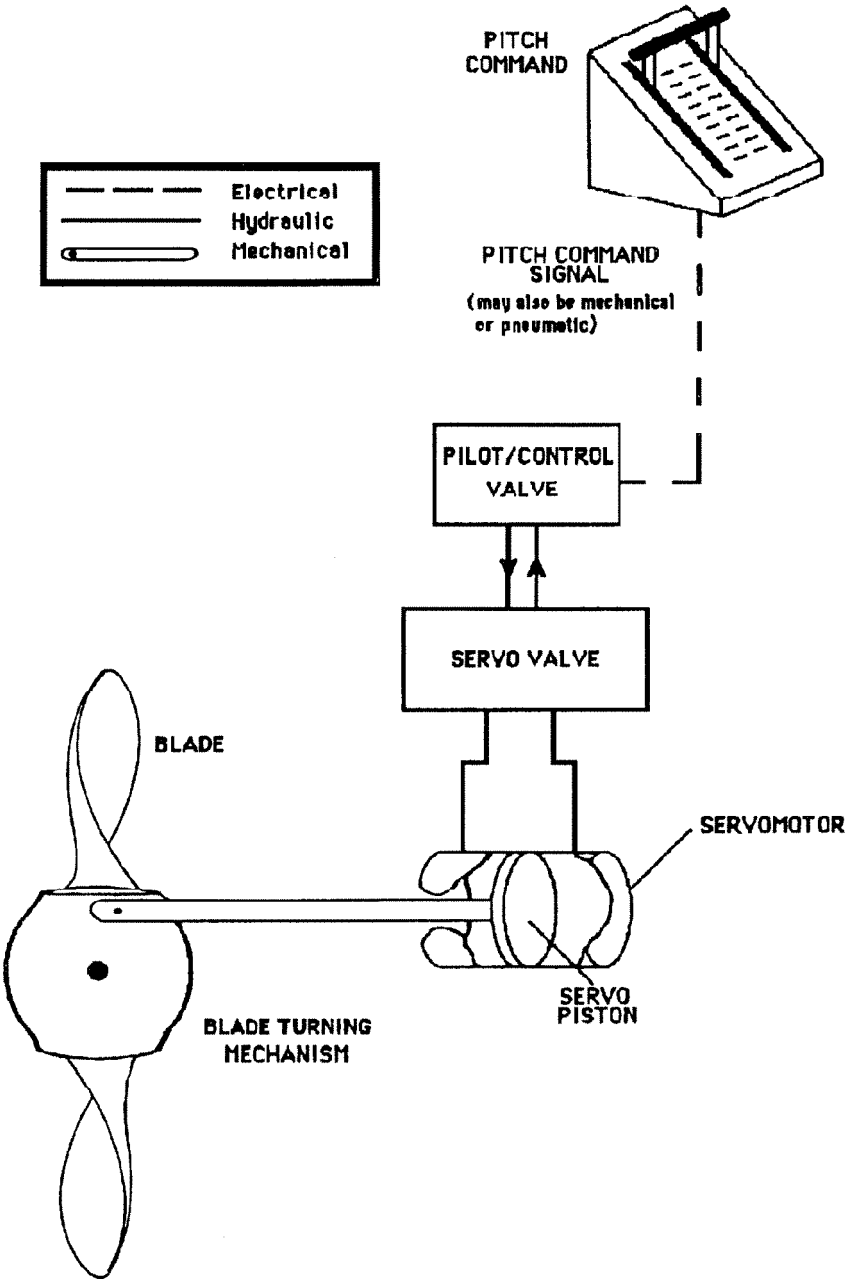

GS-0169

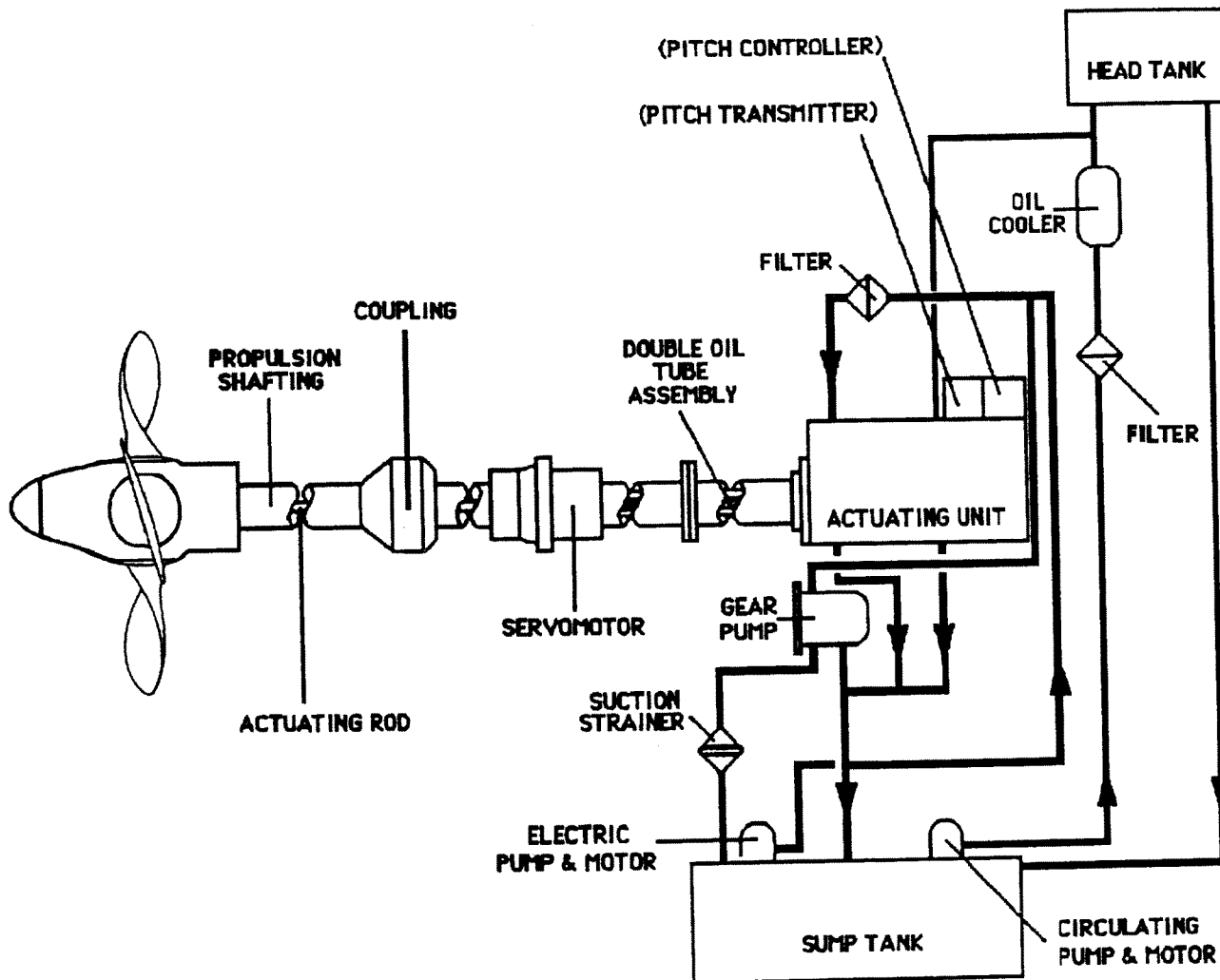

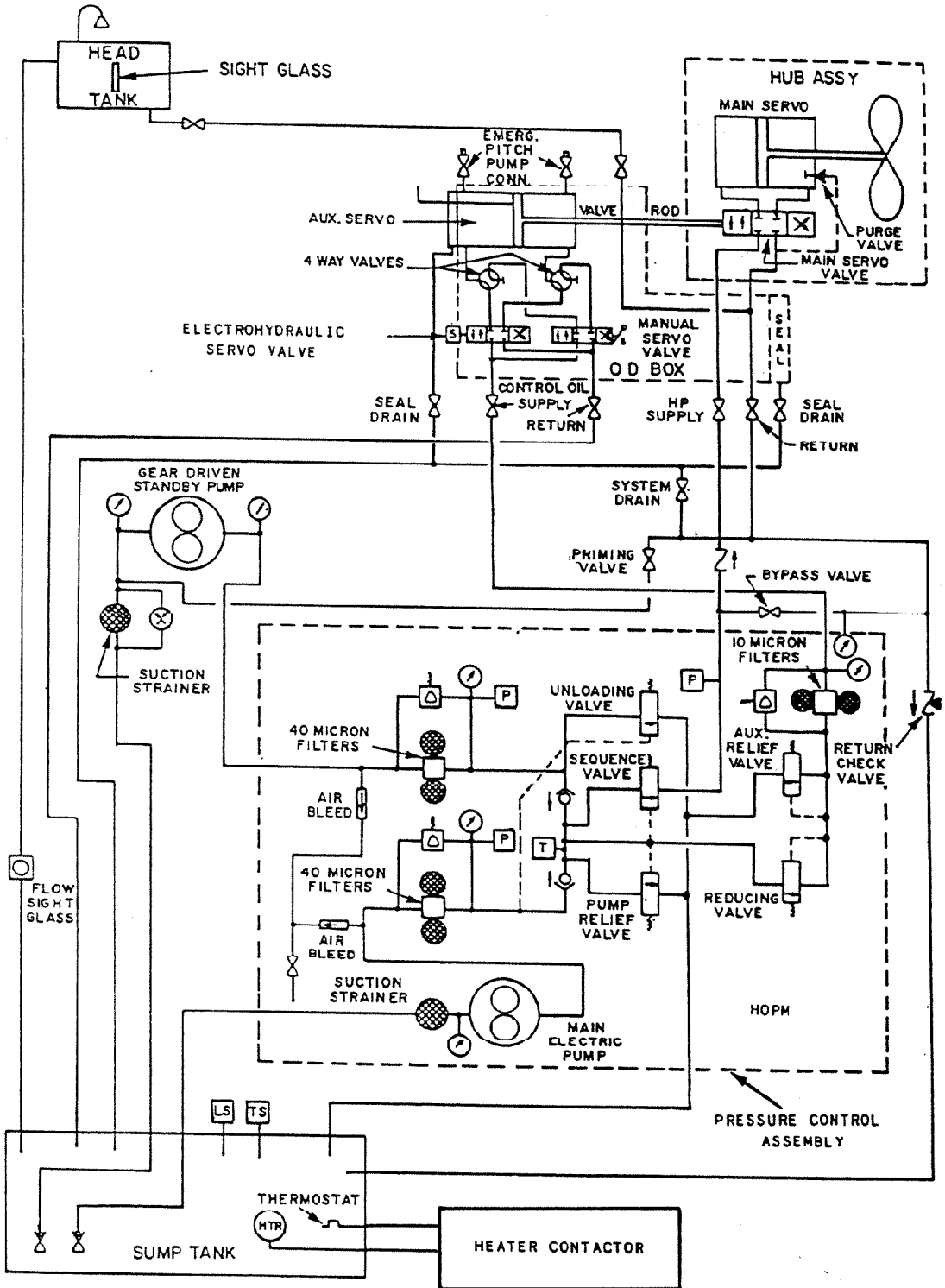

GS-0171

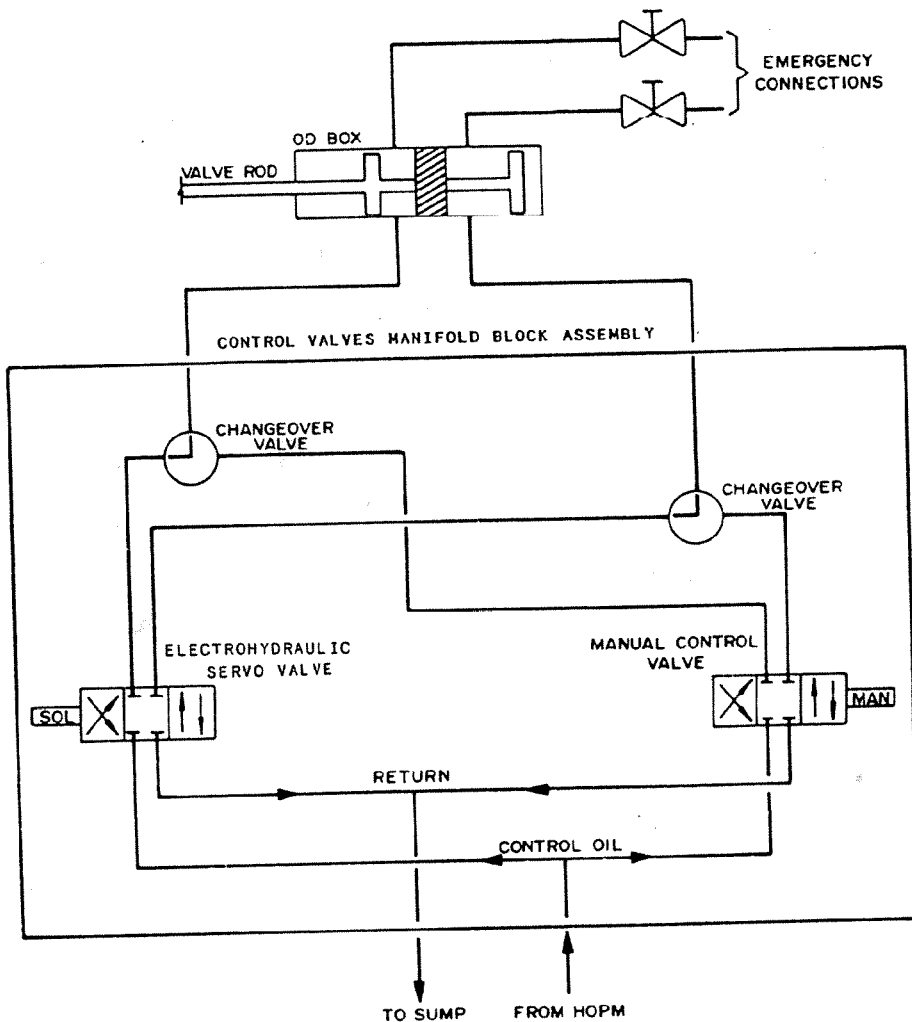

GS-0172

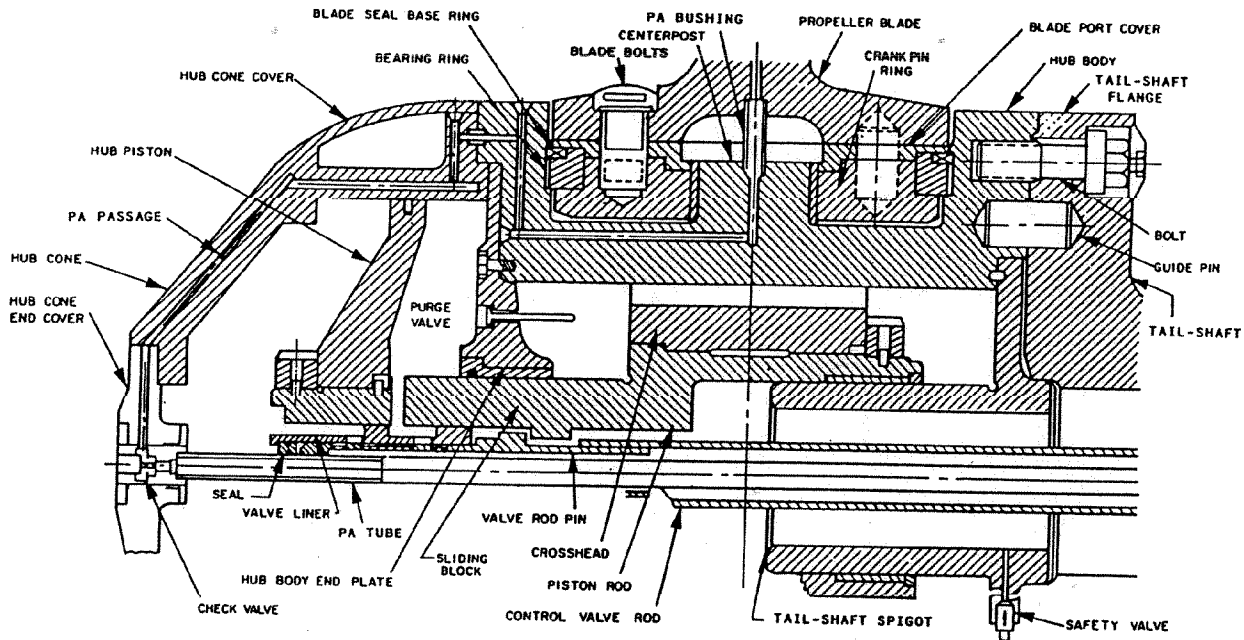

GS-0173

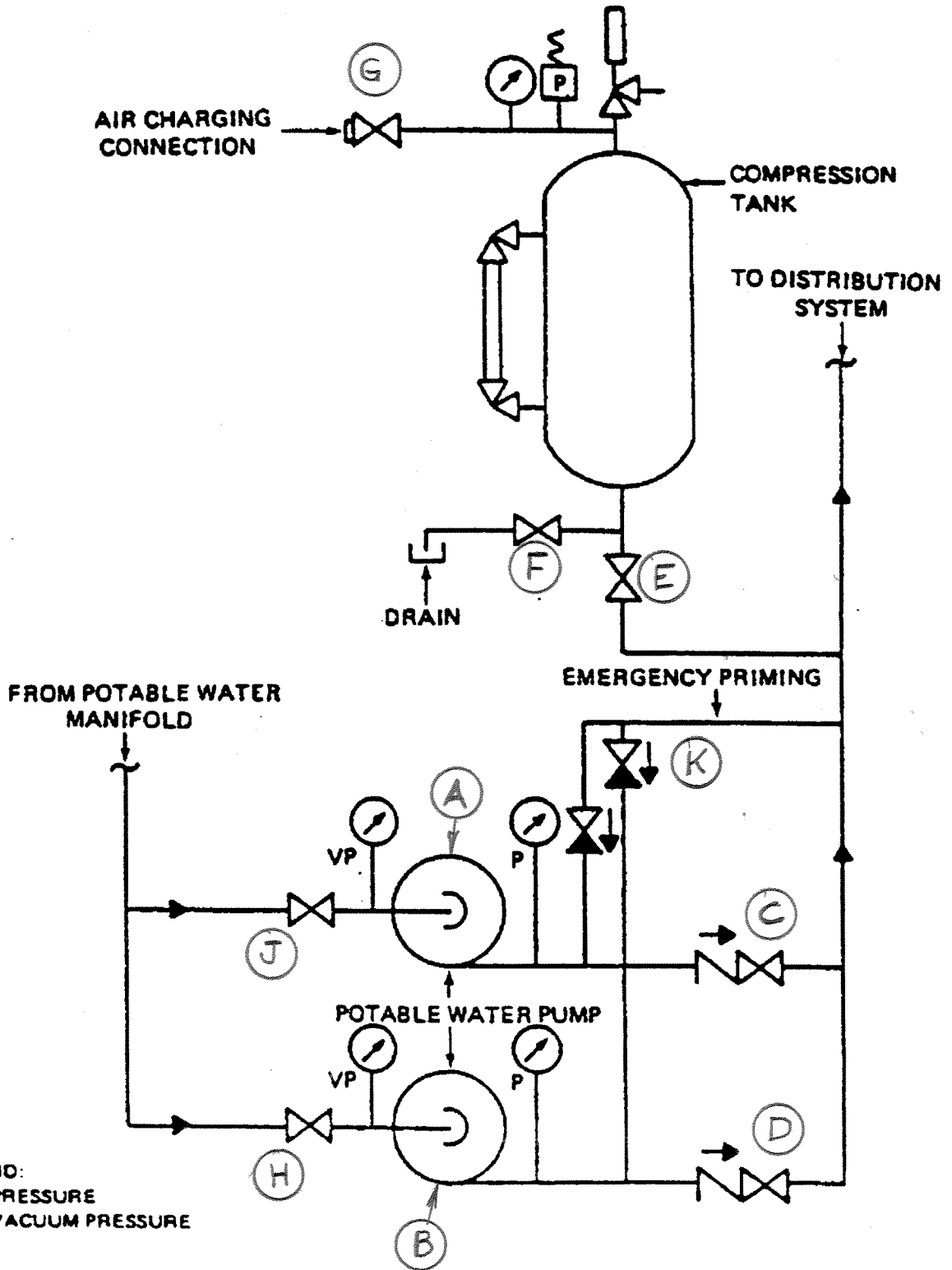

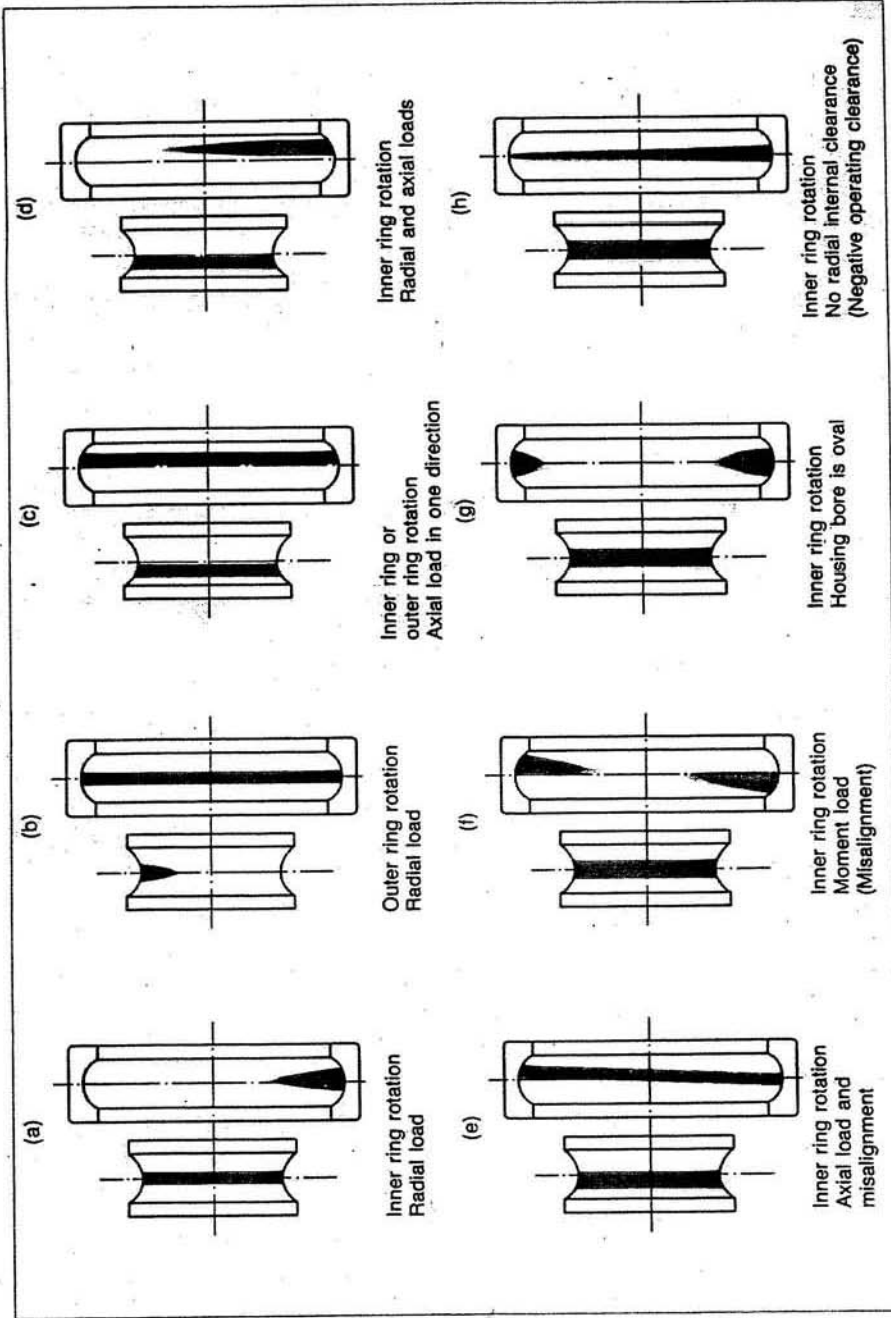

Fig. 6.1 Typical running traces of deep groove ball bearings

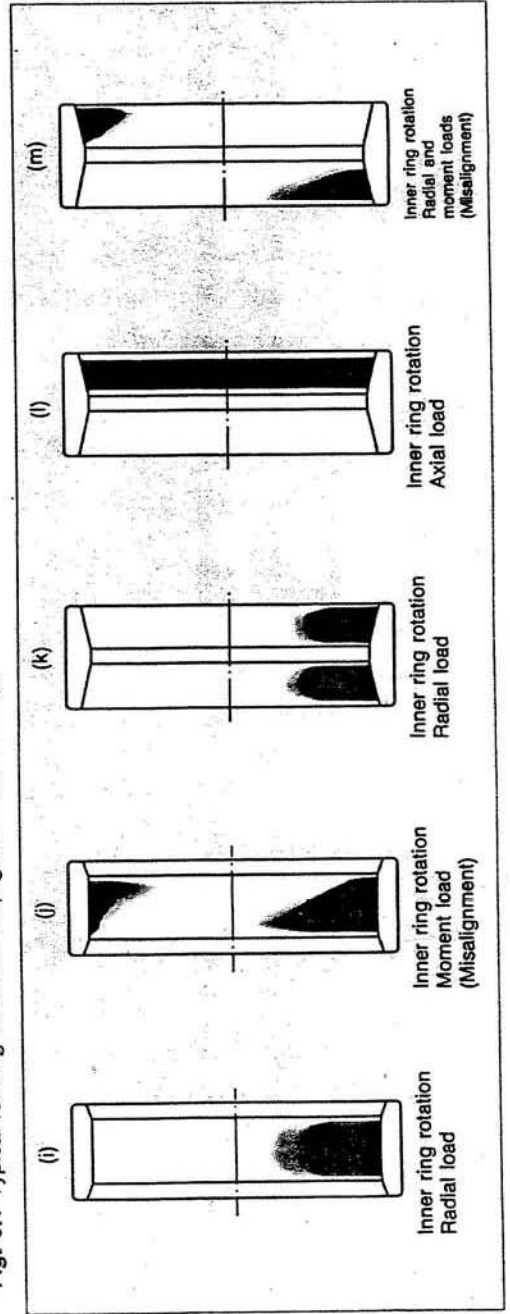
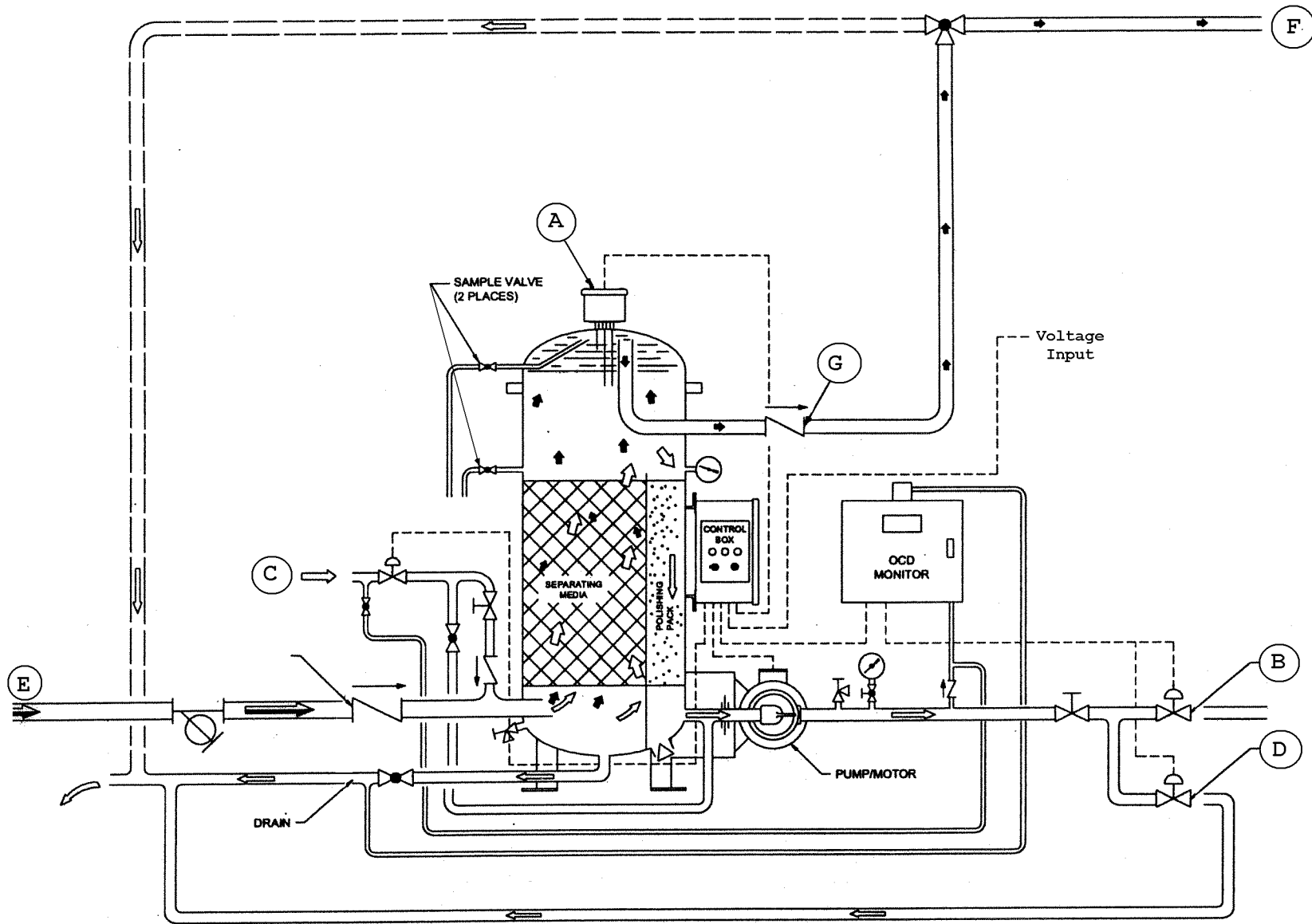
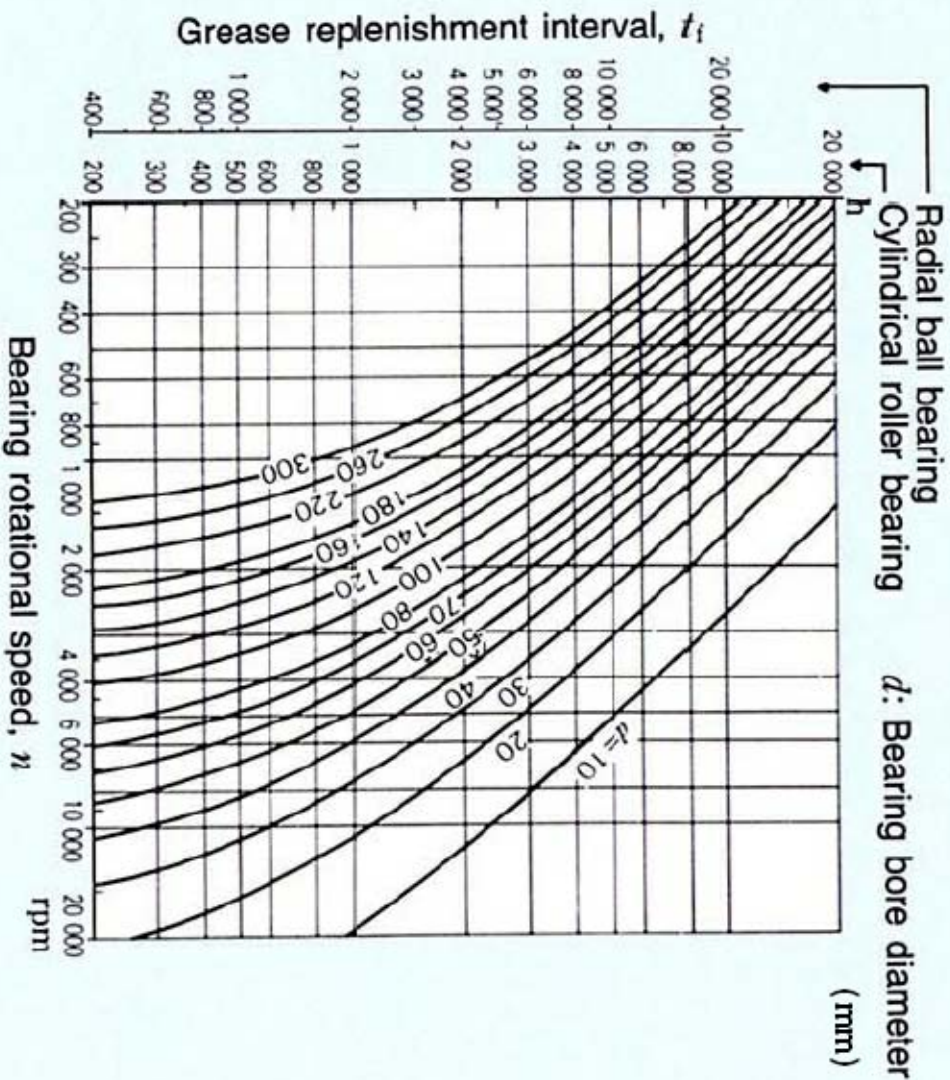
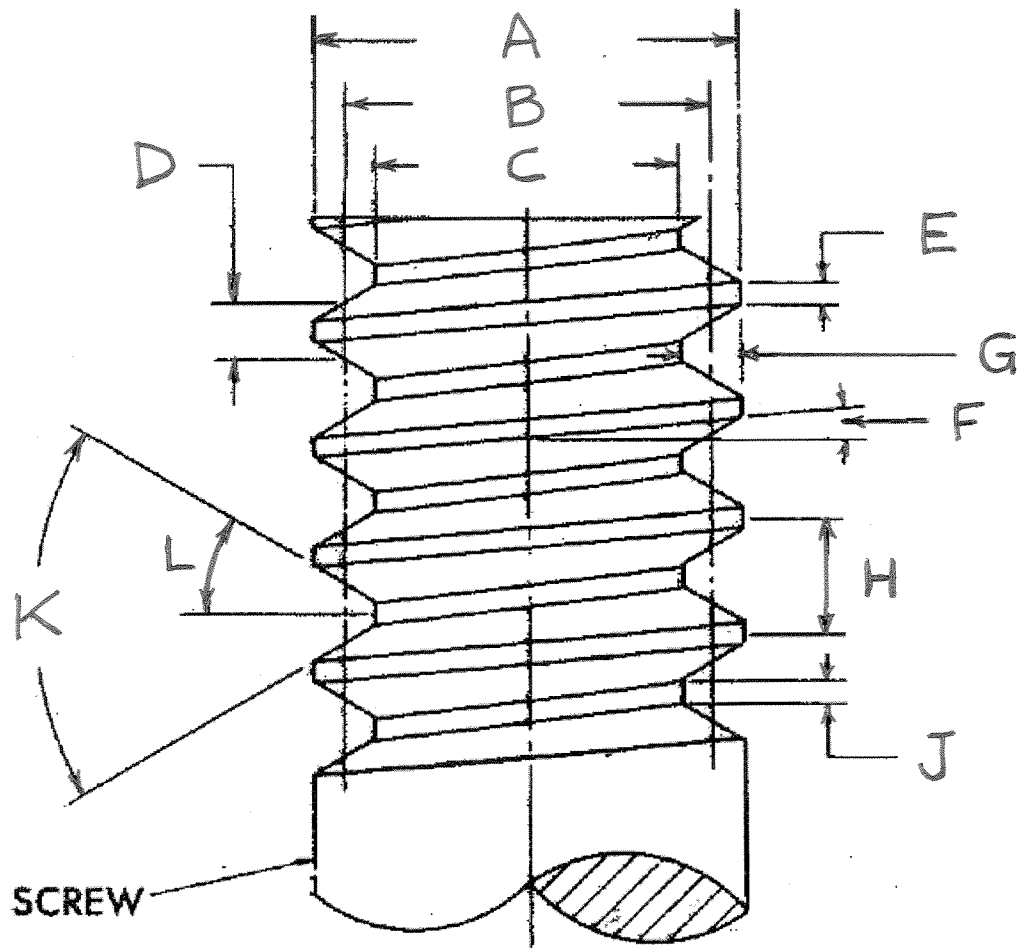

Fig. 6.2 Typical running traces on roller bearings





GS-0177



GS-0178

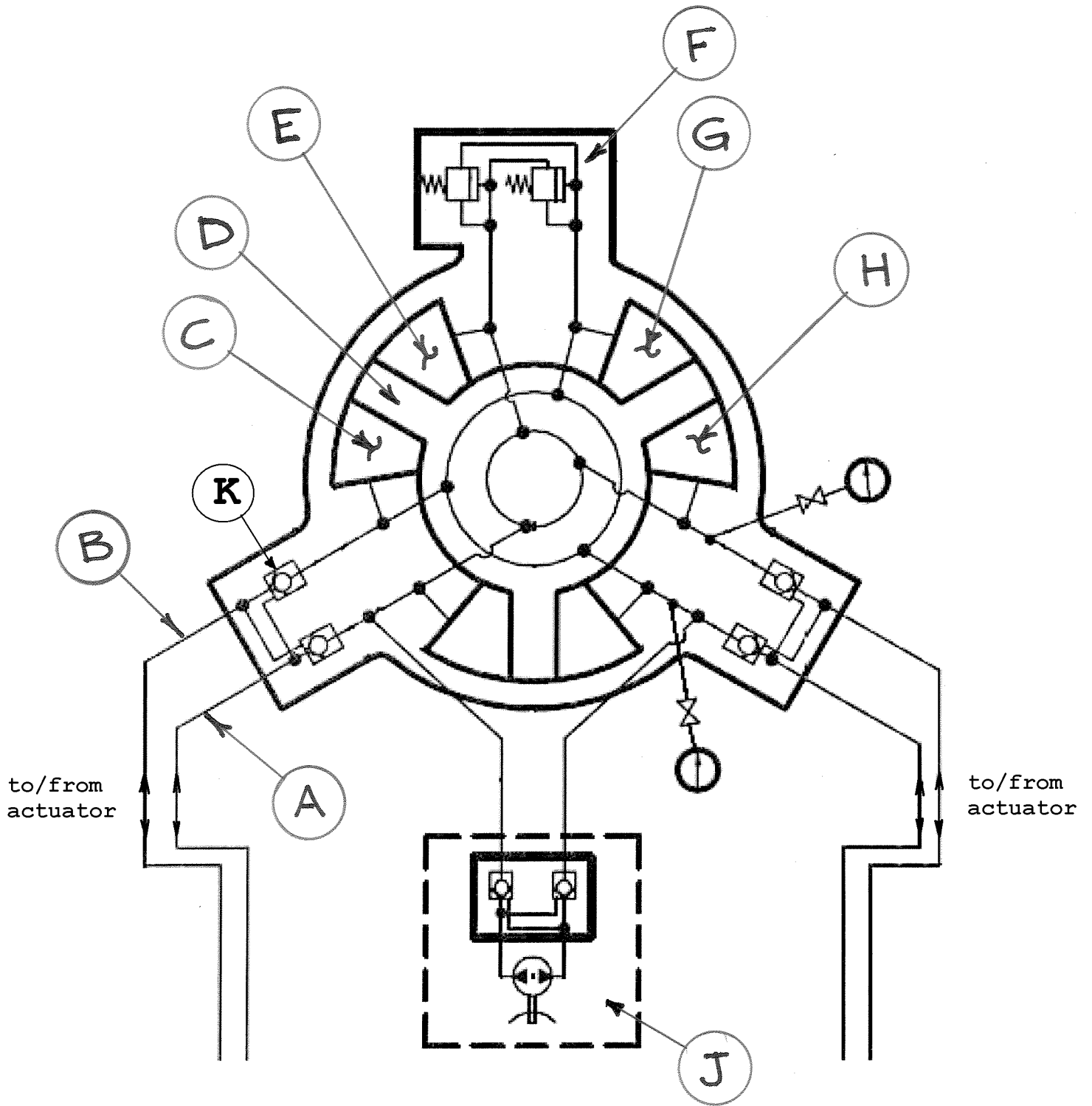

GS-0179

