

**SEVENTH QUARTERLY
TECHNICAL PROGRESS REPORT
(JANUARY, 1996 THROUGH MARCH, 1996)**

**BENCH-SCALE TESTING OF THE
MICRONIZED MAGNETITE PROCESS**

RECEIVED

NOV 26 1996

OSTI

**DOE Contract No. DE-AC22-93PC92206
Custom Coals International Project No. 94002**

DOE/PC/92206--T/3

AUGUST 13, 1996

Submitted To:

**Document Control Center
U.S. Department of Energy
Pittsburgh Energy Technology Center
Mail Stop 921-118, Wallace Road
P.O. Box 10940
Pittsburgh, PA 15236-0940**

Submitted By:

**Custom Coals Corporation
100 First Avenue, Suite 500
Pittsburgh, PA 15222
PH: (412) 642-2621
FX: (412) 642-2643**

MASTER

**RECEIVED
USDOE/PETC
56 AUG 16 AM 8:05
MANAGEMENT & ASSISTANCE DIV.**

DISTRIBUTION OF THIS DOCUMENT IS UNLIMITED

um

**CLEARED BY
PATENT COUNSEL**

DISCLAIMER

This report was prepared as an account of work sponsored by an agency of the United States Government. Neither the United States Government nor any agency thereof, nor any of their employees, makes any warranty, express or implied, or assumes any legal liability or responsibility for the accuracy, completeness, or usefulness of any information, apparatus, product, or process disclosed, or represents that its use would not infringe privately owned rights. Reference herein to any specific commercial product, process, or service by trade name, trademark, manufacturer, or otherwise does not necessarily constitute or imply its endorsement, recommendation, or favoring by the United States Government or any agency thereof. The views and opinions of authors expressed herein do not necessarily state or reflect those of the United States Government or any agency thereof.

DISCLAIMER

**Portions of this document may be illegible
in electronic image products. Images are
produced from the best available original
document.**

SEVENTH QUARTERLY TECHNICAL PROGRESS REPORT

TABLE OF CONTENTS

SECTION		<u>Page</u>
1	PROJECT DESCRIPTION	1
2	PROJECT OBJECTIVES	4
3	PROJECT SCHEDULE AND BUDGET	5
4	PROJECT TEAM ORGANIZATION	5
5	PROJECT ACCOMPLISHMENTS BY TASK SERIES	9
5.1	Task 100: Project Planning and Management (Months 1-16)	9
5.2	Task 200: Final Circuit Design (Months 1-2)	13
5.3	Task 300: Equipment Procurement And Fab. (Months 2-13)	13
5.4	Task 400: Magnetite and Coal Procurement (Months 7-13)	13
5.5	Task 500: Circuit Installation (Months 5-7)	22
5.6	Task 600: Circuit Commissioning (Month 8)	25
5.7	Task 700: Circuit Testing (Months 9-13)	27
5.8	Task 800: Analytical (Months 5-14)	53
5.9	Task 900: Circuit Decommissioning (Month 14)	54
5.10	Task 1000: Data Evaluation (Months 5-15)	54
5.11	Task 1100: Final Reporting (Months 15-16)	54
6	GOALS FOR NEXT QUARTERLY REPORTING PERIOD	55

FIGURES

FIGURE		<u>Page</u>
1	MicroMag Circuit Block Flow Diagram	2
2	MicroMag Project Schedule By Task	6
3	Project Team Organization Chart	8
4	MicroMag Project Work Breakdown Structure	10
5	MicroMag Project Detailed Schedule By Task & Schedule	11
6	MicroMag Circuit Block Flow Diagram	14
7	P&ID Drawing	15
8	Flowsheet Drawing	16
9	P&ID Drawing	24
10	Circuit Interface & Tie in Drawing	26

TABLES

TABLE		<u>Page</u>
1	Cost Plan	7
2	Project Reporting Requirements	12
3	Custom Coals Corporation MicroMag Project Equipment List	17
4	Micronized Magnetite Characteristics	19
5	Ground Raw Coal Size Analysis and Washability	20
6	Crushed Raw Coal Size Analysis and Washability	21
7	Classifying Circuit Commissioning Tests	29
8	Heavy-Media Cyclone Splits	30
9	Magnetite Losses	32
10	ASTM Standards for Coal Analytical Variances	33
11	Comparison of Coal Analyses	34
12	Wet-Splitting Results for Carpco Unit	35
13	Carpco Wet Splitter Test with Coal/Magnetite Slurry	37
14	Solids Densities	40
15	Davis-Tube and Moment Balances	41
16	Davis-Tube Separation Accuracy and Repeatability Testing	43
17	Magnetic Moment Measurement Reproducibility	44
18	QA/QC for On-Site Wet Screening	46
19	Duplicate Test Results	47
20	Duplicate Feed Sample Results	48
21	Marcy Balance Sensitivity Test Results	50
22	Reconstituted Grade-L Magnetite Comparison	51
23	Grade-L Magnetite Comparison	52
24	Comparison of Duplicate EMU Analysis	53

**SEVENTH QUARTERLY TECHNICAL PROGRESS REPORT
(January, 1996 Through March, 1996)**

**BENCH-SCALE TESTING OF THE
MICRONIZED MAGNETITE PROCESS**

DOE Contract No. DE-AC22-93PC92206
Custom Coals, Int. Project No. 94002

This document contains the Quarterly Technical Progress Report for the Micronized Magnetite Testing Project being performed at PETC's Process Research Facility (PRF). This seventh quarterly report covers the period from January, 1996 through March, 1996. No work was conducted on the Micro-mag Project this quarter since the project was placed on "hold" until August of 1996.

This report contains a short discussion of the project description, objectives, budget, schedule, and teaming arrangement. The final section contains an outline of the specific project goals for the next quarterly reporting period.

SECTION 1 - PROJECT DESCRIPTION

The major focus of the project, which is scheduled to occur through October 1996, is to install and test a 500#/hr. fine-coal cleaning circuit at DOE's Process Research Facility (PRF), located at the Pittsburgh Energy Technology Center (PETC). The circuit will utilize an extremely fine, micron-sized magnetite media and small diameter cyclones to make efficient density separations on minus-28-Mesh coal.

Figure 1 contains a block-flow diagram of the test circuit, which was installed at the PRF. The circuit consists of three subcircuits:

- **Classification Circuit** - Which consists of a feed sump and pump, a 2" Krebs Classifying Cyclone, and a 2'x 3' Sizetech Inclined Desliming Screen. The Classifying Cyclone is equipped with various orifices to make cuts (i.e., D-50) at 200M to perhaps as fine as 500M. The Desliming Screen has layered screen panels ranging from 100M to 325M. The Classification Circuit is fed 28M x 0 coal slurry from the existing PRF grinding circuit, and will remove the majority of the slimes prior to the heavy-media cycloning circuit.

Figure 1
 ET Circuit
 Block Flow Diagram
 (3 Subcircuits)

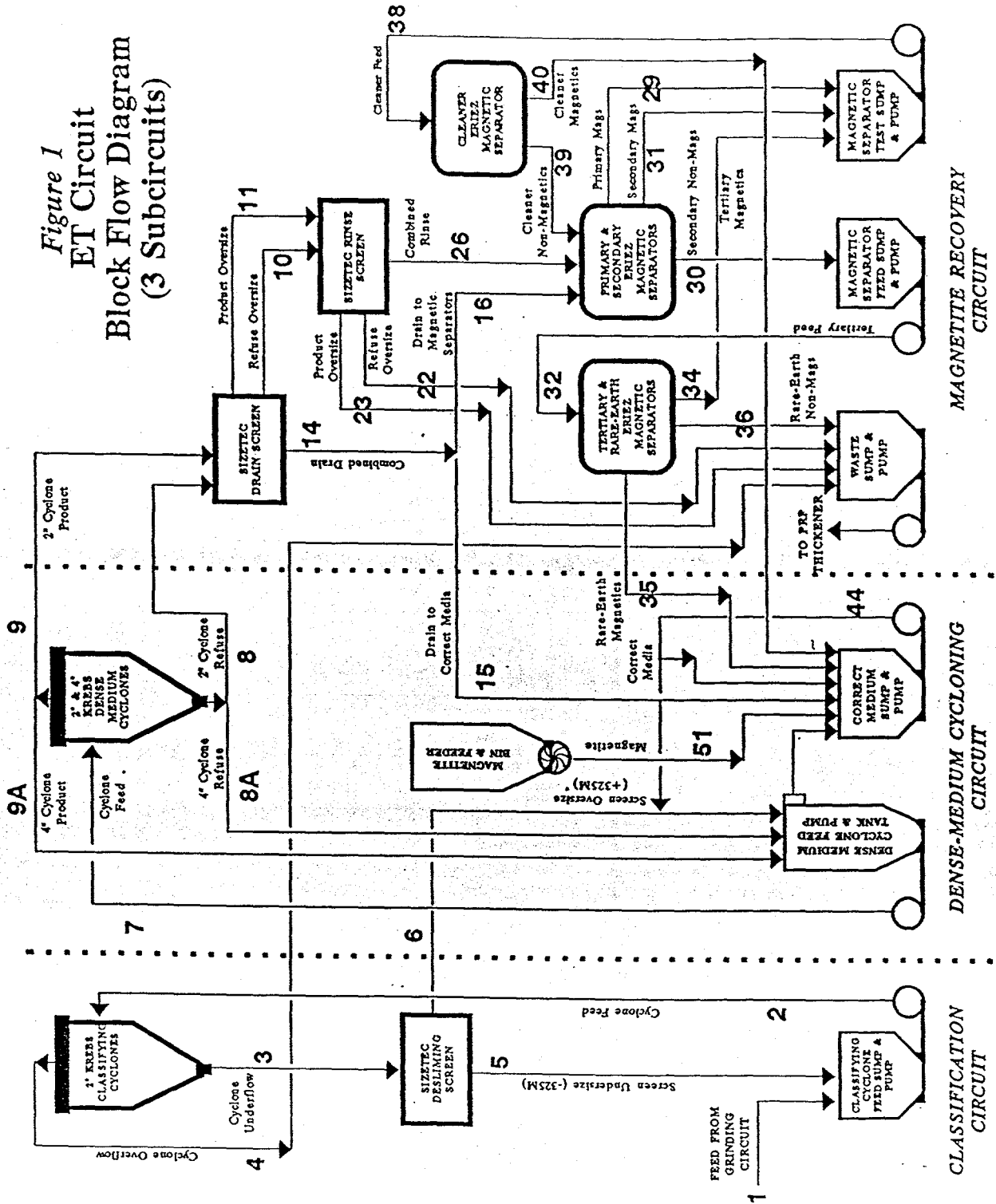

- **Dense-Medium Cycloning Circuit** - Which consists of a dense-medium cyclone feed, wing tank and feed pump, that overflows into a recirculating correct media sump and pump. Magnetite is added as required via a rotary air-lock feeder from a 0.5 ton magnetite bin. This subcircuit also consist of parallel-mounted Krebs 2" and 4" diameter Dense-Medium Cyclones. The 4" Cyclone products always recirculates back to the feed sump, and the 2" Cyclone products represents the feed to the Magnetite Recovery Circuit.
- **Magnetite Recovery Circuit** - Which consists of a 2'x3' Sizetec Inclined Desliming Screen (Drain Screen), and a 4'x 9' Sizetec Horizontal Dewatering Screen (Rinse Screen). These screens have screen panels Figure 1 MicroMag Circuit Block Flow Diagram ranging from 100M to 325M. The magnetite recovery circuit contains four 36"x24" Eriez Conventional, Wet-Drum Magnetic Separators (CLIMAXX Models), as the Primary, Secondary, Tertiary, and Cleaner Magnetic Separators. There is also an Eriez High Gauss, Rare-Earth Magnetic Separator (Concurrent Flow), which is used as a Scavenger Magnetic Separator in the circuit. The final magnetic concentrates return to the Correct Medium Sump, and the final non-magnetics tailing reports to the Waste Sump and Pump, along with the Classifying Cyclone Overflow and Rinse Screen Oversize (see Figure 1). The Waste Sump discharge is dewatered using the Sharples Centrifuge and Thickener in the existing PRF process water clarification circuit.

The circuit is contained in a new permanent structure, that Custom Coals has installed in the PRF Emerging Technology (ET) Area. In addition to the equipment shown in Figure 1, the ET circuit contains a Clarified Water Head Tank and Pump to provide all water additions to the circuit. A closed-loop system is utilized in the circuit. A Motor Control Center (MCC) in the PRF motor control room, and Control Cabinet (CC) in the field provides the power distribution to the circuit.

The testing scope involves initial closed-loop testing of each subcircuit to optimize the performance of the equipment in each subcircuit (i.e., Component Testing), followed by open-circuit testing of the entire integrated circuit to optimize the process and quantify the process efficiency (i.e., Integrated Testing). All equipment can be run in closed-loop, with the exception of the 2" Krebs Dense-Medium Cyclone and the Drain and Rinse Screens (see Figure 1).

SECTION 2 - PROJECT OBJECTIVES

The overall objectives of the project are to:

- Determine the effects of operating time on the characteristics of the recirculating medium in a continuous integrated processing circuit, and, subsequently, the sensitivity of cyclone separation performance to the quality of the recirculating medium.
- Determine the technical and economic feasibility of various unit operations and systems in optimizing the separation and recovery of the micronized magnetite from the coal products.

The specific technical objectives of the project are to:

- Establish the classifying circuit's operating conditions to make a separation at, or about 40 microns.
- Determine the effects of the magnetite particle size and medium purity on cyclone separation performance.
- Determine the effects of medium-to-coal ratio, medium density, feed pressure, and cyclone configuration on the separation efficiency of the cyclone. This testing is to verify whether cyclone separation performance equivalent to those produced in earlier research can be achieved and to determine the potential ranges of medium-to-coal ratios and medium densities expected for each cyclone product to help establish recovery circuit feed conditions.
- Quantify the amount and size of the magnetite not recovered by the individual and combined recovery circuit unit operations.
- Assess the technical and economic feasibility of various magnetite recovery circuits. Technically, the focus is on establishing the least complicated, easiest to operate circuit, that will provide the correct recirculating medium properties. Economically, determinations will be made looking at the trade offs between circuit capital and maintenance costs and overall system performance, including expected makeup magnetite requirements and cyclone separation efficiency.
- Determine the characteristics of the recirculating medium (purity and size distribution), and cyclone separation performance over time, during continuous, integrated testing of the entire circuit.

The Test, Sampling, and Analytical Plan was designed with these specific objectives in mind.

SECTION 3 - PROJECT SCHEDULE AND BUDGET

Figure 2 contains the original project schedule, by task series. The schedule in Figure 2, starts when Custom Coals began to actively work on the project (September 1994), and carries for a period of 17 months, until the scheduled completion in January 1996. The Major Milestone Tasks on the critical path contain asterisks. The project work scope and labor plan were discussed in detail in the Draft Work Plan, submitted in November, 1994.

Table 1 contains the 1996 Cost Plan estimate for the project. The upper part of the plan shows Custom Coals labor estimate, including markups. The plan incorporates Custom Coals' Project Manager, Ed Torak, working full-time on the project through October 1996. It also includes some time for other Custom Coal's personnel.

The lower part of the Cost Plan, in Table 1, shows the anticipated pass-through costs for subcontractors, as well as travel and equipment and supplies. A detailed description of the project subcontractors responsibilities and the items which have been purchased for the project are discussed in Sections 4 and 5 of this report.

SECTION 4 - PROJECT TEAM ORGANIZATION

Figure 3 contains the project team organization chart, for the project. The project team includes:

- DOE/PETC's project and site management personnel.
- Custom Coals' project and site management personnel.
- Parson's engineers and technicians to operate the existing PRF, during the circuit testing.
- H-Tech Corporation as a subcontractor to Custom Coals to procure all equipment required for the project.
- Dillner Storage as a subcontractor to Custom Coals to provide coal blending and storage services for the project.
- CLI Corporation as a subcontractor to Custom Coals to finalize the circuit design.
- Rizzo & Sons to install the circuit.

Figure 2
MICROMAG PROJECT SCHEDULE BY TASK
 (DOE Contract No. DE-AC22-93PC92206)

Revision Date: January 04, 1995

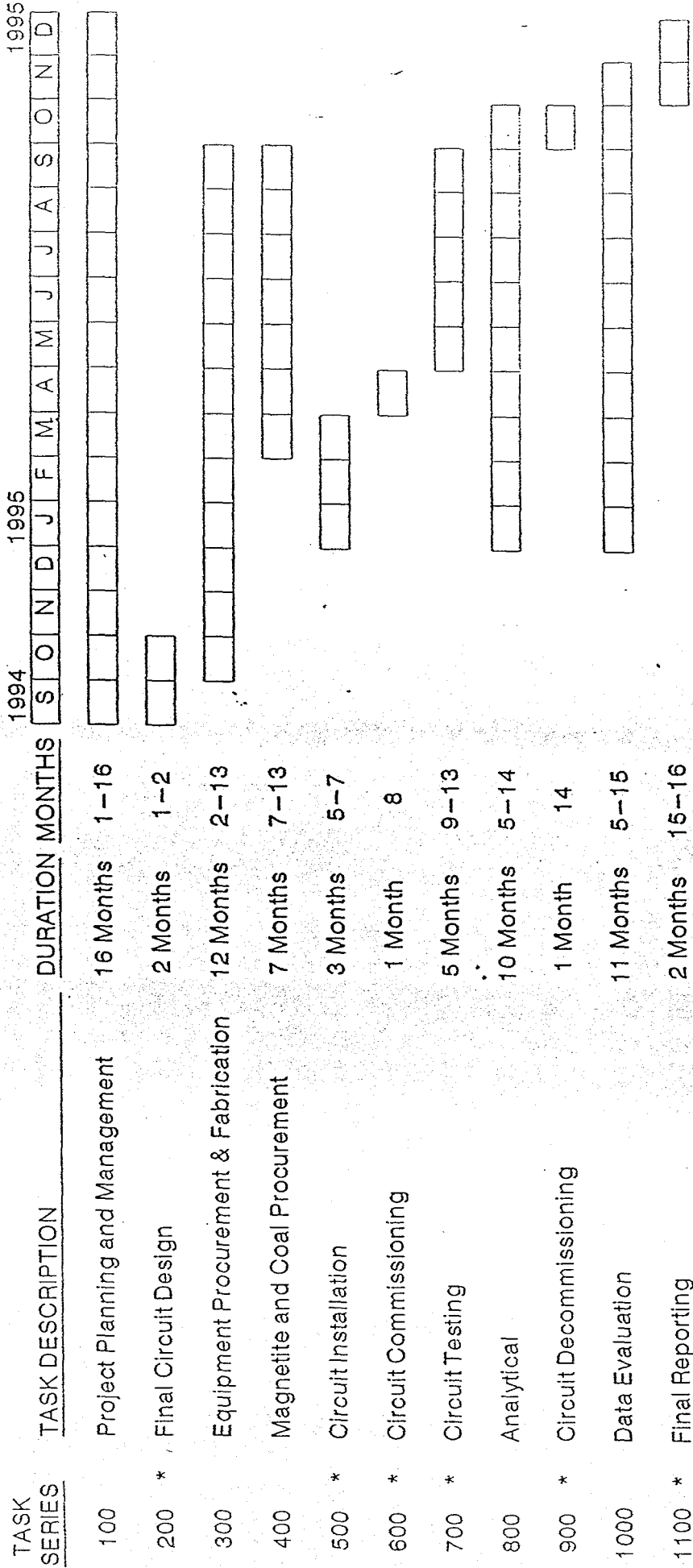

Notes: - * - Major Milestone Tasks on the Critical Path. We scheduled at least a 6-month period for Tasks 600 and 700.

Table 1
U.S. DEPARTMENT OF ENERGY
COST PLAN

1. TITLE		Bench-Scale Testing of the Micronized Magnetite Process												2. IDENTIFICATION NUMBER			
3. PARTICIPANT NAME		3. PARTICIPANT ADDRESS												DE-AC22-83PC92206			
Custom Coals, International		100 First Avenue, Suite 500 Pittsburgh, PA 15222												5. START DATE		6. COMPLETION DATE	
		CURRENT FISCAL YEAR												December 01, 1992		October 31, 1996	
7. ELEMENT CODE	8. REPORTING ELEMENT	CURRENT FISCAL YEAR												13. ADD. YEARS	14. TOTAL		
		9. PRIOR FISCAL YEARS	JAN	FEB	MAR	APR	MAY	JUN	JUL	AUG	SEP	OCT	NOV			DEC	
		PLAN	ACTUAL														
	Labor	126.9	122.9	0.7	1.7	1.7	0.3	0.0	0.0	0.0	0.0	0.0	8.5	8.5	0.0	0.0	152.8
	Fringe	69.6	55.2	0.3	0.7	0.7	0.1	0.0	0.0	0.0	0.0	0.0	3.3	3.3	0.0	0.0	66.9
	Overhead	61.6	50.6	0.3	0.8	0.8	0.1	0.0	0.0	0.0	0.0	0.0	2.7	2.7	0.0	0.0	60.7
	G&A	209.2	167.1	0.9	2.0	2.0	0.3	0.0	0.0	0.0	0.0	0.0	9.2	9.2	0.0	0.0	199.9
	Subtotal	467.3	395.8	2.2	5.2	5.2	0.8	0.0	0.0	0.0	0.0	0.0	23.7	23.7	0.0	0.0	480.3
	CUJ	100.4	99.8	0.0	0.0	0.0	0.0	0.0	0.0	0.0	0.0	0.0	0.0	0.0	0.0	0.0	99.8
	Engineer Sub	0.0	0.0	0.0	0.0	0.0	0.0	0.0	0.0	0.0	0.0	0.0	0.0	0.0	0.0	0.0	0.0
	Rizzo	160.0	139.5	0.0	0.0	0.0	0.0	0.0	0.0	0.0	0.0	0.0	0.0	0.0	0.0	0.0	139.5
	CT&E	71.0	71.9	5.2	2.8	0.0	0.0	0.0	0.0	0.0	0.0	0.0	0.0	0.0	0.0	0.0	79.9
	Many	125.0	103.6	0.0	0.0	0.0	2.5	0.0	0.0	0.0	3.0	0.0	24.4	0.0	0.0	0.0	133.5
	Dillner	6.0	8.0	0.0	0.1	1.1	0.7	0.0	0.6	0.1	0.0	0.0	0.0	0.0	0.0	0.0	10.6
	H-Tech	7.7	7.6	0.0	0.0	0.0	0.0	0.0	0.0	0.0	0.0	0.0	0.0	0.0	0.0	0.0	7.6
	Equipment	290.0	259.3	0.0	0.0	0.0	0.0	0.0	0.0	0.0	0.0	0.0	0.0	0.0	0.0	0.0	259.3
	Supplies	10.4	12.1	0.0	0.0	0.2	0.0	0.0	0.0	0.0	0.0	0.0	0.0	0.0	0.0	0.0	12.3
	Coal	6.0	3.4	0.0	0.0	0.0	0.0	0.0	0.0	0.0	0.0	0.0	0.0	0.0	0.0	0.0	3.4
	Magnetite	5.0	16.8	0.0	0.0	0.0	0.0	0.0	0.0	0.0	0.0	0.0	0.0	0.0	0.0	0.0	16.8
	Travel	14.7	18.1	0.0	0.0	1.1	1.3	0.0	0.0	0.0	0.0	0.0	0.0	0.0	0.0	0.0	20.5
	TOTAL	1263.5	1135.9	7.4	8.1	7.6	5.3	0.0	0.6	3.1	23.7	48.1	23.7	0.0	0.0	0.0	1263.5
	15. TOTAL CUMULATIVE	1,135.9	1,143.3	1,151.4	1,159.0	1,164.3	1,164.3	1,164.9	1,168.0	1,191.7	1,239.8	1,263.5	1,263.5	1,263.5	1,263.5	1,263.5	1,263.5
	16. DOLLARS EXPRESSED IN:	17. SIGNATURE OF PARTICIPANT'S PROJECT MANAGER AND DATE												18. SIGNATURE OF PARTICIPANT'S FINANCIAL REP. AND DATE			
	Thousands	<i>Ed R. B.</i> 01/10/96															

Figure 3 - PROJECT TEAM ORGANIZATION CHART

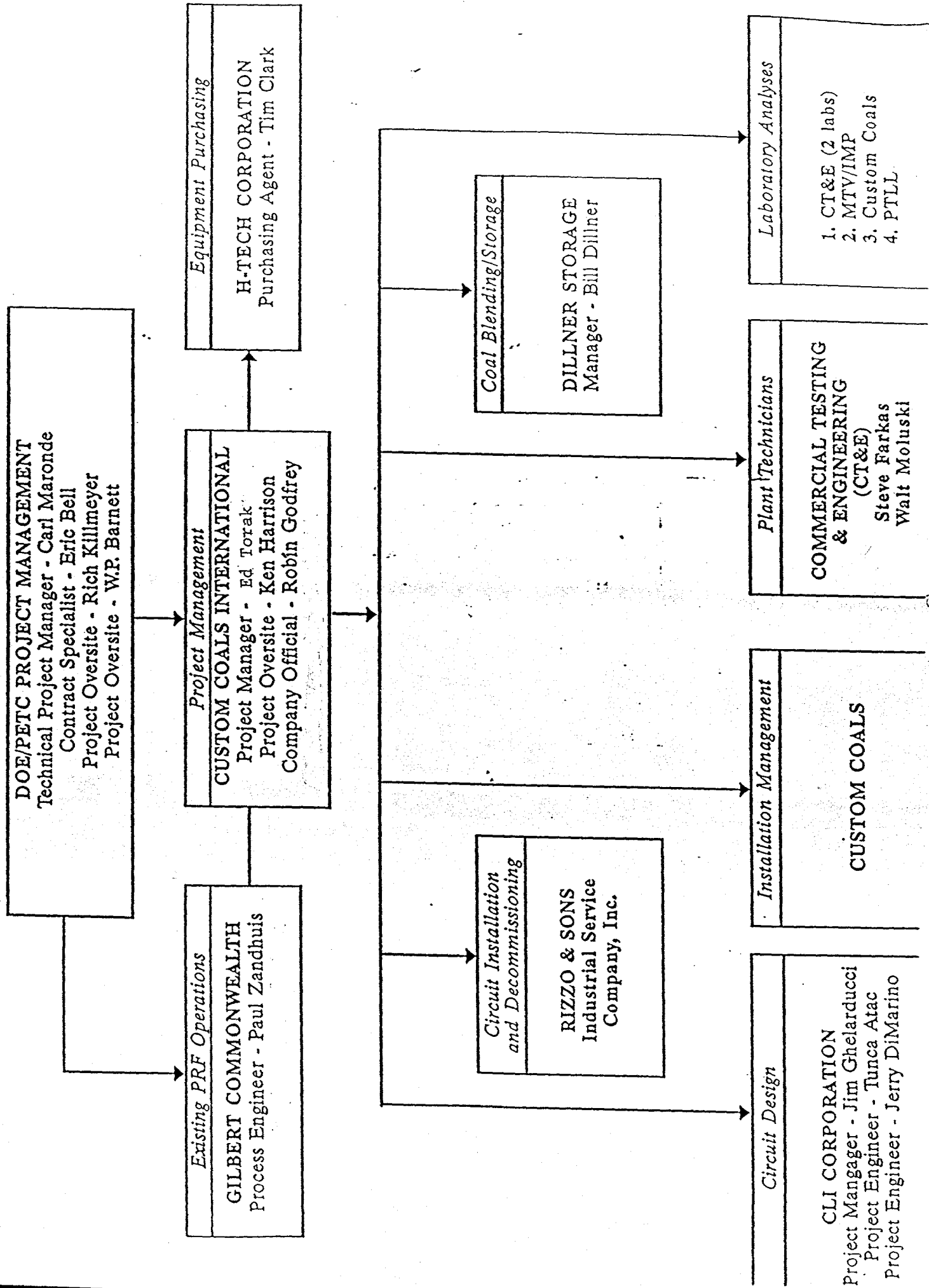

Custom Coals also performed a number of the more routine sample preparation and analytical procedures at the PRF site (ie., wet screening, coal sample filtering, preparation, pulverizing, and ashing).

All required subcontracts for the project are in place, and merely need to be managed, modified, and updated as the project testing scope evolves.

SECTION 5 - PROJECT ACCOMPLISHMENTS BY TASK SERIES

Figure 4 contains the work breakdown structure by major task, and minor subtask, for the project. Task 100 "Project Planning and Management" encompasses all the routine reporting requirements, as well as the special plans and reports that must be submitted for the project.

Figure 5 contains the detailed schedule, broken down by the subtasks within the work breakdown structure. The schedule is divided into approximately two week periods (ie., twice monthly), to allow for tighter specifications of document submission and task completion dates. Custom Coals plans to include Figure 5 in each Monthly and Quarterly Technical Progress Report to compare actual accomplishments to this initial schedule. This will be one of the main methods of controlling and monitoring the schedule and success of the project.

Section 5.1 - Task 100: Project Planning and Management (Months 1-16)

Custom Coals anticipates that the project manager, Ed Torak, will work full-time on the project through submission of the draft final report (end of September 1996). He will be responsible for on-site project management, and will also be responsible for all project reporting.

Table 2 shows the major project reporting requirements, with required frequencies and delivery dates for all documents. The table is broken down into 3 categories, which include:

- Routine Financial Reporting Requirements,
- Routine Technical Reporting Requirements, and
- Special Technical Reporting Requirements, submitted only once during the project.

During October, Custom Coal's Project Manager submitted a paper on the Micro-Mag project for publication and presentation at the SME Conference in Phoenix, Arizona.

Figure 4
MICROMAG PROJECT
WORK BREAKDOWN STRUCTURE
(DOE Contract No. DE-AC22-93PC92206)

TASK	TASK DESCRIPTION
100	PROJECT PLANNING AND MANAGEMENT
	101 Management Plan
	102 Work Plan (ESH & QA/QC)
	103 Design Report (Two SSA's)
	104 Procurement and Fabrication Plan
	105 Installation and Shakedown Plan
	106 Coal Proc., Handling, & Logistics Plan
	107 Operation and Maintenance Manual (SOP's)
	108 Slurry Commissioning Plan
	109 Test, Sampling, and Analytical Plan (QA/QC)
200	FINAL CIRCUIT DESIGN
	201 Finalize Flowsheet and P&ID
	202 Finalize Design Drawings
300	EQUIPMENT PROCUREMENT & FABRICATION
	301 Process Equipment Procurement
	302 Structural Steel Fab. & Procurement
	303 Platework Steel Fab. & Procurement
	304. Electrical Equipment Procurement
	305 Ancillary Equipment Procurement
	306 Laboratory Equipment Procurement
	307 Operating Supplies Procurement
400	MAGNETITE AND COAL PROCUREMENT
	401 Magnetite Procurement
	402 Coal Procurement
500	CIRCUIT INSTALLATION
	501 Primary Installation
	502 Piping Installation
	503 Electrical Installation
600	CIRCUIT COMMISSIONING
	601 Functionality and Leak Testing
	602 Water Commissioning
	603 Slurry Commissioning
700	CIRCUIT TESTING
	701 Component Testing (Coal #1)
	702 Integrated Testing (Coal #1)
	703 Component Testing (Coal #2)
	704 Integrated Testing (Coal #2)
800	ANALYTICAL
	801 Preliminary Magnetite/Coal Testing
	802 Circuit Testing Analytical
900	CIRCUIT DECOMMISSIONING
1000	DATA EVALUATION
1100	FINAL REPORTING

Figure 5
 MICROMAG PROJECT
 DETAILED SCHEDULE BY TASK & SUBTASK
 (DOE Contract No. DE-AC22-93PC92206)

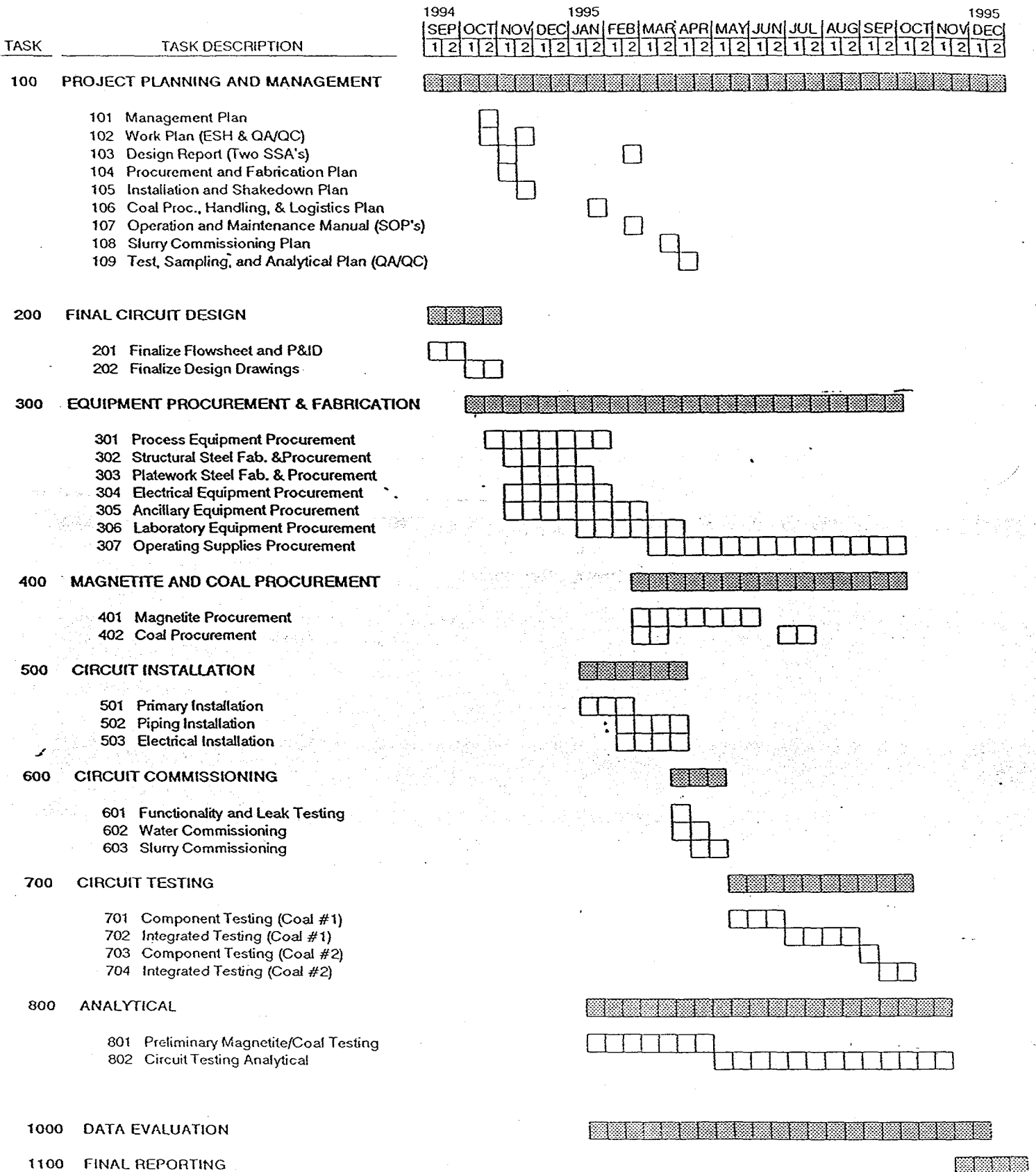

Table 2
PROJECT REPORTING REQUIREMENTS

I. Routine Financial Reporting Requirements:

Description	Frequency	Variance
1. Project Invoice	Monthly	+ 10 Days
2. Cost Management Report (Form)	Monthly	+ 10 Days
3. Summary Report (Form)	Monthly	+ 10 Days
4. Financial Summary Report	Monthly	+ 10 Days

II. Routine Technical Reporting Requirements:

Description	Frequency	Variance
1. Schedule/Status Sheet (On-Site Activities)	Weekly	Every Friday
2. Milestone Schedule/Status Report (Form)	Monthly	+ 10 Days
3. Technical Status Report	Monthly	+ 10 Days
4. Key Personnel Staffing Report	Quarterly	+ 30 Days
5. Technical Progress Report	Quarterly	+ 30 Days
6. Property Reports	Yearly & Semi-Annual	+ 30 Days

III. Special Technical Reporting Requirements:

Description	Frequency	Variance
1. Management Plan	October 31, 1994	November 15, 1994
2. Draft Work Plan (ESH & QA/QC Plans)	October 31, 1994	November 15, 1995
3. Final Work Plan (ESH & QA/QC Plans)	January 01, 1995	January 15, 1995
4. Draft ET Circuit Design Report (two SSA's)	November 15, 1994	November 30, 1994
5. Final ET Circuit Design Report (two SSA's)	February 15, 1995	March 15, 1995
6. Procurement and Fabrication Plan	November 15, 1994	November 30, 1994
7. Installation and Shakedown Plan	November 30, 1994	December 15, 1994
8. Coal Procurement, Handling, and Logistics Plan	January 31, 1995	February 15, 1995
9. Operation and Maintenance Manual (SOP's)	February 28, 1995	March 15, 1995
10. Slurry Commissioning Plan	March 31, 1995	April 15, 1995
11. Test, Sampling, and Analytical Plan (QA/QC)	April 15, 1995	April 30, 1995
12. Draft Final Report	September 30, 1996	October 15, 1996
13. Final Report	October 31, 1996	-

Section 5.2 - Task 200: Final Circuit Design (Months 1-2)

Custom Coal's subcontracted CLI Corporation to perform the final design of the ET Circuit. During the period from September through November, 1994, CLI completed the design package, and assisted Custom Coals' Project Manager in preparing the bid specification for the circuit installation. In essence, the Circuit Design Task was completed prior to the third quarterly reporting period. CLI's only efforts were to update the P&ID in late March to reflect the actual flowsheet of the as-built circuit.

Figure 6 contains the general flowsheet, including the major equipment and flow streams. Figures 7 and 8 contain the final detailed P&ID and Flowsheet Drawings, respectively. Those drawings specify all equipment and the flow balance, and include all ancillary items (ie., piping, valves, and instrumentation).

Section 5.3 - Task 300: Equipment Procurement and Fabrication (Months 2-13)

For organizational purposes, the equipment and procurement and fabrication task was broken down into a number of subtasks (see Figure 5), which include:

- 301 - Process Equipment Procurement
- 302 - Structural Steel Fabrication and Procurement
- 303 - Platework Steel Fabrication and Procurement
- 304 - Electrical Equipment Procurement
- 305 - Ancillary Equipment Procurement
- 306 - Laboratory Equipment Procurement
- 307 - Operating Supplies Procurement

Table 3 contains the equipment list and cost estimate, for all items purchased to date. All of the major equipment was ordered during the second quarterly reporting period. It was delivered to site on the last week of January, 1995. All of the laboratory equipment and project supplies were ordered during the third reporting period.

The cost estimate, at the bottom of Table 3, of approximately \$258K, committed thus far, for purchases and shipping is still well below the revised equipment and supplies budget of \$300K, in the revised cost plan (see Table 1).

Section 5.4 - Task 400: Magnetite and Coal Procurement (Months 7-13)

The two major test materials for the project are the magnetite media and the test coals. Custom Coal's is testing 3 grades of magnetites and 2 types of bituminous coals, during the circuit testing. A detailed discussion of the coal and magnetite issues was presented in the Coal and Magnetite Procurement, Handling, and Logistics Plan, submitted in late January.

Figure 6
MicroMag Circuit
Block Flow Diagram
(3 Subcircuits)

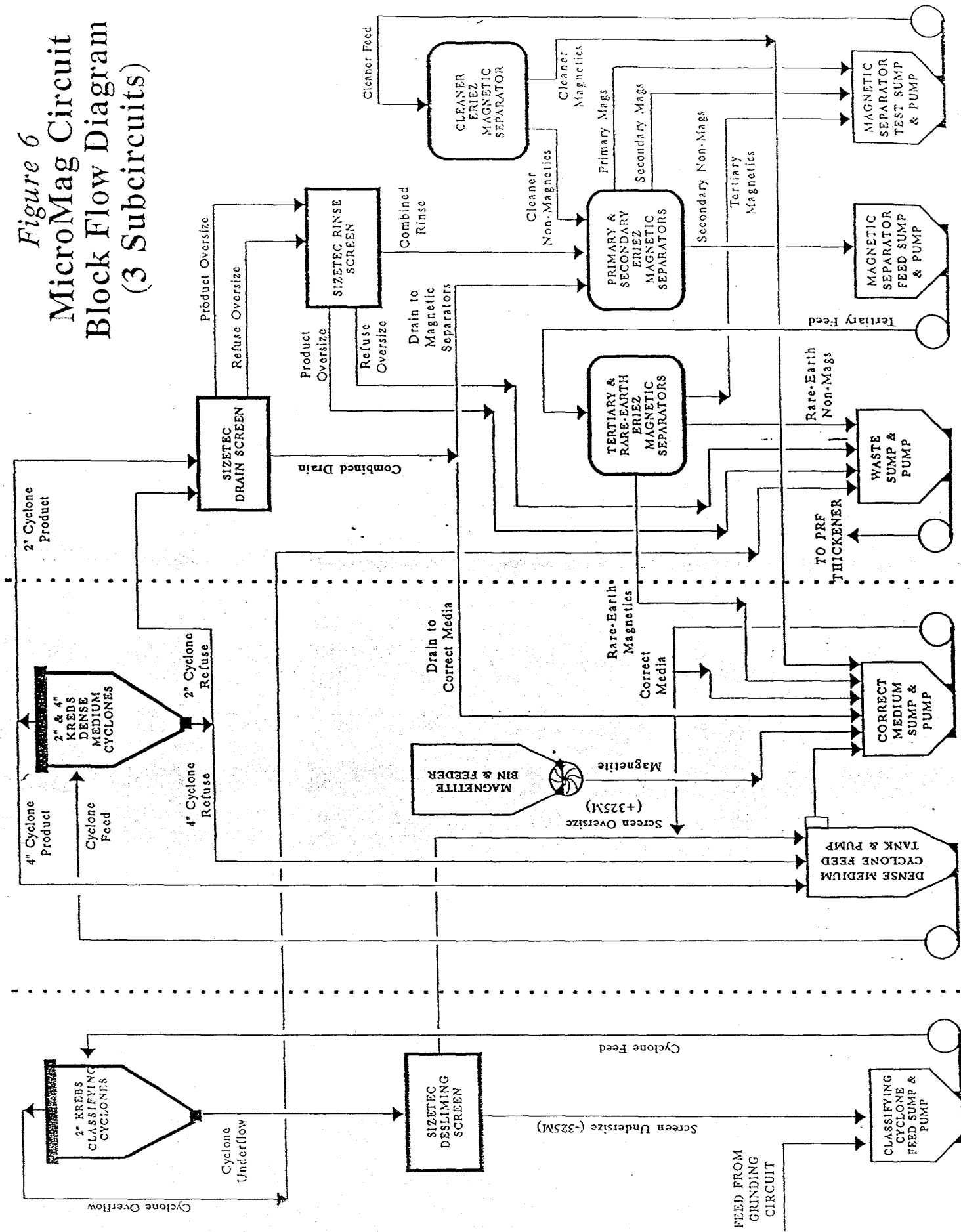

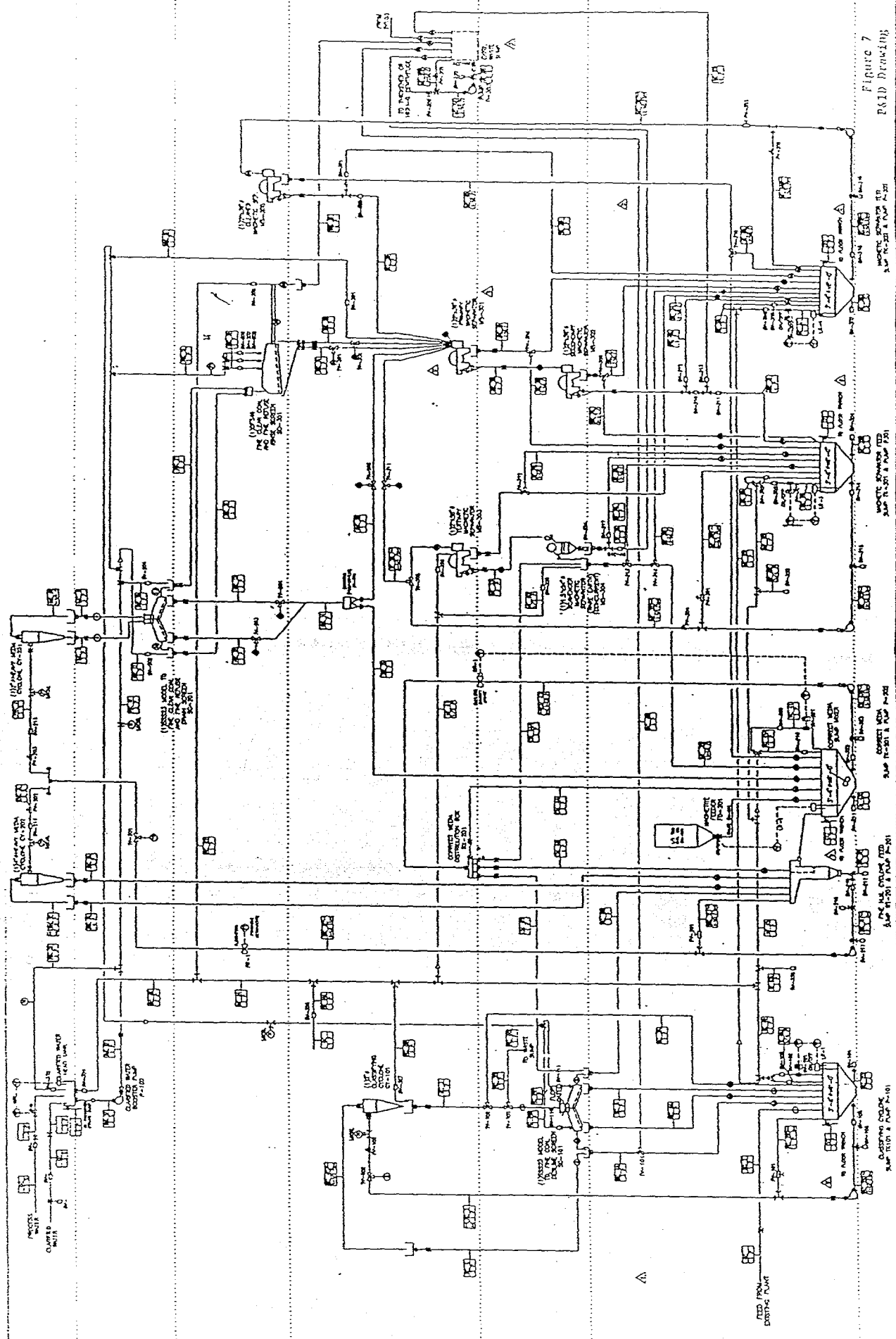
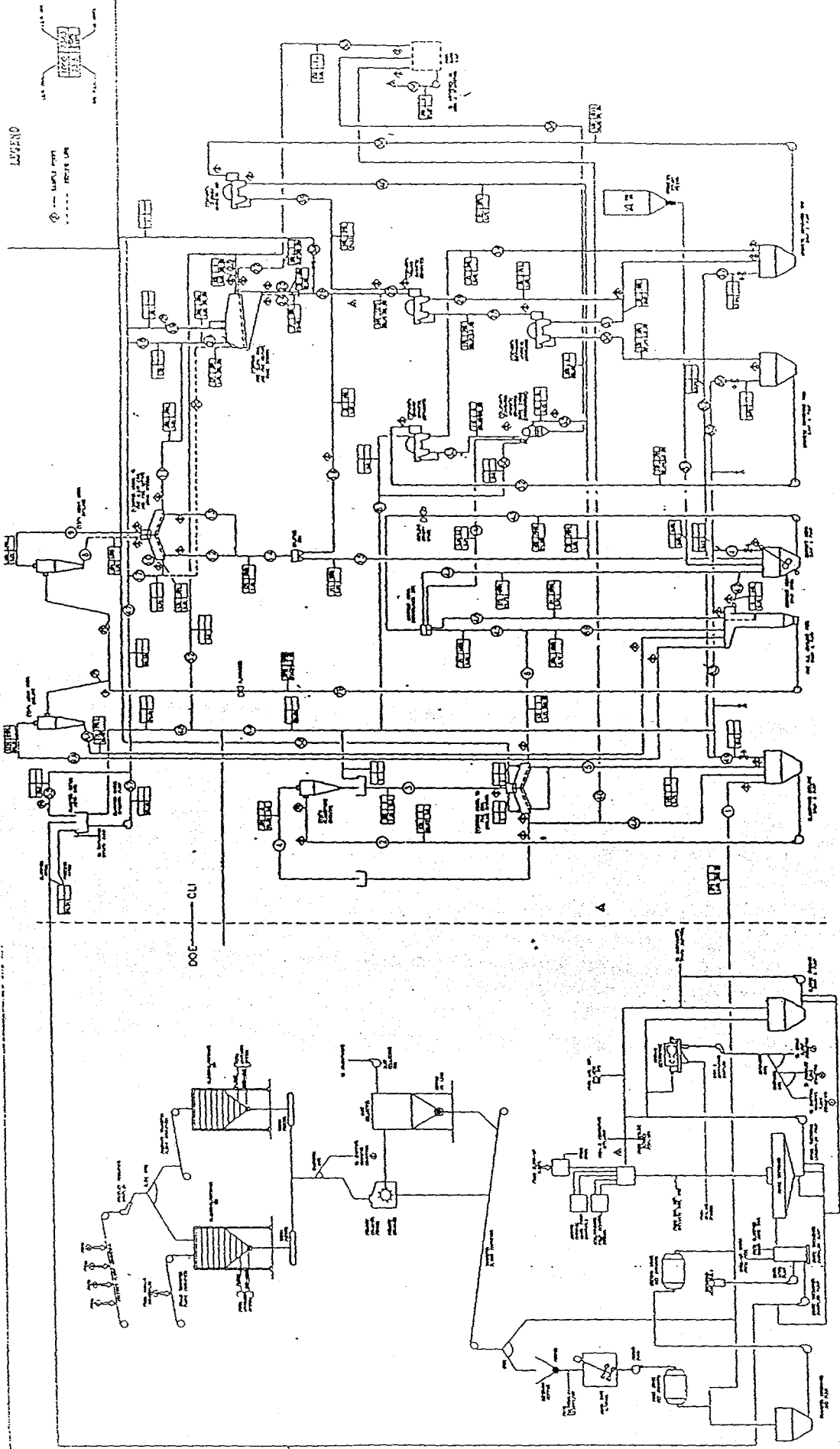

Figure 7
Rapid Drawing

PHOTOGRAPHY CENTER
US DEPT. OF ENERGY - PHOTODUPLICATION SERVICE
MICROFILM PROCESS R & D DIVISION
PITTSBURGH, PENNSYLVANIA 15223

15
WATER STORAGE TANK NO. 1
WATER STORAGE TANK NO. 2
WATER STORAGE TANK NO. 3
WATER STORAGE TANK NO. 4
WATER STORAGE TANK NO. 5
WATER STORAGE TANK NO. 6
WATER STORAGE TANK NO. 7
WATER STORAGE TANK NO. 8
WATER STORAGE TANK NO. 9
WATER STORAGE TANK NO. 10
WATER STORAGE TANK NO. 11
WATER STORAGE TANK NO. 12
WATER STORAGE TANK NO. 13
WATER STORAGE TANK NO. 14
WATER STORAGE TANK NO. 15
WATER STORAGE TANK NO. 16
WATER STORAGE TANK NO. 17
WATER STORAGE TANK NO. 18
WATER STORAGE TANK NO. 19
WATER STORAGE TANK NO. 20
WATER STORAGE TANK NO. 21
WATER STORAGE TANK NO. 22
WATER STORAGE TANK NO. 23
WATER STORAGE TANK NO. 24
WATER STORAGE TANK NO. 25
WATER STORAGE TANK NO. 26
WATER STORAGE TANK NO. 27
WATER STORAGE TANK NO. 28
WATER STORAGE TANK NO. 29
WATER STORAGE TANK NO. 30
WATER STORAGE TANK NO. 31
WATER STORAGE TANK NO. 32
WATER STORAGE TANK NO. 33
WATER STORAGE TANK NO. 34
WATER STORAGE TANK NO. 35
WATER STORAGE TANK NO. 36
WATER STORAGE TANK NO. 37
WATER STORAGE TANK NO. 38
WATER STORAGE TANK NO. 39
WATER STORAGE TANK NO. 40
WATER STORAGE TANK NO. 41
WATER STORAGE TANK NO. 42
WATER STORAGE TANK NO. 43
WATER STORAGE TANK NO. 44
WATER STORAGE TANK NO. 45
WATER STORAGE TANK NO. 46
WATER STORAGE TANK NO. 47
WATER STORAGE TANK NO. 48
WATER STORAGE TANK NO. 49
WATER STORAGE TANK NO. 50
WATER STORAGE TANK NO. 51
WATER STORAGE TANK NO. 52
WATER STORAGE TANK NO. 53
WATER STORAGE TANK NO. 54
WATER STORAGE TANK NO. 55
WATER STORAGE TANK NO. 56
WATER STORAGE TANK NO. 57
WATER STORAGE TANK NO. 58
WATER STORAGE TANK NO. 59
WATER STORAGE TANK NO. 60
WATER STORAGE TANK NO. 61
WATER STORAGE TANK NO. 62
WATER STORAGE TANK NO. 63
WATER STORAGE TANK NO. 64
WATER STORAGE TANK NO. 65
WATER STORAGE TANK NO. 66
WATER STORAGE TANK NO. 67
WATER STORAGE TANK NO. 68
WATER STORAGE TANK NO. 69
WATER STORAGE TANK NO. 70
WATER STORAGE TANK NO. 71
WATER STORAGE TANK NO. 72
WATER STORAGE TANK NO. 73
WATER STORAGE TANK NO. 74
WATER STORAGE TANK NO. 75
WATER STORAGE TANK NO. 76
WATER STORAGE TANK NO. 77
WATER STORAGE TANK NO. 78
WATER STORAGE TANK NO. 79
WATER STORAGE TANK NO. 80
WATER STORAGE TANK NO. 81
WATER STORAGE TANK NO. 82
WATER STORAGE TANK NO. 83
WATER STORAGE TANK NO. 84
WATER STORAGE TANK NO. 85
WATER STORAGE TANK NO. 86
WATER STORAGE TANK NO. 87
WATER STORAGE TANK NO. 88
WATER STORAGE TANK NO. 89
WATER STORAGE TANK NO. 90
WATER STORAGE TANK NO. 91
WATER STORAGE TANK NO. 92
WATER STORAGE TANK NO. 93
WATER STORAGE TANK NO. 94
WATER STORAGE TANK NO. 95
WATER STORAGE TANK NO. 96
WATER STORAGE TANK NO. 97
WATER STORAGE TANK NO. 98
WATER STORAGE TANK NO. 99
WATER STORAGE TANK NO. 100

LEGEND:
 1.8 RECORD LINE
 1.9 MAIN LINE
 2.0 FEED LINE
 2.1 BRANCH LINE
 2.2 WASTE LINE
 2.3 WASTE LINE
 2.4 WASTE LINE
 2.5 WASTE LINE
 2.6 WASTE LINE
 2.7 WASTE LINE
 2.8 WASTE LINE
 2.9 WASTE LINE
 3.0 WASTE LINE
 3.1 WASTE LINE
 3.2 WASTE LINE
 3.3 WASTE LINE
 3.4 WASTE LINE
 3.5 WASTE LINE
 3.6 WASTE LINE
 3.7 WASTE LINE
 3.8 WASTE LINE
 3.9 WASTE LINE
 4.0 WASTE LINE
 4.1 WASTE LINE
 4.2 WASTE LINE
 4.3 WASTE LINE
 4.4 WASTE LINE
 4.5 WASTE LINE
 4.6 WASTE LINE
 4.7 WASTE LINE
 4.8 WASTE LINE
 4.9 WASTE LINE
 5.0 WASTE LINE
 5.1 WASTE LINE
 5.2 WASTE LINE
 5.3 WASTE LINE
 5.4 WASTE LINE
 5.5 WASTE LINE
 5.6 WASTE LINE
 5.7 WASTE LINE
 5.8 WASTE LINE
 5.9 WASTE LINE
 6.0 WASTE LINE
 6.1 WASTE LINE
 6.2 WASTE LINE
 6.3 WASTE LINE
 6.4 WASTE LINE
 6.5 WASTE LINE
 6.6 WASTE LINE
 6.7 WASTE LINE
 6.8 WASTE LINE
 6.9 WASTE LINE
 7.0 WASTE LINE
 7.1 WASTE LINE
 7.2 WASTE LINE
 7.3 WASTE LINE
 7.4 WASTE LINE
 7.5 WASTE LINE
 7.6 WASTE LINE
 7.7 WASTE LINE
 7.8 WASTE LINE
 7.9 WASTE LINE
 8.0 WASTE LINE
 8.1 WASTE LINE
 8.2 WASTE LINE
 8.3 WASTE LINE
 8.4 WASTE LINE
 8.5 WASTE LINE
 8.6 WASTE LINE
 8.7 WASTE LINE
 8.8 WASTE LINE
 8.9 WASTE LINE
 9.0 WASTE LINE
 9.1 WASTE LINE
 9.2 WASTE LINE
 9.3 WASTE LINE
 9.4 WASTE LINE
 9.5 WASTE LINE
 9.6 WASTE LINE
 9.7 WASTE LINE
 9.8 WASTE LINE
 9.9 WASTE LINE
 10.0 WASTE LINE



NO.	DESCRIPTION	UNIT	QTY.	REMARKS
1
2
3
4
5
6
7
8
9
10
11
12
13
14
15
16
17
18
19
20
21
22
23
24
25
26
27
28
29
30
31
32
33
34
35
36
37
38
39
40
41
42
43
44
45
46
47
48
49
50

NO.	DESCRIPTION	UNIT	QTY.	REMARKS
1
2
3
4
5
6
7
8
9
10
11
12
13
14
15
16
17
18
19
20
21
22
23
24
25
26
27
28
29
30
31
32
33
34
35
36
37
38
39
40
41
42
43
44
45
46
47
48
49
50

Figure 8
Process Drawing

PROJECT NO. 1000
 SHEET NO. 1000
 DATE: 10/1/50
 DRAWN BY: J. M. ...
 CHECKED BY: ...

Table 3
CUSTOM COALS CORPORATION
MICROMAG PROJECT EQUIPMENT LIST
(DOE CONTRACT NO. DE-AC22-93PC92206)

Revision Date: June 13, 1995

Unit Number	Unit Description	Equip. Number	Manufacturer	Equipment Description	Motor HP	Weight Lbs	Total Cost	Vendor	FOB Location	Est. Del. Weeks	Est. Shpg Cost
1001	Classifying Cyclone Feed Pump	P-101	Gould	1'x1.5'x11" w/ VS 1350/1800 RPM	15	600	4160	Buckley Ass., Pitts.	Ashland, PA	6	0
1002	Heavy Media Feed Pump	P-201	Gould	1.5'x2'x14" w/ VS 1040/1640 RPM	40	1100	8065	Buckley Ass., Pitts.	Ashland, PA	6	0
1003	Correct Media Pump	P-202	Gould	1'x1.5'x8" w/ VS 1150 RPM (@ PETC)	3	450	317	Buckley Ass., Pitts.	Ashland, PA	6	0
1004	Magnetic Separator Feed Pump	P-301	Gould	1'x1.5'x8" w/ VS 1170 RPM (@ PETC)	5	490	564	Buckley Ass., Pitts.	Ashland, PA	6	0
1005	Magnetic Separator Test Pump	P-302	Gould	1'x1.5'x8" w/ VS 1455 RPM	5	540	3787	Buckley Ass., Pitts.	Ashland, PA	6	0
1006	Spray Water Pump and Repairs	P-102	Gould	1.5'x2'x6" w/ DC 3500 RPM	5	250	537	AT PETC	---	---	0
1007	Waste Pump	P-303	Gould	1.5'x2'x8" w/ VS 1160 RPM	5	500	4041	Buckley Ass., Pitts.	Ashland, PA	6	50
1008	Deslime Screen	SC-101	Sizetec	SSS 2315TD 2x2'x3'	8/8,5	1415	11175	Sizetec, Inc.	Canton, OH	10-12	432
1009	Drain Screen	SC-201	Sizetec	SSS 2315TD 2x2'x3'	8/8,5	1415	11175	Sizetec, Inc.	Canton, OH	10-12	0
1010	Rinse Screen	SC-301	Sizetec	DSF 48 F 2x2'x8'	2/2	4196	3200	Sizetec, Inc.	Canton, OH	10-12	0
1011	325M Layered Screen Panels	SC----	Sizetec	2'x3'x1" Frame (10@\$320)	---	10	2217	Sizetec, Inc.	Canton, OH	1	0
1012	100M Layered Screen Panels	SC----	Sizetec	2'x3'x1" Frame (6@\$273)	---	10	1638	Sizetec, Inc.	Canton, OH	1	51
1013	200M Layered Screen Panels	SC----	Sizetec	2'x3'x1" Frame (6@\$286)	---	10	1716	Sizetec, Inc.	Canton, OH	1	0
1014	90 Micron Profile Wire Screen Panels	SC----	Sizetec	2'x3'x1" Frame (2@\$604 & 1@\$393)	---	30	1601	Sizetec, Inc.	Canton, OH	4	0
1015	2" Classifying Cyclone	CY-101	Krebs	PC2-1424 w/ 1 FI, 3 VF, & 3 AP	---	40	766	Krebs Engineers	Menlo Park, CA	8	0
1016	4" Heavy Media Cyclone	CY-201	Krebs	PC2-1424 w/ 2 FI, 3 VF, & 3 AP	---	40	1051	Krebs Engineers	Menlo Park, CA	8	0
1017	Primary Magnetic Separator	MS-201	Eriez	D4B w/ 2 FI, 3 VF, & 3 AP	---	100	2470	Krebs Engineers	Menlo Park, CA	8	120
1018	Secondary Magnetic Separator	MS-301	Eriez	CLIMAXX Wet Drum 36" x 24"	3	1250	12050	Eriez Magnetics	Erie, PA	9-12	800
1019	Tertiary Magnetic Separator	MS-302	Eriez	CLIMAXX Wet Drum 36" x 24"	3	1250	12050	Eriez Magnetics	Erie, PA	9-12	0
1020	Cleaner Magnetic Separator	MS-303	Eriez	CLIMAXX Wet Drum 36" x 24"	3	1250	12050	Eriez Magnetics	Erie, PA	9-12	0
1021	Scavenger Magnetic Separator	MS-305	Eriez	Rare Earth Wet Drum 24" x 18"	3	700	24800	Eriez Magnetics	Erie, PA	9-12	0
1022	Magnetite Rotary Feeder	FD-201	Prater	6" Rotary Airlock Feeder	0.5	185	2069	J&B Industrial	Chicago, IL	4-6	150
1024	Motor Control Center (NEMA 12)	MCC-401	Allan-Brad.	4 Vertical Sections w/o TMCB	200 A	100	8458	Allen Bradley, Inc.	Milwaukee, WI	4-6	0
1025A	Customized Control Cabinet (NEMA 4)	CC-401	CDI	Square D Comp. in Hoffman Box	---	150	3150	Control Design, Inc.	Pittsburgh, PA	4-6	40
1025B	TMCB & Safety Switches	---	Square D	TMCB & 23 Man. Switches (17 New)	---	250	2974	All Phase	Pittsburgh, PA	1-2	0
1026	Heavy Media Cyclone Feed Flowmeter	FIT-1	Polysouth	MST-P Port. Ultrasonic Flowmeter	---	20	0	At PETC	---	---	0
1027A	Correct Media Nuclear Density Gauge	DIT-1	Berthold	LS-389 w/ NaI Detector & Comm.	---	2	4825	Berthold Systems	Aliquippa, PA	4-6	0
1027B	Nuclear Density Gauge Digital Meter	DIT-1A	Red Lion	IMP-20102 Digital Meter w/ Relays (2)	---	90	281	Denko Engrg.	Bell Vernon, PA	2-3	0
1028	Classifying Cyclone Sump Level Transmitter	LIT-1	Warrick	16ML1A4-X-03 w/ 2' & 2.4" Probes	---	6	291	Process Engrg.	Pittsburgh, PA	3-4	0
1029	Correct Media Sump Level Transmitter	LIT-2	Warrick	16ML1A4-X-03 w/ 2' & 2.4" Probes	---	6	291	Process Engrg.	Pittsburgh, PA	3-4	0
1030	Mag. Sep. Feed Sump Level Transmitter	LIT-3	Warrick	16ML1A4-X-03 w/ 2' & 2.4" Probes	---	6	291	Process Engrg.	Pittsburgh, PA	3-4	0
1031	Mag. Sep. Test Sump Level Transmitter	LIT-4	Warrick	16ML1A4-X-03 w/ 3' & 3.4" Probes	---	6	302	Process Engrg.	Pittsburgh, PA	3-4	0
1032	Clarified Water Head Tank Level Transmitter	LIT-5	Warrick	16ML1A4-X-03 w/ 2' & 1.8" Probes	---	6	285	Process Engrg.	Pittsburgh, PA	3-4	0
1033	Spare Level Probes	LIT----	Lightning	Spare Probes (12@ 3', 3.4', 4', & 4.4')	---	12	252	At PETC	---	---	0
1034	Correct Media Sump Mixer	MX-201	Lightning	Mixer w/ 5' Long Agitator	2.3	200	0	At PETC	---	---	0
1035	Structural Steel, Flooring, & Handrail	SS-101	Yangura	Fabricated Structure, Floor, & Rail	---	26000	37680	Yangura Iron, Inc.	W. Mifflin, PA	4-6	0
1036	Platwork Steel	PS-101	Yangura	Fabricated Stumps, Chutes, & Frames	---	6000	18285	Yangura Iron, Inc.	W. Mifflin, PA	4-6	0
1037	Deslime and Rinse Screen Spray Nozzles	---	Durex	1-1/2" Beaver Tails (26@\$14.50)	---	13	386	Howard Baird Ass.	Pittsburgh, PA	3-4	0
1038	Marcy Liquid Density Gauge (Manual)	---	Marcy	2 Hanging Scales with Spare Cups	---	20	406	Gilson Co., Inc.	Worthington, OH	1-2	0
1039	Fire Extinguishers	---	ABC Fire Prt.	Six Port. Units (5 Reg. & 1 Elec.)	---	80	561	Fire Fighter Sales	Pittsburgh, PA	1-2	0
1040	Variable Area Bypass Flowmeters	---	Cole-Parmer	Four Units (3/4", 1", 1-1/2", & 2")	---	15	1432	Cole-Parmer Inst.	Niles, IL	3-4	0
1041	Manual Ball, 3-Way, and Diaphragm Valves	---	Asahi/Grinnell	Steel Valves (41) & CPVC Valves (68)	---	500	9840	Lee Supply Co.	Charleroi, PA	3-4	0
1042	Solenoid Operated Ball Valves (w/ Actuator)	---	ASCO/Unitorq	2" Unit (1) & 1" Units (4) w/ Spares	---	25	1453	Technatic, Inc.	Sylvan Lk., MI	1-2	0
1043	Digital Meter (NEMA 4 & UL Approved)	DIT-1A	Newport	INFCP-210 Meter & SPC4 Cover	---	5	375	Newport Elec., Inc.	Santa Ana, CA	1	20
1044	Steel Flanges and Gaskets	---	Grinnell	Flanges (168) & Rubber Gaskets (99)	---	200	1377	Lee Supply Co.	Charleroi, PA	1	20
1045	Air, Water, and Slurry Gauges & Regulators	---	Ashcroft	Pressure Gauges (6) & Regulators (5)	---	50	1682	M.S. Jacobs	Pittsburgh, PA	2-4	20
1046	Lab. Matrix Separator (HGPM)	---	Eriez	Separator, Cup, and 3 Magnat Sets	---	100	2740	Eriez Magnetics	Erie, PA	4-6	0
1047	Wet Sample Splitter and Samplers	---	Carpro	Wet Splitter (110 V) & 2 Samplers	---	100	5375	Carpro	Jacksonville, FL	2-4	0
1048	Deslime and Rinse Screen Spray Nozzles	---	Spray System	36 Spray Nozzles	---	10	1208	Workman Dev.	Alum Crk., WV	1	0

Purchase Total \$ 258329 Shipping Total \$ 1703
 Delivered Total \$ 260032

Table 4 contains a complete description of the three magnetites that Custom Coals is using for the project, which include:

- PennMag Grade-K Magnetite - Ground natural magnetite, with a mean particle size of 9.8 microns.
- PennMag Grade-L Magnetite - Finely ground natural magnetite with a mean particle size of 6.6 microns.
- Pea Ridge Grade-M Magnetite - Extremely fine magnetite with a mean particle size of 3.0 microns.

Similarly, Custom Coals selected two test coals for the ET circuit testing. The coals are:

- Pittsburgh No.8 Seam bituminous raw coal from Ohio Valley Coal Company in Belmont County, Ohio.
- Lower Kittanning "B" Seam bituminous raw coal from PB&S Coal Company's, Longview Mine in Somerset County, Pennsylvania.

Tables 5 and 6 contain the size and washability analysis for the respective coals. Both coals are obtained from underground mines, and contain dry ash contents of between 20 and 30 Wt%. Over half of the sulfur in both coals is in the pyritic form, so they are good candidates for aggressive cleaning studies. They also both have anticipated yields of 70 to 80 Wt%, when cleaned at about 1.60 SG.

The major differences between the coals is that the Pittsburgh No. 8 Seam raw coal has a much higher organic sulfur content, and is much harder (HGI=60-70) than the Lower Kittanning "B" Seam raw coal (HGI=90-100). Testing of coals with different friabilities is desirable, to allow for comparison of how attrition affects fine coal contamination of the recirculating media, and subsequent media recovery and cyclone performance. The Pittsburgh No. 8 Seam Coal should be the less challenging coal. It was used for the circuit commissioning. The Lower Kittanning "B" Seam raw coal was the second coal tested. It is of major interest to Custom Coals because it will be one of the major feed coals used to make compliance coal at Custom Coals Laurel Cleaning Plant, which became operational in the winter of 1996.

TABLE 4

MICRONIZED MAGNETITE CHARACTERISTICS

Magnetite Head Analysis

Analysis	Grade-K	Grade-L	Grade-M
Moisture (Wt%)	0.1	0.20	-
Ash (Wt%)	103*	102*	102
Specific Gravity	5.0	4.9	5.1
Moment (EMU/g)	86	75	81

*Note: Magnetite gains weight during the ashing process.

Magnetite Davis-Tube Recovery Profiles

Davis-Tube Settings		Davis-Tube Recoveries (Wt%)		
Amps	Gauss	Grade-K	Grade-L	Grade-M
0.30	750	84-86	20-22	0
0.50	1,250	96-98	70-72	0
1.70	3,700	98-99	95-97	80-81

Magnetite Size

Microtrac Results	Grade-K	Grade-L	Grade-M
D ₉₀ (90% Passing)	18.0	12.8	5.0
D ₅₀ (50% Passing)	8.9	5.7	2.7
D ₁₀ (10% Passing)	3.5	2.4	1.4
MVD (Mean Volume Dia.)	9.8	6.6	3.0
Moment (EMU/g)	87	77	82

Table 5
 GROUND RAW COAL SIZE ANALYSIS AND WASHABILITY
 Pittsburgh No. 8 Seam Coal (PETC/PRF Dry Grind)
Ohio Valley Coal Company
 (HGI = 60-70)

Top x 0 size analysis representing 100.00 Wt% of total raw coal sample

<u>Size Fraction</u>			<u>Size Analysis (D.B.)</u>			<u>Cumulative Analysis (D.B.)</u>		
			Weight	Ash	Sulfur	Weight	Ash	Sulfur
<u>Pass</u>	<u>Retain</u>		<u>(Wt%)</u>	<u>(Wt%)</u>	<u>(Wt%)</u>	<u>(Wt%)</u>	<u>(Wt%)</u>	<u>(Wt%)</u>
Top	X	30M	1.00	28.68	5.19	1.00	28.68	5.19
30M	X	50M	3.30	28.68	5.19	4.30	28.68	5.19
50M	X	70M	3.50	21.50	4.64	7.80	25.46	4.94
70M	X	100M	5.40	18.74	4.74	13.20	22.71	4.86
100M	X	200M	16.00	14.98	5.00	29.20	18.47	4.94
200M	X	400M	22.60	14.08	5.25	51.80	16.56	5.07
400M	X	0	48.20	32.43	3.83	100.00	24.21	4.47
		Total	100.00	24.21	4.47			
		Head	100.00	23.40	4.51			

Top x 0 washability representing 100.00 Wt% of total raw coal sample

<u>Gravity Fraction</u>			<u>Direct Analysis (D.B.)</u>			<u>Cumulative Analysis (D.B.)</u>		
			Weight	Ash	Sulfur	Weight	Ash	Sulfur
<u>Sink</u>	<u>Float</u>		<u>(Wt%)</u>	<u>(Wt%)</u>	<u>(Wt%)</u>	<u>(Wt%)</u>	<u>(Wt%)</u>	<u>(Wt%)</u>
Float	X	1.30	46.00	2.76	2.35	46.00	2.76	2.35
1.30	X	1.40	20.20	8.13	2.60	66.20	4.40	2.43
1.40	X	1.50	6.40	17.32	3.04	72.60	5.54	2.48
1.50	X	1.60	2.50	33.31	4.67	75.10	6.46	2.55
1.60	X	1.80	2.00	34.30	4.94	77.10	7.18	2.62
1.80	X	2.20	3.10	52.69	3.23	80.20	8.94	2.64
2.20	X	Sink	19.80	83.19	10.36	100.00	23.64	4.17
		Total	100.00	23.64	4.17			
		Head	100.00	23.83	4.42			

Table 6
 CRUSHED RAW COAL SIZE ANALYSIS AND WASHABILITY
 Longview Mine, Kittanning "B" Seam
 PB&S Underground Mined Coal
 (HGI = 90-100)

1-1/2" x 0 size analysis representing 100.00 Wt% of total raw coal sample

<u>Size Fraction</u>			<u>Size Analysis (D.B.)</u>			<u>Cumulative Analysis (D.B.)</u>		
			Weight	Ash	Sulfur	Weight	Ash	Sulfur
<u>Pass</u>	<u>Retain</u>		<u>(Wt%)</u>	<u>(Wt%)</u>	<u>(Wt%)</u>	<u>(Wt%)</u>	<u>(Wt%)</u>	<u>(Wt%)</u>
1-1/2"	X	3/8"	21.78	36.77	2.88	21.78	36.77	2.88
3/8"	X	1.0mm	50.44	18.72	2.03	72.22	24.16	2.29
1.0mm	X	150M	21.64	12.74	1.93	93.86	21.53	2.20
150M	X	500M	3.69	11.82	1.88	97.55	21.16	2.19
500M	X	<u>0</u>	<u>2.45</u>	<u>18.43</u>	<u>1.21</u>	<u>100.00</u>	<u>21.10</u>	<u>2.17</u>
		Total	100.00	21.10	2.17			

1-1/2" x 500M washability representing 97.55 Wt% of total raw coal sample

<u>Gravity Fraction</u>			<u>Direct Analysis (D.B.)</u>			<u>Cumulative Analysis (D.B.)</u>		
			Weight	Ash	Sulfur	Weight	Ash	Sulfur
<u>Sink</u>	<u>Float</u>		<u>(Wt%)</u>	<u>(Wt%)</u>	<u>(Wt%)</u>	<u>(Wt%)</u>	<u>(Wt%)</u>	
Float	X	1.30	19.80	3.02	0.69	19.80	3.02	0.69
1.30	X	1.40	42.10	7.95	0.83	61.90	6.37	0.79
1.40	X	1.45	8.43	16.40	1.00	70.33	7.57	0.81
1.45	X	1.55	5.66	25.22	1.40	75.99	8.89	0.85
1.55	X	1.65	3.06	32.93	1.87	79.05	9.82	0.89
1.65	X	1.80	2.87	40.85	2.19	81.92	10.91	0.94
1.80	X	<u>Sink</u>	<u>18.08</u>	<u>68.43</u>	<u>7.80</u>	<u>100.00</u>	<u>21.31</u>	<u>2.18</u>
		Total	100.00	21.31	2.18			
		Head	100.00	21.16	2.19			

In late February, Custom Coals' procured the 80-ton bulk shipment of Pittsburgh No. 8 Seam Coal, required for the commissioning and testing phases. The coal was delivered to Dillner Storage and blended in fourteen 6-ton lots. These lots were gradually transported to the PRF as feed for the testing. During the blending, Custom Coals' obtained a 100 pound composited sample of the coal and sent it to CT&E for analyses. During July, Custom Coal's Project Manager procured a 46-ton bulk sample of the second coal, Lower Kittanning "B" Seam, and had it delivered to Dillner Storage. It was later blended and split into 6-ton piles for gradual transport to DOE's PRF. A bulk sample was collected, and the individual piles (ie., lots) were covered with poly tarps to avoid any moisture pickup.

Section 5.5 - Task 500: Circuit Installation (Months 5-7)

The major focus of the project work, during the third quarterly reporting period (January through March 1995), was the circuit installation task. Custom Coals subcontracted Rizzo & Sons to perform the circuit installation, based on their experience working at the site and the competitiveness of their bid (\$121K). The installation of the circuit began on January 23rd, and was completed on March 27th, including \$11K of additional work that was not in the work scope. For organizational purposes, Custom Coals broke down the circuit installation into 3 subtasks that Rizzo's performed according to the following schedule:

- Primary Installation: (January 23rd - February 10th) - Structure, flooring, handrail, equipment, and platework.
- Piping Installation: (February 14th - March 27th)
- Electrical Installation: (February 14th - March 27th)

From January 23rd through February, Rizzo & Sons had approximately 5-7 men working on-site on the circuit installation task. In March, the work became more detailed and the crew was reduced to 2-4 men. Rizzo's men worked 10-hour shifts (7:00AM through 5:30PM) Monday through Thursday, with Fridays off. Custom Coals' Project Manager was on-site during the entire installation period to ensure that all installations occurred in accordance with the design drawings, the SSA's and DOE's work rules.

The new structure that was installed is permanent and consists of a number of column rows, installed in the PRF's ET circuit area, and fastened to the existing structure. The floor levels match the existing structure on all except the highest floor, and consist of 3/8" checkerplate flooring with removable handrail and toeplate. Design specifications are 150#/sq.ft. live load and 2000# point loading.

The structure and equipment on each floor of the circuit is as follows:

- 1086' Elevation - The ground level concrete floor is part of the new structure. The 20'x 20' new equipment area contains the 6 slurry sumps and pumps shown on the bottom of Figure 6, as well as all sample prep equipment setup at the site. All the sumps and pumps, as well as the structural steel are bolted to the concrete floor.
- 1096' Elevation - The second floor consists of a new 22'x 13' structure adjacent to the existing circuit. It is enclosed in removable handrail and toeplate. This level contains the primary, secondary, tertiary, and scavenger rare-earth magnetic separators, as well as the magnetite hopper and deslime screen. It also contains the Berthold Density Gauge and the Polysonics Ultrasonic Flowmeter.
- 1106' Elevation - The third floor also consists of a new 22'x 13' structure adjacent to the existing circuit, enclosed in removable handrail and toeplate. This level contains the rinse screen, the media distribution and splitter boxes, and the classifying cyclone. It also contains the control cabinet used to operate and monitor the circuit.
- 1116' Elevation - The fourth floor consists of a new 10'x 20' structure adjacent to the existing circuit, and enclosed in removable handrail and toeplate. This level contains the clarified water head tank and pump, the two heavy-media cyclones, the drain screen, and the cleaner magnetic separator.

The general arrangement drawings were used to place the structural steel, flooring, handrails, equipment, and platework in the initial part of the installation.

The detailed process piping requirements are shown in the circuit P&ID, (see Figure 9). Figure 9 contains all slurry and water piping lines, including all fittings and valves. Most of the slurry piping was specified as CPVC ("P") to save money and for ease of installation. Steel piping was used for the high-pressure, dense-medium cyclone feed lines.

A detailed piping list for the slurry lines, water lines, and compressed air lines was included in the design package. The piping routes were determined in the field during installation, by Custom Coals and Rizzo staff. All gravity lines were installed first to ensure maximum slope, while maintaining sampling capabilities. Pump discharge lines, water lines, and air lines were installed later, with priorities on maintaining access to the circuit and sampling capabilities.

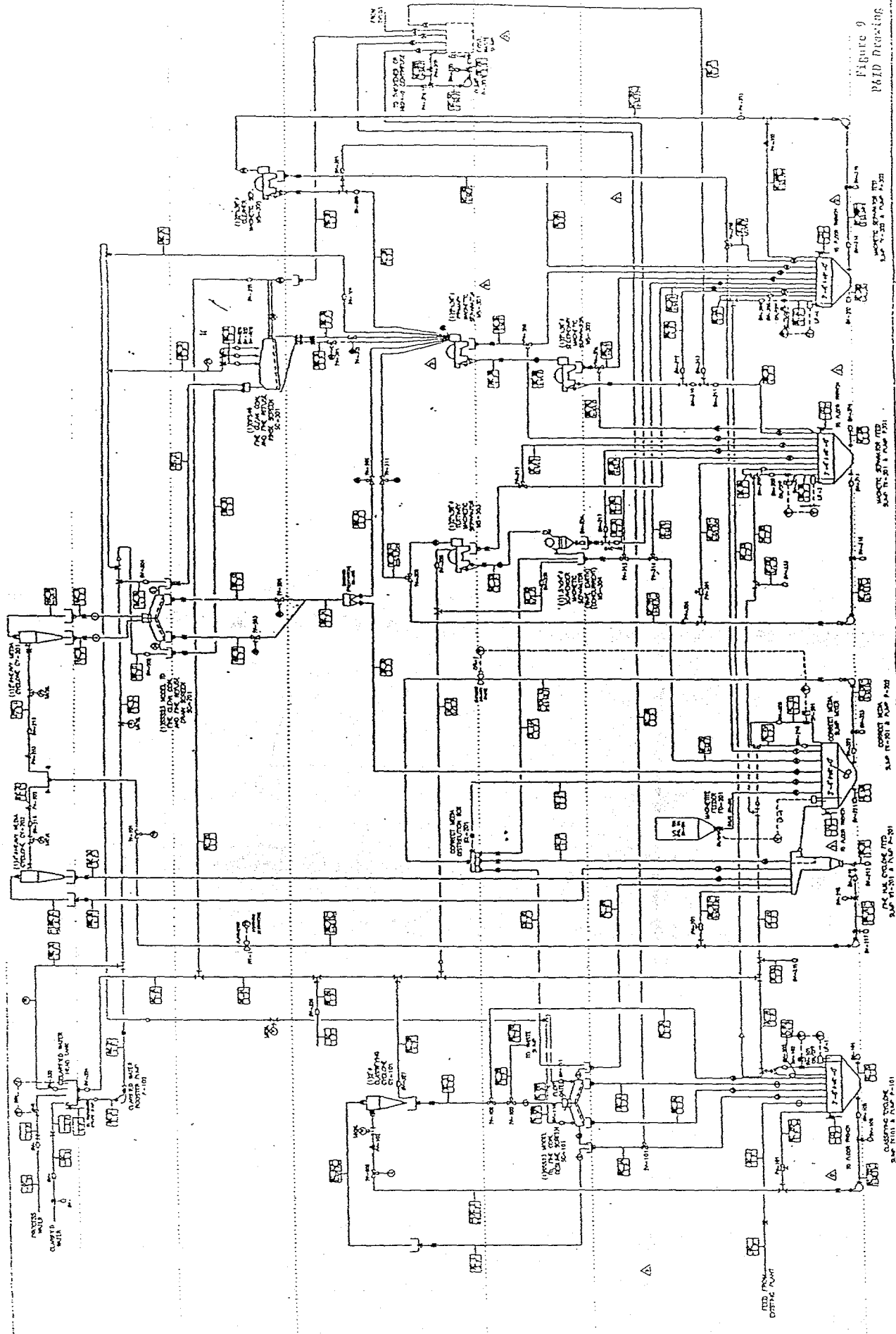

FIGURE 9
PAID DESIGN

U.S. AIR FORCE
 THE OFFICE OF CHIEF OF DEFENSE
 MICRO-MAG PROCESS R & D CONTRACT
 NUMBER W-33(616)-1-00000

LEGEND
 — LINE RESERVATION
 — PIPE VELOCITY IN FPS
 — VALVE SET & TYPE

LEGEND
 — 1/2" SLOTTED VALVE
 — 1/2" FULL BORE
 — 1/2" PIPE VELOCITY IN FPS
 — 1/2" PIPE VELOCITY IN FPS
 — 1/2" PIPE VELOCITY IN FPS
 — 1/2" PIPE VELOCITY IN FPS

The final installation subtask, the electrical installation, started in mid-February 1995 was also completed in late-March 1995. Rizzo & Sons were responsible for installing the following units:

- A new 200 Amp. Thermal Magnetic Circuit Breaker (TMCB) in DOE's existing Square D, Model 5 MCC in the PRF MCC room.
- A new, NEMA-12 Allen Bradley MCC in the PRF MCC room (3 Vertical Sections).
- A new customized Control Cabinet in the field to operate and monitor the circuit.
- 23 new disconnects in the field, one next to each new 480 Volt motor.

The electrical work included all conduit runs, wiring, and terminations between these units, and the 23, 480-Volt motors in the circuit. It also included the conduit runs, wiring, and termination between the Control Cabinet and the 11 fixed instruments in the field (1 Berthold nuclear density gauge, 5 Warrick level probe systems, and 5 air solenoids). The circuit also includes a Polysonics portable ultrasonic flowmeter, that does not require any permanent wiring. An illustration of these instrument locations is shown in Figure 9.

All aspects of the ET Circuit needed to be tied into the existing PRF system. Figure 10 contains the interface drawing for these various tie-ins. The Installation and Shakedown Plan, submitted in late December, included a more detailed discussion of the various installation tasks and work rules.

Section 5.6 - Task 600: Circuit Commissioning (Month 8)

The circuit commissioning task went very smoothly and was completed near the end of April, 1995. The operating staff, at the PRF site, during the commissioning period included:

- Custom Coals' Project Manager.
- One to two men from Rizzo's to assist with required modification and commissioning tasks.
- A part-time Project Engineer (Ed Torak), to assist with the on-site work.
- Two to three full-time Project Technicians (subcontracted from CT&E), to maintain, operate, and sample the circuit.

Figure 10
CIRCUIT INTERFACE & TIE-IN DRAWING
 GC/Existing PRF (black) & Custom Coal's MicroMag Circuit (green)

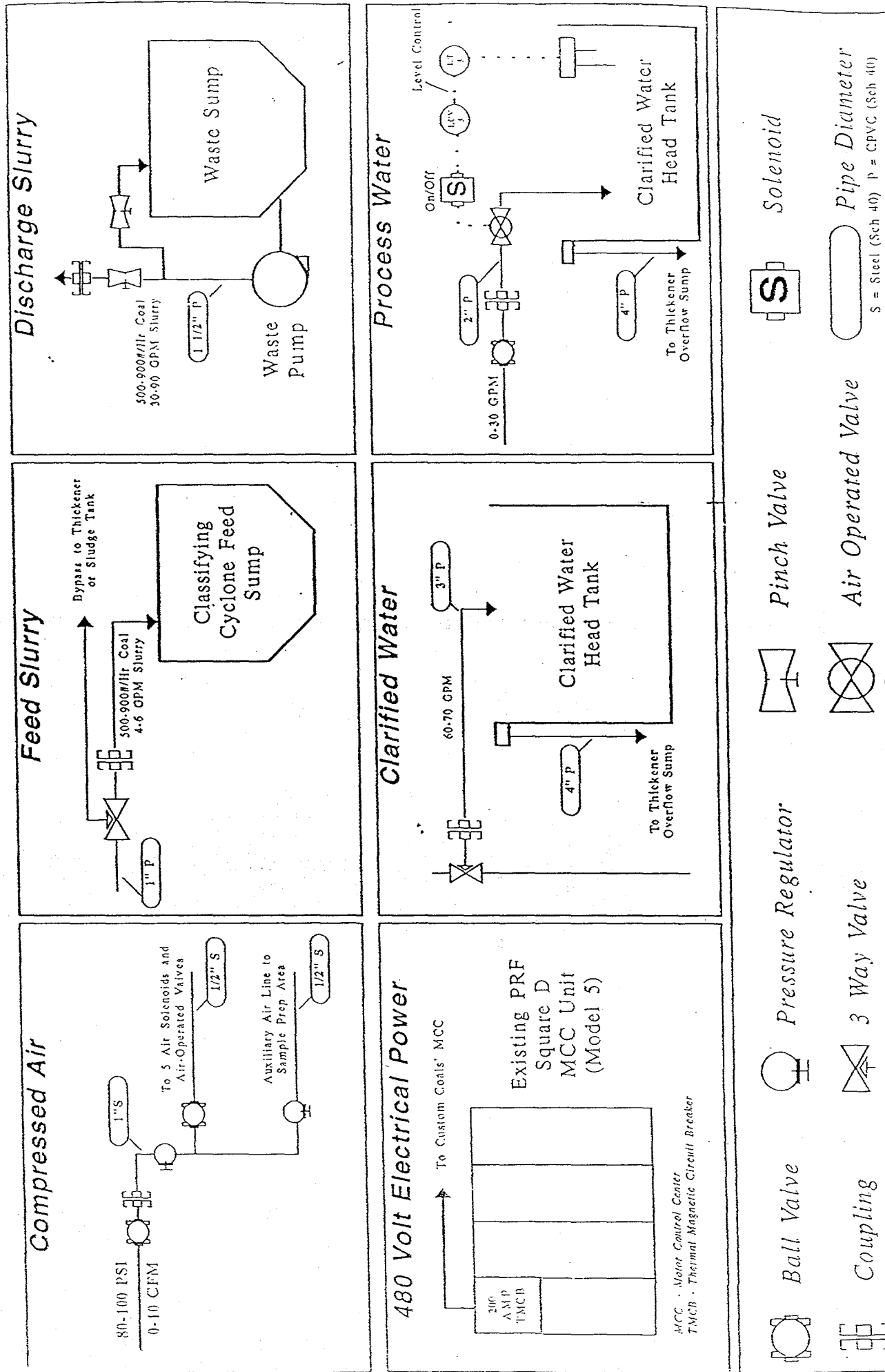

The commissioning task was broken down into three subtasks:

- Functionality and Leak Testing - to test motors and the sump level controls.
- Water Commissioning - to balance the circuit flowrates and correct any leaks.
- Slurry Commissioning - to balance the circuit with slurry and calibrate the nuclear density gauge and ultrasonic flowmeter.

The screens, cyclones, and magnetic separators were also tested for proper flow patterns and volume splits during the slurry commissioning period. The commissioning plan was discussed in detail in the Installation and Shakedown Plan, submitted late December 1994, and was discussed in even more detail in the Slurry Commissioning Plan, submitted in late March 1995.

Section 5.7 - Task 700: Circuit Testing (Months 9-13)

5.7.1 COMMISSIONING TEST RESULTS

The circuit slurry commissioning task was carried out over the entire month of April, and was broken down by the three subcircuits:

- Classifying Circuit Commissioning Tests
- Heavy-Media Cyclone Commissioning Tests
- Magnetite Recovery Circuit Commissioning Tests

Two men from Rizzo's installation staff stayed on site for the entire commissioning period to assist with required modifications and troubleshooting. The following discussion describes the commissioning results from these three areas of the circuit.

Classifying Circuit Commissioning Results

The goal of the classifying circuit commissioning was to test that subcircuits' ability to remove the majority of the -500M slimes (greater than 90Wt%), while recovering the majority of the +325M particles (greater than 90Wt%), with a high solids content product (greater than 35Wt%). A total of 7 tests were performed and completely analyzed during the testing, using two different circuits. The circuits were:

- Original Circuit - PRF feed to classifying cyclone, followed by north side of deslime screen, with deslime screen undersize recycled. This circuit was used for the first 5 tests.

- Modified Circuit - PRF feed to north side of deslime screen (desliming), followed by classifying cyclone and south side of deslime screen (dewatering), with south side screen undersize recycled to the classifying cyclone. This circuit was used for the last 2 tests.

Table 7 contains the operating conditions and results for the 7 tests.

As Table 7 illustrates, the initial circuit provided high recoveries, but it was impossible to simultaneously obtain efficient desliming and dewatering. Use of the modified circuit allowed the north side of the screen to focus on desliming and the south side of the screen to focus on dewatering. As a result, CT#6 and CT#7 were the only two tests to achieve the goal of greater than 35 Wt% solids in the final product (ie., 36.5 and 61.5 Wt%, respectively).

Custom Coals used the modified circuit to accomplish the following more aggressive objectives.

- Target over 60 Wt% solids recovery (yield) to obtain 500#/hr of solids product, from 800#/hr of solids feed.
- Target over 60% Wt% solids content in the final product.
- Target over 95 Wt% rejection of -500M particles.
- Target over 95 Wt% recovery of +325M particles.
- Target D-50 separation size of 30-40 microns.

Heavy-Media Cyclone Commissioning Results

The second slurry commissioning subtask involved two tests to assess the flow and performance of the parallel 2" and 4" Krebs Heavy-Media Cyclones. Table 8 contains a summary of the test results and conditions.

Table 8 suggests that the 4" Cyclone was separating the +500M particles very efficiently for the feedrate and operating conditions in CMT#1 (ie., 84 Wt% yield, with a 7.5 Wt% Clean Coal Ash Content and 77 Wt% Refuse Ash Content, for a 18.9 Wt% Feed Ash Content), even with the relatively coarse, Lot#1 Grade-K Magnetite. Unfortunately, the 2" Cyclone yield was only 11.2 Wt% for the +500M particles in Test CMT#1. Even with the smallest acceptable apex size of .25 inches, used in CMT#2, the 2" Cyclone yield only increased to about 50 Wt%.

TABLE 7
CLASSIFYING CIRCUIT COMMISSIONING TESTS
(Pittsburgh No. 8 Seam Raw Coal)

GENERAL DATA	Initial Tests		New Spray Bars		Modified Circuit	
	CT#1	CT#2	CT#4	CT#5	CT#6	CT#7
Date	04/03/95	04/04/95	04/13/95	04/24/95	04/27/95	05/02/95
Circuit Type	Original	Original	Original	Original	Modified	Modified
Feed Rate (#/hr)	644	712	819	783	739	769
CYCLONE CONDITIONS						
Feed Inlet (sq. in.)	0.25	0.25	0.25	0.25	0.25	0.25
Vortex (Inches)	0.625	0.625	0.625	0.625	0.625	0.80
Apex (Inches)	0.375	0.375	0.25	0.25	0.25	0.25
Feed Pressure (PSI)	33	42	46	46	48	45
Feed Rate (GPM)	17.8	20.7	18.5	18.0	17.2	22.1
SCREEN CONDITIONS						
North Side Panel (Mesh)	325	325	200	200	325	325
North Side Sprays (GPM)	5.0	5.8	9.8	14.5	15.0	18.5
South Side Panel (Mesh)	--	--	--	--	200	100
South Side Sprays (GPM)	--	--	--	--	2.4	0.0
PRODUCT QUALITY						
Solids Content (Wt%)	26.5	16.1	31.5	18.6	36.5	61.5
Solids Flowrate (#/hr)	489	561	606	424	480	396
+325 Mesh (Wt%)	--	--	80.8	91.1	77.6	83.4
325 x 500 Mesh (Wt%)	--	--	11.5	4.8	13.7	12.9
-500 Mesh (Wt%)	--	--	7.7	4.1	8.7	3.7
CIRCUIT PERFORMANCE						
Overall Recovery (Wt%)	75.9	78.8	74.0	54.1	65.0	51.5
+325 Mesh Recovery (Wt%)	--	98.5	99.1	88.0	99.7	85.9
-500 Mesh Rejection (Wt%)	--	61.2	81.7	93.9	85.0	94.8
D-50 Size of Sepn. (Microns)	--	--	30	60	30	40

- Notes: - Original Circuit - Classifying Cyclone, followed by Deslime Screen (North Side), with Deslime Screen Underflow Recycled.
- Modified Circuit - North Side of Deslime Screen (Desliming), followed by Classifying Cyclone and South Side of Deslime Screen (Dewatering), with South Side Screen Undersize Recycled to Cyclone.

TABLE 8
HEAVY-MEDIA CYCLONE SPLITS
Pittsburgh No. 8 Seam Commissioning Tests
(Grade-K Magnetite, Lot #1)

Test #	H.M. Cyclone	Conditions		Feed		Overflow			Underflow	
		Feed Rate (GPM)	Feed Pres. (PSI)	Slurry SG	+500M Ash (Wt%)	Slurry SG	+500M Yield (Wt%)	+500M Ash (Wt%)	Slurry SG	+500M Ash (Wt%)
CMT#1	4"	28	81	1.34	18.9	1.25	84.0	7.5	1.85	77.1
CMT#1	2"	10	22	1.34	18.9	1.13	11.2	4.6	1.56	20.7
CMT#2	2"	10	22	1.32	19.2	1.15	50.0	5.8	1.70	32.6

- Notes:
- The 4" Cyclone had 0.12 sq. in. inlet, 1.00 inch vortex, and 0.625 inch apex.
 - The 2" Cyclone had 0.09 sq. in. inlet, 0.375 inch vortex, and 0.375 inch apex in CMT#1 and 0.25 inch apex in CMT#2.

Magnetite Recovery Circuit Commissioning Test Results

The third and final slurry commissioning subtask involved three tests to assess the magnetite recovery circuit performance (ie., magnetite losses) for the screens and magnetic separators within the MicroMag circuit, once again using the relatively coarse, Lot#1 Grade-K Magnetite. Table 9 contains the total magnetite losses for each test, broken down by the two main sources:

- Rare-Earth Scavenger Magnetic Separator Tailing (Sample 36) - Which represents the total losses occurring within the 5 Eriez drum separators (see Figure 1).
- Combined Rinse Screen Products (Samples 22 & 23) - Which represents the magnetite trapped in the coarse particles overflowing the refuse and clean coal product screens (also see Figure 1).

The first test listed in Table 9 (MT#2), was a test performed with only magnetite, and no coal slurry. As a result, the magnetics losses were extremely low in the magnetic separator tailings (0.3-0.8 #/ton), and negligible in the Combined Rinse Screen Products (i.e., because there were no products). The magnetics contents and losses are based on two calculations (Davis-Tube based and EMU based), with Davis-Tube based values being an initial approximation, based on Davis-Tube magnetic separations, and EMU based values being a correction due to the slight inefficiency of the Davis Tube. The EMU calculations are based on magnetic moment measurements of the feed, mags, and nonmags from the Davis-Tube tests. The actual losses are probably somewhere in between, but closer to the EMU-based losses.

The last two test results listed in Table 9 are for two tests done with coal and magnetite slurry; the first (CMT#1) done with the finest, 325M drain and rinse screen panels and a deep bed in the rinse screen (-3 degree angle), and the second (CMT#2) done with coarser, 200M drain and rinse panels and a shallow bed on the rinse screen (0 degree angle). The results show that acceptable magnetics losses through the magnetic separators (1.1-3.3 #/ton) were achieved for both tests. However, the magnetics losses in the rinse screen products were unacceptably high (35-88 #/ton), for both tests. The coarser 200M panels and flattening of the rinse screen improved the results but the losses of 35-40 #/ton are still an order of magnetite above acceptable targets (2-5 #/ton). However, these were just some initial scoping tests for each of the units and no attempt was made to optimize the circuits.

**TABLE 9
MAGNETITE LOSSES
Pittsburgh No. 8 Seam Commissioning Tests
(Grade-K Magnetic, Lot #1)**

Test	Stream	Stream Info.		Davis-Tube Based Results		EMU Based Results	
		Solids (#/hr)	FI ow (GPM)	Solids	Magnetics	Solids	Magnetics
				(Wt%)	(#/Ton)	(Wt%)	(#/Ton)
MT#2	36 - Scav. Sep. Tails	5		1.5	0.3	3.9	0.8
CMT#1	36 - Scav. Sep. Tails	100		0.6	2.2	0.9	3.3
CMT#1	22/23 - Rinse Products	400		5.0	80	5.5	88
CMT#1	Total Circuit	500		4.1	82.2	4.6	91.3
CMT#1	36 - Scav. Sep. Tails	100		0.3	1.1	0.6	2.2
CMT#2	22/23 - Rinse Products	400		2.2	35	2.5	40
CMT#2	Total Circuit	500		1.8	36.1	2.1	42.2

- Notes: - MT#2 had only magnetite being fed and 22 and 23 streams were negligible.
- 36 is Rare-Earth Scavenger Magnetic Separator Tailings (Final Magnetic Separator Nonmags).
 - 22 is Rinse Screen Refuse Discharge (Final Refuse Nonmag).
 - 23 is Rinse Screen Clean Coal Discharge (Final Clean Coal Nonmags).
 - Data Assumes 500#/hr total coal feed, and that pure magnetics are 86 Emug.
 - CMT#1 done with 325M panels with -3° angle on rinse screen, and CMT#2 done with 200M panels with 0° angle on rinse screen.

5.7.2 QA/QC RESULTS

The QA/QC required for the plant testing can be broken down into three main areas:

- Sample handing, preparation, and analyses accuracy checks - Which requires adopting and adhering to certain set procedures and equipment.
- Instrument accuracy checks - Which encompasses flowmeters, pressure gauges, and nuclear density gauges.
- Sample and test, repeatability and reproducibility - Which can be affected by procedures and approach, but are more system dependent (ie., stabilization time, system consistency, and feed consistency).

The circuit is set up with a number of manual and redundant systems to routinely check the accuracy of the instruments. When coupled with the planned routine

maintenance of the instruments, Custom Coals did not experience any significant accuracy problems in those areas, at least none that would skew overall test conclusions and results.

The majority of Custom Coals QA/QC focused on the last two areas, particularly obtaining accurate sample analyses and material balances. To date, a number of issues have already been addressed. For example, Table 10 contains the ASTM Standards for within lab repeatability, and between labs reproducibility, of coal laboratory analyses. Since Custom Coals is doing all sample preparation at site, including moisture and ash analyses, a test was done to compare the analyses obtained on samples with PETC's Furnaces (the standard method) to CT&E's commercial laboratory results. Table 11 illustrates, via the duplicate analyses that Custom Coals is well within ASTM repeatability for moisture and ash analyses, using the PETC furnaces. Table 11 also illustrates that Custom Coals analyses match CT&E's for moisture and ash within ASTM reproducibility.

**TABLE 10
ASTM STANDARDS
FOR COAL ANALYTICAL VARIANCES**

ASTM Allowable Differences on Duplicate Samples

<u>Analysis</u>	<u>Coal Type</u>	<u>Repeatability Within Lab</u>	<u>Reproducibility Between Labs</u>
Moisture	Any	0.30 Wt%	0.50 Wt%
Ash	Raw Coal	0.50 Wt%	1.00 Wt%
	Clean Coal	0.20 Wt%	0.30 Wt%
	Refuse Coal	1.00 Wt%	2.00 Wt%
Btu/lb.	Any	50	100
Sulfur	< 2.0% Sulfur Coal	0.05 Wt%	0.10 Wt%
	> 2.0% Sulfur Coal	0.10 Wt%	0.20 Wt%
Pyritic Sulfur	< 2.0% Pyritic Sulfur Coal	0.05 Wt%	0.30 Wt%
	> 2.0% Pyritic Sulfur Coal	0.10 Wt%	0.40 Wt%

TABLE 11
COMPARISON OF COAL ANALYSES
PETC AND CT&E FURNACES
(Test PCT #1, 05/16/95)

Sample No.	Sample Name	Residual Moisture (Wt%)		Dry Ash Content (Wt%)	
		PETC	CT&E	PETC	CT&E
1	PRF Feed	1.93/1.93	1.86	27.31/27.48	26.89
2	Class. Cyclone Feed	1.43/1.49	1.50	25.98/25.97	25.41
3	Class. Cyclone Underflow	1.86/1.92	1.92	26.88/26.66	26.02
4	Class. Cyclone Overflow	1.77/1.88	1.70	32.21/32.37	31.73
5	Deslime Screen Unders (South)	1.04/1.04	1.02	56.25/56.00	54.97
5A	Deslime Screen Unders (North)	1.72/1.68	1.59	38.97/39.24	38.44
6	Deslime Screen Disch. (South)	1.47/1.47	1.41	20.91/21.04	20.77
6A	Deslime Screen Disch. (North)	1.77/1.83	1.69	24.19/24.15	23.65

Note: Analyses on PETC Furnace Performed by CT&E Personnel.

Another area of QA/QC testing that has been performed at site is testing of the Carpco Wet-Splitting Unit for accuracy and reproducibility. The testing was done with three types of feed:

- Water-only testing
- Coal/water slurry testing
- Magnetite/water slurry testing

The results from the testing, shown in Table 12 illustrate that the unit makes two consistent 5.5 Wt% splits, that essentially match the composition of the waste stream removed from the bottom (Split #3). The only problem is that a significant portion of the feed is retained within the unit (0.3 to 1.8 Wt%), and the retained portion is higher solids content than the splits, meaning that the splits are slightly lower solids content than the actual feed sample. It appears that the solids retained in the Carpco Unit essentially match the passing portion in composition.

TABLE 12
WET-SPLITTING RESULTS FOR CARPCO UNIT

I. Water-Only Testing: (10,000 gram Feed Sample)

<u>Portion</u>	<u>Removed Recovery (Wt%)</u>	<u>Total Recovery (Wt%)</u>
Split #1	5.4	5.4
Split #2	5.6	5.6
Split #3 (Waste)	89.0	88.7
<u>Retained</u>	<u>--</u>	<u>0.3</u>
Total	100.0	100.0

II. Coal/Water Slurry Testing: (5,000 gram at 10.0 Wt% Solids)

<u>Portion</u>	<u>Total Slurry Recovery (Wt%)</u>	<u>Total Solids Recovery (Wt%)</u>	<u>Solids Content (Wt%)</u>	<u>Ash Content (Wt%, Dry)</u>
	5.5	5.3		
Split #1	5.6	5.4	9.6	26.7
Split #2	87.3	84.2	9.7	27.2
Split #3 (Waste)	<u>1.6</u>	<u>5.1</u>	9.6	26.9
<u>Retained</u>	<u>100.0</u>	<u>100.0</u>	<u>33.2</u>	<u>--</u>
Total			10.0	--

III. Magnetite/Water Slurry Testing: (Cleaner Mag Separator Concentrate Sample)

<u>Portion</u>	<u>Total Slurry Recovery (Wt%)</u>	<u>Total Solids Recovery (Wt%)</u>	<u>Solids Content (Wt%)</u>	<u>Solids Analysis</u>		
				<u>MVD Moment (Microns)</u>	<u>Davis-Tube (Emu/g)</u>	<u>Rec. (Wt%)</u>
		5.3				
Split #1	5.4	5.4	27.3	9.9	87.0	99.8
Split #2	5.5	85.8	27.3	9.9	87.1	99.6
Split #3 (Waste)	87.3	<u>3.5</u>	27.3	9.9	87.4	99.7
<u>Retained</u>	<u>1.8</u>	<u>100.0</u>	<u>53.4</u>	<u>10.1</u>	<u>86.2</u>	<u>99.6</u>
Total	100.0		27.8	9.9	87.3	99.7

In May, additional testing was conducted using the Carpco wet-slitting device. Table 13 contains wet splitting results obtained for a Heavy-Media Cyclone Feed Sample (Sample #7), containing a coal/magnetite slurry. Two methods were employed:

- Flushing after removing the splits (Test PHT #21) - which should be the best method of obtaining an accurate "wt% solids" split.
- Flushing prior to removing the splits (Test PHT #22) - which should be the best method of obtaining an accurate "solids composition" split.

The results in Table 13 verify the theories listed above, and illustrate that the splitting accuracy of the Carpco Unit is more than acceptable, provided the slurry is well mixed as it is poured into the unit.

Throughout the test program, Custom Coals did not need to employ the Carpco wet-slitting device, because all samples were filtered in a timely fashion.

Five additional QA/QC issues were also assessed and tested. They included:

- MTU/IMP Laboratory Investigation Results
- Davis-Tube Separation and Magnetic Moment Measurement, Reproducibility Testing done by MTU's IMP.
- Wet Screening Accuracy Testing done by Custom Coals.
- Duplicate Testing and Sample Reproducibility Checks, done by Custom Coals during the Heavy-Media Cyclone Components Tests
- Marcy Balance Sensitivity Testing
- Duplicate EMU Analysis on the Grade-M magnetite.

TABLE 13
CARPCO WET SPLITTER TEST
WITH COAL/MAGNETITE SLURRY
(Pittsburgh No. 8 Seam Coal, Grade-K Magnetite)

I. Test PHT#21 - Cyclone Feed (Sample #7) - Flush after removing splits.

Sample	Slurry		Total Solids				+500M Solids		-500M Solids Analyses			
	Weight (g.)	Direct (Wt%)	Weight (g.)	Direct (Wt%)	Ash (Wt%)	Solids Content (Wt%)	Direct (Wt%)	Ash (Wt%)	Ash (Wt%)	Micotrac (MVD)	Moment (Emulg)	D.T. Rec. (Wt%)
Split #1	965.2	5.8	512.1	5.7	63.11	53.1	23.3	13.44	79.54	12.3	54.37	63.4
Split #2	932.4	5.6	495.6	5.5	62.45	53.2	23.8	13.46	80.07	12.2	54.39	61.5
<u>Split #3 (Waste)</u>	<u>14,665.0</u>	<u>88.6</u>	<u>7,803.0</u>	<u>86.8</u>	<u>66.05</u>	<u>53.2</u>	<u>21.7</u>	<u>14.14</u>	<u>79.47</u>	<u>11.3</u>	<u>56.16</u>	<u>65.0</u>
Rec. Total	16,562.6	100.0	8,810.7	98.0	65.68	53.2	21.9	14.06	79.50	11.4	55.96	64.7
<u>Split #4 (Losses)</u>	<u>397.4</u>	<u>2.3</u>	<u>183.2</u>	<u>2.0</u>	<u>75.96</u>	<u>46.1</u>	<u>33.0</u>	<u>63.56</u>	<u>84.04</u>	<u>11.4</u>	<u>57.90</u>	<u>65.9</u>
Head	16,960.0	102.3	8,993.9	100.0	65.89	53.0	22.1	15.55	79.54	11.4	55.99	64.7

Note: Split #4 represents only portion left in splitter after initial split. It does not include water required to flush it out.

II. Test PHT#22 - Cyclone Feed (Sample #7) - Flush Prior to Removing Splits.

Sample	Slurry		Total Solids				+500M Solids		-500M Solids Analyses			
	Weight (g.)	Direct (Wt%)	Weight (g.)	Direct (Wt%)	Ash (Wt%)	Solids Content (Wt%)	Direct (Wt%)	Ash (Wt%)	Ash (Wt%)	Micotrac (MVD)	Moment (Emu/g)	D.T. Rec. (Wt%)
Split #1	1,081.1	5.8	544.9	5.8	64.70	50.4	22.6	17.14	78.71	12.2	55.01	63.6
Split #2	1,064.3	5.7	526.1	5.7	67.59	49.4	23.2	16.34	81.15	12.0	56.22	63.3
<u>Split #3 (Waste)</u>	<u>16,535.0</u>	<u>88.5</u>	<u>8,260.0</u>	<u>88.5</u>	<u>65.32</u>	<u>50.0</u>	<u>20.8</u>	<u>17.41</u>	<u>82.44</u>	<u>11.5</u>	<u>56.05</u>	<u>66.6</u>
Rec. Total	18,680.4	100.0	9,331.0	100.0	65.41	50.0	21.0	17.36	82.11	11.6	56.00	66.2
Losses (+)	166.2	0.9	0.0	-	-	0.0	-	-	-	-	-	-
<u>Total Flush (-)</u>	<u>1,406.6</u>	<u>-7.5</u>	<u>0.0</u>	<u>-</u>	<u>-</u>	<u>0.0</u>	<u>-</u>	<u>-</u>	<u>-</u>	<u>-</u>	<u>-</u>	<u>-</u>
Head	17,440.0	93.4	9,331.0	100.0	65.41	53.5	21.0	17.36	82.11	11.6	56.00	66.2

MTU/IMP LABORATORY INVESTIGATION RESULTS

In February 1995, Custom Coals subcontracted MTU's IMP to perform a laboratory investigation to determine required laboratory procedures for the fine-coal and magnetite slurry and solid samples that will be generated during the project testing. The main analytical concerns were obtaining accurate and reproducible:

- density, viscosity, and agglomeration measurements
- magnetics/nonmagnetics separations
- magnetics analyses (ie., magnetic moments and compositions)
- magnetics and nonmagnetics size analyses, down to submicron sizes.

The goal was have MTU's IMP to continue to provide laboratory analyses services, for the project test samples, using the equipment and procedures they developed during this investigation.

Mictotrac Size Analyses

One of the first areas of concern was developing sample pretreatment methods to obtain accurate particle size analysis of solids and slurry samples, using the IMP's Leeds and Northrup Microtrac Particle Size Analyzer. During the testing, the IMP staff found that three pretreatment steps were necessary to obtain accurate and reproducible size analyses with the unit. It was included that:

- The samples had to be wetted in the presence of a surfactant, if they were dry, to enhance both wetting and dispersion.
- The samples had to be demagnetized to ensure that any magnetite agglomerates were broken up.
- The samples had to be treated with an ultrasonic probe, for 5-10 minutes to ensure that all coal agglomerates were broken up.

The samples had to also be well agitated during these steps, as well as during removal of the small portion for analyses, to ensure good dispersion and a representative sample.

Once these procedures were followed, the IMP staff found that they could obtain essentially identical analyses for parallel splits, even when one split had been filtered and dried and the other had not. They also found that the Microtrac analyses for feed, magnetics, and nonmagnetics balanced around their magnetics separations, which was also an important QA/QC test.

As a check of their Microtrac analyses for bias, the IMP also sent samples of the feed magnetite to another laboratory (PTLL) for testing in a similar machine (a Malvern Unit), and also did an elaborate particle counting analysis in there SEM to determine the particle size populations. The size distribution proved to be very similar with the following reported results:

- MTU's IMP Mitrotrac - 5.7 micron mean volume diameter (MVD).
- PTLL's Malvern - 5.8 micron mean volume diameter (MVD).
- MTU's IMP SEM - 6.2 micron mean volume diameter (MVD).

For the remainder of the project the -500M particle size analyses will be done with the IMP's Microtrac.

Solids Density Measurements

Table 14 shows some solids density measurements that the IMP has performed as part of their investigation. Once they switched to kerosene as the measuring media, the accuracy and reproducibility of their measurements greatly improved (to +/- .02 SG units) over those obtained with water, due to improved wetting. All required solids density measurements will be done by the IMP.

Davis-Tube Separation Testing (Magnetite Only)

The first step in MTU's IMP Davis-Tube separation testing was to determine a profile of Amps vs. Gauss for their Davis Tube and see if the separations matched earlier work during this project by Eriez Magnetics. The results provided essentially identical, except that MTU recovered all nonmags, so they could reconstitute yields from weights of both products, as well as from feed and mags weights. The IMP also determined that once magnetics saturations were reached on the Davis-Tube (ie., at about 0.7 amps), the recoveries remained constant, up to the maximum setting of 1.7 amps. This indicated that any amp level could be used between 0.7 and 1.7 amps to lead to similar results. However, they later found that when the highest 1.7 amp level was used the Davis-Tube had much higher capacity (ie., up to 6 grams of magnetics). This proved to be desirable to allow bigger samples, and subsequently more nonmagnetics to analyze, and better overall particle recovery (ie., approaching 99 Wt%). It was therefore decided that all Davis Tube measurements would be made at 1.7 amps.

TABLE 14
SOLIDS DENSITIES
(Measured with Kerosene)

<u>SAMPLE</u>	<u>SG</u>
PennMag Grade-K "Old" Magnetite	4.73
DOE 90-X Magnetite	4.86
Hi-Temp. Magnetite	4.57
Pittsburgh No. 8 (-325 M)	1.68
Lower Kittanning (-325 M)	1.42

Davis-Tube Separations & Magn. Moment Measurements (Coal & Magn.)

In combination with the Davis-Tube separations, the MTU's IMP has also made magnetic moment measurements of the feed, mags, and nonmags to compliment the measurements. Table 15 shows the results for separations with the initial PennMag Grade-K magnetite (old magnetite), which has a pure magnetics moment of about 84 Emu/g, and the coarser Lot #1, PennMag Grade-K Magnetite from PeaRidge (new magnetite) which has a pure magnetics moment of about 87 Emu/g. The results indicate the occasional and unexplained inefficiency of magnetics separation with the Davis-Tube, for coal and magnetite mixtures, as shown by the drop in Emu/g of the magnetics product (see DT-33, S-15, and S-16) and the higher than expected Emu/g of the nonmagnetics (see DT-33).

The inefficiencies, illustrated in Table 15, are not understood. As a result, the product team plans to compliment the Davis-Tube separation results, with magnetics moment measurements, so that magnetics contents and magnetics losses can be calculated two ways:

- From Davis-Tube magnetics at 1.70 amps.
- From magnetics moment of all samples (feeds, mags, and nonmags).

Another advantage of the magnetic moment measurements is that they allow a quick and inexpensive estimate of magnetics content of a sample. For instance, for the new magnetite testing the magnetics content can be estimated by measuring the sample Emu/g and dividing it by 87 Emu/g (the magnetic moment of pure magnetics). This has proven to be a valuable tool in the project testing.

TABLE 15
DAVIS-TUBE AND MOMENT BALANCES
(Old and New PennMag Grade-K Magnetite)

I. OLD MAGNETITE:

<u>Test Number</u>	<u>Feed Description</u>	<u>Sample</u>	<u>Weight (Grams)</u>	<u>Weight (Wt%)</u>	<u>Moment (Emu/g)</u>	<u>Mome Dist. (Wt%)</u>
DT-24	Magnetite Only	Mags	5.64	95.5	84.30	99.9
		<u>Non Mags</u>	<u>0.27</u>	<u>4.5</u>	<u>1.00</u>	<u>0.0</u>
		Total	5.91	100.0	80.55	100.0
DT-37	Pitts. No. 8 Coal Only	Mags	0.00	0.0	0.00	0.0
		<u>Non Mags</u>	<u>5.87</u>	<u>100.0</u>	<u>0.21</u>	<u>100.0</u>
		Total	5.87	100.0	0.21	100.0
DT-33	Sim. Cyclone Feed (1.0/4.7g. Coal/Mag.)	Mags	4.32	76.9	80.40	99.3
		<u>Non Mags</u>	<u>1.30</u>	<u>23.1</u>	<u>1.67</u>	<u>0.6</u>
		Total	5.62	100.0	62.21	100.0

II. NEW MAGNETITE:

<u>Test Number</u>	<u>Feed Description</u>	<u>Sample</u>	<u>Weight (Grams)</u>	<u>Weight (Wt%)</u>	<u>Moment (Emu/g)</u>	<u>Mome Dist. (Wt%)</u>
DT-54	Magnetite Only	Mags	4.92	99.2	86.74	99.9
		<u>Non Mags</u>	<u>0.04</u>	<u>0.8</u>	<u>7.35</u>	<u>0.0</u>
		Total	4.96	100.0	86.10	100.0
S-13	Cyclone Feed	Mags	4.00	68.7	87.07	99.7
		<u>Non Mags</u>	<u>1.83</u>	<u>31.3</u>	<u>0.53</u>	<u>0.2</u>
		Total	5.83	100.0	59.98	100.0
S-15	Final Coal Product	Mags	0.05	0.3	83.71	67.8
		<u>Non Mags</u>	<u>15.76</u>	<u>99.7</u>	<u>0.12</u>	<u>32.1</u>
		Total	15.81	100.0	0.37	100.0
S-16	Scav. Mag. Sep. Tailings	Mags	0.05	0.6	70.67	54.2
		<u>Non Mags</u>	<u>8.40</u>	<u>99.4</u>	<u>0.36</u>	<u>45.7</u>
		Total	8.45	100.0	0.78	100.0

DAVIS-TUBE AND MAGNETIC MOMENT REPRODUCIBILITY TESTING

During May, MTU's IMP performed a number of duplicate analyses to observe the reproducibility and closure of the Davis-Tube magnetics separations and magnetic moment measurements they perform, as part of their routine analyses for the project.

Table 16 illustrates duplicate Davis-Tube separations for two methods they have tested during the project. All four separations were performed with identical dried splits of a Combined Drain Screen Underflow Sample (Sample #16) from the commissioning tests. The two methods tested included:

- Complete water evaporation of the Davis-Tube products to ensure complete, particle recovery, followed by magnetics moment analyses (Lab. No. S-8-1A & S-8-1B).
- Partial settling of Davis-Tube products followed by decanting and micropore filtering (Lab. No. S-8-2A & S-8-2B).

The second method was the standard method MTU's IMP normally employs.

The results in Table 16, and in other duplicate tests, illustrates that either method leads to very good reproducibility of separations (ie., magnetics yields, moment measurements, and moment distributions). The major difference is that the water evaporation method causes a significant weight gain due to precipitation of solids from the vast amount of water used in the Davis-Tube Procedure; whereas, the normal method leads to a slight weight loss due to decanting and filtering losses. Custom Coals has decided that the normal method (ie., decanting and filtering) is preferred, and has setup procedures to maximize sample size so that the slight losses of colloidal and/or soluble particles do not skew results.

Similarly, Table 17 contain a number of duplicate magnetic moment measurements for samples with vastly differing magnetics contents. The results illustrate that the moment measurements are reproducible to within 0.3 to 0.7 EMU/g. This does not create a problem for high EMU content samples, but can cause significant percentage-basis errors for samples containing minute amounts of magnetite (ie., see R.E. Magnetic Separator Tailings in Table 17). Custom Coals plans to duplicate and triplicate the magnetic moment samples, and also plans to combine the moment measurements with Davis-Tube separations, to reduce the likelihood of errors and ensure that accurate determinations of magnetics losses are obtained during integrated testing.

TABLE 16
DAVIS-TUBE SEPARATION
ACCURACY AND REPEATABILITY TESTING
(Pittsburgh No. 8 Seam Coal, Grade-K Magnetite)

<u>MTU/IMP</u> <u>Lab. No.</u>	<u>Particle Recovery</u> <u>Method/Approach</u>	<u>Davis Tube</u> <u>Product</u>	<u>Weight</u> <u>(g)</u>	<u>Weight</u> <u>(Wt%)</u>	<u>Moment</u> <u>(Emu/g)</u>	<u>Moment</u> <u>Dist. (%)</u>
5-8-1A	Water Evaporation	Mags	6.444	82.46	85.099	99.85
		<u>NonMags</u>	<u>1.371</u>	<u>17.54</u>	<u>0.601</u>	<u>0.15</u>
		Recon. Feed	7.815	100.00	70.275	100.00
		Head	7.537	-	74.084	-
5-8-1B	Water Evaporation	Mags	6.893	82.09	86.007	99.83
		<u>NonMags</u>	<u>1.504</u>	<u>17.91</u>	<u>0.652</u>	<u>0.17</u>
		Recon. Feed	8.397	100.00	70.719	100.00
		Head	8.064	-	74.084	-
5-8-2A	Settle, Decant, & Filter	Mags	6.424	85.61	85.285	99.84
		<u>NonMags</u>	<u>1.080</u>	<u>14.39</u>	<u>0.595</u>	<u>0.16</u>
		Recon. Feed	7.504	100.00	73.096	100.00
		Head	7.527	-	74.084	-
5-8-2B	Settle, Decant, & Filter	Mags	5.301	85.96	87.052	99.84
		<u>NonMags</u>	<u>0.866</u>	<u>14.04</u>	<u>0.855</u>	<u>0.16</u>
		Recon. Feed	6.167	100.00	74.948	100.00
		Head	6.254	-	73.986	-

Notes: All four separations done with identical splits of Test CMT#1, Sample #16
(Combined Drain Screen Underflow), from Commissioning Tests.

TABLE 17
MAGNETIC MOMENT
MEASUREMENT REPRODUCIBILITY
(Pittsburgh No. 8 Seam Coal, Grade-K Magnetite)

MTU/IMP Lab No.	Test Number	Sample Number	Sample Description	Davis Tube Product	Magnetic Moment		
					Dup. #1 (Emu/g)	Dup. #2 (Emu/g)	Avg. (Emu/g)
S-2	MT #2	#40	Cleaner Magnetic Separator Conc.	Head	86.995	86.800	86.897
				Mags	87.324	86.989	87.156
S-8	CMT #1	#16	Combined Drain Screen Effluent	Head	74.886	74.783	74.834
				Mags	85.577	84.993	85.285
				NonMags	0.636	0.554	0.595
S-14	CMT #1	#22	Rinse Screen Refuse Discharge	Head	8.746	9.441	9.093
				NonMags	0.297	0.316	0.307
S-16	CMT #1	#36	R.E. Magnetic Separator Tails	Head	0.922	0.940	0.931
				NonMags	0.723	0.437	0.580

Note: All measurements done with 0.03 to 0.15 gram sample dependent on bulk density of sample.

WET SCREENING ACCURACY TESTING

Custom Coals performed QA/QC testing to assess the completeness of the 500M wet screening being done with the homemade, vibrating-vacuum unit being used at site (see results in Table 18). In the testing, samples of heavy-media cyclone overflow (Sample #9A), underflow (Sample #8A), and feed (Sample #7) were subjected to normal screening and washing, where the sample is assumed complete once the lab screen effluent becomes clear (PHT#1). The washing amounts were also doubled in a similar test to access any improvement (PHT#2). Since all the magnetite is slightly finer than 500M the distribution of magnetics offers the best possible quantification of screening efficiency. The results in Table 18 illustrate, that in all cases, over 99.95 Wt% of the sample magnetics were screened into the 500Mx0 fraction, where they belong. This is extremely efficient, and illustrates that the normal washing approach is more than adequate for our test samples.

DUPLICATE TESTING AND SAMPLE REPRODUCIBILITY

The final set of QA/QC-related tests, performed in May were duplicate testing and sampling done as part of the Heavy-Media Cyclone Component Testing. These tests were performed during the second batch of Heavy-Media Cyclone Component Tests (PHT#11-#20), at 10:1 media-to-coal ratio, after the inadequate mixing occurring during batch #1 had been principally corrected. Table 19 contains the results from two identical, back-to-back tests and illustrates the good performance reproducibility that can occur when the mixing stays steady.

By contrast, Table 20 shows the variability of a number of "actual" and "reconstituted" feed samples that were taken over a slightly longer period. The results indicate that the mixing is not yet perfect, and there are random and biased variations that occur as the sump volume is dropping that need to be considered when drawing conclusions from the data.

TABLE 18
QA/QC TEST FOR ON-SITE WET SCREENING
(Pittsburgh No. 8 Seam Coal, Grade-K Magnetite)

	<u>PHT#1 (Normal Washing)</u>		<u>PHT#2 (Double Washing)</u>		
	Sample #9A	Sample #8A	Sample #9A	Sample #8A	Sample #7
	<u>Cyclone</u> <u>Overflow</u>	<u>Cyclone</u> <u>Underflow</u>	<u>Cyclone</u> <u>Overflow</u>	<u>Cyclone</u> <u>Underflow</u>	<u>Actual</u> <u>Feed</u>
<u>Top x 325M Size Fraction</u>					
Weight Distribution (Wt%)	44.9	7.3	47.4	4.2	22.9
Magnetics (Wt%)	0.01	0.44	0.01	0.41	0.07
Magnetics Distribution (Wt%)	0.01	0.04	0.01	0.02	0.02
<u>325 x 500M Size Fraction</u>					
Weight Distribution (Wt%)	5.7	2.4	7.9	1.5	4.2
Magnetics (Wt%)	0.03	0.40	0.04	0.47	0.17
Magnetics Distribution (Wt%)	0.00	0.01	0.01	0.01	0.01
<u>500M x 0 Size Fraction</u>					
Weight Distribution (Wt%)	49.4	90.3	44.7	94.3	72.9
Magnetics (Wt%)	93.78	96.97	85.33	94.96	94.22
Magnetics Distribution (Wt%)	99.99	99.95	99.98	99.97	99.97
<u>Combined Size Fractions</u>					
Weight Distribution (Wt%)	100.0	100.0	100.0	100.0	100.0
Magnetics (Wt%)	46.33	87.61	38.15	89.57	68.71
Magnetics Distribution (Wt%)	100.00	100.00	100.00	100.00	100.00

Note: Magnetics (Wt%) determined from Davis-Tube Separations on all size fractions.

TABLE 19
DUPLICATE TEST RESULTS
HEAVY-MEDIA CYCLONE COMPONENT TESTS
(Pittsburgh No. 8 Seam Coal, Grade-K Magnetite)

	<u>Test PHT #18 Results</u>			<u>Test PHT #19 Results</u>		
	<u>Sample 9A Cyclone Overflow</u>	<u>Sample 8A Cyclone Underflow</u>	<u>Recon. Feed</u>	<u>Sample 9A Cyclone Overflow</u>	<u>Sample 8A Cyclone Underflow</u>	<u>Recon. Feed</u>
<u>SLURRY COMPOSITION</u>						
Slurry Feedrate (GPM)	-	-	36.2	-	-	36.2
Slurry SG	1.31	1.80	1.48	1.32	1.80	1.50
Solids Content (Wt%)	48.3	59.3	53.1	48.6	59.5	53.4
<u>OVERALL SOLIDS PERFORMANCE</u>						
Yield (Wt%)	51.6	48.4	100.0	50.9	49.1	100.0
Proportion (Wt%)	100.0	100.0	100.0	100.0	100.0	100.0
Ash Content (Wt%)	42.49	87.15	64.11	45.17	89.32	66.81
<u>TOP X 325M PERFORMANCE</u>						
Yield (Wt%)	79.4	20.6	100.0	78.8	21.2	100.0
Proportion (Wt%)	25.3	7.0	16.5	23.7	6.6	15.3
Ash Content (Wt%)	6.19	58.38	16.94	6.32	59.82	17.66
<u>325 X 500M PERFORMANCE</u>						
Yield (Wt%)	76.3	23.7	100.0	75.0	25.0	100.0
Proportion (Wt%)	12.1	4.0	8.2	11.3	3.9	7.7
Ash Content (Wt%)	4.83	24.00	9.37	4.96	26.24	10.28
<u>500M x 0 PERFORMANCE</u>						
Yield (Wt%)	42.8	57.2	100.0	43.0	57.0	100.0
Proportion (Wt%)	62.5	88.9	75.3	65.0	89.5	77.0
Ash Content (Wt%)	64.46	92.35	80.41	66.32	94.24	82.23

Note: Both tests performed at 10:1 media-to-coal ratio, at 90 PSI feed pressure, with 0.12 square inch inlet 1.0 inch vortex, and 0.875 inch apex in 4" Heavy-Media Cyclone.

**TABLE 20
DUPLICATE FEED SAMPLE RESULTS
HEAVY-MEDIA CYCLONE COMPONENT TESTS
(Pittsburgh No. 8 Seam Coal, Grade-K Magnetite)**

	<u>Test PHT #18 Results</u>		<u>Test PHT #19 Results</u>	<u>Test PHT #20 Results</u>	
	<u>Actual Feed</u>	<u>Recon. Feed</u>	<u>Recon. Feed</u>	<u>Recon. Feed</u>	<u>Actual Feed</u>
<u>SLURRY COMPOSITION</u>					
Slurry SG	-	1.48	1.50	1.50	-
Solids Content (Wt%)	53.4	53.1	53.4	53.4	53.4
<u>OVERALL SOLIDS ANALYSIS</u>					
Proportion (Wt%)	100.0	100.0	100.0	100.0	100.0
Ash Content (Wt%)	69.82	64.11	66.81	67.01	64.84
<u>TOP X 325M ANALYSIS</u>					
Proportion (Wt%)	13.4	16.5	15.3	15.1	16.7
Ash Content (Wt%)	19.36	16.94	17.66	17.64	16.56
<u>325 X 500M ANALYSIS</u>					
Proportion (Wt%)	7.2	8.2	7.7	7.5	8.1
Ash Content (Wt%)	11.33	9.37	10.28	9.35	9.09
<u>500M X 0 ANALYSIS</u>					
Proportion (Wt%)	79.4	75.3	77.0	77.4	75.2
Ash Content (Wt%)	83.64	80.41	82.23	82.23	81.57

Note: All Tests performed with same feed batch at 40.0 Wt% Media Contamination.

MARCY BALANCE SENSITIVITY TESTING

During June CCI conducted a sensitivity test on the Marcy Balance to assure that accurate specific gravity measurements were being obtained. CCI decided to conduct this sensitivity test since in many cases the measured specific gravities of the 4" heavy media cyclone overflow and underflow did not agree with the calculated specific gravities of the overflow and underflow. Before conducting the sensitivity test the Marcy Gauge was calibrated with water and known specific gravity test samples. The results of the calibration indicated that the Marcy Balance was producing accurate results. Next, researchers developed four means to determine the sensitivity of the Marcy Balance. First the Marcy cup was allowed to overflow the entire cup before removing it from the correct media stream. Any material that was deposited on the sides of the cup were not removed and the cup was then placed on the Marcy Balance (column #1-Table 21) and a reading was obtained. Second, the cup was then removed and the sides cleaned to remove any material that was deposited on the cup sides before another reading was obtained (column #2 - Table 21). Next the media in the cup was removed and the cup was cleaned. The cup was then filled only to the overflow holes allowing any material that was deposited on the sides of the cup to remain and another reading was taken (column #3 - Table 9). Lastly, the cup was removed and the sides cleaned to remove any material that was deposited on the cup sides before another reading was obtained (column #4 - Table 9).

As can be seen from Table 21 the small amount of material deposited on the sides of the cup had almost no influence in the specific gravity reading. However, overflowing the Marcy cup had a significant influence on the specific gravity reading. This is most likely do to the solids setting in the cup during the time the sample is taken until the cup is placed on the Marcy Balance. By the time the cup is placed on the Marcy Balance most of the solids have settled below the overflow holes concentrating the solids in the Marcy cup which falsely increases the specific gravity reading of the Marcy Balance. During future test work, efforts will be made not to overflow the Marcy cup, and calculated specific gravities will be used instead of measured specific gravities if the measured vs. the calculated specific gravities differ by a large percentage.

TABLE 21: Marcy Balance Sensitivity Test Results

Overfilling Marcy and Not Cleaning	Overfilling Marcy and Then Cleaning	Not Overfilling Marcy and Not Cleaning	Not Overfilling Marcy and Then Cleaning	Nuclear Density Gauge	
S.G.	S.G.	S.G.	S.G.	S.G.	
1.440	1.430	1.410	1.410	1.42	
1.435	1.430	1.400	1.400	1.43	
1.435	1.430	1.400	1.400	1.43	
1.435	1.425	1.405	1.405	1.43	
1.430	1.430	1.410	1.410	1.43	
1.430	1.430	1.410	1.405	1.42	
1.430	1.430	1.410	1.405	1.43	
1.433	1.429	1.406	1.405	1.427	AVE

During this quarterly technical progress report two additional QA/QC issues were assessed. They included:

- Reconstituting the Grade-L magnetite magnetics and non-magnetite size fractions to assure that their reconstituted head agreed with the "as received" magnetite size consist.
- Assuring that the Grade-L magnetite size analysis did not change after numerous hours of integrated testing.

RECONSTITUTION OF GRADE-L MAGNETITE

During August concerns arose, regarding the Microtrac results of the "as received" magnetite vs. the 1.7 Amp Davis Tube magnetics of the magnetite in that the magnetics fraction of the magnetite was approximately 1 MVD finer than that of the "as received" magnetite. As a result, MTU's IMP performed Microtrac analysis on:

- The Grade-L "as received" magnetite.
- The 1.7 Amp Davis Tube magnetics from the Grade-L magnetite, and
- The 1.7 Amp Davis Tube non-magnetics from the Grade-L magnetite.

MTU's IMP then reconstituted the magnetics and non-magnetite fractions to obtain a reconstituted "as received" sample. The results are contained in Table 22.

Table 22: Reconstituted Grade-L Magnetite Comparison

Size(μ)	Cumulative As Received (Wt%)	Cumulative Magnetics (Wt%)	Cumulative Non-Magnetics (Wt%)	Cumulative Reconstituted Head
+ 88	0.0	0.0	0.0	0.0
88 x 62	0.0	0.0	0.0	0.0
62 x 44	0.0	0.0	0.0	0.0
44 x 31	0.0	0.0	0.0	0.0
31 x 22	0.0	0.0	0.0	0.0
22 x 16	1.1	0.8	3.5	0.9
16 x 11	8.6	7.9	13.7	8.2
11 x 7.8	24.5	23.2	27.0	23.4
7.8 x 5.5	43.7	42.6	40.3	42.5
5.5 x 3.9	58.9	57.9	50.5	57.6
3.9 x 2.8	75.9	76.8	65.1	76.3
2.8 x 1.9	91.0	92.1	82.6	91.7
1.9 x 1.4	96.3	96.6	91.3	96.4
1.4 x 0.9	99.3	99.2	97.3	99.1
-0.9	100.1	100.1	99.8	100.1

As can be seen from Table 22, the reconstituted head results agree extremely well with the "as received" results. Table No. 22 also indicates that the non-magnetics fraction is coarser than the magnetics fraction which explains the 1 MVD size difference between the "as received" magnetite and the 1.7 Amp Davis Tube magnetics.

GRADE-L MAGNETITE COMPARISONS

When removing the Grade-L magnetite from the Micro-Mag circuit a sample of the circulating media was obtained and analyzed for size and magnetic moment. This was done to assure that the magnetite quality did not change after numerous hours of processing during the primary integrated testing. Table 23 compares the results for the Grade-L magnetics before processing and after processing.

Table 23: Grade-L Magnetite Magnetics Comparison

Size (μ)	As Received		After Processing	
	Vol.	Cum.	Vol.	Cum.
+ 22	3.1	100.0	3.4	100.0
22 x 16	10.7	96.9	10.1	96.6
16 x 11	17.6	86.2	16.4	86.5
11 x 7.8	20.1	68.6	19.2	70.2
7.8 x 5.5	18.3	48.5	18.0	50.9
5.5 x 3.9	15.8	30.2	17.3	32.9
3.9 x 2.8	10.0	14.5	11.1	15.6
2.8 x 1.9	2.7	4.5	2.7	4.5
1.9 x 1.4	1.5	1.7	1.5	1.8
-0.9	0.3	0.3	0.3	0.3
MVD	6.64		6.51	
D ₉₀	12.78		12.72	
D ₅₀	5.67		5.42	
D ₁₀	2.40		2.34	
EMU/gm	77.24		77.02	

As can be seen from Table 23, the magnetics fraction of the Grade-L magnetite quality after processing in the Micro-Mag circuit is identical to that of the as received.

GRADE-M DUPLICATE EMU ANALYSIS

During November while performing Davis-Tube magnetic analysis on the two Grade-M primary integrated tests (PIT #9 and #10) it became obvious from the high ash contents in the Davis Tube tailings that the Davis Tube was unable to provide accurate magnetic analysis on the Grade-M magnetite. As a result, researchers were unable to compare the Davis Tube magnetics to those of the EMU magnetics to assure accurate magnetic analysis was being obtained. With no second method to verify magnetic content of samples, researchers decided to run duplicate EMU analysis on numerous samples to assure that the EMU magnetic analysis was

repeatable and could by itself be relied upon for magnetic analysis. The results from these duplicate samples are contained in Table 24.

TABLE 24: Comparison of Duplicate EMU Analysis

Sample No.	Original EMU Measurement	Duplicate EMU Measurement
84	76.629	76.025
85	74.479	74.411
87	44.545	44.544
88	21.862	22.037
90	64.929	65.227
92	79.201	80.005
99	59.337	60.091
100	23.539	23.007
102	51.289	51.298

As can be seen from Table No. 24, the duplicate EMU measurements compare extremely well to the original EMU measurements. With such excellent duplication results, EMU measurements will be used to determine magnetic content on all Grade-M magnetite test runs.

5.7.3 CIRCUIT TESTING RESULTS

No circuit testing or analytical results are being reported this quarter since the Micro-Mag project was placed on "hold" until August of 1996.

Section 5.8 - Task 80-: Analytical (Month 5-14)

As discussed in previous Quarterly Reports the analytical requirements have been determined. They are:

- Custom Coals on site laboratory performed % solids, ashing, wet screening, and sample preparation
- MTU's IMP performed density, magnetics/nonmagnetics separations, ashing on 500M x 0 nonmagnetics and microtrac analysis.
- CTE's Kentucky laboratory performed all fine washability analysis.
- CTE's Pennsylvania laboratory performed sulfur, sulfur forms, and Btu analysis.

Section 5.9 - Task 900: Circuit Decommissioning (Month 14)

The circuit decommissioning task has been deleted from Custom Coal's Contract as DOE has elected to leave to Micro-Mag circuit in place for possible future testing. As a result, the 20K that was budgeted for decommissioning the circuit will be used for additional testing. However, all equipment will be transferred to DOE possession prior to Custom Coals leaving site.

Section 5.10 - Task 1000: Data Evaluation (Months 5-15)

The data evaluation task began in January 1995 with the Laboratory Procedure Investigation and will run through October 1996. It will include evaluation of the preliminary laboratory procedure studies done prior to the circuit commissioning, as well as evaluation of all the circuit commissioning and testing results. Custom Coals' Project Manager will keep up on all data evaluation and present it in a timely fashion, within the Monthly Technical Status Reports and Quarterly Technical Progress Reports.

Section 5.11 - Task 1100: Final Reporting (Months 15-16)

Custom Coals anticipates submitting a Draft Final Report in September 1996. The report will contain:

- A chronology of the project events by task series.
- A summary of all testing results, sample analyses, and data calculations.
- A list of the major project conclusions with specific emphasis on the project objectives.
- A discussion of the project successes and failures with specific emphasis on methods of eliminating problems in future projects.
- An economic evaluation of the micronized magnetite project, including case studies for scale-up of the as-tested circuit.

After review by DOE's Technical Project Management Team, the Draft Final Report will be revised and resubmitted.

SECTION 6 - GOALS FOR NEXT QUARTERLY REPORTING PERIOD

Since the Micro-Mag project has been placed on "hold" until August of 1996, no goals are scheduled for the next reporting period.