



Machine Permissibility Checklist

Make and Model No. Getman 200/220 Lube Vehicle
Machine Type 4 x 4 Lube Truck
Approval No. 31-96-0

Corresponding Electrical Permissibility Checklist
DE NO. - 0021 Drawing No. T1139

Corresponding Safety Component Package Permissibility Checklist
Drawing No. T-1158

If an MSHA Part 36 approval plate has been affixed to this machine, it must meet the requirements of Part 36, Title 30, Code of Federal Regulations. It is the responsibility of the user to ensure that this machine is maintained in permissible condition in accordance with this checklist.

Permissibility:

1. To remain in permissible condition, this machine must meet the requirements of this checklist and both of the corresponding checklists.
2. The design of the exhaust conditioner limits permissible operation to grades not exceeding 20%.
3. Due to braking capability limitations, this machine shall not be operated on grades greater than 30%.

Note: When operated in areas which do not require permissible machines, this machine can be operated on grades greater than the 20% grade limitation due to the design of the exhaust conditioner, but in no case can the machine be operated on grades greater than 30% due to braking capability limitations.

The following tests and inspection procedures shall be conducted on the surface or in mine ventilation intake air only.

Intake System (Engine Combustion Air)

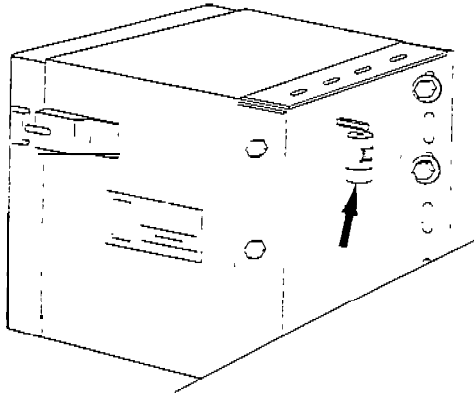

- (Weekly) 1. Restriction on air cleaner is not showing, RED.
- (Weekly) 2. Intake piping from air cleaner to air shut-off valve has no holes and is securely fastened.
- (Weekly) 3. Flame arrestor installed and properly secured.

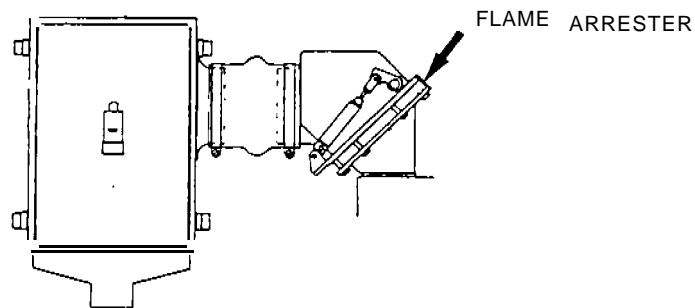

(Weekly) - Designates those inspection checks that must be performed during the weekly maintenance examination in accordance with 30 CFR Section 75.1914

Exhaust System

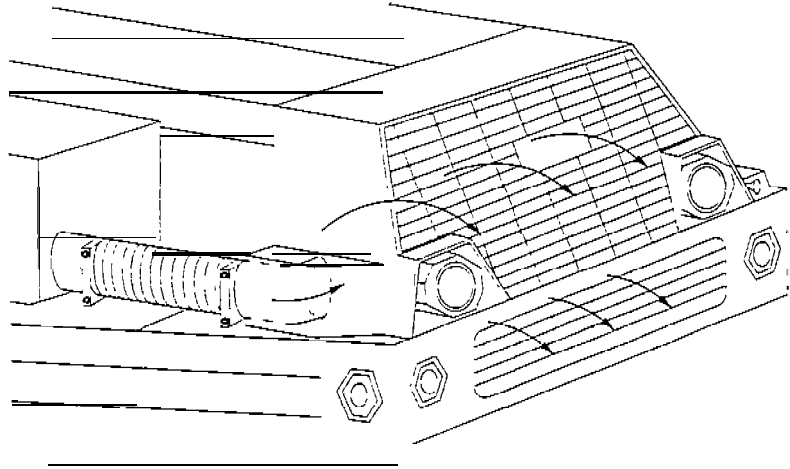

- (Weekly) 1. Check that the exhaust is discharged in front of the engine cooling fan on the side opposite the operator.

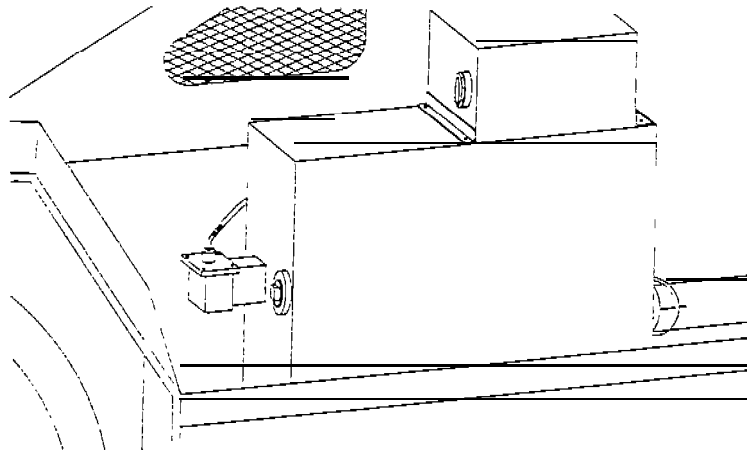

- (Weekly) 2. Check that the scrubber tank is in good condition with no open holes due to corrosion and all plugs are in place.
- (Weekly) 3. Check that exhaust scrubber outlet piping is in place and properly secured.

(Weekly) - Designates those inspection checks that must be performed during the weekly maintenance examination in accordance with 30 CFR, Section 75.1914

Fuel System

- (Weekly) 1. () There are no fuel leaks.
- (Weekly) 2. () The fuel fill cap is vented and the vent is not plugged.
- (Weekly) 3. () The fuel filler cap is self-closing and is attached to the tank in a manner which will prevent loss during refueling.

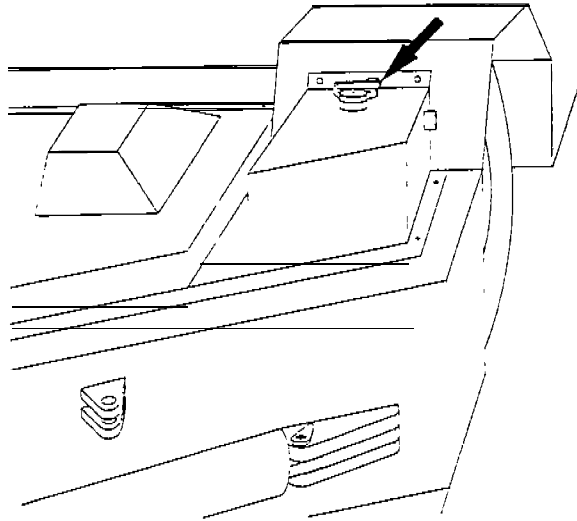

- (Weekly) 4. () Auxiliary fuel tank capacity has not been added to the vehicle.
- (Weekly) 5. () Fuel filter and water separator are properly installed and are not damaged.
- (Weekly) 6. () The fuel injection rate adjustment mechanism is lockwired locked and sealed by Caterpillar. An additional lockwire using two bolts has been installed.

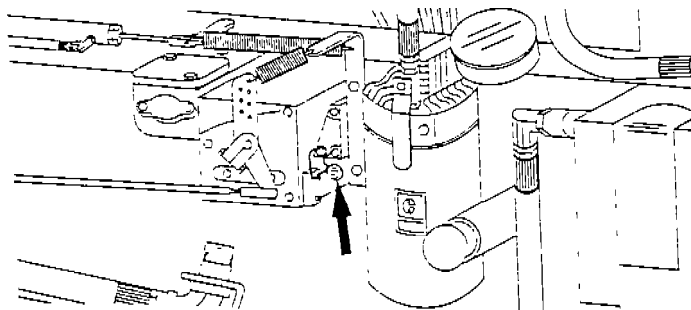

(Weekly) - Designates Those Inspection Checks That Must Be Performed During The Weekly Maintenance Examination In Accordance With 30 CFR Section 75.1914.

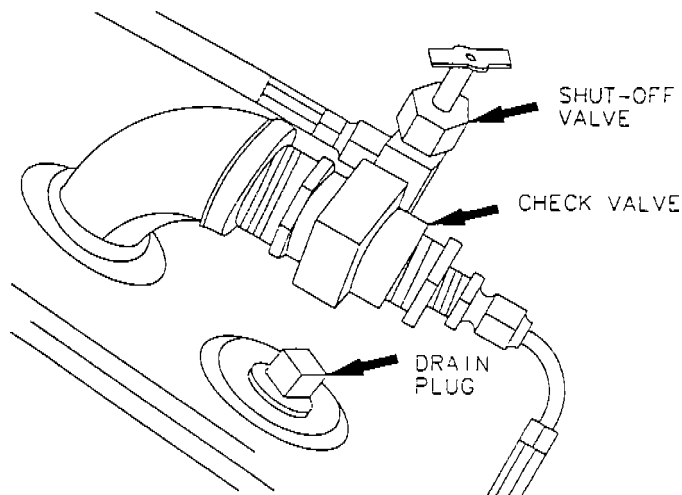

- (Weekly) 7. () The fuel shut-off valve in the fuel supply line is operable.
- (Weekly) 8. () The drain plug in the fuel tank is locked in position. (Pipe plugs are considered “locked in position” when tight.)
- (Weekly) 9. () Fuel lines are not routed near or connected to hot exhaust components and are protected from external damage.
- (Weekly) 10. () Fuel lines are adequately secured.

(Weekly) - Designates those inspection checks that must be performed during the weekly maintenance examination in accordance with 30 CFR, Section 75.1914

B. Braking System

Warning: Brake tests are to be conducted on a relatively level surface, away from traffic areas where other machines or persons may be moving about. Consider the possible consequences of testing a machine with assumed braking inadequacies, and select an area where the test machine would not cause an accident due to these inadequacies.

(Weekly) 1. () Service Brake Test.

- a. With the engine operating and the machine stationary, apply the service brake.
- b. Release all other brakes.
- c. Place the transmission gear selector in 2nd gear and the directional control selector in forward or reverse.
- d. Depress the accelerator to full throttle, allowing the engine to put the transmission torque converter into a stall condition.

If the service brake is operating satisfactorily, the unit will not move when the above procedure is followed. If movement is detected, the service brake must be repaired or adjusted.

(Weekly) 2. () Parking Brake Test.

- a. With the engine operating and the machine stationary, apply the parking brake.

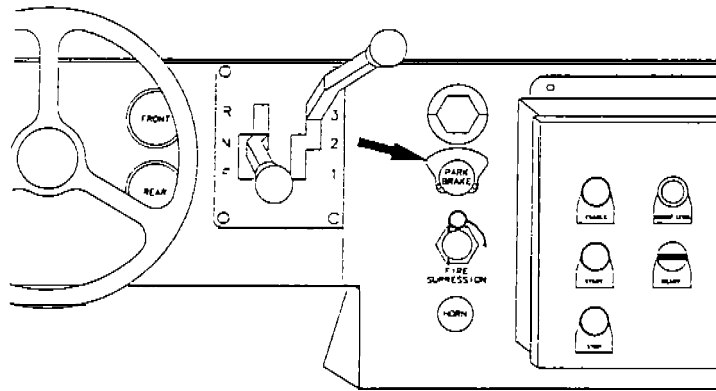

(Weekly) - Designates those inspection checks that must be performed during the weekly maintenance examination in accordance with 30 CFR, Section 75.1914

- b. Release all other brakes.
- c. Place the transmission gear selector in 2nd gear and the directional control selector in forward or reverse.
- d. Depress the accelerator to full throttle, allowing the engine to put the transmission torque converter into a stall condition.

If the parking brake is operating satisfactorily, the unit will not move when the above procedure is followed. If movement is detected, the parking brake must be repaired or adjusted.

Air Compressor (Lube Pumps Drive System)

- (Weekly) 1. Check compressor unloading valve. Set at 100 PSI cut-out pressure maximum. Do not exceed 100 PSI.
- (Weekly) 2. Check compressor RPM. Do not exceed 900 RPM. Set hand throttle (pre-set) to run engine at 1200 RPM. This will provide hydraulic oil supply to control the compressor at 900 RPM.
- (Weekly) 3. Check drive belts for wear and adjustment.
- (Weekly) 4. Check all hoses are properly routed and secured.
- 5. Drain off excess water daily in main air reservoir.
- 6. Drive belts must be static conducting.

Miscellaneous

- (Weekly) 1. Five pound fire extinguisher is available and charged.
- 2. Fire suppression systems, one on the engine end and one on the lube end, are charged and in good condition. The fire suppression systems are operable as determined by the following checks:
 - a. Note general appearance of system components for mechanical damage or corrosion.

(Weekly) - Designates those inspection checks that must be performed during the weekly maintenance examination in accordance with 30 CFR, Section 75.1914

- b. Check nameplate(s) for readability.
- c. Remove fill cap.

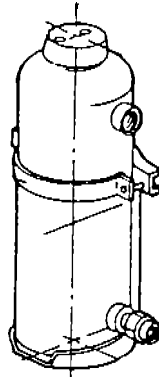

- d. Make certain tank is filled with free-flowing dry chemical to a level of not more than three (3) inches from the bottom of the fill opening.
- e. Secure fill cap, hand tighten.

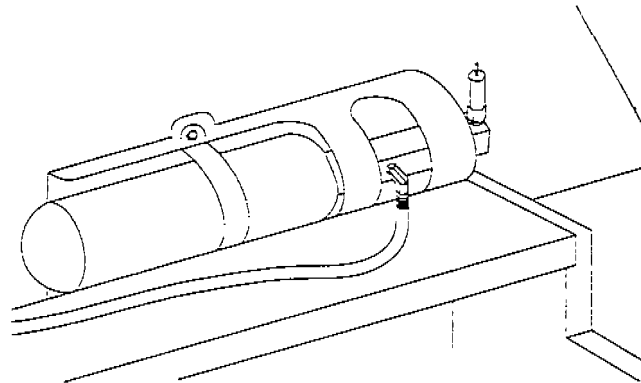

- f. Remove expellant gas cartridge and examine disc - seal should be unruptured.
- g. Return cartridge to pneumatic actuator/cartridge receiver, hand tighten and secure the bracket.
- h. Check hose, fittings and nozzles for mechanical damage and cuts.
- I. Check nozzle openings - slot on nozzle should be closed (capped) with silicon grease or covered with plastic blow-off cap.

(Weekly) - Designates Those Inspection Checks That Must Be Performed During The Weekly Maintenance Examination In Accordance With 30 CFR, Section 75.1914.

DASHBOARD ACTUATOR

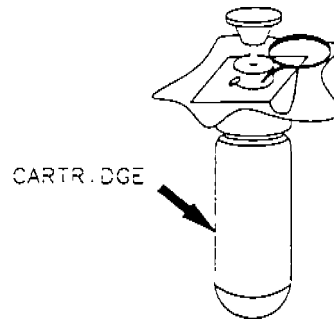

- j. Remove cartridge born manual actuator(s), and examine disc - seal should be unruptured.
- k. Return cartridge to manual actuator(s) assembly, hand tighten.
- l. Replace any broken or missing lead and wire seals.

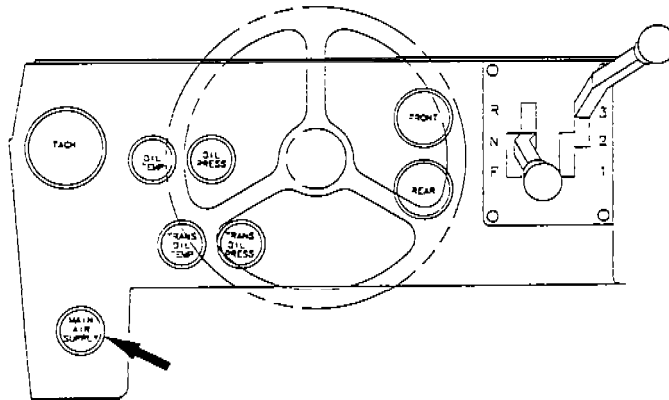

- (Weekly) 3. () The main air pressure gauge in the operator's compartment is operable.
- (Weekly) 4. () The machine has an MSHA Part 36 approval plate attached to it in the operator's compartment.
 - () The approval plate specifies a ventilation rate of- 6,500 CFM.

(Weekly) - Designates those inspection checks that must be performed during the weekly maintenance examination in accordance with 30 CFR, Section 75.1914

- (Weekly) 5. () The engine will not turn over unless the directional control selector is in the neutral position.

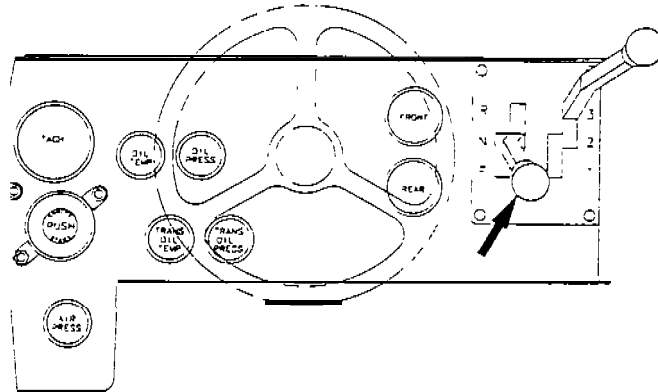

- (Weekly) 6. Front and rear running lights are operable.

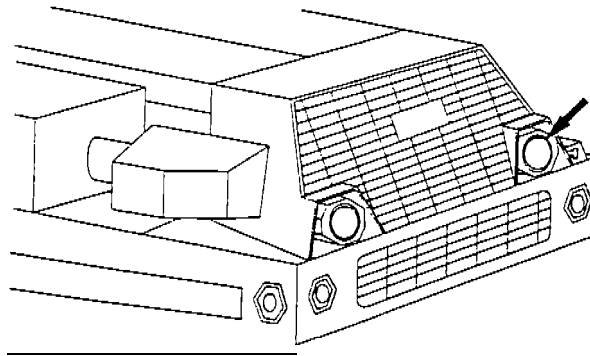

- (Weekly) 7. Electrical enclosures are properly sealed, and wiring hoses are in good condition,

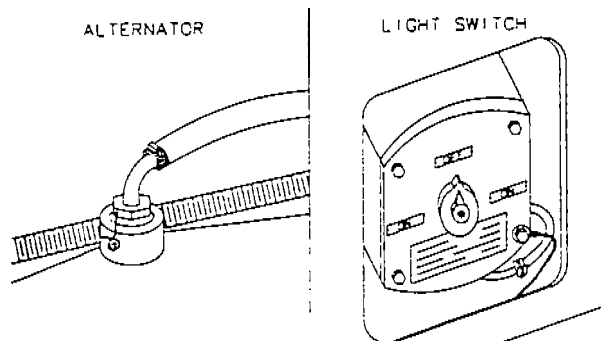

(Weekly) - Designates those inspection checks that must be performed during the weekly maintenance examination in accordance with 30 CFR Section 75.1914

MACHINE LAYOUT DIAGRAM

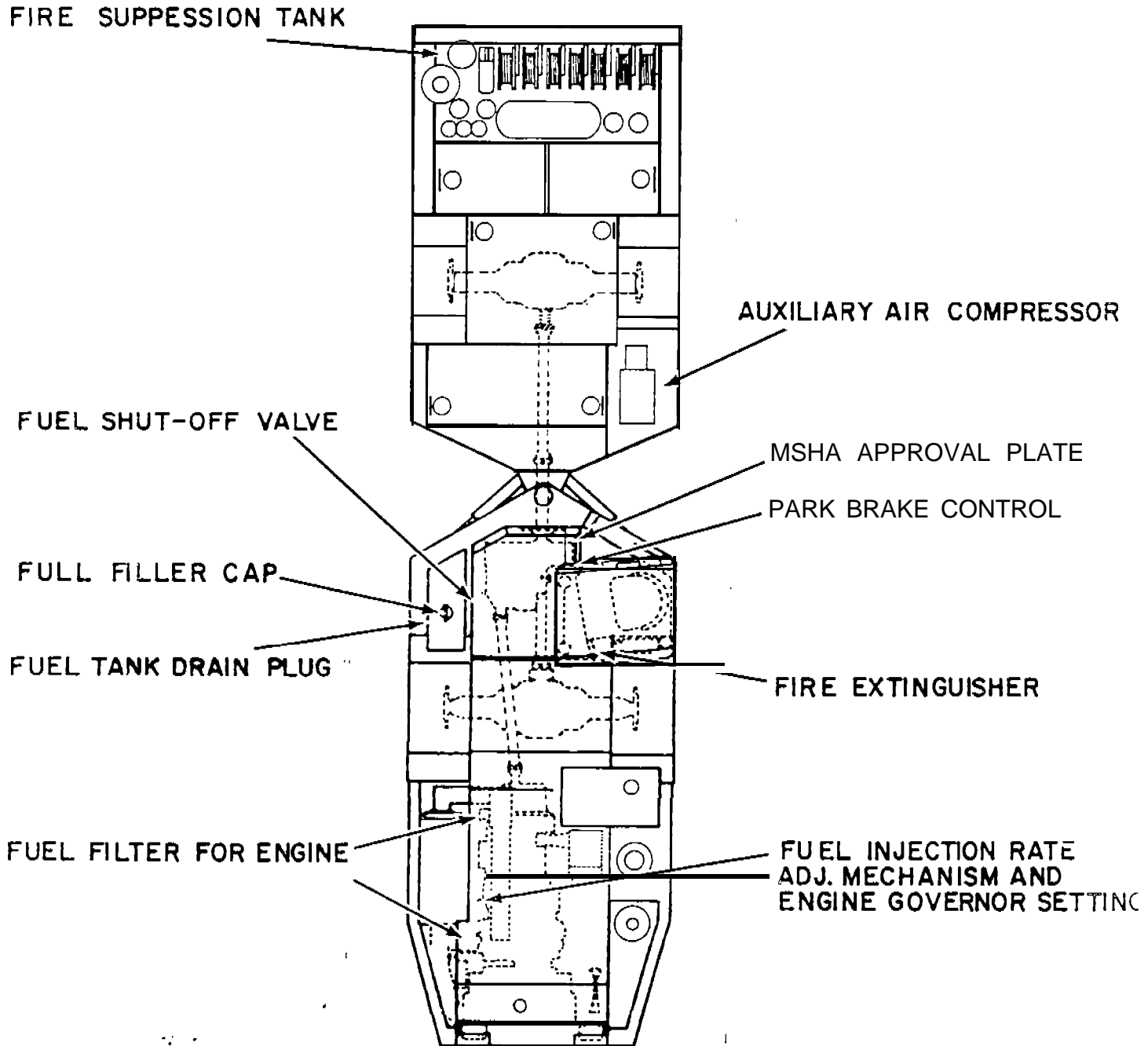

DO NOT REVISE WITHOUT PERMISSION FROM MSHA