

JEFFREY	MINING PRODUCTS	JEFFREY MINING PRODUCTS 274 EAST 1ST AVE. COLUMBUS, OHIO 43201	THIS DRAWING CONTAINS CONFIDENTIAL INFORMATION AND IS THE EXCLUSIVE PROPERTY OF JEFFREY MINING PRODUCTS. NEITHER THE DRAWING OR ITS CONTENTS ARE TO BE USED, REPRODUCED, OR DISCLOSED IN WHOLE OR PART, WITHOUT PRIOR WRITTEN CONSENT FROM JEFFREY MINING PRODUCTS.						
DRAWING NO. 553A870		SHEET NO. 1	PART 36 MACHINE APPROVAL NUMBERS THAT USE THIS CHECKLIST: 31-106-2						
DRAWN WCM	DATE 8/14/92	R E V	A KRT 4/21/97						
CHECKED	DATE								

**MACHINE/ELECTRICAL
CHECKLIST**

MAKE AND MODEL NO. - JEFFREY MODEL 4110
MACHINE TYPE: RAMCAR

IF AN MSHA PART 36 APPROVAL PLATE HAS BEEN AFFIXED TO THIS MACHINE, IT MUST MEET THE REQUIREMENTS OF PART 36, TITLE 30, CODE OF FEDERAL REGULATIONS. IT IS THE RESPONSIBILITY OF THE USER TO ENSURE THAT THIS MACHINE IS MAINTAINED IN PERMISSIBLE CONDITION IN ACCORDANCE WITH THIS CHECKLIST.

ALL INSPECTIONS AND TESTS SHALL BE PERFORMED IN FRESH AIR

PERMISSIBILITY:

- FOR A COMPLETE PERMISSIBILITY EVALUATION, THIS CHECKLIST MUST BE USED IN CONJUNCTION WITH A POWER SYSTEM CHECKLIST.
- THE DESIGN OF THE EXHAUST CONDITIONER LIMITS PERMISSIBLE OPERATION TO GRADES NOT EXCEEDING 20%.
- DUE TO BRAKING CAPABILITY LIMITATIONS, THIS MACHINE SHALL NOT BE OPERATED ON GRADES GREATER THAN 30%.

NOTE: WHEN A DPF SYSTEM IS INSTALLED, THE MACHINE SHALL NOT BE OPERATED ON A GRADE EXCEEDING 20%.

NOTE: WITHOUT A DPF SYSTEM INSTALLED AND WHEN OPERATED IN AREAS WHICH DO NOT REQUIRE PERMISSIBLE MACHINES, THIS MACHINE CAN BE OPERATED ON GRADES GREATER THAN 20% GRADE LIMITATION DUE TO THE DESIGN OF THE EXHAUST CONDITIONER, BUT IN NO CASE CAN THE MACHINE BE OPERATED ON GRADES GREATER THAN 30% DUE TO BRAKING CAPABILITY LIMITATIONS.

- THE APPROVAL PLATE SPECIFIES A VENTILATION RATE OF 5500 CFM FOR COAL MINES AND 8700 CFM FOR GASSY NON-COAL MINES.

TEST SHEET TITLE: MACHINE/ELECTRICAL CHECKLIST					MINE SAFETY & HEALTH ADMINISTRATION APPROVED PRINT. NO DEVIATION OR REVISION IS LEGAL UNTIL APPROVED BY MSHA			
DISTR. CODE SEE DRG.	STD: B	SPECIAL:	ENG. SEC L.	PRINT LOCATION:	DRAWING NUMBER 553A870	SHEET NO. 1	OF 11 SHEETS	

JEFFREY		MINING PRODUCTS	JEFFREY MINING PRODUCTS 274 EAST 1ST AVE. COLUMBUS, OHIO 43201			THIS DRAWING CONTAINS CONFIDENTIAL INFORMATION AND IS THE EXCLUSIVE PROPERTY OF JEFFREY MINING PRODUCTS. NEITHER THE DRAWING OR ITS CONTENTS ARE TO BE USED, REPRODUCED, OR DISCLOSED IN WHOLE OR PART, WITHOUT PRIOR WRITTEN CONSENT FROM JEFFREY MINING PRODUCTS.				
DRAWING NO. 553A870			SHEET NO. 2	PART 36 MACHINE APPROVAL NUMBERS THAT USE THIS CHECKLIST: 31-106-2						
DRAWN WCM	DATE 8/14/92	R E V	A KRT 4/21/97							
CHECKED	DATE									

A. FUEL SYSTEM:

*1. () THERE ARE NO FUEL LEAKS.

*2. () THE FUEL FILLER CAP (1)** IS VENTED AND THE VENT IS NOT PLUGGED (SEE FIGURE 1).

**REFERENCED ITEMS SHOWN ON MACHINE LAYOUT DIAGRAM.

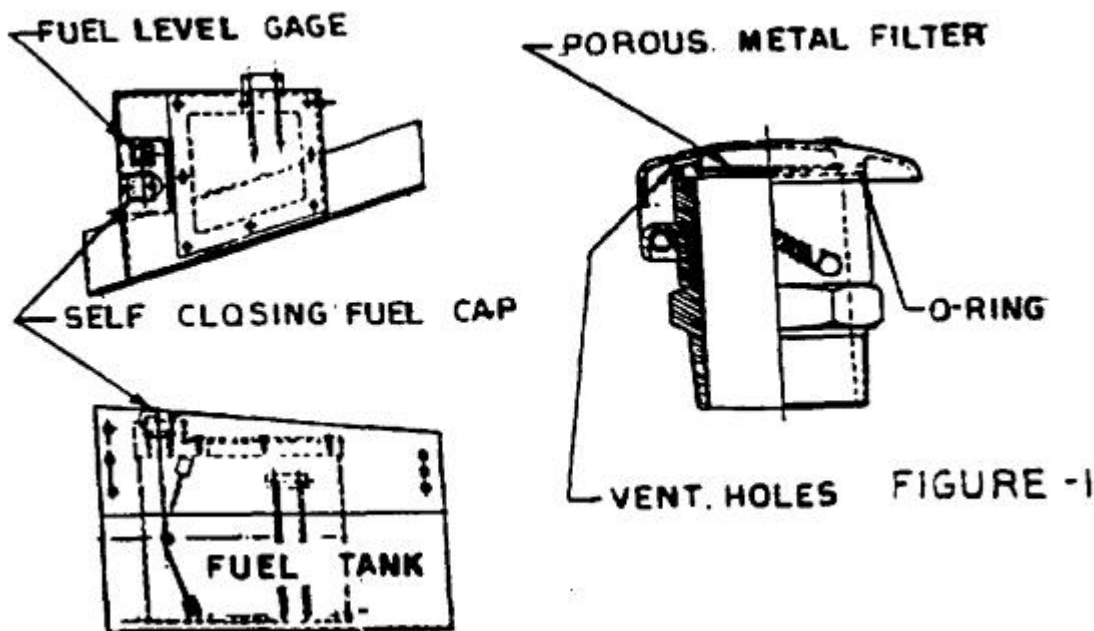

*(WEEKLY) DESIGNATES THOSE INSPECTION CHECKS THAT MUST BE PERFORMED DURING THE WEEKLY MAINTENANCE EXAMINATION IN ACCORDANCE WITH 30 CFR, SECTION 75.1914.

*3. () THE FUEL FILLER CAP IS SELF-CLOSING AND IS ATTACHED TO THE TANK IN A MANNER WHICH WILL PREVENT LOSS DURING REFUELING.

TEST SHEET TITLE: MACHINE/ELECTRICAL CHECKLIST					MINE SAFETY & HEALTH ADMINISTRATION APPROVED PRINT. NO DEVIATION OR REVISION IS LEGAL UNTIL APPROVED BY MSHA		
DISTR. CODE SEE DRG.	STD: B	SPECIAL:	ENG. SEC L.	PRINT LOCATION:	DRAWING NUMBER 553A870	SHEET NO. 2	OF 11 SHEETS

JEFFREY		MINING PRODUCTS	JEFFREY MINING PRODUCTS 274 EAST 1ST AVE. COLUMBUS, OHIO 43201			THIS DRAWING CONTAINS CONFIDENTIAL INFORMATION AND IS THE EXCLUSIVE PROPERTY OF JEFFREY MINING PRODUCTS. NEITHER THE DRAWING OR ITS CONTENTS ARE TO BE USED, REPRODUCED, OR DISCLOSED IN WHOLE OR PART, WITHOUT PRIOR WRITTEN CONSENT FROM JEFFREY MINING PRODUCTS.				
DRAWING NO. 553A870			SHEET NO. 3	PART 36 MACHINE APPROVAL NUMBERS THAT USE THIS CHECKLIST: 31-106-2						
DRAWN WCM	DATE 8/14/92	R E V	A KRT 4/21/97							
CHECKED		DATE								

- *4. () AUXILIARY FUEL TANK CAPACITY HAS NOT BEEN ADDED TO THE VEHICLE.
- *5. () FUEL FILTERS (2)** ARE PROPERLY INSTALLED AND ARE NOT DAMAGED.
- *6. () THE FUEL INJECTION RATE ADJUSTMENT MECHANISM (3)** AND THE ENGINE GOVERNOR SETTING ARE LOCKED AND SEALED (SEE FIGURE 2).

**REFERENCED ITEMS SHOWN ON MACHINE LAYOUT DIAGRAM

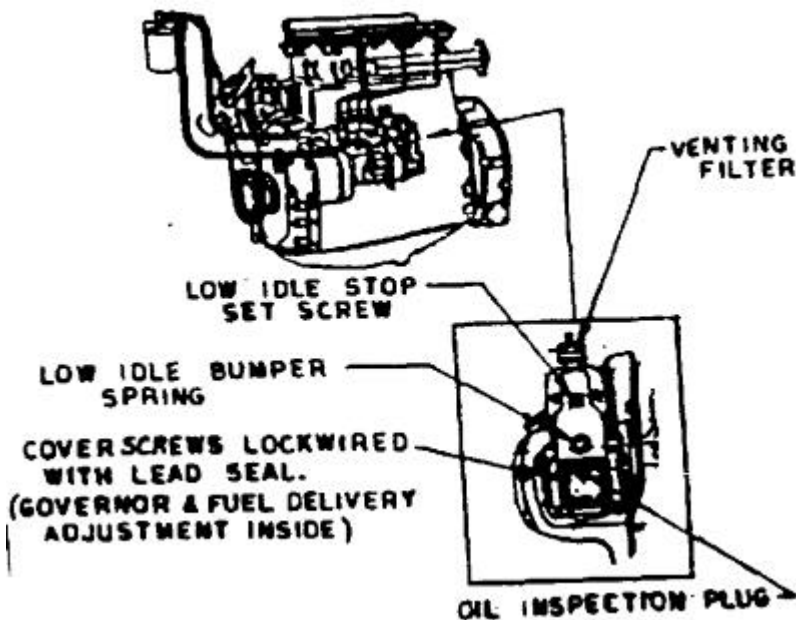

FIGURE 2

*(WEEKLY) DESIGNATES THOSE INSPECTION CHECKS THAT MUST BE PERFORMED DURING THE WEEKLY MAINTENANCE EXAMINATION IN ACCORDANCE WITH 30 CFR, SECTION 75.1914.

- *7. () THE FUEL SHUTOFF VALVE (4)** IN THE FUEL SUPPLY LINE IS OPERABLE.
- *8. () THE DRAIN PLUG (5)** IN THE FUEL TANK IS LOCKED IN POSITION.
(PIPE PLUGS ARE CONSIDERED "LOCKED IN POSITION" WHEN TIGHT).

TEST SHEET TITLE: MACHINE/ELECTRICAL CHECKLIST					MINE SAFETY & HEALTH ADMINISTRATION APPROVED PRINT. NO DEVIATION OR REVISION IS LEGAL UNTIL APPROVED BY MSHA		
DISTR. CODE SEE DRG.	STD: B	SPECIAL:	ENG. SEC L.	PRINT LOCATION:	DRAWING NUMBER 553A870	SHEET NO. 3	OF 11 SHEETS

JEFFREY		MINING PRODUCTS	JEFFREY MINING PRODUCTS 274 EAST 1ST AVE. COLUMBUS, OHIO 43201			THIS DRAWING CONTAINS CONFIDENTIAL INFORMATION AND IS THE EXCLUSIVE PROPERTY OF JEFFREY MINING PRODUCTS. NEITHER THE DRAWING OR ITS CONTENTS ARE TO BE USED, REPRODUCED, OR DISCLOSED IN WHOLE OR PART, WITHOUT PRIOR WRITTEN CONSENT FROM JEFFREY MINING PRODUCTS.				
DRAWING NO. 553A870			SHEET NO. 4	PART 36 MACHINE APPROVAL NUMBERS THAT USE THIS CHECKLIST: 31-106-2						
DRAWN WCM	DATE 8/14/92	R E V	A KRT 4/21/97							
CHECKED	DATE									

NOTE: THE FOLLOWING CHECKS MUST BE PERFORMED IF THE FUEL LINES HAVE BEEN REPAIRED OR REPLACED.

*9. () FUEL LINES ARE NOT ROUTED NEAR OR CONNECTED TO HOT EXHAUST COMPONENTS AND ARE PROTECTED FROM EXTERNAL DAMAGE.

*10. () FUEL LINES ARE SECURED.

B. BRAKING SYSTEM:

WARNING: BRAKE TESTS ARE TO BE CONDUCTED ON A RELATIVELY LEVEL SURFACE, AWAY FROM TRAFFIC AREAS WHERE OTHER MACHINES OR PERSONS MAY BE MOVING ABOUT. CONSIDER THE POSSIBLE CONSEQUENCES OF TESTING A MACHINE WITH ASSUMED BRAKING INADEQUACIES, AND SELECT AN AREA WHERE THE TEST MACHINE WOULD NOT CAUSE AN ACCIDENT DUE TO THESE INADEQUACIES.

*1. () SERVICE BRAKE TEST

A. WITH THE ENGINE OPERATING AND THE MACHINE STATIONARY, APPLY THE SERVICE BRAKE.

B. RELEASE ALL OTHER BRAKES

**REFERENCED ITEMS SHOWN ON MACHINE LAYOUT DIAGRAM

*(WEEKLY) DESIGNATES THOSE INSPECTION CHECKS THAT MUST BE PERFORMED DURING THE WEEKLY MAINTENANCE EXAMINATION IN ACCORDANCE WITH 30 CFR, SECTION 75-1914.

C. PLACE THE TRANSMISSION GEAR SELECTOR IN SECOND GEAR AND THE DIRECTIONAL CONTROL SELECTOR IN FORWARD OR REVERSE.

D. DEPRESS THE ACCELERATOR TO FULL THROTTLE, ALLOWING THE ENGINE TO PUT THE TRANSMISSION TORQUE CONVERTER INTO A STALL CONDITION.

TEST SHEET TITLE: MACHINE/ELECTRICAL CHECKLIST					MINE SAFETY & HEALTH ADMINISTRATION APPROVED PRINT. NO DEVIATION OR REVISION IS LEGAL UNTIL APPROVED BY MSHA			
DISTR. CODE SEE DRG.	STD: B	SPECIAL:	ENG. SEC L.	PRINT LOCATION:	DRAWING NUMBER 553A870	SHEET NO. 4	OF 11 SHEETS	

JEFFREY MINING PRODUCTS	JEFFREY MINING PRODUCTS 274 EAST 1ST AVE. COLUMBUS, OHIO 43201		THIS DRAWING CONTAINS CONFIDENTIAL INFORMATION AND IS THE EXCLUSIVE PROPERTY OF JEFFREY MINING PRODUCTS. NEITHER THE DRAWING OR ITS CONTENTS ARE TO BE USED, REPRODUCED, OR DISCLOSED IN WHOLE OR PART, WITHOUT PRIOR WRITTEN CONSENT FROM JEFFREY MINING PRODUCTS.						
	DRAWING NO. 553A870		SHEET NO. 5	PART 36 MACHINE APPROVAL NUMBERS THAT USE THIS CHECKLIST: 31-106-2					
DRAWN WCM	DATE 8/14/92	R E V	A KRT 4/21/97						
CHECKED	DATE								

IF THE SERVICE BRAKE IS OPERATING SATISFACTORILY, THE UNIT WILL NOT MOVE WHEN THE ABOVE PROCEDURE IS FOLLOWED. IF MOVEMENT IS DETECTED, THE SERVICE BRAKE MUST BE REPAIRED OR ADJUSTED.

- *2. () PARKING BRAKE TEST.
- A. WITH THE ENGINE OPERATING AND THE MACHINE STATIONARY, APPLY THE PARKING BRAKE (6)**.
 - B. RELEASE ALL OTHER BRAKES.
 - C. PLACE THE TRANSMISSION GEAR SELECTOR IN SECOND GEAR AND THE DIRECTIONAL CONTROL SELECTOR IN FORWARD OR REVERSE.
 - D. ACTUATE THE DECLUTCH BYPASS VALVE LOCATED ON THE LEFT SIDE WALL OF OPERATOR'S COMPARTMENT AND HOLD DURING TEST.

WARNING RELEASING THE DECLUTCH BYPASS VALVE DURING TEST WILL CAUSE THE MACHINE TO LURCH IN FORWARD OR REVERSE DIRECTION AS SELECTED. NOTE: IF THE DECLUTCH BYPASS VALVE IS RELEASED DURING TEST, THE TEST PROCEDURE MUST BE STARTED AGAIN BEGINNING WITH A.

- E. SHIFT PARK BRAKE LEVER FROM "ON" POSITION TO "AUTO" POSITION.
- F. DEPRESS THE ACCELERATOR TO FULL THROTTLE, ALLOWING THE ENGINE TO PUT THE TRANSMISSION TORQUE CONVERTER INTO A STALL CONDITION.

**REFERENCE ITEMS SHOWN ON MACHINE LAYOUT DIAGRAM

*(WEEKLY) DESIGNATES THOSE INSPECTION CHECKS THAT MUST BE PERFORMED DURING THE WEEKLY MAINTENANCE EXAMINATION IN ACCORDANCE WITH 30 CFR, SECTION 1914.

- G. AFTER TEST, RETURN ENGINE TO LOW IDLE, RELEASE DECLUTCH BYPASS VALVE AND RETURN PARK BRAKE LEVER TO "ON" POSITION.

IF THE PARKING BRAKE IS OPERATING SATISFACTORILY, THE UNIT WILL NOT MOVE WHEN THE ABOVE PROCEDURE IS FOLLOWED. IF MOVEMENT IS DETECTED, THE

TEST SHEET TITLE: MACHINE/ELECTRICAL CHECKLIST					MINE SAFETY & HEALTH ADMINISTRATION APPROVED PRINT. NO DEVIATION OR REVISION IS LEGAL UNTIL APPROVED BY MSHA			
DISTR. CODE SEE DRG.	STD: B	SPECIAL:	ENG. SEC L.	PRINT LOCATION:	DRAWING NUMBER 553A870	SHEET NO. 5	OF 11 SHEETS	

JEFFREY		MINING PRODUCTS	JEFFREY MINING PRODUCTS 274 EAST 1ST AVE. COLUMBUS, OHIO 43201			THIS DRAWING CONTAINS CONFIDENTIAL INFORMATION AND IS THE EXCLUSIVE PROPERTY OF JEFFREY MINING PRODUCTS. NEITHER THE DRAWING OR ITS CONTENTS ARE TO BE USED, REPRODUCED, OR DISCLOSED IN WHOLE OR PART, WITHOUT PRIOR WRITTEN CONSENT FROM JEFFREY MINING PRODUCTS.				
DRAWING NO. 553A870			SHEET NO. 6	PART 36 MACHINE APPROVAL NUMBERS THAT USE THIS CHECKLIST: 31-106-2						
DRAWN WCM	DATE 8/14/92	R E V	A KRT 4/21/97							
CHECKED	DATE									

PARKING BRAKE MUST BE REPAIRED OR ADJUSTED.

C. ELECTRICAL LIGHTING SYSTEM:

ALL ELECTRICAL ENCLOSURES MUST MEET THE FOLLOWING:

- *1. () ALL ELECTRICAL ENCLOSURES (I.E., ALTERNATOR (7)**, HEADLIGHT SWITCH (8)**, HEADLIGHT (9)** CONNECTION BOX(S) HAVE AN MSHA PLATE ATTACHED THAT IS CLEARLY STAMPED WITH AN MSHA CERTIFICATION NUMBER.
- *2. () ALL ELECTRICAL ENCLOSURES ARE SECURELY MOUNTED AND ALL VULNERABLE ELECTRICAL COMPONENTS ARE PROTECTED FROM PHYSICAL DAMAGE.
- *3. () ALL ELECTRICAL ENCLOSURES ARE INTACT (NOT CRACKED OR BROKEN); THE HEADLIGHT LENSES ARE NOT LOOSE. ALL SHAFT AND/OR PUSHBUTTON CONTROLS ARE OPERABLE.

**REFERENCED ITEMS SHOWN ON MACHINE LAYOUT DIAGRAM

*(WEEKLY) DESIGNATES THOSE INSPECTION CHECKS THAT MUST BE PERFORMED DURING THE WEEKLY MAINTENANCE EXAMINATION IN ACCORDANCE WITH 30 CFR, SECTION 75-1914.

- *4. () ALL THREADED COVERS ARE SECURED FROM LOOSENING BY A LOCKING SCREW, WIRE, OR OTHER MEANS.
- *5. () LOCKWASHERS OR EQUIVALENT DEVICES ARE PROVIDED FOR ALL BOLTS, SCREWS, OR STUDS THAT SECURE PARTS OF THE EXPLOSION-PROOF ENCLOSURES. ALL BOLTS, SCREWS, AND STUDS ARE IN PLACE AND TIGHTENED.

TEST SHEET TITLE: MACHINE/ELECTRICAL CHECKLIST					MINE SAFETY & HEALTH ADMINISTRATION APPROVED PRINT. NO DEVIATION OR REVISION IS LEGAL UNTIL APPROVED BY MSHA			
DISTR. CODE SEE DRG.	STD: B	SPECIAL:	ENG. SEC L.	PRINT LOCATION:	DRAWING NUMBER 553A870	SHEET NO. 6	OF 11 SHEETS	

JEFFREY		MINING PRODUCTS	JEFFREY MINING PRODUCTS 274 EAST 1ST AVE. COLUMBUS, OHIO 43201			THIS DRAWING CONTAINS CONFIDENTIAL INFORMATION AND IS THE EXCLUSIVE PROPERTY OF JEFFREY MINING PRODUCTS. NEITHER THE DRAWING OR ITS CONTENTS ARE TO BE USED, REPRODUCED, OR DISCLOSED IN WHOLE OR PART, WITHOUT PRIOR WRITTEN CONSENT FROM JEFFREY MINING PRODUCTS.				
DRAWING NO. 553A870			SHEET NO. 7	PART 36 MACHINE APPROVAL NUMBERS THAT USE THIS CHECKLIST: 31-106-2						
DRAWN WCM	DATE 8/14/92	R E V	A KRT 4/21/97							
CHECKED	DATE									

- *6. () NONE OF THE FASTENINGS USED FOR JOINTS ON THE EXPLOSION-PROOF ENCLOSURES ARE USED FOR ATTACHING NON-ESSENTIAL PARTS OR FOR MAKING ELECTRICAL CONNECTIONS.
- 7. () ALL JOINTS FORMING THE FLAME ARRESTING PATHS (FLANGES AND COVERS) ARE SMOOTH AND FREE FROM RUST, CORROSION, AND PITTING.
- *8. () USE FEELER GAUGES OF THE APPROPRIATE SIZE TO INSURE THE CLEARANCE IN ALL ACCESSIBLE FLAME PATH JOINTS, BETWEEN THE ENCLOSURES AND CORRESPONDING COVERS, ARE NOT EXCEEDED.
- *9. () HEADLIGHT(S) IS/ARE INSTALLED AT EACH END OF THE MACHINE AND OPERABLE.
- *10. () HEADLIGHT SWITCH MUST NOT CONTROL OR OPERATE ANY ELECTRICAL CIRCUITS OTHER THAN HEADLIGHTS.
- *11. () ALL LEAD ENTRANCES (PACKING GLANDS) ARE ASSEMBLED SO THAT THE CABLE JACKET PENETRATES INTO THE ENCLOSURE AND WHEN TIGHTENED, A 1/8" MINIMUM CLEARANCE REMAINS BETWEEN THE PACKING NUT AND STUFFING BOX. ALL PACKING NUTS AND STUFFING BOXES ARE SECURED FROM LOOSENING BY A LOCKING SCREW, WIRE OR OTHER MEANS.
- *12. () ALL UNUSED LEAD ENTRANCES ARE CLOSED WITH METAL PLUGS WHICH ARE SECURED IN PLACE BY SPOT WELDING, BRAZING, OR EQUIVALENT.

*(WEEKLY) DESIGNATES THOSE INSPECTION CHECKS THAT MUST BE PERFORMED DURING THE WEEKLY MAINTENANCE EXAMINATION IN ACCORDANCE WITH 30 CFR, SECTION 75-1914.

CABLES CONNECTING ELECTRICAL COMPONENTS MUST CONTINUE TO BE:

- *13. () CLAMPED IN PLACE TO PREVENT UNDUE MOVEMENT.
- *14. () PROTECTED FROM MECHANICAL DAMAGE BY POSITION, FLAME RESISTANT HOSE CONDUIT, METAL TUBING, OR TROUGHS. NOTE: FLEXIBLE OR THREADED RIGID METAL CONDUIT IS NOT ACCEPTABLE.
- *15. () NOT SUBJECT TO ABRASION FROM SHARP CORNERS OR EDGES.

TEST SHEET TITLE: MACHINE/ELECTRICAL CHECKLIST					MINE SAFETY & HEALTH ADMINISTRATION APPROVED PRINT. NO DEVIATION OR REVISION IS LEGAL UNTIL APPROVED BY MSHA			
DISTR. CODE SEE DRG.	STD: B	SPECIAL:	ENG. SEC L.	PRINT LOCATION:	DRAWING NUMBER 553A870	SHEET NO. 7	OF 11 SHEETS	

JEFFREY		MINING PRODUCTS	JEFFREY MINING PRODUCTS 274 EAST 1ST AVE. COLUMBUS, OHIO 43201				THIS DRAWING CONTAINS CONFIDENTIAL INFORMATION AND IS THE EXCLUSIVE PROPERTY OF JEFFREY MINING PRODUCTS. NEITHER THE DRAWING OR ITS CONTENTS ARE TO BE USED, REPRODUCED, OR DISCLOSED IN WHOLE OR PART, WITHOUT PRIOR WRITTEN CONSENT FROM JEFFREY MINING PRODUCTS.				
DRAWING NO. 553A870			SHEET NO. 8		PART 36 MACHINE APPROVAL NUMBERS THAT USE THIS CHECKLIST: 31-106-2						
DRAWN WCM		DATE 8/14/92		R E V	A KRT 4/21/97						
CHECKED		DATE									

- *16. () ISOLATED FROM HYDRAULIC LINES AND HYDRAULIC COMPONENTS.
- *17. () ISOLATED FROM FUEL LINES.
- *18. () FLAME RESISTANT IF NOT ENCLOSED IN HOSE CONDUIT. THIS IS INDICATED BY "MSHA" MARKINGS ON THE CABLE.
- *19. () IF HOSE CONDUIT IS USED, IT MUST BE SECURELY CLAMPED AT BOTH ENDS AND MSHA MARKINGS APPEAR AS "FLAME-RESISTANT", US MSHA, US MESA, OR USBM 2G

NOTE: THE FOLLOWING CHECK MAY BE PERFORMED WHEN AN ELECTRICAL ENCLOSURE HAS BEEN DISASSEMBLED FOR WHATEVER REASON, OR IF THERE IS CAUSE TO BELIEVE A PROBLEM EXISTS WITHIN THE ENCLOSURE.

- 20. () PROVIDED WITH SHORT CIRCUIT PROTECTION FOR EACH POWER CONDUCTOR.
- 21. () ELECTRICAL CONNECTIONS INSIDE THE ELECTRICAL ENCLOSURES ARE SECURE (NOT LOOSE) AND ARE INSULATED WHERE SPACE IS LIMITED. THE GROUND CONDUCTORS ARE NOT BROKEN AND ARE SECURELY ATTACHED.

*(WEEKLY) DESIGNATES THOSE INSPECTION CHECKS THAT MUST BE PERFORMED DURING THE WEEKLY MAINTENANCE EXAMINATION IN ACCORDANCE WITH 30 CFR, SECTION 75-1914.

E. MISCELLANEOUS:

- *1. () THE MACHINE IS EQUIPPED WITH AT LEAST ONE 5 LB. DRY CHEMICAL FIRE EXTINGUISHER (11)**. ALL FIRE EXTINGUISHERS ARE FULLY CHARGED.
- 2. () FOR MACHINES EQUIPPED WITH A FIRE SUPPRESSION SYSTEM, THE FIRE SUPPRESSION SYSTEM IS OPERABLE AS DETERMINED BY THE FOLLOWING CHECKS:

- A. () NOTE GENERAL APPEARANCE OF SYSTEM COMPONENTS FOR MECHANICAL

TEST SHEET TITLE: MACHINE/ELECTRICAL CHECKLIST					MINE SAFETY & HEALTH ADMINISTRATION APPROVED PRINT. NO DEVIATION OR REVISION IS LEGAL UNTIL APPROVED BY MSHA		
DISTR. CODE SEE DRG.	STD: B	SPECIAL:	ENG. SEC L.	PRINT LOCATION:	DRAWING NUMBER 553A870	SHEET NO. 8	OF 11 SHEETS

JEFFREY		MINING PRODUCTS		JEFFREY MINING PRODUCTS 274 EAST 1ST AVE. COLUMBUS, OHIO 43201			THIS DRAWING CONTAINS CONFIDENTIAL INFORMATION AND IS THE EXCLUSIVE PROPERTY OF JEFFREY MINING PRODUCTS. NEITHER THE DRAWING OR ITS CONTENTS ARE TO BE USED, REPRODUCED, OR DISCLOSED IN WHOLE OR PART, WITHOUT PRIOR WRITTEN CONSENT FROM JEFFREY MINING PRODUCTS.				
DRAWING NO. 553A870				SHEET NO. 9	PART 36 MACHINE APPROVAL NUMBERS THAT USE THIS CHECKLIST: 31-106-2						
DRAWN WCM		DATE 8/14/92		R E V	A KRT 4/21/97						
CHECKED				DATE							

DAMAGE OR CORROSION

- B. CHECK NAMEPLATE(S) FOR READABILITY.
- C. REMOVE FILL CAP.
- D. MAKE CERTAIN TANK IS FILLED WITH FREE-FLOWING DRY CHEMICAL TO A LEVEL OF NOT MORE THAN 3 INCHES FROM THE BOTTOM OF THE FILL OPENING.
- E. SECURE FILL CAP, HAND TIGHTEN.
- F. REMOVE EXPELLANT GAS CARTRIDGE AND EXAMINE DISC; SEAL SHOULD BE UNRUPTURED.
- G. RETURN CARTRIDGE TO PNEUMATIC ACTUATOR/CARTRIDGE RECEIVER, HAND TIGHTEN, AND SECURE IN BRACKET.
- H. CHECK HOSE, FITTINGS AND NOZZLES FOR MECHANICAL DAMAGE AND CUTS.
- I. CHECK NOZZLE OPENINGS; SLOT ON NOZZLE SHOULD BE CLOSED (CAPPED) WITH SILICONE GREASE OR COVERED WITH PLASTIC BLOW-OFF CAP.

*(WEEKLY) DESIGNATES THOSE INSPECTION CHECKS THAT MUST BE PERFORMED DURING THE WEEKLY MAINTENANCE EXAMINATION IN ACCORDANCE WITH 30 CFR, SECTION 75-1914.

**REFERENCED ITEMS SHOWN ON MACHINE LAYOUT DIAGRAM

- J. REMOVE CARTRIDGE FROM MANUAL ACTUATOR(S) AND EXAMINE DISC; SEAL SHOULD BE UPRUPTURED.
- K. RETURN CARTRIDGE TO MANUAL ACTUATOR(S) ASSEMBLY; HAND TIGHTEN.
- L. REPLACE ANY BROKEN OR MISSING LEAD AND WIRE SEALS.

*3. THE MAIN AIR PRESSURE GAUGE IN THE OPERATOR'S COMPARTMENT IS OPERABLE.

TEST SHEET TITLE: MACHINE/ELECTRICAL CHECKLIST					MINE SAFETY & HEALTH ADMINISTRATION APPROVED PRINT. NO DEVIATION OR REVISION IS LEGAL UNTIL APPROVED BY MSHA		
DISTR. CODE SEE DRG.	STD: B	SPECIAL:	ENG. SEC L.	PRINT LOCATION:	DRAWING NUMBER 553A870	SHEET NO. 9	OF 11 SHEETS

JEFFREY		MINING PRODUCTS	JEFFREY MINING PRODUCTS 274 EAST 1ST AVE. COLUMBUS, OHIO 43201			THIS DRAWING CONTAINS CONFIDENTIAL INFORMATION AND IS THE EXCLUSIVE PROPERTY OF JEFFREY MINING PRODUCTS. NEITHER THE DRAWING OR ITS CONTENTS ARE TO BE USED, REPRODUCED, OR DISCLOSED IN WHOLE OR PART, WITHOUT PRIOR WRITTEN CONSENT FROM JEFFREY MINING PRODUCTS.				
DRAWING NO. 553A870			SHEET NO. 10	PART 36 MACHINE APPROVAL NUMBERS THAT USE THIS CHECKLIST: 31-106-2						
DRAWN WCM	DATE 8/14/92	R E V	A KRT 4/21/97							
CHECKED		DATE								

- *4. () THE MACHINE HAS AN MSHA PART 36 APPROVAL PLATE (12)** ATTACHED TO IT IN THE OPERATOR'S COMPARTMENT.
- *5. () THE ENGINE WILL NOT TURN OVER UNLESS THE DIRECTIONAL CONTROL SELECTOR IS IN THE NEUTRAL POSITION.
- *6. () THE EXHAUST DIFFUSER AT THE SCRUBBER OUTLET IS INSTALLED.

IF THE OPTIONAL DIESEL PARTICULATE FILTER SYSTEM IS INSTALLED, PERFORM THE FOLLOWING CHECKS:

- *A. THE DIESEL PARTICULATE FILTER HOUSING IS IN GOOD CONDITION WITH NO OPEN HOLES, CRACKS, OR LOOSE CONNECTIONS.
- *B. A WARNING TAG SPECIFYING A MAXIMUM ALLOWABLE EXHAUST BACK-PRESSURE OF 25 INCHES OF WATER IS INSTALLED NEXT TO THE EXHAUST FILTER'S SERVICE INDICATOR.
- *C. THE SERVICE INDICATOR IS NOT DAMAGED AND APPEARS TO OPERATE PROPERLY.
- D. IT IS PERMISSIBLE TO OPERATE THE MACHINE BOTH WITH AND WITHOUT THE FILTER ELEMENT INSTALLED.

**REFERENCED ITEMS SHOWN ON MACHINE LAYOUT DIAGRAM

*(WEEKLY) DESIGNATES THOSE INSPECTION CHECKS THAT MUST BE PERFORMED DURING THE WEEKLY MAINTENANCE EXAMINATION IN ACCORDANCE WITH 30 CFR, SECTION 75-1914.

TEST SHEET TITLE: MACHINE/ELECTRICAL CHECKLIST					MINE SAFETY & HEALTH ADMINISTRATION APPROVED PRINT. NO DEVIATION OR REVISION IS LEGAL UNTIL APPROVED BY MSHA			
DISTR. CODE SEE DRG.	STD: B	SPECIAL:	ENG. SEC L.	PRINT LOCATION:	DRAWING NUMBER 553A870	SHEET NO. 10	OF 11 SHEETS	

JEFFREY		MINING PRODUCTS	JEFFREY MINING PRODUCTS 274 EAST 1ST AVE. COLUMBUS, OHIO 43201		THIS DRAWING CONTAINS CONFIDENTIAL INFORMATION AND IS THE EXCLUSIVE PROPERTY OF JEFFREY MINING PRODUCTS. NEITHER THE DRAWING OR ITS CONTENTS ARE TO BE USED, REPRODUCED, OR DISCLOSED IN WHOLE OR PART, WITHOUT PRIOR WRITTEN CONSENT FROM JEFFREY MINING PRODUCTS.				
DRAWING NO. 553A870			SHEET NO. 11	PART 36 MACHINE APPROVAL NUMBERS THAT USE THIS CHECKLIST: 31-106-2					
DRAWN WCM	DATE 8/14/92	R E V	A KRT 4/21/97						
CHECKED	DATE								

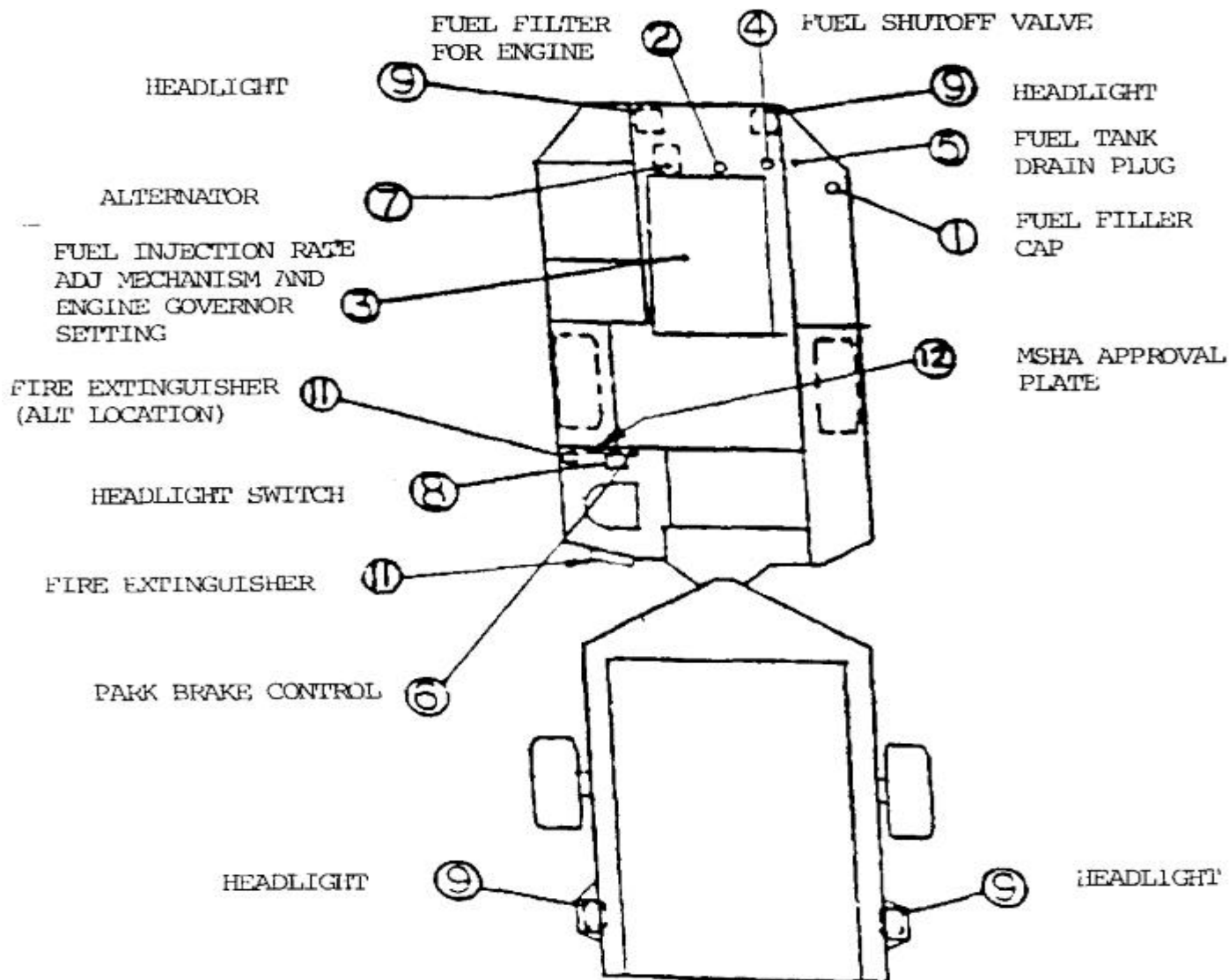

TEST SHEET TITLE: MACHINE/ELECTRICAL CHECKLIST					MINE SAFETY & HEALTH ADMINISTRATION APPROVED PRINT. NO DEVIATION OR REVISION IS LEGAL UNTIL APPROVED BY MSHA			
DISTR. CODE SEE DRG.	STD: B	SPECIAL:	ENG. SEC L.	PRINT LOCATION:	DRAWING NUMBER 553A870	SHEET NO. 11	OF 11 SHEETS	