

# Renewable Energy for Water Pumping Applications in Rural Villages

**Period of Performance:  
April 1, 2001–September 1, 2001**

N. Argaw

R. Foster and A. Ellis  
*New Mexico State University  
Las Cruces, New Mexico*



**NREL**

**National Renewable Energy Laboratory**

1617 Cole Boulevard  
Golden, Colorado 80401-3393

NREL is a U.S. Department of Energy Laboratory  
Operated by Midwest Research Institute • Battelle • Bechtel

Contract No. DE-AC36-99-GO10337

# Renewable Energy for Water Pumping Applications in Rural Villages

**Period of Performance:  
April 1, 2001–September 1, 2001**

N. Argaw

R. Foster and A. Ellis  
*New Mexico State University  
Las Cruces, New Mexico*

NREL Technical Monitor: L. Flowers

Prepared under Subcontract No. RAM-1-31224-01



**NREL**

**National Renewable Energy Laboratory**

1617 Cole Boulevard  
Golden, Colorado 80401-3393

NREL is a U.S. Department of Energy Laboratory  
Operated by Midwest Research Institute • Battelle • Bechtel

Contract No. DE-AC36-99-GO10337

## NOTICE

This report was prepared as an account of work sponsored by an agency of the United States government. Neither the United States government nor any agency thereof, nor any of their employees, makes any warranty, express or implied, or assumes any legal liability or responsibility for the accuracy, completeness, or usefulness of any information, apparatus, product, or process disclosed, or represents that its use would not infringe privately owned rights. Reference herein to any specific commercial product, process, or service by trade name, trademark, manufacturer, or otherwise does not necessarily constitute or imply its endorsement, recommendation, or favoring by the United States government or any agency thereof. The views and opinions of authors expressed herein do not necessarily state or reflect those of the United States government or any agency thereof.

Available electronically at <http://www.osti.gov/bridge>

Available for a processing fee to U.S. Department of Energy  
and its contractors, in paper, from:

U.S. Department of Energy  
Office of Scientific and Technical Information  
P.O. Box 62  
Oak Ridge, TN 37831-0062  
phone: 865.576.8401  
fax: 865.576.5728  
email: [reports@adonis.osti.gov](mailto:reports@adonis.osti.gov)

Available for sale to the public, in paper, from:

U.S. Department of Commerce  
National Technical Information Service  
5285 Port Royal Road  
Springfield, VA 22161  
phone: 800.553.6847  
fax: 703.605.6900  
email: [orders@ntis.fedworld.gov](mailto:orders@ntis.fedworld.gov)  
online ordering: <http://www.ntis.gov/ordering.htm>



## Forward

The availability of water and the ability to access it are key issues facing the world community. Faced by needs in developing regions as well as rural portions of the developed world, these issues are truly a global problem. The global nature of these issues opens the door for the application of communal solutions, as was demonstrated by the discussions surrounding the Johannesburg global climate meeting where water issues were a key concern that all nations could come together to support.

Like energy, the need for water is increasing rapidly as supplies of traditional resources continue to diminish due to overuse, waste, and pollution. Unlike energy, the ability to harness local resources to produce water is not possible. However, we do have the capability to use local energy resources to gain access to water supplies that would otherwise be unavailable. This water is either located underground in deep aquifers or in surface lakes, rivers, and streams. In many cases, the absence of available, inexpensive energy makes gaining access to this water expensive, time consuming, and potentially dangerous. The proper application of any of a number of energy options available today can make gaining access to this water a reality in many areas not previously considered.

This report, one of three written by the author, provides insight into accessing water through the use of modern pumping technology and a variety of energy sources available to rural and remote areas. The report is unique as it provides a very evenhanded approach to the selection of different pump and power choices to supply the needs of the user. It also provides comparative measures to help determine the most efficient and cost-effective method to provide energy, whether it is from renewable or non-renewable resources. Although publications on water pumping are common, few equally address all of the different technical approaches to water pumping, ranging from diesel technology to the use of photovoltaic systems.

This document is not a guidebook on the implementation of water pumping systems. Its purpose is to provide insight into the different options that are available and it provides methods to understand which technology may be the best for specific needs, conditions, and locations.

We hope to dispel some of the misconceptions about appropriate or inappropriate technologies through the publication of this document. Because water issues are so encompassing, all solutions have their place. The difficulty is determining which technologies are most appropriate for each user's specific need.

This book is one in a series of guidebooks that NREL has produced, with the support of the U.S. Department of Energy, to couple commercial renewable energy systems with rural applications, including other water issues, rural schools, health posts, and micro-enterprise. Other water related publications in this series describe the technical aspects of water pumping technology and provide insight to issues of water treatment, specifically purification, desalination, and wastewater treatment.

E. Ian Baring-Gould  
International Programs  
National Renewable Energy Laboratory



# Contents

Foreword.....	iii
Figures.....	ix
Tables.....	xi
Chapter 1: Introduction.....	1
Chapter 2: Water Resource Considerations.....	3
Water Resources.....	3
Water Demand.....	4
Water Storage and Distribution.....	6
Storage.....	6
Distribution.....	7
Chapter 3: Energy Resources: Background Information.....	10
Wind.....	10
Wind Speed Measurements.....	12
Solar.....	12
Estimating Solar Energy Resources.....	14
Grid Power.....	14
Diesel/Gasoline/Kerosene.....	15
Diesel Engines.....	17
Gasoline/Kerosene Engines.....	17
Chapter 4: Pumps and Motors Technology.....	19
Motor–Pump Subsystems.....	19
Pumps.....	20
Positive Displacement Pumps.....	20
Rotodynamic Pumps.....	22
Motors.....	24

DC Motors .....	25
AC Motors .....	26
Chapter 5: Selecting Power and Sizing Renewable Energy Water Pumping Technologies...	27
Wind Pumps .....	27
Mechanical Windpumps .....	29
Electrical Windpumps .....	30
Solar Pumps .....	32
PV Arrays .....	35
Power Conditioning Devices .....	36
Hybrid Systems .....	38
Power Source Selection .....	39
Sizing of Systems .....	43
System Performance .....	47
Chapter 6: Economics .....	49
Economic Evaluation Methods .....	50
Obtaining the Necessary Data .....	51
Economic Comparisons .....	52
Chapter 7: Installation, Operation, and Maintenance .....	59
System Installation .....	59
System Operation and Maintenance .....	60
Pumps and Motors .....	61
Pumping Options .....	61
Surface Pump Installation .....	62
Submersible Pump Installation .....	63
Pump Operation and Maintenance .....	64

Motor Operation and Maintenance.....	64
Power Sources.....	65
Wind Pumps .....	65
PV Pumps .....	67
Chapter 8: Institutional Considerations for Renewable Energy Development.....	70
Sustainability.....	70
Institutional Considerations .....	71
Policy Issues .....	71
Solid Partnerships.....	71
Capacity .....	71
Education and Training .....	71
Technical Assistance .....	72
Local Infrastructure Development.....	73
Program Implementation .....	73
Strategic Planning.....	74
Pilot Project .....	75
Sustainable Markets.....	76
Grassroots Development .....	76
Quality Hardware .....	76
Project Monitoring.....	77
Institutional Models for Renewable Energy Dissemination.....	77
Cash Sales.....	79
Consumer Financing.....	79
Revolving Credit Fund .....	80
Local Bank Credit.....	80



Leasing/Fee for Service.....	80
Dealer Credit .....	80
Subsidies.....	81
Chapter 9: Lessons Learned.....	82
Bibliography .....	84
Glossary .....	87
Appendix A: Nomograms Used to Design Windpumps.....	A-1

## Figures

Figure 2-1: PV-powered water pumping on a Colorado ranch.....	6
Figure 2-2: Schematic diagram of a village water supply powered by an electrical wind turbine with a typical water distribution network.....	8
Figure 3-1: Zone of disturbed flow.....	10
Figure 4-1: Types of pump sets for different ranges of head and flow rates.....	21
Figure 4-2: Basic operating principles of positive displacement pumps.....	21
Figure 4-3: Schematic diagrams of the four main types of electric motors.....	25
Figure 5-1: Agricultural applications: Livestock watering in Colorado.....	27
Figure 5-2: Typical vertical axis wind machines.....	28
Figure 5-3: Typical electrical windpump located at Santa Maria, Mexico.....	31
Figure 5-4: A typical village water supply using a PV pump located in Ethiopia.....	33
Figure 5-5: An irrigation PV pump in Ethiopia.....	33
Figure 5-6: The most common components of PV pumping systems.....	34
Figure 5-7: Diagram of a simple p-n junction PV cell.....	35
Figure 5-8: Arrangement of a PV array generator.....	36
Figure 5-9: Schematic presentation of stand-alone hybrid power sources with a backup generator for water pumping applications.....	39
Figure 5-10: Selected wind turbine power curves.....	41
Figure 5-11: Sensitivity analysis of hybrid systems at an average daily load of 20 kWh.....	42
Figure 5-12: Sensitivity analysis of hybrid systems based on a fuel cost of \$0.50/L.....	42
Figure 5-13: Schematic diagram of typical windpumps.....	43
Figure 5-14: Nomogram used to estimate the size of a PV array and daily water production.....	46
Figure 5-15: Power in the rotor at various wind speeds and rotor diameters, and for rotor efficiency of 40%.....	47
Figure 6-1: Unit water cost versus total pumping head using three types of mechanical pumps and two types of electrical windpumps at an average wind speed of 5.65 m/s.....	54

Figure 6-2: Sensitivity analysis of mechanical and electrical windpumps, based on average flow rate and wind speed data using Weibull distribution coefficient of $k = 2$ .....	55
Figure 6-3: The unit cost of water and the daily water production at 3, 5, and 7 kWh/m <sup>2</sup> /d .....	56
Figure 6-4: Hydraulic equivalent load limits at annual average solar radiation energy levels of 3, 5, and 7 kWh/m <sup>2</sup> /d.....	56
Figure 6-5: Economic comparison wind, PV, and diesel/gasoline pumping systems .....	57
Figure 6-6: Hydraulic equivalent load limits of PV pumps (DC and AC systems) and diesel-driven mechanical pumps (mono).....	57
Figure 6-7: Hydraulic equivalent load of electrical and mechanical windpumps at various average wind speeds using Weibull distribution coefficient of $k = 2$ ....	58
Figure 7-1: Installation of a solar surface pump (jack pump) at Rancho Guadalupe in Chihuahua, Mexico .....	62
Figure 7-2: Typical submersible pump installation in Sonora, Mexico .....	64
Figure 7-3: Typical tilt-up tower wind system installation (Bergey Excel 10 kW) in Quintana Roo, Mexico .....	66
Figure 7-4: Electrical wind water pumping system at the ADESOL training facility near Sosua, Dominican Republic.....	67
Figure 7-5: Typical PV water pumping system installation in Chihuahua, Mexico.....	68
Figure 7-6: Chihuahuan agricultural engineers learning how to conduct an acceptance test on a PV water pumping system.....	69
Figure 8-1: Wind energy training course in Oaxaca, Mexico, conducted by New Mexico State University.....	72
Figure 8-2: Mules carry PV modules to a remote site in Mexico.....	73
Figure 8-3: Pilot PV water pumping installation in the Mexican State of San Luis Potosí...75	
Figure 8-4: Average declining cost trends per installed watt for 41 pilot PV water pumping systems in Mexico implemented by the Chihuahua Renewable Energy Working Group with SNL.....	76
Figure 8-5: Institutional renewable energy sales approach pyramid .....	79

## Tables

Table 2-1: Typical Daily Water Consumption for Farm Animals .....	5
Table 2-2: Estimated Maximum Daily Water Demand for Various Types of Crop Irrigation .....	5
Table 3-1: Variation of Air Density with Altitude above Sea Level.....	11



# Chapter 1

## Introduction

Water is the primary source of life for mankind and one of the most basic necessities for rural development. The rural demand for water for crop irrigation and domestic water supplies is increasing. At the same time, rainfall is decreasing in many arid countries, so surface water is becoming scarce. Groundwater seems to be the only alternative to this dilemma, but the groundwater table is also decreasing, which makes traditional hand pumping and bucketing difficult.

As these trends continue, mechanized water pumping will become the only reliable alternative for lifting water from the ground. Diesel, gasoline, and kerosene pumps (including windmills) have traditionally been used to pump water. However, reliable solar (photovoltaic [PV]) and wind turbine pumps are now emerging on the market and are rapidly becoming more attractive than the traditional power sources. These technologies, powered by renewable energy sources (solar and wind), are especially useful in remote locations where a steady fuel supply is problematic and skilled maintenance personnel are scarce.

Although traditional windmills have been used to pump water for centuries, small wind turbines are especially appealing because they can be located further from the borehole, where the wind is strongest. Because these turbines can directly produce alternating current (AC) power, they lend themselves to applications such as lighting and other infrastructure services when water does not need to be pumped. Similarly, PV technology converts the sun's energy into electricity through electromagnetic means when the PV module (array) is exposed to sunlight. PV produces direct current (DC) power, and an inverter can be used to convert DC power to AC power. PV is especially suitable for water pumping because energy need not be stored for night pumping. Instead, water can be stored to supply water at night.

Currently, hybrids of PV and wind (with or without backup generators) are more promising for supplying uninterrupted power because they work independently of each other. Such systems do not require each component to be oversized. However, hybrid systems are generally more complex and require better qualified technicians.

This report introduces conventional and renewable energy sources for water pumping applications in rural villages by reviewing the technologies and illustrating typical applications. As energy sources for water pumping, we discuss diesel/gasoline/kerosene engines, grid power supplies, traditional windmills, electrical wind turbines, and PV.

This report is presented to form a basis for comparing and choosing various power source options for water pumping applications in rural areas. The objectives are to:

- Point out energy options for rural water pumping applications, such as water supply, irrigation, and livestock watering.

- Give readers a better understanding of resource assessment, technologies, and associated social and institutional aspects.
- Help readers to make the best choice among various technologies based on their technological, socioeconomic, and institutional aspects.
- Demonstrate how governments, nongovernmental organizations (NGOs), and other institutions can work together toward the sustainable use of renewable energy systems.

In the chapters that follow, we will see how renewable energy technologies can be used for irrigation, livestock watering, and domestic water supplies; the main necessities in rural development.

- **Chapter 2** emphasizes water resource aspects.
- **Chapter 3** briefly explains various energy resources including renewables and conventional energy sources.
- **Chapter 4** presents various types of pumps and motors used in water pumping applications.
- **Chapter 5** provides background information on renewable energy water pumping technologies and the sizing of systems.
- **Chapter 6** presents economical evaluation tools, market and technology trends of renewable energy sources, and sample evaluations of the economics of water pumping projects.
- **Chapters 7 and 8** cover operations and maintenance (O&M) and institutional considerations of renewable energy water pumping systems.
- **Chapter 9** presents the lessons learned from using renewable energy sources for water pumping application in rural areas.
- **Appendix A** contains nomograms used to design wind pumps.

## Chapter 2

# Water Resource Considerations

### Water Resources

The available water resource is an important criterion for choosing the kind of energy sources for any given water pumping application. Water can come either from surface water or groundwater, depending on:

- Availability
- Demand
- Topography
- Hydrological formation of the ground
- Annual rainfall
- Characteristics of the ground aquifer
- Type of proposed use or application

Surface water includes lakes, rivers, seawater, and rainwater; groundwater is found in underground aquifers, including springs. Groundwater can be shallow or deep depending on the ground's hydrological formation. Surface water can dry up in the dry season depending on the kind of aquifer, the annual rainfall, and the geographical location (such as arid, semiarid, and humid climates). These factors also affect the depth of the water table.

The quality of the water is another important factor in identifying water resources. If the water will be used as a domestic water supply, treatment may be needed. However, water quality may be less important for livestock watering and irrigation unless it contains harmful chemicals. Saltwater, for example, can burn some crops and damage soils.

For use in a domestic supply, surface water must be disinfected and may require additional treatment, depending on the content and sizes of particles (suspended solids) in the raw water. Human and animal activities can pollute surface water, which can contain silt and other particles from floodwater. Depending on the content of suspended solids in the raw water, it can be treated by first using a simple sedimentation tank and a slow sand-filtration system (in a rural water supply). Next, the treated water can be disinfected with a chlorine solution or gas or by using methods such as ultraviolet light disinfection or reverse osmosis. To provide clean and safe water for towns and cities, conventional water treatment methods (coagulation, flocculation, sedimentation, and filtration processes) are generally used. The water is then disinfected. Conventional treatment methods consume more power to run the chemical feeder pumps and the rapid filtration and backwashing processes. Additional power is required for booster pumps and other control systems.

Groundwater does not usually require treatment unless it contains salts or harmful chemicals such as fluoride. However, disinfection may be necessary to prevent waterborne diseases. The depth of the water table will have a great impact on the quality of the groundwater. Water pumped from shallow wells can easily be contaminated from human and animal activities and because the rising main pipe at the surface is improperly sealed.



Water pumped from deep wells can be relatively safe to drink if the rising main pipe is sealed properly.

The water resource identified should be large enough to fulfill the demand. Unusual climate changes such as droughts and seasonal variation of the water table must be considered. In general, large quantities of water are required for irrigation. The amount of water required for domestic water supplies and livestock watering in rural areas generally depends on the size of the human and livestock populations.

The amount of water available from any water source is estimated using standard methods such as weir notch (for surface water) or driller's test pumping (for boreholes). At the time of drilling, drillers test the pump or bail the well before operating the pump. During test pumping, the pump in the well should operate for about 48 hours at peak water demand while the "drawdown" is measured. The minimum water level where the water can drop in the well is referred to as the "dynamic water level." The water level cannot drop below this point, even after long hours of pumping. The distance from the static water level, which is the water level before pumping is started minus the dynamic water level, is called the drawdown. Checking these factors during test pumping allows the total pumping head to be measured, which results in design of the most suitable size and type of pump. After initial drilling, the water flow should be checked every 3–5 years to see if the well needs cleaning.

The water level in the well is measured with a special type of cable that has an electrode at the end and a measuring scale in centimeters and feet. When the cable is lowered slowly into the well and the electrode touches the water surface, a signal light will illuminate on the top of the cable, registering that position. In this manner, both the static and dynamic water levels can be measured, from which the drawdown can be calculated. For routine use, a permanent water level indicator can be installed with the pump.

## **Water Demand**

Water demand is another important criterion for designing rural water supply systems. The three main areas of need are:

- Village water supply
- Water for livestock
- Water for irrigation

These elements usually determine the water resource selection. Water demand for village water supplies is estimated from population size and from the daily per capita water consumption. However, the daily water consumption (water demand) cannot be enough because water consumption varies over 24 hours, so peak hour demand has to be estimated for a reliable water supply. The peak hour demand (usually noon) is the hour when the water consumption is highest. Water consumption is usually lowest at night.

Similarly, demand for livestock watering is estimated from the number of animals using the system multiplied by the per capita water consumption. Typical daily water consumption for farm animals is shown in Table 2-1.

**Table 2-1. Typical Daily Water Consumption for Farm Animals**

Type of Animal	Daily Water Consumption (L/animal)
Dairy cows	80
Beef brood cows	50
Horses and mules	50
Calves	30
Pigs	20
Sheep and goats	10
Chickens	0.1

Unlike demands for domestic and livestock water supplies, water demand for crop irrigation is seasonal. Because some crops require a maximum water supply for a relatively short growing season, all irrigation systems need to be designed for peak water demands. Irrigation water pumps are characterized by the need for large quantities of water. For this reason, wind- and PV-powered irrigation pumps are usually recommended for surface water resources or for shallow wells for high yield. In this case, producing high-value cash crops is advantageous, making such systems economically viable. Generally, water demand for irrigation varies from crop to crop and changes with the type of soil, soil preparation and irrigation methods, rainfall regimes, and other meteorological factors (temperature, humidity, wind speed, and cloud cover). Estimating the water demand for an irrigation application is complex and is beyond the scope of this report. However, local practice and experience are probably the best guides to estimating water requirements for a specific application. Table 2-2 shows the estimated daily water requirements for various types of crop irrigation.

**Table 2-2. Estimated Maximum Daily Water Demand for Various Types of Crop Irrigation**

Crops	Daily Water Requirement (m <sup>3</sup> /ha)
Rice	100
Rural village farms	60
Cereals	45
Sugar cane	65
Cotton	55

## **Water Storage and Distribution**

### **Storage**

Storage is necessary for good water management. Water can easily be distributed fairly and stored for critical times when the system fails or during bad weather. Water storage design is different for village water supplies, livestock watering, and irrigation. Storage for livestock water is generally designed so animals can drink directly from the tank, which is usually an open steel or concrete structure (see Figure 2-1), about 1 meter high. The size of storage area depends on the number of livestock. Generally, 3–5 days storage is recommended. Although the storage can be of any shape (hexagonal, rectangular, or square), animals can usually drink more easily from a circular tank.



**Figure 2-1. PV-powered water pumping on a Colorado Ranch**

Designing water storage for domestic water supply requires an understanding of end users, the geographical location, the power resource, and the availability of other water sources. If the end users are economically disadvantaged, water consumption will generally be very low. But if the climate is hot and humid, water consumption can be high.

The available power resource must be considered when determining storage size. For example, the storage tank should be larger for PV- or wind-powered water pumping systems, or both. Unlike conventional systems, PV/wind systems depend on daily weather conditions. Poor solar radiation or calm days create problems for meeting the daily water demand, so water tanks should be larger for such systems. Generally, 3 days of storage is recommended for renewable energy water pumping systems. However, water stored for many days can form a breeding ground for microorganisms, or can begin to smell, depending on the local climate.

The size of water tanks for conventional systems depends only on the peak and average daily water demand. However, for PV and wind pumps, local weather conditions are also important considerations.

Water tanks can be smaller if alternative water sources, such as hand pumps and rainwater, are available. In rural areas rainwater can be collected to water livestock and wash

clothes, depending on the amount of annual rainfall distribution in the area. Surface water that flows year-round (such as a river) can also be used for such tasks, reducing the need for large capacity water tanks. Every means of cost reduction must be considered when designing PV/wind pumping systems. For example, PV pumping systems may have seasonally adjustable tilt angles that can increase the daily water production by 5%–10%.

Unlike conventional pumping systems, estimating the proper size of a PV/wind pumping system, including the water tank, requires detailed consideration of each component, and of the entire system. Generally water tanks cost less than PV arrays or wind machines, and by installing a bigger water tank, water can be stored for low solar radiation or less windy days instead of oversizing the PV/wind pumping system at a much higher cost.

Water storage tanks for domestic water supply can be made of steel, polyvinyl chloride (PVC), fiberglass, concrete, or masonry. Steel, fiberglass, and PVC water tanks are used mostly for PV/wind systems. Small- to medium-sized concrete and masonry water tanks can also be used for wind and PV schemes, but they can be expensive compared to ready-made fiberglass, steel, and PVC water tanks. Larger concrete and masonry water tanks are usually more practical for big water supply schemes.

The geographical location and topography must also be considered when deciding on the material for water tanks. Storage tanks can be constructed underground, raised from the ground, or on the surface. Generally concrete storage is recommended for underground water storage and in hot climates to keep the water cool. Steel tanks can rust easily in seashore and salty locations. Although an antirust treatment can solve the problem, the right type of chemical must be selected for drinking water storage. The problem of identifying the rust risk and selecting the right type of antirust paint can be more problematic in rural areas, where the selection of painting chemicals may be limited. The other problem with steel tanks is that the water may become hot during the day. In warm climates, the water inside steel tanks heats more rapidly than in concrete or masonry tanks, which can increase the risk of bacteria growth and waterborne diseases. Ponds and dams are mainly used to store irrigation water. Long-term storage for irrigation systems using renewable energy is not economically and practically feasible. Short-term storage (a day or so) is more economical and enables better water management. The least favorable option is to pump water directly to the irrigation field. Although this is the cheapest practice, it is more difficult for farmers to manage. Generally, pumping water to an open earth or an earthen wall canal (which may be lined to minimize seepage) is recommended for irrigation.

### ***Distribution***

A large water distribution network is quite practical for rural water supplies, because of the additional cost involved in the distribution pipes and plumbing work. Also, the need to overcome head loss in a distribution network adds cost to the system. In rural villages, water is distributed through small pipes to a few water points, where each point might have four to eight water taps. The number of water points can be estimated based on the population size and density of houses. Figure 2-2 shows the schematic diagram of a

village water supply powered by an electrical wind turbine with a typical water distribution network.

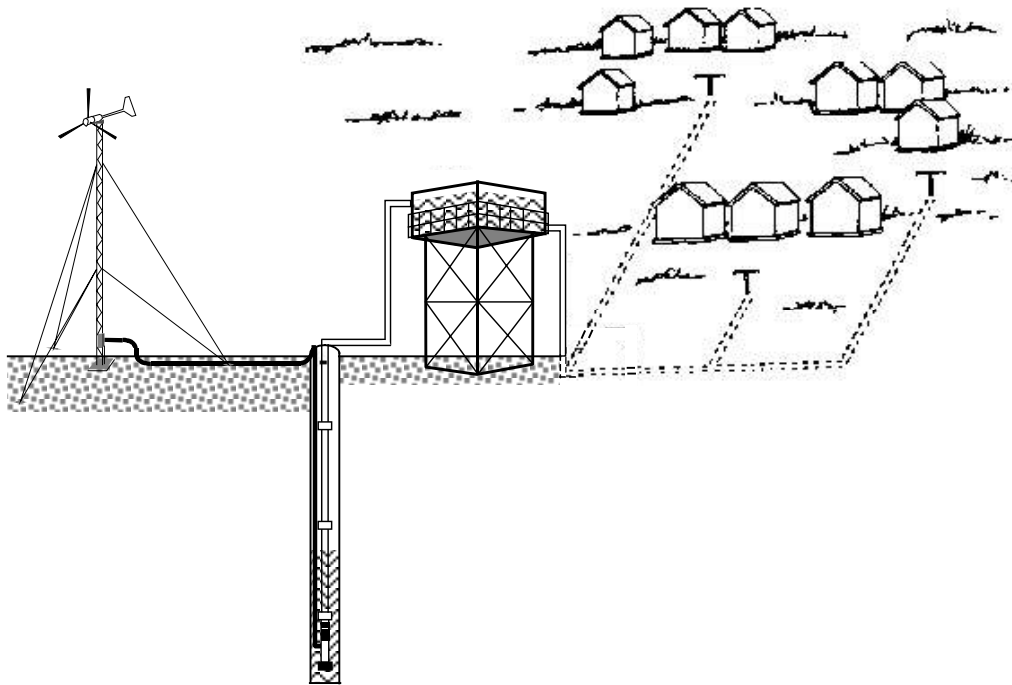

**Figure 2-2. Schematic diagram of a village water supply powered by an electrical wind turbine with a typical water distribution network.**

To distribute water fairly to the rural community, pumping it first to the tank and then distributing it from the tank by using gravity is recommended. This way, enough pressure can be built up at the water tank to distribute water by gravity. In addition, water will continuously flow in the tank, which helps to reduce the growth of bacteria. Finally, this helps maintain any leakage with little water loss and few interruptions to other distribution areas. However, distribution pipes must be sized carefully because smaller pipes create more friction than bigger pipes. Because oversized distribution pipes will raise the investment costs of the system, there are tradeoffs. The rural distribution network is relatively small, so leakage in these systems is less of a concern than in city water supplies. The water pressure in the distribution pipe is generally low in these systems and the chances of the pipe bursting are very unlikely. Water leakage caused by pipe rust is a common problem.

Water is distributed in many wind and PV water pumping systems installed for irrigation by feeding into the established network of earth channels. However, at least 40%–50% of the pumped water is wasted through seepage, weeds, and evaporation. Where costs are directly proportional to water output, losses of such magnitude are unacceptable, so it makes sense to construct canals lined with cement or earth to minimize seepage.

The most common methods of water application are channel, drip, flood, sprinkler, and hose and basin irrigation. Drip irrigation is the most effective method with minimum water losses (efficiency around 85%). The typical efficiency of a sprinkler type of application can be as high as 70%. Floor irrigation application efficiency is as much as 40%–50%. In areas where labor is cheap, a hose and basin irrigation method works best. Flood and channel irrigation methods are not economical for wind and PV systems.

Livestock watering may not require water distribution except small pipe work from water storage to the watering trough. Small distribution might be necessary if there is more than one watering trough.

## Chapter 3

### Energy Resources: Background Information

#### Wind

Wind is developed when convective currents created by the sun's rays form global air circulation across the surface of the Earth. When solar radiation reaches the Earth and heats its surface, reflection heats the surrounding air. Warm air, which is less dense than cool air, rises and cool air descends. In this process, the cool air becomes heated when it reaches the Earth's surface and rises back to the atmosphere; the raised warm air eventually cools and falls back to the Earth. This cycle will continue as long as the solar system exists. Similarly, wind is created over sea and land because of the differential heat between the land and the water. Mountain-to-valley breezes are local winds caused by heat variations. Wind speed increases as winds pass over mountain ridges and ridge tops; such places also have more frequent winds. Mountain wind is typically stronger at night and valley wind is stronger in the afternoon.

Wind tends to be calm in the morning and stronger in the afternoon. Early spring is usually windy and summer is generally calm. Winds are stronger near the shores of big lakes and along the coast because of unobstructed paths and sea-to-land breezes. Wind speed varies with height above the ground. Wind moving across the Earth's surface encounters friction caused by turbulence over and around buildings, mountains, trees, and other obstructions. These effects decrease with increasing height above the surface until unhindered airflow is maintained, so wind speed increases as turbulence decreases. Any obstruction to the wind depletes the wind's energy and creates turbulence.

Turbulence can shorten the life of a wind machine, so it should be mounted on a high tower so the rotor's bottom edge is at least 10 meters above and 100 meters away from any obstruction. Wind machines have to be located away from zone of disturbed flow (see Figure 3-1).

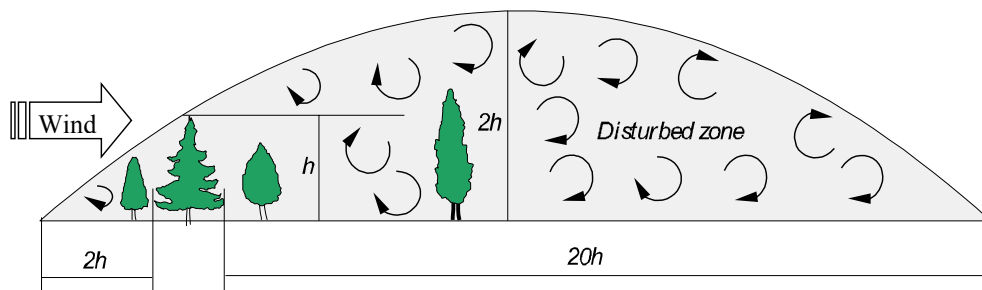

**Figure 3-1. Zone of disturbed flow.**

Wind speed increases with height. The rate of increase depends partly on height and partly on the nature of the ground surface. Rough ground with uneven trees, buildings, and other obstructions causes turbulence. Flat and unobstructed surfaces like the sea or a flat, grassy plain allow the wind to flow smoothly and result in higher wind speeds near the surface. Because the power output of a wind machine is proportional to the cube of

the wind speed, even a small increase in mean wind speed will give a sizable increase in power output. Using a larger tower to help overcome the effect of surface roughness is one of the most cost-effective ways to use the available wind resource.

Altitude also affects wind power output. High altitudes reduce the available power for a given wind speed. The power produced at any given wind speed is reduced by about 10% for every 1,000 meters (33,000 feet) above sea level. This is due to changes in the density of the air. Air density decreases with increasing temperature and altitude, and power in the wind machine is directly proportional to the wind speed and air density. For example, at 3,000 meters (10,000 feet), the density of air decreases by 30%. Air density also varies 10%–15% from season to season. Table 3-1 shows the variation of air density with altitude above sea level.

**Table 3-1. Variation of Air Density with Altitude Above Sea Level**

Altitude, ft	0	500	1000	2000	3000	5000	6000	7000	8000	9000	10000
Altitude, m	0	152	305	610	915	1524	1829	2134	2439	2744	3049
Correction factor	1.00	0.99	0.97	0.94	0.91	0.85	0.82	0.79	0.76	0.73	0.70

Sources: Gipe 1993 and Fraenkel 1986.

Unlike the changes in air density, changes in the swept area of the rotor significantly change the power. Doubling the area of the rotor doubles the wind power. However, the most important factor for the amount of available wind energy is the wind speed, because the power in the wind is a cubic function of the wind speed. Doubling the wind speed will increase the power eight times. The term *power density* is frequently used to explain the intensity of the wind energy per unit of rotor area for a given period of time.

The most confusing concept in wind power estimation is the mean power in the wind. Depending on the wind speed distribution (or the frequency of occurrence of different wind speeds), two identical wind machines located at different sites will not necessarily produce the same power output at the same mean wind speed. The reason is that the mean power in the wind depends on the mean of the cubes of the wind speeds over that time and this is different to the cube of the mean wind speed. The frequency of occurrence of different wind speeds can be approximated by a statistical curve using the Weibull distribution. Depending on the distribution, the actual power available will be greater than that estimated from the mean wind speed by a factor from 1.2 to 4. The most realistic factor acceptable to most sites is 2; the actual mean power will be 2 times the power expected from the mean wind speed for most sites.

The wind resource must be assessed before wind machines are considered as potential power sources. Wind data can be taken from meteorological records, direct site measurements, or local knowledge. However, local knowledge alone is not enough to reliably design wind machines. The more quantitative approach could be to take on-site measure-



ments for a limited period of time to determine the relationship with the nearest meteorological station, and correlate the nearest long-term data to the site. From these data, the frequency of occurrence of consecutive calm days and maximum wind speed should be noted. This will help to determine the necessary battery storage capacity and the type of wind machine that can stand the maximum gust.

### ***Wind Speed Measurements***

The simplest way to measure mean wind speeds is by using a cup-counter anemometer, which adds the wind speed by noting the time when each reading is taken and dividing the difference between the two readings by the time interval. The next simple instrument used to measure wind speed is the anemometer with a meter, which displays the wind speed instantaneously. The sensor (the anemometer head) generates an electrical signal that is proportional to wind speed. Cup anemometers, where the spinning cups drive either DC or AC alternators with digital displays, are far more common. Anemometers with AC alternators, which measure frequency, are more accurate than those with DC generators. Strip-chart recorders are now obsolete. Instruments that measure wind speed instantaneously are useless for finding the average wind speed unless someone checks them 24 hours a day.

Today, most instruments measure and store wind data and give wind speed instantaneously. They can collect, process, and store average wind speed, elapsed time, pick gust, and power density (in  $W/m^2$ ). Some advanced recorders can even record the amount of time the wind was calm, which is very useful for sizing batteries for stand-alone systems, and how much time the winds were above the cut-in speed of a typical wind machine.

According to World Meteorological Organization recommendations, wind measurements should be made at a height of 10 meters with no obstructions. Unfortunately, in most small, rural meteorological stations anemometers are often set on masts of only about 2 meters and surrounded by trees or buildings. Readings from such a site are almost useless for wind energy prediction purposes. Nevertheless, all agricultural meteorological stations use 2 meters as a standard height for estimating water use from crops. In general, 3 years of recordings are required to obtain reasonably representative averages, as the monthly average wind speeds can vary by 10%–25% from year to year.

### **Solar**

All energy forms derive directly or indirectly from solar energy. Ocean thermal energy, hydropower, wind, biomass, and tidal energy are indirect forms of solar energy. Crop drying, solar-thermal electric power generation, solar heat collection, and direct conversion of solar energy into electricity are direct forms. Solar energy can be directly converted into electricity using either thermoelectricity or PV cells. Although thermoelectricity has been understood for some time, the maximum overall efficiency apparently cannot exceed 1% at present with the best thermal conductivity materials and technology. Because PV cells for direct production of electricity from the sun are currently the most promising and widely available technology, PV is emphasized in this report.

Although radiation from the sun's surface is reasonably constant by the time it reaches the Earth's surface, it is highly variable because of absorption and scattering in the Earth's atmosphere. When skies are clear, the maximum radiation strikes the Earth's surface when the sun is directly overhead and sunlight has the shortest path through the atmosphere. When heavy clouds cover the sky at low altitude, half the direct beam radiation is recovered in the form of diffuse radiation, and two-thirds of direct beam radiation can be converted to diffuse radiation from cirrus (wispy and high altitude) clouds.

The intensity of the solar radiation that reaches a PV array depends on the effect of the sun's angle on the array, the location of the array, the effects of the Earth's orbit around the sun, and the effects of the Earth's daily rotation on its axis. The principal geometric attribute of the PV array is its facing direction, which can be characterized by a line perpendicular (normal) to the array surface. The orientation of the array can be specified by the tilt angle and the azimuth angle. The tilt angle is measured from the horizontal and is generally equal to the latitude of the PV array's location. The azimuth angle, like a compass heading, is a bearing clockwise from the north to the horizontal projection of the array normal.

The amount of solar radiation impinging on the surface of the PV array comes from the angle at which the sun's rays strike that array. As the PV array is inclined away from the sun, the intensity of the radiation on the array decreases. The amount of solar radiation intercepted by the surface varies as the cosine of the incident angle between the sun's rays and the normal to the surface. The incident angle to a horizontal surface is called the zenith angle.

The sun shines at different angles in different places. As latitude increases, the curvature of the Earth lowers the observed sun angle in the sky. The array must be tilted toward the equator to compensate for this effect. A PV array tilted south at an angle  $\beta$  at latitude  $\phi$  has the same sun incidence angle  $\theta$  as a horizontal PV array at latitude of  $\theta - \beta$ .

Because of the complex geometry of the position of the sun in relation to the Earth during various seasons, a system is needed to track the sun for PV arrays and thermal heat collectors. A tracking system can be installed for flat or concentrated PV modules and heat collectors. However, systems based on concentrated sunlight can generally accept only rays spanning a limited range of angles. They usually have to track the sun to use the direct component of sunlight, with the diffused component wasted. This tends to offset the advantage gained by such tracking systems of intercepting maximum power density by always being normal to the sun's rays. Tracking systems for village water supply are not economical and should not be considered.

A nondimensional coefficient called *tilted factor* is used to calculate the solar radiation on the tilted surface of the PV array at any location from the solar radiation on the horizontal surface. The tilted factor is the ratio of the cosine of the incidence angle to the cosine of the zenith angle or the ratio of solar radiation on a tilted surface to that on a

horizontal surface for any season, latitude, and tilt angle. Like the intensity of solar radiation energy, the tilted factor varies depending on location, season, and tilt angle.

### ***Estimating Solar Energy Resources***

The design of PV systems depends heavily on the availability and accuracy of solar radiation data. The availability of solar radiation depends not only on gross geographical features such as latitude, altitude, climate classification, and prevailing vegetation, but also on geographical features. Unfortunately, accurate solar radiation data are rarely available from remote locations where many PV systems are to be installed. However, numerous approaches for estimating solar radiation energy have been developed based on commonly available sunshine hour and satellite cloud cover data or on direct measurements.

There are various instruments for measuring insolation levels. Direct beam solar radiation is usually measured by a pyrheliometer and global solar radiation is usually measured by a pyranometer. Diffuse radiation can be measured if the pyranometer is shaded. Silicon-based sensors are used to measure incidence radiation. These types of instruments measure the intensity of solar radiation directly when the electrical characteristics change in the presence of solar radiation, and they are categorized as photoelectric devices. The other types of instruments are categorized as bolometric devices. These instruments operate on the principle of Ångström or electrical compensation. The simplest is the heliograph, which measures the bright sunshine hours by using focused light to burn a hole in a rotating chart. Campbell-strokes recorders were the commonly used instruments for many years and are still in use in many developing countries, but it can result in errors greater than  $\pm 10\%$  and is obsolete.

Silicon-based sensors are recommended for measuring the intensity of solar radiation for PV cells because they accept the same wavelength ranges as the normal pyranometers. Because solar radiation is the main source of energy for PV systems, the use of this technology for different applications, such as pumping water, requires systematically processed weather data. The most commonly used weather data for designing PV systems are solar radiation, ambient air temperature, and wind speed data. PV systems are sensitive to weather changes and their performance changes accordingly. Also, long-term weather conditions cannot be forecast, so systematically processed past weather information is needed to design PV systems. The data should cover as many years as possible. The simplest method may be to use long-term average weather data; however, average data do not reflect the extreme solar radiation days, and the system must consistently meet its intended daily requirements. For this reason, a “typical meteorological year” (TMY) is usually used for designing PV systems. “Typical” refers to the long-term database covering a year. Because no actual year has the same diurnal solar radiation pattern represented by the TMY, the TMY is a fictitious yearly database.

### **Grid Power**

Grid power is a centralized power source that can be generated from hydropower, nuclear, geothermal, diesel generator, coal, biomass, and other renewable energy sources.

Coal, hydropower, geothermal, and nuclear power are most commonly used. Localized grid power can be generated from mini-hydropower systems, diesel generators, renewable energy sources, or hybrids.

A major obstacle for centralized grid power sources in many developing countries is the lack of infrastructure. The cost of extending the grid is very high—\$5,000–\$10,000/km. Localized grid or stand-alone systems are more attractive for generating electricity in such areas.

Because grid power transmissions use high voltages to minimize power losses in wires, step-down transformers are used to reduce voltage. Step-up transformers are used at the power generation for high-voltage power transmission. Grid power sources are either 50 Hz or 60 Hz. Unlike DC power, AC power supply wires are not positive and negative, but are live and neutral. A single-phase power supply has three wires—one wire is live and the rest are neutral and ground wires. A three-phase power supply has three live wires and a neutral fourth wire for protection. The live wires must be protected by fuses and contact breakers. A single-phase supply with a 50-Hz frequency has a voltage range of 220 to 230 volts (or 110–120 volts for 60-Hz power supplies). A three-phase supply with a 50-Hz frequency is 380 or 415 volts (or 240 or 480 volts for 60 Hz). Single- or three-phase induction motors are the most popular for water pumping applications. Single-phase motors are typically used for smaller pumping applications and three-phase motors for higher water demands.

There are two main advantages of using grid power sources to pump water: there is no need for storage batteries, and the power supply can be reliable unless there are transmission or power generation problems. A simple control box with a power breaker controls the motor, the water level, and the pump. Maintenance costs are usually very low as long as the system is designed properly. The motor and the pump should be properly matched and the controller must be the right type to handle voltage fluctuations. An integrated water level control system must be installed to control dry running of the pump. The investment costs of such systems depend on the cost of the grid extension and the size of the transformer used. Usually power from high-voltage grid power transmission lines is not used for small pumping systems because the step-down transformer is expensive. The operating cost depends mainly on the electricity tariffs—high tariffs contribute to high pumping costs.

Another advantage to using the grid power source for water pumping applications is that there is no need for extra space other than a small room for the control box. In general, the grid power source system is safer and more reliable than any other power source.

### **Diesel/Gasoline/Kerosene**

In principle, there are two types of combustion engines, the external and the internal combustion engine. As the name implies, the external combustion engine burns its fuel externally; the internal combustion engine burns within the cylinder. In an external combustion engine, the fuel is used to heat a gas or vapor in an external chamber. One

advantage of this type of engine over the internal combustion engine is that the fuel can be any combustible agricultural residue or waste material, such as coal, peat, or biomass.

There are two basic types of external combustion engines: the steam engine (which operates by expanding steam or vapor to drive a mechanism) and the Sterling engine (which uses hot air or gas). Both types require a heat exchanger or a boiler to produce the heat, and both are useful for water pumping applications. The overall efficiency of steam engines as a prime mover (the basic steam engine and the boiler) is 1.5%–3%. More sophisticated engines have efficiencies of 3%–9%. However, safety is a concern because boilers can explode.

Sterling engines have the potential to be more efficient than steam engines. In particular, the direct-action types of Sterling engine-piston water pumps are more promising for further development. As heat engines, Sterling engines can be designed to work even at fractional horsepower sizes, which makes them especially attractive for small water pumping applications. However, because external combustion engines need further development before they can be commercialized for water pumping applications, we emphasize internal combustion engines in this report.

In contrast to external combustion engines, the success of internal combustion engines results from their compact size, their instant startup capabilities, and their high power-weight ratio. These capabilities make them ideal for powering small isolated machines like cars, boats, lawnmowers, and irrigation pumps. The two main types of internal combustion engine are the compression ignition engine (fueled with diesel) and the spark ignition engine (fueled with gasoline, kerosene, or liquefied petroleum gas [LPG]).

Internal combustion engines will wear prematurely if they run continuously at a rated power. The optimum efficiency—the point where the engine consumes the least amount of fuel—of most engines is achieved at around 70%–80% of the rated power. Engines should therefore be derated around 70%–80%. Further derating is also necessary at higher ambient temperature and altitudes. Usually, derating of 1% for each 5°C temperature is necessary for rises above 16°C, and 10% derating is necessary for every kilometer above sea level. For example, for a 3-kW load requirement at 2,000 meters above sea level, and at 25°C ambient temperature, the engine capacity should be 4.8–5.5 kW.

Smaller internal combustion engines are normally started using a hand crank or a pull cord starter. Larger engines require an auxiliary electrical system and a battery with an electric starter. Approximately one-third of the heat produced in the internal combustion engine is dissipated through the walls of the engine cylinder, and air or water cooling is used specially for medium to large engines. Water cooling is much better than air cooling to control the heat and for quieter operation. However, corrosion is the main problem unless special anticorrosion chemicals are used. The engine can be damaged when the cooling water runs out.

The cost of internal combustion engines depends mainly on their size and speed. A higher power-weight ratio is normally achieved by running the engine at high speed. This means

that when the engine runs at higher speed, the more air and fuel mixture is burned, producing greater amounts of energy. For the same rated power, smaller higher speed engines are cheaper than heavier lower speed engines. Engines at higher speed wear faster, so there should be tradeoffs between heavy lower speed engines and lightweight, higher speed engines.

Power transmission from the engine to a pump depends on the type of engine and pump design. Power transmission can be coupled using direct mechanical coupling to the pump, gearbox transmission, using belt drives. Transmission losses in direct couplings are generally negligible, but are high for gearbox drives. Pumps can be centrifugal or positive displacement (volumetric) pumps. (See Chapter 4 for further discussion of pumps.)

### ***Diesel Engines***

Combustion ignition engines are also called diesel engines. They ignite fuel by the heating effect that results from mixing highly compressed air with pressurized fuel sprayed into the cylinder at the appropriate time and temperature for ignition. Diesel engines are generally heavy and robust compared to spark ignition engines. The high compression ratio allows a diesel engine to draw in more air per stroke in relation to the combustion space; the fuel injection allows the air-fuel mixture to run more smoothly for ignition than in spark ignition engines. The other advantage with diesel engines is the fuel. According to Fraenkel (1986), diesel fuel has a higher density that makes it 18% richer in energy per liter than gasoline. Diesel engines can operate more hours per day than gasoline or kerosene engines, and they typically have a longer operational life. Larger diesel engines are also more efficient (generally 30%–40%) than spark ignition engines (25%–30%), but smaller diesel engines tend to be less efficient (as low as 15%). Several factors—size, type, design quality, and age—contribute to lower efficiency in diesel engines. They can be as low as 10% and as high as 35%.

Diesel engines are categorized as high-speed or low-speed. Low-speed engines operate at 450–1,200 rpm, tend to be heavier and more expensive, and have longer operational lives than high-speed engines. High-speed engines operate at 1,200–2,500 rpm and wear fast, resulting in shorter operational lives. The weight of high-speed engines per rated power is lower, almost by half, than that of the low-speed engines. High-speed engines typically operate no more than 10 hours per day; low-speed engines can operate 24 hours per day.

### ***Gasoline/Kerosene Engines***

Spark ignition engines operate by mixing the vaporized fuel (gasoline, kerosene, or LPG) with air, compressing the mixture, and igniting it at the right moment by an electrical spark in the engine cylinder. Spark plugs are used to create the electrical discharge in the cylinder. Typically, spark ignition engines are lighter, more compact, and less expensive than diesel engines. Such engines cannot be designed for a high compression ratio because the fuel-air mixture would ignite prematurely and cause knocking. The caloric values of gasoline, kerosene, and LPG are also quite low compared to those of diesel fuel.

Spark ignition engines are generally designed for small applications (to about 3 kW) and are best for small, lightweight, and portable applications, such as irrigation or lighting a few households. They are affordable, simple to maintain, and ideal for low-head and high-discharge (mainly floating) pumps, even though their operational lives are generally shorter than those of diesel engines. Gasoline engines have shorter daily operational lives (as long as 4 hours) than kerosene engines, which can operate as long as 6 hours a day. Gasoline engines are also most commonly used for cars and light trucks.

Kerosene has approximately 10% more energy per liter than gasoline and is taxed less in many countries. It is easy to store because it is less dangerous than gasoline. Because kerosene does not vaporize quickly or adequately in a cold engine, most kerosene engines are designed to be started with gasoline until the engine warms. Then they switch back to gasoline before the engine stops to make ready for the next start. Most kerosene engines have separate fuel compartments for storing gasoline and taps to switch to kerosene. However, buying and storing both fuels can be inconvenient for users (especially farmers) because two storage tanks are needed to store the fuels.

## Chapter 4

# Pump and Motor Technology

### Motor–Pump Subsystems

The motor–pump subsystem includes the motor, the pump, and the couplings. The types and characteristics of pumps and motors used for PV pumping applications are presented in the following sections. Different types of coupling are used for water pumping purposes depending on the type of application and the water demand. Various types of pumps and motors are available for water pumping application depending on the daily water requirement, the pumping head, the suction head (for surface mounted units), and the water resource. The most common types of coupling used to pump water are belt and pulley, feed screw, direct coupling (rack and pinion or bolt and flange), and gear transmission. The efficiency of the driving mechanism depends on the coupling ratio, which is the ratio of the torque of the motor to the torque of the load. The transmission power loss with direct coupling is around 98%. However, the power loss in cases of substantial speed reduction is as high as 40%. The power transmission loss in cases of gear transmission, which depends on the gearbox design and gear ratio and the size of the engine in relation to the speed reduction, can be very high.

The most common commercially available configurations of motor–pump subsystems are

- **Submerged motor–pump unit.** This is often called a submersible centrifugal motor–pump. Because it is simple to install and safe, this is the most common and suitable type of pumping system for village water supplies.
- **Submerged centrifugal pump with surface mounted motor.** Although this type of subsystem is advantageous for maintenance of the motor, the power losses in the shaft bearings and its high cost make it unattractive.
- **Floating motor–pump.** This type of pumping unit is recommended for pumping surface water for irrigation and drainage. It is portable and the chance of dry running is minimal.
- **Positive displacement pump (volumetric pump).** This type of pump is driven by a shaft from a surface-mounted motor, and is suitable for high head and low flow rate applications.
- **Surface mounted motor–pump unit.** This type of unit has a self-priming mechanism and is recommended for low head duties. The suction head should be as long as 6 meters. The pump may be centrifugal or positive displacement.

Brushless DC motors are the most attractive for smaller pumping applications and AC motors (incorporated with inverters) are more attractive for larger installations. Efficiencies of a motor–pump subsystem are 40%–60%, depending on the motor, pump, and power transmission. The optimum efficiency for motors is about 85%; for the pump



about 70%; and for the suction and delivery pipe about 80%. The friction loss in pipes depends on the diameter and pressure the pipe, as well as the amount and type of fittings used in the system. For example, friction losses for 90° elbows are higher than those experienced with “Y” connections.

## **Pumps**

There are two basic types of pumps:

- **Volumetric (positive displacement).** These pumps operate by mechanically advancing a sealed quantity of water by using several mechanisms such as pistons, cylinders, and elastic diaphragms. The flow rate or speed of a positive displacement pump is directly proportional to the motor speed and power output. At low power input a positive displacement pump will pump a quantity of water to the same vertical lift as high power input, except at slower rate. Because of this, positive displacement pumps have a high starting torque as they must always work against the full system pressure even at low speeds.
- **Centrifugal (rotodynamic) pumps.** These pumps are designed for a fixed head, meaning their efficiency decreases when the pumping head deviates from the design point. Unlike volumetric pumps, a significant decrease in a rotodynamic pump’s power supply can cause it to fail at delivering water from a borehole because its vertical lifting capability is directly proportional to the power input.

The best type of equipment for a particular pumping application depends on the daily water requirement, pumping head, suction head (for surface mounted pump-sets), and the water source. Generally, positive displacement pumps are best for low flows (less than 15 m<sup>3</sup>/d) and high pumping heads (30–150 meters). Submersible centrifugal pumps are best for high flow rates (25–100 m<sup>3</sup>/d) and medium heads (10–30 meters). Figure 4-1 shows the most suitable types of pumps for different ranges of head and flow rates for pumping applications.

### ***Positive Displacement Pumps***

Figure 4-2 illustrates the basic operating principles of positive displacement pumps. Commercially available positive displacement pumps are categorized into two types: submersible (diaphragm) and nonsubmersible (jack, piston, and rotary vane). The most common is the Jack pump. All positive displacement pumps have seals or mating surfaces that can wear, so most require regular maintenance to replace or repair worn parts. Such parts can easily wear with dirty water even though prepump filters are sometimes used.

The water output of a positive displacement pump is almost independent of head but is directly proportional to speed, meaning that the efficiency of a pump of fixed piston diameter increases with head. Different diameters of pumps need to be used for different heads to result in optimum efficiency. At high heads the frictional forces become small relative to the hydrostatic forces. At high speeds positive displacement pumps can be

more efficient than centrifugal pumps. At low heads (below about 15 meters), the total hydrostatic forces are low in relation to the frictional forces. Therefore, these pumps are less efficient and are less likely to be used (Kenna and Gillett 1985).

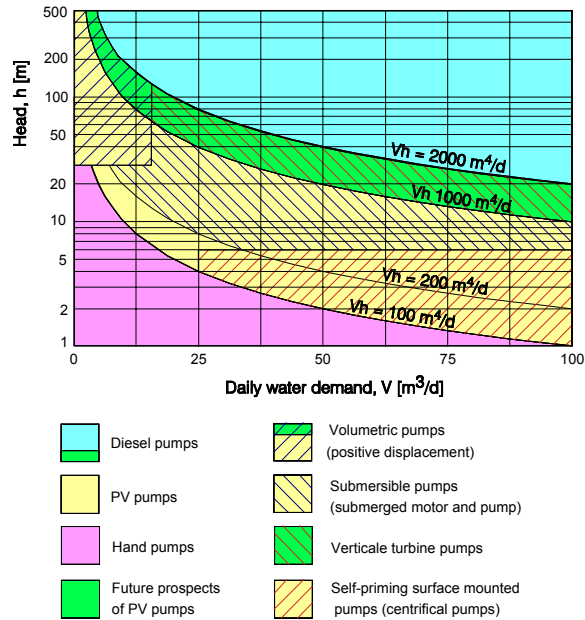

Figure 4-1. Types of pump sets for different ranges of head and flow rates.

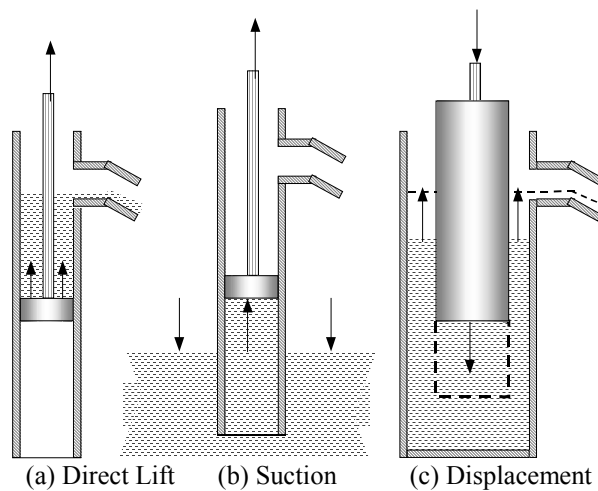

Figure 4-2. Basic operating principles of positive displacement pumps.

*Diaphragm pumps* are sometimes called submersible positive displacement pumps and are often used for small applications, such as pumping small quantities of water from deeper wells or water tanks where surface pumps are limited by their suction head. Such pumps can also be used for pressurized storage tanks to lift water to a discharge head above the ground surface. Diaphragm pumps generally use DC motors. They require

periodic maintenance depending on the depth of head pumped and their operational hours. The brushes of the DC motor must be changed every 2,000–4,000 hours and the elastic diaphragm must be replaced every 12 to 24 months depending on the hours of use.

*Jack pumps* function much like windmills except that they are powered by electric motors. Like the windmill, the reciprocating jack is connected by a long sucker rod to a cylinder. Jack pumps require regular maintenance, especially because the leathers on the plunger at the end of the long sucker rod can wear out easily and must be replaced every 6 to 24 months depending on the hours of use. The leather is used to create seal against the cylinder. Jack pumps are generally used for medium applications at medium depth.

*Piston pumps* are generally connected to a surface-mounted motor and used to pump water from shallow wells, surface water sources, and pressurized storage tanks, or through long pipes. The suction head is limited to 6 meters. They are not tolerant to silt, sand, or abrasive particles because the piston seals are easily damaged. Filters may be used to remove the dirt.

*Rotary vane pumps* (sometimes called helical rotor pumps) operate according to a displacement principle for lifting or moving water by using a rotating form of dispenser. They contain spinning rotors with vanes that seal against the casing walls. Such pumps are mostly surface-mounted because of suction head limitations. The suction head is limited to 6 meters. They produce a continuous or sometimes a slightly pulsed water output. Types of rotary vane pumps include flexible toothed rotor (or flexible vane pumps), progressive cavity (mono) pumps, Archimedean screw and open screw pumps, and coil and spiral pumps (Fraenkel 1986).

A main advantage of helical rotor pumps is their ability to pump water at either low or higher motor speed levels, which correspond to higher or low pump speeds, which leads to higher volumes of pumped water per day even at low motor speeds. Unlike reciprocating devices, rotary vane pumps have steady drive conditions, which may eliminate the problem of water hammer and cavitation. Rotary vane pumps are not tolerant to silt, sand, or abrasive particles, so filters may be used to remove dirt.

The unique advantage of helical rotor pumps over centrifugal pumps is their ability to operate efficiently over a wide speed ranges and heads, whereas the efficiency of centrifugal pumps deteriorates from the rated speed.

### ***Rotodynamic Pumps***

Rotodynamic pumps use a spinning impeller or rotor to propel water. Generally, two mechanisms pump water continuously; either using a single impeller or a combination, and they are spun either by deflecting by the blades or by using centrifugal force when water is whirled into a circular path when the shaft holding the impellers or blades rotates at a high speeds. The water flow rate in the impeller is directly proportional to the speed of the impeller because the water movement in the impeller depends on the force created by the impeller, which in turn depends on the power supply to the motor. The motor

speed may not be the same as the speed of the impellers, and there will be transmission losses at the coupling, depending on the kind of coupling used between the pump and the motor. Transmission losses between the pump and motor shafts using direct coupling are minimal; losses from a gear, belt, and pulley transmission combination are higher.

A single impeller on a centrifugal pump can lift water only through fairly low heads, so several impellers are stacked in a pump to create enough pressure to lift water to a higher head. For this reason, centrifugal pumps are good for pumping large volumes of water at low to medium heads. Rotodynamic pumps require relatively low maintenance and are fairly tolerant of dirty water because they do not have seals or mating surfaces to wear. However, the impeller can clog and erode if the water contains excessive sand or grit. Commercially available rotodynamic pumps are categorized into axial flow, radial flow, and mixed flow depending on the design of the impellers. Unlike positive displacement pumps, rotodynamic pumps are limited by their operating conditions; otherwise, efficiency will deteriorate when rated speed changes. However, wider ranges of heads and flows can be achieved using different types of impellers.

Axial flow pumps are sometimes called *propeller pumps* because the mechanism is similar to a propeller in a pipe. Because such impellers are designed for high flow and low head applications, they are most suitable for irrigation purposes. Axial flow pumps are generally designed for large flows at low heads. Large pipe diameters are required and concrete pipes are typically used instead of steel pipes to lower the high cost. However, concrete work requires significant civil works in their installation. Generally, axial flow pumps are designed at 2.5–25.0 m<sup>3</sup>/min discharge and 1.5–3.0 meters head for vertically mounted applications. However, by adding additional impellers (stages) the pump can lift up to 10 meters. Axial flow pumps are generally used in canal irrigation schemes where large volumes of water must be lifted to 2–3 meters. However, when high heads and low flow rates are required, radial flow impellers are the most suitable. For radial flow impellers, the ratio of discharge to inlet diameter of the impeller is very high, which produces a large radial flow component. In axial flow impellers, the ratio of the discharge to inlet diameter is very small because water flows by the lift generated by a moving streamlined blade fixed in a casing.

Radial flow pumps are often called centrifugal pumps because centrifugal force is applied when water is whirled into a circular path and when the shaft holding the impellers or blades rotates at high speeds. Centrifugal pumps, which are available with either AC or DC motors, can be surface-mounted, floated, or submersible depending on the requirement. Such pumps can lift medium to large volumes of water (to about 200 m<sup>3</sup>/d) from shallow to deep wells (to 150–200 meters). Series of impellers are used for surface-mounted and submersible centrifugal pumps to create a large pressure differential to attain the required pumping head. More than 20 impellers can be stacked, especially in submersible pumps. However, floating centrifugal pumps use only a single impeller where the pump is suspended just below the water surface by a float. The lifting capacity of such pumps is limited to approximately 6 meters.

The surface centrifugal pump and the motor are mounted above the water source with an intake suction pipe for a suction head of no more than 6 meters at sea level. The pumps and motors of submersible centrifugal pumps are submerged in the well.

The operational characteristics of radial flow (centrifugal) pumps are reasonably well matched with PV and wind systems. They can be directly coupled by carefully choosing the motor speed, voltage, coupling ratio, and pump characteristics. For example, electronic controls can enhance performance of a well-matched PV pumping system by 10%–15%, although they consume 4%–7% of the PV array's power output. On the other hand, the operational characteristics of volumetric pumps are not a good match to the output of PV and wind (electric) systems. The motor driving a volumetric pump requires a constant current for a given head, apart from the starting current, which tends to be higher. This condition does not match the PV and wind turbine characteristics where the current varies almost linearly with solar radiation and wind speed. Therefore, maximum power point tracking (MPPT) controllers are usually used with volumetric pumps.

Mixed flow pumps are sometimes called *vertical turbine pumps*. These pumps have internal blades in the impeller that partially propel the water, similar to the axial flow impeller, but the discharge from the impeller is at a greater diameter than the inlet so partial radial flow is involved to create velocity to the water from centrifugal forces that are generated. Vertical turbine pumps generally consist of submerged stacked impellers powered by a long drive shaft from a surface-mounted motor. Such pumps are not suitable for use with surface water sources and are best used in wells of shallow to moderate depth.

An advantage to mixed flow pumps is that the surface-mounted motor is easily accessed for repair and maintenance. However, pump efficiency is reduced by twisting, vibration, and friction in the drive shaft. These pumps may also have bearing problems. Installing them can be difficult and time consuming. There is now a move away from surface-motor shaft-driven submersible pumps for deep wells because of such difficulties. Submersible centrifugal pump-sets are now almost exclusively used in such cases. The most suitable pump-set types for various ranges of head and flow can be found in manufacturers' catalogs, motor-pump manuals, and books.

## **Motors**

Motors are generally grouped into two types—DC and AC. DC motors are divided into permanent magnet (brushed and brushless) and wound-field DC motors. In a permanent magnet DC motor, the permanent magnet is used to produce the magnetic field so no power is consumed in the field windings, which leads to higher efficiencies. This makes this type of motor more attractive for smaller PV applications. However, in a wound-field DC motor, the field windings produce the magnetic field electromagnetically. This type of motor is suitable for industrial applications.

The simplest and cheapest type of AC motor is the squirrel-cage induction motor. Its low cost and rugged construction make it the most commonly used motor for wind/PV applications. Induction motors are classified as squirrel-cage (asynchronous) motors and

wound-rotor motors. Wound-rotor motors are generally used for industrial applications. Figure 4-3 shows the schematic diagrams of the four main types of electric motors.

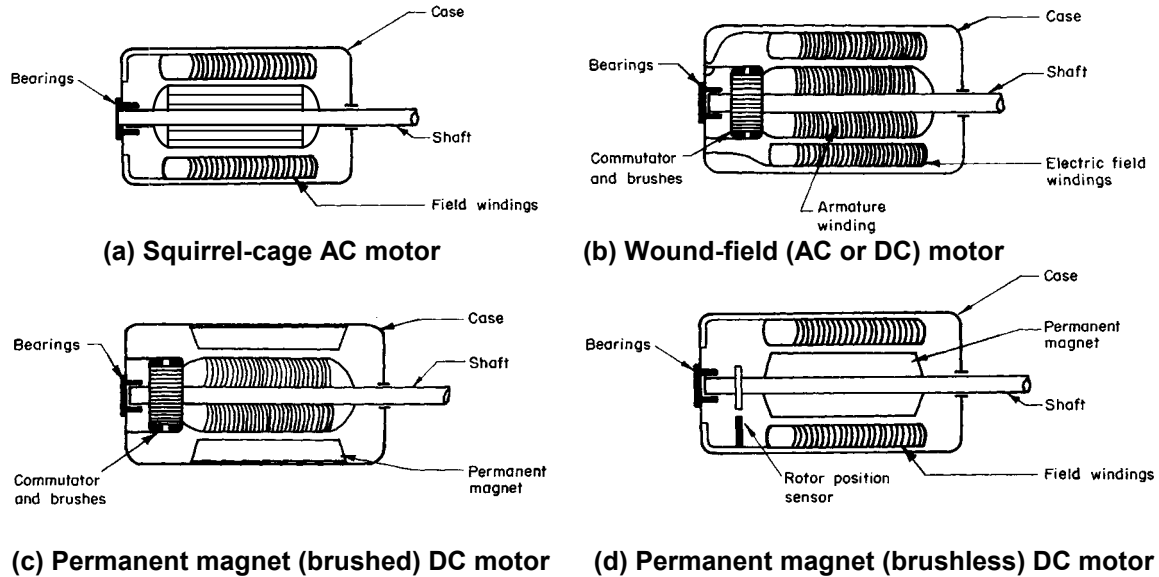

**Figure 4-3. Schematic diagrams of the four main types of electric motors.**

The main advantages of permanent magnet DC motors are their simplicity and efficiency for smaller applications—no complex control system is required. Maintenance in brushed DC motors is minimal. However, brushed motor brushes need to be replaced periodically, and brushless motors have the extra expense of electronic commutation. In contrast, AC motors are cheaper than DC motors and large ranges are available for different loads. However, AC motors are less efficient than DC motors and require inverters for PV applications, which add cost and increase breakdown risk.

### **DC Motors**

A DC power supply has two wires—one positive and the other negative. When they are connected to the DC motor, the shaft rotates as a result of the field flux supplied either by the permanent magnet or the field winding, by creating two or more poles in the armature and passing magnetic flux through it. This magnetic flux causes the current-carrying armature conductors to create torque on the shaft and rotates the load (pump).

Permanent magnet DC motors are limited to ratings of a few horsepower and have a maximum speed limitation. DC systems also have high cable-power losses as the distance from the power source increases. These limitations make these types of motors applicable for small water pumping applications for a limited cable distance from the power source to the motor. In terms of simplicity, permanent magnet DC motors are appealing for PV pumping because PV modules produce direct current and can be directly coupled to the DC motor with or without a power conditioning device.

The brushes in brushed motors need to be changed every 2,000–4,000 hours (every 2 years, on average, for PV pumps). Brushless motors have permanent magnet rotors and electronically switched field windings that operate by means of a rotor position sensor. Although these types of motors have no special maintenance requirements, they are relatively new for PV pumping applications and have not yet proved reliable. The extra electronic circuit for the rotor position sensor also adds cost. During the past few years, designs have improved greatly and they are likely to be attractive for small pumping applications in the future.

### **AC Motors**

An induction motor is simply an electric transformer whose magnetic circuit is separated by an air gap into two relatively movable portions, one carrying the primary winding and the other carrying the secondary winding. AC supplied to the primary winding from an electric power system induces an opposing current in the secondary winding, when the latter is short-circuited or closed through an external impedance. Relative motion between the primary and secondary structures is produced by the electromagnetic forces corresponding to the power thus transferred across the air gap by induction. The essential feature that distinguishes the induction machine from other types of electric motors is that the secondary currents are created solely by induction, as in a transformer, instead of being supplied by a DC exciter or other external power source, as in synchronous and DC machines. The secondary windings on the rotor of squirrel-cage motors are assembled from conductor bars short-circuited by end rings or are cast in place from a conductive alloy. There is no electrical connection to the rotating squirrel cage, so there are no brushes or slip rings to wear or need adjustment. This is the main reason that squirrel-cage induction motors are the cheapest and simplest electric motors.

The secondary windings of an induction wound-rotor motor are wound with discrete conductors with the same number of poles as the primary winding on the stator, and the rotor windings are terminated on slip rings on the motor shaft.

AC motors are generally used for medium- to high-power demand applications. Induction motors with squirrel-cage rotors are available in either single phase or three phase. An induction motor operates at nearly constant speed. However, the speed of an induction motor can be varied with electronic converters (inverters). Using inverters to control induction motor speeds is highly efficient over wide speed and load ranges.

## Chapter 5

# Selecting Power and Sizing Renewable Energy Water Pumping Technology

The most common renewable energy sources for water pumping applications are wind and solar. Wind energy can be harvested with either mechanical machines (windmills) or electrical machines (turbines).

Solar energy can be directly converted into electricity for water pumping applications with either thermoelectricity or PV cells. However, thermoelectricity is not efficient and practical for pumping water. PV is the most promising and widely used technology available today, so we emphasize windmills and turbines, along with PV, in this report.

### Wind pumps

Wind has been a traditional energy source for centuries and is still commonly used in many developing countries. It has been harnessed to separate grain from hay and to sail boats. Since the early 13<sup>th</sup> century, wind has been used to pump water to dewater polders in the Netherlands. Small wind pumps, made of wood, have been used in France, Portugal, and Spain for pumping seawater to produce salt. Then the American wind pump, made of steel with a multibladed fan-like rotor, became the most popular water pumping technology. It was introduced for domestic water supply and railroads in the late 19<sup>th</sup> century and later used to water livestock in the early 1900s when millions of cattle were brought to the North American Great Plains. During the last 100 years, more than 8 million windmills have been manufactured in the United States, and the design has proven so successful that it has been copied around the world. Today more than 1 million windmills are in use, mostly in United States, Argentina, and Australia. This type of pump drives a piston (reciprocating) pump linked via reduction gear directly located below in the borehole. But because the blades are not true airfoils and the overall operating efficiency is only about 4%–8%, traditional windmills are much less efficient than modern wind turbines. Figure 5-1 shows a typical traditional wind farm for cattle watering on a ranch in Colorado.

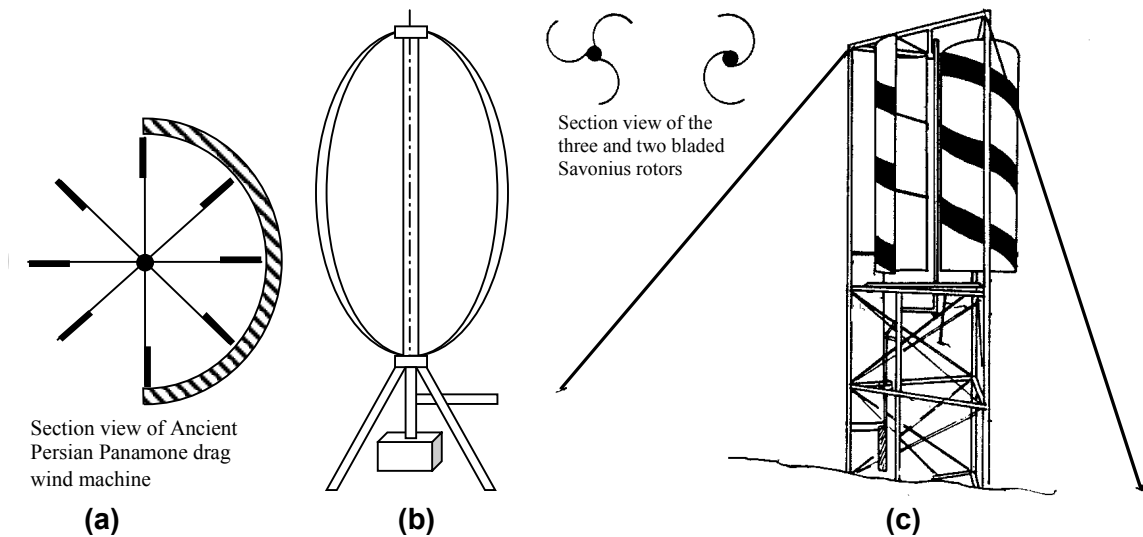

**Figure 5-1. Agricultural applications: Livestock watering in Colorado.**



Development of electrical wind turbines that could generate either DC or AC current began in the late 1920s. These turbines are designed to produce electricity from a few watts (for charging batteries) to a few megawatts. The small turbines (microturbines), which produce only few watts, can be erected and taken down by one person, and are mainly used for charging batteries on sailboats and recreational vehicles.

Typical wind machines can be designed to rotate either horizontally or vertically. The horizontal axis types are the most practical. The most common vertical axis types of wind machines are the Panemone differential drag devices, the Savonius rotor (or S-rotor), and the Darrieus wind turbine (see Figure 5-2). One of the main advantages with the vertical axis is it accepts the wind from any direction. Whether a wind machine rotates on a vertical or horizontal axis, the mechanism depends on one of two aerodynamic principles (drag or lift) to derive power from the wind. Drag force works by simply obstructing the wind and creating turbulence and the drag force acts in the same direction as the wind. Drag devices are simple wind machines that use flat, curved, or cup-shaped blades to turn the rotor. Cup anemometers, Panemones, and Savonius rotors are typical of drag devices. Because much of the rotor's area is covered with blades, drag devices can produce high starting torque, but they require more materials than do wind machines operating with lift. Drag devices are ideal for pumping water in low volumes.



**Figure 5-2. Typical vertical axis wind machines:  
(a) Panemone, (b) Darrieus, and (c) Savonius**

Wind machines with lift devices use airfoils to propel the rotor. The lifting force mechanism operates with the blades mounted at a small angle to deflect the wind and produce a bigger force perpendicular to the direction of the wind, with much smaller drag force. The maximum possible power captured from the wind using lift devices is 59% (Bert limit). This makes lift devices more attractive than drag devices for generating electricity on a larger scale. Turbines operating with airfoils can be designed with single, double, or triple blades. Those with one slender blade can capture wind power efficiently, but two blades are often used for static balance. However,

two-bladed turbines experience dynamic imbalance when the wind machine changes direction, so the three-bladed wind turbines are better for greater dynamic stability.

### ***Mechanical Wind Pumps***

Old American windmills have been modified by the Australians, the Dutch, and others to decrease their weight and cost and increase their efficiency. As a result, several options are available, ranging from modern mechanical wind pumps to modern wind-electric pumping systems. The two major developments with modern mechanical wind pumps include the design of a counterbalance on the weight of the sucker rod and the development of variable strokes. These improvements can double the water output from the traditional farm windmill.

Traditional windmills tend to speed up when the sucker begins to go down, and the rotor slows on the upstroke because it lifts the weights of the rod and the water. This speed variation changes the tip-speed ratio of the rotor and its efficiency. The second fundamental problem with the wind pumps is the relationship between the wind speed and the stroke. The power in the wind increases with the cube wind speed; the water discharge rate (pumping rate) increases linearly. This relationship affects the performance because the stroke of the old wind pumps had a fixed position. So if the stroke is adjusted for optimum production at high speed for a given well depth and pump size, the pump performs poorly at low winds, or vice versa. Therefore, adding the counterbalance weight on the sucker rod or springs and using variable-stroke technique are the main factors that have improved the mechanical wind pumps in use today.

Another crucial development with modern wind pumps is that they use only 6–8 blades of true airfoils, in contrast to traditional windmills, which have 15–18 curved steel plates. Using fewer blades decreases the cost. The rotor diameter of traditional wind pumps is 2–5 meters. The Australian-made Southern Cross machine has an available rotor diameter as long as 8 meters. Modern wind pumps are thus twice as efficient as traditional wind pumps, but they are still bulky and are best suited for light wind regions.

The so-called third generation windmills use a direct drive mechanism rather than a geared transmission. They are designed to produce high torque at low wind speeds and provide rotor speed control at high wind speeds. The main objective of this design is to reduce the starting torque. This is possible because of the counterbalance attached to the actuating pump beam, which is designed to reduce the starting rotor torque to start pumping. A report by the University of Calgary, Canada, shows that a direct drive-type wind pump (similar to an oil-field jack pump) can start pumping at 50% lower rotor torque (or 30% less wind speed) relative to a system with no counterbalance. These types of wind pumps are promising because they do not require gearboxes for power transmission from the rotor to the shaft.

The windmill uses a reciprocating or piston pump, or positive displacement pump. For these pumps to start pumping, the wind pump crank force needs enough force on the pump rod to lift the weight of the pump rods, the piston and the water in the piston, and the friction. The amount of water delivered by the pump for a given pumping head depends on the diameter of the pump and on the wind speed. The bigger the pump diameter, the larger the amount of water delivered. The size of the pump determines the starting wind speed for a given wind pump and pumping

head because bigger pumps require larger starting torque. A pump fitted to a windmill should generally be sized to run at about three-quarters of the local mean wind speed. This allows the wind pump to run frequently enough and to achieve better water output at stronger winds.

One of the main disadvantages of a mechanical wind pump is that it must be located directly over the borehole so the pump rod is directly connected with the rising main and the pump. The best water resource location is at lower ground, which is generally a poor location for winds, so mechanical wind pumps are typically limited to flat and arid regions. Efforts have been made to locate the windmills further from the borehole by using remote electrical, pneumatic, hydraulic, and mechanical transmissions. An induction generator to produce electricity, coupled with an induction motor and a pump is a good alternative technology for water pumping, which we discuss in the next section.

Pneumatic transmission wind pumps operate on the principle of compressed air by using a small industrial air compressor to drive an airlift pump or pneumatic displacement pumps. The main advantage of this method is that there is no mechanical transmission from the windmill to the pump, which avoids water hammer and other related dynamic problems. The pump can operate slowly even while the windmill is running rapidly with no dynamic problem. Other advantages are its simplicity and low maintenance. However, this technology is still under development and will require intensive field testing before it can be commercialized.

Power transmission using hydraulic means is another option for water pumping. This type of system can have either one or two pipes, and the fluid can be either water or oil. Although this mechanism has been demonstrated in the field, it is still far from commercialization. Similarly, mechanical transmission of windmills for remote pumping has been tried, but such mechanisms are robust, expensive, and not feasible in the near future.

In general, commercialized mechanical wind pumps are good for low wind speeds because of their high solidity rotors, which limit the piston pump speed to 40–50 strokes per minute. The overall conversion efficiency of mechanical pumps using an average wind speed is 7%–27%.

### ***Electrical Wind Pumps***

Electrical wind turbine pumps offer a more promising technology. Modern wind generators can produce AC or DC electrical output and can pump water directly by connecting to AC or DC motors. Because electrical wind turbines are designed for low-solidity rotors, centrifugal pumps are used. This technology:

- Eliminates the need for batteries and inverters by directly coupling the wind turbine with an AC motor, which then drives the centrifugal pump at varying speeds.
- Simplifies the matching of wind turbines with water pumps by varying the load electrically instead of mechanically (similar to varying the stroke in the case of windmills).
- Alleviates the problem of setting wind turbines over water wells because wind is best at the crest of a hill, while water is found at the foot of hills or lower elevations.

Wind turbines can be located where the winds are strongest at the optimum cable length from the well. Figure 5-3 illustrates a typical electrical wind pump.



**Figure 5-3. A Typical electrical wind pump located at Santa Maria, Mexico.**

Unlike traditional windmills, electrical wind turbines require higher starting wind speeds and perform better at high winds than at low winds. They are twice as efficient as traditional windmills; are cost competitive with diesels, PV systems, and traditional windmills; and have fewer moving parts than traditional windmills, which keeps maintenance costs low.

The theoretical maximum conversion efficiency of kinetic energy used by the perfect wind turbine is 59.3% (Betz limit, after the German scientist, Albert Betz). However, in practice, wind turbine rotors convert much less energy. Optimally designed rotors reach slightly above 40%. Electrical wind turbines capture 12%–30% of the energy in the wind. Rotor efficiency is about 40%, transmission is about 90%, generator efficiency is about 90%, and power conditioning, yawing, and gusts efficiency are about 90%. Small electric wind turbines convert 25%–30% of the power in the wind at places with average wind speeds below 5.5 m/s (12 mph) and less than 20% at windier sites. Medium-sized wind turbines perform better than small turbines at high wind sites.

Electrical wind turbines rated as low as 50 W are commercially available, and generally require high wind speeds. For example, a small wind turbine of about 1.5 kW rated output requires an

average wind speed of 4–5 m/s to start pumping, compared to mechanical wind pumps, which can start pumping at about 2.5 to 3.5 m/s. Larger wind turbines require higher wind speeds to start the rotor. They become competitive with windmills above average wind speeds of 5–6 m/s for water pumping applications. Therefore, the pumping location's wind regime determines whether mechanical or electrical wind pumps are good for pumping water. Electrical wind turbines have some potential advantages over mechanical wind turbines. They are versatile—the surplus electrical power can be stored in batteries and used for lighting or other purposes. The wind turbine need not necessarily be located directly over the borehole or near the site where the power is needed. It can be located at the best wind regime location and the power generated from the turbine can be wired to the pumping site.

## **Solar Pumps**

A solar pump is powered by solar energy, either directly by converting the solar resource into electricity or indirectly by using solar-thermal heat collectors. However, water pumping using this technology is not attractive and is not discussed in this report. A pump powered by directly converting solar energy into electricity is called a PV pump, and is one of the most reliable technologies for pumping water from boreholes, rivers, lakes, shallow wells, and canals. Because of the PV array's modularity, the pumps can be redesigned as the demand increases by changing the motor-pump subsystem as long as the borehole yield is sufficient. Unlike wind pumps, PV pumps can be easily moved with little dismantling and low reinstallation costs. Figure 5-4 shows a typical village water supply using a PV pump; Figure 5-5 shows a PV pump used for irrigation and livestock watering.

Because sunlight is the only source for electricity generation in such a system, the PV array output depends on the intensity of the solar radiation striking the PV array. The amount of water delivered by the PV array depends mainly on the amount of the solar radiation it receives, which depends on the location, the seasonal conditions, the size of the PV array, and the performance of the subsystem. Energy in the form of water produced by PV pumps can be stored and batteries for energy storage may not be necessary. However, other load profiles may require battery storage for storing electricity generated during the day for night uses.

A PV-powered water pumping system is simpler than any other pumping system. PV-powered pumping systems have a PV array, a motor and pump set, and a water storage mechanism. The PV array converts the solar energy into DC electricity and the motor and pump convert the electrical output into hydraulic power. Through its distribution system, the storage mechanism delivers water to its point of use. The PV array can be directly coupled to a DC motor, or to an AC motor through an inverter. The inverter converts the DC power into three-phase AC power and the current varies continuously as a function of the solar radiation. The most common components of PV pumping systems are presented in Figure 5-6.



**Figure 5-4. A typical village water supply using a PV pump located in Ethiopia. The system has no distribution networks.**



**Figure 5-5. An irrigation PV pump in Ethiopia. The pump is also used for livestock watering while the system is not in use.**

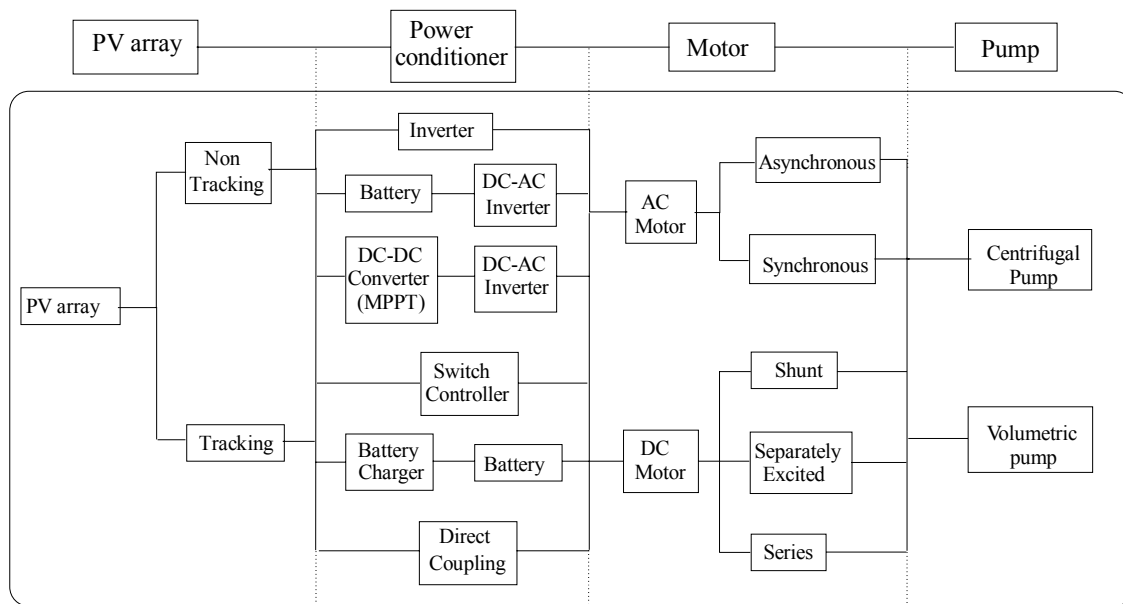

**Figure 5-6. The most common components of PV pumping systems.**

The use of PV water-pumping systems varies widely, depending on the requirements and the conditions under which water is pumped. The volume of water required varies by season, by time of day, and by type of application. For example, water supply for irrigation is seasonal. Domestic water supply requires continuous water production for the entire year. The availability of water from a PV pump over the year also depends on factors such as borehole yield, borehole recovery rate, pumping head, seasonal variability of static water level, and more importantly, the availability of solar radiation, which varies seasonally and by time of day. For all these reasons, a PV pumping system must be properly configured and designed based on the need and the type of application. The most suitable components, configuration, and location must be selected for the system to perform well and be economically viable.

The water pumping subsystems must be matched properly with a PV array for maximum use of the system; however, it is problematic with many PV systems. The main problems of the load matching with a PV array power source are related to the nonlinear solar irradiance and cell temperature-dependent voltage and current characteristics of the PV array generator. In general, volumetric pumps are linear, and can use the energy from the sun with the smart electronic controller. Centrifugal pumps are nonlinear; hence, water production drops when the pump operates away from the designed point.

The use of solar generators (PV arrays) to run water pumps, especially in sunny and developing countries, is very promising. The efficiency of PV modules is about 15%, the motor-pump subsystem efficiency is 40%–60%, and inverters are about 95%. The overall efficiency of a PV pump is 6.5%–9%.



## PV Arrays

PV cells are made of semiconductor materials that can generate electricity electromagnetically when exposed to sunlight. If a minority electron-hole pair generated by absorption of photons in the semiconductor material (the holes in n-regions, and the electrons in p-region) diffuses into a boundary region in which there is an electric field, the electron will be accelerated into the n-region, and the hole into the p-region. This causes the n-region to accumulate a negative charge and the p-region builds up a positive charge, resulting in a photovoltage. If there is a closed external circuit, a photocurrent and photovoltage can be measured by the external resistance. This process is explained using the simple diagram shown in Figure 5-7.

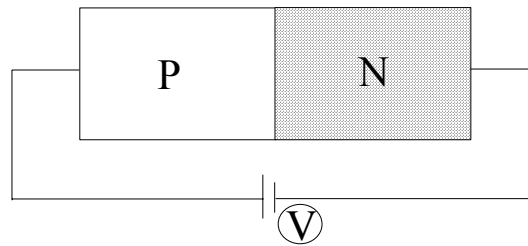

**Figure 5-7. Diagram of a simple p–n junction PV cell.**

The balance of electrons and holes can be shifted in a silicon crystal lattice by doping it with other atoms. Atoms with one more valence electron than silicon are used to produce n-type semiconductor materials. Atoms with one less valence electron result in p-type material. Once the n- and p-type semiconductor materials are reached, the process will produce photovoltage. The most common materials used in forming n- and p-type semiconductor materials are phosphorus and boron. A p–n junction can be formed either through a high-temperature diffusion process or an ion implantation process. Diffusion can be made either from a vapor phase or a solid phase. Crystalline silicon and amorphous silicon are the most dominant semiconductor materials for commercial PV cells.

Many individual cells are combined into modules sealed between layers of glass or transparent polymers to protect the electric circuit from the environment. One or more modules are then attached to the supporting structure to form a panel, and a number of panels make up an array. The array field may be subdivided electrically into a number of subarrays that perform in parallel. The array, together with the balance of system components, makes a complete system. Figure 5-8 shows the arrangement of a PV generator.

PV cells that form a module, and modules that form a PV array, should be identical. Nonidentical cells integrated to build a module create electrical and thermal imbalances. The same effect will occur in nonidentical modules. So the modules that make up the desired array size should be of the same type and size.

As the maximum voltage from a single silicon cell is only about 600 mV, cells are connected in series to obtain the desired voltage. Usually about 36 cells are used for a nominal 12-V charging system. Standard PV modules currently available in the market range in output from less than 2



W to about 110 W. The PV module constitutes the basic building block from which any PV array size can be configured to suit the application.

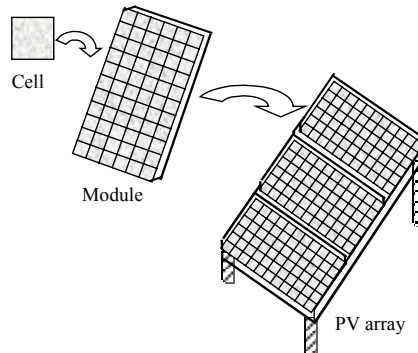

**Figure 5-8. Arrangement of a PV array generator.**

The PV array can be a fixed, flat-plate module, or it can consist of various types of collectors, either tracked or untracked. Flat-plate arrays are normally fixed with the module supported by a structure so they are oriented due south (in the northern hemisphere), or north (in the southern hemisphere), and inclined at about the angle of latitude to maximize the amount of solar radiation received annually.

Most arrays are designed to carry the modules at a fixed tilt angle, which maximizes the amount of sunlight received over the year. The rotation of the Earth positions the sun up and down in the sky, depending on the time of year. In spring and autumn, the sun has a horizontal angle, which affects the array and makes the optimum tilt angle almost equal to the latitude for that location. The angle for the array sometimes varies, so the optimization is adjusted to suit a season with more cloud cover. For example, in areas with a marked rainy season, it may be advantageous to incline the array to be more normal to the sun in that season, thereby sacrificing a little solar energy in the dry season, when perhaps more energy than necessary can be intercepted. Mounting the array at  $0^\circ$  from the horizontal (flat) position can be optimal at the Equator. Normally it is recommended that the array be mounted at  $10^\circ$  at least so there will be good rainwater runoff, which helps keep the array clean. The array can also be manually adjusted, monthly or seasonally, to allow for changing the solar elevation at noon. This is a relatively simple way to increase the power output without adding significantly to the cost. Flexibility in tilt angles for seasonal changes is marginally more economical for small systems than using a tracking system.

### **Power Conditioning Devices**

The main power conditioning devices used for PV water pumping are batteries, DC–DC converters, DC–AC inverters, AC–DC rectifiers, MPPTs, switch controllers, and charge controllers. Power conditioners are mainly used to suppress electrical power disturbances resulting from over- or undervoltage, voltage spikes, harmonics, electromagnetic interference, and chopped waveforms.

Connecting a PV array directly to a storage battery is not recommended, unless particular types of batteries are used, and solar radiation and loads are consistent. Charge controllers are recommended to prevent batteries from discharging and overcharging. Using the battery for water pumping applications is not the best combination because battery efficiency can be as low as 60% (as a result of self discharging). This offsets the benefit gained by the battery. Using tanks to store the extra available energy in the form of water from the PV array is more practical.

DC–DC converters, DC–AC inverters, and AC–DC rectifiers are called the power processors, where the DC–DC converters are used to regulate the DC power supplies in DC motor drive applications. Generally a DC–DC converter is a combination of an inverter and a rectifier. High-frequency power processors are used in DC–DC power conversion. The power processors usually consist of more than one power conversion stage where the operation of these stages is instantly decoupled by using capacitors and inductors. So the instantaneous power input does not have to have equal instantaneous power output. The functions of DC–DC converters are to:

- Convert a DC input voltage into a DC output voltage.
- Regulate the DC output voltage against load and line variations.
- Reduce the AC voltage ripple on the DC output voltage below the required level.
- Protect the supplied system from electromagnetic interference.
- Provide isolation between the input source and the load, where required.

The main functions of inverters are to:

- Invert the DC voltage of a PV array output into AC output.
- Shape the wave of the AC voltage output.
- Regulate the effective value of the voltage output.
- Ensure operation at or near the array's peak power point.

The input power source can be either a DC voltage source or a DC current source. Inverters deliver AC power to load impedance. The efficiency of a typical inverter varies with its output power. Efficiency of a conventional inverter in a given day can be very low, if it is operating at a fraction of its rated load during that day. On the other hand, the new speed control approach, for AC motor drives, uses a programmed pulse-width modulation switching technique, which can give an inverter output voltage close to unity (0.98). This technique can also optimize various objectives, such as minimizing voltage harmonics, obtaining minimum losses in the motor, reducing torque pulsation, and minimizing the generated acoustic noise.

Rectifiers convert an AC voltage or current into a DC voltage. Peak rectifiers are widely used at low frequencies of 50, 60, and 400 Hz. However, they are not used at high frequencies because the ratio of the diode peak current to the diode average current is very high, and the diode current waveforms contain a large amount of harmonics. High-performance rectifiers are available that have higher than 0.98 rated power factor, low harmonic distortion in the input current (less than 5%), and high conversion efficiency (greater than 96%).

MPPTs are intelligent devices that can provide adequate modulation to maintain the PV array's maximum power point. The power output of the PV array is sampled at frequent intervals (every

few milliseconds) and compared with previous values. If the power output increases, the PV array voltage is stepped in the same direction as the last step. If it decreases, the voltage is stepped the opposite way. This way, the MPPT always allows the PV array to operate at its peak power point. MPPT devices are currently integrated with the power processors. Generally, maximum power point controllers' power consumption is 4%–7% of the PV array output.

Using these power conditioning devices and selecting them for water pumping applications depends on population, water demand, level of service required, and economic conditions of the end users. For higher demands, AC systems requiring inverters are generally necessary because DC systems are mainly used for smaller applications. Advanced power conditioning systems (such as a tracking system with additional MPPT devices) can be integrated to the pumping system for higher level of service if it is affordable. Each power conditioning device consumes a certain amount of power, so tradeoffs may be necessary when choosing power conditioning device(s) for pumping needs.

## **Hybrid Systems**

Hybrid systems can be a combination of renewable energy technologies (mainly wind and solar) and conventional systems such as diesel, gasoline/kerosene systems, grid connections, and storage batteries. Combining renewable systems with grid power for a water pumping system is not usually the best option (except as demonstrations) because grid power is usually reliable and the cheapest option for water pumping applications. In most cases, hybrids of PV, wind, and diesel/gasoline/kerosene power generation systems are used to pump water.

Utility companies in most developed countries integrate hybrid systems with grid power supply to compensate for peak hour power demands (peak shaving) because incentives are making renewables financially attractive.

Hybrid systems are becoming more appealing for stand-alone applications. As the wind and PV technologies advance, hybrids are becoming more promising and cheaper than wind or PV for stand-alone systems. Hybrid systems can provide a reliable power source for an entire community in many developing countries. They can supply power for home and street lighting, TV and radio, and community services (water pumping, health clinics, school lighting, grain grinding mills). Possible hybrid systems for water pumping applications are wind and storage batteries with a backup diesel generator, wind and PV with batteries, PV and batteries, or wind turbines with batteries. Figure 5-9 is a schematic presentation of stand-alone hybrid power sources for water pumping applications. Because the power sources (wind and solar) are mutually independent, hybrids offer greater reliability for a water pumping system than either wind or PV technology alone. For example, in winter when solar energy is low, enough wind energy is usually available to compensate. Another advantage is their reliability in integrated applications.

Hybrid systems need not be designed for worst-case scenarios because power does not come from a single source. They permit the use of smaller component sizes, which lowers the cost of the system. However, although these systems are improving in reliability and are reducing the overall size of the power system, their initial costs are still high because of the costs of the required central control system and power conversion units (such as for converters [DC–DC],

inverters [DC–AC] and rectifiers [AC–DC]). Also, a highly skilled person must maintain the systems. Therefore, hybrid systems are good only for communities that are quite well equipped and have skilled labor available.

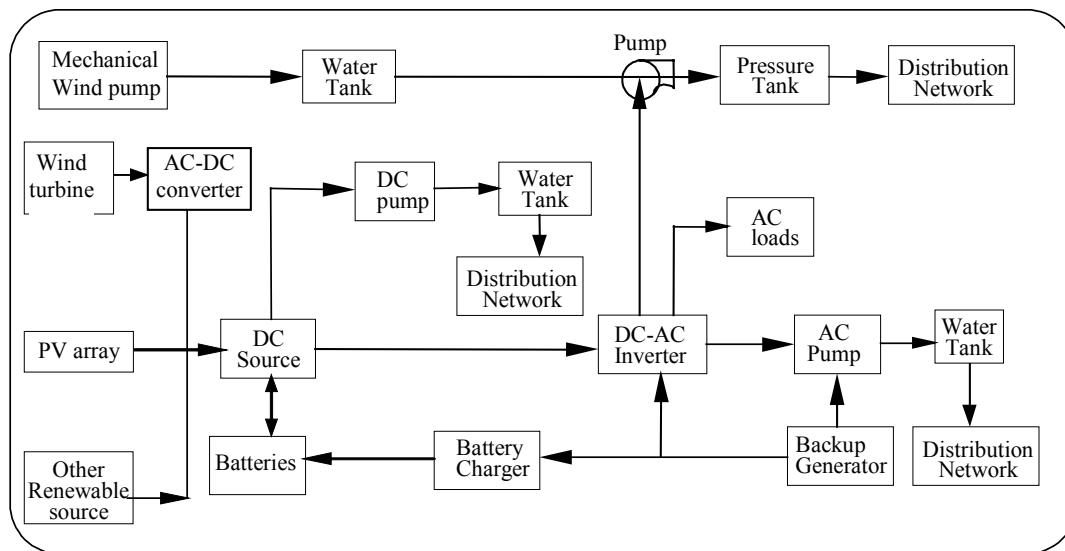

**Figure 5-9. Schematic presentation of stand-alone hybrid power sources with a backup generator for water pumping applications.**

## Power Source Selection

Selecting the optimum power source for a water pumping application is problematic because:

- There is often too little information in the area where the system is to be installed.
- The availability of long-term weather data is always a bottleneck for estimating wind and solar energy resources.
- The availability, amount, and quality of water, as well as the type of service (irrigation, water supply, or livestock watering) are major issues.

Installing the best system without a reliable water source is a waste of financial resources. Designing a system without estimating the realistic water resource might result in insufficient water supplies or unnecessary financial expenditures for an oversized system. Undersizing the pumping system in a large discharge borehole can waste resources when there is demand for water for purposes other than the domestic water supply, such as for irrigation. The quality of the water resource is a crucial factor in the overall cost of the system. Surface water resources such as river water usually need treatment because flooding and human and livestock activity in the area can contaminate the water and increase its turbidity. In such cases, a simple clarifier and filter might be enough to cleanse and disinfect the water. Spring and underground water does not typically require treatment, unless it contains chemicals such as salt and fluoride. The quality of the water is not the main issue for irrigation purposes as long as it does not contain chemicals harmful to the soil and the crops. Renewables are not usually attractive for irrigation because the

water demand is seasonal and renewables are expensive unless the system is used for other purposes during the rest of the year.

Power sources are generally selected based on the technical and economical aspects of the power source, location, and social and institutional factors. Although reliability of the power source is the main factor, the system's affordability is another important selection criterion. Indeed, affordability may be the main factor in selecting a power source, especially in rural areas of developing countries where income levels are very low. PV pumps may be more reliable than hand pumps, but if the rural community cannot afford PV, hand pumps may be used.

In a remote rural village, reliability might be the prime consideration because maintenance personnel for diesels, as well as fuels and spare parts, may be scarce. In an environmentally sensitive area, such as near an artificial reservoir, diesel systems are undesirable because of the potential risk of an oil spill. Some communities may view nearby wind turbines as "monsters." Institutional aspects also feed into power source selection. If rural water supplies are administered through a centralized government system, which is common in many developing countries, the rural water supply equipment will most likely be standardized, and power source selection may be limited to just a few standardized power source water-pumping systems. This will help minimize the problems related to the lack of spare parts, skilled labor, and shortage of currency. In many countries, trained maintenance personnel might be available for only a few selected power source systems.

Hand pumps can be ideal for single families or a few households in rural areas if the hydraulic equivalent load (the product of the daily water demand,  $V$  and the total pumping head,  $h$ ) does not exceed 250 m<sup>4</sup>/d. Hand pumps operate best in shallow wells (as deep as 15 meters). Pumping is more difficult with deeper wells. Depending on per capita water consumption, hand pumps can serve as many as 1,000 people in rural areas.

AC PV pumps are ideal for communities of 2,000–2,500 people and a hydraulic equivalent load of 1,500 m<sup>4</sup>/d. The hydraulic equivalent load of PV pumps can increase depending on the intensity of solar radiation energy of the area and the size of the PV array. PV pumps for small per capita water consumption can serve as many as 4,000 people. DC PV pumps are recommended for smaller applications up to a hydraulic equivalent load of 600 m<sup>4</sup>/d.

Diesels are best for higher water demands and larger communities. They are more economical, with a hydraulic equivalent load greater than 1,500 m<sup>4</sup>/d. Mechanical diesel pumps (positive displacement pumps) do not depend on well depths and can operate at high pumping heads with minor losses, as long as the pump operates at the designed point and the system is well matched.

Wind pumps will typically be the first choice in windier locations, such as near large lakes, sea-shores, and open plain areas. Winds are especially gusty over long ridges because wind speed accelerates as it passes over ridges and around ridge edges. Mountains and ridges often experience higher winds because of channeling and temperature inversion. PV systems are good for sunny locations (tropical, arid, and semiarid areas), where solar energy abounds.

Variability of wind pumps depends on the wind speed. Mechanical wind pumps (windmills) are designed to start pumping at low wind speeds of 2.5–3.5 m/s. Most windmills achieve their highest overall efficiency at wind speeds of 6–9 m/s. These pumps normally operate best at speeds as high as 10 m/s, then the windmill furls. Mechanical wind pumps come in three sizes: light, medium, and strong. Light wind pumps normally start pumping at wind speeds of 2–3 m/s, medium-sized pumps at 3–4 m/s, and strong pumps at 4–5 m/s.

Electrical wind turbines generally require high wind speeds to start pumping (see the selected wind turbine power curves in Figure 5-10). Small turbines (about 1.5 kW rated output) require an average wind speed of 4–5 m/s to start pumping. For medium and strong turbines, the wind speeds need to be much higher to start the rotor. For wind turbines with less than 1 kW rated output, the rotor can start at lower wind speeds (3–5 m/s). Tower height to the hub is generally about 10 meters for mechanical wind pumps; electrical wind turbines require higher towers. Electrical wind pumps can cost three times more per unit of rotor area than mechanical wind-pumps for small wind machines, and twice as much for large machines. Mechanical wind pumps begin to be economically attractive from 2.5–3.0 m/s mean wind speeds; their counter electrical pumps need 5–6 m/s wind speeds to be economically attractive.

In an area where one type of renewable energy resource is not reliable because of seasonal variations, using hybrid systems increases the reliability of the power supply. Hybrids offer greater reliability than either wind or PV technology alone because the power sources are mutually independent. The other advantage is that systems do not need to be designed for worst-case scenarios because the power does not come from a single source.

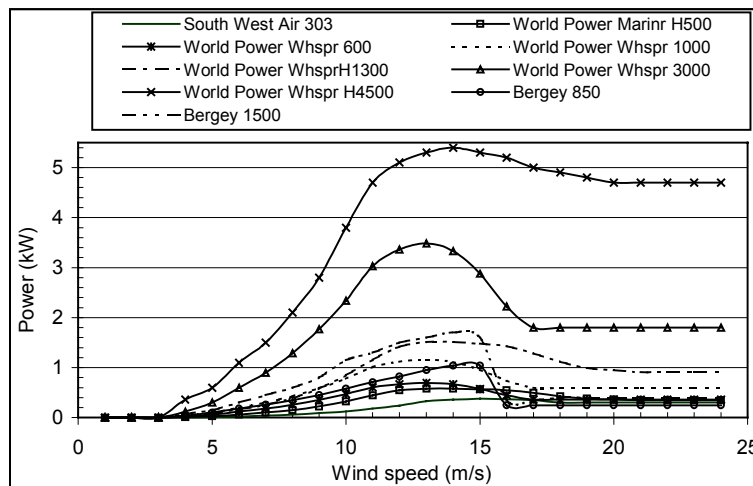

Source: Manufacturer's data.

Figure 5-10. Selected wind turbine power curves.

Figure 5-11 shows the sensitivity analysis of hybrid systems at an average daily load (any type of load) of 20 kWh at various annual wind speeds and fuel prices. According to this graph, PV technologies are competitive for smaller villages when the fuel price is higher than \$0.45/L; for larger villages the fuel price must be much higher. PV's role in moderate wind regimes is merely to supplement the wind turbine generator (WTG). At lower fuel prices, wind can be competitive in very good wind regimes. In the small size range, diesels are less cost effective at high fuel

prices and decent wind regimes; reliability rather than cost is the justification for using diesel. In the larger size range, diesels are more competitive. Batteries are very sensitive to load shape, but in many applications only a very small battery bank (or none at all) is the optimal design.

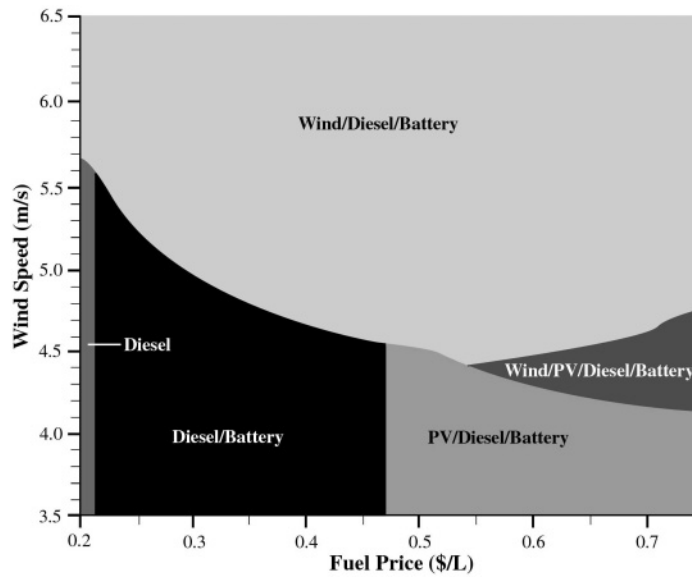

**Figure 5-11. Sensitivity analysis of hybrid systems at an average daily load of 20 kWh. The load can be any kind from simple lighting to integrated power supply purpose. This graph is made using a hybrid optimization model for electric renewables (Homer).**

Figure 5-12 shows the sensitivity analysis of hybrid systems performed on the size of the load and the average annual wind speed. This graph clearly shows a minimum load below which diesel is not cost effective, a maximum load above which PV is cost effective in conjunction with the WTG and diesel, and where diesel and WTG are cost effective. It also shows that 4 m/s is a minimum annual average wind speed for the cost-effective use of wind turbines. For very low loads in a good wind resource, one small wind turbine will produce more energy than required. In lesser wind resources or as the load increases, a combination of wind, diesel, and PV is preferred. As the wind speed diminishes, PV and diesel may be the best choices. However, at higher loads and low winds, diesel is the only preferred option. At higher winds, WTG and diesel hybrids are the best choice. PV is cost effective at low wind speeds and small loads.

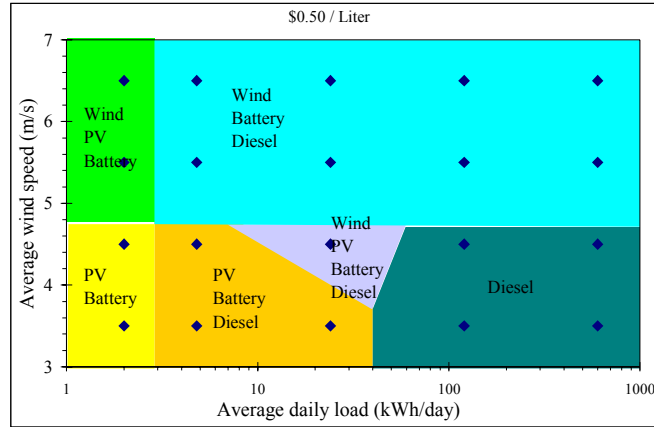

**Figure 5-12. Sensitivity analysis of hybrid systems based on a fuel cost of \$0.50/L. This graph is made using a hybrid optimization model for electric renewables (Homer).**

### Sizing of Systems

Once the proper power source type is identified, the water demand and the total pumping head can be used to size the system. These two factors are the main criteria for sizing any water pumping system. The daily water demand and the peak hour demand are estimated from the livestock or the size of the population. The water demand for irrigation is estimated based on the land area to be irrigated and the amount of water required for the crop to be planted. The per capita water consumption for domestic water supply is 10–1,000 LCD (liters per capita per day), depending on affordability, climate, and the habits of the population. In remote African villages, for example, water consumption can be as low as 10 LCD; in California, as high as 1,000 LCD.

The total pumping head is the total head required to pump water from the water source to the reservoir; that is, the sum of the pumping head, the friction, and the discharge head. The discharge head is the height from the surface of the ground to the reservoir pipe outlet. The pumping head, in case of groundwater from boreholes, is the static water level plus the drawdown. The friction head is the energy loss in pipes and fittings. For further clarification, these terms are presented in the schematic diagrams of mechanical and electrical wind pumps in Figure 5-13. Schematic diagrams of PV or diesel genset pumps have similar setups to the electrical wind pump shown in Figure 5-13(b). A mechanical diesel engine coupled with positive displacement pumps will have a setup similar to the mechanical wind pump.

A water pumping system must be sized carefully and realistically. An undersized system will frustrate its users; an oversized system is a waste of financial resources. Sizing a system for the worst seasonal variation of the energy resource (solar and wind) is recommended to ensure that users have enough water. The most common problem with the installed systems in the field arises from undersized water tanks rather than undersized PV arrays. Water tanks for PV and



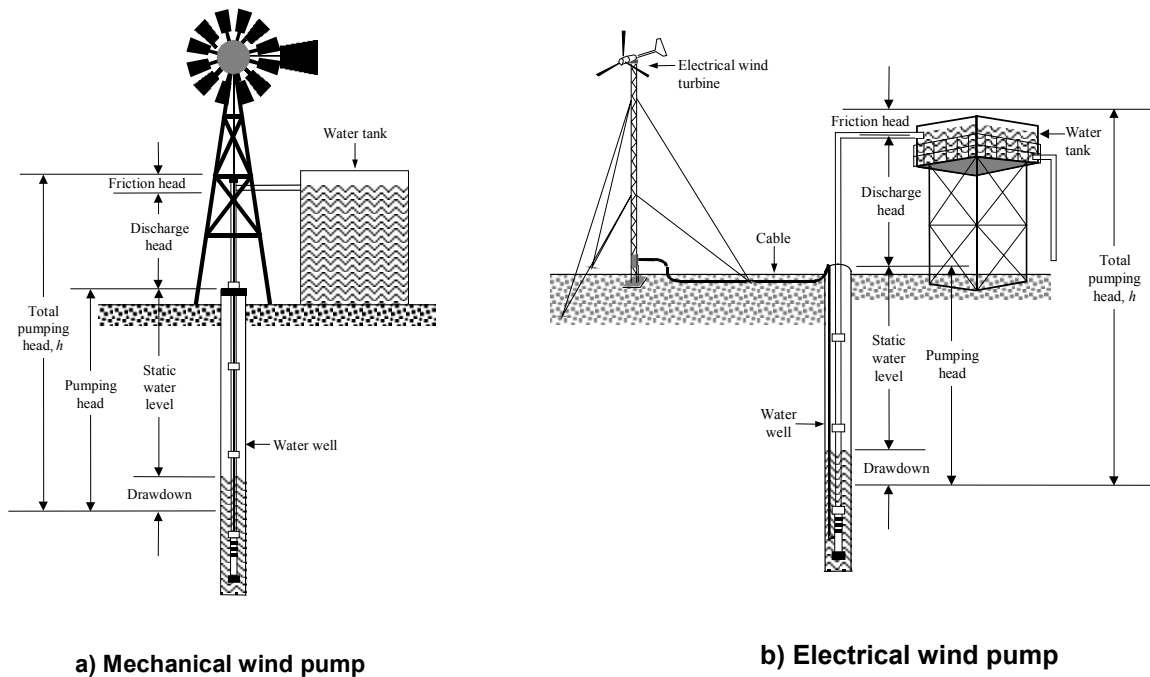

**Figure 5-13. Schematic diagram of typical wind pumps.**

wind systems need to be designed differently from conventional water pumping systems since power from genset is always there. But with PV and wind pumping systems, energy is not available on demand, so typical long-term weather data are required to design the system. From these data, the following steps are necessary:

- Identify the worst consecutive solar radiation and wind energy days and estimate the total amount of water produced over these days estimated.
- Subtract the total water demand over these consecutive worst days from its corresponding total water production and identify the biggest number with minus sign over the typical year from all the consecutive bad solar or wind days. That number is exactly the minimum size of the water tank required for that site.

Important design questions are:

- What type of service and local infrastructure are available?
- How much can the residents pay for a 100% guaranteed water supply in all seasons?
- To what extent can they tolerate a periodic lack of water?
- How many days of autonomy are possible in the case of system breakdown, where the water tank can still serve the community until the system is fixed?
- What is the availability of maintenance personnel and spare parts?

Simple nomograms can be used by anyone interested in sizing a PV pump or mechanical or electrical wind pump. They are prepared based on the mathematical relationships of the available energy from the wind or solar resource and the hydraulic energy. They can be used to size the PV array and the wind machine for the size of the motor and pump or vice versa. They do not

help to size water tanks, mainly because tank size depends on the availability and consistency of the renewable energy resources.

Figure 5-14 was developed for sizing a PV pump at an ambient air temperature,  $T_a$  at 25°C. This nomogram can be used either to determine the size of a PV array required for the desired pumping head and water demand, or to estimate the daily amount of water production for a given PV array size and pumping head. If the hydraulic energy varies from month to month because of varying water levels or water demand, the nomogram should be used for each month with the corresponding solar radiation and hydraulic energy. The month with the worst-case combination of solar radiation energy and water demand is generally the design month. The water demand must be determined from the size of the population to be served and the total pumping head. Then, a line is drawn counterclockwise or clockwise on the nomogram, using the appropriate values of the subsystem's efficiency and the average daily solar radiation, to get the required array size.

The nomograms presented in Appendix A were prepared for sizing mechanical and electrical wind pumps at various rotor diameters. The electrical power required to pump the desired amount of water is the same as the power in the rotor. The nomogram can be read either clockwise or counterclockwise like the nomogram in Figure 5-14. The desired daily amount of water (or the water demand) is known from the population size or from the area of land to be irrigated and the type of crop, then the water source is identified. The pumping head and the amount of water available in the borehole were determined during the borehole test.

Using the water demand and pumping head, a line is drawn counterclockwise to determine the hydraulic power (energy), then the appropriate motor and pump are selected. The nominal efficiency of the motor-pump subsystem can be estimated from manufacturers' catalogs. Using this known subsystem efficiency, the power required for pumping the desired amount of water at the given pumping head can be estimated. From this known electrical power, various products of wind machines and sizes are compared and the desired power to run the pump for a given wind speed of that location is selected. Alternative wind machines should be evaluated at various rotor diameters since power produced in the rotor mainly depends on the diameter and efficiency of the rotor, and the wind regime. A typical graph of power in the rotor at various wind speeds and rotor sizes is shown in Figure 5-15.

If a wind machine has been either donated or purchased before the system's location is known, the simplest way to estimate the amount of water it produces is to determine the monthly average wind speed. Then, the actual power produced from the machine should be estimated using the machine's rotor diameter and efficiency by drawing a line clockwise on the nomogram shown in Appendix A. Then the subsystem efficiency is estimated and the hydraulic power determined. Identify the water source and the pumping head to determine the amount of water produced in the machine. Once the amount of water produced is estimated, the right kinds of motor and pump can be identified.

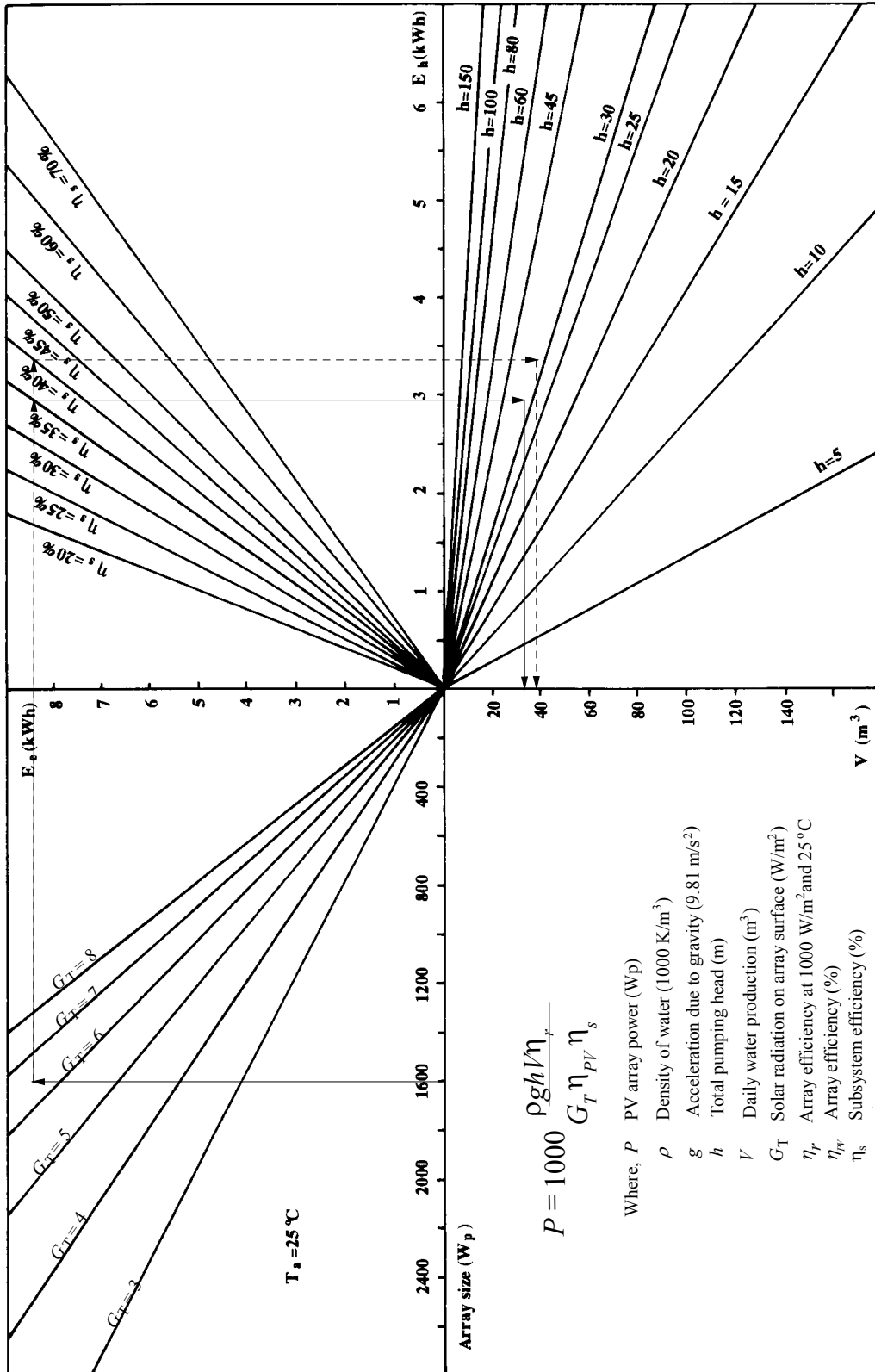
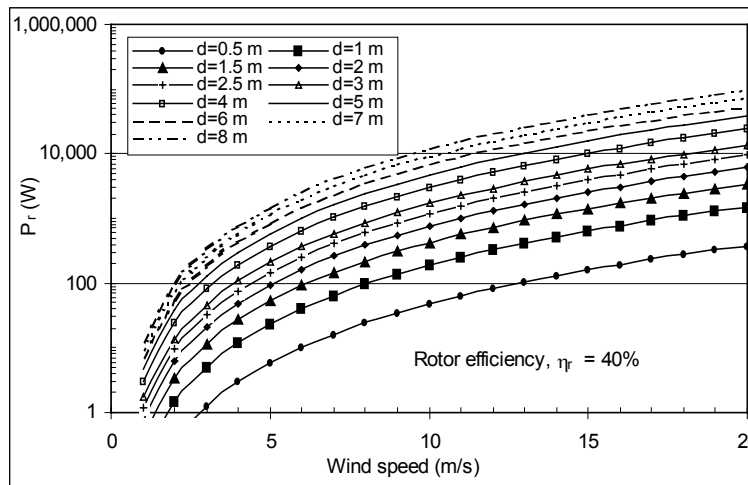

Figure 5-14. Nomogram used to estimate the size of a PV array and daily water production.



**Figure 5-15 Power in the rotor at various wind speeds and rotor diameters, and for rotor efficiency of 40%.**

## System Performance

Once the water pumping system is designed and installed, it must be monitored and its performance evaluated to determine the operating efficiency. Performance evaluation helps to check whether the pumping system functions as per design. Depending on the data requirements, the system can be monitored with simple discrete-time measurements or real-time measurements. Simple measuring instruments—such as a voltmeter for measuring the voltage drop across the shunt resistance, a simple silicon-based sensor or a pyranometer for measuring the intensity of solar radiation energy on the PV array, a temperature sensor for measuring the ambient and cell temperatures, and an anemometer for measuring the wind speed—can be used to make discrete-time measurements. However, if detailed information is needed, it is better to use data acquisition systems and data transmitter/receiver devices such as modems, to measure performance in real time.

The simplest way to measure a PV (wind) pump’s performance is to take daily readings of the solar radiation on the PV array’s plane (or, in the case of a wind pump, the wind speed), the daily volume of water pumped, and the static head of the borehole. This allows the hydraulic energy to be calculated, then the system efficiency can be estimated at different solar radiation energy or wind speed levels.

Each component of the pumping system has intrinsic characteristics that affect the overall operating conditions. Therefore, the intercepts of all respective component characteristics should follow the maximum power line of the power source. Depending on this internal matching, the efficiency of the overall system and related performances should meet acceptable limits. By using such monitoring approaches, the performance of each component can be tested whether or not each component meets this criterion.

Load matching is another type of tool used to evaluate system performance. The load matching factor is nondimensional, and is defined by the ratio of energy acquired by the hydraulic load to the maximum power extracted from the power source in a 1-day period. It can also be the ratio of the power that the source delivers to the motor–pump subsystem during the day to the maximum electrical power that can be obtained from the source throughout the day. In short, this can be defined as the ratio of the power used for water pumping to the source output capability.

## Chapter 6 Economics

This chapter contains a guide for estimating the costs and benefits of alternative water pumping options based on established techniques rather than on new methods. The main problems in economic analysis are not the use of the established techniques but the practical use of tools, the need to make assumptions, the availability of correct data, and the analysis. An economic evaluation is used to identify which alternative pumping option achieves the maximum benefit for the least cost. Economic decision-making includes generating and evaluating alternatives. Because choosing an alternative is always the object of a decision, economic decision-making can proceed only if alternatives have been established. The aim of selection is to find the best possible result for the least possible sacrifice. Economic analysis of alternative systems is undertaken to find the most profitable among the possible energy alternatives.

Installing any pumping system requires a long-term financial commitment. Inadequately assessing various factors may affect the economic and financial viability of the system. When considering economic viability, distinctions must be made between a financial and an economic assessment. The economic approach is based on the true value to a society, using benefits and costs that are free from taxes, subsidies, and interest payments. But financial viability is a concern from the purchaser's point of view; it includes taxes, subsidies, and loan payments in the evaluation. The long-term effects of the loan should be evaluated by spreading the capital cost over the loan period. However, financial and economic approaches cannot convert all relevant factors to monetary terms, so the final decision must be made after all the technical, economical, financial, and other related external impacts are considered.

The main difference between approaches to evaluating economic and external impacts is the valuing of the factors. An economic evaluation of water pumping systems is based on the monetary values of the system. All costs (investment, recurrent, and replacement) and income generated from the system are recorded, based on the time value of money. Then these costs are evaluated to determine the most viable system among all available alternatives. The external impacts evaluation method emphasizes non-monetary values that can directly or indirectly affect the selected pumping system. These two evaluation methods and a technical evaluation are the main criteria in selecting the best alternative energy source for water pumping systems. When a system meets these three criteria, it can be called "the best choice." Because a village water supply must be designed to suit the residents, several factors that affect rural water use habits should be taken into account. They include the social acceptability of the system's level of service, the cost of water, and the institutional setup to run the system. It is equally essential to evaluate and monitor the method of application (how the villagers can use the system), their reaction to the system, and its seasonal reliability. It is difficult to draw conclusions about the relative desirability of various options because the costs of technology and relative operational costs frequently vary and because sustainability may change depending on the end use.

The pumping system should be reliable and fulfill the water demand. However, in many cases, the water resource determines the best type of pumping system. If the well yield is too low, hand pumps may be the only option. In this case, well yield is the primary limiting factor. When the water resource is not a problem, the other main factor for selecting a mechanized pumping

system is the energy resource. For wind pumps, the determining factor is the availability of wind; for PV pumps it is solar radiation energy. Availability of fuel and maintenance personnel in a remote rural village can be also a determining factor for pumps driven by diesel or gasoline engines. Economic viability of such systems can be affected because of a lack of fuel or maintenance personnel, or both—days can pass without water until a technician can come to fix the system, or until fuel can be brought to the pumping site.

The familiarities of local technicians with the selected system, the frequency and ease of O&M, and the availability and cost of spare parts are important considerations. PV systems are inherently reliable and maintenance free, but spare parts are scarce and local technicians might be unfamiliar with servicing procedures. Wind pumps might be the best option in these cases, provided there is an adequate wind resource.

Another important factor is the borehole cost. Drilling is generally expensive in remote locations, and it is advisable to use a higher capacity pump for a single borehole with a higher yield. In such cases more water can be pumped from the same borehole and the unit water cost can be reduced instead of using a small pump in the same borehole. In this case, the energy source is the main factor in choosing the type of system (PV, wind, or diesel/gasoline). Therefore, different pumping options should be assessed during the pre-feasibility study.

## **Economic Evaluation Methods**

In economic analysis, all the expenditures and incomes connected with the planned investment data must be compiled for economic comparison of project options. This should include data that reflect the economic atmosphere where such investment is planned, and all associated expenditures and returns, followed by financial analysis. A quantitative formulation of the idea together with the decision-making criteria, applicability of the method, and remarks on its limitations should be presented. Various investments and the resulting annual costs and benefits must be indexed according to their time-order of accrual to properly calculate financial acceptability.

Some traditional methods for analyzing investment costs are life cycle cost (LCC); net present cost (NPC); internal rate of return (IRR); benefit-to-cost ratio (BCR) or savings-to-investment ratio (SIR); net benefits or savings (NB or NS); annuity and cost annuity comparison method; critical value method; levelized costs; and payback period. Of the three most common techniques in economic analysis—the LCC, the IRR, and the payback period—the LCC method is the most complete approach and is widely used. For this reason, we discuss the LCC in more detail below.

LCC is the sum of the capital cost and the present worth of the recurrent and replacement costs. It is a first-order indication when a particular single pumping system is considered for a particular application. To determine the unit water cost, the LCC should be converted into the annual equivalent life cycle cost (ALCC). ALCC is the reverse process of discounting. In other words, the LCC will be distributed equally over the system's economic life. Then the ALCC is divided by the annual water production (requirement) to determine the unit water cost.

When the pumping system is to supply drinking water, the comparative LCC of renewable energy source (wind and solar) pumping systems must be established with that of conventional

systems. This is necessary because the economic benefits of supplying water are difficult to quantify. For example, if both a PV pump and a diesel pump can reliably furnish the same quantity of water, it is safe to assume that they provide equal benefits. In this case, the lower cost option is preferred. In LCC analysis, the net present value (NPV) of all the capital and recurrent costs of a pump is compared to the NPV of all the costs of other pumping options. For example, if the NPV costs of a PV pumping system are less than the costs of other alternatives, PV should be the first choice for the power source. However, in most cases alternative pumping systems cannot provide as much water as conventional systems. For this reason, it is convenient to make comparisons in terms of unit water cost rather than the lowest cost pumping option.

In the economic/financial analysis, a sensitivity analysis can be used to evaluate the effects of uncertainty when input parameters, such as interest rate, discount rate, inflation rate, energy escalation rate, service life, investment and operation costs, and income are varied by a certain amount (percentage) from the expected value. Sensitivity analysis is used to quantify the economic consequences of a potential but unpredictable development in important parameters.

Sensitivity analysis covers a range of possible application loads. It is used to determine how the NPV LCC varies from the base case as the key parameters such as equipment capital cost, conventional fuel cost (diesel or kerosene), discount and interest rates, expected lifetime for conventional equipment (engine) and renewable energy sources (solar radiation and wind speed) change. Common base-case assumptions should be considered in all these investment–cost analysis methods. The common assumptions in economical analysis include discount rate, inflation rate, and fuel escalation rate. In financial analysis, salvage value, operating hour, debt service, fuel costs, inflation rate, and discount rates are included along with economic assumptions. The technical assumption is where the most important specifications for the typical system in each application are developed. The key technical assumptions common to the base-case analyses include component life (economic life), major maintenance, and engine overhaul requirements.

Graphs can be constructed to show the overall best- and worst-case viability of each alternative for a given load range. For example, the best-case PV pump viability graph is developed by compounding the extreme sensitivity limit using the lowest discount and interest rates, the highest fuel cost, the shortest conventional system lifetime, and the highest solar radiation of the sensitivity limit range. The worst case is developed using the other extremes of these ranges.

### **Obtaining the Necessary Data**

Obtaining all the necessary parameters and cost data for economic calculations can be difficult. Determining the investment cost, which might seem the easiest information to gather (because the time gap between the beginning and the end of the construction period is shorter than the economic life of the project) is not straightforward. Most of the time, recording actual financial information is impossible. Construction workers and supervisors typically have little interest in paperwork, so financial cost information may never be recorded. In such cases, making assumptions is the common practice. And assumptions of investment costs, even for similar systems, may vary because of variations in transportation and labor costs.



Another challenge is recording the O&M costs over the system's economic life because keeping records of all expenses is impossible. The interest, inflation, and fuel escalation rates must often be assumed. Although there are no alternatives to making assumptions about these rates, it is important to first investigate the past and the future trends of the country's economy. Using an incorrect assumption for long-term economic analysis can lead to erroneous results, which in turn can be misleading for the end users. For these reasons, actual cost information should be used as much as possible, and realistic assumptions made to help to reduce the risks inherent in any economic analysis.

When performing economic evaluations, the alternative systems must provide the same level of service as the conventional ones. For example, hand pumps (unlike diesels, PV, and wind pumps) require labor to pump water. The alternatives should also have similar water distribution networks. If one system has large distribution networks, where users get service without walking long distances to fetch water, and the other has a small distribution network requiring a long walk to fetch water, the level of service varies, affecting the economic analysis.

## **Economic Comparisons**

Economic comparisons of various water pumping options such as PV pumps (DC and AC systems), wind pumps (mechanical and electrical systems), diesel-driven mechanical pumps, and gasoline pumps can be made using LCC and sensitivity analysis methods. In this economic analysis, we evaluated the following pumping options:

- Seven 1.6 kWp capacity PV arrays coupled with AC motors using Grundfos inverter (SA1500) and various types of pumps (serve 2,000–4,000 people in Ethiopia).
- One 600 Wp DC PV irrigation pump (also in Ethiopia) coupled with a floating pump.
- Two DC PV pumps installed in Mexico, with capacities of 848 Wp and 800 Wp PV arrays, one coupled with a Grundfos submersible pump, the other with a Solarjack pump. They are used to water livestock and supply water.
- Four Lister diesel-driven engines installed in Ethiopia, each with 11.2 kW capacity, coupled with positive displacement (mono) pumps.
- A 6-kW gasoline-driven engine and a 15-kW diesel genset pump installed in Mexico.
- A Bergey 1500 type wind turbine at 18 meter hub height with various types of Grundfos pumps in Bushland, Texas.
- Three mechanical wind pumps in Bushland, Texas:
  - The Aermotor: rotor diameter 2.44 meters, maximum stroke 32/min, stroke length 190 mm, 18 curved, inverse-tapered, wing shaped steel blades.
  - The Dempster: rotor diameter 2.44 meters, maximum stroke 32/min, stroke length 180 mm, 15 curved, inverse-tapered, wing shaped steel blades.
  - The Dutch-Delta windmills: rotor diameter 4.88 meters, maximum stroke 38/min, stroke length 165 mm, 32 delta wing-shaped blades.

The AC PV and diesel-driven pumps installed in Ethiopia have relatively large water distribution networks; the rest are on-site water distribution systems.

The cost information we used to compare the economics of these systems was projected into 1998 prices and evaluated for 20 years of economic life (from the beginning of 1998). The economic lives of the components were assumed as follows:

- PV modules, wind turbines, windmills, and tower—20 years (from the beginning of 1998)
- Windmill pumps and cylinder—5 years each
- Motor–pump subsystem and leading edge tape of the blades for the Bergey 1500 type of wind turbine—5 years each
- Furling cable for Bergey 1500—10 years
- Diesel genset—10 years
- All the rest of the diesel/gasoline engines and the pumps—5 years
- Motor–pump subsystem for the PV pumps—10 years

The real discount rate for wind pumps installed in Bushland, Texas, is 4.1%. For pumping systems installed in Ethiopia and Mexico, we assumed the rate at 7%.

The cost information of the PV pumps in Ethiopia is actual field data found in the archives of donors, contractors, owners, and end users. The cost information for the wind machines was obtained from the USDA Agricultural Research Service (ARS). The cost information of the PV and diesel/gasoline pumping systems in Mexico was supplied by New Mexico State University. The O&M costs of the two PV pumps in Mexico are assumed to be 1% of the initial capital cost.

Labor costs—basically operators' salaries—vary from place to place, depending on the type and size of the pumping system. Diesel pump operators are generally paid more than PV pump operators because diesels require a higher skill level. Real fuel prices were used in the evaluation. The cost of fuel for the diesel pumps in Ethiopia was \$0.35/L (based on the 1998 price). The cost also varies from location to location, depending on fuel transportation cost. The oil and lubrication costs for the four diesel-driven mechanical pumps are \$2.42/L (U.S. \$). The fuel, oil, and lubrication consumption is based on manufacturers' catalogs. The cost of fuel in Mexico for the diesel genset is \$0.51/L and for the gasoline pumps \$0.47/L. There is no subsidy for any of the systems evaluated here, and we did not include taxes in the comparisons. The economic comparisons of the diesel engines in Ethiopia are based on 7 hours of operation per day.

Field investigations show that the O&M costs of PV pumps depend on whether the system has a distribution network. PV arrays are generally 30%–40% of the total investment cost. The next highest cost is the well drilling, which is about 20% of the total investment cost. The third highest cost is for the motor–pump subsystem; depending on the type of pump and motor, these can account for 10%–15% of the total investment cost. Equipment and material costs consume 60%–70% of the total investment cost and the construction and installation costs share 30%–40%, depending on whether there is a distribution system. The O&M cost for PV systems without a distribution network is close to 1% of the total investment cost. However, if the PV pump has a distribution network, the O&M cost is about 2%. Replacement costs depend on the type of motor–pump subsystem. AC systems tend to be more expensive than DC systems because AC PV pumps require an inverter and a more advanced control system.

The equipment and materials cost for diesel pumps is about 50% of the total investment cost. The construction and installation cost for diesel systems is quite high compared to PV systems because they are robust enough to require relatively better reinforced concrete foundations and shades. The O&M costs for diesels are quite high, running as much as 25% of the total investment cost. This demonstrates that the cost of keeping diesel pumps running is too high. In the long run, PV systems can offset the investment cost even though the investment cost of diesels is lower than that of PV systems. Similarly, the replacement cost for diesel pumps is very high compared to PV pumps. This makes PV pumps even more attractive. This issue will be discussed further in the following paragraphs.

Economic comparisons between windmills (Aermotor, Dempster, and Dutch-Delta) and the Bergey 1500 type of electrical wind turbine were made based on a 5-year average wind speed of 5.65 m/s. All these systems are located at the USDA ARS in Bushland, Texas, and operated in the same environment. The economic comparison showed that Aermotor and Dutch-Delta windmills, using the 70-mm inside diameter pump, performed better at well depths of about 45 meters. The Aermotor windmill with a 48-mm inside diameter pump and the Dempster windmill with a 70-mm inside diameter pump performed equally well to the Bergey 1500 wind pump at about 45 meters pumping head (see Figure 6-1). However, the graph could be different if the wind regime changes. At higher wind speed locations, the Bergey 1500 wind turbine will perform better than the windmills; the windmills perform better at lower wind speeds. This can be seen from a sensitivity analysis of these wind pumps at various wind speeds, shown in Figure 6-2. Figure 6-2 was prepared using average wind speed (Weibull distribution coefficient of  $k = 2$ ) and average flow rate data. Mechanical wind pumps can attain their optimum performance at lower wind speeds than can electrical wind turbines.

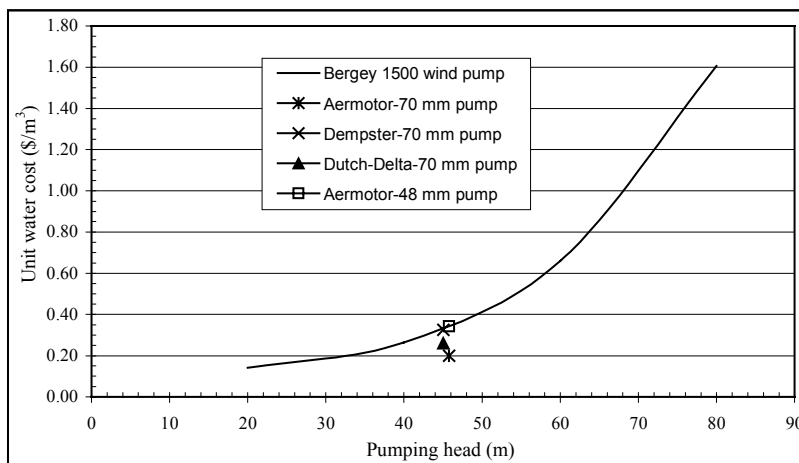

**Figure 6-1. Unit water cost versus total pumping head using three types of mechanical pumps and two types of electrical wind pumps at an average wind speed of 5.65 m/s.**

As shown in Figure 6-2, the optimum wind speed (at the lowest unit water cost) for windmills is 8 m/s and for the Bergey 1500 type electrical wind turbine is 13 m/s. Electrical wind turbines require higher wind speeds than mechanical wind machines, as the cut-in wind speed for the Bergey 1500 electrical wind turbine is higher (at 5–6 m/s) than the mechanical wind pumps (at 3.5 m/s).

The Bergey 1500 (at 20 meters well depth), installed at the USDA-ARS in Bushland, Texas, operates at an average wind speed of 5.65 m/s, based on 5 years operational data (1992–1997), and has a unit water cost of \$0.14/m<sup>3</sup>. In fact, if this pump were installed at the optimum wind speed location (13 m/s), the unit water cost could be \$0.06/m<sup>3</sup>. This shows that the system is not fully utilized at its optimum capacity. A location with an average wind speed of 13 m/s is not easily found in many parts of the world. Therefore, it might be challenging for wind turbine manufacturers to lower the optimum wind speed while keeping the performance of the system at its optimum level.

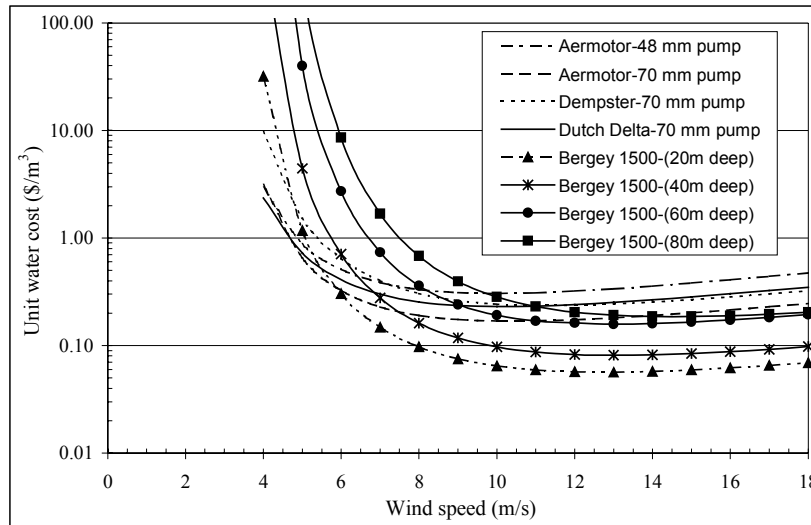
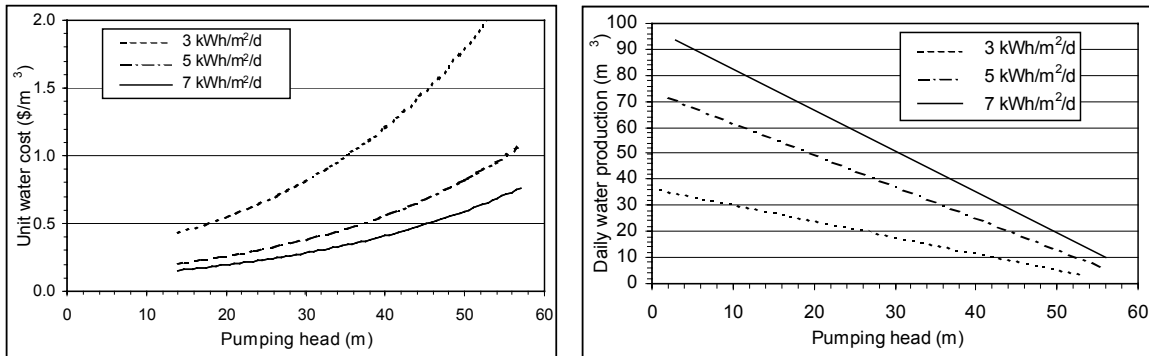

**Figure 6-2. Sensitivity analysis of mechanical and electrical wind pumps, based on average flow rate and wind speed data using Weibull distribution coefficient of  $k = 2$ .**

Figure 6-2 shows that the unit water costs of the Bergey 1500 type of pumps (at different pumping heads) tend to be lower, while those of the mechanical wind pumps tend to be higher at higher wind speeds. This shows that electrical wind turbines perform better at higher wind speeds compared to mechanical wind pumps, which furl at lower speeds; windmills are better than electrical wind turbines for pumping water at low wind speeds. It is erroneous to generalize that electrical wind pumps are cheaper or better than windmills or vice versa. Such decisions should be determined based on the average wind speed of each pumping location because the system costs depend heavily on the availability of wind. As we have discussed, it is important to identify the wind regime of the location before selecting the type of machine for a water pumping application. Figure 6-2 shows that windmills are cheaper at wind speeds up to around 6 m/s and that the Bergey 1500 begins to become less expensive above 6 m/s.

We performed a sensitivity analysis of the AC PV pumping system using 1.6 kWp PV arrays at various pumping heads, at solar radiation energy of 3, 5, and 7 kWh/m<sup>2</sup>/d, respectively. The results are presented in Figures 6-3 and 6-4. The results show that a slight change in solar radiation energy, which is the main source of energy for PV pumps, changes the unit cost and the amount of water production. This analysis indicates that the hydraulic equivalent load limits for these PV pumps (1.6-kWp array size) depend on the available solar radiation energy. The

hydraulic equivalent load limit for an annual average solar radiation energy of 3 kWh/m<sup>2</sup>/d is up to 500 m<sup>4</sup>/d, for 5 kWh/m<sup>2</sup>/d it is up to 1,000 m<sup>4</sup>/d, and for 7 kWh/m<sup>2</sup>/d it is up to 1400 m<sup>4</sup>/d (see Figure 6-4).



a) Unit cost versus pumping head

b) Daily water production versus pumping head

Figure 6-3. The unit cost of water and the daily water production at 3, 5, and 7 kWh/m<sup>2</sup>/d.

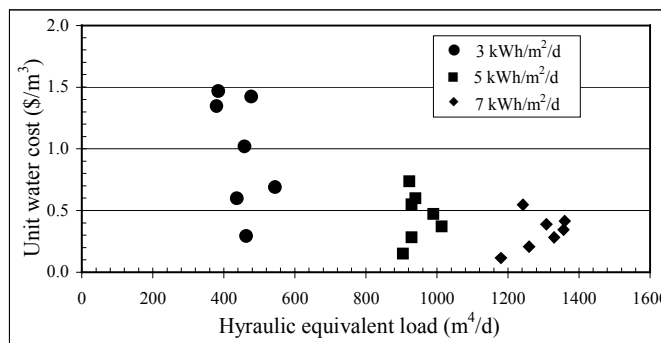
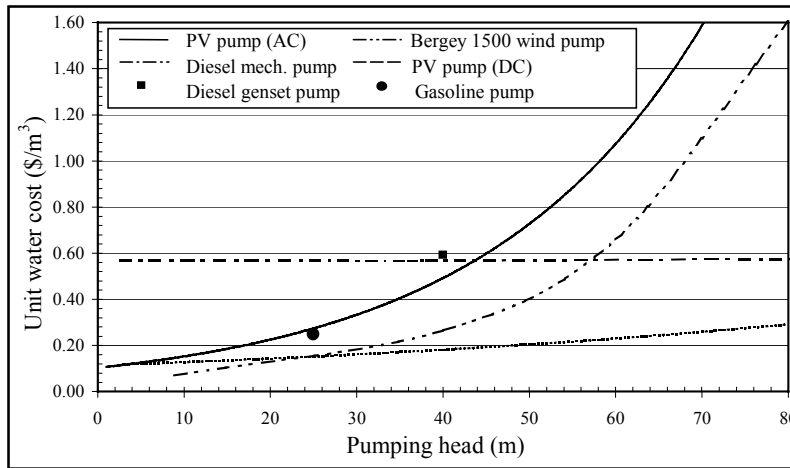

Figure 6-4. Hydraulic equivalent load limits at annual average solar radiation energy levels of 3, 5, and 7 kWh/m<sup>2</sup>/d.

Economic comparisons were made between the Bergey 1500 type wind pumps, the AC and DC PV pumps, the diesel-driven mechanical pumps, a diesel generator pump, and a gasoline pump. The results are presented in Figures 6-5, 6-6, and 6-7. The Figure 6-5 evaluation is based on the average wind speed of 5.65 m/s for the wind pump, using fuel prices of \$0.35/L for the diesel-driven mechanical pumps (in Ethiopia), and \$0.51/L and 0.47/L for diesel genset and gasoline pumps (in Mexico), respectively. The average annual solar radiation used for this evaluation in Ethiopia is about 5.5 kWh/m<sup>2</sup>/d and in Mexico is about 5.8 kWh/m<sup>2</sup>/d. The Figure 6-6 evaluation is based on the fuel prices of \$0.35/L for the diesel-driven mechanical pumps (in Ethiopia), and \$0.51/L and 0.47/L for diesel genset and gasoline pumps (in Mexico), respectively. The average annual solar radiation used for this evaluation in Ethiopia is about 5.5 kWh/m<sup>2</sup>/d and in Mexico is about 5.8 kWh/m<sup>2</sup>/d.

The economic comparison shows that small DC PV pumps are the cheapest option for small applications. Such systems are ideal for low hydraulic equivalent loads (to about 600 m<sup>4</sup>/d), as shown in Figure 6-6. The Bergey 1500 wind pump is the second cheapest pumping option, which

is competitive with diesel-driven mechanical pumps to about 60 meters total pumping head, based on the 5.65 m/s 5 years' wind data (1992–1997) from Bushland, Texas. These wind pumps are also competitive with the DC PV pumps to about 25 meters total pumping head.



**Figure 6-5. Economic comparison of wind, PV, and diesel/gasoline pumping systems.**

The comparison shows that the mechanical engine-driven pumps are cheaper than the genset pump. The economic evaluation of diesel engines for mechanical and electrical water pumping applications shows that competitiveness depends on several factors. Generally, diesel-driven mechanical pumps are more competitive than genset pumps if direct coupling (rack and pinion or bolt and flange) is used between the engine and the pump because the power transmission efficiency is very high, near 98%. However, they may not be competitive if other power transmission methods (such as gear, pulley and belt drives, and feed screw transmissions) are used because such methods have lower power transmission efficiencies. The efficiency of the driving mechanism depends on the coupling ratio, which is the ratio of the driver torque (engine, motor, or generator) to the load torque. The transmission power loss is high when speed decreases substantially: power loss between the engine and the pump can be as low as 40%. The power transmission efficiency between the engine and electrical alternator is 85%–90%.

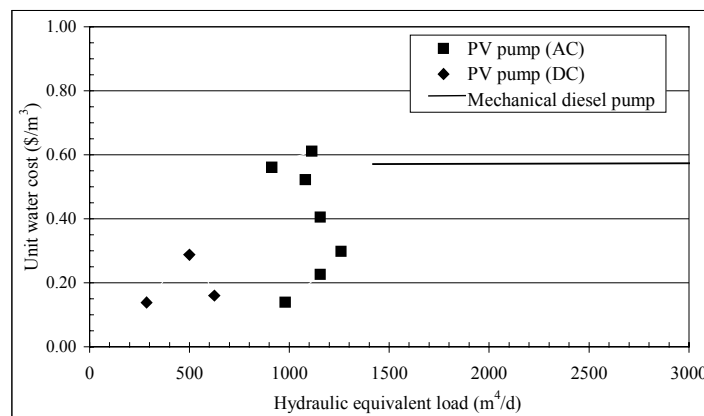

**Figure 6-6. Hydraulic equivalent load limits of PV pumps (DC and AC systems) and diesel-driven mechanical pumps (mono).**

Gasoline-driven mechanical pumps are generally cheaper than diesel-driven mechanical pumps for smaller applications, such as for supplying water to a small community or irrigating a small plot of land. Diesel-driven mechanical pumps are generally competitive for higher water demands. Higher power capacity diesel-driven mechanical engines are also available for water pumping applications integrated with a small power starting motor by using a 12 V or 24 V or even 48 V battery since such engines are too heavy for hand cranking. However, for very large pumping applications using gensets instead of direct mechanical engine drives will provide better pump options and performance.

AC PV pumps are ideal for medium water demands (to a maximum hydraulic equivalent load of about 1,500 m<sup>4</sup>/d) and medium pumping heads (to about 45–50 meters) in locations where the wind regime is low (see Figures 6-4 and 6-6). The hydraulic equivalent load generally depends on the capacity of the system; the higher the capacity the higher the hydraulic equivalent load. For PV pumps, the hydraulic equivalent load depends mainly on the solar radiation energy and on the size of the PV array. However, for wind pumps, the competitive hydraulic equivalent load depends mostly on average wind speed and turbine size. For a given size, the hydraulic equivalent load increases with the increase of wind speed, as shown in Figure 6-7. The maximum hydraulic equivalent load of the Aermotor (with 48 mm and 70 mm pump inside diameter) and the Dutch-Delta wind pumps, which occurs at 8 m/s, is about 500, 750, and 900 m<sup>4</sup>/d, respectively. The hydraulic equivalent load for the Dempster windmill is 700 m<sup>4</sup>/d, which occurs at 9 m/s. The maximum hydraulic equivalent load for the Bergey 1500 pump reaches as high as 2,100 m<sup>4</sup>/d, depending of the type of pumps used, at an optimum wind speed of 13 m/s.

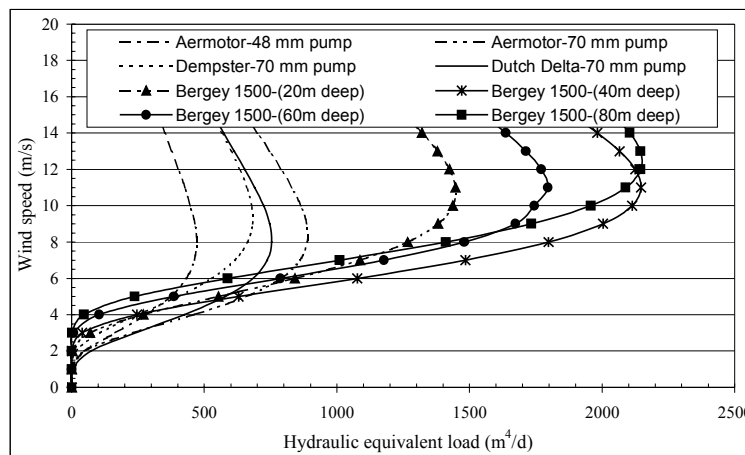

**Figure 6-7. Hydraulic equivalent load of electrical and mechanical wind pumps at various average wind speeds using Weibull distribution coefficient of  $k = 2$ .**

## **Chapter 7**

### **Installation, Operation, and Maintenance**

To achieve system reliability and safety, good installation and O&M practices are required for solar and wind energy systems. Neglecting any of these aspects results in increased system lifetime costs and poor performance. Many problems during installation and operation can be avoided in the design stage. Raggedness and high reliability often go hand in hand with efficiency and are considerations of equal importance to cost. Simplifying the system's configuration and selecting quality components can facilitate installation and reduce service requirements.

The installation and maintenance requirements for any system vary depending on the application, the system configuration, and the operating environment. Ultimately, the system installer is responsible for giving specific instructions on O&M to owners and service personnel. At a minimum, installers should follow all manufacturer recommendations for the equipment and comply with local electric code regulations. This chapter discusses the installation and service requirements of PV and windpump systems.

#### **System Installation**

Even the best equipment can fail to perform satisfactorily if it is not installed or maintained properly. Experienced personnel are needed to professionally and safely install the system. Because all water pumping systems require field assembly, permits and inspections may be required. In any case, the installer must always adhere to current minimum standards established in electrical and building codes to maximize the system reliability and durability. Ideally, the installer should be a licensed contractor with relevant experience. Planning is essential, especially in remote locations. The installer must ensure adequate timing in the delivery of components. Special equipment and tools may be needed for many installations. For instance, a tilt-up tower for a wind machine needs a winch and gin pole or a crane. Depending on the location and conditions, special provisions (freeze, flood, and lightning protection, unauthorized entry, etc.) may also be necessary.

To facilitate the work, the installer should follow installation procedures that cover the following issues:

- Water resource verification (year-round flow rates)
- Civil works (foundations, water distribution, and storage system)
- Mechanical and electrical system component test and assembly
- Mechanical and electrical connection testing
- Operating system mode testing
- System performance verification (acceptance testing)

Experience has shown that many unexpected system failures are caused by poor electrical connections. For example, sunlight can degrade improperly selected wire, and thermal stresses can cause poor electrical connections to loosen. Such problems result in loss of service and costly troubleshooting and repair. The designer should specify correctly sized



wire and type for the current, voltage, and operating conditions. All exposed wiring must either be approved for outdoor use or be placed in conduit. The wiring must be installed with adequate protection and support. In many cases, cables must be buried in a trench. Only cables specified for direct burial or wet-rated cables in conduit can be used underground. Any electrical connections in the array must be protected inside a rainproof box and mechanically secured. In general, long wiring should be avoided as much as possible to reduce voltage drops. All electronic equipment and boxes containing electrical connections should be sealed against rain, dust, and insects. All electrical connections should be made inside an approved connector box, where they can be readily accessed for inspection and repair.

A sound mechanical installation is also important. Wind loading can be the dominant structural constraint, especially for windpumps and, to a lesser extent, for PV systems. Corrosion is also a major consideration in field installations. It is always a good idea to use corrosion-resistant hardware in any outdoor installation; in coastal locations, this becomes absolutely necessary.

System grounds are a good idea and, depending on system voltage, are required by code in many countries. The grounding system consists of the grounding conductors and a grounding electrode. The grounding electrode should be installed as close as possible to the PV array. All exposed metal parts must be effectively connected (bonded) to the grounding electrode, including the array structure, the module frames, and the pump.

The PV system should be reasonably protected against mechanical damage. The following protections should be considered:

- All cable connectors should be stress free.
- All cables should be fastened to the structure (e.g., UV-resistant cable ties).
- The system should be protected from animals by fencing it off.
- The motor cable should be protected from sharp edges like the edges of borehole metal casing to avoid cutting the conductors.

After installation, the installer should test the system thoroughly in the presence of a knowledgeable, independent evaluator, exercising all possible control functions and comparing the flow rate to an expected value. This process should be done as a final acceptance test to ensure that the system meets the minimum technical specifications requested by the client.

## **System Operation and Maintenance**

Well-designed and properly installed water pumping systems are simple and easy to operate and maintain. Typically, the system has to start and stop depending on the demand and availability of water, as well as the solar or wind resource. By using float switches and electrodes, most systems can automate these functions at a relatively low additional cost, especially when an electric motor is used.

Most problems associated with water pumping systems have to do with the well. Commonly overlooked items include neglecting to accurately determine well flow rates and heads. Poor borehole construction can lead to collapses that bury a pump. Large open wells or lakes where direct sunlight penetrates can grow algae, which clog a pump. Sand or mud in the well can likewise clog the pump or even break impellers and shorten its operating lifetime. Thus, for any water pumping system, it is important to maintain and clean the water source to extend the lifetime of the pumping system.

Responsible personnel should be trained in safety and O&M procedures. The system installer should be required to provide an O&M manual that clearly states the operating principles of the system and routine maintenance and service requirements. It should also include safety information and basic troubleshooting procedures. A preventive maintenance program, designed to optimize the life of the pumping system, is the best way to maximize the benefits of a water pumping system. Of course, each type of power source has different requirements. The specific operating conditions will also impose some constraints. A water pumping system requires at least the following maintenance items:

- **Routine maintenance and minor repairs** include monitoring system performance, water level, and water quality. A visual system inspection can detect unusual noises or vibrations, corrosion, invasion by insects, loose hardware or electrical connections, leaks in the water system, or algae. Most of these conditions can be easily corrected in the field. Internal combustion engines need additional attention, such as periodic oil and filter changes. The system operator (typically the owner) should be able to perform all routine maintenance and minor repairs. Adequate routine maintenance will help detect and correct most problems before they escalate and cause extended system downtime.
- **Preventive and corrective repairs** include replacing or repairing system components such as engine overhauls, worn-out rubber diaphragms or impellers, and faulty equipment. This type of maintenance may require specialized tools and knowledge. In most situations, professional service personnel are necessary.

## **Pumps and Motors**

### ***Pumping Options***

Surface-mounted equipment has several advantages—it is easy to install and readily accessible for maintenance and repair. This option should be considered first in shallow-well applications (as deep as 8 meters). For deeper wells, it is possible to submerge the pump and keep the motor on the surface. These types of pumping systems are called vertical turbine pumps. However, field experience has shown that vertical turbine pumps are less attractive for deep wells because of bearing problems and installation difficulties, and submersible motor pumps are now almost entirely replaced. Submersible motor pumps (called submersible centrifugal pumps) are a highly reliable pumping option, especially for wells with medium depths (60 meters). Floating motor pumps (called floating pumps) are ideal for surface water pumping (like pumping water from rivers and lakes), pumping sludge, and dewatering in construction sites and manholes.

The most common surface-mounted water pumps are single-stage centrifugal pumps. Submersible pumps can be centrifugal (single- or multiple-stage) or positive displacement (diaphragm or cylinder). Because pumps must be closely matched with the mechanical prime mover (motor) to maximize performance, most manufacturers sell pump-motor sets, especially in applications that require less than 10 kW. AC or DC electric motors can be used for water pumping. Permanent-magnet DC motors are common in low-power applications (as high as 600 W); AC induction motors are dominant in larger systems. Submersible equipment requires at least minimum maintenance. For this reason, brushless DC and AC motors are often preferred, even though there may be cost and efficiency penalties.

### ***Surface Pump Installation***

For surface pumps, the installation consists of fastening the pumping set to a suitable structure (typically concrete) near or above the water source and installing the rising main pipe. The structure and the fasteners must be strong enough to absorb the vibrations and the weight of the water column in the rising main pipe. Provisions must be made for transmitting the weight of the water column away from the plumbing joints. Surface-mounted centrifugal pumps have a maximum suction capacity of about 8 meters. Surface-mounted diaphragm or piston pumps also have suction limitations. For this reason, the suction head (the vertical distance between the pump and the water level plus friction) must be minimized. Installing a pipe of bigger diameter and relegating valves and water meters to the discharge side should also minimize the friction losses in the rising main pipe. Figure 7-1 shows a surface installation.



**Figure 7-1. Installation of a solar surface pump (jack pump) at Rancho Guadalupe in Chihuahua, Mexico.**

Surface pumps use a foot valve (or check valve) at the submerged end of the rising main pipe to prevent backfeed. There must be water in the rising main pipe and pump housing for the pump to operate. After priming, this foot valve should keep the rising main pipe full of water, even when the pump stops for a period of time. If a foot valve is not

present, the system may require priming (filling the suction pipe with water) at every start. A foot valve is also recommended for positive displacement pumps, even though they have integrated foot valves. If the water distribution line is very long, it is also important to install a foot valve at the discharge side to control the effects of water hammer. The suction pipe should be installed deep enough in the water to allow for drawdown, but far enough from the bottom and sides of the water source to minimize pumping mud, sand, and debris, which can plug or damage pump components. If the water level is likely to drop below the suction pipe, a float switch or electrodes must be installed to protect the pump from operating “dry.”

Any nonsubmersible motor (electric or internal combustion) should be protected against water, dust and sand, direct exposure to the sun, freezing temperatures, and the possibility of damage. The best option is to install the engine or motor inside a well-ventilated, lockable pump house, with enough working space to allow maintenance and repairs.

### ***Submersible Pump Installation***

Installing submersible pumps generally requires more skill. For instance, pumping cylinders (such as those used by jack pumps) and shaft-driven, centrifugal pumps use heavy components (sucker rod, shaft, and metal pipe) that must be lowered into the well. Manual installation can become very difficult, if not impossible. The support structure must be heavier to support the combined weight of the water column and the rising main pipe and the shaft. Alignment and coupling of moving parts is critical for jack and shaft-driven pumps. Each manufacturer provides precise instructions for accomplishing this.

The installation procedure for submersible motor–pump sets is common and generic in nature. A typical submersible pump installation is shown in Figure 7-2. The motor–pump is lowered in the well or water source attached to the rising main pipe, together with the power cable and a safety rope or chain. The rising main pipe (not the electric cable or safety rope) must support the weight of the pump and water column. For centrifugal pumps, a rising main pipe diameter of at least 1.25 in. is recommended to reduce friction. In the case of diaphragm pumps, smaller diameters (0.50 or 0.75 in.) are more advisable to prevent sand from accumulating on the diaphragms. Splicing the pump cable is a critical step because the splice is typically submerged. The splice should also be protected against mechanical stress. It is always important to choose the right pipe material for the application. For instance, some reciprocating pumps work best with flexible pipes to damp pulsation.



**Figure 7-2. Typical submersible pump installation in Sonora, Mexico.**

### ***Pump Operation and Maintenance***

From the operational standpoint, the most important requirement is to avoid operating a pump in dry conditions, as the motor will overheat and burn out. Water is needed for lubrication and heat dissipation. Surface centrifugal pumps should be checked for leaks in the suction pipe or foot valve if the pump often needs priming. The operator should never allow the pump to work against an obstructed discharge, which can result in overheating of the motor and excessive mechanical stress, dropping system efficiency. Centrifugal pumps (surface or submersible) require little maintenance, and properly installed AC motors can last for decades. Most premature problems are caused by excessive sand, silt, corrosive water, or high mineral content. These agents attack the impellers or pump casing. The pump may not fail completely, but its efficiency will drop steadily. Some centrifugal pumps can be rebuilt by replacing the impeller and the water seal; however, replacing the pump may be more economical. Careful monitoring of water production allows the owner to determine when the pump should be replaced. Algae and other organic matter can obstruct the suction pump. Stainless steel submersible pumps and motors usually last much longer.

Positive displacement pumps use more components that are subject to wear. For this reason, maintenance requirements are higher than with other pump types. Under normal operating conditions, diaphragms need replacement every 2 to 3 years (and more often in sandy or silt water conditions). The seals in a piston-type pump may last 3 to 5 years. Diaphragms and seals can fail prematurely when there is excessive accumulation of sand that wears parts quicker and when they work against higher pressure. Most positive displacement pumps can be rebuilt in the field several times before needing replacement.

### ***Motor Operation and Maintenance***

Motor O&M varies greatly and depends on the type of motor used. Selecting the most suitable motor depends on how well the pumping system can be maintained. For isolated rural wells that are difficult for maintenance personnel to visit, it is usually best to select higher quality pumps and motors to minimize maintenance requirements. A high-quality

PV water pumping system can function for 15 years or more with little or no maintenance.

A general requirement is to verify that the motor does not overheat during normal operating conditions. Overheating is a sign of bad bearings, mechanical overload (plugged pump outlet or locked rotor), or insulation failure in the motor windings. Overheating can render a motor useless in a short time. If this condition is detected, the operator should stop the system until the problem is corrected. Some manufacturers build controls to protect the motor against mechanical overload.

Brushless DC and AC motors require little field maintenance besides preventing water, sand, and dust from entering the housing. The vibrations can cause anchoring hardware to loosen over time. Brushless DC and AC motors can last 10–20 years or more under ideal conditions. Brushed DC and AC motors require periodic replacement of brushes. Brushes are inexpensive, but the pumping unit (the motor–pump and the rising main pipe) must be removed with a winch and gin pole or a crane to replace the brushes. A decrease in performance is a sign of worn-out brushes. The brushes should be replaced according to the motor manufacturer’s recommendations to guarantee performance and prevent damage to the slip rings. Depending on the duty, a small brushed-motor may last 4 to 8 years.

## **Power Sources**

In making equipment selections, the designer and client must consider the impact of installation, as well as O&M requirements of each technology. Several system configurations are possible with each power source option. In this section, we will discuss issues related to installation and O&M of renewable energy power sources (wind and solar).

### ***Wind Pumps***

Only experienced personnel should install wind energy water pumping systems. The difficulty in installing the tower increases with the tower height. The higher the tower the more power the wind turbine can produce, but increasing the tower height decreases turbulence because turbulence occurs closer to the ground. To raise towers and install the system, a winch or a crane and a crew of three to five people are required. Some towers are short and light enough to be erected with a manual grip hoist. In any case, it is very important to follow all manufacturers’ recommendations for tower installation to avoid serious equipment damage and human injury. Installation during windy or rainy days should absolutely be avoided. Small wind water pumping systems can be installed in 2 or 3 days. Figure 7-3 shows a typical wind turbine system installation.



**Figure 7-3. Typical tilt-up tower wind system installation (Bergey Excel 10 kW) in Quintana Roo, Mexico.**

Recommended practices vary depending on the size of the turbine, the type of terrain, and the tower height. Small wind-electric machines for water pumping applications (as large as 10 kW) are typically installed on guyed towers. The guy radius is generally 50%–75% of the tower height. Guyed towers can be hinged at the base so that they can be lowered to the ground for maintenance and repairs. The tower must be attached to a concrete pad with enough area to prevent sinking. The guy wires are secured to the ground with metal anchors driven into rock or embedded in concrete pads. Some towers can be preassembled on the ground and tilted into position with the aid of a winch and a gin pole or crane. Raising the tower is a complex maneuver that should be done only by experienced professionals. Mechanical windpumps are generally installed on self-supported towers directly above the water source. This type of tower is assembled in sections with the help of a follow-along device strapped to already fastened sections. The wind machine is mounted after the tower is complete.

Fastening the blades to the rotor and the turbine to the tower are crucial steps. Only the hardware recommended by the manufacturer should be used, and the installer should be sure to tighten all hardware according to specifications. These components are constantly subject to vibration and mechanical stresses that tend to loosen the hardware.

Typically a disconnect switch, which may also contain over-current (fuses) and over-voltage protection for the electronics downstream) is installed at the foot of the tower. The controller should be mounted near the borehole.

The blades must be stopped from rotating during installation and maintenance to avoid injuries and damage. The electrical power has to be disconnected from the switch box

and mechanical constraints need to be used (by forcing the machine to furl, ropes, etc.) to stop the blades from rotating.

Mechanical and electrical wind water pumps operate autonomously. Controllers for electrical wind pumps are designed to work with the variability of the wind power generated without operator intervention during normal conditions. Most controllers accept float switches to further automate the pumping process.

Mechanical and electrical wind machines have rotating mechanical parts that are subject to high mechanical forces. High winds can threaten the mechanical integrity of the wind machine and the tower. To avoid damage, wind machines have built-in ways to protect themselves and the tower by furling out of the wind when the wind velocity becomes too strong (see Figure 7-4).



**Figure 7-4. Electrical wind water pumping system at the ADESOL training facility near Sosua, Dominican Republic.**

Unusual vibrations and noise coming from the wind machine are signs of loose hardware or broken bearings, which can quickly cause serious damage. When this happens, the operator should slow down the machine by applying mechanical or electrical brakes, or both. The system should be taken out of service until the problem is identified and corrected. Routine operation can also cause hardware to loosen. The mounting hardware should be inspected at least once a year. Tension on the guy wires should also be checked, especially before and after severe windstorms. Wind machines should be maintained regularly according to manufacturer recommendations; it is wise for users to plan for annual maintenance checkups by experienced personnel.

### ***PV Pumps***

PV water pumping systems are ideal for small to medium water pumping requirements. They are simple to install and maintenance (PV modules are solid-state devices that



require little or no maintenance). Depending on the size of the array, a crew of two can install a typical PV system in 3–6 hours. Figure 7-5 shows a typical installation.



**Figure 7-5. Typical PV water pumping system installation in Chihuahua, Mexico.**

Installers must be aware of the hazards associated with installing PV modules. Even at low solar radiation on a cloudy day, the arrays can produce enough voltage and current to cause injury. While installing the module wiring, the module front sides should be kept away from sunlight by covering them with cardboard or placing them upside down. The top covering of a PV module is durable glass, but the backside is often fragile and PV cells can crack if handled poorly. Modules can also get hot after a short time of sunlight exposure and should be handled accordingly. The designer and installer should comply with all local electric codes (the United States Article 690 of the *National Electrical Code*<sup>®</sup> covers safety concerns for PV installations).

The first step is to build the civil works. The support structure can be a frame or pole secured to a concrete foundation. The structure must be designed to resist corrosion and withstand high winds (>160 km/h is recommended). Wooden structures are not recommended because of the long module lifetimes (more than 25 years for crystalline cells). Many module support structures are pre-engineered to ensure proper alignment of mounting holes. Mechanical stress resulting from misalignment can crack modules, especially as they get hot and cold. The array should be installed in an open area with full sun exposure throughout the day and throughout the year. Even small shadows on the PV array can significantly lower its performance. The array must be mounted at the correct orientation and inclination. The designer should specify the inclination angle based on the latitude where the system is to be located. Inclination angles should not be less than 10° to prevent dust or rainwater from accumulating. For maximum sun exposure, PV array orientation should be due south in the northern hemisphere and due north in the southern hemisphere. Frames and poles can be designed to allow tilt angle adjustments for summer and winter.

System wiring, junction boxes, and switches should be installed based on the economic life of the PV array. All electricity must be connected inside a box for protection and to

allow access. All modules have terminal boxes for this purpose. The module terminal boxes should be sealed after all the wiring has been installed and checked to prevent water, dust, and insects from entering the box. For systems with more than two modules, a bypass diode with the correct polarity should be installed in every module. It is good engineering practice to run wires from several arrays in series strings to a junction box where each string can be tested individually before being connected. A manual safety disconnect switch is good practice to allow safe service and removal of equipment from the array. Overvoltage protection is also important for protecting the electronics. Most controllers have such protections. The entire system should be grounded and bonded.

PV water pumping systems are designed to operate autonomously. The controller controls the pump operation. During normal operation, there is no need to manually turn the system on or off. When the solar radiation energy is insufficient to overcome the hydraulic head, the system stops; when enough irradiance is available, the system begins to operate. Most controllers accept electrodes and float switches. If the support structure allows it, the array tilt can be adjusted twice a year for better summer and winter performance. This operation can increase the annual water production by 15%–20%.

Maintenance requirements for PV water pumping systems are low compared to other pumping technologies. One of the most important maintenance items for PV is to prevent shadows on the array. Weeds, bushes, and trees can cast shadows as they grow. Field maintenance of the controller consists of ensuring proper mounting and protection from water, dust, and insects. All installed systems should have an acceptance test to verify performance (see Figure 7-6).



**Figure 7-6. Chihuahuan agricultural engineers learning how to conduct an acceptance test on a PV water pumping system.**

## **Chapter 8**

# **Institutional Considerations for Renewable Energy Development**

This chapter addresses issues related to renewable energy development, especially for water pumping applications. Water pumping is one of the simplest and most cost-effective applications for solar and wind energy technologies in remote rural communities; however, as with all development projects, institutional issues must be considered for long-term success. The critical links for any renewable energy project are the technology and the implementing agencies and the infrastructure that support it. Technical aspects are vital to ensure successful implementation of renewable energy projects, but they are not enough to guarantee the future of a project. Technically acceptable designs and installations often fail because of a lack of focus on institutional issues. This is especially true for development programs that introduce new technologies such as solar and wind water pumping in rural settings. However, as with all mechanical and electrical systems, the implementing agency and user must be prepared to maintain it to ensure its long-term operation. A viable renewable energy program must take into account the maintenance and other institutional issues necessary for long-term sustainability, including policy and social issues, capacity building, technical assistance, education and training, and local infrastructure development.

### **Sustainability**

Sustainable development, which we will call *sustainability*, is continued economic and social development without detriment to the environment and natural resources. In using renewable energy technologies to pump water in rural areas, sustainability provides users (consumers) with local access to qualified suppliers, high-quality equipment, and maintenance capabilities with a reasonable cost and payment schedule. Because of their higher initial capital costs compared to conventional technologies, access to reasonable financing is often an important factor in the sustainability of rural renewable energy technologies. Long-term sustainability is a natural consequence of local market growth. Where demand for a product or service is high enough to allow for profit generation and competition, market forces eventually establish the infrastructure required to generate a local market.

The goal of renewable energy development programs should be to provide needed services, such as health care, while contributing to local market growth and sustainability. Development programs are often carried out in economically depressed regions where the consumer's ability to pay is low and the supply infrastructure is inadequate. Rural program implementation often takes place in the context of social programs that include various forms of subsidies by governments or other organizations. Although subsidized programs are not inherently sustainable, they are justifiable, they can make significant social contributions, and they can function as catalysts to carefully develop local markets for renewable energy technologies.

## **Institutional Considerations**

A number of institutional issues must be addressed to achieve sustainability for renewable energy water pumping projects. In the sections that follow, we discuss some key areas to consider for institutional development of renewable energy programs.

### ***Policy Issues***

Renewable energy projects are most successful when favorable national, state, and local policies are in place. Recognition of the social, environmental, and health benefits of renewable water pumping systems in rural areas can lead to sound policies on importation requirements, taxes, fossil fuel subsidies, and other government barriers that can artificially increase the cost of installed renewable energy systems. Government programs that are already working in related areas such as farming, ranching, and potable water can justify the direct involvement of government agencies in the implementation of renewable energy programs. Such programs are valuable vehicles in promoting renewable technologies and educating potential end users. Favorable policies encourage entrepreneurs and widespread market growth.

### ***Solid Partnerships***

Strong partnerships between government, industry, and development agencies should be nurtured for renewable energy water pumping programs to address the diverse cultural, technical, social, and institutional issues that arise when working to meet program goals. The success of a renewable energy water pumping program depends on working with local organizations and with industry. In addition, the program team, which is composed of members from different organizations, must function well together. It is important to choose partners very carefully.

### ***Capacity***

Significant efforts are required to help partners build the capacity necessary to independently evaluate and successfully develop renewable energy projects. Capacity building includes technical assistance, formal training workshops, focused field activities, and in-depth reviews of suppliers' quotes and designs for proposed systems as well as local manufacturing capabilities and infrastructure development.

### ***Education and Training***

A successful renewable energy program absolutely requires the development of local technical capabilities and knowledgeable consumers. Providing training to vendors, project developers, and government personnel is one component that ensures quality installation. Training also helps ensure that the technology is being used correctly. Vendors and end users must recognize the importance of the locations and applications in which PV or wind water pumping make sense, as well as those that are impractical.

Local village support and training are crucial for a successful renewable energy water pumping program. In-depth training is critical for developing the interest and knowledge required for understanding and successfully applying renewable energy technologies. A structure is essential to help partners build the capacity necessary to operate and maintain a renewable energy water pumping system. Technical assistance and training are continual processes best supplied incrementally. Not only project developers, but also local industry must be trained. System suppliers also need to occasionally check and fix installations. Success depends largely on the technical capacity of local technicians and administrators who continue to operate a water pumping system long after it has been inaugurated. Greater technical capacity of local suppliers leads to greater consumer and development agency confidence in terms of ensuring quality projects.

End users should receive training on the basic O&M of renewable energy systems to ensure the lifetime of a system. To enhance the effectiveness of the renewable energy system, end users should practice conservation and resource management. Education plays a key role in this area. The resources invested in training are justified by the better economics of more reliable and longer lasting systems. Figure 8-1 shows New Mexico State University representatives conducting a wind energy training course in Oaxaca, Mexico.



**Figure 8-1. Wind energy training course in Oaxaca, Mexico, conducted by New Mexico State University.**

### ***Technical Assistance***

Technical assistance can take a variety of forms, from working with local partners and project developers to supporting local system suppliers. It is very important to work with local partners (project developers) to develop practical technical specifications for renewable energy systems. This allows for a basic understanding of the requirements of a quality system installation that will provide years of useful life. It is also important to

work with local suppliers to make sure they understand specific requirements for meeting the technical specifications.

We cannot overstate the importance of including industry in all aspects of a renewable energy water pumping program. On a local level, sustainability and market growth can be ensured only with a strong supply infrastructure and reliable systems. Project developers must work closely with local suppliers to strengthen their ability to deliver high-quality systems at reasonable costs. Suppliers should be encouraged to attend training courses, conduct pilot system installations, and develop their own training programs.

Wind and solar resource maps of specific regions are useful for determining where to best target particular technologies. These maps are valuable tools for partner organizations and system suppliers as they work to determine the most feasible regions for renewable energy technologies. These and other forms of technical assistance are part of the capacity building process, and help program partners make informed decisions about renewable energy technologies.

### ***Local Infrastructure Development***

Establishing a local infrastructure is indispensable for sustainability. It provides access to systems, components, and qualified technical services. In rural areas, most renewable energy vendors rely on outside suppliers for equipment and system design. However, costs decrease when local vendors can handle design, installation, maintenance, and repairs. Healthier business relations between local vendors and their suppliers generally lower the overall costs for end users. In a good business environment, suppliers are more likely to support local vendors with technical assistance and discount pricing. Figure 8-2 shows mules transporting PV modules to remote sites in Mexico.



**Figure 8-2. Mules carry PV modules to a remote site in Mexico.**

### **Program Implementation**

Governments, NGOs, or private industry can successfully carry out a renewable energy program. Although each implementing organization will have different goals and

objectives, combinations of these agencies working collaboratively can improve the success of the implementation program.

Government agencies can set and enforce requirements for procurement and quality control. They usually have significant human resources and infrastructure to cover a wide geographic area. They are also in positions to promote the use of renewable energy as an alternative to conventional water pumping systems in other agricultural and potable water programs.

Government personnel often lack the technical expertise and experience needed to develop a renewable energy program on their own. However, government involvement in project implementation is crucial to better understand the problems related to project dissemination and later, if necessary, for making policy changes. Program developers need to work renewable energy into the established development programs as part of the solution for meeting program goals (rather than focusing only on renewable energy).

Experience has shown that NGOs can implement renewable energy programs quite efficiently. In recent years, some NGOs have successfully obtained funding for development projects in rural areas. The key for an NGO to successfully apply renewable energy is to avoid the trap of becoming the system installer, but rather to work with local system installers and provide an oversight role.

Unfortunately, in some cases, NGOs have received funding for renewable energy programs, but have had little real knowledge or commitment. They have applied the resources inefficiently and installed substandard systems that give the industry a black eye. In many regions, these systems have only retarded renewable energy development. The greatest pitfall for an NGO is to install a system then fail to provide any long-term project maintenance and support. It is very important for a government to devise basic guidelines where all interested groups (government, NGOs, and end users) work together toward a sustainable future. Key steps required for successful implementation of renewable energy programs are described in the sections that follow.

### ***Strategic Planning***

Strategic planning with collaborative partners helps to create realistic goals to include renewables as part of instituted programs. Early planning must be realistic and within the bounds of available resources. Planning should include enough promotional activities, including training, to accelerate acceptance of the technology. Developing a comprehensive program from the project identification stage to acceptance testing and operation is key for local developers. However, program development should be kept as simple and straightforward as possible. There are many more options for partnering and tapping into opportunities than resources can support, so it is important to focus, limit, and succeed in a few locations, rather than expand.

Government-funded programs generally impose a 1-year cycle on which to base planning and budgeting. Renewable energy development programs greatly benefit from multiyear



funding, mainly because significant results tend to be realized only after several years of diligent effort.

### ***Pilot Project***

Pilot projects (see Figure 8-3) can form an important foundation for growing sustainable renewable energy markets. Local suppliers have the opportunity to gain a better technical understanding of the integration of renewable energy systems. These suppliers have learned that with adequate planning and design, maintaining installed systems for the long term costs little. As a result of pilot projects and gradually increasing demand, prices to end users usually decline in areas where pilot project programs have been well implemented.



**Figure 8-3. Pilot PV water pumping installation in the Mexican State of San Luis Potosí.**

In Mexico, the U.S. Department of Energy and the U.S. Agency for International Development Mexico Renewable Energy Program managed by Sandia National Laboratories have helped the local renewable energy industry to expand. This growth trend and increasing competition have also had an important impact on lowering overall installed system costs. At the same time, quality levels have improved substantially. For instance, New Mexico State University has documented decreases of more than 30% from 1996 to 1998 of installed costs of PV water pumping systems in Chihuahua (see Figure 8-4). This occurred as vendors and program administrators gained experience with technologies, even though PV module prices have not similarly decreased over the same time period. (Costs include all system hardware—pumps, conductors, etc.—as well as labor and taxes.) Many of these same vendors also have expanded their service territories to other states, further contributing to increased competition and decreasing system costs across Mexico.



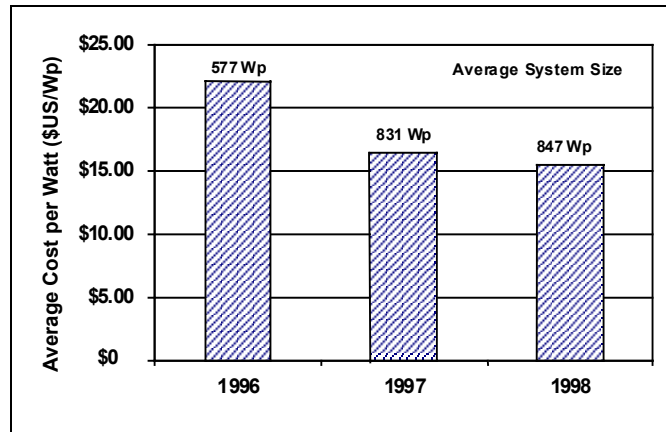

**Figure 8-4. Average declining cost trends per installed watt for 41 pilot PV water pumping systems in Mexico implemented by the Chihuahua Renewable Energy Working Group with SNL.**

### ***Sustainable Markets***

Investments in cost sharing of pilot projects greatly facilitate the introduction and acceptance of renewable technology while fostering a sense of local ownership. As project volume increases, system costs are reduced because competition increases. Rural residents must be able to afford renewables, either through either cost sharing or financing. End-user financing at an affordable level similar to conventional energy expenditures lowers out-of-pocket initial capital expenditures and expands the renewable energy market. Pilot projects should be used as a tool, not as an end. Pilot projects should be installed to establish growing and sustainable markets, not only to point to the number of installations accomplished during the project. Their primary value is as a tool for training and building the capacity of implementing organizations, businesses, and the community (end users).

### ***Grassroots Development***

An integrated and grassroots development approach is needed to develop a village hybrid system. A local and capable champion greatly facilitates the development of local renewable systems. If a rural village hybrid system is to succeed and have lasting impacts, it must be installed first from a development perspective. System ownership and responsibilities need to be established early on for installed projects.

### ***Quality Hardware***

Many renewable energy programs and systems have suffered poor reputations related to the installation of substandard components and designs. There is a tendency among some development programs, especially when dealing with poor rural populations, to offer less than quality solutions to meet their needs. But regardless of location or economic status, all communities deserve quality and safe components and designs that will result in the best service possible from renewable energy technologies.

Substandard systems create an attitude that renewable energy systems are limited, do not function well, and are prone to failure. Quality installations require quality components and designs that are safe, reliable, and designed for the long haul. Systems that cannot be done right from the start should not be installed at all.

For any renewable energy project, the first order of business for good system design is to use energy-efficient equipment. It can be entirely appropriate to establish service contracts with users for community water pumping systems. Implementing a use-based water tariff in a village where people are accustomed to paying a minimal flat fee (or nothing) for water can provide a capital fund for future maintenance actions.

### ***Project Monitoring***

One characteristic of successful renewable energy development programs is a commitment to project follow-up and monitoring. Monitoring activities should be designed into a program at its inception, and focus on several issues, including the technical, social, economic, and environmental impacts of using the technologies and applications. Monitoring data can come from a variety of sources, including interviews with partner agencies, suppliers, and end users; site visits; and performance monitoring of installed systems. Long-term impacts cannot be evaluated without monitoring activities. It is much more useful to receive photos and data from operating systems in the field after 5 years, rather than a pretty photo of a new system on the day of its inauguration that may be doomed to fail because a maintenance infrastructure is lacking. Monitoring activities should develop a bed of various projects and technologies for long-term evaluation.

Maintaining a database of applicable project and program information collected from field personnel is valuable. Such a database allows program personnel to conduct analyses and make necessary adjustments along the way during program implementation. As any program continues its transition from direct implementation of pilot projects to further replication and institutionalization of partner organizations, these monitoring efforts continue to grow in importance.

### **Institutional Models for Renewable Energy Dissemination**

Sustainable project replication is a program's ultimate measure of success or failure, and can occur in a number of ways. As partner institutions and end users gain familiarity with renewable energy technologies, they begin to implement new projects on their own. This generally occurs in a specific region first and then spreads to new regions. Through such activities, other related institutions become familiar with the merits of renewable energy technologies and initiate projects as well. The potential for this type of replication can be huge, given that the budget for development organizations can be in the millions of dollars. Private-sector spin-off replication occurs as a result of successful pilot projects. For replication to be substantial, several factors must be adequately addressed: the local population must know the technology and what it can provide; quality products and services must be available locally; and must be able to pay for the technology. For the last reason, access to applicable financing mechanisms is the key.

Renewable energy systems for water pumping can be prohibitive in initial cost for many rural farmers and ranchers in less developed regions, despite the fact that the levelized LCCs of such systems are often quite good compared to conventional water pumping systems. Sometimes development funds are available to buy down the system cost to make system affordable.

Program implementation by private enterprise is relatively rare in the area of rural renewable development, but some initiatives have been quite successful, especially in the area of financing. Programs headed by private interests have the advantage that sustainability is in the best economic interest of the implementing agency.

Four basic approaches used to encourage the purchase of renewable energy system are:

- Cash sales
- Financed sales
- Leasing (fee for service)
- Direct subsidies

Of these, market-based financing and leasing approaches for renewable energy projects have the greatest potential for expanding the access of rural households to this technology. Renewable energy for water pumping also offers the potential to generate new and important business activity in rural areas by creating jobs through local retail sales and services.

Sales of renewable technologies, especially PV systems, in rural regions of less developed countries occur at four levels, as exemplified by the sales approach pyramid in Figure 8-5. At the top of the pyramid are the few direct cash sales to relatively well-to-do rural households that can afford the high initial capital costs of a renewable energy system. Following this are many more consumers who can afford to purchase a renewable energy system if reasonable credit terms are provided. Figure 8-5 also shows that still more people could afford to simply pay a service fee for energy by leasing a renewable system. Finally, the poorest households are simply trying to survive and have other pressing issues, such as adequate housing and clean water. They would probably not choose to participate in any form of renewable electrification program unless it was subsidized directly by development agencies or the government. The exact percentage of persons in any of these categories varies greatly from country to country.

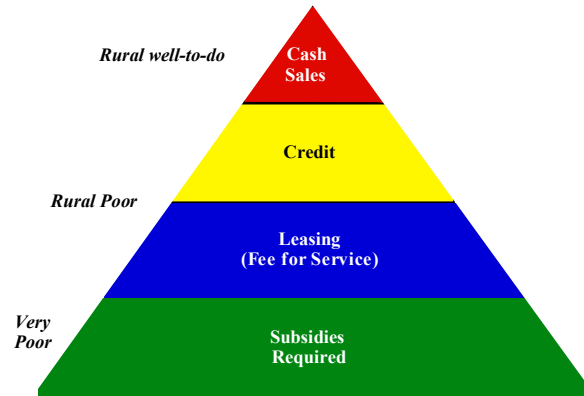

**Figure 8-5. Institutional renewable energy sales approach pyramid**

In most countries, renewable energy technologies have yet to be recognized as consumer goods that can be financed like a car or washing machine. However, some notable exceptions, such as the Dominican Republic, are establishing creative opportunities for renewable technology dissemination.

### ***Cash Sales***

A number of renewable energy systems are sold directly through cash sales around the world. This is typically the only form of sale available in many countries with no credit terms available. Most solar and wind energy distributors are smaller, family-owned entrepreneurial companies that cannot afford to offer end-user financing and have access only to supplier credit terms, thus allowing them to make only cash sales. Obviously, cash sales are restricted to only the wealthier rural customers who can afford to purchase a renewable energy system outright.

### ***Consumer Financing***

One of the important advances in the 20<sup>th</sup> century has been the development of consumer credit. Consumer financing is a common way of increasing the sale of consumer goods all over the world. This has allowed developed nations to permit citizens to have widespread ownership of homes, automobiles, and appliances that the average person could not afford to purchase outright. Unfortunately, commercial banks and vendors rarely finance the purchase of consumer goods to people living in rural areas of developing countries, and if so, only at very high interest rates.

Many more renewable energy systems could be installed if financing were readily available to allow for increased economic development of rural areas. Unfortunately, there are no financing mechanisms in most countries for renewable energy protected through product and installation codes and standards, after-sales service, and warranties.

To make financing a viable business, it should be developed at competitive interest rates. Mismatching of loan and sub-loan maturity should be avoided. Procedures should be as

simple as possible and should allow for quick disbursement when dealing with people who may be unaccustomed to financing concepts. It is important to have parallel compliance monitoring in place, which allows for end-user audits, performance audits, and customer satisfaction surveys. This way, financing program progress can be tracked in real time and adjustments made as needed before the program gets into trouble.

### ***Revolving Credit Fund***

A revolving fund credit financing is started with seed capital that allows families to purchase solar home systems. As payments are made, the families replenish the fund with monthly payments that include interest. As the fund grows, additional families can be included to expand the number of systems financed. A program established for this type of renewable energy dissemination should attempt to use an integrated development approach, providing a complete institutional support system—including service enterprises, technician training, and financing mechanisms.

### ***Local Bank Credit***

Another financing model has been implemented for renewable systems through conventional commercial banks, typically rural ones. The difficulty in getting commercial banks to finance PV systems is that the technology is relatively unknown and represents a new concept. Commercial bank financing can be successful for renewable system implementation if:

- Bank staff become familiar with renewable systems.
- Renewable systems become eligible for bank financing.
- Borrowers have convenient access to the bank.
- Loan application procedures are simple.
- Collateral requirements are reasonable (e.g., hardware can be used as collateral).
- Repayment schedules are flexible and complement borrower's income flow.

### ***Leasing/Fee for Service***

The leased systems model is another approach that has been implemented for renewable energy dissemination in rural regions. The idea behind leasing is to make solar home systems more affordable for rural people by eliminating the need for a down payment, lowering monthly charges, and reducing the financial commitment to a simple month-to-month leasing arrangement for energy service.

### ***Dealer Credit***

Dealers who sell renewable energy systems can sometimes offer customers credit. When a dealer provides consumer financing, the dealership receives a second income stream based on interest payments. The difficulty for most dealers is that they are typically small, family-owned enterprises with limited access to credit.

## ***Subsidies***

Subsidies for renewable energy technologies that do not create local infrastructure for maintaining systems or an infrastructure base are largely useless. To be successful, subsidies:

- Should be “smart”—offered with a vision toward establishing a sustainable future.
- Must be able to sustain cost reduction pressures in the technology.
- Should not stifle competition by furnishing subsidies to only a single entity.
- Should be technology and supplier neutral.
- Should finance results rather than investment costs.
- Should ensure that the needs of rural communities, as prioritized by those communities, are met. Participating households should be carefully selected and have a genuine interest in the service provided, whether it be water, electricity, or anything else.

Capital cost subsidies establish incentives for installing systems, but not for using them over the long term. To change this, a subsidy for renewable energy water pumping could be implemented in such a way as to allow for a fee-for-service approach. This would help to ensure the system’s long-term operation while establishing a viable local supply and service base. To summarize, if renewable energy water pumping systems are to be a viable and sustainable energy solution for remote village applications, an adequate and manageable institutional structure must accompany the technology intervention.

## Chapter 9

### Lessons Learned

As renewable energy technologies continue to evolve in terms of efficiency and cost reduction, more and more systems will be installed in many developing countries. Renewable systems are becoming even cheaper than conventional systems, especially for small to medium applications. Using wind and PV systems for village home systems (such as for solar home systems and battery charging) is cheaper than the traditional kerosene or car battery lighting systems. Similarly, use of renewable technologies for water pumping applications becomes more attractive for rural water supply, livestock watering, and small irrigation systems. Systems installed in the last decade have demonstrated that well-matched wind or PV designs based on proper resource assessment can operate reliably with minimum maintenance.

Currently, PV is more attractive for stand-alone water pumping applications since it does not require battery storage. The water pumped on sunny daytime can be stored for night and cloudy days use. Generally, mechanical wind pumps are relatively cheaper than PV pumps if the local prevailing mean wind speed is higher than 3.5 m/s. Electrical wind pumps are attractive above a mean wind speed of 5 m/s.

Social acceptability, affordability, and reliability should be considered in technology selection. Although renewable systems can be technically reliable and economically viable, projects can encounter difficulties if the social and cultural context in which the systems operate is not understood. Renewables are more capital intensive than conventional systems, but conventional systems have higher operating costs than renewables. Reliability, often associated with low maintenance costs, must also be considered.

Institutional factors and the local infrastructure need to be considered in the use of renewable energy technologies. Governments must provide support, which is accessible to everyone, at the national and local level, introducing policies that address: planning; financing, funding, and incentives; technology research and development; adaptation and deployment; capacity building; and institutional arrangements. Key lessons learned from successful renewable energy experiences are:

- Local village support and training is crucial.
- Long-term planning is required for all renewable energy development projects.
- System ownership and responsibilities need to be established early on.
- Maintenance is critical for long-term system survival.
- Implementing agencies should strive to work with industry to conduct project installations, strengthening local industry while developing a local infrastructure for system maintenance.

Preventive maintenance steps should be included in project planning from the start. Maintenance activities can often be funded with revenues generated by local end users. However, the lack of attention to institutional issues often leads to inadequate system maintenance and eventual system degradation to the point of failure.

To avoid failure, renewable energy water pumping systems must include realistic system sizing and proper institutional controls from the start. Planners must allow for anticipated water use growth, a realistic tariff structure on water consumption, and a means to meet future maintenance requirements. Only then can renewable energy water pumping systems deliver long-term and reliable service to users. Especially, wind energy water pumping are some of the oldest and most simple applications for the technology, and with proper attention to institutional details, these systems can provide many years of reliable service.

To summarize, renewable energy sources have created considerable opportunities for promoting rural development. For many communities, such systems can directly improve the quality of life, and help to foster the skills and experience needed to continue economic advancement in rural areas of developing countries.



## Bibliography

- American Wind Energy Association (AWEA) news release (January 7, 1999).
- Argaw, N. (In press.) *Renewable Energy Water Pumping Systems Handbook: An Introduction to the Technology, Resource Assessment, Design, Economics, and External Impacts Evaluation*. Golden, CO: National Renewable Energy Laboratory.
- Argaw, N. (1996). *Evaluation of Photovoltaic Water Pumps and Estimation of Solar Energy Availability in Ethiopia*. Ph.D. thesis. Tampere, Finland: Tampere University of Technology.
- Argaw, N. (1995). "Optimum Load Matching in Photovoltaic Water Pumps Coupled with DC/AC Inverter." *International Journal of Solar Energy* (18:1).
- Argaw, N. (1994). Evaluation Report of 6 Photovoltaic Pumps Installed in Region 1 & 3 of Ethiopia under the UNICEF-Assisted Rural Water Supply Programme. Tampere, Finland: Tampere University of Technology.
- Argaw, N. (1993). "External Impacts Evaluation: An Illustration to Energy Sources Evaluation for Water Pumping Technology." Prepared for the International Conference on Making Sense of Development, September 1–3, 1993. Tampere, Finland: Tampere University of Technology.
- Argaw, N. (1992). *Solar Energy in Water Pumping and Its Economics*. MSc Thesis. Tampere, Finland: Tampere University of Technology.
- Barlow, R.; McNelis, B.; Derrick, A. (1993). *Solar Pumping: An Introduction and Update on the Technology, Performance, Costs, and Economics*. Washington, DC: Intermediate Technology Publications and The World Bank.
- Cody, G.; Tiedje, T. (1996). "A Learning Curve Approach to Projecting Cost and Performance in Thin Film Photovoltaics." Prepared for the 25th Institute of Electrical and Electronics Engineers (IEEE) PV Specialists Conference. Washington, DC.
- Fink, D.G.; Beaty, W. (1993). *Standard Handbook for Electrical Engineers*. 13th edition. New York: McGraw-Hill.
- Foster, R. E.; Cisneros, G.; Hanley, C. (1999). "Mexican Renewable Energy Development: Creating New Markets." Prepared for the Sustainable Applications for Tropical Island States Conference 1999. San Juan, Puerto Rico: Caribbean Solar Energy Society.
- Foster, R. E. (1998). *Photovoltaic Market Development and Barriers in Mexico*. Masters Thesis, Las Cruces, NM: New Mexico State University.
- Foster, R.E.; Cisneros, G.; Carrillo, O.; Ellis, A.; Büttner, L.; Durand, S.; Hanley, C.; Strachan, J.; Richards, E.; Rovero, C.; Ojinaga, L.; Corbus, D. (1998). "The USAID Mexico Renewable Energy Program: Building Foundations for Growing Markets." In *Proceedings of the 1998 American Solar Energy Society Annual Conference*. Boulder, CO: American Solar Energy Society.

Fraenkel, P.; Barlow, R.; Crick, F.; Derrick, A.; Bokalders, V. (1993). *Windpumps: A Guide for Development Workers*. Radford Mill, Nottingham, UK: IT Publications Ltd., The Russell Press.

Fraenkel, P. (1986). *Water Pumping Devices: A Handbook for Users and Choosers*. Prepared by arrangement with the Food and Agriculture Organization of the United Nations (UNFAO). Radford Mill, Nottingham, UK: IT Publications Ltd.

Gipe, P. (1993). *Wind Power for Homes and Business: Renewable Energy for the 1990s and Beyond*. Post Mills, VT: Chelsea Green Publishing Company.

Grundfos International A/S. (1990). *Pump Catalogue*.

Herwig, L.O.; McConnell, R.D. (1995). *The Latest U. S. National Program Plan (1996–2000)*. Nice, France: 13th EC PV Solar Energy Conference.

Joint Report of the DOE Office of Power Technologies, Energy Efficiency and Renewable Energy and the Electric Power Research Institute (EPRI). Accessed June 2001 on the World Wide Web at <http://www.eren.doe.gov/power/techchar.html>

Kenna, J.; Gillett, B. (1985). *Solar Water Pumping: A Handbook*. Radford Mill, Nottingham, UK: IT Publications Ltd., The Russell Press.

Kentfield, J.; Cruson, I. (1989). "A Prototype Canadian Water Pumping Wind Turbine." In *Proceedings of the Fifth Annual National Conference of the Canadian Wind Energy Association*. Charlottetown, Canada: P. E. I.

Kraushaar, J.J.; Ristinen, R.A. (1988). *Energy and Problems of a Technical Society*. Boulder, CO: University of Colorado, Department of Physics.

Mitchell, R.L.; Witt, C.E.; Thomas, H.P.; Herwig, L.O.; Ruby, D.S.; Aldrich, C.C. (1996). "Benefits from the U.S. Photovoltaic Manufacturing Technology Project." Prepared for the 25th IEEE PV Specialists Conference.

Moesslein, J. (1994). The Significance of Photovoltaics for a Climatically Benign Energy Supply in Baden-Wuerttemberg, A State in Southern Germany. In Volume II of the *Conference Record of the 24th IEEE PV Specialists Conference, IEEE First World Conference on Photovoltaic Energy Conversion*.

Mohan, N.; Undeland, T.M.; Robbins, W.P. (1995). *Power Electronics: Converters, Applications and Design*. New York: John Wiley & Sons.

Sandia National Laboratories. (1999). "The Renewable Energy Program in Mexico." *Quarterly Highlights of Sandia's Photovoltaics Program*. Volume 4. Albuquerque, NM: Sandia National Laboratories.

Scheer, H.; Gandhi, M.; Aitken, D.; Hamakawa, Y.; Palz, W. (1994). *The Yearbook of Renewable Energies*. James and James Science Publishers Ltd, London, UK.

Solarenergie-Förderverein, E.V. (1994). "A New Path to Self-Sustaining Markets for PV." In Volume II of the *Conference Record of the 24th IEEE PV Specialists Conference, IEEE First World Conference on Photovoltaic Energy Conversion*.

Stokes, K.; Saito, P.; Hjelle, C. (1993). *Photovoltaic Power As a Utility Service: Guidelines for Livestock Water Pumping*. SAND93-7043. Albuquerque, NM: Sandia National Laboratories.

Thomas, M.G. (1993). *Water Pumping: The Solar Alternative*. SAND87-0804. Albuquerque, NM: Sandia National Laboratories, Photovoltaic Systems Design Center.

## Glossary

**Airfoil**—a blade or solid, curved in such a way that it produces lift when placed in airflow.

**Alternating current (AC)**—electric current in which the direction of flow oscillates at frequent, regular intervals.

**Altitude**—the angle between the horizon (a horizontal plane) and the sun, measured in degrees.

**Amorphous silicon**—a thin-film PV silicon cell having no crystalline structure.

**Anemometer**—an instrument for measuring wind speed, basically driven by drag forces of wind on small revolving cups.

**Annual equivalent life-cycle cost (ALCC) or simply annualized cost**—the equivalent annual cost of a project if the expenses are treated as being equal each year. The discounted total of the annualized costs over the project lifetime is equal to the net present cost (NPC) of the project. ALCC is simply the reverse process of discounting. That is, the life-cycle cost (LCC) will be distributed equally over its economic life. For example, to determine the unit water cost of a water pumping system the LCC should be converted into ALCC. Then the ALCC is divided by the annual water production (requirement) to determine the unit water cost.

**Array**—a mechanically integrated configuration of modules together with support structure designed to form a DC power-producing unit.

**Azimuth** —the angle between true south and the point directly below the location of the sun, measured in degrees.

**Balance of system (BOS)**—the components of a PV system other than the PV array.

**Battery**—two or more “cells” electrically connected for storing electrical energy.

**Battery bank**—an energy storage capacity (ampere-hour).

**Borehole**—a hole drilled on the ground to reach water. Borehole diameters vary depending on the required size of the system. Standard borehole sizes are 4–6 inches.

**Capital cost**—the initial investment in a project.

**Centrifugal pump**—a pump that delivers water using impellers centrifugally by producing a pressure difference.

**Charge controller (battery charger)**—a device that controls the charging rate or state of charge, or both, for batteries.

**Concentrator**—an optical component of a PV array used to direct and increase the amount of incident sunlight on a solar cell.

**Conversion efficiency**—the ratio of the electric energy produced by a PV system or wind turbine to the energy from incident sunlight or wind.

**Crystalline silicon**—a type of PV cell made from a single crystal or polycrystalline slice of silicon.

**Cut-in speed**—the minimum wind speed at which a particular wind turbine will produce energy.

**Cut-out speed**—the speed at which a particular wind turbine will reduce its power output to protect itself from excessive wind speeds. Most small wind turbines do this by tilting out of the wind.

**Darrieus**—a vertical axis rotor with airfoil shaped blades. The blades are often shaped according to the Troposkien profile.

**Days of autonomy**—the number of consecutive days a stand-alone system will meet a defined load without energy input.

**Design month**—the month having the lowest renewable energy production to load ratio.

**Diffuse radiation**—solar radiation scattered by the atmosphere.

**Direct radiation**—solar radiation transmitted directly through the atmosphere.

**Direct current (DC)**—electric current flowing in one direction.

**Disconnect**—a switch gear used to connect or disconnect components in a stand-alone system.

**Discount rate**—the rate at which the value of money changes relative to general inflation.

**Drag force**—the force on a body in airflow acting parallel to the flow.

**Drawdown**—the distance below the water table to which the water level in a well falls when steady-state pumping is in progress.

**Efficiency**—the ratio of output power to input power, expressed as a percentage.

**Electric circuit**—a complete path followed by electrons from a power source to a load and back to the source.

**Electric current**—the magnitude of the flow of electrons.

**Flat plate**—an arrangement of solar cells in which the cells are exposed directly to normal incident sunlight.

**Foot valve**—a one-way valve at the base of a pump through which water is sucked by the pump up-stroke.

**Furling**—mechanism that helps to stop or slow windpumps (either by turning the whole rotor head out of the wind or by rotating each blade individually).

**Global solar radiation**—the sum of diffuse and direct solar radiation incident on a horizontal surface.

**Grid**—the network of transmission lines, distribution lines, and transformers used in central power systems.

**Hub height**—the distance from the ground to a center of rotor (hub) of a wind machines.

**Hydraulic equivalent load**—the product of the daily amount of water produced by the pumping head.

**Hydraulic energy**—the energy necessary to lift water.

**Incidence angle**—the angle that refers the sun's radiation striking a surface. A “normal” angle of incidence refers to the sun striking a surface at a 90-degree (or perpendicular) angle.

**Inverter**—a solid-state device that converts a DC input to an AC output.

**Jack pump**—a reciprocating pump in which the motor is on the surface and the pump is in the borehole. This type of pump is mainly used for high pumping head applications.

**Kilowatt (kW)**—one thousand watts.

**Kilowatt-hour (kWh)**—one thousand watt hours.

**Life-cycle cost**—an estimate of the cost of owning and operating a system for the period of its useful life; usually expressed in terms of the present value of all costs incurred over the lifetime of the system. In other words, the sum of the capital cost and the present worth of the recurrent, salvage, and replacement costs.

**Load**—the amount of electrical power being consumed at any given moment. Also, any device or appliances that are using power.

**Load matching**—the process of matching the load with the input power source to maximize the power transfer to the load. This method is based on maximizing the total gross electromechanical energy delivered to a mechanical load for given solar radiation/wind energy and temperature profiles. Therefore, every component of the system should be optimized for the best possible matching of the whole system. For this reason, each component should be separately optimized beforehand, and the complete system must be configured to maximize the overall efficiency.

**Load-matching factor**—a nondimensional factor that is defined by the ratio of energy acquired by the hydraulic load to the maximum power extracted from the power source in a 1-day period. It can also be the ratio of the power that the power source delivers to the motor–pump subsystem during the day to the maximum electrical power that can be obtained from the power source throughout the day (i.e., the ratio of the actual power output used for water pumping to the power source output capability).

**Maximum power point**—the impedance matching electronics used to operate a PV array output at its maximum power.

**Module (panel)**—a predetermined electrical configuration of solar cells laminated into a protected assembly.

**Net present cost (NPC)**—the figure obtained when all project expenses are converted into today's value of money.

**Nominal voltage**—a reference voltage used to describe batteries, modules, or systems (i.e., a 12-volt or 24-volt battery, module, or system).

**Nomogram**—a diagram that can be used to perform calculations or design a system by graphical means only.

**Orientation**—placement according to the directions, N, S, E, W; azimuth is the measure in degrees from true south.

**Panel**—see module.

**Payback period**—the number of years (periods) required for the income (benefit) from a project to equalize the investment cost.

**Peak hour demand**—the maximum amount of water required in an hour. The peak hour can be at noon or in the evening, or both.

**Peak watt (Wp)**—the amount of power a PV device will produce during peak solar radiation periods when the cell is faced directly toward the sun.

**Photovoltaic (PV) cell**—a cell that generates electrical energy when incident solar radiation impinge on it.

**PV system**—an integrated system that contains a PV array, power conditioning, and other subsystems such as a motor–pump subsystem.

**Polycrystalline silicon**—silicon that has solidified at a rate that caused many small crystals to form.

**Positive displacement pump**—a type of water pump that can lift water from a borehole by means of a cavity or cylinder of variable size. This type of pump is also called a volumetric pump.

**Power conditioning**—the electrical equipment used to convert power from a PV array into a form suitable to meet the power supply requirements of more traditional loads. It is a collective term for inverter, transformer, voltage regulator, meters, switches, and controls.

**Power curve**—a graphical representation of a wind turbine's power output as a function of wind speed.

**Present worth**—the value of future costs or benefits expressed in today's value of money (present day money).

**Prime mover**—the source of power for running any given load.

**Progressive cavity pump**—a type of positive displacement pump that has a helical cavity between the rotor and stator (i.e., as the rotor rotates, the cavity progresses upward carrying the water with it).

**Pumping head**—the height of water column that would produce the pressure that the pump experiences.

**Reciprocating pump**—a type of pump that has pull/push motion rather than by rotation.

**Remote site (location)**—a site that is not located near a utility grid.

**Renewable energy**—energy produced by non-fossil fuel or nuclear means. Includes energy produced from PV, wind turbines, hydroelectric systems, and biomass feedstocks.

**Rising main**—the pipe that is used to lift water from the borehole.

**Rotor**—the rotating central section of a motor or a pump.

**Single crystal (monocrystalline) silicon**—a material formed from a single silicon crystal.

**Solar thermal electric**—a method of producing electricity from solar energy by concentrating sunlight on a working fluid that changes phase to drive a turbine generator.

**Solidity**—ratio of the total blade widths to the circumference of the rotor.

**Stand-alone system**—a system that operates independently of the utility lines. It may draw supplementary power from the utility but is not capable of providing power to the utility.

**State of charge** —the available capacity in a cell or battery expressed as a percentage of rated capacity. For example, if 25 ampere-hours have been removed from a fully charged 100 ampere-hours cell, the new state of charge is 75%.

**Static head**—the height over which water must be pumped. Static head may vary as a result of seasonal variation of well recovery rate, fluctuations of groundwater level, etc.

**Stator**—the outer stationary component of a motor or a progressive cavity pump.

**Stroke**—the maximum extent of travel of the pump rod and the piston.

**Subsystem**—the motor–pump sets.

**Sucker rod**—another name for a pump rod.

**Tilt angle**—angle of inclination of a PV array as measured in degrees from the horizontal surface. Generally equal to the latitude of the PV array's location.

**Tilted factor**—the ratio of the incidence solar radiation on a tilted PV array surface to the global solar radiation.

**Tip-speed ratio**—the ratio of the blade tip speed to the wind speed. Tip-speed ratio is higher for lower rotor solidity.

**Village water supply (rural water supply)**—a water supply for drinking and other domestic purposes (such as livestock watering or backyard irrigation (micro), such as for a vegetable garden). This term does not include water for larger scale irrigation.



**Volt (V)**—a unit of measurement of the force given to electrons in an electric circuit; electric potential (voltage).

**Water table (static water level)**—the level below the ground at which the natural water level can be found.

**Watt (W)**—a measure of electric power. Watts = volts x amps.

**Watt-hour (Wh)**—a quantity of electrical energy when 1 watt is used for 1 hour.

**Weibull distribution**—a mathematical means of describing various possible statistical wind speed distributions at different sites.

**Weibull distribution coefficient,  $k$** —the coefficients used in the Weibull equations that define the shape of the wind speed distribution.

**Wind turbine**—A general term used to describe a wind-powered electrical generator—a device that converts the wind energy into electricity.

**Yawing**—the motion of the rotor head about its vertical pivot to point into the wind.

**Zenith angle**—the incidence angle to a horizontal surface.

**Appendix A**  
**Nomograms Used to Design Wind Pumps**

## Rotor diameter, d = 0.5 meters

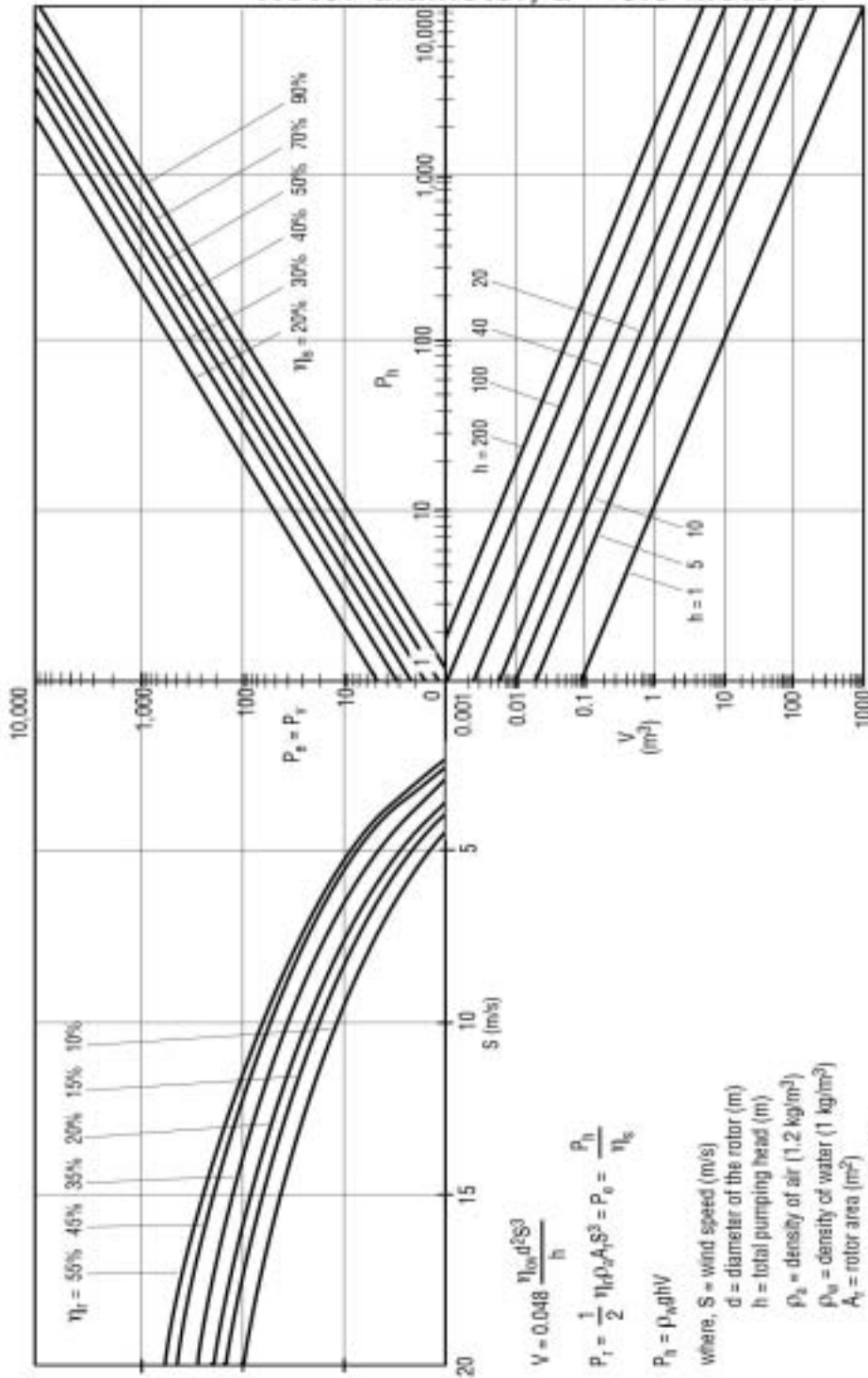

### Rotor diameter, d = 1 meter

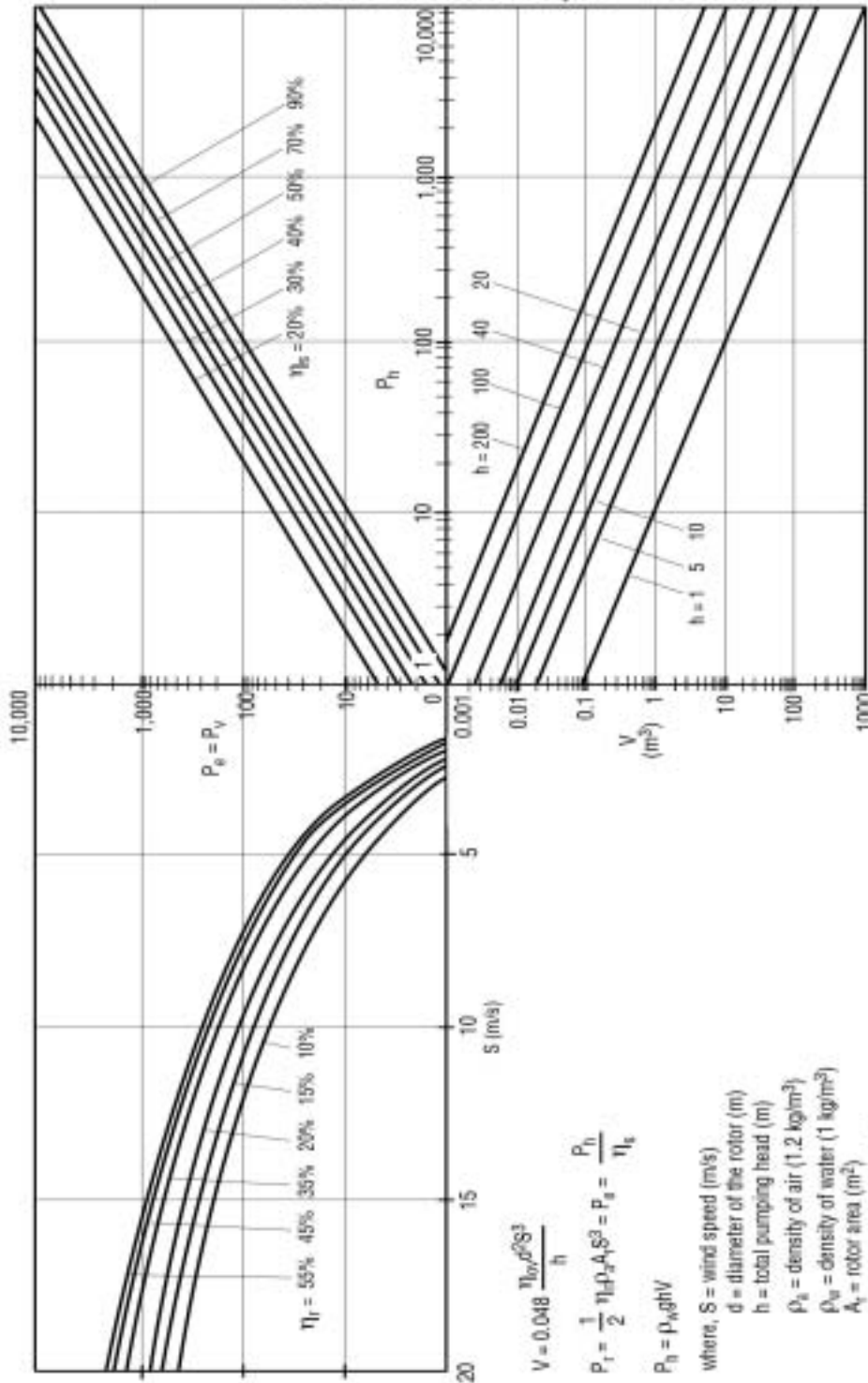

$$V = 0.048 \frac{\eta_{br} d^3 S^3}{h}$$

$$P_r = \frac{1}{2} \eta_r \rho_a A_r S^3 = P_g = \frac{P_h}{\eta_t}$$

$$P_h = \rho_w g h V$$

- where, S = wind speed (m/s)
- d = diameter of the rotor (m)
- h = total pumping head (m)
- $\rho_a$  = density of air (1.2 kg/m<sup>3</sup>)
- $\rho_w$  = density of water (1 kg/m<sup>3</sup>)
- $A_r$  = rotor area (m<sup>2</sup>)
- $\eta_r$  = rotor efficiency (%)
- $\eta_{br}$  = overall system efficiency (%)
- $\eta_g$  = motor and pump subsystem efficiency (%)
- g = acceleration due to gravity (9.81 m/s<sup>2</sup>)
- V = daily volume of water required (m<sup>3</sup>)
- $P_r$  = power in the rotor (daily electrical power requirement)(kW)
- $P_h$  = hydraulic power (kW)

### Rotor diameter, d = 1.5 meters

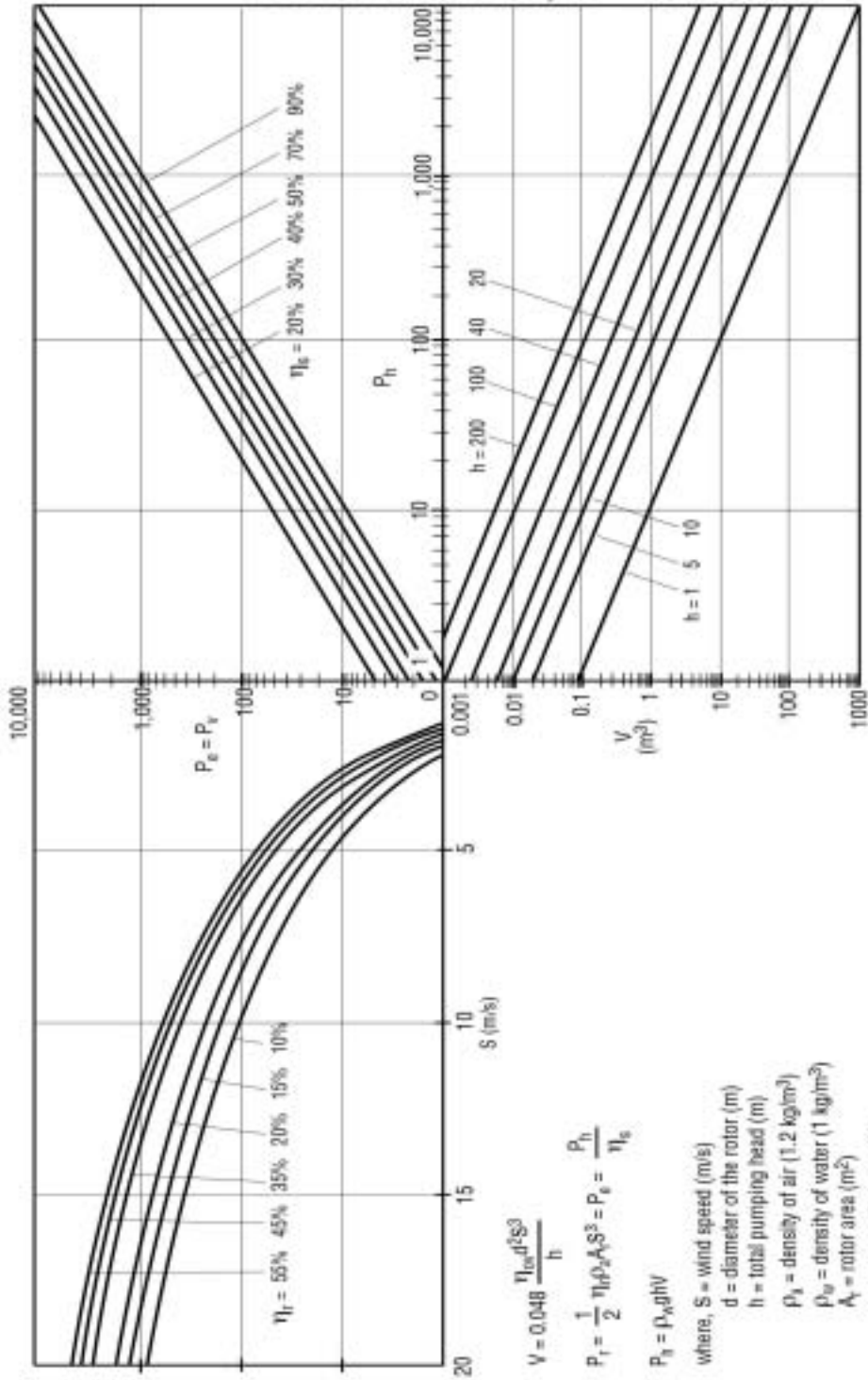

## Rotor diameter, d = 2 meters

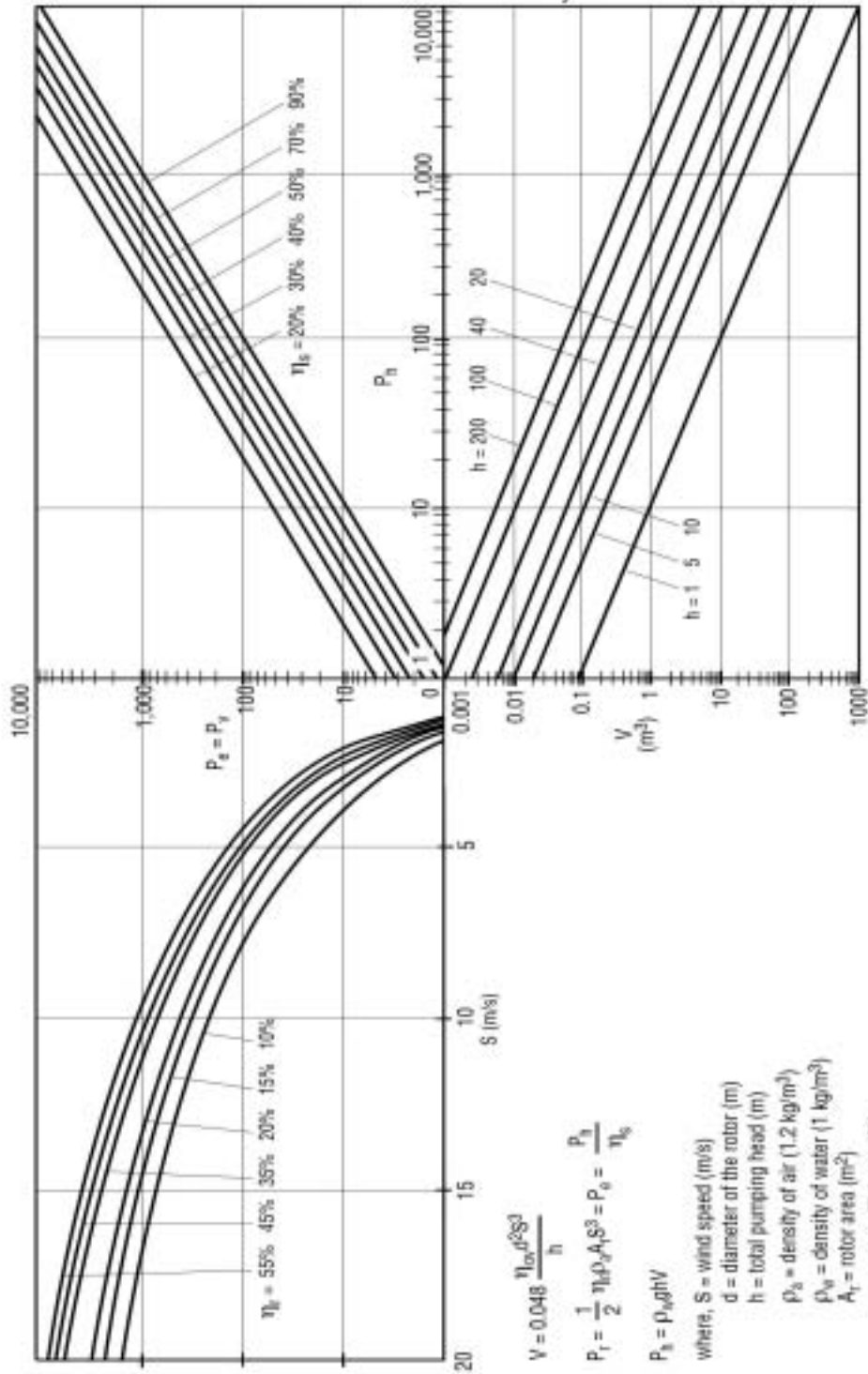

$$V = 0.048 \frac{\eta_{ov} \rho_a S^3 d^3}{h}$$

$$P_t = \frac{1}{2} \eta_{sp} \rho_w A_r S^3 = P_o = \frac{P_h}{\eta_s}$$

$$P_h = \rho_w g h V$$

- where, S = wind speed (m/s)
- d = diameter of the rotor (m)
- h = total pumping head (m)
- $\rho_a$  = density of air (1.2 kg/m<sup>3</sup>)
- $\rho_w$  = density of water (1 kg/m<sup>3</sup>)
- $A_r$  = rotor area (m<sup>2</sup>)
- $\eta_t$  = rotor efficiency (%)
- $\eta_{ov}$  = overall system efficiency (%)
- $\eta_{sp}$  = motor and pump subsystem efficiency (%)
- g = acceleration due to gravity (9.81 m/s<sup>2</sup>)
- V = daily volume of water required (m<sup>3</sup>)
- $P_t$  = power in the rotor (daily electrical power requirement)(kW)
- $P_h$  = hydraulic power (kW)

### Rotor diameter, d = 2.5 meters

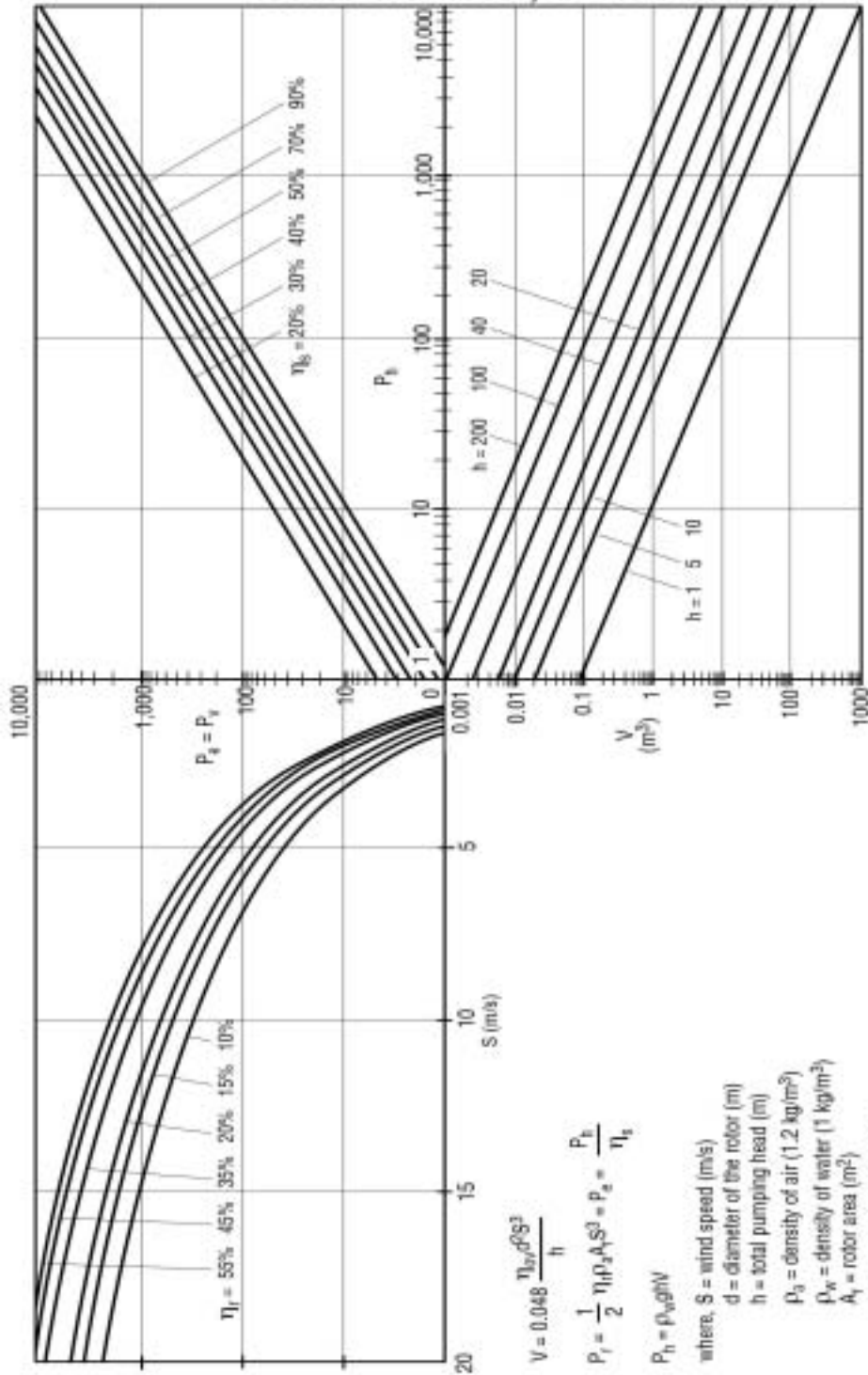

$$V = 0.048 \frac{\eta_{av} \rho S^3}{h}$$

$$P_r = \frac{1}{2} \eta_r \rho A_r S^3 = P_a = \frac{P_h}{\eta_s}$$

$$P_h = \rho_w g h V$$

- where,  $S$  = wind speed (m/s)
- $d$  = diameter of the rotor (m)
- $h$  = total pumping head (m)
- $\rho_a$  = density of air ( $1.2 \text{ kg/m}^3$ )
- $\rho_w$  = density of water ( $1 \text{ kg/m}^3$ )
- $A_r$  = rotor area ( $m^2$ )
- $\eta_r$  = rotor efficiency (%)
- $\eta_{ov}$  = overall system efficiency (%)
- $\eta_{fs}$  = motor and pump subsystem efficiency (%)
- $g$  = acceleration due to gravity ( $9.81 \text{ m/s}^2$ )
- $V$  = daily volume of water required ( $m^3$ )
- $P_r$  = power in the rotor (daily electrical power requirement) (kW)
- $P_h$  = hydraulic power (kW)

### Rotor diameter, d = 3 meters

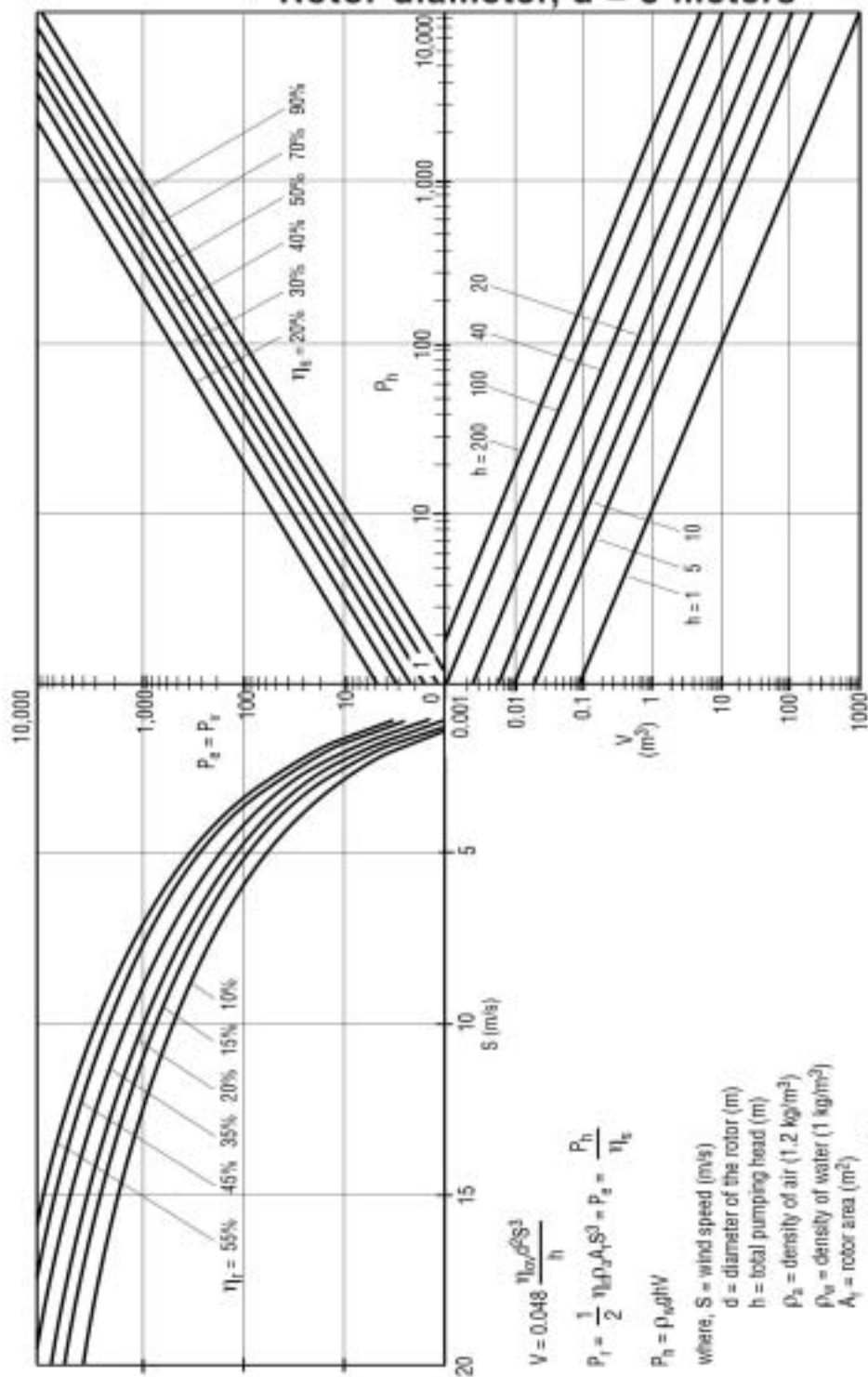

$$V = 0.048 \frac{\eta_{ov} \rho^2 S^3}{h}$$

$$P_r = \frac{1}{2} \eta_r \rho A_r S^3 = P_s = \frac{P_h}{\eta_{sp}}$$

$$P_h = \rho_w g h V$$

- where,  $S$  = wind speed (m/s)
- $d$  = diameter of the rotor (m)
- $h$  = total pumping head (m)
- $\rho_a$  = density of air (1.2  $kg/m^3$ )
- $\rho_w$  = density of water (1  $kg/m^3$ )
- $A_r$  = rotor area ( $m^2$ )
- $\eta_r$  = rotor efficiency (%)
- $\eta_{ov}$  = overall system efficiency (%)
- $\eta_{sp}$  = motor and pump subsystem efficiency (%)
- $g$  = acceleration due to gravity (9.81  $ms^{-2}$ )
- $V$  = daily volume of water required ( $m^3$ )
- $P_r$  = power in the rotor (daily electrical power requirement)(kW)
- $P_h$  = hydraulic power (kW)



## Rotor diameter, d = 4 meters

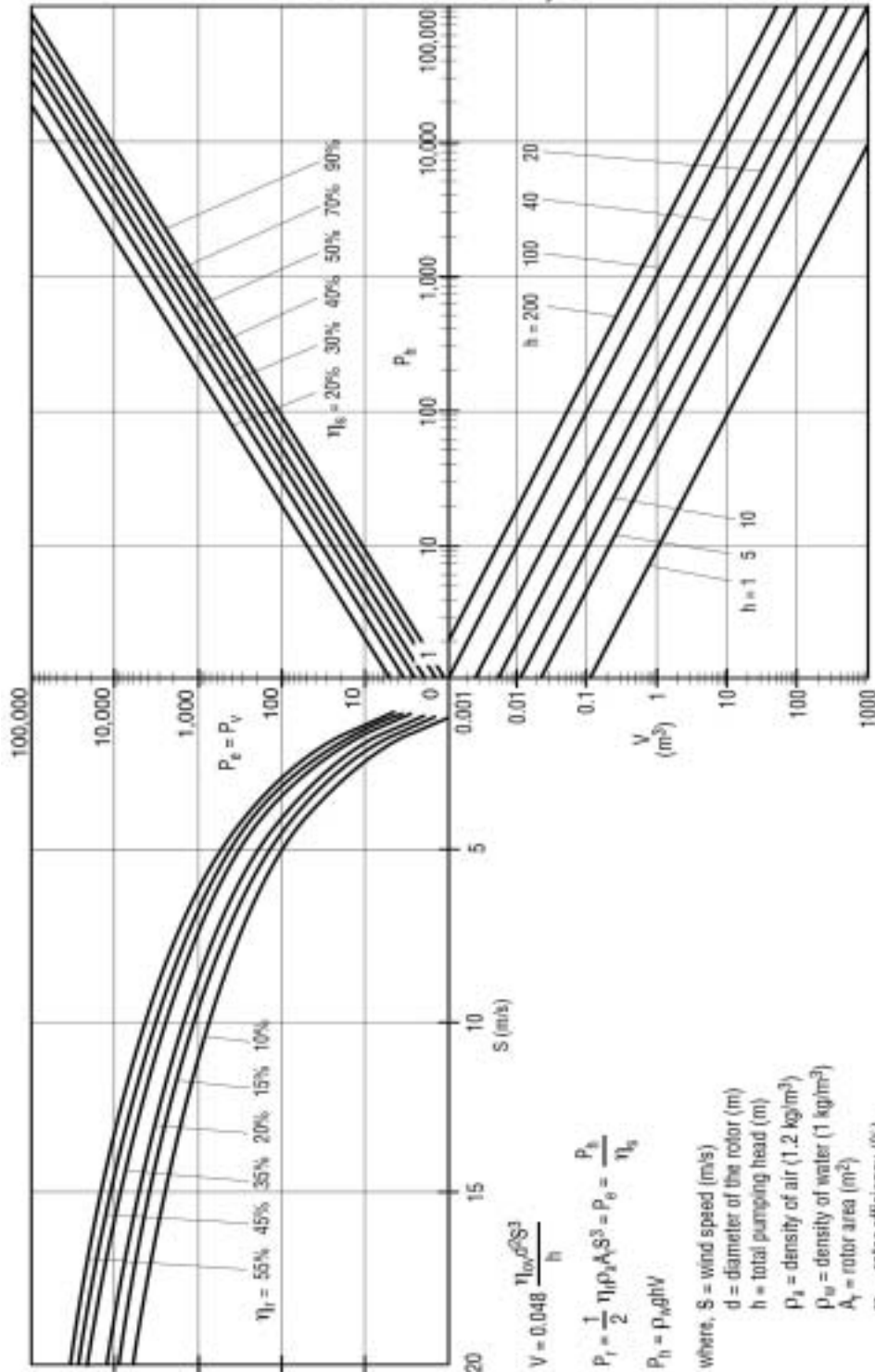

### Rotor diameter, d = 5 meters

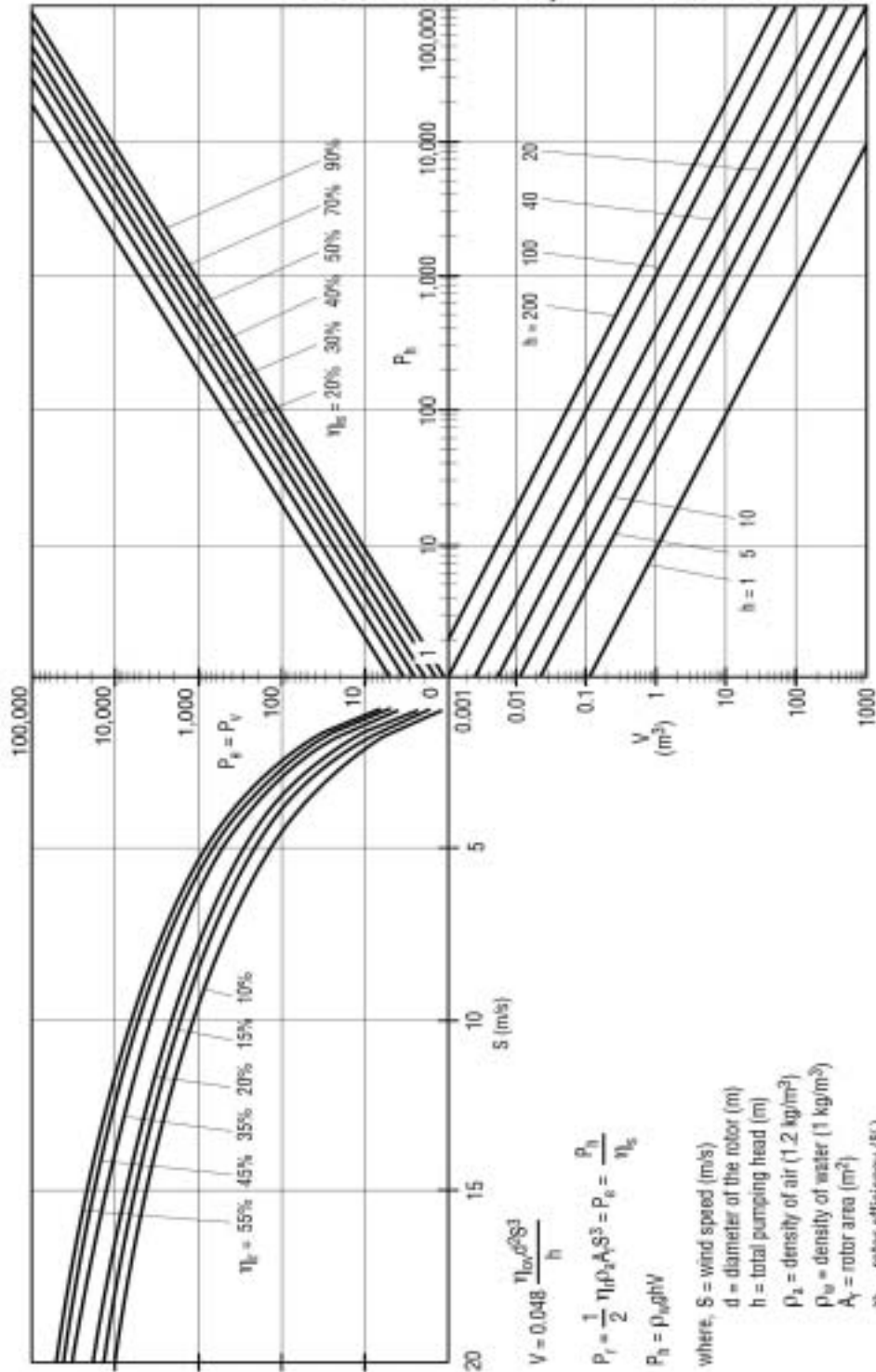

## Rotor diameter, d = 6 meters

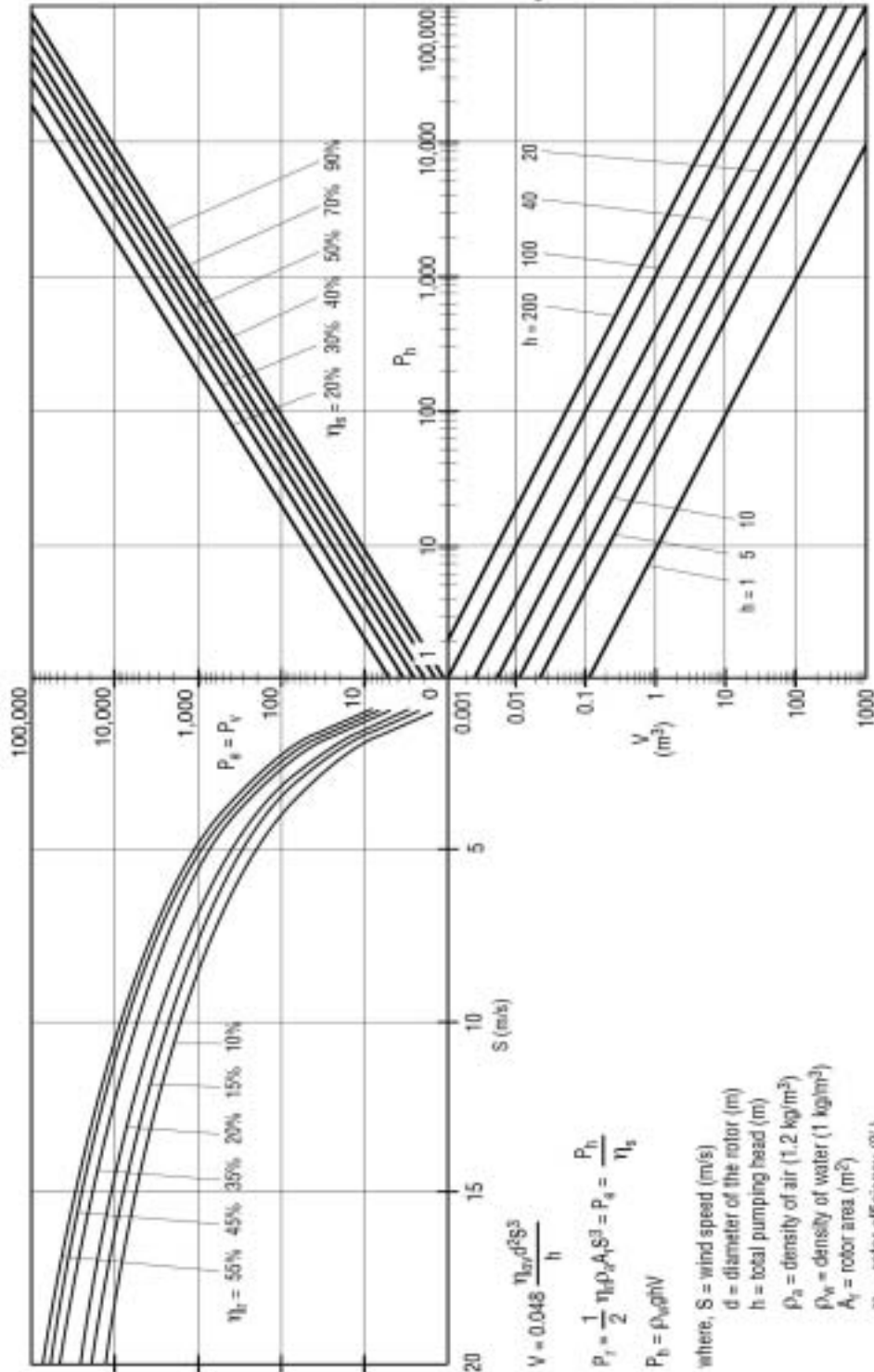

### Rotor diameter, d = 8 meters

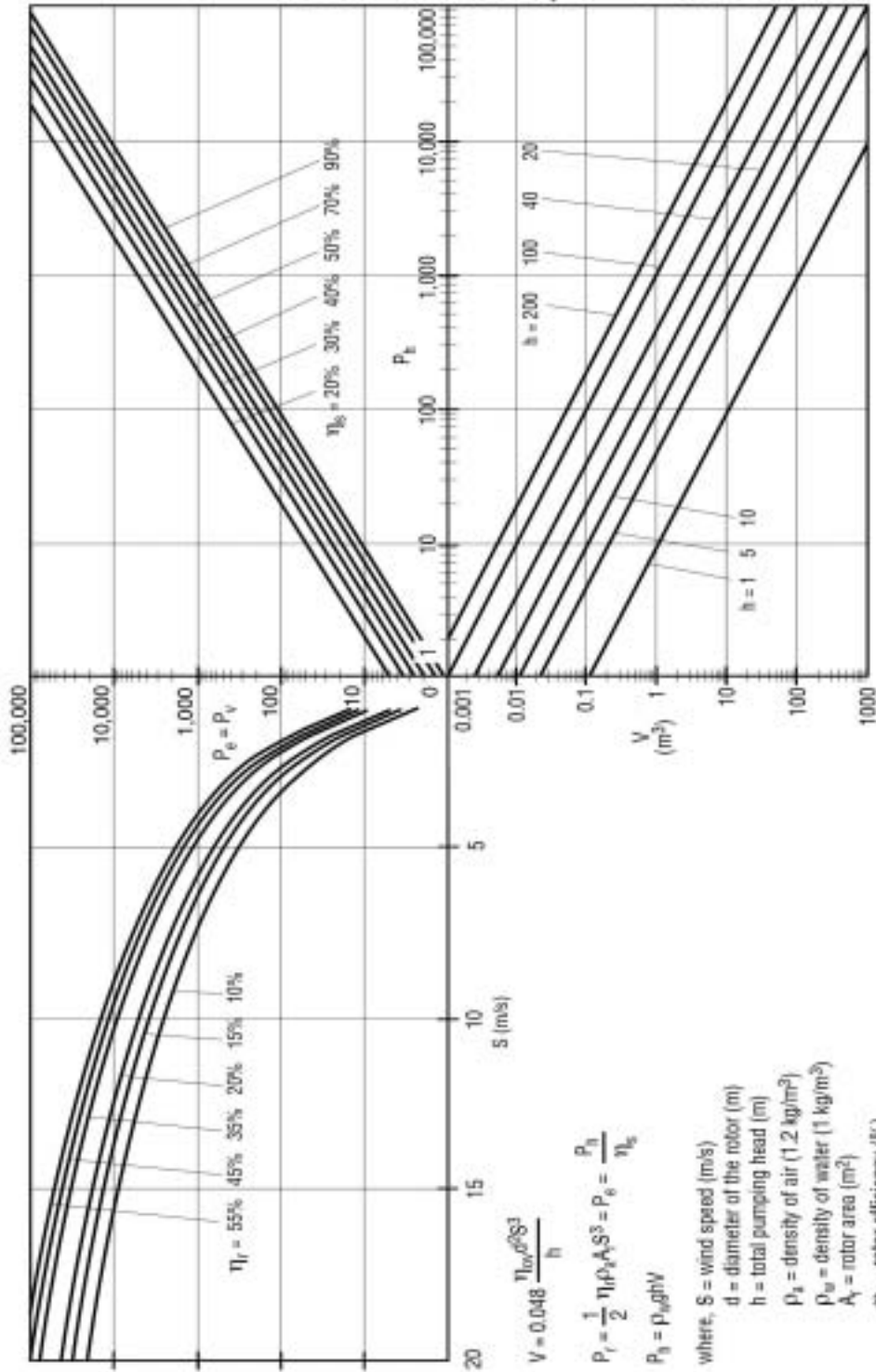

REPORT DOCUMENTATION PAGE			Form Approved OMB NO. 0704-0188
Public reporting burden for this collection of information is estimated to average 1 hour per response, including the time for reviewing instructions, searching existing data sources, gathering and maintaining the data needed, and completing and reviewing the collection of information. Send comments regarding this burden estimate or any other aspect of this collection of information, including suggestions for reducing this burden, to Washington Headquarters Services, Directorate for Information Operations and Reports, 1215 Jefferson Davis Highway, Suite 1204, Arlington, VA 22202-4302, and to the Office of Management and Budget, Paperwork Reduction Project (0704-0188), Washington, DC 20503.			
1. AGENCY USE ONLY (Leave blank)	2. REPORT DATE July 2003	3. REPORT TYPE AND DATES COVERED Subcontract report: April 1, 2001–September 1, 2001	
4. TITLE AND SUBTITLE Renewable Energy for Water Pumping Applications in Rural Areas; Period of Performance: April 1, 2001–September 1, 2001		5. FUNDING NUMBERS RAM-1-31224-01	
6. AUTHOR(S) N. Argaw, R. Foster, and A. Ellis			
7. PERFORMING ORGANIZATION NAME(S) AND ADDRESS(ES)		8. PERFORMING ORGANIZATION REPORT NUMBER	
9. SPONSORING/MONITORING AGENCY NAME(S) AND ADDRESS(ES) National Renewable Energy Laboratory 1617 Cole Blvd. Golden, CO 80401-3393		10. SPONSORING/MONITORING AGENCY REPORT NUMBER NREL/SR-500-30361	
11. SUPPLEMENTARY NOTES NREL Technical Monitor: L. Flowers			
12a. DISTRIBUTION/AVAILABILITY STATEMENT National Technical Information Service U.S. Department of Commerce 5285 Port Royal Road Springfield, VA 22161		12b. DISTRIBUTION CODE	
13. ABSTRACT (Maximum 200 words) This report introduces conventional and renewable energy sources for water pumping applications in rural villages by reviewing the technologies and illustrating typical applications. As energy sources for water pumping, the report discusses diesel/gasoline/kerosene engines, grid power supplies, traditional windmills, electrical wind turbines, and PV.			
14. SUBJECT TERMS water pumping; renewable energy; rural applications		15. NUMBER OF PAGES	
		16. PRICE CODE	
17. SECURITY CLASSIFICATION OF REPORT Unclassified	18. SECURITY CLASSIFICATION OF THIS PAGE Unclassified	19. SECURITY CLASSIFICATION OF ABSTRACT Unclassified	20. LIMITATION OF ABSTRACT UL