

## APPENDIX A – APPROVED REINFORCING STEEL PRODUCERS

The ASTM specifications for billet-steel and low-alloy reinforcing bars (A615 and A706, respectively) require identification marks to be rolled into the surface of one side of the bar to denote the producer's mill designation, bar size, type of steel and minimum yield designation. Grade 420 bars show these marks in the following order.

1<sup>st</sup> – Producing Mill (usually a letter)

2<sup>nd</sup> – Bar Size Number (#10 through #57)

3<sup>rd</sup> – Type of Steel:   **S**       for Billet (A615)

**W**       for Low-Alloy (A706)

4<sup>th</sup> – Minimum Yield Designation

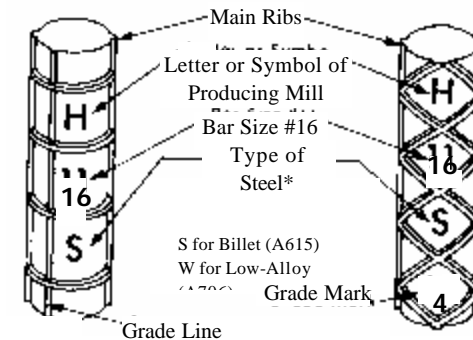

The minimum yield designation for Grade 420 bars is either one (1) single, longitudinal line (grade line) or the number 4 (grade mark).

A grade line is smaller and is located between the two main ribs, which are on opposite sides of all bars made in the United States. A grade line must be continued through at least 5 deformation spaces, and it may be placed on the side of the bar opposite the bar marks. A grade mark is the fourth mark on the bar.

**VARIATIONS:** Bar identification marks may also be oriented to read horizontally (90° to those illustrated). Grade numbers may be placed within consecutive deformation spaces to read vertically or horizontally.

The identification marks for the Approved Producers are shown in the following figures. Rebar grades shown on these pages are for reference only. Check the specs for the appropriate requirements

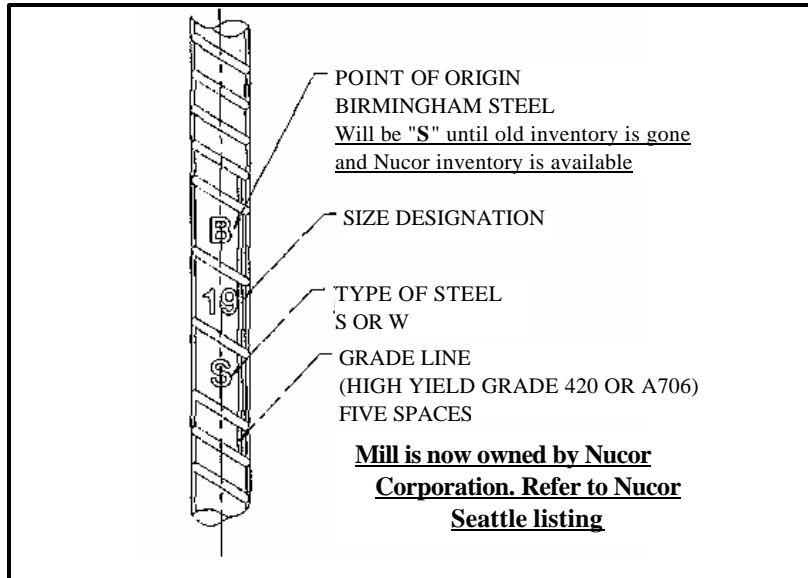

**SALMON BAY STEEL**  
(DIVISION OF BIRMINGHAM STEEL CORP.)

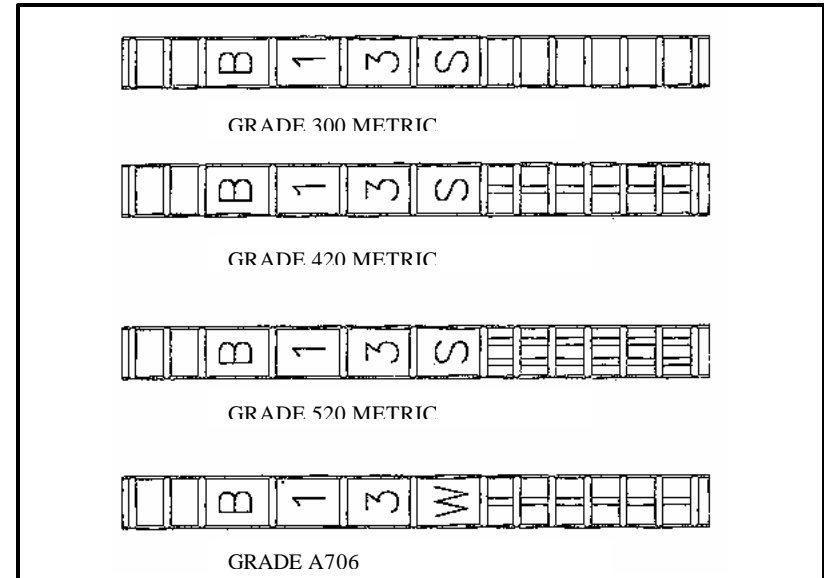

**BORDER STEEL** (El Paso Texas)

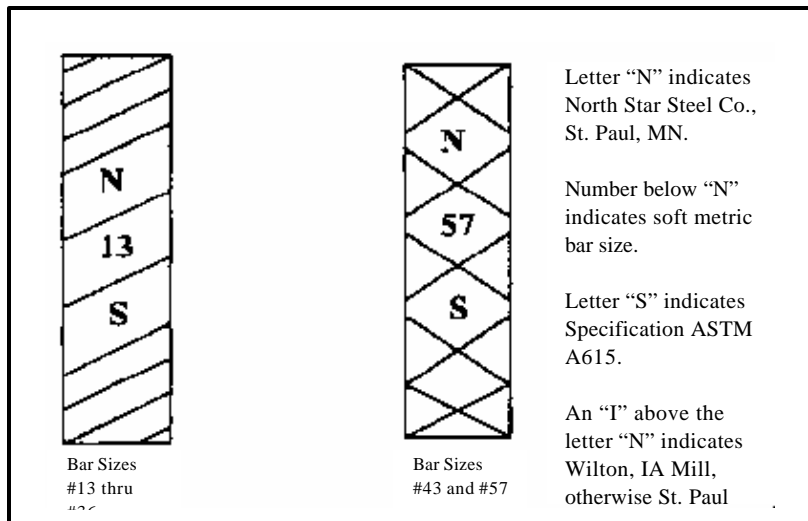

**NORTH STAR STEEL**  
(ST PAUL, MN)

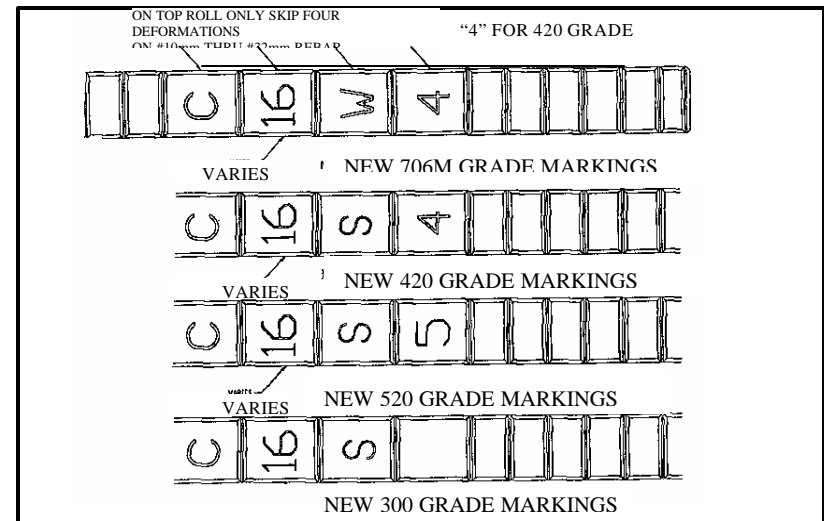

**CASCADE STEEL ROLLING MILLS**

Figure A, page 2 of 4  
Approved Producers

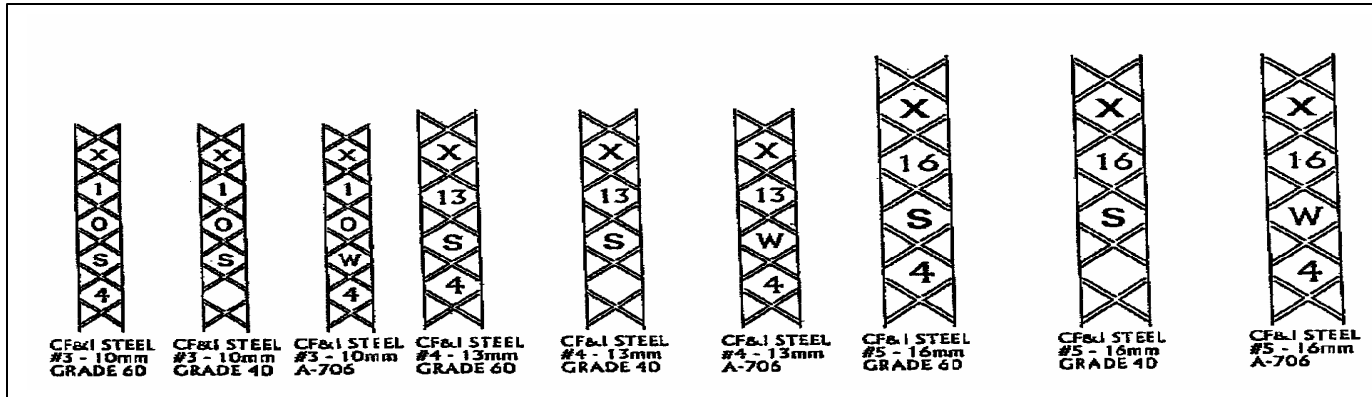

CF&I Pueblo Colorado Now Known as Rocky Mountain Steel Company

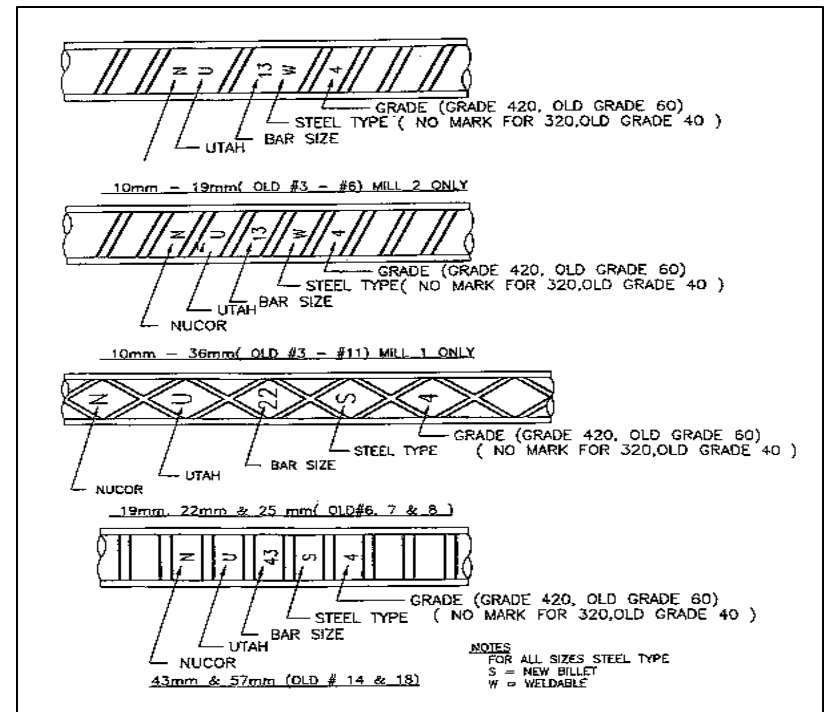
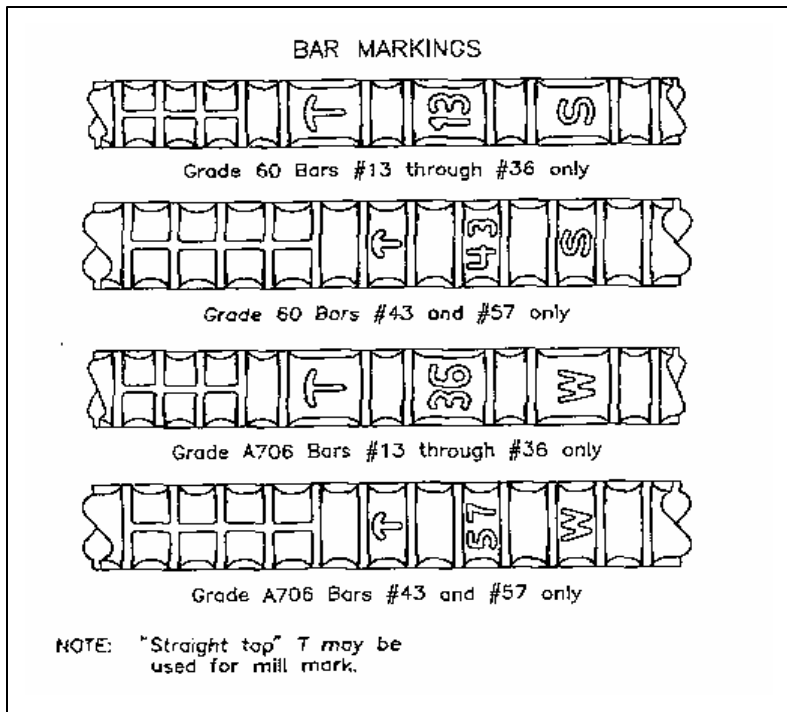

Tamco Steel (Rancho Cucamonga Mill)

Nucor Corporation (Utah Mill)

Figure A, page 3 of 4  
 Approved Producers

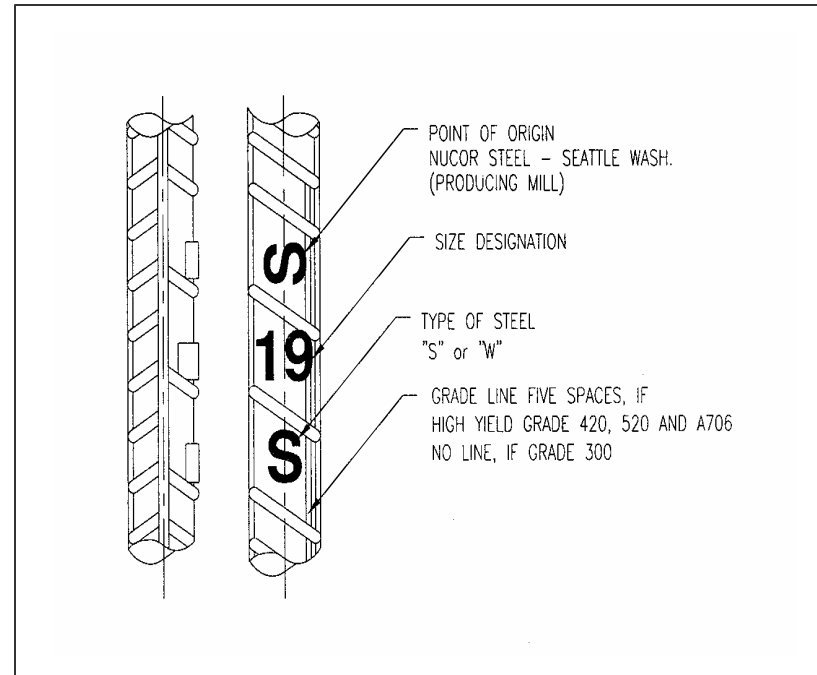
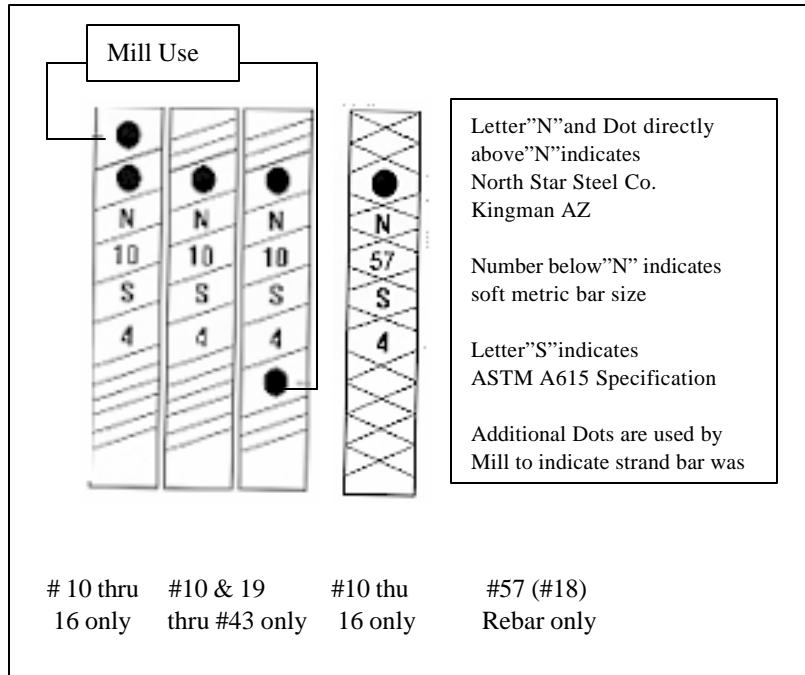

**North Star** (Kingman Arizona) Purchased by Nucor. Mill is not producing steel. as of January 2004

**Nucor Corporation** (Seattle Washington)

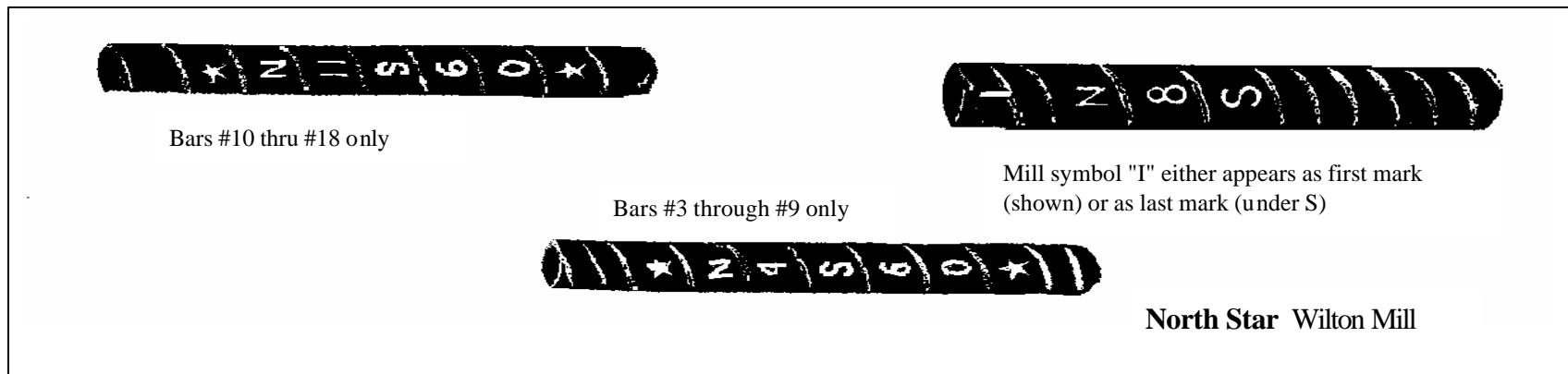

Figure A, page 4 of 4  
Approved Producers