



ISS Unpressurized Payload Accommodations

Gene Cook

NASA/OZ3

International Space Station Payloads Office

Hardware Engineering Integration

19 December 2007



Purpose and Overview

- Purpose of Presentation – To present an overview of the Unpressurized Payload Accommodations available on the International Space Station

- Presentation Overview
 - ISS External Payload Accommodation Locations
 - Columbus EPF Overview
 - ELC Overview
 - JEM-EF Overview
 - Testing
 - Documentation



Planned External Payload Attachment Locations

- Express Logistics Carrier
 - total of ten adapter sites located on the 6 truss attach sites at P3 and S3

- *Columbus* External Payload Facility (COF-EPF): 4 each Flight Releasable Attachment Mechanism (FRAM) sites (2 allocated to US Payloads)

- *Kibo* Exposed Facility (JEM-EF):
 - 12 each Payload Interface Unit (PIU)/FRAM sites; 10 for payload use (49% allocated to US Payloads)



Planned ISS External Payload Attachment Locations

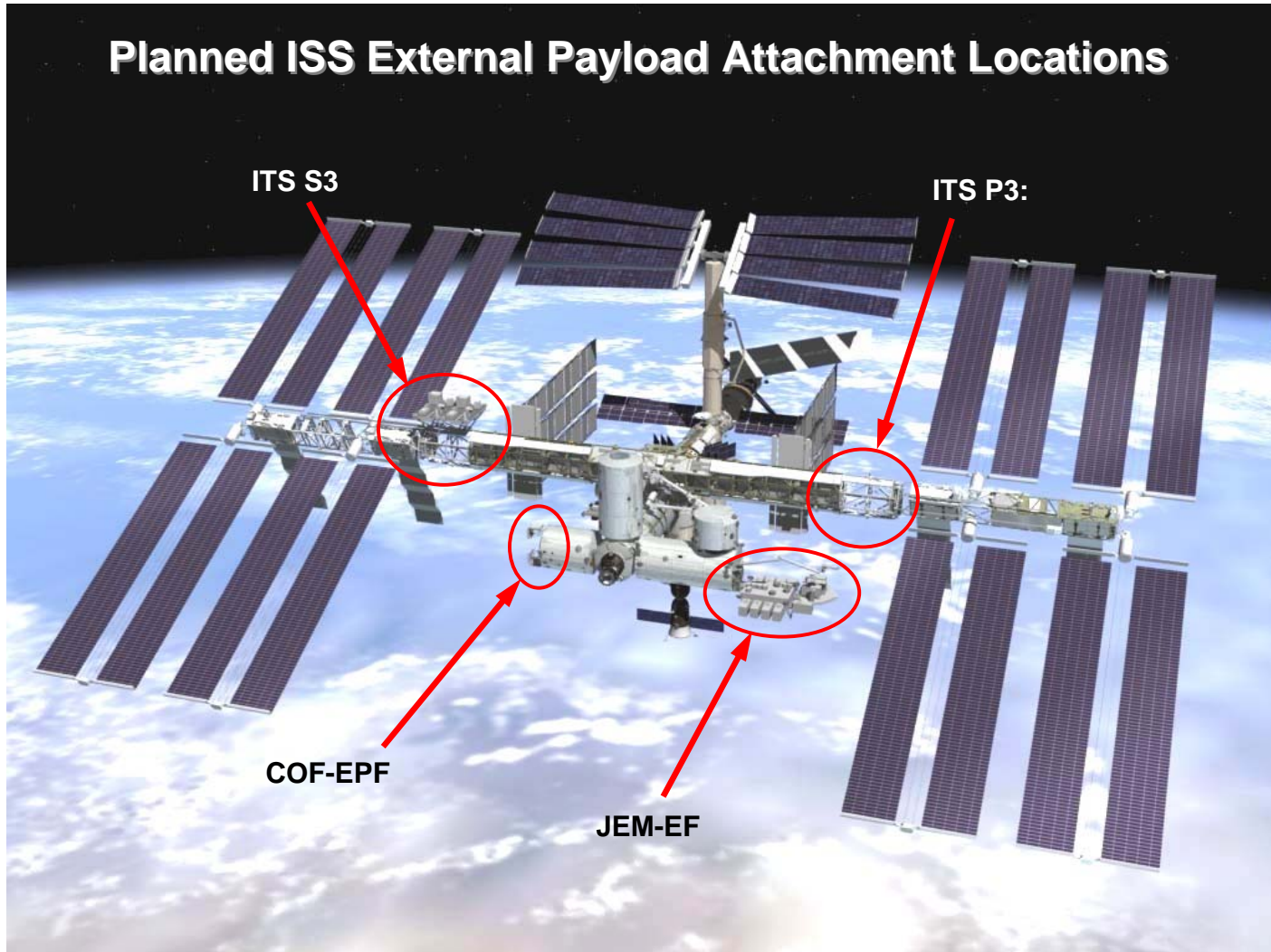



National Aeronautics and
Space Administration
Lyndon B. Johnson Space Center

Columbus Exposed Payload Facility

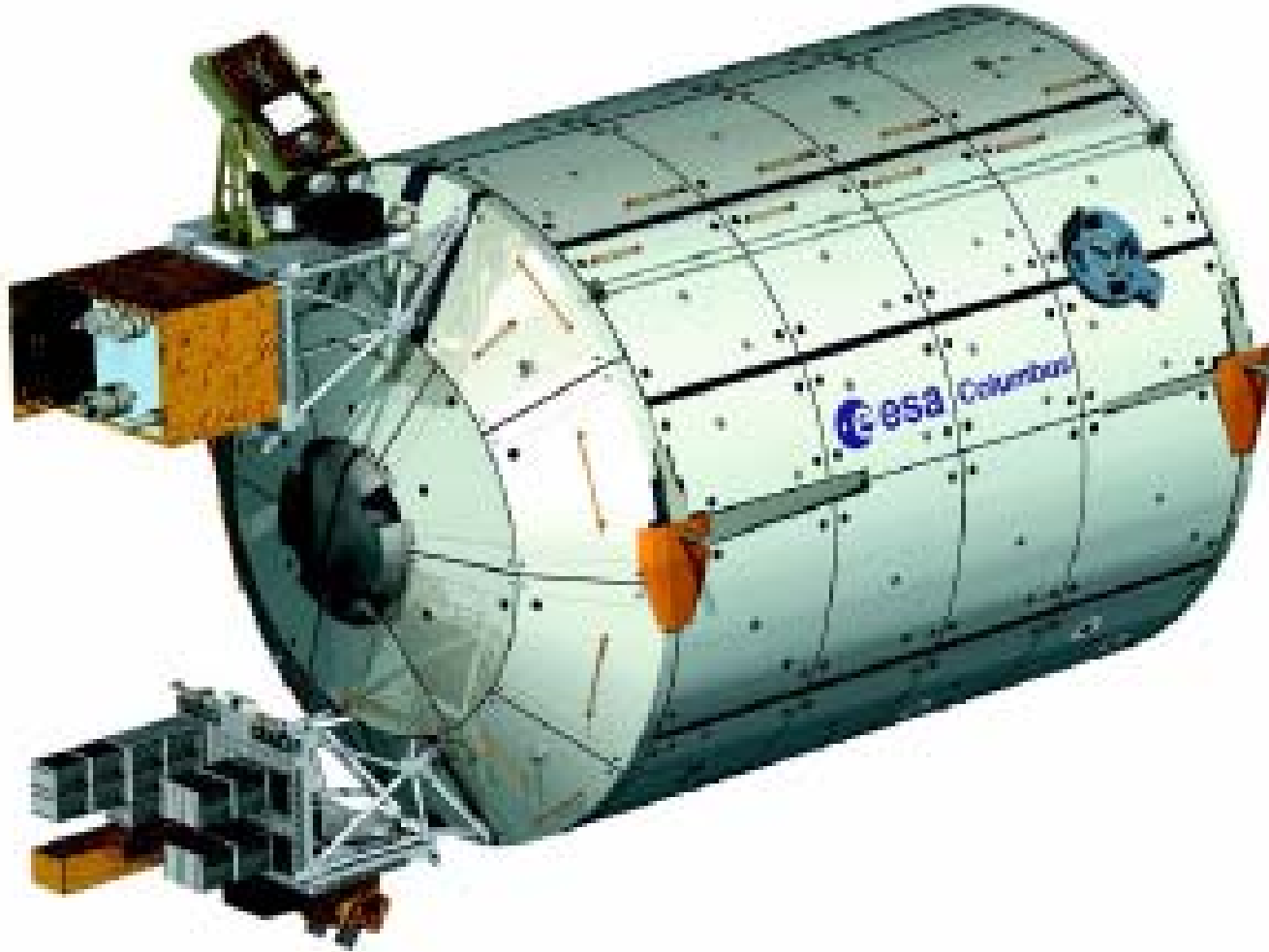



- The Columbus Module has four Exposed payload sites to perform external science investigations
 - Payloads are integrated onto a special adapter plate (Columbus Adapter Plate Assembly CEPA)
 - Each site is equipped with interface hardware that permits CEPA mounted payloads to be installed and removed on-orbit
 - Payloads can be installed by Astronauts performing Extravehicular Activity (Space walks)
 - Payloads can also be installed using the Special Purpose Dexterous Manipulator (SPDM)
 - The SPDM can perform fine robotic operations that would be difficult for the large robotic arm)



CEPA Overview

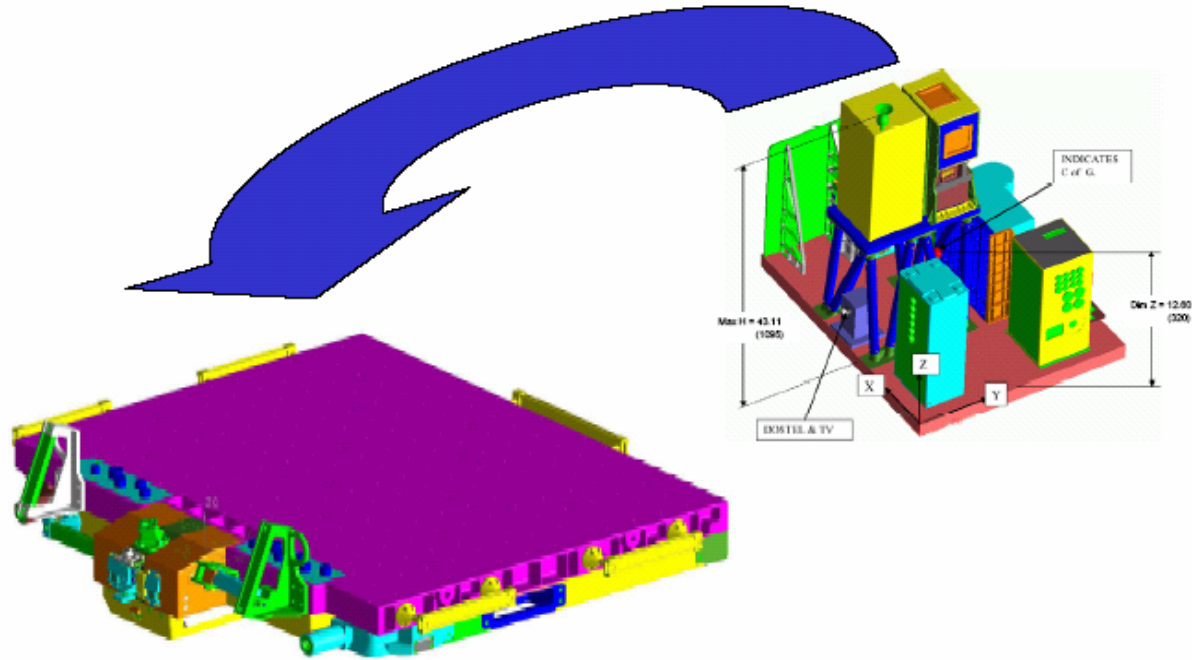

CEPA Assembly



1E Payloads

SOLAR on CEPA

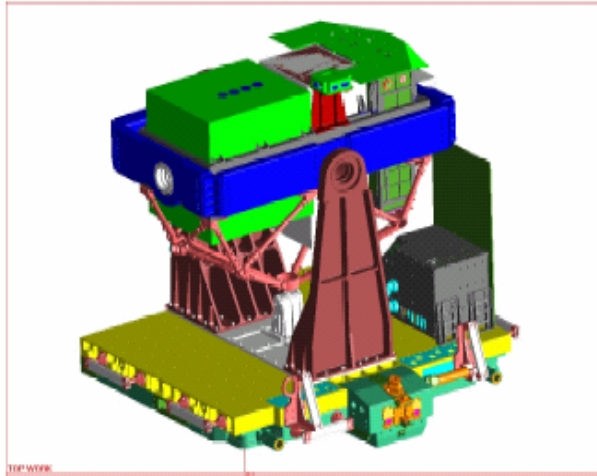

-SOLAR Payload with Integrated Carrier
(EVA mass = ~ 800 lbs)

EuTEF on CEPA

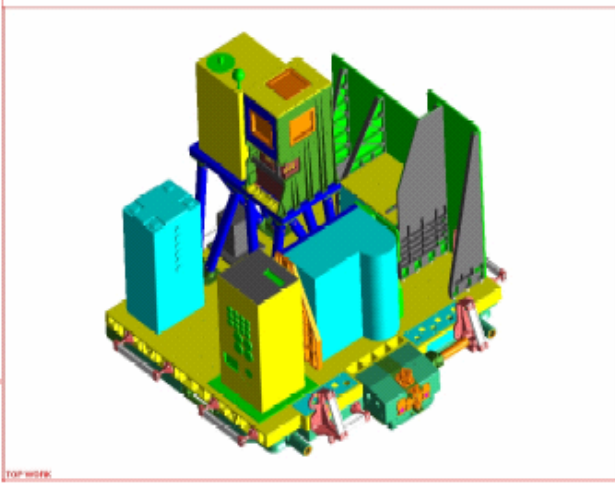

- EuTEF (European Technology Exposure Facility)
Payload with Integrated Carrier (EVA mass = ~ 752 lbs)



Small Payloads Mission of Opportunity TIM



- EPF with Integrated External Payloads
- 4 External Payload Sites

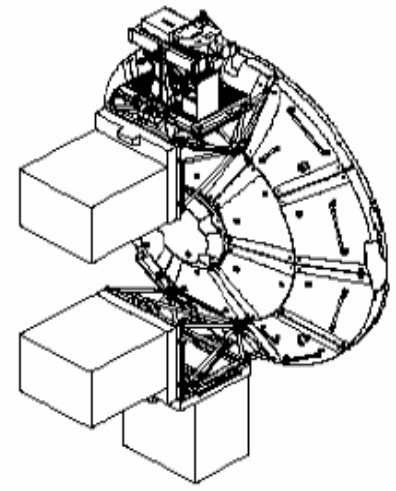

- EPF Mechanical Support Platform for Passive FRAM

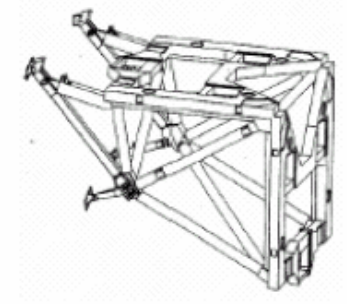

Columbus EPF Viewing



Orbit Sunrise



+X

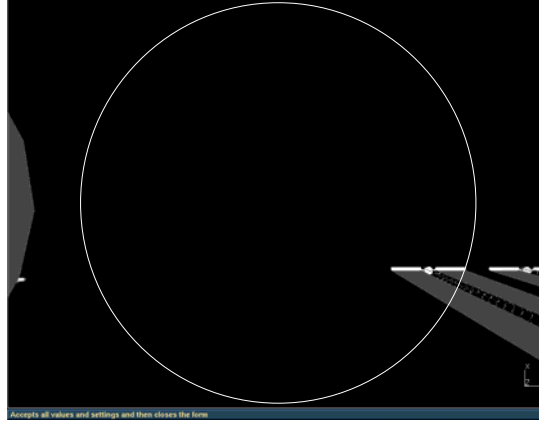

+Z

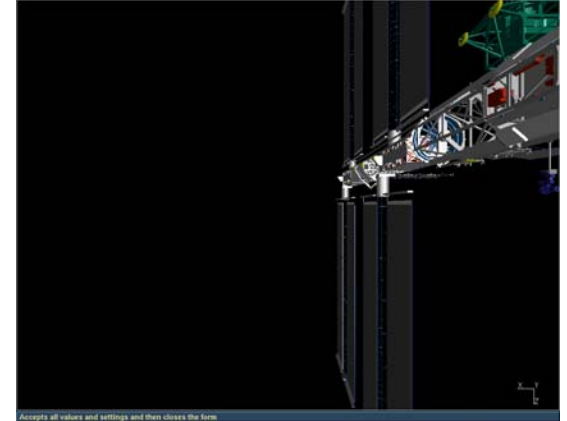

+Y

Orbit Noon

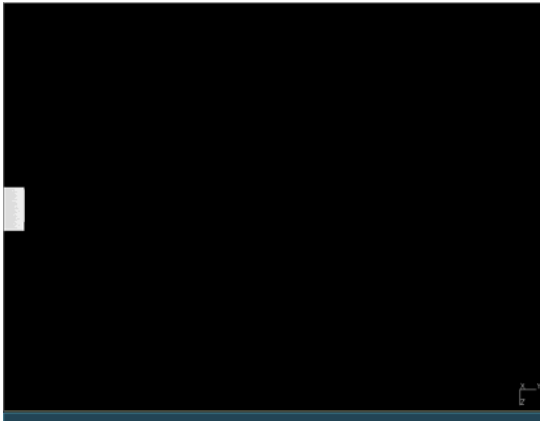

+X

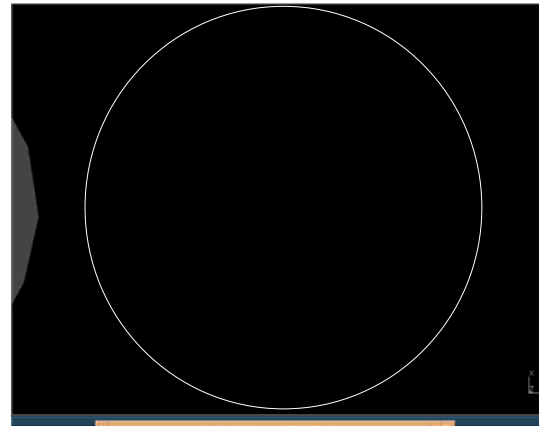

+Z

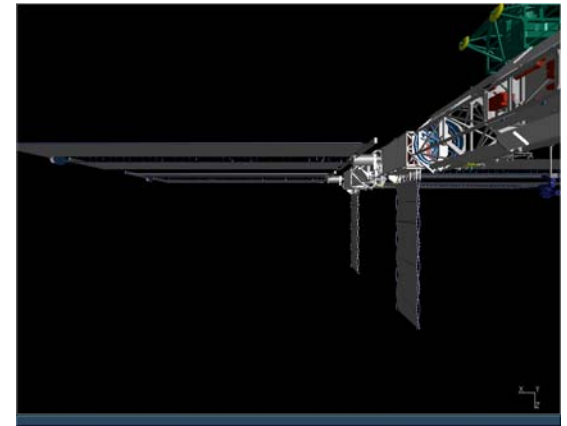

+Y



Columbus EPF Viewing



Orbit Sunrise

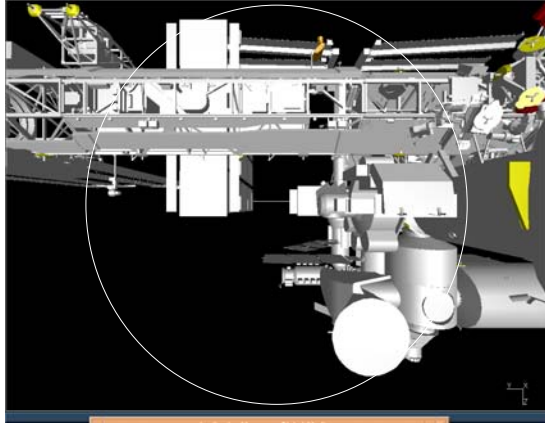

-X



-Z

Orbit Noon

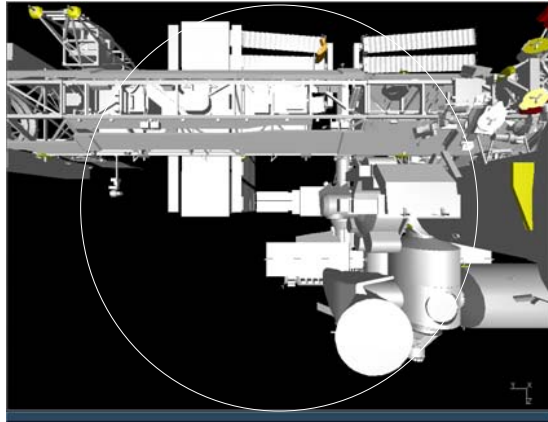

-X

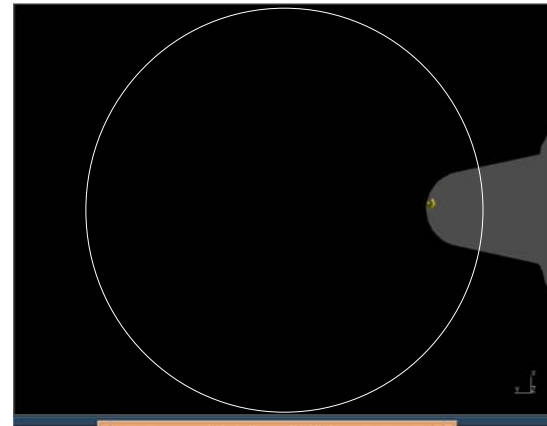

-Z



SPDM Located on the end of the SSRMS



**Mobile Servicer
Base System**

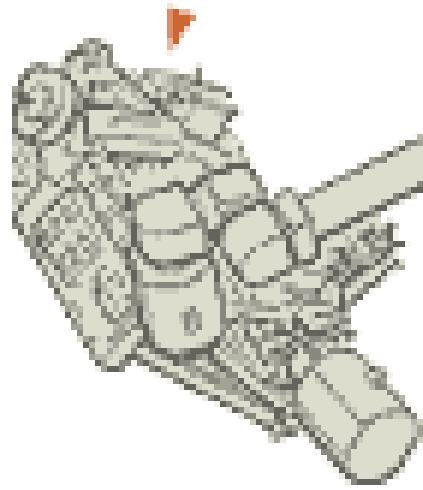

**Remote
Manipulator
System**

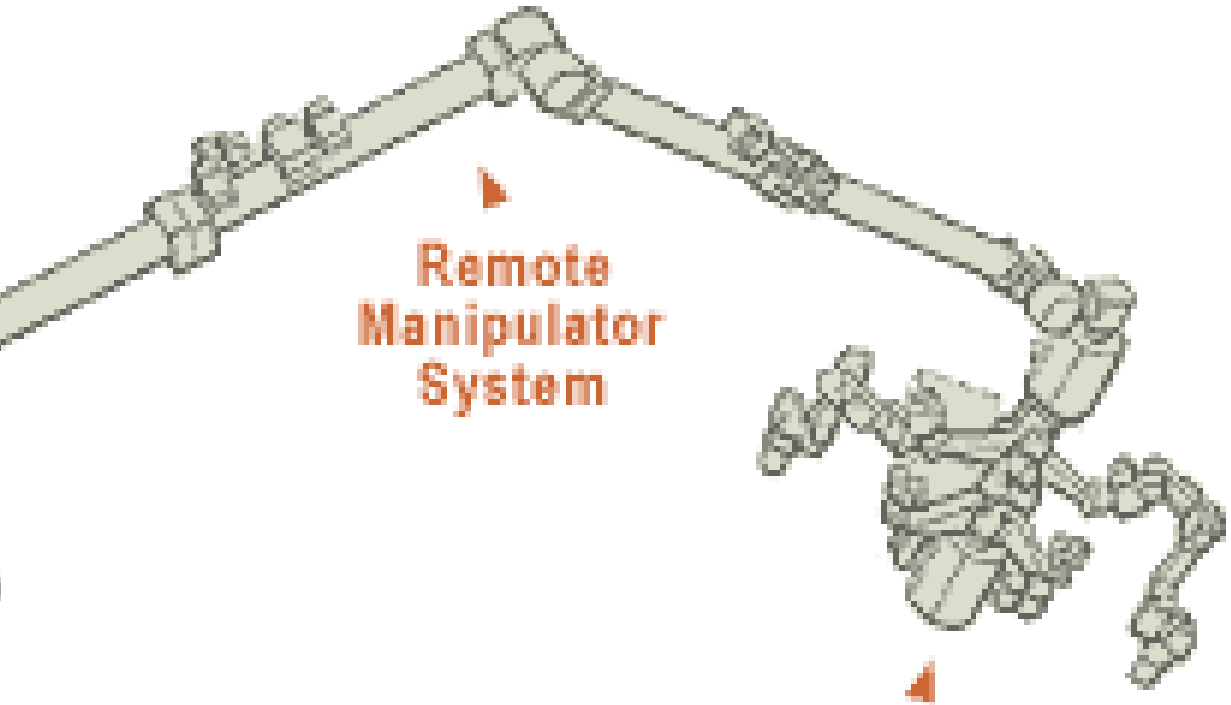

**Special Purpose
Dexterous Manipulator**

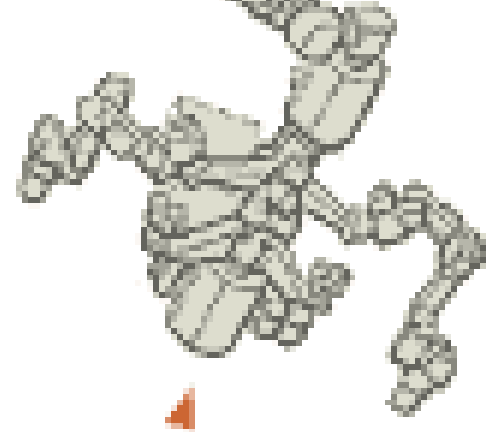



Installation of a Payload on the Columbus EPF using an EVA Crewman

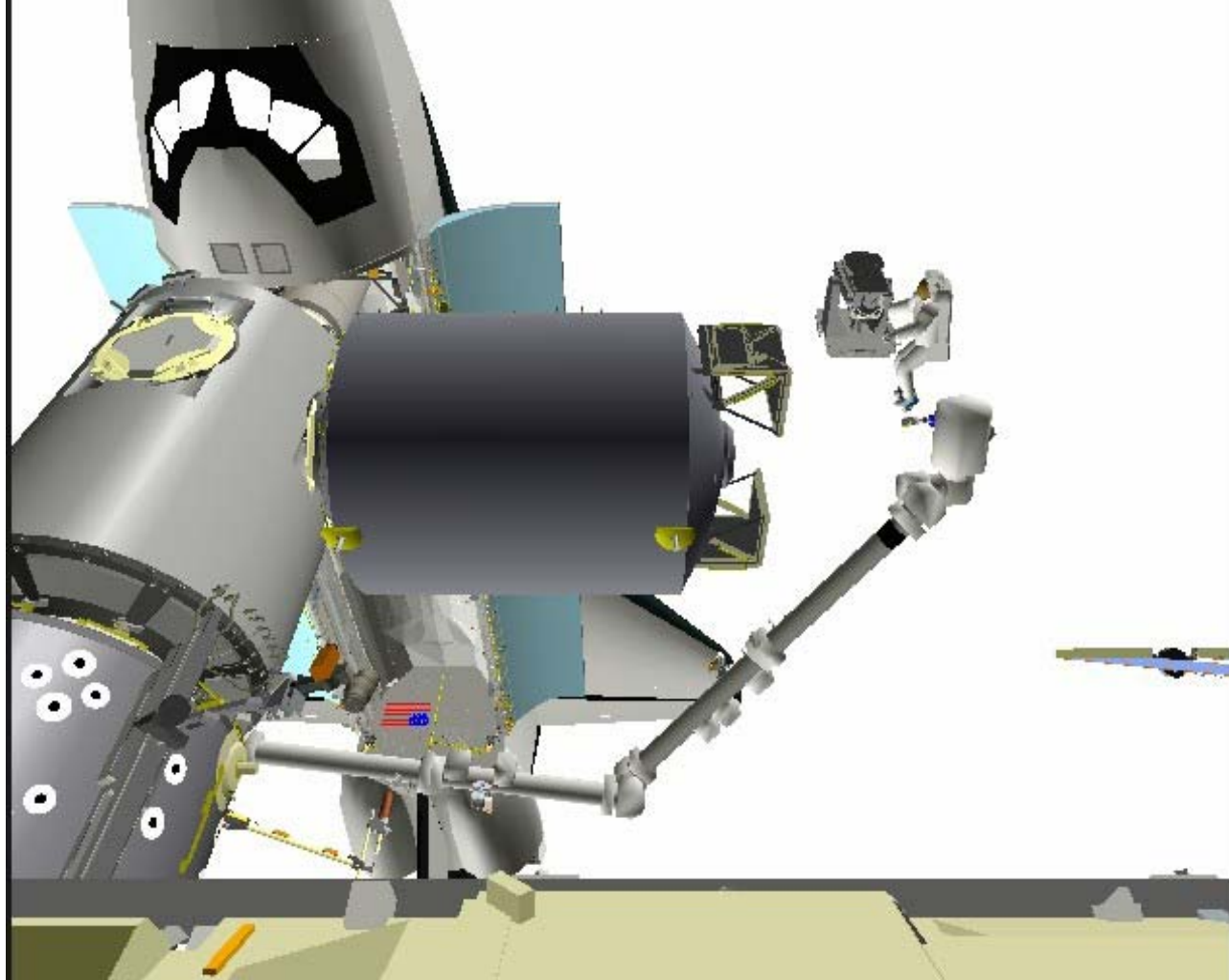



Installation of a Payload on the Columbus EPF using SPDM and SSRMS

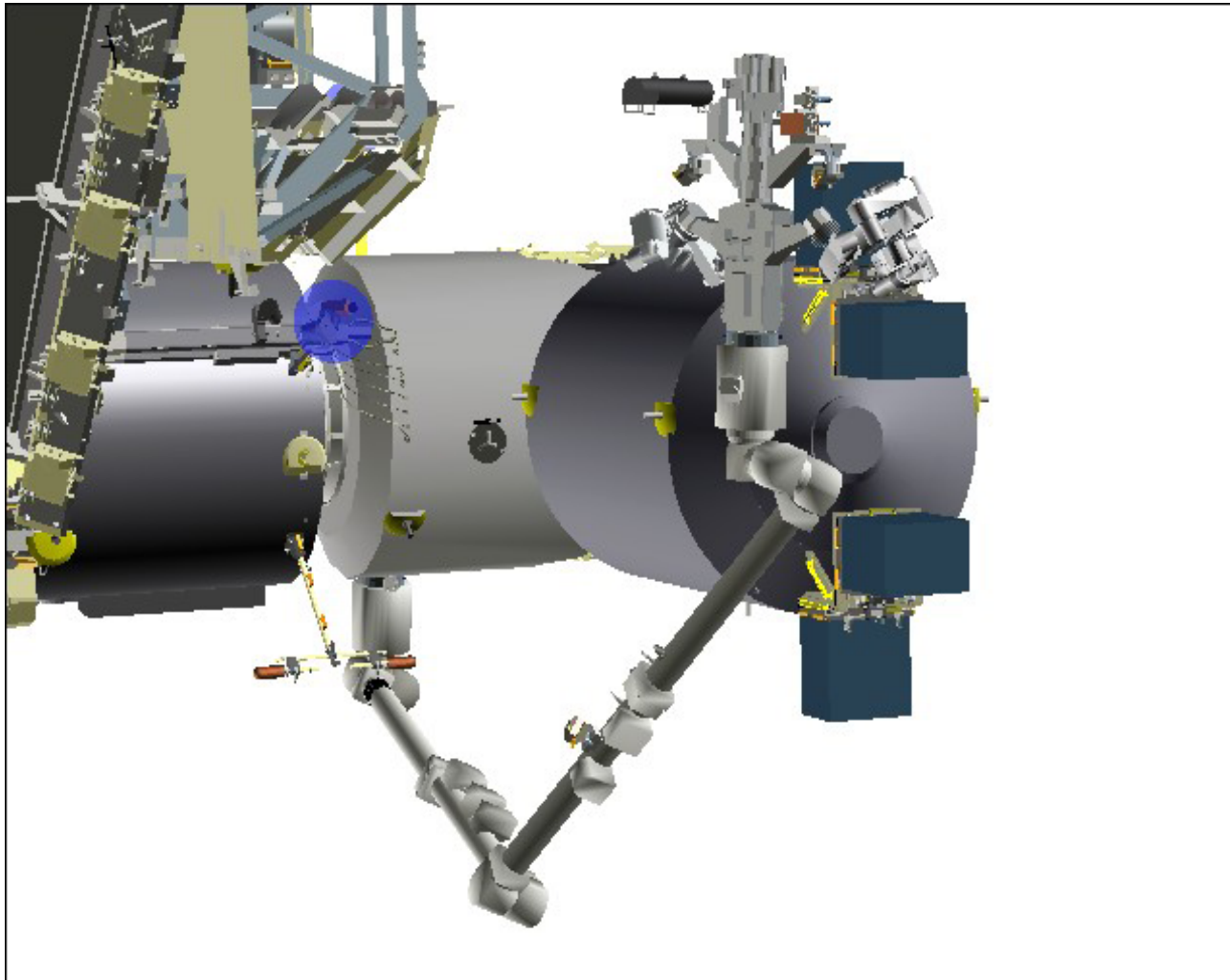



Express Logistics Carrier

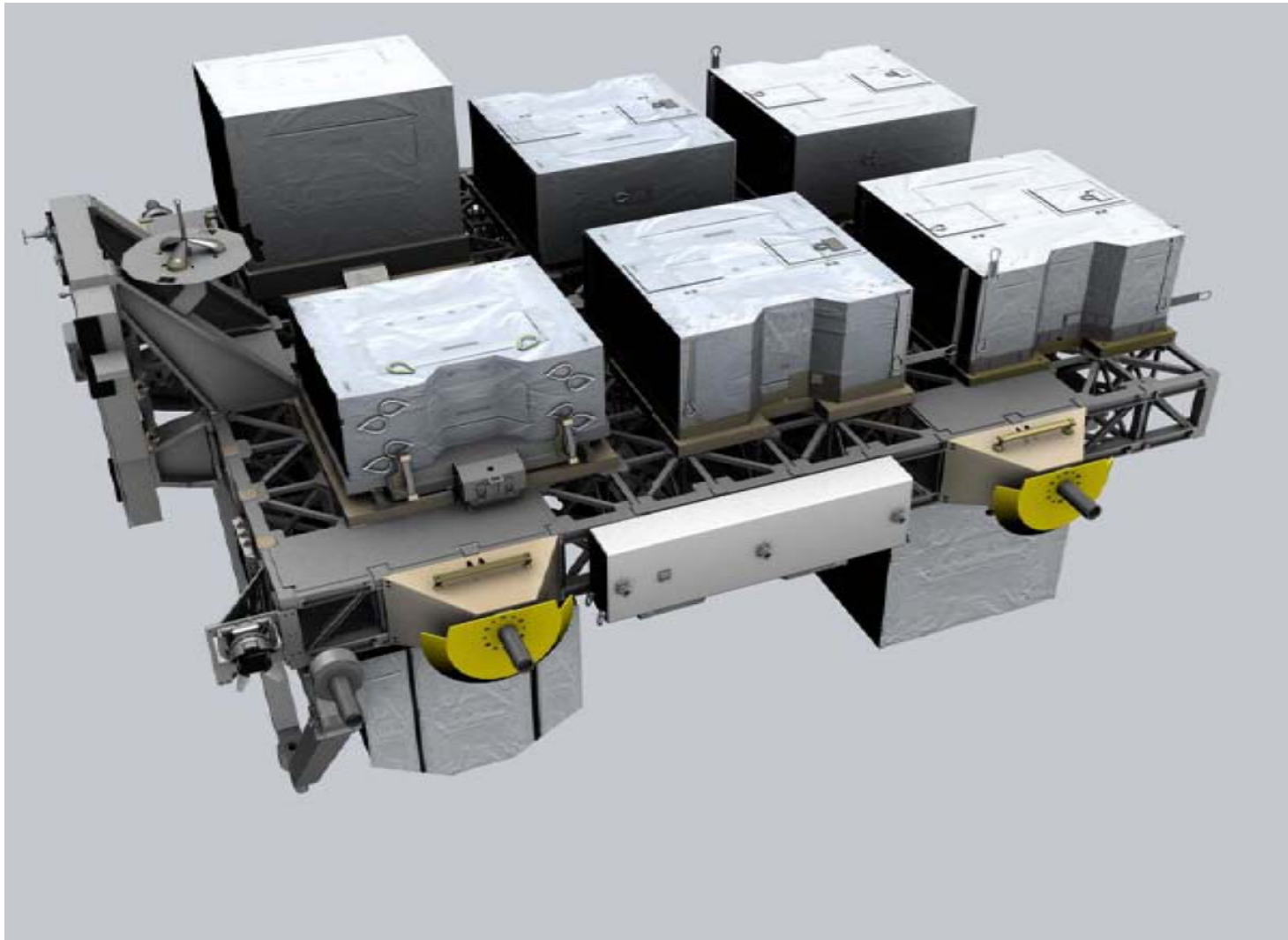



EXPRESS Logistics Carrier (ELC)

- ELC Overview
 - Launched in Shuttle Payload Bay (pre-integrated with payloads for initial delivery)
 - There are two Science Sites on each ELC to accommodate external payloads and 10 sites for Unpressurized ISS Logistics Storage
 - Each Science Site Employs an Express Payload Adapter (ExPA) to accommodate payloads
 - 28 VDC and 120 VDC power
 - 1553, Ethernet Data
 - Digital and Analog Discretes
 - Each Logistics site only provides 120V Heater power
 - The 2 Science sites can be located at any site on the ELC (prelaunch only)
 - Individual payloads can be removed and replaced on orbit via EVA or EVR using the same method that payloads are removed and replaced on the Columbus EPF



S3 Truss (Up to 4 ELCs)

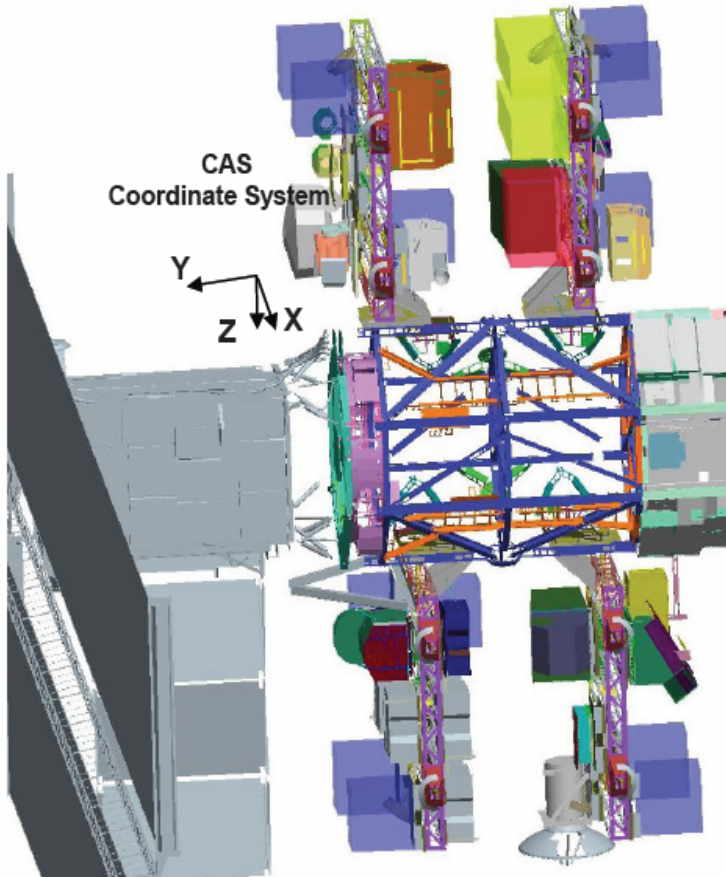

P3 Truss (Up to 2 ELCs)

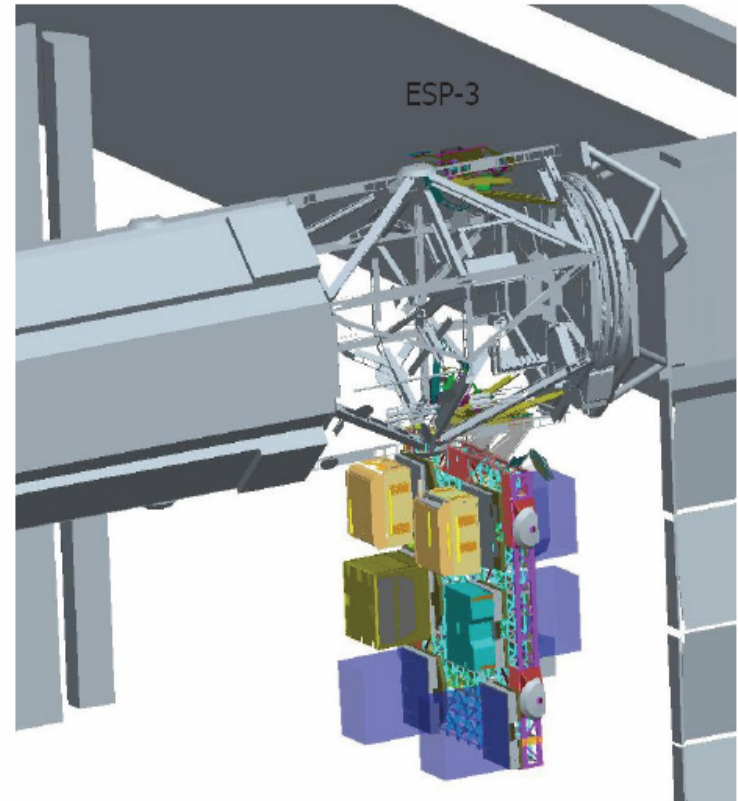

On-orbit Sites



Allowable ELC Payload Volume

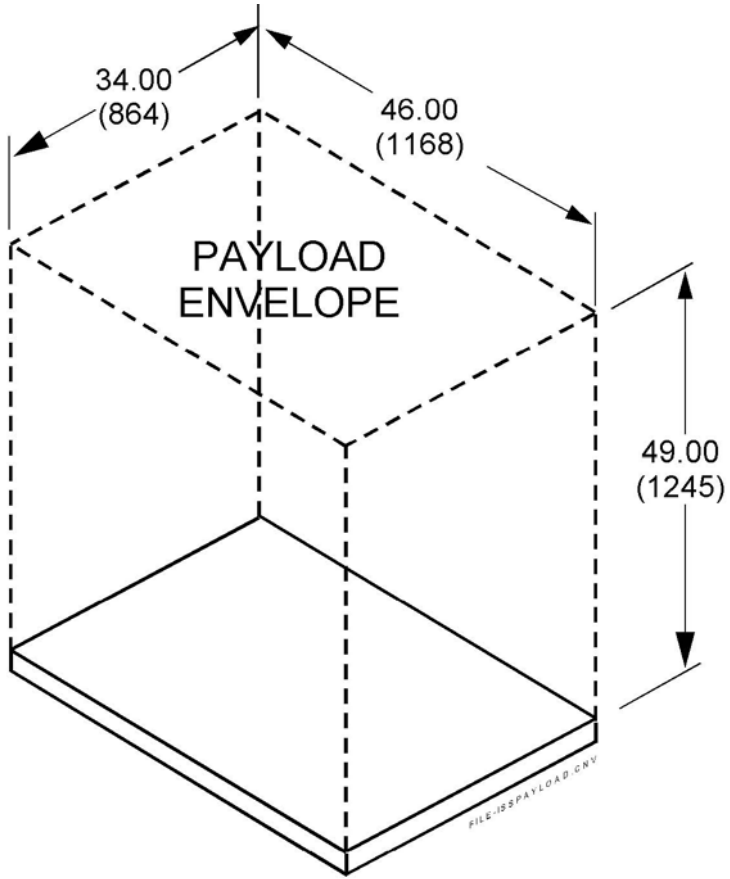



S3 Truss Viewing



Orbit Sunrise

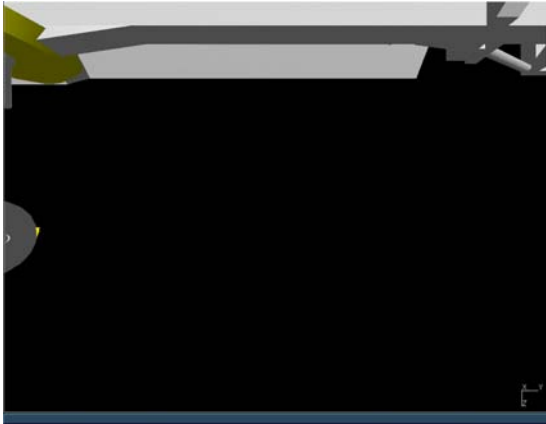

+X



+Z

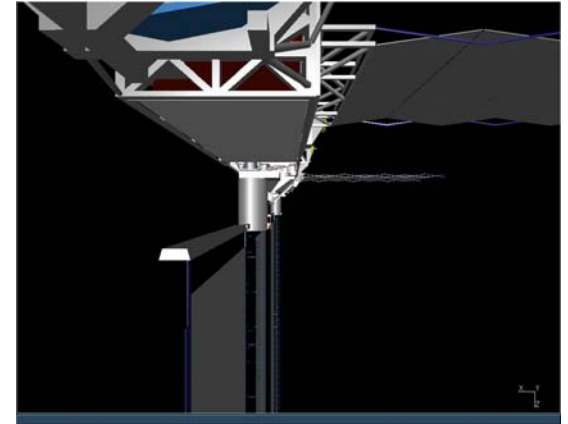

+Y

Orbit Noon

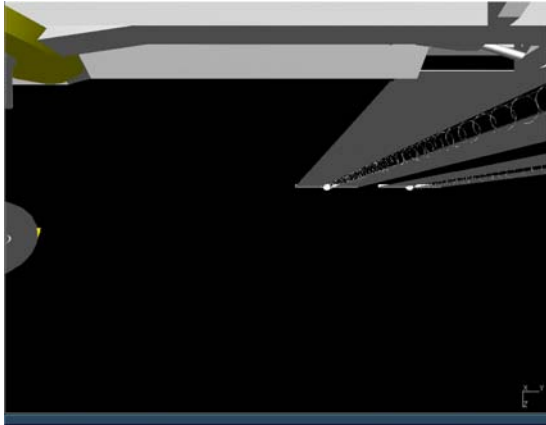

+X



+Z

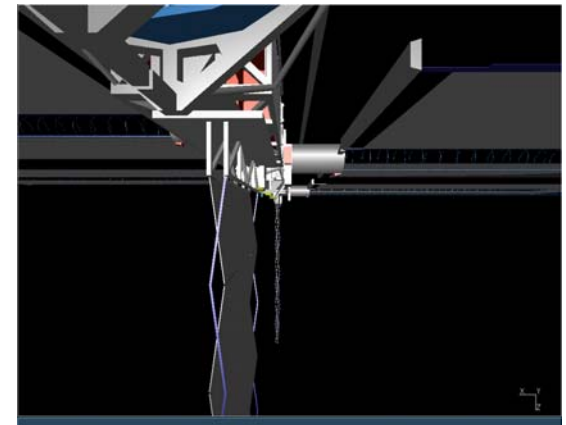

+Y



S3 Truss Viewing



Orbit Sunrise



-X

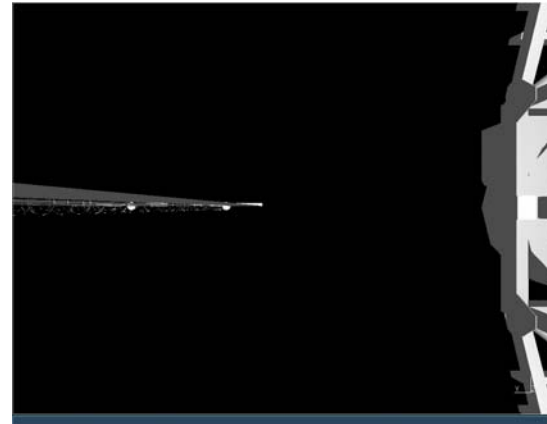

-Z

Orbit Noon

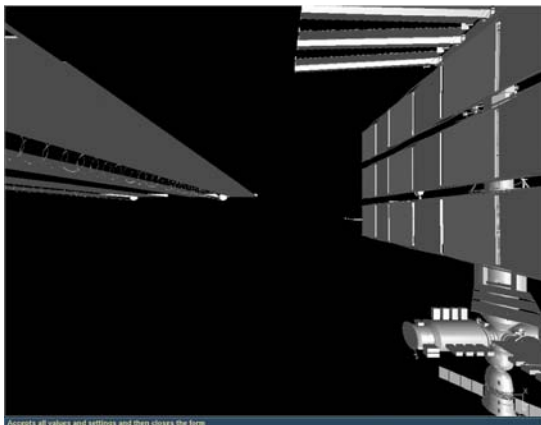

-X

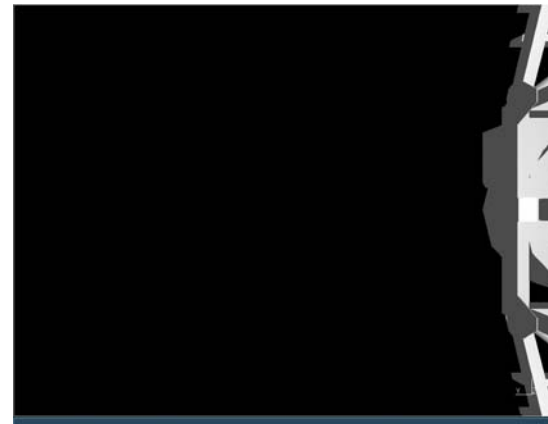

-Z



Kibo Exposed Facility Sites

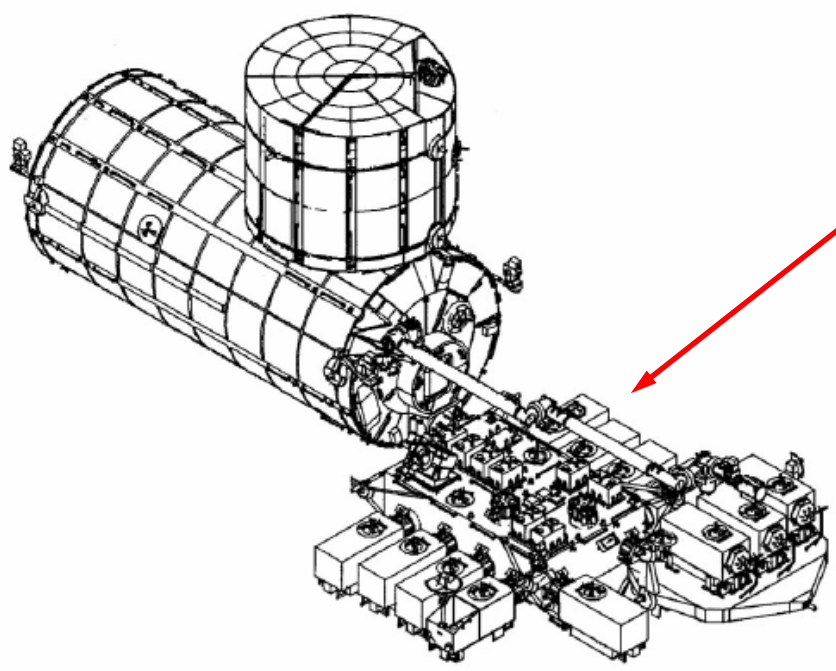

JEM - EF

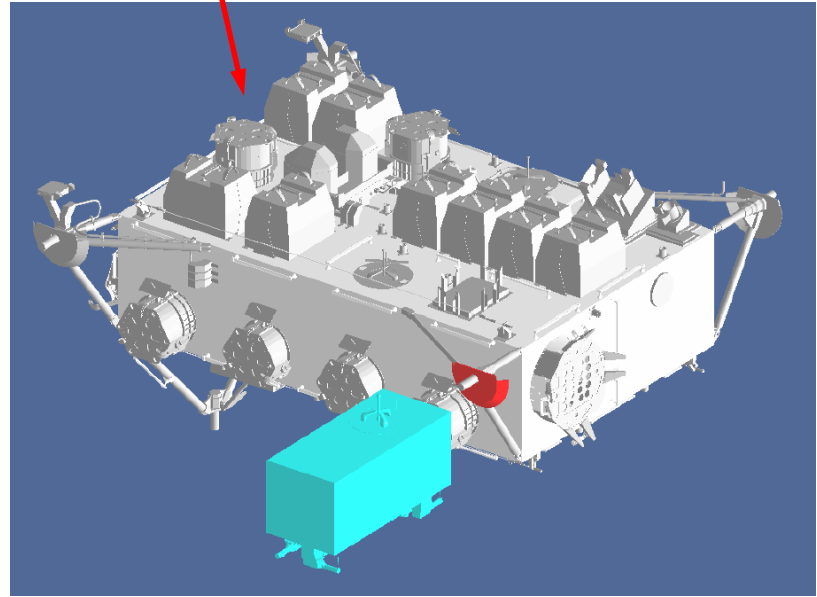



JEM-EF Carrier Attachments for Transport to the ISS



PAM-PU.....Payload Attach Mechanism - Payload Unit

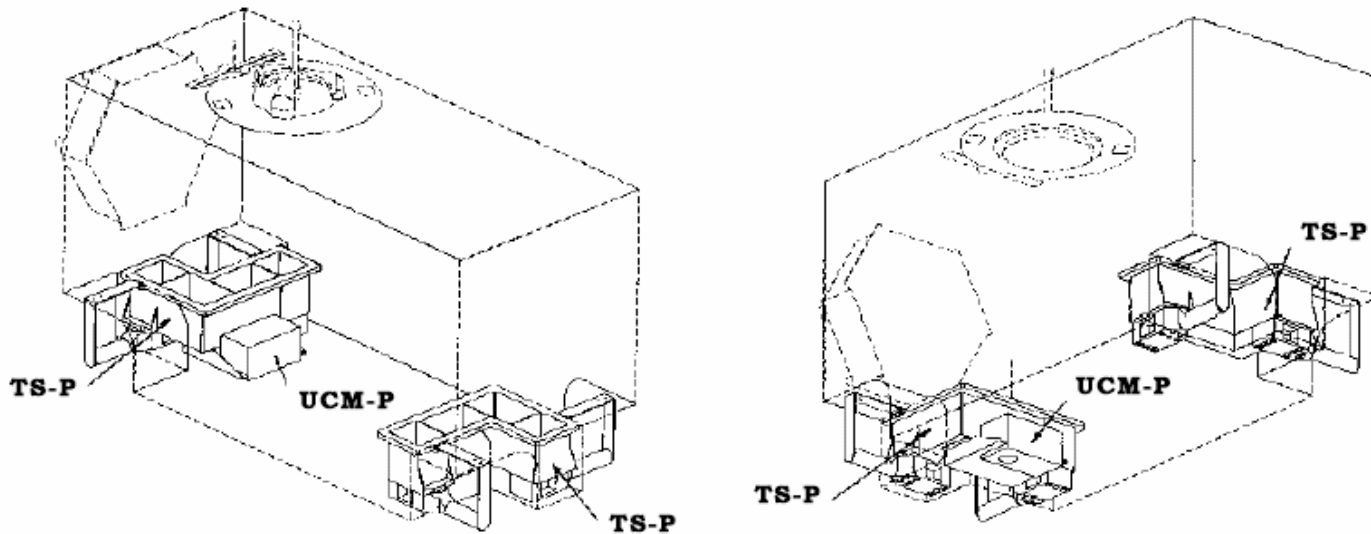

UCM-P (Umbilical Connect Mechanism-Payload Side)
TS-P (Trunnion Structure-Payload side)



Payload Interface Unit

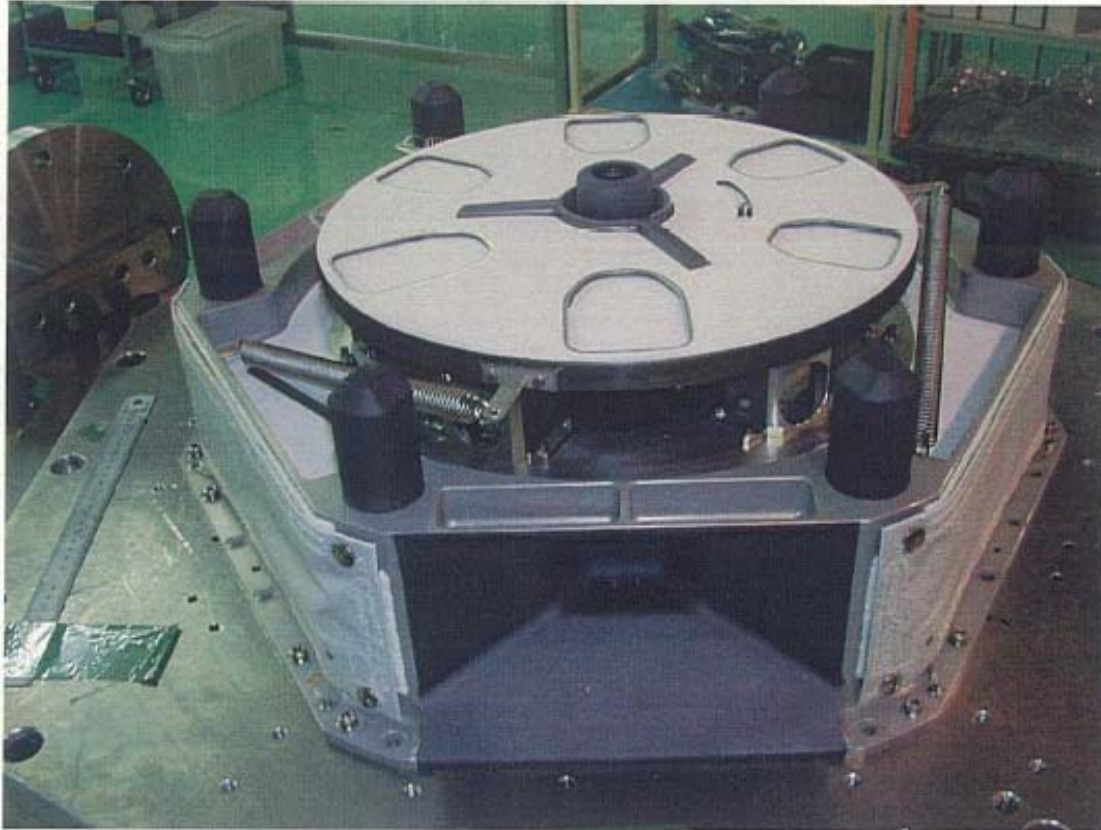

NASA Has 8 Payload Interface Units in Inventory for Payload Use



JEM-EF Viewing



Orbit Sunrise

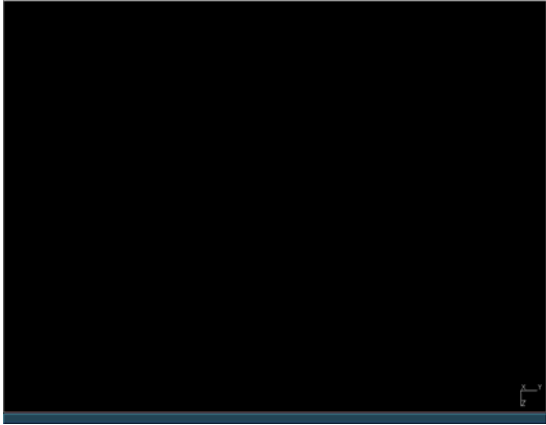

+X



+Z

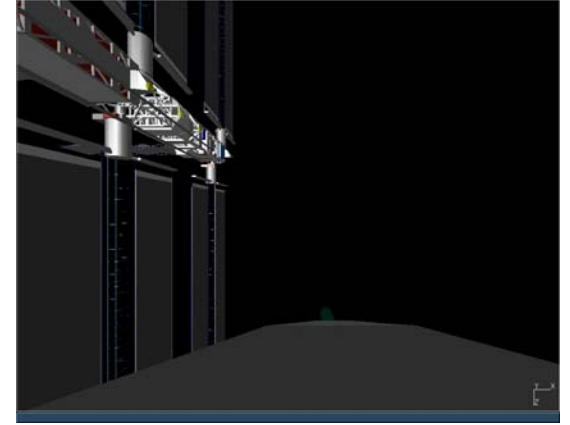

-Y

Orbit Noon

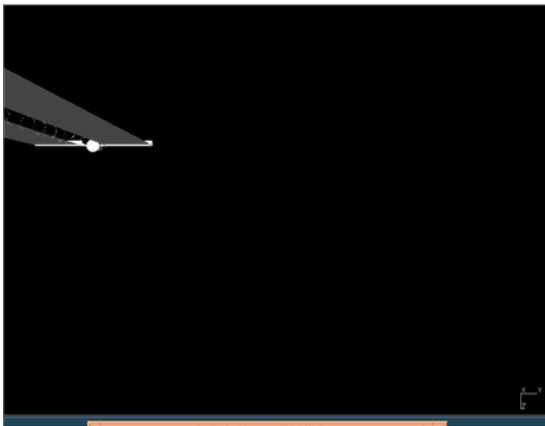

+X

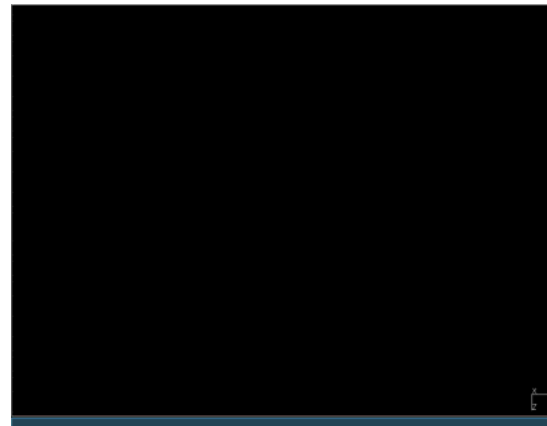

+Z

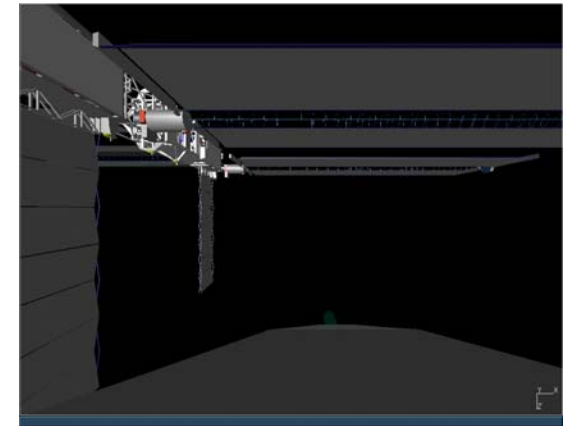

-Y



JEM-EF Viewing



Orbit Sunrise

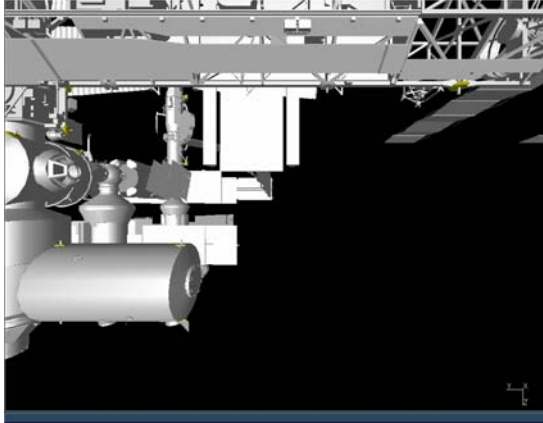

-X

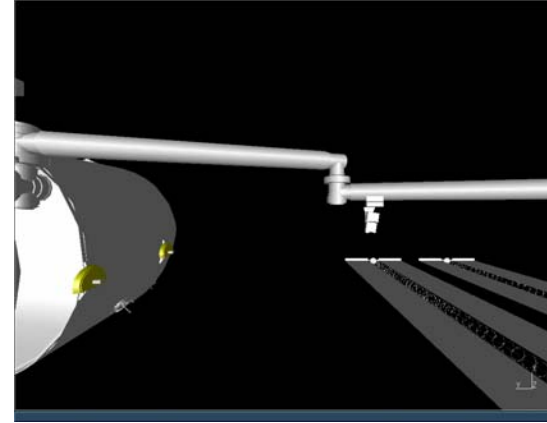

-Z

Orbit Noon

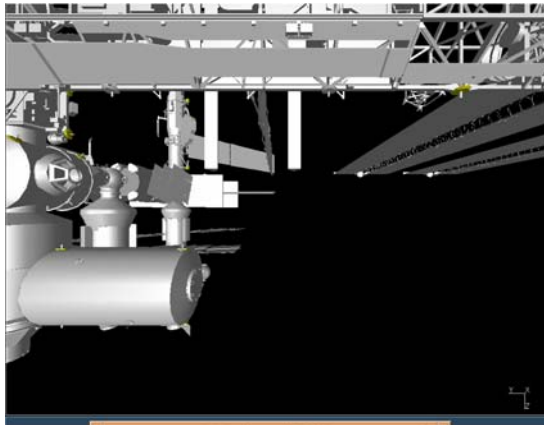

-X

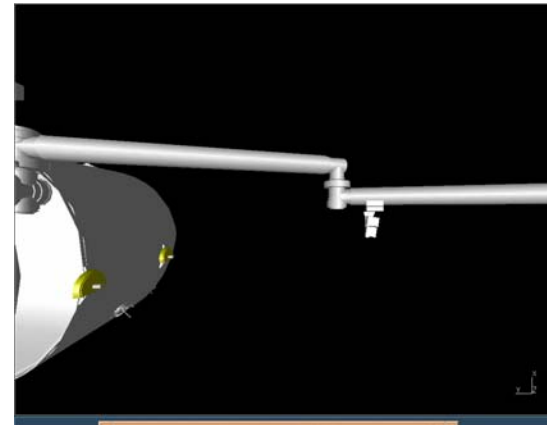

-Z



Power and Data Availability



ISS Location	Power	Voltage (Nominal VDC)	High Rate Data (Optical Fiber)	Medium Rate Data (Ethernet)	Low Rate (1553)	Active Cooling
Columbus	1.25kW	120VDC		X	X	
JEM-EF	3kW	120VDC	X	X	X	X
ELC	750W 500 W(28)	120VDC 28 VDC		X	X	



Thermal Environmental



TABLE 3.5.1.2-1 HOT AND COLD NATURAL THERMAL ENVIRONMENTS

Case	Solar Constant (W/m ²)	Earth Albedo	Earth Outgoing Long Wave Radiation (W/m ²)
Cold	1321	0.2	206
Hot	1423	0.4	286

TABLE 3.5.1.2-2 INDUCED THERMAL ENVIRONMENTS

Induced Environment	Assumed Parameters
Beta Angle	+/- 75°
Altitude	150 nmi. to 270 nmi.
Attitude Envelope Without Orbiter ⁽¹⁾	Any combination of +/-15° Roll (about X axis) ⁽²⁾ +/-15° Yaw (about Z axis) ⁽²⁾ +15 to -20° Pitch (about Y axis) ⁽²⁾
Attitude Envelope With Orbiter Docked to ISS ⁽¹⁾	Any combination of +/- 15° Roll +/- 15° Yaw 0 to 25° Pitch

Note(s):

¹ The attitude variations include variations in the Torque Equilibrium Attitude (TEA) as well as variations in the ISS attitude from the TEA attitude, both with Orbiter docked, and without Orbiter.

² XYZ axes refer to ISS coordinate system orientation.



Payload Testing



- Individual payloads are given a “Suitcase Simulator” to perform development testing on their Payload
- ELC payloads are Tested using a ELC simulator
 - ELC Payloads launched on the ELC are tested using the flight ELC and simulators of the ISS
- Columbus Payloads are tested via the Suitcase Simulator or the Rack Level Test Facility in Bremen Germany
- JEM-EF Payloads are tested via the Suitcase Simulator or at the JAXA launch facility in Tanegashima Japan



ELC Rotation Stand (KSC)

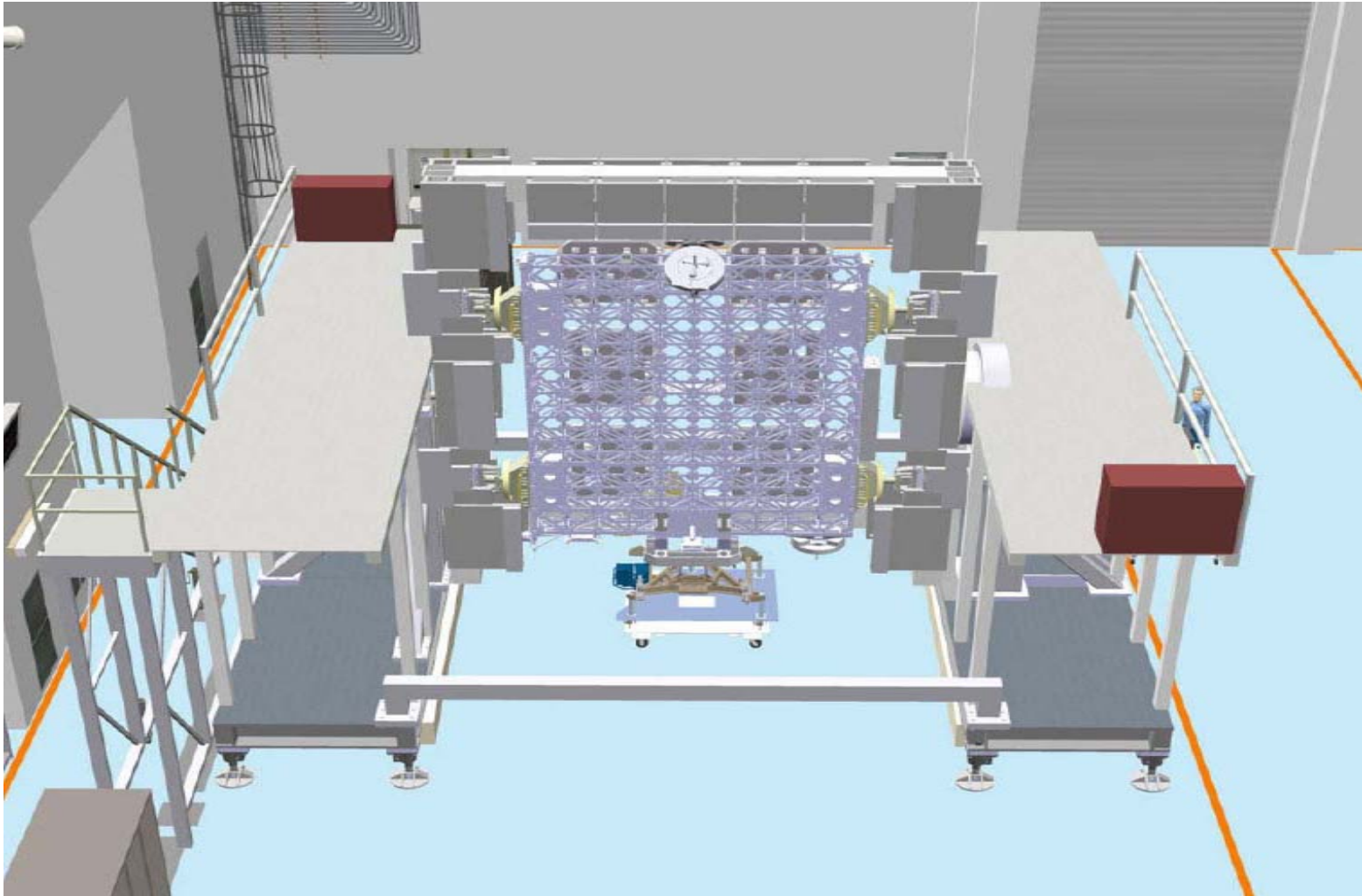



RLTF Testing of The SOLAR Payload

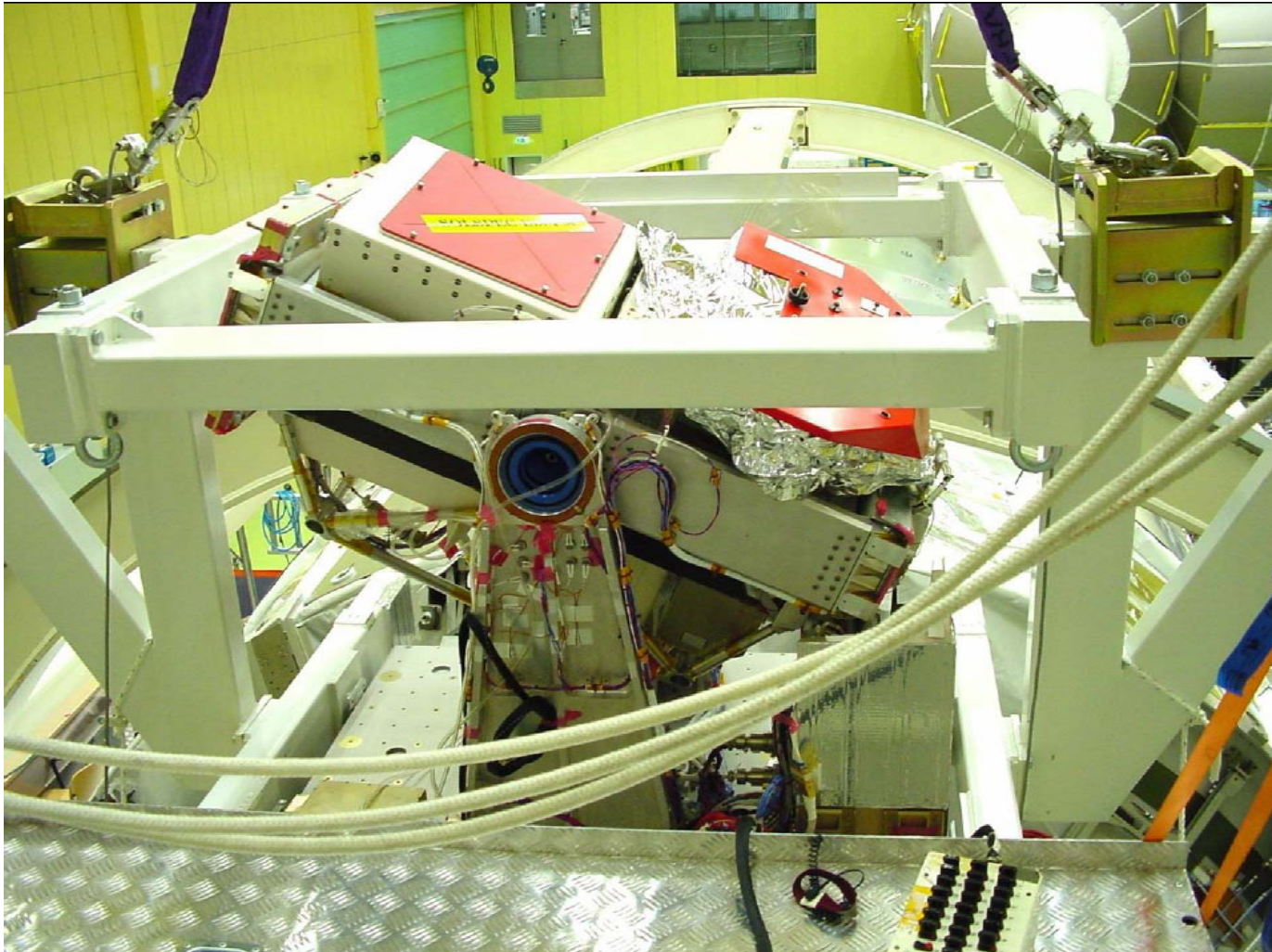



- Columbus Documentation
 - COL-RIBRE-SPE-0165

- ELC Documentation
 - SSP 57003-ELC Attached Payload IRD-ELC Cargo Interface Requirements

- JEM-EF Payloads
 - JEM JPAH Vol 3 JEM Payload Accommodations Handbook Exposed Facility Payload Standard Interface Control Document
 - JEM JPAY Vol 4 JEM RMS/Payload Standard Interface Control Document

Window Observational Research Facility (WORF)

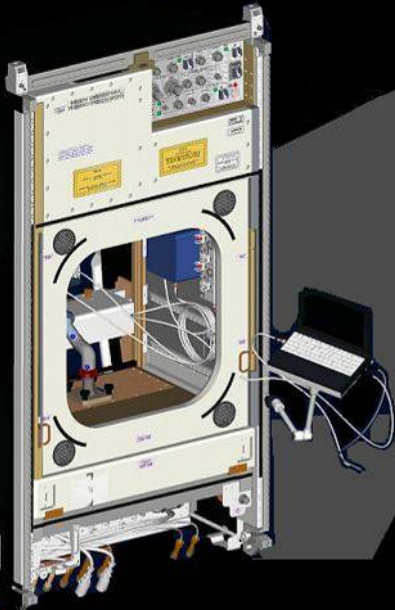
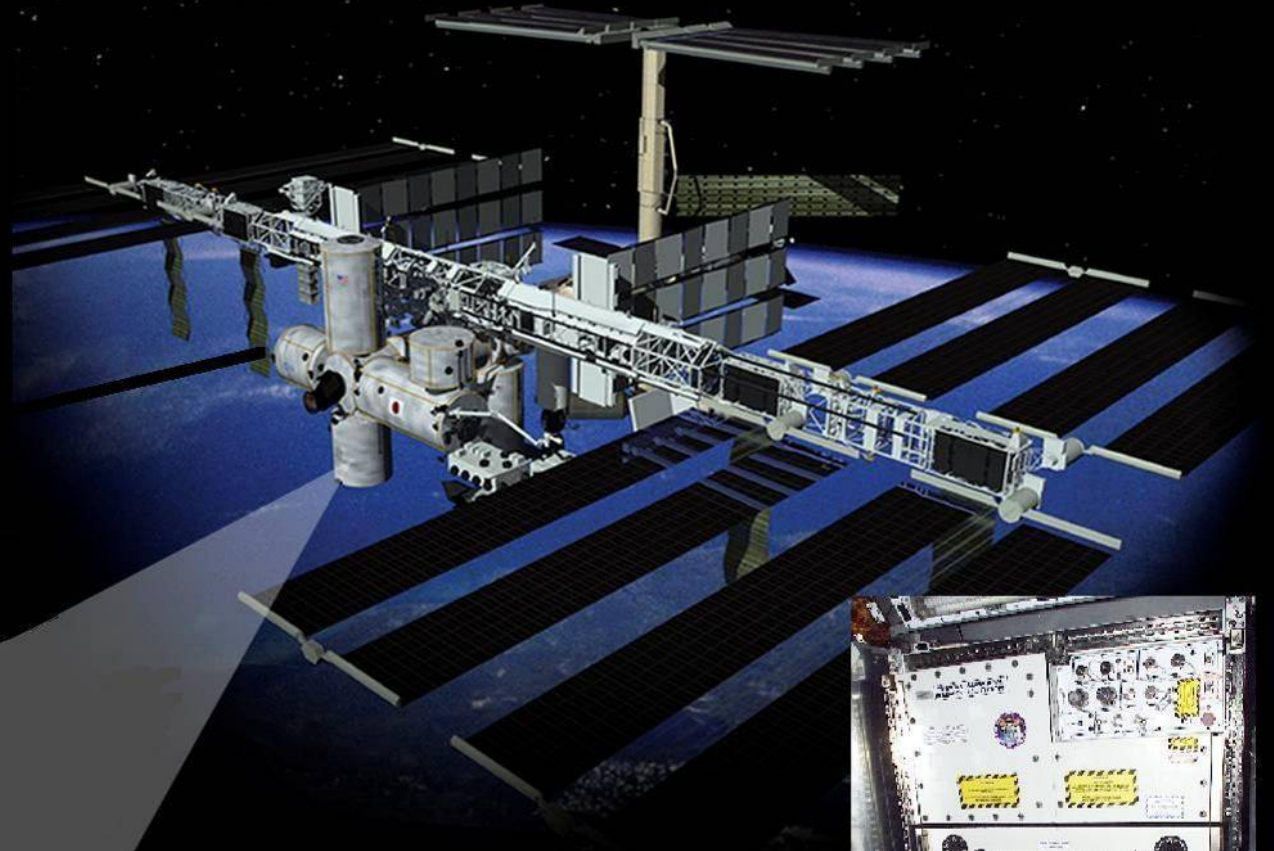

Joseph Pelfrey
NASA-MSFC/VP35
256-961-1857

Joseph.j.pelfrey@nasa.gov



WORF Objectives/Description

Project Objectives

- The **Window Observational Research Facility (WORF)** Rack is a unique facility designed for use with the US Lab Destiny Module window.
- WORF will provide valuable resources for Earth Science payloads along with serving the purpose of protecting the lab window. The facility can be used for remote sensing instrumentation test and validation in a shirt sleeve environment. WORF will also provide a training platform for crewmembers to do orbital observations of other planetary bodies. WORF payloads will be able to conduct terrestrial studies utilizing the data collected from utilizing WORF and the lab window.



Description

- Originally manifested and loaded for ULF1 Flight (impacted by Columbia accident)– **Now planned for ISS Flight 19A (2009). Rack Hardware is at KSC “ready for flight”**
- Rack Facility using standard ISPR and EXPRESS heritage hardware
- Provides Power and Data interfaces for up to 5 payloads
- Provides avionics air cooling for instruments and crew comfort; Moderate Temperature Loop Water cooling for avionics
- Provides stable mounting platform and “darkroom” environment for payload instruments



WORF Overview

- Developed as an EXPRESS Rack derivative for simplified design process and utilization of common avionics
- 1 flight rack (KSC), 1 ground rack (JSC)
- Two Small Camera Brackets provided for payload use

International Standard Payload Rack

Secondary Structure & Subsystems

~22.6cu.ft Payload Volume

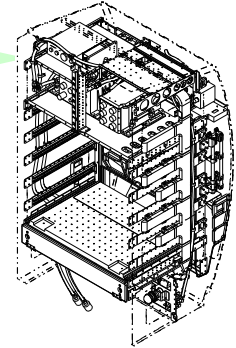

Interfaces

- Seat Track locations in payload volume
- Payload Support Shelf -161 threaded inserts for payload mounting
- QD (Water)
- Power & Data Connectors
- SCSI, Data, Video Pass-through connectors
- Cables & Hoses Available

Resources

- 28Vdc Power (20 amp) – 5 locations
- Data (1553, Ethernet, Video) - 5 locations
- Moderate Temp Loop Cooling – 2 locations
- Avionics Air Cooling – Payload Volume
- SCSI, Data, Video Pass-through connectors
- Payload Support Computer

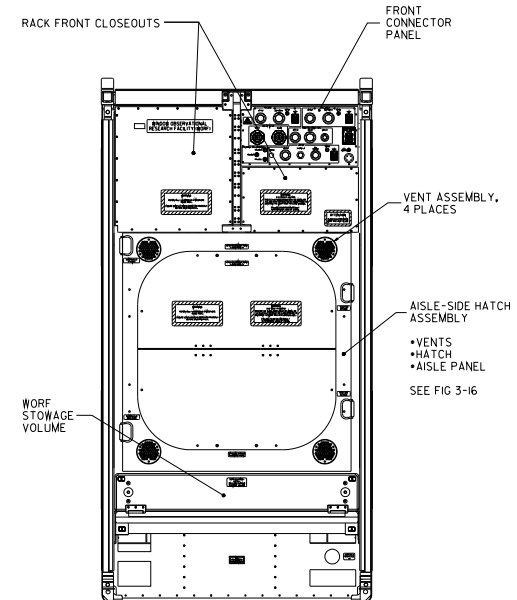



WORF Front View

RACK FRONT CLOSEOUTS

FRONT CONNECTOR PANEL

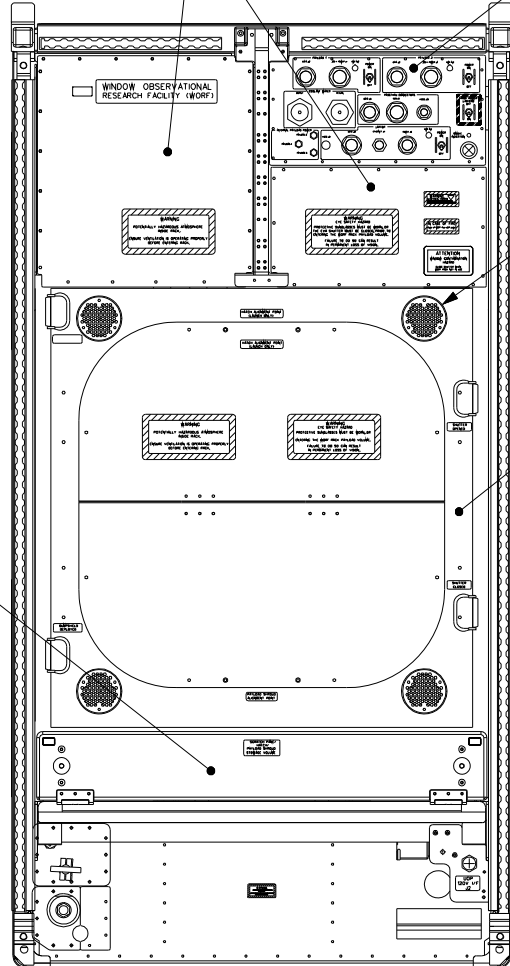

VENT ASSEMBLY, 4 PLACES

AISLE-SIDE HATCH ASSEMBLY
*VENTS
*HATCH
*AISLE PANEL
SEE FIG 3-16

WOLF STORAGE VOLUME

The WORF Rack front face consists of the following:

1. Front connector panel
2. Aisle side hatch
3. Hatch vent assemblies
4. Shutter Actuator Handle
5. Bump Shield Handle
6. Stowage Volume
7. Utility Outlet Panel (UOP) connection



WORF Hardware Exploded View

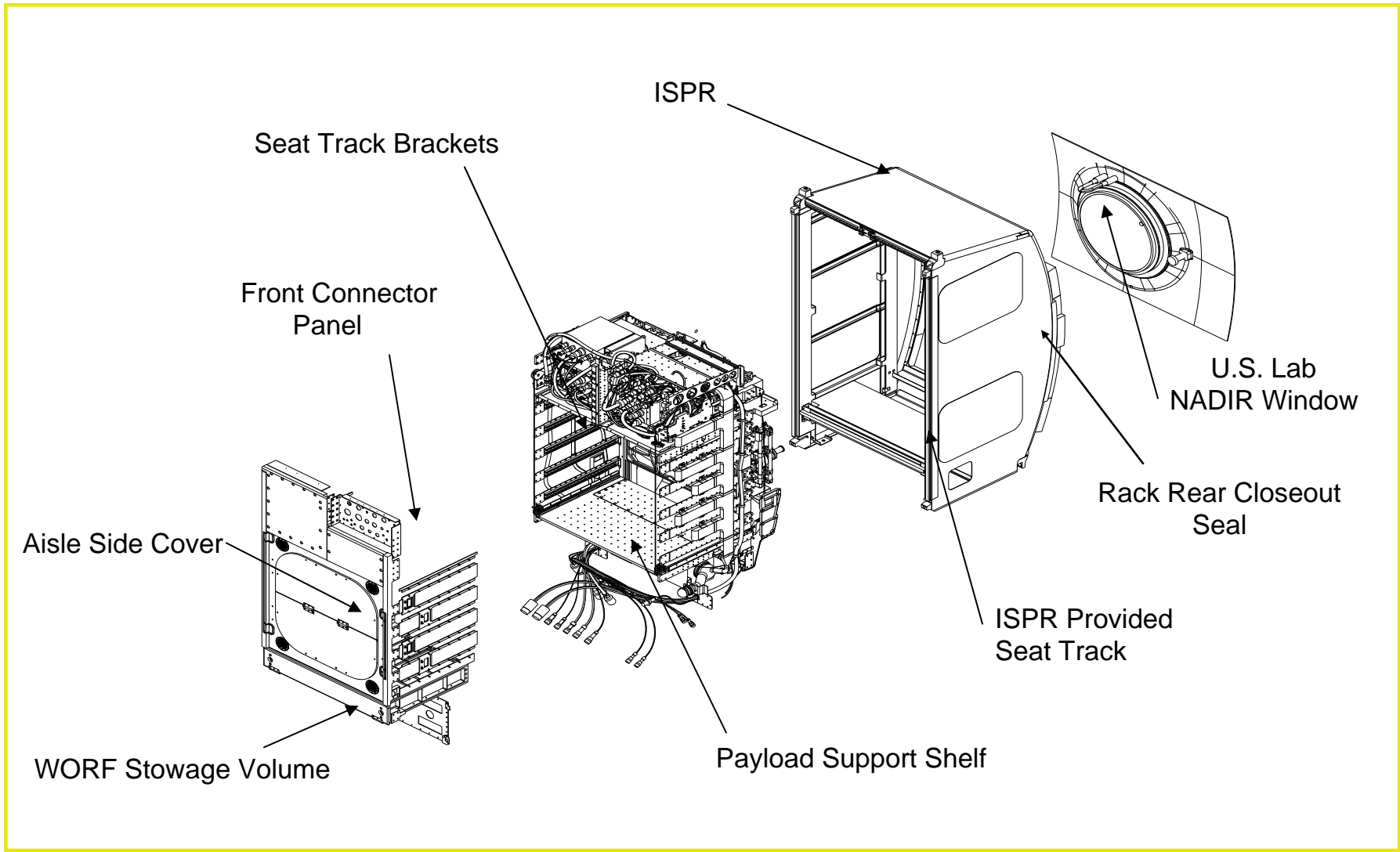



WORF Subsystems

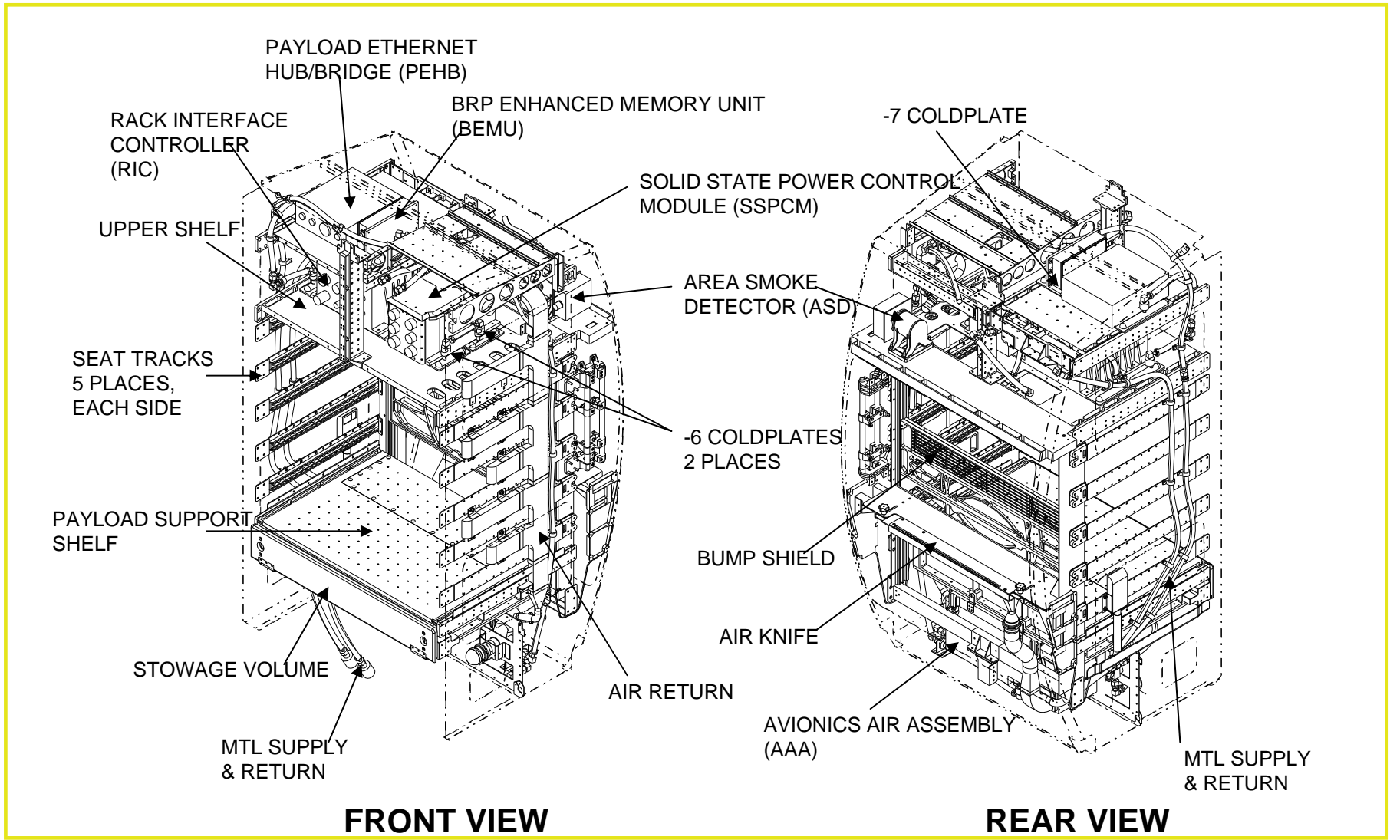



WORF Aisle Hatch

- The WORF Aisle Hatch prevents unwanted light from entering the WORF Rack volume.
- Prevents loose items and debris from entering rack volume.
- Prevents installed payloads from being disturbed by passing crew members.
- Can be installed/removed very quickly without the use of tools. Designed to be stowed (folded) in the rack stowage drawer.

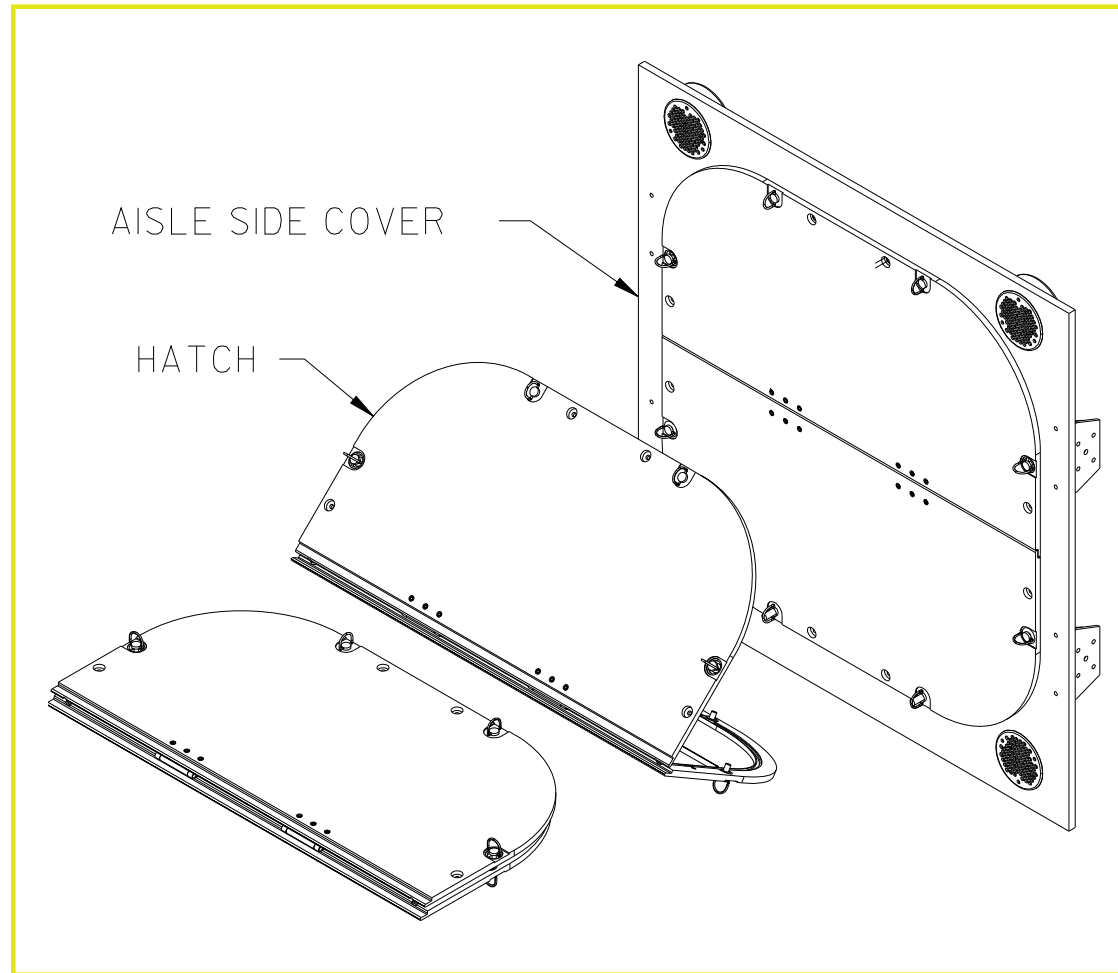



WORF Bump Shield

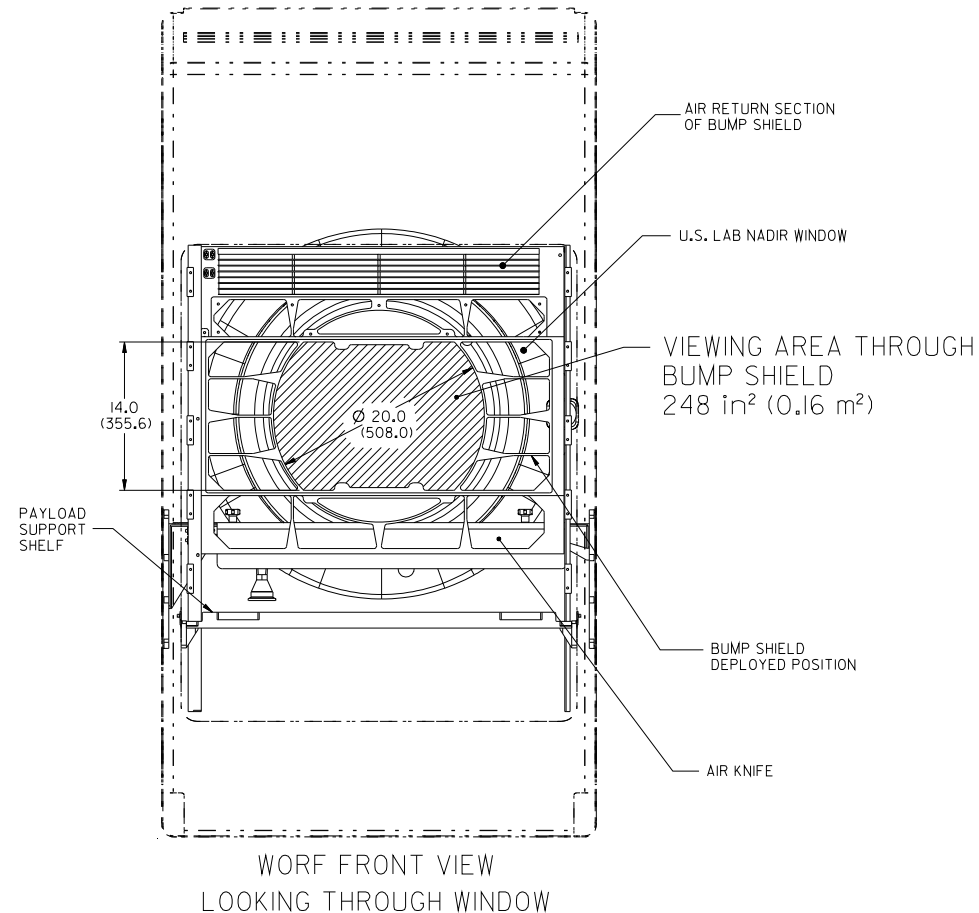
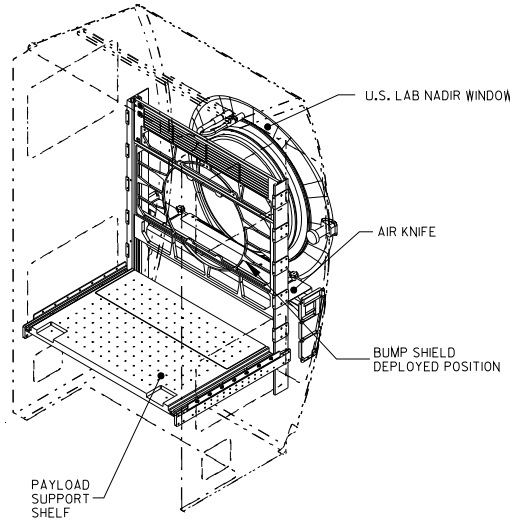

- ❑ The Bump Shield provides protection to the US Lab window when crewmembers are working inside the payload volume
- ❑ It consists of three rectangular sections 9 inches, 14 inches, and 6 inches high, respectively
- ❑ Provides optical quality sufficient for low fidelity photographic operations.
- ❑ The bump shield can be retracted for higher quality imagery
- ❑ Made of Tuffak CM-2 (a transparent polycarbonate)



WORF Payload Volume

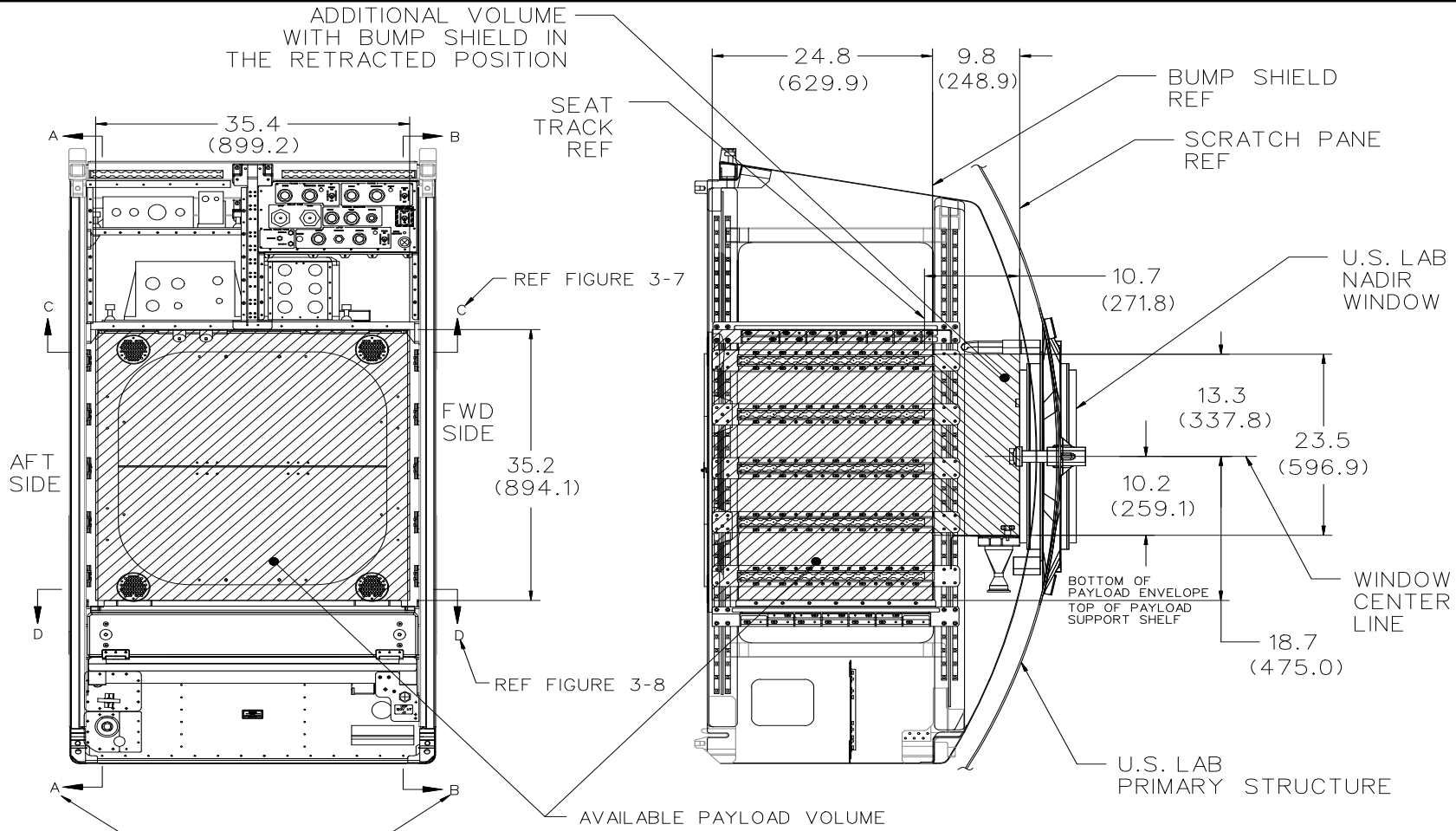

RACK FRONT VIEW

RACK SIDE VIEW
(RACK PACKAGING OMITTED FOR CLARITY)

DIMENSIONS		INCHES (mm)
DECIMAL	X.X	= REFERENCE DIMENSIONS





WORF Internal Seat Track Locations

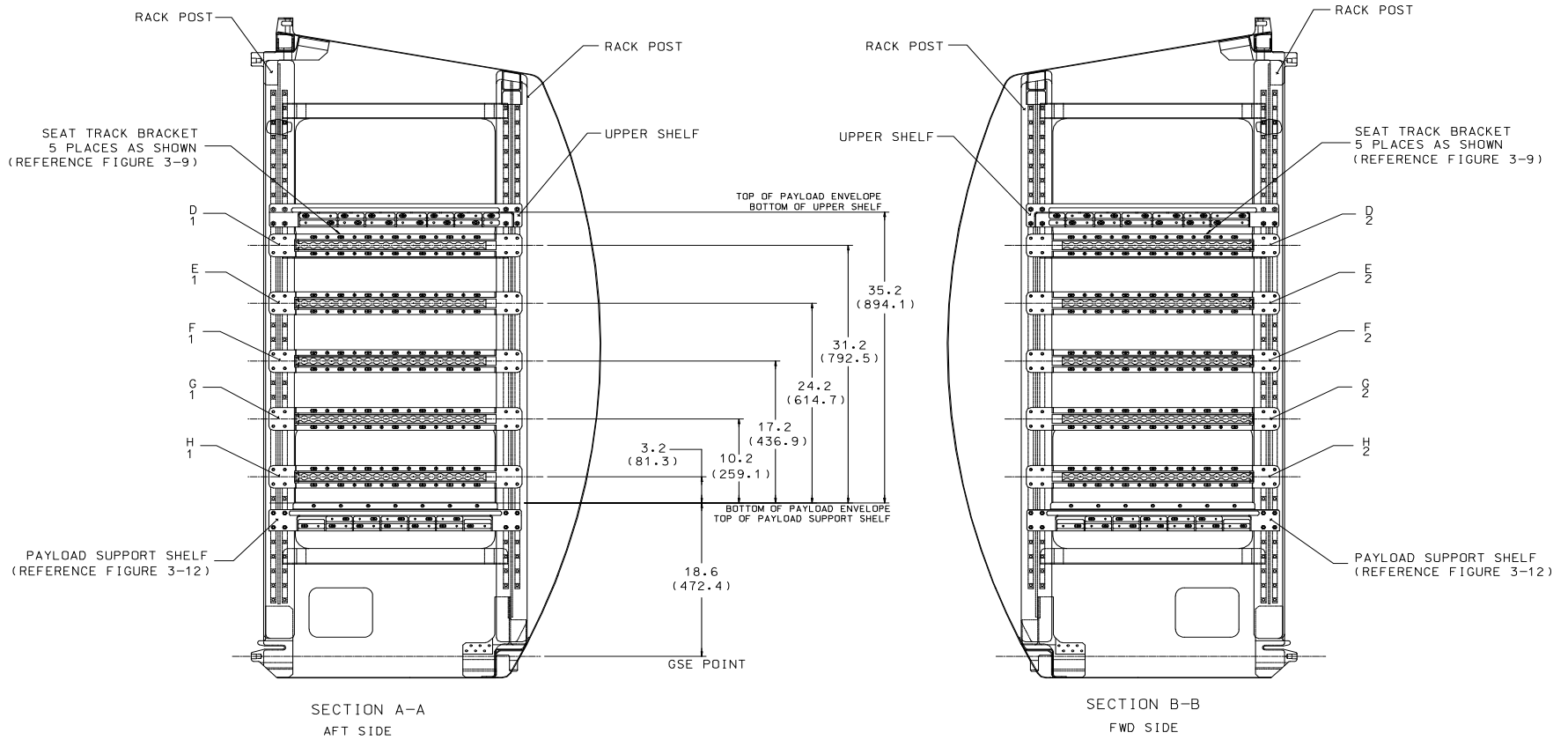

The moment produced on the seat track by payload hardware shall be less than 750 in-lbs.

SEAT TRACK LOCATION NOMENCLATURE	
D2	D1
E2	E1
F2	F1
G2	G1
H2	H1

DIMENSIONS	INCHES (mm)
DECIMAL	X.X = REFERENCE DIMENSIONS

- NOTES:
 1. RACK PACKAGING OMITTED FOR CLARITY.
 2. DIMENSIONS SHOWN THROUGH CENTER LINE OF SEAT TRACK BRACKETS.



WORF Payload Support Shelf

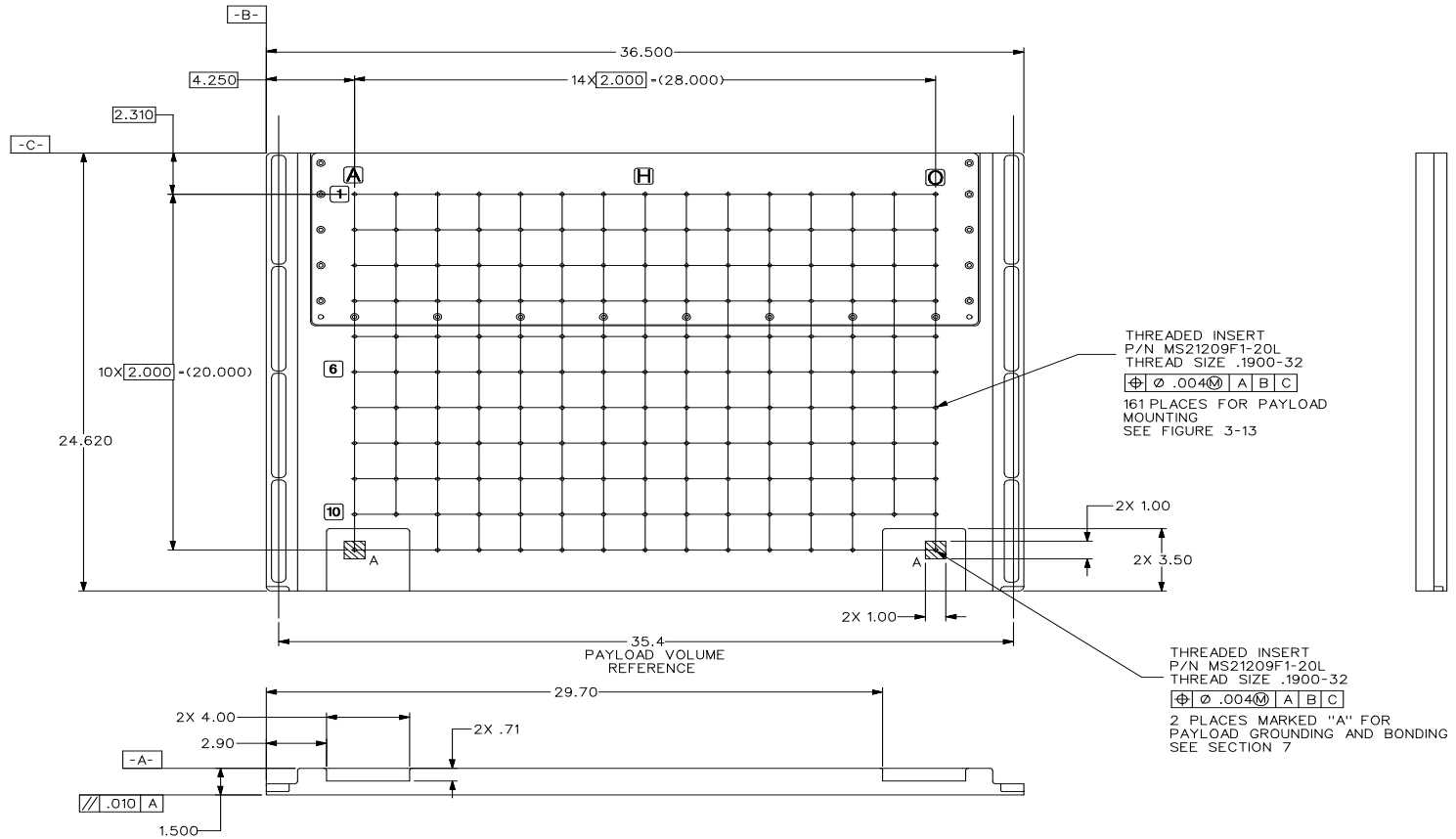

NOTES:

1. DIMENSIONING & TOLERANCING PER ANSI Y14.5M-1982.
2. MATERIAL: 7075 ALUMINUM PLATE
3. FINISH: LUSTERLESS BLACK PAINT OVER NICKEL PLATING

DIMENSIONS	INCHES
DECIMAL	X.X - REFERENCE DIMENSIONS
	X.XX - +/- 0.03 inches
	X.XXX - +/- 0.010 inches

 NICKEL PLATED SURFACE ONLY-NO PAINT



WORF Payload Support Shelf Interface

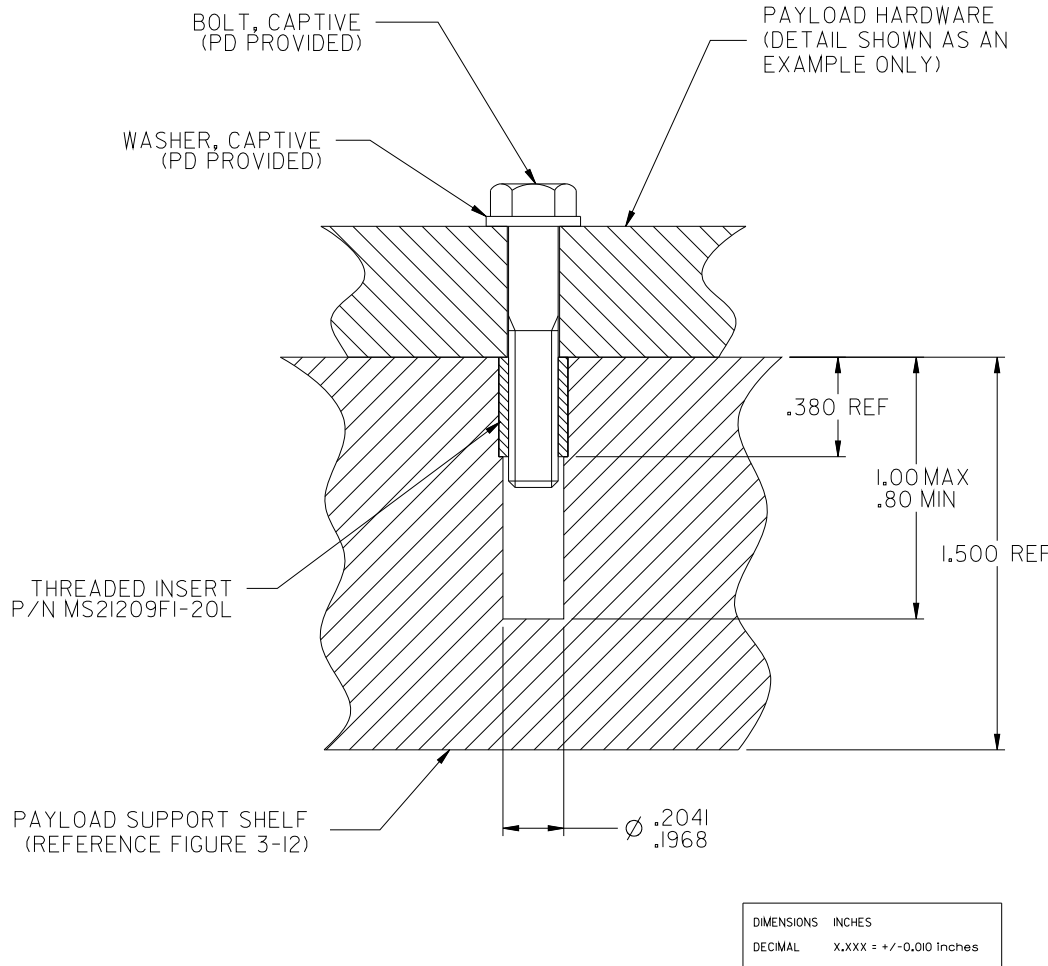

- The payload shall use the following fastener to attach to the payload support shelf: thread size: 0.19-32 (#10-32).
- The payload shall prevent fastener seizing through dry film lubrication, silver plating, or application of approved anti-seize compound.
- Payload fasteners shall be held captive to the payload side of the interface.
- Payload fasteners shall be self-retracting (i.e., spring loaded) and at least flush with the payload mounting flange.
- Payload alignment guides are recommended. Payload alignment guides shall be non-metallic, self-retracting, and not pose a damage hazard to the surface of the payload support shelf.
- Maximum payload mass on lower shelf is 299 lb/136kg.



WORF Small Camera Bracket

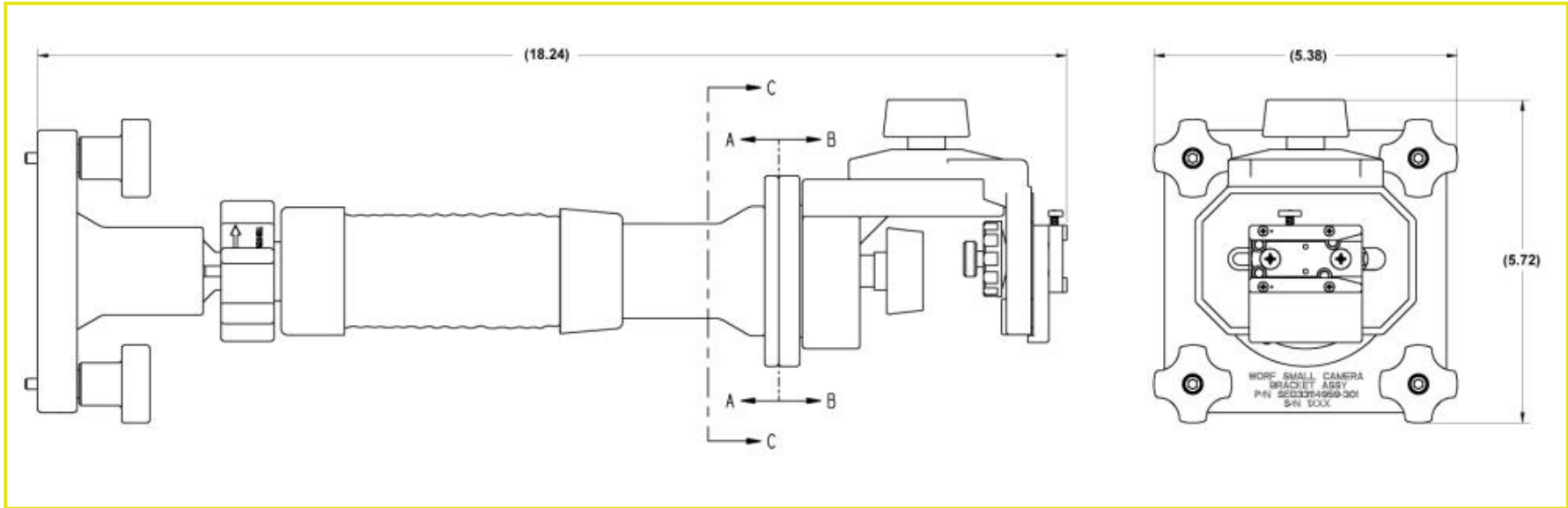

- Mounts to Payload Shelf with four base plate knobs
- Supports multiple size cameras or imagers
- Interface to standard camera shoe or 1/4-20 fastener
- Adjustable in any axis
- Shaft is adjustable by loosening the ball stack.
- Camera mount is adjustable in pan and tilt by loosening retaining screws.
- Maximum payload mass of 22lbs/10 kg allowable
- Two Small Camera Brackets are manifested with WORF.





WORF Front Connector Panel

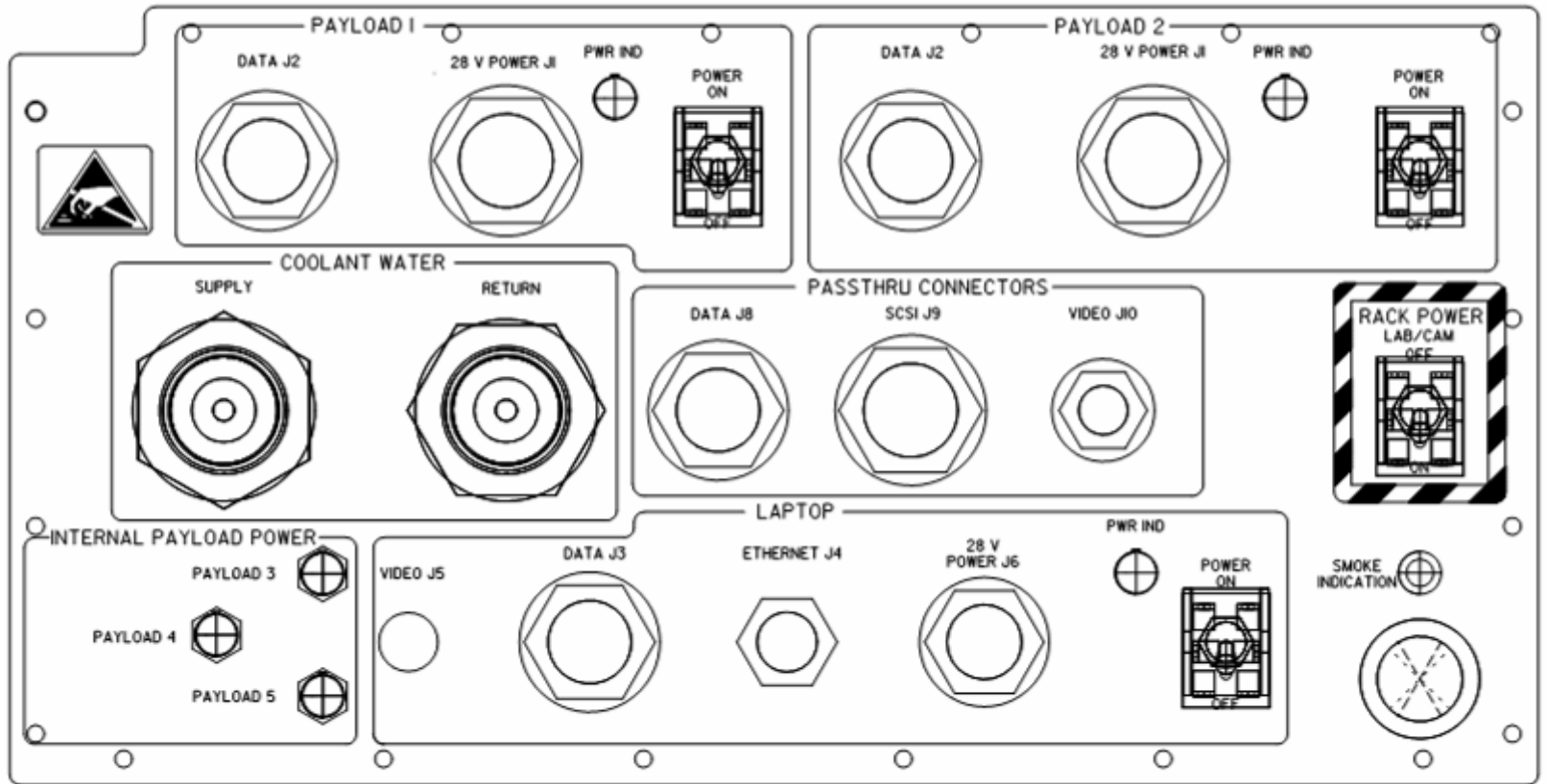

2 Payload Connections (Data, Power)

1 MTL Connection

Pass thru Connectors (Data, SCSI, Video)

Smoke Indicator LED

WORF Laptop Connections

Internal Payload Power Indicators

Rack Maintenance Switch

PFE Port



WORF Internal Connector Panels

NOTES:
1. MATERIAL: .090 THICK, 7075 ALUMINUM SHEET
2. FINISH: LUSTERLESS BLACK PAINT OVER CHEMICAL CONVERSION COAT

DIMENSIONS IN INCHES
DECIMAL X.X = REFERENCE DIMENSIONS

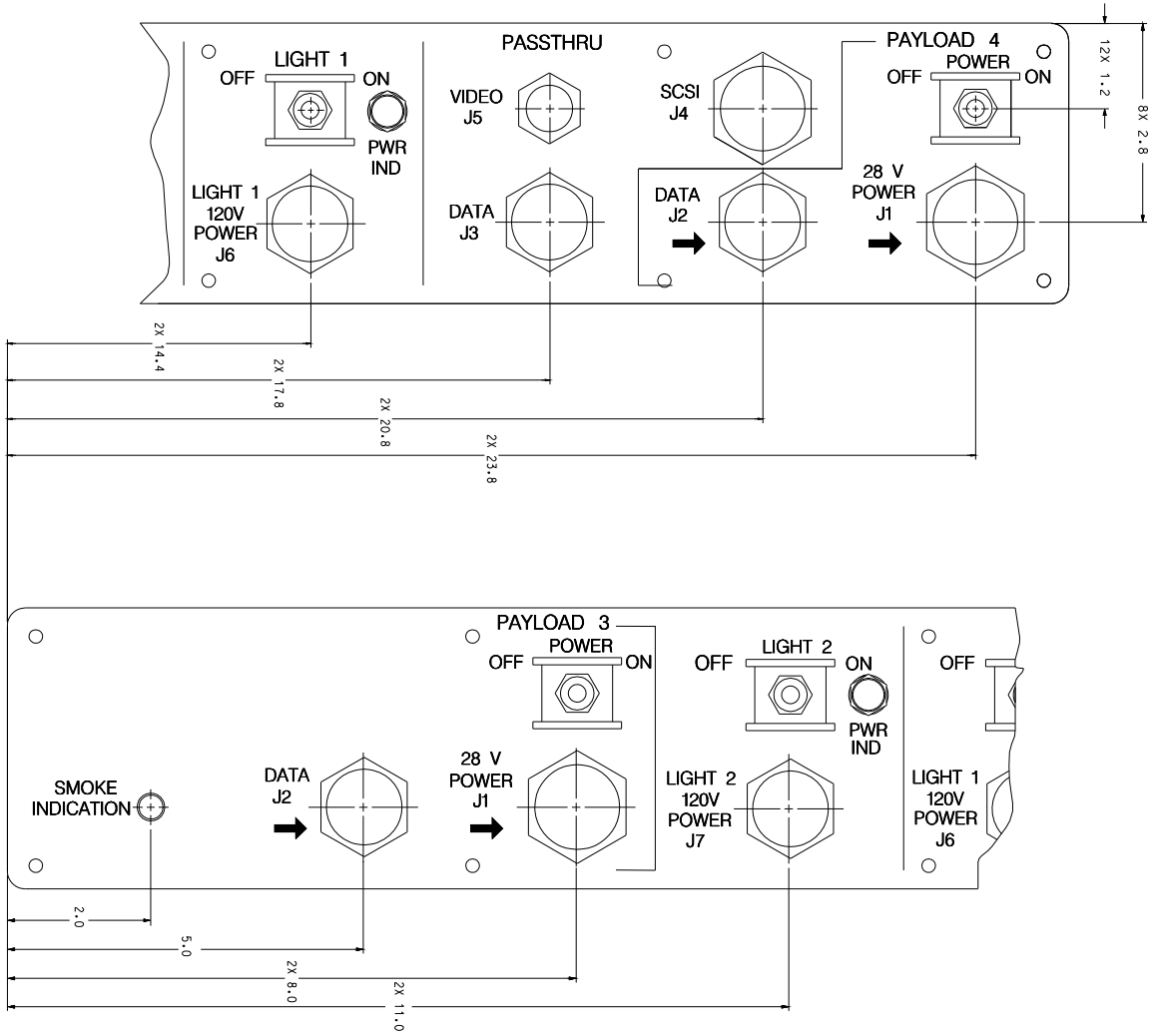

The main camera connector panel:

1. Two Payload connections (power, data)
2. Portable Light connections (120v)
3. Pass thru connections
4. Smoke indicator LED



WORF Internal Connector Panels

*View of upper shelf in
payload volume*

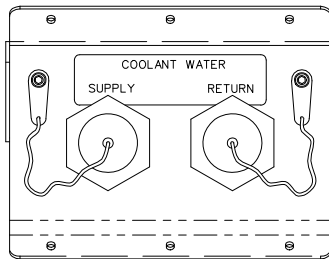
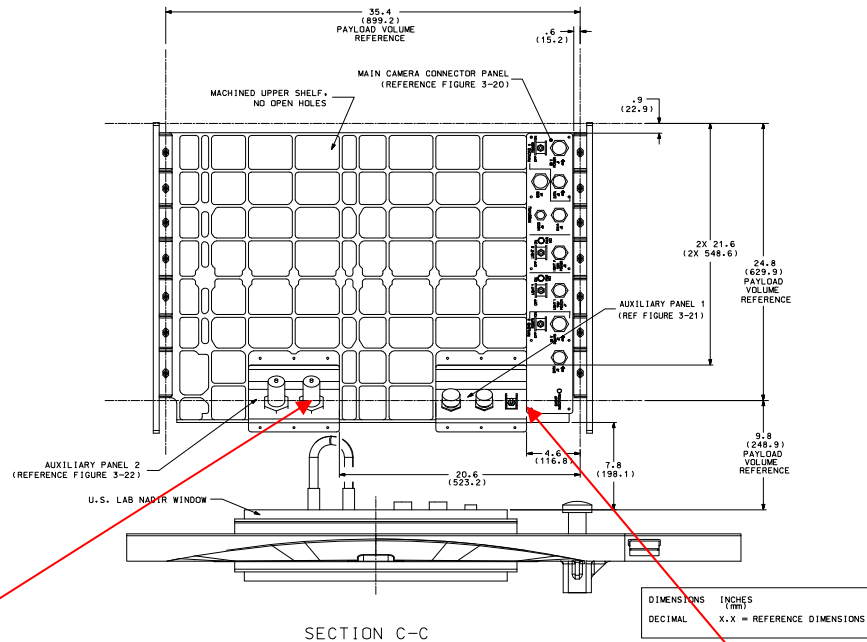

The auxiliary connector panels:

1. 1 Payload connection (power, data)
2. MTL Cooling (to support 1 payload)

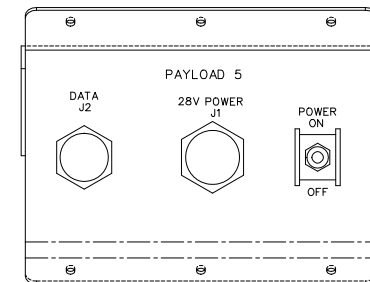



WORF Soft goods

- ❑ WORF Payload Shroud available for hand-held imagery
 - Kayak skirt that seals out ambient light with a crewmember in the rack
- ❑ WORF stowage bags available to be use in payload volume
 - Stow payload hardware; lenses, film, etc
- ❑ WORF Light Curtain is installed on front face to provide more light blockage



WORF Light Curtain

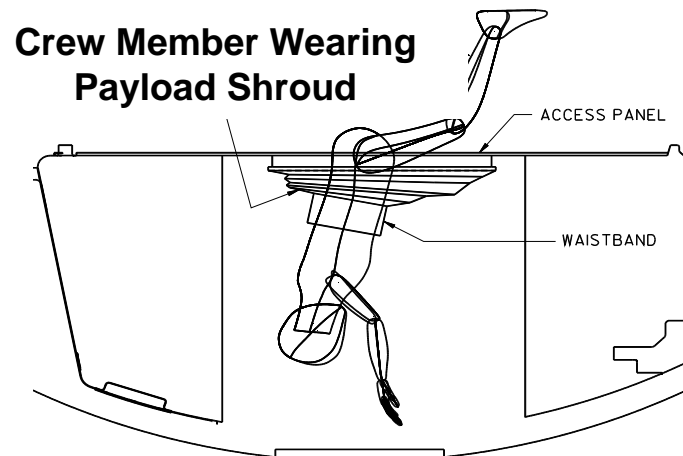

Payload Shroud Installed



WORF Resources

Power

- Solid State Power Controller Module (SSPCM) converts station power for payload use
- 28Vdc Power (+1.5, -2.5 Vdc) provided to payloads
- Current limiting available at 5, 10, 15, 20 amp settings
- 1900 W possible but total is restricted by thermal constraints and overall vehicle capability
- 120 Vdc interface in rack not for nominal payload use (can be negotiated)

Thermal

- Avionics Air Assembly (AAA) ducted cooling (50 cfm) provides 336 W heat rejection from the payload volume. An air knife provides air flow across the window to prevent condensation
- Moderate Temp Loop (MTL) water cooling (40 lbm/hr) is available for 500 W heat rejection using the connections either on the rack front or internal connector panels.
- Passive heat rejection to the cabin air is limited and allocated based on actual payload compliment.
- Smoke detection available for air-cooled payloads

Data

- Each data connector includes pins for 1553, RS-422, Ethernet, NTSC RS-170A Video
- 5 Vdc bi-directional differential discrete
- +/- 5Vdc differential analog
- Pass-through connectors include SCSI-2, S-Video, Ethernet, RS-232, RS-422
- WORF Laptop Computer available for payload-specific software and/or crew interfaces
- Parameter monitoring available for water-cooled payloads

Not Available: Vacuum Resource, Vacuum Exhaust, Nitrogen, Low Temperature Loop



WORF Internal Systems

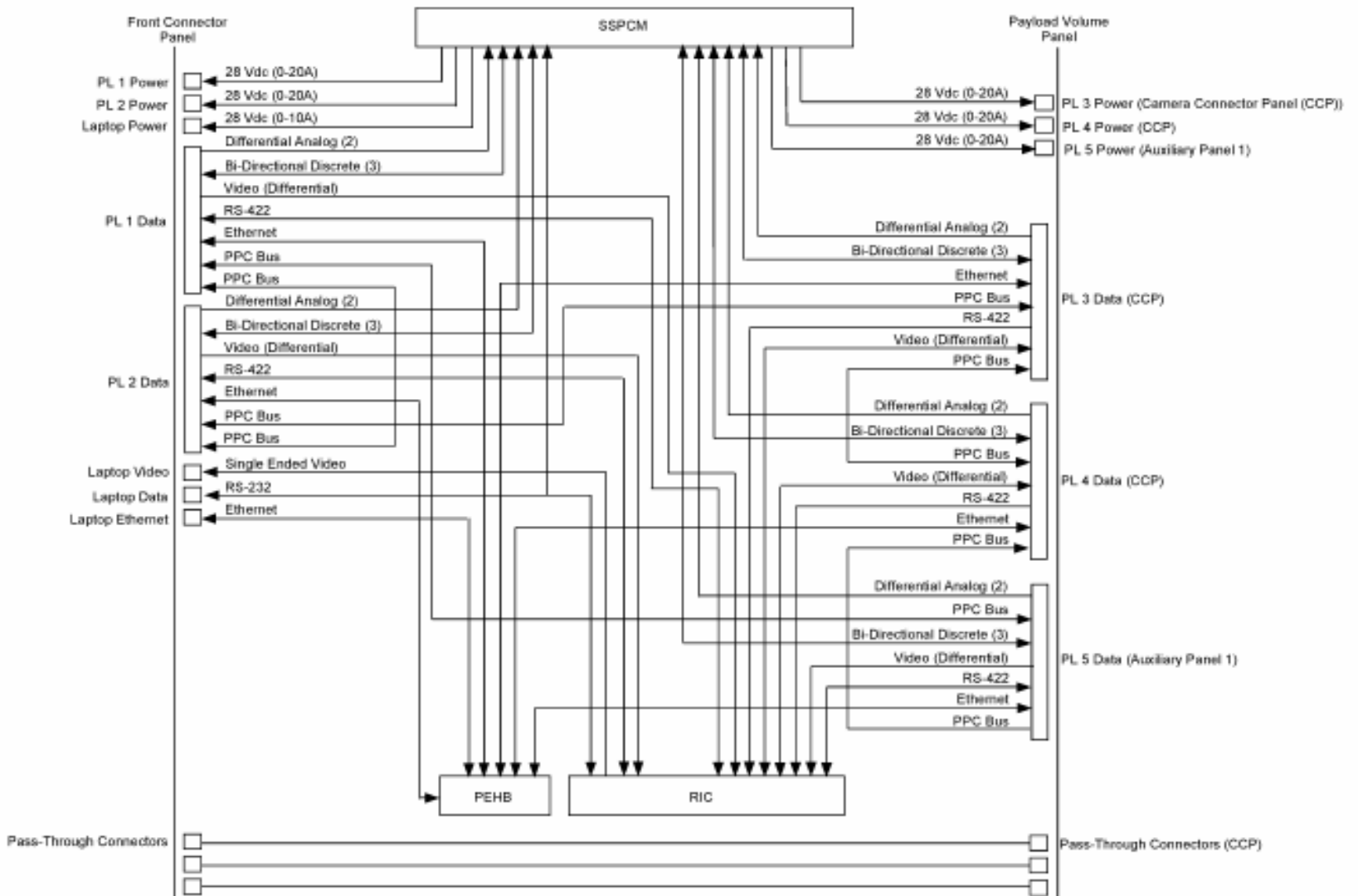



WORF Data Interfaces

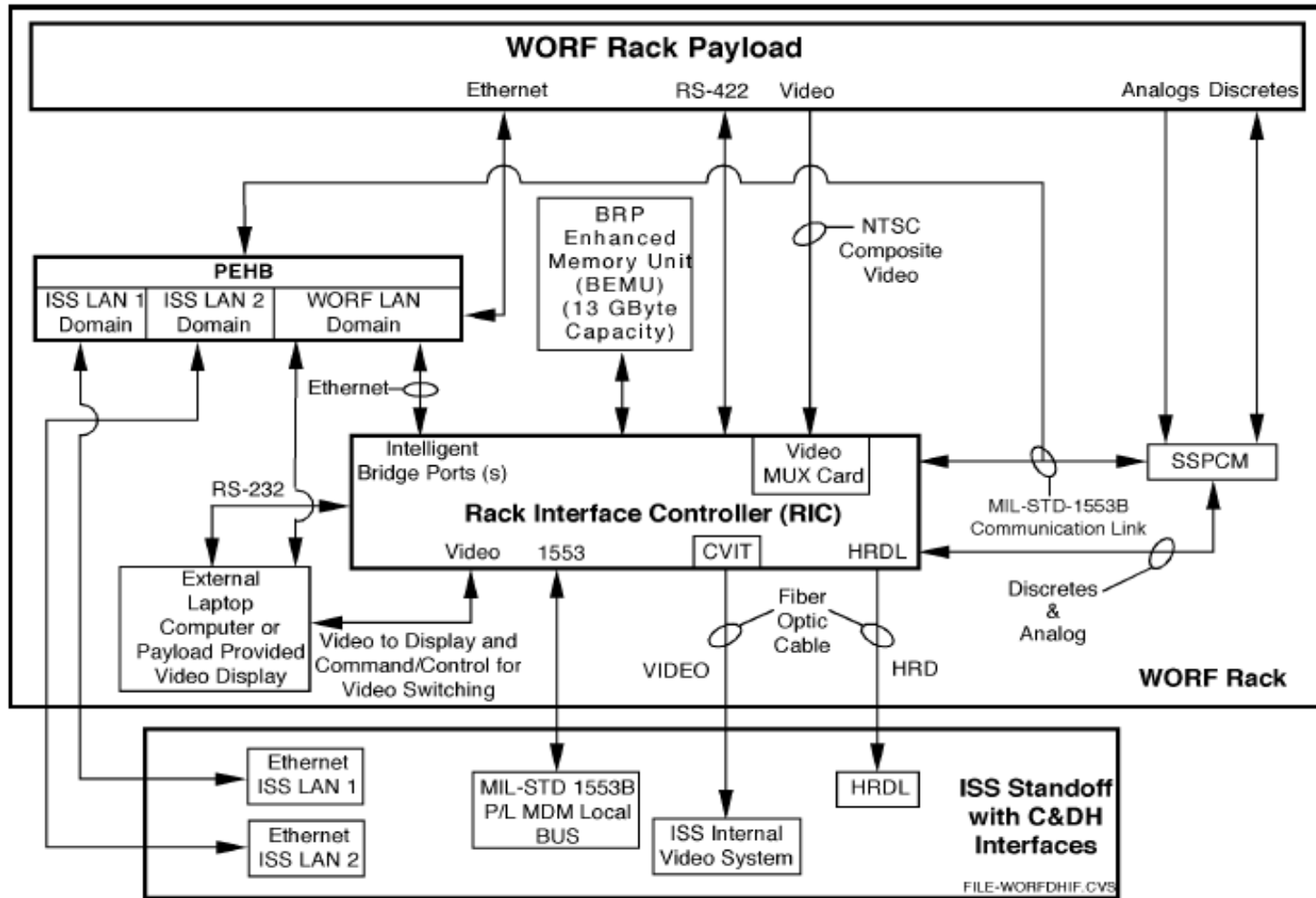

The Rack Interface Controller (RIC) processes telemetry, health and status data, as well as commands to the payload.



WORF Thermal Systems

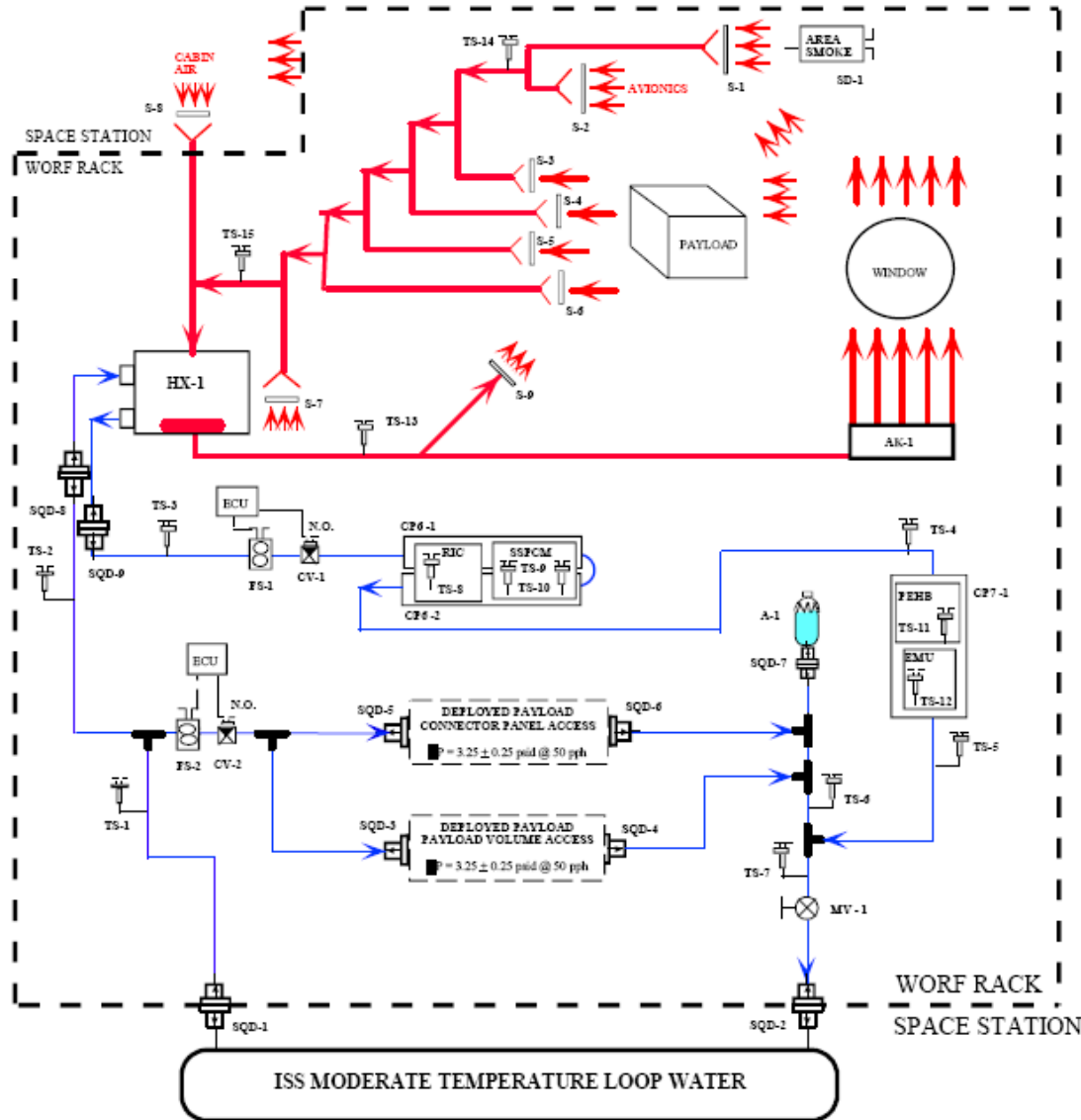

WORF ECS SCHEMATIC

LEGEND	NAME	I.D.	QTY
	Orifice/Screen	S	9
	Thermistor	TS	15
	Quick Disconnect	SQD	9
	Flow Sensor	FS	2
	Proportional Control Valve	CV	2
	Electronic Control Unit	+++	2
	Manual Valve	MV	1
	Area Smoke Detector	SD	1
	Accumulator	A	1
	Air-to-water Heat Exchanger	HX	1
	AirKnife	AK	1
	Coldplate (-6)	CP6	2
	Coldplate (-7)	CP7	1
	Air Duct	+++	AR
	Coolant Lines	+++	AR
	Branch Tee	+++	AR



WORF Specific Considerations...

- ❑ The Lab Window Scratch Pane can be removed for higher quality optical requirements.
- ❑ WORF Payloads should design their hardware to minimize glare or ambient light reflections
- ❑ WORF payloads should be designed to be installed with the bump shield deployed to prevent contact with the Lab Window.
- ❑ Payloads should maintain a 0.5 in keep-out zone around the window assembly
- ❑ Payload lenses should incorporate bumper rings to prevent damage to the Lab Window in case of inadvertent contact
- ❑ There are a number of flight rules that govern window use during certain events.
- ❑ Crewmembers are restricted to 30 minutes of operation in the payload volume without the rack powered due to concerns of CO₂ concentrations.

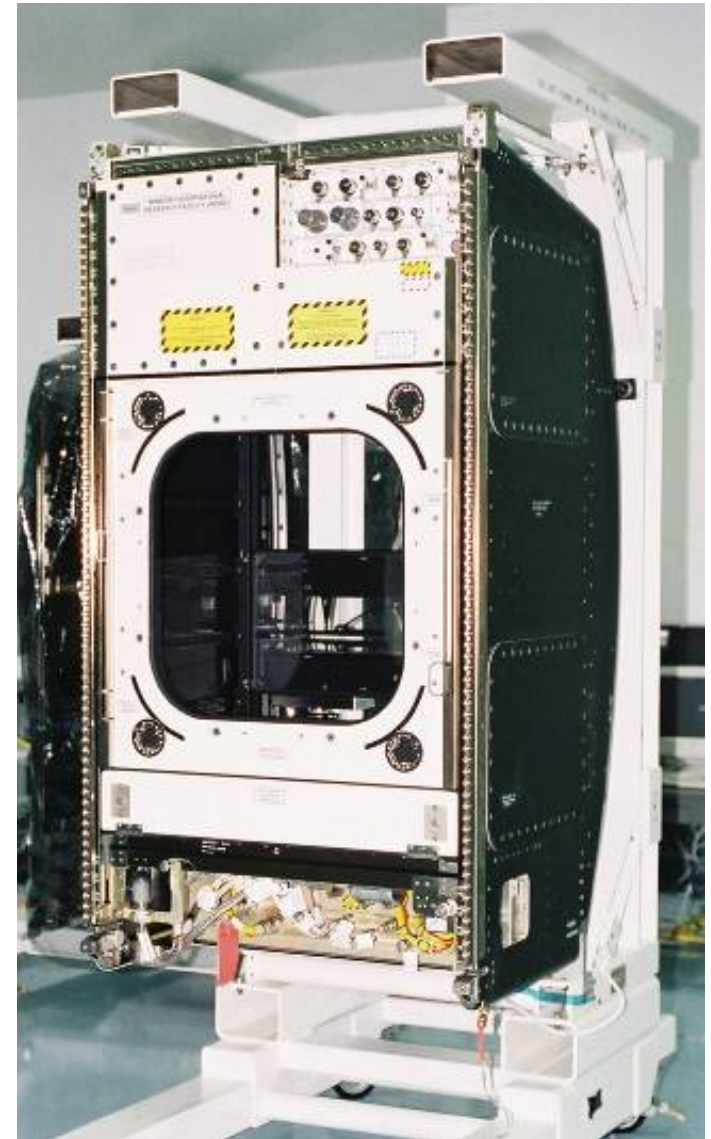



Destiny Window

Cross Section of US Lab Research Window Mount

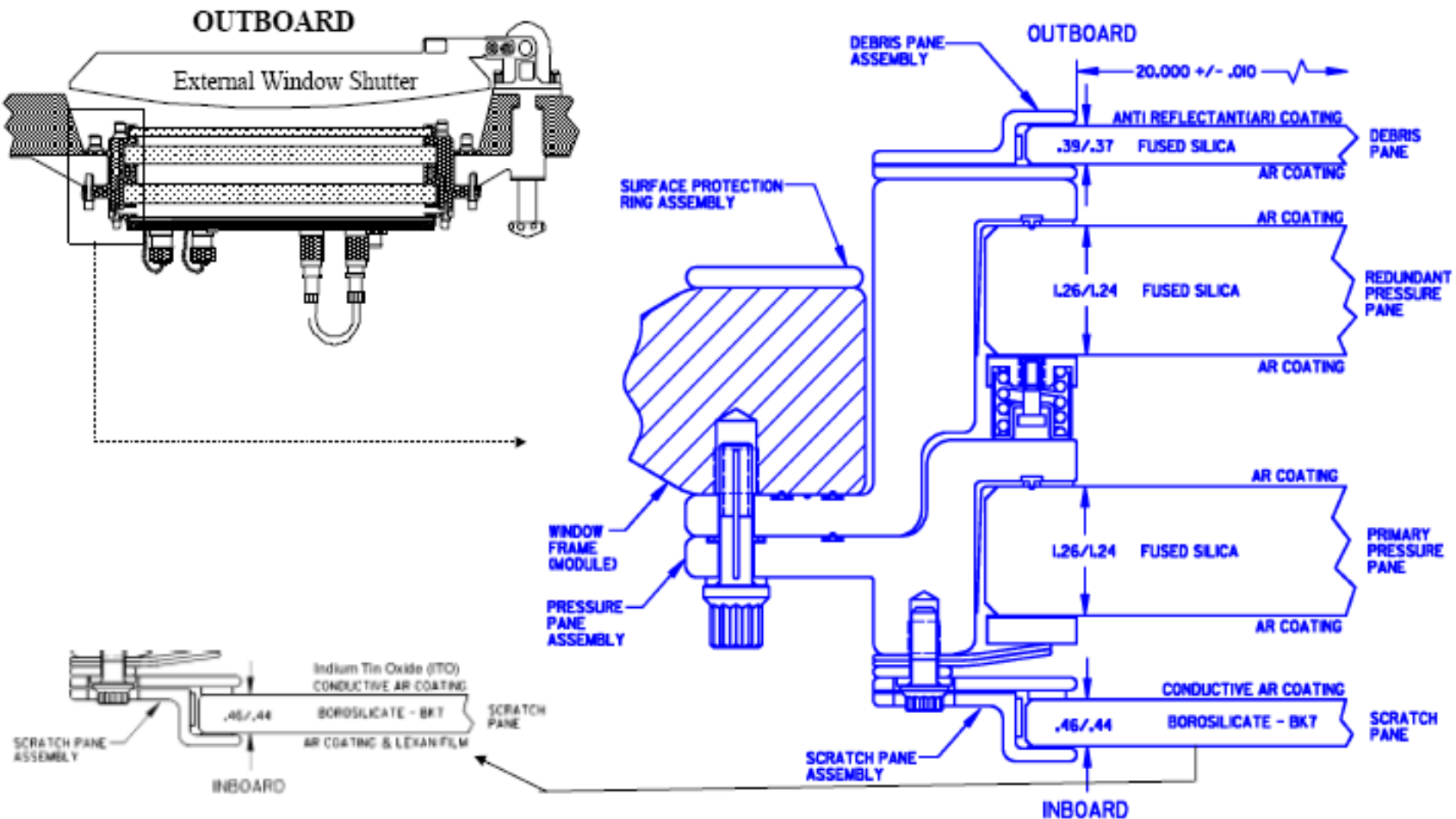



Destiny Window Transmittance (scratch pane removed)

Destiny Window Port Transmittance
(Three 7940 fused silica panes)

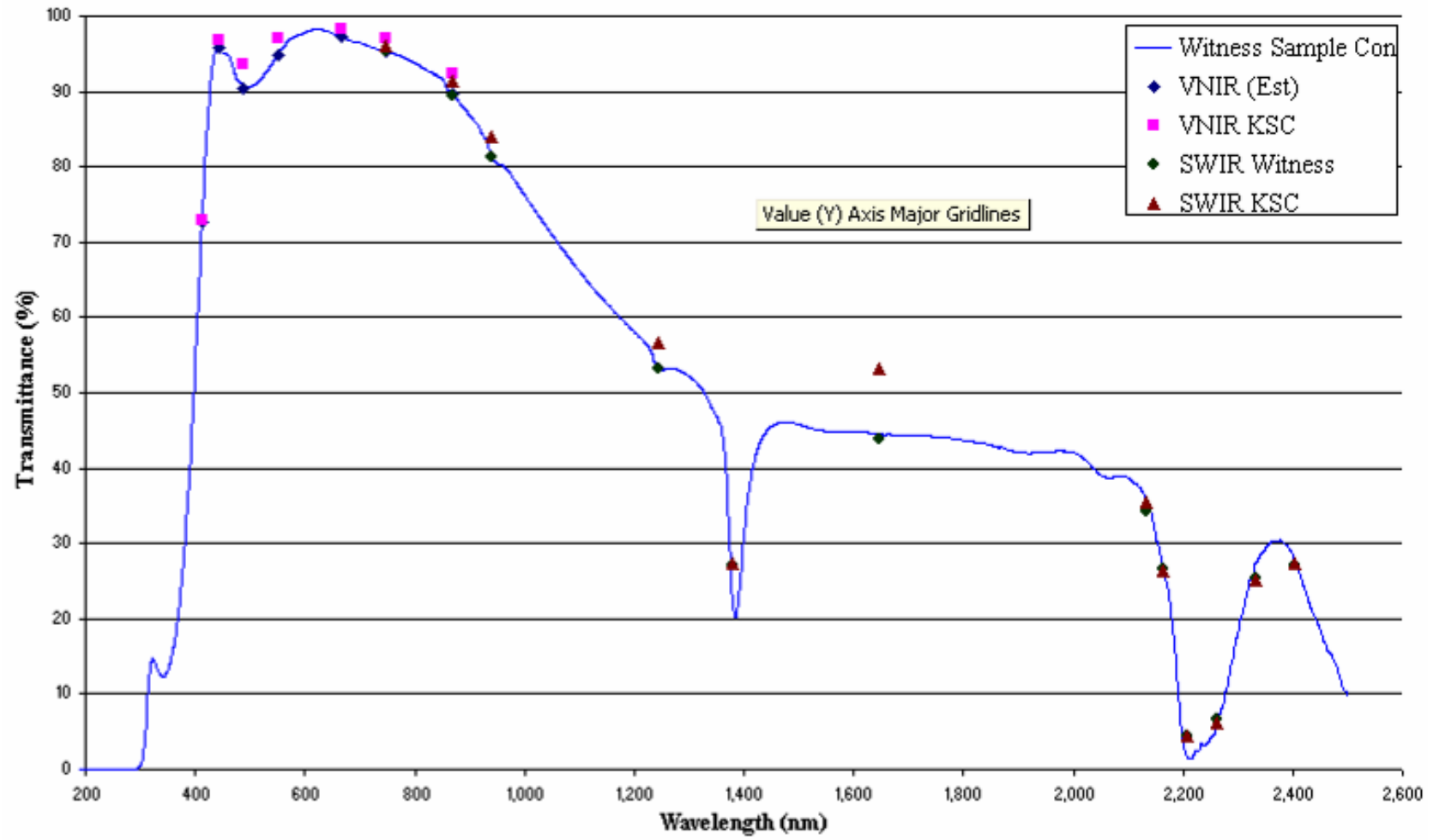

ISS Ground Track

51.6° Inclination

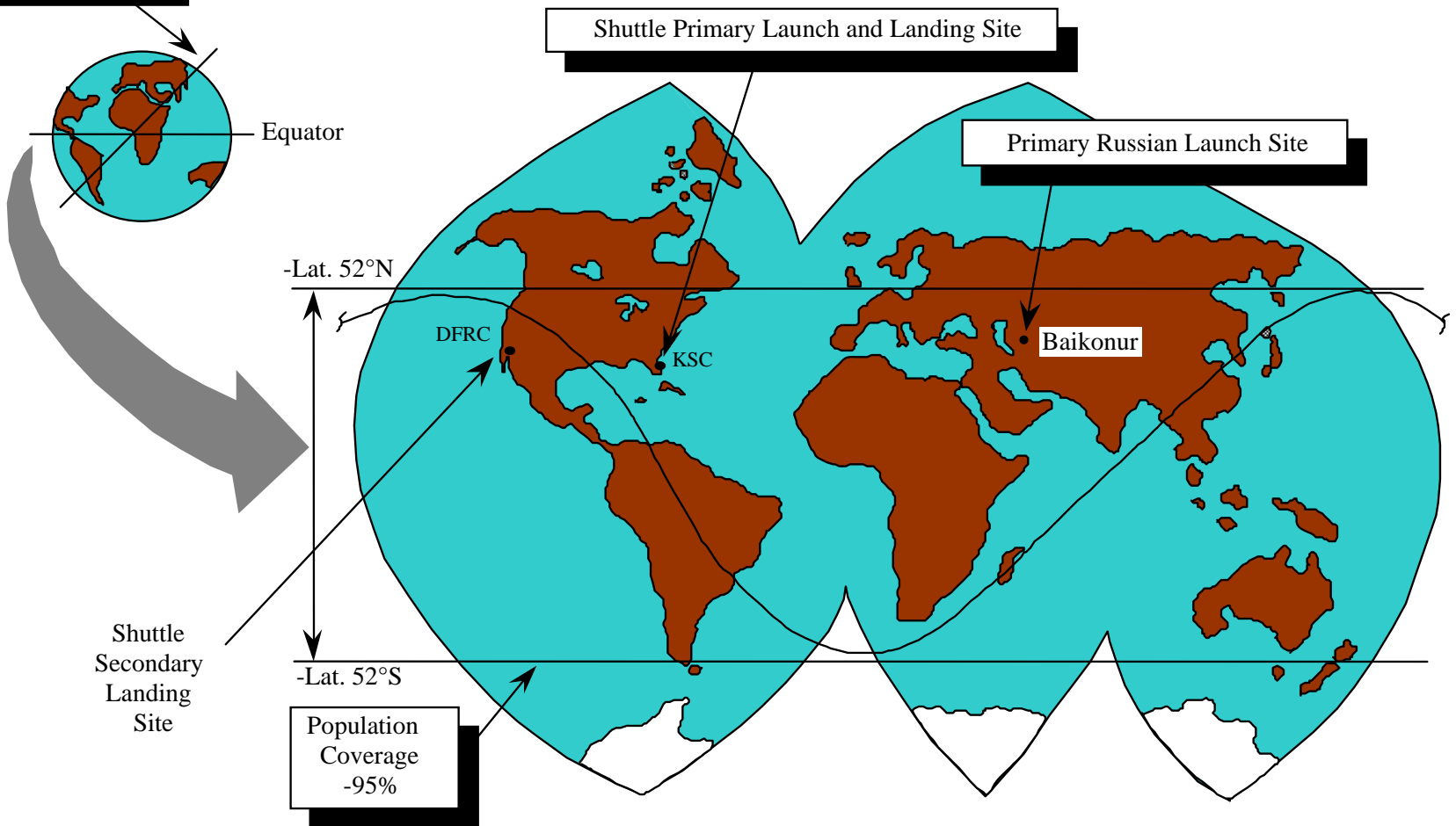

Approximate ISS re-visit time for ground targets is 3 days



WORF Subrack Payload Integration

- ❑ WORF Payloads will follow the standard ISS Payload Integration Template as outlined in SSP 57057. The general timeline is depicted below.
- ❑ For payload integration, the following products will be developed:
 - Payload Integration Agreement
 - Interface Control Document
 - Design and configuration drawings
 - Verification packages to be submitted to ISS Program
 - Certificate of Flight Readiness (CoFR) products
- ❑ Each payload will participate in the ISS Payload Safety Process by developing Phase 0/I, II, III Flight Safety Data Packages for submittal to the Payload Safety Review Panel (PSRP).
- ❑ Payload testing support is available using an EXPRESS Rack to simulate WORF data and power interfaces.

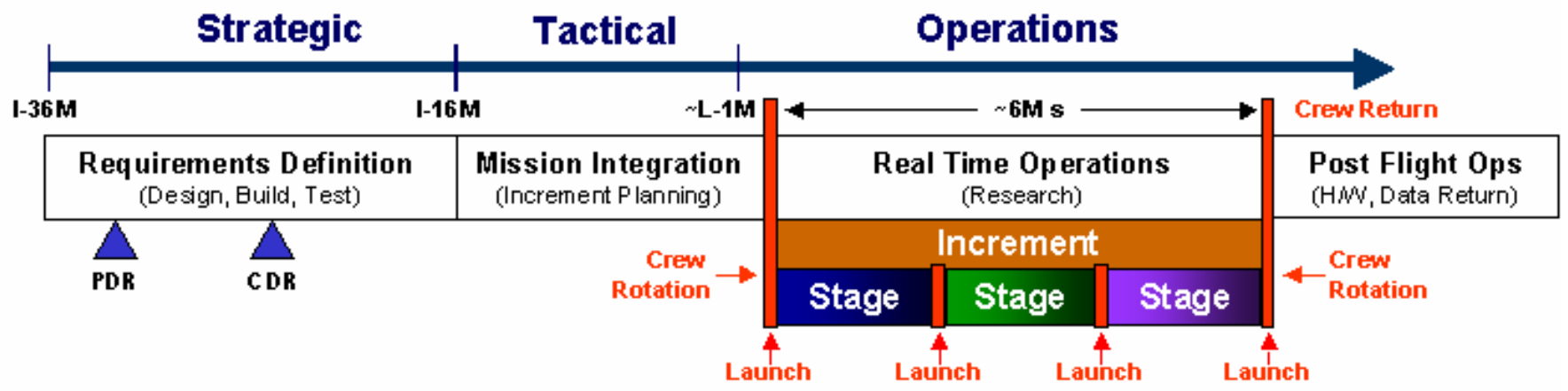



WORF – Payload Operations

The following steps represent a general flow for subrack operations in WORF:

1. *Payload hardware launched and transferred to station*
2. *Crew removes WORF Hatch and mounts payload hardware in WORF Payload Volume*
3. *Crew mates payload connections to WORF interface panels*
4. *Crew lowers bump shield and moves imagery into place*
5. *Crew egresses from payload volume and installs WORF Hatch.*
6. *Crew/ground commands power to rack and payload locations*

WORF and subrack operations are conducted at the Huntsville Operations Support Center (HOSC)

- The Payload Rack Officer (PRO) will be the ground operator of the WORF Rack
- The PRO will be responsible for the following activities:
 - WORF Ground Activation and Checkout*
 - WORF Nominal Activation and Deactivation*
 - Monitoring of WORF H&S Data*
 - Selected payload H&S may be monitored if payloads utilize the WORF for data throughput.*
 - Configuration of WORF Rack and resources to support payload operations*
 - WORF troubleshooting and recovery of off-nominal situations*

Reference Documents

- ❑ SSP 52000-PIH-WRP, Volume II – WOLF Payload Accommodations Handbook (currently at Revision B)
- ❑ SSP 52000-PIH-WRP, Volume III – WOLF Interface Definition Document (currently at Revision B)
- ❑ SSP 57057, ISS Payload Integration Template

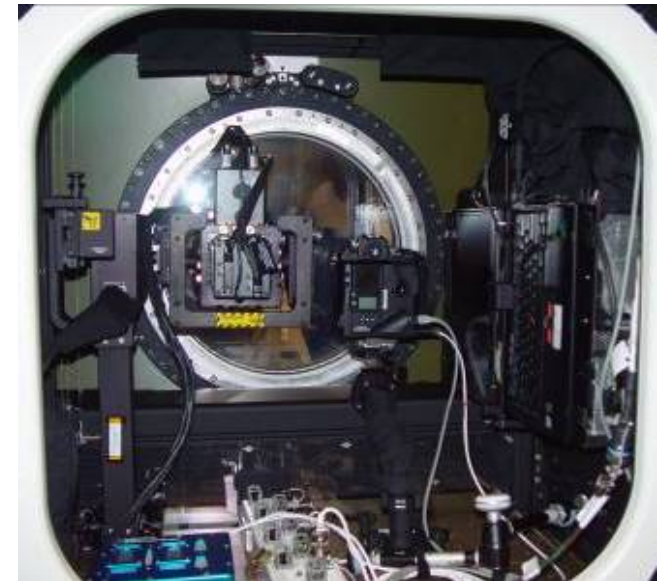



National Aeronautics and
Space Administration

Lyndon B. Johnson Space Center



Questions?



National Aeronautics and
Space Administration

Lyndon B. Johnson Space Center



Launch Vehicle (JAXA HTV)

Chi Min Chang

ISSP Payload Engineering and Hardware Integration Office

12/19/07





H-IIB/HTV Launch Rocket Integrated Assembly

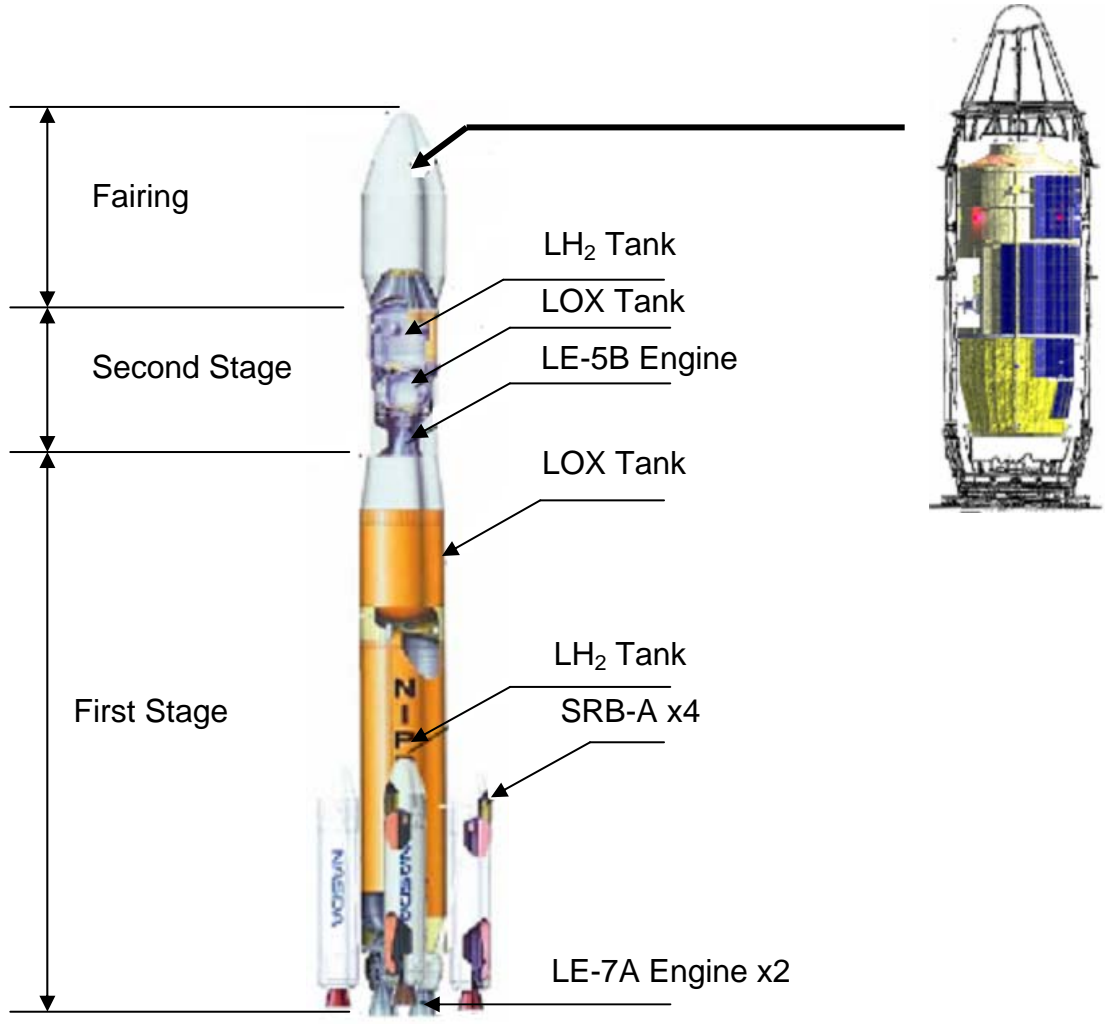



H-IIB Launch Rocket Introduction

- Japan has been developing its own launch vehicles, based upon various researches and experiments. Among launch vehicles, the H-IIA launch vehicle has been supporting satellite launch missions as a major large-scale launch vehicle with high reliability.
- H-IIB is the launch vehicle that is an upgraded version of the current H-IIA launch capacity.
- The H-IIB launch vehicle has two major purposes.
 - To launch the H-II Transfer Vehicle (HTV) to the ISS.
 - HTV will carry not only necessary daily commodities for the crew astronauts, but also experimental devices, samples, spare parts and other necessary research items for the ISS.
 - To broader launch needs by making combined use of both H-IIA and H-IIB launch vehicles.
 - H-IIB's larger launch capacity will make it possible to perform a simultaneous launch of more than one satellite, and will reduce the cost.

HTV Configuration

The HTV is an unmanned orbital carrier, designed to deliver up to six metric tons of goods to the ISS in orbit at an altitude of about 400 kilometers and return with spent equipment, used clothing, and other waste materials on the return trip. These waste materials will be incinerated when HTV makes re-entry into the atmosphere.

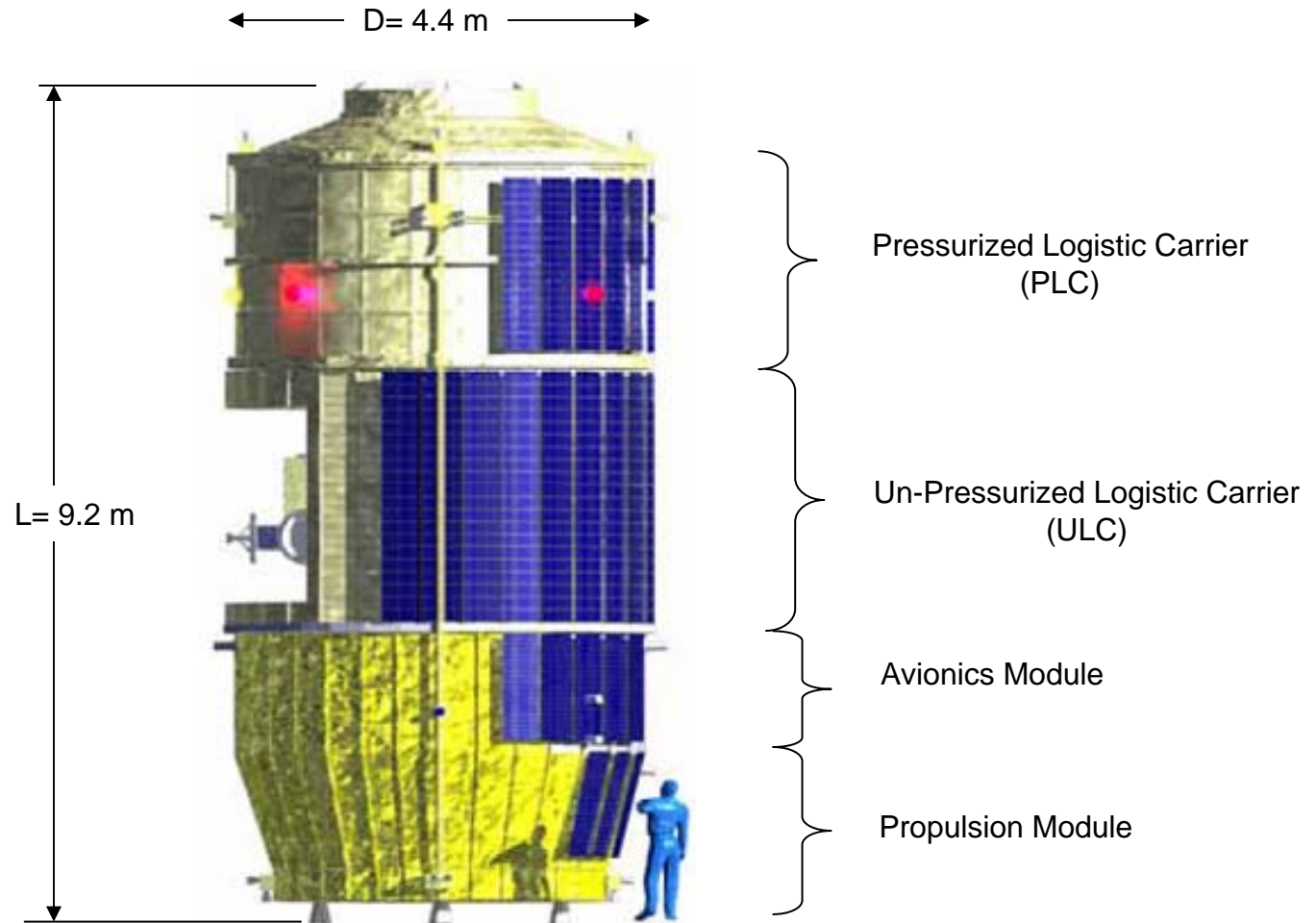



HTV Mission Cycle

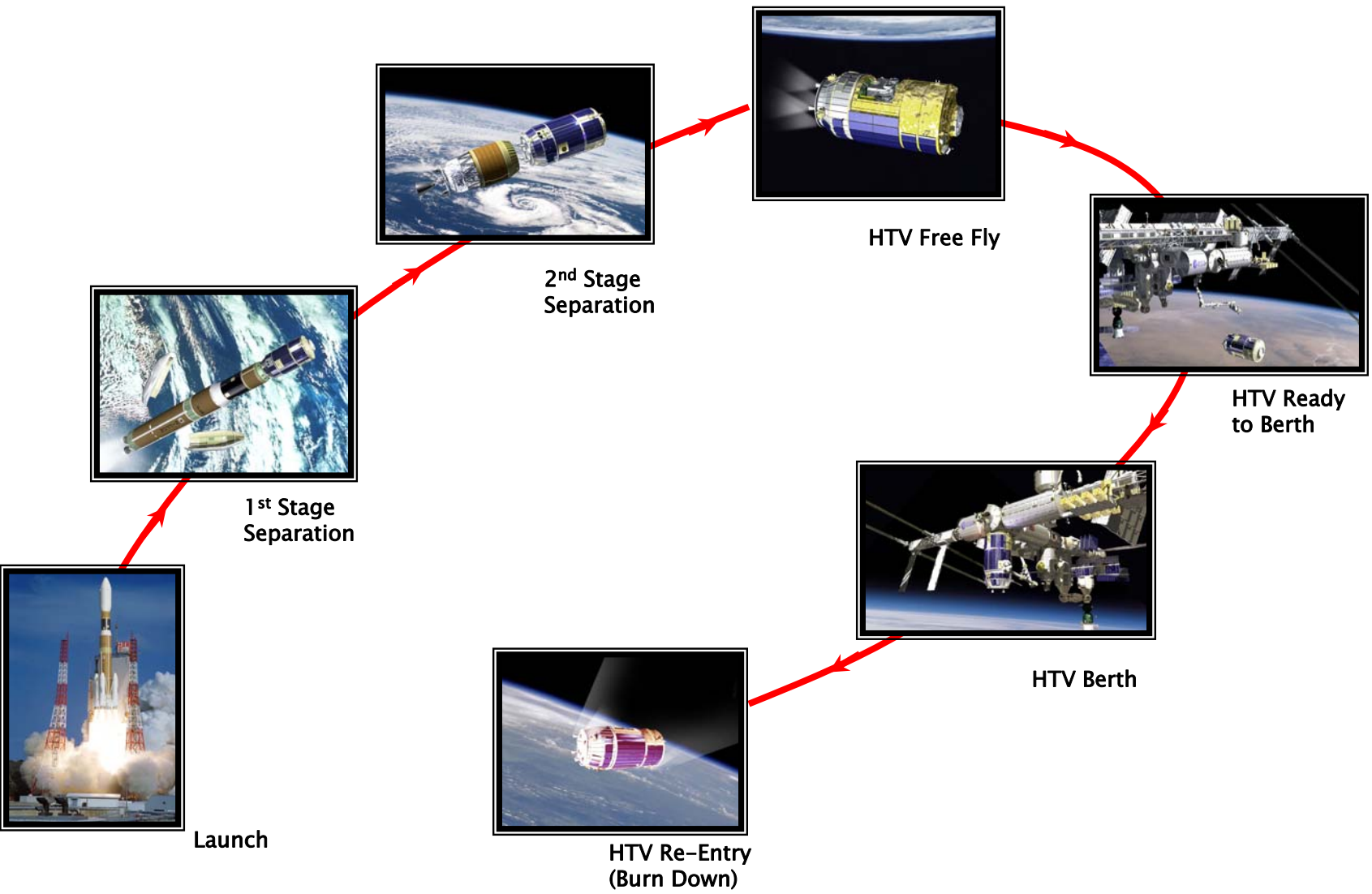



ISS Un-Pressurized Cargo On Orbit Site Layout (Post ULF 5)

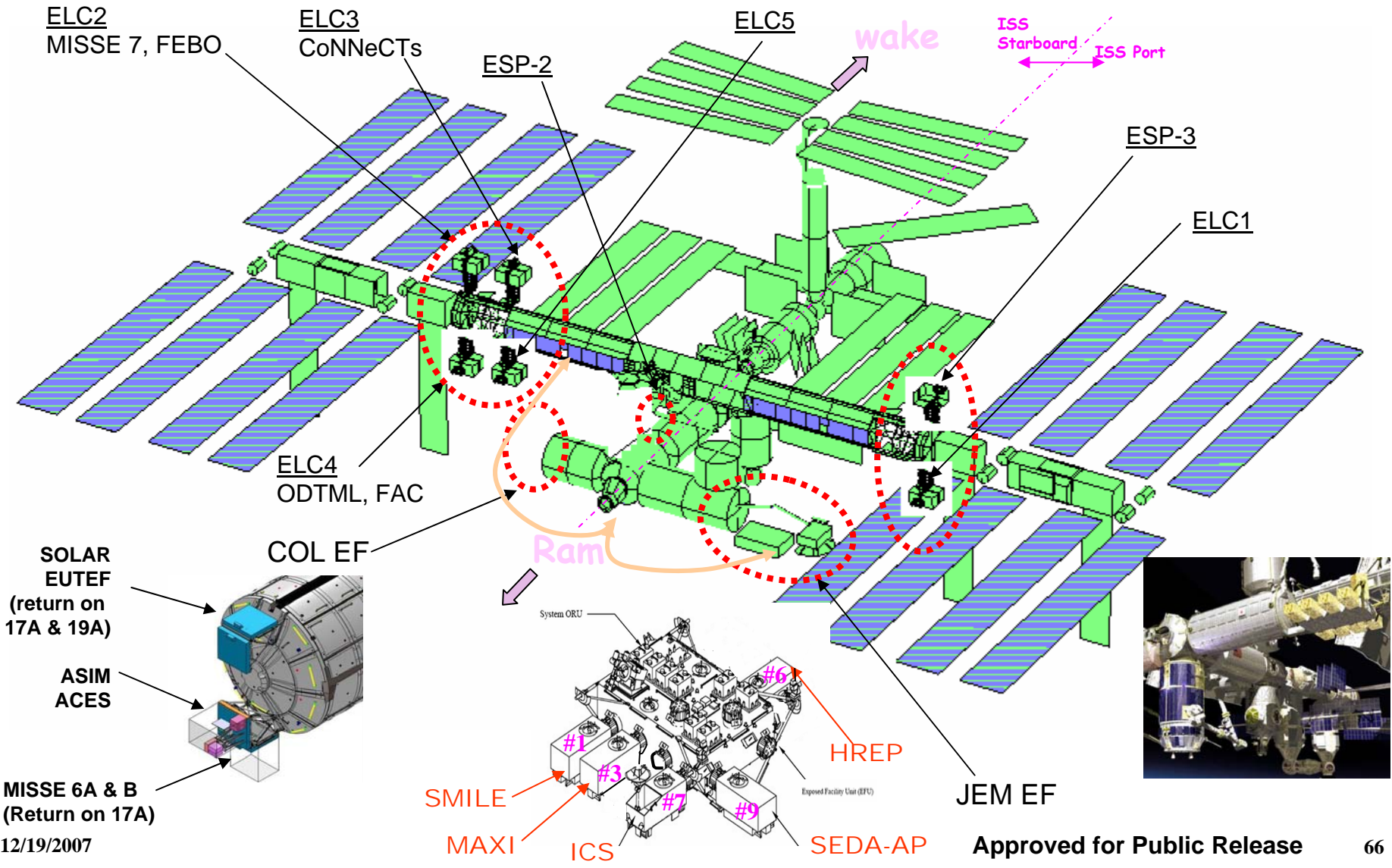



HTV Cargo Accommodation

Pressurized Cargo

JAXA "KOBAYASHI" rack

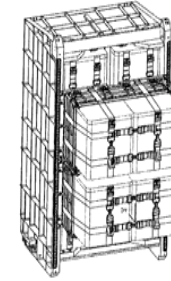

Type2
(26 CTBs)

Gradient
Heating
Furnace (GHF)

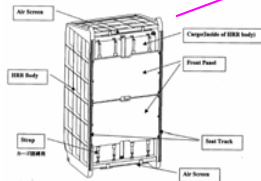

Type1
(18 CTBs)

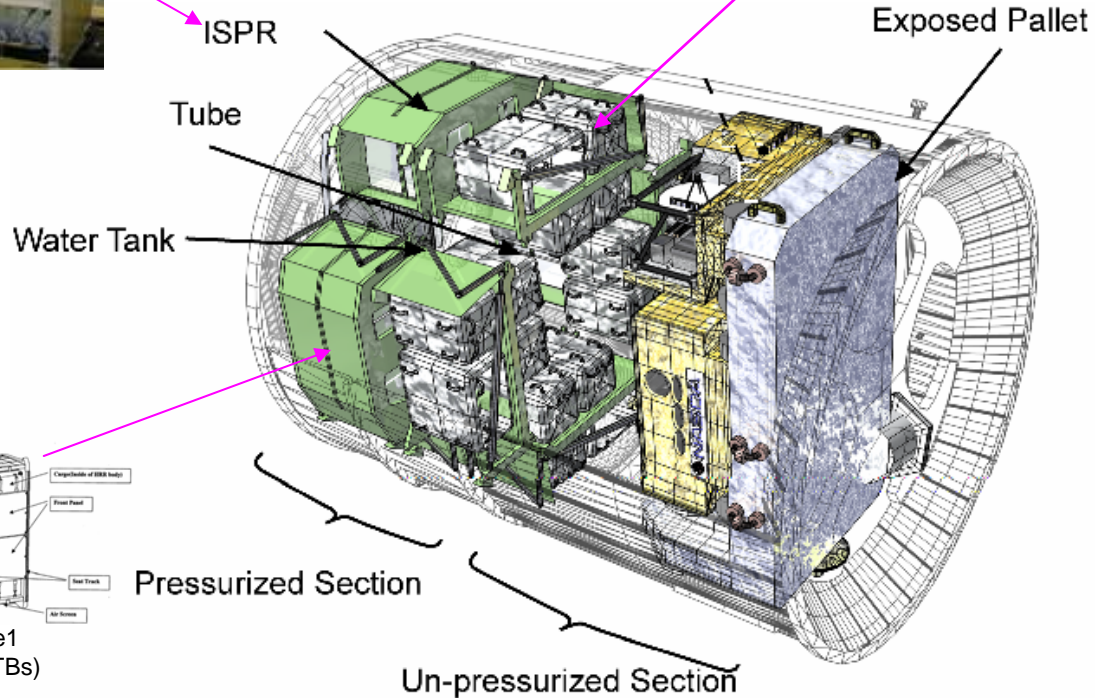

HTV Cargo Accommodation

Pressurized Cargo Service

- Payload can be soft stow or hard mounted to HRR in HTV PLC

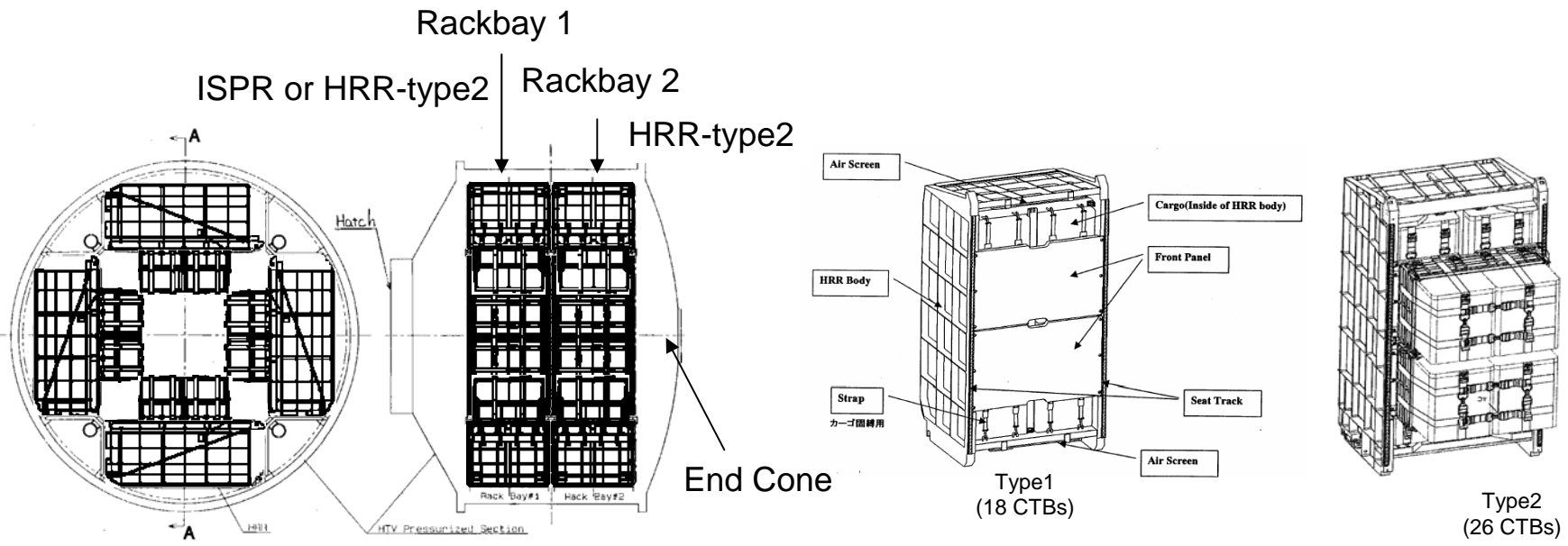

Current Baseline Configuration

Vibration Specification Pressurized Payload Manifested In HTV

- HTV PLC Acoustic level is defined in Cargo IRD
- HTV PLC rack to PLC interface random vibration level is defined in Cargo IRD
- Soft-stow characteristics and hard mounted interface vibration characteristics are not defined in Cargo IRD. It will be measured during HTV PLC vibro acoustic testing.
- For standard cargo stowed in CTBs, only the loads analysis of the cargo will be performed. Vibro-acoustic, structural, or thermal analysis will not be required.
 - Mass and Dimensions of cargo



HTV Un-Pressurized Cargo Accommodation

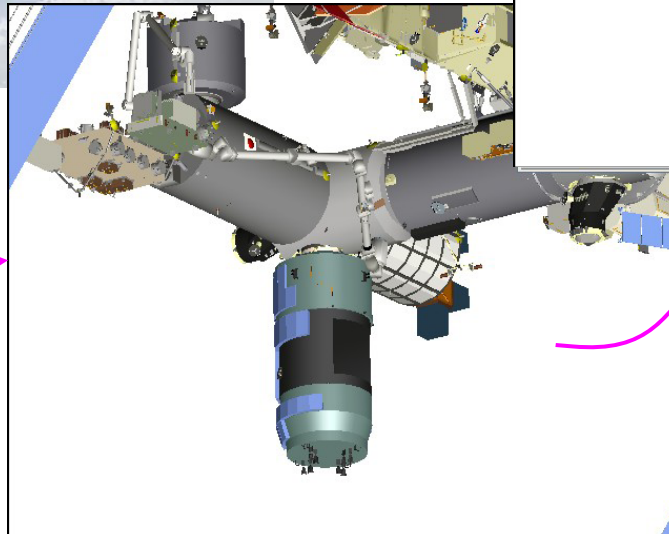
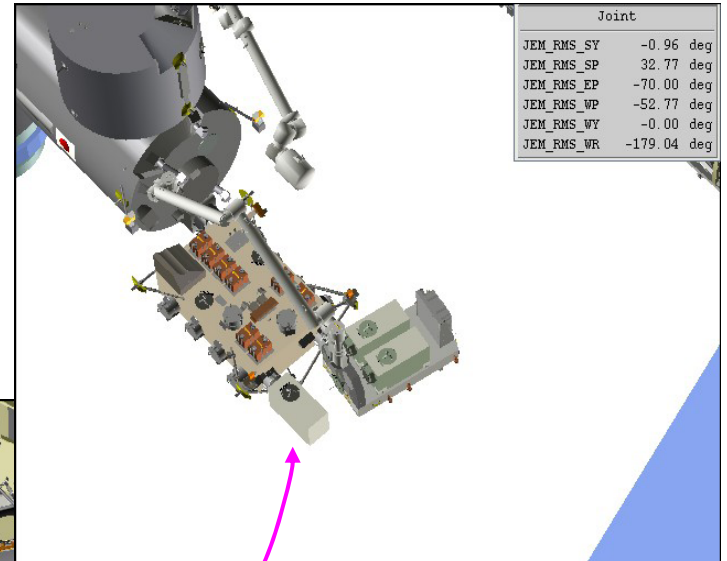



HTV Un-Pressurized Cargo Accommodation HTV#1 Manifest

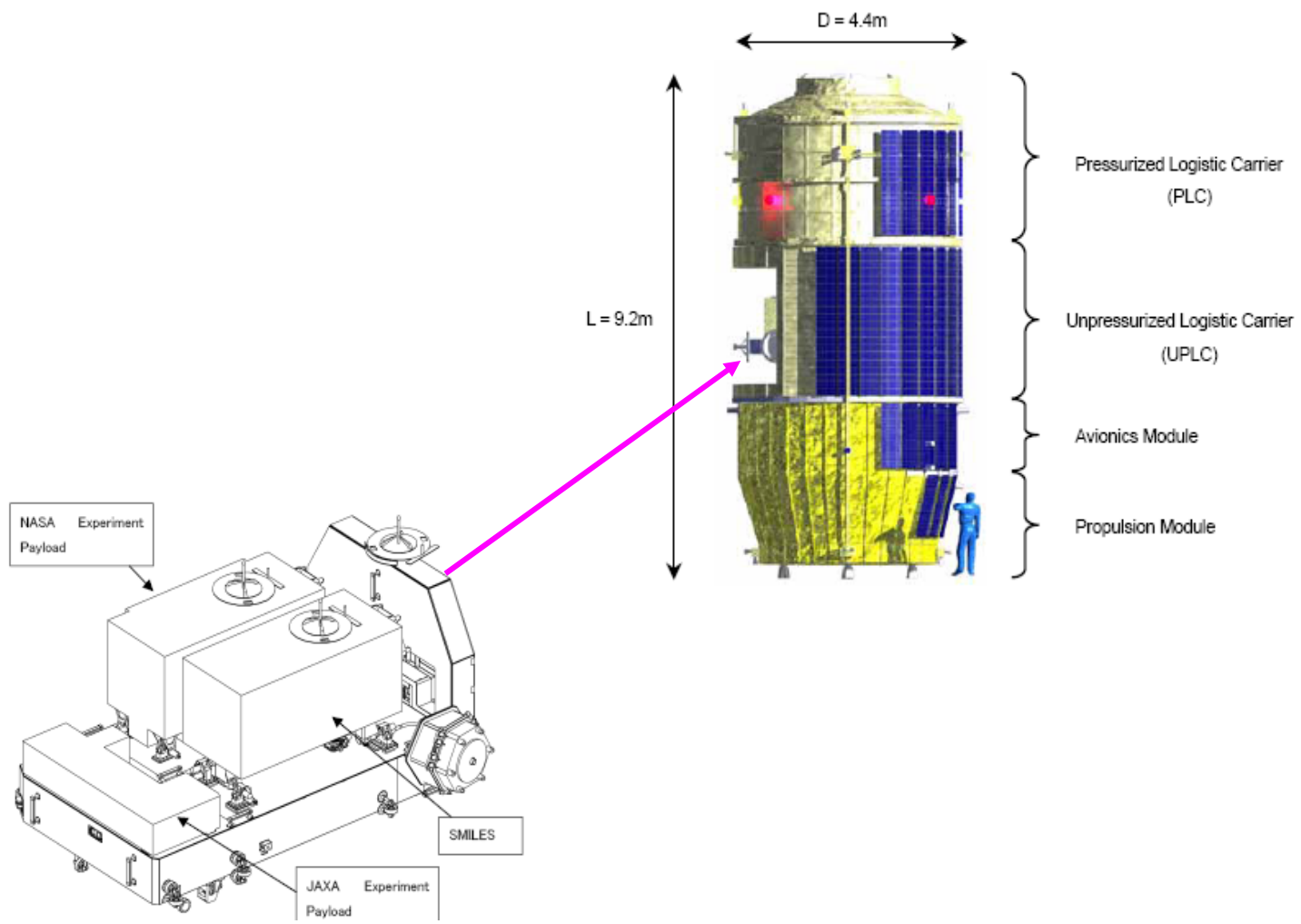



HTV EP Configuration (CDR Baseline)

Type I a (Berthed to JEM EF)

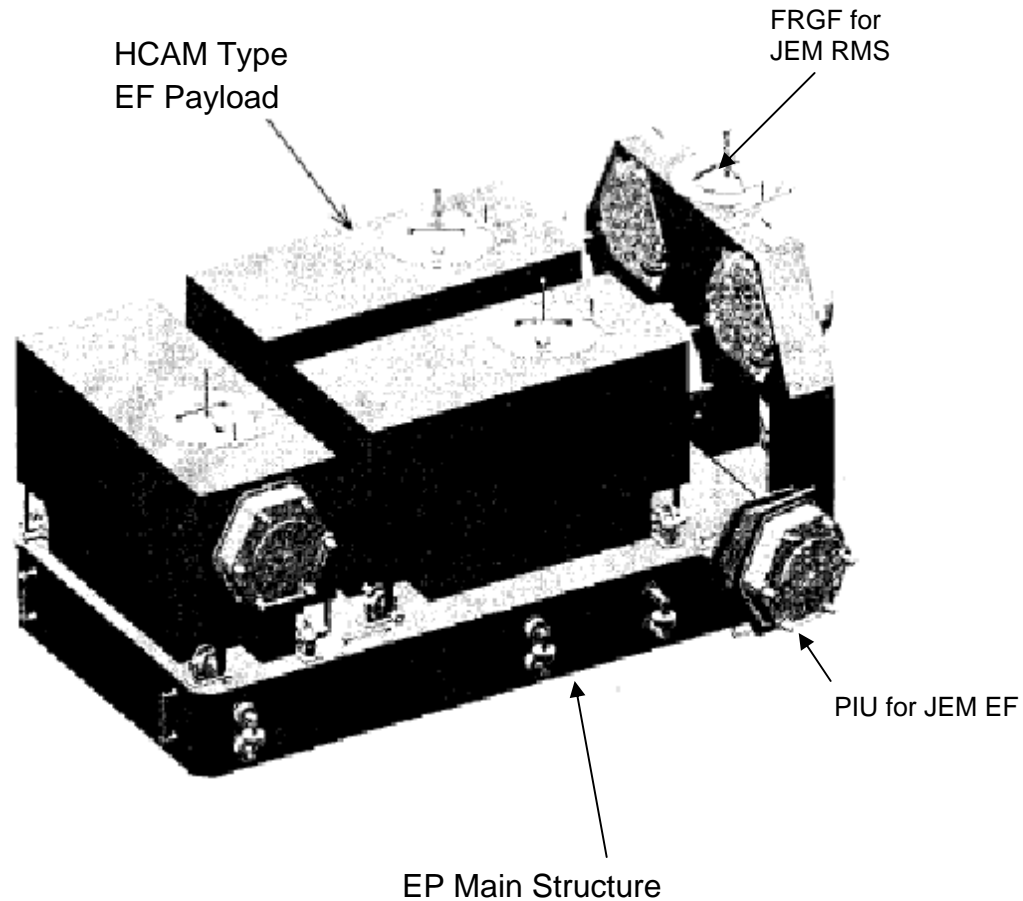



Volumetric Envelope For JEM EF Payload

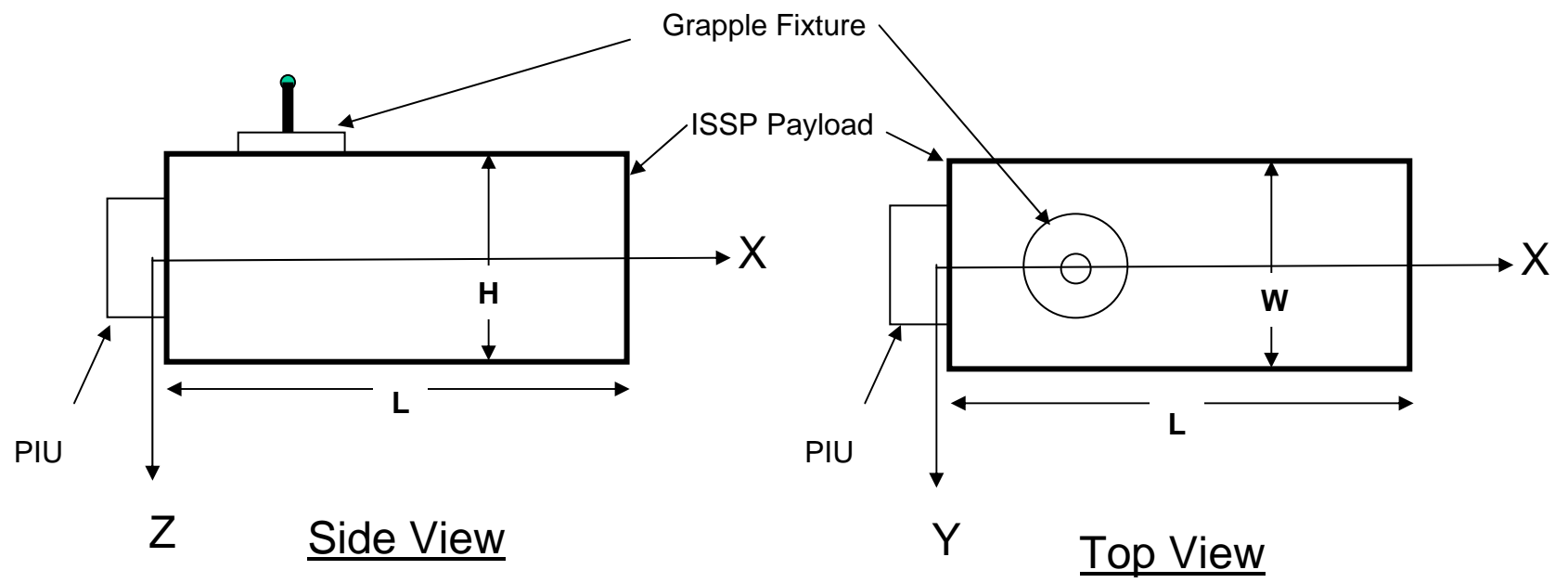

JEM EF EFU Payload Envelop

Axis	mm	ft	inch
W	800	2	7.50
H	1000	3	3.37
L	1850	6	0.83

Payload Envelop per FRAM IDD

W	36"
L	47"

HTV EP Configuration

Type I c (Berthed to JEM EF)

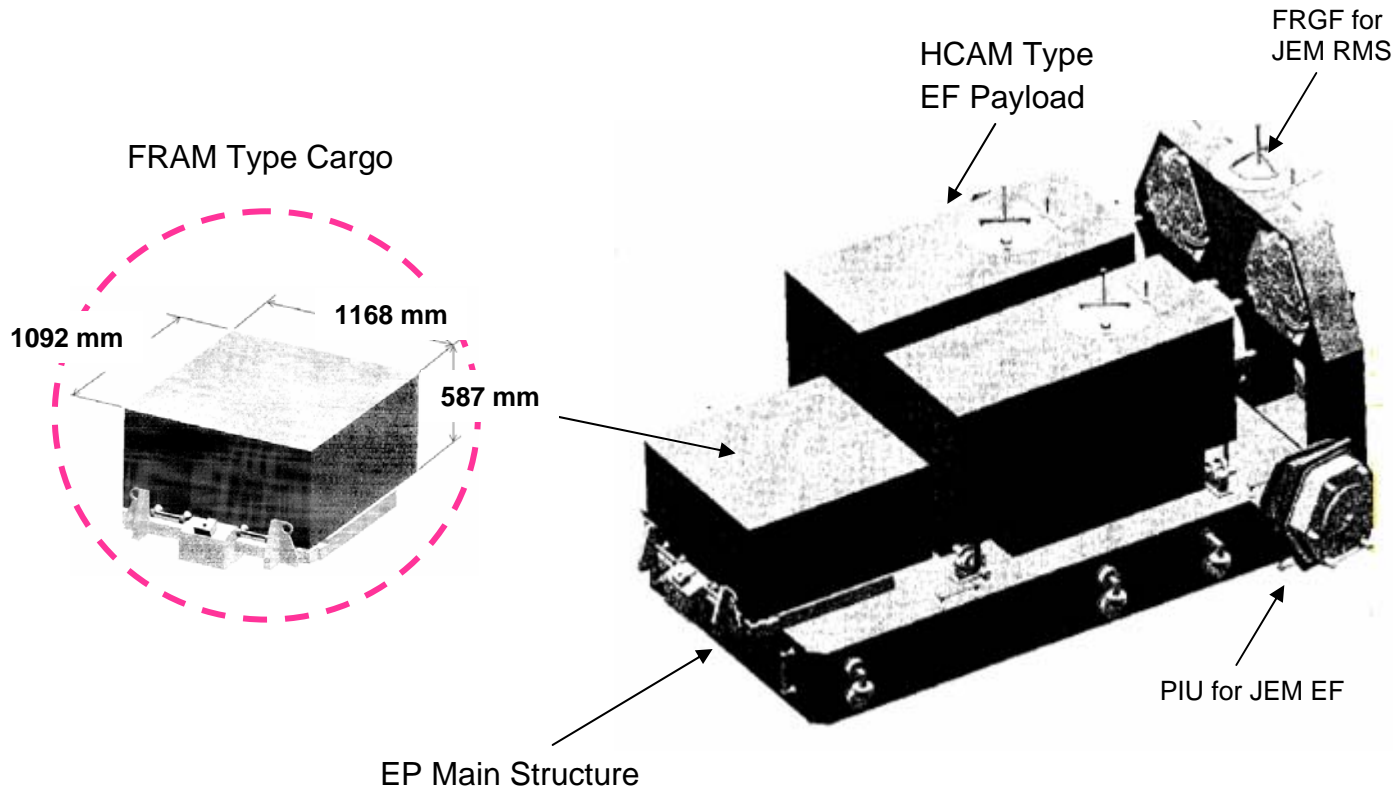

HTV EP Configuration

Type III c (Berthed to MBS POA)

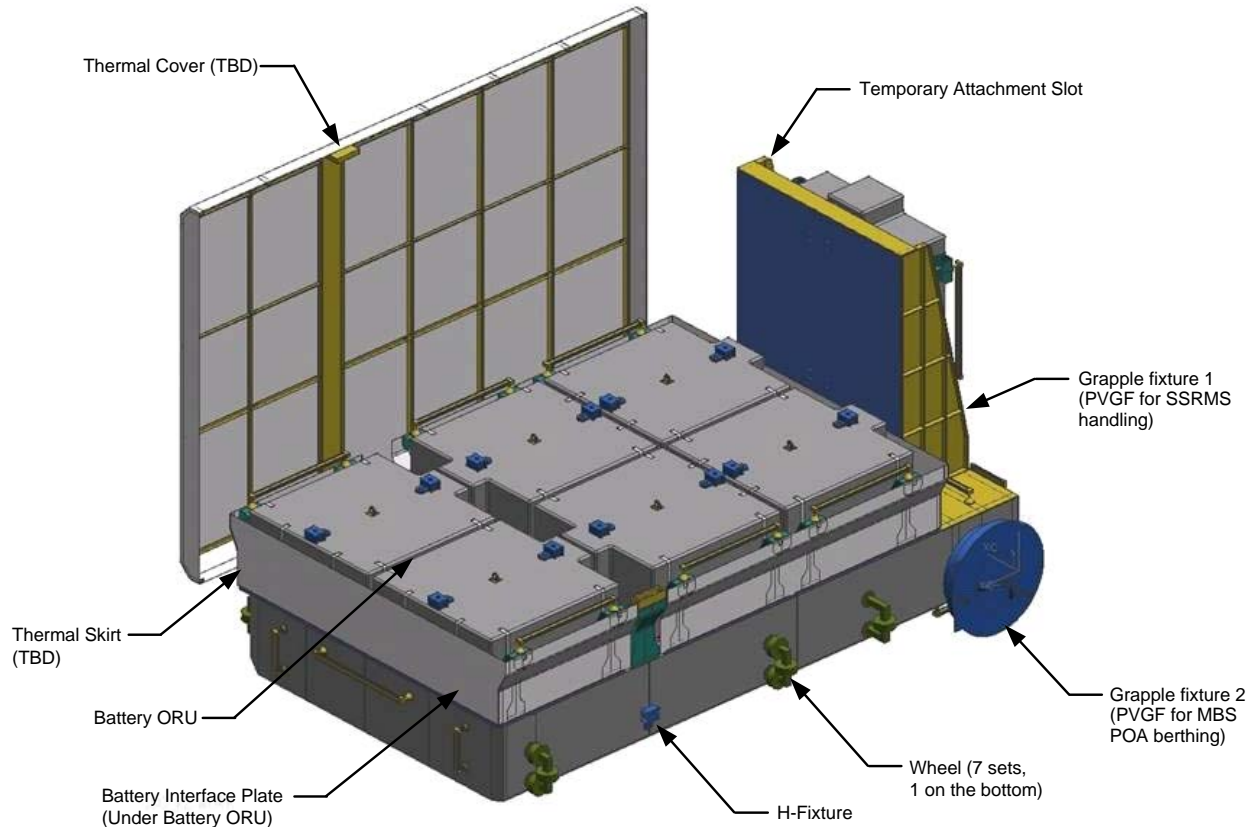

U. Tchiyama - 10-25-04
ssp50575_095v3.vsd



HTV EP Configuration Multiple Purpose Pallet (under development)

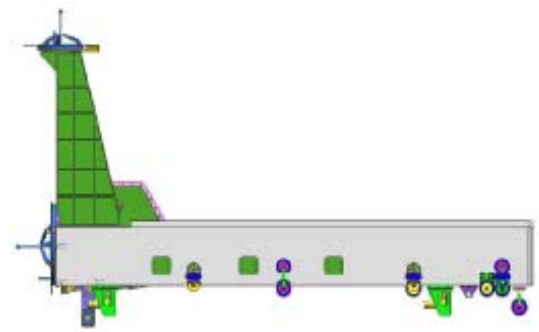
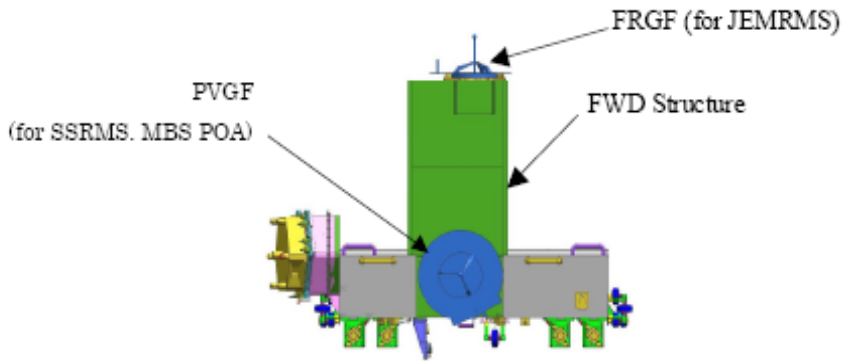
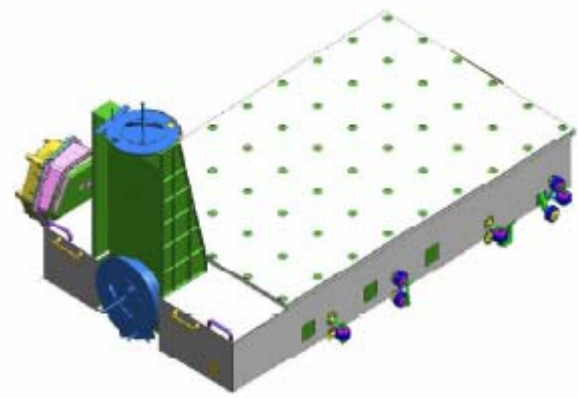
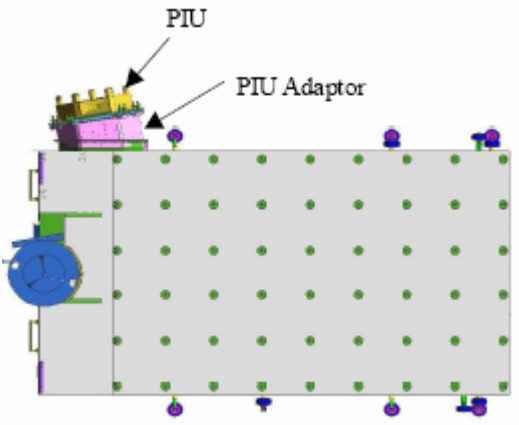

Examples Of HTV EP-MP Capability (under development)

- JEM EF Payload on EP-MP

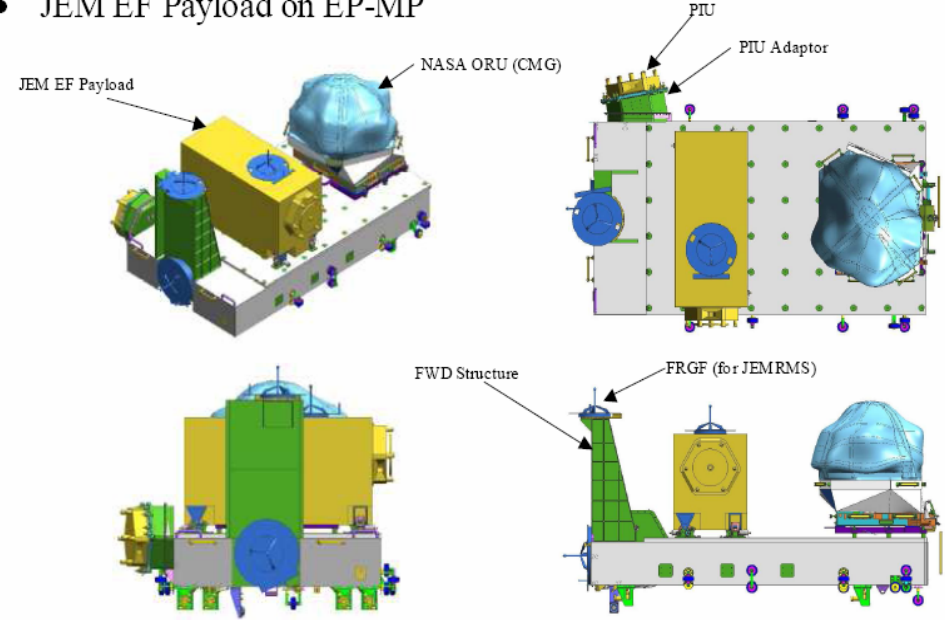
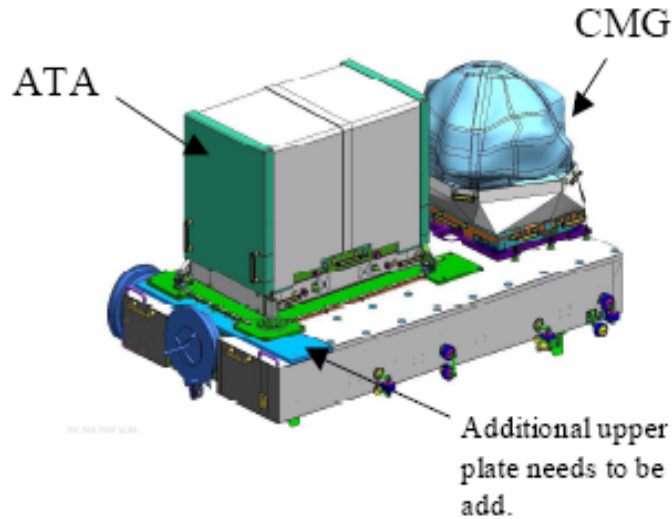



HTV Un-Pressurized Cargo Manifest Plan

HTV un-pressurized cargo manifest approach are as follows:

- (1) HTV#1 (07/2009) JEM EF payload
- (2) HTV#2 (10 (tbd)/2010) JEM EF and/or one FRAM payload (with height constraint)
- (3) HTV#3 (07/2011) to HTV#7 (07/2015) (Under Development)
 - a) JEM EF payload only flight
 - i. Berth to JEM EF
 - b) FRAM cargo only flight
 - i. Berth to MBS POA
 - c) Mixed configuration flight
 - i. Berth to both locations



HTV Un-Pressurized Cargo Interface

- FRAM Interface
 - Express Pallet Adapter Plate
 - Columbus External Payload Adapter
- Direct Mount Cargo
 - EVA compatible bolt mechanism
 - No Orbit Attach Site available
- JEM EF Payload (HCAM Type)
 - Payload Interface Unit
 - Flight Releasable Grapple Fixture
 - Four HTV Cargo Attachment Mechanism
 - One HTV Connector Separation Mechanism

Mandatory Accommodation Hardware

Mandatory Accommodation Hardware

- JEM EF payload
 1. Flight Releasable Grapple Fixture
 2. Payload Interface Unit
 3. HTV Cargo Attachment Mechanism (HCAM)
 4. HTV Connector Separation Mechanism (HCSM)

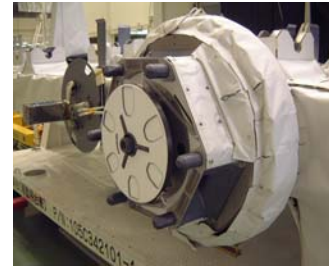

- FRAM payload (ExPA, CEPA)
 1. Flight Support Hardware
 2. Adapter plate
 3. ExPA or CEPA
 4. Passive FRAM
 5. PFRAM adapter plate

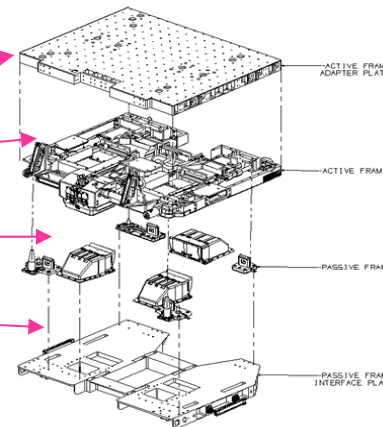



HTV Cargo Attachment Mechanism

- Nominally operated by crew command
- Active half on EP, Passive on payload
- Four for each cargo
- Cargo released by opening the arms
- Triggered by retraction of pin puller rod – one shot mechanism
- Mounting hole locations on payload are specified in HTV Cargo IRD

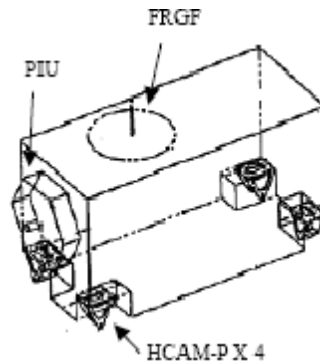



HTV Cargo Electrical Interface HCSM

- Automatic on orbit demating
- Active half on EP, Passive on payload
- One for each cargo
- One shot mechanism, no on orbit mating capability
- Mounting hole locations on payload are specified in HTV Cargo IRD

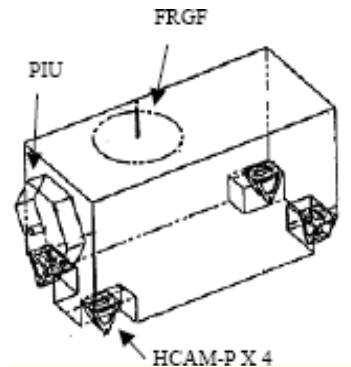



Payload Translation To Work Site Concept

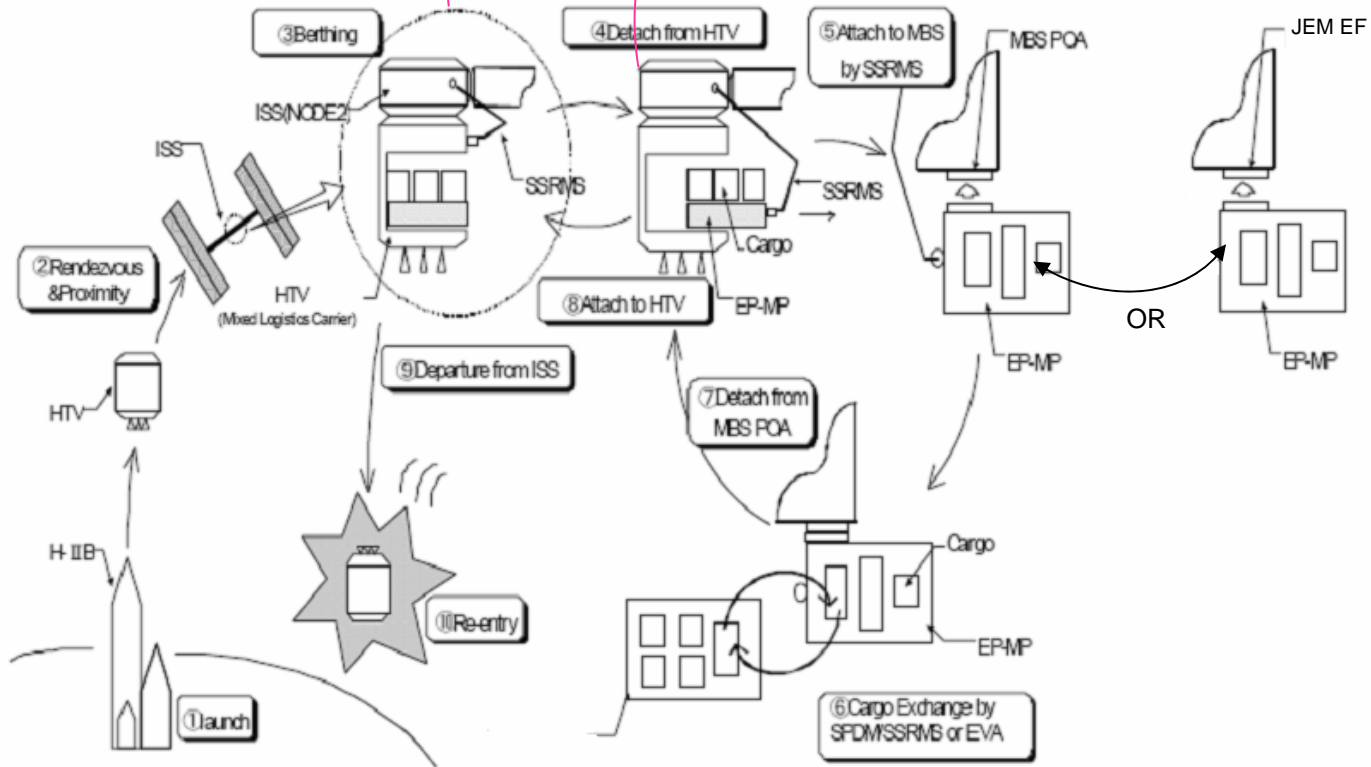



EVR Operation Scenario

HTV berth to JEM EF

- After HTV berth to Node 2 Nadir port, EVR Operation is
 - EP will be robotically removed from HTV by SSRMS and handed off to JEM RMS to translate to JEM EF
 - Each payload will then be robotically deployed to JEM EF EFU site after remotely releases the HCAMS attachment
 - Payload attached to JEM EF EFU port and ready to perform scientific experiment

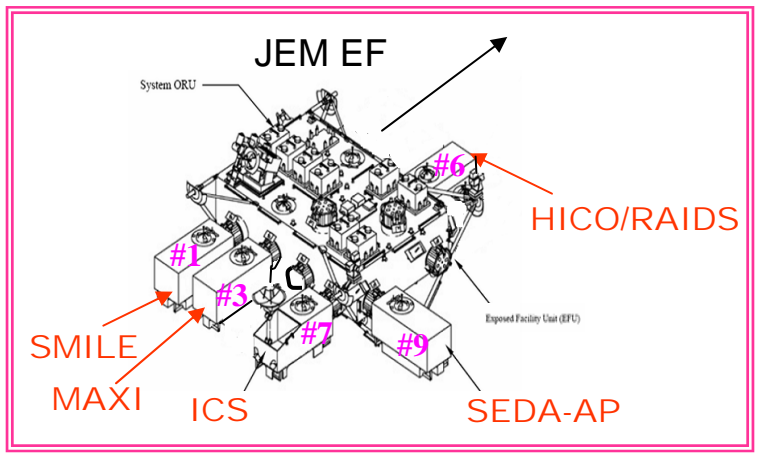
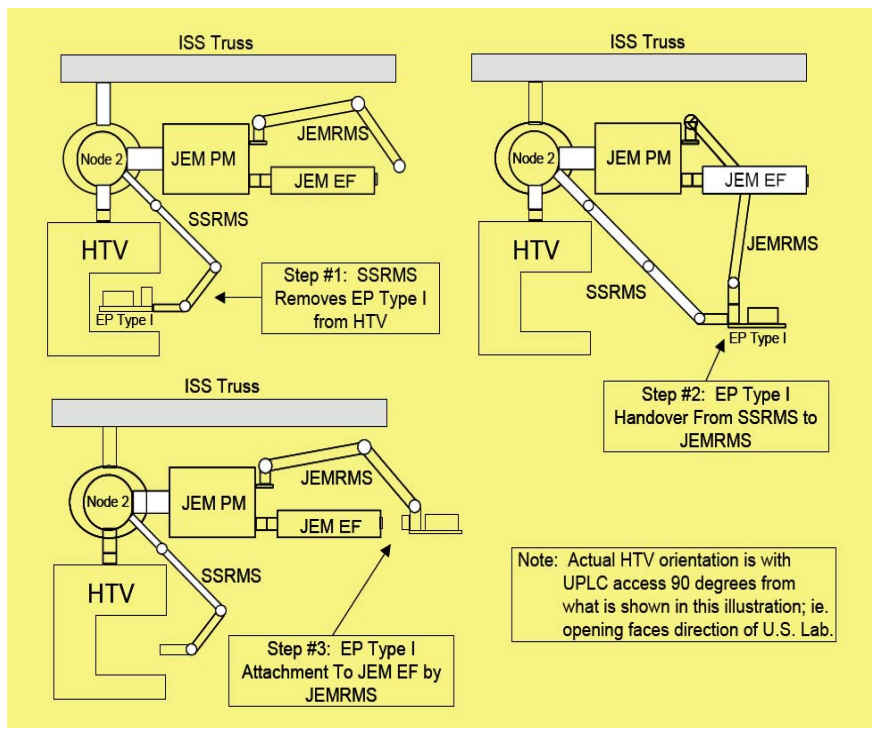

EVR Operation Scenario

Subsequent HTV Flight For ISSP ORUs

- HTV #x will carry ISSP ORUs and ExPA (or CEPA) science payload
 - FRAM mounted or directed mount ORU are all within options
 - HTV EP will be translated to POA by SSRMS
 - FRAM mounted ORUs and ExPA (or CEPA) Science Payload can be deployed robotically to ELC

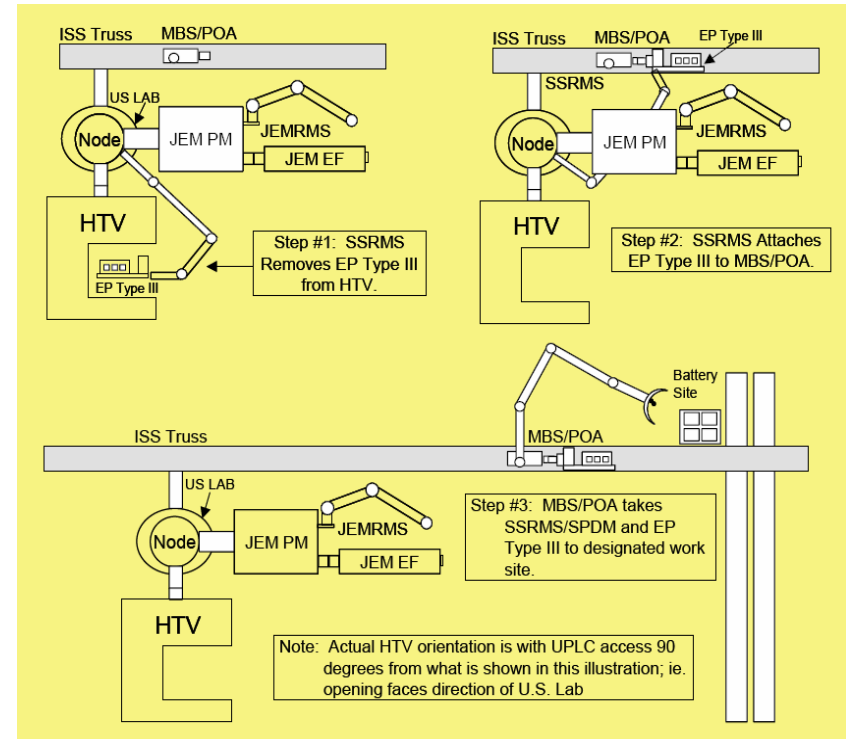
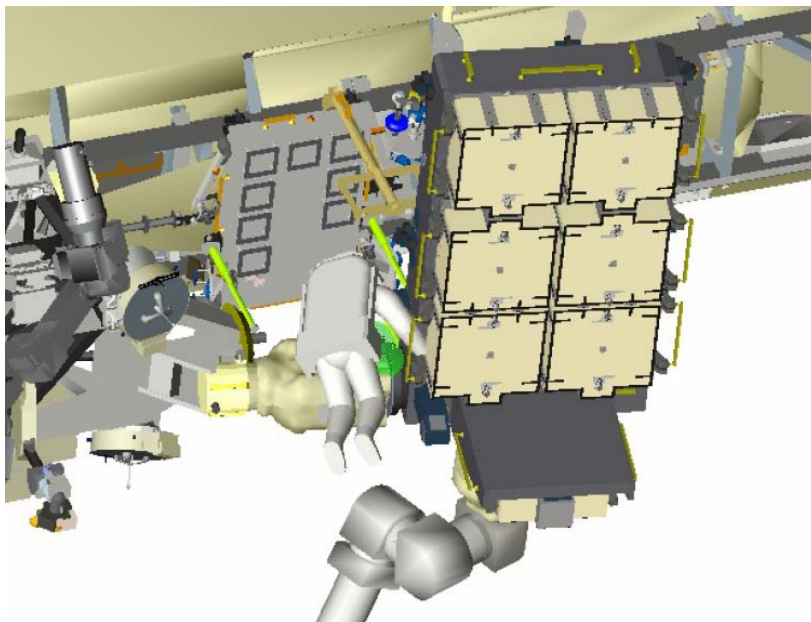



HTV EP-MP Maximum Cargo Envelope (After FRGF Forward Structure Removal)

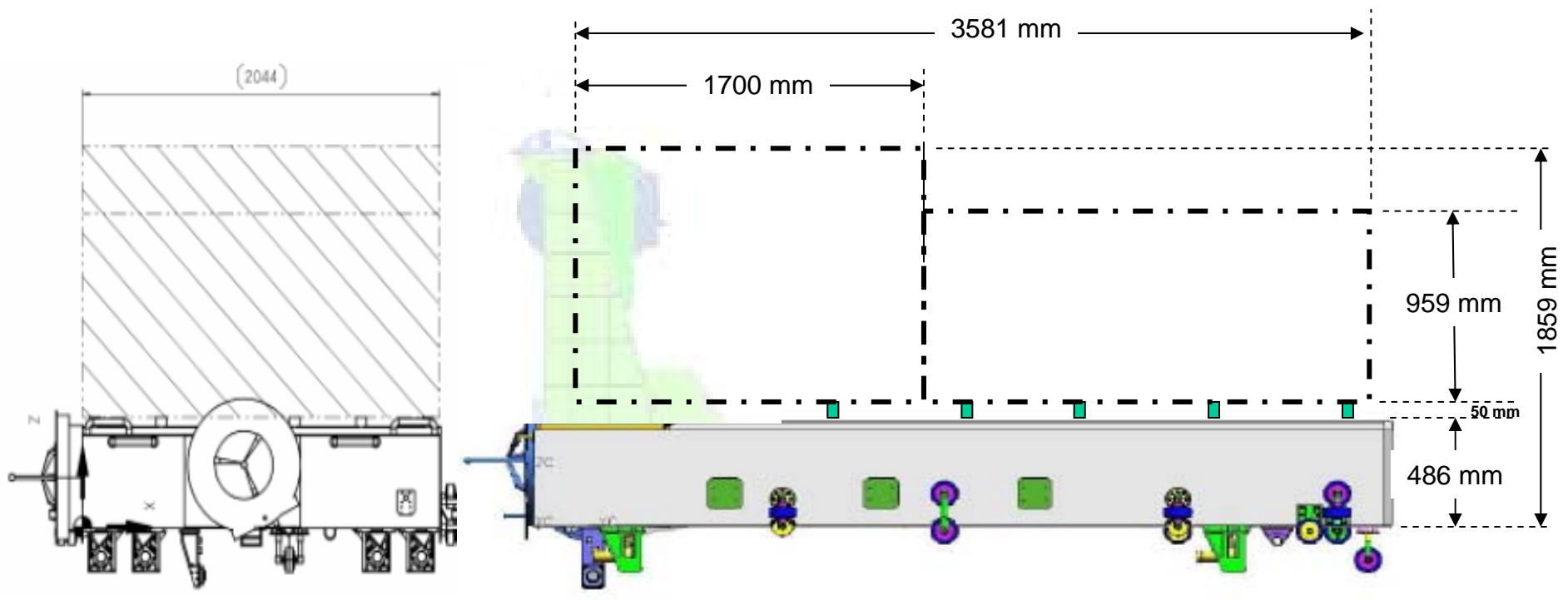



Payload Provider's Responsibility Summary

Cargo's responsibility includes the following

- Integration of the interface hardware to payload
- Provides analytical models per HTV project team's schedule template
- Supports JAXA analytical and physical integration
- Provides Safety Data Package to NASA/JAXA safety review panel and participates the safety review
- Performs post delivery functional testing
- Provides launch support



Conceptual Flow of Safety Process for On-Orbit Safety

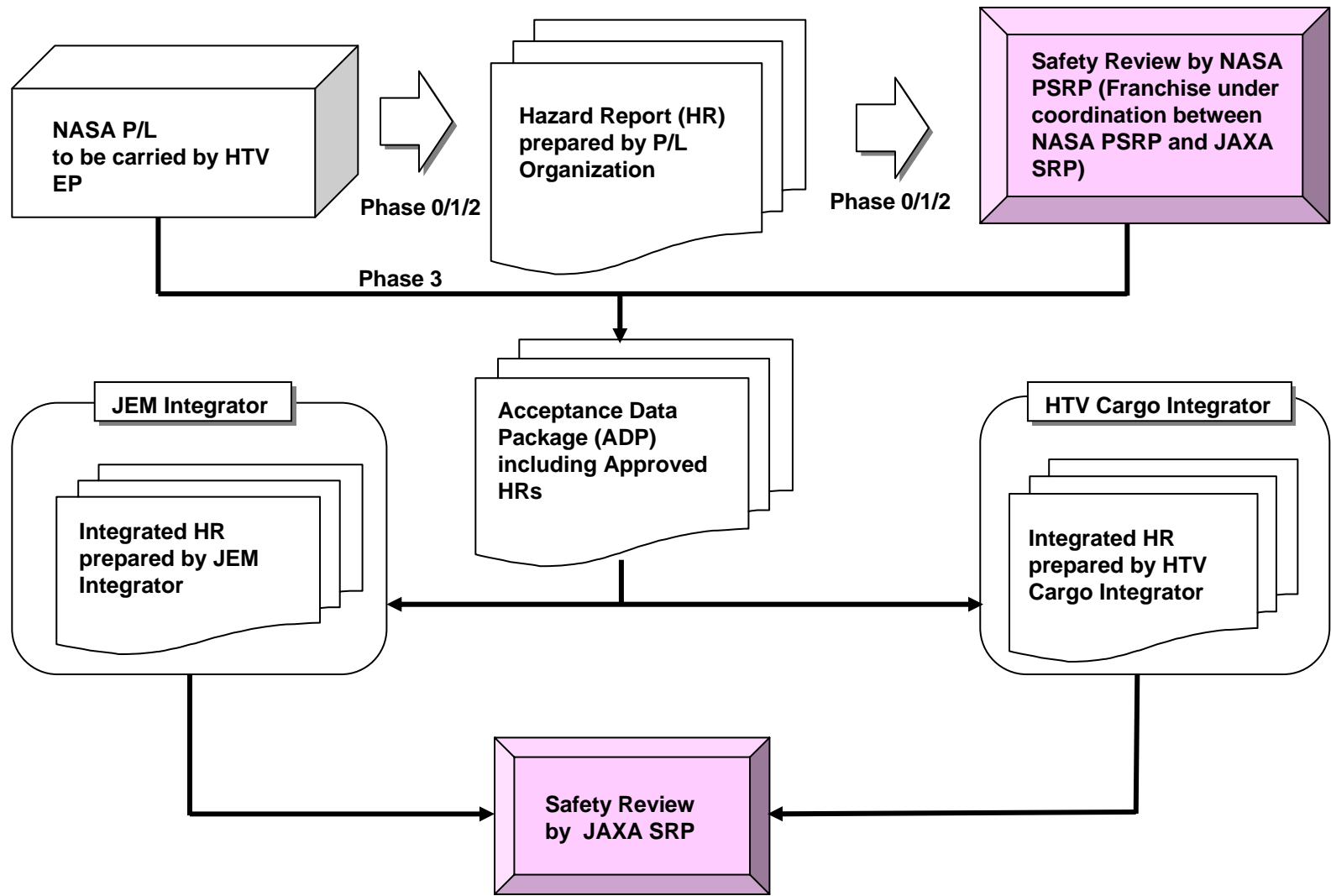



Conceptual Flow of Safety Process for Ground Safety

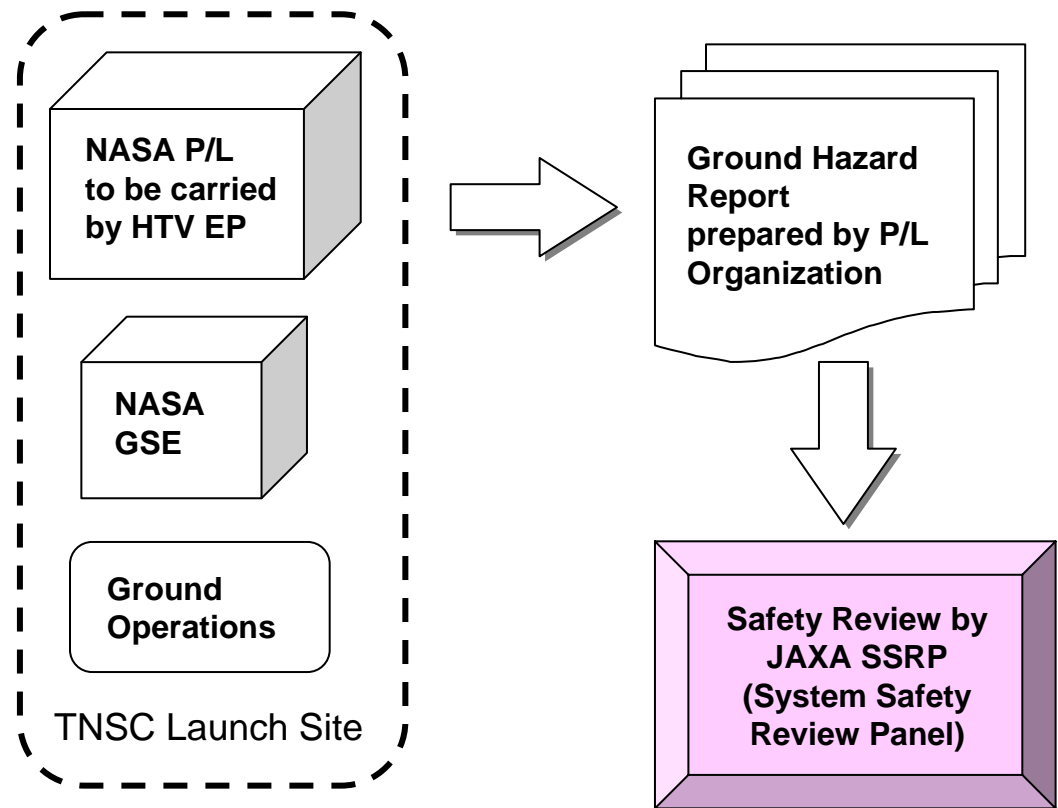

Integration Process Highlight

Pressurized Cargo

Pressurized Cargo:

- HTV pressurized cargo manifest will be baseline at L-12 months
- Cargo to HTV PLC ICD baseline at L-12 months (or at CDR)
- HTV preliminary Couple Load Analysis cycle starts at L-18 months
 - Preliminary model delivery to JAXA is required
- Cargo delivery to Bench Review: TBD
- Cargo handover to Tanegashima : L-25~21 wks (*preliminary*)

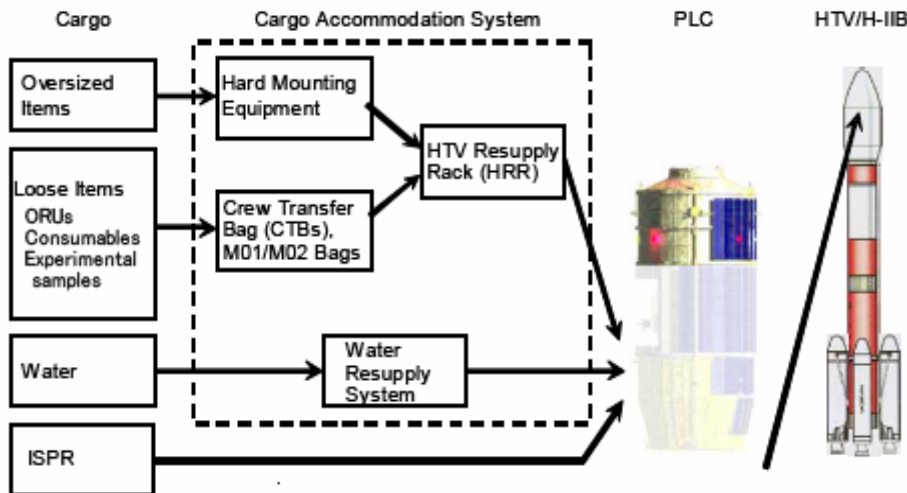

	CTB	ISPR
	L-21 week	L-17 week
PFM (HTV1)	before 4.5 months	before 3.5 months
	L-25 week	L-20 week
FM (HTV2 ~)	before 5.2 months	before 4.2 months
(Note)	Based on the launch day	



Integration Process Highlight Un-Pressurized Cargo

Un-Pressurized Cargo:

- Payload commitment delivery date to NASA: L-24 months
- JAXA HTV EP configuration baseline: L-24 months
- HTV Preliminary Analytical Integration Cycle: L-18 months
- Cargo to HTV EP ICD baseline at L-12 months (or at CDR)
- Cargo delivery: L- 4.2~3.5 months

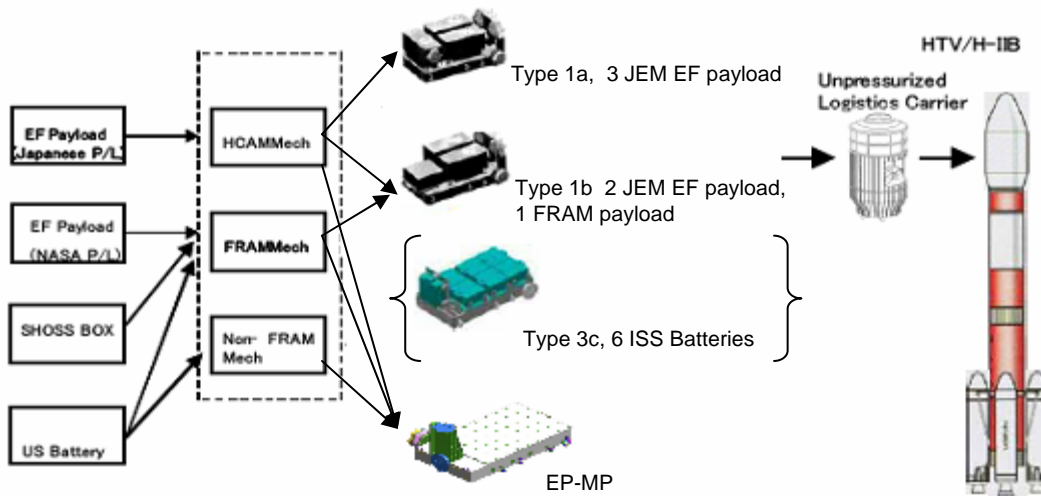

	Un-pressurizing cargo
	L-17 week
PFM (HTV1)	before 3.5 months
	L-20 week
FM (HTV2 ~)	before 4.2 months
(Note)	Based on the launch day



Summary

- All requirement document will be provided in NASA EDMS via. a web link in ISSP payload office SMEX Q/A website