



# PROCEEDINGS SPRING TERNARY

## GULF OF MEXICO STUDIES MEETING

March 1985

COR  
COPY

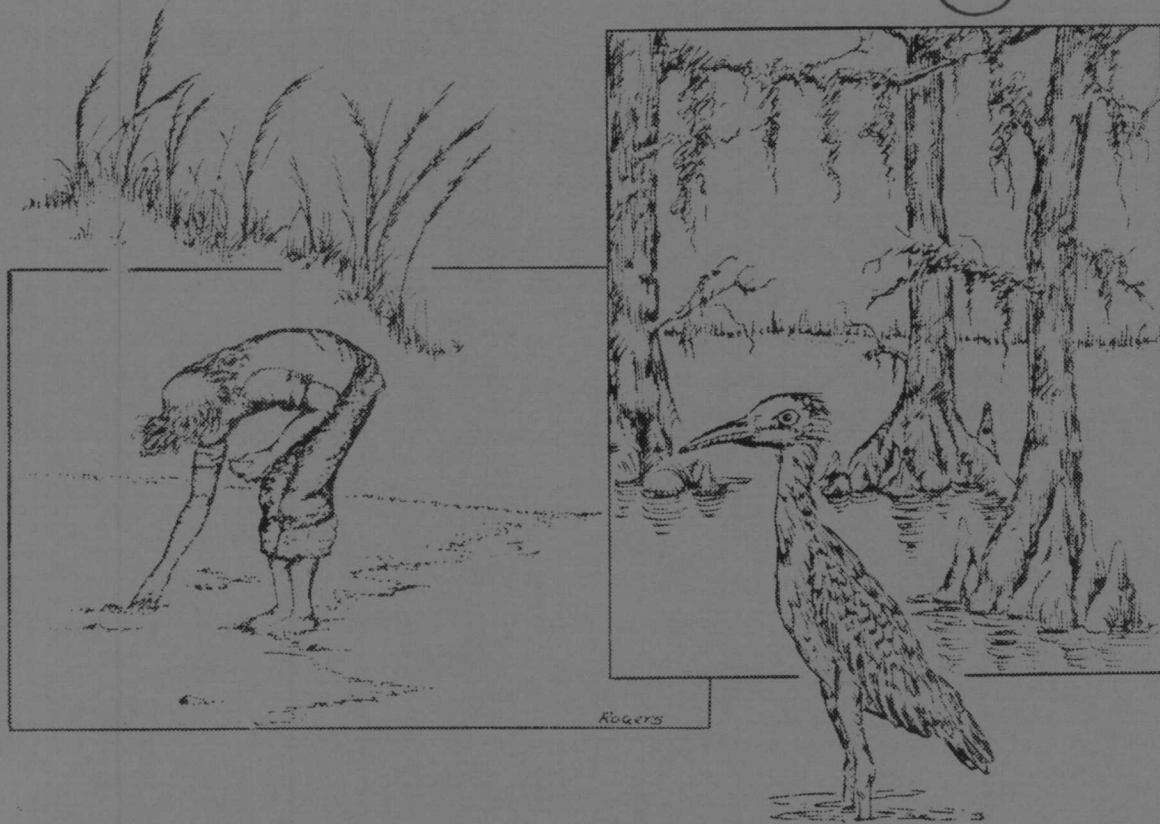

# PROCEEDINGS SPRING TERNARY GULF OF MEXICO STUDIES MEETING

held  
March 12-13, 1985

at

Gulf of Mexico OCS Regional Office  
Minerals Management Service  
Department of the Interior  
Metairie, Louisiana

Prepared under Contract 14-12-0001-29158

by

Science Applications International Corporation  
4900 Water's Edge Drive, Suite 255  
Raleigh, North Carolina 27606

submitted to

Minerals Management Service  
Gulf of Mexico OCS Regional Office  
Metairie, Louisiana 70010  
May 1985

#### REPORT AVAILABILITY

Preparation of this report was conducted under Contract between the Minerals Management Service and Science Applications, Inc. Extra copies of the report may be obtained from the Public Information Section (Mail Stop OPS-3-4) at the following address:

Minerals Management Service  
Gulf of Mexico OCS Regional Office  
U.S. Department of the Interior  
P.O. Box 7944  
Metairie, Louisiana 70010  
Attn: Public Information Section  
Phone: (504) 838-0519

#### DISCLAIMER

This report has been reviewed by the Minerals Management Service and approved for publication. Approval does not signify that the contents necessarily reflect the views and policies of the Service, nor does mention of trade names or commercial products constitute endorsement or recommendation for use.

## TABLE OF CONTENTS

	<u>Page</u>
Table of Contents	1
1. Introduction	1
2.0 Meeting Abstracts	1
2.1 Agenda	4
2.2 Extended Abstracts	
Seagrass Habitat Mapping Study	6
Tuscaloosa Trend Data Search and Synthesis	17
Socioeconomic Indicators Study	29
Physical Oceanography Field Measurements Program	38
Circulation Modeling Program	50
Gulf Meteorological Data Base and Synthesis	65
Southwest Florida Shelf Program	72
Continental Slope Ecosystems Program	86
2.3 List of Registered Attendees	118

## MEETING SUMMARY

### MARCH, 1985 TERNARY MEETING

#### 1.0 INTRODUCTION:

On March 12, the Environmental Studies Group, of the MMS, Gulf Regional Office convened the first Ternary Meeting of 1985. These public meetings are held as a forum for information exchange between interested and involved parties. This generally includes MMS personnel, representatives of various MMS funded programs, state representatives, public interest groups, other federal agencies, and invited investigators working on problems similar to or complimentary to those supported by MMS.

The meeting consists of a representative from most of the MMS funded programs making a presentation which variously defines the program goals, schedule, methodology, present status and any important or relevant insights recently developed. The meeting schedule is such that there is ample opportunity for exchange between speakers and audience. In addition, sufficient "unallocated" time is usually available for discussion between those in attendance.

#### 2.0 MEETING ABSTRACTS:

At the meeting each speaker provides an abstract of material to be discussed. This abstract is made available to meeting attendees prior to the scheduled talks so each has an opportunity to become familiar with the material to be presented. It also allows question formulation without trying to simultaneously listen to an ongoing presentation. These abstracts form the basis for this Meeting Summary.

Abstracts included in this volume are copies of those provided by each speaker. No effort has been made to adjust the form and substance of these submissions.

This report contains the following meeting material:

- o Agenda
- o Abstracts of Presentations
- o List of Attendees

These are Items 1, 2 and 3 and follow immediately.

Any questions regarding presented material should be directed to the appropriate speaker. General questions regarding the Ternary Meeting should be directed to the Environmental Studies Group in the MMS, Gulf Regional Office.

ITEM 1

AGENDA

## Agenda

### MINERALS MANAGEMENT SERVICE

#### ENVIRONMENTAL STUDIES TERNARY MEETING

March 12, 1985

Metairie, LA

<u>Time</u>	<u>Topic</u>	<u>Speaker</u>
9:00 a.m.	Seagrass Habitat Mapping Study	Mr. John Thompson Continental Shelf Assoc.
9:30	Tuscaloosa Trend Data Search and Synthesis	Mr. Kevin Shaw Barry Vittor & Associates
10:00	Socioeconomic Indicators Study	Mr. Garry Brown Centaur Assoc., Inc.
10:30	Physical Oceanography Field Measurements Program	Dr. Van Waddell Science Applications International Corporation
11:00	Circulation Modeling Program	Dr. Alan Wallcraft Jaycor, Inc.
11:30	Gulf Meteorological Data Base and Synthesis	Mr. Jerry Ford Florida A&M University
12:00	LUNCH	
1:30 p.m.	Southwest Florida Shelf Program	Dr. Larry Danek Environmental Science and Engineering, Inc.
2:00	Continental Slope Ecosystems Program	Mr. Ian Rosman LGL Ecological Research Associates



ITEM 2

EXTENDED ABSTRACTS

ABSTRACT FOR  
FLORIDA BIG BEND SEAGRASS HABITAT STUDY

(CONTRACT NO. 14-12-0001-30188)  
MMS TERNARY MEETING  
12 MARCH 1985  
METAIRIE, LOUISIANA

SUBMITTED TO:

Environmental Studies Group  
Gulf of Mexico Regional Office  
Minerals Management Service  
Metairie, Louisiana

SUBMITTED BY:

Continental Shelf Associates, Inc.  
759 Parkway Street  
P.O. Box 3609  
Jupiter/Tequesta, Florida 33458

and

Martel Laboratories, Inc.  
7100 30th Avenue North  
St. Petersburg, Florida 33710

## ABSTRACT

Continental Shelf Associates, Inc. and its subcontractor Martel Laboratories, Inc. were awarded the Florida Big Bend Seagrass Habitat Study contract in September of 1984. Objectives of this study are:

- 1) To inventory and map seagrass beds in the Florida Big Bend Area by combining aerial remote sensing and extensive ground truthing;
- 2) To determine the seaward extent of major seagrass beds present; and
- 3) To classify and delineate major ecological habitat types found in the study area.

To accomplish these objectives, the study program was divided into three parts:

- 1) Cruise 1 (24 October to 1 November 1984). During this cruise, quantitative signature control stations were established. Targets were deployed at these stations to mark their locations on the aerial imagery.
- 2) Remote sensing overflights along 27 predetermined flight lines (30 October to 17 November 1984).
- 3) Cruise 2 (19 to 27 February 1985). This cruise was conducted to verify information obtained from the remote sensing overflights.

During Cruise 1, 232 km (125 NM) of transects were surveyed using an underwater television system (Figure 1), and 50 quantitative signature control stations were established (Figure 2). Navigational fixes were

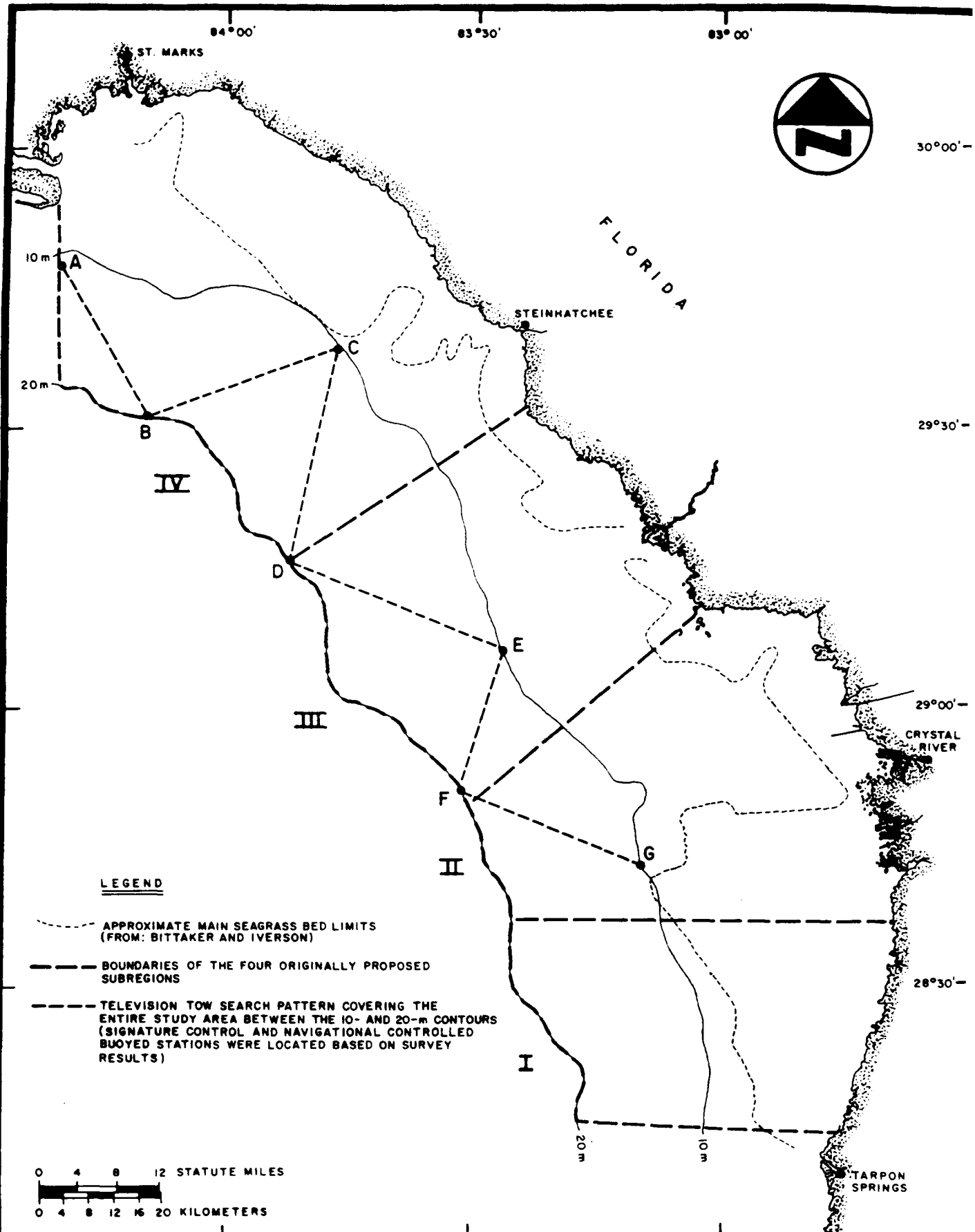

FIGURE 1. TELEVISION SURVEY TRANSECTS RUN DURING CRUISE I (24 OCT-1 NOV 1984).



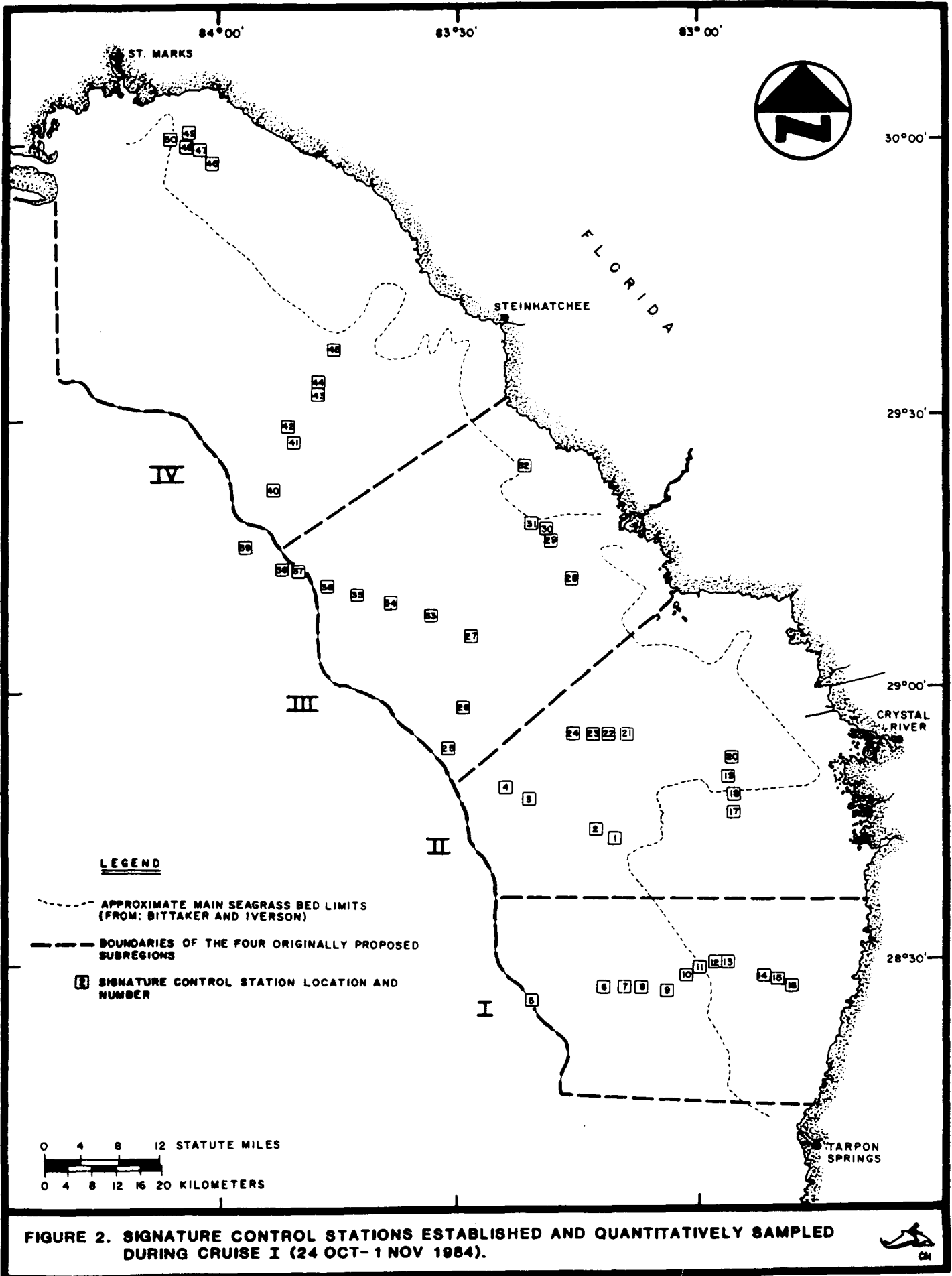

FIGURE 2. SIGNATURE CONTROL STATIONS ESTABLISHED AND QUANTITATIVELY SAMPLED DURING CRUISE I (24 OCT-1 NOV 1984).



recorded at 242-m (794-ft) intervals along the television transects. At each fix, the habitat type was classified and recorded according to eight classification codes: (1) dense seagrass and algae; (2) sparse seagrass and algae; (3) patchy seagrass and algae; (4) dense live bottom; (5) sparse live bottom; (6) patchy live bottom; (7) bare sand bottom; and (8) bare mud bottom. Table 1 shows the percentage of coverage of each habitat type along each transect. Table 2 lists the 50 quantitative stations by habitat type.

Approximately 1.6 million ha (4 million acres or 5,839 mi<sup>2</sup>) of seafloor were photographed during the remote sensing overflights. Contract specifications required an imagery scale of 1:40,000, 60% front-end overlap on all frames, and 40% side overlap for each flight line. A total of 600 [22.9 cm x 22.9 cm (9 in x 9 in)] color prints were generated, and 771,034 ha (1,905,199 acres or 2,976 mi<sup>2</sup>) of seagrass, algal, and live-bottom assemblages were mapped. Resolution was excellent on the aerial imagery, and seagrass/live-bottom assemblages can be mapped to a depth of 12 m (39 ft) over most of the study area.

Nine combination diver-tow and underwater television transects were surveyed during Cruise 2 (Figure 3). Towed divers maintained constant communication with the survey vessel while underwater and recorded specific habitat types [(1) to (8) as given above] at fixes taken every two minutes. On transects where depths became too great for towed-diver observations to be effective, the underwater television camera system was deployed and the transect continued into depths beyond the edge of the specified study area. The Cruise 2 ground-truthing effort surveyed

TABLE 1. PERCENT COVERAGE OF EACH HABITAT TYPE ALONG SIX TELEVISION TRANSECTS SURVEYED DURING CRUISE 1 OF THE FLORIDA BIG BEND SEAGRASS HABITAT STUDY.

Habitat Type	Transect					
	A to B	B to C	C to D	D to E	E to F	F to G
Dense Seagrass and Algae	20	9	12	15	-	13
Sparse Seagrass and Algae	8	20	19	11	19	36
Patchy Seagrass and Algae	-	19	17	5	8	11
Dense Live Bottom	12	5	17	7	19	9
Sparse Live Bottom	6	3	8	1	-	-
Patchy Live Bottom	26	38	17	13	27	20
Bare Sand Bottom	27	6	10	48	27	11
Bare Mud Bottom	1	-	-	-	-	-

TABLE 2. HABITAT TYPES OF THE 50 QUANTITATIVE SIGNATURE CONTROL STATIONS ESTABLISHED DURING CRUISE 1 OF THE FLORIDA BIG BEND SEAGRASS HABITAT STUDY.

Habitat Type	Station Numbers	Total Stations per Habitat Type
Dense Seagrass and Algae	9, 13, 14, 15, 16, 17, 38, 40, 41	9
Sparse Seagrass and Algae	4, 25, 44, 45, 46, 47, 50	7
Patchy Seagrass and Algae	2, 3, 29, 34, 35, 36	6
Dense Live Bottom	8, 39	2
Sparse Live Bottom	6, 11, 12, 20, 26, 37	6
Patchy Live Bottom	1, 5, 19, 42, 43, 49	6
Bare Sand Bottom	7, 10, 18, 21, 22, 23, 24, 27, 31, 32, 33	11
Bare Mud Bottom	28, 30, 48	3



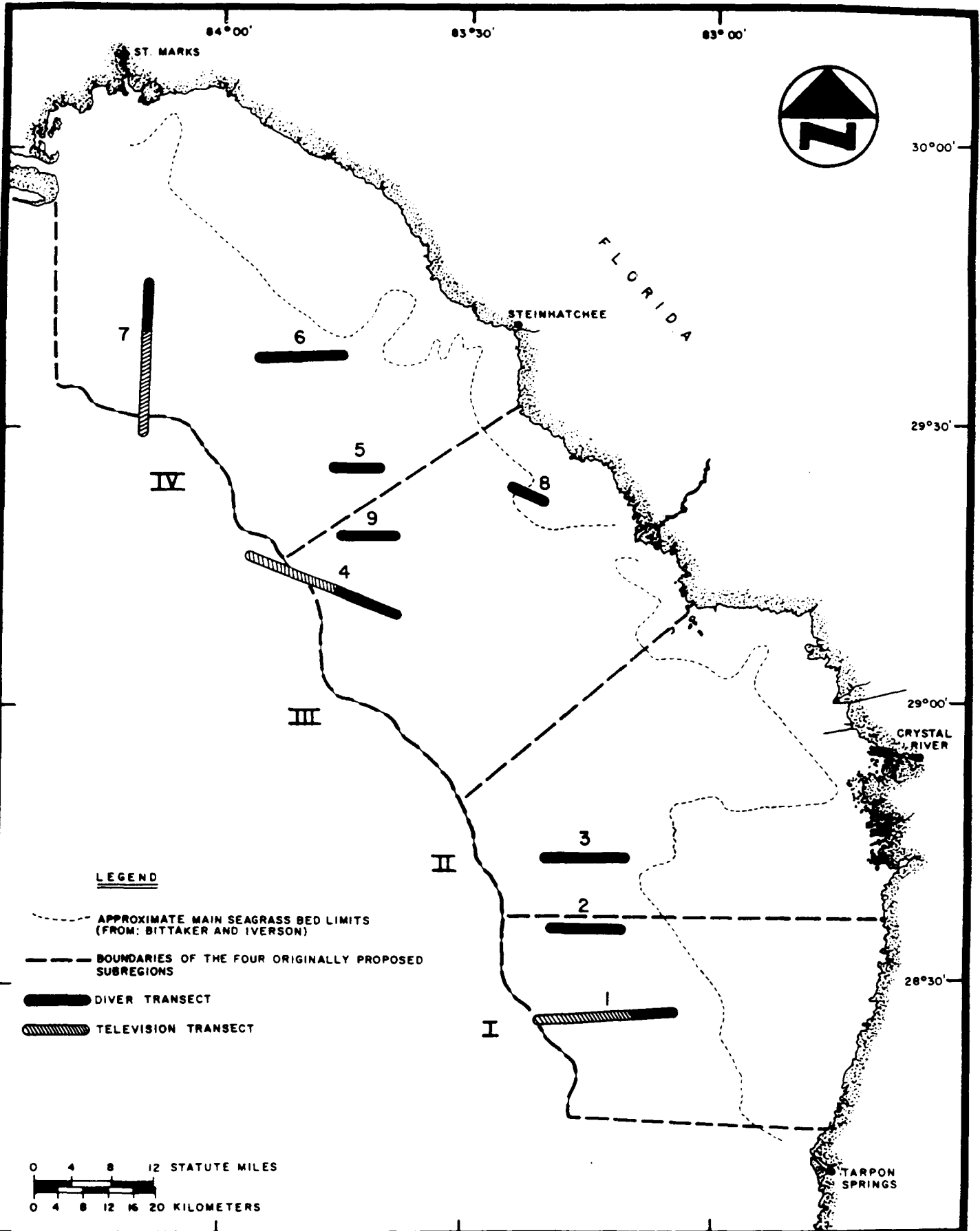

FIGURE 3. DIVER AND TELEVISION SURVEY TRANSECTS RUN DURING CRUISE II (19-27 FEB 1985).



174 km (94 NM) of seafloor. A total of 102 km (55 NM) were surveyed by towed divers and 72 km (39 NM) by underwater television.

Eleven of the 50 quantitative signature control stations established during Cruise 1 were resampled during Cruise 2 (Figure 4). These stations were specifically selected for resampling because they were located in representative seagrass, algal, and live-bottom habitats.

At the present time, data analysis and photointerpretation for the Florida Big Bend Seagrass Habitat Study are not complete. Preliminary observations indicate the ecological habitats seen in the Florida Big Bend Area form two distinct associations. There is an inshore association consisting of Thalassia testudinum, Syringodium filiforme, and Halodule wrightii. Normally occurring in less than 9 m (30 ft) of water, these species form major grass bed habitats, which can generally be easily detected on the aerial imagery. Seaward of this association and generally separated from it by a stretch of unvegetated sand bottom of variable width are large areas characterized by overlapping mixtures of algal, seagrass, and live-bottom habitats. Halophila decipiens and H. englemanni are the only vascular plant species seen in this offshore association. Attached algal species include several different forms of Caulerpa sertularioides, C. verticillata, C. prolifera, C. mexicana, Udotea sp., Penicillus sp., Halimeda sp., and Sargassum sp. Seasonally, an abundance of "drift" or unattached filamentous red algae (primarily species of Gracilaria and Spyridia) are seen in this area and may complicate photointerpretation.

Preliminary interpretation of the aerial imagery indicates 197,018 ha (486,862 acres or 760 mi<sup>2</sup>) of mixed Thalassia, Syringodium,

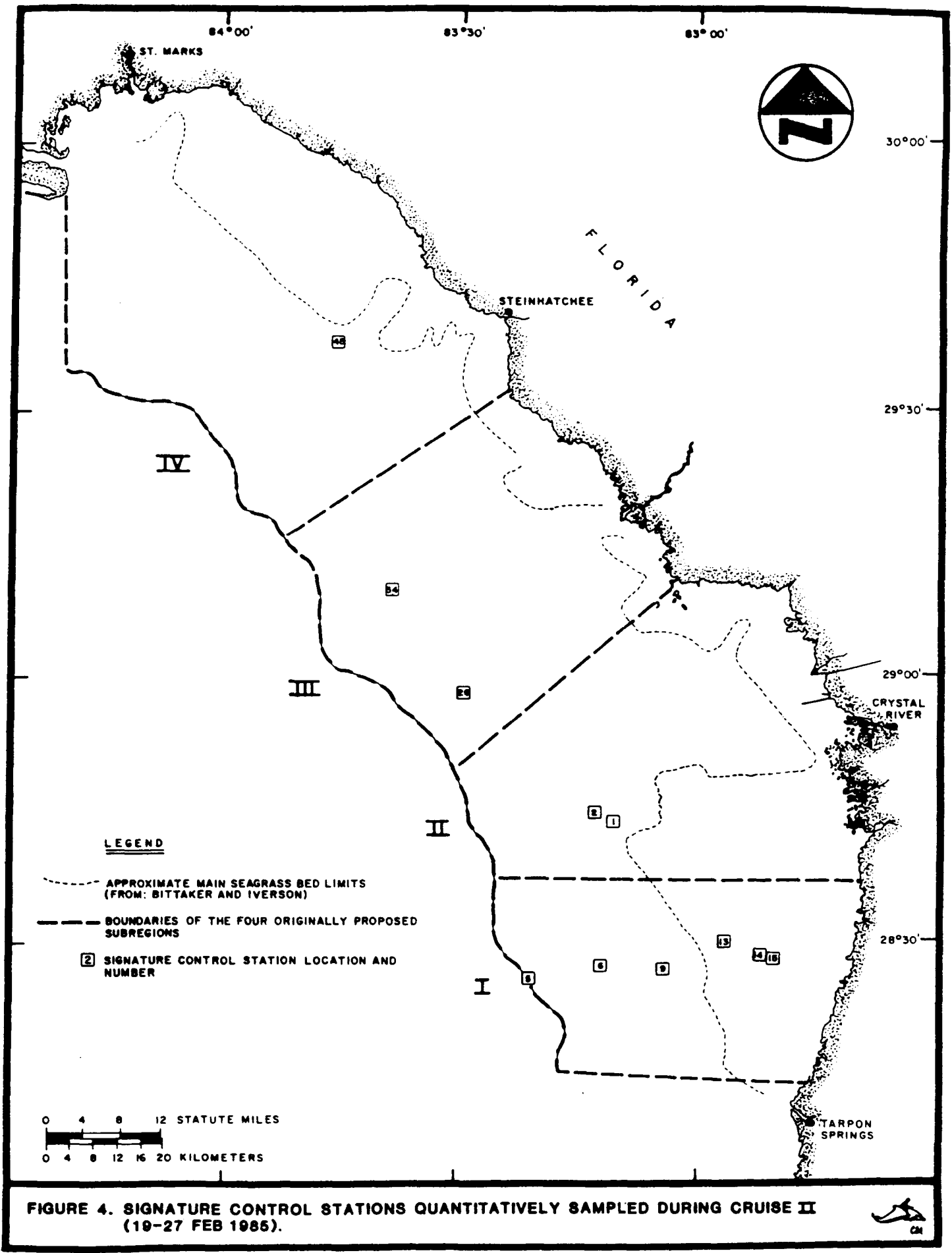

and Halodule seagrass beds in the nearshore portions of the study area, and another 574,000 ha (1,418,337 acres or 2,215 mi<sup>2</sup>) of mixed Halophila, algae, and live-bottom habitats in the offshore portions of the study area.

The final products from this study are due 15 October 1985. They will consist of a four-volume atlas containing the actual color prints with mylar overlays showing the photointerpretation; maps delineating the classified habitats on 1:250,000 scale protraction diagram base maps; and a narrative report discussing the quantitative data collected and summarizing the relevant literature.

TUSCALOOSA TREND REGIONAL CONCEPTUAL  
MODEL AND SYNTHESIS STUDY

Prepared by:

BARRY A. VITTOR & ASSOCIATES, INC.  
Mobile, Alabama

Prepared for:

MINERALS MANAGEMENT SERVICE  
Gulf Regional OCS Office  
Metairie, Louisiana

Information Transfer Meeting  
Metairie, Louisiana

March 12, 1985

## TUSCALOOSA TREND REGIONAL CONCEPTUAL MODEL SYNTHESIS STUDY

Barry A. Vittor & Associates, Inc. (contractor)  
Quantus, Inc. and Science Applications, Inc., Oak Ridge (subcontractors)

Of current interest to oil and gas exploration in the northern Gulf of Mexico is the outer continental shelf area off southeastern Louisiana, Mississippi, and Alabama. The presence of the geologic feature, known as the Tuscaloosa Trend, extends from southern Louisiana into the offshore waters of the Chandeleur Islands, eastward to the DeSoto Canyon, and promises to be highly productive in terms of recoverable oil and natural gas reserves (Figure 1). The waters adjacent to the Chandeleur Islands and within Breton Sound, Mississippi Sound, and Mobile Bay also support a significant recreational and commercial fishery, which is of concern to the adjoining states. Because of industry interest and potential for future ecological impact by accelerated OCS oil and gas activities, the Tuscaloosa Trend region was selected by Minerals Management Service for a thorough environmental characterization and ecosystem modeling effort. The first year effort consists of a comprehensive survey of available data and literature for synthesis into a report, the identification of information/data gaps, and development of an ecosystems model for management purposes.

### INFORMATION COLLECTION AND REVIEW

Information collection involved computer-based literature searches, literature and data collections, and interviews with researchers and managers within academic and government agencies within Louisiana, Mississippi, and Alabama. Over two thousand reference citations have been retrieved and cross-referenced. All citations were entered in the NEDRES format, while pertinent references were also annotated. We have completed

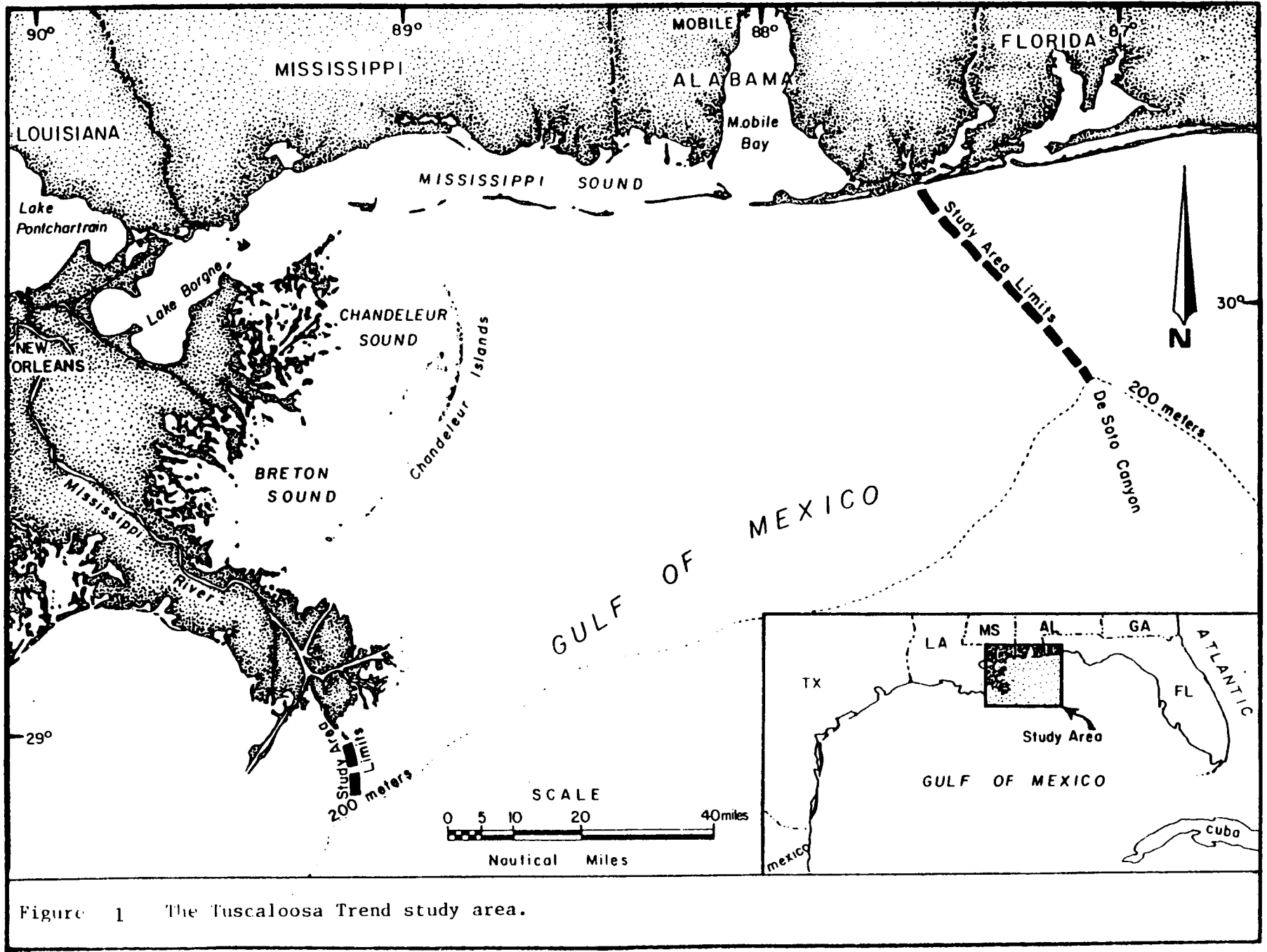

Figure 1 The Tuscaloosa Trend study area.

the review of literature collected and have organized the synthesis into the following topical areas:

Physiography  
Geology  
Physical Oceanography  
Chemical Oceanography  
Ecological Resources  
Socioeconomics

Literature review and synthesis activities were centered on establishing structural and functional relationships between and among the coastal marshes, estuarine waters, and continental shelf subsystems based on major sources of inputs and outputs and processes conceptualized within the Tuscaloosa Trend ecosystem model.

#### CONCEPTUAL ECOSYSTEM MODEL

Concomitant with the comprehensive information survey was the development of a conceptual model which interrelates processes with the various components of the Tuscaloosa Trend ecosystem.

The objectives of the conceptual modeling effort were four-fold:

1) To represent the Tuscaloosa Trend OCS region as an integrated system of physical, biogeochemical, and socioeconomic components, stressing functional relationships;

2) To show the important interactions between the Tuscaloosa Trend OCS and other adjoining ecosystems;

3) To provide the context within which the information search and synthesis activities were conducted and information gaps identified; and

4) To form a framework for managing multidisciplinary research activities in subsequent years of the program.

Basically, this dynamic offshore ecosystem is represented as an open system with upcoast, downcoast, estuarine, deep ocean, and atmospheric boundaries and exchanges (Figure 2). The major sources of inputs and



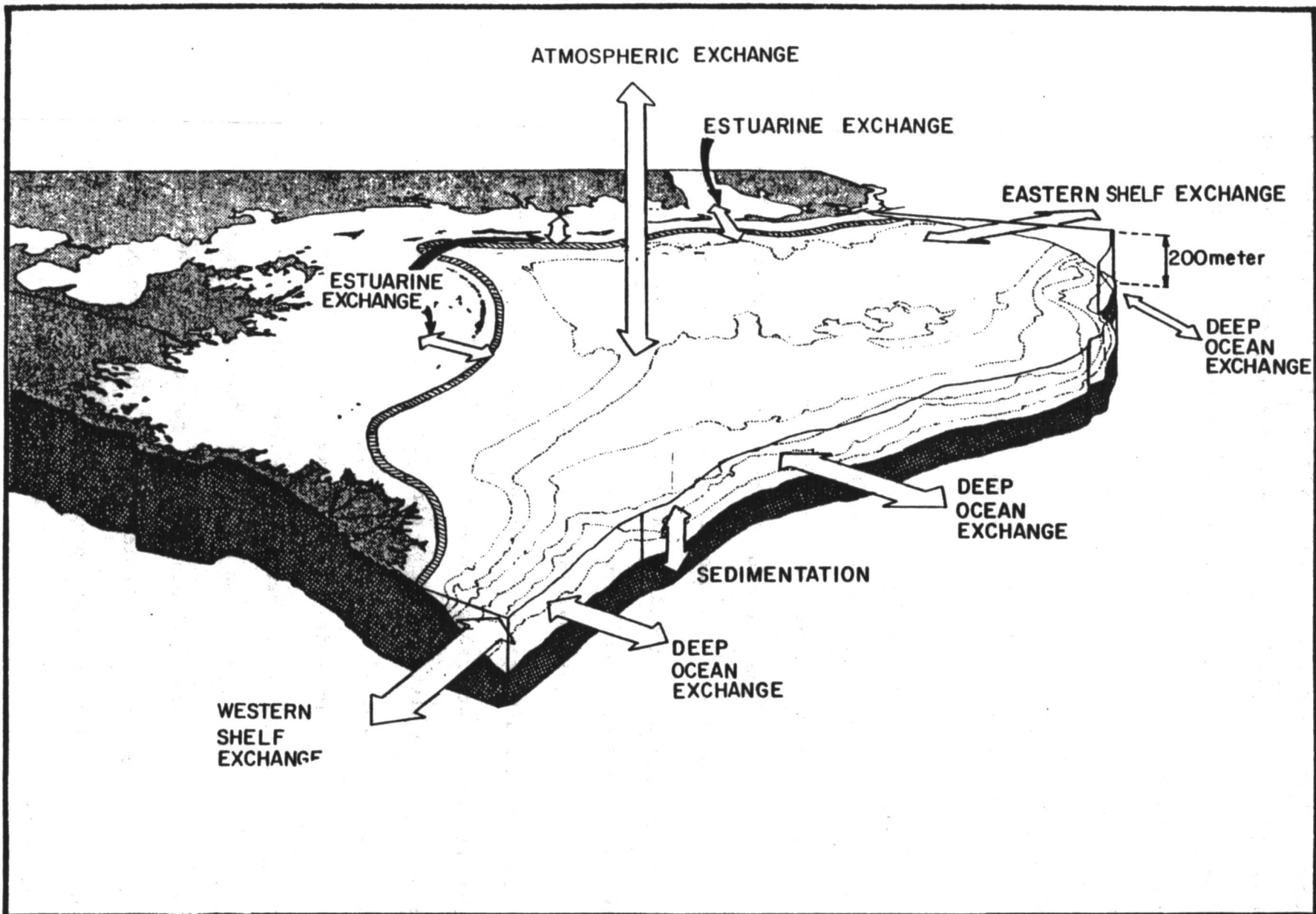

Figure 2 The boundaries and exchange processes used in the conceptual representation of the Tuscaloosa Trend ecosystem.

outputs, biotic and abiotic compartments, processes, and regulators were identified in a connectivity matrix (Table 1), and the relationships between the physical, biogeochemical and ecological subsystems were incorporated into a conceptual representation of the Tuscaloosa Trend ecosystem (Figure 3).

#### INFORMATION SYNTHESIS

Information collected for the Trend area has been synthesized to complement the conceptual ecosystem model. Some of the available data can be identified with system inputs/outputs, compartments, processes, and regulators shown in Table 1. Inputs include atmosphere, estuarine discharges, transported sediments, wastes, and organic matter, and biological population movements. The available information is generally adequate to characterize these inputs, but additional data are required for quantification. System outputs are defined by water mass circulation, sediment dispersion from the Trend OCS area, wastes, biological production (as migrating populations and fishery harvesting) and mineral resource extraction. The information regarding sediment and waste outputs is considered inadequate to characterize relationships between the OCS and adjoining systems. Additional data are also needed for circulation patterns and biological population movements out of the area.

System compartments and processes include components of physical and biological oceanography, sediments, wastes, mineral resources, navigation, and recreation. While good data exist for socioeconomic resources, only limited information has been obtained for other resource categories. Of particular importance is chemical composition of the OCS area, waste levels and fates, and biological populations, including phytoplankton and zooplankton.

Table 1 A connectivity matrix showing the components of the comprehensive conceptual representation of the Tuscaloosa Trend ecosystem.

		Compartments					Inputs				
		Pelagic Community	Benthic Community	Dissolved Materials	Particulate Material	Sediments	Atmospheric Inputs	Estuarine Inputs	Oceanic Inputs	Man	
To	Compartments	Pelagic Community	$\phi_1(\beta)$	$\phi_4(\tau, \alpha, \beta)$	$\phi_3(\tau, \beta)$	$\phi_2(\delta, \beta, \tau)$		$\phi_8(\sigma, \tau, \gamma, \alpha, \theta, \beta)$	$\phi_4(\sigma, \tau, \alpha, \beta)$	$\phi_4(\alpha, \tau, \beta)$	
	Benthic Community	$\phi_4(\tau, \beta)$	$\phi_1(\beta)$	$\phi_3(\beta, \tau, \alpha)$	$\phi_2(\delta, \beta, \tau)$	$\phi_2(\gamma, \tau, \theta)$ $\phi_6(\tau, \beta)$		$\phi_4(\sigma, \tau, \alpha, \beta)$	$\phi_4(\alpha, \tau, \beta)$		
	Dissolved Material	$\phi_7(\tau, \beta)$ $\phi_9(\tau, \beta)$	$\phi_7(\tau, \beta)$ $\phi_9(\tau, \beta)$		$\eta_9(\sigma, \tau, \theta)$	$\eta_9(\theta, \delta)$ $\eta_{11}(\alpha, \tau, \lambda)$	$\eta_5(\sigma, \tau, \gamma)$ $\eta_7(\lambda)$	$\eta_3(\theta, \sigma, \rho, \lambda)$	$\eta_3(\rho, \lambda)$	$\eta_{13}$	
	Particulate Material	$\phi_9(\tau, \beta)$	$\phi_9(\tau, \beta)$	$\eta_6(\sigma, \rho, \alpha, \theta)$ $\eta_{10}(\sigma, \tau, \alpha, \theta)$		$\eta_2(\rho, \delta, \alpha, \theta)$	$\eta_7(\lambda)$	$\eta_2(\sigma, \rho, \delta, \theta)$ $\eta_3(\theta, \sigma, \rho)$	$\eta_3(\rho, \lambda)$	$\eta_{13}$	
	Sediments		$\phi_5(\delta, \beta)$ $\phi_6(\tau, \beta)$ $\phi_9(\tau, \beta)$	$\eta_{10}(\sigma, \tau, \alpha, \theta)$	$\eta_1(\rho, \delta, \alpha, \theta)$						
	Atmosphere			$\eta_5(\sigma, \tau, \gamma)$ $\eta_8(\tau, \sigma, \rho)$							
	Inputs	Estuary	$\phi_4(\sigma, \tau, \alpha, \beta)$	$\phi_4(\sigma, \tau, \alpha, \beta)$	$\eta_3(\sigma, \rho, \lambda)$	$\eta_3(\theta, \rho, \delta)$					
	Ocean	$\phi_4(\alpha, \tau, \beta)$	$\phi_4(\alpha, \tau, \beta)$	$\eta_3(\rho, \lambda)$	$\eta_3(\theta, \rho, \delta)$						
	Man	$\phi_{10}(\lambda, \beta, \gamma)$	$\phi_{10}(\lambda, \beta, \gamma)$								

**Processes**

**Biotic**

- $\phi_1$  - biotic interactions
- $\phi_2$  - ingestion
- $\phi_3$  - nonfeeding uptake
- $\phi_4$  - spawning, migration and passive dispersal
- $\phi_5$  - bioturbation
- $\phi_6$  - decomposition
- $\phi_7$  - respiration
- $\phi_8$  - photosynthesis
- $\phi_9$  - excretion, egestion, detritus (death)
- $\phi_{10}$  - harvesting

**Physical/Chemical**

- $\eta_1$  - deposition
- $\eta_2$  - suspension
- $\eta_3$  - advection
- $\eta_4$  - turbulence
- $\eta_5$  - diffusion
- $\eta_6$  - flocculation
- $\eta_7$  - precipitation
- $\eta_8$  - volatilization
- $\eta_9$  - dissolution
- $\eta_{10}$  - absorption
- $\eta_{11}$  - upwelling
- $\eta_{12}$  - freshwater intrusion
- $\eta_{13}$  - dumping and discharging waste

**Regulators**

- $\sigma$  - salinity
- $\tau$  - temperature
- $\rho$  - water density
- $\delta$  - grain size
- $\alpha$  - advection (currents)
- $\theta$  - turbulence
- $\gamma$  - water quality
- $\beta$  - population dynamics
- $\lambda$  - climatic factors

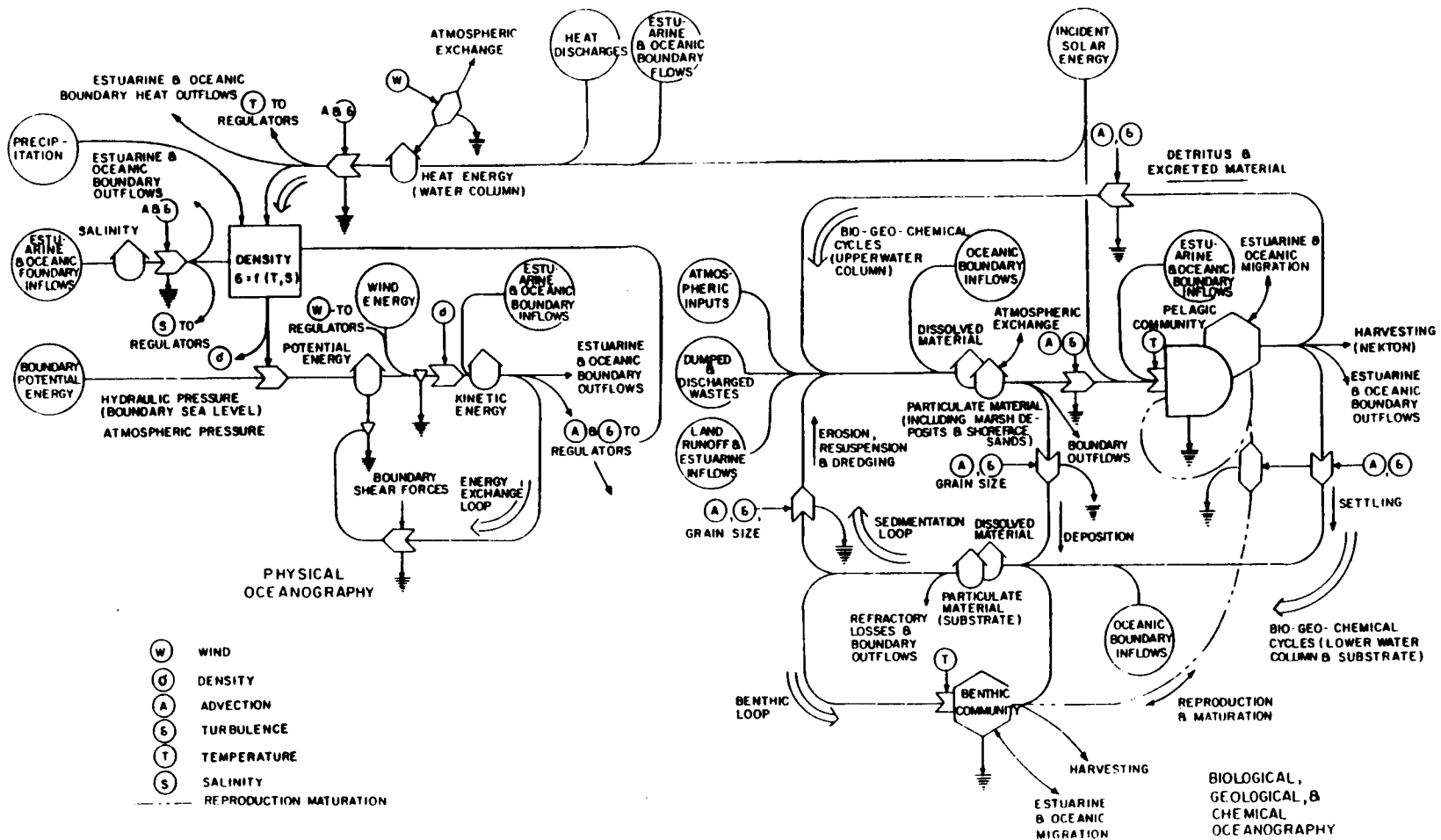

Figure 3 A comprehensive conceptual representation of the Tuscaloosa Trend ecosystem (modified from McLaughlin et al., 1975).

The regulators (such as temperature) of the system are usually generated by the physical processes and regulate many biological and geochemical processes. Although some quantitative data are available for regulators listed in Table 1, they are not sufficient for characterization of the entire shelf.

#### RECOMMENDATIONS FOR FILLING INFORMATION GAPS

Information gaps have been identified for each of the principal components of the Tuscaloosa Trend study area. Some are related to basic environmental or socioeconomic characterization of the region, while others pertain to the processes which define the dynamics of the ecosystem.

##### Geology

(1) The Minerals Management Service's Marine Geologic Atlas Series should be extended to include the remaining areas within the Tuscaloosa Trend.

(2) Efforts should be made to better define the hydrodynamic mechanisms within the Tuscaloosa Trend which influence sediment transport both nearshore and in deep water.

(3) Areas where there are potentially hazardous foundations for petroleum exploration and production structures and pipelines need to be well documented. Geologic features meriting special attention include: 1) gas at shallow depth; 2) buried stream channels; 3) active faults; 4) surficial and shallow deformation including slumping and creep; and 5) diapirs and faulting.

(4) Detailed study of the Chandeleur Sound, Breton Sound, and the adjacent continental shelf should be conducted, and should include sediment distribution mapping, bathymetric surveys, and subbottom profiles.

### Physical Oceanography

(1) Circulation patterns and driving forces in the DeSoto Canyon should be investigated in order to determine the movement of sediments and chemicals across the Trend shelf and up- and downslope.

(2) Existing Tuscaloosa Trend area data concerning currents, temperature, and salinity should be further analyzed in order to assist in description of shelf processes and to aid in designing and directing future process-oriented investigations.

(3) The occurrence and extent of the nepheloid layer in the Trend shelf area should be thoroughly studied, in support of studies of the fate and effects of hydrocarbon and heavy metal pollutants introduced from coastal, riverine, and shelf sources.

(4) Additional studies of currents and circulation patterns across the shelf should be performed, including meteorology, hydrography, horizontal currents, sea state, bottom pressure, and freshwater discharge.

(5) A model of physical oceanographic properties of the Trend area should be developed as a guide to future studies and to predict dispersion of possible pollutants.

### Chemical Oceanography

(1) Nutrient flows and distributions from the tidal passes across the shelf should be characterized in order to complement studies of biological productivity and communities.

(2) Phenomena with significance to the distribution and abundance of biota on the shelf--i.e., hypoxia and the nepheloid layer--should be investigated through field sampling.

(3) Processes of transport and dispersion of terrigenous pollutants should be examined in order to distinguish between effects of coastal and upstream activities vs. those which occur on the open shelf.

(4) Fates of pollutants associated with shelf activities--including petroleum exploration/production, dredged material disposal, and waterborne commerce--should be studied.

(5) Processes of bioaccumulation and biomagnification of chemicals introduced to the Trend shelf should be defined, in order to provide a means to assess the long-term ecological effects of pollutant influxes.

#### Ecological Resources

(1) Movements of biota through the tidal passes should be described to determine energy flux between coastal and OCS waters.

(2) Shelf benthic communities should be defined, with emphasis on habitats (sediment types) not previously described, near major points of riverine discharge, and near-slope environments (including the DeSoto Canyon).

(3) Plankton communities should be described for the shelf with emphasis on primary and secondary production, and correlated with physical and chemical processes to assess relationships between shelf/coastal waters/riverine discharge and OCS biotic potential.

(4) Further analysis of trophic relationships among the biotic components of the shelf ecosystem should be conducted, with emphasis on energy transfer within and between pelagic and benthic components.

#### Socioeconomics

(1) Patterns of navigation and vessel casualties should be examined throughout the Trend study area, in order to assess the likelihood of

accidents due to increased traffic activity from Tenn-Tom waterway and support vessels for exploration/production rigs.

(2) A model should be formulated for projecting the impacts of major oil spills on travel, tourism, and recreation in the Trend area, based on effects of the Ixtoc spill off Texas.

(3) Studies of recreational fishing activities should be standardized among the three states which border the Tuscaloosa Trend area.

(4) Areas of possible submerged prehistoric habitation should be examined through sediment coring and subbottom profiling, in order to determine the likelihood that such sites would be impacted by offshore petroleum exploration/production.



Development and Analysis of Economic  
Indicators for Offshore Oil and Gas Activity in the Gulf of Mexico

Centaur Associates, Inc. is under contract to the Minerals Management Service to develop and analyze economic impact indicators for offshore oil and gas development throughout the Gulf of Mexico.

Phase I

Objectives

The study documents primary economic impacts of all Gulf of Mexico offshore oil and gas exploration, development, and production during 1984. Primary economic impacts include: employment, wages and salaries, and non-wage expenditures. These data are provided by the primary offshore producers and the first tier of contract and service industries. Primary employment and wage impacts are derived for each of the 74 Gulf of Mexico coastal counties/parishes.

Data are also being developed to determine future economic impacts based on physical measures of activity such as per platform or mile of pipe. Future impacts will be segmented by major physical characteristics such as water depth or pipeline size.

Data Sources

The study uses four primary types of data which are being provided by the members and associate members of the Offshore Operators Committee. Primary producers participating in the effort include: Amoco, Chevron, Conoco, Exxon, Gulf, Mobil, Odeco, Shell and Texaco. Personnel data being supplied include records of: employment, wages, job type, work site, staging point (if applicable), and residence. Additional data on 1984 non-wage expenditures and individual project or activity costs are also being provided by the major producing companies.

Methodology

Direct producer employment and wages at the county/parish level are generated directly from the data base of primary producer personnel records. The county/parish allocations of employment and wages are based on the residence zip code of each employee.

Primary employment resulting from the purchases of goods and services are derived by applying key business ratios for each service industry to total expenditures by producers within that industry. Place-of-residence/place-of-employment relationships for the primary producers are used to simulate the geographic distribution of employment for offshore contract employees.

Physical measures of activity are converted to expenditures based on actual detailed project records supplied by the primary offshore producers. Once quantified these impacts may be allocated based on the 1984 distribution of activity for projects in a similar or adjacent area.

## Schedule and Contacts

Phase I of this 14 month effort is to conclude with a draft report and preliminary data in late September of 1985 and a final report delivered to MMS in December of 1985. The effort is currently about one month away from completing the necessary data collection tasks.

Further questions or requests to receive a copy of the report should be directed to:

Michael L. Frankel or  
Garry L. Brown  
Centaur Associates Inc.  
Suite 700  
1400 I Street, N.W.  
Washington, D.C. 20005  
(202) 296-4100

Norman Froomer  
Minerals Management Service  
U.S. Department of the  
Interior,  
Gulf of Mexico OCS Region  
Imperial Office Building  
3301 North Causeway Blvd.  
Metairie, LA 70010  
(504) 838-0859

## Phase II

An independent one year Phase II effort is scheduled to begin in late 1985. This follow-on effort is anticipated to build on the current effort in the following areas:

- o Indirect or secondary effects (the economic activity resulting from the purchases of goods and services by the primary producers and first tier contractors) are to be developed. This includes documenting the detailed inputs and outputs of all significant sectors supplying the offshore service industries.
- o Induced effects (the economic activity resulting from the expenditure of wages and salaries by households) are to be modeled. Induced activity is also to be determined at the county/parish level.
- o The various data bases and models are to be unified into an easily usable automated computer model for projecting the full economic effects of proposed offshore projects at the county/parish level.

**ANALYSIS OF INDICATORS FOR  
SOCIOECONOMIC IMPACTS DUE TO  
OIL AND GAS DEVELOPMENT IN  
THE GULF OF MEXICO**

Prepared for  
the Minerals Management Service  
Gulf of Mexico Region

Centaur Associates, Inc.  
-Garry Brown  
-Michael Frankel  
1400 I Street, N.W.  
Suite 700  
Washington, D.C. 20005  
(202) 296-4100

## OBJECTIVES

The study is designed to document the direct economic impacts of Gulf of Mexico offshore oil and gas activity in 1984 and establish the indicators for determining future impacts. Specifically the study is to:

● Measure the direct economic impact of offshore oil and gas exploration, development and production in 1984. Measures of economic activity include:

- employment
- income (wages, salaries, bonuses)
- non-wage capital and operating expenditures

● Measure the immediate economic impact of contract, service and all other purchases made by the offshore production companies. Measures of economic activity include:

- employment
- income (wages, salaries, bonuses)
- non-wage capital and operating expenditures

● Determine the geographic distribution of the direct economic impacts of offshore oil and gas activity. The geographic distribution is to be measured at the county and parish level for all 74 coastal counties in the Gulf of Mexico.

● Develop a framework and set of procedures for determining the direct economic impact of future offshore development activities.

● Establish a framework for handling all data such that the indirect and induced economic effects can be determined by county at a future date.

## D A T A   S O U R C E S

The primary data being collected for this assessment is being supplied by an especially established Socioeconomic Subcommittee of the Offshore Operators Committee. The Committee members participating in this effort are:

AMOCO

CONOCO

EXXON

GULF

ODECO

SHELL

TEXACO

CHEVRON

MOBIL

The Offshore Operators Committee, American Petroleum Institute and National Ocean Industries Association are also assisting with the contacts necessary to develop economic ratios for the specialized support and contract industries.

## D A T A T Y P E S

The four types of data being assembled as part of this effort are:

● Producer employment records for 1984. Approximately 12,000 employment records are being obtained from the primary producers for all employees (onshore and offshore) associated with offshore Gulf of Mexico oil and gas operations. The data contained in each employee record are: wages/salary, job description, county/parish of residence, offshore work location and staging area (if applicable). These data are to be used for determining direct employment and wages by county and the residence/place-of-work relationships.

● Producer expenditure records for 1984. Detailed expenditure records are being provided by the producing companies for 1984. This data consists of all expenditures for goods and services by activity type (ie. air transport, geophysical exploration, platform fabrication etc.) Data are required to determine immediate employment and wages resulting from expenditures made by producers.

● Economic impact ratios. Economic impact ratios necessary for converting the expenditures of the offshore producers into employment and wages are being supplied. Impact ratios being developed include: payroll to revenues, employment to revenues, percent of employment working offshore and expenditures to revenues.

● Project and activity expense records. Approximately 150 actual detailed expense reports or budgets have been provided by offshore producers. These documents and data are necessary to develop unit physical and economic activity measures for projecting the impacts of future projects. Activity measures are segmented by physical parameters (water depth, pipeline size, production capacity, etc.) and operational descriptors (ie. geophysical surveying, platform construction, etc.)

● Lease production records. MMS production data by lease area will be used to adjust total estimates for activity not captured in data supplied by primary producers represented on the Offshore Operators Subcommittee.

## Methodology

Direct producer employment and wages at the county/parish level are generated directly from the data base of primary producer personnel records. The county/parish allocations of employment and wages are based on the residence zip code of each employee.

Primary employment resulting from the purchases of goods and services are derived by applying key business ratios for each service industry to total expenditures by producers within that industry. Place-of-employment relationships for the primary producers are used to simulate the geographic distribution of employment for offshore contract employees of similar skill levels.

Physical measures of activity are converted to expenditures based on actual detailed project records supplied by the primary offshore producers. Once quantified these impacts may be allocated based on the 1984 distribution of activity for projects in a similar or adjacent area.

MMS lease production records are being used to adjust project results to account for production from producers not participating in the Offshore Operators Committee Subcommittee.

The following is a schematic representation of the data manipulations:

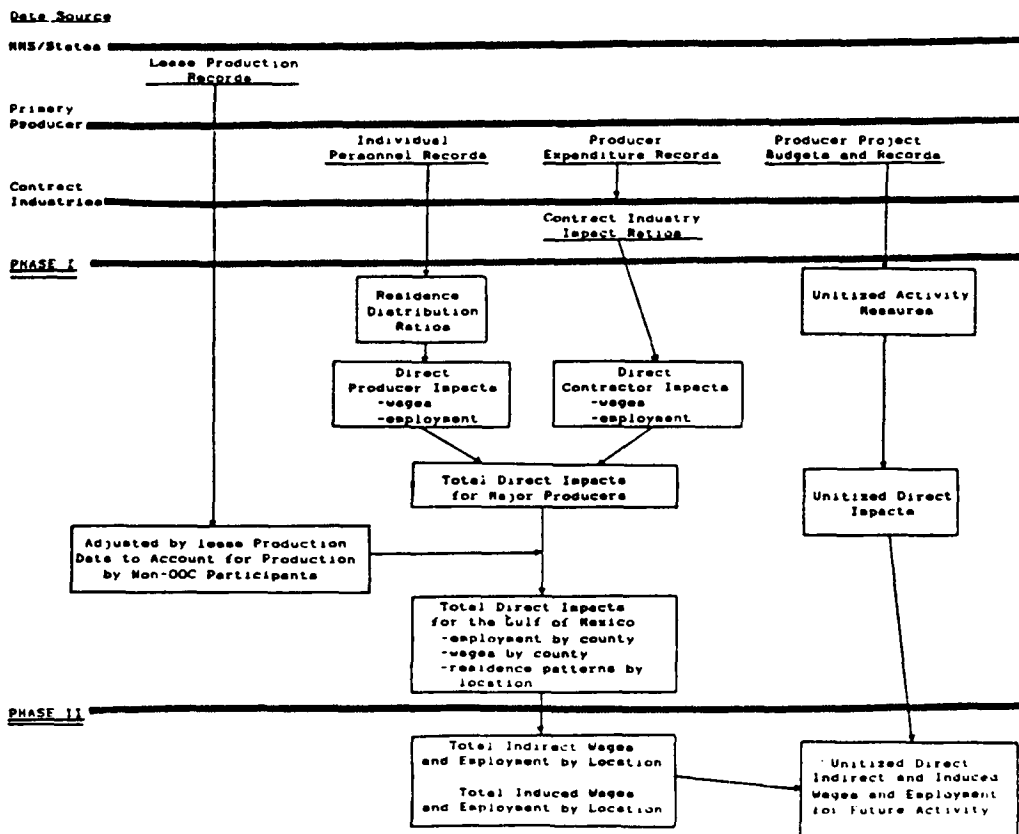

## P R O J E C T   R E S U L T S

Project results will be available in a draft form in September and in final report in December. Results are to include both a report and a data base sufficient for determining future direct impacts.

Examples of the types of questions which may be addressed for the entire MMS Gulf of Mexico Region are:

- How many persons are employed directly by offshore production companies and of this number how many work primarily offshore?
- What are the total wages and salaries paid by the offshore producers and how much is spent in each of the coastal counties and parishes?
- What is the residence distribution pattern of offshore production workers using any given staging area (by job type and offshore location)?
- What are the likely direct employment impacts of contract and service expenditures made by offshore producers?
- What are the likely direct employment impacts associated with the operation and maintenance of a planned offshore structure or project?
- What are the direct impacts associated with the addition of a new platform or pipeline in a given area?
- How are the impacts associated with a new offshore project in a given location likely to be geographically distributed?



## PHASE II

The work previously outlined represents Phase I of a two-stage project. MMS is planning an independent follow on Phase II project to run during late 1985 and 1986.

The follow-on effort is anticipated to build on the current effort in the following areas:

● Indirect or secondary effects are to be developed. The indirect effect will include the economic activity resulting from the purchases of goods and services by the primary producers and will include documenting and modeling the detailed inputs and outputs of all significant sectors supplying or interacting with the offshore service industries.

● Induced effects are to be modeled at the county/parish and regional level. The induced effects will cover the economic activity resulting from the expenditure of wages and salaries by households. This phase will result from integrating project results with national and regional economic models.

● The various data bases and models are to be unified into an easily usable automated computer model for projecting the various economic effects of offshore oil and gas exploration and development at the county/parish level.

● A unified and easily usable computer model will be developed for determining the full economic effects of any proposed offshore development projects.

**ABSTRACT**  
**for**  
**Physical Oceanography Study**

**MMS Ternary Meeting**  
**March 12, 1985**  
**Metairie, La.**

**SUBMITTED TO: MINERALS MANAGEMENT SERVICE**  
**ENVIRONMENTAL STUDIES GROUP**  
**GULF REGIONAL OFFICE**  
**METAIRIE, LA.**

**SUBMITTED BY: SCIENCE APPLICATIONS INTERNATIONAL CORP.(SAIC)**  
**4900 WATER'S EDGE DRIVE**  
**RALEIGH, NORTH CAROLINA, 27606**

# ABSTRACT

In 1982, a multi-year field program was initiated in the Gulf of Mexico. Two years of measurements emphasizing the eastern Gulf have been completed and a third year is beginning. This spring, measurements in the western Gulf will be initiated. Key program elements for the above observational program include:

- Subsurface currents, temperature and pressure
- Regional and process-oriented hydrography
- Lagrangian drifters
- Satellite thermal imagery (sea surface temperature maps)
- Ship-of-Opportunity XBT observations

During Program Year 1, subsurface currents were measured at Moorings A, C, D, and E (See Figure 1). At the beginning of Year 2, Moorings G and F were added to the existing array. Deep-water moorings (A and G) provide a basis for developing a better understanding of processes occurring in the Loop Current (LC) and along its eastern boundary. The other moorings provide information for resolving mechanisms, such as the LC and surface wind stress, which drive or influence circulation on the adjacent shelf. Buoy and coastal winds and coastal water levels are combined with subsurface measurements to help identify processes responsible for the observed circulation patterns.

Several important points are illustrated in the subsurface current data:

- Along the west Florida slope, the percent of time southward directed currents occur decreases with depth. Below 700m, currents to the north are increasingly dominant with increased depth.
- In deeper water, away from the slope, currents are quite coherent with relatively little vertical shear. These primarily southward directed currents are dominated by low-frequency fluctuations.
- At outer-shelf locations, horizontal coherence scales are weak at periods of about a week or less. At mid- and inner-shelf locations, tides and wind stress seem to be the most apparent controlling influences.

# EASTERN GULF

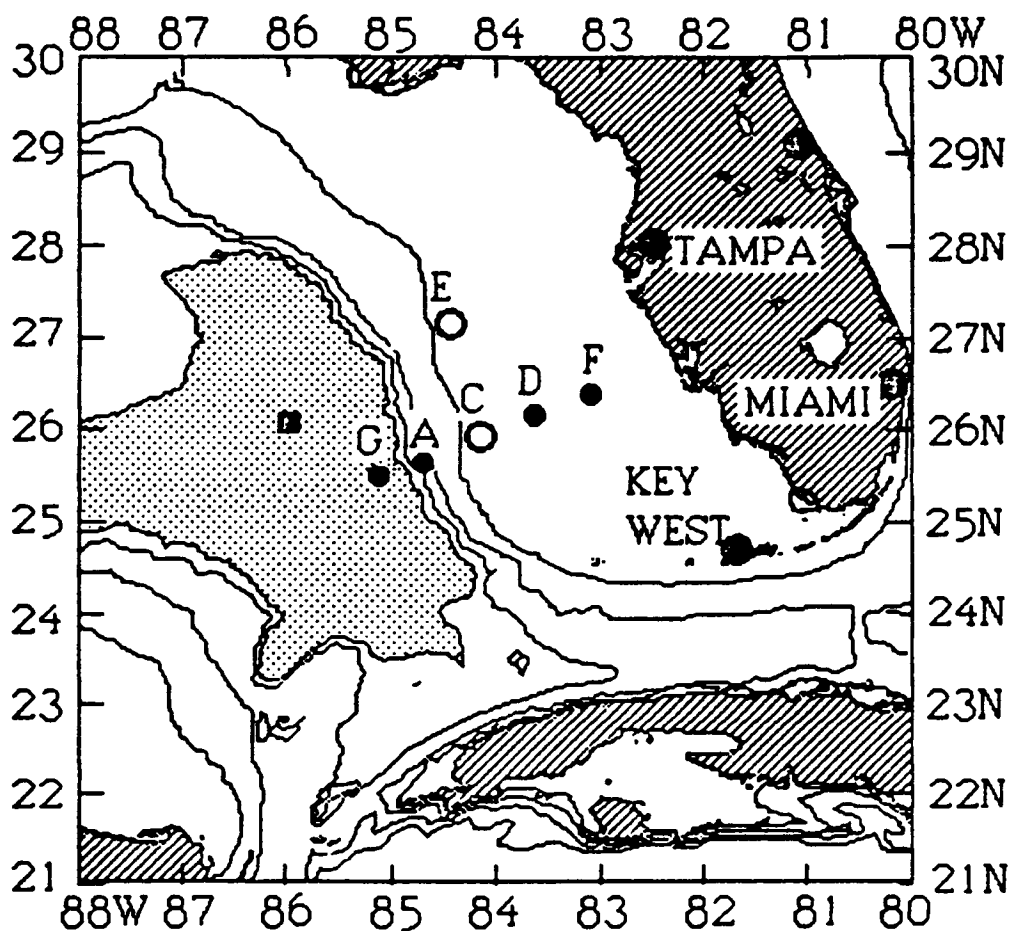

<b>ISOBATH DEPTHS</b> (in meters) 200 1000 2000 3000	● - CURRENT METERS MOORINGS  ○ - CURRENTS + PRESSURE  ■ - NDBC MET. BUOY
---	---

SAIC/Raleigh

FIGURE 1. Subsurface mooring positions during Year 2, eastern Gulf measurements. This transect coincides with a time series transect taken during the Year 2 hydrographic survey in May, 1984. It also coincides with a transect for AXBT's and AXCP's in the plane portion of that survey.

Year 1 hydrographic observations were designed to document regional characteristics of temperature, salinity, density, and nutrient fields. Although this did not provide information on time-dependent processes, it did provide an estimate of the expected range and distribution of conditions. During Year 2, a single, but extensive, hydrographic survey, which employed coordinated ship and plane observations, was designed to provide a series of regional and subregional "snapshots". These are helping resolve the evolutionary(or time-dependent), three-dimensional structure of the LC and its eastern boundary features(Figure 2).

Preliminary results of the second year survey indicate that in deep water, LC boundary features often extend to considerable depth (several hundreds of meters or more) and can produce upwelling and increased productivity in the trailing cold pool. In the absence of such features, maximum currents were found to be very close to the surface boundary and approximately coincident with the zone of strongest horizontal density gradients as might be expected for flow having a strong geostrophic component. The normal anticyclonic (clockwise) flow field expected in the LC was primarily confined to the upper 600m(Figure 3).

Across the surrounding surface front, strong shears occurred with LC surface velocities reaching 3.5kts.(170cm/sec). The horizontal shear zone was probably much more abrupt than shown in Figure 3 since a linear interpolation scheme was used in contouring.

Satellite thermal imagery is used to document and track elements in the flow field such as the LC proper and associated boundary features as well as large and small break-off eddies. During cooler months (Oct.-May), LC surface water is generally warmer than the surrounding water. Thus, remotely sensed sea-surface temperatures (radiative temperatures) provide an invaluable tool for defining the surficial extent of oceanic features having characteristic, yet contrasting, temperature fields. With a time series of thermal images, the evolution (time dependence) of phenomenon can be documented, studied and characterized. These techniques were used to create Figure 4 which shows a summary plot of ring-center trajectories for a five year period. The data suggest three preferred paths. Because of cloud cover and the seasonality of the available signal, satellite imagery does not permit rigorous, continuous tracking or even random sampling. It is a case of "get it while you can".

Lagrangian, satellite-tracked drifters have provided very valuable information on movement and dynamics of LC eddies. When placed in a ring, a buoy moves with the flow field, and hence, their trajectories reflect the cumulative influence of all the dynamic forces active in a ring. In addition, it often allows rings to be tracked when not

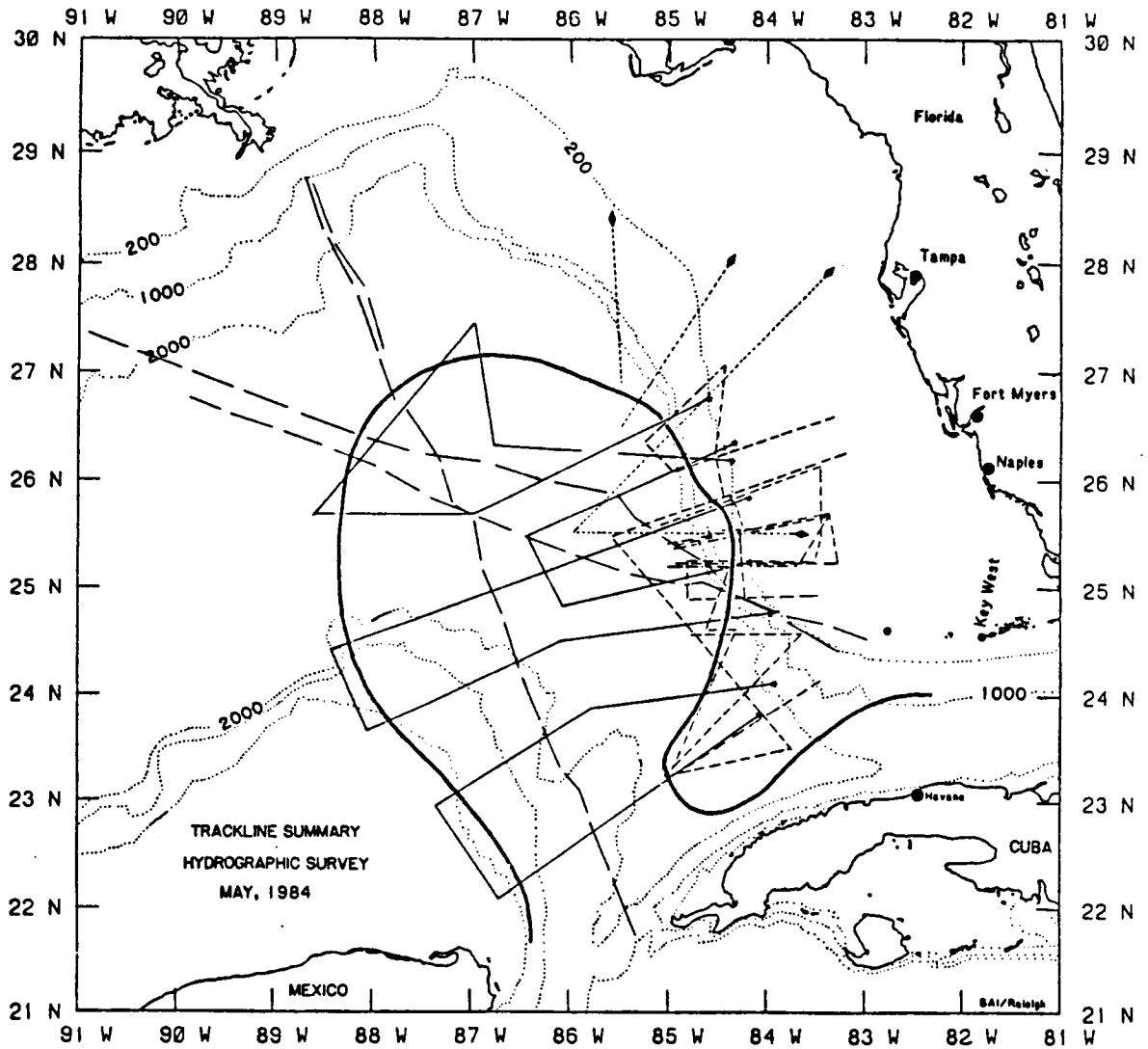

FIGURE 2a. Composite of stations occupied during the Year 2 hydrographic survey. Figures 2b-2d show elements of this composite.

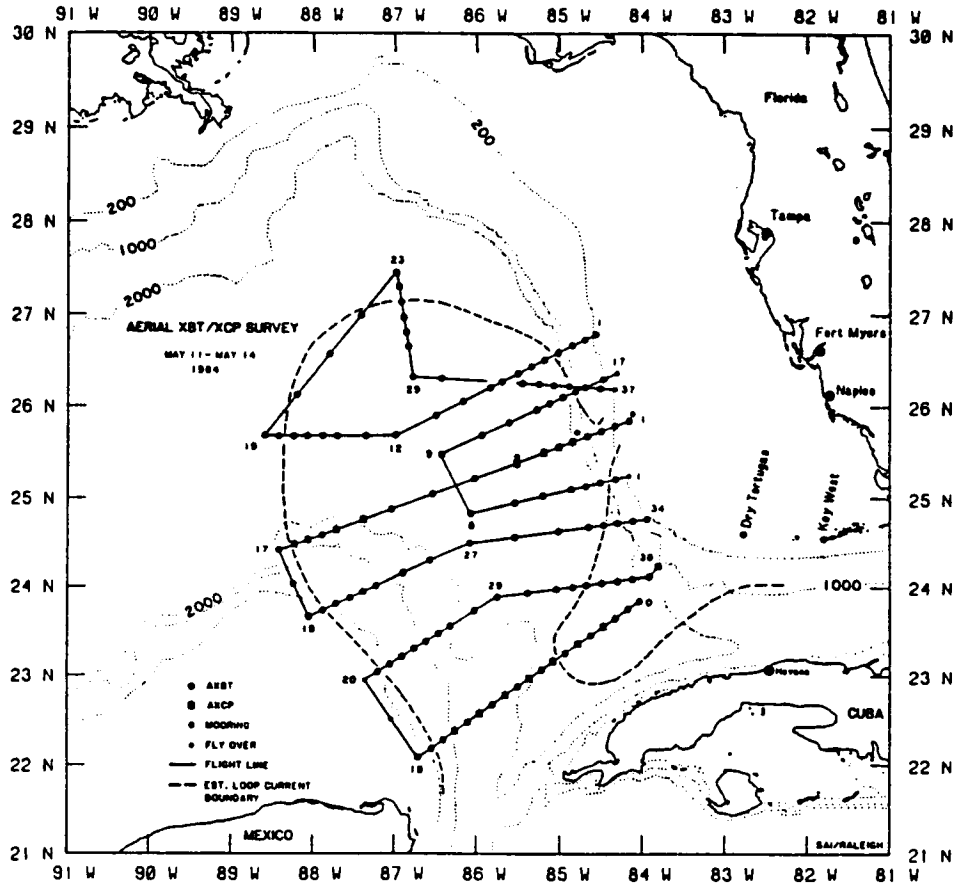

FIGURE 2b. Stations occupied during the aerial portion of the May survey. Circles indicate AXBT stations and squares indicate AXCP stations. Note that AXCP's were dropped along the subsurface mooring transect. This velocity profile data is shown in Figure 3.

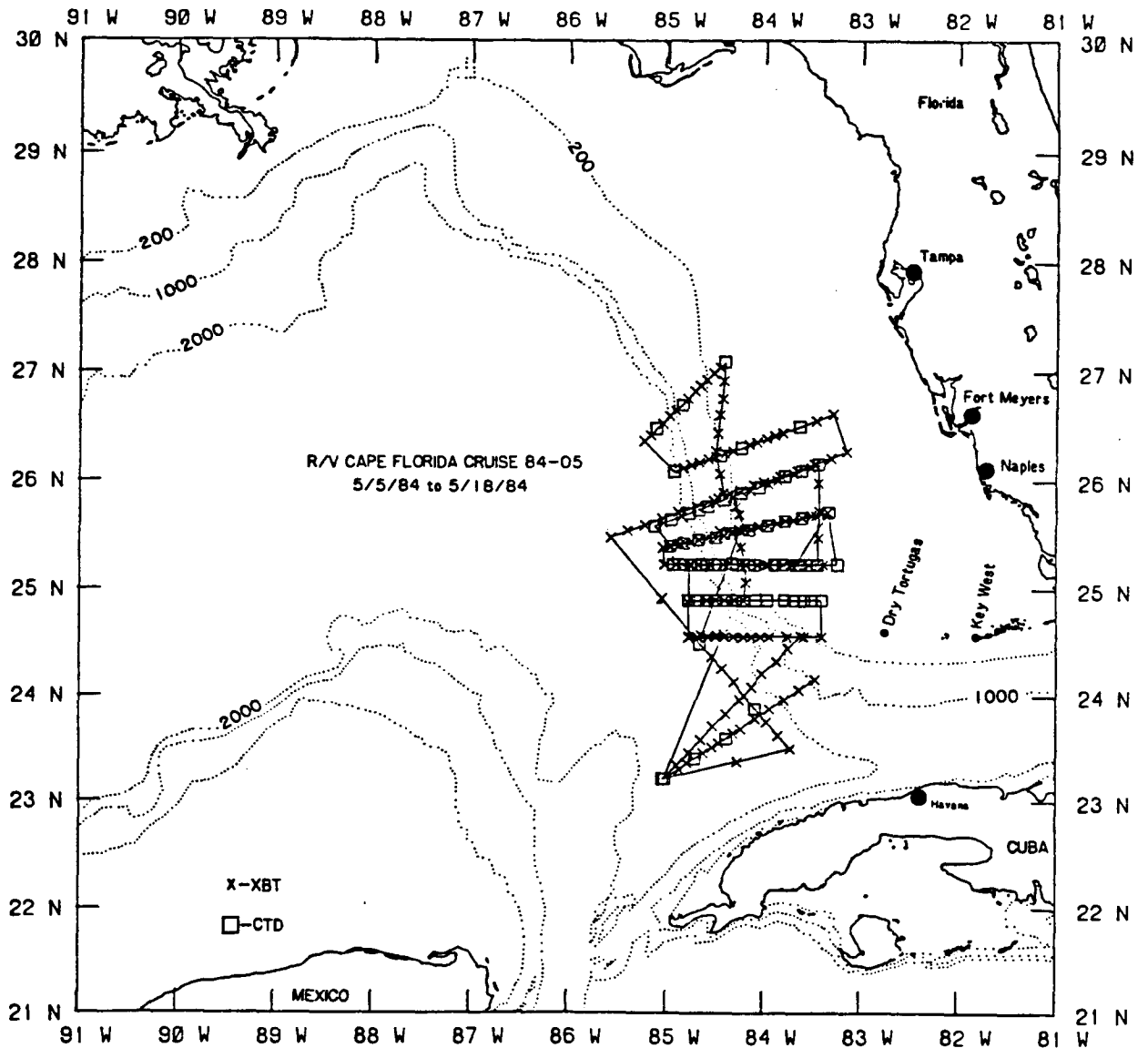

FIGURE 2c. Cruise track and stations occupied by the R/V Cape Florida. While it may look confused, it is quite orderly. Some transects were occupied at regular intervals to provide a time series of transects. Other lines were taken to provide a quasi-synoptic realization of boundary features.



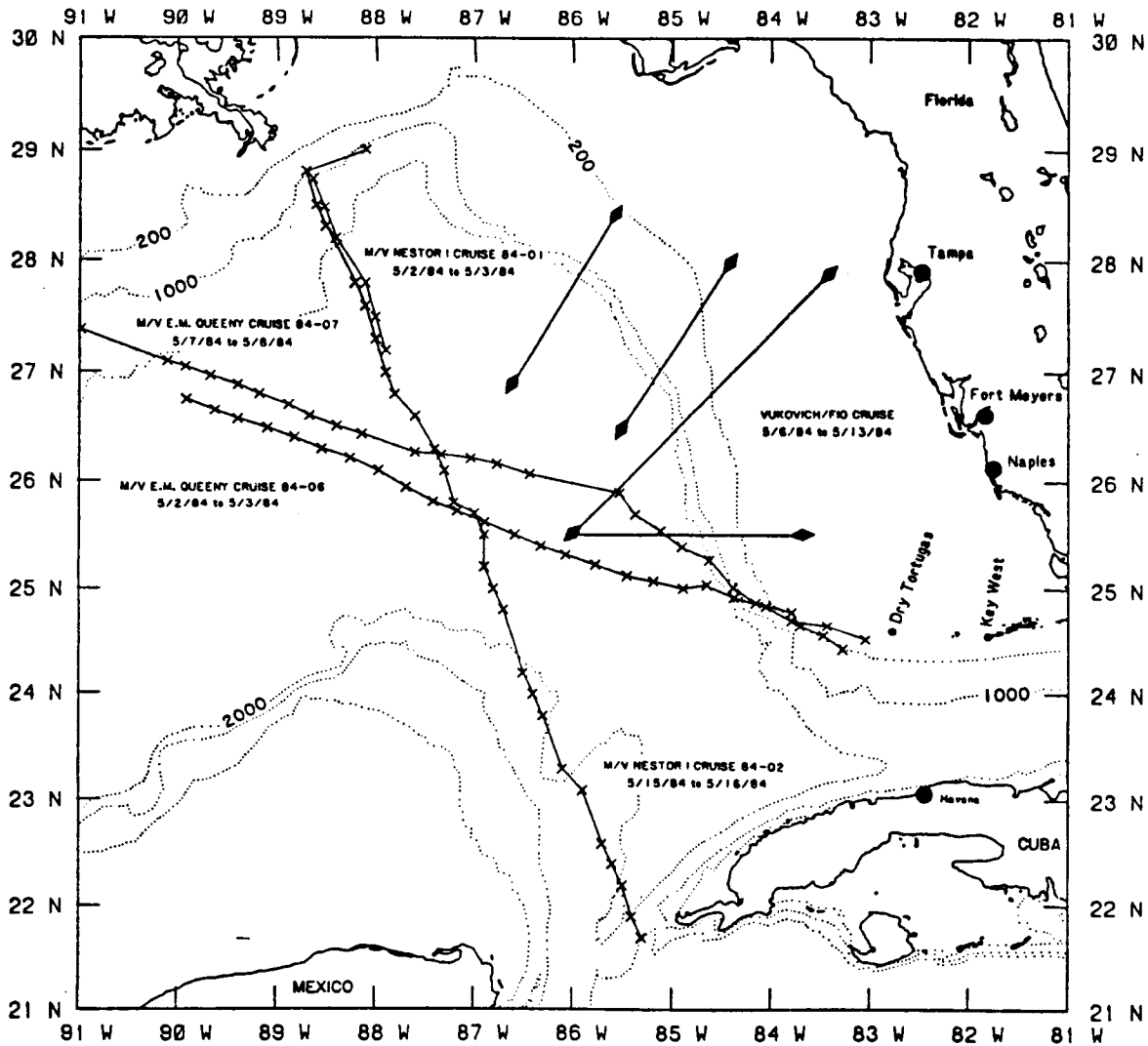

FIGURE 2d. Supplemental stations and transects taken during the general period of the May hydrographic survey. These include, as noted, Ship-of-Opportunity data from the M/V Nestor and E.M. Queeny. Not shown, but also available are XBT data taken by the R/V Gyre in transit from Galveston to the Florida Straits. The Vukovich/FIO data was coordinated with this survey and includes temperature and salinity data.

# SECTION 2A

STATION

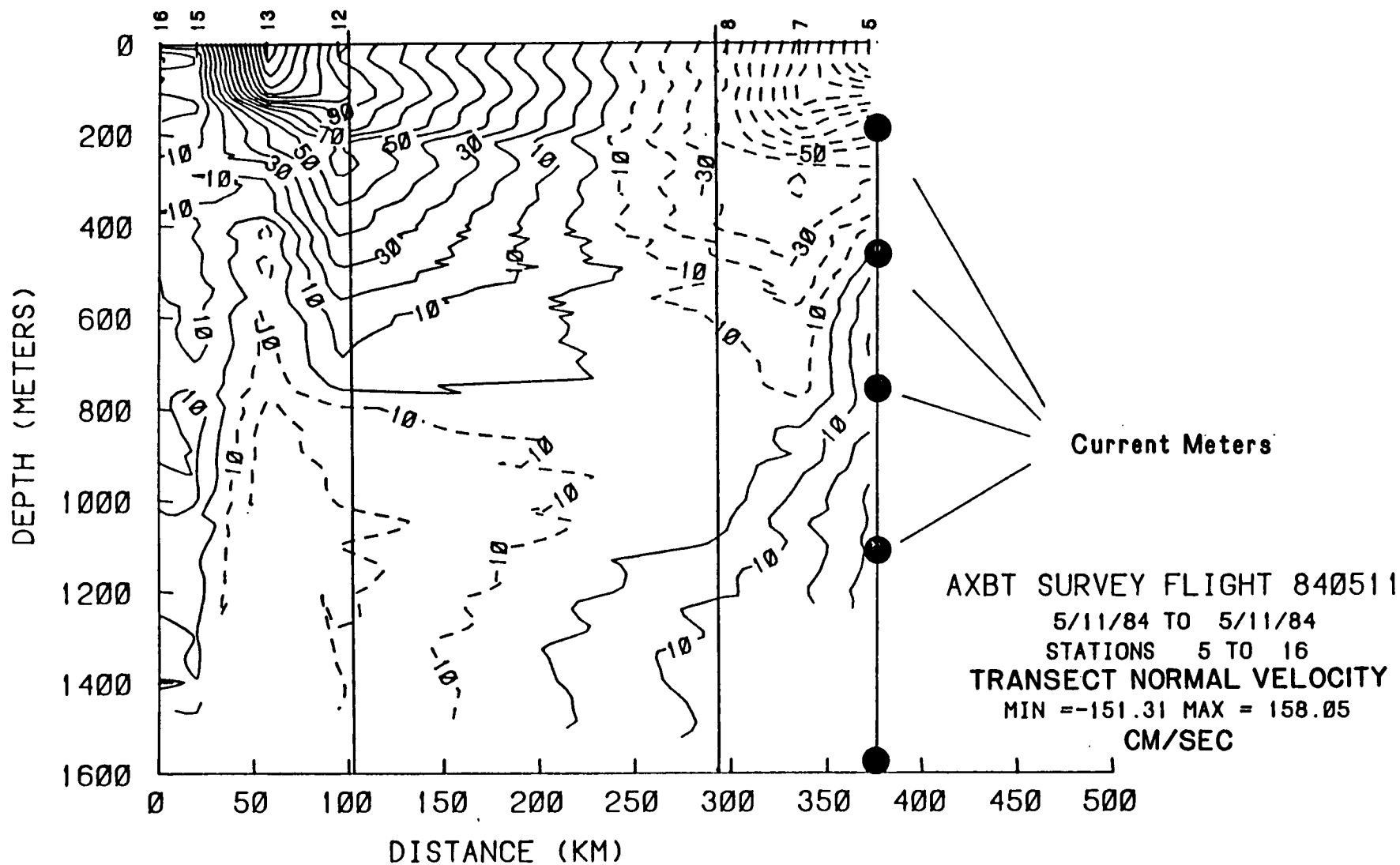

FIGURE 3 Contours of section-normal velocity as measured by AXCP's dropped during the May survey. This transect, Section 2A, coincided with the subsurface currents mooring array. Note the distribution of northward and southward directed currents as a function of across current location and in the vertical. A linear interpolation scheme is used in the contouring routine.

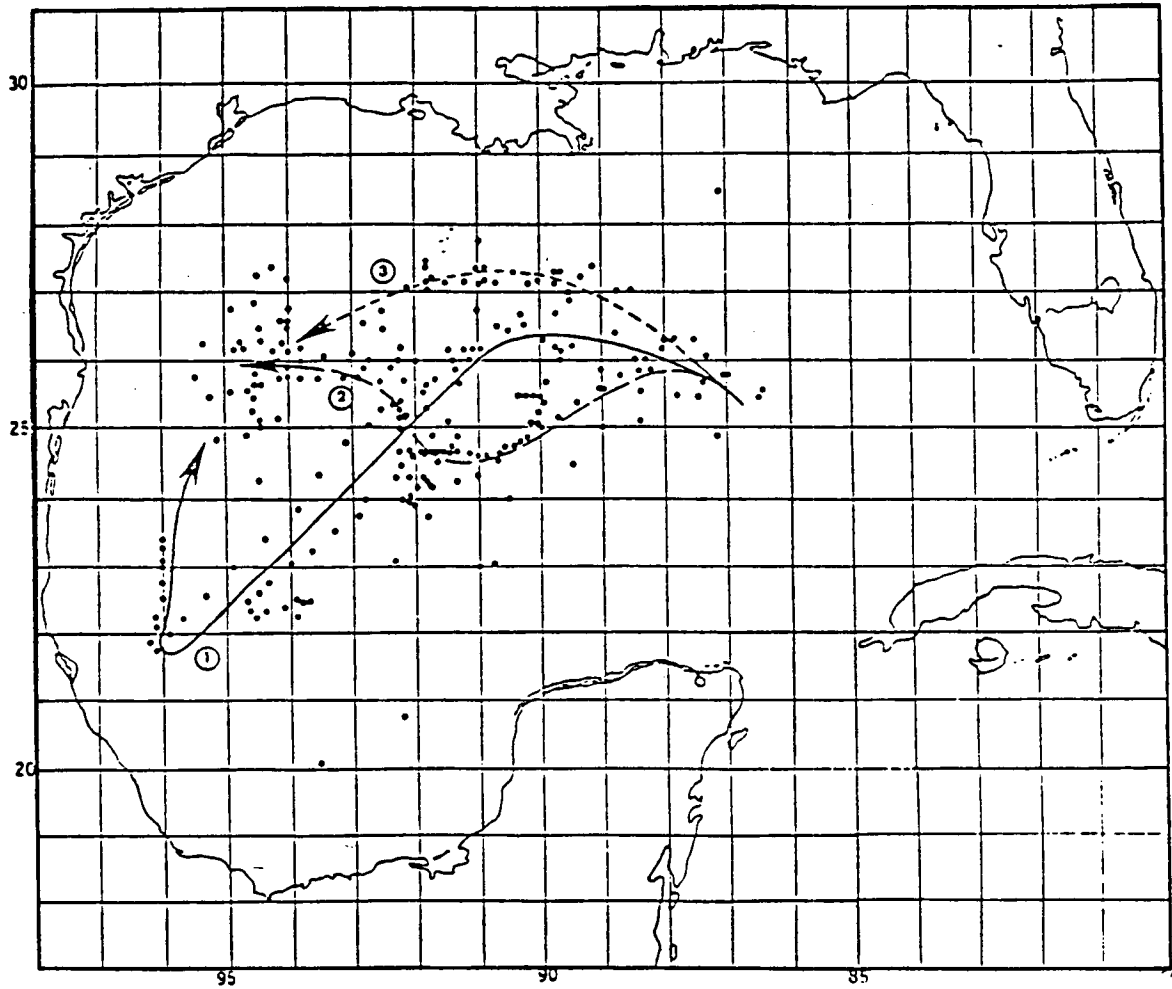

FIGURE 4. Summary drawing of eddy centers as determined from satellite thermal imagery for a five to six year period. Note that some of these points are time series of positions for one eddy while others are one or several isolated eddy centers determinations. Data to date tends to suggest the three indicated preferred eddy trajectories shown by the solid or dashed arrows.

"visible" to satellite sensors, e.g., in summer or under clouds.

Most drifter analysis has been directed toward decomposing trajectories (Figure 5) into components such as ring translation, rotation, and pulsations. In turn, the Lagrangian velocity time series is used to partition the influence and importance of various terms in the governing dynamic equations. It is expected that the number of drifters released will increase in the future and their deployment positions will be expanded to incorporate a wider range of flow fields.

The Ship-of-Opportunity (SOOP) program serves several functions. It provides regular, low-cost information regarding the vertical thermal field along a given, meaningful transect. It is also a means by which MMS can participate in truly "opportunistic" or one-time data gathering efforts which will support this program's goals. As appropriate, SOOP data is used by almost all the study's scientific principals. It also provides quasi-real time information on which operational and management decisions can be made. As an example, it helps identify if and when an eddy breaks off.

The Final Report for Program Years 1 and 2 will be submitted in October, 1985. Between now and late summer, a substantial portion of the program effort will be directed toward bringing together and organizing insights developed regarding conditions and circulation patterns in the eastern Gulf of Mexico.

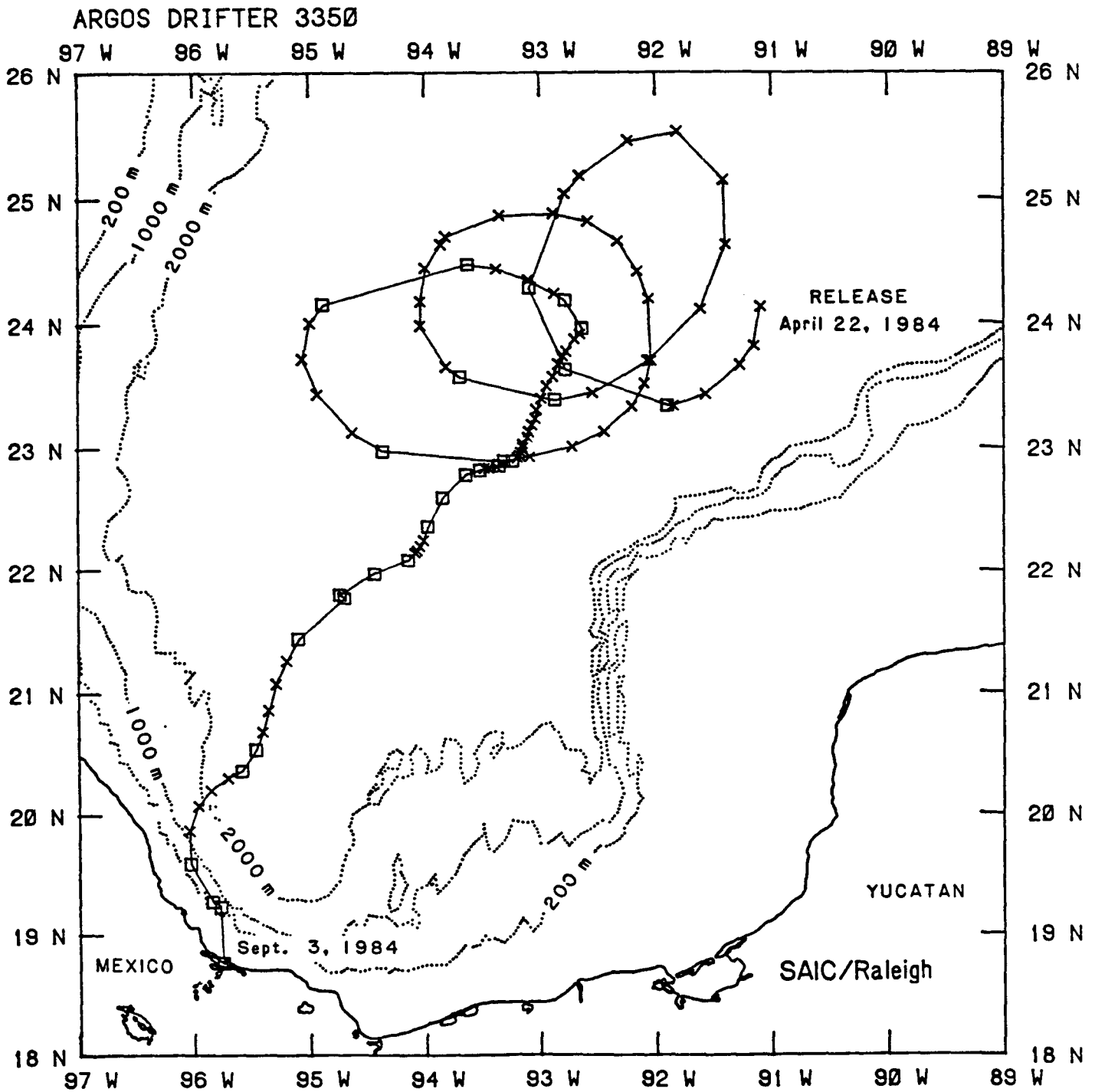

FIGURE 5. Trajectory from MMS buoy 3350. Note the anticyclonic, rotary motion during the first 45 days. After that the buoy seems to have left the ring and moved rather continuously to the southwest until it went aground. The buoy motion while it was entrained in the eddy reflects the sum of the forces acting on it. Part of the program effort is to decompose this motion into components which can be attributed to modes or causes. These include such first order effects as translation and rotation as well as more complex motions such as pulsations and shearing.

GULF OF MEXICO CIRCULATION MODELING STUDY

ALAN J. WALLCRAFT

JAYCOR

SPRING TERNARY STUDIES MEETING

March 1985

This presentation is on the first year of a four year numerical ocean circulation modeling program for the Gulf of Mexico, funded by MMS. The aim of the program is to progressively upgrade in modest increments an existing numerical ocean circulation model of the Gulf so that the final model has a horizontal resolution of about 10 km and vertical resolution approaching 1 to 10 m in the mixed layer, 10 m at the thermocline and 100 m in the deep water. Throughout the four year period, the validity of the upgraded model will be continuously tested, and velocity field time series delivered periodically based on the most realistic simulation of Gulf circulation available (JAYCOR, 1983).

Experiments in the first year were with the existing NORDA/JAYCOR two layer hydrodynamic primitive equation ocean circulation model of the Gulf on a 0.2 degree grid (Hurlburt and Thompson, 1980). They concentrated on correctly specifying the coastline and bottom topography for maximum realism in circulation simulation, and on how best to include wind forcing. Details of selected experiments are presented here.

Experiment 9 represents the best (compared to our incomplete knowledge of the real Gulf) simulation available at the beginning of the project. It is forced by flow through the Yucatan Straits only (no wind forcing), and exhibits many of the flow features observed in the Gulf, see Figure 1. Simulated surface currents sampled every ten days for three Loop Current eddy cycles (1140 days) were delivered to MMS at the start of the contract period as an 'early simulation run'.

Experiment 34 is similar to experiment 9, but with the addition of wind forcing based on a seasonal climatology from ship observations (Elliot, 1979). The basic circulation patterns show far more variability in this case. For example Figure 2 compares 360 model days from Experiments 28 and 34 (which are identical except that experiment 28 has no wind forcing). From these snapshots, taken every 90 days, there is little difference between the two experiments. But if Experiment 34 is sampled every 20 days, as in Figure 3, it is apparent that two eddies were shed in the space of about one year. Figure 3 also shows that the circulation pattern in the Western Gulf can change very rapidly at times.

Experiment 40 has no wind forcing and its total inflow transport is identical to that in Experiment 9, but the distribution of transport between the model's two layers has been changed (upper layer transport reduced). It exhibits Loop Current eddies that are nearer to the size observed in the Gulf (experiment 9 has rather large eddies), the increased lower layer flow helps prevent intrusion onto shelf areas, and its sea surface variability is remarkably similar to that obtained from satellite altimeter crossovers for the Gulf, see Figure 4. It replaces Experiment 9 as the baseline experiment against which all future simulations will be compared.

Experiment 60 is identical to experiment 40 except that the horizontal eddy viscosity has been reduced. Some of the flow features seen in experiment 9 were less obvious in experiment 40, but the latter's lower velocities allowed the reduction in eddy viscosity and experiment 60 exhibits these features plus some new circulation patterns. For example Figure 5 shows six or more small eddies in the north eastern Gulf that have been spun off the main Loop Current eddy.

Simulated drifter tracks from Experiment 60 compared well with actual drifter tracks from 1980-1981, see Figure 6. Both track a Loop Current eddy along approximately the same path into the south-west Gulf, where they move northward along the coast of Mexico as the eddy dissipates. The observed average eddy rotation period is between 14 and 17 days, with a westward translation speed of 5 to 10 cm/sec and velocity component speeds of on the

order of 50 cm/sec (Kirwan et al., 1984). The simulated eddy has a rotation period of 15 to 16 days, a westward translation speed of 3 to 6 cm/sec and velocity component speeds of on the order of 50 cm/sec.

Experiment 68 is identical to experiment 40 with the addition of wind forcing from the Navy Corrected Geostrophic Wind data set for the Gulf. This wind set has wind stresses every 12 hours from 1967 to 1982 (Rhodes et al., 1984). The addition of winds increases the velocities encountered, and attempts to add this wind forcing to experiment 60 were not successful. Simulated surface currents sampled every three days for more than 10 years were delivered to MMS from Experiment 68, as representing the best simulation available from the first year effort. Surface current snapshots taken every 30 days (i.e. of every tenth set of fields) were also delivered. Only one of these snapshots is presented here: Figure 7 shows the furthest northward penetration of the Loop Current ever attained by the ocean model, this configuration is often seen in the Gulf.

#### REFERENCES:

- Elliot, B.A. 1979. Anticyclonic rings and the energetics of the circulation in the Gulf of Mexico. Ph.D. Dissertation, Texas A&M Univ., 188 pp.
- Hurlburt, H.E. and Thompson, J.D. 1980. A numerical study of Loop Current intrusions and eddy shedding. *J. Phys. Oceanogr.* 10: 1611-1651.
- JAYCOR 1983. A proposal for a Gulf of Mexico circulation modeling study. JAYCOR Proposal Number 8206-83.
- Kirwan, A.D., Merrell W.J., Lewis, J.K. and Whitaker, R.E. 1984. Lagrangian observations of an anticyclonic ring in the western Gulf of Mexico. *J. Geophys. Res.* 89: 3417-3424.
- Leipper, D.F. 1970. A sequence of current patterns in the Gulf of Mexico. *J. Geophys. Res.* 75: 637-657.
- Marsh J.G., Cheney R.E., McCarthy, J.J. and Martin T.V. 1984. Regional mean sea surfaces based on GEOS-3 and SEASAT altimeter data. *Marine Geodesy* 8: 385-402.
- Rhodes, R.C., Thompson, J.D. and Wallcraft A.J. 1984. The Navy Corrected Geostrophic Wind data set for the Gulf of Mexico. NORDA tech. rep. (to appear) - also Rhodes in this volume.



**FIGURE CAPTIONS:**

**FIGURE 1:** (a) Instantaneous view of the interface deviation in a two-layer simulation of the Gulf of Mexico driven from rest to statistical equilibrium solely by inflow through the Yucatan Straits (Experiment 9). The contour interval is 25 m, with solid contours representing downward deviations. (b) Depth of the 22 degree isothermal surface, 4-18 August 1966 (Alaminos cruise 66-A-11), from Leipper (1970). The contour interval is 25 m.

**FIGURE 2:** Instantaneous view of the interface deviation every 90 days, from day 90 of model year 9 to day 0 of model year 10, for Experiment 28 (left) and Experiment 34 (right). Experiment 34 is identical to 28 except for the addition of wind forcing. The contour interval is 25 m.

**FIGURE 3:** Instantaneous view of the interface deviation every 20 days, from day 260 of model year 9 to day 0 of model year 10, for Experiment 34.

**FIGURE 4:** Sea surface height variability for the Gulf of Mexico. (a) Based on about 83,000 GEOS-3 and SEASAT cross overs, spanning nearly four years (from Marsh, Cheney and McCarthy, 1984). (b) Based on an ocean model simulation with port forcing only (Experiment 40), measured over three eddy cycles at statistical equilibrium with the free surface sampled every ten days for a total of over 300,000 "observations".

**FIGURE 5:** Instantaneous view of upper layer averaged velocities from Experiment 60 on model day 2170, velocities above 50 cm/sec are not shown.

**FIGURE 6:** Paths of actual and simulated drifters:

(a) NDBO drifter 1599 from November 20, 1980, through May 11, 1981. The numbers 0 through 6 give the positions on November 20, December 20, January 20, February 20, March 20, April 20, May 11, respectively (from Kirwan et al., 1984).

(b) Path of simulated drifter number 3 from model day 1680 to model day 1980 of Experiment 60. The track is drawn as a solid line for 20 days, then dashed for 20 days, and so on. There is a dot every 5 days.

**FIGURE 7:** Instantaneous view of upper layer averaged velocities from Experiment 68 on model day 3918. Vectors are only plotted at every second model grid point, i.e. every 0.4 degrees.

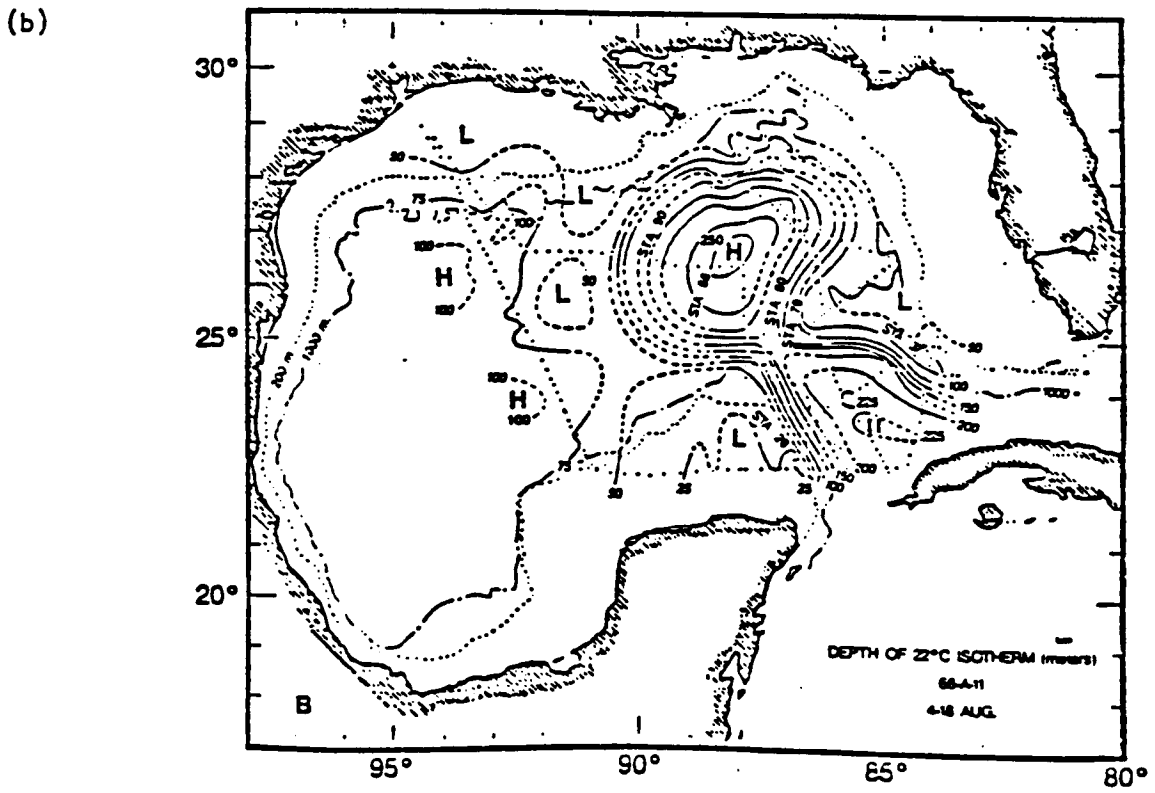
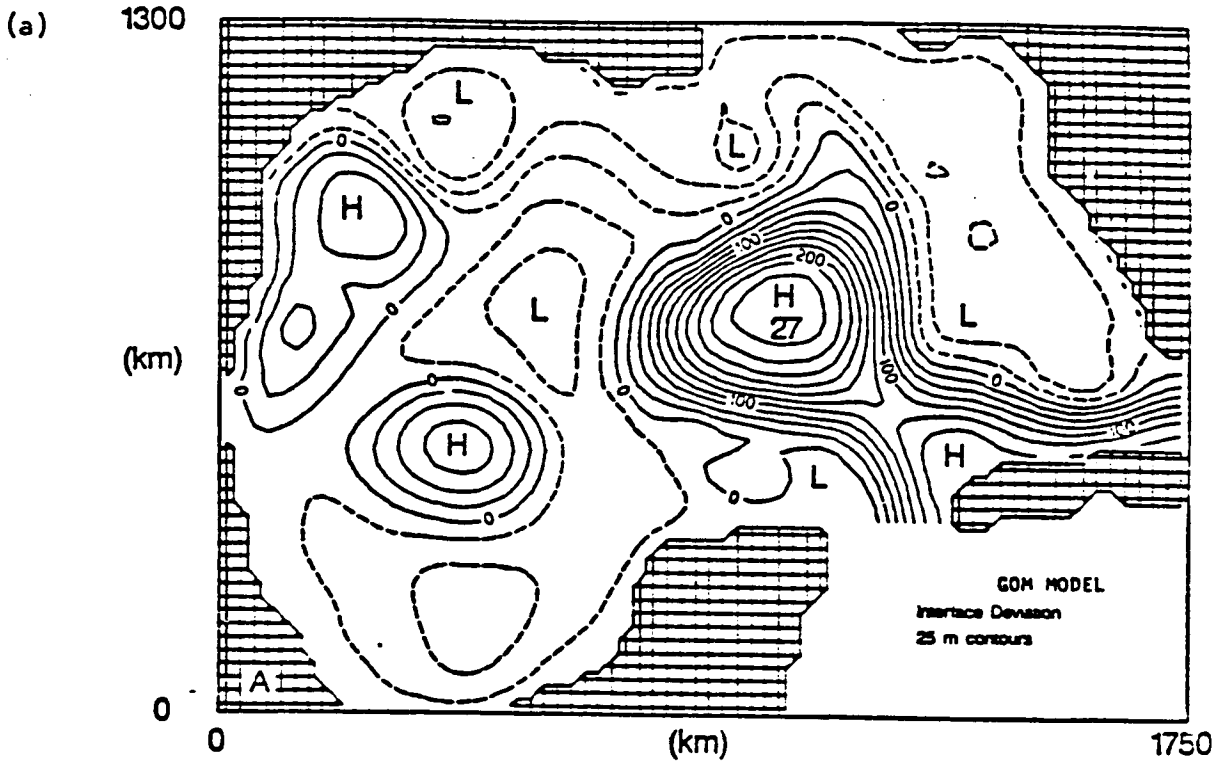

FIGURE 1

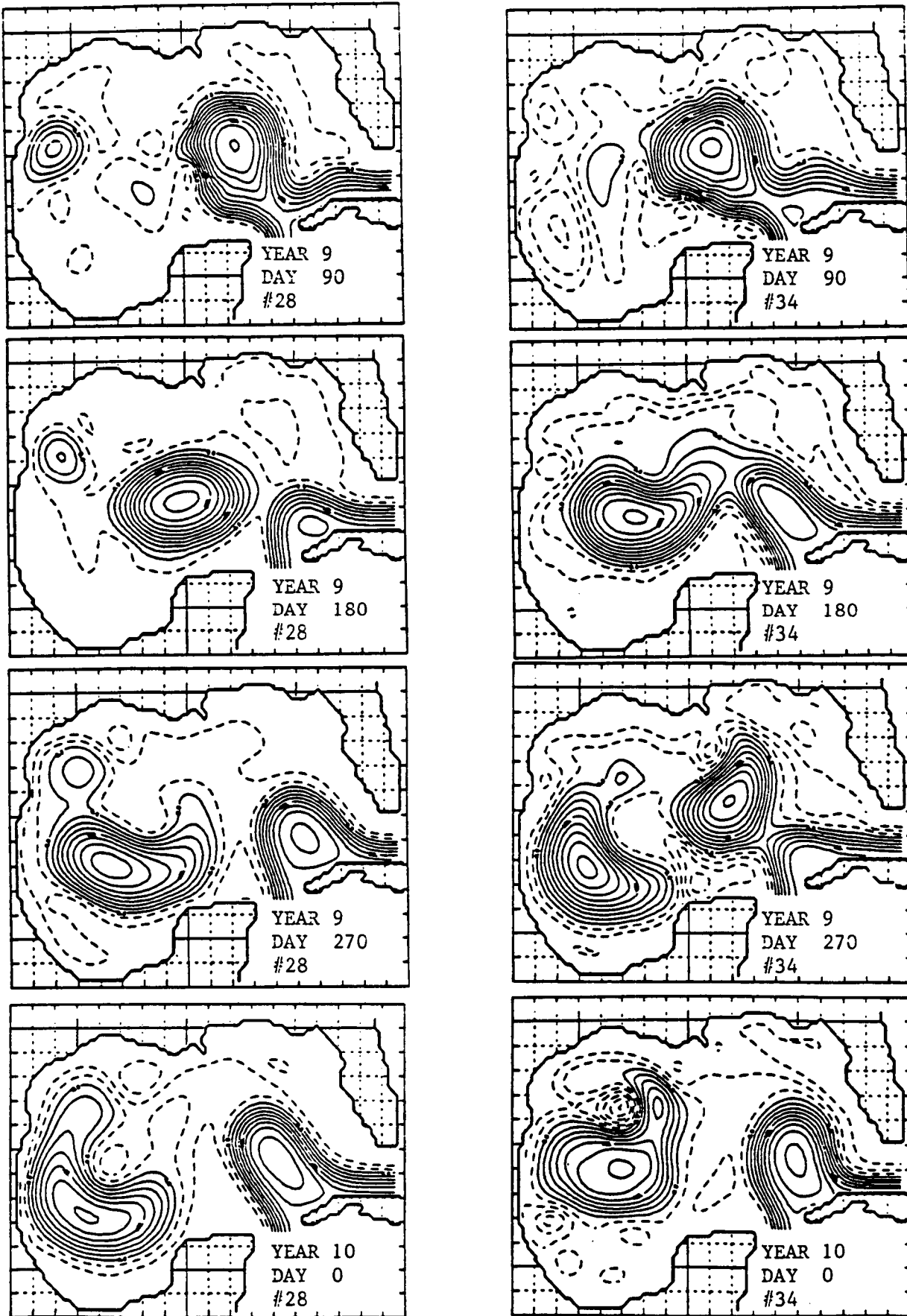

FIGURE 2

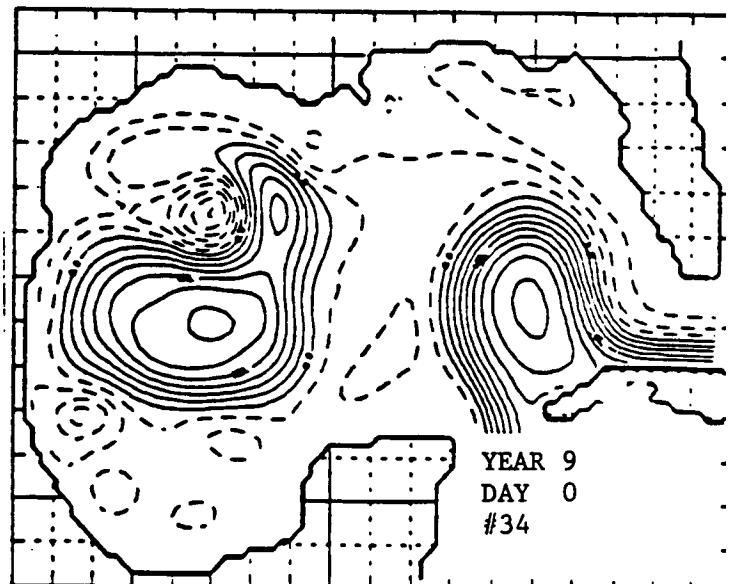
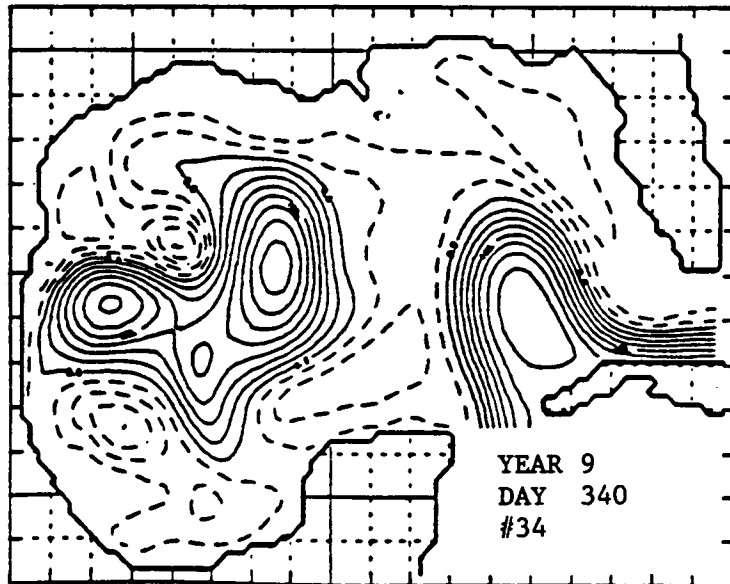
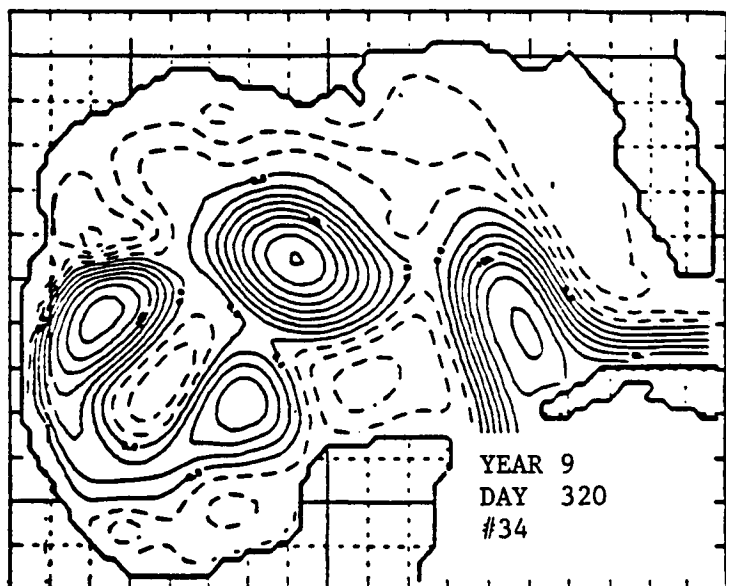
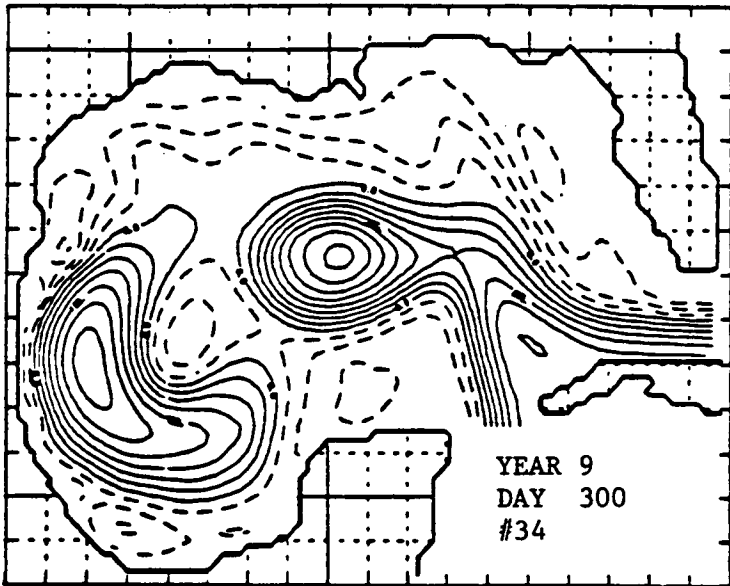
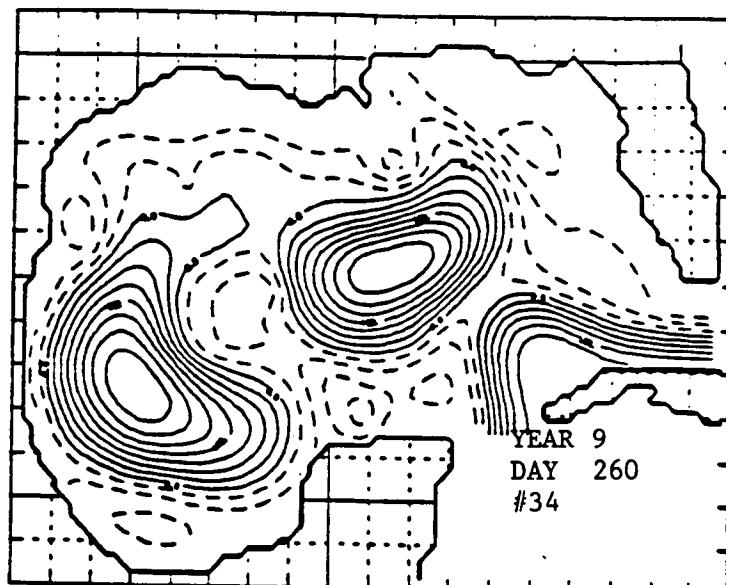
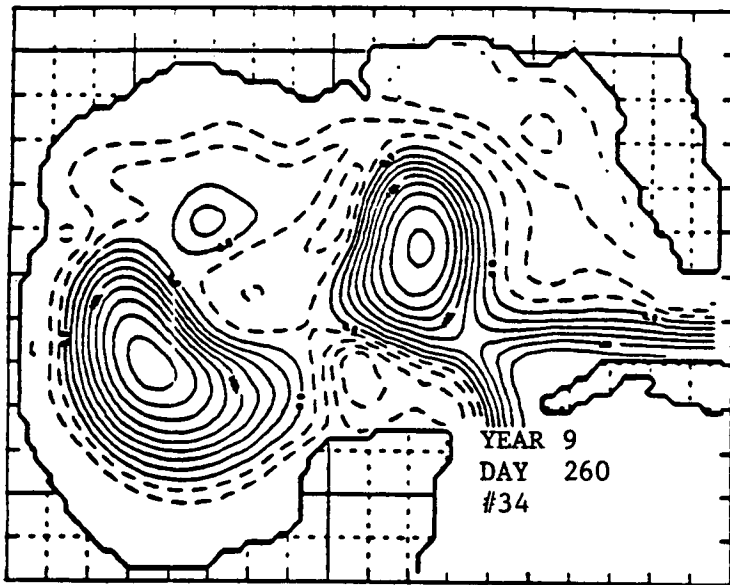
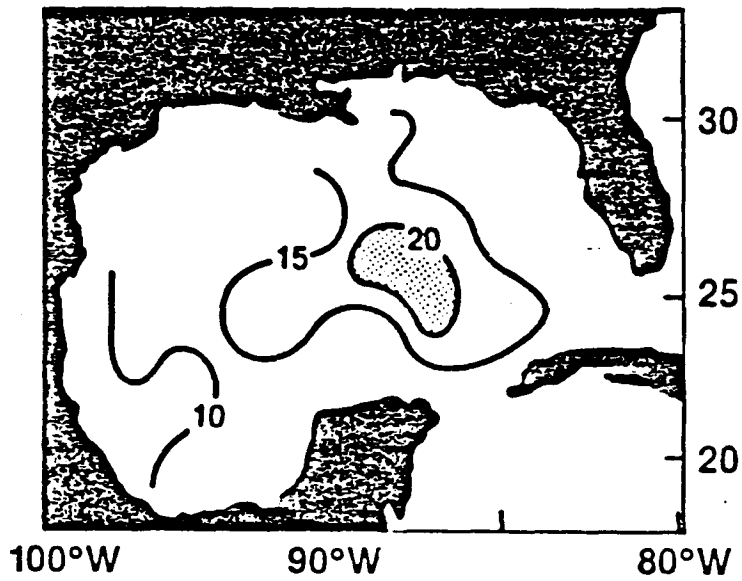

FIGURE 3

SEA SURFACE VARIABILITY FROM  
GEOS-3 AND SEASAT CROSS OVERS (CM)



SEA SURFACE VARIABILITY (CM)  
FROM NORDA MODEL

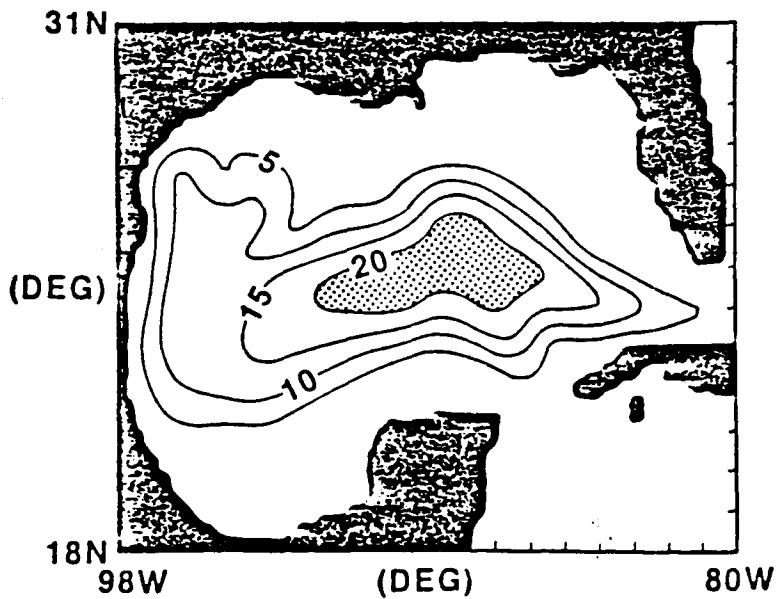
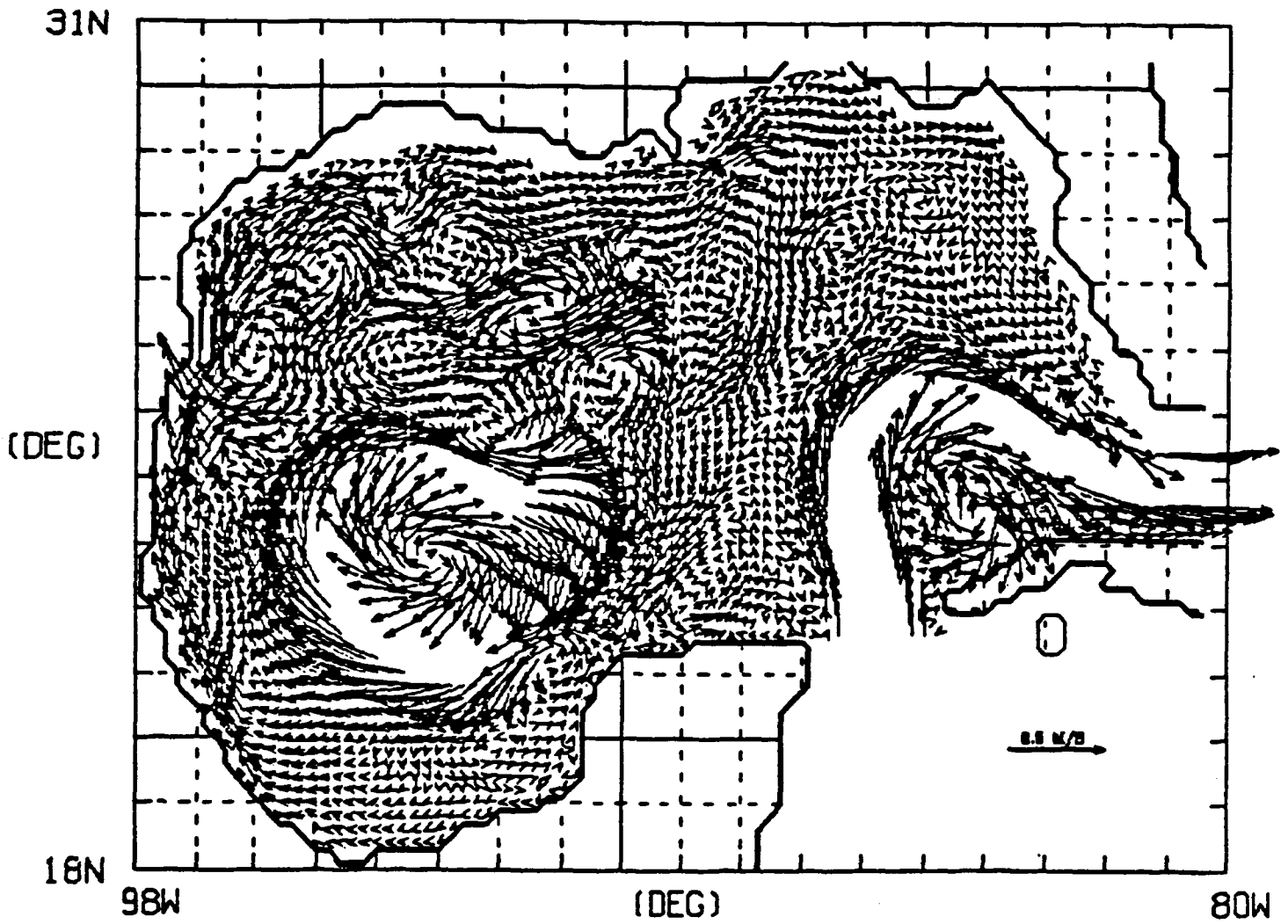

FIGURE 4

GEOSTR. CURRENTS G. OF MEXICO 0. 60  
MODEL DAY = 2170



VECTORS UP TO 0.50 M/S PLOTTED (MAX = 0.91 M/S)

FIGURE 5

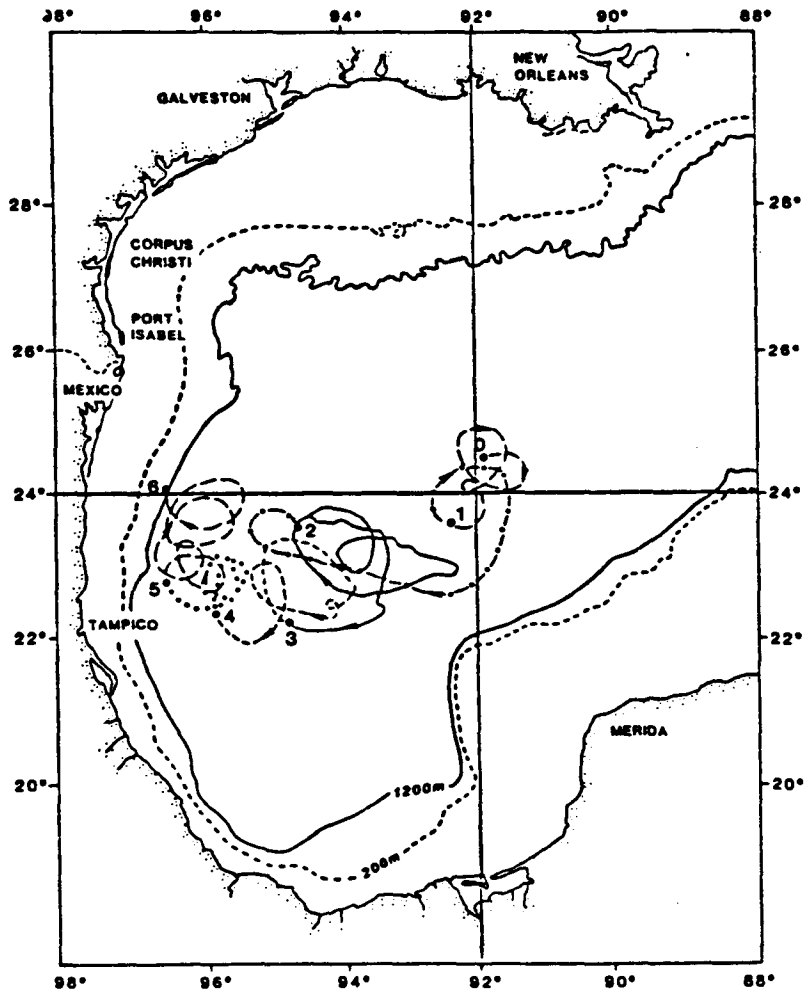

DRIFTER TRAJECTORY G. OF MEXICO 60  
 DRIFTER NO. 3 FROM 1680 TO 1980 (DAYS)

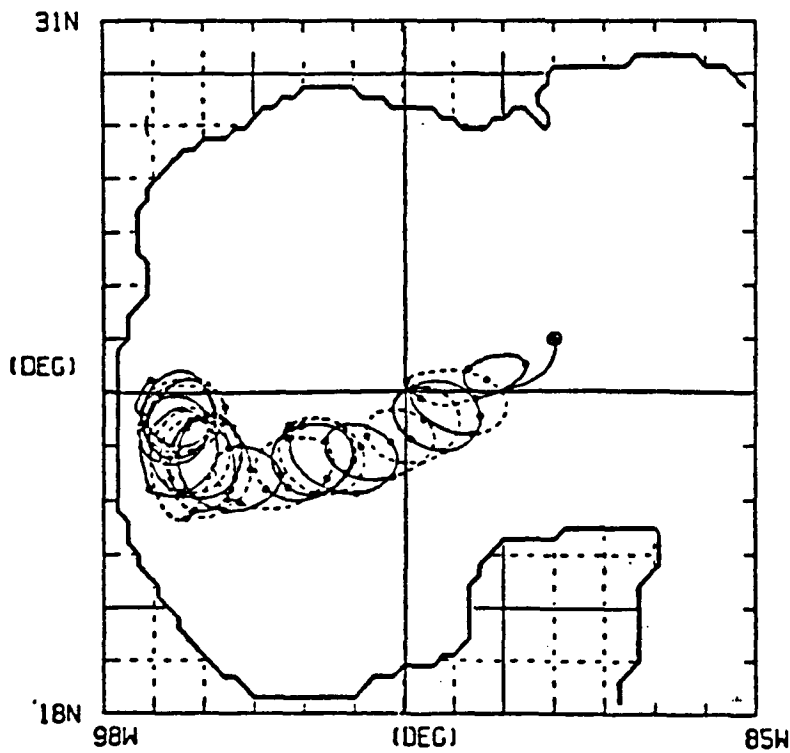

FIGURE 6

GEOSTR. CURRENTS

MODEL DAY = 3918

G. OF MEXICO

0. 68

WIND DAY = 1967/299

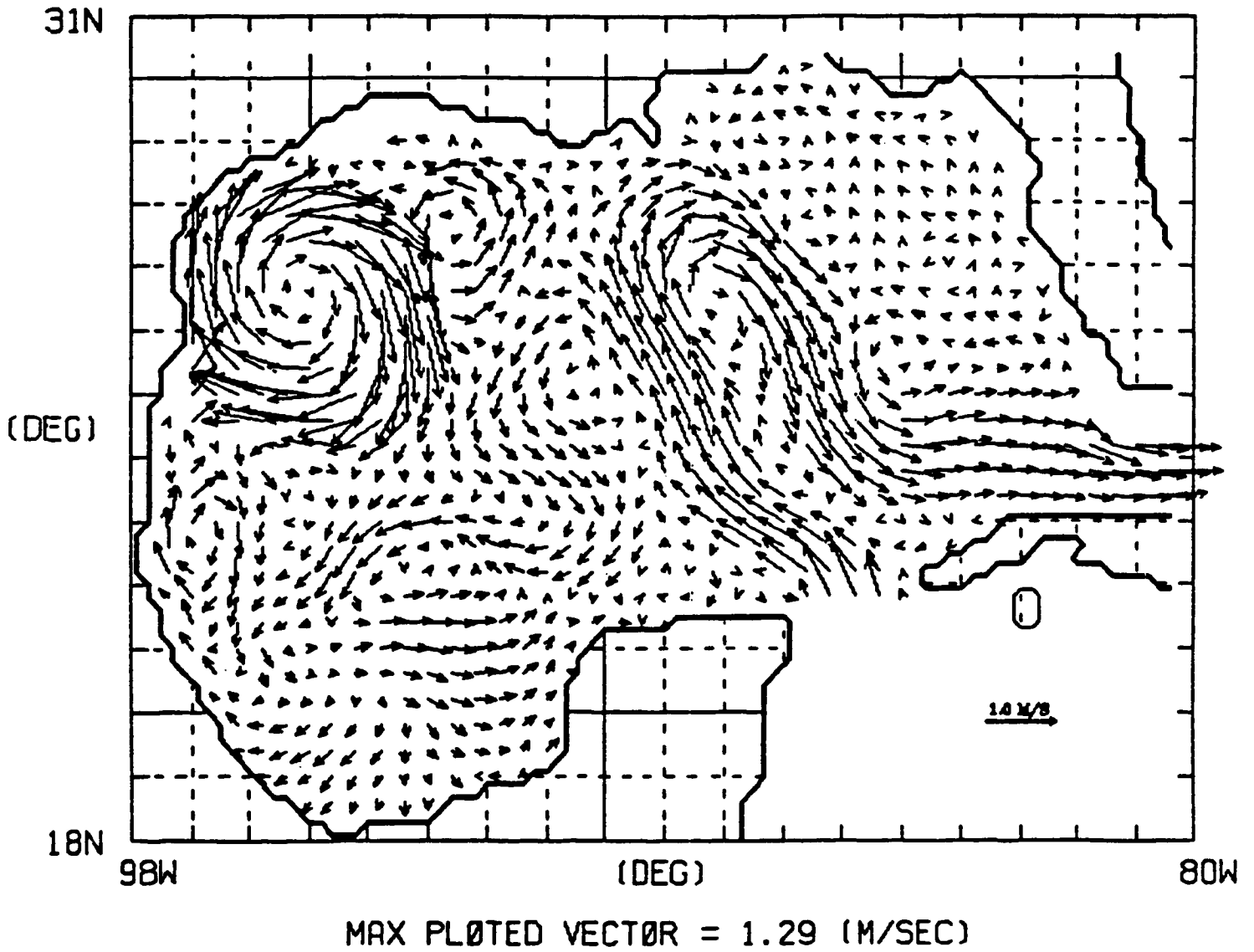

FIGURE 7



## APPENDIX A - GULF OF MEXICO CIRCULATION STAGES

Loop Current driven circulation in the Gulf of Mexico can be partitioned into five stages of development. For simplicity the Eastern Gulf, dominated by the Loop Current, and the Western Gulf, dominated by Loop Current eddies, are treated separately. The stages are:

### EASTERN GULF.

- E1: Loop Current is far south taking a short path through the Gulf (recently detached Loop Current eddy in the central Gulf).
- E2: Loop Current repenetrates northward into the Gulf.
- E3: A new large anticyclonic Loop Current eddy forms, meanders are seen on the wall of the Loop Current.

### WESTERN GULF.

- W4: Recently detached Loop Current eddy in the central Gulf (Loop Current is far south taking a short path through the Gulf).
- W5: Loop Current eddy moves into the western Gulf (eddy possibly develops into a counter-rotating vortex pair).
- W6: Loop Current eddy reaches the coast of Mexico, and moves northward as it dissipates.

Stages E1 and W4 are identical so there are a total of five distinct phases, with E1 to E2 to E3 to W4 to W5 to W6 comprising one complete eddy cycle. There are always at least two eddy cycles active, in different stages of development, in the Gulf at any one time. Therefore a description of the stage of Gulf-wide circulation would include at least two of the above. The Loop Current can only be in one state at a time, so only one eastern Gulf stage will be included in the total Gulf state. But there can be several Loop Current eddies active at once, so several western Gulf stages might be included. Typical configurations are E1-W4 (Figure 1), E2-W5 (Figure 2) and E3-W6 (Figure 3); but other combinations are possible depending on the actual Loop Current eddy shedding periods (which can be anywhere from 6 to 18 months).

The Gulf of Mexico circulation is highly variable and dynamic. The stages outlined above provide a useful reference for classifying and describing Gulf circulation. But should not be taken any further than this, it would be inappropriate to produce climatologies or a small number of 'representative' Gulf circulation patterns for example. Even as a descriptive aid the scheme is limited to the Loop Current and its major associated eddies. The addition of wind driven features, perhaps classified by season, would lead to a more complete scheme but at the expense of greatly increasing the number of possible combinations (and therefore reducing clarity).

GEOSTR. CURRENTS

G. OF MEXICO

0. 68

MODEL DAY = 3978

WIND DAY = 1967/359

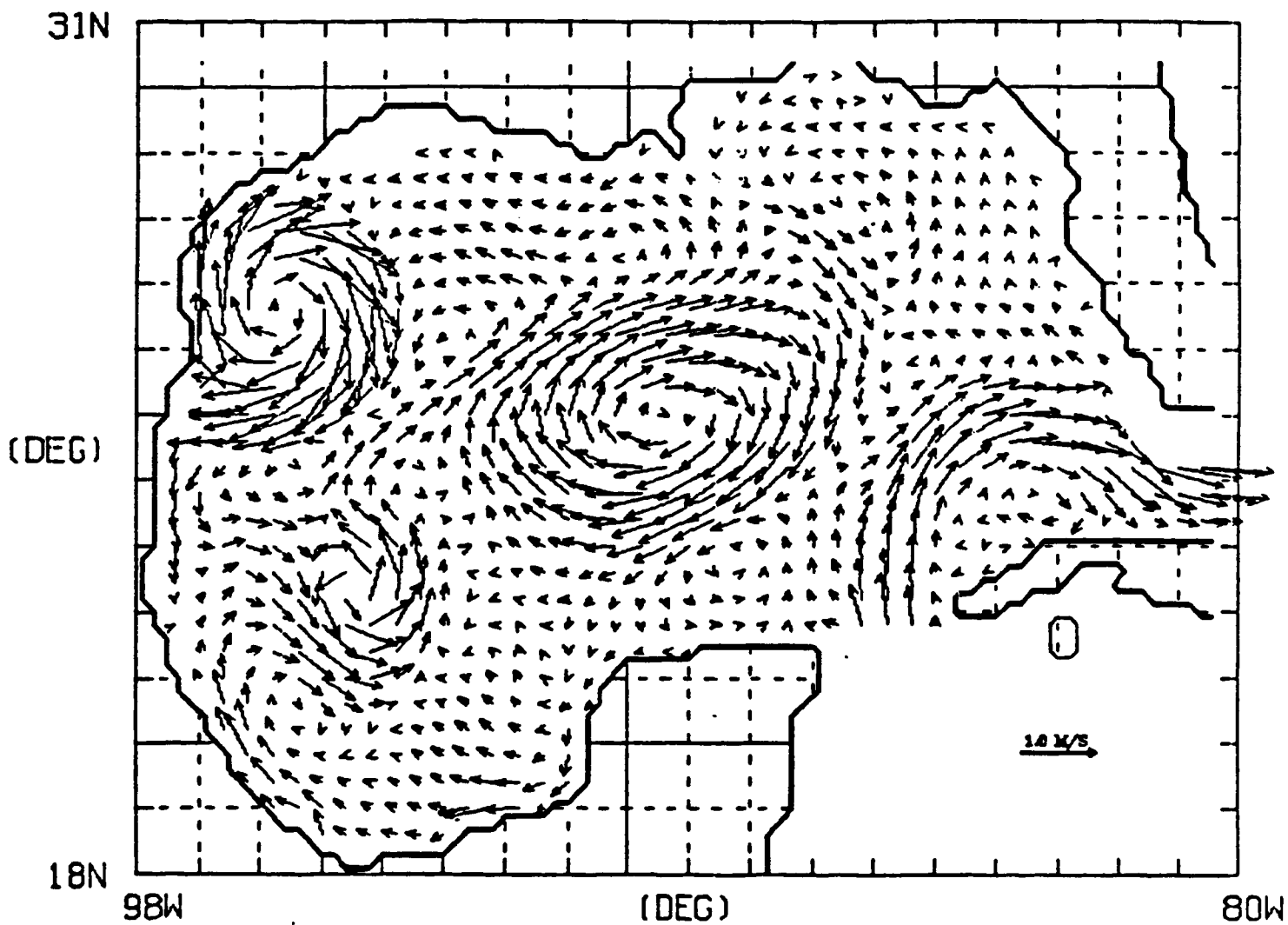

MAX PLOTTED VECTOR = 1.39 (M/SEC)

FIGURE 8

GEOSTR. CURRENTS  
MODEL DAY = 4128

G. OF MEXICO 0, 68  
WIND DAY = 1968/144

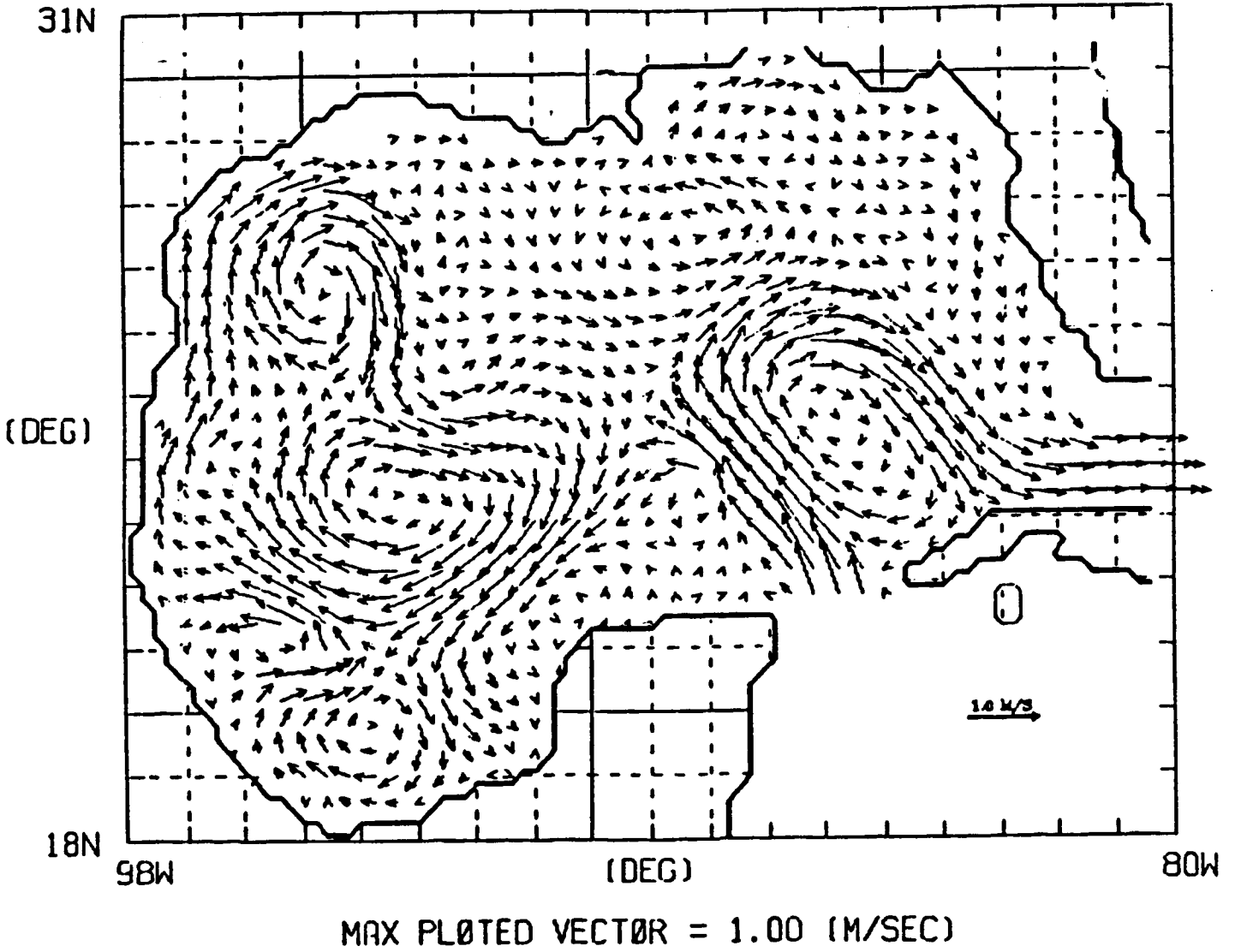

FIGURE 9

GEOSTR. CURRENTS

G. OF MEXICO 0. 68

MODEL DAY = 4218

WIND DAY = 1968/234

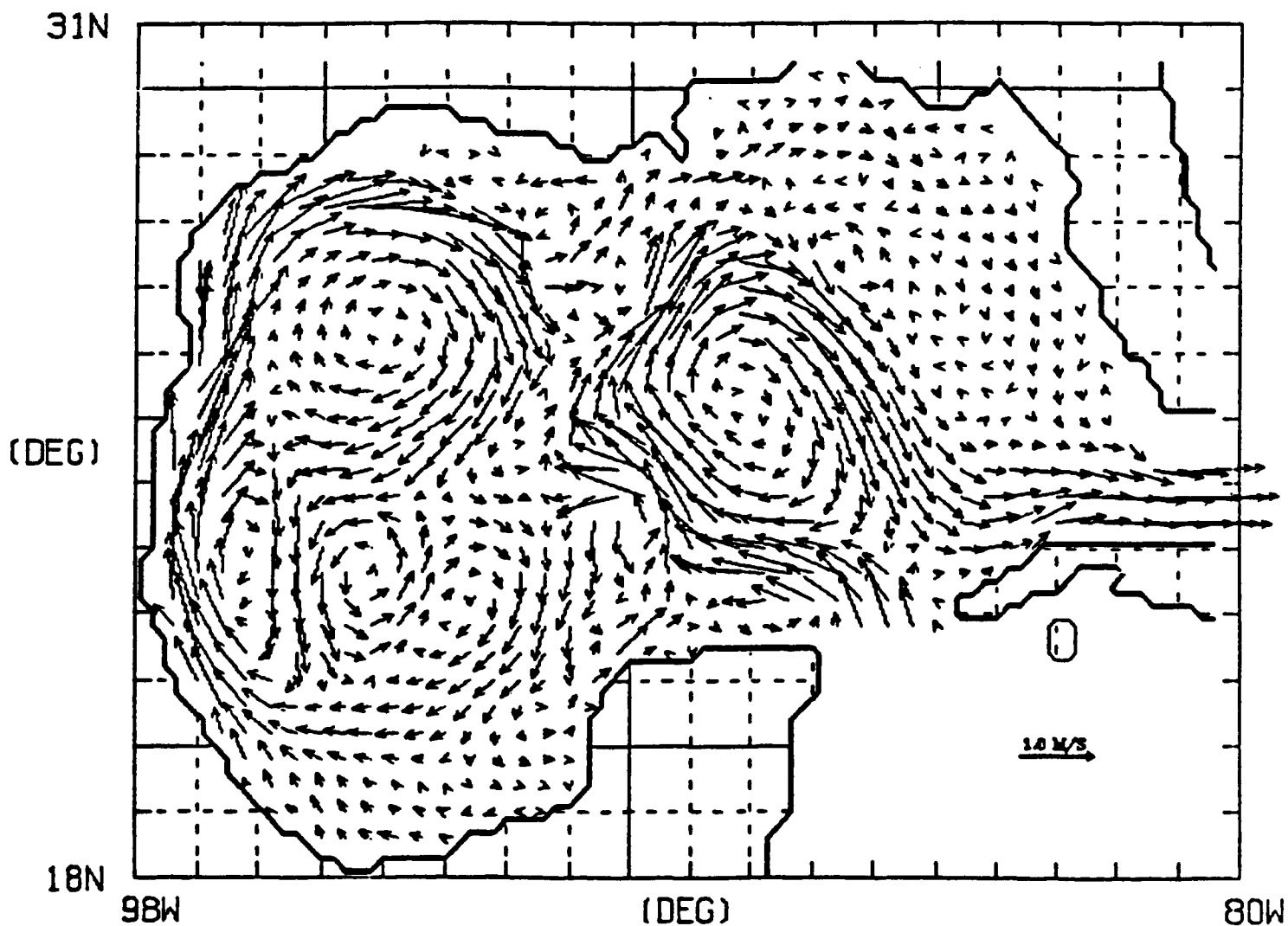

MAX PLOTED VECTOR = 1.84 (M/SEC)

FIGURE 10

MINERALS MANAGEMENT SERVICE  
GULF OF MEXICO ENVIRONMENTAL STUDIES

TERNARY MEETING

MARCH 12, 1985

ABSTRACT

"COMPILATION OF THE GULF OF MEXICO METEOROLOGICAL DATA SET"

MMS RFP 3191

JERRY W. FORD

FLORIDA A&M UNIVERSITY

"COMPILATION OF THE GULF OF MEXICO METEOROLOGICAL DATA SET"

ABSTRACT

MMS RFP 3191

MARCH 12, 1985

JERRY W. FORD

FLORIDA A&M UNIVERSITY

BACKGROUND: The Minerals Management Service (MMS) of the U. S. Department of the Interior has contracted with the Florida A&M University (FAMU) for a period of 19 months to compile a ten (10) year surface wind data set for the Gulf of Mexico. When completed, this ten year meteorological data base, along with the annotated analysis, will be archived by and available through FAMU.

WORK IN PROGRESS: FAMU began work on this project by first determining the format to use to collect the data for initial review and manipulation. It was determined that the following format would best suit our needs: 9 TRACK TAPE/1600 BPI/ASCII/UNLABELED/BLOCKED (SPECIFY BLOCKING FACTOR). This format will be used with the Harris 800 mini computer installed at FAMU.

Secondly, FAMU compiled a list of organizations/activities from which the desired meteorological data sets might be acquired and from whom assistance in the conduct of this study might be obtained. The resultant resource list as developed by FAMU for this project is attached.

As of this date FAMU has made contact with the individuals/ organizations listed on the attached resource list with the following results: From the National Climactic Data Center, FAMU has ordered and received the MARSDEN SQUARE meteorological data set for squares 81 and 82 (Gulf of Mexico). This data includes both buoy data and surface ship observations for the period 1973 through 1983. From Mr. Bob Lobel of the Environmental Modeling Branch of MMS, FAMU has obtained the publications addressed in the MMS Environmental Studies Information sheet pertaining to the treatment of winds in the Gulf of Mexico Oil Spill Trajectory Simulations. From the National Ocean Data Center (NODC), FAMU has acquired a catalog of available data set and we have ordered the Gulf of Mexico meteorological data (file 191) which contains data collected from automated buoys operated by NOAA Data Buoy Center (NDBC). At this writing this data set has not been received. From DR. Shu of the National Meteorological Center at Louisiana State University, FAMU has obtained the "promise" of data from the oil companies operating in the Gulf...there seems to be some sensitivity surrounding this data as the oil companies guard their information carefully to avoid legal entanglement. From the other resources listed, FAMU has received valuable direction and support.

FUTURE PLANS: Plans are to use the next few months for the compilation of "raw" data sets with the end of May, 1985 as a target date for having the available data sets in hand. The course of action beyond this point will depend largely upon the nature of the data sets then on hand. FAMU foresees no difficulty in fulfilling the terms of this contract.



RESOURCE LIST FOR METEOROLOGICAL DATA SETS PROJECT

-----  
RFP NO. 3191 DURATION: 19 MOS.  
CONTRACT NO. 14-12-0001-30191 OCT 1, 84 - APR 1, 86

DATA FORMAT: 1600 BPI/9 TRACK/ASCII/UNLABELED/BLOCKED/  
SPECIFY BLOCKING FACTOR

HARRIS 800: MINI COMPUTER: (1329.5 MB CAPACITY)  
1.5 MB INTERNAL  
80 MB HARD DISK  
300 MB HARD DISK  
TWO (2) 474 MB HARD DISK  
800 & 1600 BPI TAPE DISK

-----  
NAME/ADDRESS RESOURCE FOR  
-----

Mrs. Francis Sullivan MMS Contracting Officer  
U.S. Department of the Interior  
Minerals Management Service  
Procurement Operations Branch B  
Mail Stop 635  
12203 Sunrise Valley Drive  
Reston, Virginia 22091  
(703) 435-6415

Dr. Murray Brown MMS Project Officer  
U.S. Department of the Interior Approves Spending  
Minerals Management Service  
Gulf of Mexico OCS Region  
3301 N. Causeway Boulevard  
Metairie, Louisiana 70010  
(504) 838-0901

Dr. Evans Waddell Subcontracted to FAMU  
Science Applications, Inc.  
4900 Water's Edge Drive  
Suite 255  
Raleigh, N.C. 27606  
(919) 851-8356

Mr. Harold Kilpatric General Meteo.  
Department of Meteorology Information  
Love Building  
Florida State University  
Tallahassee, Fl 30308  
(904) 644-6205

Dr. Jordan Reference Books  
FSU Meteorology Library  
(904) 644-3222

## RESOURCE LIST FOR METEOROLOGICAL DATA SETS PROJECT

NAME/ADDRESS	RESOURCE FOR
Dr. Shu National Meteorological Center Louisiana State University (504) 388-2395/6	Oil Co. Wind Data
Dr. Dana Thompson NORDA (Code 324) NSTL, Mississippi 39529	Gulf Buoy Data
Mr. Ben Davis National Climactic Data Center Federal Building Asheville. N.C. 28801-2696 (704) 259-0682	General Wx Data MARSDEN SQUARE Data
Mr. Bob Lobel Acting Chief Branch of Environmental Modeling MMS 644 12201 Sunrise Valley Drive Reston, VA. 22091 (703) 860-6730	Reference Literature
Pennsylvania State University Department of Meteorology University Park, PA. 16802	Reference Material
Mr. Mike McDermit U.S. Naval Postgraduate School Department of Meteorology Monterey, CA. 93940 (408) 646-2516	Reference Material Possible Data Set
Ms. Pat Kirk National Oceanographic Data Center NOAA/NESDIS E/OC21 2001 Wisconsin Avenue, NW Washington, DC 20235	NODC Data Base
Mr. Bob Stein NODC/D 742 2001 Wisconsin Ave. N.W. Washington, D.C. 20235 (202) 634-7505	Oil Company Data (CONOCO)

RESOURCE LIST FOR METEOROLOGICAL DATA SETS PROJECT

NAME/ADDRESS	RESOURCE FOR
Mr. Al Bargeski NODC (202) 634-7500	Gulf Oil Rig Data
Mr. Fred Kramer National Weather Service Tallahassee, Fl (904) 576-6318	Local Wx Service (Tallahassee)

SOUTHWEST FLORIDA SHELF BENTHIC COMMUNITIES  
STUDY ABSTRACT

INTRODUCTION

The overall objectives for the Year IV study required to investigate biological and physical processes and to provide information needed for impact assessment are as follows:

1. Compare and contrast the community structure of both live-bottom and soft-bottom fauna and flora to determine the differences and similarities between them and their dependence on substrate type.
2. Determine and compare the hydrographic structure of the water column and bottom conditions at selected sites within the study area.
3. Determine and compare sedimentary character at selected sites within the study area, and estimate sediment transport.
4. Relate differences in biological communities to hydrographic, sedimentary, and geographic variables.
5. Develop and conduct a research program which will provide essential information on the dynamics of selected "live-bottom" communities and determine the major factors which influence their development, maturation, stability, and seasonal variability.
6. Assemble and synthesize appropriate published and unpublished data with the results of this study, summarizing on a seasonal spatial basis all biological, habitat, and environmental observations and parameters. Relationships between biological and nonbiological factors shall be delineated through illustrations (maps, diagrams, charts, etc.), as well as descriptive text. Appropriate statistical analyses shall be performed to support the interpretations leading to the synthesis and conclusions.

7. Conduct an effective quality assurance and quality control program which ensures that all data acquired are accurate and repeatable within standards normally accepted for each type of observation, measurement, or determination.
8. Assess the need for and determine the type of studies to be conducted in future studies sponsored by MMS in the eastern Gulf of Mexico.

To meet these objectives, field studies were scheduled for four seasonal cruises, with sampling conducted at two mutually exclusive sets of stations. One set of stations (Group I) was scheduled to be sampled during fall 1983 and spring 1984, and consisted of the 5 hard-bottom and 5 of the 10 soft-bottom stations that were sampled during winter 1982-1983 and summer of 1983 (Year III study). This sampling essentially completed the seasonal baseline descriptive study of the inshore area in question.

Group II stations comprise five live-bottom stations, each representing a separate epifaunal community type, which were sampled during each of four seasons--fall 1983, winter 1983-1984, spring 1984, and summer 1984. These station locations are presented in Figure 1. A description of the Group II live-bottom stations is presented in Table 1.

#### RESULTS

As of December 1984, a full year of data has been collected for the Southwest Florida Shelf Benthic Community Study. Figure 2 presents the data recovery for this entire year of data collection. These data include well over 60 kilometers of underwater television and benthic still photography (UTV/BSP) coverage of the five Group I hard-bottom and Group II live-bottom stations collected during four cruises (December 1983; March, May, and August 1984). Epifauna and macroalgae samples were collected at 10 hard-bottom stations using dredges and trawls; infauna samples were collected by SCUBA divers at the 5 soft-bottom stations. CTD hydrographic surveys were conducted and sediment samples

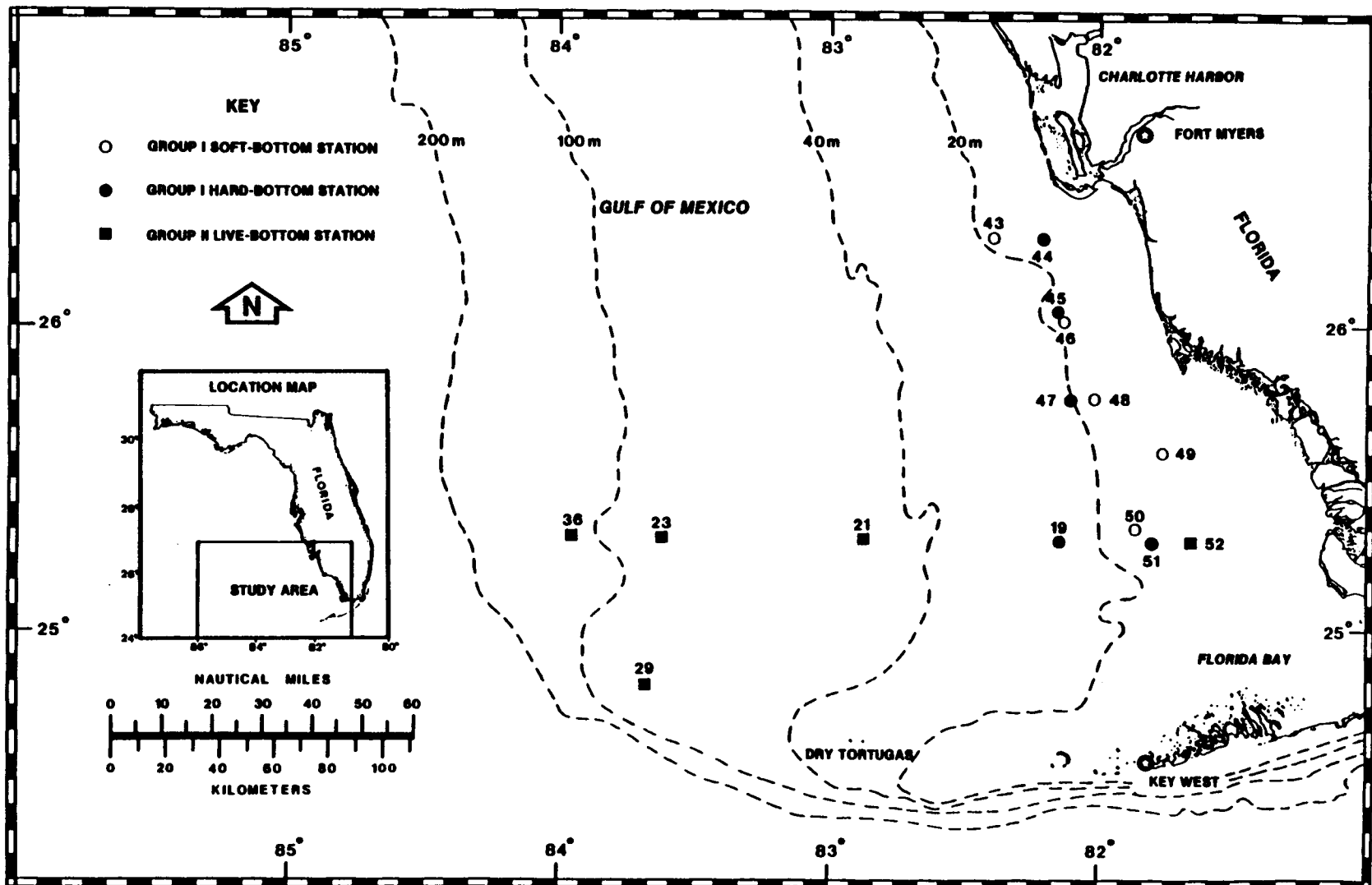

Table 1. Group II Hard-bottom Stations

Station	Depth (m)	Depth Zone	Substrate	Assemblage
52	13	Inner Shelf	Sand over hard substrate	Soft coral Assemblage I
21	47	Middle Shelf	Sand over hard substrate	Live bottom Assemblage II
23	74	Middle Shelf	Algal nodule layer/sand	Algal nodule assemblage
29	64	Middle Shelf	Algal nodule pavement	<u>Agaricia</u> coral plate
36	125	Outer Shelf	Sand over hard substrate	Crinoid assemblage

Source: ESE, 1984.

PROJECT TITLE: <u>SW FLORIDA OCS BENTHIC STUDY</u> PROJECT NO.: <u>83-513-510/MMS</u>															
DATE ISI: <u>DEC 83 / MAR 84 / MAY 84 / AUG 84</u>															
TASK OR PARAMETER DESCRIPTION	STATION NUMBER														
	43	44	45	46	47	48	49	50	51	52*	19	21*	23*	29*	36*
EPIFAUNA - UTV/BSP		▣	▣		▣					▣	▣	▣	▣	▣	▣
" - TRIANGLE DREDGE		▣	▣		▣					▣	▣	▣	▣	▣	▣
" - OTTER TRAWL		▣	▣		▣					▣	▣	▣	▣	▣	▣
INFAUNA - DIVER CORER	▣	▣	▣	▣	▣	▣	▣	▣	▣	▣	▣	▣	▣	▣	▣
SEDIMENTS - GRAB or DIVER	▣	▣	▣	▣	▣	▣	▣	▣	▣	▣	▣	▣	▣	▣	▣
HYDROGRAPHY - CSTD	▣	▣	▣	▣	▣	▣	▣	▣	▣	▣	▣	▣	▣	▣	▣
ARRAY - CURRENT METER										▣		▣	▣	▣	▣
" - FOULING PLATES										▣		▣	▣	▣	▣
" - SEDIMENT TRAPS										▣		▣	▣	▣	▣
" - TIME-LAPSE CAMERA										▣		▣	▣	▣	▣
" - WAVE & TIDE GAGE										▣		▣	▣	▣	▣

★ GROUP II

NOTE:

▣	SAMPLED ONCE	▣	UNRECOVERABLE
▣	SAMPLED SEMIANNUALLY	▣	COMPLETED
▣	SAMPLED QUARTERLY	▣	PARTIAL

Figure 2  
DATA RECOVERY STATUS FOR YEAR 4



were collected at all 15 stations. Finally, in an effort to understand the biological and physical dynamic processes occurring on the shelf, five in situ arrays were deployed at the five stations designated as Group II live-bottom stations. These arrays were equipped with meters for continuously monitoring current speed and direction, conductivity, and temperature; ceramic and steel fouling plates to be collected over nominally 3-month intervals; and sediment traps positioned 0.5, 1.0 and 1.5 meters (m) above the sea floor. In addition, the two arrays located in shallower water were equipped with wave and tide gages and time-lapse cameras for monitoring sediment transport and epifaunal recruitment. The following presents a brief summary of some of the findings.

Some of the most interesting findings to date have been obtained from the instrumented arrays. For sake of brevity, only Station 52 (13-m depth) and Station 36 (130-m depth) data are discussed. Figure 3 presents a current speed and direction plot and a current progressive vector plot for Station 52. This particular figure is for the month of January 1984; nevertheless, the trends shown here have been consistent throughout the year. These trends include the highly tidal nature of the currents, as shown by the periodic nature of the current speed. The periods are most noticeable at a daily scale (semi-diurnal tides) and bi-weekly (spring and neap tides). This same periodicity is shown in Figure 4, which presents the energy spectra for Station 52. This figure not only emphasizes the importance of the tides in terms of total energy, but also shows that these tidal currents set predominantly east and west. Figure 3 also shows this directional trend. A longer-term trend not immediately evident in the speed-direction plot is a net current setting to the southeast at approximately 4 cm/s. This net current remained relatively consistent throughout the year.

Station 36, located in deeper water, is still affected by the tides, but as Figure 5 shows, the effect is not nearly as pronounced. Currents at Station 36 do, however, seem to be affected by the Loop Current. This effect is most evident when comparing water temperature with the current

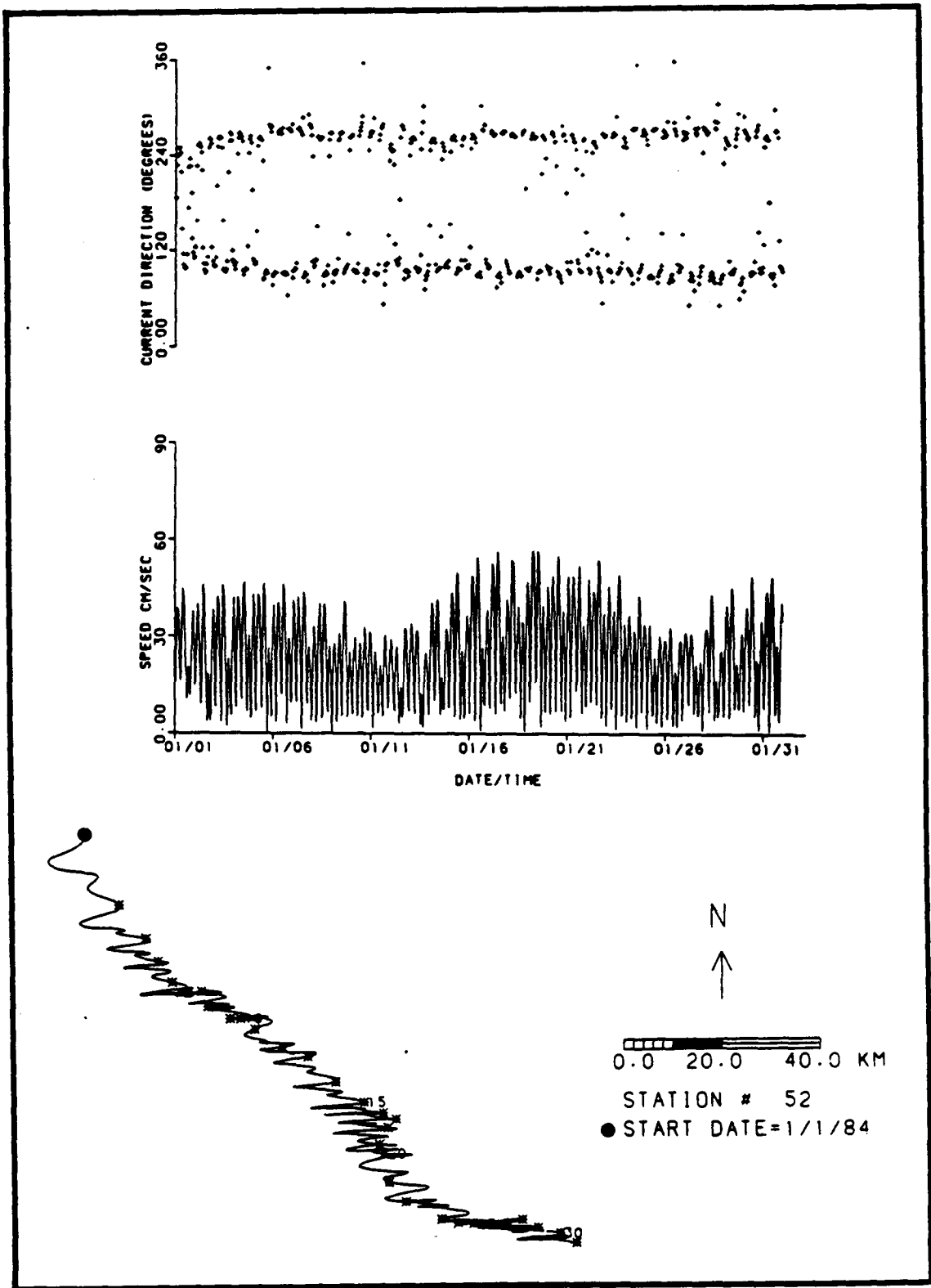

**Figure 3**  
**STATION 52 CURRENT SPEED, DIRECTION AND**  
**PROGRESSIVE VECTOR PLOTS - JANUARY 1984**

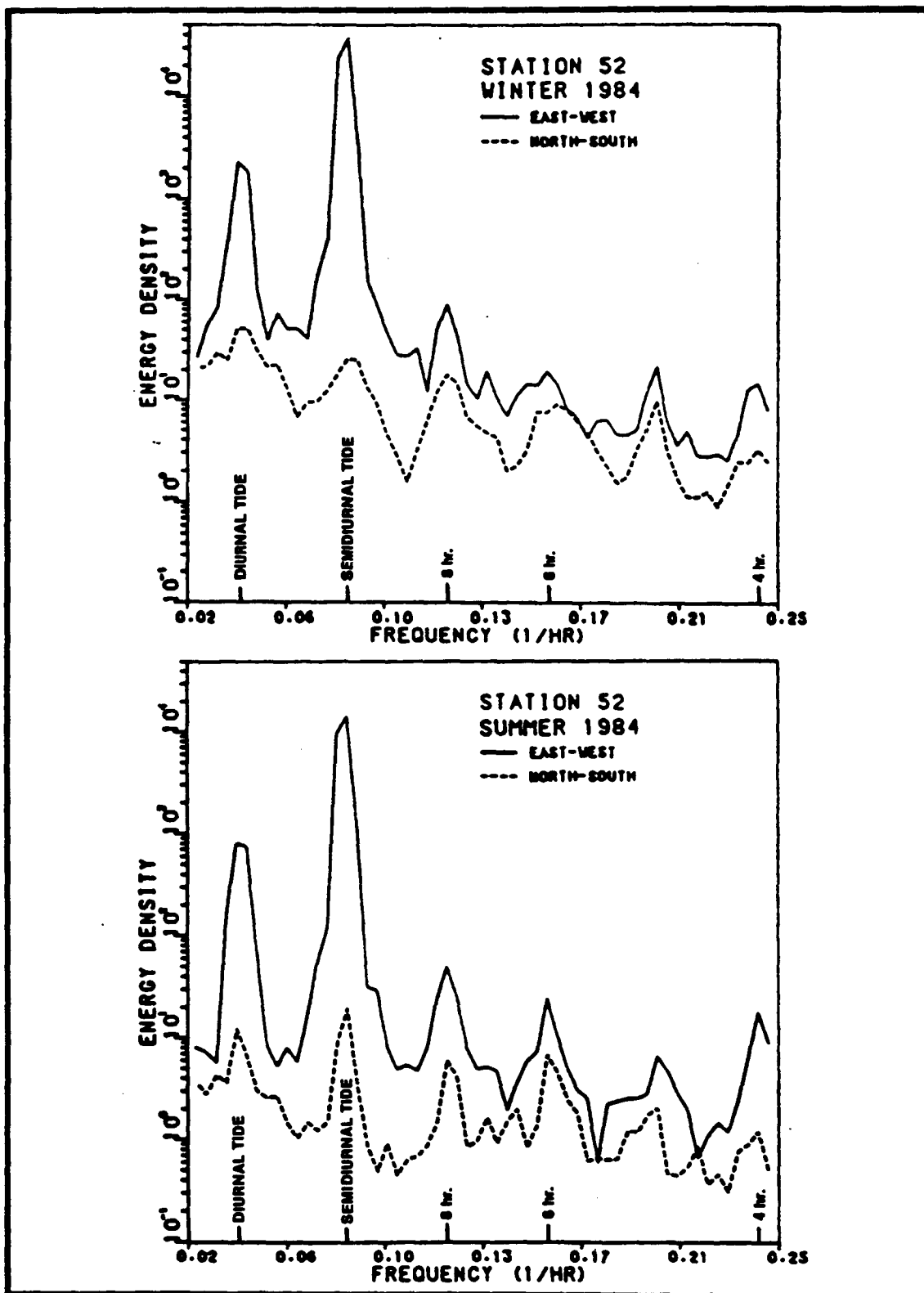
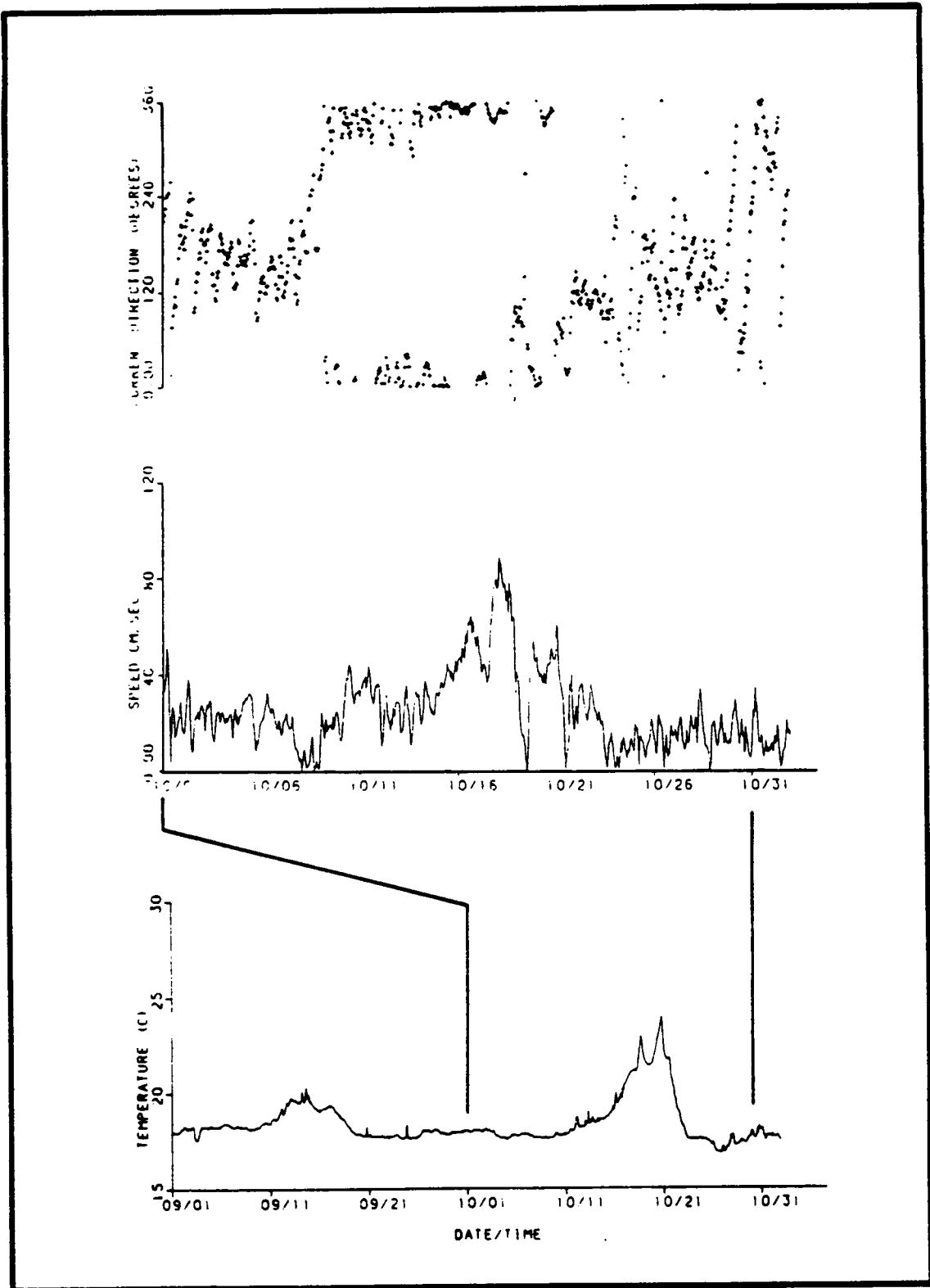

Figure 4  
ENERGY SPECTRA, STATION 52



**Figure 5**  
**STATION 36 CURRENT AND TEMPERATURE DATA FOR OCTOBER 1984**

speed-direction plot. It is apparent that as warmer water intrudes (the Loop Current) the current speeds increase and the direction stabilizes. The energy spectra (Figure 6) still show a tidal influence, but it is not as pronounced and these currents no longer set east and west. The net current at Station 36 is not as stable as the net current at Station 52. The annual average net current sets to the south at approximately 13 cm/s, but this average obscures the fact that the monthly average net currents set a variety of directions.

A final result obtained from the arrays, specifically from the time-lapse cameras (TLC), was the observation of gray snapper behavior. Gray snapper, while only rarely caught in the trawls, was the species observed most often in the view of the TLC. In addition to revealing the presence of gray snapper, the TLC revealed a trend toward increasing numbers of snapper the longer the array sat on the sea floor (Figure 7). This is probably the result of providing an artificial reef in the form of the array. Finally, by comparing total gray snapper counts with the time of day, two peaks become obvious at 12:00 and 21:00 (Figure 8). This may be an indication of diurnal foraging behavior in the gray snapper.

As data synthesis and interpretation continue, more trends will become obvious. In addition, as more data are collected during Year V, more reliability in these observations will be realized. Because of the success of the Year IV array scheme, additional emphasis will be placed on this specific technique in Year V. All eight of the stations shown in Figure 9 will be equipped with in situ arrays, and, because of the success of the TLC's, all but Station 36 will be equipped with TLC's.

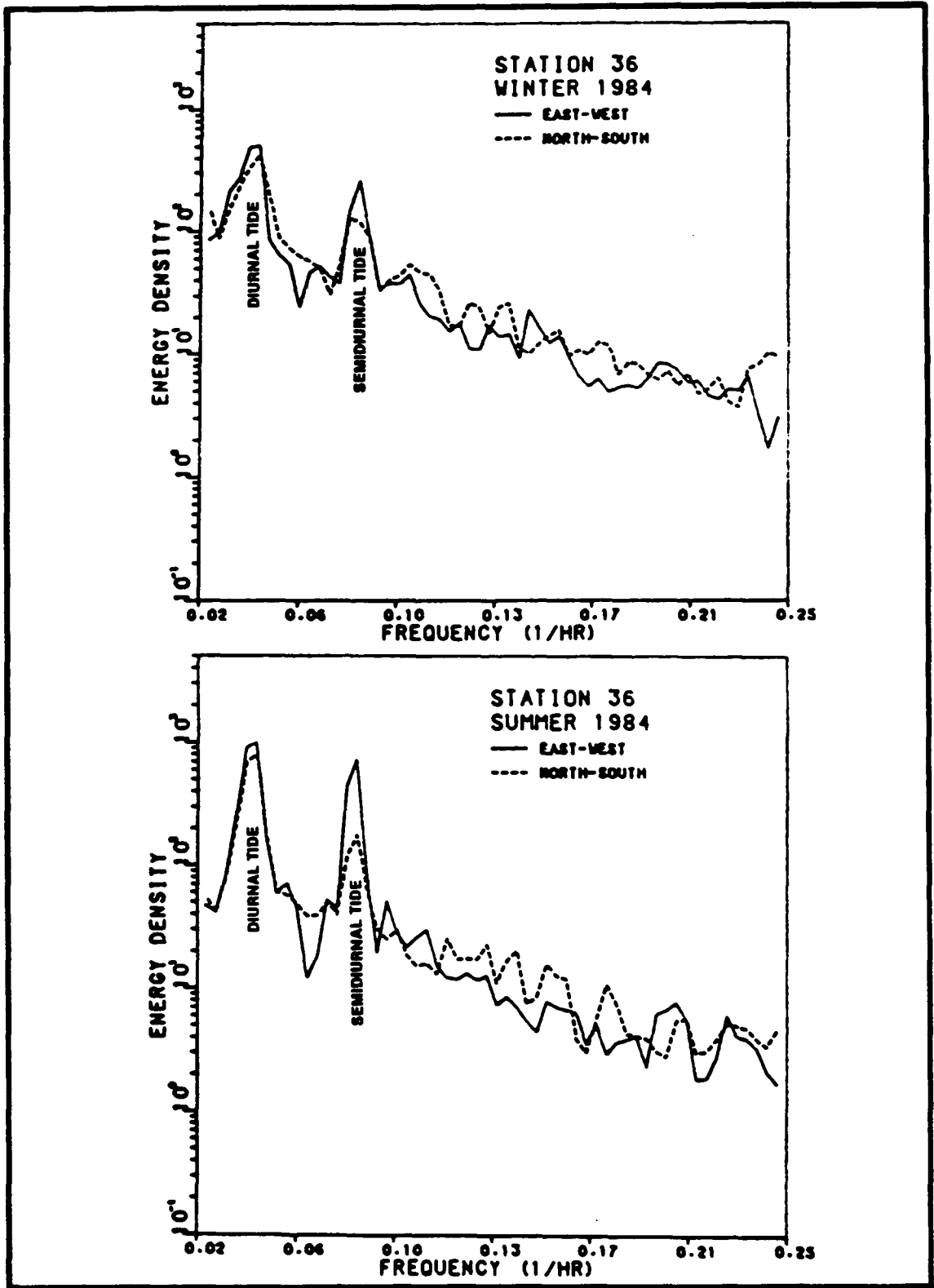
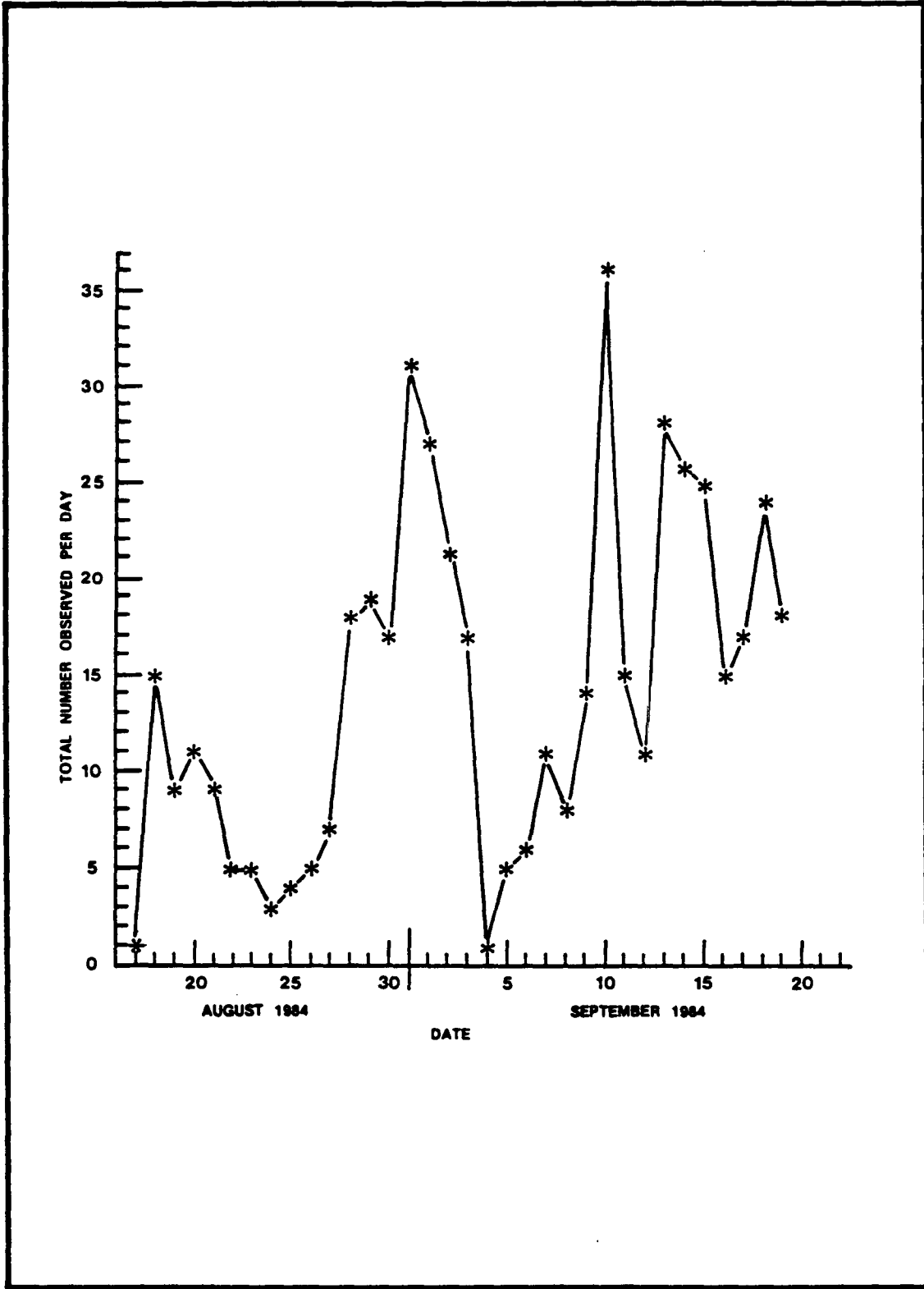
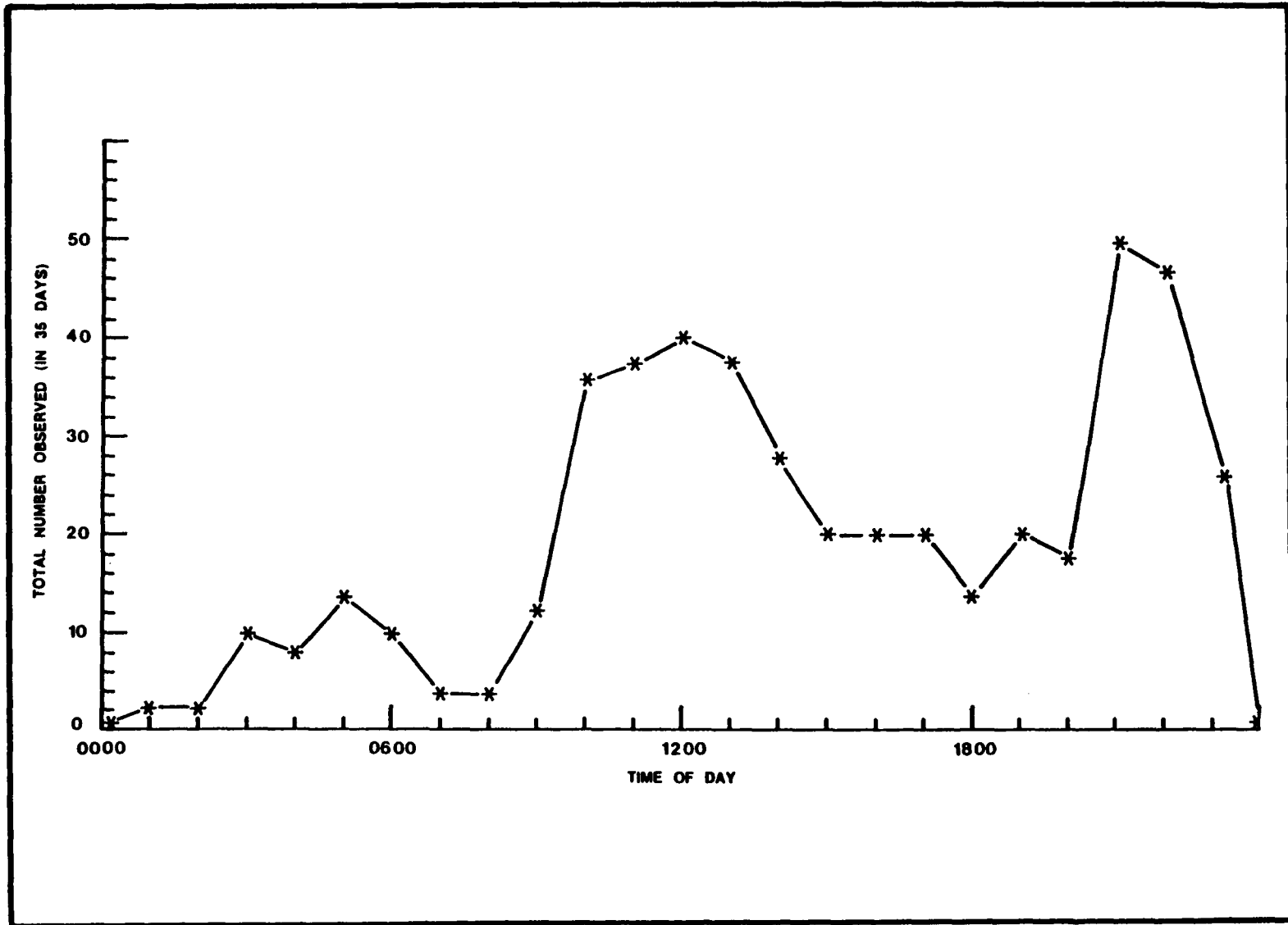

Figure 6  
ENERGY SPECTRA, STATION 36

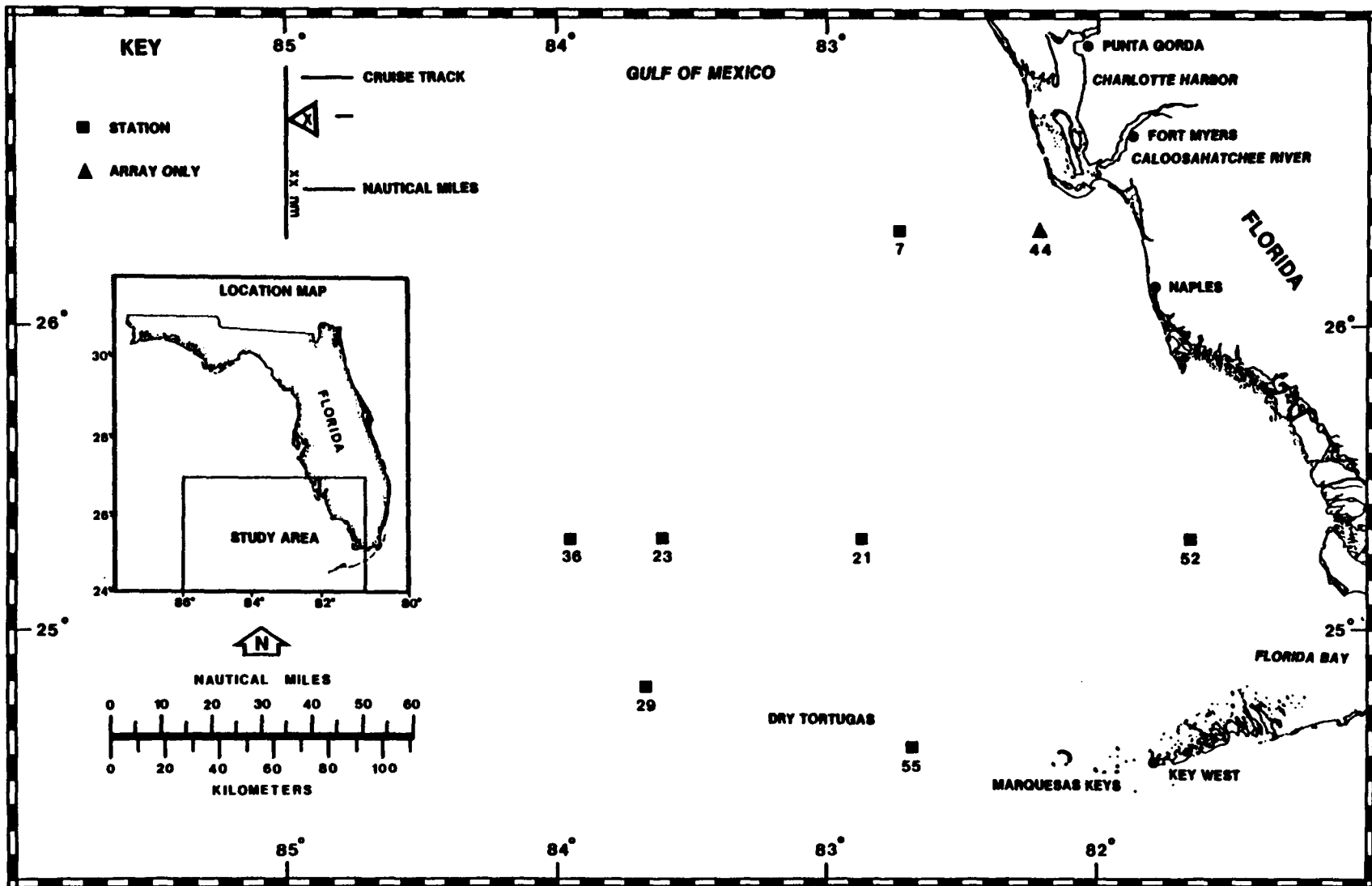

**Figure 7**  
**TOTAL NUMBER OF GRAY SNAPPER OBSERVED DAILY ON TIME-LAPSE FILM**  
**AT STATION 52 FROM AUGUST 16 TO SEPTEMBER 20, 1984**



**Figure 8**  
**TOTAL NUMBER OF GRAY SNAPPER OBSERVED HOURLY ON TIME-LAPSE**  
**FILM AT STATION 52 FROM AUGUST 16 TO SEPTEMBER 20, 1984**





**Figure 9**  
**SOUTHWEST FLORIDA SHELF BENTHIC COMMUNITIES STUDY**  
**YEAR 5 STATION LOCATIONS**

## EXECUTIVE SUMMARY

LGL Ecological Research Associates, Inc. (LGL) along with our subcontractors at Texas A&M University (TAMU), has been working on the Continental Slope Study for just over 18 months now. We have very recently completed a draft of our first annual report covering Cruise I and Cruise II, which were conducted November 1983 and April 1984 and so are able to report on findings from these cruises in a more complete form than has previously been possible. In addition, we have some preliminary observations from Cruise III to share. It should be noted that the findings contained in the draft annual report are not intended to be conclusive. It is the tactic of this study to use these initial results as a guideline for planning future research.

### Field Effort

Cruises I and II sample stations at depths from 345 m to 2880 m. These stations were distributed five to a transect along three transects shown in Figure 1.2-1. The Central Transect was judged to be of primary interest and was sampled on both cruises with greater replication, while the West and East Transects were sampled only during Cruise II. The research vessel used during the cruises was the R/V Gyre, which is operated by TAMU.

The sequence of tasks for sampling each station was the following:

- (1) Upon arrival at a station the camera sled was lowered to shoot about a half to 1 n.m. transect. The camera sled was "flown", rather than dragged, along this transect while a precision bottom altimeter was used to maintain the sled at from 1 to 3 m above bottom. 800 frames were taken per station.
- (2) Following the camera transect, the vessel returned to a position at the center of the transect. This position was maintained for the hydrocast which obtained water column samples.

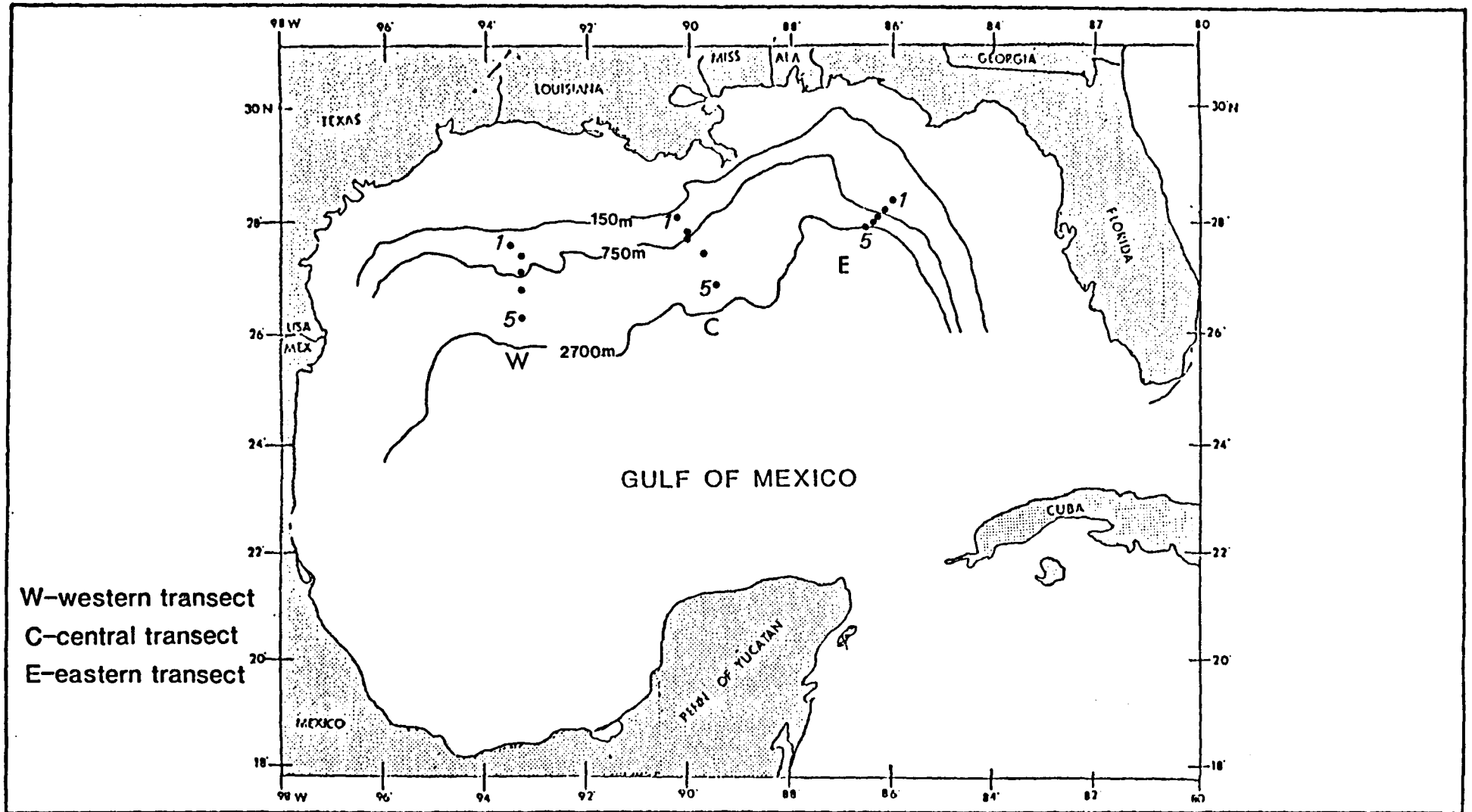

Figure 1.2-1. Location of transects and stations.

- (3) Concurrent with the hydrocast, a series of replicate bottom grabs were obtained--six on the Central Transect and three each on the East and West Transects. The sampling device was a standard box corer, fitted with six subsample tubes. Four tubes were seived onboard for meiofauna, while one each were frozen for sediment hydrocarbon and grain size analysis. The remainder of the box core was seived for macroinfauna.
- (4) The final effort was trawl sampling, using a 30' otter trawl, which was conducted along a transect similar to the camera transect.

Table 2.2-1 shows the total sampling effort for Cruises I and II. The reader should note the greater sampling effort devoted to the Central Transect.

#### Physical and Chemical Processes

The TAMU group has compiled a very thorough review of the general oceanography of the Gulf of Mexico, which is the major portion of their section of the draft annual report. A review of their findings is as follows:

##### High Molecular-Weight Hydrocarbons - Sediments

Sediments from all three transects showed a mixture of thermogenic, terrigenous and planktonic hydrocarbons. In general, hydrocarbons were only present at low concentrations especially at the East Transect. Aliphatic hydrocarbon levels ranged from 10 to 50 ppm, while values reported in the literature ranged from 1 to 3000 ppm, with values of 100,000 ppm reported from areas of pervasive seepage. Values were lowest in sandy areas and highest in shallow, polluted areas (Figs. 3.6-4 and 3.6-6).

Comparison among the transects sampled showed aliphatic hydrocarbons to be more elevated in Cruise I samples than in Cruise II samples from the Central Transect. The aliphatic UCM is presumed to have a purely

Table 2.2-1. Total sampling effort for Cruises I and II.

Station No. Gear Type	Cruise I					Cruise II															Total
	Central					West					Central					East					
	1	2	3	4	5	1	2	3	4	5	1	2	3	4	5	1	2	3	4	5	
Box cores (number)	6	6	6	6	6	3	3	3	3	3	6	6	6	6	6	3	3	3	3	3	90
Meiofauna (tubes)	24	24	24	24	24	12	12	12	12	12	24	24	24	24	24	12	12	12	12	12	432
Sediment (tubes)	6	6	6	6	6	3	3	3	3	3	6	6	6	6	6	3	3	3	3	3	90
Hydrocarbon (tubes)	6	6	6	6	6	3	3	3	3	3	6	6	6	6	6	3	3	3	3	3	90
Trawl (hours)	1.2	1.2	2.5	1.4	5.3	1.1	1.0	2.7	1.3	2.6	1.1	1.0	2.3	2.0	2.3	1.3	1.0	2.2	2.1	2.2	37.8
Camera (frames)	800	800	800	800	800	800	800	800	800	800	800	800	800	800	800	800	800	800	800	800	16,000

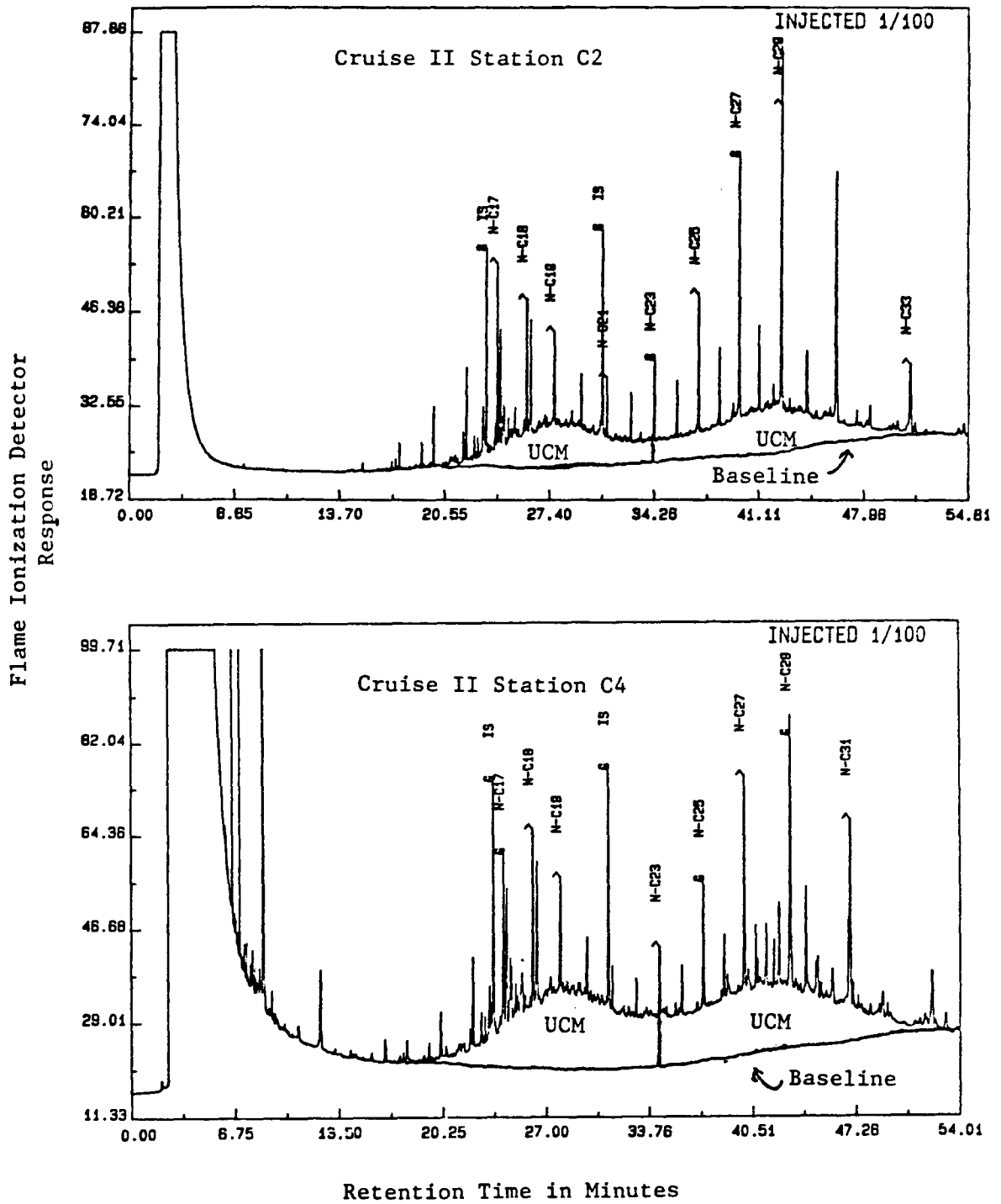

Figure 3.6-4 Representative gas chromatographic patterns of sediment hydrocarbons from the Central Transect during Cruise II.

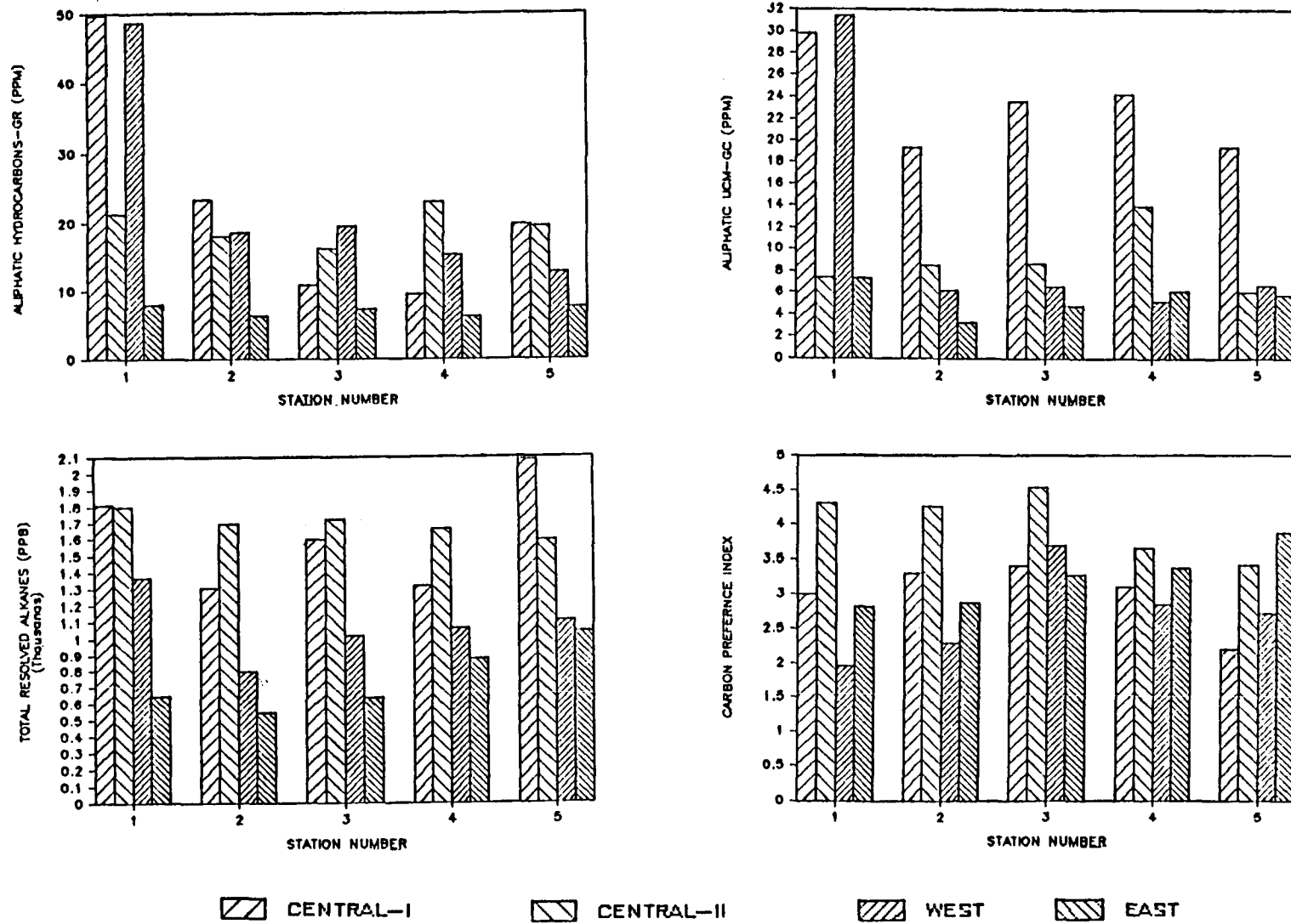

Figure 3.6-6 Comparison of selected sedimentary hydrocarbon parameters from Cruises I and II.

thermogenic source. It is probable that the lower values seen during Cruise II result from a diluting input of low aliphatic material of riverine origin; while the mix of biogenic and thermogenic material in the sediments from both cruises suggest that hydrocarbon content is a dynamic result of upward migration of thermogenic compounds in the sediments and transported input from the water mass.

In general, the influence of riverborn material decreases from the Central to the West to the East Transects. The materials being transported appeared to be compositionally constant over time.

#### High Molecular-Weight Hydrocarbons - Organisms.

At the present time hydrocarbon analysis is complete for all Cruise I organism samples and one-half complete for all Cruise II organism samples. Hydrocarbon concentrations were low compared with levels noted in the literature. The dominant alkanes were pristanes  $nC_{17}$ ,  $nC_{15}$  and  $nC_{17}$ , which are of presumed planktonic origin. No two to five ring aromatic hydrocarbons were detected. In general, all organisms seemed to be pristine with respect to thermogenic hydrocarbons. One exception is a pooled sample of five Nematocercinus rotundus having a complete suite of alkanes and UCM suggesting thermogenic hydrocarbons. Figure 3.6-9 shows contaminated and uncontaminated samples of the same species.

#### Sediment Texture

Sea floor sediment texture is an extremely important variable in evaluation of benthic ecology. General sediment characteristics of the 15 stations sampled are presented in Figure 3.7-1. All stations were predominantly clay, although East Transect stations contain considerably more sand and silt, which corresponds to the higher carbon content of these stations.

#### Carbon Isotope Analysis

Carbon isotopic analyses were performed on selected organisms to determine their food source. Ratio of  $^{12}C:^{13}C$  (Sigma  $^{13}C$ ) values are



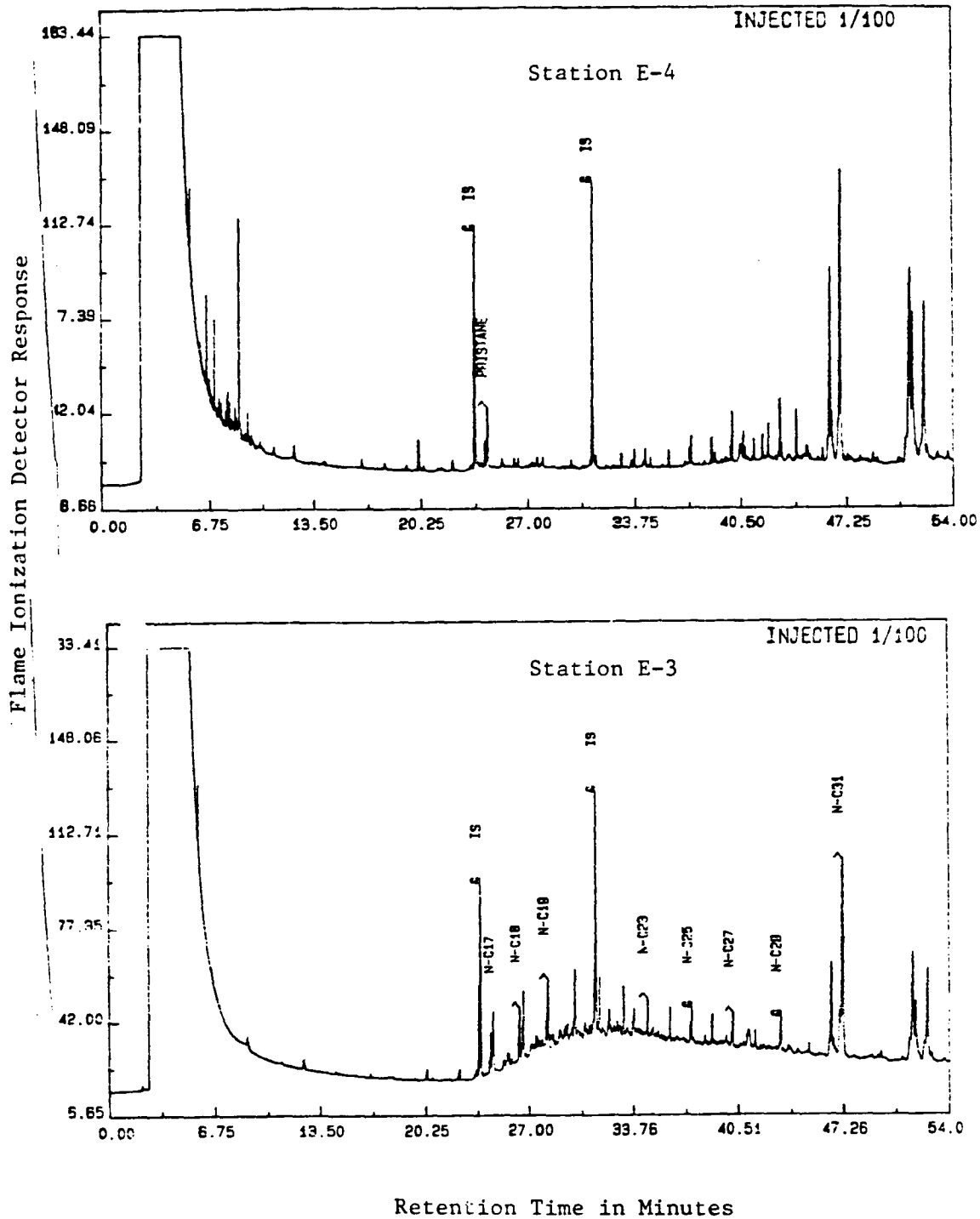

Figure 3.6-9 Aliphatic hydrocarbon gas chromatograms of *Nematocarcinus rotundus* from Stations E-3 and E-4 of Cruise II.

### 84-G-4 Grain Size

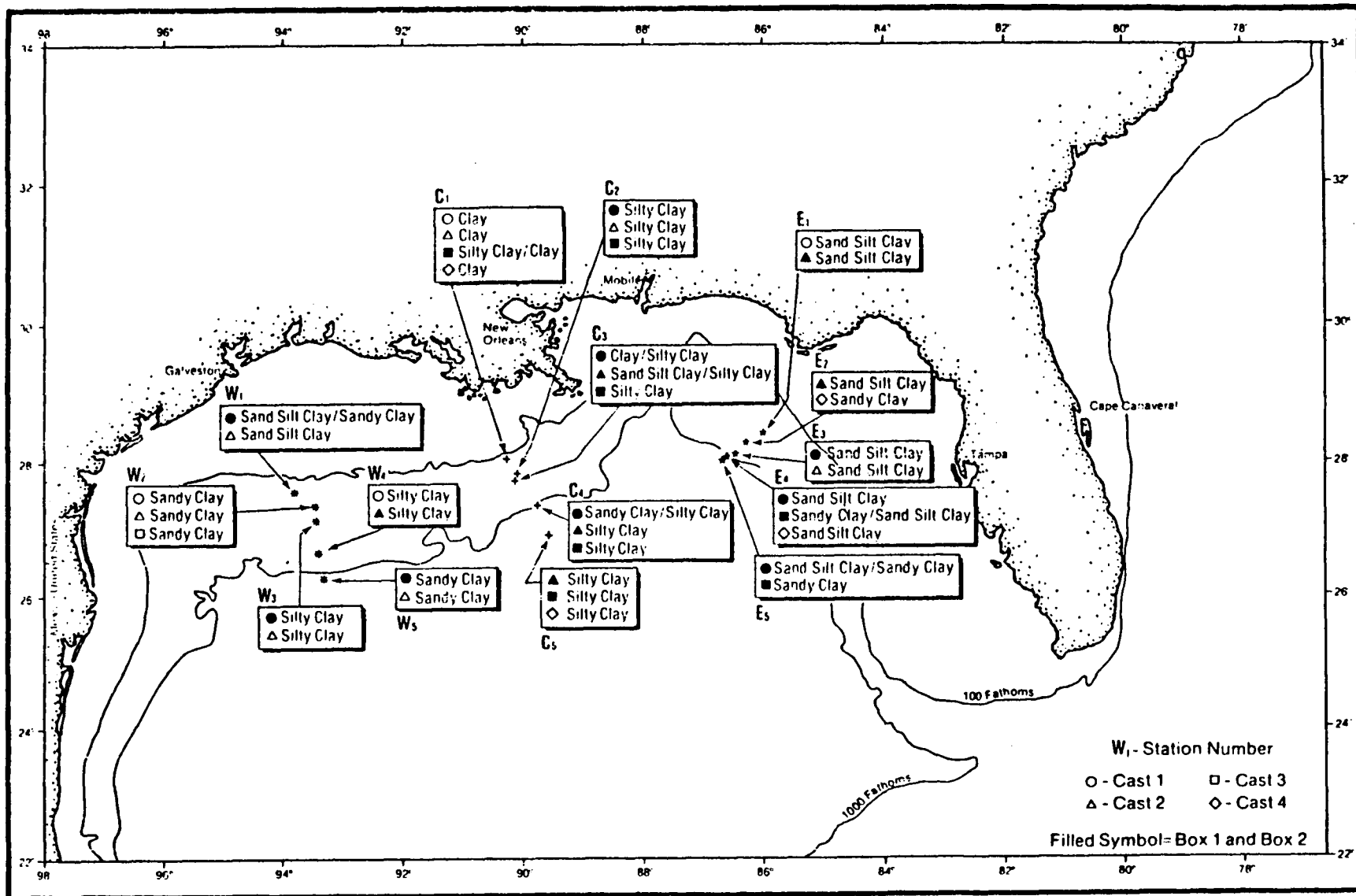

Figure 3.7-1 Grain size types (after Folk, 1974) at Cruise II stations.

indicative of the fraction of photosynthetically derived carbon from planktonic sources, versus carbon derived from chemautotrophic bacteria that oxidize hydrogen sulfide. Organisms in the planktonic food chain have sigma <sup>13</sup>C values of -19 to -20 ppt, while tissue recovered from mussels have values near -33 ppt.

Table 3.7-3 shows carbon isotopic values of organisms collected on the Gulf of Mexico Slope. Note that those organisms labeled seep area were collected by the TAMU group in samples taken independent of this study and are presented for comparison. All samples analyzed thus far for the Continental Slope Study have sigma <sup>13</sup>C values indicative of a planktonic origin. The seep organism--at least the sessile ones--show a marked departure from this baseline.

#### Physiochemical Characteristics

The water mass structure, as determined by temperature, salinity and light transmission, showed little variation from East to West. Characterizations of the principal water masses are given in Figure 3.3-8.

#### Biological Oceanographic Characteristics

Preliminary objectives for the biological oceanography were

- (1) to establish the procedures for effective collection and identification of the communities of megafauna, macroinfauna and meiofauna present on the shelf slope. To date, the Cruise I samples have been fully identified, while the Cruise II macroinfauna samples were not complete in time for this report. The pervasive impression among the taxonomic experts was that the samples were small in size and contained numerous immature specimens.
- (2) To compare species diversity and any patterns of zonation by depth with previous findings, particularly those of the TerEco Report. Although the LGL collections are much narrower than those of TerEco, the patterns of dominant species and apparent zonation fitted those of TerEco

Table 3.7-3 Carbon isotopic values ( $\delta^{13}\text{C}$  in ‰ relative to PDB) for organisms obtained from trawls on the Gulf of Mexico continental slope.

Organism	Description	Station	Depth <sup>1</sup>	$\delta^{13}\text{C}$	Position	Comment
<i>Geryon quinquedens</i>	crab	E-1	390	-17.2	28°24'N 85°58'W	
<i>Bembrops gobioides</i>	fish	E-1	390	-17.8	28°24'N 85°58'W	
<i>Synaphobranchus brevidorsalis</i>	eel	E-3	840	-18.1	28°11'N 86°26'W	
<i>Geryon quinquedens</i>	crab	E-3	840	-23.1	28°11'N 86°26'W	
<i>Synaphobranchus brevidorsalis</i>	fish	E-4	1225	-19.2	28°07'N 86°36'W	
<i>Bathypterois quadrifilis</i>	fish	E-4	1225	-18.6	28°07'N 86°36'W	
<i>Synaphobranchus oregoni</i>	eel	E-4	1225	-19.5	28°07'N 86°36'W	
<i>Nematocarcinus rotundus</i>	shrimp	E-4	1225	-18.2	28°07'N 86°36'W	
<i>Acanthephyra eximia</i>	shrimp	E-4	1225	-18.3	28°07'N 86°36'W	
<i>Geryon quinquedens</i>	crab	E-4	1225	-19.3	28°07'N 86°36'W	
<i>Synaphobranchus oregoni</i>	fish	C-1	347	-19.6	28°03'N 90°15'W	
<i>Geryon quinquedens</i>	crab	C-4	1390	-17.4	27°28'N 89°44'W	
<i>Bathygadus macrops</i>	fish	W-2	550	-17.5	27°25'N 93°19'W	
<i>Monomitopus sp.</i>	fish	W-3	791	-18.1	27°08'N 93°24'W	
<i>Dicrolene sp.</i>	fish	W-3	791	-18.3	27°08'N 93°24'W	
<i>Halosaurus guentheri</i>	fish	W-3	791	-17.5	27°08'N 93°24'W	
<i>Stereomastis sculpta</i>	shrimp	W-4	1390	-17.0	26°44'N 93°19'W	
<i>Calyptogena ponderosa</i> (2 specimens)	clam	GC-184	600	-35.4 -35.3	27°40'N 91°32'W	Seep area
<i>Lucinoma atlantis</i> (2 specimens)	clam	GC-184	600	-31.2 -33.0	27°40'N 91°32'W	Seep area
Unidentified neogastropod	snail	GC-184	600	-31.5	27°40'N 91°32'W	Seep area
<i>Lamellibrachia sp.</i>	tubeworm flesh	43	600	-27.0	27°45'N 91°14'W	Seep area
<i>Lamellibrachia sp.</i>	tube worm	43	600	-28.1	27°45'N 91°14'W	Seep area
<i>Nezumia aequalis</i>	fish <sup>2</sup>	GC-184	600	-17.6	27°40'N 91°32'W	Seep area
<i>Monomitopus sp.</i>	fish	GC-184	600	-17.9	27°40'N 91°32'W	Seep area
<i>Chaunax pictus</i>	fish	GC-184	600	-17.9	27°40'N 91°32'W	Seep area
<i>Coryphaenoides colon</i>	fish	43	600	-17.2	27°45'N 91°14'W	Seep area

<sup>1</sup>Depths are approximate since many areas of the slope are steep.

<sup>2</sup>Fish were not necessarily collected in the immediate vicinity of the seeps. They could have been collected at other areas during the trawl.



remarkably well. This was of particular interest in the Central area of the Gulf where TerEco's collections were least.

- (3) To ascertain whether well-known physiochemical variations in the water column and sediments have produced discernable biotic differences from East to West. Here, both the occurrence of deep water groups and the nodal distribution of deep water families seem to confirm a West to East deepening trend, although causes for this trend remain uncertain.

#### Decapod Crustacea

There were 78 species of Decapoda collected, led in variety by the anamurans and the galatheids. The numbers of known deep water forms appearing on each transect is shown in Table 4.1-2. The carideans and the Munidopsis spp both show greater numbers of species achieving maximum depth of penetration to the East.

#### Echinodermata

Thirty-three species of echinoderms have been identified from Cruise I and II samples. This does not include the brittle stars, which have not yet been identified. The most diverse group, the Asterridea contributed 18 species to this total--compared with 61 species seen in the TerEco collections. There is some question regarding accuracy of identification, but the trend is similar to what was seen generally with the macroepifauna. That is, LGL's collections were dominated by the same species as TerEco's, but show less species diversity. Personal communication from Bob Carney suggests that the trawl samples are not taking the variety of Holothuroidea that would be expected.

#### Fish

Ninty-four demersal species of fish belonging to 42 families were seen during Cruises I and II. This compares with 206 species in 47

Table 4.1-2 Numbers of macroepifaunal species of decapods achieving maximum depth penetration on a given transect.

	Transect		
	West	Central	East
Carideans	3	7	9
Brachyurans	2	12	3
Pagurids	3	6	3
Munidopsis	2	0	7
Penaeids	3	3	2
Munida	2	1	3
Nephropids	0	0	3
Polychelids	1	0	1
Scyllarids	1	0	0
Axiids	0	0	1
<b>TOTALS</b>	<b>17</b>	<b>29</b>	<b>32</b>

families reported by TerEco. Study of the depth of occurrence for the fish suggest that most are divisible into two bathymetric groups: those occurring below and those above 1000 m. Table 4.1-15 shows the bathymetric distribution of the major fish families and their contribution in numbers of species. Table 4.1-17 shows the results of comparison between the LGL and TerEco studies. The similarities are marked.

#### Meiofauna

Size range of the meiofauna was determined by the 0.062 to 0.3 mm mesh sizes used in the upper and lower sieves. The meiofauna seen comprised numerous juvenile macroinfaunal forms as well as the permanent meiofauna. Identification was made to rough sort taxa levels only. Figures 4.2-2, 4.2-3 and 4.2-4 show relative numbers of the rough sort groups. Comparison of the transects illustrates some of the variation in taxa that was seen. Note the change in relative numbers of forams in Central Transect stations. This variation raises some interesting questions concerning the usefulness of close identification of meiofauna. Although those forams are important in any energy budget account of the deep Gulf, their variation in abundance makes it doubtful whether observed changes in group abundance will have diagnostic significance for monitoring purposes.

#### Macroinfauna

The macroinfauna were all organisms retained on a 0.3 mm seive. The LGL collection is the first major study of this biotope for the deep Gulf and has produced some interesting taxonomic results. Samples identified for Cruise I alone have been notably abundant and diverse and produced numerous range extensions, and several probable new species in all the major groups. Table 4.3-18 shows a comparison of the abundance in the LGL collection with previous collections from shallower stations. An addendum to this table shows the numbers of species in the major groups.

Cruise II samples promise to be even more impressive. A personal communication from our tanadacean expert, Richard Heard, indicates that,



Table 4.1-15 Number of species collected in the fish taxa and their bathymetric distribution.

Family	No. of Species	% of all Fish spp.	No. Species below 1000 m	% of Group below 1000 m
Macrouridae	19	21	10	53
Rajidae	5	5	1	20
Ophidiidae	4	4	3	75
Synphobranchidae	4	4	3	75
Halosauridae	4	4	3	75
Gadidae	3	3	0	-
Bathypteroidae	3	3	3	100
Triglidae	3	3	1	33
Scorpaenidae	3	3	0	-
Apogonidae	3	3	0	-
Nettastomidae	2	2	1	50
Congridae	2	2	1	50
Thirty other families	39	41	8	21
<b>TOTAL</b>	<b>94</b>	<b>100</b>	<b>34</b>	<b>x 42</b>

Table 4.1-17 Comparison of most abundant species of fish between the LGL and TerEco studies. Arranged in order of simple abundance for convenience of comparison.

LGL		TerEco	
Species	Depth of max. Pop. (m)	Species	Depth of max. Pop. (m)
<u>Poecilopsetta beanii</u>	348	<u>Poecilopsetta beanii</u>	250
<u>Bembrops gobiodes</u>	348	<u>Bembrops gobiodes</u>	400
<u>Coelorinchus carribaeus</u>	348	<u>Coelorinchus carribaeus</u>	300
<u>Hymenocephalus italicus</u>	348	<u>Hymenocephalus italicus</u>	450
<u>Urophycis cirrata</u>	348	<u>Urophycis cirrata</u>	450
<u>Dibranchius atlanticus</u>	657	<u>Dibranchius atlanticus</u>	650
<u>Nezumia aequalis</u>	657	<u>Nezumia aequalis</u>	900
<u>Synaphobranchus sp.</u>	839	<u>Synaphobranchus sp.</u>	1000
<u>Gadomus longifilis</u>	1341	<u>Gadomus longifilis</u>	1050
<u>Monomitopus sp.</u>	839	<u>Monomitopus sp.</u>	1050
<u>Dicrolene sp.</u>	1341	<u>Dicrolene sp.</u>	1200
<u>Stephanoberyx monae</u>	1341	<u>Stephanoberyx monae</u>	1200
<u>Parasudis truculenta</u>	348	<u>Parasudis truculenta</u>	250
<u>Setarchus guentheri</u>	348	<u>Pontinus longispinus</u>	200
<u>Chlorophthalmus agassizii</u>	348	<u>Yarella blackfordi</u>	650
<u>Epigonus pandionis</u>	348	<u>Bathygadus melanobranchus</u>	900
<u>Malacocephalus occidentalis</u>	348	<u>Aldrovandia gracilis</u>	1450
<u>Peristedion grevae</u>	348	<u>Halosaurus guentheri</u>	900

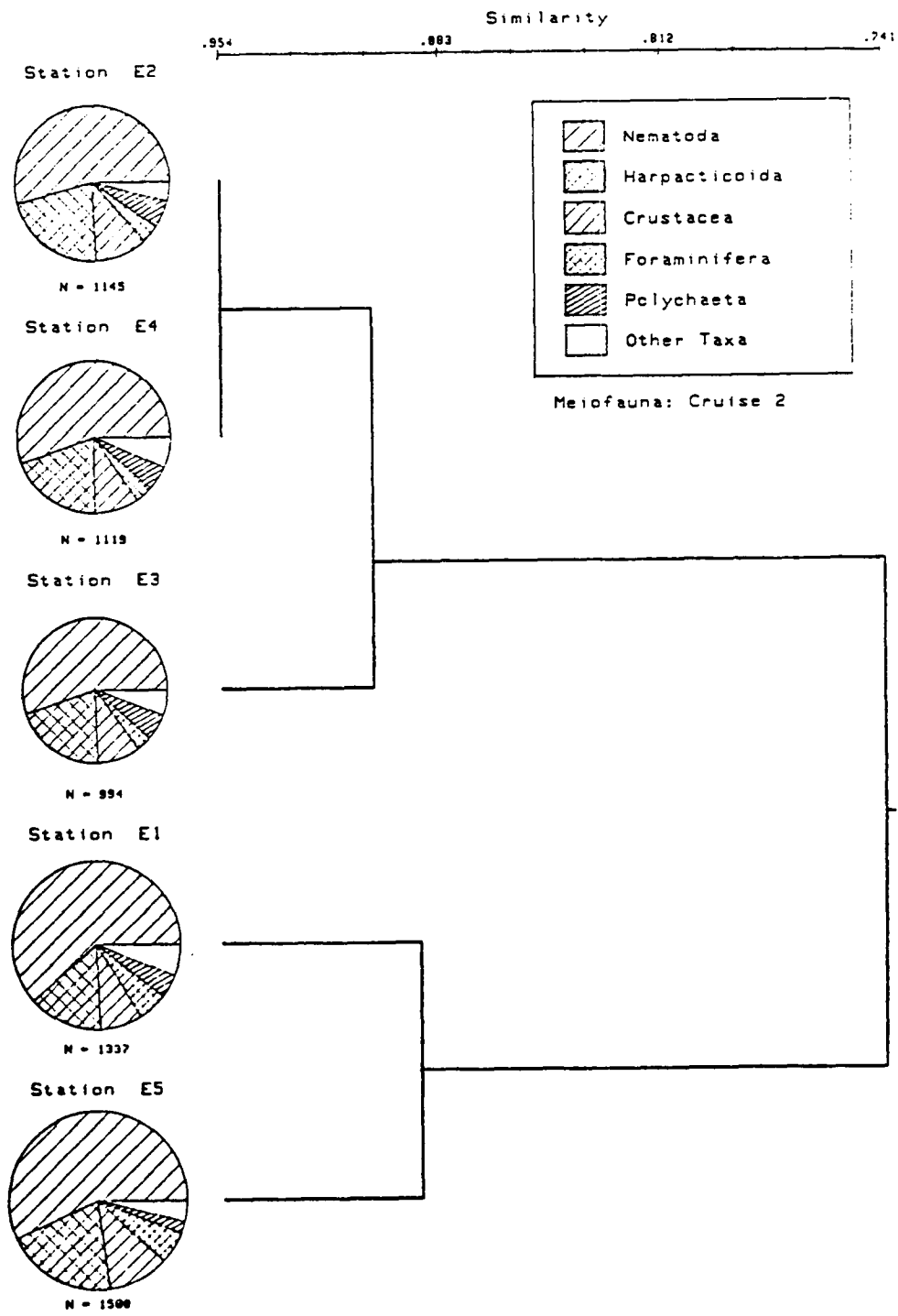

Figure 4.2-2 Similarity dendrogram for Cruise II meiofauna at the East Transect. Relative abundance of major taxa is shown for each station. The size of the station pies indicates relative abundance for all taxa.

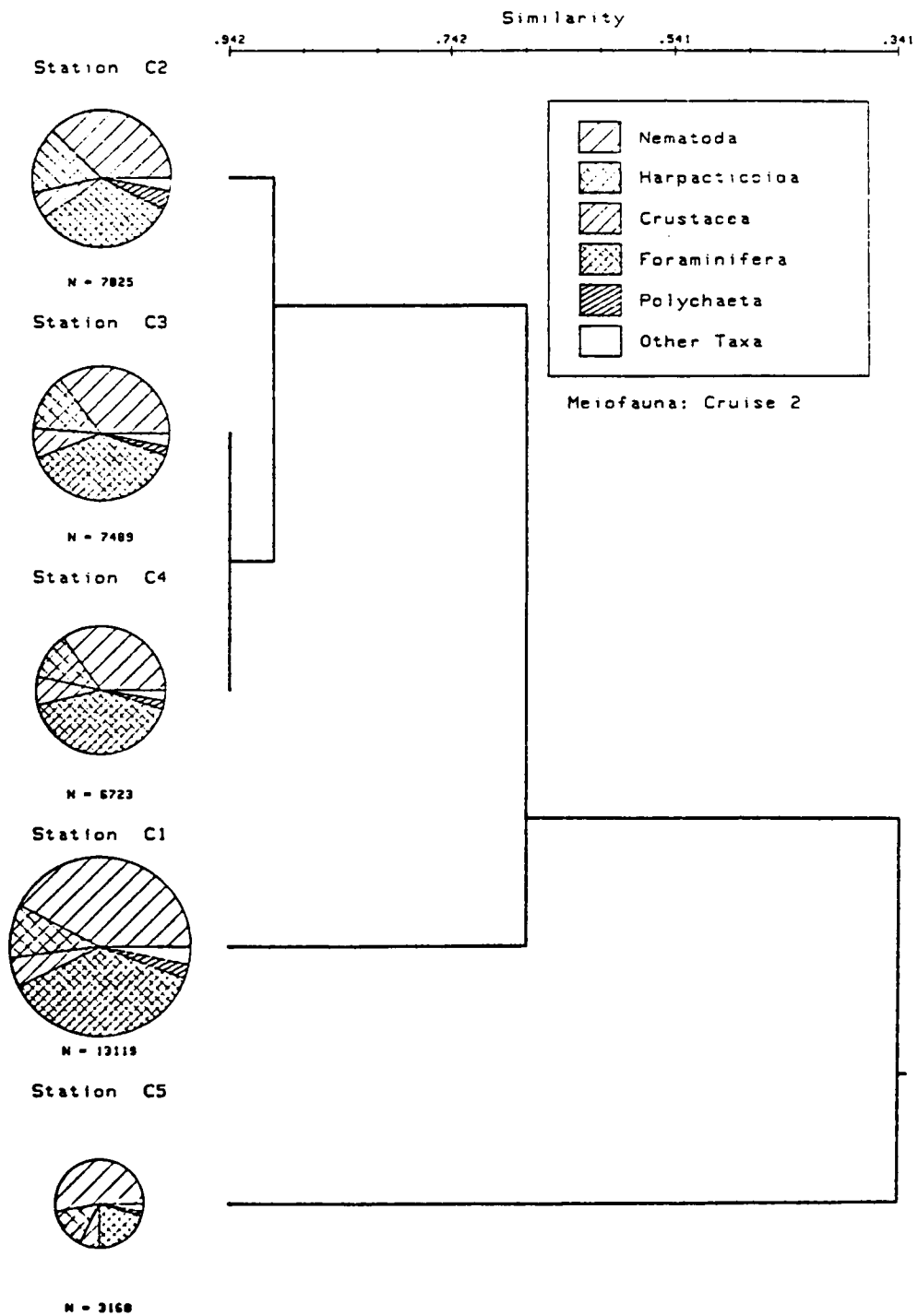

Figure 4. 2-3 Similarity dendrogram for Cruise II meiobenthos at the Central Transect. Relative abundance of major taxa is shown for each station. The size of the station pies indicates relative abundance for all taxa.

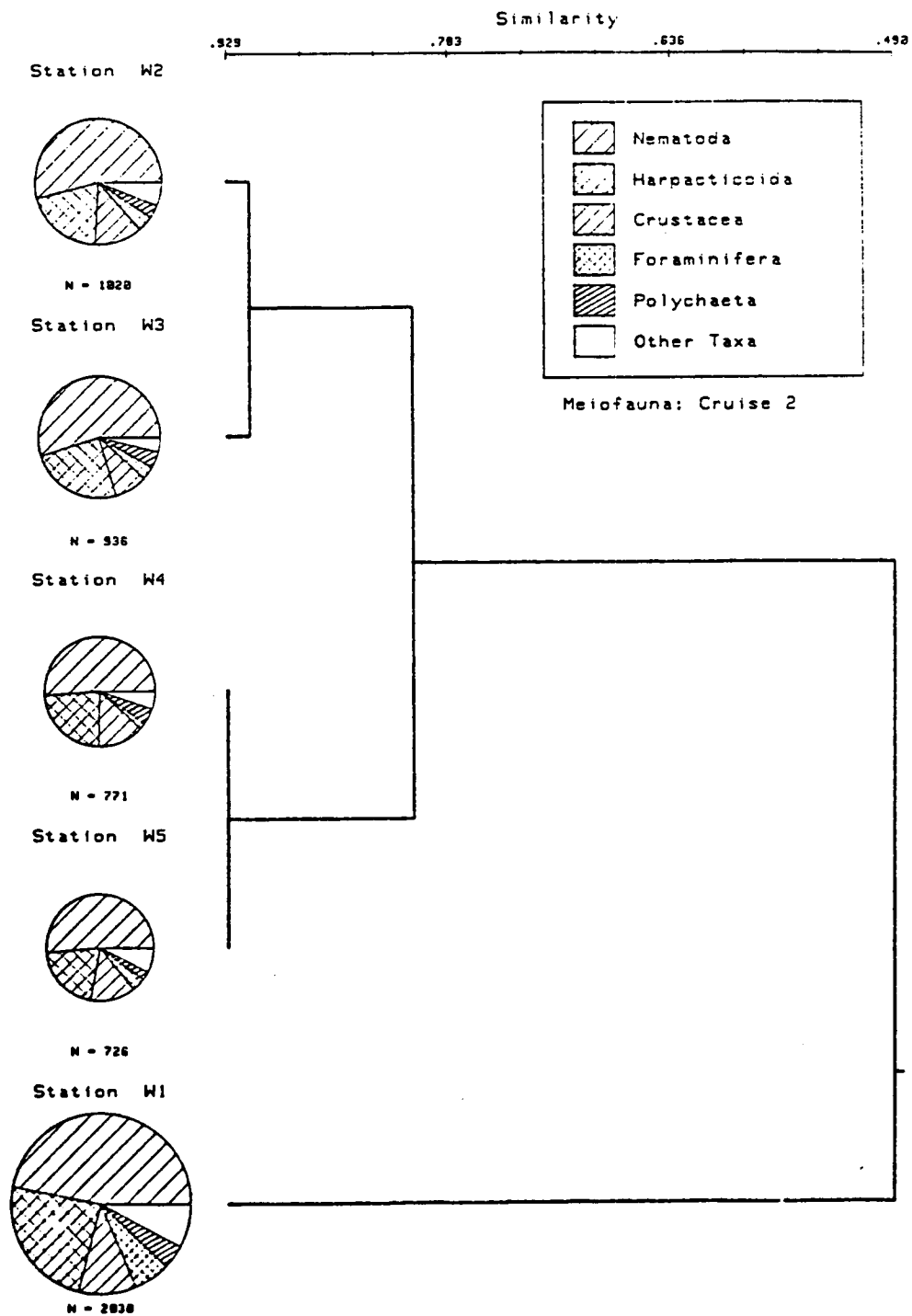

Figure 4.2-4 Similarity dendrogram for Cruise II meiofauna at the West Transect. Relative abundance of major taxa is shown for each station. The size of the station pies indicates relative abundance for all taxa.

Table 4.3-18 Comparison of Macroinfaunal Populations (No./m<sup>2</sup>) between present LGL Continental Slope Study and previous Gulf of Mexico Continental Shelf Studies.

	LGL All Stations	LGL West Transect	Hard Banks* Upcurrent	Hard Banks* Downcurrent
Range	2433-8613	2433-6209	192-1273	317-5237
Mean	5724	4482	691	2472

\*Pequegnat & Sikora, 1978.

Table 4.3-19 Comparison of mean densities of the most abundant taxonomic groups of macroinfauna between LGL Continental Slope samples and previous Gulf of Mexico Continental Shelf samples (No./m<sup>2</sup>).

	LGL All Stations	LGL West Transect	Hard* Banks
Polychaeta	2,788	2,312	583
Nematoda	1,079	834	178
Copepoda	396	331	71
Ostracoda	246	118	119
Bivalvia	224	167	127
Tanaidacea	171	121	46
Amphipoda	71	35	46
Sipuncula	82	60	279

\*Pequegnat & Sikora, 1978.

Group - No. of spp.

Bivalvia - 41  
 Isopoda - 59  
 Gastropoda - 14  
 Tanaidacea - 59  
 Scaphapoda - 8  
 Ophiuroidea - 16

if all the tanadaceans from Cruise II are described, it increases the number of known species in the group, world-wide, by 20%.

### Benthic Photography

A major effort of the program has been the development of new analytical techniques for benthic photography. Figures 5.1-1 and 5.1-2 show the apparatus for analysis and the sequence of steps in the procedure. The task of the analyst is to categorize the bottom features in a consistent manner. The digital data file that results from analysis permits quantitative evaluation of density and distribution of bottom character. Writing software to handle these data transformations and perfection of the techniques involved has consumed considerable time. Results now forthcoming are for one shallow station on each of the West, Central and East Transects.

Comparison of these three stations showed station C1 to have the greater density of both Lebensspuren and biota. The occurrence of specific types of Lebensspuren and biota was similar for all stations, although densities differed.

Choosing two broadly prevalent types of biota (fish and decapods) and two of Lebensspuren (solitary lumps and groups of depressions), shows that the occurrence of these features is quite irregular. Figures 5.2-1 through 5.2-6 show the density of objects per frame overlaid with the depth per frame. Occular impressions suggest that there is a negative trend in fish density with depth. Correlation using Spearman's Rank test confirms a significant negative correlation. A test for distributional patterning--the Index of Cluster Size--shows that groups of depressions are patchily distributed while solitary lumps are randomly distributed. Such differences in distributional pattern offer persuasive evidence that different organisms or processes are responsible for these features.

Table 6.3-1. Status of data files as of 7 March, 1985.

<u>File Name</u>	<u>Cruise</u>	<u>Received</u>	<u>Coded</u>	<u>Entered</u>	<u>Verified (KP, PJ)</u>	<u>QA</u>	<u>Sent To NODC</u>	<u>Total Records</u>
P511								
Meiofauna	1	X	X	X	X	X	X	1047
	2	X	X	X	X	X		2060
								----- 3107
P512								
Macroinfauna	1	X	X	X	X	X	X	1289
	2	X	X	X	X	X		2060
Final sort	1	X	X	X	X	X		1032
								----- 4381
P513								
Macroepifauna & Demersal Fish	1	X	X	X	X	X	X	332
	2	X	X	X	X	X		1168
								----- 1500
P514								
Benthic Photography	Stations C1, E1, W1 have been digitized and archived at LGL. This data will not be sent to NODC at this time. Total raw data records=42,000; total compressed data records=10,400.							
P515								
Ship Position and Depth	1	X	X	X	X	X	X	45
	2	X	X	X	X	X		110
								----- 155
P517								
Sediment	1	X	X	X	X	X		31
	2	X	X	X	X	X		63
								----- 94
P518								
Hydrocarbons	Cruise 1 sediment and organisms have been received and verified with a total of 779 data records. Cruise 2 sediment has been received and verified with a total of 464 data records. Total records for both cruises is 1243. Cruise 2 organisms have not been received yet.							
P519								
Hydrography	1	X	X	I/P				
	2	X	X	I/P				



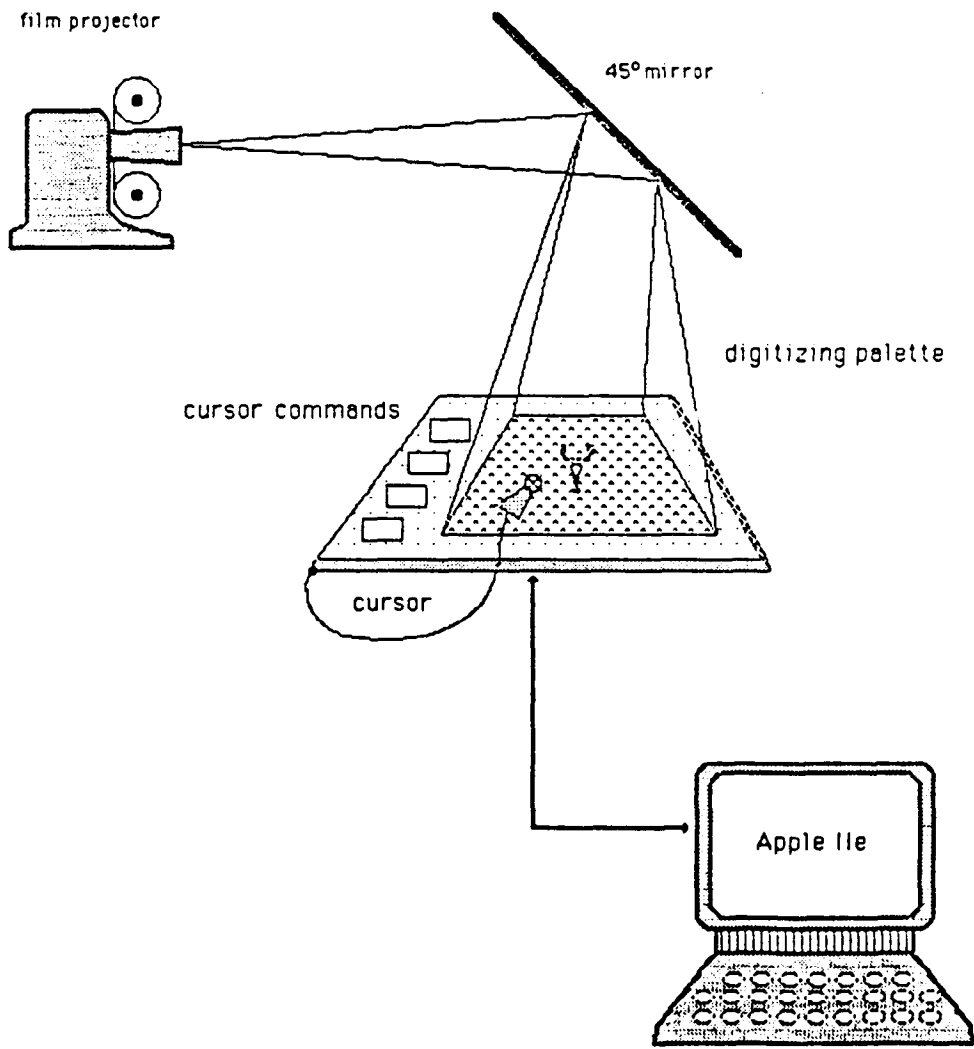

Figure 5.1-1 Schematic representation of digitizing apparatus used for processing benthic photographs.

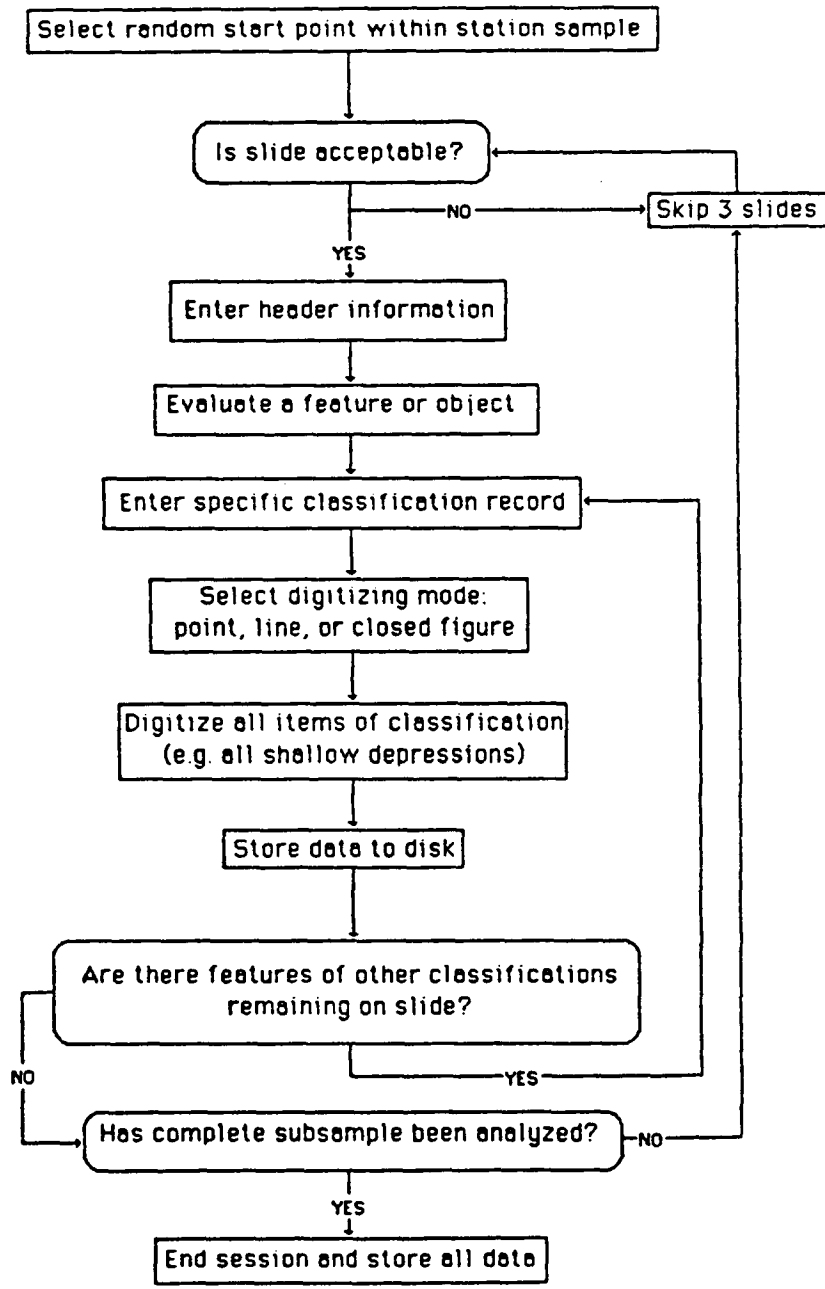

Figure 5.1-2 Sequence of steps for processing digitizing benthic photographs

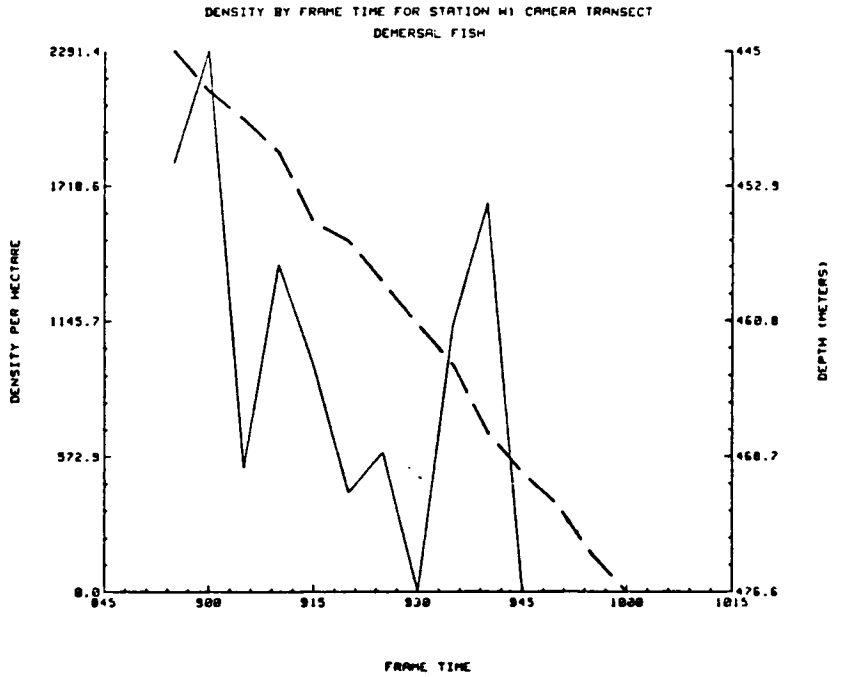
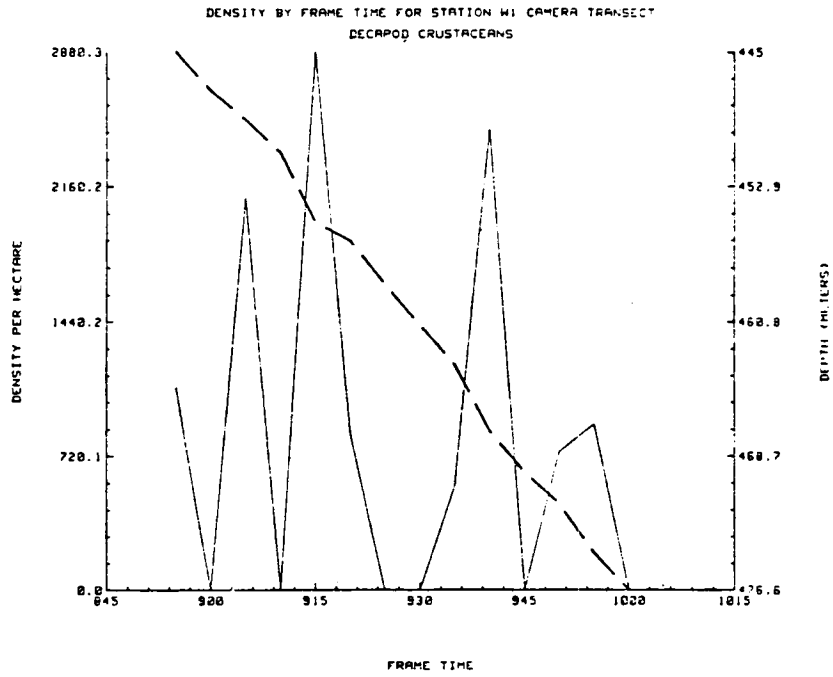

Figure 5.2-1 Density by frame time vs. depth at station W1 for decapod crustaceans and demersal fish. Dashed line represents depth.

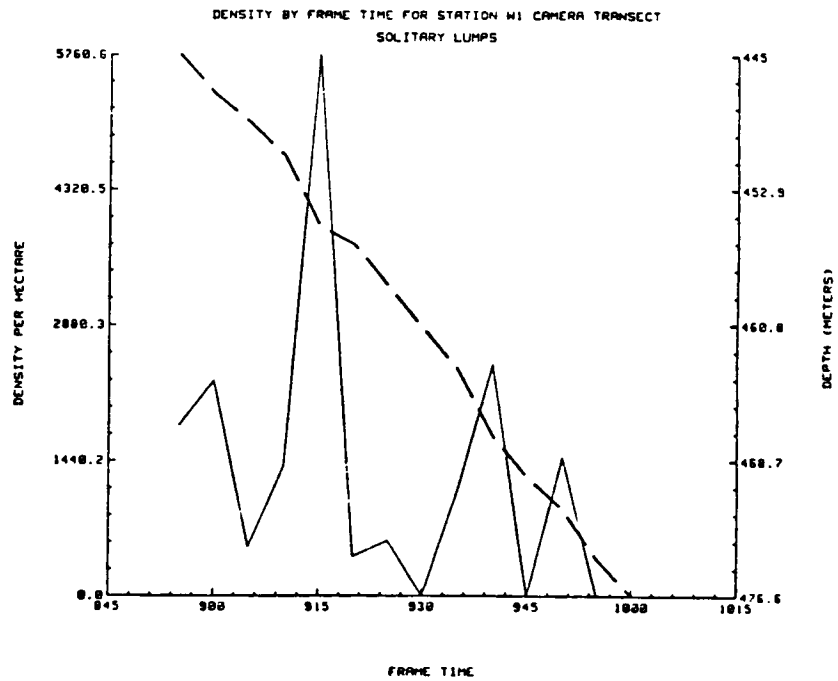
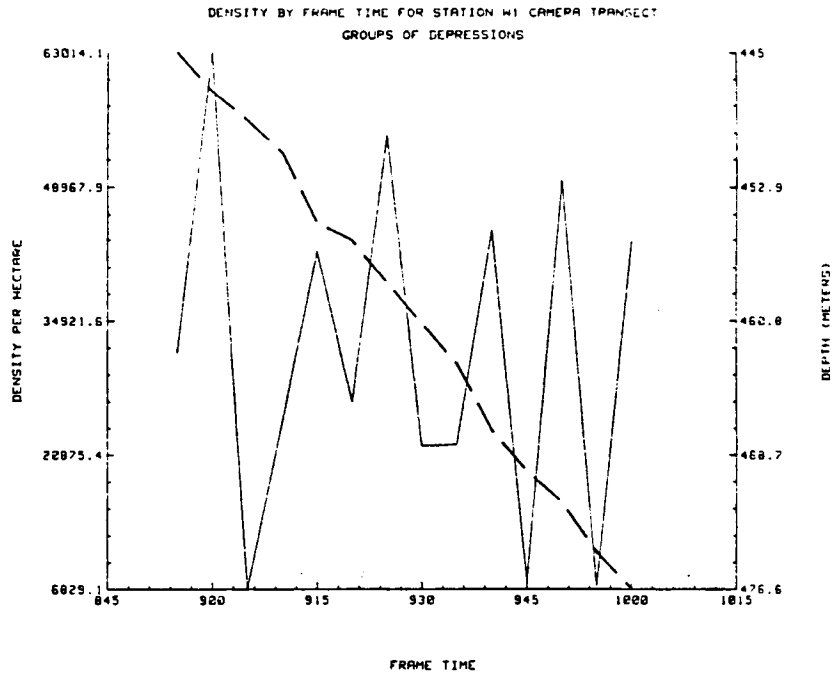

Figure 5.2-2 Density by frame time vs. depth at station W1 for lebensspuren categories of groups of depressions and solitary lumps. Dashed line represents depth.

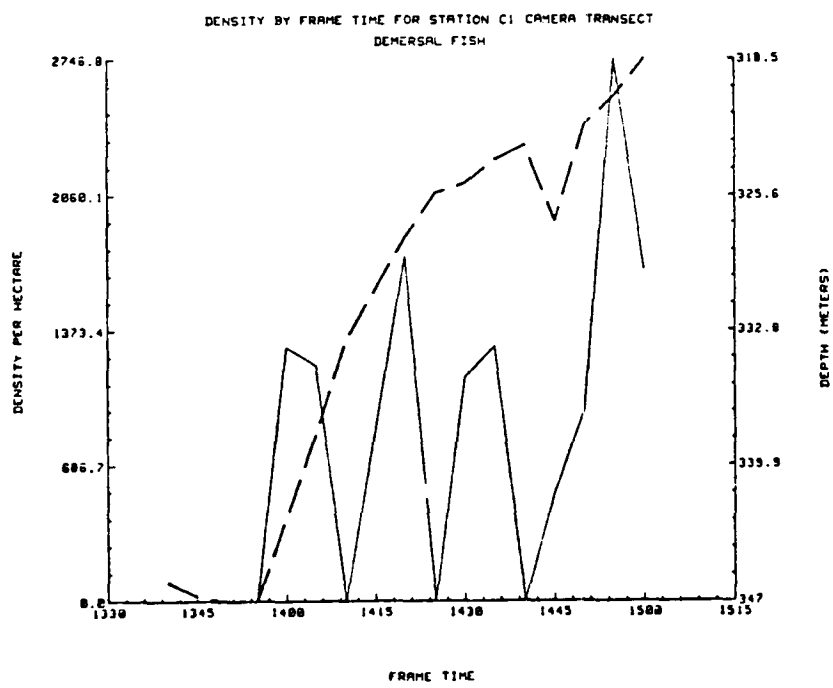
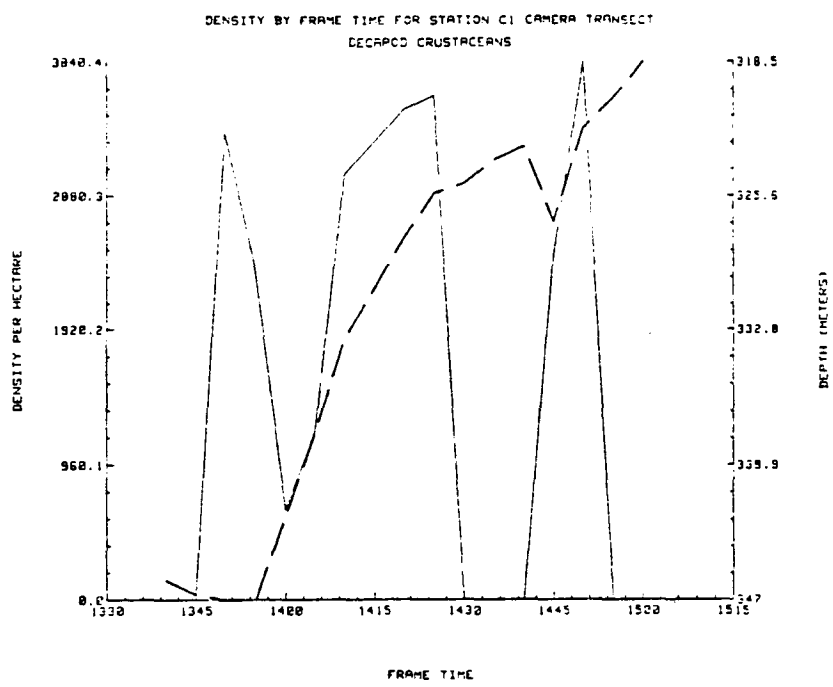

Figure 5.2-3 Density by frame time vs. depth at station C1 for decapod crustaceans and demersal fish. Dashed line represents depth.

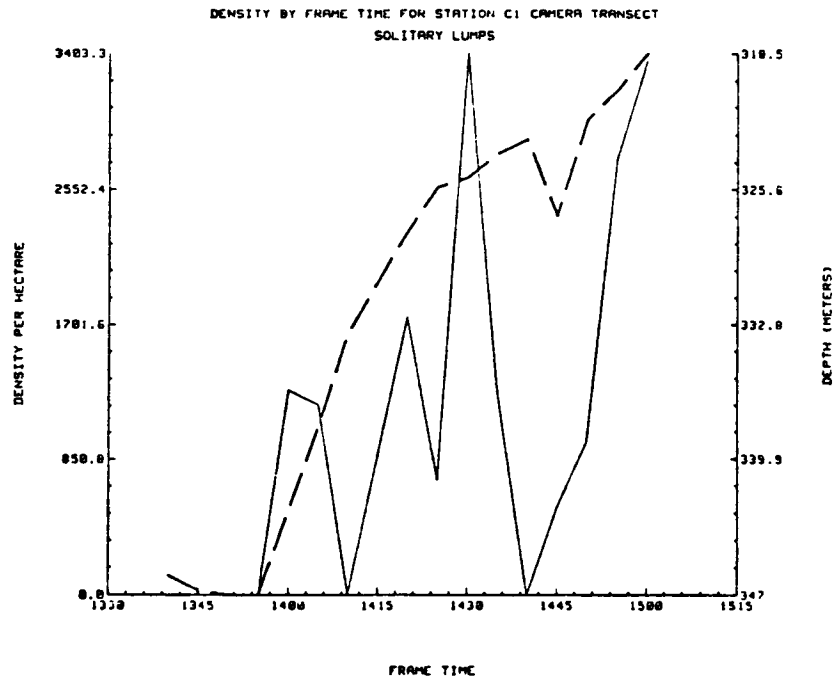
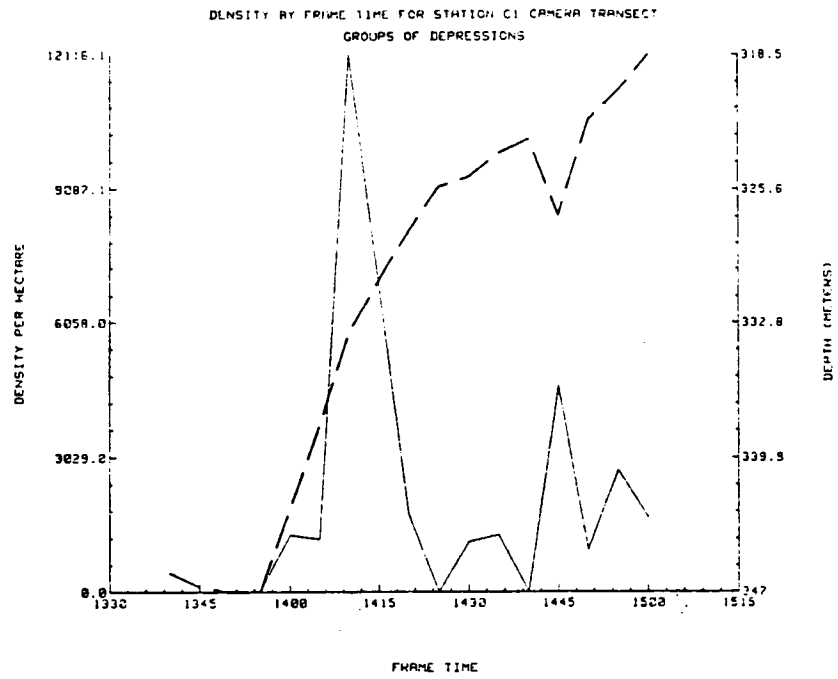

Figure 5.2-4 Density by frame time vs. depth at station C1 for lebensspuren categories of groups of depressions and solitary lumps. Dashed line represents depth.

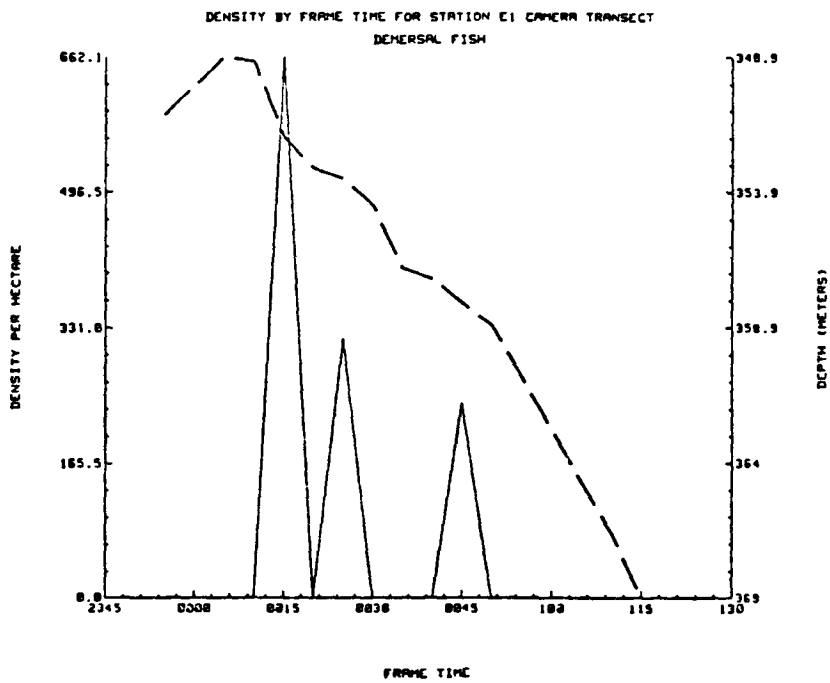
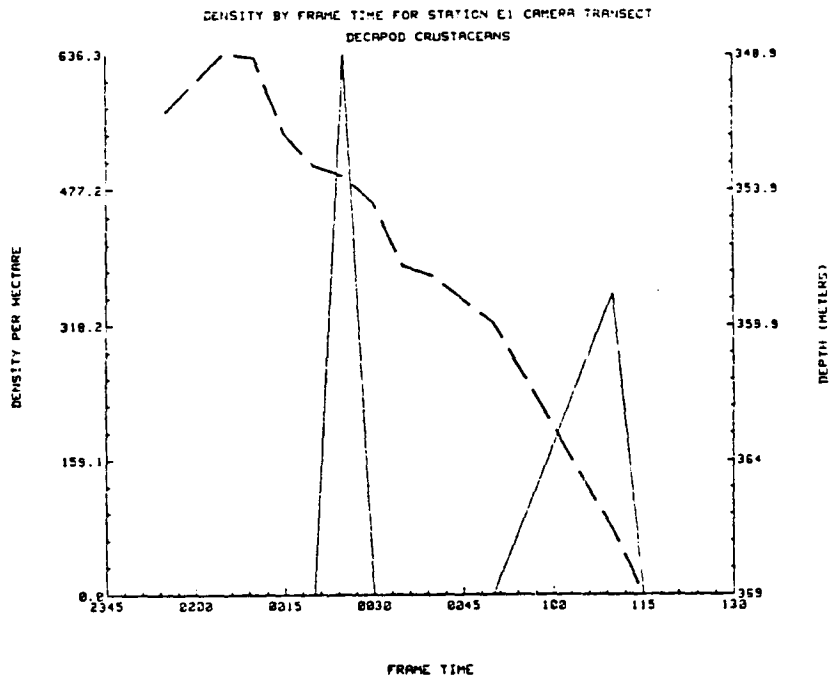

Figure 5.2-5 Density by frame time vs. depth at station E1 for decapod crustaceans and demersal fish. Dashed line represents depth.

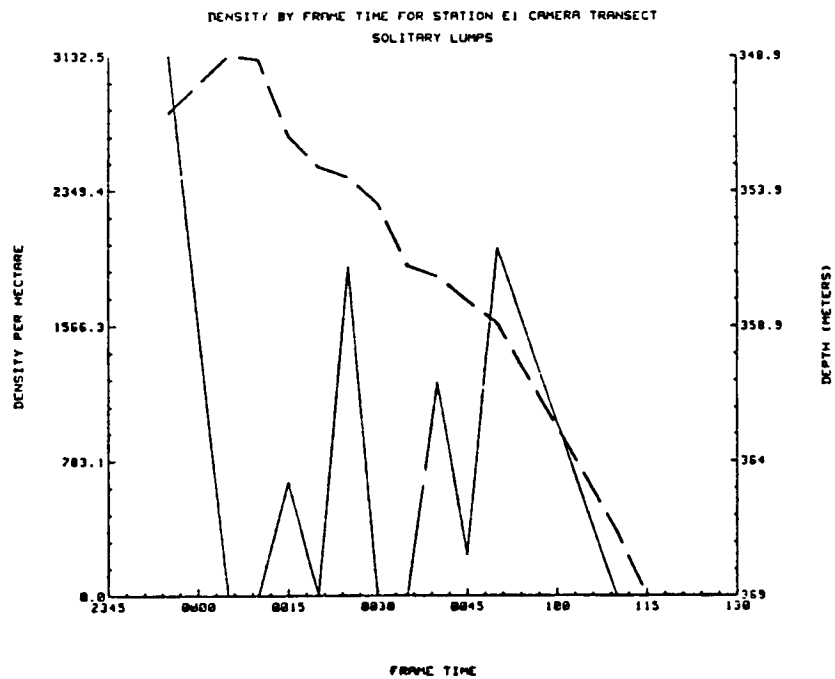
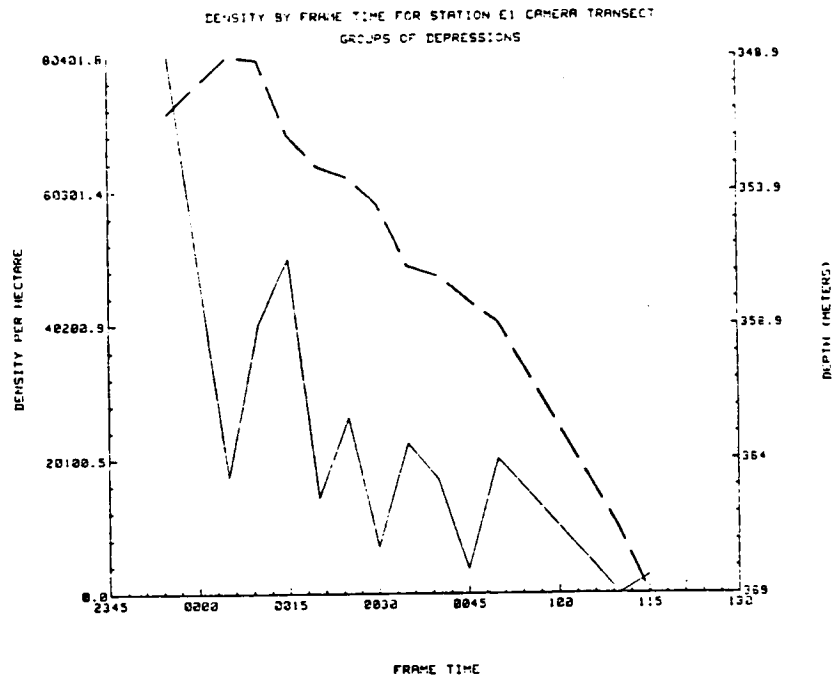

Figure 5.2-6 Density by frame time vs. depth at station E1 for lebensspuren categories of groups of depressions and solitary lumps. Dashed line represents depth.



ITEM 3

LIST OF REGISTERED ATTENDEES

Minerals Management Services  
Ternary Meeting  
March, 1985

ATTENDEES

Roger D. Anderson, Gulf & So. Atl. Fisheries Dev. Foundation  
5401 W. Kennedy Blvd., Suite 669, Tampa, FL 33609

James Barkuloo, U.S. Fish & Wildlife Serv., Ecological Services Div.  
1612 June Ave., Panama City, FL 32405

Garry Brown, Centaur Associates  
1600 I Street, N.W., Washington, D.C. 20005

Cdr. Roger A. Brunell, U. S. Coast Guard, 8th District (mps)  
500 Camp Street, New Orleans, LA 70130

Thomas E. Burke, MMS, Studies  
18th & C Street, N.W., Washington D.C. 20240

Peggy Cleary, Chevron USA, Inc., Production  
935 Gravier Street, New Orleans, LA 70118

Larry Danek, Environmental Science & Engineering  
P. O. Box ESE, Gainesville, FL 32602

Jerry Ford, Florida A & M University, College of Eng. Sci., Tech & Ag.  
1911 Myrick Road, Tallahassee, FL 32303

B. J. Gallaway, LGL  
1410 Cavitt Street, Bryan, TX 77840

Charles R. Havnen, U.S. Coast Guard, Marine Safety Div., 8th CG District  
500 Camp Street, New Orleans, LA 70130

Michael P. Jansky, U. S. EPS, Environmental Services Division  
1201 Elm Street, Dallas, TX 75270

Dianne Lindstedt, Louisiana Geological Survey, DNR  
P. O. Box G, Louisiana State University, Baton Rouge, LA 70893

Bethlyn McCloskey, RTWG  
5113 Bissonet Dr., Metairie, LA 70003

Scott Mettee, Alabama Geol. Surv.  
420 Hackberry Lane, P.O. Drawer O, University, AL 35486

Allan J. Mueller, U.S. Fish & Wildlife Service, Ecological Serv. Div.  
17629 El Camino Real, Suite 211, Houston, TX 77058

Edward Pendleton, USFWS, NCET Div.  
1010 Gause Blvd., Slidell, LA 70458

Nancy N. Rabalais, Lumcon  
Star Route, Box 541, Chauvin, LA 70344

Charles Rambo, Brown & Caldwell Consult. Engrs., Marine Sci. & Eng.  
P. O. Box 8045, Walnut Creek, CA 94596

Richard Rezak, Texas A&M University, Dept. of Oceanography  
3600 Stillmeadow Dr., Bryan, TX 77802

Ian Rosman, LGL  
1410 Cavitt Street, Bryan, TX 77801

Ken Schaudt, Marathon Oil Co., Offshore Tech. Div.  
Box 3128, Houston, TX 77253

Kevin Shaw, Vittor & Associates  
8100 Cottage Hill Road, Mobile, AL 36609

Robert E. Stewart, U.S. Fish & Wildlife Svc., Nat'l Coastal Eco. Team  
1010 Gause Blvd., NASA/Sydell Computer Complex, Sydell, LA 70458

C. D. Seinson, Gulf Oil E & P, Scioeconomic Study  
P. O. Box 61590, New Orleans, LA 70161

John Thompson, Continental Shelf Assoc., Inc., Science Division  
P. O. Box 3609, Tequesta, FL 33458

Evans Waddell, Science Applications, Inc.  
4900 Water's Edge Dr., Raleigh, NC 27606

E. G. Wermund, Texas Bureau of Economic Geology  
Box X, University Station, Austin, TX 78713

Bob Woodmansee, Gulf Coast Research Lab, Ecology Div.  
East Beach Street, Ocean Springs, MI 39564

In addition, many local MMS personnel attended the presentation, but are not listed above.



### **The Department of the Interior Mission**

As the Nation's principal conservation agency, the Department of the Interior has responsibility for most of our nationally owned public lands and natural resources. This includes fostering sound use of our land and water resources; protecting our fish, wildlife, and biological diversity; preserving the environmental and cultural values of our national parks and historical places; and providing for the enjoyment of life through outdoor recreation. The Department assesses our energy and mineral resources and works to ensure that their development is in the best interests of all our people by encouraging stewardship and citizen participation in their care. The Department also has a major responsibility for American Indian reservation communities and for people who live in island territories under U.S. administration.



### **The Minerals Management Service Mission**

As a bureau of the Department of the Interior, the Minerals Management Service's (MMS) primary responsibilities are to manage the mineral resources located on the Nation's Outer Continental Shelf (OCS), collect revenue from the Federal OCS and onshore Federal and Indian lands, and distribute those revenues.

Moreover, in working to meet its responsibilities, the **Offshore Minerals Management Program** administers the OCS competitive leasing program and oversees the safe and environmentally sound exploration and production of our Nation's offshore natural gas, oil and other mineral resources. The MMS **Minerals Revenue Management** meets its responsibilities by ensuring the efficient, timely and accurate collection and disbursement of revenue from mineral leasing and production due to Indian tribes and allottees, States and the U.S. Treasury.

The MMS strives to fulfill its responsibilities through the general guiding principles of: (1) being responsive to the public's concerns and interests by maintaining a dialogue with all potentially affected parties and (2) carrying out its programs with an emphasis on working to enhance the quality of life for all Americans by lending MMS assistance and expertise to economic development and environmental protection.