

# TEXAS BARRIER ISLAND REGION CHARACTERIZATION

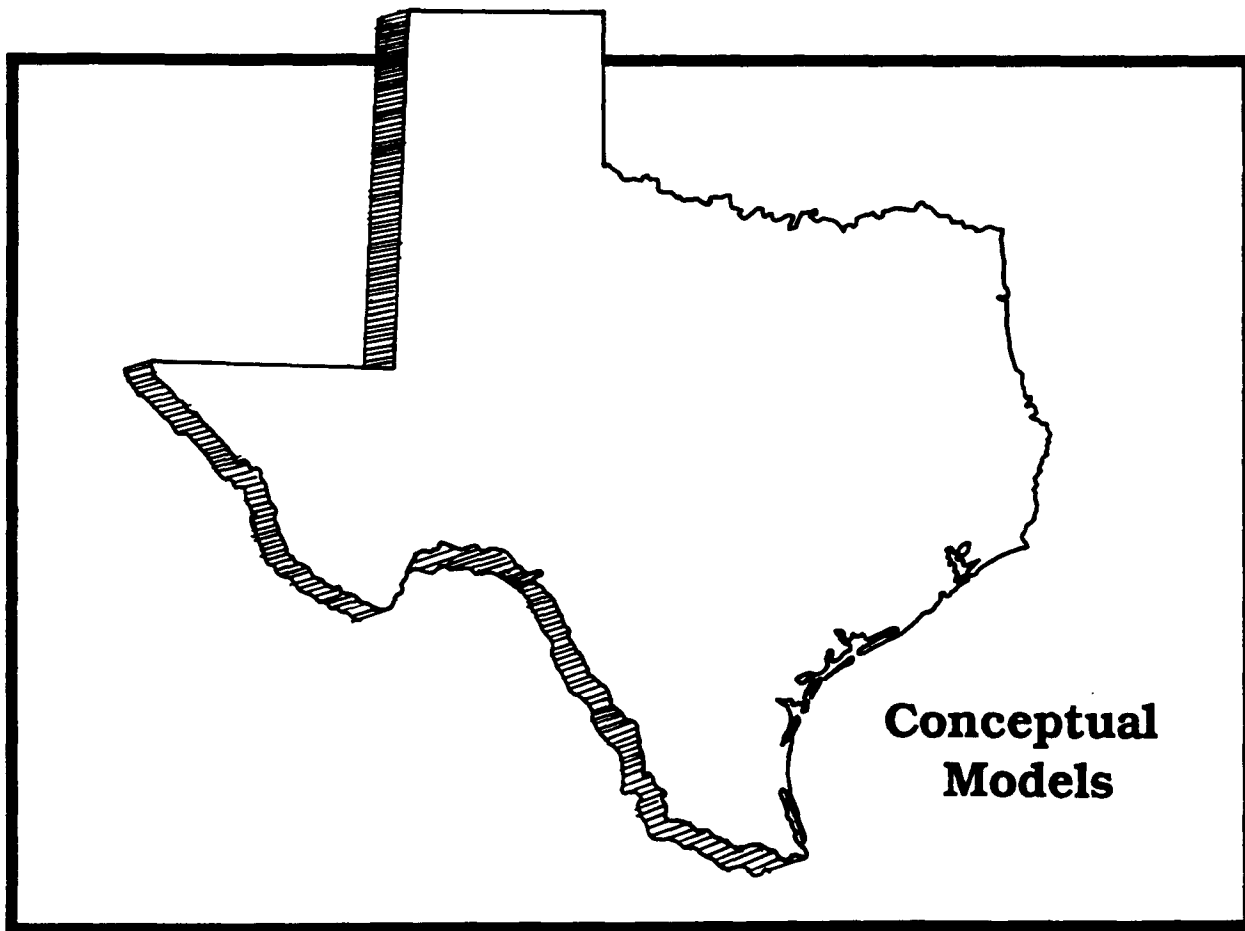

**TEXAS BARRIER ISLAND REGION CHARACTERIZATION  
Conceptual Models**

by

William L. Longley  
Texas General Land Office  
1700 N. Congress Ave.  
Austin, TX 78701

and

William B. Brogden  
Stephen N. James  
Island Cybernetics, Inc.  
P.O. Box 208  
Port Aransas, TX 78373

Cooperative Agreement No. 14-16-0009-80-995

Project Officer

Wiley M. Kitchens  
National Wetlands Research Center  
Fish and Wildlife Service  
1010 Gause Boulevard  
Slidell, LA 70458

This study was conducted  
in cooperation with the  
Texas General Land Office  
Austin, TX 78701

Performed for  
National Wetlands Research Center  
Fish and Wildlife Service  
U.S. Department of the Interior  
Washington, DC 20240

and

Gulf of Mexico OCS Regional Office  
Minerals Management Service  
U.S. Department of the Interior  
Metairie, LA 70010

#### DISCLAIMER

This final report is printed largely as first received from the authors in 1983, therefore, some of the data and interpretations are dated. In particular, the socioeconomic data are from the late 1970's and do not accurately reflect current trends in coastal Texas. These sections of the report should be considered only in the context that they were written.

The ecosystem models in this report are conceptual. They are supported by data and published references, and may be of some use to persons making field evaluations. However, because of the model's generic nature, site-specific information must also be considered before the models and supporting data can validly be used in decision-making. The opinions and interpretations expressed in this report are those of the authors and do not necessarily reflect the views of the U.S. Fish and Wildlife Service, the Minerals Management Service, or the Texas General Land Office.

#### Suggested citation:

Longley, W.L., W.B. Brogden, and S.N. James. 1989. Texas barrier island characterization conceptual models. U.S. Fish Wildl. Serv. NWRC Open File Rep. 89-05. 418 pp.

CONTENTS

	<u>Page</u>
CHAPTER I:INTRODUCTION . . . . .	1
Systems and Ecosystems . . . . .	1
Models of Systems . . . . .	3
Phases in Constructing and Ecosystem Model . . . . .	8
Conceptual Modeling Symbols and Conventions . . . . .	14
Boundaries and Scales of Resolution . . . . .	21
 CHAPTER II:TEXAS BARRIER ISLAND REGIONAL SYSTEM . . . . .	 24
Regional Geologic Setting . . . . .	24
Regional System Model . . . . .	35
Formation of the Region According to the Model . . . . .	46
Man's Effects on the Region . . . . .	50
 CHAPTER III:BASIN MODELS . . . . .	 63
Basin Hydrology . . . . .	63
Socioeconomic Interactions with Habitats . . . . .	78
Habitat Interactions . . . . .	90
Habitat Transformations . . . . .	96
Considerations of Time and Space . . . . .	100
 CHAPTER IV:HABITAT MODELS . . . . .	 104
Purpose of Habitat Models . . . . .	104
Active Dune Habitat . . . . .	105
Bay Habitat . . . . .	112
Bay Margin Habitat . . . . .	124
Beach Habitat . . . . .	137
Brackish Marsh Habitat . . . . .	149
Brush Habitat . . . . .	162
Bulkhead and Piling Habitat . . . . .	172
Channel Habitat . . . . .	178
Coastal Prairie Habitat . . . . .	196
Cropland Habitat . . . . .	206
Dune and Barrier Flat Habitat . . . . .	216
Fresh Marsh Habitat . . . . .	224
Forest Habitat . . . . .	237
Floodplain Forest Habitat . . . . .	248
Lake and Reservoir Habitat . . . . .	260
Nearshore Gulf Habitat . . . . .	269
Reef and Reef Flank Habitat . . . . .	279
River and Canal Habitat . . . . .	290
Salt Marsh Habitat . . . . .	302
Spoil Habitat . . . . .	315
Swamp Habitat . . . . .	331
Tidal Stream Reach Habitat . . . . .	344
Upper Shoreface Habitat . . . . .	358
Urban Habitat . . . . .	370
Wind Tidal Flat Habitat . . . . .	376
 LITEATURE CITED . . . . .	 392



## FIGURES

<u>Number</u>		<u>Page</u>
1	Relative sea-level changes during glacial and interglacial stages . . . . .	26
2	Landform during the Sangamon interglacial stage 150,000 yr B.P. . . . .	27
3	Landform during the Early Wisconsin glaciation 100,000 yr B.P. . . . .	29
4	Land Form during the Peorian interglacial state 75,000 yr B.P. . . . .	31
5	Landform during the Late Wisconsin glaciation 40,000 yr B.P. . . . .	32
6	Landform during modern period 2,000 yr . . . . .	34
7	Present surface land features that show sedimentary history of the Texas coastal region . . . . .	36
8	Regional system model . . . . .	38
9	Regional system model showing man's effects on the region	51
10	Location map of coastal basins and basin types . . . . .	64
11a	Hydrologic model of the Galveston Bay estuary . . . . .	67
11b	Salinity contours and major channels of the Galveston Bay estuary . . . . .	67
12a	Hydrologic model of the Matagorda Bay estuary . . . . .	68
12b	Salinity contours and major channels of the Matagorda Bay estuary . . . . .	68
13a	Hydrologic model of the San Antonio Bay estuary . . . . .	69
13b	Salinity contours and major channels of the San Antonio Bay estuary . . . . .	69
14a	Hydrologic model of the Aransas-Copano Bay estuary . . . . .	71
14b	Salinity contours and major channels of the Aransas-Copano Bay estuary . . . . .	71
15a	Hydrologic model of the Corpus Christi Bay estuary . . . . .	72
15b	Salinity contours and major channels of the Corpus Christi Bay estuary . . . . .	72
16	Hydrologic model of the Brazos tidal river mouth . . . . .	73
17	Hydrologic model of the Colorado tidal river mouth . . . . .	75
18	Hydrologic model of the Rio Grande tidal river mouth . . . . .	76

(Continued)

FIGURES (Continued)

<u>Number</u>		<u>Page</u>
19	Hydrologic model of the Brazos-Colorado lagoon system . .	77
20a	Hydrologic model of the Laguna Madre lagoon system . . . .	79
20b	Salinity contours and major channels of the Laguna Madre lagoon system . . . . .	79
21	Socioeconomic-resource demand conceptual model . . . . .	80
22	Habitat interactions: waterbourne transport and current energy transport between habitats . . . . .	92
23	Habitat interactions: wave energy movement between habitats . . . . .	94
24	Habitat interations: aquatic organism movement between habitats . . . . .	95
25	Habitat transofmrations: subsidence . . . . .	97
26	Habitat transformations: natural succession . . . . .	98
27	Habitat transofmrations: activities of Man . . . . .	99
28	Time and space relationships for atmospheric, surface and subsurface processes . . . . .	101
29	Transformations in a migrating dune field . . . . .	107
30	Active dune habitat . . . . .	108
31	Bay habitat . . . . .	113
32	Bay margin habitat . . . . .	125
33	Beach habitat . . . . .	138
34	Brackish marsh habitat . . . . .	150
35	Brush habitat . . . . .	163
36	Bulkhead and piling habitat . . . . .	173
37	Channel habitat . . . . .	179
38	Coastal prairie habitat . . . . .	197
39	Cropland habitat . . . . .	207
40	Dune and barrier flat habitat . . . . .	217
41	Fresh marsh habitat . . . . .	226
42	Forest habitat . . . . .	239
43	Floodplain forest habitat . . . . .	249

(Continued)

<u>Number</u>		<u>Page</u>
44	Lake and reservoir habitat . . . . .	261
45	Nearshore gulf habitat . . . . .	270
46	Reef and reef flank habitat . . . . .	280
47	River and canal habitat . . . . .	291
48	Salt marsh habitat . . . . .	304
49	Spoil habitat . . . . .	316
50	Swamp habitat . . . . .	333
51	Tidal stream reach habitat . . . . .	346
52	Upper shoreface habitat . . . . .	359
53	Urban habitat . . . . .	371
54	Wind tidal flat habitat . . . . .	377

TABLES

<u>Number</u>		<u>Page</u>
1	Symbols used for conceptual models . . . . .	16
2	Estimates of migration time through Aransas Pass for selected organisms . . . . .	122
3	Water quality of river segments in study area . . . . .	296
4	Water quality of tidal stream segments in study area . . .	352

## ACKNOWLEDGMENTS

This study was a cooperative effort between the U.S. Fish and Wildlife Service and the Texas General Land Office. The authors would like to acknowledge several individuals and organizations that assisted in the conduct of the study. Dr. William Brogden and Steve James of Island Cybernetics were instrumental in preparing the ecosystem models and gathering natural resource, social, and economic information; a good deal of the material they prepared is contained in the appendix.

Dr. Dale Sawyer of the University of Texas at Austin supplied information about the Gulf Coast Geosyncline and Dr. Jim Davenport with the Texas Department of Water Resources supplied data about waste loads in the region. Dr. Charles M. Woodruff reviewed some of the geologic interpretation and models, and made a number of useful suggestions. Sally Davenport provided a number of hard-to-find facts from her files and was a convenient sounding board for many ideas. Mike Hightower and Steve Stubbs provided administrative assistance and help over the period of this study. Dr. Hal Irby kindly prepared six figures for the narrative report and several others for the appendix.

The Texas Department of Health supplied information about areas closed to shellfishing as well as other health-related statistics. The staff of the Texas Natural Resources Information System provided a variety of information and materials ranging from the area of lakes used for irrigation, to a digitized map of shorelines, rivers, and streams that served as a base map for the plates. The staff of the Texas Department of Water Resources library were also very helpful in finding documents and research materials.

This report was edited in full by Muriel Wright. Rebecca Green and Sally Davenport assisted in reviewing a number of portions of the written material.

## INTRODUCTION

### SYSTEMS AND ECOSYSTEMS

Land managers and researchers are often asked to make decisions or predictions about the effects of use of resources on the surrounding environs. Their responses are usually based on some understanding of how natural systems operate, and how man's social and economic systems function.

The term "system" is not new to our vocabulary; however, the formalized study of systems---systems analysis---is a recent addition. Any phenomenon that has two or more components, some interaction between the components, and functions as a whole is considered to be a system (Patten 1971). A system has characteristics in addition to those of the individual components. Usually it is these characteristics that are the main attraction or value we associate with a system. An automobile, a computer, a network of telephones, a school district, a commercial bank, the human body, an aquarium, a forest, and a salt marsh are all examples of systems.

Much of our understanding of how systems operate is the result of observing the patterns of inputs and corresponding outputs of systems. It is not always necessary to have a detailed understanding of systems to be able to use them successfully. For most of the example systems above, no single person comprehends all aspects of the system. Although many of the examples are quite complicated, the user does not have to understand much of their internal organization to benefit from them.

Empirical understanding of systems may suffice when they are small, appear simple, or have limited numbers and patterns of inputs and outputs. Many systems, however, do not have these characteristics. To complicate matters, our interest in systems may involve the components themselves or the relationships that link components.

With fairly simple systems--particularly those with parts that can be viewed directly--it is possible to understand the components and relationships between components by directly inspecting the system. Complex systems with viewable components are more difficult to comprehend and sometimes require a simplified mechanical model to show how everything works. Systems with parts or relationships between the parts that are not directly viewable are more difficult to grasp. The most difficult systems to understand are those where not all of the components are defined, where there are many components with many relationships between components, and where the components must be indirectly measured. Ecosystems are among this latter group.

Tansley (1935) introduced the term ecosystem to describe a system composed of biotic components and abiotic components that interact with each other. To many ecologists the components of an ecosystem seem fairly obvious: biotic components include species, populations, and communities; abiotic components include sediment, water, salt, nutrients, and others. The relationships between components include predation, erosion, nutrient uptake, oxygen consumption, migration, detritus export, and light transmission. These topics have been the subject of ecological research for many years. Ecologists deal with these components and relationships because: they have traditionally used them; they know how to measure them; the components fit what ecologists can see; and ecologists have solved practical problems and

gained understanding about the systems with this set of components and relationships.

From the view of most ecologists, ecosystems contain many components, have many relationships between components, and have a large set of inputs and outputs. Much of society's immediate interest in ecosystems focuses on the system components. Fishermen are interested in the fish populations; farmers are interested in the plant or animal populations; port operators are interested in the sediment components. However, many long-term interests of society involve the relationships between components such as erosion and accretion, freshwater inflow, and subsidence. Because man's activities can influence the way that coastal ecosystems operate, it is essential to have a better understanding of these systems than is provided by merely looking at inputs and outputs.

#### MODELS OF SYSTEMS

One successful method that has been used to elucidate how complicated systems operate is to prepare models. Models are simplifications or abstractions of real systems (Hall and Day 1977).

Anyone who has studied a system has gained a perspective of it from a particular viewpoint. This perspective is an abstraction of how the system works. Usually an individual includes in his perspective those parts in which he is familiar or interested. A model of a salt marsh made by a chemist might emphasize chemical reactions in the water and sediment; a wildlife biologist's model could emphasize plants and the larger animals; a geologist would probably focus upon sediment and sedimentary processes. The sum of these perspectives, less complicated than the real ecological system, would allow a concept to be formed of how the whole system operates.



The degree of abstraction or simplification of the model is a value judgement and depends upon the purpose of the model. While a model is less complex than the system it represents, it is constructed to have the main functional attributes of the system. A balance must be struck between realism and abstraction. The model needs to be realistic enough that it can accurately represent the real system; it must be abstract enough that it allows understanding and efficient use.

The goal of modeling is to further understanding about complex systems. A major test of the adequacy of a model is how well it imitates the characteristics of the real system; often this involves the use of a quantitative model to give numerical measurements for comparison. The models presented here are not quantitative models; they are conceptual models. Conceptual models are the level of abstraction of system operation that must be available before mathematical expressions can be applied. Conceptual models show what components are included in a system and how they are connected. Conceptual models show the direction of the flows between components, forcing functions, inputs and outputs, and some degree of detail about the interactions between components.

#### Some Desirable Aspects of Models

Preparing conceptual models can be interesting and educational; there are some distinct benefits to be gained from such an effort. There are also some disadvantages that should be considered.

Organization of facts and concepts. To prepare a model of a system, a modeler must carefully organize thoughts, concepts, and information about the system. The construction of a model forces the individual to think precisely about cause and effect, how system components interact, and the order in which

they interact. The modeler must use information about the system in a logical, precise, and consistent way. While many models are prepared for a practical end, others are constructed simply because modeling is a disciplined activity that forces clear and precise consideration of the system, and can point out errors in concepts or interpretation of data. In more abstract sciences--physics, for example--model building is the essence of the science since the major components and processes under study cannot be directly viewed.

Synthesis of information. Models synthesize our current understanding of how systems operate (Shugart and O'Neill 1979). Models require that diverse information about systems be rationalized and normalized so that it can be combined into an orderly unit. The compactness of models allows one to express or find relationships that might otherwise be obscured by the volume of information available about a system.

Communication of knowledge. Because of their succinct form, models are excellent communication devices. Diagrammatic system models present a concise summary of a large amount of information on the structure and function of systems. Mathematical models, though not usually visual, represent large data bases in a very compact form (Shugart and O'Neill 1979). Diagrammatic models are particularly useful in communicating the operation of systems to persons who are not necessarily experts.

Organization of research or inquiry. Models can be useful in organizing data about systems. Often models reveal where there are gaps in data or in our understanding of system operation (Wiegert 1975). Therefore, models can guide research efforts and outline where research priorities should be placed.

Incremental improvement. The process of building a model involves the specification of the model structure, testing and assessment of the model, and successive refinement until satisfactory results are achieved. This sequence of steps is the most fundamental process of science. The success of model building to the understanding of systems is the result of the application of this process.

Experimentation with models. Once a model has been prepared and judged adequate and valid, it can be used to further study the system. With models it is possible to explore the responses of systems under conditions that would be too expensive, difficult, or destructive to the environment to actually produce. Models can be used to explore long time and spatial scales that are not conducive to direct experimentation (Hall and Day 1977). Models can be used to simulate system response under conditions not present in the past but that might be present in the future (Ward 1978). In this regard, models are of interest to environmental impact assessment, particularly where several alternative decisions or policies may be compared. In industrial applications, models are often used for optimizing production output while minimizing costs.

Insights into system dynamics. Mathematical models contain many insights into the complexities of system dynamics. Much of our knowledge about systems has been derived by experimental efforts where parts of systems are isolated, conditions controlled, single variables manipulated, and responses noted. While this method is basic to scientific inquiry, models allow simulation of many variables, all changing at once and in different patterns (Hall and Day 1977). Often the real system is more subject to these conditions than to single variable change.

Exploring emergent properties. System characteristics can be explored in depth with models. Emergent properties of systems, those qualities due to the interaction of the parts, can be probed under unusual conditions through simulation. In addition, new emergent properties that might not otherwise be recognized can be sought.

Testing hypotheses. Models can be used to test hypotheses. These may be tests of the model itself, or of expected changes in the system under a particular regime of patterns of variable change. An interesting use of models is to test the logical implications of accepted ecological concepts (Shugart and O'Neill 1979). While hypothesis testing is more often associated with mathematical models, it is possible to discover many things about systems from simple models that are qualitative or only partially quantified.

#### Negative Aspects of Models

Viewpoints in models. Making models is as much an art as a science. There are no certain formulas for preparing successful models, and often modelers must rely on instinct and familiarity with systems as much as analysis to prepare adequate models. Because models are built for specific purposes and from particular viewpoints, they cannot be applied from one situation to another without great care. They always contain biases because of their original intent and the perspective of their constructors.

Validation. There are no uniform criteria for validating models. Generally models are tested until their makers are satisfied that they fulfill the original intent. There is no way to prove that a model is true. By testing, however, it can be shown to be invalid.

Judging underlying assumptions. Models are concise syntheses of knowledge about systems. Because they are so compact and expressive of components and

relationships, underlying assumptions about the models may be hidden from view and difficult to address. For some modeling methods mathematical assumptions must be made for quantitative methods to be valid. Sometimes the assumptions are not evident or are not true.

Homogeneity. Models usually presume that processes, materials, and spatial relationships are fairly uniform in the area of interest. There is little information about the effects of spatial heterogeneity on ecosystem models (Shugart and O'Neill 1979).

Misuse of models. Models can be misused and misleading (Hedgpeth 1977). In some instances the preparation of models, particularly large mathematical versions, has become glamorous and self-justifying. The basic purposes and limitations of models must always be an uppermost consideration.

#### PHASES IN CONSTRUCTING AN ECOSYSTEM MODEL

The steps in model building have been extensively reviewed by Dale (1970), Hall and Day (1977), Patten (1971), Wiegert (1975), and Ward (1978).

##### Statement of Purpose

The first and most fundamental step in building a model is the statement of purpose. It reflects the viewpoint of the modeler and also the goal to be achieved in model preparation. As an example, the purpose of the regional model is to show the long-term forces and relationships among the water, sediment, and energy components of the system that have influenced and continue to influence the morphology of the Texas barrier island region. The statement of purpose notes that this is principally a geologic model and the purpose is explanation concerning past and present processes responsible for the region's morphology.

### Boundaries of the System

Models of ecosystems are prepared with particular boundaries of time and space. These should be specified and understood before the model is built since many decisions made during model construction depend upon the time-scale and spatial resolution intended.

Consideration of time. Driving forces and natural processes, the connections among system components, are rate functions--quantities that flow per interval of time. Components within the coastal ecosystem have important time-dependent characteristics such as the pattern of tidal flux, seasonal factors, and reproductive periods. Specification of the time period associated with an ecosystem model determines whether short-term measurements with large variances or long-term averages are appropriate. Determination of the type of mathematical function (if a quantitative model) or the interpretation of the nature of the relationship depend upon the time scale specification.

### Consideration of space

Ecosystems are three-dimensional entities, although they are often dealt with in a two-dimensional or surface area context. Many measurements of ecosystem characteristics, such as productivity, are given in units per area. Forest models and circulation models of deeper aquatic ecosystems often recognize the three-dimensionality of ecosystems.

The spatial extent of ecosystems is important for quantitative models. For the sake of simplicity, spatial homogeneity is nearly always assumed in ecosystem models. On closer inspection, however, real ecosystems are rarely homogeneous.

The juxtaposition of ecosystems is another spatial consideration. Most ecosystem models focus on an system of interest with little consideration of adjacent systems. There are examples of coupling of system models, however (Kemp et al. 1977; Hasler 1975).

### Choosing the Components

In the initial phase the modeler considers the system or systems of interest and may have a mental viewpoint of the essence of the model from firsthand knowledge, a survey of appropriate literature, or experience and intuition (Hall and Day 1977; Wiegert 1975; Ward 1978). The modeler should select components for the model. A list of biotic and abiotic components is a good first step; the list may be refined later. Components should be selected that are familiar, useful and meaningful to the purpose of the model, and can be communicated to others who will use the model. For mathematical models the components should be measurable by objective methods. For models to be used in later management of systems, the components should include manipulatable units. Man-induced stresses should be considered so that the appropriate components are sure to be included.

Once the initial list is selected, it can be refined by removing redundant components and those not important to the objectives or purpose of the model. A list of natural processes can be made concurrently; this list will depend upon the components finally selected.

### Definition of Relations Between Components

The lists of components and relationships among components can be used to determine what kind of data is available (Ward 1978; Snyder et al. 1979). This is especially important where quantified models are being prepared. It

is sometimes possible to look at the list of components and pathways and decide which are forcing functions, outputs, exports, imports, and internal components.

The modeler should determine the most important functional pathways (Snyder et al. 1979). Basic causative relations must be correctly identified; all of the other components and pathways among components will be influenced by these decisions. The major causative pathways in ecosystems usually involve water flow. Sketching out a modest but well-defined system such as water and then adding other components and pathways to it is often a successful strategy (Snyder et al. 1979). It is sometimes helpful to divide components and relationships into subsystems; simple flow diagrams can be used to assist in organizing these efforts (Ward 1978).

Focusing on interactions can simplify the specification of relationships among components. Ward (1978) suggests using interaction tables to focus attention on the interactions and away from the components themselves.

The modeler should dig deeply into the scientific literature to find specific citations or quotes from reputable documents to confirm exactly how cause and effect relationships work (Snyder et al. 1979). Determining what is cause and what is effect is sometimes difficult. In addition, many studies considering the same components and relationships among components have different terminology and shades of meaning that require interpretation. The modeler should be attentive to information about the relative magnitudes of synergistic or competing components. Evaluation of this sort of information is necessary to determine direction of flows and importance of components even in unquantified models.



Often the end result of this phase of modeling is a visual model or diagram showing components, driving forces, imports and exports, and relationships between components. Much trial and error and frequent reference to data and documents is necessary to even reach this point since there are often a variety of ways to interpret each relationship. Feedback control pathways--flows with low energy flux that interact to control other flows of greater magnitude--can be particularly baffling. Many feedback pathways may be defined during this phase. On later inspection it is often possible to eliminate a number of redundant feedback pathways. This may be a consequence of the scientific papers and documents consulted, where specific components of the system are studied in isolation with different terminologies and interpretations.

The model constructed at the completion of this phase is a conceptual model. It shows the components and relationships among the components that are appropriate for the purposes of the specific ecosystem model being built.

#### Assignment of Mathematical or Analog Functions

All quantitative and some qualitative system models specify the quantitative functions that succinctly describe the mathematic relations among components. Empirical and theoretical modeling of mechanisms represent the two philosophies for specifying quantitative relationships (Dale 1969).

Empirical mechanisms are mathematical functions that mimic the behavior of changes in components and flows (Wiegert 1975). Often these mathematical formulations are the result of "best fit" mathematical analyses.

Theoretical models emphasize cause and effect relations to explain the patterns of change in components, rather than numeric pattern reproduction (Hall and Day 1977). While empirical models are suitable under some

circumstances, it is preferable to include causal relations to the greatest extent possible (Dale 1969; Hall and Day 1977; Wiegert 1975). This preference for causality is related to the purpose of modeling systems. Output responses of the system model are but one objective of modeling. It is equally important that the internal computations in the model be indicative of the true or assumed biologic, chemical, geologic, or hydrologic mechanisms. Otherwise other uses of the model, for example, hypothesis testing or simulation of unusual conditions, will be suspect and of limited value.

The simulation conventions used in the conceptual models in this report are from Odum (1971). This graphic simulation language assumes substantial causality. Many of the modeling structures have further implications regarding the form of the mathematical functions describing the relationships (Odum 1972a). A number of system models using the Odum graphic simulation language have been prepared in sufficient detail that there is a one-to-one correspondence between components and flows in the conceptual model and the quantitative relationships used in the quantitative model.

During this phase of quantitative model preparation, it is sometimes advantageous to aggregate or condense some components and flows (Hall and Day 1977; Wiegert 1977). This is a judgement question that must balance information available, detail, resolution, model purpose, and computational resources (Hall and Day 1977; Wiegert 1975; Snyder et al. 1979).

### Validation

The final step in model preparation is validation. Models of ecosystems should reproduce known system responses. Quantitative models should test the fidelity of outputs or the range of states and changes in states experienced by the actual ecosystem (Dale 1969). Sensitivity analysis, a method of

investigating the influence of changes in system parameters, is a useful way to judge validity and confidence to be placed in a system model (Overton 1977).

Validation tests of quantitative models result in numerical data that can be compared with independent data sets from the real systems. Qualitative efforts such as conceptual models are more difficult to validate since no numerical values are calculated and there may not even be system measurement for comparison. A probing inspection of components and pathways by persons not involved in modeling that particular system is often the only validation possible; in some instances various levels of quantification can be used among components within the model to assure that internal organization is valid. Quantification in the form of order-of-magnitude estimates, typical range measurements, or extremes for components and flows can sometimes reveal weaknesses in the model structure.

When validation studies locate model weaknesses, it is incumbent on the modeler to repeat steps in earlier phases of the modeling process to refine the models (Hall and Day 1977). This incremental improvement procedure, like many previous steps in modeling, should be an effort to balance the degree of resolution and confidence in prediction with the effort required and objectives of the original model.

#### CONCEPTUAL MODELING SYMBOLS AND CONVENTIONS

Conceptual models of systems may exist in many forms—matrices, lists, groups of equations, box models, and specialized graphic formats. Forrester (1961) developed a set of graphic symbols that has been used by systems analysts in a number of fields. Odum (1967, 1971, 1972a, 1973, 1974, 1976)

developed another set of graphic symbols in his studies of ecological systems. His graphic notation parallels Forrester's (Odum 1972b), but Odum and his coworkers have carried the concept much further. They have defined quantitative relationships to accompany the graphic notation and have developed a rationale (energy quality) for putting all components and flows in terms of common energy units (Odum 1978a,b). They have applied these tools to a variety of complicated ecosystem problems of both theoretical and practical interest (Bayley and Odum 1976; Boynton 1975; Gilliland and Risser 1977; Kemp et al. 1978).

The conceptual models in this report use the notation of the network language defined in Odum (1971). However, they do not have the rigorous mathematical implications that is common to the quantitative models that have used the network diagram language. The essence of the conceptual models presented here has been the selection of system components and flows. The consideration of heat sinks, energy transformations, transactions, and a few other details have been avoided to focus upon components and relationships among them.

The network language modules are shown in Figure 1. They can be grouped into five types: flows, flow control units, components, sources and forcing functions, and sensors.

### Flows

The line with the arrowhead (Table 1) represents flows of material or energy. The flow pathways connect components within the ecosystem as well as inputs and outputs with other systems. The flow pathway not only shows that there is a connection between components but that there is a direction to the flow.

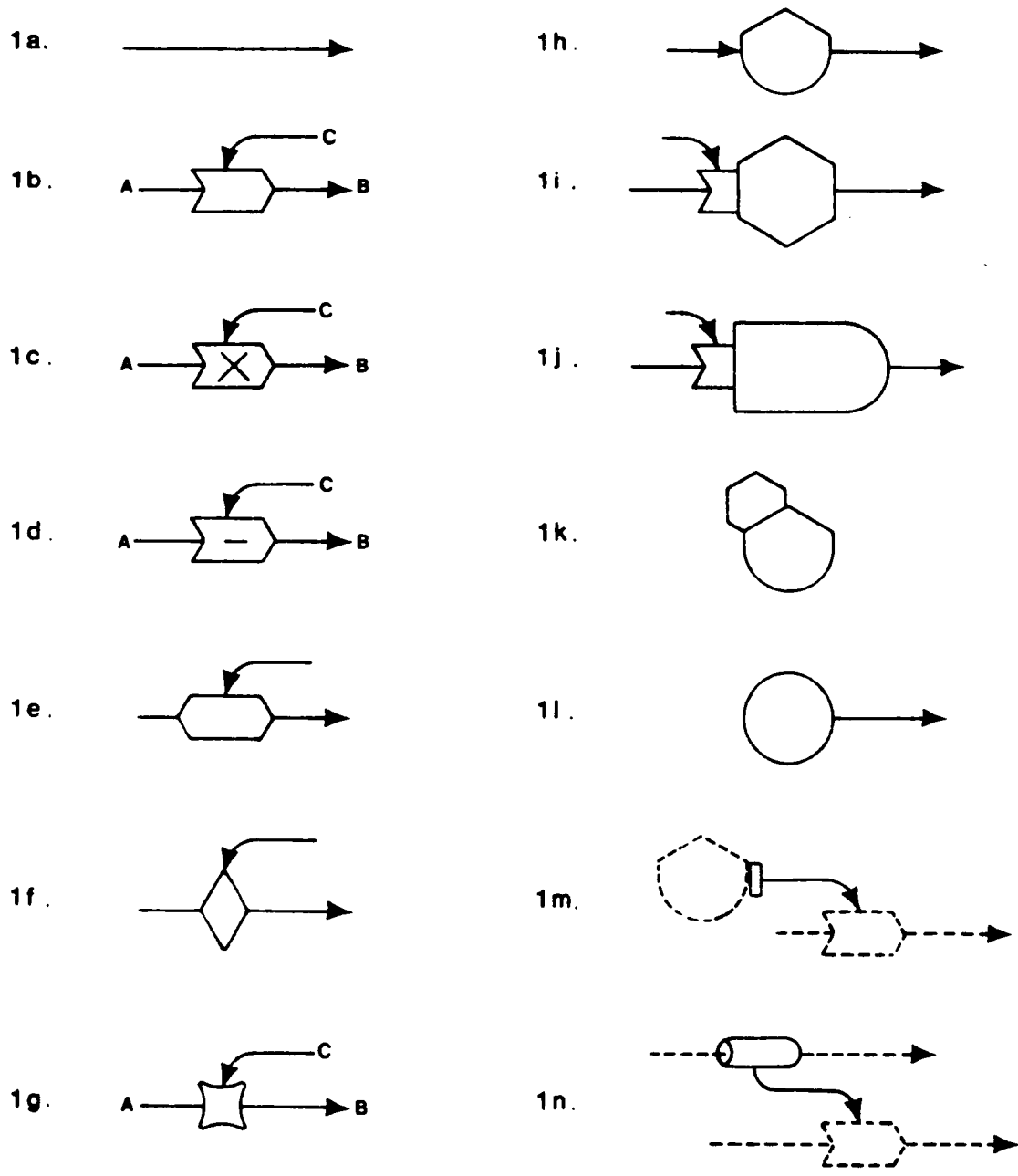

TABLE 1. Symbols used for conceptual models.

## Flow Control Units

Work gate. Work gates are symbols that show where interactions occur that control the rate of flow. Table 1b shows a flow of material or energy from flow pathway A to B. Pathway C may be a minor material or energy flow; however, it controls the flow rate from A to B. A faucet or continuously variable valve is an excellent analogy to a work gate. The main flow of liquid arrives at the faucet through a pipe (A) and exits through the nozzle (B). When a small amount of energy is used to turn the faucet handle (C), the flow rate can be controlled.

Some work gates (Table 1c) have a large "X" in the symbol. This indicates that the relationship between pathways C and B is direct; as C increases, B increases. Some work gates (Table 1d) have a negative sign in them. This indicates a negative relationship between pathway C and pathway B; as C increases, B decreases. Work gates without any internal symbols in them represent relationships between B and C that are more complicated than direct or inverse relations.

Two-way work gate. In a few cases, major flow pathways may not be predominantly in one direction or the other. Movement of water affected by tidal forces is an example of a two-way flow where direction of flow changes with time. The two-way work gate (Table 1e) controls flow rate for pathways with two-way flows. Because flow direction can reverse and flow control is complicated, no symbols indicating direct, inverse, or other relationships are placed within the two-way work gate.

On some network diagram models the shape of the two-way work gate is a diamond rather than a six-sided symbol (Table 1f). Odum (1971, p. 38) has used this symbol to indicate a transaction. For these models the diamonds do

not indicate a transaction; they are simply a smaller version of the two-way work gate used in some complicated models where space saving was essential.

Switch. A switch (Table 1g) is a special case of a work gate. There is no flow along the major pathway from A to B unless there is a flow from pathway C. If there is any flow from pathway C its magnitude has no influence upon the flow from A to B. Thus the flow from A to B is either on or off.

### Components

The storage symbol (Table 1h) is the most basic of the system component modules. The other two modules that represent system components (consumers and plants) are combinations of storage symbols and work gates (Odum 1971, p. 38). Since the latter two modules are so widely used, it is simpler and clearer to define them as separate components rather than presenting their complex structure each time a consumer or plant is used in a model. Components are the "state variables" of the system; when quantified, they represent the entities (states) that vary with time (Hall and Day 1977, p. 19).

Storage. The storage symbol (Table 1h) represents all abiotic system components. Water, nutrients, heat, and sediment are just a few of the types of storage units in system models. Storages usually have more than one input, output, or both in the models in this report. To simplify complicated models it is best to exclude storage units with only one input and one output unless the storage unit is connected to a work gate.

Consumer. Consumers (Table 1i) are self-maintaining entities. They cannot convert sunlight into an energy source, but they can use energy produced or imported into the system. They can store energy and use it at another time to maintain their internal structure and functions. They can

pass energy to other trophic levels or export it (through migration) out of the system. While consumers are most often equated with heterotrophic organisms (herbivores, omnivores, and carnivores), many of man's inventions and institutions can be represented as consumers.

The symbols for consumers exist in two forms in the models in this study. In the habitat models, the hexagon of the consumer symbol is combined with a work gate. The energy input to the consumer passes through the work gate; the controlling factors are abiotic components such as salinity or toxic materials. This interaction represents the influence on the metabolism of the consumer by external abiotic components. In the basin socioeconomic model, the hexagon is presented without being attached to a workgate. Because of the complexity and uncertainty of the control mechanisms, no control pathways are specified in that model.

Plant. Plants are represented by Table 1j. Odum (1971, p. 38) shows that green plants are a combination of storages, work gates, and the consumer symbol. Plants can receive pure wave energy and capture it in the form of protoplasm. Radiant energy trapped by plants is passed on to other trophic levels or exported from the system.

Radiant energy passes through a work gate to enter the plant symbol. This work gate represents the influence on photosynthesis and metabolism in plants from external environmental conditions such as salinity, nutrients, and turbidity. In some places there is a negative feedback from the plant itself or from other plants to the work gate through which radiant energy passes. This is the effect of shading on the flow of radiant energy.

Microbe-detritus complex. In some habitat models there is a combination of the storage and consumer modules into one symbol (Table 1k). In the case



of most consumers the organisms are distinct from their food sources. Microorganisms may inhabit the surface or interior of their food source. Consequently the organism and energy source are combined together into one unit to represent the close contact between the microorganism and the organic detritus.

#### Sources and Forcing Functions

The circular symbol (Table 11) represents materials or energy that are outside the system boundary. Along the top edge of the habitat models these symbols are used to show imports or exports to adjacent habitats. The substances that may be exchanged include water, sediment, organic matter, and biota. The imports and exports may be two-way flows, controlled by two-way work gates.

This symbol is also used to represent forcing functions or driving forces. These are sources of energy or material from outside the system that have substantial influence in controlling the entire system being modeled (Hall et al. 1977). They are distinct from imports and exports since they are one-way flows and are not themselves affected by the components of the system. Forcing functions are usually of great magnitude or are extensive in aerial extent. In general they are largely beyond man's control. The difference between imports and driving forces is sometimes a matter of choice.

#### Sensors

Sensors sample the magnitude of a component (Table 1m) or the flow rate between components (Table 1n). The pathway leading from a sensor always passes to a control device--a work gate or switch. For sensors attached to components the size of the flow along the pathway from the sensor to the control device is orders of magnitude less than the component quantity. The

sensor symbol is used to emphasize the control function of the pathway even though the flow itself may be very small.

Sensors on flow pathways express the control that one flow may have upon another. For example, sediment is transported by water; the rate of sediment transport depends upon the the flow rate of the water carrying the sediment (Morisawa 1968, Figure 4.4, Hjulstrom diagram; Boynton 1975). There is an energetic cost to sediment transport. The cost is small compared to the kinetic energy in the water flow; however the energy for transport is derived from the sensed pathway.

## BOUNDARIES AND SCALES OF RESOLUTION

### Texas Barrier Island Region

The Texas Barrier Island Region (TBIR), the area covered by the models in this study begins at the eastern edge of Galveston Bay and East Bay and extends southward to the international border on the Rio Grande River. The TBIR is adjacent to and just southwest of the Chenier Plain, the western part of the Louisiana coast and eastern portion of the Texas coast. The region extends three marine leagues (10.35 miles) into the Gulf of Mexico, to the state-federal demarcation line. Inland, the TBIR extends 40 miles and includes all counties with gulf shorelines from the eastern shore of Galveston Bay to the Mexico border.

### Scales of Modeling

The models are presented at three scales for the region, basins, and habitats. Each scale offers a different perspective of the Texas coastal region.

Region. The regional scale encompasses the entire range of variation in climate and physiography for the TBIR. Climate and landform are the most

important natural factors influencing the surface lands in the region. To understand the forces that shaped the TBIR into its present form, and which continue to influence the region, the study area should be viewed from a regional perspective.

Basin. Within the region there are 10 major basins, individual hydrological units with well-defined drainage boundaries. These include basins with: one or more rivers or creeks flowing into a single estuary; limited drainage into lagoons; and rivers that empty directly into the Gulf of Mexico. Each basin occupies a slice in the north-south climatic gradient along the Texas coast. Hydrologic units reflect the basin geologic conditions. By modeling individual hydrologic units the variation in climate, physiography, and geologic conditions becomes evident.

There are other characteristics of basins that make them convenient modeling units. The largest of man's influences, control of water flow, can conveniently be viewed at the basin level. E.P. Odum (1971, p. 16) noted that the entire drainage basin must be considered as the minimum ecosystem unit when man's interests are considered. Basins are also of approximately the right size to include entire socioeconomic and political units. Cities, counties, river authorities, drainage districts, navigation districts, water districts, and legislative and congressional districts are about the size of basins. Citizens gain a certain level of identity from basins. The climate, landform, social and economic setting where a person lives are largely predictable when a person indicates that his home is in the valley, coastal bend, or Houston area.

Habitat. Basins are not homogeneous; they include a set of habitats. The numbers, kinds, areas, and arrangement of the habitats depends upon the

basin and ultimately upon the interaction of climate and physiography (Woodruff 1975). Habitats are what individuals see when they are actually on the ground in the Texas coast. Except for very large-scale activities such as water resource projects, the habitat or combination of habitats is the appropriate scale when dealing with day-to-day management of the environment. It is at the habitat level that changes and alterations are made to the environment.

## TEXAS BARRIER ISLAND REGIONAL SYSTEM

### REGIONAL GEOLOGIC SETTING

#### Precambrian and Paleozoic Eras

Little is known about the geologic formation of the area that is now Texas during the Precambrian era (more than 500 million yr B.P.). During the Paleozoic (200-500 million yr B.P.), the geologic formations throughout most of Texas were deposited in relatively shallow seas. There is some evidence that the coastal plain as it exists today was once the western portion of a land mass that drained into seas in central Texas (Sellards et al. 1932).

#### Mesozoic Era

The Mesozoic era (70 million to 200 million yr B.P.) consisted of four periods. During the earliest period, the Triassic, considerable elevation of the land masses took place so that no deposition from the marine environment occurred. However, in the late Jurassic, a sea invaded northward from Mexico into Texas (Sellards et al. 1932). It is not clear whether a sea also entered from the present-day gulf margin at the same time. During the Lower and Upper Cretaceous periods a sea inundated the state from the south and southwest.

Throughout the entire Mesozoic era, the lands along the present Gulf Coast gradually sank and finally became submerged. There was an associated uplift of land inland, and a hingeline or flexure zone separated the lifting and falling areas. The flexure zone is a site of faulting (Williams et al. 1976). The major change in the shape of the land mass is called the Gulf

Coast Geosyncline. This tilting of the land extends from Northern Mexico to Alabama. With the change in land slope, the natural drainage of the region ceased to be from east to west and eventually developed from west to east as it is today.

### Cenozoic Era

During the Cenozoic era (4,500 to 70 million yr B.P.) the modern conditions gradually developed. The land mass that had submerged in the coastal area during the Mesozoic was buried by deposited sediments to depths as great as 65,000 ft (Williams et al. 1976). Large quantities of sediment were transported, and a series of transgressions and regressions between the sea and the land caused the shoreline to advance and retreat scores of miles.

At least four principal glacial episodes (Brown et al. 1976) took place during the Pleistocene period close to the end of the Cenozoic ( 18,000 to 1.2 million yr B.P.). Figure 1 illustrates periods of glaciation and the changes in sea level associated with the Pleistocene. The substrate characteristics and present landform of the barrier island characterization study area are largely due to the depositional processes that occurred during the Pleistocene.

Figure 2 through 6 show the sequence of development of present coastal features. The dashed outline in the figures shows the present location of various coastal features. These features are labeled in Figure 6.

Sangamon Interglacial Stage. The landform near the present coastline was particularly influenced by the last two glacial intrusions. Figure 2 represents the coastal region about 150,000 yr B.P. The uplands in area "A" resulted from fluvial processes. They were formed mainly by meanderbelt sand

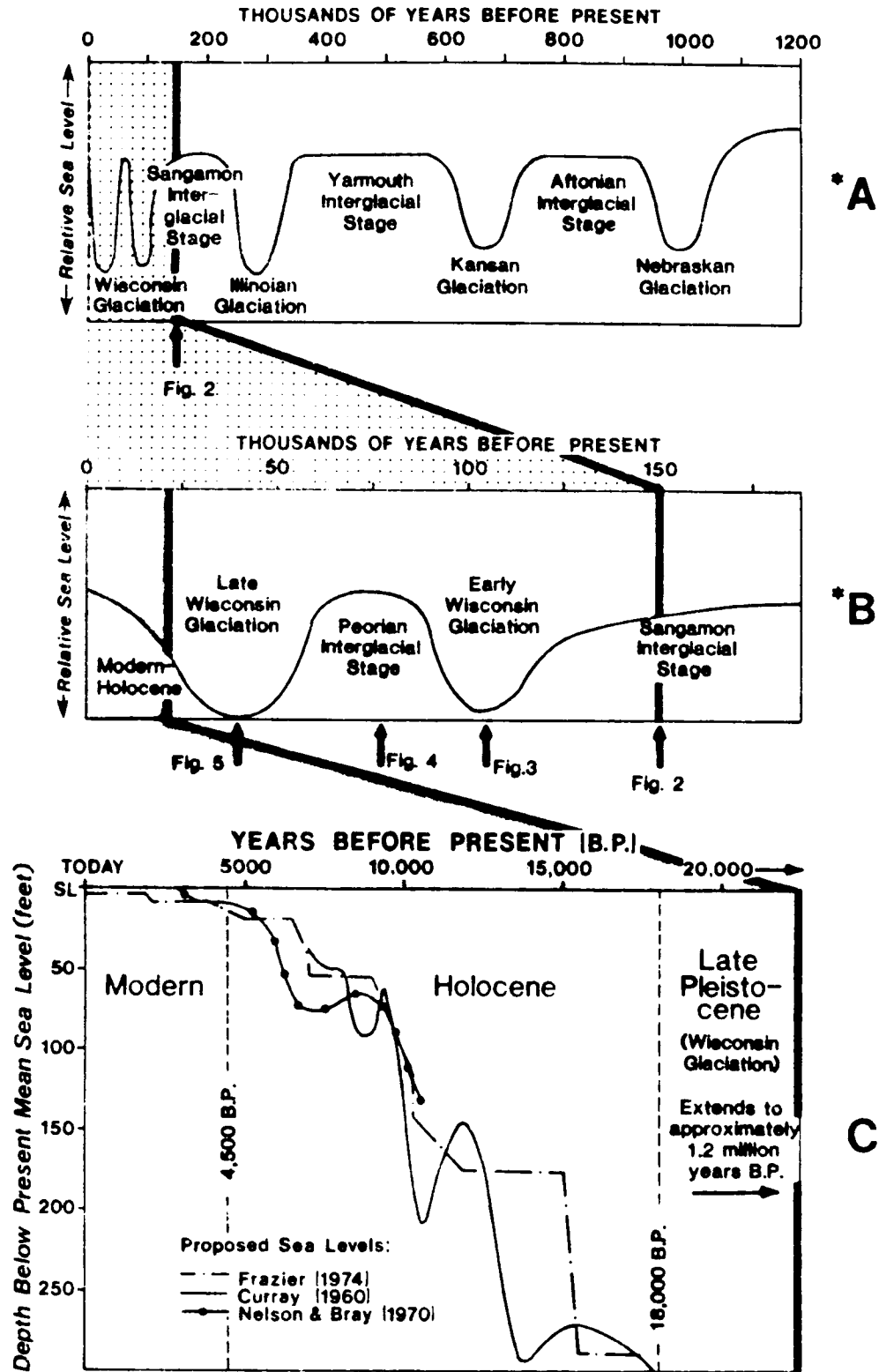

Fig. 8 & 7

\* After Fisk (1944) and Bernard & LeBlanc (1965)

FIGURE 1. Relative sea-level changes during glacial and interglacial stages.

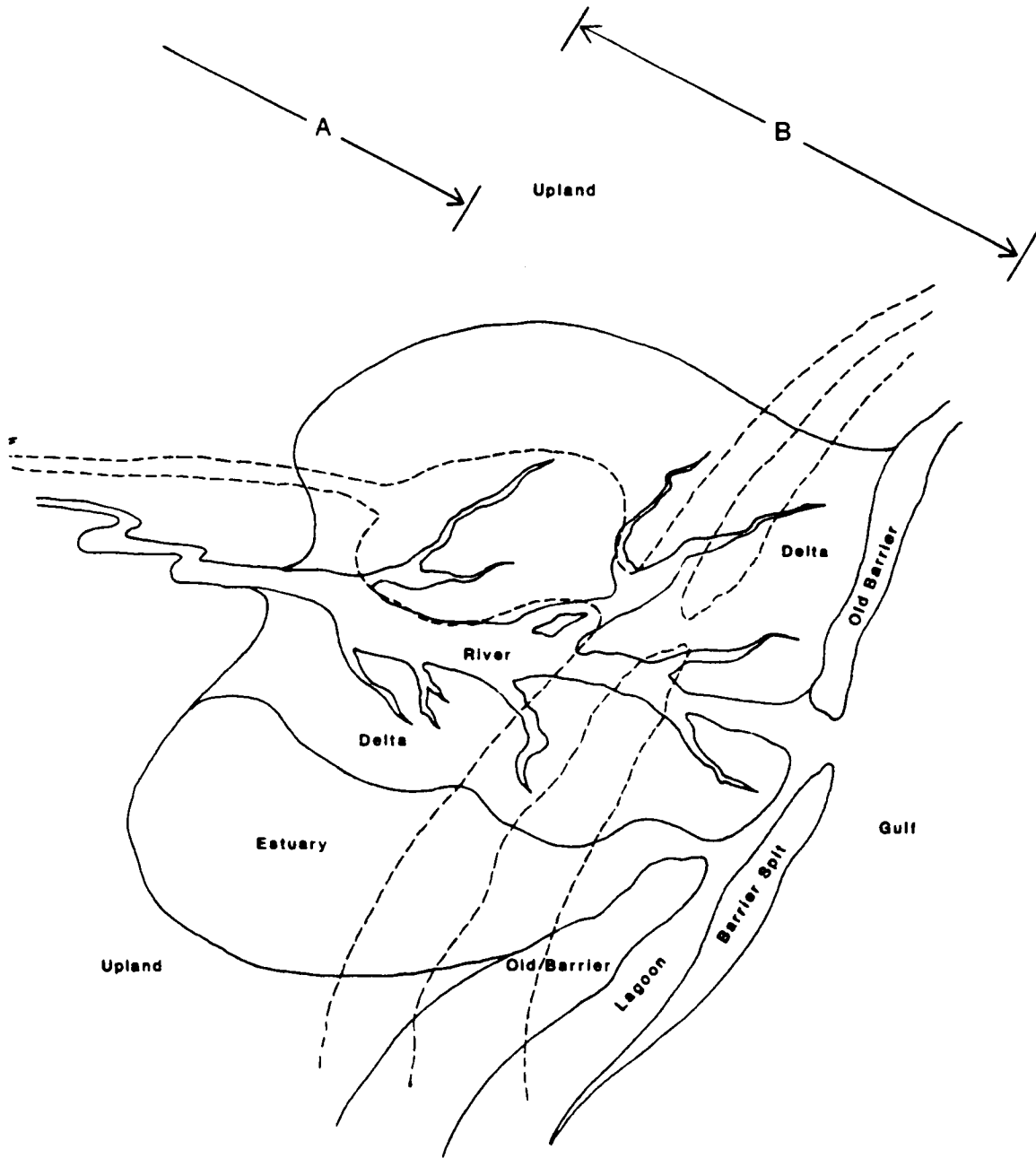

FIGURE 2. Landform during the Sangamon interglacial stage 150,000 yr B.P.



from shifting river channels and by mud and silt deposited from river flooding.

The upland in area "B" was formed by a combination of fluvial and deltaic processes. Deltas were built by the deposition of sand and mud at the mouths of distributaries. Overbank flooding spread mud and silt into the interdistributary areas. The deltas were built far into the ancient embayments until they became overextended. Changes upstream caused water and sediment to flow through new channels with higher gradients (Brown et al. 1976). Distributaries were abandoned and reoccupied again and again while the embayment filled with sediment. Occasionally, major river course were abandoned due to events far upstream. The entire process of delta formation and estuary filling could occur some distance north or south of an abandoned river mouth.

Early Wisconsin Glaciation. The fall in sea level accompanying glaciation began slowly at first and then accelerated. As sea level declined, the entire sequence of coastal land and water areas--uplands in the coastal plain, river mouth and delta, estuary, offshore bars and barriers--moved seaward. Areas that had been formed by delta processes received sediment from fluvial processes only. By the time the glaciation had reached its maximum extent, sea level was 300 to 450 ft below its present level. Deltas were still being built, but now at a shoreline 50 or more miles out on the continental shelf.

Figure 3 (approximately 100,000 yr B.P.) shows the processes occurring in the same geographic location at the time of the lowest sea elevation. The entire area had become upland and was a source of sediment for transport downstream. Erosion became the dominant sedimentary process as the river

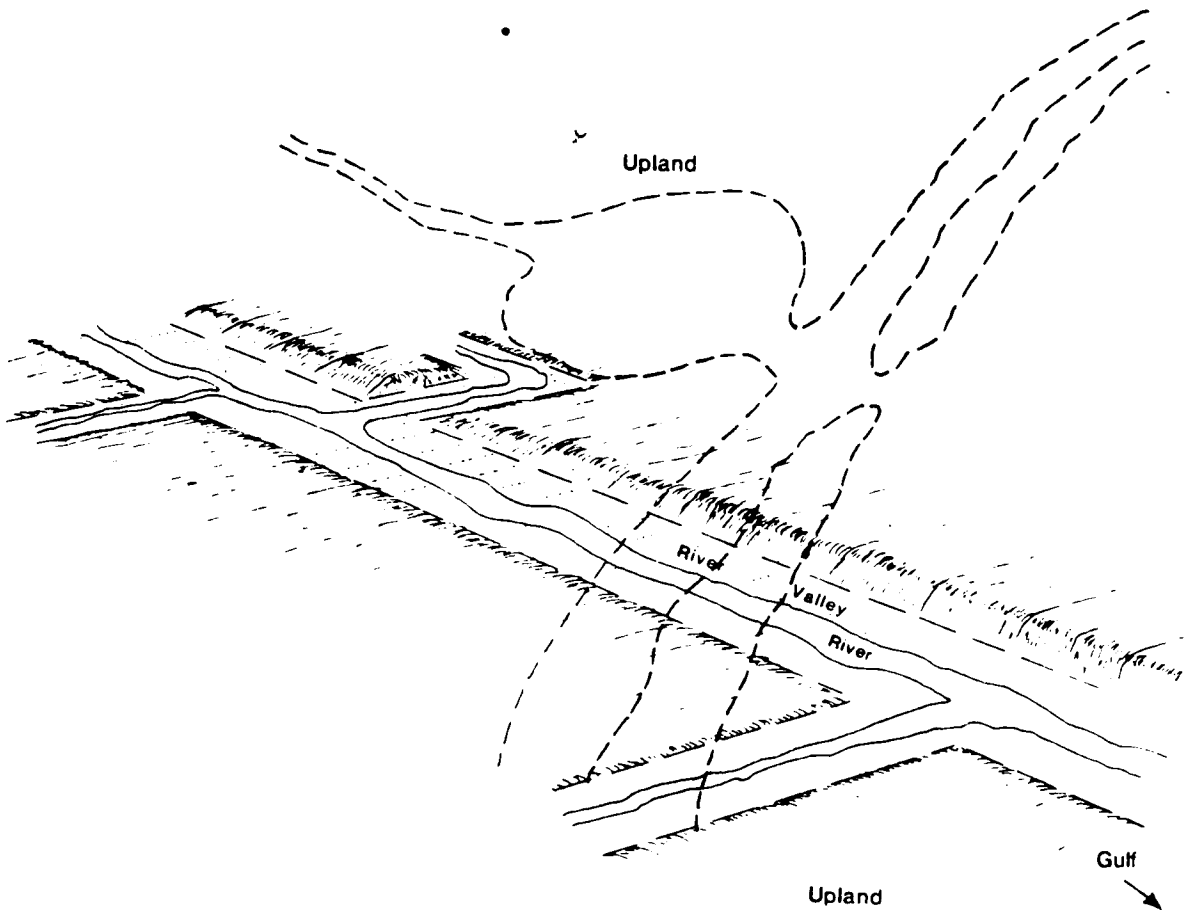

FIGURE 3. Landform during the Early Wisconsin glaciation 100,000 yr B.P.

valley widened and deepened. Tributaries developed, draining adjacent areas and carrying water and sediment to the river system.

Peorian Interglacial Stage. Sea level rose rapidly during the Peorian interglacial stage. It reached a level slightly above its present level, but did not remain there long. Figure 4 shows the land features at that time. Most rivers did not build extensive deltas. They discharged sediment directly into the nearshore areas. The sediment was carried alongshore and onshore to form a strandplain (McGowen et al. 1976a). The strandplain prograded seaward for several miles, as far as the present barrier islands (Brown et al. 1976). Some water bodies developed behind the strandplain, though they were usually brackish lakes or lagoons largely cut off from circulation with the gulf.

Along upper portions of the coast, the sand supply for building the strandplain was riverborne sediment, older Pleistocene delta deposits, and sediment imported from western lobes of the Mississippi River. Minor fluctuations in sea level and local changes in land elevation resulted in erosion of some strandplain areas and burial of others by fluvial and delta-building processes. By the time the final glacial episode occurred the strandplain was wide but not continuous along the coast.

Late Wisconsin glaciation. Sea level dropped again beginning 50,000 to 60,000 yr B.P. Figure 5 shows the processes and land areas during the period of lowest sea level elevation, approximately 40,000 yr B.P. The circumstances within the barrier island characterization study region during this glaciation were very similar to those during the early Wisconsin glaciation 60,000 yr before.

Holocene period. Meltwater from the retreating glaciers began to reach the oceans and cause sea level to rise during the Holocene period (4,500 to

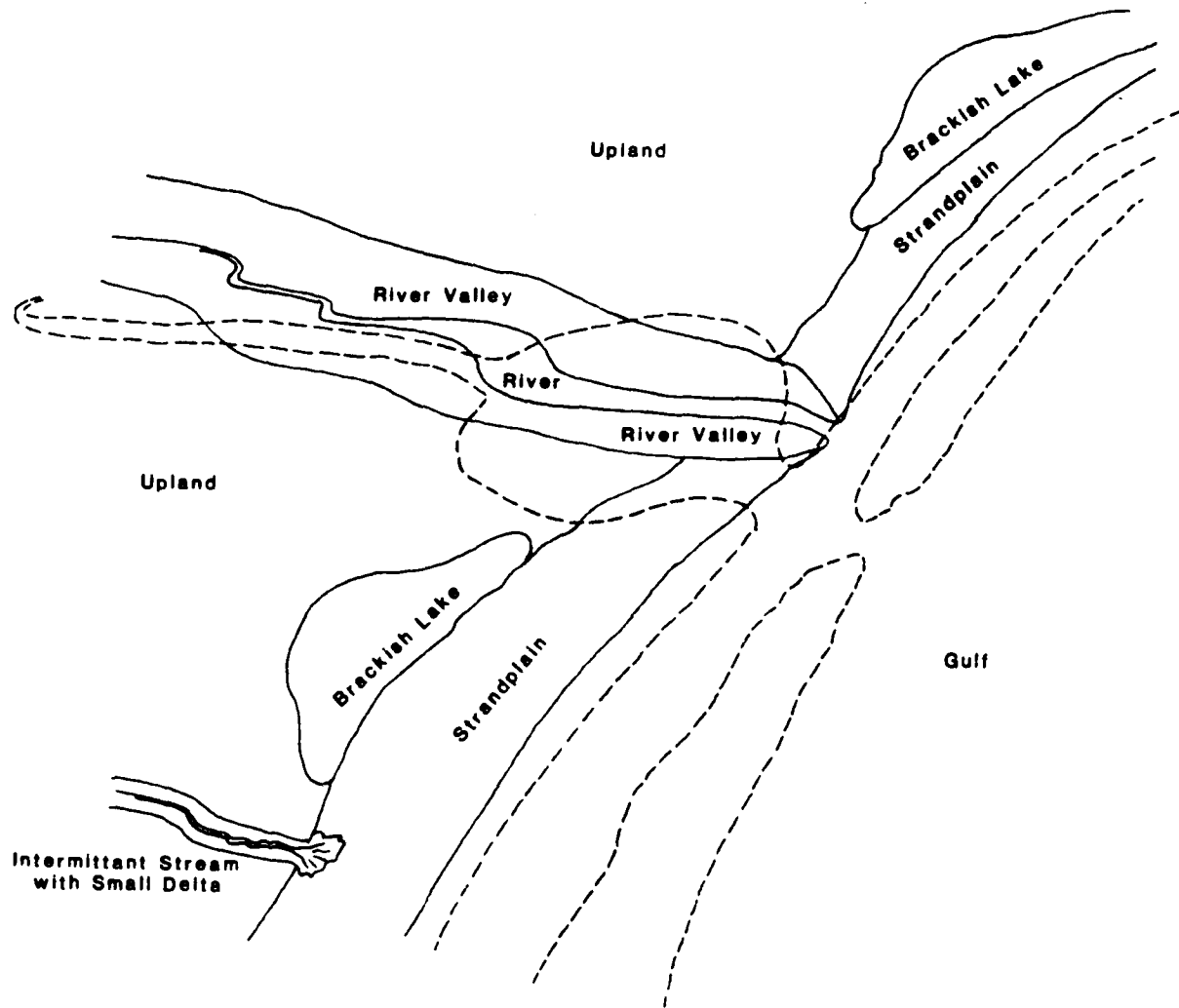

FIGURE 4. Landform during the Peorian interglacial stage 75,000 yr B.P.

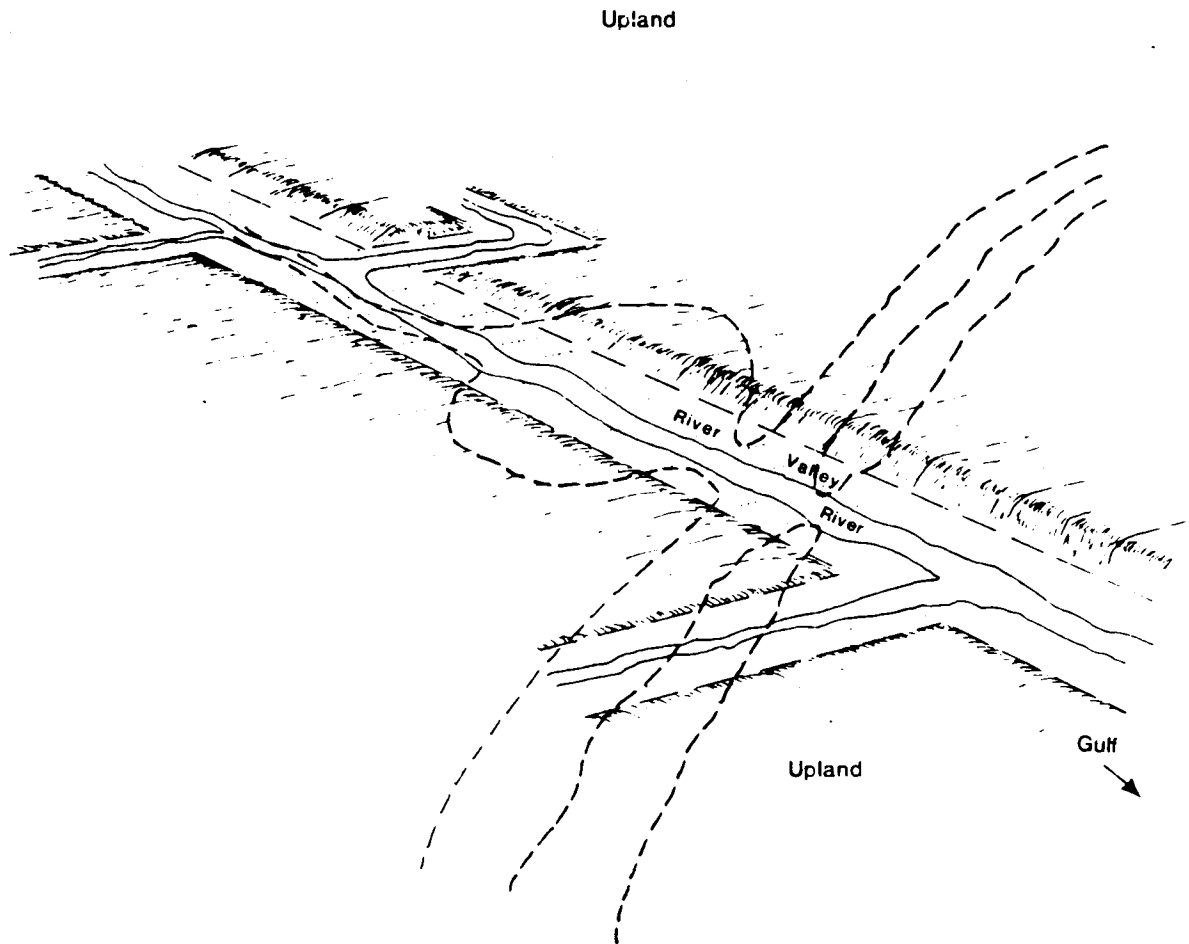

FIGURE 5. Landform during the Late Wisconsin glaciation 40,000 yr B.P.

18,000 yr B.P.) of the late Cenozoic era. The rise was slower than before and the gradient for river flow not as steep. Rivers meandered within their incised valleys and deposition commenced again in locations where just previously river valley cutting had occurred. Sea level did not rise smoothly; there were several incidents of small rises and falls.

### Modern History

Final landform morphology. The Modern period began 4,500 yr B.P. Relative sea level changes have been less than 15 ft (Brown et al. 1976) during this time. The estuaries became deep drowned river valleys as sea level rose during the Holocene. They began to fill with sediment carried in by the rivers, eroded from the river valley walls, and transported from the gulf in flood tidal deltas.

On the gulf shoreline between the major river valleys, sand from the previous Pleistocene strandplain, eroded Pleistocene headlands, and submerged Pleistocene deposits on the inner shelf was transported along the coast by longshore currents and carried onshore during storms. This material formed bars and shoals just seaward of the headlands. It eventually became the emergent barrier island and peninsula chain. Some rivers, such as the Brazos and Colorado, quickly filled their river basins and began to contribute sand directly to longshore transport (McGowen et al. 1976b). This material supplemented the Pleistocene sand forming the barrier chain. The mouths of the major river courses remained open as long as there was sufficient water flow; the opening itself, however, often shifted location as deltas formed and storms opened new drainage paths with less resistance to flow.

By 2000 yr B.P. the coastal region had achieved its present form as seen in Figure 6. Since then, many short-term changes have occurred, including:

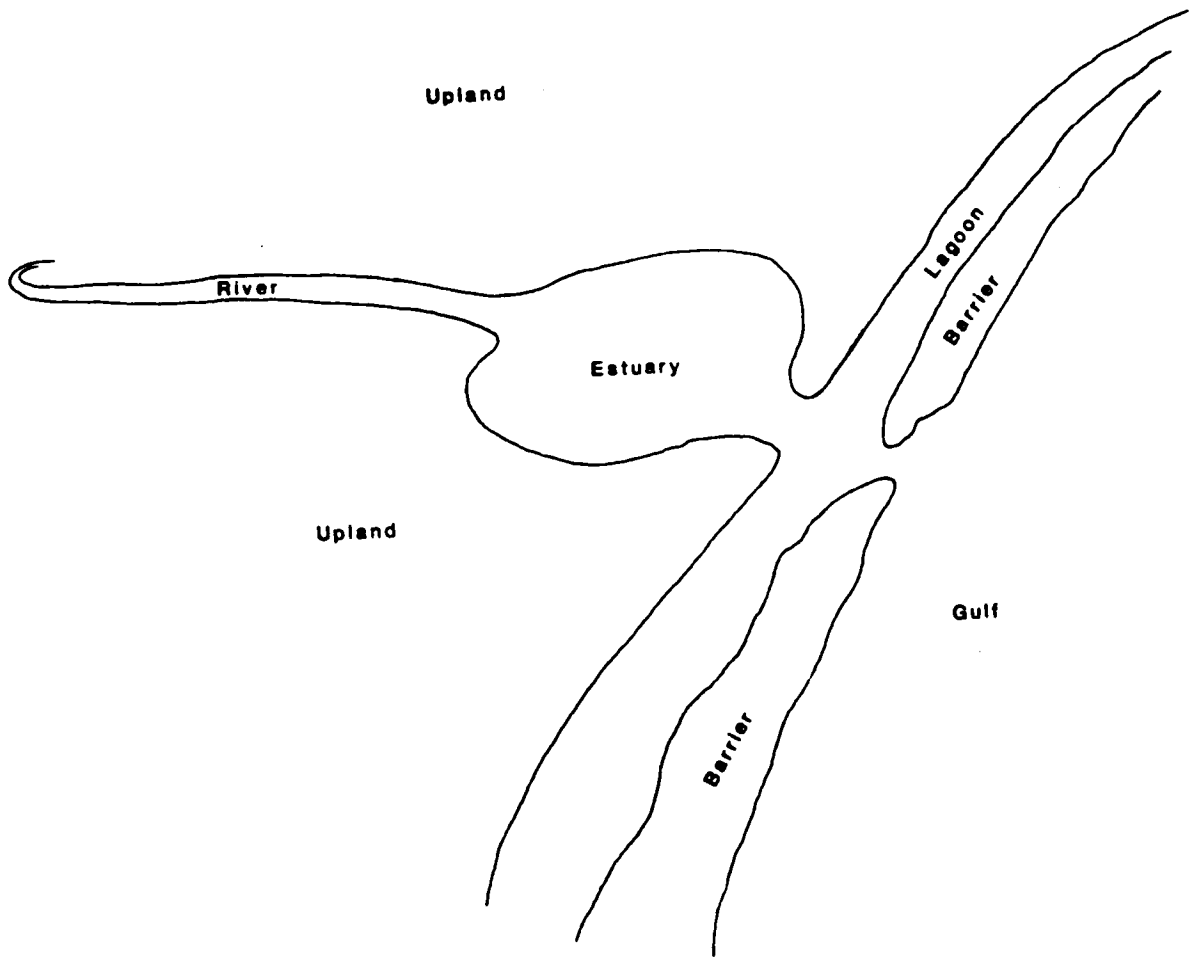

FIGURE 6. Landform during modern period 2000 yr B.P.

changes in pass location; erosion of shorelands; delta formation; headward erosion of streams; and accretion and erosion of the barrier chain. However, the general pattern of land areas has not changed.

Surface expression of sedimentary history. Figure 7 shows the origin of the present surface lands in the coastal region, using the landform from the previous diagrams. The barrier chain, lagoon, and modern marsh-lagoon margin are very recent landforms. They have developed in their present locations within the last 4000 to 5000 yr. The floodplain (Modern-Holocene fluvial deposits) developed over the past 18,000 yr. In most instances the river has been within the same river valley since the previous interglacial stage (60,000 yr B.P.). The estuary is within the old river valley but has developed its own distinctive shape through erosion since sea level stabilized.

The most inland portions of the coastal plain resulted from Pleistocene fluvial deposits. Toward the gulf, the coastal plain was formed from Pleistocene deltaic and fluvial deposits. The areas that lie parallel to the present lagoon shoreline are Pleistocene strandplains formed in the previous interglacial stage. They are not entirely continuous because of local erosion or direct deposition of deltaic material. Local areas of Modern-Holocene deposits may partially or completely fill the brackish lakes or lagoons that developed in some places behind the Pleistocene strandplains.

#### REGIONAL SYSTEM MODEL

The regional model contains a series of zones that lie approximately parallel to each other. These are: uplands above the coastal plain; uplands in the coastal plain; the estuary; barrier islands and peninsulas with washovers; and the marine environment. The river and bay systems lie roughly



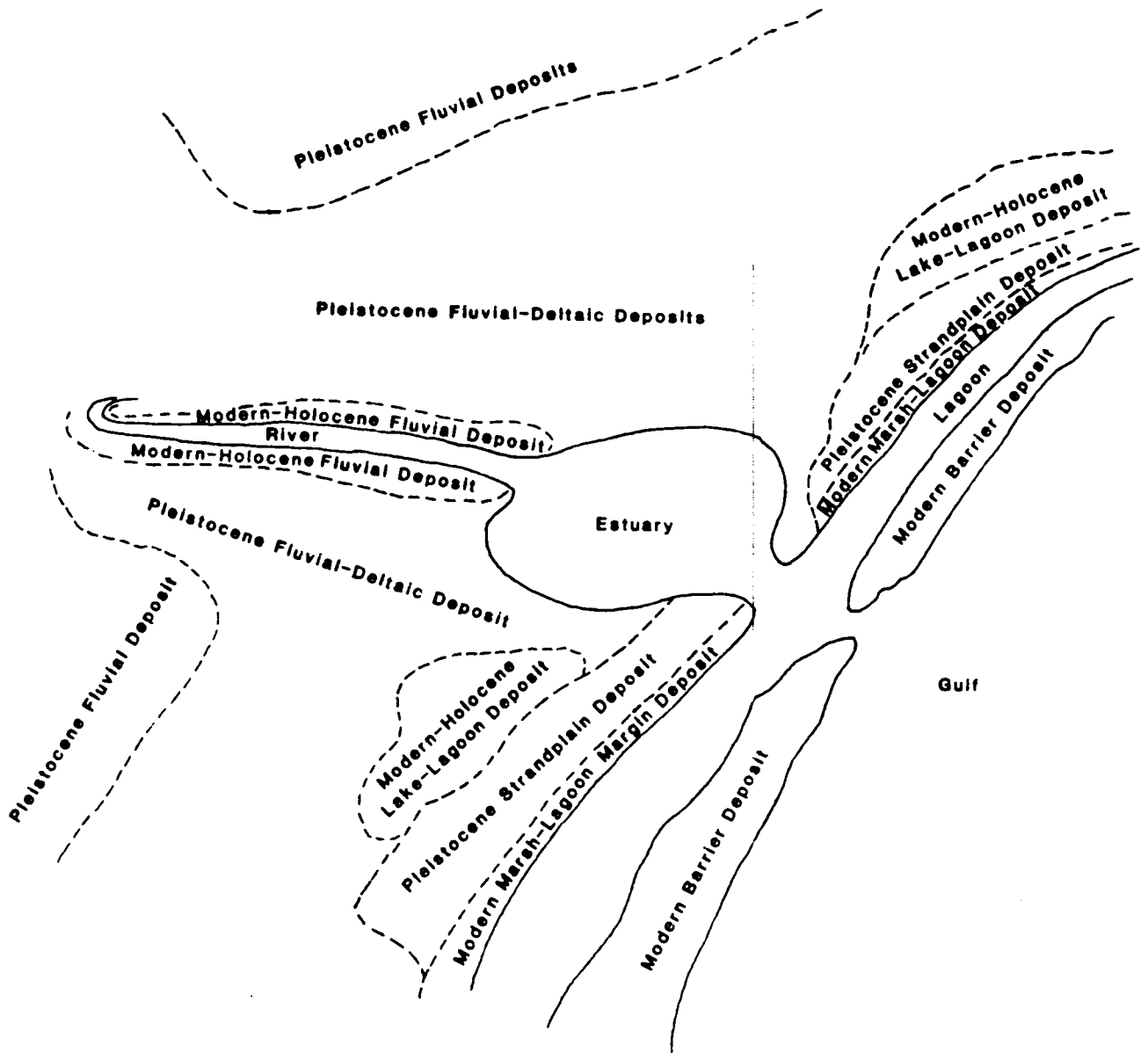

FIGURE 7. Present surface land features that show sedimentary history of the Texas coastal region.

perpendicular to the shoreline. The rivers cut across the uplands as they flow to the coast. They carry water and sediment from as far as New Mexico and Colorado to the estuaries or gulf. Sediment is deposited in deltas at the river mouths and in the estuaries as the water passes through. River water mixes with marine water in the estuary, or in the mouths of those rivers that have completely filled their estuaries. Water exits through the passes and flows into the gulf.

The upland above the coastal plain was formed by deposition in the Paleozoic and Mesozoic eras. The upper reaches of the coastal plain were deposited during the early Cenozoic. Moving toward the coast, the surface sediments were deposited progressively later. Those at a point 60 to 80 miles from the present coastline were deposited by fluvial processes during the Pleistocene. The surface sediments further toward the coastline came from Pleistocene delta formation and fluvial processes. At the present coastline there are relict strandplains that developed during the Peorian interglacial stage. The barrier islands immediately adjacent to the gulf are the most recent landforms, only a few thousand years old.

The system model presented in Figure 8 is applicable to the entire region from the latter part of the Cenozoic to the present time. In this interval coastal deposition processes similar to those of today were occurring, and a series of glacial episodes lowered sea level. During the glaciations, the series of land and water units in the model were slowly displaced down the continental shelf to the lowest sea elevation. When the ice caps melted, the entire sequence of units moved up the continental shelf to the point of maximum sea level.

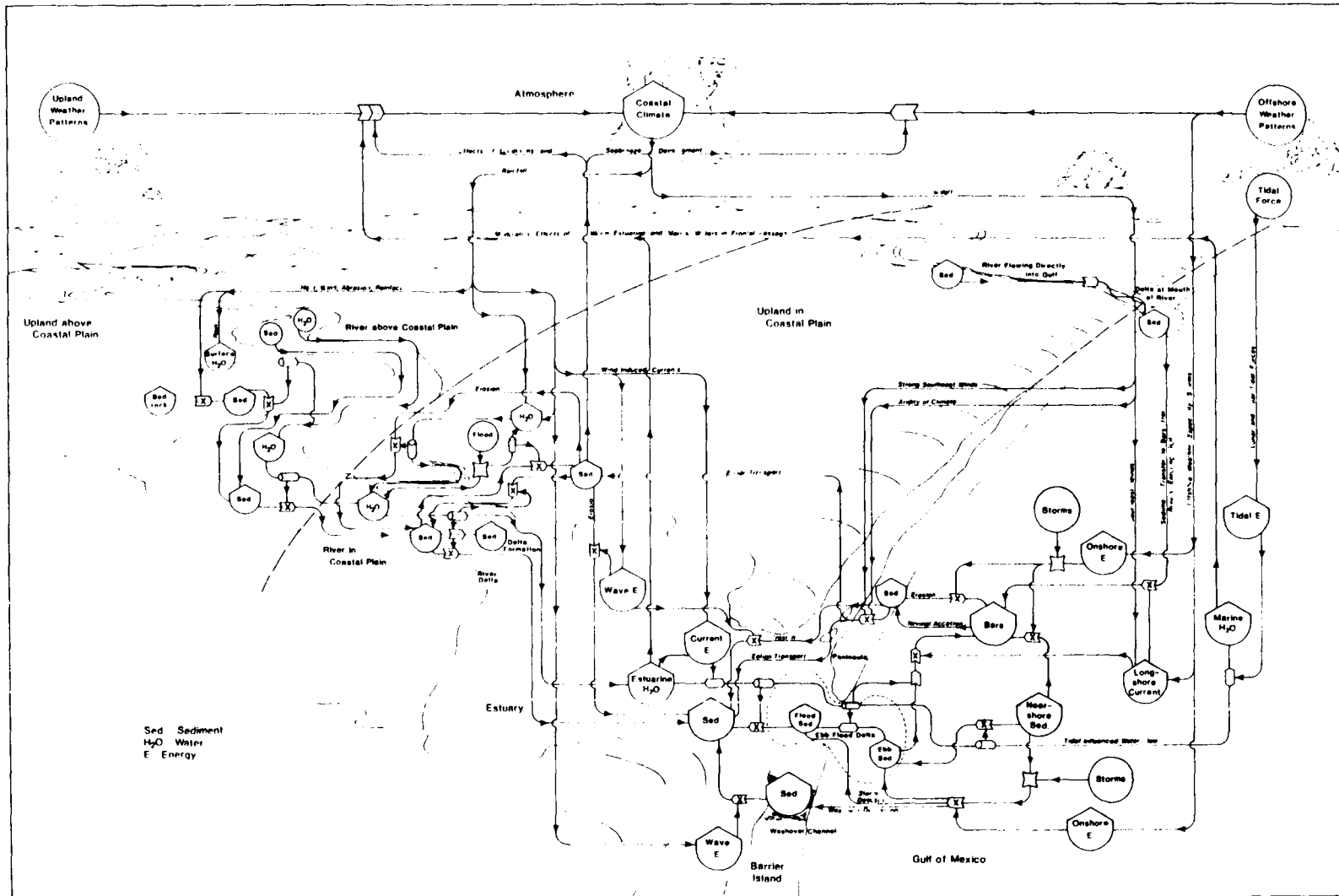

FIGURE 8. Regional system model.

This shifting of land and water units occurred four or five times in response to the glaciations. The displacement back and forth along the continental shelf resulted in changes in the depositional environment for the upland units. Areas that received sediment from fluvial and deltaic processes at normal sea level during the Pleistocene became sites for erosion with sediment transport out to the edge of the continental shelf. Areas out on the shelf that were normally marine received sediment from fluvial and deltaic processes. Deep marine areas developed strandplains and possibly barrier islands during the glacial extremes. With the rise in sea level the sequence reversed. However, with the exception of the large fluctuations of sea level, the processes responsible for forming the landscape during the Pleistocene were the same as those presently occurring.

#### Purpose of the Regional Model

The purpose of the regional model is to explain the forces and processes that shape the study area as a whole. The study area covers the Texas coast from the eastern limit of Galveston Bay to the Texas-Mexico border. It extends seaward three marine leagues (10.35 miles) and inland approximately 40 miles.

The definition of an area and the processes that shape that area as a whole determines the time scale in which a model of the area is appropriate. The time scale over which erosional and depositional processes and other forces have acted to give the Texas barrier island region its present form is approximately 60,000 to 75,000 years, an entire glacial epoch. While the overall time scale for this model is in the range of millenia, many of the forces shown operate in recognizable patterns over a much shorter time period. Storms, floods, longshore transport, and tidal cycles can be measured on a

time scale of hours to days. To interpret this model correctly, the effects of these recurrent, short-term processes should be considered over the span of decades, centuries, or longer.

### Driving Forces

Driving forces are the inputs of material or energy from outside the system boundaries that drive the internal structure of the system but are not themselves affected by the components of the system. The event that allowed the Texas barrier island region to evolve the way it has was the development of the Gulf Coast Geosyncline. After that event, the main driving force was the fall and rise of sea level during the ice ages. Sea level elevation determined the location of the barrier island region relative to other geographic locations.

Other driving forces that have affected the barrier island region within this time scale and are presented in the regional model include: water and associated sediment flow from west Texas; long-term weather patterns such as the climatic gradient of temperature and humidity running north and south; short-term weather patterns including hurricanes and northers; and tidal forces from the sun and moon. Unlike the change in sea level, these forces may be measured over short time spans. Although these forces are usually short-term and intermittent, their effects are cumulative and substantial over a long time period. Hurricanes, for example, occur on the Texas coast once every 2.5 years (Brown et al. 1974) or about 40 times per century. Since sea level stabilized 4500 years ago, as many as 1800 hurricanes may have struck the coast. Each hurricane has effects that may persist for several years before a new equilibrium is established. Opening new passes or transporting

sediment to offshore bars are two examples of discontinuous but cumulative effects of hurricanes.

### Model Compartments

The model consists of a series of connected compartments that contain energy, water, and sediment. The connections result from water flows or atmospheric phenomena.

Upland above the coastal plain. Upland above the coastal plain supplies water and sediment to the river system. Surface erosion is caused by transport of sediment through runoff. Heat, wind, abrasion, rain force, and human activities including some farming practices cause the substrate to weather and form the particles that are carried to the rivers.

River above the coastal plain. The river receives sediment and water from upland sources in the western part of the state. Sediment is transported through water movement to the river segments within the coastal plain.

Upland in the coastal plain. Upland in the coastal plain is formed by sediment deposition from flooding and by bars left by rivers as they change course. This is an episodic process, discontinuous but with cumulative effects. The uplands lose sediment to the river systems and bays through bank erosion and surface erosion. In some areas of the coast the uplands may gain sediment through eolian transport. The latter is a function of the climate; eolian transport increases from north to south with decreasing rainfall.

Williams et al. (1976) noted the effects of landform on rainfall. The shape of the coast influences temperature isotherms, the sea breeze, and zones of convergence of rainfall. This effect of landform upon climate is noted in the model.

River in the coastal plain. Water and sediment are accepted from upstream segments of the river, bank erosion, and runoff from the adjacent uplands. During flooding, water and sediment are delivered to the uplands in the coastal plain. The river, that is normally confined to the river banks, can spread out at the river mouth. This causes its velocity to decrease and some of the sediment load is deposited in a delta. The sediments in deltas tend to compact to some degree, but most deltas along the Texas coast are in a continual growth condition.

Estuary. The estuary receives sediment from the river and from mainland bank erosion. Some sediment is carried into the estuary from the flood tidal delta at passes through the barrier islands and peninsulas. Other sediment comes from erosion of storm washover fans. Wave energy produced from northers and southeast winds mediates sediment transport from washover fans, eroding bluffs along the bay and the bayside of barrier islands and peninsulas. Current energy that is derived from river inflow as well as wind mediates estuarine water flow. In large measure estuarine water flow controls sediment movement between the estuary and flood tidal delta. Some sediment is carried by the wind into the estuary from the barrier islands. Climate and southeast winds control eolian transport; it is mainly seen in the southern part of the coast, where the low rainfall limits the growth of dune vegetation that would normally stabilize and entrap sand.

Texas estuaries are net sinks for sediment from all sources. Bank erosion causes the estuaries to continually grow wider; however, they are always filling and becoming shallower. Continued dipping of the Gulf Coast Geosyncline and compaction of bottom sediments occur at slower rates than

estuarine deposition. Only in the case of subsidence due to groundwater and mineral withdrawal have parts of estuaries become deeper.

The Brazos and Rio Grande systems have completely filled their river valleys with sediment. Neither of these systems is a true estuary any longer; both are tidal streams that deposit their sediment load and water directly into the gulf. In these these systems, the ebb-tidal delta and river delta are the same unit, and there are no barrier islands or peninsulas. The uplands adjacent to these rivers have beaches and foredunes that function in the same manner as the beaches and foredunes on the barrier islands.

The Colorado River has filled almost all of its river valley. Currently a large proportion of its flow goes directly into the gulf, though some water and sediment passes through the delta that the river has built and flows into East Matagorda Bay or West Matagorda Bay.

The estuary, as a large water body, influences the climate of the region by buffering temperature changes. In addition, the sea breeze develops because of the large thermal gradient between the air masses over water or wetlands and the air masses over the uplands (Williams et al. 1976).

Ebb- and flood-tidal deltas at passes and washovers. Passes are passageways for water flow through or between peninsulas and barrier islands. A flood-tidal delta occurs at the end of a pass closest to the mainland. An ebb-tidal delta occurs at the seaward end of the pass. The sediment that forms these deltas is carried from nearshore sediments in the gulf. Storms may transport sediment directly to the flood-tidal delta. Because of the increase in storm water level and the deposition, flood deltas may be emergent after storms. If stabilized by vegetation, the delta may remain as an emergent island. Harbor Island at the opening of Aransas Pass is an emergent,



active flood tidal delta island. The sediment on flood-tidal deltas may be transported to other locations within the estuary by the estuarine current energy.

Ebb tides may move sediment from the ebb tidal delta back to the nearshore sediments or to the bar system that supplies sediment to the barrier islands. Alternating tides carry sediment back and forth between flood- and ebb-tidal deltas. Over a span of many years the net flow of sediment is to the flood delta.

Washover fans are the flood deltas of washover areas, breaches in the barrier islands opened to water flow by storm action. The dynamics of washover fans are similar to those of flood tidal deltas. However, water flow is intermittent, occurring only during major storms.

Nearshore marine environment. The nearshore environment has a supply of sediment that came from fluvial and deltaic deposition during glacial episodes and to a lesser extent from Holocene or Recent sedimentation. At present, the sediment is transported by a variety of forces including tidal energy and onshore wave energy.

Tidal forces are gravitational forces between the earth, moon, and sun that affect the exchange of water through the passes between the estuaries and the gulf. The flow through the passes has upstream effects; changes in water levels due to the rise and fall of the tides alters the hydrostatic pressure head between the rivers and estuary mouth. This influences the quantity and pattern of sediment transport in the estuary and in the tidal reaches of streams in the coastal plain.

Longshore current is a wind-driven force parallel to the shoreline. Along the upper coast the net direction of the longshore current is south;

along the lower coast, the net direction of movement is north. At a point near Port Mansfield the currents converge so that there is no net flow one way or the other. The direction of the longshore current is dependent upon the vector of average direction of wind-generated waves and the orientation of the shoreline. The resultant vector of wind-generated waves can be broken into two component vectors, one perpendicular to the coastline, the other parallel to the coastline. The latter vector shows the direction of longshore current.

Longshore current causes net movement of sediment north or south in the surf zone just off the beach. It is important in influencing the balance of sediment between the beach and bars in the surf zone.

Onshore wave energy is the component of the average wind-generated wave vector that is perpendicular to the beach and pointing toward the shore. During major storms, sediment from the nearshore area is transported to the bars. After the storm subsides, this sediment is available for movement onto the beach by normal wave action. During storms, onshore wave energy controls the erosion of the beach and foredunes. Sediment from this erosion is also stored in the bars. Onshore wave energy is almost completely controlled by wind direction and velocity.

Thus the sediment that forms barrier islands typically comes from old deposits associated with the Pleistocene era. Whether barrier islands accrete or erode is largely dependent upon the supply of sediment in the bars in the upper shoreface of the nearshore environment. These bars themselves receive sediment from the Pleistocene deposits or to a lesser degree from direct transport from rivers with filled river valleys.

Sediment from the nearshore sediment supply is occasionally transported directly to flood-tidal deltas or washover fans through storm action.

Barrier islands and peninsulas. Barrier islands and peninsulas are formed from sediments carried ashore from shallow bars in the surf zone. There is an equilibrium between erosion and accretion of barrier islands. The balance ultimately depends upon the amount of nearshore sediment available for movement to the bars and then onto the barrier island (Fisher et al. 1973). Some sediment is eroded from the backside of barrier islands and peninsulas by wave action. This sediment is transported into the estuary and remains there. Eolian transport moves some barrier island sediments to the estuary or upland areas. This process occurs mainly in the southern half of the Texas coastal region.

#### FORMATION OF THE REGION ACCORDING TO THE MODEL

The regional model is applicable to the surface conditions that have occurred during the Cenozoic and Modern eras. It directly shows neither localized short-term subsidence nor the long-term sinking associated with the Gulf Coast Geosyncline.

#### Movement of Sea Level

To use the model to illustrate the formation of the Texas coastal region requires consideration of the effects of glacial episodes and interglacial periods. During the glacial episodes, the elevation of the sea-land interface fell as much as 150 meters. While this elevation change was substantial, it was small compared to the lateral movement of the sea-land interface. During the greatest sea level decline, the gulf shoreline was more than 80 kilometers seaward of its present location. While the shoreline movement landward or seaward during the glacial cycles would be hardly noticeable in a human lifetime, the effects caused major changes among some of the zones in the regional model.

### Interglacial Period

During an interglacial period (Figure 1) the model (Figure 8) operates largely as described above. Rivers above the coastal plain transport sediment from upstream sources and from uplands above the coastal plain. Water and sediment are carried into rivers within the coastal plain. Through a combination of forces, part of the sediment in these rivers is carried into the estuary. Other portions of the sediment are deposited on upland in the coastal plain and as deltas. When river courses change, the deltas become upland areas. Thus during interglacial periods many areas of upland in the coastal plain are added to by fluvial-deltaic processes.

Water and sediment flow in the estuary, ebb- and flood-tidal deltas, barrier islands and peninsulas, and marine environments operate as shown in the model.

### Glacial Episode--The Upper Zones

When a new glacial episode begins, sea level starts to fall. The line separating areas above and within the coastal plain moves seaward since it is defined by overbank flooding and delta forming processes. Therefore, rivers and uplands formerly in the coastal plain lie above the coastal plain.

Sediment transported by rivers above the coastal plain comes from upriver sources and from upland sources (Figure 8). However the new areas above the coastal plain are not subject to fluvial, delta, or eolian deposition processes; they are mainly erosional. Consequently there is a major change in the way the original land area operates. It ceases to be a sink for sediment from upland, river, or barrier island sources and becomes a source of sediment for areas further seaward and at lower elevations.

The estuary, barrier islands and peninsulas, ebb- and flood-tidal delta, and upper portion of the seashore environment also undergo substantial changes. As sea level declines, the estuary shallows until it becomes upland with a river channel flowing through. The barrier island, peninsula, and upper region of the upper shoreface also become completely emergent as sea level drops. With time, the river channel that passes through the estuary may carve a wide river valley, all but obliterating the estuary, ebb-flood tidal delta, and parts of the adjacent barrier islands, peninsulas, and upper shoreface. Except for the river channel itself, all of the land between the old and new boundaries demarking the coastal plain becomes upland. All of these land areas become sediment sources for the areas downstream.

#### Glacial Episode--the Lower Zones

As sea level falls a rich supply of sediment becomes available for transport by the river to the edge of the gulf. Rivers cut deeper channels and recently exposed lands must reach new slope equilibria. The morphology of the lower part of the barrier island region depends upon the rate of decline in sea level. When a stable lower sea elevation has been reached, it is probable that the river and upland within the new coastal plain, estuary, upper shoreface, and other zones operate in the same fashion as shown in the regional model. It is not certain whether barrier islands have formed during this time.

#### Sea Level Rise

When sea level rises as glacial periods end, the boundary delineating the coastal plain moves landward. Areas that had been functioning completely as uplands again become uplands in the coastal plain, subject to flooding, major river meanders, and eolian processes. Figure 4 shows the circumstances that

occur when sea level has risen and finally reaches an equilibrium. The estuary is a drowned river valley. The processes of bank erosion and delta formation have not occurred to a sufficient extent to create a more classic estuary shape.

#### Observations on the Model

As sea level declines, reaches an equilibrium, rises, and reaches another equilibrium, the zones in the regional model continue to function as shown. The order of the zones also remains the same. For land areas, the order from highest to lowest elevation is: upland above the coastal plain; upland in the coastal plain; and barrier island or peninsula. For subaqueous areas, the order is: river above the coastal plain; river in the coastal plain; estuary; ebb-flood tidal delta; and upper shoreface. The location of the zones changes. All of the zones below the line marking the edge of the coastal plain during the interglacial period slide down the slope of the land as sea level declines. Except for the river channel itself, all of the areas above the new edge of the coastal plain become either upland above the coastal plain or part of the river as it forms a river valley.

The effect of the glacial episode is to elongate seaward the zones of river and upland above the coastal plain and push the other zones down the continental slope, positioned in the same way as they were during the interglacial period. During sea level rise the process is reversed. The shape of the estuary and presence of barrier islands or peninsulas depends upon the rate of sea level fall or rise, and the duration of the period of equilibrium. The classic estuarine shape and development of barriers requires a slow rate of rise or fall and a long period of equilibrium.

The areas of upland within the coastal plain, barrier islands, peninsulas, portions of estuaries, deltas, and the landward portions of the uppershore face above the new coastal plain boundary cease functioning in the usual way. Instead of having flows of water and sediment into and out of them, they become uplands above the coastal plain with only outflows into the river.

#### MAN'S EFFECTS ON THE REGION

Man has inhabited the TBIR for a few thousand years. However, he has been able to alter the region substantially for only about a century. His changes at a regional scale are the consequence of three major needs: to control natural forces to avert major and minor catastrophes, especially floods; to use components of the environment to support the human population; and to provide navigation improvements for commerce.

Although man's alterations and interventions have occurred over a short time period in the region, they have produced long-term changes in system function that can be overridden only by the major climatic and sea level changes that accompany glacial episodes.

Figure 9, a modification of the regional model, shows the places in the model where man's machines, structures, and actions intervene to control or alter the components and flows among components. The stick figures indicate each major human intervention; the numbers held by the figures refer to the more detailed discussion below.

Production of soil. Intervention number 1 shows man's effects on the production of sediment in the uplands. Some land use practices that bare the soil to increased exposure from sun and rainfall may increase the sediment available for erosion. Other efforts, including revegetation, may decrease

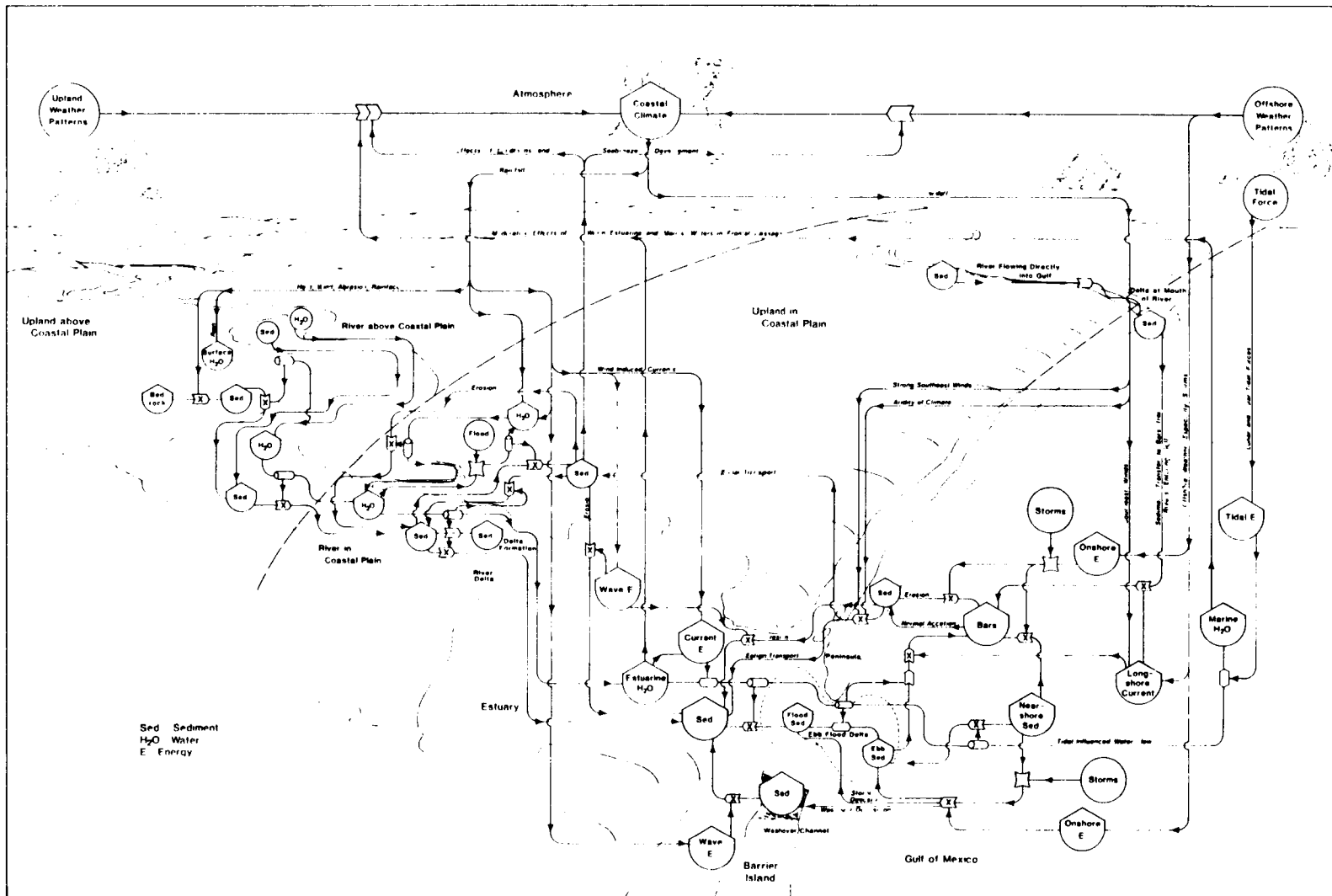

FIGURE 9. Regional system model showing man's effects on the region.



the amount of sediment that can be transported. Major changes in land use, such as urbanization of prairie or forest, may decrease the rate of soil production by reducing the exposure of sediment to the weather, leaching, and accumulation of organic material. In Texas the natural topsoil formation rate varies between 1.5 and 4 tons per acre (Scott 1978; Risser 1978).

Modification of runoff from uplands into rivers. Intervention number 2 represents changes in runoff from man's activities. Paving in urban areas, poor agricultural practices, drainage projects, and removal of surface vegetation increase runoff into the rivers and change the pattern of water flow. Vegetation retards water flow. When the land surface is denuded or tributaries are channelized and straightened, the quantity of flowing water during and after rains increases. The water runs off more rapidly and, where sediment is available, can carry a larger sediment load.

Soil conservation programs have helped to slow the rate of topsoil loss, although nationwide the erosional loss from agricultural lands ranges from 5.2 to 12 tons per acre per year (Pimentel et al. 1976; Brink et al. 1977). Statewide, the rate of soil loss from erosion is about 3 tons per acre (calculated from Texas State Soil and Water Conservation Board 1981, p. 4). Six counties in the TBIR study area have reported water erosion on cropland to be a critical problem.

Diversion of water from rivers to upland uses. Diversion of water for municipal, industrial, and agricultural use is shown by intervention number 3. These uses decrease the quantity of water flowing down the rivers even though some diverted water is eventually returned. Texas Department of Water Resources (1977) planning documents give an indication of the proportion of water diverted for some societal uses that is released in return flows. For

coastal basins where approximately 50 percent of the basin is located within the TBIR, three units of water are returned as return flows for every two that are diverted. This occurs because return flows include both surface and subsurface water. In the same geographic area, agricultural return flows are only about 25 percent of the diversions of surface water. These return flows also include both surface and subsurface water.

Control of flow in rivers above the coastal plain. Intervention number 4 illustrates the changes in river flow that are due to dams above the coastal plain. These structures change both the quantity and pattern of downstream water flow. Since water movement is responsible for sediment transport, the sediment supply as well as the water supply to the downstream components of the model are affected. The control man has on water flow is complex and cannot be characterized as a simple decrease in flow. Because of this complex effect, the controlling work gate does not have a specific relationship indicated within it. The magnitude of the effect varies with many factors including the distance from the coastal plain, flow volume, and characteristics of the transported sediment.

Control of overbank flooding in the coastal plain. Human intervention number 5 represents the control of overbank flooding in the coastal plain through placement of flood control structures such as levees. In urban areas, overbank flooding does much damage to public and private property. In rural areas where land near rivers is used for agriculture, overbank flooding can damage crops and equipment. However, there are benefits as well: sediment and nutrients are transported by floodwaters onto the land and river bottom areas provide fertile lands for agriculture.

Flood control levees indirectly control the extent of movement of rivers within their river valleys. When water is confined within levees, the areas outside the levees are rarely subject to the water flow forces that create new river channels, oxbow lakes, or sand deposits from old river bars. As a result, upland areas in the coastal plain that are adjacent to levee rarely receive inputs of sediment and other materials from the river.

Influence of river flow in the coastal plain. Human intervention number 6 represents the effects that straightening and channelization rivers and streams have on flow velocity. These modifications are usually made to hasten runoff so local flooding may be avoided; watercourses are also modified to allow navigation. Both types of modification increase flow velocities, thus enabling watercourses to pick up more sediment from the bed of the waterway and from the banks and carry it downstream. As material is eroded, the waterway deepens and widens, and flow velocity decreases. Until a new equilibrium is reached, more sediment will be transported to the estuary and less deposited in the delta.

Channelization and straightening increases the velocity of runoff during extreme events such as from major storms and hurricanes. Though infrequent, these are often the periods of greatest sediment transport to the estuary.

Controlling bank erosion in rivers in the coastal plain. To protect land bordering rivers and streams from erosion, littoral owners may erect concrete slabs, rip-rap, or sheet piling at the edge of the banks (intervention number 7). This type of bank protection is often used where the flow velocity of the watercourse has been increased by channelization and straightening as well as in places where there is substantial natural erosion on.

Erosion control structures prevent waterways from reaching the natural equilibrium between sediment transport and hydrologic forces. Where such structures are used, this equilibrium will not be reached until the waterway changes course dramatically or until people cease to expend the money and energy needed to maintain the structures. As long as the erosion control structures operate as planned, the disruption of the natural equilibrium between river flow and sediment transport will be compensated for structure. Erosion control structures may fail under increased hydrologic forces during periods of heavy river flow. When the structures are undermined, the bank areas are again subjected to erosive forces.

Control of shoreline erosion in estuary. Human intervention number 8 shows the effects of protection of estuarine shorelines. These shorelines erode naturally, as the tendency of Texas estuaries is to widen and become shallower. Erosion is particularly noticeable along the higher bluffs in some bays. Erosion control measures used along shorelines are similar to those used in rivers, although the purpose is protection against wave action rather than against unidirectional water flow.

The model shows that the protection measures decrease the amount of sediment contributed by the shoreline banks. Since many bulkheads on shorelines are flat and vertical, they reflect much of the wave energy directed at the shoreline rather than absorbing and damping the wave action as a sloping beach would. Thus localized wave energy is higher than on unprotected shoreline. Erosion protection devices are designed to withstand this effect.

As in the case of river bank protection, control of shoreline erosion in the estuary prevents the equilibrium condition that would occur if the control

structure were not present. This is advantageous to the landowner whose property is adjacent to the estuary; the amount of land that will be available over a particular time period and the uses to which it can be put are more predictable.

Bulkheads may fail and be undermined during storms, allowing the exposed shoreline areas to erode to reach a new equilibrium. By preventing continuous, incremental natural adjustments in the shoreline, both shoreline and river bank erosion control structures makes reaching equilibrium more dependent upon catastrophic events than that would occur normally.

Direct alteration of the estuary by filling. Human intervention number 9 illustrates the effect of direct placement of sediment in the estuary. Filling wetlands to create dry land for development and using wetland areas as spoil disposal sites are examples of this human intervention. Since Texas estuaries tend to fill with sediment, the direct placement of sediment simply hastens the process.

The long-term effect of spoil placement can be widespread since it alters the flow patterns in the estuary. The Texas City Dike in Galveston Bay is an example of a filled and stabilized area. Hydrologic and conservative transport models of Galveston Bay (Texas Department of Water Resources 1979, Figures 19 to 30) show that the effect of this filled area is to direct flow from the upper portions of the bay through Bolivar Roads rather than into West Bay.

Change of current energy in estuary. Deep-draft channels alter the current energy in the estuary. The effects of the Houston Ship Channel on the flow patterns in Galveston Bay are very evident from hydrologic models of the bay (Texas Department of Water Resources 1979, Figures 19 to 30). Deep

channels provide pathways for high-velocity flow from wind-induced currents, river flow, and tidal exchange. In the latter case, when substantial salinity differences exist between the estuarine and marine waters, large salinity gradients may be found between surface and bottom waters in the channels. This may result in salinity wedges intruding far up the channel into areas of low salinity.

Hydrologic changes in estuaries due to channel dredging are not limited to the immediate channel; the effects extend over a wide area, although they decrease with distance from the channel. As the channel naturally fills with sediment, the hydrologic effects of the channel decrease. Filling occurs rapidly in the Texas coastal area; only continual expenditures of money and energy for maintenance dredging allow prolonged existence of deep channels.

Stabilization of passes or cuts in barrier islands and peninsulas. Human intervention number 11 represents the effects of channelizing and stabilizing natural passes and artificial cuts through barrier islands and peninsulas. Each major bay system has a natural opening to the gulf. A few of the passes are open only intermittently because of insufficient flow from bay waters into the gulf. The unstabilized passes migrate north and south depending upon sediment availability and a complex interaction of water flow between the estuary and the gulf. Shoal areas in the natural passes change almost daily making, navigation with large vessels hazardous. To promote commerce, passes or artificial cuts have been dredged and stabilized at seven locations on the coast.

Stabilizing and deepening the passes increases the bidirectional water flow between the estuary and the gulf if there is sufficient hydrostatic head

from freshwater inflow. Because of the increased flow velocity and volume, more sediment is transported in both directions through stabilized passes.

Although design of passes may minimize shoaling within them, ebb- and flood-tidal deltas and portions of the passes do collect sediment. In time, without continued dredging of the bars and inner portions of the passes, flow would be restricted.

The three human interventions--direct alteration of the estuary by filling, channel dredging, and stabilization of passes and cuts--often occur together. For example, construction of a major navigation channel requires the provision of access through a pass to the gulf, dredging of the channel itself, and a place to deposit spoil. When these actions occur together, the result is a synergistic combination of the individual effects.

Change in longshore current patterns by man-made structures. Longshore drift transports sediment parallel to the gulf shoreline. While the direction of the longshore drift changes seasonally, there is a net yearly direction of sediment movement. From the Texas-Louisiana state boundary to the Land Cut in the Laguna Madre the net direction of movement is south; on the lower coast, from the U.S.-Mexico Border to the Land Cut the net movement is north. On some segments of the gulf shoreline longshore drift causes erosion.

To counter the erosive effects of longshore drift, structures extending out into the surf zone are erected perpendicular to the shoreline (human intervention number 12). These are often groins, narrow walls of pilings and heavy timbers. If properly placed, the groins disrupt the longshore current, reducing its velocity. Since the quantity of sediment transported by the current is determined by the current velocity, the slowed water will deposit

some of its sediment load. Where there is an adequate sediment supply, groins can be used to either retard erosion or build beaches seaward.

If there is a basic deficiency in sediment supply and longshore currents carry less than a full load, groins or other structures may not function as expected. If placement of structures is not carefully planned, taking into account the hydraulics of the site, the amount of sediment trapped may be too little to counteract the shoreline erosion, and downdrift shoreline deprived of current-borne sediment may erode severely (U.S. Coastal Engineering Research Center 1977, p. 5-31). Groins and similar structures are expensive both to build and to maintain. Because they are subject to continual, strong hydraulic forces, maintenance of the structures is critical to their operation. In a single day, the power in the waves of a storm can undermine a groin and erode all of the area that may have accreted over a period of several years.

Alteration of sediment balance on barriers and peninsulas. Most of the sediment that forms barrier islands and peninsulas comes from offshore sources or river mouths that empty directly into the gulf. Normally, sediment is transported from the surf zone to the beach and then to dune and barrier flat areas. The dunes and beaches are reservoirs of sediment, eroded by severe storms and built back over longer periods (Davis 1972). Some of the sediment that collects on the barriers and peninsulas is carried by the wind to the uplands or estuaries further inland. Human activities on the beach or in the dune area (human intervention 13) can alter the sediment balance between the surf zone, dunes, and barrier flat.

Cattle grazed on dunes and barrier flats have impeded the growth of vegetation both by trampling it and by feeding directly upon it. When



foredunes are denuded, blowout dune fields may develop that rapidly migrate across the barrier islands and peninsulas. These active sand dunes bury vegetation and allow sediment normally trapped on the beach and in the dunes to travel to the bays or mainland areas. South of the Corpus Christi area, where dune and barrier flats were seriously overgrazed, low rainfall has inhibited the reestablishment of vegetation. Baccus and Horton (1979) noted that effects of overgrazing that took place a hundred years ago were still evident in some places on Padre Island. To the north, higher rainfall has permitted more rapid revegetation.

Recreational use of the dunes for dune buggies began in the 1960's. The results of the use are similar to overgrazing although the effects occur more rapidly and are more severe. Vehicular traffic on the beach and in the foredune area decreases the standing crop of stabilizing vegetation so less sediment is trapped and held in the dune and beach sediment reservoirs (Behrens et al. 1974; McAtee and Drawe 1974). In addition, vehicular traffic loosens beach sand and facilitates its eolian transport. During storms, it is evident that beaches and foredunes that have been heavily used by vehicles are less stable than similar areas that have had little traffic (Baccus and Horton 1979).

Activities on the beach and in the dunes that destabilize barrier islands or peninsulas reduce the buffering effect of the beach and dunes to storm action. During severe storms, blowout dune fields and weakened dune areas may become washover channels, threatening areas landward. Greater amounts of sediment than usual may be carried to shallow estuarine environments. The effects may be short-lived, or may be long-term depending upon how quickly the beach and foredunes can rebuild.

Decrease in sediment contribution from rivers into the gulf. Human intervention number 14 represents decreased sediment loads in rivers directly entering the gulf. Dams and water diversion are in part responsible for the decrease.

Part of the sediment carried into the gulf is transported by longshore currents and is used in the beach and dune erosion and accretion cycle. When the sediment source from the river is reduced, there is less sediment to be carried ashore and beach erosion may occur. Sealy and Ahr (1975) attributed a portion of the accelerated erosion near Sargent, Texas, to a 50 percent decrease in Brazos River bedload due to dam construction since 1929.

Human interventions 13 and 14 may occur together. Decreases in sediment from the rivers result in erosion downstream from river mouths. To combat the erosion, man-made structures such as groins are placed into the gulf to trap sediment. If beach traffic increases, the sediment balance between the beach, dunes, and upper shoreface may be further disrupted.

Persistence of the effects of human interventions. Changes in soil production, modification of runoff from uplands to rivers, diversion of water from rivers to uplands, control of flow in rivers above the coastal plain, direct filling of estuaries with sediment, alteration of sediment balance on barrier islands and peninsulas, and decrease in sediment contribution from rivers to the gulf are the effects of human interventions which persist for a long period of time with little energetic or economic cost to man beyond the original expense. Other human interventions including control of overbank flooding in the coastal plain, influence of river flow in the coastal plain, controlling bank erosion in rivers in the coastal plain, control of shoreline erosion in estuary, change of current energy in estuary, stabilization of

passes or cuts in barrier islands and peninsulas, and change in longshore current patterns by man-made structures require continued inputs from society to maintain the alterations against the natural forces in the environment. While both groups of interventions produce noticeable changes in the region, the former group are long-lived once undertaken. In time, changes in the region from the latter group tend to return to preintervention conditions in the absence of regular human maintenance efforts.

## BASIN MODELS

This chapter presents conceptual models of the Texas Barrier Island Region at the basin level. They include models that show the water systems of each basin and a generic basin model that links natural system and socioeconomic system components.

The components in the basin models display a wide range of properties, for both natural and socioeconomic variables. The diversity in hydrologic function permits identification of distinct basin types.

The discussion of basin systems is divided into four sections. The first describes the hydrology of each basin; the second relates socioeconomic systems to the natural system components; the third describes relationships between habitats within the basins; and the fourth locates in space and time various significant processes which are not covered in the other models.

### BASIN HYDROLOGY

#### Introduction

There are three types of coastal basins: classic estuaries, tidal river mouths, and lagoon systems (Figure 10). The major hydrologic and geographic features of the coastal basins in the study area are summarized in Figures 11 through 20.

#### Classic Estuaries

Classic estuarine systems have formed at the mouths of drowned river valleys that were not filled by riverborne sediment after sea level rose

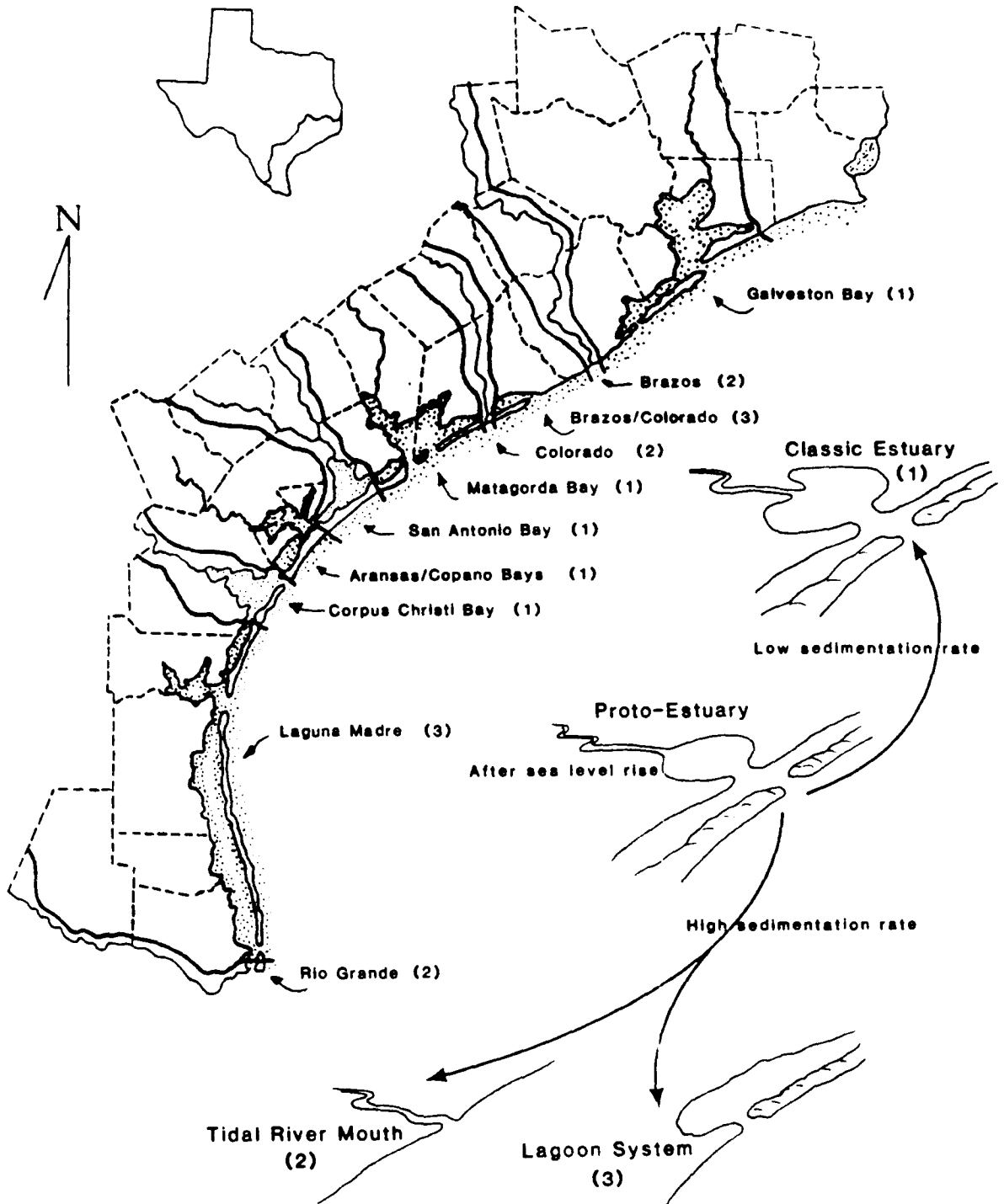

FIGURE 10. Location map of coastal basins and basin types.

following the most recent glacial episode. Barrier islands have formed from sediment transported to the river mouths from offshore. The barrier islands restrict exchange with the Gulf of Mexico, resulting in large shallow bays, typically with intermediate salinity regimes and high productivity. A general model is shown in Figure 10. Galveston Bay, Matagorda Bay, San Antonio Bay, the Aransas-Copano Bay complex, and Corpus Christi Bay are estuaries of this type.

These systems have the same type of organization. The component habitats, progressing from the Gulf of Mexico landward, are beach, then dune and barrier flats. Of these, only the beach exchanges materials with the nearshore gulf. The barrier islands have many small patches of wetlands (salt marsh and brackish marsh) which receive very limited drainage from the island uplands but exchange water freely with the bay systems.

The bay systems typically exchange water with the Gulf of Mexico through one or more passes. San Antonio Bay is an exception since Cedar Bayou, the pass at the southwest tip of the bay, is quite small and frequently closed. Some of the bays also exchange significant amounts of water with adjacent estuarine systems through the Gulf Intracoastal Waterway.

The mainland wetlands which exchange water with the bays may or may not receive substantial fresh water input from local upland drainage. In contrast, the river delta systems, which often contain extensive wetland habitats, receive fresh water input from drainage basins that may extend far from the coast.

Galveston Bay receives fresh water inflow mainly from the Trinity River, which drains a large area of East Texas, including the Dallas-Fort Worth area.

As shown in Figure 11, input from the San Jacinto River is mixed with discharges from the urbanized Houston area into the Houston Ship Channel.

Water for urban and industrial users in the Galveston basin is supplied from both surface and groundwater sources. The hydrologic model shows only the surface water supply. Figure 11 emphasizes the relative separation of West Bay from the larger portion of Galveston Bay. Sources of urban drainage to West Bay include the city of Galveston, Texas City, and various other industrial areas.

The drainage areas of the Lavaca and Navidad river basins that flow into Matagorda Bay (Figure 12) are within or are very close to the TBIR study area. These basins do not drain areas that extend hundreds of miles across the state as the Trinity, Brazos, Colorado, Nueces, and Rio Grande basins do. Urban and industrial development centers are concentrated around Lavaca Bay. In addition to exchanges with the Gulf of Mexico, Matagorda Bay receives significant input from the Colorado River system and exchanges water with the San Antonio system to the south.

In the San Antonio Bay system, the San Antonio and Guadalupe rivers have filled a much larger fraction of their bay than have the rivers emptying into other classic estuarine systems (Figure 13). The resulting delta system is large and complex. Major saltwater inflows generally come from Matagorda Bay to the north, and outflow tends to go south to the Aransas-Copano Bay complex. Cedar Bayou, depicted as a switch symbol on the diagram, provides direct exchange with the Gulf of Mexico when it is open. The Cedar Bayou exchange path may be opened as the result of both natural forces (floods) and human activities (dredging).





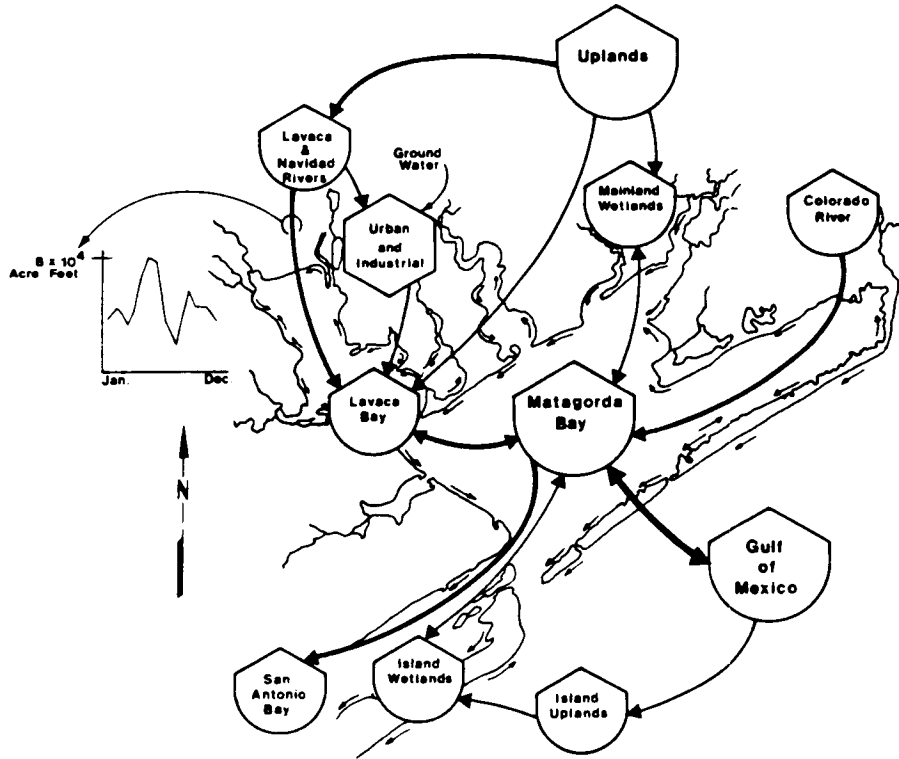

FIGURE 12a. Hydrologic model of the Matagorda Bay estuary.

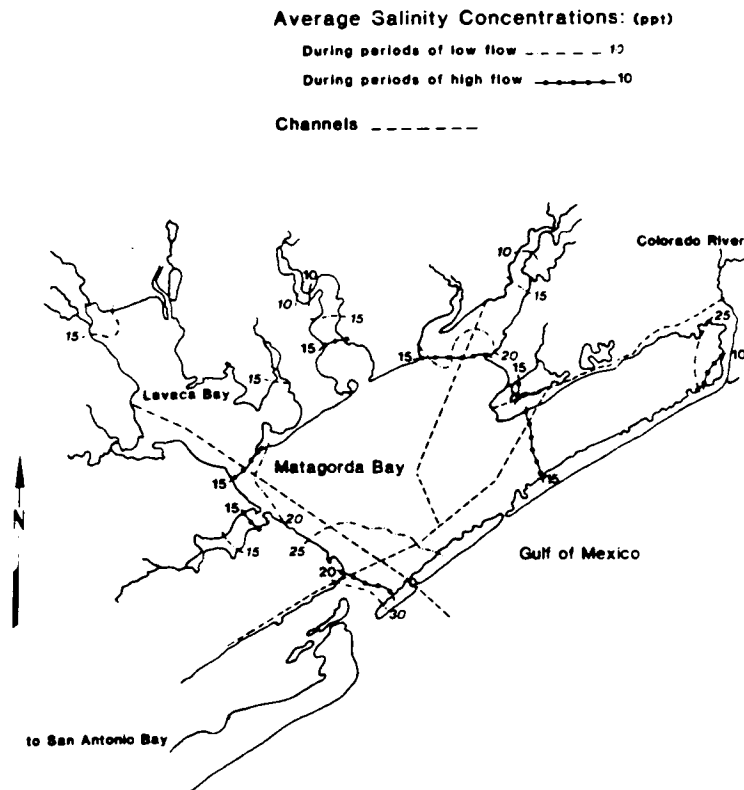

FIGURE 12b. Salinity contours and major channels of the Matagorda Bay estuary.

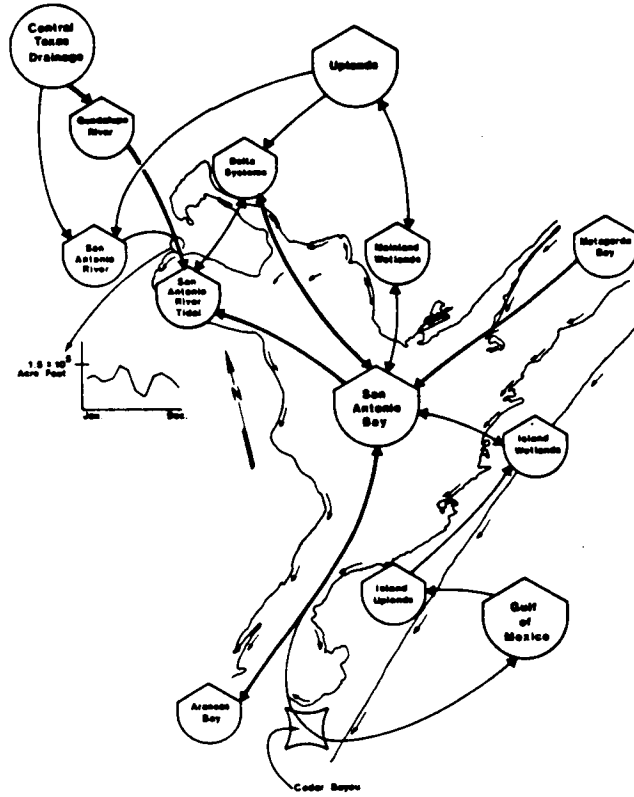

FIGURE 13a. Hydrologic model of the San Antonio Bay estuary.

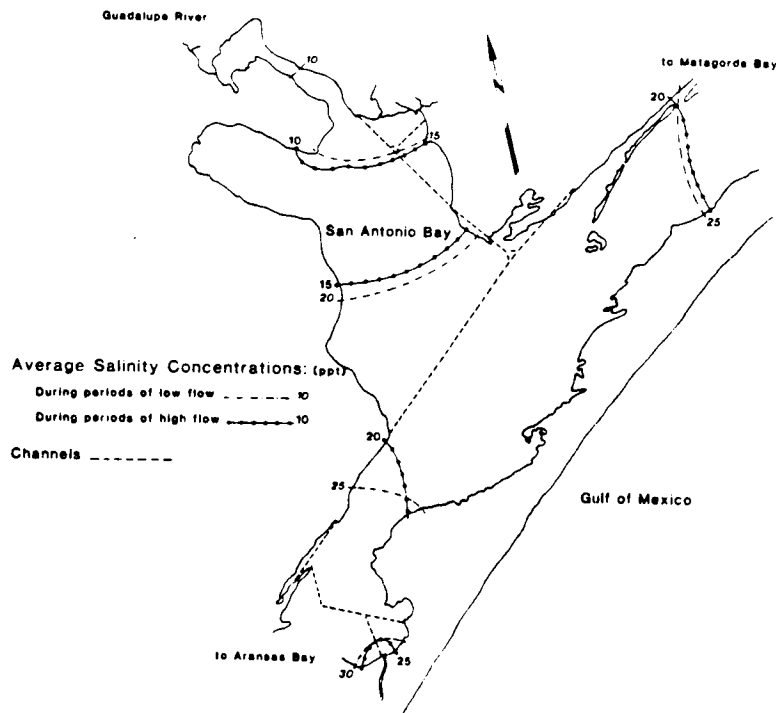

FIGURE 13b. Salinity contours and major channels of the San Antonio Bay estuary.

The Aransas-Copano Bay complex to the south (Figure 14) is strongly affected by the San Antonio system since the Aransas and Mission rivers have small local drainage areas. Exchange with the Gulf of Mexico occurs through the Aransas Pass, "shared" with the Corpus Christi Bay system. The Aransas-Copano Bay complex also exchanges water with the Corpus Christi system via several channels through Redfish Bay. The relatively small amount of drainage from urban and industrial systems enters through the Aransas and Mission rivers.

Corpus Christi Bay is the most southerly of the classic estuaries and has a much smaller fresh water inflow than the others. Figure 15 emphasizes the fact that Lake Corpus Christi controls the lower Nueces River and supplies the fresh water needs of the urban and industrial systems. The only significant wetland areas that exchange water with the main portion of the bay are those along the barrier island (Harbor Island is grouped with the barrier island). Exchange with the upper Laguna Madre is also significant.

#### Tidal River Mouths

Tidal river mouths, whose general form is shown in Figure 10, are characteristic of the Brazos, Colorado, and Rio Grande systems. These rivers have completely filled their valleys with sediment and now discharge directly into the Gulf of Mexico. Consequently there is only a limited volume of water with estuarine salinities in tidal river mouths. Most of the fresh water inflow to these rivers originates far outside the coastal study area and is subject to multiple uses before it reaches the coast. The influence which these systems have on adjacent estuaries is variable.

The Brazos estuary (Figure 16) is notable for having a large concentration of industrial development in the tidal region. For the purposes

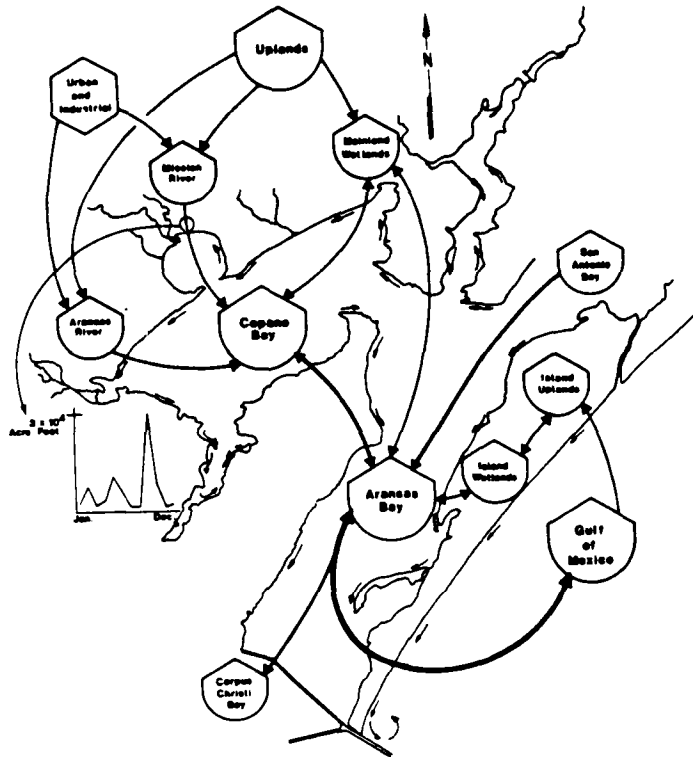

FIGURE 14a. Hydrologic model of the Aransas-Copano Bay estuary.

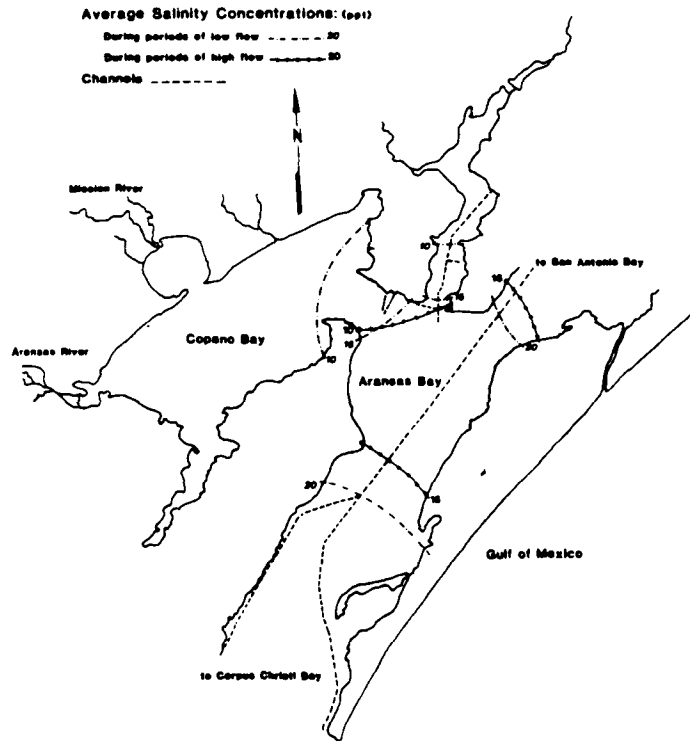

FIGURE 14b. Salinity contours and major channels of the Aransas-Copano Bay estuary.

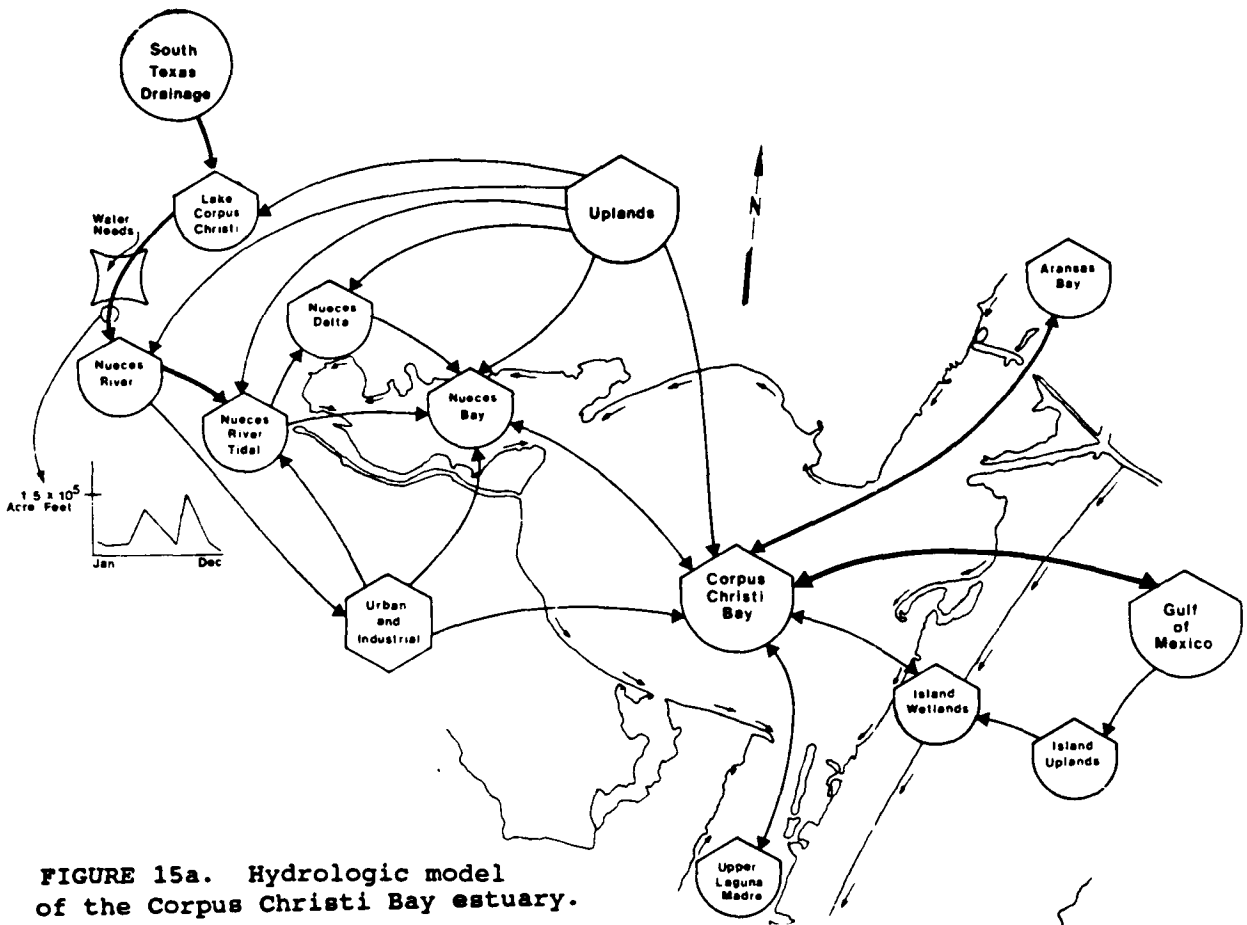

FIGURE 15a. Hydrologic model of the Corpus Christi Bay estuary.

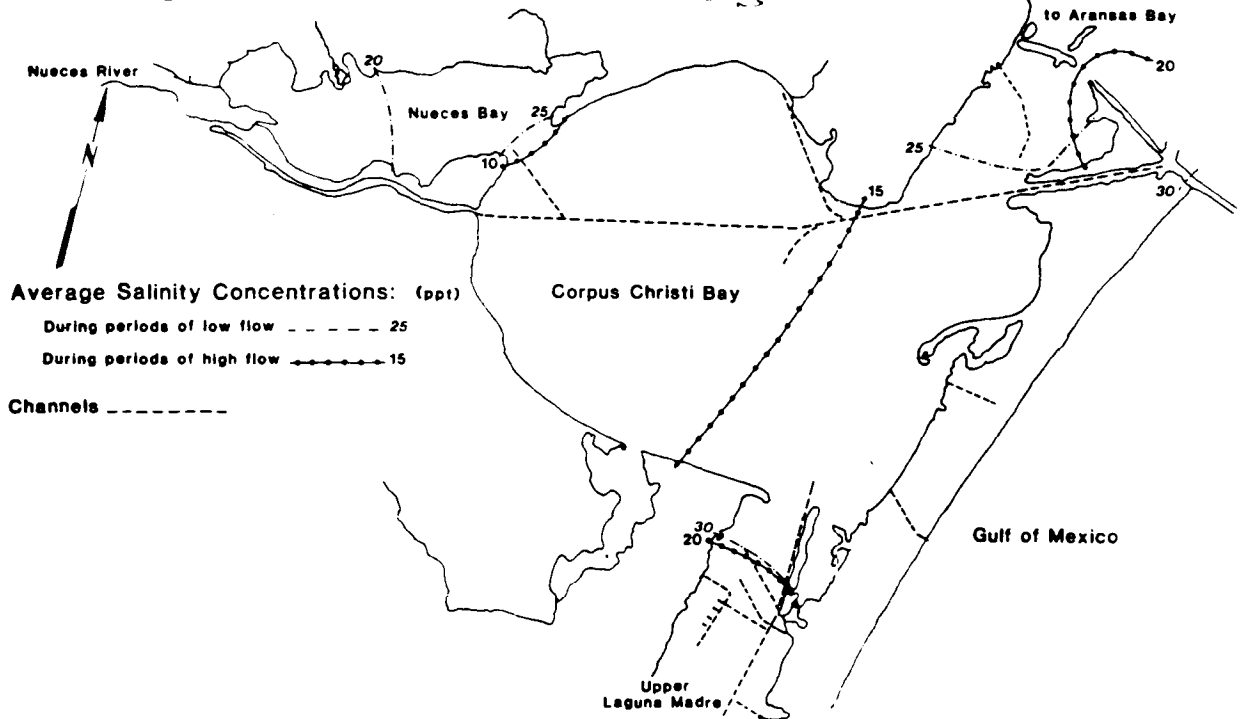

FIGURE 15b. Salinity contours and major channels of the Corpus Christi Bay estuary.

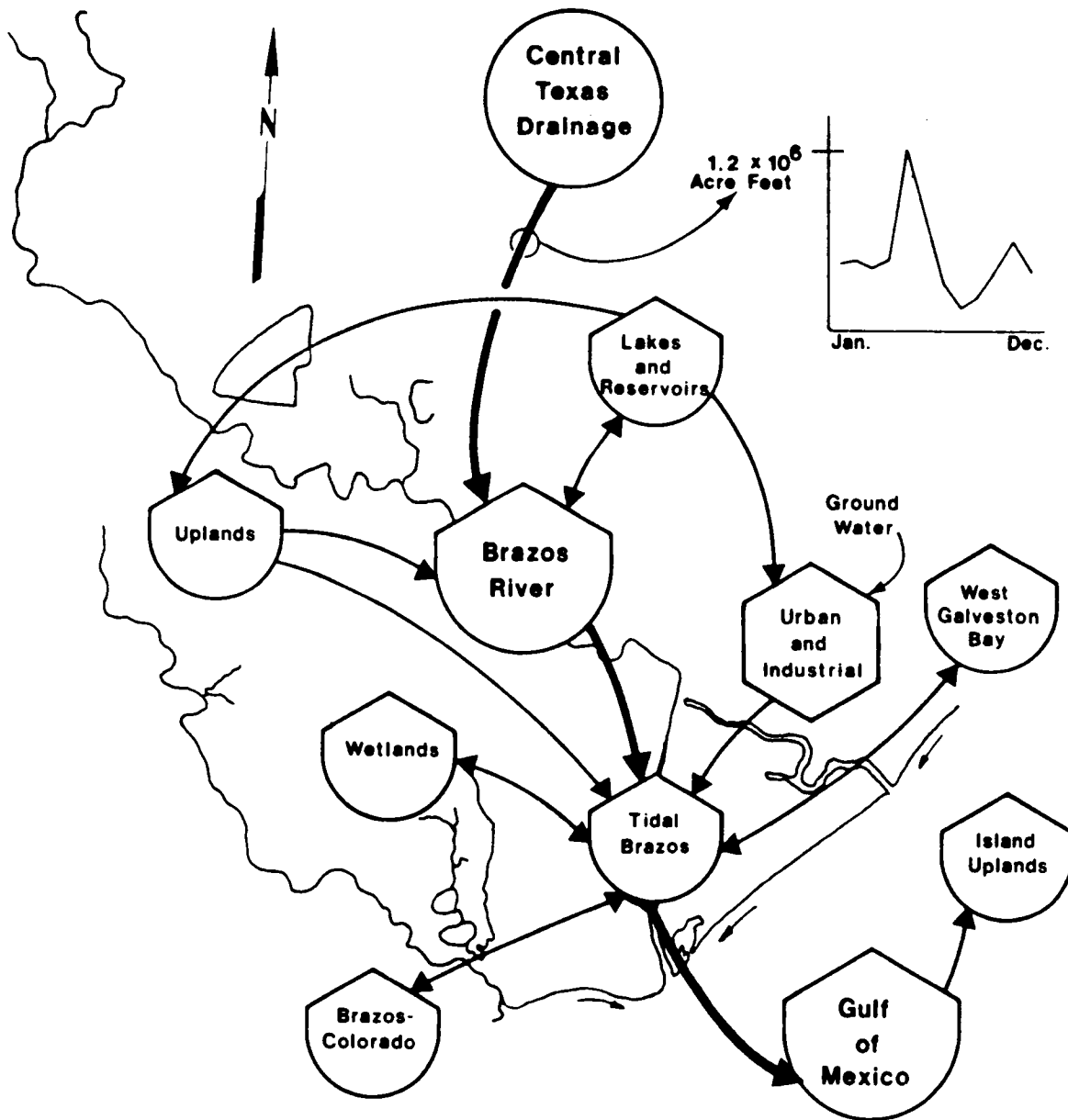

FIGURE 16. Hydrologic model of the Brazos tidal river mouth.

of the basin model, the tidal region includes the river, the adjacent Intracoastal Waterway, and the harbor channels. Several significant reservoirs draw water from the Brazos in the study area for both irrigation and industrial water needs.

In contrast with the Brazos and Rio Grande, the Colorado delta has only recently reached the Gulf. It still delivers a substantial fresh water flow to the adjacent Brazos-Colorado and Matagorda Bay systems, as shown in Figure 17. The major reservoir is associated with the South Texas Nuclear Project, currently under construction.

The large sediment supply of the Rio Grande has filled its river valley and cut off the Laguna Madre from the direct influence of the river. Currently, water from the Rio Grande is extensively used by irrigated agriculture and by urban and industrial sectors of the economy before flowing to the Laguna Madre. As shown in Figure 18, water is also diverted from the river during flooding.

#### Lagoon Systems

The Brazos-Colorado basin and Laguna Madre are both shallow lagoons whose river inputs have been cut off (Figure 10). The hydrology of both systems has been extensively modified by the Intracoastal Waterway; however, the climate and development of the two systems is vastly different.

In the Brazos-Colorado system, (Figure 19), upland drainage supplies many small creeks, ponds, and fresh to brackish marshes. The Intracoastal Waterway intercepts all drainage pathways and directs flow to either East Matagorda Bay or the mouth of the San Bernard River. The waterway also permits major inflows of water from the Brazos and Colorado rivers during high flow periods. These inflows are controlled by locks and floodgates on the waterway.

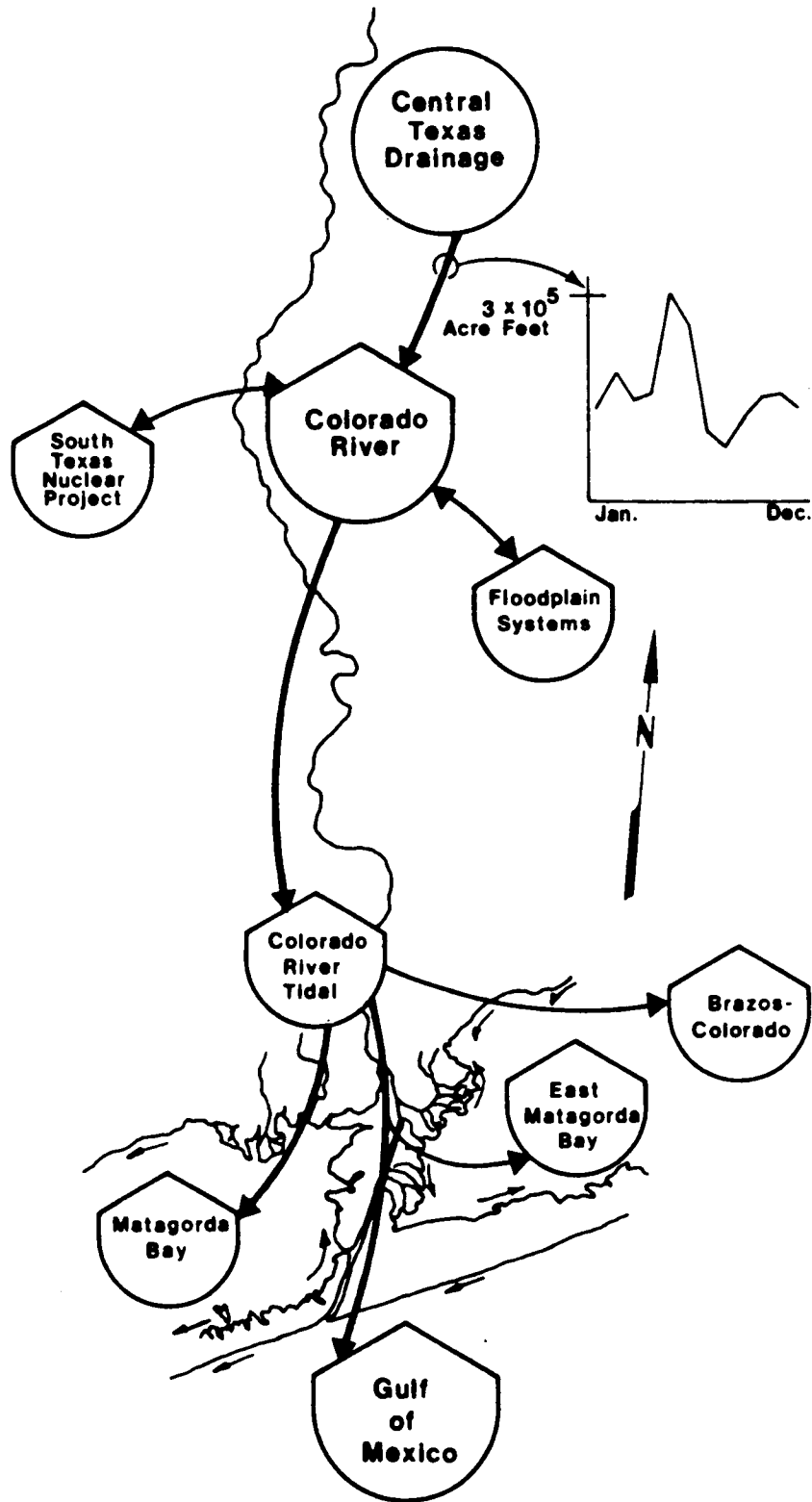

FIGURE 17. Hydrologic model of the Colorado tidal river mouth.



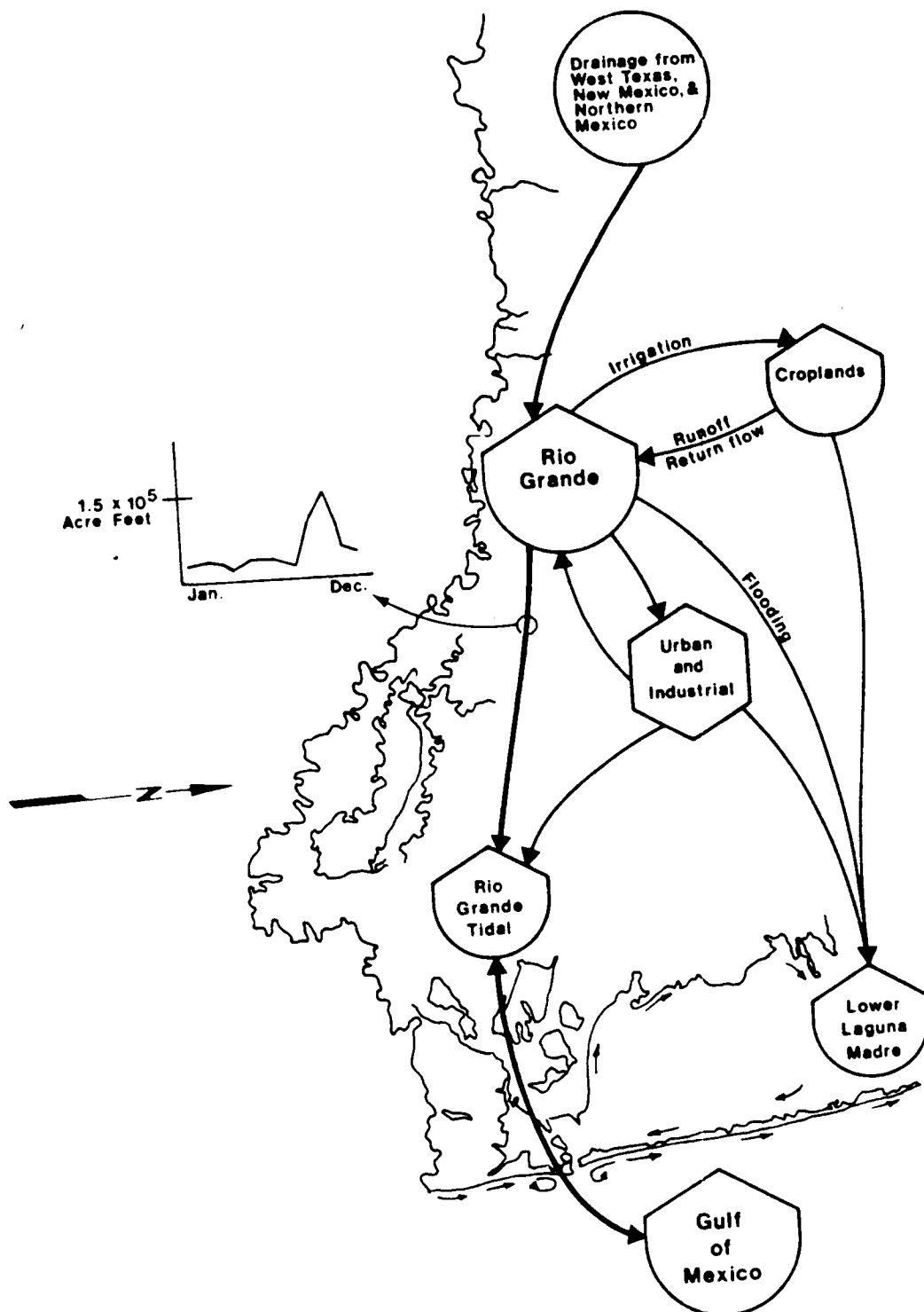

FIGURE 18. Hydrologic model of the Rio Grande tidal river mouth.

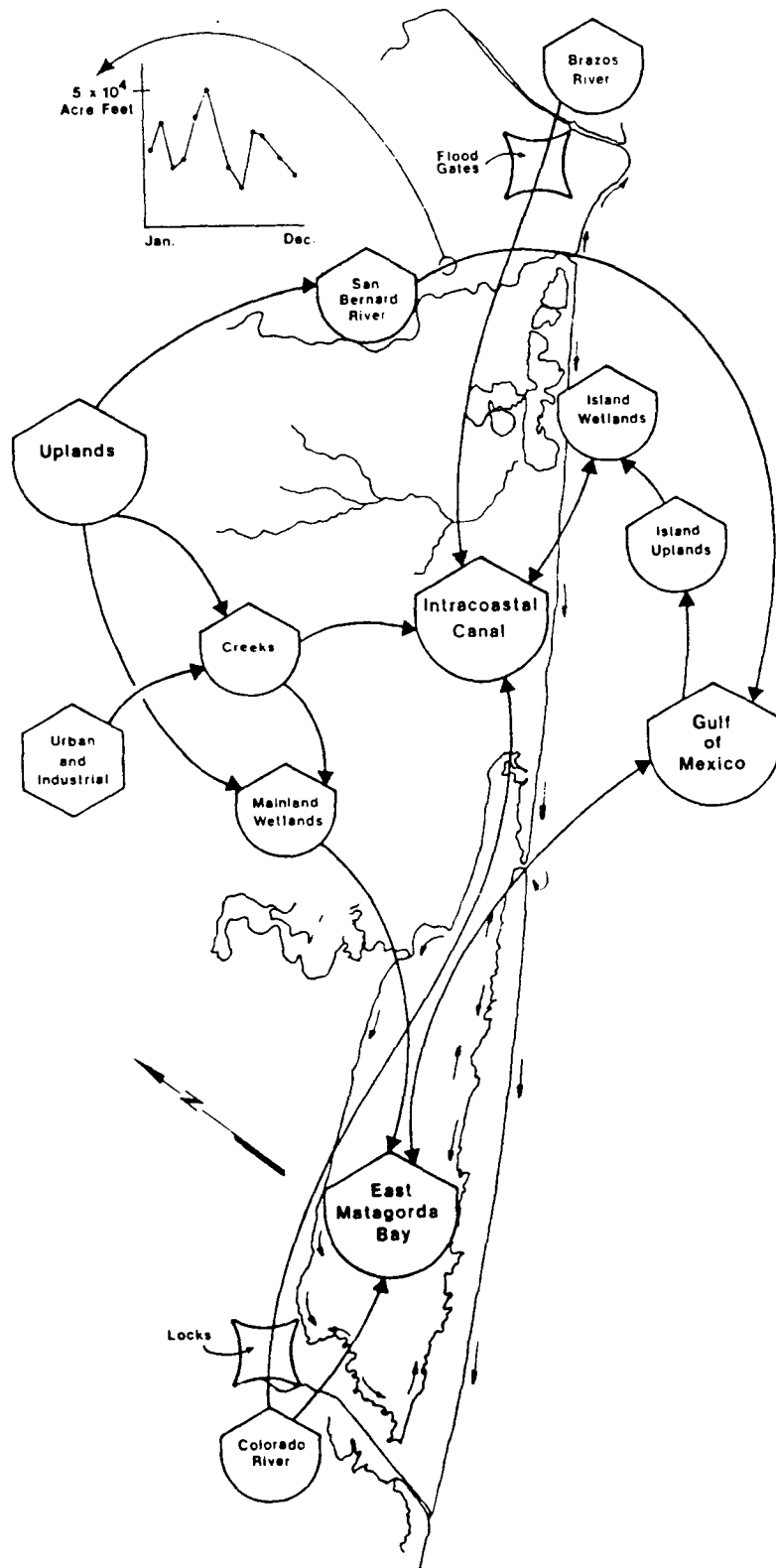

FIGURE 19. Hydrologic model of the Brazos-Colorado lagoon system.

Drainage in the Laguna Madre system (Figure 20), in contrast, is sporadic. Many upland areas drain only to isolated wetlands and playa lakes. The Lower Laguna Madre receives fresh water largely through the Arroyo Colorado, which carries floodwater, urban waste discharges, and drainage from irrigated agriculture. Water is exchanged with the Gulf of Mexico at the south end of Padre Island and through the Port Mansfield Channel. Unless the water level in the Laguna Madre is unusually high, all of the water exchange between the upper and lower portions occurs through the Intracoastal Waterway. Seasonal wind patterns have a strong influence on the currents in Laguna Madre. In summer, the southeast winds tend to cause north-flowing currents; in winter, northers and passing cold fronts cause south-flowing currents.

The Upper Laguna Madre receives a small amount of runoff, largely through intermittent creeks flowing into Baffin Bay. Water exchange takes place to the north with Corpus Christi Bay and to the south with the Lower Laguna Madre.

## SOCIOECONOMIC INTERACTIONS WITH HABITATS

### Introduction

The Socioeconomic-Resource Demand conceptual model (Figure 21) relates man's social and economic systems to the natural resource systems. The coastal zone economy consists of six components (Liebow et al. 1980). The model relates these components to the main driving forces in the general economy (labeled "External Economy") and the requirements which these components place on the coastal ecosystems (labeled "Resource Demand"). This model consists of three linked systems: the external economy, the coastal zone economy, and habitats upon which resource demands are made. Within each



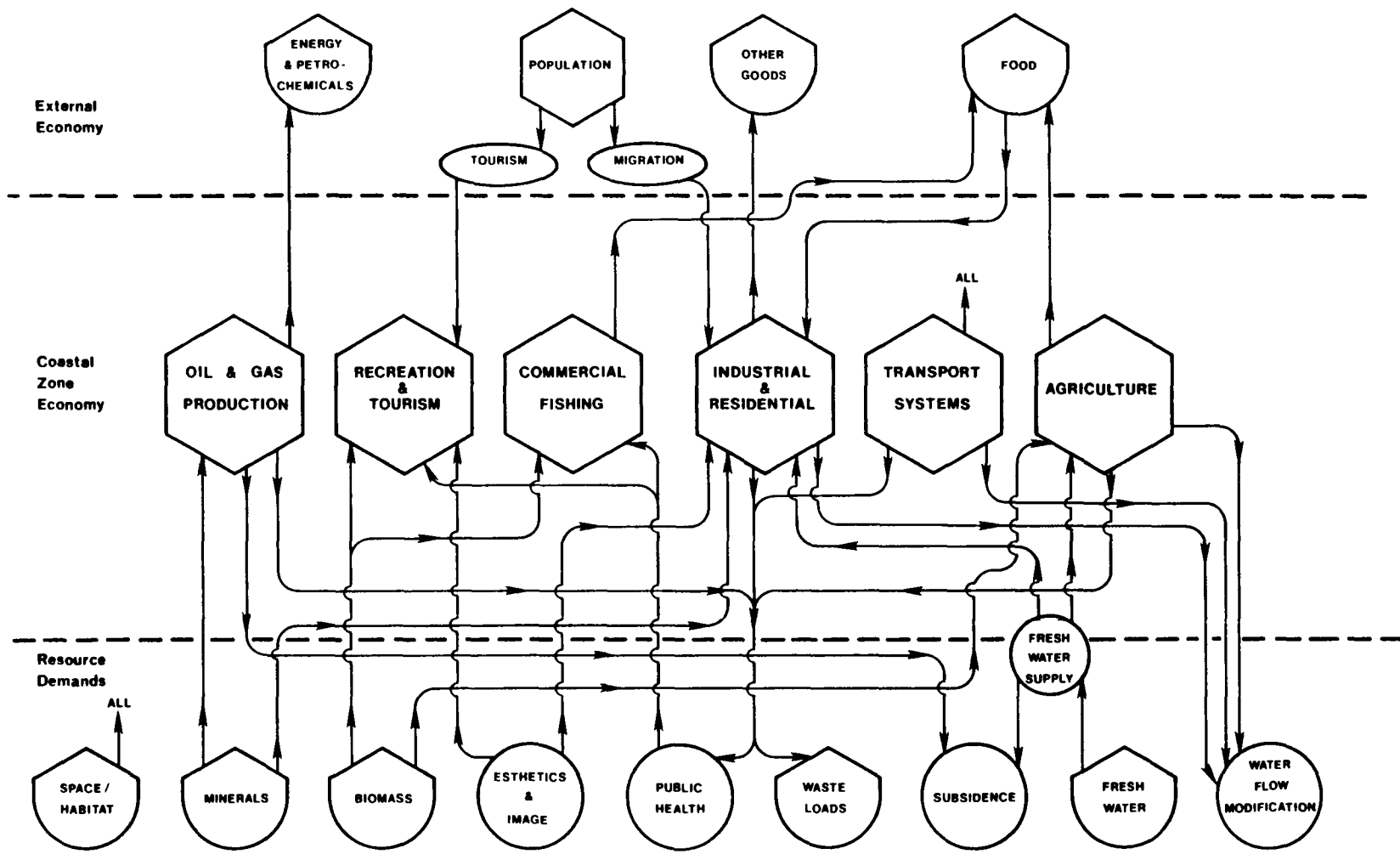

FIGURE 21. Socioeconomic-resource demand conceptual model.

system there are internal connections among components. The model shows only the relationships between systems; it does not show within-system linkages.

### The Coastal Zone Economy

The components in the coastal zone economy portion of the model were presented in the socioeconomic characterization study (Liebow et al. 1980) and include agriculture, commercial fishing, industrial and residential development, oil and gas development, recreation and tourism, and transportation systems. All of the coastal zone economy components are consumers; they actively transform and store energy for later use.

Agriculture. Agriculture in the TBIR area accounts for 16.5 percent of the market value of agricultural products statewide. Livestock and poultry account for about 20 percent of this total. Most of the agricultural production in the TBIR consists of crops including sorghum, cotton, corn, rice, sugar cane, soybeans, fruits, and nuts (Liebow et al. 1980). Products from the agricultural component are exported to the external economy.

Agriculture, like all six of the socioeconomic components, requires space, a resource demand on habitats. Agriculture uses biomass from habitats and fresh water from surface and groundwater sources for crops. Summing water use for all coastal basins and all river basins that pass through the TBIR, three times as much fresh water is used for agriculture as for municipal and industrial purposes (calculated from Texas Department of Water Resources 1977).

Agriculture imposes some other demands upon habitats. Water diversion for irrigation changes the quantity of water flow. Agricultural chemicals, although important to production, contribute to waste loads and public health problems. Fertilizers and pesticides may be transported by runoff to lakes,

rivers, and estuaries where they can cause eutrophication or can reach levels toxic to wildlife, waterfowl, and humans.

Commercial fishing. The commercial value of biological products from the estuarine area is estimated to be \$110,000,000 per year (Liebow et al. 1980). More than 95 percent of the value of this industry comes from shrimp; oysters, blue crabs, and finfish are responsible for the remaining portion.

The fishing industry has a small demand for space but a large demand for unaltered habitat. Commercial fishing collects biomass from the habitats and processes it for internal consumption and export to the external economy. Public health affects the commercial fishing industry when harvest restrictions are placed on oysters because of water quality decline in oyster beds.

Industrial and residential development. Industrial and residential development is the largest sector in the economy and includes petroleum refining and the petrochemical industry as well as other industries, residential and commercial building, and retail sales. The industrial and residential component of this model has more connections with resource demand components and external economy components than any other sector. This fact is indicative of the overwhelming importance of this sector of the economy in the TBIR.

The industrial and residential component has a large demand for space. During the period from 1970 to 1977 the amount of incorporated land in the study area, a rough measure of industrial and residential demand for space, increased by 55 percent. By 1977 more than 20 percent of the study area was incorporated (Liebow et al. 1980).

The industrial and residential component produces goods for the external economy. It imports food from the external economy and population through immigration into the TBIR. This component is the second largest user of fresh water in the coastal zone economy. Although the residential and commercial component demands less fresh water than the agricultural component, it returns about twice as much to the habitats as agriculture (calculated from Texas Department of Water Resources 1977). The return flows transport other materials that add to the waste loads and affect the public health. These can include incompletely treated sewage, high loads of coliforms, and industrial wastes.

The modifications of water flow to habitats by the industrial and residential component are partly due to modifications of estuarine flow. Cooling water for electric power generation and industrial cooling is mainly drawn from the bays. In some places the direction of flow in the estuary has been substantially altered by the pumping of large volumes of water.

Return flows from the industrial and residential development component are slightly greater than surface diversion of water for this component. This occurs because groundwater is mixed with water originally from surface water sources in return flows to rivers and streams.

The industrial and residential component of the coastal zone economy requires minerals from the natural habitats. These may include subsurface natural gas and petroleum; surface minerals such as sand, soil, shell, and coal; or minerals from natural waters such as magnesium.

Oil and gas production. The oil and gas production component includes only exploration and production; not the refining and petrochemical industry. Oil and gas production in the TBIR study area represents 15 percent of the



statewide production totals. Wellhead value of production in 1978 was nearly \$1.5 billion (Liebow et al. 1980).

Oil and gas production requires a small amount of space in the habitats. In upland and aquatic areas, reversion of space back to the natural habitat can be very rapid, taking place in only a few seasons. In wetland areas, oil and gas production effects are sometimes long-lived, especially if lengthy channels are dredged.

The oil and gas production component of the coastal zone economy removes subsurface minerals from the habitat areas. The withdrawal of gas, petroleum, and brine can contribute to subsidence. Waste load contributions and public health consequences from oil and gas production are routinely small. However, occasional catastrophic occurrences such as blowouts can cause large, rapid alterations to the natural habitats.

Recreation and tourism. Four percent of the employment in the TBIR is attributable to the recreation and tourism component of the coastal zone economy (Liebow et al. 1980, p. 86). Travel-related expenditure for the region was \$1.8 billion for 1977 (Liebow et al. 1980). The dollar value of this component of the coastal zone economy ranks ahead of commercial fishing and on a par with oil and gas production.

The resource demands on habitats for the recreation and tourism component are very similar to those of commercial fishing. Both require biomass and a high level of public health safety. In addition, the demand for recreation and tourism is dependent upon image and esthetics of the habitat.

Transportation systems. The transportation systems component of the coastal zone economy includes port development, the Gulf Intracoastal Waterway, highway construction, automobile traffic and truck freight, railway

freight, air transportation, and pipeline transport. The transportation systems component affects all of the connecting components in the external economy. In addition, all other components in the coastal zone economy depend upon the transportation component for exchange of products within that system.

Transportation systems require space within the natural habitats. Port development and the Gulf Intracoastal Waterway are the two subdivisions of the transportation component with the largest space requirement. Navigable channels and spoil disposal sites require more area than wharves and warehouses.

Navigation channels and spoil disposal sites have a larger effect on water flow modification than any other coastal zone economy components. In the past the construction of highways and bridges for automobiles or railroads has had strong water flow modification effects. Deep channels and spoil islands funnel flow in patterns substantially different from the original conditions.

Transportation systems may also contribute to waste loads and the public health component of natural habitats. Waste may include excessive turbidity due to dredging, and petroleum products from vehicles. Public health may be affected by waste gases from internal combustion engines. Noise from road traffic and aircraft is also considered to be a public health effect.

#### External Economy

The rest of the world's economy is simplified to four aspects, the demand for energy and petrochemicals, population pressure for tourism and immigration, the demand for food, and the demand for other goods. This is greatly simplified; the lines connecting the external economy to the coastal

zone economy and the directions of those flows are the relationships that occur at the present time. The connections and directions are subject to change with major alterations in the economy.

#### The Resource Demand Components

Resource demands are the mixture of materials and services which natural systems supply, and the impacts which they must absorb. The components of this portion of the model were selected to show separate functions as clearly as possible.

Material flow is implied for minerals, biomass, waste loads, and fresh water. Esthetics and image and public health are examples of information flow or non-material services. Subsidence, water flow modifications, and space-habitat consumption are compartments representing impacts the habitats must absorb.

Space/habitat. The "space/habitat" component represents the need all socioeconomic sectors have for alteration or use of existing habitats. Examples of the demand for space/habitat are the need for a new highway corridor (transportation systems) and the conversion of prairie into farmland (agriculture). Note that these connections imply conversion of space from one habitat to another rather than material consumption.

Minerals. The minerals of greatest importance in the study area are oil and gas. This yield is not directly supplied by surface systems, which are of primary concern here since the ecological effects of surface mineral extraction are observable.

Shell, sand, gravel, uranium, and sulfur are minerals that are supplied to the industrial and residential component of the coastal zone economy. They are raw materials for construction or for industrial processes. All of the

links of minerals to the socioeconomic components represent actual consumption of mass.

Biomass. Biomass is a requirement of the recreation and tourism, commercial fishing, and agricultural components of the coastal zone economy. This is an easy resource demand to measure; there are extensive data on commercial and recreational fish harvest as well as agricultural yield data. The connections between biomass and the components in the coastal zone economy represent actual consumption of mass.

Esthetics and image. Aspects of some ecosystems enhance the attractiveness of the TBIR study area. Beach areas, temperate climatic conditions, waterfowl, and fish populations are examples of the desirable features of the coastal environment to the economy outside the coastal zone. Esthetics and image affect the influx of recreation and tourism and permanent industrial and residential development.

Image is often quite a separate thing from physical reality, as can be seen by reading advertising brochures from some coastal developments. The connections between esthetics and image and the components in the coastal zone economy represent information transfer, not material flow; the habitats are not directly altered by these connections.

Public health. Inputs from all waste-generating activities, oil and gas production, industrial and residential systems, transportation systems, and agriculture are combined in the model. The impacts of these inputs are separated into "public health" and "waste loads."

The "public health" component represents the effects which the environmental conditions have on human health. This component represents such things as "fishability and swimability" of aquatic systems and air quality in

all systems. This type of connection is shown as an information flow which affects recreation and tourism and commercial fishing.

Public health effects are distinguished from waste loads. Factors such as human pathogens may have no effect on the functioning of natural systems, such as oyster reefs or beaches, but may still prevent human utilization of those systems. The 1980 water quality inventory for the state of Texas indicates that 85.6% of the stream miles are considered "fishable and swimmable." The flow pathways to public health represent actual material flows of chemicals and organisms.

Waste loads. Many waste materials from human activities can be absorbed and processed by ecosystems. Beyond critical thresholds, however, wastes from human activities can be disruptive to many ecosystems. In addition to "point source" discharges of municipal and industrial wastes, accidental spills, air pollution, and pollutants carried by runoff must be considered.

Waste loads affect the habitat components, upon which resource demands are made by the coastal zone economy. The individual habitat models (Chapter 4) illustrate which components may be affected by waste loads. The basin-level model does not show the intraconnections of the habitat resource components. Some of these components--biomass and esthetics/image, for example--may be changed substantially by large waste loads.

Subsidence. Subsidence is a consequence of the removal of water, oil, gas, or brine from the subsurface. These materials exist in fine-grained strata under pressure. With extraction of the liquid or gas, the internal pressure within the strata decreases substantially. As a consequence, the subsurface sediment layers compact and the effect of the compaction is transmitted to overlying sediments as a decrease in elevation.

The ecosystems at the land surface absorb the impact of subsidence. At higher elevations there are few noticeable effects. In lower areas subsidence forces the transformation of one type of ecosystem to another. In the Houston area, for example, some areas of coastal prairie have become bay margins because of the man-induced subsidence during the past 50 years. Long-term regional subsidence of the Gulf Coast, which occurs over a period of thousands of years, occurs at a much slower rate than the man-induced effect.

Fresh water. Fresh water is required by agriculture and by the industrial and residential components of the coastal zone economy. In coastal basins that have about half of their area within the TBIR, 70 percent of the total fresh water supply comes from surface sources while 30 percent comes from groundwater (Texas Department of Water Resources 1977). The current trend is to decrease the dependence on groundwater use and increase surface water supply and distribution.

The fresh water storage compartment in the model represents both surface water and groundwater. The arrow from the symbol labeled "fresh water supply" to the subsidence compartment represents the interaction between groundwater withdrawal and subsidence. The connections between fresh water supply and the components in the coastal zone economy are actual transfers of material. Although there are return flows from agriculture and industrial and residential development, overall they amount to only about 40 percent of the fresh water supplied to the coastal zone economy (Texas Department of Water Resources 1977). Therefore the net flow of water is from the habitats to the coastal zone economy. Individually the industrial and residential component returns an amount about equal to the volume taken; agriculture returns less than 25 percent.

Water flow modification. Water flow modification is similar to subsidence since it is an impact from the coastal zone economy to which the ecosystems adjust. Water flow modifications can be of two types, changes in volume and changes in pattern of flow. Agriculture is responsible for most of the volume change in the TBIR.

Industrial and residential development and transportation are responsible for altering flow patterns. By adding impermeable cover and channelizing natural drainage pathways, industrial and residential development shortens the period of time for runoff to reach rivers and estuaries. Industrial and residential development are also responsible for the placement of structures to stabilize the shoreline and direct water flow along particular pathways.

Transportation activities such as the construction of navigation channels, highways, and pipelines may affect areas much larger than the actual site occupied by the activity. Transportation is also responsible for the placement of jetties to stabilize navigation channels through passes and specialized structures such as the Texas City Dike to direct water flow for the enhancement of navigation channels.

## HABITAT INTERACTIONS

### Introduction

Detailed examination of the individual habitat models reveals that all interactions between habitats can be considered in terms of the transport of matter and energy. This section will describe the major matter and energy exchanges.

The figures and discussion in this section are necessarily general since area-specific data is limited. The interactions discussed are generally applicable to the TBIR study area but may or may not occur at specific sites.

### Waterborne Transport Between Habitats

Almost all transport of matter between habitats in the Texas coastal basins is waterborne. Sediments, organic detritus, nutrients, pesticides, and phytoplankton are some of the most important materials transported by water. Figure 22 shows the typical water pathways between habitats. These are also the routes taken by the major waste loads from human activities (Figure 21).

Materials from the upland habitats, urban systems, and inland portions of the basins are transported by runoff to river and canal systems. Minor amounts also flow directly to lake and reservoir systems and wetland habitats. The rivers flow to the tidal stream reach and thus into the bay or channel systems, or in the cases of the Brazos, Colorado, and Rio Grande rivers, directly to the nearshore gulf.

Materials transported from the marine habitats include saline water, suspended solids, and organisms. As shown in the model, the only habitats exchanging water and materials directly with the nearshore gulf are bay, channel, and in some cases tidal stream reach. The barrier islands effectively minimize the exchange between estuarine systems and the Gulf of Mexico. When combined with the low fresh water input characteristic of the lower coast, this impediment to water exchange leads to long residence times for water in the estuarine systems. Furthermore, pollutants originating in the Gulf of Mexico, such as oil spills, tend to influence the beach systems much more than the estuarine systems.

This model clearly shows that bay and channel systems provide the major transport pathways by which upland runoff materials and marine materials reach estuarine systems such as salt marsh, bulkhead and piling, spoil, reef and reef flank, and bay margin.



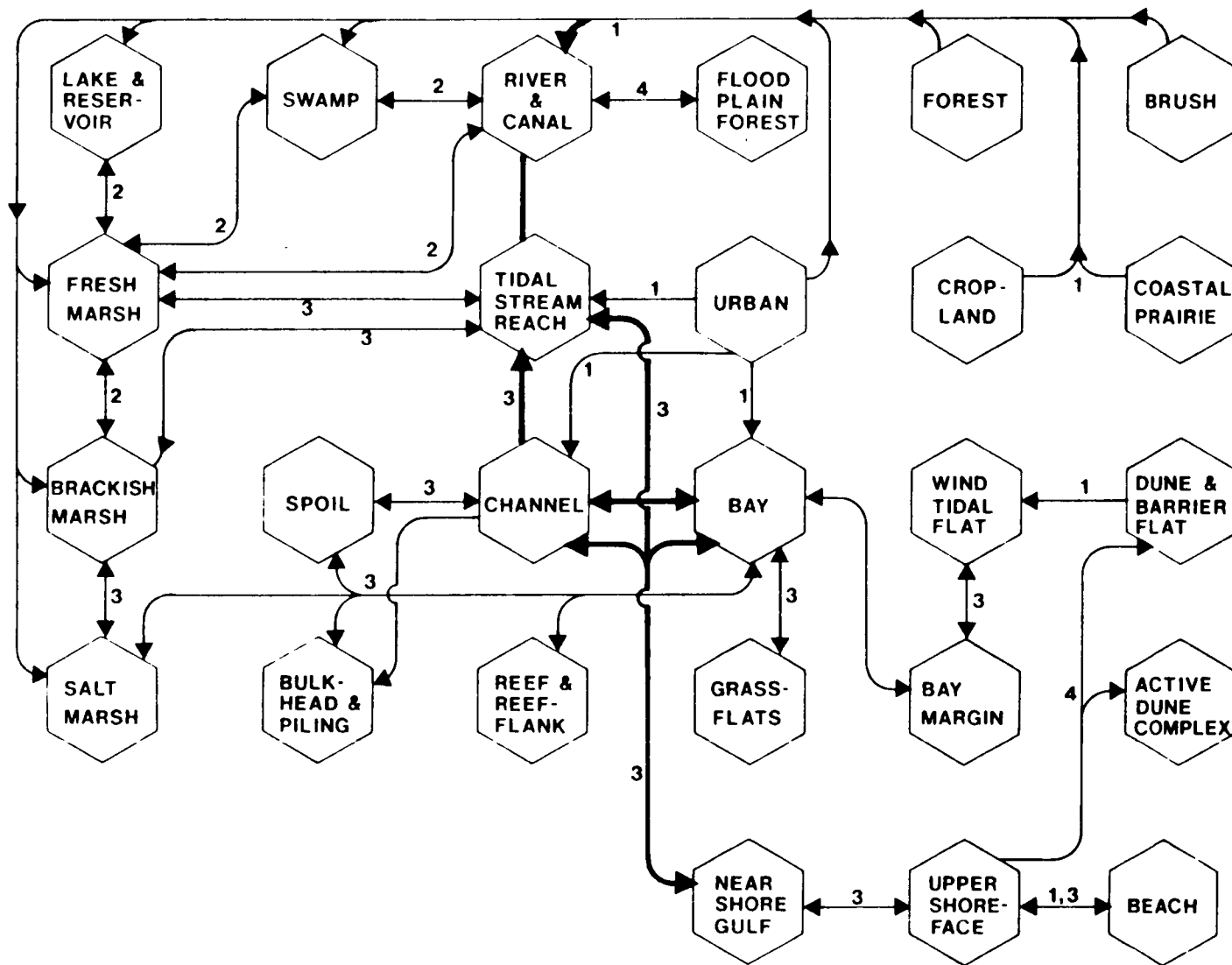

FIGURE 22. Habitat interactions: waterborne transport and current energy transport between habitats. 1-Runoff; 2-Normal flow in fresh systems; 3-Tidal exchange; 4-Hurricane and flood pathways.

In general, it appears that the bay and channel systems show net accumulation of suspended solids, although channels are routinely dredged to remove this accumulation. Historical records (Shepard, 1953) indicate that Texas bays are filling at rates between 1.0 and 1.5 feet per century. It is likely that salt marsh, reef and reef flank, and grassflat habitats also show net accumulation, but there is little data on this for the Texas coast. In addition to slowly filling in the bays, the accumulating sediments also trap organic matter, nutrients, and toxic materials.

#### Current Energy Transport

Current energy is generated by astronomical tides in the Gulf of Mexico, wind, and runoff from the land. The paths of exchange of current energy between habitats are the same as the "waterborne transport" paths.

#### Wave Energy Movement

Although some wave energy is locally generated in all aquatic habitats, the most intense wave energy is generated by wind acting over expanses of open water such as the lake and reservoir, bay, and nearshore gulf habitats. These systems export large amounts of wave energy to neighboring habitats, as shown in Figure 23.

#### Aquatic Organism Movement

Figure 24 depicts typical pathways of aquatic organism migration. As with the waterborne transport diagram, the channel and bay habitats provide the major pathways for marine organism migration. The organisms harvested from aquatic habitats may have been dependent on a variety of habitats.

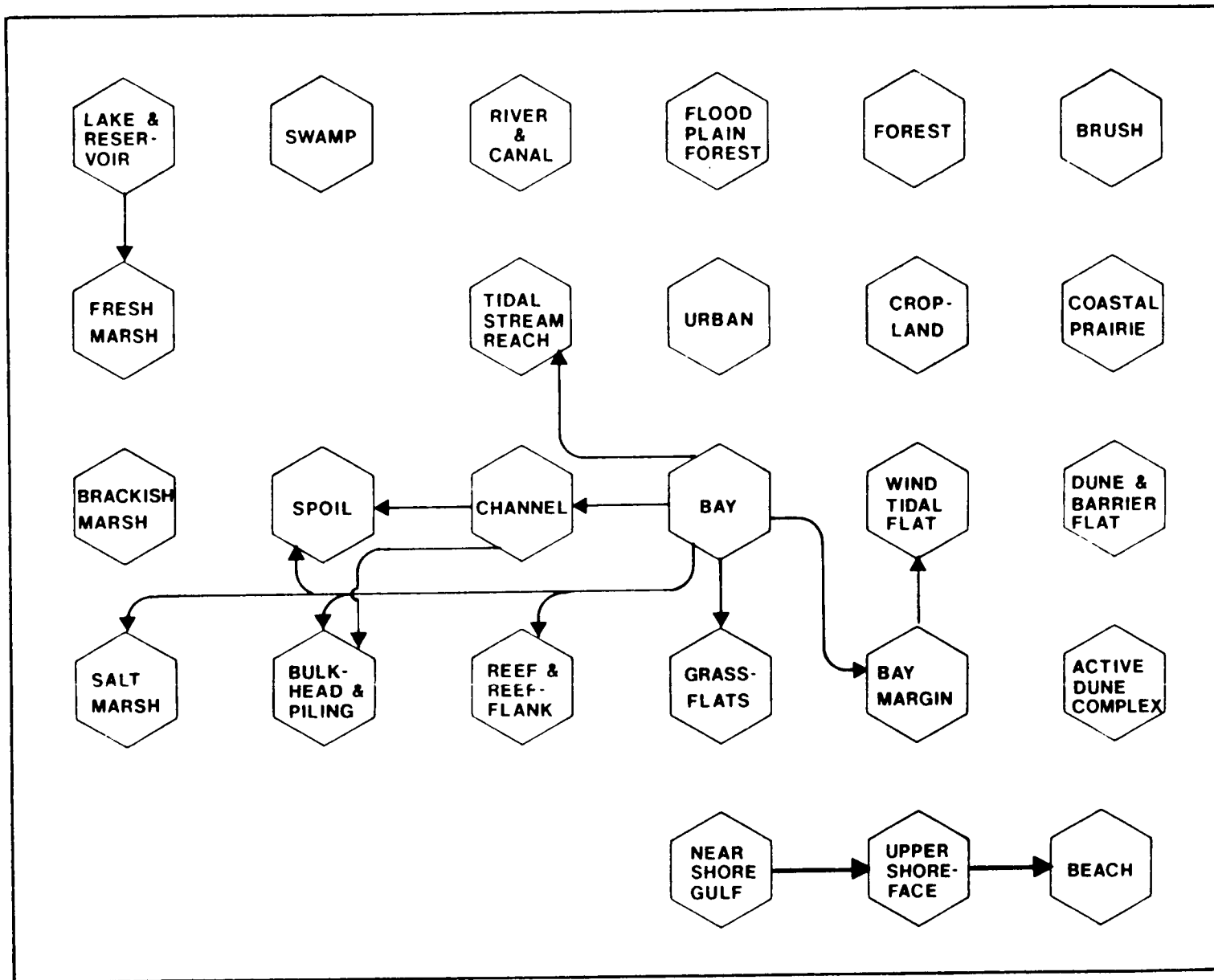

FIGURE 23. Habitat interactions: wave energy movement between habitats.

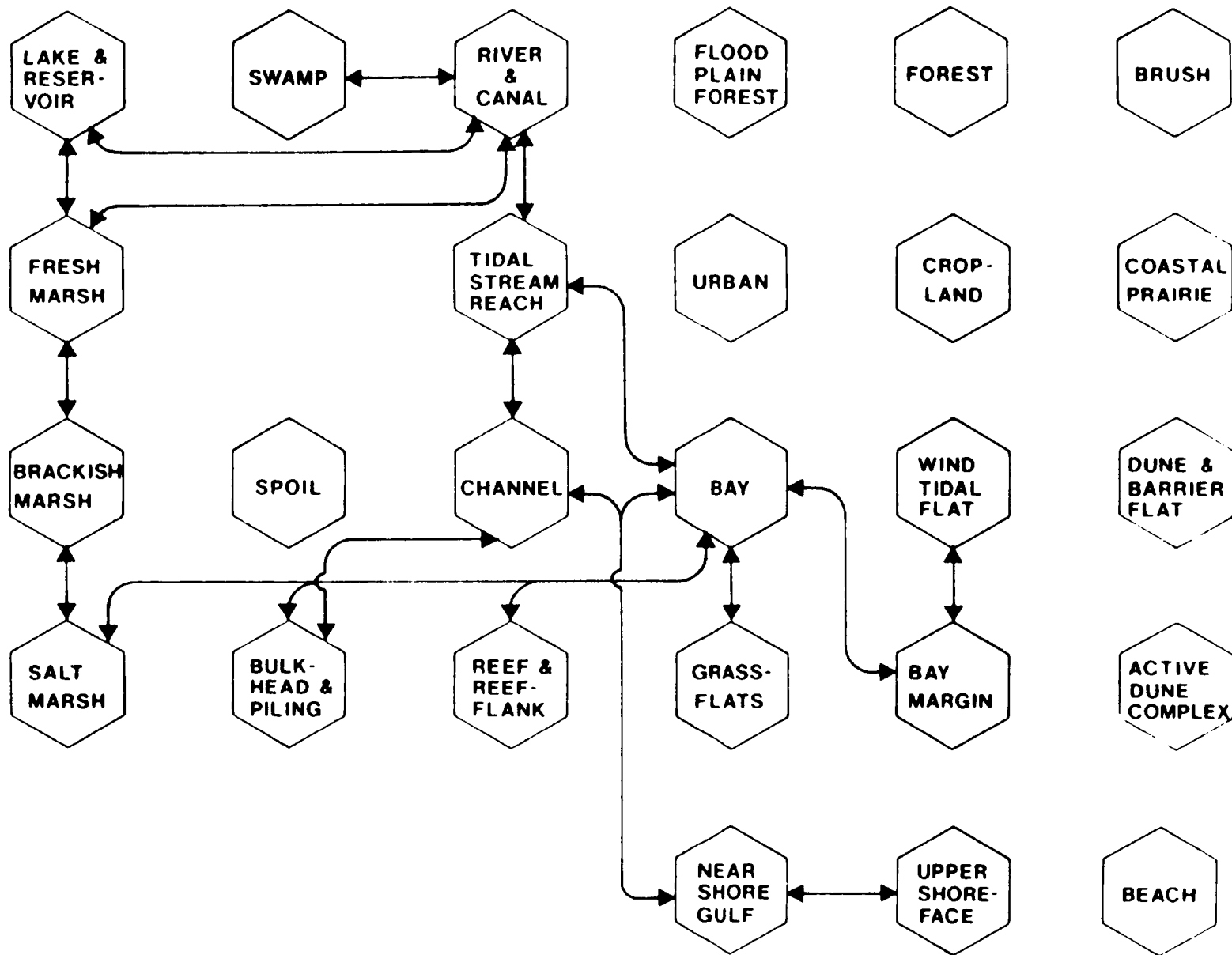

FIGURE 24. Habitat interactions: aquatic organism movement between habitats.

## HABITAT TRANSFORMATIONS

The three major causes of habitat transformation in the coastal area are subsidence (Figure 25), natural succession (Figure 26), and the activities of man (Figure 27).

Subsidence in the study area is almost entirely induced by pumping of fresh water, oil, gas, and brine. When the land surface is lowered relative to the local water level, the physical factors in habitats are changed, and changes in the biota soon follow (Figure 25). In coastal systems, these changes tend to reverse the effects of sedimentation and natural succession. The extent to which this is occurring in the TBIR study area varies from basin to basin. The Houston-Galveston area, Freeport region, and a small portion of the Corpus Christi area have had the greatest amount of man-induced subsidence.

The natural succession transformations of interest are due to erosion and sedimentation and to climatic changes. Around the bays, erosion converts upland to bay margin. The growth of deltas converts bay habitats to wetlands (Figure 26). Along the gulf shoreline, the beach habitat and the dune and barrier flat habitat advance or retreat according to the balance of erosion and deposition.

Man's activities usually represent conversion of natural systems to human-oriented uses. The transformations shown in Figure 25 are those commonly found in the study area. Dredging, urban construction, and water impoundment are probably the most significant processes at the present time in terms of area converted. Earlier in the history of man's exploitation of the coast, conversion to agricultural uses was the major transformation.

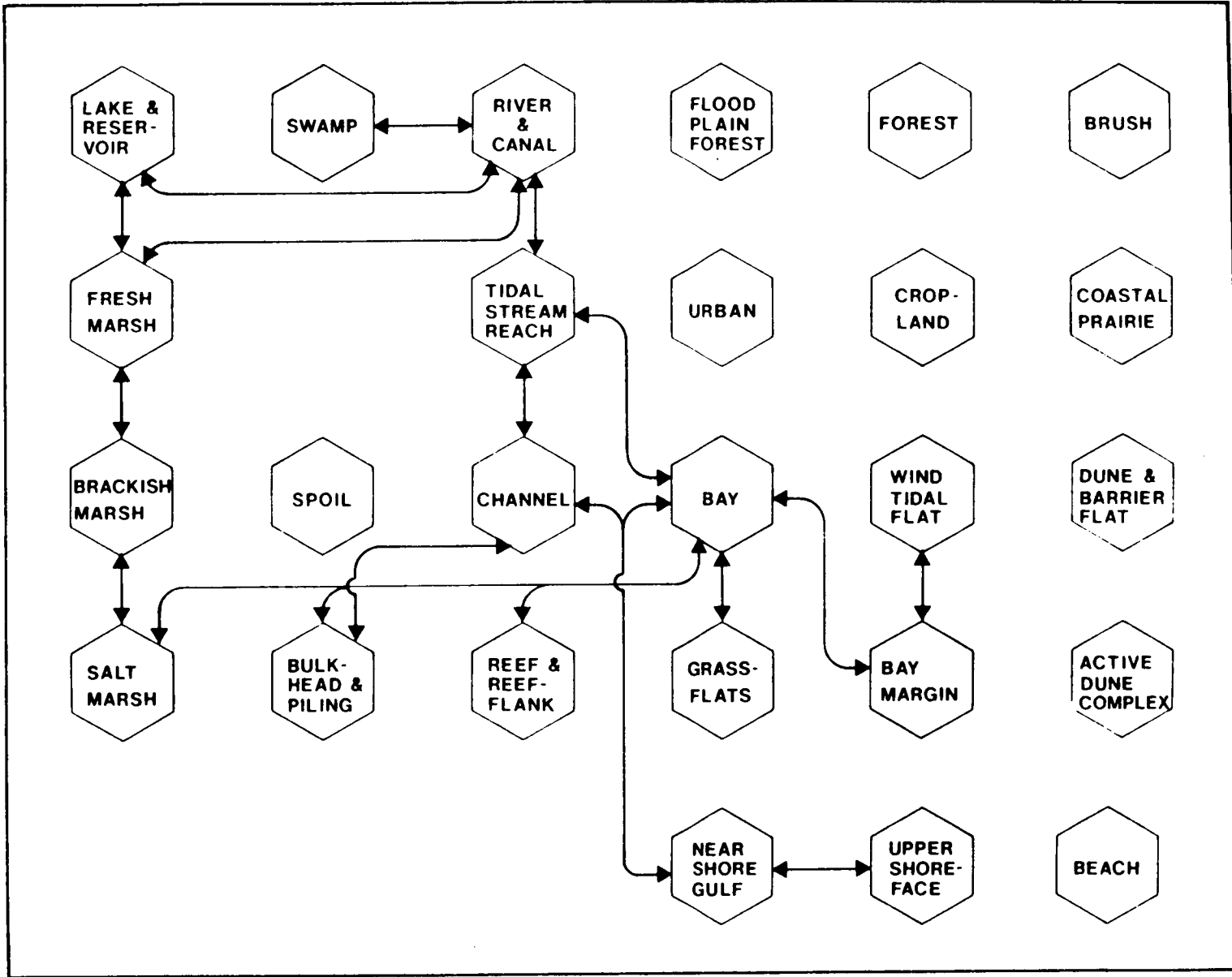

FIGURE 25. Habitat transformations: subsidence.

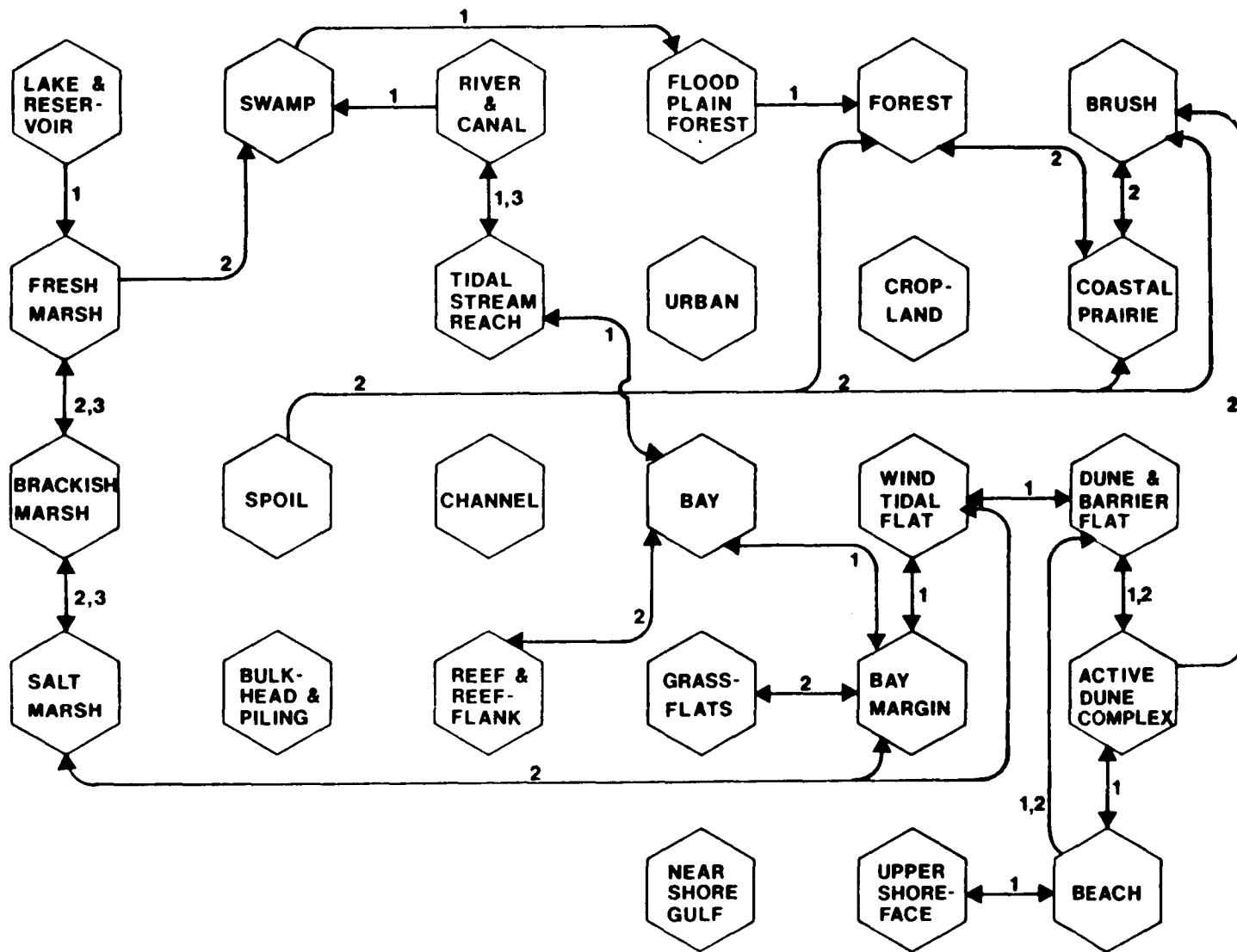

FIGURE 26. Habitat transformations: natural succession. 1-Sedimentation or erosion; 2-Biological community change; 3-Water flow or salinity change.





## CONSIDERATIONS OF TIME AND SPACE

### Introduction

The models which have been prepared for the description of the functioning of the Texas coast at the basin level all emphasize surface features and depict yearly average conditions. The habitat models also tend to show only surface features and "average" system dynamics. This reflects the orientation of many ecological scientists and regulatory agencies. For many purposes of study and regulation such a surface-yearly average orientation is sufficient.

However, many significant processes occur on shorter and longer time scales and above or below the surface. Figure 28 suggests the approximate time-scale/vertical-scale positions of a number of processes, many of which are not treated in the models but are significant to the functioning of the coastal ecosystems.

### Atmospheric Processes

Atmosphere physical and chemical. A number of significant chemical reactions take place in the atmosphere on a variety of time scales and at different characteristic altitudes. Photochemical smog reactions occur rapidly and at low altitudes, while the life span of acid rain constituents may be days to months.

On a time scale of hours to several days, weather plays a very important role in ecosystem function. Isolated severe events such as "blue northers" and hurricanes may have greater effects upon the basins and habitats in the TBIR than is indicated by the usual correlations with average winter temperatures or rainfall rates. These events may drastically alter habitats, flood them, or cause large-scale changes in a very brief period of time. For

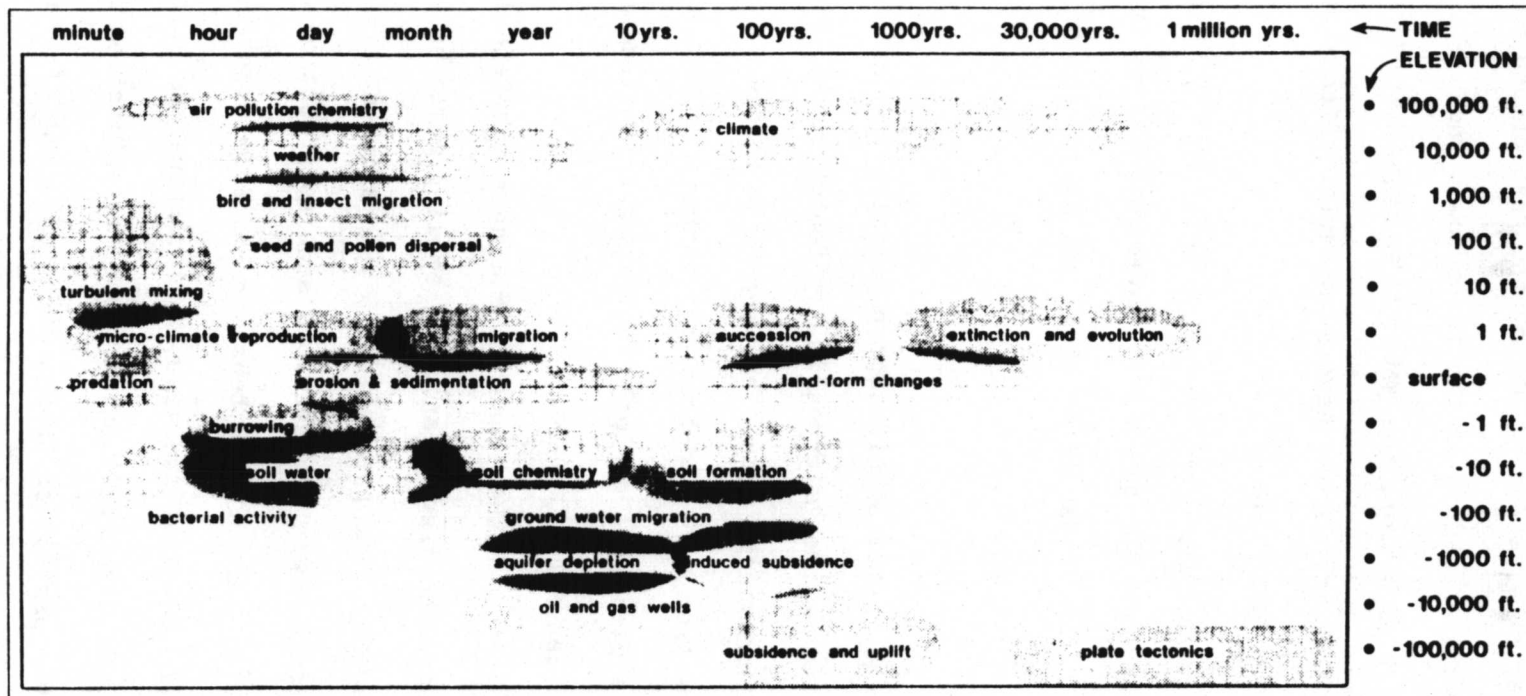

FIGURE 28. Time and space relationships for atmospheric, surface and subsurface processes.

example, in some cases basins and habitats may receive as much rainfall from a single storm as they receive during all of the rest of the year.

The major climatic features on the Texas coast include a drought cycle of roughly ten years. In addition, the potential changes due to long-term worldwide heating or cooling trends may have substantial effects upon the quantity of precipitation and changes in sea level.

Atmospheric biological. Important biological processes which take place in the atmosphere include the day-to-day movement of birds and insects, and seasonal migration. The dispersal of seeds and pollen and of pheromones also occur over a short time period.

#### Surface processes

Surface physical. Some significant physical processes which occur on a short time scale include the "micro-climate" features such as air temperature and humidity which organisms encounter very close to the surface. Short-term turbulent phenomena from wind and local air currents affect many small organisms. Surface phenomena on longer time scales include erosion, sedimentation, and landform changes.

Surface biological. Rather than attempting a complete list of surface biological processes, the diagram shows a sampling which extends from the shortest to the longest-term phenomena. On the shortest time scale, in terms of seconds, individual organism behaviors such as predation are found. On the days-to-months scale, reproductive behavior and migration occur. Processes that exceed the life spans of individuals, occurring over time periods of 10 to 500, years include plant succession. Species extinction and species evolution occur over periods of thousands to millions of years.

## Subsurface

Subsurface physical. In the near-surface area, soil water and soil chemistry are usually treated in detail in the habitat models. These processes occur in the time period of hours to years. Deeper processes such as groundwater migration and soil formation, which take place on the time scale of years to centuries, are not discussed in the habitat models.

Deeper processes with time scales on the order of months to years include the operation of wells for fresh water, or oil and gas extraction, and the associated induced subsidence. Included in this same time range is deep injection of chemical wastes, a common practice in the coastal zone.

Processes occurring deeper in the sediments have even longer time scales. For example, natural subsidence and uplift forces occur over periods of hundreds to thousands of years. At the longest time scales, the processes of continental drift and plate tectonics occur over hundreds of thousands to millions of years

Subsurface biological. Subsurface biological activities, mainly burrowing by animals and plant root growth, are confined to the near surface. Bacterial activity may continue at depths of tens of feet in undisturbed soils or sediments, and at even greater depth in conjunction with gas and oil field operations or deep waste injection.

## HABITAT MODELS

### PURPOSE OF HABITAT MODELS

Habitats represent the largest scale and most basic level of organization of the conceptual models presented in this study. Habitat models are models of the ecosystems of the TBIR that a person would see if actually standing on the ground at the site of a habitat. Habitat models are closely patterned after the environments and biologic assemblages presented in Brown et al. (1972-1977). The models of subaqueous habitats are primarily defined by assemblages of fixed or mobile benthic organisms (reef and reef flank) or by a major geologic or hydrologic process that dictates the conditions in the habitat (channel). Subaerial habitats are primarily defined by land vegetation (forest) or by man-induced activities (urban) that determine the characteristics of the area.

The subaerial habitats presented here are fairly homogeneous and may be easily recognized by the layman. Some of the subaqueous habitats may be readily identified (lake), although a few may require measurements or extended observations to characterize correctly (tidal reach).

Nearly all of the components in these models may be directly observed or their state measured with common scientific instruments. The pathways connecting the components in these models represent real natural processes which have rates that may be measured. The effects of human activities in habitats may be represented as: adding to or removing from components; and

impeding or increasing flows of materials or energy along pathways connecting components.

The time scale implied by these models may be measured in terms of several seasons to years. Although many models recognize migratory movements; the preferred interpretation of the models is as yearly average conditions. On this basis the models may be used to: identify the driving forces, imports, and exports that the habitat requires; explain the internal organization of the habitat that gives it a distinct form and way of operating; and demonstrate how man's actions or natural occurrences may affect the habitat.

## ACTIVE DUNE COMPLEX

### Introduction

The relatively barren actively migrating sand dunes found along the southern Texas coast, both on the barrier islands and the mainland, present unique management and ecological problems. These areas occur mainly south of Baffin Bay and have no counterpart on the upper coast due to the gradient of evapotranspiration along the coast. Most of the landforms on the southern coast have been generated by wind-driven migrating dune systems.

The USFWS mapping unit which most nearly corresponds to this habitat is "UBd," which is somewhat more general. The BEG has mapped "active dunes" in the coastal atlas series, and the reader should refer to the coastal atlas for an extensive discussion of mechanisms and different types of eolian habitats. Both the Brownsville-Harlingen (Brown et al. 1980) and Kingsville (Brown et al. 1980) volumes contain extensive discussions of the eolian systems.

These migrating dune systems appear both on the barrier islands and on the mainland. The general movement of these systems is towards the northwest due to the predominance of southeasterly winds during the dry summer months.

Because the active dune system undergoes more frequent transformations than other coastal habitats, two types of models are used to describe the system. The first model (Figure 29) will emphasize the transformations which can occur when a migrating dune field moves through an area, either on the mainland or barrier island. The second model (Figure 30) will concentrate on the major internal factors within the active dune habitat.

### Transformations

On the barrier islands, the sand and silt making up the dunes may be derived from the gulf beach or from dunes or barrier flat areas which have lost vegetation. Areas of active wind erosion (or "deflation") may continue to erode until the local water table is reached, since the wind energy required to move sand increases greatly when the sand becomes damp. This results in a flat-bottomed depression known as a deflation flat. A rainy period can flood this depression, resulting in a short-lived pond or fresh marsh.

In addition, a deflation flat which erodes sufficiently and can be reached by tidal inundation may become a wind tidal flat. Conversely, migrating dune fields can fill in a wind tidal flat.

On the mainland, sand, silt, and clay can be eroded from wind tidal flats, or vegetated systems damaged by drought or overgrazing. Habitats covered by the advancing dune can include prairie, brush, and forests. When dunes become stabilized by vegetation, a grass community is established first. The climax community may be the dense forests known as "oak mottes." Deflation flats can become "playa" lakes or fresh marshes during rainy periods.

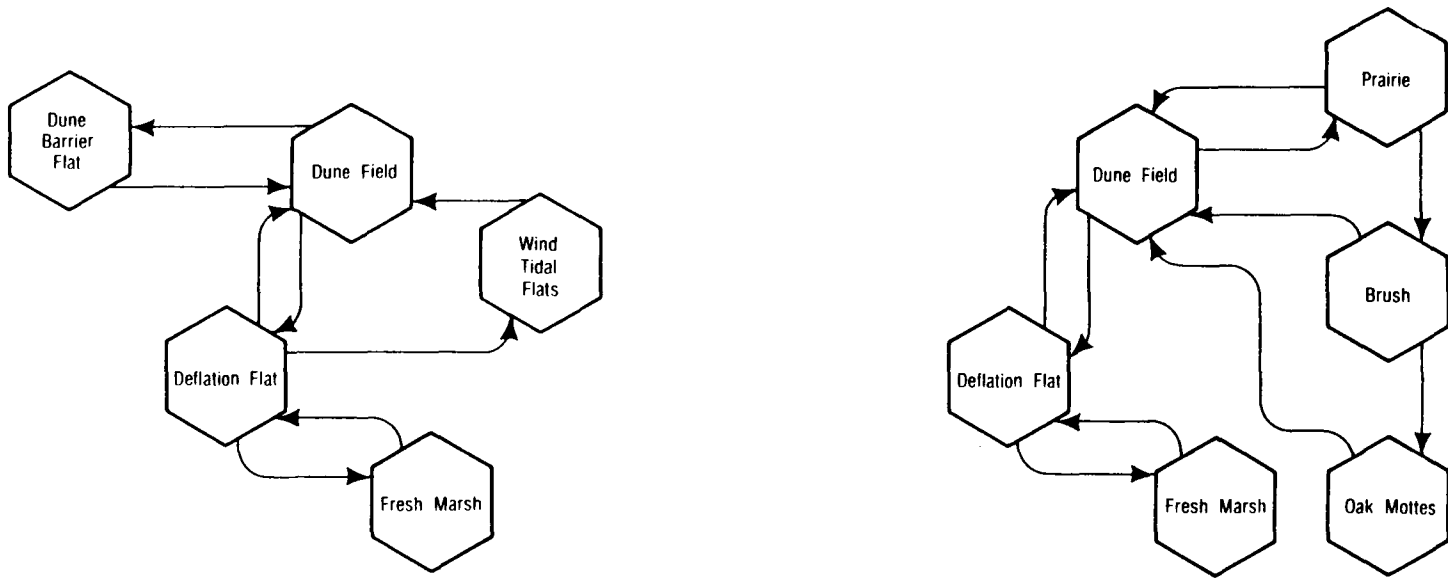

FIGURE 29. Transformations in a migrating dune field.



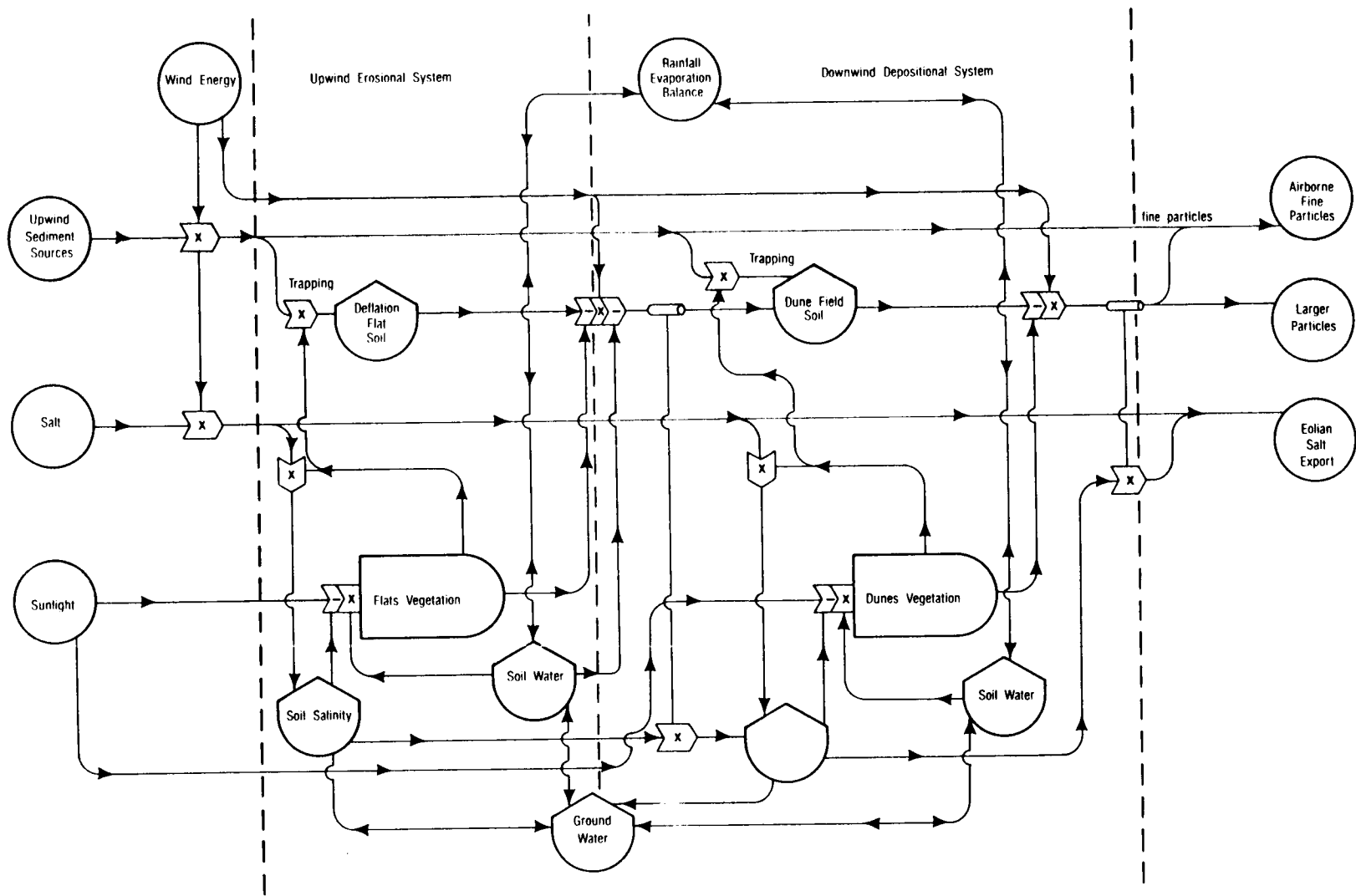

FIGURE 30. Active dune habitat.

### Energy Inputs

Sunlight. Sunlight is the driving force for photosynthesis in the system. Shading and other aspects of micro-climate are ignored in this simplified model.

Wind energy. Wind energy is one of the main controlling factors in the active dune system. The importance of both the direction and velocity of wind in determining net eolian transport is well known (Brown et al. 1977). The "predominating wind" direction is determined by a weighted average of wind duration times velocity. In South Texas, this wind is from the southeast. Most landforms in the area show some northwest-southeast orientation as a consequence.

### Material Inputs

Upwind sediment sources. In the generalized model of Figure 29 the sources of airborne sediment are not specified. On the barrier islands the beach or dunes are the source, and the sediment is predominantly sand and silt-size particles. On the mainland, additional sources include the tidal flats along the Laguna Madre which contribute silt and clay-size particles.

Salt. Airborne salt comes from breaking waves along the Gulf Coast and from salt adhering to soil particles.

### Physical Attributes - Upwind Erosional System

This section of the model represents a typical erosional area of the active dune system. These areas tend to erode down to a relatively flat surface called a deflation flat.

Flats vegetation. Under favorable conditions of high moisture and low soil salinity, deflation flats can support extensive vegetation. The exact species will depend on soil salinity, seed sources, etc., but they are

typically fresh to brackish marsh plants. Algae can frequently grow under conditions too severe for higher plants. Once established, vegetation is a major factor in both trapping windblown sand and salt spray and in preventing the remobilization of the soil.

Deflation flat soil. This compartment represents the sand and silt of the deflation flat areas. It is added to by trapping of windblown sediments and depleted when wind resuspends particles.

Soil salinity. This represents the salt content of the soil in the deflation flats, a major factor in limiting the growth of plants. It is increased by salt inputs from spray or from encrustations on soil particles. Salt can be exported in association with eolian transport of sediments or by water transport during wet seasons.

Soil water. Soil water content is largely determined by the balance between precipitation and evaporation. It is a major factor in promoting the growth of vegetation and in determining the susceptibility of the soil to wind erosion. The cohesion of damp sand grains greatly increases their resistance to erosion; thus wind-driven erosion stops when the water table is approached. This tends to make erosional areas very flat and level.

Ground water. This represents the deeper "water table" where the soil is saturated with water. In times of high rainfall or in highly eroded areas, ground water may reach the surface and thus coincide with "soil water."

#### Physical Attributes - Downwind Depositional System

Dune vegetation. Under favorable conditions of soil water and low salinity, dunes can be colonized by vegetation specifically adapted to this environment, such as sea oats. If favorable conditions last for several years, plant succession can lead to low growing brush and finally trees.

Dune field soil. This represents the sand and silt sized particles of the dunes. In non-vegetated systems especially, the soil is in a dynamic balance between deposition from upwind sources and erosion. The presence of vegetation increases deposition rate and decreases erosion by preventing wind energy from reaching the soil surface.

Soil salinity. The sources of soil salts are deposition of spray and salt encrustations on deposited particles. Because the dunes are higher above the water table, there is a greater tendency for salts to be carried out of the root zone into the ground water.

Soil water.

#### Material Exports

Airborne fine particles. The smallest silt and clay sized particles can be kept aloft by wind energy for extended periods, eventually being deposited far downwind. Thus there is a tendency for the finest particles to be removed from the active dune system. The soils resulting downwind are called loess deposits and cover extensive areas of South Texas (Brown et al. 1977, 1980.)

Larger particles. The larger sand and silt particles tend to be deposited in adjacent systems. If the deposition rate is high enough, these systems may be overcome and converted into active dunes. Thus the active dune system tends to migrate over downwind systems.

Eolian salt transport. This represents both the salt adhering to soil particles and spray from the Gulf of Mexico which was not trapped during passage over the Active Dune system.

## BAY

### Material and Energy Sources from Outside of the Bay Habitat

Sunlight. The bay habitat model is given in Figure 31. Solar energy input is the major source of energy used by the phytoplankton-based food web of the bay habitat. It also supplies heat to the system.

Runoff. Runoff from rivers, streams and overland sources is a source of current energy in the bay habitat. It is the primary supplier of nutrients, organic material and fresh water to this system. It also helps produce turbulence and changes in the water depth.

Wind energy. Wind energy largely controls the circulation of shallow Texas bays. In bays with large river inputs, it may be of secondary importance in overall current production during "normal" conditions. It provides much of the energy that produces turbulence in the bay system. Studies by Smith (1974, 1977) have shown the importance of wind energy on the circulation between Corpus Christi Bay and the Gulf of Mexico, and in the currents of the Intracoastal Waterway in Corpus Christi Bay. Hall et al. (1976) showed that "northers" affected the currents and turbidity of San Antonio Bay more than any other energy source. Turbidity appeared to be directly related to wind velocity during their study.

Tidal energy. Tidal energy is less important to circulation in the bay habitat than wind or river currents. Near the passes, the lunar tides do create currents, although the effects are restricted to only a small area (Hall et al. 1976).

### Non-Living Components Within the Bay Habitat

Salinity. Salinity is one of the most important attributes in the bay habitat (Collier and Hedgpeth 1950). It is the primary factor controlling the

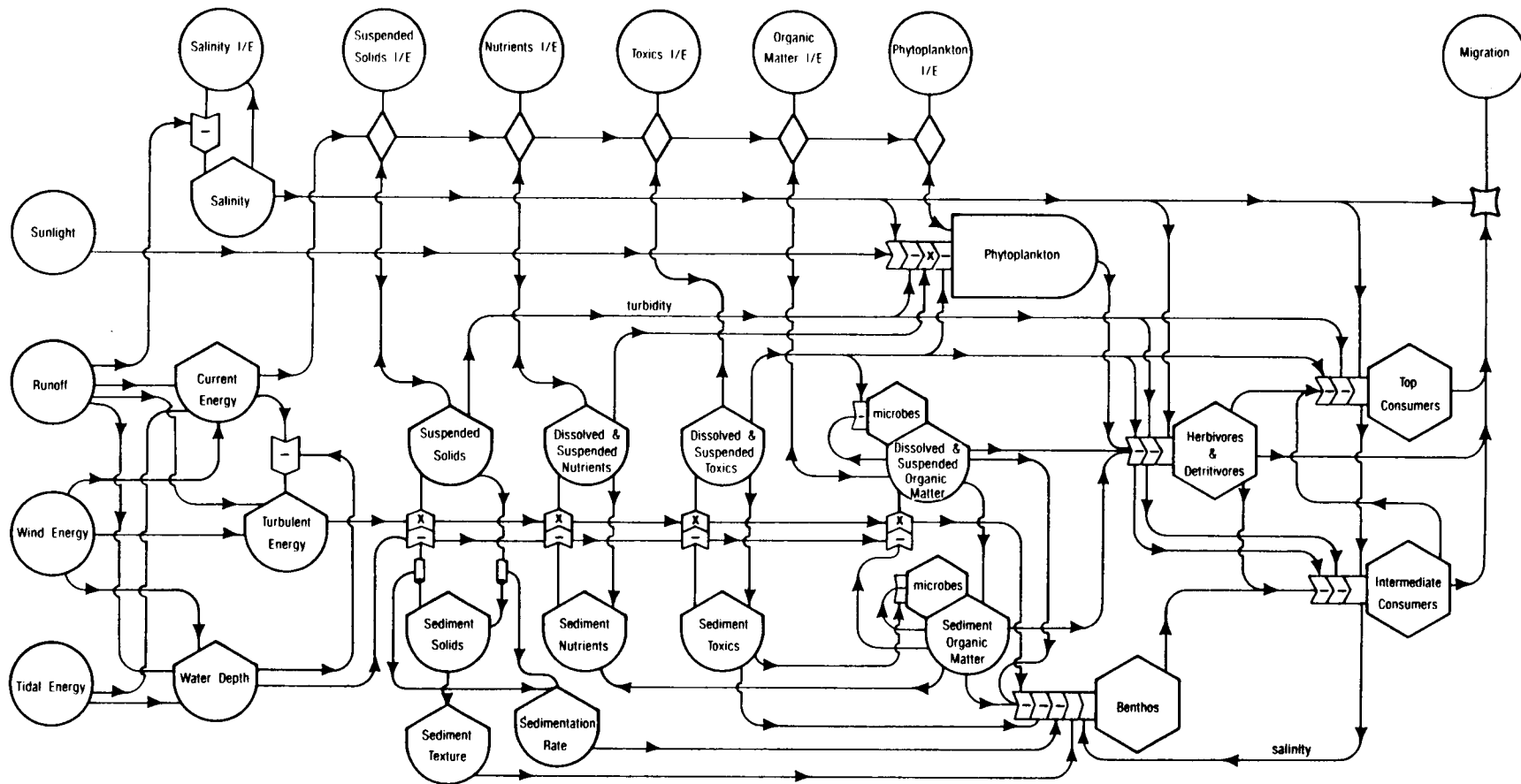

FIGURE 31. Bay habitat.

presence or absence of biota. Its seasonal variability, due primarily to the variation in river flow in most bays, partially controls the migration of mobile organisms and the distribution of benthic organisms. Salinity in the bay is controlled by runoff, precipitation and exchange with the Gulf of Mexico. It ranges generally between 10 and 35 ppt but may drop to 0 ppt after large floods or rise to over 60 ppt during severe droughts. The excessive hypersaline conditions occur primarily in the Laguna Madre area of the southern Texas coast. This bay is generally considered to be a "hypersaline" bay as opposed to the rest of the Texas bays which are considered to be "medium salinity" bays. The average salinity of the bays of Texas is generally lowest in the most northeasterly ones and highest in the southern ones because of the higher rainfall and concomitantly higher river flows in the northeastern portion of Texas.

Current energy. The energy of currents that run parallel to the land surface or the bottom is driven by a combination of runoff, wind energy, and tidal energy. Wind generally is more important to the overall circulation of the bay system than is tidal energy (Smith 1974, 1977). The direction of the currents of the bays is controlled by the wind direction, channels, and overall bay morphology (Hall et al. 1976; May 1973). The current energy drives the import and export of physical and biotic attributes, and contributes to the turbulent energy of the system.

Turbulent energy. Turbulent energy in currents that run perpendicular to the land surface or the bottom is the principal attribute controlling the resuspension of material from the sediments. It also keeps the bay system well mixed and retards stratification. Runoff, wind energy, and current

energy all contribute to the turbulent energy of the system. Turbulent energy decreases as water depth increases.

Water depth. This attribute is primarily controlled by the depth of the bay, but runoff, wind energy, and tidal energy cause hourly, daily, monthly, and seasonal variations (Hall et al. 1976). Water depth is inversely related to the resuspension of sediments by decreasing the action of turbulent energy. With the exception of man-made channels and deeper holes, the bays of Texas generally average less than 6 meters maximum depth.

Suspended solids. The suspended solids attribute is used to show the physical effects of suspended particulate matter, such as the reduction of light which reaches the phytoplankton and the covering of the bottom fauna (May 1973). Suspended solids are introduced into the bay waters by import from adjacent systems and resuspension of bottom sediments (Collier and Hedgpeth 1950). They are removed via settling and the action of filter-feeding benthic organisms. The bay systems of Texas are generally high in suspended solids due to large inputs from runoff and resuspension due to turbulence and their shallow water depth.

Sediment solids. Sediment solids is the mass or volume of sediment within a particular area of the bay. It increases through the settling of suspended solids, and decreases because of resuspension from turbulence or removal by man (dredging). Water depth is affected by change in the sediment solids; as this component of the bay habitat increases, the depth decreases. In addition to quantity, sediment solids also have distinctive textures (for example, silt, sand, and clay) that influence the benthic communities.

Sediment texture. The texture of the bay bottom sediments varies from predominantly mud in the northeastern Texas bays to mostly sand in the Laguna



Madre (Rogers 1976 in Bouma 1976; Shepard and Rusnak 1957). Some areas near oyster reefs contain significant quantities of shell. After salinity, sediment texture is the next most important factor in determining the composition of the benthic community of the bay. Benthic species are adapted for particular sediment characteristics especially for feeding and burrowing mechanisms.

Dissolved and suspended nutrients. In addition to light, organic and inorganic nutrients are required by phytoplankton for photosynthesis. Nitrogen and phosphorus are the major nutrients associated with primary production in the bay. Many additional nutrients and trace elements are also needed. Nitrogen has been generally considered to be the limiting nutrient; however, phosphorus may be limiting in some areas where excess nitrogen is introduced via treated sewage effluent from which the phosphorus has been removed. Davis (1973) noted interaction effects between nitrogen and phosphorus, and through calculation showed that augmentation of nitrogen, and sometimes phosphorus and carbon would be necessary to elicit the highest productivity response. The Texas Department of Water Resources has compiled a substantial base of information on nutrient processes in Texas bays as part of the Bay and Estuary Program required by the 64th Legislature. Inorganic materials are introduced into the bays by freshwater inflows from rivers and streams, return flows from agriculture, industry, and municipal treatment plants, runoff, direct entry from rainfall, nitrogen fixation by phytoplankton, and regeneration of nutrients bound by benthic sediments.

Sediment nutrients. The interstitial water and the solid particles in the sediments contain nutrients in both solid and dissolved forms. The slow decomposition of organic matter by micro-organisms and the activities of

benthic organisms causes the release of nutrients such as ammonia, phosphate and trace metals. These nutrients can be released to the water by diffusion, turbulent mixing of the sediments or incorporation via root uptake of seagrasses, and release through decomposition of the leaves. Sediment nutrient recycling is extremely important in Texas bays with little freshwater inflow, such as the Laguna Madre (Pulich 1979 in Fore and Peterson 1980).

Dissolved and suspended toxics. Toxic materials which could be introduced into the bay system include heavy metals, pesticides, industrial organic chemicals, well drilling fluids, crude oil and petrochemicals. Many toxic materials are readily adsorbed on particles. They are then quickly incorporated into the sediments. Some of these toxics may reach higher levels in the food chain by bioaccumulation in filter feeders and consumption by higher order consumers.

Sediment toxics. As stated above, many of the toxic materials adsorb to particles in the water and become part of the sediments. Contaminated sediments may be resuspended by turbulence or activities such as dredging or drilling; however, the adsorbed toxics usually settle out quickly rather than redissolving in the water (May 1973).

Dissolved and suspended organic matter. Because microorganisms are so intimately tied to the decomposition of particulate organic material, production of dissolved organic material, and regeneration of inorganic nutrients, they are combined with the symbol representing dissolved and suspended organic matter even though they are a biotic component of the system. Concentrations of dissolved organic carbon (DOC) ranged from 2.0 to 5.3 mgC/l in Texas estuaries during a 1972 study (Maurer and Parker 1972). A 1971 study (Maurer 1971) showed DOC values between 5 and 11 mgC/l in the

Laguna Madre and from 3 to 6 mgC/l in other bays. These concentrations are much higher than the 1 to 4 mgC/l of DOC recorded in the nearshore gulf during the same studies.

Bacteria are the most important microorganisms in the decomposition of particulate organic matter in the bay system. The populations of bacteria respond rapidly to organic matter inflows and rapidly colonize organic particles. The bacteria/organic matter complex is ingested by many important herbivores and detritivores such as shrimp and oysters in the bay system.

Sediment organic matter. Some of the particulate organic matter settles to the bottom and becomes part of this system. Benthic infauna and some of the epifauna ingest the organic matter from the sediments or the surface of the sediments as do many herbivores and detritivores such as shrimp.

#### Non-Living Materials Imported and Exported from the System

Salinity. During normal weather, bay systems of Texas receive their saline water from the Gulf of Mexico through natural passes and dredged ship channels; during large storms marine water may enter the bays by washover areas across the barrier islands and peninsulas. The waters of the Gulf have a salinity of about 35 ppt when they enter the bays. Except for storms, the flow is caused by lunar and wind tides. Marine water may penetrate far into a bay because the water may enter as a "salinity wedge" caused by a density gradient in deep ship channels. The saline water mixes with the fresh water from the rivers and other inflows to create the 10 to 25 ppt average salinity of most of the bays. The Laguna Madre has an average salinity above 30 ppt and a range from 30 to 60 ppt over the past 10 years due to little freshwater

inflow, high evaporation and little exchange with the gulf (Pulich 1979 in Fore and Peterson 1980).

Suspended solids. The bay systems receive most of their suspended solids either from runoff (primarily river flow) or from resuspension of bottom sediments during dredging or turbulent conditions. Some solids may be imported from the gulf and directly from land during storms. In the Laguna Madre, sand from washovers is blown into the bay during windy, dry periods and is an important source of solids (Shepard and Rusnak 1957).

Nutrients. Freshwater inflow from the rivers and overland flow provide the majority of the nutrients to the bay systems of Texas. Resuspension of the sediments by turbulence or dredging may also reintroduce some nutrients into the system. A smaller portion of the nutrient input to most bays comes from nitrogen-fixing plants. Direct nitrogen fixation may be more important in the Laguna Madre due to its lack of freshwater inputs.

Toxics. Toxics such as agricultural pesticides or industrial wastes may be imported along with the freshwater from rivers. Some toxic materials may be directly introduced into the bay system by spills or treatment plant discharges. Crude oil from spills or well blow-outs in the nearshore gulf, upper shoreface, or offshore systems may enter the bays through the passes.

Organic matter. Most of the organic matter enters the bay system through the freshwater inflow of the rivers. Some is blown or washed in from terrestrial systems during storms. The Gulf habitats are lower in organic matter than the bay system, and the bay generally exports organic matter to these offshore systems.

Phytoplankton. The primary productivity of the bay system is provided by the phytoplankton. The most abundant phytoplankton in several Texas bays are

diatoms, dinoflagellates, and green algae (Holland et al. 1975). Two hundred forty-seven taxa of phytoplankton were collected during this study.

The rate of photosynthesis depends on light penetration and nutrient availability (Armstrong and Hinson 1973). Texas bays are generally turbid; Masch and Espey (1967) reported that suspended solid concentrations of 200-400 mg/l were maintained in Galveston Bay. The large amounts of suspended solids in most Texas bays limit the photic zone to the top meter or so of the water column, with light being the limiting factor in some cases (Armstrong and Hinson 1973).

The possibility of suppression of photosynthesis by toxic materials exists, but its extent in Texas bays is currently unknown. Van Baalen et al. (1973) detected toxicity in Galveston Bay waters using a phytoplankton bioassay.

Benthos. There is a diverse community of benthic organisms in the bay systems. Holland et al. (1975) found 359 taxa in their sampling of several bays along the central portion of the coast. Polychaetes, nematodes, ostracods, and copepods were the most abundant groups. Most benthic organisms in Texas bays are only marginally mobile; salinity and sediment texture are probably the controlling factors in their overall distribution (Holland et al. 1975; Rogers 1976). Many of the higher trophic level organisms depend, at least partially, on the benthos for their food.

Herbivores and detritivores. Herbivores and detritivores range in size from the small zooplankton to the striped mullet, Mugil cephalus (Moore 1974). Most of the crustaceans (shrimp, crabs, etc.) are herbivorous or detritus feeders or both at one stage in their life cycle (Coastal Fisheries Branch 1975; Cook and Lindner 1978; Costello and Allen 1939; Lindner and Cook 1970).

Many of the larval stages of the higher level fish fall into this category (Dineen and Darnell 1976).

Intermediate consumers. Intermediate consumers include both free-swimming consumers and those closely associated with the bottom. This includes organisms from larval fish to jellyfish. This biotic component generally consists of predatory organisms below the level of top consumer. Free-swimming intermediate consumers include the pinfish (Lagodon rhomboides) and croaker (Micropogon undulatus); bottom species include the southern sting-ray (Dasyatis sabina) and southern flounder (Paralichthys lethostigma). Many studies have been undertaken to determine the use of the bay system by these species (Case 1974; Case and Wimer 1977; and Jones 1965).

Top consumers. Several species of commercial and sport fish, sea turtles, bottle-nosed dolphins, birds, and man are the top consumers in the bay system. Shane (1977) studied the dolphin populations of the Corpus Christi Bay area. Coastal Fisheries Branch (1975), Hoese (1965), and many other references describe the commercial and sport fish populations.

#### Import and Export of Biotic Components

Phytoplankton. Phytoplankton are exported to the upper shoreface and nearshore Gulf systems. They travel with the currents through the natural and stabilized passes between the barrier islands and peninsulas. The abundant nutrients in the bay system allows a high level of phytoplankton production.

Migration. Virtually all of the estuarine-dependent organisms migrate to or through the bay system (Copeland 1965; Hoese 1965; King 1971; Simmons and Breuer 1962; Simmons and Hoese 1959). Table 2 illustrates the migration of several sport and commercially important species through Aransas Pass. These migration times are generalized from the data in the cited field studies.

TABLE 2. Estimates of migration time through Aransas Pass for selected organisms

COMMON NAME	JAN	FEB	MAR	APR	MAY	JUN	JUL	AUG	SEP	OCT	NOV	DEC
Blue Crab	+++++					+++++					+++++	
				-----				*****				
Brown Shrimp		+++++										
Pink Shrimp									+++++			
						-----						
White Shrimp		+++				+++++					+++++	
Sand Seatrout						-----	+++					
Spotted Seatrout												
Southern Flounder						+++++						++++
Atlantic Croaker												
Redfish												
Black Drum												
Sheephead												

+++++ = Larvae in thru Aransas Pass  
 ##### = Larvae out thru Aransas Pass  
 \*\*\*\*\* = Adults and Sub-adults in thru Aransas Pass  
 ----- = Adults and Sub-adults out thru Aransas Pass

From: Copeland 1965; Copeland and Truitt 1966; King 1971; Pearson 1929; Simmons and Hoese 1959; Simmons and Breuer 1962.

Mullet are the most prominent members of the herbivore and detritivore group that migrate between the bay and the Gulf of Mexico. They spawn on the outer continental shelf and return to the bay system and surrounding areas to mature (Moore 1974).

The penaeid shrimp spawn offshore in the gulf and the postlarvae migrate into the bays to mature (Cook and Lindner 1978; Lindner and Cook 1970; Costello and Allen 1939).

Most of the intermediate consumers spend much of their life cycle in the bay or migrate through it as juveniles to the marshes or bay margin areas. They pass through the inlet-tidal delta system on their movement to and from the upper shoreface and nearshore Gulf systems.

Gamefish which comprise a large fraction of the top consumers migrate at various times of the year as do the intermediate consumers. Their migrations depend upon their spawning periods and various physical factors such as salinity and temperature. Table 2 shows that migration through the pass occurs year-round. No two species migrate at exactly the same time through the same pass.

#### Critical System Components

Freshwater inflow via runoff from the rivers is the most critical component in the bay system except for the hypersaline Laguna Madre. This inflow brings with it nutrients and organic matter and dilutes the saline water from the Gulf of Mexico. Wind energy and turbulent energy both help keep the bay system well mixed and thoroughly oxygenated. The mixing and high level of nutrients help keep the primary productivity of the phytoplankton at a high level. The benthos is a critical component since many



intermediate and top consumers feed directly on the benthic organisms or are dependent on organisms that feed on the benthos.

## BAY MARGIN

### Energy Sources

Sunlight. Figure 32 is the conceptual models for the bay margin habitat. Solar energy input provides the major source of energy used by the phytoplankton-based food web of the bay margin ecosystem. It also provides heat to the system.

Runoff. Local runoff from streams and overland sources provides a source of nutrients, toxics and organic matter for the bay margin ecosystem. It is the primary supplier of fresh water to this system. This can produce significant short-term changes in the salinity of the bay margin.

Wind and wave energy. Wind energy is a major factor in controlling the circulation in the bay margin portions of the shallow Texas bays. Along with wave energy (which it causes), it provides much of the energy that produces turbulence in the bay system. Turbulence is one of the major differences between the bay ecosystem and the bay margin ecosystem in some areas. Even small amounts of wave energy produce turbulence and therefore more suspended solids in the water column in the shallow waters of the bay margin system.

Studies by Smith (1974, 1977) have shown the importance of wind energy on the circulation between Corpus Christi Bay and the Gulf of Mexico, and in the currents of the intracoastal waterway in Corpus Christi Bay. Hall et al. (1976) showed that the effects of "northers" on the currents and turbidity of San Antonio Bay were much larger than other energy sources. Turbidity appeared to be directly related to wind velocity during their study.

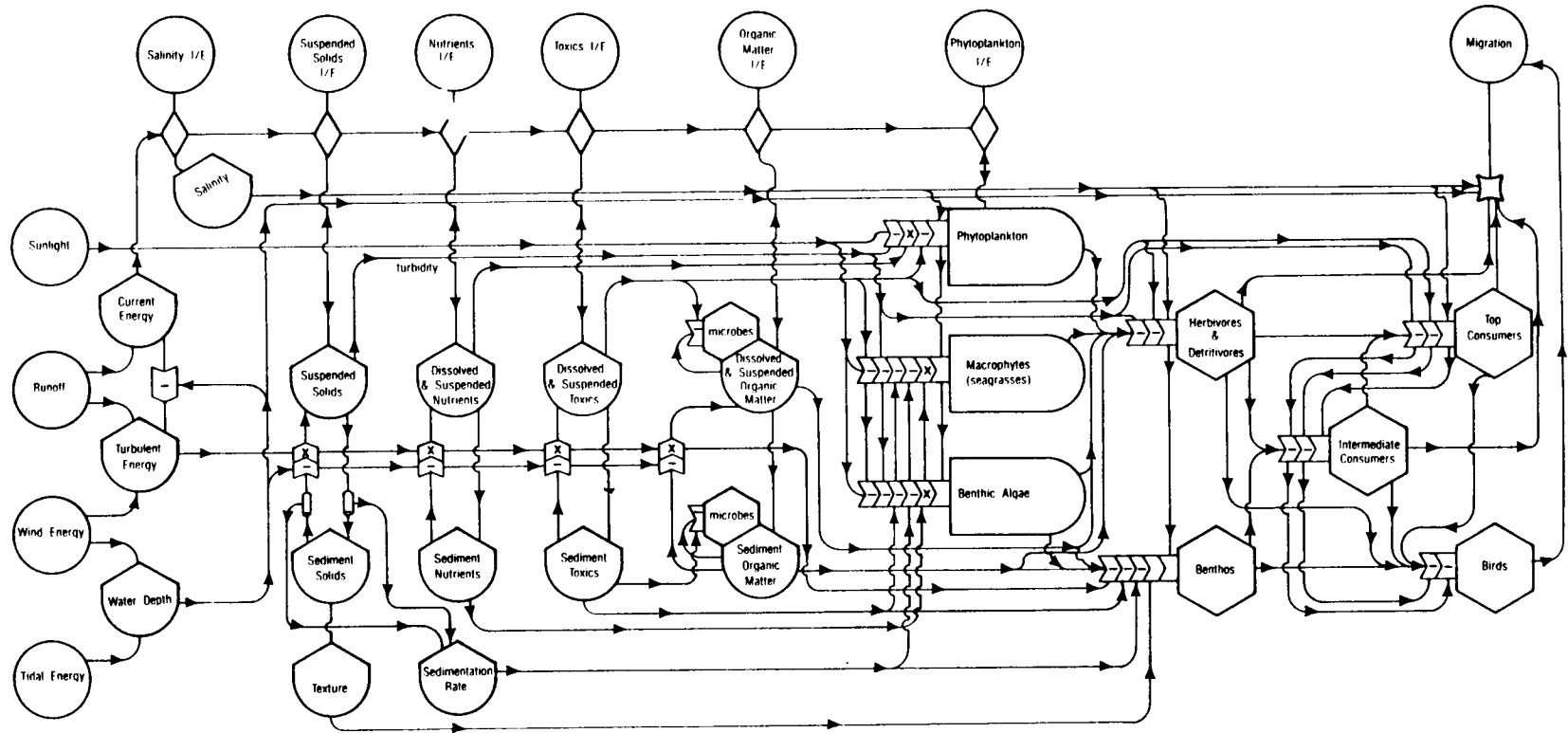

FIGURE 32. Bay margin habitat.

Tidal energy. Tidal energy is a major controlling factor of the water depth of the bay margin system, due to its shallow nature. Even though the tidal amplitude may be very small in some of the more remote portions of the bay margin systems, it may produce a large change in the amount of substrate inundated.

Current energy. Current energy is used here to represent the currents within the bay margin system. Most of the currents are directly imported from the adjacent bay ecosystem; however, tidal energy and wind energy have a small effect. The lunar tides do create currents in the vicinity of the passes between the bays and the Gulf of Mexico; however, these currents are primarily restricted to these areas and affect only a small area of most bays (Hall et al. 1976).

#### Physical Attributes

Salinity. Salinity is one of the most important attributes in the bay margin ecosystem (Collier and Hedgpeth 1950). It is one of the primary factors controlling the presence or absence of biota. Its seasonal variability, which is due primarily to the variation in the salinity of the adjacent bay ecosystem, partially controls the migration of mobile organisms and the distribution of benthic organisms. Salinity in the bay margin is controlled by the salinity of the adjacent bay system and by local runoff. Local runoff via small streams or ditches and direct overground flow may temporarily reduce the salinity during and after heavy rainfall periods. This does not affect the bay margin system in the long term, but does affect its biota during the period of reduced salinity.

Current energy. Currents in the bay margin are driven primarily by the currents in the adjacent bay ecosystem. Wind may directly affect the currents

in the bay margin system to some extent (Smith 1974, 1977), but the direction of the currents in the bay margin is controlled by the currents of the bay system, channels and overall bay morphology (Hall et al. 1976; May 1973). The current energy drives the import and export of physical and biotic attributes, and contributes to the turbulent energy of the system.

Turbulent energy. Turbulent energy is the principal attribute controlling the resuspension of material from the sediments. It also keeps the bay margin system well mixed and retards stratification. Wind and wave energy and current energy both contribute to the turbulent energy of the system. Wave energy produces the greatest amount of turbulent energy along shorelines which receive larger waves from across a long stretch of open bay. Turbulent energy decreases as water depth increases.

Water-depth. This attribute is primarily controlled by the tidal energy which causes hourly, daily, monthly and seasonal variations (Hall et al. 1976). Water depth is inversely related to the resuspension of sediments by decreasing the action of turbulent energy. The bay margin system can generally be considered to average less than one meter of water depth.

Suspended solids. The suspended solids attribute is used to show the physical effects of suspended particulate matter, such as the reduction of light which reaches the phytoplankton and the covering of the bottom fauna (May 1973). Suspended solids are introduced into the bay margin waters by import from adjacent systems, local runoff and resuspension of bottom sediments (Collier and Hedgpeth 1950). They are removed via settling and export back to the bay ecosystem. The bay margin systems of Texas are generally high in suspended solids due to large inputs from the bay ecosystem, runoff and resuspension due to turbulence and their shallow water depth.

Sediment solids. This compartment represents the mass or volume of sediment within a particular area of the bay margin. This is increased by settling of suspended solids and decreased by resuspension due to turbulence or removal by man (dredging). This attribute inversely affects water depth. It also provides the basis for sediment texture which in turn affects the benthos.

The sedimentation rate is derived from a "sensor" in the line (on Figure 32) representing sedimentation of solids. It is the primary controller of water depth and has a significant effect on the benthos. Sedimentation rates vary from bay to bay but range from 0.05 to 3.50 ft./100 years (Shepard 1953). When using soundings data, as Shepard did, subsidence of up to 1.8 ft./100 years must also be taken into account. Rapid sedimentation may be particularly detrimental to organisms such as benthic micro-algae.

Sediment texture. The texture of the bay margin sediments varies from predominantly mud in the northeastern Texas bays to mostly sand in the Laguna Madre (Rogers 1976 in Bouma 1976; Shepard and Rusnak 1957). Some areas near oyster reefs contain significant quantities of shell. Sediment texture is a major factor in determining the composition of the benthic community of the bay margin. The constant resuspension of the finer sediments by wave action in high energy areas may tend to remove these finer portions and cause the sediments to be of a coarser texture than the deeper portions of the nearby bay system.

Dissolved and suspended nutrients. Nutrients are organic and inorganic materials required by phytoplankton for photosynthesis, in addition to light. Nitrogen and phosphorus are the major nutrients associated with primary production in the bay margin, although many additional nutrients and trace

elements are also needed. Nitrogen is generally considered to be the limiting nutrient in Texas bays (Davis 1973). Dugdale (1967) discusses nutrient limitation in general. The Texas Department of Water Resources has computer data banks of nutrient data from sampling in all Texas bays. A significant portion of the nutrients used in the bay margin ecosystem may come from local runoff during periods of high rainfall.

Sediment nutrients. The interstitial water and the solid particles in the sediments contain nutrients in both solid and dissolved forms. The slow decomposition of organic matter by micro-organisms and the activities of benthic organisms causes the release of nutrients such as ammonia, phosphate and trace metals. These nutrients are released to the water in the bay margin primarily by turbulent mixing of the sediments and by incorporation via uptake by micro-algae and root uptake of seagrasses and release through their decomposition. Sediment nutrient recycling is extremely important in Texas bays with little freshwater inflow, such as the Laguna Madre (Pulich 1979 in Fore and Peterson 1980).

Dissolved and suspended toxics. Toxic materials which could be introduced into the bay margin system include heavy metals, pesticides, industrial organic chemicals, well drilling fluids, crude oil and petrochemicals. Many toxic materials are readily adsorbed on particles. They are then quickly incorporated into the sediments. Some of these toxics may reach higher levels in the food chain via bioaccumulation by filter feeders and consumption by higher order consumers. Toxics enter the bay margin system primarily via water from the adjacent bay system or via runoff from land.

Sediment toxics. As stated above, many of the toxic materials adsorb to particles in the water and become part of the sediments. Contaminated

sediments are resuspended in the bay margin system primarily by turbulence; however, the adsorbed toxics usually quickly settle out rather than redissolving in the water (May 1973). Each bay in Texas varies greatly in its sediment concentrations of toxic materials. Heavy metals, pesticides and chemicals such as PCB are found in the sediments of nearly all of the bays of Texas (TDWR Computer Data Files). McGowen (1979) studied the heavy metal concentrations in Matagorda Bay and compared them to several other Texas bays and other areas of the U.S. Only boron and mercury were found in higher concentrations in the sediments than would be expected under more or less natural conditions. Data from the TDWR files show that the sediments in the channels rather than the bays contain the higher accumulations of toxics. Most of the toxic materials settle out into the deeper portions of the bay system with the finer sediments (McGowen 1979).

Dissolved and suspended organic matter. "Microbes" are partially combined with the symbol representing dissolved and suspended organic matter in the water since they are an integral part of the cycling of energy via decomposition. The amount of dissolved and suspended organic matter in the bay margin is highly dependent upon the concentrations in the adjacent bay system. Concentrations of dissolved organic carbon (DOC) ranged from 2.0 to 5.3 mgC/l in Texas estuaries during a 1972 study (Maurer and Parker 1972). A 1971 study (Maurer 1971) showed DOC values between 5 and 11 mgC/l in the Laguna Madre and from 3 to 6 mgC/l in other bays. These are much higher than the 1 to 4 mgC/l of DOC recorded in the nearshore gulf during the same studies. There may be higher concentrations of organic matter in the water of the bay margin system than the adjacent bay system due to local runoff following rain events; however, no studies of this possible phenomenon have

been found. It is probably short-lived at best. The piling of organic drift material on the shore in the bay margin system by wind and wave action also may add organic matter to the system under certain conditions.

The bacteria are the most important microbes in the decomposition of particulate organic matter in the bay margin system. The populations of bacteria respond rapidly to organic matter inflows and rapidly colonize organic particles. The bacteria/organic matter complex is ingested by many herbivores and detritivores in the bay margin system.

Sediment organic matter and microbes. Some of the particulate organic matter settles to the bottom and becomes part of this system. The benthic infauna and some of the epifauna ingest the organic matter from the sediments or the surface of the sediments as do some of the herbivores and detritivores such as the penaeid shrimp. This is an important food source for these species. Davis (1973) conducted extensive studies on several Texas bay systems with respect to organic matter production. He gives measurements for the total organic carbon (TOC) in the sediments of several bay systems.

#### Import/Export of Physical Attributes

Salinity. The bay margin system receives most of the saline water from the adjacent bay ecosystem. Local runoff may cause lower salinities in the bay margin system for short periods of time following rain events. The TDWR water quality data base contains extensive salinity data on all of the Texas bays. The Environmental Geologic Atlas series (Brown et al. 1972-77) also discusses the distribution of salinity in the bay systems of Texas.

Suspended solids. The bay margin system receives most of its suspended solids from either erosion caused by local runoff or from resuspension and relocation of bottom sediments during turbulent conditions. Some solids may



be imported from the adjacent bay ecosystem and deposited in the bay margin system, especially following disruption by storms or man's activities such as dredging or shrimping. In the Laguna Madre, sand from washovers is blown into the bay during windy, dry periods and is an important source of solids for the bay margin (Shepard and Rusnak 1957).

Nutrients. Import from the bay system and local runoff provide the majority of the nutrients to the bay margin system. Resuspension of the sediments by turbulence or man's activities such as dredging or shrimping also reintroduces some nutrients into the system. In some more urbanized systems such as Galveston Bay, direct discharges of domestic and industrial wastes may constitute a significant input of nutrients into the bay margin. Some of the nutrient load brought to the bay margin system by runoff via streams actually results from waste discharges and agricultural runoff in some areas. A smaller portion of the nutrient input to the bay margin comes from nitrogen-fixing plants. This is somewhat more important in the Laguna Madre and other bays that lack major freshwater inputs.

Toxics. Toxics such as agricultural pesticides or industrial wastes may be imported along with the freshwater runoff into the bay margin. Some are introduced into the bay margin system via spills or treatment plant outfalls. Crude oil may be imported via the passes (inlet-tidal delta systems) from the gulf in the case of spills in the nearshore gulf or upper shoreface. Toxics from spills in the bay system or on land adjacent to the bay margin may find their way into the bay margin system.

Organic matter. Most of the organic matter that enters the bay margin system via freshwater runoff or import from the bay system is either dissolved or suspended particles of vegetation and animal matter. Some detritus is

blown or washed in from terrestrial systems during storms. No literature comparing the organic matter content of the bay margin system to the bay or other systems was found.

### Biotic Attributes

Phytoplankton. The primary productivity of the bay margin system is provided by phytoplankton, macrophytes and benthic algae. The areas covered with extensive seagrass flats are discussed separately in the grassflat ecosystem. The partition of primary productivity between these three sources varies with their abundance in the bay margin system. The more turbid areas will have less benthic growth and more phytoplankton due to light deficiency. The rate of photosynthesis depends on light penetration and nutrient availability (Armstrong and Hinson 1973). The possibility of suppression of photosynthesis by toxic materials exists, but its extent in Texas bays is currently unknown. Van Baalen et al. (1973) detected toxicity in Galveston Bay waters using a phytoplankton bioassay. The large amounts of suspended solids in most bay margin areas keeps the photic zone to the top meter or so of the water column with light being the limiting factor in some cases (Armstrong and Hinson 1973).

The primary productivity of the bay margin areas of the clearer bays of South Texas (Redfish Bay, the Laguna Madre, and others) is primarily the result of photosynthesis by seagrasses instead of phytoplankton (Pulich 1979 in Fore and Peterson 1980). Odum and Wilson (1962) also studied the relationships between the primary productivity and physical and chemical environments of several Texas bays. Little work has been done comparing the productivity of the bay margin system to the bay system.

Benthos. The benthic organisms are extremely diverse in the bay systems of Texas, with 359 taxa found by Holland et al. (1975) in their sampling of several central Texas bays. The bay margin system may not have as diverse a benthic fauna due to the turbulence of the system and its more frequent disruption by water level and salinity changes. Since the majority of the benthic organisms are either sessile or marginally mobile, salinity and sediment texture are probably the controlling factors in their overall distribution (Holland et al. 1975; Rogers 1976). Polychaetes, nematodes, ostracods and copepods were the most abundant groups during the studies of the bay systems, and the composition of the bay margin benthos is expected to be somewhat similar. Many of the higher trophic level organisms depend, at least partially, on the benthos for their food.

Herbivores and detritivores. This group comprises one of the largest consumer groups in the bay margin system and ranges in size from the small zooplankton to the striped mullet (Mugil cephalus) (Moore 1974). Most of the crustaceans (shrimp, crabs, etc.) are herbivorous or detritus feeders or both at one stage in their life cycle (Coastal Fisheries Branch 1975; Cook and Lindner 1978; Costello and Allen 1939; Lindner and Cook 1970). Many of the larval stages of the higher level fish fall into this category (Dineen and Darnell 1976). Many of these organisms move into the bay margin system to feed on the benthic algae or organic matter, and to escape larger predators in the shallow water. The young of many of these organisms spend much time in the bay margin system.

Intermediate consumers. This group comprises both the free-swimming consumers and those closely associated with the bottom. This includes organisms from larval fish to jellyfish. This compartment is primarily

concerned with the predatory organisms below the level of top consumer. Many studies have been undertaken to determine the use of the bay system by these species, but few compare it to the bay margin system. The studies by Case 1974; Case and Wimer 1977; Jones 1965 discuss the intermediate consumers that use the bay and therefore, the bay margin in many cases. Species such as Menidia beryllina, Cyprinodon variegatus and Fundulus similis, spend most of their time in the very shallow waters of the bay margin system.

Top consumers. The top consumers of the bay margin system are primarily the game fish of the bay system and birds (discussed separately in the next section). Species such as Cynoscion nebulosus, Sciaenops ocellata and Pogonias cromis frequent the bay margin system in search of prey. Coastal Fisheries Branch (1975) and Hoese (1965) are two of the more comprehensive references on the top consumers and their habitats.

Birds. The birds are discussed separately because they are somewhat concentrated in the bay margin system. Many diving birds of the open bay and wading and shore birds can be found on the edge of the water in the bay margin system. The wading and shore birds feed on the small benthic and nektonic organisms and rest in or near this system. The diving birds and some dabbling ducks may also feed on micro-organisms or vegetation in the bay margin system. Many of them rest on the shore adjacent to the bay margin where their droppings may be washed back into the bay margin to provide nutrient input. Brogden, W.B. et al. (1977 in Kier, R.S. and E.G. Fruh, 1977) discuss the use of this habitat by the birds in the Corpus Christi Bay area.

### Import/Export of Biotic Attributes

Phytoplankton. The phytoplankton populations of the bay margin system are probably quite similar to the bay system during normal conditions. Concentrations probably vary during times of high runoff.

Migration. Virtually all of the estuarine dependent organisms migrate to or through the bay system (Copeland 1965; Hoese 1965; King 1971; Simmons and Breuer 1962; Simmons and Hoese 1959). Many of the juvenile stages of these organisms migrate along the sides of the bays in the relatively safe shallow water of the bay margin system. These estuarine dependent organisms migrate through the passes from the gulf into the bays of Texas at varying times throughout the year. Their migration is cued by salinity, tides, temperature, day length and other parameters. Some species stay primarily in the bay margin and adjacent wind tidal flat or marsh systems.

Mullet are the most visible members of the herbivore and detritivore group that migrate between the bay and the Gulf of Mexico. They spawn on the outer continental shelf and return to the bay system and surrounding areas to mature (Moore 1974). The smaller juveniles can be found in large numbers during certain times of the year in the bay margin.

The Penaeid shrimp spawn offshore in the gulf and the postlarvae migrate into the bays to mature (Cook and Lindner 1978; Lindner and Cook 1970; Costello and Allen 1939). These postlarvae usually proceed to the bay margin and other shallow water systems in the bays where they feed on the benthic algae and organic matter in the relative safety of the shallows.

Most of the intermediate consumers spend much of their life cycle in the bay or migrate through it. As juveniles, many of them survive in the shallow waters of the marshes or bay margin areas.

The gamefish, which comprise the more important top consumers, migrate at various times of the year as do the intermediate consumers. Their migrations depend upon their spawning periods and various physical factors as mentioned above. No two species migrate at exactly the same time, even through the same pass. Many of the smaller individuals seek out the bay margin areas for refuge from the larger predators and to feed on the juveniles of other species in the bay margin system.

#### Critical System Components

The health of the bay ecosystem, which is normally adjacent to the bay margin ecosystem, is the most critical aspect in the survival of the bay margin ecosystem. The bay margin system receives most of its inputs from the bay system. The next most critical component is the runoff from adjacent upland areas. This freshwater runoff brings with it nutrients, organic matter and toxics. Wind and turbulent energy keep the bay margin system well mixed and thoroughly oxygenated but also keep the suspended solids concentrations relatively high. The benthos is also a critical component in that many of the more important sport and commercial species either feed directly on the benthic organisms or are dependent on organisms that do feed on the benthos.

#### BEACH

#### Energy Inputs

Solar energy. Figure 33 represents the beach habitat. Solar energy input to the pioneer plants is essentially a constant. Its utilization by the plants is controlled by the availability of nutrients, soil water, and soil salinity.

Storm wave energy. Although the beach is a terrestrial ecosystem, its greatest importance to man is evident only during storms. Thus storm processes

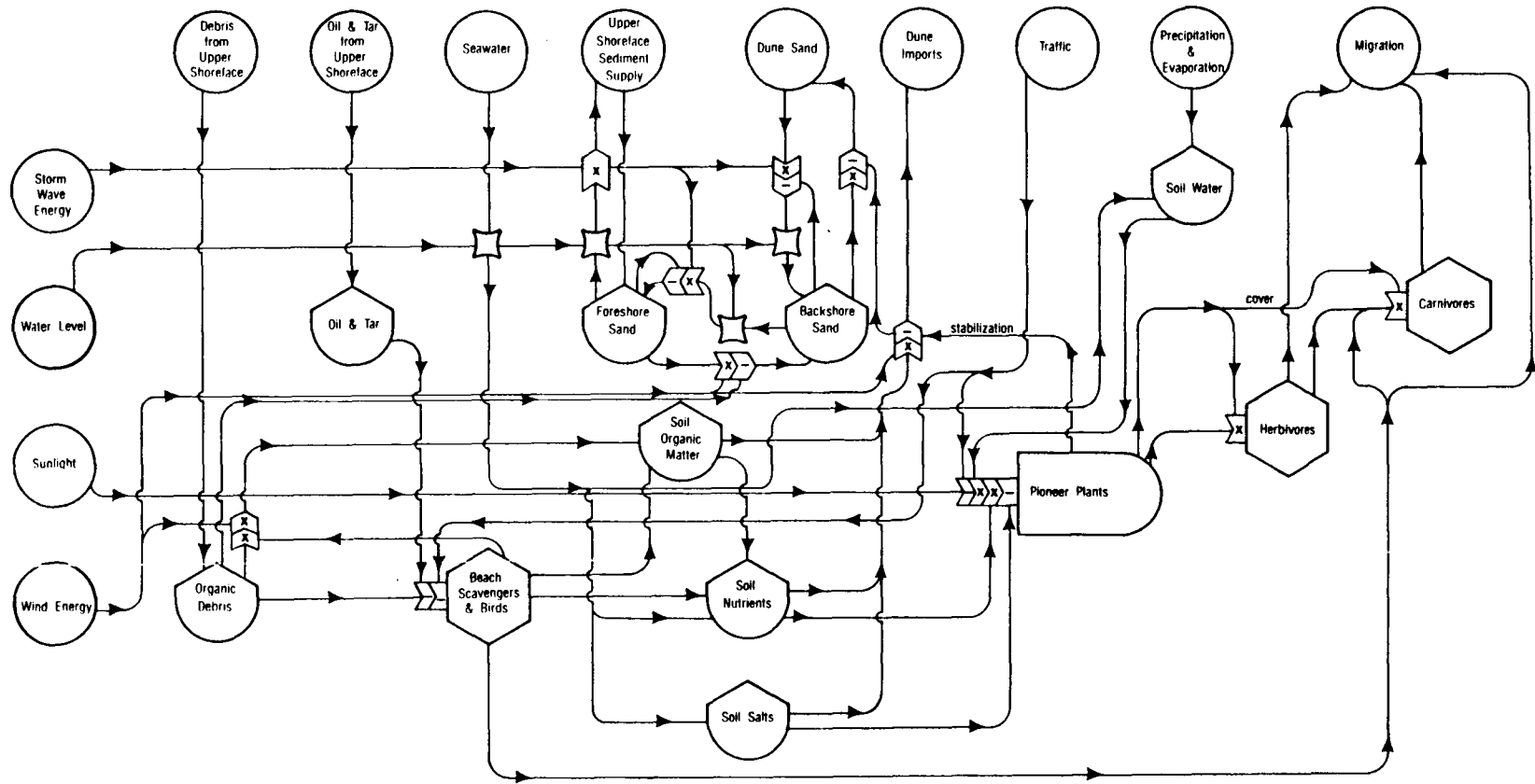

FIGURE 33. Beach habitat.

are represented in considerable detail on Figure 33. The U.S. Army Corps of Engineers (1977) "Shore Protection Manual" provides a complete summary of the physics of storm waves. Storm wave energy originates offshore and is propagated through the nearshore gulf and upper shoreface. Thus it can be modified by the depth contours in those systems. The actions of storm wave energy are controlled by the water level in combination with the height contours on the beach. These are represented by the foreshore and backshore sand volumes in the figure.

Wind energy. During normal water levels, wind energy is the main transport agent for sand, spray and various soil components. It also assists in the breaking down of large organic debris to small particles. Eigsti (1978) describes some measurements of wind patterns near the beach at Port Aransas. In general, winds at the beach were substantially faster than those reported by an inland weather station. He also found that the onshore winds peaked at night as opposed to the classical "sea breeze." Jehn (1974) reviewed existing work on coastal climatology in Texas. McAtee and Drawe (1974) measured wind velocity profiles near the beach surface.

Debris from upper shoreface. Organic debris is a major source of energy to the beach. It forms much of the food web base for the scavengers on the foreshore. Much of the natural debris is sargassum which typically comes ashore in large drifts during spring and summer. Shelby (1963) measured 85 to 150 pounds (dry weight) of sargassum per linear foot of Texas beach during an exceptionally prolific year. Other natural debris includes trees, branches and grasses.

Traffic. Pedestrian and automobile traffic constitute a significant disturbing force on many Texas beaches. In this model, it is considered as an



energy input with negative effects on pioneer plants (Behrens et al. 1974; McAtee and Drawe 1974) and on beach scavengers and birds (Hill and Hunter 1973).

#### Physical Attributes

Organic debris. This represents the large pieces of organic matter such as sargassum, wood fragments, and other debris. Debris may be resuspended by high tides and broken down in the upper shoreface system. However, breakdown of this material by scavengers and blowing sand is rapid for all but the largest fragments once it has been cast up beyond the normal tide range. Since the rate of supply depends on many factors, such as wind and currents, and since decomposition is so rapid, the standing crop of debris is quite variable.

Oil and tar. Tar on beaches can come from both natural and man-made sources. Geyer (1978) summarized the results of several years of study of natural oil and gas seeps in the Gulf of Mexico. He cites historical sources which imply that substantial amounts of tar were found on Texas beaches before modern industrial development. The wind and current forces which bring tar to the beaches also bring in organic debris. It is not surprising that tar is frequently mixed with more desirable organic matter. Since tar may be toxic to some organisms, it is shown as having a negative effect on scavengers. The adverse effects of more liquid oils on shorebirds is well known.

Soil organic matter. Breakdown of organic debris leads to particles small enough to be considered part of the soil. In spite of the rate of supply of debris, the standing level of organic matter in beach soils is low. Jones (1960) determined organic carbon content of sediment samples on two transects across Mustang Island, from 8 kilometers offshore to the bay. He

found the lowest levels, 0.030 to 0.039 percent carbon, on the gulf beaches. Wind energy transport of the lightweight organic particles to the backshore and dunes may be one reason for this low level. Backshore soil is probably as low in organic matter content as foreshore soil (0.03 to 0.04 ppm organic carbon, Jones 1960). Analyses of organic matter by Dahl et al. (1975), while not as precise as Jones, tend to substantiate these figures. The beach is definitely lower in organic matter than either the dunes or the nearshore gulf.

Soil salts. Salts may be added to the soil of the foreshore by spray and inundation with seawater. This compartment appears in the figure mainly to provide correct "bookkeeping" for soil salts, since only the backshore soil salts affect the biota. Salts are brought to the backshore soils as windblown sand, by spray, and by inundation during high tides. They are normally removed only by wind and by percolation of soil water. Salt concentration is one of the most important factors limiting the growth of pioneer vegetation species.

Data on soil salinity and other soil chemical parameters appear to be limited to the Padre Island study areas of Dahl et al. (1975) and a few others. The soil surface salinities observed by Dahl et al. (1975) varied by a factor of 200 over a two-year period, from 40 to 7,900 micro-ohm/cm. However, most of the time the values were below 4000, which is the usual criterion for a saline soil. In most cases, the surface salinity was observed to be considerably higher than that at a depth of 15 cm. This is apparently due to salts being brought to the surface during periods of evaporation. In general, beach and dune soil salinity values were similar.

Soil nutrients. In Figure 33, nutrients refers to all of the inorganic materials needed by the plants. This includes nitrogen, phosphorus, potassium, magnesium, calcium and trace metals. Nutrients are derived from the decay of organic matter, from spray and from inundation by seawater. Blowing sand transports soil nutrients from the foreshore to the backshore and dunes. Limited soil nutrient analyses by Dahl et al. (1975) indicate that all nutrients in dune and beach soils are present in low amounts relative to typical agricultural soils. Dahl et al. (1975) conducted extensive experiments with fertilization of some of the major plant species used for creation and stabilization of dunes.

Foreshore sand. The organization of this model reflects the importance of the beach for the protection of the dunes or other landward systems from storm wave energy, and its importance as a reservoir of sand in the longshore drift system. The foreshore sand compartment is considered to represent the volume of sediment (above an arbitrary reference level) in the foreshore. Volume probably represents the important aspects of sediment better than maximum height or width. For an excellent text on the energetics of movement of sand on beaches, see the U.S. Army Corps of Engineers (1977) "Shore Protection Manual." Another excellent text is Komar (1976). The longshore drift system is discussed in greater detail in the "Upper Shoreface" ecosystem documentation.

During normal weather, the upper shoreface tends to act as a source for sand. This sand can then be transported to the backshore by wind energy. During high water levels, storm wave energy can erode foreshore sand back into the gulf, as shown by the "switch" activated by high water (Figure 33). If the water level is high enough, wave energy can penetrate to the backshore and

begin erosion of this sediment; however, the volume of foreshore sand tends to reduce the amount of wave energy which passes over it.

The exact changes in beach profile (sand volume), which take place due to storms, appear to depend on the details of water level, wave energy and duration. For example, Davis (1972) shows profiles taken before and after hurricane Fern. Extensive erosion of both foreshore and backshore areas took place, but there was also some deposition at the landward edge of the backshore. This portion of the model is intended only to indicate the general tendencies of the system. Morton (1977) and Morton, McGowen and Wilkinson (1977) discuss the general historical shoreline changes, their causes, characteristics and factors in use for the Texas coast. R.A. Morton with M.J. Peiper and J.H. McGowen (all with the Bureau of Economic Geology) produced the seven-volume series entitled, "Shoreline Changes: An Analysis of Historical Changes of the Texas Gulf Shoreline." This set discusses each section of the Texas coast in great detail.

Although most Texas beaches have a high sand content, this compartment represents all inorganic sediment. Beaches with a high shell fragment content are found on central Padre Island, as described by Watson (1968).

Backshore sand. As discussed above, this compartment represents the volume of sand in the backshore (between the berm and the foot of the foredunes) above an arbitrary reference level. In the event a berm is not present, the presence of pioneer plants can be used to delimit the backshore area. In severely erosional areas, no backshore can be recognized and large portions of the model may be ignored.

Soil water. Subsurface soil water varies widely, depending on the evaporation, rainfall and tidal inundation. Dahl et al. (1975) found that the

saturation capacity of typical sands was about 21.5 percent water (by weight), with a capacity under well drained conditions of 3 to 4 percent. The depth to the water table in the backshore on Padre Island was found to be from 0.61 to 0.74 meters by Judd, Leonard and Sides (1977). Dahl et al. (1975) found similar values. The proximity of the water table accounts for the observation that the water content at 15 cm was usually above 5 percent even during moderate droughts during Dahl's study.

#### Import/Export of Physical Attributes

Water level. Sea level in the Gulf of Mexico regulates the import of wave energy and inundation of the beach by seawater. Under normal conditions, only the foreshore is exposed to wave action. Storms which permit the waves to reach the backshore are not uncommon, but hurricanes bring about the greatest water level rise and wave energy. Expected average storm surge heights for the Texas coast have been computed by Bodine (1969). With respect to the amount of storm erosion, Davis (1972) emphasizes the significance of a high storm tide and large waves rather than just high winds.

Oil and tar from upper shoreface. Oil and tar from both natural sources and accidental spills are introduced onto the beach from the upper shoreface. Geyer (1978) describes research on beach tar around the Gulf of Mexico.

Seawater. During normal weather, only the foreshore is exposed to seawater. During high water, however, the backshore can be inundated, causing sudden changes in soil water, soil salt and soil nutrient content (Dahl et al. 1975).

Upper shoreface sediment supply. Wave energy tends to bring sand toward the beach during normal weather, as discussed in the upper shoreface system

documentation. The Army Corps of Engineers (1977) "Shore Protection Manual" provides an excellent summary of sediment supply in the littoral drift system.

Dune sand. Wind transports sand, organic matter, nutrients and salts from the beach to adjacent inland systems. Since this adjacent system is frequently a dune, the interface is labeled so in the model. However, many other systems are possible. The "Environmental Geologic Atlas of the Texas Coastal Zone" by the Bureau of Economic Geology should be consulted for detailed maps. Along the southern part of the Texas coast, washover channel complexes are frequently found inland of the beach. In the middle coast, dunes are not well developed. The adjacent system is frequently a barrier flat. Along the upper Texas coast, the adjacent systems may be barrier flats or marshes.

Substantial quantities of sediment can be transported by wind from the beach. The dune-building plantings of Dahl et al. (1975) trapped all available blowing sand. The sand accumulated at the rate of 24.9 cubic yards per linear foot of beach in five years. Along rapidly eroding shorelines, this transport is probably much less.

Dune imports. This compartment represents export of organic matter, nutrients and salts to the adjoining upland systems. Low density organic matter particles are probably more easily transported by wind than sand. Both nutrients and salts are transported in close association with sand. The stimulation of dune plant growth by sand accululation indicates that nutrients are probably very important to the growth of dunes. No data has been found on the magnitude and significance of the export of salts from the beach to the dunes via blowing sand.

Precipitation and evaporation. Typical annual rates of precipitation and the balance between precipitation and evaporation vary considerably along the Texas coast. Hillaker and Jehn (1978) have summarized precipitation and evaporation data and computed soil moisture storage for the Texas coastal zone. The Texas Department of Water Resources maintains several coastal evaporation and precipitation measurement stations. McAtee and Drawe (1974) measured precipitation and evaporation rates along beach transects on Padre Island.

#### Biotic Attributes

Beach scavengers and birds. This compartment is used to represent a variety of organisms which depend to some extent on the organic detritus which is cast up on the beach from the upper shoreface. The activities of these animals break the detritus down into smaller particles. The ghost crab (Ocypode quadrata) is perhaps the best known of these organisms. Its burrows can be found from the water's edge to the foot of the foredunes. Hill and Hunter (1973) found burrow densities from 9 to more than 40 per square meter on Padre Island beaches. They observed that density was decreased by human traffic but increased by human trash.

Although the role of the ghost crab has been generally thought to be entirely that of a scavenger (Fotheringham and Brunenmeister 1975), Wolcott (1978) found that ghost crabs on a North Carolina beach derived 90 percent of their food intake by predation on Donax sp. and Mole crabs (Emerita sp.) in the swash zone. Haley (1967) observed that ghost crabs on Padre Island scavenged only animal material from the debris. He also observed that they were very effective predators on mole crabs, Donax sp., amphipods, and other

A variety of birds such as gulls, terns and plovers feed in the upper shoreface but spend much of their time resting on the beach. Some of these birds also scavenge animal remains from the beach debris. Amphipods of the genus Orchestia, commonly known as beach fleas, are found associated with detritus (Hedgepeth 1953). In addition, there are tiger beetles (Cicindela sp.) and other insects which use the beach (Fotheringham and Brunenmeister, 1975).

Pioneer plants. The data on pioneer plants found on Texas beaches comes mainly from studies on Padre and Mustang islands. Some of these are: McAtee and Drawe (1974), Behrens et al. (1977), Dahl et al. (1975) and Judd, Lonard and Sides (1977). The negative impact of both foot and automobile traffic on backshore plants is strongly documented in the papers by McAtee and Drawe, and by Behrens et al. (1977). Dahl et al. (1975) provides extensive data on the effects of soil salinity and soil nutrients on the growth of selected species.

The trapping of sand is represented in the model as the inhibition of removal from the backshore by wind energy. Many of these plants, such as sea oats (Uniola paniculata), are stimulated by the accumulation of sand and can grow quite rapidly.

Herbivores. The herbivores found in the backshore area do not appear to be permanent residents. They live in adjacent uplands and periodically feed in the beach system. Baccus (1974) found the spotted ground squirrel (Spermophilus spilosoma) and the kangaroo rat (Dipodomys ordii) among sparse vegetation in the upper beach. Dahl et al. (1975) reported severe but sporadic degradation of plantings by rabbits and insects.



Carnivores. Large carnivores such as the coyote (Canis latrans) do not live on the beach but occasionally visit it. Their abundance is controlled by conditions in adjacent upland systems.

#### Import/Export of Biotic Attributes

This is shown in the model as migration. The following sections relate the migration of various biotic types in more detail.

Scavengers and birds to other systems. While ghost crabs and beach fleas are not found outside the beach system, the bird species are found in many other ecosystems of the Texas coastal zone. Summary tables and discussions on beach birds and their habits are given in Brogden, Oppenheimer and Bowman, (1977).

Herbivores to other systems. The rodents which occasionally feed on beach plants generally have burrows in adjacent uplands, such as dune and barrier flat systems. Adjacent uplands are also a reservoir for herbivorous insects.

Carnivores to other systems. Large carnivores are also dependent on adjacent uplands and migrate into the beach system for only short periods.

#### Critical System Attributes

The most important factors in maintaining a healthy Texas beach are those which have to do with erosion and deposition of sand. The single most important factor is the supply of sand from the upper shoreface system which is dependent on littoral drift. If sediment does not accumulate during good weather, erosion during storms will produce a very narrow beach and possibly affect adjacent upland systems. Pioneer plants are also extremely important since they can control the transmission of sand from the backshore to upland

systems. On beaches heavily used for recreation, traffic may be the most important factor in controlling the growth of the pioneer plants.

## BRACKISH MARSH

### Introduction

Extensive brackish marsh areas occur in Texas on the mainland and the bay side of the barrier islands in the middle and upper portions of the coast (Brown et al. 1972-77). Brackish marshes along the drier lower coast, south of Corpus Christi Bay, are generally associated with rivers and creeks where there is a more consistent supply of fresh water. This habitat type is generally found between the salt marsh and either fresh marsh or one of the dry land habitats such as coastal prairie or brush. In many cases, it represents a transition between salt and fresh marsh habitats. This is especially noticeable in the wetter areas of the upper Texas coast. Brackish marsh is usually found in areas that are irregularly inundated by salt water, but have a high fresh water table and are regularly flooded by fresh water.

Recent reports on the influence of freshwater inflows to several Texas bay systems by the Texas Department of Water Resources (1980-81) give good accounts of studies of specific brackish marsh systems in Texas. Figure 34 represents the brackish marsh habitat.

### Energy Sources

Sunlight. Solar energy input provides the major source of energy used by the vascular plant based food web of the brackish marsh ecosystem.

Upland drainage. Drainage from streams and overland sources provides the major source of nutrients, toxics and organic matter to the brackish marsh ecosystem. It is the primary supplier of fresh water to this system. This

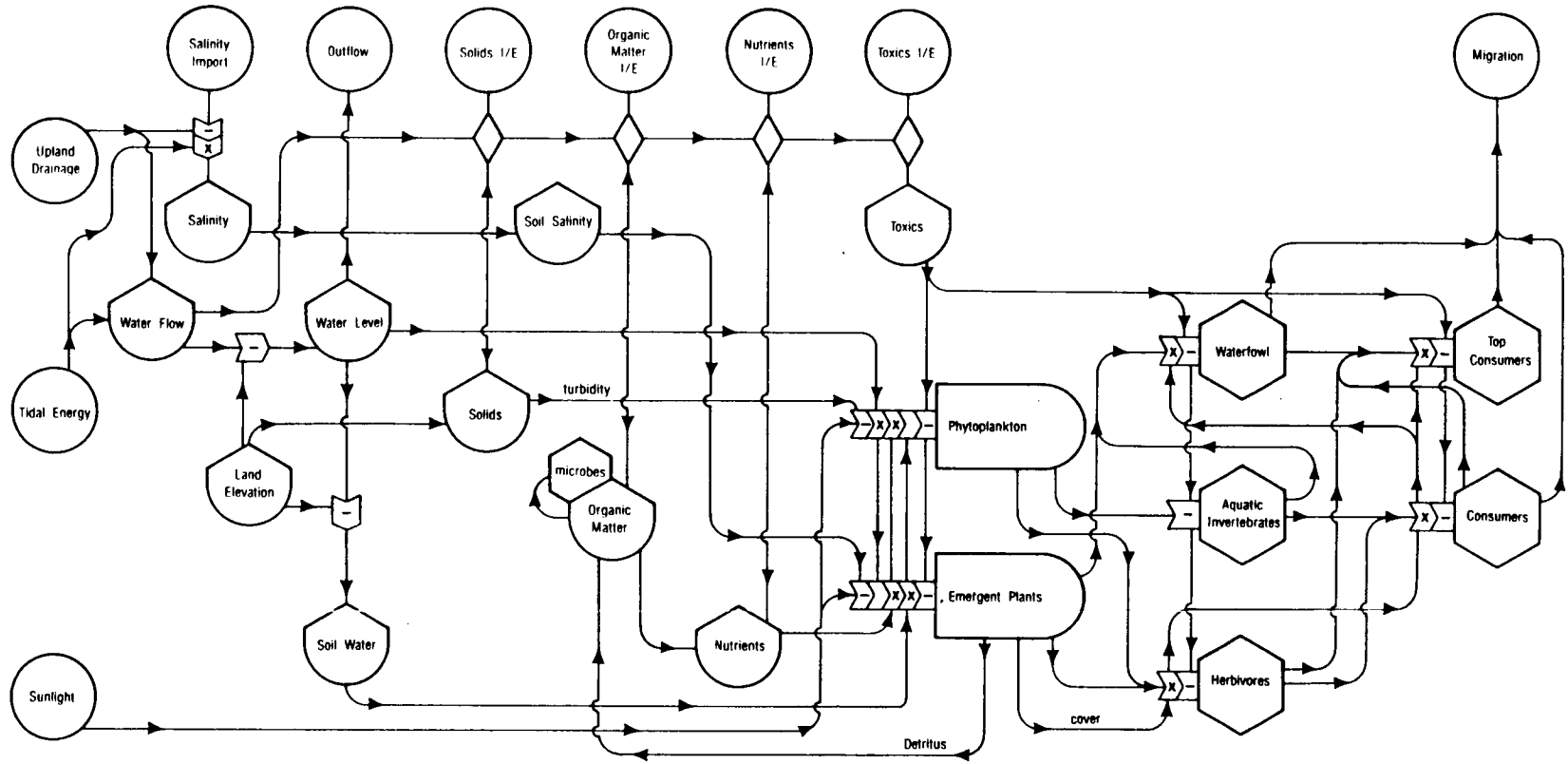

FIGURE 34. Brackish marsh habitat.

can produce significant short-term changes in the salinity of the brackish marsh.

Tidal energy. Both astronomical and wind-driven tides provide input into the water flow of the brackish marsh system. Tidal energy is generally a minor energy source but does drive the salinity input into this system.

Subsidence. Portions of the middle and upper Texas coastal plain have subsided as much as several meters (Brown et al. 1972-77). This subsidence has been caused by pumping of underground water, oil and gas reservoirs. Subsidence has a direct effect on the land elevation and thereby the water level of the brackish marshes. Subsidence tends to change brackish marsh into salt marsh by allowing more frequent tidal inundation.

#### Physical Attributes

Salinity. Salinity is one of the most important attributes in maintaining the brackish marsh ecosystem. Although the salinity of the water in the brackish marsh may temporarily vary from less than 1 ppt to over 35 ppt, most brackish marsh plants prefer water salinity less than 5 ppt (Gosselink et al. 1977). It is one of the primary factors controlling the presence or absence of aquatic biota. Its variations, which are due primarily to the frequency of inundation by salt water and the amount of local runoff, partially control the distribution and abundance of mobile organisms and the distribution of benthic organisms. Local runoff via small streams or ditches and direct overground flow reduces the salinity during and after heavy rainfall periods. This affects the brackish marsh system for some time, especially in areas that receive infrequent inundation by bay waters. In most cases, it is the presence of salt water that keeps the brackish marsh from becoming a fresh marsh.

Soil salinity. This attribute represents the salinity within the sediments or soil of the brackish marsh system. It is controlled by the salinity of the water in the system. During periods of exposure, the drying of surface sediments may cause migration of soil salts similar to that which occurs in the wind tidal flat system. When this occurs, bare areas with high soil salinities may occur within the brackish marsh system. This happens most often in the drier areas of the lower Texas coast. The salinity of the soil greatly affects the growth of the emergent plants of the brackish marsh. Although many of them can tolerate elevated soil salinities, most prefer little soil salinity (Gosselink et al. 1977).

Water flow. Water flow in the brackish marsh is used to represent the physical flow of water caused by tidal and/or wind inundation of bay water and freshwater runoff. The water flow is analogous to currents in deeper water systems. The major direction of the water flow in the brackish marsh is "in" during high enough flood tides or very strong onshore winds and "out" during ebb tides, offshore winds or periods of freshwater runoff. The water flow drives the import and export of physical and biotic attributes. Upland drainage is the primary energy source for water flow in the brackish marsh systems of Texas.

Solids. The solids attribute is used to show the physical effects of particulate matter, such as the covering of the bottom fauna as well as the mass or volume of sediment within a particular area of the brackish marsh. Suspended solids are introduced into the brackish marsh waters primarily by import from adjacent systems via water flow. They may be removed from the water column via settling in the marsh or they may be exported to adjacent ecosystems.

This attribute also provides an input to land elevation which in turn affects the water level and tidal energy. Rapid sedimentation from storm water runoff may be particularly detrimental to organisms such as benthic micro-algae via settling on them and phytoplankton by causing excess turbidity.

Land elevation. This attribute represents the physical elevation of the land mass relative to sea level. It is increased by the import of solids and decreased by subsidence. It directly affects the amount of water flow and water level in the brackish marsh as well as the amount of tidal energy that reaches the marsh.

Water level. This attribute is primarily controlled by water flow. The water level of the brackish marsh system may vary from over one meter during high water periods to dry during droughts. Many of the Texas brackish marshes have only a few centimeters of water covering them during much of the year. This may vary only a few centimeters with the tides and normal runoff. The depth of the water in the brackish marsh is one of the most important factors controlling the migration of aquatic organisms in this system. It is also highly important in controlling the primary production via phytoplankton and benthic algae, especially in marshes that are exposed for extended periods.

Soil water. This attribute is derived from water level and is used to show the amount of saturation of the soil. Since many of the brackish marshes on the Texas coast are only infrequently inundated by tides or upland drainage and rainfall, the soil water content is very important in determining the types of emergent plants that occur in the system. Increased soil water encourages increased growth of sedges and rushes. Decreased soil water promotes the growth of more of the coastal prairie species.

Nutrients. Nutrients are organic and inorganic materials required by the phytoplankton and emergent plants for photosynthesis, in addition to light. Nitrogen and phosphorus are the major nutrients associated with primary production in the brackish marsh, although many additional nutrients and trace elements are also needed. Nitrogen is generally considered to be the limiting nutrient in Texas bays (Davis 1973). A significant portion of the nitrogen used in the brackish marsh ecosystem probably comes from upland drainage. Some may be recycled from the sediments via reduction and bacterial action. The Texas Department of Water Resources has computer data banks of nutrient data from sampling in the brackish marshes of many Texas bays.

Organic Matter. "Microbes" are partially combined with the symbol representing organic matter in the water and sediments since they are an integral part of the cycling of energy via decomposition. The amount of organic matter in brackish marshes is generally very high due to the high primary productivity of the emergent plants. The annual net production of Texas brackish marshes with large amounts of Spartina patens may approach that of the Spartina alterniflora dominant salt marsh, but generally is somewhat less at 1,300 to 1,900 g/m<sup>2</sup>/yr (Henderson and Harcombe 1976). Due to the low frequency of tidal inundation, much of the production of marsh grasses may accumulate and be incorporated into the sediments until major storm events remove the litter. However, the average annual export of organic matter may still be quite large.

The benthic infauna ingest the organic matter from the sediments or the surface of the sediments as do some of the herbivores and detritivores. This is an important food source for many species.

Toxics. Toxic materials which could be introduced into the brackish marsh system include heavy metals, pesticides, industrial organic chemicals, well drilling fluids, crude oil and petrochemicals. Many toxic materials are readily adsorbed on fine particles. They are then quickly incorporated into the sediments. Some of these toxics may reach higher levels in the food chain via bioaccumulation by filter feeders and consumption by higher order consumers. Toxics enter the brackish marsh system primarily via water from upland drainage; however, high tides may push toxics into the system from the bays.

Each bay in Texas varies greatly in its sediment concentrations of toxic materials. Available data which document the concentrations of heavy metals, pesticides and chemicals such as PCB show that they are found in the sediments of nearly all of the bays of Texas (TDWR Computer Data Files). Data from the TDWR files show that the sediments in the channels, rather than the bay proper, contain the higher accumulations of toxics. Most of the toxic materials settle out into the deeper portions of the bay system with the finer sediments (McGowen 1979). This would indicate that the brackish marsh system would be expected to have elevated toxic concentrations only if they were introduced by nearby spills or via upland drainage.

#### Import/Export of Physical Attributes

Salinity Import/Export. The brackish marsh system receives most of its salinity from tidal inundation by salt water from the bay ecosystem. Local rainfall and upland drainage lower the water salinity in the brackish marsh system. The TDWR water quality data base contains extensive salinity data on all of the Texas bays. The Environmental Geologic Atlas series (Brown et al.



1972-77) also discusses the distribution of salinity in the bay systems of Texas.

Water outflow. This attribute is used to show the flow of water from the brackish marsh system to adjacent systems. It is driven by high water flow in the brackish marsh caused by upland drainage, direct rainfall or tidal inundation.

Solids Import/Export. The brackish marsh system receives most of its solids input from neighboring ecosystems via inundation by upland drainage containing high suspended solids concentrations. It exports some solids during high runoff periods, but is generally an importer of solids.

Nutrients Import/Export. Import from the neighboring ecosystems, upland drainage, nitrogen fixing by bacteria and blue-green algae and recycling of sediment nutrients provide the majority of the nutrients to the brackish marsh system. Some of the nutrient load brought to the brackish marsh system by upland drainage via streams actually originates as waste discharges and agricultural runoff in some areas.

Toxics Import/Export. Toxics such as agricultural pesticides or industrial wastes may be imported along with the fresh water runoff into the brackish marsh. Some are introduced into the brackish marsh system via spills or treatment plant outfalls. Crude oil may be imported via the passes (inlet-tidal delta systems) from the gulf in the case of spills in the nearshore gulf or upper shoreface. Toxics from spills in the adjacent bay area ecosystems may find their way into the brackish marsh system.

Organic Matter Import/Export. Most of the organic matter that enters the brackish marsh system via fresh water from upland drainage or import from the adjacent estuarine system is either dissolved or suspended particles of

vegetation and animal matter. Brackish marshes produce large amounts of their own organic matter that may be exported in large pieces during storms (Keefe 1972).

The brackish marshes containing large amounts of marshhay cordgrass may export as much as 40-50% of their annual production to the aquatic systems of the bays. Most of this export occurs during storms since they are usually subjected to relatively little regular tidal energy and water flow.

#### Biotic Attributes

Phytoplankton. The major portion of the primary productivity of the brackish marsh system is provided by the emergent marsh plants. The phytoplankton are of much lesser importance due to the small volume of water; however, they supply a relatively larger amount of primary productivity during the winter months when the emergent plant growth slows. The rate of phytoplankton photosynthesis depends on light penetration and nutrient availability (Armstrong and Hinson 1973). The possibility of suppression of photosynthesis by toxic materials exists, but its extent in Texas bays is currently unknown. Van Baalen et al. (1973) detected toxicity in Galveston bay waters using a phytoplankton bioassay.

Emergent plants. Spartina patens (marshhay cordgrass) is the primary species of emergent vegetation in most brackish marshes on the upper Texas coast. Brackish marshes may also be populated by Distichlis spicata (saltgrass), and various sedges and rushes in the upper Texas coastal areas which receive much more rainfall and upland drainage. The emergent plants provide the basis for the overall animal species richness of the brackish marsh system by providing large amounts of food and shelter.

Herbivores. This group comprises one of the largest consumer groups in the brackish marsh system. The aquatic animals range in size from the small zooplankton to the striped mullet (Mugil cephalus) (Odum 1970). Most of the crustaceans (shrimp, crabs, etc.) are herbivorous or detritus feeders or both at one stage in their life cycle (Coastal Fisheries Branch 1975; Cook and Lindner 1970; Costello and Allen 1970; Lindner and Cook 1970). Many of the larval stages of the higher level fish fall into this category (Dineen and Darnell 1976). Many of these organisms move into the brackish marsh system to feed on the benthic algae, phytoplankton or organic matter, and to escape larger predators in the shallow water. The young of many of these organisms spend much of their early life stages in the brackish marsh system.

Waterfowl and herbivorous mammals are also very prominent herbivores in the brackish marsh system. The waterfowl are discussed separately in a later section. Muskrats and nutria are common herbivores found in the brackish marsh system. They may consume large amounts of the emergent plants. The brackish marsh is the preferred habitat for these important furbearers.

Aquatic invertebrates. This attribute is used to show both the carnivorous zooplankton and benthic invertebrates of the brackish marshes of Texas. The zooplankton found in the brackish marsh are imported from the adjacent systems and may be species from fresh to brackish habitats or marine species from the bay system, depending upon the amount of runoff and tidal inundation (Cuzon du Rest 1963). Polychaetes, nematodes, ostracods, and copepods can be found in the brackish marsh benthos. These organisms feed primarily on the smaller aquatic herbivores and detritivores and comprise the second level of the detritus-based food chain for which the brackish marsh

provides the primary production. Many of the higher trophic level organisms depend, at least partially, on the aquatic invertebrates for their food.

Intermediate Consumers. This compartment is primarily concerned with the predatory organisms below the level of top consumer. Aquatic species such as the tidewater silversides Menidia beryllina, rainwater killifish (Lucania parva), blue crab (Callinectes sapidus), sheepshead minnow (Cyprinodon variegatus), which prefers water less than 10 cm deep and feeds on algae, detritus and small benthic animals, and several species of killifish (Fundulus similis, grandis and others) spend much of their time in the very shallow waters of the brackish marsh system.

Various wading birds such as egrets, bitterns, herons and ibises prey on the smaller organisms of the brackish marsh. Some also nest in the marsh. The brackish marsh is the most saline habitat that supports amphibians in significant numbers. Also, there are many reptile species which occur in the brackish marsh in addition to terrestrial and freshwater habitats. Mammals such as raccoons and mink are also intermediate consumers in this system.

Top Consumers. The top consumers of the brackish marsh system are primarily the juveniles of game fish of the bay system, birds of prey, coyotes, red wolves, and alligators. Juveniles of aquatic species such as Cynoscion nebulosus, Sciaenops ocellata and Pogonias cromis frequent the brackish marsh system, when the water level permits, in search of prey. Coastal Fisheries Branch (1975) and Hoese (1965) are two of the more comprehensive references on the top aquatic consumers and their habitats. The birds of prey (hawks, owls, osprey, eagles) may nest in trees near the brackish marsh and feed on the numerous smaller animals of the marsh. The coyote and red wolf feed on the various intermediate consumers and herbivores.

The alligator will eat practically any and all of the other marsh inhabitants if given the chance.

Waterfowl. The waterfowl are discussed separately because they are so important in the brackish marsh system. Many species of waterfowl feed on micro-organisms or vegetation in the brackish marsh system during the winter months. Many of them rest on the shore adjacent to the brackish marsh where their droppings may be washed back into the system to provide nutrient input. Brogden et al. (1977 in Kier and Fruh 1977) discuss the use of this habitat by the birds in the Corpus Christi Bay area. Most of the waterfowl found in the brackish marsh systems in Texas are the winter migrants. The brackish marsh system is the preferred habitat for many species of the millions of ducks and geese which winter along the entire Texas coast.

#### Import/Export of Biotic Attributes

Phytoplankton. The brackish marsh may contain both marine and freshwater species of phytoplankton, depending upon the salinity of the water and the amount of tidal inundation. Marine phytoplankton are imported and exported via the inundation of bay water. They are of minor importance in the overall productivity of the brackish marsh system as are the freshwater phytoplankton, due to their relatively small biomass when compared to the emergent plants. They may provide a relatively larger portion of the production in the small pools which occur within the brackish marsh system.

Migration. Migration with respect to the brackish marsh system represents the movement into and out of the brackish marsh area from other systems as opposed to the seasonal migrations of organisms between the Gulf and bay systems or seasonal waterfowl migrations. This between system migration is cued primarily by water flow and water level. The planktonic

organisms are carried into and out of the brackish marsh system during inundation by salt water or upland drainage. More motile organisms move in and out of the system when the conditions are favorable to them.

Killifish, silversides and small mullet are the most visible members of the herbivore and detritivore group that migrate between the bay and the brackish marsh systems. Smaller juveniles of many intermediate and top consumers can be found in large numbers during certain times of the year in the brackish marshes.

The Penaeid shrimp spawn offshore in the gulf and the postlarvae migrate into the bays to mature (Cook and Lindner 1978; Lindner and Cook 1970; Costello and Allen 1939). These postlarvae usually proceed to the brackish marshes and other shallow water systems in the bays where they feed on the benthic algae and organic matter in the relative safety of the shallows.

Most of the aquatic intermediate consumers spend much of their life cycle in the bay or migrate through it. As juveniles, many of them thrive in the food-laden shallow waters of the brackish marsh areas.

The gamefish, which comprise the more important top consumers, migrate at various times of the year as do the intermediate consumers. Their migrations depend upon their spawning periods and various physical factors as mentioned above. No two species migrate at exactly the same time. Many of the smaller individuals seek out the brackish marsh areas for refuge from the larger predators and to feed on the juveniles of other species in the brackish marsh system.

#### Critical System Components

The most critical component of the brackish marsh system is upland drainage (and rainfall). This freshwater input brings with it nutrients,

organic matter and toxics. It keeps the salinity to a minimum and allows the emergent plants to produce large amounts of organic matter upon which the important detritus food chain is based. The emergent plants are also a critical component since they are the source of most of the carbon produced in the brackish marsh system. Changes in the water regime will quickly result in changes in the species composition and productivity of the brackish marsh system.

## BRUSH

### Introduction

Brush areas occur in Texas on the mainland primarily in the lower portions of the coast (Brown et al. 1972-77). Over 90 percent of this habitat type in the Texas coastal zone is found in the southern portion of the state, south of Corpus Christi Bay. In Texas, brush is usually found in areas that are not inundated by salt water, but some are subject to infrequent flooding by fresh water from extreme over-bank river flooding. For the purpose of this report, brush is differentiated from coastal prairie by the higher percentage of woody plants (brush) as opposed to the grasses since these two systems are constantly competing for spatial coverage. Fire and overgrazing by domestic livestock are the two most important factors regulating these systems today (Bragg and Hulbert 1976; Daubenmire 1968; Johnston 1963).

Some of the brush areas may be occasionally flooded by salt water during extreme storms, but in general, they are not exposed to significant inundation by salt water. This system occupies over 1,000 square miles in the coastal areas of the state (Brown et al. 1972-77). Figure 35 is the conceptual model for the brush habitat.

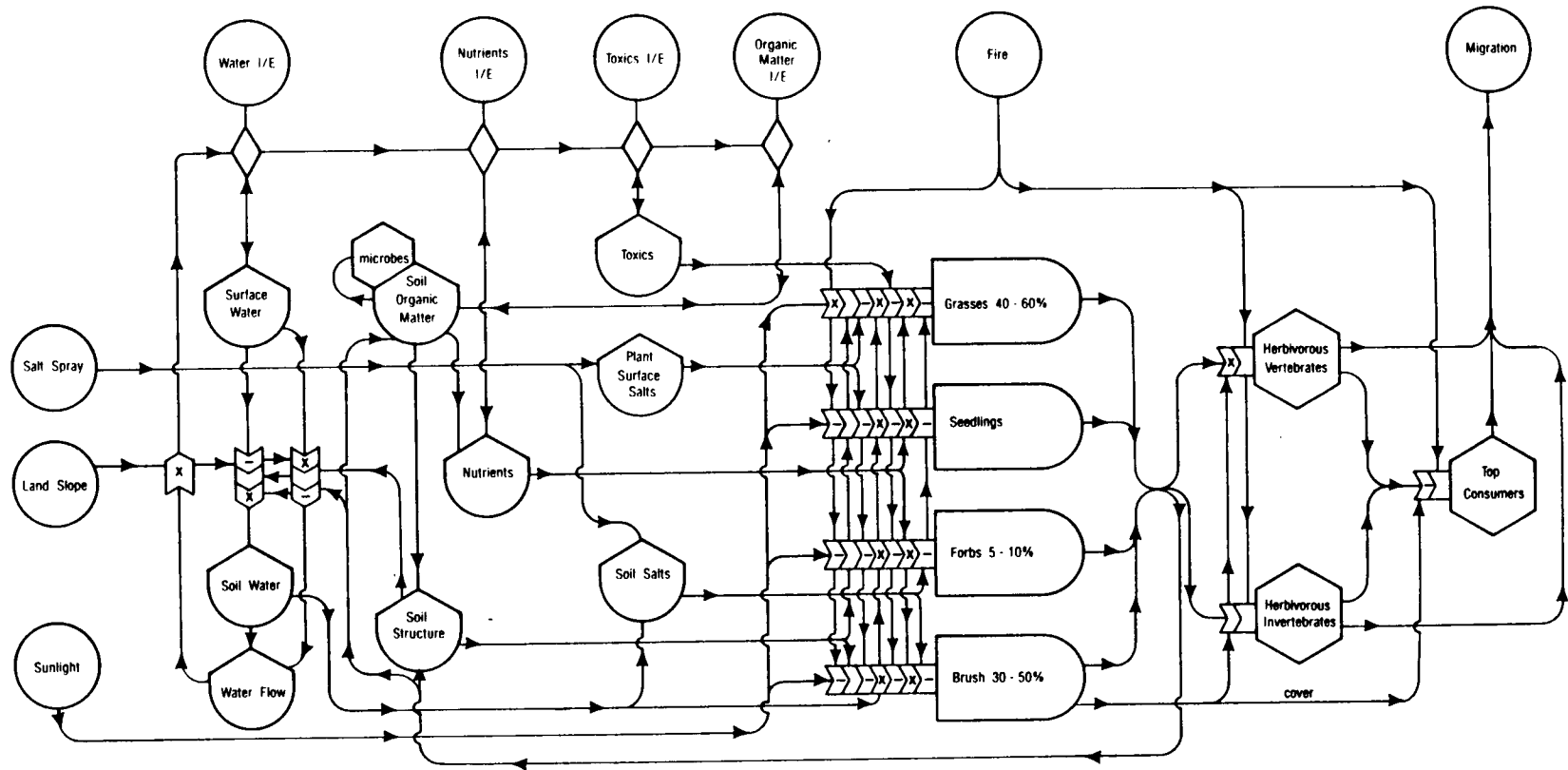

FIGURE 35. Brush habitat.



## Energy Sources

Sunlight. Solar energy input provides the major source of energy used by the vascular plant based food web of the brush ecosystem.

Precipitation. Direct input of water to the brush via precipitation may be a significant source of energy, especially in the southern portions of the upper Texas coast where the precipitation may be less than 20 inches annually. The brush species tend to have deeper roots than the grasses and are able to withstand drouths better; therefore, they may be favored in areas of little rainfall.

Salt Spray. Much of the brush is close enough to the Gulf of Mexico or Texas bays to receive salt spray, especially during periods of high winds. This salt spray introduces not only NaCl to the system, but all of the other mineral salts and nutrients, etc. that occur in the salt water of the gulf. This may be a significant factor in the growth and survival of vegetation that is constantly exposed to this spray (Boyce 1954; Oosting and Billings 1942).

Land Slope. Land slope represents the physical slope of the land surface. This greatly affects the surface water, soil water and water flow. Most of the coastal area of Texas has very little overall slope. But small scale variations in topography may be sufficient to alter the land slope and hydrologic regime. Increased land slope increases water flow and decreases the infiltration of water into the soil. Brush species may have an advantage over the grasses on the more sloping areas where the soil moisture is lower.

## Physical Attributes

Water flow. Water flow in the brush is used to represent the physical flow of water derived from surface water. The water flow is analogous to currents in aquatic systems. The major direction of the water flow in the

brush is "down slope". The water flow drives the import and export of physical and biotic attributes. The flows which accompany extreme precipitation may remove much the loose organic matter from the soil surface.

Surface water. This attribute is controlled by precipitation. The water level within a brush system may vary from several centimeters during high water periods to dry during non-flood periods. Most of the brush areas in the middle Texas coast are inundated by precipitation several times each year. This inundation may vary from only a few centimeters for a few hours with normal precipitation and overland runoff to significantly more water for longer periods during periods of high rainfall associated with tropical storms or hurricanes. The frequency and duration of inundation is one of the most important factors affecting the vegetation in the brush system. Surface water directly affects soil water.

Soil water. This attribute is derived from surface water and is used to show the frequency and amount of saturation of the soil. Soil water content is very important in determining the types and abundance of plants that occur in the brush system. Soil water provides the transport mechanism for the nutrients used by the vegetation. Frequent periods of high soil water interspersed with drying periods provide conditions more appropriate for the growth of grasses in the brush system. Adequate supplies of deeper soil water provide conditions that are more appropriate for woody plant growth and survival in the brush habitat.

Nutrients. Nutrients are organic and inorganic materials required by the plants of the brush system for photosynthesis, in addition to light. Nitrogen and phosphorus are the major nutrients associated with primary production in the brush, although many additional nutrients and trace elements are also

needed. A small portion of the nutrients used in the brush ecosystem come from upland drainage. The majority of the nutrients originate in the soil or air and are recycled by bacteria, fungi and nitrogen fixing plants. Since the leaves of the plants contain higher percentages of nutrients than the woody parts, leaf litter efficiently recycles many of the nutrients.

Soil Organic Matter. "Microbes" are partially combined with the symbol representing organic matter in the soil since they are an integral part of the cycling of energy via decomposition. The amount of soil organic matter in brush areas is generally quite small due to the high temperatures which induce rapid decomposition and accumulation of carbon in the woody species and the export of much of the primary productivity by grazers.

Soil Structure. The larger root systems of the woody species in the brush system tend to break up the relatively hard soils of the south Texas area to a greater depth than the grasses. This loosening of the soil promotes soil formation and slows the runoff of precipitation over the hard ground.

Toxics. Toxic materials which could be introduced into the brush system include heavy metals, pesticides, industrial organic chemicals, well drilling fluids, crude oil and petrochemicals. Toxics enter the brush system primarily via water from upland drainage and precipitation; however, storm tides from hurricanes may push toxics into the system from the bays. The brush system would only be expected to have elevated toxic concentrations if toxics were introduced by local spills or washed out of the air by precipitation.

Plant Surface Salts. Areas of the brush that are close to the bays or Gulf of Mexico are subject to salt spray. Trees that are more or less constantly subjected to salt spray tend to be adversely affected in their growth rates and patterns. Because of the lower precipitation in the lower

portion of the Texas coastal area, brush plants are more likely to show the effects of the buildup of plant surface salts than the areas of the middle coast where the higher rainfall tends to wash the salts from the leaves more often. Details of the effects of plant surface salts on vegetation in the coastal area can be found in Boyce (1954) and Oosting and Billings (1942).

Soil Salts. The accumulation of salts in the soil within the brush system occurs in all areas but is most noticeable in areas on the lower Texas coast which are exposed to nearly continuous salt spray and receive little precipitation. The salts of various minerals tend to accumulate on the leaves of the shrubs and are leached from the leaves by rainfall (Spurr 1964). High rainfall tends to leach the salts deep into the soil and subsoil or export them in the runoff. Small amounts of precipitation tend to transport the salts into the upper soil layers where they accumulate. Periods of drying, especially of sandy type soils, may also bring some of the deeper salts to the soil surface by capillary action. Excess soil salts, especially NaCl, can be detrimental to the brush plants (Boyce 1954).

#### Import/Export of Physical Attributes

Water outflow. This attribute is used to show the flow of water from the brush system to adjacent systems. It is driven by high water flow within the system which is caused by precipitation. Under normal conditions, there may be very little water outflow the brush areas of Texas. However, during periods of intense precipitation, especially during hurricanes and tropical storms, the water outflow is significant.

Nutrient Import/Export. Nutrient import from the neighboring ecosystems is believed to be minimal in the brush system. Nitrogen fixing by bacteria and some plants and recycling of soil nutrients provide the majority of the

nutrients to the brush system. Water flow resulting from precipitation is the major factor affecting nutrient export in the brush system.

Toxics Import/Export. Toxics such as agricultural pesticides or industrial wastes may be imported into the brush by washout from the air during precipitation or by upland drainage. Most is expected to be introduced directly into the brush system via spills. Toxics from spills in the adjacent ecosystems may find their way into the brush system during storm conditions. Brush areas that contain toxic materials may export these during periods of high precipitation. No data are available on the general concentrations of toxics in the brush habitats of Texas.

Organic Matter Import/Export. Most of the organic matter in the brush system is produced there by the vegetation. The small amount that may be imported via upland drainage is either dissolved or suspended particles of vegetation and animal matter. The amount exported directly to other systems varies primarily with the amount of leaf litter fall since much of the productivity is accumulated in the woody parts of standing vegetation such as trees. Some may be exported during storms such as hurricanes. However, most is probably exported by grazing animals, some of which are harvested by man. Excessive grazing and removal of organic matter decreases the coverage of grasses and increases the coverage of woody species in the brush system (Tharp 1925). Overgrazing also decreases the incidence of fire, the lack of which also tends to favor the growth of woody species.

Fire. Fire can be important in regulating both the plant and animal communities as well as altering the nutrient cycling within the brush system. Fire increases the rate of breakdown of vegetative matter into nutrients, opens the canopy and clears the ground of accumulated litter so that new

growth can begin, and starts the succession of plant and animal communities over again. Fire changes the relative proportions of nutrients since some such as nitrogen are consumed by fire. Fire of sufficient intensity to burn the woody species increases the coverage of grasses in the brush system (Daubenmire 1968; Weaver 1954).

### Biotic Attributes

Brush. The brush areas of the Texas coastal areas contain only a few species of trees. Dwarfed live oak tree or more likely "bush" is found in large areas along the middle portion of the Texas coast, and occasionally on the barrier islands. The live oaks are extremely hardy and are resistant to salt spray to a great extent. They will usually be found close to the bays where no other native trees will grow. Further inland, the tree species of the brush habitat are primarily mesquite, and several of the acacias. Although the trees are the most prominent, they probably contribute little net annual primary production to the brush system.

Several "shrubby" species make up the majority of the "brush" in the brush habitat. The most common of these are spiny hackberry, lime prickly-ash, yucca, pricklypear cactus and narrowleaf forestiera. These species add to the primary productivity and provide habitats for some of the species of animals which inhabit the brush.

Seedlings. The seedlings of the trees of the brush system contribute a very small portion of the primary productivity of the system. However, they are important since they perpetuate the system by replacing the trees that die from various causes.

Forbs. Many species of forbs or perennial herbs may grow in the brush habitat. Most of these are extremely hardy species. These probably

contribute only a small percentage of the net primary productivity of the brush system.

Grasses. Many species of grasses may be found in the brush habitat since it is an invader of the coastal prairie habitat. The majority of these are the same perennial grasses such as bluestems, panic grasses, buffalograss, switchgrass, indiagrass, crinkleawn, and many others (Gould 1975) which are found in the coastal prairie. They contribute significantly to the overall productivity of the brush habitat.

Herbivorous Invertebrates. This group comprises one of the largest consumer groups (in terms of total numbers of individuals) in the brush system. The majority of these invertebrates are insects and ground dwelling crustaceans. The detritivores are also included in this category. They may be the largest in total numbers since the brush habitat incurs little physical disturbance except from precipitation and water flow which would disrupt them. During the long growing season (long in days but plant growth is often interrupted by drouths), the insects probably rival the mammalian herbivores in total consumption of plant material.

Herbivorous Vertebrates. The plant-eating vertebrates are separated from the invertebrates in this model since they are so important in the brush system. Native herbivores such as deer, rabbits, mice, ground squirrels and seed-eating birds such as bob white and scaled quail are abundant in the brush habitat where excessive cattle grazing does not occur. Burrowing organisms such as gophers and ground squirrels may play an important role in the brush ecosystem. They loosen the soil with their burrowing and assist in keeping it aerated. Their burrows also allow precipitation to penetrate the soil more rapidly.

Cattle are the most important herbivore in most of the brush habitat. In areas where their populations exceed the optimum carrying capacity of the annual plant production, their presence tends to increase the spread of woody species rather rapidly, while at the same time keeping the growth of the existing grasses to a minimum. Along with fire, excessive cattle grazing is the most important regulating factor of the brush habitat (Ellison 1960).

Top Consumers. The top consumers of the brush systems are primarily the birds of prey, coyote, and bobcat. Birds of prey ( hawks, owls and eagles) may nest in the trees of the brush system and feed on the numerous smaller animals of the system. This habitat supports large numbers of birds of prey which migrate from the north during the winter months.

#### Import/Export of Biotic Attributes

Migration. Migration with respect to the brush system represents the movement into and out of the brush area from other systems. There is very little regular migration of animal species between this and other systems. Many mobile animals such as birds and larger mammals move between the brush and coastal prairie in order to find food or water; however, most true brush species prefer this habitat and move very little.

#### Critical System Components

The most critical components of the brush system are fire, herbivorous vertebrates and precipitation. Precipitation provides the energy for the exchange of nutrients, organic matter, fresh water and toxics between the brush and other systems. This freshwater input keeps the soil water levels high enough to allow the plants to produce organic matter upon which the important detritus food chain is based. Changes in the water regime,



incidence of fire and/or cattle grazing practices quickly result in changes in the species composition and productivity of the brush system.

## BULKHEAD AND PILING

### Introduction

This model is applicable to most man-made bulkheads, oil platforms, and other hard surfaces in estuarine and nearshore waters. Major unique factors include toxic materials (bottom paints, piling impregnating compounds), water flow modifications, and similar effects. Because hard surfaces are present in a variety of estuarine waters, ranging from Gulf of Mexico passes to waterfront housing developments and industrial harbors, any species mentioned are only examples.

The area covered by this habitat is very small, only the surface of the bulkhead and the immediately adjacent water column. However, this habitat is very significant to man for both recreation and industrial purposes. Its major impacts on coastal ecosystems as a whole appear to be as an increaser of habitat diversity and modifier of current and wave energies. Figure 36 represents the bulkhead and piling habitat.

### Energy Input/Output

Sunlight. Major energy inputs to the bulkhead system include sunlight, wave energy, and current energy. Sunlight energy is used by the algae community but may be reduced by the man-made structure. This shading will naturally be very site-specific, with some parts of a given structure receiving constant light and others very little.

Wave energy. Wave energy is generated by wind or boat movements in adjacent waters and enters the bulkhead system. After modification by the structure, a substantial portion of the wave energy can be reflected.

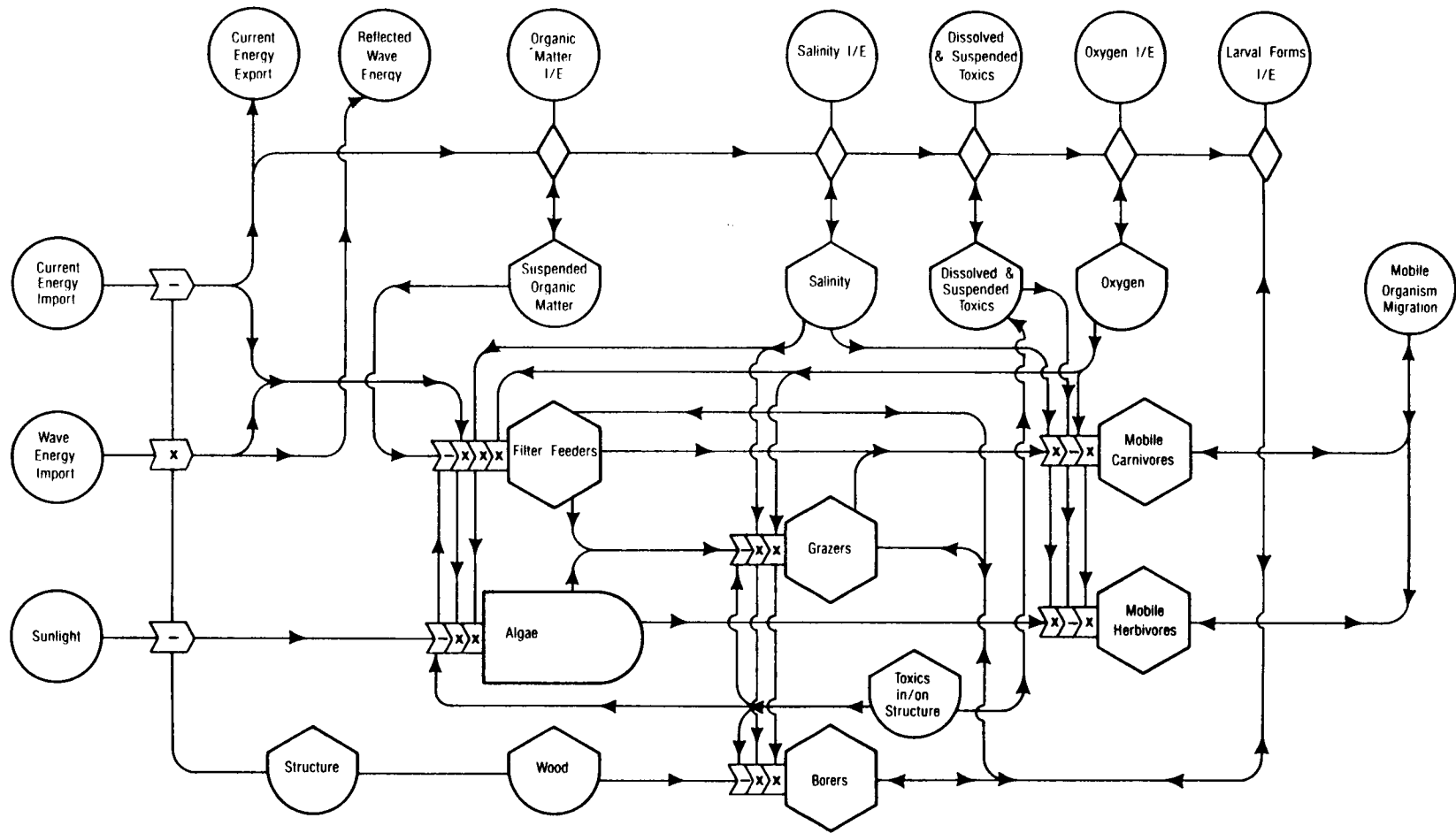

FIGURE 36. Bulkhead and piling habitat.

Reflection of wave energy is discussed extensively in the U.S. Corps of Engineers Shore Protection Manual (CERC 1977).

Current energy. Current energy also enters from adjacent systems, transporting materials in and out of the habitat. Some structures such as piers may pass most of the current energy with little modification, while others may stop it completely. The water movements induced by current and wave energy are vital to the organisms associated with the bulkhead surface. The intensity of movement may control which species can survive. Water movements bring food particles within range of the filter feeders, and dissolved nutrients to the algae.

#### Physical Attributes - Hard Surface Subsystem

The internal components of this model may be divided into a water subsystem and a hard surface subsystem. The actual species present will depend on physical factors such as salinity and exposure to wave energy; however, there will generally be some in each class shown in the model: filter feeders, borers, algae and other carnivores on the surface, and mobile carnivores and herbivores in the water subsystem.

Structure. This attribute represents the actual physical structure of the hard surface subsystem, and its effects on the transmission of solar, wave, and current energy through the system. This effect is of course dependent on the design of the individual structure and its placement with respect to the energy sources.

Wood. If wood is present in the structure, there is potential for a population of boring organisms using the wood for food or for a substrate (Lindgren 1974). The most important controlling factors for this population

will be any toxic coatings present, the water salinity, and the availability of oxygen.

Toxics. A wide variety of toxics are used to protect bulkhead structures, both impregnated into wood and as protective coatings. Toxic anti-fouling coatings are designed to slowly release the toxic component, creating a thin zone near the surface which has high enough levels of the toxicant to kill larvae which settle on the surface. Many of these materials are not biodegradable or are highly resistant; thus as they leach into the water they may become a significant factor in adjacent systems.

Filter feeders. Filter feeders such as the barnacle (Balanus sp.) and oyster (Crassostrea virginica) are quite common in this habitat. Barnacle and oyster larvae are common in the estuarine zooplankton, and they are quick to settle on any new surface. Gunter and Geyer (1955) describe the consumer communities on offshore oil platform structures from the Louisiana and Texas coasts. Much of this material should be pertinent to estuarine structures.

Algae. The development of algae on the structure surface depends on the amount of sunlight, wave energy intensity, and salinity. Only the species associated with jetties (Edwards 1976; Kapraun 1980) appear to have been studied extensively. This model does not attempt to represent the complex zonation of the algal community.

Other consumers. Consumers which may appear in close association with the surface include grazers such as limpets and snails, which feed on the algae, and carnivores such as the drill, Thais haemastoma, which feeds on barnacles and oysters. Fotheringham and Brunenmeister (1975) give an introductory treatment of these organisms.

## Physical Attributes - Water Subsystem

Suspended organic matter. This compartment includes both detritus and phytoplankton which are harvested from the water by the filter feeders. Although decomposition of algae and the activities of attached consumers produce particulate organic matter, bulkheads are probably net consumers of organic matter just as oyster reefs are. However, there is little data on the subject.

Salinity. Salinity undoubtedly exerts some control on the survival and activities of the organisms of the system just as it does in the oyster reef habitat (Galtsoff 1964).

Oxygen. Dissolved oxygen is required by all major consumers and can be a limiting factor in systems with limited re-aeration, such as some residential canals, or with high BOD loadings, such as some harbors. If stratification is present in the water, lack of oxygen may prevent development of a bulkhead surface community near the bottom, while the near-surface community flourishes.

Dissolved and suspended toxics. In addition to the toxics released by treated surfaces, the water may contain toxics from other sources such as accidental spills and industrial discharges. Floating oil spills tend to collect on bulkhead surfaces and are then hard to remove without damage to the community.

Mobile carnivores. Within the water subsystem, there are many consumers which are mobile but are usually found in association with the surface. Example carnivores include the sheepshead Archosargus probatocephalus, a common sportfishing catch around bulkheads.

Mobile herbivores. Examples of herbivores are the sea hare, Aplysia willcoxi, and the mullet, Mugil cephalus. Many mobile consumers are omnivorous, such as the blue crab.

#### Material Input/Output

Salinity import/export. The water subsystem of the bulkhead habitat exchanges with adjacent habitats by water movements and the migration of larger organisms. In most estuarine situations, this exchange will be quite rapid. A given parcel of water will spend very little time next to the bulkhead; thus salinity will be determined by exchange with adjacent systems.

Organic matter import/export. It seems likely that most bulkhead systems are net consumers of organic matter, by analogy with oyster reefs. In bulkhead systems adjacent to the open bays, phytoplankton will probably be the major form of organic matter imported. The relative importance of detritus from marshes, grassflats, or upland drainage will depend on the location of the bulkhead.

Dissolved and suspended toxics import/export. Bulkheads, pilings, and other structures which have been treated with anti-fouling paints or impregnated are expected to act as sources of these toxic materials to adjacent waters. However, adjacent aquatic systems may carry toxic loads from runoff or discharges.

Oxygen import/export. If bulkhead systems are net consumers of organic matter, they must also be net consumers of oxygen. Oxygen supply from adjacent aquatic systems may be critical in areas with limited circulation such as harbors and residential canals.

Larval form import/export. The early life stages of most of the consumers in the hard surface subsystem are planktonic. Thus colonization of new surfaces is dependent on currents.

## CHANNEL

### Energy Sources

Sunlight. Figure 37 represents the channel habitat. Light energy drives photosynthesis and also warms the upper water layer of the channel system. Light penetration is limited to the upper layer by suspended solids and phytoplankton.

External current sources. This input represents the generation of currents by forces outside the channel system, such as astronomical and wind tides. Smith (1974, 1977) describes passage of tidal energy through the Corpus Christi Ship Channel. James et al. (1977) describe the forces generating currents in the intracoastal waterway between Sabine Lake and East Galveston Bay.

Wind energy. In channels without other major current energy sources, wind energy can be a major input to surface currents and turbulent mixing energy. The orientation of the channel with respect to the wind direction is particularly important in controlling this input. Withers et al. (1973) observed the importance of wind in studies of currents and water quality in the Corpus Christi Inner Harbor, which is moderately isolated from outside current sources.

Ship traffic. Even casual observations clearly show that strong turbulent mixing can be produced by ship operations in channels. The scale of turbulent water movement caused by ship propellers is of the same order as the

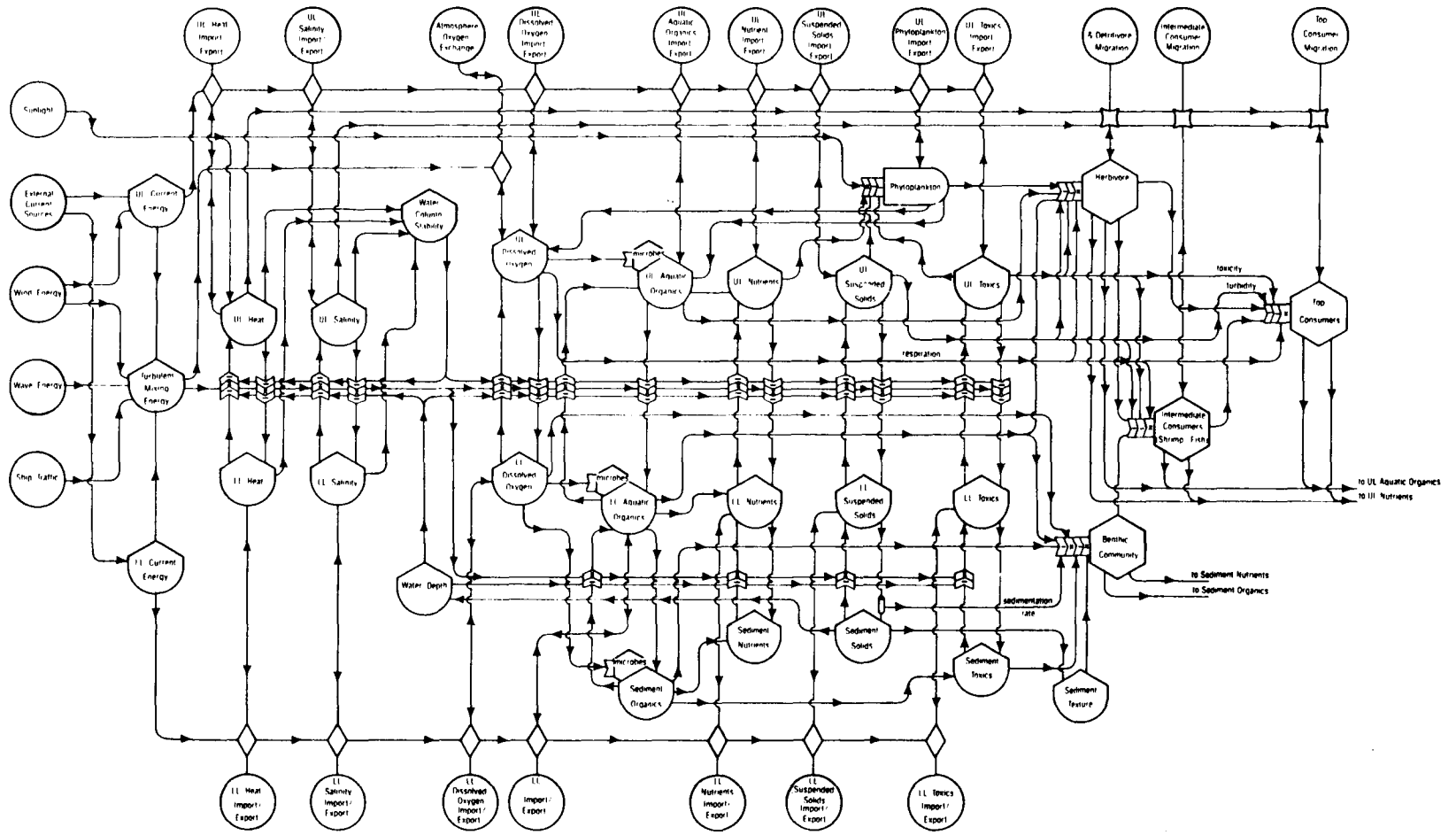

FIGURE 37. Channel habitat.



scale of stratification and should be very efficient at mixing the upper and lower layers.

A quantitative numerical model was used by Liou and Herbich (1976) to predict water velocities and the grain size of sediments which could be moved by various types of ships. This model indicates that the ratio of ship draft to the total channel depth is a major factor in sediment movement.

Wave energy. Wave energy import can be significant in channels which border expanses of open bay systems. The amount involves site-specific factors such as fetch and the depth of the adjacent system. Data on wave energy inside Texas bay systems appears to be lacking.

#### Upper Level and Lower Level Aquatic Organics Import/Export

The major sources of organic matter for the channel waters from within the channel system are phytoplankton and resuspension of bottom sediments. Imports include organics in runoff, industrial and municipal discharges (especially sewage discharges which can be significant inputs), and organics from neighboring estuarine systems. As with nutrients, channels can export organics to neighboring systems when they are heavily loaded (as from sewage discharges) or can be sinks via their high sedimentation rates. Organic matter import can constitute a significant energy source for the herbivores and detritvores, and the benthic community.

#### Physical Attributes

In order to show the effects of stratification, many of the physical parameters have been separated into upper and lower layer components. Many of the chemical and physical aspects of stratified channels resemble the stratified estuaries described by Richards (1974).

Upper level and lower level current energy. One of the important characteristics of a stratified system is that currents in upper and lower portions may be quite different. Withers et al. (1973) observed extremely complex current profiles, both vertically and horizontally, in the Corpus Christi Inner Harbor. In order to provide a manageable model, only two current energies are considered. These currents are considered to be averaged within each layer.

External current sources and wind provide energy input to currents. Current energy is lost by friction which degrades large-scale current movements into turbulent motion and finally to heat; however, this is not a significant source of heat to the system.

Wind can cause currents in both upper and lower layer but this is an indirect effect. For instance, in a dead-end channel with the wind blowing from the mouth toward the back, surface currents moving inward will be induced. Water will "pile up" at the back of the channel, thus providing the driving force for an outward moving current in the lower water layer.

Turbulent mixing energy. The energy of interest here is contained in turbulent eddies on the order of 1 to 10 meters, since these are the size which promote mixing between the upper and lower water layers. In a water column which has a stable density gradient (lower layer denser than the upper), energy input is required to produce mixing. More energy is required to overcome friction and water viscosity. Turbulent energy is rapidly lost from the system by friction and must be continually replaced.

Upper level and lower level heat. Water temperature is a major factor in water density. Thus water temperature contrast between the upper and lower layer is an extremely important parameter in promoting or disrupting water

column stability. Factors tending to increase the temperature of the upper water column include: solar heating, import of warm surface water from adjacent shallow systems, and thermal discharges from industries. The lower layer is frequently cooler due to the supply of cooler water from the Gulf of Mexico. During the winter, the upper layer can lose heat rapidly to the cold air associated with "northers."

Upper level and lower level salinity. Salinity is the other major determinant of water density and thus water column stability. Factors tending to decrease surface salinity include runoff and industrial discharges. Lower layer salinities tend to be increased by inflow from the Gulf of Mexico, or in some cases, by inflow from shallow hypersaline bays.

There are numerous observations of salinity contrast between upper and lower layers in channels. Bryan (1971) found distinct stratification in the lower Arroyo Colorado (Harlingen barge channel) during typical low flow periods. Uniform salinities only occurred a few times. Most of these were during a flood that turned the entire channel fresh. Hall, Bouma and Huebner (1976) describe salinity stratification in the Victoria Barge Canal in San Antonio Bay.

Water column stability. This attribute reflects the resistance of the system to mixing due to the waters of the lower layer being more dense than the surface layer. Under most estuarine conditions, differences in salinity are more important than differences in temperature in producing density contrast. Tables and computational formulae relating density to salinity and temperature can be found in physical oceanography texts such as Rickard (1963). A precise interpretation can be placed on water column stability by computing the difference in potential energy between the stratified water

column and the potential energy of the same water column after mixing. This is the minimum energy input (neglecting friction) required to mix the water column in a unit of area. The senior author used this method in a study of the Corpus Christi Inner Harbor as part of the "208" Areawide Waste Treatment Management Program (Coastal Bend Council of Governments, 1977, task 2.3). Most low oxygen values were found when the energy required to mix the water column exceeded 200,000 ergs per square centimeter.

Water depth. Water depth in channels is an important factor in vertical mixing of the water column and disturbance of the sediments by turbulent mixing. Without frequent maintenance dredging, most channels in the Texas coastal zone would rapidly fill in.

Upper level and lower level dissolved oxygen. Dissolved oxygen in aquatic systems represents a dynamic balance between several sources and sinks. Photosynthesis increases oxygen while respiration (both by phytoplankton and by consumers) removes it. Atmospheric exchange can either increase or decrease dissolved oxygen, depending on the sign of the concentration difference.

In addition to the oxygen demand due to respiration (Biological Oxygen Demand - BOD), abiotic chemical reactions (Chemical Oxygen Demand - COD) may consume dissolved oxygen. In natural systems, almost all COD can be indirectly related to microbial activities, such as sulfate reducers which produce hydrogen sulfide as they degrade organic matter. In view of the complexity of the chemistry of COD reactions and its relationship to microbial activity, only biological respiration is shown in the model. When using the diagram for ecosystem analysis, most COD effects occur so rapidly that they can be regarded as direct removal of oxygen.

Oxygen is required by all of the consumers for respiration. Low dissolved oxygen causes stress to all consumers except some of the benthic organisms. For the protection of marine life, Texas water quality standards require at least 5 ppm dissolved oxygen in most estuarine waters. However, these standards only apply to surface dissolved oxygen.

Low dissolved oxygen concentrations are not uncommon in the bottom waters of many channels; especially those with low levels of mixing energy. Some examples include: the Arroyo Colorado (Bryan 1971), Corpus Christi Inner Harbor (Warshaw 1975), and channels in Lavaca Bay (Bowman and Jensen 1978). The surface waters may be saturated or even supersaturated with dissolved oxygen due to photosynthesis.

Upper level and lower level aquatic organics/microbes. No attempt is made to show the complexity of the relationship between the microbes, such as bacteria and fungi, to the dissolved and suspended organic materials. The rapid reproduction rate of these organisms can expand the population to take advantage of new sources of organic matter within a few hours. The most important features of the combined organics/microbes attribute are the consumption of oxygen and the release of nutrients as the organic matter is broken down.

Major sources of organic matter for the channel waters include phytoplankton, import from other estuarine systems, resuspension of bottom sediments, runoff, and discharges. Although much of the organic matter is respired by microbes or eaten by detritivores, substantial amounts may settle to the bottom.

Sediment organics/microbes. The degree to which organic matter can accumulate in a channel system depends mainly on the levels of turbulent

mixing energy needed to resuspend the particles and the amount of current energy needed to flush them from the system. The concentration of organic matter is also determined by dilution with inorganic sediment particles. Typical concentrations of organic matter in channel sediments range from 1 to 10 percent.

Sediment organics are important as the major reservoir of organic matter within the channel ecosystem. Channel sediments are typically devoid of oxygen in spite of diffusion from overlying waters. They are maintained in this condition by the oxygen demand created by the decomposition of organic matter. This consumption of oxygen by bottom deposits is called the "benthic oxygen demand." It is an important factor in channel water quality. Renolds, Hann and Priebe (1973) measured the benthic oxygen demand of Houston Ship Channel sediments. It ranged from 120 to 220 mg oxygen per square meter per hour at 32 deg celcius. Filos and Molof (1972) performed extensive experiments on the oxygen demand of benthic deposits and on nutrient regeneration.

The model shows sediment organics/microbes generating toxics. This refers to the generation of hydrogen sulfide in typical anaerobic channel sediments by sulfate reducing bacteria. The production of hydrogen sulfide in stratified estuaries is discussed by Richards (1974).

Upper level and lower level nutrients. These compartments are used for all of the nutrients required by phytoplankton except carbon dioxide. No distinction is made between nutrients in true solution and those adsorbed to particles. In general, nutrients are supplied by inputs from other systems. These are primarily industrial and sewage discharges, input from sediment

nutrients, and regeneration of nutrients from organic matter by microbes and higher organisms.

Channels are quite variable with respect to nutrient sources and concentrations. High industrial and municipal input rates combined with low flushing rates can permit the accumulation of nutrients within a channel system; for example, the Corpus Christi Inner Harbor as described by Warshaw (1975). On the other hand, those channels with free circulation may have nutrient concentrations similar to the adjacent bays.

Sediment nutrients. The largest storage of nutrients in channel systems, just as in other shallow planktonic systems, is typically in the sediments. Most are in adsorbed or precipitated form, but some are dissolved in the interstitial water. Sources of nutrients are the sedimentation of solids out of the water column and the decomposition of sediment organics. Since channels tend to be traps for fine sediments, and fine sediments have a high surface area for adsorbed nutrients and organic matter, there is a tendency for channel sediments to be high in nutrients.

Nutrients can be released back to the water column by diffusion or by levels of turbulent mixing energy strong enough to resuspend sediment particles and release the interstitial water. Filos and Molof (1972) examined the rate of nutrient release from benthic deposits high in organic matter.

Upper level and lower level suspended solids. Texas estuaries are well known for their high levels of suspended solids; thus channels through the bay systems can import high levels of suspended solids. As shown on the model, the greater water depth in channels tends to reduce the effect of turbulent mixing. This tends to permit suspended solids to settle out in channels. Although differences in suspended solids between channels and adjacent bays

are not visible from water level, aerial photographs frequently show channels as less turbid. An example is shown in Espey Huston & Associates, Inc. (1976) for the Houston Ship Channel in lower Galveston Bay.

Sediment solids. Because of the factors discussed above, channels tend to have higher rates of sedimentation than adjacent systems. The rate of sedimentation varies with factors such as suspended sediment import rate and erosion of the channel sides. James et al. (1977) discuss the influence of bay current patterns (and thus suspended sediment supply rate) on channel sedimentation in the Lower Laguna Madre. Espey Huston and Associates, Inc. (1976) give a complete summary of sedimentation rates in the Intracoastal Waterway system in Texas, based on dredging records.

Upper level and lower level toxics. Toxic substances are introduced into channel systems by industrial and municipal waste discharges and by importation from other systems. Examples of toxic materials include heavy metals such as mercury, cadmium and zinc; pesticides such as DDT related compounds; and industrial organics such as PCBs. These materials can exist in the water column both in dissolved form and adsorbed to particles. Settling of particles tends to remove toxics from the water before they can be exported to other systems.

Problems with toxic materials in channel waters and sediments are of great concern in Texas. They have been the subject of many studies. Holmes, Slade and McLerran (1974) describe the distribution of zinc and cadmium in the Corpus Christi Inner Harbor and its apparent migration to adjoining bays. The water quality monitoring program of the Texas Department of Water Resources should be consulted for current analyses.



Sediment toxics. Toxic materials tend to become adsorbed to particles and settle to the bottom of channel systems. This attribute also includes hydrogen sulfide generated by sulfate reducing bacteria. By far the greatest mass of potentially toxic materials is always found in the sediments. An extensive survey of available data on toxic materials in the sediments of the Gulf Intracoastal Waterway system in Texas is given in Espey, Huston and Associates, Inc. (1976). This reference also includes a thorough literature review of the behavior of toxic materials in sediments.

Most data on toxic materials is in the form of bulk chemical analyses. This is not a good indicator of the potential effects on organisms due to the extremely complex physical-chemical behavior of toxics within sediments and the complex modes of action within organisms. Bioassay tests using actual sediment samples and estuarine organisms should be used when evaluating sediment toxicity.

Sediment texture. Sediment texture is used in the sense of grain size distribution for the purposes of this model. Sediment texture exerts considerable control on the composition of the benthic community in estuarine systems. Examples of studies relating benthos to sediment texture are: Holland et al. (1975) and Rogers (1976). Espey Huston and Associates, Inc. (1976) compiled data on the physical characteristics of sediments in the intracoastal waterway in Texas.

#### Physical Attribute Import/Export

Upper level and lower level heat import/export. The amount of heat exchange with neighboring systems is quite variable; depending primarily upon current energy and bay circulation patterns. Cooling water discharges by industries can be a significant source of heat to the upper layers of

channels. Details can be obtained from Texas Department of Water Resources discharge permits.

Upper level and lower level salinity import/export. Major inputs affecting salinity in the upper layer include land runoff, stream flow, exchange with adjacent systems, and discharges. Sources for the lower layer are ultimately linked to the Gulf of Mexico or hypersaline bays. Man-made sources can include industrial discharges and oil field brines.

Atmospheric oxygen. The atmosphere serves as essentially an infinite source and sink for oxygen. The exchange rate is determined largely by turbulent mixing in the water layers close to the surface (Kanwisher 1963). However, in most mathematical models of dissolved oxygen in channels, the exchange rate is depicted as being determined by current flow velocity. This works fairly well in streams where current is the main source of turbulent mixing (Bansal 1973), but leads to unsatisfactory results in channels with low current velocity. Recognizing this problem, Hann et al. (1972) used both wind and current velocity in modeling the Corpus Christi Ship Channel.

Upper level and lower level dissolved oxygen import/export. In stratified channels, the only sources of oxygen for the lower layer are inflowing water and mixing from the surface layer. Under stratified conditions, mixing is small and import predominates. This can clearly be seen in oxygen profiles of the Corpus Christi Inner Harbor given by Warshaw (1975). In the surface layer, both water inflow and atmospheric exchange can be major sources or sinks of dissolved oxygen.

Upper level and lower level nutrient import/export. The import/export balance of a channel system with respect to nutrients can be quite complex. Channels in the middle of bays can be nutrient sinks due to sedimentation

within the system. Channels receiving industrial and municipal discharges can be sources of nutrients to the rest of the bay system.

Upper level and lower level suspended solids import/export. As discussed in the section on suspended solids, channels can have high sedimentation rates and thus tend to import suspended solids from neighboring systems. However, high sedimentation can also result from erosion of the channel sides.

Upper level and lower level toxics import/export. Channels typically receive toxics from runoff, from municipal and industrial discharges, and from accidental spills related to shipping. Thus they tend to act as sources of toxics for the other estuarine systems (for example, see Holmes, Slade and McLarran, 1974).

#### Biotic Attributes.

Since the channel system passes through many of the other estuarine ecosystems, many of the same organisms will be found in the channel as are found in the neighboring systems.

Phytoplankton. Primary productivity in the channel system is due entirely to phytoplankton. The model shows these organisms only in the upper layer since only the upper portion of the water column has enough light to support photosynthesis. However, non-photosynthesizing cells will be found throughout the water column, so this picture is somewhat oversimplified. Although they produce oxygen during the presence of light, phytoplankton also respire oxygen both during the presence and absence of light. In highly turbid waters, the depth at which photosynthesis balances respiration can be as shallow as 0.3 meters (for calculations see Armstrong and Hinson 1973).

In addition to light, phytoplankton require inorganic nutrients such as nitrogen and phosphorus. Modeling the response of phytoplankton to these

factors is currently an active area of research (for example: Kremer and Nixon 1978). Toxic materials can alter the species composition of the phytoplankton by depression of the growth rates of some species but not others (Mosser, Fisher and Wurster 1972). Dunstan (1975) showed a wide variation in growth rate between phytoplankton species exposed to possibly toxic effluents. Van Baalen et al. (1973) demonstrated a reduction in growth rate of a blue-green alga by Galveston Bay water.

The species of phytoplankton found in channels are expected to be similar to those found in neighboring estuarine systems. Studies of estuarine phytoplankton, such as Holland et al. (1975) typically show large numbers of diatoms, dinoflagellates and green algae. Due to their high reproductive rate, the total numbers and species composition of the phytoplankton can change rapidly.

Channels with limited flushing rate and/or with high rates of nutrient input can have much higher nutrient levels than adjacent bay systems. Together with lower suspended solids concentrations, which permit greater light penetration, the high nutrient levels permit the development of phytoplankton blooms. Such blooms can cause supersaturated levels of dissolved oxygen in the upper layer and a high loading of organic matter to the lower water column. This may eventually lead to low dissolved oxygen levels in both the upper and lower layers of the channel. This effect is shown clearly in the Corpus Christi Inner Harbor (Warshaw 1975; Coastal Bend Council of Governments 1978 - task 2.24.). Early work on photosynthesis and respiration in such channels is given in Odum et al. (1963).

Herbivores and detritivores. A wide range of sizes and types of organisms are considered in this compartment. Many larval forms are also

included. The smaller of these organisms are the zooplankton, such as the common copepod (Acartia tonsa). A long-term study of zooplankton in a Texas bay system is described in Holland et al. (1975). Studies of zooplankton in channel systems include Odum et al. (1963) and Bowman and Jensen (1978). Modeling of zooplankton in estuarine systems is described in Kremer and Nixon (1978).

Many fish, such as the menhaden (Brevoortia patronus), feed on phytoplankton and detritus; especially during their early life stages. Menhaden are frequently the most abundant fish found in massive kills in channel systems (for example see Bryan, 1971). The striped mullet (Mugil cephalus) is also one of the most common of the herbivore and detritivore fish. The diet and energetics of the mullet are discussed in Odum (1970).

Many estuarine fish are omnivores, eating phytoplankton, detritus, zooplankton, benthic organisms and other fish (Dineen and Darnell 1976). These should be placed in the intermediate consumer class rather than this one.

Intermediate consumers. This general group contains all of the fish and invertebrates which prey primarily upon smaller consumers and are in turn eaten by top carnivores. This includes adult shrimp and the sports and commercial fish, at least in their juvenile and young adult stages. Major studies of the food items of these fish include: Dineen and Darnell (1976) and Darnell (1958). Many of these fish such as the numerous Atlantic croaker (Micropogon undulatus) and the spot (Leiostomus xanthurus) also eat small to moderate amounts of detritus (Parker 1971).

Clearly, all of the species which move through the bay systems must spend some time in the channels. However, the degree to which some species prefer the channels is unclear. Case and Wimer (1977) suggest that a distinct

channel grouping of species can be found in Corpus Christi Bay. Chambers and Sparks (1959) describe the fauna found in the Houston Ship Channel as related to environmental factors such as dissolved oxygen.

Although the model shows the potential for adverse effects on consumers due to high levels of suspended solids, most research indicates that the levels required to produce significant effects are considerably higher than normally occur in estuarine systems (see review in Espey Huston and Associates, Inc. 1976). Water quality criteria related to toxics have been summarized by the U.S. Environmental Protection Agency (1976).

Benthic community. The benthic community consists of organisms living in the bottom sediments and ranging in size from nematodes to clams. Some of these organisms filter suspended organic matter from the water, some feed on organic matter in the sediments and others are carnivorous.

The smallest of these organisms (called the meiobenthos) include nematodes, small crustaceans, and worms. Because they utilize the space between sediment grains, they are extremely sensitive to sediment texture. Rogers (1976) found maximum meiobenthos abundance in silt size sediments in San Antonio Bay.

Extensive surveys of the macro-benthos have been made in Texas bays. An example which included several stations in channels is Holland et al. (1975). Studies of the benthos in channels with low circulation and low dissolved oxygen frequently show reduced numbers and diversity (Bowman and Jensen 1978; Warshaw 1975). Holland et al. (1975, pp.82-83) remark on the apparent reduction of diversity by hydrogen sulfide in sediments and by low concentrations of dissolved oxygen.

Top consumers. Top consumers which are commonly found in channels include some of the larger sports fish such as Atlantic croaker (Micropogon undulatus), sand seatrout (Cynoscion arenarius) and southern flounder (Paralichthys lethostigma). Atlantic bottlenose dolphins, sharks, and fish-eating birds are also top consumers in the channel system. The Atlantic bottlenose dolphin (Tursiops truncatus) has been studied in the channels near Redfish Bay by Shane (1977). Birds are not shown in the model since their importance to the channel system is believed to be relatively small.

#### Biotic Attribute Import/Export

Upper level phytoplankton import/export. The phytoplankton are carried passively in or out of the channel system by currents, thus simultaneous data from adjoining systems would be needed to evaluate this factor. Those channels having high nutrient input rates will probably be net exporters of phytoplankton.

Herbivore and detritivore migration. Many of the larger estuarine consumers routinely migrate to the Gulf of Mexico as part of their life cycles. In many bays, channels provide the main migration pathways. A major study of migration through such a system is summarized by Copeland (1965). The smaller consumers, such as copepods, do not actively migrate out of the bays but tend to move within the channels with the currents. The movement of one of the most prominent herbivores and detritivores, the striped mullet (Mugil cephalus) is discussed by Moore (1974).

The model shows that salinity and temperature affect the migration of organisms. This is intended to represent both annual migrations and daily migrations related to the search for food or desirable salinities. Copeland and Bechtel (1974) give detailed information on salinity and temperature

preferences of some major estuarine organisms, including menhaden, one of the major herbivores and detritivores.

Intermediate consumer migration. Most of the intermediate consumers, including almost all of the major sports and commercial organisms, migrate between the estuaries and the Gulf of Mexico. Copeland, Odum and Moseley (1974) suggest that migration has evolved to take advantage of seasonal cycles of productivity. Copeland's 1965 paper gives considerable data on the migration of brown shrimp, Penaeus aztecus, into the estuaries. Considerable anecdotal data from fishermen suggests that sports fish migrate into channels to escape temperature extremes.

Top consumer migration. Top consumers include the larger sports fish such as Atlantic croaker, Micropogon undulatus; southern flounder, Paralichthys lethostigma; sand seatrout, Cynoscion arenarius; sharks; and mammals such as the Atlantic bottlenose dolphin, Tursiops truncatus. Shane (1977) describes both daily and seasonal migration patterns of dolphins in the channels of the Redfish Bay, Aransas Bay and Corpus Christi Bay area. Many of the other sports and commercially important fish of the Texas bays may follow the channels during their migrations between the bays and the gulf and between bay systems; however, this has not been accurately measured in the field.

#### Critical System Components

Generally speaking, the most critical attributes for the channel system appear to be those affecting vertical mixing such as water column stability, turbulent mixing energy, and depth. In the absence of sufficient mixing, oxygen consumption by the sediment organics and benthic community can reduce dissolved oxygen below the level needed for survival of many organisms. The flushing of the channel by currents from other systems is also important;



especially in those channels receiving substantial input of nutrients, toxics or organic matter from industrial or municipal discharges.

## COASTAL PRAIRIE

### Introduction

Coastal prairie areas occur primarily on the mainland all along the Texas coast (Brown et al. 1972-77). In Texas, coastal prairie is usually found in areas that are not inundated by salt water, but some are subject to infrequent flooding by fresh water from extreme over-bank river flooding. For the purpose of this report, coastal prairie is differentiated from brush habitat by the lower percentage of woody plants (brush) as opposed to the grasses since these two systems are constantly competing for spatial coverage. Fire and overgrazing by domestic livestock are the two most important factors regulating these systems today (Bragg and Hulbert 1976; Daubenmire 1968; Johnston 1963).

Some of these areas of coastal prairie may be occasionally flooded by salt water during extreme storms, but in general, they are not exposed to significant inundation by salt water. This is the most common habitat type along the Texas coast and occupies over 15,000 square miles in the coastal areas of the state (Brown et al. 1972-77). Figure 38 is the conceptual model for the coastal prairie habitat.

### Energy Sources

Sunlight. Solar energy input provides the major source of energy used by the vascular plant based food web of the coastal prairie ecosystem.

Precipitation. Direct input of water to the coastal prairie via precipitation may be a significant source of energy, especially in the eastern portions of the Texas coast where the precipitation may be more than 40 inches

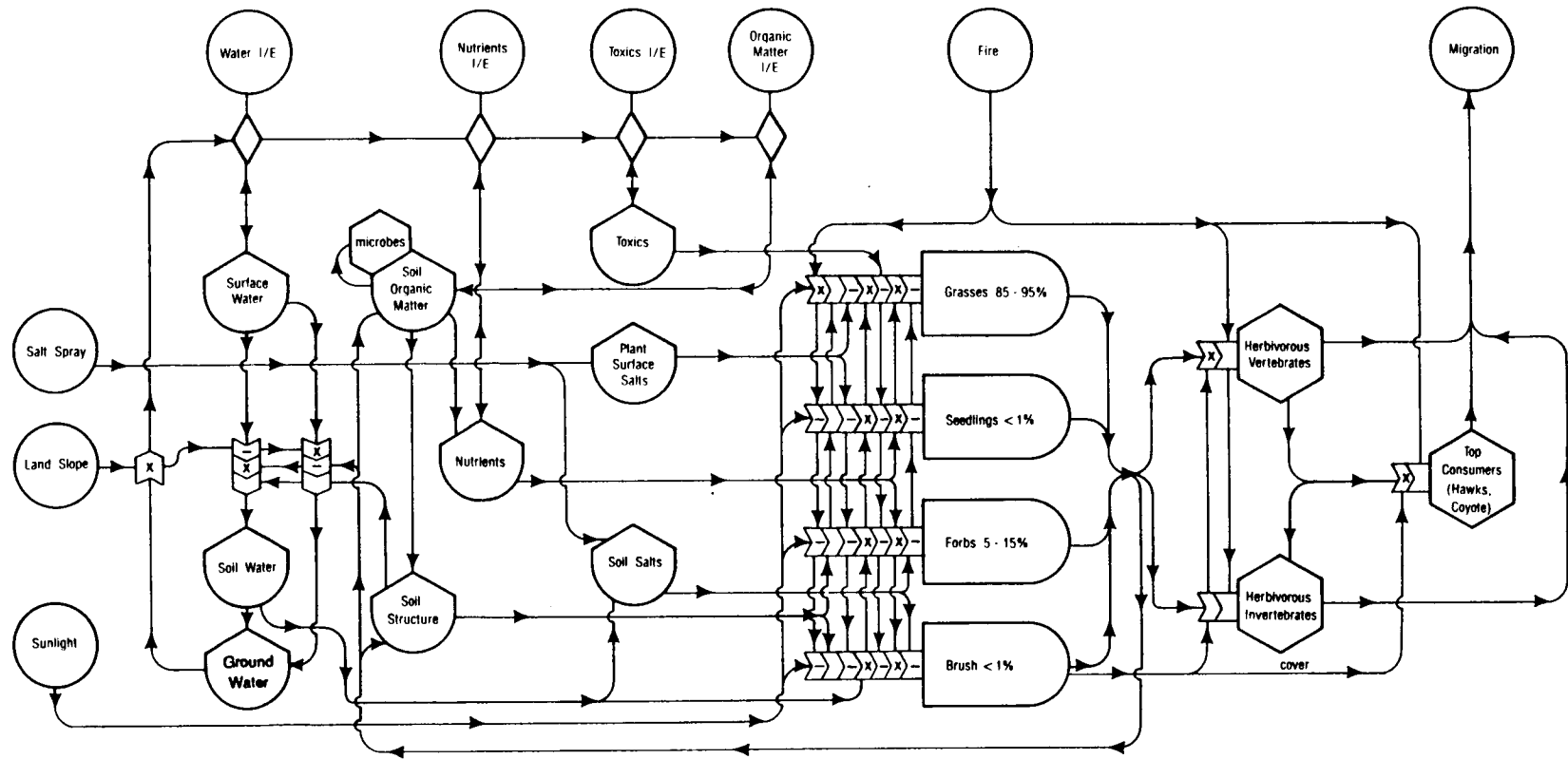

FIGURE 38. Coastal prairie habitat.

annually. The coastal prairie brush species tend to have deeper roots than the grasses and are able to withstand drouths better; therefore, they may be favored in areas of little rainfall. The prairie grasses react more rapidly to rainfall and compete better in the higher precipitation areas.

Salt Spray. Much of the coastal prairie is close enough to the Gulf of Mexico or Texas bays to receive salt spray, especially during periods of high winds. This salt spray introduces not only NaCl to the system, but all of the other mineral salts and nutrients, etc. that occur in the salt water of the gulf. This may be a significant factor in the growth and survival of vegetation that is constantly exposed to this spray (Boyce 1954; Oosting and Billings 1942).

Land Slope. Land slope represents the physical slope of the land surface. This greatly affects the surface water, soil water and water flow. Most of the coastal area of Texas has very little overall slope. But small-scale variations in topography may be sufficient to alter the land slope and hydrologic regime. Increased land slope increases water flow and decreases the infiltration of water into the soil. Brush species may have an advantage over the grasses on the more sloping areas where the soil moisture is lower.

#### Physical Attributes

Water flow. Water flow in the coastal prairie is used to represent the physical flow of water derived from surface water. The water flow is analogous to currents in aquatic systems. The major direction of the water flow in the coastal prairie is "down slope". The water flow drives the import and export of physical and biotic attributes. The flows which accompany extreme precipitation may remove much the loose organic matter from the soil surface.

Surface water. This attribute is controlled by precipitation. The water level within a coastal prairie system may vary from several meters during high water periods on the upper Texas coast to completely dry during drouths. Most of the coastal prairie areas in the upper and middle Texas coast are inundated by precipitation several times each year. This inundation may vary from only a few centimeters for a few hours with normal precipitation and overland runoff to significantly more water for longer periods during periods of high rainfall associated with tropical storms or hurricanes. The frequency and duration of inundation is one of the most important factors affecting the vegetation in the coastal prairie system. Surface water directly affects soil water.

Soil water. This attribute is derived from surface water and is used to show the frequency and amount of saturation of the soil. Soil water content is very important in determining the types and abundance of plants that occur in the coastal prairie system. Soil water provides the transport mechanism for the nutrients used by the vegetation. Frequent periods of high soil water interspersed with drying periods provides conditions more appropriate for the growth of grasses in the coastal prairie system. Adequate supplies of deeper soil water provide conditions that are more appropriate for woody plant growth and survival in the coastal prairie habitat. Therefore, the grasses are favored on the upper and middle portions of the coast while the brush species may be favored on the drier lower coast.

Nutrients. Nutrients are organic and inorganic materials required by the plants of the coastal prairie system for photosynthesis, in addition to light. Nitrogen and phosphorus are the major nutrients associated with primary production in the coastal prairie, although many additional nutrients and

trace elements are also needed. A small portion of the nutrients used in the coastal prairie ecosystem come from upland drainage. The majority of the nutrients originate in the soil or air and are recycled by bacteria, fungi and nitrogen fixing plants. Since the leaves of the plants contain higher percentages of nutrients than the woody parts of the brush species, leaf and grass litter efficiently recycles many of the nutrients.

Soil Organic Matter. "Microbes" are partially combined with the symbol representing organic matter in the soil since they are an integral part of the cycling of energy via decomposition. The amount of soil organic matter in coastal prairie areas of the lower coast is generally quite small due to the high temperatures which induce rapid decomposition and accumulation of carbon in the woody species and the export of much of the primary productivity by grazers. The coastal prairies in the upper and middle portions of the coast may contain larger amounts of soil organic matter due to their higher productivity associated with increased precipitation. Exact data on this has not been found.

Soil Structure. The larger root systems of the woody species in the coastal prairie system tend to break up the relatively hard soils of the south Texas area to a greater depth than the grasses. This loosening of the soil promotes soil formation and slows the runoff of precipitation over the hard ground. The grasses themselves may have root systems which form a tight mass which holds the soil and prevents erosion during heavy precipitation. Their roots also loosen the top layers of the soil.

Toxics. Toxic materials which could be introduced into the coastal prairie system include heavy metals, pesticides, industrial organic chemicals, well drilling fluids, crude oil and petrochemicals. Toxics enter the coastal

prairie system primarily via water from upland drainage and precipitation; however, storm tides from hurricanes may push toxics into the system from the bays. The coastal prairie system would only be expected to have elevated toxic concentrations if toxics were introduced by local spills or washed out of the air by precipitation.

Plant Surface Salts. Areas of the coastal prairie that are close to the bays or Gulf of Mexico are subject to salt spray. Plants that are more or less constantly subjected to salt spray tend to be adversely affected in their growth rates and patterns. Because of the lower precipitation in the lower portion of the Texas coastal area, coastal prairie plants are more likely to show the effects of the buildup of plant surface salts than the areas of the middle coast where the higher rainfall tends to wash the salts from the leaves more often. Details of the effects of plant surface salts on vegetation in the coastal area can be found in Boyce (1954) and Oosting and Billings (1942).

Soil Salts. The accumulation of salts in the soil within the coastal prairie system occurs in all areas but is most noticeable in areas on the lower Texas coast which are exposed to nearly continuous salt spray and receive little precipitation. The salts of various minerals tend to accumulate on the leaves of the plants and are leached from the leaves by rainfall (Spurr 1964). High rainfall tends to leach the salts deep into the soil and subsoil or export them in the runoff. Small amounts of precipitation tend to transport the salts into the upper soil layers where they accumulate. Periods of drying, especially of sandy type soils, may also bring some of the deeper salts to the soil surface by capillary action. Excess soil salts, especially NaCl, can be detrimental to the coastal prairie plants (Boyce 1954).

### Import/Export of Physical Attributes

Water outflow. This attribute is used to show the flow of water from the coastal prairie system to adjacent systems. It is driven by high water flow within the system which is caused by precipitation. Under normal conditions, there may be very little water outflow the coastal prairie areas of Texas. However, during periods of intense precipitation, especially during hurricanes and tropical storms, the water outflow is significant.

Nutrient Import/Export. Nutrient import from the neighboring ecosystems is believed to be minimal in the coastal prairie system. Nitrogen fixing by bacteria and some plants and recycling of soil nutrients provide the majority of the nutrients to the coastal prairie system. Water flow resulting from precipitation is the major factor affecting nutrient export in the coastal prairie system. The amount of nutrients exported from the coastal prairies directly to other systems is not presently known.

Toxics Import/Export. Toxics such as agricultural pesticides or industrial wastes may be imported into the coastal prairie by washout from the air during precipitation or by upland drainage. Most is expected to be introduced directly into the coastal prairie system via spills. Toxics from spills in the adjacent ecosystems may find their way into the coastal prairie system during storm conditions. Coastal prairie areas that contain toxic materials may export these during periods of high precipitation. No data are available on the general concentrations of toxics in the coastal prairie habitats of Texas.

Organic Matter Import/Export. Most of the organic matter in the coastal prairie system is produced there by the vegetation. The small amount that may be imported via upland drainage is either dissolved or suspended particles of

vegetation and animal matter. The amount exported directly to other systems varies primarily with the amount of litter and the water flow. Some may be exported during storms such as hurricanes. However, most is probably exported by grazing animals, some of which are harvested by man. Excessive grazing and removal of organic matter decreases the coverage of grasses and increases the coverage of woody species in the coastal prairie system (Tharp 1925). Overgrazing also decreases the incidence of fire, which tends to remove the woody species.

Fire. Fire can be important in regulating both the plant and animal communities as well as altering the nutrient cycling within the coastal prairie system. Fire increases the rate of breakdown of vegetative matter into nutrients, opens the canopy and clears the ground of accumulated litter so that new growth can begin, and starts the succession of plant and animal communities over again. Fire changes the relative proportions of nutrients since some such as nitrogen are consumed by fire. Fire of sufficient intensity to burn the woody species increases the coverage of grasses in the coastal prairie system (Daubenmire 1968; Weaver 1954).

#### Biotic Attributes

Brush. The coastal prairie areas of the Texas coastal areas contain only a few species of trees. Dwarfed live oak tree or more likely "bush" is found in large areas along the middle portion of the Texas coast, and occasionally on the barrier islands. The live oaks are extremely hardy and are resistant to salt spray to a great extent. They will usually be found close to the bays where no other native trees will grow. Further inland, the tree species of the coastal prairie habitat are primarily mesquite and several



of the acacias. Although the trees are the most prominent, they probably contribute little net annual primary production to the coastal prairie system.

Several "shrubby" species may be found in the coastal prairie habitat. The most common of these are spiny hackberry, lime prickly-ash, yucca, pricklypear cactus and narrowleaf forestiera. These species add little to the primary productivity but provide additional habitats for some of the species of animals which inhabit the coastal prairie.

Seedlings. The seedlings of the trees of the coastal prairie system contribute a very small portion of the primary productivity of the system. However, they are important since they are constantly invading the prairie areas and advancing the spread of the "brush" species.

Forbs. Hardy species of perennial herbs and forbs may grow in the coastal prairie habitat. However, their contribution to the net primary production of this habitat is small.

Grasses. Many species of grasses may be found in the coastal prairie habitat. The majority of these are perennial grasses such as bluestems, panic grasses, buffalograss, switchgrass, indiagrass, crinkleawn, and many others (Gould 1975). They contribute the majority of the annual productivity of the coastal prairie habitat. The species composition varies within this ecosystem, with microhabitat and climate being the major determining factors.

Herbivorous Invertebrates. This group comprises one of the largest consumer groups (in terms of total numbers of individuals) in the coastal prairie system. The majority of these invertebrates are insects and ground dwelling crustaceans. The detritivores are also included in this category. They may be the largest in total numbers since the coastal prairie habitat incurs little physical disturbance except from precipitation and water flow

which would disrupt them. During the long growing season (long in days but plant growth is often interrupted by drouths), the insects probably rival the mammalian herbivores in total consumption of plant material.

Herbivorous Vertebrates. The plant-eating vertebrates are separated from the invertebrates in this model since they are so important in the coastal prairie system. Native herbivores such as rabbits, mice, ground squirrels and seed-eating birds such as bob white and scaled quail are abundant in the coastal prairie habitat where excessive cattle grazing does not occur. Burrowing organisms such as gophers and ground squirrels may play an important role in the coastal prairie ecosystem. They loosen the soil with their burrowing and assist in keeping it aerated. Their burrows also allow precipitation to penetrate the soil more rapidly.

Cattle are the most important herbivore in most of the coastal prairie habitat. In areas where their populations exceed the optimum carrying capacity of the annual plant production, their presence tends to increase the spread of woody species rather rapidly, while at the same time keeping the growth of the existing grasses to a minimum. Along with fire, excessing cattle grazing is the most important regulating factor of the coastal prairie habitat (Ellison 1960).

Top Consumers. The top consumers of the coastal prairie systems are primarily the birds of prey, coyote, and bobcat. Birds of prey ( hawks, owls and eagles) may nest in the trees of the coastal prairie and brush systems and feed on the numerous smaller animals of both systems. This habitat helps support large numbers of birds of prey which migrate from the north during the winter months.

### Import/Export of Biotic Attributes

Migration. Migration with respect to the coastal prairie system represents the movement into and out of the coastal prairie area from other systems. There is very little regular migration of animal species between this and other systems. Many mobile animals such as birds and larger mammals move between the coastal prairie and brush in order to find food or water; however, most true coastal prairie species prefer this habitat and move very little.

### Critical System Components

The most critical components of the coastal prairie system are fire, herbivorous vertebrates and precipitation. Precipitation provides the energy for the exchange of nutrients, organic matter, fresh water and toxics between the coastal prairie and other systems. Changes in the water regime, incidence of fire and/or cattle grazing practices quickly result in changes in the species composition and productivity of the coastal prairie system.

## CROPLAND

### Introduction

A large fraction of the Texas Barrier Islands study area is devoted to agriculture. This habitat model is intended to apply to all cultivated crops but not to pasture. Rice, sorghum, cotton, citrus and vegetables are the main crops in the study area. In addition to the crop plants, the model (Figure 39) includes weeds and the plants found along fence rows and ditches because of their significance to insects, birds and small mammals.

### Energy Inputs

Fossil fuel. The modern agricultural system requires a very high input of energy derived from fossil fuels for cultivation, fertilizer, other

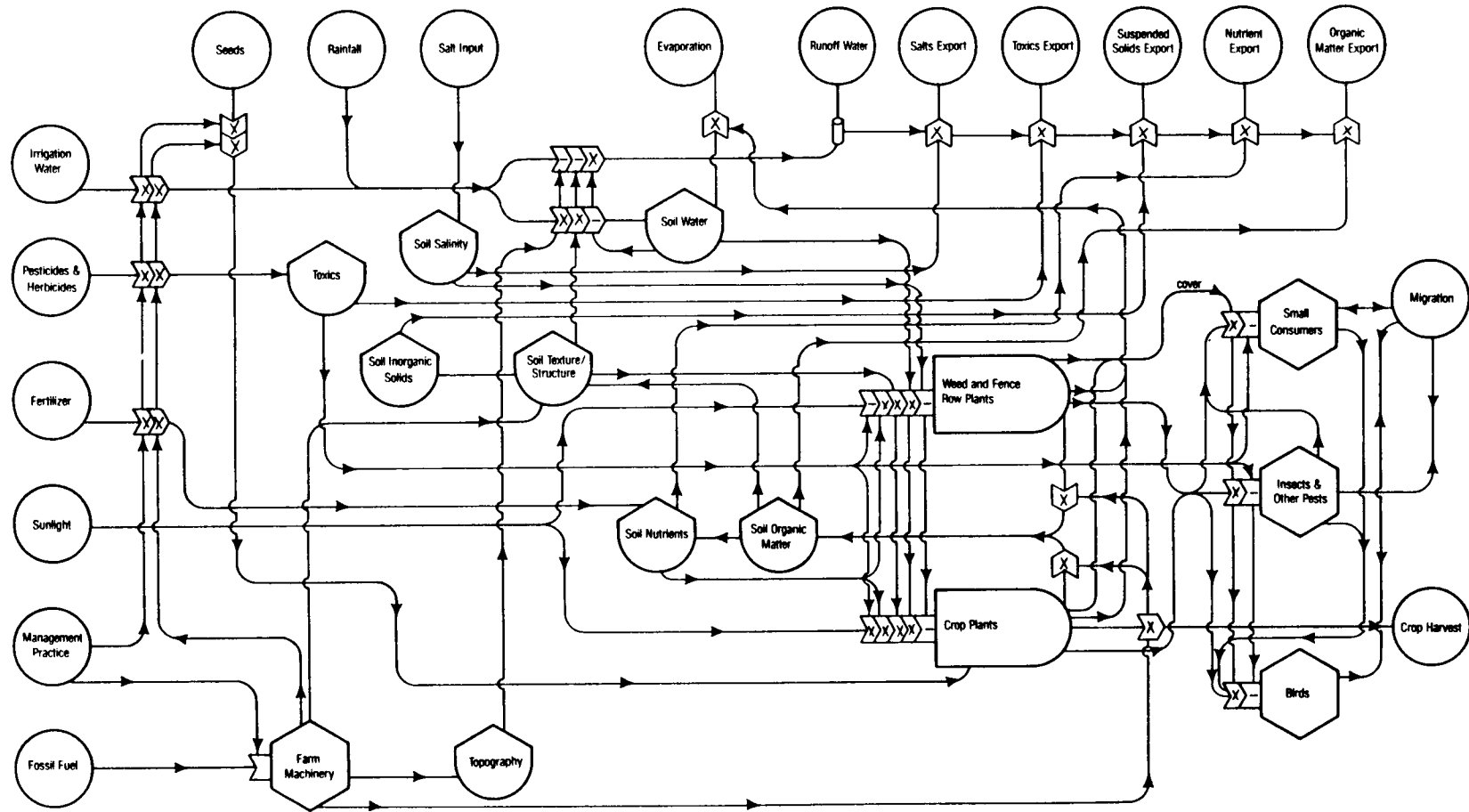

FIGURE 39. Cropland habitat.

chemicals, construction and maintenance of equipment and fuel (Pimentel 1980; Phillips et al., 1980). This model shows only the most direct inputs of fuel and electricity required to run farm machinery. The user should be aware that creation of fertilizer, pesticides, and the farm machinery itself requires large energy inputs in the industrial system.

Sunlight. The input of light energy for photosynthesis and plant growth.

Management practices. This represents the decision making and control exerted by individual farmers and regulatory agencies on the functioning of the cropland ecosystem. The major inputs affected by decision making are seeds, irrigation water, pesticides and herbicides, fertilizer and fossil fuels.

#### Material Inputs

Pesticides/herbicides. This represents input of the various chemicals used for suppression of unwanted plants, insects, fungi, and other pests, and also to control crop plants. A bewildering variety of chemicals is in use in modern agriculture. These chemicals vary widely in their method of application and behavior after entering the cropland system.

Fertilizers. The major elements applied in fertilizer are nitrogen, phosphorus and potassium. Trace elements such as iron and zinc may also be required. Generally the greatest bulk of fertilizer applied is nitrogen, either as ammonia or as nitrate.

Irrigation water. This represents water brought into the system from both surface and subsurface sources. Within the study area about 1.3 million acres are irrigated, 17 percent of a Texas state total of 7.5 million acres. (Grubb 1981.) The major irrigation water users are in the Rio Grande Valley, the area from the Guadalupe River to north of the Brazos, and around the

Trinity River. The Rio Grande area uses almost entirely surface water since the ground water is too saline for irrigation, but the other areas use significant amounts of ground water.

The Texas water plan (TWDB 1977) gives detailed estimates of present and predicted water use for irrigation. Competition between agriculture and other sectors of the economy for water is expected to produce significant problems in the future (Grubb 1981).

Rainfall. Mean annual rainfall in the study area varies from less than 22 inches in the inland Rio Grande Valley to 52 inches in Brazoria County (TDWB 1977.) This difference is the main factor in the differing agriculture practices along the coast. The week to week rainfall is of concern to the farmer but is beyond the scope of this model.

Seeds. This represents the seeds or other propagules typically supplied from outside the cropland system. This emphasizes one of the major differences between cropland and natural upland systems; the major plant species can be changed from year to year according to management decisions.

Salt input. Salts are introduced into cropland systems in irrigation water, rainfall and dry fallout of particles from the air. An acre-ft of irrigation water with salt content of 250 ppm would add 680 pounds of salt to the soil. Breaking waves in marine and estuarine systems produce salt particles which can fall to earth as dry fallout or be swept up by rainfall. Fanning and Lyles (1964) demonstrated salt deposition from rainfall ranging from 50 to 150 pounds per acre per year in the Rio Grande Valley with heaviest deposition near the coast.

Coover and Rechenthin (1965) describe serious problems due to dry deposition of salt carrying particles in Kenedy County on grazing land. These

particles were created by wind erosion of wind tidal flat deposits along the Laguna Madre.

### Physical Attributes

Soil water. This represents all forms of water in the soil. Due to the low permeability of most cropland soils in the study area, evaporation and evapotranspiration are the major pathways for loss of soil moisture. The model shows the influence of significance of existing soil moisture in determining whether rainfall will runoff or sink into the soil.

Soil salinity. The behavior of salts within the soil is too complex to be represented in detail so this component represents all soluble salts. Typically these are mainly sodium, chloride, and sulfate ions. Elevated levels of these ions can cause reduced productivity or death of crop plants. Cropland areas experiencing excessive salinity have been growing since 1950 in the southern counties of the study area. Areas severely affected in the Copano - Aransas, Corpus Christi, and Upper Laguna Madre basins were estimated at 5200 acres in 1977 (Minzenmayer pers. comm. 1981.) Most agricultural soils of the study area have a low permeability so there is little tendency for flushing of salts into the deeper ground water. Runoff is believed to be the major route of soil salinity export.

Soil nutrients. This represents essential plant nutrients such as nitrogen, phosphorus and potassium in the soil. Major input of these elements comes from inorganic fertilizer application. The resulting nutrient level is considerably higher than in natural soils.

Toxics. This compartment represents man-made toxicants, typically applied for insect or weed control. The behavior of these substances on plant surfaces and in soil is extremely complex. Many organic compounds degrade to

non-toxic molecules within a few days of application. On the other hand, toxic derivatives of DDT can be found in soils more than ten years after last application.

Soil organic matter. Soil organic matter is constantly being decomposed to release nutrients and being added to by plant residues. If more of a crop plant is removed from the system, for use as a biomass energy source for example, a lower level of soil organic matter will result (Pimentel et al. 1981.) Organic matter is of major significance in determining soil physical properties, represented here as "texture and structure." Being lighter than inorganic particles, organic matter is more easily eroded (Stewart et al. 1975, 1976.)

Soil inorganic solids. The inorganic particles which make up the majority of the soil, these are largely silt and clay sized particles in croplands of the study area. Detailed information on soil properties can be found in individual county soil surveys or in the Bureau of Economic Geology coastal atlas (Brown et al. 1972-1977)

Soil texture and structure. This represents the physical properties of the soil such as permeability, water capacity, shrink-swell potential and cohesiveness. These properties affect runoff, erosion, soil water and plant growth. Major factors affecting texture and structure include the inorganic solids, organic matter, and cultivation practices. Cropland soils in the study area are typically low in permeability. Specific details can be found in individual county soil surveys.

Topography. This represents slope, local depressions, and other topographic features which affect runoff and erosion. Examination of topographic maps of the study area indicate that almost all croplands have



slopes on the order of 0.2 to less than 0.1 percent. In computing probable erosion rates from cropland, the "universal soil loss equation" is normally used (Stewart et al. 1975, 1976); however, the topographic factor which takes both slope and length of slope into account is not defined for slopes less than 0.5 percent. This would indicate that erosion rates from croplands in the study area will be considerably less than from more hilly inland areas. In many cases, topography is adjusted by farm machinery to control irrigation water use, erosion, and runoff.

Farm machinery. Modern farming depends on equipment which uses fossil fuel energy to plant, cultivate, spray, fertilize, irrigate and harvest. Liebow et al (1980) have estimated agricultural fuel and oil use in the study area at \$ 27.6 million during 1974, about 5.5 percent of total farming costs. Total investment in farm machinery was estimated at \$ 359 million.

Crop plants. The dominant crop plants vary greatly along the climatological gradient of the Texas coast. In the northern counties, rice and soybeans are major crops. The middle counties tend to corn, cotton and sorghum. The Rio Grande Valley area is notable for citrus, vegetables, corn, cotton, sorghum and sugarcane. Summaries of production practices, growing seasons, etc. are given in Liebow et al. (1980).

In general, it is assumed that crop growth will be increased by soil nutrients, water, and structure, and decreased by salinity and toxics (herbicides.) The resulting biomass is harvested, plowed under (to soil organic matter), or eaten by consumers. Crop plants also play a major role in retarding erosion and as cover for small consumers.

Weed and fencerow plants. This represent all non-crop plants in the system, both weeds within the planted areas and the small patches of plants

occurring along fencerows, drainage ditches, and other areas. These plants are included in the cropland system for several reasons. They serve as cover and food for small consumers during parts of the year when crop plants are not available. They are heavily influenced by cultivation practices such as use of fertilizers, herbicides, and irrigation.

Insects and other pests. A rather general category for insects and all other pests which afflict crop plants and are controlled by pesticides.

Birds. These consumers are treated separately because many migratory species feed in the fields but also spend time in other habitats. For instance, the Canada goose, white-fronted goose and snow goose which feed in rice fields of the upper coast.

Small consumers. This represents mainly rodents such as rabbits, rats and mice. They are dependent on plants for cover as well as food.

#### Material Export

Crop harvest. This represents biomass removed from the ecosystem. With most crops, only a fraction of the biomass produced is removed from the field; the roots and stalks are left standing or plowed under.

Evaporation. Most water added to the crop system leaves in the form of evaporation and evapotranspiration. Estimates of evaporation rates are given for each river basin in Texas Water Development Board publications (1977).

Runoff water. Runoff from cropland systems is of major significance in most watersheds. Runoff is controlled by topography, soil texture and structure, antecedent soil water and plants. Stewart et al. (1975, 1976) discuss these factors and various management practices in detail. In addition to runoff from rainfall, drainage from irrigated fields ("return flows") can also be significant.

Data on average runoff and return flows from various drainage basins has been compiled by the Texas Water Development Board (1977). Runoff carries with it a load of dissolved and suspended materials which may have significant effects on downstream aquatic systems.

Toxics export. Pesticides are the major toxic materials of concern in cropland runoff. These compounds differ widely in their physical and chemical properties. Some are soluble and are exported mainly in dissolved form, while others are strongly adsorbed to fine particulate matter (Stewart et al. 1976.)

As described in the discussion of the "river and canal" and "tidal stream reach" habitats, ten of the water quality segments in the study area have recently shown above average levels of pesticides or PCBs (Texas Dept. of Water Resources 1980). The most notable problem area has probably been the Arroyo Colorado which drains much of the lower Rio Grande Valley agricultural area (see Twidwell 1978 for example.) Sampling programs in the mid 1960s found that oysters from the Arroyo Colorado had consistently higher DDT residues than any other estuary in the nation. DDT derivatives continue to be eroded from the soil more than 15 years after the last agricultural application.

Nutrient export. Nutrients are exported in runoff water both in dissolved form and adsorbed to particles. The greatest export occurs when rainfall finds newly applied fertilizer on the surface. Nitrate is very soluble while phosphorus and other nutrients tend to remain on particles. Factors determining nutrient export in runoff are discussed in detail in Stewart et al. (1976).

Limited monitoring of runoff from agricultural watersheds has been conducted in the study area. The Corpus Christi Bay "208" study (Coastal Bend

Council of Governments (CB-COG) 1978) summarized data from the Oso Creek drainage. It was found that most nitrogen was exported as organic nitrogen (presumably particulate) and that nitrate was the major inorganic form.

Suspended solids export. The inorganic solids eroded from croplands tend to be only the finer clay and silt particles since the low slope of the land gives only a low velocity to the runoff water.

Organic matter export. Due to their lower density, organic matter particles tend to be more easily eroded. However, since this soil organic matter has been extensively degraded by micro-organisms it does not present as large an oxygen demand in the receiving waters as an industrial or municipal discharge would. The Oso Creek agricultural runoff (CB-COG 1978) averaged 13.9 mg carbon per liter but only 1.5 mg/liter of biological oxygen demand (BOD.)

Salts export. Only runoff and seepage into deep ground water can remove soil salts from the system. Due to the low permeability of most cropland soils in the study area, it is assumed that runoff is the most significant form of salt removal.

#### Critical Components

With respect to the other habitats in the coastal area, the most critical components of cropland appear to be use of fresh water for irrigation and export of toxics, suspended solids and nutrients. The most important internal components are soil texture/structure, nutrients and salts, which determine plant growth rates.

## DUNE AND BARRIER FLAT

### Introduction

The dune and barrier flat habitat covers a significant portion of the barrier islands of the study area and is the system most heavily impacted by development on these islands. This habitat extends from the vegetated fore-dunes bordering the beach, across the barrier island to wetlands or wind tidal flats on the bay side. Although distinct plant communities of dune, barrier flat, and ephemeral wetlands can typically be recognized, the similarity of physical processes permits grouping these communities into one habitat model (Figure 40).

Barrier islands typically consist of beach, dune and barrier flat, active dune, wind tidal flat, and salt marsh habitats. The balance of areal extent between these habitats is very dynamic. Changes are mainly dependent on storms, the general climate and man's uses. Major storms tend to reduce the area of dune and barrier flat by erosion and creation of washovers. During dry periods, vegetation tends to die off and active dune areas tend to spread. During wet years, vegetation spreads and stabilizes the blowing sand of the active dunes. Examples of areal coverage changes over a time span of decades are given for the Corpus Christi Bay area by White et al. (1978).

Due to differences in physical factors such as rainfall, sediment type and shoreline erosion rates, there is considerable variation in barrier island structure in the study area. Well developed dunes are found mainly on Mustang and North Padre islands. The Bureau of Economic Geology Coastal Atlas (Brown et al. 1972-1977) should be consulted for details of individual barrier island structure.

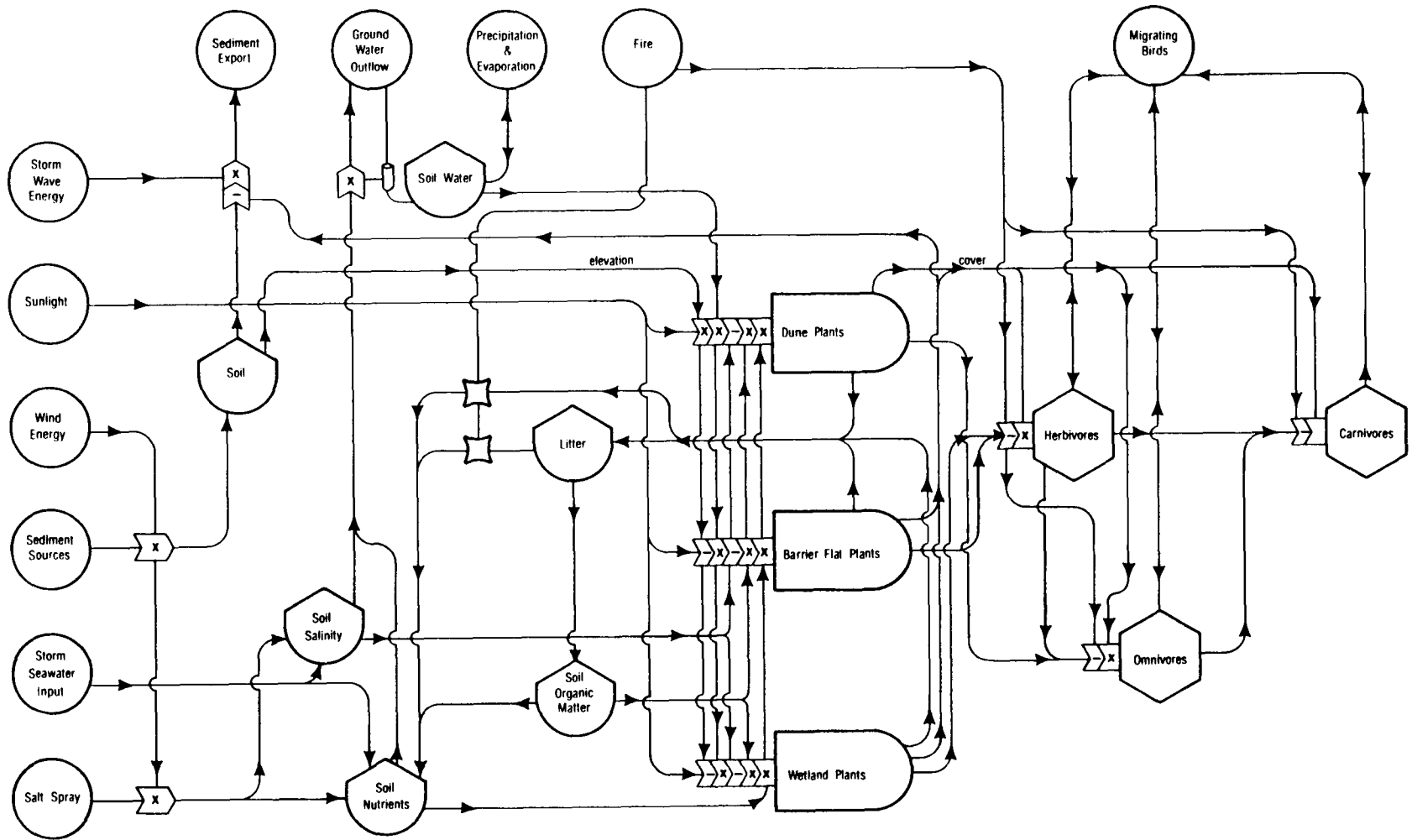

FIGURE 40. Dune and barrier flat habitat.

The economic pressures for development of the barrier islands are substantial. Population growth and economic success in Texas have created great demand for recreational opportunities. Because of ownership and transportation patterns, development pressures are focused on only a few of the barrier islands: South Padre, North Padre, Mustang and Galveston islands. Texas barrier islands constitute the most extensive undeveloped ocean shoreline in the United States.

### Energy Inputs

Sunlight. Solar energy input to the plants is essentially a constant, varying only with the seasons. Its utilization by plants, however, is determined by availability of water and nutrients.

Wind energy. The wind is the only significant transport agent acting in this habitat in normal weather. It brings sand and silt from adjacent beach or active dune habitats, and salt spray from the nearshore waters. Wind also builds up foredunes on the adjacent beach which eventually become vegetated and part of the dune and barrier flat habitat. As shown by Eigsti (1978), wind velocities on the beach are significantly higher than those reported at inland weather stations.

Storm wave energy. During hurricanes and other severe storms, wave energy can cause major erosion of the dunes and even of barrier flat soils. On the ocean side of the island, this results in conversion of dunes into beach. Plants can substantially slow erosion by storm waves.

Fire. Fire is a major ecological factor on the barrier islands as it is in other terrestrial habitats. Typical sources of fire include camper's bonfires, fireworks, cigarettes and deliberate ignition. It recycles living plants and litter to inorganic nutrients. It thus produces a short-term

negative effect but may stimulate the next season's growth of plants. The net ecological effects of fire are complex (Baccus and Horton 1979.)

### Material Input

Sediment sources. This represents the beach and active dune habitats which are the main sources of windblown sand to the dune and barrier flat habitat. Under the most favorable conditions, the beach can provide a very large amount of sand for dune building. Dahl et al. (1975) reported the accumulation of sand at a rate of 29 cubic yards of sand per foot of beach front in a managed sea oats planting.

Salt spray input. A major factor controlling the vegetation of the dune and barrier flat habitat is the deposition of salt spray. In addition to sodium chloride, spray contains significant amounts of potassium, calcium and magnesium needed by plants and thus contributes to both soil salinity and nutrients. Spray is generated both in the surf zone and in the open Gulf of Mexico by breaking waves. Actual measurements of spray concentrations in the air above a Texas beach have been performed by Whelan (1975).

The rate of deposition of spray varies with weather conditions, with distance from the surf zone, and with exposure. Measurements by van der Valk (1974) on Cape Hattaras showed that the oceanside face of the dunes receives the greatest deposition, with the dune tops second. The rear face received spray at about a third of the rate of the oceanside face.

Storm seawater input. Storm tides high enough to flood substantial portions of the barrier islands are not uncommon. These floods can add substantial amounts of salts to the soil of the barrier flats and thus have a major effect on the vegetation, even without storm wave damage. Some soil nutrients are also added, as with salt spray.



Precipitation and evaporation. The average balance between rainfall and evaporation varies substantially within the study area as described by Hillaker and Jehn (1978.) This is probably the most significant variable accounting for the differences between barrier islands of the upper and lower coasts of the study area.

#### Physical Attributes

Soil. This represents the inorganic portion of the soil and the surface elevation of the dune and barrier flat habitat. Not surprisingly, these are generally highly permeable fine sands with shell in some areas. The Bureau of Economic Geology Coastal Zone Atlas (Brown et al. 1972-1977) gives greater detail on soils for various parts of the study area.

Soil salinity. The concentration of salts in the soil of the dune and barrier flat habitat is the result of a balance between additions due to spray and seawater flooding and removal due to flushing by rain into the ground water. Soil salinity is a major limiting factor for vegetation in this system. Dahl et al. (1975) describe the effects of soil salinity on survival of various grasses used in dune building experiments.

Soil salinity is extremely variable, both in time and spatially. Data reported by Dahl et al. (1975) and McAtee and Drawe (1974) show surface soil salinities generally greater than salinities at depth, and variation of salinity by a factor of 50 over a few months in dune soils. Capillary action tends to draw soil water with dissolved salts to the surface where evaporation concentrates the salts. Salts are ultimately removed from the system by the outflow of ground water to the bay and gulf.

Organic matter. The organic matter content of dune and barrier flat soils appears to be quite low due to the high porosity of the soil, and year

round high temperatures tend to encourage rapid decomposition. However, the saturated soils of ephemeral ponds and depressions may permit accumulation of higher levels of organic matter. Soil organic matter favors plant growth due to its moisture and nutrient holding ability. The decomposition of organic matter releases nitrogen, phosphorus and other nutrients.

Litter. The standing crop of litter, on the other hand, can be comparable to the live plant biomass (Kattner 1973.) Generally, this dead plant material gradually breaks down and contributes to soil organic matter, but fire can quickly destroy litter, leaving only inorganic nutrients.

Soil nutrients. These include nitrogen, phosphorus, potassium, calcium, magnesium, and other inorganic materials essential to plant growth. The sandy soil with low organic matter content typical of dune and barrier flat habitats has a low capacity for binding nutrients; thus they are easily washed out, especially in the dunes (Van der Valk 1974.)

#### Biotic Attributes

Reflecting the observed plant zonation observed within the dune and barrier flat habitat, the model shows three types of plants: dune plants, barrier flat plants, and wetland plants. A number of studies have been done on barrier island plants, but most have concentrated on the lower coast. Examples include: Fruh et al. (1977) - Mustang Island; Dahl et al. (1975), Kattner (1973), McAtee and Drawe (1974.) - North Padre Island; and Judd et al. (1977) - South Padre Island.

Dune plants. These are typically highly specialized plants which can cope with high salinity, low soil moisture, and rapid sand deposition. Some of those found in the most exposed windward positions include sea oats (Uniola paniculata), goatfoot morning glory (Ipomea pes-caprae) and beach tea (Croton

punctatus). Elevation is also a factor in determining the location of these plants since sea oats can be found on many hummocks and dunes away from the shore. Some of the plants found on the barrier flats are also found on the leeward side of the dunes.

Barrier flat plants. The flora of the flats is more diverse and includes many of the more salt-tolerant grasses and forbs found on coastal prairies and high marshes such as *Spartina patens*. Under good soil moisture conditions, standing crops on the order of 2300 lbs dry wt per acre are typical, with a roughly equal standing crop of litter (Fruh et al. 1977).

Wetland plants. In areas where a topographic low provides standing water or saturated soil for long periods, the plants are typical of brackish to fresh marshes. These plants include the cat tail, rushes and sedges. Wetland areas expand and shrink with long-term climatic variations, and it is hard to map them or determine their areal extent.

Herbivores. This component of the model represents a large variety of animals, from insects to cattle, which graze directly on the plants. Grasshoppers are probably the most common insect herbivore. Small rodents (Baccus and Horton 1979) and seed-eating birds are also significant. Most of the barrier islands in the study area have been used for grazing at some time, and it is generally thought that overgrazing was partly responsible for conversion of many vegetated areas to active dunes (White et al. 1978).

Omnivores. In this category we find the racoon, coyote, opossum and various rodents such as the cotton rat. The habitat model indicates a general positive influence on all consumers due to cover provided by plants. Baccus and Horton (1979) discuss the vegetation cover preferences of several rodents.

A general negative effect of fire on consumers is shown, although the effect will vary with the species.

Carnivores. Major predators which are exclusively carnivorous include the badger, birds such as the marsh hawk, and snakes such as the western diamond back.

#### Material Outputs

Sediment exports. This represents the adjacent systems which may receive sediments during storm erosion of the dune and barrier flat system. Storm waves erode the dunes and return sediments to the beach and nearshore gulf. The presence of dense vegetation can bind the dune sand and reduce erosion rates.

Over the long term, the net erosion or accumulation of dunes reflects the net erosion or accumulation of the adjacent beach shoreline. Seelig and Sorensen (1973) summarize historical data on net shoreline movement which indicate that although there are some areas of accumulation, most of the study area shows net shoreline retreat on the order of several feet per year over the period from the late 19th to the mid 20th century. In areas of greatest erosion, such as Sargent, south of the Brazos River, beaches are extremely narrow and there are no dunes.

Another form of sediment export occurs when a dune and barrier flat habitat becomes an active dune due to failure of the vegetation. The prevailing winds then cause the active dune system to migrate into adjacent wind tidal flat, bay margin, and other estuarine systems. Subsequent revegetation during wet years can cause a net expansion of the dune and barrier flat habitat as observed on Mustang and North Padre islands (White et

al. 1978). Hurricane washovers also can transport sediments from the barrier island into adjacent bays.

Migrating birds. Barrier island habitats are used by a wide variety of migrating birds. For those crossing the Gulf of Mexico, the islands are the first dry land. An extensive summary of birds found on Texas barrier islands is given in Fruh et al. (1977).

### Critical Factors

The balance between rainfall and evaporation is the most critical factor for the dune and barrier flat habitat. With sufficient rainfall, the system can recover from fire and other disturbances, such as overgrazing. The dunes in particular are important to coastal systems as a barrier against storm wave damage, and as part of the dynamic sediment erosion and deposition system formed with the beach and nearshore gulf habitats.

## FRESH MARSH

### Introduction

Extensive fresh marsh areas occur in Texas on the mainland in the middle and upper portions of the coast (Brown et al. 1972-77). Fresh marshes along the drier lower coast, south of Corpus Christi Bay, are generally associated with rivers, creeks and inland lake areas where there is a more consistent supply of fresh water. This habitat type is generally found between the brackish marsh and one of the dry land habitats such as coastal prairie or brush or in low areas near a more or less permanent water supply. Fresh marsh is usually found in areas that are not inundated by salt water, but have a high water table and either are constantly submerged or are at least regularly flooded by fresh water. Much of the fresh marsh system along the upper and middle Texas coast occurs as part of a gradient from salt marsh to coastal

prairie. Therefore, some of these areas of fresh marsh may be occasionally flooded by salt water during storms, but in general they are not exposed to significant long-term inundation by salt water.

Recent reports on the influence of freshwater inflows to several Texas bay systems by the Texas Department of Water Resources (1980-81) give good accounts of studies of specific coastal fresh marsh systems in Texas. Figure 41 the fresh marsh habitat on the Texas coast.

### Energy Sources

Sunlight. Solar energy input provides the major source of energy used by the vascular plant based food web of the fresh marsh ecosystem.

Upland drainage. Drainage from streams and overland sources provides the major source of nutrients, toxics and organic matter to the fresh marsh ecosystem. It is the primary supplier of fresh water to this system.

Precipitation. Direct input of water to the fresh marsh via precipitation may be a significant source of energy, especially in the drier portions of the lower Texas coast where little drainage occurs. This may allow fresh marsh to occur in low-lying areas during wet years but not necessarily during periods of moderate to severe drought.

Subsidence. Portions of the middle and upper Texas coastal plain have subsided as much as several meters (Brown et al. 1972-77). This subsidence has been caused by pumping of underground water, oil and gas reservoirs. Subsidence has a direct effect on the land elevation and thereby the water level of the fresh marshes. Subsidence tends to change fresh marsh into brackish or salt marsh by allowing more frequent tidal inundation.

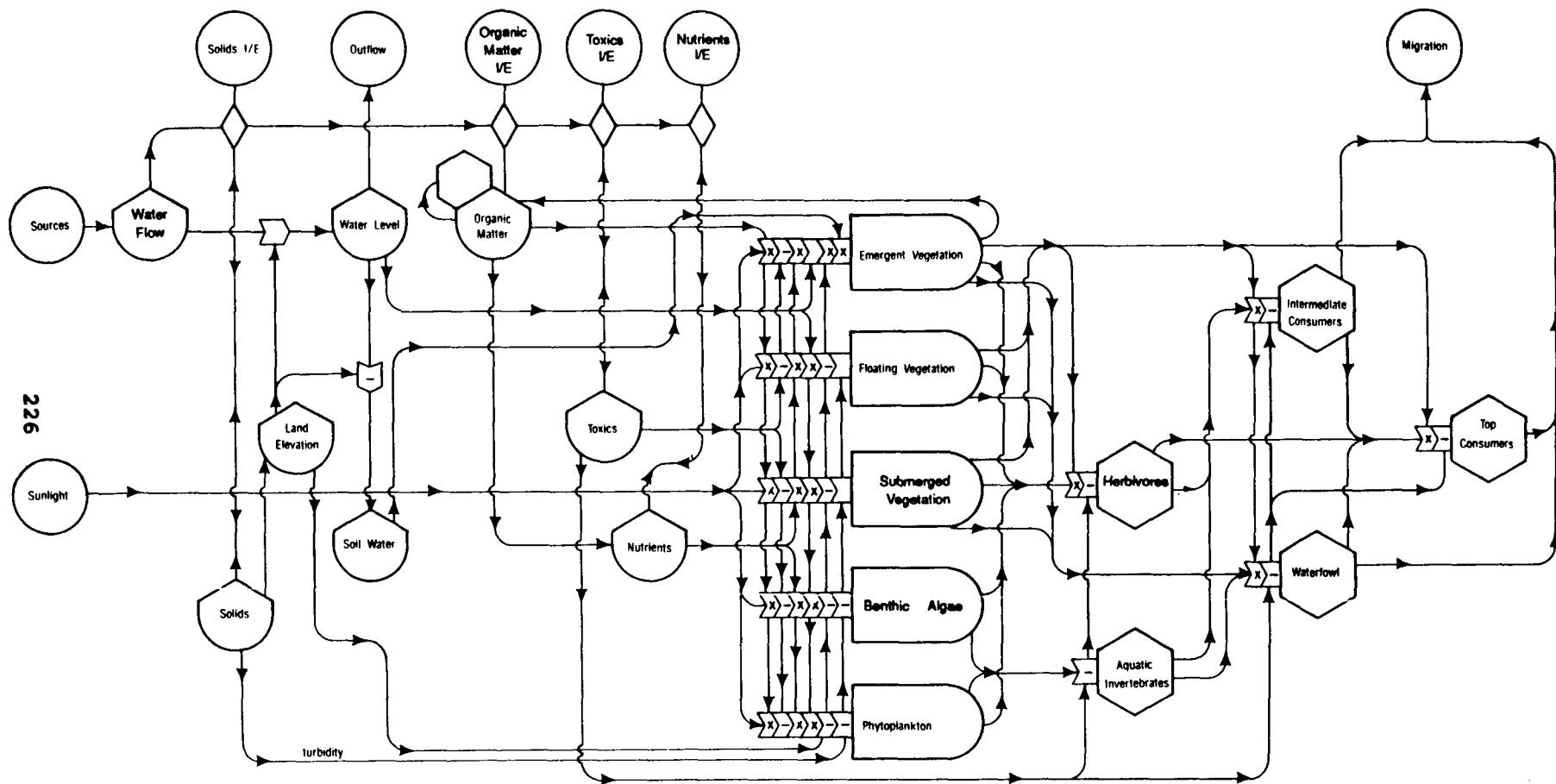

226

FIGURE 41. Fresh marsh habitat.

## Physical Attributes

Water flow. Water flow in the fresh marsh is used to represent the physical flow of water derived from upland drainage. The water flow is analogous to currents in deeper water systems. The major direction of the water flow in the fresh marsh is "in" from upland drainage and "out" when there is excess water in the system. The water flow drives the import and export of physical and biotic attributes. Upland drainage is the primary energy source for water flow in the fresh marsh systems of Texas.

Water level. This attribute is primarily controlled by water flow. The water level within a fresh marsh system may vary from over one meter in pond areas during high water periods to dry during droughts. Most of the fresh marshes in the upper and middle Texas coast have an adequate amount of fresh water covering them during most of the year. This may vary only a few centimeters with normal runoff, but may increase significantly during floods or periods of high rainfall. The depth of the water in the fresh marsh is one of the most important factors controlling the abundance of aquatic organisms in this system. It is also highly important in controlling the primary production via phytoplankton and benthic algae, especially in the transient marshes of the lower coast that are exposed for extended periods.

Solids. The solids attribute is used to show the physical effects of particulate matter, such as the covering of the bottom fauna and turbidity in the water column as well as the mass or volume of sediment within a particular area of the fresh marsh. Suspended solids are introduced into the fresh marsh waters primarily by import from adjacent systems via water flow. They may be removed from the water column via settling in the marsh or they may be exported to adjacent ecosystems.



This attribute also provides an input to land elevation which in turn affect the water level. Rapid sedimentation from storm water runoff may be particularly detrimental to organisms such as benthic micro-algae via settling on them and phytoplankton by causing excess turbidity.

Land elevation. This attribute represents the physical elevation of the land mass relative to sea level. It is increased by the import of solids and decreased by subsidence. It directly affects the amount of water flow and water level in the fresh marsh. In general, fresh marsh occurs farther above sea level than brackish or salt marsh. In a fresh to salt marsh gradient, the fresh marsh will have the highest land elevation.

Soil water. This attribute is derived from water level and is used to show the amount of saturation of the soil. Since many of the fresh marshes on the lower Texas coast are only infrequently inundated by upland drainage and precipitation, the soil water content is very important in determining the types and abundance of emergent plants that occur in the system. Increased soil water encourages increased growth of cattail, sedges and rushes. Decreased soil water promotes the growth of more of the coastal prairie species. Since much of the fresh marsh along the upper Texas coast is part of a gradient from salt marsh through brackish and fresh marsh to coastal prairie, the amount of soil water is extremely important in determining the extent of the fresh marsh habitat in a given area.

Nutrients. Nutrients are organic and inorganic materials required by the plants of the fresh marsh for photosynthesis, in addition to light. Nitrogen and phosphorus are the major nutrients associated with primary production in the fresh marsh, although many additional nutrients and trace elements are also needed. A significant portion of the nutrients used in the fresh marsh

ecosystem probably comes from upland drainage. Some may be recycled from the sediments via reduction and bacterial action. Keefe (1972) reports that the water in fresh marshes tends to be generally high in nutrients near the source and low toward the landward sides since the marsh plants quickly extract the nutrients from the water. Phosphorus appears to be the limiting nutrient in many fresh marsh systems (Palmisano 1970; Bayley and Odum 1976). The Texas Department of Water Resources has computer data banks of nutrient data from sampling in the fresh marshes of many Texas bays.

Organic Matter. "Microbes" are partially combined with the symbol representing organic matter in the water and sediments since they are an integral part of the cycling of energy via decomposition. The amount of organic matter in fresh marshes is generally very high due to the high primary productivity of the emergent, floating and submerged vegetation. The net primary production of Texas fresh marshes with large amounts of emergent vegetation may be similar to those of Louisiana which averaged an estimated 2,200 g/m<sup>2</sup>/yr (Boyd 1969; Chabreck 1972; Gosselink et al. 1977). Due to the lack of significant export, much of the production of marsh grasses may accumulate and be incorporated into the sediments. The average annual export of organic matter is probably small.

The benthic infauna ingest the organic matter from the sediments or the surface of the sediments as do some of the herbivores and detritivores. This is an important food source for many species.

Toxics. Toxic materials which could be introduced into the fresh marsh system include heavy metals, pesticides, industrial organic chemicals, well drilling fluids, crude oil and petrochemicals. Many toxic materials are readily adsorbed on fine particles. They are then quickly incorporated into

the sediments. Some of these toxics may reach higher levels in the food chain via bioaccumulation by filter feeders and consumption by higher order consumers. Toxics enter the fresh marsh system primarily via water from upland drainage; however, storm tides may push toxics into the system from the bays.

Each bay system in Texas varies greatly in its sediment concentrations of toxic materials. Available data which document the concentrations of heavy metals, pesticides and chemicals such as PCB show that they are found in the sediments of nearly all of the bays of Texas (TDWR Computer Data Files). The fresh marsh system would be expected to have elevated toxic concentrations if they were introduced by nearby spills or via upland drainage.

#### Import/Export of Physical Attributes

Water outflow. This attribute is used to show the flow of water from the fresh marsh system to adjacent systems. It is driven by high water flow within the system which is caused by upland drainage and precipitation. Under normal conditions, there may be very little water outflow from many of the fresh marshes of Texas.

Solids Import/Export. The fresh marsh system receives most of its solids input from neighboring ecosystems via inundation by upland drainage containing high suspended solids concentrations. Since the succession is generally from fresh marsh to terrestrial system, little export of solids is expected.

Nutrients Import/Export. Import from the neighboring ecosystems, Upland drainage, nitrogen fixing by bacteria and blue-green algae and recycling of sediment nutrients provide the majority of the nutrients to the fresh marsh system. Upland drainage is the major source of nutrient input to the fresh marshes. Some of the nutrient load brought to the fresh marsh system by

upland drainage via streams actually originates as waste discharges and agricultural runoff in some areas.

Toxics Import/Export. Toxics such as agricultural pesticides or industrial wastes may be imported along with the freshwater runoff into the fresh marsh. Some are introduced into the fresh marsh system via spills or treatment plant outfalls. Toxics from spills in the adjacent bay area ecosystems may find their way into the fresh marsh system during storm conditions.

Organic Matter Import/Export. Most of the organic matter that enters the fresh marsh system via fresh water from upland drainage is either dissolved or suspended particles of vegetation and animal matter. Fresh marshes produce large amounts of their own organic matter but little is exported directly to other systems.

#### Biotic Attributes

Phytoplankton. The major portion of the primary productivity of the fresh marsh system is provided by the emergent marsh plants. The phytoplankton, benthic algae, submerged and floating vegetation are of lesser importance; however, they may supply a relatively larger amount of primary productivity during the winter months when the emergent plant growth slows. The rate of phytoplankton photosynthesis depends on light penetration and nutrient availability (Armstrong and Hinson 1973). The possibility of suppression of photosynthesis by toxic materials exists, but its extent in Texas' fresh marshes is currently unknown.

Emergent vegetation. Several species of rushes and sedges, in addition to cattails and maidencane are the primary species of emergent vegetation in most fresh marshes on the upper Texas coast. Fresh marshes on the lower coast

may contain primarily cattails, especially in areas that are subject to drying in drought years. The coastal areas which receive much more rainfall and upland drainage tend to be much more diverse in the species of emergent plants. The emergent plants provide the basis for the overall animal species richness of the fresh marsh system by providing large amounts of food and shelter.

Floating vegetation. Water lily, water hyacinth, alligator weed, duck weed and other varieties of floating plants may occur in the open water portions of stable fresh marshes. They provide primary production as well as food and cover for consumers.

Submerged vegetation. Coontail, pondweed of various types, southern naiad and other submerged species may be found in fresh marshes with relatively clear water and little floating vegetation.

Benthic algae. Various types of benthic algae may be found on the bottom of fresh marshes with little floating or submerged vegetation and relatively clear water.

Herbivores. This group comprises one of the largest consumer groups in the fresh marsh system. The aquatic animals in this group consist primarily of zooplankton and small invertebrates. Most of the crustaceans (shrimp, crabs, etc.) that use the brackish marsh may also be found in fresh marshes when they occur together. These organisms are herbivorous or detritus feeders or both at one stage in their life cycle (Coastal Fisheries Branch 1975; Cook and Lindner 1970; Costello and Allen 1970; Lindner and Cook 1970). Many of the larval stages of the higher level estuarine fish fall into this category (Dineen and Darnell 1976). Many of these organisms move into the fresh marsh system to feed on the benthic algae, phytoplankton or organic matter, and to

escape larger predators in the shallow water. The young of many of these organisms may spend some of their early life stages in fresh marsh systems adjacent to brackish and salt marsh systems.

Inland fresh marshes contain freshwater species of organisms from the same major classifications as those that inhabit the brackish and salt marshes.

Waterfowl and herbivorous mammals are also very prominent herbivores in the fresh marsh system. The waterfowl are discussed separately in a later section. Muskrats and nutria are common herbivores found in the fresh marsh system. They may consume large amounts of the emergent plants. The fresh marsh is one of the important habitats for these important furbearers.

Aquatic invertebrates. This attribute is used to show both the carnivorous zooplankton and benthic invertebrates of the fresh marshes of Texas. The zooplankton found in fresh marsh systems which are adjacent to brackish or salt marshes may be imported from these adjacent systems and may be species from fresh to brackish habitats or marine species from the bay system, depending upon the amount of runoff and tidal inundation (Cuzon du Rest 1963). Inland fresh marshes also contain different species from these same major classifications of organisms. Polychaetes, nematodes, ostracods, and copepods can be found in the fresh marsh system. These organisms feed primarily on the smaller aquatic herbivores and detritivores and comprise the second level of the detritus based food chain for which the fresh marsh provides the primary production. Many of the higher trophic level organisms depend, at least partially, on the aquatic invertebrates for their food.

Intermediate Consumers. This compartment is primarily concerned with the predatory organisms below the level of top consumer. Aquatic species such as

the tidewater silversides Menidia beryllina, rainwater killifish (Lucania parva), blue crab (Callinectes sapidus), sheepshead minnow (Cyprinodon variegatus), which prefers water less than 10 cm deep and feeds on algae, detritus and small benthic animals, and several species of killifish (Fundulus similis, grandis and others) may spend some time in the very shallow waters of the fresh marsh system when it is adjacent to brackish or salt marshes. Inland fresh marshes with sufficient water depth and permanence may contain a variety of freshwater species of fish.

Various wading birds such as egrets, bitterns, herons and ibises prey on the smaller organisms of the fresh marsh. Some also nest in the marsh. The fresh marsh supports amphibians in significant numbers. Also, there are many reptile species which occur in the fresh marsh in addition to terrestrial and other freshwater habitats. Mammals such as raccoons and mink are also intermediate consumers in this system.

Top Consumers. The top consumers of the fresh marsh systems which allow ingress and egress to the bay systems may be primarily the juveniles of game fish of the bay system, birds of prey, coyotes, red wolves, and alligators. Juveniles of aquatic species such as Cynoscion nebulosus, Sciaenops ocellata and Pogonias cromis frequent the fresh marsh system, when the water level permits, in search of prey. Coastal Fisheries Branch (1975) and Hoese (1965) are two of the more comprehensive references on the top aquatic consumers and their habitats. The top aquatic consumers in inland fresh marshes are the freshwater game fish such as largemouth bass, catfish and gar.

The birds of prey ( hawks, owls, osprey, eagles) may nest in trees near the fresh marsh and feed on the numerous smaller animals of the marsh. The coyote and red wolf feed on the various intermediate consumers and herbivores.

The alligator will eat practically any and all of the other marsh inhabitants if given the chance.

Waterfowl. The waterfowl are discussed separately because they are so important in the fresh marsh system. Many species of waterfowl feed on microorganisms or vegetation in the fresh marsh system during the winter months. Many of them rest on the shore adjacent to the fresh marsh where their droppings may be washed back into the system to provide nutrient input. Most of the waterfowl found in the fresh marsh systems in Texas are the winter migrants. The fresh marsh system is the preferred habitat for many species of the millions of ducks and geese which winter along the entire Texas coast.

#### Import/Export of Biotic Attributes

Phytoplankton. The fresh marsh may contain both marine and freshwater species of phytoplankton, depending upon the amount of tidal inundation. Marine phytoplankton are imported and exported via the inundation of bay water during storms. They are of minor importance in the overall productivity of the fresh marsh system. The freshwater phytoplankton are of only slightly more importance, however, due to their relatively small biomass when compared to the emergent, floating and submerged plants. They may provide a relatively larger portion of the production in the small ephemeral pools which occur within the fresh marsh system.

Migration. Migration with respect to the fresh marsh system represents the movement into and out of the fresh marsh area from other systems as opposed to the seasonal migrations of organisms between the gulf and bay systems or seasonal waterfowl migrations. This between-system migration is cued primarily by water flow and water level. The planktonic organisms are carried into and out of the fresh marsh system during inundation by salt water



or upland drainage. More motile organisms move in and out of the system when the conditions are favorable to them.

Killifish, silversides and small mullet are the most visible members of the herbivore and detritivore group that migrate between the bay systems and the fresh marsh. Smaller juveniles of many intermediate and top consumers can be found during certain times of the year in the fresh marshes.

The Penaeid shrimp spawn offshore in the gulf and the postlarvae migrate into the bays to mature (Cook and Lindner 1978; Lindner and Cook 1970; Costello and Allen 1939). These postlarvae may proceed all the way to the fresh marshes and other shallow water systems in the bays where they feed on the benthic algae and organic matter in the relative safety of the shallows. The white shrimp is more likely to be found in the fresh marsh due to this species tolerance of low salinities (Lindner and Cook 1970).

Many of the estuarine aquatic intermediate consumers migrate into the fresh marsh and spend some of their life cycle, primarily as juveniles, in the food laden shallow waters of the fresh marsh areas which have access to the bay systems.

The gamefish, which comprise the more important top consumers, migrate at various times of the year as do the intermediate consumers. Their migrations depend upon their spawning periods and various physical factors as mentioned above. No two species migrate at exactly the same time. Many of the smaller individuals seek out the fresh marsh areas for refuge from the larger predators and to feed on the juveniles of other species in the fresh marsh system. Very little migration occurs in the inland fresh marsh systems.

### Critical System Components

The most critical components of the fresh marsh system are upland drainage and precipitation. These freshwater inputs supply the fresh marsh with nutrients, organic matter and toxics. This freshwater input keeps the soil water levels high and allows the emergent plants to produce large amounts of organic matter upon which the important detritus food chain is based. The emergent plants are also a critical component since they are the primary source of most of the carbon produced in the fresh marsh system. Changes in the water regime will quickly result in changes in the species composition and productivity of the fresh marsh system.

## FOREST

### Introduction

Forest areas occur in Texas on the mainland primarily in the middle and upper portions of the coast (Brown et al. 1972-77). No large forests occur along the drier lower coast, south of Corpus Christi Bay. Over 85 percent of this habitat type in the Texas coastal zone is found in the eastern third of the state. In Texas, forest is usually found in areas that are not inundated by salt water, but some are subject to infrequent flooding by fresh water from extreme over-bank river flooding. For the purpose of this report, forest is differentiated from floodplain forest by the lack of flooding and the lack of the occurrence of aquatic species of plants and animals. The upland forest types that occur in the coastal areas of Texas are primarily loblolly pine, loblolly pine-hardwood and live oak (mottes) (Society of American Foresters 1954).

Some of these areas of forest may be occasionally flooded by salt water during extreme storms, but in general, they are not exposed to significant

inundation by salt water. This system occupies some 3,000+ square miles in the coastal areas of the state (Brown et al. 1972-77). Figure 42 is the conceptual model for forest.

#### Energy Sources

Sunlight. Solar energy input provides the major source of energy used by the vascular plant based food web of the forest ecosystem.

Precipitation. Direct input of water to the forest via precipitation may be a significant source of energy, especially in the eastern portions of the upper Texas coast where the precipitation may exceed 50 inches annually.

Salt Spray. Some of the forests are close enough to the Gulf of Mexico or Texas bays to receive salt spray, especially during periods of high winds. This salt spray introduces not only NaCl to the system, but all of the other mineral salts and nutrients, etc. that occur in the salt water of the gulf. This may be a significant factor in the growth and survival of vegetation that is constantly exposed to this spray (Boyce 1954; Oosting and Billings 1942).

Land Slope. Land slope represents the physical slope of the land surface. This greatly affects the surface water, soil water and water flow. Most of the coastal area of Texas has very little overall slope. But small scale variations in topography may be sufficient to alter the land slope and hydrologic regime. Increased land slope increases water flow and decreases the infiltration of water into the soil.

#### Physical Attributes

Water flow. Water flow in the forest is used to represent the physical flow of water derived from surface water and upland drainage. The water flow is analogous to currents in aquatic systems. The major direction of the water flow in the forest is "down slope". The water flow drives the import and

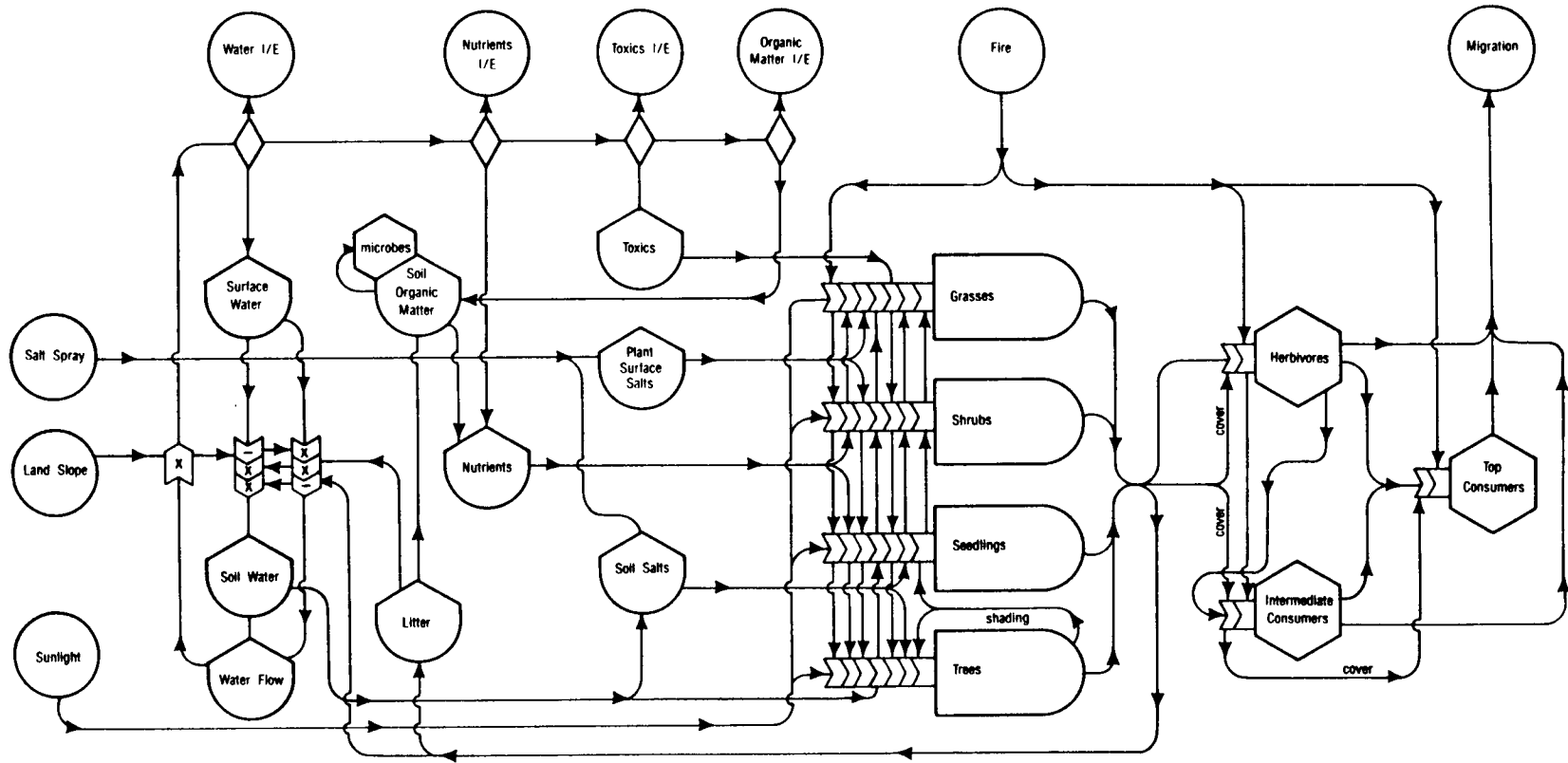

FIGURE 42. Forest habitat.

export of physical and biotic attributes. The flows which accompany extreme precipitation may remove much the forest litter.

Surface water. This attribute is controlled by precipitation. The water level within a forest system may vary from several centimeters during high water periods to dry during non-flood periods. Most of the forests in the upper and middle Texas coast are inundated by precipitation several times each year. This inundation may vary from only a few centimeters for a few hours with normal precipitation and overland runoff to significantly more water for longer periods during periods of high rainfall associated with tropical storms or hurricanes. The frequency and duration of inundation is one of the most important factors affecting the vegetation in the forest system. Adequate surface water provides for tree growth and survival in the forest habitat (Spurr 1964). Surface water directly affects soil water.

Soil water. This attribute is derived from surface water and is used to show the frequency and amount of saturation of the soil. Soil water content is very important in determining the types and abundance of plants that occur in the forest system. Soil water provides the transport mechanism for the nutrients used by the vegetation. Periods of high soil water interspersed with drying periods alternately bathe the roots of the vegetation with nutrients and then allow them to partially dry to keep from rotting or the soil becoming oxygen deficient. This provides conditions appropriate for plant growth in the forest.

Nutrients. Nutrients are organic and inorganic materials required by the plants of the forest for photosynthesis, in addition to light. Nitrogen and phosphorus are the major nutrients associated with primary production in the forest, although many additional nutrients and trace elements are also needed.

A small portion of the nutrients used in the forest ecosystem comes from upland drainage. The majority of the nutrients originate in the soil or air and are recycled by bacteria, fungi and nitrogen fixing plants. Since the leaves of the plants contain higher percentages of nutrients than the woody parts, leaf litter efficiently recycles many of the nutrients (Spurr 1964).

Soil Organic Matter. "Microbes" are partially combined with the symbol representing organic matter in the soil since they are an integral part of the cycling of energy via decomposition. The amount of soil organic matter in forests is generally quite large to the high primary productivity of the trees and other vegetation, the high soil moisture and temperature which promote rapid decomposition and the lack of significant export of litter. The net primary production of Texas forests will be less than the floodplain forests which averaged an estimated 1,574 g dry wt/m<sup>2</sup>/yr (Connor and Day 1976); however, more accurate measurements are very site specific due to the variability of the species composition and density of the vegetation in Texas' forests. Some of the production is accumulated in the woody trunks and branches of the trees and shrubs. A large amount falls to the forest floor as leaf litter.

Toxics. Toxic materials which could be introduced into the forest system include heavy metals, pesticides, industrial organic chemicals, well drilling fluids, crude oil and petrochemicals. Toxics enter the forest system primarily via water from upland drainage and precipitation; however, storm tides from hurricanes may push toxics into the system from the bays. The forest system would only be expected to have elevated toxic concentrations if toxics were introduced by local spills or washed out of the air by precipitation.

Litter. Litter includes all of the debris from the plants and animals in the system which falls to the forest floor. This material is mostly organic in nature. The majority comes from the trees and shrubs of the forest. Some is incorporated into the soil organic matter and recycled into the forest system. Some is exported as organic matter by water flow. Litter decomposition is very important in recycling nutrients within the forest system. Temperate forests may have between 3,000 and 5,000 lbs per acre of litter fall annually (Spurr 1964).

Plant Surface Salts. Areas of the forest that are close to the bays or Gulf of Mexico are subject to salt spray. Trees that are more or less constantly subjected to salt spray tend to be adversely affected in their growth rates and patterns. Because of the lower precipitation in the middle portion of the Texas coastal area, forest trees are more likely to show the effects of the buildup of plant surface salts than the areas of the upper coast where the higher rainfall tends to wash the salts from the leaves more often. Details of the effects of plant surface salts on vegetation in the coastal area can be found in Boyce (1954) and Oosting and Billings (1942).

Soil Salts. The accumulation of salts in the soil within the forest system occurs in all areas but is most noticeable in the forests of the middle Texas coast (primarily the live oak mottes) which are exposed to nearly continuous salt spray and receive little precipitation. The salts of various minerals tend to accumulate on the leaves of trees and shrubs and are leached from the leaves by rainfall (Spurr 1964). High rainfall tends to leach the salts deep into the soil and subsoil or export them in the runoff. Small amounts of precipitation tend to transport the salts into the upper soil layers where they accumulate. Periods of drying, especially of sandy type

soils, may also bring some of the deeper salts to the soil surface by capillary action. Excess soil salts, especially NaCl, can be detrimental to the forest plants (Boyce 1954).

#### Import/Export of Physical Attributes

Water outflow. This attribute is used to show the flow of water from the forest system to adjacent systems. It is driven by high water flow within the system which is caused by precipitation. Under normal conditions, there may be very little water outflow the forests of Texas. However, during periods of intense precipitation, especially during hurricanes and tropical storms, the water outflow is significant.

Nutrient Export. Nutrient import from the neighboring ecosystems is believed to be minimal in the forest system. Nitrogen fixing by bacteria and some plants and recycling of soil nutrients provide the majority of the nutrients to the forest system. Water flow resulting from precipitation is the major factor affecting nutrient export in forests.

Toxics Import/Export. Toxics such as agricultural pesticides or industrial wastes may be imported into the forest by washout from the air during precipitation or by upland drainage. Most is expected to be introduced directly into the forest system via spills. Toxics from spills in the adjacent ecosystems may find their way into the forest system during storm conditions. Forests that contain toxic materials may export these during periods of high precipitation. No data are available on the general concentrations of toxics in the forest habitats of Texas.

Organic Matter Import/Export. Most of the organic matter in the forest system is produced there by the vegetation. The small amount that may be imported via upland drainage is either dissolved or suspended particles of



vegetation and animal matter. The amount exported directly to other systems varies primarily with the amount of leaf litter fall since much of the productivity is accumulated in the woody parts of standing vegetation such as trees. Some may be exported during storms such as hurricanes; however, most is probably exported in the form of wood cut by man or by animals higher up in the detritus food chain.

Fire. Fire can be important in regulating both the plant and animal communities as well as altering the nutrient cycling within the forest system. Fire increases the rate of breakdown of vegetative matter into nutrients, opens the canopy and clears the ground of accumulated litter so that new growth can begin, and starts the succession of plant and animal communities over again. Fire changes the relative proportions of nutrients since some such as nitrogen are consumed by fire (Spurr 1964).

#### Biotic Attributes

Trees. The forests of the Texas coastal areas contain a reasonably diverse group of trees, especially since there are three general types of forest in the area. However, these upland forests are not nearly as diverse as the floodplain forests. Abbott (1966) found 34 species of woody plants in the floodplain forest habitat and only 14 species in an upland forest habitat. Some of the same species occur in both floodplain and upland forests; however, since the upland forest habitat is considerably drier with respect to soil moisture, most of the trees are adapted to use less water. The principal species in each of the forest types are: loblolly pine type--loblolly pine, sweetgum, shortleaf pine, southern red oak, post oak and blackjack oak; loblolly pine--hardwood - loblolly pine, oaks, hickories, shortleaf pine and

longleaf pine; live oak (mottes) - live oak (pure or highly dominant), holly, laurel oak and hawthorn.

The loblolly pine and loblolly pine-hardwood forests are found along the upper or eastern portions of the Texas coast. They are the predominant forest type. The live oak forest or motte is found in scattered patches, primarily along the middle portion of the Texas coast, and occasionally on the barrier islands. The live oaks are extremely hardy and are resistant to salt spray to a great extent. They will usually be found close to the bays where no other native trees will grow.

The trees undoubtedly contribute the most primary production to the forest system. In many of these forests, the canopy is closed and the understory and ground cover are very sparse. In these forests, the trees contribute practically all of the primary production.

Seedlings. The seedlings of the trees of the forest system contribute a small portion of the primary productivity of the system. However, they are important since they perpetuate the system by replacing the trees that die from various causes.

Shrubs. Few of the upland forests have water regimes and conditions suitable for the growth of many species of shrubs and small trees. However in the more moist forests, the most common species of shrub are yaupon, hawthorne and possum-haw holly. These species add to the primary productivity and provide habitats for some of the species of animals which inhabit the forest. All of these species are adapted to living in the low light conditions which occur under the nearly closed canopy of trees in the forest.

Forbs and Vines. The ground cover and understory as well as some high climbing vines are generally found only on the edges of the forest. Species

such as dewberry, pepper vine, grape, trumpet-creeper, poison ivy, greenbriar are the most common vines. Only a few species of forbs can be found in this habitat, due to the competition with the trees for both nutrients and light.

Grasses. In clearings or portions of the forest edge that do not have a closed canopy, many species of grasses may be found. These are not true forest species, but are included here since many of the forest areas of Texas are rather sparsely covered with trees or are interspersed with old fields and pastures. The overall forest ecosystem, therefore contains these species. The majority of these are perennial grasses such as the bluestems, lovegrasses, dropseeds, panic grasses, smut grasses, Indian grass and others (Gould 1975). They contribute to the overall productivity of the forest when present, but only account for a small portion of the net annual productivity.

Herbivores. This group comprises one of the largest consumer groups (in terms of total numbers of individuals) in the forest system. The majority of these are invertebrates such as insects and crustaceans; however, squirrels, deer, rabbits, mice and seed-eating birds also fall into this category. The detritivores are also included in this category. They may be the largest in total numbers since the forest floor, with its accumulation of several years of litter and little disturbance is an ideal habitat for these organisms (Spurr 1964). Organisms such as moles and earthworms play an important role in the forest ecosystem. They loosen the soil with their burrowing and assist in keeping it aerated. Their burrows also allow precipitation to penetrate the soil more rapidly.

Intermediate Consumers. This compartment is primarily concerned with the predatory organisms below the level of top consumer. Predatory insects are numerous during the growing season. The forest supports amphibians in

moderate numbers. Also, there are several reptile species which occur in the forest in addition to other terrestrial habitats. Mammals such as the raccoon, opossum, armadillo, grey fox, red fox, and various species of birds are also intermediate consumers in this system.

Top Consumers. The top consumers of the forest systems are primarily the birds of prey, coyote, red wolf and bobcat. Birds of prey (hawks, owls, osprey, eagles) may nest in trees of the forest and feed on the numerous smaller animals of the system. The coyote, bobcat and red wolf feed on the various intermediate consumers and herbivores.

#### Import/Export of Biotic Attributes

Migration. Migration with respect to the forest system represents the movement into and out of the forest area from other systems. Due to the stability of the forest system, there is very little migration of animal species between this and other systems. Many mobile animals such as birds and larger mammals move between the forest and adjacent systems in order to find food or water; however, most true forest species prefer this habitat and move very little.

#### Critical System Components

The most critical components of the forest system are the soil nutrients and precipitation. Precipitation provides the energy for the exchange of nutrients, organic matter, fresh water and toxics between the forest and other systems. This fresh water input keeps the soil water levels high enough to allow the plants to produce organic matter upon which the important detritus food chain is based. Also, without the proper soil nutrients, the plants would not be able to grow. The trees, are also a critical component since they are the primary source of most of the carbon produced in the forest

system. Changes in the water regime or depletion of the soil nutrients will quickly result in changes in the species composition and productivity of the forest system.

## FLOODPLAIN FOREST

### Introduction

Floodplain forest areas occur in Texas on the mainland in the middle and upper portions of the coast (Brown et al. 1972-77). Very few floodplain forests occur along the drier lower coast, south of Corpus Christi Bay. Over 90 percent of this habitat type in the Texas coastal zone is found in the eastern third of the state. In Texas, floodplain forest is usually found in areas that are not inundated by salt water, but are frequently flooded by fresh water from over-bank river flooding. As the name implies, the floodplain forest systems occur as part of river floodplains. Floodplain forest is differentiated from swamp forest by the lack of extended periods of flooding and the lack of the occurrence of aquatic species of plants and animals.

Some of these areas of floodplain forest may be occasionally flooded by salt water during extreme storms, but in general, they are not exposed to significant inundation by salt water. There have been few ecological studies of the floodplain forest system in Texas, partially because it is relatively fragmented. This system occupies some 1,250+ square miles in the coastal areas of the state (Brown et al. 1972-77). Figure 43 is the model of the floodplain forest habitat.

### Energy Sources

Sunlight. Solar energy input provides the major source of energy used by the vascular plant based food web of the floodplain forest ecosystem.

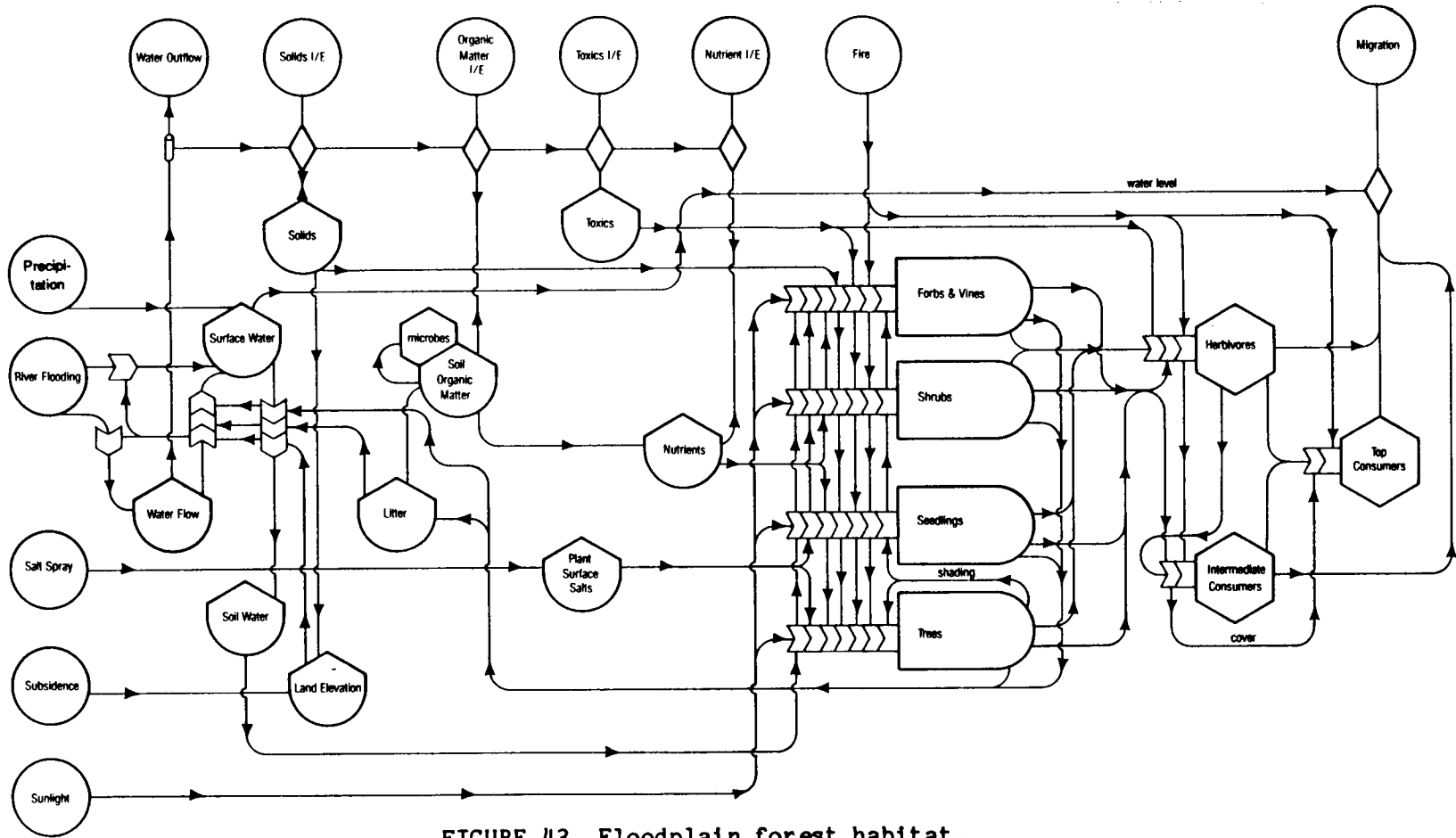

FIGURE 43. Floodplain forest habitat.

River flooding. In many instances, river flooding is the primary source of fresh water for the floodplain forest system. This is especially true of the floodplain forest areas of the middle coast where precipitation supplies only a small portion of the yearly freshwater input. This attribute contributes the majority of the energy for water flow in most of the Texas floodplain forest areas.

Precipitation. Direct input of water to the floodplain forest via precipitation may be a significant source of energy, especially in the eastern portions of the lower Texas coast where the precipitation may exceed 50 inches annually. This may allow floodplain forest vegetation to occur in wider areas adjacent to the rivers that are only irregularly inundated by river flooding but contain the appropriate soil types.

Subsidence. Portions of the middle and upper Texas coastal plain have subsided as much as several meters (Brown et al. 1972-77). This subsidence has been caused by pumping of underground water, oil and gas reservoirs. Subsidence has a direct effect on the land elevation and thereby the frequency of flooding of the floodplain forest habitat. Subsidence tends to increase the amount of floodplain forest by increasing the area flooded and period of water inundation.

Salt spray. Some of the floodplain forests are close enough to the Gulf of Mexico or Texas bays to receive salt spray, especially during periods of high winds. This salt spray introduces not only NaCl to the system, but all of the other mineral salts and nutrients, etc. that occur in the salt water of the gulf. This may be a significant factor in the growth and survival of vegetation that is constantly exposed to this spray.

## Physical Attributes

Water flow. Water flow in the floodplain forest is used to represent the physical flow of water derived from river flooding. The water flow is analogous to currents in deeper water systems. The major direction of the water flow in the floodplain forest is "in" during river flooding and "out" when the river flooding subsides. The water flow drives the import and export of physical and biotic attributes. It is primarily this attribute that separates the floodplain forest system from the upland forest system. The flows which accompany extreme river flooding remove much the forest litter and may also remove dead or dying trees.

Surface water. This attribute is controlled by precipitation and river flooding. The water level within a floodplain forest system may vary from several meters during high water periods to dry during non-flood periods. Most of the floodplain forests in the upper and middle Texas coast are inundated by fresh water several times each year. This inundation may vary from only a few centimeters for a few hours with normal precipitation and overland runoff to significantly more water for longer periods during floods or periods of high rainfall associated with tropical storms or hurricanes. The frequency and duration of inundation is one of the most important factors affecting the vegetation in the floodplain forest system. Seasonal flooding of appropriate duration appears to provide for optimum tree growth and survival in the floodplain forest habitat (Conner and Day 1976). Surface water directly affects soil water.

Solids. The solids attribute is used to show the physical effects of particulate matter, such as the covering of the bottom fauna as well as the mass or volume of sediment within a particular area of the floodplain forest.



Suspended solids are introduced into the floodplain forest waters primarily by import from adjacent systems via water flow. They may be removed from the water column via settling or they may be exported to adjacent ecosystems. In general, except in erosional areas during river flooding, floodplain forests are sinks for solids.

This attribute also provides an input to land elevation which in turn affect the soil water level. Rapid sedimentation following river flooding may be particularly detrimental to the ground cover plants and smaller terrestrial organisms such as rodents which live on or in the soil.

Land elevation. This attribute represents the physical elevation of the land mass relative to sea level. It is increased by the import of solids and decreased by subsidence. It directly affects the amount of water flow and the area and frequency of inundation in the floodplain forest. With sufficient sedimentation, floodplain forests may become upland forest habitats.

Soil water. This attribute is derived from surface water and is used to show the amount of saturation of the soil. Soil water content is very important in determining the types and abundance of plants that occur in the floodplain forest system. The amount of soil water is extremely important in determining the extent of the floodplain forest habitat as opposed to swamp forest or upland forest habitat in Texas. Increases above the optimum for floodplain forest favor the swamp, and decreases favor the upland forest. Soil water provides the transport mechanism for the nutrients used by the vegetation. Periods of high soil water interspersed with drying periods alternately bathe the roots of the vegetation with nutrients and then allow them to partially dry to keep from rotting or the soil becoming oxygen

deficient. This provides an optimum condition for plant growth in the floodplain forest.

Nutrients. Nutrients are organic and inorganic materials required by the plants of the floodplain forest for photosynthesis, in addition to light. Nitrogen and phosphorus are the major nutrients associated with primary production in the floodplain forest, although many additional nutrients and trace elements are also needed. A small portion of the nutrients used in the floodplain forest ecosystem comes from river flooding. The majority of the nutrients originate in the soil or air and are recycled by bacteria, fungi and nitrogen fixing plants. Since the leaves of the plants contain higher percentages of nutrients than the woody parts, leaf litter efficiently recycles many of the nutrients (Spurr 1964).

Soil organic matter. "Microbes" are partially combined with the symbol representing organic matter in the soil since they are an integral part of the cycling of energy via decomposition. The amount of soil organic matter in floodplain forests is generally less than marsh habitats or the swamp habitat due to the high primary productivity of the trees and other vegetation in the optimum situation of periodic flooding and drying. The net primary production of Texas floodplain forests may be similar to those of Louisiana which averaged an estimated 1,574 g dry wt/m<sup>2</sup>/yr (Connor and Day 1976). However, some of the production is accumulated in the woody trunks and branches of the trees and shrubs. A large amount falls to the forest floor as leaf litter, but in frequently flooded systems, much of it is exported to adjacent aquatic systems. In Texas floodplain forests, the high moisture and heat regime cause most of the organic matter that is not removed by river flooding to be quickly recycled in the detritus food chain.

Toxics. Toxic materials which could be introduced into the floodplain forest system include heavy metals, pesticides, industrial organic chemicals, well drilling fluids, crude oil and petrochemicals. Toxics enter the floodplain forest system primarily via water from river flooding; however, storm tides from hurricanes may push toxics into the system from the bays. The floodplain forest system would only be expected to have elevated toxic concentrations if toxics were introduced by local spills and washed in by river flooding.

Litter. Litter includes all of the debris from the plants and animals in the system which falls to the forest floor. This material is mostly organic in nature. The majority comes from the trees and shrubs of the floodplain forest. Some is incorporated into the soil organic matter and recycled into the floodplain forest system. Some is exported as organic matter by river flooding. Studies by Day et al. (1977) showed that the strong winds and heavy rains associated with hurricanes can cause early defoliation and increased litter export from this system. Litter decomposition is very important in recycling nutrients within the floodplain forest system.

Plant surface salts. Areas of the floodplain forest that are close to the bays or Gulf of Mexico are subject to salt spray. Trees that are more or less constantly subjected to salt spray tend to be adversely affected in their growth rates and patterns. Because of the lower precipitation in the middle portion of the Texas coastal area, floodplain forest trees are more likely to show the effects of the buildup of plant surface salts than the areas of the upper coast where the higher rainfall tends to wash the salts from the leaves more often. Details of the effects of plant surface salts on vegetation in the coastal area can be found in Boyce (1954) and Oosting and Billings (1942).

### Import/Export of Physical Attributes

Water outflow. This attribute is used to show the flow of water from the floodplain forest system to adjacent systems. It is driven by high water flow within the system which is caused by river flooding and precipitation. Under normal conditions, there may be very little water outflow the floodplain forests of Texas. However, under high water flows during periods of river flooding, the water outflow is highly significant.

Solids import/export. The floodplain forest system receives most of its solids input via inundation by river flooding containing high suspended solids concentrations. Since the succession is generally from floodplain forest to terrestrial forest systems, little export of solids is expected to occur under normal conditions. Erosion in certain portions of rivers during extreme floods probably accounts for any export of solids from this system.

Nutrients import/export. Import from the neighboring ecosystems, nitrogen fixing by bacteria and some plants, and recycling of soil nutrients provide the majority of the nutrients to the floodplain forest system. River flooding is the major factor affecting nutrient export in floodplain forests. Some of the nutrient load brought to the floodplain forest system by river flooding actually originates as waste discharges and agricultural runoff in some areas. Floodplain forests are generally nutrient exporters. Most of the nutrients are exported via river flooding in the form of litter.

Toxics import/export. Toxics such as agricultural pesticides or industrial wastes may be imported along with the fresh water into the floodplain forest. Some may be introduced directly into the floodplain forest system via spills. Toxics from spills in the adjacent ecosystems may find their way into the floodplain forest system during storm conditions.

Floodplain forests that contain toxic materials may export these during conditions of river flooding. No data are available on the general concentrations of toxics in the floodplain forest habitats of Texas.

Organic matter import/export. Most of the organic matter that enters the floodplain forest system via fresh water from upland drainage is either dissolved or suspended particles of vegetation and animal matter. Floodplain forests produce large amounts of their own organic matter. The amount exported directly to other systems varies primarily with the amount of leaf litter fall since much of the productivity is accumulated in the woody parts of standing vegetation such as trees. Large amounts may be exported during storms such as hurricanes (Day et al. 1977).

In the less regularly flooded floodplain forest systems, the average annual export of organic matter is probably very small. The amount of organic matter available for export can be as much as 50 percent of the net primary productivity (Day et al. 1977). However, the actual export of floodplain forest litter is probably nearer to 10 percent of the total litter fall (Butler 1975).

Fire. Fire can be important in regulating both the plant and animal communities as well as altering the nutrient cycling within the floodplain forest system. Fire increases the rate of breakdown of vegetative matter into nutrients, opens the canopy and clears the ground of accumulated litter so that new growth can begin, and starts the succession of plant and animal communities over again. Fire changes the relative proportions of nutrients since some such as nitrogen are consumed by fire (Spurr 1964).

## Biotic Attributes

Trees. The floodplain forest tends to contain a highly diverse group of trees. Abbott (1966) found 34 species of woody plants in this habitat and only 14 species in an upland forest habitat. Some of the same species occur in both floodplain and upland forests; however, the periods of flooding and the increased soil water increase the flow of nutrients and make the floodplain forest an ideal habitat for more species of trees. Most of the trees are deciduous hardwood species. The most well known are probably pecan, hickory, elm (several species), oak (several species), hackberry, mulberry and persimmon. The trees undoubtedly contribute the most primary production to the floodplain forest system.

Seedlings. The seedlings of the trees of the floodplain forest system contribute a small portion of the primary productivity of the system. However, they are important since they perpetuate the system by replacing the trees that are killed by various causes.

Shrubs. Most floodplain forests have water regimes and conditions suitable for the growth of many species of shrubs and small trees. The most common species in Texas floodplain forests are yaupon, hawthorne, possum-haw holly and prickly ash (Oppenheimer and Gordon 1972). These species add to the primary productivity and provide habitats for many species of animals which inhabit the floodplain forest. All of these species are adapted to living in the low light conditions which occur under the nearly closed canopy of trees in the floodplain forest.

Forbs and vines. The ground cover and understory as well as some high climbing vines are well represented in the floodplain forest. Species such as

dewberry, pepper vine, grape, trumpet-creeper, poison ivy, greenbriar are the most common vines. Many species of forbs can be found in this habitat.

Herbivores. This group comprises one of the largest consumer groups (in terms of total numbers of individuals) in the floodplain forest system. The majority of these are invertebrates such as insects and amphipods; however squirrels, deer, rabbits, mice and seed-eating birds also fall into this category. This system undoubtedly contains some aquatic herbivores during extended periods of inundation; however, they are only transient and are not expected to contribute significantly to energy flows within this system.

Intermediate consumers. This compartment is primarily concerned with the predatory organisms below the level of top consumer. Nearly all of these species inhabit the floodplain forest during the non-flood periods. Predatory insects are numerous during the growing season. The floodplain forest supports amphibians in large numbers. Also, there are many reptile species which occur in the floodplain forest in addition to other terrestrial habitats. Mammals such as the raccoon, opossum, armadillo, grey fox, red fox, and various species of birds are also intermediate consumers in this system. Aquatic consumers are only present during periods of flooding and do not represent a significant energy flow within this system.

Top consumers. The top consumers of the floodplain forest systems are primarily the birds of prey, coyote, red wolf and bobcat. During periods of flooding, the top freshwater aquatic consumers in inland floodplain forests are the game fish such as largemouth bass, catfish and gar.

Birds of prey may nest in trees of the floodplain forest and feed on the numerous smaller animals of the system. The coyote, bobcat and red wolf feed on the various intermediate consumers and herbivores.

### Import/Export of Biotic Attributes

Migration. Migration with respect to the floodplain forest system represents the movement into and out of the floodplain forest area from other systems as opposed to daily or seasonal migrations. This between-system migration is cued primarily by surface water level. The planktonic organisms are carried into and out of the floodplain forest system during inundation by river flooding or upland drainage. More motile aquatic organisms move in and out of the system when the conditions are favorable to them.

Aquatic members of the herbivore and detritivore group may migrate between other aquatic systems and the floodplain forest. Smaller juveniles of some intermediate and top consumers can be found during certain times of the year in the floodplain forests.

Some of the aquatic intermediate consumers move between other freshwater habitats or the bay systems and the floodplain forest.

The freshwater gamefish, which comprise the more important aquatic top consumers, may move into and out of this system with the flood waters in search of food.

### Critical System Components

The most critical component of the floodplain forest system is river flooding (Day et al. 1979). This water flow provides the energy for the exchange of nutrients, organic matter, fresh water and toxics between the floodplain forest and other systems. This freshwater input keeps the soil water levels high and allows the plants to produce large amounts of organic matter upon which the important detritus food chain is based. The plants, primarily the trees, are also a critical component since they are the primary source of most of the carbon produced in the floodplain forest system.



Changes in the water regime will quickly result in changes in the species composition and productivity of the floodplain forest system.

## LAKE AND RESERVOIR

### Introduction

This habitat model (Figure 44) is intended to describe freshwater lakes and reservoirs, habitats which correspond to the U.S. Fish and Wildlife Service L1 and L2 classes. All major freshwater bodies in the Texas barrier islands study area are reservoirs, generally created for water supply rather than flood control purposes. In addition there are a number of smaller natural lakes and ponds.

Most of the lakes and reservoirs in the study area are relatively shallow and do not appear to show extensive stratification. Therefore, this model and discussion does not treat stratification and related mixing phenomena which may be of great significance in deeper lakes in Texas.

### Energy inputs

Sunlight. Energy for plant growth and heating of the lake water is provided by sunlight. Light penetration into the water column is controlled by suspended solids and shading due to floating macrophytes.

Wind energy. The most important source of energy for mixing the lake waters is provided by the wind. Wind intensity and frequency data for coastal areas is summarized in the Bureau of Economic Geology Coastal Atlas series.

### Material Inputs

Water inflow. This represents water inflow to the system, the connection between water inflow and other inputs emphasizes the fact that the major material inputs to lakes and reservoirs are provided by local runoff and river

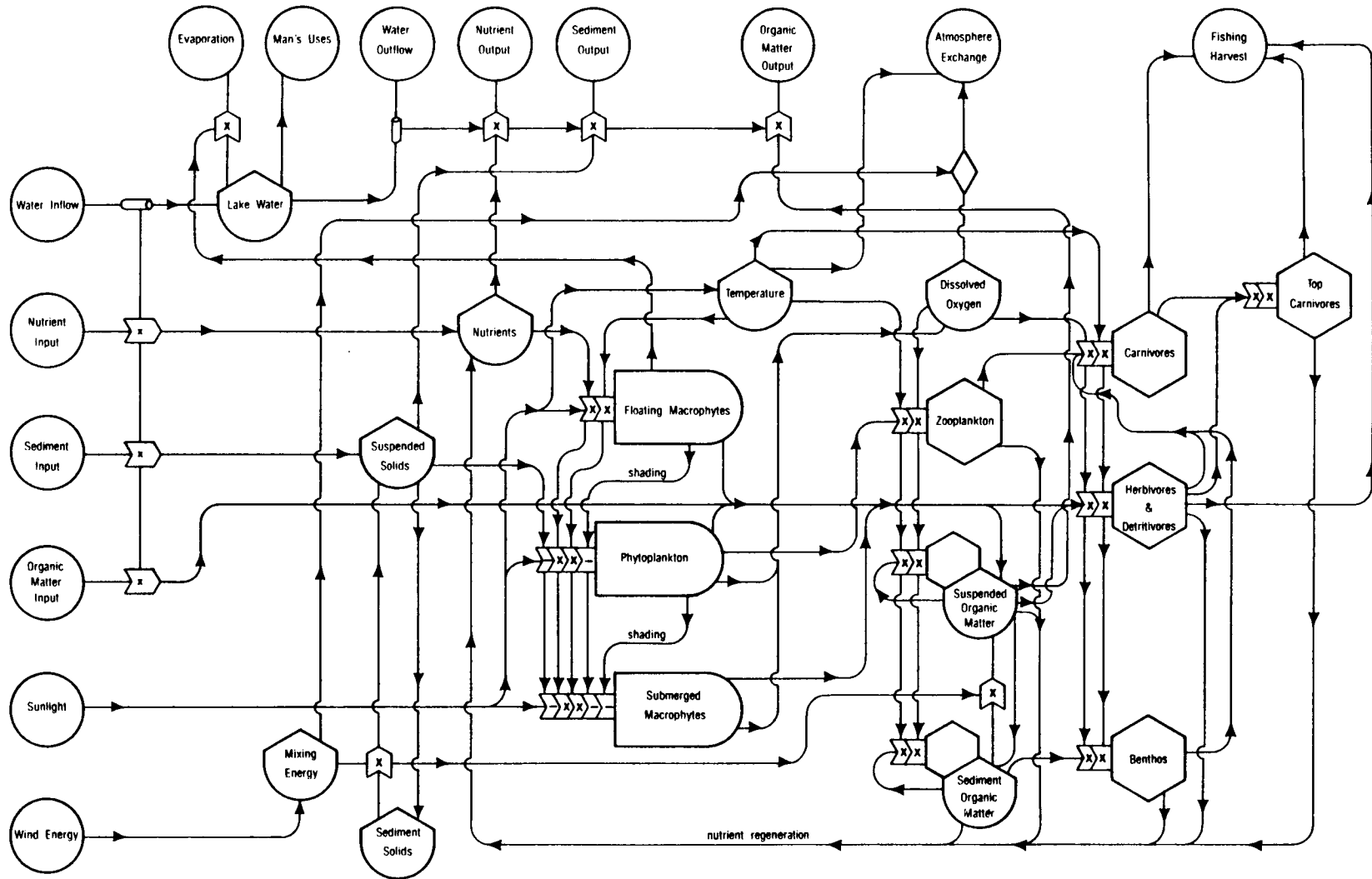

FIGURE 44. Lake and reservoir habitat.

inputs. In some reservoirs, input is accomplished by pumping, but the effects are the same.

Sediment input. Inorganic sediments are brought into the system as suspended solids and "bed load" from rivers and by erosion of the banks. Texas rivers frequently carry high levels of suspended solids; for instance, the Trinity River station at Romayor has carried over 3.9 million tons of suspended solids per year over the period of record (Dougherty 1979). The sediment content of streams is largely determined by land use practices in the drainage basin, as described in the upland habitat sections.

Nutrient input. Inflow water carries the great majority of nutrient inputs to the lake and reservoir habitat. Other minor sources include rainfall and dry fallout from the atmosphere (Hendry and Brezonik 1980). The major nutrients of concern in Texas lake ecosystems analysis have been phosphorus and nitrogen although other trace elements and organic growth factors should also be included here.

Organic matter input. Organic matter, both soluble and particulate, comes from export by upstream ecosystems and from urban discharges. This is frequently a major source of energy to the biota of the lake system, particularly in highly turbid lakes where light penetration and photosynthesis is relatively low.

#### Physical Attributes

Temperature. Water temperature has a major influence on all organisms in the lake system. Observed temperature is the result of the balance between heat energy inputs such as sunlight and heat exchange with the atmosphere. Other sources not detailed here include the heat content of inflowing waters and heat load from industrial sources. Shallow lakes in particular exhibit

wide temperature fluctuations with the seasons (Fruh et al. 1977) and even diurnally (Wunderlich 1971).

Nutrients. Nutrients in lake water are in a dynamic equilibrium between uptake by plants and regeneration by consumers. Typically, the nutrients of greatest concern in Texas lakes and reservoirs are the various inorganic forms of nitrogen and phosphorus.

Nutrients will either be removed from the system by downstream flow or by sedimentation in the form of organic matter. Generally, it is observed that lakes and reservoirs act as nutrient traps in the long term, but short-term net releases may occur (Fruh et al. 1977). The observed levels of nutrients in Texas lakes are high and place these lakes in the eutrophic class. A ranking of 87 major Texas lakes by phosphorus level and other trophic state indicators has been published by the Texas Department of Water Resources (1980).

The concept of "limiting nutrient" is frequently encountered in lake ecosystem studies. The idea is that under a given set of conditions, growth of phytoplankton will be most dependent on the single required nutrient which is in shortest supply. Rudy (1978) suggests that nitrogen is most frequently limiting to phytoplankton in Lake Livingston.

Dissolved oxygen. One of the major factors in determining the health of a body of water is the level of dissolved oxygen. This concentration is determined by the balance between production by plants and consumption by consumers, with atmospheric exchange acting to moderate the extremes. Texas water quality standards (Texas Water Quality Board 1976) require a minimum dissolved oxygen level of 5 ppm in most lakes and rivers.

Suspended solids. Since the intensity of mixing energy is much lower in lakes and reservoirs than in the inflowing rivers and streams, once suspended solids reach the lake, they tend to settle out. Thus lakes and reservoirs tend to act as sediment traps, reducing the supply of sediments to estuarine systems downstream. For example, the data in Dougherty (1979) indicate that Lake Corpus Christi exports less than 23 percent of inflowing suspended solids.

Mixing energy. This component of the model represents the energy in turbulent movement of the water column which tends to resuspend organic matter and other solids from the bottom of the lake system. It includes both the small-scale mixing due to waves and the large-scale mixing due to wind-induced currents. The high level of mixing energy provided by the wind generally prevents Texas coastal lakes from becoming stratified.

Sediment solids. This represent the lake bottom sediments, either deposited by fallout of suspended sediments or exposed as a result of reservoir construction. Although it is not represented in the model, the ability of mixing energy to resuspend sediments varies greatly with depth; thus sediments tend to be resuspended in shallow waters and deposited in deeper areas.

Organic matter in water. Sources of dissolved and suspended organic matter include inflowing water and the photosynthesis by plankton and higher plants within the lake system. The symbol in the figure incorporates a hexagon representing the micro-organisms which rapidly colonize and decompose organic matter particles.

The fraction of the total organic matter in the water which is in solution was found to be 70 to 93 percent in a Texas lake (Lind 1971). Bacteria can

directly take up dissolved organic matter as well as attack solids. The decomposition process consumes dissolved oxygen and can reduce oxygen to levels too low to support the higher organisms. For this reason, the biological oxygen demand (BOD), which is a measure of the amount of easily degraded organic matter is an important water quality measurement.

Sediment organic matter. This compartment represents the organic matter which has fallen out of the water column and become part of the sediment. Typical concentrations of organic matter in lake sediment are apparently in the range of 3 to 6 percent (for example, Lake Corpus Christi, Twidwell 1976). The decomposition of this organic matter consumes oxygen and recycles nutrients just as with the suspended organic matter. Typically, this decomposition removes all oxygen from sediment interstitial water below the upper few millimeters of sediment, creating an anaerobic zone.

#### Biota

Phytoplankton. In deeper lakes and reservoirs, the majority of the primary production is due to phytoplankton. Some of the phytoplankton taxa which may be significant in Texas lakes include green algae, blue green algae, diatoms, euglenoids and dinoflagellates. Usually "chlorophyll a" is measured in water quality studies as an indicator of phytoplankton concentration.

Detailed studies of phytoplankton populations and productivity have been carried out in several Texas reservoirs. For example, Lake Lyndon B. Johnson research is described by Fruh et al. (1977). Typically the lowest population occurred during the winter months, December through March, with population peaking in September or August. This was thought to reflect mainly the role of low temperatures in limiting phytoplankton growth.

Phytoplankton are single-celled organisms, capable of very rapid growth

and reproduction. Thus they are able to respond to favorable conditions, such as a sudden increase in nutrients much more rapidly than macrophytes. When high population densities are reached, the situation is known as a "phytoplankton bloom."

Macrophytes. In shallow portions of coastal lakes, especially lakes with low concentration of suspended solids, sufficient light reaches the bottom to promote the growth of rooted plants or macrophytes. Extensive growth of these plants may create a nuisance to recreational uses of the lake.

Floating macrophytes. The major floating macrophyte found in Texas is the water hyacinth, Eichhornia crassipes. This introduced species has become a great nuisance in many southern states because it grows so rapidly and covers the surface of lakes with an impenetrable mat. Water loss by evapo-transpiration from hyacinth mats exceeds the evaporation rate of open water.

Benton (1979) suggests that the reservoirs of east and southeast Texas may eventually have about 20 percent coverage by water hyacinth, potentially causing significantly increased evapo-transpiration losses of water. In that case, the state may have to undertake a greatly expanded hyacinth control program using herbicides.

Floating plants tend to shade out phytoplankton and rooted macrophytes, and can remove significant quantities of nutrients. McCullough (1978) suggests that nutrient removal occurs in Lake Livingston. Thus hyacinths may alter the energy base of lake ecosystem food chains. The decay of roots and leaves causes depletion of dissolved oxygen and the physical effect of the mat blocks input of wind energy reducing reaeration rates. Thus the hyacinth may cause low dissolved oxygen levels and kill off higher consumers.

Benthos. This compartment represents the invertebrates which live on or in the bottom, consuming organic matter in sediments for much of their life cycle. Insect larvae are generally the most numerous benthic organisms in Texas lakes. Other taxa include crustaceans, oligochaetes and molluscs (Fruh et al. 1977.) Benthic invertebrates are major food sources for fish.

Zooplankton. These small herbivores feed on phytoplankton and provide the first link in the food chain leading to the larger fish. Typical taxa include rotifers, cladocerans and copepods (Fruh et al. 1977) and also fish fry and early stages of benthic organisms.

Herbivores and detritivores. This represents organisms which feed predominantly on plant material and organic matter. An example species would be the "river carpsucker" *Carpoides carpio* (Klaassen and Marzolf 1971).

Carnivores. This category includes many of the smaller sunfish and young of the large sport fish. Many of these are stocked into reservoirs for recreational fishing.

Top carnivores. Here we find the largest sport fish such as the largemouth bass (Heidinger 1976), large enough to avoid being eaten by anything except man. Fruh et al. (1977) give a summary of the food habits and growth rates of many common reservoir fish.

### Material Outputs

Man's uses. Almost all Texas reservoirs were constructed to ensure water supplies for urban and agricultural uses. Extensive detail on past, present and projected future uses for each coastal region is given in the Texas Water Plan (TDWR 1977.) In most cases the water is withdrawn directly from the reservoir by pumping.



Evaporation. Evaporation and evapotranspiration is a significant pathway for water loss in Texas reservoirs. Detailed estimates are given in the Texas Water Plan (TDWR 1977.)

Water-outflow. During normal to wet years, downstream flow of water is the main loss pathway for reservoirs in the study area. However, this will be variable, depending on the use for which the reservoir was constructed. The outflowing water carries with it nutrients, suspended sediments and organic matter.

Sediment output. The output of suspended sediments from reservoirs is of critical importance in coastal ecosystems. Prior to man's intervention, sediment input to estuaries was responsible for building deltaic wetland systems and gradually filling in the estuaries (see the regional model discussion). Reservoirs, however, trap much of the suspended solids carried by rivers. Presumably, this loss of sediment input will lead to loss of wetlands as subsidence and erosion remove existing estuarine wetlands.

Nutrient output. Export of dissolved and suspended nutrients is of major importance to downstream systems. Nutrient input to estuaries from rivers is frequently cited as the cause of the high productivity of estuarine systems.

Organic matter output. Exported organic matter represents a source of energy to downstream systems and may also contain large amounts of nutrients such as nitrogen and phosphorus which can later be released by decomposition. While organic matter entering a lake or reservoir is usually from terrestrial plant debris, large amounts of phytoplankton-derived material may be in the exported organic matter. Lind (1971) also found that more of the exported organic matter was in soluble form.

Fishing harvest. The significance of fishing harvest will depend on the relative intensity of recreational and commercial fishing combined with the relative abundance of rough fish in the system.

Atmosphere exchange. This represents the exchange of oxygen and heat energy which takes place between the water and atmosphere.

## NEARSHORE GULF

### Energy Inputs

Sunlight. Figure 45 is the conceptual model of the nearshore gulf habitat. Solar energy input is the most important single energy source for the nearshore gulf ecosystem. The organic matter formed by photosynthesis, together with smaller amounts of organic matter from the rivers and estuaries, provide the base of the food web.

Wind energy. Wind energy is one of the major factors controlling circulation and wave action in the nearshore gulf system. This energy input varies seasonally, both in direction and magnitude. Recent studies (Smith 1975 and 1978) have shown current velocities on the inner shelf to be approximately 15 to 25 cm/sec (0.3 to 0.5 knots) during the winter and around 10 cm/sec (0.2 knots) during the summer. The current direction correlates well with the wind direction over 1 to 2 week periods.

Gulf circulation and tides. The effects of circulation and tides in the open gulf on the nearshore gulf are definitely smaller than the direct wind input, but are still measurable.

Offshore waves. Waves generated by wind in the open gulf are of major significance as a source of mixing energy within the system. This energy input is highly variable, both seasonally and daily.

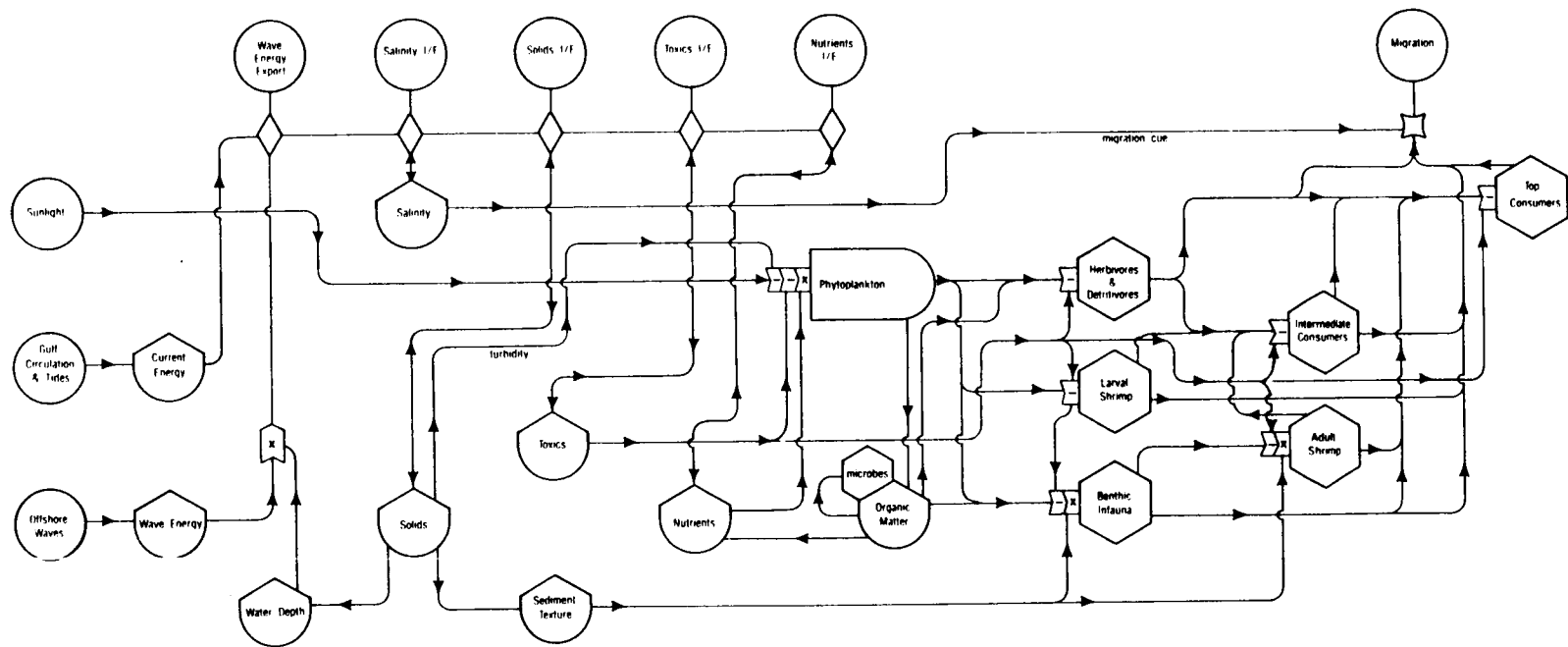

FIGURE 45. Nearshore gulf habitat.

## Physical attributes

Salinity. Salinity in the nearshore gulf ecosystem is much less variable than it is within the estuarine systems; however, significant variations do occur. In addition to the runoff from Texas rivers, the influence of the "fresh" water plume from the Mississippi River is frequently observable in eastern portions of the Texas nearshore gulf during the late spring (Smith 1979). Salinity values in the nearshore gulf ecosystem may range from 36.5 ppt, characteristic of the open gulf, to below 20 ppt around "inlet-tidal delta" areas. Horizontal and/or vertical salinity gradients of a few parts per thousand are not uncommon in the nearshore gulf (Smith 1979; Jones, Copeland and Hoese 1965).

Current energy. Currents in the nearshore gulf ecosystem are primarily wind driven. Studies by Smith (1975, 1978 and 1979) show that the current energy is largely directed parallel to the shoreline. However, there is frequently a cross-shelf component, especially during the winter. Water exchange with the offshore systems may take place in the form of "rip current" like plumes which have been photographed from space (Lindner and Bailey 1968).

Wave energy. Wave energy is largely imported from the open gulf, but is also generated within the system by wind. Most of the wave energy is exported to the upper shoreface system. Some is dissipated as the waves interact with the bottom. This interaction is primarily responsible for the resuspension of bottom sediments.

Solids. Suspended solids are introduced into the water column by resuspension of bottom sediments and by import from the upper shoreface and inlet-tidal delta systems. The strong contrast in suspended solids (as measured by light penetration) between the inner shelf and deeper gulf waters

is presumably due to the fine clay particles settling out in the deeper, less turbulent waters. This compartment is also used to represent the mass or volume of sediment within a particular area of the nearshore gulf. This is increased by settling of suspended solids and decreased by resuspension due to wave action. Sediment texture and water depth are derived from "sediment solids" and used to represent other aspects of the sediment.

Water depth. Water depth is a significant controller of wave energy via friction with the bottom and diffraction of wave fronts. When the bottom interferes with the orbital motion of water particles in waves, the wave energy produces currents along the bottom. These currents can cause mixing of the bottom sediments, thereby increasing the rate of diffusion of dissolved oxygen into the sediments. The speed of propagation of waves in shallow water depends on depth. Thus wave fronts which approach the coast may be altered in direction by the bottom contours. This effect may be highly significant in controlling the wave energy which is exported to the upper shoreface system. The Army Corps of Engineers "Shore Protection Manual" (Corps of Engineers 1977) contains an extensive treatment of this phenomenon. Computer programs for estimating the effects of bottom topography on wave energy are given in Tanner (1974).

Sediment texture. The substrate maps produced by the Bureau of Economic Geology for the Coastal Management Program provide an excellent summary of the sediment texture for the nearshore gulf system. Most of the area is "mud and silt" with some areas containing significant quantities of sand and/or shell. The sand content is higher near the boundary with the upper shoreface system.

Toxics. Toxic materials which could be introduced into the nearshore gulf include heavy metals, pesticides, industrial organic chemicals, well

drilling fluids, crude oil and petrochemicals. Most toxic materials are easily adsorbed on particles. They then become quickly incorporated into the sediments. Contaminated sediments from dredging and drilling muds would introduce toxics directly into the sediments.

Nutrients. Nutrients are considered to be the organic and inorganic materials required by phytoplankton for photosynthesis in addition to light. In the nearshore gulf system, nitrate nitrogen is considered to be the limiting nutrient. This is indicated by the fact that it is exhausted before phosphate or silicate during phytoplankton blooms (Sackett and Brooks 1979). Nutrients may exist in both dissolved form and adsorbed to the surface of particles. Sedimentation of particles, photosynthetic uptake and exchange with other systems can remove nutrients from the water column. The decomposition of organic matter by bacteria, the metabolism of higher organisms, the release of nutrients from the sediments, and the exchange of nutrients with other systems can add nutrients to the water column. The interstitial water and the solid particles in the sediments contain nutrients in both solid and dissolved forms. The slow decomposition of organic matter by micro-organisms and the activities of benthic organisms causes the release of nutrients such as ammonia, phosphate and trace metals. These nutrients can be released to the water by diffusion or by turbulent mixing of the sediments. This recycling of nutrients from the sediments is extremely important to the functioning of the nearshore gulf ecosystem.

Organic matter/microbes. The biotic component "microbes" is partially combined with the symbol representing organic matter in the water and sediment. Dissolved organic matter is present in the waters of the nearshore gulf at levels on the order of 1.0 to 3.7 mg of organic carbon per liter

(Maurer and Parker 1972). The bacteria are the most important of the microbes in the decomposition of organic matter in the nearshore gulf. The populations of bacteria respond rapidly to organic matter inflows and rapidly colonize organic particles. Thus, populations of microbes are higher near the shore and near inlet-tidal delta systems. Typical numbers may range from 500 to 155,000 cells per liter of water (Oujesky and Van Auken 1979). Significant numbers of fungi have also been found in the nearshore gulf ecosystem (Szaniszlo 1979). Because the action of waves tends to keep organic particles suspended in the water column, the concentration of organic matter in nearshore gulf sediments is relatively low. Jones (1960) found a mean concentration of 0.52 percent organic carbon in surface sediments. The numbers of bacteria found in the sediments range from 0.05 to 1.6 million cells per cubic centimeter of sediment (Schwarz 1979). In addition to the decomposition of organic matter and the release of inorganic nutrients such as ammonia and phosphate, the bacteria are believed to produce significant amounts of vitamin B-12 (Maurer and Parker 1968).

#### Import/Export of Physical Attributes

Wave energy export. During normal weather, the nearshore gulf exports most of the wave energy it receives from offshore waves, plus that added by local wind, to the upper shoreface or inlet-tidal delta systems.

Salinity import/export. The nearshore gulf receives low salinity water from the rivers and estuaries via the inlet-tidal delta system and from the Mississippi River plume via Gulf of Mexico currents from the northeast (Smith 1979). Generally, the seaward edge of the nearshore gulf exchanges with higher salinity water from the central Gulf of Mexico. During drought periods, the Laguna Madre, Corpus Christi Bay and Aransas Bay may have

salinities higher than that in the gulf, thereby reversing the normal salinity gradient (Collier and Hedgpeth 1950).

Solids import/export. The exchange of suspended solids between the nearshore gulf and its adjoining systems is extremely complex. Clearly, those inlet-tidal delta systems at the mouths of rivers such as the Colorado, Brazos or Rio Grande must act as net sources of suspended solids. However, the presence of tidal deltas in many bay systems indicates that sediment can be carried into the bays, either from offshore or from the longshore drift system in the upper shoreface. Apparently, during normal weather, wave energy tends to carry bottom particles shoreward into the upper shoreface. However, during storms this sediment may be eroded and redeposited in the nearshore gulf.

Toxics import/export. In general, the inlet-tidal delta systems will be sources of toxics such as pesticides and heavy metals which come from runoff and discharges. On the other hand, the nearshore gulf system can serve as a source of spilled crude oil and petroleum products to the other systems. Exchanges with offshore waters tend to export toxics (with the exception of oil spills). The Mississippi River plume may also act as a source of toxics.

Nutrient import/export. The generally observed gradient of nutrient concentrations and photosynthetic activity decreases going from the estuaries through the nearshore gulf to the offshore waters. This gradient indicates that estuaries are sources of nutrients for the nearshore gulf, while it, in turn, is a source for the offshore waters. However, the amounts and forms of these nutrients are by no means clear. The amount of nutrients transported in combined form as organic matter may greatly exceed the amount transported in inorganic form. In those areas where rivers directly enter the gulf without



passing through an estuarine system, the magnitude of nutrient supply can be calculated directly.

### Biotic Attributes

Phytoplankton. Photosynthesis by phytoplankton is the greatest source of organic matter for the base of the food chain in the nearshore gulf. Many studies have tended to concentrate on the "net" phytoplankton (those phytoplankton caught in a fine mesh net) which is mainly diatoms such as Skeletonema coastatum. However, "nannoplankton" is probably of equal or greater importance to the total productivity (Kamykowski and Van Baalen 1979). Kamykowski and Van Baalen (1979) found levels of chlorophyll "a" typically ranging from less than 0.5 ug/l during June, July and August to 4.0 micrograms per liter of water (ug/l) at inshore stations along a transect from Port Aransas out into the open gulf. The high levels were apparently associated with a pulse of nutrients from spring run-off. Carbon uptake rates as high as 24 milligrams of carbon per cubic meter per hour (mgC/m<sup>3</sup>/hr) were observed, but most values ranged between 4.0 and 16.0 mgC/m<sup>3</sup>/hr.

Herbivores and detritivores. There are a variety of organisms which feed on phytoplankton and organic detritus in the nearshore gulf ecosystem. The smallest are the ciliated protozoa which prey upon the nannoplankton. They are in turn fed upon by the larger zooplankton. Johansen (1979) found the protozoan biomass to be on the order of 10 to 20 percent of the larger zooplankton biomass. Larger zooplankton include copepods, ostracods, amphipods, and the larvae of crustaceans, mollusks and fishes. The extent to which these organisms feed upon phytoplankton and detritus depends on the species and its life stage. The biomass of zooplankton in the nearshore gulf was found to average 34.1 mg dry wt per cubic meter by Park (1979). It was

observed to be positively correlated with chlorophyll "a" and salinity. Menhaden and mullet and are the most common herbivorous fish in the nearshore gulf ecosystem.

Larval shrimp. Due to the economic and biological significance of Penaeid shrimp, the literature on these organisms is extensive. Synopses of the biological data on the three major commercial species have recently been published: Lindner and Cook (1978) on Penaeus setiferus (white shrimp); Costello and Allen (1978) on Penaeus duorarum (pink shrimp); and Cook and Lindner (1978) on Penaeus aztecus (brown shrimp). Spawning of white shrimp occurs largely in the nearshore gulf, where the young shrimp grow to 6 - 7 mm before entering the estuaries. Pink shrimp spawn further offshore. Brown shrimp spawn in offshore waters deeper than 14 meters. The eggs of all species sink to the bottom; however, the larvae and post-larvae are planktonic. The larvae apparently feed upon phytoplankton and small zooplankton.

Benthic infauna. For this model the complex benthic community has been simplified into a single compartment. These organisms range in size from nematodes to large polychaetes and molluscs. In most studies, the "meiofauna" are separated from the "macrofauna" by their ability to pass through a 0.5 mm seive. Nematodes are the most abundant of the meiofauna in nearshore gulf sediments (Pequegnat 1979). Other groups observed include harpacticoids, kinorhynchs, foraminifera, and polychaetes. The macrofauna is dominated by polychaetes (Holland 1979). Several authors have suggested that the benthic fauna of the nearshore gulf form a community which is distinctly different from that found further offshore. Cluster analysis of benthic invertebrates from grab samples indicated five distinct depth-related groups of infauna on

the continental shelf (Holland 1979). Defenbaugh (1979) suggested that there is an "inner shelf assemblage" found at depths from 4 to 20 meters on the Texas and Louisiana shelf. Many environmental factors such as salinity, temperature, organic matter supply and sediment texture are positively correlated to water depth. Therefore, this zonation may be related to water depth only indirectly.

Intermediate consumers. This compartment is used for both free-swimming intermediate consumers and those closely associated with the bottom. This includes a wide range of organisms from fish larvae to jellyfish.

Adult shrimp. Adult Penaeid shrimp spend most of their time in association with the bottom, either buried in the sediment for protection or searching on the bottom for food. The white shrimp (P. setiferus) is the most common Penaeid shrimp of the inshore continental shelf. But the other Penaeid shrimp are also found in the nearshore gulf system as they migrate between the estuaries and the deeper water.

Top consumers. Mammals such as porpoises, reptiles such as sea turtles, and many species of fish such as sharks and most of the important gamefish are considered top consumers in the nearshore gulf system. In most cases, these organisms do not migrate into the estuarine systems. Porpoises, sea turtles and some sharks have been found in estuarine waters. Of course, man also constitutes a major top consumer, especially of shrimp and gamefish.

#### Import/Export of Biotic Attributes

Much of the biota of the nearshore gulf is closely associated with estuarine ecosystems. These species pass into the estuarine systems via the inlet-tidal delta ecosystem. Because of the ease of sampling, most studies of migration of nearshore gulf organisms have taken place in inlet-tidal delta

systems. Examples include Simmons and Hoese's (1959), and King's (1971) studies of Cedar Bayou and Copeland's (1965) study of emigration through Aransas Pass. The user is referred to the above papers and general works such as Gunter (1945) for more details concerning organism migration.

#### Critical System Attributes

The most critical linkages for the continued productivity of the nearshore gulf appear to be the links with the estuarine and river systems. The supply of nutrients and organic matter from the estuarine systems and rivers clearly helps to maintain a high level of photosynthesis in the nearshore gulf. Among the biota, the phytoplankton and Penaeid shrimp appear to be critical to the food chain. The latter require suitable habitat in the estuaries during part of their life cycles.

#### REEF AND REEF FLANK

##### Energy Inputs

Sunlight. Figure 46 is the model for the reef and reef flank habitat. Part of the incoming solar energy drives photosynthesis by phytoplankton and benthic algae. The remainder serves to heat the system. Much of the energy used by the system is imported as organic matter; therefore, solar energy is less important at the base of the reef food web than in other estuarine systems.

Current energy sources. The current energy found in this system is largely imported from adjoining bay systems. Sources of this energy include river flow, astronomical tides and wind. The modification of current patterns by oyster reefs has long been noted (Grave, 1901 and Collier and Hedgpeth 1950).

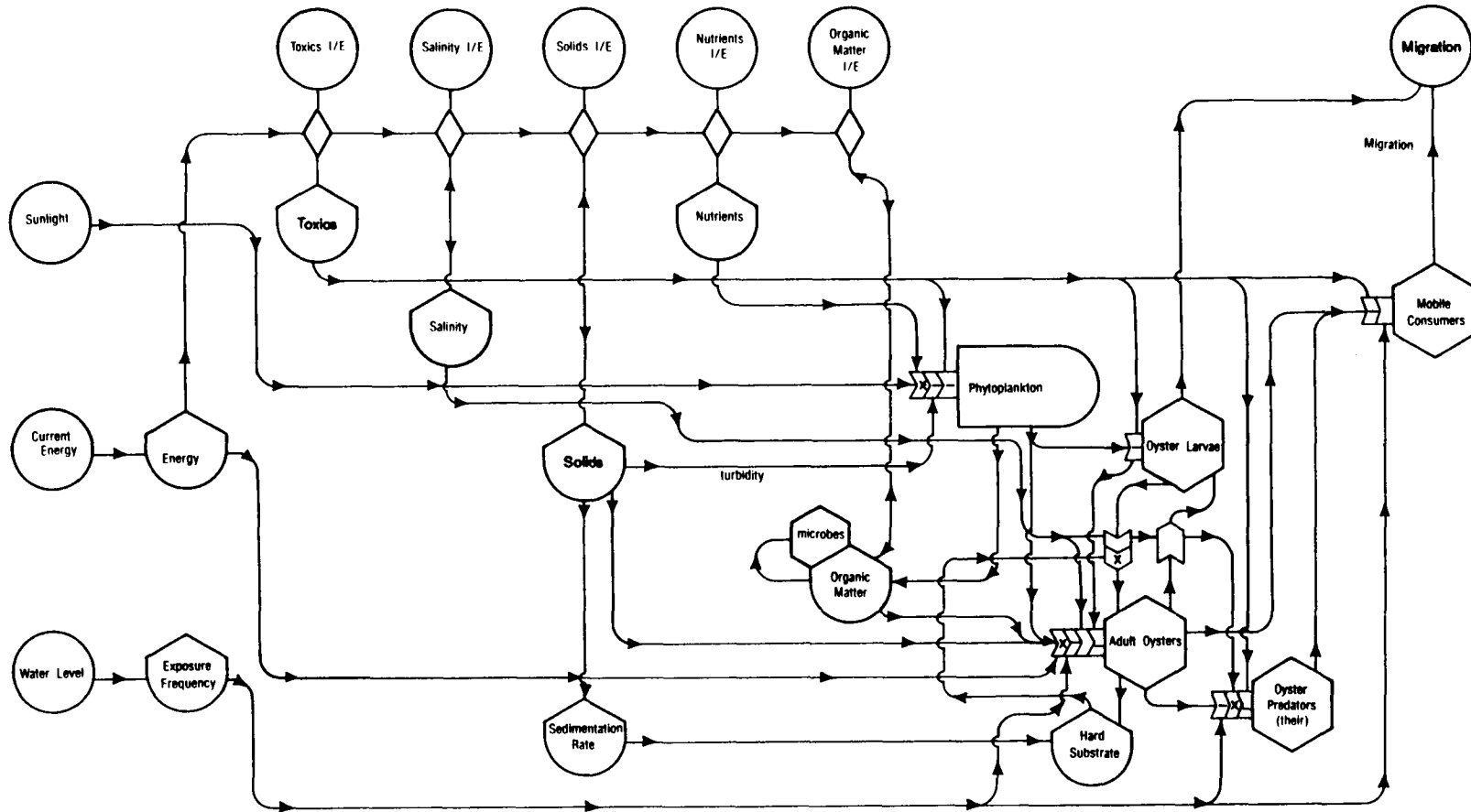

FIGURE 46. Reef and reef flank habitat.

Organic matter import/export. Imported organic matter is a major source of energy for the reef and reef flank ecosystem, as is phytoplankton import. The relative importance of these energy sources depends on the systems which lie upstream of the reef. Wilson (1963) found total organic carbon values typically ranged from 10 to 20 ppm carbon in Texas estuaries. Steed (1971) estimated that river flow provided 20.7 million kilograms (45.5 million pounds) of organic carbon per year to the San Antonio Bay system. This amount is a significant addition to the phytoplankton production.

Phytoplankton import/export. Phytoplankton are undoubtedly a major source of energy, especially for reefs surrounded by the medium salinity bay system. Odum et al. (1963) simulated a combined reef-medium salinity bay system in ponds with controlled circulation in which the area for phytoplankton was at least 10 times larger than the reef area.

#### Physical Attributes

Current energy. Current energy has major significance in three areas. First, it is responsible for the transport of various dissolved and suspended constituents in and out of the system. Second, within the system, it transports suspended materials to the individual oysters. Third, it causes resuspension of particles from the sediment.

Lund (1957a) demonstrated the importance of current in determining the rate at which oysters could filter suspended particulate material. The results of this study also suggest that current energy may be of greater significance for those oysters toward the interior of the reef, since during low flow rate periods, the first oysters to encounter a parcel of water may remove most of the particulate matter.

Exposure frequency. This attribute is used to indicate both the duration and frequency of exposure of the oyster reef to the air. Copeland and Hoese (1966) observed very high mortality rates of oysters and associated animals due to combined low water level and high temperatures during July and August. Exposure frequency also controls the access of birds and mobile consumers to the sedentary organisms of the reef.

Exposure prevents feeding activity by oysters and other filter feeders. However, oysters can close their shells and survive for extended periods if the temperatures are not extremely high (Lund 1957c).

Toxics. The ability of oysters and other filter feeders to concentrate pollutants such as heavy metals and pesticides is well known. Rather than show a separate reservoir of toxic materials in each organism type, the model shows a single "toxics" attribute which has potentially negative effects on each biotic attribute. This should be understood to incorporate both bio-concentration through the food chain and direct toxic effects.

Some recent studies of accumulation of potentially toxic materials by oysters are discussed below. This is only a sampling of the very extensive literature.

Bravo et al. (1978) measured polyaromatic hydrocarbons in oysters of the Mexican Gulf Coast. They observed higher concentrations near oil production facilities. Lund (1957d) observed reduction in oyster filtration rates by oil field brines.

Bahner et al. (1977) found that oysters could concentrate kepone up to 9000 times the concentration in the surrounding water. Almost all tissue kepone was lost within one month in clean water. Childress (1968) describes results of pesticide monitoring in oysters for Texas bays.

Greig and Wenzloff (1978) observed tissue uptake of silver, cadmium and copper by oysters exposed to waters from Milford Harbor, Connecticut.

Cunningham and Tripp (1975) observed uptake of mercuric ion and subsequent depuration in clean water with a half life of about one month. Calabrese et al. (1973) studied the toxicity of 11 heavy metals to oyster embryos.

Salinity. Salinity is the most important controlling factor in the reef and reef flank ecosystem. In typical Texas bays, salinity over the reefs is controlled by the salinity of the adjoining estuarine systems, which in turn is controlled by the balance between evaporation, precipitation and runoff. Salinity may change very rapidly due to flooding. Flood periods may be the most critical periods for the reef system.

Solids. The solids component represents both the suspended solids and sediment solids. It shows primarily the physical effects of suspended particulate matter, such as the reduction of the light which reaches phytoplankton and benthic algae. Effects due to toxicity, nutrients and organic matter are shown elsewhere.

Suspended solids are introduced into the waters of the reef and reef flank ecosystem by resuspension of bottom sediments and by import from adjacent systems. Removal from the water column is by export, settling and filtration by oysters and other filter feeders. Lund (1957a), in laboratory experiments, found that oysters removed suspended solids up to 50 times more effectively than did settling by gravity.

This attribute is also used to represent the fine inorganic particulate matter of the bottom deposits in the reef system. The ratio of fine particles to the rest of the sediment is higher in the reef flank areas than within the interior of a well developed reef.



Nutrients. This attribute is used to represent all of the inorganic materials such as phosphate, nitrate, ammonia and trace elements which are needed by photosynthesizing organisms (in addition to light and carbon dioxide). The complexity of the different forms and pathways of regeneration of these nutrients is acknowledged, but has not been included to simplify the model. As a net importer of organic matter with an excess of respiration over photosynthesis, it is reasonable to expect nutrient levels over and slightly down current from a reef to be higher than those in the adjacent bays.

Organic matter/microbes. The suspended organic particles and the micro-organisms which live in close association to them are shown as a single attribute since they work so closely together. Oysters and other filter feeders on the reef remove these particles from the water rapidly. In addition, there is some sedimentation due to gravity. The filtering activities of the oysters provide a high rate of input of organic matter into the sediment. This is a rich source of energy for deposit feeders and micro-organisms.

Sedimentation rate. This attribute is a rate which is derived from sedimentation and resuspension of inorganic and organic matter, plus the rate of shell production (Hard Substrate) by the oysters. It is important to note that the sedimentation inputs include the production of feces and pseudofeces by the oysters. Lund (1957c) found that oysters in experimental tanks could produce enough sediment to cover themselves in 36 days. This was 8 times the rate of sedimentation via gravity in the control tanks. Sedimentation rate affects the rate at which hard substrate is covered or exposed.

Hard substrate. The availability of hard substrate on which oyster spat can settle is absolutely essential to the continued life of the reef. This

material is usually composed of the shells of adult oysters, but may be any hard material. Hard substrate is shown as being removed only by being covered via sedimentation, but it can also be removed when man harvests oysters or dredges mudshell.

#### Import/Export of Physical Attributes

Water level. Water Level in the reef and reef flank ecosystem is essentially determined externally by a combination of astronomical, oceanographic and meteorological forces. Whitaker (1971) shows monthly average water levels in the gulf which are determined by seasonal changes in temperature and circulation. The low levels in January and July increase the chances of extended exposure of oysters to extremes of cold and heat. Astronomical tidal amplitudes are rather small within the bays, as Smith (1974) determined for Corpus Christi Bay. But wind tides can produce substantial level changes within a few hours (Collier and Hedgepeth 1951).

Toxics import/export. Sources of toxic material for the reef and reef flank ecosystem include river flow, runoff, industrial discharges, oil spills and municipal outfalls. Most toxics will enter or leave the system adsorbed to particulate matter.

Salinity import/export. Exchange of water with adjacent systems largely determines the salinity in the reef and reef flank ecosystem. Most oyster reefs are positioned such that they do not receive runoff directly from land but through some intervening aquatic system.

Solids import/export. The Texas bays in which oyster reefs appear are almost always highly turbid. Because of the filtering action of the oysters, the bays probably act as a net source of suspended solids.

Nutrient import/export. It is deduced that oyster reefs are net exporters of inorganic nutrients since they are net importers of organic matter. However, no measurements have been found to verify this deduction.

#### Biotic Attributes

Although the physical and biological attributes of the reef and reef flank ecosystem are dominated by the characteristics of the American eastern oyster (Crassostrea virginica), it should be emphasized that large populations of living oysters are not always present in the system. Very high mortalities can occur in the oyster population due to environmental factors. However, the population can recover within a few years as long as the substrate remains suitable for spat setting. In large part, this is due to their enormous reproductive capacity. Their widespread distribution in the estuaries ensures that some small colonies will survive floods and other catastrophies and be able to spawn when conditions again become favorable.

This habitat description assumes a reef with a substantial adult oyster population. Review papers which have been used extensively in the preparation of this discussion include Galtsoff (1964), Chestnut (1974), Fotheringham and Brunenmeister (1975), and Coastal Fisheries Branch (1975). Boynton (1975) incorporated energetics calculations on oyster reefs into an ecosystem model of the Appalachicola Bay system.

Phytoplankton. Since phytoplankton are continually being swept through the reef system by currents, the species will be similar to those found in adjacent estuarine areas. The rate of photosynthesis depends on light penetration and the availability of nutrients, as discussed by Armstrong and Hinson (1973) for Galveston Bay phytoplankton. The possibility of suppression of photosynthesis by toxic materials exists, but the extent to which this is

actually occurring in Texas is unknown. Van Baalen, Pulich and O'Donnell (1973) detected toxicity in Galveston Bay waters using a phytoplankton bioassay.

Oyster larvae. Oyster eggs develop rapidly (1-2 days) through the "trochophore" stage into a "veliger" larvae which remains free-swimming for some time. These larvae apparently feed on the smaller of the phytoplankton, such as flagellates. The free-swimming larvae must eventually find a suitable site to settle and begin sedentary life. The setting process is dependent on temperature, salinity, dissolved oxygen and hard substrate (Hofstetter 1977; Galtsoff, 1964). Presumably, larvae which do not find suitable conditions for setting eventually grow too heavy to swim, sink to the bottom and die.

Adult oysters. Although the primary oyster of the Texas reefs is the American eastern oyster (Crassostrea virginica), the horse oyster (Ostrea equestris) also occurs in the Texas coastal zone. Menzel (1955) notes that O. equestris may replace C. virginica under conditions of high salinity. Gillard (1969) found that O. equestris become the dominant oyster during the winter in West Bay. Hoffstetter (1967, 1968) and Coastal Fisheries Branch (1975) give excellent discussions and data concerning the life history, tolerances and preferences of C. virginica.

Oyster predators. This compartment represents those predators which feed largely on oysters and are not mobile enough to escape salinity extremes. The oyster drill (Thais haemastoma) is the most serious oyster predator in many localities (Galveston Bay - Hofstetter 1977; Aransas Bay - Menzel 1955). The stone crab (Menippe mercenaria) is also a major predator. Powell and Gunter (1968) describe the feeding behavior of the stone crab. Both of these

carnivores also feed on other benthic organisms. Other crab species are only strong enough to attack spat and small oysters.

Although the model shows these organisms as being influenced by toxicity, salinity and exposure, salinity is the most important factor. Since the oysters can withstand short exposures to low salinities while these predators cannot, reefs located near freshwater sources may be substantially free of these carnivores. An example of the control of oyster predators by salinity is given in Menzel, Hulings, and Hathaway (1965).

Mobile consumers. This attribute represents those carnivores which are mobile enough to avoid extremes of salinity and temperature by migration away from the reef and reef flank system. This class includes fish, shrimp, swimming crabs and birds. Data on the use of oyster reefs by these organisms is sparse due to the difficulties encountered in sampling oyster reefs with nets. White and Chittenden (1976) reported that older Atlantic croaker (Micropogon undulatus) seem to prefer areas around reefs. The black drum (Pogonias cromis) is known to feed heavily on molluscs and is believed to be an important oyster predator.

The significance of birds as predators in the reef and reef flank ecosystem is uncertain. It seems likely that many of the birds which feed in shallow water tidal flats would also feed on oyster reefs when these are exposed by low water. Since this occurs infrequently along the Texas coast, there is very little information available concerning the utilization of oyster reefs by birds. The American oystercatcher (Haematopus palliatus) is known to feed on oysters, mussels and many of the other organisms found on oyster reefs (Tomkins 1947); however, their population is small in Texas.

### Import/Export of Biotic Attributes

The model of the reef and reef flank ecosystem shows specific import/export for phytoplankton. Migration represents the import/export of oyster larvae and migration of mobile consumers. Phytoplankton import/export has already been discussed under energy inputs, since it is a major energy source for the system. Oyster larvae and mobile consumer migration are discussed below. It should be recognized that although many of the other species in the system are sedentary, import and export are important for dispersal of the eggs and/or larvae of these organisms. In addition, birds only feed in this system occasionally. They carry on most of their other activities elsewhere.

Oyster larvae import/export. Oyster larvae are transported and mixed throughout the estuarine systems by currents. This is extremely important in the repopulation of reefs depleted by environmental extremes, predators or parasites.

Mobile consumer migration. Since reef systems are relatively small and spread throughout the bays, it is reasonable to expect frequent migration in and out of this system by the mobile consumers. The model shows salinity and temperature as the major migration cues. These factors affect the distribution of the consumers throughout the bay systems.

### Critical System Attributes

Salinity as the main controlling factor in determining the health of oyster reefs is emphasized by all authors. Some of the most important pathways are the control of the distribution of predators and parasites. The extremes of salinity and the duration of these extremes are much more important than average salinity. Activities most likely to alter salinity

patterns are those which modify river flows and estuarine circulation patterns.

The other major controlling factor is the availability of hard substrate for spat setting. A reef ecosystem can recover from a complete mortality of the adult oyster population if spat can set and grow. An increase in the supply of suspended solids is the most likely cause of the elimination of hard substrate. The importation of organic matter and phytoplankton by currents is also of major importance.

## RIVER AND CANAL

### Introduction

The river and canal habitat model (Figure 47) represents the relatively slow moving rivers of the Texas coastal plain and artificial waterways such as canals. This is a flow-through system which receives drainage from upland systems and passes it to "Tidal Stream Reaches" and thus to estuarine or marine systems.

The regional model and the Bureau of Economic Geology coastal atlas (Brown et al. 1972-1977) provide adequate discussion of the role of rivers in creating most of the basic landforms of the Texas Barrier Islands study area. The present model is designed to emphasize aspects of water quality and biological productivity on a roughly yearly time scale.

### Energy Inputs

Water inflow. The major energy inputs to this system are from water flow and sunlight. Water flowing into the river has potential energy by virtue of its elevation above sea level, the last vestiges of work expended by the atmospheric circulation in lifting water vapor to form clouds and then rain.

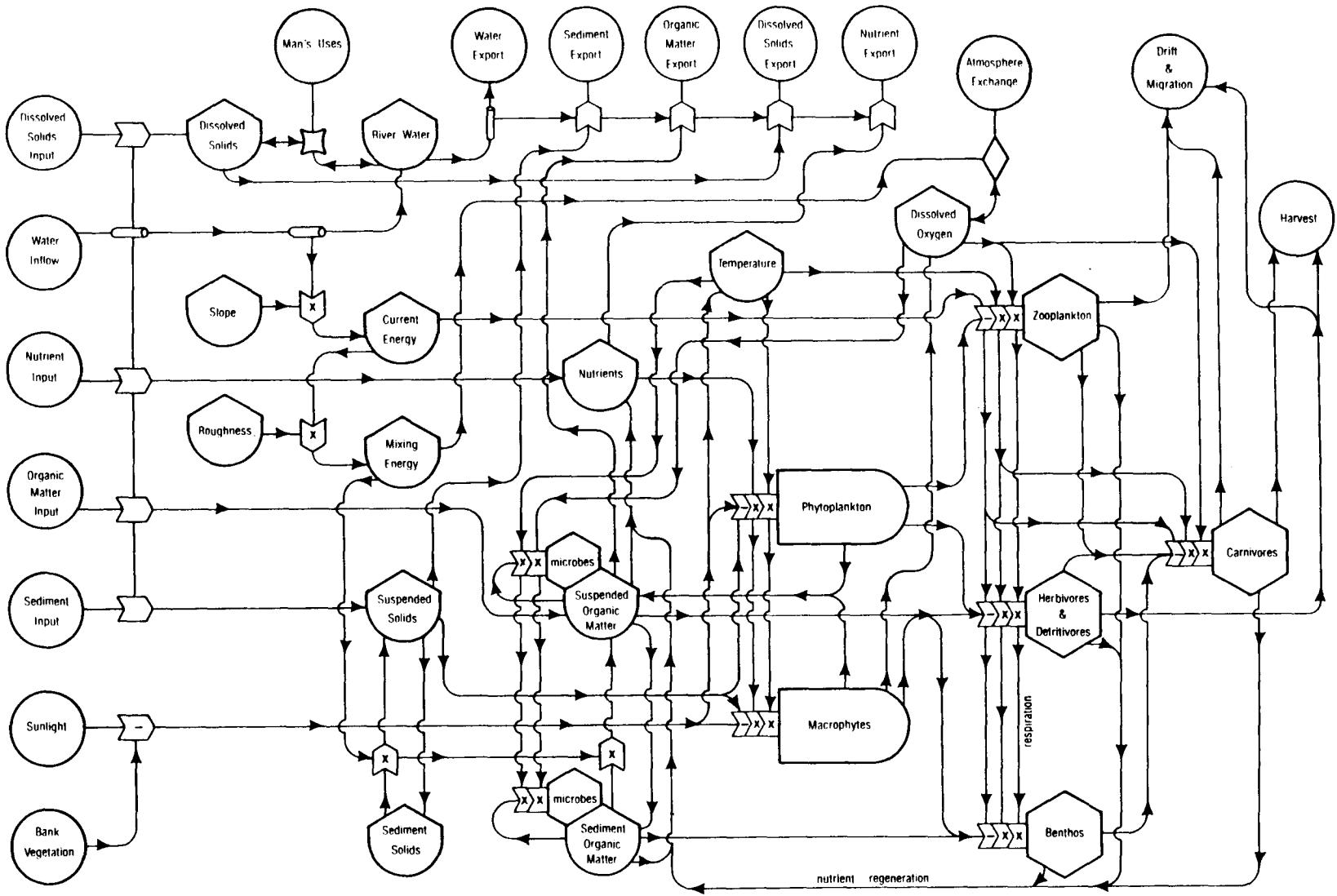

FIGURE 47. River and canal habitat.



Sunlight. The amount of solar energy reaching the river surface depends greatly on the extent of shading by bank vegetation.

### Material Inputs

There are two major sources of material input to the river and canal habitat, inflow from upstream systems and input from the adjacent banks. These vary in importance with the individual systems and with the seasons. Some of the river systems in the study area receive input from drainage basins stretching across the state, while others are entirely within the coastal area. See also lake and reservoir habitat discussion for the role of reservoirs in affecting input to downstream systems.

Water inflow. Water inflow is a material input as well as an energy input. This represents all water inflows, from upstream river or reservoir systems, local runoff, ground water infiltration, and "return flows" from urban, agricultural, and industrial uses. One of the most important characteristics of Texas rivers is the extremely variable flow rate. Months of low flow rates sustained mainly by urban and industrial discharges may be punctuated with 100 times greater flows due to floods. Present and projected flows in the major river systems are given in the Texas Water Plan (TWDB 1977).

Nutrient input. The water inflow brings with it a variety of dissolved and suspended materials. The concentration of nutrients in local runoff is a function of land use and soil type in the drainage area. Omernik (1976) shows that in general, agricultural and urban watersheds produce a much greater total nitrogen and phosphorus input to streams than forested areas. For many rivers, urban sewage treatment plant discharges are the major nutrient

sources, especially during low flow periods (Piwoni and Lee 1976, Davis et al. 1978.)

Inorganic nitrogen inputs are generally in the form of the very soluble ammonium ( $\text{NH}_4^+$ ) or nitrate ( $\text{NO}_3^-$ ) ions, with ammonia the predominant form in urban discharges (Davis et al 1978.) Inorganic phosphate may be in the easily assimilated ortho-phosphate form, in more complex polyphosphates, or adsorbed onto clay particles. Significant amounts of nitrogen and phosphorus enter the system in organic forms such as proteins and other complex molecules, and are only available to plants after decomposition of the organic matter has taken place.

Organic matter input. This represents both dissolved and particulate organic materials. In most smaller rivers, organic matter input is a major source of energy to the biota. Natural sources of organic matter include leaf fall and other vegetation debris washed in from the surrounding watershed by rainfall. Municipal and industrial discharges and runoff from urban areas are major sources for some rivers.

Sediment input. Input of particulate solids may come from erosion of the river banks, runoff, or as suspended solids load from upstream. In general, Texas streams carry a high suspended solids load when they enter the study area, typically between 50 and 500 ppm. The Brazos carries by far the greatest load, while the Nueces carries the least (from data in Dougherty 1979.)

Dissolved solids input. In general, fresh waters tend to slowly pick up dissolved solids by weathering of rock and soil particles. Other sources include seepage of saline ground waters, agricultural drainage, municipal and industrial wastes. Oil field brines were frequently discharged to streams in

previous years, creating serious problems. The practice has been outlawed, but runoff from old oilfield areas may still contain excessive dissolved solids. Runoff from high salinity soils contributes to excessive dissolved solids in many areas of Texas and is of major concern in several river basins (TDWB 1977.)

### Physical Attributes

Current energy. As described in the energy input section, current energy is derived from water flowing down the slope of the river bed. This energy is eventually dissipated into turbulent mixing by friction with the river bed. Current velocity is a major factor in the lives of all organisms of the river system.

Slope. This represents the slope of the river water surface, which determines the rate of production of current energy from water flow. Land slopes in the study area are on the order of 0.5 to 2.0 ft per mile (Brown et al. 1972-1977). The sinuosity of major rivers such as the Colorado produces a lower slope for the actual river water surface.

Roughness. This component represents the large-scale roughness of the river channel which tends to convert current energy into turbulent energy. Brandes and Stein (1979) summarize the effects of channel roughness and its effects on mixing in connection with mathematical modeling of river water quality.

Mixing energy. This represents the energy of water movements on a relatively short scale which tend to mix the water column and resuspend bottom sediments.

Dissolved oxygen. An adequate supply of dissolved oxygen is essential to the biota of the river habitat. Most water pollution control efforts for

rivers and streams are directed at ensuring a continuing level of dissolved oxygen, and water quality models concentrate on this problem (Brandes and Stein 1979); thus there is an extremely large literature on the subject. The habitat model depicts most of the factors which have been found to be significant. As shown in Table 3, low dissolved oxygen is a present or potential problem in 6 of the 27 river segments in the study area.

Oxygen is consumed almost entirely by biological activity. The respiration of microbes during the degradation of organic matter, also known as "biological oxygen demand" or BOD, is the major consumer of oxygen. Some bacteria also consume oxygen during the oxidation of ammonia to nitrate, so-called "Nitrogenous Oxygen Demand"; this is not shown specifically in the model. Phytoplankton and higher plants also respire oxygen when light energy input is low. Respiration of oxygen by higher organisms is usually less significant than that by microbes to overall oxygen levels.

Major sources of oxygen are photosynthesis and atmospheric exchange or reaeration. Gas molecules are continually exchanged across the water surface between the atmosphere and the water column. The net oxygen transport as a result of this exchange is always in the direction of oxygen saturation. Since oxygen concentration is usually below saturation in most rivers, exchange generally acts as a source of oxygen.

Photosynthesis by phytoplankton and higher plants releases oxygen as carbon dioxide is fixed and organic matter is produced. However, since most of this organic matter is later consumed in the river habitat by respiring organisms, photosynthesis is not usually a net source of oxygen. In fact, the depletion of oxygen following a phytoplankton bloom is blamed for numerous fish kills.

TABLE 3. Water quality of river segments in study area

Basin	Segment	Name	Status	Remarks
Galveston Bay				
	802	Trinity River	N	p
	902	Cedar Bayou	N	fns
	1002	Lake Houston	N	nf
	1008	Spring Creek above Lake Houston	S	fno
	1009	Cypress Creek	S	os
	1102	Clear Creek	B	fmno
	1104	Dickenson Bayou	S	fns
	1106	Bastrop Bayou	N	fn
	1108	Chocolate Bayou	N	s
	1110	Oyster Creek	S	fno
	1112	Oyster Creek upper	B	fno
Brazos River				
	1202	Brazos River	N	m
Brazos _ Colorado Basin				
	1302	San Bernard River	N	fn
	1305	Caney Creek	S	fns
Colorado River				
	1402	Colorado River	N	
Matagorda Bay				
	1502	Tres Palacios Creek	N	fn
	1602	Lavaca River	N	fp
	1603	Navidad River	N	p

Status:

N = presently fishable swimable  
 S = fishable/swimable by 1983  
 B = not fishable swimable by 1983

Remarks (present or potential water quality problems):

f = fecal or total coliform numbers high  
 h = above average heavy metals  
 n = high nutrient levels and/or eutrophication  
 o = dissolved oxygen below standard  
 p = above average pesticide or PCB levels  
 s = high dissolved solids, chlorides, sulfates, etc.

TABLE 3. (Continued) Water quality  
of river segments in study area

Basin	Segment	Name	Status	Remarks
San Antonio Bay				
	1802	Guadalupe to San Antonio confluence	N	rp
	1803	Guadalupe River	N	frp
	1807	Coleta Creek	N	fn
	1901	San Antonio River above Guadalupe confluence	N	fn (major problems are found above study area)
Copano - Aransas Basin				
	2002	Mission River	S	f
	2004	Aransas River	N	fns
Corpus Christi Bay				
	2102	Nueces River to Lake Corpus Christi	N	ns
	2103	Lake Corpus Christi	N	ns
Rio Grande River				
	2302	Rio Grande	N	

Status:

N = presently fishable swimable  
S = fishable/swimable by 1983  
B = not fishable swimable by 1983

Remarks (present or potential water quality problems):

f = fecal or total coliform numbers high  
h = above average heavy metals  
n = high nutrient levels and/or eutrophication  
o = dissolved oxygen below standard  
p = above average pesticide or PCB levels  
s = high dissolved solids, chlorides, sulfates, etc.

The rate of microbial metabolism and thus oxygen consumption goes up rapidly as temperature increases. Furthermore, the solubility of oxygen decreases at higher temperatures, leading to slower oxygen input by reaeration. These factors, together with generally lower flow rates, make the summer and fall the most critical period for dissolved oxygen.

Microbes and suspended organic matter. This compartment represents a combination of the dissolved and suspended organic matter in the water column and the micro-organisms which live in close association with it. Since bacteria, fungi, and yeasts multiply so rapidly, on the time scale which this model represents, the microbial population may be assumed to vary directly with the supply of organic matter. For the sake of simplicity, this compartment also includes chem-autotrophic bacteria which draw most of their energy from oxidation of substrates such as ammonia. The consumption of organic matter by detritivores and benthic invertebrates is an important pathway in the river habitat food web.

Note that the presence of human pathogenic bacteria may prevent human use of river habitats for recreation, sport fishing or as a water source. Because of the difficulty of testing for actual pathogens, water quality criteria are traditionally stated in terms of a maximum count of fecal coliforms. As shown in Table 3, high fecal coliform counts are considered a present or potential problem in 17 of 27 coastal river segments.

Microbes and sediment organic matter. This compartment represents the organic matter in river sediments, which can range from a few tenths to ten percent or more of the total sediment. Decomposition of organic matter in sediments can consume significant amounts of dissolved oxygen from the

overlying waters and release significant amounts of nutrients (Brandes and Stein 1979.)

Nutrients. This represents the substances such as nitrogen and phosphorus which are needed for the growth of phytoplankton and higher plants. In addition to the external sources of nutrients, they are released by the metabolism of organic matter by the consumers.

The significance of recycled nutrients to the river system will depend on the residence time of the water. In slow moving rivers, a significant fraction of the nutrients contained in organic matter can be released and recycled (for example, Stanley and Hobbie 1981.)

High nutrient levels can cause phytoplankton "blooms," which in turn can decay, causing low oxygen conditions. Bailey (1974) describes water quality problems and fish kills on the Aransas River believed to be due to high nutrient concentrations from sewage treatment plant discharge. Extremely high levels of ammonia can be toxic to fish. Davis et al. (1978) have suggested that ammonia toxicity could be significant in Texas rivers during low flow conditions. As shown in Table 3, high nutrient concentrations with possible eutrophication symptoms are considered a present or potential problem in 17 of 27 coastal river segments.

Suspended solids. The rivers of the study area are typically turbid with suspended solids. These particles range in size from silt to clay. By absorbing sunlight, suspended solids can be a major limiting factor on photosynthesis by phytoplankton and macrophytes.

Sediment solids. This compartment represents the fine-grained sediments of the river bottom. Although in general there is net accumulation of these



solids in rivers of the study area, deposits are frequently resuspended during high flows.

Dissolved solids. The concentration of dissolved solids is more significant to agricultural, industrial, and municipal users of river water than to the biota. The anions most commonly present include chloride, sulfate, and carbonate, while the most common cations are sodium, potassium, calcium and magnesium. A suggested maximum chloride-plus-sulfate concentration for domestic use is 250 parts per million (EPA 1976.) High levels of dissolved solids are considered a present or potential problem in 7 of 27 river segments in the study area (see Table 3).

#### Biota

Phytoplankton. Phytoplankton taxa expected to be significant in Texas rivers include diatoms, green algae, and blue-green algae. Light, nutrients, and temperature are the major factors affecting phytoplankton growth.

Macrophytes. The larger rooted plants are restricted to shallow waters or clear streams by their requirements for light. Attached algae, typically filamentous blue- greens are included in this group for the model.

#### Consumers

There is a connection between current energy and all of the consumers. This indicates that current is a major factor in determining the distribution of the different species; however, a detailed species-by-species account is beyond the scope of this discussion.

Zooplankton. These are the small motile consumers such as Daphnia and other crustaceans which feed mainly on phytoplankton. As with all of the consumers, temperature plays an important role in determining growth and activity (Macan 1966).

Herbivores and detritivores. There are numerous small fish and crustaceans which consume algae and detritus as a significant part of their diet. These include insect larvae, grass shrimp, and shad. Larger fish consuming significant amounts of plant material and detritus include catfish, carpsucker, and the small and large mouth buffalo.

Benthos. The most prominent benthic organisms are the insect larvae such as chironomids, which consume organic detritus and phytoplankton and in turn are major food items for many of the smaller carnivores.

Carnivores. In this compartment are grouped all of the consumers feeding almost exclusively on animals. These range in size from some insects and small fish such as sunfish up to gar and alligators. All of the fish of sportfishing interest such as large mouth bass are in this group.

#### Material Exports

Man's uses. A large amount of water is withdrawn from rivers in the study area for agricultural, industrial, and municipal uses. High levels of dissolved solids may restrict some uses. Present and projected freshwater requirements are summarized in the Texas Water Plan (Texas Water Development Board 1977).

Atmosphere exchange. This represents exchange of oxygen between the water and air. In most cases, there is net flow of oxygen into the water.

Water export. This represents the outflow of water to the downstream "tidal stream reach" and thus to marine systems. The amount of inflow required by these systems has been the subject of considerable research by the Texas Department of Water Resources (1979).

Sediment export. Export of sediments from rivers is a crucial factor in the development of the landforms of the study area as emphasized in the

regional model. In addition to the normal movement into estuarine or nearshore gulf systems, overbank flooding deposits sediments in adjacent wetland and terrestrial systems. At the present time, it is unclear what the net effect of man's alteration of river systems is in terms of sediment export. Although dams tend to trap sediments, agricultural and urban activities tend to increase the sediment load.

Nutrient export. Export of nutrients by rivers to estuarine and nearshore systems is a crucial factor in maintaining high productivity in these systems.

Organic matter export. Rivers export large amounts of organic matter to estuarine or nearshore Gulf of Mexico systems, which may depend heavily on this material as an energy source.

Drift and migration. This represents exchanges of organisms between the river and connecting aquatic environments. In the study area, a "tidal stream reach" habitat is typically the adjacent downstream system. Other connecting environments include lakes, freshwater marshes, and swamps.

Harvest. This represents harvest both by man and by carnivores from adjacent systems. Terrestrial predators such as racoons, herons, and egrets catch fish and crustaceans in the river shallows. Man's sportfishing harvest is mainly of the top carnivores.

## SALT MARSH

### Introduction

Most of the salt marsh in Texas occurs on the mainland and the bay side of the barrier islands in the middle and upper portions of the coast (Brown et al. 1972-77). Few areas of salt marsh are found south of Corpus Christi Bay due to the lack of rainfall and high evaporation rates. A few are located at the southern end of the Laguna Madre near the Rio Grande outlet. The salt

marshes of the Texas coast are quite dissimilar to the regularly inundated tidal marshes of the Atlantic coast. The Texas salt marshes may contain relatively large stands of Spartina alterniflora (smooth cordgrass) like the Atlantic marshes, but for the most part the stands in Texas are less dense and shorter. Much of the salt marsh in Texas contains no smooth cordgrass. This is referred to as a non-spartina salt marsh. These are irregularly inundated by bay waters and may even dry completely during several dry years. However, they are still considered salt marsh habitat.

Recent reports on the influence of freshwater inflows to several Texas bay systems by the Texas Department of Water Resources (1980,1981) give good accounts of studies of specific salt marsh systems in Texas. Figure 48 is the conceptual model of a Texas salt marsh.

#### Energy Sources

Sunlight. Solar energy input provides the major source of energy used by the vascular plant based food web of the salt marsh ecosystem.

Runoff. Local runoff from streams and overland sources provides one of the driving forces for the water flow within the salt marsh ecosystem. It is the primary supplier of fresh water to this system. This can produce significant short-term changes in the salinity of the salt marsh.

Wind energy. Wind energy is a factor in controlling the water flow and water level in the salt marsh portions of the shallow Texas bays, especially during winter storms or hurricanes. It affects the salt marsh by causing wind tides in the neighboring bay ecosystem which then inundate the marshes with bay water. Wind energy may be more important than astronomical tides in inundating the salt marsh with saline water since many of the marshes occur at the back of the bays where the astronomical tides have little effect.

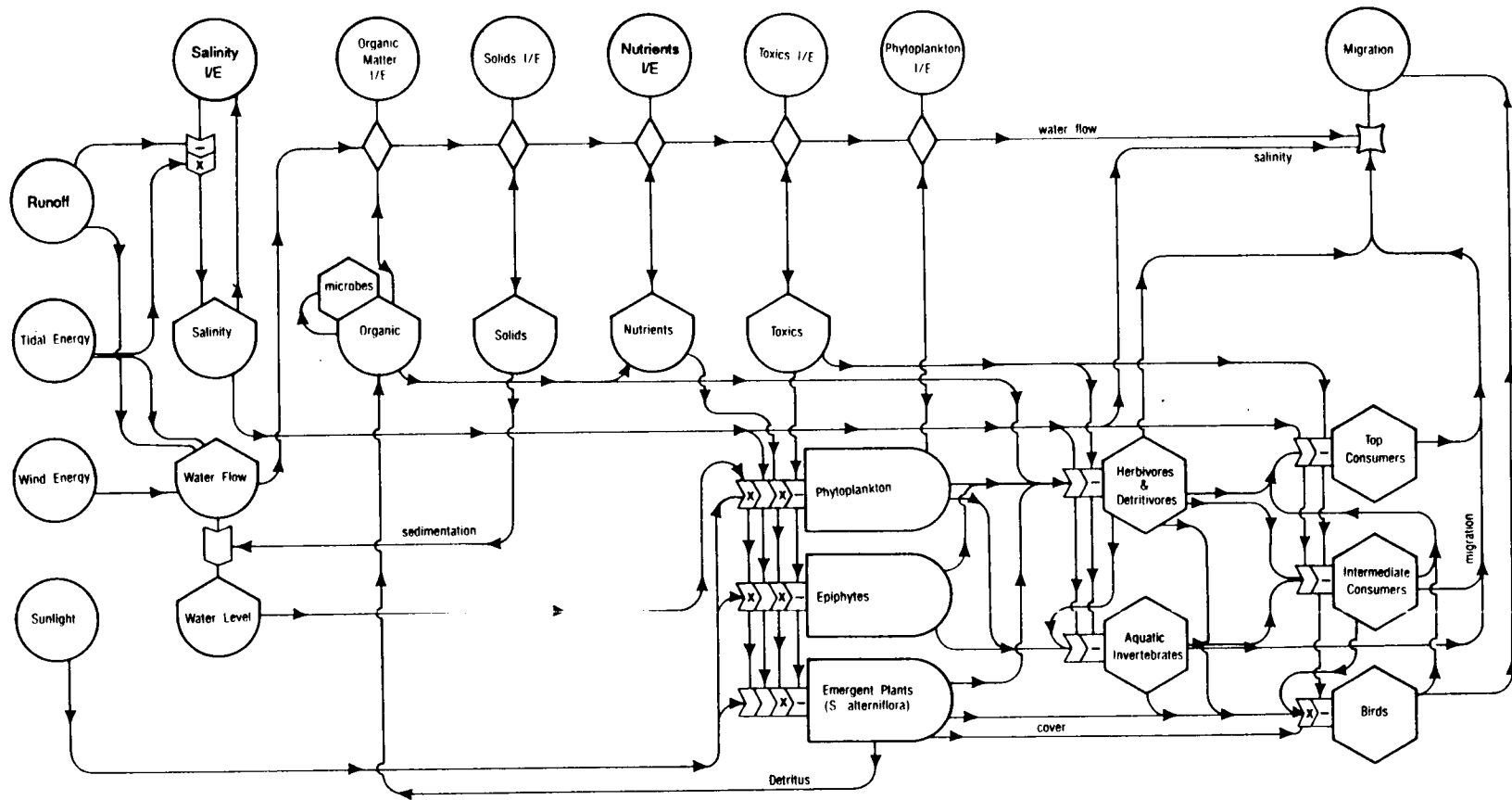

FIGURE 48. Salt marsh habitat.

Tidal energy. Tidal energy may be a major controlling factor of the water level of some of the more exposed salt marshes in Texas due to their shallow nature. Even though the tidal amplitude may be small, it may produce a large change in the amount of substrate inundated due to the relative lack of slope in the salt marshes of the Texas coast. Tidal energy is one of the major sources of energy for water flow through the salt marsh system except during periods of heavy runoff or strong "wind tides."

Subsidence. Portions of the middle and upper Texas coastal plain have subsided as much as two meters during the past 50 years (Brown et al. 1972-1977). This subsidence has been caused by pumping of underground water, oil and gas reservoirs. Subsidence has a direct, long-term effect on the land elevation and thereby the water level of the salt marshes. Subsidence along the upper Texas coast has tended to increase the amount of land inundated by bay water and therefore increase the potential amount of salt marsh habitat.

#### Physical Attributes

Salinity. Salinity is one of the most important attributes in the salt marsh ecosystem and may vary from less than 1 ppt to over 35 ppt, with most salt marsh plants preferring some salinity but less than 8 ppt (Gosselink et al. 1977). It is one of the primary factors controlling the presence or absence of biota. Its variations, which are due primarily to the variation in the salinity of the adjacent bay or bay margin ecosystem and the amount of local runoff, partially control the distribution and abundance of mobile organisms and the distribution of benthic organisms. Local runoff via small streams or ditches and direct overground flow may temporarily reduce the salinity during and after heavy rainfall periods. This may affect the salt marsh system for some time, especially in areas that receive only intermittent

inundation by bay waters. Droughts may raise the salinity in salt marshes with deleterious results (Hoese 1967).

Water flow. Water flow in the salt marsh is used to represent the physical flow of water caused by tidal and/or wind inundation of bay water and freshwater runoff. The water flow is analogous to currents in deeper water systems. The major direction of the water flow in the salt marsh is "in" during high enough flood tides or very strong onshore winds and "out" during ebb tides, offshore winds or periods of freshwater runoff. The water flow drives the import and export of physical and biotic attributes.

Solids. The solids attribute is used to show the physical effects of particulate matter, such as the covering of the bottom fauna as well as the mass or volume of sediment within a particular area of the salt marsh. Suspended solids are introduced into the salt marsh waters primarily by import from adjacent systems via water flow. They may be removed from the water column via settling in the marsh or they may be exported to the neighboring ecosystems.

This attribute also provides an input to land elevation which in turn affects the water level and tidal energy. Rapid sedimentation from storm water runoff may be particularly detrimental to organisms such as benthic micro-algae.

Land elevation. This attribute represents the physical elevation of the land mass relative to sea level. It is increased by the import of solids and decreased by erosion and subsidence. It directly affects the amount of water flow and water level in the salt marsh as well as the amount of tidal energy that reaches the marsh.

Water level. This attribute is primarily controlled by water flow. The water level of the salt marsh system may vary from over one meter during high water periods to dry during droughts. Many of the Texas salt marshes with no Spartina alterniflora may have only a few centimeters of water covering them during much of the year. This may vary only a few centimeters with the tides and normal runoff. The depth of the water in the salt marsh is one of the most important factors controlling the migration of organisms in this system. It is also highly important in controlling the primary production via phytoplankton and epiphytes, especially in marshes that are exposed for extended periods.

Nutrients. Nutrients are organic and inorganic materials required by phytoplankton, epiphytes and emergent plants for photosynthesis, in addition to light. Nitrogen and phosphorus are the major nutrients associated with primary production in the salt marsh, although many additional nutrients and trace elements are also needed. Nitrogen is generally considered to be the limiting nutrient in Texas salt marshes (De Laune et al. 1976). A significant portion of the nitrogen used in the salt marsh ecosystem probably comes from runoff during periods of high rainfall. Some may be recycled from the sediments via reduction and bacterial action (Nedwell and Aziz 1980). The Texas Department of Water Resources has computer data banks of nutrient data from sampling in the salt marshes of many Texas bays.

Organic matter. "Microbes" are partially combined with the symbol representing organic matter in the water and sediments since they are an integral part of the cycling of energy via decomposition. The amount of organic matter in salt marshes is generally very high due to the high primary productivity of both Spartina-dominant marshes and non-Spartina marshes. The



annual net production of Texas salt marshes with large amounts of Spartina alterniflora has been estimated at about 2,400 lb C/acre-yr and about 1,500 lb C/acre-yr for non-Spartina salt marshes (Brogden et al. 1977). Due to the low tidal range, much of the production of marsh grasses may accumulate and be incorporated into the sediments until major storm events remove accumulated litter and detritus from the marshes.

The benthic infauna and some of the epifauna ingest the organic matter from the sediments or the surface of the sediments as do some of the herbivores and detritivores such as the penaeid shrimp. This is an important food source for these species.

Toxics. Toxic materials which could be introduced into the salt marsh system include heavy metals, pesticides, industrial organic chemicals, well drilling fluids, crude oil and petrochemicals. Many toxic materials are readily adsorbed on fine particles. They are then quickly incorporated into the sediments. Some of these toxics may reach higher levels in the food chain via bioaccumulation by filter feeders and consumption by higher order consumers. Toxics enter the salt marsh system primarily via water from the adjacent ecosystems or via runoff from land.

Each bay in Texas varies greatly in its sediment concentrations of toxic materials. Available data which document the concentrations of heavy metals, pesticides and chemicals such as PCB show that they are found in the sediments of nearly all of the bays of Texas (TDWR Computer Data Files). Data from the TDWR files show that the sediments in the channels, rather than the bay proper, contain the higher accumulations of toxics. Most of the toxic materials settle out into the deeper portions of the bay system with the finer sediments (McGowen et al. 1979). This would indicate that the salt marsh

system would be expected to have elevated toxic concentrations if they were introduced by nearby spills, covering by dredged material or via runoff.

#### Import/Export of Physical Attributes

Salinity import/export. The salt marsh system receives most of its salinity from inundation by water from the adjacent bay margin and wind tidal flat ecosystems. Local rainfall and runoff may cause lower salinities in the salt marsh system for substantial periods of time. The TDWR water quality data base contains extensive salinity data on all of the Texas bays. The Environmental Geologic Atlas series (Brown et al. 1972-77) also discusses the distribution of salinity in the bay systems of Texas.

Water outflow. This attribute represents the outflow of water from the salt marsh to neighboring systems. It is driven by high water flow within the system, which is due to high water inflow from either runoff or tidal inundation. Water outflow occurs on the ebb tide and following periods of high freshwater inflow.

Solids import/export. The salt marsh system receives most of its solids input from neighboring ecosystems via inundation by runoff containing high suspended solids concentrations.

Nutrients import/export. Import from the neighboring ecosystems, local runoff, nitrogen fixing by bacteria and blue-green algae, and recycling of sediment nutrients provide the majority of the nutrients to the salt marsh system (Buresh et al. 1980). Some of the nutrient load brought to the salt marsh system by runoff via streams actually originates as waste discharges and agricultural runoff in some areas.

Toxics import/export. Toxics such as agricultural pesticides or industrial wastes may be imported along with the freshwater runoff into the

salt marsh. Some are introduced into the salt marsh system via spills or treatment plant outfalls. Crude oil may be imported via the passes (inlet-tidal delta systems) from the gulf in the case of spills in the nearshore gulf or upper shoreface. Toxics from spills in the adjacent ecosystems may find their way into the salt marsh system.

Organic matter import/export. Most of the organic matter that enters the salt marsh system via freshwater runoff or import from the adjacent estuarine systems, is either dissolved or suspended particles of vegetation and animal matter. Salt marshes produce large amounts of their own organic matter that may be exported in large pieces during storms (Brogden et al. 1977) or as small suspended detritus particles during periods of normal water outflow. This exported organic detritus forms the basis for the all important estuarine detritus based food chain. Depending on the type of salt marsh, the density of vegetation and the amount of water flow, the export of organic matter from Texas salt marshes with abundant smooth cordgrass may be about 45 percent of the annual net primary production and 15 percent for salt marshes without smooth cordgrass (Brogden et al. 1977).

#### Biotic Attributes

Phytoplankton. The major portion of the primary productivity of the salt marsh system is provided by the emergent marsh plants (de la Cruz 1979). The phytoplankton are of lesser importance due to the small volume of water; however, they supply a relatively larger amount of primary productivity during the winter months when the emergent plant growth slows. The rate of phytoplankton photosynthesis depends on light penetration and nutrient availability (Armstrong and Hinson 1973). The possibility of suppression of photosynthesis by toxic materials exists, but its extent in Texas' bays is

currently unknown. Van Baalen et al. (1973) detected toxicity in Galveston Bay waters using a phytoplankton bioassay.

Epiphytes. Epiphytes attached to the emergent plants of the salt marsh system supplement the overall primary productivity. The main types of epiphytes are algae and diatoms that grow primarily on the smooth cordgrass in the salt marsh. They may contribute a substantial amount of primary production in some areas (Day et al. 1973). Epiphytes are not expected to provide much primary productivity in the non-spartina salt marshes in the more xeric portions of the Texas coast.

Emergent plants. Spartina alterniflora (smooth cordgrass) is the primary species of emergent vegetation in most salt marshes on the upper Texas coast. However, many of the salt marsh areas of the middle and lower Texas coast may contain little or no smooth cordgrass. They are still considered salt marshes but may be populated primarily by Monanthochloe littoralis (shoregrass), Distichlis spicata (saltgrass), Spartina patens (saltmeadow cordgrass), Borrichia frutescens (sea ox-eye), Batis maritima (saltwort), Salicornia sp. (glasswort) and in some cases Avecennia germinans (black mangrove) (Brogden et al. 1977). The emergent plants provide the majority of the primary production in the salt marsh system. Texas salt marshes containing mostly smooth cordgrass may have an estimated net primary production of 2,400 lb C/acre-yr (Brogden et al. 1977). Salt marshes containing little or no smooth cordgrass may have an estimated net primary productivity of 1,500 lbs-dry wt/acre-yr (Brogden et al. 1977). The live biomass of Spartina alterniflora in Texas salt marshes may be comparable to that of some Atlantic coastal areas, but the dead biomass may be higher in the Texas marshes due to less tidal flushing (Turner and Gosselink 1975).

Aquatic invertebrates. This attribute is used to show both the carnivorous zooplankton and benthic invertebrates of the salt marshes of Texas. The zooplankton found in the salt marsh are imported from the adjacent systems and may be species from fresh to brackish habitats or marine species from the bay system, depending upon the amount of runoff and tidal inundation (Cuzon du Rest 1963). Polychaetes, nematodes, ostracods, and copepods can be found in the salt marsh benthos. These organisms feed primarily on the herbivores and detritivores and comprise the second level of the detritus based food chain for which the salt marsh provides the primary production. Many of the higher trophic level organisms depend, at least partially, on the aquatic invertebrates for their food.

Herbivores and detritivores. This group comprises one of the largest consumer groups in the salt marsh system and ranges in size from the small zooplankton to the striped mullet (Mugil cephalus) (Odum 1970). Most of the crustaceans (shrimp, crabs, etc.) are herbivorous or detritus feeders or both at one stage in their life cycle (Coastal Fisheries Branch 1975; Cook and Lindner 1970; Costello and Allen 1970; Lindner and Cook 1970). Many of the larval stages of the higher level fish fall into this category (Dineen and Darnell 1976). Many of these organisms move into the salt marsh system to feed on the benthic algae, epiphytes or organic matter, and to escape larger predators in the shallow water. The young of many of these organisms spend much time in the salt marsh system.

Intermediate consumers. This group comprises both the free-swimming consumers and those closely associated with the bottom. This includes aquatic organisms from larval fish to jellyfish. This compartment is primarily concerned with the predatory organisms below the level of top consumer.

Species such as the tidewater silversides (Menidia beryllina), rainwater killifish (Lucania parva), blue crab (Callinectes sapidus), and pinfish (Lagodon rhomboides) spend much of their time in the very shallow waters of the salt marsh system (Brogden et al. 1977).

There are several species of small fish that depend heavily upon the shallow water areas of the salt marsh system. These are primarily the sheepshead minnow (Cyprinodon variegatus), which prefers water less than 10 cm deep and feeds on algae, detritus and small benthic animals, and several species of killifish (Fundulus similis, grandis and others).

Fiddler crabs (Uca sp.) may be common to abundant in the salt marshes of the Texas coast (Powers 1975). Their burrows may have significant effects on the soil, algae, emergent plants and nutrient cycles in the salt marsh system (Montague 1980). They provide a prey item for many of the top consumers.

Top consumers. The top consumers of the salt marsh system are primarily the juveniles of game fish of the bay system and birds (discussed separately in the next section). Species such as Cynoscion nebulosus, Sciaenops ocellata and Pogonias cromis frequent the salt marsh system, when the water level permits, in search of prey. Coastal Fisheries Branch (1975) and Hoese (1965) are two of the more comprehensive references on the top consumers and their habitats.

Birds. The birds are discussed separately because they are important in the salt marsh system. Many wading and shore birds can be found on the edge of the water or wading in the salt marsh system. The wading and shore birds feed on the small benthic and nektonic organisms in or near this system. Many species of waterfowl also feed on micro-organisms or vegetation in the salt marsh system during the winter months. Many of them rest on the shore

adjacent to the salt marsh where their droppings may be washed back into the system to provide nutrient input. Brogden et al. (1977) discuss the use of this habitat by the birds in the Corpus Christi Bay area. The most common birds found in the salt marsh systems in Texas are the redwinged blackbird, rails, coot, grebes, and ducks in the winter.

#### Import/Export of Biotic Attributes

Phytoplankton. Phytoplankton are imported and exported via the inundation of bay water and runoff. They are of minor importance in the productivity of the salt marsh system.

Migration. Migration with respect to the salt marsh system represents the movement into and out of the salt marsh area as opposed to the seasonal migrations of organisms between the gulf and bay systems. This migration is cued primarily by water flow and salinity. The planktonic organisms are carried into and out of the salt marsh system during inundation by bay water. More motile organisms move in and out of the system when the conditions are favorable to them.

Killifish, silversides and small mullet are the most visible members of the herbivore and detritivore group that migrate between the bay and the salt marsh systems. Smaller juveniles of many intermediate and top consumers can be found in large numbers during certain times of the year in the salt marshes.

The Penaeid shrimp spawn offshore in the gulf and the postlarvae migrate into the bays to mature (Cook and Lindner 1978; Lindner and Cook 1970; Costello and Allen 1939). These postlarvae usually proceed to the salt marshes and other shallow water systems in the bays where they feed on the benthic algae and organic matter in the relative safety of the shallows.

Most of the intermediate consumers spend much of their life cycle in the bay or migrate through it. As juveniles, many of them thrive in the food-laden shallow waters of the salt marsh areas.

The gamefish, which comprise the more important top consumers, migrate at various times of the year as do the intermediate consumers. Their migrations depend upon their spawning periods and various physical factors as mentioned above. No two species migrate at exactly the same time. Many of the smaller individuals seek out the bay margin and salt marsh areas for refuge from the larger predators and to feed on the juveniles of other species in the salt marsh system.

#### Critical System Components

The health of the bay ecosystem, which supplies much of the water to the salt marsh ecosystem, is one of the critical aspects in the survival of the salt marsh ecosystem. The salt marsh system receives many of its inputs either directly or indirectly from the bay system. The next most critical component is the runoff from adjacent systems. This freshwater runoff brings with it nutrients, organic matter and toxics. The emergent plants, epiphytes and phytoplankton are also a critical component since they are the source of most of the carbon produced in the salt marsh system.

#### SPOIL

##### Introduction

The spoil habitat (Figure 49) represents the terrestrial portion of newly-deposited to middle-aged spoil on the Texas coast. Older spoil may become indistinguishable from other types of terrestrial systems.

Spoil under the surface of the water is difficult to categorize. It may quickly become like the surrounding bottom or it may stay in a sort of loose



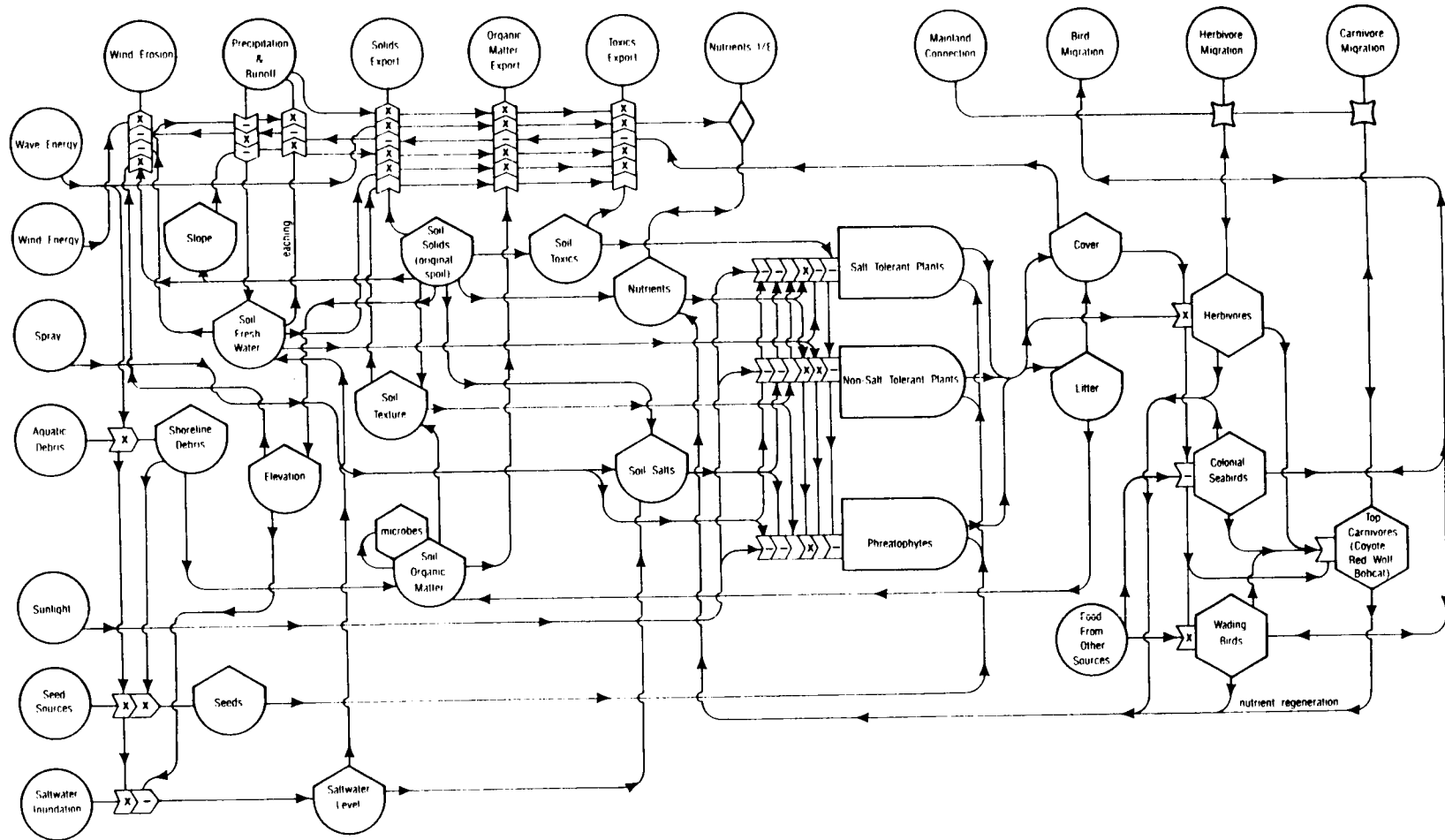

FIGURE 49. Spoil habitat.

mass for years, depending upon the currents and its original material.

### Energy Sources

Sunlight. Solar energy input to the plants is essentially a constant. Its utilization by the plants is controlled by the availability of nutrients, soil water, and soil salinity.

Wave energy. Wave energy from wind or ship created sources plays a major role in the early stages of spoil succession. It may create "drift ridges" along the high water line which provide habitat for waterborne seeds and other propagules of plants to germinate and grow (Parnell et al. 1978). Waves also transport organic debris to spoil piles. Wave energy is dissipated on the spoil shoreline where it may erode the shoreline thereby increasing water suspended solids and dissolved and suspended toxics, and decreasing the probability of vegetative colonization of the disturbed shoreline. Since much of the spoil along the Texas coast is contained in undiked piles or islands along shipping and barge channels, wave action from passing ship traffic is a major factor in the erosion and redistribution of the spoil (Chaney et al. 1978).

Aquatic debris. Waterborne organic debris is a source of energy, plant propagules and nutrients to the spoil system. It brings in much of the organic matter during the early stages of spoil succession. Natural debris includes trees, branches and grasses. This debris usually piles up along the drift ridge at the high water line where it may provide the shelter from the waves needed for plants such as smooth cordgrass (Spartina alterniflora) to become established. This is an input to the shoreline debris compartment in the model.

Wind energy. During normal water levels, wind energy may be the main transport agent for sand, spray and various soil components. On spoil over 3 to 4 meters in height, wind erosion may keep surfaces from stabilizing (Parnell et al. 1978).

Seed sources. Seed sources are significant energy inputs to the early stages of spoil deposits. The seeds are either washed up by wave energy or carried to the spoil by birds. Import of seeds and plant propagules by waves is the major source of salt-tolerant vegetation on newly deposited spoil. They are deposited on the spoil with the shoreline debris (Chaney et al. 1978). Seeds of some nonsalt-tolerant plants may be carried to the spoil via wave action. Most are either windblown or are deposited by visiting land birds via their droppings or on their plumage or muddy feet.

Birds feeding in other systems. Most of the birds that use spoil deposits feed in nearby aquatic systems and return to the spoil for resting, nesting, etc. Their droppings are sources of nutrients and organic material for the plants.

#### Physical Attributes

Slope. Slope represents the physical structure of the spoil pile. Elevation has been separated because of its great importance to the rest of the system. Slope is important in determining the types of vegetation that will colonize newly deposited spoil piles and the kinds of wildlife that will inhabit the spoil. Parnell et al. (1978) studied the utilization of diked versus undiked spoil islands in North Carolina estuaries. They found significant differences in the types of bird and vegetation communities established on the two types of spoil.

Slope, combined with soil texture and soil water, regulates the amount of rainfall which runs off versus that which infiltrates into the soil. It also helps to determine the rate of erosion of soil solids and the soil toxics. In considering changes in this attribute, an "increase" is a change which tends to reduce runoff and/or erosion.

Elevation. Elevation is a significant factor in determining the zonation of pioneer plants on spoil piles (Allen et al. 1978; Cole 1978; Falco and Cali 1977; Zieman and Odum 1977). This parameter is generated from soil solids and partially regulates soil water migration which in turn affects salts, toxics and nutrients. Elevation is affected by wind erosion in dry climates when the spoil is sandy in texture.

Shoreline debris. This represents the large pieces of organic matter such as wood fragments, grasses and other debris. Debris may be resuspended by high tides and broken down in the neighboring aquatic systems. Shoreline debris breaks down to provide soil organic matter and may also contain seeds or other propagules of salt-tolerant plants. Since the rate of supply depends on many factors, such as wind and currents, the standing crop of debris is quite variable.

Soil solids. This attribute represents the physical bulk or total volume of the soil. It is necessary in the model in order to provide a compartment upon which many of the inputs may operate. Precipitation, wave energy and wind energy, regulated by slope and elevation, physically erode the soil solids creating suspended solids in the nearby aquatic systems. Soil solids also create soil texture when acted upon by the above-mentioned physical factors.

Soil texture. Soil texture represents the "particle size" of the soil solids. It may range from large shell fragments to very fine clay/silt particles, depending upon the dredged material being deposited as spoil. Soil texture is regulated by the action of physical factors on soil solids. It in turn regulates the rate of infiltration of precipitation into the soil, the movement of soil water, the erosion of suspended solids and dissolved and suspended toxics, and the growth and survival of colonizing plants. Falco and Cali (1977) suggest that the texture had little influence on the establishment of smooth cordgrass on spoil deposits but definitely affected its growth and long-term survival. They further suggest that this occurs via the regulation of soil water and soil salts by the soil texture. Lunz et al. (1978) found that it took only two years for the soil characteristics of their experimental spoil marshes to become quite similar to the natural marsh (control) areas.

Several studies (Barko et al. 1977; Soots and Parnell 1975; CZRC 1977) have discussed the distribution of particle sizes on spoil deposits. Weathering of newly deposited spoil generally leaves the coarse fraction (shells, pebbles, and coarse sand) on the dome (top of the spoil pile) and upper slopes and medium to fine sand on the lower slopes. The fine particulates (silt, clay and fine sand) may be washed completely off the spoil into the water (Parnell et al. 1978).

Soil fresh water. Soil fresh water is separated from salt water level in the model in order to separate the conditions existing within the spoil deposits from those in the ground water system below the spoil. The soil water regime will differ greatly between diked and undiked spoil deposits (Parnell et al. 1978). Slope, elevation, soil texture, and precipitation all affect soil water via regulation of infiltration and runoff. Since most spoil

on the Texas coast comes from hydraulic dredging of subaqueous material, the initial spoil deposit is completely saturated with salt water. Weathering of the spoil deposit resorts the soil texture and with it, the soil's water holding capacity and soil salinity. Dewatering of newly deposited subaerial spoil occurs rapidly in undiked deposits and somewhat slower in the subcrust portions of diked deposits. Vaughan and Kimber (1977) suggest that soil water is the limiting factor for salt marsh vegetation growth on spoil deposits along the GIWW near Cedar Lakes, Texas.

Salt water level. Salt water level refers to the level of the salt water in the subsoil. This will occur under the freshwater lens or fresh ground water table on large spoil islands and land-based spoil areas. Small, low spoil islands may not have a fresh "ground water" system. The seawater level may directly underlie the fresh soil water. The salt water level determines the zone in which salt-tolerant plants may exist.

Soil toxics. Soil toxics include all elements and compounds that may be toxic to plant and animal life. Since much of the spoil is dredged from the bottom of channels where the sedimentation of fine particles enhances the accumulation of toxic materials, high levels of potentially toxic materials may be initially present in many spoil deposits. Inundation by seawater that contains toxics from chemical spills is the other method of toxics import. Plants may concentrate various elements and compounds found in the spoil. Studies by Lee et al. (1978) showed concentrations of zinc, copper, cadmium and lead to be an order of magnitude higher in some marsh plants growing on certain spoil deposits than the same plant species growing in natural conditions nearby. Several other studies (LSU Center for Wetland Resources 1977; Gunnison 1978; Lee et al. 1976; Lunz et al. 1978; Mang et al. 1978;

Windom 1977) have been conducted on the uptake of heavy metals and pesticides from spoil deposits by plants and the ultimate fate of these substances in spoil.

Soil organic matter. Initially, spoil deposits have a highly variable organic matter content depending on the source of dredged material. The soil organic matter appears to be inversely related to soil texture. The coarser sediments such as sand and shell fragment are low in organic matter while the finer clays are much higher in organic matter.

Cammen (1975) determined that the soil organic matter in a salt marsh, and in vegetated and unvegetated dredge spoil decreased logarithmically with depth. He also concluded that the main source was tidal import of detritus and benthic algae, and not Spartina decomposition.

Soil salts. Elemental salts are a part of the newly deposited spoil, since most spoil comes from below saline water in the Texas coastal area. Salts may also be added to the spoil by spray and inundation with seawater. Soil salinity, primarily sodium chloride, is one of the most important factors in determining the establishment and survival of plants on subaerial spoil. Falco and Cali (1977); Gallagher et al. (1977); Gosselink et al. (1977); Barko et al. (1977); Woodhouse et al. (1974) all determined that plant survival and growth were inversely related to soil salinity. This was even true for salt marsh species such as smooth cordgrass (Spartina alterniflora), which can survive in water from 0 to 125 ppt salinity (Lee et al. 1978) but is inhibited by salinities greater than 8 ppt (Gosselink et al. 1977).

Nutrients. Nutrients refers to all of the inorganic materials needed by the plants. This includes nitrogen, phosphorus, potassium, magnesium, calcium and trace metals. Nutrients are derived from the original spoil material,

decay of organic matter, spray, and inundation by seawater. Nutrient leaching by soil water movement is a major regulating factor of the amount of soil nutrients available to the plants. Barko et al. (1977) found that growth of several species of marsh and freshwater plants was nutrient limited on sandy dredge spoil. Eleuterius (1974), in studies of transplanting vegetation to spoil deposits, found that old spoil areas showed the poorest survival and growth due to nutritional limitations.

Gosselink et al. (1977) determined that plant biomass in marsh-estuarine areas is not strongly related to soil nutrients or organic matter; nor does any single soil parameter (that they measured) account for more than 11 percent of the observed biomass variability. The interaction of the available nutrients with plant growth and survival is quite complex on successional spoil deposits. Birds may significantly increase the available nutrients on heavily used spoil deposits (Chaney et al. 1978).

Many nutrients are adsorbed so tightly to small sand and clay particles that they are not available to plants. These bound nutrients can be measured along with the available nutrients; however, they do not aid in plant growth until they are released by chemical changes, such as pH, which affect solubilization, adsorption, complexation, ion exchange and redox potential in the soil (Mang et al. 1978).

Cover. Cover is used in the model to represent the physical presence of habitat for animals and factors tending to reduce erosion. As plant cover increases, animal usage generally increases and soil solids are much less susceptible to erosion by wind or waves. Plant cover includes cover by litter from the plants as well as root and vegetative cover.



Litter. Litter is composed of dead plant pieces from the vegetation growing on the spoil deposit. It combines with the living vegetation to protect the soil solids from erosion. It eventually breaks down to small particles which join the soil organic matter or are eroded from the spoil system.

Mainland connection. This attribute refers to a connection between the spoil deposit and any large piece of land to which it is connected. The purpose of this attribute is to show the relationship between the subaerial spoil system and herbivores and carnivores which depend upon a physical connection between their source and the spoil in order for them to invade the spoil system. This attribute acts as a switch to allow herbivores and/or carnivores to get to the spoil system or to keep them from it.

#### Import/Export of Physical Attributes

Precipitation and runoff. Typical annual rates of precipitation and the balance between precipitation and evaporation vary considerably along the Texas coast. Hillaker and Jehn (1978) have summarized precipitation and evaporation data and computed soil moisture storage for the Texas coastal zone. The Texas Department of Water Resources maintains several coastal evaporation and precipitation measurement stations.

Precipitation provides the freshwater input that leaches the soil salts, soil toxics and available nutrients from the spoil. It also erodes the surface of the spoil thereby increasing the suspended solids and dissolved and suspended toxics in the neighboring aquatic systems. It provides the fresh water necessary for the establishment and growth of most of the plants on spoil deposits.

Runoff exports fresh water from precipitation to neighboring aquatic systems. The amount of precipitation which becomes runoff depends on topography, soil texture and soil moisture. The flow of runoff provides driving energy for erosion of soil solids or soil toxics.

Solids export. Solids export represents the erosion of soil solids from the spoil pile by precipitation-induced runoff and wave action. Parnell et al. (1978) suggest that "under most circumstances, fine particulate matter (very fine sand, silt, and clay) is washed off the emergent dome into the adjacent water."

Toxics export. Toxics export represents the export of soil toxics by runoff and wave action.

Nutrient import/export. Nutrients are imported via seawater inundation, bird and other animal droppings and other animal and plant detritus. They are exported via soil water and ground water migration in coarse-textured spoil where the water movement is most rapid. Mang et al. (1978) determined that manganese, iron, total phosphorus, nitrogen and calcium (all plant nutrients) had high to intermediate probabilities of migrating into the ground water system, and therefore out of the root zone of most plants.

Spray. Spray is generated in the surf zone, in the open gulf and in the larger bays by breaking or blowing waves. Although the source is seawater, the chemical composition is highly modified by surface phenomena and other processes. The smaller particles of spray may move many kilometers from their source as observed in the Rio Grande valley by Fanning and Lyles (1964). For these reasons, spray may be a significant source of salts for spoil deposits relatively near a spray source.

Saltwater inundation. Saltwater inundation during storms may increase soil salts and soil toxics on spoil deposits. The areal extent will depend upon the topography and elevation of the spoil.

Wind erosion. On relatively high sandy spoil deposits in the drier southern portions of the Texas coast, the wind may cause considerable export of sand to neighboring systems. Increases in cover and soil water lessen this export.

Organic matter export. Soil organic matter is exported to neighboring systems primarily via runoff. It is affected by the same mechanisms as soil toxics and soil solids. The amount of export is not well documented at this time.

#### Biotic Attributes

The spoil model is intended to represent the early and middle stages of spoil succession, and not the climax stage, which may be any number of other ecosystems. Some spoil stays in a sub-climax stage due to various physical and chemical factors such as low elevation and frequent seawater inundation etc. The biota of the sub-climax stages of spoil deposits are quite variable, depending upon the physical and chemical nature of the spoil. Some of the most prominent organisms found on spoil deposits along the Texas coast are birds. The amount of plant cover is a primary factor in determining their use of a given spoil deposit.

Plant colonization and succession may be rapid on new deposits of spoil. For simplicity the model shows only the major plant types and their major relationships to the system, and not the successional features. The user is directed to the major works of the U.S Army Engineer Waterways Experiment

Station - Dredge Material Research Program and other sources cited in the following sections for details concerning plant succession on dredge spoil.

Seeds and propagules. Plant seeds and vegetative propagules (plant parts that are capable of growing into entire plants) from outside sources provide inputs to the salt-tolerant plants, the nonsalt-tolerant plants and the phreatophytes. Plant seeds and propagules are separated from the plants in the model in order to show the action of outside forces on their import and export. Those that do not germinate or grow may provide additional organic matter to the spoil deposits.

Salt-tolerant plants. Salt-tolerant plants are those species that can survive in habitats with relatively high soil salinity and sometimes high salt spray conditions. The most prominent salt-tolerant plant is smooth cordgrass (Spartina alterniflora). It has been studied extensively for use in stabilizing the shoreline of spoil deposits since it grows both in and out of the water. Other salt-tolerant, and therefore pioneer plants, are the morning-glories and glassworts. These plants are capable of colonizing newly deposited spoil since they can tolerate relatively high soil salinities. They help to stabilize the spoil thereby reducing erosion during the early successional stages of the spoil deposit. Landin (1978) and Coastal Zone Resources Division of Ocean Data Systems (1978) thoroughly cover the subject of plant species growing on spoil throughout the United States.

Nonsalt-tolerant plants. This compartment represents all of the plants that do not specifically tolerate high soil salinity (for examples, see Landin, 1978). These plants colonize the spoil after the soil salinity reaches the level of their tolerance. They are basically upland plants or in some cases, fresh marsh plants. They stabilize the majority of the subaerial

spoil deposit when conditions are appropriate for their establishment. These plants are the primary cover plants that provide habitat for many nesting birds. Many of the Dredge Material Research Program reports contain information concerning these plants. Chaney et al. (1978) contains an excellent discussion of the plant species and succession on older (25 years) dredge spoil islands along the Texas coast.

Phreatophytes. Phreatophytes are plants that have very deep root systems which extend down into the ground water zone. They also transpire large amounts of the water extracted via their roots. For these reasons, they are able to survive in apparently xeric habitats (low surface and soil water content) as long as sufficient fresh ground water is within reach of their roots. Along the Texas coast the most prominent phreatophytes found on spoil deposits are the salt cedar (Tamarix gallica) and mesquite (Prosopis glandulosa). Lee et al. (1976) studied several species of phreatophytes and their use in dewatering spoil deposits.

Colonial seabirds. These are the birds that generally nest on somewhat bare, undiked spoil islands along the Texas coast. Chaney et al. (1978) identified 25 species of colonial seabirds and wading birds nesting on spoil islands along the Texas coast during 1976-1977. They found that, on a yearly basis, approximately 60 percent of all the nesting pairs of these birds used dredge spoil material. Schreiber and Schreiber (1978) found that about 50 percent of the colonial seabirds and wading birds along the Florida Gulf Coast used dredge spoil islands for nesting sites.

Different species prefer different types of spoil for nesting. According to Chaney et al. (1978) most species of tern and the black skimmer prefer barren areas; Forester's terns prefer low forbs or drift accumulations; brown

pelicans and laughing gulls prefer dense forbs; and olivaceous cormorants prefer trees or shrubs for nesting areas. These preferences may differ slightly from one area to another.

Wading birds. The wading birds are dominated on the Texas coast by the large herons and egrets. However, several other species including storks, ibises and spoonbills also use spoil islands for nesting (Chaney et al. 1978). Most of these species nest in trees or low shrubs on relatively old spoil islands although Louisiana herons, reddish egrets, white-faced ibis and some great blue herons may nest in areas of dense forbs. This forb community is usually dominated by sea oxeye (Borrichia frutescens) (Chaney et al. 1978). Both the wading and colonial seabirds may be significant importers of nutrients to the spoil islands via their droppings (Chaney et al. 1978).

Herbivores. The role of herbivores in the energy flow of the spoil system is unclear. Certainly some spoil deposits with connections or close proximity to the mainland contain rodents and rabbits which eat the vegetation. Insects also play a role in the consumption of the vegetation on spoil deposits. During some spoil vegetation studies, geese and muskrats have caused a problem by eating the young Spartina alterniflora shoots (Garbisch et al. 1975).

Top carnivores. Large carnivores such as the coyote (Canis latrans) and the raccoon (Procyon lotor) may prey upon birds and their eggs on some spoil deposits. However, they do not usually reside on the early and middle successional stages of spoil deposits. Predation upon the large concentrations of nesting birds on spoil islands is controlled by the presence of absence of a mainland connection.

Raptors may utilize the spoil islands for resting places during migrations. They may also prey upon the colonial seabirds found on these islands. The extent that this occurs is not clear from the literature.

#### Import/Export of Biotic Attributes

Bird migration. The birds move in and out of the subaerial spoil system quite freely. Many nest on the spoil islands thereby bringing nutrients from their feeding areas to the spoil deposits. Some birds use spoil deposits as resting places or roosts. Others, including land birds, may use the system during their spring or fall migrations. Some of the small seed-eating birds may stop briefly to feed on vegetated spoil islands. Chaney et al. (1978) and Coastal Resources Division of Ocean Data Systems (1978) cover the subject of bird usage of spoil quite well.

Herbivore migration. Except for insects, herbivores seldom live on the early stages of spoil deposits. This may be due to the lack of good burrowing substrate or other unknown factors. They primarily feed on the emergent spoil vegetation and live in other systems. They are primarily found on dredge spoil that is connected to land in some way. This is shown in the model by the mainland connection.

In the Chesapeake Bay area, Garbisch et al. (1975) found that geese and muskrats may consume significant amounts of salt marsh vegetation growing on dredge spoil. The geese were obvious migrants; however, the muskrats may live in some older spoil areas.

Carnivore migration. Large carnivores such as the coyote and small ones such as birds of prey seldom stay on spoil deposits for any significant time. They may hunt for herbivores and birds in the area but generally live elsewhere. The presence of the non-flying carnivores on spoil deposits is

controlled by the mainland connection. They are seldom found on spoil deposits that are not connected to the mainland in some way.

#### Critical System Components

Availability of seeds and plant propagules, soil salts content, soil water and elevation are the most critical components for the establishment of vegetation on newly deposited dredge spoil. The stabilization of the shoreline is dependent to a large extent upon the amount of wave energy causing erosion. Plant cover in varying amounts is critical for use of the spoil by seabirds and wading birds. The presence of a mainland connection is critical to the availability of the spoil for bird nesting. Birds will generally not use spoil that is connected to the mainland since predators may use the connection to gain access to them.

#### SWAMP

##### Introduction

Swamp areas occur in Texas on the mainland in the middle and upper portions of the coast (Brown et al. 1972-77). Very few swamps occur along the drier lower coast, south of Corpus Christi Bay. Over 90 percent of this habitat type in the Texas coastal zone is found in the eastern third of the state. In Texas, swamp is usually found in areas that are not inundated by salt water, but have a high water table and are either constantly submerged or are at least flooded by fresh water (from river flooding or high rainfall) most of the time.

Much of the swamp system along the upper and middle Texas coast occurs as part of river floodplains. However, for the purpose of this report, swamp is differentiated from floodplain forest by the extended period of flooding and the presence of aquatic species of plants and animals.



Some of these areas of swamp may be occasionally flooded by salt water during extreme storms, but in general, they are not exposed to significant inundation by salt water. There have been few studies specifically aimed at the swamp system in Texas since it is relatively fragmented and occupies less than 100 square miles in the coastal areas of the state (Brown et al. 1972-77). Figure 50 is the conceptual model of the swamp habitat.

### Energy Sources

Sunlight. Solar energy input provides the major source of energy used by the vascular plant based food web of the swamp ecosystem.

Upland drainage. Drainage from streams and overland sources provides a major source of fresh water to this system. This attribute directly affects the water flow and water level which control the flow of nutrients, toxics and organic matter in the swamp ecosystem.

River flooding. In many instances, river flooding is the primary source of fresh water for the swamp system. This is especially true of the swamp areas of the middle coast where precipitation supplies only a small portion of the yearly fresh water input. This attribute contributes much of the energy for water flow and water level in many of the Texas swamp areas.

Precipitation. Direct input of water to the swamp via precipitation may be a significant source of energy, especially in the eastern portions of the lower Texas coast where the precipitation may exceed 50 inches annually. This may allow swamp to occur in low lying areas that are not regularly flooded by upland drainage or river flooding.

Subsidence. Portions of the middle and upper Texas coastal plain have subsided as much as several meters (Brown et al. 1972-77). This subsidence has been caused by pumping of underground water, oil and gas reservoirs.

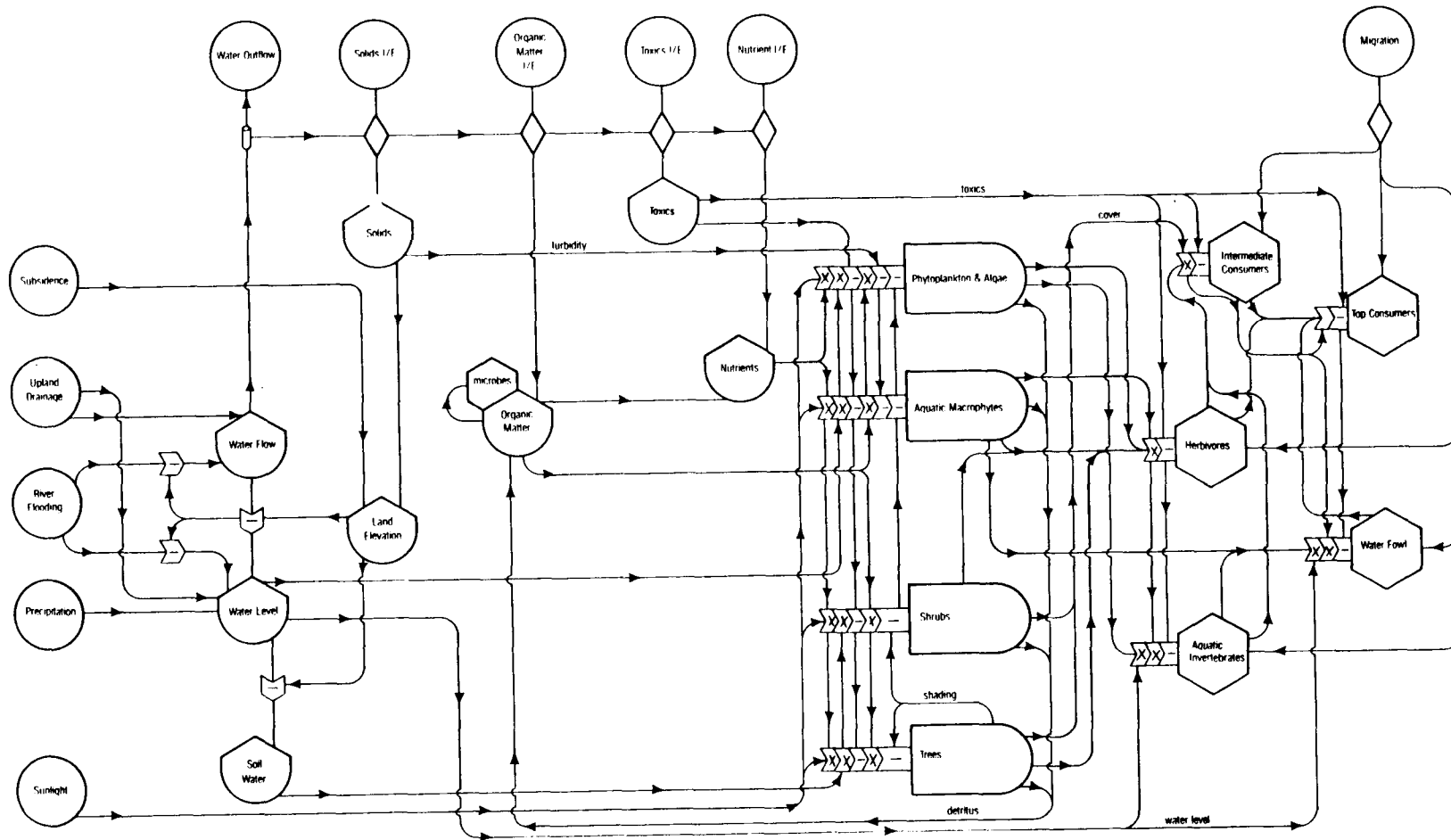

FIGURE 50. Swamp habitat.

Subsidence has a direct effect on the land elevation and thereby the water level of the swamp habitat. Subsidence tends to increase the occurrence of swamp by increasing the period of water inundation.

#### Physical Attributes

Water flow. Water flow in the swamp is used to represent the physical flow of water derived from upland drainage and river flooding. The water flow is analogous to currents in deeper water systems. The major direction of the water flow in the swamp is "in" from upland drainage and river flooding and "out" when there is excess water in the system. The water flow drives the import and export of physical and biotic attributes.

Water level. This attribute is primarily controlled by water flow. The water level within a swamp system may vary from over one meter in pond areas during high water periods to dry during severe droughts. Most of the swamps in the upper and middle Texas coast have an adequate amount of fresh water covering them during most of the year. This may vary only a few centimeters with normal runoff, but may increase significantly during floods or periods of high rainfall. The depth of the water in the swamp is one of the most important factors controlling the abundance of aquatic organisms in this system. Seasonal flooding rather than continuous inundation by standing water appears to provide for optimum tree growth and survival in the swamp habitat (Conner and Day 1976). Diameter growth of hardwood species of trees increased from 50 to 100 percent during flood years in a Mississippi swamp (Broadfoot and Williston 1973).

Solids. The solids attribute is used to show the physical effects of particulate matter, such as the covering of the bottom fauna and turbidity in the water column as well as the mass or volume of sediment within a particular

area of the swamp. Suspended solids are introduced into the swamp waters primarily by import from adjacent systems via water flow. They may be removed from the water column via settling or they may be exported to adjacent ecosystems. In general, except during periods of extreme river flooding, swamps are sinks for solids.

This attribute also provides an input to land elevation which in turn affects the water level. Rapid sedimentation following river flooding may be particularly detrimental to organisms such as benthic micro-algae via settling on them.

Land elevation. This attribute represents the physical elevation of the land mass relative to sea level. It is increased by the import of solids and decreased by subsidence. It directly affects the amount of water flow and water level in the swamp. With sufficient sedimentation, swamps may become floodplain forests or upland forest habitats.

Soil water. This attribute is derived from water level and is used to show the amount of saturation of the soil. Soil water content is very important in determining the types and abundance of emergent plants that occur in the system. Increased soil water encourages increased growth of species such as cypress which need nearly constant inundation. Decreased soil water promotes the growth of more of the forest species. Since much of the swamp along the Texas coast is part of river floodplains, the amount of soil water is extremely important in determining the extent of the swamp habitat as opposed to floodplain forest. The soil water is extremely important in making the soil nutrients available to the plants, thereby greatly affecting their growth.

Nutrients. Nutrients are organic and inorganic materials required by the plants of the swamp for photosynthesis, in addition to light. Nitrogen and phosphorus are the major nutrients associated with primary production in the swamp, although many additional nutrients and trace elements are also needed. A small portion of the nutrients used in the swamp ecosystem comes from either upland drainage or river flooding. The majority of the nutrients are derived from the soil and air and are recycled through the sediments via reduction and bacterial action. Determining the limiting nutrient(s) in swamp systems is very difficult due to the complexity of the chemistry of the system which is highly affected by local physical, hydrological and geological conditions (Day et al. 1979). Swamps with little water flow tend to have anerobic sediments and are high in dissolved organic nitrogen and phosphorus but low in nitrates. When oxygen levels are high (winter or high flow periods) phosphorus may be removed from the water by the sediments by the redox-related reversible uptake-release phenomenon (Day et al. 1979).

Organic matter. "Microbes" are partially combined with the symbol representing organic matter in the water and sediments since they are an integral part of the cycling of energy via decomposition. The amount of organic matter produced in swamps is generally less than marsh habitats but is still high due to the high primary productivity of the trees and other vegetation. The net primary production of Texas swamps may be similar to those of Louisiana which averaged an estimated 1,140 g dry wt/m<sup>2</sup>/yr (Connor and Day 1976). Much of the production is accumulated in the trunks, branches and leaves of the trees. Some is incorporated into the sediments but much of the leaf litter in constantly inundated swamps tends to form peat in the reducing environment.

The benthic infauna ingest the organic matter from the sediments or the surface of the sediments as do some of the herbivores and detritivores. This is an important food source for many of the aquatic species which inhabit swamps.

Toxics. Toxic materials which could be introduced into the swamp system include heavy metals, pesticides, industrial organic chemicals, well drilling fluids, crude oil and petrochemicals. Many toxic materials are readily adsorbed on fine particles. They are then quickly incorporated into the sediments. Some of these toxics may reach higher levels in the food chain via bioaccumulation and consumption by higher order consumers. Toxics enter the swamp system primarily via water from upland drainage and river flooding; however, storm tides from hurricanes may push toxics into the system from the bays. The swamp system would only be expected to have elevated toxic concentrations if toxics were introduced by local spills and washed in by upland drainage.

#### Import/Export of Physical Attributes

Water outflow. This attribute is used to show the flow of water from the swamp system to adjacent systems. It is driven by high water flow within the system which is caused by river flooding, upland drainage and precipitation. Under normal conditions, there may be very little water outflow from many of the swamps of Texas. Many of the swamp systems which are associated with river floodplains will have high water flows during periods of river flooding.

Solids Import/Export. The swamp system receives most of its solids input from neighboring ecosystems via inundation by upland drainage and river flooding containing high suspended solids concentrations. Since the

succession is generally from swamp to terrestrial forest systems, little export of solids is expected to occur under normal conditions.

Nutrients Import/Export. Import from the neighboring ecosystems, river flooding, upland drainage, nitrogen fixing by bacteria and blue-green algae and recycling of sediment nutrients provide the majority of the nutrients to the swamp system. Soil derived nutrients are the major source of nutrients to the swamps. Some of the nutrient load brought to the swamp system by upland drainage via streams and river flooding actually originates as waste discharges and agricultural runoff in some areas. Swamps export nitrogen and phosphorus during periods of river flooding (Day et al. 1977). These may be important to downstream fresh water and estuarine systems.

Toxics Import/Export. Toxics such as agricultural pesticides or industrial wastes may be imported along with the fresh water runoff into the swamp. Some are introduced into the swamp system via spills or treatment plant outfalls. Toxics from spills in the adjacent ecosystems may find their way into the swamp system during storm conditions. Swamps that contain toxic materials may export these during conditions of river flooding.

Organic matter Import/Export. Most of the organic matter that enters the swamp system via fresh water from upland drainage is either dissolved or suspended particles of vegetation and animal matter. Swamps produce large amounts of their own organic matter but much of it is accumulated in the standing vegetation such as trees. In poorly drained swamp systems, the average annual export of organic matter is very small. The majority of organic matter export occurs during extreme river flooding in most Texas swamp systems. Some is exported during storms such as hurricanes (Day et al. 1977).

Estimates have been suggested that only about 10 percent of the litterfall is exported from swamps (Butler 1975).

#### Biotic Attributes

Trees. The primary tree species which indicates Texas swamp habitat is cypress (Taxodium distichum). Several other species of trees such as tupelo, swamp cottonwood, water oak, sweetgum and black willow are also found in some swamp habitats. The trees represent the primary type of vegetation in most swamp habitats since the varying water level and periodic flooding tend to discourage other types of vegetation from becoming established. Most of the primary production of the swamp is provided by the trees.

Shrubs. Some swamps have water regimes and conditions suitable for the growth of several species of shrubs. The most common species are swamp privet, swamp bay, Virginia willow, elderberry, wax myrtle, American snowbell, bigleaf snowbell and buttonbush (Conner 1975). These species add to the primary productivity and provide habitats for many species of animals which inhabit the swamp. All of these species are adapted to living in the low light conditions which occur under the nearly closed canopy of trees in many hardwood swamps.

Aquatic macrophytes. Aquatic macrophytes of various types may be found in the open areas of some swamps which are not subject to strong water flow during river flooding. These plants occur on the edges of lakes within swamps or may completely cover shallow depressions, within swamps, which for one reason or another do not contain a tree cover. Some of the common aquatic macrophytes found in Texas swamps are alligatorweed, coontail, common rush, bulltongue, duckweed, pennywort and spider lily.



Phytoplankton and algae. The phytoplankton and algae are of lesser importance; however, they may supply a relatively larger amount of primary productivity during the winter months when the emergent plant growth slows. Since the rate of phytoplankton photosynthesis depends on light penetration and nutrient availability, the primary productivity of the phytoplankton and algae in "closed canopy" swamps is expected to be quite low due to the lack of light. The high availability of nutrients in the water of most swamps and the high primary productivity of phytoplankton and algae in open water areas within swamps (Day et al. 1977) tends to show that light may be a limiting factor with respect to phytoplankton and algae growth in some swamp habitats. In more open swamps which are inundated most of the time, the availability of carbon may be the limiting factor (Day et al. 1977).

Herbivores. This group comprises one of the largest consumer groups (in terms of total numbers of individuals) in the swamp system. The aquatic animals in this group consist primarily of zooplankton and small invertebrates. The crayfish may be the most important detritivore in some swamp systems. It may contribute more to the breakdown of leaf litter than the numerous amphipods (Thomas 1975). Some of the swamps in Texas have outlets that eventually lead to estuarine systems. Some of the estuarine dependent organisms may move into the swamp system to feed on the benthic algae, phytoplankton or organic matter, and to escape larger predators in the shallow water. The young of some of the larger estuarine organisms may spend some of their early life stages in swamp systems which are aquatically connected to brackish or salt marsh systems. The young of the blue crab, Atlantic croaker, sea catfish, gulf menhaden, bay anchovy, and striped mullet have all been found in the fresh waters of swamps on the Gulf Coast.

Inland swamps contain fresh water species of organisms from the same major classifications as those that inhabit the river and canal, and lake and reservoir systems.

Waterfowl and herbivorous mammals are also very prominent herbivores in the swamp system. The waterfowl are discussed separately in a later section. Muskrats and nutria are common herbivores found in swamp systems with marsh type emergent vegetation. They may consume large amounts of these plants. The swamp is one, but not the prime, habitat for these important furbearers.

Aquatic invertebrates. This attribute is used to show both the carnivorous zooplankton and benthic invertebrates of the swamps of Texas. Some of the herbivores and detritivores are also part of this group. The zooplankton found in swamp systems are generally imported from the adjacent freshwater aquatic systems. Inland closed swamps may also contain some different species from these same major classifications of organisms. Polychaetes, nematodes, ostracods, and copepods can be found in the swamp system. These organisms feed primarily on the smaller aquatic herbivores and detritivores and comprise the second level of the detritus based food chain for which the fresh marsh provides the primary production. Many of the higher trophic level organisms depend, at least partially, on the aquatic invertebrates for their food. As stated in the herbivore section, the crayfish is one of the most important aquatic invertebrates in the swamp system.

Intermediate consumers. This compartment is primarily concerned with the predatory organisms below the level of top consumer. Estuarine dependent aquatic species such as spotted seatrout and sand seatrout may be found in some swamp habitats with connections to the bays. Inland swamps with

sufficient water depth may contain a variety of freshwater species of fish. The species composition may vary greatly with the inundation period and water level.

Various wading birds such as egrets, bitterns, herons and ibises prey on the smaller organisms of the swamp. Some also nest in the trees of the swamp. The swamp supports amphibians in large numbers. Also, there are many reptile species which occur in the swamp in addition to terrestrial and other freshwater habitats. Mammals such as raccoons and mink are also intermediate consumers in this system.

Top consumers. The top consumers of the swamp systems are primarily the game fish of the river and canal or lake and reservoir systems, birds of prey, coyotes, red wolves, and alligators. Adults of estuarine aquatic species such as spotted seatrout and sand seatrout may visit the swamp system, when the water level permits, in search of prey. The top fresh water aquatic consumers in inland swamps are the game fish such as largemouth bass, catfish and gar.

Birds of prey (hawks, owls, osprey, eagles) may nest in trees near the swamp and feed on the numerous smaller animals of the marsh. The coyote and red wolf feed on the various intermediate consumers and herbivores. The alligator will eat practically any and all of the other swamp inhabitants if given the chance.

Waterfowl. The waterfowl are discussed separately because they are so important in the swamp system. Many species of waterfowl feed on micro-organisms or vegetation in the swamp system during the winter months. Many of them rest on the shore adjacent to the swamp where their droppings may be washed back into the system to provide nutrient input. Most of the waterfowl

found in the swamp systems in Texas are the winter migrants. The swamp system is one of the preferred habitats for many species of the millions of ducks which winter along the entire Texas coast. Species such as the wood duck, mallard and pintail are especially fond of swamps. The wood duck nests in hollow trees in swamps.

#### Import/Export of Biotic Attributes

Phytoplankton and algae. The freshwater phytoplankton are of little importance, due to their relatively small biomass, when compared to the other swamp vegetation. They may provide a relatively larger portion of the production in the open water pools which occur within the swamp system.

Migration. Migration with respect to the swamp system represents the movement into and out of the swamp area from other systems as opposed to daily vertical migration of plankton or seasonal waterfowl migrations. This between-system migration is cued primarily by water flow and water level. The planktonic organisms are carried into and out of the swamp system during inundation by river flooding or upland drainage. More motile organisms move in and out of the system when the conditions are favorable to them.

Aquatic members of the herbivore and detritivore group may migrate between the bay systems and the swamp. Smaller juveniles of some intermediate and top consumers can be found during certain times of the year in the swamps.

Some of the aquatic intermediate consumers move between other freshwater habitats or the bay systems and the swamp.

The freshwater gamefish, which comprise the more important aquatic top consumers, do not migrate in Texas. Some of the estuarine species which may occasionally visit the swamp migrate at various times of the year as do the intermediate consumers. Their migrations depend upon their spawning periods

and various physical factors. No two species migrate at exactly the same time.

### Critical System Components

The most critical components of the swamp system are river flooding, upland drainage and precipitation. These freshwater inputs supply the swamp with nutrients, organic matter and toxics. This freshwater input keeps the soil water levels high and allows the emergent plants to produce large amounts of organic matter upon which the important detritus food chain is based. The emergent plants, primarily the trees, are also a critical component since they are the primary source of most of the carbon produced in the swamp system. Changes in the water regime will quickly result in changes in the species composition and productivity of the swamp system.

## TIDAL STREAM REACH

### Introduction

The lower sections of streams and rivers which flow into estuarine or marine waters and are influenced by the chemistry and circulation of these waters are called tidal stream reaches. The effective upstream and downstream boundaries of this habitat vary with stream flow rate. For purposes of mapping and water quality segment designation, the upstream boundary is usually taken to be the greatest upstream penetration of salt water during low flow. The downstream boundary is usually taken to be the shoreline of the estuarine or marine system.

This system is the interface between fresh water systems, which tend to flow only in one direction, and estuarine systems which have more complex flow patterns influenced by tides and winds. Therefore, it is not surprising that water flow is complex. Tidal stream reaches typically exhibit vertical

stratification, with lighter fresher water flowing out at the surface of the downstream boundary and more saline water flowing in at depth. This stratification is one of the dominant factors in the tidal stream reach habitat. The habitat model (Figure 51) is quite complex, with chemical and physical parameters shown separately for the upper and lower levels. This has been done in order to show stratification and its consequences correctly.

It should be recognized that during periods of high river flow, most tidal stream reaches are entirely fresh and behave like rivers. During periods of very low flow, they may become well mixed saline systems similar to estuarine systems. However, most tidal stream reaches on the Texas coast exhibit the stratification discussed here during much of the year.

Tidal stream reaches which enter estuarine systems typically flow through deltaic systems and exchange water with fresh, brackish and salt marshes in complex patterns.

#### Energy Inputs

Stream flow. At the inland boundary of the system, stream flow brings in kinetic energy to the upper layer. This stream flow also brings in significant amounts of dissolved oxygen, nutrients, organic matter, suspended solids and toxics.

Tidal energy. Another source of kinetic energy to the system is the current pattern of the downstream system, simplified here as tidal energy. The amount of tidal energy input to tidal stream reach systems is quite variable. Rivers such as the Brazos, emptying directly into the Gulf of Mexico, respond to a daily tidal range of one to two feet, while back in the bays, the astronomical tidal range may be as little as an inch or so.

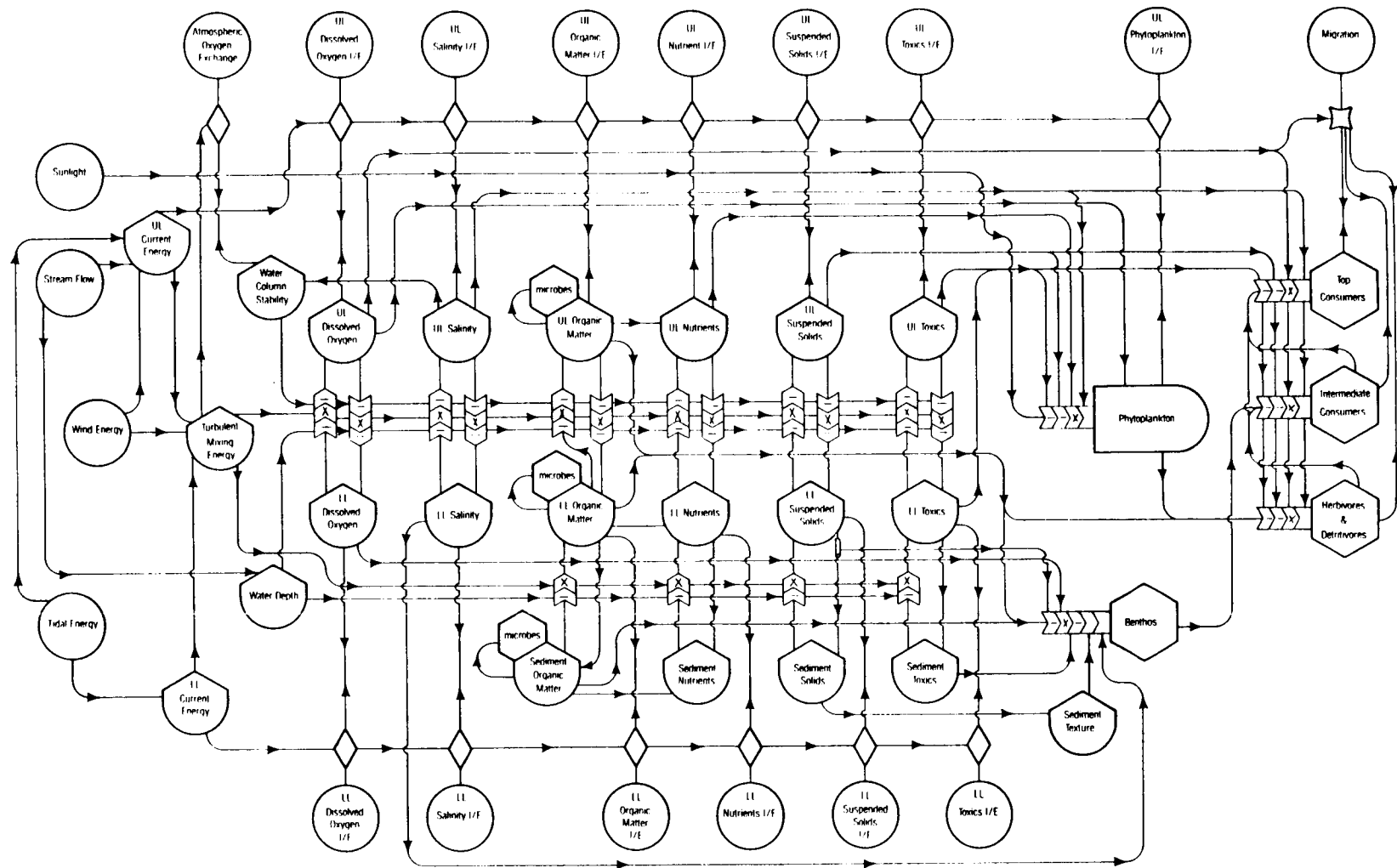

FIGURE 51. Tidal stream reach habitat.

Wind energy. Wind energy enters the system by interacting with the surface and creating waves. Since tidal stream reaches are long and narrow, the wind direction determines how much energy is introduced by a given wind speed. Wind parallel to the length of the reach introduces much more energy than wind across the reach.

Sunlight. This represents input of light energy to the phytoplankton. In general only the upper layer receives significant amounts of sunlight.

#### Material Import/Export

In order to avoid needless repetition, upper layer and lower layer import/export relationships for physical attributes will be discussed together. Note that in the model, the abbreviation I/E is used to designate Import/Export pathways, UL designates Upper Layer and LL designates Lower Layer.

Dissolved oxygen import/export. Generally the inflowing waters of both the fresh and estuarine systems contain substantial oxygen. Due to the higher solubility of oxygen in fresh water, the upper level inputs will generally have a higher oxygen content than the estuarine inputs. Exceptions might occur where the river receives a substantial industrial or municipal sewage load. Oxygen export can also be high due to the high phytoplankton photosynthesis.

Atmospheric oxygen exchange. Exchange of oxygen between the surface waters and the air is controlled by the degree of turbulent mixing at the surface and the degree of saturation of the surface waters. Oxygen can move either into or out of the water.

Salinity import/export. The major source of salinity is the lower layer waters inflowing from the estuarine system side. Some salts are also brought



in by the river input or by discharges. Brine discharges from oilfield operations were once a major factor in some Texas tidal stream reaches (Johnson, 1974); however such discharges are supposedly no longer permitted. Since salinity is conserved in the system, all imported salts are exported in the outflow of the upper layer.

Organic matter import/export. Organic matter input from upstream is a major energy source for this system. The amount of organic matter which is exported at the downstream interface depends on current flow rates. During low flows there may be substantial trapping of organic matter within the system, but floods can flush out the accumulated sediments to downstream systems. Exchanges of the surface layer with adjacent marshes can be quite complex.

Nutrient import/export. Freshwater inflows, and in some cases, municipal and industrial discharges, bring in substantial amounts of nutrients to this system, which in turn delivers nutrients downstream to estuarine or marine systems. As discussed above, the amount of nutrient trapping will depend on current flow rates. Quantitative work on nutrient inflows to the bay systems has been summarized by the Texas Department of Water Resources in numerous publications (1980a,b; 1981a,b).

Suspended solids import/export. Input of suspended solids comes largely from inflowing freshwater streams, which are typically quite turbid. Data on suspended solids concentrations in rivers are given in Dougherty (1979). During low flows, the tidal stream reach tends to trap sediments, but these may be flushed out during floods.

Toxics import/export. Input of toxic materials to this system is typically associated with discharges and stream inflow. The most common

toxics are pesticides and herbicides. Since these compounds tend to become associated with particles, export depends on the same factors which control organic matter and suspended solids export.

### Physical Attributes

The most striking feature of the model is the separation of physical attributes into upper and lower layer compartments. Although tidal stream reaches do not always exhibit this stratification, it is a major feature most of the time and dominates the behavior of this habitat. The following discussion describes each physical attribute and its behavior in upper and lower layers.

Current energy. The following discussion of current patterns is generalized. It should not be assumed to apply to all tidal stream reaches regardless of depth, channel configurations, and other physical factors.

During low to moderate freshwater inflow, the average currents show inflow of more saline water along the bottom with outflow of fresher water at the surface. However, superimposed on this average flow, there may be short term tidal or wind driven currents in either direction.

During high river flows the current energy input is large enough to sweep the saline lower layer out of the system entirely. During these short-lived flood events the tidal stream reach behaves like an extension of the river.

Extremely low flow permits turbulent mixing energy to completely mix the water column. In this event the system tends to resemble an open bay or bay margin habitat.

Turbulent mixing energy. This energy is derived from input of wind energy and the interaction of upper and lower layer currents with each other and with the bottom and sides of the channel. Turbulent mixing transports

materials between upper and lower layers, and stirs up the bottom sediments. It is thus vital in the functioning of the tidal stream reach system. In some systems which are used as shipping channels, such as the Arroyo Colorado, a major source of turbulent energy is boat traffic (Broden and Oppenheimer 1977).

Water column stability. This abstract quality represents the resistance of the two water layers to being mixed. Stability is due to the difference in density between the upper and lower water layers, which is in turn due mainly to the difference in salinity of these layers. Differences in temperature also contribute to water column stability but temperature differences are usually much smaller than salinity difference. For this reason, temperature is not shown explicitly in the model.

Since turbulent mixing energy continually acts to reduce the difference in salinity between upper and lower layers, a continuous input of both fresh water and more saline water is required to maintain water column stability.

Water depth. For a given level of turbulent mixing energy, the shallowest systems receive the greatest mixing of upper and lower layers. Bottom sediments are more likely to be stirred up in shallow systems. Many of the smaller coastal streams with small drainage areas are so shallow where they meet the estuary that they do not exhibit stratification. Some of the larger streams have been modified by dredging. The resulting greater water depth increases stratification.

Dissolved oxygen. This is the most important water quality factor in determining the utilization of this habitat by organisms. Tidal stream reaches frequently show extreme differences in dissolved oxygen between upper and lower layers.

In the lower water layer, oxygen is consumed by decomposition of sediment and suspended organic matter and by respiration of benthic organisms. Dissolved oxygen can only reach the lower layer by turbulent mixing from above or in inflowing water. During periods of low turbulent mixing energy or high water column stability dissolved oxygen levels can approach zero.

Dissolved oxygen in the upper water layer is consumed by decomposition of organic matter, but is also produced by photosynthesis. Under favorable conditions for phytoplankton growth, dissolved oxygen concentrations above saturation can be observed. Exchange with atmospheric oxygen tends to keep the concentration near saturation.

Example water quality surveys showing these effects in various Texas tidal stream reaches are: the Arroyo Colorado, Bryan (1971), Twidwell (1978); Neches River, Harrel et al. (1976); and Texas coast in general, Lind and Ratzlaff, (1979). Johnson (1974) describes water quality in Cedar Bayou (Galveston Bay), a tidal stream reach heavily disturbed by man's activities. Extreme variations in dissolved oxygen due to phytoplankton blooms have been found in Dickinson Bayou (Warshaw 1976.) Older water quality surveys by the Texas Water Quality Board may not show stratification because frequently only surface samples were taken.

Evaluations of water quality problems in tidal stream reach segments from the 1980 inventory of water quality in the state (TDWR 1980c) are summarized in Table 4. Note that low dissolved oxygen is considered to present a potential problem in 5 of 23 segments.

Salinity. Salinity is important as the main factor in water column stability and in control of the distribution of organisms. Tidal stream reaches show the greatest salinity variation of all estuarine habitats. A

TABLE 4. Water quality of tidal stream reach segments in study area

Basin	Segment	Name	Status	Remarks
<b>Galveston Bay</b>				
	801	Trinity River tidal	N	
	901	Cedar Bayou tidal	N	fn
	1001	San Jacinto R. tidal	N	fhn
	1005	Houston Ship Channel	B	fhnop
	1006	Houston Ship Channel	B	fhnop
	1007	Houston Ship Channel	B	fhnop
	1101	Clear Creek tidal	B	fmnop
	1103	Dickenson Bayou tidal	S	no
	1105	Bastrop Bayou tidal	N	fn
	1107	Chocolate Bayou tidal	N	fnm
	1109	Oyster Creek tidal	B	fn
<b>Brazos River</b>				
	1201	Brazos tidal	N	fnm
<b>Brazos _ Colorado Basin</b>				
	1301	San Bernard R. tidal	N	f
	1304	Caney Creek tidal	N	fn
<b>Colorado River</b>				
	1401	Colorado River tidal	N	
<b>Matagorda Bay</b>				
	1501	Tres Palacios Ck. tidal	N	fn
	1601	Lavaca River tidal	N	f

Status: N = presently fishable swimable  
 S = fishable/swimable by 1983  
 B = not fishable swimable by 1983

Remarks (present or potential water quality problems):  
 f = fecal or total coliform numbers high  
 h = above average heavy metals  
 n = high nutrient levels and/or eutrophication  
 o = dissolved oxygen below standard  
 p = above average pesticide or PCB levels  
 s = high dissolved solids, chlorides, sulfates, etc.

TABLE 4. (Continued) Water quality of tidal stream reach segments in study area

Basin	Segment	Name	Status	Remarks
San Antonio Bay	1801	Guadalupe tidal	N	fn
Copano - Aransas Basin	2001	Mission River tidal	S	
	2003	Aransas River tidal	N	n
Corpus Christi Bay	2101	Nueces River tidal	N	
Laguna Madre	2201	Arroyo Colorado tidal	S	fnmop
Rio Grande River	2301	Rio Grande tidal	S	fn

Status: N = presently fishable swimable  
 S = fishable/swimable by 1983  
 B = not fishable swimable by 1983

Remarks (present or potential water quality problems):  
 f = fecal or total coliform numbers high  
 h = above average heavy metals  
 n = high nutrient levels and/or eutrophication  
 o = dissolved oxygen below standard  
 p = above average pesticide or PCB levels  
 s = high dissolved solids, chlorides, sulfates, etc.

salinity contrast of 15 to 20 parts per thousand between surface and lower waters is not unusual. Because of rapid changes in freshwater inflow, the salinity at a given location can change from nearly marine to nearly fresh within a day. These rapid salinity changes place considerable stress on organisms of the system, especially the benthic organisms which are unable to flee unsuitable conditions.

Organic matter. This compartment represents both dissolved and particulate organic matter. Because of high input from stream flow and phytoplankton productivity, organic matter content of tidal stream reaches is expected to be fairly high. There is a tendency for organic matter particles to settle into the lower layer and then to the bottom. Bacteria and fungi are always found in close association with organic matter. The metabolism of these microbes consumes organic matter and oxygen, releasing inorganic nutrients.

Sediment organic matter. Both imported organic matter from upland systems and local phytoplankton productivity are sources for organic matter which settles to the bottom where it serves as a food source for benthic organisms. Decomposition of the organic matter releases nutrients and consumes dissolved oxygen from the overlying water.

Nutrients. High nutrient input rates generally produce nutrient levels in tidal stream reaches which are higher than in adjacent estuarine systems. The rapid growth of phytoplankton which this encourages causes wide swings of dissolved oxygen. High nutrient levels are considered a problem in 17 of the segments in Table 4.

Sediment nutrients. This represents nutrients adsorbed on particles and dissolved in interstitial water in the sediments. The decomposition of

organic matter continually releases soluble nutrients to the interstitial water. These nutrients are released slowly by diffusion or rapidly by turbulent mixing during floods or other disturbances.

Suspended solids. The level of suspended solids is quite variable, depending on inflow rates and turbulent mixing. Particles kept in suspension by the high turbulent energy of the river tend to settle out on reaching the slower currents of the tidal stream reach (during moderate to low flows). High levels of suspended solids reduce light energy reaching phytoplankton and high sedimentation rate can be a negative factor for benthic organisms.

Exposure to dissolved salts completely changes the physical behavior of the clay sized particles brought in by freshwater inflows. In fresh water, these particles have a surface electrical charge which keeps them separated, and because of their small size they settle very slowly. Exposure to dissolved salts reduces the surface charge and the clay sized particles readily form aggregates which have a much more rapid settling velocity (Ariathurai 1977).

Sediment solids. This represents the inorganic fraction of the sediments. As discussed above, during periods with low mixing energy, suspended solids tend to settle out in the tidal stream reach system. However, during high flow periods, the particles can be resuspended and swept out.

Sediment texture. This represents those physical properties of the sediment, such as grain size and bearing strength, which affect the benthic organisms.

Toxics. Toxic materials found in tidal stream reaches include pesticides, other toxic organics such as PCBs, and heavy metals. As shown in



Table 4, toxics are considered a possible problem in 8 tidal stream reach segments. There is little data on actual effects of present levels of toxics on tidal stream reach organisms. The complex behavior of different toxic materials is beyond the scope of this model.

Sediment toxics. Most toxic materials tend to be associated with particulate matter and thus end up in the sediment. Thus, sedimentation in the tidal stream reach tends to reduce the amount of toxics reaching estuarine or marine systems. This apparently occurs in the Arroyo Colorado where pesticide residues are much higher than in the adjoining Laguna Madre.

#### Biological Attributes

The following discussion draws on several biological surveys of tidal stream reach habitats. The areas studied were: Cedar Bayou (Galveston Bay) - Johnson (1979); Dickinson Bayou (Galveston Bay) - Warshaw (1976); Aransas River - Petrick (no date) - Renfro (1960), Copano Bay tributaries - Heffernan (1970); Nueces delta - Henningson et al. (1979); Rio Grande - Breuer (1970).

Phytoplankton. The phytoplankton found in this system include diatoms and bluegreen algae, both freshwater and estuarine species. Productivity may be high due to the high nutrient levels, as long as suspended solids are low enough to give adequate light penetration.

Benthos. This is a difficult environment for benthic organisms, due to periods of stratification with little or no oxygen in subsurface waters. Low numbers of individuals and species are not uncommon in benthic surveys. Benthic organisms may be restricted to the shallows along the banks and to man made substrates such as bridges and docks.

Herbivores and detritivores. Frequently abundant estuarine fish in this category include the gulf menhaden, *Brevoortia patronus*, and the mullet, *Mugil cephalus*. The ubiquitous estuarine zooplankter *Acartia tonsa* is common.

Intermediate consumers. Many consumers in estuarine systems are opportunistic and may consume detritus or plant material as well as smaller consumers. A variety of common estuarine fish such as the Atlantic croaker, *Micropogon undulatus*, the spot croaker, *Leiostomus xanthurus* and anchovie, *Anchoa mitchelli* fall in this category. Fish more commonly associated with fresh water, such as catfish and sunfish are also found in tidal stream reach areas. Invertebrates include estuarine species such as penaeid shrimp, and blue crabs and freshwater shrimp such as *Macrobrachium ohione*.

Top consumers. Typical top consumers in the tidal stream reach include the alligator gar, *Lepisosteus spatula* and sand trout, *Cynoscion nothus* and numerous fish-eating birds.

#### Import/Export of Biota

Phytoplankton import/export. Since this is a flow through system, freshwater phytoplankton are continuously brought in by stream drainage, while estuarine phytoplankton are brought in by exchange with estuarine systems. Due to the high nutrient level and consequent growth within the habitat, it is expected that there will generally be net export to the downstream systems.

Migration. In estuarine systems, tidal stream reaches may represent an important migration pathway for organisms trying to reach brackish and salt marshes. Salinity is probably the main environmental cue for this migration.

## UPPER SHOREFACE

### Energy Import/Export

Sunlight. Figure 52 represents the upper shoreface habitat. Solar energy input which is not used by the micro-algae for photosynthesis appears as heat. Turbidity due to suspended solids reduces light penetration and thus availability to the algae.

Wave energy. The energy in waves in the open ocean dissipates in the upper shoreface as the wave steepens and finally breaks. This energy is converted to turbulence and to current energy. The last of the energy is dissipated in the swash zone and may move sediment and macro-organic debris, such as Sargassum weed, towards or away from the beach. The angle the waves make with the shoreline as they approach determines the magnitude and direction of the longshore current. Rip currents perpendicular to the shoreline, also created. These tend to cause exchange of water between the upper shoreface and the nearshore gulf. A very complete treatment of these phenomena is given in the U.S. Army Corps of Engineers "Shore Protection Manual" (1977). Studies of longshore sediment transport in Texas include: Sealy and Ahr (1975), and Watson (1975).

Organic detritus import/export. Winds and currents tend to bring large amounts of organic material into the upper shoreface from the open sea. Typical organic matter includes Sargassum weed from the open gulf, trees and wood which has washed down rivers, sea grasses and salt marsh vegetation which have been flushed out of the bays, and a large variety of man-made discards. This debris is partially degraded by wave energy in the surf zone, then typically cast up on the beach. The amount of organic matter exported can be substantial, but the supply is irregular. Shelby (1963) measured from 127 to

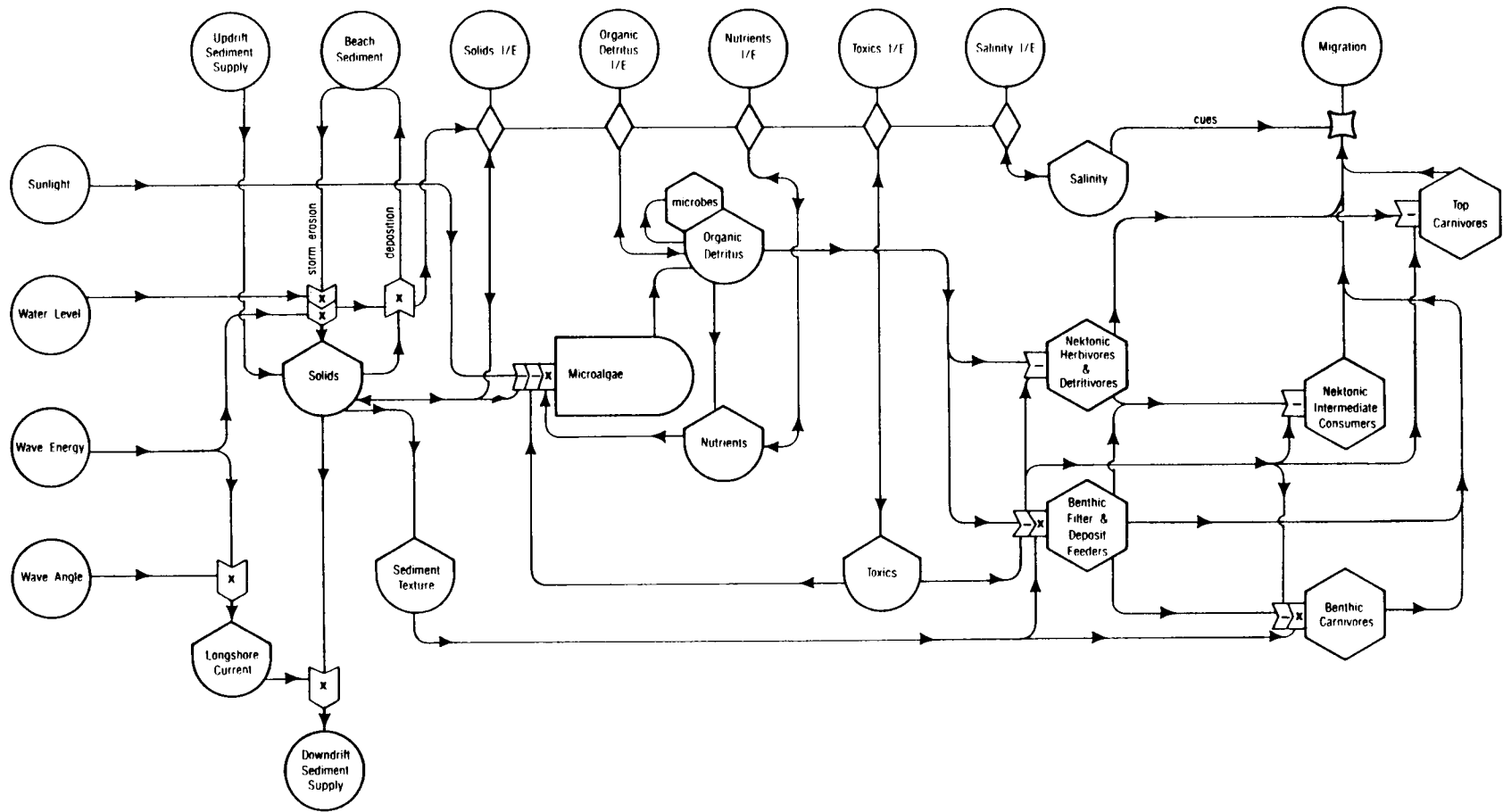

FIGURE 52. Upper shoreface habitat.

223 kg (dry weight) of Sargassum per linear foot of beach for selected portions of the Texas coast during the spring and early summer of 1962. This input constitutes an important source of organic matter for the base of the food web. The movement of macro-organic debris is essentially one way, to the beach. However, smaller suspended "detritus" particles may be both imported and exported. Since many of the organisms in the upper shoreface feed on detritus, this can be an important energy source.

### Physical Attributes

Longshore current. The predominant current in the upper shoreface is directed parallel to the shoreline. This is called the longshore current. Methods for predicting the magnitude of this current as a function of the angle of wave approach and the wave energy are given in the U.S. Army Corps of Engineers "Shore Protection Manual" (1977). Studies of longshore current generation in Texas include Watson (1975) and Sealy and Ahr (1975).

Solids. This attribute represents the physical effects of solid particles ranging from clay to sand size. The only biological effect shown is the blocking of light supply to micro-algae in the sediments, since the organisms of the upper shoreface have evolved in an environment with high suspended solid content.

Suspended solids settle out to form sediment solids. Particle sizes from clays through sand and up to large shell fragments exhibit a strong differential in settling rate which leaves the finest particles in suspension. This eventually leads to their removal by exchange with offshore systems (Riedl and McMahan, 1974). This compartment also represents the volume of solids (suspended and sediment) within a given segment of shoreline. The movement of sediment in the upper shoreface is very dynamic, with bar

structure changing from day to day. The outer limit of the upper shoreface system is the limit of the extensive disturbance of sediments by wave energy. Hallermeier (1977) derives such a depth limit as twice the height of the maximum waves expected for 12 hours per year.

Sediment texture. The influence of sediment texture on the biota is related not only to mean grain size but also to the amounts of both smaller and larger particles. Finer particles tend to block the circulation of water through the sands of the swash zone, thereby reducing the availability of oxygen to the infauna. Studies relating the distribution of different species with respect to texture include Matta (1977) and Cox (1976). Riedl and McMahan (1974) discuss texture and related factors extensively.

Organic detritus/microbes. This symbol is used to simplify the model by combining micro-organisms with the detritus with which they are closely associated. Bacteria are probably the most numerous of the microbes, but significant numbers of fungi, yeasts and protozoa are also included. Oppenheimer and Jannasch (1962) determined bacterial counts of 1.6 million cells per milliliter of water in the surf zone, and 0.9 million cells per ml in clear water just outside the surf zone off Padre Island. These counts were an order of magnitude less than the counts obtained in estuarine waters. This is possibly due to lower levels of organic matter in the surf zone.

Typical large organic debris includes sargassum weed, wood pieces up to tree size, vegetation fragments from various sources, and dead fish and other aquatic animals. This debris may be partially broken down by wave action before being cast up on the beach. However, it is difficult to estimate the average residence time or standing crop of this debris at any one time.

There appear to have been no detailed surveys of organic matter in water or sediment of the upper shoreface in Texas. Matta's (1977) study of a North Carolina beach found the organic matter content of the sediment to be quite variable over short distances and from month to month. Organic detritus enters the food chain in several ways. It is filtered from the water by benthic filter feeders, such as clams. It is also selectively browsed from sediments by benthic deposit feeders and detritivores such as striped mullet (Mugil cephalus). Suspended detritus in the water can be filtered out by the swash zone sediments as the water sinks into the sand (Riedl and McMahan 1974).

Nutrients. The concentration of nutrients in the upper shoreface is expected to be higher than that in the nearshore gulf due to the decomposition of imported organic matter (Pearse, Humm and Wharton 1942). However, this subject does not appear to have been addressed by direct measurement in any of the available literature.

Toxics. Tar and oil tend to be the major toxic materials that occasionally occur in the upper shoreface system on the Texas coast. The use of the Gulf Intracoastal Waterway by most of the barge traffic carrying other toxic materials tends to keep spills away from the upper shoreface and beach ecosystems. Most of the observations concerning the effects of oil and tar on the Texas coast have centered around its effects on the beach rather than the high energy upper shoreface system. Geyer (1978) outlines some of the research conducted at Texas A&M University on beach tar.

Salinity. Salinity in the upper shoreface is largely controlled by exchange of water with adjacent systems. McFarland (1963b) found considerable variability of salinity along Mustang Island. Longshore currents occasionally

brought in low-salinity water from the adjacent inlet-tidal delta system. The northeast coast of Texas would be expected to have lower average salinities due to the higher freshwater supply from precipitation and possibly the effects of the Mississippi River's discharge.

#### Import/Export of Physical Attributes

Water level. One of the factors controlling delivery of wave energy to the beach for erosion is water level. Representation of this on the upper shoreface model provides slight overlap with the beach system model. The water level affects primarily the storm erosion of the beach.

Wave angle. The angle of approach of waves is the controlling factor which determines the amount of wave energy which goes into the longshore current and the direction of flow. It is determined by the winds which originally generated the waves, and modified by refraction due to bottom topography in the nearshore gulf. Tanner (1974) gives a computer program to predict wave refraction and its effect on longshore currents and sediment transport. Watson (1975) describes measurement of littoral drift as a function of wave energy and approach angle. The U.S. Army Corps of Engineers Shore Protection Manual (1977) also treats this problem.

Updrift sediment supply. By far the largest movement of sediment on any section of shoreline is the "longshore drift," which is caused by the transport of suspended solids in the longshore current. Although the direction of transport varies from day to day with the wave approach angle, the annual average is rather consistent. Net longshore drift is southerly along the northern and central Texas coast and northerly along the South Padre Island coast. These opposing currents converge at the shell beaches on central Padre Island (Watson 1968).



In the investigation of impacts in the upper shoreface ecosystem, changes in the longshore drift system are likely to be extremely important. If the activity changes longshore drift, one section of shoreline will have its "updrift sediment supply" altered, while the next section has its "downdrift sediment supply" altered.

Downdrift sediment supply. This attribute should be interpreted as supply to the neighboring downdrift section of shoreline or other system. The U.S. Army Corps of Engineers (1977) Shore Protection Manual treats problems associated with longshore drift in detail.

Beach sediment. Wave energy can transport sediment onto the beach or erode it, depending on a set of complex factors. The most important factor for net change over long time periods is the balance of supply and removal of sediment in the longshore drift. Seelig and Sorensen (1973b) analyzed shoreline changes south of Freeport where the beach is being eroded at approximately 9 meters per year.

Solids import/export. This represents primarily suspended solids imported from or exported to the nearshore gulf or other seaward systems. The quantity of sediments involved in such transport is "uncertain" (U.S. Army Corps of Engineers 1977, p. 4-133).

Nutrient import/export. It appears likely that the upper shoreface acts as a net supplier of inorganic nutrients to the neighboring deeper systems as postulated by Pearse, Humm and Wharton (1942). These nutrients result from the decomposition of imported organic matter on the beach and in the surf zone. The paucity of literature reflects the small amount of work done on this aspect of surf zone ecology.

Toxics import/export. Possible sources of toxic materials to the upper shoreface include oil and chemical spills and toxic waters or suspended solids from neighboring estuaries or rivers. Most studies of the impact of oil spills indicate that high concentrations of dissolved oil components are required to exhibit toxic effects. However, since the surf zone tends to concentrate both floating oil and tar balls within a relatively small volume of water, this system is probably the most likely to feel the impact of spills. McMahan (1974) gives a good discussion of "oil shores" and the effects of oil on the biota of various types of shore biota. Vaughn (1973) presents detailed technical discussions on bioassays and the effects of oil and chemically dispersed oil on selected marine organisms.

The impact of pesticides, heavy metals and industrial organic compounds found in runoff or discharges would be most likely to occur in inlet-tidal delta systems. These compounds tend to be associated with the fine particle sizes of the suspended solids. Since these particles tend to be winnowed out of the sediments in the upper shoreface, the level of these toxics should be low in this system.

Salinity import/export. Water exchange between the upper shoreface and the nearshore gulf is so rapid that import and export are expected to control salinity. Occasional import from the adjacent Aransas Pass (inlet-tidal delta) was found to cause considerable salinity variation on Mustang Island beaches (McFarland 1963b).

#### Biotic Attributes

The following section discusses the biota of the upper shoreface ecosystem. General references which have been drawn upon for this discussion

include: Pearse, Humm and Wharton (1942), Fotheringham and Brunenmeister (1975), and Reidl and McMahan (1974).

Micro-algae. In spite of the high degree of turbulence and turbidity, a high level of primary productivity is maintained in the upper shoreface system by micro-algae. Both phytoplankton and sediment living forms are present. McFarland (1963a) measured productivity in the waters of the surf zone of Mustang Island by the light and dark bottle method. He found that photosynthesis exceeded respiration in the planktonic community throughout the year except when very high numbers of decapod larvae were present during the spring. Net photosynthesis was found to average 0.99 grams of oxygen per cubic meter per day ( $\text{gm O}_2/\text{m}^3/\text{day}$ ) during the summer and early fall, and 0.36  $\text{gm O}_2/\text{m}^3/\text{day}$  during the rest of the year. Respiration averaged 1.05  $\text{gm O}_2/\text{m}^3/\text{day}$  during the summer and early fall and 0.26 during the rest of the year.

The major toxic materials of concern in the upper shoreface system are crude oil and petrochemicals. Pulich, Winters, and Van Baalen (1974) reported on the toxicity of crude oils and refined fuel to micro-algae. Other factors affecting micro-algae include nutrient availability and light penetration. Pearse, Humm and Wharton (1942) suggest that the high rate of organic matter decomposition in the surf zone should provide a high nutrient level for the micro-algae.

Nektonic herbivores and detritivores. The most prominent of the nektonic herbivore/detritivores is the striped mullet (Mugil cephalus). McFarland (1963b) found this fish in substantial numbers at all times of the year. It was the most abundant of all fish by weight. While the mullet eats almost

exclusively algae and detritus (Odum 1970), many organisms incorporate these items into their diet to some extent.

Benthic filter and deposit feeders. Several invertebrates live in or on the sediment and feed on suspended or sedimentary organic matter such as organic detritus and micro-algae. The coquina clam (Donax variabilis) is one of the most prominent of these organisms, since it lives in the swash zone (Loesch 1957). Another example is the hermit crab (Isocheles wurdemanni), which filters particles as small as 25 microns with its antennae (Caine 1978). A number of smaller invertebrates also live in the sediment and have special adaptations for this environment (Riedl and McMahan 1974). There appear to have been no detailed long-term surveys of Texas upper shoreface benthic organisms comparable to Matta's (1977) year-long survey of a North Carolina beach. Organisms found in this survey included many of the same species found in the Texas upper shoreface system. Matta's statistical analysis of the physical factors affecting the distribution of the benthic organisms indicated important effects by season and sediment texture. Limited surveys of benthic organisms in Texas include Seadock, Inc. (1975) and summer class studies at the University of Texas Marine Science Institute, Port Aransas laboratory (Rabalais personal communication).

Benthic carnivores. Several carnivorous molluscs such as the moon snail (Polynices duplicatus) feed on Donax and other small clams (Pearse, Humm and Wharton 1942). Other carnivores which spend most of their time on the bottom include the blue crab (Callinectes sapidus) and the speckled crab (Arenaeus cribrarius). In an excellent review of benthic organisms of the upper shoreface, Cox (1976) suggests that there are two separate food chains: one leading from the larger filter and deposit feeders to benthic carnivores and

eventually to birds and fish, and one, based on the small detritus feeders and bacteria, leading only to predators within the sediment such as nematodes.

Nektonic intermediate consumers. Considering the smallest first, the zooplankton include many fish and crustacean larvae in addition to copepods and amphipods (see McFarland 1963a). Carnivorous fish and invertebrates are also included in this category.

Top consumers. The aquatic top consumers in the upper shoreface system include many sport fish such as redfish (Sciaenops ocellata), black drum (Pogonias cromis), spotted seatrout (Cynoscion nebulosus), sharks, and mammals such as the Atlantic bottlenose dolphin (Tursiops truncata). Fedler (1978) provides a convenient summary of the sport fish found in the Texas surf zone, including food habits and seasonality.

A variety of birds can be found in the upper shoreface. The diving birds feed primarily on small fish. The wading birds feed on invertebrates such as Donax in the swash zone (Loesch 1957). Lists of some of the most common shore birds of the Texas coast can be found in Brogden, Oppenheimer and Bowman (1977).

Although the ghost crab (Ocypode quadrata) is frequently described as a scavenger, Wolcott (1978) and Haley (1967) found that they are significant predators. They feed on the benthic filter feeders such as coquina clams (Donax sp.) and mole crabs (Emerita sp.) in the swash zone. In general Ghost crabs are nocturnal.

#### Import/Export of Biotic Attributes

For simplicity, all import/export of biotic attributes has been designated as the single migration component in the model. The following

sections briefly discuss the major biotic energy flows associated with the migration of various organism groups.

Herbivore and detritivore migration. All of the nektonic herbivores and detritivores migrate into and out of the upper shoreface from the nearshore gulf. Moore (1973) discusses migration and spawning by the most prominent of these organisms, the striped mullet (Mugil cephalus). Information concerning the seasonal abundance of nektonic organisms is given in McFarland (1963b) and Gunter (1958). Penaeid shrimp larvae, spawned offshore, find their way into the upper shoreface during their migrations into the bay systems. McFarland (1963a) reports peaks of abundance of shrimp and crab larvae during the spring. Data concerning the life history of shrimp and crabs have been summarized by the Coastal Fisheries Branch of the Texas Parks and Wildlife Department (1975) in a report to the Coastal Management Project.

Birds and ghost crabs to beach. Birds and ghost crabs use the upper shoreface on a very short-term basis. They spend most of their time on the adjacent beach. More details are given in Brogden, Oppenheimer and Bowman (1977). The nocturnal migrations of ghost crabs are described by Wolcott (1978) and Haley (1967).

Intermediate consumer migration. McFarland (1963a) and Gunter (1958) describe the seasonal abundance of various fish species found in the upper shoreface system. Gunter (1950) gives limited information on the migration of some of the invertebrates. Since many of these consumer species spend part of their life cycles in the bays, studies of migration through the passes, such as Copeland (1965) and King (1971) may contain appropriate information.

Top consumer migration. Information on the seasonal appearance of sports fish in the surf zone is contained in Fedler (1978) and Coastal Fisheries

Branch (1975). Observations of one incident of migration of sharks and rays into the upper shoreface along Padre Island is described by Parker and Bailey (in press).

#### Critical System Attributes

The most important physical factors in the upper shoreface are the input of wave energy and the movement of the sediment in the longshore drift. These factors control the accumulation of sediment and the advance or retreat of the shoreline. The supply of nutrients and light penetration are probably the major limitations on micro-algae production, which provides much of the base of the food chain.

#### URBAN

##### Introduction

The urban habitat model (Figure 53) emphasizes the major energy and material inputs and outputs of typical Texas coastal urbanized areas. It is intended to apply not only to cities but to all industrialized and built-up areas. The emphasis is on input/output relationships rather than on internal transformations because it is the inputs and outputs which are of greatest importance in understanding the impact of urban areas on other habitats. The internal structure of the urban habitat is very complicated and requires a far more intricate model than presented here to show much detail.

Many of the "resource demands" described with the basin model are shown in greater detail in the urban habitat model. The socioeconomic resource demand model shows that the industrial and residential development segment of the economy supplies "other goods" to the outside economy and receives population migration. The industrial and residential component generates various "resource demands" including water flow modification, fresh water,

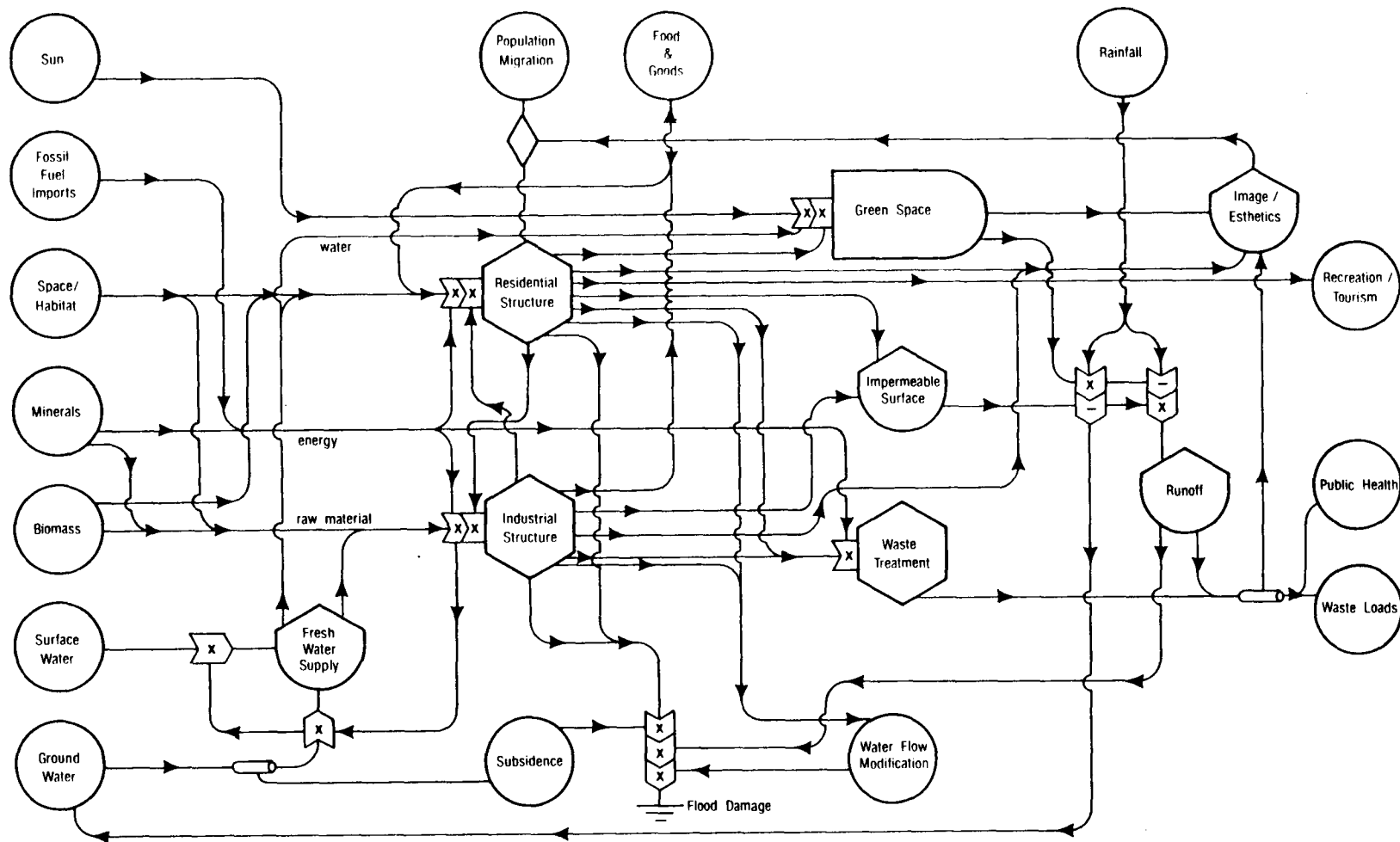

FIGURE 53. Urban habitat.



subsidence, waste loads, public health, esthetics and image, biomass, minerals, and space/habitat. The purpose of the urban habitat model is to show how these demands are generated.

### Energy Inputs

Fossil fuel. The major energy input for coastal urban areas comes from fossil fuel, mostly oil and gas. Of the 21 electric power generating plants in the coastal region, only one is coal fired (Table PU-1, Liebow et al. 1980). This will change in the future when the South Texas Nuclear Project begins operation. Other power sources, including geothermal energy, may become available in the future, although their proportion will be small compared fossil and nuclear sources for some time. A number of industries were initially attracted to the Texas coast by cheap fossil fuel energy sources. Some of the industries, such as the steel and aluminum producers, require large amounts of energy for their products. They are now dependent to a substantial degree on imported fossil fuels.

Sunlight. The only significant role of solar energy in the urban habitat model is to drive photosynthesis in the "green space" component. In future decades, solar energy may become a more directly used energy source by man, and : y require modification of the urban model.

### Material Inputs

Materials used as inputs to the urban habitat include space/habitat, minerals, biomass, esthetics and image, surface water, groundwater, and rainfall. Except for rainfall, the sources of all the other material inputs are the adjacent natural or managed habitats. These materials are actively sought.

Space/habitat. This represents the consumption of other habitats by expansion of components of the urban habitat. Most material inputs to urban systems shown in the model are directly related to the "resource demands" of basin socioeconomic model.

Minerals. The "oil and gas production" sector harvests fossil fuel and raw material for the petrochemical industry and for general energy consumption. Mineral resources such as gravel and shell are also harvested as raw materials for industry.

Biomass. Biomass is harvested by the "agriculture" and "commercial fishery" segments of the economy. Total harvest data is given in Liebow et al. (1980), but it is not clear how much of this harvest is consumed in the urban habitats of the study area.

Surface water and ground water. Substantial quantities of water from both sources are consumed by industrial and residential structures and in the upkeep of "green space." Detailed breakdown of the sources and consumers of fresh water in the study area is given in the Texas Water Plan (TWDB 1977).

Rainfall. An additional material input which is not under man's control is shown in the model. Rainfall is included because of the interactions which produce runoff with accompanying pollution load and flood damage.

### Physical Attributes

Residential structure. The internal components of the urban habitat model are greatly simplified. All structures, buildings, roads, power lines, homes, etc., are lumped into either "residential" or "industrial" structure. These structures are the main energy and material consumers and waste producers. For this model residential structure includes housing, public facilities, stores, and transportation facilities.

Industrial structure. This is intended to include all manufacturing and processing facilities including the construction industry. In this highly simplified model, industry consumes imported fossil fuel, local minerals, biomass, fresh water, and labor (from "residential structure). It creates additional structure, goods for export, and waste.

Green space. This is the area of the urban habitat with significant plant cover, such as parks, green belts, residential lawns, and undeveloped lots. It is significant to neighboring habitats both as a consumer of fresh water and as a moderating influence on runoff. It is also a major input to the esthetics of the area.

Impermeable surface. This component is derived from the residential and industrial structures. Impermeable surfaces tend to increase both the total amount and peak flow velocity of runoff from rainfall. The increased flow rates can carry more suspended solids and thus the waste load to adjacent aquatic habitats. Runoff from urban areas is high in hydrocarbons, trace metals, bacteria, and BOD load as has been shown in numerous studies such as Sartor and Boyd (1972).

Waste treatment. This represents the structural facilities and processes which are used to treat and dispose of solid, liquid, and gaseous wastes. This component of the urban habitat is shown separately to emphasize the significance of energy consumption by the processes and the direct relationship to the waste loads emitted to the other coastal habitats.

Runoff. Runoff is significant as a carrier of waste loads and as a factor in losses due to flooding. In general, runoff is increased by impermeable surfaces and decreased by green space.

Image/esthetics. This component represents all of the economic, social, esthetic, and psychological factors which determine the attractiveness of a given urban system and thus regulate migration of people in and out of the system. For the purposes of this model, it is considered to be derived from the industrial and residential structure, green space, and waste loads within the urban system.

#### Material Outputs

Food and goods. The balance of the exchange of food and goods with other systems may show either net import or export depending on the type of urban area.

Population migration. The net migration of population into the study area as a whole was 1.3 percent per year for the period 1970-77 (Liebow 1980.) However, the different urban areas differ considerably in their net population migration.

Waste loads. The most significant exports from the point of view of neighboring habitats are waste loads. These may be in the form of air pollution, water pollution, or solid wastes.

Public health. Public health is distinguished from "waste loads" as an output of the urban system because it reflects the suitability of the receiving habitat for human activities. For example, human pathogens have little effect on oysters, but a great effect on humans who eat the oysters.

#### Non-material Outputs/Effects

Recreation/Tourism. The urban population will generate some activity in the "recreation/tourism" sector both within and outside of the coastal zone. This resource demand will be exerted in a variety of habitats.

Water flow modifications. This output represents the effect of urban system structures such as buildings and highways in changing the direction and characteristics of water flow patterns. Flow modification can also lead to increased flood damage in urban systems.

subsidence. This phenomenon, which has been described extensively in the study area, is largely due to ground water pumping in urban areas. The Houston area shows the greatest effect (Fisher et al. 1972), but subsidence is also observable in other urban areas.

### Critical Functions

From the point of view of coastal ecosystems as a whole, the major functions of urban habitat are consumption of energy, water, minerals, biomass and natural habitats, and production of waste loads. From the economic point of view, the urban habitat is a producer and consumer of goods and a generator of recreation/tourism demands.

## WIND TIDAL FLAT

### Introduction

The wind tidal flat habitat (Figure 54) is actually a group of three interrelated subsystems along the Texas coast. Sand flats, mud flats and blue-green algal flats are all discussed in the wind tidal flat system. In many cases, there is a gradation from one of these subsystems to another. Areas with lower water flow may have more fine sediments and act as a mud flat while the adjacent area that receives more tidal energy may be a sand flat. These low energy areas may become colonized by mat forming blue-green algae and become algal flats. In many portions of the Texas coast, it is extremely difficult to determine where one of these subsystems stops and another starts. Although they have somewhat different productivities and different physical

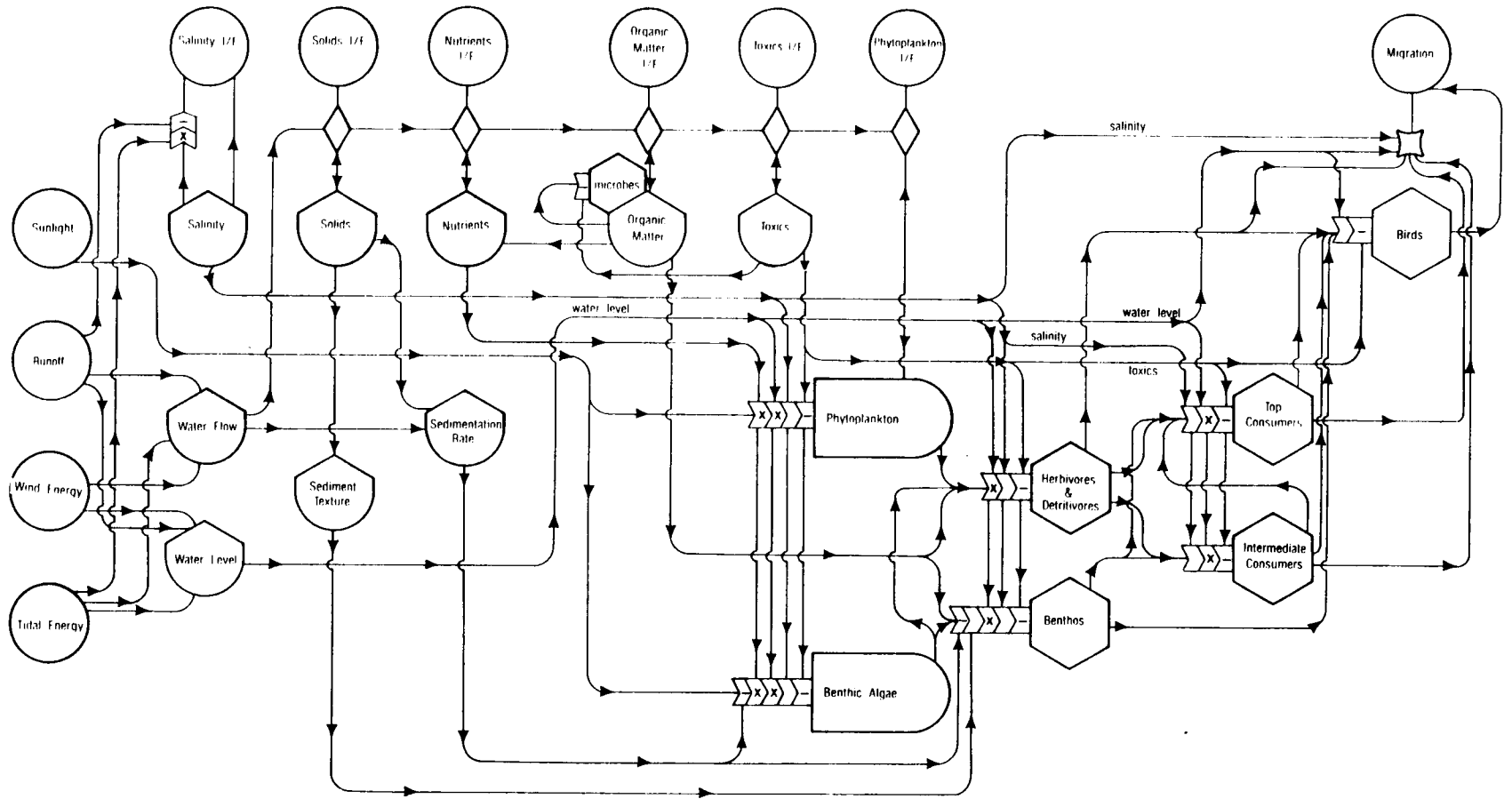

FIGURE 54. Wind tidal flat habitat.

characteristics, their faunal components are similar as are their overall energy flows.

Most of the wind tidal flats along the Texas coast occur on the bay side of the barrier islands (Brown et al. 1972-77). Large expanses of flats occur in the Laguna Madre area (Breuer 1962).

#### Energy Sources

Sunlight. Solar energy input provides the major source of energy used by the benthic algal based food web of the wind tidal flat ecosystem. It also provides heat to the system.

Runoff. Local runoff from streams and overland sources provides a source of nutrients, toxics and organic matter for the wind tidal flat ecosystem. It is the primary supplier of fresh water to this system. This can produce significant short-term changes in the salinity of the wind tidal flat .

Wind energy. Wind energy is a major factor in controlling the water flow and water depth in the wind tidal flat portions of the shallow Texas bays. The lack of turbulence is one of the major differences between the bay margin ecosystem and the wind tidal flat ecosystem. The shallow waters of the wind tidal flat system rapidly damp out waves from the bay margin making the wind tidal flat system relatively low in turbidity. Studies by Smith (1977) have shown the importance of wind energy on the water depth of the wind tidal flat system.

Tidal energy. Tidal energy is a major controlling factor of the water depth of the wind tidal flat system, due to its shallow nature. Even though the tidal amplitude may be very small in some of the more remote portions of the wind tidal flat system, it may produce a large change in the amount of substrate inundated due to the relative lack of slope in the system. Tidal

energy is the major source of energy for water flow through the wind tidal flat system except during periods of heavy runoff. Some wind tidal flat systems only receive tidal inundation during extremely high seasonal tides such as spring and fall.

#### Physical Attributes

Salinity. Salinity is one of the most important attributes in the wind tidal flat ecosystem and may vary from less than 10 ppt to over 200 ppt in algal flats (Sorensen and Conover 1962). It is one of the primary factors controlling the presence or absence of biota. Its seasonal variations, which are due primarily to the variation in the salinity of the adjacent bay or bay margin ecosystem and the amount of local runoff, partially control the distribution and abundance of mobile organisms and the distribution of benthic organisms. Local runoff via small streams or ditches and direct overground flow may temporarily reduce the salinity during and after heavy rainfall periods. This may affect the wind tidal flat system for some time, especially in areas that receive only intermittent inundation by bay waters.

Oppenheimer and Ward (1963) found that during periods of drying, inorganic materials including salts travel from the lower levels of the sediments to the surface via capillary action. These deposits are enriched with chloride and phosphorus. When reinundated following a drying period, the salinity will be raised by the dissolving of these halite deposits.

Heat. This attribute is used to represent the amount of light energy trapped by the wind tidal flat and released in the form of heat. Since there is seldom more than 10 to 20 cm of water over the flats, the water absorbs the heat and the resulting water temperature (summer months) may vary diurnally from 27 to 39 C (Odum and Wilson 1962). It may vary from below freezing to



over 70 C annually in some of the more exposed flats (Sorensen and Conover 1962). When these high temperatures are combined with the wide diurnal variations in dissolved oxygen, they may place extreme limitations on the biota of the flats. The amount of heat in the system at any given time affects the migration of the motile organisms that inhabit the flats. The high temperature also increases the evaporation and tends to raise the salinity of the wind tidal flat system.

Dissolved oxygen. The amount of oxygen that is dissolved in the water of most estuarine systems is highly dependent upon reaeration from the air via wave-caused surface turbulence. Since there is little turbulence in the wind tidal flat system, reaeration is not as important as oxygen production by the algae in the system (Odum and Wilson 1962). Oxygen concentrations in blue-green algal flats of Texas may vary from anerobic (caused by nighttime algal respiration) to 240 percent saturation during the brightly sunlit portion of the same day (Odum and Wilson 1962). In areas without a dense algal mat, the benthic algae may still contribute significant amounts of oxygen to the system during the day and remove it via respiration at night. In wind tidal flat systems where anerobic conditions occur during the night, the motile animals undoubtedly migrate to areas of adequate oxygen concentrations.

Water flow. Water flow in the wind tidal flat is used to represent the physical flow of water caused by tidal and/or wind inundation of bay water and fresh water runoff. The water flow is analogous to currents in deeper water systems. Wind may directly cause some small currents in the wind tidal flat system, but the major direction of the water flow in the wind tidal flat is "in" during flood tides or onshore wind and "out" during ebb tides, offshore

winds or periods of freshwater runoff. The water flow drives the import and export of physical and biotic attributes.

Water depth. This attribute is primarily controlled by the wind and tidal energy which cause hourly, daily, monthly and seasonal variations. The water depth of the wind tidal flat system may vary from over one meter during high water periods to completely dry during droughts. Many flats have only a few centimeters of water covering them during much of the year. This may vary only a few centimeters with the tides, but the wind may cause changes of one third to one half meter over less than two hours following the passage of a "norther" (Collier and Hedgpeth 1950). The depth of the water in the wind tidal flat is one of the most important factors controlling the migration of organisms in this system. It is also highly important in controlling the primary production via phytoplankton and benthic algae, especially in flats that are only aperiodically flooded.

Solids. The solids attribute is used to show the physical effects of suspended particulate matter, such as the reduction of light which reaches the phytoplankton and the covering of the bottom fauna (May 1973) as well as the mass or volume of sediment within a particular area of the wind tidal flat. Suspended solids are introduced into the wind tidal flat waters primarily by import from adjacent systems and local or storm runoff (Collier and Hedgpeth 1950). They are removed from the water column via settling and export back to the bay ecosystem. The wind tidal flat systems of Texas are generally low in suspended solids due to the small amount of water flow from the bay ecosystem, lack of runoff and little resuspension due to lack of turbulence.

This attribute also provides the basis for sediment texture and sediment rates which in turn affect the benthic algae and benthos. The sedimentation

rate partially controls the water depth and has a significant effect on the benthos. Sedimentation rates for the wind tidal flat vary from bay system to bay system. They are generally small except during storm events (hurricanes) during which deposition of up to 10 cm of fresh sediment may occur (Hayes 1965). Rapid sedimentation may be particularly detrimental to organisms such as benthic micro-algae.

Sediment texture. The texture of the wind tidal flat sediments varies from predominantly mud in the northeastern Texas bays to mostly sand in the Laguna Madre (Brown et al. 1972-77; Shepard and Rusnak 1957). Sediment texture is a major factor in determining the composition of the benthic community of the wind tidal flat. The finer sediments tend to settle out in the areas of low water flow. High energy areas may tend to remove these finer portions and cause the sediments to be of a coarser texture. Blue-green algal mats tend to form on the lower energy areas of finer sediment texture (Brogden et al. 1977).

Nutrients. Nutrients are organic and inorganic materials required by phytoplankton and benthic algae for photosynthesis, in addition to light. Nitrogen and phosphorus are the major nutrients associated with primary production in the wind tidal flat, although many additional nutrients and trace elements are also needed. Nitrogen is generally considered to be the limiting nutrient in Texas bays (Davis 1973); however, a significant portion of the nitrogen used in the wind tidal flat ecosystem may come from nitrogen fixation by the blue-green algae or the anaerobic bacteria in the sediments under the algal mat (Brogden et al. 1977). Local runoff during periods of high rainfall as well as the redissolving of sediment nutrients brought to the surface via capillary action during drying periods (Oppenheimer and Ward 1963)

may also be significant nutrient sources. The Texas Department of Water Resources has computer data banks of nutrient data from sampling in all Texas bays.

Organic matter. "Microbes" are partially combined with the symbol representing organic matter in the water and sediments since they are an integral part of the cycling of energy via decomposition. The amount of organic matter in sand and mud flats is highly dependent upon the concentrations in the bay or fresh water that inundates the system. Concentrations of dissolved organic carbon (DOC) ranged from 2.0 to 5.3 mgC/l in Texas estuaries during a 1972 study (Maurer and Parker 1972). A 1971 study (Maurer 1971) showed DOC values between 5 and 11 mgC/l in the Laguna Madre and from 3 to 6 mgC/l in other bays. These are much higher than the 1 to 4 mgC/l of DOC recorded in the nearshore gulf during the same studies. There may be higher concentrations of organic matter in the water of the wind tidal flat (algal) system than the sand or mud flats due to the productivity of the algae.

The bacteria are the most important microbes in the decomposition of particulate organic matter in the wind tidal flat system. The populations of bacteria respond rapidly to organic matter inflows and rapidly colonize organic particles. The organic carbon content of the sediments of the wind tidal flat system is highly variable (Volkman and Oppenheimer 1962). They measured the organic carbon content of an algal flat and found it to be 1.5 percent carbon by dry weight. Further data can be found in Davis (1973); McGowen et al. (1979) and the TDWR computer data files.

The benthic infauna and some of the epifauna ingest the organic matter from the sediments or the surface of the sediments as do some of the

herbivores and detritivores such as the penaeid shrimp. This is an important food source for these species.

Toxics. Toxic materials which could be introduced into the wind tidal flat system include heavy metals, pesticides, industrial organic chemicals, well drilling fluids, crude oil and petrochemicals. Many toxic materials are readily adsorbed on fine particles. They are then quickly incorporated into the sediments. Some of these toxics may reach higher levels in the food chain via bioaccumulation by filter feeders and consumption by higher order consumers. Toxics enter the wind tidal flat system primarily via water from the adjacent bay system or via runoff from land.

Although each bay in Texas varies greatly in its sediment concentrations of toxic materials, very little data are available which specifically document the concentrations in the wind tidal flat system. Heavy metals, pesticides and chemicals such as PCB are found in the sediments of nearly all of the bays of Texas (TDWR Computer Data Files). Data from the TDWR files show that the sediments in the channels, rather than the bay proper, contain the higher accumulations of toxics. Most of the toxic materials settle out into the deeper portions of the bay system with the finer sediments (McGowen 1979). This would indicate that the wind tidal flat system would only have elevated toxic concentrations if they were introduced by nearby spills or via runoff.

#### Import/Export of Physical Attributes

Salinity. The wind tidal flat system receives much of its salinity from inundation by water from the adjacent bay ecosystem. However, the redissolving of halite deposits from the sediment surface following long dry periods (Volkman and Oppenheimer 1962) and accelerated evaporation of ponded water by the high temperatures of the wind tidal flat may also significantly

increase the salinity of the water. Local runoff may cause lower salinities in the wind tidal flat system for substantial periods of time following rain events. The TDWR water quality data base contains extensive salinity data on all of the Texas bays. The Environmental Geologic Atlas series (Brown et al. 1972-77) also discusses the distribution of salinity in the bay systems of Texas.

Suspended solids. The wind tidal flat system receives most of its suspended solids from either erosion caused by local runoff or by inundation of water containing high suspended solids concentrations from adjacent bay ecosystems, especially following disruption by storms or man's activities such as dredging or shrimping. In the Laguna Madre, sand from washovers is blown into the wind tidal flat areas during windy, dry periods and is an important source of solids for the wind tidal flat (Shepard and Rusnak 1957).

Nutrients. Import from the bay system, local runoff, nitrogen fixing by bacteria and blue-green algae and redissolution of sediment nutrients that have been brought to the sediment surface following drying periods provide the majority of the nutrients to the wind tidal flat system. In some more urbanized areas, direct discharges of domestic and industrial wastes may constitute a significant input of nutrients into the wind tidal flat. Some of the nutrient load brought to the wind tidal flat system by runoff via streams actually originates as waste discharges and agricultural runoff in some areas. Nitrogen fixing plants may be somewhat more important in the Laguna Madre and other areas that lack major freshwater inputs.

Toxics. Toxics such as agricultural pesticides or industrial wastes may be imported along with the freshwater runoff into the wind tidal flat. Some are introduced into the wind tidal flat system via spills or treatment plant

outfalls. Crude oil may be imported via the passes (inlet-tidal delta systems) from the gulf in the case of spills in the nearshore gulf or upper shore face. Toxics from spills in the bay system or on land adjacent to the wind tidal flat may find their way into the wind tidal flat system.

Organic matter. Most of the organic matter that enters the wind tidal flat system via freshwater runoff or import from the bay system is either dissolved or suspended particles of vegetation and animal matter. Algal flats may produce large amounts of their own organic matter that may be exported in large pieces during storms especially after periods of drying (Brogden et al. 1977). Some detritus is blown or washed in from terrestrial systems during storms. No literature concerning the origins of the organic matter content of the wind tidal flat system has been found.

#### Biotic attributes

Phytoplankton. The primary productivity of the wind tidal flat system is provided by phytoplankton and benthic algae. The phytoplankton are of minor importance in most wind tidal flat systems due to the small volume of water and the concentration of benthic algae, even in the sand and mud flat systems. The rate of photosynthesis depends on light penetration and nutrient availability (Armstrong and Hinson 1973). The possibility of suppression of photosynthesis by toxic materials exists, but its extent in Texas bays is currently unknown. Van Baalen et al. (1973) detected toxicity in Galveston Bay waters using a phytoplankton bioassay.

Benthic algae. The primary productivity of the wind tidal flat areas of most of the bays of Texas is primarily the result of photosynthesis by benthic algae instead of phytoplankton. Odum and Wilson (1962) studied the relationships between the primary productivity and physical and chemical

environments of several Texas bays. They found that the extreme variations in temperature, dissolved oxygen and salinity allowed the blue-green algae and some diatoms to proliferate over other forms of algae. They determined that the gross productivity in an algal mat averaged about 5.0 gm O<sub>2</sub>/m<sup>2</sup>-day. However, they measured respiration at about the same rate as photosynthesis, thereby making the net production of carbon negligible. Sorensen and Conover (1962) determined that Lyngbya confervoides is the dominant blue-green alga in the mats of south Texas algal flats. Wood (1963) provides an extensive listing of the species of diatoms found in the sediments of Texas bay systems.

Little work has been done comparing the productivity of the sand and mud dominated wind tidal flat system to other systems; however, Burkholder (1965) reported gross productivities between 0.23 and 37.5 gm C/meter squared-day in some Long Island Sound intertidal communities. Pamatmat (1968) measured gross production of 0.41 gm C per sq meter per day on an intertidal sand flat, with respiration of 0.116 gm C per sq meter per day. Brogden et al. (1977) estimated that the sand flat areas of Texas may have a productivity on the order of 1.0 gm C/meter sq.-day while emersed.

Benthos. The benthic organisms of the wind tidal flats of Texas are not nearly as diverse as the benthos found in the open water bay systems of Texas. Holland et al. (1975) found 359 taxa in their sampling of several central Texas bays. The wind tidal flat system may not have as diverse a benthic fauna due to the periodic drying of the system and its frequent disruption by water level, dissolved oxygen, temperature and salinity changes. Since the majority of the benthic organisms are either sessile or marginally mobile, they are found primarily in the portions of the wind tidal flat system that are more regularly inundated (Brogden et al. 1977). Polychaetes, nematodes,



ostracods, copepods and some molluscs can be found in the wind tidal flat benthos. Many of the higher trophic level organisms depend, at least partially, on the benthos for their food.

Herbivores and detritivores. This group comprises one of the largest consumer groups in the wind tidal flat system and ranges in size from the small zooplankton to the striped mullet (Mugil cephalus) (Moore 1974). Most of the crustaceans (shrimp, crabs, etc.) are herbivorous or detritus feeders or both at one stage in their life cycle (Coastal Fisheries Branch 1975; Cook and Lindner 1978; Costello and Allen 1939; Lindner and Cook 1970). Many of the larval stages of the higher level fish fall into this category (Dineen and Darnell 1976). Many of these organisms move into the wind tidal flat system to feed on the benthic algae or organic matter, and to escape larger predators in the shallow water. The young of many of these organisms spend much time in the wind tidal flat system.

There are several species of small fish that depend heavily upon the shallow water areas of the wind tidal flat system, as well as shallow marshes. These are primarily the sheepshead minnow (Ciprinodon variegatus), which prefers water less than 10 cm deep and feeds on algae, detritus and small benthic animals, and several species of killifish (Fundulus similis, grandis and others). All of these fish appear to be able to tolerate the extremes of salinity and temperature found in the wind tidal flat system.

Intermediate consumers. This group comprises both the free-swimming consumers and those closely associated with the bottom. This includes organisms from larval fish to jellyfish. This compartment is primarily concerned with the predatory organisms below the level of top consumer. Due to the difficulties encountered in sampling the wind tidal flat system, few

studies have been undertaken to determine its use by these species. The studies by Case 1974; Case and Wimer 1977; Jones 1965 discuss the intermediate consumers that use the bay and therefore, may forage in the wind tidal flat system in many cases. Species such as the tidewater silversides (Menidia beryllina), rainwater killifish (Lucania parva), blue crab (Callinectes sapidus), and pinfish (Lagodon rhomboides) spend much of their time in the very shallow waters of the wind tidal flat system.

Top consumers. The top consumers of the wind tidal flat system are primarily the game fish of the bay system and birds (discussed separately in the next section). Species such as Cynoscion nebulosus, Sciaenops ocellata and Pogonias cromis frequent the wind tidal flat system, when the water level permits, in search of prey. Coastal Fisheries Branch (1975) and Hoese (1965) are two of the more comprehensive references on the top consumers and their habitats.

Birds. The birds are discussed separately because they are somewhat concentrated in the wind tidal flat system. Many diving birds of the open bay and wading and shore birds can be found on the edge of the water or wading in the wind tidal flat system. The wading and shore birds feed on the small benthic and nektonic organisms and rest in or near this system. The diving birds and some dabbling ducks may also feed on micro-organisms or vegetation in the wind tidal flat system. Many of them rest on the shore adjacent to the wind tidal flat where their droppings may be washed back into the system to provide nutrient input. Brogden et al. (1977 in Kier and Fruh 1977) discuss the use of this habitat by the birds in the Corpus Christi Bay area. The most common birds found during this survey of the flats on the bay side of Mustang Island were the great blue heron and reddish egret.

### Import/Export of Biotic Attributes

Phytoplankton. Phytoplankton are imported and exported via the inundation of bay water. They are of minor importance in the productivity of the wind tidal flat system.

Migration. Migration with respect to the wind tidal flat system represents the movement into and out of the wind tidal flat area as opposed to the seasonal migrations of organisms between the gulf and bay systems. This migration is cued by water depth, water flow, salinity, dissolved oxygen and heat (water temperature). The planktonic organisms are carried into and out of the wind tidal flat system during inundation by bay water. More motile organisms move in and out of the system when the conditions are favorable to them.

Killifish, silversides and small mullet are the most visible members of the herbivore and detritivore group that migrate between the bay and the wind tidal flat systems. Smaller juveniles of many intermediate and top consumers can be found in large numbers during certain times of the year in the wind tidal flat.

The Penaeid shrimp spawn offshore in the gulf and the postlarvae migrate into the bays to mature (Cook and Lindner 1978; Lindner and Cook 1970; Costello and Allen 1939). These postlarvae usually proceed to the wind tidal flat, marshes and other shallow water systems in the bays where they feed on the benthic algae and organic matter in the relative safety of the shallows.

Most of the intermediate consumers spend much of their life cycle in the bay or migrate through it. As juveniles, many of them survive in the shallow waters of the marshes or wind tidal flat areas.

The gamefish, which comprise the more important top consumers, migrate at various times of the year as do the intermediate consumers. Their migrations depend upon their spawning periods and various physical factors as mentioned above. No two species migrate at exactly the same time. Many of the smaller individuals seek out the bay margin and wind tidal flat areas for refuge from the larger predators and to feed on the juveniles of other species in the wind tidal flat system.

#### Critical System Components

The health of the bay ecosystem, which supplies most of the water to the wind tidal flat ecosystem, is one of the critical aspects in the survival of the wind tidal flat ecosystem. The wind tidal flat system receives most of its inputs from the bay system. The next most critical component is the runoff from adjacent upland areas. This freshwater runoff brings with it nutrients, organic matter and toxics. The benthic algae are also a critical component since, even in the sand and mud flats, they are the source of most of the carbon and oxygen produced in the wind tidal flat system.

#### LITERATURE CITED

- Abbott, W. Analysis and comparison of an upland deciduous forest and a river forest. *J. Miss. Acad. Sci.* 12: 50-64; 1966.
- Allen, H.H.; Clairain, E.J., Jr.; Diaz, R.J.; Ford, A.W.; Hunt, L.J.; Wells., B.R. Habitat development field investigations, Bolivar Peninsula, marsh and upland habitat development site, Galveston Bay, Texas. Vicksburg, MS: U.S. Army Engineers Waterway Exp. Sta.; Tech. Rep. D-78-15 DMRP; 1978; 75 p.
- Ariathurai, R.; MacArthur, R.C.; Krone, R.B. Mathematical model of estuarial sediment transport. Vicksburg, MS: U. S. Army Engineers Waterways Exp. Sta.; Tech. Rep. D-77-12 DRMP; 1977; 70 p + ap.
- Armstrong, N.E.; Hinson, M.O., Jr. Galveston Bay ecosystem freshwater requirements and phytoplankton productivity. Oppenheimer, C.H.; Brogden, W.B.; Gordon, K.G., eds. Toxicity studies of Galveston Bay project. Port Aransas, TX: University of Texas, Marine Science Institute; Final Report to the Texas Water Quality Board for Contract IAC (72-73) 183; 1973:II-1 to II-97.
- Baccus, J. A preliminary ecological study of the mammals of Padre Island National Seashore. *Trans. Southwest Regional Natural Science Conf., National Park Service* (Nov. 19-21, 1974): 144-145; 1974.
- Baccus, J.T.; Horton, J.K. An ecological and sedimentary study of Padre Island National Seashore. San Marcos, TX: Southwest Texas State University, Dept. of Biology; Report to the Office of Natural Resources, Southwest Region, National Park Service, Contract CX 702970059; 1979; 272 p + map.
- Bahner, L.H.; Wilson, A.J., Jr.; Sheppard, J.M.; Patrick, J.M., Jr.; Goodman, L.R.; Walsh, G.E. Kepone bioconcentration, accumulation, loss, and transfer through estuarine food chains. *Chesapeake Sci.* 18 (3): 299-308; 1977.
- Bailey, L., 1974, Water quality segment report for segment no. 2004, Aransas River (above tidal). Austin, TX: Texas Water Quality Board, Report no. WAS-6; 1974; 13 p + ap.
- Bansal, M.K. Atmospheric reaeration in natural streams. *Water Research* 7(5): 769-782; 1973.

- Barko, J.W.; Smart, R.M.; Lee, C.R. Establishment and growth of selected freshwater and coastal marsh plants in relation to characteristics of dredged sediments. Vicksburg, MS: U.S. Army Corps of Engineers Waterways Exp. Sta.; Tech. Rep. D-77-2 DMRP; 1977; 41 p.
- Bayley, S.; Odum, H.T. Simulation of interrelations of the Everglades' marsh, peat, fire, water, and phosphorus. *Ecological Modelling* 2: 169-188; 1976.
- Bechtel, T. J. 1970. Fish species diversity indices as pollution indicators in Galveston Bay, Texas. Austin, TX: University of Texas at Austin; 1970. Thesis.
- Behrens, E.W.; Watson, R.L.; Carangelo, P.D.; Sohl, W.H.; Finkelstein, H.S. 1974. Beach impact study, Padre Island National Seashore. Trans. Southwest Regional Natural Science Conf., National Park Service (Nov. 19-21, 1974): 137-140; 1974.
- Bella, D. A.; Ramm, A.E.; Peterson, P.E. Effects of tidal flats on estuarine water quality. *Jour. Water Poll. Control Fed.* 44: 541-556; 1972.
- Benton, A. R., Jr; James, W.P.; Rouse, J.W., Jr. Evapotranspiration from water hyacinth in Texas reservoirs. *Water Resources Bull.* 14: 919-930; 1978.
- Bodine, B.G. Hurricane surge frequency estimated for the Gulf Coast of Texas. Fort Belvoir, VA: U.S. Army Corps of Engineers, Coastal Engineering Research Center; Tech. Mem. no. 26; 1969; 32 p.
- Bowman, J.; Jensen, D.A. Intensive surface water monitoring survey for segment no. 2101, Nueces River tidal. Austin, TX: Texas Water Quality Board; Report no. IMS-53; 1977; 25 p + ap.
- Bowman, J.; Jensen, D.A. Intensive surface water monitoring survey for segment no. 2453 Lavaca Bay. Austin, TX: Texas Dept. of Water Resources; Report no. IMS-70; 1978; 59 p + ap.
- Boyce, S.G. The salt spray community. *Ecol. Monogr.* 24: 29-67; 1954.
- Boyd, C.E. Production, mineral nutrient absorption, and biochemical assimilation by Justica Americana and Alternanthera philoxeroides. *Arch. Hydrobiol.* 66: 139-160; 1969.
- Boynton, W.R. Energy basis of a coastal region: Franklin County and Apalachicola Bay, Florida. Gainesville, FL: University of Florida; 1975. 389 p. Dissertation.
- Bragg, T.B.; Hulbert, L.C. Woody plant invasion of unburned Kansas bluestem prairie. *Range Mgt.* 29(1): 19-24; 1976.
- Brandes, R. J.; Stein, A.B. WREDUN model documentation report with Lake Dunlap application. Austin, TX: Water Resources Engineers; Report to Texas Department of Water Resources; 1979.

- Bravo, A.; Salazar, H.S.; Botello, A.V.; Mandelli, E.F. Polyaromatic hydrocarbons in oysters from coastal lagoons along the eastern coast of the Gulf of Mexico, Mexico. *Bull. Environ. Contam. Toxicol.* 19(2): 171-176; 1978.
- Breuer, J. An ecological survey of Baffin and Alizan Bays, Texas. *Pub. Inst. Mar. Sci.* 4(2): 134-155; 1957.
- Breuer, J. P. A biological survey of the tidewater areas of the Rio Grande. Austin, TX: Texas Parks and Wildlife Dept.; Coastal Fisheries Project Reports, 1969-70; 1970: 127-140.
- Broadfoot, W.M.; Williston, H.L. Flooding effects on southern forests. *J. For.* 71: 584-587; 1973.
- Brogden, W. B.; Oppenheimer, C.H.; Bowman, D. Selected biological data, Mustang and North Padre Islands. R. S. Kier and E. G. Fruh, eds. Environmental and economic impacts of recreational community development, Mustang Island and North Padre island. Chap. IV. Austin, TX: University of Texas at Austin; 1977.
- Brogden, W. B.; Oppenheimer, C.H. Transferability of methodology to the lower Rio Grande valley. R.S. Kier and E. G. Fruh, eds. Methodology to evaluate alternative coastal zone management policies. Chapt. VII. Austin, TX: University of Texas at Austin; 1977: VII-1 to VII-64.
- Brown, L.F. Jr., Project Coordinator. Environmental geologic atlas of the Texas coastal zone. Austin, TX: University of Texas at Austin, Bureau of Economic Geology; 1972-1977; 7 vol.
- Brown, L.F., Jr.; Morton, R.A.; McGowen, J.H.; Kreitler, C.W.; Fisher, W.L. Natural hazards of the Texas coastal zone. Austin, TX: University of Texas at Austin, Bureau of Economic Geology; Special Report; 1974; 13 p. + 7 maps.
- Brown, L.F., Jr.; Brewton, J.L.; Evans, T.J.; McGowen, J.H.; White, W.A.; Groat, C.G.; Fisher, W.L. Environmental geologic atlas of the Texas coastal zone: Brownsville-Harlingen area. Austin, TX: University of Texas at Austin, Bureau of Economic Geology; 1980; 139 p.
- Brown, L.F.; Brewton, J.L.; McGowen, J.H.; Evans, T.J.; Fisher, W.L.; Groat, C.G. Environmental geologic atlas of the Texas coastal zone: Corpus Christi area. Austin, TX: University of Texas at Austin, Bureau of Economic Geology; 1976; 123 p + 9 maps.
- Brown, L.F., Jr.; McGowen, J.H.; Evans, T.J.; Groat, C.G.; Fisher, W.L. Environmental geologic atlas of the Texas coastal zone: Kingsville area. Austin, TX: University of Texas at Austin, Bureau of Economic Geology; 1977; 131 p.

- Bryan, C. E. An ecological survey of the Arroyo Colorado, Texas, 1966-1969. Austin, TX: Texas Parks and Wildlife Dept.; Tech. Series no. 10; 1971; 28 p.
- Buresh, R.J.; DeLaune, R.D.; Patrick, W.H., Jr. Nitrogen and phosphorus distribution and utilization by Spartina alterniflora in a Louisiana Gulf coast marsh. *Estuaries* 3: 111-121; 1980.
- Butler, T.J. Aquatic metabolism and nutrient flux in a south Louisiana swamp and lake system. Baton Rouge, LA: Louisiana State University; 1975. Thesis.
- Caillouet, C.W., Jr.; Fontenot, B.J., Jr.; Dugas, R.J. Diel fluctuations in catch of postlarval white shrimp, Penaeus setiferus (Linnaeus), with the Renfro beam trawl. *Bull. Mar. Sci.* 18(4): 829-835; 1968.
- Caillouet, C.W., Jr.; Perret, W.S.; Dugas, R.J. Diel fluctuations in catch of postlarval brown shrimp, Penaeus aztecus Ives, with the Renfro beam trawl. *Bull. Mar. Sci.* 20(3): 721-730; 1970.
- Caine, E.A. Habitat adaptations of Isocheles wurdemanni Stimpson (Crustacea: Anomura: Diogenidae) and seasonality of occurrences in northwestern Florida. *Contrib. Mar. Sci.* 21: 117-123; 1978.
- Calabrese, A.; Collier, R.S.; Nelson, D.A.; MacInnes, J.R. The toxicity of heavy metals to embryos of the American oyster Crassostrea virginica. *Mar. Biol.* 18(3): 162-166; 1973.
- Cammen, L.M. Accumulation rate and turnover time of organic carbon in a salt marsh sediment. *Limnol. Oceanog.* 20(6): 1012-1015; 1975.
- Case, R. J. Jr. Computer analysis of a one-year trawl study in an area of shell dredging: San Antonio Bay, Texas. College Station, TX: Texas A&M University; 1974. 93 p. Thesis.
- Case, R. J.; Wimer, A.A. A trawl study of Corpus Christi Bay. Vol I. San Antonio, TX: Southwest Research Institute; Final Report SWRI project 22-4237; 1977; 76 p + ap.
- Cech, J.J., Jr. Seasonal and short term respiratory, cardiovascular and hematological responses of the striped mullet, Mugil cephalus L., to seasonal temperature extremes, with information on striped mullet growth rates in south Texas coastal waters. Austin, TX: University of Texas at Austin. 1973; Dissertation.
- Center for Wetland Resources. Trace and toxic metal uptake by marsh plants as affected by EH, pH, and salinity. Vicksburg, MS: U.S. Army Corps of Engineers Waterways Exp. Sta.; Tech. Rep. D-77-40 DMRP; 1977; 124 p.
- Chabrek, R.H. Vegetation, water and soil characteristics of the Louisiana coastal region. Baton Rouge, LA: Louisiana State University, Agri. Exp. Sta.; *La. Agri. Exp. Sta. Bull.* 664; 1972; 72 p.



- Chambers, G.V.; Sparks, A.K. An ecological survey of the Houston Ship Channel and adjacent bays. Pub. Inst. Mar. Sci. 6: 213-250; 1959.
- Chaney, A.H.; Chapman, B.R.; Karges, J.P.; Nelson, D.A.; Schmidt, R.R.; Thebeau, L.C. Use of dredged material islands by colonial seabirds and wading birds in Texas. Vicksburg, MS: U.S. Army Corps of Engineers Waterways Exp. Sta.; Tech. Rep. D-78-8 DMRP; 1978; 238 p.
- Chestnut, A.F. Oyster Reefs. Odum, H.T.; Copeland, B.J.; McMahan, E.A., eds. Coastal ecological systems of the United States. Vol. III. Washington, DC: The Conservation Foundation; 1974: 171-203.
- Childress, U.R. An investigation into levels of concentration, seasonal variations and source of pesticide toxicants in some species from selected bay areas. Austin, TX: Texas Parks and Wildlife Dept., Coastal Fisheries Project Report 1966; 1966: 39-54.
- Childress, U.R. Levels of concentration and incidence of various pesticide toxicants in some species from selected bay areas. Austin, TX: Texas Parks and Wildlife Dept., Coastal Fisheries Project Report 1968; 1968: 1-22.
- Childress, U.R.; Bradley, E.; Hagen, E.; Williamson, S. The effects of freshwater inflows on hydrological and biological parameters in the San Antonio Bay system, Texas. Austin, TX: Texas Parks and Wildlife Dept.; 1975; 190 p.
- Cisneros, B. Coastal vegetational communities of two Texas barrier islands, Boca Chica and Brazos. Edinburg, TX: Pan American University; 1974. Thesis.
- Coastal Bend Council of Governments. Areawide waste treatment management plan. Section 2.17. Corpus Christi, TX: Coastal Bend Council of Governments; Report to Texas Water Quality Board. 1978.
- Coastal Fisheries Branch. Information on the biology and the life history of important fish and shellfish of the Texas Coast. Austin, TX: Texas Parks and Wildlife Dept.; Preliminary Draft Report to the General Land Office, Coastal Management Program; 1975; 299 p.
- Coastal Zone Resources Corporation (CZRP). A comprehensive study of successional patterns of plants and animals at upland disposal areas, Wilmington, N.C. Vicksburg, MS: U.S. Army Corps of Engineers Waterways Exp. Sta.; Tech. Rep. D-77-2 DMRP; 1977.
- Cole, J. Habitat development field investigations, Buttermilk Sound marsh development site, Atlantic Intracoastal Waterway, Georgia. Vicksburg, MS: U.S. Army Corps of Engineers Waterways Exp. Sta.; Tech. Rep. D-78-26 DMRP; 1978; 34 p.

- Collier, A.; Hedgpeth, J.W. An introduction to the hydrography of tidal waters of Texas. Pub. Inst. Mar. Sci. 1(2): 125-194; 1950.
- Conner, W.H. Productivity and composition of a freshwater swamp in Louisiana. Baton Rouge, LA: Louisiana State University; 1975. Thesis.
- Connor, W.H.; Day, J.W. Productivity and composition of a bald cypress-water tupelo site and a bottomland hardwood site in a Louisiana swamp. Am. J. Bot. 63(10): 1354-1364; 1976.
- Cook, H.L.; Lindner, M.J. Synopsis of biological data on the brown shrimp Penaeus aztecus Ives 1891. FAO Fish. Rep. 57(4): 1471-1497; 1970.
- Coover, J.R.; Rechenthin, C.A. Report of a preliminary investigation of the wind erosion and salt problem on the salt flats of Laguna Madre. Temple, TX: USDA Soil Conservation Service ; 1965; 32 p.
- Copeland, B. J. Fauna of the Aransas Pass inlet, Texas. I. Emigration as shown by tide trap collections. Pub. Inst. Mar. Sci. 10: 9-21; 1965.
- Copeland, B.J.; Bechtel, T.J. Some environmental limits of six Gulf Coast estuarine organisms. Contrib. Mar. Sci. 18: 169-204; 1974.
- Copeland, B.J.; Hoese, H.D. Growth and mortality of the American oyster, Crassostrea virginica, in high salinity shallow bays in central Texas. Pub. Inst. Mar. Sci. 11: 149-158; 1966.
- Copeland, B.J.; Odum, H.T.; Moseley, F.N. Migrating subsystems. Odum, H.T.; Copeland, B.J.; McMahan, E.A., eds. Coastal ecological systems of the United States. Vol. III. Washington, DC: The Conservation Foundation; 1974: 422-453.
- Copeland, B.J.; Truitt, M.V. Fauna of the Aransas Pass inlet, Texas. Penaeid shrimp postlarvae. Tex. J. Sci. 18: 65-74; 1966.
- Costello, T.J.; Allen, D.M. Synopsis of biological data on the pink shrimp (Penaeus duorarum duorarum) Burkenroad, 1939. FAO Fish. Rep. 57(4): 1499-1537; 1970.
- Cox, J.L. Sampling variation in sandy beach littoral and nearshore meiofauna and macrofauna. Fort Belvoir, VA: U.S. Army Corps of Engineers, Coastal Engineering Research Center; TP 76-14; 1976; 28 p.
- Cunningham, P.A.; Tripp, M.R. Factors affecting the accumulation and removal of mercury from tissues of the American oyster, Crassostrea virginica. Mar. Biol. 31(4): 311-319; 1975.
- Cuzon du Rest, R. P. Distribution of the zooplankton in the salt marshes of southeastern Louisiana. Pub. Inst. Mar. Sci. 9: 132-155; 1963.

- Dahl, B. E.; Fall, B.A.; Lohse, A.; Appan, S.G. Construction and stabilization of coastal foredunes with vegetation: Padre Island, Texas. Fort Belvoir, VA: U. S. Army Corps of Engineers Coastal Engineering Research Center; Misc. paper 9-75, 1975; 188 p. NTIS number ADA018065.
- Darnell, R.M. Food habits of fishes and larger invertebrates of Lake Ponchartrain, Louisiana, an estuarine community. Pub. Inst. Mar. Sci. 5: 353-416; 1958.
- Daubenmire, R. Ecology of fire in grasslands. J.B. Cragg, ed. Advances in ecological research. Vol. 5. New York: Academic Press; 1968: 209-266.
- Davis, E.M. An investigation of tertiary estuary productivity and nutrient optimization in Texas coastal waters. Houston, TX: University of Texas at Houston School of Public Health, Institute of Environmental Health; Report to the Texas Water Development Board IAC-(72-73)-909; 1973; 355 p.
- Davis, E.M.; Downs, T.D.; Gray, W.G. Ammonia in Texas streams during low flow from municipal wastewater. Water Resources Bull. 14: 1417-1422; 1978.
- Davis, R.A., Jr. Beach changes on the central Texas coast associated with hurricane Fern, September, 1971. Contrib. Mar. Sci. 16: 89-98; 1972.
- Day, J.W., Jr.; Butler, T.J.; Conner, W.H. Productivity and nutrient export studies in a cypress swamp and lake system in Louisiana. M. Wiley, ed. Estuarine Processes. Vol. II. New York: Academic Press; 1977.
- Day, J.W., Jr.; Conner, W.H.; Kemp, G.P. Contribution of wooded swamps and bottomland forests to estuarine productivity. Fore, P.L.; Peterson, R.D., eds. Proceedings of the Gulf of Mexico Coastal Ecosystem Workshop. Albuquerque, NM: U.S. Fish and Wildlife Service; FWS/OBS-80/30; 1980; 214 p.
- Day, J.W., Jr.; Smith, W.G.; Wagner, P.; Stowe, W. Community structure and carbon budget in a salt marsh and shallow bay estuarine system in Louisiana. Baton Rouge, LA: Louisiana State University, Center for Wetland Resources; LSU-SG-72-04; 1973; 30 p.
- Defenbaugh, R.E. A study of the benthic macroinvertebrates of the continental shelf of the northern Gulf of Mexico. College Station, TX: Texas A&M University; 1976. 476 p. Dissertation.
- de la Cruz, A.A. Recent advances in our understanding of salt marsh ecology. Fore, P.L.; Peterson, R.D., eds. Proceedings of the Gulf of Mexico coastal ecosystems workshop. Albuquerque, NM: U.S. Fish and Wildlife Service; FWS-OBS-80-30; 1980; 214 p.
- Delaune, R.D.; Patrick, W.H.; Brannon, J.M. Nutrient transformations in Louisiana salt marsh soils. Baton Rouge, LA: Louisiana State University, Center for Wetland Resources; LSU-SG-T-76-009; 1976.

- Diener, R. A. Observations on the hydrology and marine organisms of the tidal Colorado River and adjacent waters, Texas, February-June 1962. *Contrib. Mar. Sci.* 17: 99-110; 1972.
- Dineen, C.F.; Darnell, R.M. The effects of dredging on food habits of fishes of San Antonio Bay. A.H. Bouma, ed. *Shell dredging and its influence on Gulf Coast environments*. Houston, TX: Gulf Publishing Co.; 1976: 345-355.
- Dougherty, J.P. Suspended-sediment load of Texas streams: compilation report October 1971 - September 1975. Austin, TX: Texas Dept. of Water Resources; Report no. 233; 1979; 82 p + map.
- Dugdale, R. C. Nutrient limitation in the sea: dynamics, identification, and significance. *Limnol. Oceanogr.* 12: 685-695; 1967.
- Dunstan, W.M. Problems of measuring and predicting influence of effluents on marine phytoplankton. *Env. Sci. and Tech.* 9: 635-638; 1975.
- Edwards, P. Illustrated guide to the seaweeds and seagrasses in the vicinity of Port Aransas, Texas. *Contrib. Mar. Sci.* 15(suppl.); 1970; 128 p.
- Edwards, P. Illustrated guide to the seaweeds and sea grasses in the vicinity of Port Aransas, Texas. Austin, TX: University of Texas Press; (previously published as a supplement to vol. 15 of *Contrib. Mar. Sci.*, 1970); 1976.
- Edwards, P.; Kaprun, D.F. Benthic marine algal ecology in the Port Aransas, Texas area. *Contrib. Mar. Sci.* 17: 15-52; 1973.
- Eigsti, S. L. The coastal diurnal wind cycle at Port Aransas, Texas. Austin, TX: University of Texas at Austin, Atmospheric Science Group; Report no. 48; 1978; 19 p.
- Ellison, L. Influence of grazing on plant succession of rangelands. *Bot. Rev.* 26(1): 1-78; 1960.
- Eleuterius, L.N. A study of plant establishment on spoil areas in Mississippi Sound and adjacent waters. Mobile, AL: Originators Rep. No. FR-74, U.S. Army Corps of Engineers; 1974; 327 p.
- Environmental Protection Agency. Report on Lake Corpus Christi, Jim Wells, Live Oak and San Patricio counties, Texas. EPA Region IV Working Paper no. 641; 1977; 16 p + ap.
- Environmental Protection Agency. Quality Criteria for Water. EPA-440/9-76-023; 1976; 501 p.
- Espey, Huston and Associates. A study of the placement of materials dredged from Texas ports and waterways. Vol 1. Austin, TX: General Land Office, Coastal Management Program; 1976.

- Falco, P.K.; Cali, F.J. Pregermination requirements and establishment techniques for salt marsh plants. Vicksburg, MS: U.S. Army Corps of Engineers Waterways Exp. Sta.; Tech. Rep. D-77-1 DMRP; 1977; 44 p.
- Fanning, C.D.; Lyles, L.; Salt concentration of rainfall and shallow groundwater across the lower Rio Grande valley. J. Geophysical Research 69: 599-604; 1964.
- Fedler, T. Fishing the Texas surf. College Station, TX: Texas A&M University, Sea Grant College Program; TAMU-SG-79-605; 1978.
- Fillos, J.; Molof, A.H. Effect of benthal deposits on oxygen and nutrient economy of flowing waters. J. Water Pollution Control Federation 44(4): 644-662; 1972.
- Fisher, W. L.; McGowen, J.H.; Brown, L.F., Jr.; Groat, C.G. Environmental Geologic Atlas of the Texas Coastal Zone, Galveston: Houston Area. Austin, TX: University of Texas at Austin, Bureau of Economic Geology; 1972; 91 p.
- Fore, P.L.; Peterson, R.D., eds. Proceedings of the Gulf of Mexico coastal ecosystems workshop. Albuquerque, NM: U.S. Fish and Wildlife Service; FWS-OBS-80-30; 1980; 214 p.
- Forrester, J.W. Industrial dynamics. Cambridge, MA: M.I.T. Press; 1961.
- Fotheringham, N.; Brunenmeister, S. Common marine invertebrates of the northwestern Gulf Coast. Houston, TX: Gulf Publishing Co.; 1975; 197 p.
- Fruh, E.G.; Maguire, B., Jr.; Schmidt, P.S. Before and after studies on the effects of a power plant installation on lake Lyndon B. Johnson: after studies. Austin, TX: University of Texas at Austin, Center for Research in Water Resources; Final Report to the Lower Colorado River Authority; 1977.
- Fruh, E. G. Methodology to evaluate alternative coastal zone management policies: application in the Texas coastal zone. Example application III. Environmental and economic impacts of recreational community development, Mustang Island and North Padre Island. Austin, TX: University of Texas at Austin, Center for Research in Water Resources; 1977; 2 vols.
- Gallagher, J.L.; Plumley, F.G.; Wolf, P.L. Underground biomass dynamics and substrate selective properties of Atlantic coastal salt marsh plants. Vicksburg, MS: U.S. Army Corps of Engineers Waterways Exp. Sta.; Tech. Rep. D-77-28 DMRP; 1977; 131 p.
- Galtsoff, P.S. The American oyster, Crassostrea virginica Gmelin. Fishery Bull. Fish & Wild. Serv., U.S., 64: 1-480; 1964.
- Garbish, E.W., Jr.; Woller, P.B.; McCallum, R.J. Salt marsh establishment and development. Fort Belvoir, VA: U.S. Army Corps of Engineers Coastal Eng. Res. Cent.; Tech. Mem. 52; 1975; 110 p.

- Geyer, R.A., ed. Naturally occurring hydrocarbon seeps in the Gulf of Mexico and Caribbean Sea. College Station, TX: Texas A&M University, Oceanography Dept.; 1978; 19 p.
- Gillard, R.M. An ecological study of an oyster population, including selected associated organisms in West Bay, Galveston, Texas. College Station, TX: Texas A&M University; 1969. 136 p. Thesis.
- Gilliland, M.W.; Risser, P.G. The use of systems diagrams for environmental impact assessment: procedures and an application. Ecological Modeling 3: 183\_209; 1977.
- Gosselink, J.G.; Hopkinson, C.S., Jr.; Parrondo, R.T. Common marsh plant species of the Gulf Coast area. Vol. II: Growth dynamics. Vicksburg, MS: U. S. Army Corps of Engineers Waterway Exp. Sta.; Tech. Rep. D-77-44, DMRP; 1977; 56 p.
- Gould, F.W. Texas plants: a checklist and ecological summary. College Station, TX: Texas A&M University, Texas Agri. Exp. Sta.; MP-585/Revised; 1975.
- Grave, C. The oyster reefs of North Carolina. Johns Hopkins Circ. no. 151; 1901; 9 p.
- Greig, R.A.; Wenzloff, D.R. Metal accumulation and depuration by the American oyster, Crassostrea virginica. Bull. Envir. Contam. Toxicol. 20(4): 4 9-504; 1978.
- Grubb, H. W. Water issues in Texas agriculture. College Station, TX: Texas A&M University, Texas Agri. Exp. Sta.; Rep. no. MP-1485; 1981. 14 p.
- Gunnison, D. Mineral cycling in salt marsh-estuarine ecosystems. Vicksburg, MS: U.S. Army Corps of Engineers Waterways Exp. Sta.; Tech. Rep. D-78-3 DMRP; 1978; 142 p.
- Gunter, G. Studies on marine fishes of Texas. Pub. Inst. Mar. Sci. 1: 1-190; 1945.
- Gunter, G. Seasonal population changes and distributions, as related to salinity, of certain invertebrates of the Texas coast, including the commercial shrimp. Pub. Inst. Mar. Sci. 1(2): 7-51; 1950.
- Gunter, G. Population studies of the shallow water fishes of an outer beach in south Texas. Pub. Inst. Mar. Sci. 5: 186-193; 1958.
- Gunter, G.; Geyer, R.A. Studies on fouling organisms of the northwestern Gulf of Mexico. Pub. Inst. Mar. Sci. 4: 37-68; 1955.
- Haley, S.R. Reproductive biology of the Texas ghost crab, Ocypode albicans Bosc, (Decapoda: Ocypodidae). Austin, TX: University of Texas at Austin; 1967. 134 p. Dissertation.

- Hall, C.A.S.; Day, J.W., Jr.; Odum, H.T. A circuit language for energy and matter. Hall, C.A.S.; Day, J.W., Jr. (eds.). Ecosystem modeling in theory and practice. New York, NY: John Wiley and Sons, Inc.; 1977; 38-48.
- Hall, G. L.; Bouma, A.H.; Huebner, G.L., Jr. Overall circulation and tides in San Antonio Bay. A. H. Bouma, ed. Shell dredging and its influence on Gulf Coast environments. Houston, TX: Gulf Publishing Co.; 1976: 71-78.
- Halliermeir, R.J. Calculating a yearly limit depth to the active beach profile. Fort Belvoir, VA: U.S. Army Corps of Engineers, Coastal Engineering Research Center; TP 77-9; 1977; 28 p.
- Hann, R.W.; Withers, R.E., Jr.; Burnett, N.C.; Allison, R.C.; Nolley, B.W. Pilot field and analytical studies of the Corpus Christi Ship Channel and contiguous waters. College Station, TX: Texas A&M University; Final Report to the Texas Water Quality Board for Contract IAC (72-73) 156 Project 1906; 1972.
- Harrel, R. C.; Ashcraft, J.; Howard, R.; Patterson, L. Stress and community structure of macrobenthos in a Gulf Coast riverine estuary. Contrib. Mar. Sci. 20: 69-85; 1976.
- Hasler, A.D. (ed.). Coupling of land and water systems. New York, NY: Springer-Verlag; 1975; 309 p.
- Hayes, M. O. Sedimentation on a semiarid, wave-dominated coast (south Texas) with emphasis on hurricane effects. Austin, TX: University of Texas at Austin; 1965. 350 p. Dissertation.
- Hedgpeth, J.W. An introduction to the zoogeography of the northwestern Gulf of Mexico with reference to the invertebrate fauna. Pub. Inst. Mar. Sci. 3: 107-224; 1953.
- Hill, G.W.; Hunter, R.E. Burrows of the ghost crab, Ocypode quadrata (Fabricus), on the barrier islands, south-central Texas coast. J. Sedimentary Petrology, 43(1): 24-30; 1973.
- Heffernan, T.L. An ecological evaluation of some tributaries of the Aransas Bay area. Austin, TX: Texas Parks and Wildlife Dept.; Coastal Fisheries Project Reports 1969-1970; 1970: 23-125.
- Heidinger, R.C. Synopsis of biological data on the largemouth bass Micropterus salmoides (Lacepede) 1802. FAO Fisheries Symposia no. 115; 1976; 85 p.
- Henderson, G.A.; Harcombe, P. Net primary productivity of the Chambers County marshes. P. Rowe, project director. Environmental analysis for development planning in Chambers County, Texas. Vol 7. Houston, TX: Rice University; 1976: 139-151.
- Hendry, C.D.; Brezonik, P.L. Chemistry of precipitation at Gainesville, Florida. Env. Sci. Tech. 14: 843-849; 1980.

- Henningson, Durham and Richardson, Inc. Phase 3 final report: additional studies on freshwater needs of fish and wildlife resources in Nueces-Corpus Christi Bay area, Texas: data report. Austin, TX: Henningson, Durham and Richardson; Report to U. S. Fish and Wildlife Service on Contract no. 14-16-0009-77-074; 1979; 543 p.
- Hillaker, H.J., Jr.; Jehn, K.H. Atlas of water balance computations for 48 Texas coastal zone stations, 1941-1970. Austin, TX: University of Texas at Austin, Atmospheric Science Group; Report no. 50; 1978; 92 p.
- Hoese, H.D. Spawning of marine fishes in the Port Aransas, Texas area as determined by the distribution of young and larvae. Austin, TX: University of Texas at Austin; 1965. 144 p. Dissertation.
- Hoese, H.D. Effect of higher than normal salinities on salt marshes. *Contrib. Mar. Sci.* 12: 249-261; 1967.
- Hoffstetter, R.P. Oyster studies along the Texas coast: 1967. Austin, TX: Texas Parks and Wildlife Dept.; Coastal Fisheries Proj. Rept. 1967; 1967; 49 p.
- Hoffstetter, R.P. Oyster studies along the Texas coast. Austin, TX: Texas Parks and Wildlife Dept.; Coastal Fisheries Proj. Rep. 1968; 1968: 23-33.
- Hoffstetter, R.P. Trends in population levels of the American oyster, Crassostrea virginica Gmelin, on public reefs in Galveston Bay, Texas. Austin, TX: Texas Parks and Wildlife Dept.; Tech. Series no. 24.; 1977; 86 p.
- Holland, J.S.; Maciolek, N.J.; Oppenheimer, C.H. Galveston Bay benthic community structure as an indicator of water quality. *Contrib. Mar. Sci.* 17: 169-188; 1973.
- Holland, J.S.; Maciolek, N.J.; Kalke, R.D.; Mullins, L.; Oppenheimer, C.H. The benthos and plankton study of the Corpus Christi, Copano and Aransas Bay system. III. Report on data collected during the period July 1974 - May 1975 and summary of the three year project. Port Aransas, TX: University of Texas Marine Science Institute; Final Report to Texas Water Development Board; 1975; 174 p.
- Holland, J.S. Benthic invertebrates: macrofauna and epifauna. Environmental studies, South Texas outer continental shelf, biology and chemistry. Port Aransas, TX: University of Texas Marine Science Institute; Final Report for 1977 to the Bureau of Land Management, Washington, D.C. on Contract AA550-CT7- 11; 1979: 17-1 to 17-56.
- Holmes, C.W.; Slade, E.A.; McLerran, C.J. Migration and distribution of zinc and cadmium in marine estuarine systems. *Env. Sci. and Tech.* 8(3): 255-259; 1974.



- Holt, G.J.D. Community structure of macro-zooplankton in Trinity and upper Galveston bays, with special reference to the cooling water system of Cedar Bayou electric generating station. College Station, TX: Texas A&M University; 1976; 95 p.
- Humm, H.J.; Bert, T.M. The benthic marine algae of Timbalier Bay, Louisiana. C. H. Ward, M. E. Bender, and D. J. Reish, eds. The offshore ecology investigation. Houston, TX: Rice University; Rice University Studies 65(4,5); 1979: 379-399.
- James, W.P.; Giesler, S.; DeOtte, R.; Inoue, M. Environmental considerations relating to operation and maintenance of the Texas Gulf Intracoastal Waterway. College Station, TX: Texas A&M University, Sea Grant Program; TAMU-SG-78-204; 1977.
- Jehn, K. H. The role of the atmospheric sciences in the Texas coastal zone. Austin, TX: University of Texas at Austin, Atmospheric Science Group; Report no. 40; 1974; 70 p.
- Johansen, P.L. Ciliated protozoa. Environmental studies, south Texas continental shelf, biology and chemistry. Port Aransas, TX: University of Texas Marine Science Institute at Port Aransas; Final Report for 1977 to the Bureau of Land Management, Washington D.C. on Contract AA550-CT7-11. 1979: 13-1 to 13-40.
- Johnson, R.B., Jr. Ecological changes associated with the industrialization of Cedar Bayou and Trinity Bay, Texas. Austin, TX: Texas Parks and Wildlife Dept.; Tech. Series no. 16; 1974; 80 p.
- Johnston, M.C. Past and present grasslands of south Texas and northeastern Mexico. *Ecol.* 44: 456-465; 1963.
- Jones, D.K. Organic and inorganic carbon in the recent sediments of the open Gulf, barrier island and bay environments, Mustang Island, Texas. Austin, TX: University of Texas at Austin; 1960. 58 p. Thesis.
- Jones, R.S. Fish stocks from a helicopter-borne purse net sampling of Corpus Christi Bay, Texas 1962-1963. *Pub. Inst. Mar. Sci.* 10: 68-75; 1965.  
 Jones, R.S.; Copeland, B.J.; Hoese, H.D. A study of the hydrography of inshore waters in the western Gulf of Mexico off Port Aransas, Texas. *Pub. Inst. Mar. Sci.* 10: 22-32; 1965.
- Judd, F.W.; Lonard, R.I.; Sides, S.L. The vegetation of South Padre Island, Texas in relation to topography. *Southwestern Naturalist* 22(1): 31-48; 1977.
- Kamykowski, D.; Van Baalen, C. Phytoplankton and productivity. Environmental studies, south Texas outer continental shelf, biology and chemistry. Port Aransas, TX: University of Texas Marine Science Institute at Port Aransas; Final Report for 1977 to the Bureau of Land Management, Washington, D.C. on Contract AA550-CT7- 11; 1979: 11-1 to 11-57.

- Kanwisher, J. On the exchange of gases between the atmosphere and the sea. Deep Sea Research 10: 195-207; 1963.
- Kapraun, D.F. Summer aspect of algal zonation on a Texas jetty in relation to wave exposure. Contrib. Mar. Sci. 23: 101-109; 1980.
- Kattner, K.R. Secondary successional vegetation on Padre Island National Seashore. Kingsville, TX: Texas A&I University; 1973. 70 p. Thesis.
- Keefe, C.W. Marsh production: a summary of the literature. Contrib. Mar. Sci. 16: 163-181; 1972.
- Keiser, R.K., Jr.; Aldrich, D.V. Salinity preference of postlarval brown and white shrimp (Penaeus aztecus and P. setiferus) in gradient tanks. College Station, TX: Texas A&M University, Sea Grant Program; TAMU-SG-75-228; 1976.
- Kemp, W.M.; Smith, W.H.B.; McKellar, H.N.; Lehman, M.E.; Homer, M.; Young, D.L.; Odum, H.T. Energy cost-benefit analysis applied to power plants near Crystal River, Florida. Hall, C.A.S.; Day, J.W., Jr. (eds.). Ecosystem modeling in theory and practice. New York, NY: John Wiley and Sons, Inc.; 1977; p. 508-543.
- King, B.D. Study of migratory patterns of fish and shellfish through a natural pass. Austin, TX: Texas Parks and Wildlife Department; Tech. Series no. 9; 1971; 54 p.
- Klaassen, H.E.; Marzolf, G.R. Relationships between distributions of benthic insects and bottom-feeding fishes in Tuttle Creek reservoir. G.E. Hall, ed. Reservoir Fisheries and Limnology. Bethesda, MD: American Fisheries Society; Special Publication no. 8; 1971: 385-395.
- Komar, P.D. Beach processes and sedimentation. Englewood Cliffs, NJ: Prentice Hall, Inc.; 1976; 429 p.
- Kremer, J.N.; Nixon, S.W. A coastal marine ecosystem, simulation and analysis. New York, NY: Springer-Verlag; 1978; 217 p.
- Ladd, H.S. Brackish-water and marine assemblages of the Texas coast, with special reference to mollusks. Pub. Inst. Mar. Sci. 2(1): 125-163; 1951.
- Landin, M.C. Annotated tables of vegetation growing on dredged material throughout the United States. Vicksburg, MS: U.S. Army Corps of Engineers Waterways Exp. Sta.; Misc. Paper D-78-7 DMRP; 1978; 155 p.
- Lee, C.R., Hoepfel, R.E.; Hunt, P.G.; Carlson, C.A.. Feasibility of the functional use of vegetation to filter, dewater and remove contaminants from dredged material. Vicksburg, MS: U.S. Army Corps of Engineers Waterways Exp. Sta.; Tech. Rep. D-761-4 DMRP; 1976.

- Lee, C.R.; Smart, R.M.; Sturgis, T.C.; Gordon, R.N., Sr.; Landin, M.C. Prediction of heavy metal uptake by marsh plants based on chemical extraction of heavy metals from dredged material. Vicksburg, MS: U.S. Army Corps of Engineers Waterways Exp. Sta.; Tech. Rep. D-78-6 DMRP; 1978; 105 p.
- Lee, C.R.; Sturgis, T.C.; Landin, M.C. A hydroponic study of heavy metal uptake by selected marsh plant species. Vicksburg, MS: U.S. Army Corps of Engineers Waterways Exp. Sta.; Tech. Rep. D-76-5 DMRP; 1976.
- Liebow, E. B.; Butler, K.S.; Plaut, T.R.; Arnold, V.L.; Ford, G.H.; Kahn, T.D.; Klein, M.A.; Allday-Bondy, C.; Parker, V. Texas barrier islands region ecological characterization: a socioeconomic study. Vol 1: synthesis papers. Washington, DC: U.S. Fish and Wildlife Service, Office of Biological Services; FWS/OBS-80/19; 1980.
- Lind, O.T. The organic matter budget of a central Texas reservoir. G.E. Hall ed. Reservoir fisheries and limnology. Bethesda, MD: American Fisheries Society; Special Publication no. 8; 1971: 193-202.
- Lind, W.B.; Ratzlaff, K.W. Chemical and physical characteristics of water in estuaries of Texas: October 1973 - September 1974. Austin, TX: Texas Dept. of Water Resources; Report no. 231; 1979; 217 p.
- Lindgren, E. W. Treated piling systems. Odum, H.T.; Copeland, B.J.; McMahan, E.A. Coastal ecological systems of the United States. Washington, DC: The Conservation Foundation; 1974; 4 vols.
- Lindner, M.J.; Bailey, J.S. Distribution of brown shrimp Penaeus aztecus aztecus Ives as related to turbid water photographed from space. Fishery Bull. 67: 289-294; 1968.
- Lindner, M.J.; Cook, H.L. Synopsis of biological data on the white shrimp Penaeus setiferus (Linnaeus) 1767. FAO Fish. Rep. 57(4): 1439-1469; 1970.
- Liou, Y.; Herbich, J.B. Sediment movement induced by ships in restricted waterways. College Station, TX: Texas A&M University, Sea Grant Program; TAMU-SG-76-209; 1976; 85 p.
- Loesch, H.C. Studies of the ecology of two species of Donax on Mustang Island, Texas. Pub. Inst. Mar. Sci. 4(2): 201-227; 1957.
- Lund, E.J. A quantitative study of clearance of a turbid medium and feeding by the oyster. Pub. Inst. Mar. Sci. 4(2): 296-312; 1957a.
- Lund, E.J. Self-silting, survival of the oyster as a closed system, and reducing tendencies of the environment of the oyster. Pub. Inst. Mar. Sci. 4(2): 315-319; 1957c.
- Lund, E.J. Effect of bleedwater "soluble fraction" and crude oil on the oyster. Pub. Inst. Mar. Sci. 4(2): 328-341; 1957d.

- Lunz, J.D.; Zeigler, T.W.; Huffman, R.T.; Diaz, R.J.; Clairain, E.J.; Hunt, L.J. Habitat development field investigations: Windmill Point Marsh development site, James River, Virginia. Summary Report. Vicksburg, MS: U.S. Army Corps of Engineers Waterways Exp. Sta.; Tech. Rep. D-77-23 DMRP; 1978; 116 p.
- Macan, T.T. Freshwater ecology. New York, NY: John Wiley & Sons; 1966; 338 p.
- Mang, J.L.; Lu, J.C.S.; Lofy, R.J.; Stearns, R.P. A study of leachate from dredged material in upland areas and/or in productive uses. Vicksburg, MS: U.S. Army Corps of Engineers Waterways Exp. Sta.; Tech. Rep. D-78-20 DMRP; 1978; 435 p.
- Masch, F.D.; Espey, W.H., Jr. Shell dredging. A factor in sedimentation in Galveston Bay. Austin, TX: University of Texas at Austin, Center for Research in Water Resources; Tech. Rep. HYD 06-6702 CRWR-7; 1967.
- Matta, J.F. Beach fauna study of the CERC field research facility, Duck, North Carolina. Fort Belvoir, VA: U. S. Coastal Engineering Research Center; Misc. Report no. 77-6; 1977; 102 p.
- Maurer, L.G. The nearshore distribution and macromolecular contents of the dissolved organic matter of Texas estuarine and Gulf of Mexico water. Austin, TX: University of Texas at Austin; 1971. 96 p. Dissertation.
- Maurer, L.G.; Parker, P.L. A study of the geochemistry of vitamin B12. Contrib. Mar. Sci. 13: 29-43; 1968.
- Maurer, L.G.; Parker, P.L. The distribution of dissolved organic matter in the near-shore waters of the Texas coast. Contrib. Mar. Sci. 16: 109-124; 1972.
- May, E.B. Environmental effects of hydraulic dredging in estuaries. Dauphin Island, AL: Alabama Marine Resources Laboratory; Alabama Marine Resources Bull. no. 9; 1973; 85 p.
- McAtee, J.W.; Drawe, D.L. A preliminary study of human impact on the vegetation and microclimate of the beach and foredunes on Padre Island National Seashore. Transactions Southwest Regional Natural Science Conference, National Park Service (November 19-21, 1974): 97-136; 1974.
- McCarley, S. Water quality segment report for segment no. 1901, San Antonio River. Austin, TX: Texas Water Quality Board; Report no. WQS-1; 1975; 27 p + ap.
- McCullough, J.D. A study of phytoplankton primary productivity and nutrient concentrations in Livingston Reservoir, Texas. Tex. J. Sci. 30: 377-87; 1978.
- McFarland, W.N. Seasonal plankton productivity in the surf zone of a south Texas beach. Pub. Inst. Mar. Sci. 9: 77-90; 1963a.

- McFarland, W.N. Seasonal changes in the number and the biomass of fishes from the surf at Mustang Island, Texas. Pub. Inst. Mar. Sci. 9: 91-105; 1963b.
- McGowen, J.H.; Brown, L.F., Jr.; Evans, T.J.; Fisher, W.L.; Groat, C.G. Environmental geologic atlas of the Texas coastal zone: Bay City-Freeport area. Austin, TX: University of Texas at Austin, Bureau of Economic Geology; 1976a; 98 p + 9 maps.
- McGowen, J.H.; Byrne, J.R.; Wilkinson, B.H. Geochemistry of bottom sediments, Matagorda Bay system, Texas. Austin, TX: University of Texas at Austin, Bureau of Economic Geology; 1979; 64 p.
- McGowen, J.H.; Proctor, C.V., Jr.; Brown, L.F., Jr.; Evans, T.J.; Fisher, W.L.; Groat, C.G. Environmental geologic atlas of the Texas coastal zone: Port Lavaca area. Austin, TX: University of Texas at Austin, Bureau of Economic Geology; 1976b; 107 p + 9 maps.
- McMahan, E.A. Oil Shores. Odum, H.T.; Copeland, B.J.; McMahan, E.A., eds. Coastal ecological systems of the United States. Vol III. Washington, DC: The Conservation Foundation; 1974: 280-300.
- Menzel, R.W. Some phases of the biology of Ostrea equestris Say and a comparison with Crassostrea virginica Gmelin. Pub. Inst. Mar. Sci. 4(1): 69-153; 1955.
- Menzel, R.W.; Hulings, N.C.; Hathaway, R.R. Oyster abundance in Apalachicola Bay, Florida in relation to biotic associations influenced by salinity and other factors. Gulf. Res. Reports 2(2): 73-96; 1965.
- Minzenmayer, F. U.S. Soil Conservation Service, Alice, Texas. [ Letter to Dr. W.B. Brogden, Port Aransas, TX.] 1981.
- Montague, C.L. A natural history of temperate western Atlantic fiddler crabs (genus Uca) with reference to their impact on the salt marsh. Contrib. Mar. Sci. 23: 25-55; 1980.
- Moore, R.H. Age, growth, respiration and general ecology of the mullets, Mugil cephalus and Mugil curema, on the south Texas coast. Austin, TX: University of Texas at Austin; 1973. 180 p. Dissertation.
- Moore, R. H. General ecology, distribution and relative abundance of Mugil cephalus and Mugil curema on the south Texas coast. Contrib. Mar. Sci. 18: 241-255; 1974.
- Morisawa, M. 1968. Streams--their dynamics and morphology. New York, NY: McGraw-Hill Book Company; 1968.
- Mosser, J.L.; Fisher, N.S.; Wurster, C.F. Polychlorinated biphenyls and DDT alter species composition in mixed cultures of algae. Science 176: 533-535; 1972.

- Nedwell, D.B.; bin Abdul Aziz, A.B. Heterotrophic nitrogen fixation in an intertidal saltmarsh sediment. *Estuarine Coast. Mar. Sci.* 10: 699-702; 1980.
- Ocean Data Systems, Inc. Handbook for terrestrial wildlife habitat development on dredged material. Vicksburg, MS: U.S. Army Corps of Engineers Waterways Exp. Sta.; Tech. Rep. D-78-37 DMRP; 1978; 380 p.
- Odum, E.P. *Fundamentals of ecology*. Philadelphia, PA: W.B. Saunders Company; 1971; 574 p.
- Odum, H.T. Biological circuits in the marine systems of Texas. Olson, T.A.; Burgess, F.J. (eds.). *Proceedings of the conference on the status of knowledge, critical research needs, and potential research facilities relating to ecology and pollution problems in the marine environment*. New York, NY: John Wiley and Sons, Inc.; 1967; p. 99-157.
- Odum, H.T. *Environment, power, and society*. New York, NY: John Wiley and Sons, Inc.; 1971; 331 p.
- Odum, H.T. An energy circuit language for ecological and social systems: its physical basis. Patten, B.C. (ed.). *Systems analysis and simulation in ecology*. Vol. II. New York, NY: Academic Press; 1972a; p. 139-211.
- Odum, H.T. Use of energy diagrams for environmental impact statements. In: *Tools for coastal management. Proceeding of the Conference*. Washington, DC: Marine Technology Society; 197-213; 1972b.
- Odum, H.T. Energy, ecology, and economics. *Ambio* 2(6): 220-227; 1973.
- Odum, H.T. Combining energy laws and corollaries of the maximum power principle with visual systems mathematics. *SIAM Institute for Mathematics and Society; Proceedings of a Conference on Ecosystem Analysis and Prediction*, July 1-4, 1974, Alta, Utah; 1974; 239-263.
- Odum, H.T. Energy analysis, energy quality, and environment. Gilliland, M.W. (ed.). *Energy analysis: a new public policy tool*. Washington, DC: American Association for the Advancement of Science; AAAS Selected Symposium 9: 55-87; 1978a.
- Odum, H.T. Energy quality control of ecosystem design. Columbia, SC: University of South Carolina Press; Belle Baruch Library in Marine Science no. 9: 221-235; 1978b.
- Odum, H.T.; Odum, E.C. *Energy basis for man and nature*. New York, NY: McGraw-Hill; 1976; 292 p.
- Odum, H.T.; Siler, W.L.; Beyers, R.J.; Armstrong, N. Experiments with engineering of marine ecosystems. *Pub. Inst. Mar. Sci.* 9: 373-403; 1963.
- Odum, H.T.; Wilson, R.F. Further studies on reaeration and metabolism of Texas bays, 1958-1960. *Pub. Inst. Mar. Sci.* 8: 23-55; 1962.

- Odum, W.E. Utilization of the direct grazing and plant detritus food chains by the striped mullet Mugil cephalus. Steele, J.H., ed. Marine Food Chains. Berkeley, CA: University of Calif. Press; 1970: 222-240.
- Omernik, J.M. The influence of land use on stream nutrient levels. U.S. Environmental Protection Agency; Report EPA-600/3-7-014; 1976; 112 p.
- Oosting, H.; Billings, W. Factors effecting vegetational zonation on coastal dunes. *Ecol.* 23: 131-142; 1942.
- Oppenheimer, C.H.; Jannasch, H.W. Some bacterial populations in turbid and clear sea water near Port Aransas, Texas. *Pub. Inst. Mar. Sci.* 8: 56-60; 1962.
- Oppenheimer, C.H.; Gordon, K.G. Texas coastal zone biotopes: an ecography. Port Aransas, TX: University of Texas Marine Science Institute at Port Aransas; Interim Report for the Bay and Estuary Management Program of the Office of the Governor; 1972.
- Oujesky, H.V.; Van Auken, O.W. Water column bacteriology. Environmental studies, south Texas outer continental shelf, biology and chemistry. Port Aransas, TX: University of Texas Marine Science Institute at Port Aransas; Final Report for 1977 to the Bureau of Land Management, Washington, D.C. on Contract AA550-CT7-11; 1979: 8-1 to 8-128.
- Overton, W.S. A strategy of model construction. Hall, C.A.S.; Day, J.W., Jr. (eds.). *Ecosystem modeling in theory and practice*. New York, NY: John Wiley and Sons, Inc.; 1977; p. 49-73.
- Palmisano, A. Plant community-soil relationships in Louisiana coastal marshes. Baton Rouge, LA: Louisiana State University; 1970. Thesis.
- Park, E.T. Zooplankton project. Environmental studies, south Texas outer continental shelf, biology and chemistry. Port Aransas, TX: University of Texas Marine Science Institute; Final Report for 1977 to the Bureau of Land Management, Washington, D.C. on Contract AA550-CT7-11; 1979; 14-1 to 14-58.
- Parker, J. C. The biology of the spot, Leiostomus xanthurus Lacepede, and Atlantic croaker, Micropogon undulatus (Linnaeus), in two Gulf of Mexico nursery areas. College Station, TX: Texas A&M University, Sea Grant Program; TAMU-SG-71-210; 1971.
- Parker, F.R.; Bailey, C.M. Massive aggregations of elasmobranchs near Mustang and Padre Islands, Texas. *Texas Jour. Sci.* 31(3): 255-266; 1979.
- Parker, P.L.; Gibbs, A.; Lawler, R. Cobalt, iron, and manganese in a Texas bay. *Pub. Inst. Mar. Sci.* 9: 28-32; 1963.

- Parnell, J.F.; DuMond, D.M.; Needham, R.N. A comparison of plant succession and bird utilization on diked and undiked dredge material islands in North Carolina estuaries. Vicksburg, MS: U.S. Army Corps of Engineers Waterways Exp. Sta.; Tech. Rep. D-78-9 DMRP; 1978; 350 p.
- Pearse, A.S.; Humm, H.J.; Wharton, G.W. Ecology of sand beaches at Beaufort, N.C. Ecological Monographs 12(2): 135-190; 1942.
- Pearson, J.C. Natural history and conservation of the redfish and other commercial sciaenids on the Texas coast. Washington, DC: Bureau of Fisheries; Bull. Bur. Fish. vol. XLIV; 214 p.
- Peterson, C.H.; Peterson, N.M. The ecology of intertidal flats of North Carolina: a community profile. Washington, DC: U.S. Fish and Wildlife Service, Office of Biological Services; FWS-OBS-79-39; 1979; 73 p.
- Petrick, D. Intensive surface water monitoring survey for Chiltipin Creek. Austin, TX: Texas Water Quality Board; Report no. IMS-40; No Date; 32 p + ap.
- Phillips, R.E.; Blevins, R.L.; Thomas, G.W.; Frye, W.W.; Phillips, S.H. No-tillage agriculture. Science 208: 1108-13; 1980.
- Pickard, G.L. Descriptive physical oceanography: an introduction. London: Pergamon Press; 1963; 199 p.
- Pimentel, D., ed. Handbook of energy utilization in agriculture. Boca Raton, FL: CRC Press; 1980.
- Pimentel, D.; Moran, M.A.; Fast, S.; Weber, G.; Bukantis, R.; Balliett, L.; Boveng, P.; Cutler, C.; Hindman, S.; Young, M. Biomass energy from crop and forest residues. Science 212: 1110-15; 1981.
- Piwoni, M.D.; Lee, G.F. The role of man in the excessive fertilization of surface waters. Tex. J. Sci. 27: 477-487; 1976.
- Powers, L.W. Fiddler crabs in a nontidal environment. Contrib. Mar. Sci. 19: 67-78; 1975.
- Pulich, W.M. Ecology of a hypersaline lagoon: the Laguna Madre. Fore, P.L.; Peterson, R.D., eds. Proceedings of the Gulf of Mexico Coastal Ecosystems Workshop. Albuquerque, NM: U.S. Fish and Wildlife Service; FWS-OBS-80-30; 1980; 214 p.
- Pulich, W.M., Jr.; Winters, K.; Van Baalen, C. The effects of a no. 2 fuel oil and two crude oils on the growth and photosynthesis of microalgae. Marine Biology 28: 87-94; 1974.
- Rawson, J.; Chitwood, E.S. Water-quality records for selected reservoirs in Texas, 1974-75 water years. Austin, TX: Texas Department of Water Resources; 1979; 162 p.



- Renfro, W.C. Salinity relations of some fishes in the Aransas River, Texas. *Tulane Studies in Zoology*, 8: 83-91; 1960.
- Reynolds, T.D.; Hann, R.W., Jr.; Priebe, W.F.; Benthic oxygen demands of Houston Ship Channel sediments. College Station, TX: Texas A&M University, Sea Grant Program; TAMU-SG-73-204; 1973.
- Richards, F.A. Stratified estuaries. Odum, H.T.; Copeland, B.J.; McMahan, E.A., eds. *Coastal ecosystems of the United States. Vol II.* Washington, DC: The Conservation Foundation; 1974: 397-441.
- Riedl, R.; McMahan, E.A. High energy beaches. Odum, H.T.; Copeland, B.J.; E.A. McMahan, eds. *Coastal ecosystems of the United States. Vol I.* Washington, DC: The Conservation Foundation; 1974: 180-251.
- Risser, J. Soil erosion creates a crisis down on the farm. *Conservation Foundation Letter*, December, 1978: 16 p.
- Rogers, R.M. Distribution of meiobenthic organisms in San Antonio Bay in relation to season and habitat disturbance. Bouma, A.H., ed. *Shell dredging and its influence on Gulf Coast environments.* Houston, TX: Gulf Publishing Co.; 1976: 337-344.
- Rudy, K. C. A review of phytoplankton studies in Lake Livingston, Texas, Tex. *J. Sci.* 30: 271-282; 1978.
- Sackett, W.M.; Brooks, J.M. Low molecular weight hydrocarbons and hydrographic project. Environmental studies, south Texas outer continental shelf, biology and chemistry. Port Aransas, TX: University of Texas Marine Science Institute at Port Aransas; Final Report for 1977 to the Bureau of Land Management, Washington, D.C. on Contract AA550-CT7-11; 1979: 3-1 to 3-128.
- Sartor, J.D.; Boyd, G.B. Water pollution aspects of street surface contaminants. Washington, DC: U.S. Environmental Protection Agency; EPA-R2-72-081; 1972; 236 p.
- Schreiber, R.W.; Schreiber, E.A. Colonial bird use and plant succession on dredged material islands in Florida. Vol. I. Sea and wading bird colonies. Vicksburg, MS: U.S. Army Corps of Engineers Waterways Exp. Sta.; Tech. Rep. D-78-14 DMRP; 1978; 126 p.
- Schwarz, J.R. Benthic bacteriology. Environmental studies, south Texas outer continental shelf, biology and chemistry. Port Aransas, TX: University of Texas Marine Science Institute at Port Aransas; University of Texas, Final Report for 1977 to the Bureau of Land Management, Washington, D.C. on Contract AA550-CT7-11; 1979: 10-1 to 10-31.
- Scott, F.I., Jr. Soil fertility and farm economics. *American Laboratory* 10(7): 6-7; 1978.

- Seadock, Inc. Survey of sandy beach areas. Seadock Environmental Report. Chapt. 10: Technical Data. Houston, TX; Dames and Moore; Environmental Report for Seadock, Inc.; 1975: 10.4-485 to 10.4-531.
- Sealy, J.E., Jr.; Ahr, W.M. Quantitative analysis of shoreline change, Sargent, Texas. College Station, TX: Texas A&M University, Sea Grant Program; TAMU-SG-75-209; 1975.
- Seelig, W.N.; Sorensen, R.M. Historic shoreline changes in Texas. College Station, TX: Texas A&M University, Sea Grant Program; TAMU-SG-73-206; 1973; 19 p.
- Seelig, W.N.; Sorensen, R.M. Investigation of shoreline changes at Sargent Beach, Texas. College Station, TX: Texas A&M University, Sea Grant Program; TAMU-SG-73-212; 1973a.
- Sellards, E.H.; Adkins, W.S.; Plummer, F.B. The geology of Texas. Volume I. Stratigraphy. Austin, TX: University of Texas at Austin; The University of Texas Bull. no. 3232; 1932; 1007 p.
- Shane, S.H. The population biology of the Atlantic bottlenose dolphin, Tursiops truncatus in the Aransas Pass area of Texas. College Station, TX: Texas A&M University; 1977. 238 p. Thesis.
- Shelby, C.A. Radioactive fallout in sargassum drift on Texas Gulf Coast beaches. Pub. Inst. Mar. Sci. 9: 33-36; 1963.
- Shepard, F. P. Sedimentation rates in Texas estuaries and lagoons. Bull. A. A. P. G. 37: 1919-34; 1953.
- Shepard, F.P.; Rusnak, G.A. Texas Bay Sediments. Pub. Inst. Mar. Sci. 4(2): 3-13; 1957.
- Simmons, E.G.; Hoese, H.D. Studies on the hydrography and fish migrations of Cedar Bayou, a natural tidal inlet on the central Texas coast. Pub. Inst. Mar. Sci. 6: 56-80; 1959.
- Simmons, E.G.; Breuer, J.P. A study of redfish, Sciaenops ocellata Linnaeus and black drum Pogonias cromis Linnaeus. Pub. Inst. Mar. Sci. 8: 184-211; 1962.
- Smith, N. P. meteorological and tidal exchanges between Corpus Christi Bay, Texas, and the Northwestern Gulf of Mexico. Estuarine Coast. Mar. Sci. 5: 511-520; 1977.
- Smith, N.P. Intracoastal tides of Corpus Christi Bay. Contrib. Mar. Sci. 18: 206-219; 1974.
- Smith, N.P. Seasonal variations in nearshore circulation in the northwestern Gulf of Mexico. Contrib. Mar. Sci. 19: 49-65; 1975.

- Smith, N.P. Hydrographic project. Environmental studies, south Texas outer continental shelf, biology and chemistry. Port Aransas, TX: University of Texas Marine Science Institute; Final Report for 1977 to the Bureau of Land Management, Washington, D.C. on Contract AA550-CT7-11; 1979: 2-1 to 2-130.
- Snyder, B.; Longley, W.L.; Jackson, R.G. Ecological system diagrams: theory and construction. Austin, TX: Texas General Land Office, Coastal Management Program; Technical Paper No. 12; 1978; 91 p.
- Society of American Foresters. Forest cover types of North America. Bethesda, MD: Society of American Foresters; 1954.
- Soots, R.F., Jr.; Parnell, J.F. Ecological succession of breeding birds in relation to plant succession on dredge islands in North Carolina. Raleigh, NC: North Carolina Sea Grant Publ. UNC-SG-75-27; 1975.
- Sorensen, L.O.; Conover, J.T. Algal mat communities of Lyngbya confervoides (C. Agardh) Gromont. Pub. Inst. Mar. Sci. 8: 61-74; 1962.
- Spurr, S.H. Forest Ecology. New York, NY: The Roland Press Co.; 1964; 352 p.
- Stanley, D.W.; Hobbie, J.E. Nitrogen recycling in a North Carolina coastal river. Limnol. Oceanogr. 26: 30-42; 1981.
- Steed, D.L. Some aspects of organic carbon transport in the Guadalupe- San Antonio estuary, Texas. Austin, TX: University of Texas at Austin; 1971. Dissertation.
- Stewart, E.A.; Woolhiser, D.A.; Wischmeir, W.H.; Caro, J.H.; Frere, M.H. Control of water pollution from cropland. Volume I. A manual for guideline development. Washington, DC: U. S. EPA; Report no. EPA-600/2-75-026a; 1975; 111 p.
- Stewart, E.A.; Woolhiser, D.A.; Wischmeir, W.H.; Caro, J.H.; Frere, M.H. Control of water pollution from cropland. Volume II. An overview. Report no. EPA-600/2-75-026b; 1976; 187 p.
- Stokes, G. M. The distribution and abundance of penaeid shrimp in the Lower Laguna Madre of Texas, with a description of the live bait shrimp fishery. Austin, TX: Texas Parks and Wildlife Dept.; Tech. Series no. 15; 1974; 32 p.
- Szaniszlo, P.J. Water column and benthic microbiology - micology. Environmental studies, south Texas outer continental shelf, biology and chemistry. Washington, DC: University of Texas Marine Science Institute at Port Aransas; Final Report for 1977 to the Bureau of Land Management, Washington, D.C. on Contract AA550-CT7-11; 1979; 9-1 to 9-67.

- Tanner, W.F., ed. Sediment transport in the nearshore zone. Proceedings of a symposium at Tallahassee, FL. Tallahassee, FL: proceedings published jointly by Coastal Research Notes and the Dept. of Geology, Fla. State University; 1974; 147 p.
- Tansley, A.G. The use and abuse of vegetational concepts and terms. Ecology 47: 284-307; 1935.
- Texas Department of Water Resources. Continuing water resources planning and development for Texas: Phase 1—Planning methods, revised estimates of present water demand and availability, projections of future water needs, and identification of some potential sources of water supply for use in modifying and amending the Texas Water Plan. Austin, TX: Texas Department of Water Resources; draft report never reissued as a final report; 1977; 2 volumes.
- Texas Department of Water Resources. The influence of freshwater inflows upon the major bays and estuaries of the Texas Gulf Coast: Executive Summary. Austin, TX: Texas Department of Water Resources; LP-115; 1979.
- Texas Department of Water Resources. Trinity-San Jacinto estuary: an analysis of bay boundaries, physical characteristics, and nutrient processes. Austin, TX: Texas Department of Water Resources; LP-86; 1979; 115 p.
- Texas Department of Water Resources. Lavaca-Tres Palacios estuary: a study of the influence of freshwater inflows. Austin, TX: Texas Department of Water Resources; LP-106; 1980; 300 p.
- Texas Department of Water Resources. Guadalupe estuary: a study of the influence of freshwater inflows. Austin, TX: Texas Department of Water Resources; LP-107; 1980a; 300 p.
- Texas Department of Water Resources. The state of Texas water quality inventory, 5th ed. Austin, TX: Texas Department of Water Resources; 1980; 540 p + map.
- Texas Department of Water Resources. Lavaca-Tres Palacios estuary: an analysis of bay segment boundaries, physical characteristics, and nutrient processes. Austin, TX: Texas Department of Water Resources; LP-78; 1981; 73 p.
- Texas Department of Water Resources. Nueces and Mission-Aransas estuaries: a study of the influence of freshwater inflows. Austin, TX: Texas Department of Water Resources; LP-108; 1981b; 300 p.
- Texas State Soil and Water Conservation Board. Soil and water conservation: the Texas approach. Temple, TX: Texas State Water and Soil Conservation Board; 1981; 288 p.
- Texas Water Development Board. Continuing water resources planning and development for Texas. Austin, TX: Texas Water Development Board; 1977; 2 vol.

- Tharp, B.C. Structure of Texas vegetation east of 98th meridian. Austin, TX: University of Texas; 1925. Thesis.
- Thomas, J.D. Gammarid amphipods of the Barataria Bay, Louisiana region. Baton Rouge, LA: Louisiana State University; 1975. Thesis.
- Tomkins, I.R. The oyster-catcher of the Atlantic coast of North America and its relation to oysters. *Wilson Bull.* 59(4): 204-208; 1947.
- Turner, R.E.; Gosselink, J.G. A note on standing crops of Spartina alterniflora in Texas and Florida. *Contrib. Mar. Sci.* 19: 113-118; 1975.
- Twidwell, S.R. Intensive surface water monitoring survey for segment 2103 Lake Corpus Christi. Austin, TX: Texas Water Quality Board; Report IMS-29; 1976; 366 p + ap.
- Twidwell, S.R. Intensive surface water monitoring survey for segment no. 2201, Arroyo Colorado Tidal. Austin, TX: Texas Department of Water Resources; Report no. IMS-72; 1978; 24 p + ap.
- U. S. Coastal Engineering Research Center. Shore protection manual. Fort Belvoir, VA: U.S. Coastal Engineering Research Center; 1977; 3 vol + ap.
- Van Baalen, C.; Pulich, W.; O'Donnell, R. A blue-green algal assay of water quality. Oppenheimer, C.H.; Brogden, W.B.; Gordon, K.G., eds. Toxicity studies of Galveston Bay project. Port Aransas, TX: University of Texas Marine Science Institute at Port Aransas; Final Report to the Texas Water Quality Board for Contract IAC (72-73) 183; 1973: V-1 to V-11.
- Van Der Valk, A.G. Mineral cycling in coastal foredune plant communities in Cape Hattaras National Seashore, *Ecology*, 55: 1349-58; 1974.
- Vaughn, R.; Kimber, C. Maintenance dredging effects on vegetation adjacent to the Gulf Intracoastal Waterway - Cedar Lakes section. College Station, TX: Texas A&M University, Sea Grant Program; TAMU- SG-77-207; 1977; 64 p.
- Volkman, C.M.; Oppenheimer, C.H. The microbial decomposition of organic carbon in surface sediments of marine bays of the central Texas Gulf coast. *Pub. Inst. Mar. Sci.* 8: 80-96; 1962.
- Warshaw, S. Water quality segment report for segment no. 1103, Dickinson Bayou Tidal. Austin, TX: Texas Water Quality Board; Report no. WQS-24; 1976; 39 p + ap.
- Watson, R.L. Origin of shell beaches, Padre Island, Texas. Austin, TX: University of Texas at Austin; 1968. 121 p. Thesis.
- Watson, R.L. The relationship between littoral drift rate and the longshore component of wave energy flux. Austin, TX: University of Texas at Austin; 1975. 106 p. Dissertation.

- Weaver, J. North American prairie. Lincoln, NB: Johnsen Publ. Co.; 1954; 348 p.
- Whelan, T., III. Low altitude aerosol distribution along a barrier island coast. *Contrib. Mar. Sci.* 19: 3-11; 1975.
- White, M.L.; Chittenden, M.E., Jr. Aspects of the life history of the Atlantic croaker, Micropogon undulatus. College Station, TX: Texas A&M University, Sea Grant Program; TAMU-SG-16- 205; 1976.
- White, W.A.; Morton, R.A. Land and water resources, historical changes, and dune criticality: Mustang and North Padre Islands, Texas. Austin, TX: University of Texas, Bureau of Economic Geology; Report of Investigations no. 92; 1978; 46 p + map.
- Whitten, H.L.; Rosene, H.F.; Hedgpeth, J.W. The invertebrate fauna of Texas coast jetties; a preliminary survey. *Pub. Inst. Mar. Sci.* 1(2): 53-87; 1950.
- Williams, D.L.; Rowe, P.G.; Ellison, H.C.; Blackburn, J.B., Jr.; Dietzmann, J.W.; Handel, W.G.; Justice, B.; Kreger, K.; Mixon, S.J.; Mugler, M.W.; Paransky, E.; Reynolds, J.L.; Setzer, F.M.; Sharpe, C.P.; Shuley, K.A.; Sulkowski, N.; Timmer, W.F.; Watson, T.L.; Wendt, V.; Woods, P. Texas Gulf Coast program. Houston, TX: Rice Center for Community Design and Research; Research Report 1; 1976; 262 p + 16 maps.
- Wilson, R.F. Studies of organic matter in aquatic ecosystems. Austin, TX: University of Texas at Austin; 1963. 112 p. Dissertation.
- Windom, H.L. Ability of salt marshes to remove nutrients and heavy metals from dredged material disposal area effluents. Vicksburg, MS: U.S. Army Corps of Engineers Waterways Exp. Sta.; Tech. Rep. D-77-37 DMRP; 1977; 43 p.
- Withers, R.E., Jr.; Slowey, J.F.; Burnett, N.C.; Nolley, B.W. Field and analytical studies of the Corpus Christi Ship Channel and contiguous waters. College Station, TX: Texas A&M University; Final Report to the Texas Water Quality Board for Contract IAC (72-73)-910 Project 1906; 1973.
- Wolcott, T.G. Ecological role of ghost crabs, Ocypode quadrata (Fabricus), on an ocean beach: scavengers or predators? *J. Exp. Mar. Biol. Ecol.* 31(1): 67-82; 1978.
- Woodhouse, W.W., Jr.; Seneca, E.D.; Broom, S.W. Propagation of Spartina alterniflora for substrate stabilization and salt marsh development. Fort Belvoir, VA: U.S. Army Corps of Engineers Coastal Eng. Res. Center; Tech. Mem. 46; 1974; 161 p.
- Woodruff, C.M., Jr. Resources of the Texas coastal region. Austin, TX: Texas General Land Office, Coastal Management Program; 1975; 45 p. + 11 plates.

Wunderlich, W.O. The dynamics of density stratified reservoirs. G.E. Hall, ed. Reservoir Fisheries and Limnology. Bethesda, MD: American Fisheries Society; Special Publication no. 8.; 1971: 219-231.

Zieman, J.C.; Odum, W.E. Modeling of ecological succession and production in estuarine marshes. Vicksburg, VA: U.S. Army Corps of Engineers Waterways Exp. Sta.; Tech. Rep. D-77-35 DMRP; 1977; 177 p.



**DEPARTMENT OF THE INTERIOR**  
**U.S. FISH AND WILDLIFE SERVICE**



As the Nation's principal conservation agency, the Department of the Interior has responsibility for most of our nationally owned public lands and natural resources. This includes fostering the wisest use of our land and water resources, protecting our fish and wildlife, preserving the environmental and cultural values of our national parks and historical places, and providing for the enjoyment of life through outdoor recreation. The Department assesses our energy and mineral resources and works to assure that their development is in the best interests of all our people. The Department also has a major responsibility for American Indian reservation communities and for people who live in island territories under U.S. administration.