



**STATE OF HAWAII**

**DEPARTMENT OF COMMERCE AND CONSUMER AFFAIRS**

**LOSS MITIGATION GRANT PROGRAM**

**WIND RESISTIVE DEVICES TECHNICAL SPECIFICATIONS**

Version 2.1      June 13, 2007

This version is subject to update by the Insurance Division



*Hurricane Iniki roof damage to an unprotected home*

## Table of Contents

	Page No.
<b>Section 1. Introduction .....</b>	<b>1</b>
<b>Section 2. Overall Wind Resistive Device Requirements.....</b>	<b>2</b>
<b>Available Options .....</b>	<b>2</b>
<b>Sequencing Requirements.....</b>	<b>3</b>
<b>Condition of Property Premises .....</b>	<b>3</b>
<b>Grant Application .....</b>	<b>3</b>
<b>Notes on the Use of Hurricane Ties and Their Installation.....</b>	<b>3</b>
<b>Section 3. Background On Historical Vulnerabilities.....</b>	<b>7</b>
<b>Section 4. WRD Option 1: Roof to Wall Uplift Restraint Ties at Roof Ridges and Roof Framing Members to Wall or Beam Supports. ....</b>	<b>10</b>
<b>Section 5. WRD Option 2: Fastening of Roof Wood Sheathing or Roof Metal Decking for High Wind Uplift.....</b>	<b>18</b>
<b>Section 6. WRD Option 3: Exterior Opening Protection.....</b>	<b>29</b>
<b>Section 7. WRD Option 4: Foundation Uplift Restraint Strengthening.....</b>	<b>35</b>
<b>Section 8. WRD Option 5: Hawaii Residential Safe Room Performance Specifications .....</b>	<b>37</b>
<b>Section 9. Glossary Common Terminology for Roof Elements.....</b>	<b>40</b>

**Figures:**

**Figure 1: Wind Resistive Device Options Eligible for Grants.....6**

**Figure 2: “Single Wall” House with Wood Piers and Concrete “Tofu” Block Foundation (Note Columns May Not Exist) .....9**

**Figure 3: Exterior Roof-Wall Connection Upgrades for Houses with Conventional Stud Wall Construction ..... 12**

**Figure 4: Roof to Wall Uplift Resistant Ties for “Single Wall” Construction .....13**

**Figure 4A: Roof to Wall Uplift Resistant Ties for “Single Wall” Construction-Existing Fascia Not Extending Below Rafter ..... 14**

**Figure 4B: Roof to Wall Uplift Resistant Ties for “Single Wall” Construction-Existing Fascia Extending Below Rafter ..... 15**

**Figure 4C: Roof to Wall Uplift Resistant Ties for Hawaii Custom Clips on Construction Where Rafter Spacing Does Not Exceed 24 Inches and Roof Span Does Not Exceed 24 Feet ..... 16**

**Figure 5: Exterior Roof-Wall Connection Upgrades for Houses with Masonry Construction ..... 17**

**Figure 6: Examples of Deformed Shank Nails..... 19**

**Figure 7: Example of an Older Roof Framed With Wood Trusses and Continuous Lumber Roof Decking (Viewed From Inside the Attic).....20**

**Figure 8: The Preferred Upgrade of Structural Sheathing for Houses with Tile or Wood Shake Roofing .....21**

**Figure 9: The Minimally Acceptable Upgrade of Structural Sheathing for Houses with Tile or Wood Shake Roofing.....22**

**Figure 10: Upgrade of Structural Plywood Sheathing for Houses with Asphalt Shingle Roofing .....23**

**Figure 11: Upgrade of Structural Plank Sheathing for Houses with Asphalt Shingle Roofing .....24**

**Figure 12: Upgrade of Structural Plywood Sheathing for Houses with Built-up Roofing .....25**

**Figure 13: Upgrade of Structural Plank Sheathing for Houses with Built-up Roofing .....26**

**Figure 14: Upgraded Connections for Houses with Metal Roof Decking on Purlins and Rafter Trusses .....28**

**Figure 15: Retrofit for Single Wall Houses on “Tofu” Foundation Blocks .....36**

**Tables:**

**Table 1: Summary of the ASTM E 1996-05 Standard for Impact Protective Systems for Windborne Debris in Hurricanes and the ASTM Ratings Necessary for Product Approval by the Hawaii Loss Mitigation Grant Program .....30**

**Table 2: Opening Protection Shall Consist of One or More of the Following Opening Protective Devices Tested for Compliance with the ASTM Small and Large Missile Impact Standards and Approved After Submission of Test Results to the State Of Hawaii.....33**

**Table 3: Windborne Debris Protection Fastening Schedule for Wood Structural Panels .....34**

**Table 4: Windborne Debris Protection for Residential Safe Rooms .....38**

**Table 5: Saffir/Simpson Hurricane Scale Ranges With Additional Hawaii Damage Descriptions .....44**



**STATE OF HAWAII**  
**DEPARTMENT OF COMMERCE AND CONSUMER AFFAIRS**  
**LOSS MITIGATION GRANT PROGRAM**  
**WIND RESISTIVE DEVICES TECHNICAL SPECIFICATIONS**

**Section 1. Introduction.** The grants under the Loss Mitigation Grant Program reimburse thirty-five per cent of the costs incurred for certain specified wind resistive devices ("WRD") and their installation in a single or multi-family residential dwelling, up to a maximum total reimbursement of \$2,100 per dwelling.

This document sets forth the technical requirements for wind resistive devices installed only in a single or multi-family residential dwelling for which grants may be awarded pursuant to the grant program established under Chapter 431:22, Hawaii Revised Statutes ("HRS") ("Loss Mitigation Grant Program"). The grant program is administered by the Department of Commerce and Consumer Affairs Insurance Division in accordance with Chapter 431:22-104, HRS.

By using these Specifications, the user acknowledges that the State of Hawaii makes no representations, guaranty, or warranty, expressed or implied, regarding the technical performance, suitability, or effectiveness of the wind resistive devices installed pursuant to these Specifications in actual wind conditions including, but not limited to, tropical storms and hurricanes with respect to personal injury, property loss prevention or reduction, or life safety purposes, or its fitness for a particular purpose. Those using these Specifications and/or installing wind resistive devices acknowledge that installation of wind resistive devices may not protect their homes, property, or persons from any loss, damage, or injury. Users further acknowledge that the grant program for which these Specifications are established is subject to the availability of funds, which are limited, and further recognize that grant program applicants may receive no funds. Users of these Specifications acknowledge and agree that in no event shall the State of Hawaii be liable for any damages or loss sustained due to any person's utilization of any wind resistive device pursuant to these Specifications. Any and all use of or reliance upon wind resistive devices or these Specifications, including but not limited to any selection of products or vendors, is solely the responsibility of the user and the user assume all risks and liabilities, if any, with respect to the use of the wind resistive devices or the information in these Specifications. The State of Hawaii does not assume any responsibility for the accuracy or completeness of any information contained in these Specifications. The Specifications are intended for use without warranty of any kind.

## Section 2. Overall Wind Resistive Device Requirements.

**(a) Available Options:** Subject to the availability of funds and the standards herein, grants for wind resistive devices may be awarded for the installation of assemblages consisting of the following wind resistive device (WRD) options only:

- (1)** Roof to Wall uplift restraint ties at roof ridges and roof framing members to wall or beam supports;
- (2)** Fastening of roof wood sheathing or roof metal decking for high wind uplift and a secondary waterproofing membrane;
- (3)** Exterior Opening Protection, consisting of impact and pressure resistant exterior opening protective devices on
  - a)** all openings in the building enclosure or in a permanently partitioned residential unit, including fixed or operable windows, sliding door openings, and all entry doors, but excluding openings not exceeding a total of 2 square feet in any wall, or
  - b)** for enclosed attached garages, garage roll-up doors, and all openings in the garage enclosure, including fixed or operable windows, glazed sliding door openings, and all garage entry doors, but excluding openings not exceeding a total of 2 square feet in any wall;
- (4)** Foundation uplift restraint strengthening of the connections for "single walls" bearing on wood beams and foundation posts on shallow footings;
- (5)** Residential Safe Rooms built in accordance with approved engineered and impact and pressure tested designs meeting the Hawaii-specific performance criteria for enhanced hurricane protection areas, capable of withstanding a five hundred-year hurricane event as developed by the State of Hawaii pursuant to Act 5, Special Session Laws of Hawaii 2005

These devices shall meet the more detailed technical specifications provided in this document as well as these general descriptions.

### Attached Carports and Garages and Detached Garages

- A carport is a roof projecting from the side of building used to provide an open shelter for an automobile. An attached carport would be eligible for roof to wall ties and roof sheathing fastening.



- A garage is an enclosed structure for housing automobiles. An attached garage would be eligible for roof to wall ties, roof sheathing fastening, and opening protection.
- A detached garage is not eligible for grants.

**(b) Sequencing Requirements:** Certain devices specified in subsection (a) may only be eligible for awarded grant awards if the following sequencing of installation requirements has been met:

- (1) For “single wall” construction, no other grant except for a Residential Safe Room may be awarded unless the roof to wall connections have been previously or concurrently installed.
- (2) No grant may be awarded for foundation uplift strengthening unless the roof to wall connections have been previously or concurrently installed.

**(c) Condition of Property Premises:** A person’s eligibility for this grant program is contingent upon the person’s premises and/or land associated with the property complying with the following conditions:

- (1) All buildings shall be properly maintained. For example, there shall be no portions of exterior walls or roof in serious disrepair, missing areas of sheathing, structural supports or walls overstressed or bowed, missing wall sections or roof framing, or large through the thickness of masonry walls. There shall be no unrepaired structural damage due to termite, dry-rot, or wind, fire, or water damage.
- (2) Any detached buildings (not part of the dwelling), including sheds, portable buildings, or other lightly constructed structures on the premises of the property shall have walls and roofs adequately connected to each other and anchored to the ground.

**(d) Grant Application:** A grant may be made to an applicant only if the applicant has complied with the Loss Mitigation Grant Program Guidelines (available from the Department of Commerce and Consumer Affairs).

**(e) Notes on the Use of Hurricane Ties and Their installation:** the WRD Technical Specifications indicate the use of certain types of metal connectors, straps, and ties by reference to the “Simpson” (The Simpson Strong-Tie® Company) trade name for the product. This is done mainly for convenience in this publication. Other manufacturers produce similarly configured products that may be used if they have been given equivalent allowable load value ratings in accordance with International Building Code and ASTM D1761 accepted testing procedures. In general, the allowable

load of a connector is the lesser of the ultimate test load divided by a safety factor of 3, the test load at 1/8" deflection, and the calculated capacity of the fasteners and the strap of strap-type connectors. If the test load governs, no increase is permitted, but if the calculation limit governs, one may increase the load by 1.6 when the connector is used to resist wind or seismic loads. Generally it is recommended that a nail should have at least 2.5 times its diameter distance to the edge of wood and 10 times its diameter when the nail is loaded parallel to grain. It is recommended to pre-drill if the nail connection would split the wood. For Douglas Fir-Larch wood members, the pre-drilled hole is to not exceed 75% of the nail diameter. The allowable load values are given in the manufacturer's product catalogs. A licensed professional architect or structural engineer will be familiar with these products. You may wish to hire one of them as a consultant to provide guidance for types of connectors suitable for your home, especially if your home is a single wall home or if it has long span roofs or other unusual features or site conditions.

**Hawaii Certifications are required to be obtained by the manufacturers of the following devices, in accordance with the "Submittal Requirements for Product Evaluation":**

- Use in Single Wall Construction: any roof to wall strap / tie and any opening protection device;
- Any hurricane clip or tie-down restraint not having a national code or national standard recognized evaluation report for testing performed in accordance with ASTM standard and / or ICC-ES Acceptance Criteria;
- Any opening protection device not having an national code or ASTM E1996 ICC Acceptance or Criteria AC294 evaluation report for testing complying with the minimum rating of Section 6 of these specifications;
- Engineered designs or test reports for the typical attachment details of opening protection devices to specific wood-framed types of Hawaii residential construction.
- Product Evaluation Reports are available from the Insurance Division.

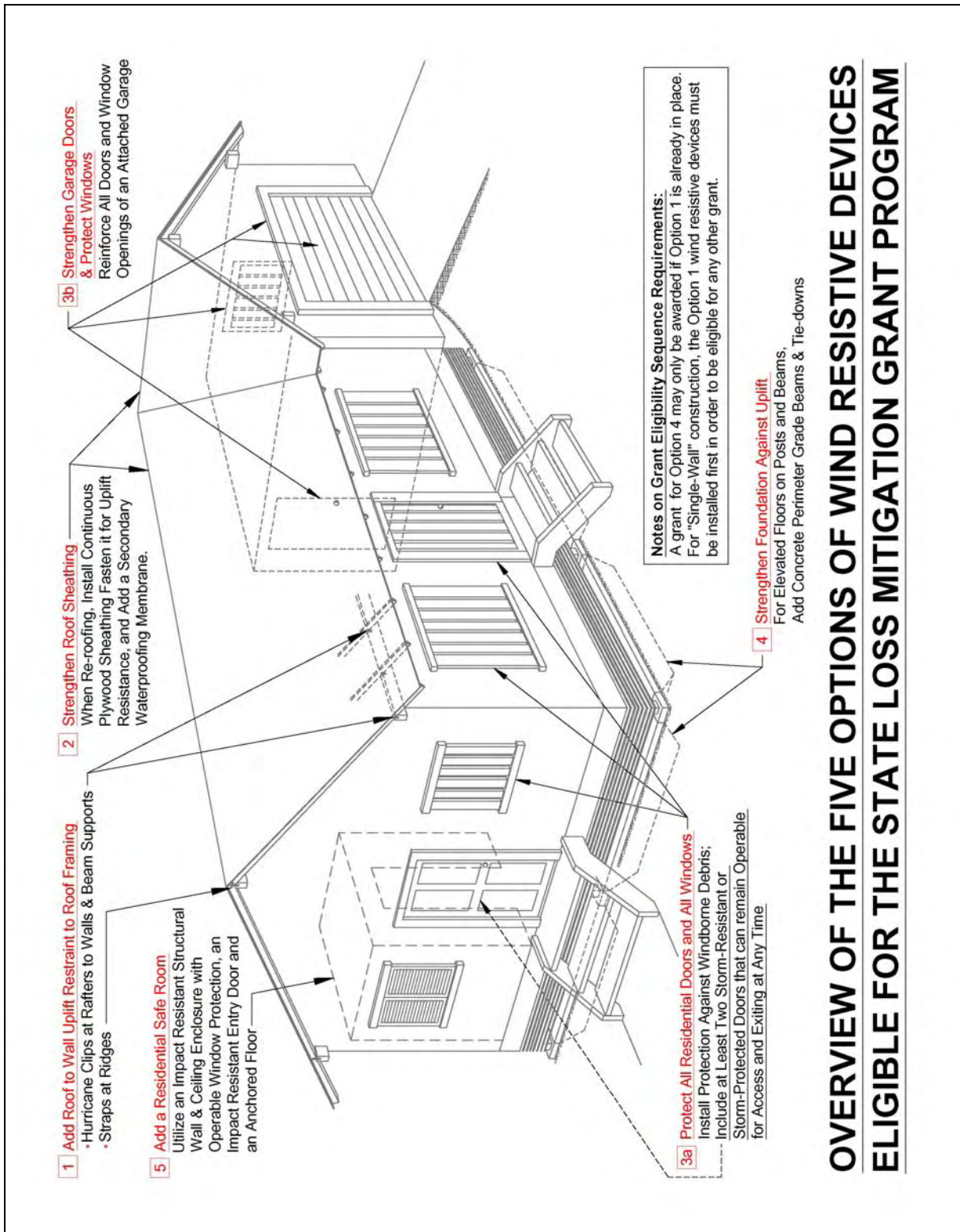
**When the homeowner need to prepare drawings or other documents before starting the work:**

- Roof to wall WRD Option 1 and Temporary Plywood Panels installed under WRD Option 3: "Do it yourself" work may be performed by the homeowner, provided an inspector files a certification of compliance with the Specifications. Pre-arrange the services of the inspector and coordinate the work schedule so that it can be viewed as it is completed as well as afterwards. In that case, the grant



reimbursement would just be for the cash outlays for materials and inspection, but not labor.

- Plywood panel WRD Option 3: A Hawaii architect or structural engineer should be engaged to prepare construction drawings for permanent corrosion-resistant hardware attachment details and plans for the deployment of the plywood panels indexed to panel ID marks.
- Wall to foundation uplift strengthening WRD Option 4: A Hawaii structural engineer should be engaged to prepare construction drawings that may incorporate alternative designs to be submitted for county building permit approval.
- Submit Residential Safe Room WRD Option 5: A Hawaii structural engineer should be engaged to design the safe room and prepare its construction drawings, following the performance specifications issued in a separate document. These drawings should be submitted for county building permit approval.



## OVERVIEW OF THE FIVE OPTIONS OF WIND RESISTIVE DEVICES ELIGIBLE FOR THE STATE LOSS MITIGATION GRANT PROGRAM

Figure 1: Wind Resistive Device Options Eligible for Grants

### **Section 3. Background Information on Historical Vulnerabilities**

Most Hawaii single family homes were not built with adequate protection against hurricane force winds. It is important to know when your home was constructed because building code requirements for high wind resistance were only implemented in relatively recent times. Single-family residential construction was typically permitted to be built using “conventional construction” provisions based on historical trade practices that did not consider hurricanes. The weaknesses of these practices were demonstrated by the unacceptable levels of wind damage to homes during Hurricanes Iwa (1982) and Iniki (1992). **There were no requirements for high wind connectors in single-family residences built up through the late 1980’s and early 1990’s.**

**After Hurricane Iwa, roof to wall uplift ties were required for new single family residential construction in Hawaii after the benchmark dates listed below.** Accordingly, most code-conforming single family homes of wood construction built after these dates may not require WRD Option 1, Roof to Wall Uplift Restraint Ties.

#### **Benchmark Years when roof to wall wind uplift ties were first required:**

<b><u>County</u></b>	<b><u>Date of Plans</u></b>	<b><u>Probable Construction Period</u></b>
<b>Kauai</b>	<b>1989</b>	<b>1990 to 1993</b>
<b>Oahu</b>	<b>1987</b>	<b>1988 to 1995</b>
<b>Maui</b>	<b>1989</b>	<b>1990 to 1995</b>
<b>Hawaii</b>	<b>1993</b>	<b>1994 and later</b>

**After Hurricane Iniki, additional ties to create a more complete load path throughout the structure were required for new single-family residential construction in Hawaii after the benchmark dates listed below.** The Uniform Building Code (UBC) Appendix for Conventional Light-Frame Construction in High-Wind was gradually adopted at the following dates:

#### **Benchmark Years when a complete load path of connectors was first required:**

<b><u>County</u></b>	<b><u>Date of Plans</u></b>	<b><u>Probable Construction Period</u></b>
<b>Kauai</b>	<b>1992</b>	<b>1993 and later</b>
<b>Honolulu</b>	<b>1994</b>	<b>1995 and later</b>
<b>Maui</b>	<b>1994</b>	<b>1995 and later</b>
<b>Hawaii</b>	<b>1993</b>	<b>1994 and later</b>

Accordingly, most code-conforming conventional stud wall or masonry single family homes of wood construction built after these complete load path benchmark dates may not require Foundation Uplift Restraint Strengthening.

**Homes built after the complete load path benchmark dates would still be eligible for:**

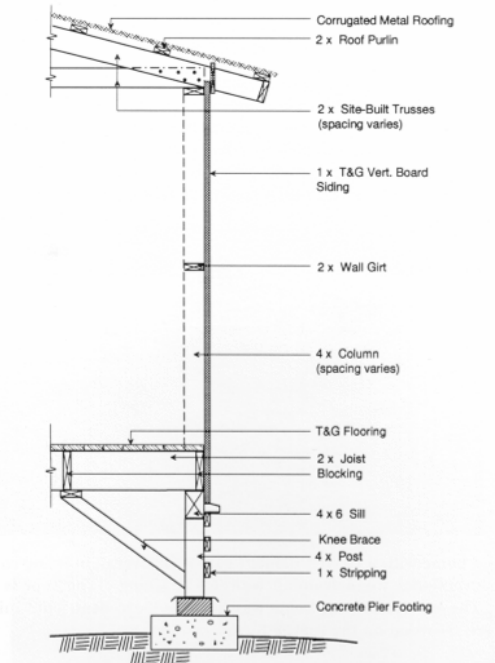
- (a) **Additional fastening of roof wood sheathing** for high wind uplift and a secondary waterproofing membrane, together with hurricane ties at rake rafters and outlooker beams; and
- (b) **Opening Protection**, consisting of impact and pressure resistant exterior opening protective devices on:
  - (1) all openings in the building enclosure or in a permanently partitioned residential unit, including fixed or operable windows, sliding door openings, and all entry doors, but excluding openings not exceeding a total of 4 square feet in any wall, or
  - (2) for enclosed attached garages, garage roll-up doors, and all openings in the garage enclosure, including fixed or operable windows, glazed sliding door openings, and all garage entry doors, but excluding openings not exceeding a total of 4 square feet in any wall; and
- (c) **Residential Safe Rooms** built in accordance with approved engineered and impact and pressure tested designs meeting Hawaii-specific performance criteria for enhanced hurricane protection areas, capable of withstanding a five hundred-year hurricane event as developed by the Hawaii Department of Defense pursuant to Act 5, Special Session Laws of Hawaii 2005.

**New home construction would be eligible for secondary waterproofing, opening protection, and residential safe rooms:**

Current building codes do not require additional fastening of roof sheathing with secondary waterproofing membranes and opening protection. New home construction can be eligible for matching grants for mitigation measures consisting of WRD options 2 and 3 as well as option 5 construction of a residential safe room, if added as an enhancement option to the buyers beyond the minimum code requirements and documented as a separate cost line item.

**Single Wall Construction:** Single wall construction is the most vulnerable type of residential construction during hurricanes. Wind uplift connectors are typically non-existent. The wood vertical board siding is typically

redwood, which is a low-density softwood. Fasteners driven into redwood are not as strong. Note that the figure below only shows one style of single wall construction. The wall girt is more commonly found on the exterior of the home, and the columns and roof perimeter beams and columns may not be present in older single wall homes. The roof may be a corrugated metal roof or consist of asphalt shingles on tongue & groove wood decking. The foundation is typically unanchored and without connectors to resist lateral movement or uplift.



**Figure 2: “Single Wall” House with Wood Piers and Concrete “Tofu” Block Foundation (note columns may not exist)**

**Single Wall Construction Requires Specifically Certified Devices:**

Because of its unique construction materials and vulnerabilities, unless specifically shown in the installation drawing details of these specifications, any roof to wall restraint tie or opening protection device shall be submitted for approval by the State of Hawaii for application to single wall construction. Each manufacturer is responsible for making a submittal of test data for review and approval by the Insurance Division of the Department of Commerce and Consumer Affairs. The primary intent of the testing is to verify the strength of the attachment connections of the device in Hawaii single wall construction. Manufacturers should follow the “Submittal Requirements for Product Evaluation” available from the Hawaii Insurance Division.

## **Section 4. WRD Option 1: Roof to Wall Uplift Restraint Ties At Roof Ridges And Roof Framing Members to Wall or Beam Supports**

In order to qualify a house for a roof to wall uplift restraint ties grant, hurricane "clips" or "straps" shall be installed to provide uplift resistance between each rafter or roof truss and corresponding supporting structural wall or beam supports at the perimeter of the structure.

All devices shall be corrosion-resistant and installed as per the manufacturer's specifications. Corrosion resistance may be satisfied by Type 316 stainless steel or galvanized steel with a zinc coating thickness equal to or greater than 1.5 ounces of zinc per square foot of surface area per ASTM A653. ASTM A653 with a zinc coating thickness of equal to or greater than 0.90 ounces of zinc per square foot of surface area also shall have an approved three-coat system consisting of a primer coating, an intermediate and a marine finish coating formulated of urethane, epoxies, and polyurethane, or an equivalent zinc-based protective coating. Stainless steel clips and straps shall be installed with stainless steel nails or screws. Galvanized clips or straps shall be installed with ASTM A153 galvanized nails or ASTM A153 galvanized hex-drive screws.

The WRD Specifications only recognizes connectors that can be validated by testing to achieve the loads indicated in the Specifications. Manufacturers shall submit test data to substantiate any hurricane tie that has not been approved by a national code.

To qualify as a WRD, a metal hurricane clip with at least 400 lbs. of allowable wind uplift load resistance (after any increase for load duration) is required at each roof rafter framing connection to an exterior wall with double top plates or to a beam support. If rafter framing is spaced at more than 24 inches on center, the required clip capacity shall be increased proportionately or additional clips installed to achieve at least 200 lbs. of allowable wind uplift load capacity per linear foot of roof perimeter. The capacity of the connection should also be increased proportionately for roof truss spans greater than 24 feet from bearing wall to bearing wall. A minimum of four to five 8d ("eight-penny") or larger nails with at least 1.25 inches of penetration into the support and four to five 8d or larger nails with at least 1.25 inches of penetration into the rafter (or roof truss) are required at each connector. Note: It is recommended that the highest load rated connectors be utilized wherever possible.

In addition, rim rafters at gable end eaves shall be strapped down to all supporting beams using connections with at least 1,000 lbs. of allowable uplift resistance. Exterior beams supported on corner columns shall be strapped with at least 2,000 lbs. of allowable uplift resistance.

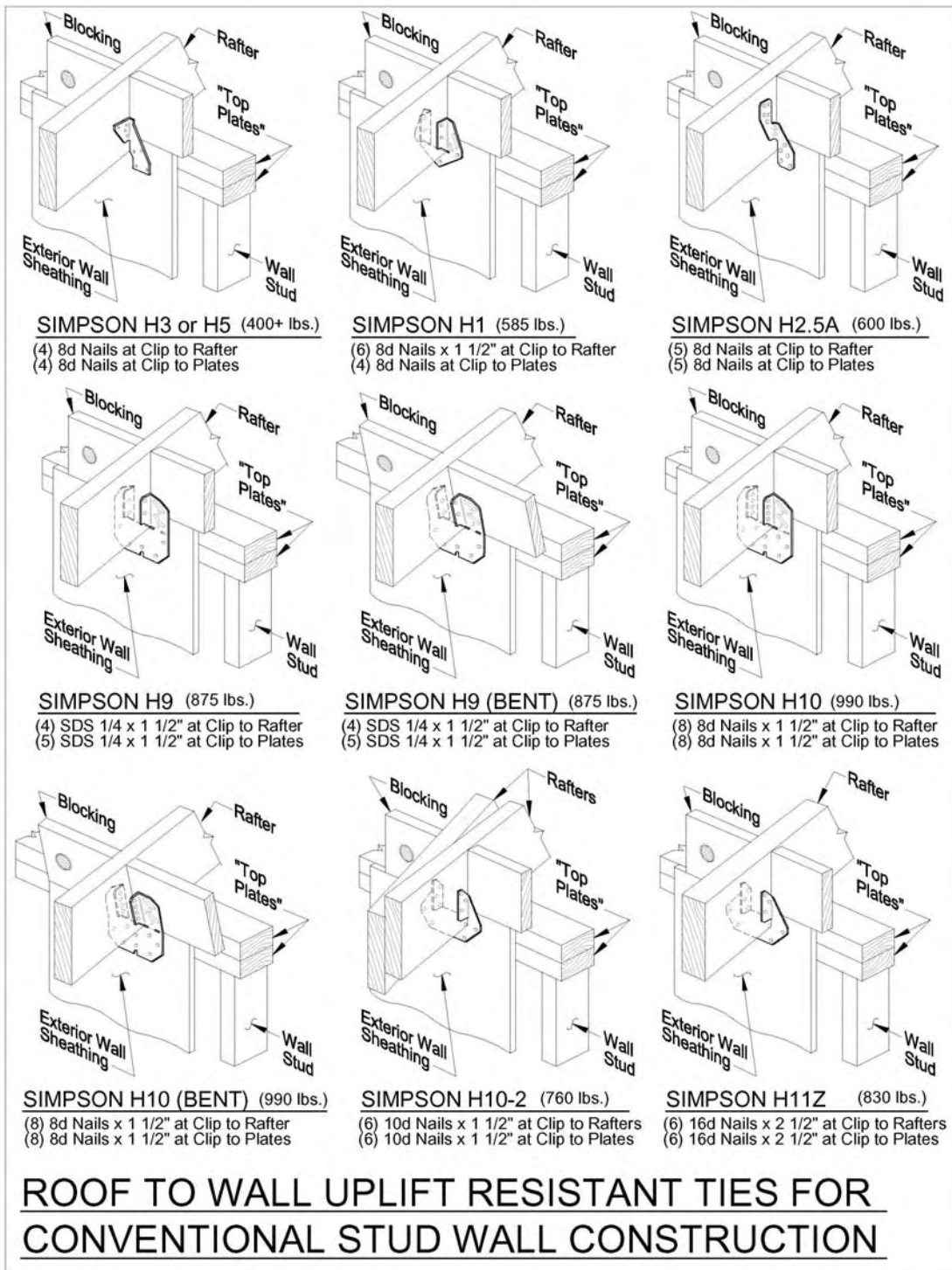


For houses with post and beam roof construction rather than wall and trussed roof framing, the requirements also include approved wind resistive devices at each connection point. These connection points include roof rafter to roof beams, top of post to horizontal ridge beam, and post to beam connections located at the exterior wall.

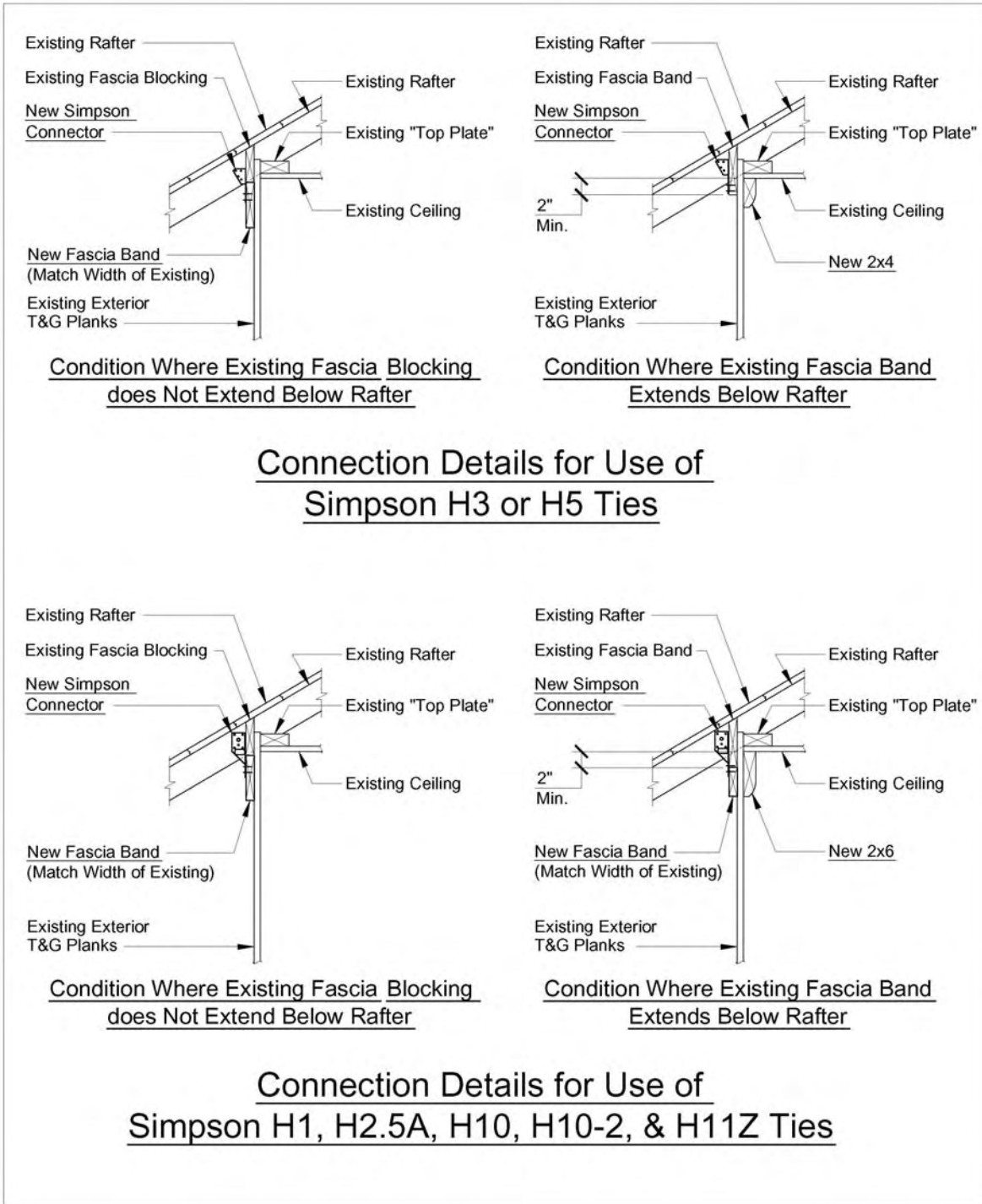
Roof rafter to wall clips are not required where individual rafters are obstructed by existing power lines or boxes. Also, they shall not be required where nailing would structurally damage existing window frames; in this case, the clips should have at least 800 lbs. of allowable capacity at each jamb end of the window.

**Inspection:**

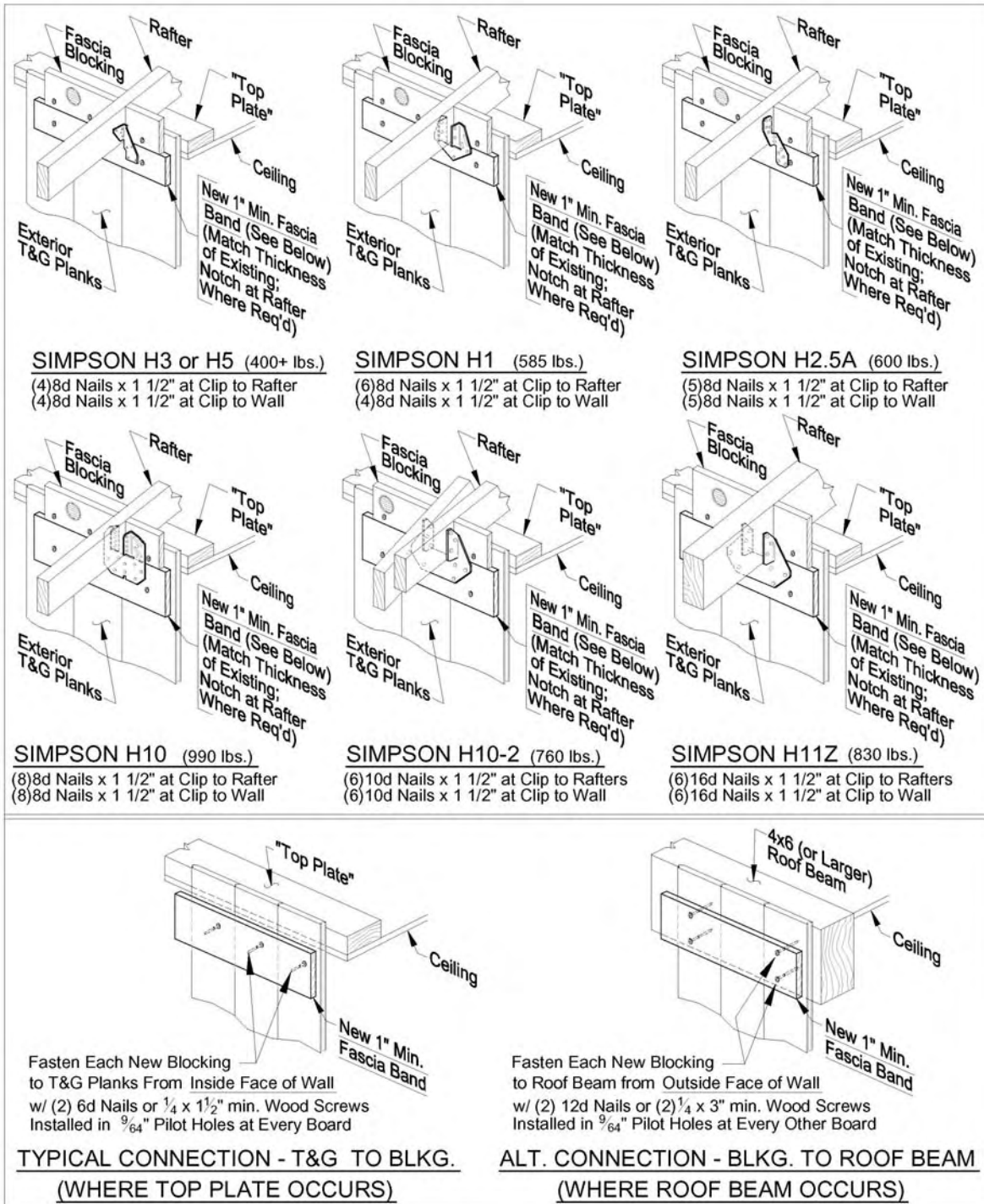
Verify to be in substantial conformance through a combination of direct inspection and photographic evidence taken during construction: correct fit-up to achieve fastener penetration for the type and number of fasteners of the connector ties to the framing and wall top plates, adequate type of hurricane clip for the spacing of rafters, connectors at rakes and rafters to any supporting beams, and connectors between roof beams and posts.



**Figure 3: Exterior Roof-Wall Connection Upgrades for Houses with Conventional Stud Wall Construction**

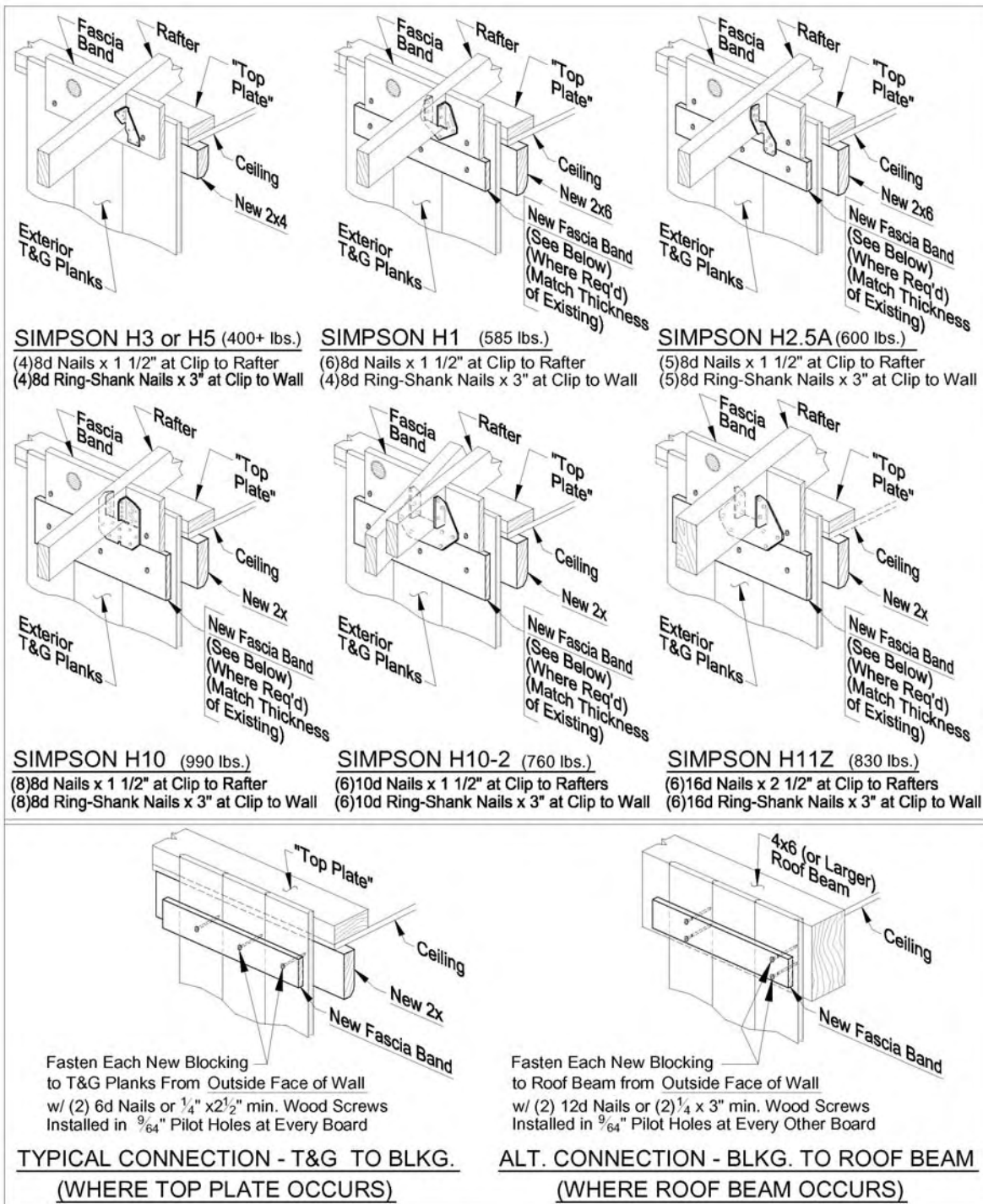


**Figure 4: Roof to Wall Uplift Resistant Ties for "Single Wall" Construction**

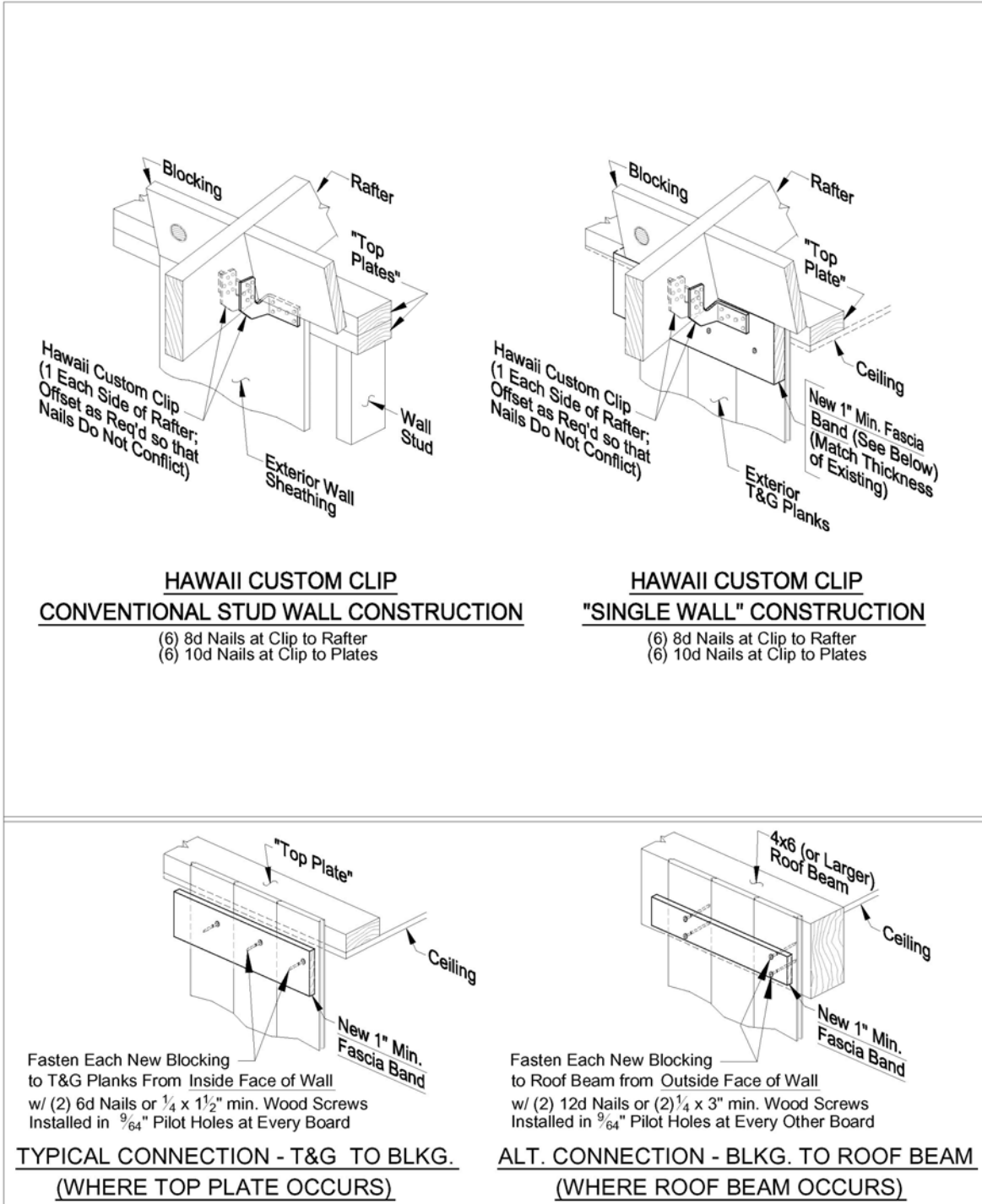


**Figure 4A: Roof to Wall Uplift Resistant Ties for "Single Wall" Construction— Existing Fascia Not Extending Below Rafter**



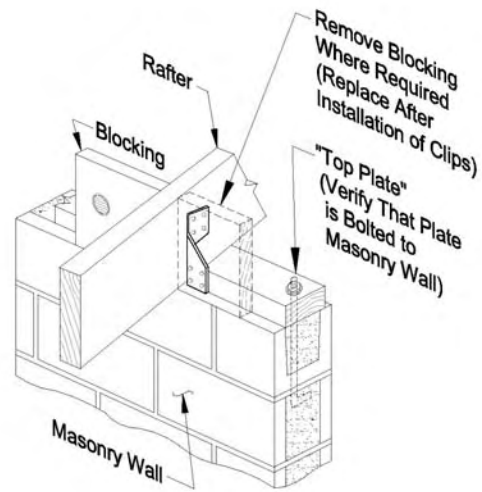


**Figure 4B: Roof to Wall Uplift Resistant Ties for "Single Wall" Construction – Existing Fascia Extending Below Rafter**

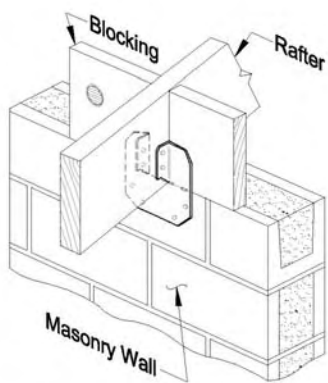


**Figure 4C: Roof to Wall Uplift Resistant Ties for Hawaii Custom Clips on Construction Where Rafter Spacing Does Not Exceed 24 Inches and Roof Span Does Not Exceed 24 Feet**

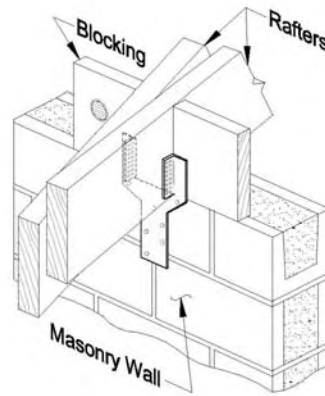




**SIMPSON H3 (455 lbs.)**  
 (For Use at Single Top Plate)  
 (4) 8d Nails at Clip to Rafter  
 (4) 8d Nails at Clip to Plate



**SIMPSON HM9 (595 lbs.)**  
 (4) SDS 1/4 x 1 1/2" at Clip to Rafter  
 (5) 1/4 X 2 1/4" Titen at Clip to Masonry



**SIMPSON LGT2 (2150 lbs.)**  
 (16) 16d Sinker at Clip to Rafter  
 (7) 1/4 X 2 1/4" Titen at Clip to Masonry

**ROOF TO WALL UPLIFT RESISTANT TIES FOR  
 GROUTED REINFORCED MASONRY CONSTRUCTION**

**Figure 5: Exterior Roof-Wall Connection Upgrades for Houses with Masonry Construction**

## **Section 5. WRD Option 2. Fastening of roof wood sheathing or roof metal decking for high wind uplift**

In general, the roof decking upgrades for houses require that the entire roofing (tiles, shakes, shingles, etc.) be removed and that any damaged or rotted decking materials be repaired or replaced. Existing roof structural sheathing or decks shall be additionally fastened and new plywood decking shall be installed at roofs without any structural sheathing. In addition, the entire roof deck shall be covered with self-adhering polyethylene or rubberized asphalt underlayment to provide secondary water resistance. Additional requirements include the installation of (1.5 oz./sq. ft. galvanized) Simpson MSTA18 or equivalent tie straps through the sheathing into the rafters or trusses at 48" spacing along the ridges. Roofing shall be installed per the manufacturer's or industry association's recommendations for high wind uplift. (For example, the recommendation may be the use of six roofing nails per shingle or the use of special tiedown clips for tiles.)

**The State will provide a matching grant only on the retrofit portion of the total cost that is above and beyond the cost of a standard re-roofing job.** For example, for houses without existing plywood sheathing or continuous dimensional lumber decking, the cost of installing new plywood decking would be eligible for a matching grant. Accordingly, all contractor invoices shall be itemized to identify the portion of cost attributable to the hurricane retrofit work that is in excess of a standard re-roofing job that matches the pre-existing condition. The State will not provide a matching grant for the cost of upgrading from one type of roofing to another (for example, asphalt shingle to cedar wood shake or concrete tile).

### **Inspection:**

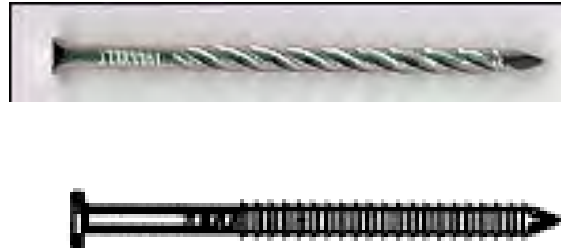
Verify to be in substantial conformance to the drawings and details shown in the Wind Resistive Devices Grant Program Technical Specifications for the type of roofing and sheathing installed through a combination of direct inspection and photographic evidence taken during construction. Verify correct fit-up of sheathing and correct type and spacing of fasteners and ridge straps.

### **Upgraded Roof Decking for Houses with Existing Wood Roof Decking**

For houses with plywood roof decks, the roof decking upgrade would consist of adding additional 8d ring shank nails to achieve a net maximum spacing of 6 inches in the body of the plywood panel and along the edges of each plywood panel into all truss, rafter, beam or joist supports to improve the connection of the wood decking to the roof frame, and the application of a self-adhering polyethylene or rubberized asphalt underlayment sheet

membrane to the plywood decking to provide secondary water resistance. Lapped sheets of self-adhering polyethylene or rubberized asphalt membrane underlayment are required over the entire plywood decking. The purpose of this upgrade is to provide uplift resistance and secondary water resistance for water damage control in the event that much of the roofing material is blown off the roof in high winds.

Ring-shank or Spiral Shank nails shall be used for the attachment of roof structural sheathing. These deformed shank nails have annular deformations or grooves along the shank of the fastener, which increases the friction between the nail and the surrounding wood, resulting in a significant increase in pull-out strength. These nails can be driven with pneumatic nail guns just as smooth shank nails.



**Figure 6: Examples of Deformed Shank Nails**

For houses with continuous dimensional lumber roof decks, the roof decking upgrade consists of at least two 8d ring shank nails installed in each decking board at each supporting rafter or truss (see Figure 7).

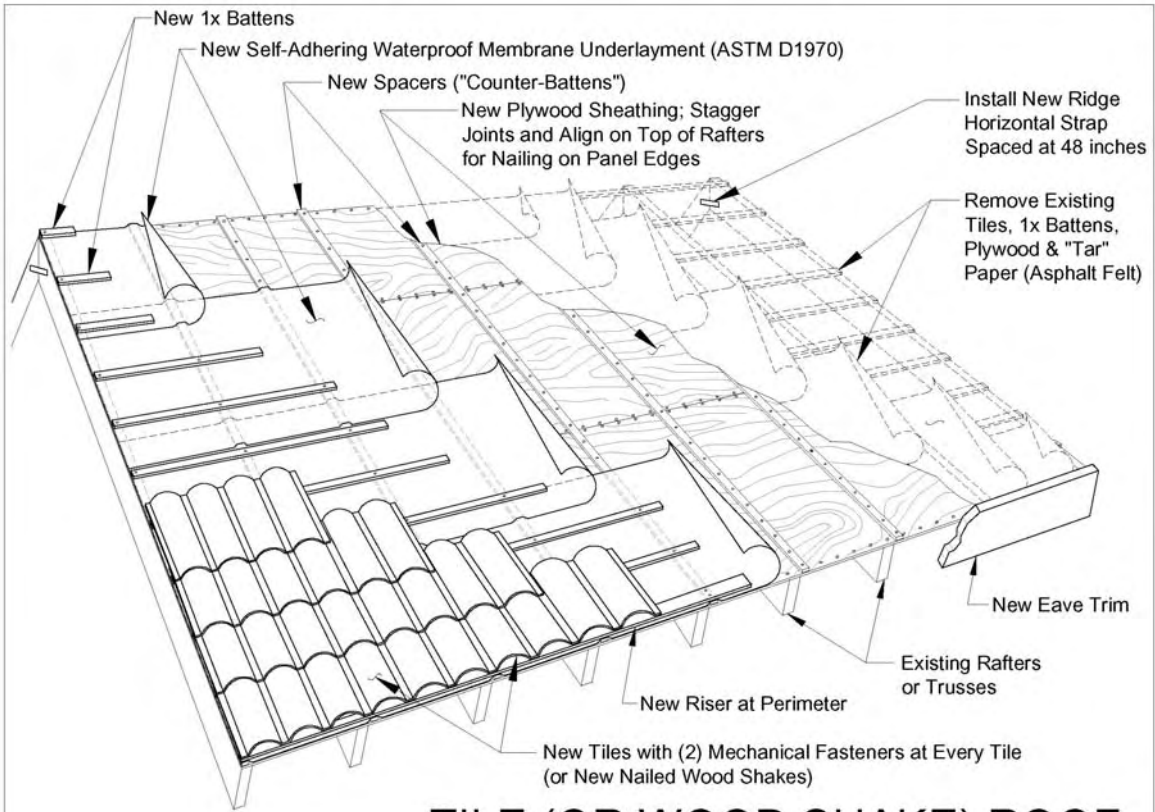


**Figure 7: Example of an Older Roof Framed With Wood Trusses and Continuous Lumber Roof Decking (Viewed From Inside the Attic)**

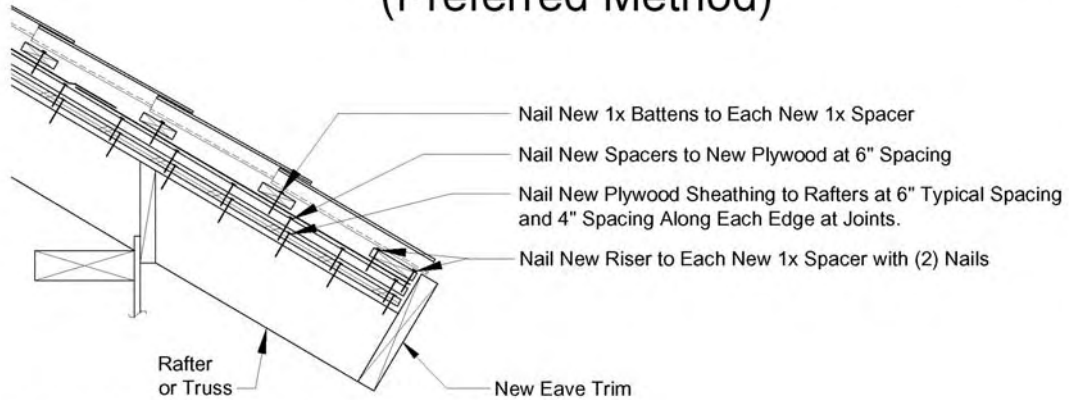
### **New Wood Decking for Houses without Wood Roof Decking**

For houses without plywood sheathing or continuous dimensional lumber roof decks (e.g., typically those houses with tiles or shakes on spaced furring strips), a fully sheathed, 19/32-inch-thick (nominal 5/8-inch thick) plywood deck shall be installed to qualify for a roof decking upgrade grant. This could be accomplished either by: (a) removing the roofing materials down to the rafters (or trusses) and then installing plywood sheathing and secondary water resistance as described previously for houses with existing plywood roofs, or (b) removing the roofing materials down to the battens, ensuring that each batten is fastened to each rafter or truss with a minimum of two 8d (2-1/2 inch long x 0.120 inch diameter) deformed shank nails, securing the plywood through the battens with 2-1/2" screws at 12 inch spacing along each batten, and then adding secondary water resistance as described previously for houses with existing plywood roofs.





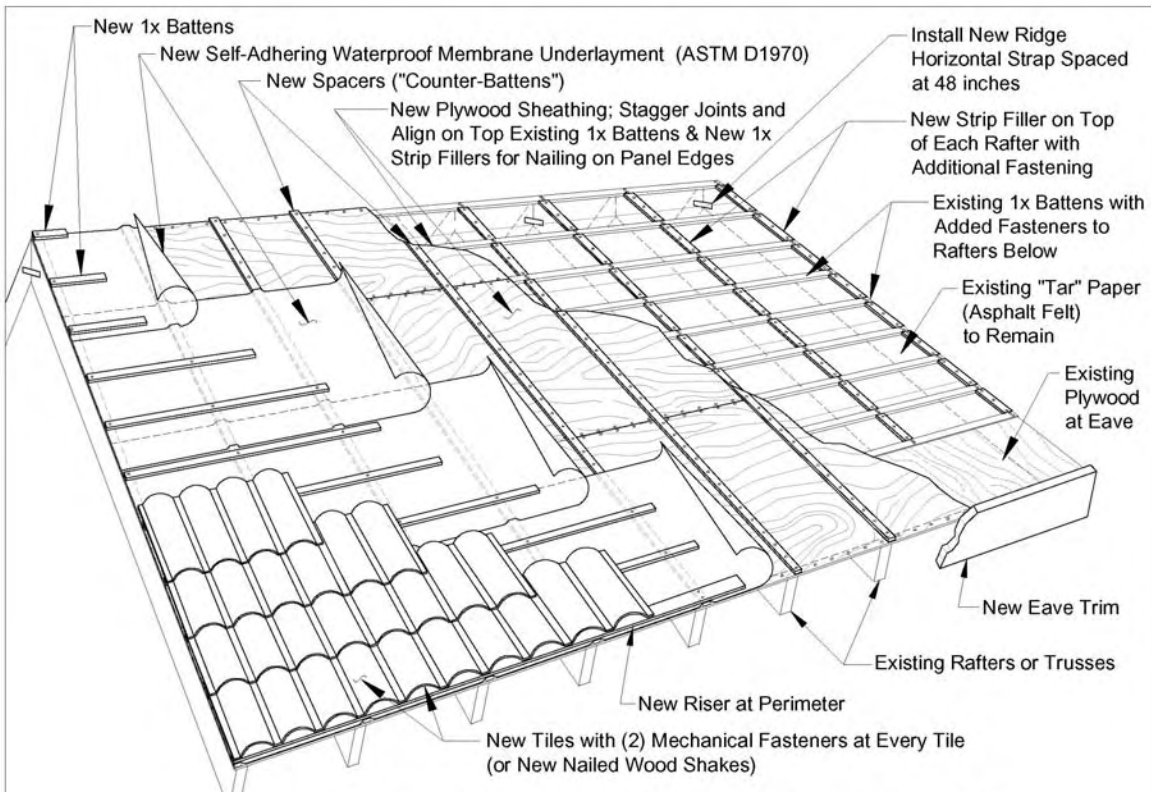
## TILE (OR WOOD SHAKE) ROOF (Preferred Method)



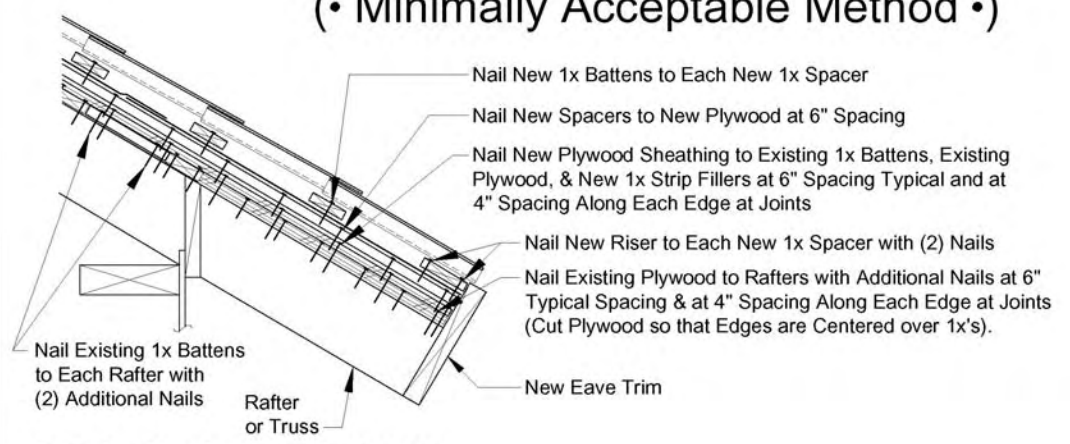
### SECTION AT EAVE

## STRUCTURAL SHEATHING WITH ADDITIONAL FASTENING FOR HIGH WIND UPLIFT

**Figure 8: The Preferred Upgrade of Structural Sheathing for Houses with Tile or Wood Shake Roofing**



**TILE (OR WOOD SHAKE) ROOF**  
 (• Minimally Acceptable Method •)

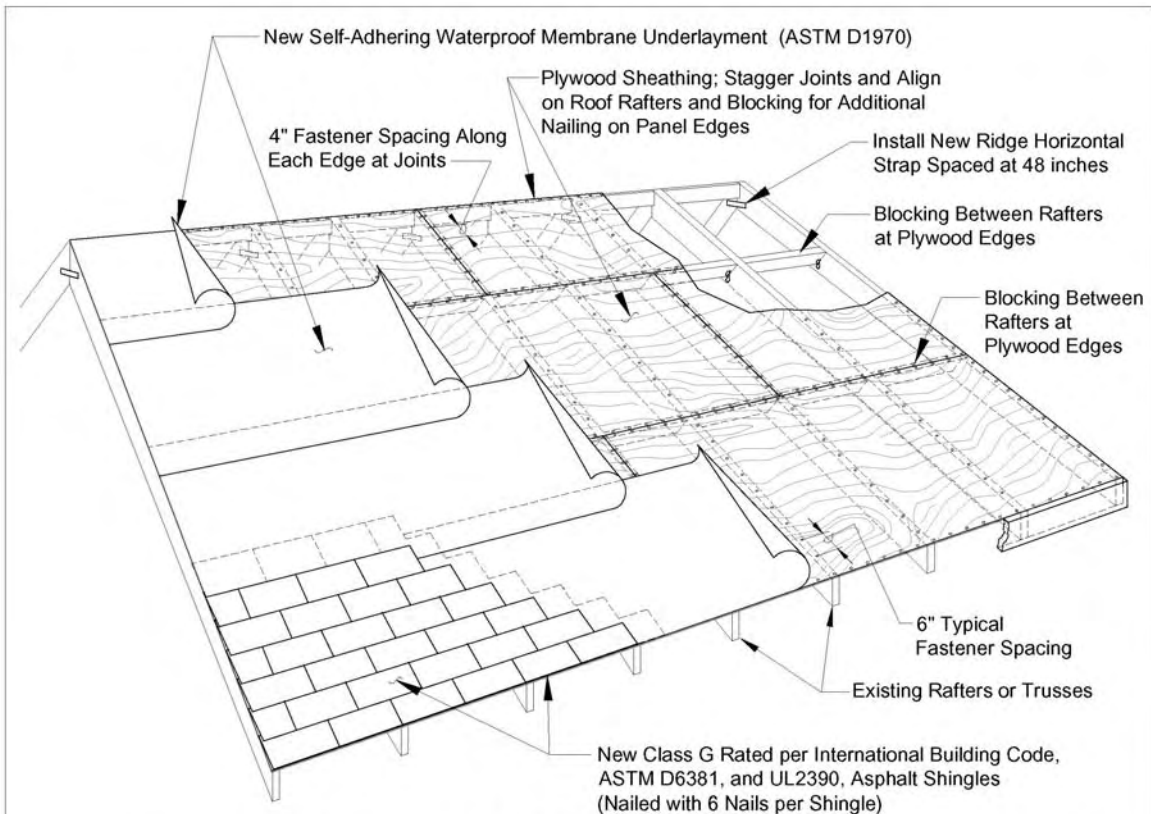


**SECTION AT EAVE**

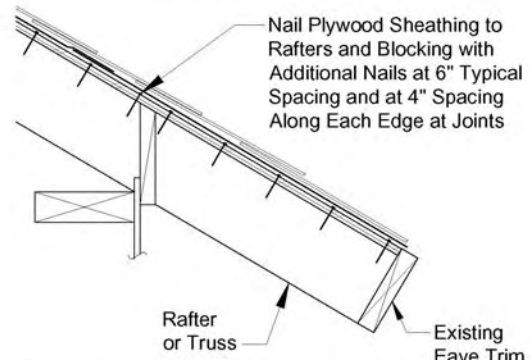
**STRUCTURAL SHEATHING WITH  
 ADDITIONAL FASTENING FOR HIGH WIND UPLIFT**

**Figure 9: The Minimally Acceptable Upgrade of Structural Sheathing for Houses with Tile or Wood Shake Roofing**

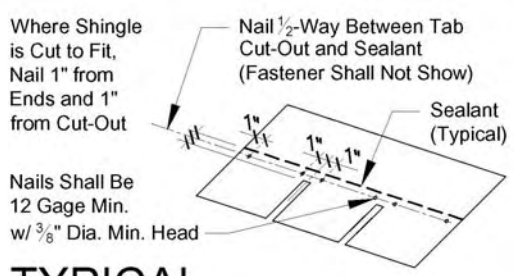




**ASPHALT SHINGLE ROOF OVER PLYWOOD**



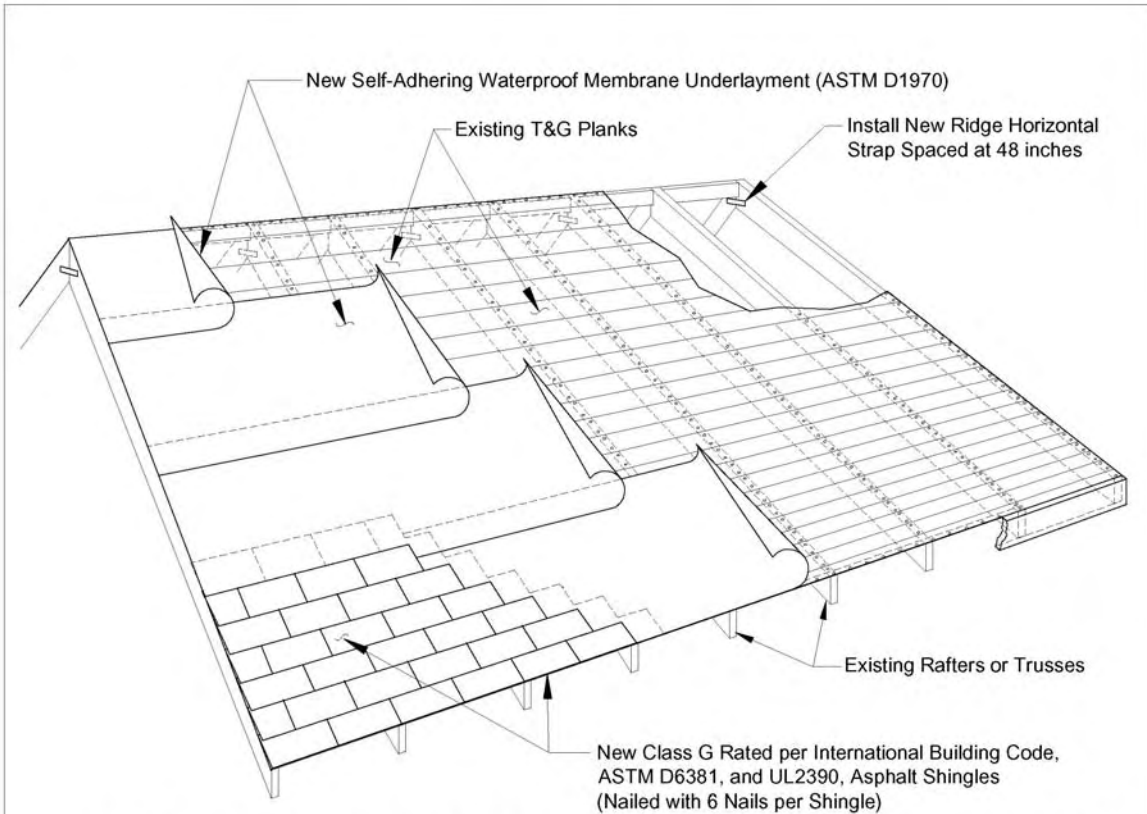
**SECTION AT EAVE**



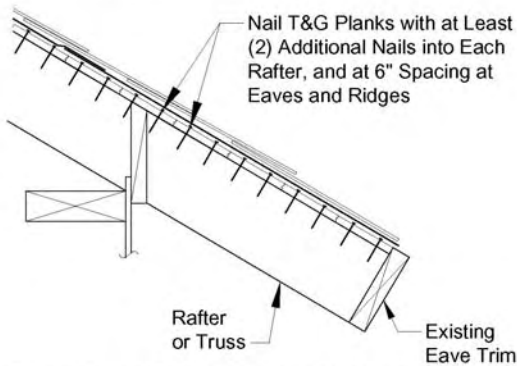
**TYPICAL ASPHALT SHINGLE ATTACHMENT**

**STRUCTURAL SHEATHING WITH ADDITIONAL FASTENING FOR HIGH WIND UPLIFT**

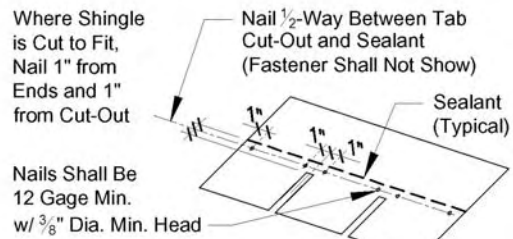
**Figure 10: Upgrade of Structural Plywood Sheathing for Houses with Asphalt Shingle Roofing**



## ASPHALT SHINGLE ROOF OVER T&G PLANKS



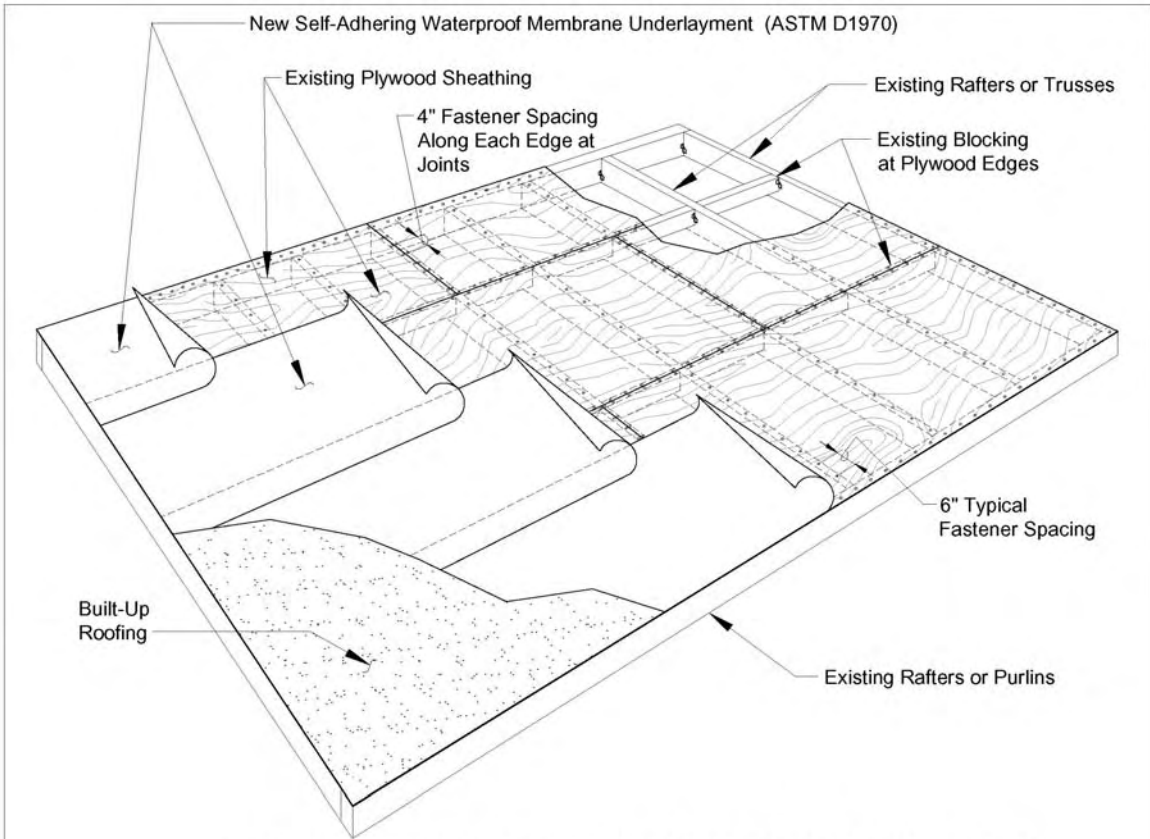
### SECTION AT EAVE



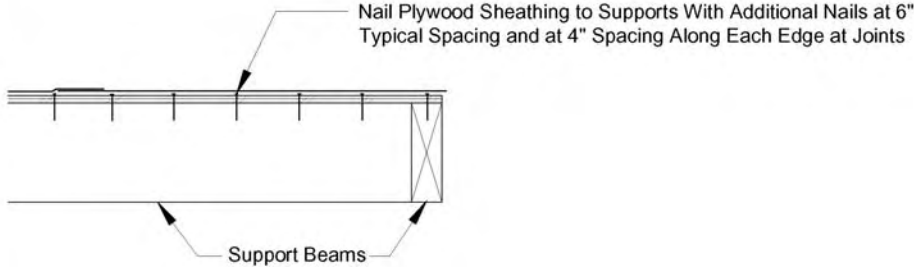
### TYPICAL ASPHALT SHINGLE ATTACHMENT

## STRUCTURAL SHEATHING WITH ADDITIONAL FASTENING FOR HIGH WIND UPLIFT

**Figure 11: Upgrade of Structural Plank Sheathing for Houses with Asphalt Shingle Roofing**



**BUILT-UP ROOFING OVER PLYWOOD**

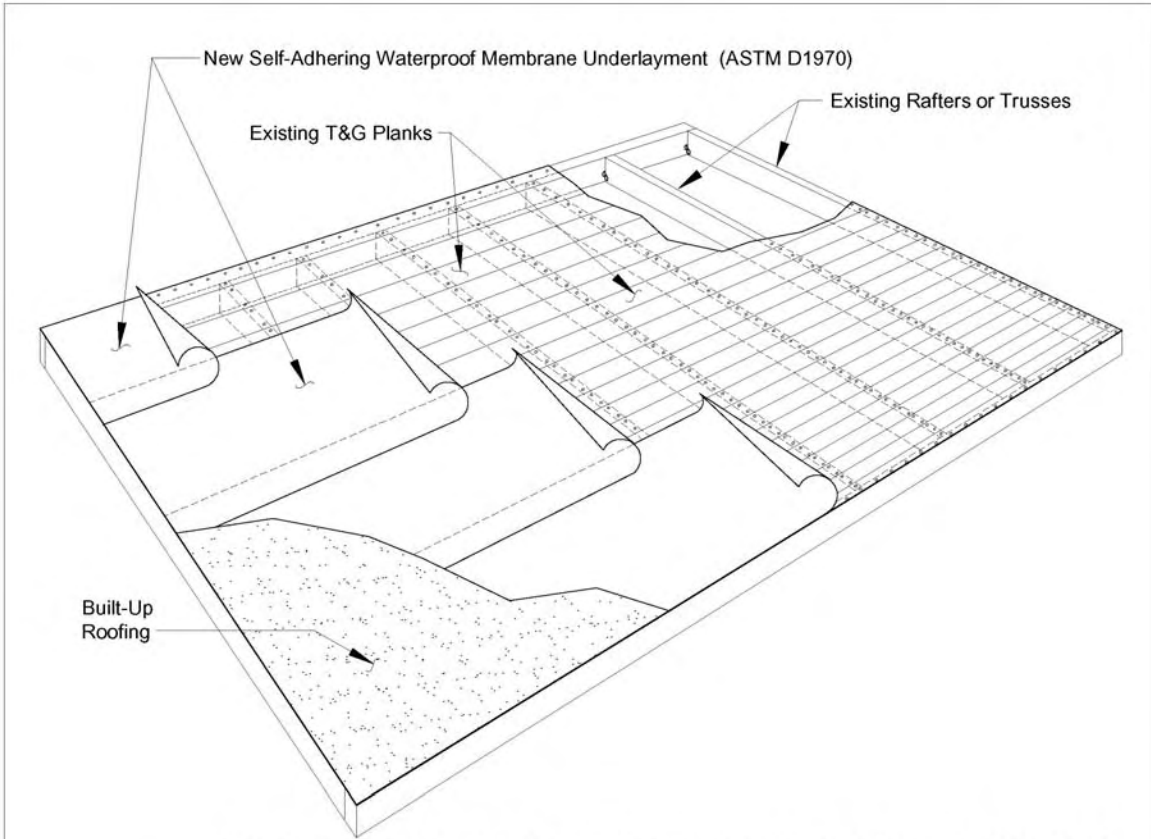


**SECTION AT EAVE**

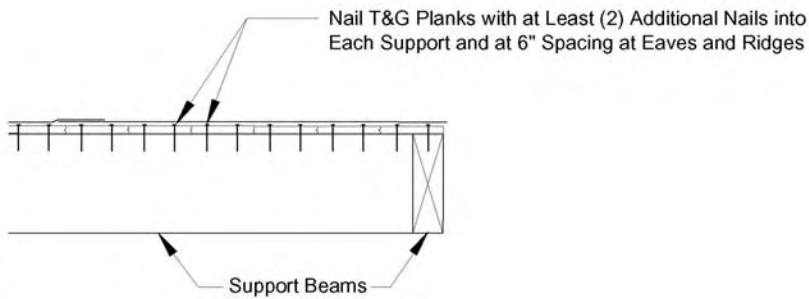
**STRUCTURAL SHEATHING WITH  
ADDITIONAL FASTENING FOR HIGH WIND UPLIFT**

**Figure 12: Upgrade of Structural Plywood Sheathing for Houses with Built-up Roofing**





**BUILT-UP ROOFING OVER T&G PLANKS**



**SECTION AT EAVE**

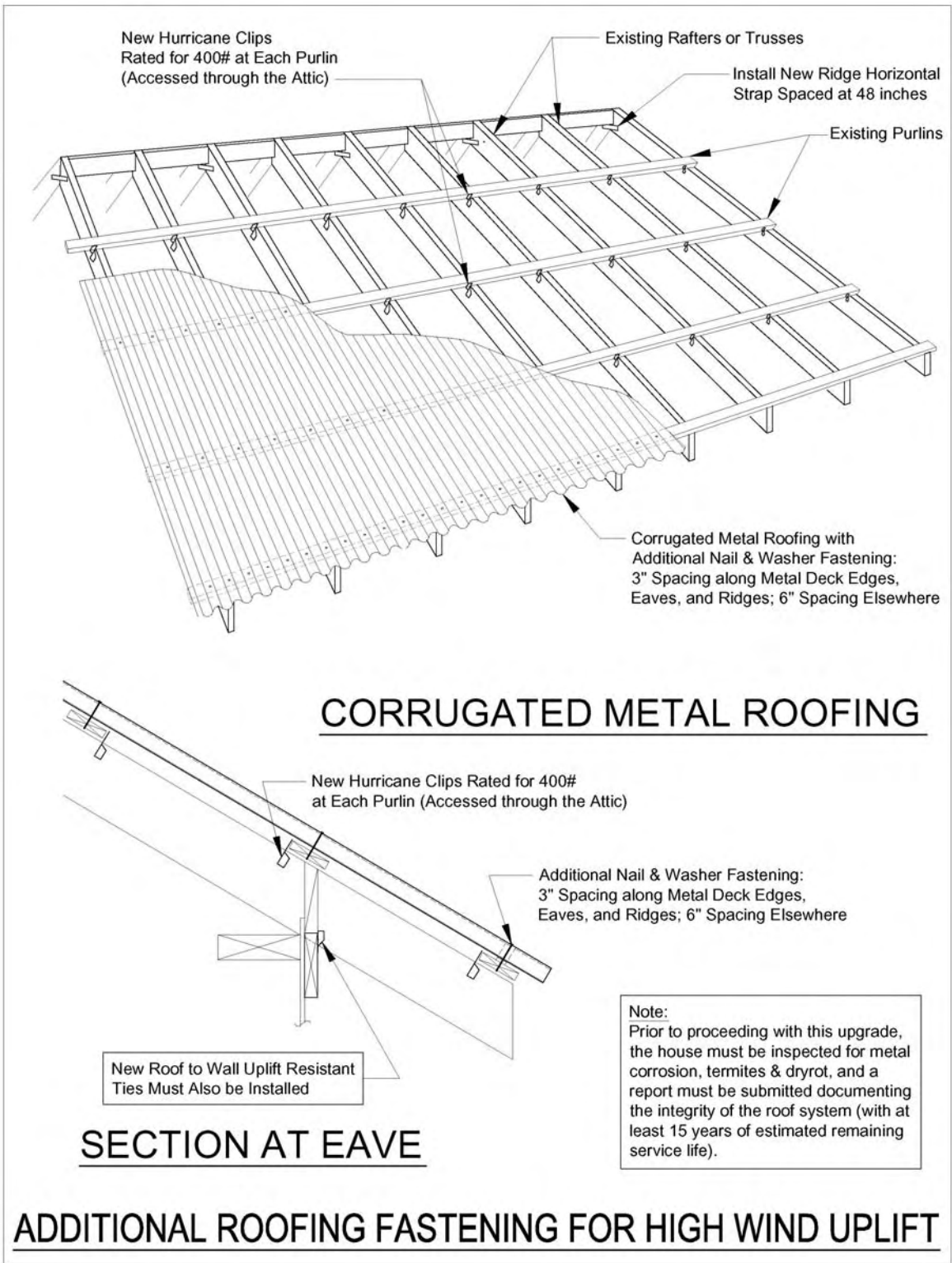
**STRUCTURAL SHEATHING WITH  
ADDITIONAL FASTENING FOR HIGH WIND UPLIFT**

**Figure 13: Upgrade of Structural Plank Sheathing for Houses with Built-up Roofing**

## **Upgraded Roof Decking for Houses with Metal Roofs**

For houses having corrugated metal roofs in good condition with at least 15 years of remaining life, the roof decking upgrade consists of adding additional fasteners to improve the connection of the decking to the roof frame. In order to qualify a house with a corrugated metal roof for an upgraded roof decking matching grant, 8d nails with neoprene washers shall be installed every 3 inches (i.e., at every crest) along the metal deck edges, eaves, and ridges and at every 6 inches (every second crest) elsewhere in the field of the decking panel. In addition, positive uplift resistance using a (Simpson H3 or equivalent) 400 lb. allowable uplift hurricane clip shall be provided at each connection between each purlin and roof truss (or rafter) as shown in Figure 10. The house shall be inspected for corrosion, termites, and dry rot, and a report submitted to the Department of Commerce and Consumer Affairs to document the condition of the metal roof and integrity of the roof framing prior to proceeding with this upgrade.

Alternatively, consider a new lightweight roofing system (for example, asphalt shingles) installed with high wind uplift measures that include plywood sheathing and a secondary waterproofing membrane.



**Figure 14: Upgraded Connections for Houses with Metal Roof Decking on Purlins and Rafter Trusses**



## Section 6. WRD Option 3: Exterior Opening Protection

**Extent and Strength of Exterior Opening Protection:** In order to qualify a house for an Opening Protection matching grant, all windows, sliding glass doors, entry doors, garage doors, and skylights, but excluding openings not exceeding a total of 2 square feet in any wall, shall be protected from windborne debris and wind pressure in accordance with ASTM E 1996-05, Standard Specification for Performance of Exterior Windows, Curtain Walls, Doors and Impact Protective Systems Impacted by Windborne Debris, 2005, as summarized in the Table 1. This option requires the manufacturer or installer to prepare prototypical drawing details for the attachment of the device to the specific types of construction and openings that are similar installations to an applicant's home.

**Garages may be protected separately:** A separate grant application may be submitted for the exterior openings of an attached garage, provided all openings and walls between the attached garage and the residential portion of the structure are protected to an ASTM E1996 Level C rating. If installing a new roll-up door, make sure it is certified according to the International Code Council AC222 Acceptance Criteria for Upward Acting Exterior Garage Doors with Specified Allowable Wind Pressures.

**Impact and Cyclic Pressure Testing:** Impact test regimens have a series of required tests: large missile, small missile, and cyclic loading.

The large missile test involves the use of a large object to test the glazing, simulating the impact of windborne debris such as building materials and other sizeable materials. The assembly to be tested is installed in a supporting frame, or "test chamber", and the large missile is a piece of 2x4 lumber that is fired from a specially built cannon that uses compressed air as the propellant. The length & weight of the 2x4 and the speed at which it impacts with the test specimen are determined in accordance with the code-specified design windspeed. The small missile test involves the use of small steel balls fired at the specimen in order to simulate the effect of small windborne debris such as roof gravel and other debris lifted by high winds.

The cyclic load testing is performed *after* the impact regimen to simulate the action of the hurricane winds on the impacted specimen. The test chamber is usually a sealed room into which the assembly to be tested is installed. The pressure in the chamber can be varied by the use of a compressor or blower to force air into or out of the chamber. The cyclic load is applied as a number of fluctuations of positive or negative pressure in an incremental fashion with the number, duration and magnitude of the cycles specified by the test standard. Cyclic pressure tests are not applicable to porous shutters and screens, i.e., those devices that function as debris impact protection devices without sealing of the opening.

**Table 1: Summary of the ASTM E 1996-05 Standard for Impact Protective Systems for Windborne Debris in Hurricanes and the ASTM Ratings Necessary for Product Approval by the Hawaii Loss Mitigation Grant Program**

Missile Level Rating	Debris Missile Size	Debris Impact Speed	Opening Protection Type	Cyclic Air Pressure Testing maximum inward and maximum outward pressures
<b>A</b>	Ten steel balls, each 2 g +- 5%	130 ft./sec or at least 88.6 mph	This is the minimum protective standard for <u>Skylights</u> required by the Loss Mitigation Grant Program	20 psf inward 55 psf outward
<b>B</b>	2 x 4 weighing 2.0 lb. +- 0.25 lb., and with min. length 1ft.-9-inch +- 4-inch	50 ft./sec. or at least 34 mph	This is a higher protective standard for <u>Skylights</u> than required by the Loss Mitigation Grant Program	30 psf inward 75 psf outward
<b>C</b>	2 x 4 weighing 4.5 lb. +- 0.25 lb., and with min. length of 4ft. +- 4-inch	40 ft./sec. or at least 27.3 mph	To meet the minimum requirements of the Loss Mitigation Grant Program, all fixed or operable windows, sliding door openings, all entry doors, but excluding openings not exceeding a total of 2 square feet in any wall shall meet both Level A and Level C requirements of ASTM E 1996	25 psf inward 35 psf outward
<b>D</b> (see note below)	2 x 4 weighing 9.0 lb. +- 0.25 lb., and with min. length 8 ft. +- 4-inch	50 ft./sec. or at least 34 mph	This is the protective standard for protection applicable to Hawaii Residential Safe Rooms required by the Loss Mitigation Grant Program	35 psf inward 45 psf outward
<b>E</b>	2 x 4 weighing 9.0 lb. +- 0.25 lb., and with min. length 8 ft. +- 4-inch	80 ft./sec. or at least 54.6 mph	This is a higher protective standard for opening protection than required by the Loss Mitigation Grant Program	40 psf inward 55 psf outward

**Note: Entry doors and windows of Residential Safe Rooms shall comply with ASTM E 1996-05 Level D requirements or better. (See Section 8.)**

**Hawaii Certification:** All devices shall be installed as per the manufacturer's specifications or as indicated in this document. All devices shall have a minimum 20-year design lifespan in a coastal environment including a marine atmosphere. All devices that must have ASTM approved ratings for the body of the device, and the manufacturers shall submit the test results and evaluation agency approvals substantiating compliance with ASTM standards along with typical attachment details to specific types of residential construction. Manufacturers or their representatives are required to submit either documented engineered designs prepared by a Hawaii structural engineer or test data reports for the attachment of the device. Separate submittals of typical details shall be furnished for each installation to a type of wall or frame construction (wood stud, single wall board, masonry/concrete, etc.). Approvals of devices shall be conditional based on evaluation of the documentation submitted for approval. In addition, see the following paragraph for devices intended for single wall construction. (A current list of approved devices and manufacturers may be provided on the DCCA Website.)

**Single Wall construction requires specifically certified devices:** If intended for installation on single wall homes, the manufacturer of an opening protection device shall design attachment details and perform testing of that installation on a sample single wall mock-up assemblage. For "single wall" construction, the WRD opening protection shall have been tested as installed onto a mock-up of a window or door opening in a representative single wall assemblage that is at least 6 ft. wide by 8 ft. high, secured at top and bottom to a laterally braced 4 x 8 wood beam section. The primary intent of the tests is to verify the strength of the proposed attachments to the single wall assembly for impact and pressurization. A Hawaii approval for the device on single wall shall be obtained by submittal of test results to DCCA.

**Deployable temporary protective devices:** Any deployable temporary protective system that requires final installation prior to an approaching storm shall have the attachment fittings permanently installed on the building. For example, wood or metal panels may require bolts, inserts, screws, and tracks in order for the panels to be installed correctly. These bolts, inserts, screws, and other fittings shall be permanently installed.

**Impact-resistant glass systems:** Impact-resistant glass systems are used in place of standard glass. Impact-resistant glass systems are available as complete units, including the frame, and they can be installed as

replacements for conventional windows. These windows are made of a clear plastic-like film, sandwiched between two glass units and have greater strength than glass alone. It is important to note that impact-resistant glass systems consist of specially treated glass and window frames that are specifically designed to meet a combination of impact and pressure loads. For typical installations, industry recommendations determined through testing include: 4-sided edge engagement of 3/4" minimum for a pressure plate system, 1" engagement on a fixed pocket, and a structural seal on the interior side of the glass lite. When the glass is broken in a monolithic application, the structural seal keeps the laminate "glued" into the opening, thus preventing a breach of the opening. To perform as designed, impact-resistant glass shall be installed in a tested and approved high-strength frame according to the manufacturer's specifications.

**Laminated Films:** This option requires the manufacturer or installer to prepare prototypical drawing details for the attachment of the device to various types of window openings and frames. Protective laminated films on the surface of glass windows shall not be approved without details for securing of glazing to the window frame, and submittal of test data reports substantiating a complete assembly complying with the requirements of ASTM E 1996 and this section.

**Standard Reference Testing Procedures:** More detailed requirements for the testing procedures necessary for product approval are given in ASTM standards E1886 and E1996.

**Open Sided Buildings not Eligible:** Buildings constructed to be open, defined as those buildings having each wall open by more than 80% of the total gross surface area, shall not be eligible for the opening protection grant, unless structurally retrofitted as an enclosed or partially enclosed building.

**Inspection:** Verify to be in substantial conformance to the Wind Resistive Devices Grant Program Technical Specifications through a combination of direct inspection and photographic evidence taken during construction. Verify that the work proceeded per engineered drawings or details that are adapted for the individual home. Check that there is a Hawaii approval certification for the device and attachment system for the type of wall construction (wood stud, single wall, masonry/concrete, etc.). Verify correct fit-up and correct number of fasteners of the connectors. For deployable devices witness the completed trial installation.

**Table 2: Opening protection shall consist of one or more of the following opening protective devices tested for compliance with the ASTM small and large missile impact standards and approved after submission of any required test results to the State of Hawaii**

<b>Locations Required to be Protected</b>	<b>Generic Types of Opening Protection Devices that can be used after the manufacturer obtains State approval</b>
<b>Windows or louvers and all sliding doors</b>	<p>Install impact debris protection devices meeting the ASTM E 1996-05 Level C requirements or better, utilizing:</p> <ul style="list-style-type: none"> <li>Permanently Installed Operable Shutters;</li> <li>Permanently Installed Perforated Metal Screen Window Barriers;</li> <li>Impact Resistant Glazing and Glazing Mounting System;</li> <li>Pre-assembled and Marked Deployable Storm Panels or Sliding Screen Panels with Permanently Installed Mountings and Anchorages; or</li> <li>Pre-assembled and Marked Deployable Porous Impact Deflecting Screens with Permanently Installed Mountings and Anchorages.</li> </ul>
<b>Entry doors</b>	<p>Install impact debris protection devices meeting the ASTM E 1996-05 Level C requirements or better, whereby the applicant:</p> <ul style="list-style-type: none"> <li>Remove and replace at least two entry doors with new Level C rated doors or provide Level C windborne debris impact protection devices that allow operation of Level C pressure-rated doors for entry/exiting, and install deployable debris impact screens or pre-assembled deployable ½-inch-thick termite-treated wood storm panels or storm panels on all remaining entry doors; and</li> <li>Reinforce any double entry doors with slide bolts at the top header and bottom threshold of the “inactive” door and a deadbolt with at least a one-inch throw length between each door. Each door shall have at least three hinges.</li> </ul>
<b>Garage doors</b>	<p>Remove and replace each garage door with a new manufactured door meeting ICC Acceptance Criteria AC222 and ASTM E-1996-05 Level C Protection consisting of:</p> <ul style="list-style-type: none"> <li>Garage Door Horizontal Bracing Girts;</li> <li>A Garage Door Deployable Vertical Bracing Strut; or</li> <li>Installation of a Garage Door Bracing Kit including additional roller track brackets and/or blocking and deployable tension restraint anchor straps on each side of the door.</li> </ul>
<b>Skylights larger than 2 square feet</b>	<p>Remove and replace each skylight with a new skylight meeting ASTM E-1996-05 Level A Protection or better.</p>



### Option for Temporary Plywood Panels:

Preservative-treated wood structural panels with a minimum thickness of 19/32 inch (nominal 5/8-inch) to 3/4-inch thick plywood and maximum panel spans of 6 feet shall be permitted for opening protection, when site-adapted in construction drawings prepared by a licensed architect or engineer that include comprehensive details for the attachment of the panels to the building. There shall not be any unsupported joints. Panels shall be pre-cut and pre-drilled to cover the glazed openings with permanent corrosion-resistant attachment hardware designed to resist the maximum inward and outward pressures indicated in Table 1. In the calculation of design wind loads, the algebraic sum of the pressures acting on opposite faces shall be taken into account by the architect or engineer. Attachment in accordance with Table 3 is permitted for buildings with a mean roof height of 33 feet or less. All wood panels shall be permanently marked to indicate the opening location for their installation.

**Table 3: Windborne Debris Protection Fastening Schedule for Wood Structural Panels<sup>a, b</sup>**

Fastener Type	Maximum Fastener Spacing in inches		
	Panel Span up to 4 ft.	Panel Span greater than 4 feet up to 6 ft.	Panel Span greater than 6 feet up to 8 ft.
No. 8 Wood Screws with 2-inch embedment	16 inches	9 inches	6 inches
No. 10 Wood Screws with 2-inch embedment	16 inches	12 inches	9 inches
1/4" Lag Screw Anchor with 2-inch embedment	16 inches	16 inches	16 inches

- a. Fasteners shall be installed at opposing ends of the wood structural panel.
- b. Where screws are attached to masonry or masonry/stucco, they shall be attached utilizing vibration-resistant anchors having a minimum withdrawal capacity of 500 pounds.

Wood structural panels in accordance with the APA-The Engineered Wood Association Form No. T450E (2004) based on a 3-second wind gust speed of 120 mph shall be accepted, when site-adapted in construction drawings prepared by a licensed architect or engineer.

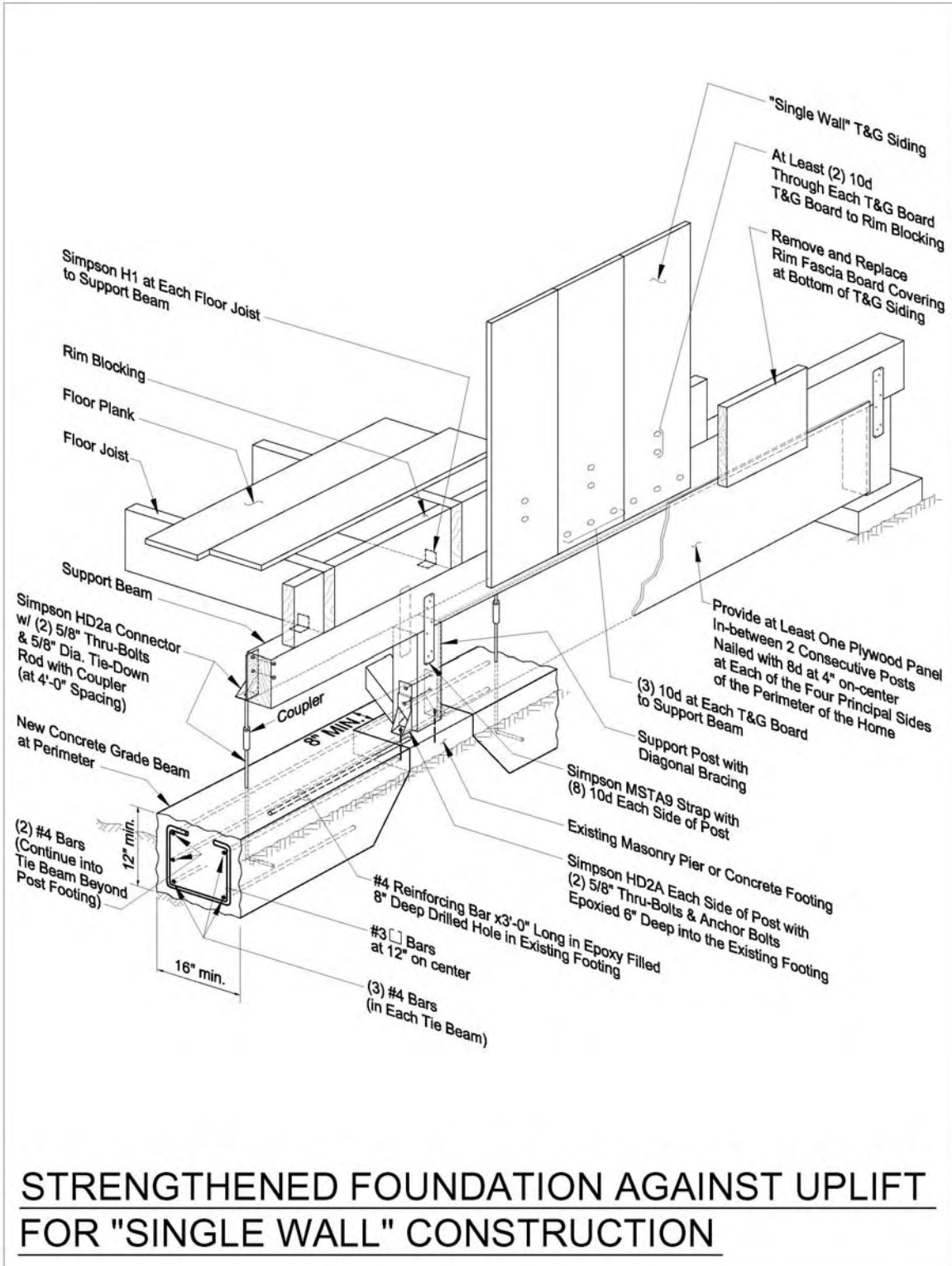
**Inspection:** The owner shall submit a record copy of the as-built deployment drawings including the panel ID piece list and shall submit an inspector's report of a successfully completed trial exercise deployment of all of the wood protective panels.

## **Section 7. WRD Option 4: Foundation Uplift Restraint Strengthening**

Many single wall houses in Hawaii utilize a post and beam system to support the first floor. In most instances, the posts rest on concrete blocks with no uplift resistance. In order to qualify a house for an upgraded foundation matching grant, the foundation retrofits specified in Figure 11 shall be installed between each pair of foundation blocks along the entire perimeter of the house. This device is designed to prevent sliding and overturning of single wall houses on "tofu" blocks. This grant shall be applicable only to single wall homes on post and beam systems with elevated first floors. This work requires preparation of plan drawing and details of the foundation retrofit for the site and foundation conditions of the individual home. Plans directly prepared by a licensed professional structural engineer may make use of alternative designs rather than the technique shown. A county building permit will be required for this work.

### **Inspection:**

Verify to be in substantial conformance through a combination of direct inspection and photographic evidence taken during construction. Verify conformance to the site-adapted drawings and details consistent with the intent of the Wind Resistive Devices Grant Program Technical Specifications. Verify correct fit-up of straps and ties and correct type and number of fasteners and bolts.



**Figure 15: Retrofit for Single Wall Houses on "Tofu" Foundation Blocks**

## **Section 8. WRD Option 5: Hawaii Residential Safe Room Performance Specifications**

In Hawaii, residents *cannot* readily evacuate away from a hurricane's landfall, as they do on the U.S. mainland, to reduce its life-threatening risk. They must generally remain in-place and seek refuge in immediately available hurricane resistant homes and shelters. The intent of the Hawaii Residential Safe Room is to temporarily provide an enhanced hurricane protection area, fully enclosed within a dwelling or within an accessory structure to a residence, that is designed and constructed to withstand the high wind pressures and windborne debris impacts expected during landfall of a Saffir-Simpson Category 3 hurricane. The use of a Residential Safe Room does not eliminate the risk of injury, given that the effects of a hurricane are highly variable and are subject to considerable uncertainty. Nevertheless, installing a properly designed and constructed residential safe room shelter can provide an area of enhanced protection within your home. To qualify for a grant, the residential safe room shall meet the minimum design and construction performance specifications established by the State of Hawaii. A county building permit will be required for this work.

**Because of the intense rainfall that can occur during hurricanes, one should not construct a Residential Safe Room within areas subject to stream flooding, coastal flooding or dam failure** inundation within any of the areas defined by:

1. FEMA Special Flood Hazard Areas (SFHA) subject to rainfall runoff flooding or stream or flash flooding;
2. Coastal zones "V" or "A" identified in the Flood Insurance Rate Map (FIRM) issued by FEMA for floodplain management purposes, in which the sources of the 100-year flood hazard are tides, storm surge, waves, tsunamis, or a combination of these hazards;
3. Areas subject to Dam Failure Inundation.

**Debris Impact Resistance:** The entire enclosure including all walls, ceilings, and openings, fixed or operable windows, and all entry doors, shall meet or exceed Level D requirements of ASTM E 1996 (Table 4). Any wall or ceiling penetration greater than 4 square inches shall be considered an opening. Electrical outlet boxes and interior lighting switches not penetrating more than 2.5 inches into the interior wall surface and a plumbing piping or conduit not greater than 1.5-inch in diameter shall be exempted from this requirement.

**Table 4: Windborne Debris Protection for Residential Safe Rooms**

ASTM E 1996 Missile Level Rating	Debris Missile Size	Debris Impact Speed	Protection Type required by the Loss Mitigation Grant Program	Enclosure Wall Ceiling, and Floor Cyclic Air Pressure Testing - maximum inward and maximum outward pressures
D	2 x 4 weighing 9.0 lb. +/- 0.25 lb., and with min. length 8 ft. +/- 4-inch	50 ft./sec. or at least 34 mph	This is the ASTM standard for enhanced protection applicable to Hawaii Residential Safe Rooms	35 psf inward 45 psf outward

**Ventilation:** The room shall be naturally ventilated to allow the enclosure to have approximately one air change every 2 hours. This requirement may be satisfied by 12 square inches of venting per occupant. There shall be at least two operable vents. The vents shall be protected by a cowling or other device that shall be impact tested to comply with ASTM E 1996 Level D.

**Exiting:** The room shall be equipped with an inward-swinging door and an impact-protected operable window suitable for a means of alternative exiting in an emergency.

**Communication:** The safe room shall be equipped with a phone line and telephone that does not rely on a separate electrical power outlet (but it may rely on a Uninterruptible Power Supply (UPS) battery device).

**Maximum Occupancy:** The safe room is permitted to be used for a maximum occupancy based on at least 15 square feet per person with a maximum of 8 persons in a room of up to 128 square feet of floor area.

**Readiness:** The safe room shall be fully constructed in all respects. It shall be readily accessible and ready for occupancy to person(s) residing on the property within 2 hours notice.

**Construction Documents Required:** Construction documents for the installation of the safe room in the residence of the applicant shall be directly prepared by a Hawaii licensed professional structural engineer.

**Minimum Structural Integrity:** The safe room shall be built with a self-sufficient structural system and a complete load path for vertical and lateral loads caused by gravity and wind. The ceiling structure and wall shall be



capable of supporting a superimposed debris load of the full weight of any building floors and roof above, but not less than 125 psf. The safe room enclosure shall be capable of simultaneously resisting lateral and uplift wind pressures corresponding to a 160 mph 3-second peak gust, determined in accordance with ASCE Standard 7, Minimum Design Loads for Buildings and Other Structures, calculated using Load, Importance, and Directionality Factors of 1.0. The site exposure factor shall be based on Exposure C. Gust factor shall be taken as 0.85. Topographic wind amplification caused by mountainous terrain shall be considered in accordance with the local county building code. The building that the safe room is built within shall be assumed to be destroyed by the storm and shall not be taken as offering any protective shielding to the safe room enclosure. The safe room shall be anchored to a foundation system capable of resisting the above loading.

**Manufactured Safe Room Designs Subject to Approval:** In lieu of constructing a customized safe room, a manufactured safe room or safe room kit may be substituted if documentation is submitted and approved by the Insurance Commissioner. The safe room shall be engineered, tested, and manufactured to meet or exceed the criteria of this section.

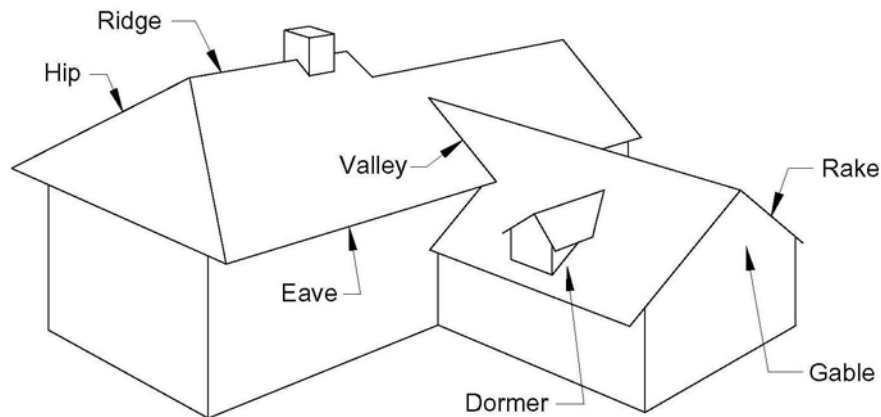
**FEMA In-Residence Shelter Designs Permitted:** It shall be permissible to build FEMA In Residence Shelters of up to 64 square feet of floor area with walls up to 8 feet long, that are built in accordance with construction details of FEMA 320, "Taking Shelter From the Storm: Building a Safe Room Inside Your House."

**Inspection Required:** The construction or installation of the safe room shall be verified for conformance to the drawings and details consistent with the Wind Resistive Devices Technical Specifications. Verify correct fit-up of sheathing and correct type and spacing of fasteners. The inspector shall submit a written opinion to the Insurance Division that the safe room was constructed in accordance with the requirements of this section.

**Registration and Reporting:** The applicant shall register the property's Tax Map Key or Global Positioning System coordinates of the safe room with the Department of Defense and County Civil Defense Agency. The occupants of the safe room are responsible for all essential items necessary for unassisted sustenance and personal medical care. A standing waiver of evacuation must be submitted by every new owner or head of household occupant of the residence in order to use the Residential Safe Room during a hurricane. It is recommended that the occupants of the safe room report their status to the American Red Cross shelter or a civil defense Disaster Assistance and Recovery Center after passage of the storm.

## Section 9. Glossary

### Common Terminology used for Roof Elements



#### **ANCHORING**

Tying down a wall to resist racking or lift. Walls can be “anchored” to the ground using foundation bolts, straps, and special brackets.

#### **CARPORT**

A carport is a roof projecting from the side of a building used to provide an open shelter for an automobile.

#### **CLADDING**

Cladding can mean several different things. Cladding as siding includes vinyl siding, wood siding, cementitious, or aluminum siding. Cladding for windows and doors refers to the vinyl or aluminum skin used on the outside in place of paint i.e. “vinyl clad” or “aluminum clad.” Cladding in general can refer to skylights, glazing, glass block, shutters, or any other external protection device.

#### **CONNECTOR**

A mechanical device for securing two or more pieces, parts, or members together, including anchors, wall ties, and fasteners.

#### **FASTENERS**

These include, but are not limited to, nails, wood screws, sheet metal screws, self tapping screws, “Tek” screws, bolts & nuts with washers, epoxy (glued) anchors, lag bolts or “J” bolts, etc.

## **GABLE END**

The entire end wall of a house having a gable roof (see terminology for roof elements).

## **GARAGE**

A garage is an enclosed structure for housing automobiles.

## **HURRICANE STRAPS**

Galvanized or stainless steel brackets used to strengthen "wood to wood" and "wood to concrete" connections. These may also be referred to as "hurricane clips".

## **IMPACT RESISTANT GLASS**

Glass formed when two pieces of annealed glass are bonded together with an interlayer that holds the glass in the window frame even when it is broken or shattered.

## **IMPACT-PROTECTION**

Shutter systems or impact-resistant glass systems that are used to protect windows, doors and openings from wind-borne debris.

## **LOAD PATH**

When wind forces are placed on a house, the force (load) shall ultimately make its way into the ground. For example, a wind load path can follow from the roof to the framing through a wall into the foundation and then into the ground. The path that the wind force takes is called the load path.

## **MODIFIED BITUMEN ROOF COVERING**

One or more layers of polymer modified asphalt sheets. The sheet materials shall be fully adhered or mechanically attached to the substrate or held in place with an approved ballast layer.

## **PURLINS**

Purlins are the framing members placed at right angles to rafters reduce the roof board span.

## **ROOF JOIST/RAFTER**

The pitched roof board used in conventional framing. This is also referred to as the "top chord" of the truss.

## **ROOF SHEATHING**

The boards or sheet material fastened to the roof rafters on which the shingle or other roof covering is laid.

## **SINGLE WALL**

Single wall construction utilizes flat tongue and groove boards placed vertically to form a load-bearing wall without studs. A flat wood top plate is attached against the vertical siding board to serve as a supporting ledger for the ceiling, and the vertical board is nailed at the bottom to a rim joist and sill beam, transferring its load through vertical shear. Some forms of single wall construction have additional posts and beams to help carry the roof load. The connections typically have minimal uplift capacity. Roof construction in single wall residences is typically light non-engineered framing with composition shingles on tongue and groove (T & G) wood decking, or corrugated metal deck roofing directly attached to rafters.

## **TENSION TIE DOWNS**

Metal connectors that secure masonry or other material to adjoining frames or the foundation.

## **TOP PLATE**

The horizontal board, typically two-ply, nailed to the top of the partition or wall studs in a building.

## **TRUSS**

A truss system includes the top chord or rafter (where roof sheathing is nailed), a joist or bottom chord (where the interior ceiling is nailed) and angled pieces that form a web and are used to add strength.

## **UNDERLAYMENT**

One or more layers of felt, sheathing paper, non-bituminous saturated felt, or other approved material over which a steep-slope roof covering is applied.

## **UPLIFT**

The force of wind moving over a structure causes negative wind pressure (suction) to be placed on a building that creates upward forces. Roofs should be designed to resist uplift caused when high winds travel over and across the roof.

## **WALL STUDS**

Usually 2"x 4" or 2"x 6" wood or metal that run vertically from the bottom plate (floor) to the top plate (ceiling).

## **WALL TOP PLATE**

Usually consists of 2- 2"x 4" or 2- 2"x 6" nailed on top of each other at the top of your wall. Supports the roof trusses and provides the attachment point for wall to roof.

## **WIND-BORNE DEBRIS**

Missiles or airborne projectiles that cause glass breakage and other damage to buildings during severe wind events.



**Table 5: Saffir/Simpson Hurricane Scale Ranges with Additional Hawaii Damage Indications**

Hurricane Category	Central Pressure - Mm of mercury	Sustained Winds	Peak Gust (mph)	Approximate Storm Surge Height (ft.)not including wave action	Damage Potential Indications
<b>Tropical Storm</b>	979-1007	40-73 mph	45 to 81	2-3 ft	<b>Some.</b> Minor damage to buildings of light material. Moderate damage to banana trees, papaya trees, and most fleshy crops. Large dead limbs, ripe coconuts, many dead palm fronds, some green leaves, and small branches blown from trees.
<b>1</b>	980-992	74-95 mph	82-108	4-5 ft	<b>Significant.</b> Corrugated metal and plywood stripped from poorly constructed or termite-infested structures and may become airborne. Some damage to wood roofs. Major damage to banana trees, papaya trees, and fleshy crops. Some palm fronds torn from the crowns of most types of palm trees, many ripe coconuts blown from coconut palms. Some damage to poorly constructed signs. Wooden power poles tilt, some rotten power poles break, termite-weakened poles begin to snap. Low-lying coastal roads inundated, minor pier damage, some small craft in exposed anchorage torn from moorings.
<b>2</b>	965-979	96-110 mph	108-130	6-8 ft	<b>Moderate.</b> Considerable damage to structures made of light materials. Moderate damage to houses. Exposed banana trees and papaya trees totally destroyed, 10%-20% defoliation of trees and shrubbery. Many palm fronds crimped and bent through the crown of coconut palms and several green fronds ripped from palm trees; some trees blown down. Weakened power poles snap. Considerable damage to piers; marinas flooded. Small craft in unprotected anchorages torn from moorings. Evacuation from some shoreline residences and low-lying areas required.
<b>3</b>	945-964	111-131 mph	130-156	9-12 ft	<b>Extensive.</b> Extensive damage to houses and small buildings; weakly constructed and termite-weakened house heavily damaged or destroyed; buildings made of light materials destroyed; extensive damage to wooden structures. Major damage to shrubbery and trees; up to 50% of palm fronds bent or blown off; numerous ripe and many green coconuts blown off coconut palms; crowns blown off of palm trees; up to 10% of coconut palms blown down; 30%-50% defoliation of many trees and shrubs. Large trees blown down. Many wooden power poles broken or blown down; many secondary power lines downed. Air is full of light projectiles and debris; poorly constructed signs blown down. Serious coastal flooding; larger structures near coast damaged by battering waves and floating debris.
<b>4</b>	920-944	131-155 mph	156-191	13-18 ft	<b>Extreme.</b> Extreme structural damage; even well-built structures heavily damaged or destroyed; extensive damage to non-concrete failure of many roof structures, window frames and doors, especially unprotected, non-reinforced ones; well-built wooden and metal structures severely damaged or destroyed. Shrubs and trees 50%-90% defoliated; up to 75% of palm fronds bent, twisted, or blown off. Many crowns stripped from palm trees; numerous green and virtually all ripe coconuts blown from trees; severe damage to sugar cane; large trees blown down; bark stripped from trees; most standing trees are void of all but the largest branches (severely pruned), with remaining branches stubby in appearance; trunks and branches are sandblasted. Most wood poles downed/snapped; secondary and primary power lines downed. Air is full of large projectiles and debris. All signs blown down. Major damage to lower floors of structures due to flooding and battering by waves and floating debris. Major erosion of beaches.
<b>5</b>	< 920	> 155 mph	>191	> 18 ft	<b>Catastrophic.</b> Building failures; extensive or total destruction to non-concrete residences and industrial buildings; devastating damage to roofs of buildings; total failure of non-concrete reinforced roofs. Severe damage to virtually all wooden poles; all secondary power lines and most primary power lines downed. Small buildings overturned or blown away.