

Purpose of Issue	Rev	Date of Issue	Author	Agreed	Approved
Draft Issued to PSC	0	August 1996	DJM/RJvF		
Second Draft Issue to PSC	1	February 1997	<i>DJM.</i>	<i>AS</i>	<i>AS</i>

"This document has been prepared by MSL Engineering Limited for the Participants of the Joint Industry Project on Development of Grouted Tubular Joint Technology for Offshore Strengthening and Repair. This document is confidential to the Participants in the Joint Industry Project, under the terms of their contract for participation in the project."

JOINT INDUSTRY PROJECT

**DEVELOPMENT OF GROUTED
TUBULAR JOINT TECHNOLOGY
FOR OFFSHORE
STRENGTHENING AND REPAIR**

Draft Final Report

DOC REF C14100R020 Rev 1 FEBRUARY 1997

273.B

**MSL Engineering Limited
MSL House**

5-7 High Street, Sunninghill,
Ascot, Berkshire. SL5 9NQ

Tel: + 44 (0)1344 874424

Fax: + 44 (0)1344 874338

NUMBER	DETAILS OF REVISION
0	Draft issued to PSC, August 1996
1	Second draft issue to PSC, February 1997



SUMMARY

The document presents a detailed description and the results of a test programme examining the effect of complete grout filling of the chord members of tubular joints on SCF behaviour and ultimate bending strength. The results have been used as a basis for generating new guidance or confirming previously uncorroborated guidance in these areas. An initial study was performed to investigate the effects of preload history on subsequent SCF behaviour so that appropriate testing procedures could be specified with which to conduct the tests. A full test programme was conducted on five T joints and seven DT joints of various geometries ($0.4 \leq \beta \leq 1.0$ and $12 \leq \gamma \leq 26$) fabricated to industry practice and using pipes up to 406mm in diameter. Typically, each joint in the programme was subjected to the following tests:

- SNCF measurement, on both the brace and the chord sides of the weld, in the as-welded condition for axial compression, axial tension, in-plane bending (IPB) and out-of-plane bending (OPB) on the braces.
- SNCF measurements in the grouted condition for the same four load cases following the selected preload.
- An ultimate load test in either IPB or OPB.

A large test frame was specifically designed and fabricated to apply axial tension, axial compression, IPB and OPB loads. The specimens were of relatively large scale (i.e. 406mm diameter chord members). Specimen size is an important issue when considering local behaviour such as SCFs and especially when grouted joints are involved.

All specimens were instrumented with strip gauges and single element gauges. The strip gauges contained five individual single element strain gauges at 2mm spacings, two of which were unused. At each measurement location (e.g. chord crown) a strip gauge and a single element gauge were placed on a line orthogonal to the weld. The first gauge of the strip was placed $0.4 \times (T \text{ or } t)$ but not less than 4mm. The single element gauge was placed at the HSE recommended last gauge position.

As-welded SCF/SNCF ratios are well documented so it remained to establish the SCF/SNCF ratio for specimens in the grouted condition. The first grouted specimen to be tested was instrumented with additional rosette gauges. The rosette gauges established that the grouted SCF/SNCF ratio remains consistent with the as-welded ratio for all load cases.

In addition to strain gauges, transducers were mounted for measurement of deflection. The deflection measurements were used to establish deformation local to the joint under axial load or bending moment and overall deformation under bending.

Load cells, or strain gauges on tie rods/bars, were used to measure applied load for the various load cases.

The first grouted specimen was subjected to a preload investigation to establish the effects of loading history on measured strain concentration factors (SNCFs). SNCFs were measured after each application of compression/tension preload. The preload levels were increased in 10 - 20% increments of ISO predicted as-welded joint capacity up to approximately 130%. The preload applied to the remaining specimens was based on the results of the preload investigations.

Prior to the preload investigations, all specimens were subjected to as-welded SNCF measurements. Table Summ-1 presents a summary of the derived as-welded SCFs with predicted SCFs using Efthymiou and Lloyds parametric equations. The majority of predicted as-welded SCFs are to within 15% of the measured values.

SNCF measurements were also taken for all specimens in the grouted condition. A number of measurements were taken for each specimen for increasing preload levels. An SCF/SNCF ratio of 1.2 was used to convert SNCFs to SCFs. Subsequent grouted SCFs presented in Table Summ-2 represent those derived from measurements taken after a preload level of 60% of ISO as-welded joint capacity. Table Summ-2 also presents the derived grouted SCFs using formulations derived as part of the project. Typically the as-welded SCF is smaller than the grouted SCF. The ratio of grouted SCF to as-welded SCF is referred to as the Reduction Factor (RF). RFs derived from the measured grouted SCF over measured as-welded SCF, and measured grouted SCF over as-welded SCF, derived

using parametric formulae, were used to develop equations to predict RFs for the two scenarios. Table Summ-3 presents the measured RFs and the derived RFs.

The final phase of testing consisted of ultimate strength tests. The specimens were tested in either in-plane bending or out-of-plane bending. Table Summ-4 presents the measured results and corresponding predicted values. The predicted values are well correlated to the measured values.

The data from the programme are fully reported in various appendices and these have been assessed to enable firm recommendations to be made with respect to estimating SCFs and ultimate strength behaviour of grouted joints.



Specimens Ident.	D (mm)	d (mm)	T (mm)	t (mm)	L (mm)	θ (°)	P	p (Modified)	Y	Source	Chord SCFs						Brace SCFs							
											IPB Crown	OPB Saddle	Comp.		Tens.		IPB Crown	OPB Saddle	Comp.		Tens.			
													As-c	Ax-c	As-c	Ax-c			As-c	Ax-c	As-c	Ax-c		
T1	406.78	167.81	16.39	16.32	2440	90.0	0.413	0.413	12.409	Eibhymion Lloyds Measured	3.65	8.29	13.28	6.06	13.28	6.06	2.87	5.85	8.37	3.08	8.37	3.08	3.08	3.08
											3.07	7.08	10.92	6.61	10.92	6.61	1.89	3.91	6.12	1.85	6.12	1.85	6.12	1.85
											2.93	7.30	11.23	6.95	10.43	6.42	1.61	3.70	6.47	0.30	5.95	0.29	5.95	0.29
T3	406.78	407.02	16.39	16.10	2440	90.0	1.000	0.961	12.409	Eibhymion Lloyds Measured	3.20	7.92	5.10	8.25	5.10	8.25	2.44	4.23	3.46	3.53	3.46	3.53	3.53	
											2.69	6.82	3.85	7.42	3.85	7.42	1.62	3.67	3.20	1.57	3.20	1.57		
											3.37	8.41	3.54	10.27	3.26	10.27	1.38	5.77	5.15	2.48	5.21	2.50		
T5	407.05	273.34	10.19	9.82	2440	90.0	0.672	0.672	19.973	Eibhymion Lloyds Measured	4.80	17.86	19.97	6.59	19.97	6.59	3.39	10.84	11.84	2.62	11.84	2.62	11.84	
											4.05	16.33	18.28	7.08	18.28	7.08	2.58	8.82	10.34	1.80	10.34	1.80		
											4.36	16.86	21.35	10.30	21.16	9.62	1.82	9.26	13.16	1.32	13.00	1.21		
T7	406.96	168.41	7.86	8.31	2440	90.0	0.414	0.414	25.888	Eibhymion Lloyds Measured	6.52	18.41	29.62	7.25	29.62	7.25	4.38	12.11	16.53	2.52	16.53	2.52	16.53	
											5.47	15.72	28.06	7.67	28.06	7.67	2.88	8.87	14.83	1.98	14.83	1.98		
											5.69	21.17	33.31	10.20	31.09	9.59	1.99	7.96	12.55	1.14	12.44	1.16		
T9	406.96	406.96	7.86	7.86	2440	90.0	1.000	0.981	25.888	Eibhymion Lloyds Measured	4.11	16.83	10.84	9.25	10.84	9.25	2.84	8.58	5.85	2.62	5.85	2.62	5.85	
											3.46	12.51	7.71	7.57	7.71	7.57	2.29	6.96	5.95	1.36	5.95	1.36		
											3.22	19.38	14.53	9.30	13.94	8.99	1.68	8.44	8.53	2.62	8.26	2.58		
DT2	406.78	273.09	16.39	15.76	2440	90.0	0.671	0.671	12.409	Eibhymion Lloyds Measured	3.70	10.32	18.97	2.28	18.97	2.28	2.82	6.42	10.40	2.35	10.40	2.35	10.40	
											2.89	7.65	14.14	1.29	14.14	1.29	2.23	4.78	9.48	1.45	9.48	1.45		
											3.98	8.08	15.73	2.08	15.92	2.11	1.81	5.44	10.96	0.06	11.11	0.08		
DT3	406.78	407.02	16.39	16.10	2440	90.0	1.001	0.961	12.409	Eibhymion Lloyds Measured	3.20	2.64	4.67	2.36	4.67	2.36	2.44	1.41	3.08	2.35	3.08	2.35	3.08	
											2.36	2.45	4.19	0.55	4.19	0.55	1.86	2.07	3.52	1.32	3.52	1.32		
											2.88	3.10	4.07	0.78	4.06	0.79	1.43	2.53	4.31	0.86	4.24	0.86		
DT4	407.05	168.57	10.19	9.95	2440	90.0	0.414	0.414	19.973	Eibhymion Lloyds Measured	5.06	12.28	27.99	3.99	27.99	3.99	3.68	8.54	15.70	2.27	15.70	2.27	15.70	
											4.15	11.65	24.19	2.88	24.19	2.88	2.76	7.38	15.52	1.84	15.52	1.84		
											5.14	11.81	31.32	4.38	31.37	4.44	2.64	4.74	13.27	1.07	13.50	1.23		
DT5	407.05	273.34	10.19	9.82	2440	90.0	0.672	0.672	19.973	Eibhymion Lloyds Measured	4.80	16.64	30.60	2.71	30.60	2.71	3.39	10.09	16.15	1.84	16.15	1.84		
											3.88	14.23	26.30	1.06	26.30	1.06	2.98	8.74	16.78	1.45	16.78	1.45		
											6.06	18.20	35.92	4.12	35.72	4.54	1.97	9.07	19.01	0.08	18.60	0.06		
DT6	407.05	407.60	10.19	9.61	2440	90.0	1.001	0.976	19.973	Eibhymion Lloyds Measured	3.59	4.01	7.12	2.78	7.12	2.78	2.65	2.14	4.24	1.84	4.24	1.84		
											2.89	3.22	5.65	0.45	5.65	0.45	2.33	2.46	4.39	1.31	4.39	1.31		
											3.10	5.18	8.53	0.61	7.94	0.62	1.62	2.89	5.24	1.12	5.00	1.18		
DT8	406.96	273.21	7.86	7.88	2440	90.0	0.671	0.671	25.888	Eibhymion Lloyds Measured	5.72	22.44	41.26	3.08	41.26	3.08	3.82	13.15	21.03	1.42	21.03	1.42	21.03	
											4.69	20.74	38.34	0.95	38.34	0.95	3.65	12.88	24.00	1.46	24.00	1.46		
											4.79	21.59	43.92	1.70	44.39	1.58	1.92	10.46	21.53	0.50	21.70	0.52		
DT9	406.96	406.96	7.86	7.86	2440	90.0	1.000	0.981	25.888	Eibhymion Lloyds Measured	4.11	5.70	10.02	3.25	10.02	3.25	2.84	2.90	5.43	1.42	5.43	1.42	5.43	
											3.46	4.31	7.64	0.42	7.64	0.42	2.81	3.00	5.58	1.31	5.58	1.31		
											3.47	6.90	10.16	0.72	9.98	0.74	1.64	2.71	4.45	1.25	4.25	1.26		

Note :- Assumed Stress/Strain relationship = 1.2

Table Summ-1: Summary of as-welded SCFs



Specimen Ident.	Chord SCFs										Brace SCFs															
	D (mm)	d (mm)	T (mm)	T ₁ (mm)	t (mm)	L (mm)	θ (°)	β	γ	Y _c		α	ε	Condition	IPB	OPB	Comp.		Tens.	IPB	OPB	Comp.		Tens.		
										AX-X	AX-C						AX-X	AX-C				AX-X	AX-C			
T1	406.78	167.81	16.39	29.4	16.32	2440	90.0	0.413	12.409	6.92	11.71	12.00	0.996	Predicted Q	2.93	5.20	6.19	6.83	5.53	5.81	1.73	3.28	3.41	1.36	3.87	1.10
														Predicted R	2.83	5.19	6.27	7.05	5.69	5.75	1.60	3.31	3.65	1.30	3.66	1.16
														Measured	2.83	5.26	6.20	7.00	5.64	5.87	1.62	3.28	3.60	1.33	3.68	1.12
T3	406.78	407.02	16.39	29.4	16.10	2440	90.0	1.000	12.409	6.92	11.71	12.00	0.982	Predicted Q	3.17	2.27	0.33	10.79	0.82	11.50	1.55	1.89	1.46	2.96	1.56	2.76
														Predicted R	3.20	2.20	0.36	10.74	0.85	11.20	1.51	1.92	1.54	2.95	1.63	2.76
														Measured	3.10	2.26	0.34	10.68	0.80	11.34	1.52	1.88	1.56	2.89	1.60	2.69
T5	407.05	273.34	10.19	23.6	9.82	2440	90.0	0.672	19.973	8.62	18.36	11.99	0.964	Predicted Q	3.81	6.19	6.45	9.59	5.94	9.17	2.29	4.18	4.44	2.74	4.59	2.01
														Predicted R	3.88	6.22	6.39	9.58	6.32	9.16	2.26	4.24	3.97	2.75	4.37	2.03
														Measured	3.91	6.18	6.32	9.56	6.10	9.13	2.26	4.21	3.95	2.74	4.36	2.03
T7	406.96	168.41	7.86	21.4	8.31	2440	90.0	0.414	25.888	9.49	23.42	11.99	1.057	Predicted Q	3.90	10.07	7.06	6.00	14.05	6.63	2.41	5.90	3.35	4.57	6.12	1.25
														Predicted R	3.81	10.09	6.74	5.90	14.74	6.80	2.39	5.93	3.32	1.56	5.81	1.29
														Measured	3.95	10.21	6.84	5.93	14.50	6.77	2.42	5.88	3.32	1.58	5.93	1.31
T9	406.96	406.96	7.86	21.4	7.86	2440	90.0	1.000	25.888	9.49	23.42	11.99	1.000	Predicted Q	3.02	5.32	3.33	9.77	3.49	8.91	2.11	2.20	3.57	3.11	2.48	2.51
														Predicted R	3.01	5.35	3.25	9.55	3.41	8.82	2.07	2.16	3.07	3.32	2.43	2.41
														Measured	3.05	5.32	3.26	9.60	3.35	8.81	2.09	2.17	3.03	3.24	2.39	2.43
DT2	406.78	273.09	16.39	29.4	15.76	2440	90.0	0.671	12.409	6.92	11.71	12.00	0.962	Predicted Q	2.97	5.21	5.73	3.34	6.00	2.05	2.46	3.93	3.79	0.26	4.64	0.12
														Predicted R	3.28	5.92	5.90	2.94	6.90	2.00	2.52	4.04	3.83	2.07	4.53	0.88
														Measured	3.16	5.32	6.08	3.26	6.20	2.02	2.50	4.03	3.74	2.00	4.51	0.88
DT3	406.78	407.02	16.39	29.4	16.10	2440	90.0	1.001	12.409	6.92	11.71	12.00	0.982	Predicted Q	1.95	3.06	3.75	1.49	4.14	1.11	2.36	2.57	4.05	1.15	3.80	1.00
														Predicted R	1.90	3.17	4.74	1.68	4.48	1.51	2.40	2.56	4.14	1.07	3.48	0.96
														Measured	1.93	3.01	3.86	1.45	4.14	1.02	2.29	2.44	3.89	1.07	3.34	0.96
DT4	407.05	168.57	10.19	23.6	9.95	2440	90.0	0.414	19.973	8.62	18.36	11.99	0.976	Predicted Q	2.91	6.55	3.77	3.26	8.84	2.49	3.53	3.93	2.05	2.56	4.13	1.31
														Predicted R	2.92	6.78	3.95	3.36	8.61	3.21	3.68	4.00	2.03	2.38	3.96	1.24
														Measured	2.94	6.55	3.91	3.12	8.33	2.52	3.58	4.02	2.11	2.39	4.13	1.24
DT5	407.05	273.34	10.19	23.6	9.82	2440	90.0	0.672	19.973	8.62	18.36	11.99	0.964	Predicted Q	3.60	9.26	9.99	6.89	11.15	5.55	2.77	5.20	4.68	0.36	6.32	0.07
														Predicted R	3.06	8.30	9.29	2.32	10.76	1.48	2.77	4.96	4.26	2.14	6.46	0.92
														Measured	3.30	8.59	8.96	1.98	11.59	0.74	2.76	4.90	4.33	2.32	6.36	0.96
DT6	407.05	407.60	10.19	23.6	9.61	2440	90.0	1.001	19.973	8.62	18.36	11.99	0.943	Predicted Q	1.86	4.94	8.22	1.78	6.62	1.11	2.68	2.73	4.95	1.80	3.37	1.11
														Predicted R	1.87	4.83	7.15	1.80	5.94	1.14	2.60	2.69	4.43	1.76	3.92	1.31
														Measured	1.93	5.04	7.61	1.79	6.46	1.31	2.84	2.89	4.80	1.58	3.95	1.28
DT8	406.96	273.21	7.86	21.4	7.88	2440	90.0	0.671	25.888	9.49	23.42	11.99	1.003	Predicted Q	2.28	8.67	9.25	2.94	11.59	2.25	2.78	4.77	3.63	2.10	6.04	0.64
														Predicted R	2.52	9.89	12.27	2.82	14.12	1.87	2.90	5.05	3.84	2.07	6.54	0.74
														Measured	2.35	9.00	8.72	2.86	12.60	2.32	2.76	5.10	3.88	1.93	6.43	0.72
DT9	406.96	406.96	7.86	21.4	7.86	2440	90.0	1.000	25.888	9.49	23.42	11.99	1.000	Predicted Q	1.88	6.35	10.06	2.64	6.82	1.54	2.71	2.39	4.18	2.34	2.10	1.30
														Predicted R	1.89	6.83	9.90	3.25	7.31	1.79	2.78	2.36	4.37	2.03	2.02	1.23
														Measured	1.82	6.42	10.15	2.54	6.84	1.34	2.57	2.29	4.20	2.18	1.98	1.24

Note :- Assumed Stress/Strain relationship = 1.2

Table Summ-2: Summary of grouted SCFs



Specimen Ident.	Chord SCFs											Brace SCFs															
	D (mm)	d (mm)	T (mm)	T _c (mm)	t (mm)	L (mm)	θ (°)	β	γ	T _c		α	Condition	IPB	Comp.		Tens.		IPB	OPB		Comp.		Tens.			
										AR+OPB	IPB				AR+	AR-	AR+	AR-		AR+	AR-	AR+	AR-	AR+	AR-		
T1	406.78	167.81	16.39	29.4	16.32	2440	90.0	0.413	12.409	6.92	11.71	0.996	12.00	Predicted Q	1.00	0.71	0.55	0.98	0.91	0.53	0.91	1.07	0.89	0.53	4.53	0.65	3.82
													Predicted R	0.78	0.63	0.47	1.16	0.43	0.95	0.42	0.56	0.57	0.44	0.42	0.44	0.38	
													Measured	0.97	0.72	0.55	1.01	0.54	0.91	0.62	1.01	0.89	0.56	4.43	0.62	3.89	
T3	406.78	407.02	16.39	29.4	16.10	2440	90.0	1.000	12.409	6.92	11.71	0.982	12.00	Predicted Q	0.94	0.27	0.09	1.05	0.25	1.13	1.12	0.33	0.28	1.19	0.30	1.11	
													Predicted R	1.00	0.28	0.07	1.30	0.17	1.36	0.62	0.45	0.44	0.84	0.84	0.47	0.78	
													Measured	0.92	0.27	0.09	1.04	0.25	1.11	1.10	0.33	0.30	1.16	0.31	1.08		
T5	407.05	273.34	10.19	23.6	9.82	2440	90.0	0.672	19.973	8.62	18.36	0.964	11.99	Predicted Q	0.87	0.37	0.30	0.93	0.28	0.95	1.26	0.45	0.34	2.07	0.35	1.65	
													Predicted R	0.81	0.35	0.32	1.45	0.32	1.39	0.67	0.39	0.33	1.05	0.37	0.78		
													Measured	0.90	0.37	0.30	0.93	0.29	0.95	1.24	0.45	0.30	2.07	0.34	1.67		
T7	406.96	168.41	7.86	21.4	8.31	2440	90.0	0.414	25.888	9.49	23.42	1.057	11.99	Predicted Q	0.68	0.48	0.21	0.59	0.45	0.69	1.21	0.74	0.27	1.37	0.49	1.08	
													Predicted R	0.58	0.55	0.23	0.81	0.50	0.94	0.55	0.49	0.20	0.62	0.35	0.51		
													Measured	0.69	0.48	0.21	0.58	0.47	0.71	1.22	0.74	0.26	1.39	0.48	1.13		
T9	406.96	406.96	7.86	21.4	7.86	2440	90.0	1.000	25.888	9.49	23.42	1.000	11.99	Predicted Q	0.94	0.27	0.23	1.05	0.25	0.99	1.26	0.26	0.42	1.19	0.30	0.97	
													Predicted R	0.73	0.32	0.30	1.03	0.31	0.95	0.73	0.25	0.53	1.27	0.42	0.92		
													Measured	0.95	0.27	0.22	1.03	0.24	0.98	1.24	0.26	0.36	1.24	0.29	0.94		
DT2	406.78	273.09	16.39	29.4	15.76	2440	90.0	0.671	12.409	6.92	11.71	0.962	12.00	Predicted Q	0.74	0.65	0.36	1.61	0.38	0.97	1.36	0.72	0.35	4.34	0.42	1.47	
													Predicted R	0.89	0.57	0.31	1.29	0.36	0.87	0.89	0.63	0.37	0.88	0.44	0.38		
													Measured	0.79	0.66	0.39	1.57	0.39	0.95	1.38	0.74	0.34	33.40	0.41	10.43		
DT3	406.78	407.02	16.39	29.4	16.10	2440	90.0	1.001	12.409	6.92	11.71	0.982	12.00	Predicted Q	0.68	0.99	0.92	1.91	1.02	1.40	1.65	1.02	0.94	1.34	0.90	1.15	
													Predicted R	0.60	1.20	1.02	0.71	0.96	0.64	0.98	1.81	1.34	1.34	0.46	1.13	0.41	
													Measured	0.67	0.97	0.95	1.86	1.02	1.29	1.61	0.96	0.90	1.24	0.79	1.11		
DT4	407.05	168.57	10.19	23.6	9.95	2440	90.0	0.414	19.973	8.62	18.36	0.976	11.99	Predicted Q	0.57	0.55	0.12	0.74	0.28	0.56	1.34	0.83	0.15	2.39	0.31	1.06	
													Predicted R	0.58	0.55	0.14	0.84	0.31	0.80	1.00	0.47	0.13	1.05	0.25	0.55		
													Measured	0.57	0.55	0.12	0.71	0.27	0.57	1.35	0.85	0.16	2.23	0.31	1.00		
DT5	407.05	273.34	10.19	23.6	9.82	2440	90.0	0.672	19.973	8.62	18.36	0.964	11.99	Predicted Q	0.60	0.95	0.51	0.28	1.67	0.31	1.22	1.41	0.57	4.24	0.34	1.20	
													Predicted R	0.64	0.50	0.30	0.85	0.35	0.55	0.82	0.49	0.26	1.16	0.40	0.50		
													Measured	0.54	0.47	0.25	0.48	0.32	0.16	1.40	0.54	0.23	27.57	0.34	16.00		
DT6	407.05	407.60	10.19	23.6	9.61	2440	90.0	1.001	19.973	8.62	18.36	0.943	11.99	Predicted Q	0.60	0.95	0.96	2.90	0.83	1.78	1.65	0.94	0.94	1.62	0.92	0.95	
													Predicted R	0.52	1.20	1.00	0.65	0.83	0.41	0.98	1.26	1.05	0.96	0.92	0.71		
													Measured	0.62	0.97	0.89	2.92	0.81	2.10	1.76	1.00	0.92	1.42	0.79	1.09		
DT8	406.96	273.21	7.86	21.4	7.88	2440	90.0	0.671	25.888	9.49	23.42	1.003	11.99	Predicted Q	0.48	0.40	0.21	1.73	0.26	1.42	1.45	0.46	0.17	4.47	0.28	1.23	
													Predicted R	0.44	0.44	0.30	0.91	0.34	0.61	0.76	0.38	0.18	1.46	0.31	0.52		
													Measured	0.49	0.42	0.20	1.68	0.28	1.46	1.44	0.49	0.18	3.83	0.30	1.40		
DT9	406.96	406.96	7.86	21.4	7.86	2440	90.0	1.000	25.888	9.49	23.42	1.000	11.99	Predicted Q	0.54	0.92	0.99	3.67	0.68	2.07	1.65	0.88	0.94	1.88	0.49	1.03	
													Predicted R	0.46	1.20	0.99	1.00	0.73	0.55	0.98	0.81	0.80	1.43	0.37	0.86		
													Measured	0.53	0.93	1.00	3.53	0.69	1.81	1.56	0.85	0.94	1.75	0.47	0.98		

Note 1:- Assumed Stress/Strain relationship = 1.2

Predicted Q values based on RFs given by formulations in Tables Q3 and Q4

Predicted R values based on RFs given by formulations in Tables R2 and R3

Table Summ-3: Summary of reduction factors



Specimen	PREDICTED														MEASURED		Test/Pred.						
	Moment Capacity (kNm)				Yield strength				α	β	γ	τ	θ	L	t	T	d	D	Loading Type	Failure Mode	Predicted Failure Mode	Joint Capacity	
	IPB	OPB	Brace	Joint ⁽¹⁾	Chord	Brace	z_p	At chord C.L.														At chord face	At chord C.L.
T1	149	149	348	359	348	12.00	0.996	12.00	0.413	12.409	0.996	12.00	3.76E+05	122	152	131	131	OPB	Shear chord saddle	Brace	1.02	0.82	
T3	877	877	383	359	383	12.00	0.982	12.00	1.001	12.409	0.982	12.00	2.46E+06	839	923	943	943	OPB	Rig capacity	Joint	1.05	0.96	
T5	230	230	284	335	284	11.99	0.964	11.99	0.672	19.973	0.964	11.99	6.82E+05	217	249	194	194	OPB	Shear chord saddle	Brace	1.08	0.95	
T7	67	67	246	332	246	11.99	1.057	11.99	0.414	25.888	1.057	11.99	2.13E+05	51	63	52	52	OPB	Shear chord saddle	Brace	0.95	0.77	
T9	389	389	332	332	332	11.99	1.000	11.99	1.000	25.888	1.000	11.99	1.23E+06	465	512	416	416	OPB	Brace buckle	Joint	1.32	1.20	
DT2	395	392	496	339	496	12.00	0.962	12.00	0.671	12.409	0.962	12.00	1.04E+06	370	425	518	518	OPB	Shear chord saddle	Joint	1.08	0.94	
DT3	877	877	383	339	383	12.00	0.982	12.00	1.001	12.409	0.982	12.00	2.46E+06	739	813	943	943	OPB	Rig capacity	Joint	1.24	1.13	
DT4	87	87	339	335	339	11.99	0.976	11.99	0.414	19.973	0.976	11.99	2.51E+05	78	97	85	85	IPB	Brace buckle	Brace	1.11	0.89	
DT5	230	228	284	335	284	11.99	0.964	11.99	0.672	19.973	0.964	11.99	6.82E+05	232	267	194	194	IPB	Brace buckle	Brace	1.16	1.01	
DT6	510	380	363	335	363	11.99	0.943	11.99	1.001	19.973	0.943	11.99	1.52E+06	557	613	553	553	IPB	Brace buckle	Joint	1.20	1.09	
DT8	175	174	329	332	329	11.99	1.003	11.99	0.671	25.888	1.003	11.99	5.55E+05	188	216	183	183	OPB	Shear chord saddle	Joint	1.24	1.08	
DT9	389	290	332	332	332	11.99	1.000	11.99	1.000	25.888	1.000	11.99	1.23E+06	365	402	416	416	IPB	Brace buckle	Joint	1.03	0.94	

(1) Reference 1, Formulation from Design Recommendations, MSL Document Reference C1100R223 Rev 0, April 1993
Italics represent those joints which experienced brace failure or reached rig capacity.

$$M = Q_u F_y I^2 d$$

$$\text{For DT OPB; } Q_u = 1.8 \beta \gamma / (Q_f)^{0.5}$$

$$\text{for } \beta > 0.6 \quad Q_f = 0.3 / (\beta (1 - 0.333\beta))$$

$$\text{for } \beta \leq 0.6 \quad Q_f = 1.0$$

$$\text{Else; } Q_u = 1.8 \beta \gamma$$

Table Summ-4: Summary of ultimate strength results



JOINT INDUSTRY PROJECT

**DEVELOPMENT OF GROUTED
TUBULAR JOINT TECHNOLOGY
FOR OFFSHORE
STRENGTHENING AND REPAIR**

Draft Final Report

CONTENTS

	<u>Page</u>
SUMMARY	
CONTENTS	
NOMENCLATURE	
1. INTRODUCTION.....	15
1.1 Description of Test Programme.....	17
1.2 Background	19
1.2.1 Existing Guidance.....	19
1.2.2 Previous Research.....	19
2. TEST SPECIMENS	22
2.1 T-Joints.....	22
2.2 DT-Joints.....	22
2.3 Welding of Test Specimens.....	23
2.4 Grouting of Test Specimens	25
2.5 Material Properties.....	28
2.5.1 Circular Hollow Sections	28
2.5.2 Grout.....	28
2.5.3 Welds	30

2.6	Measured Dimensions	30
2.6.1	Circular Hollow Sections for the Specimens	30
2.6.2	Welds	31
3	INSTRUMENTATION	32
3.1	Strain Gauges	32
3.2	Electrical Transducers	36
4	TEST RIG AND TESTING PROCEDURE	39
4.1	General	39
4.2	Test Rig and Loading System for T-joints.....	39
4.3	Test Rig and Loading System for DT-joints	41
4.4	Data Recording	43
4.5	Testing Sequence	43
5	DETERMINATION OF STRAIN CONCENTRATION FACTORS	46
5.1	Nominal Strains	46
5.2	Hot Spot Strain and SNCF	46
6	OVERVIEW OF GROUTED TUBULAR JOINT BEHAVIOUR.....	49
6.1	General	49
6.2	Load Case Effects.....	49
6.2.1	Axial Loading.....	49
6.2.2	In-plane Bending	50
6.2.3	Out-of-Plane Bending.....	50
6.3	Preload Effects	50
7	TEST RESULTS.....	52
7.1	Preload Investigation Results on Specimen T7	52
7.2	SCF/SNCF ratio	54



7.3	As-welded SNCF Results and Measurements	59
7.3.1	T-Joints	60
7.3.2	DT-Joints	61
7.4	Grouted SNCF Results and Measurements	63
7.4.1	T-Joints	63
7.4.2	DT-Joints	68
7.4.3	Discussion of Test Results	72
7.5	Ultimate Strength Test Results and Measurements	74
7.6	Local Joint Flexibility	76
8.	ANALYSIS OF TEST RESULTS	79
8.1	General	79
8.2	As-welded Measured SCFs vs Predicted SCFs	79
8.3	Grouted Measured SCFs	80
8.4	Measured vs Predicted Reduction Factors	80
8.5	Ultimate Strength	80
9.	CONCLUDING REMARKS	86
9.1	SCF Determination	86
9.2	RF Determination	88
9.2.1	RF for Application to As-Welded Measured SCFs	88
9.2.2	RF for Application to As-Welded Efthymiou SCFs	91
9.3	Ultimate Strength Determination	93
	ACKNOWLEDGEMENTS	95
	REFERENCES	97

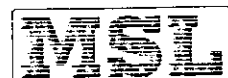

APPENDIX A.	Welded Procedure and Weld Shapes
APPENDIX B.	Specification and Procedure for Grouting of Test Specimens
APPENDIX C.	Grout Material Properties
APPENDIX D.	Tubular Section Material Properties
APPENDIX E.	Measured Dimensions
APPENDIX F.	Specification for the Strain Gauging of Test Specimens
APPENDIX G.	Strain Gauge Positions
APPENDIX H.	Transducer Positions
APPENDIX I.	Loading Conditions and Dimensions
APPENDIX J.	Preload Investigation Sequence
APPENDIX K.	Preload Investigation Results
APPENDIX L.	As-welded SNCF Measurements
APPENDIX M.	Grouted SNCF Measurements
APPENDIX N.	Ultimate Strength Test Results
APPENDIX O.	Photographs of Failures for Ultimate Tests
APPENDIX P.	Local Joint Flexibilities
APPENDIX Q.	Development of Measured Grouted SNCF/Measured As-welded SNCF Reduction Factors
APPENDIX R.	Development of Measured Grouted SNCF (x 1.2)/Efthymiou As-welded SCF Reduction Factors
APPENDIX S.	Summary As-welded and Grouted SCFs/RFs

NOMENCLATURE

D	Outside diameter of chord
T	Wall thickness of chord
T_p	Wall thickness of pile
T_e	Effective thickness
d	Outside diameter of brace
t	Wall thickness of brace
γ	Gamma ratio = $D/2T$
β	Beta ratio = d/D
τ	Tau ratio = t/T
SCF	Stress concentration factor
SNCF	Strain concentration factor
cs	Chord saddle
bs	Brace saddle
cc	Chord crown
bc	Brace crown
F_y	Yield stress
F_u	Ultimate stress
ϵ	Permanent elongation
ipb	In-plane bending
opb	Out-of-plane bending
ax-c	Axial compression
ax-t	Axial tension
θ	Brace/joint intersect angle

1. INTRODUCTION

The modification, strengthening and repair of existing offshore installations has received significant attention and forms an important and integral part of offshore engineering. The need for strengthening/repair stems from increased load by placement of additional equipment, increase in operational safety, increase in operational service life, damage and/or regulatory requirements. It has increasingly been recognised that chord grout filling offers an extremely technically-efficient and cost-effective method to meet these strengthening/repair requirements for tubular joints. However, there is little or no guidance available in codes, guidance documents or the technical literature. This is not surprising, as the available pertinent data relate to a single K joint, two T joints and one DT joint. The DNV research in this area in the early 1980s related to double-skin tubular joints only, subjected to axial loads only, and is therefore not applicable to the strengthening/repair of tubular joints, which requires the chord of the joint to be completely grout filled over a characteristic length. One project conducted in the later 1970s/early 1980s remains confidential. However, the dominant data generated in that project relate to double-skin joints or joints with γ ratios well in excess of ratios which cover current practice and, therefore, the data which fall in these two categories are equally unapplicable. An examination of the few available data and field experience in this area revealed the following:

- The presence of the grout increases the radial stiffness of the chord member. The grout restricts local chord wall deformations, which leads to a reduction of deformation-induced bending stresses and associated SCFs.
- Any reduction in SCF implies an enhancement in fatigue life.
- The chord member bending stiffness is increased, resulting in a reduction of stress at crown locations which are driven by the α ratio. The increased chord bending stiffness also implies that the capacity of large β ratio, grouted T/Y joints, subjected to axial loads, may not be limited by chord failure in the beam-bending sense.

- The grout severely restricts ovalisation of the chord cross-section, which indicated an increase in the capacity of grouted joints when compared with the ungrouted cases.
- The data available indicated that fatigue lives of grouted joints may be increased by over 10-fold when compared with equivalent ungrouted joints. These data also indicated substantial enhancements in joint strength and joint impact resistance, to the extent that, in perhaps the majority of cases, the capacity of the joint is greater than the capacity of the in-coming braces.
- Grouting technology is well proven and offshore grouting works can be executed with confidence.
- The deployment of this technique offshore has low equipment and resource requirements compared with other techniques and, hence, significant cost savings can be accrued.
- This technique is amenable to deployment using ROV technology with no diver intervention, resulting in substantial safety and costs benefits.
- A study of offshore installation times indicate that this technique can be implemented offshore within a time frame which is less than half the time required to implement other comparable techniques. The cost benefits in this respect are self-evident.

In response to the above observations, the identified need and the identified substantial economic, safety and technical benefits, MSL Engineering (MSL) launched a joint industry initiative to develop grouted joint technology as a repair/strengthening measure. The primary objectives of this project were, firstly, to generate specific data and information on grouted joint behaviour to develop a detailed design practice for the practical range of applications and parameters and, secondly, to develop and prepare a deployment procedure to ensure safe, cost-effective and technically-compliant applications. The offshore installation study was completed and documented in a separate report.

1.1 Description of Test Programme

Experimental work has been conducted to determine the effects of grout filling of chord members on the stress concentrations at brace-chord intersections and on the bending strength. The experimental programme consisted of a series of as-welded SNCF measurements, grouted SNCF measurements and ultimate strength tests on T and DT joints. The specimen test matrices are summarised in Table 1-1 and 1-2. The test series consisted of seven DT-joints and five T-joints, with nominal values of the following geometrical parameters: $\beta = 0.41, 0.67$ and 1.0 , $\gamma = 12.7, 20.3$ and 25.7 and $\tau = 1.0$.

Test series for T joints $\tau=1.0$			
γ	$\beta = 0.41$	$\beta = 0.67$	$\beta = 1.0$
12.7	T1		T3
20.3		T5	
25.7	T7		T9

Table 1-1: Test matrix for T-joints - Specimen Designation

Test series for DT joints $\tau=1.0$			
γ	$\beta = 0.41$	$\beta = 0.67$	$\beta = 1.0$
12.7		DT2	DT3
20.3	DT4	DT5	DT6
25.7		DT8	DT9

Table 1-2: Test matrix for DT-joints - Specimen Designation

The configuration and dimensions of the specimens are presented in Figure 1-1 for the T-joints and in Figure 1-2 for the DT-joints. The chord length was equal to 6 times the chord diameter. The brace length was 5 times the brace diameter. The specific selection of the joint parameters was dictated to a degree by the availability of pipe sizes and material strengths. The resultant joint parameters were optimised, where possible, to facilitate joint failure rather than brace failure during the ultimate strength tests. Generally, the brace tubulars were of a higher yield strength than the chord tubulars. This increased the likelihood of a joint failure without affecting the

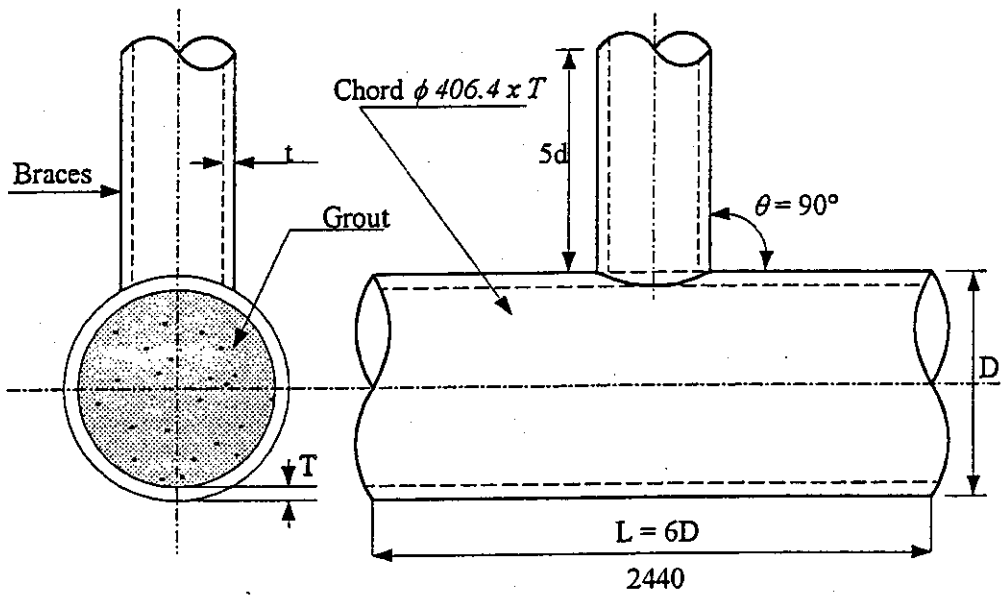

Figure 1-1: T-joint configuration and dimensions

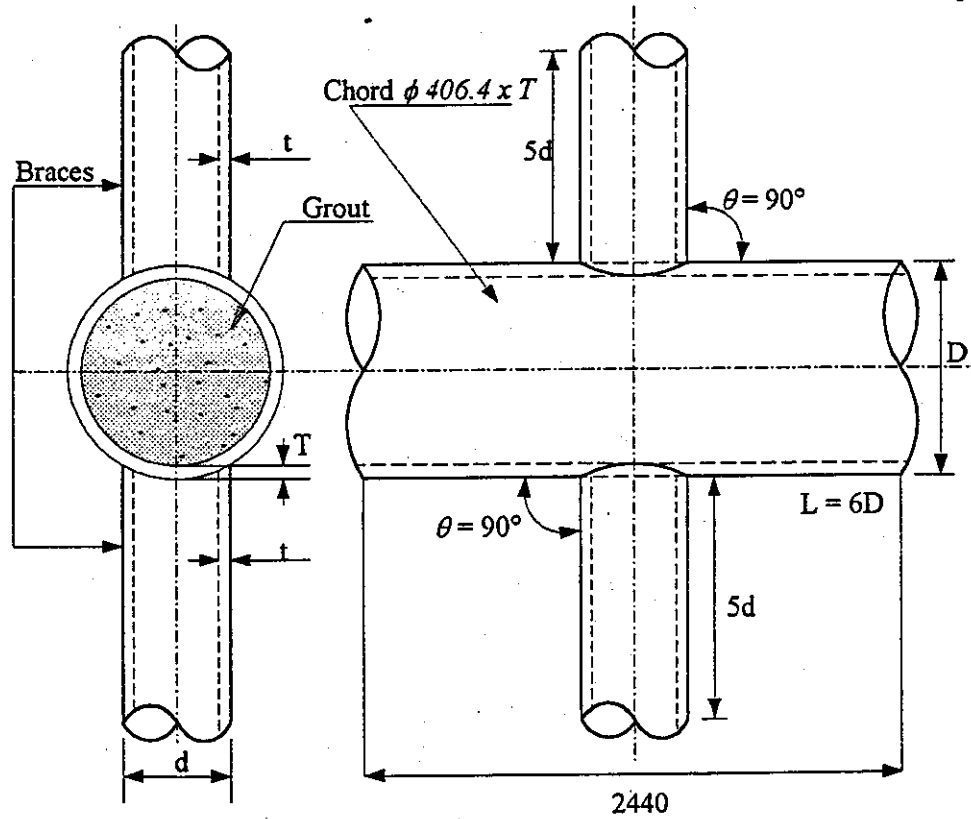

Figure 1-2: DT-joint configuration and dimensions

measured SNCFs. The chosen size of tubulars resulted in large scale specimens which minimises potential scale effects. However, the specimens were kept to a size which enabled the test rig to assume sensible proportions. The resultant test rig was substantial due to the size of specimens and to satisfy the requirement of having the ability to test in all four loading modes with the specimens remaining in-situ.

1.2 Background

1.2.1 Existing Guidance

The provisions of major design codes on any aspect of grouted joints are limited. API RP2A⁽¹⁾, HSE Guidance Notes⁽²⁾, NPD⁽³⁾ and DNV⁽⁴⁾ all state that the capacity of grouted joints may be established by testing and/or analytical methods.

With the exception of Lloyds⁽⁵⁾, no specific guidance on the determination of stresses is given. Lloyds provides guidance to cover double-skin joints only. Lloyds recommend the determination of an effective thickness which gives the same moment of inertia as that calculated from treating the chord shell and pile as a composite section, but neglecting grout. Lloyds recommend that the effective thickness calculated on this basis should be limited to 1.75T. The resultant effective thickness is then used in parametric SCF equations developed for as-welded joints.

1.2.2 Previous Research

A number of research and development programmes have been carried out to investigate the behaviour of grouted joints. The research has typically been conducted on double-skin 'pile sleeve' type joints or ad hoc tests on individual grouted joints commissioned by Operators with geometries specific to offshore platform joints requiring strengthening.

Results from the EEC Composite Jacket Project⁽⁶⁾ are confidential, although general trends noted from the findings are described. A series of elastic, ultimate strength and fatigue tests on either double-skin or fully grouted joints have been carried out.

It is understood, however, that a portion of the experimental programme concentrated on thin chord sections, giving γ ratios in excess of the ratios for joints in existing offshore installations.

A Veritec joint industry project has addressed the elastic, ultimate strength and fatigue response of double-skin grouted joints through both experimental and numerical means.

Tebbett et al⁽⁷⁾ summarise the results of ten T joint tests, in which the chords of five specimens were reinforced with a grouted pile, i.e. grout was placed in the annulus and in the pile. Unfortunately, no thickness values for the joints are given in the paper.

Lalani et al⁽⁸⁾ report on a series of elastic tests (axial and bending) and an ultimate balanced axial load test on a non-overlapping grouted K-joint.

References 9 and 10 report on a series of elastic tests (axial and bending) on a grouted T joint.

Marshall⁽¹¹⁾ reviews SCF formulations for simple steel reinforced and double-skin/grouted joints. Marshall proposed that the γ value in SCF equations can be modified to take account of the additional stiffness for grouted joints. The effective thickness is defined as:

$$T_e = ((T^3 + T_p^3)/T)^{0.5}$$

The effective thickness is limited to $2T$, compared with the Lloyds' limitation of $1.75T$.

Brown et al⁽¹²⁾ report on a series of elastic tests (axial and bending) and fatigue tests on two grouted T joints.

Review of the available literature indicates that much of the testing reported is of an ad hoc nature and addresses technology specific to an identified problem. In particular, the number of tests carried out on fully grouted specimens with varying geometric parameters are limited.

2. TEST SPECIMENS

2.1 T-Joints

The configuration and nominal dimensions of the T-joints are shown in Figure 1-1 and Table 2-1. The chord length is equal to 6 times the chord diameter, i.e. $\alpha=2L/D=12$. The brace length is equal to 5 times the brace diameter.

Test series and nominal dimensions for T-joints - Dimensions in (mm)							
Chord		$\beta = 0.41$		$\beta = 0.67$		$\beta = 1.0$	
	$\gamma = D/2T$	Braces	Specimen	Braces	Specimen	Braces	Specimen
406.4x16	12.7	168.3x16.	T1			406.4x16.	T3
406.4x10	20.3			273x10.	T5		
406.4x7.9	25.7	168.3x8.	T7			406.4x7.9	T9

Table 2-1: Nominal dimensions for T-joints

2.2 DT-Joints

The configuration and nominal dimensions for the DT-joints are shown in Figure 1-2 and Table 2-2. The chord length is equal to 6 times the chord diameter, i.e. $\alpha=2L/D = 12$. The brace length is equal to 5 times the brace diameter.

Test series and nominal dimensions for DT-joints - Dimensions in (mm)							
Chord		$\beta = 0.41$		$\beta = 0.67$		$\beta = 1.0$	
	$\gamma = D/2T$	Braces	Specimen	Braces	Specimen	Braces	Specimen
406.4x16	12.7			273x16.	DT2	406.4x16.	DT3
406.4x10	20.3	168.3x10.	DT4	273x10	DT5	406.4x9.5	DT6
406.4x7.9	25.7			273x7.8	DT8	406.4x7.9	DT9

Table 2-2: Nominal dimensions for DT-joints

2.3 Welding of Test Specimens

The weld design is based on full brace capacity, which is dependent upon the brace dimensions and material strength. All welding was carried out using shielded metal arc welding (SMAW), in welding position 2G (axis of the weld horizontal) in accordance with section 5.8 of ANSI/AWS D1.1-90 Structural Welding Code for Steel⁽¹³⁾. The welding sequence for the tubular connection is shown in Figure 2-1, and the weld details for the T-joints and DT-joints are shown in Figure 2-2. The welding procedures and weld profiles are presented in Appendix A.

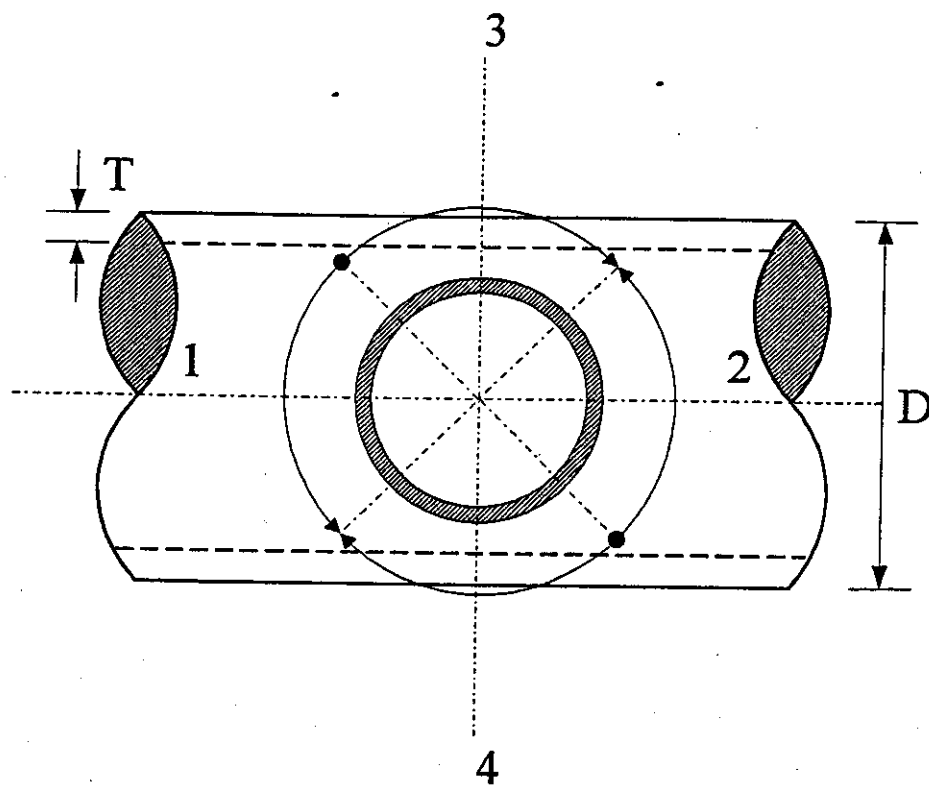

Figure 2-1: Welding sequence

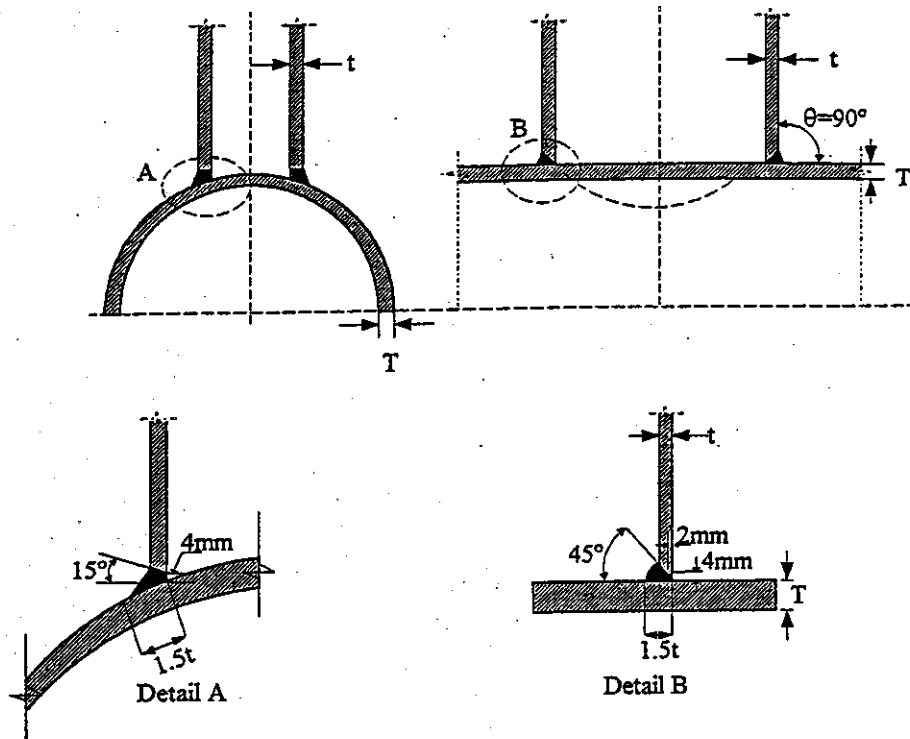
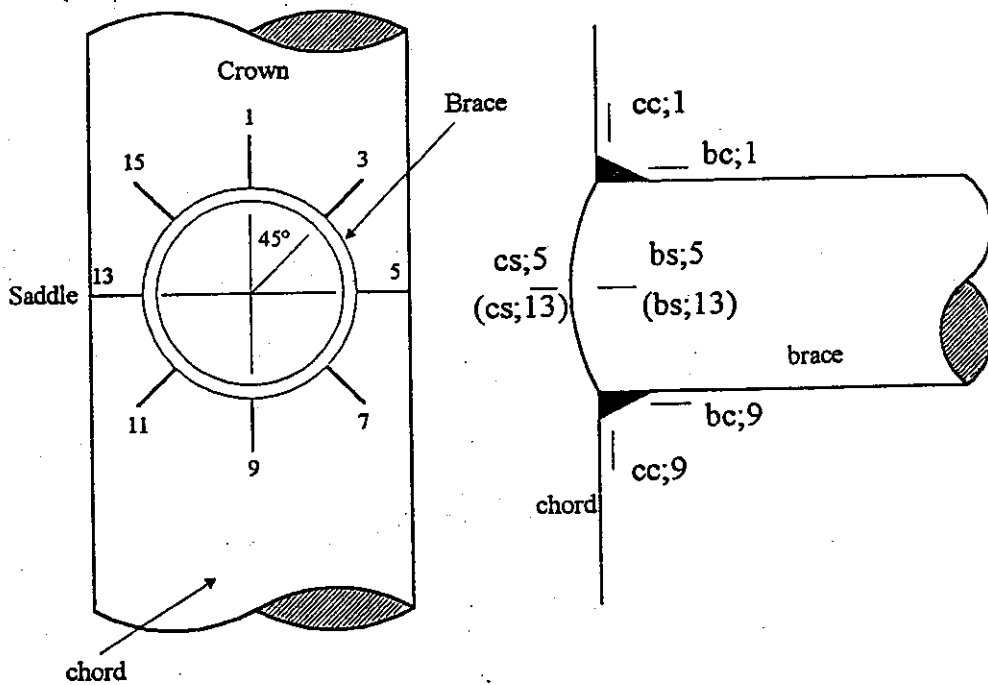

Figure 2-2: Welding details of T-joints and DT-joints

The locations correspond to the positions identified in Figure 2-3.



Note: Weld shapes measured at 45° intervals around joint intersect

Figure 2-3: Location of weld shapes

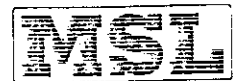

2.4 Grouting of Test Specimens

A detailed description of the grouting procedure for the chord grout-filling of the tubular joints is given in Appendix B. The grouting of the 5 T-joints and 7 DT-joints was done on November 1st 1995 at the TNO laboratory by Halliburton. The grouting spread is illustrated in Figure 2-4. The duration of grouting the twelve test specimens was approximately two hours. Four cubes were taken from each batch mixed and eight cubes from each test specimen. The majority of mix batches completely filled two chords. The grout was taken from the outlet in order to determine the compressive strength.

All chord tubulars were grouted in the upright position with grout injection at the base. The chords were filled with potable water prior to grouting. The water was displaced through outlets at the top of the chords as the grout was injected. During the grouting procedure, two additional tubulars ($D = 350\text{mm}$) were grouted. Approximately six months after grouting, one tube was sliced open. Figures C-1 and C-2 in Appendix C present the sliced sections. No crack was observed in the grout core but an extremely fine gap between the grout core and inside wall of the tubular was found.

The chosen grout was Oilwell G cement with a specific gravity of 2.02 ± 0.02 . The specific gravity was measured during the grouting of the test specimens, in accordance with the grouting procedures, using a pressurised mud-balance. The measured specific gravity for each batch is presented in Table 2-3.

Batch	Specific gravity at pump	Specimen	Specific gravity at outlet
1	2.03	350Ø tubular 1 350Ø tubular 2	1.99 2.0
2	2.02	T5	2.0
3	2.02	T3 DT4	2.0 2.0
4	2.03	T9 DT8	2.0 2.0
5	2.02	DT2 DT5	2.01 2.01
6	2.02	T7 T1	2.0 2.01
7	2.02	DT9 DT6	2.0 2.0
8	2.02	DT3	2.0

Table 2-3: Specific gravity of the grout

During the first few days of curing, external temperature measurements were taken on one of the dummy steel tubes. These are presented in Table 2-4.

Hours after grouting	Average External Temperature [°C] on pipe
0	17
2	21
3	23
7	46
16	55
21	48
25	45
45	25
74	20

Table 2-4: Temperature measurements during curing of the grout

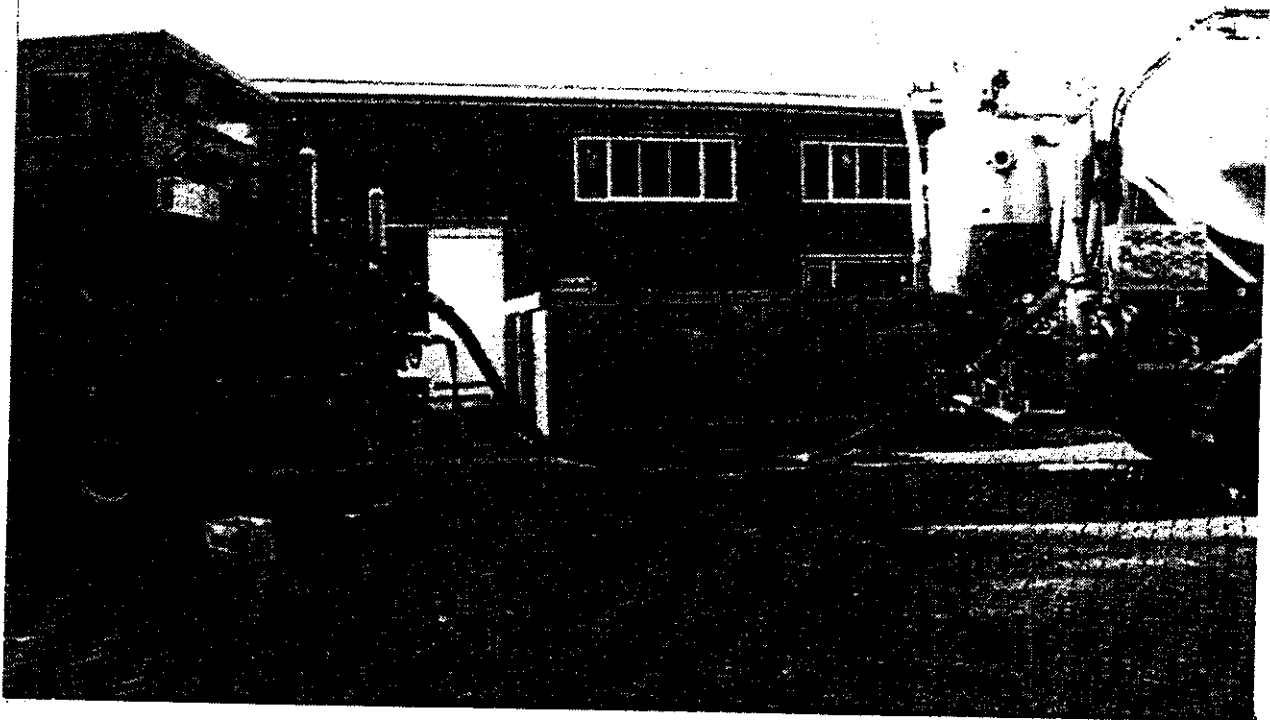

Figure 2-4: Equipment used for grouting

2.5 Material Properties

2.5.1 Circular Hollow Sections

The circular hollow sections used for the specimens were hot-finished seamless steel tubes in accordance with API-5L Gr. X52N or steel grade Fe 510 D in accordance with Euronorm EN 10025 (or prEN 10210 draft). The actual mechanical properties F_y (yield stress), F_u (ultimate stress), permanent elongation ϵ and necking of the different circular hollow sections was determined by tensile tests (dp 5) and carried out in accordance with Euronorm EN 10.002 "Tensile tests for steel". The tubular sections were provided with mill certificates. The nominal and the actual material properties of the different tubulars are tabulated in Appendix D.

The coupon test results are summarised in the following Table 2-5.

Specimen	Yield str. (Fy)	Yield str. (Fy)	Ult. str. (Fu)	Ult. str. (Fu)
	Brace	Chord	Brace	Chord
T1	347.8	358.5	520.3	507.1
T3	383.3	358.5	581.6	507.1
T5	283.6	334.5	408.0	427.0
T7	245.6	331.6	405.1	499.5
T9	331.6	331.6	499.5	499.5
DT2	495.5	358.5	585.2	507.1
DT3	383.3	358.5	581.6	507.1
DT4	339.4	334.5	550.0	427.0
DT5	283.6	334.5	408.0	427.0
DT6	363.4	334.5	508.2	427.0
DT8	328.5	331.6	509.9	499.5
DT9	331.6	331.6	499.5	499.5

Table 2-5: Tensile coupon tests referenced by test specimen (MPa)

2.5.2 Grout

The results of the cube tests are presented in Appendix C. The cube test results are summarised in the following Tables 2-6 and 2-7.

Batch	Age	Specimen	Average
DRUM	7 day	-	23.95
	14 day	-	33.80
	21 day	-	40.00
	28 day	-	35.00
1	28 day	S-D1/D2	45.77
2	28 day	T5	33.60
3	28 day	T3 DT4	35.50
4	28 day	T9 DT8	37.07
5	28 day	DT2 DT5	39.10
6	28 day	T7 T1	37.50
7	28 day	DT9 DT6	35.00
8	28 day	DT3	38.57

Table 2-6: Compressive strength per batch after 7, 14, 21 and 28 days (MPa)

Specimen	Average
T1	39.05
T3	37.15
T5	43.25
T7	43.58
T9	41.50
DT2	45.48
DT3	51.23
DT4	39.08
DT5	49.43
DT6	44.95
DT8	46.93
DT9	49.05

Table 2-7: Compressive strength at time of ultimate test (MPa)

Table 2-6 presents the average compressive strengths using cubes taken from batch mixes. With the exception of specimens T5 and DT3 all batches were sufficient for the filling of two specimens. The results for the joint specimen cubes were obtained 28 days after filling of the chords. Table 2-7 presents the average compressive strengths obtained by testing the relevant grout cubes at the time of the joint specimen ultimate strength test. The age of the cubes range from 3 months to 7 months.

2.5.3 Welds

All specimens were welded by SMAW process. Test specimens T1, T3, T5, DT2, DT3, DT4, DT5 and DT6 were welded with a KRYO 1 electrode and specimens T7, T9, DT8 and DT9 were welded with a Safdry 58 electrode.

The welding procedures are presented in Appendix A

2.6 Measured Dimensions

2.6.1 Circular Hollow Sections for the Specimens

The actual dimensions for the T-joints and DT-joints were determined by measuring the wall thickness and diameter at several locations on the test specimens and on separate pieces of left-over pipe material, from which the specimens were fabricated. (These separate pieces were used for the determination of material properties). For the fabrication of test specimens, eleven different tubulars were used. Wall thickness measurements were taken using a micrometer for the DT-joint chords at 90° intervals at one chord end. These were combined with micrometer measurements taken at 90° intervals on each end of the associated tubulars used in specimen fabrication to provide an averaged wall thickness. In addition the chord and brace wall thicknesses were measured using ultra-sonic methods. The measurements were taken at 90° intervals at near to the fabricated specimen joint. The results are presented in Appendix E.

The following Table 2-8 presents a summary of diameter and wall thickness measurements.

Specimen	Chord		Brace	
	D	T	d	t
T1	406.78	16.39	167.81	16.32
T3	406.78	16.39	407.02	16.10
T5	407.05	10.19	237.34	9.82
T7	406.96	7.86	168.41	8.31
T9	406.96	7.86	406.96	7.86
DT2	406.78	16.39	273.09	15.76
DT3	406.78	16.39	407.02	16.10
DT4	407.05	10.19	168.57	9.95
DT5	407.05	10.19	273.34	9.82
DT6	407.05	10.19	407.60	9.61
DT8	406.96	7.86	273.21	7.88
DT9	406.96	7.86	406.96	7.86

Table 2-8: Summary of the average actual dimensions

2.6.2 Welds

The actual weld shapes at the crown and saddle location, and also between these locations for the $\beta=1.0$ specimens, are presented in Appendix A for each test specimen.

3 INSTRUMENTATION

3.1 Strain Gauges

Little test data exists for SNCF measurements on grouted tubular joints. The guidance available for as-welded joints^(2 and 4) states that the nearest gauge should be located at a minimum of 4mm from the weld toe in order to avoid the concentrating effect of the weld. The available guidance also gives recommendation for gauge positioning in the region of stress variation, between the region effected by the weld and where the stress becomes equal to the nominal stress. Puthli et al⁽¹⁴⁾ go one step further by giving guidance for the location of gauges to enable non-linear extrapolation, i.e. quadratic extrapolation. Strain gauge positions were chosen to bound the possibility of either linear or non-linear extrapolation.

All specimens were instrumented with strip gauges and single element gauges. The strip gauges contained five individual single element strain gauges at 2mm spacings, two of which were unused. At each measurement location (e.g. chord crown) a strip gauge and a single element gauge were placed on a line orthogonal to the weld. The first gauge of the strip was placed at $0.4 \times (T \text{ of } t)$ but not less than 4mm. The single element gauge was placed at the HSE⁽²⁾ recommended last gauge position. Appendix F contains the specification for the strain gauging of specimens.

The T-joint specimens were instrumented at all saddle and crown locations on both the chord and brace, as shown in Figure 3-1. In addition, the $\beta = 1.0$ T-joint specimens were gauged with two sets of gauges at 30° intervals in two diagonally opposite quadrants on both the chord and brace. The DT-joint specimens were instrumented at one saddle and crown location for each brace on both the chord and brace, as shown in Figure 3-2. In addition, the $\beta = 1.0$ DT-joint specimens were gauged with a set of gauges at 30° intervals in one quadrant on one brace and the opposite quadrant on the other brace. The strain gauge locations are presented in Appendix G.

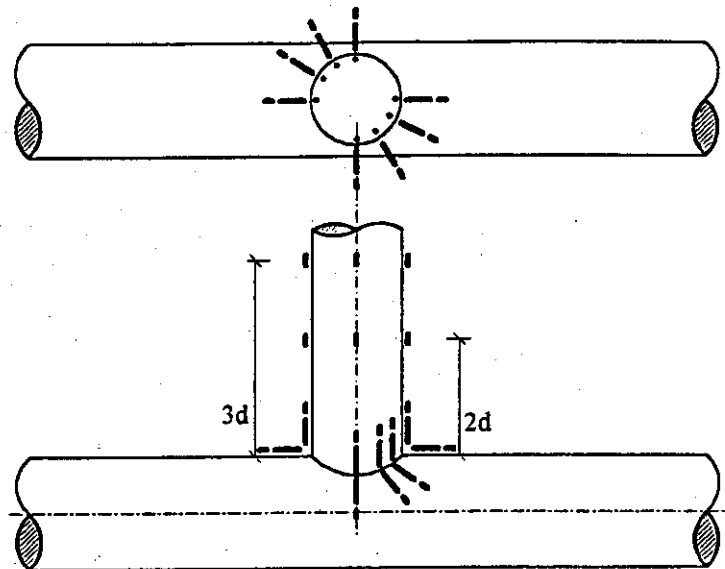

Note: Intermediate gauges @
30° & 60° positions on both
braces are for $\beta = 1.0$ joints.

Key:

- Strip gauge, consisting of 5 strain gauges, 3 of which are used
- Single strain gauge

Nº: of gauges per specimen

Location	$\beta = 0.41 \text{ \& } 0.67$		$\beta = 1.0$	
	Strip gauges	Single gauges	Strip gauges	Single gauges
Brace	4	12	(+4) 8	(+4) 16
Chord	4	4	(+4) 8	(+4) 8
Total	8	16	(+8) 16	(+8) 24

Note: The first $\beta = 1.0$ joint tested was gauged with a full compliment of gauges, by providing additional intermediate gauges.()

Figure 3-1: Strain gauging of T-joint specimens

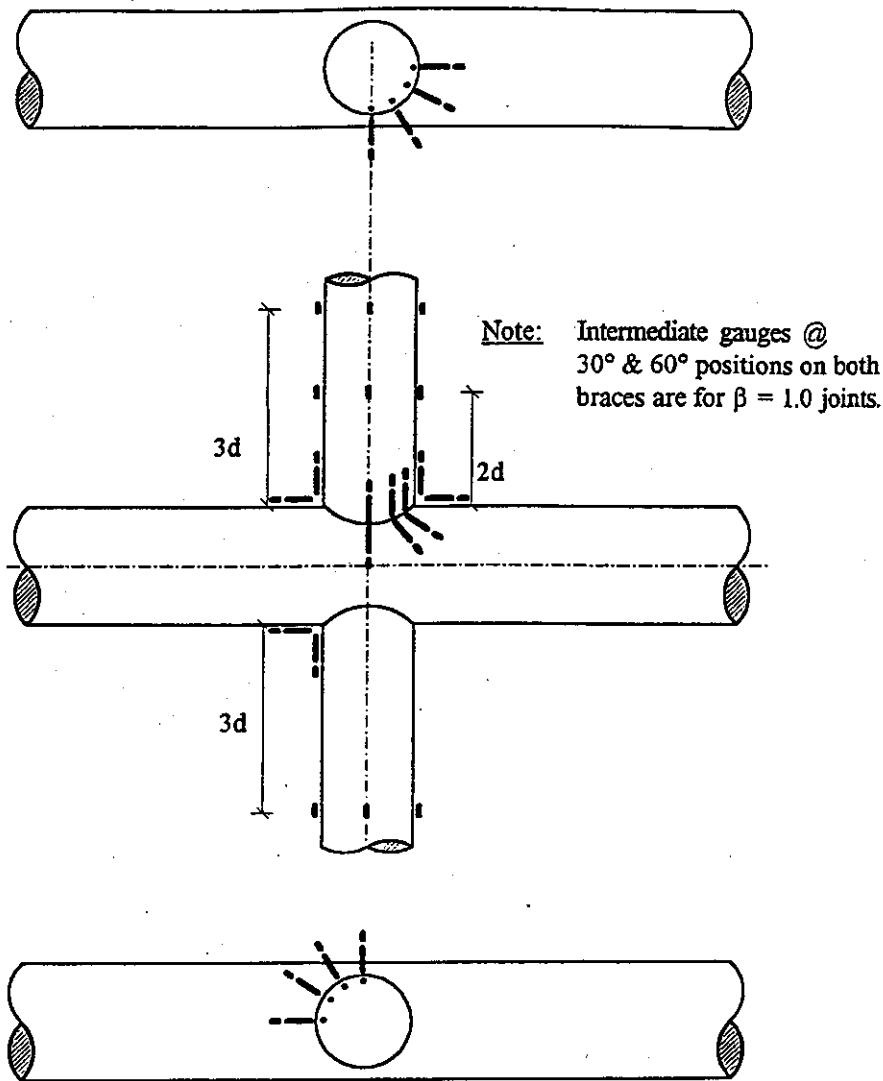

Key:

- Strip gauge, consisting of 5 strain gauges, 3 of which are used
- Single strain gauge

Nº: of gauges per specimen

Location	$\beta = 0.41$ & 0.67		$\beta = 1.0$	
	Strip gauges	Single gauges	Strip gauges	Single gauges
Braces	4	16	(+6) 8	(+6) 20
Chord	4	4	(+6) 8	(+6) 8
Total	8	20	(+12) 16	(+12) 28

Note: The first $\beta = 1.0$ joint tested was gauged around the full compressive side of brace & gauged around the full tensile side of the other brace for I.P.B.

Figure 3-2: Strain gauging of DT-joint specimens

As-welded SCF/SNCF ratios have been well documented and it was necessary to establish the SCF/SNCF ratio for specimens in the grouted condition and whether or not it differed to that of the as-welded condition. Therefore, in addition to the single element strain gauges, Specimen T7 was instrumented with 2mm rosette gauges to enable the determination of SCF/SNCF ratios in the grouted condition. Each rosette gauge consisted of three single element gauges set at 0° , 45° and 90° directions. The rosette gauges were placed on a line orthogonal to the weld at one crown and one saddle location on both the chord and brace. Section 6.2 presents the results of the SCF/SNCF ratio measurements. The SCF/SNCF ratios measured for specimen T7 in the grouted condition were similar to the as-welded condition.

Strain gauges were also used at two cross section locations away from the weld to measure the nominal axial and/or bending strain and to verify the loads measured by the dynamometers, see Figure 3-3.

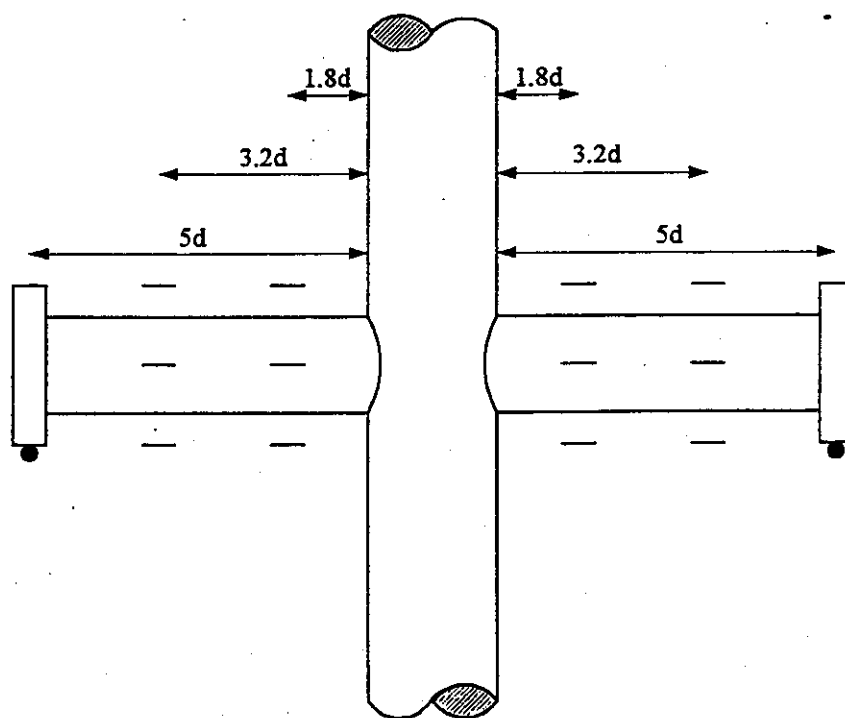

Figure 3-3: Location of the strain gauges for nominal strains on brace

3.2 Electrical Transducers

Electrical displacement transducers were used to measure (1) the local deformation of the joint under axial load or bending moment, see Figures 3-4 and 3-5, and (2) the deflection of the braces under bending, to determine overall deformation of the test specimen by measurement at two points along each brace, see Figures 3-6 and 3-7. Appendix H contains the transducer measurements.

For axial load and out-of-plane bending load, the local joint deformation was determined for the DT-joints by the measurement of distances between two points, each positioned 100mm along each brace from the saddle position. Measurement data on either side of the joints were averaged for the axial conditions; the difference between the data were used to calculate rotation for the out-of-plane bending case, see Figure 3-4. The T-joint specimens were similar with the exception that one brace point was replaced by an attachment to the chord on the opposite side of the joint to the brace, see Figure 3-5. The transducer mounting locations were chosen to minimise the effect any local deformation of tubular walls may have on the measurement of joint deformation. For in-plane bending load, the local joint deformation was determined in a similar manner to that discussed above. The transducer mounting points were located 130mm along the brace from the crown positions. Again, the locations were chosen to minimise the effects of local tubular wall deformations.

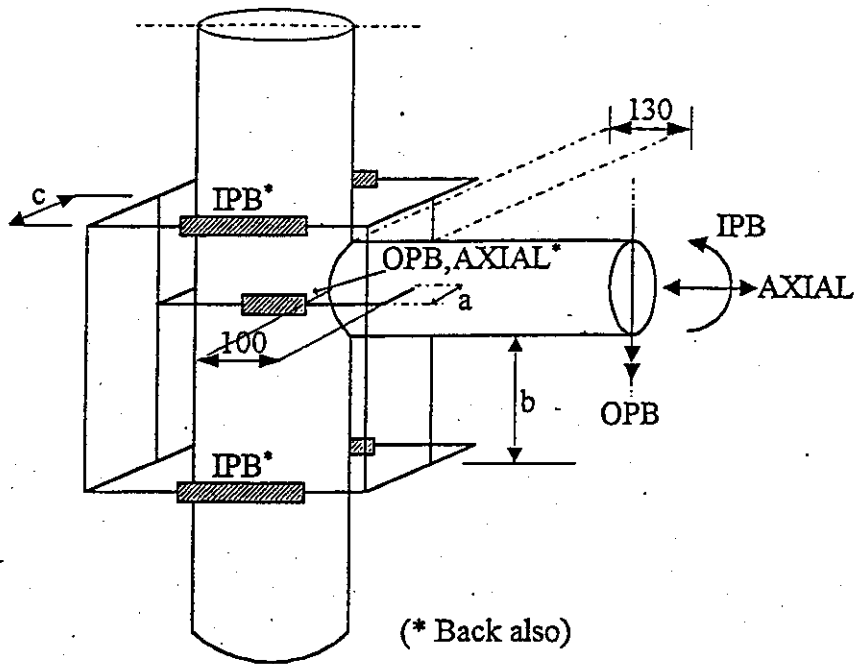

Figure 3-4: Measurement of T-joint local deformations.

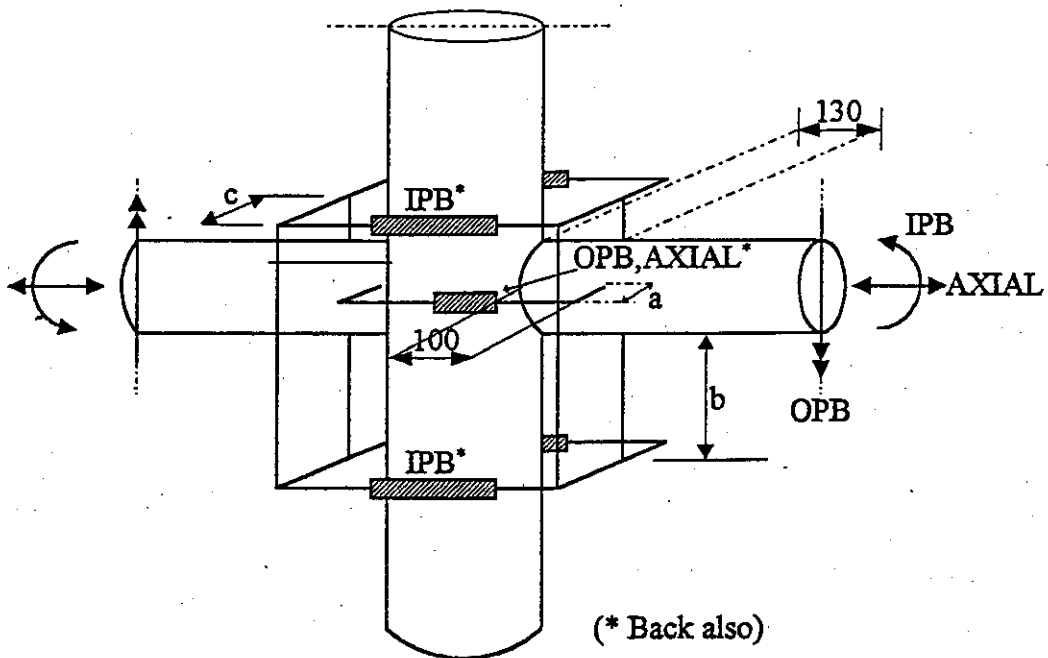

Figure 3-5: Measurement of DT-joint local deformations

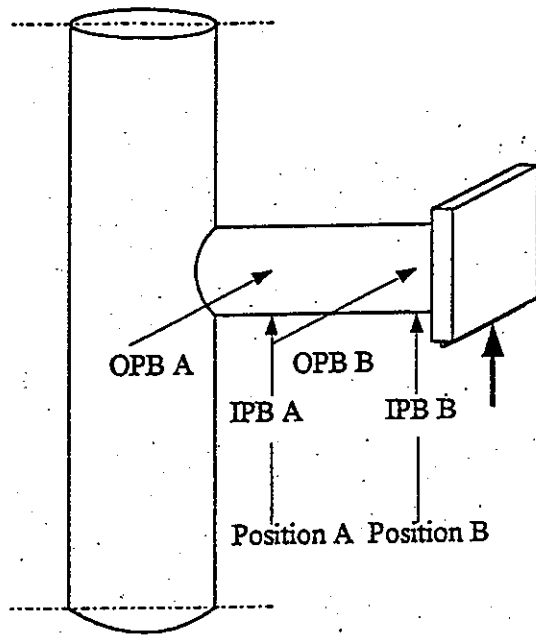

Figure 3-6: Measurement of T-joint global bending deformation

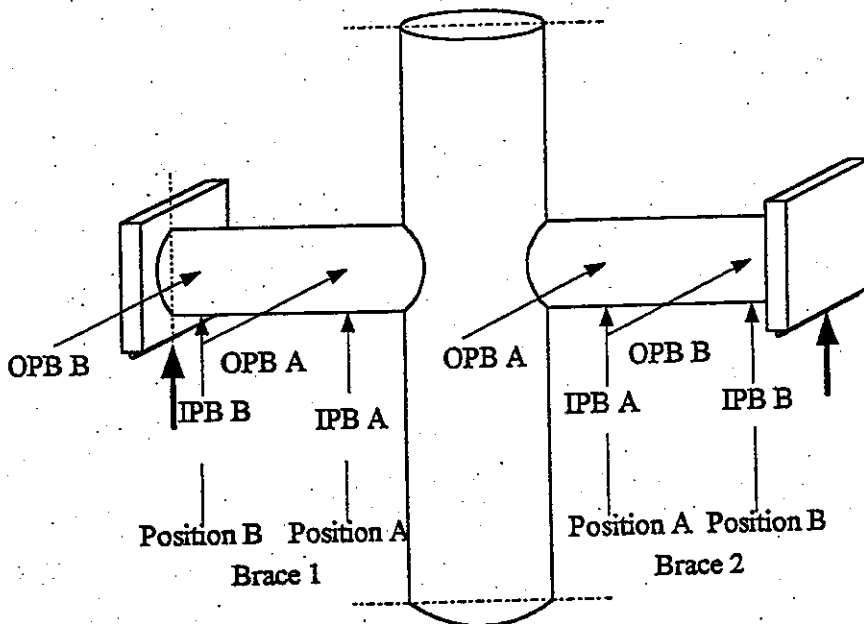

Figure 3-7: Measurement of DT-joint global bending deformation

4 TEST RIG AND TESTING PROCEDURE

4.1 General

Before the test specimens were placed into the test rig, their actual geometries were measured, strain gauges were attached, and preparations for attachment of displacement transducers were made. Appendix I contains the loading conditions considered and the overall dimensions of the specimens. The test rig configuration for the T-joints and DT-joints was essentially the same, with a modification of columns and beams to accommodate the two joint types.

4.2 Test Rig and Loading System for T-joints

The test rig configuration for T-joints is presented in Figure 4-1. The chord ends are connected to the test rig by hinges for all loading conditions. The axial load in the braces was applied by a hydraulic jack at the brace end. In the axial tension loading condition, the axial load was applied to the test specimen by means of four or six bars, equally loaded and distributed around the brace end. During axial loading of the DT-joint, the compression load was recorded by a 500 kN or a 4000 kN dynamometer, depending on specimen size and required load level. The axial tension loading was recorded by strain gauges on the loading bars. The maximum capacity of the six bars was 2000 kN. The nominal strain gauges on the braces were used to verify the applied load.

For the in-plane bending loading condition, the moment was applied by pulling the brace ends with bars attached to jacks. The load was measured with a dynamometer. The maximum bending moment applied to the joint was taken as the load at the brace end times the distance to the intersection of the centrelines of chord and braces. The load was measured by a 200 kN or 800 kN dynamometer. The strain gauges on the braces were used to verify the applied bending moment. Similarly, the out-of-plane bending moment was applied by a tensile bar at the end of the braces. The chord was restricted from torsion by mounting plates attached to

the chord ends. The applied loads were again measured at each end by a 200 kN or 800 kN dynamometer. The strain gauges on the braces were again used to verify the applied bending moment.

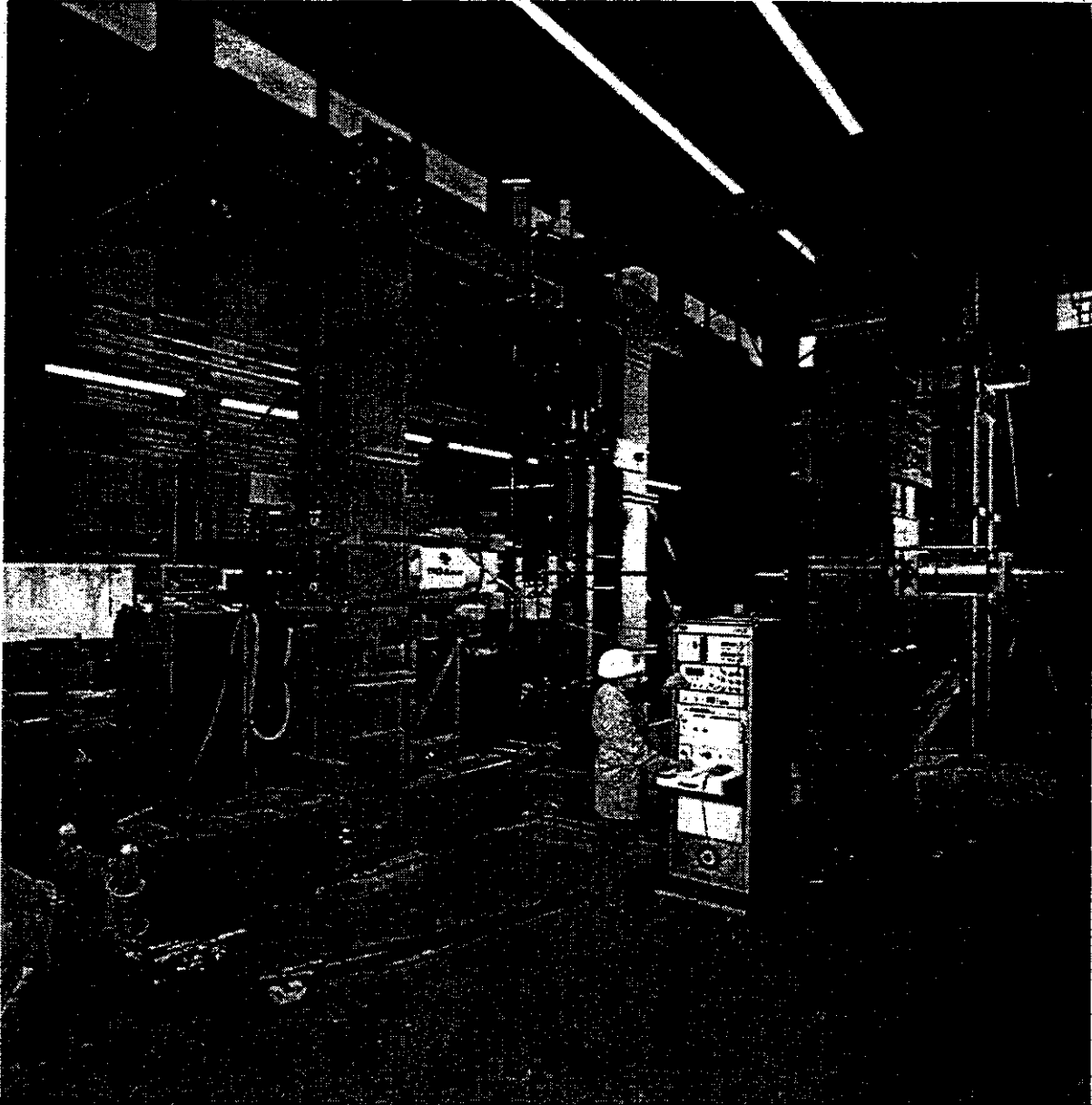

Figure 4-1: Test rig for T-joints

4.3 Test Rig and Loading System for DT-joints

The test rig for DT-joints is presented in Figure 4-2. The axial load in the braces was applied by a hydraulic jack at one brace end. The other brace end was axially restrained. For the axial compression loading, a spherical bearing was used to assure the required end conditions. For the axial tension loading condition, the tensile loading was applied to one brace end by means of four or six bars, which were equally loaded. The chord ends were restrained against out-of-plane movement by the attachment of mounting plates on the chord ends to the test frame. During axial loading of the DT-joint, the compression load was recorded by a 500 kN or 4000 kN dynamometer. The dynamometer used depended on specimen size and therefore the required load level. The axial tension loading was recorded by four or six bars instrumented with strain gauges. The strain gauges on the braces were used to verify the applied load.

For the in-plane-bending load, one chord end was pushed with a hydraulic jack while the brace ends were restrained against movement in the direction of the chord axis. Movement of the brace end in the axial direction of the brace and rotation of the brace end were, however, allowed. The chord was supported in the lateral direction. The load was measured with a dynamometer aligned with the chord axis. The maximum bending moment in the brace was taken as the load in the dynamometer times the distance from the chord centreline to the restrained end of the braces. The load was measured by a 500 kN or 2000 kN dynamometer. The strain gauges on the braces were used to verify the applied bending moment.

The out-of-plane bending moment was applied by a tensile bar at the end of the braces. The load was applied at each brace end using jacks. The jack loads were kept the same by use of a system which monitors the loads applied and adjusts as necessary. The applied load was measured at each end by a 200 kN or 800 kN dynamometer. The strain gauges on the braces were used to verify the applied bending moment.

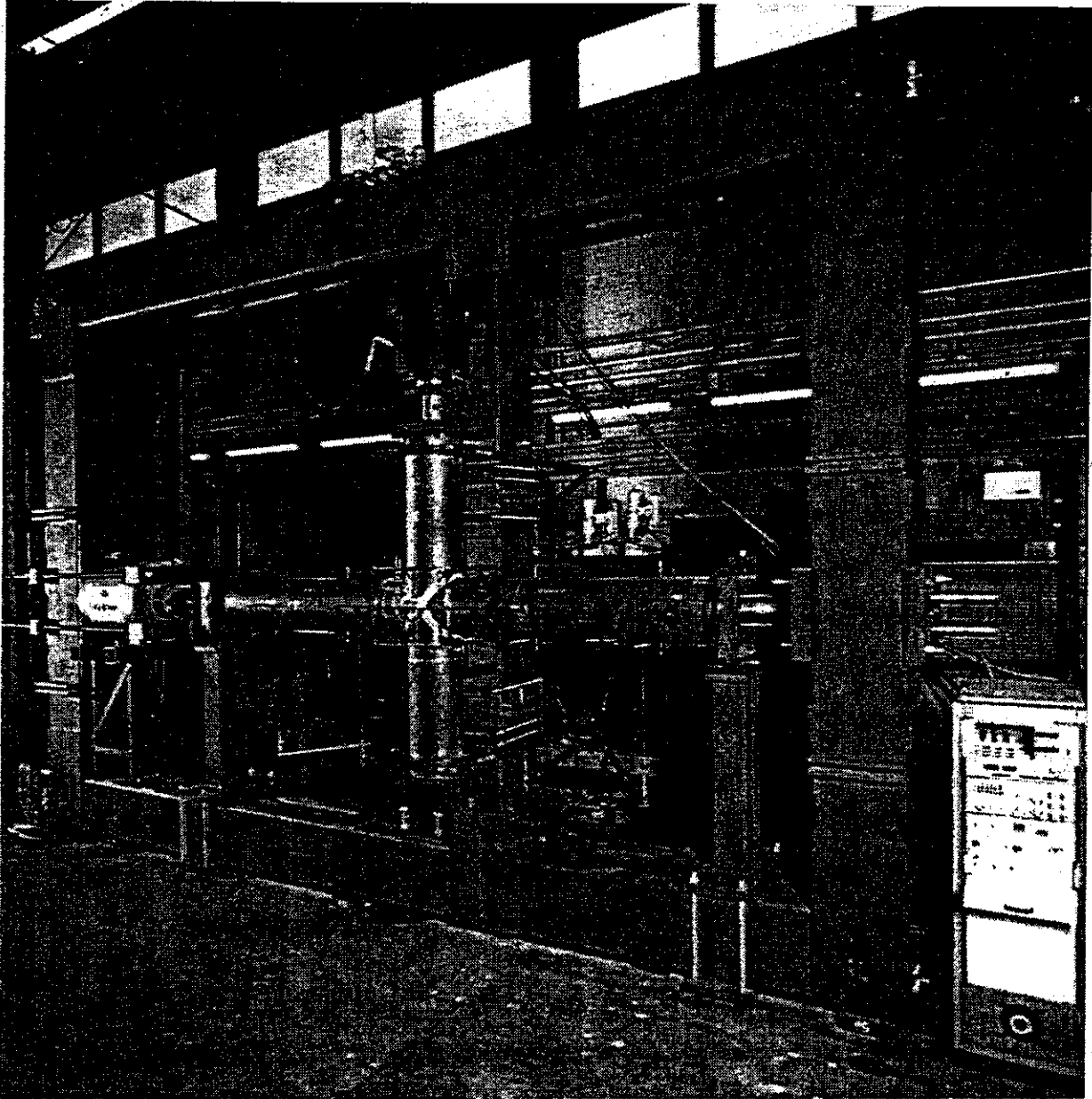

Figure 4-2: Test rig for DT-joints

C14100R020 Rev 1 February 1997

Page 42 of 98

MSL

4.4 Data Recording

During testing, discrete measurements were taken of:

- relative displacement between chord and brace from which local joint flexibility could be obtained;
- displacement at two points along brace from which rotation could be calculated;
- strains:
 - for the axial compression load case: (load cell and strain gauges on brace);
 - for the axial tension load case: (tensile bar strain gauges and strain gauges on brace);
 - for the in-plane bending moment case: (load cell for applied load and strain gauges on brace);
 - for the out-of-plane bending moment case: (load cell of applied load and strain gauges on brace);

The measurement of displacements, strains and loads were performed by means of HP dataloggers and a micro-computer.

4.5 Testing Sequence

The DT-joint test specimens were first tested in the as-welded condition in the following sequence: DT4, DT8, DT5, DT2, DT9, DT6 and DT3. After the testing of the DT-joints, the test rig was modified to accommodate the T-joints which were then tested in the as-welded condition in the following order: T9, T3, T5, T7 and T1. After grouting of the specimen chords, the specimens were tested in the following order T7, T1, T5, T9, T3, DT4, DT8, DT5, DT8, DT9, DT6 and DT3.

The following loading sequence was used to generate strain gauge data for the as-welded (ungROUTED) specimens:

1. Application of ten cycles of in-plane bending load on the brace at 15-20% of the (ISO) predicted ultimate load of the ungrouted joint subjected to in-plane bending.
2. Application of in-plane bending load to the brace in three equal increments, up to the applied load in step 1. After each load increment, strain gauge measurements, displacements and applied load were taken. Subsequently, the load was reduced in three equal stages back to zero, taking measurements at each load level.
3. Repetition of steps 1 and 2 for out-of-plane bending, axial compression and axial tension.

Prior to testing of the specimens in the grouted condition, an investigation on the effects of preload on local strain measurement was carried out in order to establish an appropriate level of maximum preload to apply to the grouted joint specimens. This investigation is discussed in Section 7.

With the exception of specimen T7, which was utilised for the conduct of the above mentioned preload investigations, the loading sequence for the grouted specimens was as follows:

1. Application of ten cycles of in-plane bending load on the brace at 15-20% of the (ISO) predicted ultimate load of the ungrouted joint subjected to in-plane bending.
2. Application of in-plane bending load to the brace in three equal increments, up to the applied load in step 1. After each load increment, measurements of strain, displacement and applied load were taken. The load was then reduced in three equal stages, taking measurements at each load level.

3. Repetition of steps 1 and 2 for out-of-plane bending, axial compression and axial tension.
4. Application of an axial compression and tension load of 65% of ungrouted ultimate load.
5. Repetition of steps 1,2 and 3.
6. Application at an axial compression and tension load of 130% of ungrouted ultimate load.
7. Repetition of steps 1,2 and 3.
8. Conduct ultimate bending capacity test (ipb or opb).

5 DETERMINATION OF STRAIN CONCENTRATION FACTORS

5.1 Nominal Strains

The nominal strain is defined as the maximum elastic strain on the OD of the tubular assuming that the brace behaves as a beam (M/Z) or axial (P/A) member. For the bending load cases, the moment was determined as the load applied at the brace end times the distance to the intersection of the chord and the brace.

5.2 Hot Spot Strain and SNCF

The procedure for the determination of the hot spot strain was an extrapolation of strains from a defined region adjacent to the weld, defined as the extrapolation region, see Figure 5-1. The extrapolation region was defined by a specified minimum and maximum distance from the weld toe of the joint, in such a way that the effects of the global geometry of the weld (flat, concave, convex) and the condition at the weld toe (angle, undercut) were not included in the hot spot strain.

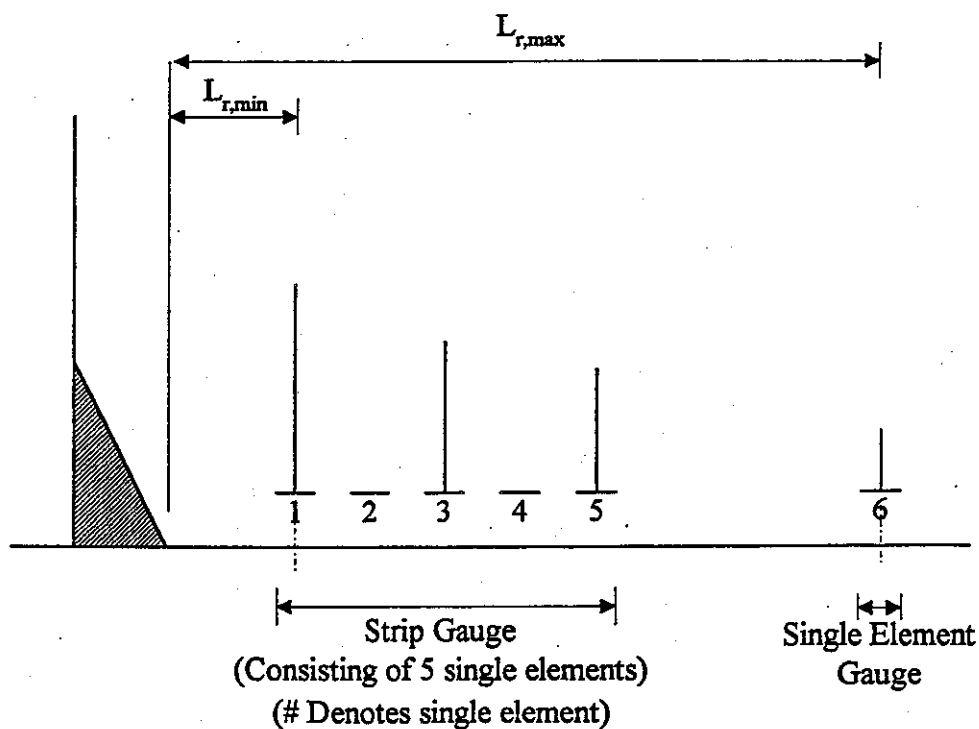

Figure 5-1: Extrapolation region

The adopted extrapolation region is defined by the following minimum distance ($l_{r,min}$) and maximum distance ($l_{r,max}$) from the weld toe as a function of the chord and brace dimensions,

Chord Side

- $l_{r,min} = 0.4T$ but not less than 4mm for crown and saddle
- $l_{r,max} = 0.4 (rtRT)^{1/4}$ for crown
- $l_{r,max} = R\pi 5/180$ for saddle

Brace Side

- $l_{r,min} = 0.4t$, but not less than 4mm for crown and saddle
- $l_{r,max} = 0.65 (rt)^{1/2}$ for crown and saddle

The hot spot strain was determined by parabolic curve fitted through data points and parabolic extrapolation to the weld toe. The extrapolation was based on the strain component perpendicular to the weld.

The SNCF value was calculated by the ratio of the hot spot strain divided by the nominal strain.

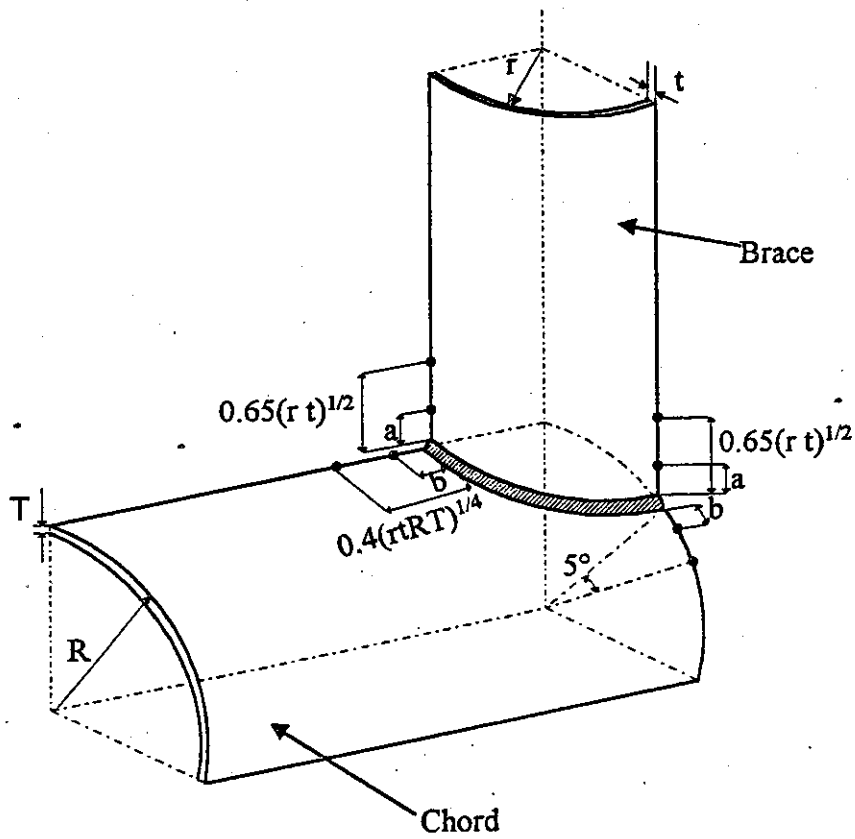

$$a = 0.4t \text{ but not less than } 4\text{mm}$$

$$b = 0.4T \text{ but not less than } 4\text{mm}$$

Figure 5-2: Minimum and maximum distance from the weld toe

6 OVERVIEW OF GROUTED TUBULAR JOINT BEHAVIOUR

6.1 General

The following sections present a technical appraisal of the behaviour of grouted tubular 'T' and 'DT' joints. Section 6.2 discusses in general terms the reduction in SCFs (Stress Concentration Factors) for the various load cases.

Stress Concentration Factors (SCFs) are to some extent dependent on the previous loading history for grouted tubular joints. Under tensile loading or on the tension side of in-plane or out-of-plane bending, some level of local separation and yielding occurs giving rise to the notion of SCF dependency on preload. This aspect is discussed further in Section 6.3.

6.2 Load Case Effects

The presence of grout significantly stiffens the chord member in the beam bending sense, restricts ovalisation of the chord and restricts chord wall deformations. The presence of grout has the effect of providing a more even distribution of stresses around the joint intersection. For the majority of specimens tested this resulted in an increase of SCF for the grouted condition at the crown location.

The effect of grout on SCFs for the various load cases are discussed in more detail below.

6.2.1 Axial Loading

Reduced grouted SCFs, compared to as-welded SCFs, exist at the saddle location. Resistance to axial loading at this location is predominantly by chord wall bending for small β ratio joints, and membrane action for high β ratio joints. The presence of grout restricts chord wall deformations and ovality and therefore results in a reduction in SCFs. Behaviour is similar for the chord side and brace side.

An increase in SCFs, over as-welded SCFs, particularly for compressive loading is present at the crown location due to the increased stiffness afforded by the grout,

which attracts additional load. Behaviour is similar for the chord side and brace side.

6.2.2 In-plane Bending

The reduction in SCFs for in-plane bending loads is low on the chord side, given the greater relative stiffness at crown locations viz a viz saddle locations. The presence of grout causes the neutral axis to shift towards the compressive side of the crown. Therefore, the reduction in SCFs differs between the tension side and the compressive side of the brace as indicated in the test results.

6.2.3 Out-of-Plane Bending

The reduction in SCFs is similar to that for in-plane bending loading. Again, the reduction in SCFs differ between the tension side and compressive side of the brace.

6.3 Preload Effects

Preload is defined here as the load history a particular joint has been subjected to. Preload and its magnitude and load sign have been seen to affect SCFs for a grouted joint.

Preload investigations carried out by Veritec⁽¹⁵⁾ indicated that a threshold SCF value existed for double skin grouted joints. The SCF threshold value is defined as being the highest SCF measured for any preload. The SCF threshold value was obtained by steadily increasing tensile preload prior to SCF measurements at lower loads, until a drop in the measured SCF was observed. It was observed that substantial yielding occurred at the hot spot location for that preload which gave the SCF threshold value.

It was found that measured SCFs in specimens which had received reversed preloads, i.e. tension and compression, were larger than in those which had experienced uni-directional preload.

The Veritec work also measured residual strains as the specimens went through the first SCF measurement cycle. These residual strains increased as the preload levels increased. Subsequent shake-down procedures were adopted. A number of cycles, at a load corresponding to a maximum stress less than the yield stress at the hot spot location, were applied until the measured residual strain was less than 1%.

For the joint types tested in this test programme, the behaviour for the fully grouted test specimens has shown that the grouted SCF remains constant at increasing preload levels, for tension loading. This is the case for the tension side of bending load cases and at all gauge positions for the axial tension case. Conversely, the grouted SCF begins to increase above 60% preload (as-welded ultimate tensile capacity) on the compressive side for the bending load cases and for the majority of gauge positions for the axial compression case. In this instance, the SCF increases to a greater extent at the chord saddle location. Section 7 presents the results in more detail.

7 TEST RESULTS

7.1 Preload Investigation Results on Specimen T7

Specimen T7 was subjected to preload under compression/tension levels from 20% to 130% of ISO predicted as-welded joint capacity in steps of 10% to 20%. Figure 7-1 summarises the SNCF measurement and preloading sequence. Appendix J contains a detailed description of the test sequence for the preload investigation.

SCNFs were determined for T7 at several preload levels. Figures 7-2 to 7-5 present a summary of the results contained in Appendix K, which contains further details of the SNCF measurements taken.

Figure 7-2 presents the in-plane bending SNCFs for brace and chord crown positions as a function of the axial preload level expressed as a percentage of the mean ultimate strength of the joint as given by ISO code. After 60 % preload, the SNCFs at the compression loaded side of the chord crown position increase marginally. In general the SNCFs remain constant at all SNCF measurement locations.

Figure 7-3 presents the out-of-plane bending SNCFs for brace and chord saddle as a function of the axial preload level. After 60 % preload, the SNCFs at the compression side of the chord saddle positions increase. At all other measurement locations the SNCFs remain constant.

Figure 7-4 presents the average SNCFs for axial compression loading and are shown for the saddle and crown positions on the brace and chord. After 60 % preload, a significant increase in the SNCFs is indicated for the saddle positions on the chord side. Increases in SNCFs are also found at the chord crown and brace saddle positions. The SNCF at the brace crown location remains constant.

Figure 7-5 presents the average SNCFs for axial tension loading and are shown for the saddle and crown positions on the brace and chord. The SNCFs remain constant for all preload levels.

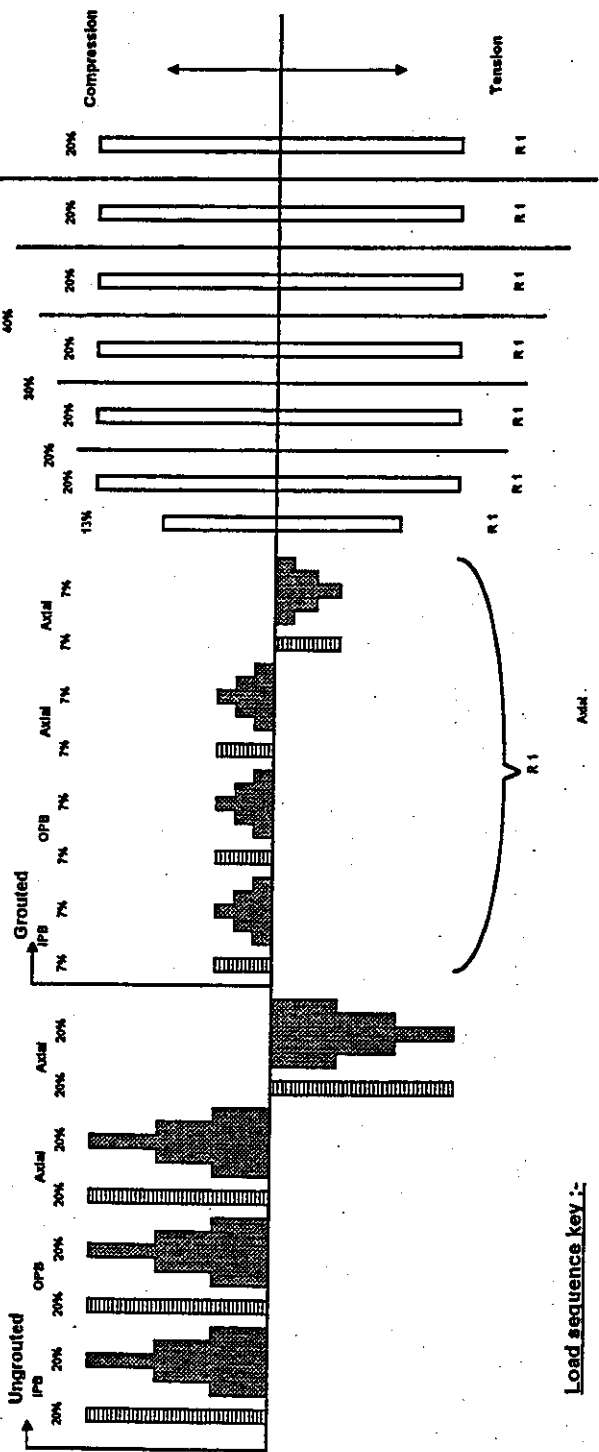

Load sequence key :-





-  IPB 20%
 Shake down with application of 10 cycles of in-plane bending load at 20% of predicted ultimate load of joint
-  Axial 20%
 SNCF measurements at three equal increments up to a maximum of 20% of the predicted as-welded ultimate load for axial compression
-  OPS 7%
 SNCF measurements at 20% of as-welded predicted joint capacity to match load level used in as-welded SNCF measurements
-  Axial 7%
 Axial pre-load (compression then tension) at 50% of predicted as-welded joint strength under axial tension/compression
-  Repeat sequence R1

Figure 7-1: SNCF measurement and preload sequence for specimen T7



The results presented for the preload investigations on Specimen T7, indicate the SNCFs remain constant, for all loading conditions, at preload levels between 15% and 60% of the as-welded predicted mean ultimate joint tensile strength as given by the ISO code. The results also indicate that the SNCFs for the tension side of bending cases and the axial compression case, even at the high preload levels, do not increase beyond the SNCF measured at 60% preload. The SNCFs remain constant, to a large extent, for the axial tension case. The SNCFs increase beyond preload levels of 60% for the axial compression case, and only marginally exceed the SNCFs measured for the axial tension case at 130% preload. Below the 130% preload level, the SNCFs measured for the axial tension case are higher than those measured for the axial compression case.

Based on the results obtained from the preload investigation on Specimen T7, the remaining specimens were preloaded in increments up to a maximum level of 130%. SNCF measurements were taken, after each preload increment.

7.2 SCF/SNCF ratio

With additional strain gauge rosettes mounted on Specimen T7, at one crown and one saddle position on the chord and brace, the actual stresses were determined. Using single strain gauges only a strain concentration can be determined at the hot spot location. However, using rosette gauges, the stress concentration can be determined at the hot spot location. Appendix K contains summary tables of SCF/SNCF ratios for Specimen T7. The SCF/SNCF ratios for the preload levels applied are presented in Figure 7-6, 7-7 and 7-8 for each of the loading conditions.

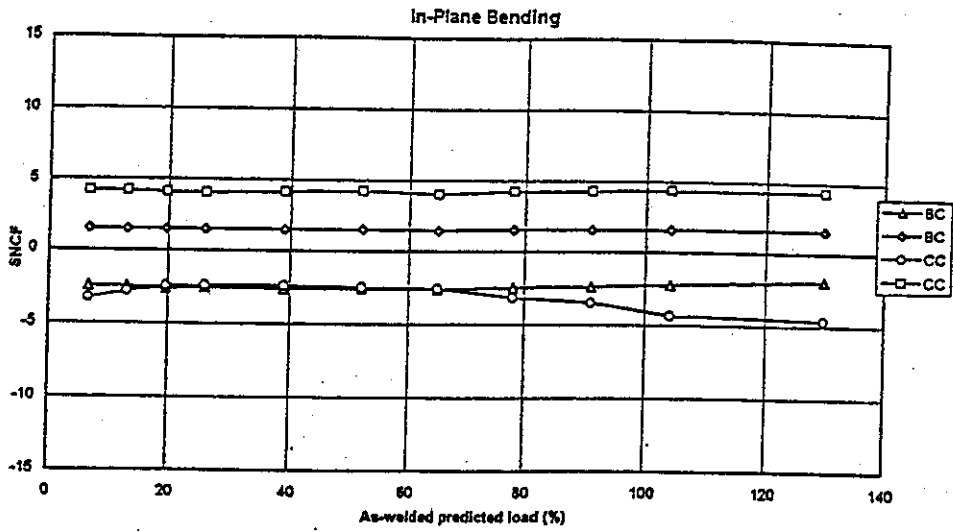

Figure 7-2: SNCFs as function of the axial preload for in-plane bending

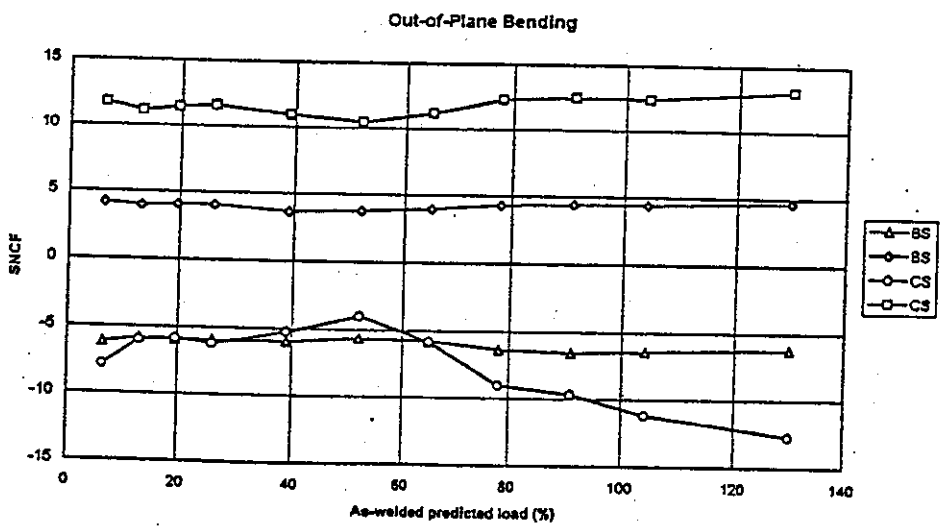

Figure 7-3: SNCFs as function of the axial preload for out-of-plane bending



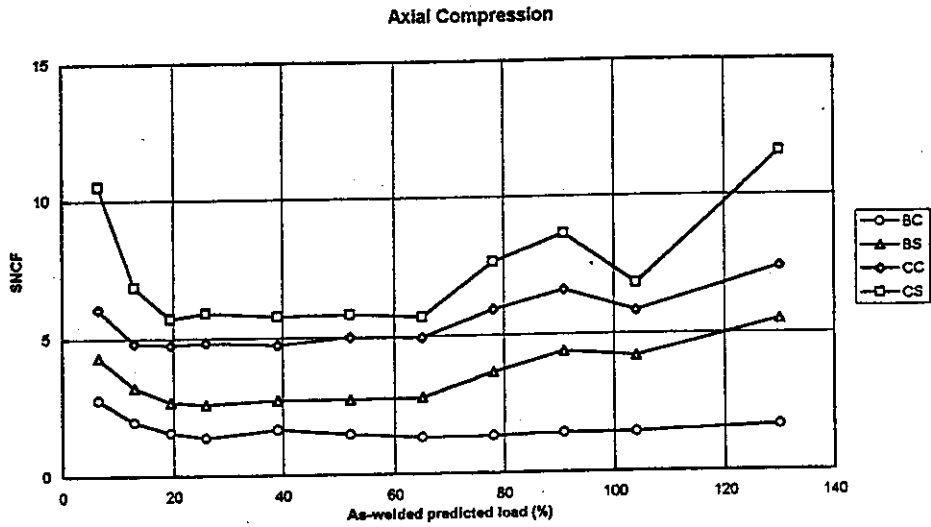

Figure 7-4: SNCFs as function of the axial preload for axial compression

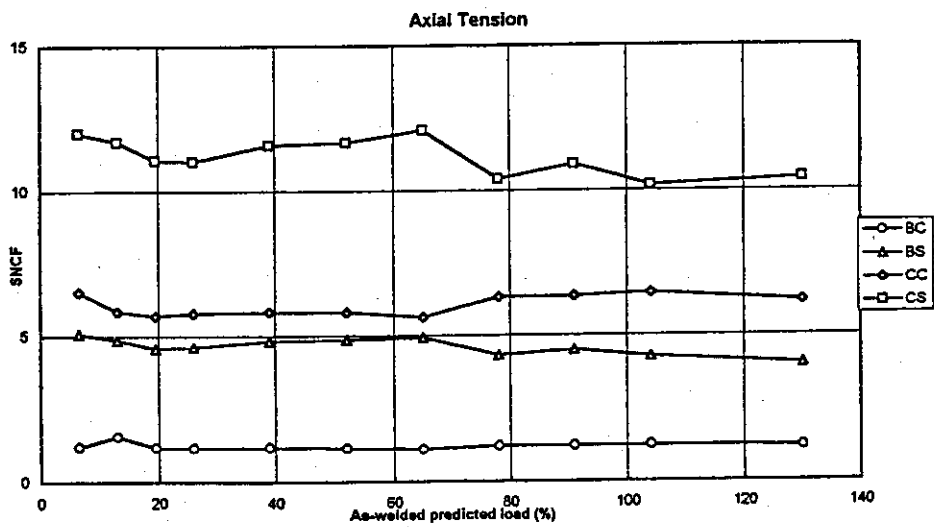
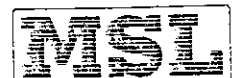

Figure 7-5: SNCFs as function of the axial preload for axial tension



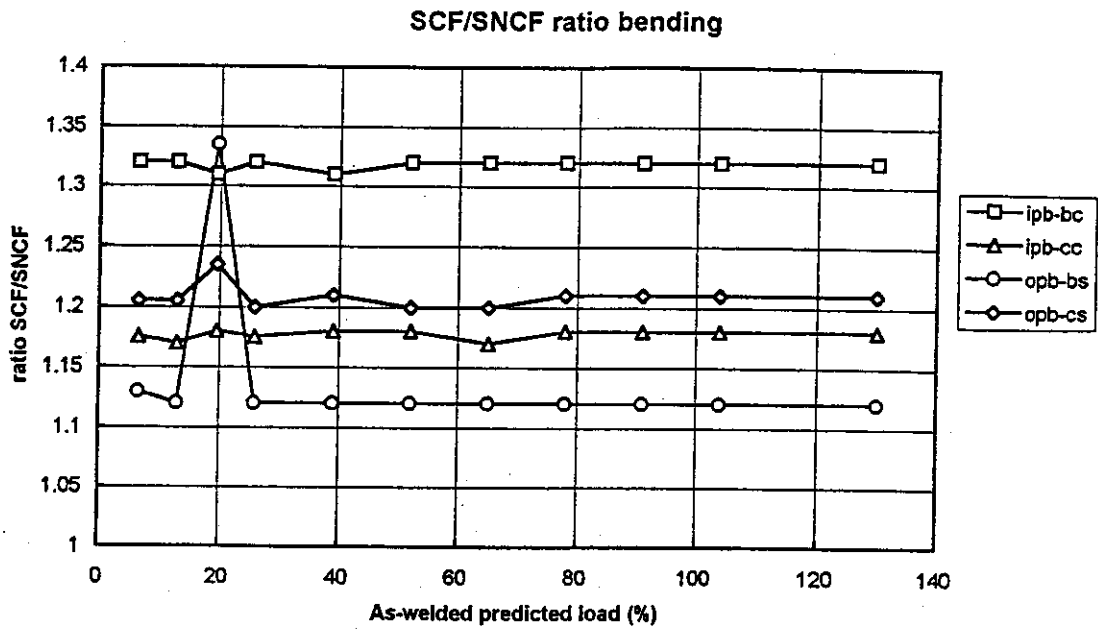

Figure 7-6: SCF/SNCF ratios for in-plane and out-of-plane bending as function of the applied preload level.

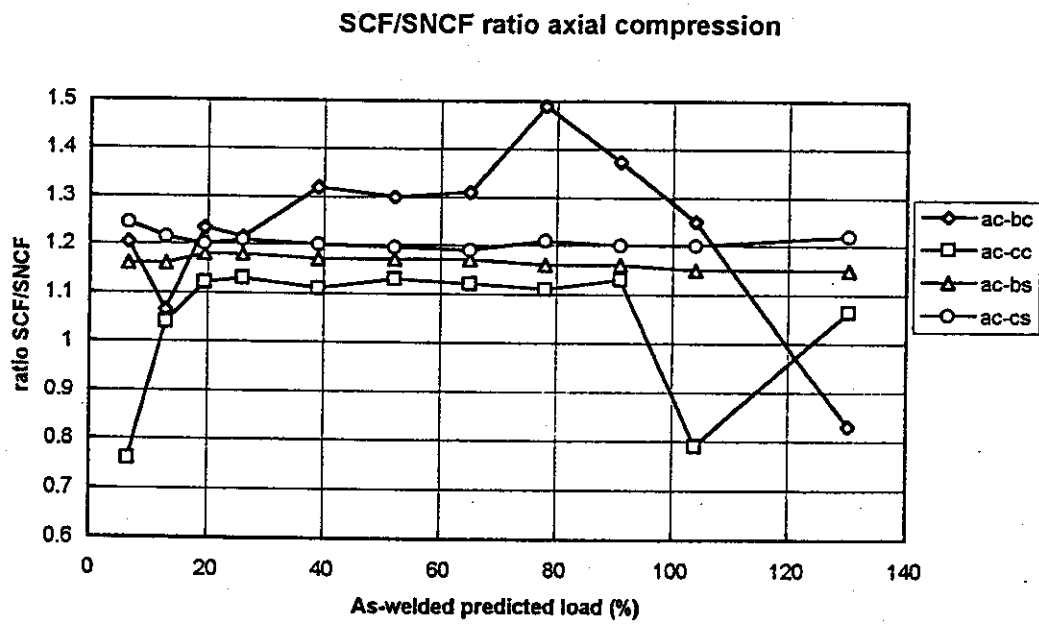

Figure 7-7: SCF/SNCF ratios for axial compression as function of the applied preload level.

SCF/SNCF ratio axial tension

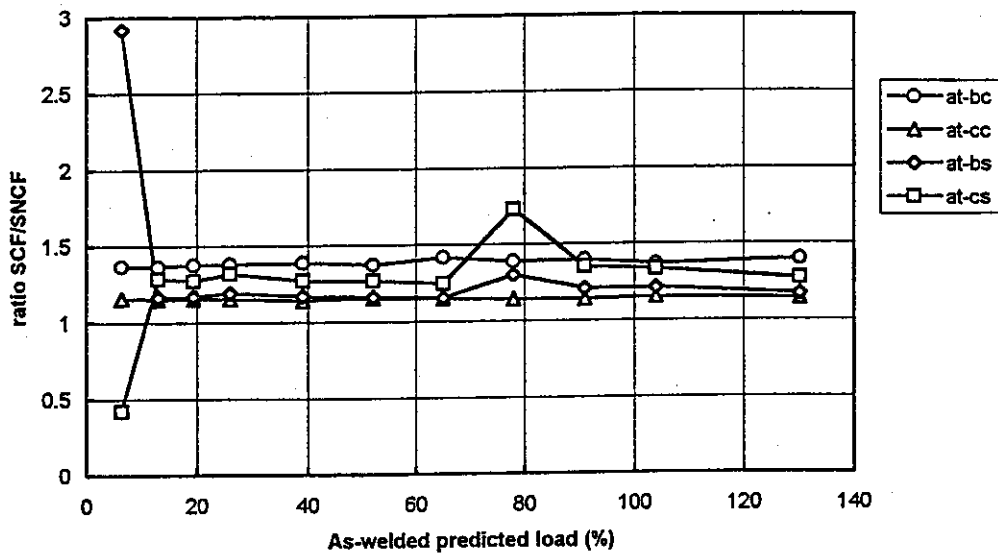

Figure 7-8: SCF/SNCF ratios for axial tension as function of the applied preload level.

From the results in Figure 7-6, it would appear that the SCF/SNCF ratio should remain constant at all measurement locations through the range of applied preload levels for axial tension and axial compression loading conditions. Figure 7-7 and Figure 7-8 also demonstrate this to a degree. It is therefore concluded that the variations seen in Figure 7-7 and Figure 7-8 can be attributed to malfunctioning gauges and/or mis-readings.

Figure 7-6 demonstrates stability in the SCF/SNCF ratio for both the tension side and compression side of bending load through the full range of applied preload levels. The visible peak experienced by the brace saddle location gauges, for out-of-plane bending, can be attributable to a mis-read gauge.

The results indicate that the grouted SCF/SNCF ratios range between 1.10 and 1.37 at the 50% preload level for all loading modes. The average grouted SCF/SNCF ratio was approximately 1.2 which was subsequently used for the conversion of grouted SNCFs to grouted SCFs for all specimens. The 1.2 ratio was also utilised as the factor for converting the as-welded SNCFs to as-welded SCFs.

7.3 As-welded SNCF Results and Measurements

As-welded SNCF measurements were taken for all specimens for in-plane bending, out-of-plane bending, axial compression and axial tension load cases, in turn. SNCFs were measured in the above noted sequence, since in-plane bending typically results in the lowest SNCFs and axial tension typically gives rise to the highest SNCFs, i.e. the sequence was chosen so that load cases would have minimal effect on the next load case SNCF measurement. Prior to each SNCF measurement load case, a minimum of ten cycles of that load were applied to 'shake' out any residual strains. SNCF measurements were taken in three equal increments up to approximately 20% of the ISO predicted as-welded ultimate joint capacity for that load case. SNCF measurements were also taken in three equal increments as the load was reduced back to zero. The SNCF measurements were repeated for each load case considered.

SNCFs are presented for the tension side and compression side of the bending load cases to enable comparison to the corresponding grouted SNCFs contained in Section 7.4.

Appendix L contains the full set of SNCF measurements taken for each of the test specimens.

7.3.1 T-Joints

A summary of the SNCF results for the T-joints are presented in Table 7-1 for in-plane bending loading, Table 7-2 for out-of-plane bending loading, Table 7-3 for axial compression loading and Table 7-4 for axial tension loading.

Specimen T9 was investigated twice. It was placed in the test rig and loaded in all four loading modes twice in order to determine any possible influence of assembly/disassembly of the test specimen into the test rig on the load and strain measurements. The second investigation is marked by '(s) second'. The full results of this exercise are presented in Appendix L. However, little influence of assembly/disassembly was found as can be inferred from an inspection of Table 7-1 to 7-4.

Specimen	β	γ	Brace Crown		Chord Crown	
			Tension Side	Compression Side	Tension Side	Compression Side
T1	0.41	12.4	1.37	1.32	2.42	2.45
T3	1.0	12.4	1.16	1.14	3.09	2.51
T5	0.67	20.0	1.59	1.43	3.96	3.23
T7	0.41	25.9	1.66	1.67	5.00	4.50
T9	1.0	25.9	1.37	1.45	2.89	2.51
T9(s)	1.0	25.9	1.36	1.45	2.87	2.51

Table 7-1: Summary of SNCF results for in-plane bending

Specimen	β	γ	Brace Saddle		Chord Saddle	
			Tension Side	Compression Side	Tension Side	Compression Side
T1	0.41	12.4	2.97	3.18	6.14	6.0
T3	1.0	12.4	4.97	4.64	6.66	7.35
T5	0.67	20.0	7.71	7.78	13.84	14.35
T7	0.41	25.9	6.24	7.07	18.43	17.01
T9	1.0	25.9	6.57	7.53	15.44	16.99
T9(s)	1.0	25.9	6.43	7.45	15.12	16.76

Table 7-2: Summary of SNCF results for out-of-plane bending

Specimen	β	γ	Averaged Values			
			Brace Crown	Brace Saddle	Chord Crown	Chord Saddle
T1	0.41	12.4	0.25	5.39	5.79	9.36
T3	1.0	12.4	2.07	4.29	8.56	2.95
T5	0.67	20.0	1.10	10.97	8.58	17.79
T7	0.41	25.9	1.37	10.46	8.50	27.76
T9	1.0	25.9	2.18	7.11	7.73	12.13
T9(s)	1.0	25.9	2.21	7.00	7.84	11.93

Table 7-3: Summary of SNCF results for axial compression loading

Specimen	β	γ	Averaged Values			
			Brace Crown	Brace Saddle	Chord Crown	Chord Saddle
T1	0.41	12.4	0.24	4.96	5.35	8.69
T3	1.0	12.4	2.08	4.34	8.51	2.72
T5	0.67	20.0	1.01	10.83	8.02	17.63
T7	0.41	25.9	0.71	10.37	7.99	25.91
T9	1.0	25.9	2.15	6.88	7.49	11.62
T9(s)	1.0	25.9	2.21	6.77	7.72	11.41

Table 7-4: Summary of SNCF results for axial tension loading

7.3.2 DT-Joints

Summaries of the SNCF results for the DT-joints are presented in Table 7-5 for in-plane bending loading, Table 7-6 for out-of-plane bending loading, Table 7-7 for axial compression loading and Table 7-8 for axial tension loading.

Appendix L contains the full set of SNCF measurements taken for each of the test specimens.

Specimen	β	γ	Brace Crown		Chord Crown	
			Tension Side	Compression Side	Tension Side	Compression Side
DT2	0.67	12.4	1.45	1.54	3.12	3.43
DT3	1.0	12.4	1.33	1.03	2.59	2.19
DT4	0.41	20.0	2.36	2.56	4.08	4.38
DT5	0.67	20.0	1.45	1.78	5.88	4.09
DT6	1.0	20.0	1.46	1.23	2.51	2.62
DT8	0.67	25.9	1.57	1.57	4.03	3.84
DT9	1.0	25.9	1.47	1.26	2.79	2.96

Table 7-5: Summary of SNCF results for in-plane bending

Specimen	β	γ	Brace Saddle		Chord Saddle	
			Tension Side	Compression Side	Tension Side	Compression Side
DT2	0.67	12.4	4.76	4.22	5.71	7.65
DT3	1.0	12.4	2.28	1.95	2.49	2.65
DT4	0.41	20.0	3.47	4.06	9.65	8.91
DT5	0.67	20.0	7.64	7.47	18.16	12.08
DT6	1.0	20.0	2.58	2.25	5.62	3.04
DT8	0.67	25.9	8.39	9.14	18.85	17.32
DT9	1.0	25.9	2.26	2.27	4.50	7.06

Table 7-6: Summary of SNCF results for out-of-plane bending

Specimen	β	γ	Averaged Values			
			Brace Crown	Brace Saddle	Chord Crown	Chord Saddle
DT2	0.67	12.4	0.05	9.13	1.73	13.11
DT3	1.0	12.4	0.72	3.59	0.65	3.39
DT4	0.41	20.0	0.71	11.06	3.65	26.27
DT5	0.67	20.0	0.07	15.84	3.43	29.93
DT6	1.0	20.0	0.93	4.37	0.51	7.11
DT8	0.67	25.9	0.42	17.94	1.42	36.60
DT9	1.0	25.9	1.04	3.71	0.60	8.47

Table 7-7: Summary of SNCF results for axial compression loading

Specimen	β	γ	Averaged Values			
			Brace Crown	Brace Saddle	Chord Crown	Chord Saddle
DT2	0.67	12.4	0.07	9.26	1.76	13.27
DT3	1.0	12.4	0.72	3.53	0.66	3.38
DT4	0.41	20.0	0.00	11.25	3.70	26.14
DT5	0.67	20.0	0.05	15.50	3.78	29.77
DT6	1.0	20.0	0.98	4.17	0.52	6.62
DT8	0.67	25.9	0.43	18.08	1.32	36.99
DT9	1.0	25.9	1.05	3.54	0.62	8.32

Table 7-8: Summary of SNCF results for axial tension loading

7.4 Grouted SNCF Results and Measurements

SNCF measurements were taken for in-plane bending, out-of-plane bending, axial compression and axial tension load cases, in turn. Based on the findings from the preload investigation on Specimen T7, in general 0%, 60% and 130% preload levels were applied to the remaining specimens. As with the as-welded SNCF measurements, the grouted SNCF measurements were taken in three equal load increments corresponding to those used in the as-welded condition for each of the specimens. The SNCFs were measured for each of the load cases. The SNCFs were calculated from an average of two values. One value relates to the SNCF obtained during the loading path (between zero load and peak load), and the other to the unloading path (between peak and zero load).

The following sections summarise the measured SNCFs at the crown and saddle positions for each specimen for the load cases considered. Appendix M contains the data generated during testing from which the data in the following sections have been extracted.

7.4.1 T-Joints

A summary of the SNCF results for the grouted T-joint specimens are presented in the following tables. Each table contains the results of the SNCF at the brace

crown, brace saddle, chord crown and chord saddle positions for each of the preload levels.

The two values given in the tables for in-plane bending and out-of-plane bending represent tension side SNCF and compression side SNCF in that order. The format for the tables presenting results for specimen T7 differ to those of the other specimens due to the number of preload levels tested. For specimen T7, separate tables have been generated for each of the loading conditions.

Preload	Loadcase	Brace		Chord	
		Saddle	Crown	Saddle	Crown
0%	IPB		1.35/1.49		2.22/2.02
	OPB	2.38/2.81		4.5/3.5	
	COMPRESSION	2.07	1.42	3.47	4.65
	TENSION	3.71	0.94	4.98	4.84
45%	IPB		1.38/1.33		2.43/2.29
	OPB	2.46/3.0		4.68/4.07	
	COMPRESSION	3.35	1.02	5.72	5.90
	TENSION	3.07	0.93	4.70	4.89
90%	IPB		1.39/1.32		2.22/2.34
	OPB	2.34/2.90		4.32/4.04	
	COMPRESSION	3.12	1.00	4.74	5.34
	TENSION	2.45	1.12	3.55	4.77
130%	IPB		1.40/1.31		2.26/2.34
	OPB	2.33/2.84		4.46/4.15	
	COMPRESSION	2.92	0.96	4.50	5.21
	TENSION	2.42	1.02	3.65	4.87

Table 7-9: Summary of grouted SNCFs for specimen T1, $\gamma = 12.4$, $\beta = 0.41$, after four levels of compression and tension preload

Preload	Loadcase	Brace		Chord	
		Saddle	Crown	Saddle	Crown
0%	IPB		1.29/1.53		2.78/2.0
	OPB	1.32/2.11		2.31/2.19	
	COMPRESSION	1.72	2.77	0.42	8.13
	TENSION	1.75	2.33	0.52	9.05
50%	IPB		1.27/1.27		2.84/2.32
	OPB	1.28/1.86		1.82/1.94	
	COMPRESSION	1.30	2.41	0.28	8.90
	TENSION	1.33	2.24	0.67	9.45

Table 7-10: Summary of grouted SNCFs for specimen T3, $\gamma = 12.4$, $\beta = 1.0$, after two levels of compression and tension preload

Preload	Loadcase	Brace		Chord	
		Saddle	Crown	Saddle	Crown
0%	IPB		1.74/2.18		3.59/2.76
	OPB	2.88/3.97		3.38/6.58	
	COMPRESSION	2.76	2.41	4.47	7.00
	TENSION	3.66	1.49	5.31	6.35
50%	IPB		1.74/2.02		3.62/2.90
	OPB	2.96/4.06		3.64/6.66	
	COMPRESSION	3.75	2.28	5.94	8.43
	TENSION	3.63	1.69	5.08	7.61
100%	IPB		1.84/1.75		3.46/3.27
	OPB	3.83/3.95		5.13/6.40	
	COMPRESSION	4.33	2.13	5.91	8.77
	TENSION	2.73	1.86	3.73	7.42

Table 7-11: Summary of grouted SNCFs for specimen T5, $\gamma = 20.0$, $\beta = 0.67$, after three levels of compression and tension preload

Preload Level %	Brace Crown		Chord Crown	
	Tension Side	Compression Side	Tension Side	Compression Side
7	1.50	2.45	4.16	3.26
13	1.49	2.51	4.17	2.84
20	1.48	2.62	4.07	2.45
26	1.47	2.57	4.05	2.43
40	1.48	2.62	4.14	2.40
52	1.50	2.60	4.20	2.51
65	1.41	2.63	4.00	2.57
78	1.52	2.50	4.22	3.18
90	1.51	2.41	4.28	3.47
105	1.57	2.29	4.36	4.35
130	1.56	1.98	4.31	4.65

Table 7-12: Summary of grouted SNCFs for specimen T7 for in-plane bending, $\gamma = 25.9$, $\beta = 0.41$, measured during preload investigations

Preload Level %	Brace Saddle		Chord Saddle	
	Tension Side	Compression Side	Tension Side	Compression Side
7	4.20	6.15	11.71	7.85
13	4.00	5.84	11.16	5.96
20	4.10	5.92	11.42	5.81
26	4.11	5.91	11.59	6.20
40	3.65	5.98	10.95	5.22
52	3.78	5.63	10.48	4.01
65	4.01	5.79	11.21	5.82
78	4.35	6.35	12.30	9.03
90	4.43	6.52	12.49	9.69
105	4.41	6.41	12.41	11.14
130	4.66	6.19	13.07	12.68

Table 7-13: Summary of grouted SNCFs for specimen T7 for out-of-plane bending, $\gamma = 25.9$, $\beta = 0.41$, measured during preload investigations

Preload Level %	Brace Crown	Chord Crown	Brace Saddle	Chord Saddle
7	2.87	6.07	4.31	1.051
13	1.96	4.82	3.22	6.87
20	1.57	4.76	2.69	5.72
26	1.37	4.83	2.60	5.89
40	1.65	4.73	2.73	5.77
52	1.48	5.00	2.73	5.80
65	1.32	4.94	2.77	5.70
78	1.36	5.93	3.67	7.64
90	1.41	6.61	4.38	8.66
105	1.43	5.82	4.20	6.81
130	1.66	7.39	5.49	11.60

Table 7-14: Summary of grouted SNCFs for specimen T7 for axial compression, $\gamma = 25.9$, $\beta = 0.41$, measured during preload investigations

Preload Level %	Brace Crown	Chord Crown	Brace Saddle	Chord Saddle
7	1.20	6.54	5.10	11.99
13	1.54	5.87	4.88	11.69
20	1.17	5.71	4.59	11.07
26	1.17	5.81	4.63	11.02
40	1.19	5.83	4.84	11.57
52	1.14	5.82	4.88	11.65
65	1.09	5.64	4.94	12.08
78	1.19	6.34	4.33	10.38
90	1.21	6.36	4.51	10.89
105	1.23	6.47	4.27	10.16
130	1.19	6.20	4.02	9.85

Table 7-15: Summary of grouted SNCFs for specimen T7 for axial tension, $\gamma = 25.9$, $\beta = 0.41$, measured during preload investigations

Preload	Loadcase	Brace		Chord	
		Saddle	Crown	Saddle	Crown
0%	IPB		1.43/2.06		2.63/2.31
	OPB	1.59/3.21		4.19/4.82	
	COMPRESSION	2.51	2.54	6.63	3.05
	TENSION	1.98	1.85	6.77	2.64
50%	IPB		1.42/2.06		2.65/2.43
	OPB	1.56/2.06		4.28/4.59	
	COMPRESSION	2.70	2.53	2.72	8.00
	TENSION	2.03	1.99	2.79	7.34
100%	IPB		1.45/1.92		2.63/2.15
	OPB	0.77/1.52		1.99/3.58	
	COMPRESSION	2.62	1.66	7.74	1.86
	TENSION	2.19	1.62	7.86	2.03

Table 7-16: Summary of grouted SNCFs for specimen T9, $\gamma = 25.9$, $\beta = 1.0$, after three levels of compression and tension preload

7.4.2 DT-Joints

A summary of the SNCF results of the grouted DT-joint specimens are presented in the following tables. Each table contains the results of the SNCF at the brace crown, brace saddle, chord crown and chord saddle position for the different preload levels.

The two values given in the tables for in-plane bending and out-of-plane bending represent tension side SNCF and compression side SNCF in that order.

Preload	Loadcase	Brace		Chord	
		Saddle	Crown	Saddle	Crown
0%	IPB		2.43/1.59		2.18/2.76
	OPB	2.96/3.57		4.30/4.25	
	COMPRESSION	2.93	1.54	4.70	2.47
	TENSION	3.74	0.79	5.11	1.77
50%	IPB		2.53/1.63		2.38/2.89
	OPB	3.07/3.65		4.50/4.36	
	COMPRESSION	3.12	1.67	5.07	2.72
	TENSION	3.76	0.73	5.17	1.68
100%	IPB		2.38/1.64		2.56/2.88
	OPB	3.33/3.60		5.10/4.26	
	COMPRESSION	4.18	1.43	6.41	3.11
	TENSION	3.40	0.78	4.60	1.59

Table 7-17: Summary of grouted SNCFs for specimen DT2, $\gamma = 12.4$, $\beta = 0.67$, after three levels of compression and tension preload

Preload	Loadcase	Brace		Chord	
		Saddle	Crown	Saddle	Crown
0%	IPB		2.51/1.19		1.52/1.75
	OPB	1.79/2.06		2.60/2.39	
	COMPRESSION	3.36	0.79	3.27	1.03
	TENSION	2.11	0.84	3.09	0.93
50%	IPB		2.62/1.21		1.44/1.77
	OPB	1.89/2.18		2.61/2.41	
	COMPRESSION	3.24	0.89	3.22	1.21
	TENSION	2.78	0.80	3.45	0.85
100%	IPB		2.71/1.24		1.53/1.77
	OPB	1.97/2.22		2.76/2.48	
	COMPRESSION	3.30	1.21	3.33	1.20
	TENSION	3.11	0.81	3.53	0.86

Table 7-18: Summary of grouted SNCFs for specimen DT3, $\gamma = 12.4$, $\beta = 1.0$, after three levels of compression and tension preload

Preload	Loadcase	Brace		Chord	
		Saddle	Crown	Saddle	Crown
0%	IPB		3.58/2.24		1.62/3.19
	OPB	3.57/2.68		3.89/6.39	
	COMPRESSION	1.69	2.05	3.51	2.37
	TENSION	3.32	1.11	6.91	2.19
50%	IPB		3.70/2.27		1.67/3.24
	OPB	3.89/2.82		4.23/6.70	
	COMPRESSION	1.76	1.99	3.26	2.60
	TENSION	3.44	1.03	6.94	2.10
100%	IPB		3.69/2.23		1.60/3.18
	OPB	3.92/2.85		4.26/6.70	
	COMPRESSION	1.77	1.89	3.60	2.85
	TENSION	4.11	1.29	8.35	2.59

Table 7-19: Summary of grouted SNCFs for specimen DT4, $\gamma = 20.0$, $\beta = 0.41$, after three levels of compression and tension preload

Preload	Loadcase	Brace		Chord	
		Saddle	Crown	Saddle	Crown
0%	IPB		2.77/1.82		2.30/3.19
	OPB	3.47/4.31		3.68/9.91	
	COMPRESSION	3.55	1.76	7.01	2.74
	TENSION	4.61	0.87	8.38	1.14
50%	IPB		2.77/1.82		2.28/3.22
	OPB	4.20/4.92		4.94/11.49	
	COMPRESSION	3.61	1.93	7.47	1.65
	TENSION	5.30	0.80	9.66	0.62
100%	IPB		2.84/1.85		2.45/3.26
	OPB	4.54/4.93		4.88/11.37	
	COMPRESSION	4.08	1.98	7.44	2.97
	TENSION	5.42	0.74	9.82	0.42

Table 7-20: Summary of grouted SNCFs for specimen DT5, $\gamma = 20.0$, $\beta = 0.67$, after three levels of compression and tension preload



Preload	Loadcase	Brace		Chord	
		Saddle	Crown	Saddle	Crown
0%	IPB		3.05/1.44		1.30/2.32
	OPB	2.55/2.09		3.44/4.77	
	COMPRESSION	3.74	1.41	5.91	1.57
	TENSION	2.59	1.08	4.75	1.21
50%	IPB		3.31/1.43		0.95/2.27
	OPB	2.60/2.28		3.53/4.86	
	COMPRESSION	4.00	1.32	6.34	1.49
	TENSION	3.29	1.07	5.38	1.09
100%	IPB		3.10/1.42		1.29/2.27
	OPB	2.52/2.33		3.45/5.10	
	COMPRESSION	3.98	1.49	6.41	1.45
	TENSION	3.19	1.06	5.24	1.07

Table 7-21: Summary of grouted SNCFs for specimen DT6, $\gamma = 20.0$, $\beta = 1.0$, after three levels of compression and tension preload

Preload	Loadcase	Brace		Chord	
		Saddle	Crown	Saddle	Crown
0%	IPB		2.96/1.53		1.07/2.74
	OPB	3.71/4.34		4.11/9.41	
	COMPRESSION	2.44	1.99	4.67	1.54
	TENSION	4.04	0.59	6.90	1.80
50%	IPB		3.07/1.53		1.15/2.77
	OPB	3.95/4.55		5.23/9.77	
	COMPRESSION	3.23	1.61	7.27	2.38
	TENSION	5.36	0.60	10.50	1.93
100%	IPB		3.10/1.51		1.21/2.73
	OPB	4.15/4.80		5.82/10.29	
	COMPRESSION	2.62	1.60	4.19	1.19
	TENSION	5.75	0.60	11.05	2.00

Table 7-22: Summary of grouted SNCFs for specimen DT8, $\gamma = 25.9$, $\beta = 0.67$, after three levels of compression and tension preload

Preload	Loadcase	Brace		Chord	
		Saddle	Crown	Saddle	Crown
0%	IPB		2.77/1.51		0.51/2.51
	OPB	2.33/1.47		6.97/3.59	
	COMPRESSION	3.37	1.56	8.05	2.06
	TENSION	1.64	1.03	5.57	1.15
50%	IPB		2.78/1.51		0.52/2.52
	OPB	2.27/1.55		6.88/3.82	
	COMPRESSION	3.50	1.82	8.46	2.12
	TENSION	1.65	1.03	5.70	1.12
100%	IPB		2.89/1.52		0.69/2.57
	OPB	2.23/1.76		6.73/4.29	
	COMPRESSION	3.44	1.98	8.19	1.98
	TENSION	2.25	1.01	7.62	1.08

Table 7-23: Summary of grouted SNCFs for specimen DT9, $\gamma = 25.9$, $\beta = 1.0$, after three levels of compression and tension preload

7.4.3 Discussion of Test Results

A summary of the results are presented by the Figures contained in Appendix M which compare the grouted SNCFs with the as-welded SNCFs at the crown and saddle positions for the chord and brace. The results are presented as functions of β for constant γ . The SNCFs presented for the grouted joints were taken following the 50% preloading level.

Table 7-24 presents a summary of SNCF results for in-plane bending and out-of-plane bending for specimens in the as-welded condition and grouted condition. In the as-welded condition the SNCFs are comparable between the tension side and compression side for the bending load cases, as presented in Table 7-24. However, in the grouted condition the SNCFs deviate between the tension side and compression side for the bending load cases. Although deviation between tension side and compression side SNCFs exists, the average SNCF values were used for subsequent data reduction.

In-Plane Bending SNCF Results

As-welded IPB SNCF

Specimen	Brace Crown		Chord Crown	
	Tens	Comp	Tens	Comp
T1	1.37	1.32	2.42	2.45
T3	1.16	1.14	3.09	2.51
T5	1.59	1.43	3.96	3.23
T7	1.66	1.67	5.00	4.50
T9	1.37	1.45	2.89	2.51
DT2	1.45	1.54	3.12	3.43
DT3	1.33	1.03	2.59	2.19
DT4	2.36	2.56	4.08	4.38
DT5	1.45	1.78	5.88	4.09
DT6	1.46	1.23	2.51	2.62
DT8	1.57	1.57	4.03	3.84
DT9	1.47	1.26	2.79	2.96

Grouted IPB (50% preload) SNCF

Specimen	Brace Crown		Chord Crown	
	Tens	Comp	Tens	Comp
T1	1.38	1.33	2.43	2.29
T3	1.27	1.27	2.84	2.32
T5	1.74	2.02	3.62	2.90
T7	1.50	2.60	4.20	2.51
T9	1.42	2.06	2.65	2.43
DT2	2.53	1.63	2.38	2.89
DT3	2.62	1.21	1.44	1.77
DT4	3.70	2.27	1.67	3.24
DT5	2.77	1.82	2.28	3.22
DT6	3.31	1.43	0.95	2.27
DT8	3.07	1.53	1.15	2.77
DT9	2.78	1.51	0.52	2.52

Av. Grout/Av. As-weld

Specimen	Brace Crown		Chord Crown	
	Tens	Average	Tens	Average
T1	1.01	1.01	1.00	0.93
T3	1.09	1.11	1.10	0.92
T5	1.09	1.41	1.25	0.91
T7	0.90	1.56	1.23	0.84
T9	1.04	1.42	1.23	0.92
DT2	1.74	1.06	1.40	0.76
DT3	1.97	1.17	1.57	0.56
DT4	1.57	0.89	1.23	0.41
DT5	1.91	1.02	1.47	0.39
DT6	2.27	1.16	1.71	0.38
DT8	1.96	0.97	1.46	0.29
DT9	1.89	1.20	1.54	0.19

Out-of-Plane Bending SNCF Results

As-welded OPB SNCF

Specimen	Brace Saddle		Chord Saddle	
	Tens	Comp	Tens	Comp
T1	2.97	3.18	6.14	6.00
T3	4.97	4.64	6.66	7.35
T5	7.71	7.78	13.84	14.35
T7	6.24	7.07	18.43	17.01
T9	6.57	7.53	15.44	16.99
DT2	4.76	4.22	5.71	7.65
DT3	2.28	1.95	2.49	2.65
DT4	3.47	4.06	9.65	8.91
DT5	7.64	7.47	18.16	12.08
DT6	2.58	2.25	5.62	3.04
DT8	8.39	9.14	18.85	17.32
DT9	2.26	2.27	4.50	7.06

Grouted OPB (50% preload) SNCF

Specimen	Brace Saddle		Chord Saddle	
	Tens	Comp	Tens	Comp
T1	2.46	3.00	4.68	4.07
T3	1.28	1.86	1.82	1.94
T5	2.96	4.06	3.64	6.66
T7	3.78	5.63	10.48	4.01
T9	1.56	2.06	4.28	4.59
DT2	3.07	3.65	4.50	4.36
DT3	1.89	2.18	2.61	2.41
DT4	3.89	2.82	4.23	6.70
DT5	4.20	4.92	4.94	11.49
DT6	2.60	2.28	3.53	4.86
DT8	3.95	4.55	5.23	9.77
DT9	2.27	1.55	6.88	3.82

Av. Grout/Av. As-weld

Specimen	Brace Saddle		Chord Saddle	
	Tens	Average	Tens	Average
T1	0.89	0.94	0.76	0.68
T3	0.33	0.40	0.33	0.26
T5	0.45	0.52	0.45	0.26
T7	0.71	0.80	0.70	0.24
T9	0.26	0.27	0.26	0.27
DT2	0.75	0.86	0.75	0.57
DT3	0.96	1.12	0.97	1.05
DT4	0.89	0.69	0.91	0.44
DT5	0.60	0.66	0.60	0.27
DT6	1.01	1.01	1.01	0.63
DT8	0.48	0.50	0.48	0.28
DT9	0.84	0.68	0.84	1.53

R.F. In-plane bending

Specimen	Brace Crown		Chord Crown	
	Tens	Average	Tens	Average
T1	1.01	1.01	1.00	0.93
T3	1.09	1.11	1.10	0.92
T5	1.09	1.41	1.25	0.91
T7	0.90	1.56	1.23	0.84
T9	1.04	1.42	1.23	0.92
DT2	1.74	1.06	1.40	0.76
DT3	1.97	1.17	1.57	0.56
DT4	1.57	0.89	1.23	0.41
DT5	1.91	1.02	1.47	0.39
DT6	2.27	1.16	1.71	0.38
DT8	1.96	0.97	1.46	0.29
DT9	1.89	1.20	1.54	0.19

R.F. Out-of-plane bending

Specimen	Brace Saddle		Chord Saddle	
	Tens	Average	Tens	Average
T1	0.83	0.94	0.76	0.68
T3	0.26	0.40	0.33	0.26
T5	0.38	0.52	0.45	0.26
T7	0.61	0.80	0.70	0.24
T9	0.24	0.27	0.26	0.27
DT2	0.64	0.86	0.75	0.57
DT3	0.83	1.12	0.97	1.05
DT4	1.12	0.69	0.91	0.44
DT5	0.55	0.66	0.60	0.27
DT6	1.01	1.01	1.01	0.63
DT8	0.47	0.50	0.48	0.28
DT9	1.00	0.68	0.84	1.53

Table 7-24: Summary of tension side and compression side bending SNCFs



This is based on the recognition that a joint in-situ on a platform could well be subjected to cyclic loading which causes alternating tension and compression loading at a hot spot location. The hot spot stress range is more accurately calculated using the average SNCF (SCF) value rather than either the tension side value alone or the compression side value alone.

Table 7-25 presents the Reduction Factors derived using the measured grouted SNCFs over the measured as-welded SNCFs. In the grouted condition there is a reduction in SNCF at the saddle location for out-of-plane bending and axial tension, on the chord side and brace side. There is also a reduction in SNCF at the crown location for in-plane bending on the chord side. The brace side SNCF however, increases for in-plane bending. Also, the SNCF at the crown location generally increases for axial tension and axial compression on both the chord side and brace side. For some joints the SNCFs for the grouted condition are significantly higher than SNCFs for the as-welded condition, i.e. the RF is above unity, at brace crown locations for all pertinent load cases. The largest RF recorded at the brace crown location is 4.43, despite excluding four factors in excess of 10 due to the near zero values of the as-welded SNCF. In the grouted condition the SNCFs increased, but do not represent the critical SNCF for the grouted condition. For the chord side crown, the absolute highest recorded factor is 3.53.

7.5 Ultimate Strength Test Results and Measurements

The specimens were loaded up to failure in in-plane or out-of-plane bending, see Table 7-26. The load-rotation plots for the ultimate load tests are presented in Appendix N. Pictures of the failure modes are presented in Appendix O.

Specimen Ident.	D (mm)	d (mm)	T (mm)	T ₁ (mm)	t (mm)	L (mm)	θ (°)	β	γ	α	Condition	Chord SCFs						Brace SCFs								
												IPB	OPB	Comp.		Tens.		IPB	OPB	Comp.		Tens.				
														As-c	As-s	As-c	As-s			As-c	As-s	As-c	As-s			
T1	406.78	167.81	16.39	29.4	16.32	2440	90.0	0.413	12.409	6.92	11.71	0.996	12.00	Measured	0.97	0.72	0.55	1.01	0.54	0.91	1.01	0.89	0.56	4.43	0.62	3.89
T3	406.78	407.02	16.39	29.4	16.10	2440	90.0	1.000	12.409	6.92	11.71	0.982	12.00	Measured	0.92	0.27	0.09	1.04	0.25	1.11	1.10	0.33	0.30	1.16	0.31	1.08
T5	407.05	273.34	10.19	23.6	9.82	2440	90.0	0.672	19.973	8.62	18.36	0.964	11.99	Measured	0.90	0.37	0.30	0.93	0.29	0.95	1.24	0.45	0.30	2.07	0.34	1.67
T7	406.96	168.41	7.86	21.4	8.31	2440	90.0	0.414	25.888	9.49	23.42	1.057	11.99	Measured	0.69	0.48	0.21	0.58	0.47	0.71	1.22	0.74	0.26	1.39	0.48	1.13
T9	406.96	406.96	7.86	21.4	7.86	2440	90.0	1.000	25.888	9.49	23.42	1.000	11.99	Measured	0.95	0.27	0.22	1.03	0.24	0.98	1.24	0.26	0.36	1.24	0.29	0.94
DT2	406.78	273.09	16.39	29.4	15.76	2440	90.0	0.671	12.409	6.92	11.71	0.962	12.00	Measured	0.79	0.66	0.39	1.57	0.39	0.95	1.38	0.74	0.34	33.40	0.41	10.43
DT3	406.78	407.02	16.39	29.4	16.10	2440	90.0	1.001	12.409	6.92	11.71	0.982	12.00	Measured	0.67	0.97	0.95	1.86	1.02	1.29	1.61	0.96	0.90	1.24	0.79	1.11
DT4	407.05	168.57	10.19	23.6	9.95	2440	90.0	0.414	19.973	8.62	18.36	0.976	11.99	Measured	0.57	0.55	0.12	0.71	0.27	0.57	1.35	0.85	0.16	2.23	0.31	1.00
DT5	407.05	273.34	10.19	23.6	9.82	2440	90.0	0.672	19.973	8.62	18.36	0.964	11.99	Measured	0.54	0.47	0.25	0.48	0.32	0.16	1.40	0.54	0.23	27.57	0.34	16.00
DT6	407.05	407.60	10.19	23.6	9.61	2440	90.0	1.001	19.973	8.62	18.36	0.943	11.99	Measured	0.62	0.97	0.89	2.92	0.81	2.10	1.76	1.00	0.92	1.42	0.79	1.09
DT8	406.96	273.21	7.86	21.4	7.88	2440	90.0	0.671	25.888	9.49	23.42	1.003	11.99	Measured	0.49	0.42	0.20	1.68	0.28	1.46	1.44	0.49	0.18	3.83	0.30	1.40
DT9	406.96	406.96	7.86	21.4	7.86	2440	90.0	1.000	25.888	9.49	23.42	1.000	11.99	Measured	0.53	0.93	1.00	3.53	0.69	1.81	1.56	0.85	0.94	1.75	0.47	0.98

Note :- Assumed Stress/Strain relationship = 1.2

Table 7-25: Summary of measured Reduction Factors



Joint	Maximum moment [kNm]		Loading type	Failure mode
	At Chord C.L.	At Chord Face		
T1	152	122	opb	shear failure in chord at saddle
T3	923	839	opb	near to failure but limited by test rig capacity
T5	249	217	opb	shear failure in chord saddle
T7	63	51	opb	shear failure in chord saddle
T9	512	465	opb	brace buckling
DT2	425	370	opb	shear failure in chord saddle
DT3	813	739	opb	near to failure but limited by testing capacity
DT4	97	78	ipb	brace buckling
DT5	267	232	ipb	brace buckling
DT6	613	557	ipb	brace buckling
DT8	216	188	opb	shear failure in chord saddle
DT9	402	365	ipb	brace buckling

Table 7-26: Summary of Ultimate Load Tests

7.6 Local Joint Flexibility

Local joint flexibility was calculated from data obtained with displacement transducers. These measurements were taken across the joint and give bending and axial rotations and displacements respectively. Appendix H presents the layouts of transducers utilised in measuring displacements for 'T' and 'DT' joints. Flexibilities were measured in the as-welded and grouted conditions for in-plane bending, out-of-plane bending, axial compression and axial tension. Appendix P contains local bending and local axial deformation plots for all specimens. Figures 7-9 and 7-10 present typical local bending and local axial deformation plots respectively.

For all specimens, the grout significantly increases the rotational stiffness at the joint for in-plane bending. The relative stiffness increases as γ increases. As expected, the grout has little or no effect on the rotational stiffness of the $\beta = 1.0$ 'DT' joints for out-of-plane bending. There is also little or no effect on the axial stiffness for this joint type for axial tension and compression. The presence of grout significantly increases the stiffness of the 'T' joint specimens for all loading modes.



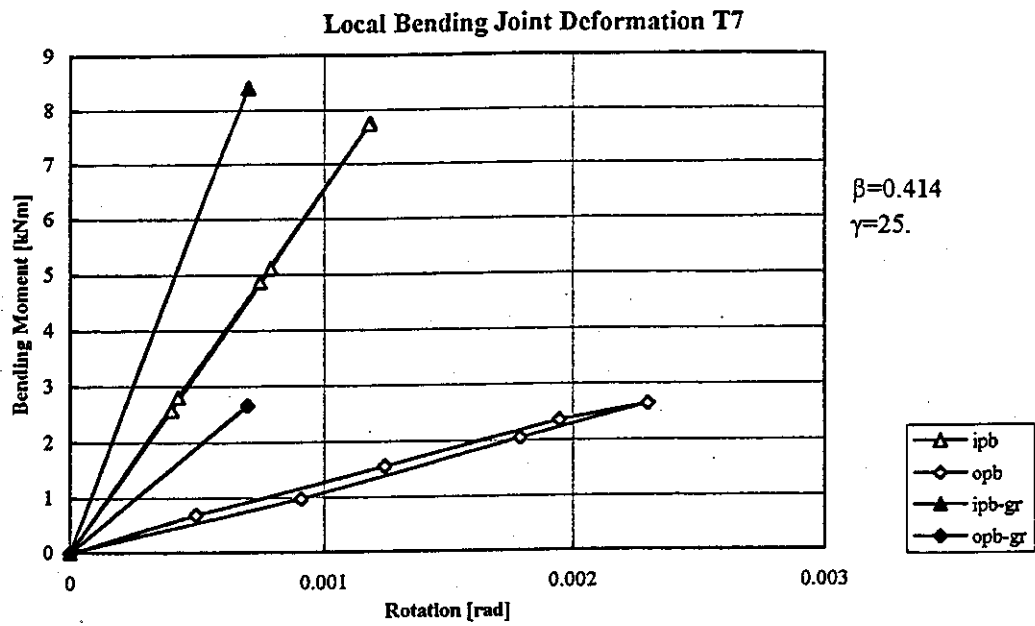

Figure 7-9: Typical local bending joint flexibility plot

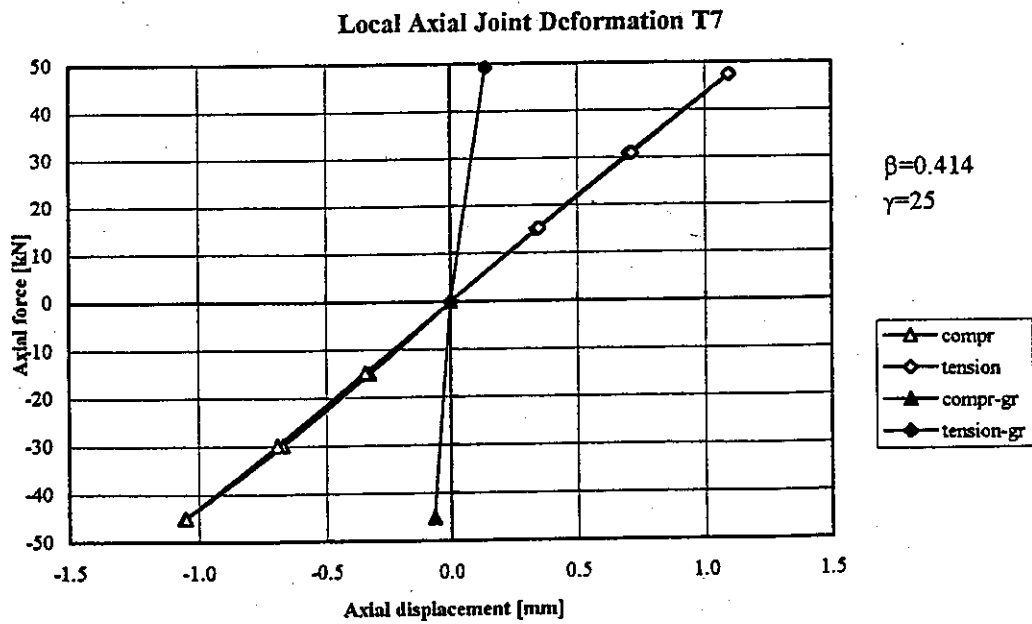

Figure 7-10: Typical local axial joint flexibility plot



8. ANALYSIS OF TEST RESULTS

8.1 General

This section presents comparisons between measured as-welded SCFs and predicted as-welded SCFs and the findings of studies conducted on the development of formulations to predict SCF Reduction Factors (RFs), i.e. the ratio of grouted SCF to as-welded SCF. The as-welded predicted SCFs were derived using Efthymiou⁽¹⁵⁾ and Llyods⁽⁵⁾ parametric equations. Appendix Q contains the development of formulations, using the measured as-welded and 'measured' grouted SNCs (inferred from measured SNCFs), to predict the RF for each joint and load type for both the chord and brace side of the weld. Appendix R contains the development of formulations using Efthymiou predicted as-welded and measured grouted SNCs, to predict the RF for each joint and load type.

Appendix S contains Tables S-1 to S-6 which present summaries of measured as-welded SCFs, grouted SCFs and Reduction Factors in a matrix format for chord side and brace side locations.

8.2 As-welded Measured SCFs vs Predicted SCFs

Table 8-1 presents a summary of as-welded SCF results. The table contains measured values and the corresponding predicted values using Efthymiou parametric equations and Lloyd's parametric equations. Based on the SCF/SNCF results of Specimen T7 presented in Section 7.2, an assumed stress/strain ratio of 1.2 has been adopted and applied to the as-welded SNCF results in the creation of Table 8-1. Table 8-2 presents the ratios between measured as-welded SCFs and predicted SCFs.

Actual measured geometries have been used in Table 8-1 for the derivation of predicted SCFs. The table presents predicted and measured SCFs for both the chord side and brace side in all four loading conditions. The saddle and crown positions are presented separately for the axial tension and compression cases.

The majority of predicted as-welded SCFs are to within 15% of the measured as-welded SCFs. It is seen that the Efthymiou parametric equations generally yield a closer prediction to the measured as-welded SCF than that of the Lloyd's equations.

8.3 Grouted Measured SCFs

Table 8-3 presents a summary of grouted SCF results for all specimens. The table contains measured SCFs for both the chord side and brace side in all four loading conditions. The saddle and crown positions are presented separately for the axial tension and compression cases.

8.4 Measured vs Predicted Reduction Factors

Table 8-4, presents a summary of predicted and measured RFs. This table was generated using the measured grouted SCFs contained in Table 8-3 divided by the measured as-welded SCFs contained in Table 8-1. Table 8-4 also presents the predicted RFs as derived using equations developed in Appendix Q and Appendix R.

8.5 Ultimate Strength

Table 8-5, presents a summary of the measured results for the ultimate strength test and the predicted failure loads using formulations from Design Recommendations⁽¹⁶⁾. The predicted values give good correlation to the measured values.

It is noted that five of the specimens failed with a true joint failure. The remaining seven specimens failed with a brace failure, with the exception of specimens T3 and DT3 which reached test rig capacity. These seven specimens were, however, extremely close to joint failure and are therefore of interest. The ratios of predicted to measured capacities are therefore shown in italics for these seven specimens.

Specimen Ident.	Chord SCFs										Brace SCFs											
	D (mm)	d (mm)	T (mm)	t (mm)	L (mm)	θ (°)	β	β (Modified)	γ	Source	IPB Crown	OPB Saddle	Comp.		IPB Crown	OPB Saddle	Comp.		Tens. Ax-e	Tens. Ax-e		
													Ax-a	Ax-e			Ax-a	Ax-e				
T1	406.78	167.81	16.39	16.32	2440	90.0	0.413	0.413	12.400	Ethyminou Lloyds Measured	3.65	8.29	13.28	6.06	2.87	5.85	8.37	3.08	8.37	3.08	8.37	3.08
											3.07	7.08	10.92	6.61	1.89	3.91	6.12	1.85	6.12	1.85	6.12	1.85
T3	406.78	407.02	16.39	16.10	2440	90.0	1.000	0.961	12.409	Ethyminou Lloyds Measured	3.20	7.92	11.23	6.95	1.61	3.70	6.47	0.30	5.95	0.29	5.95	0.29
											2.69	6.82	8.25	5.10	2.44	4.23	3.46	3.53	3.46	3.53	3.46	3.53
T5	407.05	273.34	10.19	9.82	2440	90.0	0.672	0.672	19.973	Ethyminou Lloyds Measured	3.37	8.41	10.27	3.26	1.38	5.77	5.15	2.48	5.21	2.50	5.21	2.50
											4.80	17.86	19.97	6.59	3.39	10.84	11.84	2.62	11.84	2.62	11.84	2.62
T7	406.96	168.41	7.86	8.31	2440	90.0	0.414	0.414	25.888	Ethyminou Lloyds Measured	5.47	18.41	29.62	7.25	4.38	12.11	16.53	2.52	16.53	2.52	16.53	2.52
											5.17	15.72	28.06	7.67	2.88	8.87	14.83	1.98	14.83	1.98	14.83	1.98
T9	406.96	406.96	7.86	7.86	2440	90.0	1.000	0.981	25.888	Ethyminou Lloyds Measured	5.69	21.17	33.31	10.20	1.99	7.96	12.55	1.14	12.44	1.16	12.44	1.16
											4.11	16.83	10.84	9.25	2.84	8.58	5.85	2.62	5.85	2.62	5.85	2.62
DT2	406.78	273.09	16.39	15.76	2440	90.0	0.671	0.671	12.409	Ethyminou Lloyds Measured	3.70	10.32	18.97	2.28	2.82	6.42	10.40	2.35	10.40	2.35	10.40	2.35
											2.89	7.65	14.14	1.29	2.23	4.78	9.48	1.45	9.48	1.45	9.48	1.45
DT3	406.78	407.02	16.39	16.10	2440	90.0	1.001	0.961	12.409	Ethyminou Lloyds Measured	3.98	8.08	15.73	2.08	1.81	5.44	10.96	0.06	11.11	0.08	11.11	0.08
											3.20	2.64	4.67	2.36	2.44	1.41	3.08	2.35	3.08	2.35	3.08	2.35
DT4	407.05	168.57	10.19	9.95	2440	90.0	0.414	0.414	19.973	Ethyminou Lloyds Measured	2.88	3.10	4.07	0.78	1.43	2.53	4.31	0.86	4.24	0.86	4.24	0.86
											5.06	12.28	27.99	3.99	3.68	8.54	15.70	2.27	15.70	2.27	15.70	2.27
DT5	407.05	273.34	10.19	9.82	2440	90.0	0.672	0.672	19.973	Ethyminou Lloyds Measured	4.15	11.65	24.19	2.88	2.76	7.38	15.52	1.84	15.52	1.84	15.52	1.84
											5.14	11.81	31.52	4.38	2.64	4.74	13.27	1.07	13.27	1.07	13.27	1.07
DT6	407.05	407.60	10.19	9.61	2440	90.0	1.001	0.976	19.973	Ethyminou Lloyds Measured	6.06	18.20	35.92	4.12	1.97	9.07	19.01	0.08	18.60	0.06	18.60	0.06
											3.59	4.01	7.12	2.78	2.65	2.14	4.24	1.84	4.24	1.84	4.24	1.84
DT8	406.96	273.21	7.86	7.88	2440	90.0	0.671	0.671	25.888	Ethyminou Lloyds Measured	3.10	5.18	8.53	0.61	1.62	2.89	5.24	1.12	5.00	1.18	5.00	1.18
											5.72	22.44	41.26	3.08	3.82	13.15	21.03	1.42	21.03	1.42	21.03	1.42
DT9	406.96	406.96	7.86	7.86	2440	90.0	1.000	0.981	25.888	Ethyminou Lloyds Measured	4.79	21.59	43.92	1.70	1.92	10.46	21.53	0.30	21.70	0.52	21.70	0.52
											4.11	5.70	10.02	3.25	2.84	2.90	5.43	1.42	5.43	1.42	5.43	1.42
											3.46	4.31	7.64	0.42	2.81	3.00	5.58	1.31	5.58	1.31		
											3.47	6.90	10.16	0.72	1.64	2.71	4.45	1.25	4.25	1.26	4.25	1.26

Note 1- Assumed Stress/Strain relationship = 1.2

Table 8-1: Summary of as-welded SCFs



Specimen Ident.	D (mm)	d (mm)	T (mm)	t (mm)	L (mm)	θ (°)	ρ	β (Modified)	γ	τ	α	Source	Chord SCFs						Brace SCFs					
													IPB Crown	OPB Saddle	Comp.		Tens.		IPB Crown	OPB Saddle	Comp.		Tens.	
															Ar-c	Ar-c	Ar-s	Ar-s			Ar-c	Ar-c	Ar-s	Ar-s
T1	406.78	167.81	16.39	16.32	2440	90.0	0.413	0.413	12.400	0.906	12.00	Ethyl/Mean	1.25	1.14	1.18	0.87	1.27	0.94	1.79	1.58	1.29	10.27	1.41	10.70
													Lloyd/Mean	1.05	0.97	0.95	1.05	1.03	1.17	1.06	0.95	6.17	1.03	6.43
T3	406.78	407.02	16.39	16.10	2440	90.0	1.000	0.961	12.400	0.982	12.00	Ethyl/Mean	0.95	0.94	1.44	0.80	1.56	0.81	1.77	0.73	0.67	1.42	0.66	1.41
													Lloyd/Mean	0.80	0.81	1.09	0.72	1.18	0.73	1.17	0.64	0.62	0.63	0.61
T5	407.05	273.34	10.19	9.82	2440	90.0	0.672	0.672	19.973	0.964	11.99	Ethyl/Mean	1.19	1.16	1.32	1.11	1.32	1.11	1.51	1.15	1.08	2.24	1.08	2.24
													Lloyd/Mean	1.10	1.06	0.94	0.64	0.94	0.68	1.86	1.17	0.90	1.98	0.91
T7	406.96	168.41	7.86	8.31	2440	90.0	0.414	0.414	25.888	1.057	11.99	Ethyl/Mean	0.93	0.87	0.89	0.71	0.95	0.76	2.20	1.52	1.32	2.21	1.33	2.17
													Lloyd/Mean	0.96	0.74	0.84	0.75	0.90	0.80	1.44	1.11	1.18	1.74	1.19
T9	406.96	406.96	7.86	7.86	2440	90.0	1.000	0.981	25.888	1.000	11.99	Ethyl/Mean	1.19	1.17	1.06	0.95	1.06	0.95	1.52	1.37	1.11	1.27	1.11	1.27
													Lloyd/Mean	1.28	0.87	0.75	0.99	0.78	1.03	1.69	1.02	0.69	1.00	0.71
DT2	406.78	273.09	16.39	15.76	2440	90.0	0.671	0.671	12.400	0.963	12.00	Ethyl/Mean	0.93	1.28	1.21	1.10	1.19	1.08	1.56	1.18	0.95	39.10	0.94	27.93
													Lloyd/Mean	0.73	0.95	0.90	0.62	0.89	0.61	1.23	0.88	0.87	24.11	0.85
DT3	406.78	407.02	16.39	16.10	2440	90.0	1.001	0.961	12.400	0.982	12.00	Ethyl/Mean	1.28	1.35	1.34	1.77	1.34	1.77	1.26	1.34	1.10	1.62	1.10	1.62
													Lloyd/Mean	1.11	0.85	1.15	3.02	1.15	2.98	1.71	0.56	0.72	2.72	0.73
DT4	407.05	168.57	10.19	9.95	2440	90.0	0.414	0.414	19.973	0.976	11.99	Ethyl/Mean	0.82	0.79	1.03	0.71	1.03	0.70	1.30	0.82	0.82	1.53	0.83	1.53
													Lloyd/Mean	1.35	1.08	1.11	4.26	1.11	4.26	1.32	0.68	0.88	1.78	0.88
DT5	407.05	273.34	10.19	9.82	2440	90.0	0.672	0.672	19.973	0.964	11.99	Ethyl/Mean	0.98	1.04	0.89	0.91	0.89	0.90	1.40	1.18	1.18	2.12	1.16	1.84
													Lloyd/Mean	0.81	0.99	0.77	0.66	0.77	0.65	1.04	1.56	1.17	1.72	1.15
DT6	407.05	407.60	10.19	9.61	2440	90.0	1.001	0.976	19.973	0.943	11.99	Ethyl/Mean	0.79	0.91	0.85	0.66	0.86	0.60	1.72	1.11	0.85	21.93	0.87	30.70
													Lloyd/Mean	0.64	0.78	0.73	0.56	0.74	0.23	1.51	0.96	0.88	17.31	0.90
DT8	406.96	273.21	7.86	7.88	2440	90.0	0.671	0.671	25.888	1.003	11.99	Ethyl/Mean	1.24	1.25	1.26	1.16	1.26	1.16	1.14	0.87	0.97	1.41	0.97	1.41
													Lloyd/Mean	1.19	1.04	0.94	1.81	0.93	1.94	1.99	1.26	0.98	2.82	0.97
DT9	406.96	406.96	7.86	7.86	2440	90.0	1.000	0.981	25.888	1.000	11.99	Ethyl/Mean	0.98	0.96	0.87	0.56	0.86	0.60	1.90	1.23	1.11	2.80	1.11	2.82
													Lloyd/Mean	1.22	1.08	1.08	3.24	1.08	3.24	1.03	1.02	0.88	0.97	0.88
												Ethyl/Mean	1.18	0.83	0.99	4.52	1.00	4.37	1.73	1.07	1.14	1.28	1.13	
												Lloyd/Mean	1.00	0.62	0.75	0.58	0.76	0.56	1.71	1.11	1.25	1.05	1.31	1.04
												Ethyl/Lloyd	1.19	1.32	1.31	7.75	1.31	7.75	1.01	0.97	1.09	0.97	1.09	1.09

Note :- Assumed Stress/Strain relationship = 1.2

Table 8-2: Summary of as-welded SCF statistics



Specimen Ident.	Chord SCFs												Brace SCFs													
	D (mm)	d (mm)	T (mm)	T _c (mm)	t (mm)	L (mm)	θ (°)	β	γ	Y _c		τ	α	Condition	IPB	OPB	Comp.		Tens.	IPB	OPB	Comp.		Tens.		
										AX & OPB	IPB						AX-s	AX-c				AX-s	AX-c		AX-s	AX-c
T1	406.78	167.81	16.39	29.4	16.32	2440	90.0	0.413	12.409	6.92	11.71	0.996	12.00	Predicted Q	2.93	5.20	6.19	6.83	5.53	5.81	1.73	3.28	3.41	1.36	3.87	1.10
														Predicted R	2.83	5.19	6.27	7.05	5.69	5.75	1.60	3.31	3.65	1.30	3.66	1.16
														Measured	2.83	5.26	6.20	7.00	5.64	5.87	1.62	3.28	3.60	1.33	3.68	1.12
T3	406.78	407.02	16.39	29.4	16.10	2440	90.0	1.000	12.409	6.92	11.71	0.982	12.00	Predicted Q	3.17	2.27	0.33	10.79	0.82	11.50	1.55	1.89	1.46	2.96	1.56	2.76
														Predicted R	3.20	2.20	0.36	10.74	0.85	11.20	1.51	1.92	1.54	2.95	1.63	2.76
														Measured	3.10	2.26	0.34	10.68	0.80	11.34	1.52	1.88	1.56	2.89	1.60	2.69
T5	407.05	273.34	10.19	23.6	9.82	2440	90.0	0.672	19.973	8.62	18.36	0.964	11.99	Predicted Q	3.81	6.19	6.45	9.59	5.94	9.17	2.29	4.18	4.44	2.74	4.59	2.01
														Predicted R	3.88	6.22	6.39	9.58	6.32	9.16	2.26	4.24	3.97	2.75	4.37	2.03
														Measured	3.91	6.18	6.32	9.56	6.10	9.13	2.26	4.21	3.95	2.74	4.36	2.03
T7	406.96	168.41	7.86	21.4	8.31	2440	90.0	0.414	25.888	9.49	23.42	1.057	11.99	Predicted Q	3.90	10.07	7.06	6.00	14.05	6.63	2.41	5.90	3.35	1.57	6.12	1.25
														Predicted R	3.81	10.09	6.74	5.90	14.74	6.80	2.39	5.93	3.32	1.56	5.81	1.29
														Measured	3.95	10.21	6.84	5.93	14.50	6.77	2.42	5.88	3.32	1.58	5.93	1.31
T9	406.96	406.96	7.86	21.4	7.86	2440	90.0	1.000	25.888	9.49	23.42	1.000	11.99	Predicted Q	3.02	5.32	3.33	9.77	3.49	8.91	2.11	2.20	3.57	3.11	2.48	2.51
														Predicted R	3.01	5.35	3.25	9.55	3.41	8.82	2.07	2.16	3.07	3.32	2.43	2.41
														Measured	3.05	5.32	3.26	9.60	3.35	8.81	2.09	2.17	3.03	3.24	2.39	2.43
DT2	406.78	273.09	16.39	29.4	15.76	2440	90.0	0.671	12.409	6.92	11.71	0.962	12.00	Predicted Q	2.97	5.21	5.73	3.34	6.00	2.05	2.46	3.93	3.79	0.26	4.64	0.12
														Predicted R	3.28	5.92	5.90	2.94	6.90	2.00	2.52	4.04	3.83	2.07	4.53	0.88
														Measured	3.16	5.32	6.08	3.26	6.20	2.02	2.50	4.03	3.74	2.00	4.51	0.88
DT3	406.78	407.02	16.39	29.4	16.10	2440	90.0	1.001	12.409	6.92	11.71	0.982	12.00	Predicted Q	1.95	3.06	3.75	1.49	4.14	1.11	2.36	2.57	4.05	1.15	3.80	1.00
														Predicted R	1.90	3.17	4.74	1.68	4.48	1.51	2.40	2.56	4.14	1.07	3.48	0.96
														Measured	1.93	3.01	3.86	1.45	4.14	1.02	2.29	2.44	3.89	1.07	3.34	0.96
DT4	407.05	168.57	10.19	23.6	9.95	2440	90.0	0.414	19.973	8.62	18.36	0.976	11.99	Predicted Q	2.91	6.55	3.77	3.26	8.84	2.49	3.53	3.93	2.05	2.56	4.13	1.31
														Predicted R	2.92	6.78	3.95	3.36	8.61	3.21	3.68	4.00	2.03	2.38	3.96	1.24
														Measured	2.94	6.55	3.91	3.12	8.33	2.52	3.58	4.02	2.11	2.39	4.13	1.24
DT5	407.05	273.34	10.19	23.6	9.82	2440	90.0	0.672	19.973	8.62	18.36	0.964	11.99	Predicted Q	3.60	9.26	9.99	6.89	11.15	5.55	2.77	5.20	4.68	0.36	6.32	0.07
														Predicted R	3.06	8.30	9.29	2.32	10.76	1.48	2.77	4.96	4.26	2.14	6.46	0.92
														Measured	3.30	8.59	8.96	1.98	11.59	0.74	2.76	4.90	4.33	2.32	6.36	0.96
DT6	407.05	407.60	10.19	23.6	9.61	2440	90.0	1.001	19.973	8.62	18.36	0.943	11.99	Predicted Q	1.86	4.94	8.22	1.78	6.62	1.11	2.68	2.73	4.95	1.80	3.37	1.11
														Predicted R	1.87	4.83	7.15	1.80	5.94	1.14	2.60	2.69	4.43	1.76	3.92	1.31
														Measured	1.93	5.04	7.61	1.79	6.46	1.31	2.84	2.89	4.80	1.58	3.95	1.28
DT8	406.96	273.21	7.86	21.4	7.88	2440	90.0	0.671	25.888	9.49	23.42	1.003	11.99	Predicted Q	2.28	8.67	9.25	2.94	11.59	2.25	2.78	4.77	3.63	2.10	6.04	0.64
														Predicted R	2.52	9.89	12.27	2.82	14.12	1.87	2.90	5.05	3.84	2.07	6.54	0.74
														Measured	2.35	9.00	8.72	2.86	12.60	2.32	2.76	5.10	3.88	1.93	6.43	0.72
DT9	406.96	406.96	7.86	21.4	7.86	2440	90.0	1.000	25.888	9.49	23.42	1.000	11.99	Predicted Q	1.88	6.35	10.06	2.64	6.82	1.54	2.71	2.39	4.18	2.34	2.10	1.30
														Predicted R	1.89	6.83	9.90	3.25	7.31	1.79	2.78	2.36	4.37	2.03	2.02	1.23
														Measured	1.82	6.42	10.15	2.54	6.84	1.34	2.57	2.29	4.20	2.18	1.98	1.24

Note 1: Assumed Stress/Strain relationship = 1.2

Table 8-3: Summary of grouted SCFs



Specimen Ident.	Chord SCFs										Brace SCFs														
	D (mm)	d (mm)	T (mm)	T ₁ (mm)	t (mm)	L (mm)	θ (°)	β	γ	T _c		α	Condition	IPB	OPB	Comp.		Tens.		IPB	OPB	Comp.		Tens.	
										AX & OPB	IPB					AX-c	AX-s	AX-c	AX-s			AX-c	AX-s	AX-c	AX-s
T1	406.78	167.81	16.39	29.4	16.32	2440	90.0	0.413	12.409	6.92	11.71	12.00	Predicted Q	1.00	0.71	0.55	0.98	0.53	0.91	1.07	0.89	0.53	0.43	0.65	3.82
T3	406.78	407.02	16.39	29.4	16.10	2440	90.0	1.000	12.409	6.92	11.71	12.00	Predicted R	0.78	0.63	0.47	1.16	0.43	0.95	0.56	0.89	0.56	0.43	0.62	3.89
T5	407.05	273.34	10.19	23.6	9.82	2440	90.0	0.672	19.973	8.62	18.36	11.99	Measured	0.94	0.27	0.09	1.05	0.25	1.13	1.12	0.33	0.28	1.19	0.30	1.11
T7	406.96	168.41	7.86	21.4	8.31	2440	90.0	0.414	25.888	9.49	23.42	11.99	Predicted Q	0.87	0.37	0.30	0.93	0.28	0.95	1.26	0.45	0.34	2.07	0.35	1.65
T9	406.96	406.96	7.86	21.4	7.86	2440	90.0	1.000	25.888	9.49	23.42	11.99	Predicted R	0.81	0.35	0.32	1.45	0.32	1.39	0.67	0.39	0.33	1.05	0.37	0.78
DT2	406.78	273.09	16.39	29.4	15.76	2440	90.0	0.671	12.409	6.92	11.71	12.00	Measured	0.90	0.37	0.20	0.93	0.29	0.95	1.24	0.45	0.30	2.07	0.34	1.67
DT3	406.78	407.02	16.39	29.4	16.10	2440	90.0	1.001	12.409	6.92	11.71	12.00	Predicted Q	0.68	0.99	0.92	1.91	1.02	1.40	1.65	1.02	0.94	1.34	0.90	1.15
DT4	407.05	168.57	10.19	23.6	9.95	2440	90.0	0.414	19.973	8.62	18.36	11.99	Predicted R	0.73	0.32	0.30	1.03	0.31	0.95	0.73	0.25	0.53	1.27	0.42	0.92
DT5	407.05	273.34	10.19	23.6	9.82	2440	90.0	0.672	19.973	8.62	18.36	11.99	Measured	0.95	0.27	0.22	1.03	0.24	0.98	1.24	0.26	0.36	1.24	0.29	0.94
DT6	407.05	407.60	10.19	23.6	9.61	2440	90.0	1.001	19.973	8.62	18.36	11.99	Predicted Q	0.74	0.65	0.36	1.61	0.38	0.97	1.36	0.72	0.35	4.34	0.42	1.47
DT8	406.96	273.21	7.86	21.4	7.88	2440	90.0	0.671	25.888	9.49	23.42	11.99	Predicted R	0.89	0.57	0.31	1.29	0.36	0.87	0.89	0.63	0.37	0.88	0.44	0.38
DT9	406.96	406.96	7.86	21.4	7.86	2440	90.0	1.000	25.888	9.49	23.42	11.99	Measured	0.79	0.66	0.39	1.57	0.39	0.95	1.38	0.74	0.34	33.40	0.41	10.43
													Predicted Q	0.68	0.99	0.92	1.91	1.02	1.40	1.65	1.02	0.94	1.34	0.90	1.15
													Measured	0.67	0.97	0.95	1.86	1.02	1.29	1.61	0.96	0.81	1.34	0.46	1.13
													Predicted R	0.57	0.55	0.12	0.74	0.28	0.36	1.34	0.83	0.15	2.39	0.31	1.06
													Measured	0.58	0.55	0.14	0.84	0.31	0.80	1.00	0.47	0.13	1.05	0.25	0.55
													Predicted Q	0.57	0.55	0.12	0.71	0.27	0.57	1.35	0.85	0.16	2.23	0.31	1.00
													Measured	0.59	0.51	0.28	1.67	0.31	1.22	1.41	0.57	0.25	4.24	0.34	1.20
													Predicted R	0.64	0.50	0.30	0.85	0.35	0.55	0.82	0.49	0.26	1.16	0.40	0.50
													Measured	0.54	0.47	0.25	0.48	0.32	0.16	1.40	0.54	0.23	27.57	0.34	16.00
													Predicted Q	0.60	0.95	0.96	2.90	0.83	1.78	1.65	0.94	0.94	1.62	0.67	0.95
													Measured	0.52	1.20	1.00	0.65	0.83	0.41	0.98	1.26	1.05	0.96	0.92	0.71
													Predicted R	0.62	0.97	0.89	2.92	0.81	2.10	1.76	1.00	0.92	1.42	0.79	1.09
													Measured	0.48	0.40	0.21	1.73	0.26	1.42	1.45	0.46	0.17	4.17	0.28	1.23
													Predicted Q	0.44	0.44	0.44	0.30	0.91	0.34	0.61	0.76	0.38	0.18	1.46	0.31
													Measured	0.49	0.42	0.20	1.68	0.28	1.46	1.44	0.49	0.18	3.83	0.30	1.40
													Predicted R	0.54	0.92	0.99	3.67	0.68	2.07	1.65	0.88	0.94	1.88	0.49	1.03
													Measured	0.46	1.20	0.99	1.00	0.73	0.55	0.98	0.81	0.80	1.43	0.37	0.86
													Predicted Q	0.53	0.93	1.00	3.53	0.69	1.81	1.56	0.85	0.94	1.75	0.47	0.98

Note :- Assumed Stress/Strain relationship = 1.2
Predicted Q values based on RFs given by formulations in Tables Q3 and Q4
Predicted R values based on RFs given by formulations in Tables R2 and R3

Table 8-4: Summary of reduction factors



Specimen	PREDICTED														MEASURED		Test/Pred.			
	Moment Capacity (kNm)				Yield strength		α	τ	β	γ	θ	L (mm)	t (mm)	T (mm)	d (mm)	Max. Applied Moment (kNm)	Failure Mode	Predicted Failure Mode	Joint Capacity	At chord face
	IPB	OPB	Brace	Joint ⁽¹⁾	Chord	Brace														
T1	406.78	167.81	16.39	16.32	2440	90.0	0.413	12.409	0.996	12.00	3.76E+05	359	348	149	149	131	122	1.02	0.82	
T3	406.78	407.02	16.39	16.10	2440	90.0	1.001	12.409	0.982	12.00	2.46E+06	359	383	877	877	943	839	1.03	0.96	
T5	407.05	273.34	10.19	9.82	2440	90.0	0.672	19.973	0.964	11.99	6.82E+05	335	284	230	230	194	217	1.08	0.95	
T7	406.96	168.41	7.86	8.31	2440	90.0	0.414	25.888	1.057	11.99	2.13E+05	332	246	67	67	52	51	0.95	0.77	
T9	406.96	406.96	7.86	7.86	2440	90.0	1.000	25.888	1.000	11.99	1.25E+06	332	332	389	389	416	465	1.32	1.20	
DT2	406.78	273.09	16.39	15.76	2440	90.0	0.671	12.409	0.962	12.00	1.04E+06	359	496	395	392	518	370	1.08	0.94	
DT3	406.78	407.02	16.39	16.10	2440	90.0	1.001	12.409	0.982	12.00	2.46E+06	359	383	877	654	943	739	1.24	1.13	
DT4	407.05	168.57	10.19	9.95	2440	90.0	0.414	19.973	0.976	11.99	2.51E+05	335	339	87	87	85	78	1.11	0.89	
DT5	407.05	273.34	10.19	9.82	2440	90.0	0.672	19.973	0.964	11.99	6.82E+05	335	284	230	228	194	232	1.16	1.01	
DT6	407.05	407.60	10.19	9.61	2440	90.0	1.001	19.973	0.943	11.99	1.52E+06	335	363	510	380	553	557	1.30	1.09	
DT8	406.96	273.21	7.86	7.88	2440	90.0	0.671	25.888	1.003	11.99	5.55E+05	332	329	175	174	183	188	1.24	1.08	
DT9	406.96	406.96	7.86	7.86	2440	90.0	1.000	25.888	1.000	11.99	1.25E+06	332	332	389	290	416	365	1.03	0.94	

(1) Reference 1, Formulation from Design Recommendations, MSL Document Reference C11100R223 Rev 0, April 1993
Italics represent those joints which experienced brace failure or reached rig capacity.

$$M = Q_a F_y T^2 d$$

$$\text{For DT OPB ; } Q_a = 1.8 \beta \gamma / (Q_b)^{0.5}$$

$$\text{for } \beta > 0.6 \quad Q_b = 0.3 / (\beta(1 - 0.333\beta))$$

$$\text{for } \beta \leq 0.6 \quad Q_b = 1.0$$

$$\text{Else ; } Q_a = 1.8 \beta \gamma$$

Table 8-5: Summary of ultimate strength tests

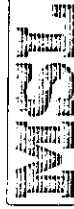

9. CONCLUDING REMARKS

9.1 SCF Determination

9.1.1 As-welded SCF

Results presented in Section 7.3 indicate comparable values between the tension side and compression side SNCFs under in-plane bending and out-of-plane bending load.

This is observed for the chord side and brace side SNCFs and is consistent for both the T-joint specimens and DT-joint specimens.

The results presented in Section 8.2 generally demonstrate good correlation between the measured and predicted as-welded SCFs. The predicted as-welded SCFs were derived using the Efthymiou parametric equations and Lloyd's parametric equations, which were typically to within 15% of the measured as-welded SCFs.

A detailed examination of the results presented in Section 8.2 reveals that the SCF prediction perform better for the chord side locations. The SCF predictions perform equally well for the DT-joint and T-joint specimens. Generally, the chord side as-welded SCF is higher than the brace side as-welded SCF and therefore, the accuracy of predicted as-welded SCFs is more critical for the chord side.

The variation between measured and predicted as-welded SCFs can be attributed to a number of factors. The most likely cause for variation can be assigned to the size and profile of the weld. This is particularly true at the saddle location as may be inferred from the results presented in Section 8.2, for the axial and out-of-plane bending loading conditions.

The Efthymiou equations for the derivation of as-welded SCFs perform well and recognising that these equations represent the most popular and preferred set by the offshore industry, it is recommended that the Efthymiou equations are adopted.

9.1.2 Grouted SCFs

Results presented in Section 7.4 indicate a variation between the tension side and compression side grouted SNCF values under in-plane bending and out-of-plane bending loads. The corresponding as-welded SNCF results show little difference between the tension side and compression side. The variation is attributable to the variation in stiffness, afforded by the presence of grout, between the saddle and crown locations. The results indicate that the highest SNCF variation, i.e. between the tension side and compression side, is dependent on the specimen joint type, on which side is being considered (chord side or brace side) and on the geometric parameters β and γ . For the majority of specimens the side which yields the highest SNCF on the chord is opposite to the side causing the highest SNCF on the brace, i.e. if the compression side SNCF is highest on the chord, then generally the tension side SNCF is highest on the brace. In addition, the trend remains constant, with the exception of Specimen T3, throughout the SNCF measurement/preload regime applied to each specimen, i.e. regardless of load history the dominant SNCF remains on the same side for in-plane and out-of-plane bending.

The results indicate that the presence of grout enhances the stiffness of the chord wall under compressive loading at the crown location. Under in-plane bending and axial load the resultant chord side and brace side SCFs are higher than for the as-welded condition. The stiffness at the saddle location has less effect on SCFs due to the membrane action of the chord wall. Although the crown SCFs increase from the as-welded condition to the grouted condition, the saddle SCFs generally remain dominant for the DT-joint specimens. It is therefore concluded that the grouting of the DT-joint will reduce the dominant SCF and therefore increase fatigue resistance.

The grouted SCFs are similar to the as-welded SCFs at the crown location for the T-joint specimen. Given that the crown SCF is dominant in the grouted condition and in some instances greater than the dominant saddle SCF in the as-welded condition, it is concluded that grouting of the T-joint may reduce fatigue resistance.

This observation is based on the test results obtained for Specimen T3.

9.2 RF Determination

The results presented in Section 8.4 demonstrate good correlation between the measured RFs and those derived using the developed formulations, as presented in Appendix Q and Appendix R.

The developed RF formulations are of general applicability, i.e. the SCF for a grouted joint can be estimated by the product of the predicted RF and an as-welded SCF value obtained from any one of a number of sources. The derivation of RFs using formulations developed in Appendix Q may make use of as-welded SCFs obtained from one of the following sources.

- SCF calculated from a Finite Element analysis of the as-welded joint
- SCF measured from steel specimens
- SCF measured from photoelasticity specimens

The derivation of RFs using formulations developed in Appendix R may make use of as-welded SCFs obtained from the following source:

- SCF calculated from a suitable parametric equation

9.2.1 RF for Application to As-Welded Measured SCFs

The form of the equations for the derivation of RFs to be utilised in determining grouted SCFs using measured as-welded SCFs are presented in Tables 9-1 and 9-2 for chord side and brace side respectively. The tables also contain ranges of validity.

RF = $a_0 + a_1\beta + a_2\gamma + a_3\beta\gamma + a_4\beta^2$ but RF ≥ 0.10						
Joint Type	Load (Position)	a_0	a_1	a_2	a_3	a_4
DT	COMP (Saddle)	1.46	-3.1	-0.045	0.05	2.5
	COMP (Crown)*	4.10	-4.0	-0.240	0.37	0.2
	TENS (Saddle)	0.43	-1.6	0.025	-0.05	2.5
	TENS (Crown)*	-0.92	3.2	0	0.05	-1.5
	IPB (Crown)	1.28	-0.33	-0.040	0.03	-0.15
	OPB (Saddle)	2.25	-3.8	-0.045	0.04	2.6
T	COMP (Saddle)	1.37	-1.1	-0.05	0.06	-0.3
	COMP (Crown)	1.35	0.2	-0.05	0.05	-0.5
	TENS (Saddle)	1.35	-2.3	-0.01	0.01	1.2
	TENS (Crown)	0.75	1.1	-0.02	0.01	-0.6
	IPB (Crown)	1.54	-0.6	-0.04	0.04	0
	OPB (Saddle)	1.77	-2.4	-0.03	0.03	0.9
Ranges of validity: $0.4 \leq \beta \leq 1.0$, $12 \leq \gamma \leq 26$, $\tau \approx 1.0$, $\theta = 90^\circ$						

* Unduly conservative RF may be predicted at crown position for axially loaded DT joints.

Table 9-1: Recommended formulations for reduction factors on chord side

RF = $a_0 + a_1\beta + a_2\gamma + a_3\beta\gamma + a_4\beta^2 + a_5\gamma^2$ but RF ≥ 0.10							
Joint Type	Load (Position)	a_0	a_1	a_2	a_3	a_4	a_5
DT	COMP (Saddle)	1.64	-3.7	-0.04	0.04	3.0	0
	COMP (Crown)*	-5.36	32.0	-0.12	0.16	-25.8	0
	TENS (Saddle)	0.07	-0.30	0.03	-0.06	1.5	0
	TENS (Crown)*	2.0	2.5	-0.15	0.26	-2.27	0.003
	IPB (Crown)	1.05	-0.21	0.02	-0.02	0.8	0
	OPB (Saddle)	3.04	-5.5	-0.04	0.03	3.6	0
T	COMP (Saddle)	1.36	-1.6	-0.04	0.05	0.4	0
	COMP (Crown)	11.84	-10.6	-0.40	0.04	-0.05	0
	TENS (Saddle)	1.6	-2.4	-0.02	0.02	1.1	0
	TENS (Crown)	10.33	-10.0	-0.34	0.33	0.9	0
	IPB (Crown)	0.5	1.5	0.01	0	-1.0	0
	OPB (Saddle)	2.09	-3.2	-0.015	0.01	1.5	0
Ranges of validity: $0.4 \leq \beta \leq 1.0$, $12 \leq \gamma \leq 26$, $\tau \approx 1.0$, $\theta = 90^\circ$							

* Non-conservative RF may be predicted at crown position for axially loaded DT joints.

Table 9-2: Recommended formulations for reduction factors on brace side

9.2.2 RF for Application to As-Welded Efthymiou SCFs

The form of the equations for the derivation of RFs to be utilised in determining grouted SCFs are presented in Tables 9-3 and 9-4 for chord side and brace side respectively. The resultant RFs are applicable to grouted SCFs derived using Efthymiou parametric equations. The tables contain ranges of validity.

RF = $a_0 + a_1\beta + a_2\gamma + a_3\beta\gamma + a_4\beta^2 + a_5\gamma^2$ but RF ≥ 0.10							
Joint Type	Load (Position)	a_0	a_1	a_2	a_3	a_4	a_5
DT	COMP (Saddle)	0.57	-2.08	0.001	-0.003	2.55	0
	COMP (Crown)	4.9	-1.7	-0.32	0.15	-1.15	0.005
	TENS (Saddle)	0.25	-1.28	0.03	-0.047	2.2	0
	TENS (Crown)	3.9	-2.9	-0.2	0.04	1.01	0.004
	IPB (Crown)	1.8	-0.08	-0.08	0.07	-1	0
	OPB (Saddle)	2.35	-5.15	-0.03	0.03	4	0
T	COMP (Saddle)	1.07	-0.68	-0.043	0.06	-0.53	0
	COMP (Crown)	-0.55	6.9	-0.03	0.01	-4.8	0
	TENS (Saddle)	0.87	-1.49	0.001	0.01	0.65	0
	TENS (Crown)	-1.37	7.4	0.02	-0.05	-4.3	0
	IPB (Crown)	0.45	1.5	-0.01	-0.01	-0.7	0
	OPB (Saddle)	1.56	-2.62	-0.012	0.015	1.3	0
Ranges of validity: $0.4 \leq \beta \leq 1.0$, $12 \leq \gamma \leq 26$, $\tau \approx 1.0$, $\theta = 90^\circ$							

Table 9-3: Recommended formulations for reduction factors on chord side

RF = $a_0 + a_1\beta + a_2\gamma + a_3\beta\gamma + a_4\beta^2 + a_5\gamma^2 + a_6\beta^3\gamma^3$ but RF ≥ 0.10								
Joint Type	Load Position	a_0	a_1	a_2	a_3	a_4	a_5	a_6
DT	COMP (Saddle)	-0.01	-1.3	0.04	-0.08	3.15	0	0
	COMP (Crown)	1.1	0.56	-0.056	0.09	-1.78	0.001	0
	TENS (Saddle)	1.92	-4.4	-0.08	0.1	3.4	0.001	-0.001
	TENS (Crown)	1.37	-3.09	0.002	0.07	1.39	-0.001	0
	IPB (Crown)	2.45	-3.5	-0.03	0.03	2.03	0	0
	OPB (Saddle)	-0.43	-0.64	0.096	-0.17	3.8	0	0
T	COMP (Saddle)	1.25	-1.64	-0.036	0.04	0.8	0	0
	COMP (Crown)	-1.26	5.0	0.002	0.03	-3.3	0	0
	TENS (Saddle)	0.72	-0.7	-0.008	0.004	0.5	0	0
	TENS (Crown)	2.86	-2.9	-0.09	0.1	0.7	0	0
	IPB (Crown)	0.31	0.91	-0.007	0.015	-0.7	0	0
	OPB (Saddle)	0.88	-0.84	0.001	-0.016	0.6	0	0
Ranges of validity: $0.4 \leq \beta \leq 1.0$, $12 \leq \gamma \leq 26$, $\tau \approx 1.0$, $\theta = 90^\circ$								

Table 9-4: Recommended formulations for reduction factors on brace side

9.3 Ultimate Strength Determination

The results presented in Section 8.5 demonstrate good correlation between the measured and predicted ultimate joint capacity.

The following equation is essentially that derived in Design Recommendations⁽¹⁵⁾. An allowance for the presence of axial and moment loads in the chord has been removed as this is beyond the scope of work for this project. A minimum grout strength of 41.4 Nmm² at 28 days must be achieved as the strength of grout affects the strength of a grouted joint. The following equation is based on a mean prediction rather than a characteristic prediction as used in the comparison between predicted and measured ultimate joint capacities presented in Table 7-10, Appendix S.

The moment capacity of a grouted joint subjected to unidirectional loading may be derived as follows:

$$M_i, M_o = Q_u \frac{F_y T^2 d}{\sin \theta} \quad \dots 9.3.1$$

M_i = strength for brace in-plane moment load

M_o = strength for brace out-of-plane moment load

F_y = characteristic yield stress of the chord member at the joint (or 0.7 times the characteristic tensile strength if less). If characteristic values are not available specified minimum values may be substituted.

T = chord wall thickness

d = brace diameter.

θ = brace/joint intersect angle

Q_u is a strength factor which varies with the joint and load type. Q_u is defined in Table 9-5.

Load Direction	Joint Configuration	
	T	DT
In-plane bending	$1.5 \beta \gamma$	$1.5 \beta \gamma$
Out-of-plane bending	$1.5 \beta \gamma$	$1.5 \beta \gamma / \sqrt{Q_\beta}$
Notes:		
	$Q_\beta = 1.0$	for $\beta \leq 0.6$
	$= 0.3/\beta(1 - 0.833\beta)$	for $\beta > 0.6$

Table 9-5: Q_u factor for grouted joints

ACKNOWLEDGEMENTS

This document has been prepared by MSL Engineering Limited for seven sponsoring organisations:

British Gas plc

Chevron U.K. Limited

Exxon Production Research Company

Health and Safety Executive (HSE)

Mineral Management Service (MMS)

Mobil North Sea Limited

Shell U.K. Exploration and Production

A project steering committee including representatives of the sponsoring organisations oversaw the work and contributed to the development of this document. During the life of the project the following individuals served on the committee:

Dr J Buitrago

Mr D Choat

Dr A F Dier

Mr R J van Foeken

Mr D Galbraith (chairman)

Mr S Igbenabor

Mr M Lalani

Mr V Kasparian

Mr C de Koning

Dr J Mitchell

Mr D J Morahan

Dr J V Sharp

Dr C E Smith

Mr T Turner

The Project Manager at MSL Engineering was Mr D J Morahan who carried out the work with guidance and support from Mr M Lalani and Dr A F Dier and technical assistance from a number of MSL Engineering staff. The Manager at TNO, where all the testing was conducted, was R J van Foeken and he was assisted by a number of technicians.

The recommendations presented in this document are based upon the knowledge available at the time of publication. However, no responsibility of any kind for injury, death, loss, damaged or delay however caused, resulting from the use of the recommendations can be accepted by MSL Engineering or others with its preparation.

REFERENCES

- [1] American Petroleum Institute. 'Recommended Practice for Planning, Designing and Constructing Fixed Offshore Platforms'. API RP2A, Twentieth Edition, July 1993.
- [2] Health and Safety Executive. 'Offshore Installations: Guidance on Design and Construction'. Fourth Edition HMSO, London 1990.
- [3] Norwegian Petroleum Institute. 'Acts, Regulations and Provisions for the Petroleum Activities'. Volumes 1 and 2, ISBN 82-7257-369-5, updated annually.
- [4] Det norske Veritas. 'Rules for Classification of Fixed Offshore Installations'. DNV Rules, Parts 1 to 5, July 1991.
- [5] Lloyds Register of Shipping. 'Fatigue Analysis of Fixed Steel Platform Tubular Joints'. Fatigue Appendix, Issue 5, July 1980.
- [6] Tebbett I E. 'The Reappraisal of Steel Jacket Structures Allowing for the Composite Action of Grouted Piles'. Paper OTC 4194 of Offshore Technology Conference, Texas, May 1982.
- [7] Tebbett IE et al. 'The Punching Shear Strength of Tubular Joints Reinforced with a Grouted Pile'. Paper OTC 3463 of Offshore Technology Conference, Texas, May 1979.
- [8] Lalani M et al. 'Justification of Enhanced Capacities for As-welded and Grouted K-joints'. Paper OTC 5025 of Offshore Technology Conference, Texas, May 1985.
- [9] Wimpey Laboratories Limited. 'Occidental of Britain Inc. Piper and Claymore Node Tests - Results of Static Tests on X Nodes'. Report No ST 71/80, September 1980.
- [10] Wimpey Laboratories Limited. 'Occidental of Britain Inc. Piper and Claymore Node Tests - Results of Static Tests on T Nodes'. Report No ST 91/80, October 1980.
- [11] Marshall PW. 'Interpretive Report on Grouted K-joints'. Shell Oil Company, October 1977.
- [12] Brown GM et al. 'Improving Structural Integrity by Injection of grout into fatigue-critical nodes in offshore structures'. Paper OTC 5984 of Offshore Technology Conference, Texas, May 1989.
- [13] ANSI/AWS D1.1-90 Structural Welding Code - Steel

- [14] R.S. Puthli, J. Wardenier, C.H.M. de Koning, A.M. van Wingerde and F.J. van Dooren. 'Numerical and experimental determination of strain (stress) concentration factors of welded joints between square hollow section'. Heron, Vol. 33 no. 2 (1988)
- [15] Efthymiou M. 'Development of SCF formulae and generalised influence functions for use in fatigue analysis'. OTJ '88, Surrey, October 1988, plus updates.
- [16] Formulation from Design Recommendations, MSL Document Reference C11100R223, Rev 0, April 1993.

APPENDIX A
Welded Procedure and Weld Shapes

C14100R020 Rev 1 February 1997

MSL

APPENDIX A

Welding Procedures and Weld Shapes

Table of Contents

Appendix A 1 Welding Procedure.....	2
Appendix A 2 Weld Shape Specimen DT2.....	7-8
Appendix A 3 Weld Shape Specimen DT3.....	9-10
Appendix A 4 Weld Shape Specimen DT4.....	11-12
Appendix A 5 Weld Shape Specimen DT5.....	13-14
Appendix A 6 Weld Shape Specimen DT6.....	15-16
Appendix A 7 Weld Shape Specimen DT8.....	17-18
Appendix A 8 Weld Shape Specimen DT9.....	19-20
Appendix A 9 Weld Shape Specimen T1.....	21
Appendix A 10 Weld Shape Specimen T3.....	22
Appendix A 11 Weld Shape Specimen T5.....	23
Appendix A 12 Weld Shape Specimen T7.....	24
Appendix A 13 Weld Shape Specimen T9.....	25

Welding Procedure

The weld shape locations are presented in the following Figure A.1.

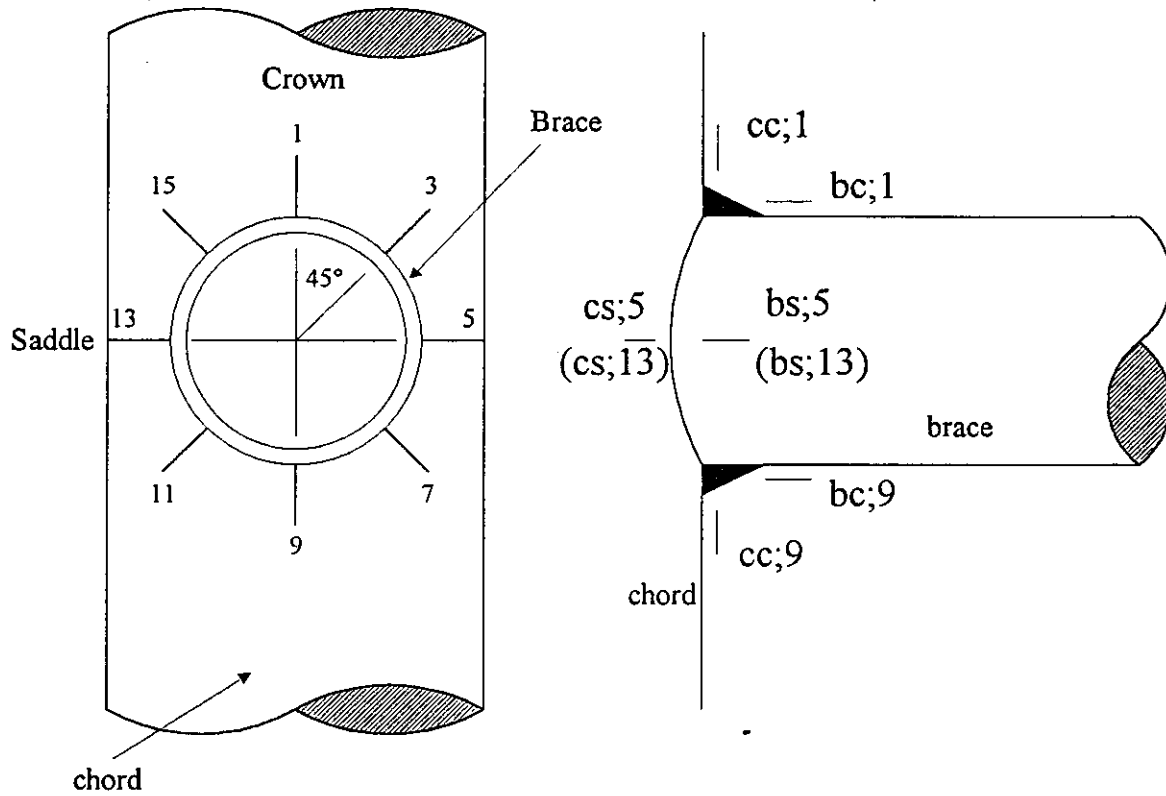

Note: Weld shapes measured at 45° intervals around joint intersect

Figure A.1: Location of weld shapes



Lasmethode beschrijving
welding procedure specification

wps nr.: **250**
rev nr.: **1**
geschr. (prep. by):
C.W.R. Hoogenboom

kiant (client):
TNO BOUW DELFT

inspectie (rep. by):

HSM ordernr.:
21227

toepassing (scope): **Welding of testpieces T7-T9/DT8-DT9**
Grouted tubular joint technology for strengthening/repair

tekening nr.:
-

basismateriaal (base material)	1	Fe 360 or equal		CE -	afm. (dim.): O.D. 406.4 / Wt 7.9-16		
	2	Fe 360 or equal		CE -	afm. (dim.): O.D. ≥ 168.3 / Wt 8		
lasproces (welding process)	grondslag (root)		vulslag (filling pass)	tegenlas (backwelding)	oplassen (overlay welding)		
	gl:	SMAW	vt:	SMAW	tl:	NA	ot:
laspositie (welding position)	2G/TKY		hechten (backwelding): As per tackweld procedure		proces (process)	min. temp.	
					hl:	NA	T > 0°C
warmtebehandeling (heat treatment)	voorwarm temperatuur (pre-heating temp.): As per AWS D1.1; App. XI			temp. tijdens lassen (interp. temp.): 250°C		nawarm temp. (soaking temp.): NA	
	voorwarmdetails (pre-heating details): NA			isolatie (insulation): NO		nawarmtijd (soaking time): NA	
gloeien (postweld heatr.)	NA				gloeïinstr. (heatr. instr.): NA		

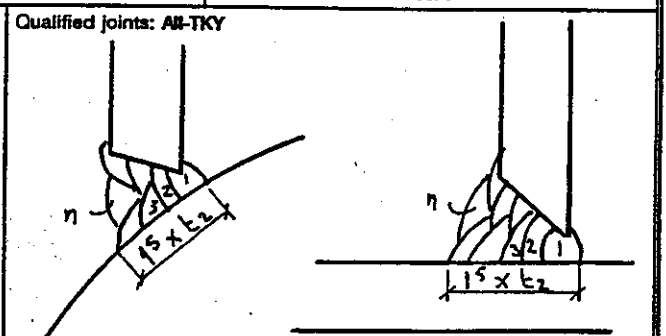
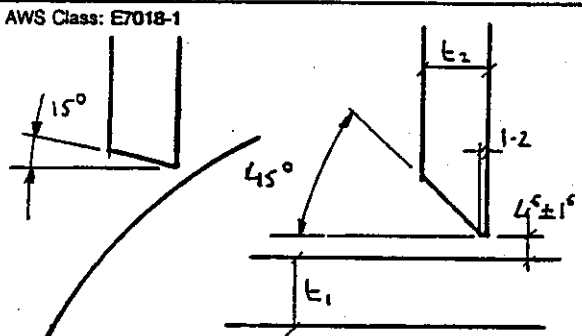

Lasnaadvorm:
(edge preparation) As per AWS D1.1; Section 10

Lasvolgorde:
(bead sequence / welding sequence nrs.)

lasvolgorde (bead- or welding seq. nrs.)	bestrif (appl. to)	lasvoorg- materiaal (filler- material)	afm. (dim.)	schuifgas/poeder (shielding gas/filler)	stroom (current)			voltage	Gas l/min.	HL kJ/mm.	WTS mm/min. - PCL/mm.
					=/~ (dc/ac)	+/-	ampérage				
1	Root	Safety 58	3.18	-	AC		85-100	24	-	1.8 / 2.6	80 - 80
2	Fill	Safety 58	3.18	-	AC		80 - 110	24	-	1.2 / 2.0	85 - 120
3 - n	Fill/cap	Safety 58	4.0	-	AC		100 - 175	24	-	1.4 / 1.8	185 - 200

bewerking laskanten (prepared weldedges):
Flame-cutting and grinding

bewerking tegenlas (treatment of root):
NA

opmerking (remarks):
Weld area shall be dry and free of scale, rust etc.

link rapport nr. (pqr. nr.):
NA
serial nr.:
AWS D1.1 '94
volgens (acc.):

geldigheidsgebied link (validity range proc. qualification):
afm. (dim.):
A8
positie (pos.):
A8/TKY

isoverificaties volgens:
(welder performance qual. ecc.)
ASME IX and AWS D1.1

inspectie: (inspection)	ic	QC 1	100%	mt/pt	100%	others:	Visual
datum: (date)	appr. QA dept. HSM:	27.02.95		appr. customer:		appr. insp. auth.:	





Lasmethode beschrijving
welding procedure specification

wps nr.: **150**
rev nr.: **1**
geschr. (prep. by):
C.W.R. Hoogenboom

klient (client):
TNO BOUW DELFT

inspectie (insp. by):

HSM ordernr.:
21227

toepassing (scope): **Welding of testpieces T1-T3-T5/DT2-DT3-DT4-DT5-DT6**
Grouted tubular joint technology for strengthening/repair

tekening nr.:
-

basismateriaal (base material)	1	Fe 360 or equal	CE -	afm. (dim.): O.D. 406.4 / Wt 7.9-16			
	2	Fe 510 or equal	CE ≤ 0.43	afm. (dim.): O.D. ≥ 168.3 / Wt 7.9-16			
lasproces (welding process)	grondlaag (root)		vullag (filling pass)	tegenlas (backwelding)	oplassen (overlay welding)		
	gl:	SMAW	vl:	SMAW	tl:	NA	cl:
laspositie (welding position)	2G/TWY	hechten (tackwelding): As per tackweld procedure		process (process)	min. temp.		
				ht:	NA	T > 0°C	
warmtebehandeling (heat treatment)	voorwarm temperatuur (pre-heating temp.): As per AWS D1.1; App. XI		temp. tijdens lassen (interp. temp.): 250°C		nawarm temp. (soaking temp.): NA		
	voorwarmdetails (pre-heating details): NA		isolatie (insulation): NO		nawarmtijd (soaking time): NA		
gloeien (postweld heattr.)	NA				gloeinstr. (heattr. instr.): NA		

AWS Class: **E7018-G**

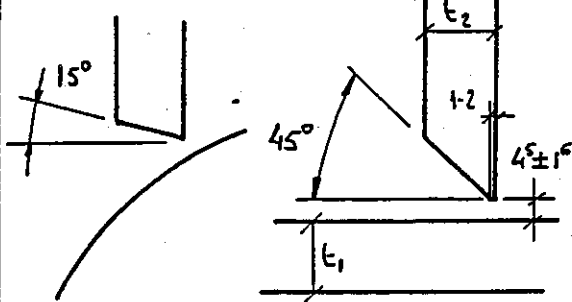

Qualified joints: **All-TKY**

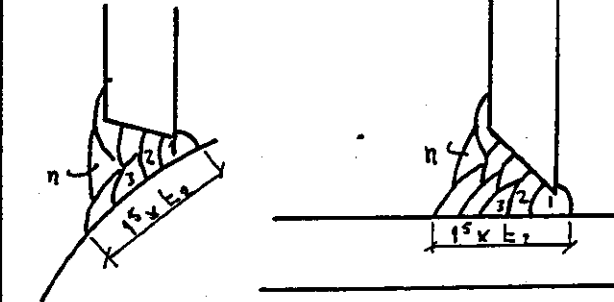

Lasnaadvorm:
(edge preparation) **As per AWS D1.1; Section 10**

Lasvolgorde:
(bead sequence / welding sequence nrs.)

lasvolgorde (bead- or welding seq- nrs.)	betreff (appl. to)	lasvoeg- materiaal (filler- material)	afm. (dim)	schuifgas/poeder (shielding gas/flux)	stroom (current)			voltage	Gas V/min.	FL K./mm.	WTS mm/min. - FCL/mm.
					-/+ (dc/ac)	+/-	amp/age				
1	Root	KRYO 1	3.0	-	AC		85-100	24	-	1.8 / 2.6	80 - 80
2	Fill	KRYO 1	3.0	-	AC		80 - 110	24	-	1.2 / 2.0	80 - 120
3 - n	Fill/cap	KRYO 1	4.0	-	AC		185 - 175	24	-	1.4 / 1.8	185 - 200

bewerking laskanten (prep weldedges):
Flame-cutting and grinding

bewerking tegenlas (treatment of root):
NA

opmerking (remarks):
Weld area shall be dry and free of scale, rust etc.

limt rapport nr. (per. nr.):
NA
serial nr.:
AWS D1.1 '94
volgens (acc.):

geldigheidsgebied limt (validity range proc. qualification):
afm. (dim.):
All
posities (pos.):
All/TKY

lasser/welificatie volgens:
(welder performance qual. acc.)
ASME IX and AWS D1.1

inspectie: (inspection)	ic:	uc:	mt/pt:	others:
		QC 12 100%	100%	Visual
datum: (date)	appr. QA dept. HSM:	appr. customer:	appr. insp. auth.:	
	23.02.95			





Lasmethode beschrijving
welding procedure specification

wps nr.: **106**
rev nr.: **0**
geschr. (prep. by):
C.W.R. Hoogenboom

klant (client):
TNO BOUW DELFT

inspectie (rep. by):

HSM ordernr.:
21227

toepassing (scope):
Testpieces; Welding of end-plates
Grouted tubular joint technology for strengthening/repair

tekening nr.:
-

basismateriaal (base material)	1	Fe 360 / Fe 510 or equal		CE ≤ 0.43	afm. (dim.): O.D. ≥ 168.3 / Wt 7.9-16		
	2	Fe 510 or equal		CE ≤ 0.43	afm. (dim.): Wt 30 - 100		
lasproces (welding process)	grondlaag (root)		vulslag (filling pass)	legering (backwelding)	oplassen (overlay welding)		
	gi:	SMAW	vt:	SMAW	tt:	NA	ot:
laspositie (welding position)	All	hechten (ackwelding): As per tackweld procedure			proces (process)	min. temp.	
					ht:	NA	T > 0°C
warmtebehandeling (heat treatment)	voorwarm temperatuur (pre-heating temp.): As per AWS D1.1; App. XI			temp. tijdens lassen (temp. temp): 250°C	nawarm temp. (soaking temp.): NA		
	voorwarmdetails (pre-heating details): NA			isolatie (insulation): NO	nawarmtijd (soaking time): NA		
gloeien (postweld heatr.)	NA				gloeifinstr. (heatr. instr.): NA		

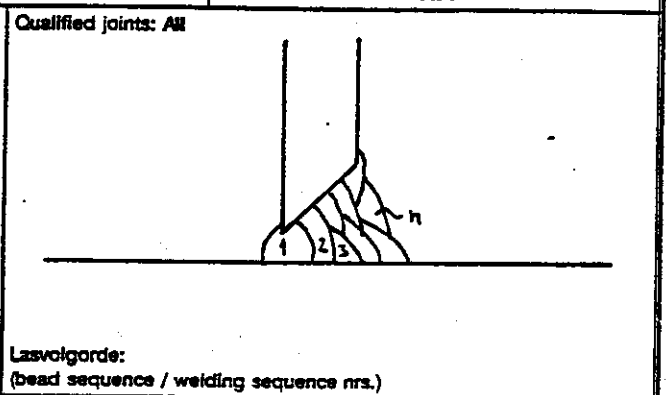
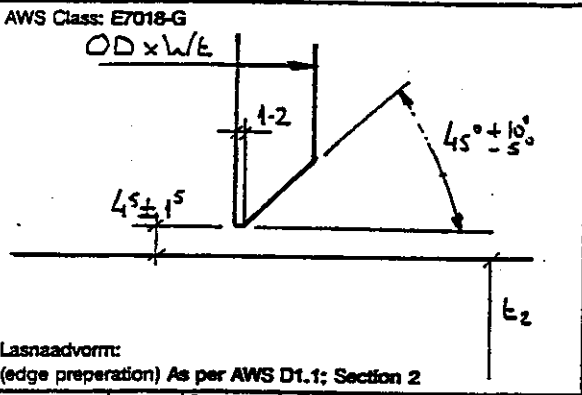

lasvolgorde (bead- or welding seq.- nrs.)	betrof (appl. to)	lasvulling- materiaal (filler- material)	afm. (dim)	schutgas/poeder (shielding gas/flux)	stroom (current)			voltage	Gas l/min.	H _e KJ/mm.	WTS mm/min. - FOL/mm.
					-/+ (dc/ac)	+/-	amplitude				
1	Root	KRYO 1	3.0	-	AC		85-100	24	-	1.8 / 2.0	80 - 80
2	Fill	KRYO 1	3.0	-	AC		90 - 110	24	-	1.2 / 2.0	85 - 120
3 - n	FWcap	KRYO 1	4.0	-	AC		125 - 175	24	-	1.4 / 1.8	165 - 200

bewerking lastanten (prepared welded joint):
Flame-cutting and grinding

bewerking legering (treatment of root):
NA

opmerking (remarks):
Weld area shall be dry and free of scale, rust etc.

test rapport nr. (por. nr.):
NA

serial nr.:
AWS D1.1 '94

volgens (acc.):

geldigheidsgebied test (validity range proc. qualification):
afm. (dim.):
All
positie (pos.):
All

testresultaten volgens:
(welder performance qual. acc.):
ASME IX and AWS D1.1

inspectie (inspection):

ic: -

uc: **QC 1**

100%

nr/pc: **100%**

others: **Visual**

appr. customer:

appr. insp. auth.:

datum (date):
14.02.95

QC 1
MSL



		Lasmethode beschrijving welding procedure specification		wps nr.: 060							
				rev nr.: 0							
klant (client): TNO BOUW DELFT		inspectie (insp. by): -		geschr. (prep. by): C.W.R. Hoogenboom							
toepassing (scope): Welding of Testpieces; Tackwelding Grouted tubular joint technology for strengthening/repair				HSM ordernr.: 21227							
toepassing (scope):				tekening nr.: -							
basismateriaal (base material)	1	Fe 360 / Fe 510 or equal	CE ≤ 0.43	afm. (dim.): AII							
	2	Fe 360 / Fe 510 or equal	CE ≤ 0.43	afm. (dim.): AII							
lasproces (welding process)	grondslag (root)		vulling (filling pass)	legaties (backwelding)	oplassen (overlay welding)						
	gt:	AII	vt: NA	dt: NA	ot: NA						
laspositie (welding position)	AII		hechten (backwelding): -		proces (process)						
			hl: NA		min. temp.						
warmtebehandeling (heat treatment)	voorwarm temperatuur (pre-heating temp.): T °C		temp. tijdens lassen (inter.temp.):		nawarm temp. (soaking temp.): NA						
	voorwarmdetails (pre-heating details): GASBURNER		isolatie (insulation): -		nawarmtijd (soaking time): NA						
gloeien (postweld heat.)	NA			gloeïnstr. (heat. instr.): NA							
AWS Class: NA			Qualified joints: -								
Lasnaadvorm: (edge preparation) -			Lasvolgorde: (bead sequence / welding sequence nrs.)								
lasvolgorde (bead- or welding seq- nrs.)	betreff. (appl. to)	lastoeweg- materiaal (filler material)	afm. (dim.)	schutgas/poeder (shielding-gas/fill)	stroom (current)			voltage	Gas l/min.	HL KJ/mm.	WTS mm/min - FOL/mm.
					-/+ (defect)	+/-	amperage				
1	Tack	LM4 28	1.0	85Ar-15CO ₂	DC	+	± 220	22 - 24	± 15	-	-
2	Tack	Sulfurd 200	1.2	85Ar-15CO ₂	DC	+	200 - 230	± 28	± 15	-	-
3	Tack	DWABSL	1.2	85Ar-15CO ₂	DC	+	200 - 230	± 28	± 15	-	-
4	Tack	KRYO 1	4.0	-	AC	-	140 - 180	24 - 28	-	-	-
<ul style="list-style-type: none"> - T₀ = preheat-temperature as per WPS. - T = 50°C minimum or T = T₀ + 50°C. - Minimum tack-weld length; l = 50mm. - Minimum weld-size; a = 4mm. 											
opmerking (remarks): Weld area shall be dry and free of scale, rust etc.											
link rapport nr. (pr. nr.): NA			geldigheidsgebied link (validity range proc. qualification):			lasoperatorificaties volgens: (welder performance qual. acc.)			ASME IX and AWS D1.1		
serial nr.: AWS D1.1 '94			afm. (dim.): AII			positie (pos.): AII					
volgens (acc.):											
inspectie (inspection)	ic:	OC 1		uc:	mt/pt:	others: Visual					
datum: (date)	appr. GA dept. HSM:		appr. customer:		appr. insp. auth.:						
	14.02.2015										

WELD SHAPE SPECIMEN DT2

Intersection between Chord and Brace 1 of DT2

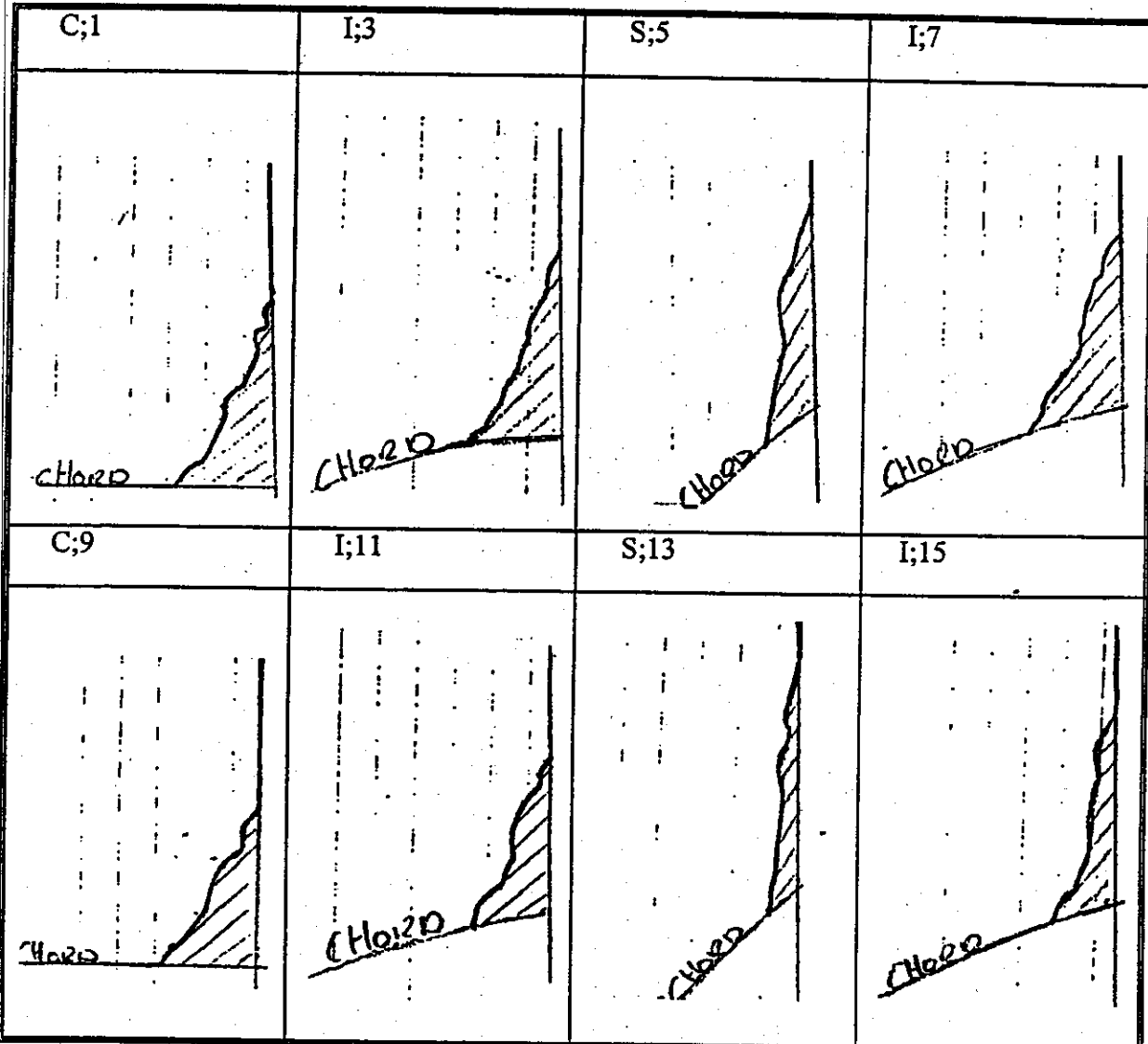

Key :-

- I - Intermediate weld position
- C - Crown weld position
- S - Saddle weld position

Refer to Figure A.1 for corresponding numbered weld shape locations.

Weld shape dimensions [mm]

Weld leg length	C,1	I,3	S,5	I,7	C,9	I,11	S,13	I,15
L_{brace}	25.8	26.2	28.3	24.2	21.8	21.7	32.7	26.7
L_{chord}	13.8	12.7	9.0	13.5	13.4	10.6	5.2	9.4

WELD SHAPE SPECIMEN DT2

Intersection between Chord and Brace 2 of DT2

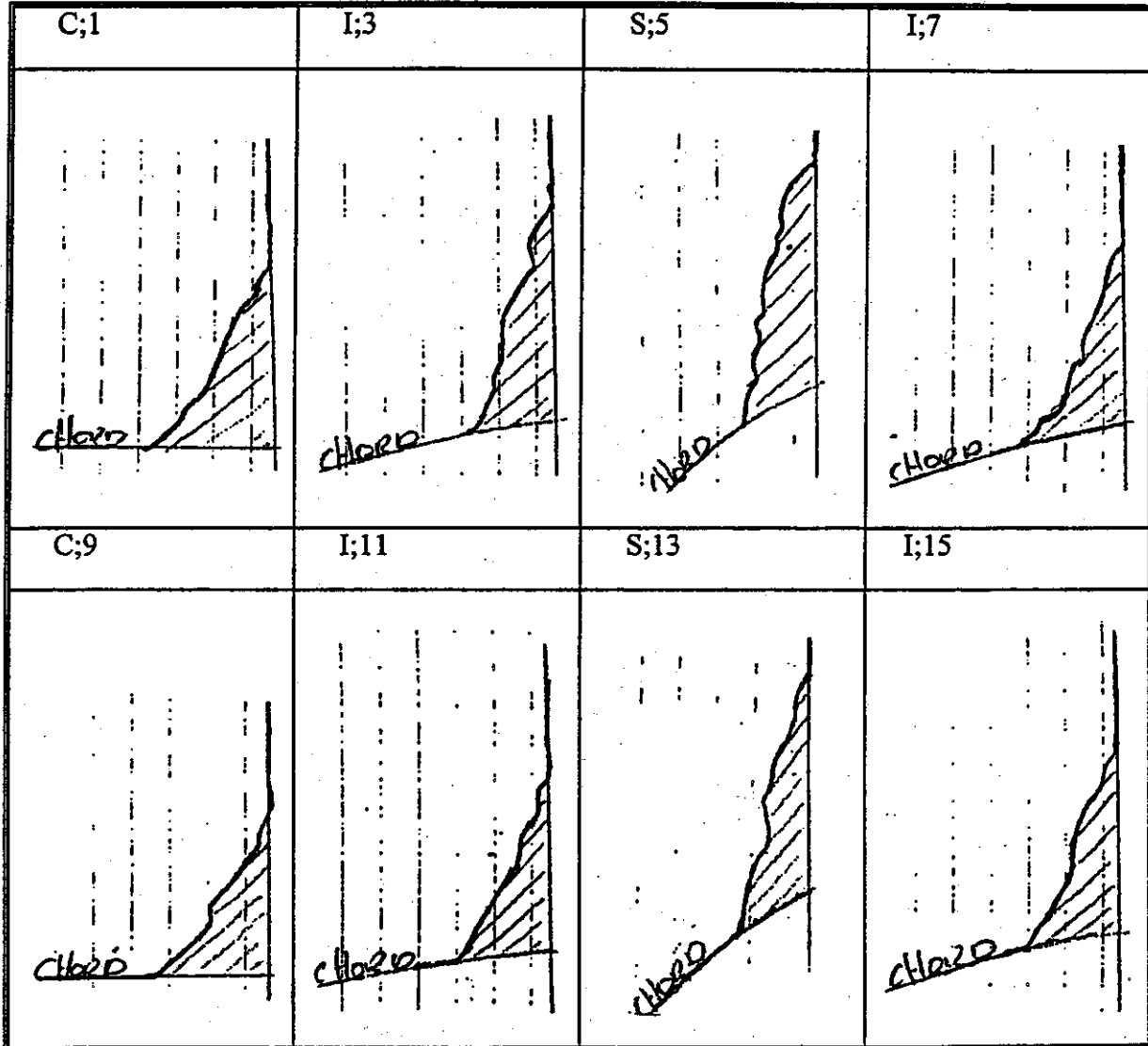

Key :-

- I - Intermediate weld position
- C - Crown weld position
- S - Saddle weld position

Refer to Figure A.1 for corresponding numbered weld shape locations.

Weld shape dimensions [mm]

Weld leg length	C,1	I,3	S,5	I,7	C,9	I,11	S,13	I,15
L_{brace}	26.2	29.6	30.7	24.7	22.2	25.0	30.7	26.4
L_{chord}	17.2	12.3	11.6	15.3	15.9	13.5	11.6	13.5

WELD SHAPE SPECIMEN DT3

Intersection between Chord and Brace 1 of DT3

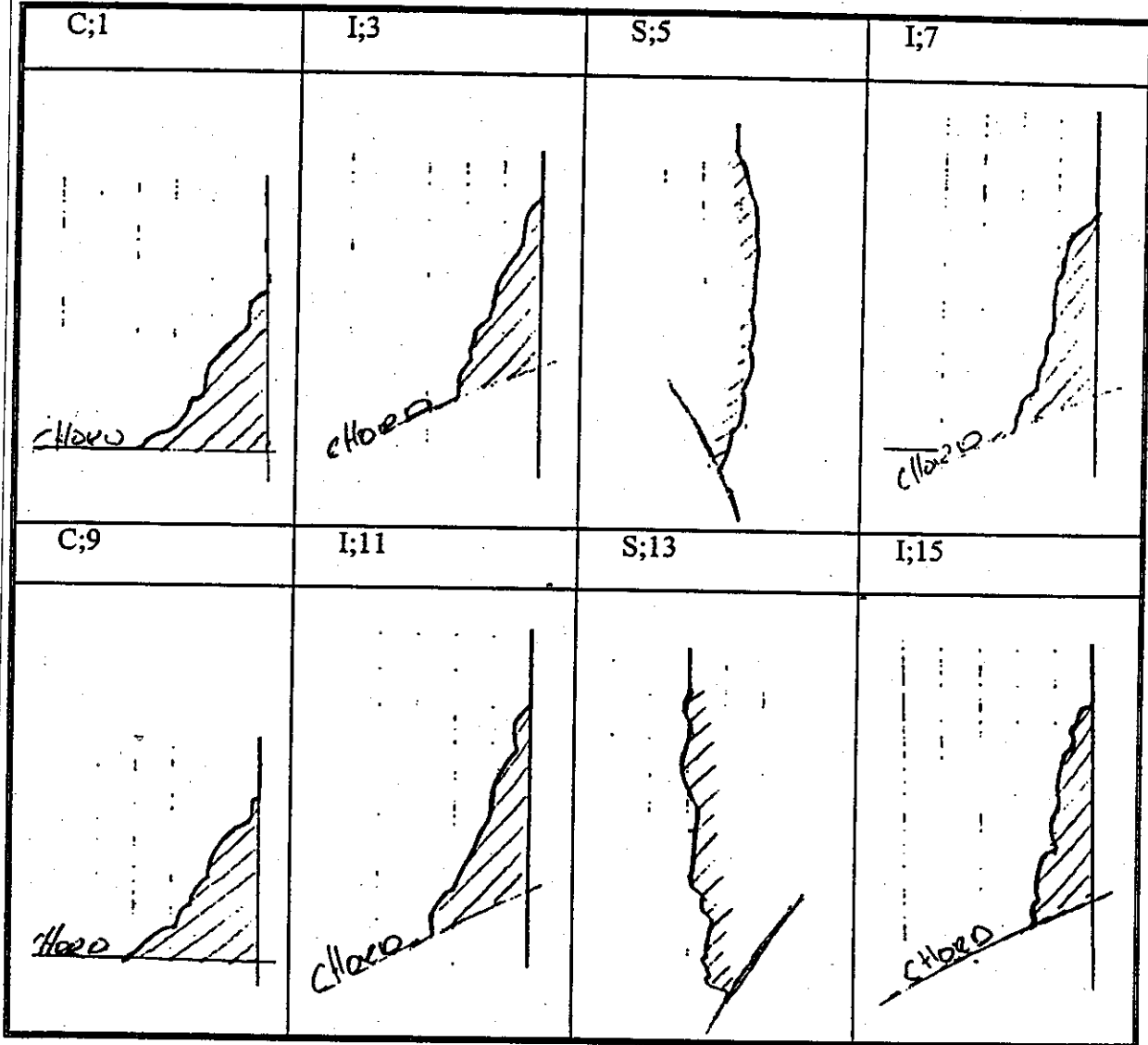

Key :-

- I - Intermediate weld position
- C - Crown weld position
- S - Saddle weld position

Refer to Figure A.1 for corresponding numbered weld shape locations.

Weld shape dimensions [mm]

Weld leg length	C,1	I,3	S,5	I,7	C,9	I,11	S,13	I,15
L_{brace}	22.7	23.4		25.7	23.4	27.8		26.4
L_{chord}	17.9	12.4		12.8	18.4	9.8		14.9

WELD SHAPE SPECIMEN DT3

Intersection between Chord and Brace 2 of DT3

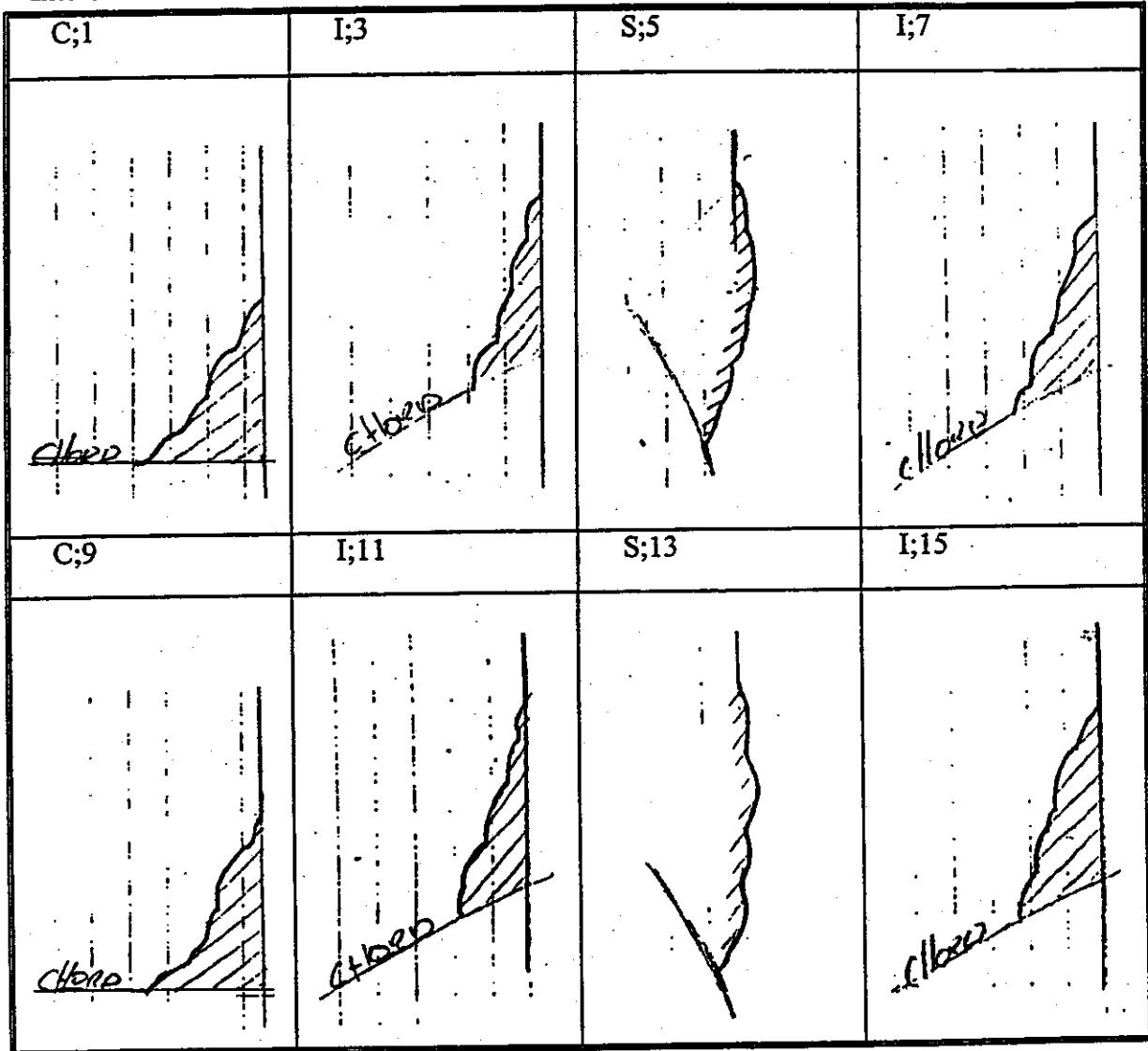

Key :-

- I - Intermediate weld position
- C - Crown weld position
- S - Saddle weld position

Refer to Figure A.1 for corresponding numbered weld shape locations.

Weld shape dimensions [mm]

Weld leg length	C,1	I,3	S,5	I,7	C,9	I,11	S,13	I,15
L_{brace}	23.2	22.4		22.3	24.9	26.2		24.7
L_{chord}	17.6	10.5		13.4	16.2	10.1		13.0

WELD SHAPE SPECIMEN DT4

Intersection between Chord and Brace 1 of DT4

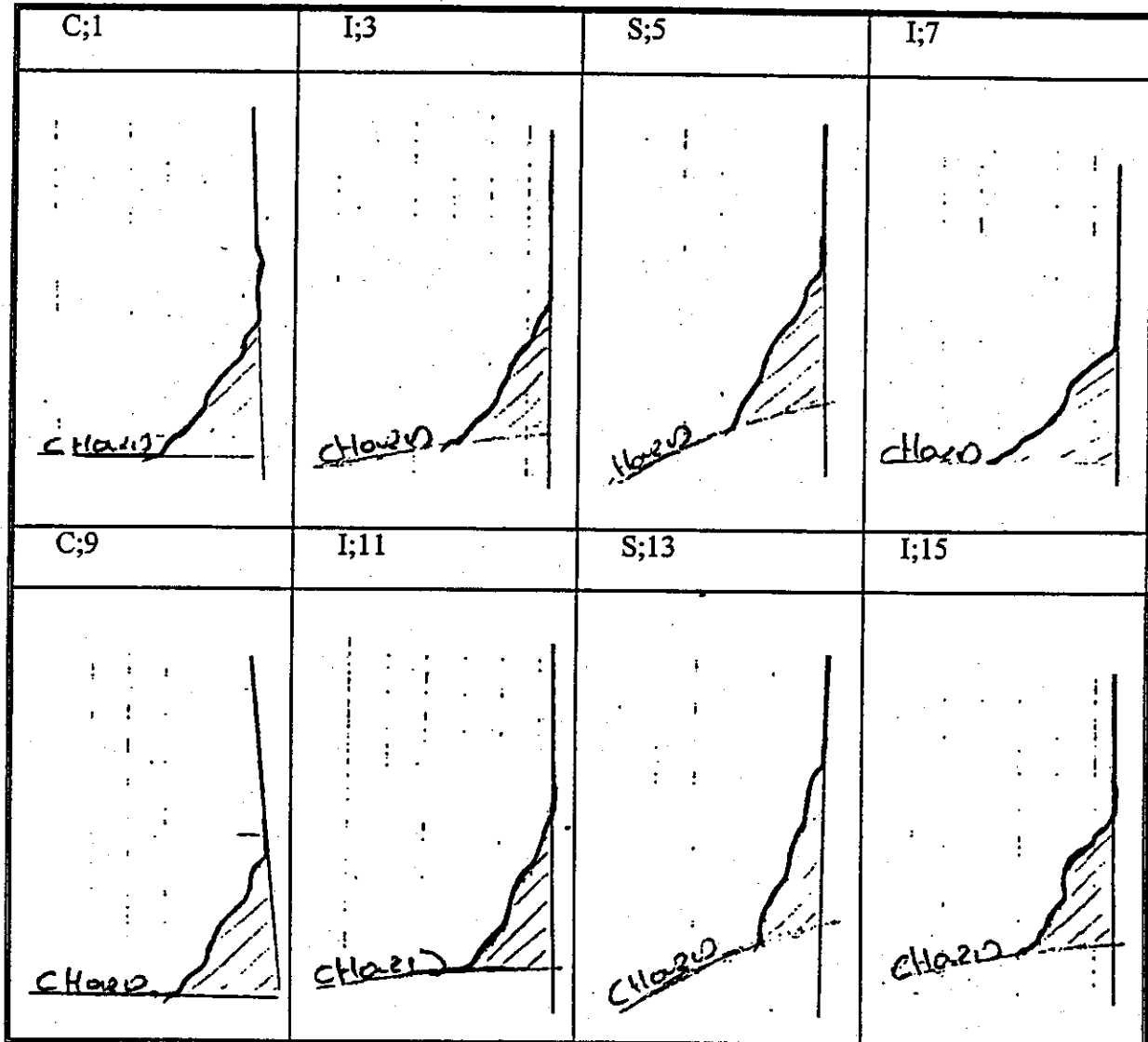

Key :-

- I - Intermediate weld position
- C - Crown weld position
- S - Saddle weld position

Refer to Figure A.1 for corresponding numbered weld shape locations.

Weld shape dimensions [mm]

Weld leg length	C,1	I,3	S,5	I,7	C,9	I,11	S,13	I,15
L_{brace}	21.1	19.3	19.5	18.2	22.7	22.7	24.7	18.7
L_{chord}	14.8	13.7	13.2	17.3	14.9	12.6	8.4	12.6

WELD SHAPE SPECIMEN DT4

Intersection between Chord and Brace 2 of DT4

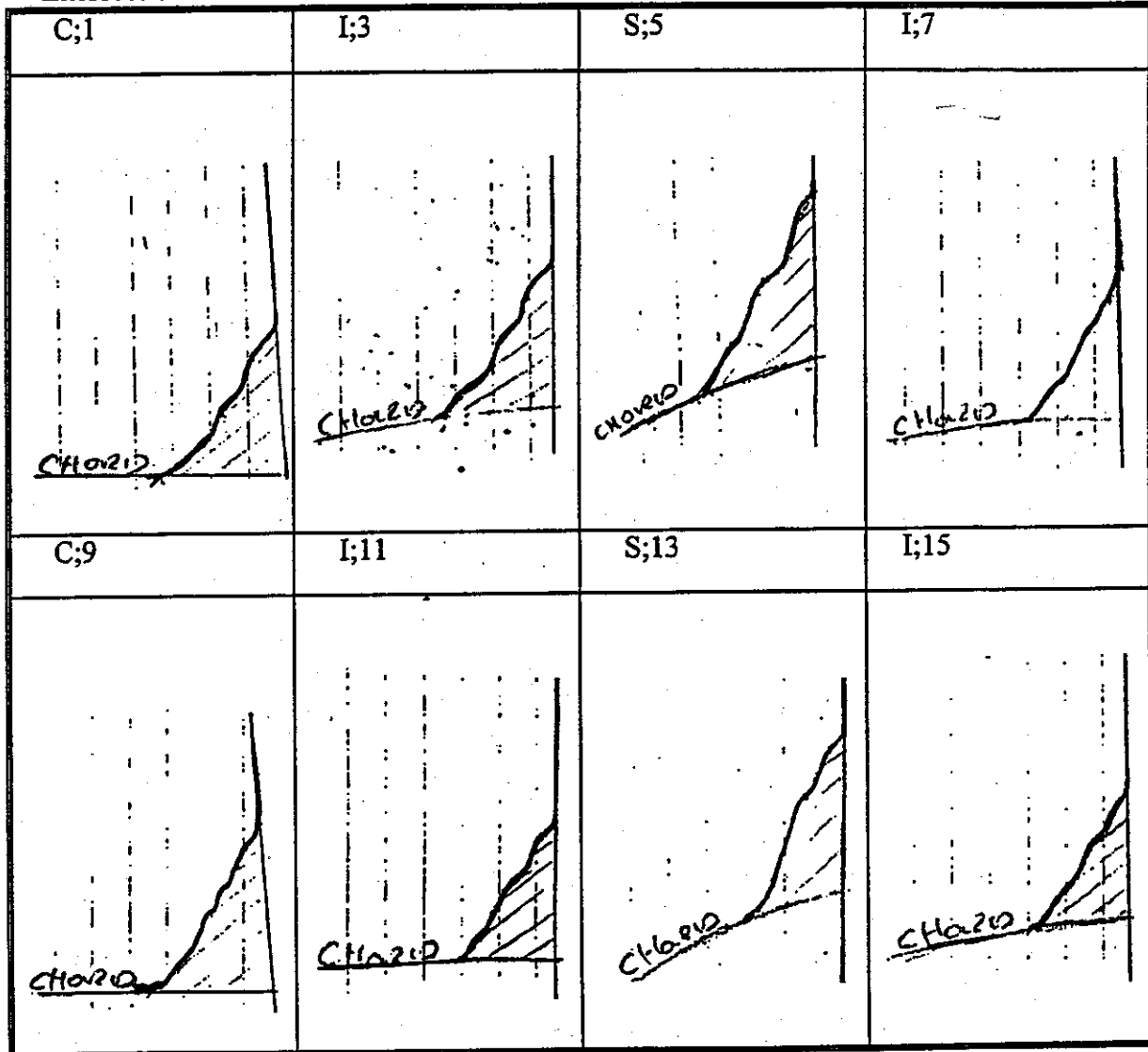

Key :-

- I - Intermediate weld position
- C - Crown weld position
- S - Saddle weld position

Refer to Figure A.1 for corresponding numbered weld shape locations.

Weld shape dimensions [mm]

Weld leg length	C,1	I,3	S,5	I,7	C,9	I,11	S,13	I,15
L_{brace}	21.9	20.0	23.1	21.2	23.9	19.9	23.9	18.4
L_{chord}	18.0	15.0	17.7	12.7	18.5	12.1	14.0	13.1

WELD SHAPE SPECIMEN DT5

Intersection between Chord and Brace 1 of DT5

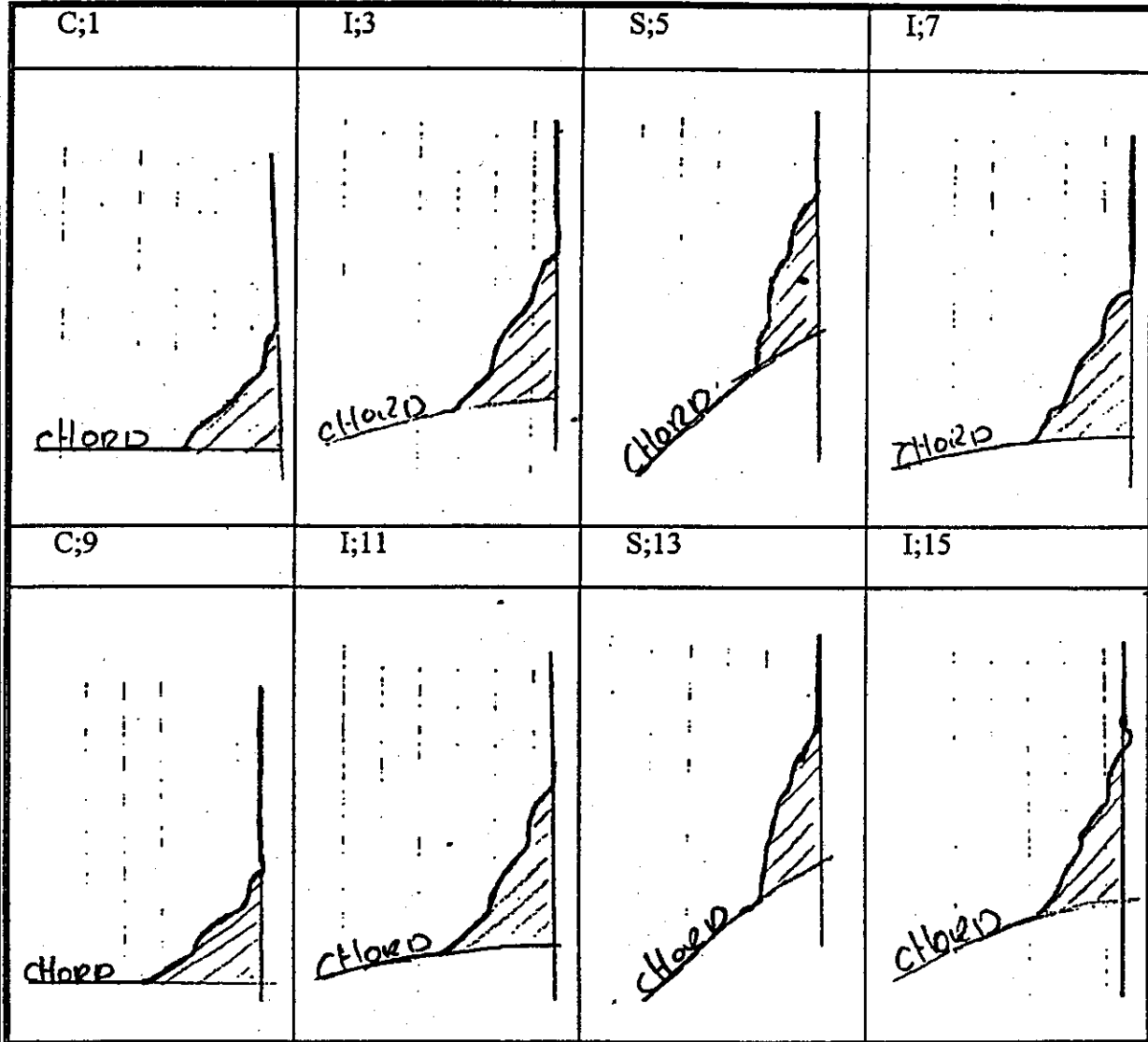

Key :-

- I - Intermediate weld position
- C - Crown weld position
- S - Saddle weld position

Refer to Figure A.1 for corresponding numbered weld shape locations.

Weld shape dimensions [mm]

Weld leg length	C,1	I,3	S,5	I,7	C,9	I,11	S,13	I,15
L_{brace}	17.6	19.7	19.4	20.5	15.5	22.1	20.3	20.9
L_{chord}	13.1	14.2	10.1	13.9	15.9	15.8	10.2	11.7

WELD SHAPE SPECIMEN DT5

Intersection between Chord and Brace 2 of DT5

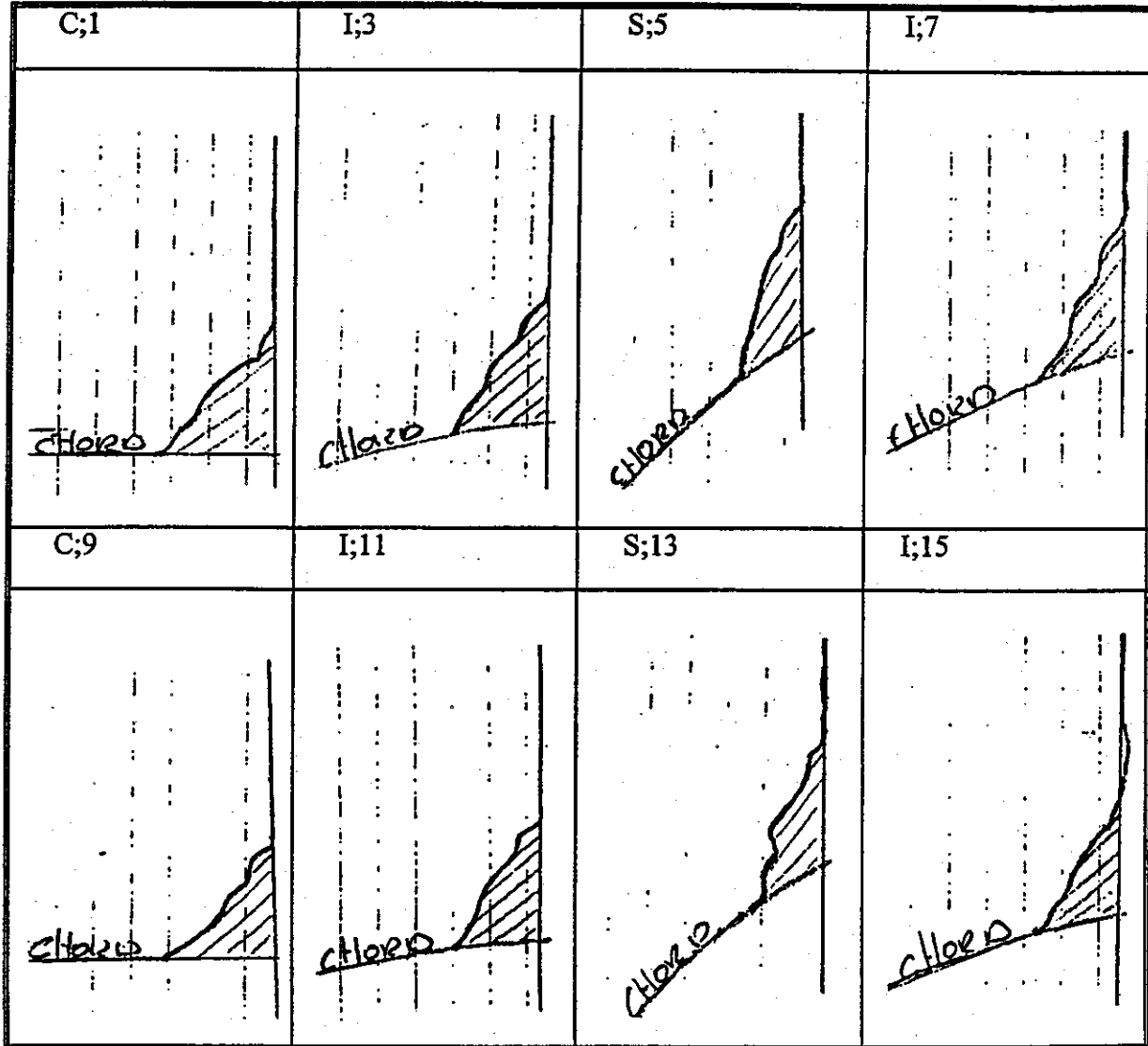

Key :-

- I - Intermediate weld position
- C - Crown weld position
- S - Saddle weld position

Refer to Figure A.1 for corresponding numbered weld shape locations.

Weld shape dimensions [mm]

Weld leg length	C,1	I,3	S,5	I,7	C,9	I,11	S,13	I,15
L_{brace}	18.4	18.1	17.8	19.1	15.5	17.7	18.0	17.6
L_{chord}	15.9	13.0	10.6	12.3	15.0	11.9	10.2	11.3

WELD SHAPE SPECIMEN DT6

Intersection between Chord and Brace 1 of DT6

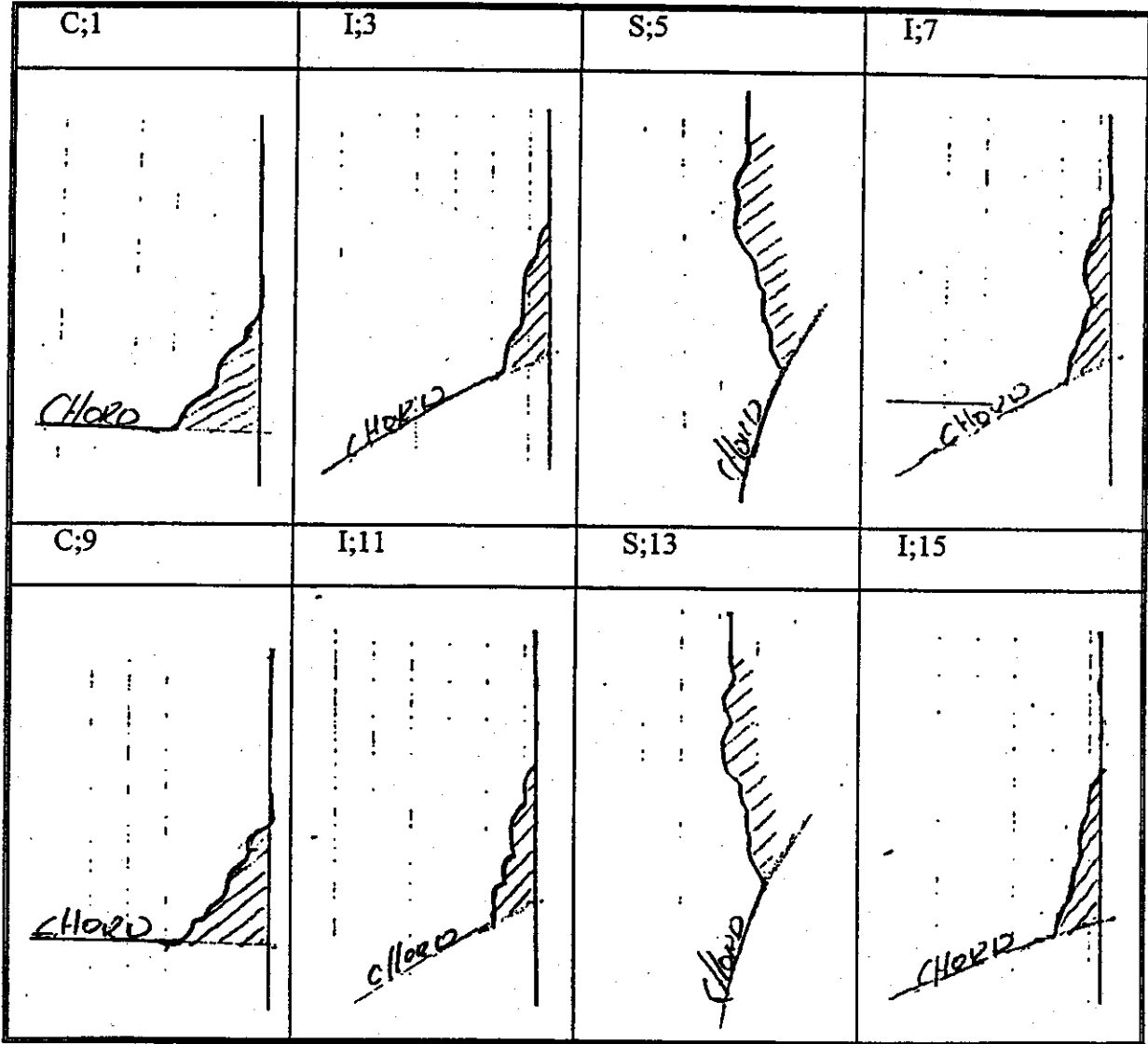

Key :-

- I - Intermediate weld position
- C - Crown weld position
- S - Saddle weld position

Refer to Figure A.1 for corresponding numbered weld shape locations.

Weld shape dimensions [mm]

Weld leg length	C,1	I,3	S,5	I,7	C,9	I,11	S,13	I,15
L _{brace}	18.0	18.6		22.6	20.2	20.0		21.3
L _{chord}	13.0	7.7		7.1	15.1	6.6		6.9

WELD SHAPE SPECIMEN DT6

Intersection between Chord and Brace 2 of DT6

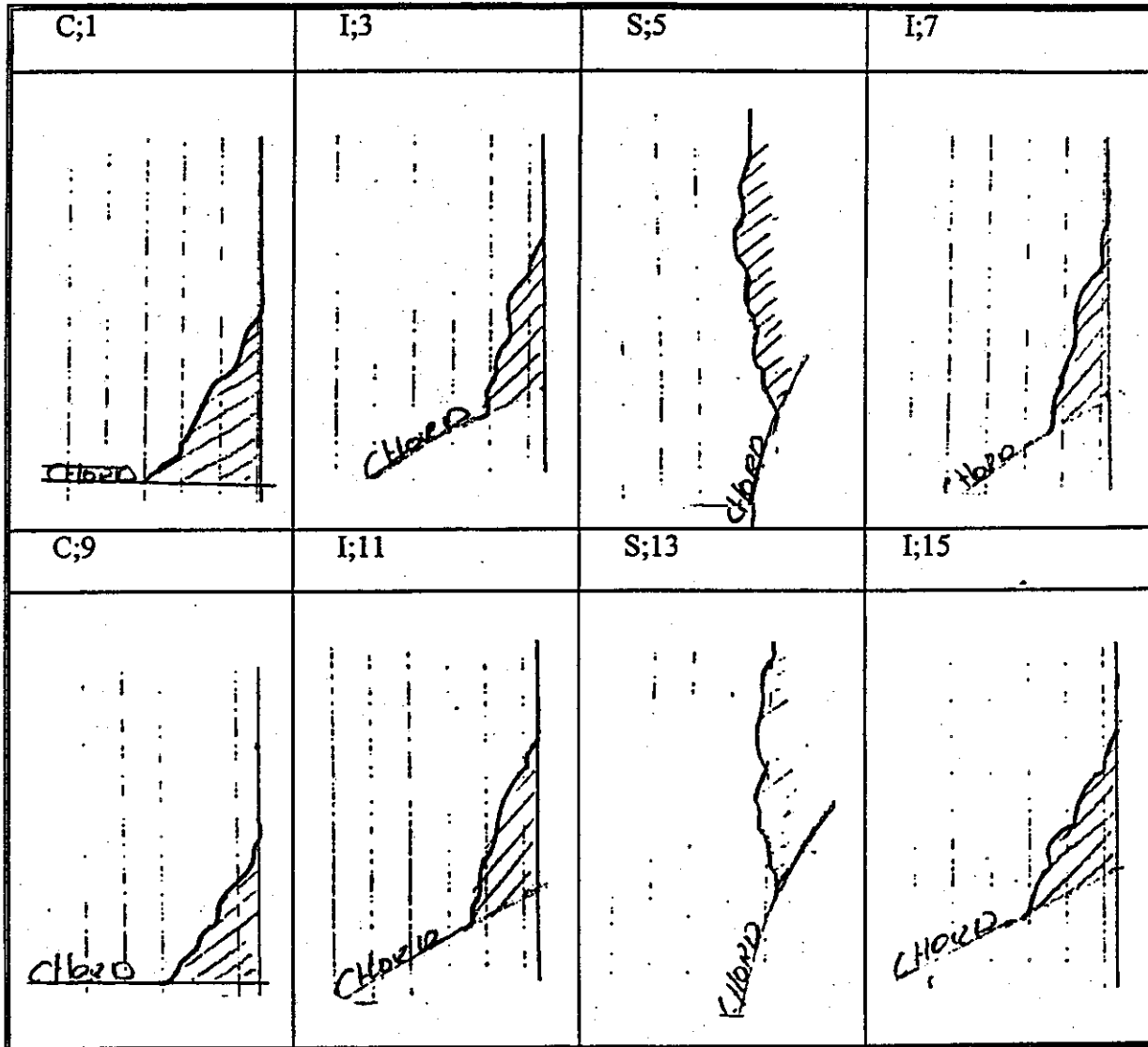

Key :-

- I - Intermediate weld position
- C - Crown weld position
- S - Saddle weld position

Refer to Figure A.1 for corresponding numbered weld shape locations.

Weld shape dimensions [mm]

Weld leg length	C,1	I,3	S,5	I,7	C,9	I,11	S,13	I,15
L_{brace}	24.2	21.8		24.1	22.3	21.1		19.6
L_{chord}	16.3	9.6		9.7	13.3	11.3		14.2

WELD SHAPE SPECIMEN DT8

Intersection between Chord and Brace 1 of DT8

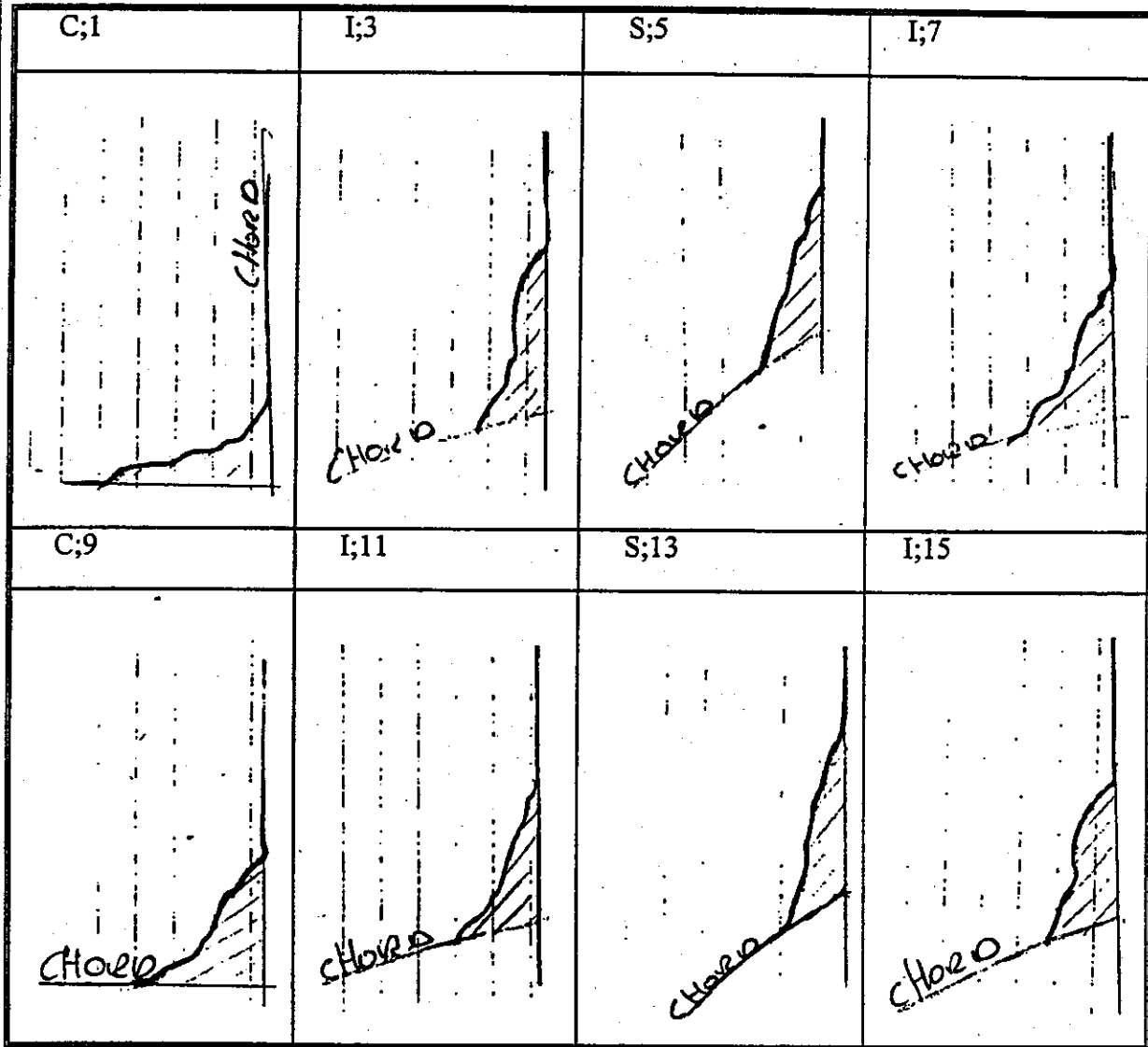

Key :-

- I - Intermediate weld position
- C - Crown weld position
- S - Saddle weld position

Refer to Figure A.1 for corresponding numbered weld shape locations.

Weld shape dimensions [mm]

Weld leg length	C,1	I,3	S,5	I,7	C,9	I,11	S,13	I,15
L_{brace}	23.4	23.2	20.3	21.2	20.2	19.7	24.8	18.7
L_{chord}	12.1	9.8	10.4	14.6	16.6	12.0	10.1	10.7

WELD SHAPE SPECIMEN DT8

Intersection between Chord and Brace 2 of DT8

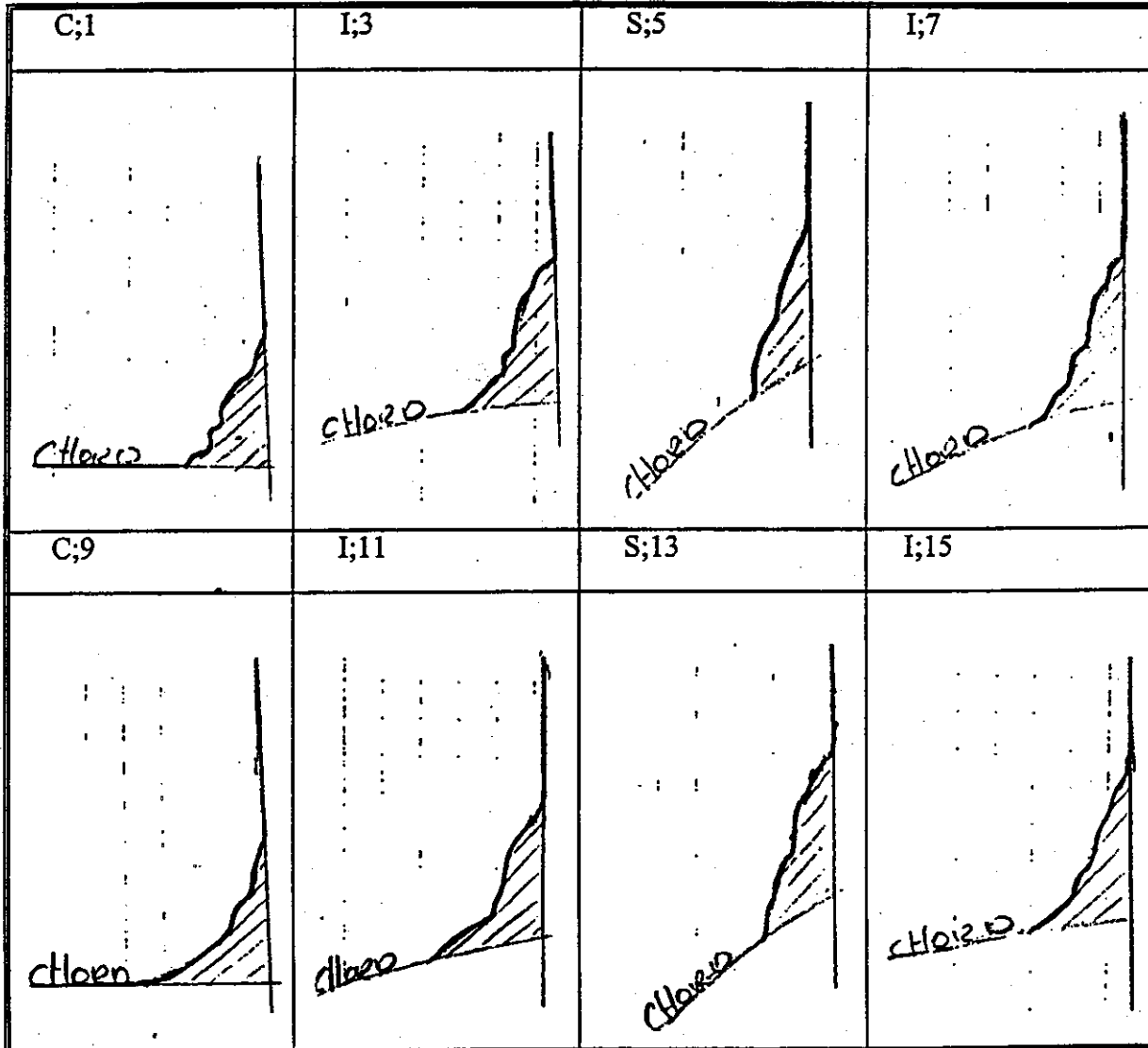

Key :-

- I - Intermediate weld position
- C - Crown weld position
- S - Saddle weld position

Refer to Figure A.1 for corresponding numbered weld shape locations.

Weld shape dimensions [mm]

Weld leg length	C,1	I,3	S,5	I,7	C,9	I,11	S,13	I,15
L_{brace}	19.3	19.4	20.3	21.3	21.0	20.0	20.8	22.9
L_{chord}	11.2	13.7	9.8	12.8	16.7	16.1	11.5	13.9

WELD SHAPE SPECIMEN DT9

Intersection between Chord and Brace 1 of DT9

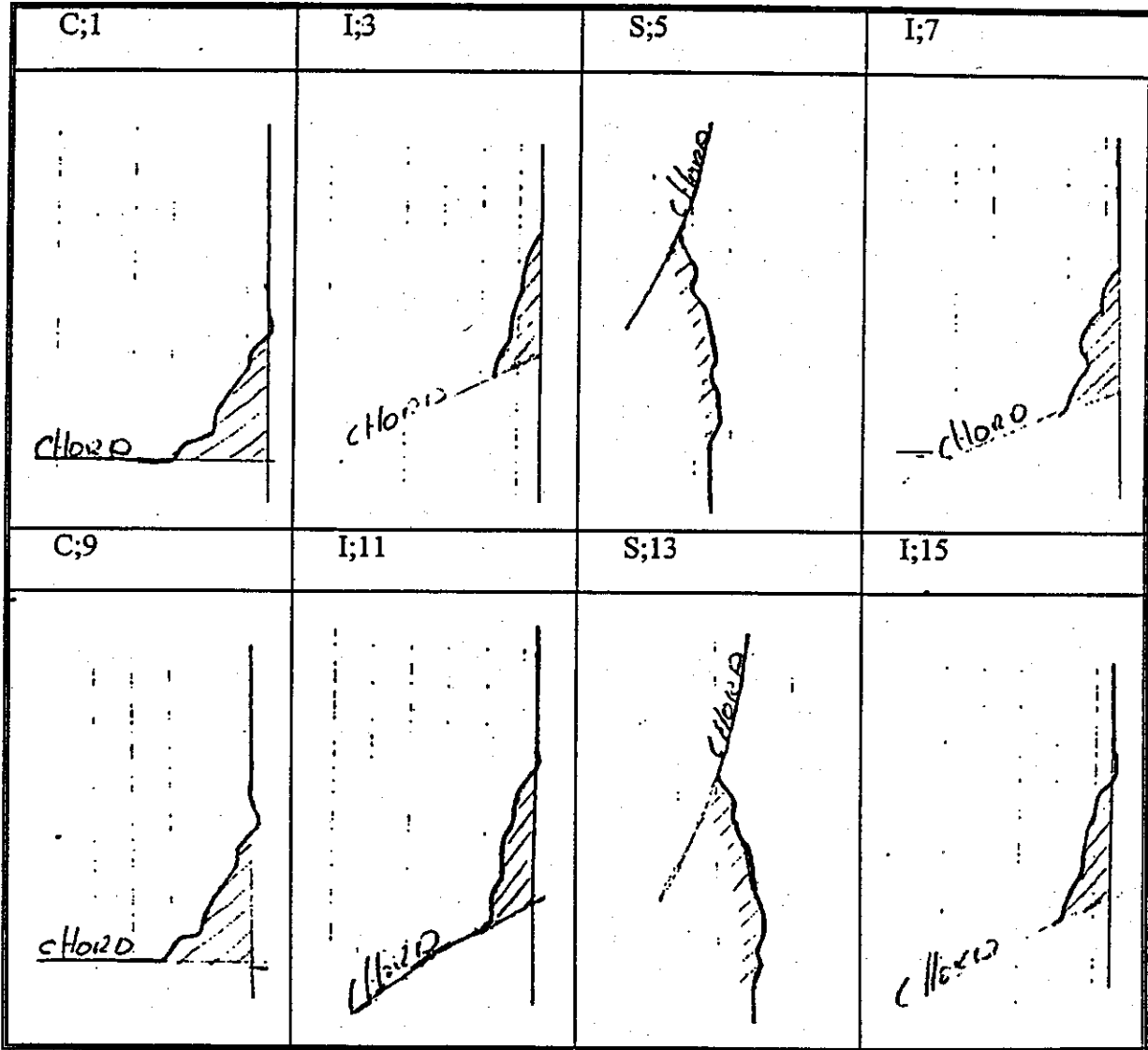

Key :-

- I - Intermediate weld position
- C - Crown weld position
- S - Saddle weld position

Refer to Figure A.1 for corresponding numbered weld shape locations.

Weld shape dimensions [mm]

Weld leg length	C,1	I,3	S,5	I,7	C,9	I,11	S,13	I,15
L_{brace}	21.8	17.2		17.9	24.3	20.8		20.3
L_{chord}	14.1	7.1		8.7	12.8	7.9		8.4

WELD SHAPE SPECIMEN DT9

Intersection between Chord and Brace 2 of DT9

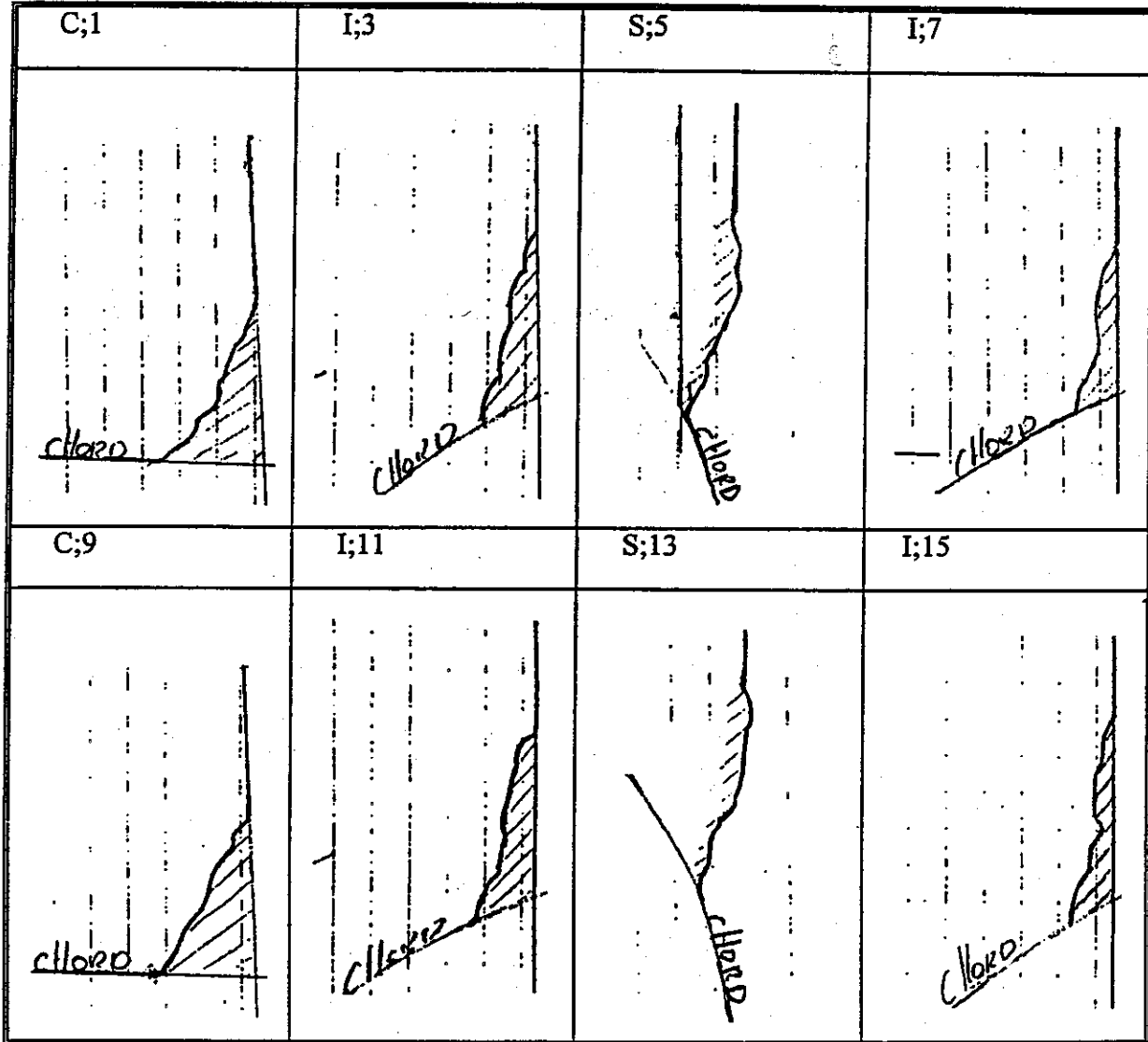

Key :-

- I - Intermediate weld position
- C - Crown weld position
- S - Saddle weld position

Refer to Figure A.1 for corresponding numbered weld shape locations.

Weld shape dimensions [mm]

Weld leg length	C,1	I,3	S,5	I,7	C,9	I,11	S,13	I,15
L_{brace}	24.1	23.2		20.8	23.7	24.7		26.2
L_{chord}	15.4	8.5		6.4	14.3	9.3		7.3

WELD SHAPE SPECIMEN T1

Intersection between Chord and Brace of T1

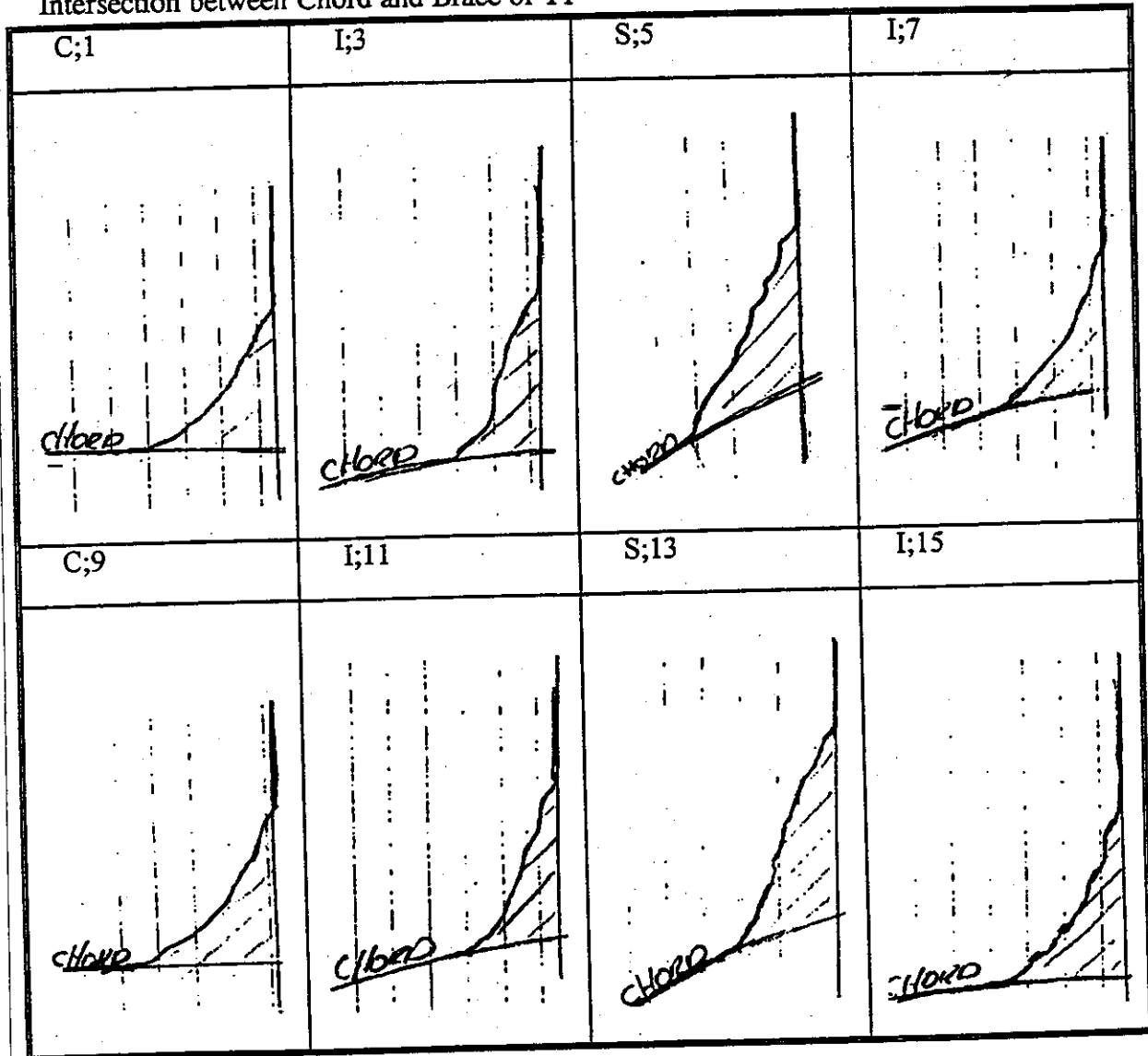

Key :-

- I - Intermediate weld position
- C - Crown weld position
- S - Saddle weld position

Refer to Figure A.1 for corresponding numbered weld shape locations.

Weld shape dimensions [mm]

Weld leg length	C,1	I,3	S,5	I,7	C,9	I,11	S,13	I,15
L_{brace}	20.6	23.0	22.0	20.3	22.5	22.7	27.5	25.2
L_{chord}	18.0	12.2	17.0	14.1	20.2	13.5	14.8	17.0

WELD SHAPE SPECIMEN T3

Intersection between Chord and Brace of T3

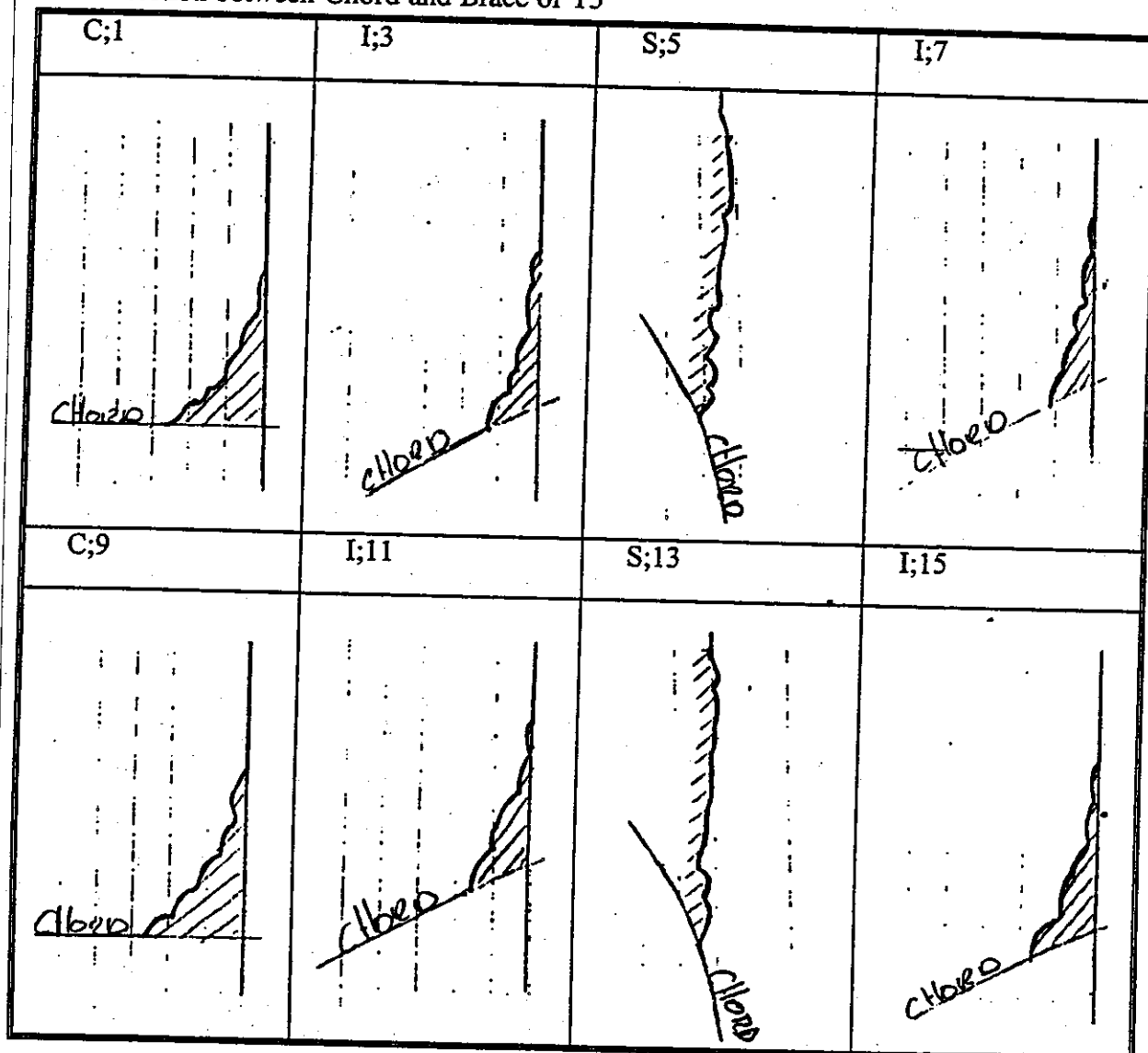

Key :-

- I - Intermediate weld position
- C - Crown weld position
- S - Saddle weld position

Refer to Figure A.1 for corresponding numbered weld shape locations.

Weld shape dimensions [mm]

Weld leg length	C,1	I,3	S,5	I,7	C,9	I,11	S,13	I,15
L_{brace}	23.0	22.6		23.6	24.6	20.7		24.1
L_{chord}	13.9	8.1		7.2	14.0	8.6		10.0

WELD SHAPE SPECIMEN T5

Intersection between Chord and Brace of T5

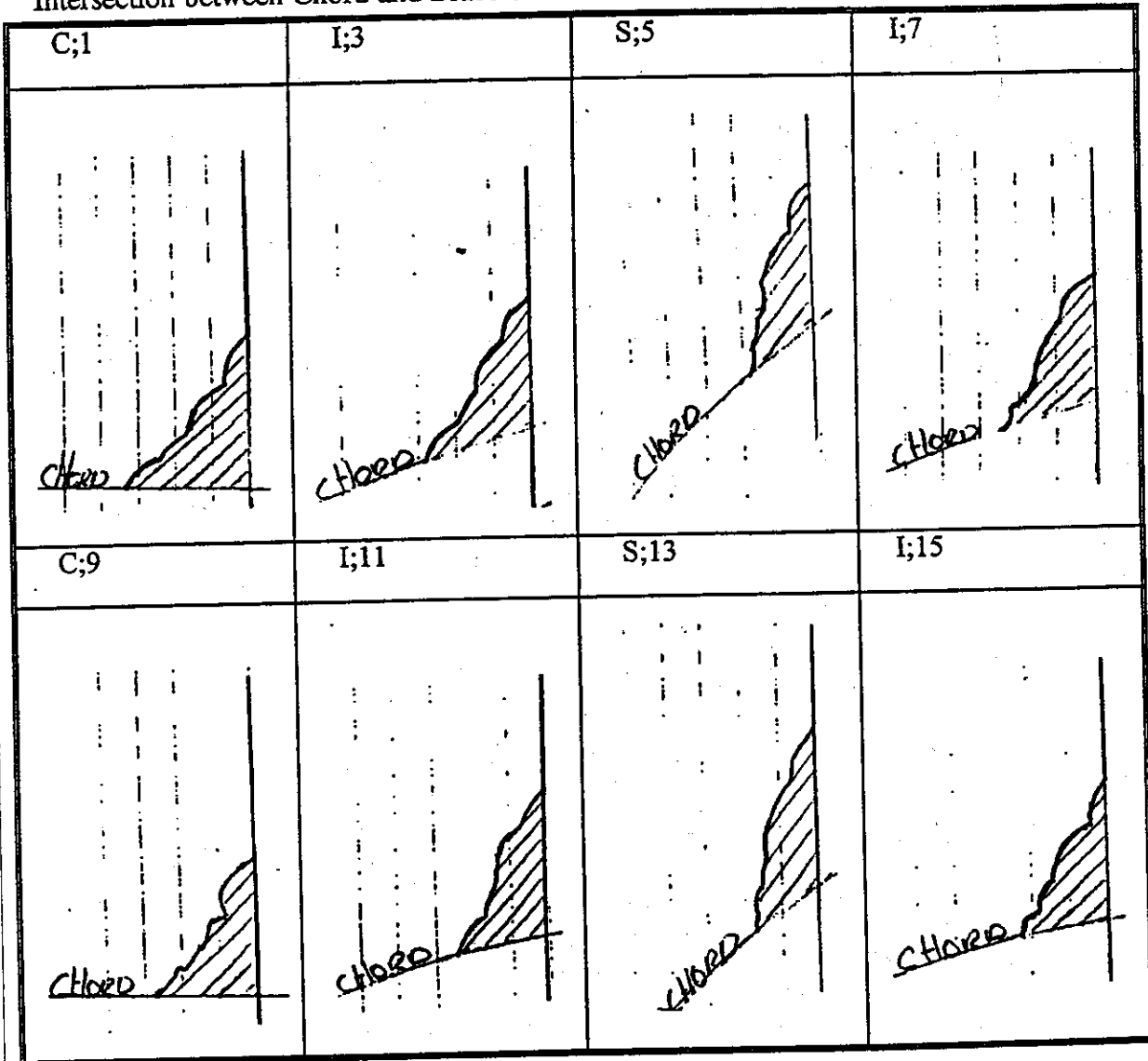

Key :-

- I - Intermediate weld position
- C - Crown weld position
- S - Saddle weld position

Refer to Figure A.1 for corresponding numbered weld shape locations.

Weld shape dimensions [mm]

Weld leg length	C,1	I,3	S,5	I,7	C,9	I,11	S,13	I,15
L_{brace}	21.7	18.6	20.0	18.2	20.0	20.2	22.6	19.9
L_{chord}	17.7	15.7	11.4	13.5	14.3	13.0	10.5	12.1

WELD SHAPE SPECIMEN T7

Intersection between Chord and Brace of T7

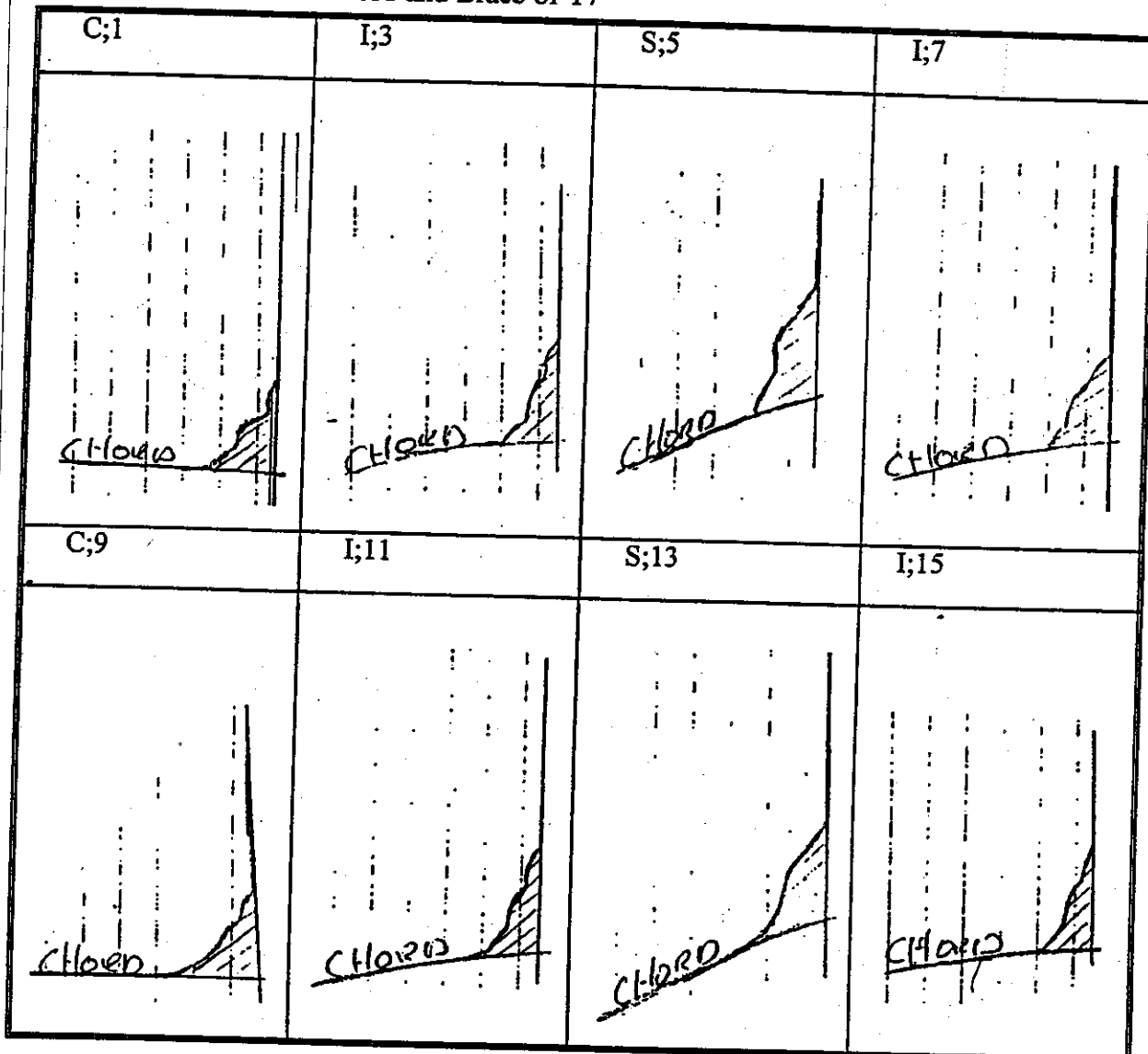

Key :-

- I - Intermediate weld position
- C - Crown weld position
- S - Saddle weld position

Refer to Figure A.1 for corresponding numbered weld shape locations.

Weld shape dimensions [mm]

Weld leg length	C,1	I,3	S,5	I,7	C,9	I,11	S,13	I,15
L_{brace}	13.6	14.3	16.5	12.7	12.8	14.9	14.0	15.4
L_{chord}	11.9	7.7	8.6	8.6	13.1	7.6	11.8	9.9

WELD SHAPE SPECIMEN T9

Intersection between Chord and Brace of T9

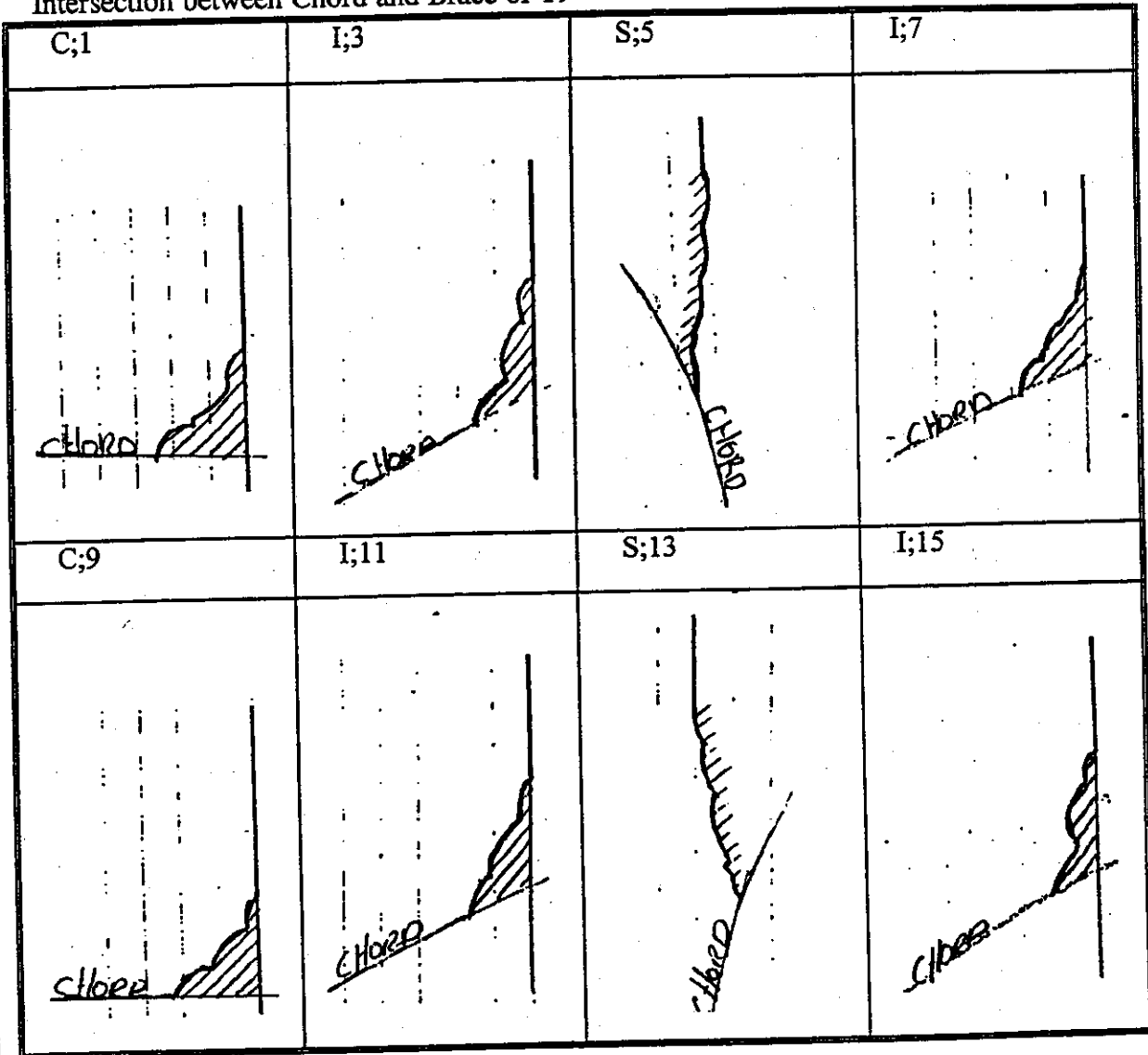

Key :-

- I - Intermediate weld position
- C - Crown weld position
- S - Saddle weld position

Refer to Figure A.1 for corresponding numbered weld shape locations.

Weld shape dimensions [mm]

Weld leg length	C,1	I,3	S,5	I,7	C,9	I,11	S,13	I,15
L_{brace}	15.6	16.1		14.7	15.0	15.6		17.2
L_{chord}	13.1	9.5		10.4	12.2	9.5		7.7

MSE

APPENDIX B

Specification and Procedure for Grouting of Test Specimens

C14100R020 Rev 1 February 1997

NSI

Purpose of Issue	Rev	Date of Issue	Author	Agreed	Approved
Issued to PSC	0	March 1994	DJM	NS	NS
Final Issue	1	December 1994	DJM	ML	ML
Issued with minor amendments	2	January 1995	<i>DJM</i>	<i>ML</i>	<i>ML</i>

"This document has been prepared by MSL Engineering Limited for the Participants of the Joint Industry Project on Development of Grouted Tubular Joint Technology for Offshore Strengthening and Repair. This document is confidential to the Participants in the Joint Industry Project, under the terms of their contract for participation in the project"

JOINT INDUSTRY PROJECT

**DEVELOPMENT OF GROUDED
TUBULAR JOINT TECHNOLOGY
FOR OFFSHORE STRENGTHENING AND REPAIR**

**SPECIFICATION AND
PROCEDURE FOR GROUING
OF TEST SPECIMENS**

DOC REF C14100R006 Rev 2 JANUARY 1995

MSL Engineering Limited

MSL House
5 - 7 High Street, Sunninghill,
Ascot, Berkshire. SL5 9NQ

Tel: +44 (0)1344-874424
Fax: +44 (0)1344-874338

NUMBER	DETAILS OF REVISION
0	Issued to PSC, March 1994
1	Final Issue, December 1994
2	Issued with minor amendments, January 1995



JOINT INDUSTRY PROJECT
**DEVELOPMENT OF GROUTED
TUBULAR JOINT TECHNOLOGY
FOR OFFSHORE STRENGTHENING AND REPAIR**

**SPECIFICATION AND
PROCEDURE FOR GROUTING
OF TEST SPECIMENS**

CONTENTS

	<u>Page</u>
CONTENTS	3
1. INTRODUCTION	4
2. GROUT FILLING OF SPECIMENS	5
2.1 General Description	5
2.2 Grout Connections	5
2.3 Filling Chord with Water	5
2.4 Grouting the Tubular Joints	5
2.4.1 Mix grout	6
2.4.2 Grouting operation	6
2.4.3 Short stoppages	6
2.4.4 Longer stoppages	7
2.4.5 Flushing procedure	7
2.5 Post Grouting Procedure	7
3. GROUT MIX AND TESTING SPECIFICATION	8
3.1 Design Requirements	8
3.2 Materials	8
3.3 Grout Mix Proportions	8
3.4 Grout Mixing	9
3.5 Slurry Density Measurements	9
3.6 Cube Preparation and Curing	9
3.7 Sampling and Testing Procedures	9
3.8 Equipment	10



1. INTRODUCTION

This document presents a detailed procedure for the chord grout-filling of tubular joints to be used as test specimens in a Joint Industry Project (JIP) on the 'Development of Grouted Tubular Joint Technology for Offshore Strengthening and Repair'.

The tubular joints will be used for SCF tests for the ungrouted and grouted conditions. Once tests are complete for the ungrouted condition, grouting can commence in accordance with the specifications and procedure presented within this document.

This document makes reference to the following American Standards:-

- API Specification 10 - Specification for Materials and Testing for Well Cements
- ASTM Specification C150 - Standard Specification for Portland Cement.

2. GROUT FILLING OF SPECIMENS

2.1 General Description

The tubular joint specimens comprise T joints and DT/X Joints. Each of the tubular joints is to be chord grout-filled for SNCF measurements and subsequent ultimate strength tests.

The tubular joints are to be cast with the chord placed in the vertical position. This will ensure complete grout filling of the chord and reduce the number of parameters to consider when interpreting test results. Displacement of water whilst grout filling will be a requirement since grouting offshore in strengthening/repairs will also displace water.

The grout mix and testing specification shall conform to Section 3 herein.

Tubular joints shall be grout-filled using the same procedures, mixing equipment and facilities. This will ensure consistency in grout mix, test cube preparation, grout placement and grout strength once cured. Grout mixer capacity may limit the number of specimens that can be grouted in one operation. In this case measures will be taken to ensure consistency between batches.

2.2 Grout Connections

Grout connection arrangements are shown in Figures 2.1 and 2.2.

For each tubular joint, one inlet shall be provided at the base of the vertical chord and the outlet in either the top cover plate or the top of the chord. The operation of all valves shall be checked, prior to fitting.

All connections shall be well greased. The grout inlet shall be attached to the chord at the grout inlet point. All grout shall be input through this point.

2.3 Filling Chord with Water

The vertical chord members shall be filled with water prior to grout filling. Any leaks identified shall be remedied prior to the grouting operation.

2.4 Grouting the Tubular Joints

This operation shall follow immediately after successful filling of the chord with water.

2.4.1 Mix grout

Grout shall be mixed to a specific gravity of 2.02 ± 0.02 for Oilwell or Portland cement (see Section 3.2 for cement specification). Confirmation of the specific gravity shall be carried out using a pressurised mud-balance. If acceptable, samples will be taken for grout cubes. If the specific gravity is not within the limits specified above, grout shall be mixed until desired density is achieved. Samples for grout cubes will then be taken.

See Section 3 for mixing, sampling and testing of grout.

2.4.2 Grouting operation

- Ensure grout inlet hose is free of any obstructions, 'kinks' or 'crimps' when connected to test specimen.
- Open inlet valves.
- Begin pumping grout through the inlet hose. Pump continuously.
- When good consistency grout flows from the chord outlet point, continue pumping slowly, and take density measurements.
- Following confirmation of satisfactory grout densities, stop pumping, and close inlet valves. Disconnect quick release coupling and reconnect to next specimen. Open inlet valves and begin pumping. When good consistency grout flows from the outlet point, continue pumping slowly and take density measurement. Repeat this cycle for subsequent tubular joints.
- Once all tubular joints are grouted, disconnect grout inlet at quick release union connection, open valve connected to inlet line and pump water down the grout inlet line, to flush.

2.4.3 Short stoppages

If a blockage occurs during grouting of a specimen, adopt the following procedure:-

Stop pumping

Close both inlet valves at inlet point. Disconnect grout line at quick release union connection.

Open grout line inlet valve.

Begin pumping slowly.

If no grout flows, change the inlet grout hose. If grout flows, the problem is not in the hose. Therefore, it is a fault either in the inlet valve, the outlet hose or in the tubular specimen.

Reconnect grout inlet and open inlet valve. Begin pumping. If grout does not flow, then a piece of wire inserted through the outlet point may prove successful in removing any blockage there. If grout still does not flow then the blockage is at the inlet valve or within the tubular specimen and the following course of action may be taken.

- Abort the grouting operation, remedy the fault at the inlet valve or from within the tubular specimen and instigate flushing procedures.

Specimens successfully grouted prior to blockage, shall remain grouted.

2.4.4 Longer stoppages

In the event of a grout flow problem or delay during grouting operations of a specimen, where such delays may exceed one hour, chord flushing procedures must start.

2.4.5 Flushing procedure

Flushing must be carried out if grout flow problems occur which may delay operations for more than one hour.

Specimens successfully grouted prior to blockage, shall remain grouted.

- (i) Disconnect grout inlet at quick release union connection, open valve connected to inlet hose and flush inlet hose. Wash out grout mixer.
- (ii) Inspect all valves and 'rake out' where necessary.
- (iii) Flush specimen through either the inlet or outlet points.

2.5 Post Grouting Procedure

Immediately after satisfactory grouting, close all inlet valves, disconnect at quick release union, open valve connected to inlet hose and flush the grout inlet line.

3. GROUT MIX AND TESTING SPECIFICATION

3.1 Design Requirements

All grout to be used shall achieve a minimum compressive strength of 41.4 N/mm² (6000 psi) at 28 days.

3.2 Materials

Cement shall be class 'B' or 'G', moderate sulphate resistant oilwell cement to API Spec 10. Alternatively, moderate sulphate resisting Portland Cement to ASTM C150 Type II may be substituted and used in the same proportions.

Manufacturer's Certificates of Quality with respect to the materials shall be obtained before use.

The cement shall be stored and transported in accordance with the manufacturer's instructions. The cement shall be kept free from moisture at all times and a careful visual inspection of all materials shall be made prior to their use to ensure their suitability for the work. Cement shall be stored out of direct sunlight.

Drinkable water is to be used for mixing, with a temperature not exceeding 20°C.

3.3 Grout Mix Proportions

The grout mix shall be as follows:-

Cement	-	100 parts by weight
Water	-	34 parts by weight (for Oilwell or Portland cement)

NO ADMIXTURES SHALL BE PERMITTED

Figure 3 shows the rate of gain of strength for Oilwell 'B' grouts cured at 8°C (46°F). This is based upon extensive onshore and offshore test data collated from many years of grouting experience.

3.4 Grout Mixing

The grout shall be mixed using a suitable mixer (eg. Craelius CEMIX 175 or Colcrete DD4). An initial mix shall be made to line the mixer. This mix shall be discarded. Subsequent batches shall be used to grout the specimens. All batches shall be mixed for a minimum of two minutes.

3.5 Slurry Density Measurements

Measurement of slurry densities shall be made using a pressurised slurry density balance in the manner described in API Spec. 10. Particular attention shall be paid to ensure that the external surfaces of the balance are cleaned and dried after filling and prior to balancing.

Grout shall not be pumped until a specific gravity within the limits noted in Section 2.4.1 is achieved. Slurry densities shall be checked immediately prior to pumping and throughout the grouting operations, sampling every batch mixed.

3.6 Cube Preparation and Curing

Cubes shall be cast in accordance with API Spec. 10, with the exception that 75mm (3 inch) cubes shall be used.

The cubes shall be placed in polyurethane bags immediately after casting and cured with and at the same temperature as the grouted joints until removed for demolding or testing.

Cubes may be demolded after 24 hours, during which the time out of the bags must not be more than 1 (one) hour. At or after 28 days, cubes shall be weighed, measured and crushed within 30 minutes of removal from the bags.

The cube age shall be measured from the time the cube is struck to the time it is crushed.

Each cube shall be marked with a unique mark and this mark correlated with the batch number, specimen number, time and date made and slurry density, as measured by a pressurised slurry density balance.

3.7 Sampling and Testing Procedures

For each batch 4 N^o cubes are to be cast from the grout in the grout mixer.

From the 4 N^o cubes cast from the grout in the mixer, three (3 N^o) cubes shall be tested at 28 days.

An additional 8 N^o cubes are to be cast for each grouted test specimen.

From the 8 N^o cubes cast with each specimen;

Three (3 N^o) cubes shall be tested at or after 28 days on the commencement of SCF tests on each grouted specimen.

Three (3 N^o) cubes shall be tested at the commencement of ultimate strength tests on each grouted specimen.

Each cube shall be crushed in accordance with the procedure given in API Spec. 10, except that the rate of loading will be no faster than 14 N/mm² per min (2000 lbf/in² per min).

The following information shall be collated for the final report:-

- Test specimen identification reference
- Cube identification reference
- Time and date of casting of the cube and test specimen
- Time and date of testing of the cube and test specimen
- Fluid grout density at time of casting
- Weight and density of the grout cube
- Failure load and cube strength
- Average strength from 3 N^o cubes tested at 28 days.
- Average strength from the 3 N^o cubes tested at commencement of SCF test on each grouted specimen and 3 N^o cubes tested at commencement of ultimate strength test on each grouted specimen.

3.8 Equipment

Calibration certificates are to be supplied for all weighing, balancing, cube making and cube crushing equipment.

FIGURES

C14100R006 Rev 2 January 1995

MSL

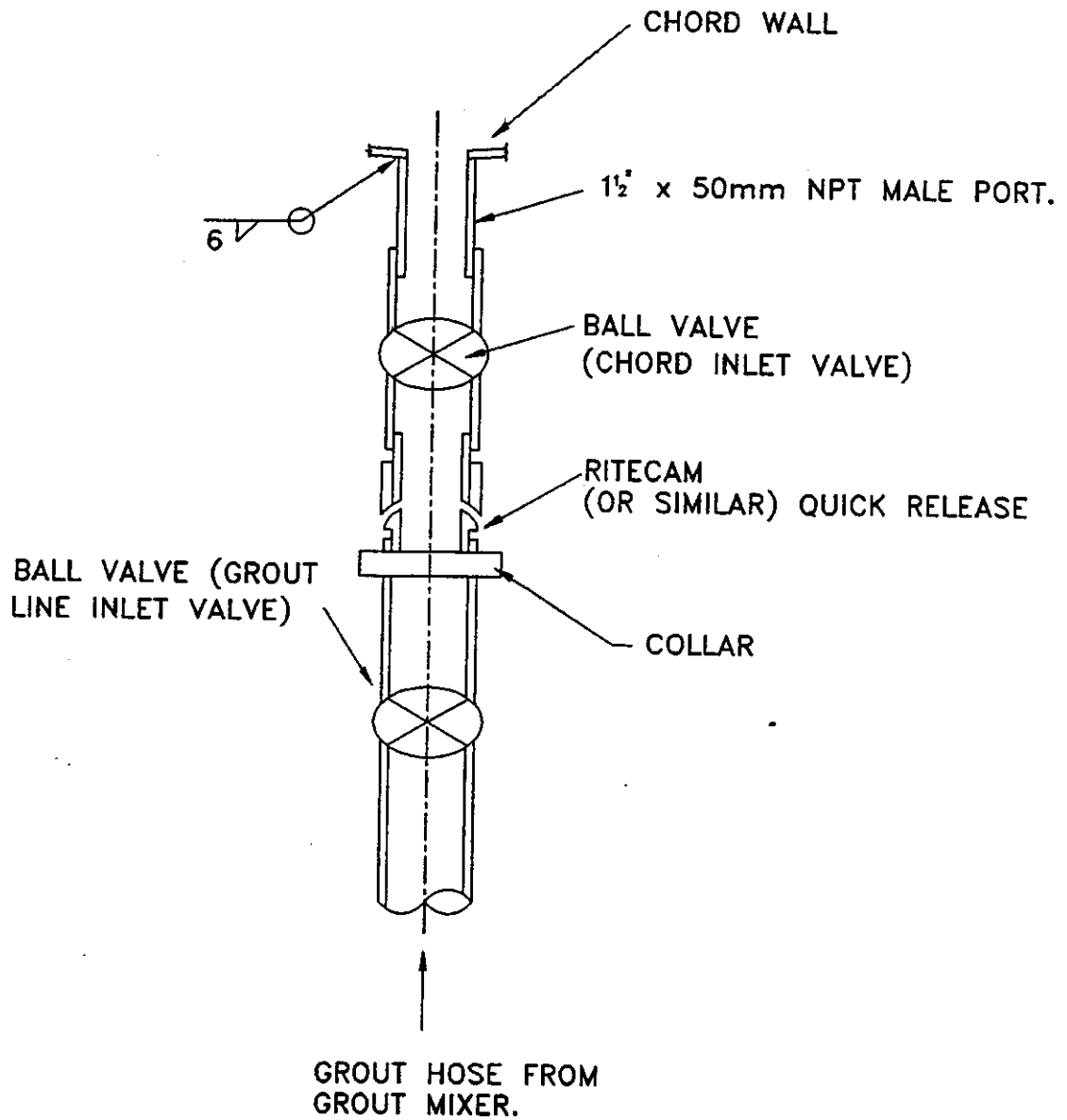

NOTES:-

1. DIMENSIONS TO ALLOW CLEARANCES TO OPERATE VALVE HANDLES.
2. ALL VALVES TO BE 1 1/2" BALL VALVES.

FIGURE 2.1. ARRANGEMENT OF CHORD GROUT INLET.

SCH 40 PIPE THREADED TO SUIT
1½" NPT MALE PORT (TYP.)

1½" NPT MALE PORT

CHORD CAPPING PLATE
OR CHORD WALL

LOCKING RING

LOCKING RING

FIGURE 2.2. ARRANGEMENT OF CHORD GROUT OUTLET.

MSL

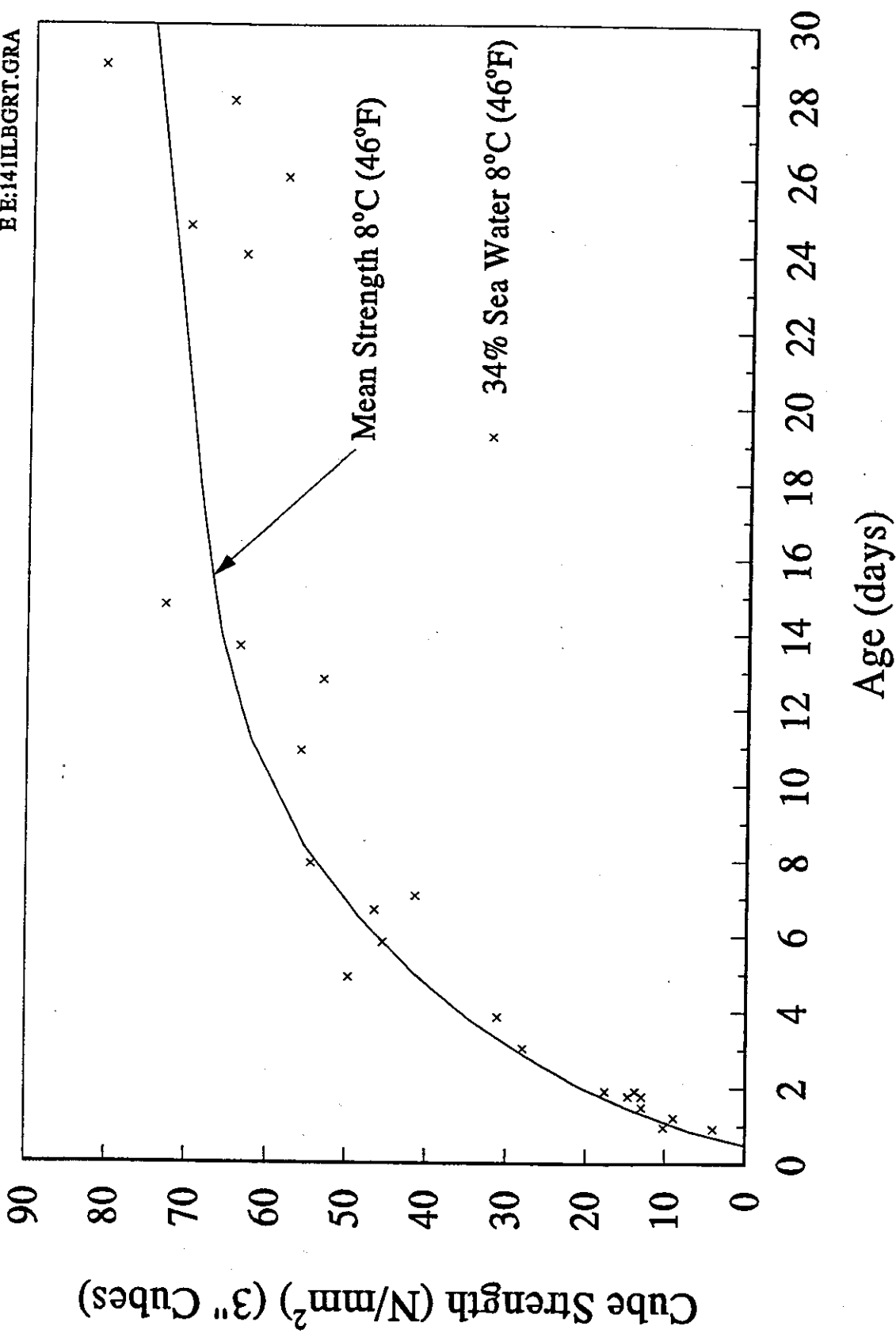

Figure 3 Design Curve for Oilwell B Grout

APPENDIX C
Grout Material Properties

C14100R020 Rev 1 February 1997

M&E

APPENDIX C

Grout Material Properties

Table of contents

Table of contents	1
Appendix C1 Grout material properties	2
Appendix C2 Cross section	3

Appendix C1 Grout material properties

The compressive strength from the cubes were determined and are presented in Table C-1.

Batch	Duration*	Specimen	Cube 1	Cube 2	Cube 3	Average
Taken	7 days	-	24.9	23	-	23.95
from	14 days	-	34.6	33	-	33.80
mix	21 days	-	45	35	-	40.00
drum	28 days	-	36.3	33.7	-	35.00
1	"	S-'D1/D2	40.7	45.2	51.4	45.77
2	"	T5	29.7	26.2	44.9	33.60
3	"	T3 DT4	36.3	36	34.2	35.50
4	"	T9 DT8	33.8	46	31.4	37.07
5	"	DT2 DT5	42.3	33	42	39.10
6	"	T7 T1	40.1	28.6	43.8	37.50
7	"	DT9 DT6	33.7	36.6	34.7	35.00
8	"	DT3	39.8	46.3	29.6	38.57

*after chord filling

Table C-1: Compressive strength per batch after 7, 14, 21 and 28 days from chord filling (MPa)

Specimen	Cube 1	Cube 2	Cube 3	Cube 4	Average
T1	37.00	33.60	39.30	46.30	39.05
T3	34.50	37.60	38.30	38.20	37.15
T5	34.60	41.90	49.00	47.50	43.25
T7	52.40	39.20	38.60	44.00	43.55
T9	42.90	43.80	42.30	37.00	41.50
DT2	41.40	46.30	46.30	47.90	45.48
DT3	53.70	52.30	50.00	48.90	51.23
DT4	42.10	39.40	33.80	41.00	39.08
DT5	47.30	52.90	49.10	48.40	49.43
DT6	47.50	43.70	43.10	45.50	44.95
DT8	53.50	51.90	33.00	49.30	46.93
DT9	52.80	50.50	41.30	51.60	49.05

Table C-2: Compressive strength at time of specimen ultimate test (MPa)

Appendix C2 Cross section

During the grouting procedure two additional tubes ($D=350$ mm) were grouted and cured inside the laboratory (i.e. D1 & D2). Approximately 6 months after grouting one tube was sliced. The results are presented in Figures C-1 and C-2. Cracks within the grout core were not observed. The gap between grout and inside wall of the tubular was extremely fine.

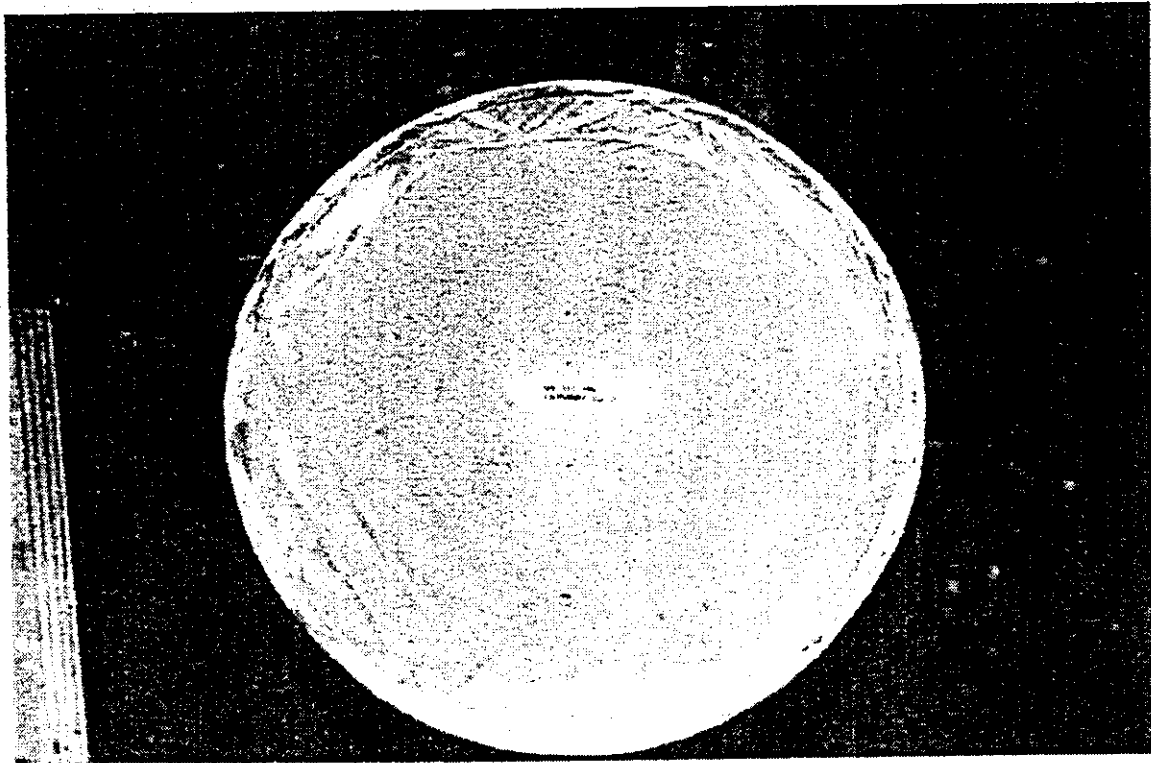

Figure C-1: Cross section of tube fully grouted

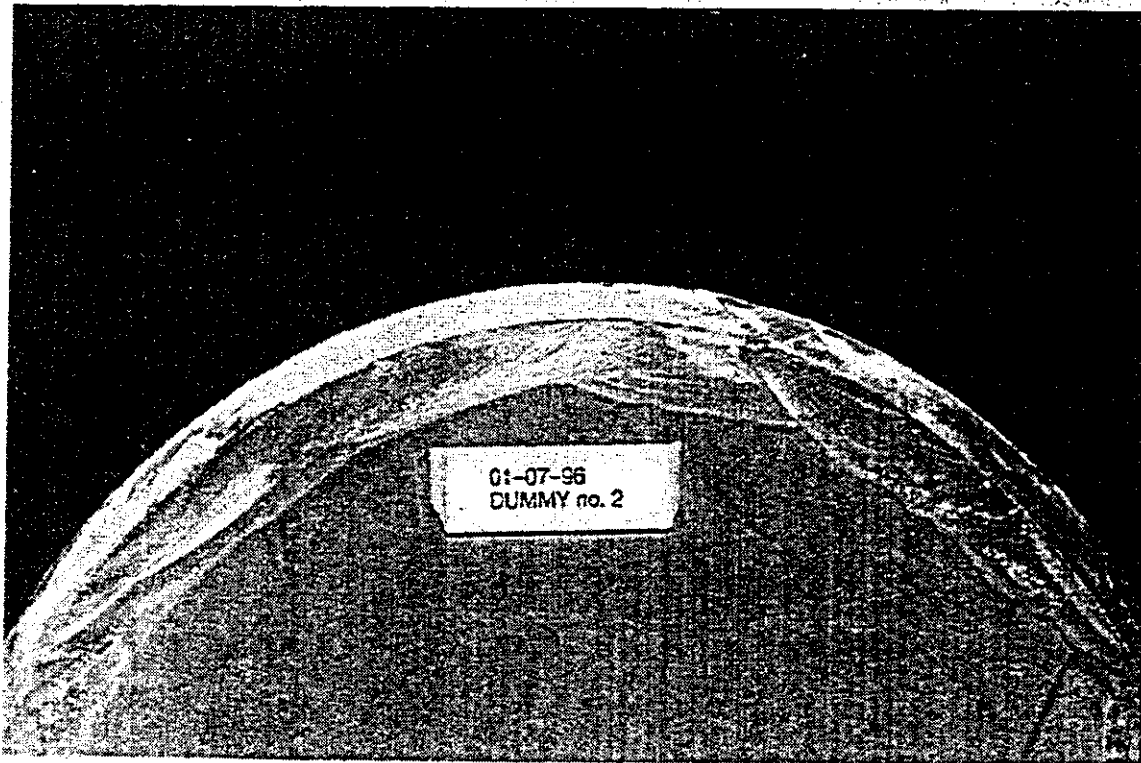

Figure C-2: Cross section of tube fully grouted

APPENDIX D

Tubular Section Material Properties

C14100R020 Rev 1 February 1997

MSL

APPENDIX D

Tensile coupon tests

The material properties from the certificates are listed in table D-1. For each reference pipe, two tensile coupon tests have been performed. The yield stress and tensile strength (ultimate strength) are listed in Table D-2 and Table D-3 respectively.

SPECIMEN	CERTIFICATE			
	Yield str. Brace	Yield str. Chord	Ult. str. Brace	Ult. str. Chord
T1	376	318	538	415
T3	397	318	596	415
T5	365	345	503	435
T7	278	351	395	539
T9	351	351	539	539
DT2	355	318	490	415
DT3	397	318	596	415
DT4	395	345	534	435
DT5	365	345	503	435
DT6	360	345	575	435
DT8	353	351	470	539
DT9	351	351	539	539

Table D-1: Material properties from certificates (MPa).

SPECIMEN	LOCATION	REFERENCE TUBULAR	YIELD STRESS			ULTIMATE		
			a	b	average	a	b	average
DT4	Braces	1	330.4	348.4	339.4	547.0	553.0	550.0
T1	Brace	2	327.4	368.1	347.8	520.9	519.6	520.3
T3	Brace	3	382.5	384.0	383.3	579.9	583.3	581.6
T7	Brace	4	263.8	227.5	245.7	409.3	400.9	405.1
DT8	Braces	5	315.5	341.8	328.7	511.6	508.2	509.9
DT4,DT5,DT6,T5	Chord	6	332.2	336.8	334.5	426.4	427.5	427.0
DT8,DT9,T7,T9	Chord	7-1	347.8	340.1	344.0	507.3	499.5	503.4
DT9,T9	Braces	7-2	319.9	318.5	319.2	496.2	495.0	495.6
DT2,DT3,T1,T3	Chord	8	346.0	371.0	358.5	502.8	511.4	507.1
DT5,T5	Braces	9-1	276.2	301.5	288.9	409.9	406.1	408.0
	Braces	9-2	275.9	280.9	278.4	408.2	407.7	408.0
DT6	Brace	10	365.8	361.0	363.4	508.1	508.3	508.2
DT2	Brace	11	489.0	502.4	495.7	571.2	599.2	585.2

Table D-2: Tensile coupon tests on pipe sections (MPa)

SPECIMEN	COUPON			
	Yield Str. Brace	Yield Str. Chord	Ult. Str. Brace	Ult. Str. Chord
T1	347.8	358.5	520.3	507.1
T3	383.3	358.5	281.6	507.1
T5	283.6	334.5	408.0	427.0
T7	245.6	331.6	405.1	499.5
T9	331.6	331.6	599.5	499.5
DT2	495.7	358.5	585.2	507.1
DT3	383.3	358.5	581.6	507.1
DT4	339.4	334.5	550.0	427.0
DT5	283.6	334.5	408.0	427.0
DT6	363.4	334.5	508.2	427.0
DT8	328.5	331.6	509.9	499.5
DT9	331.6	331.6	499.5	499.5

Table D-3: Tensile coupon tests referenced by test specimen (MPa)

APPENDIX E
Measured Dimensions

C14100R020 Rev 1 February 1997

NAL

APPENDIX E

Measured Dimensions

Table of contents

Appendix E1 Piece Reference	2
Appendix E2 Wall thickness measurements	3
Appendix E3 Diameter Measurements	5
Appendix E4 Summary of measured dimensions	7

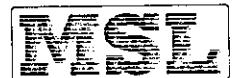

Appendix E1 Piece Reference

For the fabrication of test specimens, eleven different tubulars were used. From each type of tube the wall thickness was measured at four points around the circumference. The pieces used for the fabrication of the test specimens are shown in Table E-1

DT- / T-Joint	Brace 1	Chord	Brace 2
DT2	11	8	11
DT3	3	8	3
DT4	1	6	1
DT5	9	6	9
DT6	10	6	10
DT8	5	7	5
DT9	7	7	7
T1	2	8	-
T3	3	8	-
T5	9	6	-
T7	4	7	-
T9	7	7	-

Table E-1: Tubular references for specimens.

Appendix E2 Wall thickness measurements

The wall thickness measurements were taken using a micrometer. Table E-2 presents reference tubular wall thickness measurements taken before specimen fabrication. Table E-3 presents sample specimen wall thicknesses measured at one chord end after fabrication. The wall thickness for the braces and chords were also checked by Ultra Sonic measurements and are presented in Tables E-4 and E-5 respectively.

		MEASUREMENTS							
		End 1				End 2			
Tub. Ref.	Average	0°	90°	180°	270°	0°	90°	180°	270°
1	9.95	9.52	9.64	10.41	10.02	9.69	10.51	10.37	9.40
2	16.32	16.22	16.68	16.38	16.16	16.51	16.54	16.11	15.96
3	16.10	17.17	17.39	15.11	15.19	17.25	16.54	15.15	15.02
4	8.31	8.46	8.30	8.23	8.03	8.30	8.19	8.16	8.77
5	7.88	7.82	7.98	8.17	7.69	7.90	7.76	8.12	7.57
6	10.25	10.05	10.60	9.97	10.47	10.03	10.78	10.42	9.66
7	7.90	8.05	8.44	7.74	7.54	8.03	7.93	7.68	7.78
7		8.06	7.50	7.43	7.78	7.65	7.90	7.99	7.70
7		7.91	8.38	7.84	7.75	8.14	8.00	8.09	8.19
8	16.74	16.92	17.32	16.00	16.45	16.57	17.34	16.97	16.52
8		17.14	17.39	16.84	17.00	16.08	16.26	16.59	16.40
9	9.82	9.58	9.84	10.00	9.85	9.81	9.68	9.85	9.96
10	9.62	9.63	9.36	9.75	9.97	9.57	9.39	9.85	9.43
11	15.76	15.88	15.45	15.70	16.24	15.86	15.65	15.62	15.68

Table E-2: Wall thickness measurements using a micrometer.

			MEASUREMENTS			
Tub. Ref.	Part	Average	0°	90°	180°	270°
6	DT4-C	10.38	10.95	10.70	9.94	9.94
6	DT5-C	9.80	9.49	9.78	10.10	9.84
6	DT6-C	10.33	10.11	10.67	10.02	10.51
7	DT8-C	8.13	8.46	8.01	7.98	8.05
7	DT9-C	7.48	7.17	7.83	7.42	7.50
8	DT2-C	16.32	15.77	16.50	17.25	15.77
8	DT3-C	16.00	15.80	16.29	15.52	16.37

Table E-3: Sample specimen measurements using a micrometer

			MEASUREMENTS							
Tub. Ref.	Part	Average	Brace 1				Brace 2			
			0°	90°	180°	270°	0°	90°	180°	270°
1	DT4-B	10.19	10.40	9.80	9.90	10.60	10.00	9.60	10.40	10.80
2	T1-B	16.40	15.80	16.40	17.00	16.40				
3	DT3-B	16.46	15.90	16.10	17.20	16.20	15.40	17.40	17.10	16.40
3	T3-B	15.88	16.80	15.20	15.10	16.40				
4	T7-B	8.30	8.50	8.40	8.30	8.00				
5	DT8-B	8.18	8.40	8.30	8.20	7.80	8.40	8.10	8.10	8.10
7	DT9-B	7.91	7.80	7.70	8.00	8.10	7.80	7.80	8.10	8.00
7	T9-B	8.10	8.10	8.00	8.00	8.30				
9	DT5-B	9.98	10.40	10.00	9.70	9.90	9.80	10.20	10.00	9.80
9	T5-B	9.98	10.10	9.90	9.90	10.00				
10	DT6-B	9.93	9.80	9.90	10.20	9.70	10.00	10.00	9.60	10.20
11	DT2-B	16.05	16.20	16.00	16.30	16.50	16.00	15.40	15.80	16.20

Table E-4: Brace ultra sonic wall thickness measurements

			MEASUREMENTS			
Tub. Ref.	Part	Average	0°	90°	180°	270°
6	T5-C	9.83	9.70	9.80	9.40	10.40
6	DT4-C	10.53	10.50	9.90	11.20	10.50
6	DT5-C	9.73	9.90	9.40	9.90	9.70
6	DT6-C	10.57	10.90	10.10	10.70	
7	DT8-C	8.25	8.50	8.50	8.00	8.00
7	DT9-C	7.78	8.10	7.70	7.30	8.00
7	T7-C	8.05	7.70	8.10	8.10	8.30
7	T9-C	8.25	7.90	7.90	8.50	8.70
8	DT2-C	16.18	16.30	16.00	16.10	16.30
8	DT3-C	17.03	17.00	17.50	16.70	16.90
8	T1-C	16.23	15.80	16.10	16.50	16.50
8	T3-C	16.05	15.90	16.10	15.70	16.50

Table E-5: Chord ultra sonic wall thickness measurements



Appendix E3 Diameter Measurements

The diameter measurements for the reference tubulars and for the specimens (chord and braces) are presented in Table E-6 , Table E-7 and Table E-8, respectively.

MEASUREMENTS					
		End 1		End 2	
Tub. Ref.	Average	0°/180°	90°/270°	0°/180°	90°/270°
1	168.73	169.40	168.60	168.10	168.80
2	167.83	167.90	167.90	167.70	167.80
3	407.28	406.90	407.30	407.90	407.00
4	168.53	167.70	169.30	168.40	168.70
5	273.35	273.30	273.70	272.70	273.70
6	406.45	407.00	405.10	406.20	407.50
7	406.80	406.30	407.30	405.30	408.30
8	406.56	406.60	406.60	406.60	406.70
8		406.70	406.10	406.30	406.90
9	273.20	273.00	273.20	273.40	273.20
10	407.48	408.60	406.50	406.90	407.90
11	273.00	272.90	273.10	273.10	272.90

Table E-6: Specimen diameter measurements

MEASUREMENTS						
			End 1		End 2	
Tub. Ref.	Part	Average	0°/180°	90°/270°	0°/180°	90°/270°
1	DT4-B	168.41	168.49	168.71	168.31	168.12
2	T1-B	167.80	167.90	167.70		
3	DT3-B	407.03	405.00	405.30	408.90	408.90
3	T3-B	406.75	405.50	408.00		
4	T7-B	168.30	168.70	167.90		
5	DT8-B	273.08	274.80	273.50	272.30	271.70
7	DT9-B	403.45	404.10	402.80		
7	T9-B	407.50	405.80	409.20		
9	DT5-B	273.22	274.13	274.11	272.23	272.42
9	T5-B	273.60	274.40	272.80		
10	DT6-B	407.73	404.60	404.90	411.40	410.00
11	DT2-B	273.19	272.98	272.57	273.87	273.33

Table E-7: Brace diameter measurements

Tub. Ref.	Part	Average	MEASUREMENTS	
			0°/180°	90°/270°
6	DT4-C	407.05	404.10	410.00
6	DT5-C	406.78	411.58	401.98
6	DT6-C	407.86	408.16	407.55
6	T5-C	407.10	404.60	409.60
7	DT8-C	406.90	415.60	398.20
7	DT9-C	407.77	411.76	403.77
7	T7-C	407.80	405.60	410.00
7	T9-C	407.65	407.50	407.80
8	T1-C	407.70	407.20	408.20
8	T3-C	407.20	407.30	407.10
8	DT2-C	406.76	407.96	405.56
8	DT3-C	405.90	406.50	405.30

Table E-8: Chord diameter measurements

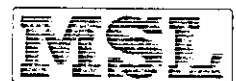

Appendix E4 Summary of measured dimensions

Table E-9 presents a summary of the average actual dimensions.

SPECIMEN	CHORD			BRACE		
	Tub. Ref.	D	T	Tub. Ref.	d	t
T1	8	406.78	16.39	2	167.81	16.32
T3	8	406.78	16.39	3	407.02	16.1
T5	6	407.05	10.19	9	273.34	9.82
T7	7	406.96	7.86	4	168.41	8.31
T9	7	406.96	7.86	7	406.96	7.86
DT2	8	406.78	16.39	11	273.09	15.76
DT3	8	406.78	16.39	3	407.02	16.1
DT4	6	407.05	10.19	1	168.57	9.95
DT5	6	407.05	10.19	9	273.34	9.82
DT6	6	407.05	10.19	10	407.6	9.61
DT8	7	406.96	7.86	5	273.21	7.88
DT9	7	406.96	7.86	7	406.96	7.86

Table E-9: Summary of averaged measured dimensions

MSL

APPENDIX F

Specification for the Strain Gauging of Test Specimens

C14100R020 Rev 1 February 1997

NSI

F-1. INTRODUCTION

The objective of the grouted joints test programme was to measure Strain Concentration Factors (SNCFs) for both ungrouted and grouted T and DT tubular joints of various geometries.

There are three aspects which need consideration to enable the correct measurement of strains. These are as follows:

- o adequate number of strain gauges and correct positioning to enable extrapolation of strain to the weld toe.
- o adequate number of strain gauges around the circumferential chord/brace intersect to enable interpolation to the hot spot location.
- o rosette gauges are required to enable measurement of principal strains when the principal stress direction is not orthogonal to the chord/brace intersect.

These aspects are addressed in Section 2 which also details current guidance for gauge positions to enable measurement of strains and extrapolation to the weld toe. The strain gauge instrumentation used for the test specimens is contained in Section 3.

F-2. BACKGROUND

Determination of SNCFs at the weld toe can be carried out using either linear or non-linear extrapolation of strain measurements. Either method should not be influenced by the stress concentrating effect of the weld. With the exception of K and Y joints (ungrooved), determination of SNCFs in tubular joints can generally be carried out using linear extrapolation. Due to the variation in gauge locations between each method, it is therefore important to either predict which type of extrapolation is required or make provision for both.

Very little test data exist for SNCF measurements on grouted tubular joints. The type of extrapolation to be used is not known and therefore it is necessary to bound the possibility of either linear or non-linear extrapolation.

Table F-1 presents recommended strain gauge positions for the test matrix based on the following guidance:

- o HSE and ECSC give essentially the same guidance for strain gauge locations to enable linear extrapolation to the weld toe.
- o DNV recommends the first strip gauge location to be $0.25T$ (where T is the thickness of the tubular) from the weld toe with four subsequent strip gauges at 2 mm centres, for linear extrapolation.
- o R S Puthli, et al, give guidance for gauge locations to enable either linear or non-linear extrapolation.

All the above state that the first strip gauge should be located a minimum 4 mm from the weld toe in order to avoid the concentrating effect of the weld. The guides attempt to position the gauges in the region of stress linearity, between the region effected by the weld and where the stress becomes equal to the nominal stress.

Puthli, et al, go one step further by giving guidance for the location of gauges to enable non-linear extrapolation, ie. quadratic extrapolation.

For any of the above methods, extrapolation is made from several strain gauge measurements. This, therefore, influences the number of gauges required to enable either linear or non-linear extrapolation.

Specimen T7, used for the preload investigations and the first specimen to be tested in the grouted condition, was instrumented with additional rosette gauges. The resultant SCF/SNCF ratio results were utilised to determine the requirement for the use of rosette gauges on the remaining grouted specimens.

F-3. STRAIN GAUGING

Table F-2 presents the strip gauge positions utilised on the specimens to enable either linear or non-linear extrapolation. The gauge region, ie. between the first and last gauges, was sufficient to adequately bound the variation and increase in stress towards the chord/brace intersect. A sufficient number of gauges were mounted, as shown in Figures F-1 and F-2, on both the brace and chord side of the intersection to enable determination of the hot spot location.

The first, third and fifth gauges of the strip gauge were connected. The first gauge position was $0.4 \times (T \text{ or } t)$ but not less than 4mm. The HSE recommended first gauge position coincided or was interpolated within the strip gauge. A single gauge was placed at the HSE recommended last gauge position. The second and fourth gauges in each strip acted as contingency, should one of the nominated gauges fail to function.

For both joint types all $\beta = 1.0$ specimens were gauged with additional intermediate gauges between crown and saddle positions on the chord side and brace side. Specimen T9 was instrumented with a full set of gauges on the chord side and brace side. This enabled an assessment of strain distribution around the intersect.

Additional strain gauges are provided on the brace(s) to enable measurement of nominal axial strains and brace bending strains. Depending on joint type, gauges were placed as follows:

T joints

Saddle and crown locations on both the chord and brace as shown in Figure F-1. Additionally for $\beta = 1.0$ test specimens, two diagonally opposite quadrants were instrumented with a further two sets of gauges, at equal spacing, on both the chord and brace.

DT joints

Saddle and crown locations on both the chord and brace as shown in Figure F-2. Additionally for $\beta = 1.0$ test specimens, the appropriate quadrant on each brace was instrumented with a further two sets of gauges, at equal spacing, on both the chord and brace.

Table F-1 presents the strain gauge positions for the first and last gauges for each of the specimens. These positions include the HSE recommendations and bound the gauge positions from the other formulations.

Specimen Ident.	Geometry				Chord Crown				Chord Saddle				Brace Crown				Brace Saddle							
	D	T	d	t	1st		Last		1st		Last		1st		Last		1st		Last					
	(mm)	(mm)	(mm)	(mm)	HSE	DnV	Puthli	HSE	DnV	Puthli	HSE	DnV	Puthli	HSE	DnV	Puthli	HSE	DnV	Puthli	HSE	DnV	Puthli		
T1	406.4	16	168.30	16.0	7.3	4.0	16.0	7.3	4.0	16.0	7.3	4.0	16.0	7.3	4.0	16.0	7.3	4.0	16.0	7.3	4.0	16.0	7.3	4.0
T3	406.4	16	406.40	16.0	11.4	4.0	6.4	11.4	4.0	6.4	11.4	4.0	6.4	11.4	4.0	6.4	11.4	4.0	6.4	11.4	4.0	6.4	11.4	4.0
T5	406.4	10	273.00	10.0	7.4	4.0	4.0	7.4	4.0	4.0	7.4	4.0	4.0	7.4	4.0	4.0	7.4	4.0	4.0	7.4	4.0	4.0	7.4	4.0
T7	406.4	7.9	168.30	8.0	5.2	4.0	4.0	5.2	4.0	4.0	5.2	4.0	4.0	5.2	4.0	4.0	5.2	4.0	4.0	5.2	4.0	4.0	5.2	4.0
T9	406.4	7.9	406.40	7.9	8.0	4.0	4.0	8.0	4.0	4.0	8.0	4.0	4.0	8.0	4.0	4.0	8.0	4.0	4.0	8.0	4.0	4.0	8.0	4.0
DT2	406.4	16	273.00	16.0	9.3	4.0	6.4	9.3	4.0	6.4	9.3	4.0	6.4	9.3	4.0	6.4	9.3	4.0	6.4	9.3	4.0	6.4	9.3	4.0
DT3	406.4	16	406.40	16.0	11.4	4.0	6.4	11.4	4.0	6.4	11.4	4.0	6.4	11.4	4.0	6.4	11.4	4.0	6.4	11.4	4.0	6.4	11.4	4.0
DT4	406.4	10	168.30	10.0	5.8	4.0	4.0	5.8	4.0	4.0	5.8	4.0	4.0	5.8	4.0	4.0	5.8	4.0	4.0	5.8	4.0	4.0	5.8	4.0
DT5	406.4	10	273.00	10.0	7.4	4.0	4.0	7.4	4.0	4.0	7.4	4.0	4.0	7.4	4.0	4.0	7.4	4.0	4.0	7.4	4.0	4.0	7.4	4.0
DT6	406.4	10	406.40	9.5	8.8	4.0	4.0	8.8	4.0	4.0	8.8	4.0	4.0	8.8	4.0	4.0	8.8	4.0	4.0	8.8	4.0	4.0	8.8	4.0
DT8	406.4	7.9	273.00	7.8	6.5	4.0	4.0	6.5	4.0	4.0	6.5	4.0	4.0	6.5	4.0	4.0	6.5	4.0	4.0	6.5	4.0	4.0	6.5	4.0
DT9	406.4	7.9	406.40	7.9	8.0	4.0	4.0	8.0	4.0	4.0	8.0	4.0	4.0	8.0	4.0	4.0	8.0	4.0	4.0	8.0	4.0	4.0	8.0	4.0

Strip Gauge Locations (in mm) from weld toe defining regions of strain linearity

Formulation :-

Location	Gauge Position	HSE / ECSC	DnV	Puthli	
				Linear	Quadratic
Chord Crown	1st	$0.2(n)^{0.5}$	0.25T	0.4T	0.4T
	Last	$0.4(nRT)^{0.25}$	0.25T + 8mm	1.0T	1.4T
Chord Saddle	1st	$0.2(n)^{0.5}$	0.25T	0.4T	0.4T
	Last	$(5/360)2AR$	0.25T + 8mm	1.0T	1.4T
Brace Crown	1st	$0.2(n)^{0.5}$	0.25T	0.4t	0.4t
	Last	$0.65(n)^{0.5}$	0.25t + 8mm	1.0t	1.4t
Brace Saddle	1st	$0.2(n)^{0.5}$	0.25t	0.4t	0.4t
	Last	$0.65(n)^{0.5}$	0.25t + 8mm	1.0t	1.4t

Note :-

For all, 1st point, 4mm minimum from weld toe

For Puthli :- Linear extrapolation for (T or t) < 10mm Last position = 4mm + 0.6 x (T or t)

Quadratic extrapolation for (T or t) < 10mm Last position = 4mm + 1.0 x (T or t)

For quadratic extrapolation, sufficient number of data points are required between 1st and last

The above dimensions are based on nominal tubular thickness. Gauge positions based on actual tubular thickness may vary.

Table F-1 Guidance for location of strain gauges to enable extrapolation of strains to chord/brace wall intersect

Specimen Ident.	Geometry			Chord Crown		Chord Saddle		Brace Crown		Brace Saddle		
	D	T	d	t	1st	Last	1st	Last	1st	Last	1st	Last
T1	406.4	16	168.30	16.0	6.4	18.3	6.4	17.7	6.4	23.9	6.4	23.9
T3	406.4	16	406.40	16.0	6.4	22.8	6.4	17.7	6.4	37.1	6.4	37.1
T5	406.4	10	273.00	10.0	4.0	16.3	4.0	17.7	4.0	24.0	4.0	24.0
T7	406.4	7.9	168.30	8.0	4.0	12.9	4.0	17.7	4.0	16.9	4.0	16.9
T9	406.4	7.9	406.40	7.9	4.0	16.0	4.0	17.7	4.0	26.0	4.0	26.0
DT2	406.4	16	273.00	16.0	6.4	20.6	6.4	17.7	6.4	30.4	6.4	30.4
DT3	406.4	16	406.40	16.0	6.4	22.8	6.4	17.7	6.4	37.1	6.4	37.1
DT4	406.4	10	168.30	10.0	4.0	14.5	4.0	17.7	4.0	18.9	4.0	18.9
DT5	406.4	10	273.00	10.0	4.0	16.3	4.0	17.7	4.0	24.0	4.0	24.0
DT6	406.4	10	406.40	9.5	4.0	17.8	4.0	17.7	4.0	28.6	4.0	28.6
DT8	406.4	7.9	273.00	7.8	4.0	14.5	4.0	17.7	4.0	21.2	4.0	21.2
DT9	406.4	7.9	406.40	7.9	4.0	16.0	4.0	17.7	4.0	26.0	4.0	26.0

Notes:-

- (1) All dimensions given in (mm)
- (2) First gauge position based on 0.4 times wall thickness with a minimum of 4mm
- (2) Last gauge position based on HSE formulation

The above dimensions are based on nominal tubular dimensions. Gauge positions based on actual tubular dimensions may vary.

Table F-2 Strain gauge locations for 1st and last gauges

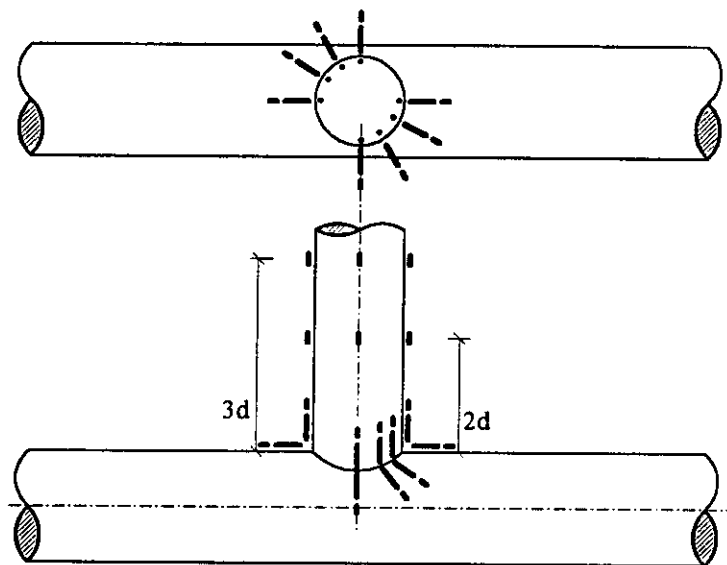

Note: Intermediate gauges @
30° & 60° positions on both
braces are for $\beta = 1.0$ joints.

Key:

- Strip gauge, consisting of 5 strain gauges, 3 of which are used
- Single strain gauge

N^o: of gauges per specimen

Location	$\beta = 0.41$ & 0.67		$\beta = 1.0$	
	Strip gauges	Single gauges	Strip gauges	Single gauges
Brace	4	12	(+4) 8	(+4) 16
Chord	4	4	(+4) 8	(+4) 8
Total	8	16	(+8) 16	(+8) 24

Note: The first $\beta = 1.0$ joint tested was gauged with a full compliment of gauges, by providing additional intermediate gauges.()

Figure F.1: Strain Gauging of T-joint Specimen

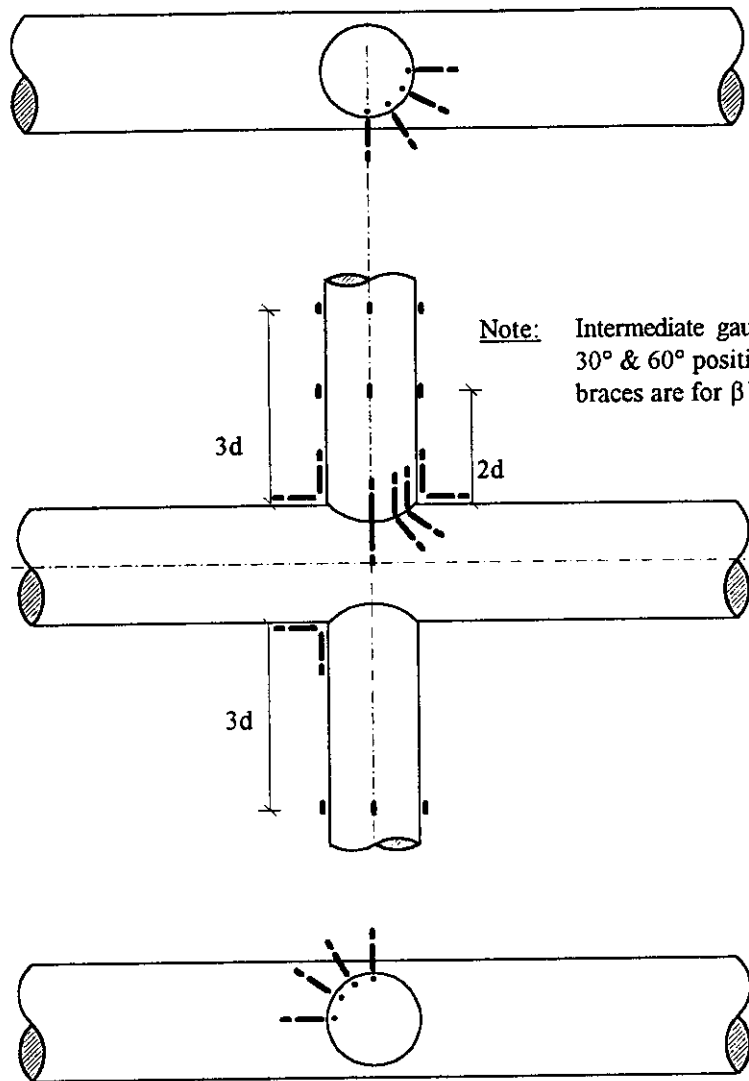

Note: Intermediate gauges @ 30° & 60° positions on both braces are for $\beta = 1.0$ joints.

Key:-

- Strip gauge, consisting of 5 strain gauges, 3 of which are used
- Single strain gauge

Nº: of gauges per specimen

Location	$\beta = 0.41 \text{ \& } 0.67$		$\beta = 1.0$	
	Strip gauges	Single gauges	Strip gauges	Single gauges
Braces	4	16	(+6) 8	(+6) 20
Chord	4	4	(+6) 8	(+6) 8
Total	8	20	(+12) 16	(+12) 28

Note: The first $\beta = 1.0$ joint tested was gauged around the full compressive side of brace & gauged around the full tensile side of the other brace for I.P.B.

Figure F.2: Strain Gauging of DT-joint Specimen

APPENDIX G
Strain Gauge Positions

C14100R020 Rev 1 February 1997

MSL

APPENDIX G

Strain Gauge Positions

Table of contents

Appendix G 1 Nominal distance of strain gauges from weld toe for SNCF measurement	2
Appendix G 2 Actual distance from weld toe to strain gauges on DT2	5
Appendix G 3 Actual distance from weld toe to strain gauges on DT3	5
Appendix G 4 Actual distance from weld toe to strain gauges on DT4	6
Appendix G 5 Actual distance from weld toe to strain gauges on DT5	6
Appendix G 6 Actual distance from weld toe to strain gauges on DT6	7
Appendix G 7 Actual distance from weld toe to strain gauges on DT8	7
Appendix G 8 Actual distance from weld toe to strain gauges on DT9	8
Appendix G 9 Actual distance from weld toe to strain gauges on T1	8
Appendix G 10 Actual distance from weld toe to strain gauges on T3	9
Appendix G 11 Actual distance from weld toe to strain gauges on T5	9
Appendix G 12 Actual distance from weld toe to strain gauges on T7	10
Appendix G 13 Actual distance from weld toe to strain gauges on T9	10

Appendix G 1 Nominal distance from weld toe to strain gauges for SNCF measurement

Strips with five strain gauges, followed by a single strain gauge at the HSE recommended last gauge position, were placed at predefined positions in order to determine a Strain Concentration Factor (SNCF). The distance between the five gauges on the strip was 2 mm. In the following text, the distance between the weld toe and the first gauge on the strip is denoted by $l_{r,min}$ and the distance between the weld toe and the last (single) strain gauge by $l_{r,max}$. The first, third and fifth single element strain gauges of the strip gauge and the last single strain gauge were used for interpolation and extrapolation of SNCFs.. The nominal positions of the strain gauges used to measure the SNCFs at certain locations are based on the average dimensions of the test specimen, see Table E-9.

The positions used are presented below:

CHORD	$l_{r,min}$ = greater of 0.4 T or 4 mm	for (cc), (cs)
	$l_{r,max}$ = $0.4 (R T r t)^{1/4}$	for (cc)
	$l_{r,max}$ = $R \pi 5/180$	for (cs)
BRACE	$l_{r,min}$ = greater of 0.4 t or 4 mm	for (bc), (bs)
	$l_{r,max}$ = $0.65 (r t)^{1/2}$	for (bc), (bs)

The nominal distances from the weld toe to the first and to the last strain gauges are given in Table G-1. The distance of the last strain gauge to the weld toe for the two intermediate positions between crown and saddle, for test specimens T3, T9, DT3, DT6 and DT9, were determined by linear interpolation of the last strain gauge positions for the crown and saddle positions. The distance to the side of the chord for the nominal brace strain gauges are given in Table G-2.

The reference numbers for the gauge positions are given in Figure G-1.

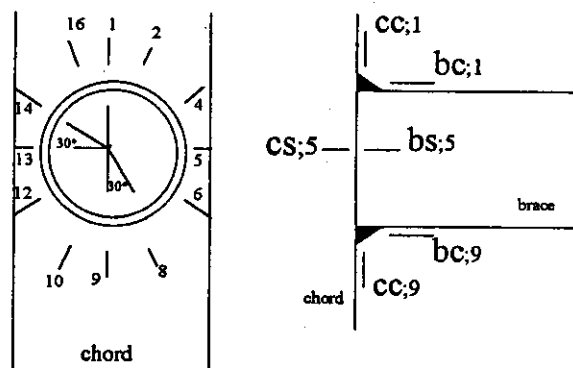

Figure G-1: Position of strain gauges at intersection of brace and chord

- Note:**
- Strain gauge positions at 30° intervals.
 - Locations 2, 4, 6, 8, 10, 12, 14 and 16 represent intermediate gauge positions.

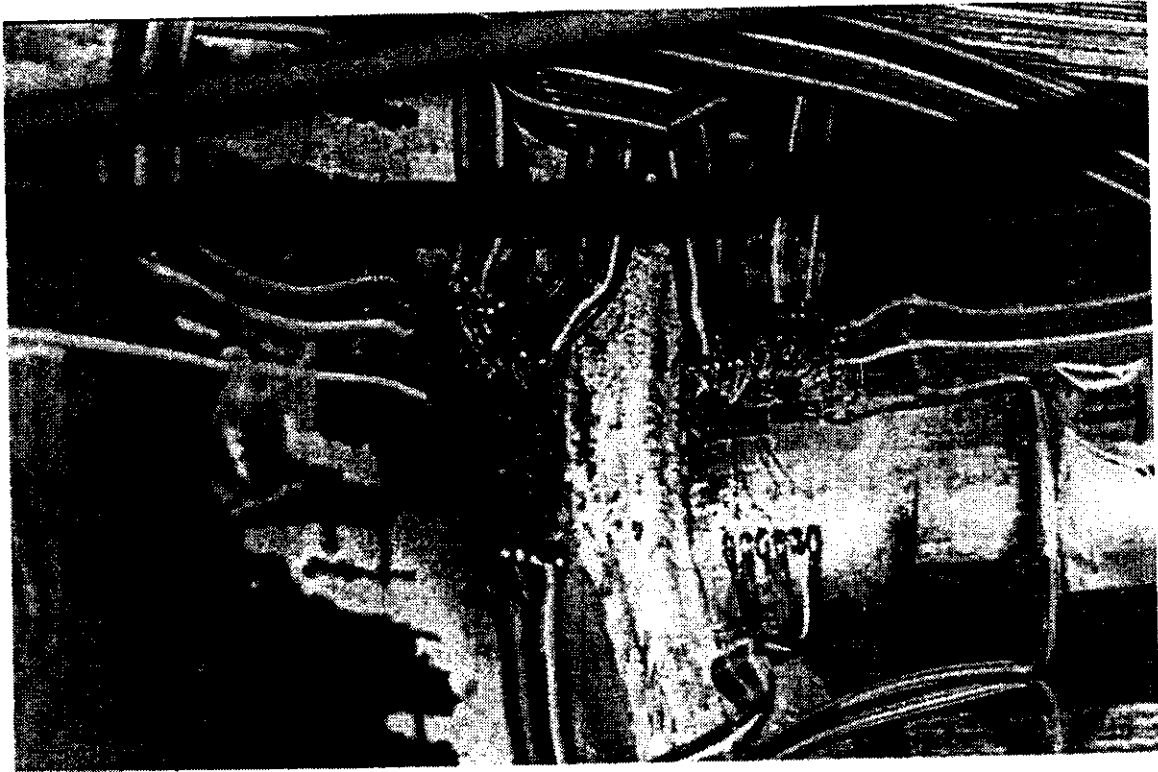

Figure G-2: Strain gauge rosettes placed besides the strip and single gauges (T7)

Specimen	CHORD		BRACE		Chord Crown	Chord Saddle	Brace Crown	Brace Saddle
	Gauge 1	Gauge 5	Gauge 1	Gauge 5	Gauge 6	Gauge 6	Gauge 6	Gauge 6
T1	6.62	14.62	6.53	14.53	18.53	17.75	24.05	24.05
T3	6.62	14.62	6.44	14.44	23.05	17.75	37.21	37.21
T5	4.08	12.08	4.00	12.00	16.34	17.76	23.81	23.81
T7	4.00	12.00	4.00	12.00	13.01	17.76	17.19	17.19
T9	4.00	12.00	4.00	12.00	16.01	17.76	26.02	26.02
DT2	6.62	14.62	6.30	14.30	20.75	17.75	30.15	30.15
DT3	6.62	14.62	6.44	14.44	23.05	17.75	37.21	37.21
DT4	4.08	12.08	4.00	12.00	14.53	17.76	18.82	18.82
DT5	4.08	12.08	4.00	12.00	16.34	17.76	23.81	23.81
DT6	4.08	12.08	4.00	12.00	17.96	17.76	28.76	28.76
DT8	4.00	12.00	4.00	12.00	14.49	17.76	21.32	21.32
DT9	4.00	12.00	4.00	12.00	16.01	17.76	26.02	26.02

Note: Gauge number refer to figure G-3

Table G-1: Distance of strain gauges from weld toe (mm)

Brace	First	Second
1	1.8*d	3.2*d
2	1.8*d	

Table G-2: Distance of circumferential gauges on brace from joint intersect (mm).

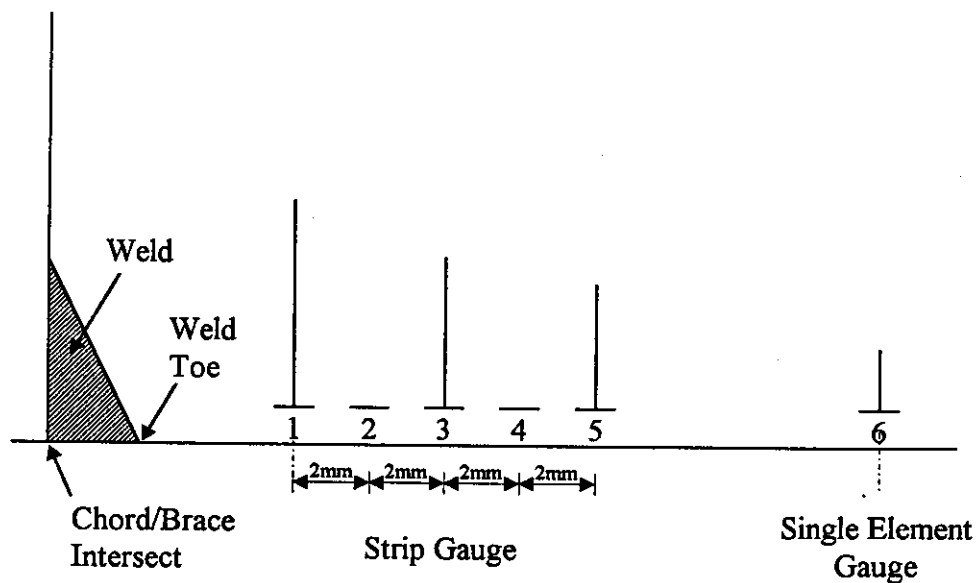

Figure G-3: Diagram indicating position of gauges.

Appendix G 2 Actual distance from weld toe to strain gauges on DT2

The actual distance from the weld toe to the first and last strain gauge for test specimen DT2 is given in Table G-3.

Position	CHORD SIDE		BRACE SIDE	
	Gauge 1	Gauge 6	Gauge 1	Gauge 6
S;5,br1	6.8	19.8	6.1	29.5
C;9,br1	6.3	20.3	6.4	29.6
C;1,br2	6.8	21.2	6.6	30.5
S;13,br2	6.6	19.6	6.3	28.3

Key:

S: Saddle
 C: Crown
 #: Location of gauge
 br: Brace
 I: Intermediate position

Table G-3: Actual distance from weld toe to first and last strain gauges on DT2 [mm]

Appendix G 3 Actual distance from weld toe to strain gauges on DT3

The actual distance from the weld toe to the first and last strain gauge for test specimen DT3 is given in Table G-4.

Position	CHORD SIDE		BRACE SIDE	
	Gauge 1	Gauge 6	Gauge 1	Gauge 6
C;1,br1	6.4	23.0	6.0	37.6
I;2,br1	6.5	21.4	6.4	37.3
I;4,br1	6.4	20.3	6.5	37.4
S;5,br1	6.5	19.5	6.3	37.3
C;9,br2 ¹	6.5	22.9	6.5	37.3
I;10,br2	6.6	21.3	6.5	37.2
I;12,br2	6.4	19.8	6.4	37.1
S;13,br2	6.5	19.5	6.5	37.3

1) 3.5 mm from crown

Table G-4: Actual distance from weld toe to first and last strain gauges on DT3 [mm]



Appendix G 4 Actual distance from weld toe to strain gauges on DT4

The actual distance from the weld toe to the first and last strain gauge for test specimen DT4 is given in Table G-5.

Position	CHORD SIDE		BRACE SIDE	
	Gauge 1	Gauge 6	Gauge 1	Gauge 6
C;1,br1	4.1	14.5	4.1	18.8
S;5,br1	4.1	17.8	4.1	18.8
C;9,br1	4.1	14.5	4.1	18.8
S;13,br1	4.1	17.8	4.1	18.8
C;1,br2	4.1	14.5	4.1	18.8
S;5,br2	4.1	17.8	4.1 ²	18.8
C;9,br2	4.1 ¹	14.5	4.1	18.8
S;13,br2	4.1	17.8	4.1	18.8

1) Middle strain gauge inactive of strip

2) First strain gauge inactive of strip

Table G-5: Actual distance from weld toe to first and last strain gauges on DT4 [mm]

Appendix G 5 Actual distance from weld toe to strain gauges on DT5

The actual distance from the weld toe to the first and last strain gauge for test specimen DT5 is given in Table G-6.

Position	CHORD SIDE		BRACE SIDE	
	Gauge 1	Gauge 6	Gauge 1	Gauge 6
C;1,br1	5.8	18.3	4.4	23.6
S;13,br1	4.0	17.2	4.3	23.8
S;5,br2	4.7	18.1	4.0	23.6
C;9,br2	4.1	16.6	4.3	21.6

Table G-6: Actual distance from weld toe to first and last strain gauges on DT5 [mm]

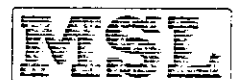

Appendix G 6 Actual distance from weld toe to strain gauges on DT6

The actual distance from the weld toe to the first and last strain gauge for test specimen DT6 is given in Table G-7.

Position	CHORD SIDE		BRACE SIDE	
	Gauge 1	Gauge 6	Gauge 1	Gauge 6
C;1,br1	4.1	17.1	4.0	29.0
I;2,br1	4.0	17.0	4.0	29.1
I;4,br1	4.1	17.2	4.0	28.8
S;5,br1	4.1	17.5	4.0	28.7
C;9,br2	4.0	17.2	4.0	28.4
I;10,br2	4.0	17.4	4.0	28.8
I;12,br2	3.6	17.7	4.0	28.8
S;13,br2	4.1	17.8	4.0	29.0

Table G-7: Actual distance from weld toe to first and last strain gauges on DT6 [mm]

Appendix G 7 Actual distance from weld toe to strain gauges on DT8

The actual distance from the weld toe to the first and last strain gauge for test specimen DT8 is given in Table G-8.

Position	CHORD SIDE		BRACE SIDE	
	Gauge 1	Gauge 6	Gauge 1	Gauge 6
C;1,br1	4.0	16.7	3.5	21.6
S;13,br1	4.0	17.0	4.2	21.5
S;5,br2	4.2	18.7	4.5	22.3
C;9,br2	4.0	17.0	4.0	21.2

Table G-8: Actual distance from weld toe to first and last strain gauges on DT8 [mm]



Appendix G 8 Actual distance from weld toe to strain gauges on DT9

The actual distance from the weld toe to the first and last strain gauge for test specimen DT9 is given in Table G-9.

Position	CHORD SIDE		BRACE SIDE	
	Gauge 1	Gauge 6	Gauge 1	Gauge 6
C;1,br1	4.0 *	16.5	4.0	26.0
I;2,br1	4.0	16.8	4.0	26.0
I;4,br1	4.0	17.5	4.0	26.5
S;5,br1	4.0	17.8	4.5	26.5
C;9,br2	4.0	16.5	4.0	26.0
I;10,br2	4.0 *	16.8	4.0	26.5
I;12,br2	4.0	17.5	4.0	25.5
S;13,br2	4.0	17.8	4.0	26.0

*) Average distance to weld toe.

Table G-9: Actual distance from weld toe to first and last strain gauges on DT9 [mm]

Appendix G 9 Actual distance from weld toe to strain gauges on T1

The actual distance from the weld toe to the first and last strain gauge for test specimen T1 is given in Table G-10.

Position	CHORD SIDE		BRACE SIDE	
	Gauge 1	Gauge 6	Gauge 1	Gauge 6
C;1	6.0	18.75	6.5	24.1
S;5	6.2	18.0	6.5	24.5
C;9	6.5	18.5	6.5	23.8
S;13	6.0	17.9	6.5	24.1

Table G-10: Actual distance from weld toe to first and last strain gauges on T1 [mm]

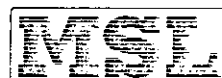

Appendix G 10 Actual distance from weld toe to strain gauges on T3

The actual distance from the weld toe to the first and last strain gauge for test specimen T3 is given in Table G-11.

Position	CHORD SIDE		BRACE SIDE	
	Gauge 1	Gauge 6	Gauge 1	Gauge 6
C;1	6.6	23.0	6.5	37.9
I;2	6.5	21.3	6.3	37.6
I;4	6.5	19.6	6.5	37.1
S;5	6.4	18.9	6.5	36.8
C;9	6.5	21.4	6.4	36.9
I;10	6.5	21.5	6.5	36.9
I,12	6.5	19.5	6.4	37.0
S;13	6.5	19.0	6.5	37.2

Table G-11: Actual distance from weld toe to first and last strain gauges on T3 [mm]

Appendix G 11 Actual distance from weld toe to strain gauges on T5

The actual distance from the weld toe to the first and last strain gauge for test specimen T5 is given in Table G-12.

Position	CHORD SIDE		BRACE SIDE	
	Gauge 1	Gauge 6	Gauge 1	Gauge 6
C;1	4.1	16.0	4.0	23.8
S;5	4.1	17.5	4.0	23.5
C;9	4.1	16.2	4.2	23.8
S;13	5.0	17.0	4.0	24.4

Table G-12: Actual distance from weld toe to first and last strain gauges on T5 [mm]

Appendix G 12 Actual distance from weld toe to strain gauges on T7

The actual distance from the weld toe to the first and last strain gauge for test specimen T7 is given in Table G-13.

Position	CHORD SIDE		BRACE SIDE	
	Gauge 1	Gauge 6	Gauge 1	Gauge 6
C;1	4.0	16.1	4.2	17.4
S;5	4.2	17.8	4.0	17.3
C;9	4.0	16.1	4.0 ¹	17.7
S;13	4.0	17.6	3.9	17.2

1) Middle strain gauge strip inactive

Table G-13: Actual distance from weld toe to first and last strain gauges on T7 [mm]

Appendix G 13 Actual distance from weld toe to strain gauges on T9

The actual distance from the weld toe to the first and last strain gauge for test specimen T9 is given in Table G-14.

Position	CHORD SIDE		BRACE SIDE	
	Gauge 1	Gauge 6	Gauge 1	Gauge 6
C;1	4.1 ¹	16.6	4.0	26.0
I;2	4.0	16.5	3.9	25.9
I;4	4.2	17.0	4.0	25.7
S;5	3.8	17.6	3.8	26.2
I;6	4.0	17.0	4.1	26.0
I;8	4.1	16.7	4.0	26.2
C;9	3.8	16.6	4.0 ²	25.8
I;10	4.0	16.9	4.0	25.8
I;12	4.0 ³	17.0	3.8	25.9
S;13	4.1 ⁴	17.8	3.9	25.7
I;14	4.0 ⁵	17.2	4.0	25.8
I;16	3.8	16.5	4.0	25.8

- 1) 3,5 mm from crown in direction of 16
- 2) 3,5 mm from crown in direction of 10
- 3) Second strain gauge of strip inactive
- 4) Last strain gauge of strip inactive
- 5) First strain gauges of strip inactive

Table G-14: Actual distance from weld toe to first and last strain gauges on T9 [mm]



APPENDIX H
Transducer Positions

C14100R020 Rev 1 February 1997

NSI

APPENDIX H

Transducer Positions

Table of contents

Appendix H-1 Joint Deformation Measurement of DT Specimens2
Appendix H-2 Joint Deformation Measurement of T Specimens.....4

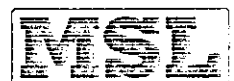

Appendix H-1 Joint Deformation of DT Specimen

The local joint deformation is measured for all loading conditions. The displacement transducers for out-of-plane deformation are also used to measure the axial deformation under tension and compression. For in-plane bending another four displacement transducers are used to measure the local joint deformation, see Figure H-1. The distances of the transducers for local joint deformation are given in Table H-1. The displacement transducers for out-of-plane bending are measured from points on both braces located 100 mm from the chord side. For in-plane bending the points on the brace are located 130 mm from the chord side. The distances were chosen to avoid local joint deformation effects and apply to all specimens

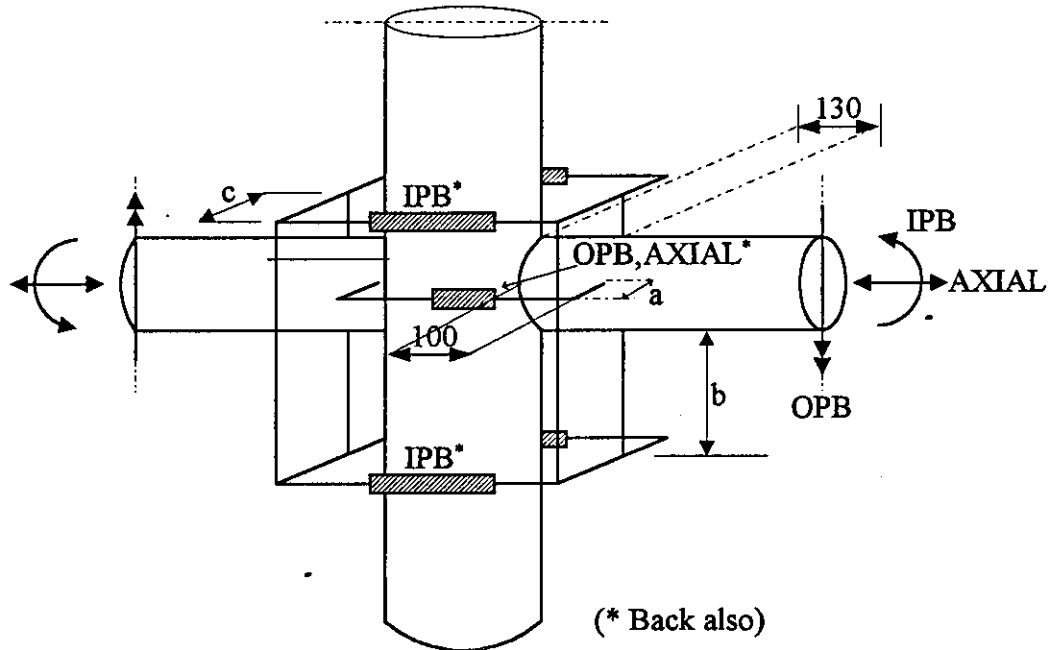

Figure H-1: Positions of displacement transducers for DT specimens.

Specimen	Instr. C/L to Brace wall (a)		Instr. C/L to Brace wall (b)		Instr. C/L to Brace C/L (c)	
	OPB-front	OPB-back	IPB-top	IPB-bottom	IPB-front	IPB-back
DT2	145	145	85	65	270	270
DT3	145	100	80	55	272	272
DT4	145	142.5	79	70.5	270	270
DT5	145	145	82.5	65	270	270
DT6	145	100	80	55	272	272
DT8	145	145	82.5	74	270	270
DT9	145	100	75	55	270	270

Note: All dimensions in (mm) Instr. = Instrument C/L = Centre line

Table H-1: Position of displacement transducers relative to specimens

The global rotation of the DT joint under bending was calculated based on the difference between displacements measured at points along the braces. The distance of the points to the chord side are given in Table H-2, see also Figure H-2.

Specimen	IPB A	IPB B	OPB A	OPB B
DT2	355.0	955.0	437.0	1038.0
DT3	529.0	1425.0	651.0	1546.0
DT4	200.0	563.0	253.0	625.0
DT5	355.0	955.0	437.0	1038.0
DT6	529.0	1425.0	651.0	1546.0
DT8	355.0	955.0	437.0	1038.0
DT9	529.0	1425.0	651.0	1546.0

Table H-2: Position of displacement transducers along the braces relative to chord side [mm]

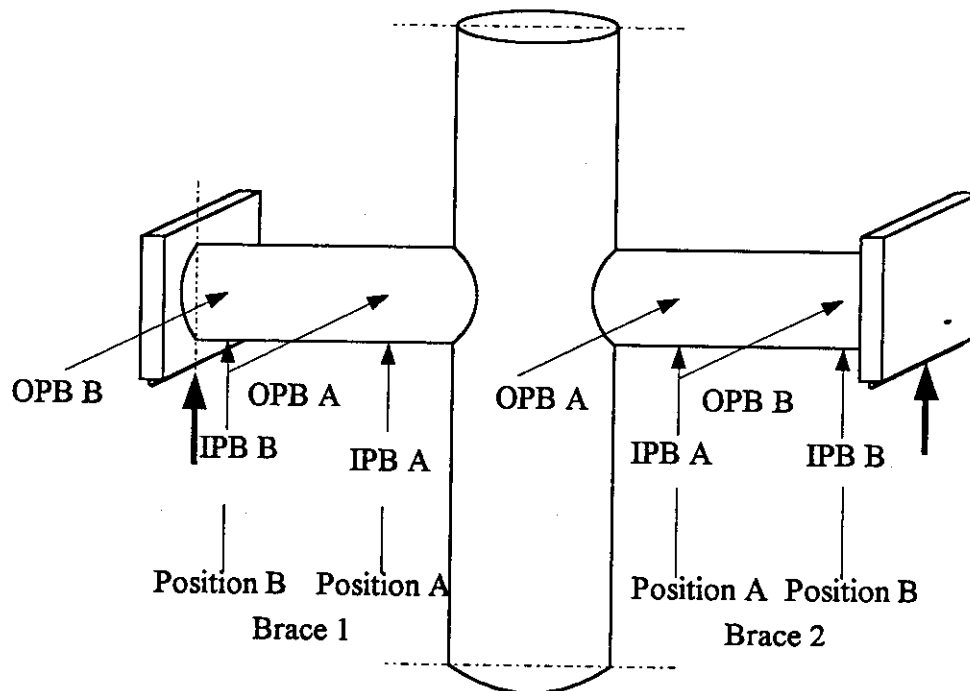

Figure H-2: Figure presenting positions of transducers on DT specimen

Appendix H-2 Joint Deformation of T Specimen

The local joint deformation is measured for all loading conditions. The displacement transducers for out-of-plane bending were also used to measure the axial deformation under tension and compression. For in-plane bending, another four displacement transducers were used to measure the local joint deformation, see Figure H-3. The distances of the transducers for local joint deformation are given in Table H-3. The displacement transducers for out-of-plane bending were measured from a point on the brace located 100 mm from the chord side. For in-plane bending the point on the brace is located 130 mm from the chord side. This was the case for all specimens. The deformation was measured relative to the section of chord diametrically opposite the brace.

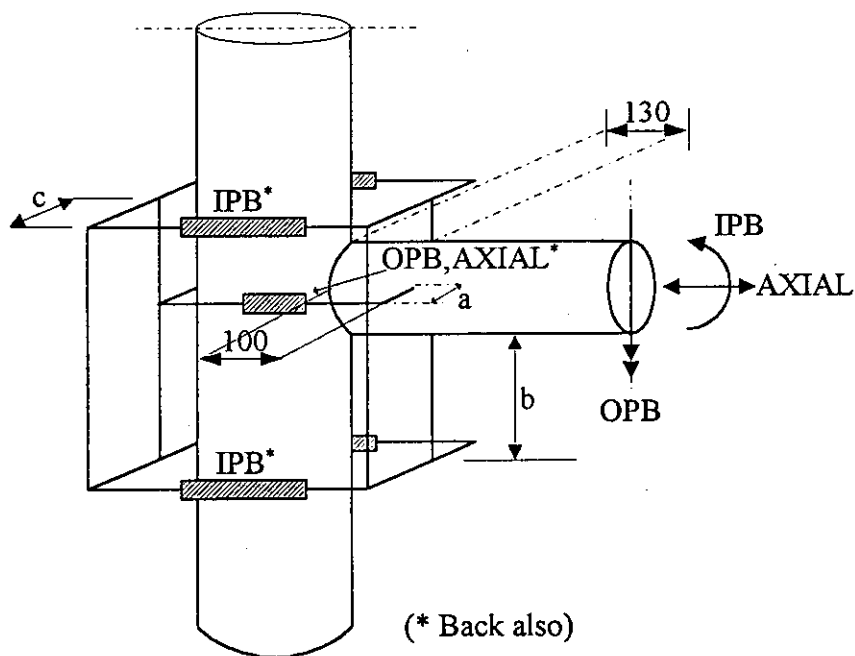

Figure H-3: Positions of displacement transducers for T specimens

Specimen	Instr. C/L to Brace wall (a)		Instr. C/L to Brace wall (b)		Instr. C/L to Brace C/L (c)	
	OPB-front	OPB-back	IPB-top	IPB-bottom	IPB-front	IPB-back
T1	195	140	85	55	270	270
T3	140	93	82	73	270	270
T5	190	140	80	60	270	270
T7	195	140	85	55	270	270
T9	138	95	80	65	270	270

Note:- All dimensions in (mm)

Table H-3: Position of displacement transducers relative to specimens

The global rotation of the T joint under bending was calculated based on the measured displacement difference between points along the brace. The distance of the points to the chord side are given in Table H-4, see also Figure H-4.

Specimen	IPB A	IPB B	OPB A	OPB B
T1	218	587	269	638
T3	520	1365	651	1500
T5	355	957	437	1039
T7	219	589	269	640
T9	520	1365	651	1500

Table H-4: Position of displacement transducers along the brace relative to chord side [mm]

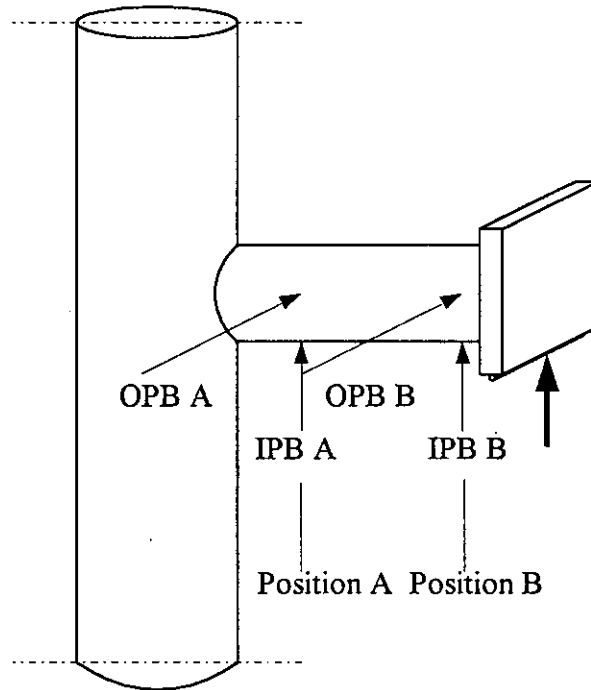

Figure H-4: Figure presenting positions of transducers on T specimens

MSL

APPENDIX I
Loading Conditions and Dimensions

C14100R020 Rev 1 February 1997

MSL

APPENDIX I

Loading Condition and Dimensions

Table of Contents

Appendix I 1 Loading on DT Specimens.....	2
Appendix I 2 Loading on T Specimens.....	3



Appendix I 1 Loading on DT specimen

The load for in plane bending was applied by a jack at one end of the chord. The braces were supported at the ends. The distance from the chord side to the centre of the support for each specimen is given in Table I-1. Out of plane bending is applied by a force out of plane to the joint at the ends of the braces. The distance of the load position to the side of the chord is given in Table I-1, see also Figure I-1.

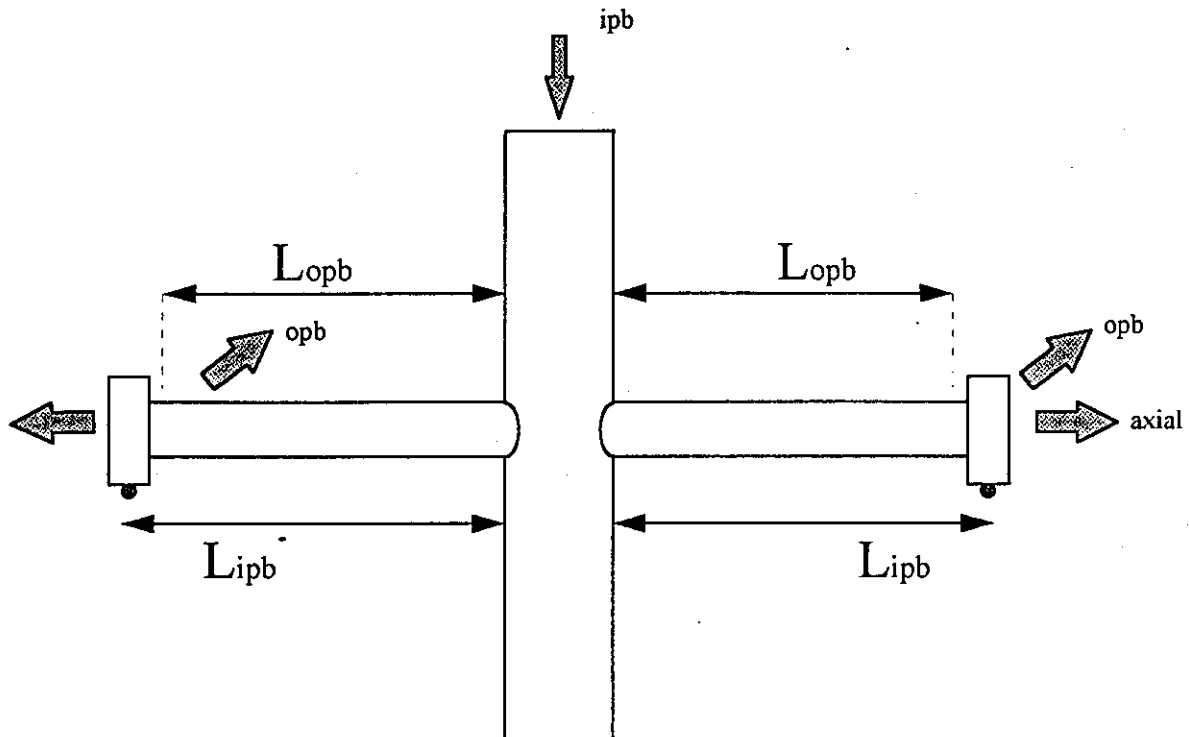

Figure I-1: Definition of L_{ipb} and L_{opb} .

Specimen	L_{ipb}	L_{opb}
DT2	1365	1295
DT3	2036	1945
DT4	843	788
DT5	1365	1285
DT6	2036	1945
DT8	1365	1285
DT9	2036	1945

Table I-1: Distance to chord side from points of loading [mm].

Appendix I 2 Loading on T specimen

In plane and out of plane bending was achieved by applying a force at the end of the brace. The distance from the chord side to the load position for each specimen is given in Table I-2, see also Figure I-2.

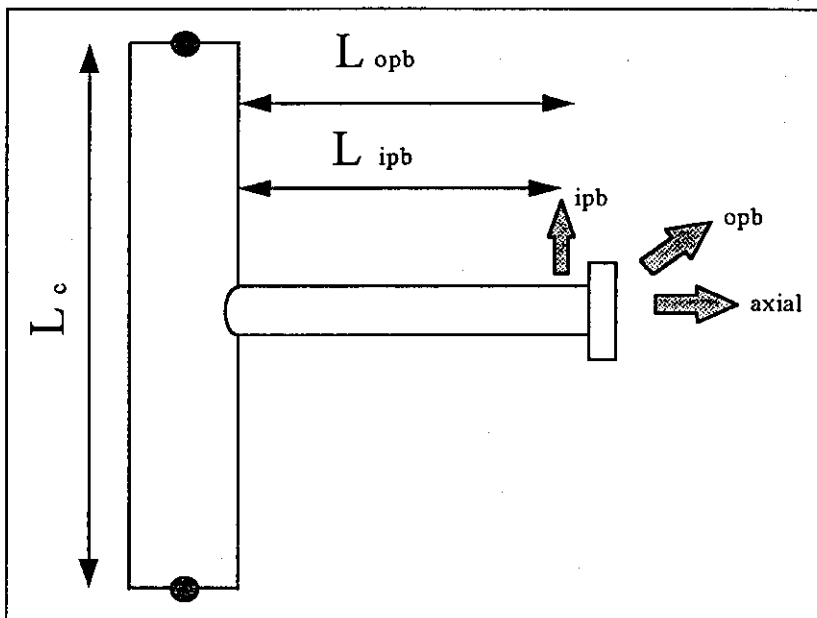

Figure I-2: Definition of L_{ipb} and L_{opb} .

Specimen	L_{ipb}	L_{opb}
T1	755	785
T3	1965	1915
T5	1265	1315
T7	790	760
T9	1965	1915

Table I-2: Distance from chord side to points of loading [mm].

APPENDIX J

Preload Investigation Sequence

C14100R020 Rev 1 February 1997

MSL

TESTING

Pre-load Investigations on Specimen T7

Examination and assessment of public domain information indicated that pre-load and the magnitude of pre-load may have a significant effect on the SCF values for a fully grouted tubular joint. It was therefore proposed that the first test specimen (T7) be used to investigate the effects of pre-load. The specimen was investigated for SCF determination for in-plane, out-of-plane, axial compression and axial tension loading cases, in turn. SCFs were calculated for loading in the above-noted sequence, since in-plane loading results in the lowest SCFs and axial tension gives rise to the highest SCFs. The proposed test procedure and sequence for specimen T7 is presented in the following table and graphically in Figure J-1:

STEP	FORM	LOAD CONDITION
1	Ungouted	Apply ten cycles of in-plane bending load on the brace at 20% of the predicted ultimate load of the ungouted joint subjected to in-plane bending. The purpose of this is to 'shake' out residual strains.
2	Ungouted	Apply in-plane bending loads to the brace in three equal increments, up to a maximum of 20% of the predicted ultimate load of the ungouted joint subjected to in-plane bending. At each load increment level, measure SNCFs. Reduce the load in three stages, taking SNCF measurements at each load level.
3	Ungouted	Repeat steps 1 and 2 for out-of-plane bending, axial compression and axial tension, in turn. For each load condition the shake out loading and the limiting load will be taken as 20% of the appropriate predicted ultimate load of the ungouted joint for the load condition under investigation.
4	Grouted	Apply in-plane bending loads to the brace in three equal increments, up to a maximum of 7% of the predicted ultimate load of the grouted joint subjected to in-plane bending. At each load increment level, measure SNCFs. Reduce the load in three stages, taking SNCF measurements of each load level.

STEP	FORM	LOAD CONDITION
5	Gouted	Repeat step 4 for out-of-plane bending, axial compression and axial tension, in turn.
6	Gouted	Repeat steps 4 and 5, but up to a maximum of 13% of the predicted ultimate load of the gouted joint for the load condition under investigation.
7	Gouted	Repeat steps 4 and 5, but up to a maximum of 20% of the predicted ultimate load of the gouted joint for the load condition under investigation.
8	Gouted	Apply axial pre-load (compression then tension) to the brace member. The magnitude of pre-load shall be 20% of the predicted ultimate strength of the gouted joint under axial tension.
9	Gouted	Remove load from the brace member.
10	Gouted	Repeat step 7.
11	Gouted	Repeat steps 8 and 9, but with a pre-load of 25%.
12	Gouted	Repeat step 7.
13	Gouted	Repeat steps 8, 9 and 7, but with a pre-load of 40%.
14	Gouted	Repeat steps 8, 9 and 7 for 40% and thereafter in 15% increments of the predicted ultimate strength of the joint under axial tension.
15	Gouted	Terminate the test at point of threshold - ie. at point where SNCFs begin to decrease or become constant.

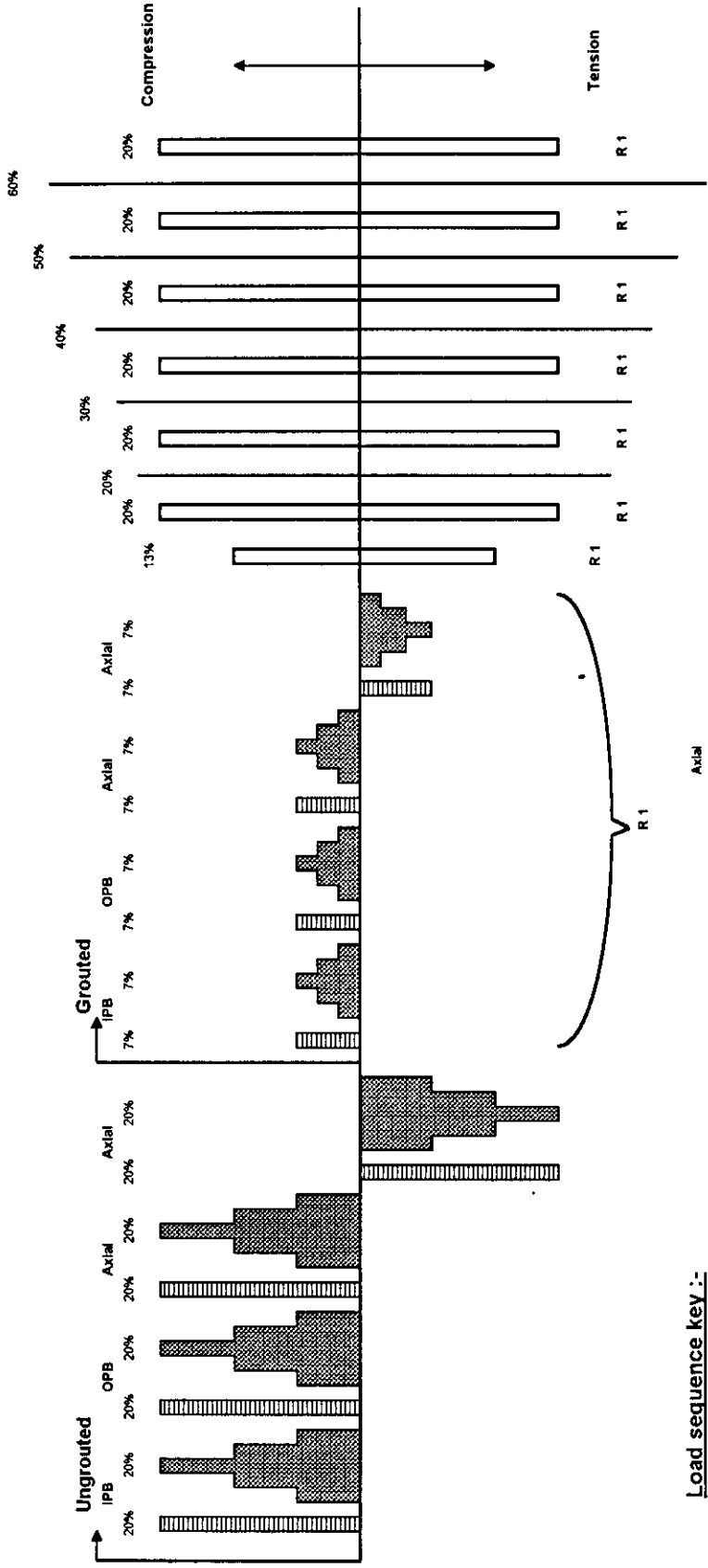

Load sequence key :-

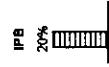

Shake down with application of 10 cycles of in-plane bending load at 20% of predicted ultimate load of joint



SNCF measurements at three equal increments up to a maximum of 20% of the predicted as-welded ultimate load for axial compression



SNCF measurements at 20% of as-welded predicted joint capacity to match load level used in as-welded SNCF measurements



Axial pre-load (compression then tension) at 50% of predicted as-welded joint strength under axial tension/compression



Repeat sequence R1

A sequence (R 1) of SNCF measurements and shakedown to be repeated

Figure J-1 Pre-load Investigations on Specimen T7



APPENDIX K
Preload Investigation Results

C14100R020 Rev 1 February 1997

MSL

APPENDIX K

Preload Investigation Results for Specimen T7 Measured SNCFs

Appendix K 1 Table of Contents

Appendix K 1 Table of Contents	1
Appendix K 2 General Information	2
Appendix K 3 First SNCF measurement cycle to 7 % joint as-welded capacity	3
Appendix K 4 Second SNCF measurement cycle to 13 % joint as-welded capacity	6
Appendix K 5 Third SNCF measurement cycle to 20 % joint as-welded capacity	9
Appendix K 6 Fourth SNCF measurement cycle to 20 % joint as-welded capacity, preload at 26 %	12
Appendix K 7 Fifth SNCF measurement cycle to 20 % joint as-welded capacity, preload at 40 %	15
Appendix K 8 Sixth SNCF measurement cycle to 20 % joint as-welded capacity, preload at 52 %	18
Appendix K 9 Seventh SNCF measurement cycle to 20 % joint as-welded capacity, preload at 65 %	21
Appendix K 10 Eighth SNCF measurement cycle to 20 % joint as-welded capacity, preload at 78 %	24
Appendix K 11 Ninth SNCF measurement cycle to 20 % joint as-welded capacity, preload at 90 %	27
Appendix K 12 Tenth SNCF measurement cycle at 20 % joint as-welded capacity, preload at 105 %	30
Appendix K 13 Eleventh SNCF measurement cycle to 20 % joint as-welded capacity, preload at 130 %	33

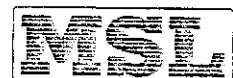

Appendix K 2 General Information

The preload investigation was conducted on specimen T7 in the grouted condition following the measurement and loading cycles presented in Figure J-1, appendix J. The preload levels correspond to the ISO predicted as-welded joint capacity. During the preload investigation, specimen T7 was loaded by in-plane bending, out-of-plane bending, axial compression and axial tension. Ten cycles of shake-down were applied, followed by SNCF measurements for each load condition. The SNCF measurements for each loading mode were repeated between applications of increasing preload levels.

Key to Tables:

Level	Load level (% of capacity)
BS	Brace Saddle
BC	Brace Crown
CS	Chord Saddle
CC	Chord Crown
#	Gauge position (see diagram below)
r	Rosette gauge
s	Single gauge

Example:

The diagram below shows all the possible locations of the strain gauges. The outer numbers show the positions of the chord gauges whilst the inner circle of numbers show the position of the brace gauges. In the tables that follow, the gauges are denoted by a two letter code followed by a position number. For example BC;9 denotes brace crown at position 9.

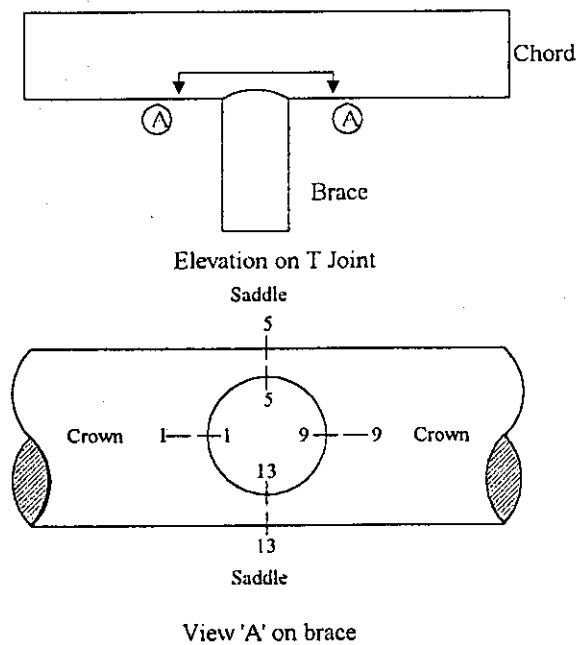

Appendix K 3 First SNCF measurement cycle to 7 % joint as-welded capacity

The measured SNCFs for the first cycle for each of the four loading conditions are presented in Table K-1. Measurements made with additional strain rosettes are presented in Table K-2. The corresponding single strain gauge measurements are also presented for comparison. The applied load levels are also presented in the following tables. The SCF/SNCF ratio as calculated from the strain rosettes is presented in Table K-3.

Table K-1: Measured SNCFs on intersection of brace and chord for T7 at first cycle.

	level	BC;1	BS;5	BC;9	BS;13	CC;1	CS;5	CC;9	CS;13
ipb	0.0179	-1.81	0.16	1.59	-0.16	-4.29	0.28	4.35	-0.46
ipb	0.0357	-2.5	0.17	1.54	0.13	-3.34	0.37	4.2	0.4
ipb	0.0354	-2.4	0.17	1.45	0.14	-3.17	0.42	4.12	0.33
ipb	0.0170	-1.83	0.12	1.49	-0.1	-4.44	0.26	4.69	-0.46
opb	0.0066	0.39	-6.8	0.05	4.87	0.97	-12.07	0.5	13.44
opb	0.0125	0.15	-6.21	-0.09	4.21	0.9	-7.84	0.5	11.68
opb	0.0126	0.15	-6.08	0.14	4.19	0.84	-7.86	0.38	11.74
opb	0.0074	0.31	-6.73	0	4.66	0.86	-11.49	0.35	13.4
axi-c	-0.0035	6.78	9.12	-3.41	5.77	21.91	21.13	-5.23	16.24
axi-c	-0.0067	6.75	7.35	-1.38	3.81	14.42	16.52	-0.49	10.43
axi-c	-0.0099	6.53	5.53	-0.89	3.11	11.32	12.66	0.87	8.49
axi-c	-0.0099	6.62	5.56	-1.15	3.05	11.32	12.25	0.75	8.64
axi-c	-0.0066	7.26	6.78	-2.01	4.08	15.45	14.97	-1.75	11.51
axi-c	-0.0035	7.04	9.59	-2.98	5.8	21.39	20.46	-5.46	16.88
axi-t	0.0035	-0.49	16.42	2.5	-4.68	2.23	37.51	13.17	-6.84
axi-t	0.0073	0.57	10.94	1.7	0.64	4.47	24.57	8.9	2.97
axi-t	0.0118	0.35	10.49	1.65	-0.31	4.2	23.69	8.89	0.5
axi-t	0.0119	0.42	10.21	2.36	-0.01	4.33	22.83	8.73	0.94
axi-t	0.0076	0.62	13.3	2.32	-2.57	5.05	29.67	9.11	-3.36
axi-t	0.0037	1.94	19.5	1.76	-6.48	9.07	43.45	8.27	-8.39

Table K-2: SNCFs measured with rosettes compared to single strain gauge measurements for first cycle of T7.

	level	BC;9-s	BC;9-r	CC;9-s	CC;9-r	CS;13-s	CS;13-r	BS;13-s	BS;13-r
ipb	0.0179	1.59	1.44	4.35	4.34	-0.46	-0.85	-0.16	-0.31
ipb	0.0357	1.54	1.45	4.2	4.17	0.4	0.04	0.13	-0.06
ipb	0.0354	1.45	1.42	4.12	4.07	0.33	0.04	0.14	-0.02
ipb	0.0170	1.49	1.47	4.69	4.56	-0.46	-0.86	-0.1	-0.21
opb	0.0066	0.05	-0.07	0.5	0.22	13.44	13.64	4.87	4.68
opb	0.0125	-0.09	0	0.5	0.38	11.68	11.89	4.21	4.01
opb	0.0126	0.14	0.02	0.38	0.45	11.74	11.98	4.19	4.22
opb	0.0074	0	0.05	0.35	0.43	13.4	13.61	4.66	4.71
axi-c	-3.3194	-3.41	-3.17	-5.23	-5.32	16.24	17.98	5.77	6.32
axi-c	-1.3433	-1.38	-1.26	-0.49	-0.45	10.43	11.52	3.81	4.14
axi-c	-0.8663	-0.89	-0.97	0.87	0.68	8.49	9.24	3.11	3.24
axi-c	-1.1194	-1.15	-0.89	0.75	0.78	8.64	9.07	3.05	3.02
axi-c	-1.9566	-2.01	-1.57	-1.75	-1.4	11.51	12.29	4.08	4.16
axi-c	-2.9008	-2.98	-2.73	-5.46	-4.78	16.88	18.34	5.8	6.15
axi-t	2.4336	2.5	3.3	13.17	13.54	-6.84	-6.73	-4.68	-3.96
axi-t	1.6548	1.7	2.08	8.9	8.97	2.97	2.95	0.64	0.69
axi-t	1.6062	1.65	2.17	8.89	8.91	0.5	0.34	-0.31	-0.33
axi-t	2.2973	2.36	2.15	8.73	8.49	0.94	0.83	-0.01	-0.14
axi-t	2.2583	2.32	2.1	9.11	8.91	-3.36	-3.4	-2.57	-2.64
axi-t	1.7132	1.76	1.5	8.27	7.47	-8.39	-8.14	-6.48	-6.15

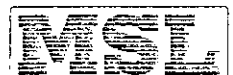

Table K-3: SCF/SNCF ratio for first cycle of T7.

	level	BC;9	CC;9	CS;13	BS;13
ipb	0.0179	1.33	1.17	1.13	1.16
ipb	0.0357	1.32	1.17	1.64	0.92
ipb	0.0354	1.32	1.18	1.92	0.4
ipb	0.0170	1.32	1.18	1.1	1.12
opb	0.0066	0.83	1.62	1.13	1.2
opb	0.0125	-0.55	1.33	1.13	1.21
opb	0.0126	0.63	1.29	1.13	1.2
opb	0.0074	0.26	1.24	1.13	1.2
axi-c	-0.0035	1.28	1.42	1.14	1.23
axi-c	-0.0067	1.22	1.84	1.15	1.21
axi-c	-0.0099	1.19	0.76	1.16	1.24
axi-c	-0.0099	1.22	0.76	1.16	1.25
axi-c	-0.0066	1.3	1.44	1.15	1.24
axi-c	-0.0035	1.3	1.27	1.14	1.24
axi-t	0.0035	1.37	1.16	1.07	1.16
axi-t	0.0073	1.35	1.15	1.23	1.4
axi-t	0.0118	1.36	1.15	4.29	0.72
axi-t	0.0119	1.37	1.16	1.55	0.12
axi-t	0.0076	1.37	1.15	1.02	1.12
axi-t	0.0037	1.46	1.15	1.07	0.66

Appendix K 4 Second SNCF measurement cycle to 13 % joint as-welded capacity

The measured SNCFs for the second cycle are presented for each of the four loading conditions in Table K-4. Measurements made with additional strain rosettes are presented in Table K-5. The applied load levels are presented in the tables. The SCF/SNCF ratio as calculated from the strain rosettes is presented in Table K-6.

Table K-4: Measured SNCFs on intersection of brace and chord for T7 at second cycle.

	level	BC;1	BS;5	BC;9	BS;13	CC;1	CS;5	CC;9	CS;13
ipb	0.0238	-1.54	0.18	1.49	-0.21	-4.14	0.57	4.45	-0.7
ipb	0.0466	-2.22	0.2	1.51	0.05	-3.45	0.52	4.35	0.1
ipb	0.0685	-2.51	0.22	1.49	0.16	-2.83	0.57	4.16	0.42
ipb	0.0684	-2.51	0.23	1.48	0.18	-2.85	0.55	4.17	0.43
ipb	0.0483	-2.36	0.2	1.56	0.1	-3.53	0.48	4.48	0.21
ipb	0.0239	-1.69	0.1	1.61	-0.03	-4.52	0.2	4.88	-0.33
opb	0.0069	0.07	-6.22	-0.04	4.63	0.7	-13	0.33	13.26
opb	0.0153	0.14	-6.32	-0.07	4.18	0.99	-8.23	0.34	11.95
opb	0.0228	0.15	-5.78	-0.09	4.01	1	-6.24	0.4	11.2
opb	0.0204	0.12	-5.9	-0.1	3.98	1.07	-5.67	0.46	11.13
opb	0.0124	0.09	-6.78	-0.04	4.37	1.03	-8.17	0.39	12.18
opb	0.0048	-0.05	-7.67	-0.09	5.11	0.97	-14.14	0.49	14.26
axi-c	-0.0066	7.16	7.95	-2.23	3.87	16.3	17.79	-2.62	10.23
axi-c	-0.0132	5.16	4.19	-0.73	3.27	9.85	9.32	1.03	8.84
axi-c	-0.0199	4.11	2.68	-0.19	3.72	7.51	6	2.11	7.69
axi-c	-0.0199	4.1	2.71	-0.19	3.78	7.5	6	2.15	7.79
axi-c	-0.0132	4.27	3.02	-0.92	4.97	9.81	6.72	0.43	10.52
axi-c	-0.0067	5.51	5.09	-2.37	5.96	15.61	11.14	-3.21	15.29
axi-t	0.0075	-0.71	10.21	3.34	1.98	1.35	22.55	11.97	5.77
axi-t	0.0137	0.1	8.57	2.35	2.35	3.31	18.93	8.95	6.91
axi-t	0.0206	0.61	7.59	1.83	2.14	4.32	16.86	7.44	6.63
axi-t	0.0206	0.64	7.5	3.09	2.28	4.3	16.54	7.41	6.72
axi-t	0.0133	0.67	9.66	2.51	1.15	4.6	21.19	7.5	3.64
axi-t	0.0069	0.45	12.03	2.54	0.48	4.47	26.39	8.55	1.71

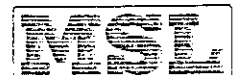

Table K-5: SNCFs measured with rosettes compared to single strain gauge measurements for second cycle of T7.

	level	BC;9-s	BC;9-r	CC;9-s	CC;9-r	CS;13-s	CS;13-r	BS;13-s	BS;13-r
ipb	0.0238	1.49	1.48	4.45	4.44	-0.7	-1.09	-0.21	-0.32
ipb	0.0466	1.51	1.44	4.35	4.28	0.1	-0.24	0.05	-0.1
ipb	0.0685	1.49	1.42	4.16	4.15	0.42	0.12	0.16	0.01
ipb	0.0684	1.48	1.42	4.17	4.16	0.43	0.15	0.18	0.02
ipb	0.0483	1.56	1.48	4.48	4.41	0.21	-0.12	0.1	-0.08
ipb	0.0239	1.61	1.61	4.88	4.89	-0.33	-0.72	-0.03	-0.25
opb	0.0069	-0.04	-0.02	0.33	0.21	13.26	13.39	4.63	4.6
opb	0.0153	-0.07	-0.16	0.34	0.19	11.95	12.02	4.18	4.07
opb	0.0228	-0.09	-0.07	0.4	0.38	11.2	11.29	4.01	3.82
opb	0.0204	-0.1	-0.07	0.46	0.38	11.13	11.29	3.98	3.82
opb	0.0124	-0.04	-0.09	0.39	0.17	12.18	12.45	4.37	4.24
opb	0.0048	-0.09	-0.14	0.49	-0.07	14.26	14.8	5.11	4.94
axi-c	-0.0066	-2.23	-2.13	-2.62	-2.52	10.23	11.54	3.87	4.13
axi-c	-0.0132	-0.73	-0.78	1.03	1.01	8.84	9.38	3.27	3.34
axi-c	-0.0199	-0.19	-0.21	2.11	2.05	7.69	8.09	3.72	3.67
axi-c	-0.0199	-0.19	-0.23	2.15	2.05	7.79	8.13	3.78	3.71
axi-c	-0.0132	-0.92	-0.84	0.43	0.36	10.52	11.04	4.97	4.94
axi-c	-0.0067	-2.37	-2.19	-3.21	-3.24	15.29	16.3	5.96	6.24
axi-t	0.0075	3.34	3.04	11.97	11.71	5.77	5.36	1.98	1.93
axi-t	0.0137	2.35	2.14	8.95	8.88	6.91	6.79	2.35	2.26
axi-t	0.0206	1.83	1.67	7.44	7.49	6.63	6.6	2.14	2.06
axi-t	0.0206	3.09	1.69	7.41	7.43	6.72	6.73	2.28	2.05
axi-t	0.0133	2.51	1.7	7.5	7.57	3.64	3.67	1.15	0.95
axi-t	0.0069	2.54	1.97	8.55	8.33	1.71	1.9	0.48	0.54



Table K-6: SCF/SNCF ratio for second cycle of T7.

	level	BC;9	CC;9	CS;13	BS;13
ipb	0.0238	1.32	1.17	1.13	1.2
ipb	0.0466	1.32	1.17	1.07	1.05
ipb	0.0685	1.32	1.17	1.25	2.49
ipb	0.0684	1.32	1.17	1.25	2.28
ipb	0.0483	1.32	1.17	1.01	1.03
ipb	0.0239	1.32	1.17	1.12	1.2
opb	0.0069	5.48	1.11	1.13	1.2
opb	0.0153	1.37	1.22	1.13	1.21
opb	0.0228	1.56	1.18	1.12	1.2
opb	0.0204	1.38	1.24	1.12	1.21
opb	0.0124	1.47	1.33	1.13	1.21
opb	0.0048	1.32	0.18	1.13	1.21
axi-c	-0.0066	1.26	0.74	1.15	1.22
axi-c	-0.0132	1.24	0.89	1.16	1.24
axi-c	-0.0199	1.06	1.04	1.16	1.21
axi-c	-0.0199	1.07	1.04	1.16	1.22
axi-c	-0.0132	1.23	0.32	1.15	1.22
axi-c	-0.0067	1.26	1.27	1.15	1.24
axi-t	0.0075	1.36	1.15	1.19	1.31
axi-t	0.0137	1.36	1.15	1.17	1.28
axi-t	0.0206	1.36	1.14	1.17	1.29
axi-t	0.0206	1.36	1.15	1.16	1.27
axi-t	0.0133	1.38	1.14	1.2	1.36
axi-t	0.0069	1.4	1.15	1.22	1.47



Appendix K 5 Third SNCF measurement cycle to 20 % joint as-welded capacity

The measured SNCFs for the third cycle are presented for each of the four loading conditions in Table K-7. Measurements made with additional strain rosettes are presented in Table K-8. The applied load levels are presented in the tables. The SCF/SNCF ratio as calculated from the strain rosettes is presented in Table K-9.

Table K-7: Measured SNCFs on intersection of brace and chord for T7 at third cycle.

	level	BC:1	BS:5	BC:9	BS:13	CC:1	CS:5	CC:9	CS:13
ipb	0.0352	-1.91	0.05	1.62	0.09	-4.13	0.15	4.68	0.12
ipb	0.0679	-2.52	0.14	1.57	0.23	-3.01	0.38	4.35	0.6
ipb	0.1031	-2.63	0.2	1.52	0.28	-2.46	0.53	4.09	0.75
ipb	0.1036	-2.62	0.19	1.43	0.26	-2.44	0.53	4.06	0.75
ipb	0.0691	-2.56	0.16	1.53	0.2	-3.07	0.41	4.42	0.61
ipb	0.0364	-2.01	0.05	1.61	0.07	-4.36	0.16	4.84	0.22
opb	0.0114	0.15	-8.53	-0.08	5.52	0.88	-14.47	0.25	16.17
opb	0.0235	0.12	-7.22	-0.1	4.67	0.95	-8.3	0.42	13.19
opb	0.0366	0.11	-6.17	-0.07	4.18	0.93	-6.05	0.51	11.64
opb	0.0386	0.07	-5.66	-0.08	4.02	0.86	-5.56	0.5	11.2
opb	0.0268	0.06	-6.31	-0.12	4.36	0.87	-7.28	0.42	12.36
opb	0.0146	0.04	-7.04	-0.12	5.09	0.73	-11.67	0.38	14.49
axi-c	-0.0100	1.77	6.14	1.71	3.66	7.96	14.14	6.96	10.94
axi-c	-0.0199	1.65	2.86	1.32	3.72	5.88	6.83	5.17	8
axi-c	-0.0297	1.75	2.1	1.46	3.3	5.02	5.07	4.55	6.4
axi-c	-0.0297	1.74	2.11	1.34	3.25	4.99	5.03	4.49	6.36
axi-c	-0.0199	1.62	2.67	0.91	4.14	5.86	6.18	4.88	8.62
axi-c	-0.0099	1.76	4.39	0.7	5.94	7.64	9.91	5.11	13.2
axi-t	0.0103	-0.23	8.82	2.62	3.06	2.61	19.31	10.15	8.38
axi-t	0.0208	0.37	7.75	1.9	2.57	3.94	17.17	7.89	7.27
axi-t	0.0323	0.81	7.01	1.5	2.17	4.72	15.56	6.69	6.56
axi-t	0.0322	0.81	7.03	1.57	2.16	4.74	15.54	6.68	6.6
axi-t	0.0206	0.43	8.01	2.03	2.43	4.02	17.68	7.87	6.95
axi-t	0.0108	-0.39	8.56	2.61	3.4	2.57	18.83	10.39	9.28



Table K-8: SNCFs measured with rosettes compared to single strain gauge measurements for third cycle of T7.

	level	BC;9-s	BC;9-r	CC;9-s	CC;9-r	CS;13-s	CS;13-r	BS;13-s	BS;13-r
ipb	0.0352	1.62	1.54	4.68	4.62	0.12	-0.16	0.09	-0.06
ipb	0.0679	1.57	1.47	4.35	4.32	0.6	0.31	0.23	0.08
ipb	0.1031	1.52	1.43	4.09	4.05	0.75	0.48	0.28	0.13
ipb	0.1036	1.43	1.42	4.06	4.03	0.75	0.46	0.26	0.11
ipb	0.0691	1.53	1.47	4.42	4.37	0.61	0.26	0.2	0.05
ipb	0.0364	1.61	1.58	4.84	4.79	0.22	-0.19	0.07	-0.08
opb	0.0114	-0.08	-0.11	0.25	0.09	16.17	18.23	5.52	5.79
opb	0.0235	-0.1	-0.13	0.42	0.23	13.19	14.41	4.67	4.7
opb	0.0366	-0.07	-0.11	0.51	0.37	11.64	12.48	4.18	4.14
opb	0.0386	-0.08	-0.1	0.5	0.37	11.2	10.82	4.02	3.86
opb	0.0268	-0.12	-0.11	0.42	0.29	12.36	11.67	4.36	4.22
opb	0.0146	-0.12	-0.13	0.38	0.17	14.49	13.25	5.09	4.89
axi-c	-0.0100	1.71	1.51	6.96	6.75	10.94	11.03	3.66	3.46
axi-c	-0.0199	1.32	1.21	5.17	4.98	8	8.11	3.72	3.55
axi-c	-0.0297	1.46	1.37	4.55	4.42	6.4	6.51	3.3	3.12
axi-c	-0.0297	1.34	1.37	4.49	4.42	6.36	6.5	3.25	3.15
axi-c	-0.0199	0.91	0.91	4.88	4.75	8.62	8.74	4.14	4.05
axi-c	-0.0099	0.7	0.71	5.11	5.12	13.2	13.58	5.94	5.66
axi-t	0.0103	2.62	2.46	10.15	10.16	8.38	8.01	3.06	2.69
axi-t	0.0208	1.9	1.84	7.89	7.83	7.27	7.13	2.57	2.36
axi-t	0.0323	1.5	1.45	6.69	6.68	6.56	6.53	2.17	2.09
axi-t	0.0322	1.57	1.42	6.68	6.71	6.6	6.61	2.16	2.09
axi-t	0.0206	2.03	1.78	7.87	7.98	6.95	6.9	2.43	2.23
axi-t	0.0108	2.61	2.52	10.39	10.41	9.28	9.06	3.4	3.06



Table K-9: SCF/SNCF ratio for third cycle of T7.

	level	BC:9	CC:9	CS:13	BS:13
ipb	0.0352	1.32	1.17	1.12	1.1
ipb	0.0679	1.32	1.17	1.18	1.43
ipb	0.1031	1.31	1.18	1.16	1.35
ipb	0.1036	1.31	1.18	1.17	1.41
ipb	0.0691	1.32	1.17	1.2	1.64
ipb	0.0364	1.32	1.17	1.1	1.02
opb	0.0114	1.83	1.25	1.13	1.21
opb	0.0235	1.43	1.28	1.13	1.21
opb	0.0366	1.37	1.24	1.12	1.21
opb	0.0386	1.3	1.23	1.12	1.21
opb	0.0268	1.3	1.23	1.12	1.21
opb	0.0146	1.45	1.3	1.13	1.21
axi-c	-0.0100	1.3	1.13	1.16	1.26
axi-c	-0.0199	1.29	1.12	1.17	1.21
axi-c	-0.0297	1.24	1.12	1.18	1.2
axi-c	-0.0297	1.23	1.12	1.18	1.2
axi-c	-0.0199	1.33	1.11	1.16	1.19
axi-c	-0.0099	1.43	1.11	1.15	1.21
axi-t	0.0103	1.37	1.15	1.17	1.26
axi-t	0.0208	1.37	1.15	1.17	1.26
axi-t	0.0323	1.37	1.15	1.17	1.27
axi-t	0.0322	1.38	1.15	1.17	1.27
axi-t	0.0206	1.38	1.15	1.16	1.26
axi-t	0.0108	1.37	1.15	1.16	1.25



Appendix K 6 Fourth SNCF measurement cycle to 20 % joint as-welded capacity, preload at 26 %

The measured SNCFs for the fourth cycle are presented for each of the four loading conditions in Table K-10. Measurements made with additional strain rosettes are presented in Table K-11. The applied load levels are presented in the tables. The SCF/SNCF ratio as calculated from the strain rosettes is presented in Table K-12.

Table K-10: Measured SNCFs on intersection of brace and chord for T7 at fourth cycle.

	level	BC;1	BS;5	BC;9	BS;13	CC;1	CS;5	CC;9	CS;13
ipb	0.0350	-1.89	0.12	1.59	0.06	-3.99	0.26	4.63	0.02
ipb	0.0689	-2.44	0.16	1.52	0.22	-2.94	0.42	4.28	0.56
ipb	0.1031	-2.58	0.21	1.48	0.26	-2.43	0.55	4.05	0.7
ipb	0.1031	-2.56	0.2	1.46	0.26	-2.43	0.54	4.06	0.71
ipb	0.0691	-2.45	0.13	1.52	0.24	-3.03	0.35	4.38	0.61
ipb	0.0361	-1.99	-0.01	1.63	0.15	-4.26	0.1	4.9	0.28
opb	0.0138	0.14	-6.99	-0.18	5.03	0.87	-12.96	0.08	14.5
opb	0.0257	0.15	-6.44	-0.14	4.44	0.89	-8.11	0.28	12.55
opb	0.0371	0.12	-5.85	-0.13	4.1	0.89	-6.25	0.41	11.55
opb	0.0354	0.1	-5.97	-0.1	4.12	0.9	-6.15	0.44	11.62
opb	0.0250	0.06	-6.62	-0.11	4.47	0.92	-7.95	0.33	12.72
opb	0.0127	0.09	-7.58	-0.19	5.23	0.9	-13.34	0.06	15.16
axi-c	-0.0100	0.72	6.36	3.2	3.53	5.55	14.26	8.52	10.58
axi-c	-0.0198	0.65	3.07	2.1	3.3	4.77	7.24	5.92	7.79
axi-c	-0.0296	0.83	2.25	2.11	2.91	4.45	5.45	5.2	6.33
axi-c	-0.0297	0.89	2.25	1.65	2.97	4.43	5.45	5.24	6.34
axi-c	-0.0199	0.8	2.99	1.52	3.68	4.95	6.88	6.02	8.29
axi-c	-0.0101	0.88	5.2	1.91	5	5.89	11.93	8.43	12.5
axi-t	0.0110	-0.56	7.58	2.59	3.87	1.25	16.65	11.25	11.09
axi-t	0.0208	0.48	8.21	1.65	2.13	3.92	18.21	8	6.42
axi-t	0.0324	0.77	7.95	1.32	1.24	4.62	17.58	7.04	4.35
axi-t	0.0323	0.78	7.99	1.79	1.35	4.6	17.65	6.96	4.51
axi-t	0.0211	0.48	8.53	1.96	2.07	4.07	18.88	7.69	6.06
axi-t	0.0106	-0.37	8.04	2.93	3.94	1.66	17.81	10.7	11.22

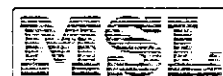

Table K-11: SNCFs measured with rosettes compared to single strain gauge measurements for fourth cycle of T7.

	level	BC;9-s	BC;9-r	CC;9-s	CC;9-r	CS;13-s	CS;13-r	BS;13-s	BS;13-r
ipb	0.0350	1.59	1.49	4.63	4.62	0.02	-0.35	0.06	-0.15
ipb	0.0689	1.52	1.45	4.28	4.29	0.56	0.25	0.22	0.04
ipb	0.1031	1.48	1.41	4.05	4.01	0.7	0.41	0.26	0.1
ipb	0.1031	1.46	1.4	4.06	4.01	0.71	0.43	0.26	0.11
ipb	0.0691	1.52	1.45	4.38	4.32	0.61	0.29	0.24	0.06
ipb	0.0361	1.63	1.57	4.9	4.85	0.28	-0.11	0.15	-0.03
opb	0.0138	-0.18	-0.13	0.08	-0.11	14.5	14.54	5.03	4.94
opb	0.0257	-0.14	-0.14	0.28	0.17	12.55	12.71	4.44	4.29
opb	0.0371	-0.13	-0.1	0.41	0.3	11.55	11.75	4.1	3.98
opb	0.0354	-0.1	-0.11	0.44	0.31	11.62	11.86	4.12	4
opb	0.0250	-0.11	-0.14	0.33	0.19	12.72	12.91	4.47	4.36
opb	0.0127	-0.19	-0.18	0.06	-0.15	15.16	15.36	5.23	5.07
axi-c	-0.0100	3.2	3.38	8.52	8.27	10.58	10.83	3.53	3.61
axi-c	-0.0198	2.1	2.23	5.92	5.67	7.79	7.92	3.3	3.24
axi-c	-0.0296	2.11	2.01	5.2	5.03	6.33	6.42	2.91	2.83
axi-c	-0.0297	1.65	2.08	5.24	5.1	6.34	6.29	2.97	2.89
axi-c	-0.0199	1.52	1.94	6.02	5.78	8.29	8.31	3.68	3.59
axi-c	-0.0101	1.91	2.24	8.43	8.17	12.5	12.4	5	4.72
axi-t	0.0110	2.59	2.8	11.25	11.17	11.09	10.78	3.87	3.69
axi-t	0.0208	1.65	1.8	8	8.04	6.42	6.23	2.13	2.07
axi-t	0.0324	1.32	1.49	7.04	7.09	4.35	4.22	1.24	1.25
axi-t	0.0323	1.79	1.45	6.96	6.95	4.51	4.49	1.35	1.29
axi-t	0.0211	1.96	1.67	7.69	7.6	6.06	6.01	2.07	1.91
axi-t	0.0106	2.93	2.45	10.7	10.44	11.22	10.87	3.94	3.75



Table K-12: SCF/SNCF ratio for fourth cycle of T7.

	level	BC:9	CC:9	CS:13	BS:13
ipb	0.0350	1.32	1.17	1.1	1.07
ipb	0.0689	1.32	1.17	1.2	1.76
ipb	0.1031	1.32	1.17	1.17	1.43
ipb	0.1031	1.32	1.18	1.17	1.4
ipb	0.0691	1.32	1.17	1.18	1.55
ipb	0.0361	1.32	1.17	1.03	0.58
opb	0.0138	1.52	1.09	1.13	1.21
opb	0.0257	1.39	1.25	1.13	1.21
opb	0.0371	1.31	1.22	1.12	1.2
opb	0.0354	1.31	1.23	1.12	1.2
opb	0.0250	1.29	1.21	1.12	1.21
opb	0.0127	1.45	1.17	1.13	1.21
axi-c	-0.0100	1.23	1.15	1.16	1.26
axi-c	-0.0198	1.22	1.44	1.17	1.22
axi-c	-0.0296	1.21	1.13	1.18	1.21
axi-c	-0.0297	1.22	1.13	1.18	1.21
axi-c	-0.0199	1.26	1.13	1.17	1.2
axi-c	-0.0101	1.32	1.07	1.16	1.22
axi-t	0.0110	1.36	1.15	1.15	1.26
axi-t	0.0208	1.37	1.15	1.17	1.27
axi-t	0.0324	1.38	1.15	1.19	1.32
axi-t	0.0323	1.38	1.15	1.19	1.31
axi-t	0.0211	1.38	1.15	1.17	1.28
axi-t	0.0106	1.21	1.15	1.15	1.25



Appendix K 7 Fifth SNCF measurement cycle to 20 % joint as-welded capacity, preload at 40 %

The measured SNCFs for the fifth cycle are presented for each of the four loading conditions in Table K-13. Measurements made with additional strain rosettes are presented in Table K-14. The applied load levels are presented in the tables. The SCF/SNCF ratio as calculated from the strain rosettes is presented in Table K-15.

Table K-13: Measured SNCFs on intersection of brace and chord for T7 at fifth cycle.

	level	BC;1	BS;5	BC;9	BS;13	CC;1	CS;5	CC;9	CS;13
ipb	0.0328	-1.81	0.18	1.53	-0.04	-3.94	0.44	4.54	-0.22
ipb	0.0662	-2.47	0.28	1.56	0.15	-2.89	0.65	4.35	0.34
ipb	0.1013	-2.61	0.29	1.5	0.22	-2.39	0.7	4.12	0.57
ipb	0.1008	-2.63	0.28	1.46	0.22	-2.41	0.7	4.15	0.58
ipb	0.0662	-2.56	0.24	1.55	0.16	-3.01	0.58	4.51	0.38
ipb	0.0332	-2.02	0.17	1.65	0	-4.28	0.39	5.06	-0.11
opb	0.0125	0.2	-7.01	-0.35	4.82	0.94	-12.14	0.1	13.88
opb	0.0248	0.15	-6.37	-0.16	4.23	0.99	-7.27	0.34	11.99
opb	0.0382	-0.12	-6	0.1	3.72	0.95	-5.46	0.41	11.03
opb	0.0368	-0.17	-5.95	-0.32	3.57	0.98	-4.98	0.4	10.86
opb	0.0249	0.14	-6.24	-0.03	4.12	1.05	-6.51	0.27	11.8
opb	0.0117	0.16	-6.94	0.02	4.65	1.07	-11.2	0.05	13.54
axi-c	-0.0099	3.16	5.16	0.36	4.19	8.64	11.68	4.62	11.73
axi-c	-0.0199	2.47	2.55	0.65	4.13	5.8	5.84	4.58	8.6
axi-c	-0.0298	2.42	2.02	0.89	3.42	4.89	4.72	4.57	6.82
axi-c	-0.0298	2.41	2.07	0.86	3.4	4.86	4.78	4.58	6.77
axi-c	-0.0200	2.33	2.38	0.46	4.49	5.82	5.31	4.24	9.04
axi-c	-0.0100	2.68	3.39	-0.08	6.06	8.4	7.59	3.15	13.75
axi-t	0.0111	0.46	9.31	1.91	3.08	4.49	20.67	8.23	8.59
axi-t	0.0212	0.64	9.08	1.7	1.79	4.64	19.94	7.52	5.21
axi-t	0.0323	1.01	7.46	1.25	2.27	5.32	16.44	6.33	6.76
axi-t	0.0324	1.08	7.4	1.4	2.24	5.37	16.32	6.3	6.74
axi-t	0.0210	0.93	8.89	1.7	2.03	5.22	19.58	7.1	5.99
axi-t	0.0111	0.71	10.46	1.94	2.27	4.91	23.23	8.41	6.55



Table K-14: SNCFs measured with rosettes compared to single strain gauge measurements for fifth cycle of T7.

	level	BC;9-s	BC;9-r	CC;9-s	CC;9-r	CS;13-s	CS;13-r	BS;13-s	BS;13-r
ipb	0.0328	1.53	1.46	4.54	4.54	-0.22	-0.63	-0.04	-0.2
ipb	0.0662	1.56	1.47	4.35	4.33	0.34	0.03	0.15	-0.01
ipb	0.1013	1.5	1.43	4.12	4.07	0.57	0.29	0.22	0.06
ipb	0.1008	1.46	1.44	4.15	4.1	0.58	0.29	0.22	0.06
ipb	0.0662	1.55	1.52	4.51	4.42	0.38	0.06	0.16	-0.01
ipb	0.0332	1.65	1.68	5.06	5.05	-0.11	-0.46	0	-0.15
opb	0.0125	-0.35	-0.12	0.1	-0.03	13.88	14	4.82	4.75
opb	0.0248	-0.16	-0.11	0.34	0.21	11.99	12.22	4.23	4.12
opb	0.0382	0.1	-0.19	0.41	0.22	11.03	11.03	3.72	3.64
opb	0.0368	-0.32	-0.23	0.4	0.22	10.86	10.8	3.57	3.55
opb	0.0249	-0.03	-0.19	0.27	0.23	11.8	11.94	4.12	4.02
opb	0.0117	0.02	-0.27	0.05	-0.03	13.54	13.95	4.65	4.61
axi-c	-0.0099	0.36	0.4	4.62	4.5	11.73	11.92	4.19	4.14
axi-c	-0.0199	0.65	0.57	4.58	4.49	8.6	8.69	4.13	3.92
axi-c	-0.0298	0.89	0.82	4.57	4.51	6.82	6.96	3.42	3.26
axi-c	-0.0298	0.86	0.82	4.58	4.47	6.77	6.95	3.4	3.25
axi-c	-0.0200	0.46	0.46	4.24	4.05	9.04	9.27	4.49	4.32
axi-c	-0.0100	-0.08	0	3.15	2.99	13.75	14.22	6.06	5.97
axi-t	0.0111	1.91	1.74	8.23	8.2	8.59	8.62	3.08	2.89
axi-t	0.0212	1.7	1.6	7.52	7.57	5.21	5.18	1.79	1.66
axi-t	0.0323	1.25	1.23	6.33	6.36	6.76	6.84	2.27	2.16
axi-t	0.0324	1.4	1.26	6.3	6.37	6.74	6.83	2.24	2.14
axi-t	0.0210	1.7	1.51	7.1	7.1	5.99	5.93	2.03	1.94
axi-t	0.0111	1.94	1.76	8.41	8.46	6.55	6.39	2.27	2.11



Table K-15: SCF/SNCF ratio for fifth cycle of T7.

	level	BC:9	CC:9	CS:13	BS:13
ipb	0.0328	1.33	1.17	1.11	1.16
ipb	0.0662	1.32	1.17	1.48	-0.28
ipb	0.1013	1.31	1.18	1.19	1.53
ipb	0.1008	1.31	1.18	1.19	1.54
ipb	0.0662	1.32	1.17	1.4	-0.65
ipb	0.0332	1.33	1.17	1.09	1.11
opb	0.0125	1.53	0.31	1.13	1.21
opb	0.0248	1.41	1.25	1.13	1.21
opb	0.0382	1.21	1.33	1.12	1.21
opb	0.0368	1.2	1.29	1.12	1.21
opb	0.0249	1.33	1.19	1.12	1.2
opb	0.0117	1.36	1.11	1.13	1.22
axi-c	-0.0099	1.5	1.1	1.15	1.24
axi-c	-0.0199	1.39	1.11	1.16	1.2
axi-c	-0.0298	1.32	1.11	1.17	1.2
axi-c	-0.0298	1.32	1.11	1.17	1.2
axi-c	-0.0200	1.45	1.11	1.16	1.19
axi-c	-0.0100	1.32	1.09	1.15	1.22
axi-t	0.0111	1.37	1.14	1.16	1.26
axi-t	0.0212	1.37	1.14	1.18	1.3
axi-t	0.0323	1.39	1.14	1.17	1.27
axi-t	0.0324	1.38	1.14	1.17	1.27
axi-t	0.0210	1.37	1.14	1.17	1.29
axi-t	0.0111	1.37	1.14	1.18	1.29

Appendix K 8 Sixth SNCF measurement cycle to 20 % joint as-welded capacity, preload at 52 %

The measured SNCFs for the sixth cycle are presented for each of the four loading conditions in Table K-16. Measurements made with additional strain rosettes are presented in Table K-17. The applied load levels are presented in the tables. The SCF/SNCF ratio as calculated from the strain rosettes is presented in Table K-18.

Table K-16: Measured SNCFs on intersection of brace and chord for T7 at sixth cycle.

	level	BC;1	BS;5	BC;9	BS;13	CC;1	CS;5	CC;9	CS;13
ipb	0.0333	-1.83	0.05	1.59	0.07	-4.18	0.14	4.78	0.04
ipb	0.0670	-2.4	0.14	1.5	0.23	-3.09	0.33	4.46	0.61
ipb	0.1010	-2.6	0.18	1.47	0.27	-2.52	0.46	4.2	0.77
ipb	0.1011	-2.59	0.19	1.54	0.28	-2.51	0.46	4.2	0.76
ipb	0.0664	-2.43	0.11	1.6	0.25	-3.19	0.27	4.57	0.65
ipb	0.0338	-1.87	0.01	1.71	0.12	-4.45	0.04	4.98	0.2
opb	0.0108	0.06	-7.31	-0.12	4.26	0.94	-7.67	0.74	11.83
opb	0.0234	0.04	-6.25	-0.06	3.93	0.86	-4.72	0.76	10.87
opb	0.0349	0.06	-5.58	-0.08	3.72	0.82	-3.79	0.76	10.28
opb	0.0357	0.08	-5.68	0	3.84	0.88	-4.23	0.67	10.67
opb	0.0248	0.07	-6.36	-0.04	4.04	0.92	-5.36	0.6	11.36
opb	0.0123	0.16	-7.4	-0.14	4.37	1.06	-8.72	0.53	12.41
axi-c	-0.0098	0.95	5.31	2.16	4.42	5.79	11.81	8.55	11.91
axi-c	-0.0200	1.18	2.8	1.91	3.93	4.61	6.13	6.45	8.29
axi-c	-0.0297	1.45	2.18	2.03	3.35	4.17	4.87	5.84	6.68
axi-c	-0.0297	1.43	2.07	0.99	3.33	4.16	4.9	5.81	6.76
axi-c	-0.0199	1.12	2.41	0.78	4.33	4.66	5.59	6.1	9.03
axi-c	-0.0099	1.14	3.21	0.85	6.97	5.61	7.09	6.39	14.31
axi-t	0.0105	-1.41	9.41	3.65	2.49	-0.46	20.92	13.67	6.89
axi-t	0.0212	-0.05	8.89	2.26	1.69	3.01	19.82	9.25	5.13
axi-t	0.0319	0.64	7.35	1.48	2.36	4.46	16.34	7.17	7.02
axi-t	0.0319	0.65	7.4	1.77	2.39	4.44	16.25	7.19	6.99
axi-t	0.0210	0.17	8.76	2.34	2.2	3.5	19.26	8.75	6.14
axi-t	0.0105	-1.07	10.38	3.66	2.44	0.72	22.7	12.77	6.31



Table K-17: SNCFs measured with rosettes compared to single strain gauge measurements for sixth cycle of T7.

	level	BC;9-s	BC;9-r	CC;9-s	CC;9-r	CS;13-s	CS;13-r	BS;13-s	BS;13-r
ipb	0.0333	1.59	1.53	4.78	4.77	0.04	-0.33	0.07	-0.11
ipb	0.0670	1.5	1.48	4.46	4.43	0.61	0.26	0.23	0.06
ipb	0.1010	1.47	1.45	4.2	4.17	0.77	0.46	0.27	0.12
ipb	0.1011	1.54	1.45	4.2	4.17	0.76	0.46	0.28	0.12
ipb	0.0664	1.6	1.51	4.57	4.54	0.65	0.3	0.25	0.09
ipb	0.0338	1.71	1.6	4.98	4.93	0.2	-0.22	0.12	-0.07
opb	0.0108	-0.12	-0.05	0.74	0.7	11.83	12.09	4.26	4.11
opb	0.0234	-0.06	-0.03	0.76	0.67	10.87	10.95	3.93	3.8
opb	0.0349	-0.08	-0.05	0.76	0.7	10.28	10.48	3.72	3.58
opb	0.0357	0	-0.09	0.67	0.61	10.67	10.86	3.84	3.7
opb	0.0248	-0.04	-0.13	0.6	0.54	11.36	11.52	4.04	3.92
opb	0.0123	-0.14	-0.2	0.53	0.39	12.41	12.65	4.37	4.26
axi-c	-0.0098	2.16	1.65	8.55	8.24	11.91	12.07	4.42	4.11
axi-c	-0.0200	1.91	1.3	6.45	6.33	8.29	8.4	3.93	3.64
axi-c	-0.0297	2.03	1.37	5.84	5.7	6.68	6.73	3.35	3.12
axi-c	-0.0297	0.99	1.4	5.81	5.72	6.76	7.17	3.33	3.2
axi-c	-0.0199	0.78	1.19	6.1	6.03	9.03	9.54	4.33	4.13
axi-c	-0.0099	0.85	1.27	6.39	6.41	14.31	15.05	6.97	6.64
axi-t	0.0105	3.65	3.75	13.67	13.65	6.89	6.59	2.49	2.08
axi-t	0.0212	2.26	2.28	9.25	9.27	5.13	5.14	1.69	1.64
axi-t	0.0319	1.48	1.58	7.17	7.16	7.02	7.14	2.36	2.27
axi-t	0.0319	1.77	1.6	7.19	7.25	6.99	6.97	2.39	2.23
axi-t	0.0210	2.34	2.14	8.75	8.89	6.14	6.04	2.2	2.01
axi-t	0.0105	3.66	3.35	12.77	12.99	6.31	6.14	2.44	2.04



Table K-18: SCF/SNCF ratio for sixth cycle of T7.

	level	BC:9	CC:9	CS:13	BS:13
ipb	0.0333	1.33	1.17	1.09	1.05
ipb	0.0670	1.33	1.17	1.22	1.6
ipb	0.1010	1.32	1.18	1.17	1.4
ipb	0.1011	1.32	1.18	1.16	1.38
ipb	0.0664	1.33	1.17	1.18	1.46
ipb	0.0338	1.33	1.17	1.08	0.87
opb	0.0108	1.77	1.16	1.12	1.2
opb	0.0234	1.3	1.16	1.12	1.2
opb	0.0349	1.17	1.2	1.12	1.2
opb	0.0357	1.16	1.21	1.12	1.2
opb	0.0248	1.25	1.21	1.12	1.2
opb	0.0123	1.29	1.2	1.13	1.21
axi-c	-0.0098	1.35	1.13	1.16	1.23
axi-c	-0.0200	1.34	1.13	1.16	1.19
axi-c	-0.0297	1.3	1.13	1.17	1.19
axi-c	-0.0297	1.3	1.13	1.17	1.2
axi-c	-0.0199	1.34	1.13	1.16	1.2
axi-c	-0.0099	1.39	1.13	1.15	1.2
axi-t	0.0105	1.35	1.15	1.17	1.29
axi-t	0.0212	1.36	1.15	1.18	1.3
axi-t	0.0319	1.37	1.15	1.16	1.27
axi-t	0.0319	1.37	1.15	1.16	1.26
axi-t	0.0210	1.36	1.15	1.17	1.27
axi-t	0.0105	1.35	1.15	1.17	1.29

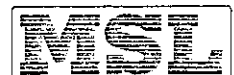

Appendix K 9 Seventh SNCF measurement cycle to 20 % joint as-welded capacity, preload at 65 %

The measured SNCFs for the seventh cycle are presented for each of the four loading conditions in Table K-19. Measurements made with additional strain rosettes are presented in Table K-20. The applied load levels are presented in the tables. The SCF/SNCF ratio as calculated from the strain rosettes is presented in Table K-21.

Table K-19: Measured SNCFs on intersection of brace and chord for T7 at seventh cycle.

	level	BC:1	BS:5	BC:9	BS:13	CC:1	CS:5	CC:9	CS:13
ipb	0.0339	-2.13	-0.06	1.49	0.05	-4.47	-0.3	4.42	0.07
ipb	0.0662	-2.25	0.06	1.52	0.26	-3.09	0.21	4.32	0.65
ipb	0.1016	-2.61	0.13	1.4	0.26	-2.56	0.35	3.98	0.7
ipb	0.1003	-2.64	0.15	1.43	0.25	-2.59	0.4	4.02	0.66
ipb	0.0649	-2.47	0.09	1.6	0.24	-3.31	0.25	4.74	0.53
ipb	0.0332	-1.88	0.03	1.72	0.09	-4.86	0.25	4.37	-0.12
opb	0.0126	0.23	-7.09	-0.27	4.98	1.12	-12.37	0.15	14.13
opb	0.0244	0.16	-6.55	-0.2	4.36	1.09	-7.61	0.29	12.3
opb	0.0359	0.16	-5.92	-0.15	4.09	1.01	-5.82	0.39	11.4
opb	0.0392	0.15	-5.65	-0.15	3.92	0.97	-5.82	0.32	11.01
opb	0.0274	0.16	-6.16	-0.2	4.09	1.03	-7.5	0.18	11.69
opb	0.0082	0.28	-5.12	-0.3	4.34	0.85	-11.8	-0.5	12.92
axi-c	-0.0097	1.02	4.39	1.61	5.59	5.9	9.88	7.42	12.62
axi-c	-0.0196	1.1	2.64	1.33	4.22	5.02	5.85	5.84	8.4
axi-c	-0.0294	1.34	1.98	1.36	3.59	4.54	4.6	5.33	6.78
axi-c	-0.0294	1.35	1.93	1.23	3.59	4.54	4.61	5.34	6.79
axi-c	-0.0197	1.19	2.29	0.97	4.62	5.11	5.26	5.38	9.06
axi-c	-0.0098	1.53	2.67	0.75	7.77	6.47	5.87	5.27	15.04
axi-t	0.0108	1.23	11.98	0.87	-0.07	6.25	27.04	6.2	0.75
axi-t	0.0211	1.15	9.69	1.11	1.07	5.8	21.45	6.18	3.74
axi-t	0.0322	1.01	6.57	1.07	3.34	5.3	14.53	5.98	9.71
axi-t	0.0323	1.03	6.51	1.23	3.34	5.32	14.43	5.95	9.65
axi-t	0.0208	0.79	7.88	1.58	3.21	4.95	17.4	6.89	9.07
axi-t	0.0108	-0.05	9.74	2.53	2.59	3.35	21.7	9.53	7.38



Table K-20: SNCFs measured with rosettes compared to single strain gauge measurements for seventh cycle of T7.

	level	BC;9-s	BC;9-r	CC;9-s	CC;9-r	CS;13-s	CS;13-r	BS;13-s	BS;13-r
ipb	0.0339	1.49	1.39	4.42	3.94	0.07	-0.26	0.05	-0.1
ipb	0.0662	1.52	1.43	4.32	4.33	0.65	0.3	0.26	0.07
ipb	0.1016	1.4	1.38	3.98	4.01	0.7	0.42	0.26	0.11
ipb	0.1003	1.43	1.4	4.02	4.06	0.66	0.39	0.25	0.1
ipb	0.0649	1.6	1.5	4.74	4.34	0.53	0.22	0.24	0.07
ipb	0.0332	1.72	1.38	4.37	4.85	-0.12	-0.34	0.09	-0.13
opb	0.0126	-0.27	-0.17	0.15	-0.16	14.13	14.33	4.98	4.76
opb	0.0244	-0.2	-0.15	0.29	0.16	12.3	12.49	4.36	4.23
opb	0.0359	-0.15	-0.14	0.39	0.24	11.4	11.53	4.09	3.94
opb	0.0392	-0.15	-0.16	0.32	0.18	11.01	11.17	3.92	3.79
opb	0.0274	-0.2	-0.18	0.18	0.04	11.69	11.92	4.09	3.97
opb	0.0082	-0.3	-0.33	-0.5	-0.91	12.92	13.11	4.34	4.14
axi-c	-0.0097	1.61	1.47	7.42	7.2	12.62	12.81	5.59	5.23
axi-c	-0.0196	1.33	1.16	5.84	5.73	8.4	8.56	4.22	4.01
axi-c	-0.0294	1.36	1.21	5.33	5.25	6.78	6.91	3.59	3.43
axi-c	-0.0294	1.23	1.21	5.34	5.29	6.79	6.99	3.59	3.45
axi-c	-0.0197	0.97	0.92	5.38	5.24	9.06	9.31	4.62	4.46
axi-c	-0.0098	0.75	0.76	5.27	5.02	15.04	15.55	7.77	7.61
axi-t	0.0108	0.87	0.99	6.2	6.24	0.75	0.94	-0.07	-0.11
axi-t	0.0211	1.11	1.16	6.18	6.19	3.74	3.79	1.07	1.08
axi-t	0.0322	1.07	1.12	5.98	6	9.71	9.97	3.34	3.3
axi-t	0.0323	1.23	1.12	5.95	6.09	9.65	9.92	3.34	3.29
axi-t	0.0208	1.58	1.32	6.89	7.06	9.07	9.2	3.21	3.13
axi-t	0.0108	2.53	2.21	9.53	9.97	7.38	7.52	2.59	2.57

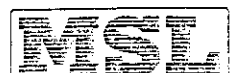
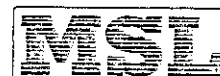

Table K-21: SCF/SNCF ratio for seventh cycle of T7.

	level	BC;9	CC;9	CS;13	BS;13
ipb	0.0339	1.28	1.18	1.06	0.99
ipb	0.0662	1.33	1.17	1.2	1.44
ipb	0.1016	1.32	1.17	1.18	1.41
ipb	0.1003	1.32	1.17	1.18	1.42
ipb	0.0649	1.31	1.17	1.23	1.45
ipb	0.0332	1.33	1.17	1.09	1.19
opb	0.0126	1.62	1.08	1.13	1.22
opb	0.0244	1.49	1.31	1.12	1.21
opb	0.0359	1.4	1.32	1.12	1.2
opb	0.0392	1.37	1.31	1.12	1.2
opb	0.0274	1.42	1.45	1.12	1.21
opb	0.0082	1.51	1.18	1.13	1.23
axi-c	-0.0097	1.36	1.13	1.16	1.21
axi-c	-0.0196	1.34	1.13	1.17	1.19
axi-c	-0.0294	1.31	1.12	1.17	1.19
axi-c	-0.0294	1.31	1.12	1.17	1.19
axi-c	-0.0197	1.35	1.12	1.16	1.18
axi-c	-0.0098	1.39	1.12	1.15	1.19
axi-t	0.0108	1.46	1.14	1.48	-0.84
axi-t	0.0211	1.42	1.14	1.21	1.35
axi-t	0.0322	1.41	1.14	1.15	1.25
axi-t	0.0323	1.42	1.15	1.15	1.24
axi-t	0.0208	1.41	1.14	1.16	1.25
axi-t	0.0108	1.38	1.15	1.16	1.26



Appendix K 10 Eighth SNCF measurement cycle to 20 % joint as-welded capacity, preload at 78 %

The measured SNCFs for the eighth cycle are presented for each of the four loading conditions in Table K-22. Measurements made with the additional strain rosettes are presented in Table K-23. The applied load levels are presented in the tables. The SCF/SNCF ratio as calculated from the strain rosettes is presented in Table K-24.

Table K-22: Measured SNCFs on intersection of brace and chord for T7 at eighth cycle.

	level	BC;1	BS;5	BC;9	BS;13	CC;1	CS;5	CC;9	CS;13
ipb	0.0334	-1.54	0.03	1.51	-0.03	-4.12	0.1	4.55	-0.2
ipb	0.0664	-2.14	0.01	1.53	0.12	-4.1	0.03	4.5	0.31
ipb	0.1017	-2.48	0.09	1.5	0.2	-3.17	0.28	4.21	0.54
ipb	0.1009	-2.51	0.1	1.53	0.2	-3.19	0.27	4.24	0.54
ipb	0.0658	-2.2	0.03	1.59	0.12	-4.21	0.08	4.67	0.27
ipb	0.0341	-1.67	-0.05	1.59	0.01	-4.47	-0.03	4.84	-0.09
opb	0.0126	0.14	-6.66	-0.22	5.6	0.52	-15.36	-0.39	16.28
opb	0.0261	0.12	-6.77	-0.12	4.81	0.67	-11.99	0	13.73
opb	0.0364	0.14	-6.44	-0.12	4.44	0.71	-9.28	0.17	12.56
opb	0.0359	0.14	-6.25	-0.1	4.25	0.65	-8.78	0.25	12.04
opb	0.0241	0.15	-6.47	-0.14	4.52	0.57	-11.91	0.07	12.97
opb	0.0122	0.16	-6	-0.15	5.19	0.46	-13.92	-0.23	15.01
axi-c	-0.0098	4.04	5.67	-0.34	7.03	12.66	11.56	3.77	18.17
axi-c	-0.0197	2.8	3.06	-0.49	5.73	8.4	6.58	4.58	12.7
axi-c	-0.0295	2.51	2.4	-0.02	4.91	6.97	5.38	4.89	9.92
axi-c	-0.0295	2.58	2.33	0.36	5.03	6.97	5.22	4.89	10.04
axi-c	-0.0196	2.68	2.33	-0.02	6.58	8.39	5.19	4.1	13.68
axi-c	-0.0097	3.6	2.41	-0.5	9.71	12.11	5.18	2.64	23.07
axi-t	0.0108	-0.64	9.21	2.87	1.87	1.79	20.37	11.82	5.3
axi-t	0.0208	0.46	9.02	1.8	0.74	4.4	19.97	8.78	2.94
axi-t	0.0321	0.82	8.31	1.39	0.35	5.15	18.56	7.49	2.27
axi-t	0.0323	0.91	8.31	1.65	0.36	5.24	18.49	7.47	2.2
axi-t	0.0209	0.65	9.38	1.97	0.21	4.74	20.8	8.54	1.53
axi-t	0.0107	-0.24	10.55	2.89	0.4	2.73	23.42	11.4	1.31

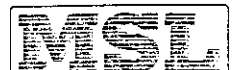

Table K-23: SNCFs measured with rosettes compared to single strain gauge measurements for eighth cycle of T7.

	level	BC;9-s	BC;9-r	CC;9-s	CC;9-r	CS;13-s	CS;13-r	BS;13-s	BS;13-r
ipb	0.0334	1.51	1.42	4.55	4.49	-0.2	-0.61	-0.03	-0.2
ipb	0.0664	1.53	1.47	4.5	4.47	0.31	-0.04	0.12	-0.03
ipb	0.1017	1.5	1.45	4.21	4.18	0.54	0.23	0.2	0.05
ipb	0.1009	1.53	1.47	4.24	4.23	0.54	0.23	0.2	0.05
ipb	0.0658	1.59	1.55	4.67	4.57	0.27	-0.08	0.12	-0.05
ipb	0.0341	1.59	1.55	4.84	4.85	-0.09	-0.47	0.01	-0.17
opb	0.0126	-0.22	-0.23	-0.39	-0.61	16.28	16.64	5.6	5.47
opb	0.0261	-0.12	-0.12	0	-0.2	13.73	14.04	4.81	4.72
opb	0.0364	-0.12	-0.11	0.17	-0.02	12.56	12.83	4.44	4.33
opb	0.0359	-0.1	-0.07	0.25	0.06	12.04	12.26	4.25	4.15
opb	0.0241	-0.14	-0.08	0.07	-0.16	12.97	13.13	4.52	4.45
opb	0.0122	-0.15	-0.12	-0.23	-0.54	15.01	15.18	5.19	5.08
axi-c	-0.0098	-0.34	-0.18	3.77	3.89	18.17	19.01	7.03	7.06
axi-c	-0.0197	-0.49	0.29	4.58	4.48	12.7	12.96	5.73	5.63
axi-c	-0.0295	-0.02	0.46	4.89	4.77	9.92	10.05	4.91	4.76
axi-c	-0.0295	0.36	0.49	4.89	4.77	10.04	10.15	5.03	4.84
axi-c	-0.0196	-0.02	0.18	4.1	4.01	13.68	13.87	6.58	6.38
axi-c	-0.0097	-0.5	-0.49	2.64	2.39	23.07	23.56	9.71	9.52
axi-t	0.0108	2.87	2.86	11.82	11.98	5.3	5.09	1.87	1.71
axi-t	0.0208	1.8	1.9	8.78	8.89	2.94	2.8	0.74	0.66
axi-t	0.0321	1.39	1.48	7.49	7.59	2.27	2.23	0.35	0.35
axi-t	0.0323	1.65	1.44	7.47	7.49	2.2	2.21	0.36	0.36
axi-t	0.0209	1.97	1.73	8.54	8.45	1.53	1.5	0.21	0.18
axi-t	0.0107	2.89	2.59	11.4	11.28	1.31	1.12	0.4	0.14



Table K-24: SCF/SNCF ratio for eighth cycle of T7.

	level	BC;9	CC;9	CS;13	BS;13
ipb	0.0334	1.33	1.17	1.12	1.15
ipb	0.0664	1.33	1.17	0.72	0.67
ipb	0.1017	1.32	1.18	1.22	1.55
ipb	0.1009	1.32	1.18	1.22	1.63
ipb	0.0658	1.32	1.18	0.9	0.89
ipb	0.0341	1.33	1.17	1.1	1.18
opb	0.0126	1.43	1.12	1.13	1.22
opb	0.0261	1.48	1.01	1.13	1.21
opb	0.0364	1.46	-0.07	1.12	1.21
opb	0.0359	1.66	1.76	1.12	1.21
opb	0.0241	1.76	0.97	1.13	1.21
opb	0.0122	1.76	1.12	1.13	1.22
axi-c	-0.0098	0.75	1.07	1.15	1.24
axi-c	-0.0197	1.69	1.1	1.16	1.23
axi-c	-0.0295	1.51	1.11	1.16	1.21
axi-c	-0.0295	1.47	1.11	1.16	1.21
axi-c	-0.0196	1.74	1.1	1.15	1.22
axi-c	-0.0097	1.14	1.03	1.15	1.23
axi-t	0.0108	1.36	1.15	1.2	1.34
axi-t	0.0208	1.37	1.14	1.02	1.53
axi-t	0.0321	1.38	1.14	1.3	1.76
axi-t	0.0323	1.39	1.14	1.3	1.7
axi-t	0.0209	1.38	1.14	2	4.69
axi-t	0.0107	1.37	1.15	1.49	2.54

Appendix K 11 Ninth SNCF measurement cycle to 20 % joint as-welded capacity, preload at 90 %

The measured SNCFs for the ninth cycle are presented for each of the four loading conditions in Table K-25. Measurements made with additional strain rosettes are presented in Table K-26. The applied load levels are presented in the tables. The SCF/SNCF ratio as calculated from the strain rosettes is presented in Table K-27.

Table K-25: Measured SNCFs on intersection of brace and chord for T7 at ninth cycle.

	level	BC;1	BS;5	BC;9	BS;13	CC;1	CS;5	CC;9	CS;13
ipb	0.0315	-1.58	0.03	1.49	-0.01	-4.22	-0.03	4.63	-0.11
ipb	0.0637	-1.92	0.01	1.51	0.02	-4.38	-0.03	4.51	-0.02
ipb	0.0988	-2.4	0.07	1.48	0.11	-3.47	0.15	4.27	0.3
ipb	0.0985	-2.41	0.05	1.54	0.12	-3.48	0.13	4.29	0.34
ipb	0.0645	-2.04	-0.06	1.61	0.07	-4.52	-0.11	4.67	0.12
ipb	0.0306	-1.73	-0.09	1.67	0.1	-4.56	-0.19	5.01	0.12
opb	0.0125	0.16	-6.25	-0.13	5.02	0.28	-13.92	0.13	14.22
opb	0.0235	0.15	-6.41	-0.05	4.54	0.47	-11.99	0.25	12.88
opb	0.0358	0.12	-6.31	-0.08	4.22	0.58	-9.04	0.32	11.86
opb	0.0380	0.12	-6.72	0	4.63	0.56	-10.33	0.24	13.11
opb	0.0246	0.14	-7.12	0.03	5.24	0.39	-14.17	0.12	14.91
opb	0.0149	0.17	-7.5	-0.01	6.03	0.29	-16.77	-0.02	17.33
axi-c	-0.0099	0.49	5.72	2.88	8	5.47	12.77	12.72	20.93
axi-c	-0.0199	1.01	3.48	2	7.41	5.42	7.66	9.34	14.41
axi-c	-0.0296	1.2	2.8	1.68	5.99	5.2	6.11	8.01	11.21
axi-c	-0.0296	1.2	2.76	1.57	5.96	5.16	6.06	8.05	11.26
axi-c	-0.0198	1.13	3	1.58	7.98	5.66	6.64	8.69	15.48
axi-c	-0.0100	0.8	3.11	2.07	11.78	5.93	6.43	10.66	26.59
axi-t	0.0106	-1.03	7.73	3.3	3.04	0.66	17.15	13.16	8.7
axi-t	0.0212	0.78	9.81	1.76	-0.47	5.03	22.09	8.37	0.1
axi-t	0.0318	1.08	7.67	1.28	1.32	5.71	17.27	7	4.54
axi-t	0.0318	1.08	7.7	1.41	1.36	5.71	17.08	7	4.68
axi-t	0.0211	0.83	9.19	1.79	0.76	5.3	20.27	8.21	3.12
axi-t	0.0110	0.08	11.26	2.77	0.1	3.35	24.8	10.97	0.85



Table K-26: SNCFs measured with rosettes compared to single strain gauge measurements for ninth cycle of T7.

	level	BC;9-s	BC;9-r	CC;9-s	CC;9-r	CS;13-s	CS;13-r	BS;13-s	BS;13-r
ipb	0.0315	1.49	1.47	4.63	4.54	-0.11	-0.49	-0.01	-0.16
ipb	0.0637	1.51	1.48	4.51	4.45	-0.02	-0.38	0.02	-0.14
ipb	0.0988	1.48	1.46	4.27	4.22	0.3	-0.03	0.11	-0.04
ipb	0.0985	1.54	1.47	4.29	4.25	0.34	0.01	0.12	-0.02
ipb	0.0645	1.61	1.53	4.67	4.62	0.12	-0.26	0.07	-0.1
ipb	0.0306	1.67	1.57	5.01	4.96	0.12	-0.3	0.1	-0.09
opb	0.0125	-0.13	0	0.13	-0.19	14.22	14.33	5.02	4.79
opb	0.0235	-0.05	-0.01	0.25	0	12.88	13.07	4.54	4.39
opb	0.0358	-0.08	-0.02	0.32	0.1	11.86	12.05	4.22	4.07
opb	0.0380	0	-0.07	0.24	0.06	13.11	13.36	4.63	4.52
opb	0.0246	0.03	-0.07	0.12	-0.07	14.91	15.17	5.24	5.07
opb	0.0149	-0.01	-0.07	-0.02	-0.31	17.33	17.52	6.03	5.89
axi-c	-0.0099	2.88	2.56	12.72	12.78	20.93	20.99	8	7.59
axi-c	-0.0199	2	1.75	9.34	9.18	14.41	14.54	7.41	7.1
axi-c	-0.0296	1.68	1.47	8.01	7.86	11.21	11.32	5.99	5.7
axi-c	-0.0296	1.57	1.51	8.05	7.82	11.26	11.35	5.96	5.69
axi-c	-0.0198	1.58	1.57	8.69	8.5	15.48	15.62	7.98	7.68
axi-c	-0.0100	2.07	2.05	10.66	10.4	26.59	26.85	11.78	11.5
axi-t	0.0106	3.3	3.13	13.16	13.18	8.7	-8.37	3.04	3.01
axi-t	0.0212	1.76	1.74	8.37	8.54	0.1	0.1	-0.47	-0.43
axi-t	0.0318	1.28	1.28	7	7.08	4.54	4.66	1.32	1.35
axi-t	0.0318	1.41	1.3	7	7.1	4.68	4.69	1.36	1.31
axi-t	0.0211	1.79	1.66	8.21	8.34	3.12	2.92	0.76	0.67
axi-t	0.0110	2.77	2.48	10.97	11.11	0.85	0.27	0.1	-0.08

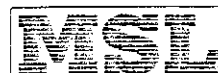

Table K-27: SCF/SNCF ratio for ninth cycle of T7.

	level	BC:9	CC:9	CS:13	BS:13
ipb	0.0315	1.33	1.17	1.14	1.11
ipb	0.0637	1.33	1.17	1.1	1.07
ipb	0.0988	1.32	1.18	0.4	0.7
ipb	0.0985	1.32	1.18	3.44	0.3
ipb	0.0645	1.32	1.17	1.07	1.04
ipb	0.0306	1.33	1.17	1.1	1.04
opb	0.0125	-13.77	1.03	1.13	1.22
opb	0.0235	3.34	8.5	1.12	1.21
opb	0.0358	2.44	1.48	1.12	1.21
opb	0.0380	1.55	1.99	1.12	1.21
opb	0.0246	1.7	0.56	1.13	1.21
opb	0.0149	1.73	0.93	1.13	1.22
axi-c	-0.0099	1.37	1.14	1.15	1.25
axi-c	-0.0199	1.38	1.13	1.16	1.21
axi-c	-0.0296	1.38	1.13	1.16	1.2
axi-c	-0.0296	1.37	1.13	1.16	1.2
axi-c	-0.0198	1.37	1.13	1.15	1.2
axi-c	-0.0100	1.37	1.13	1.14	1.22
axi-t	0.0106	1.36	1.15	1.17	1.28
axi-t	0.0212	1.37	1.15	5.21	0.65
axi-t	0.0318	1.39	1.14	1.21	1.35
axi-t	0.0318	1.4	1.14	1.2	1.35
axi-t	0.0211	1.38	1.14	1.25	1.49
axi-t	0.0110	1.38	1.14	2.47	-1.12



Appendix K 12 Tenth SNCF measurement cycle at 20 % joint as-welded capacity, preload at 105 %

The measured SNCFs for the tenth cycle are presented for each of the four loading conditions in Table K-28. Measurements made with additional strain rosettes are presented in Table K-29. The applied load levels are presented in the tables. The SCF/SNCF ratio as calculated from the strain rosettes is presented in Table K-30.

Table K-28: Measured SNCFs on intersection of brace and chord for T7 at tenth cycle.

	level	BC;1	BS;5	BC;9	BS;13	CC;1	CS;5	CC;9	CS;13
ipb	0.0325	-1.68	-0.01	1.61	-0.03	-4.45	0.08	5.02	-0.23
ipb	0.0651	-1.85	-0.15	1.61	0	-4.68	-0.31	4.68	-0.08
ipb	0.1003	-2.29	-0.07	1.57	0.07	-4.36	-0.12	4.38	0.16
ipb	0.1009	-2.28	-0.07	1.57	0.07	-4.34	-0.14	4.35	0.18
ipb	0.0660	-1.85	-0.12	1.63	0	-4.71	-0.31	4.74	-0.09
ipb	0.0331	-1.71	-0.05	1.58	0.01	-4.52	-0.12	4.86	-0.12
opb	0.0123	0.23	-6.84	-0.3	5.42	0.63	-15.27	-0.78	15.7
opb	0.0256	0.27	-6.28	-0.14	4.64	0.64	-13.03	-0.28	13.32
opb	0.0370	0.23	-6.44	-0.1	4.42	0.6	-11.19	0.02	12.46
opb	0.0364	0.25	-6.38	-0.04	4.4	0.59	-11.08	0.05	12.35
opb	0.0240	0.32	-6.35	-0.05	4.83	0.55	-13.4	-0.17	13.69
opb	0.0122	0.31	-6.58	-0.2	5.41	0.83	-15.16	-0.7	15.68
axi-c	-0.0098	6.37	-4.99	-3.24	17.15	18.53	-11.85	-5.89	35.29
axi-c	-0.0197	4.41	-1.03	-1.37	10.8	12.83	-2.68	-0.45	19.6
axi-c	-0.0296	3.61	-0.32	-0.74	8.74	10.44	-1.02	1.24	14.61
axi-c	-0.0296	3.74	-0.38	-0.89	8.76	10.79	-1.06	0.82	14.7
axi-c	-0.0197	4.66	-2.03	-1.78	11.96	13.59	-4.83	-1.46	21.28
axi-c	-0.0099	6.78	-5.53	-3.8	18.28	19.68	-12.91	-7.08	38.63
axi-t	0.0110	-0.46	8.16	2.95	2.17	1.62	18.42	11.88	5.27
axi-t	0.0214	0.24	8.56	2.34	0.58	3.65	19.1	9.85	1.88
axi-t	0.0322	0.65	7.03	1.78	1.53	4.61	15.76	8.33	4.59
axi-t	0.0322	0.61	7.04	1.86	1.47	4.59	15.52	8.33	4.78
axi-t	0.0212	0.38	8.7	2.26	0.52	4.05	19	9.5	2.31
axi-t	0.0112	0.12	10.79	2.87	-0.53	3.05	23.65	10.92	-1.03



Table K-29: SNCFs measured with rosettes compared to single strain gauge measurements for tenth cycle of T7.

	level	BC;9-s	BC;9-r	CC;9-s	CC;9-r	CS;13-s	CS;13-r	BS;13-s	BS;13-r
ipb	0.0325	1.61	1.56	5.02	4.78	-0.23	-0.59	-0.03	-0.18
ipb	0.0651	1.61	1.54	4.68	4.58	-0.08	-0.42	0	-0.15
ipb	0.1003	1.57	1.5	4.38	4.31	0.16	-0.17	0.07	-0.08
ipb	0.1009	1.57	1.48	4.35	4.29	0.18	-0.16	0.07	-0.08
ipb	0.0660	1.63	1.56	4.74	4.69	-0.09	-0.48	0	-0.17
ipb	0.0331	1.58	1.57	4.86	4.95	-0.12	-0.52	0.01	-0.17
opb	0.0123	-0.3	-0.2	-0.78	-1.01	15.7	16.39	5.42	5.38
opb	0.0256	-0.14	-0.07	-0.28	-0.44	13.32	13.74	4.64	4.61
opb	0.0370	-0.1	-0.06	0.02	-0.18	12.46	12.82	4.42	4.33
opb	0.0364	-0.04	-0.08	0.05	-0.16	12.35	12.61	4.4	4.29
opb	0.0240	-0.05	-0.11	-0.17	-0.45	13.69	13.99	4.83	4.67
opb	0.0122	-0.2	-0.21	-0.7	-0.9	15.68	16.18	5.41	5.32
axi-c	-0.0098	-3.24	-3.28	-5.89	-6.29	35.29	36.79	17.15	17.14
axi-c	-0.0197	-1.37	-1.41	-0.45	-0.63	19.6	20.48	10.8	10.66
axi-c	-0.0296	-0.74	-0.72	1.24	1.1	14.61	15.17	8.74	8.6
axi-c	-0.0296	-0.89	-0.89	0.82	0.67	14.7	15.32	8.76	8.66
axi-c	-0.0197	-1.78	-1.79	-1.46	-1.79	21.28	22.28	11.96	11.83
axi-c	-0.0099	-3.8	-3.73	-7.08	-7.39	38.63	40.36	18.28	18.33
axi-t	0.0110	2.95	2.89	11.88	11.88	5.27	4.95	2.17	1.88
axi-t	0.0214	2.34	2.25	9.85	10	1.88	1.69	0.58	0.45
axi-t	0.0322	1.78	1.73	8.33	8.39	4.59	4.53	1.53	1.42
axi-t	0.0322	1.86	1.76	8.33	8.39	4.78	4.62	1.47	1.4
axi-t	0.0212	2.26	2.11	9.5	9.61	2.31	1.98	0.52	0.41
axi-t	0.0112	2.87	2.66	10.92	11.11	-1.03	-1.67	-0.53	-0.66



Table K-30: SCF/SNCF ratio for tenth cycle of T7.

	level	BC:9	CC:9	CS:13	BS:13
ipb	0.0325	1.33	1.17	1.11	1.2
ipb	0.0651	1.33	1.18	1.11	1.12
ipb	0.1003	1.32	1.18	1.07	1.04
ipb	0.1009	1.32	1.18	1.06	1.05
ipb	0.0660	1.32	1.17	1.1	1.14
ipb	0.0331	1.33	1.17	1.12	1.14
opb	0.0123	1.54	1.11	1.13	1.22
opb	0.0256	2.01	1.08	1.12	1.21
opb	0.0370	1.96	0.92	1.12	1.21
opb	0.0364	1.72	0.88	1.12	1.21
opb	0.0240	1.69	1.03	1.13	1.21
opb	0.0122	1.59	1.11	1.13	1.22
axi-c	-0.0098	1.3	1.23	1.14	1.21
axi-c	-0.0197	1.26	1.7	1.15	1.21
axi-c	-0.0296	1.24	0.89	1.15	1.2
axi-c	-0.0296	1.26	0.69	1.15	1.2
axi-c	-0.0197	1.29	1.37	1.14	1.21
axi-c	-0.0099	1.31 -	1.23	1.14	1.21
axi-t	0.0110	1.34	1.15	1.2	1.28
axi-t	0.0214	1.36	1.15	1.36	1.59
axi-t	0.0322	1.37	1.15	1.21	1.33
axi-t	0.0322	1.36	1.15	1.21	1.33
axi-t	0.0212	1.36	1.15	1.33	1.65
axi-t	0.0112	1.34	1.14	0.91	0.93

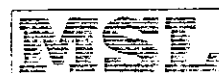

Appendix K 13 Eleventh SNCF measurement cycle to 20 % joint as-welded capacity, preload at 130 %

The measured SNCFs for the eleventh cycle are presented for each of the four loading conditions in Table K-31. Measurements made with additional strain rosettes are presented in Table K-32. The applied load levels are presented in the tables. The SCF/SNCF ratio as calculated from the strain rosettes is presented in Table K-33.

Table K-31: Measured SNCFs on intersection of brace and chord for T7 at eleventh cycle.

	level	BC;1	BS;5	BC;9	BS;13	CC;1	CS;5	CC;9	CS;13
ipb	0.0329	-1.75	-0.01	1.51	-0.07	-4.26	-0.01	4.58	-0.26
ipb	0.0661	-1.74	-0.2	1.57	-0.05	-4.46	-0.42	4.48	-0.24
ipb	0.1010	-1.99	-0.17	1.56	-0.06	-4.67	-0.35	4.34	-0.19
ipb	0.1020	-1.97	-0.17	1.56	-0.04	-4.62	-0.35	4.28	-0.19
ipb	0.0658	-1.8	-0.19	1.61	-0.07	-4.53	-0.39	4.6	-0.33
ipb	0.0325	-1.71	-0.04	1.52	-0.01	-4.33	-0.05	4.76	-0.27
opb	0.0079	0.29	-6.77	-0.46	5.78	1.28	-15.59	-1.28	16.35
opb	0.0207	0.42	-6.07	-0.08	4.81	0.9	-13.02	-0.46	13.48
opb	0.0331	0.33	-6.01	-0.06	4.45	0.77	-12.21	-0.16	12.44
opb	0.0360	0.11	-6.36	0.2	4.86	0.18	-13.14	0.41	13.7
opb	0.0237	0.04	-6.66	0.29	5.45	-0.06	-14.53	0.47	15.33
opb	0.0112	-0.33	-7.66	0.37	6.66	-0.83	-17.55	0.91	19.09
axi-c	-0.0100	4.48	0.57	-1.7	10.45	15.59	0.91	-0.74	29.03
axi-c	-0.0199	3.76	1.28	-0.63	10.22	12.87	2.47	2.53	26.12
axi-c	-0.0298	3.46	1.65	-0.11	9.34	11.3	3.48	3.48	19.73
axi-c	-0.0298	3.46	1.65	-0.16	9.32	11.26	3.5	3.52	19.7
axi-c	-0.0200	3.95	0.76	-0.85	11.01	13.17	1.28	2.07	27.8
axi-c	-0.0100	4.71	-2.33	-2.22	13.89	16.53	-5.51	-1.57	38.14
axi-t	0.0106	0.37	7.34	2.18	1.68	4.03	15.59	8.82	5.4
axi-t	0.0213	0.82	6.03	1.74	2.49	5.05	12.99	7.52	7.39
axi-t	0.0319	1.12	5.22	1.39	2.85	5.7	11.33	6.74	8.37
axi-t	0.0320	1.11	5.19	1.13	2.81	5.65	11.44	6.69	8.27
axi-t	0.0208	0.78	6	1.42	2.43	5	13.2	7.52	7.09
axi-t	0.0107	-0.04	7.45	2.32	1.42	2.72	16.6	10.18	4.25



Table K-32: SNCFs measured with rosettes compared to single strain gauge measurements for eleventh cycle of T7.

ipb	0.0329	1.51	1.54	4.58	4.47	-0.26	-0.7	-0.07	-0.2
ipb	0.0661	1.57	1.51	4.48	4.46	-0.24	-0.62	-0.05	-0.2
ipb	0.1010	1.56	1.53	4.34	4.32	-0.19	-0.57	-0.06	-0.21
ipb	0.1020	1.56	1.51	4.28	4.28	-0.19	-0.55	-0.04	-0.2
ipb	0.0658	1.61	1.57	4.6	4.55	-0.33	-0.74	-0.07	-0.24
ipb	0.0325	1.52	1.53	4.76	4.69	-0.27	-0.7	-0.01	-0.23
opb	0.0079	-0.46	-0.34	-1.28	-1.43	16.35	16.64	5.78	5.62
opb	0.0207	-0.08	-0.06	-0.46	-0.59	13.48	13.75	4.81	4.74
opb	0.0331	-0.06	-0.03	-0.16	-0.38	12.44	12.64	4.45	4.33
opb	0.0360	0.2	0.16	0.41	0.2	13.7	13.87	4.86	4.76
opb	0.0237	0.29	0.22	0.47	0.25	15.33	15.55	5.45	5.3
opb	0.0112	0.37	0.28	0.91	0.6	19.09	19.27	6.66	6.54
axi-c	-0.0100	-1.7	-1.8	-0.74	-0.77	29.03	30.3	10.45	10.47
axi-c	-0.0199	-0.63	-0.68	2.53	2.35	26.12	26.93	10.22	10.11
axi-c	-0.0298	-0.11	-0.18	3.48	3.36	19.73	20.31	9.34	9.22
axi-c	-0.0298	-0.16	-0.18	3.52	3.34	19.7	20.22	9.32	9.22
axi-c	-0.0200	-0.85	-0.84	2.07	1.89	27.8	28.54	11.01	10.9
axi-c	-0.0100	-2.22	-2.29	-1.57	-1.97	38.14	39.29	13.89	13.83
axi-t	0.0106	2.18	1.79	8.82	8.82	5.4	4.91	1.68	1.57
axi-t	0.0213	1.74	1.45	7.52	7.57	7.39	7.22	2.49	2.39
axi-t	0.0319	1.39	1.17	6.74	6.78	8.37	8.39	2.85	2.75
axi-t	0.0320	1.13	1.19	6.69	6.8	8.27	8.31	2.81	2.74
axi-t	0.0208	1.42	1.5	7.52	7.62	7.09	7.04	2.43	2.36
axi-t	0.0107	2.32	2.44	10.18	10.25	4.25	3.84	1.42	1.33

Table K-33: SCF/SNCF ratio for eleventh cycle of T7.

	level	BC:9	CC:9	CS:13	BS:13
ipb	0.0329	1.32	1.17	1.13	1.16
ipb	0.0661	1.32	1.17	1.12	1.16
ipb	0.1010	1.32	1.18	1.11	1.14
ipb	0.1020	1.32	1.18	1.11	1.15
ipb	0.0658	1.33	1.18	1.12	1.2
ipb	0.0325	1.33	1.17	1.13	1.18
opb	0.0079	1.33	1.14	1.13	1.21
opb	0.0207	2.24	1.07	1.13	1.21
opb	0.0331	2.93	1	1.12	1.21
opb	0.0360	1.07	1.47	1.12	1.21
opb	0.0237	1.1	1.45	1.13	1.21
opb	0.0112	1.21	1.27	1.13	1.21
axi-c	-0.0100	1.27	1.61	1.14	1.24
axi-c	-0.0199	1.19	1.01	1.14	1.23
axi-c	-0.0298	0.83	1.07	1.15	1.22
axi-c	-0.0298	0.83	1.06	1.15	1.22
axi-c	-0.0200	1.2	0.97	1.14	1.23
axi-c	-0.0100	1.27	1.37	1.14	1.22
axi-t	0.0106	1.4	1.15	1.19	1.35
axi-t	0.0213	1.38	1.14	1.17	1.29
axi-t	0.0319	1.4	1.14	1.17	1.27
axi-t	0.0320	1.39	1.14	1.17	1.27
axi-t	0.0208	1.43	1.14	1.17	1.27
axi-t	0.0107	1.4	1.15	1.22	1.33



MSE

APPENDIX L
As-welded SNCF Measurements

C14100R020 Rev 1 February 1997

MSL

APPENDIX L

As-welded SNCF Measurements

Appendix L 1 Table of Contents

Appendix L 1 Table of Contents	1
Appendix L 2 General information	2
Appendix L 3 SNCFs ungrouted Test Specimen: DT2	3
Appendix L 4 SNCFs ungrouted Test Specimen: DT3	4
Appendix L 5 SNCFs ungrouted Test Specimen: DT4	6
Appendix L 6 SNCFs ungrouted Test Specimen: DT5	8
Appendix L 7 SNCFs ungrouted Test Specimen: DT6	9
Appendix L 8 SNCFs ungrouted Test Specimen: DT8	11
Appendix L 9 SNCFs ungrouted Test Specimen: DT9	12
Appendix L 10 SNCFs ungrouted Test Specimen: T1	14
Appendix L 11 SNCFs ungrouted Test Specimen: T3	15
Appendix L 12 SNCFs ungrouted Test Specimen: T5	17
Appendix L 13 SNCFs ungrouted Test Specimen: T7	18
Appendix L 14 SNCFs ungrouted Test Specimen: T9	19
Appendix L 15 SNCFs ungrouted Test Specimen: T9 second	23
Appendix L 16 SCF/SNCF ratios for Test Specimen: T7	27

Appendix L 2 General Information

KEY:-

BC	Brace Crown
BS	Brace Saddle
BI	Brace Intermediate
CC	Chord Crown
CS	Chord Saddle
CI	Chord Intermediate
br1	Brace 1
br2	Brace 2
#	Gauge location (see figure)

The table rows correspond to SNCF measurements taken at 3 equal increments up to approximately 20 % as-welded joint capacity and 3 equal decrements back down to zero load. This has been repeated for each of the four loading modes.

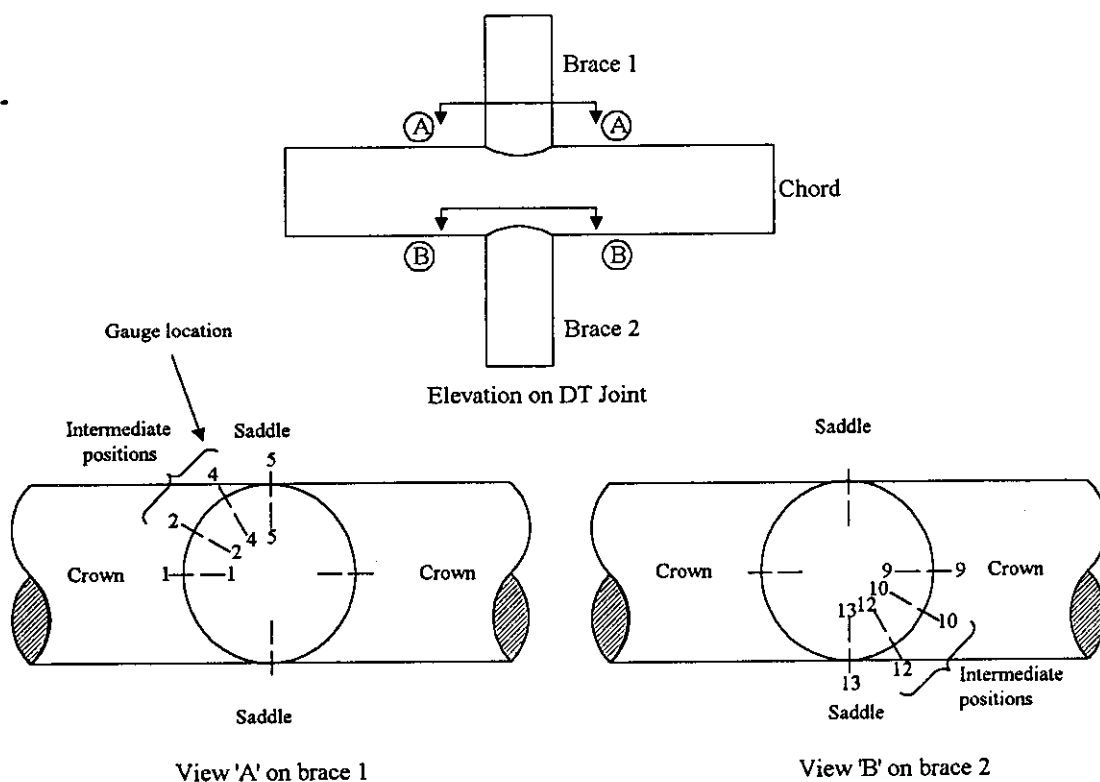

Appendix L 3 SNCFs ungrouted Test Specimen: DT2

Table L-1: Measured SNCFs on intersections of brace 1,2 and chord for DT2

DT2	BC;1,br2	BS;5,br1	BC;9,br1	BS;13,br2	CC;1,br2	CS;5,br1	CC;9,br1	CS;13,br2
ipb 1/3	1.52	0.09	-1.66	0.11	3.31	0.07	-3.64	0.18
ipb 2/3	1.47	0.08	-1.58	0.18	3.24	0.07	-3.51	0.35
ipb 3/3	1.45	0.07	-1.54	0.21	3.12	0.1	-3.45	0.39
ipb 3/3	1.45	0.07	-1.54	0.21	3.12	0.1	-3.41	0.39
ipb 2/3	1.48	0.08	-1.57	0.22	3.2	0.09	-3.53	0.41
ipb 1/3	1.52	0.1	-1.65	0.08	3.3	0.09	-3.66	0.19
opb 1/3	-0.04	4.96	-0.05	-4.14	-0.07	5.96	-0.2	-7.5
opb 2/3	-0.03	4.8	-0.03	-4.38	0	5.7	-0.11	-7.93
opb 3/3	-0.05	4.78	-0.03	-4.24	-0.04	5.71	-0.07	-7.69
opb 3/3	-0.04	4.74	-0.03	-4.2	-0.03	5.7	-0.08	-7.61
opb 2/3	-0.03	4.82	-0.03	-4.26	-0.02	5.77	-0.12	-7.72
opb 1/3	-0.02	4.65	-0.09	-4.24	0.02	5.58	-0.2	-7.67
axi-c 1/3	-0.12	9.11	0.27	8.86	1.29	10.62	2.29	15.4
axi-c 2/3	0.07	9.28	0.05	8.86	1.76	10.78	1.79	15.42
axi-c 3/3	0.08	9.65	0.01	8.6	1.78	11.15	1.7	15.01
axi-c 3/3	0.09	9.68	0	8.6	1.77	11.13	1.68	15.05
axi-c 2/3	0.22	9.91	-0.12	8.47	2.01	11.48	1.38	14.84
axi-c 1/3	-0.07	10.17	-0.04	8.12	1.61	11.63	1.66	14.33
axi-t 1/3	0	10.12	0.21	8.24	1.45	11.53	2.12	14.29
axi-t 2/3	-0.04	10.01	0.19	8.52	1.46	11.46	2.06	14.98
axi-t 3/3	-0.04	10.06	0.18	8.4	1.43	11.44	2.1	16.41
axi-t 3/3	-0.09	10.06	0.21	8.46	1.4	11.52	2.07	14.52
axi-t 2/3	-0.04	10.08	0.22	8.48	1.41	11.54	2.11	14.25
axi-t 1/3	-0.09	10.12	0.25	8.39	1.36	11.6	2.17	13.17

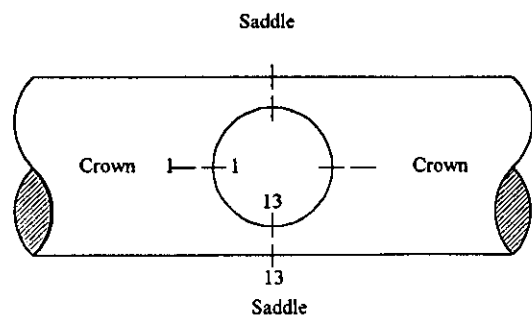
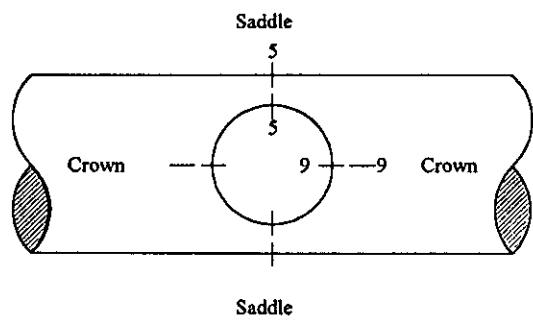
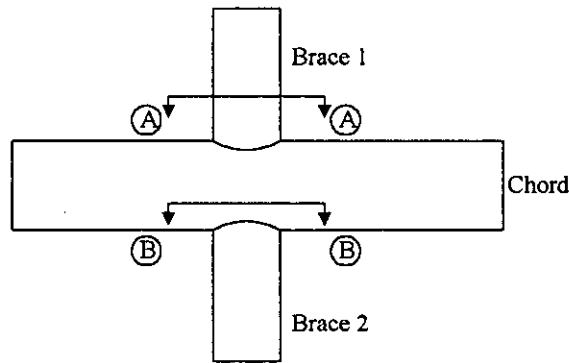

Appendix L 4 SNCFs ungrouted Test Specimen: DT3

Table L-2: Measured SNCFs on intersection on brace 1 and brace2 for DT3

DT3	BC;1,br1	BI;2,br1	BI;4,br1	BS;5,br1	BC;9,br2	BI;10,br2	BI;12,br2	BS;13,br2
ipb 1/3	1.39	1.65	2.28	-0.15	-1.05	-1.43	-1.84	-0.09
ipb 2/3	1.36	1.61	2.29	-0.13	-1.04	-1.43	-1.82	-0.12
ipb 3/3	1.32	1.6	2.28	-0.1	-1.03	-1.43	-1.8	-0.12
ipb 3/3	1.33	1.59	2.28	-0.11	-1.02	-1.42	-1.79	-0.12
ipb 2/3	1.37	1.61	2.31	-0.13	-1.05	-1.45	-1.81	-0.14
ipb 1/3	1.41	1.64	2.39	-0.16	-1.04	-1.48	-1.82	-0.12
opb 1/3	-0.07	0.36	1.32	2.29	-0.03	-0.41	-0.95	-1.94
opb 2/3	-0.07	0.4	1.33	2.29	-0.06	-0.43	-0.95	-1.93
opb 3/3	-0.07	0.39	1.31	2.28	-0.05	-0.43	-0.93	-1.95
opb 3/3	-0.07	0.38	1.32	2.28	-0.05	-0.44	-0.93	-1.95
opb 2/3	-0.06	0.39	1.36	2.33	-0.07	-0.45	-0.94	-1.9
opb 1/3	-0.05	0.38	1.38	2.38	-0.06	-0.51	-1	-1.92
axi-c 1/3	0.46	0.91	2.45	4.2	0.87	1.37	2.28	3.09
axi-c 2/3	0.8	1.24	2.92	4.32	0.63	1.01	1.79	2.93
axi-c 3/3	0.85	1.28	2.95	4.24	0.59	0.93	1.75	2.93
axi-c 3/3	0.85	1.25	2.97	4.24	0.59	0.93	1.75	2.9
axi-c 2/3	0.85	1.24	3.01	4.33	0.61	0.95	1.74	2.83
axi-c 1/3	0.68	1.05	2.78	4.19	0.72	1.1	1.98	2.89
axi-t 1/3	0.72	1.13	2.55	3.7	0.65	1.07	2.02	3.3
axi-t 2/3	0.79	1.18	2.65	3.88	0.63	1.03	1.91	3.12
axi-t 3/3	0.79	1.17	2.73	3.99	0.64	1.04	1.92	3.14
axi-t 3/3	0.82	1.17	2.73	3.99	0.61	1.04	1.92	3.13
axi-t 2/3	0.83	1.2	2.67	3.88	0.61	1.03	1.91	3.12
axi-t 1/3	0.86	1.12	2.54	3.71	0.57	1.06	2.03	3.31

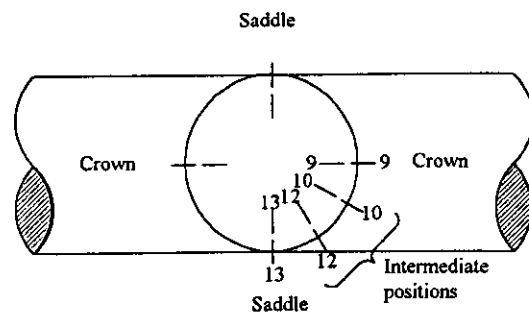
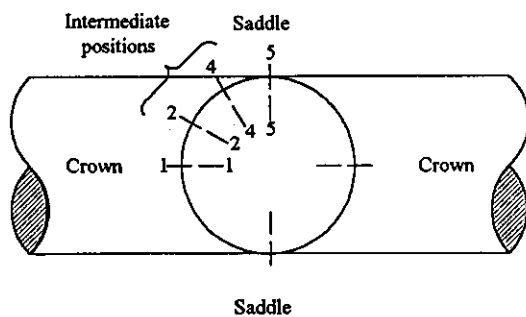
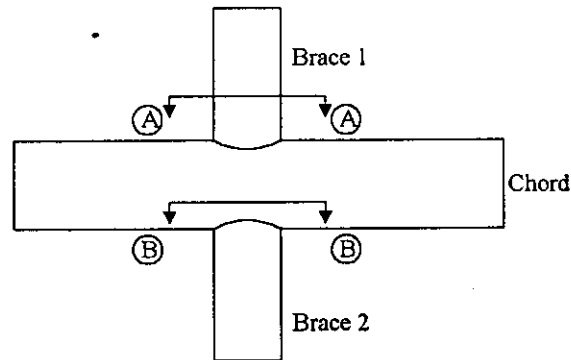
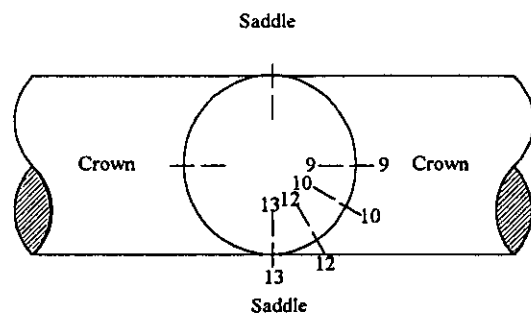
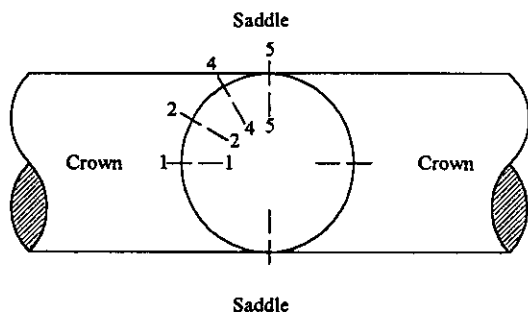
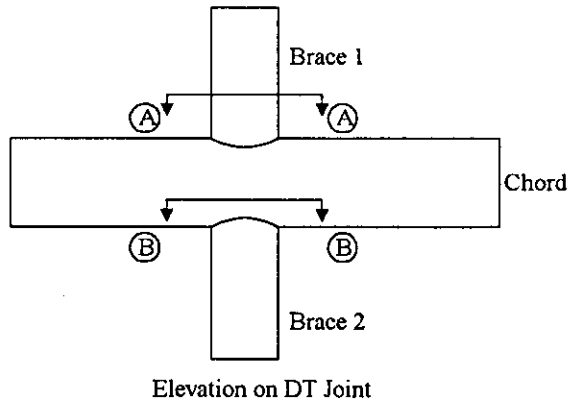

Table L-3: Measured SNCFs on intersection of chord with braces 1 and 2 for DT3

DT3	CC;1,br1	CI;2,br1	CI;4,br1	CS;5,br1	CC;9,br2	CI;10,br2	CI;12,br2	CS;13,br2
ipb 1/3	2.67	2.39	2.18	-0.16	-2.21	-2.47	-2.79	-0.06
ipb 2/3	2.6	2.4	2.15	-0.18	-2.21	-2.44	-2.79	-0.11
ipb 3/3	2.58	2.36	2.16	-0.16	-2.18	-2.45	-2.77	-0.13
ipb 3/3	2.59	2.36	2.14	-0.17	-2.2	-2.39	-2.78	-0.13
ipb 2/3	2.65	2.39	2.17	-0.2	-2.22	-2.46	-2.83	-0.15
ipb 1/3	2.73	2.43	2.2	-0.28	-2.26	-2.53	-2.82	-0.14
opb 1/3	-0.21	0.16	1	2.5	-0.15	-0.27	-1.04	-2.62
opb 2/3	-0.21	0.14	1	2.5	-0.22	-0.32	-1.09	-2.64
opb 3/3	-0.21	0.13	0.97	2.49	-0.2	-0.32	-1.07	-2.66
opb 3/3	-0.19	0.13	0.97	2.49	-0.2	-0.32	-1.07	-2.64
opb 2/3	-0.19	0.14	1.02	2.6	-0.24	-0.32	-1.07	-2.58
opb 1/3	-0.21	0.2	1.09	2.59	-0.29	-0.39	-1.16	-2.58
axi-c 1/3	0.15	0.46	1.79	3.72	1.22	1.52	2.96	3.21
axi-c 2/3	0.6	0.91	2.26	3.8	0.67	1.03	2.33	2.94
axi-c 3/3	0.73	1.02	2.28	3.73	0.57	0.89	2.23	3.07
axi-c 3/3	0.72	1.02	2.29	3.7	0.59	0.88	2.23	3.1
axi-c 2/3	0.68	0.97	2.32	3.78	0.62	0.92	2.2	3
axi-c 1/3	0.41	0.69	2.09	3.67	0.92	1.19	2.38	3.1
axi-t 1/3	0.57	0.93	1.98	2.98	0.65	1.04	2.71	3.65
axi-t 2/3	0.65	0.9	2.06	3.32	0.65	0.95	2.53	3.4
axi-t 3/3	0.66	0.93	2.12	3.41	0.67	1.01	2.54	3.36
axi-t 3/3	0.66	0.9	2.12	3.43	0.67	1.01	2.49	3.36
axi-t 2/3	0.67	0.88	2.08	3.38	0.66	0.95	2.42	3.39
axi-t 1/3	0.65	0.85	1.89	3.15	0.67	0.94	2.55	3.7



Appendix L 5 SNCFs ungrouted Test Specimen: DT4

Table L-4: Measured SNCFs on intersection of brace 1 and chord for DT4

DT4	BC;1,br1	BS;5,br1	BC;9,br1	BS;13,br1	CC;1,br1	CS;5,br1	CC;9,br1	CS;13,br1
ipb 1/3	2.22	0.17	-2.67	-0.3	4.3	0.19	-5.09	-0.67
ipb 2/3	2.17	0.04	-2.46	-0.26	4.1	-0.05	-4.9	-0.52
ipb 3/3	2.09	0.06	-2.38	-0.24	4	-0.09	-4.84	-0.44
ipb 3/3	2.1	0.04	-2.34	-0.23	4.01	-0.08	-4.88	-0.47
ipb 2/3	2.17	0.03	-2.39	-0.22	4.21	-0.03	-5	-0.54
ipb 1/3	2.25	0.08	-2.5	-0.26	4.3	0.03	-5.24	-0.68
opb 1/3	0.17	5.89	0.19	-4.25	0.2	12.55	-0.06	-11.46
opb 2/3	-0.05	5.23	0.07	-3.98	0.12	11.28	0.29	-11.06
opb 3/3	0.06	4.64	0.04	-3.54	0.09	10.05	0.08	-9.27
opb 3/3	-0.05	3.72	0.09	-2.69	0.16	7.89	0.18	-7.31
opb 2/3	-0.17	5.13	0.03	-3.71	0.2	10.91	0.43	-10.31
opb 1/3	-0.16	4.58	0.07	-2.67	0.38	9.67	0.33	-8.41
axi-c 1/3	-1.12	13.82	0.13	9.01	1.84	29.65	5.61	23.71
axi-c 2/3	-0.98	13.18	-0.14	9.34	2.26	28.63	4.84	24.43
axi-c 3/3	-0.79	13.02	-0.27	9.39	2.6	28.31	4.51	24.69
axi-c 3/3	-0.84	13.02	-0.18	9.4	2.51	28.34	4.62	24.66
axi-c 2/3	-1.06	13.25	-0.09	9.27	2.3	28.77	4.85	24.25
axi-c 1/3	-1.5	13.88	0.46	8.95	1.32	30.08	5.9	23.35
axi-t 1/3	1.96	-12.63	-0.72	-11.1	-1.03	-27.37	-6.82	-27.09
axi-t 2/3	1.14	-12.24	0	-10.66	-2.04	-26.36	-5.19	-26.85
axi-t 3/3	1.02	-12.19	0.18	-10.36	-2.3	-26.34	-4.77	-26.4
axi-t 3/3	0.97	-12.02	0.23	-10.17	-2.29	-25.97	-4.63	-26.53
axi-t 2/3	1.07	-12.15	0.11	-10.1	-2.12	-26.21	-4.91	-26.27
axi-t 1/3	1.59	-12.47	-0.2	-10.12	-1.47	-27.02	-5.8	-26.08

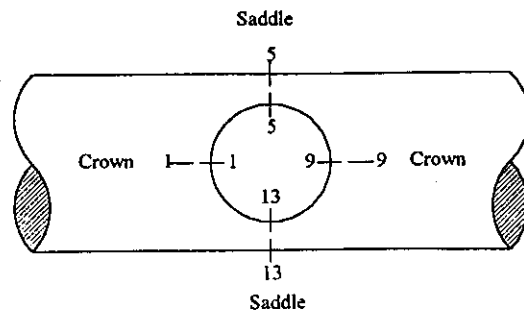
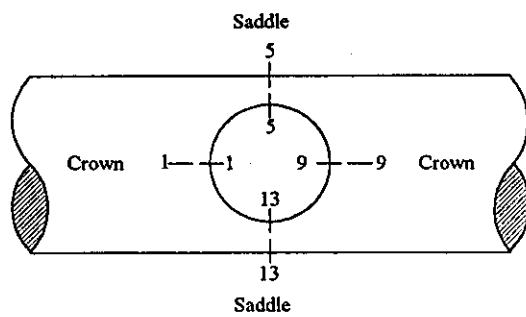
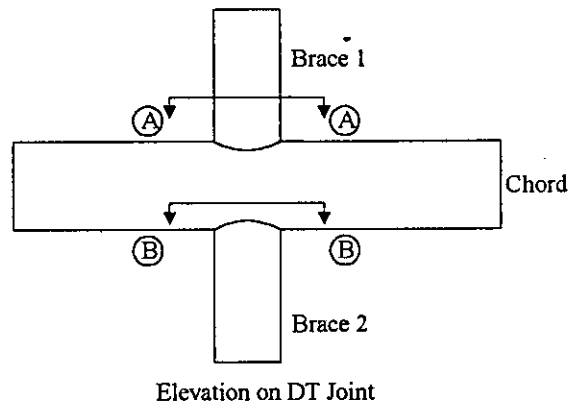
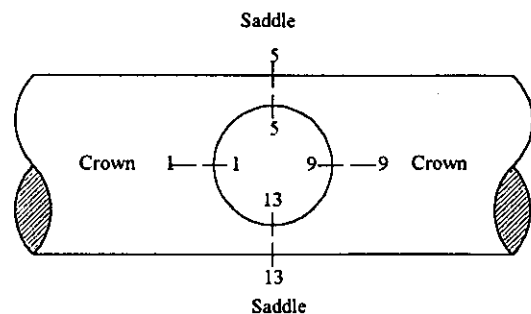
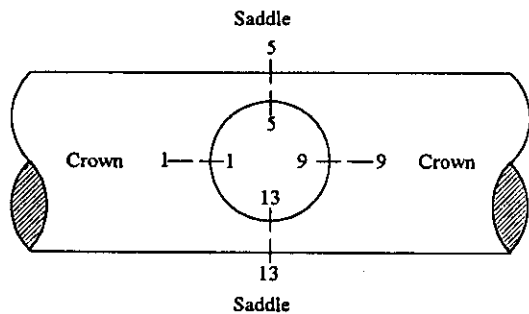
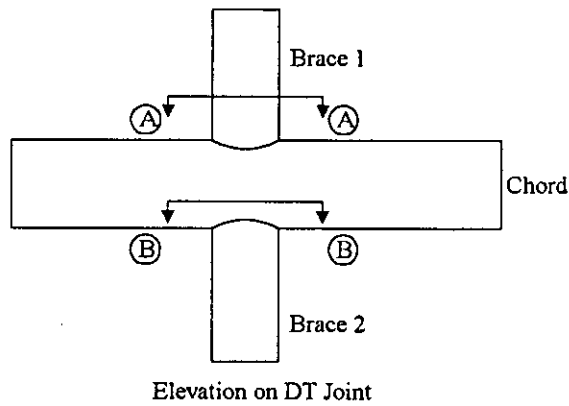

Table L-5: Measured SNCFs on intersection of brace 2 and chord for DT4

DT4	BC;1,br2	BS;5,br2	BC;9,br2	BS;13,br2	CC;1,br2	CS;5,br2	CC;9,br2	CS;13,br2
ipb 1/3	2.83	-0.09	2.65	0.16	4.35	0.15	-3.96	-0.09
ipb 2/3	2.71	0.03	0.18	0.28	4.24	-0.07	-3.9	0.14
ipb 3/3	2.62	-0.13	-0.63	0.24	4.15	-0.13	-3.83	0.16
ipb 3/3	2.62	-0.13	-2.77	0.22	4.15	-0.14	-3.94	0.13
ipb 2/3	2.73	-0.06	-2.87	0.14	4.29	-0.01	-4.05	0.03
ipb 1/3	2.82	-0.09	-2.97	0.11	4.41	0.04	-4.21	-0.11
opb 1/3	-0.16	2.5	-0.04	-4.84	-0.21	9.61	-0.16	-9.27
opb 2/3	-0.02	2.11	-0.28	-4.9	-0.04	9.97	-0.18	-9.09
opb 3/3	-0.16	2.58	-0.29	-4.92	-0.21	9.7	-0.25	-9.26
opb 3/3	-0.04	2.93	-0.21	-5.1	-0.12	10.97	-0.3	-9.81
opb 2/3	0.07	3.25	-0.13	-4.82	-0.01	11.12	-0.33	-9.36
opb 1/3	0.17	3.48	-0.42	-4.87	0.04	11.56	-0.45	-9.48
axi-c 1/3	-2.14	7.2	-0.42	14.48	2.2	25.59	5.42	26.86
axi-c 2/3	-1.52	7.18	-0.94	14.62	3.1	24.81	4.28	27.23
axi-c 3/3	-1.31	7.03	-1.17	14.79	3.46	24.4	4	27.63
axi-c 3/3	-1.39	7.01	-1.12	14.71	3.38	24.49	4.12	27.55
axi-c 2/3	-1.59	7.13	-0.92	14.6	3.02	24.71	4.52	27.35
axi-c 1/3	-2.51	7.18	0.04	14.25	1.8	25.47	5.74	26.69
axi-t 1/3	4.86	-6.2	-0.02	-17.54	-2.9	-21.03	-5.87	-32.94
axi-t 2/3	2.87	-6.25	0.74	-16.51	-3.44	-21.72	-4.69	-30.7
axi-t 3/3	2.27	-6.48	0.98	-15.89	-3.57	-22.48	-4.27	-29.47
axi-t 3/3	1.36	-6.43	1.07	-15.97	-3.26	-21.95	-4.18	-29.49
axi-t 2/3	1.48	-6.18	0.93	-16.44	-3.06	-21.09	-4.43	-30.4
axi-t 1/3	1.89	-5.8	0.46	-17.47	-2.56	-19.8	-5.07	-32.35



Appendix L 6 SNCFs ungrouted Test Specimen: DT5

Table L-6: Measured SNCFs on intersection of brace 1 and 2 with chord for DT5

DT5	BC;1,br1	BS;5,br2	BC;9,br2	BS;13,br1	CC;1,br1	CS;5,br2	CC;9,br2	CS;13,br1
ipb 1/3	1.6	-0.06	-1.93	0.12	6.37	-2.04	-4.48	0
ipb 2/3	1.5	0	-1.82	0.13	6.03	-1.87	-4.22	0.03
ipb 3/3	1.45	-0.04	-1.78	0.22	5.88	-1.92	-4.09	0.16
ipb 3/3	1.44	-0.03	-1.78	0.22	5.88	-1.92	-4.08	0.17
ipb 2/3	1.48	0.01	-1.83	0.14	5.99	-1.83	-4.2	0.04
ipb 1/3	1.58	0	-1.96	0.09	6.3	-1.98	-4.48	0
opb 1/3	0.08	8.11	0.08	-6.92	-6.7	19.33	0.3	-11.04
opb 2/3	0.1	7.87	0.06	-7.19	-6.6	18.84	0.24	-11.59
opb 3/3	0.07	7.73	0.05	-7.33	-6.46	18.4	0.23	-11.82
opb 3/3	0.07	7.54	0.05	-7.61	-6.26	17.92	0.21	-12.33
opb 2/3	0.07	7.69	0.06	-7.52	-6.38	18.33	0.19	-12.13
opb 1/3	0.15	7.38	0.08	-7.64	-6	17.52	0.2	-12.33
axi-c 1/3	0.38	13.18	-0.44	19.2	-5.92	29.15	-0.02	30.69
axi-c 2/3	0.23	14.51	-0.38	17.23	-7.41	32.23	0.49	27.65
axi-c 3/3	0.2	14.42	-0.34	17.2	-7.45	32.16	0.51	27.69
axi-c 3/3	0.2	14.44	-0.34	17.12	-7.45	32.2	0.54	27.59
axi-c 2/3	0.25	14.47	-0.4	17.3	-7.16	32.01	0.47	27.91
axi-c 1/3	0.37	14.16	-0.44	17.89	-6.48	31.22	0.2	28.77
axi-t 1/3	-0.32	15.83	0.4	15.03	-10.29	35.57	2.36	23.97
axi-t 2/3	-0.2	15.65	0.28	15.28	-9.8	35.03	2.1	24.47
axi-t 3/3	-0.21	15.76	0.29	15.32	-9.58	35.15	2.02	24.52
axi-t 3/3	-0.19	15.72	0.29	15.31	-9.54	35.11	2.02	24.42
axi-t 2/3	-0.17	15.79	0.34	15.14	-9.62	35.23	2.14	24.21
axi-t 1/3	-0.27	16.06	0.47	14.57	-10.24	35.99	2.5	23.34

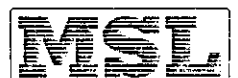
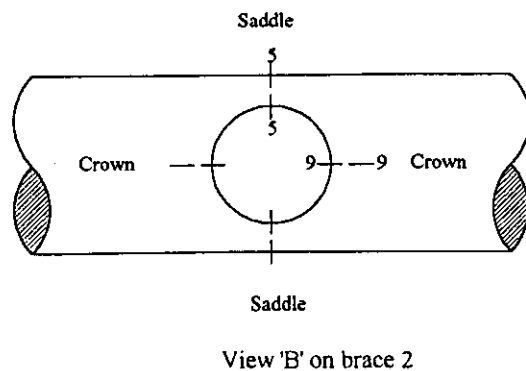
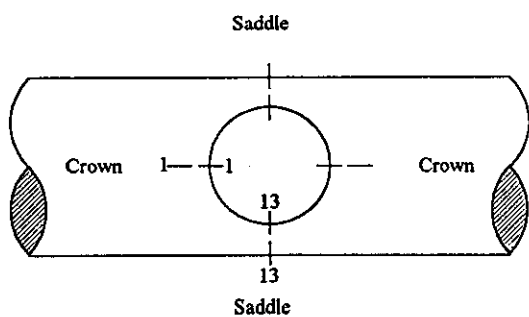
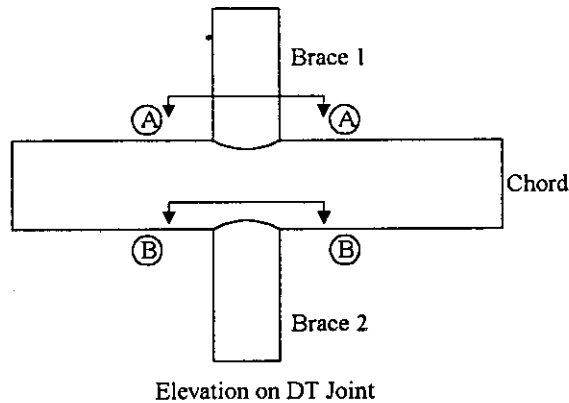

Appendix L 7 SNCFs ungrouted Test Specimen: DT6

Table L-7: Measured SNCFs on intersection of brace 1 and 2 on brace for DT6

DT6	BC;1,br1	BI;2,br1	BI;4,br1	BS;5,br1	BC;9,br2	BI;10,br2	BI;12,br2	BS;13,br2
ipb 1/3	1.51	1.65	2.26	0	-1.31	-1.44	-2.7	-0.02
ipb 2/3	1.47	1.59	2.17	-0.01	-1.25	-1.37	-2.56	-0.01
ipb 3/3	1.45	1.56	2.14	0.04	-1.23	-1.36	-2.52	0.03
ipb 3/3	1.46	1.56	2.13	0.03	-1.22	-1.37	-2.52	0.03
ipb 2/3	1.48	1.58	2.17	-0.01	-1.25	-1.39	-2.59	-0.02
ipb 1/3	1.54	1.67	2.32	-0.06	-1.31	-1.46	-2.75	-0.07
opb 1/3	-0.15	0.32	1.07	2.35	-0.05	-0.51	-1.37	-2.42
opb 2/3	-0.19	0.33	1.11	2.44	-0.08	-0.53	-1.33	-2.36
opb 3/3	-0.18	0.34	1.15	2.59	-0.07	-0.53	-1.32	-2.23
opb 3/3	-0.17	0.35	1.14	2.56	-0.07	-0.51	-1.32	-2.26
opb 2/3	-0.17	0.33	1.09	2.43	-0.1	-0.53	-1.34	-2.42
opb 1/3	-0.18	0.32	1.12	2.54	-0.15	-0.5	-1.35	-2.34
axi-c 1/3	-0.09	0.07	0.58	4.09	1.86	2.19	4.55	4.31
axi-c 2/3	0.51	0.77	1.64	4.73	1.36	1.52	3.45	3.98
axi-c 3/3	0.76	1.08	2.15	4.86	1.09	1.24	2.88	3.88
axi-c 3/3	0.76	1.05	2.12	4.84	1.09	1.24	2.85	3.92
axi-c 2/3	0.69	0.97	1.97	4.87	1.2	1.36	3.02	3.87
axi-c 1/3	0.17	0.42	1.18	4.76	1.6	1.76	3.86	3.8
axi-t 1/3	1.2	1.38	2.32	3.92	0.86	0.89	2.55	4.55
axi-t 2/3	1.11	1.27	2.34	4.04	0.85	0.97	2.51	4.35
axi-t 3/3	1.09	1.27	2.28	4.1	0.86	0.99	2.56	4.27
axi-t 3/3	1.09	1.3	2.28	4.1	0.86	0.99	2.59	4.24
axi-t 2/3	1.14	1.36	2.32	4.02	0.85	0.98	2.55	4.25
axi-t 1/3	1.2	1.41	2.23	3.94	0.86	0.88	2.5	4.17

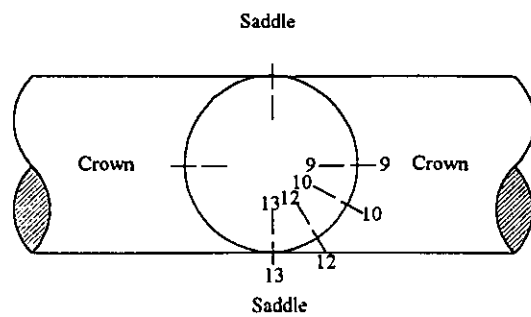
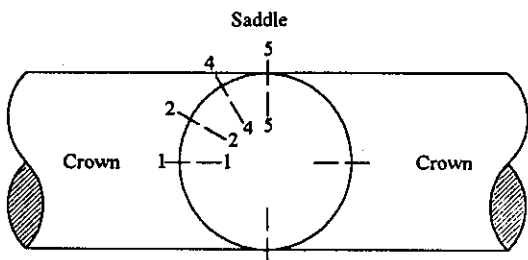
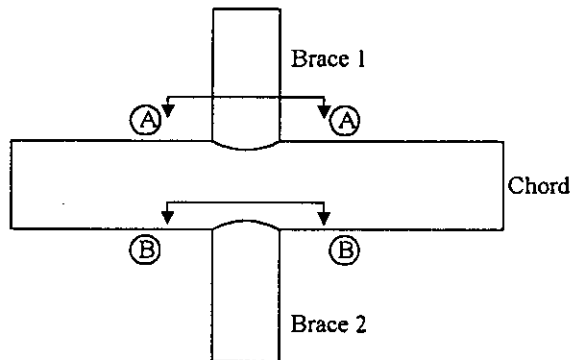
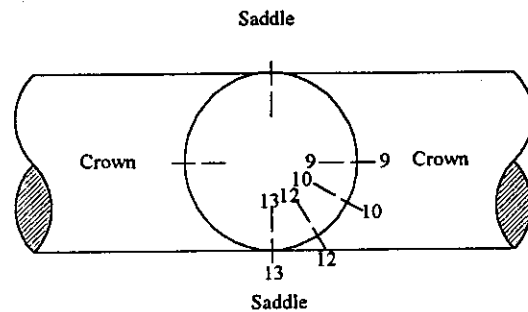
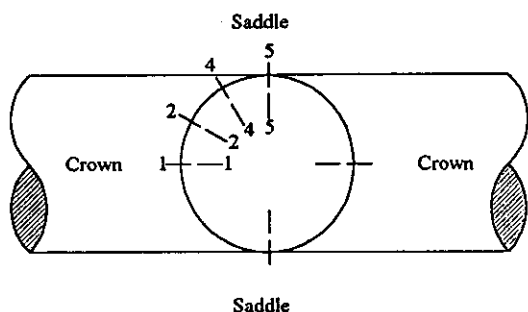
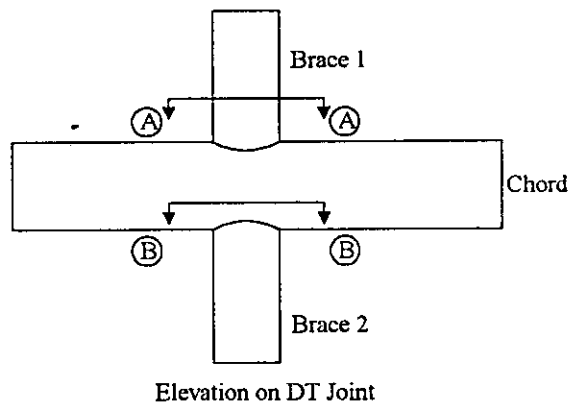

Table L-8: Measured SNCFs on intersection of brace 1 and 2 on chord for DT6

DT6	CC;1,br1	CI;2,br1	CI;4,br1	CS;5,br1	CC;9,br2	CI;10,br2	CI;12,br2	CS;13,br2
ipb 1/3	2.65	3.42	4.19	-0.08	-2.74	-2.74	-3.75	0.14
ipb 2/3	2.55	3.3	3.98	-0.11	-2.64	-2.6	-3.58	0.16
ipb 3/3	2.51	3.24	3.94	-0.02	-2.6	-2.56	-3.51	0.19
ipb 3/3	2.51	3.23	3.93	-0.01	-2.63	-2.51	-3.53	0.19
ipb 2/3	2.54	3.32	4.05	-0.08	-2.66	-2.55	-3.62	0.13
ipb 1/3	2.65	3.55	4.31	-0.15	-2.78	-2.74	-3.85	0.03
opb 1/3	-0.39	0.15	1.62	5.06	-0.31	-0.25	-1.06	-3.37
opb 2/3	-0.47	0.08	1.74	5.32	-0.32	-0.29	-1.04	-3.3
opb 3/3	-0.44	0.07	1.81	5.65	-0.29	-0.33	-0.99	-3.01
opb 3/3	-0.41	0.08	1.79	5.58	-0.27	-0.33	-0.98	-3.06
opb 2/3	-0.43	0.03	1.74	5.32	-0.35	-0.29	-1.01	-3.31
opb 1/3	-0.44	0.04	1.81	5.6	-0.35	-0.34	-0.94	-3.08
axi-c 1/3	-1.48	-1.39	0.39	8.02	2.42	2.62	5.28	4.96
axi-c 2/3	-0.37	-0.13	2.34	9.55	1.42	1.62	3.9	4.54
axi-c 3/3	0.12	0.49	3.1	9.84	0.86	1.11	3.24	4.43
axi-c 3/3	0.13	0.45	3.08	9.83	0.85	1.12	3.25	4.44
axi-c 2/3	-0.04	0.27	2.8	9.92	1.14	1.32	3.51	4.3
axi-c 1/3	-1	-1.04	1.34	9.88	2.05	2.22	4.63	4.21
axi-t 1/3	0.76	1.35	3.67	7.92	0.03	0.5	2.57	5.12
axi-t 2/3	0.77	1.28	3.66	8.15	0.18	0.54	2.61	5.06
axi-t 3/3	0.7	1.2	3.6	8.3	0.33	0.61	2.63	4.98
axi-t 3/3	0.69	1.19	3.61	8.3	0.37	0.61	2.63	4.98
axi-t 2/3	0.79	1.27	3.7	8.18	0.3	0.59	2.53	5.02
axi-t 1/3	0.81	1.28	3.73	7.97	0.28	0.56	2.43	4.96



Appendix L 8 SNCFs ungrouted Test Specimen: DT8

Table L-9: Measured SNCFs on intersection of brace 1 and 2 with chord for DT8

DT8	BC;1,br1	BS;5,br2	BC;9,br2	BS;13,br1	CC;1,br1	CS;5,br2	CC;9,br2	CS;13,br1
ipb 1/3	1.73	0.21	-1.7	-0.3	4.39	0.17	-4.12	-0.41
ipb 2/3	1.62	0.18	-1.61	-0.16	4.16	0.15	-3.88	-0.18
ipb 3/3	1.56	0.27	-1.56	-0.11	4.01	0.05	-3.82	-0.11
ipb 3/3	1.58	0.23	-1.58	-0.1	4.05	0.13	-3.86	-0.11
ipb 2/3	1.62	0.15	-1.64	-0.13	4.2	0.24	-3.94	-0.26
ipb 1/3	1.74	0.02	-1.76	-0.23	4.45	0.28	-4.19	-0.43
opb 1/3	0.09	8.13	0	-9.32	0.29	18.33	0	-17.47
opb 2/3	0.05	8.48	0.04	-9.55	0.2	19.1	0.02	-17.98
opb 3/3	0.05	8.36	0.04	-9.02	0.19	18.78	0.06	-17.47
opb 3/3	0.06	8.42	0.04	-9.26	0.17	18.91	0.03	-17.16
opb 2/3	0.11	8.17	0.06	-8.53	0.28	18.45	0.12	-16.06
opb 1/3	0.16	7.87	0.12	-8.46	0.54	17.83	0.26	-15.89
axi-c 1/3	-0.83	16.31	-0.02	19.42	0.22	36.56	2.64	36.35
axi-c 2/3	-0.57	16.72	-0.22	19.08	0.84	37.35	2.04	35.63
axi-c 3/3	-0.5	16.58	-0.34	19.25	1.21	37.23	1.69	36
axi-c 3/3	-0.48	16.62	-0.41	19.29	1.27	37.21	1.52	36.01
axi-c 2/3	-0.5	16.9	-0.33	19.08	1.07	37.66	1.7	35.68
axi-c 1/3	-0.69	17.33	-0.26	18.73	0.54	38.33	2.11	34.84
axi-t 1/3	-0.54	17.41	-0.22	18.47	0.93	39.03	1.77	34.45
axi-t 2/3	-0.6	17.53	-0.2	18.44	0.81	39.35	1.79	34.36
axi-t 3/3	-0.6	17.64	-0.27	18.65	0.92	39.47	1.68	34.65
axi-t 3/3	-0.64	17.65	-0.27	18.57	0.89	39.51	1.79	34.59
axi-t 2/3	-0.66	17.77	-0.19	18.35	0.74	39.81	1.94	34.18
axi-t 1/3	-0.79	18.72	-0.08	18.12	0.71	41.97	2.12	33.71

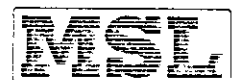
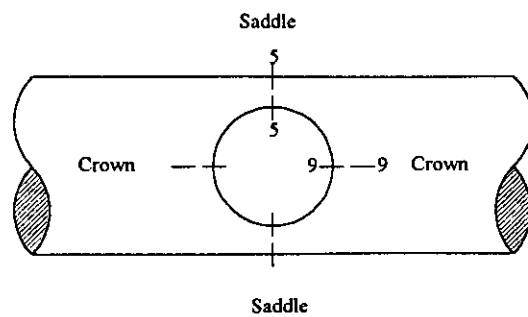
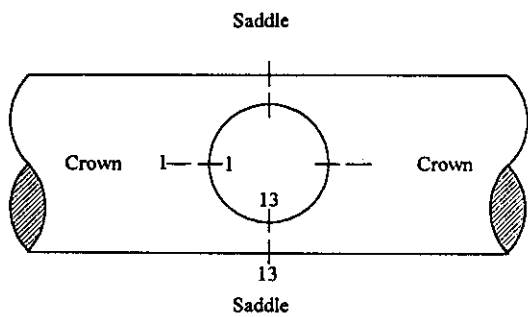
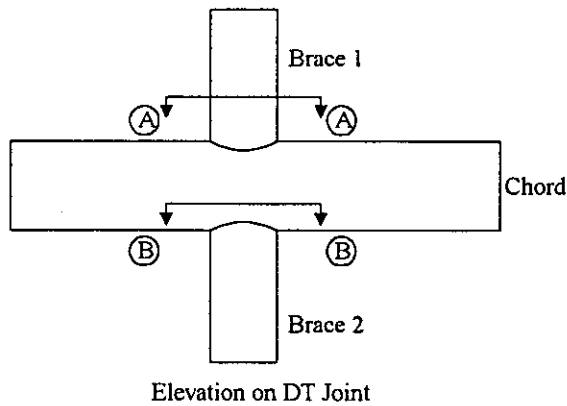

Appendix L 9 SNCFs ungrouted Test Specimen: DT9

Table L-10: Measured SNCFs on intersection of brace 1 and 2 on brace for DT9

DT9	BC;1,br1	BI;2,br1	BI;4,br1	BS;5,br1	BC;9,br2	BI;10,br2	BI;12,br2	BS;13,br2
ipb 1/3	1.55	1.49	1.93	-0.04	-1.32	-1.07	-2.02	0.19
ipb 2/3	1.5	1.45	1.86	-0.06	-1.27	-1.03	-1.96	0.14
ipb 3/3	1.46	1.43	1.82	-0.03	-1.25	-1.01	-1.92	0.14
ipb 3/3	1.47	1.43	1.83	-0.02	-1.26	-1.02	-1.93	0.13
ipb 2/3	1.49	1.45	1.88	-0.08	-1.27	-1.05	-2	0.07
ipb 1/3	1.57	1.5	1.98	-0.07	-1.35	-1.09	-2.09	0.1
opb 1/3	0.03	0.46	0.91	2.11	-0.02	-0.43	-0.92	-2.39
opb 2/3	0.02	0.49	0.9	2.23	-0.02	-0.42	-0.88	-2.29
opb 3/3	0.04	0.5	0.89	2.25	-0.02	-0.42	-0.88	-2.28
opb 3/3	0.03	0.49	0.89	2.27	-0.01	-0.4	-0.88	-2.26
opb 2/3	0.06	0.49	0.85	2.28	-0.03	-0.42	-0.87	-2.22
opb 1/3	0.12	0.5	0.85	2.31	0	-0.34	-0.8	-2.15
axi-c 1/3	1.04	1.31	1.91	4.16	1.13	1.27	2.16	3.14
axi-c 2/3	1.15	1.49	2.27	4.75	0.95	0.99	1.72	2.71
axi-c 3/3	1.3	1.62	2.47	4.83	0.79	0.87	1.52	2.65
axi-c 3/3	1.27	1.59	2.47	4.8	0.77	0.83	1.49	2.61
axi-c 2/3	1.31	1.63	2.56	4.84	0.77	0.78	1.42	2.51
axi-c 1/3	1.23	1.64	2.46	4.76	0.78	0.83	1.47	2.34
axi-t 1/3	1.21	1.21	1.94	3.52	0.89	1.08	1.65	2.79
axi-t 2/3	1.21	1.31	2.09	4.01	0.91	1	1.76	2.98
axi-t 3/3	1.18	1.34	2.13	4.16	0.94	1.01	1.76	2.97
axi-t 3/3	1.18	1.37	2.11	4.18	0.91	1.01	1.73	2.97
axi-t 2/3	1.17	1.36	2.06	4.08	0.88	1.05	1.74	2.96
axi-t 1/3	1.11	1.29	1.84	3.75	0.87	1.08	1.69	2.86

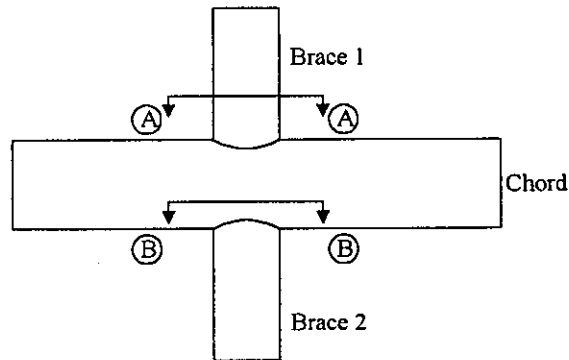

Elevation on DT Joint

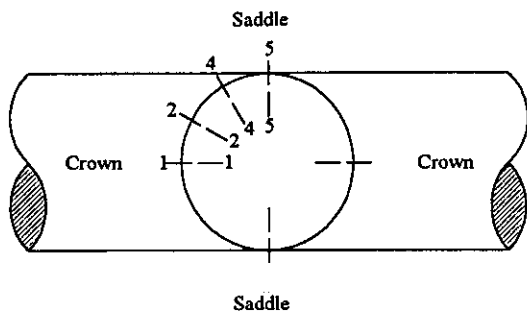

View 'A' on brace 1

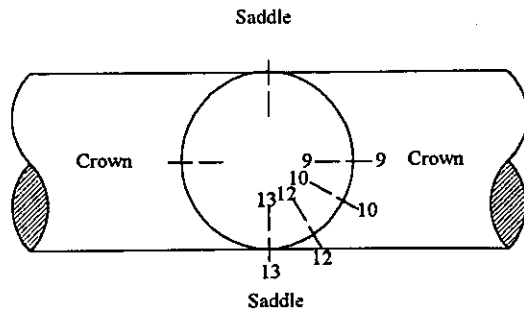

View 'B' on brace 2

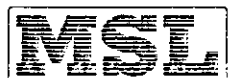
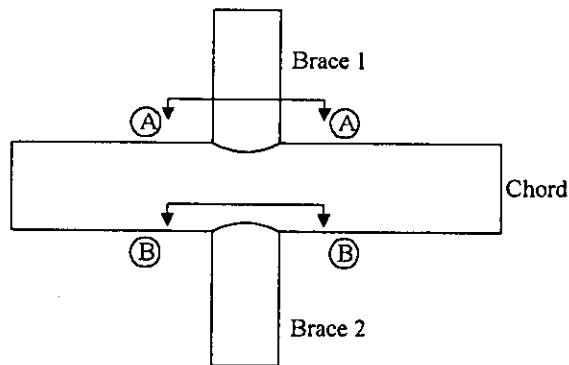
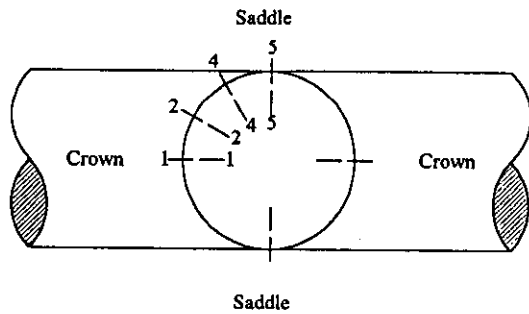

Table L.11: Measured SNCFs on intersection of brace 1 and 2 on chord for DT9

DT9	CC;1,br1	CI;2,br1	CI;4,br1	CS;5,br1	CC;9,br2	CI;10,br2	CI;12,br2	CS;13,br2
ipb 1/3	2.94	3.33	3.95	0.12	-3.13	-2.8	-3.93	0.56
ipb 2/3	2.85	3.22	3.79	0.03	-2.98	-2.67	-3.8	0.43
ipb 3/3	2.79	3.17	3.7	0.08	-2.95	-2.62	-3.71	0.46
ipb 3/3	2.79	3.19	3.73	0.08	-2.97	-2.63	-3.74	0.46
ipb 2/3	2.81	3.24	3.84	-0.03	-3.01	-2.69	-3.85	0.3
ipb 1/3	2.89	3.38	4.09	-0.02	-3.14	-2.83	-4.07	0.33
opb 1/3	-0.03	0.06	1.19	4.24	-0.11	-0.07	-1.27	-7.31
opb 2/3	0.04	0.05	1.13	4.42	-0.09	-0.07	-1.2	-7.05
opb 3/3	0.03	0.05	1.1	4.48	-0.12	-0.09	-1.16	-7.07
opb 3/3	0.03	0.08	1.09	4.51	-0.1	-0.09	-1.16	-7.04
opb 2/3	0.07	0.09	1.02	4.62	-0.09	-0.09	-1.13	-6.83
opb 1/3	0.28	0.21	0.89	4.6	-0.01	-0.06	-1.06	-6.81
axi-c 1/3	0.27	0.5	2.51	7.54	1.2	1.21	3.36	9.59
axi-c 2/3	0.56	0.84	3.19	8.8	0.76	0.9	2.76	8.19
axi-c 3/3	0.77	1.11	3.59	8.97	0.36	0.6	2.32	7.96
axi-c 3/3	0.77	1.11	3.6	8.98	0.35	0.6	2.32	7.97
axi-c 2/3	0.84	1.2	3.75	9.16	0.35	0.57	2.21	7.74
axi-c 1/3	0.62	1.07	3.54	8.9	0.53	0.77	2.42	7.62
axi-t 1/3	0.6	0.91	2.81	6.61	0.5	0.59	2.39	8.71
axi-t 2/3	0.66	0.87	3	7.43	0.54	0.67	2.53	9.07
axi-t 3/3	0.63	0.9	3.03	7.77	0.57	0.73	2.54	8.98
axi-t 3/3	0.68	0.89	3.02	7.74	0.57	0.73	2.53	9.03
axi-t 2/3	0.71	0.86	3.03	7.47	0.62	0.73	2.49	9.04
axi-t 1/3	0.69	0.76	2.75	6.72	0.62	0.64	2.51	8.8



Elevation on DT Joint



View 'A' on brace 1

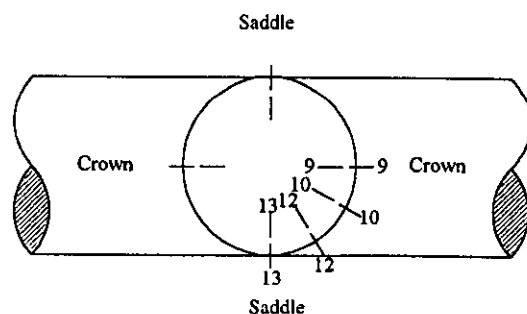

View 'B' on brace 2



Appendix L 10 SNCFs ungrouted Test Specimen: T1

Table L.12: Measured SNCFs on intersection of brace and chord for T1

T1	BC;1	BS;5	BC;9	BS;13	CC;1	CS;5	CC;9	CS;13
ipb 1/3	-1.32	-0.04	1.34	0.03	-2.45	-0.08	2.39	0.09
ipb 2/3	-1.3	-0.06	1.36	0.02	-2.43	-0.08	2.4	0.1
ipb 3/3	-1.31	-0.06	1.36	0.03	-2.45	-0.07	2.42	0.09
ipb 3/3	-1.32	-0.05	1.37	0.04	-2.45	-0.07	2.42	0.09
ipb 2/3	-1.33	-0.06	1.38	0.03	-2.48	-0.08	2.43	0.08
ipb 1/3	-1.37	-0.05	1.4	0.06	-2.48	-0.08	2.46	0.09
opb 1/3	0.02	-3.24	-0.07	3.03	0.03	-6.08	-0.1	6.24
opb 2/3	0.02	-3.19	-0.04	2.98	0.03	-6	-0.1	6.15
opb 3/3	0.02	-3.18	-0.05	2.97	0.03	-6	-0.07	6.12
opb 3/3	0.02	-3.17	-0.04	2.97	0.03	-6.02	-0.08	6.16
opb 2/3	0.02	-3.17	-0.03	2.99	0.04	-6.04	-0.1	6.13
opb 1/3	0.03	-3.17	0	2.97	0.05	-6.04	-0.13	6.12
axi-c 1/3	1.02	6.35	-0.62	4.56	7.66	10.56	3.94	8.09
axi-c 2/3	0.9	5.71	-0.39	5.1	7.3	9.32	4.3	9.33
axi-c 3/3	0.83	5.78	-0.33	5	7.07	9.47	4.47	9.24
axi-c 3/3	0.81	5.79	-0.32	4.98	7.06	9.48	4.47	9.22
axi-c 2/3	0.97	5.44	-0.48	5.3	7.41	8.86	4.26	9.96
axi-c 1/3	1.07	5.58	-0.62	5.33	7.71	9.08	3.86	9.71
axi-t 1/3	1.07	3.88	-0.71	5.92	7.2	5.94	3.51	11.24
axi-t 2/3	0.91	4.14	-0.42	5.75	6.81	6.42	3.85	10.99
axi-t 3/3	0.77	4.34	-0.29	5.59	6.47	6.85	4.13	10.54
axi-t 3/3	0.78	4.35	-0.26	5.59	6.78	6.86	4.08	10.52
axi-t 2/3	0.9	4.26	-0.46	5.65	6.93	6.63	3.73	10.7
axi-t 1/3	1.18	4.21	-0.72	5.58	7.39	6.53	3.06	10.68

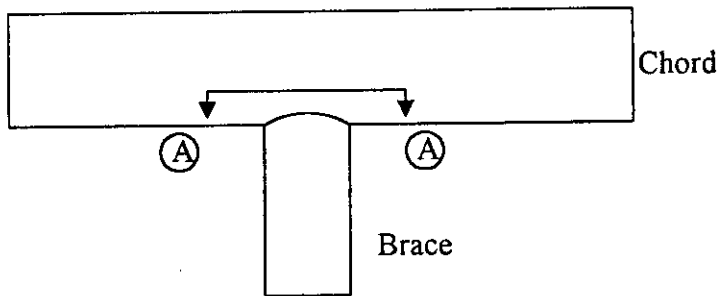

Elevation on T Joint

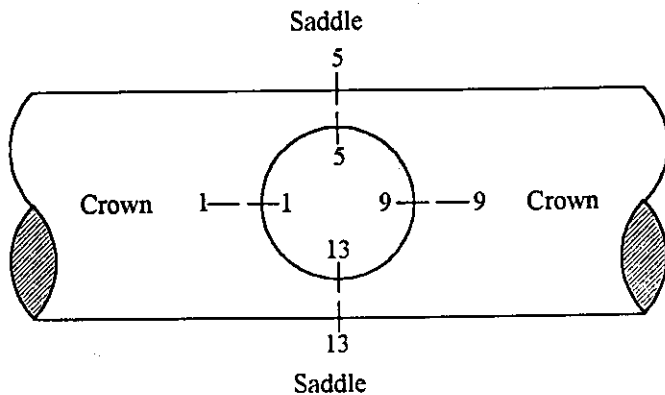

View 'A' on brace

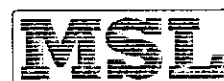

Appendix L 11 SNCFs ungrouted Test Specimen: T3

Table L.13: Measured SNCFs on intersection of brace and chord for T3

T3	BC;1	BI;2	BI;4	BS;5	BC;9	BI;10	BI;12	BS;13
ipb 1/3	-1.13	-1.07	-1.32	0.04	1.18	1.25	1.36	-0.08
ipb 2/3	-1.13	-1.1	-1.35	0.02	1.16	1.29	1.37	-0.06
ipb 3/3	-1.13	-1.11	-1.33	0.02	1.17	1.29	1.37	-0.05
ipb 3/3	-1.14	-1.11	-1.33	0.03	1.15	1.27	1.36	-0.04
ipb 2/3	-1.14	-1.1	-1.33	0.02	1.18	1.29	1.38	-0.04
ipb 1/3	-1.16	-1.12	-1.33	0.04	1.19	1.31	1.37	-0.1
opb 1/3	0.03	-0.3	-2.16	-4.66	-0.1	0.38	2.29	4.94
opb 2/3	0.01	-0.34	-2.21	-4.66	-0.03	0.44	2.3	4.96
opb 3/3	0	-0.34	-2.22	-4.64	-0.02	0.44	2.32	4.98
opb 3/3	0.01	-0.34	-2.22	-4.64	-0.01	0.44	2.32	4.95
opb 2/3	0.02	-0.33	-2.21	-4.68	-0.04	0.44	2.31	4.98
opb 1/3	0.06	-0.33	-2.18	-4.7	-0.08	0.37	2.24	5.04
axi-c 1/3	3.04	3.65	6.18	5.55	1.05	1.89	3.06	3.01
axi-c 2/3	2.66	3.24	5.93	5.87	1.47	2.25	3.36	2.71
axi-c 3/3	2.51	3.08	5.57	5.36	1.59	2.43	3.8	3.2
axi-c 3/3	2.51	3.05	5.58	5.35	1.61	2.42	3.77	3.21
axi-c 2/3	2.61	3.11	5.79	5.64	1.58	2.36	3.5	2.97
axi-c 1/3	2.87	3.19	5.68	5.16	1.39	2.19	3.5	3.61
axi-t 1/3	3.16	3.45	5.15	2.58	1.06	2.08	4.74	6.15
axi-t 2/3	2.88	3.22	4.93	2.56	1.21	2.32	4.89	6.08
axi-t 3/3	2.85	3.18	4.88	2.79	1.34	2.43	4.97	5.93
axi-t 3/3	2.85	3.2	4.91	2.79	1.35	2.43	4.97	5.89
axi-t 2/3	2.97	3.29	4.83	2.24	1.2	2.34	5.07	6.46
axi-t 1/3	3.24	3.42	4.91	1.75	1.07	2.19	5.13	7.13

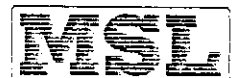
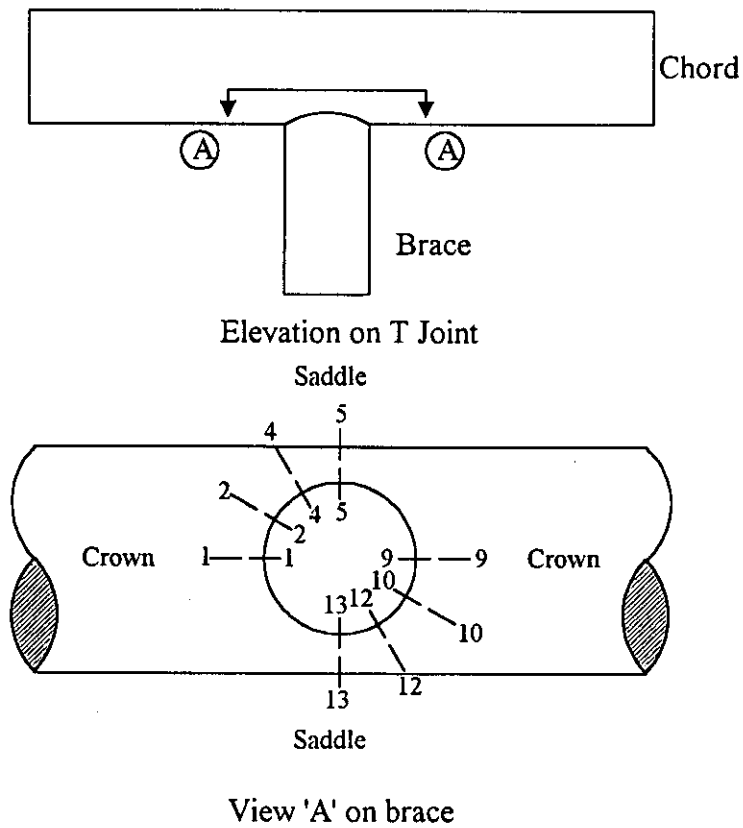
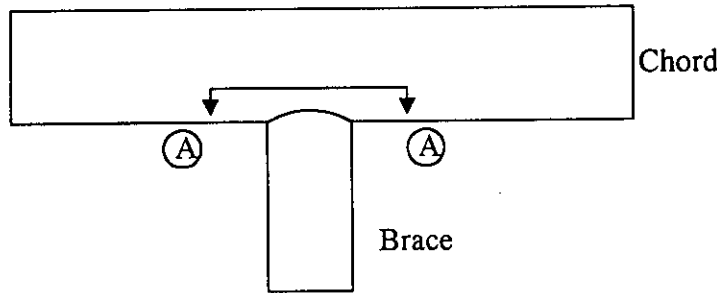
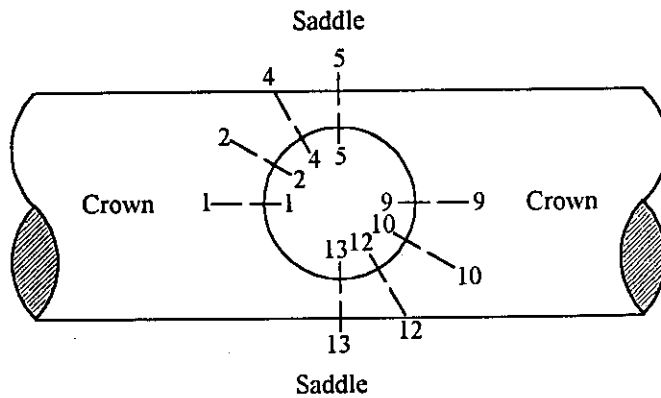

Table L.14: Measured SNCFs on intersection of brace and chord for T3

T3	CC;1	CI;2	CI;4	CS;5	CC;9	CI;10	CI;12	CS;13
ipb 1/3	-2.51	-2.24	-1.3	0.05	3.11	2.6	1.23	-0.08
ipb 2/3	-2.51	-2.23	-1.29	0.05	3.1	2.58	1.26	-0.08
ipb 3/3	-2.51	-2.24	-1.31	0.05	3.09	2.57	1.26	-0.06
ipb 3/3	-2.51	-2.39	-1.32	0.06	3.09	4.52	1.25	-0.05
ipb 2/3	-2.56	-2.28	-1.31	0.05	3.08	2.51	1.3	-0.05
ipb 1/3	-2.54	-2.24	-1.35	0.03	3.11	2.5	1.27	-0.06
opb 1/3	0.16	-0.48	-3.28	-7.35	-0.17	0.49	2.88	6.63
opb 2/3	0.09	-0.55	-3.33	-7.36	-0.1	0.52	2.9	6.66
opb 3/3	0.06	-0.57	-3.3	-7.35	-0.08	0.56	2.92	6.66
opb 3/3	0.05	-0.56	-3.29	-7.34	-0.07	0.47	2.95	6.65
opb 2/3	0.06	-0.54	-3.31	-7.36	-0.09	0.42	2.92	6.69
opb 1/3	0.15	-0.48	-3.26	-7.33	-0.17	0.35	2.86	6.7
axi-c 1/3	10	8.24	7.57	5.49	7.07	4.37	3.18	0.59
axi-c 2/3	9.19	7.64	7.36	5.87	7.9	5.23	3.46	0.08
axi-c 3/3	8.8	7.35	7.16	5.13	8.24	6.05	4.24	0.75
axi-c 3/3	8.82	7.34	7.15	5.09	8.23	5.88	4.23	0.75
axi-c 2/3	9.15	7.44	7.1	5.53	8.17	5.61	3.72	0.41
axi-c 1/3	9.66	7.53	6.63	4.63	7.77	4.94	3.25	1.18
axi-t 1/3	10.19	8.92	7.06	0.61	6.56	5.45	6.02	4.76
axi-t 2/3	9.72	8.27	6.63	0.73	7.11	5.72	6.26	4.65
axi-t 3/3	9.52	8.12	6.57	1.08	7.57	5.98	6.29	4.41
axi-t 3/3	9.55	8.14	6.5	1.11	7.61	5.9	6.31	4.41
axi-t 2/3	9.88	8.37	6.35	0.19	7.11	5.51	6.39	5.17
axi-t 1/3	10.34	8.92	6.65	-0.54	6.72	5.21	6.6	6.06



Elevation on T Joint



View 'A' on brace

Appendix L 12 SNCFs ungrouted Test Specimen: T5

Table L.15: Measured SNCFs on intersection of brace and chord for T5

T5	BC;1	BS;5	BC;9	BS;13	CC;1	CS;5	CC;9	CS;13
ipb 1/3	-1.38	0.08	1.56	0.15	-3.16	-0.18	3.85	0.3
ipb 2/3	-1.41	0.13	1.56	0.09	-3.2	-0.07	3.92	0.2
ipb 3/3	-1.42	0.13	1.57	0.08	-3.23	-0.08	3.95	0.18
ipb 3/3	-1.43	0.13	1.61	0.08	-3.23	-0.08	3.96	0.19
ipb 2/3	-1.51	0.15	1.66	0.09	-3.39	-0.06	4.16	0.19
ipb 1/3	-1.46	0.14	1.6	0.08	-3.31	-0.1	4.02	0.2
opb 1/3	-0.03	-7.83	-0.06	7.66	0.07	-14.41	-0.31	13.88
opb 2/3	-0.05	-7.76	-0.04	7.67	0.01	-14.3	-0.29	13.84
opb 3/3	-0.03	-7.79	-0.05	7.7	0.02	-14.36	-0.32	13.85
opb 3/3	-0.03	-7.77	-0.05	7.71	-0.01	-14.33	-0.32	13.83
opb 2/3	-0.04	-7.69	-0.06	7.66	-0.01	-14.19	-0.3	13.7
opb 1/3	-0.06	-7.63	-0.06	7.55	0.02	-14.08	-0.28	13.61
axi-c 1/3	0.21	14.5	1.99	7.44	5.9	24.37	11.59	11.3
axi-c 2/3	0.52	12	1.69	9.93	6.6	19.85	10.66	15.74
axi-c 3/3	0.52	10.88	1.63	11.03	6.61	17.82	10.48	17.7
axi-c 3/3	0.55	10.88	1.63	11	6.61	17.83	10.45	17.7
axi-c 2/3	0.35	10.71	1.9	11.33	6.15	17.42	11.1	18.27
axi-c 1/3	-0.06	12.43	2.36	9.78	5.25	20.4	12.27	15.54
axi-t 1/3	1.34	9.28	0.7	12.36	8.12	15.23	7.78	20.16
axi-t 2/3	1.15	9.92	0.88	11.74	7.79	16.24	8.21	19.04
axi-t 3/3	1.11	9.43	0.95	12.26	7.57	15.39	8.41	19.78
axi-t 3/3	1.09	9.43	0.95	12.21	7.58	15.31	8.47	19.93
axi-t 2/3	1.16	9.89	0.81	11.79	7.91	16.18	8.21	19.18
axi-t 1/3	1.19	9.42	0.67	11.98	7.95	15.3	7.93	19.8

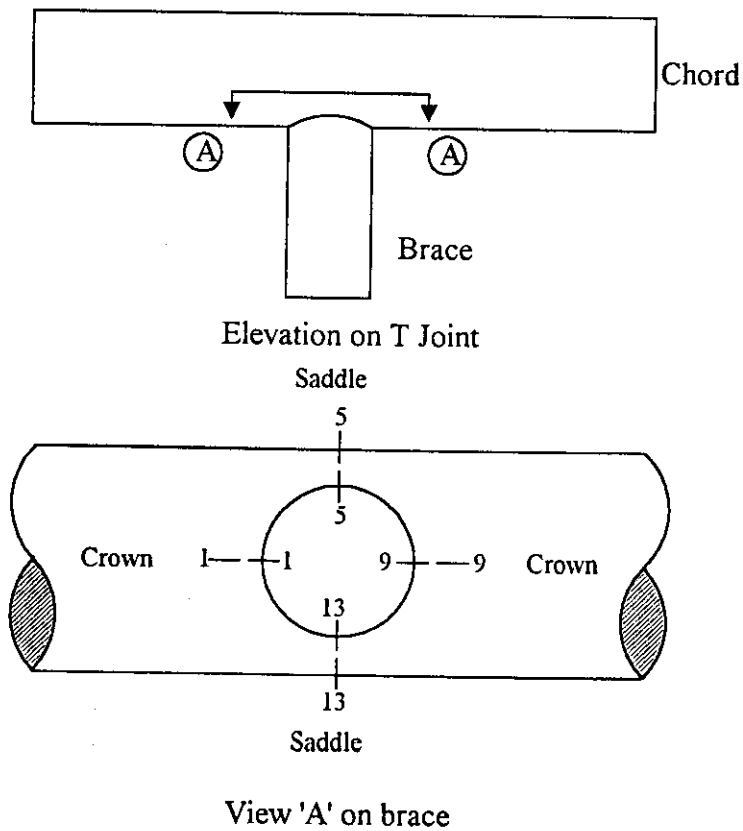

Appendix L 13 SNCFs ungrouted Test Specimen: T7

Table L.16: Measured SNCFs on intersection of brace and chord for T7

T7	BC;1	BS;5	BC;9	BS;13	CC;1	CS;5	CC;9	CS;13
ipb 1/3	-1.63	-0.01	1.63	-0.08	-4.46	0.05	4.9	-0.35
ipb 2/3	-1.65	-0.02	1.64	-0.06	-4.49	-0.01	4.97	-0.35
ipb 3/3	-1.66	-0.03	1.65	-0.09	-4.5	0.01	5.01	-0.42
ipb 3/3	-1.67	-0.02	1.67	-0.09	-4.5	0.01	4.97	-0.38
ipb 2/3	-1.67	-0.01	1.67	-0.07	-4.5	0.02	4.99	-0.34
ipb 1/3	-1.68	0.04	1.69	-0.06	-4.51	0.13	5.02	-0.33
opb 1/3	-0.07	-6.16	-0.25	5.45	0.35	-14.79	-0.47	15.99
opb 2/3	0.05	-6.88	-0.26	6.05	0.36	-16.44	-0.45	17.85
opb 3/3	0.04	-6.88	-0.24	6.09	0.27	-16.56	-0.44	17.95
opb 3/3	0.11	-7.25	-0.18	6.39	0.32	-17.46	-0.52	18.91
opb 2/3	0.12	-7.2	-0.18	6.29	0.36	-17.26	-0.54	18.68
opb 1/3	0.14	-7.69	-0.41	6.77	0.54	-18.54	-0.81	20
axi-c 1/3	0.32	4.47	1.53	15.96	6.56	9.76	10.6	46.51
axi-c 2/3	0.49	7.77	1.36	13.04	7.02	17.72	9.97	37.93
axi-c 3/3	0.53	9.26	1.37	11.74	7.1	21.21	9.93	34.15
axi-c 3/3	0.53	9.25	1.35	11.73	7.12	21.18	9.89	34.1
axi-c 2/3	0.59	7.98	1.38	12.93	7.09	18.13	9.91	37.67
axi-c 1/3	0.3	5.14	1.61	15.51	6.27	11.24	10.71	45.13
axi-t 1/3	0.47	14.78	1.41	5.8	6.51	34.21	9.48	16.55
axi-t 2/3	1.07	13.92	0.8	6.75	8.07	32.27	7.87	19.3
axi-t 3/3	1.26	13.33	0.68	7.47	8.59	30.73	7.43	21.37
axi-t 3/3	1.3	13.23	0.64	7.57	8.69	30.44	7.37	21.71
axi-t 2/3	1.28	13.66	0.71	6.99	8.46	31.56	7.42	19.91
axi-t 1/3	0.8	14.24	1.12	5.85	7.05	32.99	8.34	16.72

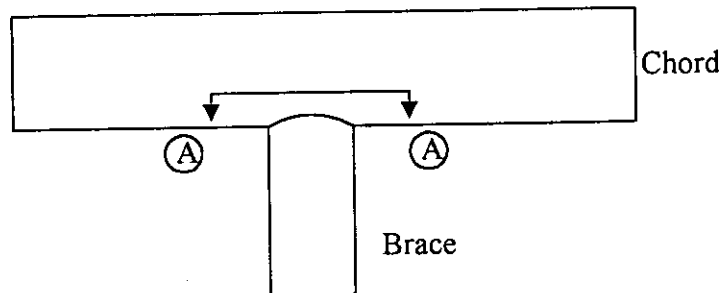

Elevation on T Joint

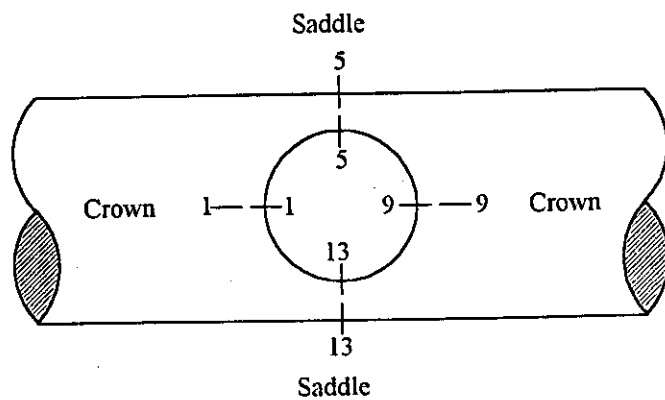

View 'A' on brace

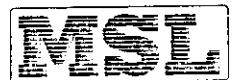

Appendix L 14 SNCFs ungrouted Test Specimen: T9

Table L.17: Measured SNCFs on intersection of brace and chord for T9

T9	BC;1	BI;2	BI;4	BS;5	BI;6	BI;8	BC;9	BI;10
ipb 1/3	-1.35	-1.36	-1.35	-0.37	1.11	1.17	1.29	1.44
ipb 2/3	-1.42	-1.41	-1.37	-0.21	1.24	1.24	1.36	1.5
ipb 3/3	-1.44	-1.43	-1.39	-0.19	1.27	1.26	1.37	1.52
ipb 3/3	-1.45	-1.43	-1.38	-0.2	1.27	1.26	1.37	1.51
ipb 2/3	-1.44	-1.41	-1.38	-0.21	1.25	1.25	1.37	1.5
ipb 1/3	-1.35	-1.34	-1.35	-0.35	1.1	1.21	1.32	1.46
opb 1/3	-0.02	-0.63	-2.55	-7.41	-2.44	-0.63	0.07	0.69
opb 2/3	-0.02	-0.6	-2.56	-7.51	-2.42	-0.63	0.04	0.74
opb 3/3	-0.02	-0.57	-2.55	-7.53	-2.42	-0.66	0.04	0.75
opb 3/3	-0.02	-0.56	-2.55	-7.53	-2.42	-0.66	0.04	0.76
opb 2/3	-0.02	-0.58	-2.54	-7.46	-2.37	-0.65	0.04	0.76
opb 1/3	-0.07	-0.61	-2.5	-7.39	-2.36	-0.61	0.07	0.75
axi-c 1/3	2.85	3.28	5.73	7.94	4.41	2.3	1.56	2.25
axi-c 2/3	2.51	3.07	5.74	8.45	4.82	2.54	1.84	2.48
axi-c 3/3	2.44	3.01	5.71	8.72	5.01	2.61	1.91	2.52
axi-c 3/3	2.4	3.01	5.67	8.68	5.02	2.63	1.93	2.52
axi-c 2/3	2.57	3.14	5.89	8.89	4.93	2.56	1.85	2.35
axi-c 1/3	2.92	3.49	6.13	8.8	4.58	2.32	1.55	2.1
axi-t 1/3	2.81	3.48	5.4	7.03	4.27	1.76	1.42	2.31
axi-t 2/3	3.09	3.75	5.72	7.23	4.15	1.62	1.25	2.06
axi-t 3/3	2.75	3.48	5.56	7.77	4.62	1.92	1.53	2.29
axi-t 3/3	2.75	3.47	5.55	7.72	4.6	1.89	1.53	2.29
axi-t 2/3	2.92	3.59	5.41	6.75	4.14	1.63	1.39	2.26
axi-t 1/3	2.75	3.25	4.56	4.71	3.56	1.59	1.5	2.53

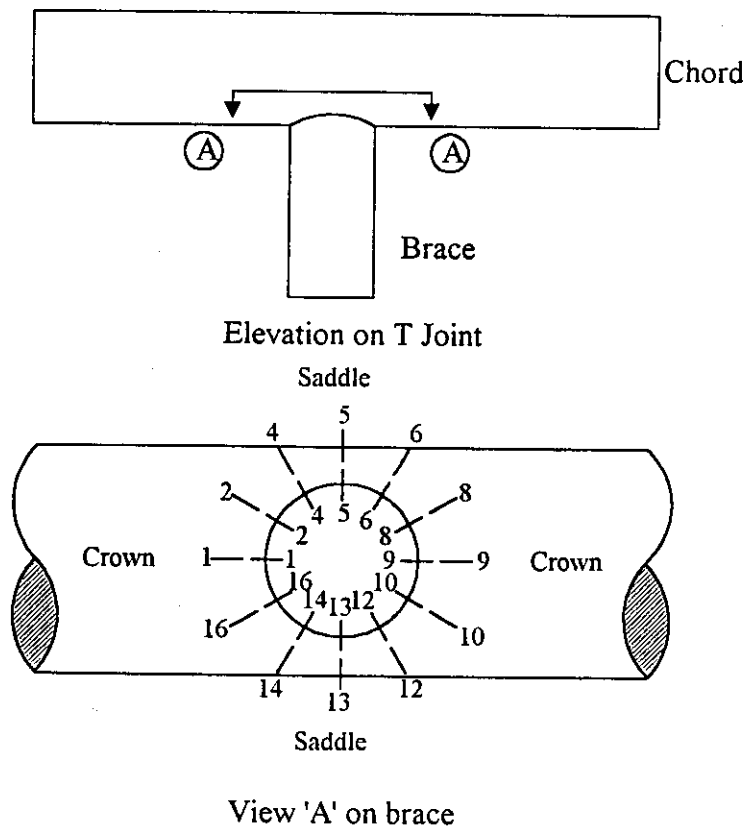
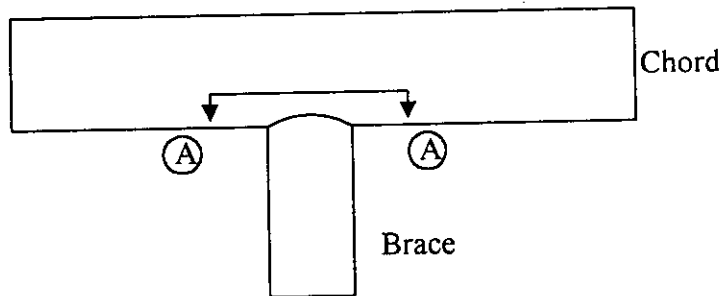
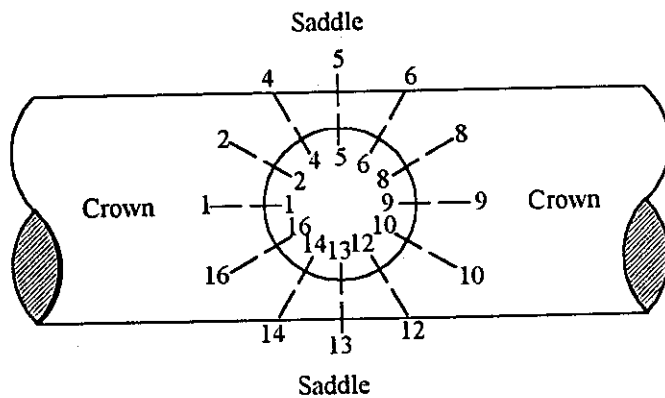

Table L.18: Measured SNCFs on intersection of brace and chord for T9

T9	CC;1	CI;2	CI;4	CS;5	CI;6	CI;8	CC;9	CI;10
ipb 1/3	-2.35	-2.39	-1.84	-0.65	1.76	2.51	2.68	2.18
ipb 2/3	-2.46	-2.55	-1.97	-0.35	2.05	2.77	2.82	2.22
ipb 3/3	-2.51	-2.62	-2.01	-0.3	2.12	2.82	2.88	2.24
ipb 3/3	-2.51	-2.62	-2	-0.32	2.13	2.82	2.89	2.24
ipb 2/3	-2.48	-2.59	-1.99	-0.36	2.06	2.78	2.88	2.25
ipb 1/3	-2.36	-2.47	-1.88	-0.67	1.77	2.58	2.77	2.21
opb 1/3	-0.01	-0.71	-3.77	-16.64	-3.12	-0.26	0	0.24
opb 2/3	-0.06	-0.72	-3.79	-16.89	-3.06	-0.2	0.01	0.21
opb 3/3	-0.05	-0.7	-3.84	-17	-3.03	-0.21	-0.04	0.16
opb 3/3	-0.06	-0.66	-3.82	-16.98	-3.01	-0.21	-0.04	0.18
opb 2/3	-0.09	-0.68	-3.79	-16.78	-2.93	-0.2	-0.03	0.17
opb 1/3	-0.12	-0.67	-3.77	-16.48	-2.98	-0.23	0.04	0.26
axi-c 1/3	8.03	8.21	9.21	14.05	5.69	5.29	7.54	6.15
axi-c 2/3	7.57	7.85	9.21	15.22	6.36	5.95	7.96	6.43
axi-c 3/3	7.33	7.63	9.05	15.8	6.88	6.28	8.1	6.44
axi-c 3/3	7.41	7.62	9	15.78	6.85	6.3	8.08	6.45
axi-c 2/3	7.69	8.05	9.52	16.32	6.38	5.89	7.88	6.46
axi-c 1/3	8.28	8.72	10.11	16.18	5.54	5.17	7.31	6.13
axi-t 1/3	8.26	6.98	6.39	11.62	7.76	6.71	6.9	4.4
axi-t 2/3	8.66	7.48	6.72	11.91	7.92	6.54	6.45	3.87
axi-t 3/3	7.96	6.81	6.49	13.15	8.58	7.1	6.99	4.25
axi-t 3/3	7.93	6.82	6.49	13.1	8.6	7.1	6.98	4.24
axi-t 2/3	8.28	7.09	6.23	10.92	8.04	6.81	6.7	4
axi-t 1/3	7.84	6.71	5.1	6.6	7.23	6.78	6.88	4.36



Elevation on T Joint



View 'A' on brace

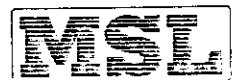

Table L.19: Measured SNCFs on intersection of brace and chord for T9

T9	BC;1	BI;16	BI;14	BS;13	BI;12	BI;10	BC;9	BI;8
ipb 1/3	-1.35	-1.2	-1	0.25	1.52	1.44	1.29	1.17
ipb 2/3	-1.42	-1.27	-1.11	0.12	1.53	1.5	1.36	1.24
ipb 3/3	-1.44	-1.29	-1.13	0.11	1.54	1.52	1.37	1.26
ipb 3/3	-1.45	-1.28	-1.14	0.12	1.54	1.51	1.37	1.26
ipb 2/3	-1.44	-1.26	-1.12	0.12	1.53	1.5	1.37	1.25
ipb 1/3	-1.35	-1.19	-1.03	0.24	1.52	1.46	1.32	1.21
opb 1/3	-0.02	0.6	2.37	6.49	2.48	0.69	0.07	-0.63
opb 2/3	-0.02	0.61	2.39	6.53	2.52	0.74	0.04	-0.63
opb 3/3	-0.02	0.61	2.44	6.58	2.5	0.75	0.04	-0.66
opb 3/3	-0.02	0.6	2.41	6.56	2.49	0.76	0.04	-0.66
opb 2/3	-0.02	0.6	2.4	6.51	2.47	0.76	0.04	-0.65
opb 1/3	-0.07	0.6	2.31	6.42	2.46	0.75	0.07	-0.61
axi-c 1/3	2.85	3.1	5.2	6.23	4.66	2.25	1.56	2.3
axi-c 2/3	2.51	2.81	4.75	5.76	4.69	2.48	1.84	2.54
axi-c 3/3	2.44	2.66	4.62	5.52	4.66	2.52	1.91	2.61
axi-c 3/3	2.4	2.64	4.63	5.5	4.64	2.52	1.93	2.63
axi-c 2/3	2.57	2.77	4.72	5.37	4.51	2.35	1.85	2.56
axi-c 1/3	2.92	3.1	5.1	5.43	4.3	2.1	1.55	2.32
axi-t 1/3	2.81	3.04	5.53	6.71	4.47	2.31	1.42	1.76
axi-t 2/3	3.09	3.21	5.67	6.62	4.15	2.06	1.25	1.62
axi-t 3/3	2.75	2.89	5.16	5.96	4.21	2.29	1.53	1.92
axi-t 3/3	2.75	2.9	5.16	5.96	4.22	2.29	1.53	1.89
axi-t 2/3	2.92	3.16	5.72	7.03	4.45	2.26	1.39	1.63
axi-t 1/3	2.75	3.19	6.22	8.78	5.27	2.53	1.5	1.59

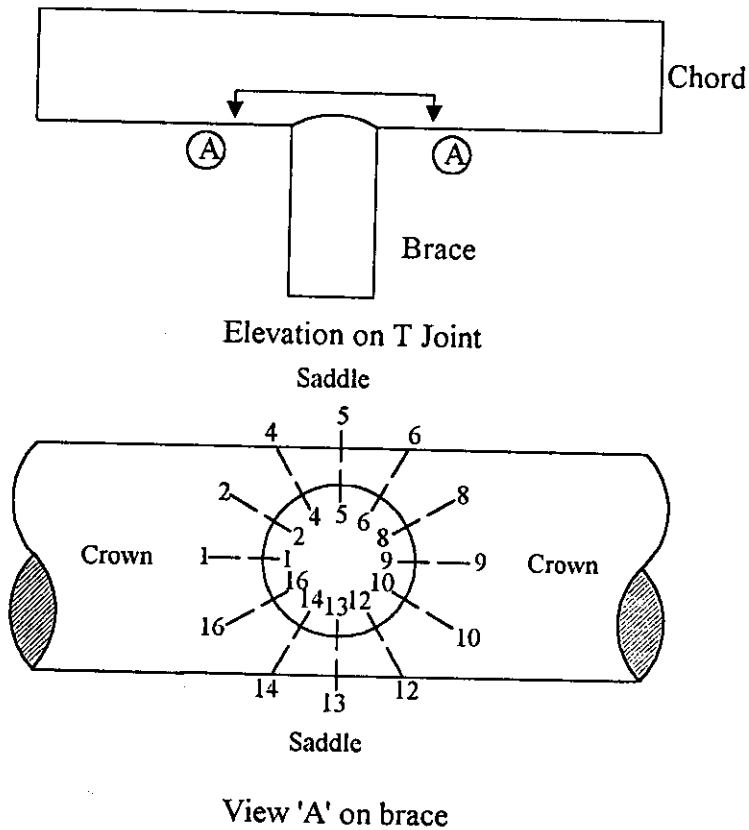
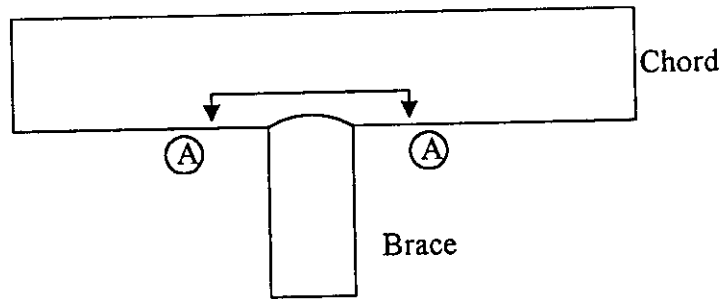
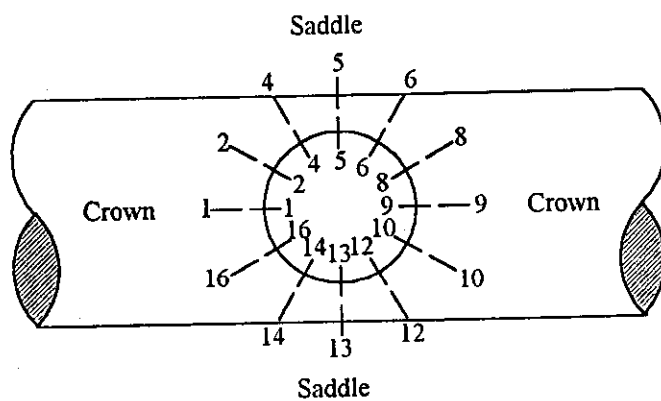

Table L.20: Measured SNCFs on intersection of brace and chord for T9

T9	CC;1	CI;16	CI;14	CS;13	CI;12	CI;10	CC;9	CI;8
ipb 1/3	-2.35	-2.37	-1.71	0.56	1.82	2.18	2.68	2.51
ipb 2/3	-2.46	-2.47	-1.76	0.29	1.75	2.22	2.82	2.77
ipb 3/3	-2.51	-2.5	-1.75	0.28	1.72	2.24	2.88	2.82
ipb 3/3	-2.51	-2.5	-1.74	0.28	1.72	2.24	2.89	2.82
ipb 2/3	-2.48	-2.48	-1.73	0.27	1.74	2.25	2.88	2.78
ipb 1/3	-2.36	-2.38	-1.67	0.51	1.81	2.21	2.77	2.58
opb 1/3	-0.01	0.35	2.75	15.2	2.9	0.24	0	-0.26
opb 2/3	-0.06	0.35	2.83	15.37	2.81	0.21	0.01	-0.2
opb 3/3	-0.05	0.39	2.96	15.45	2.75	0.16	-0.04	-0.21
opb 3/3	-0.06	0.39	2.9	15.42	2.73	0.18	-0.04	-0.21
opb 2/3	-0.09	0.36	2.83	15.33	2.71	0.17	-0.03	-0.2
opb 1/3	-0.12	0.28	2.58	15.17	2.74	0.26	0.04	-0.23
axi-c 1/3	8.03	7.26	6.4	9.82	7.51	6.15	7.54	5.29
axi-c 2/3	7.57	6.7	5.49	8.81	7.57	6.43	7.96	5.95
axi-c 3/3	7.33	6.53	5.37	8.49	7.41	6.44	8.1	6.28
axi-c 3/3	7.41	6.53	5.34	8.44	7.39	6.45	8.08	6.3
axi-c 2/3	7.69	6.76	5.23	8.04	7.57	6.46	7.88	5.89
axi-c 1/3	8.28	7.27	5.78	8.15	7.45	6.13	7.31	5.17
axi-t 1/3	8.26	8.51	8.44	11.54	4.91	4.4	6.9	6.71
axi-t 2/3	8.66	9.03	8.85	11.48	4.34	3.87	6.45	6.54
axi-t 3/3	7.96	8.37	8.16	9.98	4.31	4.25	6.99	7.1
axi-t 3/3	7.93	8.37	8.26	10.04	4.32	4.24	6.98	7.1
axi-t 2/3	8.28	8.84	9.01	12.37	4.52	4	6.7	6.81
axi-t 1/3	7.84	8.58	9.38	16.3	5.61	4.36	6.88	6.78



Elevation on T Joint



View 'A' on brace

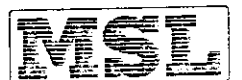

Appendix L 15 SNCFs ungrouted Test Specimen: T9 second

Following the first set of ungrouted SNCF measurements, specimen T9 was removed and replaced into the test rig and received a second set of ungrouted SNCF measurements. The following Tables present the SNCF measurements for this second cycle.

Table L.21: Measured SNCFs on intersection of brace and chord for T9-second

T9-s	BC;1	BI;2	BI;4	BS;5	BI;6	BI;8	BC;9	BI;10
ipb 1/3	-1.39	-1.38	-1.33	-0.13	1.23	1.24	1.32	1.47
ipb 2/3	-1.43	-1.41	-1.33	-0.08	1.28	1.27	1.35	1.48
ipb 3/3	-1.45	-1.42	-1.34	-0.06	1.3	1.27	1.36	1.5
ipb 3/3	-1.44	-1.41	-1.32	-0.03	1.3	1.26	1.36	1.43
ipb 2/3	-1.46	-1.44	-1.33	0	1.33	1.28	1.39	1.52
ipb 1/3	-1.42	-1.41	-1.32	-0.07	1.28	1.26	1.37	1.52
opb 1/3	0.05	-0.52	-2.46	-7.43	-2.4	-0.75	-0.01	0.64
opb 2/3	0.05	-0.55	-2.52	-7.45	-2.45	-0.73	-0.03	0.69
opb 3/3	0.03	-0.55	-2.53	-7.45	-2.44	-0.72	-0.01	0.69
opb 3/3	0.02	-0.55	-2.53	-7.44	-2.45	-0.72	0	0.7
opb 2/3	0.04	-0.56	-2.51	-7.39	-2.4	-0.72	-0.02	0.68
opb 1/3	0.02	-0.52	-2.53	-7.36	-2.43	-0.76	0	0.68
axi-c 1/3	3.35	3.72	5.51	5.92	3.34	1.61	1.23	1.98
axi-c 2/3	2.95	3.52	5.87	7.92	4.41	2.1	1.5	2.15
axi-c 3/3	2.63	3.26	5.76	8.37	4.83	2.4	1.79	2.4
axi-c 3/3	2.64	3.25	5.74	8.37	4.83	2.4	1.77	2.39
axi-c 2/3	2.86	3.44	5.96	8.37	4.63	2.24	1.57	2.2
axi-c 1/3	3.39	3.88	6.29	8.16	4.13	1.82	1.12	1.73
axi-t 1/3	2.62	3.67	6.51	10.86	5.68	2.33	1.68	2.21
axi-t 2/3	2.76	3.51	5.79	8.26	4.82	2.07	1.65	2.36
axi-t 3/3	2.72	3.4	5.49	7.63	4.64	2.11	1.68	2.42
axi-t 3/3	2.73	3.4	5.49	7.58	4.62	2.08	1.7	2.44
axi-t 2/3	2.83	3.55	5.59	7.64	4.57	1.93	1.67	2.38
axi-t 1/3	2.91	3.58	5.4	6.82	4.22	1.73	1.62	2.52

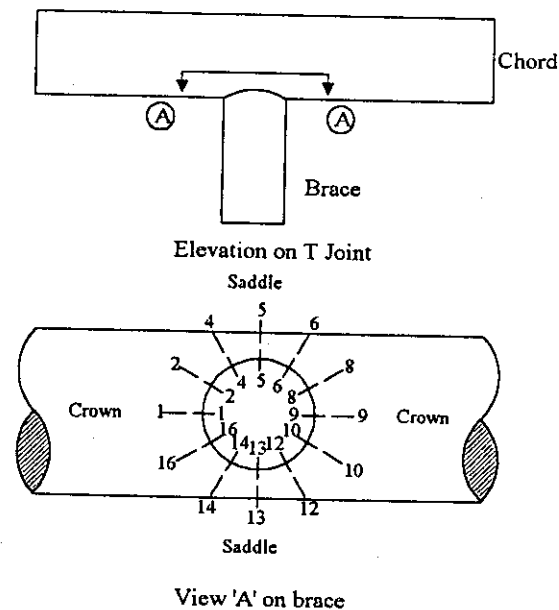
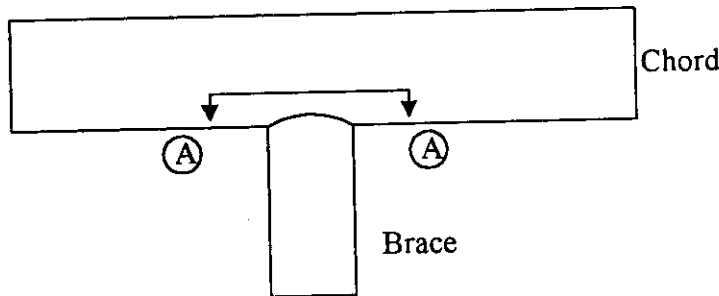
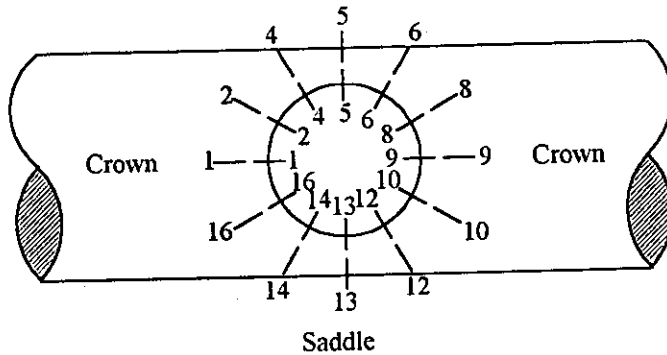

Table L.22: Measured SNCFs on intersection of brace and chord for T9-second

T9-s	CC;1	CI;2	CI;4	CS;5	CI;6	CI;8	CC;9	CI;10
ipb 1/3	-2.43	-2.5	-1.83	-0.16	2	2.7	2.8	2.18
ipb 2/3	-2.47	-2.57	-1.89	-0.05	2.11	2.79	2.84	2.19
ipb 3/3	-2.51	-2.6	-1.9	-0.01	2.13	2.8	2.87	2.21
ipb 3/3	-2.5	-2.59	-1.89	0.05	2.14	2.79	2.86	2.2
ipb 2/3	-2.53	-2.63	-1.93	0.11	2.21	2.86	2.92	2.24
ipb 1/3	-2.48	-2.6	-1.92	0	2.09	2.77	2.84	2.22
opb 1/3	0.12	-0.65	-3.86	-16.54	-3	-0.34	-0.21	0.13
opb 2/3	0.05	-0.72	-3.92	-16.69	-2.96	-0.29	-0.17	0.04
opb 3/3	0.03	-0.73	-3.92	-16.76	-2.95	-0.25	-0.15	0.02
opb 3/3	0.03	-0.74	-3.92	-16.75	-2.97	-0.23	-0.15	0
opb 2/3	0.07	-0.75	-3.89	-16.61	-2.93	-0.22	-0.16	0
opb 1/3	0.06	-0.78	-3.9	-16.45	-3	-0.24	-0.17	0.04
axi-c 1/3	9.14	8.98	8.41	9.44	4.66	4.82	6.47	5.09
axi-c 2/3	8.4	8.38	8.8	13.81	6.36	5.71	7.23	5.48
axi-c 3/3	7.9	7.82	8.59	14.91	7.09	6.38	7.78	5.83
axi-c 3/3	7.89	7.77	8.58	14.86	7.06	6.34	7.77	5.85
axi-c 2/3	8.32	8.26	9.01	14.76	6.52	5.88	7.4	5.66
axi-c 1/3	9.2	9.18	9.62	14.38	5.5	4.73	6.45	5.05
axi-t 1/3	7.86	7.15	7.86	19.97	10.05	7.48	7.56	4.61
axi-t 2/3	8.09	7.2	6.92	14.29	8.63	7.23	7.39	4.68
axi-t 3/3	7.99	7.16	6.86	12.93	8.07	7.05	7.45	4.88
axi-t 3/3	7.99	7.14	6.86	12.84	8.09	7.07	7.46	4.87
axi-t 2/3	8.18	7.16	6.7	12.78	8.44	7.2	7.33	4.51
axi-t 1/3	8.39	7.04	6.06	11.02	8.39	7.29	7.26	4.22



Elevation on T Joint
Saddle



View 'A' on brace

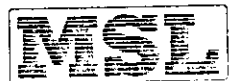
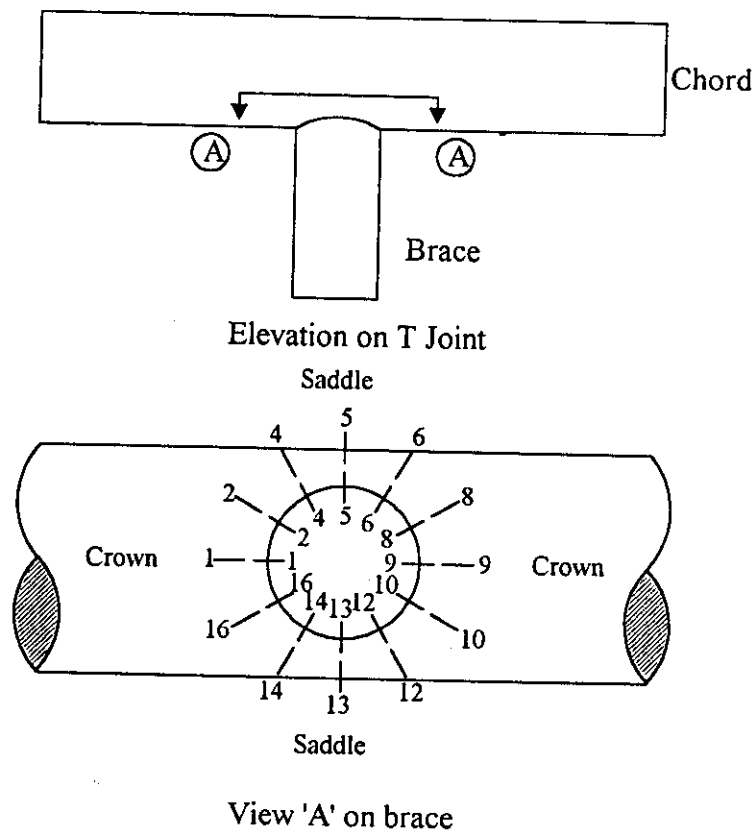

Table L.23: Measured SNCFs on intersection of brace and chord for T9-second

T9-s	BC;1	BI;16	BI;14	BS;13	BI;12	BI;10	BC;9	BI;8
ipb 1/3	-1.39	-1.23	-1.11	0.01	1.47	1.47	1.32	1.24
ipb 2/3	-1.43	-1.28	-1.14	0.01	1.47	1.48	1.35	1.27
ipb 3/3	-1.45	-1.29	-1.16	0	1.49	1.5	1.36	1.27
ipb 3/3	-1.44	-1.29	-1.16	-0.01	1.48	1.43	1.36	1.26
ipb 2/3	-1.46	-1.31	-1.18	-0.04	1.48	1.52	1.39	1.28
ipb 1/3	-1.42	-1.29	-1.15	0.01	1.47	1.52	1.37	1.26
opb 1/3	0.05	0.65	2.52	6.43	2.39	0.64	-0.01	-0.75
opb 2/3	0.05	0.67	2.49	6.46	2.4	0.69	-0.03	-0.73
opb 3/3	0.03	0.66	2.5	6.43	2.41	0.69	-0.01	-0.72
opb 3/3	0.02	0.65	2.51	6.43	2.42	0.7	0	-0.72
opb 2/3	0.04	0.65	2.5	6.43	2.41	0.68	-0.02	-0.72
opb 1/3	0.02	0.67	2.53	6.44	2.43	0.68	0	-0.76
axi-c 1/3	3.35	3.63	6.21	7.85	4.62	1.98	1.23	1.61
axi-c 2/3	2.95	3.13	5.2	6.07	4.34	2.15	1.5	2.1
axi-c 3/3	2.63	2.8	4.77	5.64	4.47	2.4	1.79	2.4
axi-c 3/3	2.64	2.82	4.77	5.61	4.46	2.39	1.77	2.4
axi-c 2/3	2.86	3.06	5	5.7	4.31	2.2	1.57	2.24
axi-c 1/3	3.39	3.53	5.45	5.89	3.95	1.73	1.12	1.82
axi-t 1/3	2.62	2.42	3.96	3.23	3.46	2.21	1.68	2.33
axi-t 2/3	2.76	2.83	4.89	5.46	4.16	2.36	1.65	2.07
axi-t 3/3	2.72	2.85	5.03	5.93	4.39	2.42	1.68	2.11
axi-t 3/3	2.73	2.85	5.02	5.94	4.4	2.44	1.7	2.08
axi-t 2/3	2.83	2.96	5.16	6.07	4.34	2.38	1.67	1.93
axi-t 1/3	2.91	3.1	5.56	6.91	4.54	2.52	1.62	1.73



MSL

APPENDIX M
Grouted SNCF Measurements

C14100R020 Rev 1 February 1997

NSI

Appendix M

SNCFs grouted specimen

TABLE OF CONTENTS

Appendix M 1 Table of Contents	1
Appendix M 2 Key	2
Appendix M 3 SNCFs grouted Test Specimen: DT2	3
Appendix M 4 SNCFs grouted Test Specimen: DT3	5
Appendix M 5 SNCFs grouted Test Specimen: DT4	9
Appendix M 6 SNCFs grouted Test Specimen: DT5	13
Appendix M 7 SNCFs grouted Test Specimen: DT6	15
Appendix M 8 SNCFs grouted Test Specimen: DT8	19
Appendix M 9 SNCFs grouted Test Specimen: DT9	21
Appendix M 10 SNCFs grouted Test Specimen: T1	25
Appendix M 11 SNCFs grouted Test Specimen: T3	28
Appendix M 12 SNCFs grouted Test Specimen: T5	31
Appendix M 13 SNCFs grouted Test Specimen: T9	33
Appendix M 14 UngROUTED/Grouted SNCF Plots	40

Appendix M 2 Key:

pl. cap
design
BS
BC
CS
CC
br1
br2

Plastic Capacity (%)
ISO Design Load Level
Brace Saddle
Brace Crown
Chord Saddle
Chord Crown
Brace 1
Brace 2

Example:

For the test setup shown below, brace 1 has strain gauges located at positions 5 and 9 on both the chord and the brace. Note that the brace gauge positions are shown inside the brace and the chord gauges are shown on the outside. Similarly on the second brace, they are located at positions 1 and 13.

BC9;br1: Brace Crown 9 at brace 1

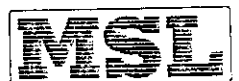
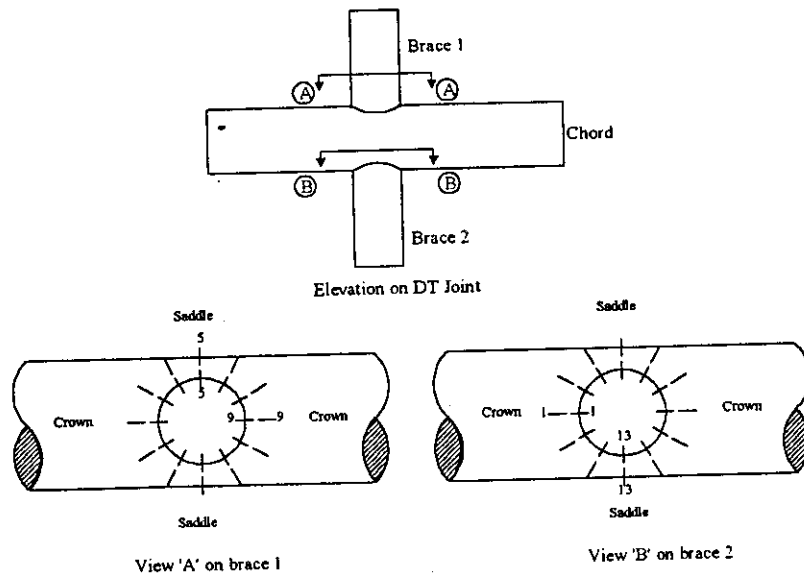

APPENDIX M 3 SNCFs grouted Test Specimen: DT2

Table M-1: Measured SNCFs on intersections of brace 1,2 and chord for DT2 before preloading

DT2	pl. cap	design	BC;1,br2	BS;5,br1	BC;9,br1	BS;13,br2	CC;1,br2	CS;5,br1	CC;9,br1	CS;13,br2
ipb 1/3	-0.0277	-0.0506	2.33	-0.16	-1.7	-0.11	3.41	-0.26	-3.2	-0.19
ipb 2/3	-0.0541	-0.0985	2.5	-0.19	-1.62	-0.15	2.55	-0.23	-2.9	-0.24
ipb 3/3	-0.0801	-0.1459	2.43	-0.2	-1.58	-0.18	2.16	-0.25	-2.74	-0.29
ipb 3/3	-0.0805	-0.1468	2.44	-0.21	-1.6	-0.17	2.19	-0.24	-2.77	-0.29
ipb 2/3	-0.0547	-0.0996	2.58	-0.2	-1.68	-0.13	2.67	-0.22	-3.03	-0.22
ipb 1/3	-0.0273	-0.0498	2.44	-0.26	-1.79	0	3.72	-0.24	-3.41	-0.05
opb 1/3	-0.0139	-0.0475	0.02	-4.7	-0.04	4.26	0.05	-5.61	0.11	7.61
opb 2/3	-0.0284	-0.0975	0.01	-4.03	-0.04	3.55	-0.06	-4.88	0.01	5.81
opb 3/3	-0.0435	-0.149	-0.01	-3.57	-0.03	2.95	-0.1	-4.25	-0.08	4.29
opb 3/3	-0.0438	-0.15	-0.02	-3.56	0	2.96	-0.1	-4.25	-0.07	4.3
opb 2/3	-0.0287	-0.0985	0	-4.02	0.05	3.58	0	-4.77	0.03	5.86
opb 1/3	-0.014	-0.0481	0.08	-4.71	0.11	4.27	-0.02	-5.63	0.16	7.85
axi-c 1/3	-0.0105	-0.0546	0.6	6.69	1.72	5.26	2.51	7.77	4.34	9.21
axi-c 2/3	-0.0209	-0.1089	1.62	4.23	1.4	3.63	3.27	5.36	3.19	6.86
axi-c 3/3	-0.0317	-0.1651	1.68	3.24	1.39	2.61	2.6	4.28	2.34	5.11
axi-c 3/3	-0.0317	-0.1651	1.68	3.24	1.39	2.61	2.6	4.28	2.34	5.11
axi-c 2/3	-0.0209	-0.109	1.73	4.39	1.26	3.54	3.41	5.63	3.08	6.72
axi-c 1/3	-0.0106	-0.0549	1.22	6.97	1.24	5.2	3.48	8.06	3.53	9.11
axi-t 1/3	0.0107	0.0444	0.6	7.06	0.78	4.17	1.52	8.19	2.36	7.01
axi-t 2/3	0.0212	0.0883	0.71	5.14	0.8	3.49	1.54	5.97	2.05	5.81
axi-t 3/3	0.0317	0.1322	0.77	4.43	0.82	3.04	1.56	5.16	1.98	5.05
axi-t 3/3	0.0317	0.1322	0.75	4.45	0.82	3.04	1.54	5.19	1.99	5.05
axi-t 2/3	0.0211	0.0878	0.73	5.23	0.75	3.55	1.53	6.04	2	5.84
axi-t 1/3	0.0106	0.0443	0.63	7.17	0.62	4.35	1.84	8.21	2.09	7.21

Table M-2: Measured SNCFs on intersections of brace 1,2 and chord for DT2 after preload level of 50 %

DT2	pl. cap	design	BC;1,br2	BS;5,br1	BC;9,br1	BS;13,br2	CC;1,br2	CS;5,br1	CC;9,br1	CS;13,br2
ipb 1/3	-0.0273	-0.0498	2.39	-0.22	-1.72	-0.08	3.44	-0.25	-3.21	-0.07
ipb 2/3	-0.0524	-0.0955	2.54	-0.23	-1.63	-0.12	2.57	-0.27	-2.98	-0.17
ipb 3/3	-0.0524	-0.0955	2.54	-0.23	-1.63	-0.12	2.57	-0.27	-2.98	-0.17
ipb 3/3	-0.0799	-0.1456	2.52	-0.2	-1.62	-0.11	2.18	-0.26	-2.79	-0.2
ipb 2/3	-0.0533	-0.0971	2.63	-0.24	-1.71	-0.08	2.65	-0.26	-3.05	-0.12
ipb 1/3	-0.027	-0.0493	2.43	-0.22	-1.8	0.06	3.69	-0.35	-3.4	0.04
opb 1/3	-0.0142	-0.0486	0.07	-4.81	-0.01	4.28	0	-5.66	0.13	7.72
opb 2/3	-0.029	-0.0995	0.01	-4.09	0.01	3.67	-0.05	-4.79	0.02	5.97
opb 3/3	-0.0439	-0.1504	-0.03	-3.64	-0.01	3.07	-0.12	-4.31	-0.07	4.48
opb 3/3	-0.044	-0.1506	-0.02	-3.66	0	3.07	-0.11	-4.4	-0.09	4.51
opb 2/3	-0.029	-0.0993	0	-4.12	0.03	3.71	0	-4.96	0.01	6.07
opb 1/3	-0.0143	-0.0491	0.08	-4.8	0.08	4.31	0.05	-5.9	0.07	7.83
axi-c 1/3	-0.0105	-0.0547	0.11	6.22	2.25	6.24	1.45	7.2	5.36	10.75
axi-c 2/3	-0.021	-0.1092	1.37	4.45	1.81	3.88	2.97	5.54	3.93	7.45
axi-c 3/3	-0.0317	-0.1651	1.66	3.48	1.67	2.76	2.49	4.61	2.94	5.55
axi-c 3/3	-0.0317	-0.1651	1.66	3.48	1.67	2.76	2.49	4.56	2.95	5.56
axi-c 2/3	-0.0209	-0.1089	1.6	4.64	1.58	3.84	3.27	5.74	3.8	7.35
axi-c 1/3	-0.0105	-0.0545	0.74	6.99	1.48	5.82	2.55	7.93	4.1	10.13
axi-t 1/3	0.0107	0.0444	0.65	5.29	0.45	5.28	1.57	6.15	1.78	8.96
axi-t 2/3	0.0211	0.0881	0.68	4.54	0.64	4.08	1.48	5.23	1.95	6.68
axi-t 3/3	0.0319	0.1328	0.72	4.09	0.75	3.4	1.46	4.77	1.91	5.59
axi-t 3/3	0.0318	0.1326	0.66	4.14	0.78	3.39	1.43	4.83	1.92	5.48
axi-t 2/3	0.0212	0.0883	0.64	4.62	0.71	4.06	1.51	5.38	1.89	6.58
axi-t 1/3	0.0106	0.0443	0.62	5.78	0.45	5.43	1.6	6.71	1.94	8.88

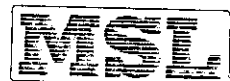
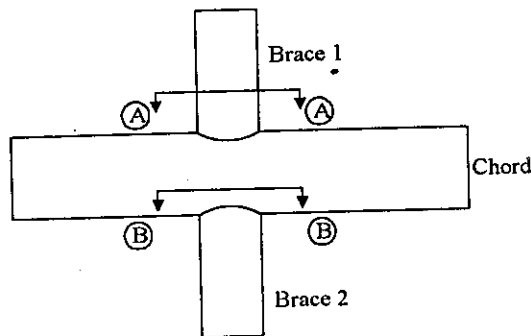
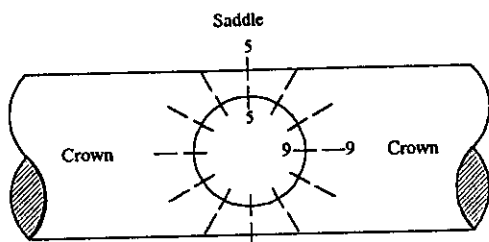

Table M-3: Measured SNCFs on intersections of brace 1,2 and chord for DT2 after preload level of 100%

DT2	pl. cap	design	BC;1,br2	BS;5,br1	BC;9,br1	BS;13,br2	CC;1,br2	CS;5,br1	CC;9,br1	CS;13,br2
ipb 1/3	-0.0265	-0.0483	1.79	0.1	-1.76	0.34	3.49	0.12	-3.42	0.54
ipb 2/3	-0.0541	-0.0985	2.21	0	-1.7	0.14	3.13	-0.02	-3.09	0.19
ipb 3/3	-0.0801	-0.146	2.37	-0.04	-1.64	0.05	2.57	-0.05	-2.89	0.03
ipb 3/3	-0.0802	-0.1461	2.38	-0.05	-1.63	0.05	2.55	-0.06	-2.86	0.03
ipb 2/3	-0.0541	-0.0986	2.3	0.02	-1.7	0.15	3.19	0.02	-3.11	0.22
ipb 1/3	-0.0282	-0.0514	1.95	0.2	-1.84	0.33	3.69	0.2	-3.51	0.53
opb 1/3	-0.0134	-0.046	-0.01	-4.4	-0.06	4.32	-0.02	-5.48	0.12	8.41
opb 2/3	-0.0291	-0.0998	-0.02	-3.93	-0.04	3.94	0.01	-4.82	0.06	6.63
opb 3/3	-0.0434	-0.1489	-0.04	-3.59	-0.03	3.29	-0.07	-4.27	-0.02	5.05
opb 3/3	-0.0438	-0.1501	-0.04	-3.6	-0.02	3.36	-0.07	-4.24	-0.04	5.14
opb 2/3	-0.0286	-0.0981	-0.02	-4	-0.02	4.13	0.03	-4.8	0.08	6.99
opb 1/3	-0.0135	-0.0461	-0.01	-4.27	-0.01	4.61	0.07	-5.16	0.07	8.48
axi-c 1/3	-0.0105	-0.0545	-0.28	7.86	1.23	7.33	1.24	9.12	3.75	12.93
axi-c 2/3	-0.0209	-0.1088	1.09	6.4	1.25	4.85	3.06	7.54	3.56	8.92
axi-c 3/3	-0.0318	-0.1652	1.49	5.07	1.35	3.29	3.06	6.31	3.14	6.51
axi-c 3/3	-0.0318	-0.1652	1.52	5.05	1.35	3.32	3.06	6.27	3.18	6.53
axi-c 2/3	-0.0209	-0.109	1.24	6.5	1.14	4.87	3.29	7.73	3.49	8.93
axi-c 1/3	-0.0105	-0.0545	0.22	8.72	0.69	6.86	2.21	10.14	2.88	12.11
axi-t 1/3	0.0111	0.0463	0.61	5.58	0.62	3.34	1.38	6.46	1.82	5.73
axi-t 2/3	0.0214	0.089	0.7	4.78	0.7	2.81	1.4	5.48	1.78	4.78
axi-t 3/3	0.032	0.1334	0.78	4.24	0.79	2.54	1.42	4.89	1.79	4.33
axi-t 3/3	0.032	0.1334	0.76	4.21	0.79	2.6	1.37	4.86	1.79	4.31
axi-t 2/3	0.0212	0.0884	0.72	4.78	0.62	2.92	1.46	5.49	1.64	4.74
axi-t 1/3	0.0107	0.0448	0.92	5.92	0.38	3.52	1.76	6.78	1.31	5.64



Elevation on DT Joint



View 'A' on brace 1

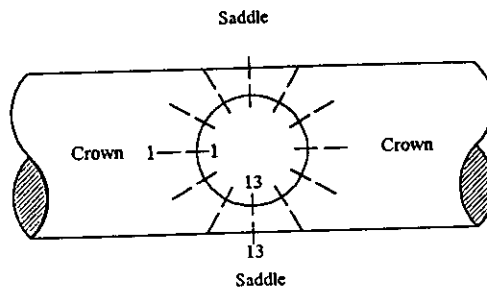

View 'B' on brace 2

Appendix M 4 SNCFs grouted Test Specimen: DT3

Table M-4: Measured SNCFs on brace of intersections of brace and chord for DT3

DT3	pl. cap	design	BC;1,br1	BI;2,br1	BI;4,br1	BS;5,br1	BC;9,br2	BI;10,br2	BI;12,br2	BS;13,br2
ipb 1/3	-0.0274	-0.041	2.61	1.51	1.6	0.31	-1.3	-1.55	-1.28	-0.05
ipb 2/3	-0.055	-0.0822	2.62	1.45	1.28	0.19	-1.2	-1.5	-1.12	-0.06
ipb 3/3	-0.0813	-0.1216	2.51	1.45	1.11	0.12	-1.19	-1.45	-1.02	-0.06
ipb 3/3	-0.0813	-0.1216	2.51	1.45	1.11	0.12	-1.19	-1.46	-1.01	-0.06
ipb 2/3	-0.0549	-0.0821	2.67	1.47	1.31	0.18	-1.23	-1.52	-1.14	-0.06
ipb 1/3	-0.027	-0.0405	2.71	1.6	1.7	0.31	-1.31	-1.67	-1.31	-0.06
opb 1/3	-0.0229	-0.0482	0.02	-0.42	-1.24	-2.27	-0.02	0.41	0.93	1.96
opb 2/3	-0.0475	-0.0999	0.03	-0.4	-1.17	-2.16	-0.04	0.37	0.9	1.92
opb 3/3	-0.0728	-0.153	0.02	-0.39	-1.12	-2.06	-0.04	0.36	0.82	1.79
opb 3/3	-0.0729	-0.1531	0.02	-0.38	-1.12	-2.06	-0.02	0.35	0.82	1.79
opb 2/3	-0.0479	-0.1006	0.03	-0.39	-1.19	-2.14	0	0.38	0.93	1.96
opb 1/3	-0.0235	-0.0494	0.05	-0.37	-1.25	-2.26	0.02	0.39	0.95	1.98
axi-c 1/3	-0.0146	-0.0372	1.05	1.49	3.13	4.31	0.54	0.72	1.66	2.93
axi-c 2/3	-0.0291	-0.0742	1.07	1.49	3.39	4.43	0.45	0.64	1.35	2.8
axi-c 3/3	-0.0436	-0.1111	1.05	1.41	3.14	4.22	0.53	0.58	1.15	2.49
axi-c 3/3	-0.0436	-0.1111	1.05	1.41	3.12	4.22	0.53	0.58	1.15	2.49
axi-c 2/3	-0.0291	-0.0742	1.1	1.61	3.44	4.45	0.42	0.61	1.36	2.83
axi-c 1/3	-0.0146	-0.0371	1.2	1.71	3.57	4.49	0.39	0.57	1.4	2.86
axi-t 1/3	0.0144	0.0482	0.94	1.35	2.41	3.49	0.71	0.93	1.59	2.58
axi-t 2/3	0.0286	0.0962	1.02	1.29	2.1	2.87	0.64	0.86	1.43	2.1
axi-t 3/3	0.0428	0.1436	1.05	1.32	1.91	2.45	0.63	0.83	1.31	1.79
axi-t 3/3	0.0428	0.1436	1.05	1.31	1.89	2.44	0.63	0.81	1.31	1.77
axi-t 2/3	0.0286	0.0959	1.02	1.32	2.12	2.92	0.62	0.82	1.47	2.14
axi-t 1/3	0.0143	0.0479	0.94	1.27	2.34	3.44	0.63	0.89	1.64	2.7

Table M-5: Measured SNCFs on chord of intersections of brace and chord for DT3

DT3	pl. cap	design	CC;1,br1	CI;2,br1	CI;4,br1	CS;5,br1	CC;9,br2	CI;10,br2	CI;12,br2	CS;13,br2
ipb 1/3	-0.0274	-0.041	2.18	1.92	1.41	0.28	-2.07	-2.35	-1.76	-0.17
ipb 2/3	-0.055	-0.0822	1.7	1.62	1.16	0.1	-1.84	-2.17	-1.54	-0.18
ipb 3/3	-0.0813	-0.1216	1.52	1.42	1.02	0.01	-1.75	-2.08	-1.43	-0.21
ipb 3/3	-0.0813	-0.1216	1.52	1.43	1	0.01	-1.75	-2.07	-1.43	-0.22
ipb 2/3	-0.0549	-0.0821	1.76	1.69	1.17	0.1	-1.88	-2.22	-1.57	-0.19
ipb 1/3	-0.027	-0.0405	2.35	2.05	1.48	0.22	-2.21	-2.5	-1.81	-0.15
opb 1/3	-0.0229	-0.0482	0.13	-0.17	-0.93	-2.45	0	0.22	1.15	2.7
opb 2/3	-0.0475	-0.0999	0.14	-0.14	-0.86	-2.42	-0.04	0.19	1.08	2.65
opb 3/3	-0.0728	-0.153	0.12	-0.15	-0.84	-2.38	-0.07	0.17	1	2.59
opb 3/3	-0.0729	-0.1531	0.1	-0.15	-0.83	-2.39	-0.08	0.17	1.01	2.61
opb 2/3	-0.0479	-0.1006	0.11	-0.14	-0.86	-2.42	-0.07	0.2	1.1	2.72
opb 1/3	-0.0235	-0.0494	0.15	-0.13	-0.89	-2.46	0.03	0.26	1.13	2.82
axi-c 1/3	-0.0146	-0.0372	1.09	1.15	2.46	3.95	0.5	0.63	1.83	3.21
axi-c 2/3	-0.0291	-0.0742	1.31	1.35	2.58	3.99	0.47	0.6	1.61	2.87
axi-c 3/3	-0.0436	-0.1111	1.43	1.44	2.38	3.87	0.62	0.68	1.44	2.67
axi-c 3/3	-0.0436	-0.1111	1.43	1.48	2.38	3.87	0.62	0.72	1.48	2.67
axi-c 2/3	-0.0291	-0.0742	1.42	1.51	2.64	3.97	0.36	0.54	1.62	2.9
axi-c 1/3	-0.0146	-0.0371	1.52	1.61	2.8	4.01	0.25	0.51	1.69	3.03
axi-t 1/3	0.0144	0.0482	0.76	0.86	1.67	3.45	0.83	1.14	2.27	2.97
axi-t 2/3	0.0286	0.0962	0.83	1	1.54	3.19	0.88	1.11	2.11	3.02
axi-t 3/3	0.0428	0.1436	0.94	1.14	1.53	3.22	0.92	1.14	1.99	2.97
axi-t 3/3	0.0428	0.1436	0.94	1.14	1.52	3.18	0.92	1.14	1.97	2.98
axi-t 2/3	0.0286	0.0959	0.83	1.01	1.64	3.14	0.89	1.13	2.1	3.04
axi-t 1/3	0.0143	0.0479	0.69	0.87	1.71	3.2	0.82	1.15	2.33	3.06

Table M-6: Measured SNCFs on brace of intersections of brace and chord for DT3 at preload level of 50%

DT3	pl. cap	design	BC;1,br1	BF;2,br1	BI;4,br1	BS;5,br1	BC;9,br2	BI;10,br2	BI;12,br2	BS;13,br2
ipb 1/3	-0.0272	-0.0407	2.91	1.39	1.28	-0.14	-1.28	-1.57	-1.3	-0.24
ipb 2/3	-0.0534	-0.0799	2.78	1.36	1.06	-0.13	-1.22	-1.51	-1.13	-0.17
ipb 3/3	-0.081	-0.1213	2.62	1.38	0.93	-0.11	-1.21	-1.46	-1.02	-0.15
ipb 3/3	-0.0811	-0.1213	2.61	1.37	0.94	-0.12	-1.21	-1.46	-1.02	-0.15
ipb 2/3	-0.0548	-0.082	2.79	1.36	1.08	-0.14	-1.24	-1.52	-1.15	-0.19
ipb 1/3	-0.0273	-0.0409	2.99	1.48	1.32	-0.19	-1.34	-1.63	-1.37	-0.25
opb 1/3	-0.0232	-0.0487	0.06	-0.35	-1.28	-2.33	0.01	0.35	0.82	1.94
opb 2/3	-0.0476	-0.1001	0.05	-0.36	-1.25	-2.3	-0.03	0.34	0.85	1.88
opb 3/3	-0.0724	-0.1521	0.03	-0.36	-1.18	-2.17	-0.03	0.33	0.84	1.88
opb 3/3	-0.0733	-0.1541	0.04	-0.38	-1.2	-2.19	-0.05	0.33	0.85	1.89
opb 2/3	-0.0486	-0.1021	0.04	-0.38	-1.21	-2.21	-0.06	0.34	0.91	2.02
opb 1/3	-0.0243	-0.051	0.04	-0.34	-1.09	-1.84	-0.15	0.17	0.83	2.02
axi-c 1/3	-0.0146	-0.0373	0.46	0.79	2.33	4.38	1.2	1.53	2.34	3.08
axi-c 2/3	-0.0291	-0.0743	0.56	0.93	2.53	4.13	0.99	1.23	1.95	2.97
axi-c 3/3	-0.0436	-0.1112	0.65	0.94	2.39	3.78	1.13	1.12	1.65	2.69
axi-c 3/3	-0.0436	-0.1112	0.65	0.94	2.37	3.79	1.11	1.12	1.65	2.69
axi-c 2/3	-0.0291	-0.0742	0.6	0.94	2.54	4.16	0.99	1.25	1.96	3
axi-c 1/3	-0.0146	-0.0373	0.46	0.87	2.31	4.38	1.12	1.45	2.28	3.03
axi-t 1/3	0.0147	0.0492	0.68	1.16	2.84	4.33	0.67	0.98	1.68	2.48
axi-t 2/3	0.0288	0.0968	0.81	1.14	2.62	3.91	0.7	0.95	1.62	2.62
axi-t 3/3	0.0431	0.1448	0.88	1.18	2.33	3.31	0.7	0.89	1.47	2.23
axi-t 3/3	0.0431	0.1447	0.88	1.21	2.36	3.34	0.72	0.89	1.47	2.25
axi-t 2/3	0.0288	0.0966	0.81	1.19	2.66	3.99	0.72	0.95	1.67	2.68
axi-t 1/3	0.0146	0.0489	0.68	1.24	2.94	4.4	0.77	0.94	1.65	2.43

Table M-7: Measured SNCFs on chord of intersections of brace and chord for DT3 at preload level of 50%

DT3	pl. cap	design	CC;1,br1	CI;2,br1	CI;4,br1	CS;5,br1	CC;9,br2	CI;10,br2	CI;12,br2	CS;13,br2
ipb 1/3	-0.0272	-0.0407	2.01	1.74	1.05	-0.11	-2.11	-2.39	-1.73	-0.18
ipb 2/3	-0.0534	-0.0799	1.62	1.49	0.91	-0.13	-1.9	-2.21	-1.52	-0.15
ipb 3/3	-0.081	-0.1213	1.44	1.31	0.81	-0.17	-1.77	-2.08	-1.39	-0.17
ipb 3/3	-0.0811	-0.1213	1.44	1.32	0.83	-0.17	-1.77	-2.09	-1.38	-0.19
ipb 2/3	-0.0548	-0.082	1.64	1.5	0.92	-0.14	-1.89	-2.23	-1.52	-0.17
ipb 1/3	-0.0273	-0.0409	2.13	1.82	1.17	-0.14	-2.2	-2.54	-1.79	-0.23
opb 1/3	-0.0232	-0.0487	0.18	-0.16	-0.9	-2.55	-0.05	0.15	1.05	2.58
opb 2/3	-0.0476	-0.1001	0.13	-0.13	-0.9	-2.54	-0.08	0.15	1.02	2.53
opb 3/3	-0.0724	-0.1521	0.12	-0.15	-0.83	-2.39	-0.07	0.17	1.06	2.59
opb 3/3	-0.0733	-0.1541	0.11	-0.14	-0.84	-2.43	-0.08	0.17	1.05	2.62
opb 2/3	-0.0486	-0.1021	0.13	-0.13	-0.83	-2.39	-0.09	0.18	1.12	2.73
opb 1/3	-0.0243	-0.051	0.17	-0.08	-0.65	-1.92	-0.31	0.02	1.11	2.79
axi-c 1/3	-0.0146	-0.0373	-0.03	0.34	1.71	3.89	1.74	1.91	3.07	3.24
axi-c 2/3	-0.0291	-0.0743	0.51	0.68	1.74	3.69	1.54	1.58	2.57	3.18
axi-c 3/3	-0.0436	-0.1112	0.83	0.89	1.73	3.48	1.59	1.47	2.18	2.95
axi-c 3/3	-0.0436	-0.1112	0.83	0.85	1.76	3.48	1.58	1.46	2.18	2.95
axi-c 2/3	-0.0291	-0.0742	0.56	0.65	1.85	3.75	1.55	1.57	2.55	3.16
axi-c 1/3	-0.0146	-0.0373	0.06	0.34	1.71	3.96	1.64	1.77	3.07	3.28
axi-t 1/3	0.0147	0.0492	0.5	0.82	2.19	4.03	0.95	1.07	2.15	2.57
axi-t 2/3	0.0288	0.0968	0.66	0.86	2.09	3.75	0.87	1.06	2.19	3.08
axi-t 3/3	0.0431	0.1448	0.8	1	1.88	3.77	0.89	1.1	2.11	3.13
axi-t 3/3	0.0431	0.1447	0.81	1.01	1.82	3.75	0.89	1.1	2.08	3.13
axi-t 2/3	0.0288	0.0966	0.68	0.88	2	3.7	0.82	1.03	2.19	3.03
axi-t 1/3	0.0146	0.0489	0.54	0.72	2.01	3.82	0.96	1.05	2.09	2.44

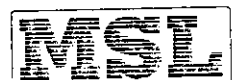

Table M-8: Measured SNCFs on brace of intersections of brace and chord for DT3 at preload level of 100 %

DT3	pl. cap	design	BC;1,br1	BI;2,br1	BI;4,br1	BS;5,br1	BC;9,br2	BI;10,br2	BI;12,br2	BS;13,br2
ipb 1/3	-0.0287	-0.0429	3.1	1.51	1.35	-0.06	-1.23	-1.59	-1.34	-0.21
ipb 2/3	-0.0548	-0.0819	2.87	1.43	1.12	-0.12	-1.22	-1.51	-1.15	-0.18
ipb 3/3	-0.0819	-0.1226	2.71	1.45	1.01	-0.12	-1.23	-1.48	-1.06	-0.18
ipb 3/3	-0.0814	-0.1218	2.72	1.46	1.01	-0.14	-1.24	-1.48	-1.06	-0.19
ipb 2/3	-0.0549	-0.0822	2.94	1.47	1.16	-0.14	-1.25	-1.55	-1.18	-0.22
ipb 1/3	-0.0272	-0.0407	3.21	1.57	1.44	-0.16	-1.27	-1.61	-1.38	-0.23
opb 1/3	-0.0234	-0.0491	0.11	-0.4	-1.25	-2.2	-0.02	0.38	0.95	2.05
opb 2/3	-0.0477	-0.1002	0.07	-0.39	-1.28	-2.23	-0.01	0.38	0.95	2.05
opb 3/3	-0.072	-0.1513	0.05	-0.39	-1.24	-2.21	-0.02	0.36	0.91	1.96
opb 3/3	-0.0722	-0.1518	0.04	-0.4	-1.23	-2.22	-0.02	0.37	0.91	1.98
opb 2/3	-0.0479	-0.1006	0.06	-0.4	-1.26	-2.28	0	0.4	0.97	2.07
opb 1/3	-0.0236	-0.0496	0.09	-0.4	-1.27	-2.29	-0.02	0.39	0.97	2.13
axi-c 1/3	-0.0146	-0.0371	0.87	1.46	3.28	4.68	0.64	0.88	1.58	2.91
axi-c 2/3	-0.0291	-0.0741	1.19	1.55	3.3	4.52	0.71	0.79	1.41	2.7
axi-c 3/3	-0.0436	-0.1112	1.58	1.43	2.99	4.18	0.83	0.67	1.2	2.42
axi-c 3/3	-0.0436	-0.1112	1.58	1.43	2.96	4.18	0.83	0.67	1.2	2.42
axi-c 2/3	-0.0291	-0.0742	1.32	1.68	3.41	4.63	0.6	0.7	1.34	2.66
axi-c 1/3	-0.0145	-0.0371	1.17	1.63	3.57	4.77	0.42	0.65	1.35	2.91
axi-t 1/3	0.0147	0.0493	1.16	1.56	3.21	4.14	0.42	0.76	1.43	2.91
axi-t 2/3	0.029	0.0972	1.08	1.35	3.02	3.89	0.55	0.81	1.55	3.03
axi-t 3/3	0.0432	0.1449	1.04	1.34	2.66	3.43	0.58	0.85	1.52	2.79
axi-t 3/3	0.0432	0.1451	1.04	1.34	2.68	3.4	0.57	0.84	1.49	2.8
axi-t 2/3	0.0289	0.0971	1.09	1.47	3.07	3.88	0.5	0.79	1.55	3.13
axi-t 1/3	0.0146	0.0492	1.17	1.59	3.37	4.08	0.36	0.59	1.19	2.82

Table M-9: Measured SNCFs on chord of intersections of brace and chord for DT3 at preload level of 100 %

DT3	pl. cap	design	CC;1,br1	CI;2,br1	CI;4,br1	CS;5,br1	CC;9,br2	CI;10,br2	CI;12,br2	CS;13,br2
ipb 1/3	-0.0287	-0.0429	2.16	1.86	1.19	-0.08	-1.97	-2.42	-1.85	-0.11
ipb 2/3	-0.0548	-0.0819	1.73	1.59	1.02	-0.08	-1.85	-2.24	-1.57	-0.13
ipb 3/3	-0.0819	-0.1226	1.52	1.39	0.9	-0.11	-1.76	-2.11	-1.42	-0.17
ipb 3/3	-0.0814	-0.1218	1.53	1.41	0.91	-0.1	-1.77	-2.14	-1.43	-0.18
ipb 2/3	-0.0549	-0.0822	1.78	1.68	1.03	-0.08	-1.9	-2.31	-1.63	-0.17
ipb 1/3	-0.0272	-0.0407	2.33	2.08	1.24	-0.04	-2.05	-2.53	-1.96	-0.14
opb 1/3	-0.0234	-0.0491	0.17	-0.16	-0.97	-2.46	-0.03	0.22	1.22	2.79
opb 2/3	-0.0477	-0.1002	0.15	-0.15	-0.9	-2.47	-0.03	0.26	1.18	2.8
opb 3/3	-0.072	-0.1513	0.13	-0.16	-0.89	-2.49	-0.04	0.21	1.14	2.75
opb 3/3	-0.0722	-0.1518	0.12	-0.13	-0.88	-2.48	-0.02	0.22	1.12	2.76
opb 2/3	-0.0479	-0.1006	0.15	-0.12	-0.9	-2.5	0.03	0.28	1.17	2.81
opb 1/3	-0.0236	-0.0496	0.21	-0.08	-0.94	-2.45	0.03	0.29	1.19	2.85
axi-c 1/3	-0.0146	-0.0371	1.04	1.29	2.65	4.31	0.65	0.79	2.06	3.18
axi-c 2/3	-0.0291	-0.0741	1.47	1.44	2.58	4.21	0.73	0.66	1.71	2.93
axi-c 3/3	-0.0436	-0.1112	1.57	1.42	2.33	3.97	0.84	0.67	1.54	2.71
axi-c 3/3	-0.0436	-0.1112	1.54	1.45	2.33	3.93	0.84	0.67	1.52	2.69
axi-c 2/3	-0.0291	-0.0742	1.67	1.58	2.69	4.29	0.52	0.56	1.62	2.9
axi-c 1/3	-0.0145	-0.0371	1.27	1.77	3.02	4.42	0.18	0.34	1.69	3.06
axi-t 1/3	0.0147	0.0493	1.24	1.43	2.56	3.73	0.13	0.52	1.67	3.12
axi-t 2/3	0.029	0.0972	1.16	1.31	2.42	3.51	0.41	0.7	1.9	3.4
axi-t 3/3	0.0432	0.1449	1.07	1.21	2.18	3.39	0.62	0.86	2.07	3.69
axi-t 3/3	0.0432	0.1451	1.09	1.24	2.17	3.36	0.66	0.87	2.05	3.68
axi-t 2/3	0.0289	0.0971	1.21	1.39	2.46	3.62	0.43	0.69	1.88	3.38
axi-t 1/3	0.0146	0.0492	1.43	1.6	2.71	3.78	0.14	0.39	1.5	3.01



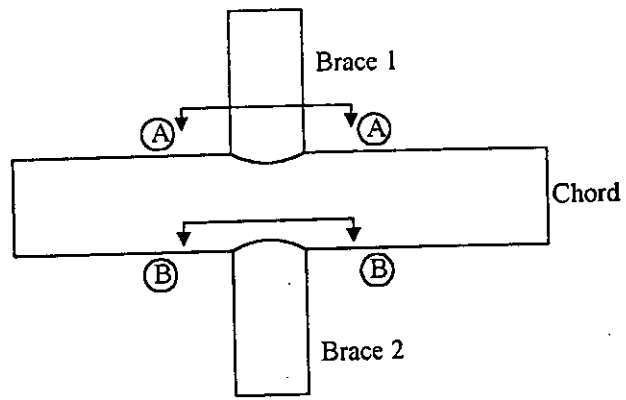

Elevation on DT Joint

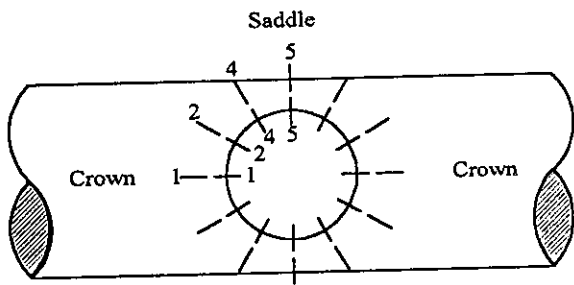

View 'A' on brace 1

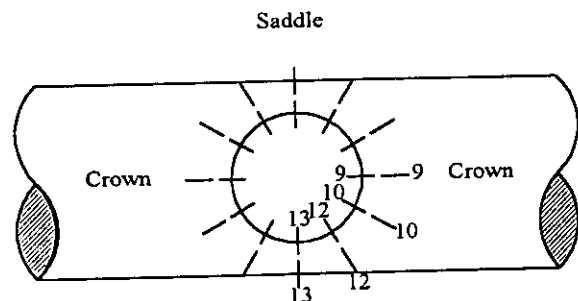

View 'B' on brace 2

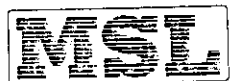

Appendix M 5 SNCFs grouted Test Specimen: DT4

Table M-10: Measured SNCFs on intersections of brace 1 and chord for DT4

DT4	pl. cap	design	BC;1,br1	BS;5,br1	BC;9,br1	BS;13,br1	CC;1,br1	CS;5,br1	CC;9,br1	CS;13,br1
ipb 1/3	-0.0312	-0.0543	3.39	-0.4	-2.06	-0.66	2.16	-0.84	-3.76	-1.56
ipb 2/3	-0.0603	-0.1049	3.29	-0.39	-2.09	-0.62	1.94	-0.83	-3.68	-1.46
ipb 3/3	-0.0895	-0.1557	3.18	-0.37	-2.07	-0.56	1.82	-0.8	-3.61	-1.4
ipb 3/3	-0.0917	-0.1596	3.15	-0.38	-2.04	-0.56	1.78	-0.82	-3.56	-1.37
ipb 2/3	-0.0637	-0.1108	3.34	-0.41	-2.12	-0.61	1.99	-0.85	-3.74	-1.44
ipb 1/3	-0.0325	-0.0566	3.57	-0.44	-2.21	-0.69	2.36	-0.92	-4	-1.52
opb 1/3	-0.0106	-0.037	-0.14	-4.34	-0.18	3.39	-0.27	-8.45	-0.47	7.4
opb 2/3	-0.0239	-0.0836	-0.17	-3.64	-0.2	3.03	-0.35	-7.11	-0.57	4.79
opb 3/3	-0.0366	-0.1281	-0.2	-3.4	-0.26	3.01	-0.41	-6.7	-0.6	3.86
opb 3/3	-0.0379	-0.1326	-0.21	-3.34	-0.21	2.95	-0.36	-6.64	-0.58	3.79
opb 2/3	-0.0238	-0.0834	-0.23	-3.82	-0.15	3.2	-0.3	-7.54	-0.56	5.09
opb 1/3	-0.0111	-0.0388	-0.1	-4.52	0.05	3.42	-0.16	-8.96	-0.33	7.65
axi-c 1/3	-0.0123	-0.069	-0.79	2.93	4.45	1.61	-0.25	5.91	9.69	5.43
axi-c 2/3	-0.0238	-0.1341	-0.18	2.05	3.59	1.4	0.72	3.73	6.54	4.43
axi-c 3/3	-0.0357	-0.2009	0.05	1.58	3.29	1.55	0.89	2.77	4.96	3.8
axi-c 3/3	-0.0357	-0.2009	0.05	1.6	3.29	1.55	0.89	2.79	4.92	3.85
axi-c 2/3	-0.024	-0.1347	-0.15	1.92	3.64	1.59	0.67	3.7	6.45	4.83
axi-c 1/3	-0.0121	-0.068	-1.03	2.46	4.87	2.02	-0.4	5.48	10.62	6.79
axi-t 1/3	0.0127	0.0642	-0.28	0.03	2.23	6.35	-0.07	0.16	5.49	15.79
axi-t 2/3	0.0243	0.1234	0.57	1.88	1.33	4.87	1.13	3.29	3.89	12
axi-t 3/3	0.0361	0.1831	0.69	2.45	1.29	4	1.23	4.56	3.49	9.93
axi-t 3/3	0.036	0.1828	0.69	2.52	1.28	3.98	1.23	4.56	3.5	9.81
axi-t 2/3	0.0241	0.1221	0.57	1.88	1.41	4.95	1.1	3.21	3.94	12.13
axi-t 1/3	0.0121	0.0615	0.3	0.1	1.73	6.75	0.9	0.43	4.91	16.58

Table M-11: Measured SNCFs on intersections of brace 2 and chord for DT4

DT4	pl. cap	design	BC;1,br2	BS;5,br2	BC;9,br2	BS;13,br2	CC;1,br2	CS;5,br2	CC;9,br2	CS;13,br2
ipb 1/3	-0.0312	-0.0543	4.13	-0.2	-2.33	-0.73	1.66	-0.68	-2.84	-1.23
ipb 2/3	-0.0603	-0.1049	4.1	-0.24	-2.41	-0.7	1.54	-0.67	-2.79	-1.18
ipb 3/3	-0.0895	-0.1557	4.02	-0.23	-2.44	-0.68	1.46	-0.66	-2.81	-1.17
ipb 3/3	-0.0917	-0.1596	3.97	-0.23	-2.4	-0.65	1.42	-0.65	-2.76	-1.15
ipb 2/3	-0.0637	-0.1108	4.15	-0.24	-2.45	-0.7	1.55	-0.66	-2.87	-1.2
ipb 1/3	-0.0325	-0.0566	4.32	-0.28	-2.5	-0.7	1.82	-0.63	-2.99	-1.28
opb 1/3	-0.0106	-0.037	-0.32	-2.35	0.06	4.95	0.01	-7.84	0.22	7.2
opb 2/3	-0.0239	-0.0836	-0.28	-2.18	0.07	4.38	-0.29	-6.5	-0.01	5
opb 3/3	-0.0366	-0.1281	-0.31	-1.98	0.02	4.18	-0.29	-6.13	-0.14	3.89
opb 3/3	-0.0379	-0.1326	-0.28	-1.99	0.03	4.13	-0.28	-6.09	-0.14	4
opb 2/3	-0.0238	-0.0834	-0.24	-2.13	0.14	4.51	-0.21	-6.77	0.01	5.45
opb 1/3	-0.0111	-0.0388	-0.18	-2.49	0.17	4.78	0.05	-7.7	0.27	7.55
axi-c 1/3	-0.0123	-0.069	-2.88	3.39	8.4	1.63	-2.8	8.8	9.6	3.17
axi-c 2/3	-0.0238	-0.1341	-0.72	2.02	6.03	1.91	-0.18	5.27	5.7	3.76
axi-c 3/3	-0.0357	-0.2009	-0.02	1.51	4.89	2.1	0.67	3.72	4.06	3.71
axi-c 3/3	-0.0357	-0.2009	0.02	1.53	4.84	2.07	0.61	3.75	4.12	3.72
axi-c 2/3	-0.024	-0.1347	-0.83	2.11	6.14	1.99	-0.23	5.21	5.83	4.01
axi-c 1/3	-0.0121	-0.068	-3.35	3.35	9.43	1.68	-3.51	8.94	10.78	3.55
axi-t 1/3	0.0127	0.0642	0.06	1.73	2.2	5.88	0.38	5.08	4.13	9.73
axi-t 2/3	0.0243	0.1234	0.99	1.86	1.41	5.47	1.26	5.22	2.95	9.01
axi-t 3/3	0.0361	0.1831	1.08	1.81	1.37	5.05	1.43	4.92	2.65	8.32
axi-t 3/3	0.036	0.1828	1.01	1.72	1.45	4.99	1.33	4.89	2.68	8.32
axi-t 2/3	0.0241	0.1221	0.95	1.69	1.48	5.79	1.23	4.75	3.05	9.63
axi-t 1/3	0.0121	0.0615	0.52	1.51	1.8	6.78	0.96	4.62	3.78	11.39

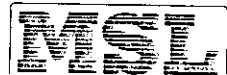

Table M-12: Measured SNCFs on intersections of brace 1 and chord for DT4 at preload level of 50%

DT4	pl. cap	design	BC;1,br1	BS;5,br1	BC;9,br1	BS;13,br1	CC;1,br1	CS;5,br1	CC;9,br1	CS;13,br1
ipb 1/3	-0.0286	-0.0498	3.29	-0.36	-1.96	-0.57	2.13	-0.78	-3.64	-1.41
ipb 2/3	-0.0545	-0.0948	3.29	-0.41	-2.07	-0.55	1.95	-0.83	-3.66	-1.35
ipb 3/3	-0.0801	-0.1394	3.22	-0.44	-2.07	-0.52	1.83	-0.88	-3.6	-1.26
ipb 3/3	-0.0818	-0.1422	3.25	-0.4	-2.08	-0.57	1.88	-0.83	-3.65	-1.35
ipb 2/3	-0.0563	-0.0979	3.39	-0.37	-2.12	-0.62	2.09	-0.82	-3.82	-1.44
ipb 1/3	-0.0298	-0.0519	3.54	-0.28	-2.19	-0.74	2.51	-0.66	-4.05	-1.74
opb 1/3	-0.0111	-0.039	-0.06	-3.75	-0.13	3.26	-0.17	-7.63	-0.38	7.01
opb 2/3	-0.024	-0.0839	-0.15	-3.58	-0.21	3.25	-0.29	-7.07	-0.53	4.85
opb 3/3	-0.0342	-0.1197	-0.17	-3.5	-0.2	3.22	-0.35	-6.91	-0.57	4.04
opb 3/3	-0.0347	-0.1216	-0.2	-3.56	-0.18	3.25	-0.38	-7.05	-0.54	4.2
opb 2/3	-0.0241	-0.0844	-0.2	-3.93	-0.2	3.54	-0.36	-7.83	-0.51	5.33
opb 1/3	-0.0106	-0.037	-0.16	-4.49	-0.09	3.86	-0.31	-9.21	-0.24	8.42
axi-c 1/3	-0.0119	-0.0669	-2.76	9.22	6.2	-2.45	-4.06	12.64	11.32	-6.18
axi-c 2/3	-0.0239	-0.1344	-1.09	5.2	4.64	-0.37	-1.19	6.86	7.72	-0.38
axi-c 3/3	-0.0358	-0.2015	-0.48	3.15	4.28	0.45	-0.05	4.52	6.05	2.14
axi-c 3/3	-0.0358	-0.2015	-0.48	3.18	4.41	0.49	0.06	4.53	6.37	2.18
axi-c 2/3	-0.0238	-0.1341	-0.97	4.83	4.79	-0.01	-0.75	6.65	8.3	0.54
axi-c 1/3	-0.012	-0.0674	-3.03	9.49	6.75	-2.33	-3.89	12.93	12.7	-5.89
axi-t 1/3	0.0123	0.0624	0.92	1.91	1.02	5.37	1.73	2.77	3.4	13.2
axi-t 2/3	0.0245	0.1246	0.89	2.73	1.01	4.36	1.66	4.78	3.06	10.65
axi-t 3/3	0.036	0.1828	0.7	2.95	1.17	3.89	1.34	5.38	3.14	9.37
axi-t 3/3	0.0361	0.1831	0.66	3.02	1.17	3.82	1.32	5.43	3.1	9.2
axi-t 2/3	0.0247	0.1252	0.86	2.94	0.98	4.31	1.6	5.15	3.02	10.4
axi-t 1/3	0.0124	0.0627	1.14	2.08	0.74	5.53	2.27	3.12	2.65	13.35

Table M-13: Measured SNCFs on intersections of brace 2 and chord for DT4 at preload level of 50%

DT4	pl. cap	design	BC;1,br2	BS;5,br2	BC;9,br2	BS;13,br2	CC;1,br2	CS;5,br2	CC;9,br2	CS;13,br2
ipb 1/3	-0.0286	-0.0498	4.08	-0.28	-2.3	-0.6	1.7	-0.67	-2.78	-1.02
ipb 2/3	-0.0545	-0.0948	4.21	-0.3	-2.45	-0.63	1.58	-0.75	-2.87	-1.04
ipb 3/3	-0.0801	-0.1394	4.14	-0.3	-2.46	-0.58	1.46	-0.78	-2.83	-1
ipb 3/3	-0.0818	-0.1422	4.17	-0.29	-2.48	-0.61	1.5	-0.75	-2.86	-1.06
ipb 2/3	-0.0563	-0.0979	4.36	-0.24	-2.53	-0.66	1.69	-0.75	-2.97	-1.14
ipb 1/3	-0.0298	-0.0519	4.58	-0.29	-2.62	-0.74	2.02	-0.61	-3.14	-1.29
opb 1/3	-0.0111	-0.039	-0.2	-2.41	0.09	4.59	-0.1	-6.96	0.01	6.81
opb 2/3	-0.024	-0.0839	-0.28	-2.07	0.02	4.62	-0.26	-6.52	-0.02	5.2
opb 3/3	-0.0342	-0.1197	-0.28	-2.08	0.02	4.52	-0.34	-6.36	-0.1	4.24
opb 3/3	-0.0347	-0.1216	-0.27	-2.15	0.03	4.55	-0.34	-6.47	-0.07	4.42
opb 2/3	-0.0241	-0.0844	-0.32	-2.32	0.09	4.79	-0.27	-6.99	0.02	5.64
opb 1/3	-0.0106	-0.037	-0.21	-2.61	0.17	5.01	-0.1	-8.06	0.1	8.08
axi-c 1/3	-0.0119	-0.0669	-4.04	7.87	5.79	-4.24	-4.6	13.51	7.53	-7.5
axi-c 2/3	-0.0239	-0.1344	-1.54	4.48	4.59	-1.03	-1.5	7.41	5.1	-1.61
axi-c 3/3	-0.0358	-0.2015	-0.57	2.7	4.68	0.69	-0.06	4.85	4.22	1.51
axi-c 3/3	-0.0358	-0.2015	-0.67	2.7	4.76	0.68	-0.17	4.81	4.34	1.56
axi-c 2/3	-0.0238	-0.1341	-1.64	4.04	4.98	-0.42	-1.44	7.01	5.64	-0.36
axi-c 1/3	-0.012	-0.0674	-4.73	7.3	6.87	-3.79	-5.19	13.5	8.89	-6.33
axi-t 1/3	0.0123	0.0624	0.48	2.02	1.67	5.77	0.89	5.22	3.53	9.61
axi-t 2/3	0.0245	0.1246	0.94	1.73	1.23	5.39	1.38	4.84	2.73	9.03
axi-t 3/3	0.036	0.1828	0.9	1.62	1.39	5.26	1.3	4.33	2.66	8.77
axi-t 3/3	0.0361	0.1831	0.85	1.73	1.43	5.21	1.28	4.39	2.66	8.64
axi-t 2/3	0.0247	0.1252	0.86	1.84	1.33	5.75	1.37	4.41	2.73	9.44
axi-t 1/3	0.0124	0.0627	0.79	1.9	1.35	6.62	1.52	4.38	3.1	11.09

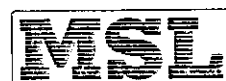

Table M-14: Measured SNCFs on intersections of brace 1 and chord for DT4 at preload level of 100 %

DT4	pl. cap	design	BC;1,br1	BS;5,br1	BC;9,br1	BS;13,br1	CC;1,br1	CS;5,br1	CC;9,br1	CS;13,br1
ipb 1/3	-0.0274	-0.0477	2.81	-0.28	-1.63	-0.58	1.85	-0.44	-3.12	-1.33
ipb 2/3	-0.0578	-0.1006	3.16	-0.33	-1.95	-0.54	1.83	-0.65	-3.44	-1.27
ipb 3/3	-0.0844	-0.1468	3.13	-0.36	-1.97	-0.5	1.72	-0.7	-3.44	-1.21
ipb 3/3	-0.0811	-0.1411	3.31	-0.35	-2.08	-0.54	1.81	-0.71	-3.63	-1.33
ipb 2/3	-0.055	-0.0956	3.43	-0.32	-2.12	-0.6	2.03	-0.67	-3.77	-1.43
ipb 1/3	-0.0274	-0.0477	3.53	-0.25	-2.18	-0.71	2.47	-0.49	-4.02	-1.74
opb 1/3	-0.0115	-0.0404	-0.25	-4.04	-0.09	3.51	-0.35	-8.19	-0.46	7.68
opb 2/3	-0.0233	-0.0815	-0.24	-3.73	-0.15	3.4	-0.38	-7.44	-0.53	5.5
opb 3/3	-0.0348	-0.1218	-0.22	-3.58	-0.17	3.31	-0.41	-7.08	-0.52	4.41
opb 3/3	-0.0348	-0.1218	-0.21	-3.56	-0.19	3.28	-0.39	-7.06	-0.52	4.33
opb 2/3	-0.0243	-0.0852	-0.24	-3.76	-0.19	3.47	-0.35	-7.62	-0.54	5.42
opb 1/3	-0.0113	-0.0395	-0.22	-4.39	-0.13	3.73	-0.32	-8.83	-0.35	8.07
axi-c 1/3	-0.012	-0.0673	-1.84	8.38	5.56	-1.6	-2.43	14.04	10.81	-4.05
axi-c 2/3	-0.0239	-0.1344	-0.62	4.69	4.31	0.01	-0.28	7.55	7.68	0.83
axi-c 3/3	-0.0357	-0.2007	-0.04	3.39	3.88	0.46	0.59	5.4	5.96	2.14
axi-c 3/3	-0.0357	-0.2006	-0.07	3.39	3.88	0.46	0.59	5.33	6.25	2.18
axi-c 2/3	-0.0238	-0.1337	-0.57	4.94	4.03	-0.04	-0.12	7.73	7.85	0.64
axi-c 1/3	-0.0119	-0.0667	-2.03	9.52	5.38	-2.27	-2.41	14.97	11.28	-5.59
axi-t 1/3	0.0127	0.0645	1.02	1.09	1.19	7.41	2.09	1.82	4.04	17.93
axi-t 2/3	0.0248	0.1258	0.81	1.34	1.49	6.67	1.53	2.55	4.15	16.13
axi-t 3/3	0.0364	0.1846	0.76	2.07	1.55	5.7	1.45	3.83	3.99	13.75
axi-t 3/3	0.0364	0.1846	0.79	2.08	1.57	5.7	1.45	3.83	4.03	13.76
axi-t 2/3	0.0248	0.1261	0.83	1.26	1.54	6.75	1.53	2.48	4.3	16.41
axi-t 1/3	0.0128	0.0651	1.05	-0.34	1.47	8.66	1.92	0.59	4.62	21.11

Table M-15: Measured SNCFs on intersections of brace 2 and chord for DT4 at preload level of 100 %

DT4	pl. cap	design	BC;1,br2	BS;5,br2	BC;9,br2	BS;13,br2	CC;1,br2	CS;5,br2	CC;9,br2	CS;13,br2
ipb 1/3	-0.0274	-0.0477	3.64	-0.17	-2.04	-0.53	1.55	-0.56	-2.48	-0.91
ipb 2/3	-0.0578	-0.1006	4.05	-0.23	-2.33	-0.58	1.51	-0.68	-2.75	-0.96
ipb 3/3	-0.0844	-0.1468	4.04	-0.28	-2.37	-0.57	1.4	-0.69	-2.74	-0.98
ipb 3/3	-0.0811	-0.1411	4.27	-0.3	-2.5	-0.6	1.47	-0.72	-2.9	-1.05
ipb 2/3	-0.055	-0.0956	4.45	-0.31	-2.54	-0.62	1.65	-0.73	-3.02	-1.06
ipb 1/3	-0.0274	-0.0477	4.62	-0.31	-2.62	-0.62	2.04	-0.72	-3.21	-1.15
opb 1/3	-0.0115	-0.0404	-0.28	-2.13	0	4.61	-0.04	-7.05	0.04	6.74
opb 2/3	-0.0233	-0.0815	-0.27	-2.23	-0.01	4.66	-0.23	-6.59	-0.08	5.26
opb 3/3	-0.0348	-0.1218	-0.23	-2.12	-0.05	4.55	-0.28	-6.33	-0.14	4.15
opb 3/3	-0.0348	-0.1218	-0.23	-2.12	-0.08	4.53	-0.28	-6.34	-0.14	4.16
opb 2/3	-0.0243	-0.0852	-0.25	-2.15	-0.05	4.68	-0.22	-6.67	-0.08	5.21
opb 1/3	-0.0113	-0.0395	-0.29	-2.19	-0.11	4.98	-0.02	-7.61	0.11	7.35
axi-c 1/3	-0.012	-0.0673	-3.29	7.63	5.22	-4.18	-3.17	16.3	7.43	-7.31
axi-c 2/3	-0.0239	-0.1344	-1.06	4.13	4.11	-0.83	-0.57	8.6	5.09	-1.16
axi-c 3/3	-0.0357	-0.2007	-0.15	2.91	3.87	0.3	0.56	5.97	4.15	0.93
axi-c 3/3	-0.0357	-0.2006	-0.24	2.92	4	0.34	0.42	5.93	4.3	0.95
axi-c 2/3	-0.0238	-0.1337	-1.14	4.37	4.1	-0.83	-0.67	8.67	5.23	-1.25
axi-c 1/3	-0.0119	-0.0667	-3.9	8.23	5.66	-4.58	-3.87	17.04	8.11	-8.22
axi-t 1/3	0.0127	0.0645	0.7	2.05	1.95	8.02	1.51	5.09	4.19	13.27
axi-t 2/3	0.0248	0.1258	1.01	1.53	1.79	7.77	1.63	4.1	3.51	12.8
axi-t 3/3	0.0364	0.1846	1.03	1.53	1.79	7.1	1.63	4.19	3.29	11.63
axi-t 3/3	0.0364	0.1846	1	1.52	1.86	7.14	1.53	4.12	3.33	11.65
axi-t 2/3	0.0248	0.1261	0.87	1.28	2.01	8.12	1.41	3.63	3.7	13.39
axi-t 1/3	0.0128	0.0651	0.75	1.16	2.11	9.52	1.39	3.02	4.2	15.89



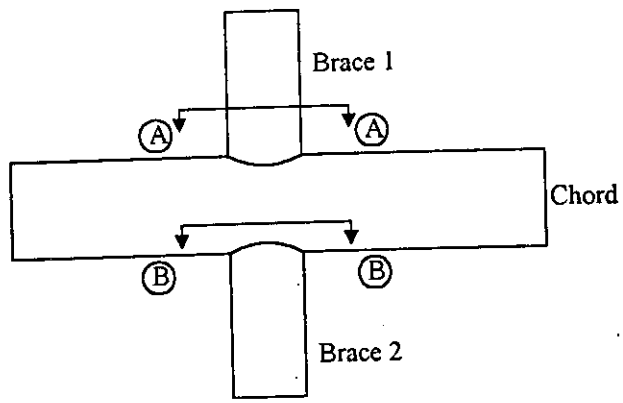

Elevation on DT Joint

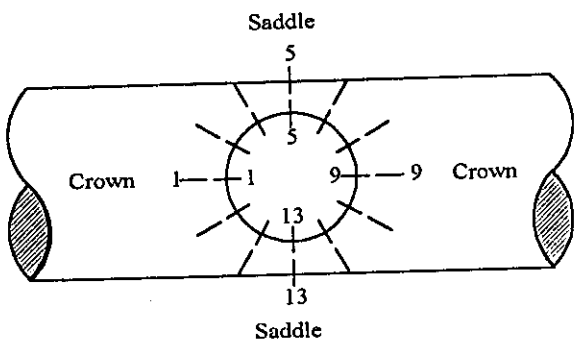

View 'A' on brace 1

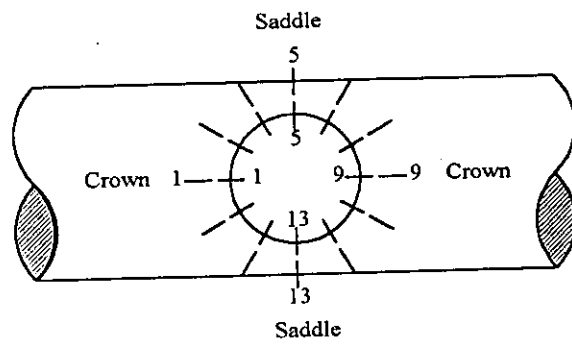

View 'B' on brace 2



Appendix M 6 SNCFs grouted Test Specimen: DT5

Table M-16: Measured SNCFs on intersections of brace 1,2 and chord for DT5

DT5	pl. cap	design	BC;1,br1	BS;5,br2	BC;9,br2	BS;13,br1	CC;1,br1	CS;5,br2	CC;9,br2	CS;13,br1
ipb 1/3	-0.0486	-0.0732	3.2	-0.21	-1.94	-0.39	3.79	-1.11	-3.67	-0.57
ipb 2/3	-0.0971	-0.1462	3.01	-0.25	-1.86	-0.35	2.64	-0.97	-3.35	-0.57
ipb 3/3	-0.1425	-0.2146	2.76	-0.25	-1.82	-0.33	2.29	-0.91	-3.19	-0.54
ipb 3/3	-0.1426	-0.2147	2.77	-0.25	-1.82	-0.32	2.3	-0.92	-3.19	-0.52
ipb 2/3	-0.0978	-0.1472	3.05	-0.25	-1.9	-0.35	2.69	-0.96	-3.42	-0.53
ipb 1/3	-0.0486	-0.0733	3.34	-0.22	-2.04	-0.38	3.98	-1.16	-3.82	-0.55
opb 1/3	-0.0176	-0.0571	0.01	-6.29	-0.1	6.06	5.91	-15.39	-0.25	8.88
opb 2/3	-0.0376	-0.1215	-0.03	-4.82	-0.07	4.25	3.93	-11.37	-0.49	4.78
opb 3/3	-0.0569	-0.184	-0.02	-4.28	-0.05	3.43	3.17	-9.86	-0.5	3.54
opb 3/3	-0.0578	-0.187	-0.03	-4.35	-0.06	3.52	3.27	-9.95	-0.5	3.81
opb 2/3	-0.0383	-0.1239	-0.03	-4.92	-0.09	4.33	4.06	-11.3	-0.43	5.17
opb 1/3	-0.0185	-0.0598	-0.02	-6.2	-0.12	6.39	5.82	-14.91	-0.19	9.56
axi-c 1/3	-0.0115	-0.0617	1.31	7.65	3.74	7.86	-0.36	16.97	8.4	12.15
axi-c 2/3	-0.0232	-0.1241	1.16	4.53	3	5.24	1.06	10.58	5.41	8.45
axi-c 3/3	-0.0348	-0.1861	1.15	3.27	2.38	3.83	1.59	7.67	3.84	6.39
axi-c 3/3	-0.0348	-0.1861	1.14	3.29	2.38	3.79	1.69	7.57	3.85	6.42
axi-c 2/3	-0.0231	-0.1234	1.24	4.61	2.78	5.24	1.66	10.5	5.35	8.56
axi-c 1/3	-0.0116	-0.062	1.22	8.53	4.01	7.03	-1	18.63	9.02	10.88
axi-t 1/3	0.012	0.0513	0.93	8.16	1.45	5.06	-3.19	17.34	4.34	8.03
axi-t 2/3	0.0235	0.1006	0.76	6.13	1.11	4.63	-1.45	12.41	3.34	6.97
axi-t 3/3	0.0348	0.1492	0.75	5.15	1	4.08	-0.65	10.45	2.97	6.23
axi-t 3/3	0.0347	0.1488	0.71	5.22	1.02	3.99	-0.73	10.72	2.98	6.11
axi-t 2/3	0.0234	0.1003	0.61	6.11	1.22	4.71	-1.77	12.73	3.25	7.08
axi-t 1/3	0.012	0.0513	0.41	7.8	1.37	6.03	-3.4	16.82	4.15	9.08

Table M-17: Measured SNCFs on intersections of brace 1,2 and chord for DT5 at preload level of 50%

DT5	pl. cap	design	BC;1,br1	BS;5,br2	BC;9,br2	BS;13,br1	CC;1,br1	CS;5,br2	CC;9,br2	CS;13,br1
ipb 1/3	-0.0467	-0.0703	3.06	-0.14	-1.89	-0.48	3.94	-0.91	-3.68	-0.87
ipb 2/3	-0.0952	-0.1434	2.98	-0.18	-1.85	-0.49	2.65	-0.76	-3.41	-0.83
ipb 3/3	-0.1414	-0.2129	2.76	-0.2	-1.81	-0.43	2.27	-0.78	-3.21	-0.74
ipb 3/3	-0.1412	-0.2127	2.79	-0.2	-1.82	-0.45	2.29	-0.8	-3.23	-0.73
ipb 2/3	-0.0941	-0.1417	3.06	-0.19	-1.9	-0.51	2.73	-0.85	-3.47	-0.81
ipb 1/3	-0.0467	-0.0703	3.23	-0.14	-1.99	-0.57	4.18	-1.05	-3.9	-0.9
opb 1/3	-0.0169	-0.0547	-0.1	-6.59	-0.07	6.75	6.32	-16.07	-0.17	10
opb 2/3	-0.0368	-0.1189	-0.07	-5.01	-0.08	4.63	4.18	-11.82	-0.39	5.21
opb 3/3	-0.0563	-0.1822	-0.04	-4.44	-0.05	3.56	3.34	-10.19	-0.47	3.71
opb 3/3	-0.0604	-0.1953	-0.04	-4.58	-0.02	3.74	3.46	-10.59	-0.41	4.15
opb 2/3	-0.04	-0.1293	-0.07	-5.26	-0.02	4.65	4.38	-12.39	-0.28	5.73
opb 1/3	-0.0209	-0.0675	-0.07	-6.53	0	5.79	6.24	-16.22	-0.05	9.26
axi-c 1/3	-0.0116	-0.0622	-1.24	7.65	6.68	5.93	-9.19	19.37	12.24	9.28
axi-c 2/3	-0.0231	-0.1238	-0.41	4.62	4.97	4.77	-3.92	12.08	7.03	7.34
axi-c 3/3	-0.0348	-0.1863	0.08	3.32	3.78	3.89	-1.54	8.71	4.77	6.26
axi-c 3/3	-0.0348	-0.1862	0.08	3.34	3.77	3.87	-1.43	8.64	4.79	6.26
axi-c 2/3	-0.0231	-0.1236	-0.26	4.69	4.93	4.91	-3.38	11.88	6.97	7.53
axi-c 1/3	-0.0115	-0.0614	-1.26	8.45	7.14	5.14	-10.09	21.15	13.35	7.79
axi-t 1/3	0.0118	0.0504	0.74	9.38	1.09	6.48	-3.88	20.22	3.98	9.76
axi-t 2/3	0.0233	0.0999	0.6	7.14	0.98	5.33	-2.43	14.89	3.2	7.84
axi-t 3/3	0.0347	0.1486	0.6	5.83	0.98	4.77	-1.5	12.08	2.93	7.12
axi-t 3/3	0.0347	0.1486	0.61	5.9	0.99	4.71	-1.82	12.38	2.85	7.04
axi-t 2/3	0.0232	0.0993	0.63	7.07	1.08	5.47	-2.39	14.57	3.17	8.16
axi-t 1/3	0.0118	0.0508	0.53	9.31	1.26	6.7	-4.32	19.99	3.95	10.32

Table M-18: Measured SNCFs on intersections of brace 1,2 and chord for DT5 at preload level of 100 %

DT5	pl. cap	design	BC;1,br1	BS;5,br2	BC;9,br2	BS;13,br1	CC;1,br1	CS;5,br2	CC;9,br2	CS;13,br1
ipb 1/3	-0.0489	-0.0737	3.09	-0.2	-1.95	-0.29	4.47	-1.28	-3.74	-0.54
ipb 2/3	-0.0968	-0.1458	3.03	-0.2	-1.88	-0.33	2.91	-0.97	-3.42	-0.54
ipb 3/3	-0.1418	-0.2136	2.84	-0.2	-1.84	-0.26	2.45	-0.89	-3.25	-0.46
ipb 3/3	-0.1421	-0.2139	2.84	-0.21	-1.85	-0.26	2.45	-0.89	-3.27	-0.45
ipb 2/3	-0.0968	-0.1458	3.09	-0.22	-1.93	-0.28	3	-1.01	-3.52	-0.45
ipb 1/3	-0.0496	-0.0747	3.21	-0.21	-2.03	-0.27	4.65	-1.36	-3.91	-0.47
opb 1/3	-0.0186	-0.0601	-0.06	-6.44	-0.1	6.28	6.33	-15.53	-0.14	10.17
opb 2/3	-0.0181	-0.0586	-0.09	-6.74	-0.07	7.2	6.29	-16.06	-0.07	10.63
opb 3/3	-0.0378	-0.1222	-0.08	-5.26	-0.07	5.14	4.35	-12.09	-0.34	5.67
opb 3/3	-0.0579	-0.1874	-0.03	-4.59	-0.04	3.94	3.52	-10.64	-0.39	4.08
opb 2/3	-0.0376	-0.1216	-0.05	-5.18	-0.08	4.97	4.46	-12.32	-0.29	5.66
opb 1/3	-0.0178	-0.0577	-0.02	-6.7	-0.11	6.74	6.67	-16.55	-0.01	10.71
axi-c 1/3	-0.0116	-0.0619	0.2	3.21	4.56	13.56	0.25	6.48	9.43	21.12
axi-c 2/3	-0.0232	-0.1241	0.55	3.34	3.72	7.29	0.81	6.72	6.34	12.36
axi-c 3/3	-0.0349	-0.1867	0.8	2.96	3.16	5.17	1.18	6.17	4.78	8.71
axi-c 3/3	-0.0349	-0.1866	0.8	3	3.17	5.17	1.18	6.17	4.74	8.72
axi-c 2/3	-0.0232	-0.124	0.67	3.54	3.75	7.21	1.02	7	6.4	12.33
axi-c 1/3	-0.0116	-0.0619	0.02	4.74	5.42	12.3	-1.17	9.93	10.95	19.33
axi-t 1/3	0.0121	0.0519	0.64	9.54	0.95	6.8	-5.01	20.85	3.66	10.08
axi-t 2/3	0.0238	0.1021	0.55	6.92	0.95	5.77	-2.72	14.49	3.13	8.58
axi-t 3/3	0.0353	0.1512	0.58	6.06	0.87	4.81	-1.92	12.55	2.75	7.07
axi-t 3/3	0.0353	0.1512	0.58	6	0.91	4.81	-1.92	12.49	2.77	7.15
axi-t 2/3	0.0236	0.1012	0.58	7.21	0.97	5.32	-3.19	15.45	2.99	8
axi-t 1/3	0.0121	0.0519	0.53	9.96	1.05	5.97	-5.69	22.21	3.48	9.11

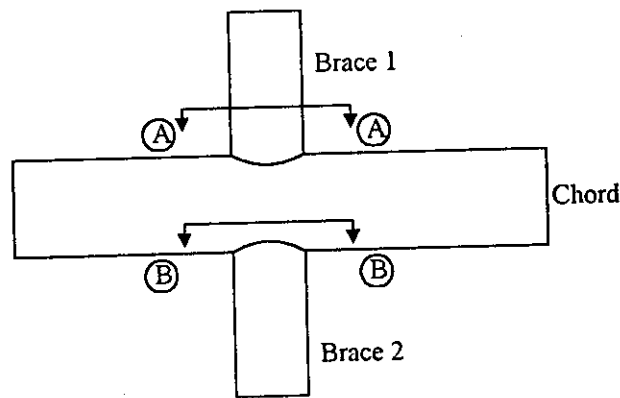

Elevation on DT Joint

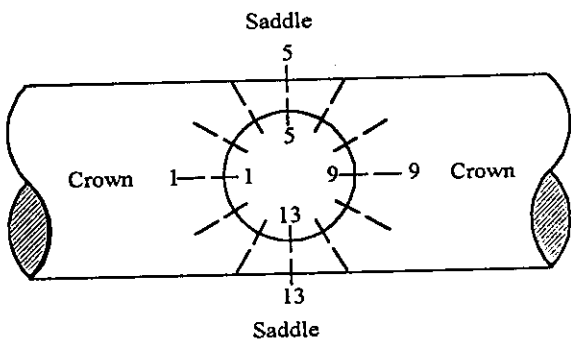

View 'A' on brace 1

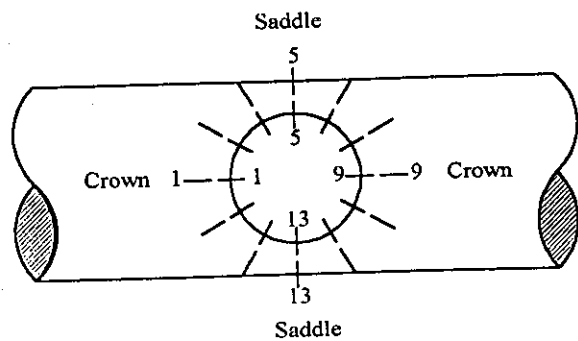

View 'B' on brace 2

Appendix M 7 SNCFs grouted Test Specimen: DT6

Table M-19: Measured SNCFs on braces at intersections of brace and chord of DT6

DT6	pl. cap	design	BC;1,br1	BI;2,br1	BI;4,br1	BS;5,br1	BC;9,br2	BI;10,br2	BI;12,br2	BS;13,br2
ipb 1/3	-0.0283	-0.0548	3.62	1.82	1.22	0.11	-1.5	-1.66	-1.67	0.09
ipb 2/3	-0.0562	-0.1089	3.39	1.84	1.04	0.07	-1.48	-1.64	-1.51	0.01
ipb 3/3	-0.0825	-0.1598	3.05	1.89	0.94	0.06	-1.45	-1.6	-1.4	-0.02
ipb 3/3	-0.0826	-0.16	3.05	1.89	0.93	0.07	-1.43	-1.6	-1.4	-0.02
ipb 2/3	-0.0563	-0.1091	3.42	1.87	1.03	0.1	-1.47	-1.66	-1.54	0
ipb 1/3	-0.0281	-0.0545	3.68	1.84	1.24	0.14	-1.52	-1.69	-1.73	0.06
opb 1/3	-0.0156	-0.0423	0.05	-0.45	-1.09	-2.49	-0.03	0.38	1.29	2.44
opb 2/3	-0.0325	-0.0883	0.05	-0.42	-1.11	-2.46	-0.03	0.41	1.35	2.52
opb 3/3	-0.0499	-0.1354	0.07	-0.38	-1.01	-2.18	-0.01	0.44	1.34	2.54
opb 3/3	-0.0501	-0.1361	0.07	-0.37	-0.94	-1.99	-0.02	0.46	1.36	2.56
opb 2/3	-0.0327	-0.0887	0.07	-0.41	-1.02	-2.21	-0.08	0.43	1.3	2.48
opb 1/3	-0.0152	-0.0413	0.08	-0.36	-0.98	-2.28	-0.14	0.36	1.21	2.31
axi-c 1/3	-0.0097	-0.0401	0.34	0.45	1.25	3.81	2.6	2.23	3.68	4.2
axi-c 2/3	-0.0195	-0.0805	1.1	1.25	2.05	3.87	1.76	1.48	2.62	4.04
axi-c 3/3	-0.0298	-0.1229	1.15	1.24	2	3.51	1.69	1.39	2.45	3.98
axi-c 3/3	-0.0298	-0.1229	1.15	1.24	1.96	3.47	1.66	1.39	2.47	3.99
axi-c 2/3	-0.0195	-0.0803	1.18	1.26	2.01	3.71	1.57	1.41	2.73	4.31
axi-c 1/3	-0.0097	-0.0402	0.76	0.86	1.36	3.23	1.85	1.95	3.67	4.89
axi-t 1/3	0.0115	0.0435	1.61	1.7	2.51	3.84	0.99	1.19	2.61	4.61
axi-t 2/3	0.0223	0.0845	1.43	1.54	2.1	3.07	0.93	1.11	2.33	3.51
axi-t 3/3	0.0332	0.1259	1.3	1.39	1.74	2.38	0.87	1.02	2.04	2.79
axi-t 3/3	0.0332	0.1259	1.3	1.39	1.71	2.38	0.83	0.99	2.04	2.79
axi-t 2/3	0.0224	0.0849	1.38	1.53	2.01	3.02	0.82	1.05	2.34	3.59
axi-t 1/3	0.0113	0.043	1.59	1.64	2.33	3.97	0.81	1	2.55	4.47

Table M-20: Measured SNCFs on chord at intersections of brace and chord of DT6

DT6	pl. cap	design	CC;1,br1	CI;2,br1	CI;4,br1	CS;5,br1	CC;9,br2	CI;10,br2	CI;12,br2	CS;13,br2
ipb 1/3	-0.0283	-0.0548	2.67	2.76	1.89	0.33	-2.58	-2.74	-2.06	0.17
ipb 2/3	-0.0562	-0.1089	1.57	2.13	1.58	0.18	-2.39	-2.63	-1.82	0.06
ipb 3/3	-0.0825	-0.1598	1.3	1.78	1.4	0.09	-2.31	-2.55	-1.69	0
ipb 3/3	-0.0826	-0.16	1.3	1.77	1.39	0.08	-2.32	-2.53	-1.69	0
ipb 2/3	-0.0563	-0.1091	1.56	2.16	1.6	0.2	-2.43	-2.66	-1.84	0.05
ipb 1/3	-0.0281	-0.0545	2.71	2.82	1.92	0.26	-2.64	-2.79	-2.14	0.18
opb 1/3	-0.0156	-0.0423	0.03	-0.3	-1.37	-5.25	-0.03	0.17	1.11	3.35
opb 2/3	-0.0325	-0.0883	0.07	-0.25	-1.52	-5.28	-0.08	0.15	1.14	3.4
opb 3/3	-0.0499	-0.1354	0.06	-0.28	-1.49	-4.87	-0.08	0.19	1.17	3.43
opb 3/3	-0.0501	-0.1361	0.06	-0.26	-1.42	-4.67	-0.09	0.17	1.17	3.45
opb 2/3	-0.0327	-0.0887	0.11	-0.23	-1.46	-5.11	-0.15	0.1	1.09	3.34
opb 1/3	-0.0152	-0.0413	0.14	-0.2	-1.3	-5.64	-0.23	-0.05	0.77	3.12
axi-c 1/3	-0.0097	-0.0401	-0.32	-0.1	1.86	7.53	3.73	2.89	3.75	4.87
axi-c 2/3	-0.0195	-0.0805	0.94	1.36	3.06	7.73	2	1.42	2.48	4.83
axi-c 3/3	-0.0298	-0.1229	1.29	1.63	2.91	7.09	1.83	1.42	2.18	4.75
axi-c 3/3	-0.0298	-0.1229	1.31	1.6	2.85	7.04	1.83	1.41	2.18	4.77
axi-c 2/3	-0.0195	-0.0803	1.01	1.33	2.99	7.42	1.83	1.27	2.59	5.2
axi-c 1/3	-0.0097	-0.0402	0.28	0.43	1.95	6.2	2.48	2.11	3.61	5.94
axi-t 1/3	0.0115	0.0435	1.56	2.12	3.53	7.67	0.85	1.04	2.55	5.57
axi-t 2/3	0.0223	0.0845	1.41	2.06	3.33	6.39	0.95	1.13	2.44	4.36
axi-t 3/3	0.0332	0.1259	1.34	2	3.08	5.52	1.08	1.17	2.48	3.98
axi-t 3/3	0.0332	0.1259	1.33	2	3.08	5.49	1.08	1.1	2.5	3.99
axi-t 2/3	0.0224	0.0849	1.39	2.05	3.31	6.24	0.91	0.94	2.56	4.55
axi-t 1/3	0.0113	0.043	1.54	2.01	3.57	7.76	0.71	0.57	2.52	5.57

Table M-21: Measured SNCFs on braces at intersections of brace and chord of DT6 at preload level of 50 %

DT6	pl. cap	design	BC;1,br1	BI;2,br1	BI;4,br1	BS;5,br1	BC;9,br2	BI;10,br2	BI;12,br2	BS;13,br2
ipb 1/3	0.0001	0.0002	-3.75	0.52	-0.48	-0.5	-6.83	-0.5	0	3.55
ipb 2/3	-0.0272	-0.0527	3.66	1.75	1.22	0.11	-1.47	-1.68	-1.76	0.04
ipb 3/3	-0.0552	-0.1069	3.45	1.77	1.02	0.06	-1.46	-1.66	-1.58	-0.03
ipb 3/3	-0.0278	-0.0539	3.16	1.77	0.82	0.02	-1.4	-1.6	-1.33	-0.06
ipb 2/3	-0.0546	-0.1057	2.78	1.92	0.77	0	-1.41	-1.57	-1.26	-0.07
ipb 1/3	-0.0276	-0.0534	3.25	1.78	0.83	0	-1.45	-1.62	-1.34	-0.06
opb 1/3	-0.0152	-0.0413	0.03	-0.42	-0.96	-2.34	-0.03	0.49	1.39	2.57
opb 2/3	-0.033	-0.0895	0.05	-0.4	-0.99	-2.34	-0.05	0.44	1.36	2.59
opb 3/3	-0.0505	-0.137	0.05	-0.38	-0.95	-2.22	-0.04	0.44	1.37	2.6
opb 3/3	-0.0509	-0.1383	0.05	-0.38	-0.94	-2.2	-0.04	0.43	1.38	2.61
opb 2/3	-0.0335	-0.0911	0.05	-0.37	-0.97	-2.31	-0.07	0.4	1.37	2.59
opb 1/3	-0.0161	-0.0437	0.03	-0.39	-0.98	-2.37	-0.08	0.38	1.37	2.61
axi-c 1/3	-0.0098	-0.0403	0.8	1.12	1.95	4.5	1.78	1.68	2.76	3.83
axi-c 2/3	-0.0195	-0.0804	1.38	1.66	2.52	4.33	1.19	1.08	2.2	4.01
axi-c 3/3	-0.0298	-0.1229	1.47	1.56	2.34	3.9	1.17	1.13	2.28	4.11
axi-c 3/3	-0.0298	-0.1229	1.47	1.56	2.37	3.9	1.15	1.11	2.35	4.1
axi-c 2/3	-0.0195	-0.0806	1.51	1.68	2.59	4.18	1.05	1.03	2.37	4.21
axi-c 2/3	-0.0195	-0.0806	1.51	1.68	2.43	4.06	1.04	1.16	2.75	4.51
axi-c 1/3	-0.0098	-0.0403	1.32	1.58	2.43	4.06	1.04	1.16	2.75	4.51
axi-t 1/3	0.0112	0.0423	0.97	0.93	1.84	3.85	1.33	1.47	3.07	4.56
axi-t 2/3	0.0112	0.0423	0.97	0.93	1.84	3.85	1.33	1.47	3.07	4.56
axi-t 3/3	0.0223	0.0845	1.05	1.13	1.85	3.43	1.16	1.28	2.7	3.86
axi-t 3/3	0.0223	0.0845	1.05	1.13	1.85	3.43	1.16	1.28	2.7	3.86
axi-t 3/3	0.0333	0.1261	1.03	1.18	1.69	2.73	1.03	1.18	2.39	3.15
axi-t 2/3	0.0223	0.0844	0.98	1.22	1.85	3.32	1.13	1.32	2.77	3.96
axi-t 2/3	0.0223	0.0844	0.98	1.22	1.85	3.32	1.13	1.32	2.77	3.96
axi-t 1/3	0.0112	0.0423	0.93	1.1	1.7	3.6	1.28	1.55	3.39	4.89

Table M-22: Measured SNCFs on chord at intersections of brace and chord of DT6 at preload level of 50 %

DT6	pl. cap	design	CC;1,br1	CI;2,br1	CI;4,br1	CS;5,br1	CC;9,br2	CI;10,br2	CI;12,br2	CS;13,br2
ipb 1/3	0.0001	0.0002	12.44	6.53	-1.54	-6.27	0	6.72	-4.32	11.82
ipb 2/3	-0.0272	-0.0527	2.69	2.69	1.88	0.36	-2.59	-2.78	-2.23	0.14
ipb 3/3	-0.0552	-0.1069	1.53	2.1	1.55	0.17	-2.4	-2.64	-1.93	0.04
ipb 3/3	-0.0278	-0.0539	0.36	1.52	1.22	0.03	-2.13	-2.48	-1.61	-0.01
ipb 2/3	-0.0546	-0.1057	0.57	1.26	1.12	-0.03	-2.11	-2.41	-1.53	-0.05
ipb 1/3	-0.0276	-0.0534	0.38	1.59	1.28	0.05	-2.2	-2.52	-1.62	-0.05
opb 1/3	-0.0152	-0.0413	0.01	-0.13	-1.41	-4.96	-0.11	0.13	1.22	3.48
opb 2/3	-0.033	-0.0895	0.11	-0.18	-1.43	-5.06	-0.14	0.1	1.23	3.49
opb 3/3	-0.0505	-0.137	0.11	-0.17	-1.45	-4.88	-0.11	0.14	1.25	3.52
opb 3/3	-0.0509	-0.1383	0.11	-0.17	-1.44	-4.85	-0.1	0.13	1.26	3.54
opb 2/3	-0.0335	-0.0911	0.09	-0.18	-1.42	-5.02	-0.14	0.07	1.24	3.53
opb 1/3	-0.0161	-0.0437	0.07	-0.12	-1.47	-5.1	-0.17	0.02	1.21	3.53
axi-c 1/3	-0.0098	-0.0403	0.5	0.77	2.76	8.9	2.18	1.62	2.72	4.26
axi-c 2/3	-0.0195	-0.0804	1.38	1.83	3.73	8.64	0.91	0.67	2.03	4.7
axi-c 3/3	-0.0298	-0.1229	1.66	2.02	3.38	7.8	1.28	0.86	2.02	4.87
axi-c 3/3	-0.0298	-0.1229	1.66	2.02	3.43	7.81	1.36	0.93	2.09	4.87
axi-c 2/3	-0.0195	-0.0806	1.55	1.97	3.81	8.35	0.78	0.69	2.23	5
axi-c 2/3	-0.0195	-0.0806	1.55	1.97	3.81	8.35	0.78	0.69	2.23	5
axi-c 1/3	-0.0098	-0.0403	1.46	1.63	3.52	7.93	0.84	0.94	2.75	5.2
axi-t 1/3	0.0112	0.0423	0.66	0.96	2.7	7.79	1.44	1.32	3.19	5.6
axi-t 2/3	0.0112	0.0423	0.66	0.96	2.7	7.79	1.44	1.32	3.19	5.6
axi-t 3/3	0.0223	0.0845	0.86	1.32	3.02	6.91	1.33	1.23	2.92	4.77
axi-t 3/3	0.0223	0.0845	0.86	1.32	3.02	6.91	1.33	1.23	2.92	4.77
axi-t 3/3	0.0333	0.1261	0.93	1.5	2.86	5.85	1.24	1.3	2.84	3.99
axi-t 2/3	0.0223	0.0844	0.75	1.22	2.82	6.77	1.26	1.38	3.07	4.84
axi-t 2/3	0.0223	0.0844	0.75	1.22	2.82	6.77	1.26	1.38	3.07	4.84
axi-t 1/3	0.0112	0.0423	0.51	0.85	2.38	7.12	1.3	1.44	3.49	5.95

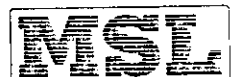
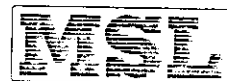

Table M-23: Measured SNCFs on braces at intersections of brace and chord of DT6 at preload level of 100%

DT6	pl. cap	design	BC:1.br1	Bl:2.br1	Bl:4.br1	BS:5.br1	BC:9.br2	Bl:10.br2	Bl:12.br2	BS:13.br2
ipb 1/3	-0.029	-0.0561	3.47	1.8	1.16	0.01	-1.49	-1.62	-1.76	0.1
ipb 2/3	-0.0581	-0.1126	3.42	1.7	0.97	-0.03	-1.46	-1.61	-1.55	0.01
ipb 3/3	-0.0855	-0.1656	3.1	1.82	0.87	-0.03	-1.43	-1.57	-1.43	-0.03
ipb 3/3	-0.0855	-0.1656	3.1	1.83	0.89	-0.02	-1.41	-1.56	-1.41	-0.02
ipb 2/3	-0.0583	-0.1129	3.43	1.71	1	-0.02	-1.43	-1.59	-1.55	0.02
ipb 1/3	-0.0304	-0.0588	3.55	1.78	1.19	-0.01	-1.49	-1.63	-1.77	0.1
opb 1/3	-0.0169	-0.0459	0.02	-0.42	-1.08	-2.53	-0.31	0.13	0.97	2.27
opb 2/3	-0.0344	-0.0935	0.02	-0.42	-1.04	-2.46	-0.2	0.26	1.15	2.4
opb 3/3	-0.0513	-0.1392	0.03	-0.41	-1	-2.34	-0.14	0.32	1.23	2.5
opb 3/3	-0.0521	-0.1414	0.04	-0.4	-0.99	-2.33	-0.15	0.32	1.24	2.53
opb 2/3	-0.0355	-0.0963	0.04	-0.41	-0.97	-2.35	-0.24	0.27	1.23	2.66
opb 1/3	-0.0172	-0.0466	0.07	-0.43	-0.92	-2.32	-0.4	0.13	1.11	2.81
axi-c 1/3	-0.0098	-0.0404	2.21	2.35	3.24	4.11	0.32	0.32	1.37	4.39
axi-c 2/3	-0.0196	-0.0807	2.38	2.44	3.16	4.12	0.24	0.27	1.36	4.23
axi-c 3/3	-0.0298	-0.1231	2.43	2.19	2.71	3.79	0.55	0.54	1.69	4.2
axi-c 3/3	-0.0299	-0.1232	2.43	2.19	2.7	3.77	0.55	0.54	1.69	4.16
axi-c 2/3	-0.0196	-0.0807	2.51	2.47	3.11	3.95	0.21	0.3	1.44	4.34
axi-c 1/3	-0.0098	-0.0405	2.57	2.56	3.33	3.59	-0.15	0.16	1.37	4.98
axi-t 1/3	0.0113	0.0429	0.64	0.73	1.44	3.7	1.63	1.86	3.56	4.87
axi-t 2/3	0.0221	0.0839	0.87	0.97	1.69	3.51	1.39	1.54	3.11	4.23
axi-t 3/3	0.0333	0.126	0.93	1.08	1.64	2.95	1.18	1.33	2.62	3.43
axi-t 3/3	0.0333	0.126	0.93	1.08	1.63	2.95	1.2	1.32	2.63	3.43
axi-t 2/3	0.0222	0.0843	0.89	1.03	1.71	3.5	1.34	1.48	3.04	4.22
axi-t 1/3	0.0111	0.0421	0.7	0.66	1.43	3.58	1.65	1.8	3.59	4.93

Table M-24: Measured SNCFs on chord at intersections of brace and chord of DT6 at preload level of 100%

DT6	pl. cap	design	CC:1.br1	Cl:2.br1	Cl:4.br1	CS:5.br1	CC:9.br2	Cl:10.br2	Cl:12.br2	CS:13.br2
ipb 1/3	-0.029	-0.0561	2.92	2.87	1.88	0.15	-2.61	-2.68	-2.21	0.28
ipb 2/3	-0.0581	-0.1126	1.58	2.26	1.56	0.05	-2.38	-2.57	-1.85	0.12
ipb 3/3	-0.0855	-0.1656	1.29	1.8	1.38	-0.01	-2.27	-2.47	-1.7	0.03
ipb 3/3	-0.0855	-0.1656	1.29	1.81	1.37	-0.01	-2.27	-2.46	-1.67	0.04
ipb 2/3	-0.0583	-0.1129	1.58	2.29	1.57	0.04	-2.39	-2.56	-1.85	0.1
ipb 1/3	-0.0304	-0.0588	2.84	2.89	1.91	0.11	-2.64	-2.7	-2.18	0.22
opb 1/3	-0.0169	-0.0459	0.05	-0.22	-1.51	-5.42	-0.66	-0.36	0.75	3.03
opb 2/3	-0.0344	-0.0935	0.04	-0.21	-1.47	-5.3	-0.39	-0.12	0.98	3.31
opb 3/3	-0.0513	-0.1392	0.03	-0.23	-1.45	-5.11	-0.3	-0.05	1.11	3.44
opb 3/3	-0.0521	-0.1414	0.02	-0.23	-1.44	-5.08	-0.3	-0.05	1.12	3.46
opb 2/3	-0.0355	-0.0963	0.04	-0.19	-1.36	-5.15	-0.44	-0.18	1.07	3.7
opb 1/3	-0.0172	-0.0466	0.03	-0.17	-1.11	-4.95	-0.8	-0.44	1.01	4.03
axi-c 1/3	-0.0098	-0.0404	2.65	3.25	4.96	8.37	-1.01	-0.76	1.12	5.35
axi-c 2/3	-0.0196	-0.0807	2.96	3.36	4.84	8.34	-0.95	-0.6	1.08	5.1
axi-c 3/3	-0.0298	-0.1231	2.95	3.01	4.09	7.72	-0.07	-0.05	1.33	5.13
axi-c 3/3	-0.0299	-0.1232	2.95	3.01	4.06	7.66	-0.03	-0.05	1.27	5.13
axi-c 2/3	-0.0196	-0.0807	3.11	3.39	4.68	7.97	-1.01	-0.67	1.05	5.4
axi-c 1/3	-0.0098	-0.0405	3.22	3.83	5.25	7.13	-1.71	-1.09	0.96	6.22
axi-t 1/3	0.0113	0.0429	0.07	0.38	2.13	7.31	2.14	1.82	3.72	5.87
axi-t 2/3	0.0221	0.0839	0.55	0.89	2.57	7.01	1.64	1.53	3.35	5.11
axi-t 3/3	0.0333	0.126	0.74	1.22	2.67	6.25	1.39	1.39	3.01	4.22
axi-t 3/3	0.0333	0.126	0.74	1.2	2.67	6.25	1.41	1.43	3.04	4.24
axi-t 2/3	0.0222	0.0843	0.52	0.89	2.64	7.02	1.55	1.47	3.31	5.15
axi-t 1/3	0.0111	0.0421	0.19	0.24	2.11	7.36	2.05	1.97	3.81	6.11



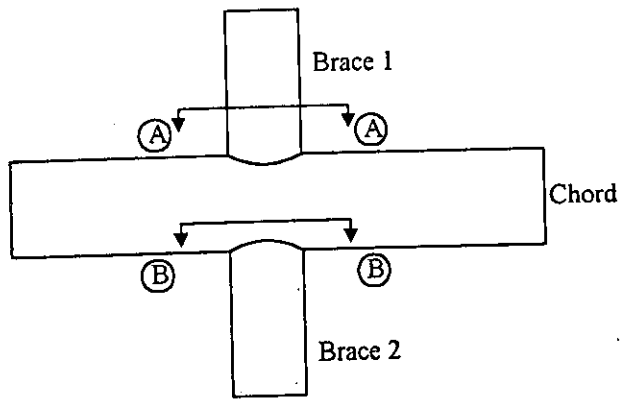

Elevation on DT Joint

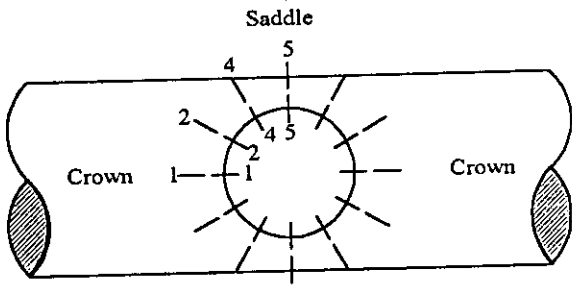

Saddle
View 'A' on brace 1

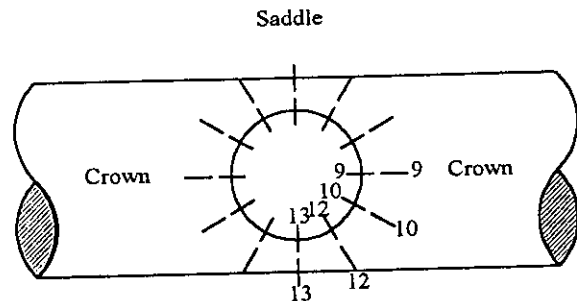

Saddle
View 'B' on brace 2

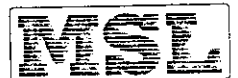

Appendix M 8 SNCFs grouted Test Specimen: DT8

Table M-25: Measured SNCFs on intersections of brace 1,2 and chord for DT8

DT8	pl. cap	design	BC:1,br1	BS:5,br2	BC:9,br2	BS:13,br1	CC:1,br1	CS:5,br2	CC:9,br2	CS:13,br1
ipb 1/3	-0.0329	-0.0696	3.42	-0.3	-1.51	-0.49	1.34	-0.59	-2.88	-0.69
ipb 2/3	-0.0647	-0.1367	3.16	-0.26	-1.53	-0.49	1.16	-0.57	-2.8	-0.77
ipb 3/3	-0.0965	-0.2039	2.95	-0.26	-1.52	-0.49	1.09	-0.6	-2.73	-0.8
ipb 3/3	-0.0946	-0.1999	2.97	-0.26	-1.54	-0.48	1.05	-0.61	-2.75	-0.82
ipb 2/3	-0.0624	-0.1319	3.24	-0.23	-1.57	-0.49	1.14	-0.52	-2.88	-0.83
ipb 1/3	-0.0305	-0.0644	3.6	-0.23	-1.61	-0.5	1.36	-0.46	-3.03	-0.8
opb 1/3	-0.0124	-0.0605	-0.09	-6.26	-0.12	5.57	-0.61	-13.63	-0.34	8.63
opb 2/3	-0.0244	-0.119	-0.06	-4.69	-0.09	4.39	-0.64	-10.38	-0.5	5.19
opb 3/3	-0.0346	-0.1685	-0.08	-4.36	-0.09	3.72	-0.68	-9.52	-0.54	4.01
opb 3/3	-0.0344	-0.1675	-0.08	-4.31	-0.09	3.7	-0.68	-9.3	-0.55	4.21
opb 2/3	-0.0236	-0.1149	-0.08	-4.73	-0.11	4.33	-0.59	-10.13	-0.4	5.5
opb 1/3	-0.0118	-0.0574	-0.06	-5.69	-0.1	5.72	-0.47	-12.39	-0.21	9.61
axi-c 1/3	-0.0079	-0.0667	-2.39	6.63	5.66	1.31	-4.87	13.88	9.57	1.74
axi-c 2/3	-0.0153	-0.1301	-1.39	3.57	5.94	2.47	-2.18	7.73	6.2	4.6
axi-c 3/3	-0.0233	-0.1974	-0.81	2.99	4.83	1.92	-1.15	5.77	4.27	3.6
axi-c 3/3	-0.0233	-0.1974	-0.86	2.96	4.79	1.89	-1.16	5.69	4.21	3.61
axi-c 2/3	-0.0153	-0.1302	-1.32	4.22	5.04	1.94	-2.19	8.2	5.86	3.42
axi-c 1/3	-0.0078	-0.066	-2.5	8.24	4.83	-0.31	-4.57	15.6	8.32	-1.04
axi-t 1/3	0.0092	0.0628	0.59	0.61	0.35	7.22	1.67	0.49	1.81	12.54
axi-t 2/3	0.0174	0.1183	0.57	2.21	0.51	6.16	1.86	2.65	1.67	10.86
axi-t 3/3	0.0259	0.176	0.71	2.57	0.46	5.5	1.97	3.91	1.58	9.88
axi-t 3/3	0.0258	0.1753	0.71	2.55	0.49	5.52	2.07	3.95	1.58	9.84
axi-t 2/3	0.0172	0.1167	0.67	1.93	0.43	6.51	2.13	2.46	1.58	11.35
axi-t 1/3	0.0088	0.0599	0.67	0.48	0.45	8.26	2.27	1.42	1.73	14.24

Table M-26: Measured SNCFs on intersections of brace 1,2 and chord for DT8 at preload level of 50%

DT8	pl. cap	design	BC:1,br1	BS:5,br2	BC:9,br2	BS:13,br1	CC:1,br1	CS:5,br2	CC:9,br2	CS:13,br1
ipb 1/3	-0.031	-0.0655	3.67	-0.34	-1.57	-0.58	1.62	-0.71	-2.99	-0.93
ipb 2/3	-0.064	-0.1353	3.32	-0.31	-1.55	-0.57	1.27	-0.67	-2.86	-0.94
ipb 3/3	-0.095	-0.2008	3.07	-0.3	-1.53	-0.52	1.17	-0.68	-2.77	-0.91
ipb 3/3	-0.0939	-0.1985	3.07	-0.29	-1.53	-0.52	1.12	-0.68	-2.77	-0.92
ipb 2/3	-0.0617	-0.1303	3.37	-0.3	-1.55	-0.55	1.24	-0.67	-2.9	-0.95
ipb 1/3	-0.0307	-0.0649	3.81	-0.28	-1.61	-0.58	1.62	-0.65	-3.12	-0.98
opb 1/3	-0.0109	-0.053	-0.18	-6.14	-0.02	6.64	-0.47	-13.46	-0.3	12.45
opb 2/3	-0.0226	-0.1104	-0.14	-4.99	-0.02	4.77	-0.6	-10.74	-0.43	7.03
opb 3/3	-0.0331	-0.1615	-0.09	-4.54	-0.04	4.01	-0.62	-9.78	-0.51	5.33
opb 3/3	-0.0339	-0.1654	-0.08	-4.56	-0.06	3.88	-0.64	-9.77	-0.53	5.12
opb 2/3	-0.0239	-0.1166	-0.11	-4.95	-0.06	4.62	-0.65	-10.56	-0.45	6.66
opb 1/3	-0.012	-0.0586	-0.08	-6.04	-0.08	6.3	-0.48	-13	-0.35	11.42
axi-c 1/3	-0.0077	-0.0656	-0.5	8.17	4.39	5.77	-0.06	19.06	8.15	10.55
axi-c 2/3	-0.0154	-0.1306	0.08	4.17	3.58	4.49	1.47	10.57	4.67	8.76
axi-c 3/3	-0.0232	-0.1968	0.24	3.06	2.99	3.39	1.44	7.63	3.31	6.91
axi-c 3/3	-0.0232	-0.1967	0.22	3.06	2.99	3.39	1.44	7.66	3.33	6.88
axi-c 2/3	-0.0153	-0.1301	0.17	4.27	3.34	4.47	1.67	10.98	4.63	8.62
axi-c 1/3	-0.0077	-0.0657	-0.06	8.35	3.71	5.47	0.89	20.43	7.4	9.77
axi-t 1/3	0.0092	0.0628	0.81	5.76	0.56	9.42	2.9	12.97	1.8	16.25
axi-t 2/3	0.0176	0.1198	0.72	5.42	0.42	6.97	2.36	12	1.61	12.07
axi-t 3/3	0.0256	0.1741	0.65	4.63	0.6	6.04	2.08	10.38	1.83	10.6
axi-t 3/3	0.0256	0.1741	0.69	4.86	0.45	5.92	1.97	10.48	1.82	10.55
axi-t 2/3	0.0175	0.1192	0.72	5.35	0.38	7.12	2.07	11.35	1.84	12.6
axi-t 1/3	0.0093	0.0634	0.63	5.78	0.4	9.27	2	11.97	2.19	16.68

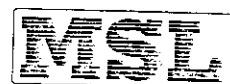
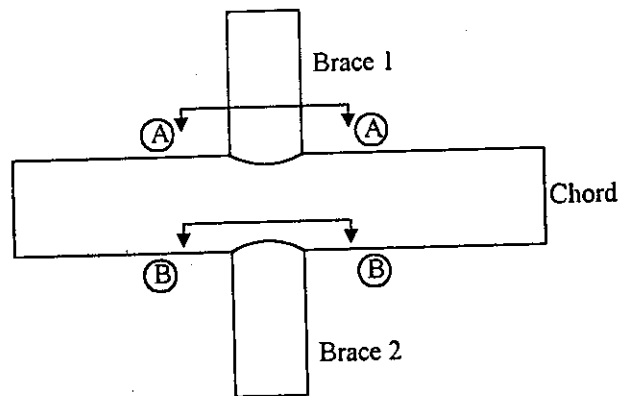
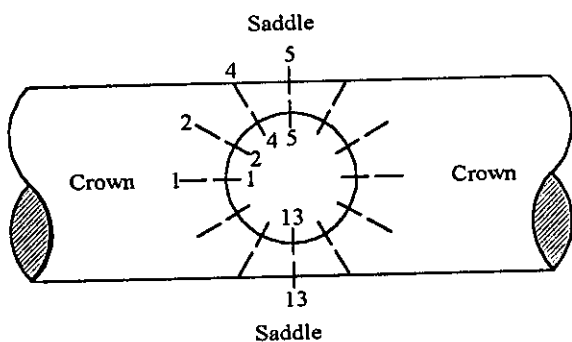

Table M-27: Measured SNCFs on intersections of brace 1,2 and chord for DT8 at preload level of 100 %

DT8	pl. cap	design	BC:1,br1	BS:5,br2	BC:9,br2	BS:13,br1	CC:1,br1	CS:5,br2	CC:9,br2	CS:13,br1
ipb 1/3	-0.0328	-0.0692	3.64	-0.35	-1.52	-0.47	1.74	-0.69	-2.91	-0.67
ipb 2/3	-0.0633	-0.1338	3.35	-0.33	-1.52	-0.46	1.35	-0.68	-2.83	-0.74
ipb 3/3	-0.0957	-0.2023	3.09	-0.31	-1.51	-0.45	1.21	-0.71	-2.73	-0.74
ipb 3/3	-0.0955	-0.2018	3.11	-0.31	-1.51	-0.45	1.21	-0.73	-2.74	-0.74
ipb 2/3	-0.0633	-0.1337	3.39	-0.3	-1.54	-0.47	1.38	-0.7	-2.86	-0.72
ipb 1/3	-0.0314	-0.0664	3.83	-0.34	-1.6	-0.47	1.89	-0.72	-3.08	-0.64
opb 1/3	-0.0111	-0.0542	-0.03	-6.34	-0.09	8.62	-0.23	-13.27	-0.18	15.52
opb 2/3	-0.0233	-0.1135	-0.06	-5.17	-0.1	5.65	-0.44	-10.98	-0.41	8.42
opb 3/3	-0.0338	-0.1649	-0.08	-4.71	-0.07	4.52	-0.47	-10.11	-0.48	6.26
opb 3/3	-0.034	-0.1658	-0.11	-4.89	-0.06	3.77	-0.47	-10.47	-0.5	5.37
opb 2/3	-0.0236	-0.115	-0.1	-5.32	-0.03	6.37	-0.32	-13.42	-0.26	12.01
opb 1/3	-0.0129	-0.0628	-0.16	-6.18	-0.03	6.37	-0.32	-13.42	-0.26	12.01
axi-c 1/3	-0.0077	-0.0655	-1.88	9.03	3.67	-2.19	-3.54	18.62	6.41	-5.39
axi-c 1/3	-0.0154	-0.1306	-1.52	6.67	3.91	-1	-2.95	11.03	5.21	-2.28
axi-c 2/3	-0.0233	-0.1976	-0.95	4.7	4.14	0.54	-1.72	7.74	4.11	0.68
axi-c 3/3	-0.0232	-0.1971	-0.98	4.55	4.18	0.7	-1.82	7.3	4.19	1.04
axi-c 3/3	-0.0232	-0.1971	-0.98	4.55	4.18	0.7	-1.82	7.3	4.19	1.04
axi-c 2/3	-0.0153	-0.1297	-1.53	6.74	3.85	-0.99	-3.12	10.73	5.35	-2.22
axi-c 1/3	-0.0076	-0.0646	-2.73	13.64	4.06	-8.28	-6.32	21.14	6.9	-15.89
axi-t 1/3	0.0085	0.058	1	5.54	0.39	10.59	2.59	11.6	1.89	18.67
axi-t 1/3	0.0085	0.058	1	5.54	0.39	10.59	2.59	11.6	1.89	18.67
axi-t 2/3	0.017	0.1157	0.77	4.78	0.43	8.25	2.13	10.19	1.94	14.54
axi-t 2/3	0.017	0.1157	0.77	4.78	0.43	8.25	2.13	10.19	1.94	14.54
axi-t 3/3	0.0254	0.1725	0.76	4.5	0.43	7.03	2.1	9.82	1.88	12.33
axi-t 3/3	0.0254	0.1725	0.76	4.5	0.43	7.03	2.1	9.82	1.88	12.33
axi-t 3/3	0.0254	0.1728	0.81	4.51	0.4	6.96	2.15	9.84	1.88	12.19
axi-t 3/3	0.0254	0.1728	0.81	4.51	0.4	6.96	2.15	9.84	1.88	12.19
axi-t 2/3	0.0167	0.1139	0.98	4.91	0.29	8.1	2.34	10.45	1.82	14.03
axi-t 2/3	0.0167	0.1139	0.98	4.91	0.29	8.1	2.34	10.45	1.82	14.03
axi-t 1/3	0.0087	0.0593	1.19	5.08	0.04	9.53	3.05	10.74	1.52	16.89
axi-t 1/3	0.0087	0.0593	1.19	5.08	0.04	9.53	3.05	10.74	1.52	16.89



Elevation on DT Joint



View 'A' on brace 1

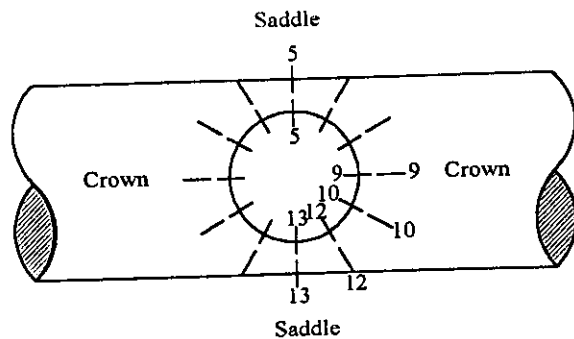

View 'B' on brace 2

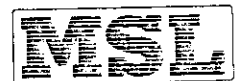

Appendix M 9 SNCFs grouted Test Specimen: DT9

Table M-28: Measured SNCFs on braces at intersections of brace and chord for DT9

DT9	pl. cap	design	BC;1,br1	BI;2,br1	BI;4,br1	BS;5,br1	BC;9,br2	BI;10,br2	BI;12,br2	BS;13,br2
ipb 1/3	-0.0382	-0.083	3.45	1.84	0.78	0.05	-1.51	-1.39	-1.23	0.04
ipb 2/3	-0.0737	-0.1603	3	1.87	0.69	0.03	-1.49	-1.35	-1.05	0.05
ipb 3/3	-0.1106	-0.2403	2.78	1.82	0.65	0.02	-1.51	-1.33	-0.95	0.05
ipb 3/3	-0.1115	-0.2423	2.76	1.8	0.63	0.01	-1.51	-1.33	-0.95	0.05
ipb 2/3	-0.0743	-0.1616	3.04	1.88	0.7	0.02	-1.53	-1.36	-1.07	0.06
ipb 1/3	-0.0384	-0.0835	3.57	1.82	0.82	0.04	-1.58	-1.4	-1.25	0.06
opb 1/3	-0.0162	-0.0496	0.11	-0.5	-0.78	-2.34	0.05	0.44	0.97	2.33
opb 2/3	-0.036	-0.1102	0.07	-0.42	-0.74	-1.73	-0.05	0.42	0.95	2.34
opb 3/3	-0.0551	-0.1684	0.07	-0.38	-0.69	-1.49	-0.03	0.39	0.94	2.33
opb 3/3	-0.0555	-0.1696	0.07	-0.4	-0.68	-1.45	-0.02	0.39	0.96	2.33
opb 2/3	-0.036	-0.11	0.06	-0.43	-0.69	-1.64	-0.04	0.38	0.94	2.38
opb 1/3	-0.0162	-0.0496	0.11	-0.5	-0.72	-2.09	-0.11	0.31	0.83	2.47
axi-c 1/3	-0.0123	-0.065	1.45	1.28	1.26	2.45	1.5	1.5	2.45	4.05
axi-c 2/3	-0.0245	-0.1293	1.59	1.42	1.67	2.87	1.27	1.25	2.03	4.05
axi-c 3/3	-0.0368	-0.1943	1.82	1.51	1.66	2.98	1.29	1.06	1.82	3.73
axi-c 3/3	-0.0368	-0.1944	1.82	1.51	1.67	2.98	1.31	1.1	1.82	3.77
axi-c 2/3	-0.0245	-0.1296	1.88	1.71	1.88	2.76	0.99	1.2	1.96	4.24
axi-c 1/3	-0.0123	-0.0651	1.91	1.5	1.48	1.38	0.95	1.39	2.36	5.14
axi-t 1/3	0.0125	0.0465	1.31	1.64	1.87	3.32	0.83	0.87	1.81	2.87
axi-t 2/3	0.0245	0.0908	1.38	1.6	1.58	2.42	0.78	0.81	1.46	2.04
axi-t 3/3	0.0364	0.135	1.35	1.48	1.28	1.79	0.72	0.71	1.22	1.49
axi-t 3/3	0.0363	0.1348	1.3	1.47	1.28	1.78	0.74	0.74	1.2	1.49
axi-t 2/3	0.0244	0.0906	1.31	1.55	1.54	2.38	0.75	0.85	1.46	2.07
axi-t 1/3	0.0122	0.0453	1.35	1.67	1.87	2.96	0.83	1.11	1.89	3.18

Table M-29: Measured SNCFs on chord at intersections of brace and chord for DT9

DT9	pl. cap	design	CC;1,br1	CI;2,br1	CI;4,br1	CS;5,br1	CC;9,br2	CI;10,br2	CI;12,br2	CS;13,br2
ipb 1/3	-0.0382	-0.083	0.49	2.07	1.23	0.17	-2.65	-2.98	-1.79	0.2
ipb 2/3	-0.0737	-0.1603	0.5	1.62	1.1	0.06	-2.55	-2.87	-1.55	0.14
ipb 3/3	-0.1106	-0.2403	0.51	1.41	1.02	-0.02	-2.51	-2.8	-1.43	0.06
ipb 3/3	-0.1115	-0.2423	0.5	1.41	1.01	-0.02	-2.5	-2.77	-1.42	0.04
ipb 2/3	-0.0743	-0.1616	0.5	1.67	1.14	0.08	-2.58	-2.89	-1.57	0.12
ipb 1/3	-0.0384	-0.0835	0.55	2.2	1.3	0.18	-2.72	-3.05	-1.8	0.2
opb 1/3	-0.0162	-0.0496	0.1	-0.31	-0.99	-4.41	-0.13	0.17	1.29	7.01
opb 2/3	-0.036	-0.1102	0.1	-0.25	-1.17	-3.79	-0.19	0.07	1.32	7.03
opb 3/3	-0.0551	-0.1684	0.06	-0.25	-1.22	-3.6	-0.17	0.09	1.35	6.96
opb 3/3	-0.0555	-0.1696	0.04	-0.24	-1.2	-3.58	-0.15	0.11	1.35	6.98
opb 2/3	-0.036	-0.11	0.08	-0.23	-1.12	-3.79	-0.22	0.06	1.32	7.09
opb 1/3	-0.0162	-0.0496	0.12	-0.18	-0.82	-4.09	-0.38	-0.08	1.1	7.36
axi-c 1/3	-0.0123	-0.065	0.91	1.43	1.72	4.22	2.15	1.58	3.48	12.56
axi-c 2/3	-0.0245	-0.1293	1.64	1.75	2.08	5.13	1.81	0.92	2.8	12.23
axi-c 3/3	-0.0368	-0.1943	2.12	2.3	2.09	5.3	1.96	0.89	2.3	10.78
axi-c 3/3	-0.0368	-0.1944	2.12	2.29	2.08	5.28	2.02	0.89	2.37	10.84
axi-c 2/3	-0.0245	-0.1296	2.14	2.06	2.32	4.96	1.26	0.62	2.71	12.58
axi-c 1/3	-0.0123	-0.0651	1.69	2.17	2	2.02	0.82	0.64	3.34	15.65
axi-t 1/3	0.0125	0.0465	0.93	2.21	2.91	6.08	1.28	1	2.68	8.69
axi-t 2/3	0.0245	0.0908	1.04	2.36	2.87	5.03	1.23	1.04	2.48	7.41
axi-t 3/3	0.0364	0.135	1.08	2.39	2.76	4.6	1.21	1.11	2.33	6.55
axi-t 3/3	0.0363	0.1348	1.07	2.36	2.78	4.66	1.23	1.1	2.32	6.47
axi-t 2/3	0.0244	0.0906	1.02	2.34	2.87	5.05	1.2	1.06	2.45	7.41
axi-t 1/3	0.0122	0.0453	1.13	2.53	2.72	5.41	1.2	0.96	2.69	9.25



Table M-30: Measured SNCFs on braces at intersections of brace and chord for DT9 at preload level of 50%

DT9	pl. cap	design	BC:1,br1	BI:2,br1	BI:4,br1	BS:5,br1	BC:9,br2	BI:10,br2	BI:12,br2	BS:13,br2
ipb 1/3	-0.0395	-0.0858	3.42	1.9	0.79	0.03	-1.46	-1.35	-1.21	0.07
ipb 2/3	-0.0755	-0.164	2.99	1.96	0.72	-0.01	-1.5	-1.36	-1.07	0.06
ipb 3/3	-0.1122	-0.2439	2.77	1.89	0.68	-0.02	-1.51	-1.34	-0.97	0.05
ipb 3/3	-0.1121	-0.2437	2.78	1.89	0.68	-0.03	-1.51	-1.33	-0.98	0.06
ipb 2/3	-0.0753	-0.1636	3.07	2.01	0.74	-0.02	-1.52	-1.37	-1.09	0.09
ipb 1/3	-0.0397	-0.0863	3.58	1.97	0.82	-0.03	-1.56	-1.42	-1.26	0.11
opb 1/3	-0.0166	-0.0508	0.08	-0.52	-0.96	-2.27	0.05	0.49	0.98	2.31
opb 2/3	-0.036	-0.11	0.07	-0.4	-0.77	-1.71	0.01	0.45	0.97	2.28
opb 3/3	-0.0546	-0.1668	0.07	-0.35	-0.73	-1.55	-0.01	0.43	0.96	2.27
opb 3/3	-0.0547	-0.1671	0.05	-0.35	-0.71	-1.56	-0.01	0.43	0.97	2.26
opb 2/3	-0.0353	-0.1079	0.04	-0.39	-0.75	-1.75	-0.03	0.42	0.95	2.26
opb 1/3	-0.0158	-0.0484	-0.03	-0.45	-0.86	-2.35	-0.08	0.34	0.83	2.25
axi-c 1/3	-0.0124	-0.0654	0.32	0.33	0.6	2.91	2.82	2.31	3.17	4.28
axi-c 2/3	-0.0246	-0.1296	0.96	0.9	1.4	3.01	2.32	1.59	2.35	4.22
axi-c 3/3	-0.0368	-0.1944	1.24	1.07	1.59	3.15	2.4	1.4	2.03	3.86
axi-c 3/3	-0.0368	-0.1944	1.24	1.07	1.6	3.15	2.4	1.4	2.01	3.85
axi-c 2/3	-0.0246	-0.1299	1.09	1.02	1.49	2.85	1.9	1.56	2.28	4.38
axi-c 1/3	-0.0123	-0.065	0.9	0.51	0.55	1.32	1.9	2.04	3.34	5.68
axi-t 1/3	0.0123	0.0456	1.33	1.51	1.94	3.75	1.05	1.15	1.98	3.28
axi-t 2/3	0.0244	0.0907	1.19	1.36	1.49	2.32	0.95	1	1.65	2.14
axi-t 3/3	0.0366	0.1357	1.18	1.29	1.29	1.74	0.9	0.88	1.42	1.56
axi-t 3/3	0.0366	0.1357	1.15	1.29	1.27	1.73	0.9	0.88	1.4	1.57
axi-t 2/3	0.0246	0.0913	1.18	1.35	1.5	2.27	0.9	1	1.66	2.24
axi-t 1/3	0.0121	0.045	1.35	1.53	1.84	3.49	1.02	1.26	2.06	3.47

Table M-31: Measured SNCFs on chord at intersections of brace and chord for DT9 at preload level of 50%

DT9	pl. cap	design	CC:1,br1	CI:2,br1	CI:4,br1	CS:5,br1	CC:9,br2	CI:10,br2	CI:12,br2	CS:13,br2
ipb 1/3	-0.0395	-0.0858	0.5	2.11	1.26	0.11	-2.61	-2.87	-1.8	0.31
ipb 2/3	-0.0755	-0.164	0.53	1.65	1.13	-0.01	-2.55	-2.86	-1.59	0.24
ipb 3/3	-0.1122	-0.2439	0.52	1.44	1.05	-0.07	-2.52	-2.78	-1.46	0.13
ipb 3/3	-0.1121	-0.2437	0.52	1.44	1.06	-0.07	-2.53	-2.8	-1.47	0.13
ipb 2/3	-0.0753	-0.1636	0.54	1.71	1.17	-0.01	-2.61	-2.93	-1.63	0.25
ipb 1/3	-0.0397	-0.0863	0.59	2.25	1.38	0.05	-2.79	-3.05	-1.88	0.38
opb 1/3	-0.0166	-0.0508	-0.02	-0.24	-1.18	-4.6	0.12	0.25	1.33	6.93
opb 2/3	-0.036	-0.11	0.04	-0.19	-1.25	-3.97	-0.04	0.17	1.3	6.9
opb 3/3	-0.0546	-0.1668	0.04	-0.19	-1.3	-3.82	-0.08	0.13	1.31	6.89
opb 3/3	-0.0547	-0.1671	0.06	-0.19	-1.29	-3.82	-0.08	0.14	1.29	6.88
opb 2/3	-0.0353	-0.1079	0.09	-0.17	-1.21	-4.05	-0.11	0.1	1.23	6.91
opb 1/3	-0.0158	-0.0484	0.1	-0.15	-1.02	-4.65	-0.21	0.03	0.98	6.96
axi-c 1/3	-0.0124	-0.0654	-0.65	-0.55	0.65	5.15	5.26	3.1	4.6	12.97
axi-c 2/3	-0.0246	-0.1296	0.59	0.62	1.76	5.45	3.43	1.64	3.4	12.77
axi-c 3/3	-0.0368	-0.1944	1.41	1.26	1.84	5.61	2.84	1.3	2.71	11.28
axi-c 3/3	-0.0368	-0.1944	1.41	1.3	1.87	5.63	2.83	1.27	2.72	11.32
axi-c 2/3	-0.0246	-0.1299	0.83	0.85	1.96	5.25	2.86	1.36	3.36	13.32
axi-c 1/3	-0.0123	-0.065	0.19	0.23	0.75	2.24	3.14	2.05	4.98	17.31
axi-t 1/3	0.0123	0.0456	1.01	1.63	2.58	7.06	1.19	1.12	3.05	9.73
axi-t 2/3	0.0244	0.0907	0.89	1.75	2.73	5.38	1.32	1.19	2.78	7.85
axi-t 3/3	0.0366	0.1357	0.96	1.95	2.65	4.68	1.3	1.3	2.71	6.74
axi-t 3/3	0.0366	0.1357	0.95	1.97	2.64	4.67	1.28	1.33	2.71	6.71
axi-t 2/3	0.0246	0.0913	0.89	1.8	2.65	5.23	1.25	1.23	2.82	8.05
axi-t 1/3	0.0121	0.045	1.04	1.74	2.46	6.58	1.15	1.24	3.14	10.3

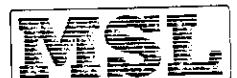

Table M-32: Measured SNCFs on braces at intersections of brace and chord for DT9 at preload level of 100%

DT9	pl. cap	design	BC;1,br1	BI;2,br1	BI;4,br1	BS;5,br1	BC;9,br2	BI;10,br2	BI;12,br2	BS;13,br2
ipb 1/3	-0.0383	-0.0832	3.61	1.72	0.82	-0.02	-1.47	-1.36	-1.25	0.05
ipb 2/3	-0.0767	-0.1668	3.18	1.87	0.74	-0.03	-1.5	-1.37	-1.1	0.05
ipb 3/3	-0.1132	-0.2461	2.9	1.86	0.68	-0.03	-1.52	-1.36	-0.99	0.06
ipb 3/3	-0.1131	-0.2459	2.89	1.87	0.67	-0.03	-1.52	-1.37	-0.99	0.07
ipb 2/3	-0.076	-0.1653	3.23	1.95	0.73	-0.01	-1.54	-1.43	-1.11	0.07
ipb 1/3	-0.0387	-0.0841	3.77	1.89	0.84	-0.03	-1.56	-1.52	-1.35	0.09
opb 1/3	-0.0164	-0.0501	0.11	-0.41	-0.77	-2.44	0.08	0.49	0.93	2.12
opb 2/3	-0.0361	-0.1103	0.06	-0.41	-0.77	-2.04	0	0.45	0.91	2.21
opb 3/3	-0.0557	-0.1703	0.08	-0.39	-0.74	-1.77	-0.01	0.43	0.94	2.23
opb 3/3	-0.0562	-0.1717	0.07	-0.38	-0.73	-1.76	-0.01	0.43	0.95	2.22
opb 2/3	-0.0365	-0.1117	0.07	-0.41	-0.74	-2.03	-0.02	0.43	0.91	2.19
opb 1/3	-0.0168	-0.0514	0.05	-0.35	-0.7	-2.42	0	0.43	0.86	2.2
axi-c 1/3	-0.0122	-0.0645	0	0.24	0.66	3.81	3.6	2.39	2.79	2.96
axi-c 2/3	-0.0246	-0.1297	0.87	0.98	1.57	3.64	2.53	1.52	1.97	3.45
axi-c 3/3	-0.0367	-0.1937	1.03	1.09	1.73	3.64	2.95	1.36	1.65	3.13
axi-c 3/3	-0.0367	-0.1936	1.03	1.12	1.8	3.69	2.92	1.36	1.74	3.3
axi-c 2/3	-0.0245	-0.1294	0.96	1.15	1.78	3.7	2.21	1.51	2.14	3.78
axi-c 1/3	-0.0123	-0.065	0.46	0.51	1.02	3.14	2.61	2.14	3.09	4.6
axi-t 1/3	0.0126	0.0468	1.19	1.24	1.62	3.68	1.02	1.25	2.19	3.96
axi-t 2/3	0.0245	0.091	1.14	1.34	1.65	3.08	0.99	1.11	1.95	3.16
axi-t 3/3	0.0366	0.1357	1.15	1.33	1.38	2.21	0.89	0.93	1.59	2.3
axi-t 3/3	0.0366	0.1358	1.12	1.35	1.4	2.18	0.89	0.93	1.56	2.32
axi-t 2/3	0.0246	0.0911	1.1	1.34	1.63	3.07	0.99	1.15	1.94	3.23
axi-t 1/3	0.0123	0.0458	1.13	1.19	1.53	3.26	1.13	1.45	2.29	4.44

Table M-33: Measured SNCFs on chord at intersections of brace and chord for DT9 at preload level of 100%

DT9	pl. cap	design	CC;1,br1	CI;2,br1	CI;4,br1	CS;5,br1	CC;9,br2	CI;10,br2	CI;12,br2	CS;13,br2
ipb 1/3	-0.0383	-0.0832	0.97	2.28	1.26	0.11	-2.72	-3.06	-1.72	0.28
ipb 2/3	-0.0767	-0.1668	0.74	1.76	1.07	0.03	-2.65	-2.99	-1.53	0.22
ipb 3/3	-0.1132	-0.2461	0.69	1.49	1	-0.05	-2.57	-2.88	-1.43	0.15
ipb 3/3	-0.1131	-0.2459	0.69	1.48	1.01	-0.05	-2.57	-2.88	-1.43	0.15
ipb 2/3	-0.076	-0.1653	0.77	1.8	1.14	0.02	-2.68	-3.05	-1.58	0.23
ipb 1/3	-0.0387	-0.0841	1.08	2.39	1.41	0.07	-2.84	-3.21	-1.86	0.27
opb 1/3	-0.0164	-0.0501	0.15	0.14	-0.83	-5.02	0.07	0.25	1.18	6.48
opb 2/3	-0.0361	-0.1103	0.1	-0.09	-1.02	-4.59	-0.06	0.12	1.23	6.71
opb 3/3	-0.0557	-0.1703	0.1	-0.14	-1.17	-4.3	-0.08	0.15	1.28	6.71
opb 3/3	-0.0562	-0.1717	0.11	-0.13	-1.16	-4.28	-0.09	0.16	1.28	6.74
opb 2/3	-0.0365	-0.1117	0.14	-0.07	-1	-4.59	-0.11	0.12	1.19	6.78
opb 1/3	-0.0168	-0.0514	0.19	0.29	-0.7	-4.85	-0.07	0.09	0.96	6.79
axi-c 1/3	-0.0122	-0.0645	-1.04	-1.07	0.58	6.91	6.82	3.68	4	9
axi-c 2/3	-0.0246	-0.1297	0.52	0.63	2.14	6.74	3.79	1.66	2.83	10.36
axi-c 3/3	-0.0367	-0.1937	1.13	1.18	2.1	6.64	2.83	1.35	2.38	9.47
axi-c 3/3	-0.0367	-0.1936	1.17	1.15	2.13	6.81	2.77	1.35	2.51	9.85
axi-c 2/3	-0.0245	-0.1294	0.7	0.67	2.33	6.92	3.41	1.52	2.97	11.25
axi-c 1/3	-0.0123	-0.065	-0.23	-0.46	1.09	5.85	4.74	2.71	4.52	13.5
axi-t 1/3	0.0126	0.0468	0.72	0.96	2.3	6.66	1.22	1.17	3.25	11.78
axi-t 2/3	0.0245	0.091	0.74	1.38	2.43	6.31	1.33	1.27	3.29	11.85
axi-t 3/3	0.0366	0.1357	0.85	1.73	2.56	5.6	1.31	1.2	3.03	9.64
axi-t 3/3	0.0366	0.1358	0.84	1.73	2.52	5.57	1.3	1.18	3.03	9.68
axi-t 2/3	0.0246	0.0911	0.7	1.43	2.31	6.26	1.32	1.24	3.32	12.06
axi-t 1/3	0.0123	0.0458	0.71	0.94	1.88	5.87	1.24	1.1	3.55	13.28



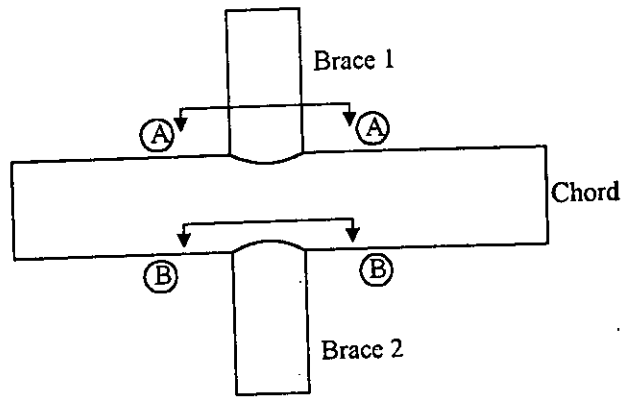

Elevation on DT Joint

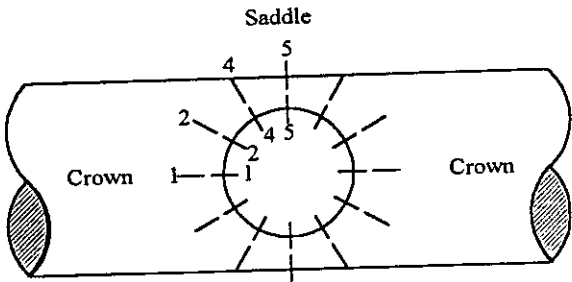

Saddle
View 'A' on brace 1

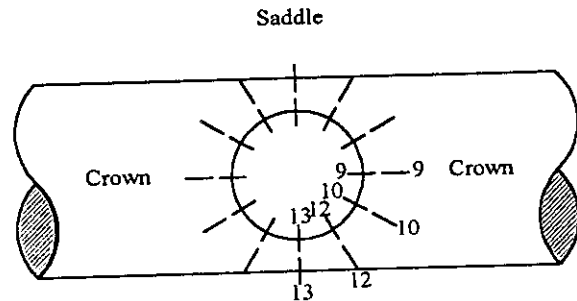

Saddle
View 'B' on brace 2

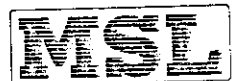

Appendix M 10 SNCFs grouted Test Specimen: T1

Table M-34: Measured SNCFs on intersection of brace and chord for T1

T1	pl. cap	design	BC;1	BS;5	BC;9	BS;13	CC;1	CS;5	CC;9	CS;13
ipb 1/3	0.0416	0.0513	-1.29	-0.08	1.35	0.01	-2.3	-0.06	2.32	0.04
ipb 2/3	0.0845	0.1042	-1.37	-0.03	1.37	0	-2.32	-0.01	2.31	0.04
ipb 3/3	0.1265	0.1559	-1.5	0.02	1.34	0.07	-2.02	0.06	2.22	0.15
ipb 3/3	0.1264	0.1557	-1.49	0.02	1.35	0.06	-2.02	0.04	2.21	0.13
ipb 2/3	0.0844	0.104	-1.36	-0.03	1.4	0.01	-2.37	-0.05	2.32	0.03
ipb 1/3	0.0418	0.0516	-1.35	-0.08	1.39	0.03	-2.4	-0.09	2.38	0.06
opb 1/3	0.028	0.057	0.04	-3.05	0.07	2.66	0.16	-4.86	0.11	5.15
opb 2/3	0.0594	0.1207	0.1	-2.92	0.05	2.49	0.15	-4.3	0.11	4.78
opb 3/3	0.0895	0.1819	0.11	-2.81	0.08	2.38	0.17	-3.5	0.13	4.5
opb 3/3	0.0907	0.1844	0.11	-2.81	0.07	2.37	0.18	-3.5	0.11	4.51
opb 2/3	0.0607	0.1234	0.08	-3	0.05	2.55	0.14	-4.46	0.06	4.93
opb 1/3	0.03	0.0609	0.05	-3.13	0.03	2.74	0.07	-5.12	0.09	5.35
axi-c 1/3	-0.0155	-0.0445	0.89	1.15	1.09	5.89	5.73	0.85	5.14	10.41
axi-c 2/3	-0.031	-0.0892	1.75	1.53	0.64	3.53	6.02	2.1	4.12	6.17
axi-c 3/3	-0.0464	-0.1337	2.15	1.69	0.7	2.45	5.49	2.48	3.79	4.46
axi-c 3/3	-0.0464	-0.1337	2.16	1.69	0.67	2.45	5.49	2.48	3.81	4.46
axi-c 2/3	-0.0311	-0.0895	1.83	1.39	0.48	3.84	6.04	1.86	3.92	6.48
axi-c 1/3	-0.0155	-0.0446	1.56	0.25	0.07	7.14	6.75	-0.57	4.02	11.96
axi-t 1/3	0.0157	0.0356	0.6	3.49	0.71	4.78	5.51	4.93	4.84	8.55
axi-t 2/3	0.0313	0.0709	0.79	3.35	0.88	4.07	5.24	4.68	4.52	6.98
axi-t 3/3	0.0467	0.1058	0.83	2.85	1.13	5.42	5.18	2.91	4.6	6.54
axi-t 3/3	0.0467	0.1059	0.95	2.75	0.84	3.82	5.18	3.84	4.39	6.63
axi-t 2/3	0.0315	0.0715	0.87	2.63	0.74	4.64	5.38	3.64	4.49	8.22
axi-t 1/3	0.0159	0.036	0.75	1.46	0.72	6.4	5.55	1.87	4.87	12.05

Table M-35: Measured SNCFs on intersection of brace and chord for T1 at preload level of 45%

T1	pl. cap	design	BC;1	BS;5	BC;9	BS;13	CC;1	CS;5	CC;9	CS;13
ipb 1/3	0.0419	0.0517	-1.31	-0.03	1.36	0.03	-2.39	-0.02	2.28	0.06
ipb 2/3	0.0845	0.1042	-1.33	-0.06	1.36	0.01	-2.42	-0.06	2.31	0
ipb 3/3	0.1264	0.1557	-1.33	-0.08	1.38	-0.01	-2.43	-0.08	2.29	-0.02
ipb 3/3	0.1265	0.1559	-1.33	-0.08	1.37	-0.02	-2.43	-0.08	2.28	-0.01
ipb 2/3	0.085	0.1047	-1.33	-0.03	1.37	0	-2.44	-0.04	2.33	0.03
ipb 1/3	0.042	0.0518	-1.34	-0.02	1.34	0	-2.47	-0.02	2.3	0.1
opb 1/3	0.0286	0.0582	0.09	-3.04	0	2.63	0.09	-4.73	-0.04	5.02
opb 2/3	0.059	0.1199	0.09	-2.98	0.01	2.53	0.08	-4.58	-0.1	4.77
opb 3/3	0.0895	0.1819	0.13	-3	0.02	2.45	0.11	-4.04	-0.09	4.65
opb 3/3	0.0904	0.1838	0.13	-3	0.02	2.46	0.12	-4.1	-0.09	4.71
opb 2/3	0.0598	0.1215	0.11	-3.02	-0.01	2.54	0.11	-4.89	-0.14	5.07
opb 1/3	0.0309	0.0628	0.18	-2.98	-0.11	2.66	0.28	-5.02	-0.23	5.24
axi-c 1/3	-0.0155	-0.0446	0.97	1.35	0.58	7.12	6.74	1.1	5.33	13.3
axi-c 2/3	-0.0309	-0.089	1.57	2.33	0.41	4.89	7.34	3.03	4.71	9.12
axi-c 3/3	-0.0464	-0.1336	1.73	2.5	0.52	3.5	6.96	3.67	4.73	6.63
axi-c 3/3	-0.0464	-0.1336	1.7	2.5	0.49	3.5	6.94	3.72	4.71	6.65
axi-c 2/3	-0.031	-0.0892	1.58	2.04	0.3	5.37	7.28	2.61	4.67	9.89
axi-c 1/3	-0.0155	-0.0445	1.45	0.1	-0.18	8.61	7.76	-1.1	4.27	16.5
axi-t 1/3	0.016	0.0362	0.63	2.8	0.92	4.67	5.13	3.56	5.17	8.5
axi-t 2/3	0.0313	0.071	0.89	2.88	0.81	3.82	5.24	3.78	4.72	6.64
axi-t 3/3	0.0464	0.1051	0.93	2.54	0.92	3.59	5.14	3.3	4.62	6.11
axi-t 3/3	0.0464	0.1051	0.94	2.54	0.92	3.59	5.18	3.3	4.62	6.08
axi-t 2/3	0.0313	0.071	0.88	2.54	0.84	4.12	5.31	3.25	4.72	7.23
axi-t 1/3	0.0158	0.0357	0.78	2.14	0.7	5.39	5.55	2.55	4.93	9.92

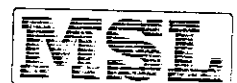

Table M-36: Measured SNCFs on intersection of brace and chord for T1 at preload level of 90 %

T1	pl. cap	design	BC:1	BS:5	BC:9	BS:13	CC:1	CS:5	CC:9	CS:13
ipb 1/3	0.0424	0.0522	-1.32	-0.07	1.39	0	-2.19	-0.11	2.21	-0.03
ipb 2/3	0.0849	0.1047	-1.31	-0.09	1.39	-0.04	-2.27	-0.11	2.21	-0.04
ipb 3/3	0.1267	0.1562	-1.31	-0.09	1.39	-0.04	-2.34	-0.13	2.23	-0.05
ipb 3/3	0.1267	0.1562	-1.32	-0.09	1.39	-0.04	-2.33	-0.13	2.21	-0.05
ipb 2/3	0.0852	0.105	-1.32	-0.08	1.39	-0.03	-2.33	-0.09	2.25	-0.05
ipb 1/3	0.0419	0.0517	-1.33	-0.05	1.41	-0.02	-2.3	-0.05	2.27	-0.03
opb 1/3	0.0276	0.0561	0.16	-2.89	0.05	2.53	0.11	-4.48	0	4.63
opb 2/3	0.0576	0.117	0.16	-2.95	0.03	2.43	0.09	-4.34	-0.08	4.53
opb 3/3	0.0882	0.1794	0.17	-2.89	0.03	2.35	0.1	-4.03	-0.05	4.31
opb 3/3	0.0903	0.1836	0.17	-2.91	0.04	2.33	0.11	-4.05	-0.05	4.33
opb 2/3	0.0601	0.1223	0.17	-2.97	0.03	2.37	0.15	-4.39	-0.07	4.59
opb 1/3	0.0295	0.06	0.21	-2.92	-0.02	2.45	0.22	-4.46	-0.19	4.66
axi-c 1/3	-0.0155	-0.0446	2.21	-0.88	-0.35	6.53	7.33	-2.63	2.43	11.59
axi-c 2/3	-0.0309	-0.0891	2.05	1.31	-0.23	4.75	7.34	0.92	2.87	8.39
axi-c 3/3	-0.0463	-0.1334	1.89	2.49	0.08	3.74	7.2	3.05	3.48	6.44
axi-c 3/3	-0.0463	-0.1334	1.93	2.52	0.09	3.71	7.19	3.05	3.48	6.41
axi-c 2/3	-0.0365	-0.1051	2.02	1.88	-0.21	4.33	7.36	1.93	3.13	7.69
axi-c 1/3	-0.0154	-0.0442	2.57	-0.88	-0.63	6.76	7.93	-3.06	2.28	12.19
axi-t 1/3	0.0157	0.0357	1.6	2.02	0.48	2.88	5.91	2.35	3.76	4.92
axi-t 2/3	0.0316	0.0716	1.23	2.37	1.05	2.86	5.22	2.76	4.38	4.46
axi-t 3/3	0.0464	0.1051	1.09	2.22	1.18	2.74	4.98	2.72	4.61	4.38
axi-t 3/3	0.0464	0.1051	1.08	2.17	1.11	2.68	4.9	2.75	4.6	4.35
axi-t 2/3	0.0315	0.0714	1.15	2.05	0.93	2.96	5.1	2.52	4.5	4.86
axi-t 1/3	0.0157	0.0356	1.24	1.22	0.79	3.87	5.42	1.43	4.34	6.5

Table M-37: Measured SNCFs on intersection of brace and chord for T1 at preload level of 130 %

T1	pl. cap	design	BC:1	BS:5	BC:9	BS:13	CC:1	CS:5	CC:9	CS:13
ipb 1/3	0.0428	0.0527	-1.33	-0.06	1.38	0.02	-2.26	-0.07	2.25	0.02
ipb 2/3	0.0859	0.1059	-1.32	-0.08	1.39	-0.01	-2.32	-0.09	2.27	-0.01
ipb 3/3	0.1271	0.1567	-1.31	-0.1	1.39	-0.03	-2.35	-0.09	2.26	-0.03
ipb 3/3	0.1273	0.1569	-1.3	-0.1	1.4	-0.03	-2.33	-0.09	2.26	-0.03
ipb 2/3	0.0855	0.1054	-1.31	-0.06	1.4	-0.03	-2.37	-0.07	2.3	-0.01
ipb 1/3	0.0425	0.0524	-1.32	-0.07	1.41	0.01	-2.37	-0.02	2.37	-0.01
opb 1/3	0.0289	0.0587	0.09	-2.87	0.02	2.5	0.06	-4.51	-0.08	4.77
opb 2/3	0.0588	0.1195	0.14	-2.84	-0.01	2.43	0.07	-4.44	-0.1	4.71
opb 3/3	0.091	0.185	0.15	-2.82	0	2.32	0.08	-4.15	-0.09	4.46
opb 3/3	0.0924	0.1879	0.16	-2.85	-0.01	2.34	0.11	-4.15	-0.09	4.46
opb 2/3	0.0621	0.1262	0.16	-2.83	-0.03	2.38	0.14	-4.4	-0.12	4.67
opb 1/3	0.0302	0.0614	0.19	-2.96	-0.11	2.59	0.27	-4.59	-0.26	4.78
axi-c 1/3	-0.0154	-0.0443	1.28	-1.32	0.51	6.67	6.14	-3.4	3.87	11.91
axi-c 2/3	-0.0309	-0.089	1.54	0.9	0.3	4.74	6.46	0.33	3.8	8.5
axi-c 3/3	-0.0463	-0.1333	1.29	1.84	0.61	3.98	6.09	1.97	4.38	7.04
axi-c 3/3	-0.0463	-0.1333	1.29	1.84	0.64	4	6.05	2.02	4.33	6.97
axi-c 2/3	-0.031	-0.0893	1.44	0.82	0.35	4.93	6.38	0.31	3.95	8.72
axi-c 1/3	-0.0154	-0.0443	1.45	-1.61	0.31	7.21	6.59	-3.89	3.87	13.1
axi-t 1/3	0.0159	0.036	0.9	0.5	1.16	4.46	5.36	0.04	4.64	7.7
axi-t 2/3	0.0311	0.0706	1.02	1.55	1.03	3.35	5.29	1.81	4.61	5.72
axi-t 3/3	0.0464	0.1052	1.07	2.07	0.91	2.77	5.38	2.67	4.41	4.64
axi-t 3/3	0.0464	0.1052	1.18	2.1	0.92	2.75	5.26	2.64	4.43	4.64
axi-t 2/3	0.0315	0.0714	1.36	1.95	0.77	3.07	5.6	2.35	4.21	5.22
axi-t 1/3	0.0157	0.0357	1.53	0.99	0.42	4.09	6.07	0.76	3.95	7.29



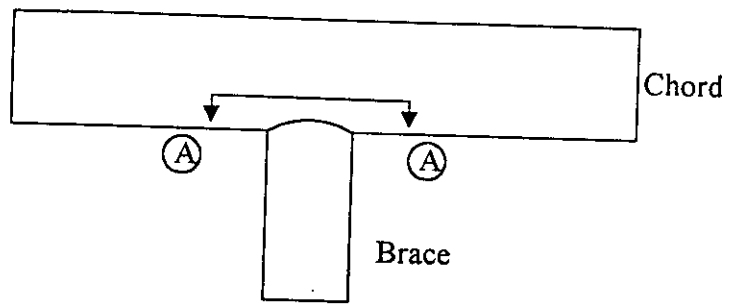

Elevation on T Joint

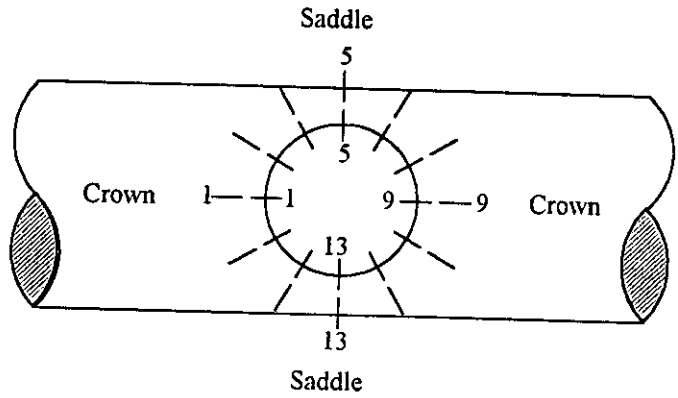

View 'A' on brace



Appendix M 11 SCNFs grouted Test Specimen: T3

Table M-38: Measured SNCFs on brace at intersection of brace and chord for T3

T3	pl. cap	design	BC:1	BI:2	BI:4	BS:5	BC:9	BI:10	BI:12	BS:13
ipb 1/3	0.0312	0.0467	-1.23	-1.02	-1.04	-0.09	1.38	1.34	0.92	-0.11
ipb 2/3	0.0624	0.0934	-1.48	-0.99	-0.92	-0.01	1.31	1.3	0.98	-0.03
ipb 3/3	0.0937	0.1403	-1.53	-1.02	-0.84	0.02	1.29	1.28	0.95	-0.01
ipb 3/3	0.0938	0.1404	-1.53	-1.01	-0.84	0.01	1.29	1.28	0.96	-0.01
ipb 2/3	0.0626	0.0937	-1.48	-0.98	-0.93	-0.03	1.32	1.3	0.98	-0.03
ipb 1/3	0.0314	0.047	-1.26	-1.02	-1.07	-0.12	1.38	1.3	0.97	-0.09
opb 1/3	-0.0289	-0.0607	0.13	0.58	1.02	1.89	-0.4	-0.84	-1.95	-2.69
opb 2/3	-0.0587	-0.1234	0.06	0.52	0.86	1.48	-0.22	-0.66	-1.69	-2.29
opb 3/3	-0.0891	-0.1873	0.02	0.52	0.85	1.31	-0.18	-0.57	-1.51	-2.1
opb 3/3	-0.0897	-0.1886	0.02	0.53	0.84	1.32	-0.18	-0.56	-1.5	-2.11
opb 2/3	-0.0594	-0.1249	0.07	0.53	0.87	1.51	-0.23	-0.64	-1.66	-2.33
opb 1/3	-0.0308	-0.0648	0.13	0.58	1.01	1.9	-0.34	-0.79	-1.94	-2.69
axi-c 1/3	-0.0145	-0.04	3.61	3.35	4.01	1.74	1.29	1.5	2.4	2.86
axi-c 2/3	-0.0291	-0.08	3.19	2.62	3.27	1.68	2.22	2	2.53	2.19
axi-c 3/3	-0.0435	-0.1199	3.26	2.63	3.22	1.9	2.27	1.86	2.27	1.54
axi-c 3/3	-0.0435	-0.1199	3.26	2.63	3.2	1.9	2.27	1.87	2.25	1.54
axi-c 2/3	-0.0291	-0.08	3.24	2.65	3.28	1.65	2.12	1.94	2.5	2.13
axi-c 1/3	-0.0145	-0.04	3.88	3.48	4.06	1.56	1.02	1.39	2.4	2.93
axi-t 1/3	0.0144	0.0371	2.69	3.11	4.4	2.04	2.43	2.63	3.82	2.45
axi-t 2/3	0.0286	0.0737	2.61	2.81	3.73	1.41	2.2	2.59	3.73	2.17
axi-t 3/3	0.0428	0.1103	2.72	2.79	3.56	1.3	2.09	2.61	3.88	2.33
axi-t 3/3	0.0428	0.1102	2.55	2.65	3.36	1.18	1.96	2.6	3.73	2.19
axi-t 2/3	0.0286	0.0736	2.52	2.77	3.61	1.26	2.04	2.65	3.74	2.17
axi-t 1/3	0.0143	0.0368	2.35	2.96	4.2	2.16	2.24	2.53	3.55	1.99

Table M-39: Measured SNCFs on chord at intersection of brace and chord for T3

T3	pl. cap	design	CC:1	CI:2	CI:4	CS:5	CC:9	CI:10	CI:12	CS:13
ipb 1/3	0.0312	0.0467	-2.35	-2.01	-0.95	-0.11	2.96	2.37	0.74	-0.11
ipb 2/3	0.0624	0.0934	-2.22	-1.8	-0.79	-0.02	2.86	2.4	0.81	-0.02
ipb 3/3	0.0937	0.1403	-1.99	-1.63	-0.66	0.04	2.78	2.34	0.78	0.02
ipb 3/3	0.0938	0.1404	-2	-1.63	-0.66	0.05	2.77	2.32	0.76	0
ipb 2/3	0.0626	0.0937	-2.25	-1.83	-0.79	0	2.86	2.37	0.77	-0.04
ipb 1/3	0.0314	0.047	-2.5	-2.05	-1.03	-0.07	3.01	2.33	0.75	-0.11
opb 1/3	-0.0289	-0.0607	0.17	1.1	2.03	3.25	-0.56	-1.61	-2.69	-2.8
opb 2/3	-0.0587	-0.1234	0.04	0.85	1.55	2.63	-0.46	-1.42	-2.31	-2.37
opb 3/3	-0.0891	-0.1873	-0.06	0.77	1.39	2.31	-0.4	-1.26	-2.06	-2.18
opb 3/3	-0.0897	-0.1886	-0.06	0.75	1.39	2.3	-0.41	-1.26	-2.07	-2.2
opb 2/3	-0.0594	-0.1249	0.02	0.85	1.6	2.7	-0.46	-1.41	-2.34	-2.44
opb 1/3	-0.0308	-0.0648	0.18	1.06	2	3.32	-0.61	-1.66	-2.73	-2.87
axi-c 1/3	-0.0145	-0.04	10.78	7.67	4.22	0.08	6.83	3.77	2.47	1.54
axi-c 2/3	-0.0291	-0.08	9.19	6.39	3.33	0.29	7.79	4.52	2.25	0.74
axi-c 3/3	-0.0435	-0.1199	8.6	6.34	3.52	0.79	7.65	4.49	2.07	0.05
axi-c 3/3	-0.0435	-0.1199	8.63	6.35	3.52	0.76	7.65	4.54	2.09	0.08
axi-c 2/3	-0.0291	-0.08	9.4	6.48	3.41	0.21	7.85	4.57	2.2	0.8
axi-c 1/3	-0.0145	-0.04	11.42	8.1	4.21	-0.09	6.54	3.89	2.62	1.71
axi-t 1/3	0.0144	0.0371	8.54	7.99	6.46	0.12	8.92	6.94	5.31	0.88
axi-t 2/3	0.0286	0.0737	8.45	7.92	6.02	-0.3	9.08	7.66	5.82	1.04
axi-t 3/3	0.0428	0.1103	8.9	8.08	5.71	-0.31	9.15	7.88	6.05	1.19
axi-t 3/3	0.0428	0.1102	9	8.21	5.84	-0.13	9.14	7.71	6.07	1.32
axi-t 2/3	0.0286	0.0736	8.76	8.25	6.12	-0.11	8.96	7.39	5.9	1.3
axi-t 1/3	0.0143	0.0368	8.63	8.41	7.08	0.9	9.14	7.14	5.43	1.24



Table M-40: Measured SNCFs on brace at intersection of brace and chord for T3 at preload level of 50%

T3	pl. cap	design	BC:1	BI:2	BI:4	BS:5	BC:9	BI:10	BI:12	BS:13
ipb 1/3	0.0315	0.0471	-1.11	-0.95	-0.9	-0.02	1.25	1.04	0.82	-0.01
ipb 2/3	0.0626	0.0938	-1.19	-0.92	-0.9	-0.02	1.24	1.13	0.9	0
ipb 3/3	0.0941	0.1408	-1.27	-0.9	-0.86	-0.01	1.26	1.17	0.91	0.01
ipb 3/3	0.094	0.1408	-1.27	-0.9	-0.86	-0.01	1.26	1.17	0.91	0.01
ipb 2/3	0.0627	0.0938	-1.2	-0.94	-0.92	-0.03	1.26	1.18	0.92	0.01
ipb 1/3	0.0312	0.0467	-1.14	-0.98	-0.99	-0.02	1.31	1.14	0.93	0
opb 1/3	-0.0288	-0.0606	0.15	0.51	1.37	1.54	-0.29	-0.55	0.94	0.02
opb 2/3	-0.0591	-0.1242	0.06	0.47	1.14	1.39	-0.21	-0.51	-1.42	-1.95
opb 3/3	-0.0886	-0.1864	0.03	0.47	1.03	1.28	-0.17	-0.48	-1.37	-1.89
opb 3/3	-0.0892	-0.1876	0.03	0.48	1.03	1.28	-0.17	-0.48	-1.34	-1.85
opb 2/3	-0.0594	-0.1248	0.07	0.48	1.14	1.43	-0.22	-0.48	-1.33	-1.86
opb 1/3	-0.03	-0.063	0.15	0.52	1.4	1.65	-0.31	-0.51	-1.38	-1.92
axi-c 1/3	-0.0145	-0.0401	3.09	2.87	3	0.63	1.43	-0.57	-1.46	-2.03
axi-c 2/3	-0.029	-0.08	2.76	2.46	2.85	0.92	1.89	1.82	2.63	2.2
axi-c 3/3	-0.0436	-0.1199	2.71	2.29	2.78	1.02	2.11	1.92	2.62	1.81
axi-c 3/3	-0.0436	-0.1199	2.73	2.26	2.8	1.02	2.08	1.99	2.52	1.6
axi-c 2/3	-0.0291	-0.0801	2.82	2.41	2.79	0.82	1.83	1.96	2.48	1.56
axi-c 1/3	-0.0146	-0.0401	3.45	3.06	3.42	0.69	1.03	1.38	2.25	1.83
axi-t 1/3	0.0145	0.0373	1.94	2.25	3.06	0.81	2.37	2.43	3.68	2.11
axi-t 2/3	0.0287	0.074	2.34	2.5	3.11	0.68	1.94	2.28	3.62	1.65
axi-t 3/3	0.043	0.1106	2.43	2.54	3.19	0.96	2.03	2.41	3.52	1.7
axi-t 3/3	0.0429	0.1105	2.48	2.53	3.22	0.96	2.01	2.4	3.51	1.7
axi-t 2/3	0.0286	0.0738	2.27	2.44	3.23	0.76	2.05	2.39	3.69	1.69
axi-t 1/3	0.0144	0.0372	1.98	2.14	3.23	0.77	2.37	2.55	3.69	1.48

Table M-41: Measured SNCFs on chord at intersection of brace and chord for T3 at preload level of 50%

T3	pl. cap	design	CC:1	CI:2	CI:4	CS:5	CC:9	CI:10	CI:12	CS:13
ipb 1/3	0.0315	0.0471	-2.32	-1.77	-0.81	0.1	2.85	2.03	0.76	-0.09
ipb 2/3	0.0626	0.0938	-2.37	-1.76	-0.71	0.08	2.86	2.14	0.76	-0.05
ipb 3/3	0.0941	0.1408	-2.32	-1.72	-0.64	0.09	2.84	2.19	0.76	-0.05
ipb 3/3	0.094	0.1408	-2.32	-1.72	-0.64	0.09	2.84	2.19	0.76	-0.05
ipb 2/3	0.0627	0.0938	-2.41	-1.8	-0.73	0.06	2.91	2.18	0.79	-0.06
ipb 1/3	0.0312	0.0467	-2.46	-1.89	-0.84	0.07	2.96	2.15	0.8	-0.1
opb 1/3	-0.0288	-0.0606	0.33	1.1	2.09	2.01	-0.63	-1.12	-1.79	-1.97
opb 2/3	-0.0591	-0.1242	0.07	1.02	2.03	1.93	-0.51	-1.02	-1.68	-1.96
opb 3/3	-0.0886	-0.1864	-0.04	0.97	1.88	1.82	-0.47	-0.99	-1.62	-1.94
opb 3/3	-0.0892	-0.1876	-0.05	0.97	1.9	1.81	-0.47	-1	-1.62	-1.93
opb 2/3	-0.0594	-0.1248	0.05	1.04	2.09	2.02	-0.54	-1.05	-1.7	-2.02
opb 1/3	-0.03	-0.063	0.28	1.13	2.32	2.28	-0.69	-1.15	-1.83	-2.11
axi-c 1/3	-0.0145	-0.0401	10.68	7.08	2.95	-0.58	7.75	4.54	2.52	1.28
axi-c 2/3	-0.029	-0.08	9.71	6.5	2.89	-0.18	8.39	5.05	2.51	0.81
axi-c 3/3	-0.0436	-0.1199	9.29	6.37	3.07	-0.02	8.54	5.34	2.64	0.57
axi-c 3/3	-0.0436	-0.1199	9.21	6.35	3.07	-0.02	8.54	5.39	2.58	0.57
axi-c 2/3	-0.0291	-0.0801	9.81	6.44	2.76	-0.28	8.6	5.21	2.49	0.86
axi-c 1/3	-0.0146	-0.0401	11.51	7.74	3.39	-0.47	7.26	4.18	2.26	1.29
axi-t 1/3	0.0145	0.0373	8.58	7.29	5.61	-0.06	9.6	7.5	5.41	1.29
axi-t 2/3	0.0287	0.074	9.27	7.88	5.54	-0.12	9.02	7.31	5.56	1.4
axi-t 3/3	0.043	0.1106	9.43	7.91	5.46	0.18	9.47	7.31	5.22	1.21
axi-t 3/3	0.0429	0.1105	9.39	7.87	5.38	0.13	9.5	7.36	5.2	1.16
axi-t 2/3	0.0286	0.0738	9.06	7.76	5.66	-0.02	9.53	7.56	5.58	1.27
axi-t 1/3	0.0144	0.0372	8.38	7.28	5.8	0.17	9.99	7.73	5.48	1.11



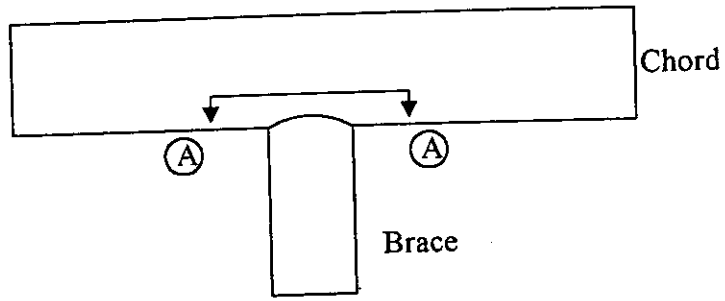

Elevation on T Joint
Saddle

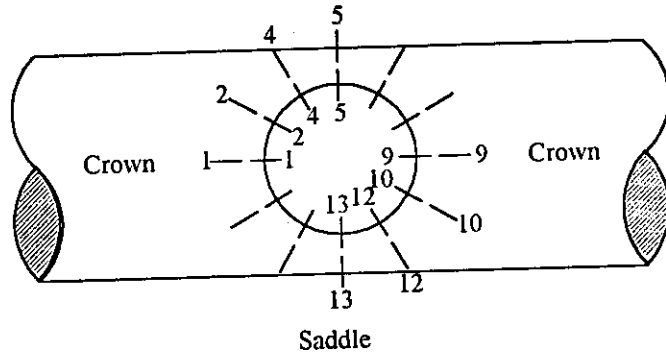

View 'A' on brace

Appendix M 12 SCNFs grouted Test Specimen: T5

Table M-42: Measured SNCFs on intersection of brace and chord for T5

T5	pl. cap	design	BC:1	BS:5	BC:9	BS:13	CC:1	CS:5	CC:9	CS:13
ipb 1/3	0.0445	0.0672	-1.55	0.05	1.84	-0.1	-3.29	-0.2	4.11	-0.14
ipb 2/3	0.0871	0.1313	-1.97	0.13	1.79	-0.04	-3.48	-0.06	3.85	-0.08
ipb 3/3	0.1315	0.1984	-2.18	0.2	1.74	0.05	-2.77	0.09	3.59	0.08
ipb 3/3	0.1323	0.1996	-2.18	0.2	1.73	0.05	-2.75	0.1	3.59	0.08
ipb 2/3	0.0885	0.1335	-1.96	0.13	1.77	-0.04	-3.49	-0.05	3.87	-0.06
ipb 1/3	0.0442	0.0666	-1.54	0.07	1.82	-0.08	-3.21	-0.17	4.15	-0.11
opb 1/3	-0.0216	-0.0701	-0.11	4.33	-0.17	-5.11	-0.24	6.52	-0.58	-8.42
opb 2/3	-0.0418	-0.1355	-0.08	3.26	-0.16	-4.33	-0.32	4.18	-0.71	-7.2
opb 3/3	-0.0624	-0.2021	-0.08	2.81	-0.11	-3.89	-0.37	3.27	-0.72	-6.45
opb 3/3	-0.0615	-0.1992	-0.06	2.94	-0.14	-4.05	-0.34	3.48	-0.78	-6.71
opb 2/3	-0.0425	-0.1377	-0.02	3.43	-0.18	-4.56	-0.24	4.47	-0.8	-7.51
opb 1/3	-0.0207	-0.0672	0.05	4.86	-0.31	-5.65	0.07	7.45	-0.83	-9.35
axi-c 1/3	-0.0175	-0.0787	1.6	5.41	3.64	3.43	7.07	8.83	8.87	4.63
axi-c 2/3	-0.0348	-0.1567	2.01	3.22	2.95	3.43	7.93	5.31	6.97	5.67
axi-c 3/3	-0.0522	-0.2349	2.13	2.65	2.69	2.87	7.62	4.29	6.37	4.66
axi-c 3/3	-0.0522	-0.2349	2.13	2.65	2.7	2.87	7.61	4.25	6.41	4.69
axi-c 2/3	-0.0349	-0.157	2.05	3.06	2.91	3.68	8.07	4.86	7.04	6.31
axi-c 1/3	-0.0174	-0.0783	1.91	4.61	3.46	5.02	7.96	6.98	8.92	7.88
axi-t 1/3	0.0169	0.0556	1.98	2.26	1.08	7.27	6.94	3.07	5.97	11.06
axi-t 2/3	0.0337	0.1112	1.57	3.1	1.51	5.16	5.91	4.31	6.99	7.62
axi-t 3/3	0.0503	0.1658	1.63	2.86	1.39	4.49	5.92	4.03	6.77	6.58
axi-t 3/3	0.0502	0.1655	1.59	2.78	1.36	4.52	5.94	3.93	6.78	6.71
axi-t 2/3	0.0336	0.1108	1.53	2.89	1.44	5.37	5.98	4.02	6.95	8.08
axi-t 1/3	0.0168	0.0553	1.33	3.2	1.88	7.11	5.89	4.24	7.84	10.69

Table M-43: Measured SNCFs on intersection of brace and chord for T5 at preload level of 50%

T5	pl. cap	design	BC:1	BS:5	BC:9	BS:13	CC:1	CS:5	CC:9	CS:13
ipb 1/3	0.0434	0.0655	-1.5	0.1	1.73	-0.07	-3.17	-0.03	4.03	-0.12
ipb 2/3	0.0868	0.1309	-1.75	0.16	1.75	-0.09	-3.38	0.02	3.84	-0.14
ipb 3/3	0.13	0.1961	-2.03	0.21	1.74	-0.01	-2.9	0.13	3.62	-0.02
ipb 3/3	0.13	0.1961	-2.02	0.23	1.74	-0.03	-2.9	0.16	3.62	-0.05
ipb 2/3	0.0869	0.1311	-1.72	0.17	1.75	-0.11	-3.4	0.04	3.85	-0.18
ipb 1/3	0.0432	0.0652	-1.48	0.17	1.74	-0.13	-3.19	0.08	4.05	-0.12
opb 1/3	-0.0203	-0.0657	-0.11	4.39	-0.14	-5.05	-0.25	6.41	-0.32	-8.31
opb 2/3	-0.0398	-0.1289	-0.09	3.31	-0.11	-4.4	-0.33	4.35	-0.48	-7.26
opb 3/3	-0.059	-0.191	-0.1	2.89	-0.1	-4.01	-0.37	3.48	-0.53	-6.59
opb 3/3	-0.0605	-0.1961	-0.09	3.01	-0.11	-4.11	-0.35	3.79	-0.55	-6.73
opb 2/3	-0.0408	-0.1322	-0.07	3.5	-0.13	-4.62	-0.23	4.91	-0.47	-7.51
opb 1/3	-0.0207	-0.067	-0.06	4.8	-0.13	-5.3	-0.12	7.52	-0.31	-8.92
axi-c 1/3	-0.0175	-0.0788	0.43	6.18	4.26	3.74	5.24	9.45	13.44	5.24
axi-c 2/3	-0.0348	-0.1567	1.06	3.74	3.57	4.33	6.65	5.72	10.56	7.03
axi-c 3/3	-0.0522	-0.2347	1.36	3.02	3.2	3.55	6.96	4.63	8.95	5.91
axi-c 3/3	-0.0522	-0.2346	1.36	3.02	3.2	3.56	6.96	4.64	8.98	5.88
axi-c 2/3	-0.0347	-0.1562	1.16	3.58	3.39	4.83	7.04	5.23	10.74	8.01
axi-c 1/3	-0.0174	-0.0782	0.94	4.9	3.72	6.93	6.71	6.95	13.34	10.54
axi-t 1/3	0.0168	0.0553	0.5	4.24	2.99	5.88	4.92	5.76	11.76	8.36
axi-t 2/3	0.0333	0.1098	1.4	3.59	1.92	4.77	6.45	4.94	9.27	6.75
axi-t 3/3	0.05	0.1646	1.44	3.18	1.93	4.09	6.32	4.39	8.88	5.79
axi-t 3/3	0.05	0.1646	1.44	3.18	1.93	4.07	6.34	4.36	8.88	5.77
axi-t 2/3	0.0332	0.1093	1.22	3.35	1.94	4.73	6.18	4.53	8.96	6.69
axi-t 1/3	0.017	0.0562	0.73	3.95	2.67	6.25	5.4	5.16	10.96	8.98

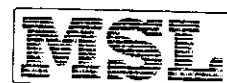
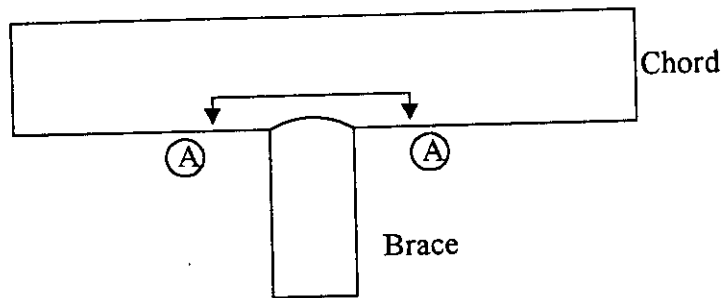
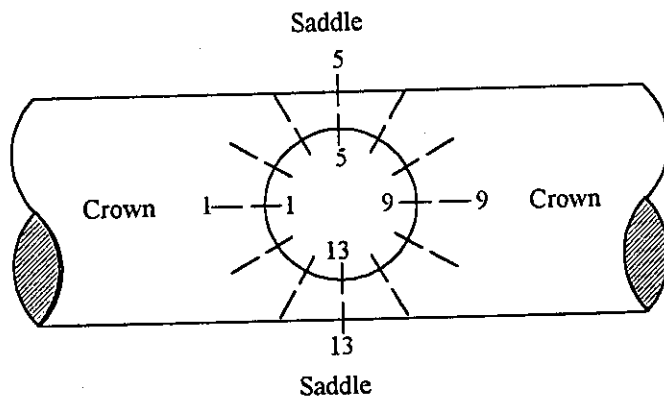

Table M-44: Measured SNCFs on intersection of brace and chord for T5 at preload level of 100 %

T5	pl. cap	design	BC;1	BS;5	BC;9	BS;13	CC;1	CS;5	CC;9	CS;13
ipb 1/3	0.043	0.0649	-1.53	-0.11	1.86	-0.21	-2.93	-0.29	3.48	-0.27
ipb 2/3	0.0867	0.1307	-1.59	-0.14	1.86	-0.27	-3.09	-0.32	3.51	-0.36
ipb 3/3	0.1311	0.1978	-1.76	-0.1	1.84	-0.24	-3.28	-0.29	3.45	-0.32
ipb 3/3	0.131	0.1976	-1.75	-0.1	1.84	-0.23	-3.26	-0.29	3.46	-0.29
ipb 2/3	0.0856	0.1291	-1.56	-0.13	1.84	-0.25	-3.14	-0.33	3.51	-0.32
ipb 1/3	0.0432	0.0652	-1.48	-0.11	1.81	-0.18	-2.99	-0.31	3.48	-0.15
opb 1/3	-0.0172	-0.0557	-0.4	4.66	-0.06	-4.36	-0.22	6.85	0.1	-6.91
opb 2/3	-0.0381	-0.1234	-0.39	4.53	-0.1	-4.29	-0.3	6.38	0.01	-6.84
opb 3/3	-0.0589	-0.1908	-0.31	3.81	-0.09	-3.92	-0.32	5.1	-0.17	-6.36
opb 3/3	-0.059	-0.191	-0.29	3.84	-0.1	-3.98	-0.29	5.15	-0.19	-6.44
opb 2/3	-0.0388	-0.1256	-0.36	4.54	-0.12	-4.29	-0.2	6.46	-0.01	-6.93
opb 1/3	-0.0184	-0.0595	-0.31	4.64	-0.1	-4.48	-0.08	6.77	0.08	-7.05
axi-c 1/3	-0.0176	-0.079	0.61	4.9	3.38	2.4	5.57	6.59	11.63	2.86
axi-c 2/3	-0.035	-0.1574	1.49	3.72	2.45	4.62	7.14	4.73	9.94	6.4
axi-c 3/3	-0.0523	-0.2353	1.75	3.8	2.5	4.85	7.82	4.94	9.7	6.86
axi-c 3/3	-0.0523	-0.2353	1.75	3.8	2.5	4.85	7.82	4.96	9.73	6.88
axi-c 2/3	-0.0349	-0.1571	1.57	3.05	2.28	5.56	7.37	3.7	9.67	7.91
axi-c 1/3	-0.0175	-0.0788	1.27	2.11	2.62	5.58	6.72	2.1	10.24	7.98
axi-t 1/3	0.0169	0.0557	1.44	1.18	2.3	4.64	6.44	1.32	8.62	6.68
axi-t 2/3	0.0337	0.111	1.72	2.01	1.95	3.7	6.84	2.55	8.12	5.21
axi-t 3/3	0.0502	0.1654	1.91	2.11	1.83	3.35	7.06	2.81	7.8	4.66
axi-t 3/3	0.0501	0.1652	1.89	2.1	1.82	3.35	7.05	2.8	7.78	4.66
axi-t 2/3	0.0334	0.1102	1.8	1.79	1.84	3.92	7.04	2.26	7.78	5.54
axi-t 1/3	0.017	0.0562	1.46	1.41	2.16	4.72	6.59	1.44	8.39	6.79



Elevation on T Joint



View 'A' on brace



Appendix M 13SCNFs grouted Test Specimen: T9

Table M-45: Measured SNCFs on brace intersection of brace and chord for T9

T9	pl. cap	design	BC:1	BI:2	BI:4	BS:5	BI:6	BI:8	BC:9	BI:10
ipb 1/3	0.0326	0.0709	-1.57	-1.44	-1.3	-0.27	1.05	1.31	1.46	1.62
ipb 2/3	0.0658	0.1432	-1.94	-1.39	-1.14	-0.17	1.03	1.34	1.45	1.64
ipb 3/3	0.0985	0.2143	-2.06	-1.36	-1.01	-0.1	1.01	1.34	1.43	1.61
ipb 3/3	0.0984	0.2139	-2.07	-1.37	-1.01	-0.1	1.01	1.34	1.42	1.61
ipb 2/3	0.0658	0.1432	-1.95	-1.42	-1.15	-0.17	1.07	1.34	1.44	1.64
ipb 1/3	0.0322	0.0701	-1.55	-1.42	-1.24	-0.18	1.09	1.3	1.41	1.62
opb 1/3	-0.0172	-0.0525	0	0.48	1.65	3.5	1.93	1.42	-0.19	-1.14
opb 2/3	-0.0355	-0.1086	0.14	0.48	0.97	2.03	1.13	0.82	-0.26	-0.92
opb 3/3	-0.0542	-0.1658	0.15	0.47	0.83	1.58	0.88	0.59	-0.26	-0.81
opb 3/3	-0.0548	-0.1676	0.14	0.48	0.83	1.59	0.9	0.58	-0.27	-0.83
opb 2/3	-0.0365	-0.1117	0.26	0.63	0.99	2.1	1.06	0.61	-0.39	-1.03
opb 1/3	-0.0179	-0.0546	0.52	1	1.95	3.6	1.64	0.56	-0.72	-1.54
axi-c 1/3	-0.0147	-0.0837	2.69	3.11	4.28	3.78	2.68	2.68	2.88	3.13
axi-c 2/3	-0.0293	-0.1668	2.55	2.92	3.94	3.2	2.35	2.56	2.69	2.81
axi-c 3/3	-0.0437	-0.2491	2.31	2.57	3.53	3.03	2.26	2.49	2.73	2.6
axi-c 3/3	-0.0438	-0.2492	2.28	2.58	3.5	3.01	2.26	2.49	2.73	2.59
axi-c 2/3	-0.0292	-0.1663	2.63	3.05	3.93	3.15	2.31	2.54	2.68	2.81
axi-c 1/3	-0.0147	-0.0836	3.16	3.58	4.46	3.23	2.21	1.75	2.18	2.95
axi-t 1/3	0.0148	0.0788	2.6	2.92	3.27	2.27	2.73	1.46	1.51	2.22
axi-t 2/3	0.0296	0.1572	2.63	2.94	2.91	1.95	2.59	1.45	1.37	1.89
axi-t 3/3	0.0441	0.2346	2.58	2.74	2.62	1.76	2.41	1.49	1.37	1.91
axi-t 3/3	0.0442	0.2348	2.6	2.76	2.6	1.79	2.41	1.49	1.37	1.93
axi-t 2/3	0.0293	0.1559	2.69	2.92	2.82	1.9	2.55	1.46	1.38	2.04
axi-t 1/3	0.0146	0.0778	2.36	2.5	2.69	1.87	2.6	1.63	1.8	2.62

Table 0-46: Measured SNCFs on brace intersection of brace and chord for T9

T9	pl. cap	design	BC:1	BI:16	BI:14	BS:13	BI:12	BI:10	BC:9	BI:8
ipb 1/3	0.0326	0.0709	-1.57	-1.37	-1.02	-0.02	1.32	1.62	1.46	1.31
ipb 2/3	0.0658	0.1432	-1.94	-1.35	-0.97	-0.02	1.21	1.64	1.45	1.34
ipb 3/3	0.0985	0.2143	-2.06	-1.31	-0.86	-0.01	1.13	1.61	1.43	1.34
ipb 3/3	0.0984	0.2139	-2.07	-1.3	-0.86	-0.01	1.13	1.61	1.42	1.34
ipb 2/3	0.0658	0.1432	-1.95	-1.34	-1	-0.03	1.23	1.64	1.44	1.34
ipb 1/3	0.0322	0.0701	-1.55	-1.35	-1.07	-0.06	1.28	1.62	1.41	1.3
opb 1/3	-0.0172	-0.0525	0	-0.52	-1.72	-3.48	-1.95	-1.14	-0.19	1.42
opb 2/3	-0.0355	-0.1086	0.14	-0.33	-1.32	-2.65	-1.62	-0.92	-0.26	0.82
opb 3/3	-0.0542	-0.1658	0.15	-0.29	-1.15	-2.21	-1.47	-0.81	-0.26	0.59
opb 3/3	-0.0548	-0.1676	0.14	-0.29	-1.16	-2.21	-1.46	-0.83	-0.27	0.58
opb 2/3	-0.0365	-0.1117	0.26	-0.25	-1.25	-2.65	-1.68	-1.03	-0.39	0.61
opb 1/3	-0.0179	-0.0546	0.52	-0.11	-1.43	-3.54	-2.2	-1.54	-0.72	0.56
axi-c 1/3	-0.0147	-0.0837	2.69	2.7	3.59	2.59	2.42	3.13	2.88	2.68
axi-c 2/3	-0.0293	-0.1668	2.55	2.56	3.36	2.39	2.2	2.81	2.69	2.56
axi-c 3/3	-0.0437	-0.2491	2.31	2.28	2.95	2.07	2.05	2.6	2.73	2.49
axi-c 3/3	-0.0438	-0.2492	2.28	2.3	2.95	2.05	2.05	2.59	2.73	2.49
axi-c 2/3	-0.0292	-0.1663	2.63	2.69	3.44	2.38	2.2	2.81	2.68	2.54
axi-c 1/3	-0.0147	-0.0836	3.16	3.31	4.19	2.98	2.44	2.95	2.18	1.75
axi-t 1/3	0.0148	0.0788	2.6	2.84	4	3.72	3.5	2.22	1.51	1.46
axi-t 2/3	0.0296	0.1572	2.63	2.46	3.02	2.32	2.88	1.89	1.37	1.45
axi-t 3/3	0.0441	0.2346	2.58	2.34	2.72	1.92	2.68	1.91	1.37	1.49
axi-t 3/3	0.0442	0.2348	2.6	2.35	2.71	1.92	2.69	1.93	1.37	1.49
axi-t 2/3	0.0293	0.1559	2.69	2.53	3.21	2.52	3.09	2.04	1.38	1.46
axi-t 1/3	0.0146	0.0778	2.36	2.64	4.18	4.27	4.1	2.62	1.8	1.63

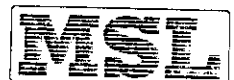

Table M-47: Measured SNCFs on chord intersection of brace and chord for T9

T9	pl. cap	design	CC;1	CI;2	CI;4	CS;5	CI;6	CI;8	CC;9	CI;10
ipb 1/3	0.0326	0.0709	-2.6	-2.47	-1.68	-0.35	1.45	2.64	2.84	2.3
ipb 2/3	0.0658	0.1432	-2.84	-2.33	-1.54	-0.22	1.49	2.84	2.78	2.34
ipb 3/3	0.0985	0.2143	-2.31	-2.11	-1.35	-0.1	1.5	2.86	2.63	2.28
ipb 3/3	0.0984	0.2139	-2.32	-2.12	-1.35	-0.11	1.5	2.86	2.64	2.29
ipb 2/3	0.0658	0.1432	-2.92	-2.36	-1.55	-0.21	1.55	2.88	2.78	2.36
ipb 1/3	0.0322	0.0701	-2.55	-2.44	-1.65	-0.2	1.59	2.67	2.81	2.31
opb 1/3	-0.0172	-0.0525	-0.07	0.74	2.9	7.53	1.79	0.61	-0.45	-0.63
opb 2/3	-0.0355	-0.1086	0	0.91	2.96	5.25	1.01	0.06	-0.74	-0.67
opb 3/3	-0.0542	-0.1658	-0.04	1.01	2.54	4.18	0.78	0	-0.76	-0.69
opb 3/3	-0.0548	-0.1676	-0.04	0.98	2.52	4.2	0.82	0.03	-0.76	-0.69
opb 2/3	-0.0365	-0.1117	0.15	1.11	3.16	5.38	1	-0.03	-0.95	-0.77
opb 1/3	-0.0179	-0.0546	0.67	1.58	3.66	7.94	1.64	-0.06	-1.33	-1.15
axi-c 1/3	-0.0147	-0.0837	8.43	8.22	6.6	5.39	3.87	5.73	7.04	5.19
axi-c 2/3	-0.0293	-0.1668	8.1	7.88	5.82	4.17	2.88	4.49	5.92	4.5
axi-c 3/3	-0.0437	-0.2491	7.62	7.44	5.36	4.06	2.83	4.27	5.63	4.2
axi-c 3/3	-0.0438	-0.2492	7.65	7.45	5.38	4.03	2.84	4.27	5.63	4.21
axi-c 2/3	-0.0292	-0.1663	8.31	8.19	5.94	4.11	2.9	4.59	6.01	4.62
axi-c 1/3	-0.0147	-0.0836	9.28	9.38	7.16	4.23	2.91	4.61	6.67	5.53
axi-t 1/3	0.0148	0.0788	7.93	6.39	3.41	2.44	6.24	6.52	6.62	4.65
axi-t 2/3	0.0296	0.1572	7.68	6.36	3.04	2.4	6.53	6.78	6.21	4.34
axi-t 3/3	0.0441	0.2346	7.43	6.07	2.82	2.28	6.06	6.74	6.12	4.41
axi-t 3/3	0.0442	0.2348	7.42	6.08	2.85	2.31	6.06	6.73	6.12	4.39
axi-t 2/3	0.0293	0.1559	7.77	6.3	2.91	2.24	6.5	6.92	6.33	4.36
axi-t 1/3	0.0146	0.0778	7.23	5.64	2.79	1.75	6.2	7.1	7.15	4.97

Table M-48: Measured SNCFs on chord intersection of brace and chord for T9

T9	pl. cap	design	CC;1	CI;16	CI;14	CS;13	CI;12	CI;10	CC;9	CI;8
ipb 1/3	0.0326	0.0709	-2.6	-2.53	-1.62	0.01	1.39	2.3	2.84	2.64
ipb 2/3	0.0658	0.1432	-2.84	-2.38	-1.35	-0.01	1.15	2.34	2.78	2.84
ipb 3/3	0.0985	0.2143	-2.31	-2.07	-1.15	0.02	1.05	2.28	2.63	2.86
ipb 3/3	0.0984	0.2139	-2.32	-2.07	-1.12	0.03	1.05	2.29	2.64	2.86
ipb 2/3	0.0658	0.1432	-2.92	-2.39	-1.35	-0.03	1.1	2.36	2.78	2.88
ipb 1/3	0.0322	0.0701	-2.55	-2.51	-1.45	-0.01	1.34	2.31	2.81	2.67
opb 1/3	-0.0172	-0.0525	-0.07	-0.68	-2.54	-7.45	-2.32	-0.63	-0.45	0.61
opb 2/3	-0.0355	-0.1086	0	-0.62	-2.28	-5.63	-1.83	-0.67	-0.74	0.06
opb 3/3	-0.0542	-0.1658	-0.04	-0.66	-2.22	-4.81	-1.71	-0.69	-0.76	0
opb 3/3	-0.0548	-0.1676	-0.04	-0.64	-2.22	-4.82	-1.7	-0.69	-0.76	0.03
opb 2/3	-0.0365	-0.1117	0.15	-0.46	-2.18	-5.71	-1.86	-0.77	-0.95	-0.03
opb 1/3	-0.0179	-0.0546	0.67	0.05	-2.08	-7.55	-2.45	-1.15	-1.33	-0.06
axi-c 1/3	-0.0147	-0.0837	8.43	7.83	4.32	2.73	4.11	5.19	7.04	5.73
axi-c 2/3	-0.0293	-0.1668	8.1	7.45	3.92	2.52	3.76	4.5	5.92	4.49
axi-c 3/3	-0.0437	-0.2491	7.62	6.85	3.46	2.05	3.44	4.2	5.63	4.27
axi-c 3/3	-0.0438	-0.2492	7.65	6.88	3.55	2.05	3.43	4.21	5.63	4.27
axi-c 2/3	-0.0292	-0.1663	8.31	7.68	4.13	2.51	3.96	4.62	6.01	4.59
axi-c 1/3	-0.0147	-0.0836	9.28	8.6	5.15	3.66	4.87	5.53	6.67	4.61
axi-t 1/3	0.0148	0.0788	7.93	8.42	6.74	5.95	4.78	4.65	6.62	6.52
axi-t 2/3	0.0296	0.1572	7.68	7.83	5.33	3.59	3.97	4.34	6.21	6.78
axi-t 3/3	0.0441	0.2346	7.43	7.46	4.99	2.99	3.86	4.41	6.12	6.74
axi-t 3/3	0.0442	0.2348	7.42	7.47	5	2.98	3.85	4.39	6.12	6.73
axi-t 2/3	0.0293	0.1559	7.77	8	5.72	3.78	4.2	4.36	6.33	6.92
axi-t 1/3	0.0146	0.0778	7.23	8.04	7.25	7.05	5.24	4.97	7.15	7.1



Table M-49: Measured SNCFs on brace intersection of brace and chord for T9 at preload level of 50%

T9	pl. cap	design	BC:1	BI:2	BI:4	BS:5	BI:6	BI:8	BC:9	BI:10
ipb 1/3	0.0333	0.0724	-1.63	-1.4	-1.18	-0.11	1.14	1.26	1.4	1.53
ipb 2/3	0.0663	0.1442	-1.89	-1.39	-1.09	-0.08	1.09	1.32	1.4	1.58
ipb 3/3	0.0992	0.2158	-2.05	-1.38	-0.99	-0.05	1.03	1.34	1.41	1.58
ipb 3/3	0.0988	0.2148	-2.06	-1.39	-1	-0.05	1.03	1.35	1.42	1.59
ipb 2/3	0.0662	0.1439	-1.91	-1.44	-1.13	-0.08	1.12	1.34	1.42	1.62
ipb 1/3	0.032	0.0696	-1.65	-1.48	-1.21	-0.14	1.15	1.28	1.44	1.56
opb 1/3	-0.0163	-0.0499	0.03	0.53	1.34	3.2	1.66	0.81	-0.09	-0.74
opb 2/3	-0.0346	-0.1058	0.11	0.51	0.78	2	1.02	0.61	-0.2	-0.69
opb 3/3	-0.0533	-0.1631	0.11	0.48	0.7	1.54	0.81	0.49	-0.2	-0.65
opb 3/3	-0.0545	-0.1668	0.13	0.48	0.72	1.57	0.83	0.49	-0.19	-0.68
opb 2/3	-0.0363	-0.111	0.25	0.62	0.87	2.03	0.97	0.45	-0.26	-0.82
opb 1/3	-0.0173	-0.0528	0.48	0.93	1.65	3.37	1.39	0.22	-0.54	-1.18
axi-c 1/3	-0.0147	-0.0836	2.9	3	4.37	4.13	3.31	2.27	2.36	2.77
axi-c 2/3	-0.0292	-0.1663	2.72	2.8	3.95	3.41	2.91	2.08	2.51	2.82
axi-c 3/3	-0.0437	-0.249	2.44	2.43	3.38	2.99	2.72	2.31	2.95	2.87
axi-c 3/3	-0.0437	-0.249	2.44	2.43	3.35	2.97	2.69	2.31	2.95	2.88
axi-c 2/3	-0.0292	-0.1661	2.78	2.9	4.02	3.32	2.91	2.04	2.43	2.8
axi-c 1/3	-0.0146	-0.0832	3.37	3.36	4.34	3.3	2.68	1.78	1.74	2.53
axi-t 1/3	0.0151	0.0801	2.19	2.4	2.69	1.9	2.52	1.58	1.75	2.59
axi-t 2/3	0.0297	0.158	2.36	2.67	2.51	1.73	2.48	1.56	1.55	2.27
axi-t 3/3	0.0444	0.2359	2.61	2.82	2.6	1.79	2.47	1.62	1.44	2.05
axi-t 3/3	0.0443	0.2358	2.71	2.92	2.68	1.78	2.39	1.54	1.35	1.96
axi-t 2/3	0.0296	0.1575	2.7	2.99	2.72	1.73	2.38	1.37	1.33	1.96
axi-t 1/3	0.0149	0.0792	2.65	2.72	2.78	1.74	2.12	1.23	1.42	2.39

Table M-50: Measured SNCFs on brace intersection of brace and chord for T9 at preload level of 50%

T9	pl. cap	design	BC:1	BI:16	BI:14	BS:13	BI:12	BI:10	BC:9	BI:8
ipb 1/3	0.0333	0.0724	-1.63	-1.4	-0.97	0.05	1.32	1.53	1.4	1.26
ipb 2/3	0.0663	0.1442	-1.89	-1.35	-0.94	0.03	1.22	1.58	1.4	1.32
ipb 3/3	0.0992	0.2158	-2.05	-1.31	-0.84	0.04	1.15	1.58	1.41	1.34
ipb 3/3	0.0988	0.2148	-2.06	-1.31	-0.85	0.04	1.15	1.59	1.42	1.35
ipb 2/3	0.0662	0.1439	-1.91	-1.37	-0.95	0.05	1.25	1.62	1.42	1.34
ipb 1/3	0.032	0.0696	-1.65	-1.38	-1.02	0.12	1.35	1.56	1.44	1.28
opb 1/3	-0.0163	-0.0499	0.03	-0.58	-1.67	-3.33	-1.81	-0.74	-0.09	0.81
opb 2/3	-0.0346	-0.1058	0.11	-0.39	-1.27	-2.46	-1.52	-0.69	-0.2	0.61
opb 3/3	-0.0533	-0.1631	0.11	-0.32	-1.11	-2.06	-1.36	-0.65	-0.2	0.49
opb 3/3	-0.0545	-0.1668	0.13	-0.32	-1.09	-2.06	-1.33	-0.68	-0.19	0.49
opb 2/3	-0.0363	-0.111	0.25	-0.33	-1.19	-2.45	-1.52	-0.82	-0.26	0.45
opb 1/3	-0.0173	-0.0528	0.48	-0.2	-1.39	-3.29	-2.11	-1.18	-0.54	0.22
axi-c 1/3	-0.0147	-0.0836	2.9	2.85	3.64	2.94	3.23	2.77	2.36	2.27
axi-c 2/3	-0.0292	-0.1663	2.72	2.59	3.49	2.6	3.03	2.82	2.51	2.08
axi-c 3/3	-0.0437	-0.249	2.44	2.21	3	2.09	2.83	2.87	2.95	2.31
axi-c 3/3	-0.0437	-0.249	2.44	2.18	3	2.08	2.81	2.88	2.95	2.31
axi-c 2/3	-0.0292	-0.1661	2.78	2.63	3.59	2.63	3.14	2.8	2.43	2.04
axi-c 1/3	-0.0146	-0.0832	3.37	3.28	4.23	3.49	3.24	2.53	1.74	1.78
axi-t 1/3	0.0151	0.0801	2.19	2.76	4.05	4.05	3.98	2.59	1.75	1.58
axi-t 2/3	0.0297	0.158	2.36	2.53	3.21	2.67	3.22	2.27	1.55	1.56
axi-t 3/3	0.0444	0.2359	2.61	2.5	2.88	2.17	2.87	2.05	1.44	1.62
axi-t 3/3	0.0443	0.2358	2.71	2.61	2.91	2.22	2.81	1.96	1.35	1.54
axi-t 2/3	0.0296	0.1575	2.7	2.86	3.38	2.72	3.02	1.96	1.33	1.37
axi-t 1/3	0.0149	0.0792	2.65	3.13	4.6	4.62	3.95	2.39	1.42	1.23

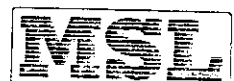

Table M-51: Measured SNCFs on chord intersection of brace and chord for T9 at preload level of 50%

T9	pl. cap	design	CC:1	CI:2	CI:4	CS:5	CI:6	CI:8	CC:9	CI:10
ipb 1/3	0.0333	0.0724	-2.74	-2.41	-1.5	-0.07	1.63	2.53	2.78	2.19
ipb 2/3	0.0663	0.1442	-2.87	-2.34	-1.41	-0.05	1.6	2.8	2.73	2.32
ipb 3/3	0.0992	0.2158	-2.42	-2.17	-1.3	0.02	1.53	2.87	2.64	2.28
ipb 3/3	0.0988	0.2148	-2.43	-2.18	-1.3	0	1.52	2.89	2.66	2.3
ipb 2/3	0.0662	0.1439	-2.94	-2.42	-1.48	-0.08	1.63	2.88	2.81	2.39
ipb 1/3	0.032	0.0696	-2.75	-2.49	-1.57	-0.19	1.69	2.62	2.88	2.33
opb 1/3	-0.0163	-0.0499	-0.11	0.83	3.07	7.48	1.28	0.27	-0.44	-0.47
opb 2/3	-0.0346	-0.1058	-0.09	1.04	3.07	5.31	0.8	0.08	-0.64	-0.58
opb 3/3	-0.0533	-0.1631	-0.09	1.16	2.6	4.27	0.63	0.01	-0.68	-0.62
opb 3/3	-0.0545	-0.1668	-0.09	1.18	2.57	4.28	0.66	0.03	-0.65	-0.61
opb 2/3	-0.0363	-0.111	0.12	1.31	3.15	5.34	0.76	-0.06	-0.78	-0.65
opb 1/3	-0.0173	-0.0528	0.61	1.74	3.75	7.76	0.98	-0.39	-1.14	-0.92
axi-c 1/3	-0.0147	-0.0836	9.08	7.97	6.53	5.66	4.67	6.25	8.74	6.58
axi-c 2/3	-0.0292	-0.1663	8.97	8.2	6.27	4.31	3.95	5.82	8.07	6.01
axi-c 3/3	-0.0437	-0.249	8.43	7.88	5.77	3.78	4	5.72	7.56	5.54
axi-c 3/3	-0.0437	-0.249	8.43	7.86	5.75	3.78	3.97	5.71	7.58	5.57
axi-c 3/3	-0.0437	-0.249	8.43	7.86	5.75	3.78	3.97	5.71	7.58	5.57
axi-c 2/3	-0.0292	-0.1661	9	8.36	6.37	4.07	4.03	6.02	8.32	6.37
axi-c 1/3	-0.0146	-0.0832	9.55	8.9	7.18	4.08	3.5	5.13	7.9	7.07
axi-t 1/3	0.0151	0.0801	7.02	5.63	2.89	2.74	5.98	7.09	7.46	5.1
axi-t 2/3	0.0297	0.158	7.29	6.09	2.67	2.35	6.35	7.46	7.12	4.87
axi-t 3/3	0.0444	0.2359	7.64	6.48	3.03	2.3	6.14	7.48	7.02	4.94
axi-t 3/3	0.0443	0.2358	7.83	6.69	3.13	2.31	5.98	7.31	6.85	4.84
axi-t 2/3	0.0296	0.1575	7.92	6.7	2.88	2.38	6.23	7.1	6.73	4.44
axi-t 1/3	0.0149	0.0792	7.78	6.34	2.82	2.47	5.83	6.77	6.93	4.67

Table M-52: Measured SNCFs on chord intersection of brace and chord for T9 at preload level of 50%

T9	pl. cap	design	CC:1	CI:16	CI:14	CS:13	CI:12	CI:10	CC:9	CI:8
ipb 1/3	0.0333	0.0724	-2.74	-2.57	-1.35	0.06	1.29	2.19	2.78	2.53
ipb 2/3	0.0663	0.1442	-2.87	-2.37	-1.23	0.06	1.11	2.32	2.73	2.8
ipb 3/3	0.0992	0.2158	-2.42	-2.1	-1.1	0.09	1.01	2.28	2.64	2.87
ipb 3/3	0.0988	0.2148	-2.43	-2.12	-1.08	0.11	1.02	2.3	2.66	2.89
ipb 2/3	0.0662	0.1439	-2.94	-2.4	-1.2	0.08	1.11	-2.39	2.81	2.88
ipb 1/3	0.032	0.0696	-2.75	-2.57	-1.3	0.2	1.41	2.33	2.88	2.62
opb 1/3	-0.0163	-0.0499	-0.11	-0.94	-2.71	-7.06	-2.28	-0.47	-0.44	0.27
opb 2/3	-0.0346	-0.1058	-0.09	-0.84	-2.4	-5.31	-1.71	-0.58	-0.64	0.08
opb 3/3	-0.0533	-0.1631	-0.09	-0.84	-2.32	-4.59	-1.58	-0.62	-0.68	0.01
opb 3/3	-0.0545	-0.1668	-0.09	-0.82	-2.34	-4.58	-1.56	-0.61	-0.65	0.03
opb 2/3	-0.0363	-0.111	0.12	-0.71	-2.32	-5.36	-1.67	-0.65	-0.78	-0.06
opb 1/3	-0.0173	-0.0528	0.61	-0.32	-2.5	-7.09	-2.36	-0.92	-1.14	-0.39
axi-c 1/3	-0.0147	-0.0836	9.08	8.24	4.38	3.1	4.96	6.58	8.74	6.25
axi-c 2/3	-0.0292	-0.1663	8.97	7.9	4.1	2.4	4.75	6.01	8.07	5.82
axi-c 3/3	-0.0437	-0.249	8.43	7.22	3.69	1.68	4.46	5.54	7.56	5.72
axi-c 3/3	-0.0437	-0.249	8.43	7.22	3.69	1.65	4.48	5.57	7.58	5.71
axi-c 3/3	-0.0437	-0.249	8.43	7.22	3.69	1.65	4.48	5.57	7.58	5.71
axi-c 2/3	-0.0292	-0.1661	9	8.01	4.2	2.35	5.22	6.37	8.32	6.02
axi-c 1/3	-0.0146	-0.0832	9.55	8.76	5.08	4.12	6.12	7.07	7.9	5.13
axi-t 1/3	0.0151	0.0801	7.02	8.19	6.6	6.78	4.92	5.1	7.46	7.09
axi-t 2/3	0.0297	0.158	7.29	8.11	5.95	4.15	4.1	4.87	7.12	7.46
axi-t 3/3	0.0444	0.2359	7.64	8.16	5.47	3.28	3.88	4.94	7.02	7.48
axi-t 3/3	0.0443	0.2358	7.83	8.32	5.63	3.28	3.86	4.84	6.85	7.31
axi-t 2/3	0.0296	0.1575	7.92	8.83	6.39	4.13	3.82	4.44	6.73	7.1
axi-t 1/3	0.0149	0.0792	7.78	9.09	7.94	7.66	4.95	4.67	6.93	6.77

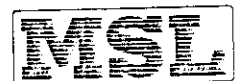

Table M-53: Measured SNCFs on brace intersection of brace and chord for T9 at preload level of 100 %

T9	pl. cap	design	BC;1	BI;2	BI;4	BS;5	BI;6	BI;8	BC;9	BI;10
ipb 1/3	0.0317	0.069	-1.52	-1.32	-1.01	-0.05	0.91	1.01	1.42	1.53
ipb 2/3	0.0648	0.141	-1.75	-1.34	-0.98	-0.07	0.98	1.11	1.44	1.53
ipb 3/3	0.0979	0.2129	-1.92	-1.33	-0.89	-0.05	0.93	1.21	1.45	1.54
ipb 3/3	0.0975	0.2121	-1.92	-1.33	-0.89	-0.06	0.92	1.24	1.45	1.55
ipb 2/3	0.0653	0.1421	-1.64	-1.33	-0.98	-0.08	0.97	1.11	1.38	1.51
ipb 1/3	0.0312	0.0678	-1.48	-1.3	-0.97	-0.06	0.87	1.08	1.38	1.42
opb 1/3	-0.0173	-0.053	-0.09	0.54	0.53	1.12	0.53	0.59	0.04	-0.56
opb 2/3	-0.0359	-0.1098	0.07	0.59	0.34	0.9	0.41	0.62	-0.08	-0.65
opb 3/3	-0.055	-0.1682	0.09	0.56	0.35	0.76	0.38	0.54	-0.15	-0.68
opb 3/3	-0.0551	-0.1686	0.09	0.57	0.35	0.78	0.37	0.54	-0.14	-0.69
opb 2/3	-0.0364	-0.1115	0.16	0.7	0.37	0.92	0.31	0.46	-0.18	-0.78
opb 1/3	-0.0179	-0.0546	0.35	0.94	0.72	1.25	0.2	0.16	-0.36	-0.97
axi-c 1/3	-0.0146	-0.083	3.55	3.49	3.46	1.97	1.84	1.43	1.3	1.52
axi-c 2/3	-0.0292	-0.1663	3.09	2.97	3.15	1.93	2	1.74	1.86	1.99
axi-c 3/3	-0.0437	-0.2491	2.88	2.64	2.84	1.94	2.14	2.08	2.36	2.33
axi-c 3/3	-0.0437	-0.2491	2.88	2.64	2.84	1.94	2.14	2.06	2.36	2.37
axi-c 2/3	-0.0291	-0.1659	3.09	2.99	3.19	1.91	2.06	1.68	1.86	2.07
axi-c 1/3	-0.0146	-0.0834	3.94	3.59	3.65	1.68	1.71	1.18	1.05	1.52
axi-t 1/3	0.0151	0.0805	3.07	3.04	2.95	1.36	1.76	1.15	1.35	1.75
axi-t 2/3	0.0297	0.1582	2.97	2.96	2.94	1.61	2.04	1.2	1.53	1.85
axi-t 3/3	0.0445	0.2366	2.67	2.7	2.72	1.67	2.16	1.41	1.71	2.12
axi-t 3/3	0.0446	0.2369	2.69	2.67	2.73	1.66	2.15	1.44	1.69	2.12
axi-t 2/3	0.0298	0.1585	2.77	2.69	2.82	1.45	2.02	1.29	1.64	1.88
axi-t 1/3	0.015	0.0799	2.61	2.43	2.56	0.98	1.82	1.34	1.84	2.09

Table M-54: Measured SNCFs on brace intersection of brace and chord for T9 at preload level of 100 %

T9	pl. cap	design	BC;1	BI;16	BI;14	BS;13	BI;12	BI;10	BC;9	BI;8
ipb 1/3	0.0317	0.069	-1.52	-1.23	-0.79	0.05	1.12	1.53	1.42	1.01
ipb 2/3	0.0648	0.141	-1.75	-1.19	-0.8	0	1.05	1.53	1.44	1.11
ipb 3/3	0.0979	0.2129	-1.92	-1.15	-0.76	0	1.01	1.54	1.45	1.21
ipb 3/3	0.0975	0.2121	-1.92	-1.14	-0.77	-0.01	1.02	1.55	1.45	1.24
ipb 2/3	0.0653	0.1421	-1.64	-1.18	-0.83	-0.02	1.08	1.51	1.38	1.11
ipb 1/3	0.0312	0.0678	-1.48	-1.18	-0.82	0.02	1.07	1.42	1.38	1.08
opb 1/3	-0.0173	-0.053	-0.09	-0.44	-0.84	-1.68	-0.95	-0.56	0.04	0.59
opb 2/3	-0.0359	-0.1098	0.07	-0.39	-0.88	-1.61	-1.02	-0.65	-0.08	0.62
opb 3/3	-0.055	-0.1682	0.09	-0.36	-0.84	-1.51	-1.02	-0.68	-0.15	0.54
opb 3/3	-0.0551	-0.1686	0.09	-0.37	-0.85	-1.53	-1.02	-0.69	-0.14	0.54
opb 2/3	-0.0364	-0.1115	0.16	-0.3	-0.84	-1.63	-1.1	-0.78	-0.18	0.46
opb 1/3	-0.0179	-0.0546	0.35	-0.14	-0.69	-1.82	-1.2	-0.97	-0.36	0.16
axi-c 1/3	-0.0146	-0.083	3.55	3.11	3.49	1.25	2.25	1.52	1.3	1.43
axi-c 2/3	-0.0292	-0.1663	3.09	2.65	3.06	1.4	2.44	1.99	1.86	1.74
axi-c 3/3	-0.0437	-0.2491	2.88	2.28	2.74	1.38	2.44	2.33	2.36	2.08
axi-c 3/3	-0.0437	-0.2491	2.88	2.28	2.74	1.38	2.44	2.37	2.36	2.06
axi-c 2/3	-0.0291	-0.1659	3.09	2.64	3.11	1.5	2.54	2.07	1.86	1.68
axi-c 1/3	-0.0146	-0.0834	3.94	3.44	3.7	1.5	2.34	1.52	1.05	1.18
axi-t 1/3	0.0151	0.0805	3.07	2.73	2.97	1.58	2.23	1.75	1.35	1.15
axi-t 2/3	0.0297	0.1582	2.97	2.62	2.72	1.55	2.21	1.85	1.53	1.2
axi-t 3/3	0.0445	0.2366	2.67	2.35	2.53	1.58	2.28	2.12	1.71	1.41
axi-t 3/3	0.0446	0.2369	2.69	2.33	2.53	1.58	2.28	2.12	1.69	1.44
axi-t 2/3	0.0298	0.1585	2.77	2.37	2.65	1.48	2.17	1.88	1.64	1.29
axi-t 1/3	0.015	0.0799	2.61	2.27	2.72	1.54	2.41	2.09	1.84	1.34

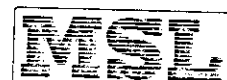
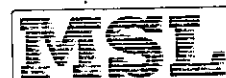

Table M-55: Measured SNCFs on chord intersection of brace and chord for T9 at preload level of 100 %

T9	pl. cap	design	CC;1	CI;2	CI;4	CS;5	CI;6	CI;8	CC;9	CI;10
ipb 1/3	0.0317	0.069	-2.54	-2.2	-1.22	-0.04	1.21	2.13	2.68	2.13
ipb 2/3	0.0648	0.141	-2.49	-2.21	-1.28	-0.01	1.39	2.4	2.66	2.21
ipb 3/3	0.0979	0.2129	-2.13	-2.09	-1.2	0.02	1.37	2.54	2.62	2.16
ipb 3/3	0.0975	0.2121	-2.17	-2.11	-1.2	0.01	1.37	2.54	2.63	2.19
ipb 2/3	0.0653	0.1421	-2.53	-2.24	-1.29	-0.05	1.41	2.31	2.6	2.13
ipb 1/3	0.0312	0.0678	-2.38	-2.12	-1.26	-0.07	1.2	2.05	2.49	2.11
opb 1/3	-0.0173	-0.053	-0.35	0.96	2.36	2.38	0.69	-0.05	-0.2	-0.76
opb 2/3	-0.0359	-0.1098	-0.27	1.09	2.63	2.06	0.5	-0.19	-0.51	-0.72
opb 3/3	-0.055	-0.1682	-0.25	1.15	2.43	1.98	0.42	-0.21	-0.67	-0.74
opb 3/3	-0.0551	-0.1686	-0.24	1.17	2.44	1.99	0.43	-0.22	-0.7	-0.72
opb 2/3	-0.0364	-0.1115	-0.08	1.35	2.75	2.18	0.4	-0.36	-0.77	-0.83
opb 1/3	-0.0179	-0.0546	0.37	1.66	2.95	2.68	0.28	-0.7	-1.06	-1.18
axi-c 1/3	-0.0146	-0.083	10.17	9.41	6.39	3.54	3.76	5.38	7.27	5.54
axi-c 2/3	-0.0292	-0.1663	9.39	8.54	5.85	3.07	3.78	5.42	7.3	5.62
axi-c 3/3	-0.0437	-0.2491	8.46	7.86	5.35	2.81	3.84	5.4	7	5.28
axi-c 3/3	-0.0437	-0.2491	8.49	7.83	5.34	2.82	3.84	5.42	7	5.29
axi-c 2/3	-0.0291	-0.1659	9.33	8.45	5.89	2.97	3.93	5.64	7.54	5.88
axi-c 1/3	-0.0146	-0.0834	10.39	9.54	6.78	3.05	3.23	4.84	6.82	5.68
axi-t 1/3	0.0151	0.0805	8.9	7	3.52	1.94	4.67	6.17	7.12	4.58
axi-t 2/3	0.0297	0.1582	8.63	6.98	3.37	2.07	5.15	6.65	7.45	4.7
axi-t 3/3	0.0445	0.2366	8.01	6.61	3.2	1.97	5.08	6.98	7.72	5.2
axi-t 3/3	0.0446	0.2369	7.99	6.59	3.19	1.97	5.08	6.97	7.7	5.21
axi-t 2/3	0.0298	0.1585	8.13	6.43	3.13	2.04	5.27	6.68	7.53	4.61
axi-t 1/3	0.015	0.0799	7.77	5.93	2.76	1.76	4.98	6.38	7.65	4.86

Table M-56: Measured SNCFs on chord intersection of brace and chord for T9 at preload level of 100 %

T9	pl. cap	design	CC;1	CI;16	CI;14	CS;13	CI;12	CI;10	CC;9	CI;8
ipb 1/3	0.0317	0.069	-2.54	-2.46	-1.26	0.01	1.3	2.13	2.68	2.13
ipb 2/3	0.0648	0.141	-2.49	-2.34	-1.12	0.09	1.08	2.21	2.66	2.4
ipb 3/3	0.0979	0.2129	-2.13	-2.12	-1.02	0.13	0.92	2.16	2.62	2.54
ipb 3/3	0.0975	0.2121	-2.17	-2.13	-1.03	0.16	0.91	2.19	2.63	2.54
ipb 2/3	0.0653	0.1421	-2.53	-2.3	-1.15	0.12	1.03	2.13	2.6	2.31
ipb 1/3	0.0312	0.0678	-2.38	-2.34	-1.33	0.12	1.19	2.11	2.49	2.05
opb 1/3	-0.0173	-0.053	-0.35	-1.28	-2.03	-3.8	-1.34	-0.76	-0.2	-0.05
opb 2/3	-0.0359	-0.1098	-0.27	-1.16	-2.1	-3.74	-1.18	-0.72	-0.51	-0.19
opb 3/3	-0.055	-0.1682	-0.25	-1.01	-2.02	-3.56	-1.17	-0.74	-0.67	-0.21
opb 3/3	-0.0551	-0.1686	-0.24	-1	-2.02	-3.59	-1.19	-0.72	-0.7	-0.22
opb 2/3	-0.0364	-0.1115	-0.08	-0.89	-2.01	-3.78	-1.19	-0.83	-0.77	-0.36
opb 1/3	-0.0179	-0.0546	0.37	-0.64	-1.92	-3.99	-1.49	-1.18	-1.06	-0.7
axi-c 1/3	-0.0146	-0.083	10.17	9.04	4.56	0.65	4.1	5.54	7.27	5.38
axi-c 2/3	-0.0292	-0.1663	9.39	7.98	3.85	0.93	4.3	5.62	7.3	5.42
axi-c 3/3	-0.0437	-0.2491	8.46	7.24	3.56	0.91	4.19	5.28	7	5.4
axi-c 3/3	-0.0437	-0.2491	8.49	7.26	3.56	0.91	4.16	5.29	7	5.42
axi-c 2/3	-0.0291	-0.1659	9.33	8.01	4.16	1.11	4.62	5.88	7.54	5.64
axi-c 1/3	-0.0146	-0.0834	10.39	9.43	4.69	1.39	4.82	5.68	6.82	4.84
axi-t 1/3	0.0151	0.0805	8.9	9.32	5.87	2.21	2.64	4.58	7.12	6.17
axi-t 2/3	0.0297	0.1582	8.63	8.96	5.69	2.17	2.69	4.7	7.45	6.65
axi-t 3/3	0.0445	0.2366	8.01	8.17	5.04	2.09	2.81	5.2	7.72	6.98
axi-t 3/3	0.0446	0.2369	7.99	8.13	5.05	2.07	2.81	5.21	7.7	6.97
axi-t 2/3	0.0298	0.1585	8.13	8.42	5.76	2.28	2.78	4.61	7.53	6.68
axi-t 1/3	0.015	0.0799	7.77	8.22	5.9	2.52	3.14	4.86	7.65	6.38



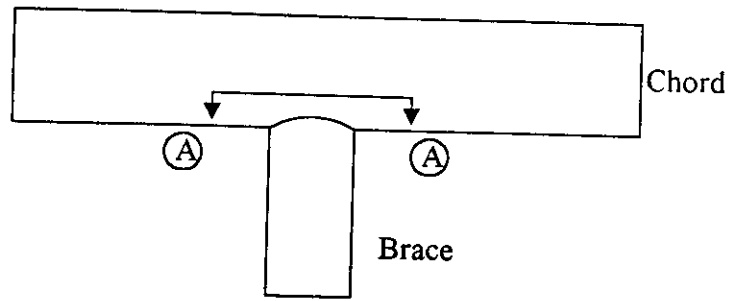

Elevation on T Joint
Saddle

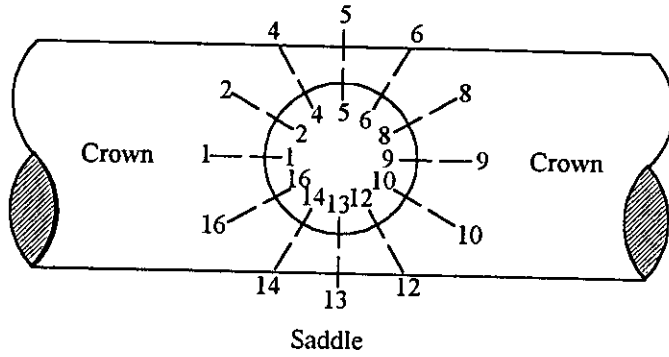

View 'A' on brace

APPENDIX M 14 UngROUTED/GROUTED SNCF Plots.

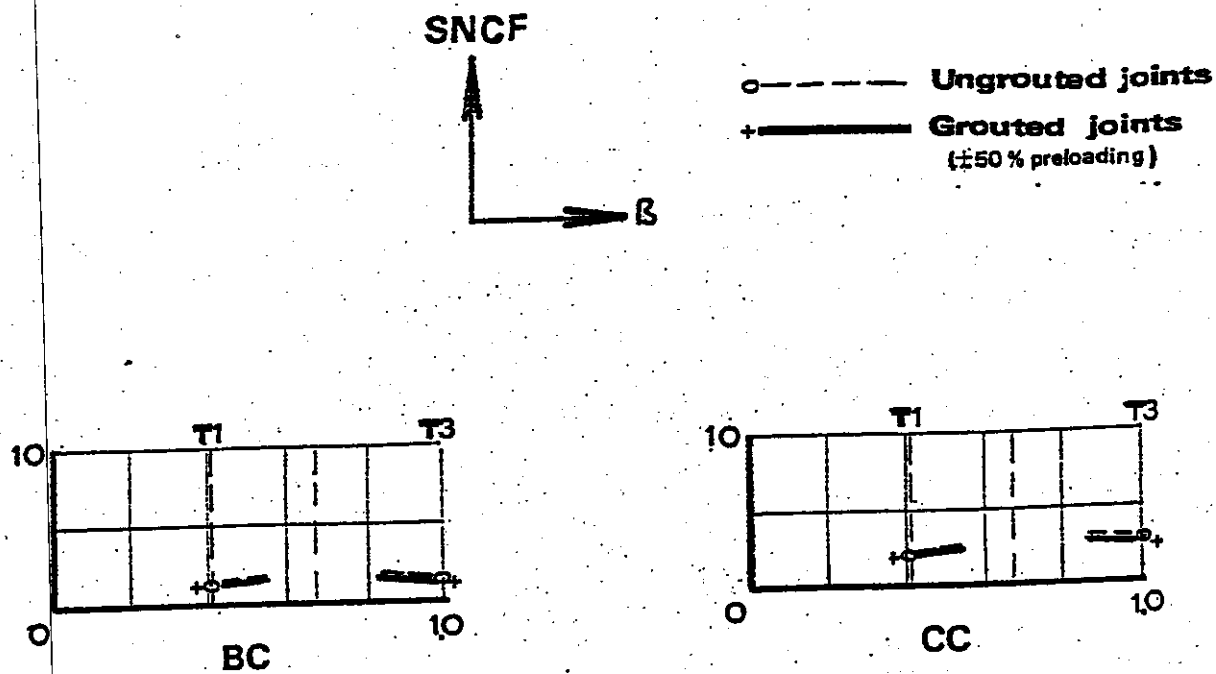

Figure M-1: SNCFs for T-joints with $\gamma = 12.7$ for in-plane bending at crown

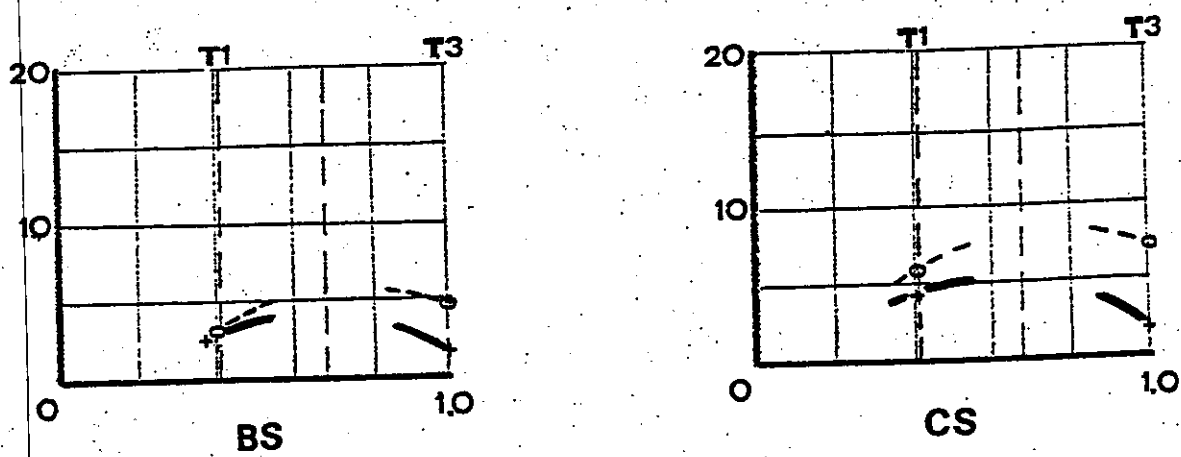

Figure M-2: SNCFs for T-joints with $\gamma = 12.7$ for out-plane bending at saddle

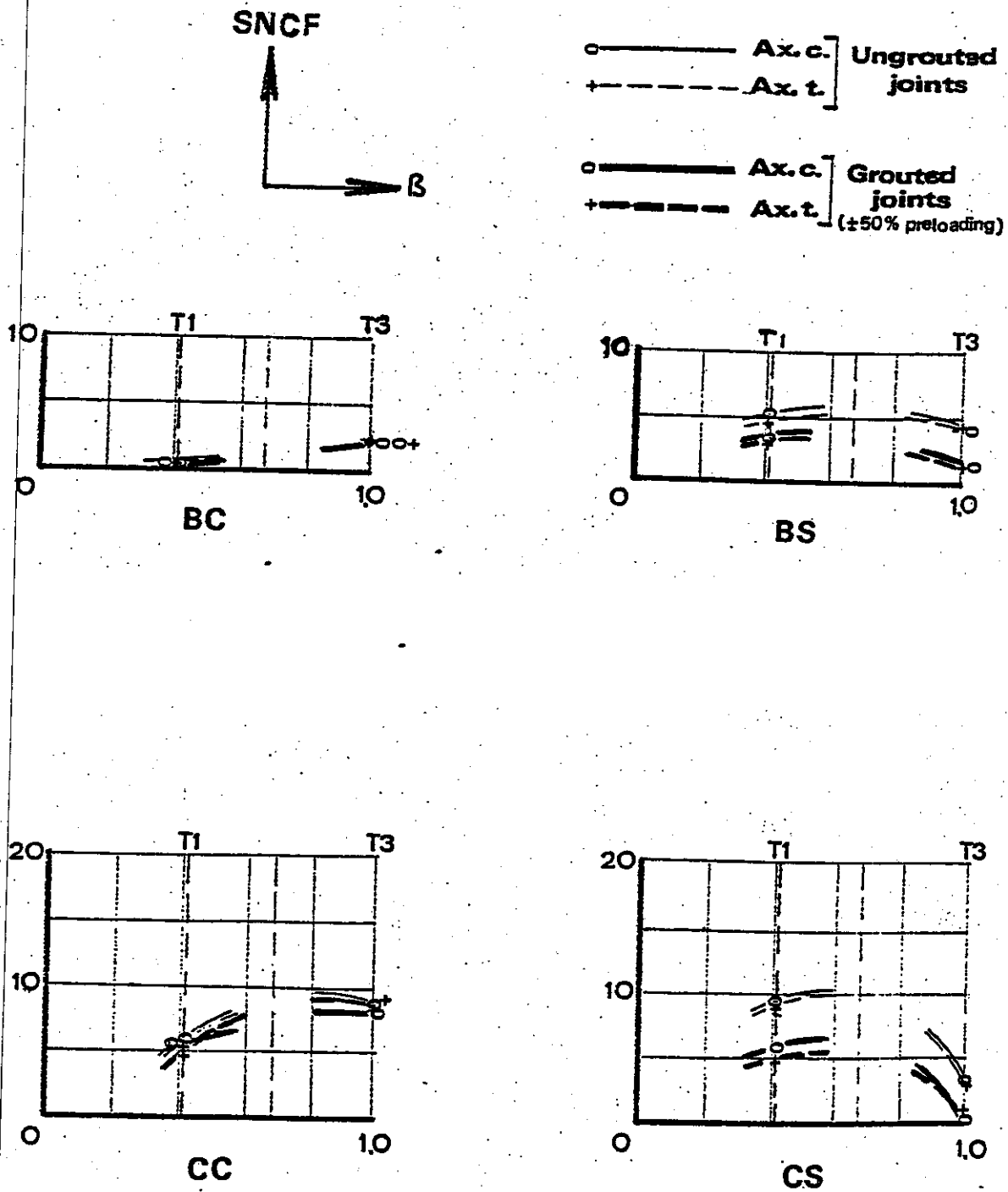

Figure M-3: SNCFs for T-joints with $\gamma=12.7$ for axial loads at the crown and saddle.

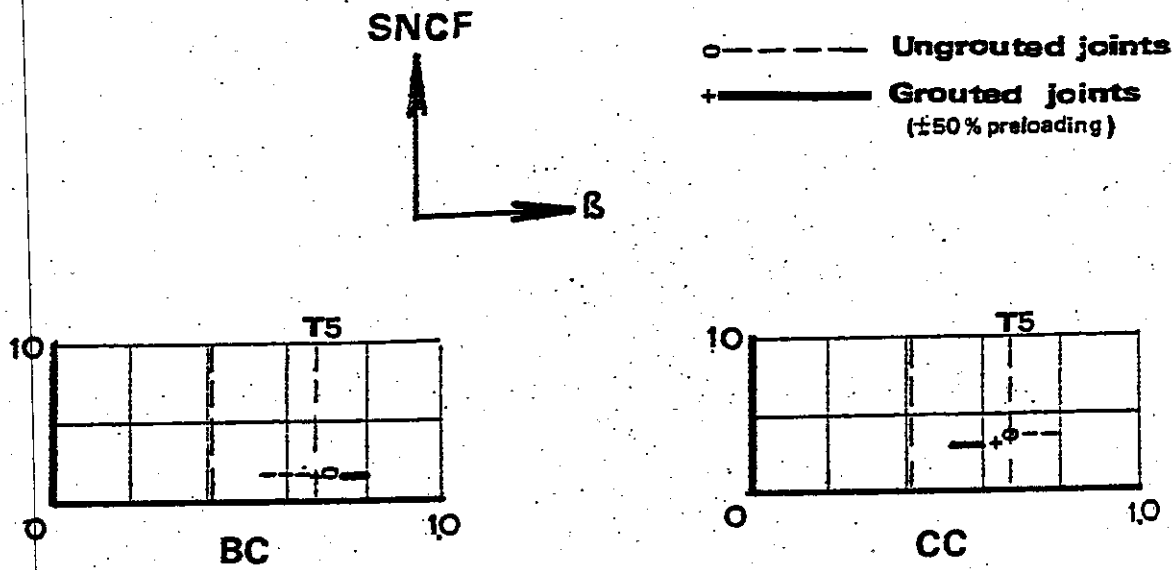

Figure M-4: SNCFs for T-joints with $\gamma=20.3$ for in-plane bending at crown.

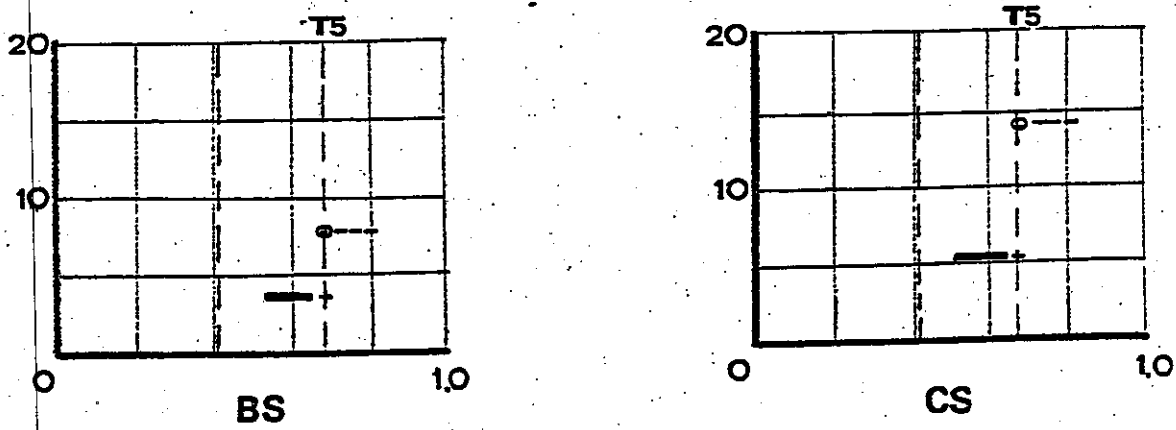

Figure M-5: SNCFs for T-joints with $\gamma=20.3$ for out-of-plane bending at saddle.

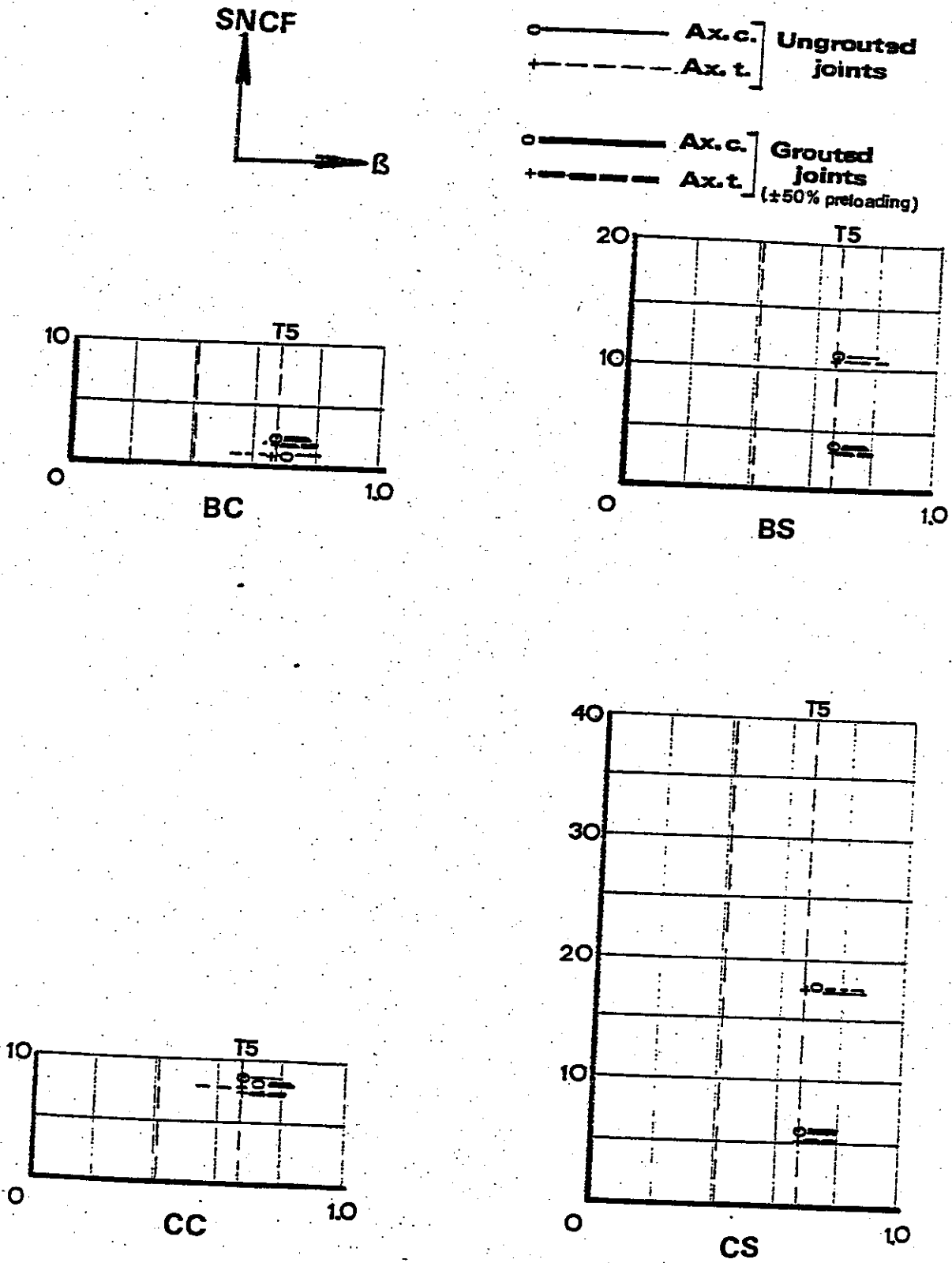

Figure M-6: SNCFs for T-joints with $\gamma=20.3$ for axial loads at crown and saddle.

SNCF



○ - - - - - UngROUTed joints
+ - - - - - Grouted joints
(±50% preloading)

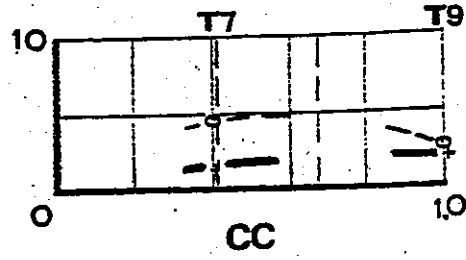
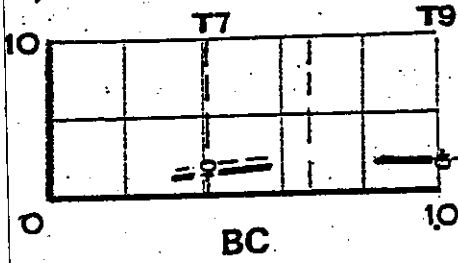

Figure M-7: SNCFs for T-joints with $\gamma = 25.7$ for in-plane bending at crown.

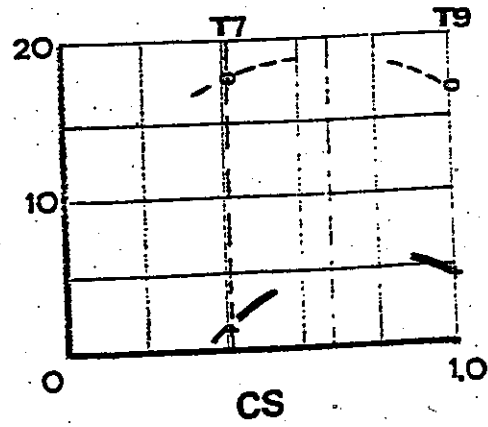
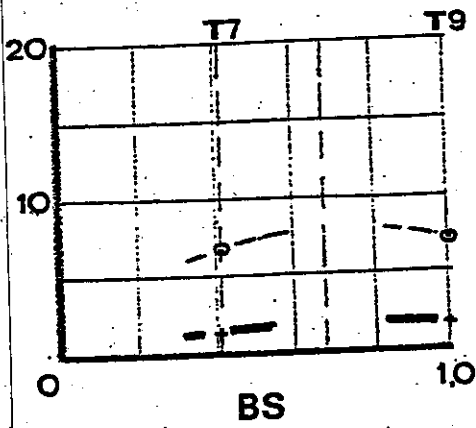
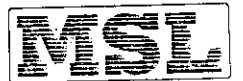

Figure M-8: SNCFs for T-joints with $\gamma = 25.7$ for out-of-plane bending at saddle.



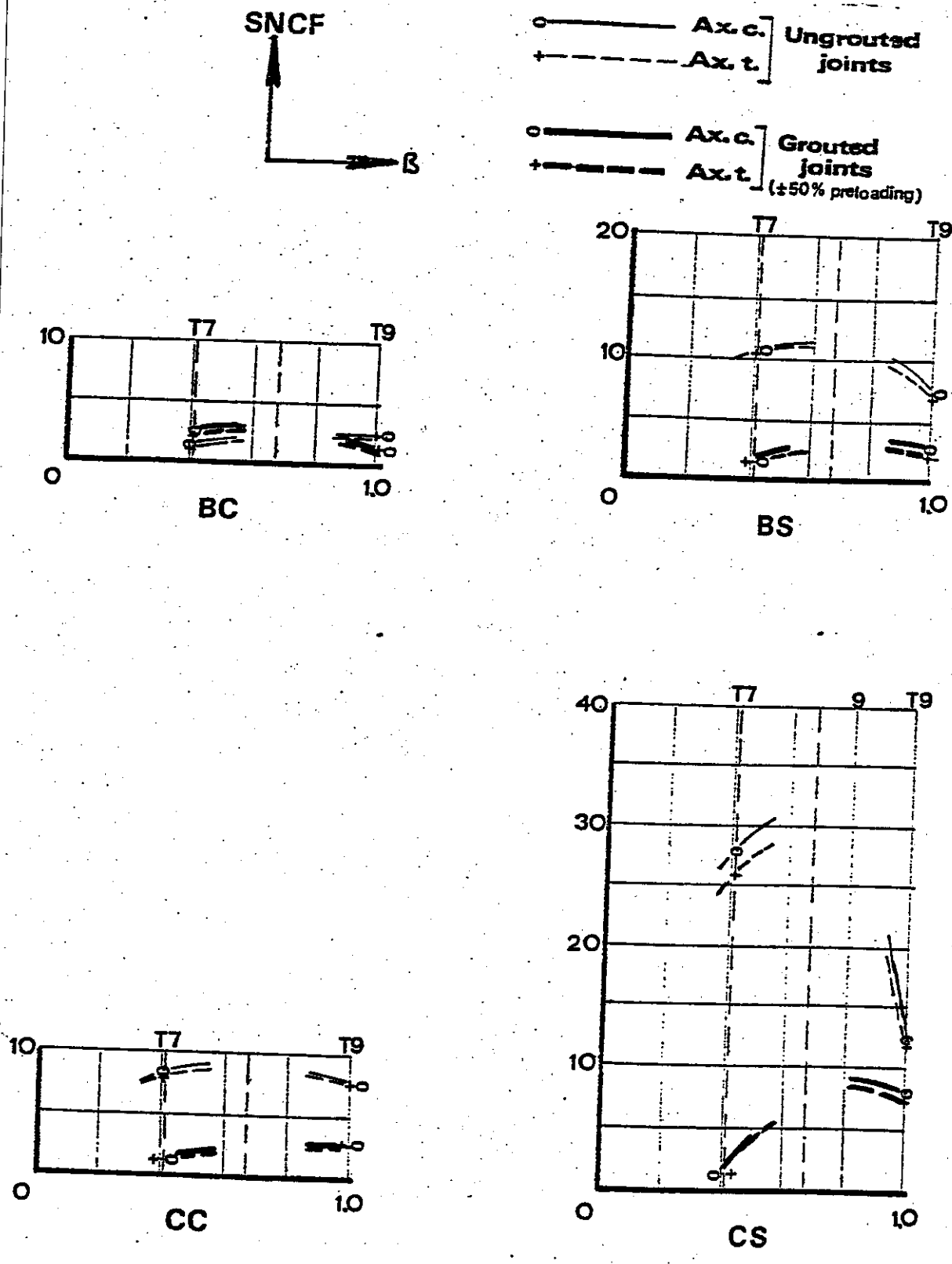
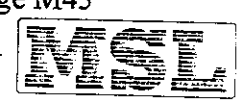

Figure M-9: SNCFs for T-joints with $g=25.7$ for axial loads at crown and saddle.



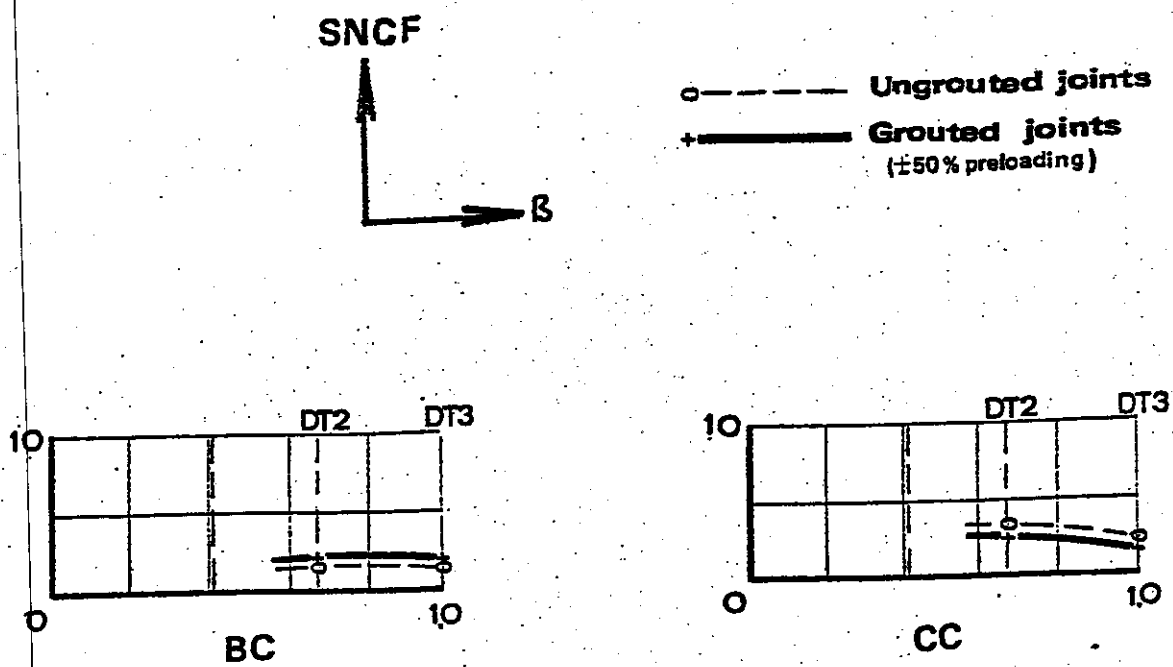

Figure M-10: SNCFs for DT-joints with $\gamma=12.7$ for in-plane bending at crown.

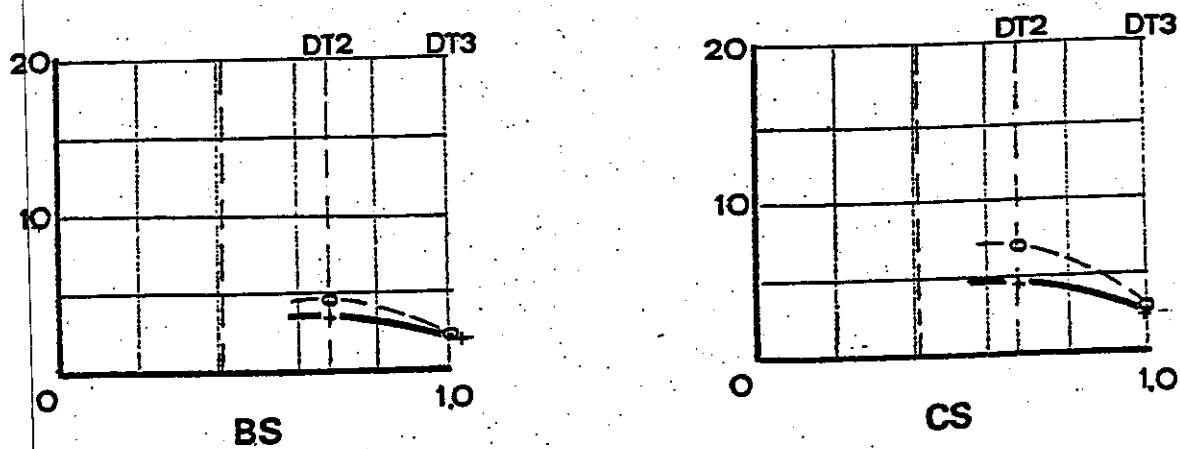
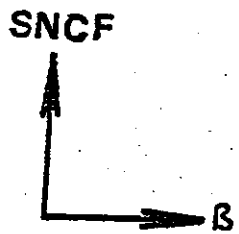

Figure M-11: SNCFs for DT-joints with $\gamma=12.7$ for out-of-plane bending at saddle.



- — Ax. c. } UngROUTED joints
- + — Ax. t. }
- — Ax. c. } Grouted joints
- + — Ax. t. } (+50% preloading)

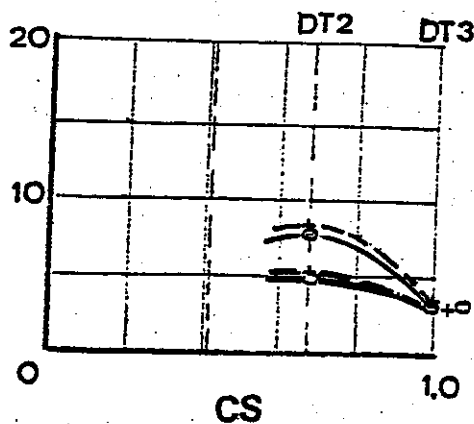
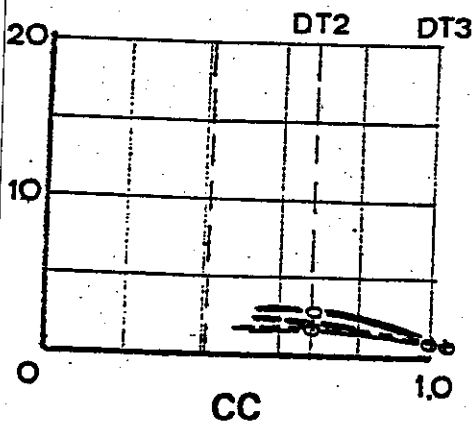
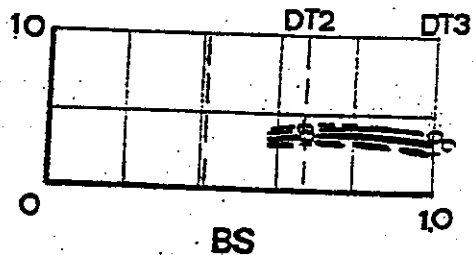
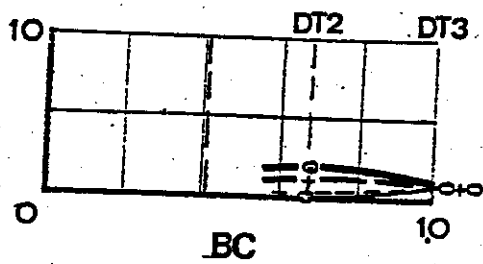

Figure M-12: SNCFs for DT-joints with $\gamma=12.7$ for axial loads at crown and saddle.

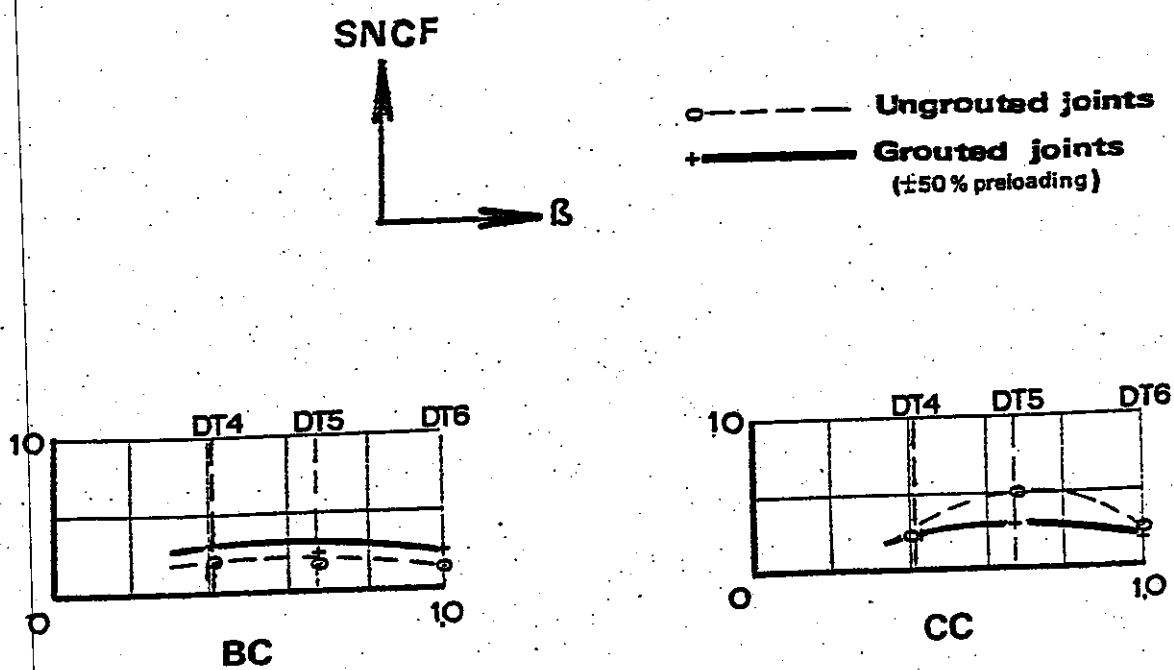

Figure M-13: SNCFs for DT-joints with $\gamma=20.3$ for in-plane bending at crown

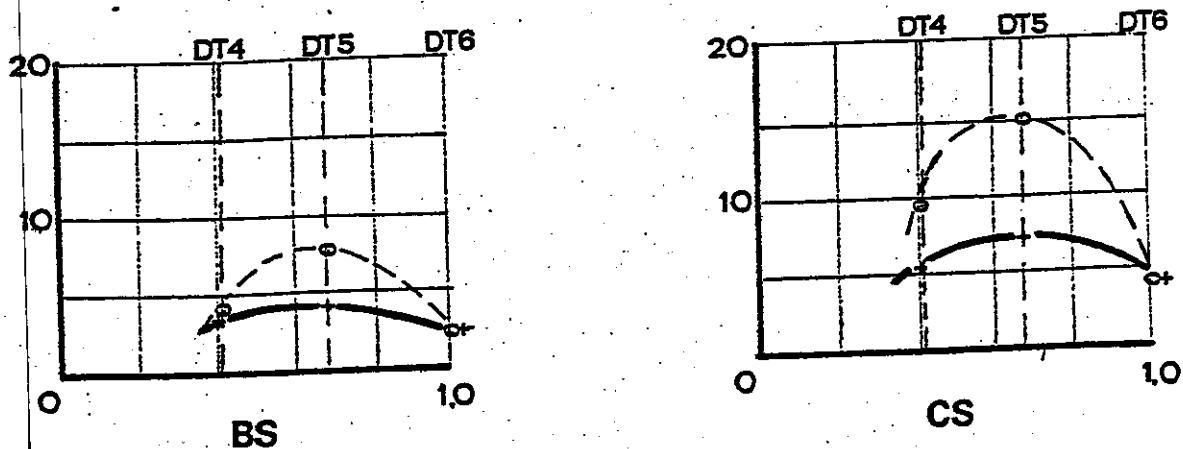

Figure M-14: SNCFs for DT-joints with $\gamma=20.3$ for out-of-plane bending at saddle.

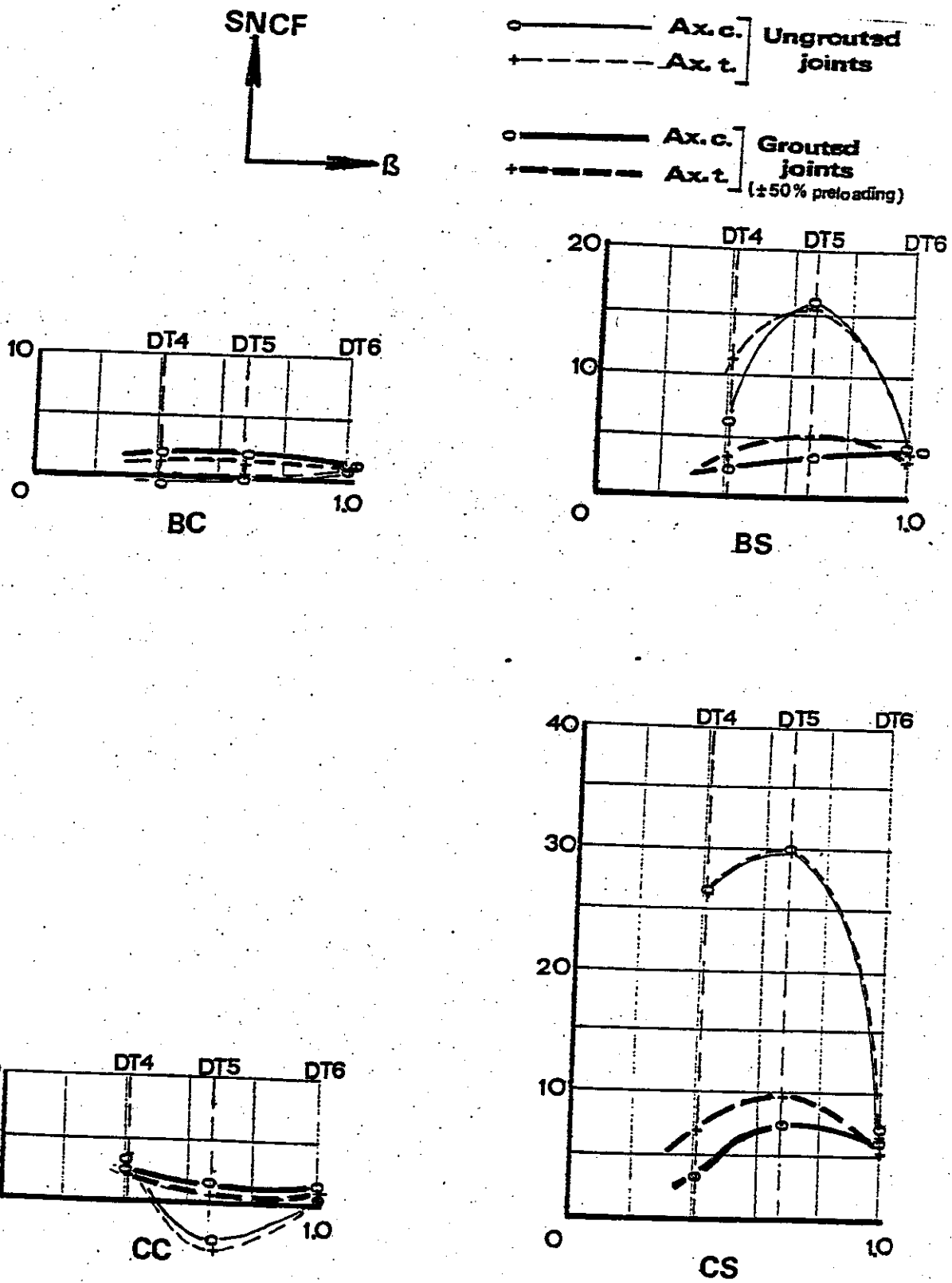

Figure M-15: SNCFs for DT-joints with $\gamma = 20.3$ for axial loads at crown and saddle.

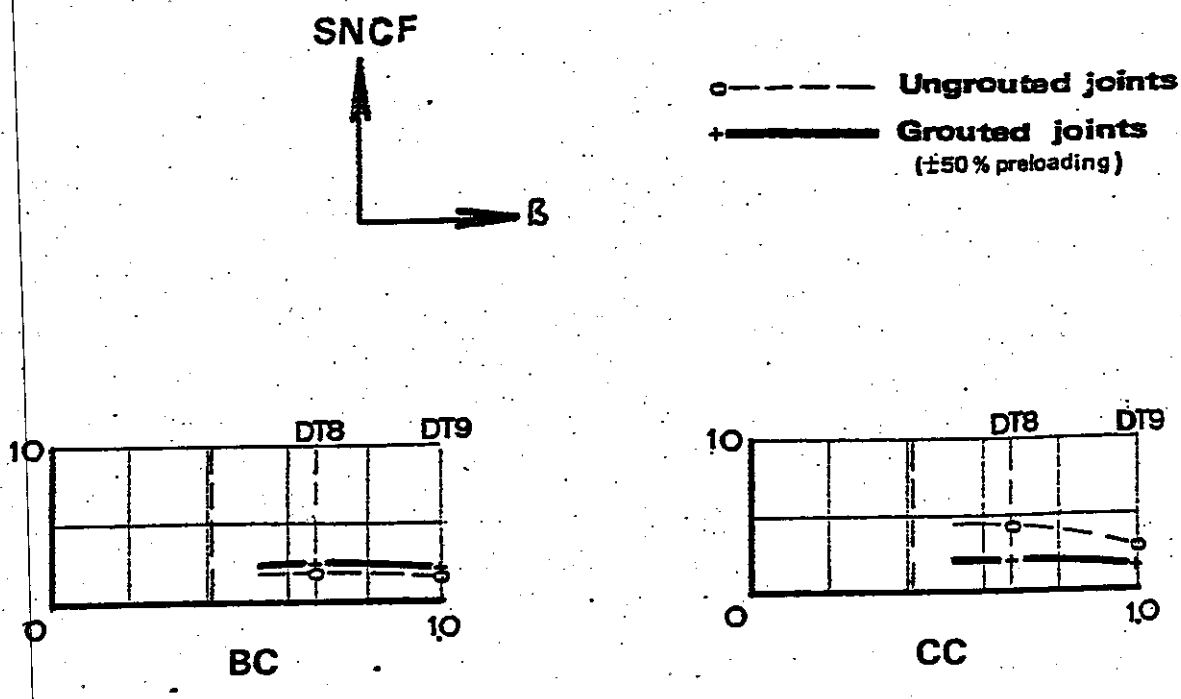

Figure M-16: SNCFs for DT-joints with $\gamma=25.7$ for in-plane bending at crown.

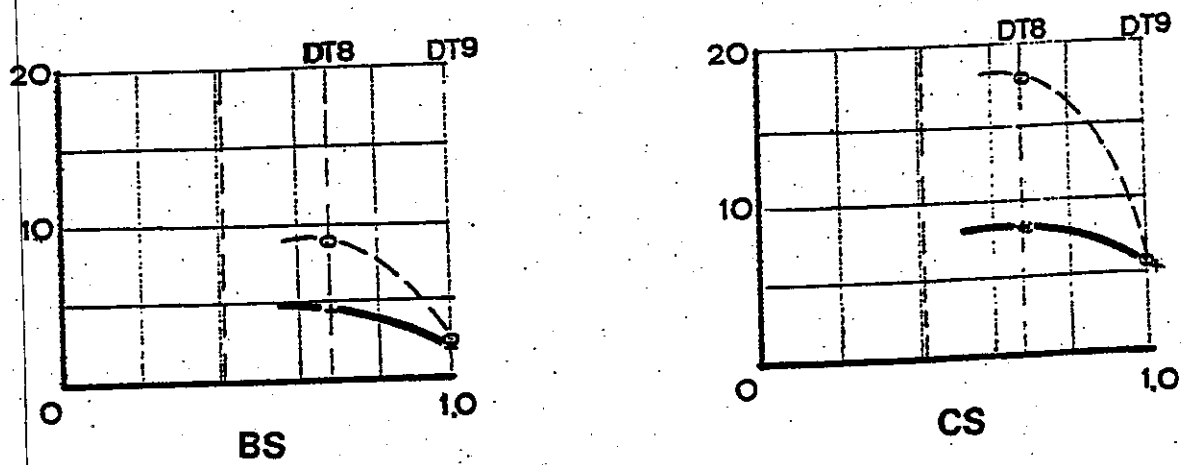

Figure M-17: SNCFs for DT-joints with $\gamma=25.7$ for out-of-plane bending at saddle.

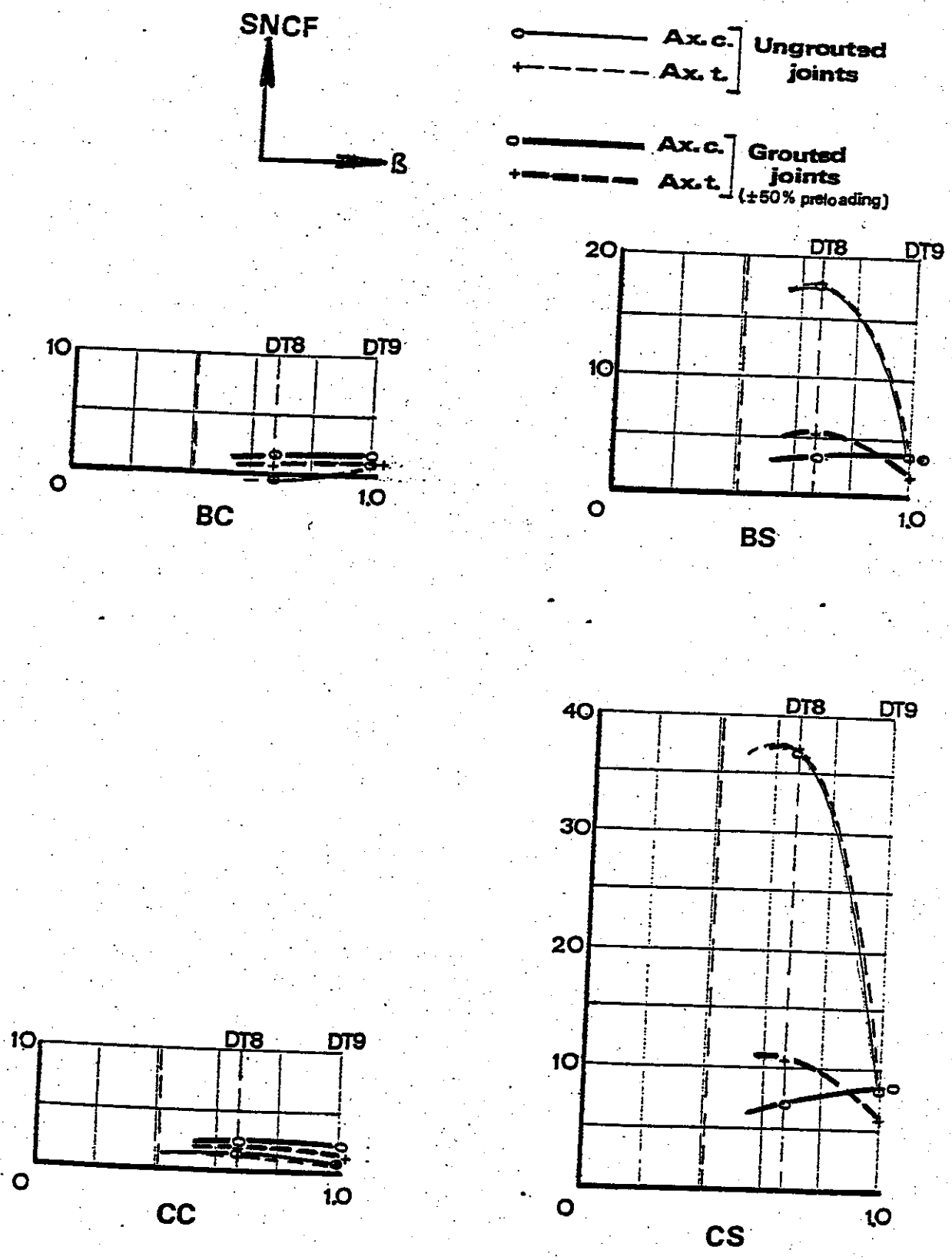
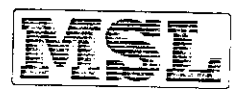

Figure M-18: SNCFs for DT-joints with $\gamma = 25.7$ for axial loads at crown and saddle.



MSL

APPENDIX N
Ultimate Strength Test Results

C14100R020 Rev 1 February 1997

NSI

APPENDIX N

Ultimate Strength Test Results

Table of contents

Appendix N 1 T-Joints	2
Appendix N 2 DT-Joints	5

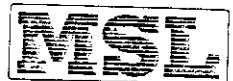

Appendix N 1 T-Joints

The brace rotation and joint rotation are presented as functions of the applied bending moments. The out of plane loading conditions also led to a rotation of the chord at the support. This rotation was not eliminated from the brace global rotation. The local joint rotation was measured from the section of chord diametrically opposite the brace. The results are presented below.

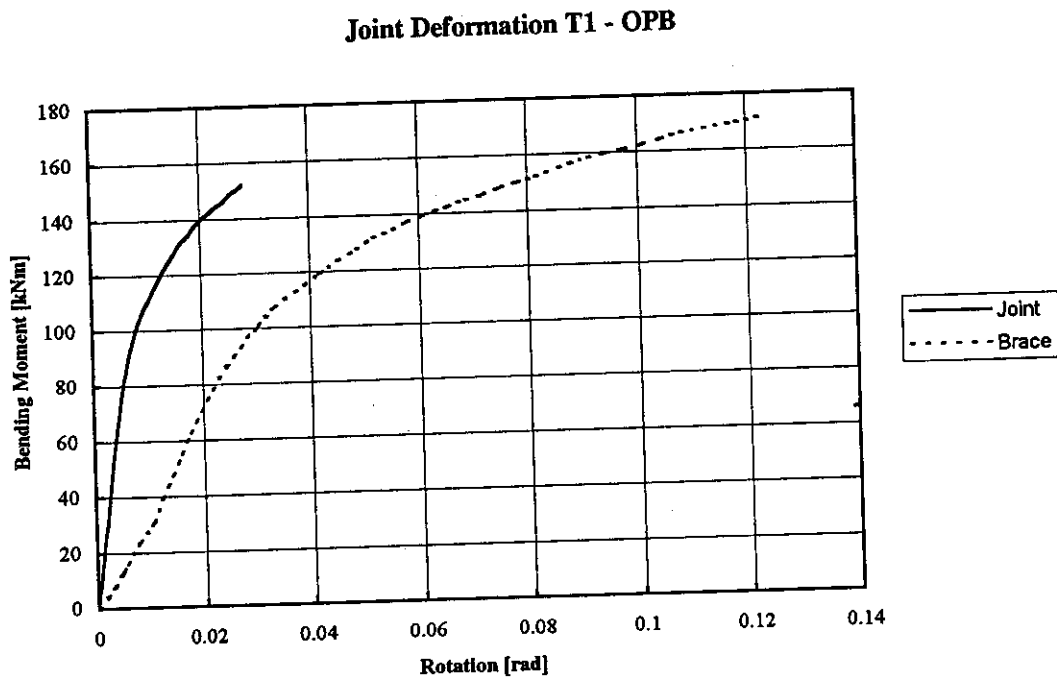

Figure N-1: Bending-rotation behaviour of T1

Joint Deformation T3 - OPB

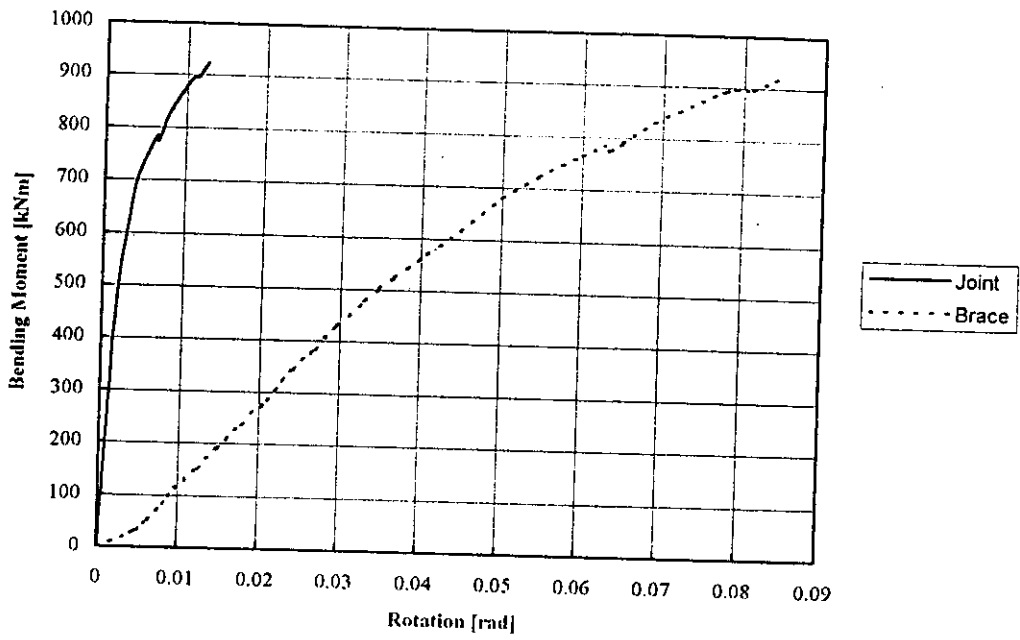

Figure N-2: Bending-rotation behaviour of T3

Joint Deformation T5 - OPB

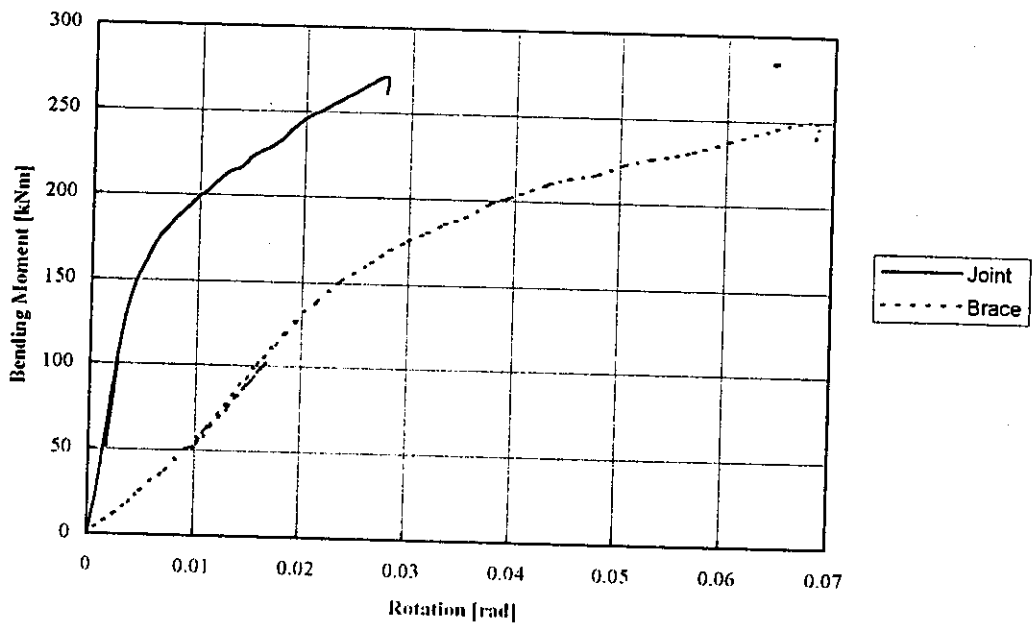

Figure N-3: Bending-rotation behaviour of T5



Joint deformation T7 OPB

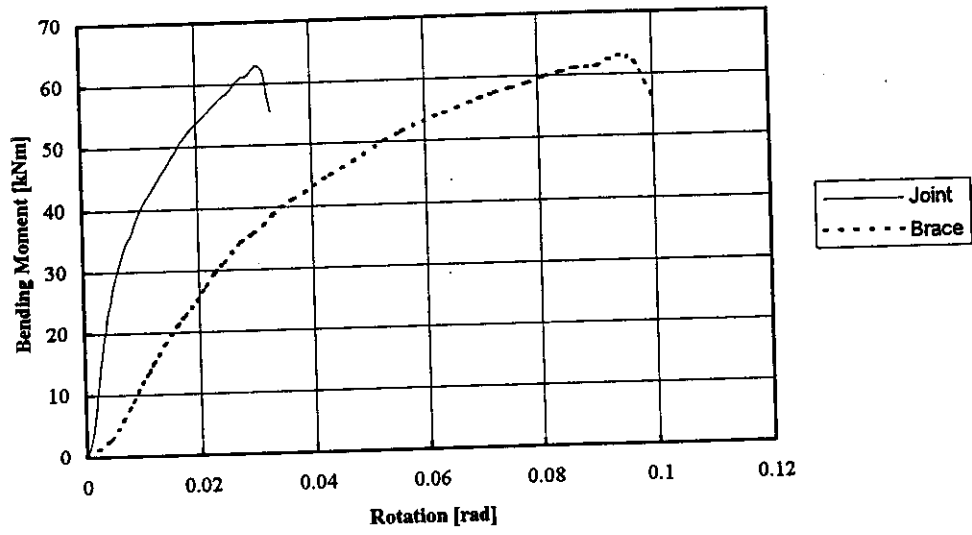

Figure N-4: Bending-rotation behaviour of T7

Joint Deformation T9 - OPB

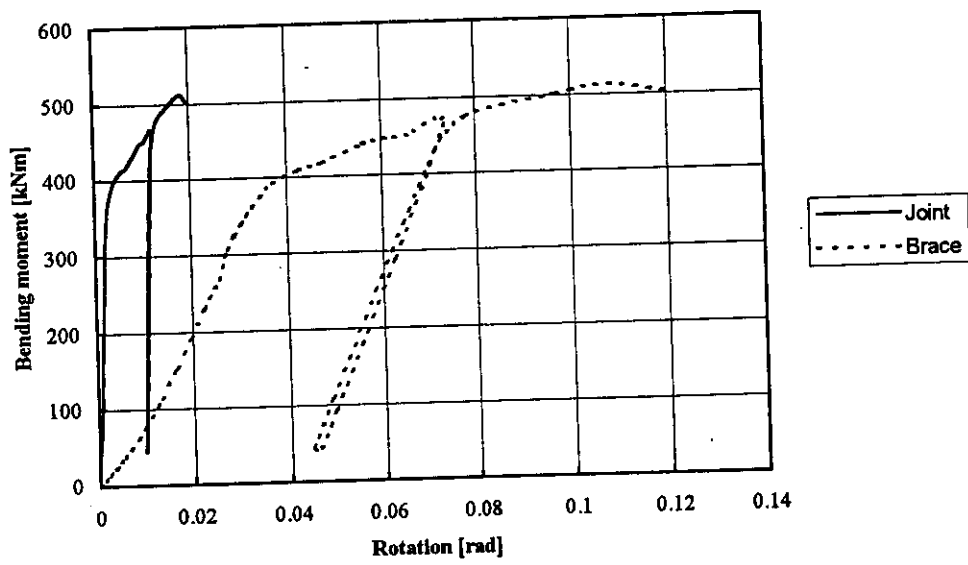
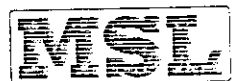

Figure N-5: Bending-rotation behaviour of T9



Appendix N 2 DT-Joints

The brace rotation and joint rotation are presented as functions of the applied bending moment. The joint rotation was measured relative to the two brace rotations.

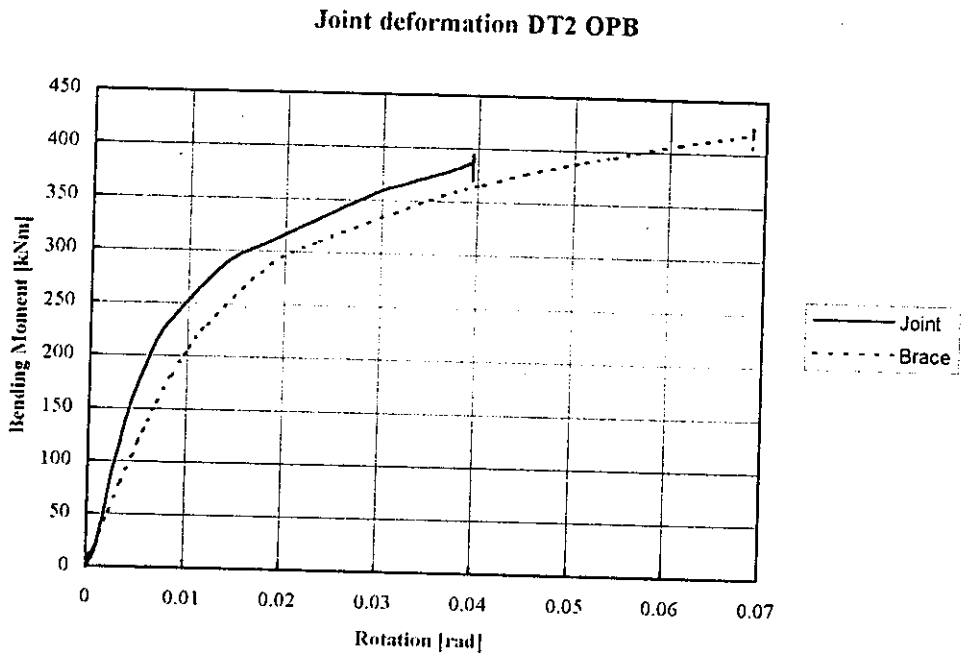

Figure N-6: Bending-rotation behaviour of DT2

Joint deformation DT3 OPB

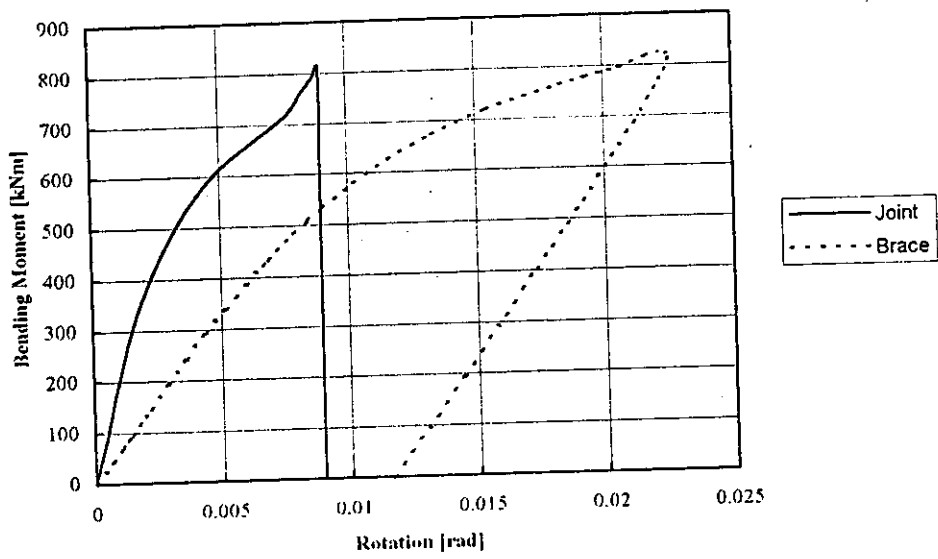

Figure N-7: Bending-rotation behaviour of DT3

Joint deformation DT4 IPB

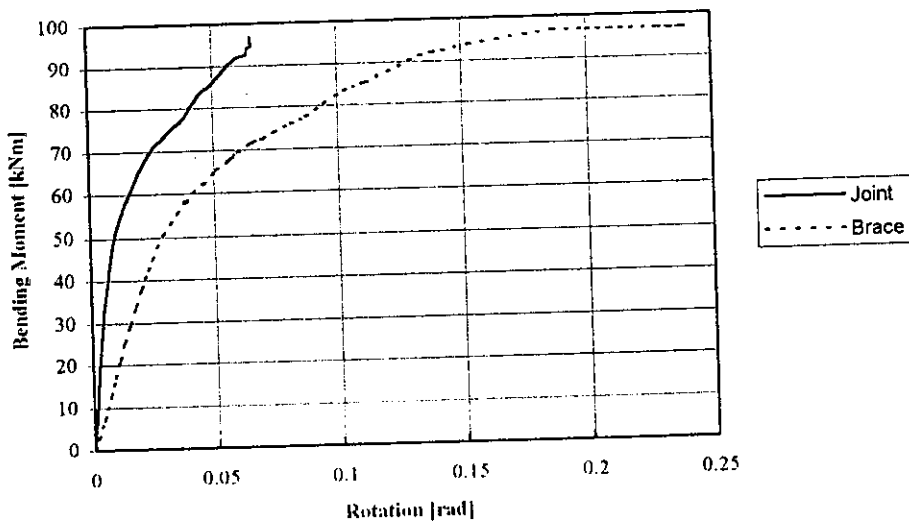
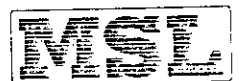

Figure N-8: Bending-rotation behaviour of DT4



Joint Deformation DT5 IPB

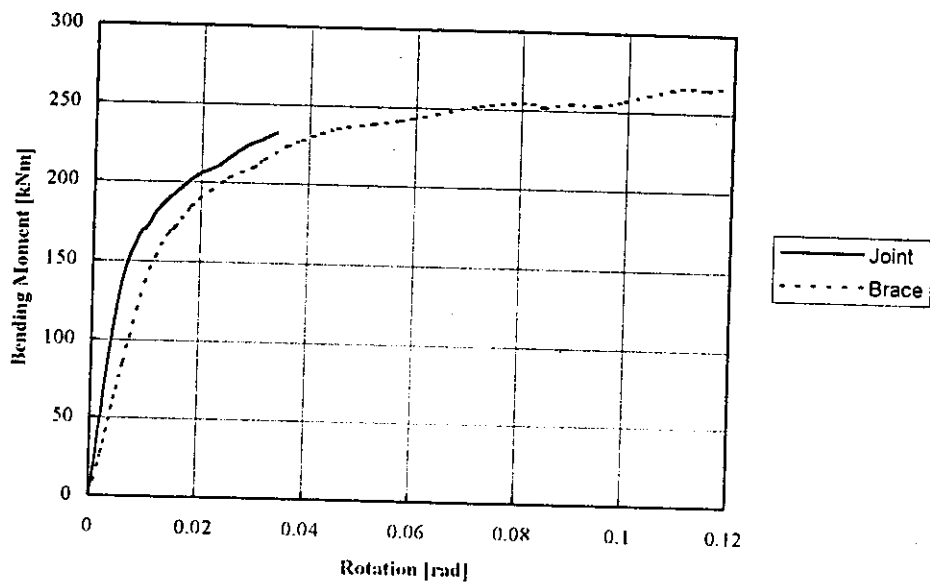

Figure N-9: Bending-rotation behaviour of DT5

Joint deformation DT6 IPB

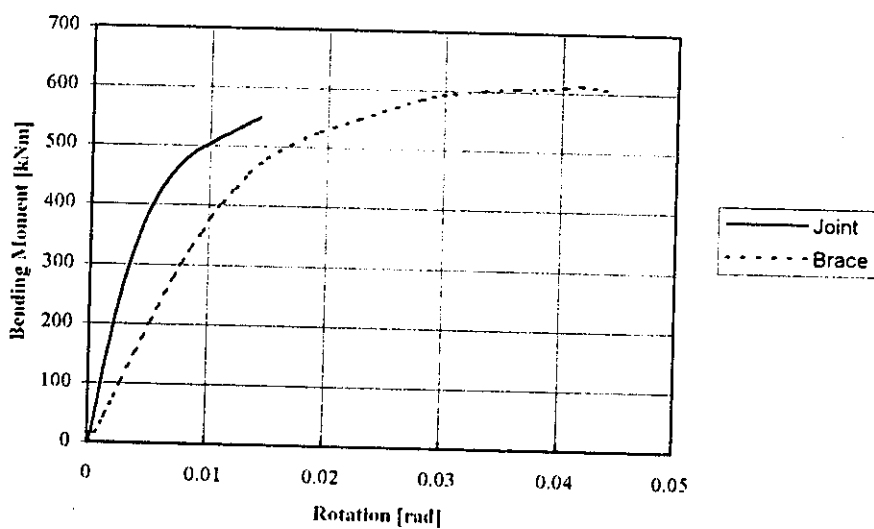

Figure N-10: Bending-rotation behaviour of DT6



Joint deformation DT6 IPB

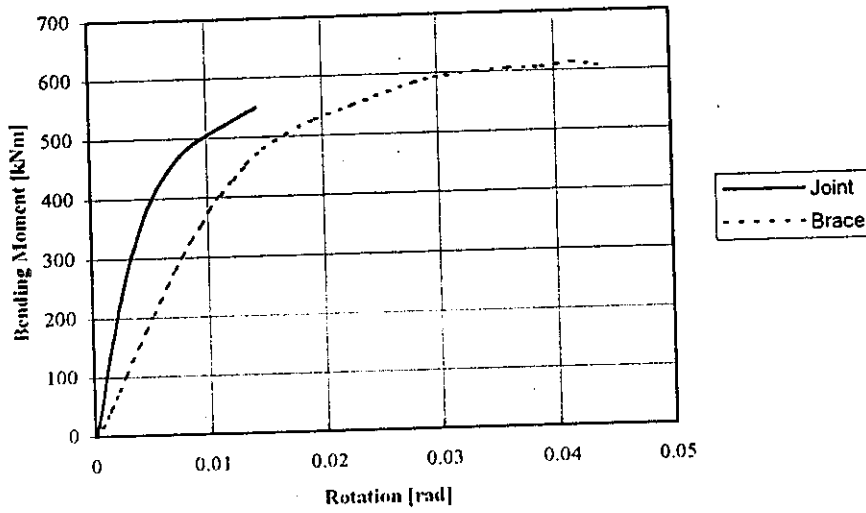

Figure N-11: Bending-rotation behaviour of DT8

Joint deformation DT6 IPB

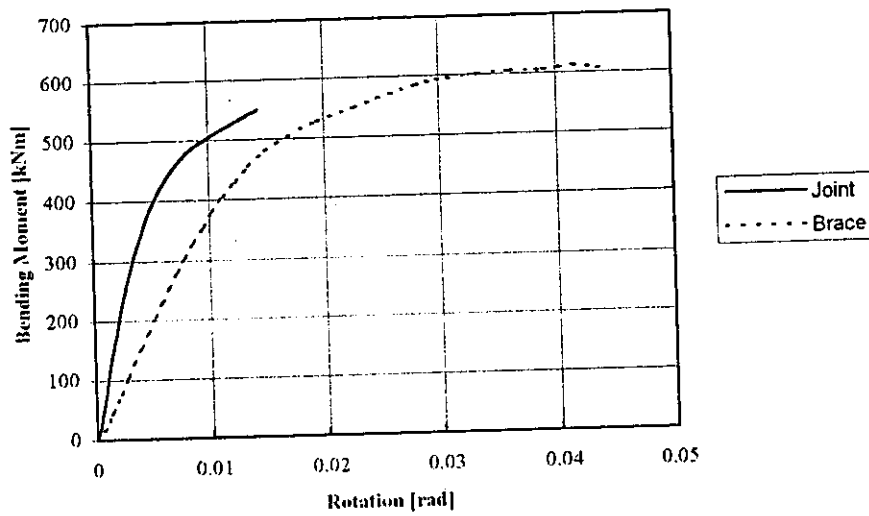
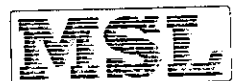

Figure N-12: Bending-rotation behaviour of DT9



APPENDIX O

Photographs of Failures for Ultimate Tests

C14100R020 Rev 1 February 1997

NS

Appendix O

Photographs of failures for ultimate test

Table of contents

Appendix O 1 T-joints	2
Appendix O 2 DT-joints	6



Appendix O-1 T-joints

The failure modes of T1, T5, T7 and T9 are presented below. Specimen T3 did not fail due to the limited test rig capacity.

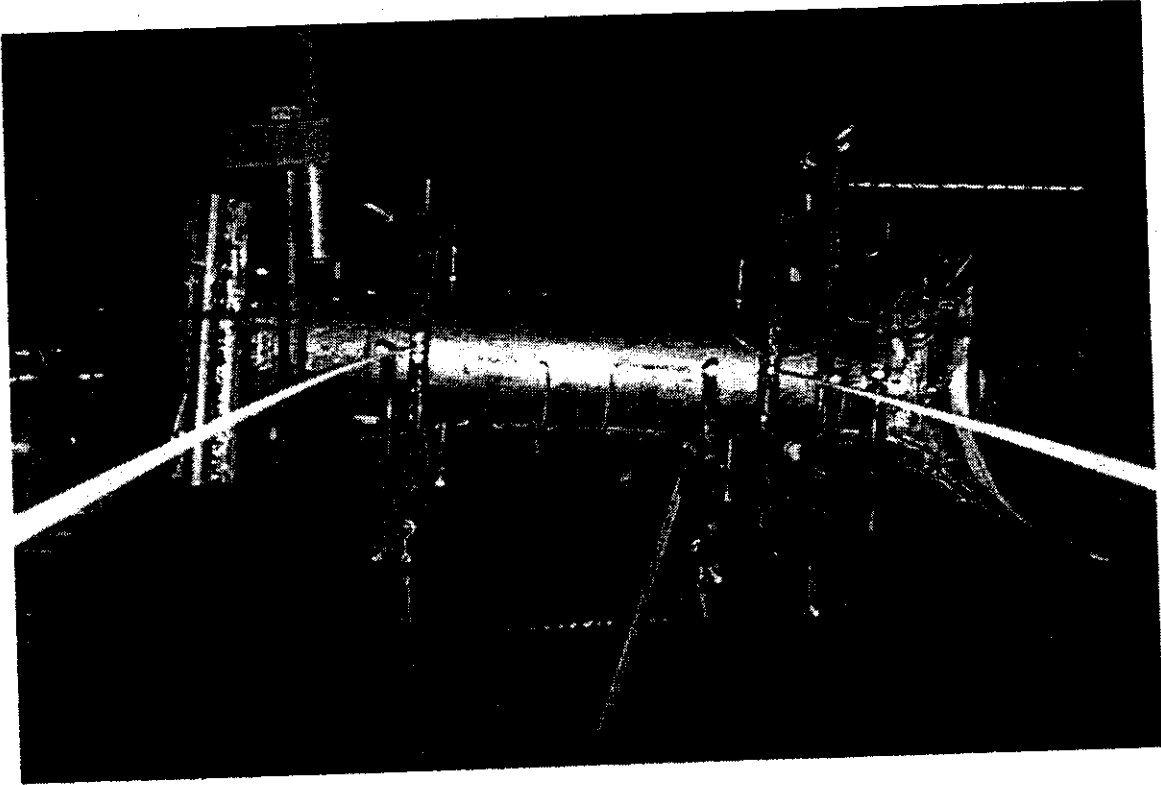

Figure O-1: Failure mode of specimen T1 (OPB Ultimate test)

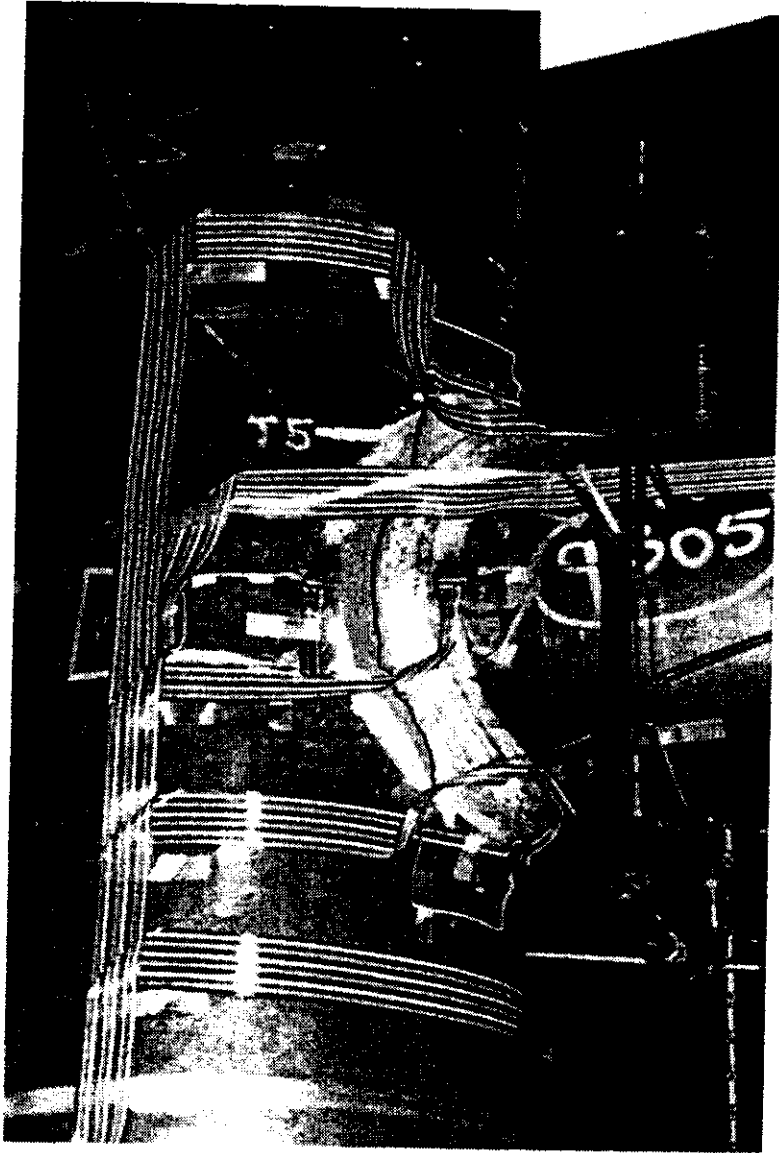

Figure O-2: Failure mode of specimen T5 (OPB Ultimate test)

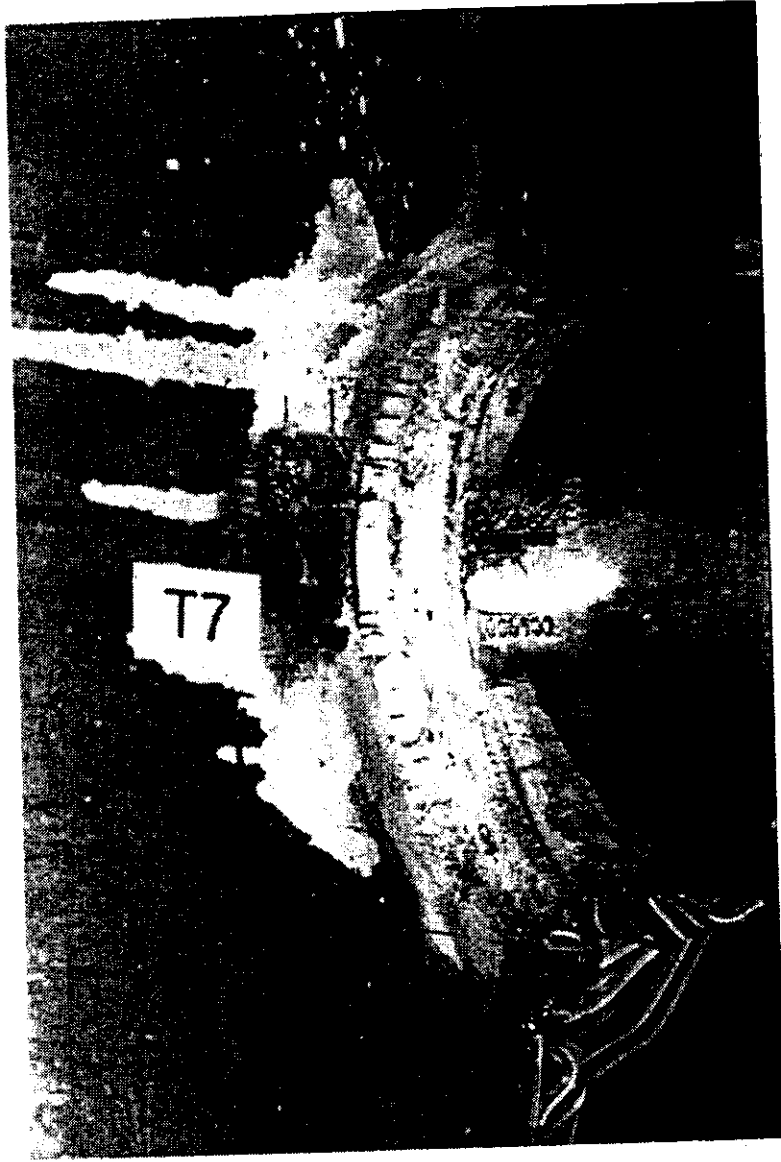

Figure O-3: Failure mode of specimen T7 (OPB Ultimate test)

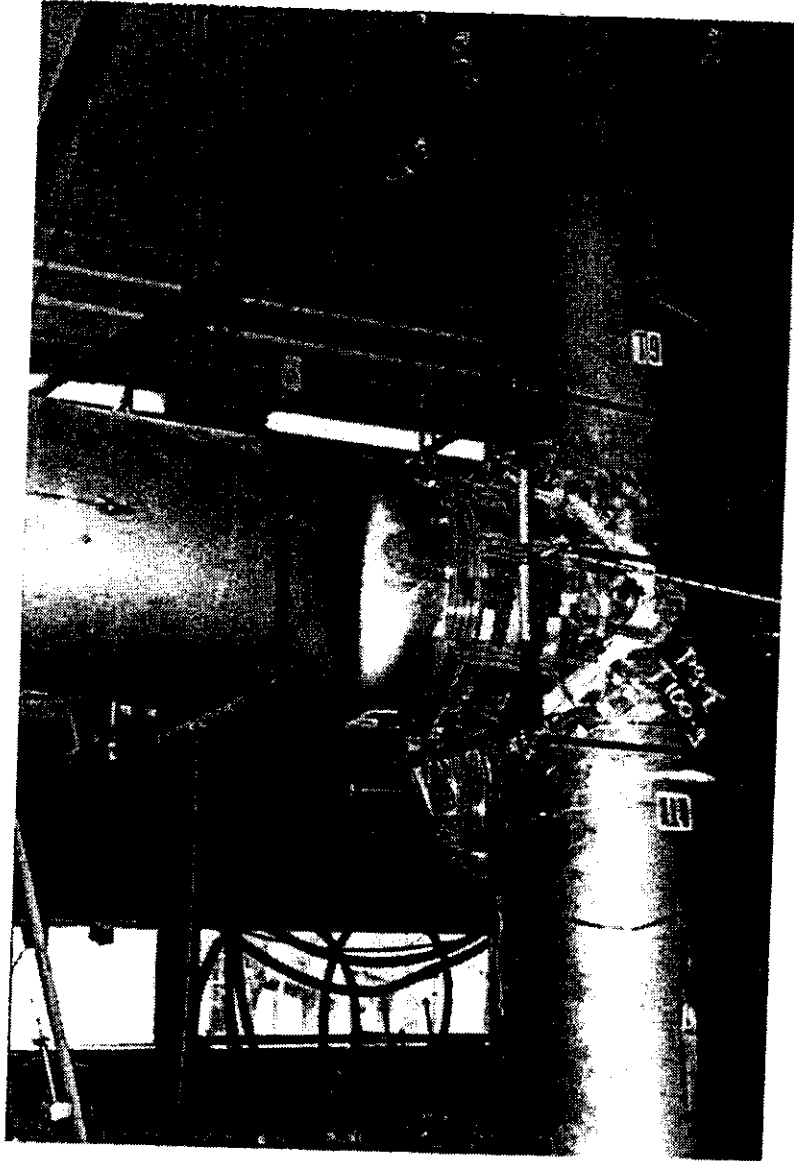

Figure O-4: Failure mode of specimen T9 (OPB Ultimate test)

Appendix O-2 DT-joints

The failure modes of DT2, DT4, DT5, DT6, DT8 and DT9 are presented below. Specimen DT3 did not fail due to the limited test rig capacity.

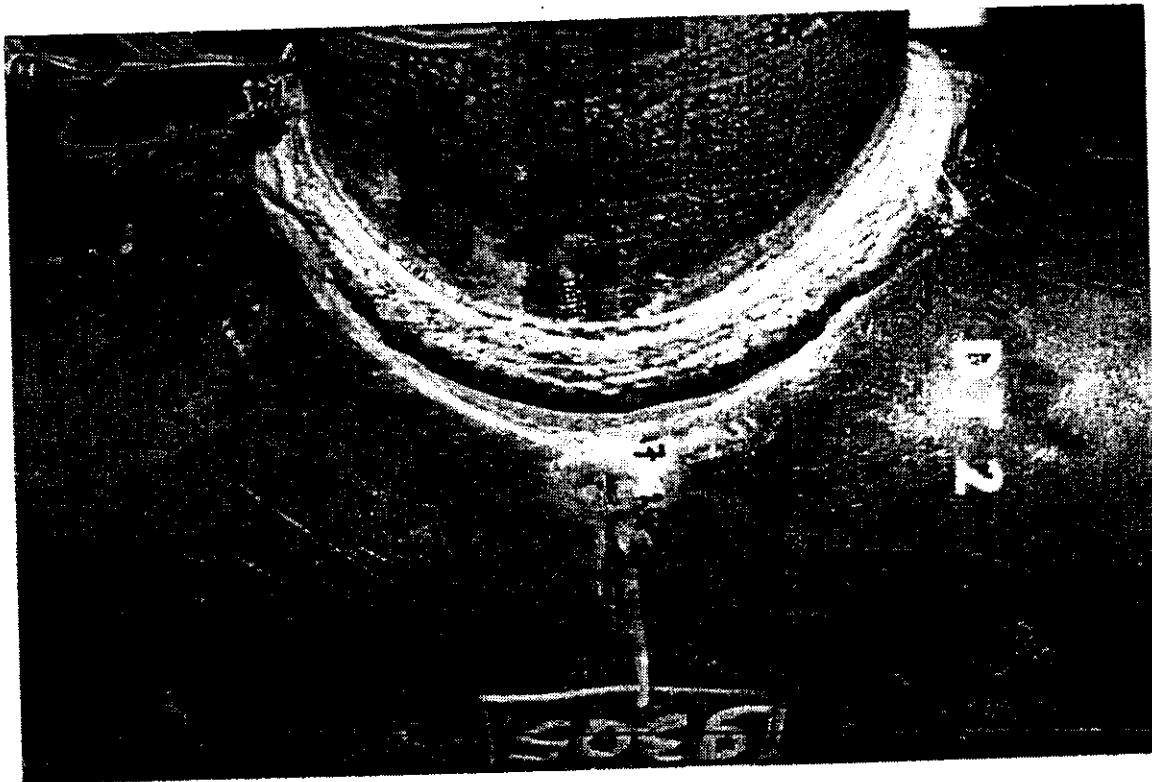

Figure O-5: Failure mode of specimen DT2 (OPB Ultimate test)



Figure O-6: Failure mode of specimen DT4 (IPB Ultimate test)

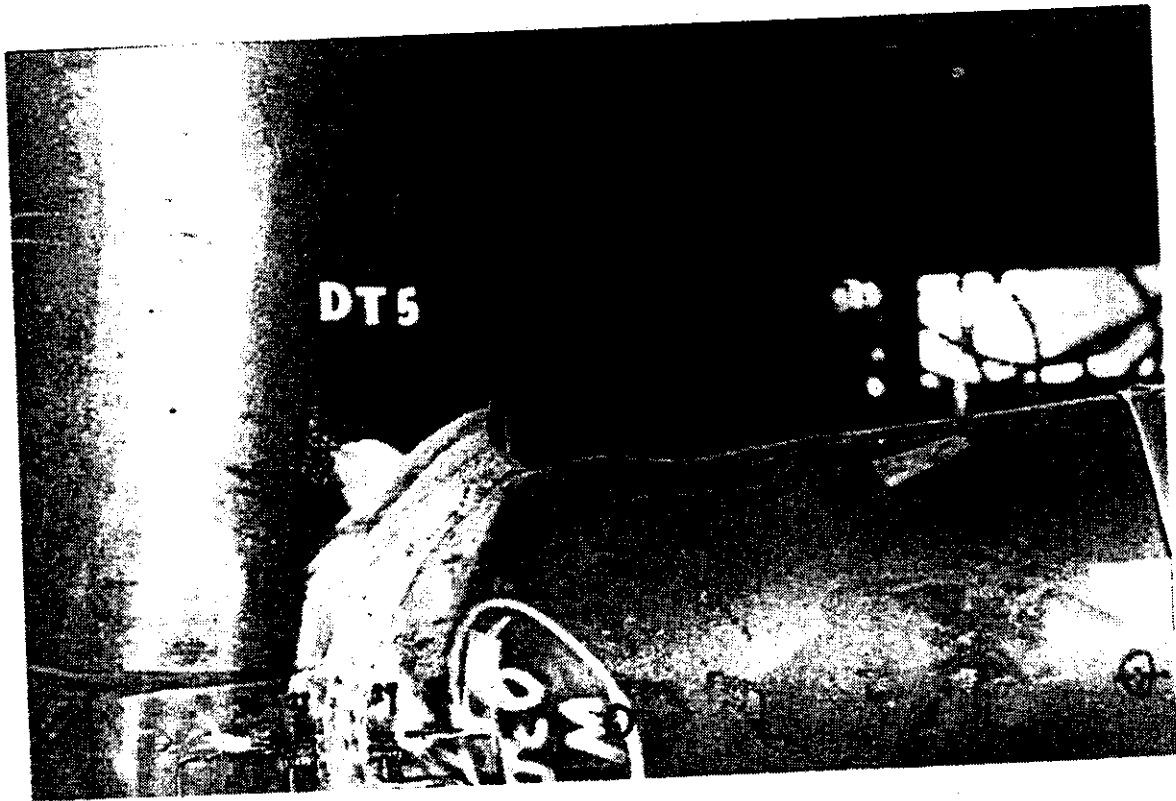

Figure O-7: Failure mode of specimen DT5 (IPB Ultimate test)

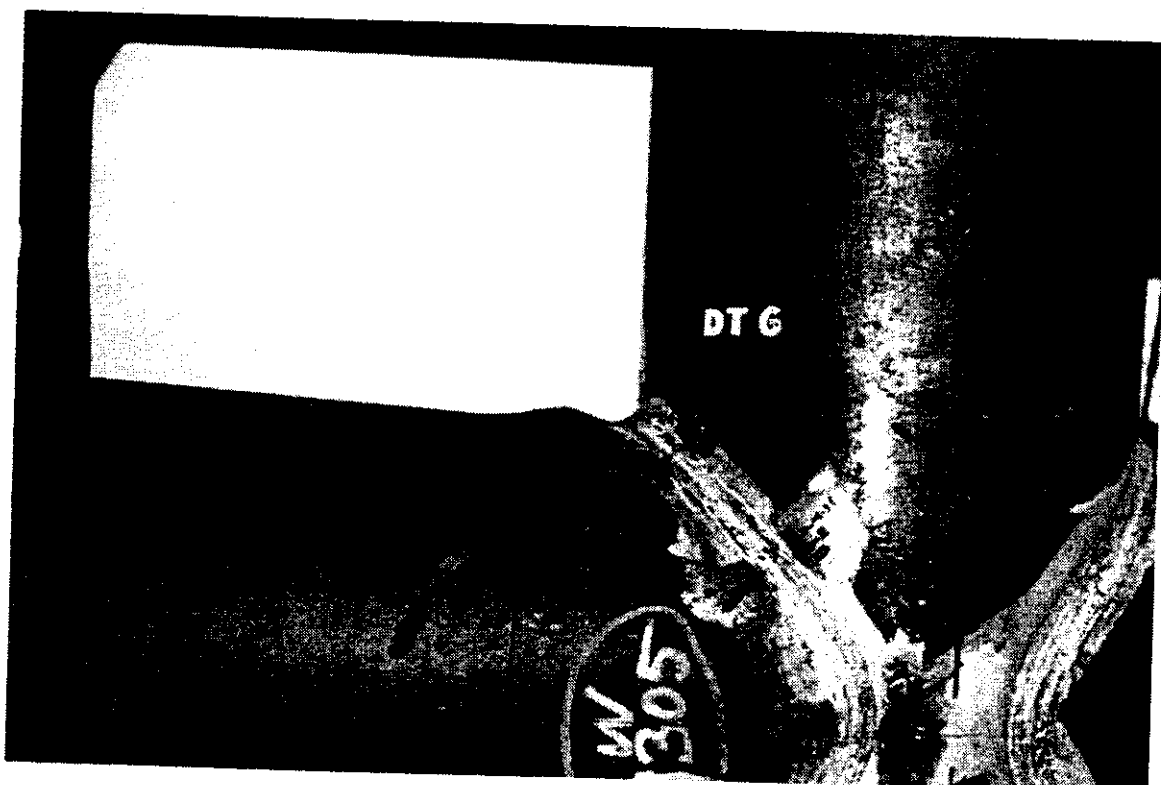

Figure O-8: Failure mode of specimen DT6 (IPB Ultimate test)



Figure O-9: Failure mode of specimen DT8 (OPB Ultimate test)

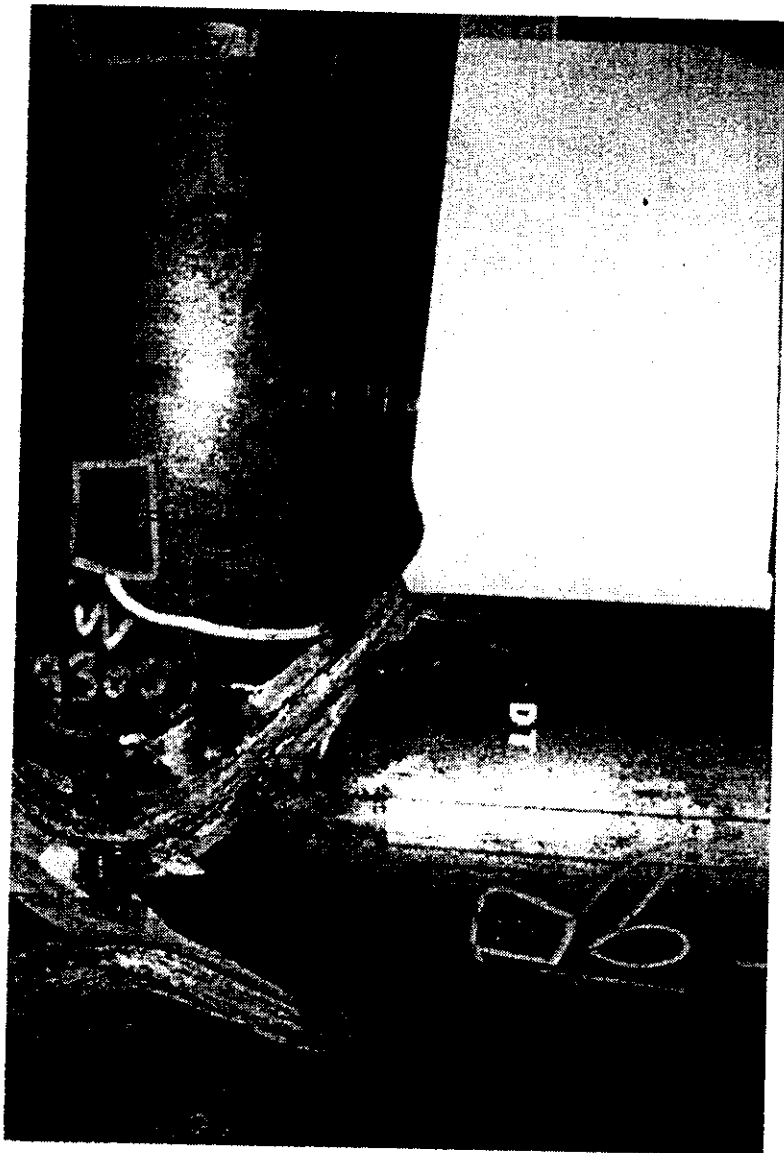

Figure O-10: Failure mode of specimen DT9 (IPB Ultimate test)

MSE

APPENDIX P
Local Joint Flexibilities

C14100R020 Rev 1 February 1997

NSI

APPENDIX P

Local Joint Deformation

Table of contents

Appendix P-1 Nonclementure	2
Appendix P-2 Local Joint deformation of DT2	3
Appendix P-3 Local Joint deformation of DT3	4
Appendix P-4 Local Joint deformation of DT4	5
Appendix P-5 Local Joint deformation of DT5	6
Appendix P-6 Local Joint deformation of DT6	7
Appendix P-7 Local Joint deformation of DT8	8
Appendix P-8 Local Joint deformation of DT9	9
Appendix P-9 Local Joint deformation of T1	10
Appendix P-10 Local Joint deformation of T3	11
Appendix P-11 Local Joint deformation of T5	12
Appendix P-12 Local Joint deformation of T7	13
Appendix P-13 Local Joint deformation of T9	14

Appendix P-1 Nonclementure

IPB	As welded joint subjected to in-plane bending.
OPB	As welded joint subjected to out-of-plane bending.
IPB-gr	Grouted joint subjected to in-plane bending.
OPB-gr	Grouted joint subjected to out-of-plane bending.
Compr	As welded joint subjected to compression loading.
Tension	As welded joint subjected to brace tension bending.
Comp-gr	Grouted joint subjected to compression bending.
Tension-gr	Grouted joint subjected to tension bending.

Appendix P-2 Local Joint deformation of DT2

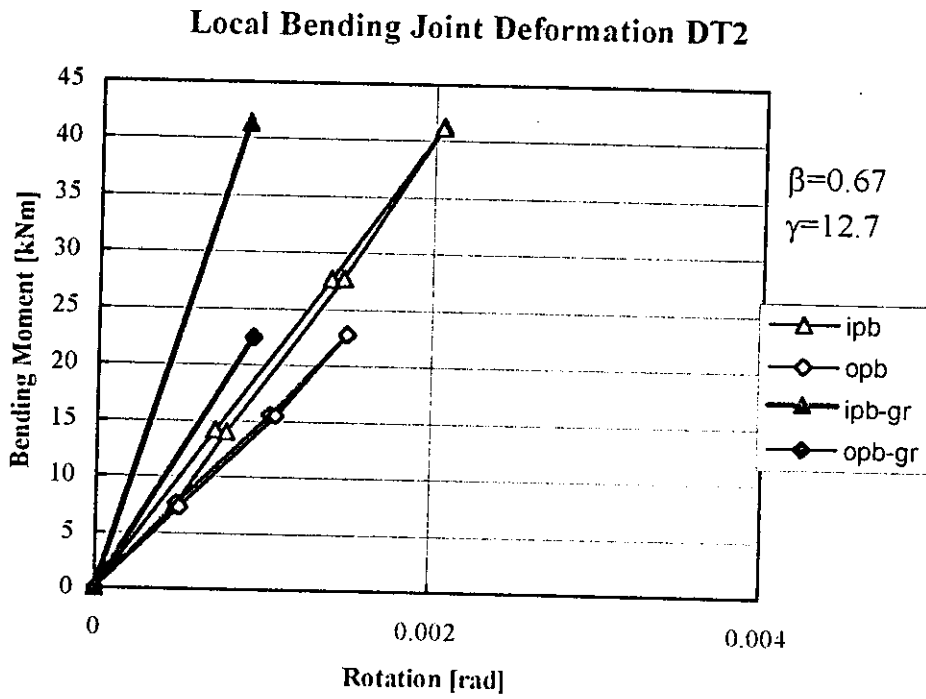

Figure P-1: Local bending joint deformation of specimen DT2

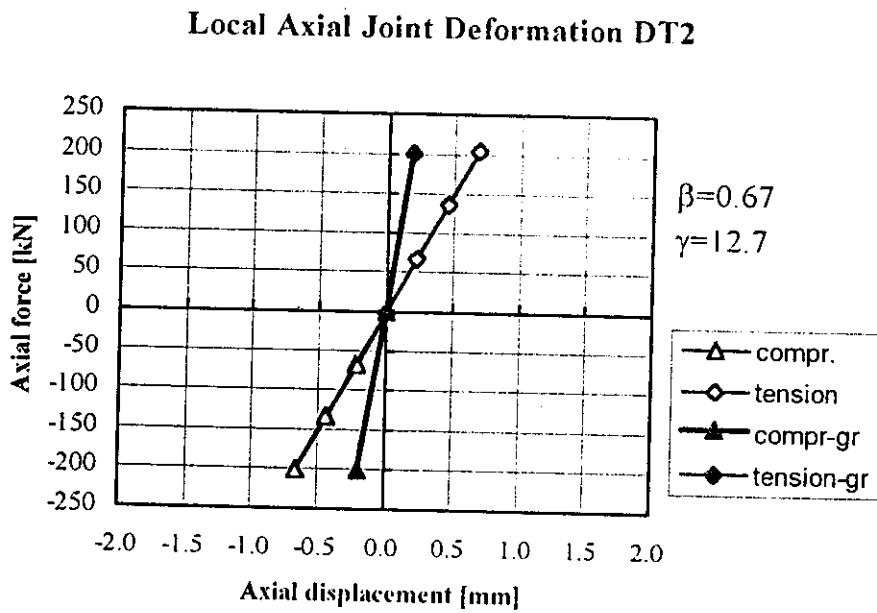

Figure P-2: Local axial joint deformation of specimen DT2

Appendix P-3 Local Joint deformation of DT3

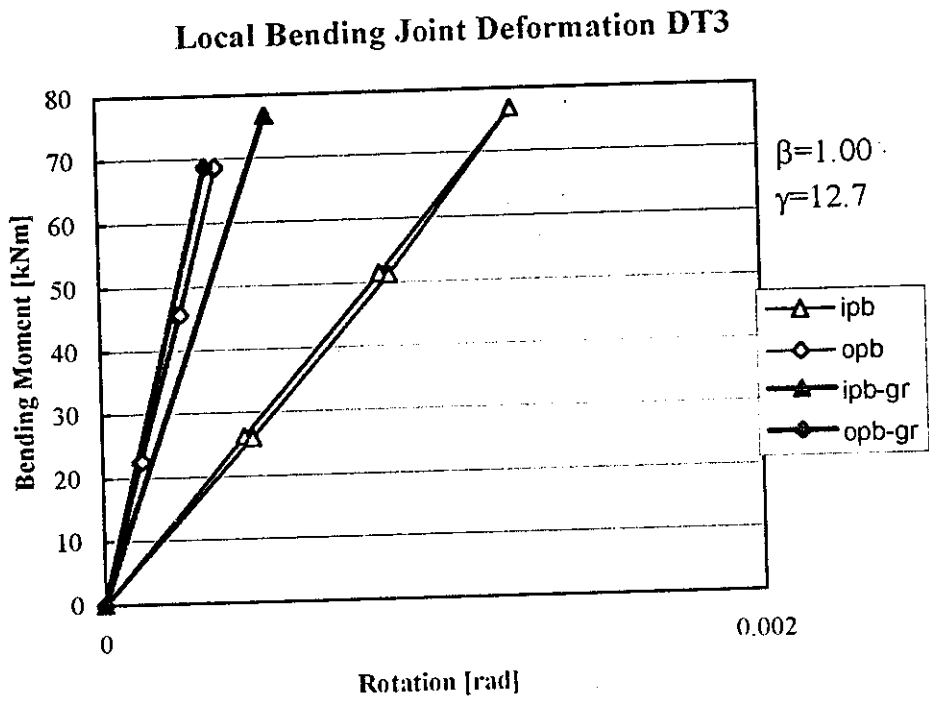

Figure P-3: Local bending joint deformation of specimen DT3

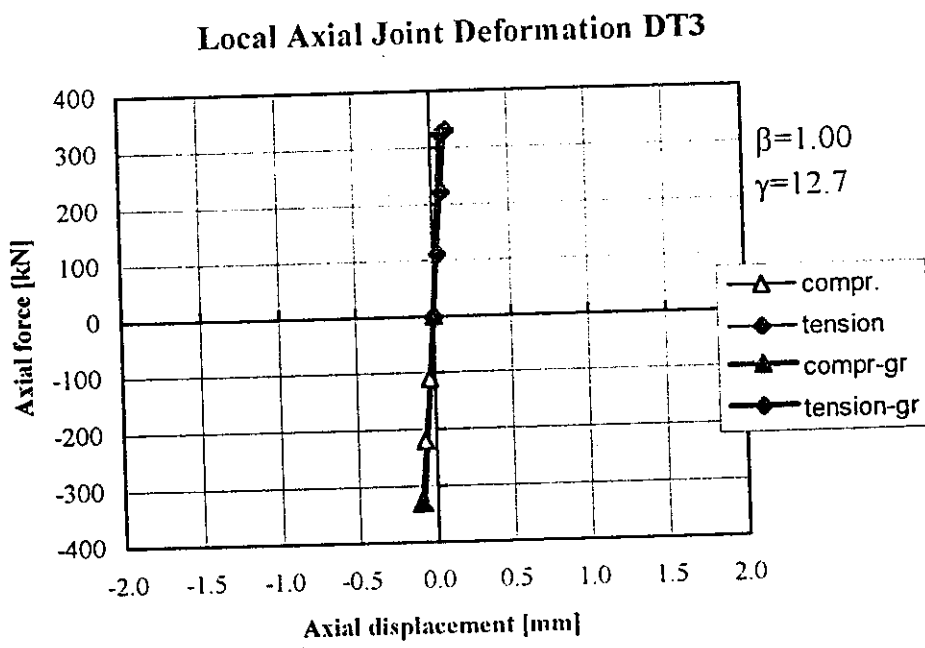
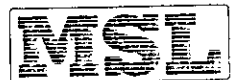

Figure P-4: Local axial joint deformation of specimen DT3



Appendix P-4 Local Joint deformation of DT4

Local Bending Joint Deformation DT4

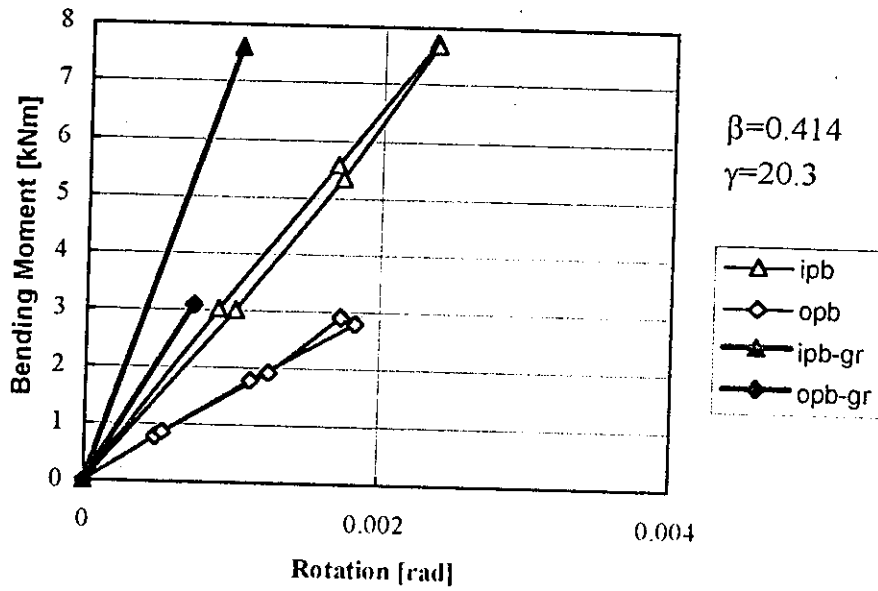

Figure P-5: Local bending joint deformation of specimen DT4

Local Axial Joint Deformation DT4

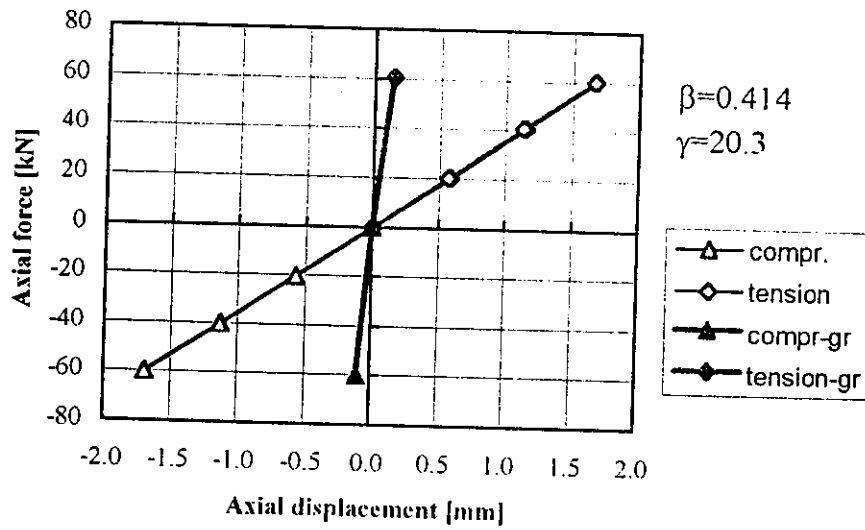

Figure P-6: Local axial joint deformation of specimen DT4

Appendix P-5 Local Joint deformation of DT5

Local Bending Joint Deformation DT5

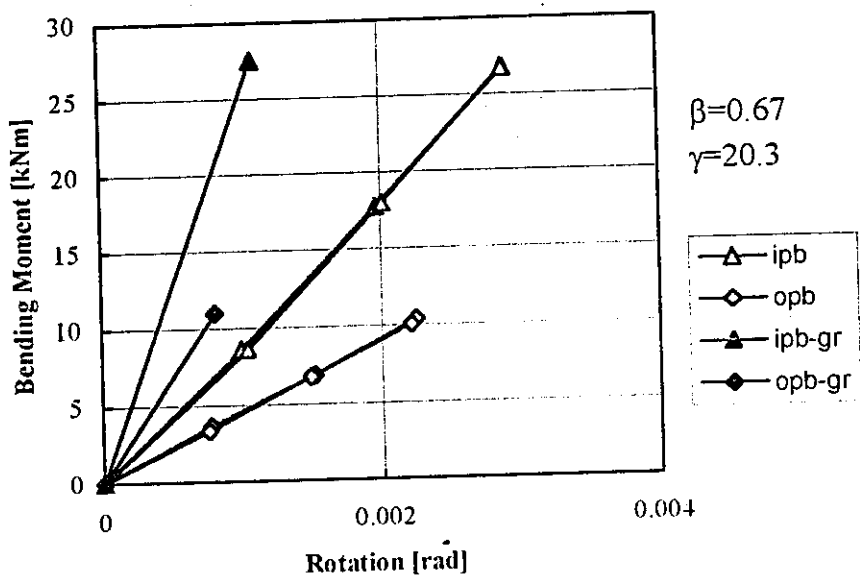

Figure P-7: Local bending joint deformation of specimen DT5

Local Axial Joint Deformation DT5

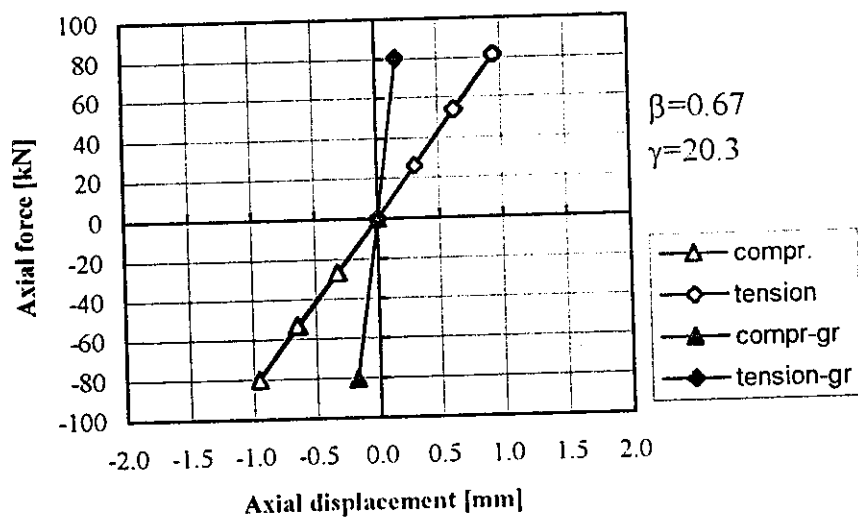

Figure P-8: Local axial joint deformation of specimen DT5

Appendix P-6 Local Joint deformation of DT6

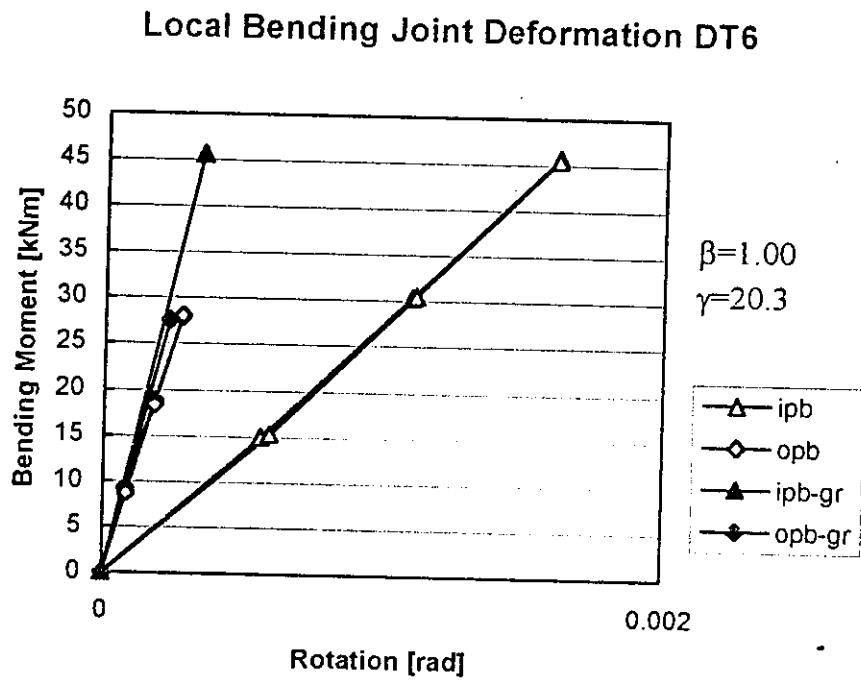

Figure P-9: Local bending joint deformation of specimen DT6

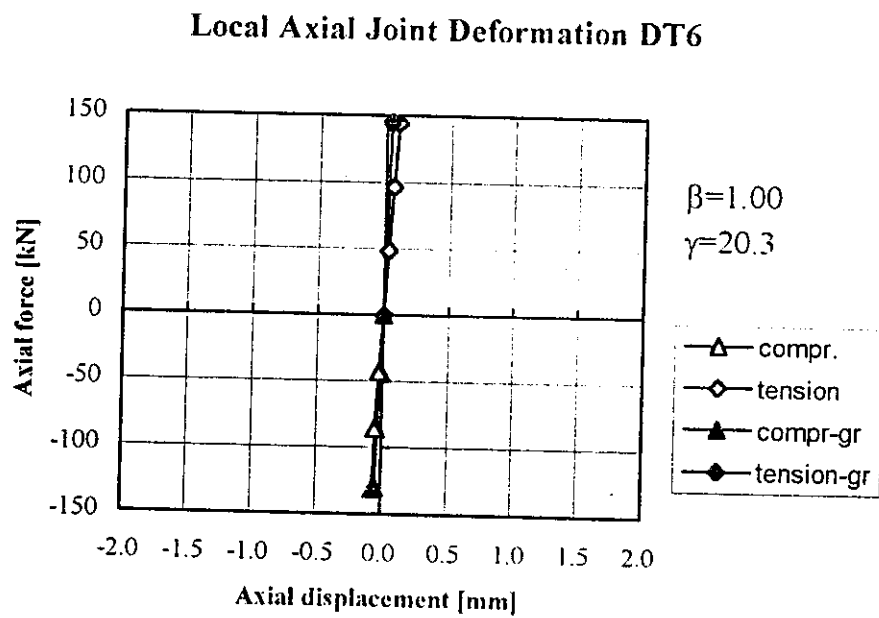

Figure P-10: Local axial joint deformation of specimen DT6

Appendix P-7 Local Joint deformation of DT8

Local Bending Joint Deformation DT8

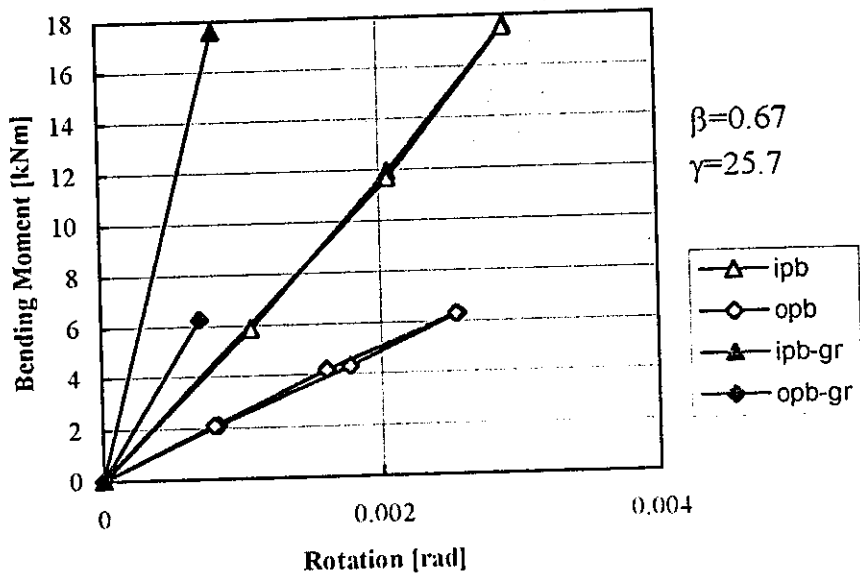

Figure P-11: Local bending joint deformation of specimen DT8

Local Axial Joint Deformation DT8

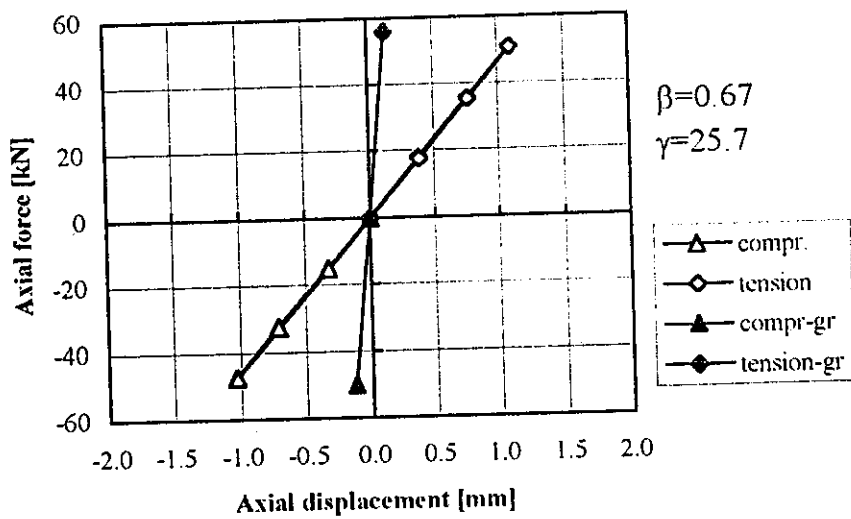

Figure P-12: Local axial joint deformation of specimen DT8

Appendix P-8 Local Joint deformation of DT9

Local Bending Joint Deformation DT9

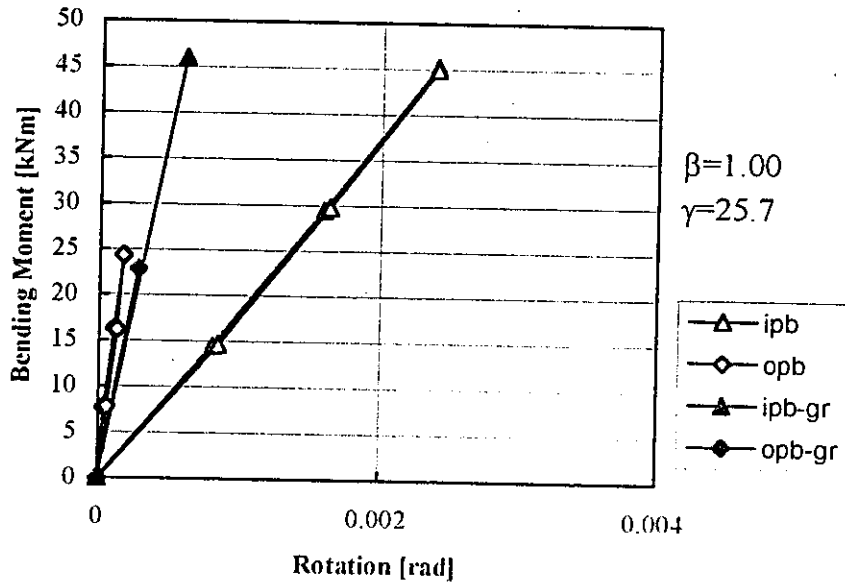

Figure P-13: Local bending joint deformation of specimen DT9

Local Axial Joint Deformation DT9

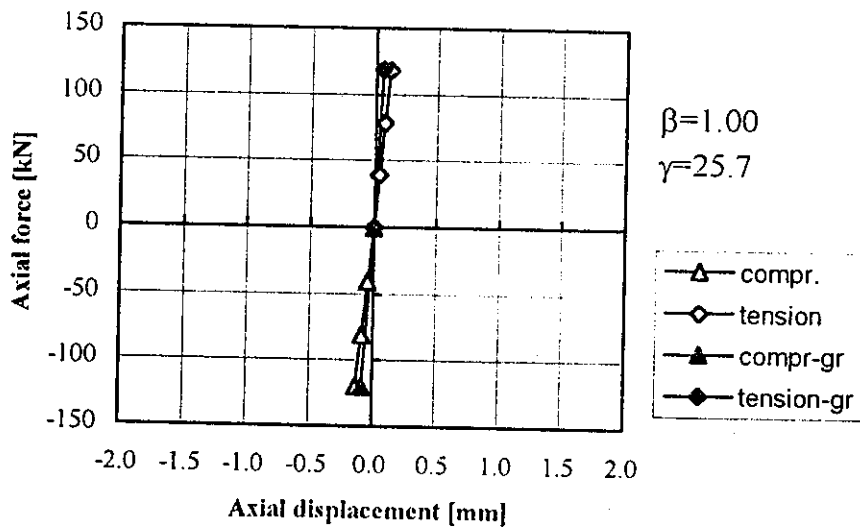

Figure P-14: Local axial joint deformation of specimen DT9

Appendix P-9 Local Joint deformation of T1

Local Bending Joint Deformation T1

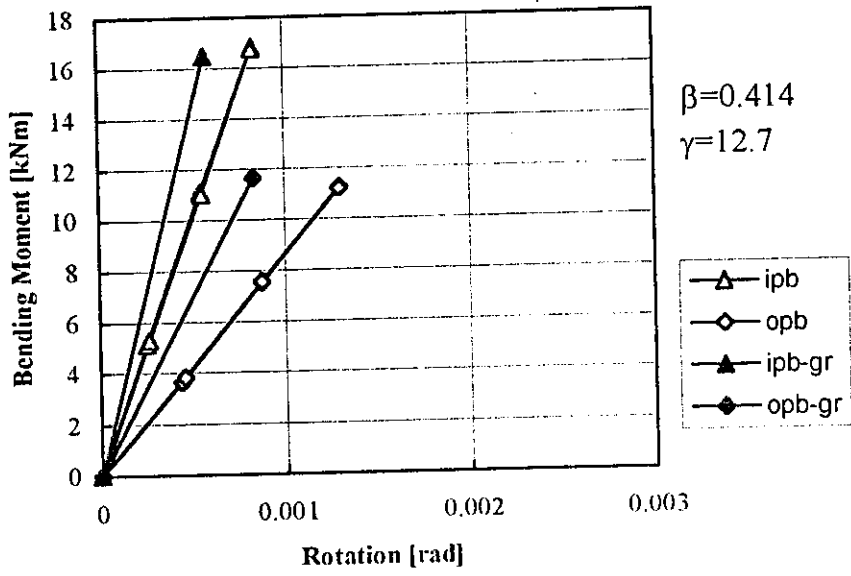

Figure P-15: Local bending joint deformation of specimen T1

Local Axial Joint Deformation T1

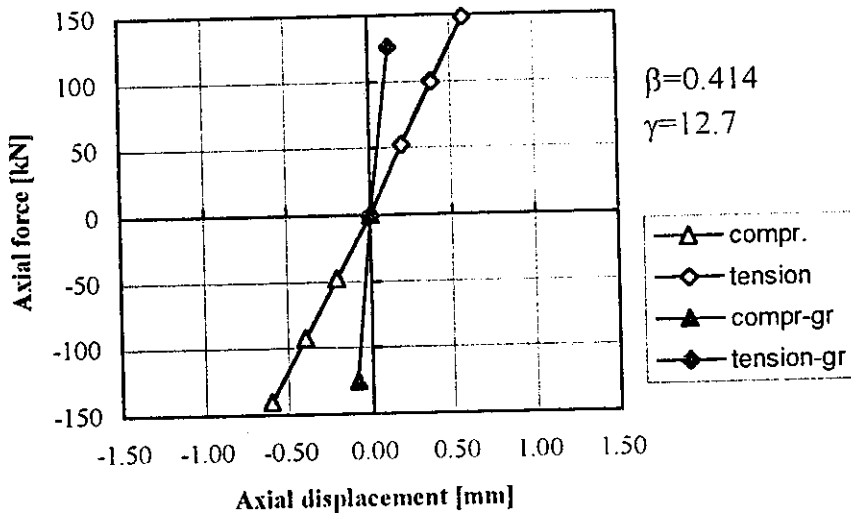

Figure P-16: Local axial joint deformation of specimen T1



Appendix P-10 Local Joint deformation of T3

Local Bending Joint Deformation T3

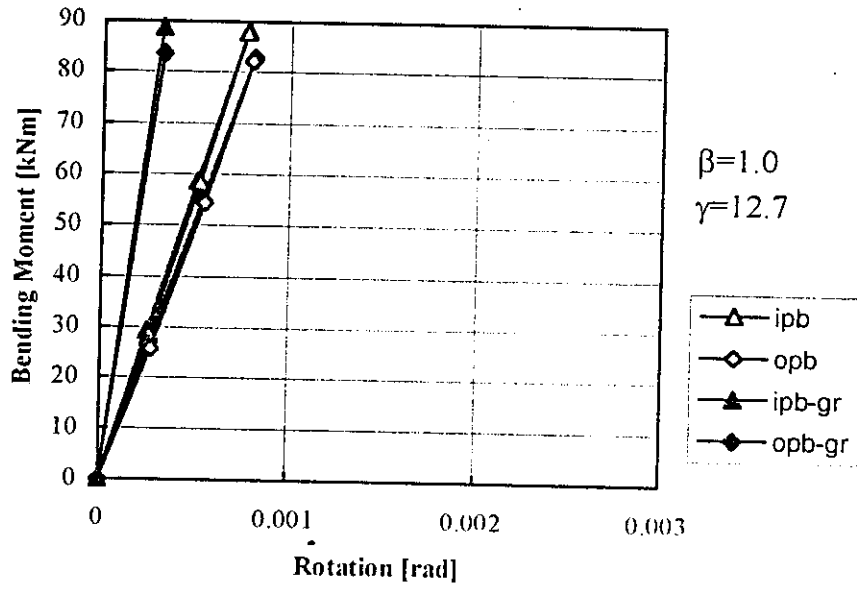

Figure P-17: Local bending joint deformation of specimen T3

Local Axial Joint Deformation T3

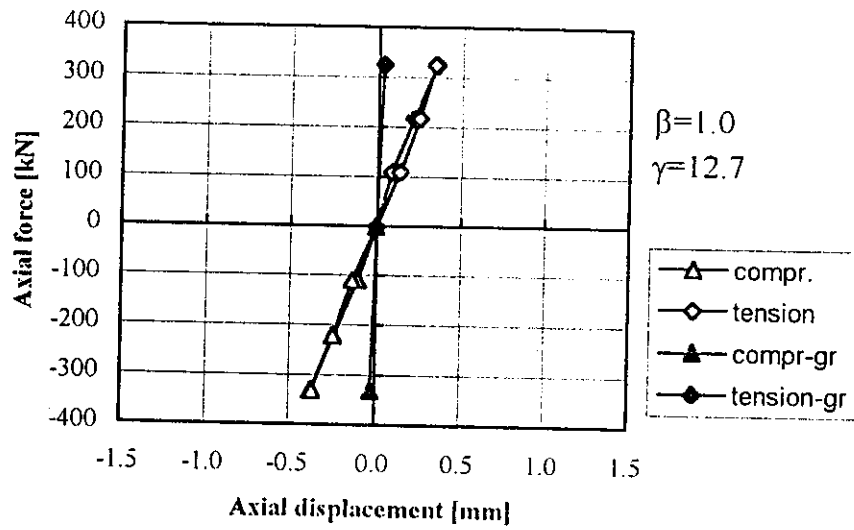

Figure P-18: Local axial joint deformation of specimen T3

Local Bending Joint Deformation T5

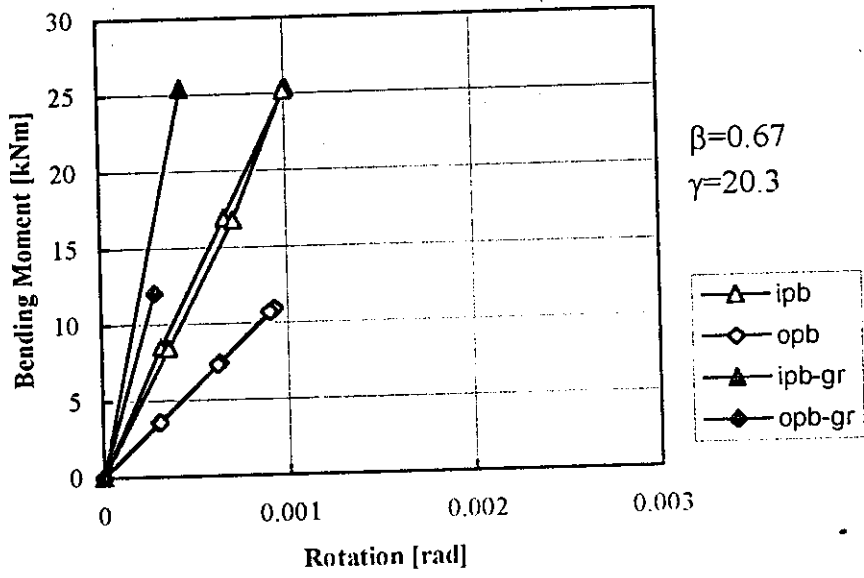

Figure P-19: Local bending joint deformation of specimen T5

Local Axial Joint Deformation T5

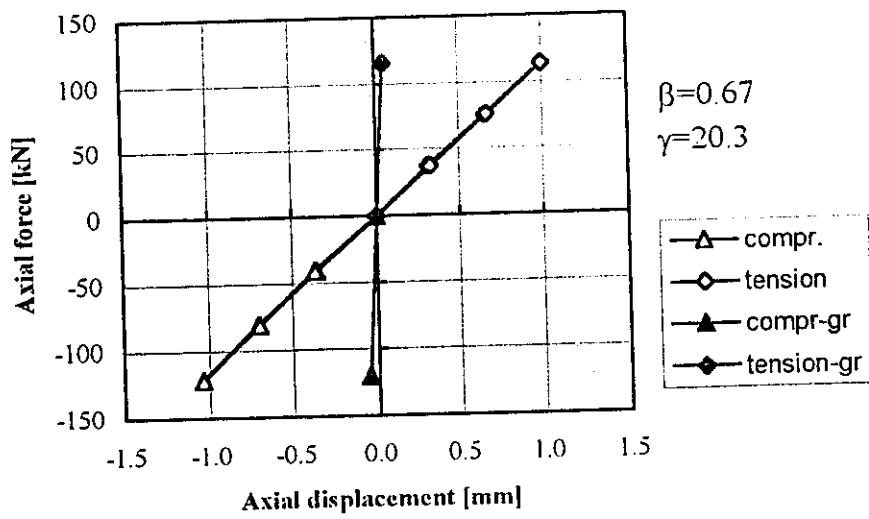

Figure P-20: Local axial joint deformation of specimen T5

Appendix P-12 Local Joint deformation of T7

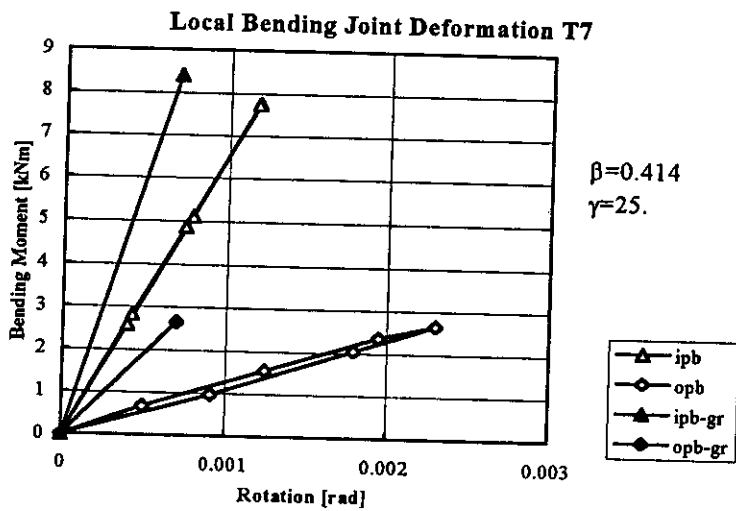

Figure P-21: Local bending joint deformation of specimen T7

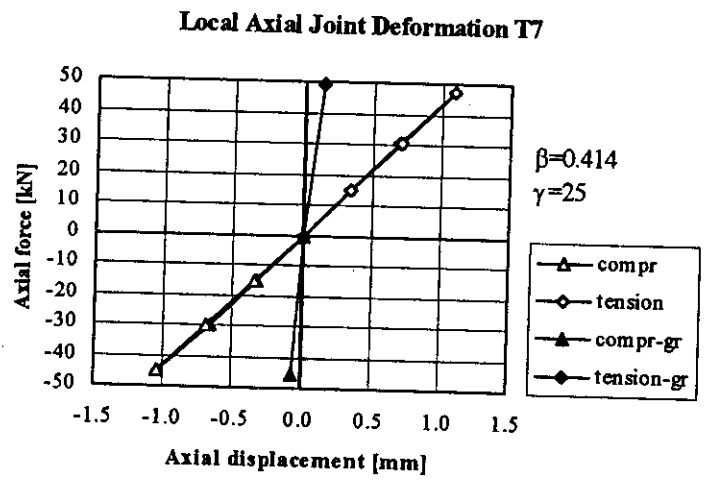
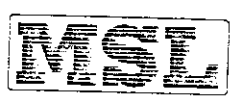

Figure P-22: Local axial joint deformation of specimen T7



Appendix P-13 Local Joint deformation of T9

Local Bending Joint Deformation T9

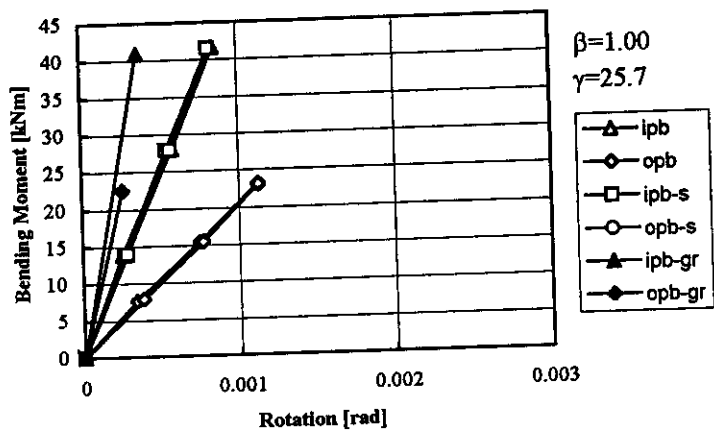

Figure P-23: Local bending joint deformation of specimen

Local Axial Joint Deformation T9

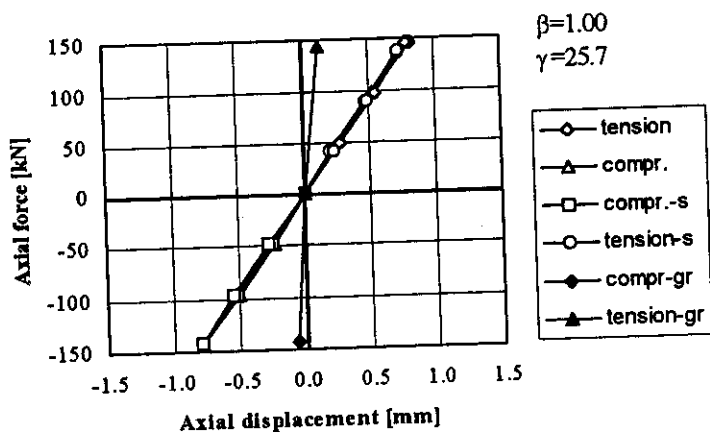

Figure P-24: Local axial joint deformation of specimen T9

APPENDIX Q
Development of Measured Grouted SNCF/Measured
As-welded SNCF Reduction Factors

C14100R020 Rev 1 February 1997

MSL

APPENDIX Q

DEVELOPMENT OF REDUCTION FACTORS

Q1 INTRODUCTION

This appendix presents the development of formulations to predict the SCF Reduction Factor (RF) for each joint and load type for both the chord and brace side of the weld. The definition of RF from which the formulations are derived is:

$$RF = \frac{\text{Measured value of SCF for grouted joint}}{\text{Measured value of SCF for as-welded joint}}$$

It may be noted that the RFs so derived reduce many of the inaccuracies normally associated with SCF measured values. SCF inaccuracies, for example, may arise from errors in the positioning of strain gauges or slight eccentricities in the loading arrangements. These effects will largely cancel when ratios of the SCFs, as in the case of RFs, are taken.

Q2 DATA

The baseline data are, of course, the measured SCF values of the as-welded and grouted joints. These data are discussed in Section 7 of the main text and also in Appendices L and M. It is noted here that the grouted SCFs used in this appendix relate to the values obtained following the 50% preload cycle.

The resulting RFs, found by applying the above definition, are summarised in Table Q1. The table shows the RF for each joint and load type, and differentiates between the saddle and crown position for axially loaded joints. For the sake of completeness, the RFs for the brace side of the weld are also given. In addition to the measured RF values, the values predicted by the formulations given below are also shown in the table. As can be observed, good agreement between the observed and predicted values is indicated across the board except for the axially loaded DT joints at the crown position (this is discussed further below).

The data in Table Q1 are presented in a series of figures (Figures Q1 to Q24), each figure relating to a single joint type (DT or T), load type (compression, tension, IPB or OPB) and, the SCF location (saddle or crown). Figures Q1 to Q12 relate to data on the chord side of the weld and Figures Q13 to Q24 to the brace side. Each figure contains three diagrams:

- plot of RF vs. β
- plot of RF vs. γ
- a 3-D representation of RF vs β and γ .

The first two plots may have up to three lines, each line corresponding to a constant γ or β parameter. To visualise better these two diagrams, 3-D bar charts are given. Note, however, the bar chart axes are not true to scale (the 'skyscrapers' fall on a 3 x 3 regular matrix associated with the discrete values of β and γ).

Q3 FITTING OF RF-SURFACES

The objective now is to find suitable functions

$$RF = f(\beta, \gamma)$$

for the various joint and load types. The functions should capture the shapes of the RF - β - γ surfaces, as illustrated in Figures Q1 to Q24, yet be reasonably simple.

An examination of the surface shapes suggests that RFs are not simple functions of β and γ . Some surfaces exhibit a very strong twisted shape, especially for axially loaded T joints, and all surfaces do to some extent. This means that certain types of functions, such as those that increase monotonically (e.g. $RF = a\beta^b \gamma^c$ or $RF = a_0 + a_1\beta^b + a_2\gamma^c$), prove unsuitable. Figure Q25 illustrates the simplest twisted surface: a twisted plane bounded by four RF values at the corners of the defined region. The equation on this figure is of the form:

$$RF = a_0 + a_1\beta + a_2\gamma + a_3\beta\gamma$$

To allow for deviations of additional RF points away from this twisted plane, the two second order terms of β and γ are added to give the following basic equation:

$$RF = a_0 + a_1\beta + a_2\gamma + a_3\beta\gamma + a_4\beta^2 + a_5\gamma^2$$

where a_0 to a_5 are constants to be fitted.

The above equation has 6 unknown constants whereas for T joints, only 5 data exist (for a given load type). Preliminary fitting trials and the behaviour of DT joints favoured the dropping of the $a_5\gamma^2$ term.

The constants were fitted using a multivariate technique based on minimising the sum of the squares of percentage (not absolute) differences between measured and predicted RF values. In general, it was found that the solution obtained during a fitting cycle was dependent on assumed starting values of the constants, to the extent that sometimes divergent behaviour was observed. Application of the equation shown on Figure Q25 resolved all difficulties in selecting suitable starting constants.

During the course of fitting trials, the constants were successively rounded off starting with the higher order terms and ending with rounding off the lead constant (a_0) after the final fitting. The goodness of fit was monitored during the fitting process by observing the Coefficient of Variation (COV) of predicted RF to measured RF values and the maximum/minimum errors between the data points and fitted surfaces.

MSL

Q3.1 Chord Side RF Values

The results of the fitting process are summarised in Table Q2.

The predicted RF values across the full range of β and γ are shown in Figures Q26 to Q37. These figures also show the measured RF values (some of the predicted values have been set to zero to enable low measured RF values to be observed). As can be seen, the predicted RF - β - γ surfaces are sensibly smooth and, on the whole, capture the measured values well. In one instance (DT joint in compression at the saddle position, Figure Q26), the function predicts negative RF values on extrapolation to the high γ , very low β region. It is therefore necessary to set a lower limit on RF. The following lower limit is suggested:

$$RF \geq 0.10$$

Inspection of table Q2 shows that the poorest fit relates to axially loaded DT joints at the crown position for the tension case, see Figure Q29. The high RF values obtained at the crown position for both tension and compression load cases were capped to prevent a poor fit. The RFs were capped to values consistent with the results obtained for both DT and T joint specimens. The resultant fits give good prediction for grouted SCFs. The maximum error on the non-conservative side is 15.3%. The next 'poorest' fit (for DT joint in tension at the saddle position) gives a non-conservative error of only 6.7%. Examining the measured RF data in Figures Q2 and especially Q4, the problem seems to be associated with a deep well in the mid β and γ range, which the polynomial cannot easily model. The fitting process has given a fitted function that is generally non-conservative away from the mid β and γ region. Since this may be unacceptable, new fits were undertaken by ignoring the central data point. The resulting recommended functions for the DT crown cases are shown in Table Q3 along with all other functions. The COV and error band for the DT crown compression case are 0.016 and 2.2/-2.7 respectively; and 0.106 and 15.3/-14.6 for the tension case. The revised RF - β - γ comparison plots are shown in Figures Q38 and Q39.

One final comment is worth making. This concerns the relatively high RF values for $\beta = 1$ DT joints under axial or OPB loads. For these cases, load transference across the chord is dominated by membrane action (which is why the RF values approach unity) and this membrane action quickly decays as β is reduced from unity. In the fitting process, no attempt has been made to reflect more accurately the rapid decay (indeed, there are no data on which to base a suitable decay function). However, it is noted that the selected RF function will overestimate the RF value at β values approaching unity. The selected RF function is, therefore, conservative.

Q3.2 Brace Side RF Values

A similar fitting exercise was carried out for the brace RF values as was performed for the chord side. The recommended functions for predicting brace side RF values are given in Table Q4. The comparisons of predicted and measured RF values are illustrated in Figures Q40 to Q51.

The fitting of the RF- β - γ surfaces usually proceeded without difficulty. However, again, the crown positions of axially loaded DT joints needed specific consideration. An

examination of the data shown in Figures Q14 and Q16 show that extremely high brace side RF values may exist for joints of intermediate β . The high RF values arise from very low measured as-welded SCF values coupled with the above definition of RF. It was considered that a fitted surface to the RF values as they stand would be suspect, and in any case highly dependent on the accuracy of the measured as-welded SCFs. In these cases, therefore, it was decided to treat the high RF values as being somewhat spurious and to replace both the high values at $\gamma = 12$ and 20 by a RF value of unity. Having made these replacements, functions were fitted and these are compared with the original data in Figures Q41 and Q43 for the compression and tension cases respectively.

The high measured RF values are approximately an order greater than corresponding predicted RF values and, therefore, the latter are potentially very non-conservative. Indeed they would be if applied to measured as-welded SCFs for estimating grouted SCFs. The predicted RFs are quite conservative, however, when used in conjunction with calculated as-welded SCFs from the Efthymiou set of parametric equations, see Tables Q5 to Q8.

Q4. Concluding Remarks

Tables Q5 to Q8 present a comparison of predicted and measured as-welded and grouted SCFs for the two joint types at all locations. Of note are the predicted grouted SCFs derived using predicted RFs, from joint parameters, with measured as-welded SCFs and Efthymiou predicted as-welded SCFs. The results demonstrate that for a number of joint configurations, the crown SCF becomes critical, in the grouted condition, and even supercedes the highest as-welded SCF.

Specimen Ident.	D (mm)	d (mm)	T (mm)	t (mm)	L (mm)	θ (°)	β	γ	τ	α	Condition	Chord RFs						Brace RFs					
												IPB	OPB	Comp.		Tens.		IPB	OPB	Comp.		Tens.	
														Ax-s	Ax-c	Ax-s	Ax-c			Ax-s	Ax-c	Ax-s	Ax-c
T1	406.78	167.81	16.39	16.32	2440	90.0	0.413	12.409	0.996	12.00	Measured	0.97	0.72	0.55	1.01	0.54	0.91	1.01	0.89	0.56	4.43	0.62	3.89
T3	406.78	407.02	16.39	16.10	2440	90.0	1.000	12.409	0.982	12.00	Predicted	1.00	0.71	0.55	0.98	0.53	0.91	1.07	0.89	0.53	4.53	0.65	3.82
T5	407.05	273.34	10.19	9.82	2440	90.0	0.672	19.973	0.964	11.99	Measured	0.92	0.27	0.09	1.04	0.25	1.11	1.10	0.33	0.30	1.16	0.31	1.08
T7	406.96	168.41	7.86	8.31	2440	90.0	0.414	25.888	1.057	11.99	Predicted	0.94	0.27	0.09	1.05	0.25	1.13	1.12	0.33	0.28	1.19	0.30	1.11
T9	406.96	406.96	7.86	7.86	2440	90.0	1.000	25.888	1.000	11.99	Measured	0.90	0.37	0.30	0.93	0.29	0.95	1.24	0.45	0.30	2.07	0.34	1.67
DT2	406.78	273.09	16.39	15.76	2440	90.0	0.671	12.409	0.962	12.00	Predicted	0.87	0.37	0.30	0.93	0.28	0.95	1.26	0.45	0.34	2.07	0.35	1.65
DT3	406.78	407.02	16.39	16.10	2440	90.0	1.001	12.409	0.982	12.00	Measured	0.69	0.48	0.21	0.58	0.47	0.71	1.22	0.74	0.26	1.39	0.48	1.13
DT4	407.05	168.57	10.19	9.95	2440	90.0	0.414	19.973	0.976	11.99	Predicted	0.68	0.48	0.21	0.59	0.45	0.69	1.21	0.74	0.27	1.37	0.49	1.08
DT5	407.05	273.34	10.19	9.82	2440	90.0	0.672	19.973	0.964	11.99	Measured	0.95	0.27	0.22	1.03	0.24	0.98	1.24	0.26	0.36	1.24	0.29	0.94
DT6	407.05	407.60	10.19	9.61	2440	90.0	1.001	19.973	0.943	11.99	Predicted	0.94	0.27	0.23	1.05	0.25	0.99	1.26	0.26	0.42	1.19	0.30	0.97
DT8	406.96	273.21	7.86	7.88	2440	90.0	0.671	25.888	1.003	11.99	Measured	0.79	0.66	0.39	1.57	0.39	0.95	1.38	0.74	0.34	33.40	0.41	10.43
DT9	406.96	406.96	7.86	7.86	2440	90.0	1.000	25.888	1.000	11.99	Predicted	0.74	0.65	0.36	1.61	0.38	0.97	1.36	0.72	0.35	4.34	0.42	1.47
											Measured	0.67	0.97	0.95	1.86	1.02	1.29	1.61	0.96	0.90	1.24	0.79	1.11
											Predicted	0.68	0.99	0.92	1.91	1.02	1.40	1.65	1.02	0.94	1.34	0.90	1.15
											Measured	0.57	0.55	0.12	0.71	0.27	0.57	1.35	0.85	0.16	2.23	0.31	1.00
											Predicted	0.57	0.55	0.12	0.74	0.28	0.56	1.34	0.83	0.15	2.39	0.31	1.06
											Measured	0.54	0.47	0.25	0.48	0.32	0.16	1.40	0.54	0.23	27.57	0.34	16.00
											Predicted	0.59	0.51	0.28	1.67	0.31	1.22	1.41	0.57	0.25	4.24	0.34	1.20
											Measured	0.62	0.97	0.89	2.92	0.81	2.10	1.76	1.00	0.92	1.42	0.79	1.09
											Predicted	0.60	0.95	0.96	2.90	0.83	1.78	1.65	0.94	0.94	1.62	0.67	0.95
											Measured	0.49	0.42	0.20	1.68	0.28	1.46	1.44	0.49	0.18	3.83	0.30	1.40
											Predicted	0.48	0.40	0.21	1.73	0.26	1.42	1.45	0.46	0.17	4.17	0.28	1.23
											Measured	0.53	0.93	1.00	3.53	0.69	1.81	1.56	0.85	0.94	1.75	0.47	0.98
											Predicted	0.54	0.92	0.99	3.67	0.68	2.07	1.65	0.88	0.94	1.88	0.49	1.03

Predicted RF values given by formulations in Tables Q3 and Q4.

Table Q1 : Summary of Reduction Factors



$$RF = a_0 + a_1\beta + a_2\gamma + a_3\beta\gamma + a_4\beta^2 + a_5\gamma^2$$

Joint type	Load (Position)	a ₀	a ₁	a ₂	a ₃	a ₄	a ₅	COV	Max/min Error (%)
DT	COMP (Saddle)	1.963	-3.471	-0.082	0.0534	2.670	0.0008	0.019	2.0/-3.7
		1.505	-3.125	-0.047	0.0498	2.507	0	0.051	4.4/-8.9
		1.46	-3.1	-0.045	0.05	2.5	0	0.062	6.6/-11.2
	COMP (Crown)	4.0337	-3.959	-0.238	0.6073	0.2103	0.0001	0.015	2.6/-2.0
		4.1	-4.0	-0.24	0.37	0.2	0	0.016	2.2/-2.7
	TENS (Saddle)	0.418	-1.312	0.016	-0.0491	2.285	0.0002	0.006	0.6/-1.2
		0.307	-1.238	0.025	-0.0490	2.239	0	0.013	1.1/-2.0
0.43		-1.6	0.025	-0.05	2.5	0	0.038	6.7/-2.6	
TENS (Crown)	-0.948	3.091	0.003	0.052	-1.445	0.0001	0.105	14.9/-16.5	
	-0.92	3.2	0	0.05	-1.5	0	0.106	15.3/-14.6	
IPB (Crown)	1.623	-0.611	-0.065	0.0322	-0.003	0.0006	0.044	5.6/-6.7	
	1.328	-0.365	-0.042	0.0318	-0.153	0	0.048	4.6/-10.3	
	1.28	-0.33	-0.040	0.03	-0.15	0	0.049	5.8/-10.0	
OPB (Saddle)	2.709	-4.212	-0.081	0.0452	2.801	0.0009	0.024	4.0/-2.5	
	2.255	-3.844	-0.046	0.0430	2.600	0	0.037	3.7/-8.0	
	2.25	-3.8	-0.045	0.04	2.6	0	0.039	4.4/-8.2	
T	COMP (Saddle)	2.300	-3.518	-0.081	0.1228	0.783		0	0/0
		1.37	-1.1	-0.05	0.06	-0.3		0.02	-0.2/-4.5
	COMP (Crown)	-0.023	4.769	-0.020	-0.032	-3.071		0	0/0
		1.35	0.2	-0.05	-0.05	-0.5		0.018	2.6/-1.9
	TENS (Saddle)	2.052	-4.447	-0.029	0.0570	2.295		0	0/0
		1.35	-2.3	-0.01	0.01	1.2		0.032	3.2/-1.0
	TENS (Crown)	-0.365	4.492	0.013	-0.068	-2.335		0	0/0
0.75		1.1	-0.02	0.01	-0.6		0.016	2.5/-1.4	
IPB (Crown)	1.305	-0.028	-0.037	0.0393	-0.385		0	0/0	
	1.54	-0.6	-0.04	0.04	0		0.024	2.8/-3.2	
OPB (Saddle)	1.789	-2.423	-0.030	0.030	0.904		0	0/0	
	1.77	-2.4	-0.03	0.03	0.9		0.005	1.0/0	

Notes:

- 1) Values in bold were fixed during fitting run
- 2) Error = (RF measured - RF predicted) / RF measured; therefore -ve error is conservative.

Table Q2: Summary of RF Results from Fitting Process for Chord Side

MSL

$$RF = a_0 + a_1\beta + a_2\gamma + a_3\beta\gamma + a_4\beta^2 \text{ but } RF \geq 0.10$$

Joint Type	Load (Position)	a_0	a_1	a_2	a_3	a_4
DT	COMP (Saddle)	1.46	-3.1	-0.045	0.05	2.5
	COMP (Crown)*	4.10	-4.0	-0.240	0.37	0.2
	TENS (Saddle)	0.43	-1.6	0.025	-0.05	2.5
	TENS (Crown)*	-0.92	3.2	0	0.05	-1.5
	IPB (Crown)	1.28	-0.33	-0.040	0.03	-0.15
	OPB (Saddle)	2.25	-3.8	-0.045	0.04	2.6
T	COMP (Saddle)	1.37	-1.1	-0.05	0.06	-0.3
	COMP (Crown)	1.35	0.2	-0.05	0.05	-0.5
	TENS (Saddle)	1.35	-2.3	-0.01	0.01	1.2
	TENS (Crown)	0.75	1.1	-0.02	0.01	-0.6
	IPB (Crown)	1.54	-0.6	-0.04	0.04	0
	OPB (Saddle)	1.77	-2.4	-0.03	0.03	0.9

Ranges of validity: $0.4 \leq \beta \leq 1.0$, $12 \leq \gamma \leq 26$, $\tau \approx 1.0$, $\theta = 90^\circ$

* Unduly conservative RF may be predicted at crown position for axially loaded DT joints.

Table Q3: Recommended Formulations for Reduction Factors on Chord Side

MSL

RF = $a_0 + a_1\beta + a_2\gamma + a_3\beta\gamma + a_4\beta^2$ but RF ≥ 0.10						
Joint Type	Load (Position)	a_0	a_1	a_2	a_3	a_4
DT	COMP (Saddle)	1.64	-3.7	-0.04	0.04	3.0
	COMP (Crown)*	-3.0	22.7	-0.06	0.10	-19.0
	TENS (Saddle)	0.07	-0.30	0.03	-0.06	1.5
	TENS (Crown)*	-0.54	1.9	+0.09	-0.1	-0.1
	IPB (Crown)	1.05	-0.21	0.02	-0.02	0.8
	OPB (Saddle)	3.04	-5.5	-0.04	0.03	3.6
T	COMP (Saddle)	1.36	-1.6	-0.04	0.05	0.4
	COMP (Crown)	11.84	-10.6	-0.40	+0.04	-0.05
	TENS (Saddle)	1.6	-2.4	-0.02	0.02	1.1
	TENS (Crown)	10.33	-10	-0.34	0.33	0.9
	IPB (Crown)	0.5	1.5	0.01	0	-1.0
	OPB (Saddle)	2.09	-3.2	-0.015	0.01	1.5
Ranges of validity: $0.4 \leq \beta \leq 1.0$, $12 \leq \gamma \leq 26$, $\tau \approx 1.0$, $\theta = 90^\circ$						

* Non-conservative RF may be predicted at crown position for axially loaded DT joints.

Table Q4: Recommended Formulations for Reduction Factors on Brace Side

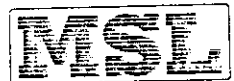

γ	β = 0.414									
	Measured as-welded SCF		Measured grouted SCF		Measured RF		Table Q4 Predicted RF		Predicted grouted SCF	
	Crown	Saddle	Crown	Saddle	Crown	Saddle	Crown	Saddle	Crown	Saddle
12.409										
Comp.	0.30	6.47	1.33	3.60	4.43	0.56	4.53	0.53	1.36	3.41
Ten.	0.29	5.95	1.12	3.68	3.89	0.62	3.82	0.65	1.10	3.87
OPB		3.70		3.28		0.89		0.89		3.28
IPB	1.61		1.62		1.01		1.07		1.73	
19.973										
Comp.										
Ten.										
OPB										
IPB										
25.888										
Comp.	1.14	12.55	1.58	3.32	1.39	0.26	1.37	0.27	1.57	3.35
Ten.	1.16	12.44	1.31	5.93	1.13	0.48	1.08	0.49	1.25	6.12
OPB		7.96		5.88		0.74		0.74		5.90
IPB	1.99		2.42		1.22		1.21		2.41	

γ	β = 0.672									
	Measured as-welded SCF		Measured grouted SCF		Measured RF		Table Q4 Predicted RF		Predicted grouted SCF	
	Crown	Saddle	Crown	Saddle	Crown	Saddle	Crown	Saddle	Crown	Saddle
12.409										
Comp.										
Ten.										
OPB										
IPB										
19.973										
Comp.	1.32	13.16	2.74	3.95	2.07	0.30	2.07	0.34	2.74	4.44
Ten.	1.21	13.00	2.03	4.36	1.67	0.34	1.65	0.35	2.01	4.59
OPB		9.26		4.21		0.45		0.45		4.18
IPB	1.82		2.26		1.24		1.26		2.29	
25.888										
Comp.										
Ten.										
OPB										
IPB										

γ	β = 1.000									
	Measured as-welded SCF		Measured grouted SCF		Measured RF		Table Q4 Predicted RF		Predicted grouted SCF	
	Crown	Saddle	Crown	Saddle	Crown	Saddle	Crown	Saddle	Crown	Saddle
12.409										
Comp.	2.48	5.15	2.89	1.56	1.16	0.30	1.19	0.28	2.96	1.46
Ten.	2.50	5.21	2.69	1.60	1.08	0.31	1.11	0.30	2.76	1.56
OPB		5.77		1.88		0.33		0.33		1.89
IPB	1.38		1.52		1.10		1.12		1.55	
19.973										
Comp.										
Ten.										
OPB										
IPB										
25.888										
Comp.	2.62	8.53	3.24	3.03	1.24	0.36	1.19	0.42	3.11	3.57
Ten.	2.58	8.26	2.43	2.39	0.94	0.29	0.97	0.30	2.51	2.48
OPB		8.44		2.17		0.26		0.26		2.20
IPB	1.68		2.09		1.24		1.26		2.11	

Table Q5: Comparison of Brace T-Joint Measured and Predicted As-welded and Grouted SCFs.

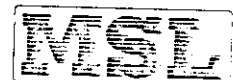

γ	β = 0.414									
	Measured as-welded SCF		Measured grouted SCF		Measured RF		Table Q4 Predicted RF		Predicted grouted SCF	
	Crown	Saddle	Crown	Saddle	Crown	Saddle	Crown	Saddle	Crown	Saddle
12.409										
Comp.	6.95	11.23	7.00	6.20	1.01	0.55	0.98	0.55	6.83	6.19
Ten.	6.42	10.43	5.87	5.64	0.91	0.54	0.91	0.53	5.81	5.53
OPB		7.30		5.26		0.72		0.71		5.20
IPB	2.93		2.83		0.97		1.00		2.93	
19.973										
Comp.										
Ten.										
OPB										
IPB										
25.888										
Comp.	10.20	33.31	5.93	6.84	0.58	0.21	0.59	0.21	6.00	7.06
Ten.	9.59	31.09	6.77	14.50	0.71	0.47	0.69	0.45	6.63	14.05
OPB		21.17		10.21		0.48		0.48		10.07
IPB	5.69		3.95		0.69		0.68		3.90	

γ	β = 0.672									
	Measured as-welded SCF		Measured grouted SCF		Measured RF		Table Q4 Predicted RF		Predicted grouted SCF	
	Crown	Saddle	Crown	Saddle	Crown	Saddle	Crown	Saddle	Crown	Saddle
12.409										
Comp.										
Ten.										
OPB										
IPB										
19.973										
Comp.	10.30	21.35	9.56	6.32	0.93	0.30	0.93	0.30	9.59	6.45
Ten.	9.62	21.16	9.13	6.10	0.95	0.29	0.95	0.28	9.17	5.94
OPB		16.86		6.18		0.37		0.37		6.19
IPB	4.36		3.91		0.90		0.87		3.81	
25.888										
Comp.										
Ten.										
OPB										
IPB										

γ	β = 1.000									
	Measured as-welded SCF		Measured grouted SCF		Measured RF		Table Q4 Predicted RF		Predicted grouted SCF	
	Crown	Saddle	Crown	Saddle	Crown	Saddle	Crown	Saddle	Crown	Saddle
12.409										
Comp.	10.27	3.54	10.68	0.34	1.04	0.09	1.05	0.09	10.79	0.33
Ten.	10.21	3.26	11.34	0.80	1.11	0.25	1.13	0.25	11.50	0.82
OPB		8.41		2.26		0.27		0.27		2.27
IPB	3.37		3.10		0.92		0.94		3.17	
19.973										
Comp.										
Ten.										
OPB										
IPB										
25.888										
Comp.	9.30	14.53	9.60	3.26	1.03	0.22	1.05	0.23	9.77	3.33
Ten.	8.99	13.94	8.81	3.35	0.98	0.24	0.99	0.25	8.91	3.49
OPB		19.38		5.32		0.27		0.27		5.23
IPB	3.22		3.05		0.95		0.94		3.02	

Table Q6: Comparison of Chord T-Joint Measured and Predicted As-welded and Grouted SCFs.



γ	β = 0.414									
	Measured as-welded SCF		Measured grouted SCF		Measured RF		Table Q4 Predicted RF		Predicted grouted SCF	
	Crown	Saddle	Crown	Saddle	Crown	Saddle	Crown	Saddle	Crown	Saddle
12.409										
Comp.										
Ten.										
OPB										
IPB										
19.973										
Comp.	1.07	13.27	2.39	2.11	2.23	0.16	2.39	0.15	2.56	2.05
Ten.	1.23	13.50	1.24	4.13	1.00	0.31	1.06	0.31	1.31	4.13
OPB		4.74		4.02		0.85		0.83		3.93
IPB	2.64		3.58		1.35		1.34		3.53	
25.888										
Comp.										
Ten.										
OPB										
IPB										

γ	β = 0.672									
	Measured as-welded SCF		Measured grouted SCF		Measured RF		Table Q4 Predicted RF		Predicted grouted SCF	
	Crown	Saddle	Crown	Saddle	Crown	Saddle	Crown	Saddle	Crown	Saddle
12.409										
Comp.	0.06	10.96	2.00	3.74	33.40	0.34	4.34	0.35	0.26	3.79
Ten.	0.08	11.11	0.88	4.51	10.43	0.41	1.47	0.42	0.12	4.64
OPB		5.44		4.03		0.74		0.72		3.93
IPB	1.81		2.50		1.38		1.36		2.46	
19.973										
Comp.	0.08	19.01	2.32	4.33	27.57	0.23	4.24	0.25	0.36	4.68
Ten.	0.06	18.60	0.96	6.36	16.00	0.34	1.20	0.34	0.07	6.32
OPB		9.07		4.90		0.54		0.57		5.20
IPB	1.97		2.76		1.40		1.41		2.77	
25.888										
Comp.	0.50	21.53	1.93	3.88	3.83	0.18	4.17	0.17	2.10	3.63
Ten.	0.52	21.70	0.72	6.43	1.40	0.30	1.23	0.28	0.64	6.04
OPB		10.46		5.10		0.49		0.46		4.77
IPB	1.92		2.76		1.44		1.45		2.78	

γ	β = 1.000									
	Measured as-welded SCF		Measured grouted SCF		Measured RF		Table Q4 Predicted RF		Predicted grouted SCF	
	Crown	Saddle	Crown	Saddle	Crown	Saddle	Crown	Saddle	Crown	Saddle
12.409										
Comp.	0.86	4.31	1.07	3.89	1.24	0.90	1.34	0.94	1.15	4.05
Ten.	0.86	4.24	0.96	3.34	1.11	0.79	1.15	0.90	1.00	3.80
OPB		2.53		2.44		0.96		1.02		2.57
IPB	1.43		2.29		1.61		1.65		2.36	
19.973										
Comp.	1.12	5.24	1.58	4.80	1.42	0.92	1.62	0.94	1.80	4.95
Ten.	1.18	5.00	1.28	3.95	1.09	0.79	0.95	0.67	1.11	3.37
OPB		2.89		2.89		1.00		0.94		2.73
IPB	1.62		2.84		1.76		1.65		2.68	
25.888										
Comp.	1.25	4.45	2.18	4.20	1.75	0.94	1.88	0.94	2.34	4.18
Ten.	1.26	4.25	1.24	1.98	0.98	0.47	1.03	0.49	1.30	2.10
OPB		2.71		2.29		0.85		0.88		2.39
IPB	1.64		2.57		1.56		1.65		2.71	

Table Q7: Comparison of Brace DT-Joint Measured and Predicted As-welded and Grouted SCFs.



γ	β = 0.414									
	Measured as-welded SCF		Measured grouted SCF		Measured RF		Table Q4 Predicted RF		Predicted grouted SCF	
	Crown	Saddle	Crown	Saddle	Crown	Saddle	Crown	Saddle	Crown	Saddle
12.409										
Comp.										
Ten.										
OPB										
IPB										
19.973										
Comp.	4.38	31.52	3.12	3.91	0.71	0.12	0.74	0.12	3.26	3.77
Ten.	4.44	31.37	2.52	8.33	0.57	0.27	0.56	0.28	2.49	8.84
OPB		11.81		6.55		0.55		0.55		6.55
IPB	5.14		2.94		0.57		0.57		2.91	
25.888										
Comp.										
Ten.										
OPB										
IPB										

γ	β = 0.672									
	Measured as-welded SCF		Measured grouted SCF		Measured RF		Table Q4 Predicted RF		Predicted grouted SCF	
	Crown	Saddle	Crown	Saddle	Crown	Saddle	Crown	Saddle	Crown	Saddle
12.409										
Comp.	2.08	15.73	3.26	6.08	2.47	0.15	1.61	0.36	3.34	5.73
Ten.	2.11	15.92	2.02	6.20	0.91	0.15	0.97	0.38	2.05	6.00
OPB		8.08		5.32		0.43		0.65		5.21
IPB	3.98		3.16		0.63		0.74		2.97	
19.973										
Comp.	4.12	35.92	1.98	8.96	0.48	0.25	1.67	0.28	6.89	9.99
Ten.	4.54	35.72	0.74	11.59	0.16	0.32	1.22	0.31	5.55	11.15
OPB		18.20		8.59		0.47		0.51		9.26
IPB	6.06		3.30		0.54		0.59		3.60	
25.888										
Comp.	1.70	43.92	2.86	8.72	1.68	0.20	1.73	0.21	2.94	9.25
Ten.	1.58	44.39	2.32	12.60	1.46	0.28	1.42	0.26	2.25	11.59
OPB		21.59		9.00		0.42		0.40		8.67
IPB	4.79		2.35		0.49		0.48		2.28	

γ	β = 1.000									
	Measured as-welded SCF		Measured grouted SCF		Measured RF		Table Q4 Predicted RF		Predicted grouted SCF	
	Crown	Saddle	Crown	Saddle	Crown	Saddle	Crown	Saddle	Crown	Saddle
12.409										
Comp.	0.78	4.07	1.45	3.86	1.86	0.95	1.91	0.92	1.49	3.75
Ten.	0.79	4.06	1.02	4.14	1.29	1.02	1.40	1.02	1.11	4.14
OPB		3.10		3.01		0.97		0.99		3.06
IPB	2.88		1.93		0.67		0.68		1.95	
19.973										
Comp.	0.61	8.53	1.79	7.61	2.92	0.89	2.90	0.96	1.78	8.22
Ten.	0.62	7.94	1.31	6.46	2.10	0.81	1.78	0.83	1.11	6.62
OPB		5.18		5.04		0.97		0.95		4.94
IPB	3.10		1.93		0.62		0.60		1.86	
25.888										
Comp.	0.72	10.16	2.54	10.15	3.53	1.00	3.67	0.99	2.64	10.06
Ten.	0.74	9.98	1.34	6.84	1.81	0.69	2.07	0.68	1.54	6.82
OPB		6.90		6.42		0.93		0.92		6.35
IPB	3.47		1.82		0.53		0.54		1.88	

Table Q8: Comparison of Chord DT-Joint Measured and Predicted As-welded and Grouted SCFs.

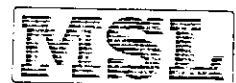

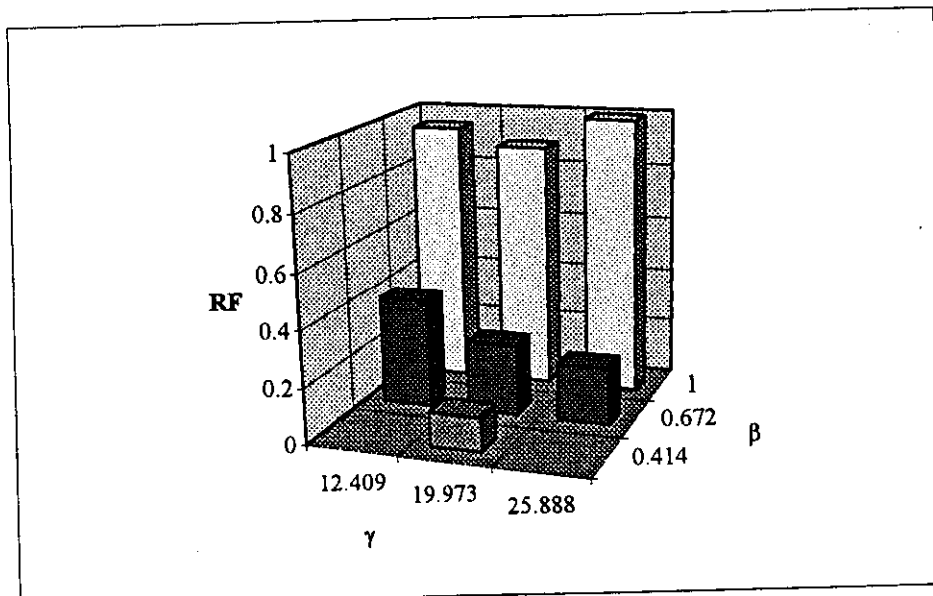
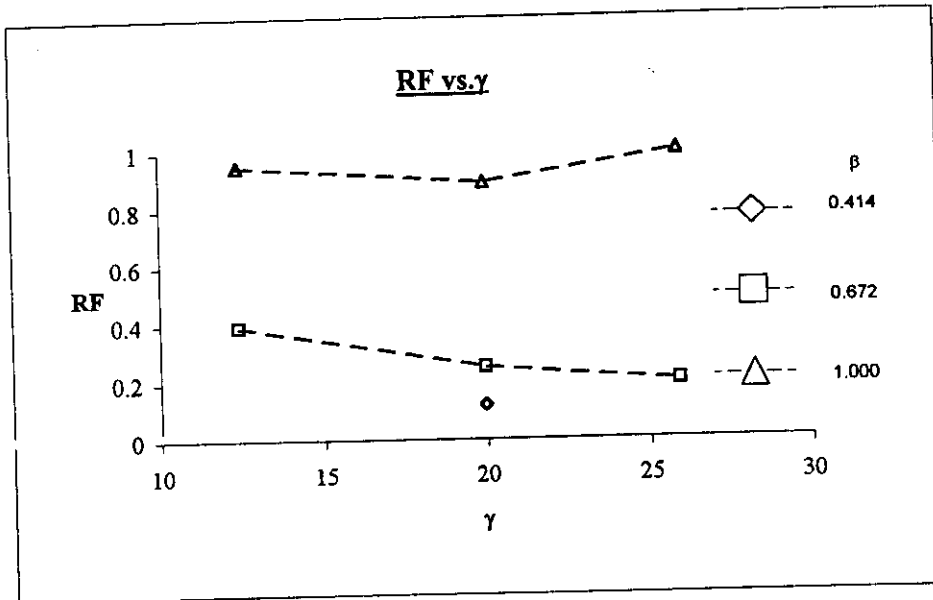
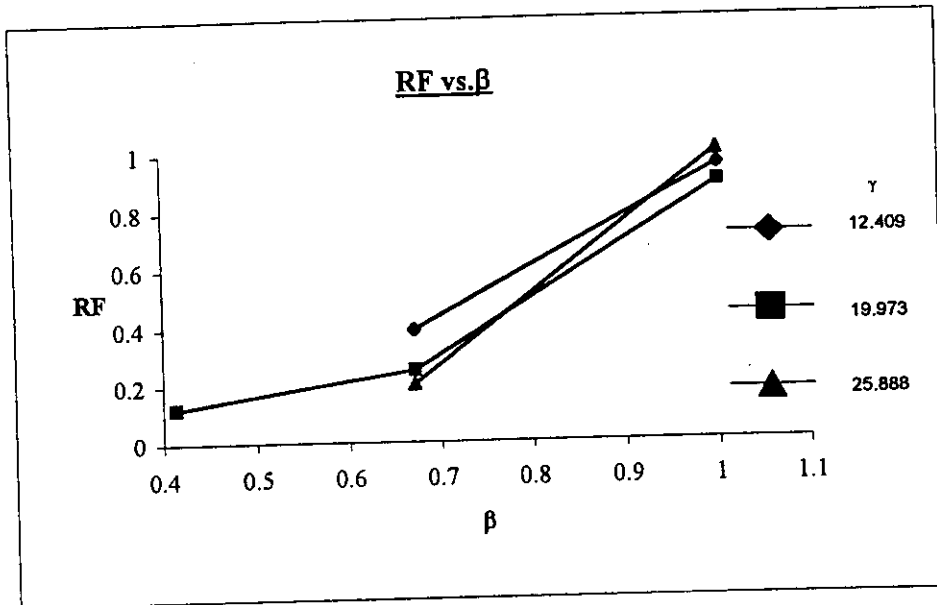

Fig. Q1: DT Joints Under Compression, Chord Saddle

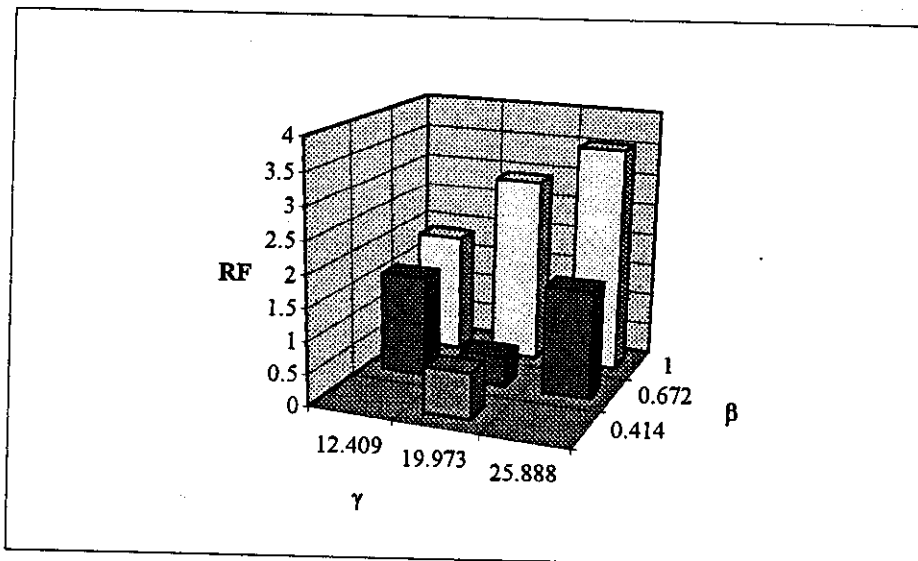
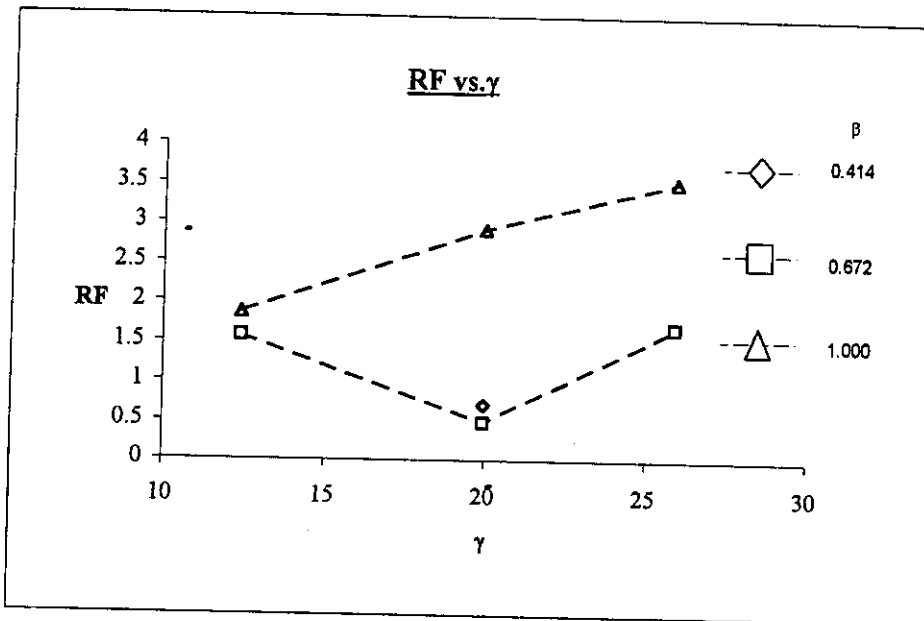
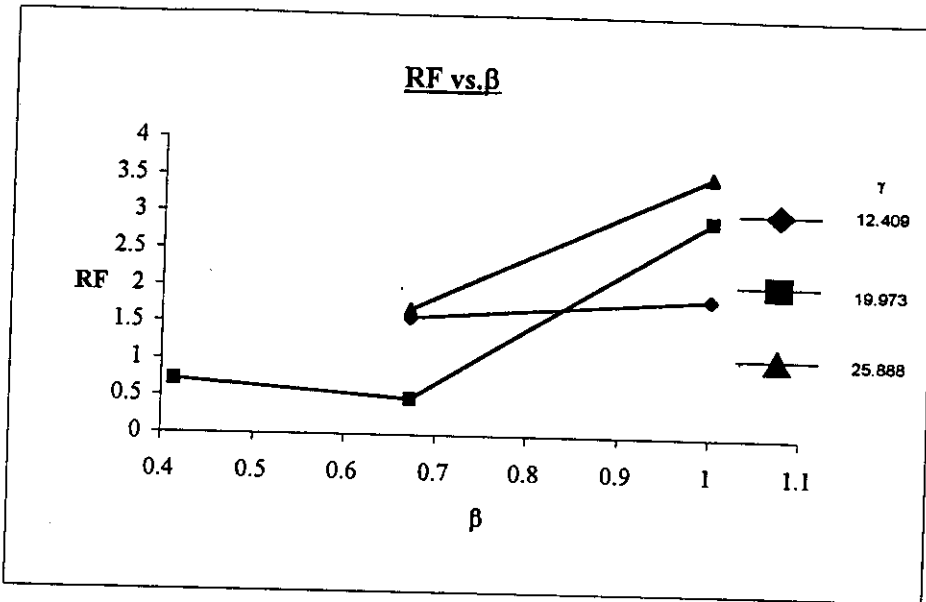

Fig. Q2: DT Joints Under Compression, Chord Crown

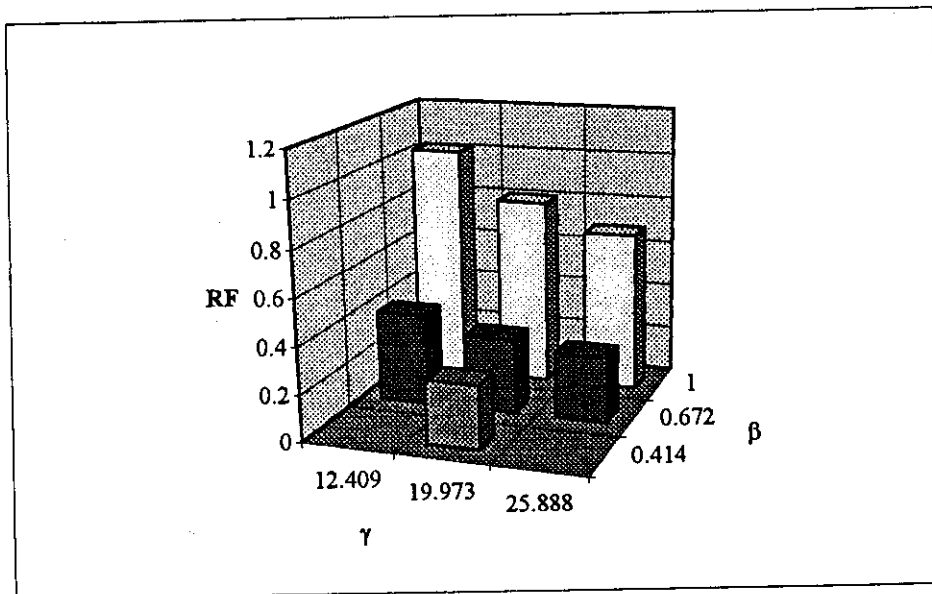
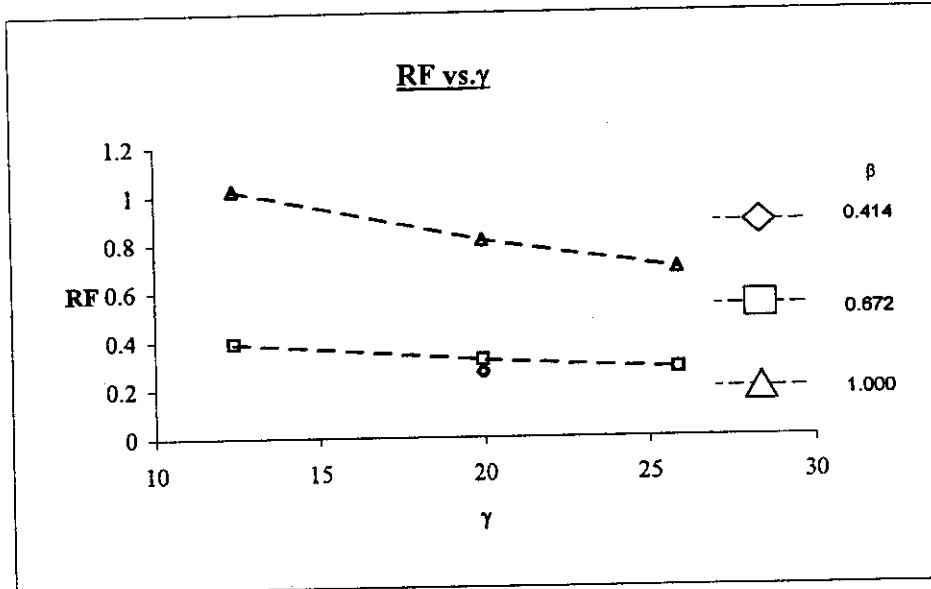
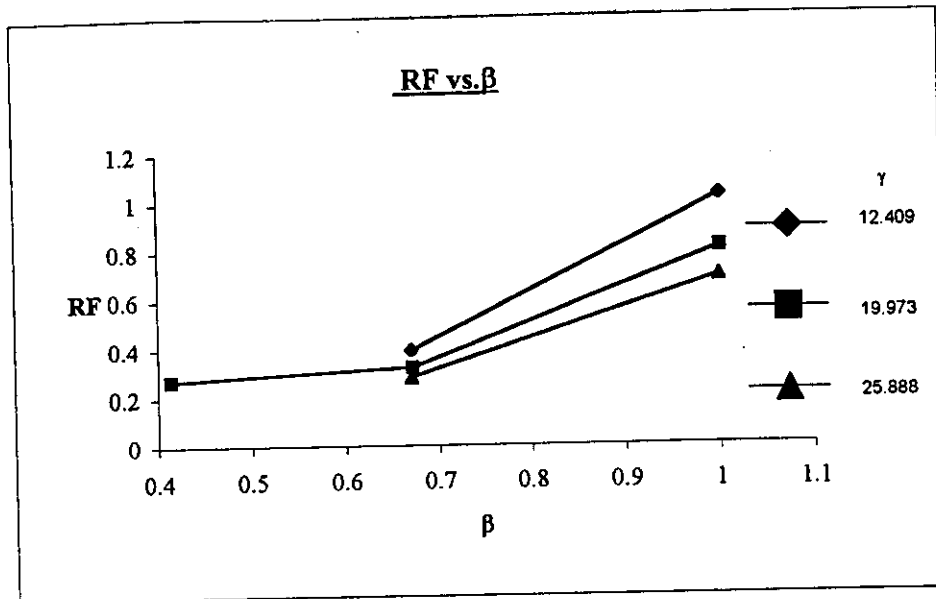

Fig. Q3: DT Joints Under Tension, Chord Saddle

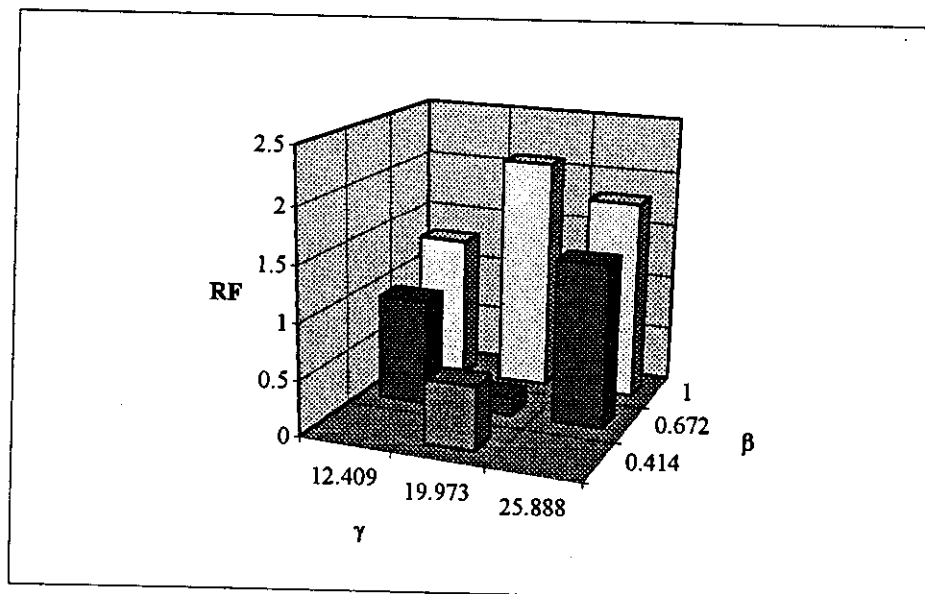
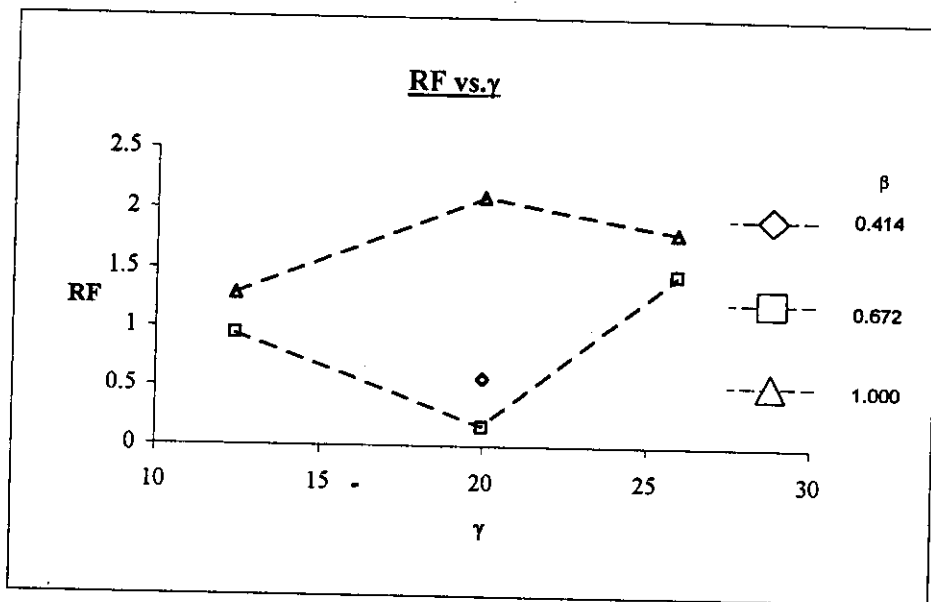
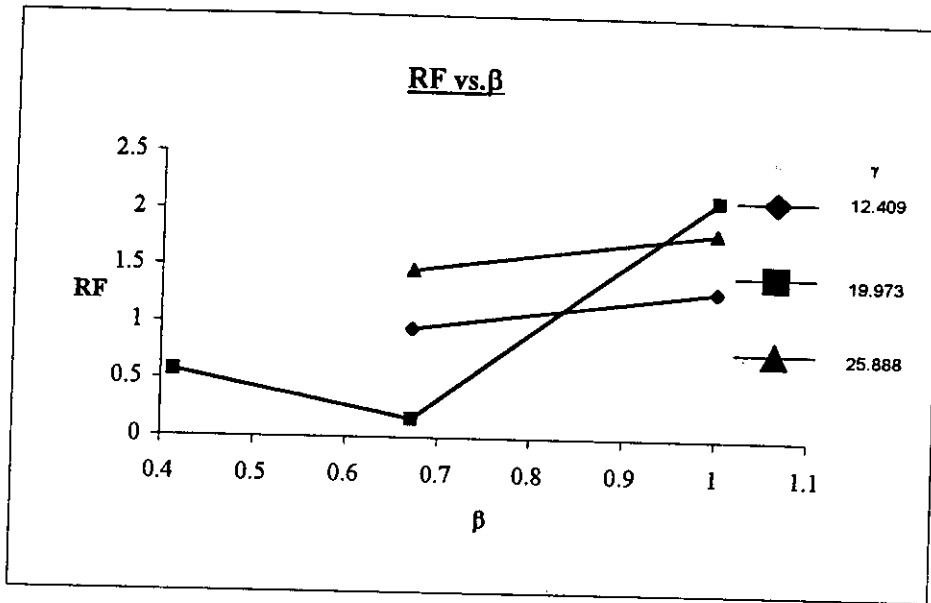

Fig. Q4: DT Joints Under Tension, Chord Crown

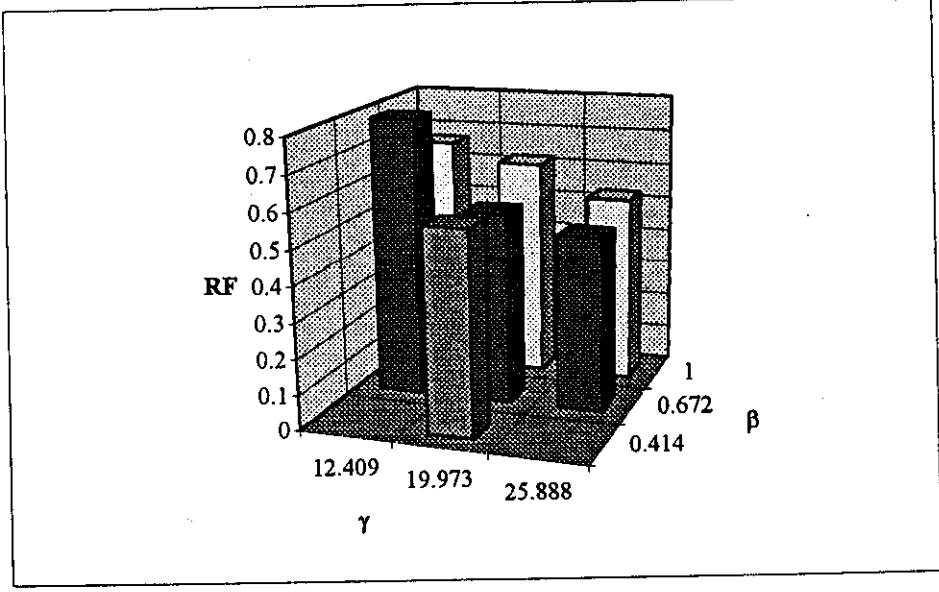
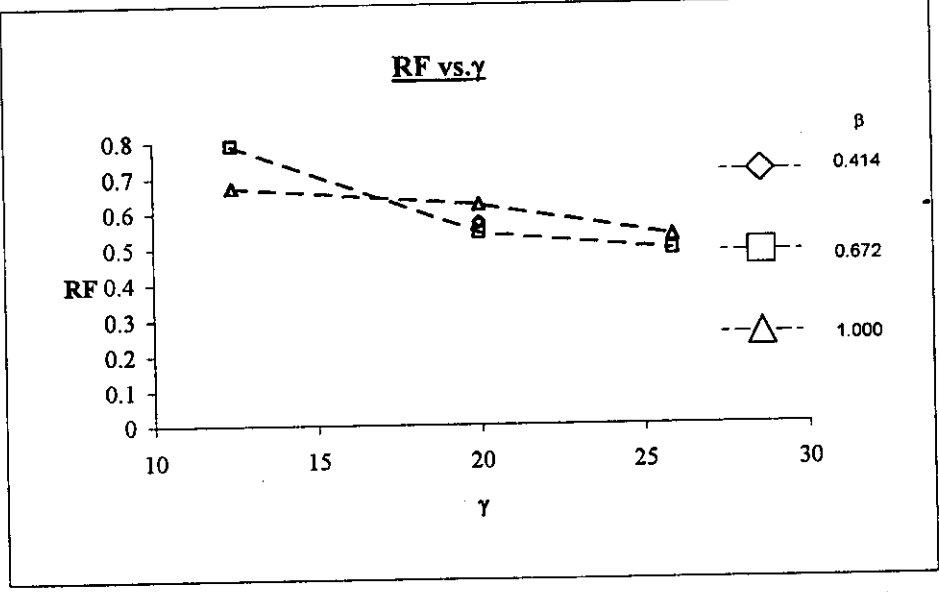
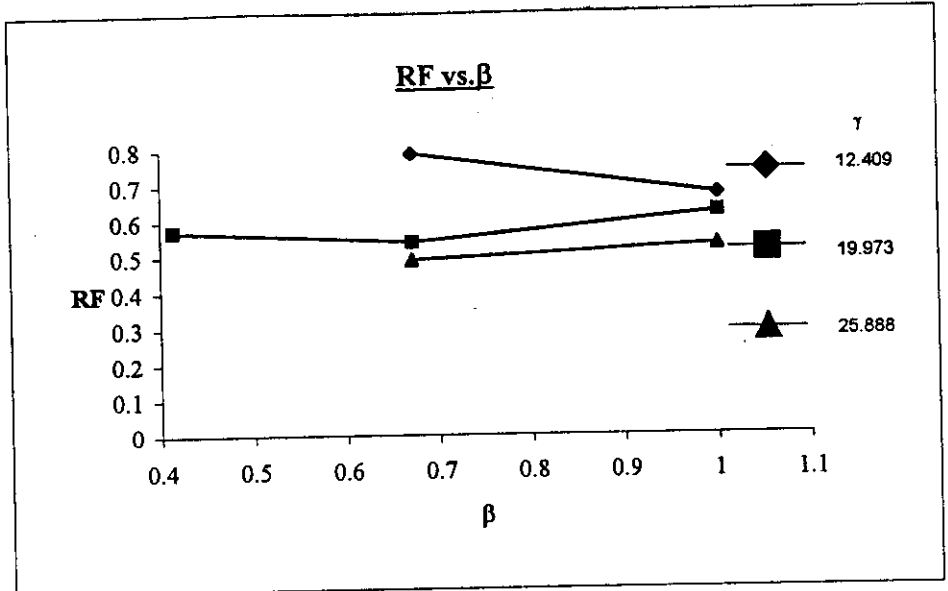
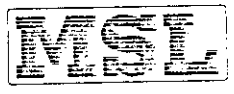

Fig. Q5: DT Joints Under IPB, Chord Crown



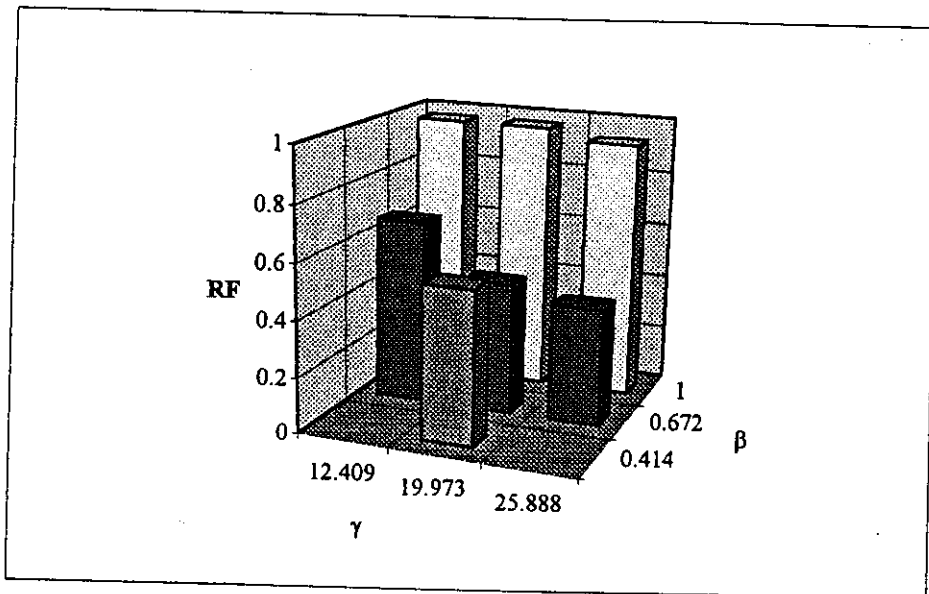
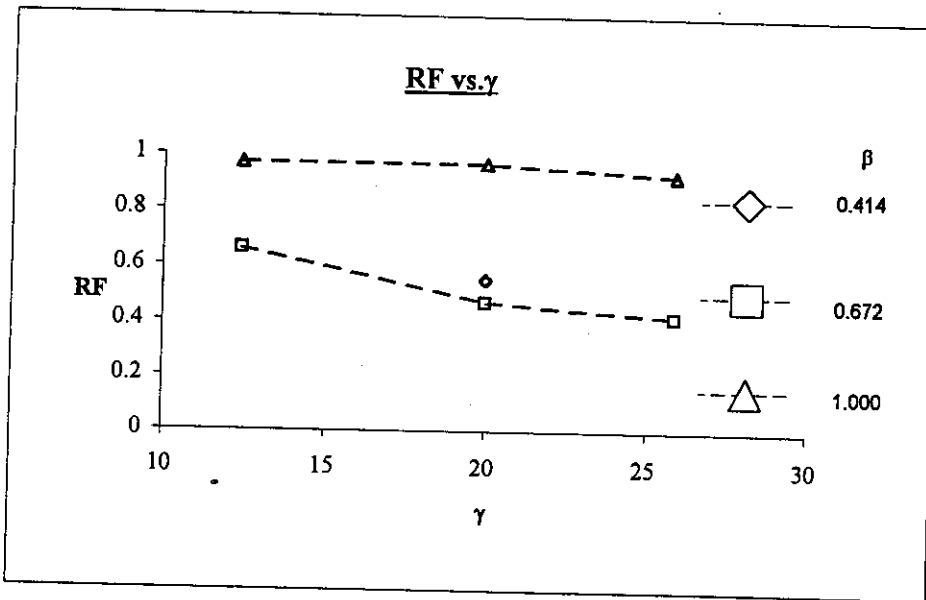
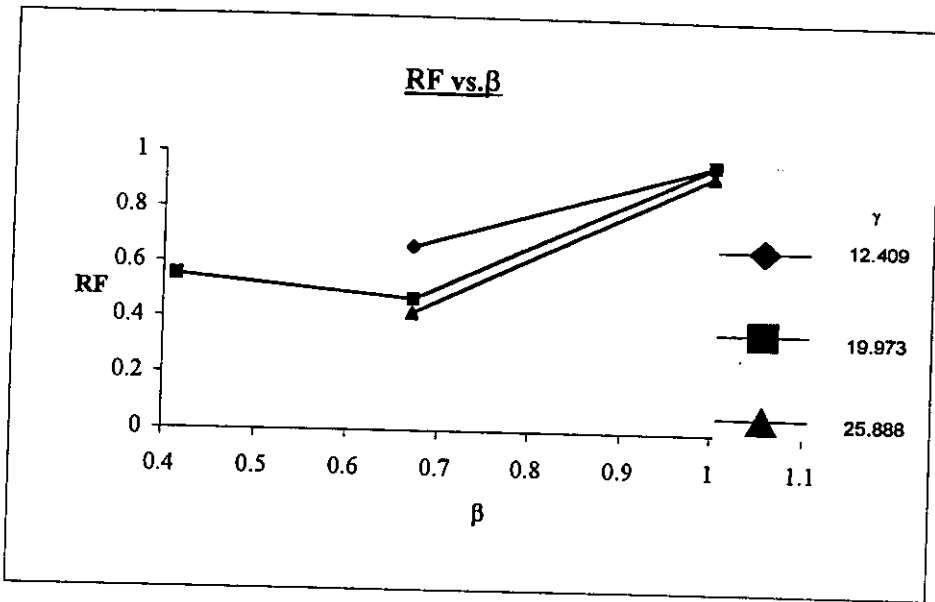

Fig. Q6: DT Joints Under OPB, Chord Saddle

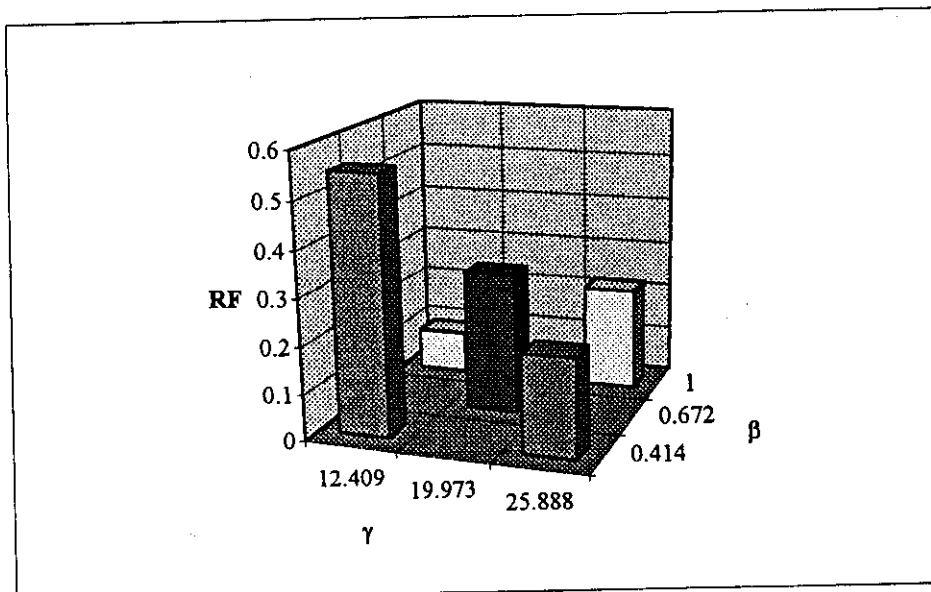
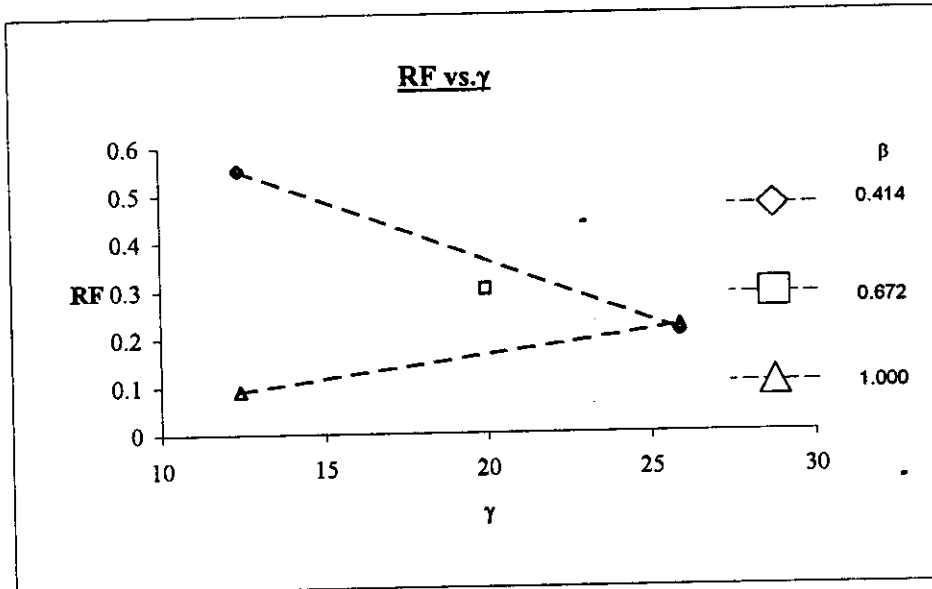
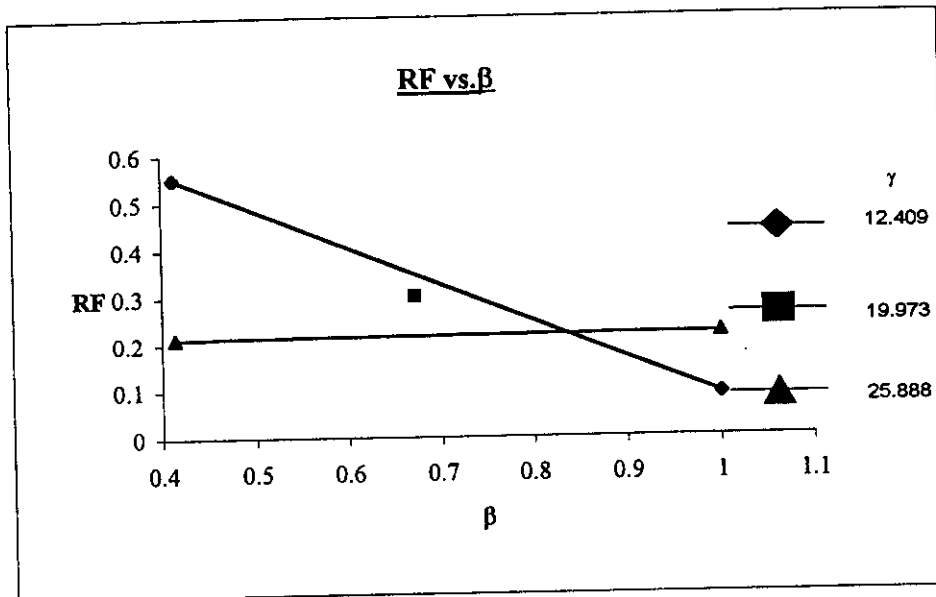

Fig. Q7: T Joints Under Compression, Chord Saddle

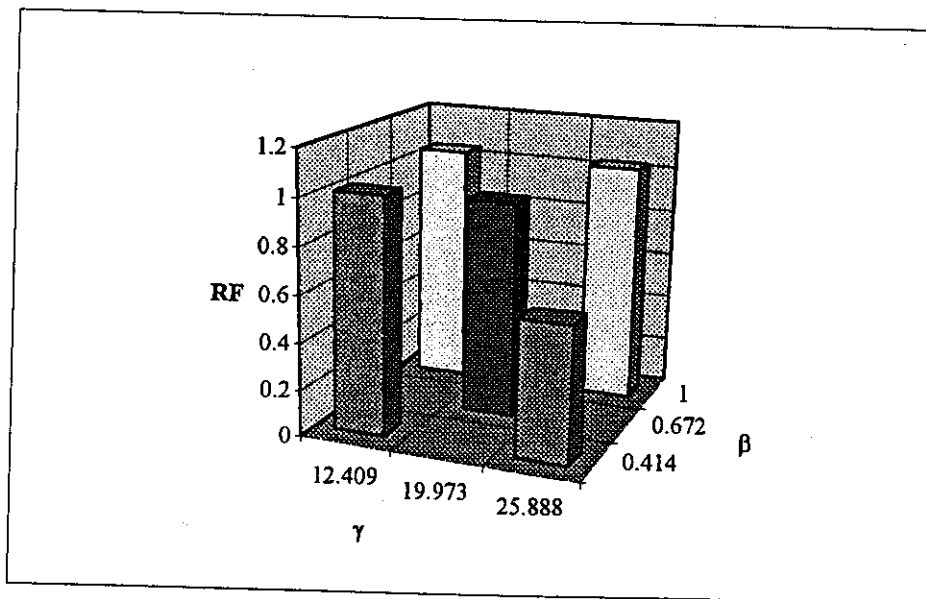
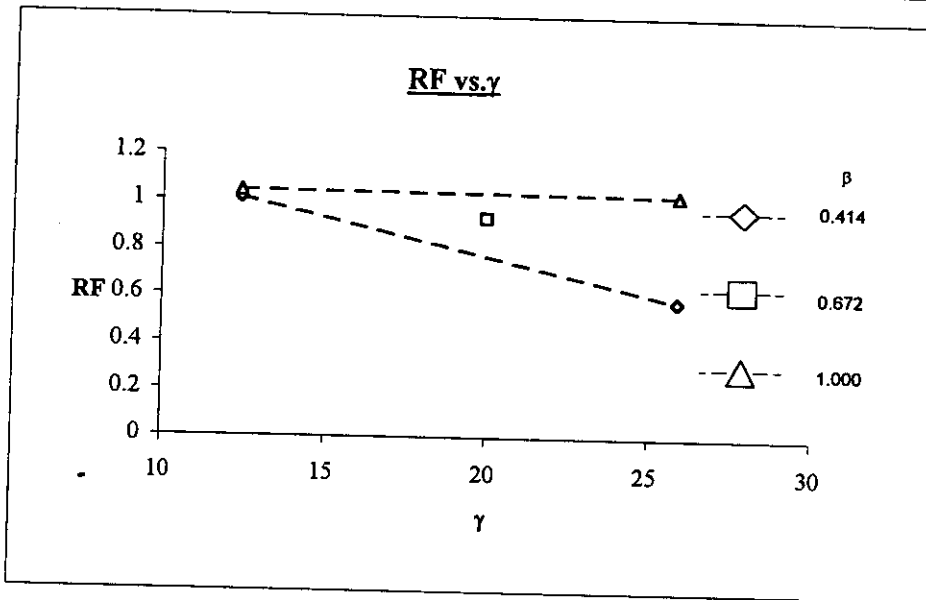
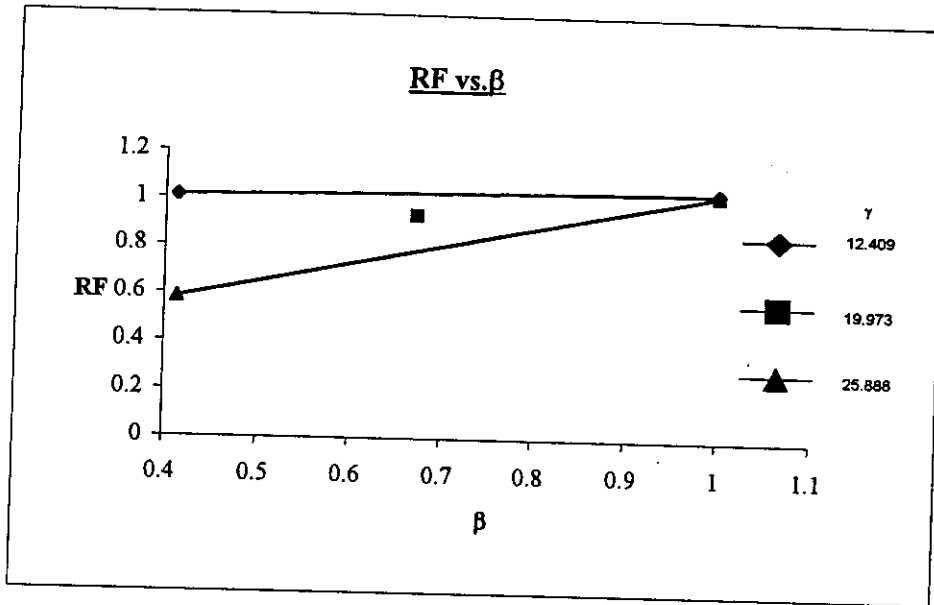

Fig. Q8: T Joints Under Compression, Chord Crown

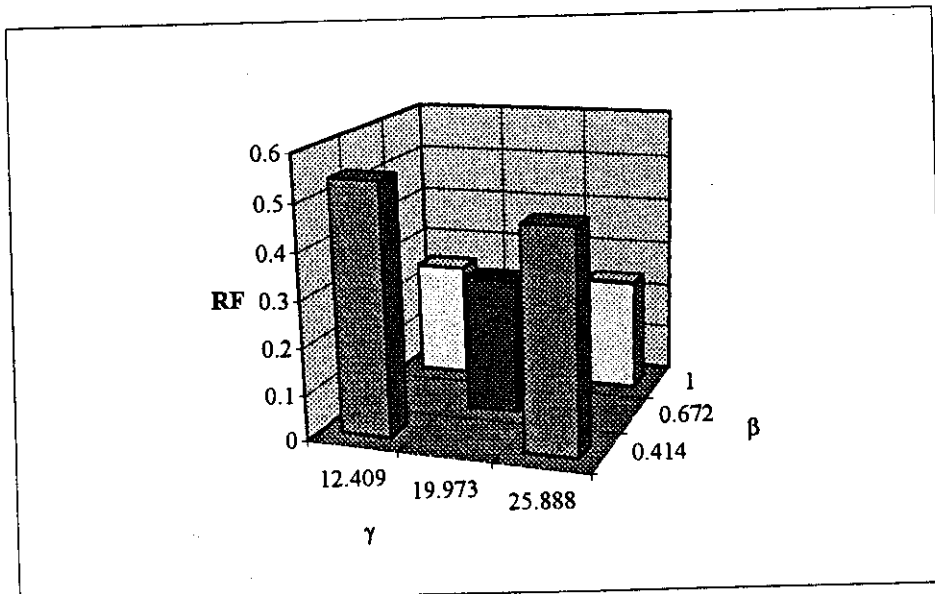
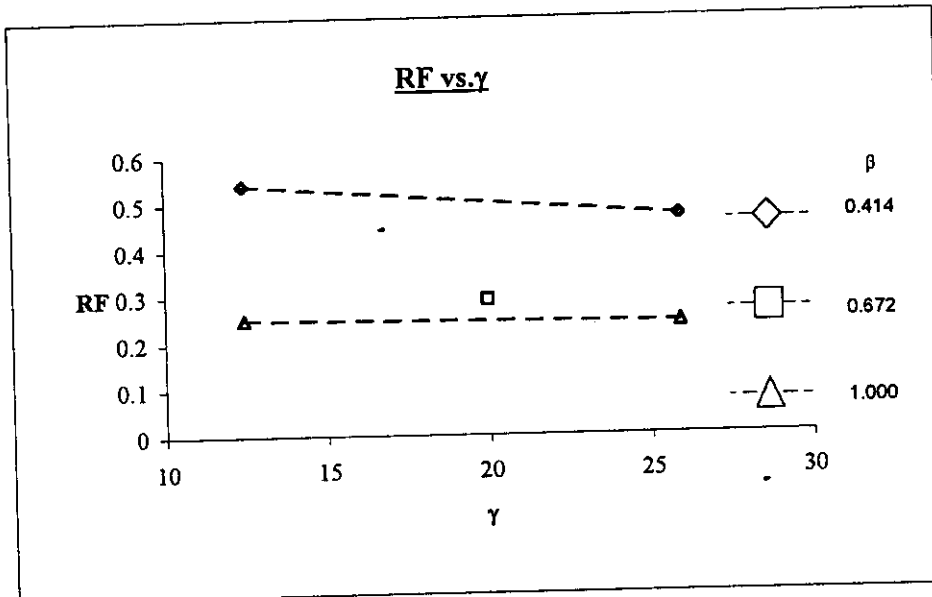
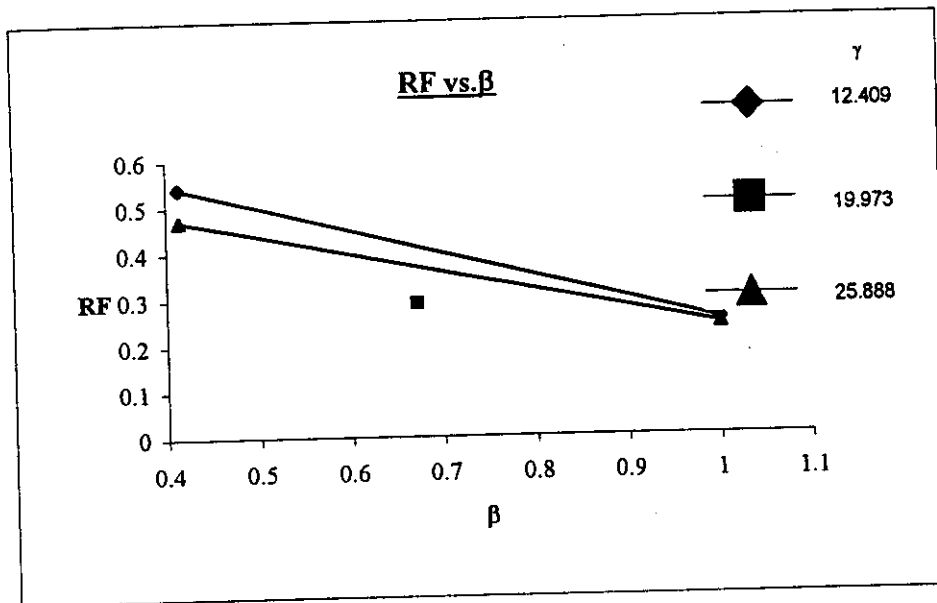

Fig. Q9: T Joints Under Tension, Chord Saddle

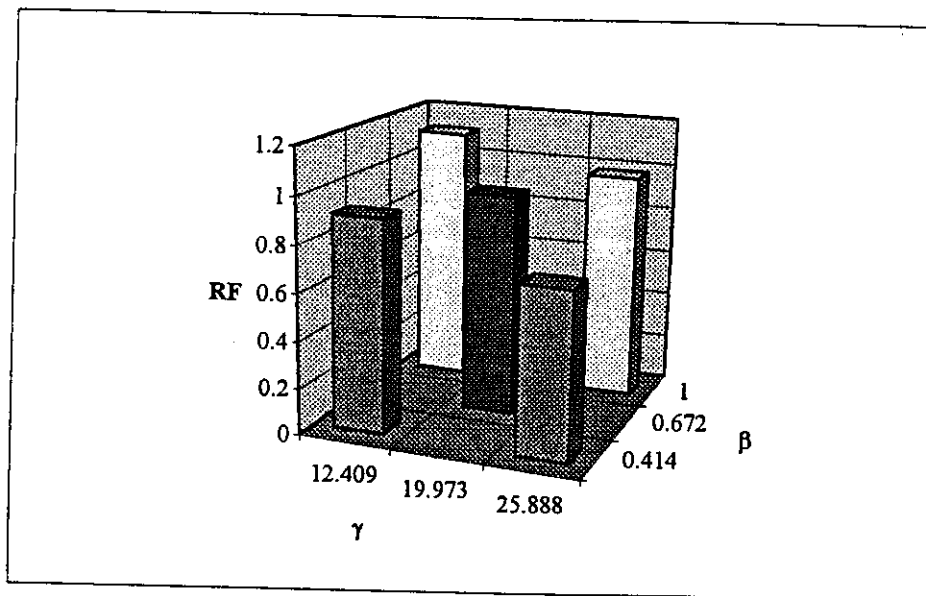
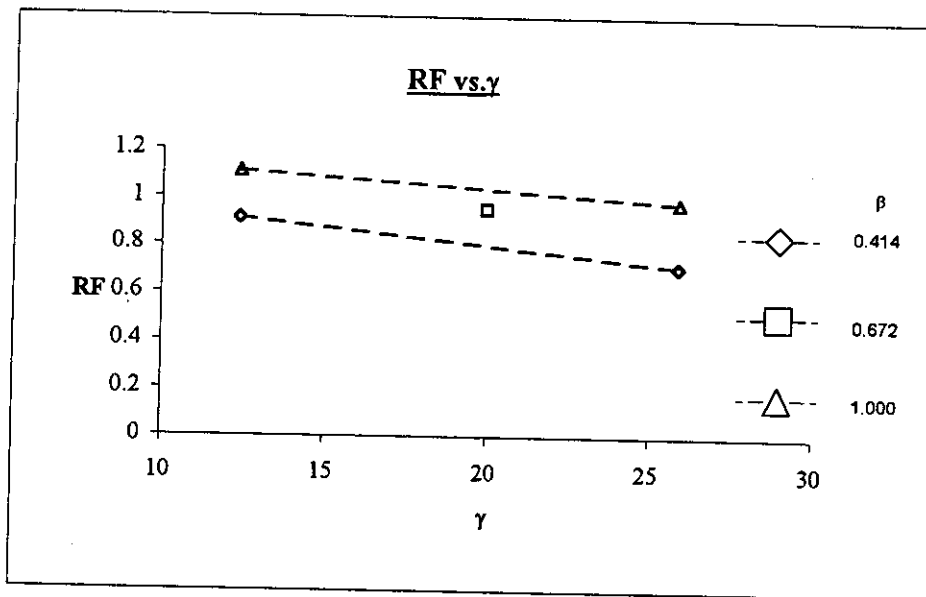
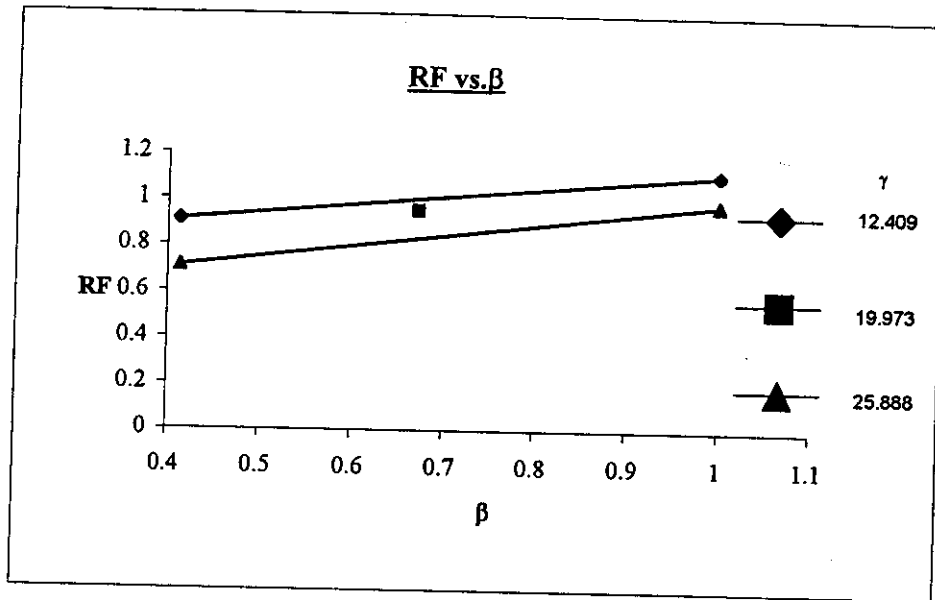

Fig. Q10: T Joints Under Tension, Chord Crown

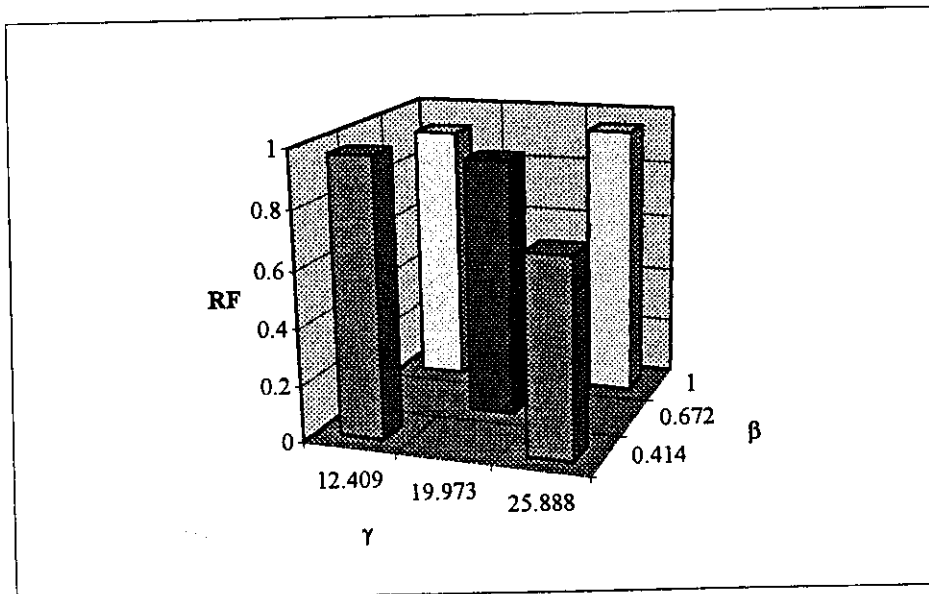
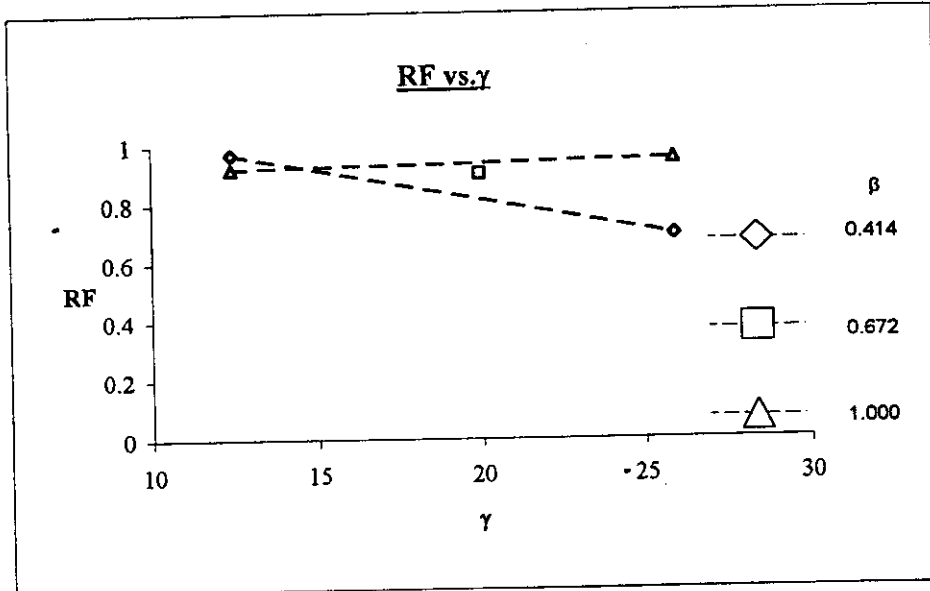
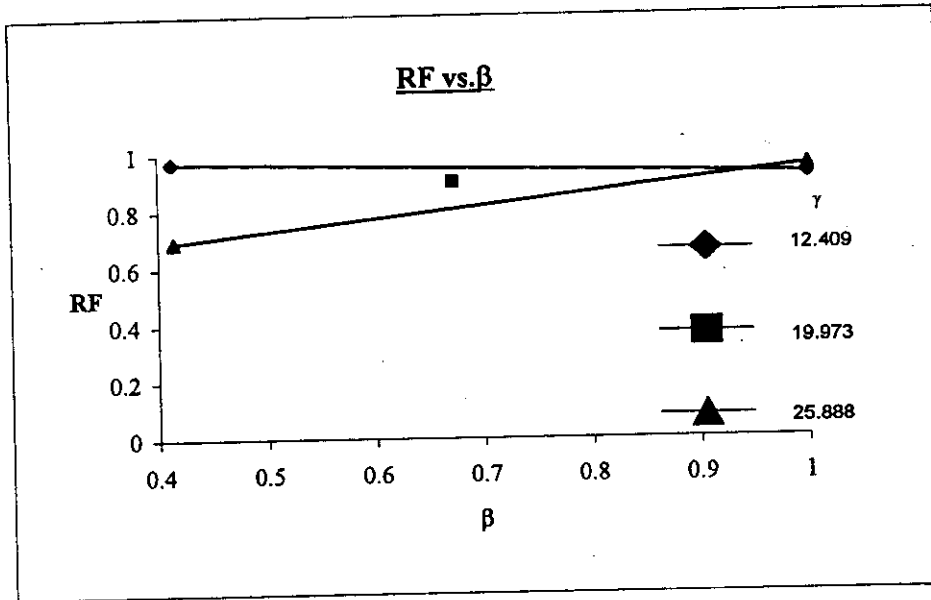

Fig. Q11: T Joints Under IPB, Chord Crown

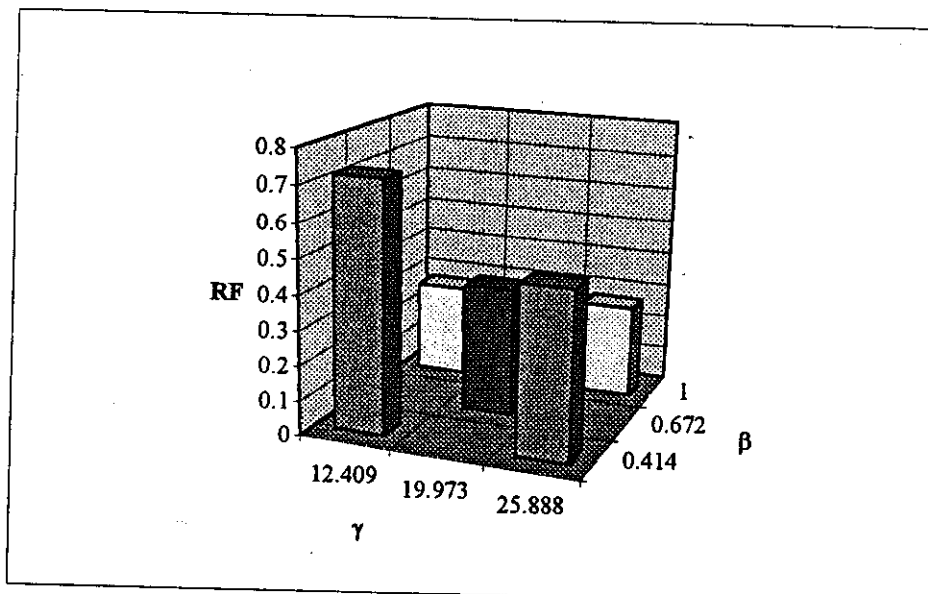
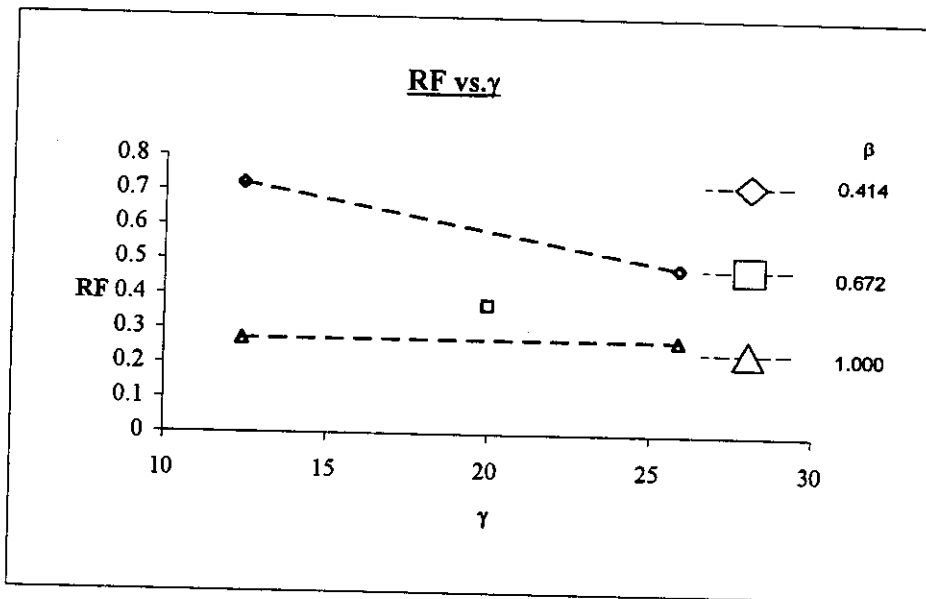
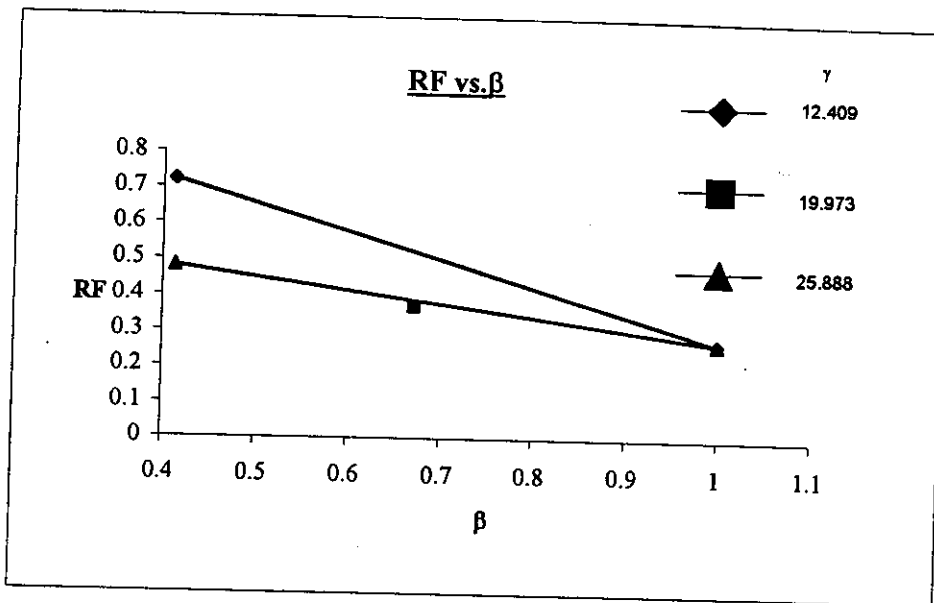

Fig. Q12: T Joints Under OPB, Chord Saddle

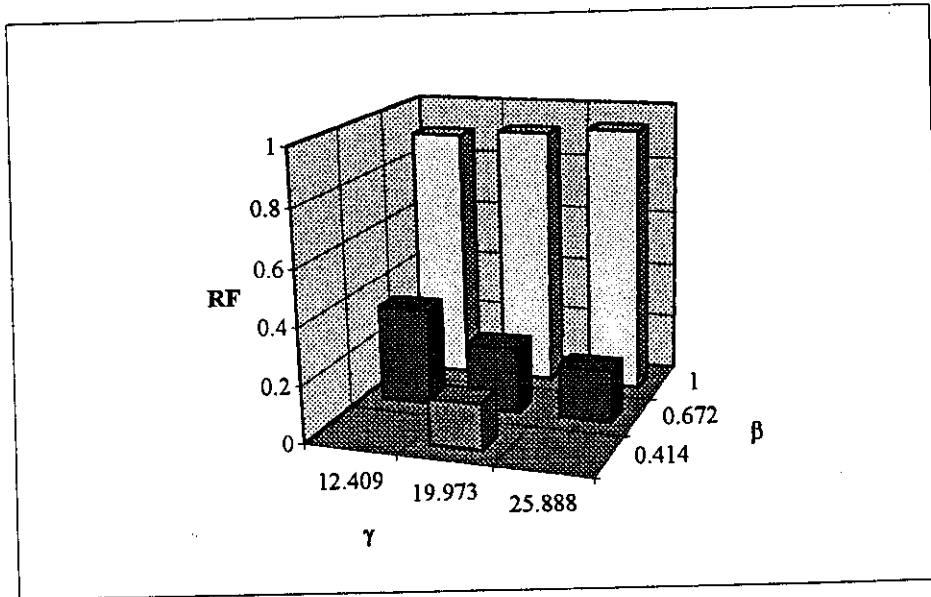
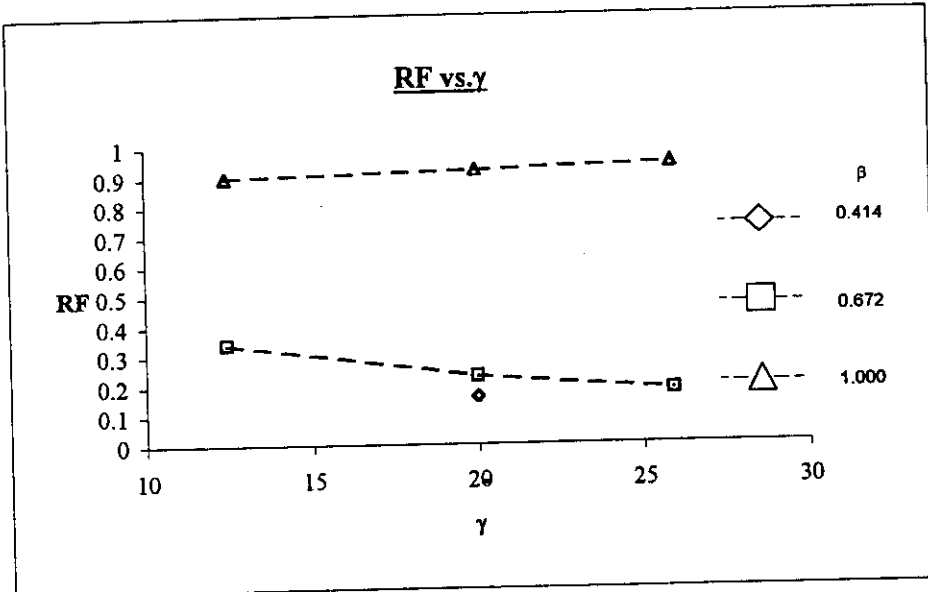
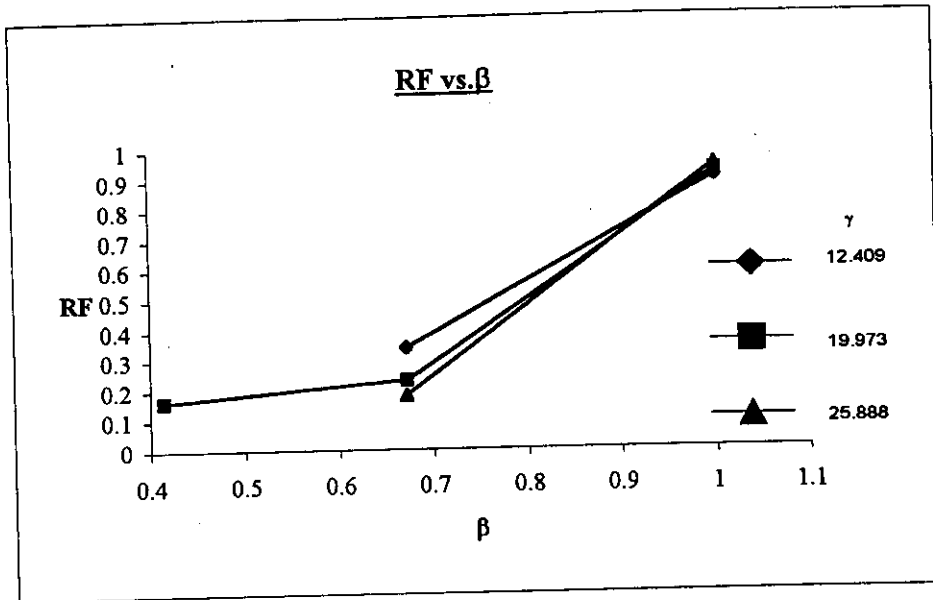

Fig. Q13: DT Joints Under Compression, Brace Saddle

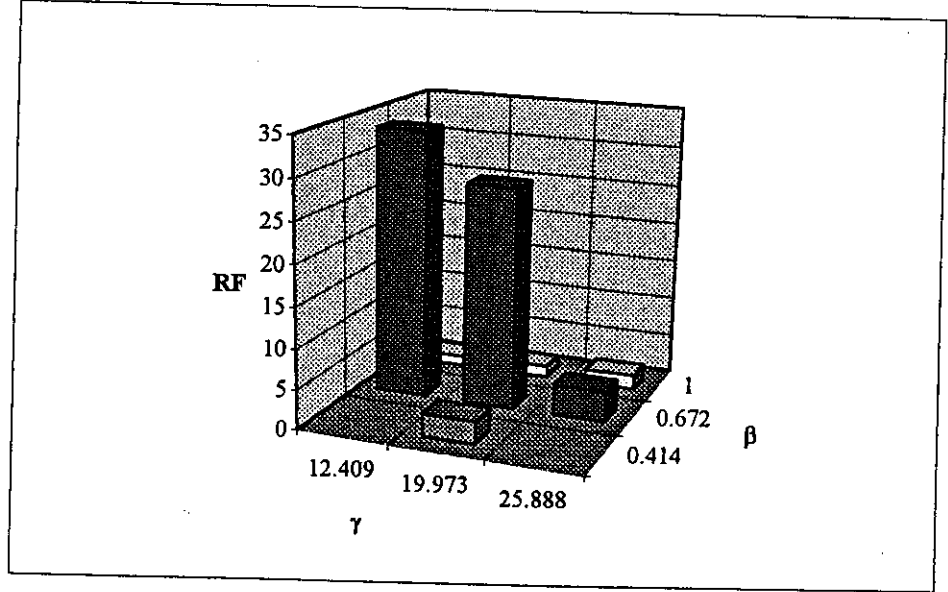
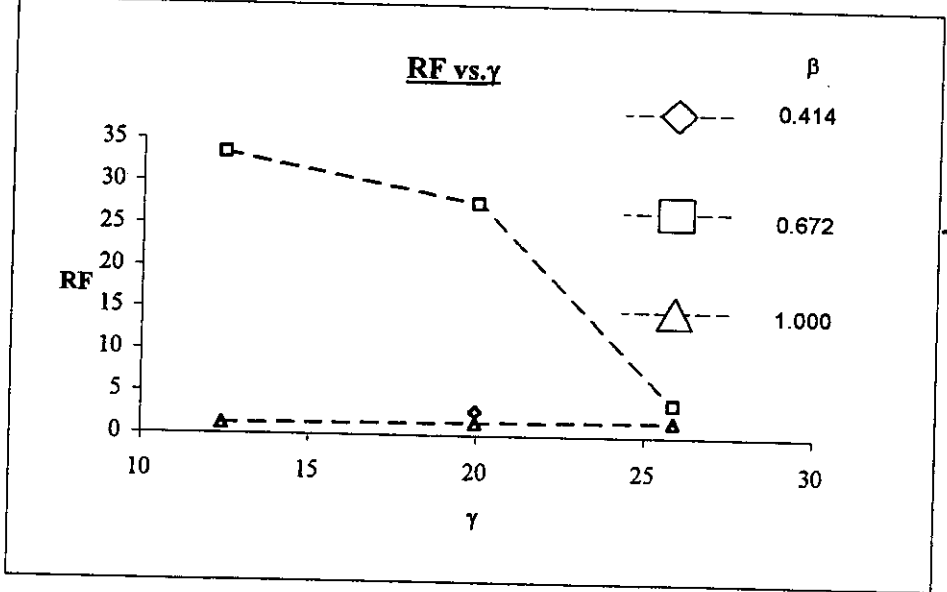
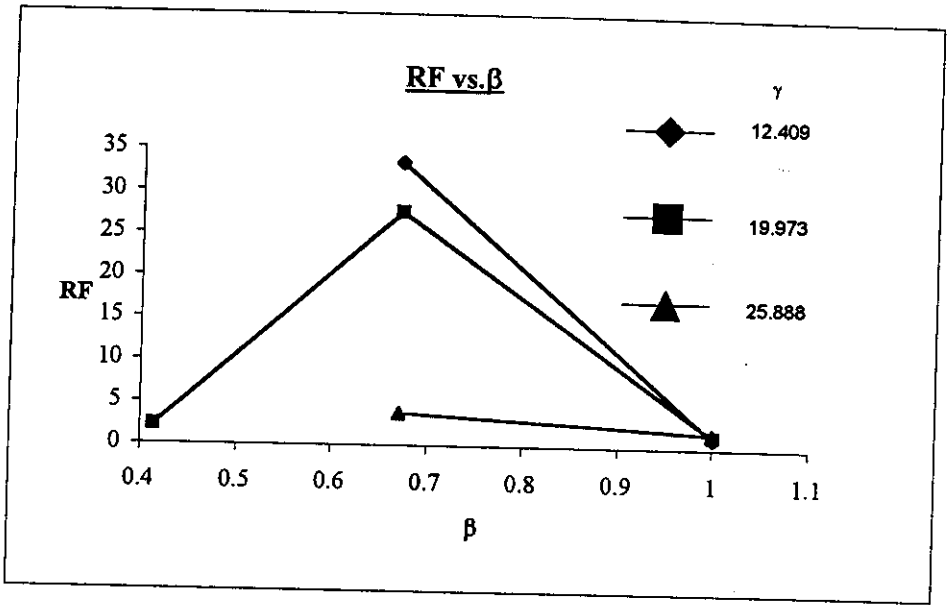

Fig. Q14: DT Joints Under Compression, Brace Crown



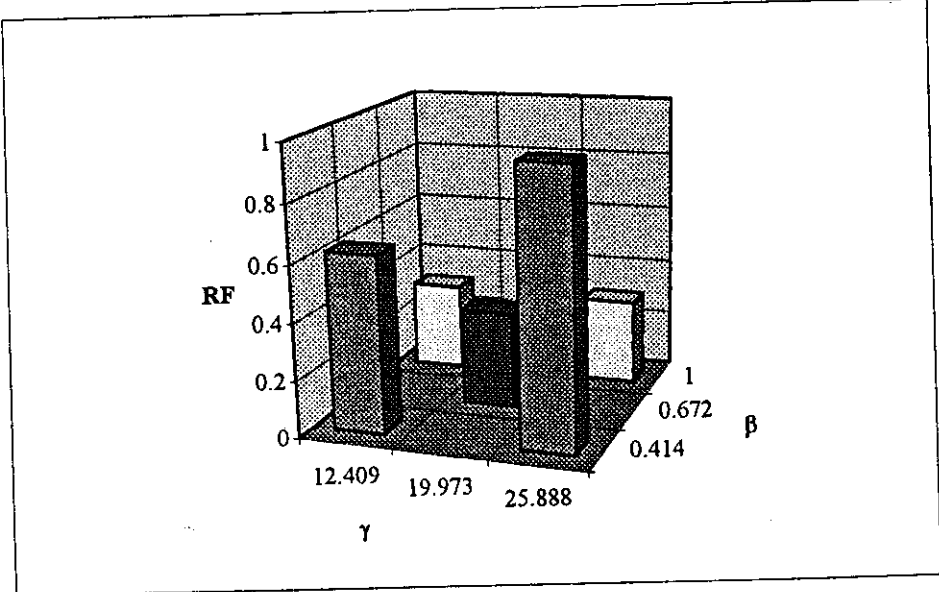
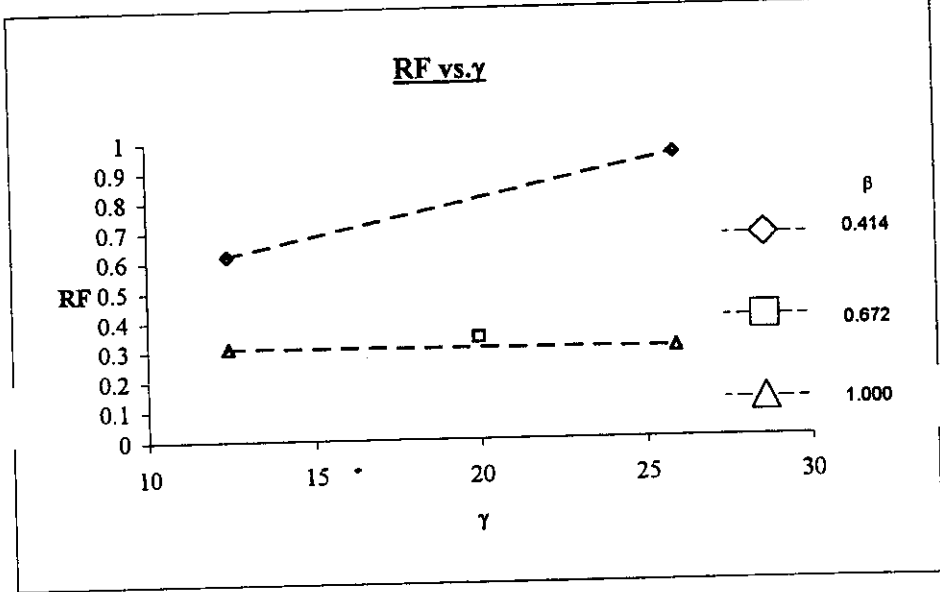
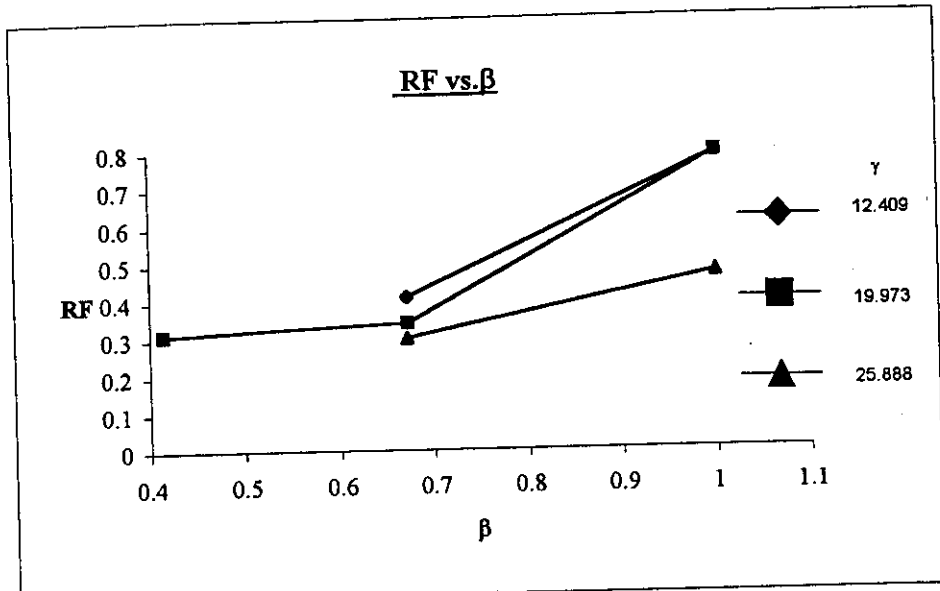
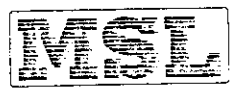

Fig. Q15: DT Joints Under Tension, Brace Saddle



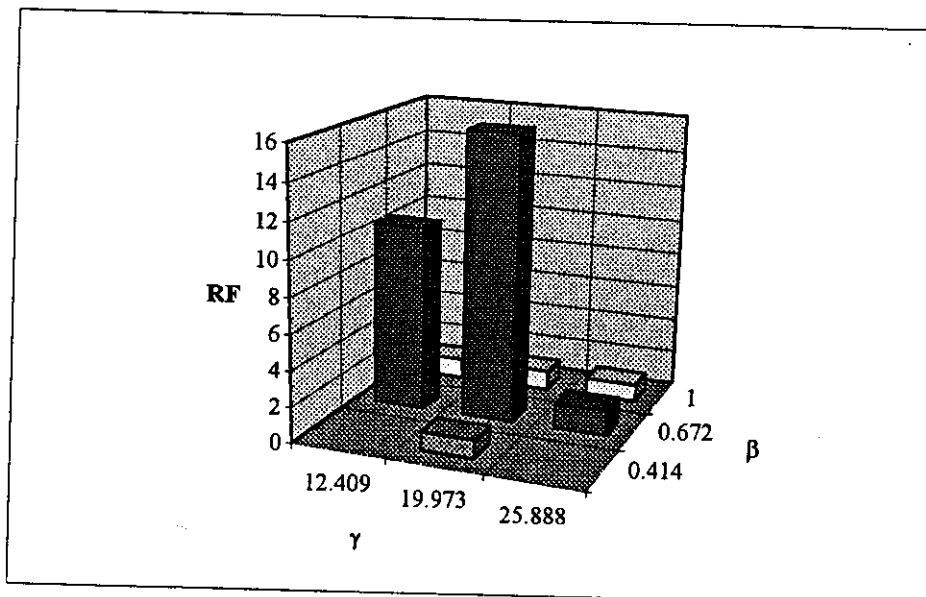
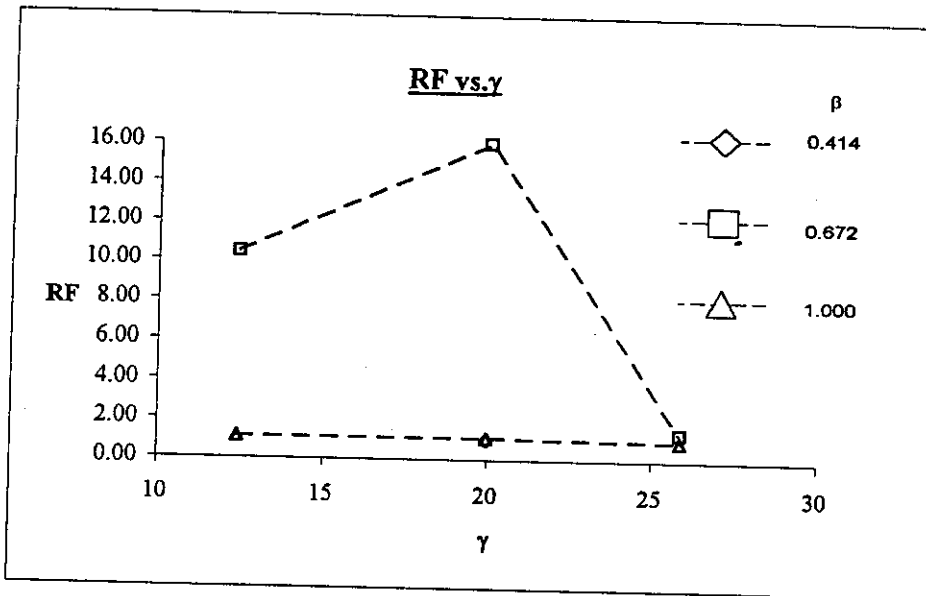
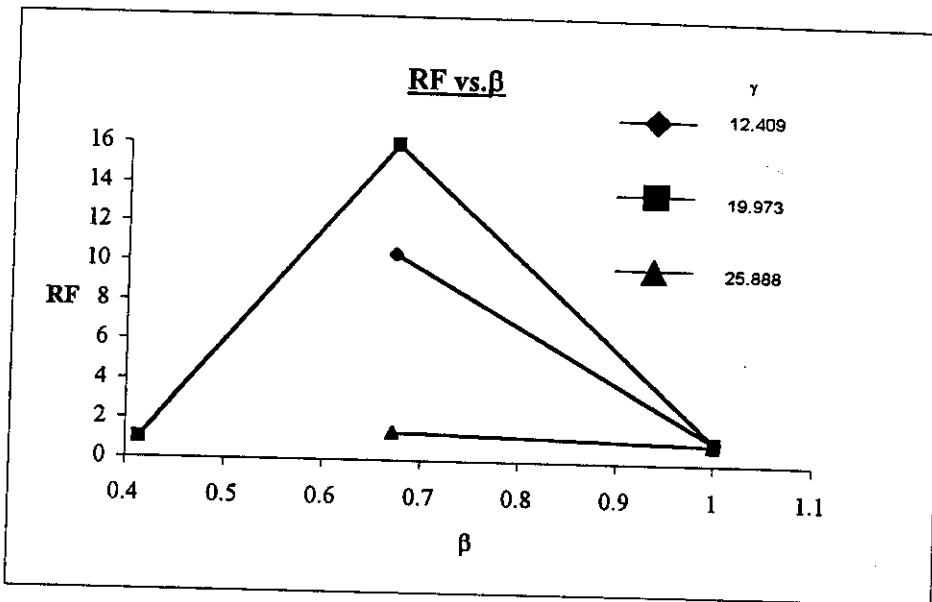
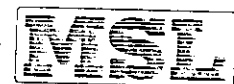

Fig. Q16: DT Joints Under Tension, Brace Crown



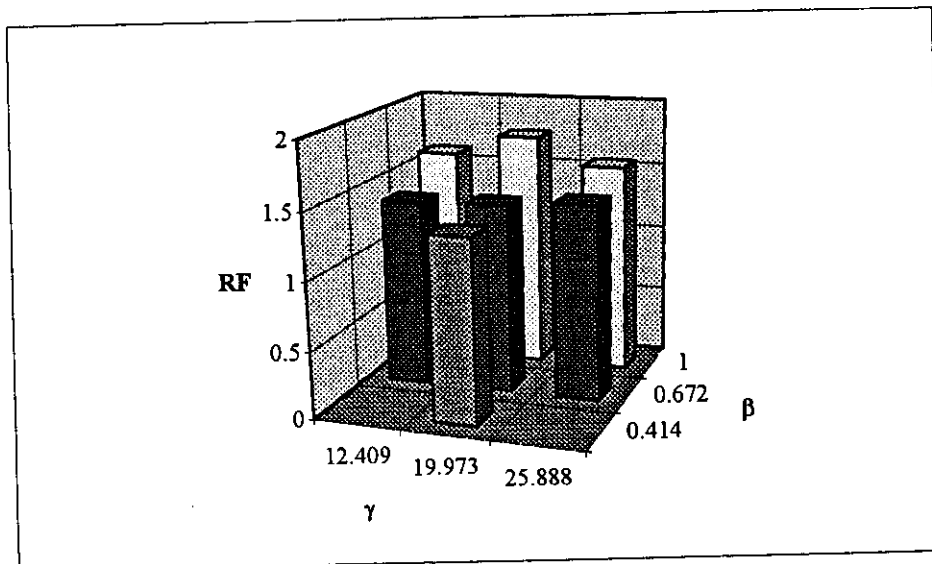
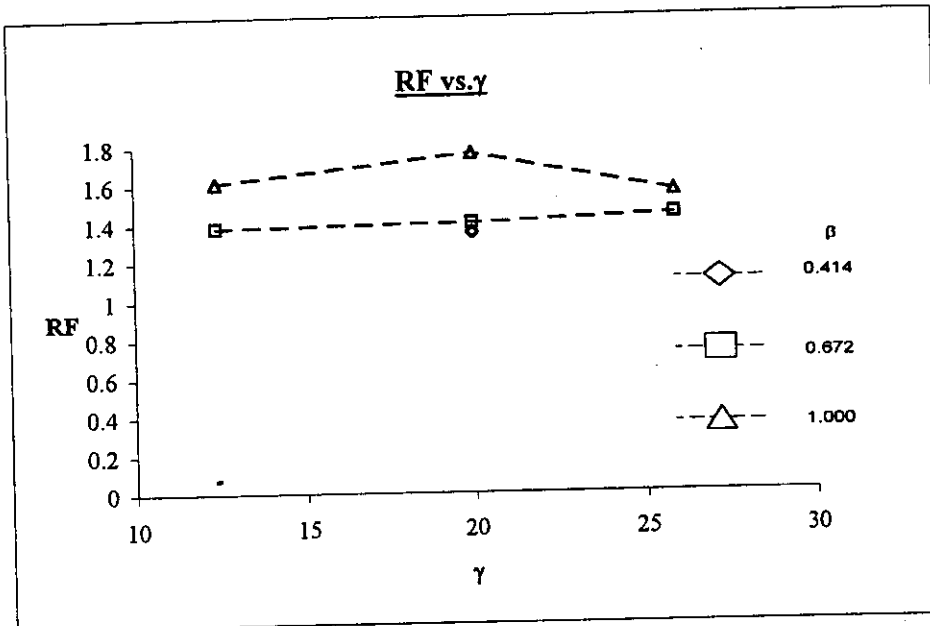
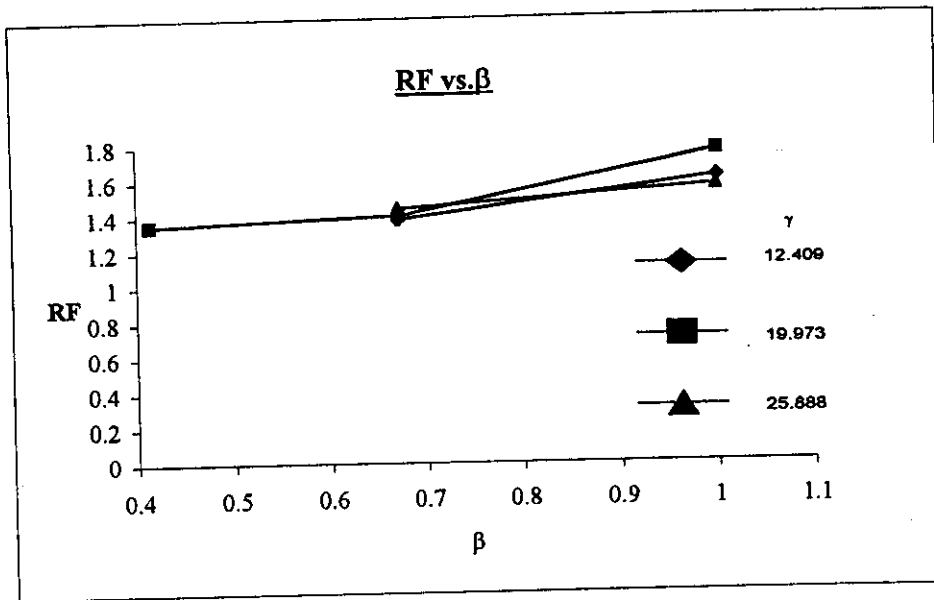

Fig. Q17: DT Joints Under IPB, Brace Crown

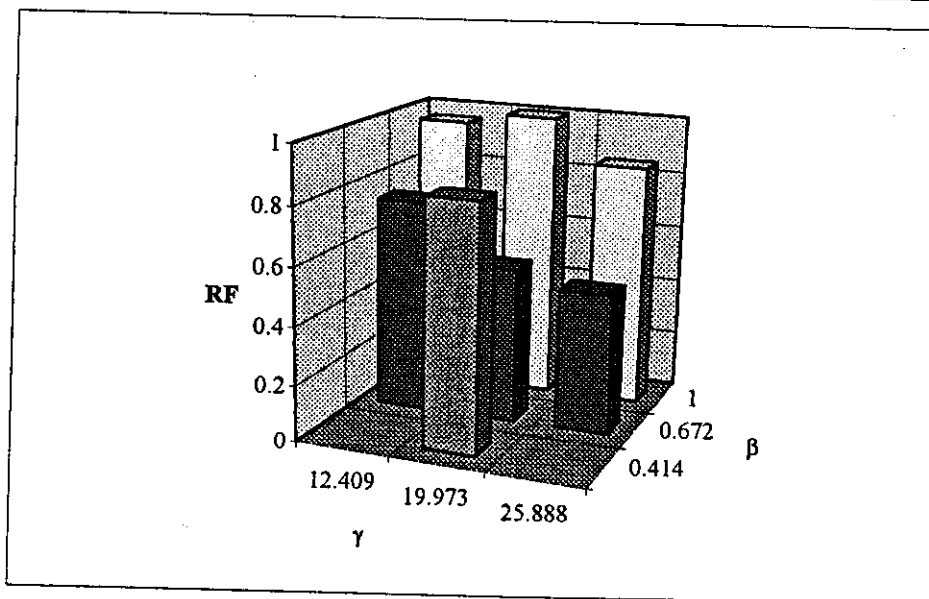
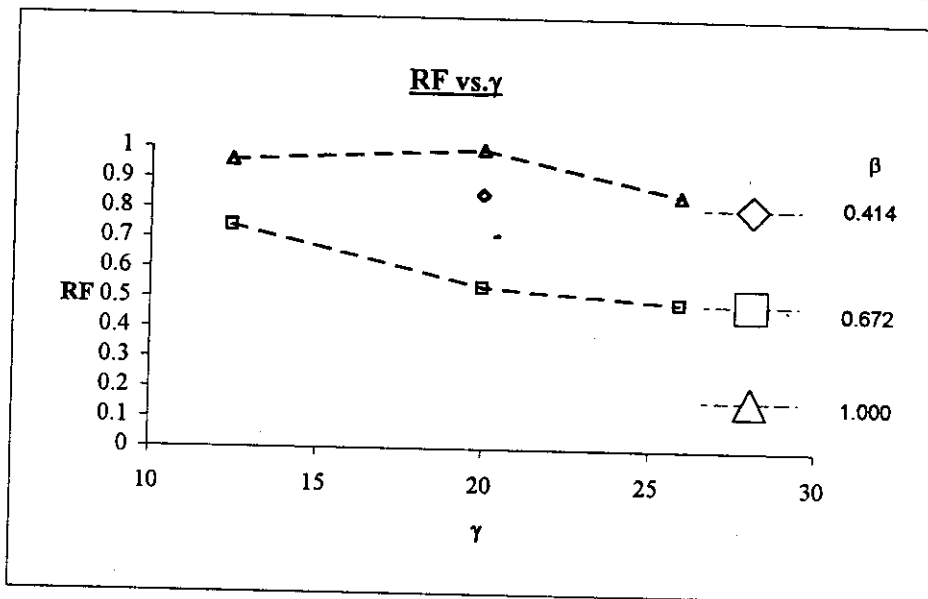
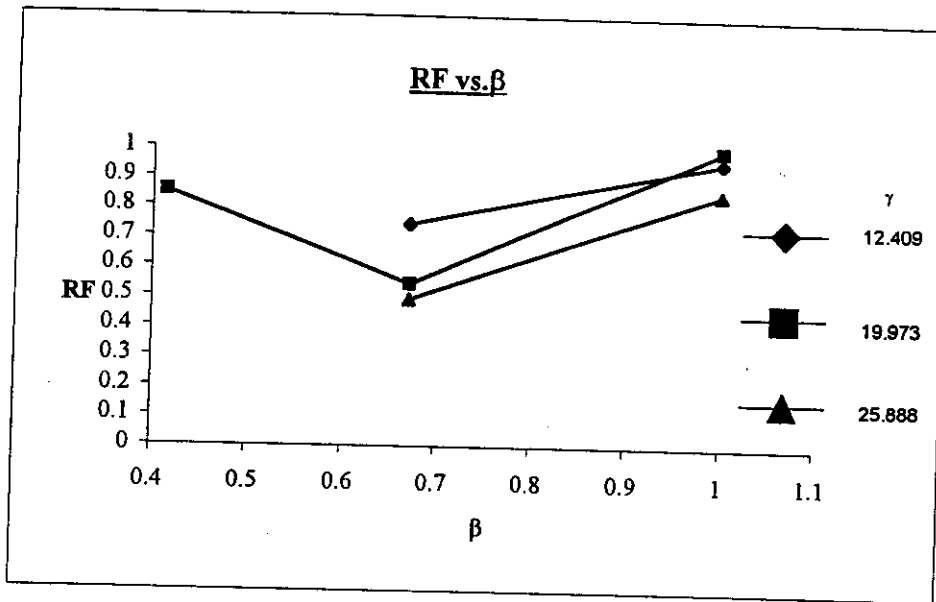

Fig. Q18: DT Joints Under OPB, Brace Saddle

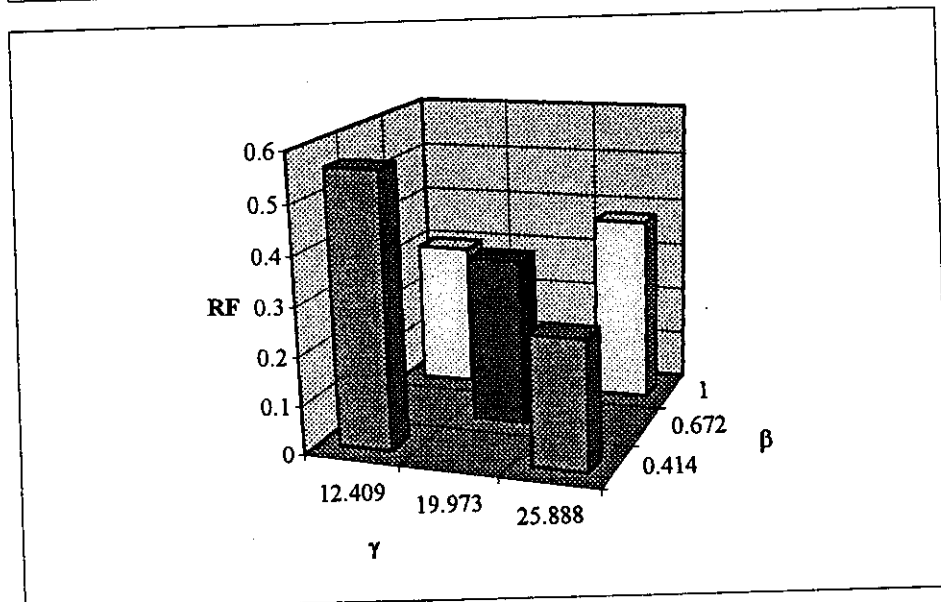
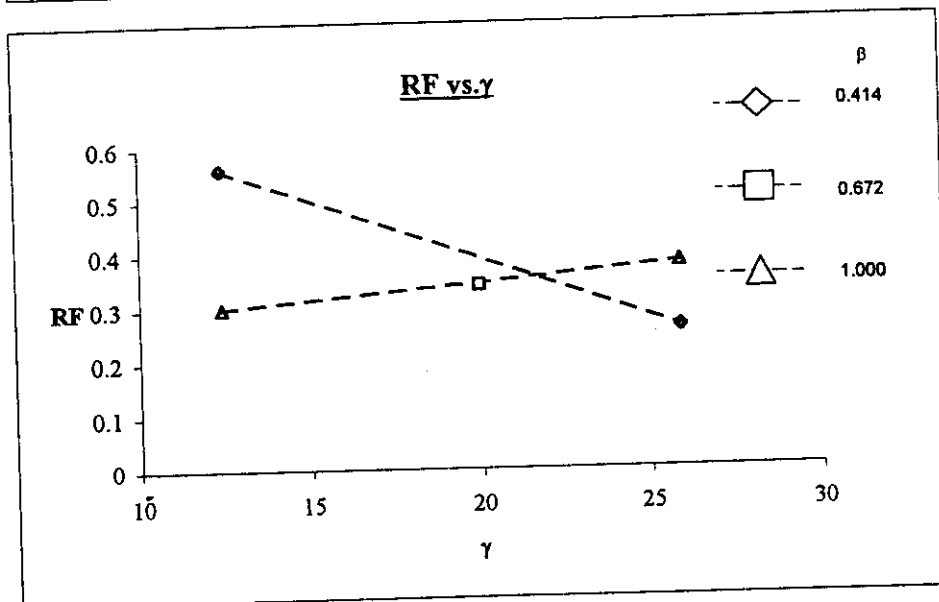
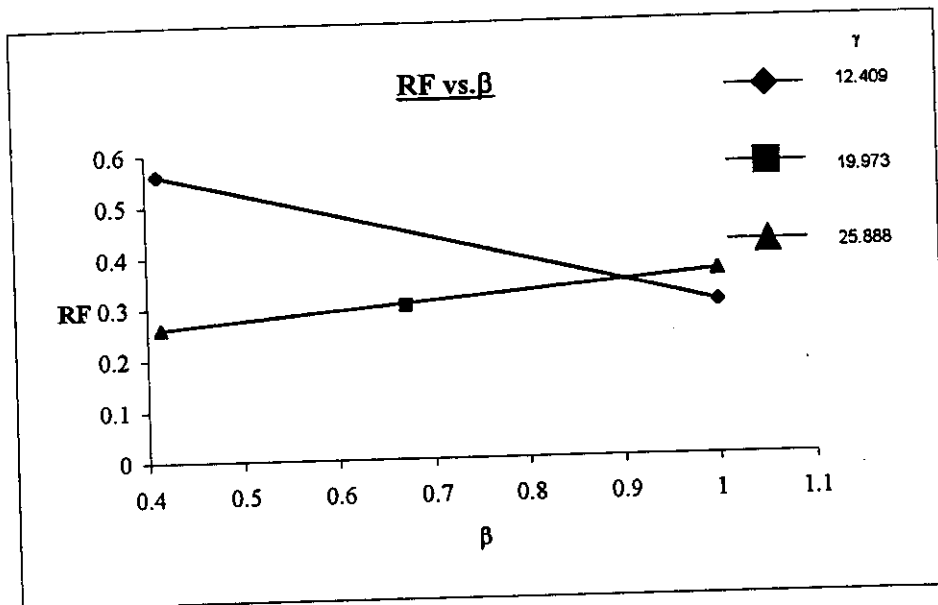

Fig. Q19: T Joints Under Compression, Brace Saddle

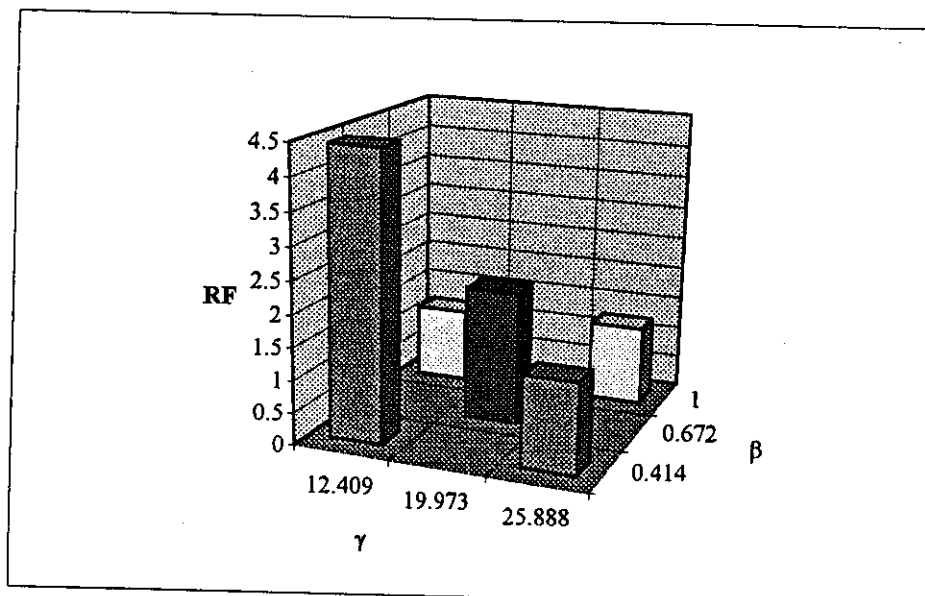
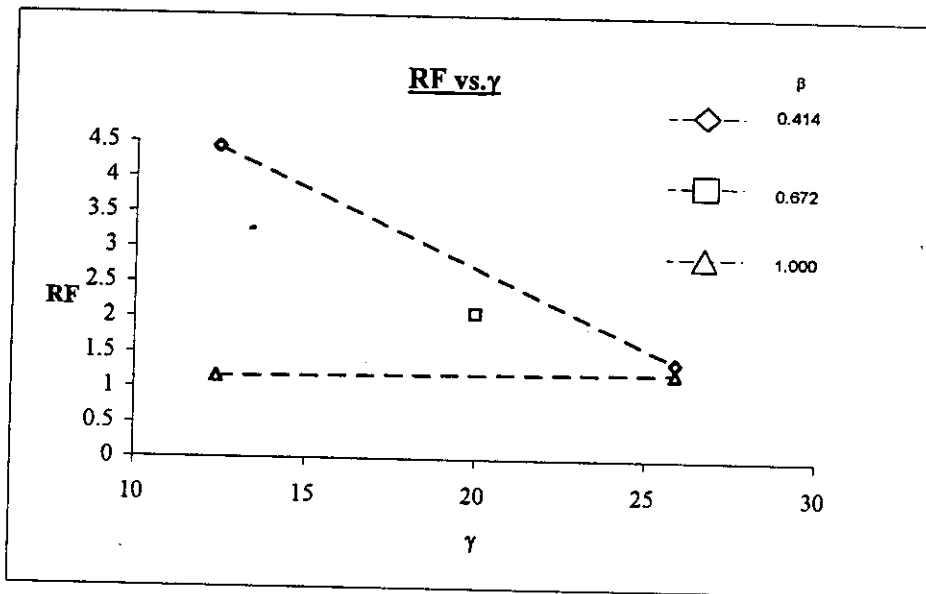
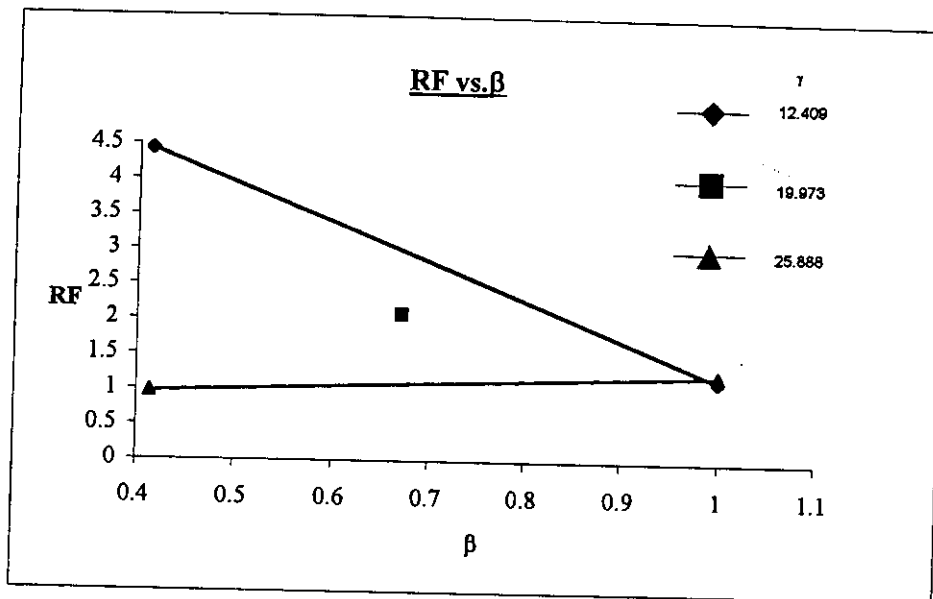

Fig. Q20: T Joints Under Compression, Brace Crown

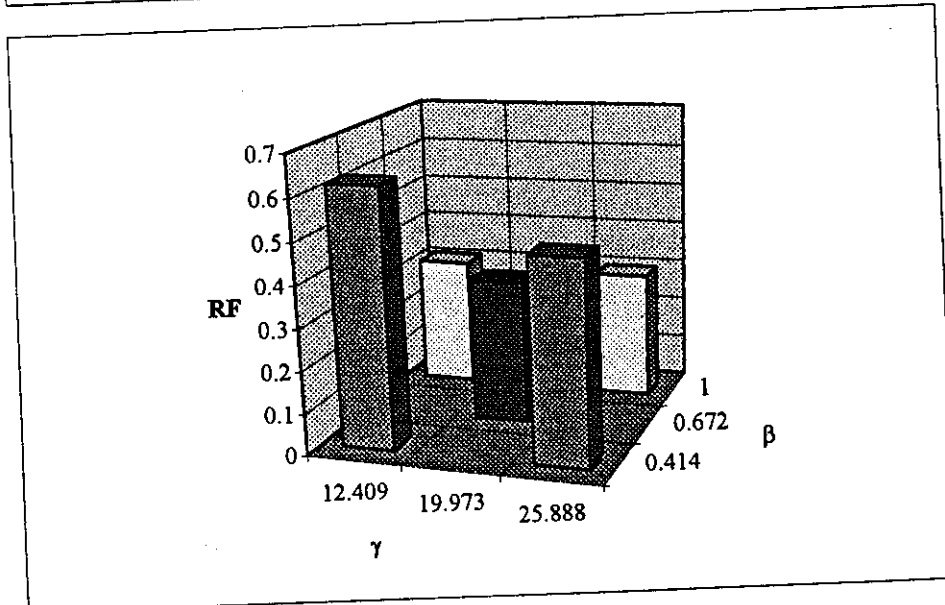
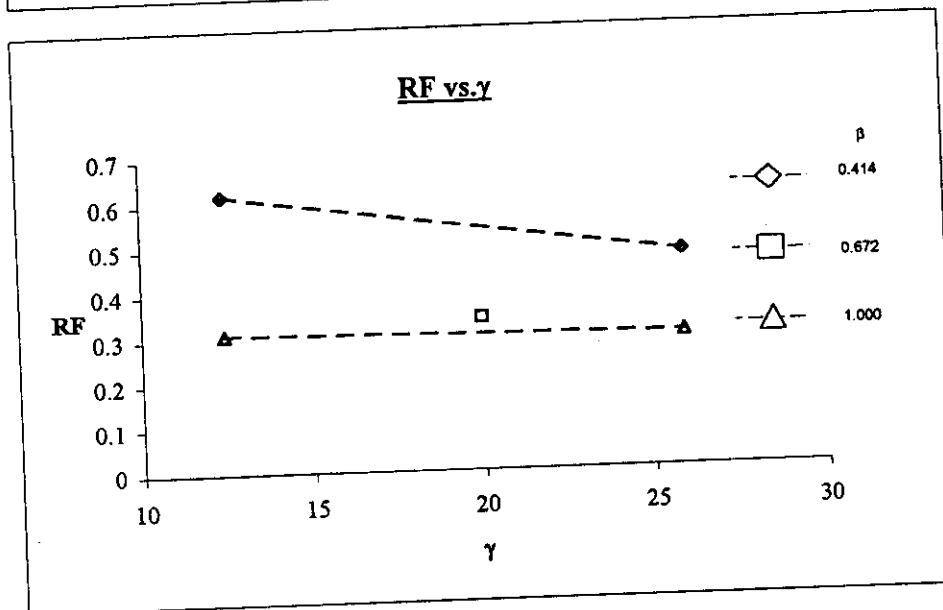
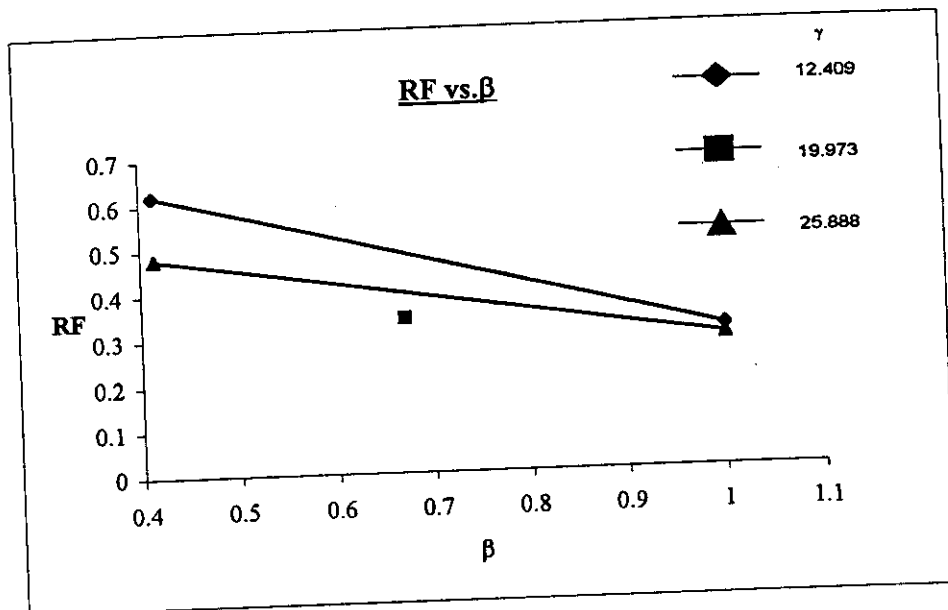

Fig. Q21: T Joints Under Tension, Brace Saddle

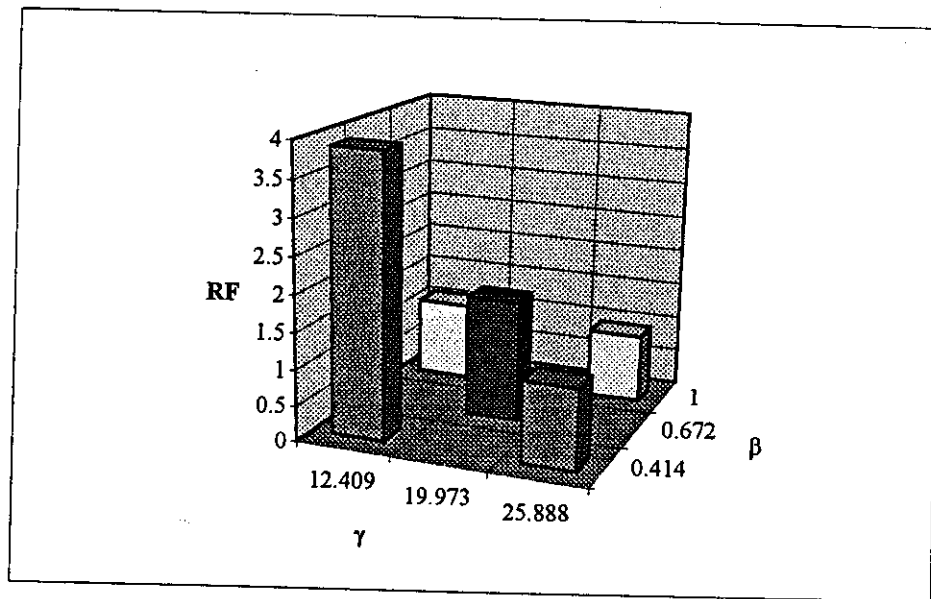
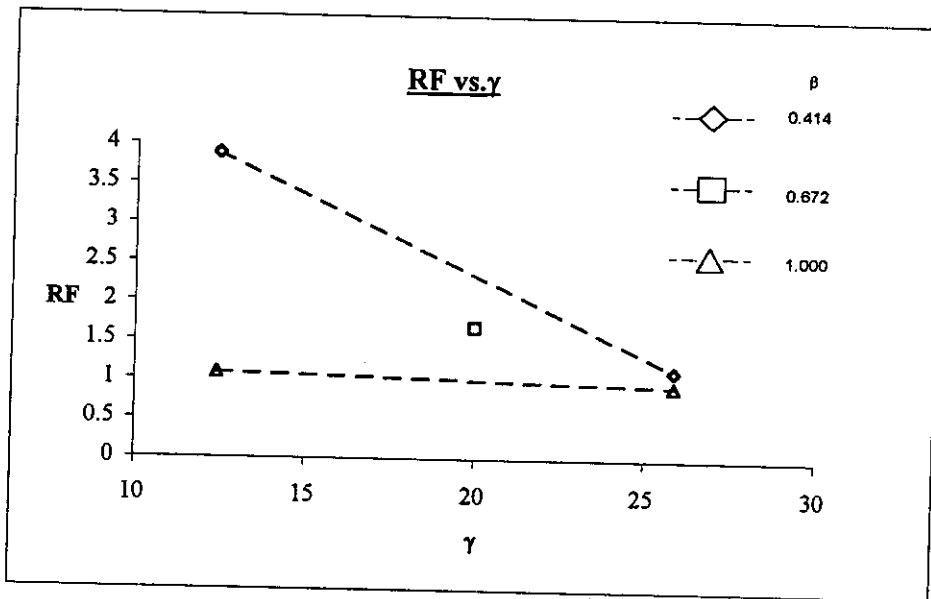
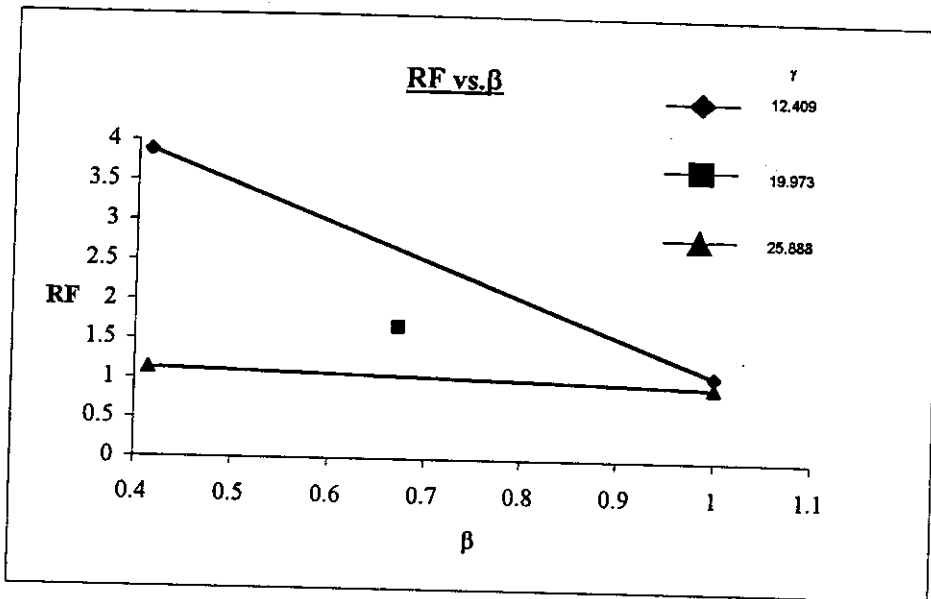

Fig. Q22: T Joints Under Tension, Brace Crown

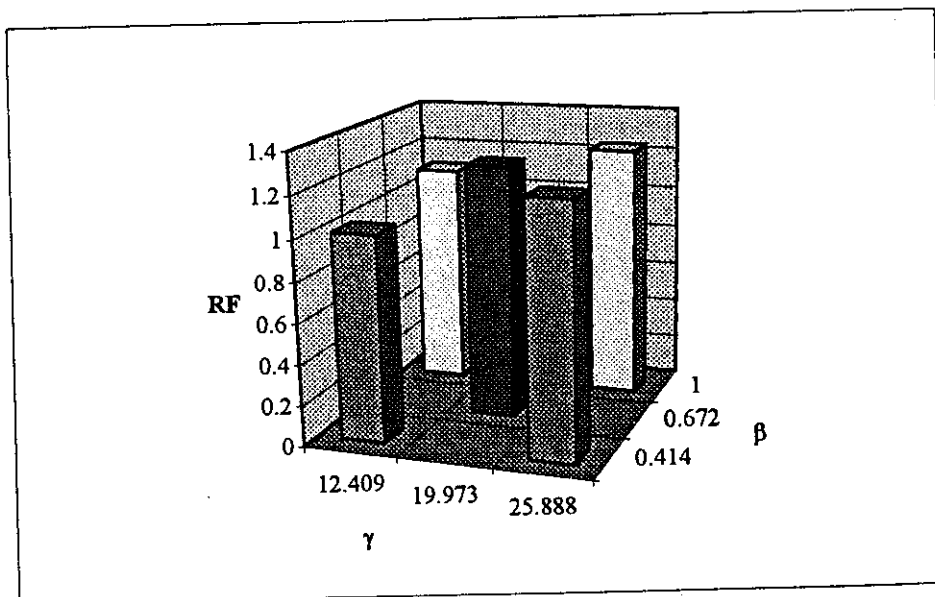
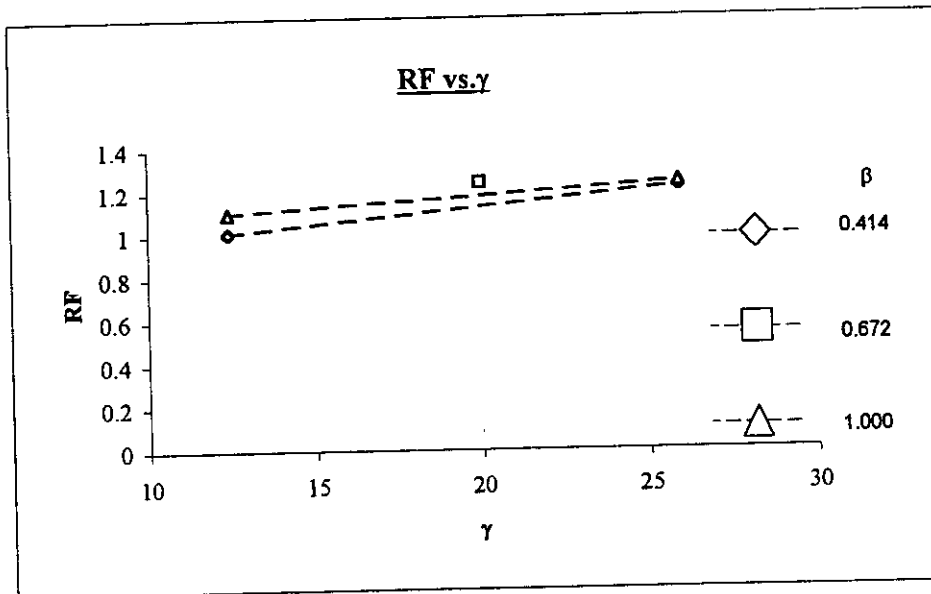
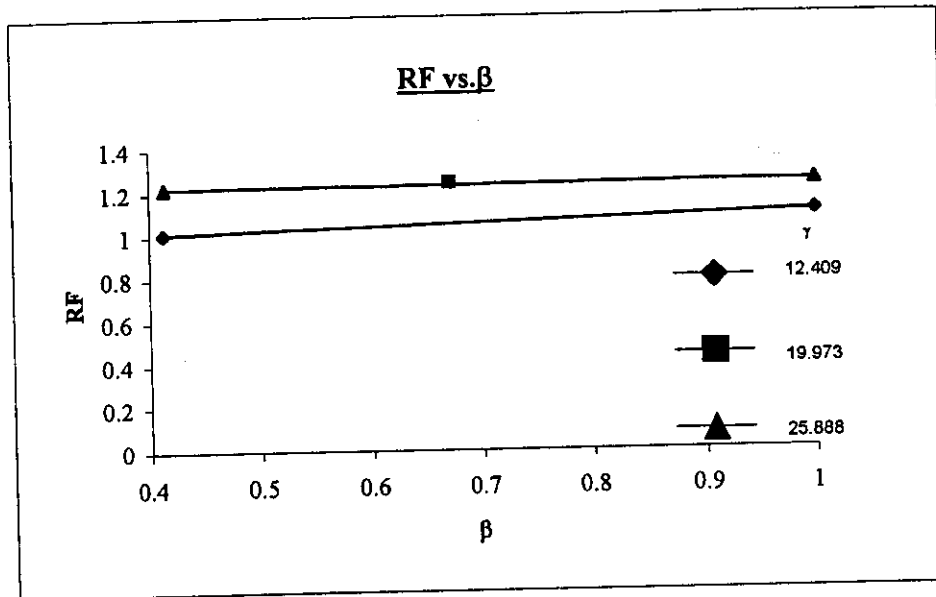

Fig. Q23: T Joints Under IPB, Brace Crown

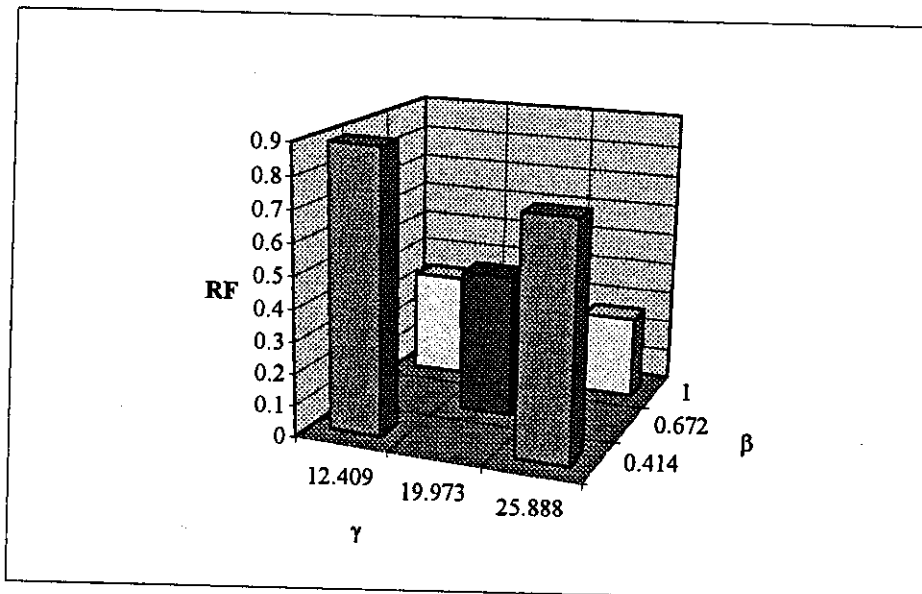
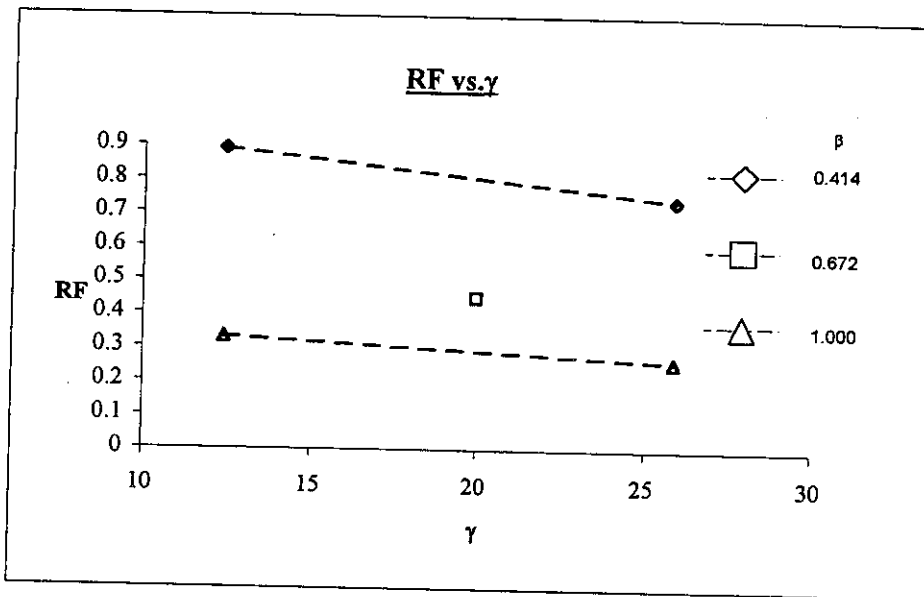
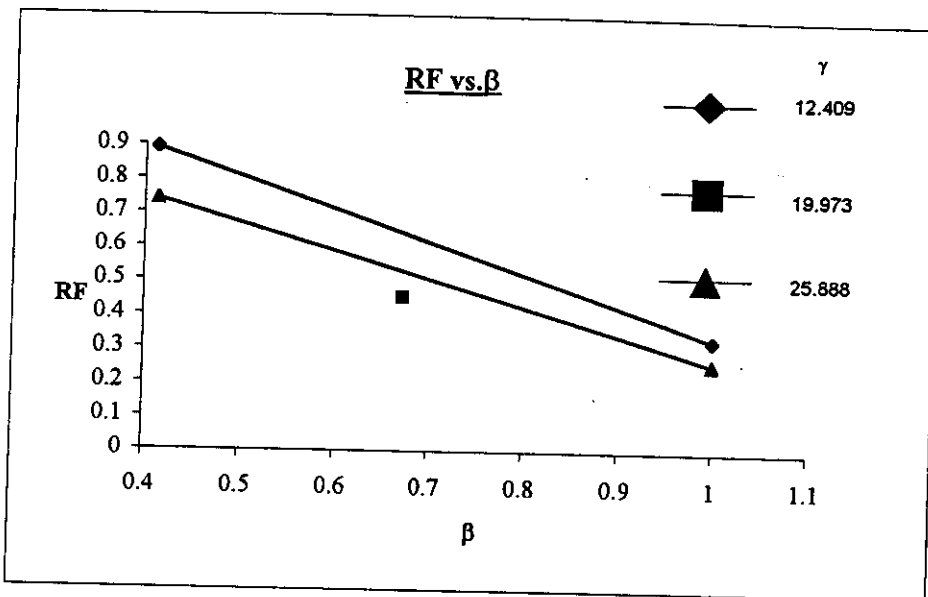
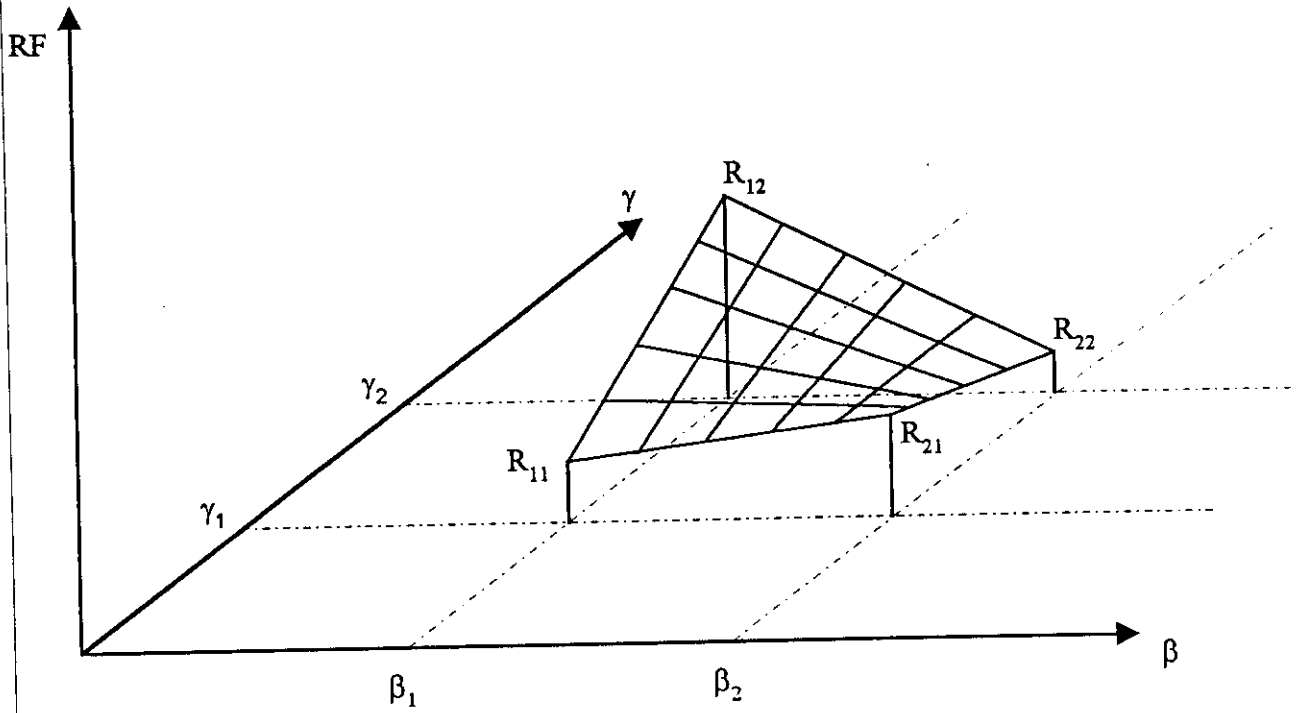

Fig. Q24: T Joints Under OPB, Brace Saddle



$$\begin{aligned}
 RF = \frac{1}{(\beta_2 - \beta_1)(\gamma_2 - \gamma_1)} & \{ (R_{11}\beta_2\gamma_2 - R_{12}\beta_2\gamma_1 - R_{21}\beta_1\gamma_2 + R_{22}\beta_1\gamma_1) \\
 & + \beta(-R_{11}\gamma_2 + R_{12}\gamma_1 + R_{21}\gamma_2 - R_{22}\gamma_1) \\
 & + \gamma(-R_{11}\beta_2 + R_{12}\beta_2 + R_{21}\beta_1 - R_{22}\beta_1) \\
 & + \beta\gamma(R_{11} - R_{12} - R_{21} + R_{22}) \}
 \end{aligned}$$

Fig. Q25: Geometry of a Twisted Plane

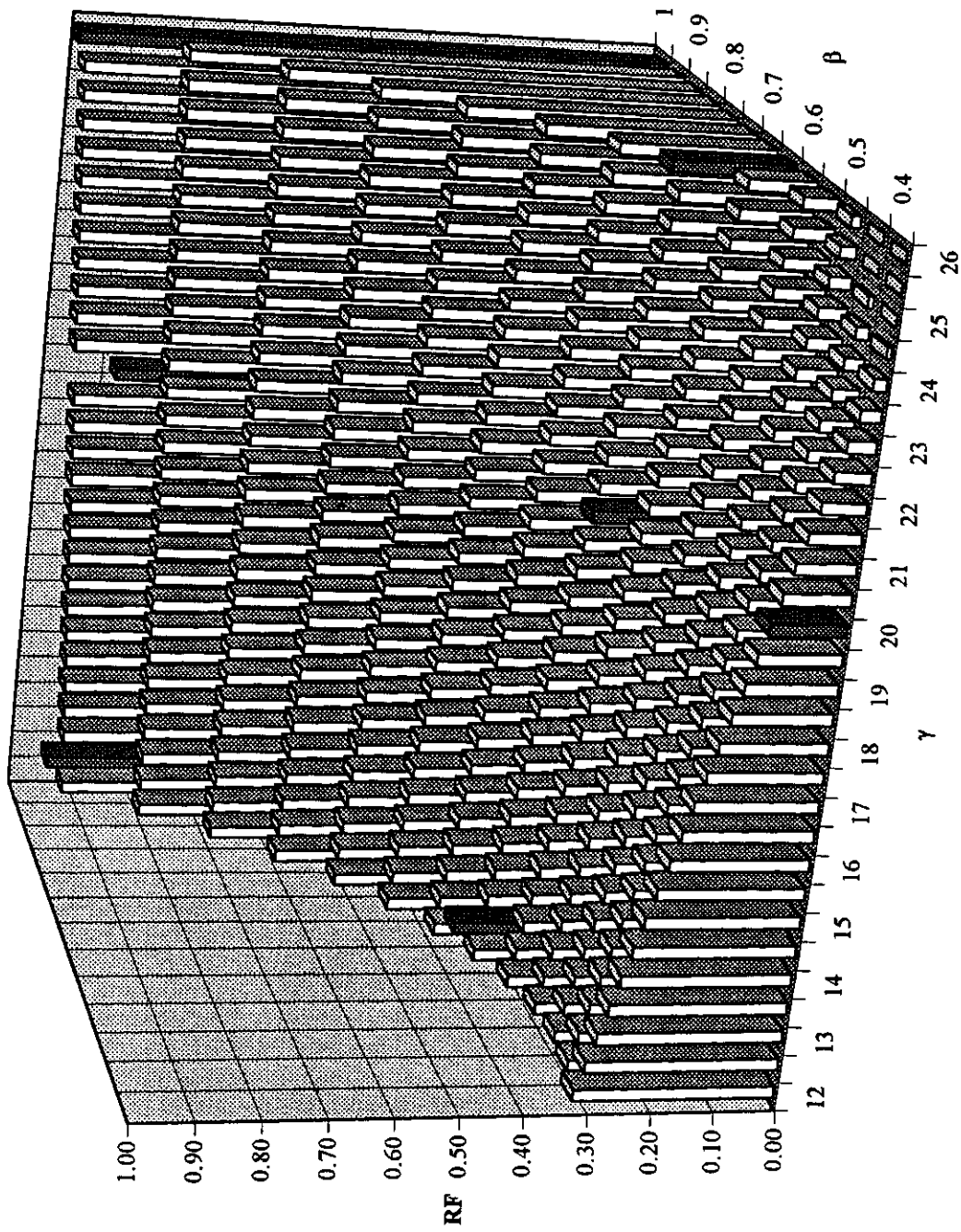

Fig. Q26: Comparison of Fitted Surface with Measured Values for DT Joints under Compression, Chord Saddle

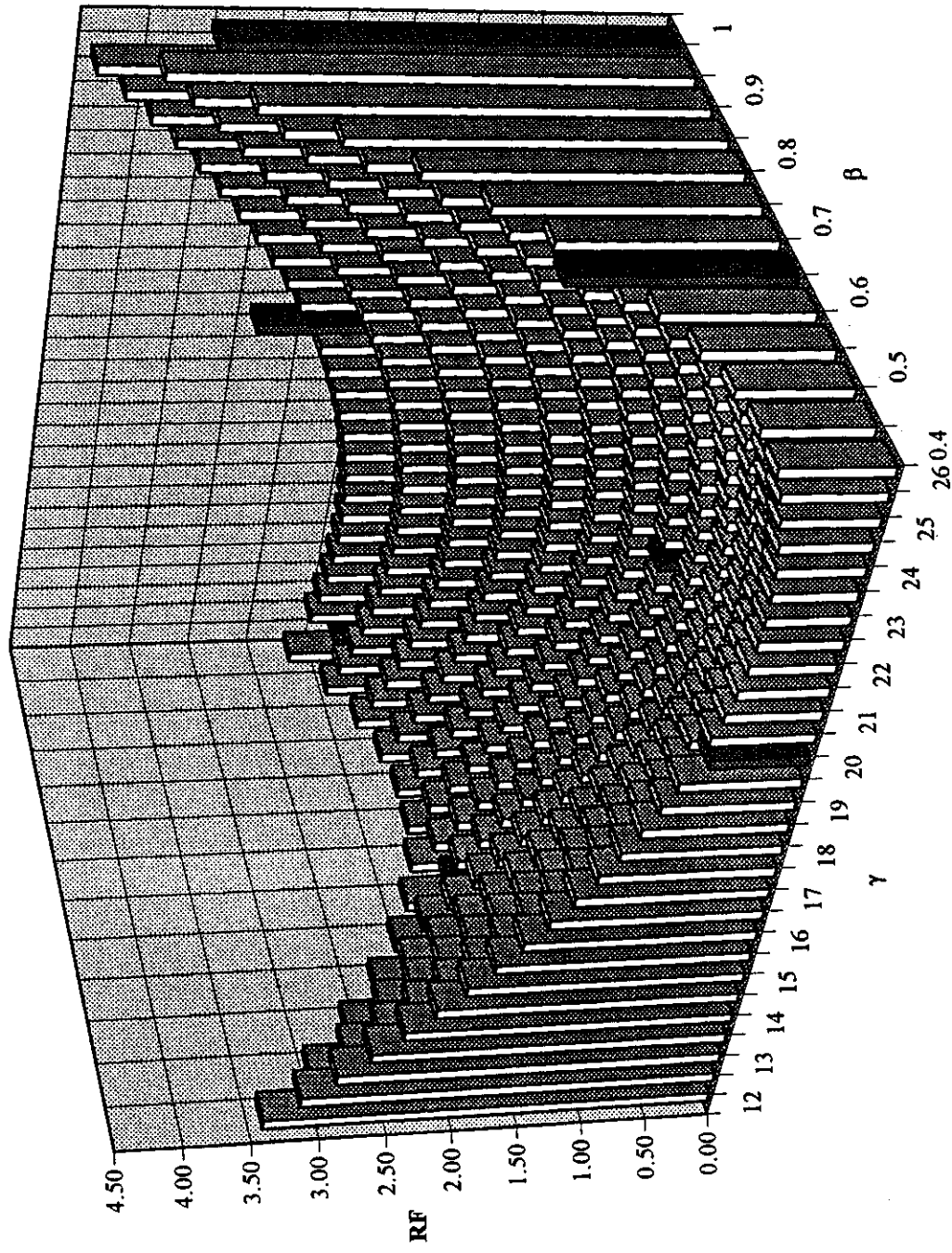

Fig. Q27: Comparison of Fitted Surface with Measured Values for DT Joints under Compression, Chord Crown (Interim)

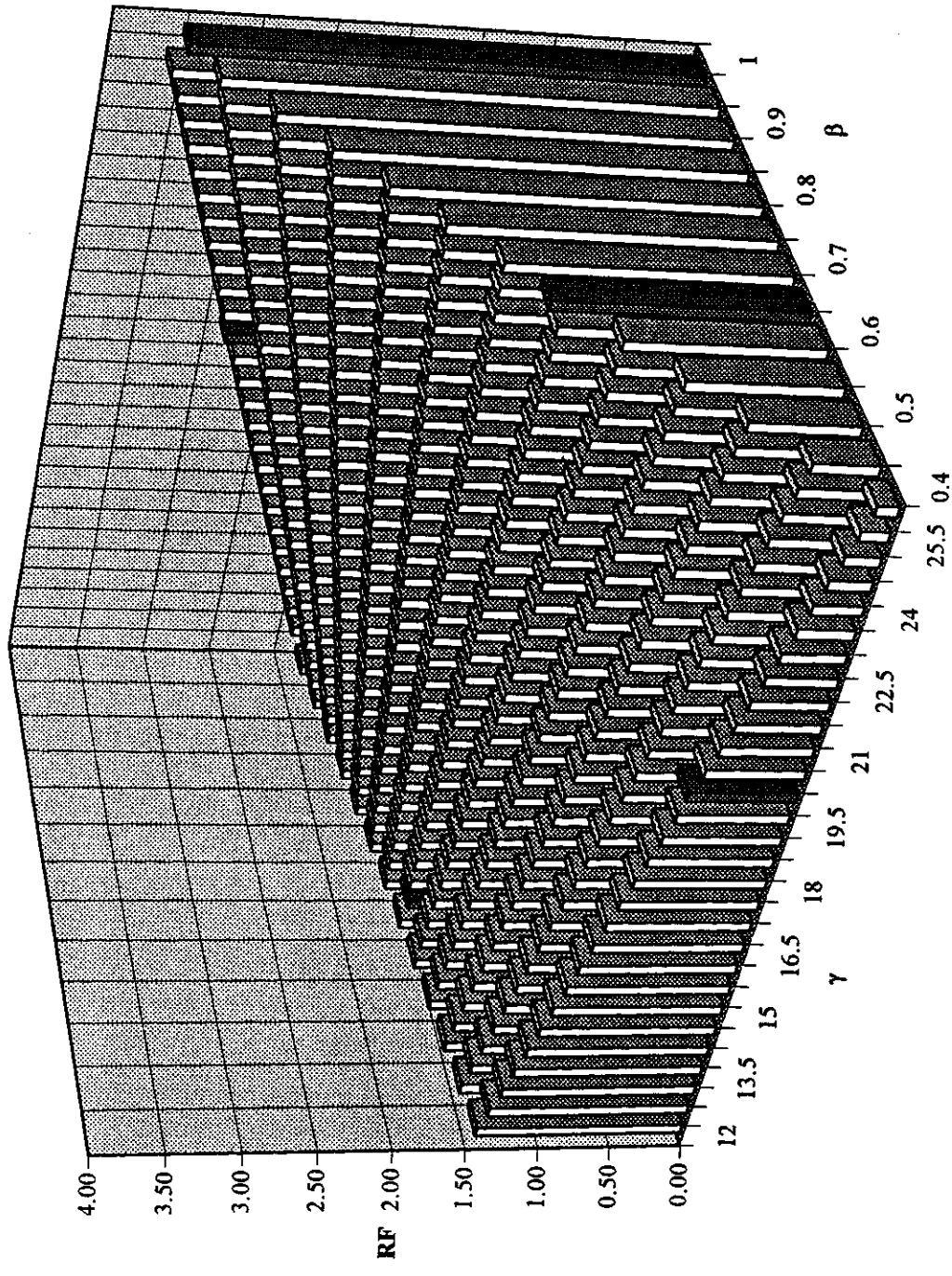
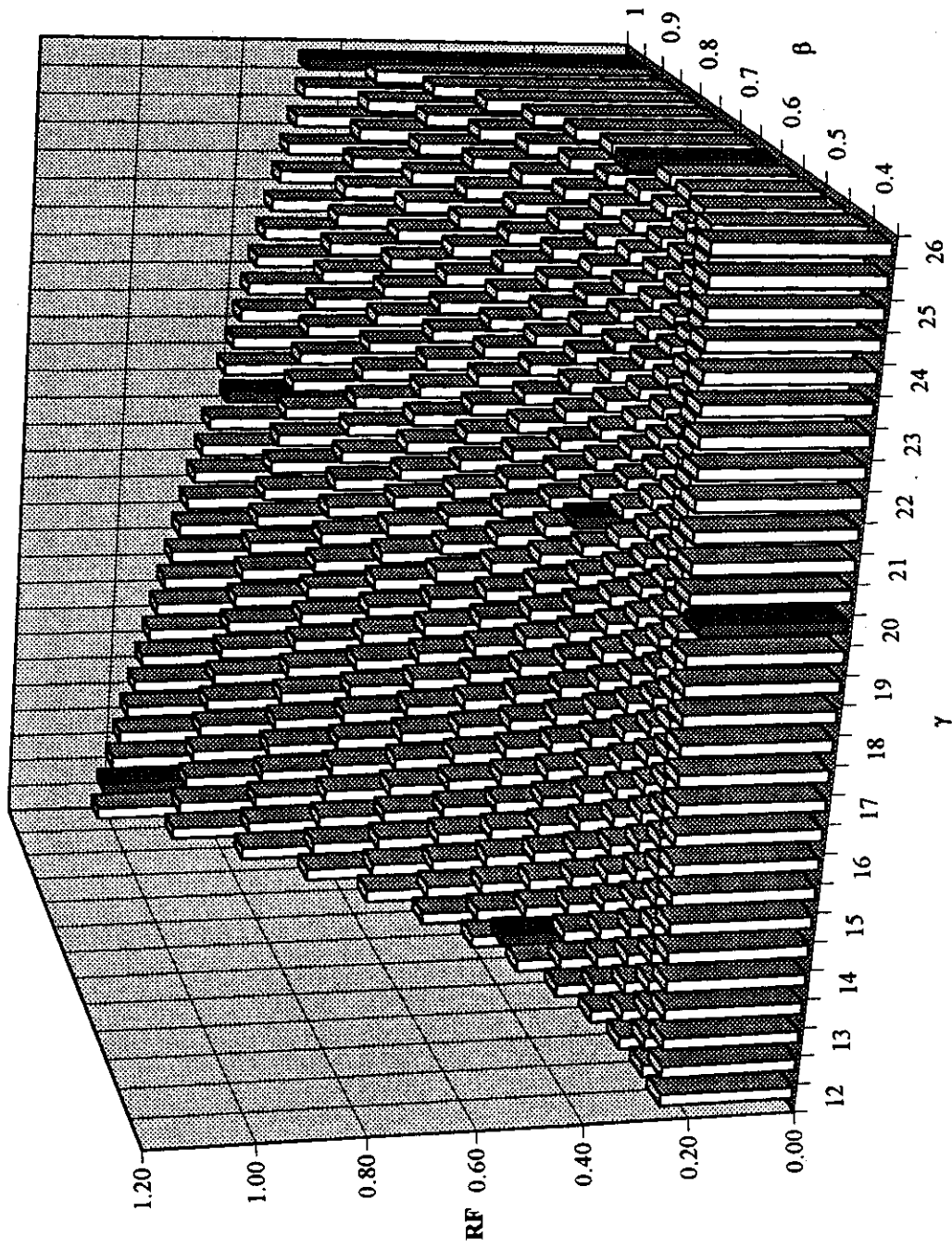

Fig. Q28: Comparison of Fitted Surface with Measured Values for DT Joints under Compression, Chord Crown (Final)



**Fig. Q29: Comparison of Fitted Surface with Measured Values for
DT Joints under Tension, Chord Saddle**

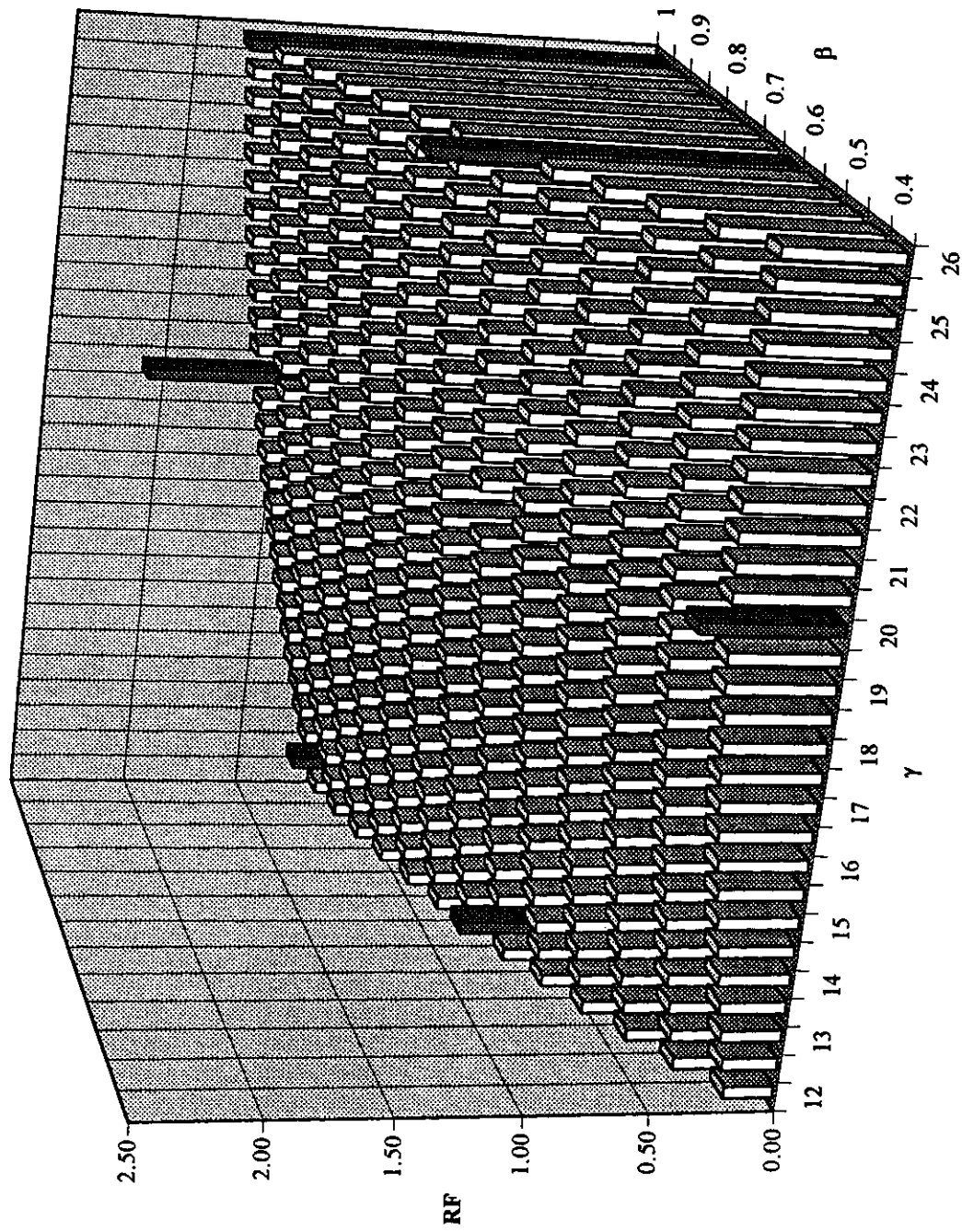

Fig. Q30: Comparison of Fitted Surface with Measured Values for DT Joints under Tension, Chord Crown (Interim)

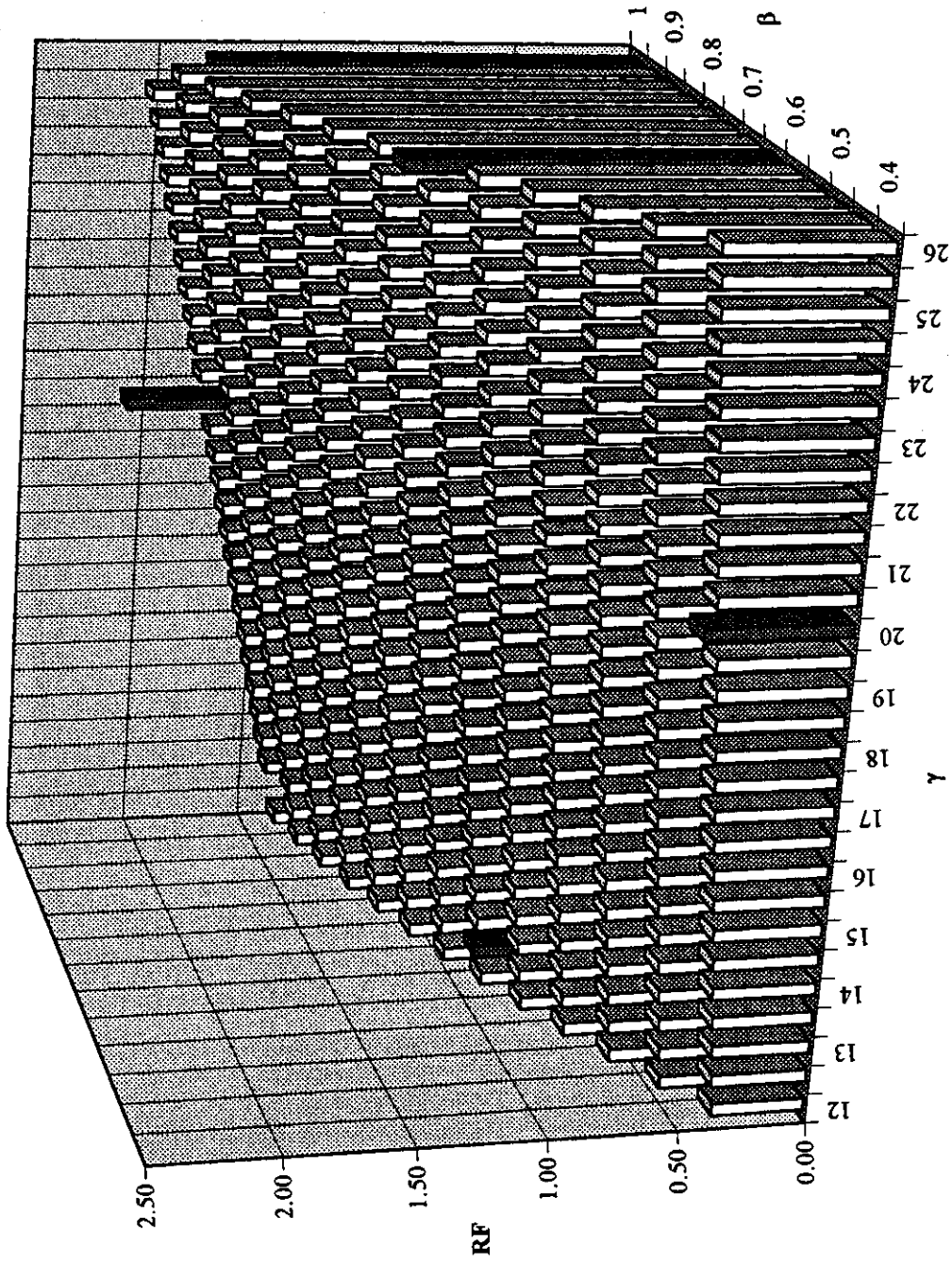

Fig. Q31: Comparison of Fitted Surface with Measured Values for DT Joints under Tension, Chord Crown (Final)

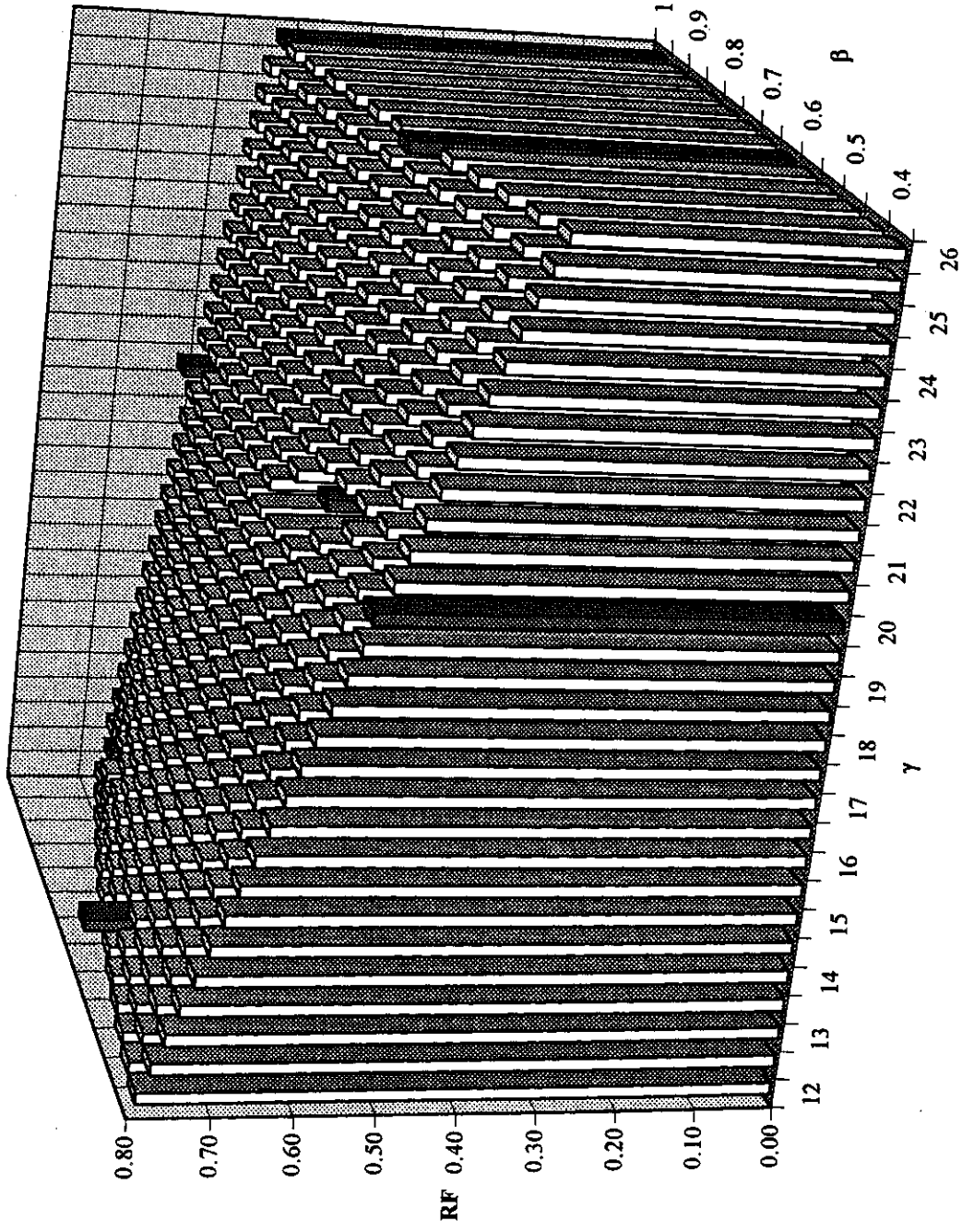

Fig. Q32: Comparison of Fitted Surface with Measured Values for DT Joints under IPB, Chord Crown

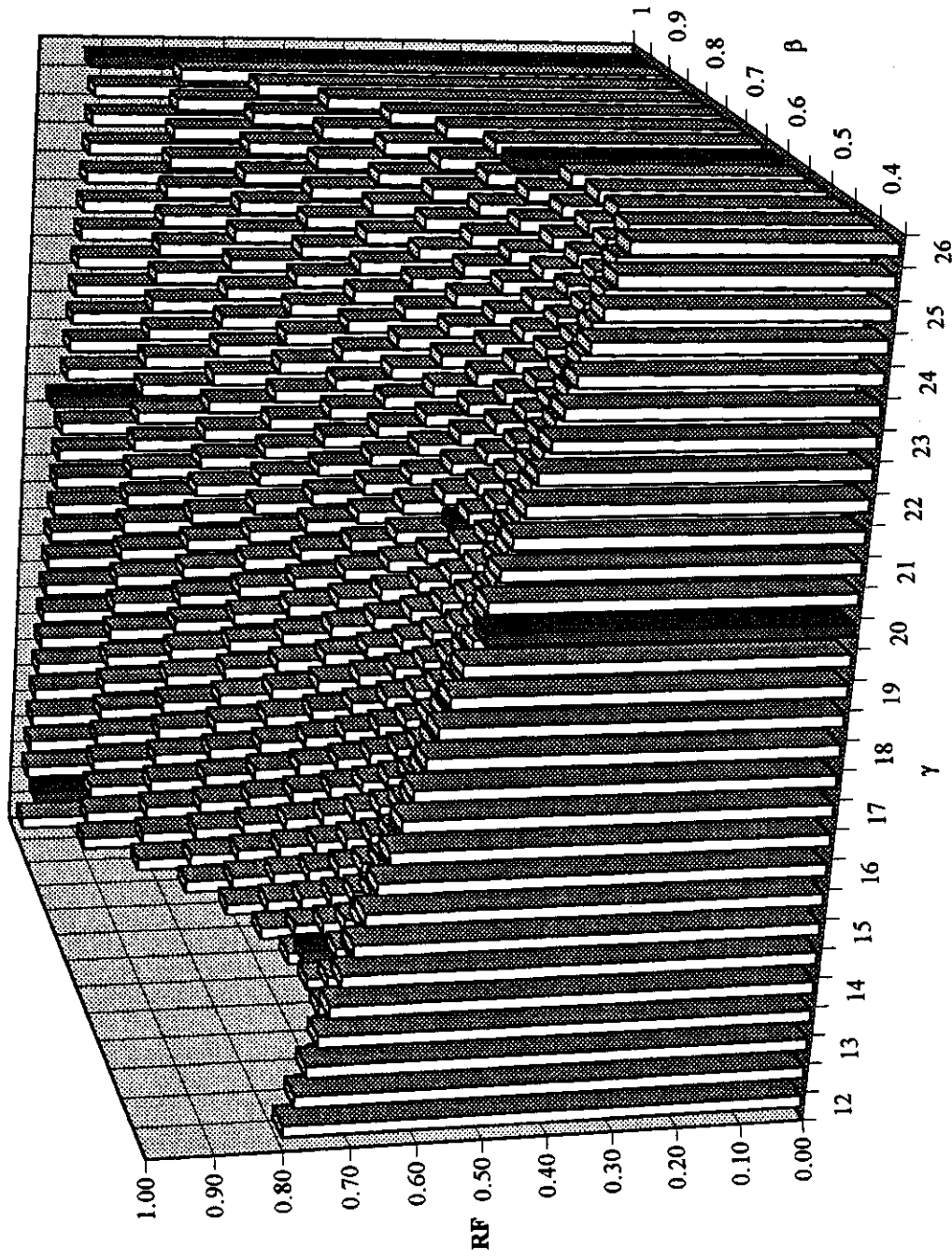

Fig. Q33: Comparison of Fitted Surface with Measured Values for DT Joints under OPB, Chord Saddle

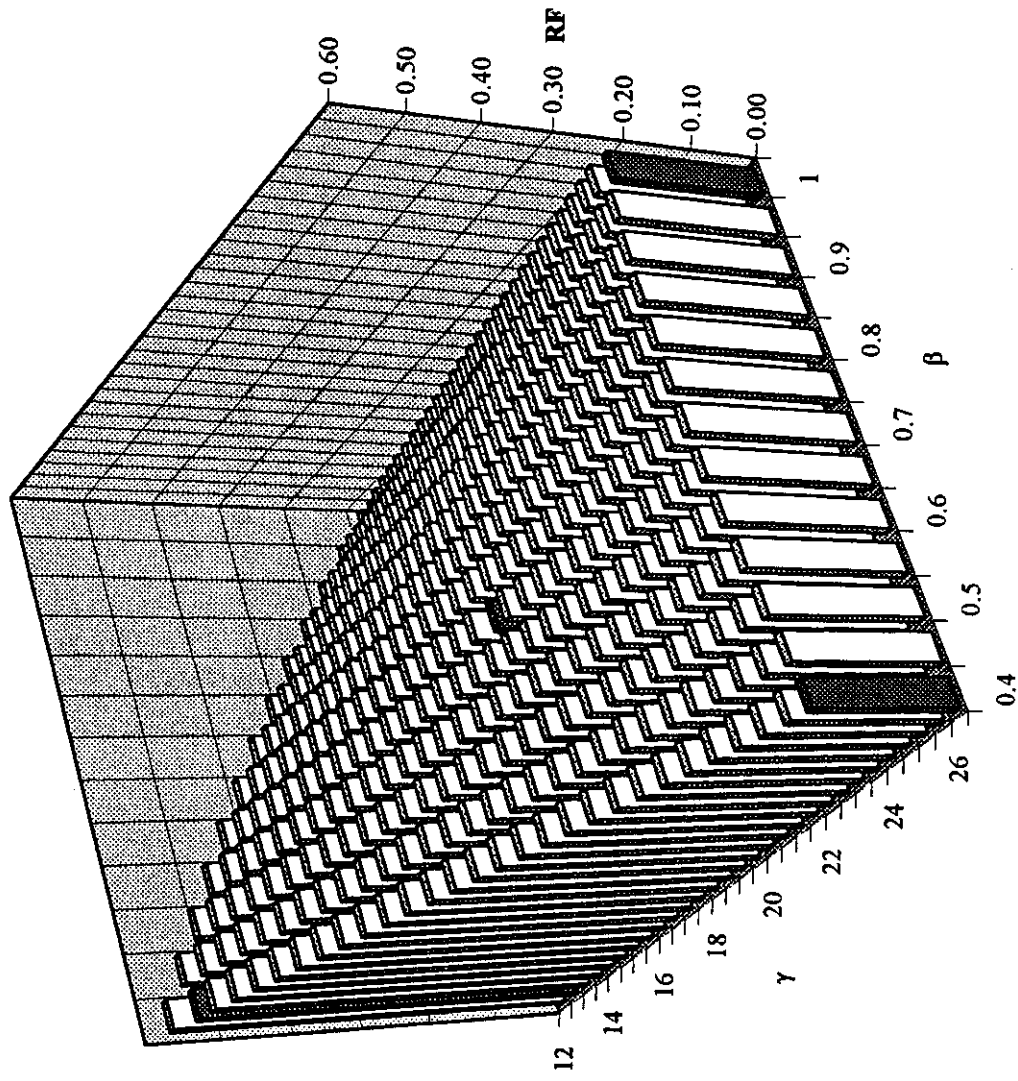

Fig Q34: Comparison of Fitted Surface with Measured Values for T Joints under Compression, Chord Saddle

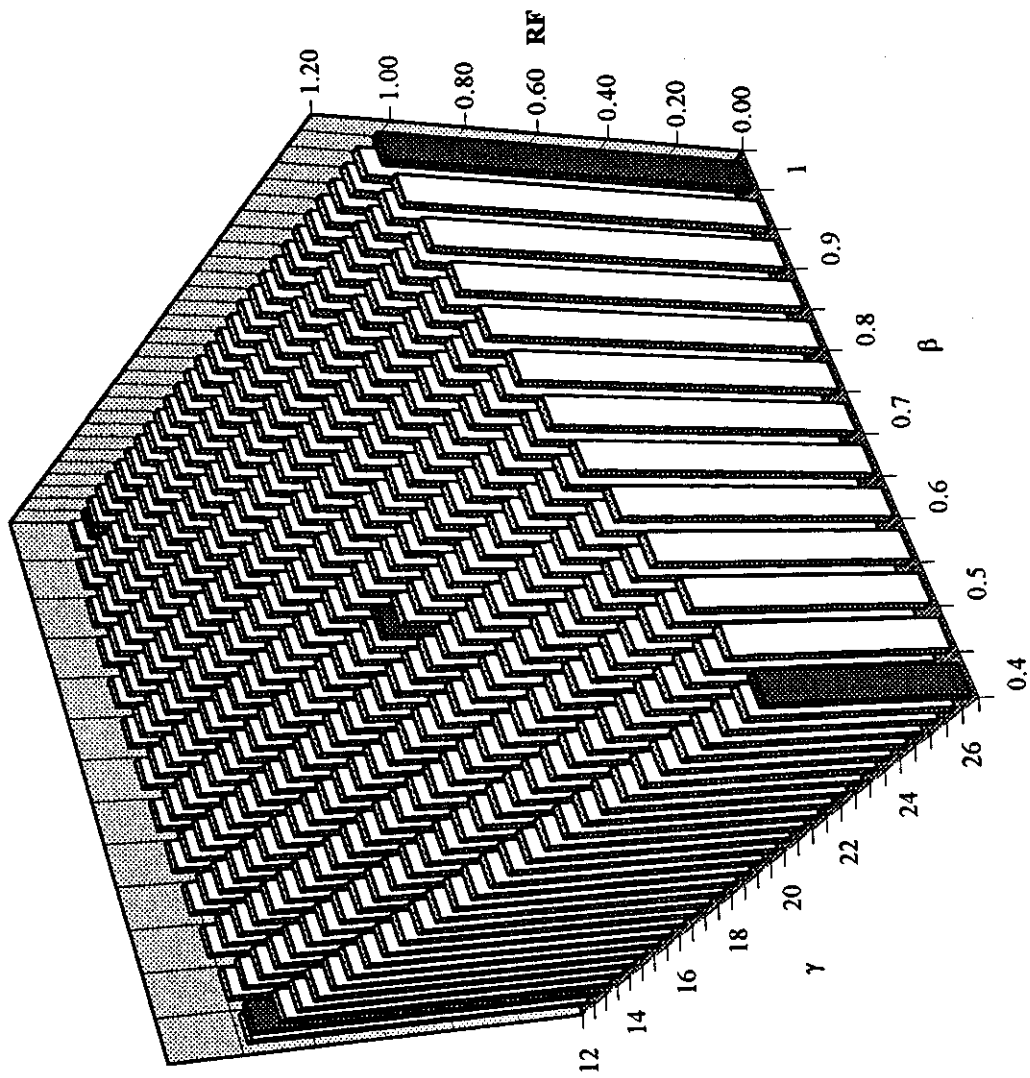

Fig. Q35: Comparison of Fitted Surface with Measured Values for
T Joints Compression, Chord Crown

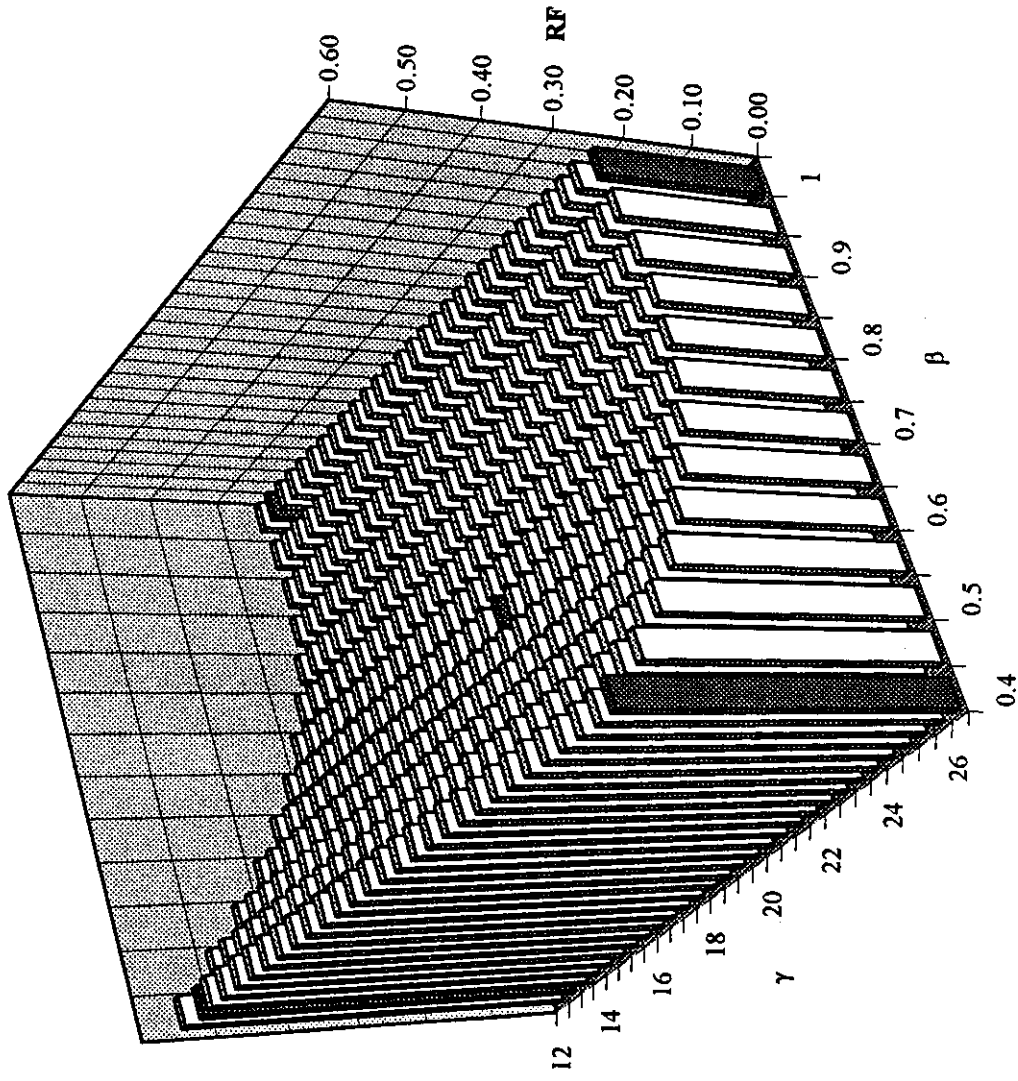

Fig Q36: Comparison of Fitted Surface with Measured Values for T joints under Tension, Chord Saddle

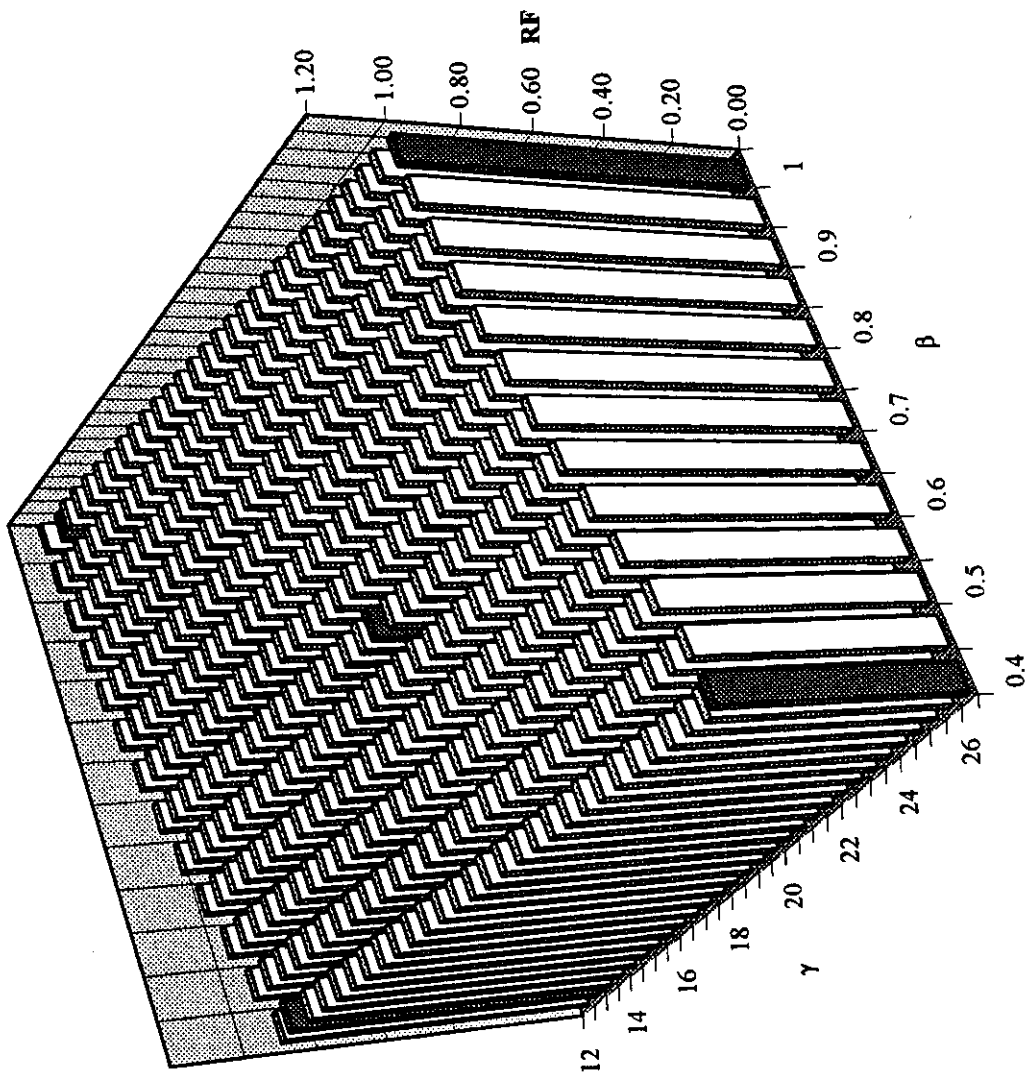

Fig. Q37: Comparison of Fitted Surface with Measured Values for T Joints under Tension, Chord Crown

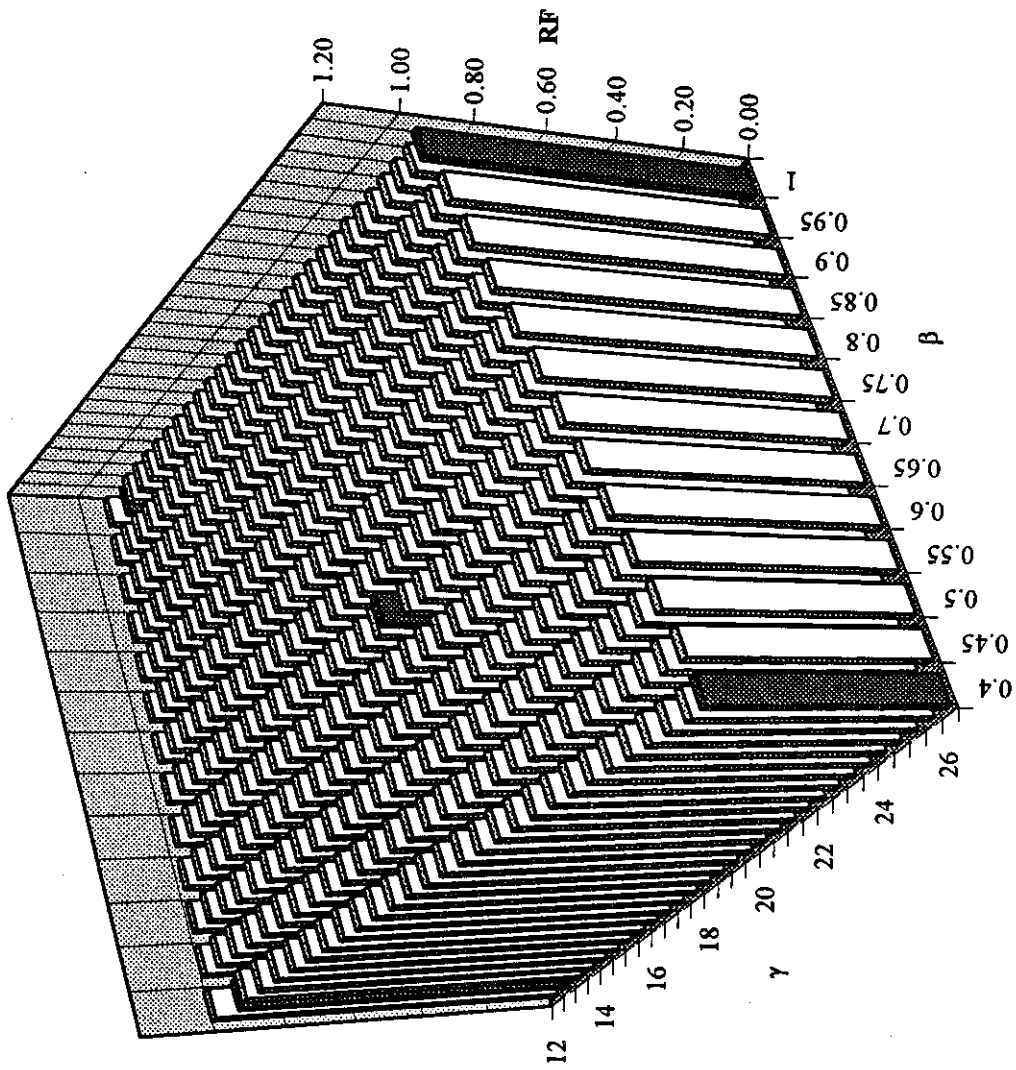
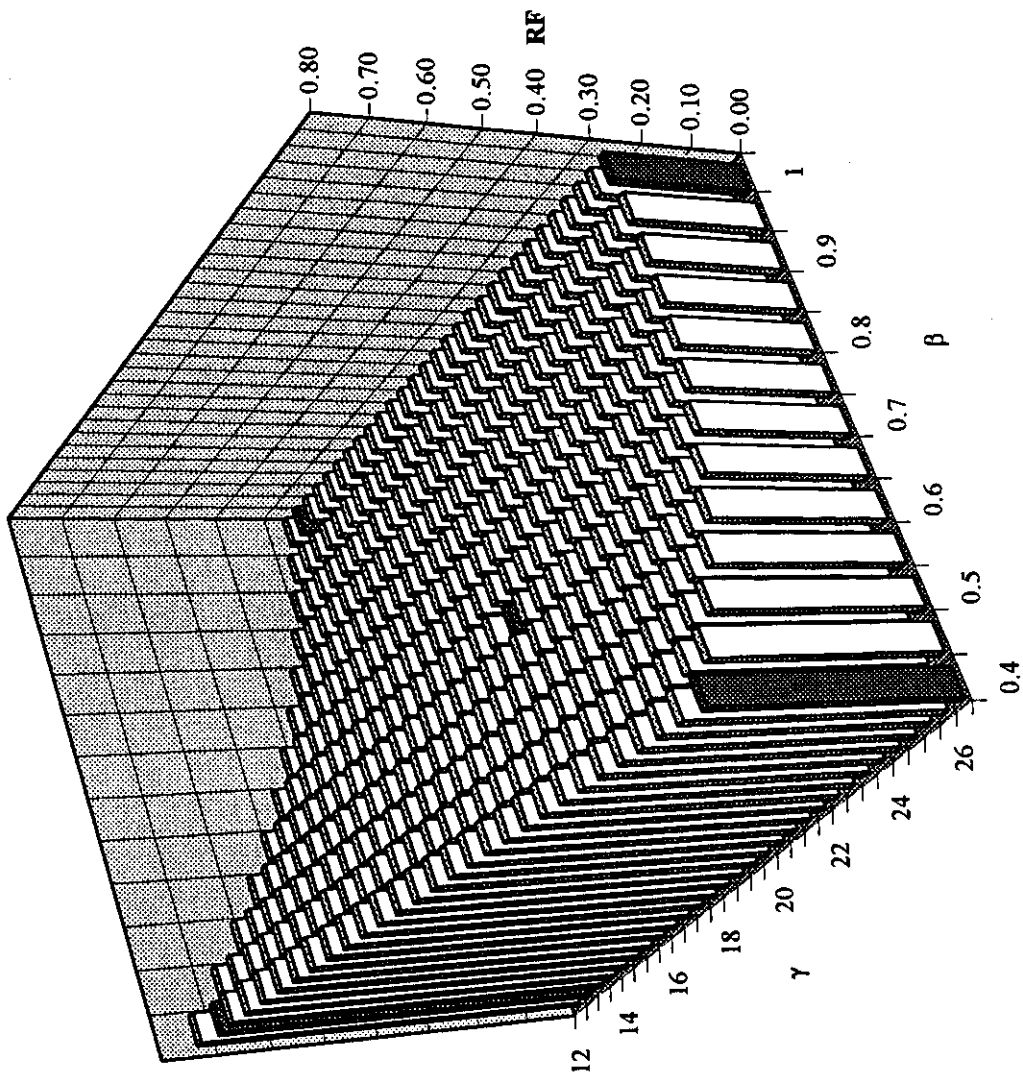

Fig. Q38: Comparison of fitted Surface with Measured Values for T Joints under IPB, Chord Crown



**Fig. Q39: Comparison of Fitted Surface with Measured Values for
T Joints under OPB, Chord Saddle**

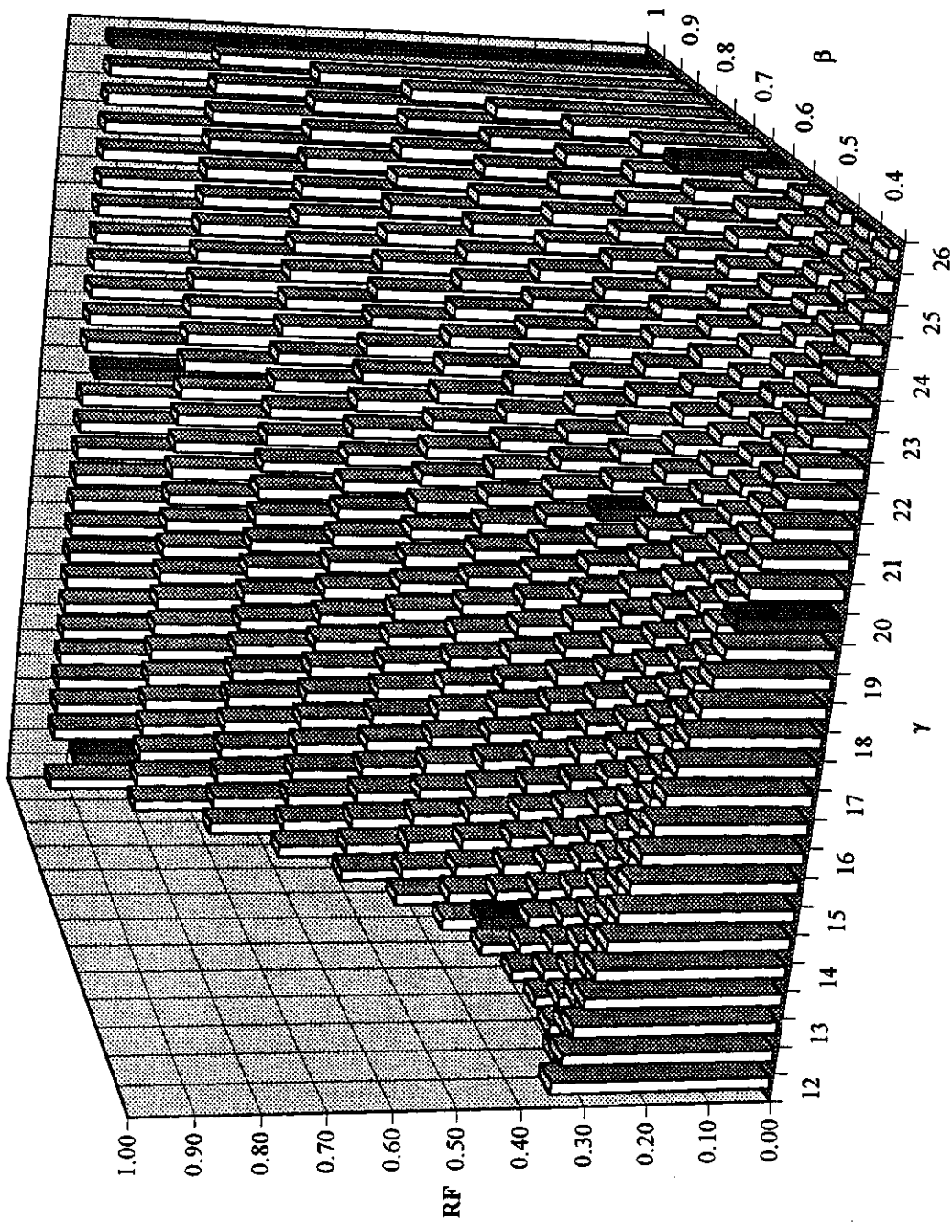

Fig. Q40: Comparison of Fitted Surface with Measured Values for DT Joints under Compression, Brace Saddle

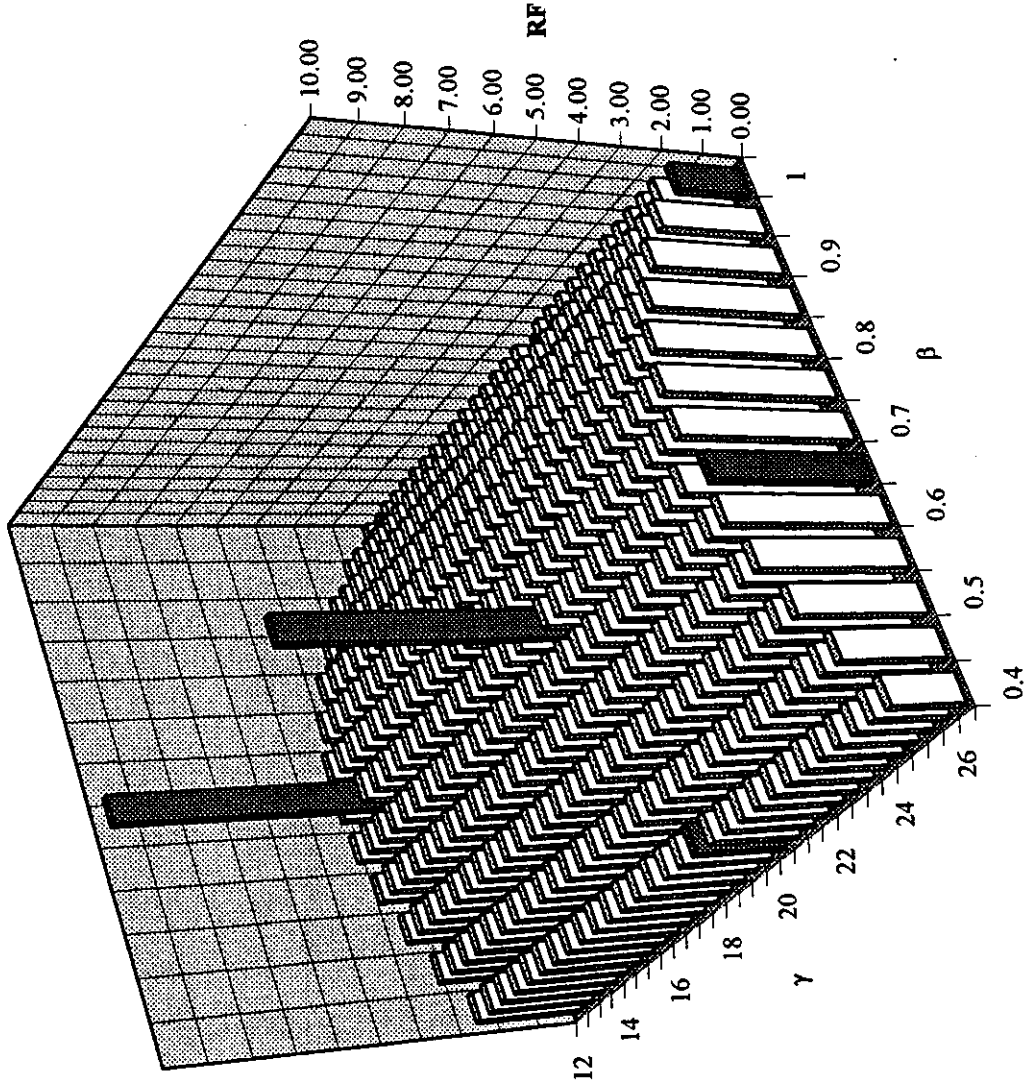

Fig. Q41: Comparison of Fitted Surface with Measured Values for DT Joints under Compression, Brace Crown

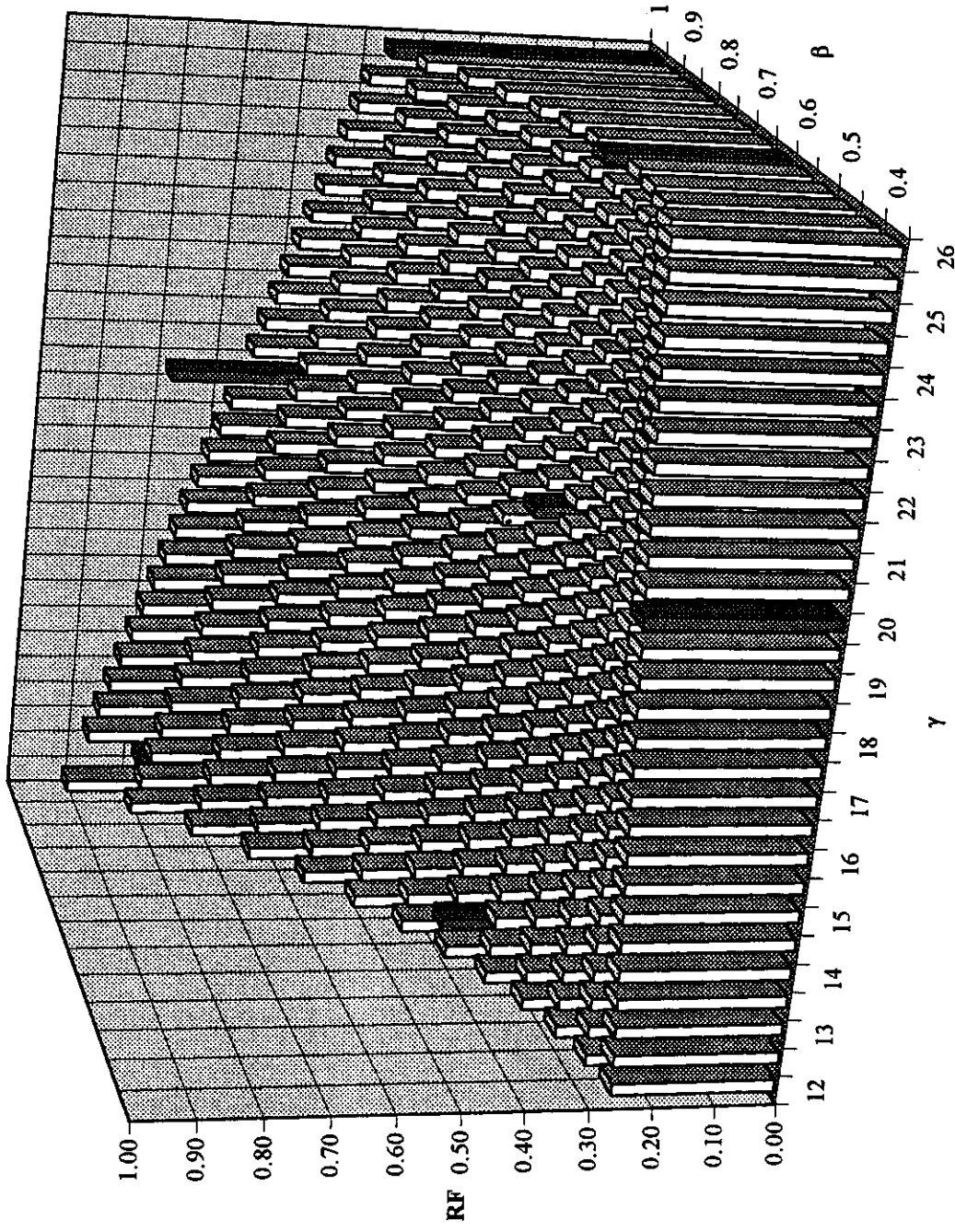
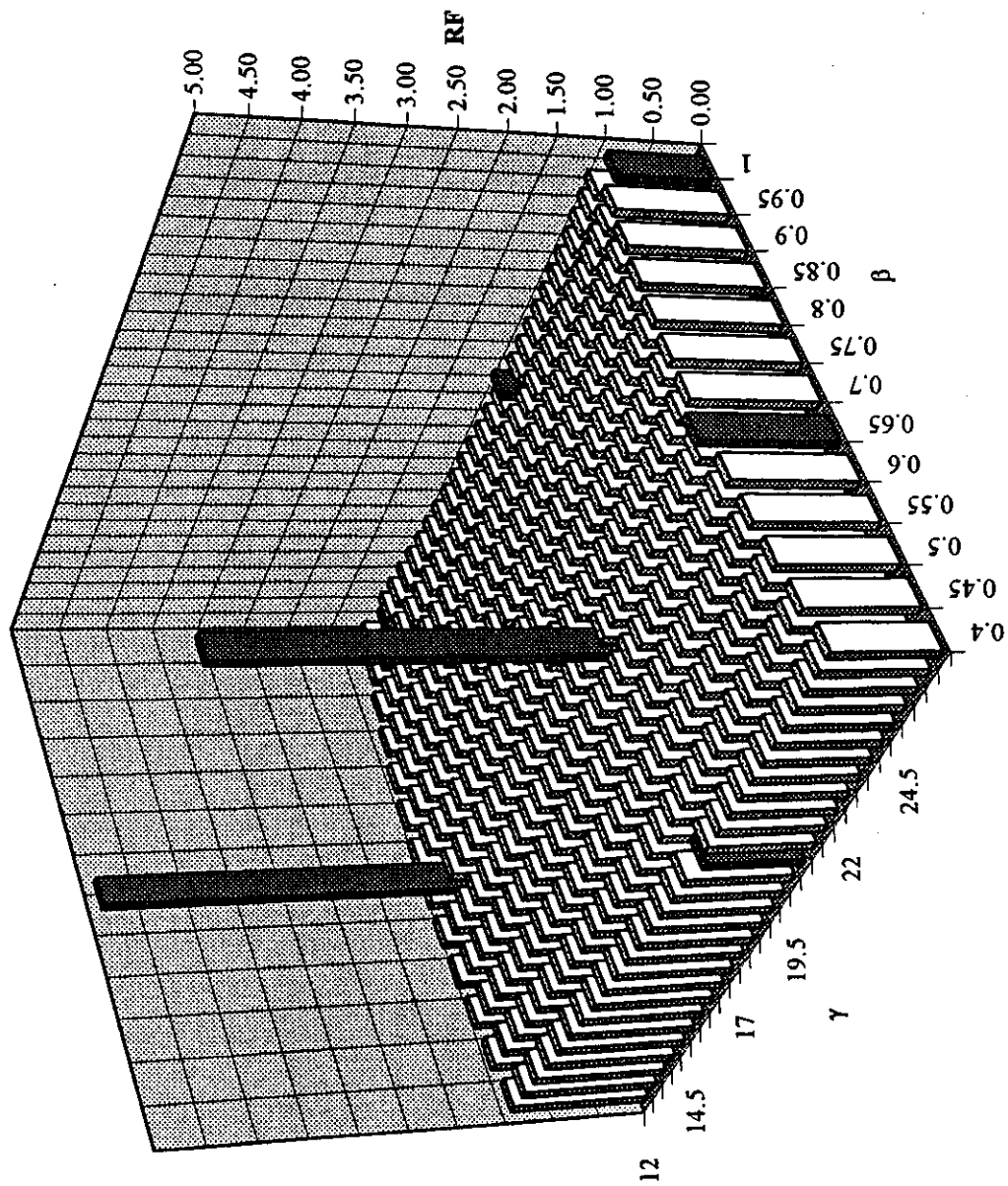

Fig. Q42: Comparison of Fitted Surface with Measured Values for DT Joints under Tension, Brace Saddle



**Fig. Q43: Comparison of Fitted Surface with Measured Values for
DT Joints under Tension, Brace Crown**

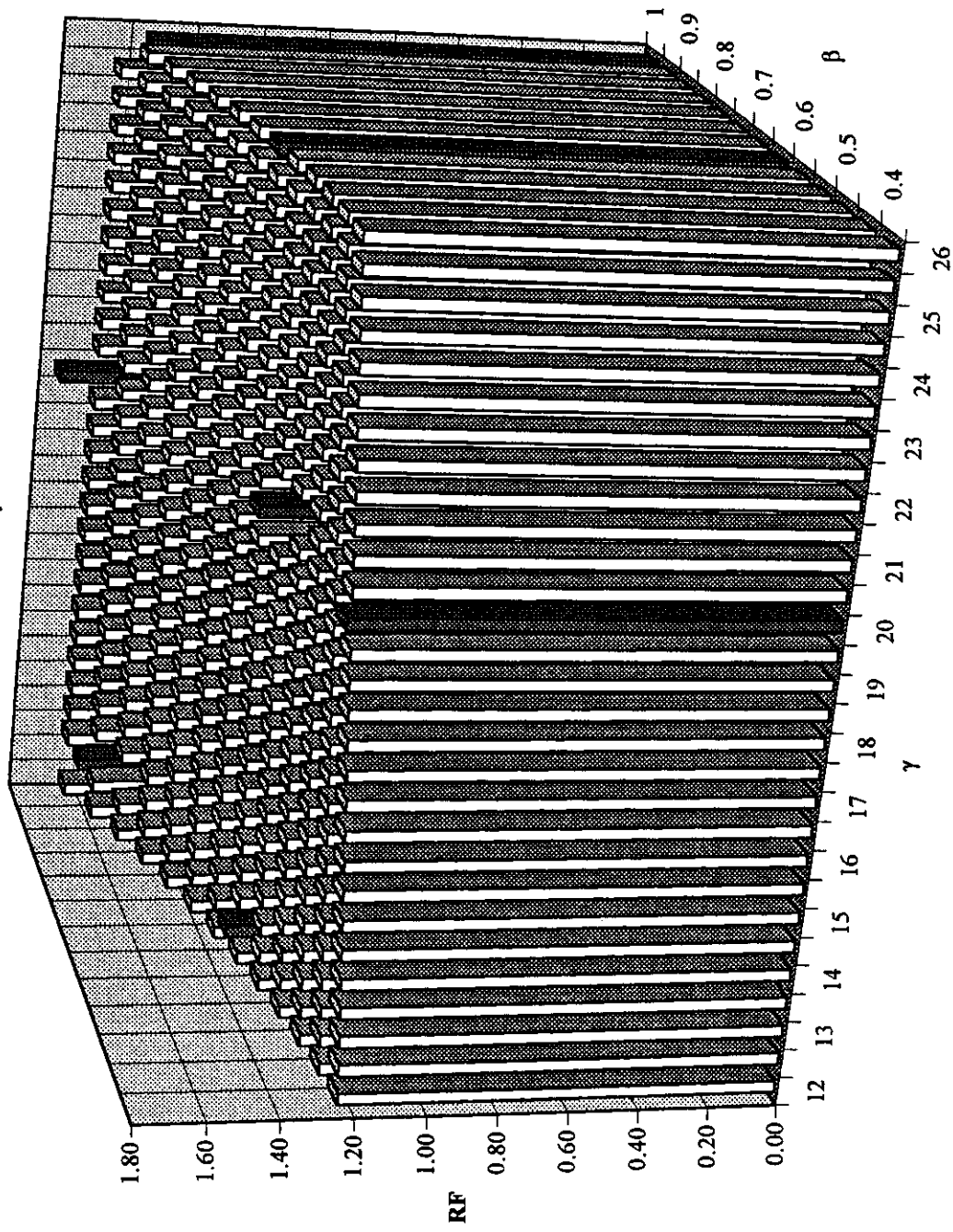

Fig. Q44: Comparison of Fitted Surface with Measured Values for DT Joints under IPB, Brace Crown

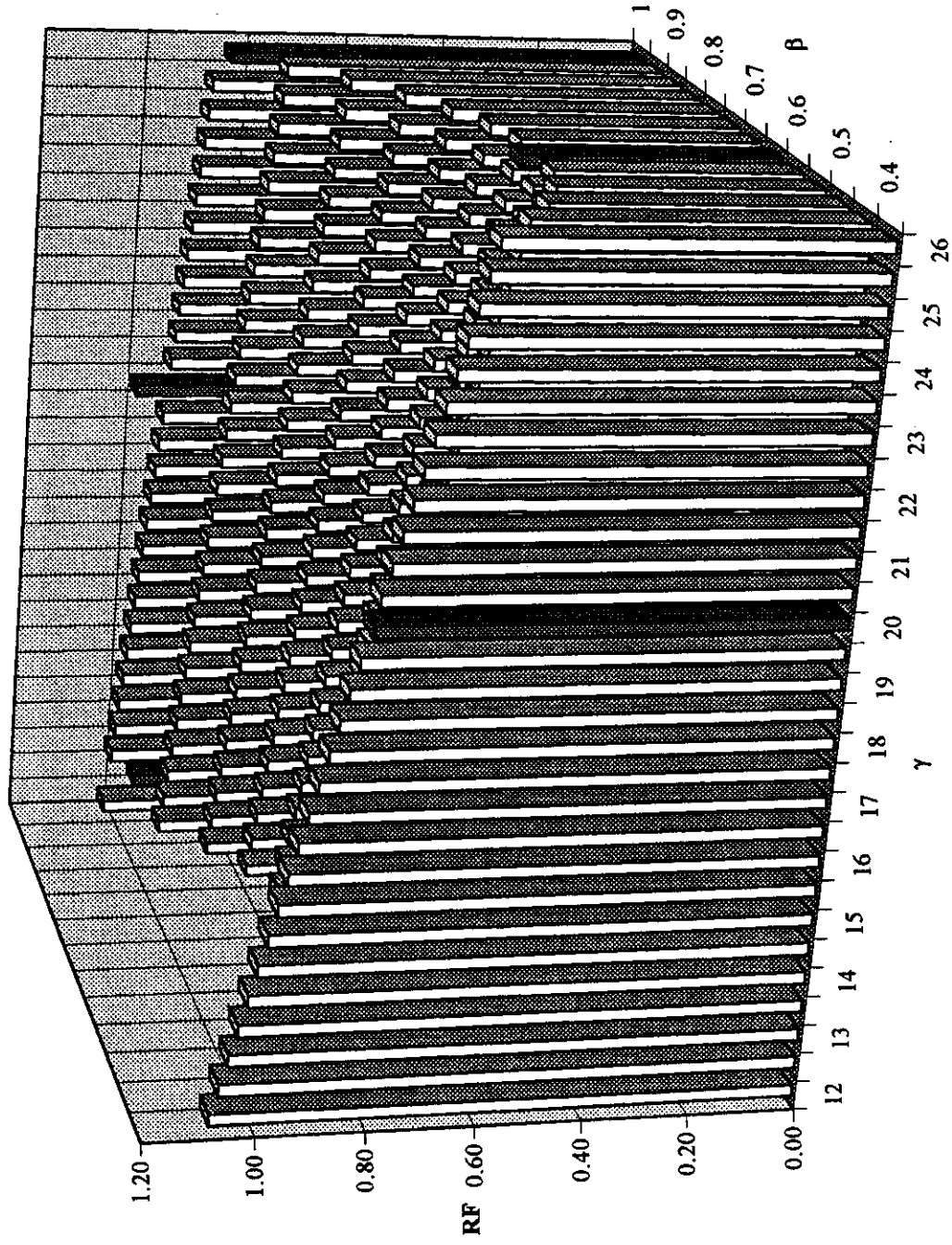

Fig. Q45: Comparison of Fitted Surface with Measured Values for DT Joints under OPB, Brace Saddle

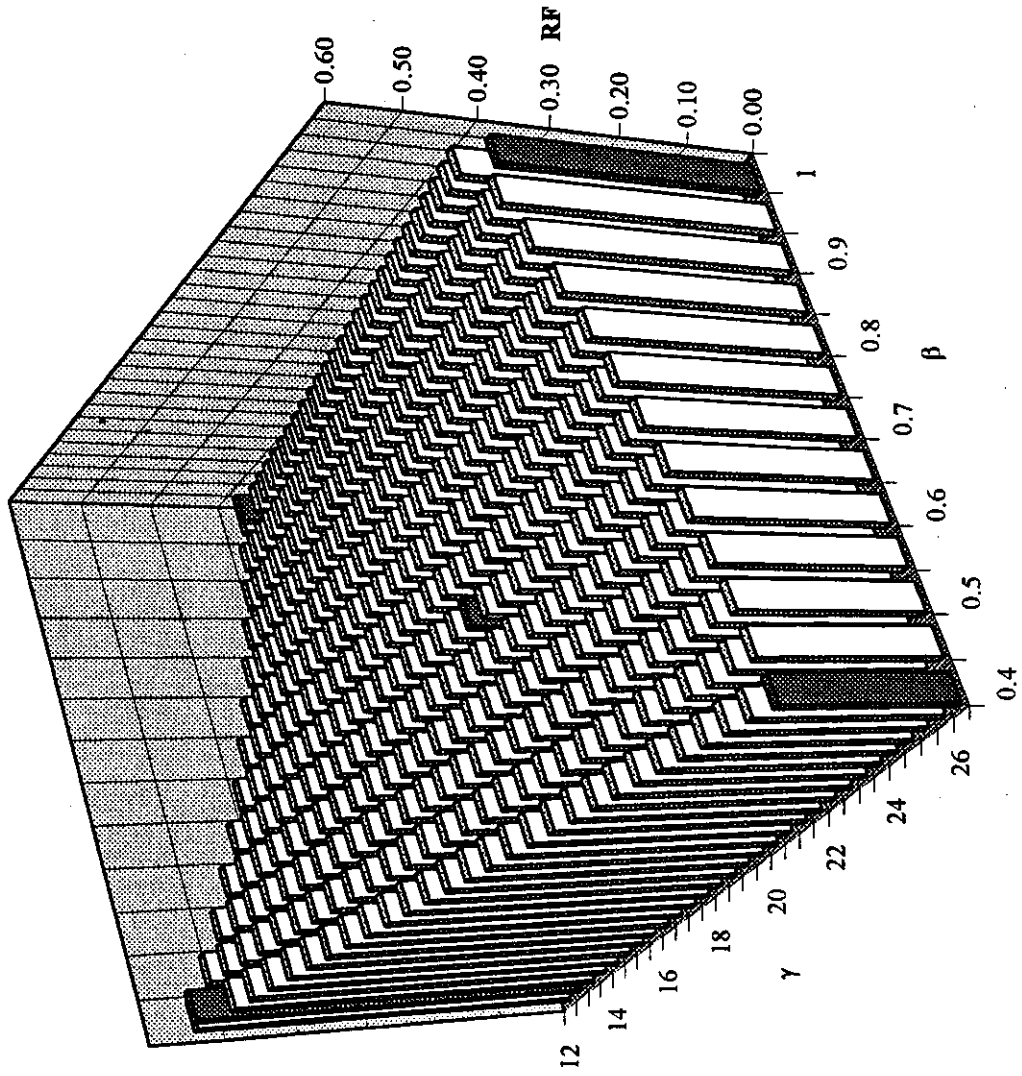

Fig Q46: Comparison of Fitted Surface with Measured Values for T Joints under Compression, Brace Saddle

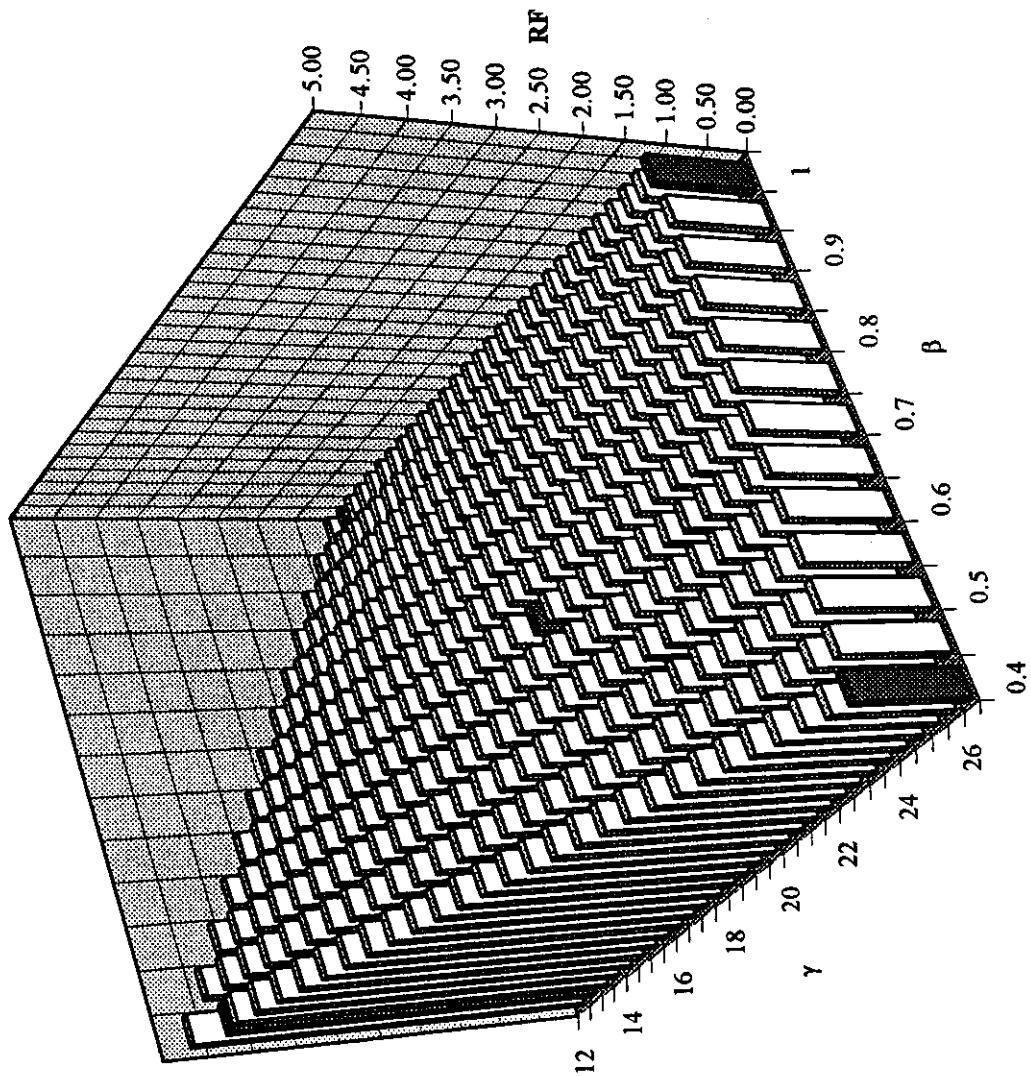

Fig. Q47: Comparison of Fitted Surface with Measured Values for T Joints Compression, Brace Crown

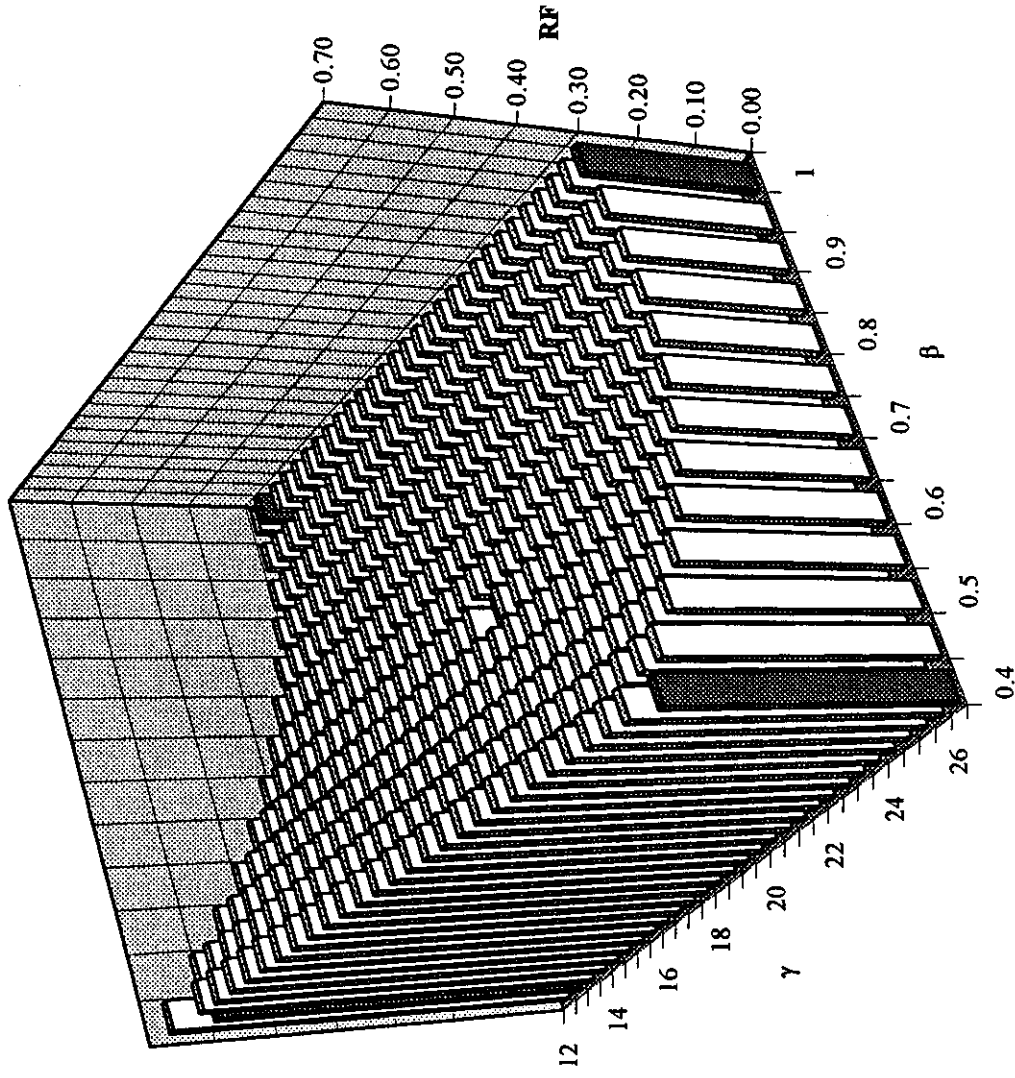

Fig Q48: Comparison of Fitted Surface with Measured Values for T joints under Tension, Brace Saddle

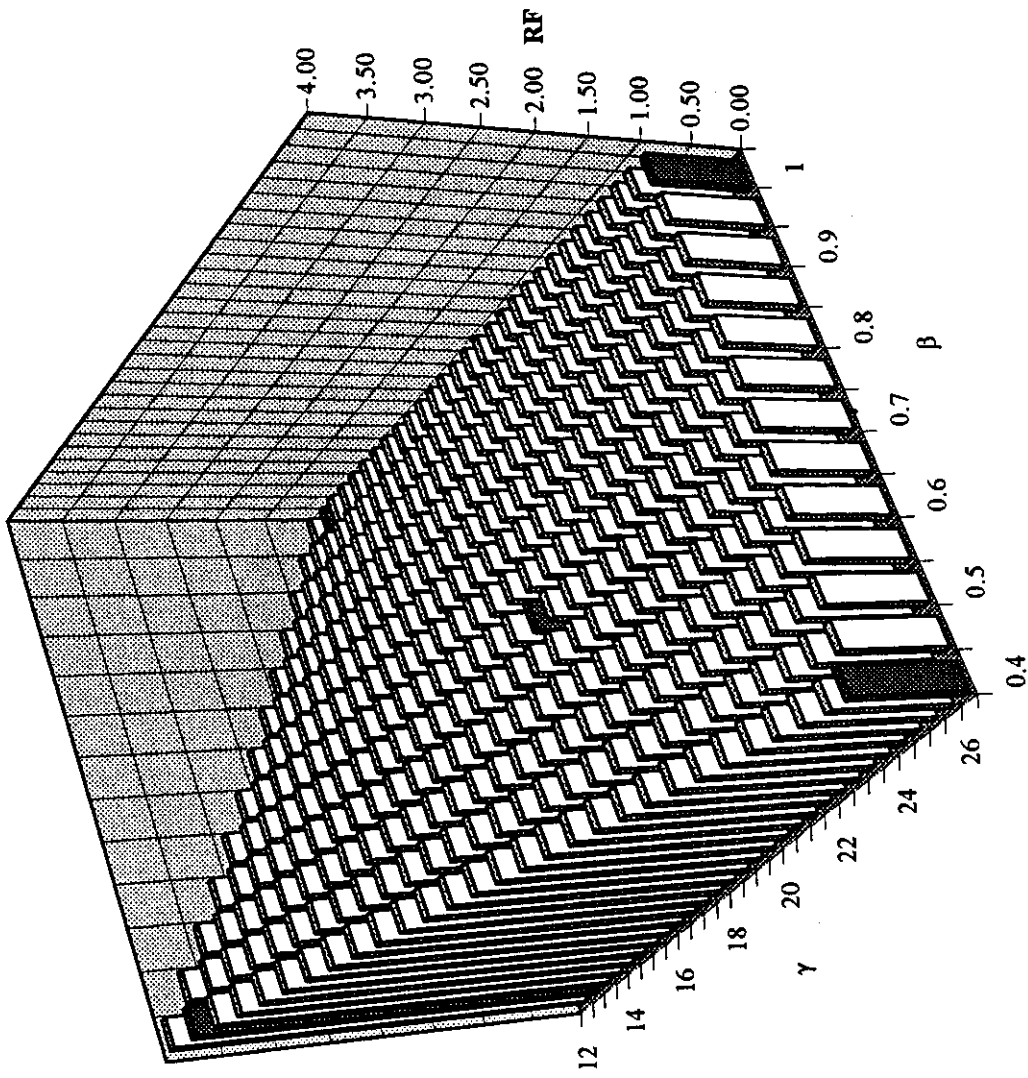

Fig. Q49: Comparison of Fitted Surface with Measured Values for
T Joints under Tension, Brace Crown

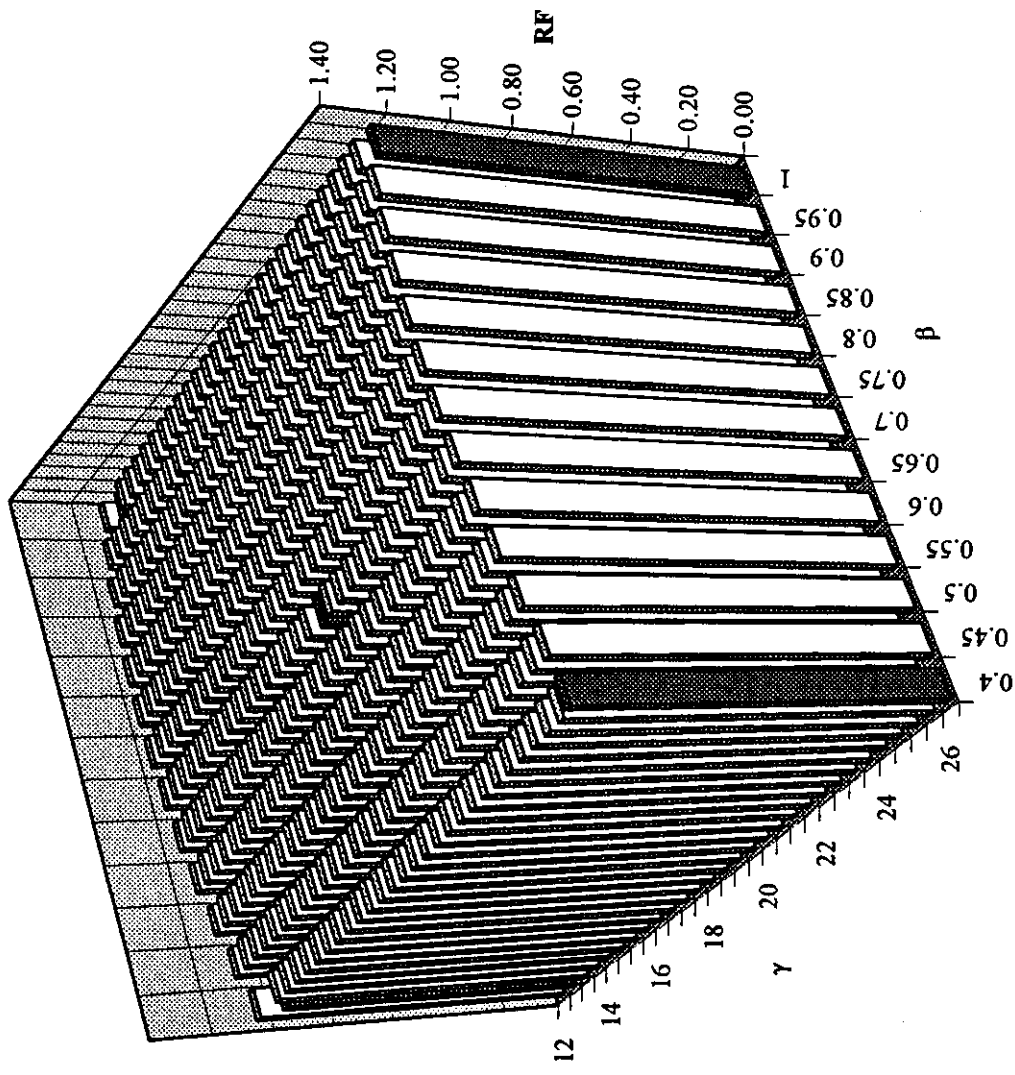

Fig. Q50: Comparison of fitted Surface with Measured Values for T Joints under IPB, Brace Crown

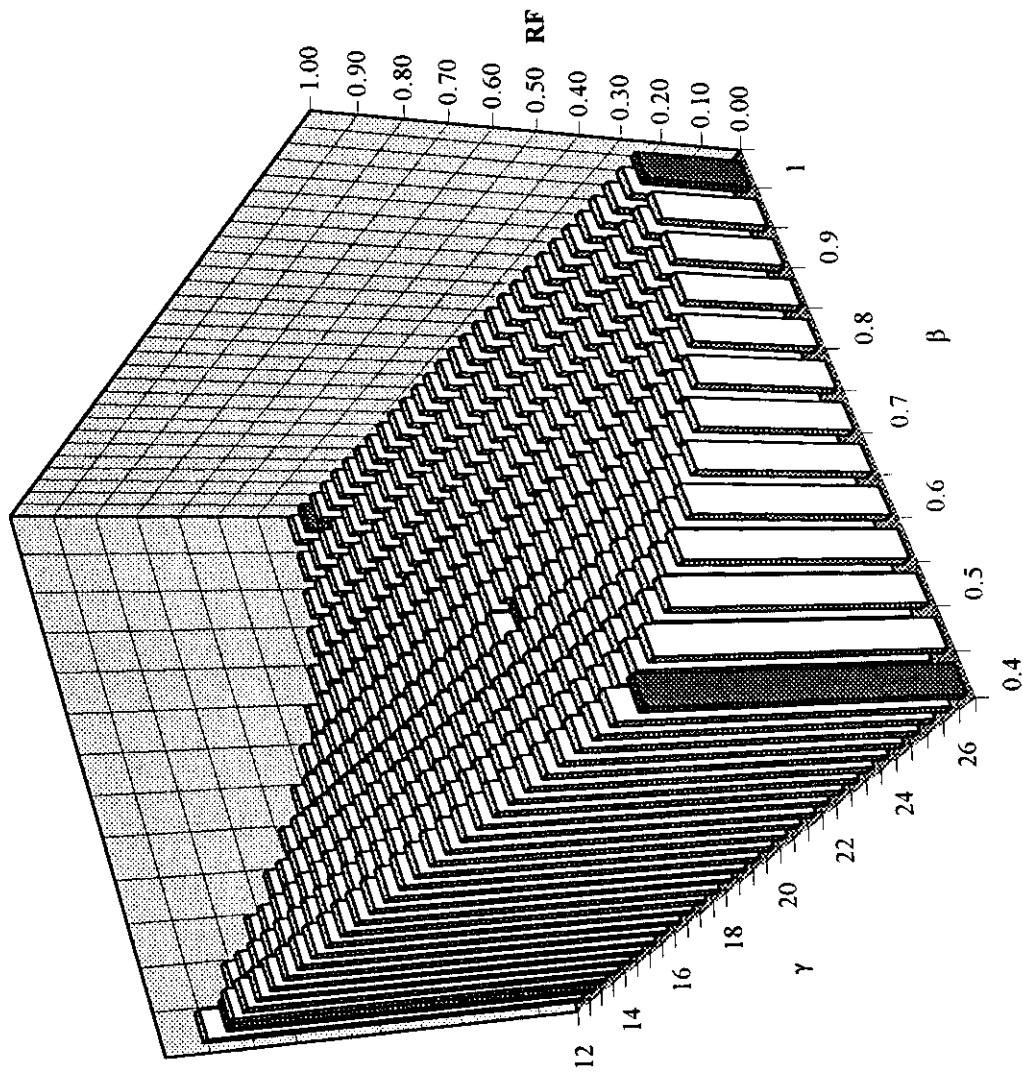

Fig. Q51: Comparison of Fitted Surface with Measured Values for
T Joints under OPB, Brace Saddle

APPENDIX R

Development of Measured Grouted SNCF (x 1.2)/Efthymiou

As-welded SCF Reduction Factors

C14100R020 Rev 1 February 1997

NSI

APPENDIX R

DEVELOPMENT OF REDUCTION FACTORS

R1 INTRODUCTION

This appendix presents the development of formulations to predict the SCF Reduction Factor (RF) for each joint and load type for both the chord and brace side of the weld. The definition of RF from which the formulations are derived is:

$$\text{RF} = \frac{\text{Measured value of SCF for grouted joint}}{\text{Efthymiou derived SCF for as-welded joint}}$$

R2 DATA

The baseline data are the measured SCF values of the grouted joints and the as-welded SCF values derived using Efthymiou parametric equations. These data are discussed in Sections 7 and 8 of the main text and also in Appendices M and S. It is noted here that the grouted SCFs used in this appendix relate to the values obtained following the 50% preload cycle.

The resulting RFs, found by applying the above definition, are summarised in Table R1. The table shows the RF for each joint and load type, and differentiates between the saddle and crown position for axially loaded joints. For the sake of completeness, the RFs for the brace side of the weld are also given. In addition to the measured RF values, the values predicted by the formulations given below are also shown in the table. As can be observed, good agreement between the observed and predicted values is indicated across the board.

The data in Table R1 are presented in a series of figures (Figures R1 to R24), each figure relating to a single joint type (DT or T), load type (compression, tension, IPB or OPB) and, the SCF location (saddle or crown). Figures R1 to R12 relate to data on the chord side of the weld and Figures R13 to R24 to the brace side. Each figure contains three diagrams:

- plot of RF vs. β
- plot of RF vs. γ
- a 3-D representation of RF vs β and γ .

The first two plots may have up to three lines, each line corresponding to a constant γ or β parameter. To visualise better these two diagrams, 3-D bar charts are given. Note, however, the bar chart axes are not true to scale (the 'skyscrapers' fall on a 3 x 3 regular matrix associated with the discrete values of β and γ).

The philosophy adopted for those RF functions derived in Appendix Q also apply to the functions derived in this Appendix R. The resultant RF functions, albeit including additional terms, perform well.

R3. Concluding Remarks

Tables R4 to R7 present a comparison of predicted and measured as-welded and grouted SCFs for the two joint types at all locations. Of note are the predicted grouted SCFs derived using predicted RFs, from joint parameters, with measured as-welded SCFs and Efthymiou predicted as-welded SCFs. The results demonstrate that for a number of joint configurations, the crown SCF becomes critical, in the grouted condition, and even supercedes the highest as-welded SCF.

Specimen Ident.	Chord RFs														Brace RFs								
	D (mm)	d (mm)	T (mm)	t (mm)	L (mm)	θ (°)	β	γ	τ	α	Condition	IPB	OPB		Comp.		Tens.						
													AX-s	AX-c	AX-s	AX-c	AX-s	AX-c					
T1	406.78	167.81	16.39	16.32	2440	90.0	0.413	12.409	0.996	12.00	Measured	0.78	0.63	0.47	1.15	0.42	0.97	0.56	0.43	0.43	0.44	0.36	
											Predicted	0.78	0.63	0.47	1.16	0.43	0.95	0.56	0.44	0.42	0.44	0.38	
T3	406.78	407.02	16.39	16.10	2440	90.0	1.000	12.409	0.982	12.00	Measured	0.97	0.28	0.07	1.29	0.16	1.37	0.62	0.45	0.45	0.46	0.76	
											Predicted	1.00	0.28	0.07	1.30	0.17	1.36	0.62	0.45	0.44	0.84	0.47	0.78
T5	407.05	273.34	10.19	9.82	2440	90.0	0.672	19.973	0.964	11.99	Measured	0.81	0.35	0.32	1.45	0.31	1.39	0.67	0.39	0.33	1.05	0.37	0.77
											Predicted	0.81	0.35	0.32	1.45	0.32	1.39	0.67	0.39	0.33	1.05	0.37	0.78
T7	406.96	168.41	7.86	8.31	2440	90.0	0.414	25.888	1.057	11.99	Measured	0.61	0.55	0.23	0.82	0.49	0.93	0.55	0.49	0.20	0.63	0.36	0.52
											Predicted	0.58	0.55	0.23	0.81	0.50	0.94	0.55	0.49	0.20	0.62	0.35	0.51
T9	406.96	406.96	7.86	7.86	2440	90.0	1.000	25.888	1.000	11.99	Measured	0.74	0.32	0.30	1.04	0.31	0.95	0.73	0.25	0.52	1.24	0.41	0.93
											Predicted	0.73	0.32	0.30	1.03	0.31	0.95	0.73	0.25	0.53	1.27	0.42	0.92
DT2	406.78	273.09	16.39	15.76	2440	90.0	0.671	12.409	0.962	12.00	Measured	0.85	0.52	0.32	1.43	0.33	0.88	0.89	0.63	0.36	0.85	0.43	0.37
											Predicted	0.89	0.57	0.31	1.29	0.36	0.87	0.89	0.63	0.37	0.88	0.44	0.38
DT3	406.78	407.02	16.39	16.10	2440	90.0	1.001	12.409	0.982	12.00	Measured	0.60	1.14	0.83	0.62	0.89	0.43	0.94	1.72	1.26	0.46	1.08	0.41
											Predicted	0.60	1.20	1.02	0.71	0.96	0.64	0.98	1.81	1.34	0.46	1.13	0.41
DT4	407.05	168.57	10.19	9.95	2440	90.0	0.414	19.973	0.976	11.99	Measured	0.58	0.53	0.14	0.78	0.30	0.63	0.97	0.47	0.13	1.05	0.26	0.55
											Predicted	0.58	0.55	0.14	0.84	0.31	0.80	1.00	0.47	0.13	1.05	0.25	0.55
DT5	407.05	273.34	10.19	9.82	2440	90.0	0.672	19.973	0.964	11.99	Measured	0.69	0.52	0.29	0.73	0.38	0.27	0.81	0.49	0.27	1.26	0.39	0.52
											Predicted	0.64	0.50	0.30	0.85	0.35	0.55	0.82	0.49	0.26	1.16	0.40	0.50
DT6	407.05	407.60	10.19	9.61	2440	90.0	1.001	19.973	0.943	11.99	Measured	0.54	1.26	1.07	0.64	0.91	0.47	1.07	1.35	1.13	0.86	0.93	0.70
											Predicted	0.52	1.20	1.00	0.65	0.83	0.41	0.98	1.26	1.05	0.96	0.92	0.71
DT8	406.96	273.21	7.86	7.88	2440	90.0	0.671	25.888	1.003	11.99	Measured	0.41	0.40	0.21	0.93	0.31	0.75	0.72	0.39	0.18	1.36	0.31	0.51
											Predicted	0.44	0.44	0.30	0.91	0.34	0.61	0.76	0.38	0.18	1.46	0.31	0.52
DT9	406.96	406.96	7.86	7.86	2440	90.0	1.000	25.888	1.000	11.99	Measured	0.44	1.13	1.01	0.78	0.68	0.41	0.90	0.79	0.77	1.54	0.36	0.87
											Predicted	0.46	1.20	0.99	1.00	0.73	0.55	0.98	0.81	0.80	1.43	0.37	0.86

Measured RF values refer to measured grouted SNCFs/Ethymiou as-welded SNCFs.
 Predicted RF values given by formulations in Tables R2 and R3.

Table R1 : Summary of Reduction Factors



$$RF = a_0 + a_1\beta + a_2\gamma + a_3\beta\gamma + a_4\beta^2 + a_5\gamma^2 + a_6\beta^3\gamma^3$$

Joint Type	Load (Position)	a ₀	a ₁	a ₂	a ₃	a ₄	a ₅	COV	Max/Min Error
DT	COMP (Saddle)	0.57	-2.08	0.001	-0.003	2.55	0	0.140	6.54% -41.66%
	COMP (Crown)	4.9	-1.7	-0.32	0.15	-1.15	0.005	0.119	9.92% -28.20%
	TENS (Saddle)	0.25	-1.28	0.03	-0.047	2.2	0	0.083	8.74% -10.43%
	TENS (Crown)	3.9	-2.9	-0.2	0.04	1.01	0.004	0.307	19.56% -101.95%
	IPB (Crown)	1.8	-0.08	-0.08	0.07	-1	0	0.054	7.78% -7.66%
	OPB (Saddle)	2.35	-5.15	-0.03	0.03	4	0	0.061	4.76% -10.28%
T	COMP (Saddle)	1.07	-0.68	-0.043	0.06	-0.53	0	0.009	1.08% -1.36%
	COMP (Crown)	-0.55	6.9	-0.03	0.01	-4.8	0	0.009	0.68% -1.13%
	TENS (Saddle)	0.87	-1.49	0.001	0.01	0.65	0	0.010	-1.54% -4.06%
	TENS (Crown)	-1.37	7.4	0.02	-0.05	-4.3	0	0.013	2.28% -0.91%
	IPB (Crown)	0.45	1.5	-0.01	-0.01	-0.7	0	0.026	4.10% -3.28%
	OPB (Saddle)	1.56	-2.62	-0.012	0.015	1.3	0	0.002	0.99% 0.32%

Ranges of validity: $0.4 \leq \beta \leq 1.0$, $12 \leq \gamma \leq 26$, $\tau \cong 1.0$, $\theta = 90^\circ$

Table R2: Recommended Formulations for Reduction Factors on Chord Side



$$RF = a_0 + a_1\beta + a_2\gamma + a_3\beta\gamma + a_4\beta^2 + a_5\gamma^2 + a_6\beta^3\gamma^3$$

Joint Type	Load (Position)	a ₀	a ₁	a ₂	a ₃	a ₄	a ₅	a ₆	COV	Max/Min Error
DT	COMP (Saddle)	-0.01	-1.3	0.04	-0.08	3.15	0	0	0.049	7.87% -6.64%
	COMP (Crown)	1.1	0.56	-0.056	0.09	-1.78	0.001	0	0.070	7.87% -11.40%
	TENS (Saddle)	1.92	-4.4	-0.08	0.1	3.4	0.001	-0.0001	0.026	2.86% -4.73%
	TENS (Crown)	1.37	-3.09	0.002	0.07	1.39	-0.001	0	0.021	3.50% -2.07%
	IPB (Crown)	2.45	-3.5	-0.03	0.03	2.03	0	0	0.056	8.41% -8.89%
	OPB (Saddle)	-0.43	-0.64	0.096	-0.17	3.8	0	0	0.040	7.26% -5.33%
T	COMP (Saddle)	1.1	-1.33	-0.034	0.04	0.6	0	0	0.011	1.23% -1.51%
	COMP (Crown)	-1.26	5	0.002	0.03	-3.3	0	0	0.020	1.95% -2.29%
	TENS (Saddle)	0.72	-0.7	-0.008	0.004	0.5	0	0	0.018	2.32% -2.25%
	TENS (Crown)	-0.74	3.1	0.01	0	-1.7	0	0	0.023	1.75% -3.33%
	IPB (Crown)	0.31	0.91	-0.007	0.015	-0.7	0	0	0.002	0.67% 0.12%
	OPB (Saddle)	0.88	-0.84	0.001	-0.016	0.6	0	0	0.004	0.11% -0.94%

Ranges of validity: $0.4 \leq \beta \leq 1.0$, $12 \leq \gamma \leq 26$, $\tau \cong 1.0$, $\theta = 90^\circ$

Table R3: Recommended Formulations for Reduction Factors on Brace Side

BRACE (T)

γ	$\beta = 0.414$									
	Efthymiou as-welded SCF		Measured grouted SCF		RF		Table R2 Predicted RF		Predicted grouted SCF	
	Crown	Saddle	Crown	Saddle	Crown	Saddle	Crown	Saddle	Crown	Saddle
12.409										
Comp.	3.08	8.37	1.33	3.60	0.43	0.43	0.42	0.44	1.30	3.65
Ten.	3.08	8.37	1.12	3.68	0.36	0.44	0.38	0.44	1.16	3.66
OPB		5.85		3.28		0.56		0.57		3.31
IPB	2.87		1.62		0.56		0.56		1.60	
19.973										
Comp.										
Ten.										
OPB										
IPB										
25.888										
Comp.	2.52	16.53	1.58	3.32	0.63	0.20	0.62	0.20	1.56	3.32
Ten.	2.52	16.53	1.31	5.93	0.52	0.36	0.51	0.35	1.29	5.81
OPB		12.11		5.88		0.49		0.49		5.93
IPB	4.38		2.42		0.55		0.55		2.39	

γ	$\beta = 0.672$									
	Efthymiou as-welded SCF		Measured grouted SCF		RF		Table R2 Predicted RF		Predicted grouted SCF	
	Crown	Saddle	Crown	Saddle	Crown	Saddle	Crown	Saddle	Crown	Saddle
12.409										
Comp.										
Ten.										
OPB										
IPB										
19.973										
Comp.	2.62	11.84	2.74	3.95	1.05	0.33	1.05	0.33	2.75	3.97
Ten.	2.62	11.84	2.03	4.36	0.77	0.37	0.78	0.37	2.03	4.37
OPB		10.84		4.21		0.39		0.39		4.24
IPB	3.39		2.26		0.67		0.67		2.26	
25.888										
Comp.										
Ten.										
OPB										
IPB										

γ	$\beta = 1.000$									
	Efthymiou as-welded SCF		Measured grouted SCF		RF		Table R2 Predicted RF		Predicted grouted SCF	
	Crown	Saddle	Crown	Saddle	Crown	Saddle	Crown	Saddle	Crown	Saddle
12.409										
Comp.	3.53	3.46	2.89	1.56	0.82	0.45	0.84	0.44	2.95	1.54
Ten.	3.53	3.46	2.69	1.60	0.76	0.46	0.78	0.47	2.76	1.63
OPB		4.23		1.88		0.45		0.45		1.92
IPB	2.44		1.52		0.62		0.62		1.51	
19.973										
Comp.										
Ten.										
OPB										
IPB										
25.888										
Comp.	2.62	5.85	3.24	3.03	1.24	0.52	1.27	0.53	3.32	3.07
Ten.	2.62	5.85	2.43	2.39	0.93	0.41	0.92	0.42	2.41	2.43
OPB		8.58		2.17		0.25		0.25		2.16
IPB	2.84		2.09		0.73		0.73		2.07	

Table R4: Comparison of Brace T-Joint Measured and Predicted As-welded and Grouted SCFs.

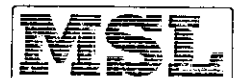

CHORD (T)

γ	β = 0.414									
	Efthymiou as-welded SCF		Measured grouted SCF		RF		Table R2 Predicted RF		Predicted grouted SCF	
	Crown	Saddle	Crown	Saddle	Crown	Saddle	Crown	Saddle	Crown	Saddle
12.409										
Comp.	6.06	13.28	7.00	6.20	1.15	0.47	1.16	0.47	7.05	6.27
Ten.	6.06	13.28	5.87	5.64	0.97	0.42	0.95	0.43	5.75	5.69
OPB		8.29		5.26		0.63		0.63		5.19
IPB	3.65		2.83		0.78		0.78		2.83	
19.973										
Comp.										
Ten.										
OPB										
IPB										
25.888										
Comp.	7.25	29.62	5.93	6.84	0.82	0.23	0.81	0.23	5.90	6.74
Ten.	7.25	29.62	6.77	14.50	0.93	0.49	0.94	0.50	6.80	14.74
OPB		18.41		10.21		0.55		0.55		10.09
IPB	6.52		3.95		0.61		0.58		3.81	

γ	β = 0.672									
	Efthymiou as-welded SCF		Measured grouted SCF		RF		Table R2 Predicted RF		Predicted grouted SCF	
	Crown	Saddle	Crown	Saddle	Crown	Saddle	Crown	Saddle	Crown	Saddle
12.409										
Comp.										
Ten.										
OPB										
IPB										
19.973										
Comp.	6.59	19.97	9.56	6.32	1.45	0.32	1.45	0.32	9.58	6.39
Ten.	6.59	19.97	9.13	6.10	1.39	0.31	1.39	0.32	9.16	6.32
OPB		17.86		6.18		0.35		0.35		6.22
IPB	4.80		3.91		0.81		0.81		3.88	
25.888										
Comp.										
Ten.										
OPB										
IPB										

γ	β = 1.000									
	Efthymiou as-welded SCF		Measured grouted SCF		RF		Table R2 Predicted RF		Predicted grouted SCF	
	Crown	Saddle	Crown	Saddle	Crown	Saddle	Crown	Saddle	Crown	Saddle
12.409										
Comp.	8.25	5.10	10.68	0.34	1.29	0.07	1.30	0.07	10.74	0.36
Ten.	8.25	5.10	11.34	0.80	1.37	0.16	1.36	0.17	11.20	0.85
OPB		7.92		2.26		0.28		0.28		2.20
IPB	3.20		3.10		0.97		1.00		3.20	
19.973										
Comp.										
Ten.										
OPB										
IPB										
25.888										
Comp.	9.25	10.84	9.60	3.26	1.04	0.30	1.03	0.30	9.55	3.25
Ten.	9.25	10.84	8.81	3.35	0.95	0.31	0.95	0.31	8.82	3.41
OPB		16.83		5.32		0.32		0.32		5.35
IPB	4.11		3.05		0.74		0.73		3.01	

Table R5: Comparison of Chord T-Joint Measured and Predicted As-welded and Grouted SCFs.

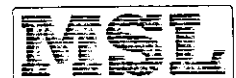

BRACE (DT)

γ	$\beta = 0.414$									
	Efthymiou as-welded SCF		Measured grouted SCF		RF		Table R2 Predicted RF		Predicted grouted SCF	
	Crown	Saddle	Crown	Saddle	Crown	Saddle	Crown	Saddle	Crown	Saddle
12.409										
Comp.										
Ten.										
OPB										
IPB										
19.973										
Comp.	2.27	15.70	2.39	2.11	1.05	0.13	1.05	0.13	2.38	2.03
Ten.	2.27	15.70	1.24	4.13	0.55	0.26	0.55	0.25	1.24	3.96
OPB		8.54		4.02		0.47		0.47		4.00
IPB	3.68		3.58		0.97		1.00		3.68	
25.888										
Comp.										
Ten.										
OPB										
IPB										

γ	$\beta = 0.672$									
	Efthymiou as-welded SCF		Measured grouted SCF		RF		Table R2 Predicted RF		Predicted grouted SCF	
	Crown	Saddle	Crown	Saddle	Crown	Saddle	Crown	Saddle	Crown	Saddle
12.409										
Comp.	2.35	10.40	2.00	3.74	0.85	0.36	0.88	0.37	2.07	3.83
Ten.	2.35	10.40	0.88	4.51	0.37	0.43	0.38	0.44	0.88	4.53
OPB		6.42		4.03		0.63		0.63		4.04
IPB	2.82		2.50		0.89		0.89		2.52	
19.973										
Comp.	1.84	16.15	2.32	4.33	1.26	0.27	1.16	0.26	2.14	4.26
Ten.	1.84	16.15	0.96	6.36	0.52	0.39	0.50	0.40	0.92	6.46
OPB		10.09		4.90		0.49		0.49		4.96
IPB	3.39		2.76		0.81		0.82		2.77	
25.888										
Comp.	1.42	21.03	1.93	3.88	1.36	0.18	1.46	0.18	2.07	3.84
Ten.	1.42	21.03	0.72	6.43	0.51	0.31	0.52	0.31	0.74	6.54
OPB		13.15		5.10		0.39		0.38		5.05
IPB	3.82		2.76		0.72		0.76		2.90	

γ	$\beta = 1.000$									
	Efthymiou as-welded SCF		Measured grouted SCF		RF		Table R2 Predicted RF		Predicted grouted SCF	
	Crown	Saddle	Crown	Saddle	Crown	Saddle	Crown	Saddle	Crown	Saddle
12.409										
Comp.	2.35	3.08	1.07	2.11	0.46	0.69	0.46	1.34	1.07	4.14
Ten.	2.35	3.08	0.96	3.34	0.41	1.08	0.41	1.13	0.96	3.48
OPB		1.41		2.44		1.72		1.81		2.56
IPB	2.44		2.29		0.94		0.98		2.40	
19.973										
Comp.	1.84	4.24	1.58	4.80	0.86	1.13	0.96	1.05	1.76	4.43
Ten.	1.84	4.24	1.28	3.95	0.70	0.93	0.71	0.92	1.31	3.92
OPB		2.14		2.89		1.35		1.26		2.69
IPB	2.65		2.84		1.07		0.98		2.60	
25.888										
Comp.	1.42	5.43	2.18	4.20	1.54	0.77	1.43	0.80	2.03	4.37
Ten.	1.42	5.43	1.24	1.98	0.87	0.36	0.86	0.37	1.23	2.02
OPB		2.90		2.29		0.79		0.81		2.36
IPB	2.84		2.57		0.90		0.98		2.78	

Table R6: Comparison of Brace DT-Joint Measured and Predicted As-welded and Grouted SCFs.

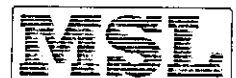

CHORD (DT)

γ	β = 0.414									
	Efthymiou as-welded SCF		Measured grouted SCF		RF		Table R2 Predicted RF		Predicted grouted SCF	
	Crown	Saddle	Crown	Saddle	Crown	Saddle	Crown	Saddle	Crown	Saddle
12.409										
Comp.										
Ten.										
OPB										
IPB										
19.973										
Comp.	3.99	27.99	3.12	3.91	0.78	0.14	0.84	0.14	3.36	3.95
Ten.	3.99	27.99	2.52	8.33	0.63	0.30	0.80	0.31	3.21	8.61
OPB		12.28		6.55		0.53		0.55		6.78
IPB	5.06		2.94		0.58		0.58		2.92	
25.888										
Comp.										
Ten.										
OPB										
IPB										

γ	β = 0.672									
	Efthymiou as-welded SCF		Measured grouted SCF		RF		Table R2 Predicted RF		Predicted grouted SCF	
	Crown	Saddle	Crown	Saddle	Crown	Saddle	Crown	Saddle	Crown	Saddle
12.409										
Comp.	2.28	18.97	3.26	6.08	1.43	0.32	1.29	0.31	2.94	5.90
Ten.	2.28	18.97	2.02	6.20	0.88	0.33	0.87	0.36	2.00	6.90
OPB		10.32		5.32		0.52		0.57		5.92
IPB	3.70		3.16		0.85		0.89		3.28	
19.973										
Comp.	2.71	30.60	1.98	8.96	0.73	0.29	0.85	0.30	2.32	9.29
Ten.	2.71	30.60	0.74	11.59	0.27	0.38	0.55	0.35	1.48	10.76
OPB		16.64		8.59		0.52		0.50		8.30
IPB	4.80		3.30		0.69		0.64		3.06	
25.888										
Comp.	3.08	41.26	2.86	8.72	0.93	0.21	0.91	0.30	2.82	12.27
Ten.	3.08	41.26	2.32	12.60	0.75	0.31	0.61	0.34	1.87	14.12
OPB		22.44		9.00		0.40		0.44		9.89
IPB	5.72		2.35		0.41		0.44		2.52	

γ	β = 1.000									
	Efthymiou as-welded SCF		Measured grouted SCF		RF		Table R2 Predicted RF		Predicted grouted SCF	
	Crown	Saddle	Crown	Saddle	Crown	Saddle	Crown	Saddle	Crown	Saddle
12.409										
Comp.	2.36	4.67	1.45	3.86	0.62	0.83	0.71	1.02	1.68	4.74
Ten.	2.36	4.67	1.02	4.14	0.43	0.89	0.64	0.96	1.51	4.48
OPB		2.64		3.01		1.14		1.20		3.17
IPB	3.20		1.93		0.60		0.60		1.90	
19.973										
Comp.	2.78	7.12	1.79	7.61	0.64	1.07	0.65	1.00	1.80	7.15
Ten.	2.78	7.12	1.31	6.46	0.47	0.91	0.41	0.83	1.14	5.94
OPB		4.01		5.04		1.26		1.20		4.83
IPB	3.59		1.93		0.54		0.52		1.87	
25.888										
Comp.	3.25	10.02	2.54	10.15	0.78	1.01	1.00	0.99	3.25	9.90
Ten.	3.25	10.02	1.34	6.84	0.41	0.68	0.55	0.73	1.79	7.31
OPB		5.70		6.42		1.13		1.20		6.83
IPB	4.11		1.82		0.44		0.46		1.89	

Table R7: Comparison of Chord DT-Joint Measured and Predicted As-welded and Grouted SCFs.

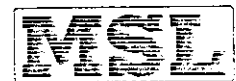

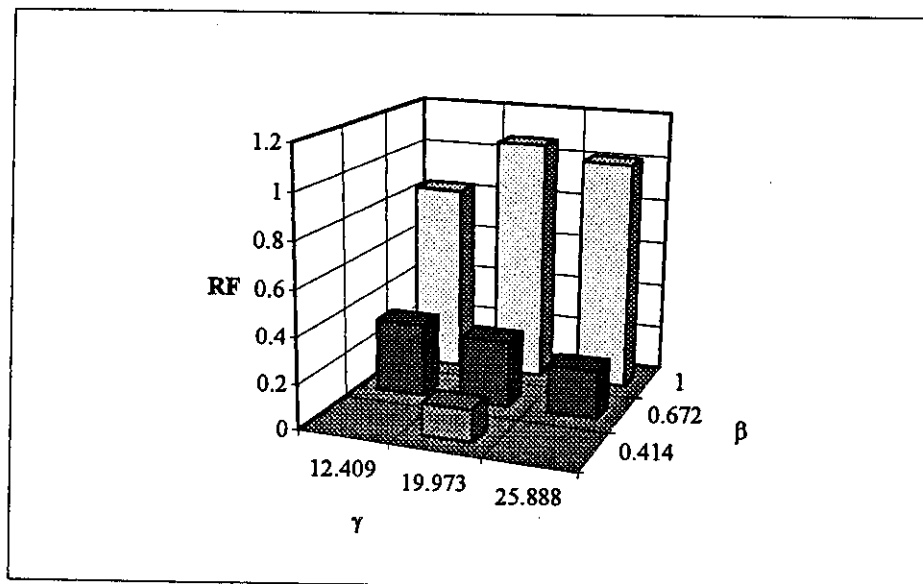
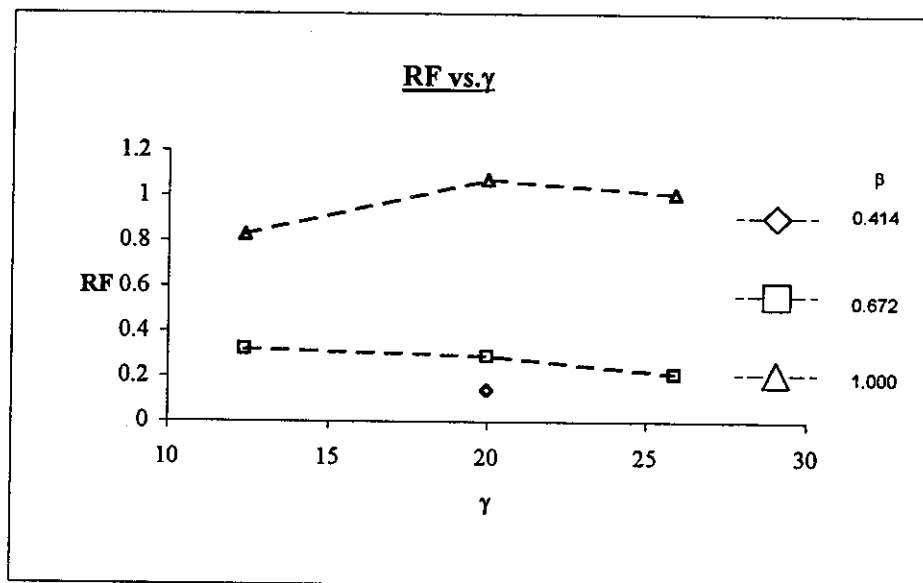
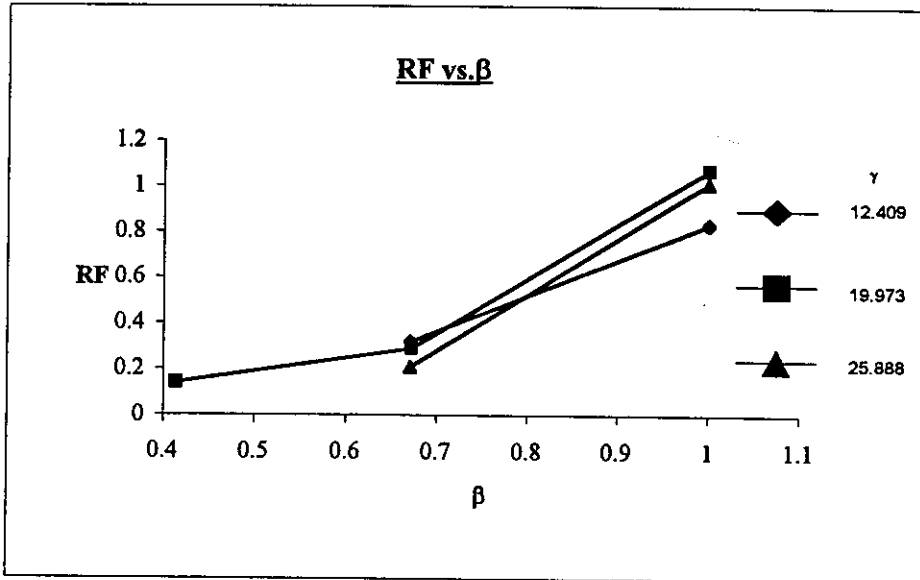

Fig. R1: DT Joints Under Compression, Chord Saddle

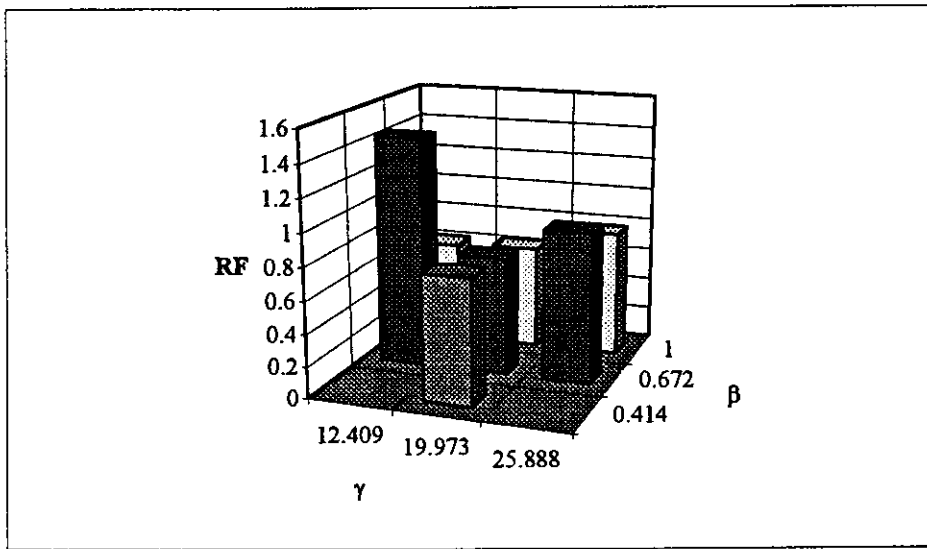
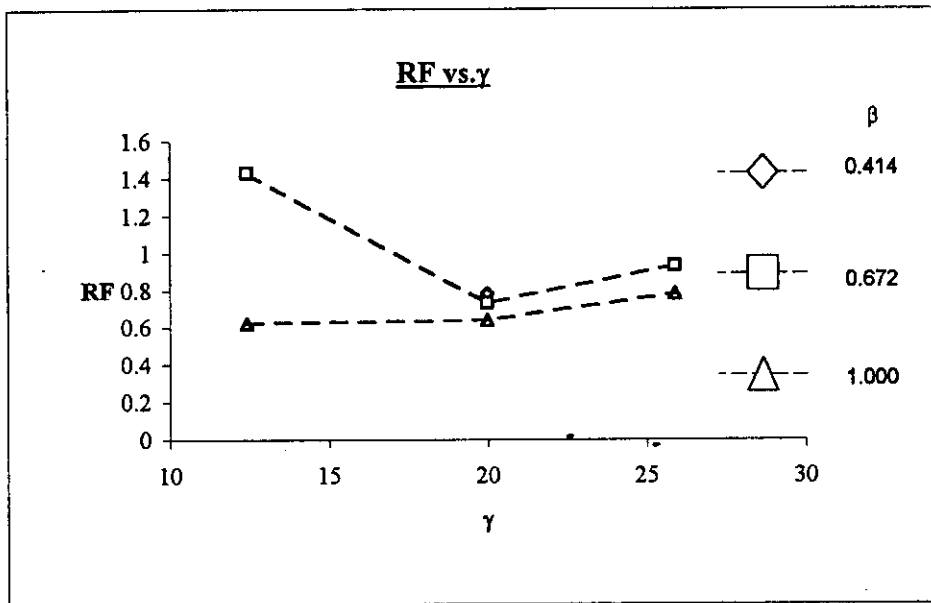
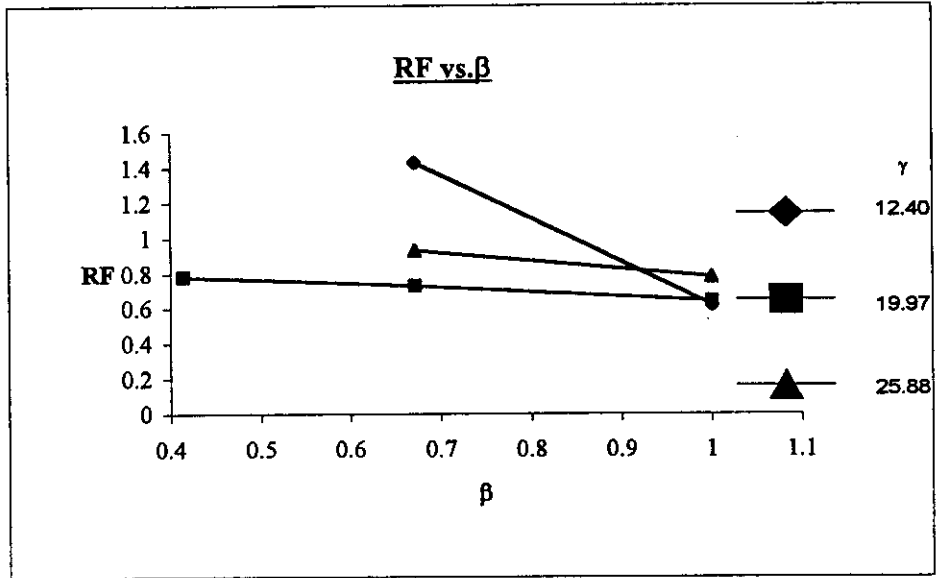

Fig. R2: DT Joints Under Compression, Chord Crown

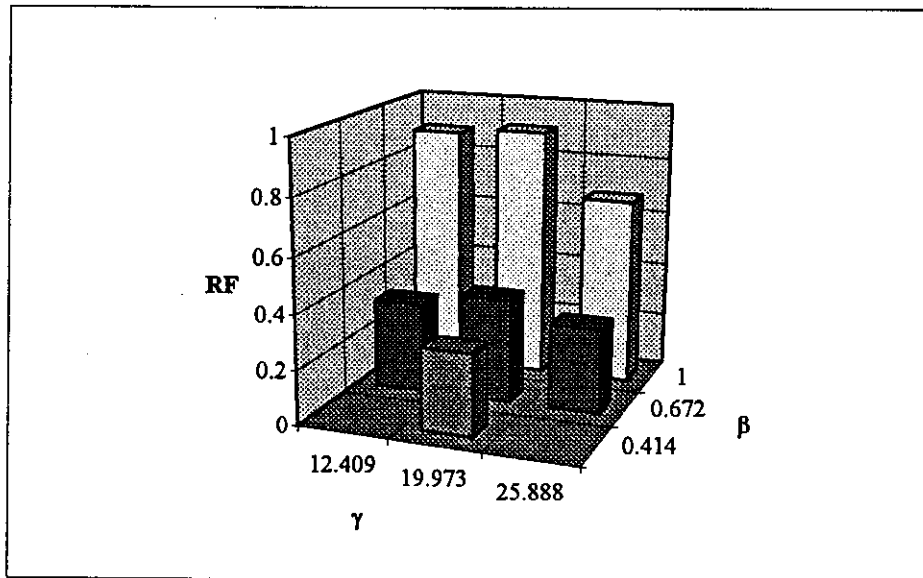
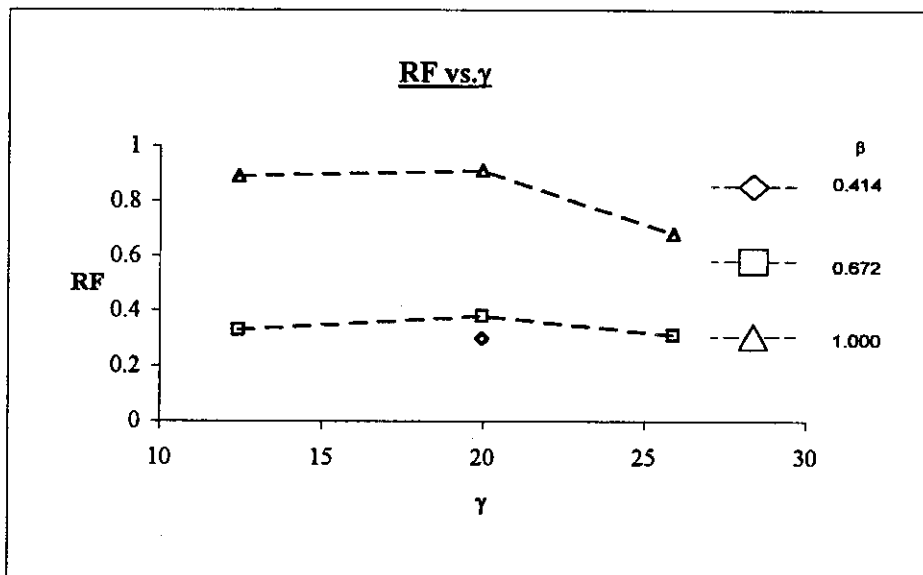
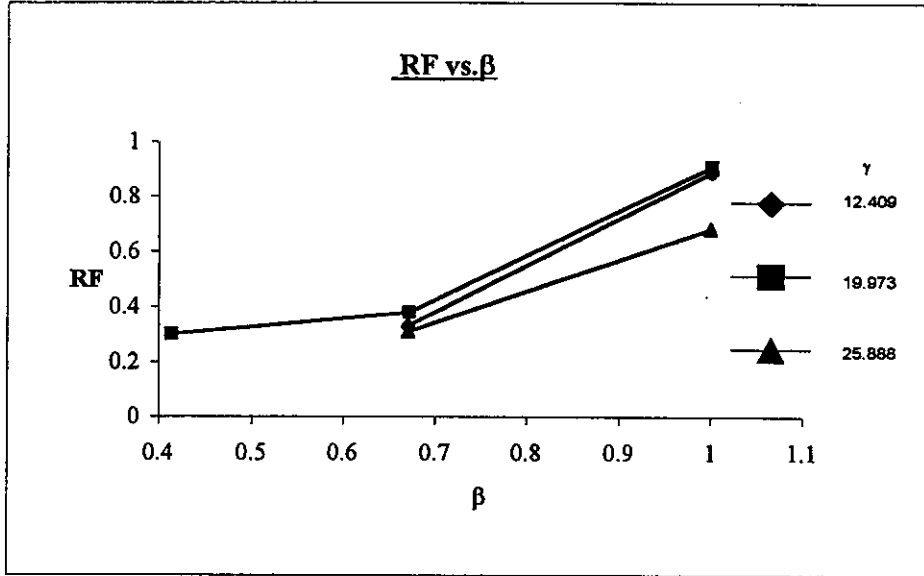

Fig. R3: DT Joints Under Tension, Chord Saddle

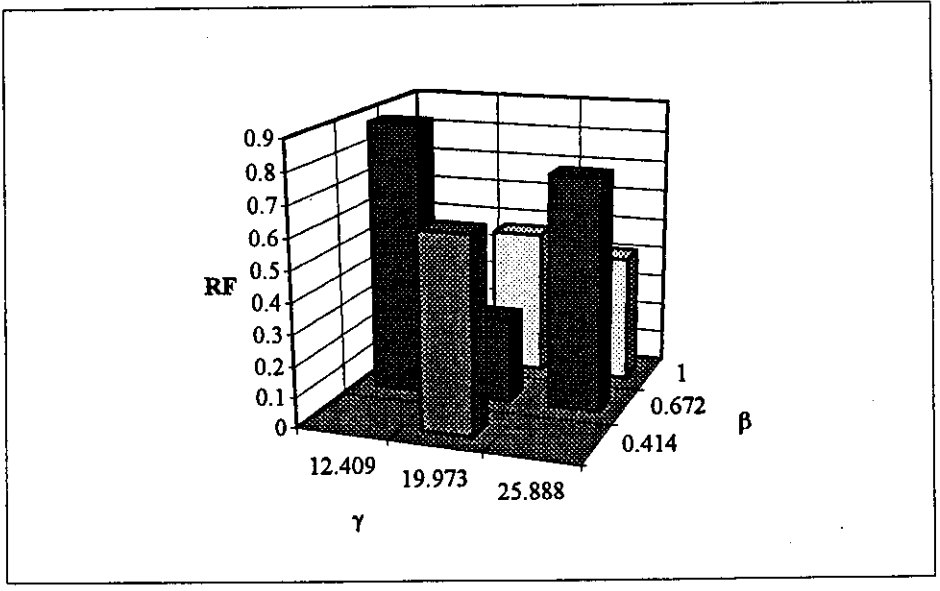
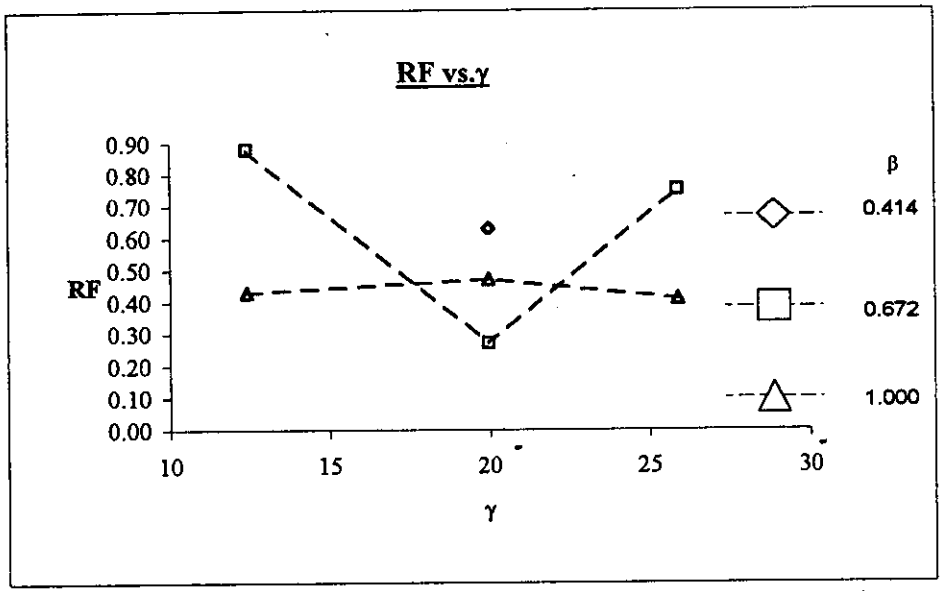
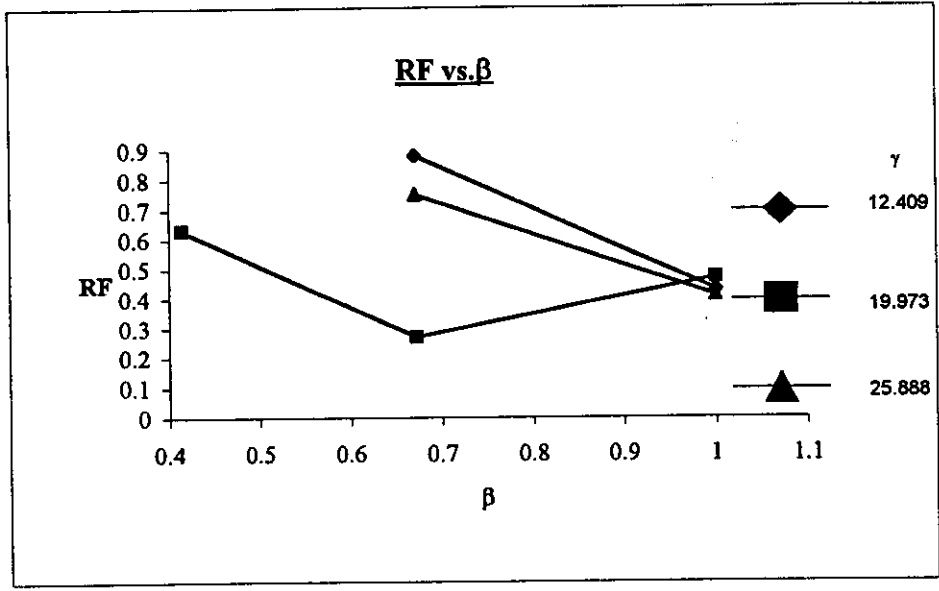
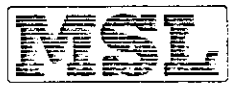

Fig. R4: DT Joints Under Tension, Chord Crown



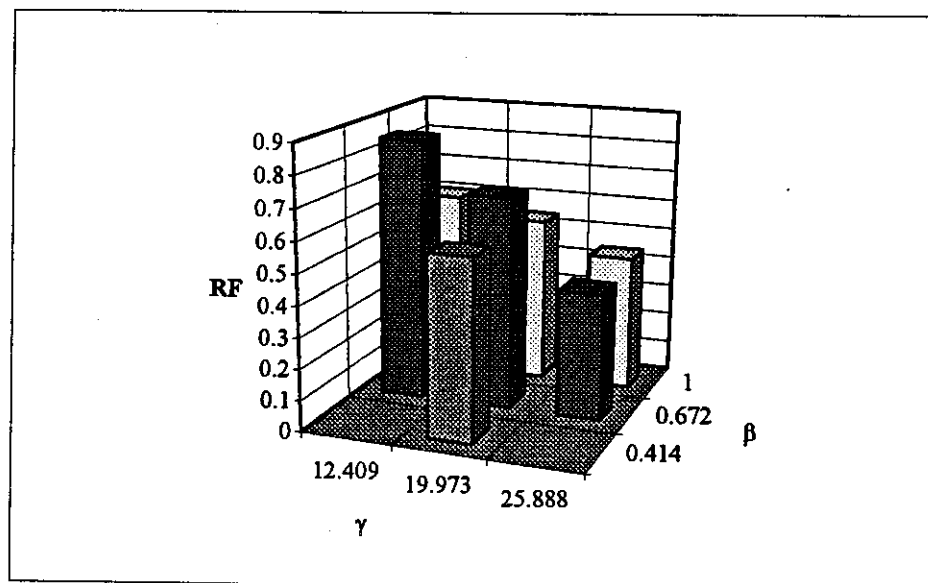
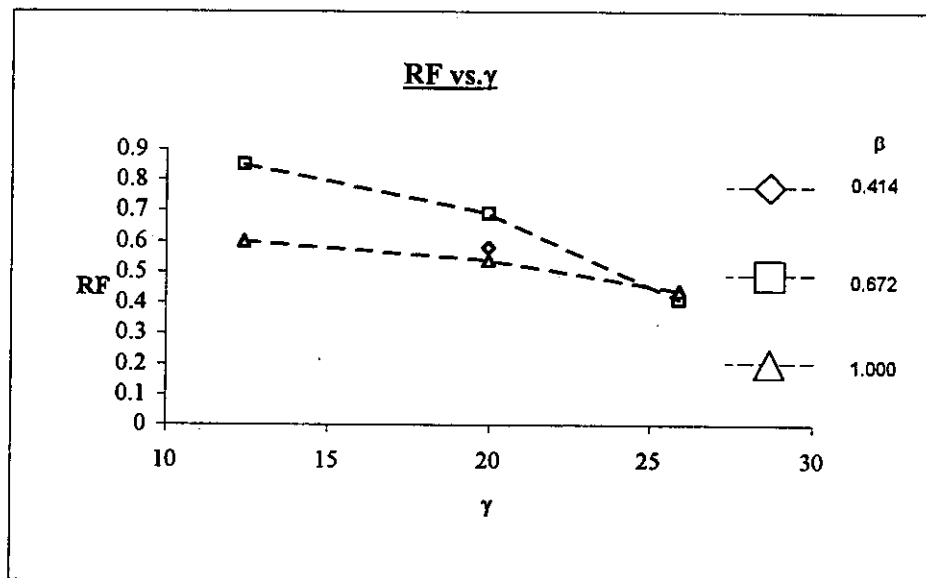
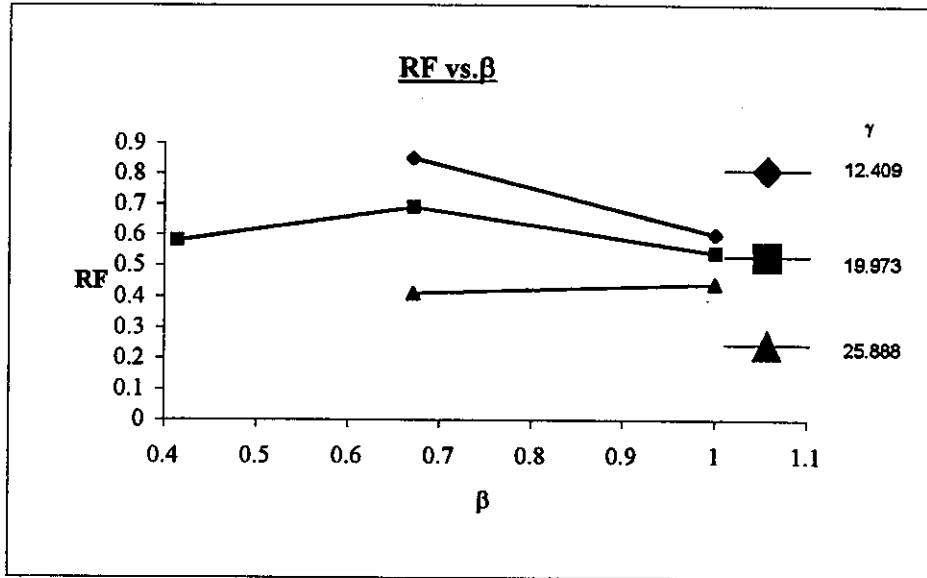

Fig. R5: DT Joints Under IPB, Chord Crown

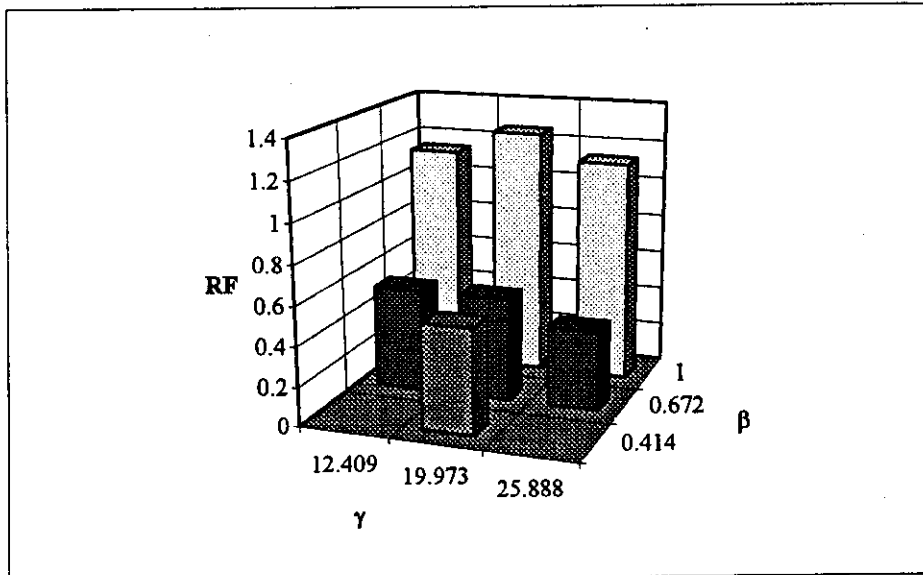
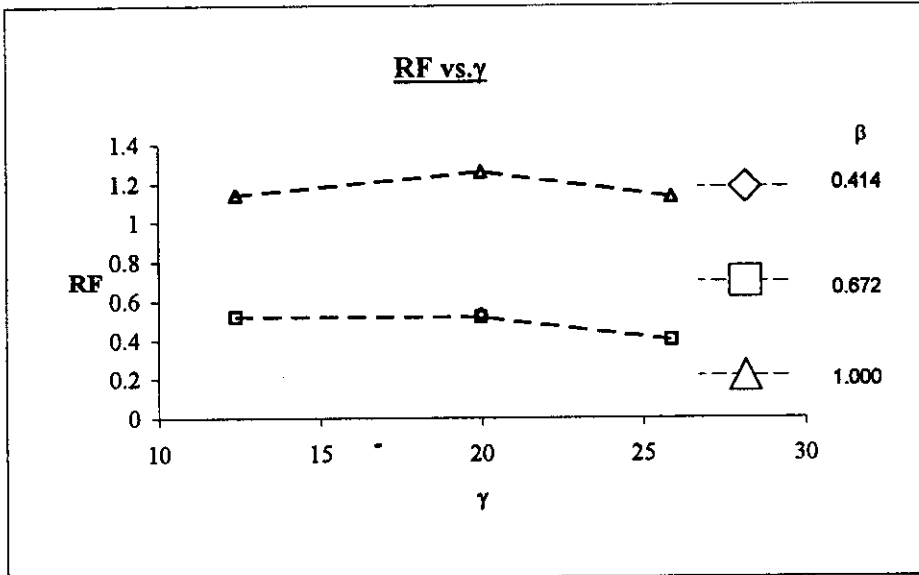
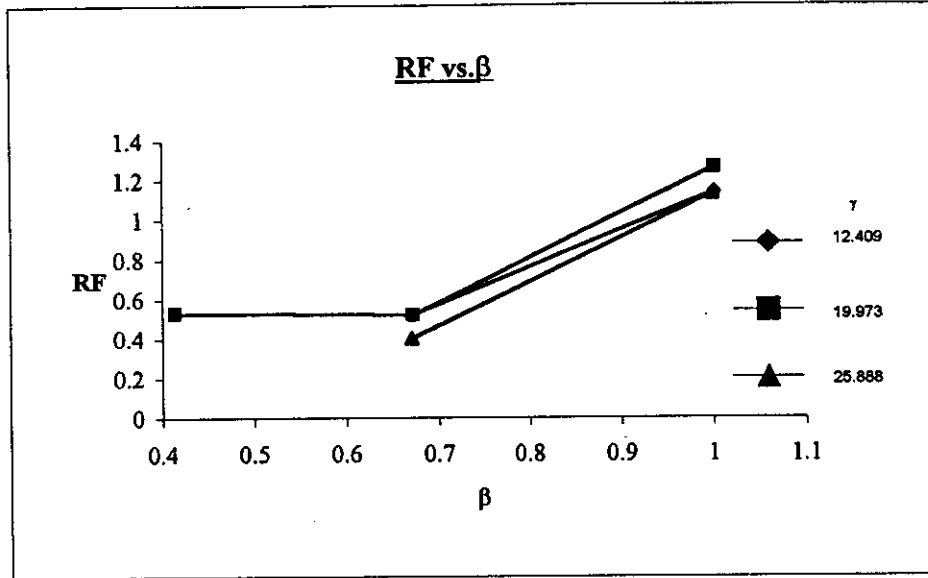

Fig. R6: DT Joints Under OPB, Chord Saddle

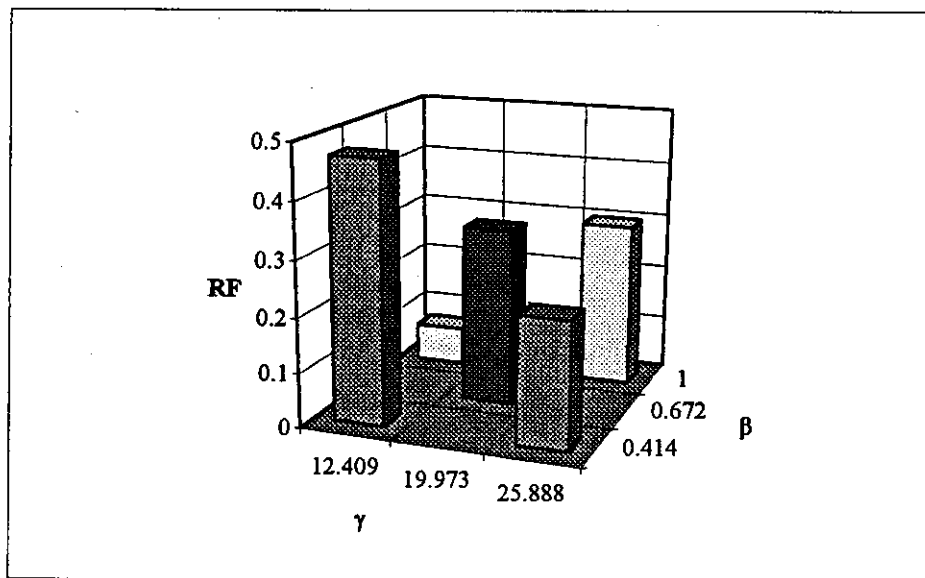
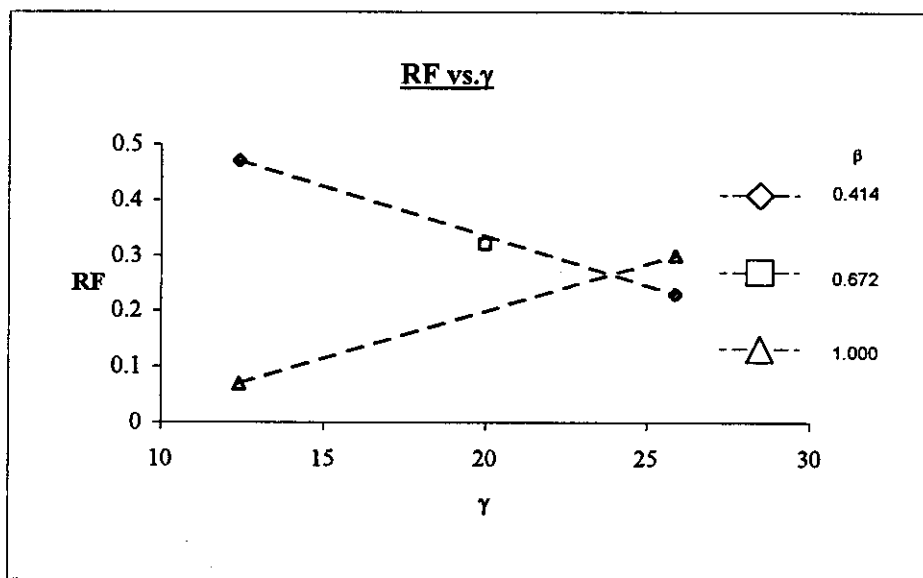
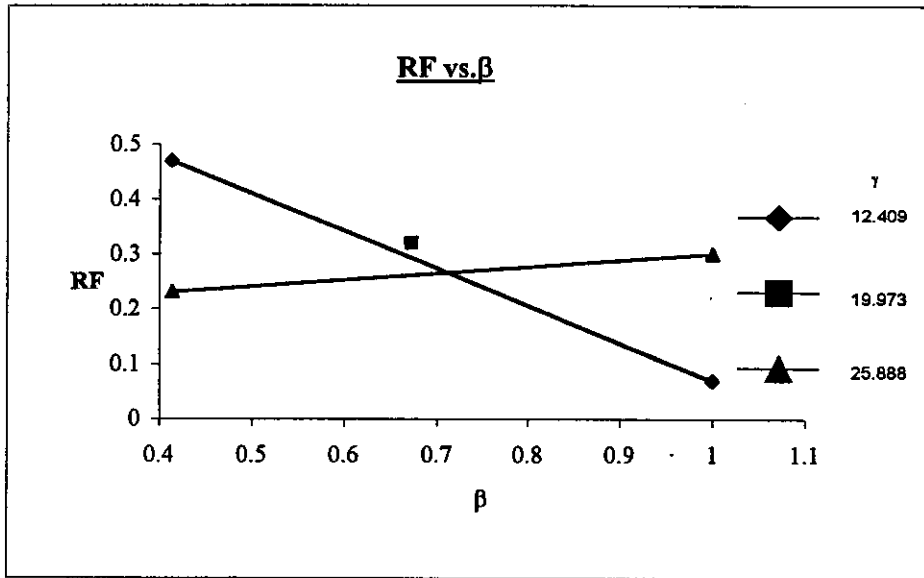

Fig. R7: T Joints Under Compression, Chord Saddle

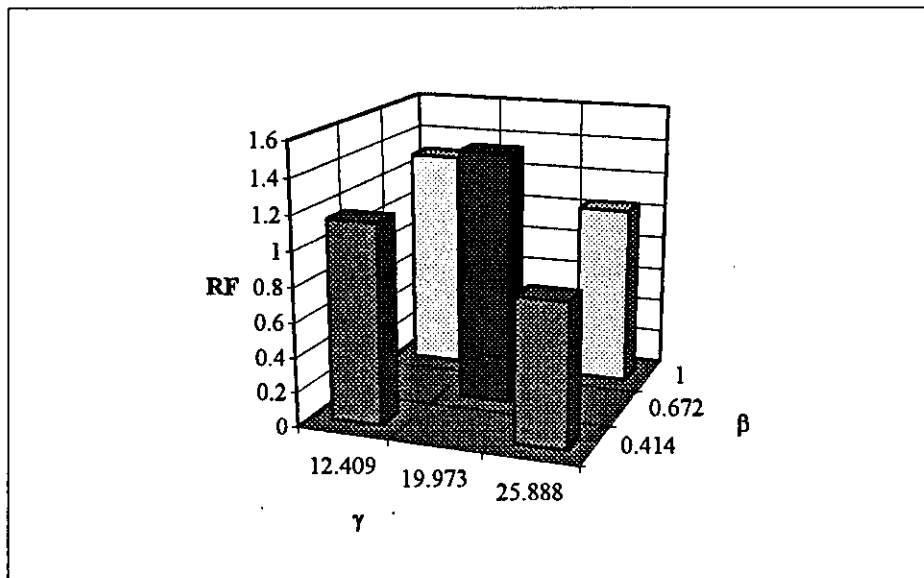
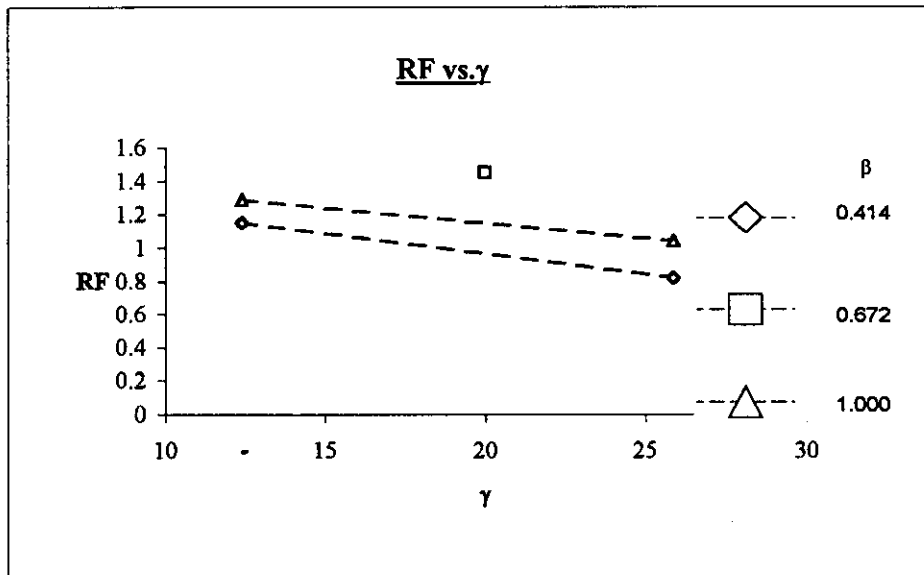
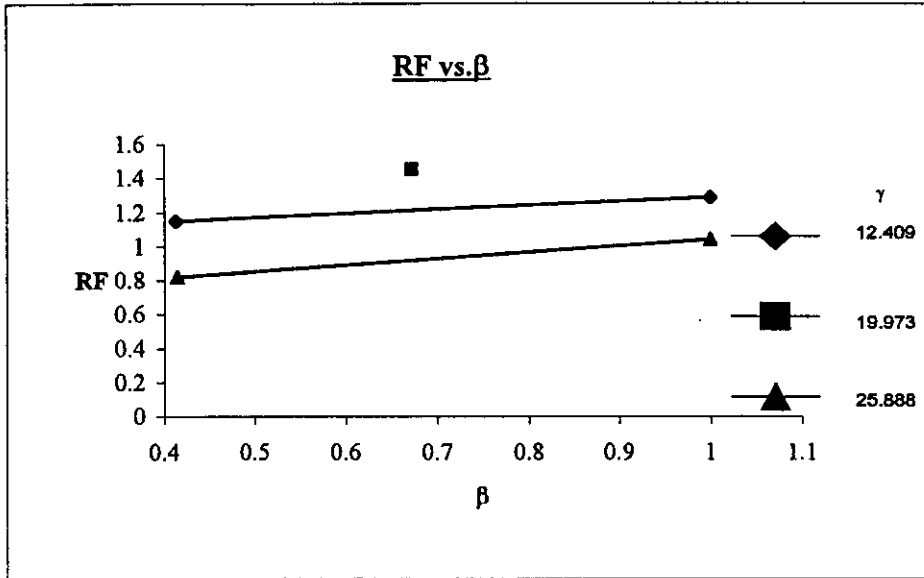

Fig. R8: T Joints Under Compression, Chord Crown

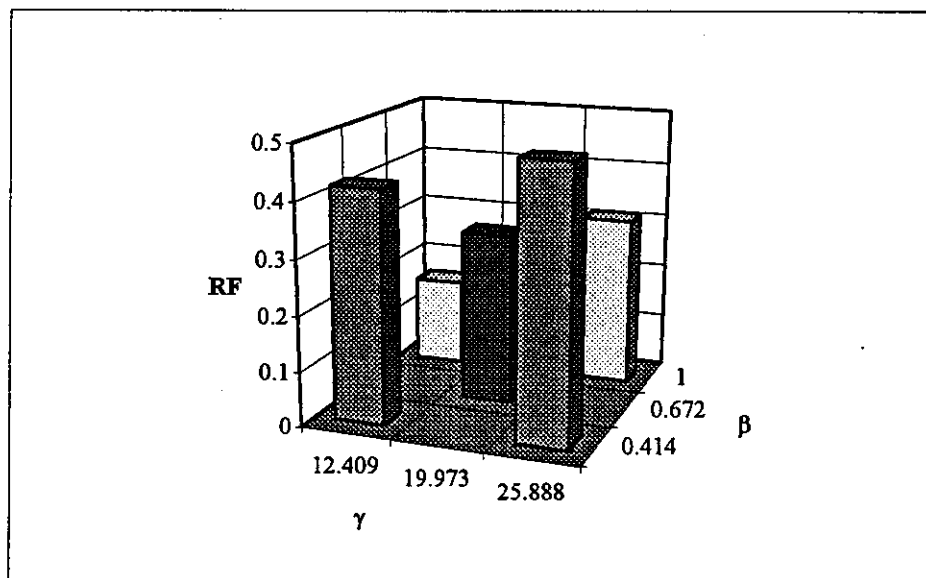
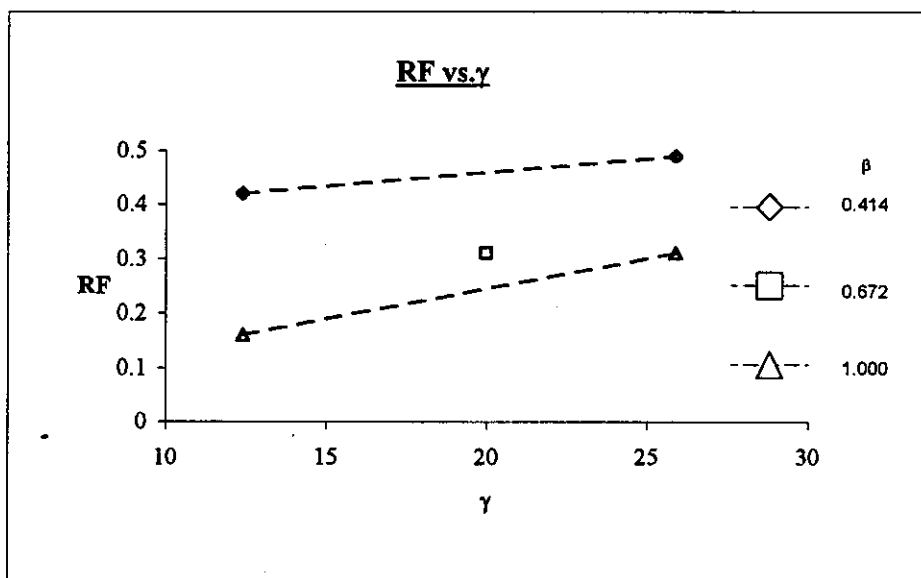
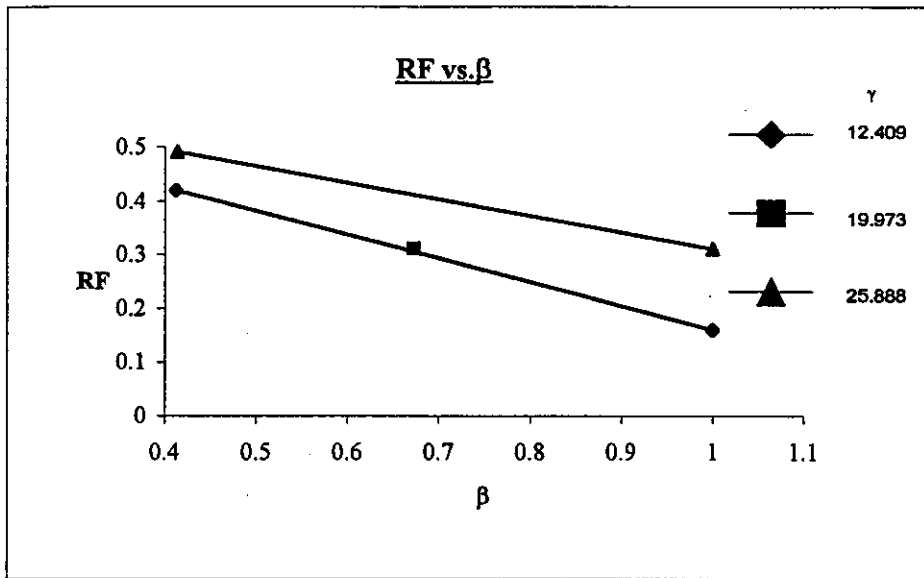

Fig. R9: T Joints Under Tension, Chord Saddle

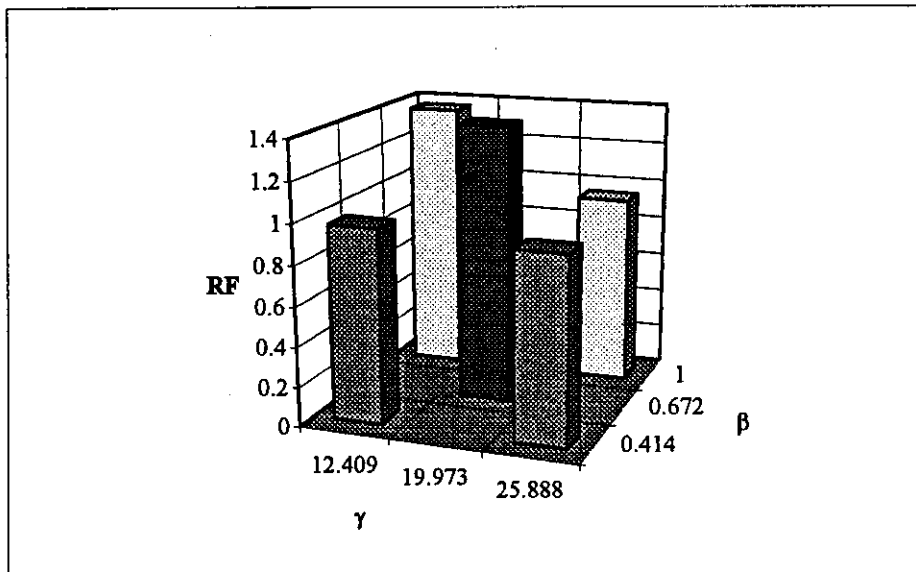
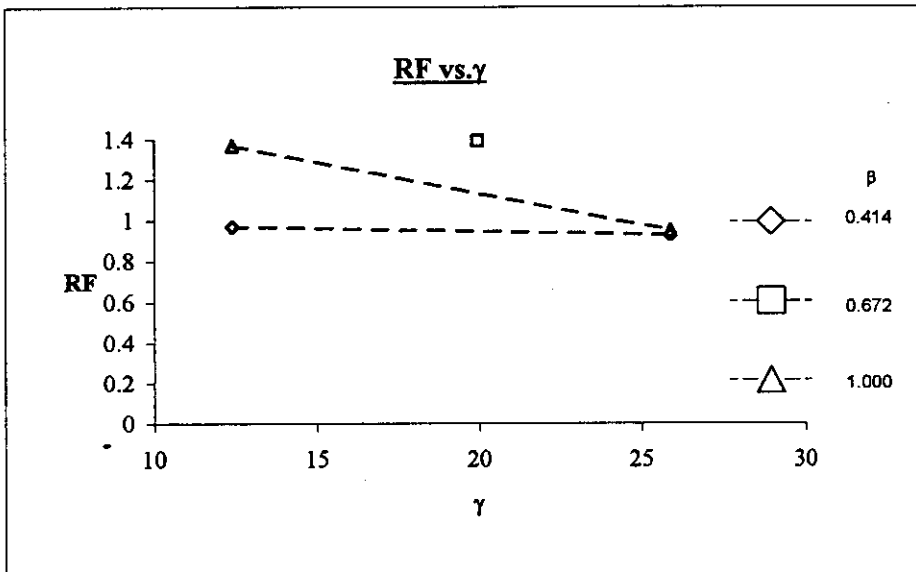
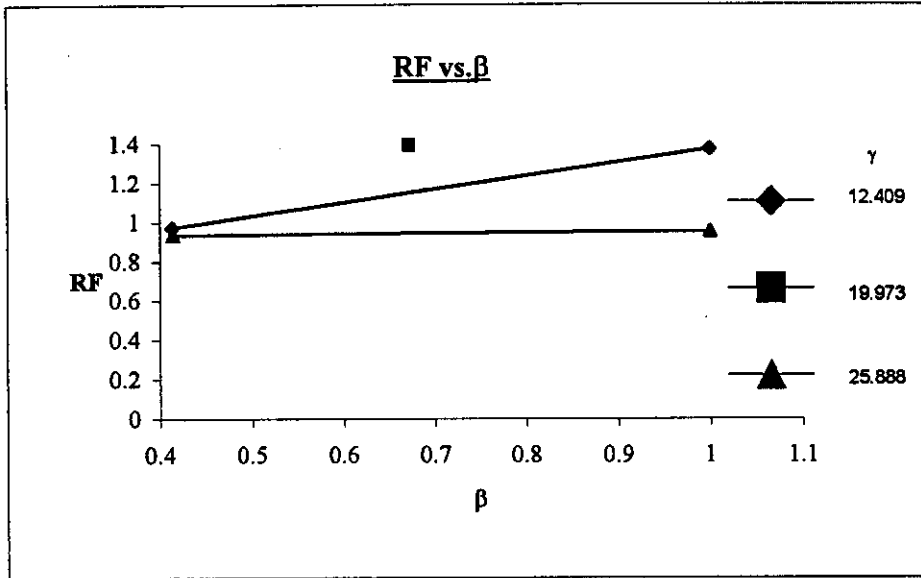

Fig. R10: T Joints Under Tension, Chord Crown

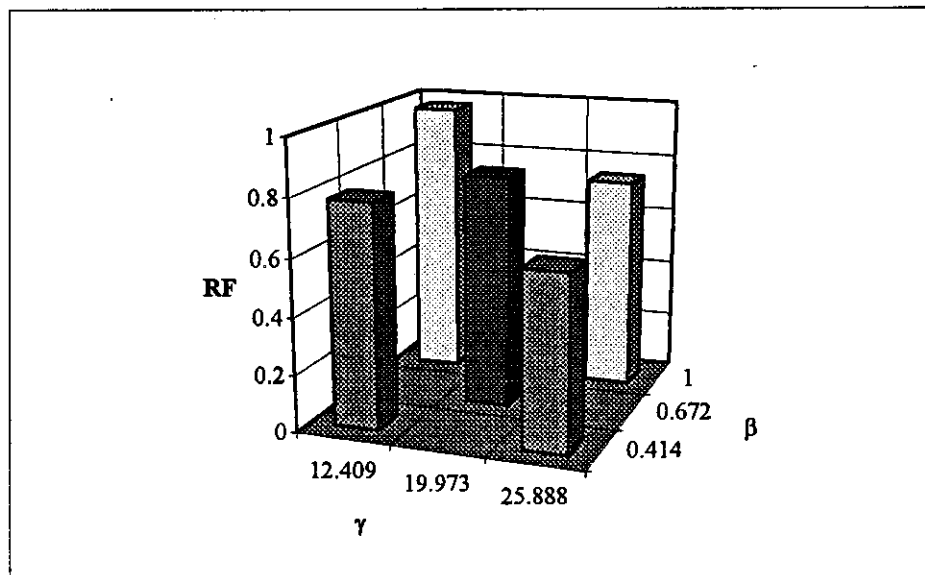
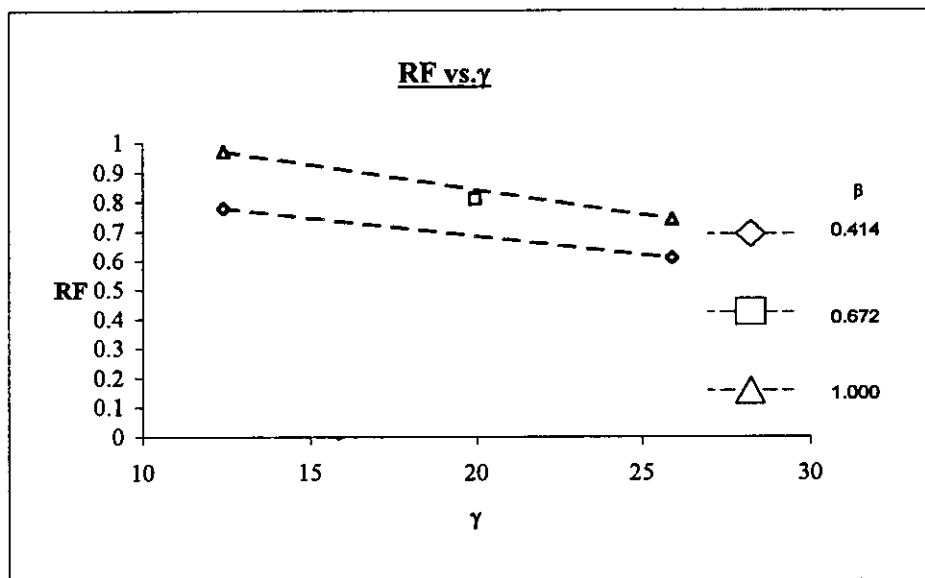
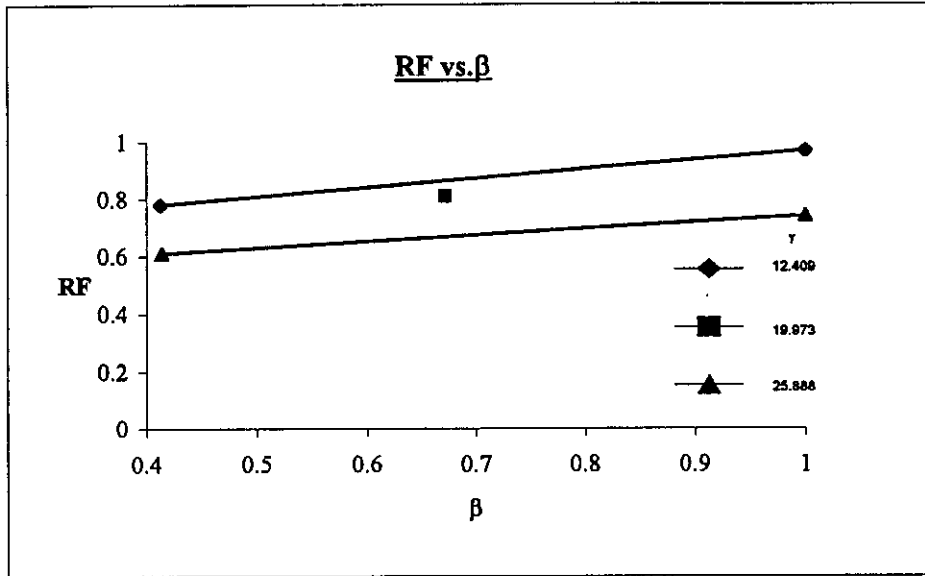

Fig. R11: T Joints Under IPB, Chord Crown

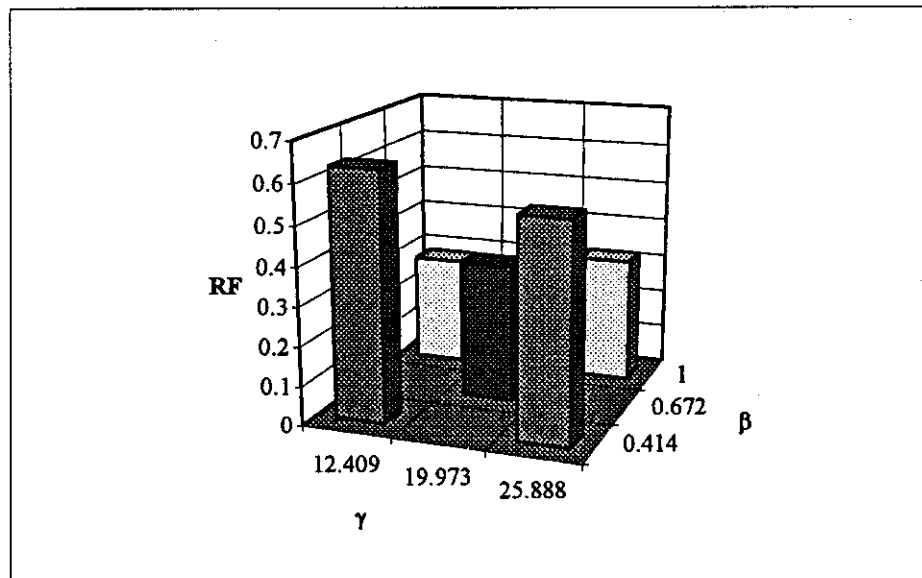
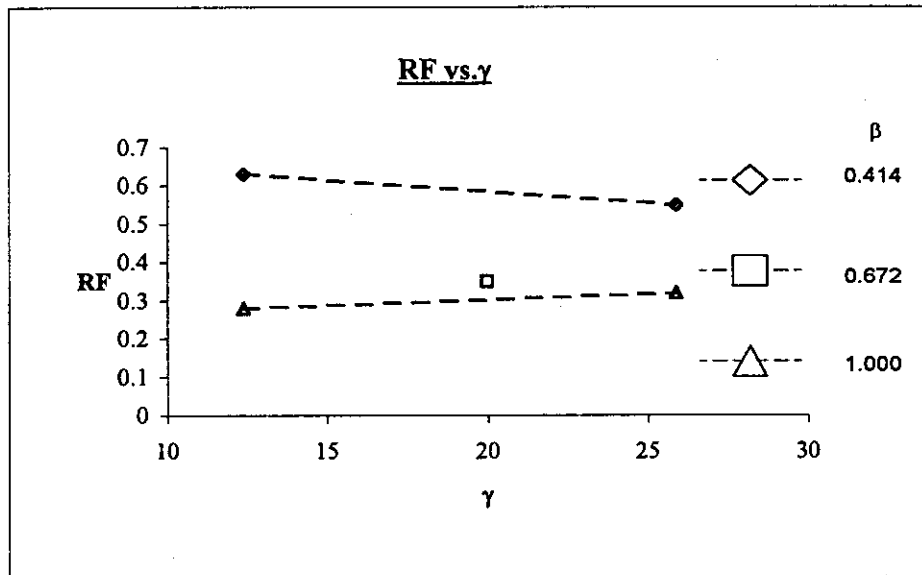
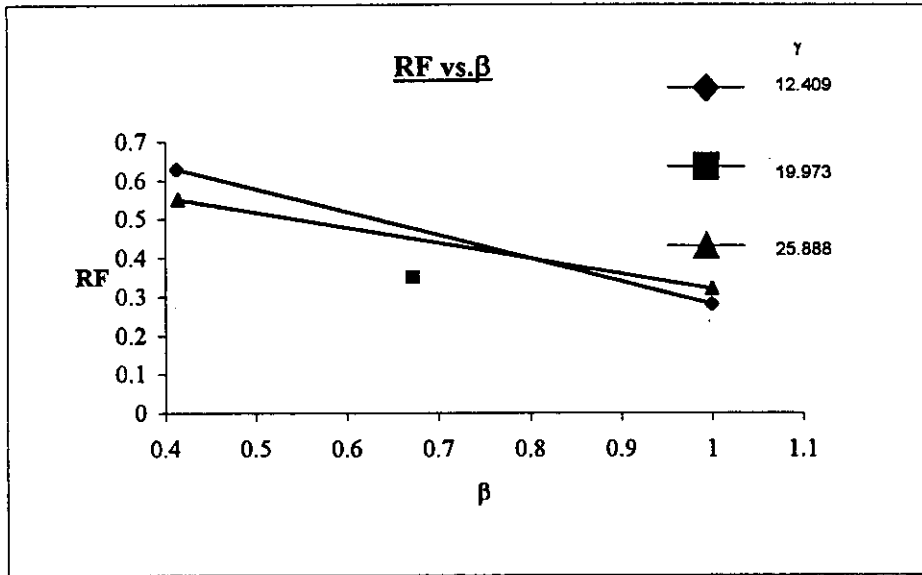

Fig. R12: T Joints Under OPB, Chord Saddle

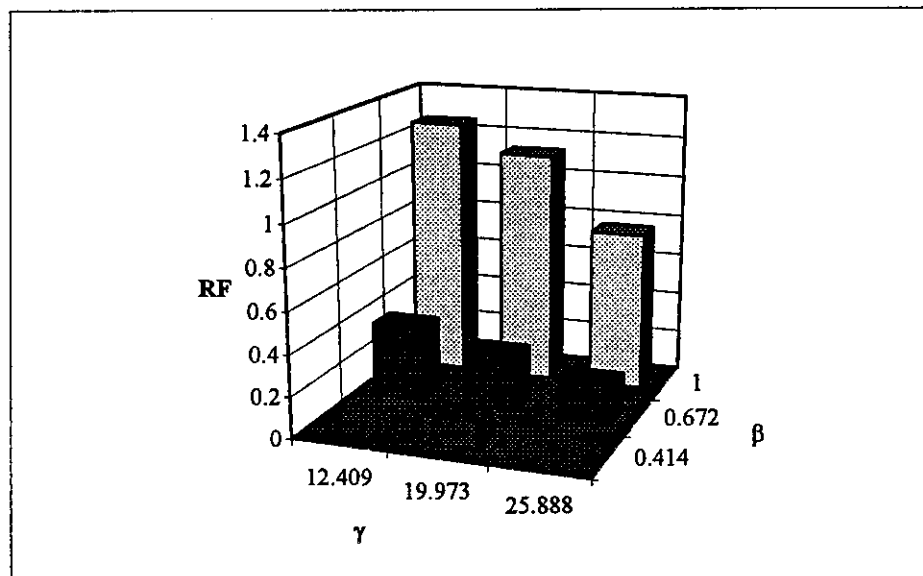
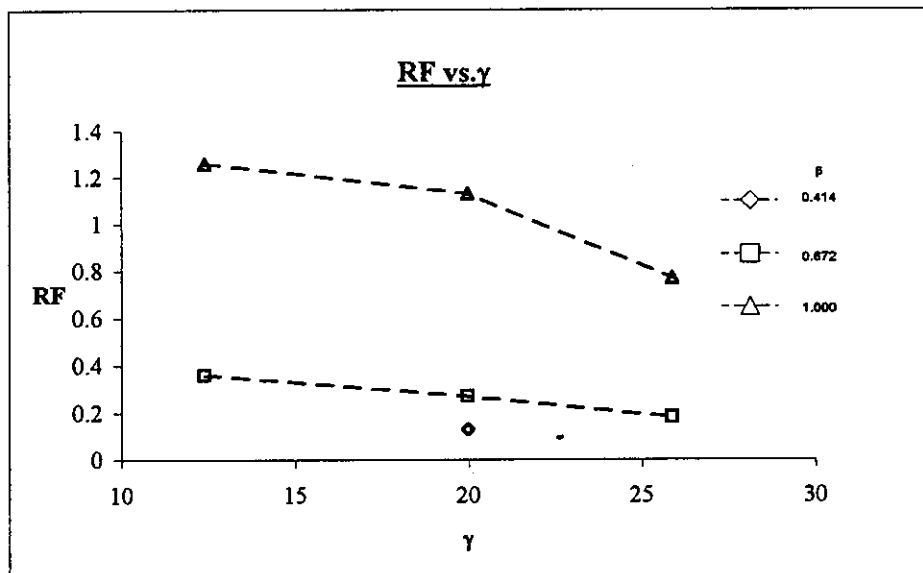
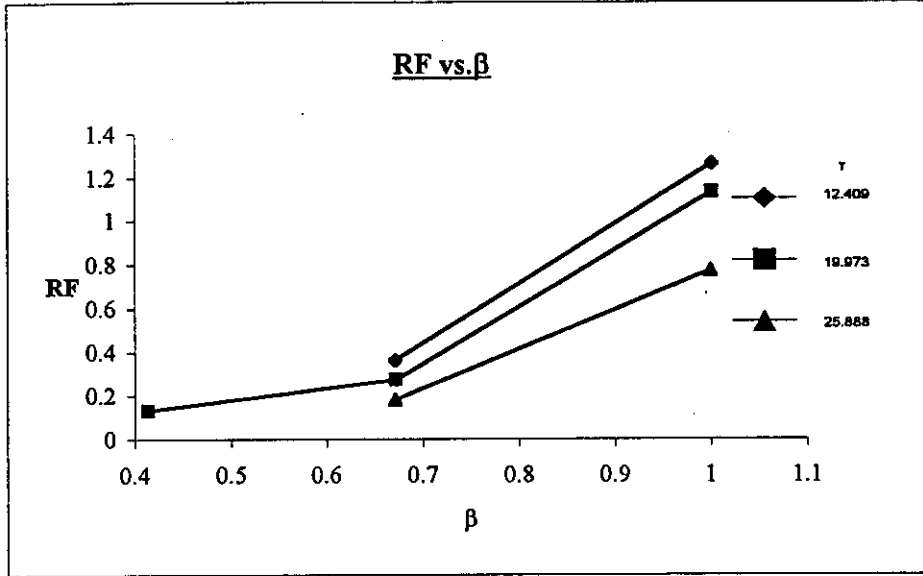

Fig. R13: DT Joints Under Compression, Brace Saddle

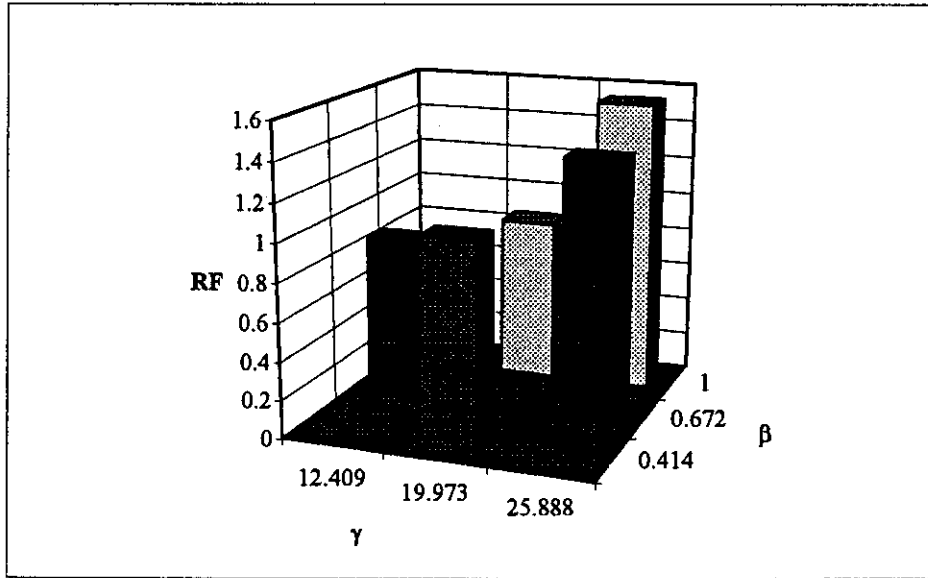
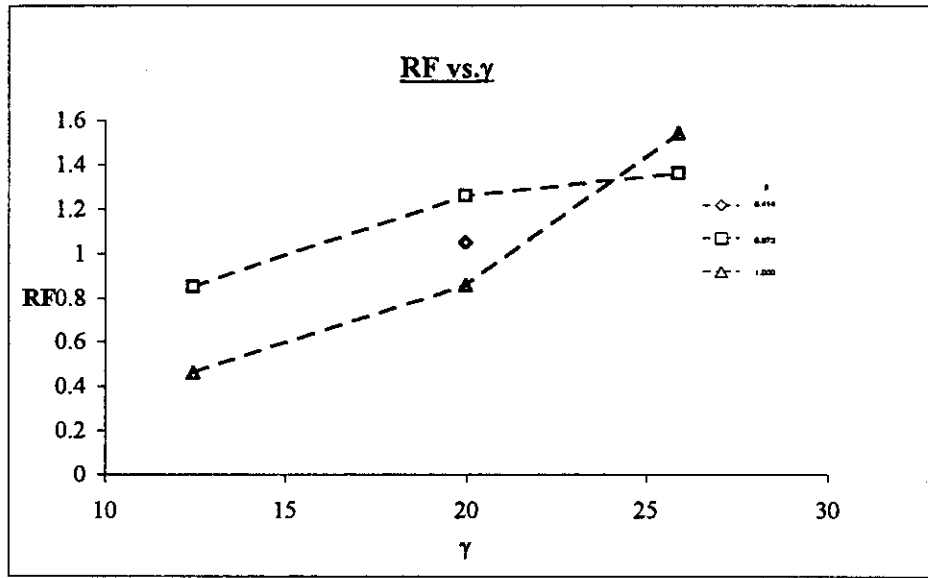
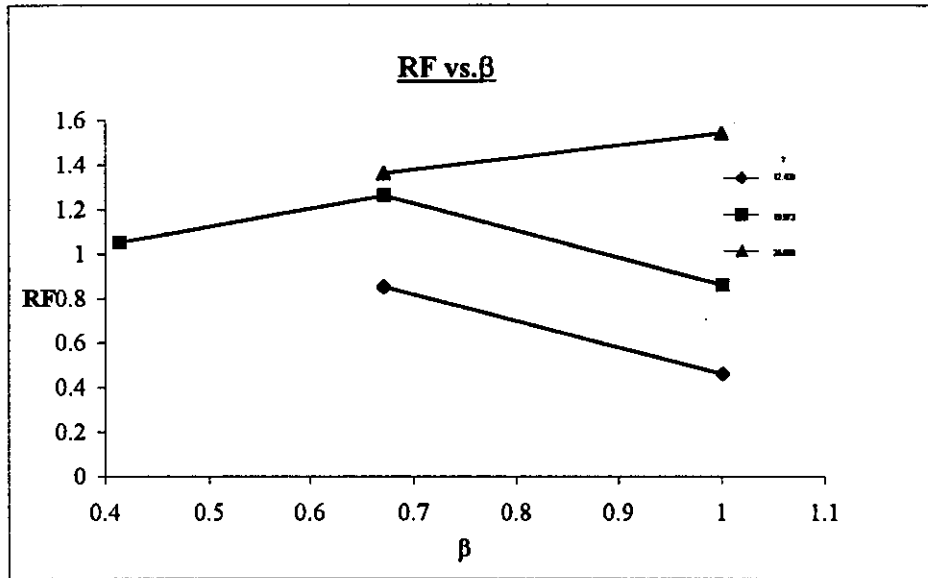

Fig. R14: DT Joints Under Compression, Brace Crown

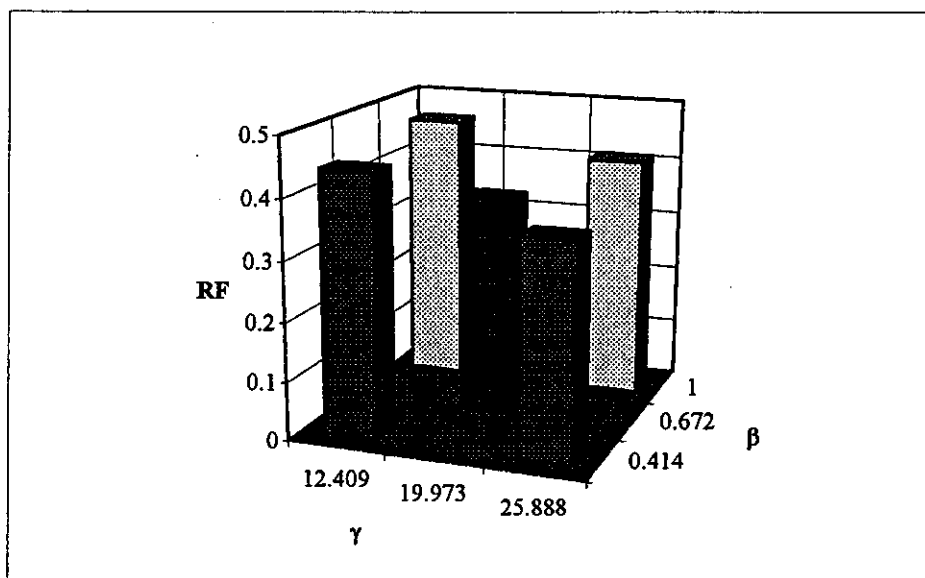
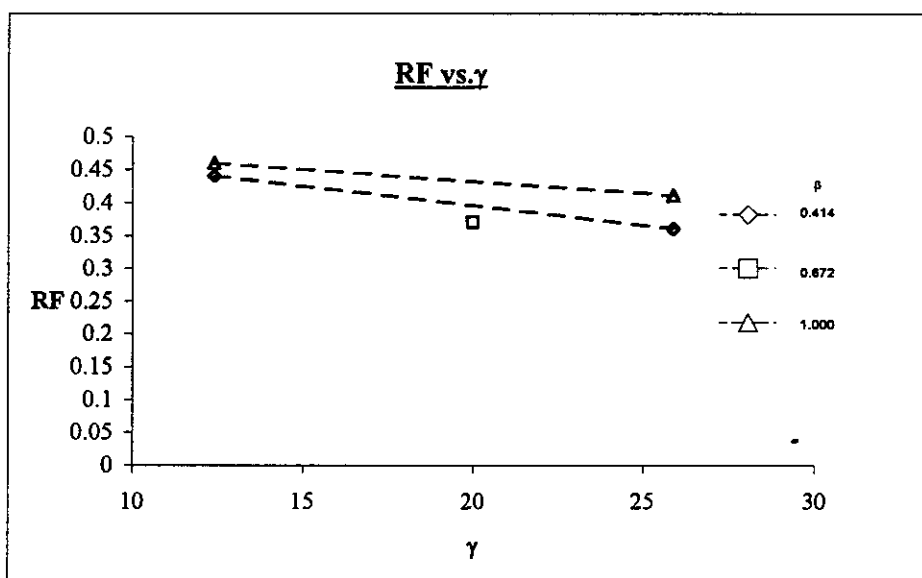
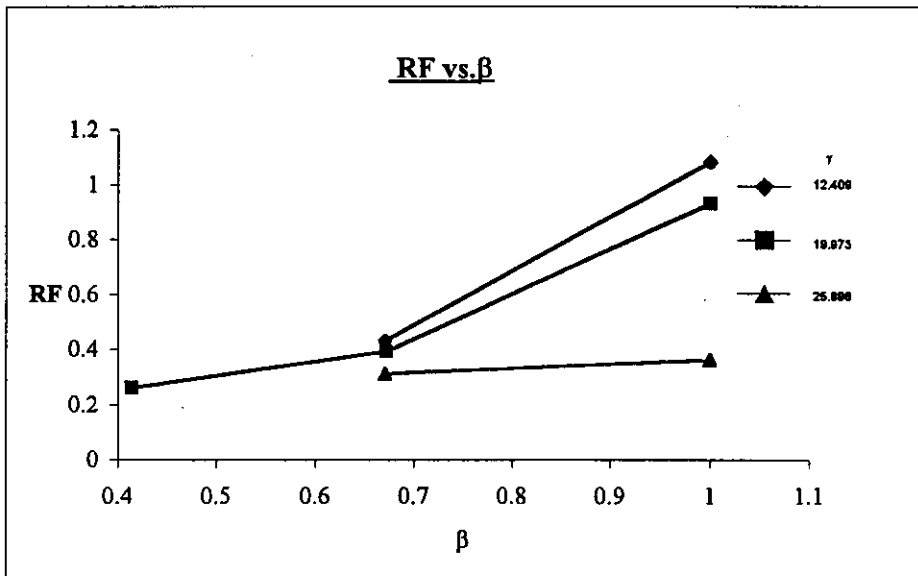

Fig. R15: DT Joints Under Tension, Brace Saddle

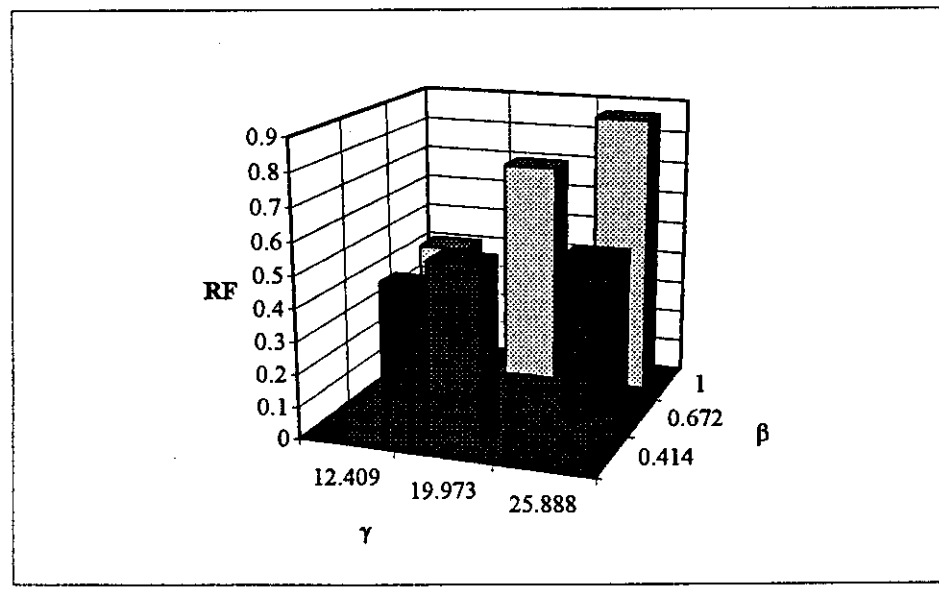
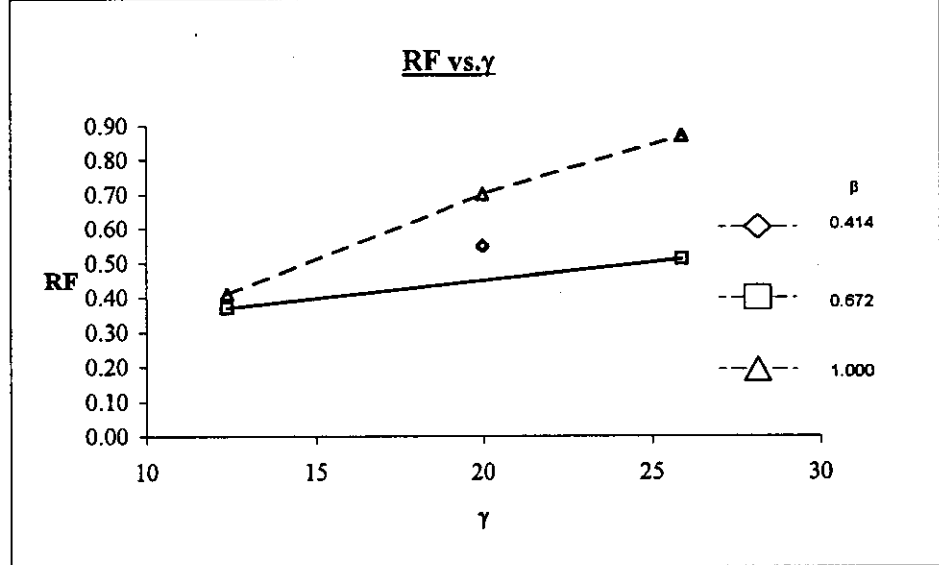
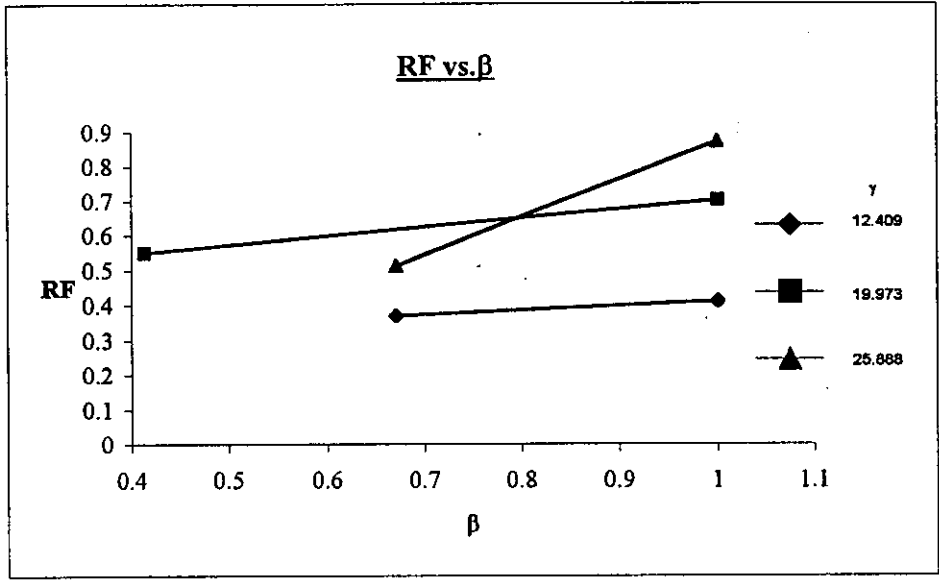

Fig. R16: DT Joints Under Tension, Brace Crown



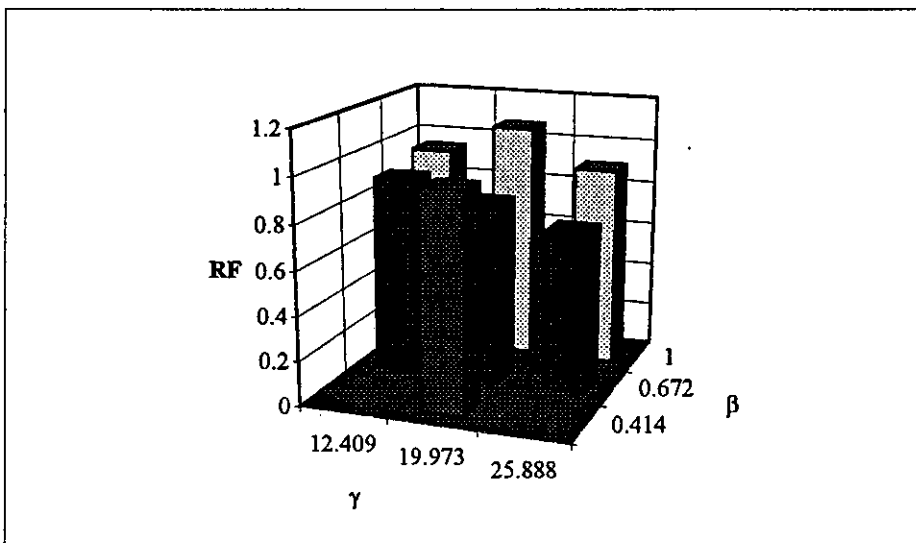
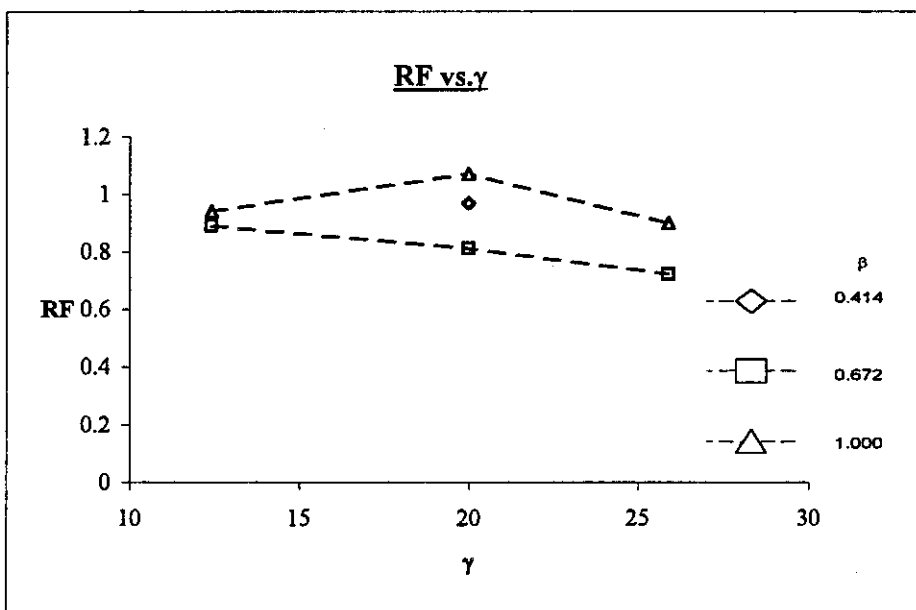
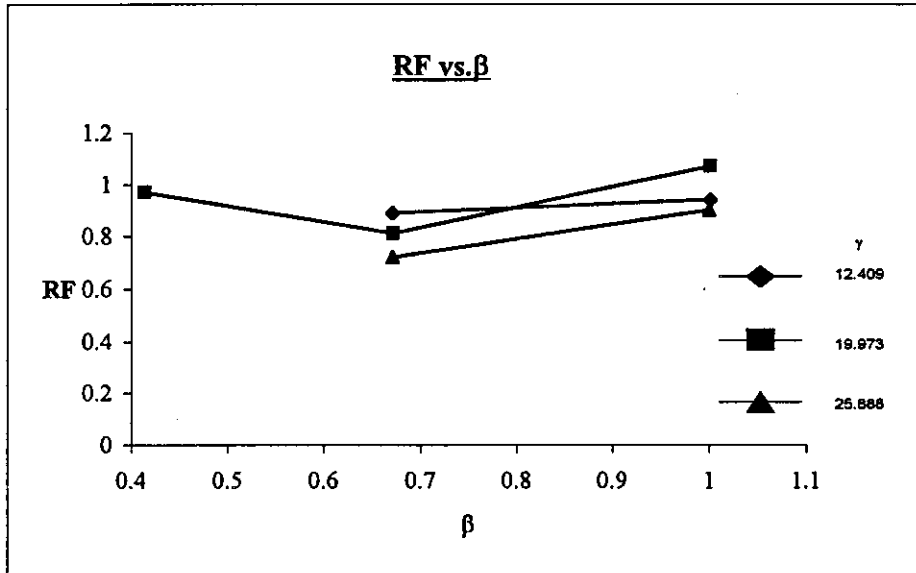

Fig. R17: DT Joints Under IPB, Brace Crown

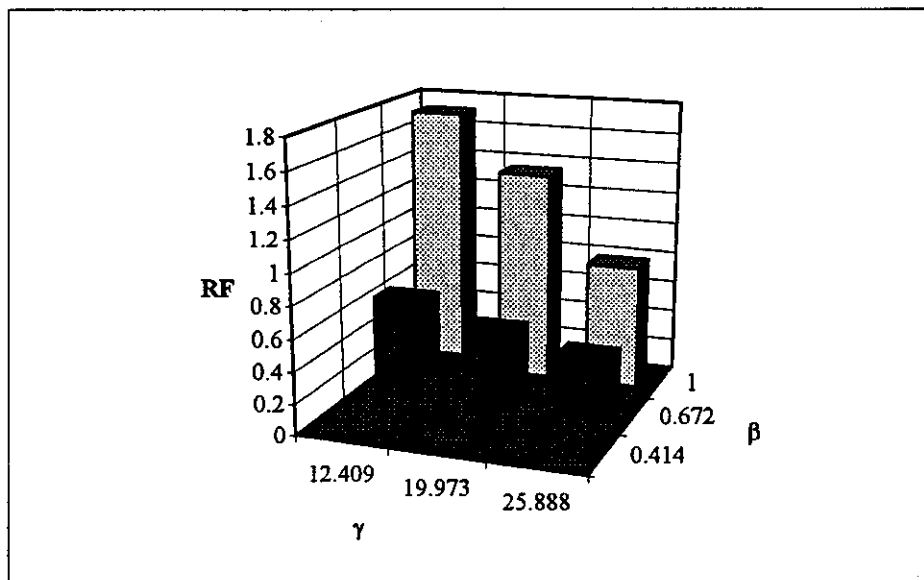
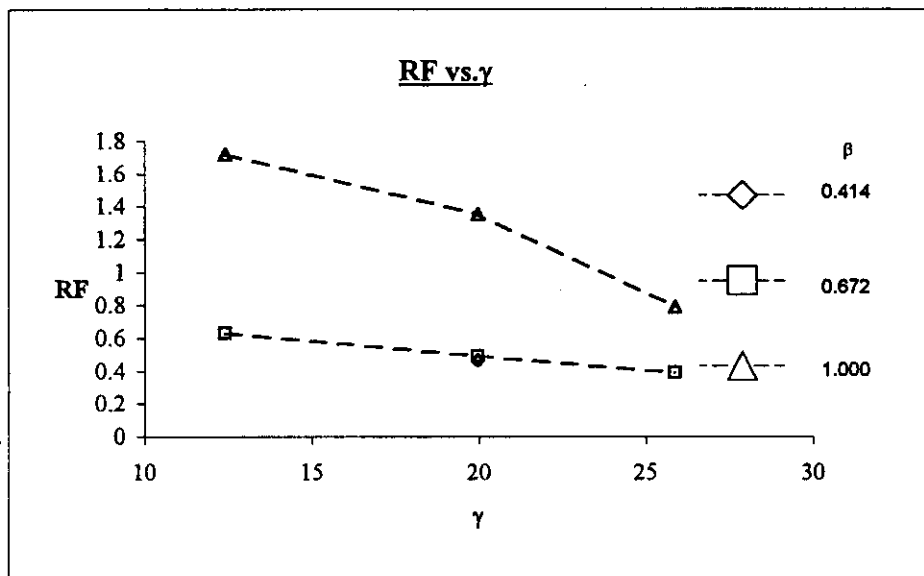
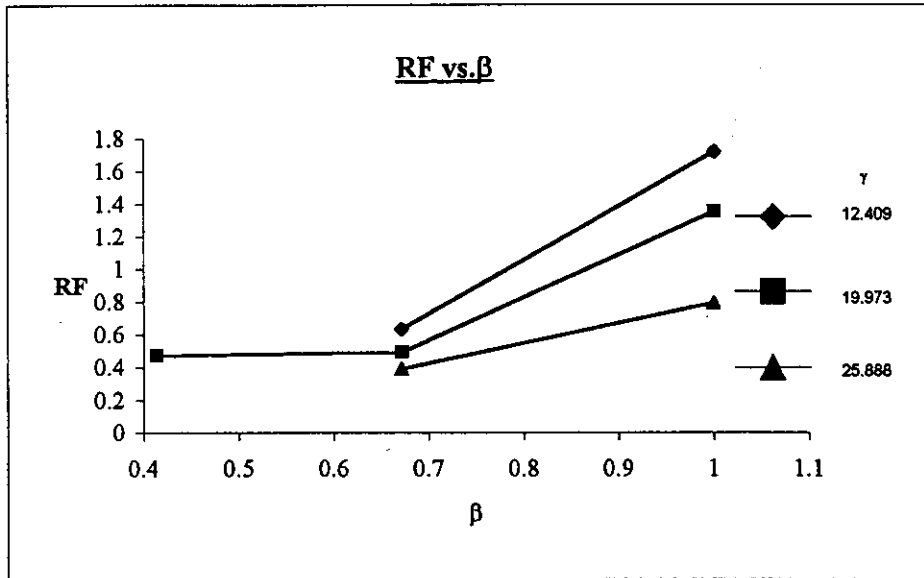

Fig. R18: DT Joints Under OPB, Brace Saddle

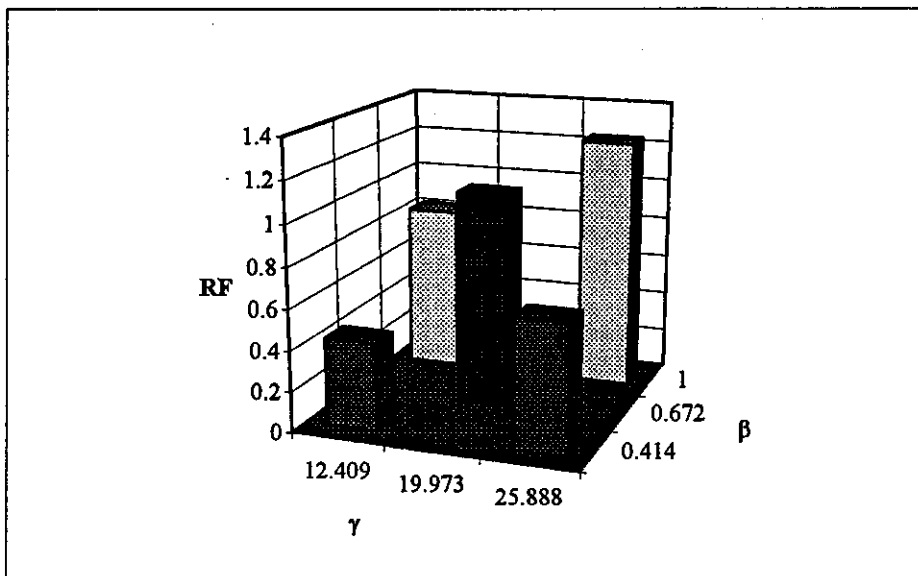
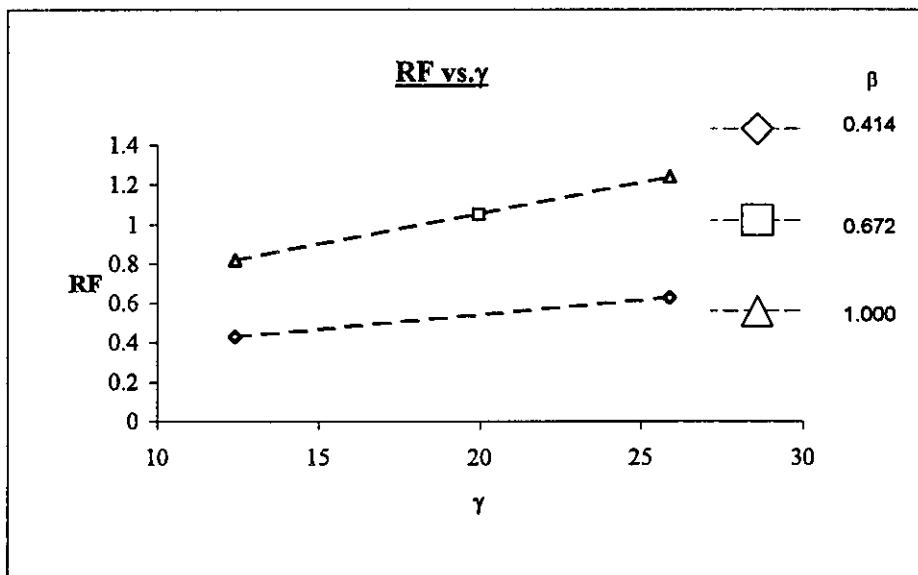
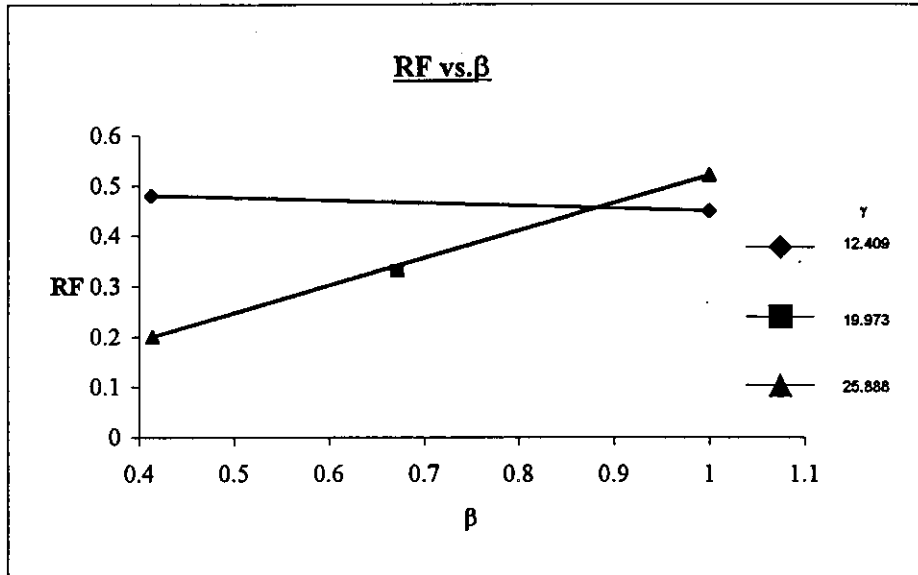

Fig. R19: T Joints Under Compression, Brace Saddle

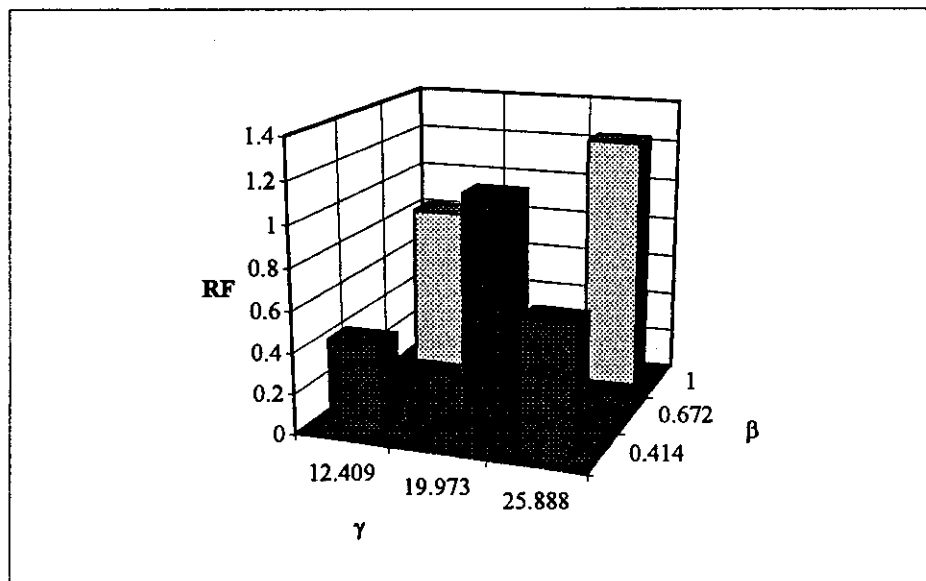
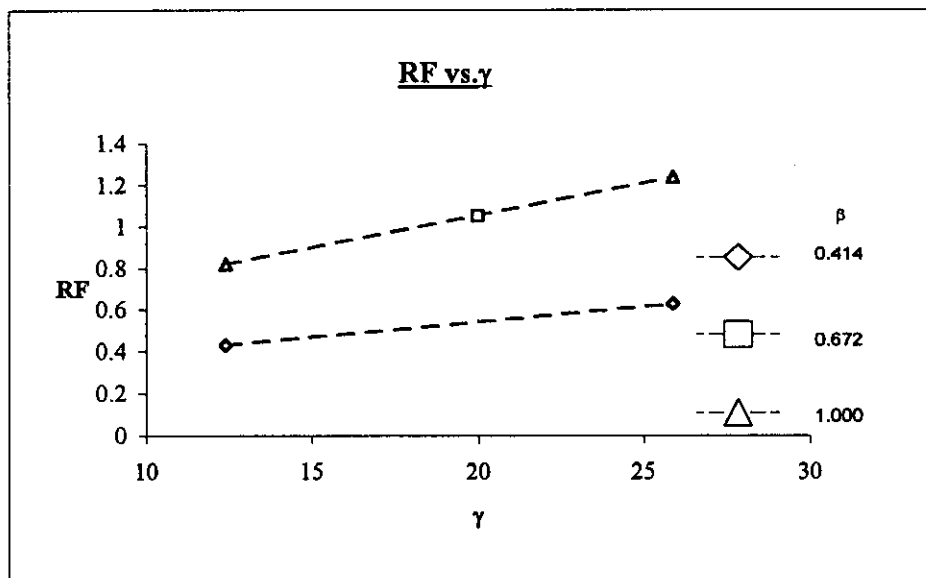
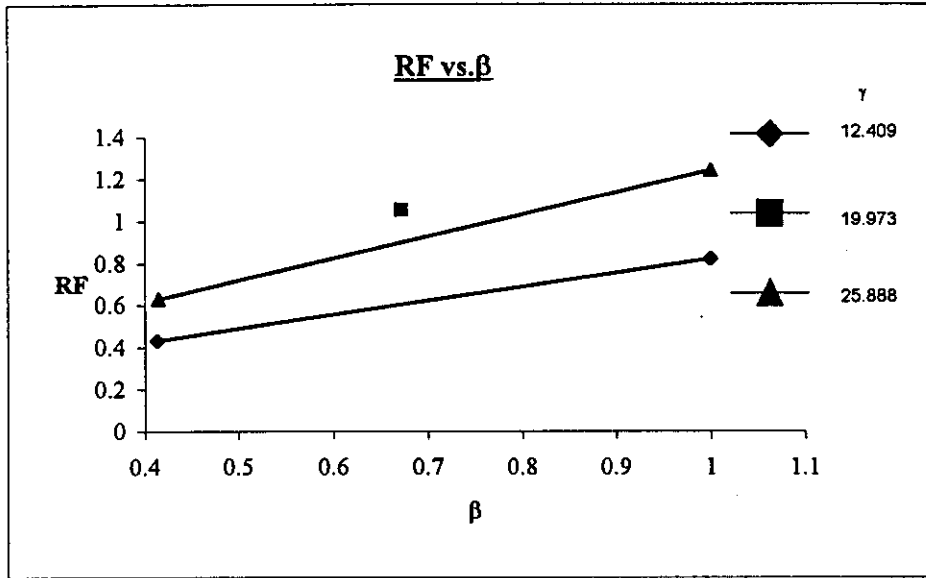

Fig. R20: T Joints Under Compression, Brace Crown

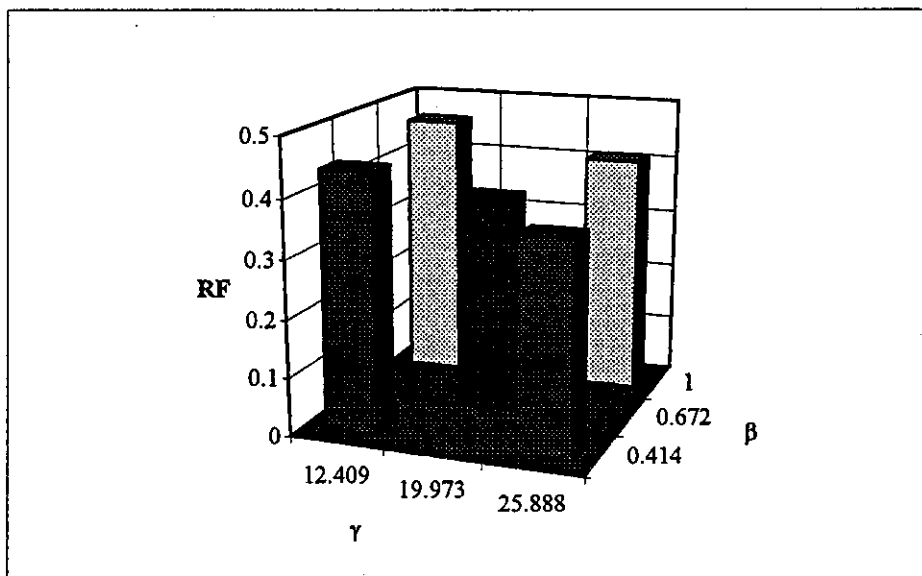
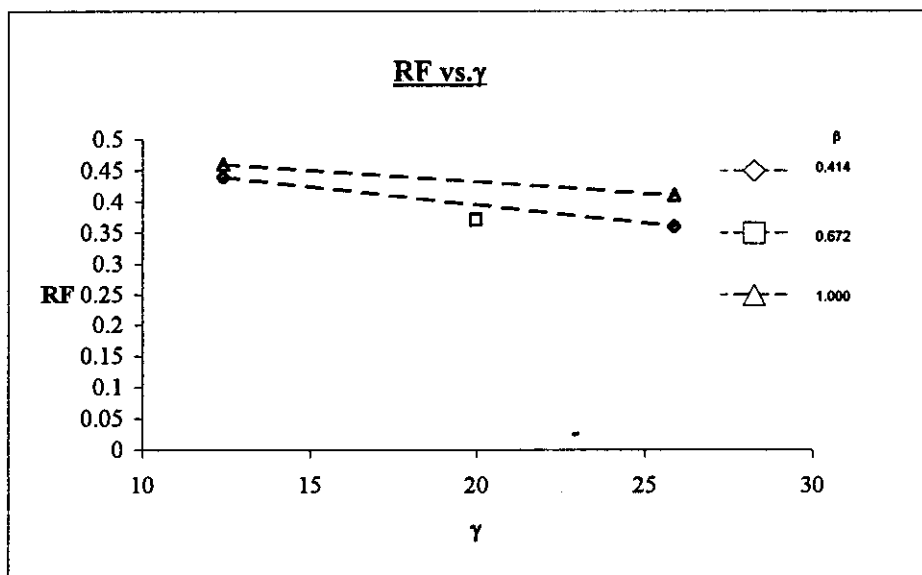
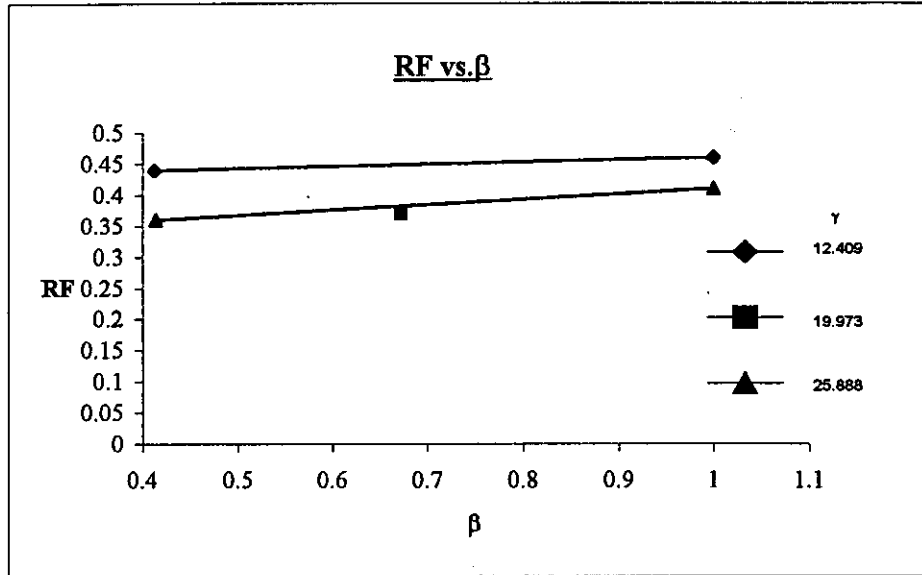

Fig. R21: T Joints Under Tension, Brace Saddle

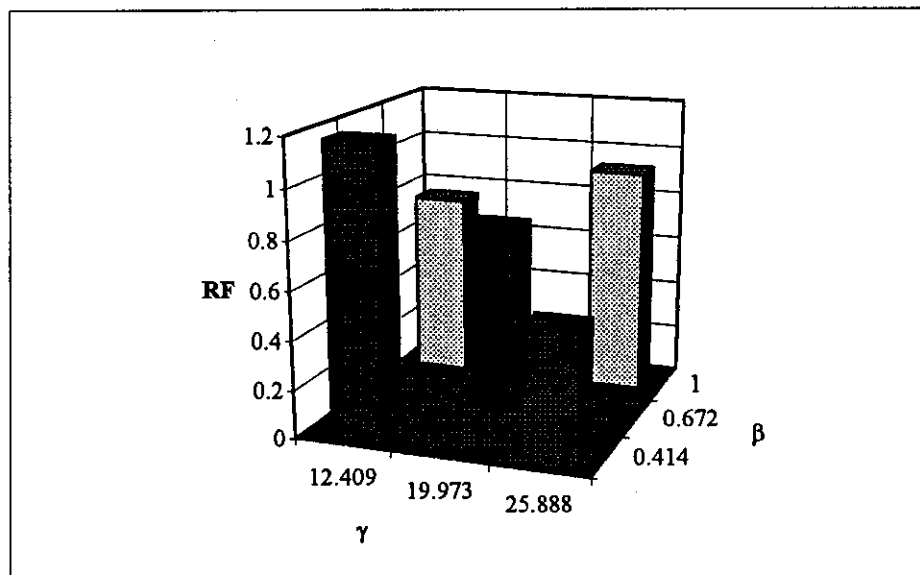
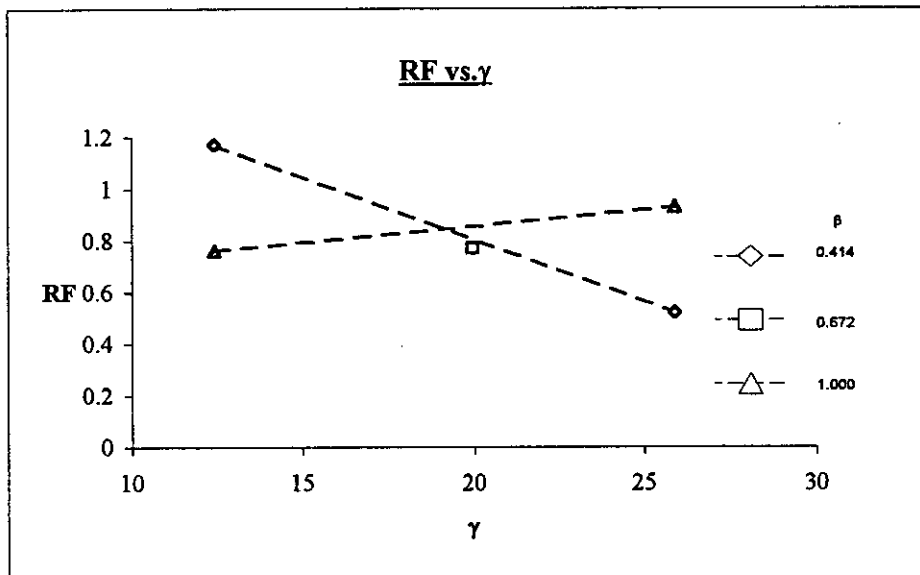
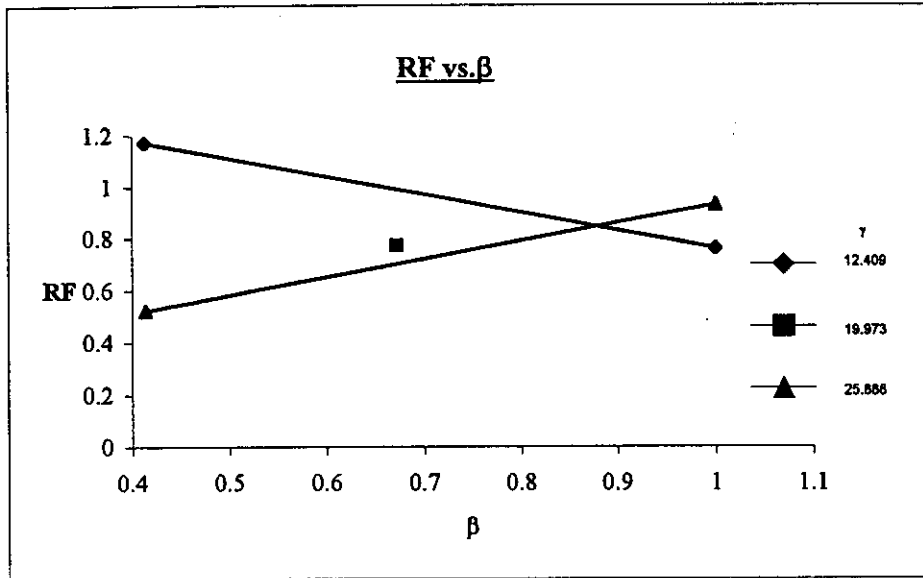

Fig. R22: T Joints Under Tension, Brace Crown

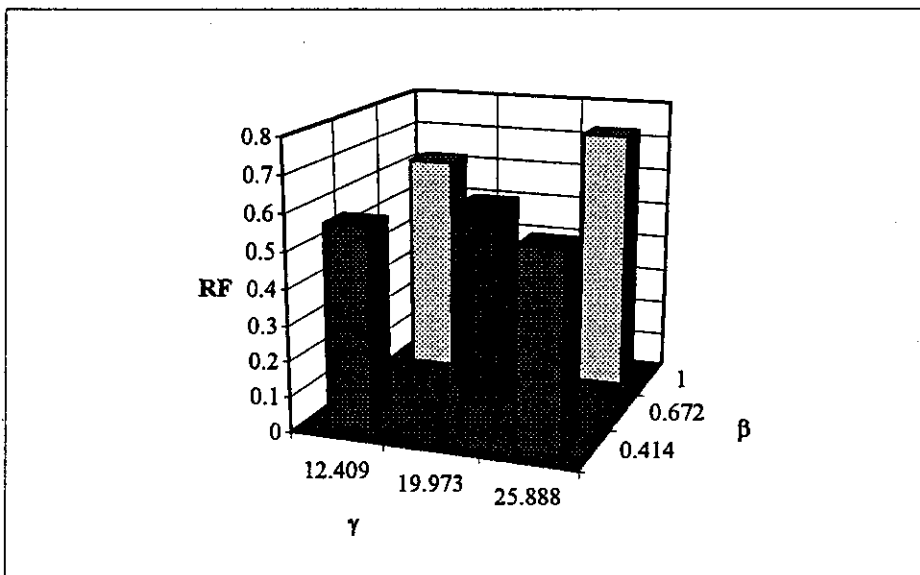
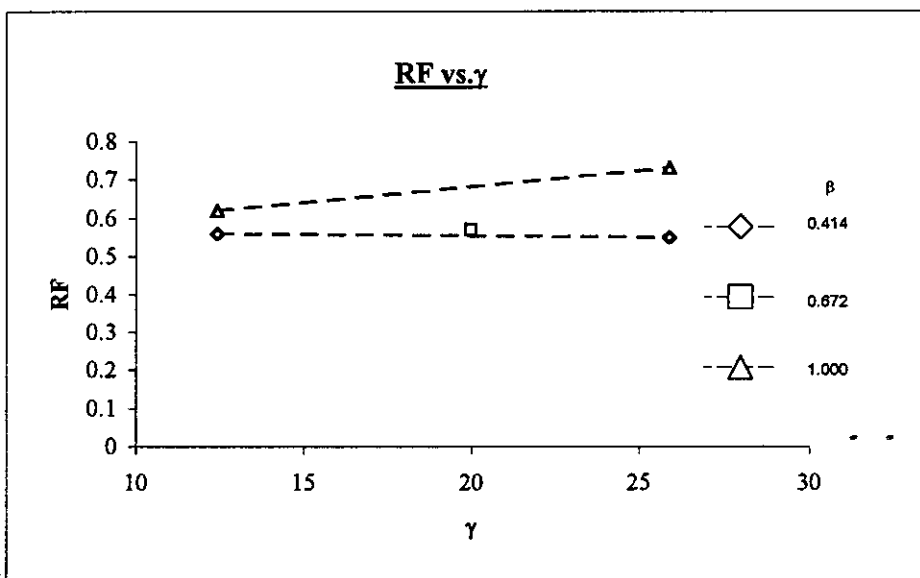
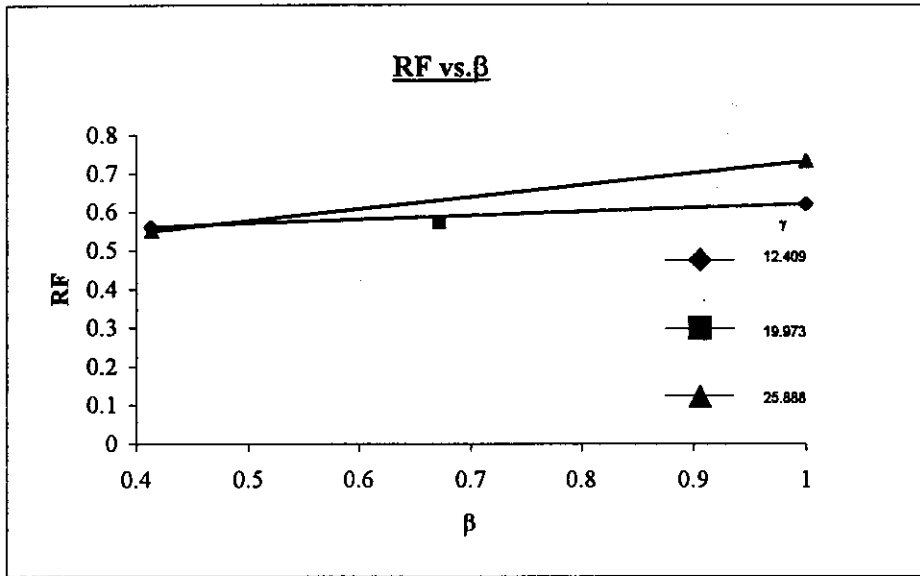

Fig. R23: T Joints Under IPB, Brace Crown

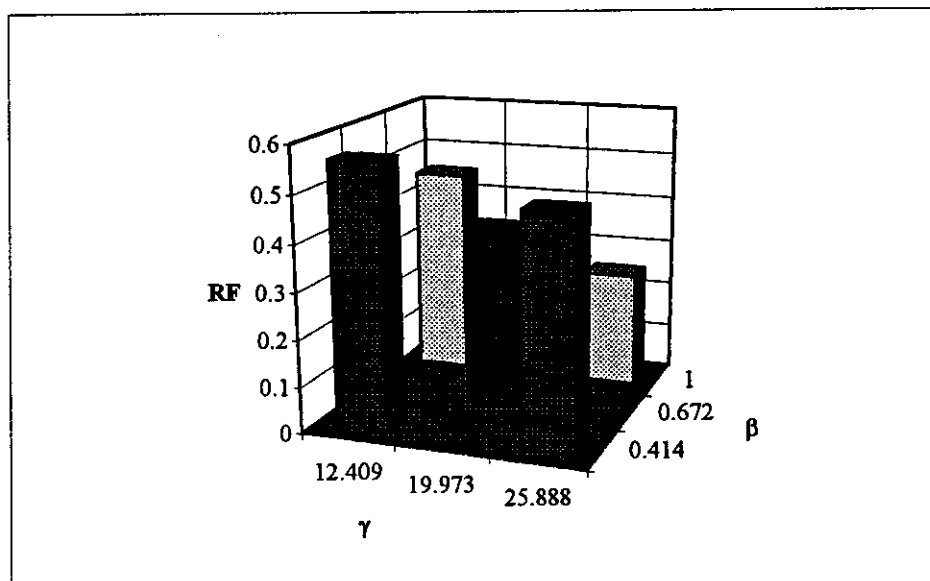
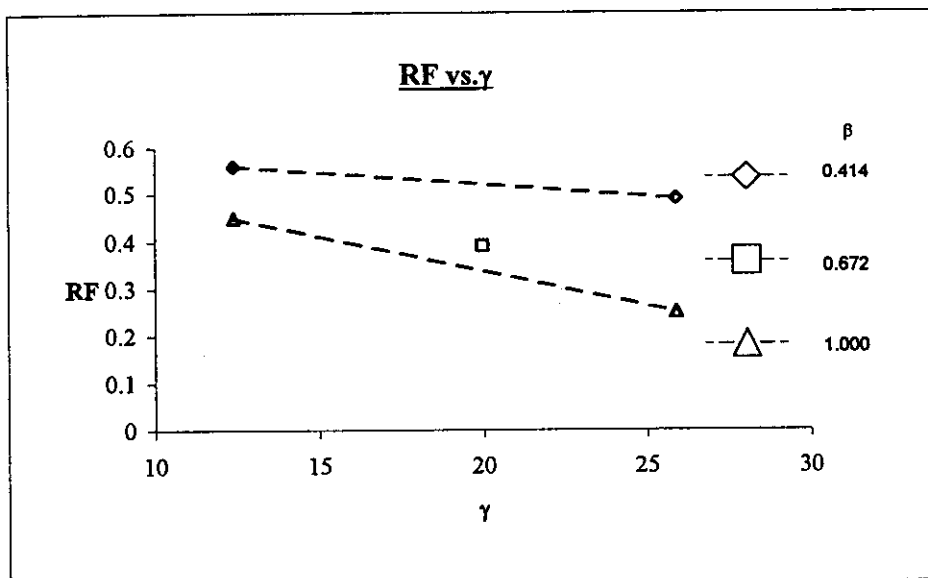
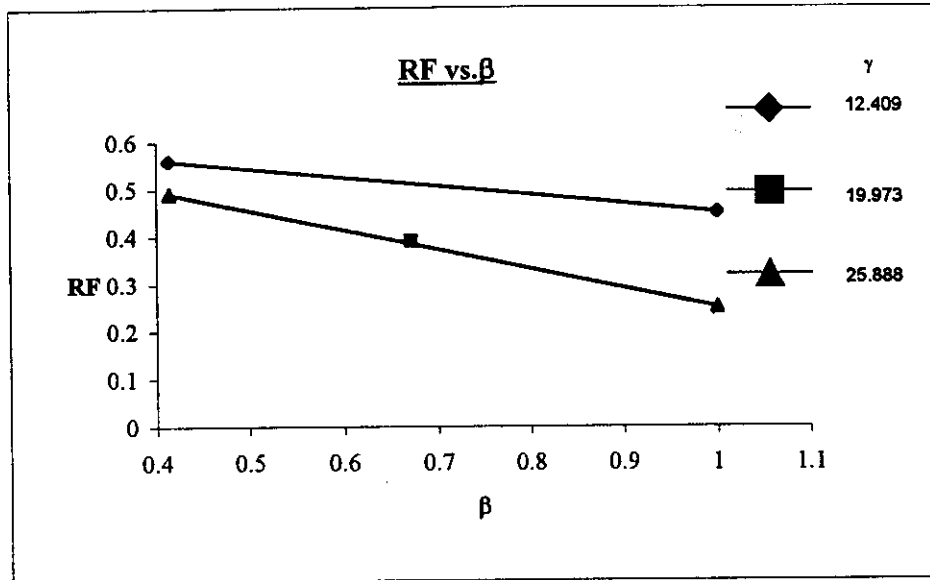
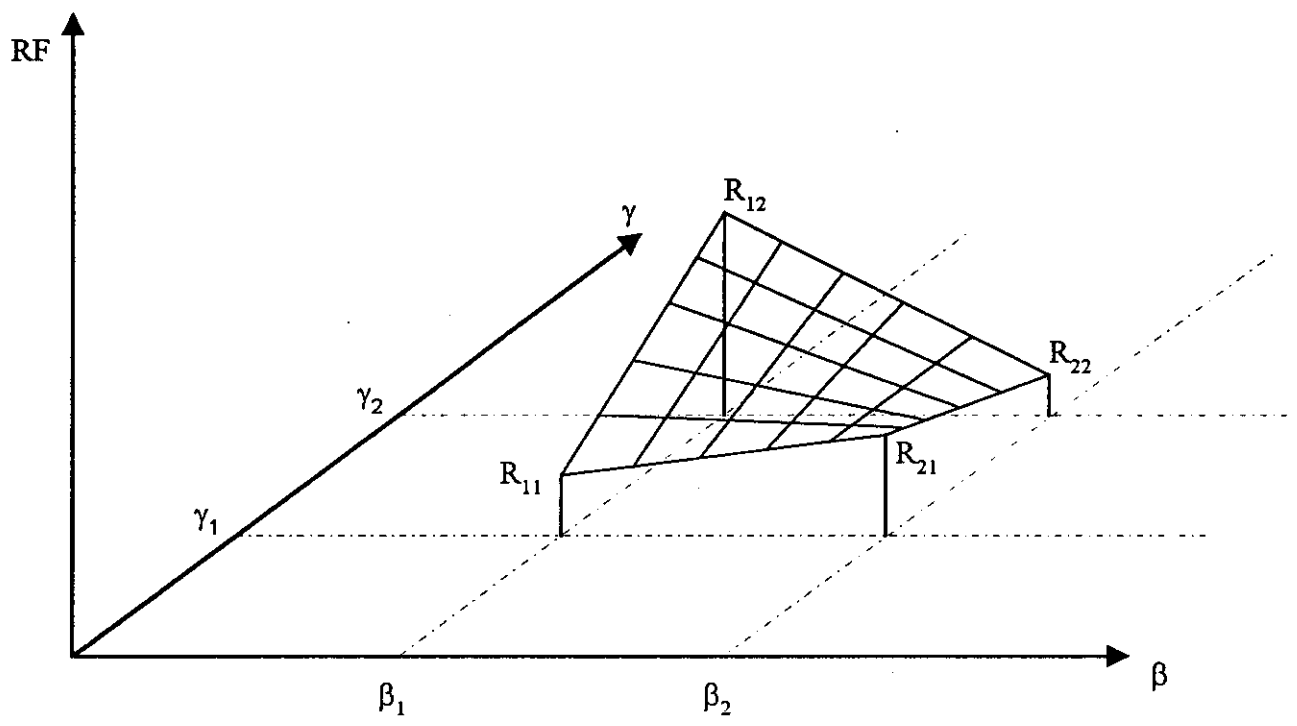

Fig. R24: T Joints Under OPB, Brace Saddle



$$\text{RF} = \frac{1}{(\beta_2 - \beta_1)(\gamma_2 - \gamma_1)} \left\{ \begin{aligned}
 & (R_{11}\beta_2\gamma_2 - R_{12}\beta_2\gamma_1 - R_{21}\beta_1\gamma_2 + R_{22}\beta_1\gamma_1) \\
 & + \beta(-R_{11}\gamma_2 + R_{12}\gamma_1 + R_{21}\gamma_2 - R_{22}\gamma_1) \\
 & + \gamma(-R_{11}\beta_2 + R_{12}\beta_2 + R_{21}\beta_1 - R_{22}\beta_1) \\
 & + \beta\gamma(R_{11} - R_{12} - R_{21} + R_{22}) \end{aligned} \right\}$$

Fig. R25: Geometry of a Twisted Plane

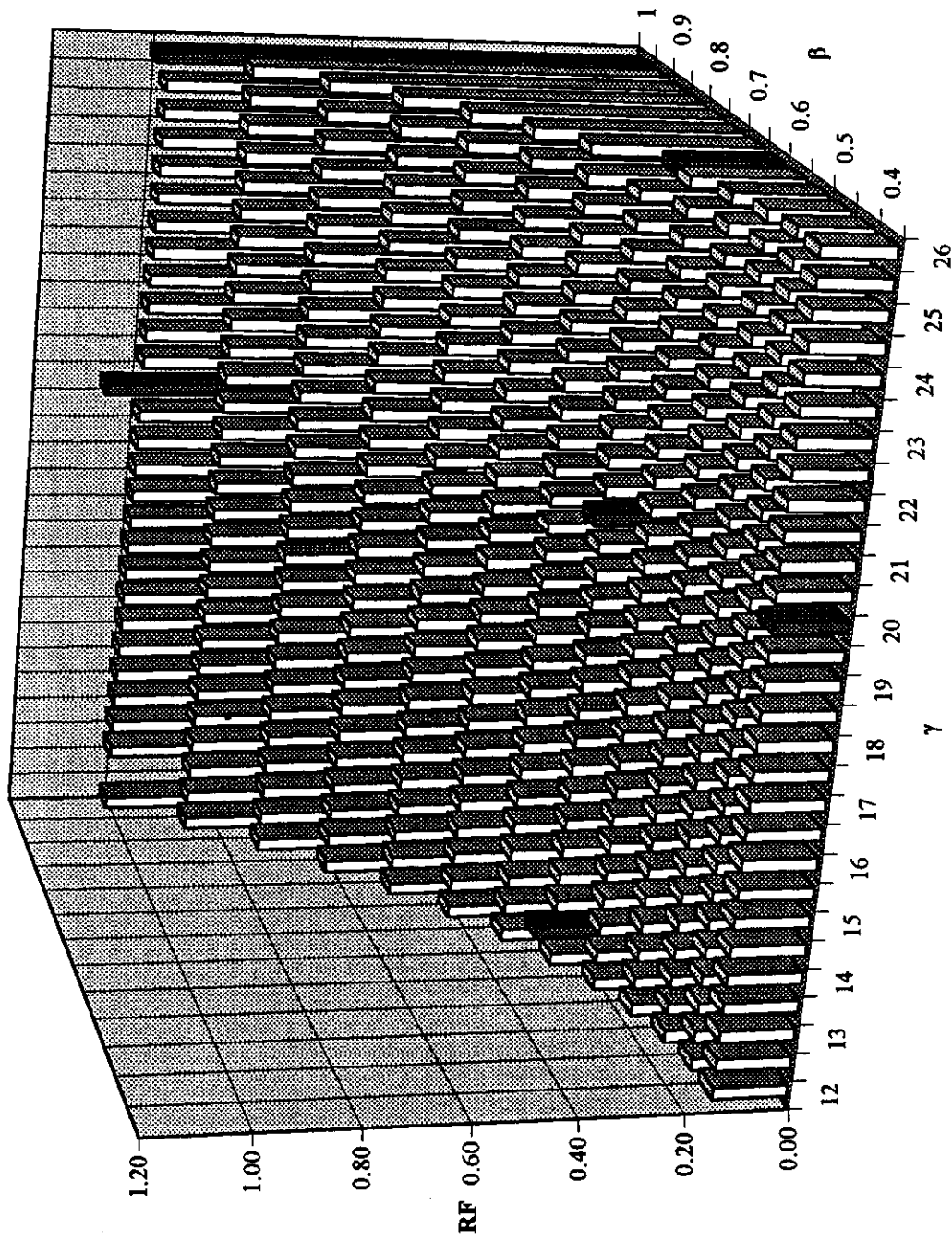

Fig. R26: Comparison of Fitted Surface with Measured Values for DT Joints under Compression, Chord Saddle



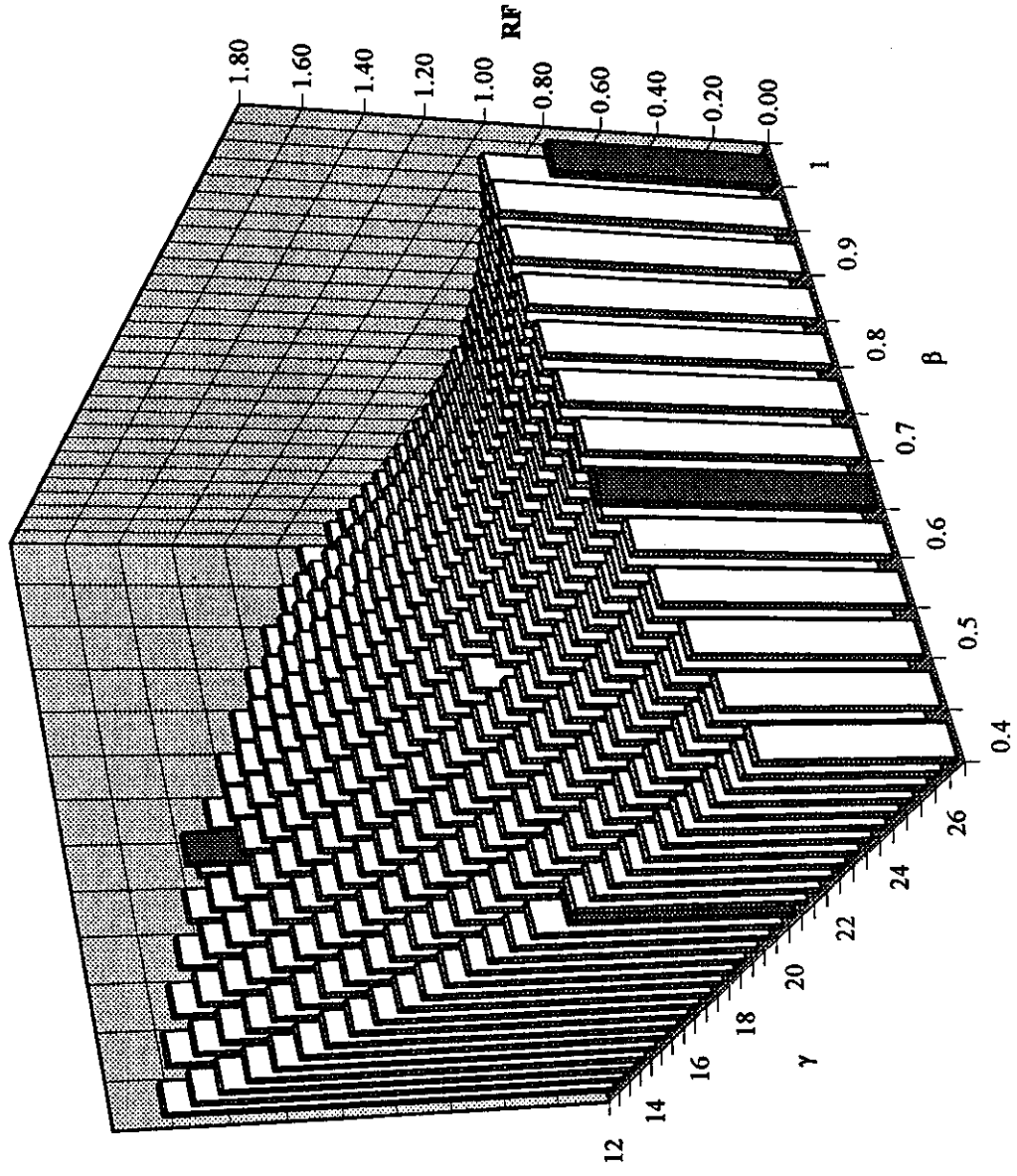

Fig. R27: Comparison of Fitted Surface with Measured Values for DT Joints under Compression, Chord Crown (Final)

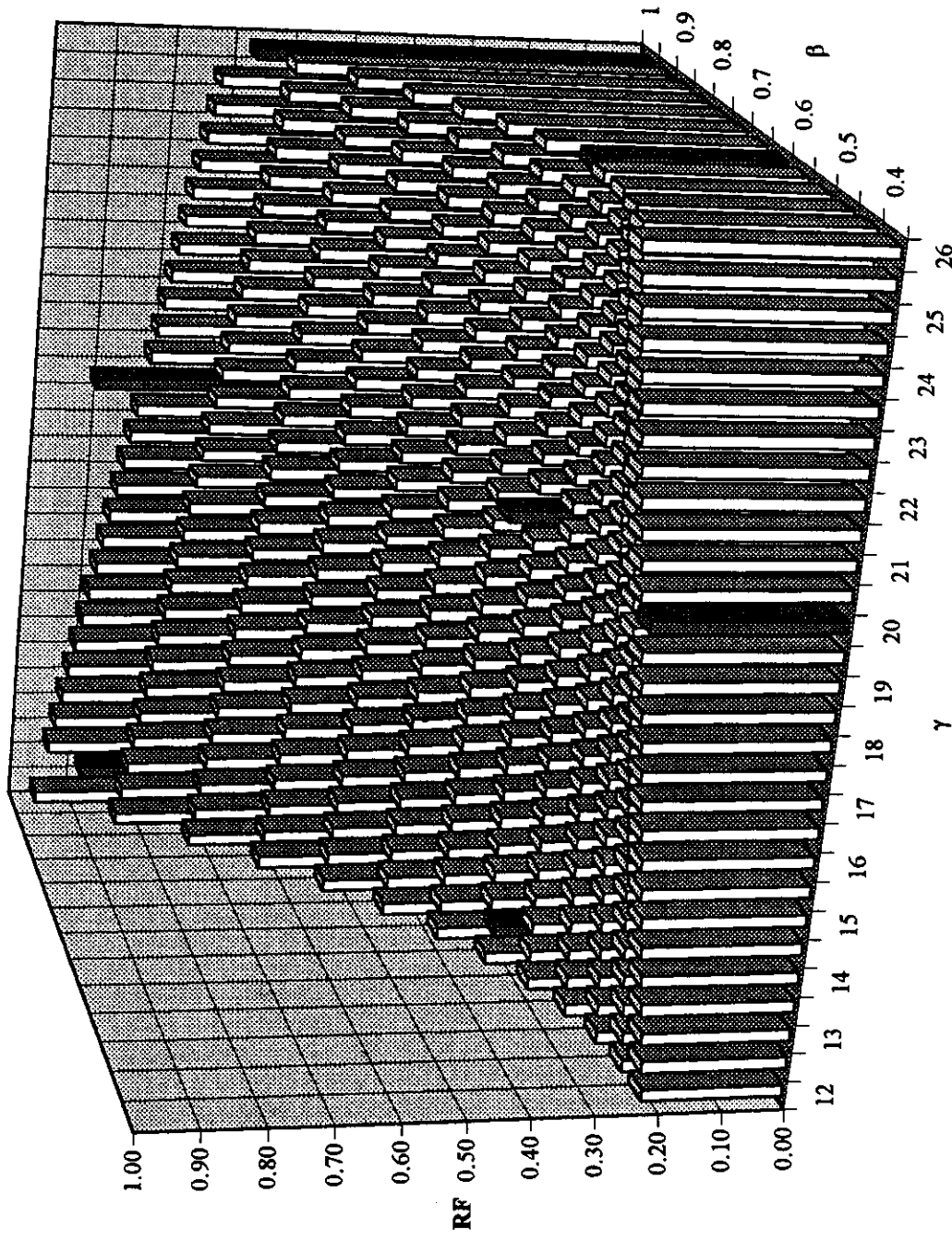

Fig. R28: Comparison of Fitted Surface with Measured Values for DT Joints under Tension, Chord Saddle

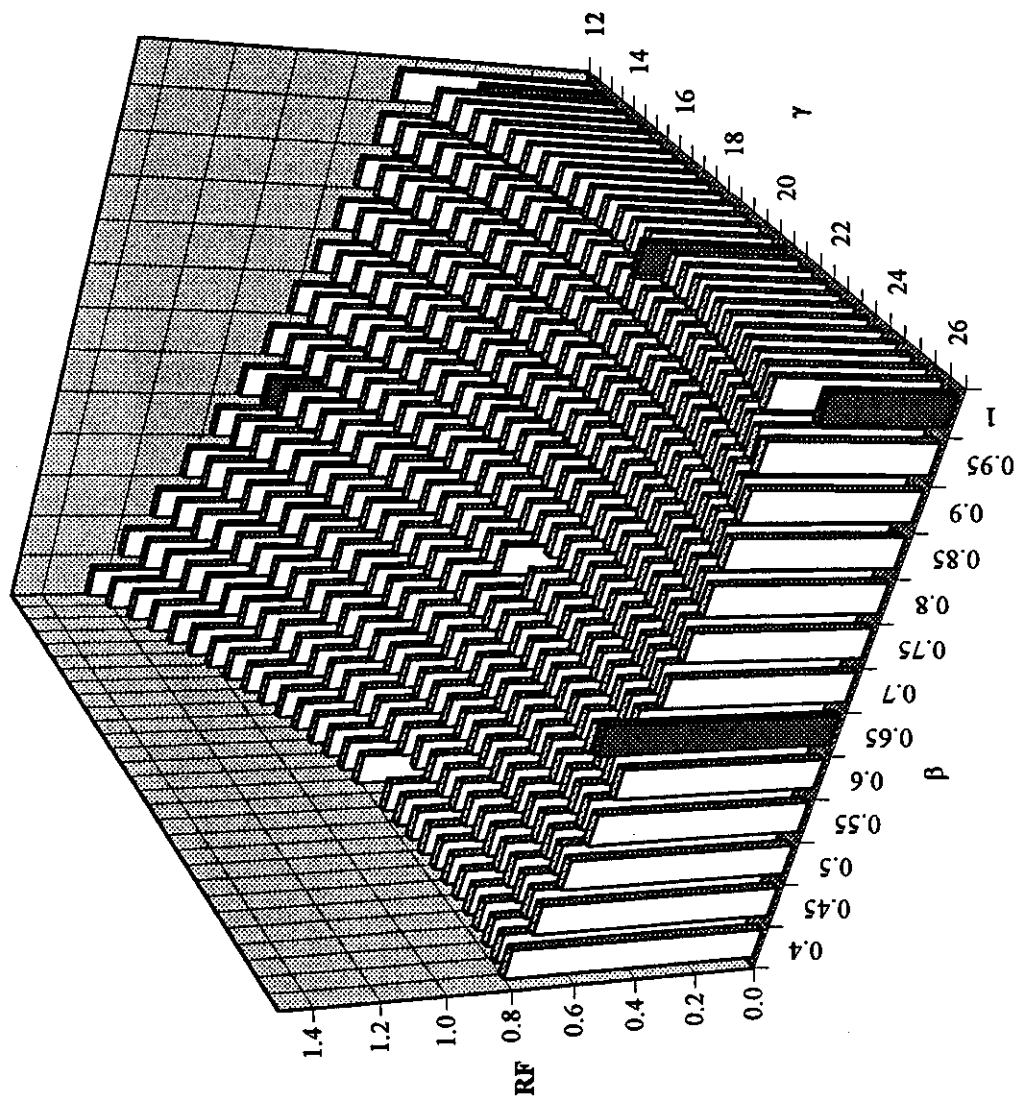

Fig. R29: Comparison of Fitted Surface with Measured Values for DT Joints under Tension, Chord Crown (Final)

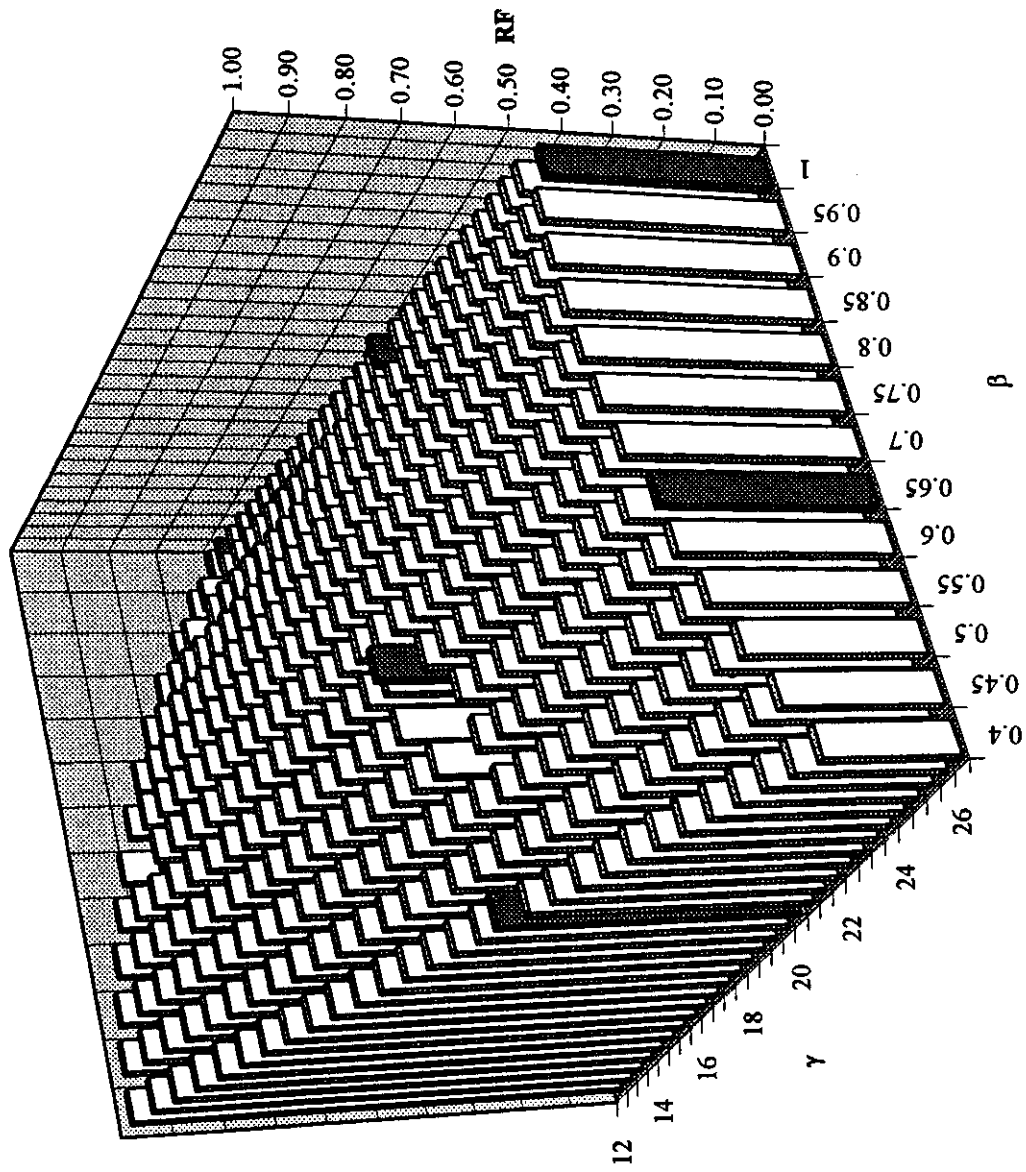

Fig. R30: Comparison of Fitted Surface with Measured Values for DT Joints under IPB, Chord Crown

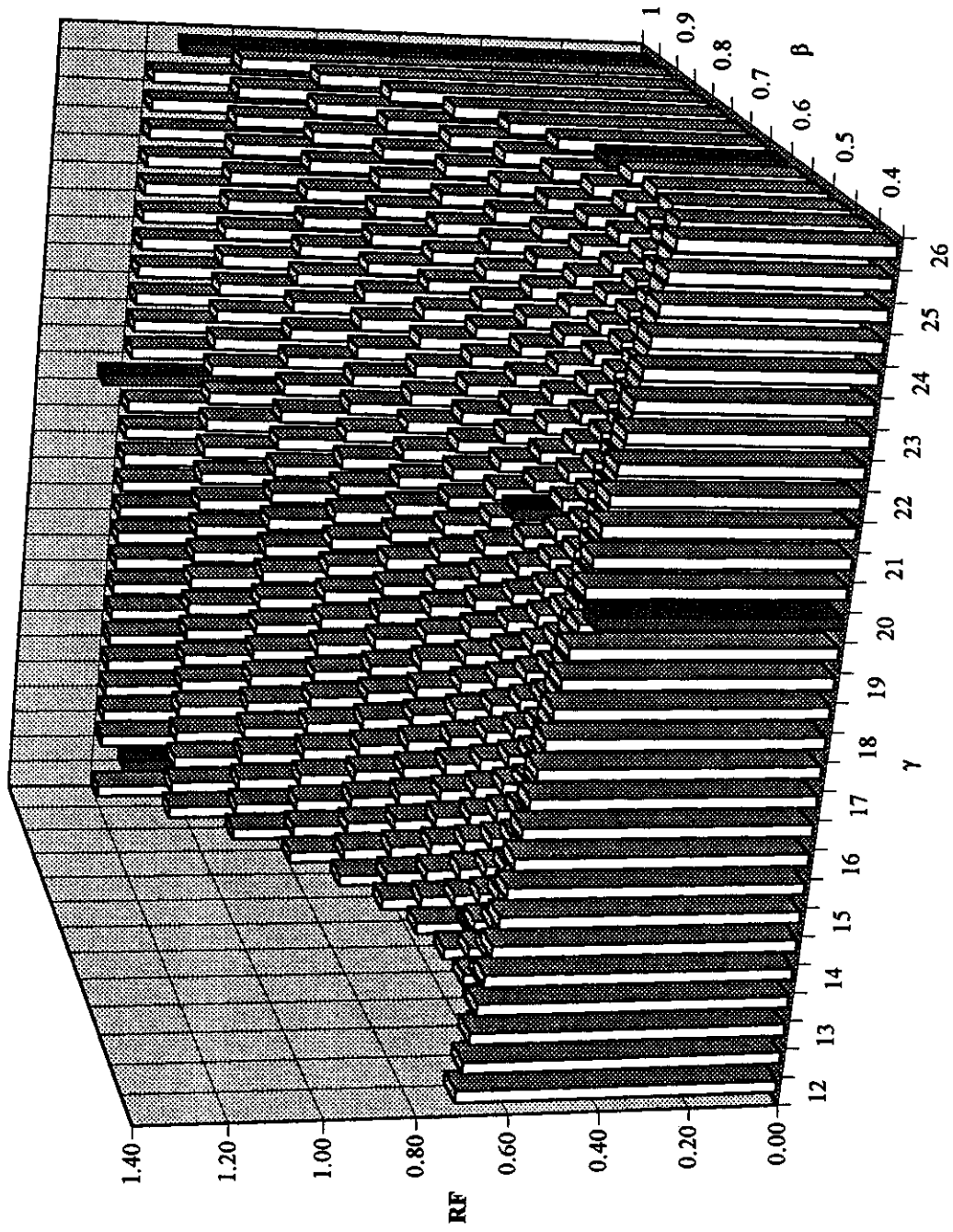

Fig. R31: Comparison of Fitted Surface with Measured Values for DT Joints under OPB, Chord Saddle

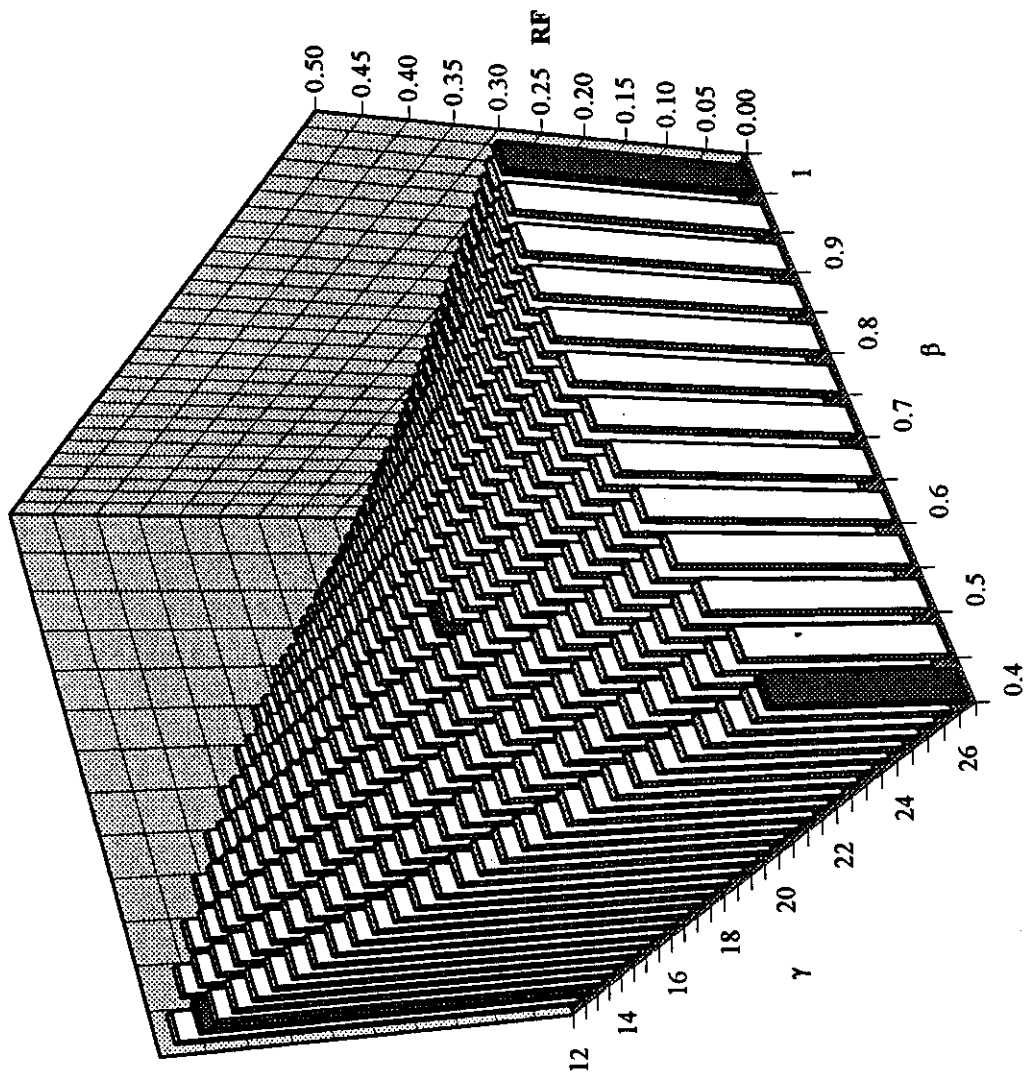

Fig R32: Comparison of Fitted Surface with Measured Values for T Joints under Compression, Chord Saddle

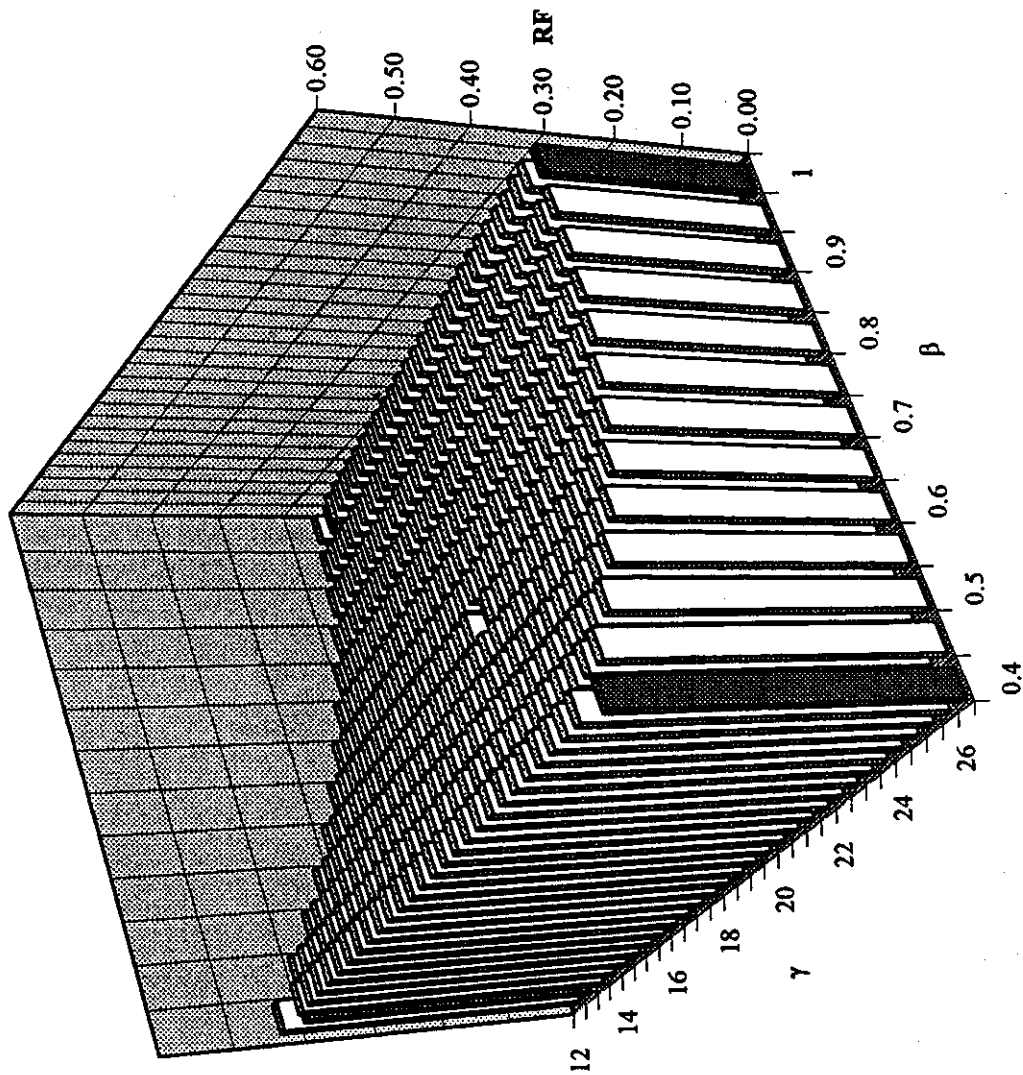

Fig R34: Comparison of Fitted Surface with Measured Values for T joints under Tension, Chord Saddle

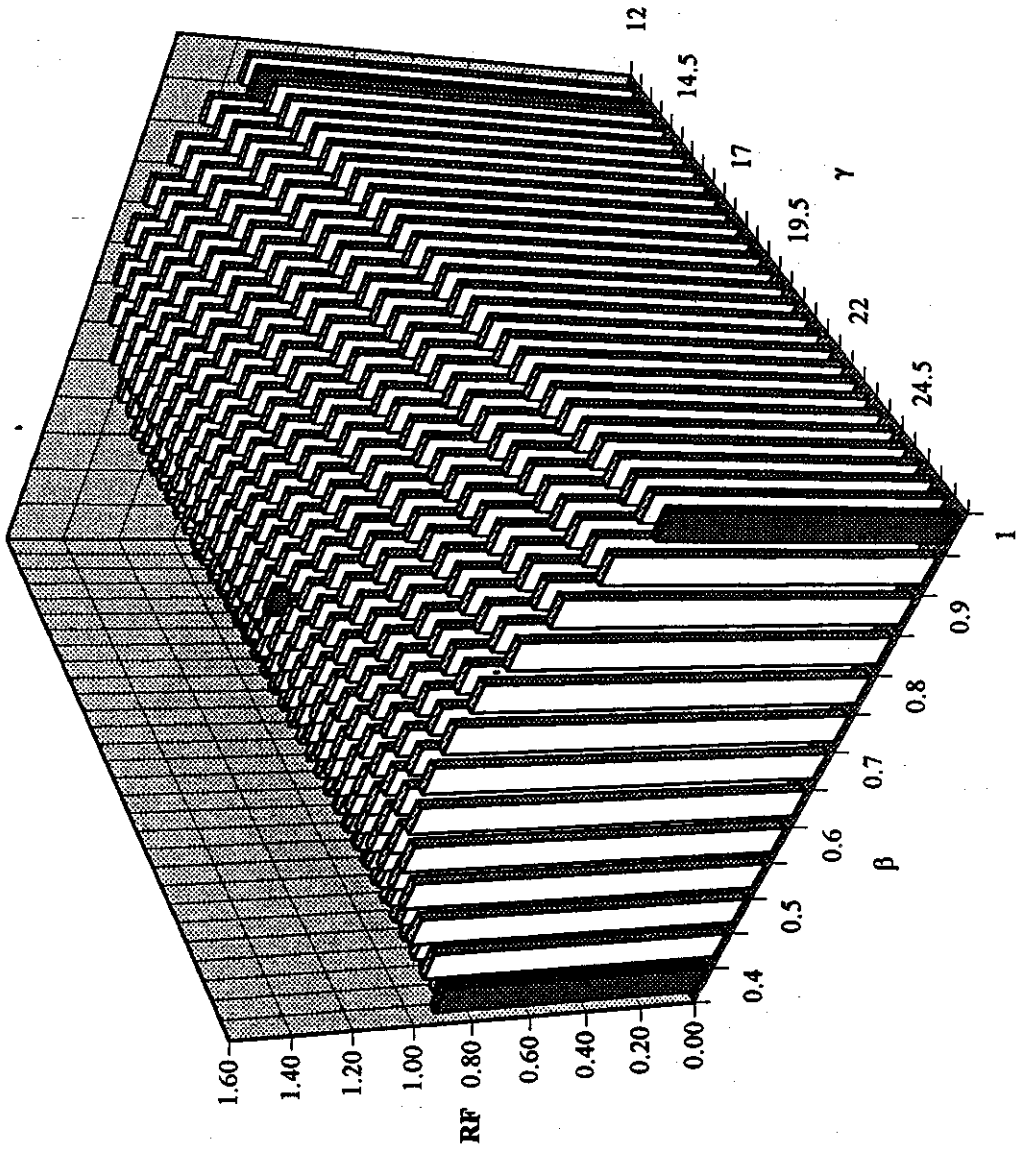

Fig. R35: Comparison of Fitted Surface with Measured Values for T Joints under Tension, Chord Crown

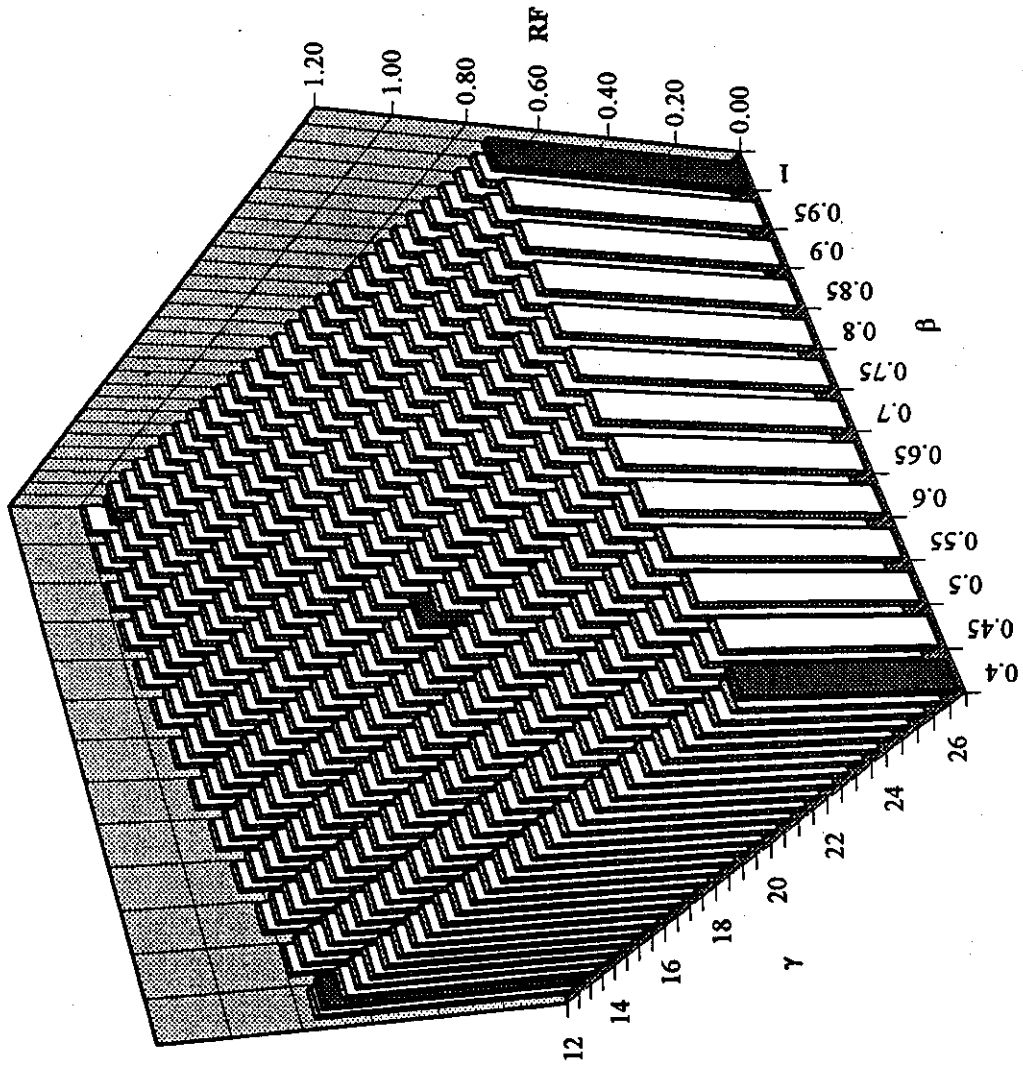

Fig. R36: Comparison of fitted Surface with Measured Values for T Joints under IPB, Chord Crown

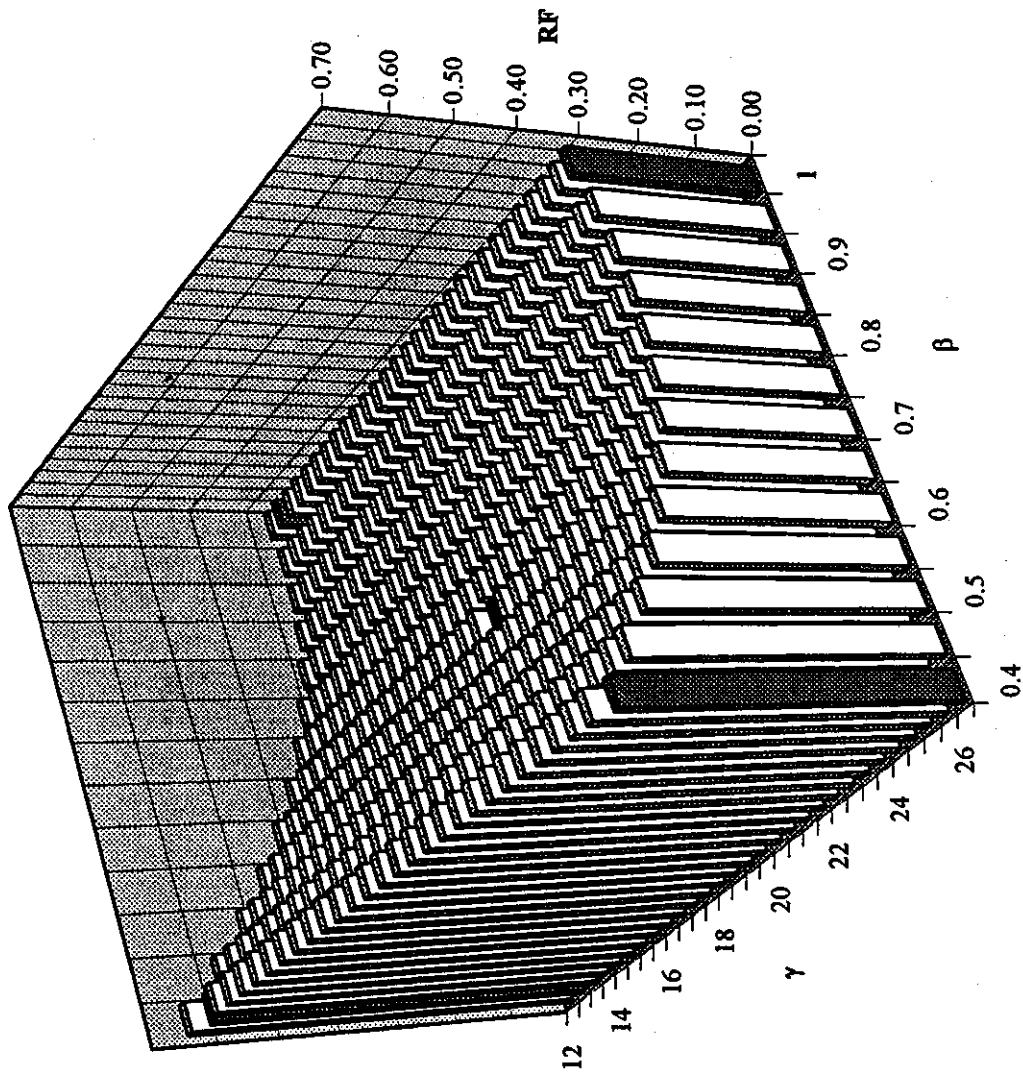
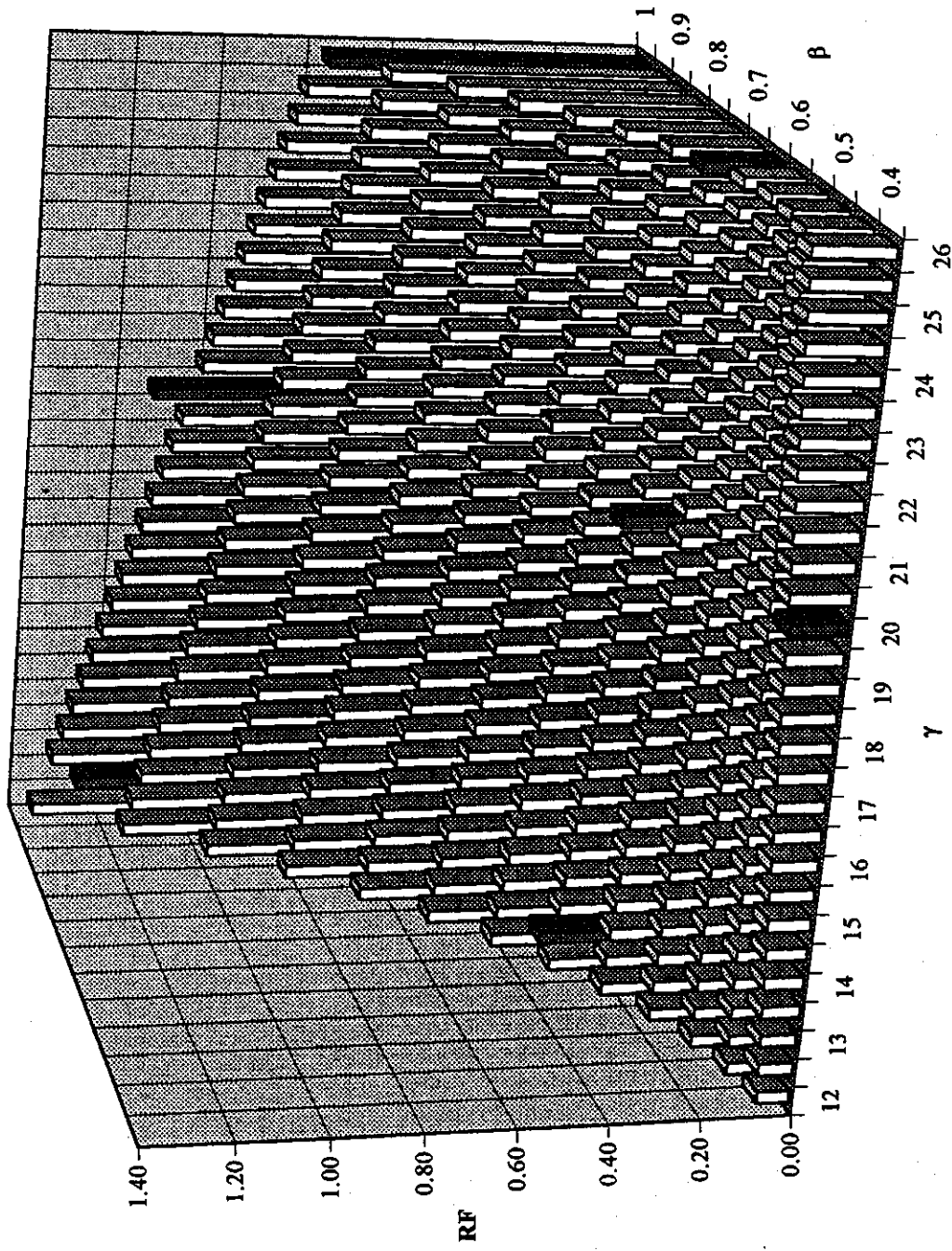

Fig. R37: Comparison of Fitted Surface with Measured Values for T Joints under OPB, Chord Saddle



**Fig. R38: Comparison of Fitted Surface with Measured Values for
DT Joints under Compression, Brace Saddle**

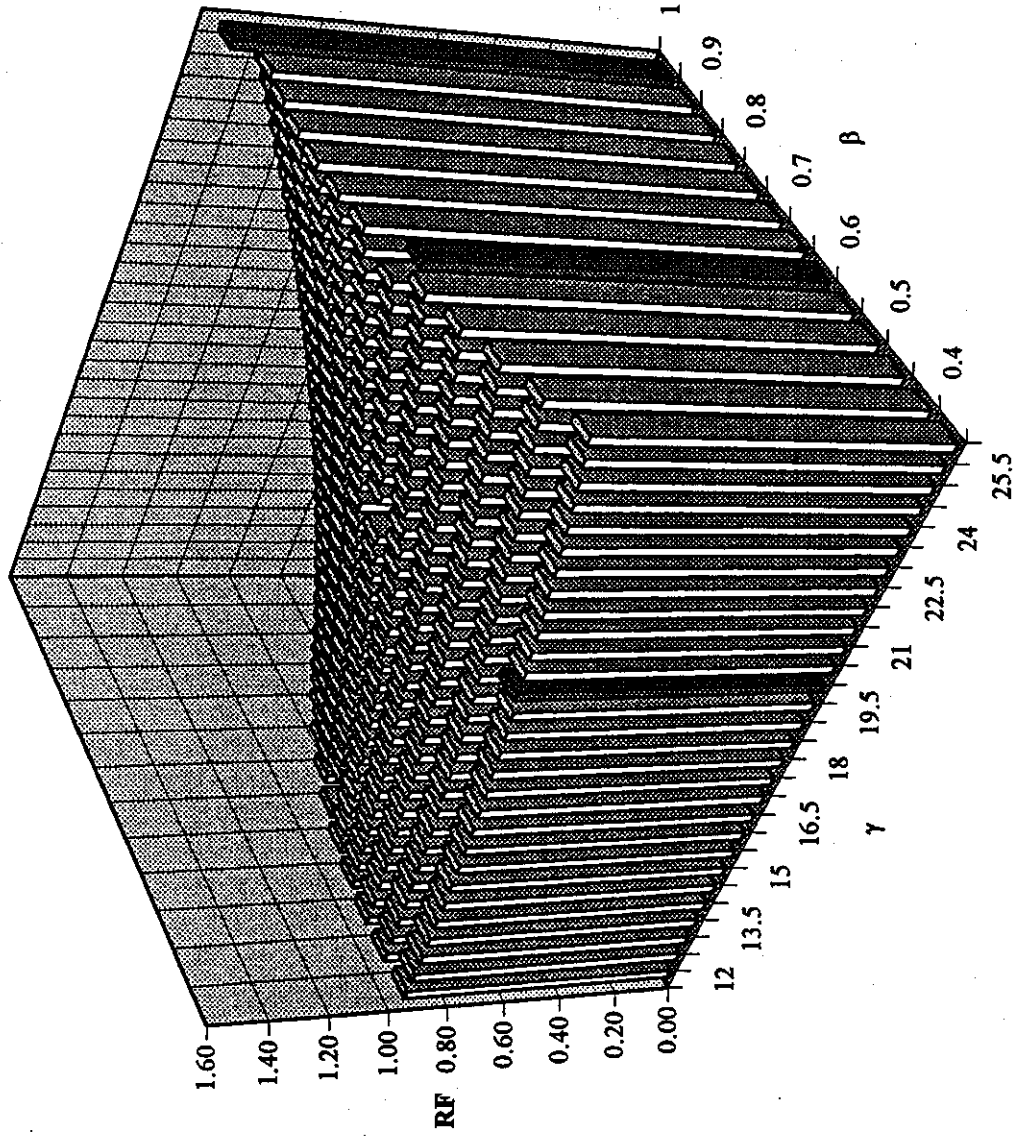
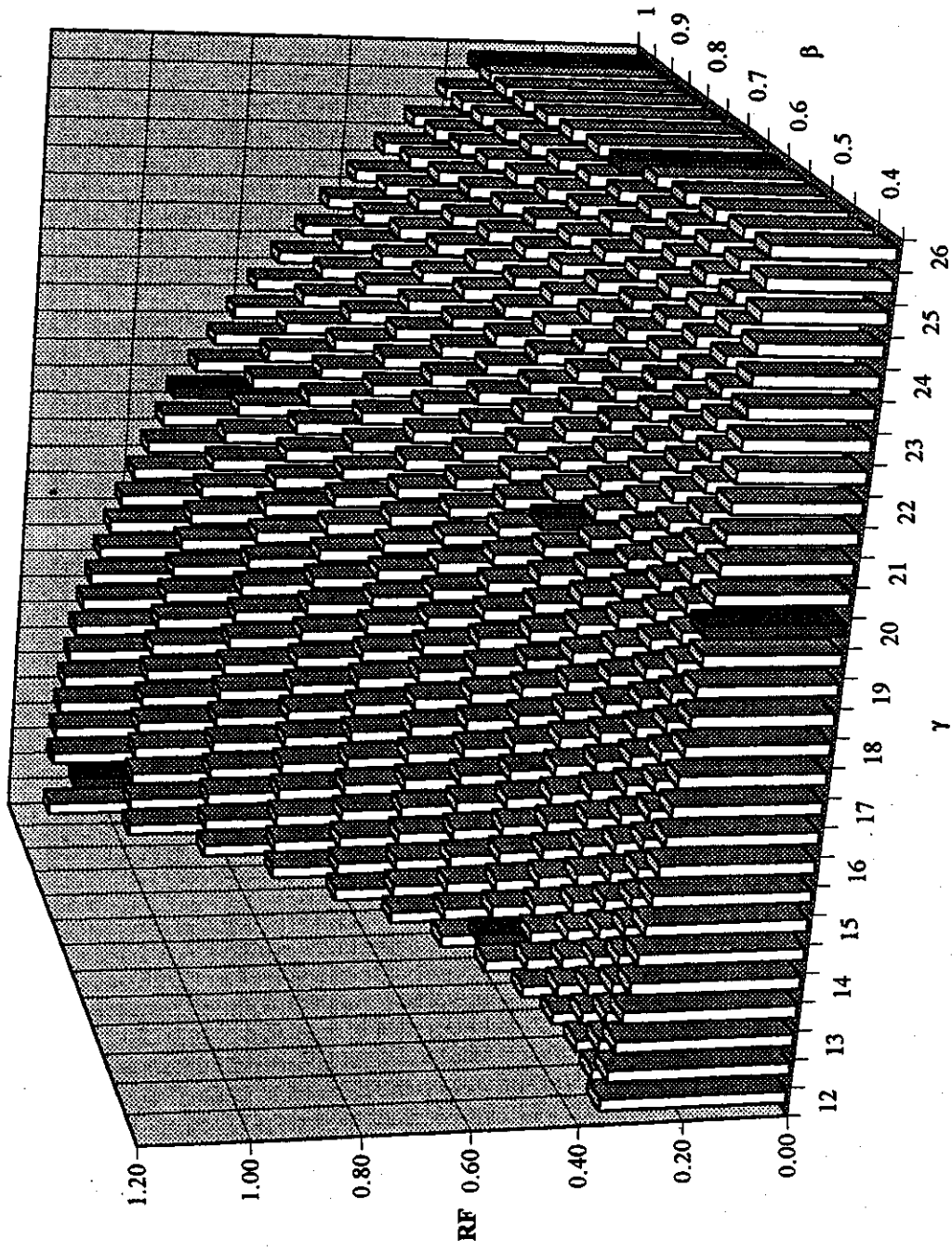

Fig. R39: Comparison of Fitted Surface with Measured Values for DT Joints under Compression, Brace Crown



**Fig. R40: Comparison of Fitted Surface with Measured Values for
DT Joints under Tension, Brace Saddle**

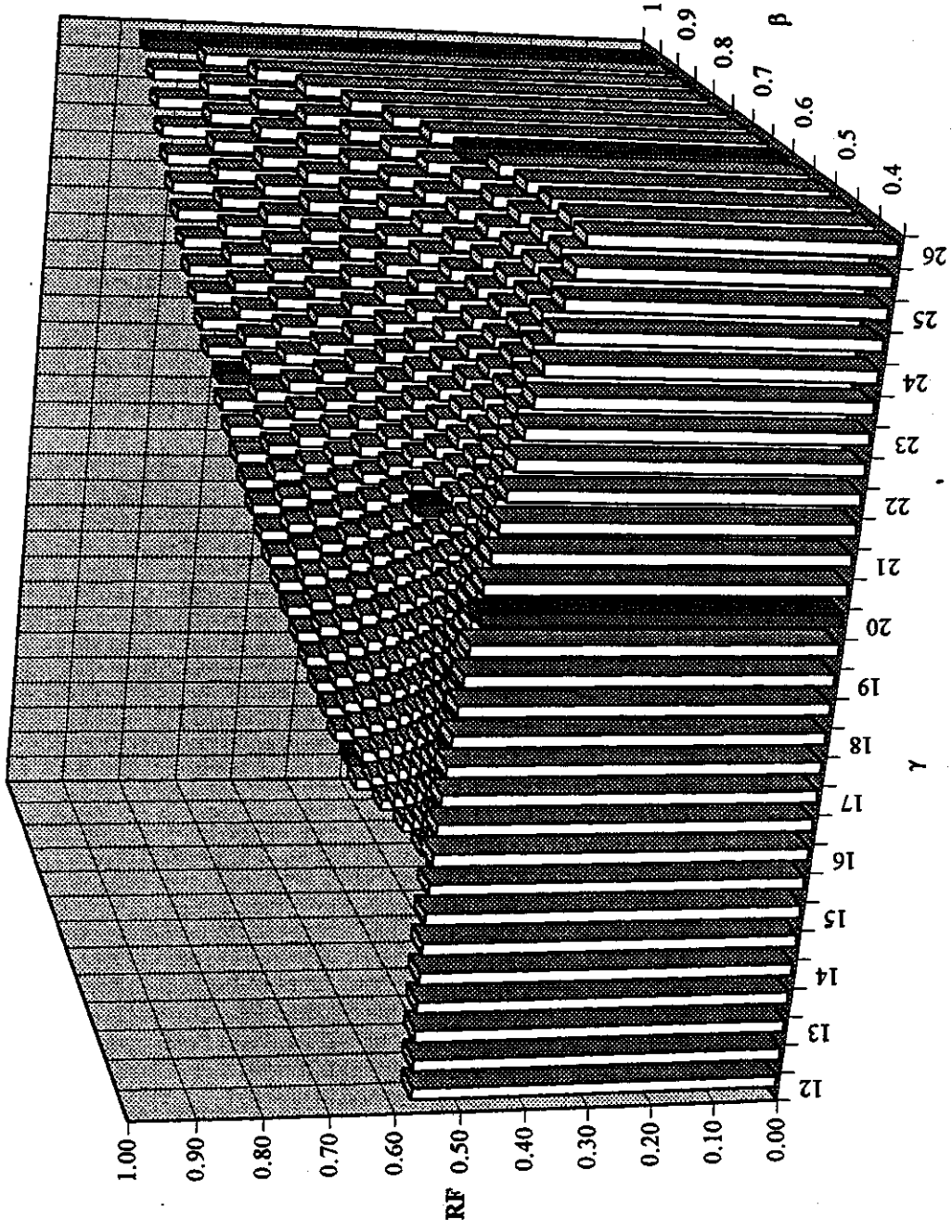

Fig. R41: Comparison of Fitted Surface with Measured Values for DT Joints under Tension, Brace Crown

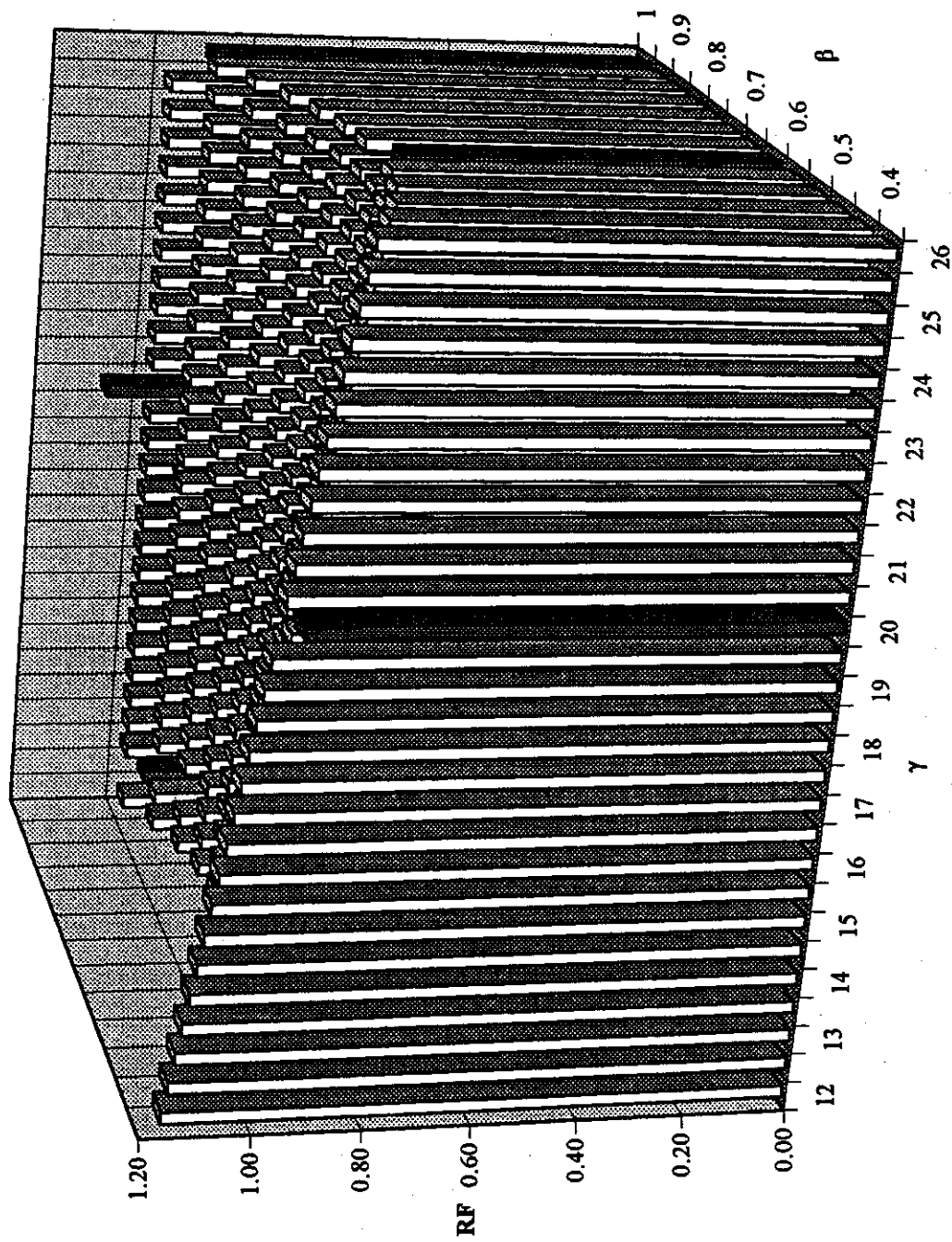

Fig. R42: Comparison of Fitted Surface with Measured Values for DT Joints under IPB, Brace Crown

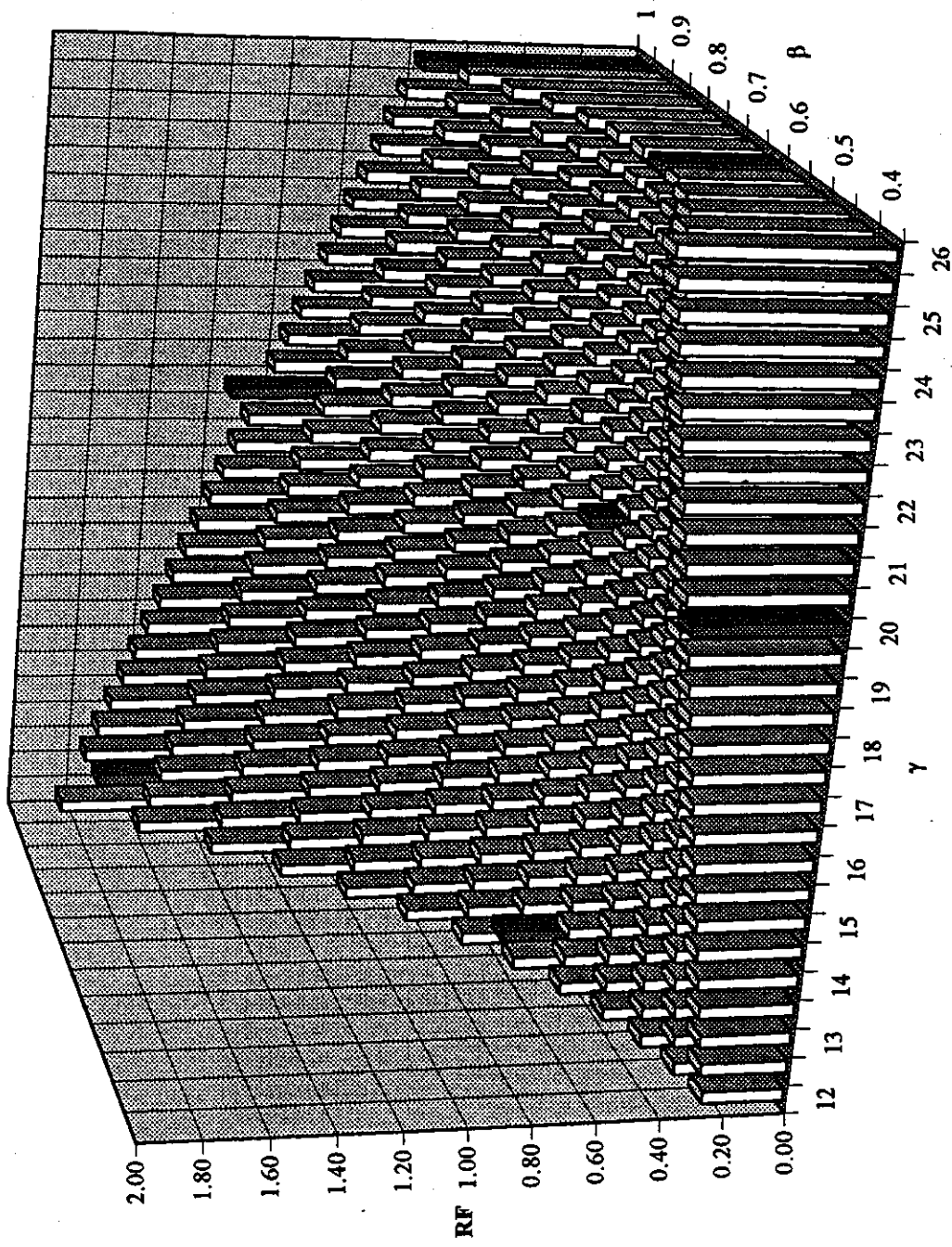

Fig. R43: Comparison of Fitted Surface with Measured Values for DT Joints under OPB, Brace Saddle

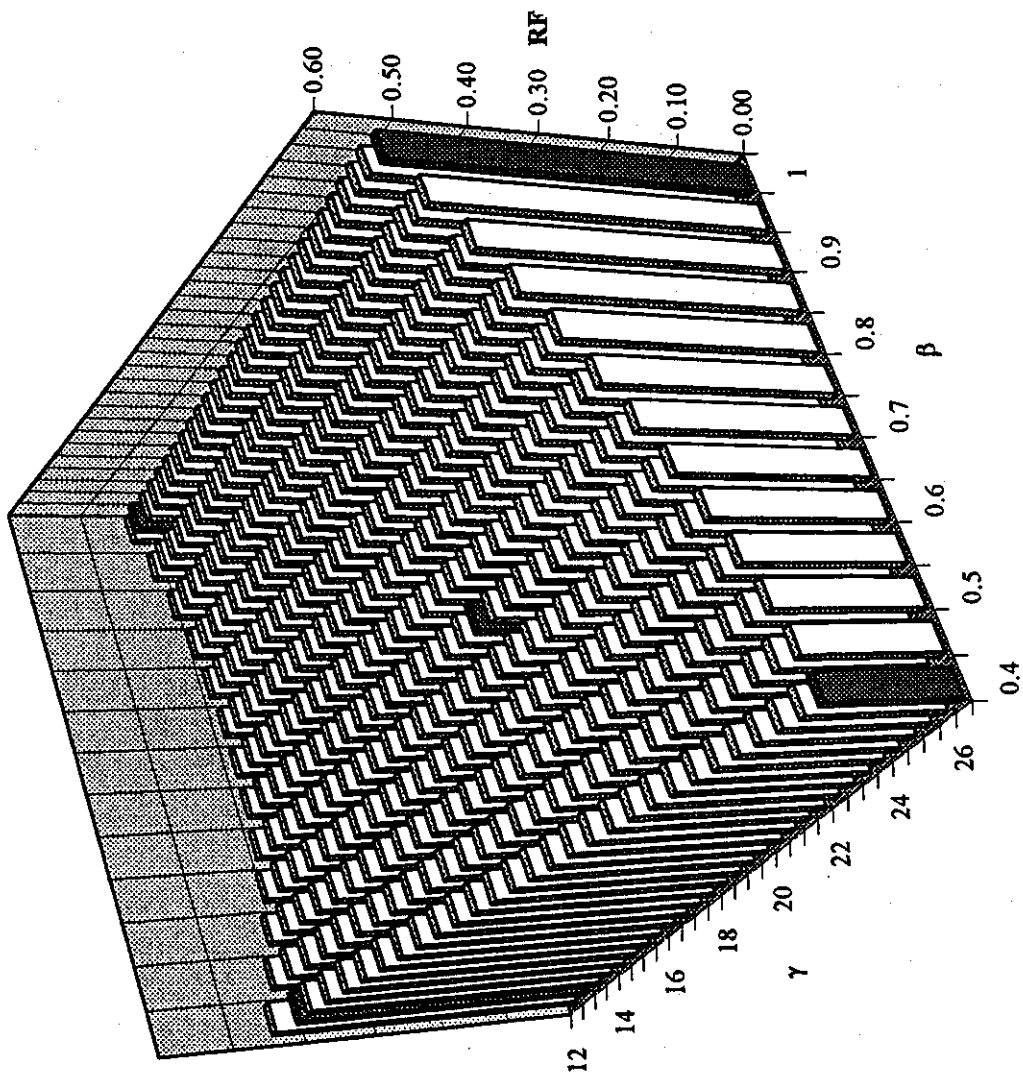

Fig R44: Comparison of Fitted Surface with Measured Values for T Joints under Compression, Brace Saddle

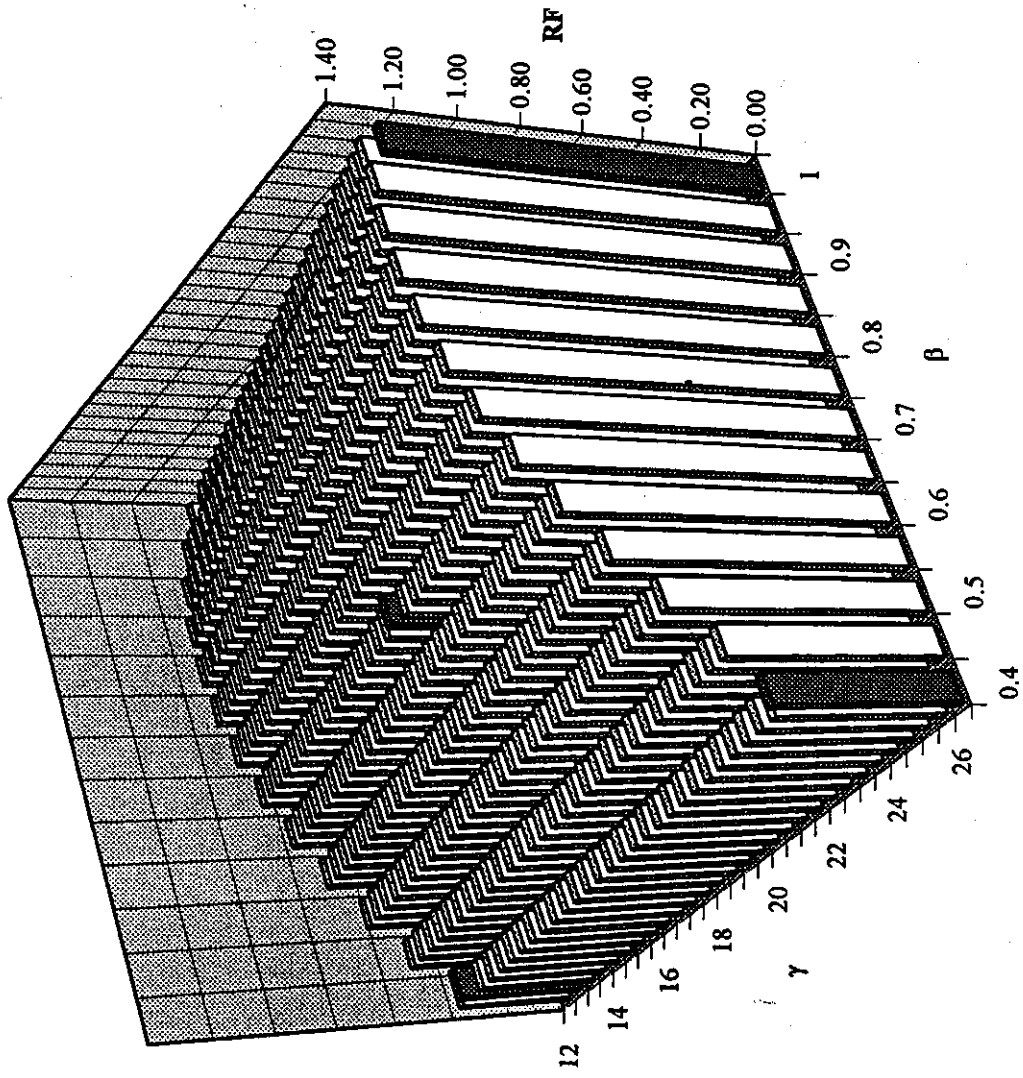

Fig. R45: Comparison of Fitted Surface with Measured Values for T Joints Compression, Brace Crown

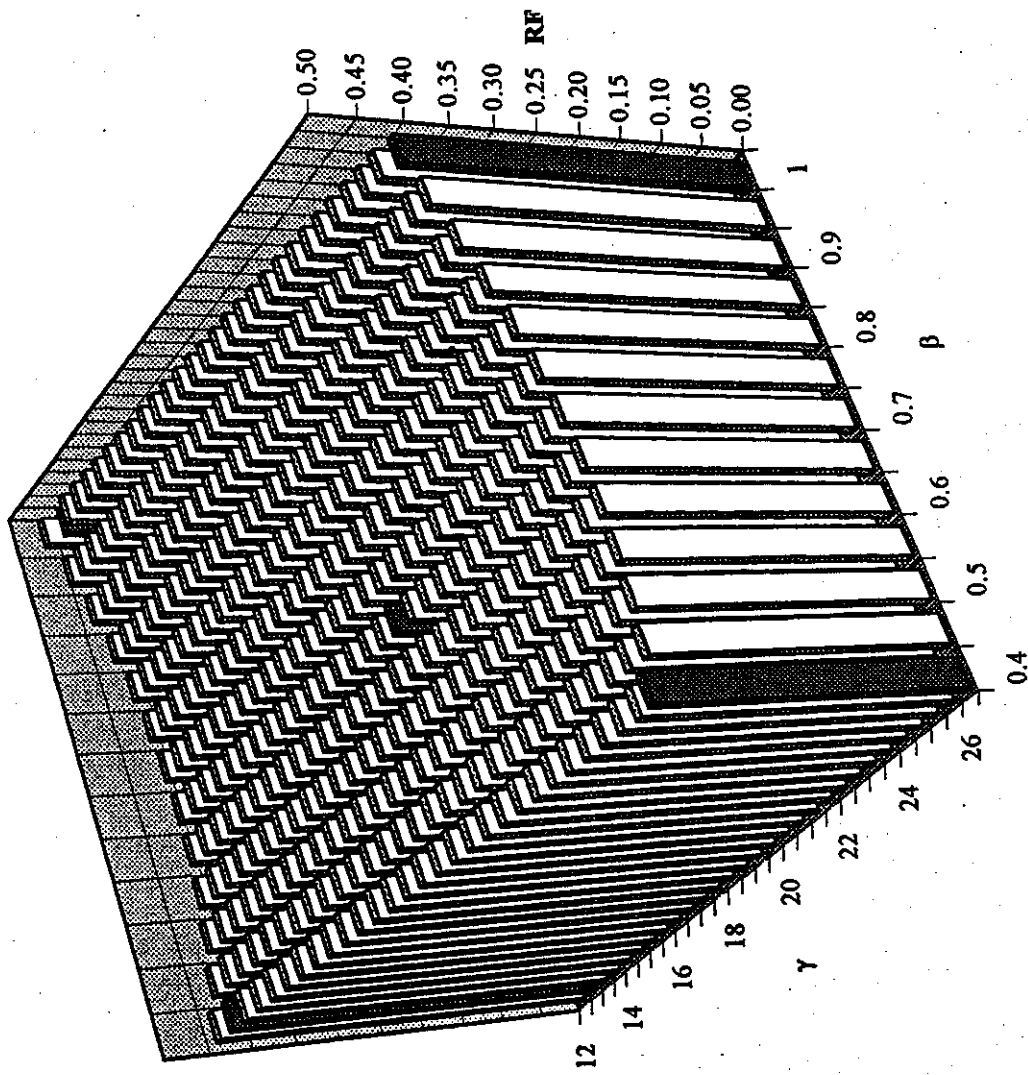

Fig R46: Comparison of Fitted Surface with Measured Values for T joints under Tension, Brace Saddle

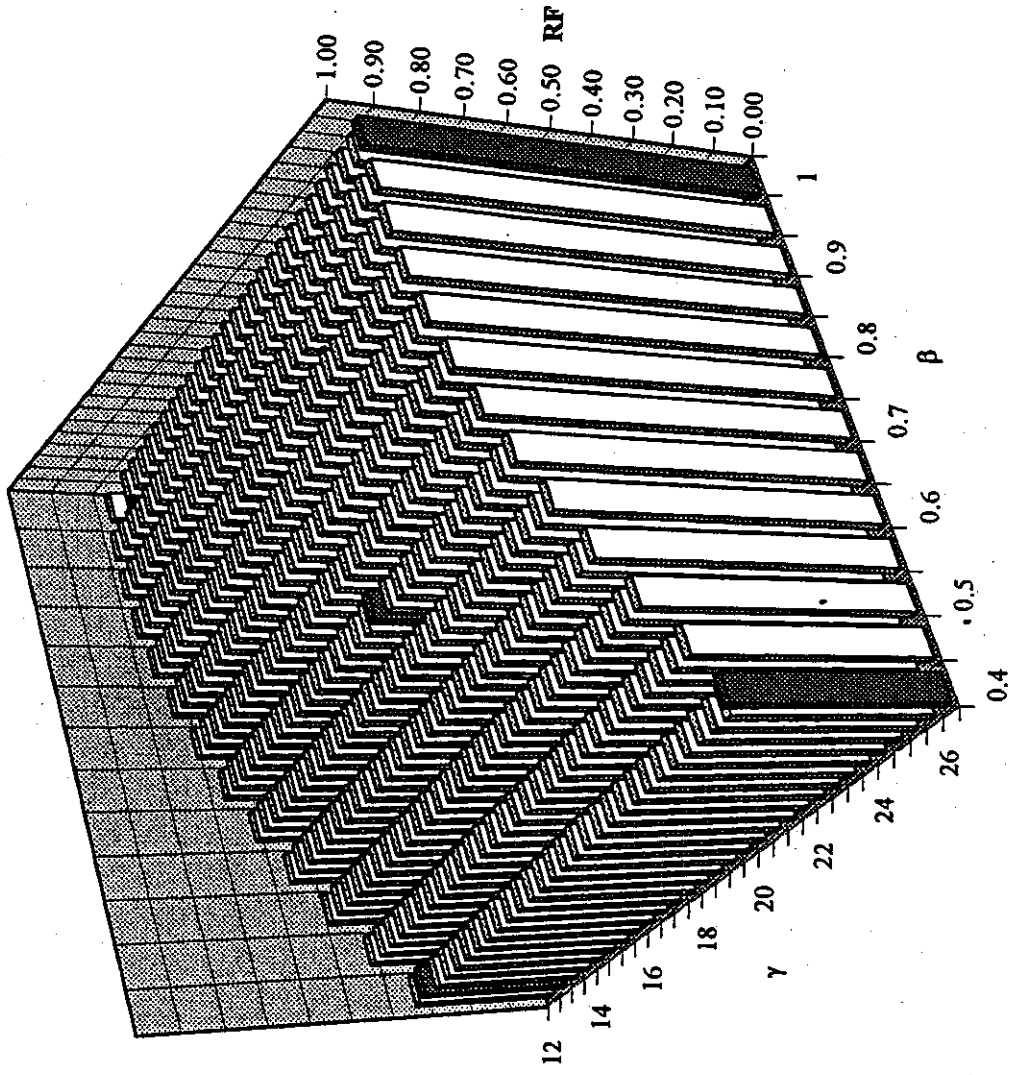

Fig. R47: Comparison of Fitted Surface with Measured Values for T Joints under Tension, Brace Crown

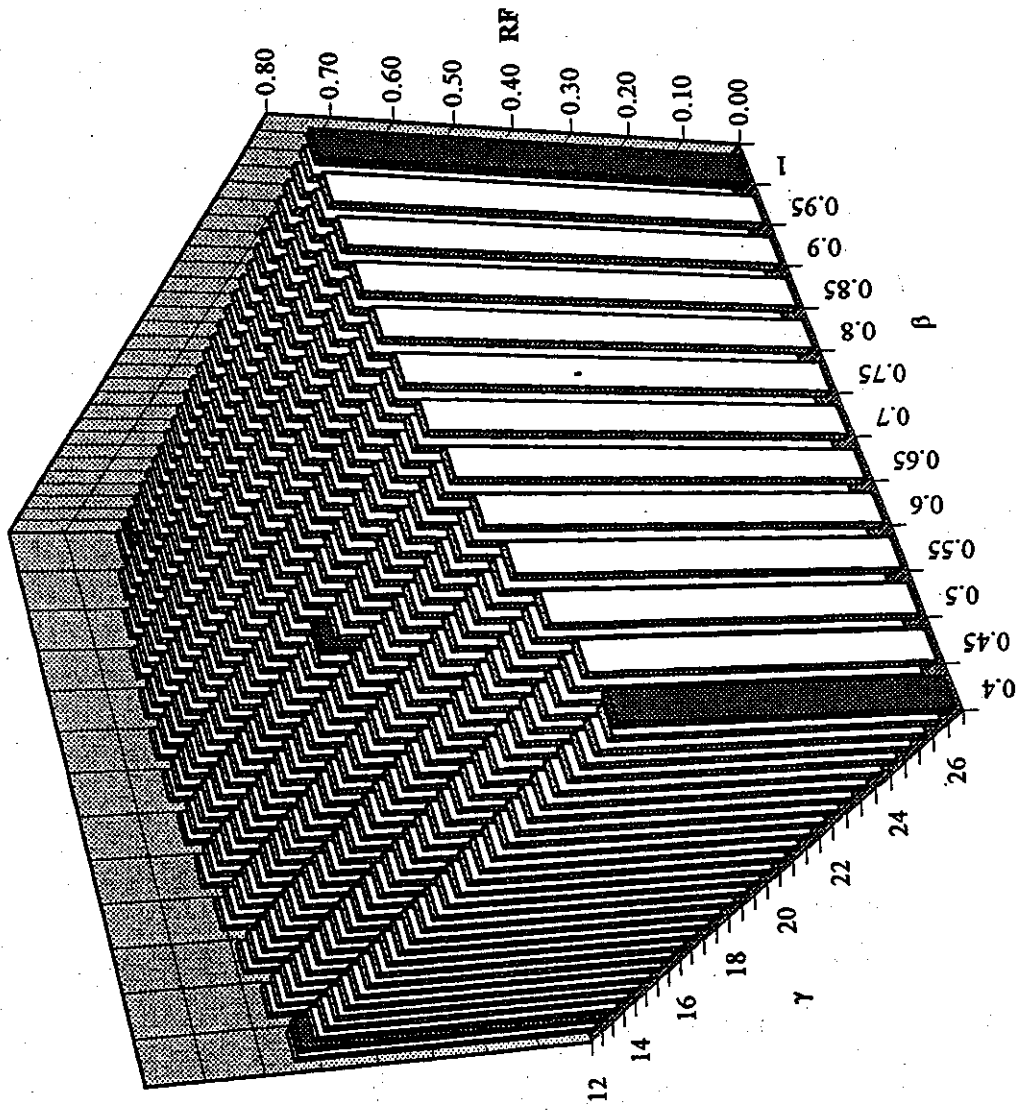

Fig. R48: Comparison of fitted Surface with Measured Values for T Joints under IPB, Brace Crown

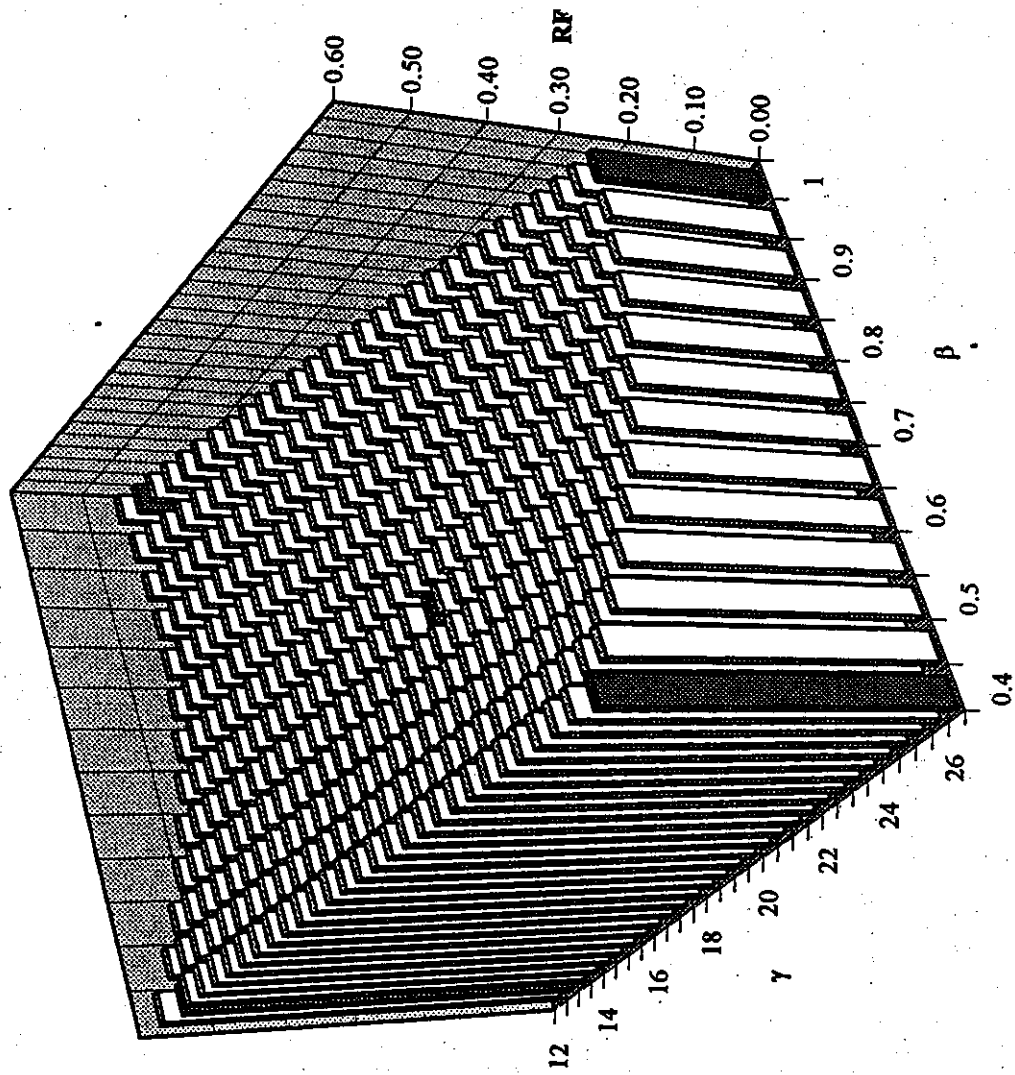

Fig. R49: Comparison of Fitted Surface with Measured Values for T Joints under OPB, Brace Saddle

APPENDIX S

Summary As-welded and Grouted SCFs/RFs

C14100R020 Rev 1 February 1997

MSL

T joints - Chord side As-Welded SCFs

		β			1		
		0.414		0.67			
12.7		2.93	7.30			3.37	8.41
		6.42	T1 10.43			10.21	T3 3.26
		6.95	11.23			10.27	3.54
γ 20.3				4.36	16.86		
				9.62	T5 21.16		
				10.30	21.35		
25.7		5.69	21.17	IPB	OPB	3.22	19.38
		9.59	T7 31.09	Ax-Tc	Ax-Ts	8.99	T9 13.94
		10.20	33.31	Ax-Cc	Ax-Cs	9.30	14.53

DT joints - Chord side As-Welded SCFs

		β			1		
		0.414		0.67			
12.7				3.98	8.08	2.88	3.10
				2.11	DT2 15.92	0.79	DT3 4.06
				2.08	15.73	0.78	4.07
γ 20.3		5.14	11.81	6.06	18.20	3.10	5.18
		4.44	DT4 31.37	4.54	DT5 35.72	0.62	DT6 7.94
		4.38	31.52	4.12	35.92	0.61	8.53
25.7				4.79	21.59	3.47	6.90
				1.58	DT8 44.39	0.74	DT9 9.98
				1.70	43.92	0.72	10.16

Table S.7-1 : Summary of As-welded Chord side SCFs



T joints - Chord side Grouted SCFs

		β					
		0.414	0.67	1			
12.7		2.83	5.26		3.10	2.26	
		5.87	T1	5.64		11.34	T3
		7.00	6.20		10.68	0.80	0.34
γ 20.3							
			3.91	6.18			
			9.13	T5	6.10		
25.7		3.95	10.21		3.05	5.32	
		6.77	T7	14.50	8.81	T9	3.35
		5.93	6.84		9.60	3.26	

DT joints - Chord side Grouted SCFs

		β					
		0.414	0.67	1			
12.7			3.16	5.32	1.93	3.01	
			2.02	DT2	6.20	1.02	DT3
			3.26	6.08	1.45	3.86	
γ 20.3		2.94	6.55		1.93	5.04	
		2.52	DT4	8.33	1.31	DT6	6.46
		3.12	3.91		1.79	7.61	
25.7			2.35	9.00	1.82	6.42	
			2.32	DT8	12.60	1.34	DT9
			2.86	8.72	2.54	10.15	

Table S.7-2 : Summary of Grouted Chord side SCFs



T joints - Chord side Measured RFs

		0.414			β 0.67			1		
12.7		0.97	0.72				0.92	0.27		
		0.91	T1	0.54			1.11	T3	0.25	
		1.01		0.55			1.04		0.09	
γ 20.3					0.90	0.37				
					0.95	T5	0.29			
					0.93		0.30			
25.7		0.69	0.48		IPB	OPB	0.95	0.27		
		0.71	T7	0.47	Ax-Tc	Ax-Ts	0.98	T9	0.24	
		0.58		0.21	Ax-Cc	Ax-Cs	1.03		0.22	

DT joints - Chord side Measured RFs

		0.414			β 0.67			1		
12.7					0.79	0.66	0.67	0.97		
					0.95	DT2	0.39	1.29	DT3	
					1.57		0.39	1.86	0.95	
γ 20.3		0.57	0.55		0.54	0.47	0.62	0.97		
		0.57	DT4	0.27	0.16	DT5	0.32	2.10	DT6	
		0.71		0.12	0.48		0.25	2.92	0.89	
25.7					0.49	0.42	0.53	0.93		
					1.46	DT8	0.28	1.81	DT9	
					1.68		0.20	3.53	1.00	

Table S.7-3 : Summary of Chord side RFs

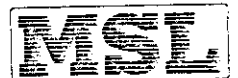

T joints - Brace side As-Welded SCFs

		0.414			β 0.67			1		
12.7		1.61		3.70				1.38		5.77
		0.29	T1	5.95				2.50	T3	5.21
		0.30		6.47				2.48		5.15
γ 20.3					1.82		9.26			
					1.21	T5	13.00			
					1.32		13.16			
25.7		1.99		7.96	IPB		OPB	1.68		8.44
		1.16	T7	12.44	Ax-Tc		Ax-Ts	2.58	T9	8.26
		1.14		12.55	Ax-Cc		Ax-Cs	2.62		8.53

DT joints - Brace side As-Welded SCFs

		0.414			β 0.67			1		
12.7					1.81		5.44	1.43		2.53
					0.08	DT2	11.11	0.86	DT3	4.24
					0.06		10.96	0.86		4.31
γ 20.3		2.64		4.74	1.97		9.07	1.62		2.89
		1.23	DT4	13.50	0.06	DT5	18.60	1.18	DT6	5.00
		1.07		13.27	0.08		19.01	1.12		5.24
25.7					1.92		10.46	1.64		2.71
					0.52	DT8	21.70	1.26	DT9	4.25
					0.50		21.53	1.25		4.45

Table S.7-4 : Summary of As-welded Brace side SCFs

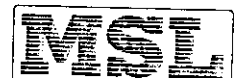

T joints - Brace side Grouted SCFs

		0.414		β 0.67		1	
12.7		1.62	3.28			1.52	1.88
		1.12	3.68			2.69	T3 1.60
		1.33	3.60			2.89	1.56
γ 20.3				2.26	4.21		
				2.03	T5 4.36		
				2.74	3.95		
25.7		2.42	5.88	IPB	OPB	2.09	2.17
		1.31	5.93	Ax-Tc	Ax-Ts	2.43	T9 2.39
		1.58	3.32	Ax-Cc	Ax-Cs	3.24	3.03

DT joints - Brace side Grouted SCFs

				0.67			
12.7				2.50	4.03	2.29	2.44
				0.88	DT2 4.51	0.96	DT3 3.34
				2.00	3.74	1.07	3.89
γ 20.3		3.58	4.02	2.76	4.90	2.84	2.89
		1.24	DT4 4.13	0.96	DT5 6.36	1.28	DT6 3.95
		2.39	2.11	2.32	4.33	1.58	4.80
25.7				2.76	5.10	2.57	2.29
				0.72	DT8 6.43	1.24	DT9 1.98
				1.93	3.88	2.18	4.20

Table S.7-5 : Summary of Grouted Brace side SCFs



T joints - Brace side Measured RFs

		0.414			β 0.67			1		
12.7		1.01	0.89				1.10	0.33		
		3.89	T1	0.62			1.08	T3	0.31	
		4.43		0.56			1.16		0.30	
γ 20.3					1.24	0.45				
					1.67	T5	0.34			
					2.07		0.30			
25.7		1.22	0.74		IPB	OPB	1.24	0.26		
		1.13	T7	0.48	Ax-Tc	Ax-Ts	0.94	T9	0.29	
		1.39		0.26	Ax-Cc	Ax-Cs	1.24		0.36	

DT joints - Brace side Measured RFs

		0.67			0.67					
12.7					1.38	0.74	1.61	0.96		
					10.43	DT2	0.41	1.11	DT3	0.79
					33.40		0.34	1.24		0.90
γ 20.3		1.35	0.85		1.40	0.54	1.76	1.00		
		1.00	DT4	0.31	16.00	DT5	0.34	1.09	DT6	0.79
		2.23		0.16	27.57		0.23	1.42		0.92
25.7					1.44	0.49	1.56	0.85		
					1.40	DT8	0.30	0.98	DT9	0.47
					3.83		0.18	1.75		0.94

Table S.7-6 : Summary of Brace side RFs

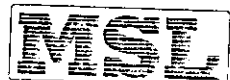

Specimen Ident.	D (mm)	d (mm)	T (mm)	T _c (mm)	t (mm)	L (mm)	θ (°)	β	γ	Y _c	Y _c (mm)	τ	α	Condition	Chord SCFs						Brace SCFs							
															IPB	OPB		Comp.		Tens.		IPB	OPB		Comp.		Tens.	
																AX-S	AX-C	AX-S	AX-C	AX-S	AX-C		AX-S	AX-C	AX-S	AX-C	AX-S	AX-C
T1	406.78	167.81	16.39	29.4	16.32	2440	90.0	0.413	12.409	6.92	11.71	0.996	12.00	Predicted Q	2.93	5.20	6.19	6.83	5.53	5.81	1.73	3.28	3.41	1.36	3.87	1.10		
															2.83	5.19	6.27	7.05	5.69	5.75	1.60	3.31	3.65	1.30	3.66	1.16		
															2.83	5.26	6.20	7.00	5.64	5.87	1.62	3.28	3.60	1.33	3.68	1.12		
T3	406.78	407.02	16.39	29.4	16.10	2440	90.0	1.000	12.409	6.92	11.71	0.982	12.00	Predicted R	3.17	2.27	0.33	10.79	0.82	11.50	1.55	1.89	1.46	2.96	1.56	2.76		
															3.20	2.20	0.36	10.74	0.85	11.20	1.51	1.92	1.54	2.95	1.63	2.76		
															3.10	2.26	0.34	10.68	0.80	11.34	1.52	1.88	1.56	2.89	1.60	2.69		
T5	407.05	273.34	10.19	23.6	9.82	2440	90.0	0.672	19.973	8.62	18.36	0.964	11.99	Predicted Q	3.81	6.19	6.45	9.59	5.94	9.17	2.29	4.18	4.44	2.74	4.59	2.01		
															3.88	6.22	6.39	9.58	6.32	9.16	2.26	4.24	3.97	2.75	4.37	2.03		
															3.91	6.18	6.32	9.56	6.10	9.13	2.26	4.21	3.95	2.74	4.36	2.03		
T7	406.96	168.41	7.86	21.4	8.31	2440	90.0	0.414	25.888	9.49	23.42	1.057	11.99	Predicted Q	3.90	10.07	7.06	6.00	14.05	6.63	2.41	5.90	3.35	1.57	6.12	1.25		
															3.81	10.09	6.74	5.90	14.74	6.80	2.39	5.93	3.32	1.56	5.81	1.29		
															3.95	10.21	6.84	5.93	14.50	6.77	2.42	5.88	3.32	1.58	5.93	1.31		
T9	406.96	406.96	7.86	21.4	7.86	2440	90.0	1.000	25.888	9.49	23.42	1.000	11.99	Predicted R	3.02	5.32	3.33	9.77	3.49	8.91	2.11	2.20	3.57	3.11	2.48	2.51		
															3.01	5.35	3.25	9.55	3.41	8.82	2.07	2.16	3.07	3.32	2.43	2.41		
															3.05	5.32	3.26	9.60	3.35	8.81	2.09	2.17	3.03	3.24	2.39	2.43		
DT2	406.78	273.09	16.39	29.4	15.76	2440	90.0	0.671	12.409	6.92	11.71	0.962	12.00	Predicted Q	2.97	5.21	5.73	3.34	6.00	2.05	2.46	3.93	3.79	0.26	4.64	0.12		
															3.28	5.92	5.90	2.94	6.90	2.00	2.52	4.04	3.83	2.07	4.53	0.88		
															3.16	5.32	6.08	3.26	6.20	2.02	2.50	4.03	3.74	2.00	4.51	0.88		
DT3	406.78	407.02	16.39	29.4	16.10	2440	90.0	1.001	12.409	6.92	11.71	0.982	12.00	Predicted Q	1.95	3.06	3.75	1.49	4.14	1.11	2.36	2.57	4.05	1.15	3.80	1.00		
															1.90	3.17	4.74	1.68	4.48	1.51	2.40	2.56	4.14	1.07	3.48	0.96		
															1.93	3.01	3.86	1.45	4.14	1.02	2.29	2.44	3.89	1.07	3.34	0.96		
DT4	407.05	168.57	10.19	23.6	9.95	2440	90.0	0.414	19.973	8.62	18.36	0.976	11.99	Predicted R	2.91	6.55	3.77	3.26	8.84	2.49	3.53	3.93	2.05	2.56	4.13	1.31		
															2.92	6.78	3.95	3.36	8.61	3.21	3.68	4.00	2.03	2.38	3.96	1.24		
															2.94	6.55	3.91	3.12	8.33	2.52	3.58	4.02	2.11	2.39	4.13	1.24		
DT5	407.05	273.34	10.19	23.6	9.82	2440	90.0	0.672	19.973	8.62	18.36	0.964	11.99	Predicted Q	3.60	9.26	9.99	6.89	11.15	5.55	2.77	5.20	4.68	0.36	6.32	0.07		
															3.06	8.30	9.29	2.32	10.76	1.48	2.77	4.96	4.26	2.14	6.46	0.92		
															3.30	8.59	8.96	1.98	11.59	0.74	2.76	4.90	4.33	2.32	6.36	0.96		
DT6	407.05	407.60	10.19	23.6	9.61	2440	90.0	1.001	19.973	8.62	18.36	0.943	11.99	Predicted Q	1.86	4.94	8.22	1.78	6.62	1.11	2.68	2.73	4.95	1.80	3.37	1.11		
															1.87	4.83	7.15	1.80	5.94	1.14	2.60	2.69	4.43	1.76	3.92	1.31		
															1.93	5.04	7.61	1.79	6.46	1.31	2.84	2.89	4.80	1.58	3.95	1.28		
DT8	406.96	273.21	7.86	21.4	7.88	2440	90.0	0.671	25.888	9.49	23.42	1.003	11.99	Predicted R	2.28	8.67	9.25	2.94	11.59	2.25	2.78	4.77	3.63	2.10	6.04	0.64		
															2.52	9.89	12.27	2.82	14.12	1.87	2.90	5.05	3.84	2.07	6.54	0.74		
															2.35	9.06	8.72	2.86	12.60	2.32	2.76	5.10	3.88	1.93	6.43	0.72		
DT9	406.96	406.96	7.86	21.4	7.86	2440	90.0	1.000	25.888	9.49	23.42	1.000	11.99	Predicted Q	1.88	6.35	10.06	2.64	6.82	1.54	2.71	2.39	4.18	2.34	2.10	1.30		
															1.89	6.83	9.90	3.25	7.31	1.79	2.78	2.36	4.37	2.03	2.02	1.23		
															1.82	6.42	10.15	2.54	6.84	1.34	2.57	2.29	4.20	2.18	1.98	1.24		

Note :- Assumed Stress/Strain relationship = 1.2

Table S.7-9 : Summary of Grouted SCF Results



Specimen Ident.	D (mm)	d (mm)	T (mm)	T ₁ (mm)	t (mm)	L (mm)	θ (°)	β	γ	Y _c		τ	α	Condition	Chord SCFs						Brace SCFs						
										AX & OPB	IPB				IPB	OPB	Comp.		Tens.		IPB	OPB	Comp.		Tens.		
																	AX-s	AX-c	AX-s	AX-c			AX-s	AX-c	AX-s	AX-c	AX-s
T1	406.78	167.81	16.39	29.4	16.32	2440	90.0	0.413	12.409	6.92	11.71	0.996	12.00	Predicted Q	1.00	0.71	0.55	0.98	0.53	0.91	1.07	0.89	0.53	0.53	4.53	0.65	3.82
															0.78	0.63	0.47	1.16	0.43	0.95	0.56	0.57	0.44	0.42	0.44	0.38	0.38
T3	406.78	407.02	16.39	29.4	16.10	2440	90.0	1.000	12.409	6.92	11.71	0.982	12.00	Predicted R	1.00	0.28	0.07	1.30	0.17	1.36	0.62	0.45	0.44	0.84	0.47	0.78	
															0.94	0.27	0.09	1.05	0.25	1.13	1.01	0.89	0.56	4.43	0.62	3.89	
T5	407.05	273.34	10.19	23.6	9.82	2440	90.0	0.672	19.973	8.62	18.36	0.964	11.99	Predicted Q	0.87	0.37	0.30	0.93	0.28	0.95	1.26	0.45	0.34	2.07	0.35	1.65	
															0.81	0.35	0.32	1.45	0.32	1.39	0.67	0.39	0.33	1.05	0.37	0.78	
T7	406.96	168.41	7.86	21.4	8.31	2440	90.0	0.414	25.888	9.49	23.42	1.057	11.99	Predicted R	0.58	0.55	0.23	0.81	0.50	0.94	0.55	0.49	0.20	0.62	0.35	0.51	
															0.69	0.48	0.21	0.58	0.47	0.71	1.22	0.74	0.26	1.39	0.48	1.13	
T9	406.96	406.96	7.86	21.4	7.86	2440	90.0	1.000	25.888	9.49	23.42	1.000	11.99	Predicted Q	0.94	0.27	0.23	1.05	0.25	0.99	1.26	0.26	0.42	1.19	0.30	0.97	
															0.73	0.32	0.30	1.03	0.31	0.95	0.73	0.25	0.53	1.27	0.42	0.92	
DT2	406.78	273.09	16.39	29.4	15.76	2440	90.0	0.671	12.409	6.92	11.71	0.962	12.00	Predicted Q	0.74	0.65	0.36	1.61	0.38	0.97	1.36	0.72	0.35	4.34	0.42	1.47	
															0.89	0.57	0.31	1.29	0.36	0.87	0.89	0.63	0.37	0.88	0.44	0.38	
DT3	406.78	407.02	16.39	29.4	16.10	2440	90.0	1.001	12.409	6.92	11.71	0.982	12.00	Predicted R	0.68	0.99	0.92	1.91	1.02	1.40	1.65	1.02	0.94	1.34	0.90	1.15	
															0.60	1.20	1.02	0.71	0.96	0.64	0.98	1.81	1.34	0.46	1.13	0.41	
DT4	407.05	168.57	10.19	23.6	9.95	2440	90.0	0.414	19.973	8.62	18.36	0.976	11.99	Predicted Q	0.57	0.55	0.12	0.74	0.28	0.56	1.34	0.83	0.15	2.39	0.31	1.06	
															0.58	0.55	0.14	0.84	0.31	0.80	1.00	0.47	0.13	1.05	0.25	0.55	
DT5	407.05	273.34	10.19	23.6	9.82	2440	90.0	0.672	19.973	8.62	18.36	0.964	11.99	Predicted R	0.59	0.51	0.28	1.67	0.31	1.22	1.41	0.57	0.25	4.24	0.34	1.20	
															0.64	0.50	0.30	0.85	0.35	0.55	0.82	0.49	0.26	1.16	0.40	0.50	
DT6	407.05	407.60	10.19	23.6	9.61	2440	90.0	1.001	19.973	8.62	18.36	0.943	11.99	Predicted Q	0.60	0.95	0.96	2.90	0.83	1.78	1.65	0.94	0.94	1.62	0.67	0.95	
															0.52	1.20	1.00	0.65	0.83	0.41	0.98	1.26	1.05	0.96	0.92	0.71	
DT8	406.96	273.21	7.86	21.4	7.88	2440	90.0	0.671	25.888	9.49	23.42	1.003	11.99	Predicted R	0.48	0.40	0.21	1.73	0.26	1.42	1.45	0.46	0.17	4.17	0.28	1.23	
															0.44	0.44	0.30	0.91	0.34	0.61	0.76	0.38	0.18	1.46	0.31	0.52	
DT9	406.96	406.96	7.86	21.4	7.86	2440	90.0	1.000	25.888	9.49	23.42	1.000	11.99	Predicted Q	0.54	0.92	0.99	3.67	0.68	2.07	1.65	0.88	0.94	1.88	0.49	1.03	
															0.46	1.20	0.99	1.00	0.73	0.55	0.98	0.81	0.80	1.43	0.37	0.86	
														Measured	0.53	0.93	1.00	3.53	0.69	1.81	1.56	0.85	0.94	1.75	0.47	0.98	

Note :- Assumed Stress/Strain relationship = 1.2
 Predicted Q values based on RFs given by formulations in Tables Q3 and Q4
 Predicted R values based on RFs given by formulations in Tables R2 and R3

Table S.7-10 : Summary of RF Results



Braces	$\beta = 0.413$		$\beta = 0.671$		$\beta = 1.0$	
Chords						
406.78 x 16.39 $\gamma = 12.41$ Fy = 359	167.81 x 16.32 $\tau = 1.0$ Fy = 348	T1	273.09 x 15.76 $\tau = 0.96$ Fy = 496	DT2	407.02 x 16.1 $\tau = 0.98$ Fy = 383	DT3 T3
407.05 x 10.19 $\gamma = 19.97$ Fy = 335	168.57 x 9.95 $\tau = 0.98$ Fy = 339	DT4	273.34 x 9.82 $\tau = 0.96$ Fy = 284	DT5 T5	407.6 x 9.61 $\tau = 0.94$ Fy = 363	DT6
406.96 x 7.86 $\gamma = 25.89$ Fy = 332	168.41 x 8.31 $\tau = 1.06$ Fy = 246	T7	273.21 x 7.88 $\tau = 1.0$ Fy = 329	DT8	406.96 x 7.86 $\tau = 1.0$ Fy = 332	DT9 T9

Notes

All values are measured
All units in (N) and/or (mm)

Test Matrix

