

Proceedings of a Workshop

Workshop on Crane Safety



Organized by:
Minerals Management Service
and
Offshore Technology Research Center

Proceedings of a Workshop

Workshop on Crane Safety

Lafayette, Louisiana
28 March 2000

edited by:

William S. Hauser
Minerals Management Services
Engineering and Research Branch
381 Elden Street
Herndon, VA 20170-4817

and

J. Phil Wilbourn
Offshore Technology Research Center
Texas A&M University
1200 Mariner Drive
College Station, Texas 77845

Sponsored by: Minerals Management Service, U.S. Department of Interior

MMS Crane Workshop Proceedings

FORWARD

OBJECTIVE: Conduct a workshop to assess the safety and develop recommendations for improving the safety of crane operations on offshore drilling and production platforms.

APPROACH: There have been a number of accidents involving the use of cranes on offshore platforms in recent years. A workshop was held with a variety of experts to (1) examine and review these accidents in light of current equipment design, operational practices, worker practices and training, and regulations, and (2) develop recommended courses of action that could improve safety. Workshop attendees included a variety of invited experts on crane equipment and operations, the work environment and work practices associated with crane operations on offshore platforms, offshore safety planning, and personnel safety.

Background information on MMS' review of crane incidents is available on the MMS website. The address for this internet site is <http://www.mms.gov/cranes/>. MMS will continue to update this internet site as we gather or obtain new information regarding safe crane operations.

The principal focus of this workshop was on operation of platform cranes. Crane design may be a factor that needs to be considered in improving operational safety, but structural and mechanical design issues were not a main focus. This workshop focused on platform cranes and not cranes used in offshore construction or heavy lifts.

These proceedings contain the overhead slides presented by each speaker at the Workshop and a short summary of their presentation. Please feel free to use the information presented to improve crane safety. If you have any questions about the presentations or the overheads, please contact the individual presenters. Telephone numbers and email addresses of the presenters and workshop attendees can be found in the appendix.

These proceedings also contain MMS' response (called Crane Position Paper, Appendix "D") to the questions that Larry Smith of Applied Hydraulics raised on crane inspections. This response answers the questions in a general manner instead of specifically addressing each individual question. MMS believes that this general position statement and the referenced Potential Incidents of Noncompliance (PINC) List and Guidelines will provide answers to most, if not all, questions about MMS inspections.

Table of Contents

page □

Introduction	1
<i>Don Howard, MMS Regional Supervisor, Field Operations, Gulf of Mexico Region</i>	

Session One - Operators

“Unocal’s Crane Standards Policy for Offshore Pedestal Mounted Units, Operations and Maintenance”	7
---	---

O.L (Johnny Johnson), Maintenance Superintendent Offshore Operations, Unocal

“Chevron’s Crane Program”	33
---------------------------------	----

Don Norton, Field Coordinator, Chevron

“Crane and Rigging Safety in BP Amoco’s Gulf of Mexico Operations”	43
--	----

Michael F. Brasic, Safety Supervisor Offshore GOM Business Units

Session Two - Contractors/Manufacturers

“Questions Concerning Crane Inspections”	111
--	-----

Larry Smith, Operations Manager, Applied Hydraulics

“Operating Techniques”	127
------------------------------	-----

Doug Morrow, President, Seatrax

“Y2K Leap for Safety”	135
-----------------------------	-----

J.R. Guidry, Safety Training Coordinator, American Aero

Session Three - Minerals Management Service

“Highlights on Issues and Concerns”	153
---	-----

Appendix

Appendix A - MMS PINC (Potential Incident of Non-Compliance) List; Rigging and material Handling PINC’s G-190 to G-194)	A-3
--	-----

Appendix B - MMS PINC (Potential Incident of Non-Compliance) List; Cranes (PINC’s G-202 to G-227)	A-7
--	-----

Appendix C - MMS PINC Appendix 24- Crane Use Categories and Inspections	A-15
--	------

Appendix D - MMS Crane Position Paper	A-17
--	------

Appendix E - Seatrax Design Feature Patented Anti “Two-Block” System	A-19
---	------

Appendix F - American Aero Crane, MMS PINC List 5-2000	A-25
---	------

List of Participants

Business Cards

Opening of Workshop on Crane Safety

By Don Howard

Gulf of Mexico Regional Supervisor for Field Operations

Minerals Management Service

Welcome and Purpose

The opening remarks by Don Howard focused on welcoming the audience and panel members to the crane safety workshop and to encourage their participation in discussions. The purpose for the workshop is to examine the safety of crane operations on the OCS, allow interested parties to discuss how they are addressing crane safety, and identify ways to improve crane safety. The following summarizes what Don discussed.

Summary of Crane Incidents since 1995

Since 1995, there have been at least 50 crane incidents reported to MMS. The majority of incidents involved pedestal mounted cranes, but a few incidents involved booms, hoists, or other material handling equipment. These incidents have occurred on both fixed platforms and floating facilities (both MMS and USCG jurisdiction). Here's a brief summary of the incident statistics:

- 10 fatalities (6 have were riggers)
- at least 25 injuries (over half were riggers)
- over 10 incidents with major damage to the crane or facilities
- at least 2 serious crane incidents have occurred in 2000, both involved the crane breaking from the pedestal

Recent MMS Actions

MMS requested API to revise API RP 2D to include rigger training. API quickly revised this document and MMS has incorporated it into the regulations (the effective date for incorporating the document was April 23, 2000). MMS also published a new regulation for booms, hoists, and other materials-handling equipment in the final rule for Subpart A in December 1999. The rule requires lessees to operate and maintain that equipment in a manner that ensures safe operation. We have not incorporated a standard that addresses hoists, booms, or materials-handling equipment, so lessees are responsible for determining what practices must be followed. Lastly, we are drafting a proposed rule that would require all new cranes be manufactured to API Spec 2C. That proposed rule would also discuss and possibly propose requiring anti-two block devices on all existing cranes.

Way Forward

Finally, please participate in the discussions after the presentations and help identify areas where improvements can be made. You are the key to safe crane operations.

CRANE SAFETY WORKSHOP



IMPROVING CRANE SAFETY

MMS Workshop March 28, 2000



PURPOSE FOR WORKSHOP



- Focus on crane operations and safety
- Quick update on MMS actions
- Allow interested parties to discuss issues
- Identify ways to improve safety

OCS CRANE ACCIDENTS SINCE 1995



- Over 50 crane incidents
- 10 fatalities
- Over 25 injuries
- Over 10 incidents with major damage

RECENT MMS ACTIONS



- Recommended API RP 2D to include rigger training
- New regulations for booms and hoists on fixed platforms
- Drafting Proposed Rule to incorporate API Spec 2C

FUTURE ACTIONS



- Listen to today's speakers and discussion
- Identify areas where improvements can be made
- Identify a way to forward to improved crane operations

SESSION One PAPER One

**“Unocal’s Crane Standards Policy for Offshore
Pedestal Mounted Units, Operations and Maintenance”**

O.L. (Johnny Johnson)

SESSION One PAPER One

“Unocal’s Crane Standards Policy for Offshore Pedestal Mounted Units, Operations and Maintenance”

O.L. (Johnny Johnson)

SPIRIT ENERGY 76

Crane Management System

- *A team was charged by Management (Jack Schanck) to develop and formalize a Crane Management Program for Offshore Pedestal Mounted Cranes (Spirit and Contract).*

- *Team members are as follows:*

Jim Shew

HES Manager

Carl Smith

Joint Ventures Project Manager

Nelson Emery

Drilling Superintendent

Mark Naquin

Production Foreman

Eric Broussard

Construction Superintendent

Johnny Johnson

Maintenance Superintendent

Recommended Practice for Operation and Maintenance of Offshore Cranes

API RECOMMENDED PRACTICE 83
FOURTH EDITION, AUGUST 1993



American
Petroleum
Institute

Helping You
Get The Job
Done Right!

MODEL: MANWIN 800
 SERIAL NO: 3181
 ROOM LENGTH: 80 feet

CRANE LOCATION: VAR #7 B

FAD- IDS IN FEET	[ROOM] A	4-PART LINE MAIN DRUM		5-PART LINE MAIN DRUM		6-PART LINE MAIN DRUM		SEWER LINE FOX. DRUM									
		API LOAD LBS	Static	Dynamic	API LOAD LBS	Static	Dynamic	API LOAD LBS	Static	Dynamic							
15		32,960	B	32,960	A	41,200	B	33,928	A	49,440	B	33,928	A	9,044	B	9,044	A
20		32,960	B	27,764	A	41,200	B	27,764	A	41,647	B	27,764	A	9,044	B	9,044	A
25		32,960	B	23,521	A	35,057	A	23,931	A	35,897	B	23,931	A	9,044	B	9,044	A
30		32,049	B	21,306	A	32,049	A	21,306	A	32,049	B	21,306	A	9,044	B	9,044	A
35		29,197	A	19,464	A	29,197	A	19,464	A	29,197	B	19,464	A	9,044	B	9,044	A
40		26,928	A	17,952	A	26,928	A	17,952	A	26,928	B	17,952	A	9,044	B	9,044	A
45		25,021	A	16,680	B	25,021	A	16,680	A	25,021	B	16,680	B	9,044	B	9,044	A
50		23,219	A	15,479	A	23,219	A	15,479	A	23,219	B	15,479	A	9,044	B	9,044	A
55		20,953	A	13,968	A	20,953	A	13,968	A	20,953	B	13,968	A	9,044	B	9,044	A
60		19,060	A	12,706	A	19,060	A	12,706	A	19,060	B	12,706	A	9,044	B	9,044	A
65		17,454	A	11,636	A	17,454	A	11,636	A	17,454	B	11,636	A	9,044	B	9,044	A
70		16,074	A	10,716	A	16,074	A	10,716	A	16,074	B	10,716	A	9,044	B	9,044	A
75		14,876	A	9,917	A	14,876	A	9,917	A	14,876	B	9,917	A	9,044	B	9,044	A
80		13,827	A	9,218	A	13,827	A	9,218	A	13,827	B	9,218	A	9,044	B	9,044	A

- (1) WORKING SAFETY IS MEASURED FROM THE MAIN BEAM TO CENTERLINE OF REVOLUTION.
- (2) STATIC RATED LOADS ARE TO BE USED ONLY FOR LIFTS TO OR FROM STATIONARY PLATFORMS. DYNAMIC RATED LOADS ARE TO BE USED FOR LIFTS TO OR FROM VEHICLES.
- (3) LOADS FOLLOWED BY "A" ARE LIMITED BY PAR. 2.1.1(a). (STRUCTURAL DESIGN.)
- (4) LOADS FOLLOWED BY "B" ARE LIMITED BY PAR. 2.1.2(b). (LOAD LINE STRENGTH.)
- (5) LOADS FOLLOWED BY "C" ARE LIMITED BY PAR. 2.1.1(c). (AVAILABLE WEIGHT LINE FULL.)
- (6) RATED LOADS ARE GROSS LOADS. A _____ lb. BOOK BLOCK & B _____ lb. OVERHAUL. BALL MUST BE EXCLUDED FROM GROSS LOADS.
- (7) MAIN DRUM CABLE Dia. 5/8" CLASS 30 x 19 FIBER LENGTH _____ ft.
- (8) FOX. DRUM CABLE Dia. 3/4" CLASS 10 x 19 FIBER LENGTH _____ ft.

LOAD CHART CALCULATED BY:
AMERICAN AERO CRANE

OPERATOR: _____ MAKE: _____
 FIELD: _____ MODEL: _____
 PLATFORM: _____ SERIAL NO.: _____
 CRANE ID: _____ *** ACTUAL BOOM LENGTH: _____

* AUX. BLOCK WEIGHT _____ LBS.
 * MAIN BLOCK WEIGHT _____ LBS.

WIRE ROPE:
 BOOM: _____
 MAIN LINE: _____
 AUX. LINE: _____

LIFTING CAPACITIES (DOES NOT INCLUDE BLOCK OR RIGGING)

BOOM ANGLE (DEGREES)	LOAD RADIUS **** (FEET)	MAIN HOIST		AUX. HOIST		PERSONNEL LIFTING CAPACITY **
		PART LINES		AUX. LINE		
		STATIC **	DYNAMIC **	STATIC **	DYNAMIC **	

* WEIGHTS MUST BE ADDED TO REQUIRED LIFT ** ALL WEIGHTS CALCULATED IN POUNDS

STATIC LIFT: LIFTING OFF OF OR ONTO A STATIONARY DECK OR PLATFORM.
 DYNAMIC LIFT: LIFTING OFF OF OR ONTO A MOVING DECK OR FLOATING VESSEL (BOAT).

*** Actual Boom Length refers to the distance from heel pin to boom tip.
 **** Actual Radius refers to the distance from the center of rotation to the center of the main hook.

LOAD CHART CALCULATED BY:
AMERICAN AERO CRANE

OPERATOR: UNOCAL
 FIELD: HI-573
 PLATFORM: HI-573 A
 CRANE ID: HI573K1

MAKE: UNIT CRANE
 MODEL: 480-H
 SERIAL NO.: 21271
 *** ACTUAL BOOM LENGTH: 80 FT.

* AUX. BLOCK WEIGHT 250 LBS.
 * MAIN BLOCK WEIGHT 550 LBS.

WIRE ROPE:
 BOOM: 3/4 6 X 19
 MAIN LINE: 5/8 19 X 7 (900)
 AUX. LINE: 5/8 19 X 7 (300)

LIFTING CAPACITIES (DOES NOT INCLUDE BLOCK OR RIGGING)

BOOM ANGLE (DEGREES)	LOAD RADIUS **** (FEET)	MAIN HOIST		AUX. HOIST		PERSONNEL LIFTING CAPACITY **
		6 PART LINES		AUX. LINE		
		STATIC **	DYNAMIC **	STATIC **	DYNAMIC **	
77	20	40,320	31,940	6,700	6,700	NO LIFT
73	25	40,320	28,030	6,700	6,700	NO LIFT
70	30	37,220	24,751	6,700	6,700	2,100
66	35	33,590	22,337	6,700	6,700	2,100
62	40	29,240	19,445	6,700	6,700	2,100
58	45	25,330	16,844	6,700	6,700	2,100
53	50	22,250	14,796	6,700	6,700	2,100
49	55	19,680	13,087	6,700	6,700	2,100
44	60	17,540	11,664	6,700	6,700	2,100
38	65	15,720	10,454	6,700	6,700	NO LIFT
32	70	14,160	9,416	6,700	6,700	NO LIFT
25	75	12,810	8,519	6,700	6,700	NO LIFT
15	80	11,660	7,754	6,700	6,700	NO LIFT

* WEIGHTS MUST BE ADDED TO REQUIRED LIFT

** ALL WEIGHTS CALCULATED IN POUNDS

STATIC LIFT: LIFTING OFF OF OR ONTO A STATIONARY DECK OR PLATFORM.
 DYNAMIC LIFT: LIFTING OFF OF OR ONTO A MOVING DECK OR FLOATING VESSEL (BOAT).

*** Actual Boom Length refers to the distance from heel pin to boom tip.
 **** Actual Radius refers to the distance from the center of rotation to the center of the main hook.

L7042GSIU
Serial #254830
With vibration dampner and flywheel, no oil cooler, turbochargers on engine
Weight - 21,000 lbs.



1197
No Tag
With vibration dampner and flywheel, oil cooler on engine
Weight - 4,4000 lbs.

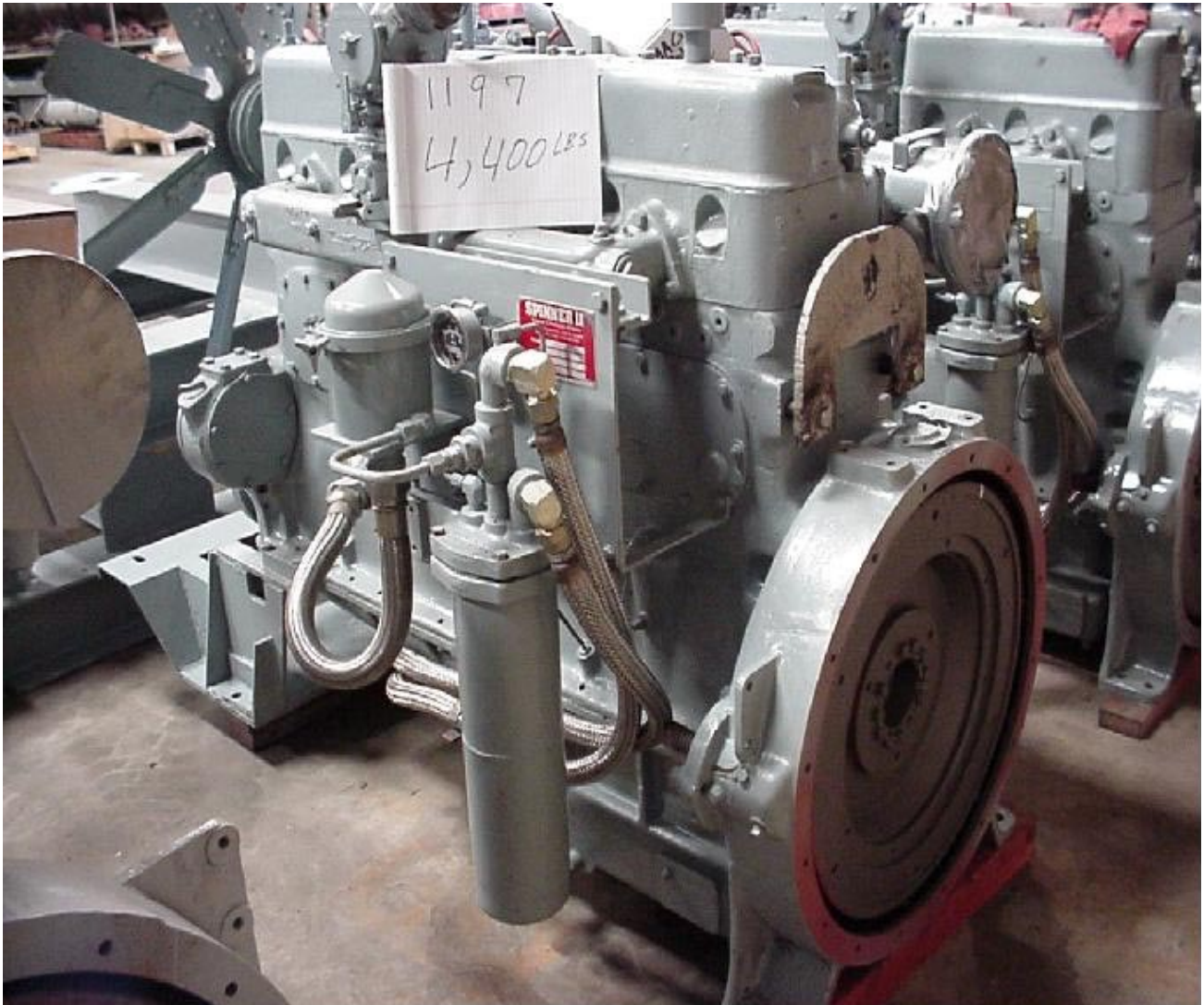



April 27, 1999

TO: Logistics Coordinators
Logistics Contract Personnel
Marine Vessel Captain & Crew

FROM: Rodney Montz
Logistics Loss Control Coordinator

SUBJECT: **Marine Vessel Communications, Equipment Weight Verification & Manifesting**

Due to past incidents involving shorebase and vessel transferring activities, the lack of knowledge and non-use of the Unocal Offshore Pedestal Mounted Crane Policy the following operational guidelines must be issued, reviewed and posted at all shorebase facilities.

Marine Vessel Communications

- Prior to any offshore loading or offloading activities radio communications must be established and operational between the captain & crane operator.
(Refer to the Unocal offshore pedestal crane policy for additional information)

If Radio Communication is Lost

1. All transferring activity must be terminated **immediately**.
2. Re-establish radio communications and continue transfer activities.
3. If radio communications **can not** be re-established notify facility personnel and/or shorebase dispatcher of radio problem.

Equipment Weights Verified At Shorebases

- Shorebase crane operators must verify all equipment weights **over 3,000 pounds** against third party shipping papers, Spirit Energy Operation Crane Service Request and any stenciled or grease pen markings on equipment.
- Incorrect stenciled or grease pen marked weights must be covered or removed.
- If crane operator notes a **significant** difference in the actual measured weight and the stenciled or reported weight, he shall:
 1. Notify the base Logistics Coordinator (dispatcher) of weight discrepancy.

2. Logistics Coordinator shall notify the responsible job supervisor ASAP.

- **Cargo manifest must reflect actual measured weights over 3,000 pounds and e-mailed or faxed to the affected field or job site, as soon as practicable.**
- **Shorebase Logistics Coordinators are responsible for equipment weight verifications at the base and for any “Re-directed” equipment loadouts, initiated by logistics base personnel (i.e., off site third party location).**

Manifesting Of Waste

- **Logistics personnel shall not adjusted or altered waste manifest without first contacting the manifest originator, affected job site supervisor or operating group for verification.**
- **Document and retain all related conversations and correspondence concerning manifest adjustments or alterations.**

C/logistics/baseguidelines.doc□

MEMORANDUM



OFFSHORE OPERATIONS
LAFAYETTE, LOUISIANA
January 20, 1999

TO: Operations Production Engineers
Concentric Superintendents
Construction Superintendent
Drilling Superintendents

FROM: Jerry Arceneaux
Aubin Buquet
Terry Duhon
Steve Miller
John Johnson

SUBJECT:
Offshore Crane Pre-Use Inspections

Safe, effective crane use is paramount in Spirit's offshore operations. It is important to insure that our offshore cranes are properly inspected and tested prior to making heavy lifts that are required in our concentric, drilling, construction, and production activities.

Prior to making a critical lift, as defined in Spirit's *Crane Management Policy*, responsible Operations, Concentric, and Drilling Engineers, and Construction Foremen shall:

- Contact (verbal) the Maintenance Superintendent and the Maintenance Foremen assigned to the field that the critical lift is scheduled to take place in advising them of the impending critical lift and requesting the required crane preuse inspection and testing be performed.
- Submit to the Maintenance Superintendent and the Maintenance Foremen assigned to the field that the critical lift is scheduled to take place in, the Maintenance Department's service request form located on our Offshore Operations web page listed under "Forms".

The above contact & request should be made allowing sufficient time to complete the preuse inspection and testing prior to performing the critical lift.

Offshore Crane Pre-Use Inspections
Page 2

The Maintenance Superintendent **has requested to be, AND WILL BE RESPONSIBLE for assuring that cranes are properly inspected and if capable, can make the critical lifts to be preformed.**

A cost estimate of \$1,000, excluding transportation, should be added projects that inspections are deemed necessary by my Maintenance Group.

SPIRIT ENERGY 76

OFFSHORE OPERATIONS

CRANE SERVICE REQUESTS

ASSET: Central Gulf FIELD: VR 39

REQUESTED BY: Bruce Poret DATE: 05/03/99

CRANE LOCATION: VR 39 I

CONDITIONS:

A. HEAVIEST LIFT 8,500 lbs. (the reel on an Electric line unit.)

B. RADIUS LIFT IS TO BE PLACED 20'

C. DIMENSIONS OF HEAVIEST LIFT 8'L x 6'W x 4'H

D. PROJECT START TIME: Thursday, May 6, 1999

E. LOAD CHARTS REQUESTED: YES OR NO Yes (you already gave it to me)

F. REQUESTED INFORMATION BACK TO TEAM BY: 5/4/99

G. COST CENTER FOR JOB VR 39 I (see Dale if you need a code for your time)

INFORMATION: **TO BE FILLED BY MAINTENANCE DEPARTMENT**

A. LAST ANNUAL INSPECTION 5/20/98

B. LAST LOAD TEST N/A (longer than a year)

C. MAXIMUM WEIGHT AT SPECIFIED RADIUS 11,330 - static 9045 - dyanamic

D. PROJECTED CRANE READY DATE 05/06/98

E. LOAD CHARTS PROVIDED: YES OR NO YES

F. DATE INFORMATION FORWARDED: 05/04/98

G. REMARKS: The annual inspection is due this month and is being performed as I write this.

The inspection and load test shoul be completed by 5/6/99. I will let Bruce know by e-mail when

the inspection is complete.

Safe Practice Standard

Business Unit

Crane Lifting Equipment Inspection and Operation

Date of Issue April 1, 1997
Rev.

Approved by Earl Champagne V. P. Field Operations

David Thompson V. P. Exploitation

PURPOSE

To ensure that all pedestal mounted lifting equipment used at Offshore SPIRIT ENERGY 76 facilities are properly inspected, maintained and operated according to manufacturer's recommendations, API guidelines, OSHA regulations, Company policies and good business practices.

SCOPE

This standard applies to all offshore pedestal mounted crane lifting equipment and associated rigging, and the operation thereof.

STANDARDS

A. General

1. Only operators who are qualified shall be designated to operate cranes in the Business Unit.
2. The On-site Supervisor at any given SPIRIT ENERGY 76 facility shall be responsible for assuring that the cranes and all associated rigging equipment used in the Business Unit are inspected, maintained and operated in compliance with this Standard.
3. The Maintenance Superintendent, through the Maintenance Supervisor(s) shall be responsible for providing training, consultation and on-site support necessary to ensure compliance with this Standard.
4. Appropriate SPIRIT ENERGY 76 management will be subject to annual policy awareness training under Element 1 of our Loss Control Program.
5. Personnel qualified to conduct training, inspections, testing, certification and Crane Operator qualification on SPIRIT ENERGY 76 cranes will be designated or approved by the Maintenance Superintendent.
6. The Offshore Loss Control Coordinator will be responsible for the tracking of OSHA regulations and API RP 2D recommendations for impact to this Standard.
7. All cranes and associated rigging equipment used in the Business Unit will be inspected, maintained and operated in compliance with appropriate State and Federal regulations and API RP 2D guidelines.
8. Personnel lifts shall be done in accordance with Section 3.4 of API RP 2D, Third Edition, June 1, 1995.
9. Master Service Agreement will require contractor to develop standards to administer its crane program.

B. Crane Operator Qualification

1. The minimum requirements to qualify as a Crane Operator are as defined in 3.1.2 of API RP 2D, Third

Edition, June 1, 1995.

2. The On-site Supervisor shall verify that a crane operator is qualified. The Offshore Loss Control Coordinator shall maintain the list of qualified SPIRIT ENERGY 76 Crane Operators.

C. Operations

1. When using a crane to off-load or on-load to a boat, radio communication will be established among the crane operator, boat captain, and crew/rigger.
2. The crane operator and the boat captain shall be jointly responsible for determining whether conditions are satisfactory for loading operations. Notwithstanding this, the On-site Supervisor shall retain the right to shutdown crane loading operations, but shall not override a decision not to load. Loads are to be located directly below the crane boom tip.
3. Operational, maintenance and inspection records shall be maintained for a minimum of two years. Original records are to be kept on site, with copies of SPIRIT ENERGY 76 equipment records sent to the Maintenance Supervisor's shore base office.
4. All cranes shall be equipped with a functional weight indicator.
5. The crane operator shall know the weight of the load and assure that it is within acceptable limits on the load chart before lifting. The crane operator in conjunction with the rigger shall be responsible for ensuring that all loads are properly rigged before lifting.
6. Spotters and signal men shall be competent in the use of hand signals. Hand Signal Charts will be posted at strategic locations.
7. "Critical lifts" can be defined as those lifts that are out of the ordinary or may approach the limitations of the lifting equipment, proven skill level of the operator or are done in a hostile environment. Additionally, a "critical lift" may be one that the consequences of failure may lead to significant financial burden to the facility or company. Some discretion should be left with the crane operator in determining when a lift is critical.

Critical lifts include, but are not limited to the following characteristics:

- A. Engineered Lift
- B. Heavy Lift (>80% of crane capacity)
- C. High Wind Exposure Lift
- D. High Cargo Cost Lift
- E. High Risk to Fire or Explosion Lift
- F. Fragile Cargo Lift
- G. Hazardous Environmental/Visibility Lift

If a lift is classified as critical, additional precautions should be taken (i.e. inspections, consultations, dry runs or additional safety precautions) to increase the assurance that the lift will be completed without incident.

8. Crane load-radius charts for static and dynamic (where applicable) lifting shall be located in plain sight of the operator.
9. Crane load limits shall be adhered to at all times.
10. The crane operator, rigger or spotter will warn workers away while cargo picks are in motion.

11. Under normal operation personnel shall avoid being under any part of crane boom or load.
12. Any malfunction of the crane must be reported to the On-site supervisor immediately and addressed as a discrepancy.

D. Wire Rope, Slings, Shackles and Miscellaneous Rigging Devices

All cable, and pendants through the hook block shall be referred to as crane related. All eyebolts, shackles, clevis and related rigging equipment below the hook block shall be referred to as rigging related.

E. Supporting Documents

The following Appendices support this Standard.

- A. Rigging
- B. Crane Inspection
- C. Crane Maintenance
- D. Referenced in Appendix A



New Name. Same Spirit.
A Business Unit of Unocal

GULF OF MEXICO/COASTAL LA OPERATIONS

PREVENTIVE MAINTENANCE PROGRAM **(VERSION 4.0)**

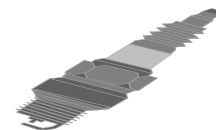
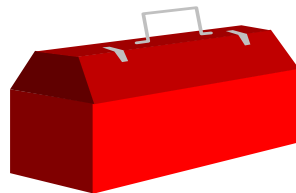
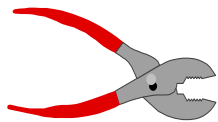

(Revised 04/01/00)

**"Spirit is our name."
Maintenance is our Game.**

**UNOCAL/SPIRIT ENERGY 76
GULF OF MEXICO/COASTAL LA OPERATIONS**

**PREVENTIVE MAINTENANCE PROGRAM
CRANE PRIOR TO USE CHECKLIST**

1. Check all fluid levels in prime mover.
2. Check prime mover start and stop.
3. Check for oil leakage.
4. Check control mechanism for proper operation.
5. Check brakes for proper operation.
6. Check clutches for proper operation.
7. Check boom hoist pawl for proper operation.
8. Check helicopter warning light operation.
9. Visually examine boom for damage.
10. Check that correct load chart is visible.
11. Visually check wire rope for damage.
12. Check for loose or missing bolts, pin, etc.
13. Visually check slings, sling hooks, shackles to be used.
14. Check boom angle indicator.
15. Visually ensure that all wire rope is resting in the sheave groove.
16. The crane hours on the crane hour meter must be called in and recorded on the Prior to Use Crane Inspection Record before the crane is used for the day.

NOTE: After inspecting, it is the crane operator's responsibility that the inspection is recorded at the main facility.

*** Any discrepancies found should be addressed as per Spirit's Safe Practice Standard (Spirit's Crane Policy).**

**UNOCAL/SPIRIT ENERGY 76
GULF OF MEXICO/COASTAL LA OPERATIONS
PRIOR TO USE CRANE INSPECTION RECORD**

ASSET GROUP: _____

NOTE: Initial of Operator - Top Box
Initial of Recorder - Middle Box

Main Facility Location: _____ FOR MONTH-

CRANE LOCATION	1	2	3	4	5	6	7	8	9	10	11	12	13	14	15	16	17	18	19	20	21	22	23	24	25
Counter Reading																									
Counter Reading																									
Counter Reading																									
Counter Reading																									
Counter Reading																									
Counter Reading																									
Counter Reading																									
Counter Reading																									
Counter Reading																									
Counter Reading																									
Counter Reading																									
Counter Reading																									
Counter Reading																									
Counter Reading																									
Counter Reading																									
Counter Reading																									
Counter Reading																									
Counter Reading																									
Counter Reading																									
Counter Reading																									
Counter Reading																									

ver 4.0 * Hours on crane counter must be recorded on this form before the crane is used for the day. This is part of the "Prior to Use Inspect

**UNOCAL/SPIRIT ENERGY 76
GULF OF MEXICO/COASTAL LA OPERATIONS**

**PREVENTIVE MAINTENANCE PROGRAM
CRANE INSPECTION(S)/ALL FREQUENCIES**

NOTE: In addition to the following, personnel will follow UNOCAL's Crane Management System Policy.

1. **USAGE CATEGORIES:** Crane usage is based on actual crane usage not engine hours:
 - a) **Infrequent usage** cranes are used 10 hours or less per month, based on the average use over a quarter as per API RP 2D.
 - b) **Moderate usage** cranes are used more than 10 hours, but less than 50 hours, per month, based on the average use over a quarter as per API RP 2D.
 - c) **Heavy usage** cranes are used 50 hours or more per month.

2. **REQUIRED INSPECTIONS PER CATEGORIES:**

NOTE: A crane that is taken out of service for 12 months will have an out-of-service sign placed over the primary controls. Before the crane can be placed into service, it will be given an annual inspection.

- a) **Infrequent usage** requires prior to use and annual inspections.
- b) **Moderate usage** requires prior to use, quarterly and annual inspections.
- c) **Heavy usage** requires prior to use, monthly, quarterly and annual inspections.

3. **DETERMINATION OF CRANE USAGE CATEGORY:**

- a) **To determine the crane usage category,** note the last reading on the crane hour meter of the month. Subtract this reading from the last reading of the previous month. This will, if readings were taken more than once, give you the usage for the current month. At the end of the month, the prior to use inspection record must be sent in. The Lead Mechanic will then enter the last reading onto a crane usage tracking form that will calculate a three month average every quarter.

4. **DOCUMENTATION OF INSPECTIONS:**

- a) Prior to use inspections require the use of the Prior to Use Crane Inspection Record found on page 5-1. Following the guidelines of the daily Crane Prior to Use Inspection Checklist, page 2-31, the crane operator will inspect the crane. Before the crane is operated, it is the responsibility of the crane operator to record or call in to where the prior to use inspection form is kept. The initial of the crane operator must be noted in the top box of the date corresponding to the inspection. The recorder's initial must be noted in the middle box of the same date. The hours on the crane counter must be called in and recorded each day the crane is used, after the prior to use inspection.

- c) Any check marks in the repair column must be explained in the remark sections. This means that all corrective actions done to the crane must be listed in the remark sections. All repairs must be corrected in a timely manner, listed and dated in the remark sections.
- d) Any deficiencies that could cause the crane to be operated in an unsafe manner, and cannot be corrected at the time of the inspection must be documented on "Unocal's Crane Deficiency Report" as per Spirit's Safe Practice Standard (Spirit's Crane Policy), and must be signed off on by both the Production Foreman & the Maintenance Foreman before the crane can be used.

5. EQUIPMENT PROCEDURAL INSPECTIONS/TESTS:

a) **Engine:**

- 1) Any procedures needing clarification on engine inspection can be referenced on text sheet, page 2-21 of Class VI Engine/Driven. Engine oil and filter changes will be done on an annual basis for infrequent usage cranes and on six (6) month intervals for moderate and heavy category usages. Engine oil sample will be taken before each oil and filter change.

NOTE: Cranes used continuously for special projects may require more frequent oil changes.

b) **Winches:**

NOTE: Environmentally friendly Hyd oil should be utilized. See page 2-32 for Hyd oil change procedure.

- 1) Braden recommends the use of gear oils without an anti-friction additive in their winches. To satisfy the above recommendation, the Preventive Maintenance Program requires the use of Texaco Meropa 220 in Braden winches.
- 2) All winch drum oil samples should be taken annually and inspected using a cheese cloth type material to look for signs of free solids before changing oil in drums. All comments should be noted in the remark sections.
- 3) Whenever oil is noticed coming from the vent hole of the drum of any winch, the motor seal and the brake cylinder o-ring must be checked, and the problem corrected.
- 4) All winches will have a minimum of 5 full wraps on the drum at all times.
- 5) Winch service work must be performed by an "OEM" representative and shall be **labeled** suitable for handling personnel.
- 6) Guidelines for Winch Brake Test Procedures:
 - 6a) Remove the lock wire on the test valve handle; close the valve tightly.
 - 6b) Remove the plug in the tee.
 - 6c) With hydraulic power unit running, move the directional control valve handle to full-open, lowering position.

- 6d) Increase the engine speed, if necessary, to bring system pressure up to the relief valve setting. The hoist drum should remain stationary.
- 6e) If the drum rotates at this point, make appropriate repairs if possible. If not, contact the Maintenance Foreman for further instructions.
- 6f) When testing is complete, be sure to reinstall the plug in the tee; fully open the test valve, and replace the lock wire.

c) **Swing Drive:**

- 1) House lock is a positive pawl locking device that has to be manually engaged. Check for proper operation.
- 2) Main bearing block, this piece is to be visually inspected annually and is only found on Seakings and other King post type designs.

d) **Wire Rope:**

- 1) Wire rope will be measured with a caliper every inspection, except prior to use and monthly inspections. These inspections must be recorded.
- 2) Cut and retie dead ends on the annual inspections.
- 3) Inspect the drum end of the cable for proper wedge size and that the cable is properly secured.
- 4) If wire rope is changed, record information on Crane Wire Rope Service Record, page 5-4.
- 5) Wire rope construction, 6 x 25 EIP (extra improved plow) IWRC (independent wire core center) RRL (right regular lay), will be used on all boom line replacements. Dyform 18, Flex-x 19 or Super Flex, Rotation Resistant, will be used on all main and auxiliary line replacements. Cable length and construction must be verified as per the load chart on the crane.
- 6) Assure that the hook can reach the water at all angles while still maintaining at least 5 (five) wraps of cable on the winch drum.

e) **Boom:**

- 1) Spirit's standardized load chart template must be in plain view of the operator.
- 2) When confirming angle/rad indicator, two (2) boom positions should be physically measured; verify indicator.
- 3) Hand signal chart needs to be attached to the crane in plain view of the crane operator.

f) **Slings:**

- 1) When slings and/or personnel nets are found to be damaged, they must be rendered unusable (cut up) and replacements ordered.

NOTE: Request certification papers with new slings.

- 2) If slings are missing their data tags, they will be sent in for recertification and retagging. New certification paperwork will accompany return of slings and be filed. Old certification paperwork will be discarded.

g) **Mag Particle Tests:**

- 1) All mag-particle tests will be performed only if a crack is suspected. Spirit's MI / QA Department must be contacted at this time.

h) **Personnel Handling:**

- 1) As specified by Spirit's Safe Practice Standard (Crane Policy), personnel baskets will be made available on all manned complexes.
- 2) Hooks used in lifting personnel must have a positive safety latch.
- 3) Personnel nets used for lifting personnel must be in good condition.
- 4) Crane counter must be operating normally.

i) **Swing Ball / Roller Bearing Inspection:**

- 1) The procedure for inspecting / checking swing bearing wear can be found on page 20 in API RP2D. Tilt method will be used utilizing jacks when counter weights are not available.

j) **Load Tests:**

- 1) A load test is required under the following conditions:
 - a) New cranes being placed into service.
 - b) Cranes that are being permanently relocated.
 - c) Temporary / rental cranes after each rig-up or relocation.
 - d) Upon the completion of the annual inspection.
- 2) Once a crane service request is initiated, it is up to the discretion of the Maintenance Foreman whether to perform an annual inspection / load test, before and or after the project.
- 3) The use of waterbags during a load test should **only** be used on initial installation of pedestal mounted cranes.
- 4) Crane weight indicators shall not be used to test cranes, but the readings shall be recorded on each lift where load indicators are installed on the crane. Dynamometers will be used to test cranes.
- 5) Two pulls will be made during the load test. The first pull will be made at a low angle or a long radius to test the structure at a lighter load. The second pull will be made at a high angle or short radius to test the actual capacity of the crane.
- 6) All weights lifted during a load test, will not exceed the static capacities of the posted load chart by more than 25% at that specified angle / radius if the crane's capacity is less than 40,000 lbs., or by 10,000 lbs. on cranes who's capacity is rated between 40,000 lbs. and 100,000 lbs. Refer to page 21 & 22 Appendix E - Commentary on load testing in API RP 2D for more detail.

UNOCAL/SPIRIT ENERGY 76
GULF OF MEXICO/COASTAL LA OPERATIONS
CRANE INSPECTION

ASSET GROUP _____

PAGE: 1

USAGE CATEGORY
HEAVY MONTHLY MODERATE QUARTERLY INFREQUENT ANNUALLY
(CHECK TYPE OF INSPECTION PERFORMED)

FIELD: _____
CRANE MAKE: _____
S/N: _____
CURRENT HR. READING: _____
OPERATING HOURS SINCE LAST INSPECTION _____

PLATFORM: _____
MODEL: _____
BOOM LENGTH: _____

DATE: _____
INSPECTED BY: _____
APPROVED BY: _____
(UNOCAL)

GENERAL

1. OVERALL APPEARANCE & PAINT
2. MAIN FRAME
3. FIRE EXTINGUISHER
4. WALKWAYS/HANDRAILS/LADDERS
5. CONTROLS/SAFETY LABELS
6. MAINTENANCE RECORDS IN OFFICE?
7. GREASE ALL BEARINGS & LINKAGES?

GOOD REPAIR** N/A

AUX. WINCH DRUM

GOOD REPAIR** N/A

CLASS VII @
ENGINE MAKE: _____ MODEL: _____
HOURS: _____

8. OIL LEVEL
9. CHANGE OIL & FILTER (SA OR A)
(INFREQUENT=ANNUAL/ALL ELSE=6 MONTHS)
10. ENGINE OIL SAMPLE (BEFORE OIL CHANGE)
11. COOLANT LEVEL
12. RADIATOR HOSES
13. FUEL LEVEL
14. FAN BELTS & PULLEYS
15. ENGINE INSTRUMENTS
16. THROTTLE CONTROLS ARE FREE
17. EMERGENCY ENGINE SHUTDOWN
18. SPARK ARRESTOR AND EXHAUST SYS.
19. OIL, FUEL, OR WATER LEAKS?
20. ENGINE RUNS OK?

60. DRUM OIL SAMPLE? (A)*
61. WINCH GEAR OIL CHANGE? (A)*
62. WINCH MOTOR
63. OIL COMING FROM DRUM VENT?***
64. COUNTERBALANCE VALVE
65. WINCH BRAKE
66. RACHET & PAWL
67. PILOT HOSES
68. EXT. BRAKE TEST PERFORMED? (Q)
69. PLUMBED FOR BRAKE TEST?
70. VISUALLY INSPECT WEDGE SOCKET?
71. MIN. OF 5 WRAPS ON DRUM AT ALL TIMES?

HYDRAULIC SYSTEM

21. HYD. OIL SAMPLE (A)*
22. HYDRAULIC PUMP
23. SUCTION HOSES
24. RETURN HOSES
25. HYDRAULIC OIL LEVEL

SWING DRIVE

72. DRIVE GEAR OIL CHANGE? (A)*
73. SWING MOTOR
74. SWING BRAKE
75. SWING GEAR LUBRICATE?
76. HOUSE LOCK
77. PEDESTAL KINGPOST
78. PEDESTAL SPROCKET & CHAIN
79. MAIN BEARING BLOCK (A)*
80. PEDESTAL (CONVENTIONAL)
81. VISUALLY CHECK WELDS
82. TURNTABLE BEAR. DEFLECT
83. MOUNTING BOLTS TORQUE
84. TURNTABLE GEAR & PINION

CONTROL VALVES & HOSES

26. BOOM HOIST VALVE
27. BOOM HOIST HOSES
28. MAIN HOIST VALVE
29. MAIN HOIST HOSES
30. AUX. HOIST VALVE
31. AUX. HOIST HOSES
32. SWING VALVE
33. SWING HOSES
34. CONTROL LEVERS
35. RELIEF VALVES

SAFETY EQUIPMENT

85. BOOM HOIST LIMITING DEVICE
86. ANTI-2 BLK (MAIN)
87. ANTI-2 BLK (AUX)
88. WEIGHT INDICATOR
89. HELICOPTER WARNING LIGHT

BOOM WINCH DRUM

36. DRUM OIL SAMPLE? (A)*
37. WINCH GEAR OIL CHANGE? (A)*
38. WINCH MOTOR
39. OIL COMING FROM DRUM VENT?***
40. COUNTERBALANCE VALVE
41. WINCH BRAKE
42. RACHET & PAWL
43. PILOT HOSES
44. EXT. BRAKE TEST PERFORMED? (Q)
45. PLUMBED FOR BRAKE TEST?
46. VISUALLY INSPECT WEDGE SOCKET?
47. MIN. OF 5 WRAPS ON DRUM AT ALL TIMES?

WIRE ROPE INSPECTION

- BOOM HOIST ROPE TYPE (6x25, etc) DIA.
90. MEASURED DIAMETER (Q,A)*
 91. BROKEN WIRES
 92. CUT & RETIE WEDGE SOCKET (A)*
- MAIN HOIST ROPE TYPE(non-rot, etc) DIA.
93. MEASURED DIAMETER (Q. A.)*
 94. BROKEN WIRES
 95. CUT & RETIE WEDGE SOCKET (A)*

MAIN WINCH DRUM

48. DRUM OIL SAMPLE? (A)*
49. WINCH GEAR OIL CHANGE? (A)*
50. WINCH MOTOR
51. OIL COMING FROM DRUM VENT?***
52. COUNTERBALANCE VALVE
53. WINCH BRAKE
54. RACHET & PAWL
55. PILOT HOSES
56. EXT. BRAKE TEST PERFORMED? (Q)
57. PLUMBED FOR BRAKE TEST?
58. VISUALLY INSPECT WEDGE SOCKET?
59. MIN. OF 5 WRAPS ON DRUM AT ALL TIMES?

- AUX. HOIST ROPE TYPE(non-rot, etc) DIA.
96. MEASURED DIAMETER (Q. A.)*
97. BROKEN WIRES
98. CUT & RETIE WEDGE SOCKET (A)*
99. PENDANTS
100. WIRE ROPE LUBE (Q. A.)*
(If rope is changed, record on service record.)
- BLOCKS**
101. MAIN HOOK/SWIVEL/LATCH
102. HOOK BLOCK SHEAVES
103. AUX. HOOK/SWIVEL/LATCH

104. **MAIN HOOK MEASUREMENTS**
ab _____ ac _____ bc _____
DIMENSION "A" WITH LATCH
DYE TEST? (A)* YES NO
105. **AUX. HOOK MEASUREMENTS**
ab _____ ac _____ bc _____
DIMENSION "A" WITH LATCH
DYE TEST? (A)* YES NO

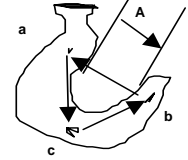

NOTES* Items with letters following indicate items due only on the corresponding inspection.
** Use the remark section on page 48 to list items with a check mark in the repair column.
*** If hydraulic fluid is leaking into winch housing, check: motor, seal, and brake 'o' rings. If winch cannot lower a load or

**UNOCAL/SPIRIT ENERGY 76
GULF OF MEXICO/COASTAL LA OPERATIONS
Crane Management Program
Deficiency Report**

Location: _____

Date: _____

Crane Operator: _____

Job Title: _____

Type of Crane: _____

Crane Tagged Out of Service:

Yes	No
-----	----

Deficiency Found

Crane can be used at this time with noted deficiency:

Production Foreman: _____

Maintenance Foreman: _____

Deficiency must be corrected before crane is returned to service:

Production Foreman: _____

Maintenance Foreman: _____

* Note: Both signatures are needed for approval.

Deficiencies Corrected

Date: _____

Signature: _____

SESSION One PAPER Two

“Chevron’s Crane Program”

Don Norton



Crane Program Overview

Crane Program Overview

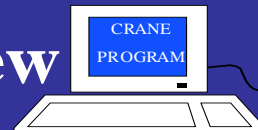

- Chevron's Gulf of Mexico, Company Policy on Cranes.
- Documentation of Company preventive maintenance program for cranes (as required by API RP 2D).
- Highlights key regulatory requirements for cranes (MMS, US Coast Guard, OSHA).
- Not intended to replace regulatory documents (API RP 2D, 29 CFR, 30 CFR, etc.).
- Approved by all area Operations Managers.

Gulf of Mexico Crane Team



- Representation from New Orleans & Lafayette.

- Function & Discipline Representation:

 - Operations/Maintenance
 - Facilities Engineering
 - Environmental & Safety
 - Legal Consultation & Review

New Program Highlights



- Conversion to Web-based format.

- Change from numbered list format to topical/outline format.

- Removal of some redundant information for brevity and clarity.

Program Contents



- Crane Requirements
- Safety
- Liftboats/Temporary Cranes
- Personnel Transfers
- Crane Operation
- Aviation
- Riggers
- Vessels
- Cargo/Rigging
- Crane Inspection/Repairs
- Heavy lift Inspections
- Transportation/Shore-base Responsibilities
- Training
- Overhead Hoist Inspections
- Definitions

Key Program Highlights



Crane Requirements

- ≥ Crane files: Include names and certification records of all Qualified Crane Inspectors working in the Profit Center.
- ≥ Wire rope and sling certifications - documentation process. Stainless Steel tag for wire rope to be placed on the brake line of the hoist the rope goes on.
- ≥ Introduction of Management of Change Process for changes in crane configuration/ operating procedures (i.e. boom length, cable size, number of parts of line, etc.)

Key Program Highlights

(continued)



Liftboats/Temporary Cranes

- Liftboats: “Specification for Liftboat Crane Inspections in State and OCS Waters”.
- Temporary Cranes: “Specifications for Temporary Cranes in OCS Waters”.

Key Program Highlights

(continued)



Personnel Transfers

- Hooks on headache balls or blocks will be of the type that can be closed and locked (API 2C).
- If a stinger is used, both hooks (headache & stinger) will be of a type that can be closed and locked.

Key Program Highlights

(continued)



Riggers

Only Chevron Personnel who have successfully completed the Chevron Rigger Training Course or Contract Personnel who have successfully completed a rigger training course will rig loads at Chevron facilities.

Key Program Highlights

(continued)



Crane Inspections/Repairs

Pre-use Inspection will be performed prior to crane use and then as the Qualified Operator deems necessary during the day for extended operations. A Qualified Operator will perform this inspection, and it will apply to all cranes regardless of category. If the qualified operator changes, a new pre-use inspection will be performed and documented by the new operator. The inspection also includes rigging gear (i.e. slings, cargo baskets, personnel baskets, drum racks, etc.)

Key Program Highlights

(continued)



Crane Inspections/Repairs

Monthly Inspection will be performed on all cranes assigned a heavy usage category. This inspection will be performed by a Qualified Crane Operator or a Qualified Crane Inspector.

Key Program Highlights

(continued)

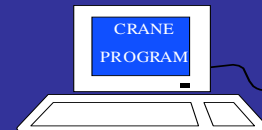

Crane Inspections/Repairs

Quarterly Inspection will be performed once every three (3) months for all cranes assigned a heavy usage or a moderate usage category. This inspection will be performed by a Qualified Crane Inspector.

Key Program Highlights

(continued)



Crane Inspections/Repairs

Annual Inspection will be performed once every twelve (12) months, not to exceed 365 days, for all cranes regardless of usage category. This inspection will be performed by a Qualified Crane Inspector.

Key Program Highlights

(continued)



Heavy Lift Inspections

Quarterly Inspection with a Pull Test. A pull test is a test, using a suspended weight or a dynamometer, to verify crane capability for the expected lift, not to exceed 100% of the rated crane load chart capacity. This is not a **LOAD TEST**.

Valid for 21 days.

Heavy Lift JSA.

Key Program Highlights

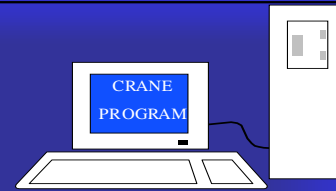

LIFTBOATS

- Movable cranes (e.g. jack-up, spud barges, liftboats, and wireline barges) will be inspected by a Chevron-approved crane inspection company before they are operated on Chevron's property. Each crane is required to meet API RP 2D specifications and all other requirements set forth in Chevron's [Specification for Liftboat Cranes in State and OCS Waters](#). Copies of inspections will be forwarded to the appropriate **Shorebase Supervisors** office. Chevron inspection requirements are intended to supplement, not replace, the contractor's inspection program and compliance with all applicable regulations, rules, and standards will remain the primary responsibility of the contractor.

Key Program Highlights

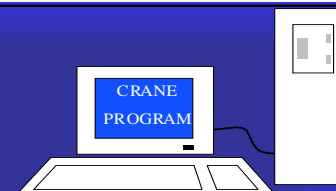

TEMP CRANES

- All Temporary Crane installations will be governed by the latest API standards and all other requirements set forth in Chevron's [Specification for Temporary Cranes in OCS Waters](#). All documentation (including installation load testing) will be forwarded to the Facility Engineer in charge of the Temporary Crane installation. These requirements are intended to supplement, not replace, the contractor's installation standards and compliance with all applicable regulations, rules, and standards will be the primary responsibility of the contractor.

SESSION One - PAPER Three

**“Crane and Rigging Safety in BP Amoco’s Gulf of
Mexico Operations
Michael F. Basic**

June 12, 2000

BP Amoco Crane and Rigging Program

Development of the BP Amoco Crane and Rigging Program was in response to an increase in significant crane and rigging incidents. The following short-term actions were taken to immediately reverse the crane and rigging incident trend:

- Conduct Safety Standdowns to immediately raise awareness across GoM
- Issue Crane and Rigging Safety Alerts
- Perform API training across GoM
- Perform crane and rigging audits at 17 GoM locations

A comprehensive program was developed by a cross disciplinary team with input from all disciplines including contractors and crane consultant specialists to provide crane and rigging safe operating assurance. The program addresses all aspects of crane, rigging and material handling based upon best practices and API standards.

The program exceeds API standards in an effort to address specific BPA operational risks. The program exceeds API in the following areas:

- Additional inspections by third party specialists
- Inspection cycle time reduced from 4 years to 2 years
- Enhanced signal man qualifications
- On-site proficiency testing of crane operators
- Weight load indicators required
- Radio communications required for marine transfers
- Enhanced load test criteria
- Required JSA prior to all lifts focusing all job planning and execution

In summary, BP Amoco's crane and rigging program is a comprehensive program addressing all aspects of crane and rigging with particular attention to job planning and proper execution of the lift.



BP Amoco



A background image showing a worker silhouetted against a sunset sky, standing on a platform and operating a crane that is lifting a large, conical metal cage. The sea is visible in the distance.

BP Amoco Crane and Rigging Program

**MMS Crane Safety Workshop
28 March 2000
Lafayette, Louisiana
Mike Brasic-Presenter**



GoM Crane and Rigging Program



Crisis in Crane & Rigging Safety

1999

- Twenty-Eight Significant Crane/Rigging Incidents
- Five Injuries had Potential for Fatality

2000

- Five Significant Crane/Rigging Incidents
- One Incident Resulted in the Crane and Operator Falling into the Gulf
- One LTA, One Recordable, Two First Aid

The Above Incidents are Unacceptable in our Operations.



Gulf of Mexico HSE

Actions Taken



- One Management Intervention in Progress
- 3 Safety Stand Downs
- 3 Crane / Rigging Safety Alerts
- Crane / Rigging Specific Safety Meetings
- API Re-Training Performed Across Operations
- Survey of Crane Operations at 17 Facilities
- Crane / Rigging Work Team to Develop Crane / Rigging Program

(Jan 24, 2000)



Gulf of Mexico HSE

getting **H S E** right
What is the Program?

BP Amoco



A Comprehensive Crane & Rigging and Material Handling Program Based on Best Practices and API , with Increased Performance Measures, which exceed API.



Gulf of Mexico HSE

getting **H S E** right
How Does this Program Exceed API RP 2D?

BP Amoco



- **Increased Inspection & Maintenance**
 - Third Party Annual Inspection
- **2 Yr Training Refresher Cycle**
- **Weight Load Indicator**
- **Radio Communication for Marine Transfers**
- **Signalmen Qualification**
- **Onsite Proficiency Testing**
- **Supervisor Competence**
- **Load Test Criteria**
 - Annual Requirement
 - Third Party, Conducted
 - BPA Rep., Witness
- **JSA Reviews Required for All Lifts**



Gulf of Mexico HSE

How Does this Program Address the Identified Risks & Root Causes of Our Crane/Rigging Incidents?



Risk/ Root Cause

Prevention

- Poor Communication → 2-Way Radio Communication Required Among Lift Teams
- Inadequate Crane/Equipment Integrity → Increased Inspections & Maintenance
- Poor Job Planning → JSA reviews Mandatory for all Lifts/JSA Assurance/ Boat Deck Inventory Process
- Lack of Standard Equipment & Procedure → API Plus Specific BPA Requirements
- Lack of Skills/ Competence (Operators, Riggers, Supervisors) → Required Training & On-Site Testing



Gulf of Mexico HSE

How Does this Program Address the Identified Risks & Root Causes of Our Crane/Rigging Incidents?



Risk/ Root Cause

Prevention

- Lifting Loads with Unknown Weights → Revised Cargo Marking Criteria/ Load Weight Indicators
- Improper Rigging → Specific Training & BPA Training
- Lack of Understanding of Static vs. Dynamic Load Implications → BPA Procedures
- Inadequate Load Testing → BPA Procedure/ Criteria



Gulf of Mexico HSE

getting **H S E** right
How Does This Program Effect Me, the BPA
Representative/ Supervisor?

BP Amoco



- Raises Your Level of Engagement to Ensure Compliance
- Provides You Clear and Common Information to Deliver Crane & Rigging Safety
- Provides You a Tool to Measure the Competency of Crane & Rigging Personnel and their Supervision in Crane Operations
- Have to Participate in a Crane & Rigging Training Program
- May Have to Sign Acknowledgment Page for Personal Accountabilities



Gulf of Mexico HSE

getting **H S E** right
How Does This Program Effect Crane
Operators and Rigging Personnel?

BP Amoco



- API RP 2D Training Required every Two Years (Includes Hands-On)
- May have to Demonstrate Proficiency/ Competency
- Subject to *Zero Tolerance* on Program Compliance Issues
- Personal Accountabilities to Provide the Leadership Engagement to Conduct Safe Operations



Gulf of Mexico HSE

How Does This Program Effect BP Amoco / Contractors Business?



- Establishes an Expectation to Raise the Level of Performance
- Training and Testing Criteria Strengthened
- Stringent Documentation Program
- Establish Comprehensive Preventative Maintenance Program for All Cranes
- Identify or Secure Qualified Inspectors



Gulf of Mexico HSE

Recap Program Issue



- Personal Accountability
- Personal Training
 - Supervisors
 - Crane Operators
 - Riggers
 - Signalmen
- All Crane Assurance Based on API RP 2D Heavy Usage Criteria
- Annual Load Testing Requirements
- Increased Documentation Requirements
- Critical Lift Criteria
- All Offshore Lifts are Dynamic Lifts
- Radio Communication
- JSA Reviews
- Weight Load Indicators Installed on all Cranes

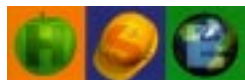

Gulf of Mexico HSE

Crane & Rigging Operation and Maintenance Manual 

BPA Gulf of Mexico Crane Operating and Maintenance Program		Page
I. Scope		5
II. Crane Program Requirements		6
A. General		
B. Crane Operator, Mechanic, Inspector and Rigger Qualifications		
C. Operations		
D. Maintenance		
III. Critical Personnel		10
A. Qualified Operator		
B. Qualified Inspector		
C. Qualified Rigger		
D. Site Supervisor		
E. Designated Signal Person		
IV. Operating Practices		12
A. Crane Operating Personnel		
B. Crane Operator Responsibilities		
C. Transferring Personnel with a Crane		
D. Crane Operator and Rigger Proficiency Test		
E. JSA Requirements		
V. Crane Maintenance and Inspection		17
A. Crane Re-rating		
B. Crane Usage		
C. Inspection Requirements		
D. Record Keeping		
E. Crane Maintenance		
F. Crane Maintenance Precautions		
G. Crane Repairs and Replacements		
H. Lubrication		
I. Anti-Two Block Requirements		
J. Crane Lifting Capacity		
K. Welding Criteria		
L. Load Test Criteria		
VI. Sling and Wire Rope Criteria		22
A. Sling Guidelines		
B. Sling Usage Guidelines		
C. Wire Rope Inspection		
D. Wire Rope Replacement		
E. Wire Rope Maintenance		

VII. Assurance		26
VIII. Supporting Documentation		28
• Attachment 1	GoM Certified Sling and Rigging Procedure Summary	
• Attachment 2	GoM Bottle Rack Design Guidelines	
• Attachment 3	Qualifications for <i>Qualified Rigger/Operator</i>	
• Attachment 4	Crane Hand Signals	
• Attachment 4A	Signaling Guidelines for Riggers	
• Attachment 5	Crane Pre-use Inspection	
• Attachment 6	Moving the Load	
• Attachment 7	Crane Inspection Categories	
• Attachment 8	Crane Inspections Standard Operating Guidelines	
• Attachment 9	Crane Maintenance Standard Operating Guidelines	
• Attachment 10	Rigging Standard Operating Guidelines	
• Attachment 11	<i>Qualified Operator</i> Training and Test	
• Attachment 12	<i>Qualified Rigger</i> Training and Test	
• Attachment 13	Monthly Crane Inspections	
• Attachment 14	Quarterly Crane Inspections	
• Attachment 15	Annual Crane Inspections	
• Attachment 16	Advanced Safety Audit Criteria	
• Attachment 17	Procedures and Precautions (Sling Angles)	
• Attachment 18	Determining Crane Capacity With Load Charts	
• Attachment 19	Production Platform Crane Lifting Capabilities	
• Attachment 20	BP Amoco GoM Crane Operator Proficiency Test	
• Attachment 21	BP Amoco GoM Rigger Proficiency Test	
• Attachment 22	GoM Crane Rigging Safety Meeting - Protocol	
• Attachment 23	Cargo Manifesting & Material Identification Procedure	
• Attachment 24	Deck Layout Tracking - Marine Vessel Tender Operations	





***BP AMOCO
GULF OF MEXICO***

***CRANE OPERATING AND
MAINTENANCE PROGRAM***

BP AMOCO

Gulf of Mexico

Assurance Commitment for Crane Operator and Rigging Safety

Acknowledgment Page

BP Amoco / Contract BP Amoco/ Contract Field, Facility or Rig Supervisor – read this program, complete the information below and retain a copy at location.

I hereby commit as senior line manager in the BPA location that I understand the criticality of complying with this program.

I have read this program and will abide by the procedures contained herein.

Specifically, I will ensure:

- All crane operations meet or exceed API RP 2D and this program.
- All riggers and crane operators are qualified and that I have personally verified their qualifications meet or exceed API RP 2D.
- All cranes are inspected and maintained in proper safe working order and are used within their safe operating envelopes.
- All crane operation personnel at this location have read the BPA Crane Operating and Maintenance Program.

Location: _____

Signature: _____

Print Name: _____

Date: _____

Company Name: _____

BPA Gulf of Mexico
Crane Operating and Maintenance Program

	Page
I. Scope	5
II. Crane Program Requirements	6
A. General	
B. Crane Operator, Mechanic, Inspector and Rigger Qualifications	
C. Operations	
D. Maintenance	
III. Critical Personnel	10
A. Qualified Operator	
B. Qualified Inspector	
C. Qualified Rigger	
D. Site Supervisor	
E. Designated Signal Person	
IV. Operating Practices	12
A. Crane Operating Personnel	
B. Crane Operator Responsibilities	
C. Transferring Personnel with a Crane	
D. Crane Operator and Rigger Proficiency Test	
E. JSA Requirements	
V. Crane Maintenance and Inspection	17
A. Crane Re-rating	
B. Crane Usage	
C. Inspection Requirements	
D. Record Keeping	
E. Crane Maintenance	
F. Crane Maintenance Precautions	
G. Crane Repairs and Replacements	
H. Lubrication	
I. Anti-Two Block Requirements	
J. Crane Lifting Capacity	
K. Welding Criteria	
L. Load Test Criteria	
VI. Sling and Wire Rope Criteria	22
A. Sling Guidelines	
B. Sling Usage Guidelines	
C. Wire Rope Inspection	
D. Wire Rope Replacement	
E. Wire Rope Maintenance	
F. Wire Rope Sling Replacement	
G. Wire Rope Proof Loading and Labeling	

VII.	Assurance	26
VIII.	Supporting Documentation	28
	•□ Attachment 1	GoM Certified Sling and Rigging Procedure Summary
	•□ Attachment 2	GoM Bottle Rack Design Guidelines
	•□ Attachment 3	Qualifications for <i>Qualified Rigger/Operator</i>
	•□ Attachment 4	Crane Hand Signals
	•□ Attachment 4A	Signaling Guidelines for Riggers
	•□ Attachment 5	Crane Pre-use Inspection
	•□ Attachment 6	Moving the Load
	•□ Attachment 7	Crane Inspection Categories
	•□ Attachment 8	Crane Inspections Standard Operating Guidelines
	•□ Attachment 9	Crane Maintenance Standard Operating Guidelines
	•□ Attachment 10	Rigging Standard Operating Guidelines
	•□ Attachment 11	<i>Qualified Operator</i> Training and Test
	•□ Attachment 12	<i>Qualified Rigger</i> Training and Test
	•□ Attachment 13	Monthly Crane Inspections
	•□ Attachment 14	Quarterly Crane Inspections
	•□ Attachment 15	Annual Crane Inspections
	•□ Attachment 16	Advanced Safety Audit Criteria
	•□ Attachment 17	Procedures and Precautions (Sling Angles)
	•□ Attachment 18	Determining Crane Capacity With Load Charts
	•□ Attachment 19	Production Platform Crane Lifting Capabilities
	•□ Attachment 20	BP Amoco GoM Crane Operator Proficiency Test
	•□ Attachment 21	BP Amoco GoM Rigger Proficiency Test
	•□ Attachment 22	GoM Crane Rigging Safety Meeting - Protocol
	•□ Attachment 23	Cargo Manifesting & Material Identification Procedure
	•□ Attachment 24	Deck Layout Tracking - Marine Vessel Tender Operations

I. SCOPE

BP Amoco (BPA) Gulf of Mexico (GoM) Crane Program

This program is to ensure that all GoM cranes, hoists, slings and wire rope used on BPAs operated facilities and rigs are properly inspected, maintained and operated according to manufacturer's recommendations, API recommended practices, OSHA regulations and company policies/ procedures.

The Crane Operation and Maintenance Procedures outlined in this program apply to ALL existing and future GoM offshore pedestal mounted crane lifting equipment and associated rigging, and their operation.

Compliance with this program is mandatory. Deviations from the program will require an approved Management of Change.

II. CRANE PROGRAM SUMMARY REQUIREMENTS

The crane program requirements are divided into four specific areas as shown below.

A. General

1. Every employee is authorized to stop any unsafe crane operation.
2. The BPA Crane Program is based on API RP's and additional BPA requirements.
3. All crane operators will be "qualified" as per the latest edition of API RP2D and be designated to operate cranes.
4. All riggers will be "qualified" as per the latest edition of API RP 2D and be designated riggers.
5. BPA & Contract Crane Operator Supervisors at the location will be "crane operator qualified." (See Section III "*Qualified Operator.*")
6. A *Qualified Operator* and a *qualified rigger* must re-qualify every two (2) years to maintain their designation within BPA operations.
7. Signaller will be qualified riggers.
8. Anti-two-blocking systems will be installed on all cranes. See Section V "Crane Maintenance and Inspection" for additional information.
9. All GoM offshore cranes will be equipped with a functional weight indicator on the main hoist and a boom angle indicator, both visible by the operator.
10. All cranes on BP Amoco operated facilities and rigs will default to the API RP2D heavy usage schedule for preventative maintenance .
11. Annual load testing is required. See Section V "Crane Maintenance and Inspections" for additional information.
12. The BP Amoco/Contract BP Amoco/ Contract Field, Facility or Rig Supervisor is responsible for assuring that GoM cranes and all associated rigging equipment are inspected, maintained and operated in compliance with this program.
13. The BP Amoco/Contract BP Amoco/ Contract Field, Facility or Rig Supervisor is responsible for providing training, consultation and on-site support necessary to ensure compliance with this program.
14. All GoM BPA and contract cranes and associated rigging equipment will be inspected, maintained and operated in compliance with appropriate State and Federal regulations, current API RP 2D guidelines and BP Amoco crane, sling and rigging procedures.
15. Any change to crane configuration (boom length, cable size, number of parts of line, etc.) will require authorization from the BP Amoco/Contract BP Amoco/ Contract Field, Facility or Rig Supervisor. See Section V "Crane Maintenance and Inspection" for additional information.

B. Crane Operator, Mechanic, Inspector and Rigger Qualifications

1. The BP Amoco/Contract BP Amoco/ Contract Field, Facility or Rig Supervisor will maintain a current list of qualified crane operators and riggers for his/her facility.
2. Mechanics and inspectors will be qualified as per the latest edition of API RP 2D and designated by the BP Amoco/ Contract Field, Facility or Rig Supervisor.
3. In addition to the API RP 2D requirement, all crane operators and riggers will be required to undergo proficiency testing before being allowed to operate cranes or rigging in BP Amoco operations.

Failure to pass will disqualify him/her from operating a crane or rigging on a BPA facility. The BP Amoco/ Contract Field, Facility or Rig Supervisors are responsible for ensuring that testing is done on all crane operators and riggers.

C. Operations

1. All offshore lifts require a Job Safety Analysis (JSA) Review.
2. All offshore loads will meet BPA Cargo Manifesting and Material Identification Procedure (Reference Attachment 23)
3. During ALL GoM offshore crane/boat material transfers, two-way radio communication will be maintained with the crane operator, boat captain and riggers.
4. All BPA managed facilities with cranes are required to hold a Crane and Rigging Safety Meeting on a quarterly basis. (Reference Attachment 22 "GoM Crane Rigging Safety Meeting - Protocol"
5. BP Amoco/ Contract Field, Facility or Rig Supervisor, the crane operator and the boat captain will be jointly responsible for determining weather conditions are satisfactory for loading operations. However, the Field, Facility or Rig Supervisor will retain the right to shut down crane operations, but will not override a decision not to load made by the crane operator and/or boat captain.
6. If a lift is classified as critical, additional precautions should be taken (e.g., inspections, load test, consultations, dry runs, risk reviews or additional safety precautions) to increase the assurance that the lift will be completed without incident.

"Critical lifts" can be defined as those lifts that are out of the ordinary or may approach the limitations of the lifting equipment or skill level of the operator.

Critical lifts include, but are not limited to the following characteristics:

- Engineered Lift (requires BP Amoco/ Contract Field, Facility or Rig Supervisor approval)
- Heavy Lift (80% of crane capacity)
- High Wind Exposure Lift
- High Cargo Cost Lift
- High Risk (Fire or Explosion) Lift
- Fragile Cargo Lift
- Hazardous Environmental/Visibility Lift

10. Crane load-radius charts for static and dynamic lifting will be located in plain sight of the operator and used for each lift.
11. When lifting to or from a boat the Dynamic weights of the load chart will be used.
12. Crane load limits will be adhered to at all times.
13. Cranes will not be operated while the helicopter is landing, taking off, or running on the heliport. See Section IV "Operating Practices".
12. When lifts are in progress, the crane operator, rigger or spotter will warn workers away while cargo lifts are being made.
13. Personnel will avoid being under any part of crane boom or load.
14. Personnel lifts will be done in accordance with Section 3.4 of API RP 2D.
15. The crane operator will know the weight of the load and assure that it is within acceptable limits on the load chart before lifting. The crane operator, in conjunction with the rigger, will be responsible for ensuring that all loads are properly rigged before lifting.
16. Riggers and signal men will be competent in the use of appropriate hand signals.
17. Riggers will ensure all rigging arrangements being used have a rated capacity that is greater than the weight of the load. Each shackle will be rated at or above load weights.
18. Riggers will check loads before rigging to ensure they are free to be lifted and clear of obstructions.
19. Before the lift is made, the crane operator, the rigger and the boat captain will discuss the circumstances of the lift.
20. If the crane operator is unable to see the load being worked, the crane operator will be aided by a second qualified rigger acting as a signalman. See Section III "API RP 2D".
21. The crane operator will obtain all pertinent information contained on the shipping manifest before cargo transfer begins (weights, hazardous material, etc.).
22. A stinger, of sufficient length, will be attached to the main hook to keep the main hoist load block or auxiliary hoist headache ball from coming in contact with personnel rigging loads on the deck of a vessel offshore. Stingers are not to be used as slings. Do not connect the stinger hook directly to load when rigging.
23. The stinger is not required when making heavy lifts or when rigging to the personnel basket.
24. Bypassing of the boom kick-out, anti-two blocking or other safety devices on any GoM crane will not be allowed!
25. All Marine Vessel Tender Operations require deck cargo inventory tracking. (Reference Attachment 24)

D. Maintenance

1. A Preventive Maintenance (PM) program is required for all cranes. See Section V "Crane Maintenance and Inspections".
2. The main load block and auxiliary hoist headache ball will be painted with a safety color paint, for maximum visibility. The hook will not be painted.
3. Weight Indicators will be maintained according to manufactures recommendations.
4. Repairs will be done by Qualified Mechanics or Qualified Operators. Repairs to critical components (structural parts, ball ring bolts, wire rope, winches, sheaves, pins, boom sections) will be done by a Qualified Inspector.
5. Operational, maintenance and inspection records will be maintained for a minimum of two years. Original records are to be kept onsite.
6. The BP Amoco/ Contract Field, Facility or Rig Supervisors are responsible for documenting all inspection, preventive maintenance and corrective work orders.
7. Any malfunction of the crane must be reported to the Field, Facility or Rig Supervisor immediately. The discrepancy will be documented and addressed. See Section V "Crane Maintenance and Inspections".

III. CRITICAL PERSONNEL

Personnel critical to the proper operation, inspection and maintenance of offshore cranes are defined below.

A. Qualified Operator

1. Person(s) designated, either BPA or contractors, by the BP Amoco/ Contract Field, Facility or Rig Supervisor to operate cranes. This designation is based on the designee having appropriate offshore experience and training (classroom and “hands-on” field training on cranes) and has met the requirements of a qualified rigger.
2. The minimum requirements to be classified as a *Qualified Operator* are outlined in detail in API RP 2D. (Reference Attachment 3 “Qualifications for *Qualified Operator*.”)
3. A *Qualified Operator* is also qualified to perform crane inspections as outlined in API RP 2D 4.1.2 with the exception of the initial, quarterly and annual inspections.
4. A *Qualified Operator* must attend refresher training every two (2) years to maintain the designation as a *Qualified Operator* as required by BP Amoco.

B. Qualified Inspector

1. Person(s) designated, either BPA or contractor, by the BP Amoco/ Contract Field, Facility or Rig Supervisor to inspect cranes. This designation is based on the designee having appropriate offshore experience, training, being designated as a *Qualified Operator* and having successfully completed formal training on crane maintenance and troubleshooting, in hoist troubleshooting and overhaul, and the structural aspects of offshore cranes which provided the designee with knowledge of structurally critical components and critical inspection areas.
2. A *Qualified Inspector* can perform pre-use, initial, quarterly, and annual inspections.

C. Qualified Rigger

1. A person with training and experience who has successfully completed a rigger training program. A *Qualified Rigger* must attend refresher training every two (2) years to maintain the designation as a *Qualified Rigger* as required by BP Amoco. Training should incorporate familiarization with rigging hardware, slings and safety issues associated with rigging, lifting loads and planning.
2. *Qualified Riggers* will be the only personnel allowed in the work area during lifting operations.

D. Site Supervisor

BPA and Contractor Site Supervisors, having direct supervisory responsibility for crane operations, will meet the qualifications of a crane operator.

E. Designated Signal Person

This person will meet all the requirements of a *Qualified Rigger*. This individual should be qualified by experience with the operations and knowledgeable of the standard hand signals as shown in Attachment 4 “Crane Hand Signals” and Attachment 4-A “Signaling Guidelines for Riggers.”

IV. OPERATING PRACTICES

A. Crane Operating Personnel

1. Only the following BP Amoco or contract personnel will operate cranes:
 - a. *Qualified Operators*.
 - b. Trainees under the direct supervision of a *Qualified Operator*.
 - c. Appropriate maintenance and supervisory personnel, when required for them to perform their duties.
2. Only those personnel specified above should enter a crane cab.

B. Crane Operator Responsibilities

The *Qualified Operator* is responsible for the crane operations under his/her control. The *Qualified Operator* is authorized to stop and refuse to handle loads or continue operations as safety dictates.

The operator will be familiar with the equipment and its proper care. If adjustments or repairs to the crane are necessary or any deficiencies that impair safe operations are known, the *Qualified Operator* will take the crane out of service, document deficiencies and/or restrict its service to eliminate the unsafe condition.

Before starting the crane, the *Qualified Operator* will do at least the following:

1. Conduct and document the pre-use inspection as outlined in Attachment 6 "Crane Pre-use Inspection." The pre-use inspection records will be maintained at the platform.
2. Ensure all controls are in the "off" or "neutral" position.
3. Ensure all personnel are in the clear.
4. Ensure the appropriate static and dynamic load rating charts are in place and visible from the crane control station for the crane configuration in use i.e., boom length, load line reeving, counter-weight, jib, etc.
5. Ensure that there is sufficient lighting for safe operation if loading at night.
6. Ensure that the load and landing area are illuminated if loading at night.
7. Ensure that fire extinguishers, of proper type and size, are in the cab or vicinity of the crane.

Before using the crane, the *Qualified Operator* will do at least the following:

1. Ensure that a JSA Review has been performed for the lift.
2. Know that the hook load is within the crane's applicable static or dynamic rated load at the radius at which the load is to be lifted.
3. For mechanical cranes, function the brakes prior to handling heavy loads.
4. Prior to raising the load, exposed brakes should be warmed.
5. Prior to raising the load, rusted surfaces on the drums should be cleaned by raising and lowering the boom and load lines under slight pressure.

While using the crane, the *Qualified Operator* will do at least the following:

1. Start load movement only if the load is within the vision of the *Qualified Operator* or the appointed signal person is within the sight of the *Qualified Operator* and has given the appropriate signal.
2. Have the load attached to the hook by means of slings or other suitable devices. The latch will be closed to secure loose slings.
3. Not allow the hoist rope to be wrapped around the load.
4. Properly use slings in accordance API RP 2D C.3.2.2c and 5.2.1.
5. Only respond to signals from the appointed signal person (but will obey an emergency signal regardless of who gives it).
6. Move the load in accordance with the guidance outlined on Attachment 7 "Moving the Load."
7. Not apply external forces that will produce side loading of the boom.
8. Take care when swinging the crane to minimize the swinging pendulum action of the hook and suspended load.
9. Not use the crane for dragging loads unless properly rigged for a vertical pull that does not exceed the rated capacity.
10. Not hoist, lower or swing the load while personnel are on the load (unless in an approved personnel carrier).
11. Not hoist a load over personnel.
12. Block or crib loads that are suspended by slings or hoists prior to letting someone work beneath or between the loads.
13. Always maintain at least five (5) wraps on the drum in any operating condition unless recommended by crane manufacturer.
14. Designate a single *Qualified Operator-in-Charge* in the event two cranes are used to perform a lift of a single load. The designated *Qualified Operator-in-Charge* will analyze the operations, and instruct all personnel involved in the proper positioning, rigging of the load and the movements to be made.
15. Ensure that appropriate tag or restraining lines are used to control the load.
16. The boom hoist auxiliary holding device, where fitted, will be engaged when a crane is to be operated at a fixed radius or when booming up. This is especially important in the case of mechanical cranes or those without automatic pawl control.
17. Ensure that signals from the designated signal person are always understandable either verbally or visually. The *Qualified Operator* will not respond unless signals are clearly understood.
18. Ensure that the designated signal person is in clear view.
19. Ensure that the designated signal person can clearly see the load, crane, personnel and area of operation.
20. Utilize a second designated signal person to work with the primary designated signal person if the *Qualified Operator's* view of the primary designated signal person is obstructed.

21. Ensure the use of standard hand signals.
22. Develop special signals when the situation requires it and ensure that the designated signal person understands and agrees with the special signals.
23. Ensure that the crane is not refueled while the engine is running.

Before leaving the control station unattended, the *Qualified Operator* will:

1. Land or secure the attached load.
2. Disengage the master clutch, where applicable.
3. Set all locking devices.
4. Put controls in the “off” or “neutral” position.
5. Stop the prime mover.
6. Ensure that no component of the crane will interfere with normal helicopter flight operations.

When the crane is not in use, the *Qualified Operator* will:

1. Secure the crane against swinging or interference with other crane operations.
2. Not allow field welding on load hooks or sling hooks.
3. Not allow the hooks to be exposed to excessive heat.
4. Ensure that fuel tanks will be filled in a manner that any fuel spills or overflows will not run onto the engine, exhaust or electrical equipment.
5. Ensure that spill containment is in place to provide environmental protection during refueling operations.
6. Place an Out-of-Service sign on the crane’s primary controls and disable the start system if the crane has been taken out of service. (Lock Out/Tag Out)

If power or a necessary control function fails during crane use, the *Qualified Operator* will:

1. Set all brakes and locking devices.
2. Move all clutch or other power controls to the “neutral” or “off” position.
3. If practical, land the suspended load by controlled lowering and stopping.

When the crane is positioned near a helideck or the approach/take-off zones, a *Qualified Operator* will:

1. Complete all critical and personnel lifts before leaving the control station.
2. Not operate the crane while a helicopter is landing, taking off or in operation on the helideck.
3. Position and secure the boom where there will be no interference with the flight operations.
4. Not be at the crane control station unless the *Qualified Operator* is in direct radio communication with the pilot.

C. Transferring Personnel with the Crane

NOTE: Hoists used to transfer personnel will have a certification on file which states:

“Approved For Personnel Handling.” This certification will be maintained in the crane file on the facility. Cranes used to transfer personnel will follow the recommendations outlined in the most recent editions of API Spec. 2C and API RP 2D Section 3.4 Personnel Transfer. The BP Amoco/ Contract Field, Facility or Rig Supervisor will determine what cranes in his/her area are approved to handle personal and provide that list on request.

A Qualified Operator will do the following when transferring personnel with the crane:

1. Only use hooks with a locking type safety latch.
2. Close the safety latch when the load is attached.
3. Ensure that the load is under control in both up and down directions. No free fall operations allowed.
4. Ensure all personnel transferred with a crane are wearing personnel flotation devices (PFD).
5. Ensure that personnel riding a net-type personnel carrier are standing on the outer rim facing inward.
6. Ensure that the weight of the loaded personnel carrier or net does not exceed the personnel rated load as defined by API RP 2C, latest edition.
7. When transferring personnel between vessels or from a vessel to a platform, raise the personnel carrier only high enough off the deck to clear all obstructions, swing the personnel carrier over the water, raise or lower it in such a manner as to minimize swinging, position it slightly above the landing area and gently lower it to the deck.

D. Crane Operator and Rigger Proficiency Test

BPA requires ALL crane operators and riggers to pass a written proficiency test prior to operating a crane or rigging in BPA operations. The BP Amoco/ Contract Field, Facility or Rig Supervisor or his/her delegate will administer the test. Test records will be kept at the facility. Successful test score is determined by the supervisor. If the employee or contract employee fails the test, he/she will not be allowed to operate a crane or rig. All incorrect answers will be reviewed with the operator/rigger by the supervisor to ensure adequate understanding. The BP Amoco/ Contract Field, Facility or Rig Supervisor may also require a hands-on demonstration of crane operation or rigging skill utilizing the equipment at the site.

E.

JSA Requirements

JSA's reviews are required for all lifts.

1. To provide assurance that JSA Reviews are being conducted a documentation system will be maintained at the field facility. This system will note when the JSA review was conducted and the names of the personnel in attendance.
2. The documentation system at a minimum will consist of at least a Log Book with date, time, personnel and supervisor of the lift involved in the JSA review.
3. JSA assurance process will be verified through ASA, annual HSE audits, routine WIP reviews, supervisor and management reviews.

V. CRANE MAINTENANCE AND INSPECTION

A. Crane Re-rating

1. All GoM crane re-rating will be in accordance with the crane manufacturer or other qualified source such as an API licensed 2C crane manufacturer, or a licensed engineer experienced in the design of the crane. Re-rating reports will be maintained on the facility and by appropriate office personnel indefinitely. Crane re-rating will require issuing revised load charts.
2. No GoM cranes will be re-rated in excess of the original load ratings unless such rating changes are approved by the crane manufacturer or other qualified source such as an API licensed 2C crane manufacturer, or a licensed engineer experienced in the design of the crane. Crane re-rating will require issuing revised load charts.

B. Crane Usage

1. The amount of crane usage determines the appropriate intervals for inspection. Crane usage is divided into three API categories as shown below:
 - Infrequent Usage - used less than 10 hours/month based on a quarterly monthly average.
 - Moderate Usage - used between 10 to 50 hours/month based on a quarterly monthly average.
 - Heavy Usage - used more than 50 hours/month based on a quarterly monthly average.
2. All cranes on BP Amoco operated facilities and rigs will default to the heavy usage category.
3. The following inspection schedule is required for heavy usage:
 - Pre-use Inspection
 - Monthly Inspection
 - Quarterly Inspection
 - Annual Inspections
4. The crane pre-use inspection will be documented and available at the location. This documentation can be kept in the crane cab, a weather tight enclosure on the crane, or inside the nearest building on the platform. The pre-use inspection will be done every time the crane is used.

C. Inspection Requirements

1. There are four types of inspections performed on cranes as shown below:
 - Pre-use Inspection - Performed by a *Qualified Operator*
 - Monthly Inspection - Performed by a *Qualified Operator*
 - Quarterly Inspection - Performed by a *Qualified Inspector*
 - Annual Inspection - Performed by a *Qualified 3rd Party Inspector*

2. A description of these different types of inspections is shown in Attachment 8 “Crane Inspection Categories.”

D. Record Keeping

1. Inspection reports, repair records and modification records must be documented and kept at the platform for two (2) years and kept in an archive file for at least five (5) years.
2. Inspection reports must be written, dated and initialed by the individual performing the inspection and the person preparing the inspection report, if different. This applies to the following types of inspections:
 - Pre-use or Rig Shift Log Book
 - Monthly
 - Quarterly
 - Annual
3. When a load test is required, a written report will be prepared by a *Qualified Inspector* and given to the BP Amoco/ Contract Field, Facility or Rig Supervisor. The report will show the test procedure and results.

E. Crane Maintenance

1. A Preventive Maintenance (PM) program is required for all cranes. This program will ensure that cranes are reliable and safe to operate. Key factors considered in designing the maintenance plan are crane type, usage, maintenance history and manufacturer’s recommendations.
2. All PM work will be documented and scheduled. The PM activities will be completed as scheduled. Actions will be taken promptly to correct a deficiency or the crane will be taken out of service.
3. The BP Amoco/ Contract Field, Facility or Rig Supervisor will ensure all deficiencies are corrected.
4. Temporary, rental and platform drilling rig cranes will comply with BP Amoco’s PM program requirements.
5. Crane Preventive Maintenance Programs are subject to audits and BP Amoco approval.

F. Crane Maintenance Precautions

1. The following precautions will be followed prior to performing maintenance:
 - Render all means of starting the crane inoperable.
 - Place out-of-service signs on the control station and/or on the prime mover.
 - Make adjustments in compliance with the manufacturer’s recommendations.

G. Crane Repairs and Replacements

The following guidelines have been established if repairs or part replacement is required:

1. Immediately take a crane out-of-service if an unsafe condition is identified or restrict the crane's operation to eliminate the unsafe condition.
2. Repair or replace all critical components promptly.
3. An API 2 C licensed shop or the Original Equipment Manufacturer will supply crane parts or components (booms, winches, bearings, gantry's pedestals, etc.). Repairing of the structural members by a non-authorized shop that does not have either an API or a QUALITY Plan and PROCEDURES is not acceptable.
4. Document in writing all repairs or replacements as per the PM program.
5. Any change in a crane's configuration (boom length, cable size, number of parts of line, etc.) will require a load test before it is returned to service. An approved load chart reflecting the current crane's configuration will be attached to the crane before the crane can be operated.
6. Use only replacement parts that meet or exceed the OEM specifications.
7. No welding repairs will be made to critical components such as booms and swing circle assemblies unless a repair procedure and recommendations are obtained from the crane manufacturer or other qualified source (licensed 2C crane manufacturer, or licensed engineer experienced in the design of the crane).
8. Care will be taken to ensure that arcing does not occur across the bearings.
9. No welding on load hooks or sling hooks.
10. Hooks should not be exposed to excessive heat.

H. Lubrication

The crane manufacturer's recommendations should be considered for:

- Lubrication Points
- Lubrication Frequency
- Maintenance of Lubricant Levels
- Lubricant Compatibility

I. Anti-Two Blocking Requirements

All cranes will be equipped with anti-two blocking system for the main hoist and auxiliary hoist circuit. A high boom angle limit device will be incorporated on all lattice boom style cranes and any crane that uses wire rope to raise and lower the boom assembly.

NOTE: The two blocking systems will be of the type that stops the hoist from pulling. The hoist will stop with or without a load attached.

J. Crane Lifting Capacity

Cranes will not be utilized to lift equipment that exceeds dynamic and/or static capacities identified on the crane load chart. All offshore lifts from/to boats will be considered dynamic. Anyone planning to order equipment that will be shipped out to a BPA operating facility will contact the BP Amoco/ Contract Field, Facility or Rig Supervisor to confirm the weight and/or other limitations of the crane. The dynamic and static lift capability of the crane will be documented at this time. The BP Amoco/ Contract Field, Facility or Rig Supervisor will be contacted with any questions or concerns in regard to this matter. This must be done prior to ordering and mobilization the equipment.

NOTE: Confirmation of adequate platform or rig space to support the equipment will also be made at this time. Attachment 19 "Production Platform Crane Lifting Capabilities" outlines the preparation process.

K. Welding Criteria

1. No welding repairs will be made to the critical components, such as booms and swing circles assemblies, without specific repair procedures and recommendations.
2. These recommendations must come from the original crane manufacturer or other qualified source (such as an API licensed 2C crane manufacturer or a licensed engineer experienced in the design of the crane, as determined by BP Amoco).
3. Field welding will not be performed on load hooks or slings. Welding leads need to be grounded directly to the work.
4. The BP Amoco/ Contract Field, Facility or Rig Supervisor will approve all such repairs.

L. Load Test Criteria

1. A crane load test is required under the following conditions:
 - New cranes being placed into service
 - Cranes that are being permanently relocated
 - Temporary/rental cranes after each rig-up or relocation
 - Annual crane Inspections by Qualified 3rd Party Inspector

A crane load testing is not required to determine the fitness of repairs or alterations, provided the repair and replacement procedures outlined in Section 5.5 "Crane Maintenance" are followed.

The designated *Qualified Inspector* must carefully choose the load applied to the crane during the test. Since the test loads are based on the crane rating chart, the *Qualified Inspector* must be familiar with the applicable load rating chart. Since it is obviously impossible to test all of the crane components at the same time, the *Qualified Inspector* should choose test loads that specifically stress the repaired or altered component.

Since the crane's hoists and ropes will be used to impose the overload on the crane,

the *Qualified Inspector* will choose a test load that is within the capacity of the hoist(s) and rope(s) as normally rigged. The crane will not be rigged with extra parts of line to lift a greater test load at a closer radius.

The test load can be imposed on the crane with a lesser load at a greater radius. However, the test load will be to API RP 2D requirements and will be based on the heaviest specified or the typical load weight to be lifted. A water bag is recommended to perform the test. A BP Amoco representative or his/her delegate will witness the load test and all annual crane inspections.

VI. SLING AND WIRE ROPE CRITERIA

A. Sling Guidelines

1. Slings are made of numerous types of material, construction, combinations and various types of hitches. The sling manufacturer will be consulted when a questions arises concerning sling rating, use, care and/or inspections.
2. Slings will be inspected and tested in accordance with the Wire Rope Technical Board, Web Sling Association, National Association of Chain Manufacturers, or ANSI B30.9 latest edition, whichever is applicable.
3. Visually check all slings prior to use. A *Qualified Operator, Inspector or Rigger* will perform these inspections.
4. Sling inspection is based on the following:
 - Sling usage.
 - Severity of service conditions.
 - Type of lifts being made.
 - Experience based on service life of slings used in similar applications.
5. Attachment 1 “GoM Certified Sling and Rigging Procedure Summary” has additional information.

B. Slings Usage Guidelines

1. Suitable protection should be provided between the sling and sharp surfaces of the load to be lifted.
2. Slings should be store properly when not in use.
3. Slings should never be choked in the splice.
4. Sharp kinks or knots should not be permitted in wire rope slings.
5. Loads should not be lifted with one leg of a multi-leg sling until the unused legs are secured.

C. Wire Rope Inspection

1. Wire rope is a structural component of the crane that requires periodic replacement. Loss of strength occurs due to wear, abuse and other forms of deterioration. The *Qualified Inspector* determines whether replacement is necessary.
2. Wire rope inspection program is part of the required PM program and is based on the following:
 - Crane type.
 - Crane usage.
 - Crane maintenance history.
 - Wire rope manufacturer’s recommendations.

- ☐ Crane manufacturer's recommendations.
 - ☐ Visual inspections of the wire rope by the *Qualified Operators* or *Qualified Inspector* during pre-use and monthly inspections.
 - ☐ Quarterly and annual Inspections by the *Qualified Inspector*.
3. Areas affecting rope performance and rope life will be checked when rope is replaced or when quarterly and annual inspections are performed.

D. Wire Rope Replacement

The following guidelines will be followed to determine continued use or retirement of the wire rope:

- Rope conditions found during inspection
- Inspection records will be kept such that a rope replacement time interval can be determined
- Inspection records on observed wire rope deterioration
- Worn out wire rope will be identified as unfit for use and removed from service

E. Wire Rope Maintenance

Wire rope should be handled with care. The following guidelines should be followed to maintain the wire rope in optimum condition:

1. Store and handle wire rope carefully to prevent damage and deterioration.
2. Unreeling or uncoiling of rope will be done as recommended by the rope manufacturers.
3. When unreeling or uncoiling wire rope, attention will be given to avoid the introduction of kinks or twists into the rope. Wire rope in the boom hoist and load hoist systems will be installed and reeved as recommended by the crane and/or wire rope manufacturer.
4. Prior to cutting a wire rope, seize the rope at either side of the cut to prevent unlaying of the strands.
5. Do not contaminate, nick, scrape or sharply bend the wire rope.
6. Wedge socketing or terminating of the wire rope will be performed or supervised by a *Qualified Operator* or a *Qualified Inspector* as per API 2D Figure G8.
7. Wire rope clips will be installed in accordance with wire rope or clip manufacturer's recommendations.
8. Malleable wire rope clips will not be used.
9. Drop forged clips are acceptable.
10. The saddle portion of the clip will be applied to the live rope segment and the U-bolt to the dead or shortened end segment.

11. Wire rope clip nuts will be tightened after initial use of the wire rope and periodically checked for proper torque.
12. Wedge-type sockets will be properly installed.
13. Maintain the wire rope in a well-lubricated condition to minimize internal and external corrosion or friction. Apply lubricant to wire rope as rope passes over a sheave.
14. Field applied lubricant must be compatible with the lubricant applied by the manufacturer.
15. Used oil will not be used as a lubricant because of possible contamination.
16. Obtain a wire rope manufacturer's test certificate when purchasing new wire rope. These tests will include an actual break test certificate. Certificates will be kept on file at the platform.

F. Wire Rope Sling Replacement

If there is any question relative to the integrity of a sling, the sling will be properly disposed of. The following lists some of the reasons for replacing a sling:

1. In single part slings constructed of 6x19 class and 6x37 class wire rope in single-part slings, ten (10) randomly distributed broken wires in one lay length or five (5) broken wires in one strand in one lay length. For other constructions, refer to the Wire Rope Sling Users Manual and/or ANSI B30.9.
2. Severe localized abrasion or scraping.
3. Kinking, crushing, birdcaging or any other damage resulting in distortion of the rope strand, wires, core configuration, eyes and splices.
4. Evidence of heat damage or exposure to severe heat.
5. Cracked, deformed or worn-end attachments.
6. Hooks that have been opened more the 15% of the normal throat opening or twisted more than 10 degrees from the plane of the unbent hook.
7. Severe corrosion of the rope or end attachments.
8. Reduction in rope diameter.
9. Loss of certification tag.
10. All wire rope slings will be certified on an annual basis, not to exceed 12 months, or removed from service.

G. Wire Rope Slings Proof Loading and Labeling

All slings should be properly labeled and tested as follows:

1. All slings will be proof loaded by the manufacturer.
2. All slings will be labeled showing sling manufacturer and the pertinent working limits, proof test certification number, length, diameter and date of proof test.

3. Slings constructed of materials other than wire rope will be inspected and tested in accordance with the sling manufacturer and industry recommendations.
4. All wire rope slings will be certified on an annual basis, not to exceed 12 months, or removed from service.

VII. ASSURANCE

Assurance for the Crane and Rigging program is accomplished by:

1. Management engagement and implementation of this program.
2. Audit Program
 - HSE Annual Audit Review (includes crane specialist)
 - Work in Progress audits
 - GHSER audits
 - Field safety coordinators audit
 - AD Hoc audits by HSE, BPA management or contract consultants
 - Supervisor ASA
 - Pre contractor audits
3. Equipment Inspection
 - Pre use and monthly inspection by operator
 - Quarterly inspection by Quality inspector
 - Annual inspection by 3rd party
4. Government Agency inspection and audits
 - OSHA
 - USCG
 - MMS
5. Documentation
 - Supervisor assurance Letter
 - JSA'S-Required for all Lifts
 - JSA Assurance process checked via ASA and annual audit
 - Inspection Reports
 - Repair Records
 - Modification Records
 - Training Records
 - Load Test Records
 - Rigging Certification

- Proficiency Tests (Operator & Rigger)
- Quarterly Crane/Rigging Safety Meeting

6. Training

- API-RP 2D requirements for all crane and rigging personnel
- Supervisory, crane & rigging personnel have (2) two year training cycle
- Competency & proficiency testing
- Facility quarterly crane & rigging safety meetings.

7. Periodic Review and Program Updates

8. Non-compliance reporting

- Stop and other similar programs (behavior based programs)
- Incident / accident / near miss notification

8. Crane Maintenance

- Preventive Maintenance Program required for all units
- Critical Equipment replacement parameters
- All repairs and discrepancies documented
- Increased frequency of inspections and maintenance

VIII. SUPPORTING DOCUMENTATION

The following attachments support this program:

	<u>Topic</u>
1	GoM Certified Sling and Rigging Procedure Summary
2	GoM Bottle Rack Design Guidelines
3	Qualifications for <i>Qualified Rigger/Operator</i>
4	Crane Hand Signals
4A	Signaling Guidelines for Riggers
5	Crane Pre-use Inspection
6	Moving the Load
7	Crane Inspection Categories
8	Crane Inspection Guideline
9	Crane Maintenance Guideline
10	Rigging Guideline
11	<i>Qualified Operator</i> Training and Test
12	<i>Qualified Rigger</i> Training and Test
13	Monthly Crane Inspection
14	Quarterly Crane Inspection
15	Annual Crane Inspection
16	Advanced Safety Audit Criteria
17	Procedures and Precautions (Sling Angles)
18	Determining Crane Capacity with Load Chart
19	Production Platform Crane Lifting Capabilities
20 21 22 23 24	BP Amoco Crane Operator Proficiency Test BP Amoco Rigger Proficiency Test GoM Crane Rigging Safety Meeting Protocol Cargo Manifesting and Material Identification Procedure Deck Layout tracking - Marine Vessel Tender Operations

GOM CERTIFIED SLING AND RIGGING PROCEDURE SUMMARY

BP Amoco GoM will utilize certified slings within all operations both at dock facilities as well as within operations in the Gulf of Mexico. Those contractors providing services to BP Amoco at dock facilities and on managed sites offshore will also be required to utilize certified slings. The slings will be inspected prior to each use and the slings will either be replaced or re-certified on an annual basis. Certification means that a proof test was performed on the sling. Utilization of rubber hoses that act as a protective cover on slings are prohibited. All certified slings will be in compliance with API RP 2D and they will have a label from the manufacturer that identifies the sling certification date. Note that nylon lifting straps do not need annual certification.

Rigging will be designed so personnel can hook / unhook from the deck, dock, rig or platform level. Proper length slings will prevent personnel from climbing or using ladders to hook / unhook equipment. The rating on the shackles will be equal to or greater than the rating on the slings. All shackles utilized will be Crosby or equivalent and utilize a secondary securement method (i.e. bolt & pin, safety wire or tie-wrap). It is prohibited to weld shackle pins to any shackle.

In addition, those contractors that provide equipment to our offshore operations (i.e. production, drilling, construction), will be required to attach certified slings and shackles to their equipment under the following circumstances:

- Equipment exceeds five thousand pounds (or)
- Equipment exceeds six feet in height (or)
- Equipment requires a four point hook-up.

Those contractors that are sending equipment (i.e. bottle racks, tool boxes, welding machines, etc.) to BP Amoco shore bases for transportation offshore will ensure that the equipment is designed appropriately and that the weight of the equipment is permanently marked on the equipment. The safe working load of baskets will also be permanently marked on the basket. Contractor/vendor supplied equipment that does not meet this criteria will be returned to the contractor at their expense. In addition, BPA shore bases will mark all outbound loads as to weight according to BPA load marking criteria.

Offshore - Lifts to/from vessels require radio communication among the lifting team, i.e.; crane operator, riggers, signal men as appropriate and boat captain. All lifts to/from vessels are dynamic and will be lifted according to dynamic load chart limitations. All lifts to/from vessels will utilize confirmed load weights.

Drilling - All tubulars (casing, drill pipe, tubing, etc.) will be pre-slung with certified slings prior to transport to/from offshore facilities. All subs, stabilizers, bits and mills less than 4' in length will have a fit for purpose and engineered lifting cap installed and will be transported in a container, bolster or basket provided by the vendor. All subs, stabilizers and mills greater than 4' in length will not be required to have lifting caps but will be preslung with certified slings prior to arriving at a BPA Dock Facility and will be transported in a container, bolster or basket provided by the vendor.

GOM BOTTLE RACK DESIGN GUIDELINES

Guidelines for Acceptance of Compressed Gas Cylinder Racks being Shipped Offshore

The following criteria is provided to assist shore based and offshore facility personnel in the determination to accept bottle racks carrying compressed gas to our offshore facilities:

1. All bottle racks to be of sound and workmanlike construction, free of defects
2. All racks will have at least two (2) lifting padeyes or lifting hook arrangements for hoisting the unit
3. All racks will be built to be inherently stable and not easily tipped on side
4. All racks to have individual bottle securement provisions
5. Bottle keeping bars should be secured by railing or channel slotted into the rack frame held in place by non-load bearing nut/bolt threaded arrangements or safety pins
6. T-handle bolts or nuts are not acceptable
7. Gas cylinders should be secured both top and bottom
8. Racks transporting both Oxygen and Acetylene cylinders will have firewall barriers between the two types of gas bottles
9. Chain can be utilized only as secondary securement for bottles in any rack
10. BP Amoco Shorebase and Offshore personnel retain the final decision as to rack acceptance/non-acceptance
11. Bottle racks containing manifolded cylinders will be equipped with overhead dropped object protection
12. Compressed gas cylinder racks that do not meet this criteria will be removed from BPA property and returned to the contractor at their expense.

QUALIFICATIONS FOR *QUALIFIED RIGGER/OPERATOR*

Qualified Riggers and Operators must meet the following qualifications:

1. At least 20/30 Snellen in one eye and at least 20/50 Snellen in the other eye with or without glasses, and must have depth perception.
2. Be able to distinguish red, green and yellow, regardless of position of colors, if color differentiation is required for crane operation
3. Have hearing, with or without a hearing aid, adequate for the specific operation
4. Have no history of a disabling medical condition which may be sufficient reason for disqualification.
5. Successfully complete the training and testing as required in Attachment 12 or 13 as applies.
6. The *Qualified Rigger/Operator* must re-qualify every 2 years. This will include attending the appropriate refresher training and evaluation of the operator's current vision and medical condition.

CRANE HAND SIGNALS

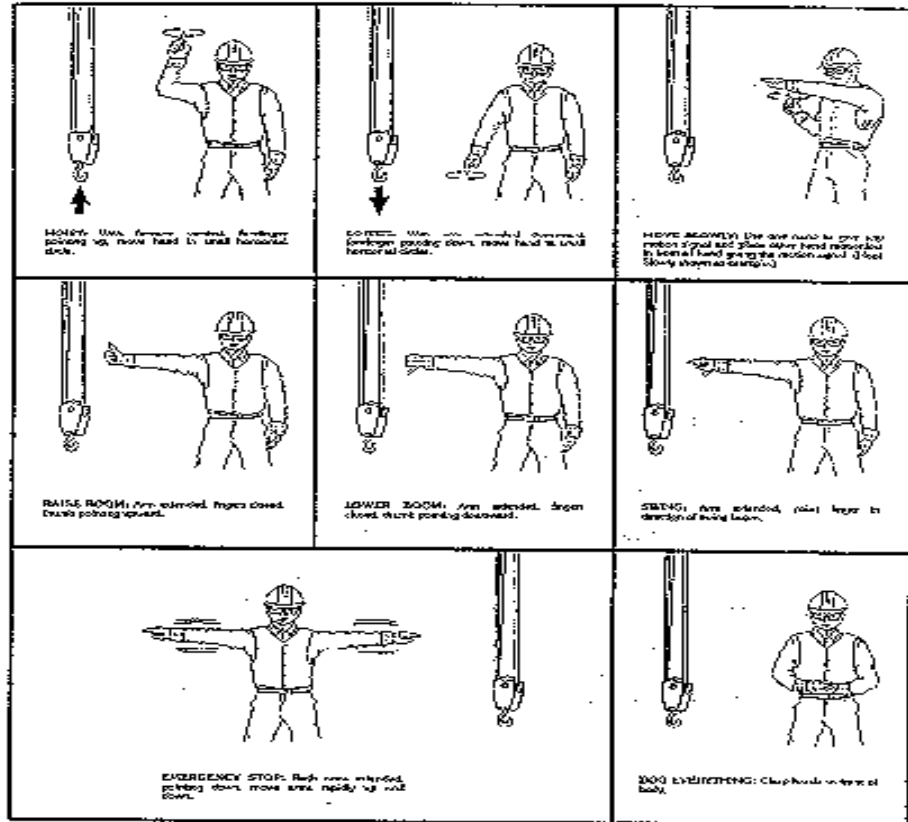

Standard Hand Signals for Controlling Crane Operations

SIGNALING GUIDELINES FOR RIGGERS

The rigger will be responsible to:

1. Verify that the load is secure and properly balanced before signaling to lift.
2. Verify that planned lift and swing paths are clear of personnel and free of obstructions.
3. Verify that the load is free to be lifted and clear of obstruction before giving hoist signal.
4. Verify that lines are not twisted around each other before giving hoist signal.
5. Signal the operator to boom or swing until the hook is centered over the load before hoisting.
6. Do not direct load movement such that the crane, rope, or load contacts any obstruction.
7. Do not give load movement signals while personnel are on the load or hook, unless in a personnel basket.
8. Do not direct load movements over personnel.
9. If the load must remain suspended, give the “dog everything” signal.
10. When directing personnel lifts, signal to raise the carrier only high enough to clear obstructions, and avoid raising or lowering the carrier over the deck of a vessel.

CRANE PRE-USE INSPECTION

1. Check all fluid levels of prime mover
2. Check control mechanisms including brakes and clutches for proper operations.
3. Visually check for hoist lubricant oil leakage. In hoists where a sight glass is provided, also check the fluid level.
4. Visually check for leakage or damage in the air and non-mechanical systems.
5. Check the following devices where applicable
6. Boom Hoist Pawl
7. Helicopter Warning Light
8. Crane Hook Latch
9. Perform a “walk-around” visual examination for the crane boom and support structure to ensure that no damage exists.
10. Ensure the correct load rating chart for the configuration in use is visible to the crane operator at the primary control station
11. Visually check wire rope for evident deterioration and damage, or improper reeving.
12. Visually check for loose, missing, or corroded bolts, pins, keepers or cotter pins.
13. Visually check loose gear to be used, such as slings, sling hooks and shackles
14. Lubricate components and correct deficiencies as required based on the results of these inspections.

MOVING THE LOAD

1. The *Qualified Operator* and the designated signal person directing the lift will determine that:
 - The load is secured and properly balanced in the sling or lifting device before it is lifted.
 - The lift and swing paths are clear of obstructions and personnel.
2. Before starting to lift, the following conditions will be verified
 - The load is free to be lifted.
 - Multiple part lines are not twisted around each other in such a manner that all of the lines will not separate upon application of the load.
 - The hook is brought over the load in such a manner as to minimize swinging.
 - If there is a slack rope condition, the rope is properly seated on the drum and in the sheaves.
 - The correct slings have been selected for the weight to be lifted.
3. During lifting, care will be taken that:
 - Acceleration or deceleration of the moving load is accomplished in a smooth manner.
 - Load, boom, or other parts of the machine do not contact any obstruction.
4. The *Qualified Operator* should engage the controls smoothly to avoid excessive stress on crane machinery
5. When rotating the crane, sudden starts and stops should be avoided. Rotational speed will be such that the load does not swing out beyond the radius at which it can be controlled.

CRANE INSPECTION CATEGORIES

DESCRIPTIONS

1. Initial Inspection

Applies to new cranes that are being placed into service and to cranes that have been relocated and permanently installed at a new location. The initial inspection is performed by the *Qualified Inspector* and will include a load test performed per the procedure shown in Attachment 11.

2. Pre-use Inspection or Rig Shift Log Book

Performed on cranes prior to use (typically daily) and then as a *Qualified Operator or Qualified Inspector* deems necessary during the day for extended operations. The Pre-Use Inspection will be performed by a *Qualified Operator or Qualified Inspector*. Details of this inspection are shown in Attachment 12.

3. Monthly Inspection

Performed monthly on all cranes designated as “heavy use”. The inspection will be performed by a *Qualified Operator or Qualified Inspector*. This inspection report will be written, dated and initialed by the inspector and the person who prepares the report, if different. The reports will be stored at the platform indefinitely.

4. Quarterly Inspection

Performed once every three months on all cranes designated as either “moderate” or “heavy usage”. The inspection will be performed by a *Qualified Inspector*. This inspection report will be written, dated and initialed by the inspector and the person who prepares the report, if different. The reports will be stored at the platform indefinitely.

5. Annual Inspection

Performed once every year on all cranes. Cranes out of service for more than 12 months will be given an annual inspection prior to placing it back in service. The inspection will be performed by a *Qualified Inspector*. This inspection report will be written, dated and initialed by the inspector and the person who prepares the report, if different. The reports will be stored at the platform indefinitely.

CRANE INSPECTION GUIDELINE

Purpose

Inspections are intended to identify all deficiencies or items that would affect the safe operation or reduce the lifting capability of the crane.

General

1. Inspection procedures and scheduling have been established as PM job plans.
2. These job plans are in accordance with API RP 2D. Fourth Edition, 1999.
3. Contractor cranes will be under this program.
4. BP Amoco requires that initial, quarterly and annual inspections are to be conducted by a qualified inspector.
5. *Qualified Inspector* is a person so designated by BP Amoco who by reason of appropriate experience and training is designated as such (See paragraph 2.2, API-2D). These may include:
 - Mechanic (Contract of BP Amoco)
 - Crane Operator
 - Outside third party inspection service company
 - Crane distributor or crane manufacturer's service representative.
 - Any person who meets BP Amoco inspection parameters and who is designated by BP Amoco's Maintenance Coordinator.
6. All GoM cranes will default to the into the HEAVY usage category.
7. PM inspection forms will be available before the inspection is performed. BP Amoco platform rig and rental cranes will use BP Amoco's form.
8. Completed inspection forms will be filed at each facility. All inspection records will be kept for a minimum of two years.
9. The BP Amoco/ Contract Field, Facility or Rig Supervisor will keep Crane operating, inspection, and maintenance training records for BP Amoco personnel. Training records will be kept indefinitely.

CRANE MAINTENANCE GUIDELINE

Purpose

To communicate and ensure that all BP Amoco GoM pedestal mounted lifting cranes conform to one safe, standardized crane maintenance program.

General

Contractor cranes will be under this program.

Procedures

1. Any noted discrepancies on inspection must be addressed promptly.
2. Major or safety related discrepancies must be repaired prior to crane continuing operation.
3. *Critical Components* will be defined by Appendix A of API RP 2C, Fifth Edition, 1995.

Training

Maintenance training will be On-the-job supplemented by appropriate classroom instruction, as determined by the BP Amoco/ Contract Field, Facility or Rig Supervisor.

RIGGING GUIDELINE

Purpose

To communicate and ensure that all BP Amoco GoM pedestal mounted lifting cranes with associated below-the-hook rigging conforms to safe practice standard criteria.

General

Contractor crane rigging will be under the program and authority of their respective companies in accordance with API RP 2D.

Definitions:

1. Rigging

Rigging consists of the following items:

- Wire Slings
- Nylon Slings
- Shackles/Eye Bolts/Clevises
- Spreader Bars
- Taglines
- Personnel Baskets
- Cargo Baskets
- Hooks
- Chains and Binders

2. Rigging Personnel

Rigging personnel consist of the following:

- Designated Rigger(s)
- Designated Signaller(s)

3. Rigging Materials

All rigging related items purchased for the GoM will be certified by the manufacturer and/or fabricator according to the appropriate ANSI Standards, or will be equal to Crosby industrial grade or better quality.

4. Rigging Procedures

- Each facility conduct inventory/inspections of the rigging equipment as necessary.
- All rigging will be visually inspected for wear/damage prior to each use.
- Any suspect rigging will be immediately removed from service and shipped to the appropriate shore base for further inspection and/or testing as per 5.2.4 of API RP 2D.
- All rigging will be clearly marked with manufacturer's name, load rating, and date of manufacture.
- Tagline length and diameter will be appropriate for the load
- Chains will not be used.

QUALIFIED OPERATOR TRAINING AND TEST

Training

Qualified Operator training refers to the written BPA training program as well as “Hands On” training for cranes. An outline of the major items included in the training is shown below:

Classroom Training:

1. Types of Cranes Used Offshore
 - Mechanical cranes
 - Non-mechanical cranes
 - Electric powered cranes
 - Other crane types

2. Crane Components and Lifting Capacities
 - Components of a stationary mounted crane
 - Boom Angle and Load Radius, reading a range diagram or load rating chart
 - Number of parts of line and relationship to rated load
 - Limitations of the size and type of wire ropes used in boom hoist lines,
 - pendants and load hoist line
 - Lifting capacity of the auxiliary hook
 - Lifting capacity of load and boom hoist drums

3. Wire Rope Construction and Use
 - Mechanics of wire rope
 - Classes, designation and characteristics of wire rope
 - Handling of wire rope
 - Guidelines for replacement of wire rope
 - Wire rope slings

4. Mounting Features of the Revolving upper structure
 - Hookrollers
 - Ball ring
 - King post
 - Others

5. Boom Structure
 - Types of boom construction (Lattice, Box, etc.)
 - Wire rope guides
 - Boom bolts
 - Pin connections

6. Limit Devices
 - Boom-hoist limit
 - Load hoist limits
 - Boom stops
 - All locking devices
 - Anti-two block devices

7. Additional Items
 - Sheaves

- Hand signals
- Control Markings
- Engine emergency stop
- Gauges and indicators

8. API RP 2D Review

9. Testing Requirements

- Successful completion of a written test that covers the material outlined above

Hands On Training

1. OPERATOR - Perform “hands on” demonstration that displays sufficient dexterity and coordination to successfully operate the various cranes he will utilize. Proficiency will be demonstrated in a minimum of twenty supervised lifts of sufficient complexity and characteristics in the various conditions typical to offshore GOM crane operations. Each lift will be supervised by a qualified operator. The BP Amoco/ Contract Field, Facility or Rig Supervisor will approve, document the lifts and the final qualification of the operator.

QUALIFIED RIGGER TRAINING AND TEST

Training

Qualified Rigger training refers to a formalized, written employer training program as well as “Hands On” training for cranes. An outline of the major items that are included in the training is shown below:

Classroom Training:

1. Rigging Hardware:
 - Sheaves, Blocks
 - Hooks, Safety latches
 - Rings, Links, Swivels
 - Shackles
 - Turnbuckles
 - Spreader and equalizer beams
 - Cable Clips
 - Pad eyes, eyebolts, other attachment points
2. Slings:
 - Sling configuration
 - Sling angle
 - Safe working limits
 - Sling types (Synthetic, wire, chain, etc.)
 - Cargo nets, baskets
3. Procedures and Precautions:
 - Load control/taglines
 - Lift planning (load weight, center of gravity, etc.)
 - Inspection/rejection criteria
 - Unbinding loads
 - Personnel transfer
 - Sling handling and storage
4. Rigging Basics:
 - Pinch points/body position
 - Personal Protective Equipment (PPE)
 - Signals/communication
 - Load stability
8. API RP 2D Review
9. Testing Requirements
 - Successful completion of a written test that covers the material outlined above

Hands On Training

1. RIGGER - Attend a “hands on” workshop focused on proper inspection, use, and maintenance of loose gear i.e., slings, shackles, hooks, nylon slings, etc.
2. Testing Requirements
 - Successful completion of a “hands on” test which demonstrates proficiency in the material outlined above as it applies to the cranes and rigging the rigger will use.

MONTHLY CRANE INSPECTIONS

1. Check all fluid levels of prime mover
2. Check control mechanisms including brakes and clutches for proper operations.
3. Visually check for hoist lubricant oil leakage. In hoists where a sight glass is provided, also check the fluid level.
4. Visually check for leakage or damage in the air and non mechanical systems.
5. Check the following devices where applicable
6. Boom Hoist Pawl
7. Helicopter Warning Light
8. Crane Hook Latch
9. Perform a “walk-around” visual examination for the crane boom and support structure to ensure that no damage exists.
10. Ensure the correct load rating chart for the configuration in use is visible to the crane operator at the primary control station
11. Visually check wire rope for evident deterioration and damage, or improper receiving.
12. Visually check for loose, missing, or corroded bolts, pins, keepers or cotter pins.
13. Visually check loose gear to e used, such as slings, sling hooks and shackles
14. Further check all control mechanisms for proper adjustment, excessive wear of components, and contamination by foreign matter
15. Check electrical apparatus for proper function
16. Check boom hoist limit and anti-two block devices for proper operation. Care should be exercised to prevent damage to crane components.
17. Lubricate components and correct deficiencies as required based on the results of these inspections. Document these results on paper and store in the Crane inspection manual located at the platform.

QUARTERLY CRANE INSPECTIONS

1. Check all fluid levels of prime mover
2. Check control mechanisms including brakes and clutches for proper operations.
3. Visually check for hoist lubricant oil leakage. In hoists where a sight glass is provided, also check the fluid level.
4. Visually check for leakage or damage in the air and non mechanical systems.
5. Check the following devices where applicable
6. Boom Hoist Pawl
7. Helicopter Warning Light
8. Crane Hook Latch
9. Perform a "walk-around" visual examination for the crane boom and support structure to ensure that no damage exists.
10. Ensure the correct load rating chart for the configuration in use is visible to the crane operator at the primary control station
11. Visually check wire rope for evident deterioration and damage, or improper receiving.
12. Visually check for loose, missing, or corroded bolts, pins, keepers or cotter pins.
13. Visually check loose gear to e used, such as slings, sling hooks and shackles
14. Further check all control mechanisms for proper adjustment, excessive wear of components, and contamination by foreign matter
15. Check electrical apparatus for proper function
16. Check boom hoist limit and anti-two block devices for proper operation, Care should be exercised to prevent damage to crane components.
17. Boom should be inspected for bent chord members, missing or broken lacing and cracked welds on critical members. Boom section end connections will be inspected for cracked welds, deformation and corrosion.
18. Check boom angle/radius indicators over full range for accuracy.
19. Sheaves will be inspected for wear, cracks, rope path alignment and bearing condition.
20. Check power plants for proper performance compliance with safety requirements.

Attachment 14 (Continued)

21. Check belts and chains for proper adjustment
22. Visually check crane hooks for deformation, and discard if deformations exceed those manufacturer's recommendations.
23. Inspect wire rope
24. Check lubricant level in all hoists and slew drives, including those not fitted with sight glasses.
25. Lubricate components and correct deficiencies as required based on the results of these inspections. Document these results on paper and store in the Crane inspection manual located at the platform. Oil sample analysis as suggested by the hoist manufacturer is intended primarily to evaluate its mechanical integrity. Oil sample analysis need not necessarily mean a laboratory analysis. It can be effectively achieved by qualitative tests performed in the field by a *Qualified Inspector* or *Operator* (such as "cheese cloth" smell and texture tests.)

ANNUAL CRANE INSPECTIONS

1. Check all fluid levels of prime mover
2. Check control mechanisms including brakes and clutches for proper operations.
3. Visually check for hoist lubricant oil leakage. In hoists where a sight glass is provided, also check the fluid level.
4. Visually check for leakage or damage in the air and non mechanical systems.
5. Check the following devices where applicable
6. Boom Hoist Pawl
7. Helicopter Warning Light
8. Crane Hook Latch
9. Perform a “walk-around” visual examination for the crane boom and support structure to ensure that no damage exists.
10. Ensure the correct load rating chart for the configuration in use is visible to the crane operator at the primary control station
11. Visually check wire rope for evident deterioration and damage, or improper receiving.
12. Visually check for loose, missing, or corroded bolts, pins, keepers or cotter pins.
13. Visually check loose gear to e used, such as slings, sling hooks and shackles
14. Further check all control mechanisms for proper adjustment, excessive wear of components, and contamination by foreign matter
15. Check electrical apparatus for proper function
16. Check boom hoist limit and anti-two block devices for proper operation. Care will be exercised to prevent damage to crane components.
17. Boom will be inspected for bent chord members, missing or broken lacing and cracked welds on critical members. Boom section end connections should be inspected for cracked welds, deformation and corrosion.
18. Check boom angle/radius indicators over full range for accuracy.
19. Sheaves will be inspected for wear, cracks, rope path alignment and bearing condition.
20. Check power plants for proper performance compliance with safety requirements.
21. Check belts and chains for proper adjustment
22. Visually check crane hooks for deformation, and discard if deformations exceed those manufacturer’s recommendations.
23. Inspect wire rope
24. Check lubricant level in all hoists and slew drives, including those not fitted with sight glasses.
25. Lubricate components and correct deficiencies as required based on the results of these inspections. Document these results on paper and store in the Crane inspection manual located at the platform. Oil sample analysis as suggested by the hoist manufacturer is intended primarily to evaluate its mechanical integrity. Oil sample analysis need not neces-

sarily mean a laboratory analysis. It can be effectively achieved by qualitative tests performed in the field by a *Qualified Inspector* or *Operator* (such as “cheese cloth” smell and texture tests.)

26. Inspect the hoist assemblies
27. Visually inspect the foundation for fracture, deformation and corrosion.
28. Inspect the swing circle assembly. The three types typically used are the:
 - Hook and Roller Assemblies
 - King Posts
 - Ball/Roller Bearings
29. Perform Load Test according to Section 5 BPA Crane Operating and Maintenance Program.

ADVANCED SAFETY AUDITS

1. Crane Audit Areas

- A. Training - Operator \ Inspector \ Rigger as Per API RP 2D
- B. Record Keeping - Training \ Equipment Upgrades \ Maintenance \ Inspection Reports as per API RP 2D
- C. Crane Maintenance - Preventative Maintenance Program (Crane Inspections)
- D. Quality Control - Guideline Established When Repairs \ Part Replacements are Crane Rebuilds are Required \ Done.
- E. Wire Rope Inspection - Crane Type \ Crane Usage as per API 2D
- F. Rigging Program - Hand Signals \ Shackles \ Slings \ Spreader Bars as per API RP 2D
- G. Roles - Operators \ Inspectors \ Riggers as per API RP 2D
- H. JSA Policy - When \ How
- I. Crane Lifting Capabilities - Static \Dynamic \Crane Position
- J. Load Testing - When \ How

2. Generic ASA and Discussion Items

- A. Overview of BP Amoco Safety Statistics as it Relates to Cranes in GOM
- B. Overview of BP Amoco Crane Operating and Maintenance Program for GOM
- C. Overview of their Crane Operating and Maintenance Policy and Procedures
- D. Agree on Interview Sessions (At Least 3) to Validate Applications and Consistent use of Policies in Field. A Series of Questions should be devised based on the Overview to Stimulate Conversation and Validate Management Program Outlined.

PROCEDURES AND PRECAUTIONS

Sling Angles

Whenever slings are rigged at an angle to the vertical hoisting direction, the actual tension applied to the slings from the load weight depends on the size of the angle formed. In general, this principle applies to multileg bridle and double choker hitches. BP Amoco Program specifies that the "sling angle" is the largest included angle between 2 sling legs.

As the sling angle increases, the tension in the legs also increases. Even though the weight of a load is fixed, the actual tension developed in sling legs may be much greater than the load weight. For this reason, only slings which are rated for angular loading may be used for bridle or multiple choker hitches.

The capacity tag for all slings in BP Amoco GoM which are rated for angular loading will show capacities at a 45° and a 60° sling angle.

When doubt exists in estimating the size of the angle, and where the load weight is near capacity, the sling angle may be determined by measuring the longest distance between sling legs at the point of hitching, if the length of the legs is known.

DETERMINING CRANE CAPACITY WITH LOAD CHART

1. Loads with weight marked:
 - A. Add weight of hook block to load weight.
 - B. Add weight of rigging to load weight (unless pre-rigged) (if pre-rigged, weight of slings is included in load weight).
 - C. Verify boom angle/radius needed to make lift - both hoisting and lowering if different. Indicator is approximate - if possible, measure radius for capacity lifts.
 - D. Find capacity of crane in proper column on load chart.
 - Do not interpolate if angle, radius or load weight falls between chart values, go to safer case.
 - Use static rating (at static radius to be used) for lifts off or onto a fixed platform.
 - Use dynamic ratings (at dynamic radius to be used) for lifts off or onto a boat.
2. Do Not exceed the lowest rated capacity for the lift. Example: To move a load from the platform to the boat, there will be a rated static capacity (capacity to lift the load from the platform at the radius used), and a rated dynamic capacity (capacity to get down on the boat at a possibly different radius). Do Not exceed the least of the two capacities on this lift.
3. Do Not boom down to a lower angle (longer radius) than shown on the load chart for the weight while moving the load. Keep this “minimum angle” in mind at all times.

LIFTING UNKNOWN LOADS TO DETERMINE WEIGHT

Dock Facilities

1. Verify angle or radius to be used.
2. Find capacity of crane on chart.
3. Subtract weight of hook block or ball from capacity - check/adjust zero setting on weight indicator.
4. Hoist load carefully, be aware of capacity limit on weight indicator (if available).
5. If capacity is reached on load indicator before load rises, lift cannot be made at the radius used.
6. Do Not show the weight of slings as part of the load unless pre-rigged (slings stay with load).

**PRODUCTION PLATFORM CRANE LIFTING CAPABILITIES
WELL WORKOVER / COILED TUBING**

The BP Amoco/ Contract Field, Facility or Rig Supervisor will confirm that the crane is in good repair an operating condition prior to the equipment arriving on location. Confirmation of the crane condition as well as necessary repairs made will be communicated to the Engineer that is coordinating the project, and if appropriate the Construction Foreman. All inspections will be current in preparation for the job.

When the dock receives the above mentioned equipment, they will contact the offshore facility that will be receiving the equipment. At this time the dock will confirm the equipment weight and the location that the equipment will be placed on the boat deck to facilitate off-loading.

GoM platform cranes will not be utilized to lift equipment that exceeds dynamic and/or static weights identified on the platform crane load chart. If it is determined that equipment that arrives in the field exceeds the dynamic and/or static weight capacity of the platform crane, then the equipment will be sent back to the vendor. The BP Amoco/ Contract Field, Facility or Rig Supervisor will be contacted if this situation takes place.

BP AMOCO CRANE OPERATOR PROFICIENCY TEST

NAME: _____ DATE: _____

COMPANY: _____

This test consists of True/False, Fill in the Blank, and Multiple Choice questions.

NOTE: *On the multiple choice questions, there is a possibility of more than one correct answer.*

1. It is up to the _____ to report to the owner any deficiency.
 - *Qualified Operator*
 - Gauger
 - Instrument Technician
 - *Qualified Inspector*

2. The qualified operator should obey signals from anyone who gives signals.
 TRUE FALSE

3. The qualified operator will verify that the proper static and dynamic load charts are in place at the control station.
 TRUE FALSE

4. The qualified operator will be aware of operating characteristics of the individual crane he/she is to operate.
 TRUE FALSE

5. No fewer than five (5) full wraps will remain on the drum under normal operating conditions.
 TRUE FALSE

6. Signals between the crane operator and the designated signal person will be discernible, audible, or visual at all times.
 TRUE FALSE

7. Pre-use inspection applies to:
 - A Platform cranes
 - B Permanently relocated cranes
 - C Rental/Temporary cranes
 - D Drilling rig cranes
 - E All of the above

Attachment 20 (Continued)

8. If unsafe conditions exist, the crane will be taken out of service or operations restricted to eliminate unsafe conditions.
TRUE FALSE
9. Wire rope slings or other load carrying devices, unfit for use on cranes, will be removed from service and identified as unfit for use.
TRUE FALSE
10. When making a lift off of a boat, the weight of the load, the angle, or the radius must be known.
TRUE FALSE
11. When making a lift off of a boat, the qualified operator should operate all crane functions smoothly, avoiding jerks and sudden stops and starts; this will prevent damage or failure and possible shock loading.
TRUE FALSE
12. Any load that is lifted by the platform crane from a boat can be set on the platform deck.
TRUE FALSE
13. The load chart on the crane you are operating reads 37,920 pounds at 78 degrees and 36,420 pounds at 60 degrees. The load to be lifted weighs 37,800 pounds. Which of the following boom angles would be safe to lift the load?
A 65 degrees
B 40 degrees
C 90 degrees
D 75 degrees
14. The load chart on the crane you are operating reads 16,970 pounds at 52 degrees and 15,370 pounds at 47 degrees. The load to be lifted weighs 16,250 pounds. What boom angles would be safe to lift this load?
A 47 degrees
B 60 degrees
C 45 degrees
D 52 degrees
15. The anti-two block devices prevent the auxiliary and load block from being pulled into the boom tip.
TRUE FALSE

Attachment 20 (Continued)

16. A shock load can occur to a crane when:
- A Lifting loads from a boat
 - B When lowering loads at a fast rate of speed and suddenly stopping the load.
 - C While holding a load still for extended periods of time.
 - D A sling breaks while lifting a load.
17. A static lift occurs when:
- A Lifting loads from a boat.
 - B Lifting loads with the platform crane and putting it on the boat.
 - C Moving the load from one position on the platform to another position on the platform while the crane is mounted on a boat.
 - D The crane is mounted on the platform and the load is being moved from one position to another on the platform.
18. A dynamic lift occurs when:
- A Lifting loads from a boat.
 - B Lifting loads with the platform crane and putting it on the boat.
 - C Moving the load from one position on the platform to another position on the platform while the crane is mounted on a boat.
 - D The crane is mounted on the platform and the load is being moved from one position to another on the platform.
19. Dynamic charts are based on extreme sea conditions of 10 feet and above.
TRUE FALSE
20. When it comes to crane operations, safety dictates.
TRUE FALSE

Rigger Proficiency Test

Example Test

SLING, CHAIN and WEB LIFTING SAFELY

NAME _____ DATE _____ Location _____

(Answer TRUE-OR FALSE to the following questions)

1. Screw pin shackles may be overloaded up to 2 times because they are designed for a 5 to 1 safety factor.
TRUE FALSE
2. When placing synthetic slings or wire rope slings on load hooks make sure the hook width is less than one half the length of the sling's eye
TRUE FALSE
3. Always beat the sling down to tighten the hook or the shackle to keep the load from slipping.

TRUE FALSE
4. Slings must be inspected each time used.
TRUE FALSE
5. It is possible for only three legs of a four-legged bridal to carry the full load at times
TRUE FALSE
6. Before a load is lifted the wire rope on the drum must be checked to verify that the drum is properly spooling.
TRUE FALSE
7. High angle tension is caused by using too short of a sling.
TRUE FALSE
8. Synthetic slings may be used if they are frayed only if the capacity is not exceeded by 10% or more.
TRUE FALSE
9. Sling angle increases when the length (L) is shorter than the height (H).
TRUE FALSE
10. Wire slings, web slings, and chain slings are required to have tags with capacity, size and identification at all times.
TRUE FALSE

GOM Crane and Rigging Safety Meeting - Protocol

Please conduct a quarterly Crane and Rigging Safety Meeting at each BP Amoco GoM facility utilizing the following protocol:

Purpose: To provide a forum whereby policies, best practices, and lessons learned can be shared and discussed in order to improve the safety of crane and rigging operations.

Frequency: A planned meeting to be held quarterly (Increased frequency will be implemented as determined by management to communicate policy changes and review incidents as deemed necessary)

Attendees: Crane operators, Riggers, Safety Officers, Management Observers and a BP Amoco Supervisor/Facilitator (Safety Officers and BP Amoco Supervisor/Facilitator will ensure that the correct policy interpretation is provided)

Objectives: To develop and implement solutions to reduce incidents and promote safe work practices, identify training needs, share best practices, and establish performance expectations.

Reporting: A written report should be submitted to the HSE department and Operations Management (Drilling and Productions). The report should reflect the issues discussed, resulting ideas, and implementation plans. The HSE department will then communicate the issues and lessons learned as appropriate.

Lessons Learned from previously held meetings:

- A JSA to be completed prior to every crane transfer between the platform and boats.
- The JSA will include an assessment of the weather conditions.
- Improved crane inspection and maintenance
- A loading - list / contents manifest
- Deck management on boats to improve offloading and back-loading efficiency
- Riggers on the platform and boats to be in radio contact at all times
- A designated signalman ALWAYS
- Slings are to be inspected prior to every lift
- Know the accurate weight of the load
- Improved bottle racks design
- Improved subs racks design
- Institute meeting to specifically address crane safety

Cargo Manifesting and Material Identification Procedure

For shipping all cargo from shore base to offshore facility, from offshore facility to offshore facility, and from offshore facility to shore base:

- 1) All transported material shall be manifested on a BPA Cargo Manifest. A description of the material must also include an accurate weight.
- 2) Any special lifting instructions, e.g. high center of gravity, should be noted on the Cargo Manifest and verbally communicated to receiving facility.
- 3) Pictures of all boat decks should be taken with a digital camera and forwarded via e-mail to receiving location.
- 4) All facilities will affix a BPA color-coded weight decal (described below) to every manifested lift.

GREEN DECAL - all lifts under 4,999 pounds

YELLOW DECAL - all lifts between 5,000 and 9,999 pounds

RED DECAL (Octagon shaped) - all lifts 10,000 pounds and higher.

- 5) Color coded decals also have blank spaces for date, actual weight, and from and to. An indelible marker should be used to:
 - Insert date of shipment
 - Insert actual weight of cargo in space provided on decal
 - Insert shipping point and destination of cargo
- 6) All facilities will have available a 8-1/2" x 11" laminated sheet collectively displaying all color coded decals. If practical, this should be posted in the crane for easy and ready reference by the Crane Operator.
- 7) It is incumbent on every facility to ensure they have an adequate supply of color coded decals.

Deck Layout Tracking
Marine Vessel Tender Operations

Objective

The intent is to gain and share complete knowledge of inventory on Tender operations.

Definitions

Tender refers to the use of a boat for storing equipment and/or people whether the boat is or is not being used to transport to another location.

Use

1. The BPA / Contract BP Amoco/ Contract Field, Facility or Rig Supervisor will ensure that an accurate drawing of the boat deck being used to store equipment is maintained for current inventory. All loads on boats will have an accurate weight written on the proper color coded decal as per BPA GoM procedures.
2. The drawing will include;
 - name of load (description)
 - weight of load
 - location of load on boat (indicated by position on drawing)
1. The drawing will be updated;
 - after every loading or off loading operation
1. The drawing will be used for planning boat loading and off loading operations during;
 - tour planning and safety meetings
 - JSA creation
 - pre-job safety meetings
 - ensuring that all loads are tagged with accurate weights
 - producing complete and accurate manifests for transport
1. Date, time, boat name, and location will be recorded on each deck layout sketch.
2. Proper color coded decals are available at all BP Amoco dock facilities.
3. This sketch can be hand drawn, drawn using a template, or computer generated but, must be a hard copy.

SESSION Two - PAPER One

**“Questions Concerning Crane Inspections”
Larry Smith**

Questions Concerning Crane Inspections
Per API RP2D

Documents:

- I. Recommended Practices for Operations and Maintenance of Offshore Cranes (API RP 2D, Fourth Edition, August 1999)
- II. Specification for Offshore Cranes (Manufacturing Specifications) (API Specification 2C, Fifth Edition, April 3, 1995)

1. API RP 2D (August 1999) references API SPEC 2C in several places. Does MMS recognize the API Specification 2C document?
2. Over the years API SPEC 2C has had numerous changes in the requirements of various items. Will the older machines be required to meet the new requirements?

Example:

- a. Pre 1983 cranes did not require two-blocking systems.
 1. Will these older cranes be required to have two-blocking systems installed?
 2. If so, will MMS accept one of the three options listed in the 1995 API SPEC 2C?
- b. Pre 1983 cranes did not have dynamic load charts.
 1. Will these cranes be required to have static/dynamic/as rigged load charts?
3. There are cranes on some offshore locations that were not built to any API standard. What type of inspection or guideline should be followed or expected?
4. When are crane inspections due?
 - a. Pre-use Inspections:
This inspection is required before the crane is operated the first time in a calendar day, is it required each time a different operator starts to operate the crane even if it is the same day?
 - b. Monthly Inspections:
When required, will this inspection be allowed anytime during a month or will the inspection be required to be accomplished by the date of the previous month? Example: January 15th the monthly inspection was completed, is February's monthly inspection due by the 15th?
 - c. Quarterly Inspections:
When required, this inspection is to be performed every three months. Is the calendar day the deadline or can the inspection be performed at anytime within the third month?
 - d. Annual Inspections:
Is the calendar day the deadline or will there be some allowable time (one to two weeks)?
5. Wire rope and slings
 - a. API RP 2D sections 5.1.6 refers to break test certificates being supplied to the owner for running rope and 5.2.4 refers to slings be proof loaded and tagged with specific information. Pendant lines are not referred to specifically, although they are structural components of the crane and made of wire rope. Most pendant lines, when originally manufactured are supplied with the same type of tag as slings. Will pendant lines need to be tagged and proof loaded or, if the tags are missing, will an inspection by a Qualified Inspector be sufficient?

6. Section 1 paragraph b. in API RP2D states: Action taken to correct a deficiency will be made as soon as practicable. Section 4.3.3 paragraph b. states: Repairs or replacements of critical components will be made promptly. Comments of this nature are made in several other places. Will there be a time limit to correct these deficiencies (30, 60, 90, days etc.)? Who will make this determination?
7. Section 1 paragraph c. in API RP 2D addresses limited or restricted service. If a crane has been de-rated due to corrosion, a bent boom section or other reasons and the de-rated capacity is adequate for operations, can the crane be permanently de-rated and used without correcting the deficiencies? Who is qualified or responsible for the de-rating? How should it be documented and where should the documents be filed?
8. Discrepancies of various types are noted during inspections, from damaged wire rope, bent boom lacings and chords, hydraulic hoses worn, cracked or end connections corroded, cab glass cracked, broken or missing, etc. Where discrepancies are noted (such as a rear cab window being cracked or missing) that may not pose an environmental nor an operational safety problem. How will this type of discrepancy be addressed?
9. When structural welding repairs are performed on cranes, what type of paperwork will be expected to be on file at the platform location?
10. API SPEC 2C requires a 10 to 1 safety for wire rope when personnel are being handled. API RP 2D states under section 3.4 Personnel Transfer
 - 3.4.1 All hooks used for the support of personnel will have a safety latch. When the load is attached, the latch will be closed securely.
 - 3.4.2 When making personnel lifts, the load will be under control in both up and down directions.
 - 3.4.3 All personnel to be lifted on a personnel carrier will use approved personnel flotation devices (or PFD). Personnel riding on net type personnel carriers should stand on the outer rim facing inward. For other carrier types, personnel should follow local instructions.
 - 3.4.4 The weight of the loaded personnel carrier or net will not exceed the Personnel Rated Load as defined by API Specification 2C, latest edition.

Will other safety devices such as two-blocking systems and personnel qualified hoist be required when handling personnel?

11. Crane Operator Training: There have been several questions asked concerning operator training. One specific question that has been asked is: Have your operators been trained on every model crane of which they operate? The question was directed toward various sizes and model numbers of hydraulic (non-mechanical) cranes. API RP 2D section 2.1 paragraph 2 states, At least two levels of proficiency can be demonstrated by qualifying operators: One for the operation of non-mechanical cranes and another for the operations of mechanical cranes (those with free-fall capability). The wording of this statement seems to be confusing to some people.
 - a. Non-mechanical cranes in my opinion refers to hydraulic cranes. These cranes consist of a power source that drives a hydraulic pump that transfers fluid through a series of valves, motors and cylinders to perform the driving force to function the raising and lowering motion of the crane. These cranes have failsafe brake systems that automatically allow brakes to set if hydraulic system failures occur.
 - b. Mechanical cranes in my opinion refers to friction cranes. These cranes consist of a power source that drives a torque converter which drives a gear train, therefore the operator must release and engage the brakes manually and engage clutch levers in order to raise and lower loads. This description is very simplified due to the many arrangements that are actually used. If the drive train fails the operator in most cases must engage the brakes manually.

One of the primary differences between the operations of the two types of cranes is the manner in which the speed of the crane is controlled. Mechanical cranes generally must use the engine to control the speed of the drive train, this can be accomplished with the use of the torque converter. Hydraulic cranes generally require minimum oil flows to accomplish smooth operations, to overcome internal by pass of components and for failsafe brake systems operations. The hydraulic control valves are used to control the speed of operations. These cranes are generally operated at a consistent engine rpm (1800 to 2400) to maintain oil flows above the minimum flow rate for the crane's hydraulic system.

Hydraulic cranes of various sizes and manufacturers work on the same principle, therefore the inspections that are required by a qualified operator generally follow the same ideas. It is not practicable to attempt to perform hands on training for every different model crane that a company may own. API RP 2D section 3.1.5 paragraph b. states: The Operator will be aware of the operating characteristics of the crane. The operator training should bring up this point, therefore if the operators are required to operate a crane that they have not operated before they should familiarize themselves with the specific crane and it's operating characteristics before lifting any loads. You could compare hydraulic cranes operating characteristics in the same manner as you would the operating characteristics of a Volkswagen to a Cadillac.

Will additional crane operator training be required past the two types of cranes described in section 10 above for each type of hydraulic or friction type cranes?

12. API RP 2D section C.4.1.2d. discusses Annual Inspection

- a. Ball/Roller Bearings: This type of swing circle assembly is either bolted and/or welded to the pedestal and rotating crane turntable. The three (3) major inspections that should be performed are for a) bearing wear, b) crane/bearing connection integrity, and c) operating characteristics.

Due to the manner in which some of the cranes were originally manufactured and mounted to the platforms it is impossible to use the methods described for bearing wear. Taking grease samples and checking for metal particles and foreign matter is relatively easy to do and it does show whether the bearing has suffered any internal damage.

How will this be addressed if the bearing wear measurement can not be taken with the dial indicator as described under bearing wear (pages 20 & 21)?

- b. King Post bearing areas of the crane should be inspected to assure that there is no significant wear or damage to either the rotating or stationary load bearing members, that left uncorrected, might result in loss of structural integrity of the mounting system. The King Post crane inspection procedure will depend on the design of the crane being inspected. The inspection should include but not be limited to the following:
*Upper thrust bearing, *Upper radial bearing, *Lower thrust bearings or wear bands, *King pin wear and condition

To perform this type of inspection on some kingpost cranes will take a considerable amount of time due to the amount of corrosion around the upper radial bear block retainer plate and the fact that the majority of them have not been inspected since they were originally installed.

How will this area of inspection be addressed?

13. Will dockside cranes that are used to load out offshore boats and weigh cargo be required to be inspected under the guidelines of API RP 2D?

14. Many accidents or injuries that occur offshore, occur during the loading and unloading of boats. Many boats are loaded at dockside and in some cases accessible walkways between cargo are limited, therefore the riggers offshore can not make the required connections to the cargo and have a safe escape route to get away from the load as it is be lifted or set on the boats.

- a. Is there a regulation concerning the manner in which boats are loaded as far as space between cargo?

The above questions and concerns have been brought to my attention by several different Offshore Production and Drilling Companies. I would like to see if these questions can be reviewed and some reasonable definitions be brought forth in order to know what to expect and how they can be dealt with in a safe and reasonable manner.

Respectfully,

Larry Smith
Operations Manager

Questions / Answers
Larry Smith

**The following answers to these questions are
from Larry Smith.**

Questions Concerning Crane Inspections Per API RP2D

The following questions and concerns have been brought to my attention by several different offshore production and drilling companies. I believe these questions require answers which define safe, reasonable, and economical work practices.

My answers to these questions are my recommendations only. They are based on 25 years of experience working offshore, on and around cranes, boats, production and rig operations.

The following documents are referred to in the questions listed below:

- I. Recommended Practices for Operations and Maintenance of Offshore Cranes (API RP 2D, Fourth Edition, August 1999)
- II. Specification for Offshore Cranes (Manufacturing Specifications) (API Specification 2C, Fifth Edition, April 3, 1995)

1. API RP 2D (August 1999) references API SPEC 2C in several places.

Question: Does MMS recognize the API Specification 2C document?

Answer: API SPEC 2C should be recognized due to the number of times that the API RP2D document makes references to it. Due to the different ages of the cranes, the appropriate 2C document for the year the crane was manufactured should be used.

2. Over the years API SPEC 2C has had numerous changes in the requirements of various items.

Question: Will the older machines be required to meet the new requirements?

Answer: It would be economically unreasonable for many of the older cranes to meet the latest edition of API SPEC 2C.

Example:

- a. Pre 1983 cranes did not require two-blocking systems.

Question: 1. Will these older cranes be required to have two-blocking systems installed?

Answer: Prior to 1983 there was not a requirement for anti-two blocking devices. Two blocking systems are installed to protect the cranes from the crane operators. The personnel that operate cranes offshore are production hands that operate cranes not crane operators that operate production equipment. As a minimum, I recommend that, if the cranes are used for handling personnel, they should be equipped with a two blocking system for the hoist circuit that is involved in personnel transfers.

Question: 2. If so, will MMS accept one of the three options listed in the 1995 API SPEC 2C?

Answer: In my opinion, one of the three methods listed in API SPEC 2C should be adequate and cost effective to be installed on a wide range of different types of cranes. Unfortunately, even cranes with two blocking systems are still

involved in incidents where the overhaul ball can be pulled off the crane. Some of the two blocking systems are designed for the trip valve to be mounted on the boom and a hanging weight is used to keep the crane in the “run” mode. With this type of mounting, the two blocking system can fail if the trip valve spring doesn’t disengage the valve as the hanging weight is lifted. The two blocking system and boom limit systems, where installed, should be checked during the pre use inspection.

Presently API RP 2D recommends these two safety systems be checked on a monthly basis but not on a “pre-use” inspection.

b. Pre 1983 cranes did not have dynamic load charts.

Question: 1. Will these cranes be required to have static/dynamic/as rigged load charts?

Answer: I recommend it should be a requirement that all pre-1983 cranes have “as rigged” load charts showing both static and dynamic ratings. There have been many incidents where the older cranes were equipped with structural load charts only, and when the crane operator tried to make a lift, the crane could not lift what the load chart specified because the “as rigged” load capacity was lesser than the structural load capacity chart indicated. The crane operators are not hydraulic nor design engineers, therefore the posted load charts are all they have to work from. One of my major concerns are those cranes that were not built to any API standard. Without any guidelines to work from, it would be extremely expensive to create a dynamic load chart for these types of cranes, especially if the original crane manufacturer is no longer in business.

3. There are cranes on some offshore locations that were not built to any API standard.

Question: What type of inspection or guideline should be followed or expected?

Answer: Use the API RP 2D document to the best of the ability of the Qualified Inspector. There has never been a regulatory requirement that offshore cranes be built to API SPEC 2C. Over the years quite a few land cranes were converted to be offshore cranes. If one compiled a history of all the crane accidents that have occurred offshore, I believe a large portion would be linked to these converted cranes that were not built with dynamic loading conditions in mind.

4. When are crane inspections due?

a. Pre-use Inspections:

Question: This inspection is required before the crane is operated the first time in a calendar day, is it required each time a different operator starts to operate the crane even if it is the same day?

Answer: In my opinion, a pre use inspection should be performed each time a different crane operator starts to operator a crane.

b. Monthly Inspections:

Question: When required, will this inspection be allowed anytime during a month or will the inspection be required to be accomplished by the date of the previous

month? Example: January 15th the monthly inspection was completed, is February's monthly inspection due by the 15th?

Answer: This inspection is required to be performed by a Qualified Operator on cranes that fall in the heavy usage category. The crane operator performs the pre use inspection typically daily and there is very little difference between the pre use and monthly inspections, therefore, filling out the monthly inspection form within the calendar month that the inspection is due should be adequate.

- c. Quarterly Inspections: When required, this inspection is to be performed every three months.

Question: Is the calendar day the deadline or can the inspection be performed at anytime within the third month?

Answer: These inspections are required to be performed by a Qualified Inspector on cranes that are operated in the moderate to heavy usage category. Due to weather conditions, available transportation, and available Qualified Inspectors these inspections should be performed on any day within the third month of the quarter.

- d. Annual Inspections:

Question: Is the calendar day the deadline or will there be some allowable time (one to two weeks)?

Answer: These inspections are required to be performed by a Qualified Inspector on all cranes, regardless of their usage category. Due to weather conditions, available transportation, and available Qualified Inspectors these inspections should be performed on any day of the twelfth month.

5. Wire rope and slings

- a. API RP 2D sections 5.1.6 refers to break test certificates being supplied to the owner for running ropes and 5.2.4 refers to slings be proof loaded and tagged with specific information. Pendant lines are not referred to specifically, although they are structural components of the crane and made of wire rope. Most pendant lines, when originally manufactured are supplied with the same type of tag as slings.

Question: (a.) Will pendant lines need to be tagged and proof loaded or, (b.) if the tags are missing, will an inspection by a Qualified Inspector be sufficient?

Answer (a.): New pendant lines should be proof loaded and tagged with the same information that is required for slings.

Answer (b.): Pendant lines that have been on a crane for an extended period of time that have been properly lubricated and maintained, but do not have certification tags should be inspected by a Qualified Inspector and if they are found to be in good condition should not have to be replaced. These pendant lines have been tested, due to use, over the period of time that they have been on the crane.

6. Section 1 paragraph b. in API RP2D states: Action taken to correct a deficiency will be made as soon as practicable. Section 4.3.3 paragraph b. states: Repairs or replacements of critical components will be made promptly. Comments of this nature are made in several other places.

Question: Will there be a time limit to correct these deficiencies (30, 60, 90, days etc.)?

Answer: Each situation will vary according to the age of the individual crane and the availability of the necessary parts to perform the repairs. The manufacturer of some cranes that are still being used offshore may have been out of business for quite some time. Therefore, replacement parts that equal or exceed the original manufacturer's specification may be difficult to acquire. The end user of the equipment should post the necessary caution signs and designate in their crane records what a reasonable time factor would be as well as the reason for any extended repair time. The usage factor of the crane may need to be limited or taken out of service depending on the severity of the deficiency.

Question: Who will make this determination?

Answer: The owner or owner's representative, perhaps in consultation with the original crane manufacturer, an API 2C crane manufacturer, or an engineer that is familiar with the design of offshore cranes.

7. Section 1 paragraph c. in API RP 2D addresses limited or restricted service. If a crane has been de-rated due to corrosion, a bent boom section or other reasons and the de-rated capacity is adequate for operations:

Question: Can the crane be permanently de-rated and used without correcting the deficiencies?

Answer: This is a very difficult question to answer. It would depend on the type of damage that has actually occurred as described in the following examples.

Example #1: If the auxiliary extension on a crane had been damaged from corrosion or damaged by some other means and the auxiliary hoist circuit was taken completely out of service. This could be done by removing the auxiliary wire rope and overhaul ball, removing auxiliary control lever, or removing auxiliary hoist. In this case it should be acceptable to operate the crane with the load hoist and boom circuit without correcting the deficiency, since the safety problem was eliminated.

Example #2: If the gantry of a lattice boom style crane had been damaged from corrosion, and the corrosion had penetrated the main gantry leg (pipe or square tubing style), then the crane should be de-rated. In this case the inside of the gantry legs were not sandblasted and coated, now the corrosion factor that can take place inside the leg is unknown. In this case a permanent de-rate should not be allowed. The end user should de-rate the crane with the intention of replacing or repairing the gantry within 6 to 12 months, or take the crane out of service at the end of the time that was set forth when the original discrepancy was found.

Question: Who is qualified or responsible for the de-rating?

Answer: The end user should be responsible for de-rating a crane perhaps with the recommendations from the original crane manufacturer, an API 2C manufacturer, or an engineer that is familiar with the design of offshore cranes.

Question: How should it be documented and where should the documents be filed?

Answer: The crane inspection records should document the deficiency. The inspection reports should be filed with the other crane records for the specific crane and location. Due to some outlying platforms not having a reasonable place to file these records, then the records should be kept at the nearest location that has a

reasonable place to store files. These records could also be kept on a computer data base if this type of equipment is available.

8. Discrepancies of various types are noted during inspections, from damaged wire rope, bent boom lacings and chords, hydraulic hoses worn, cracked or end connections corroded, cab glass cracked, broken or missing, etc. Where discrepancies are noted (such as a rear cab window being cracked or missing) that may not pose an environmental nor an operational safety problem.

Question: How will this type of discrepancy be addressed?

Answer: If the discrepancies do not pose an environmental or safety problem, then it should be left up to the owner or owner's representative to determine whether the discrepancy should be repaired or not.

Example #1: Rear cab window cracked or missing, crane operator seat in poor condition. If these types of discrepancies are noted during an inspection and the discrepancies do not affect the crane operator's vision nor impair their ability to safely operate the crane, then the owner should be allowed to make the decision concerning whether or not to make the repairs.

Example #2: Hydraulic hose from second stage of hydraulic pump to boom control valve has minor cracks in the outer rubber sheathing. This type of discrepancy needs to be monitored only as well as checked on future inspections.

Example #3: Hydraulic hose from first stage of hydraulic pump to main control valve has cracks in the outer rubber sheathing, the internal wires are corroded, and several wires broken. This type of discrepancy needs to be addressed in the near future (1 to 2 weeks) depending on the intended usage factor of the crane. If heavy lifts are to be made, then the hose should be replaced before an environmental problem can occur and before the heavy lifts are made.

9. When structural welding repairs are performed on cranes:

Question: What type of paperwork will be expected to be on file at the platform location?

Answer: Structural welding on cranes require special welding procedures depending on the type of metals that is used in a specific component. These welding procedures are generally proprietary information that a specific company has spent a considerable amount of time and money to develop. In this case, the company that performs the structural repairs should not be required to leave the welding procedure documents at the field location. A copy of the welder's certification papers should be placed in the crane file and the weld procedure identification number should be logged down in the description of work performed for reference purposes. At the actual time of the structural welding repairs the certified welder should have a copy of the weld procedures on hand at the specific location until the job is completed.

10. API SPEC 2C requires a 10 to 1 safety for wire rope when personnel are being handled.

API RP 2D states under Section 3.4 (Personnel Transfer)

- 3.4.1 All hooks used for the support of personnel will have a safety latch. When the load is attached, the latch will be closed securely.
- 3.4.2 When making personnel lifts, the load will be under control in both up and down directions.
- 3.4.3 All personnel to be lifted on a personnel carrier will use approved personnel flotation devices (or PFD). Personnel riding on net type personnel carriers should stand on the outer rim facing inward. For other carrier types, personnel should follow local instructions.

3.4.4 The weight of the loaded personnel carrier or net will not exceed the Personnel Rated Load as defined by API Specification 2C, latest edition.

Question: Will other safety devices such as two-blocking systems and personnel qualified hoist be required when handling personnel?

Answer: When personnel are being handled with cranes, I have to agree with OSHA that two-blocking systems should be utilized for safety purposes. The hoists that are used for personnel handling also lifts cargo. At one point in time most hoists were marked with a disclaimer concerning the handling of personnel. Most companies continued to use the hoists to handle personnel regardless of the disclaimers, due to necessity. There are companies now that build hoists that are personnel rated if you follow their recommended maintenance program (typically performing a tear down inspection, by a qualified person, at different time intervals that take in account the usage factor of the hoists). For safety purposes, the hoists should be personnel rated by the manufacturer of the hoists, and their recommended maintenance program and guidelines for inspections should be of public record. There are some hoists that are still used on offshore cranes for which the original manufacturer will not offer a maintenance program or any inspection procedure which will permit their hoists to be personnel rated.

11. Crane Operator Training: There have been several questions asked concerning operator training. One specific question that has been asked is:

Question: Have your operators been trained on every model crane of which they operate? The question was directed toward various sizes and model numbers of hydraulic (non-mechanical) cranes.

Answer: Crane operators should be trained in the two basic categories listed in API RP 2D. Refer to the explanation below.

API RP 2D section 2.1 paragraph 2 states: "At least two levels of proficiency can be demonstrated by qualifying operators: One for the operation of non-mechanical cranes and another for the operations of mechanical cranes (those with free-fall capability)." The wording of this statement seems to be confusing to some people.

- a. Non-mechanical cranes, in my opinion, refers to hydraulic cranes. These cranes consist of a prime mover that drives a hydraulic pump that transfers fluid through a series of valves, motors and cylinders to perform the driving force to function the raising, lowering, and rotating motion of the crane. These cranes have fail-safe brake systems that automatically brakes the lowering functions if hydraulic system failures occur.
- b. Mechanical cranes, in my opinion, refers to friction cranes. These cranes typically consist of a prime mover that drives a torque converter which in turn drives a gear train, which, using clutches and brakes, provides the rotation, raising and lowering functions. The operator must release and engage the brakes manually and engage clutch levers in order to raise and lower loads. If the drive train fails, the operator, in most cases, must engage the brakes manually.

One of the primary differences between the operations of the two types of cranes is the manner in which the speed of the crane is controlled. Mechanical cranes generally must use the engine to control the speed of the drive train. This can be accomplished with the use of the torque converter. Hydraulic cranes generally require minimum hydraulic oil flows to accomplish smooth operations, to overcome internal by pass of components and for failsafe brake system operations. The hydraulic control valves are used to control the speed of operations. These cranes

are generally operated at a consistent engine speed of 1800 to 2400 rpm to maintain hydraulic oil flows above the minimum flow rate for the crane's hydraulic system.

Hydraulic cranes of various sizes and manufacturers work on the same principle. Therefore, the inspections that are required by Qualified Operators are generally similar. It is often not practical to attempt to perform hands-on training for every different model crane that a company may own. API RP 2D section 3.1.5, paragraph b. states: "The Operator will be aware of the operating characteristics of the crane." Operator training should bring up this point. If the operators are required to operate a crane that they have not operated before, they should familiarize themselves with the specific crane and its operating characteristics before lifting any loads. You could roughly compare the differences in hydraulic cranes operating characteristics in the same manner as you would to the operating characteristics of a Volkswagen to a Cadillac.

Question: Will additional crane operator training be required beyond the two types of cranes described in section 10 above for each type of hydraulic or friction type crane?

Answer: This training may be necessary if a crane is equipped with a special device that is not normally installed on a basic crane. This should be the responsibility of the owner of the equipment to arrange training of this type.

Example #1: When electronic weight indicators are installed the operators may need a brief overview of how the system works and how to use it properly.

Example #2: If the crane's hydraulic system is being used to power an auxiliary device that is not associated with the crane.

Most of these special devices are generally simple to operate, therefore formal training should not be necessary.

12. API RP 2D Section C.4.1.2d. discusses Annual Inspection for ball/roller bearings:
- a. This type of swing circle assembly is either bolted and/or welded to the pedestal and rotating crane turntable. The three (3) major inspections that should be performed are for a) bearing wear, b) crane/bearing connection integrity, and c) operating characteristics.

Due to the manner in which some of the cranes were originally manufactured and mounted to the platforms, it is impossible to use the "Tilt, Depression, or Rotation" methods described for bearing wear. Taking grease samples and checking for metal particles and foreign matter is relatively easy to do and it does show whether the bearing has suffered any internal damage.

Question: How will this be addressed if the bearing wear measurement can not be taken with the dial indicator as described under bearing wear (pages 20 & 21) of API RP 2D August 1999?

Answer: When it is impossible to take a ballring wear measurement due to the manner in which the crane was originally manufactured, it is very important that a grease sample is taken and inspected by a Qualified Inspector. The condition of the grease sample and the general operating characteristics of the ballring should be monitored and logged down in the crane inspection files.

- a. API RP 2D Section C.4.1.2d discusses Annual Inspections for King Posts:
"Bearing areas of the crane should be inspected to assure that there is no significant wear or damage to either the rotating or stationary load bearing members, that left uncorrected, might result in loss of

structural integrity of the mounting system. The King Post crane inspection procedure will depend on the design of the crane being inspected. The inspection should include but not be limited to the following:

- * Upper thrust bearing
- * Upper radial bearing
- * Lower thrust bearings or wear bands
- * King pin wear and condition
- * Lower king post wear band: The wear band condition is critical as it protects the king post from the lower thrust rollers or wear bands. On cranes not equipped with a wear band or if the wear band is excessively worn, the wear zone on the king post must be carefully monitored to ensure the structural integrity of the king post
- * King post-to-platform structural connection.

To perform this type of inspection on some kingpost cranes will take a considerable amount of time due to the amount of corrosion around the upper radial bearing block retainer plate, coupled with the fact that the majority of them in the Gulf of Mexico have not been inspected since they were originally installed.

Question: How will this area of inspection be addressed?

Answer: Due to the amount of corrosion that I have seen on cranes of this type, as a result of standing water in the king pin area, this inspection should be performed. All too often the bolt heads for fastening the bearing block retainer plate to the gantry are corroded to the point that a wrench can no longer be used to remove the bolts. On the older cranes of this type that have never been inspected before, this will take a considerable amount of time to perform this inspection. The following year should be considerably easier and less time consuming if the prior inspection was performed correctly and drain holes are incorporated to allow the standing water to drain properly.

13. **Question:** Will dockside cranes that are used to load out offshore boats and weigh cargo be required to be inspected under the guidelines of API RP 2D?

Answer: These cranes should be inspected by the applicable OSHA standards. Special attention should be made to assure (1) the crane operators thoroughly understand how to use the weight indicators, (2) to make sure the weight indicator systems are kept in good working order, and (3) the weight indicators are calibrated at least on an annual basis. The weight of each item loaded on an offshore boat should be weighed and logged down on a manifest. When the boat arrives on location offshore, the first item that the crane operator would lift would be the manifest that tells him the weight of each lift to be made. If items of identical appearance are shipped, such as full tanks and empty tanks then the items should be marked clearly to avoid any possibility of confusion.

14. Many accidents or injuries that occur offshore occur during the loading and unloading of boats. Many boats are loaded at dockside and in some cases, accessible, safe passageways between cargo are limited. When the vessel arrives at the platform, the riggers offshore can not make the required sling connections to the cargo and have a safe escape route to get away from the load as it is lifted or set on the boats.

- a. **Question:** Is there a regulation concerning the manner in which boats are loaded as far as safe accessible passageways between cargo?

Answer: To my knowledge there is not a regulation concerning the loading of boats which addresses accessible passageways allowed between cargo. Many accidents and near misses of riggers offshore are a direct result of

the manner in which the boats are loaded at the dock facility. There should be at least a guideline that would allow for a reasonably safe passageway. When the vessel is being loaded, the rigger must stand under or near a load in order to catch tag lines to assist with the alignment of a free-hanging load to be landed on the deck of a boat, he must have adequate room to escape from a descending load.

SESSION Two - PAPER Two

**“Operating Techniques”
Doug Morrow**

March 16, 2000

Basic Crane Operating Techniques

Speed Control

Friction versus Hydraulic Cranes

The Problem:

Many experienced crane operators are using inappropriate techniques when operating the latest generation of hydraulic driven Offshore Cranes. In other words, they are operating these cranes in the same manner in which they were taught to run the older “Friction” or “Mechanical” cranes. When working on the deck of the facility upon which the crane is mounted, **this practice is exposing personnel working near the loads to unnecessary risk of injury, as well as contributing to the premature replacement of crane components.**

Background Information:

First, let’s take a look at “Friction” Cranes.

In the 50’s, 60’s and 70’s, most of the Cranes used on Offshore Drilling Rigs were adaptations of land based “Crawler” type cranes which were fitted to fixed pedestal mounts for offshore use. These cranes are “Mechanical” or “Friction” driven machines in that hoisting power is transmitted to the hoist drums by means of diesel engines driving through friction clutches. Lowering operations are accomplished primarily by controlling the descent of the load by foot operated friction brakes. Hence the designation “Friction Cranes”. The safe use of this type of crane requires a Crane Operator with a high level of skill and experience as there are many ways to inadvertently drop a load or damage the crane by improper use of the controls.

With this type of drive, it is very important not to “slip” the friction clutches when hoisting as this can result in rapid wear and even loss of control of the load. Many of these cranes are equipped with a feature called “power load lowering”. This is a system whereby the drums are connected to the diesel engine through the drive train by other clutches when lowering a load. This lets the engine act as a “dynamic brake” to absorb energy and significantly reduces the work load on the friction brakes. It is also important not to “slip” the lowering clutches.

Because of this, crane operators were taught to smartly “snap” the control levers into full engagement when hoisting and lowering a load. This prevents slipping of the clutches. Speed

during hoisting is controlled by the use of the engine throttle. Speed during lowering is accomplished either by the engine throttle (power load lowering mode) or by modulation of the friction brake (free-fall mode).

Please note that if the crane is not equipped with a torque converter or similar device, it will be necessary to “rev-up” the engine to high speed in order to have enough torque available to lift substantial loads without “killing” the engine. **This method of operation will result in extremely “jerky” hook motions and presents a real danger to personnel near the load.** For this reason, almost all of the “Friction” cranes are equipped with torque converters which allow the engine / converter combination to “lug down” and develop high torque at low speed (similar to an automatic transmission in a car). **This allows the crane operator to lift substantial loads more smoothly, thus reducing the risk to personnel near the load.**

Now, let’s discuss the “**Hydraulic**” Cranes.

Almost all of the new Offshore Cranes installed during the last 20 years are what we describe as “**Hydraulic**” cranes. Cranes of this type have either diesel engine or electric motor prime movers. These prime movers transmit power to the hoist drums by means of hydraulic pumps and hydraulic motors. Usually three separate hydraulic systems are incorporated. One for each of the three major crane motions Hoist, Luff (boom) and Slew (swing). The pumps for these three systems are usually mounted on a common gear case which is driven by the crane’s single prime mover.

With this type of drive, all dynamic braking is accomplished hydraulically. Friction brakes are used only to hold the load after the hydraulic system has stopped the descent. These friction brakes are automatically applied by springs upon release of the respective control lever (“dead man” controls). There are no separate brake controls or brake pedals for the crane operator to contend with.

These cranes are much easier to operate than their “Friction” crane predecessors. The major controls usually consist of only a throttle control (if diesel powered) and four separate control levers for each of the primary crane motions. (Main Hoist, Aux. Hoist, Luff Hoist & Slew). To use either hook or the boom, an operator need merely pull back on the appropriate lever to raise, center the lever to stop, and push on the lever to lower. As previously mentioned, the levers are spring loaded to the center position which stops the motion and sets the holding brake. All lowering is done by means of the hydraulic systems dynamic braking feature (power load lowering). The capability to freefall the load or hooks is no longer available to the crane operator.

These cranes are designed to control the speeds of the primary motions by “metering” the flow of hydraulic oil to the individual hydraulic drive motors. This metering is done with the control lever. Pull back a little bit and the function moves slowly. Pull back a lot and the function runs faster. Let go and it stops. In other words the speed of a motion is proportional to the lever movement (proportional speed control).

Cranes of this type do not have torque converters. Therefore, in order to handle substantial loads, the engines are normally run at full governed speed in order to develop sufficient power.

The speed of each individual motion is controlled by the proportional movement of the control lever, not the engine throttle. This means that the speed of each individual motion can be metered from “dead slow” to “full speed”, in either direction, independently of the other motions, and with the prime mover running at full speed.

This provides operational capabilities which cannot be matched by the older Friction Cranes. This brings us back to our problem.

Root Cause of the Problem:

To an operator used to the older “Friction” cranes, **controlling the motion speed by proportional movement of the control lever, feels just like slipping the clutches!** Remember this is something that he has been taught never to do. In fact, some operators of “Friction” cranes have been fired for not briskly “snapping” the control levers into the full throw positions.

However, this “snapping” action is **exactly the wrong thing to do with a new generation “Hydraulic” crane.** The “proportional control” just feels wrong to these older experienced operators. Therefore, no matter what we say or write, when under pressure they naturally revert to the operating techniques which have served them so well in the past.

They “snap” the control lever from neutral to full speed just as fast as they can. This technique leads to the following consequences.

Effects Caused by the Problem:

With a Hydraulic crane, drum rotation will almost instantaneously follow the control lever movement. Therefore when the control lever is quickly snapped from center to full throw, the drum will immediately go to full speed. This imparts an extreme “jerking” motion to the hoist line, hook, and load.

When hoisting, this motion is much like setting a hook in a fish, the load jumps up, falls back, and then bounces around due to the stretch in the hoist and boom lines.

When lowering, the drum can often accelerate faster than the weight of the block, ball, or load can fall. This results in the cable becoming loose on the drum. This is similar to “backlashing” a bait casting fishing reel. (See figures 1 & 2)

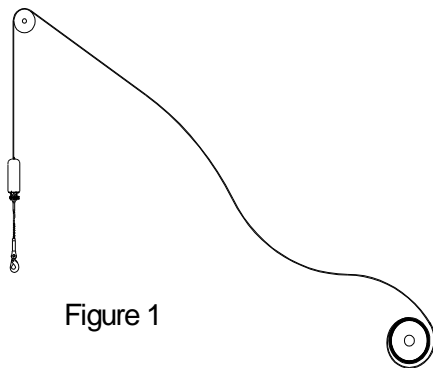

This “backlash” can occur even with the boom suspension reeving, especially when the boom is at a high elevation with no load on the hooks. This is shown in figures 3 & 4.



This “backlash” can again cause the hook to jump up, fall back, and then bounce around due to the stretch in the hoist and boom lines.

A similar thing happens when the crane operator “snaps” the slew (swing) control from neutral to full speed. The crane will “jerk” somewhat violently as it accelerates thus imparting a wild swing motion to the hook. This motion is much greater without a load on the hook..

Consequences of the Effects:

This “backlash” and “hook bounce” presents two areas of concern. The first is **safety of the personnel working around the hooks**. The second is the effect on the **service life of the**

crane's components. Let's look at the **safety issues** first.

Many of the offshore crane related injuries have involved personnel being struck either by a hook or load in some manner. Abrupt, "jerky" hook or load movements can be a contributory factor in accidents of this type. In any case, working in close proximity to a crane hook which is moving about like this is certainly not the safest way to get the job done, **especially if the crane is capable of moving the hook smoothly and precisely.**

Other injuries have occurred due to the failure of slings and other load attachment gear. Abrupt, "jerky" hook or load movements may cause high "shock" loading to these items, thus contributing to accidents of this type.

Now, let's examine the **Service Life** issue.

Damage to the crane's structure and machinery due to "jerky" operation when **hoisting the load or boom** is much less of a problem than one might think. This is because the elasticity or "stretch" in the crane's wire rope members dissipate much of the shock energy before it reaches most critical components. However, **lowering the hooks or boom** is an entirely different story.

Please refer back to **Figures 1,2,3, & 4** and remember that the hoist drums can be accelerated faster than the boom or hooks can fall. This is especially true with a "no load" situation. This causes the wire ropes to go slack and try to unwind from the drums. Please refer to Figure 5 for an extreme example of this. When operating a **Hydraulic** crane in this manner, **you really can "push on a rope"**.

The wire rope manufacturers teach that, for a wire rope to **spool properly**, it must first be **wound tightly** on the hoist drum. It then logically follows that proper spooling also requires that the rope **remain tight**. The rope cannot remain tight when a crane is operated as shown in Figure 5.



Rope tension, to ensure proper spooling, is very important with respect to wire rope life. Loose cable can quickly lead to “crushing” type failures or damage. This is specifically addressed in **API RP 2D**, 3rd Edition paragraphs **C5.1.4d,2 “Installation Guidelines”** and **C.5.1.5. “Operations”**. According to RP 2D, the wire rope on the drum shown in Figure 5 should be re-spooled.

Additionally, we believe that this “**pushing on a rope**” is a major contributing factor to some of the “**core protrusion**” type failures that we have seen on some rotation resistant wire ropes. We also know, from experience, that this loss of tension can easily cause “**block spinning**” or “**cabling**” problems with multi-part blocks.

Wire ropes are not the only components to suffer from this “lever snapping” technique. With most hydraulic hoists, torque can arrive at the hoist drum before the friction parking brakes have time to fully release, sometimes even before the dynamic brake valve has time to fully open. This “spikes” the pressure in the hydraulic system up to (and even above) the pressure relief valve setting.

With this operating technique, **these pressure “spikes” occur every time a hook or boom is lowered**. This is **very destructive** to many of the mechanical and hydraulic components in the drive train and will **drastically reduce the fatigue or service life** of these components. We believe that many different component failures, occurring in many different “brands” of cranes, can be directly attributed to this **common cause**.

Recommendations to Solve the Problem:

- First, we must be aware that the problem exists. This is easily done by simple observation of the crane’s motions when moving supplies and equipment about the deck of the facility upon which it is mounted.
- If erratic or “jerky” motions are observed, and the crane is not faulty, then the solution is to re-train the crane operator to operate the crane in the proper manner. All current generation hydraulic cranes (of all brands) are capable of moving the hooks in a smooth precise manner. We should expect nothing less from our operators.

Conclusions:

This issue of operating technique is much more important on some facilities than others. For example, cranes used on a M.O.D.U. can average around 4,000 of hours of use annually (Drilling Duty Cranes). These cranes, especially the newer ones, also tend to be larger and much faster than their predecessors (and also the cranes used on most existing production platforms). This means that the “lever snapping” problem can have very significant effects on these newer machines. The faster the crane, the worse the effects. While the safety concerns are very important, the reduction in component service life experienced by Drilling Duty Cranes can have a significant financial impact on maintenance costs in a very short period of time.

This is in contrast to the smaller cranes such as those used on shallow water production platforms (Production Duty Cranes). A large percentage of these cranes have relatively low hook speeds. This limits the potential severity of the hook movements. Also Production Duty Cranes are not typically “frequent use” machines, accumulating less than 150 hours per year on the average. This low duty cycle spreads out the reduction in component service life over a long period of time.

The industry trend with respect to Drilling Duty Cranes is toward larger and faster machines. This is because more projects are directed toward prospects in deeper water. Many of the facilities contemplated for these projects will combine both Drilling and Production duty requirements for the same cranes, depending on the phase of activity.

Therefore, this problem will only get worse unless it is recognized and addressed. Fortunately, this can, in our opinion, be accomplished without any new regulations or expenditures for equipment. **This is simply an awareness and training issue.**

Think of it like this. We would never drive our cars by always “revving up” the engine and then slamming the shift lever into reverse every time we back up. So why do the same with our cranes?

SESSION Two - PAPER Three

“Y2K Leap for Safety”

J.R. Guidry

MINERALS MANAGEMENT SERVICE (MMS)
Workshop on Crane Safety

Wilfred Guidry (JR)
American Aero Crane
Houston Texas
Jrguidry@americanaero.com
2-21-2000

Subject matter for presentation

1. Crane parts or components (Booms, Winches, Bearings, Gantry's, Pedestals) be supplied by a API 2 C Licensed shop, or OEM. Repairing of the same structural members by Non-Authorized shops that do not have either API or a QUALITY plan, procedures or engineers qualified to establish procedures.
2. Suggest the removal of 4.1.1.1 of 2 D The elimination of the Infrequent Usage category or the addition of a Quarterly Inspection to the requirements of this category.
3. Qualified Inspectors receive training from API 2 C Manufacturers, and the experience criteria be that an inspector performing annual inspections have a minimum of 5 years as an offshore mechanic.
4. De-Rated cranes be operated only by QUALIFIED Operators. The cranes be operated under conditions which the crane is rated to perform. No personnel to be lifted with a crane which has been De-Rated. A crane may be De-Rated only with a new load chart and the calculations by a API 2C manufacturer, OEM or licensed engineer with experience in the design of Offshore Cranes.
5. Crane Operator Training administered per API 2 D requirements and by API 2 C approved agency.
6. Anti-Two Block Systems be of the shut off design and not CRASH DESIGN.
7. Lifts from shorebase facilities be marked in such a way the operator and rigger can identify the weights by color stickers attached to the lifted item.

Y2K-- LEAP FOR SAFETY A STEP FORWARD

■ American Aero Cranes*

- Houston, Texas

- * a division of Aero International, LLC

SUBJECTS OF DISCUSSION

- 1-REPLACEMENT PARTS
- 2-REMOVAL OF INFREQUENT USAGE CATEGORY
- 3-TRAINING OF QUALIFIED INSPECTORS
- 4-DE-RATE OF CRANES
- 5-CRANE OPERATOR TRAINING
- 6-ANTI-TWO BLOCK SYSTEMS
- 7-COLOR TAGGING OF LIFTS SHIPPED OFFSHORE

1- REPLACEMENT PARTS

- Crane parts or components (BOOMS, WINCHES, BEARINGS, GANTRY'S, PEDESTALS ETC.) be **SUPPLIED** by a API 2 C Licensed shop, or the OEM.
- Repairing of the structural members by a Non-Authorized shops that do not have either API or a QUALITY Plan, Procedures or even Engineers that are not qualified to establish procedures should be enforced.
- **CRANES ARE BUILT TO API 2C, ABS Etc. THESE CRANES SHOULD BE REPAIRED USING THE SAME STANDARDS (TRACEABILITY AND VERIFICATION)**

1-

REPLACEMENT PARTS

CRANE PARTS OR COMPONENTS SUCH AS BOOMS, WINCHES, BALLRING BEARINGS, GANTRY'S and PEDESTALS.

Boom repairs or replacement booms. In the past we have found boom sections with patches (splices) in the chords, extra lacings, handrail pipe used as lacing material, boom connectors with poor welding, no trace-ability or records as to who built, tested or installed the item. The Qualified Inspector on finding this problem has to first convince the customer that this does not meet the API requirements and that it is unsafe. The next problem arises when the operator says that it has been in service like that for 5 years and now you want to change something that has been working for years.

Repairs or replacement of Gantry, Body and Pedestal weldments should not be left up to Non-Authorized shops that are not API or have a **QUALITY PLAN** or **PROCEDURE** to complete **CRITICAL** manufacturing criteria.

A licensed API shop or the OEM takes that **Responsibility** - THE RESULT **TRACEABILITY AND VERIFICATION EXISTS.**

Offshore cranes built to API 2 C or ABS standards should maintained and repaired to these same **API STANDARDS**

2-INFREQUENT USAGE REMOVAL

- Elimination of the infrequent use category or modification to existing requirement.
 - Cranes not used for 11 months need only a Pre-Use inspection prior to usage.
 - Cranes used in such a manner need more attention.
 - I suggest that these cranes have a QUARTERLY inspection during those months not in use.
- Add QUARTERLY Inspection to category.

2-REMOVAL OF INFREQUENT USAGE CATEGORY

Current API 2 D recommendations 4.1.1.1 state that a crane may be out of service for a period of 11 + months and the only requirement for operation is that the crane have a PRE-USE inspection prior to operation.

Cranes which are in Infrequent Usage Category are more apt to have problems that those which are in the Moderate or Heavy usage Category.

Cranes sitting for long periods have several problems which occur during these times of inactivity.

- Condensation in all the fluid containers.
- Swing drive upper bearings get dry and moisture settles on the topside.
- Hoist drums which are vented to the atmosphere have a severe problem of rusting in the upper housings where the planetary's and bearings are exposed to the moisture.
- Winch brakes sticking to the drum and open areas developing rust to the point of drum replacement.
- □ Swing bearings getting moisture in the bearing area.
- □ Fuel and Hydraulic tank
- Control Valves mounted on the floor of cranes-
- Water filling up the drain pans and causing the control valves to fill with water through the end caps thereby causing the spools, springs and lever pins to freeze up.
- Wire rope rust due to lubrication loss due to nature and the Seagull Industry

Cranes should have a quarterly added to this Category as a minimum. By performing these inspections the chance of failure or accidents is decreased.

3-TRAINING OF QUALIFIED INSPECTORS

- Qualified and Competent Inspectors should receive training from API 2 C manufacturers.
- Experience for an inspector performing annual inspections be a minimum of **5** years as an offshore crane mechanic.
 - Qualified-formal training and experience
 - Competent-know regulations, requirements and standards

3-TRAINING OF QUALIFIED INSPECTORS

Qualified and Competent Inspectors should receive training from API 2 C Manufacturers.

- API RP 2 D 2.2 Defines the requirements of a Qualified Inspector
 - Designated by the employer who has appropriate offshore experience and training, and also be a Qualified Operator

- API 2C a person who has extensive knowledge, training, and experience

Competent Inspectors

- OSHA 29 CFR 1926.32 (a) (5) & (a) (6) Competent person as one that has a thorough knowledge of the requirements, regulations and standards

Persons performing Annual Inspections should have a minimum of 5 years of Offshore Crane Service Experience.

This process would lessen the danger of persons performing inspections that are not familiar or aware of critical inspection requirements.

4- DE-RATE OF CRANES

- API 2D does not address this issue.
 - Re-rating is the only addressed issue
- De-Rated cranes due to problems must be operated only by trained operators and only under the conditions which the De-Rate identifies.
- No personnel shall be lifted when a crane is De-Rated.
- A crane may be De-Rated only by an OEM, API 2C Manufacturer or Licensed Engineer with experience in the design of Offshore Cranes, with a new load chart.

4- DE-RATE OF CRANES

API 2 D does not address this Issue.

Cranes having problems and cannot be shut down, need guidelines so the crane operation can be limited but used until repairs or components can be obtained. Just for a person to say that the crane is De-Rated to **fast line operation only** says that the crane may lift Fast line capacity at any angle. Some cranes structurally are not rated to lift a load at 15 degrees that the fast line is capable of lifting. The load chart must be considered when De-Rating a crane.

- De-Rated cranes should be operated only by Qualified Operators
- De-Rated Cranes must not be used to lift personnel
- Cranes that have been De-Rated must have a WARNING placed inside the cab, Record Book and a NEW LOAD CHART must be assigned to the crane. The chart must be calculated by OEM, API 2 C Manufacturer or Licensed Engineer with the experience in the design of Offshore Cranes.

5-CRANE OPERATOR TRAINING

- Crane operator and Rigger Training performed to API RP 2 D requirements.
 - Hands on training to be accomplished on the job .
 - Hands on training to be performed on the equipment to be operated.
- Follow the requirements of 2 D

5- CRANE OPERATOR TRAINING

APPENDIX A1 defines the requirements for training.

Class programs must follow these guidelines.

Customers have told us of classroom training of 2 hours.

Customers have scheduled training **VIA** joke telling.

Training programs should be **ACCREDITED** and have means of checks and balances.

An Offshore Operator is now in the process of developing a TEST.

This test will be administered to the Qualified Operator upon arrival on structure. This will ascertain the qualifications of the Qualified Operator.

Some of the suggested questions:

- What are the requirements of a Pre-Use inspection?
- Explain the differences and when to use Static or a Dynamic load chart?
- Explain boom angle and radius?

Other questions are being prepared and will only be to satisfy the operator in knowing that the Qualified Operator is qualified.

6- ANTI-TWO BLOCK

- Eliminate the usage of **CRASH BLOCK**
 - API 2 C defines Two-Block as the condition when the lower block comes in contact with the upper load block or boom point sheave assembly.
 - A Proximity device or Stalling is acceptable.
- Anti-Two blocking does not deliberately occur during operation, unless during testing. Two-Blocking occurs when an Operator is not paying attention or is unfamiliar with the crane controls.

6- ANTI-TWO BLOCK SYSTEMS

ELIMINATE THE USAGE OF CRASH BLOCK

- API 2 C 12.6 defines Two-Block as the condition when the lower block comes in contact with the upper load block or boom point sheave assembly.
- 29 CFR 1926.550 (g) (3) (ii) (c) defines Two-Block as a positive acting device which prevents contact between the load block or overhaul ball and the boom tip (anti-two-blocking device), or a system shall be used which deactivates the hoisting action before damage occurs in the event of a two-blocking situation (two-block damage prevention feature).

TWO BLOCKING DOES NOT DELIBERATELY OCCUR DURING OPERATION (UNLESS DURING TESTING). TWO-BLOCKING OCCURS WHEN AN OPERATOR IS NOT PAYING ATTENTION OR IS UNFAMILIAR WITH THE CRANE CONTROLS (Operator Error).

Again, crane operators should be trained on the crane models that they are to operate.

The effort exerted, when the CRASH STOP is used, on the wire rope, structure, headache ball, rope socket and the boom point is TWO (2) times the amount of line pull.

- Hoist 30,000 # at full engine and hoist control speed the CRASH STOP at the boom point is 60,000# of effort.
- How many times can this type of two-block work without causing serious damage?
- What happens when personnel are on a basket and the headache ball suddenly flips forward when it comes in contact with the jib guard?

7- COLOR TAGGING OF LIFTS SHIPPED OFFSHORE

- Lifts from shorebase operations be marked, either by the vendor or the operator, in such a way that the operator can identify the weights from the crane.
- Suggestion and Implemented by several producers.
 - GREEN Lifts under 5,000 #
 - YELLOW Lifts 5,000 to 10,000#
 - RED Lifts 10,000 to 20,000#

7- COLOR TAGGING OF LIFTS SHIPPED OFF-SHORE

Some Producers have color coded tags (stickers). These are applied by Shore-Base personnel with the weight marked on the tag.

The colors vary but this gives the operator a visual to then decide whether to make the lift with the Auxiliary or the Main Hoist.

Examples:

Green	Lifts Under 5,000 #
Yellow	Lifts 5,000 to 10,000 #
Red	Lifts 10,000 to 20,000#

**WORKS FOR SOME FOLKS.
THIS CAN WORK FOR THE WHOLE GULF**

Wilfred Guidry Jr. AKA JR Guidry

Employed by American Aero Cranes, Houston Service and manufacturing facility.

35 years as a Mechanic and Welder.

30 years as Crane mechanic specializing in Manitowoc and P&H Construction cranes from 5 to 400 tons, Hydraulic and Mechanical cranes.

15 Years Offshore Mechanic, Instructor and Inspector.

Started in the Oilfield with Scurlock Oil Co. as a Rig-Up welder and Component Re-builder for a fleet of 200 Crude Oil Tankers and Trucks.

Worked as Field service Technician and Service Manager for Tide Equipment and Cranetex Crane and Equipment services.

Current Position is Training Specialist along with Ambrose Thibadoux of our Houma Louisiana Service Center.

American Aero Crane has Manufacturing Facilities in Theodore, Alabama, Houston, Tex. With Service Facilities in Houston, Houma, La. Lagos Nigeria, and Singapore.

We found the need for training and developed courses for the offshore industry. The Training courses available are;

Crane Operator

Qualified Inspector

Rigger Training

We also provide PEC (Petroleum Education Council) Training.

SESSION Three
Minerals Management Service

Highlights on Issues and Concerns

**Highlights of Discussion
on Issues and Concerns**

Highlights on Issues and Concerns

Operators Bin

- Temporary/rental cranes
- Pre-use inspection policy
- Lift boat anti two-block device requirements
- Training card requirement (when employee goes from operator to operator or contractor to contractor)
- Temporary Cranes (what regulations govern)
- Maintenance of hoists and booms
- How do you certify that crane operator has training?
- Verifying pre-slung loads
- Infrequent usage
 - Pre-use inspection
 - Quarterly inspection
 - Yearly inspection
- Consistency problems
- Storage of slings

Contractors/Manufacturers Bin

- How to handle questionnaire handed out by Larry Smith, applied hydraulics
- Hydraulic versus mechanical cranes-operator qualifications
- Follow-up to this workshop; tradeshow; another workshop

Highlights of Discussion on Issues and Concerns

On the subject of how to treat temporary and rental cranes the following comments were made:

- Why not treat them the same as any other platform crane.
- Have API RP 2C apply to all cranes.
- Give rental cranes more attention due to their history of lack of maintenance.
- Give a lot of attention to how we mount the rental crane on the platform (the welding procedure to the platform deck)
- Question whether we are having problems with rental cranes. Need to collect more data.
- What is the percentage of rental cranes out in the Gulf.
- Should concentrate on where the problem is.
- MMS should look into the 50 incidents and determine what percentage were hydraulic, percent mechanical and percent rental.
- The operator should ultimately be responsible for determining that rental crane is acceptable for intended use.

Where should the anti two block devices be located? The responses ranged as follows:

- MMs must regulate by API 2D using API 2C
- Device should be located on any crane that lifts personnel
- Device should not be put on every crane that is undergoing a retrofit
- BP Amoco retrofits everything with anti two block devices

Anti two block devices should be on all pre-85 cranes

One alternative would be to add proximity warning devices if the facility has compressed air. There are some battery-operated devices out now.

On the question of whether crane operators should carry cards showing they are qualified, the MMS will get with the API to work on a solution.

The maintenance of booms and hoists is a new MMS requirement. Apparently bop hoists have been a problem. Ultimately a performance standard will be written.

How do you determine if a crane operator is qualified? The IADC training committee is working on the skills required to be a crane operator. Minutes of a conference on the subject held in Galveston are available from Allen Kelly with Diamond Offshore.

Consistency problems can be handled by contacting Jack Leezy with the MMS. His job is to follow up on inspections to verify the consistency between inspectors. He can be reached by e-mail at JACK.LEEZY@MMS.GOV

Apparently the problem with sling storage has been the protection of slings from UV rays. API 2D states that slings should be properly stored in a box.

Are mechanical cranes more difficult to operate than hydraulic cranes? The answer appears to be yes. How many mechanical cranes are left in the Gulf? Apparently a lot because drilling contractors need them more than the production people. How many accidents are they causing – nobody seems to know. California has 80 percent mechanical cranes.

On the subject of a follow-up workshop there were several suggestions:

Need a Workshop of just companies providing rigger services, and specifically address the question of how do you provide training to meet API 2D.

Need a workshop to look at root cause analysis. Could start with the root causes listed in BP Amoco's paper and add to them

Need to address weight indicators at the next workshop

Bob Watson, ex-Shell and now American Aero employee, suggested a trade show and actually had an outline of what all the show should cover.

The physical requirements for crane operators are the subject for further study. Should the doctor sign the form specifying the person is qualified to be a crane operator? Keep in mind that a crane operator is qualified not certified. All agreed that crane operators should have a physical every four years.

Appendix

Appendix A

MMS PINC
(Potential Incident of Non-Compliance) List
Rigging and Material Handling
(PINC's G-190 to G-194)

RIGGING AND MATERIAL HANDLING

(Last update - April 2000)

G-190 DO ONLY QUALIFIED PERSONNEL PERFORM RIGGING OPERATIONS IN ACCORDANCE WITH API RP 2D, PARAGRAPHS 2.3, 3.1.3, AND 3.1.4?

Authority: 108 **Enforcement Action:** W/C

DEFINITION:

A rigger is anyone who attaches or detaches lifting equipment to loads or lifting devices and who has received training in accordance with API RP 2D, paragraph 3.1.4 and Appendix A2.

INSPECTION PROCEDURE:

1. Verify from facility crane records that previous rigging operations were performed by qualified personnel.
2. If rigging operations are in progress at the time of inspection, verify that personnel involved are qualified.

IF NONCOMPLIANCE EXISTS:

Issue a warning (W) INC if records indicate that rigging operations were previously performed by unqualified personnel. Issue a component shut-in (C) INC if rigging operations are in progress and personnel involved are not qualified.

INSPECTION FORM:

Enter one item checked per crane inspected.

G-191 WHENEVER THERE IS ANY DOUBT AS TO SAFETY, DOES THE CRANE OPERATOR STOP AND REFUSE TO HANDLE LOADS OR CONTINUE OPERATIONS AS SAFETY DICTATES IN ACCORDANCE WITH API RP 2D, PARAGRAPH 3.1.5a?

Authority: 108 **Enforcement Action:** W

Note: Crane operations should be restricted during periods of bad weather, such as lightning, high winds or high seas, or when the Crane Operator's ability to see the signal person is impaired by darkness, fog, rain, etc.

INSPECTION PROCEDURE:

PINC can only be used if crane operations continued under adverse conditions and caused an accident or near miss which resulted in injury, death, pollution, or property damage.

IF NONCOMPLIANCE EXISTS:

Issue a warning (W) INC if inspection reveals that crane was operated under adverse conditions and caused an accident which resulted in injury, death, pollution, or property damage.

INSPECTION FORM:

Enter one item checked per crane inspected.

G-192 ARE PROCEDURES FOR PERSONNEL TRANSFER PERFORMED IN ACCORDANCE WITH RECOMMENDED PRACTICES SPECIFIED IN API RP 2D, PARAGRAPH 3.4 AND APPENDIX B, PARAGRAPH C.3.4?

Authority: 108 **Enforcement Action:** C

INSPECTION PROCEDURE:

If at the time of inspection, personnel are being transferred via personnel carrier from vessel to vessel, vessel to platform, or from platform to vessel, verify that:

1. Personnel carrier is of an approved type and is maintained in a safe condition.
2. All hooks used for support of personnel carrier are equipped with a safety latch.
3. Personnel are riding the carrier in a safe manner and are wearing an approved PFD.
4. Personnel are not raised or lowered directly over a vessel.

IF NONCOMPLIANCE EXISTS:

Issue a component shut-in (C) INC for a violation of 1 thru 4 above.

INSPECTION FORM:

Enter one item checked per crane inspected.

G-193 ARE SLINGS OF ALL TYPE, GRADE, AND CONSTRUCTION IDENTIFIED AS REQUIRED IN API RP 2D, PARAGRAPH 5.2.4b?

Authority: 108 **Enforcement Action:** C

Note: Slings identification includes sling manufacturer's name, pertinent working load limits, proof test certification number, length, diameter, and date of proof test.

INSPECTION PROCEDURE:

Verify that the slings have the specified ID tags attached.

IF NONCOMPLIANCE EXISTS:

Issue a component shut-in (C) INC if sling identification tag is missing.

INSPECTION FORM:

Enter one item checked per sling inspected.

G-194 ARE SLINGS PROPERLY STORED WHEN NOT IN USE IN ACCORDANCE WITH API RP 2D, APPENDIX G, PARAGRAPH C.5.2.1?

Authority: 108 **Enforcement Action:** W/C

Note: Slings should be stored in an area where they will not be exposed to water, extreme heat, or corrosive fumes, liquids and sprays. Slings should not be stored on the deck. All slings, when not in use, should be kept on a rack. Use of a rack minimizes accidental damage and allow easier monitoring of condition between regular inspections. Slings that are routinely used, should be stored in a well ventilated building or shed. If space limitations require that slings be stored along the side of the platform, they should be secured in a manner to prevent abrasion due to rubbing and maintained in a manner to minimize corrosion.

INSPECTION PROCEDURE:

Visually inspect areas near cranes for slings which are not properly stored and maintained.

IF NONCOMPLIANCE EXISTS:

Issue a warning (W) INC if slings are not properly stored.

Issue a component shut-in (C) INC if slings are not maintained in a manner to prevent loss of integrity due to abrasion or corrosion.

INSPECTION FORM:

Enter one item checked per sling inspected.

Appendix B
MMS PINC
(Potential Incident of Non-Compliance) List
Cranes
(PINC's G-202 to G-227)

CRANES

(Last update - April 2000)

G-202 ARE CRANES OPERATED ONLY BY QUALIFIED PERSONNEL IN ACCORDANCE WITH API RP 2D, PARAGRAPH 3.1.1?

Authority: 108 **Enforcement Action:** W/C

DEFINITION:

Qualified Person:

1. A person who has met and passed the requirements of API RP 2D, paragraphs 2.1 and 3.1.2;
2. A trainee under the direct supervision of a Qualified Crane Operator;
3. Appropriate maintenance and supervisory personnel, when it is necessary for them to do so in the performance of their duties.

Note: No one other than the personnel specified above should enter a crane cab.

INSPECTION PROCEDURE:

1.

Verify from facility crane records that crane operations were performed by qualified personnel.

2.

If crane is in operation, verify that the person operating the crane is qualified.

Note:

1. A crane operator is not qualified if qualifications are not maintained, at a minimum, every four years.
2. A written document from the facility operator stating that qualifications have been met is sufficient.

IF NONCOMPLIANCE EXISTS:

Issue a warning (W) INC if facility records indicate that the crane was previously operated by unqualified personnel.

Issue a component shut-in (C) INC if the crane in operation during the inspection is operated by unqualified personnel.

INSPECTION FORM:

Enter one item checked per crane inspected.

G-204 ARE PROPER CRANE OPERATING PRACTICES FOR ATTACHING AND MOVING THE LOAD BEING UTILIZED IN ACCORDANCE WITH API RP 2D, PARAGRAPHS 3.2.1, 3.2.2 AND 3.2.3?

Authority: 108 **Enforcement Action:** C

INSPECTION PROCEDURE:

If crane operations are in progress, verify that:

1. Load is attached to the hook by means of slings or other suitable devices. Sling use shall be in accordance with the guidelines of API RP 2D, Appendix B, paragraph C.3.2.2.c, and Appendix G, paragraph C.5.2.1.
2. Procedures for moving the load are in accordance with the guidelines of API RP 2D, Appendix B, paragraph C.3.2.3.

IF NONCOMPLIANCE EXISTS:

Issue a component shut-in (C) INC if procedures for attaching and/or moving the load are not within specified guidelines.

INSPECTION FORM:

Enter one item checked per crane inspected.

G-205 HAVE MANUFACTURER'S RECOMMENDATIONS BEEN INCLUDED IN ESTABLISHING ALL INSPECTION REQUIREMENTS IN ACCORDANCE WITH API RP 2D, PARAGRAPH 4.1.2 AND APPENDIX C?

Authority: 108 **Enforcement Action:** W

INSPECTION PROCEDURE:

Check facility records of crane inspections to verify that the manufacturers recommendations have been included in establishing all inspection requirements.

IF NONCOMPLIANCE EXISTS:

Issue a warning (W) INC if records indicate that manufacturer's recommendations have been excluded from establishing inspection requirements.

INSPECTION FORM:

Enter one item checked per crane inspected.

G-206 HAVE NEW OR RELOCATED CRANES RECEIVED AN INITIAL INSPECTION BY A QUALIFIED INSPECTOR IN ACCORDANCE WITH API RP 2D, PARAGRAPH 4.1.2.1?

Authority: 108 **Enforcement Action:** W/C

Note: Cranes in this category are required to be load tested in accordance with API RP 2D, Appendix E.

INSPECTION PROCEDURE:

1. Verify that records are readily available and are kept for a period of two years.
2. Verify that inspection and load test was performed by a qualified inspector.
3. Verify that records include date and time of inspection and name/initial of person performing the inspection.

IF NONCOMPLIANCE EXISTS:

Issue a warning (W) INC if:

1. Records of inspection are not available and/or not kept for two years;
2. Records of inspections are incomplete or inaccurate, but are sufficient to indicate that the required inspection occurred.

Issue a component shut-in (C) INC if:

1. The crane was not inspected prior to use when new or prior to use after being permanently relocated;
2. The crane was not load tested.

INSPECTION FORM:

Enter one item checked per crane inspected.

G-207 HAVE PRE-USE INSPECTIONS BEEN PERFORMED PRIOR TO USE (TYPICALLY DAILY) BY A QUALIFIED CRANE OPERATOR/INSPECTOR WITH RECORDS MAINTAINED AT AN APPROPRIATE LOCATION IN ACCORDANCE WITH API RP 2D, PARAGRAPHS 4.1.1.1 AND 4.1.2.2?

Authority: 108 **Enforcement Action:** W/C

Note:

1. Applies to all cranes, regardless of usage category. The pre-use inspection must be conducted and recorded prior to using the crane. Pre-use inspection record shall be a record, a record book, a logbook, a computerized data collector, or an electronic data collector which is to be kept in the crane cab, in a weather-tight enclosure on the crane, or inside the nearest building to the crane. Inspection criteria shall be in accordance with API RP 2D, Appendix C, paragraph C.4.1.2a.
2. Reference Appendix 24 for descriptions of "Usage Category."

INSPECTION PROCEDURE:

1. Verify that records are kept at an appropriate location.
2. Verify that records including date and time of inspection and name/initial of person performing the inspection.
3. Verify that previous pre-use inspections were performed by qualified personnel.
4. If a crane is in operation during inspection, verify that it has received a pre-use inspection by qualified personnel.

IF NONCOMPLIANCE EXISTS:

Issue a warning (W) INC if:

1. Records of inspection are not available and/or not kept at an appropriate location.
2. Records of inspections are incomplete or inaccurate, but are sufficient to indicate that the required inspection occurred.
3. Records indicate that previous inspections were performed by unqualified personnel.

Issue a component shut-in (C) INC if the crane in operation during inspection has not received a pre-use inspection by qualified personnel.

INSPECTION FORM:

Enter one item checked per crane inspected.

G-208 HAVE MONTHLY INSPECTIONS BEEN PERFORMED BY A QUALIFIED CRANE OPERATOR/INSPECTOR WITH RECORDS READILY AVAILABLE FOR A PERIOD OF TWO YEARS IN ACCORDANCE WITH API RP 2D, PARAGRAPH 4.1.2.3?

Authority: 108 **Enforcement Action:** W/C

Note:

1. Applies to Heavy Usage Category cranes. An Operator's failure to document usage category will cause the crane to default to the Heavy Usage category. Inspection criteria shall be in accordance with API RP 2D, Appendix C, paragraph C.4.1.2b.

2. Reference Appendix 24 for definition of “Monthly” and description of “Usage Category.”

INSPECTION PROCEDURES:

1. Verify that records are readily available and are kept for a period of two years.
2. Verify that records include date and time of inspection and name/initial of person performing the inspection.
3. Verify that previous monthly inspections were performed by qualified personnel.
4. If a crane is in operation during inspection, verify that it has received a monthly inspection by qualified personnel.

IF NONCOMPLIANCE EXISTS:

Issue a warning (W) INC if:

1. Records of inspection are not available and/or not kept for a period of two years.
2. Records of inspection are incomplete or inaccurate, but are sufficient to indicate that the required inspection occurred.
3. Records indicate that previous inspections were performed by unqualified personnel.

Issue a component shut-in (C) INC if crane has not received a monthly inspection by qualified personnel.

INSPECTION FORM:

Enter one item checked per crane inspected.

G-209 HAVE QUARTERLY INSPECTIONS BEEN PERFORMED BY A QUALIFIED CRANE INSPECTOR WITH RECORDS READILY AVAILABLE FOR A PERIOD OF TWO YEARS IN ACCORDANCE WITH API RP 2D, PARAGRAPH 4.1.2.4?

Authority: 108 **Enforcement Action:** W/C

Note:

1. Applies to Moderate Usage Category cranes and Heavy Usage Category cranes. An Operator’s failure to document usage category will cause the crane to default to the Heavy Usage category. Inspection criteria shall be in accordance with API RP 2D, Appendix C, paragraph C.4.1.2c.
2. Reference Appendix 24 for definition of “Quarterly” and descriptions of “Usage Category.”

INSPECTION PROCEDURE:

1. Verify that records are readily available and are kept for a period of two years.
2. Verify that previous quarterly inspections were performed by a qualified crane inspector.
3. Verify that records include date and time of inspection and name/initial of person performing the inspection.
4. If crane is in operation during inspection, verify that it has received a quarterly inspection by a qualified crane inspector.

IF NONCOMPLIANCE EXISTS:

Issue a warning (W) INC if:

3. Records of inspection are not available and/or not kept for a period of two years.
4. Records of inspection are incomplete or inaccurate, but are sufficient to indicate that the required inspection occurred.
5. Records indicate that previously quarterly inspections were performed by unqualified personnel

Issue a component shut-in (C) INC if crane has not received a quarterly inspection by qualified personnel.

INSPECTION FORM:

Enter one item checked per crane inspected.

G-210 HAVE ANNUAL INSPECTIONS BEEN PERFORMED BY A QUALIFIED CRANE INSPECTOR WITH RECORDS READILY AVAILABLE FOR A PERIOD OF TWO YEARS IN ACCORDANCE WITH API RP 2D, PARAGRAPHS 4.1.1.1 AND 4.1.2.5?

Authority: 108 **Enforcement Action:** W/C

Note:

1. Applies to all cranes, regardless of usage category. Cranes that have been out of service for 12 months or more must have an annual inspection before being used. Additionally, annual inspections shall include inspection of crane critical components in accordance with API RP 2D, Appendix C, paragraph C.4.1.2d, items 22, 23, and 24.
2. Reference Appendix 24 for definition of “Annual” and descriptions of “Usage Category.”

INSPECTION PROCEDURE:

1. Verify that records are readily available and are kept for a period of two years.
2. Verify that previous annual inspections were performed by a qualified crane inspector.
3. Verify that records include date and time of inspection and name/initial of person performing the inspection.
4. If a crane is in operation during inspection, verify that it has received an annual inspection by a qualified crane inspector.

IF NONCOMPLIANCE EXISTS:

Issue a warning (W) INC if:

1. Records of inspections are not available and/or not kept for a period of two years.
 2. Records of inspection are incomplete or inaccurate, but are sufficient to indicate that the required inspection occurred.
 3. Records indicate that previous annual inspections were performed by unqualified personnel.
- Issue a component shut-in (C) INC if crane has not received an annual inspection by qualified personnel.

INSPECTION FORM:

Enter one item checked per crane inspected.

G-211 IS THE CORRECT LOAD RATING CHART FOR THE CRANE CONFIGURATION AT THE PRIMARY CONTROL STATION IN ACCORDANCE WITH API RP 2D, PARAGRAPH 3.2.1?

Authority: 108 **Enforcement Action:** C

INSPECTION PROCEDURE:

Verify that the load chart is posted and visible in the primary control station for the crane configuration in use.

IF NONCOMPLIANCE EXISTS:

Issue a component shut-in (C) INC for the crane if the correct load rating chart is not posted and visible at the primary control station for the crane.

INSPECTION FORM:

Enter one item checked per crane inspected.

G-216 ARE WRITTEN REPORTS ON LOAD TESTS PREPARED BY A QUALIFIED CRANE INSPECTOR SHOWING LOAD TEST PROCEDURES AND RESULTS WHEN LOAD TESTS ARE REQUIRED IN ACCORDANCE WITH API RP 2D, PARAGRAPH 4.2.3?

Authority: 108 **Enforcement Action:** C

Note: Load tests are required under the following conditions:

1. New cranes being placed in service.
2. Cranes that are being permanently relocated.
3. Temporary/rental cranes after each rig-up or relocation.
4. When repairs or replacement do not meet the requirements of API RP 2D, paragraph 4.3.3.

INSPECTION PROCEDURE:

Verify from facility crane records that load tests were conducted when required by a qualified crane inspector using API RP 2D, Appendix E as a reference guide.

IF NONCOMPLIANCE EXISTS:

Issue a component shut-in (C) INC if load tests are not conducted when necessary by a qualified crane inspector using API RP 2D, Appendix E, as a referenced guide.

INSPECTION FORM:

Enter one item checked per crane inspected.

G-217 ARE WRITTEN REPORTS MAINTAINED CONFIRMING ADEQUACY OF REPAIRS OR ALTERATIONS IN ACCORDANCE WITH API RP 2D, PARAGRAPH 4.3.3c?

Authority: 108 **Enforcement Action:** W/C

Note: All replacement parts must be equal to or better than the original equipment. No welding repairs may be made to critical components, such as booms and swing circle assemblies, without specific repair procedures and recommendations from the original crane manufacturer or other similar qualified source.

INSPECTION PROCEDURES:

Verify the availability of written reports confirming adequacy of major repairs or alterations.

IF NONCOMPLIANCE EXISTS:

Issue a warning (W) INC if the inadequate repairs are non-operational, readiness repairs.

Issue a component shut-in (C) INC if:

1. Records are not available.
2. Records are incomplete or inaccurate.

INSPECTION FORM:

Enter one item checked per crane inspected.

G-218 HAS A PREVENTATIVE MAINTENANCE PROGRAM BEEN ESTABLISHED WITH RECORDS READILY AVAILABLE FOR A PERIOD OF TWO YEARS IN ACCORDANCE WITH API RP 2D, PARAGRAPH 4.3.1?

Authority: 108 **Enforcement Action:** W/C

Note:

1. A preventative maintenance program takes into consideration crane type, frequency of usage, history of maintenance, and manufacturer's recommendations.
2. Reference Appendix 24 for descriptions of "Frequency of Usage."

INSPECTION PROCEDURE:

Verify the availability of a preventative maintenance program.

IF NONCOMPLIANCE EXISTS:

Issue a warning (W) INC if:

1. Records are not immediately available and/or not kept for a period of two years.
2. Records are incomplete or inaccurate, but are sufficient to indicate that a preventive maintenance program has been established.

Issue a component shut-in (C) INC if records do not indicate that a preventive maintenance program has been established.

INSPECTION FORM:

Enter one item checked per crane inspected.

G-220 ARE CRANES WHICH ARE POSITIONED IN THE PROXIMITY OF HELIDECKS OR APPROACH/TAKE-OFF ZONES NOT OPERATED DURING HELICOPTER OPERATIONS IN ACCORDANCE WITH API RP 2D, PARAGRAPH 3.1.5L?

Authority: 108 **Enforcement Action:** W

Note: Crane boom will be positioned and secured against swinging so there will be no interference with flight operations. The Crane Operator will not be at the control station unless he is in direct voice communication with the helicopter pilot.

INSPECTION PROCEDURE:

If the crane and helicopter operations are in progress at the time of the inspection, verify that the crane boom is positioned and secured as required and the Crane Operator is out of the cab unless he is in direct voice communications with the pilot.

IF NONCOMPLIANCE EXISTS:

Issue a warning (W) INC if the crane boom is not positioned and secured as required or if the Crane Operator remains in the cab without direct voice communications with the pilot during landings/take-offs.

INSPECTION FORM:

Enter one item checked per crane observed.

G-221 IS THERE A FIRE EXTINGUISHER OF APPROPRIATE SIZE AND TYPE KEPT IN THE CAB OR VICINITY OF THE CRANE IN ACCORDANCE WITH API RP 2D, PARAGRAPH 3.5.2?

Authority: 108 **Enforcement Action:** C

Note: ASME B30.4c recommends a portable fire extinguisher with a basic minimum extinguisher rating of 10 BC. (10 = 10 lbs., B = Flammable Fluids, C = Energized Electrical)

INSPECTION PROCEDURE:

Verify that a fire extinguisher is located in the crane cab or near the crane.

IF NONCOMPLIANCE EXISTS:

Issue a component shut-in (C) INC if fire extinguisher:

1. Is not located where required.
2. Is not of the appropriate size or type.
3. Does not exist or is inoperable.

INSPECTION FORM:

Enter one item checked per crane observed.

G-223 ARE CRANE INSPECTORS QUALIFIED IN ACCORDANCE WITH API RP 2D, PARAGRAPH 2.2?

Authority: 108 **Enforcement Action:** C

DEFINITION:

Qualified Crane Inspector - A person so designated by the employer who by reason of appropriate experience and training, in addition to meeting the requirements of Qualified Crane Operator, has attended formal training in and successfully

completed courses on crane maintenance and troubleshooting, hoist troubleshooting and overhaul, and on structural aspects of offshore cranes, which gives a knowledge of structurally critical components and critical inspection areas for non-mechanical and/or mechanical cranes, as applicable.

INSPECTION PROCEDURE:

Verify from facility crane records that duties requiring a qualified crane inspector have been performed by qualified personnel.

Note:

1. A crane inspector is not qualified if qualifications are not maintained, at a minimum, every four years.
2. A written document from the Operator stating that qualifications have been met is sufficient.

IF NONCOMPLIANCE EXISTS:

Issue a component shut-in (C) INC if records indicate that duties requiring a qualified crane inspector have been performed by unqualified personnel.

INSPECTION FORM:

Enter one item checked per crane inspected.

G-224 IF DEFICIENCIES THAT IMPAIR SAFE OPERATION ARE KNOWN, IS THE CRANE TAKEN OUT OF SERVICE OR ITS OPERATION RESTRICTED TO ELIMINATE THE UNSAFE CONDITION IN ACCORDANCE WITH API RP 2D, PARAGRAPH 3.1.5c?

Authority: 108 **Enforcement Action:** C

Note: Limited (restricted) service may, in some cases, be continued after the identification and before correction of a deficiency. In such cases, the deficiency must be documented and cautionary notices posted in accordance with API RP 2D, paragraph 1, item c.

INSPECTION PROCEDURE:

1. Check facility crane inspection records to determine if any deficiencies have been identified.
2. If deficiencies have been identified, verify that cautionary notices have been posted.

IF NONCOMPLIANCE EXISTS:

Issue a component shut-in (C) INC if deficiencies have been identified and cautionary notices have not been posted.

INSPECTION FORM:

Enter one item checked per crane inspected.

G-225 HAVE STATIC AND DYNAMIC LOAD RATING CHARTS BEEN ESTABLISHED FOR ALL CRANES IN ACCORDANCE WITH API RP 2D, PARAGRAPH 3.1.5h?

Authority: 108 **Enforcement Action:** C

Note:

1. Static Load Ratings must be established for lifting from or setting on the crane-supporting structure (platform).
2. Dynamic Load Ratings must be established for lifting from or setting on vessels.

INSPECTION PROCEDURE:

Verify from facility crane records that static and dynamic load ratings charts have been established for all cranes.

IF NONCOMPLIANCE EXISTS:

Issue a component shut-in (C) INC if records indicate that:

1. Static and dynamic load ratings have not been established for all cranes.
2. Crane has operated without appropriate load rating charts established and posted.

INSPECTION FORM:

Enter one item checked per crane inspected.

G-226 ARE REPAIRS OR REPLACEMENTS OF CRITICAL COMPONENTS MADE PROMPTLY IN ACCORDANCE WITH API RP 2D, PARAGRAPH 4.3.3b?

Authority: 108 **Enforcement Action:** C

Note: All replacement parts must be equal to or exceed the original equipment. No welding repairs may be made to critical components, such as booms and swing circle assemblies, without specific repair procedures and recommendations from the original crane manufacturer, or other qualified source. Promptly means "Done Without Delay."

INSPECTION PROCEDURE:

1. Check facility crane records for evidence of crane repair or replacements of critical components.

2. If repair or replacement has been made, verify work was done promptly and accomplished in accordance with API RP 2D, Appendix F, paragraph C.4.3.3, item b.

IF NONCOMPLIANCE EXISTS:

Issue a component shut-in (C) INC if records indicate that work is not done promptly or accomplished in accordance with API RP 2D, Appendix F, paragraph C.4.3.3, item b.

INSPECTION FORM:

Enter one item checked per crane inspected.

G-227 HAS A WIRE ROPE INSPECTION PROGRAM BEEN ESTABLISHED IN ACCORDANCE WITH API RP 2D, PARAGRAPH 5.1.2?

Authority: 108 **Enforcement Action:** W

DEFINITION:

A wire rope inspection program is an inspection program which takes into consideration crane type, frequency of usage, history of maintenance, wire rope manufacturer's recommendations, and crane manufacturer's recommendations.

Note:

1. Inspection records must be maintained per API RP 2D, paragraph 4.2 to determine the time interval for retirement of the wire rope. Records must be readily available until the specific wire rope is retired. All observed wire rope deterioration as listed in API RP 2D, Appendix G, paragraph C.5.2.1b must be recorded on these inspection records.
2. Reference Appendix 24 for descriptions of "Frequency of Usage."

INSPECTION PROCEDURE:

Verify the existence of a wire rope inspection program.

IF NONCOMPLIANCE EXISTS:

Issue a warning (W) INC if:

1. Records are not readily available.
2. Records are incomplete or inaccurate, but are sufficient to indicate that a wire rope inspection program has been established.

INSPECTION FORM:

Enter one item checked per crane inspected.

Appendix C
MMS PINC's Appendix 24
Crane Use Categories and Inspections

CRANE USE CATEGORIES AND INSPECTIONS

Infrequent Usage

Used 10 hours or less per month, based on the average use over a quarter. These cranes will be subject to a pre-use and an annual inspection.

Moderate Usage

Used more than 10 hours but less than 50 hours per month, based on quarter average. These cranes will be subject to a pre-use, quarterly, and an annual inspection.

Heavy Usage

Used 50 or more hours per month. These cranes will be subject to a pre-use, monthly, quarterly, and an annual inspection.

INSPECTIONS

Monthly - Anytime during the calendar month.

Quarterly - Every three months (January, February, & March = 1st quarter; April, May, & June = 2nd quarter, etc.)

Annual - Every 12 months

FREQUENTLY ASKED QUESTIONS

Q:

Crane was inspected for monthly on 3/5/2000, when is my next monthly due?

R:

No later than 4/30/2000, O.K. to the last day of the month.

Q:

Crane was inspected for quarterly on 1/20/2000, when is my next quarterly due?

R:

No later than 4/30/2000, O.K. to the last day of the month.

Q:

Crane was inspected for annual on 4/1/1999, when is my next annual due?

R:

No later than 4/30/2000, O.K. to the last day of the month.

Q:

When a crane shifts from infrequent to moderate use, when is the quarterly due?

R:

By the end of the first month of the quarter following the shift.

Q:

When a crane shifts from moderate to heavy use, when is the monthly due?

R:

By the end of the month following the shift, followed by a monthly or quarterly, as needed to set up the required inspection schedule.

Appendix D
MMS Crane Position Paper

Crane Position Paper

At the Minerals Management Service (MMS) sponsored crane safety workshop in March 2000, a number of questions were asked relative to equipment safety and safe operating practices, and the associated requirements stated in current industry standards (i.e., API RP 2D and API SPEC 2C). The MMS revised and published in April 2000 a National Potential Incident of Noncompliance (PINC) List and Guidelines that identifies what MMS will do to ensure, to the maximum extent possible, the safety of cranes and crane operations on fixed offshore platforms on the Outer Continental Shelf (OCS). These PINC's are numbered G-190 through G-227.

The current regulations for cranes and other material handling equipment are contained in 30 CFR 250, Subpart A, effective January 27, 2000, and API RP 2D, fourth edition, dated August 1999, which is incorporated by reference in Subpart A. The MMS is continuing to review historical crane accident information to better understand the mechanisms and procedures that contribute to crane accidents on the OCS and what regulatory actions could be taken to improve safety. Other industry standards, including API SPEC 2C, fifth edition, dated April 1995, are being review for possible incorporation into MMS regulations. Therefore, the MMS regulations do not currently require cranes to have anti-two block devices.

The current MMS PINC List and Guidelines addresses rigging and material handling safety (PINC's G-190 through G-194) and crane safety (PINC's G-202 through G-227). Appendix 24 provides additional information and clarification on crane use categories and inspections. These PINC's and appendix are available on the MMS web page at <http://www.mms.gov/regcompliance/inspect.htm> (also included in the appendix of these proceedings) and became effective on April 24, 2000. The MMS will expect the fixed offshore facility operator to maintain all of the specified records on site and available for review by the MMS Inspector, and to be responsible for the correctness and accuracy of the records.

The rigging and material handling PINC's first appeared in the April 2000 update to the MMS PINC List and Guidelines. One PINC, G-190, references the new rigger training requirements first stated in the fourth edition of API RP 2D. Since this is a new requirement, MMS proposes lenient enforcement of this requirement until October 1, 2000. Crane Operator authority over material or personnel handling operations is addressed by PINC G-191, personnel transfer practices are addressed by PINC G-192, and sling tagging and storage are addressed by PINC's G-193 and G-194.

The crane operations, inspections, maintenance and repair, and the crane operator and inspector qualifications are addressed by PINC's G-202 through G-227 and Appendix 24. Of particular concern are the medical records and the physical qualifications of the crane operator. The MMS will expect that these records and qualifications be certified by a medical doctor licensed to practice in the United States.

The MMS has no regulatory responsibility for dockside operations and cargo storage on vessels; therefore, no PINC's have been written to address these material handling issues.

Appendix E
Seatrax Design Features
Patented Anti “Two-Block” System

Seatrax Design Features Patented Anti "Two-Block" System

One of the historical causes of accidents during crane operations has been the unintentional contact between the Hook Block or Ball and the boom point. This is sometimes referred to as **"TWO-BLOCKING"** while lowering the boom or **"BOOMING DOWN INTO THE BLOCK "**.

This "Two-Blocking" action is due to the fact that, on most cranes, the hoist drum is mounted on the Revolving Superstructure as shown in Figure Number 1.

With this arrangement, the distance between the hoist drum and the Boom Tip Sheaves increases as the boom is lowered. This increase causes the Lower Block (hook block) to be drawn closer to the Upper Block (boom tip sheaves).

When these two blocks touch, "TWO-BLOCKING" has occurred.

If the boom is lowered past the point where "TWO-BLOCKING" occurs, the load will transfer from the Multi-part Boom Line to the Single Part Hoist Line. This load transfer will usually cause the Hoist Line to break and thus drop the load.

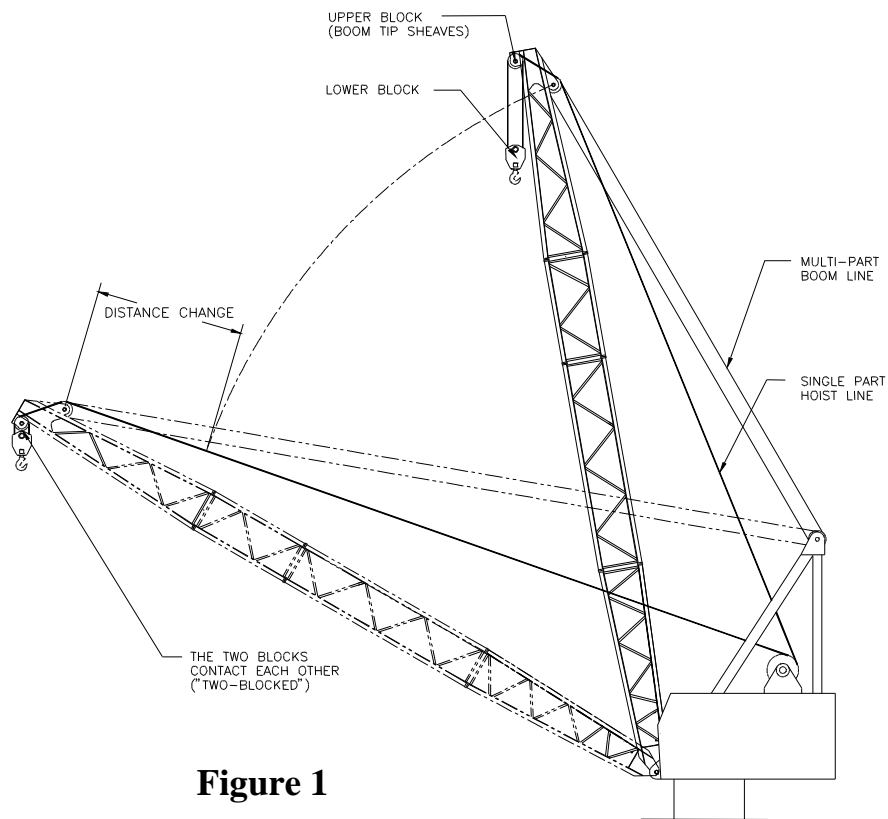

Figure 1

Because of this, almost all Crane Specifications or Regulations require that a crane be fitted with some means to prevent this "TWO-BLOCKING".

For cranes with the hoist located as shown in Figure Number 1, this "means" is most often a switch or valve which interrupts power to the load hoist and/or the boom hoist, thus stopping the offending

Sheaves. This is usually done by means of a weight hanging from a rope or chain. This weight normally has a hole through which one of the lines to the Hook Block passes. When the block is hoisted to a predetermined position, it “lifts” the hanging weight, thereby actuating the switch or valve.

In offshore service, this type of solution to the problem has proven to be marginal at best.

With all Seatrax cranes, **the problem is solved through GEOMETRY, not GADGETRY**. The hoists are located in the base section of the Boom instead of on the Revolving Superstructure.

With this arrangement, as shown in **Figure Number 2**, the Hook Block cannot be drawn into the Boom Tip Sheaves as the boom is lowered. The Hoist moves with the boom, therefore the distance between the Hoist and the Boom Tip Sheaves does not change.

This means that “Two-Blocking” while lowering the boom just cannot exist with a Seatrax crane. No external power source, switches, valves, hanging weights, or other gadgets are required to defeat this problem. This is taken care of by the basic design.

There is however, another way that “TWO-BLOCKING” can occur. This can happen if the crane operator “over hoists” the Hook Block or Auxiliary Hook regardless of the position or angle of the boom. In other words, the operator just runs into the boom point by accident. This is also a serious problem.

As before, almost all Crane Specifications or Regulations require that a crane be fitted with some means to prevent this “TWO-BLOCKING”.

Most crane manufacturers accomplish this with the same “Gadgets” as previously mentioned.

However, with all Seatrax cranes, the problem is solved with the system shown in **Figures 3,4 & 5**.

This is an extremely simple system that takes advantage of the fact that the Hoists on all Seatrax cranes are powered by hydraulic motors. Therefore the maximum line pull that the Hoist can develop is limited to a safe value by the hydraulic system pressure relief valves. In other words, the hoist just cannot produce sufficient pull to break the line, even in the stalled condition.

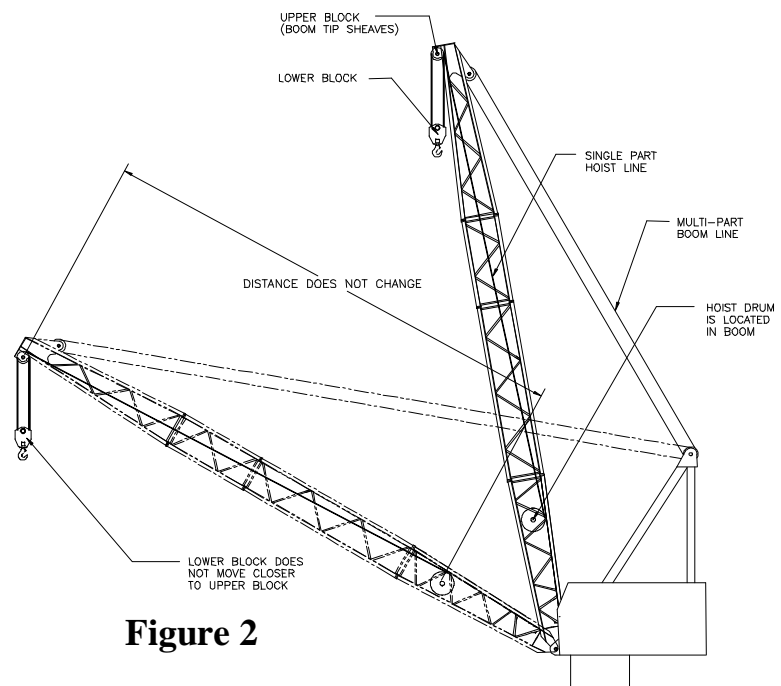

Figure 2

Therefore, rather than attempting to prevent the operator from “running into” something if the blocks are overhoisted, the Seatrax system provides “bumpers” which allow this to take place in a controlled manner and without causing any damage.

This simple system consists of a special “**Swinging Bumper Frame**” which follows the angle of the Hook Block and a mating “vee” shaped “**Bumper Frame**” fixed to the Hook Block. This allows the Hook Block to come into contact with the “Swinging Bumper Frame” as shown in Figure Number 3 without causing damage to any component.

In a similar manner, a “**Bumper Frame**” is provided on the Jib to receive the Auxiliary Hook Weight as shown. The wedge socket is enclosed inside of, and protected by, the special “Headache Ball”.

Coupled with the Hoist location, which completely eliminates the possibility of increasing the tension in the hoist ropes by lowering the boom, the patented Seatrax system solves all of the “TWO-BLOCKING” problems associated with offshore crane operations.

Again, the solution is accomplished by Design and GEOMETRY, not GADGETRY.

In summary, the optional, patented, Seatrax Anti Two-Block System provides the following **Operational Advantages:**

- **Prevents damage** to any component in the event that the Auxiliary Hook is overhoisted.
- **Prevents damage** to any component in the event that the Main Block is overhoisted.
- Provides a “parking place” for the Auxiliary Hook and positively **prevents fouling** of the Auxiliary Hook with the Main Block when the Auxiliary Hook is not in use.
- Provides a “parking place” for the Main block and positively **prevents fouling** of the Auxiliary Hook with the Main block when the Main block is not in use.
- Permits the boom to be raised or lowered without regard to the position of either the Auxiliary Hook or the Main Block. **No damage** can occur during this operation because the hoist drums are mounted in, and move with the boom.

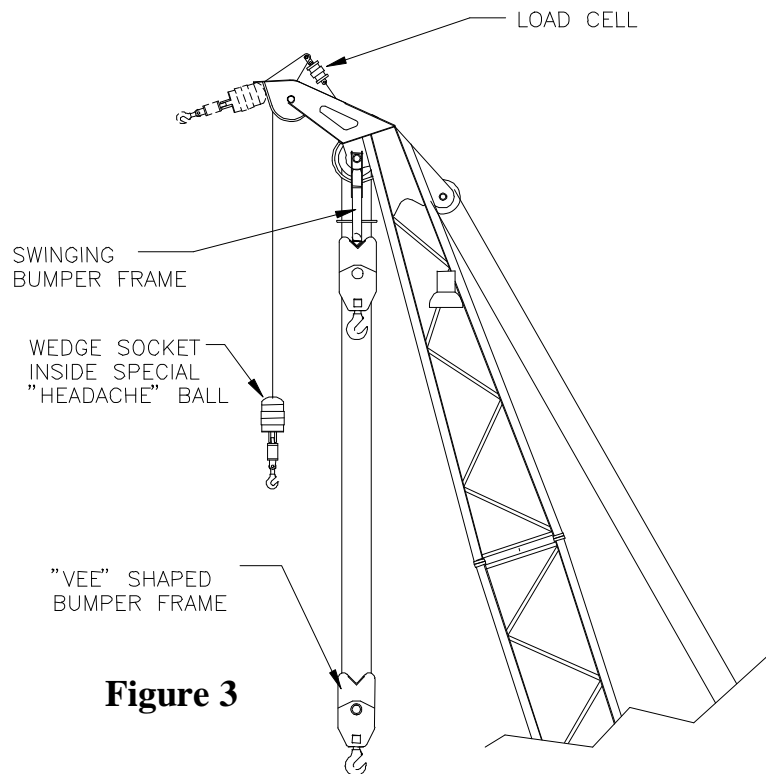
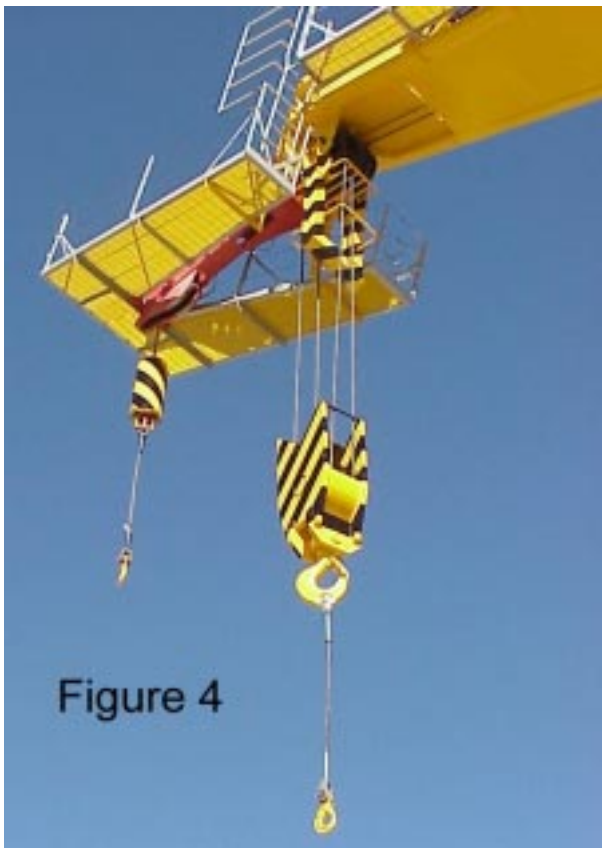

Figure 3

- Provides a “caged” path for both the Main and Auxiliary lead lines, hence protecting the operator and other personnel in the event of a wire rope breakage.
- Allows the Weight Indicator and maximum lift capability of the crane to be checked prior to each lift by pulling the Main Block into it’s “parking place”.
- The performance of the engine and hydraulic system can be checked in the same manner as this action will cause the hydraulic pressure to rise to the relief valve setting and safely place the machinery under full load.



This **Seatrax Patented Anti “Two-Block” System** has been used since 1977 and is accepted by international Certifying Authorities, including **ABS, DNV, and Lloyds**. Additionally, this system meets the requirements of **API Spec 2C, 5th edition paragraph 12.6**.

Appendix F
American Aero Cranes
MMS PINC List 5-2000

MMS PINC List 5-2000

- G 150 Is all exhaust piping from each diesel engine or engine-driven equipped with spark arresters? (straight exhaust not acceptable)
- G152 Is each engine exhaust and other hot surfaces equipped to comply with the insulation and personnel protection requirements of API UP 14 C?
 1. Any surface with a normal operating temperature in excess of 160°F and the hot surface is located where accidental contact by unprotected personnel is likely;
 2. Any surface with a temperature in excess of 400°F is protected from spillage or leakage of crude oil.
 3. Any surface with a temperature in excess of 725°F is protected from accumulations of combustible gasses.
- G 155 Are diesel engines which are continuously attended equipped with either an operable remote operated manual or automatic air intake shutdown device? (definition: Continuously attended- a person standing by the engine at all times)
- G 156 Are Diesel engines which are not continuously attended equipped with and operable automatic air intake shutdown device?
-
- G 190 (NEW) Do only Qualified personnel perform rigging operations in accordance with API RP 2 D? Verify previous rigging and if in progress verify.
- G 191 (NEW) Whenever there is any doubt as to the safety, does the crane operator stop and refuse to handle loads or continue operations as safety dictated in accordance with API RP 2 D? Restricted during periods of Bad weather, lighting, high winds, high seas, etc.
- G 192 (NEW) Are procedures for personnel transfer performed in accordance with recommended practices in accordance with API RP 2?
- G 201 Are records of crane inspection, testing, maintenance and operator qualifications maintained at the Lessee's nearest Field Office?
- G 202 (C) Are cranes operated only by Qualified personnel in accordance with API RP 2 D? (note: 1. A crane operator is not qualified if qualification are not maintained, at a minimum, every four years. 2. **A written document from the facility operator stating that qualifications have been met is sufficient.**)
- G 203 DELETED (referenced operator training)
- G 204 Are proper crane operating practices for attaching and moving the load being utilized with API RP 2 D?
- G 205 Have manufacturer's recommendations been included in establishing all inspection requirements in accordance with API RP 2 D?
- G 206 Have new or relocated cranes received an initial inspection by a Qualified inspector in accordance with API RP 2 D?
- G 207 Have pre-use inspections been performed prior to use (typically daily) by a qualified operator/inspector with records maintained at an appropriate location in accordance with API RP 2 D?
- G 208 Have monthly inspections been performed by a qualified operator/inspector with records readily available for a period of two years in accordance with API RP 2 D? (note: applies to cranes in Heavy Usage Category)

Page 1

- G 209 Have quarterly inspections been performed by a qualified inspector with records readily

available for a period of two years in accordance with API RP 2 D? (note: applies to cranes in Moderate and Heavy Usage Category's)

- G 210 Have annual inspections been performed by a qualified inspector with records readily available for a period of two years in accordance with API RP 2 D? (note: all cranes regardless of Usage Category)
- G 211 Is the correct load rating chart for the crane configuration at the primary control station in accordance with API RP 2 D?
- G 216 Are written reports on load tests prepared by a qualified inspector showing load test procedures and results when tests are required in accordance with API RP 2 D?
- G 217 Are written reports maintained confirming adequacy of repairs or alterations in accordance with API RP 2 D?
- G 218 Has a preventative maintenance program been established with records readily available for a period of two years in accordance with API RP 2 D?
- G 220 Are cranes which are positioned in the proximity of helidecks or approach/take-off zones not operated during helicopter operations in accordance with API RP 2 D?
- G 221 Is there a fire extinguisher of appropriate size and type kept in the cab or vicinity of the crane in accordance with API RP 2 D?
- G 223 (NEW) Are crane Inspectors qualified in accordance with API RP 2 ? Four year qualification interval, **A written document from the Operator is sufficient.**
- G 224 (NEW) If deficiencies that impair safe operation are known, is the crane taken out of service or its operation restricted to eliminate the unsafe condition in accordance with API RP 2 D?
- G 225 (NEW) Have Static and Dynamic load rating charts been established for ALL cranes in accordance with API RP 2 D?
- G 226 (NEW) Are repairs or replacements of critical components made promptly in accordance with API RP 2 D? (Promptly means "Done Without Delay")
- G 227 (NEW) Has a wire rope inspection program been established in accordance with API RP 2 D?

Notes:

INC's are issued to the operator (our CUSTOMER)

Most INC's are issued as a warning and / or as an component shut in.

Serious offenses may require shut in of the facility.

The average cost for an INC is \$7,500.00 Can you afford this. And can you afford the shut in of a 10, 20 or 100,000 bbl. Facility.

List of Participants

NAME	COMPANY	E-MAIL
CANNON, ROYCE	ACME HYDRAULICS INC.	AHII@BELLSOUTH.NET
McCAFFERTY	ABS	dmccafferty@eagle.org
GUIDRY, WILFRED JR	AMERICAN AERO CRANES	jrguidry@americanaero.com
ANGELO, DALE	AMERICAN AERO CRANES	dangelo@americanaero.com
DIBELLO, MIKE	AGIPPETROLEUM	mike.dibello@agippetroleum.agip.it
PASQUA, JOE	AMERICON SAFETY AND TRAINING	joe.pasqua@americon-hr.com
THIBODAU, AMBROSE	AMERICAN AERO CRANES	
MACALUSO, TIM	AMERICAN AERO CRANES	tmacaluso@americanaero.com
HOFFMAN, TERRY	APPLIED HYDRAULIC SYSTEM, INC	
FAVVOR, KIM	APACHE	kim.favvor@usa.apachecorp.com
BEGLEY, DOUG	ANADARKO	doug_begley@anadarko.com
TRAHAN, TERY	BAKER ENERGY	ttrahan@mbakercorp.com
WHITE, PHILIP	AVIARA	pwhite@aviarenergy.com
LOPEZ, JOHNNY	APPLIED HYDRAULIC SYSTEM, INC	ls@cajun.net
COGAR, JOHN	BURLINGTON RESOURCES	jcogar@br-inc.com
LERY, DENNIS	BRITISH-BORNEO EXPLORATION, INC	dlery@british-borneo.com
SANDERS, MARK	BRADEN CARCO GEARMATIC	msanders@paccar.com
GOMEZ, A.M (MIKE)	CHEVRON	AGOM@CHEVRON.COM
BUTLER, C.A. (CLIFF)	CHEVRON	abut@chevron.com
LEMANCZYK, DAN	CARDINAL SERVICES	danl@aisp.net
RECASNER, ANDREA	CHEVRON	ambm@chevron.com
JEFFCOAT, C.D. JR	CHEVRON	
CHERAMIE, MARK	CNG PRODUCING COMPANY	MARK_P_CHERAMIE@cngp.cng.com
SPINKS, AL	CNG PRODUCING COMPANY	AL_M_SPINKS@cngp.cng.com
HOLCOMB, M.R. (MIKE)	CMS ENERGY	mrholcomb@cmsenergy.com
DUMAS, DARRELL	CONOCO	Darrell.W.Dumas@usa.conoco.com
LANDRY, MARTIN	CONOCO	marty.o.landry@usa.conoco.com
PRUITT, JACK	THE CROSBY GROUP INC.	
STINSON, GUY	DEVON ENERGY CORPORATION	guy.stinson@dvn.com
AUTH, JOHN	DIAMOND OFFSHORE	jauth@dodi.ocm
MANESS, BRIAN	DIAMOND OFFSHORE	bmaness@dodi.com
ROBICHAUX, RANDY	DANBURY RESOURCES INC.	randyr@denbury.com
LECOMPTE, CAROL	DANBURY RESOURCES INC.	carol@denbury.com
BAUDOIN, STUART	EAGLE CONSULTING, LLC	
BORNE, JOHN	EAGLE CONSULTING, LLC	
COMEAX, PAT	EAGLE INSURANCE GROUP, INC	patc@eig.com
BROUSSARD, BURT	EOG RESOURCES, INC.	bbroussard@beci.net
GROVES, NICK	EOG RESOURCES, INC.	NICK_GROVES@EOGRESOURCES.COM
BENOIT, STEPHEN	EOG RESOURCES, INC.	stephen_benoit@EOGRESOURCES.COM
GIBSON, NORMAN	EL PASO FIELD SERVICES	gibsonn@epenergy.com
LUKE, JOHN PETE	EL PASO FIELD SERVICES	lukep@epenergy.com
RICHARD, MICHAEL	EL PASO PRODUCTION	richardm2@epenergy.com
DOUGHTY, MARK	ENERGY RESOURCE TECHNOLOGY, INC	
PERCLE, G. L.	EQUILON	glpercle@equilon.com
RISHER, STEPHENIE	EQUILON	serisher@equilon.com
BRENDEL, JEFF	EQUIPMENT SAFETY SERVICES	KEYWEST01@AOL.COM
THERIOT, KEVIN	FLOW PETROLEUM SERVICES, INC	flowps@net-connect.net
HENDERSON, JAMES	FORCENERGY INC	richard.charpentier@worldnet.att.net
GAUDET, BOBBY	GRASSO PRODUCTION MANAGEMENT, INC.	bgaudet@gpmi.com
LABOWE, TIM	GRASSO PRODUCTION MANAGEMENT, INC.	
BOLLINGER, BRANDON	GULF CRANE SERVICES, INC.	bbollinger@gulferaneservices.com
BOLLINGER, CHARLIE	GULF CRANE SERVICES, INC.	
MASSON, KERRY	HESS	kmasson@hess.com
VASTVEDT, JAN	HITEC O	jan.vastvedt@hitecvision.com
BROOKS, T. S.	EXXON COMPANY, U.S.A.	steve.brooks@exxon.com
BOYACI, DEAN	HELMERICH & PAYNE INTERNATIONAL DRILLING CO.	dean.boyaci@hpidc.com
HEDRICK, WILLIAM	ROWAN COMPANES, INC.	bill.hedrick@rowancompanies.com
MAJOR, CHRISTOPHER	HELMERICH & PAYNE INTERNATIONAL DRILLING CO.	
MILLS, MICHAEL	HOUMA INDUSTRIES	
BOUDREAUX, BOBBY	ISLAND OPERATING CO., INC	
MECOM, LARRY	KERR-MCGEE OIL & GAS CORPORATION	lmecom@kmg.com
YOUNG, C.H. (CHUCK)	KERR-MCGEE OIL & GAS CORPORATION	cyoung@kmg.com
JOHNSON, PATRICK	LOUIS DREYFUS NATURAL GAS	Johnspe@ldng.com
TUMLINSON, JAMES	MARATHON OIL COMPANY	JPTUMLINSON@MARATHONOIL.COM
LAGUENS, DEBBIE	MARINE DRILLING COMPANIES, INC.	dlaguens@mardril.com
O'NEILL, TIM	MARINE & MAINLAND	
SCHAEFER, ALAN	MARINE & MAINLAND	
PLUNKETT, J.J.	MARINE SAFETY OFFICE MOBILE	jplunkett@msomobile.uscg.mil
JOWERS, CHUCK	MARTEC CRANE COMPANY, INC	
DICK, WILLIAM	J. RAY McDERMOTT, INC.	wtick@mcdermott.com

LeBOUEF, BARRY	J. RAY McDERMOTT, INC.	barry.l.lebouef@mcdermott.com
BRIDGES, MICHEAL	MORENO & ASSOCIATES, INC	mtbridges@aol.com
LoPICCOLO, GARY D.	MORENO & ASSOCIATES, INC	Gary.LoPiccol@oceanenergy.com
BOURGEOIS, GARY	MSI CRANE & EQPT. CO.	
LUKE, STEPHEN	MSI CRANE & EQPT. CO.	Luke6@mindspring.com
THRASHER, DAVID L.	MSI CRANE & EQPT. CO.	dthrasher@msicrane.com
WEYDERT, BRIAN	MURPHY EXPLORATION & PRODUCTION COMPANY	brian_weydert@murphyoilcorp.com
CAGLE, JIM	MURPHY EXPLORATION & PRODUCTION COMPANY	Jim_Cagle@murphyoilcorp.com
PARBS, BOB	NABORS OFFSHORE CORPORATIN	rparbs@nabors.com
CRAWFORD, ERIC	NATCO GROUP	ecrawford@natco-us.com
CAIN, CARLOS	NEXCO CORPORATION	nexcocorp@aol.com
ELLIS, RANDY	NEXCO CORPORATION	nexco@email.com
COMEAX, TONY	NEWFIELD	
PROSPER, MERLIN R.	NEWFIELD	
GUIDRY, JACK A.	OCEAN ENERGY	
MASTERSON, MITCH	OCEAN ENERGY	Mitch.Masterson@oceanenergy.com
PONTHIEUX, DARRIS	OCEAN ENERGY	
DEARE, RICK	OILFIELD PRODUCTION CONTRACTORS, INC	Rick_Deare@hotmail.com
LEGER, GREG	PARKER DRILLING	Greg.Leger@parkerdrilling.com
TATUM, ED	PARKER DRILLING	ed.tatum@parkerdrilling.com
MATT, CARL	PETROCOM	cmatt@petrocom.com
CAUGHMAN, GORDON R.	PHILLIPS 66	grcaugh@ppco.com
SPENCER, JOHN M.	PHILLIPS 66	jmspenc@ppco.com
DEGEYTER, MICHEAL J.	PIONEER NATURAL RESOURCES USA, INC.	
GIROUARD, CAL	PIONEER NATURAL RESOURCES USA, INC.	girouarc@pioneerinc.com
THOMAS, ZIE SR.	PIONEER NATURAL RESOURCES USA, INC.	
MARGOT, RON	PLATFORM CRANE SERVICE, INC	RMARGOT@PLATFORMCRANE.COM
MARCANTEL, BLAINE	PRODUCTION MANAGEMENT INDUSTRIES, INC	marcantelb@prodmgt.com
JOHNSON, LUTHER B.	R&B FALCON	ljohnson@falconoffshore.com
ELMORE, STAN	ROCLAN SYSTEMS, INC	roclansys@aol.com
FLEMING, VICTOR	ROWAN COMPANES, INC.	victorfleming@cs.com
LEE, HOYED R. JR.	SAFETY, ENVIROMENTAL & OPERATIONAL TRAINING, INC.	hoyed@seot.com
SHUMAN, STEVE	SAMEDAN OIL CORPORATION	
HEBERT, MICHEAL L.	SCHLUMBERGER	mhebert@lafayette.prodop.slb.com
MORROW, DOUG	SEATRAX MARINE CRANES	dmarrow@seatrax.com
EVANS, R.T. (BOB)	SENECA RESOURCES CORPORATION	
KADLECEK, JOHN G.	SENECA RESOURCES CORPORATION	jkadlecek@senecaresources.com
TIMOTHY, RICHARD	SENECA RESOURCES CORPORATION	
ARCENEAX, THOMAS	SHELL OFFSHORE INC.	tparceneaux@shellus.com
DAVIS, M.W. (MARK)	SHELL OFFSHORE INC.	markwdavis@shellus.com
MANNING, DOUG	SHELL OFFSHORE INC.	
ROGERS, ARD	SHELL OFFSHORE INC.	ardrogers@shellus.com
GUIDRY, ERIC	RANDY SMITH TRAINING SCHOOLS	Eric@RandySmith.com
COMEAX, JIMMY	SOLA COMM	
MORRIS, RICHARD J.	SPIRIT ENERGY 76	
ROGERS, JAN J.	SPIRIT ENERGY 76	Jan.Rogers@unocal.com
SELLERS, WILL	SPIRIT ENERGY 76	will.sellers@unocal.com
DUPLIHAN, ROCKY	STARS SAFETY TRAINING AND REGULATORY SERVICES	
SMITH, MICHAEL W.	STARS SAFETY TRAINING AND REGULATORY SERVICES	
BARNHILL, DALTON	STOLT COMEX SEAWAY INC.	DBT@stoltcomexseawayus.com
MILLS, H.G."BUD"	STOLT COMEX SEAWAY INC.	BDM@stoltcomexseawayus.com
HEBERT, TOMMY	SUPERIOR WELL SERVICE, INC	
RUSICH, WARREN O. JR.	SUPERIOR WELL SERVICE, INC	weusich@superiorenergy.com
BECNEL, MILES J.	TEXACO EXPLORATION AND PRODUCTION, INC.	Becnemj@Texaco.com
BURKE, FRANCIS C. JR.	TEXACO EXPLORATION AND PRODUCTION, INC.	burkefc@Texaco.com
COLLINS, GERALD	TEXACO WORLDWIDE EXPLORATION & PRODUCTION	colligetexaco.com
FLICE, ROBERT "BOB"	TEXACO-GULF OF MEXICO PRODUCTION BUS. UNIT	filcera@texaco.com
HUNT, I.C. JR.	TEXACO WORLDWIDE EXPLORATION & PRODUCTION	huntic@texaco.com
MATHERNE, KEVIN J.	TEXACO EXPLORATION AND PRODUCTION, INC.	
SCOTT, JESSIE C.	TEXACO NORTH AMERICAN PRODUCING TNAPEAST	scottjc@texaco.com
STARK, J.R.	TEXACO WORLDWIDE EXPLORATION & PRODUCTION	starkjr@texaco.com
VINING, MARVIN A.	TEXACO EXPLORATION AND PRODUCTION, INC.	vininma@texaco.com
PFISTER, JOHN	TITAN INDUSTRIES	jpffister@titanranes.com
LANDRY, JAMES D.	TITAN INDUSTRIES	JLANDRY@TITANCRANES.COM
BERGERON, CHUCK	TITAN INDUSTRIES	cbergeron@titanranes.com
BABIN, MIKE	TORCH RIG SERVICES, INC.	m.babin@torchinc.com
HOCAMP, JOE	TORCH, INC.	HOCAMPJ@VEN.TEAI.COM
MURPHY, KEVIN	TRANSOCEAN	kmurphy@deepwater.com
RUDOLPH, SCOT	TRANSOCEAN SEDCOFOREX	srudolph@deepwater.com
MUECK, TOMMY	UNION PACIFIC RESOURCES COMPANY	
GASPARD, DONALD	UNOCAL 76	donald.gaspard@unocal.com

JOHNSON, O.L. III
FARRELL, MIKE
LEE, MICHAEL E.
MANNING, MICHAEL R.
MOORE, JOEL K.
CHAMPAGNE, STAN
NUHEZ, DAVID
ROBINSON, LARRY
THIBODEAUX, J. RUSTY
FONTENOT, ERIC J.
HAUSER, WILLIAM S.
MARTIN, WILLIAM H.
MASRI, NABIL F.

UNOCAL 76
U.S.C.G. MARINE SAFETY OFFICE
UNITED STATES COAST GUARD
UNITED STATES COAST GUARD
UNITED STATES COAST GUARD
VASTAR RESOURCES, INC.
VASTAR RESOURCES, INC.
VASTAR RESOURCES, INC.
VASTAR RESOURCES, INC.
MINERALS MANAGEMENT SERVICE
MINERALS MANAGEMENT SERVICE
MINERALS MANAGEMENT SERVICE
MINERALS MANAGEMENT SERVICE

o.l.j@unocal.com
mfarrell@msomorgancity.uscg.mil

Jmoore@d8.uscg.mil
Schampa@vastar.com
Dnuhez@vastar.com

eric.fontenot@mms.gov

nabil_masri@mms.gov

Business Cards

A.H.I.

ACME HYDRAULICS INC.

Pump, Cylinder & Winch Repairs
Hydraulic Crane Repair

Royce Cannon

Shop (504) 781-3020 Beeper (504) 639-5220
1-888-882-6437

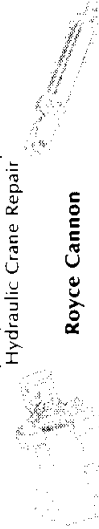

E-MAIL A.H.I.I @ Robert.USA

A.H.I.

ACME HYDRAULICS INC.

Pump, Cylinder & Winch Repairs
Hydraulic Crane Repair

Royce Cannon

Shop (504) 781-3020 Beeper (504) 639-5220
1-888-882-6437



DENISE B. McCAFFERTY

ABS STAFF CONSULTANT
SAFETY ASSESSMENT & HUMAN FACTORS

16855 NORTHCHASE DRIVE
HOUSTON, TX 77060-6008 USA
TEL: (281) 877-6576
FAX: (281) 877-5943
TLX: 6732233 ABS
e-mail: dmccafferty@eagle.org



American Aero Cranes, LLC

WILFRED (J.R.) GUIDRY, JR.

Service Sales, Training, and Technician

6707 NORTHWINDS DR. • HOUSTON, TX 77041
PHONE: (713) 896-0002 • FAX: (713) 856-5442
PAGER: (713) 312-7346

EMAIL: jrguidry@americanacro.com
Member I.A.D.C. - HSE

www.americon-hr.com



Joe Pasqua

Compliance and Safety Consultant

8216 HWY 182 (70380)
P.O. BOX 1599
MORGAN CITY, LA 70381
joe.pasqua@american-hr.com
(504) 385-0074
(800) 565-0074
FAX: (504) 385-0094



Crane Sales - Service - Rentals

Applied Hydraulic Systems, Inc.

Terry Hoffman
Vice President - Engineering

(504) 851-5600
FAX No. 504-851-0754
Station 1, Box 10155
Houma, La. 70363-5990



TITAN INDUSTRIES
A Division of Aero International, LLC

DALE ANGELO

Director of Health, Safety & Environmental

13189 HIGHWAY 190 W.
COVINGTON, LA 70435
E-mail: dangelo@americanacro.com
Phone: (504) 893-1818
Fax: (504) 893-1879
Pager: (504) 773-1849



Mike Dibello

Superintendent of Production Operations



Agip Petroleum

Brookhollow Central III
2950 North Loop West / Suite 300
Houston, Texas 77092
E-mail: mike.dibello@agippetroleum.agip.it

Bus. (713) 680-4597
Res. (281) 487-7549
Fax (713) 688-6548
Pager (888) 274-2567



American Aero Cranes
A Division of Aero International, LLC

TIM MACALUSO

Texas Service and Crane Sales Representative

6707 NORTHWINDS DR. • HOUSTON, TX 77041
PHONE: (713) 896-0002 • FAX: (713) 856-5442
PAGER: (800) 210-9642
EMAIL: tmacaluso@americanacro.com

DOUG BEGLEY
FIELD FOREMAN COM



SABINE BASE, 409/971-2076
SABINE FAX, 409/971-2072
PAGER, 800/532-4598
RES, 337/862-6576
P.O. BOX 1330, HOUSTON, TX 77251-1330
P.O. BOX 1028, SABINE PASS, TX 77655-1028
MOBILE, 337/277-0199
E-MAIL: doug_begley@anadarko.com

CORPORATION

KIM FAWVOR

Regulatory Foreman
E-Mail: kim.fawvor@usa.apachecorp.com

2014 W. PINHOOK ROAD, SUITE 800 / LAFAYETTE, LA 70508
Telephone (318) 232-9289 / Facsimile (318) 232-4537
WWW.APACHECORP.COM



Terry Trahan
Safety Manager

Baker Energy
A Unit of Michael Baker Corporation
500 Dover, Suite 210
Lafayette, Louisiana 70503
(337) 406-8900 FAX (337) 406-8690
Pager (337) 273-8437
e-mail trahan@mbakercorp.com



John D. Cogar
Production Supervisor

102 Asma Blvd.
Suite 200, Room 210
Lafayette, LA 70508-8020
(337) 267-9347
Fax: (337) 267-9309
Pager: (800) 541-1793
Mobile: (337) 278-5245
jcogar@br-inc.com



Chevron
504-592-1762

A. M. (Mike) Gomez
Mechanical Specialist
MPPC Mechanical Support Group
Phone: 504-592-6791
Fax: 504-534-6741
E-Mail: AGOM@CHEVRON.COM



Chevron

Andrea M. Recasner, P.E.
Mechanical Maint. Supervisor
Reliability Automation
Maintenance Group
Phone 504.592.7076
Fax 504.368.1819
Pager: 800.541.6447

Chevron U.S.A. Production Company
1050 Peters Road
Harvey, LA 70058
E-Mail: ambm@chevron.com



PHILIP R. WHITE
PRODUCTION SUPERINTENDENT

TEL: (713) 871-3430
PAGER: (800) 256-2308
MOBILE: (713) 906-9138
FAX: (713) 871-3472
E-mail: pwhite@aviaraenergy.com
One Riverway Ste 700 (77056)
P.O. Box 1350
Houston, TX 77251-1350



DENNIS LERY
HSE ENGINEER CONSULTANT

1201 LOUISIANA
SUITE 3600
HOUSTON, TEXAS 77002
DIRECT: (713) 393-6168
MAIN: (713) 393-6100
FAX: (713) 393-6208
dleri@british-borneo.com



C. A. (Cliff) Butler
Trainer
Production Company - ERTC
Phone 337 572 3714
877 811 3782
Fax 337 572 3720
E-Mail: abut@chevron.com

Chevron U.S.A. Production Company
200 Galibert Road
Lafayette, LA 70506
E-Mail: train@chevron.com



Chevron

Andrea M. Recasner, P.E.
Mechanical Maint. Supervisor
Reliability Automation
Maintenance Group
Phone 504.592.7076
Fax 504.368.1819
Pager: 800.541.6447

Chevron U.S.A. Production Company
1050 Peters Road
Harvey, LA 70058
E-Mail: ambm@chevron.com



Crane Sales - Service - Rentals

Applied Hydraulic Systems, Inc.
Sales
Johnny R. Lopez

(504) 851-5600
FAX No. 5048510754
jsr@ejun.net
Station I, Box 10155
Houma, La. 70363-5990



PACCAR WINCH DIVISIONS
75 Celebrating 75 Years of Quality (1924 - 1999)

MARK SANDERS
Marketing and Product Support Manager

800 E. DALLAS
P.O. BOX 547
BROKEN ARROW, OK U.S.A.
74013-0547
DIRECT LINE: 918-258-3925
MAIN OFFICE: 918-251-8511
FAX: 918-258-1575
E-MAIL: msanders@paccar.com



CARDINAL SERVICES
DANIEL P. "Dan" LEMANCZYK
Safety Director

P.O. Drawer 9350
New Iberia, LA 70562-9350
e-mail: daniel@atasp.net
Pager: 318/374-9026
Phone: 318-364-4545
Fax: 318-367-8373
Home: 318-269-4004
Mobile: 318-380-3335



Chevron

C.D.(David) Jeffcoat, Jr.
Planner Scheduler / Coordinator

Eastern Shelf
Mid-Shelf Profit Center
Phone: (504) 592-7763
Fax: (504) 368-1819
Res.: (601) 798-2759
Page: (504) 551-8135

Chevron North America
Exploration & Production

RAM Group

Reliability, Automation
Maintenance Organization
1050 Peters Rd.
Harvey, La. 70058

Mark Cheramie

CNG Producing Company



Al Spinks

CNG Producing Company



CMS Trunkline Gas Company
CMS Trunkline LNG Company

Tel: 318.475.4266
Fax: 318.475.4207
Residence: 318.474.6886
Cellular: 318.529.7784
E-Mail: mmholcomb@cmsenergy.com Pager: 877.267.9283

M.R. (Mike) Holcomb
Sr. Safety Representative, Transmission
Lake Charles Division

An International Energy Company

CROSBY CLIPS ■ **LAUHLIN FITTINGS** ■ **LEBUS LOAD BINDERS**
McKISSICK BLOCKS ■ **WESTERN BLOCKS** ■ **NATIONAL SWAGING SYSTEMS**

JACK PRUITT
DISTRICT REPRESENTATIVE



1429 CONSTITUTION
SLIDELL, LA 70458
(504) 643-9577
FAX: (504) 643-9577



An ISO 9001
Certified Company

D I A M O N D
O F F S H O R E



BRIAN D. MANESS
Inspector

DIAMOND OFFSHORE DRILLING, INC.
15415 Katy Freeway, Suite 110
Houston, Texas 77094
Direct: (281) 647-8074
Fax: (281) 647-2285
E-Mail: bmaness@dodi.com

G E • M • S

EAGLE CONSULTING, LLC
P. O. Box 250 — Gibson, LA 70356



STUART BAUDOIN

Office: 504-631-3278 Fax: 504-631-3281 Pager: 504-476-8012

Drilling & Production
Planning
Management
Supervision

Offshore / Land Personnel
Gaugers
Roustabouts
Mechanics



Conoco Inc.
400 East Kaliste Saloom Road (70508)
P.O. Box 51266
Lafayette, LA 70505
(337) 269-2308
Fax: (337) 269-2310
Pager: (337) 297-0971

mary.o.landry@usa.conoco.com

D I A M O N D
O F F S H O R E



JOHN AUTH
Safety Manager

DIAMOND OFFSHORE DRILLING, INC.
15415 Katy Freeway, Suite 100
Houston, Texas 77094
Direct: (281) 492-5332
Pager: (888) 329-7114
Fax: (281) 647-8061
E-Mail: jauth@dodi.com

G E • M • S



Denbury Resources Inc.

2503 Petroleum Drive
Houma, Louisiana 70363
Telephone: (504) 857-9215
Facsimile: (504) 868-9264
Corporate Headquarters
Telephone: (972) 673-2000
Fax: (972) 673-2150

Carol LeCompte

Production Superintendent
DIRECT (504) 857-9215 EXT. 209
DEPARTMENT FAX (504) 868-9264
CELLULAR (504) 854-9203
PAGER (504) 854-0715
E-MAIL: carol@denbury.com

Subsidiaries
Denbury Marine, L.L.C.
Denbury Energy Services



Conoco Inc.
400 East Kaliste Saloom Road (70508)
P.O. Box 51266
Lafayette, LA 70505
(318) 269-3236
Fax: (318) 269-2258

Email = Darrell.W.Dumas@usa.conoco.com

Darrell Dumas
Safety and Health Coordinator
Gulf Coast Region
Exploration Production, North America

Guy T. Stinson

Maintenance Superintendent - Southern Division
Residence: (409) 925-8364
Pager: 800-496-1548
Direct Phone: (713) 286-5960
Direct Fax: (713) 286-5777
E-Mail: guy.stinson@dvm.com

C O R P O R A T I O N

Mailing Address: P.O. Box 4616
Houston, Texas 77210-4616
(713) 286-5700 • Fax: (713) 286-5787
1200 Smith Street, Suite 3300
Houston, Texas 77002



2503 Petroleum Drive
Houma, Louisiana 70363
Telephone: (504) 857-9215
Facsimile: (504) 868-9264
Corporate Headquarters
Telephone: (972) 673-2000
Fax: (972) 673-2150



Denbury Resources Inc.

2503 Petroleum Drive

Houma, Louisiana 70363
Telephone: (504) 857-9215
Facsimile: (504) 868-9264
Corporate Headquarters
Telephone: (972) 673-2000
Fax: (972) 673-2150

Randy Robichaux

Environmental Specialist
DIRECT (504) 857-9215 EXT. 214
DEPARTMENT FAX (504) 868-9264
CELLULAR (504) 852-8274
PAGER (504) 857-5066
E-MAIL: randy@denbury.com

Subsidiaries
Denbury Marine, L.L.C.
Denbury Energy Services

EOG Resources, Inc.
1400 Smith Street
Houston, TX 77002-7361

broussard@beci.net

P. O. Box 4362
Houston, TX 77210-4362
Home (318) 738-5167
EE 135 (337) 715-7324

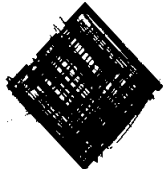

Burt J. Broussard
Production Foreman
Operations



Stephen V. Benoit
Maintenance Foreman

EOG Resources, Inc.
1200 Smith Street, Suite 300
Houston, TX 77002
(318) 993-1092

P.O. Box 4362
Houston, TX 77210-4362
Fax: (318) 993-1092
Pager: (888) 858-4320
Cellular: (713) 907-3614



Michael J. Richard
Production Supervisor
Offshore Production

El Paso Production Company
301 Kaishie Saloom
Lafayette, Louisiana 70508
Phone (713) 402-4558/4559
Fax (713) 402-4561
Pager (800) 360-5874
Home (337) 406-9664
E-mail: richardm2@epenergy.com



Stephanie E. Risher
Safety & Health
Coordinator

Two Shell Plaza
P.O. Box 2099
Houston, Texas 77252-2099
Tel: (713) 241-0447
Fax: (713) 241-5772
Pager: (800) 458-6934
Mobile: (713) 705-9339
Home: (713) 880-4076
E-mail: senshete@equilon.com



EAGLE CONSULTING, LLC
P. O. Box 250 — Gibson, LA 70356

JOHN D. BORNE
Office: 504-631-3278
Res: 504-876-9142
Fax: 504-631-3281

Drilling & Production
Planning
Management
Supervision

Offshore / Land Personnel
Gaugers
Roustabouts
Mechanics

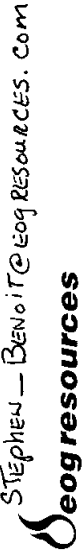

STEPHEN — BENOIT@EOGRESOURCES.COM

EOG Resources, Inc.
1200 Smith Street, Suite 300
Houston, TX 77002
(318) 993-1092

P.O. Box 4362
Houston, TX 77210-4362
Fax: (318) 993-1092
Pager: (888) 858-4320
Cellular: (713) 907-3614

Stephen V. Benoit
Maintenance Foreman



John Pete Luke
Manager
Houma District

148 Clendinning Road
Houma, Louisiana 70363

El Paso Field Services Company
P. O. Box 7037
Houma, Louisiana 70361
Phone (504) 857-8002
Fax (504) 857-9797
Pager (800) 632-8543
E-mail: lukejp@epenergy.com



Nick Groves
Safety Specialist
Environmental Health & Safety

P.O. Box 4362
Houston, TX 77210-4362
Fax: (713) 651-6441
Nick_Groves@eogresources.com



Norman Gibson
Production Superintendent
Houma District

148 Clendinning Road
Houma, Louisiana 70363

El Paso Field Services Company
P. O. Box 7037
Houma, Louisiana 70361
Phone (504) 857-8002
Fax (504) 857-9797
Pager (800) 634-5402
E-mail: gibsonn@epenergy.com

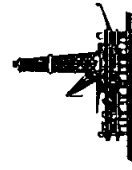

MARK DOUGHTY
Production Foreman

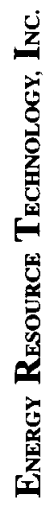

400 N. Sam Houston Parkway E., Suite 400
Houston, Texas 77060

337-761-
Pager: 800-458-10289
281-557-1855

**EQUIPMENT
SAFETY
SERVICES**

10352 E. Sharon Drive
Scottsdale, AZ 85260
Phone: (480) 860-4329
Fax: (602) 530-2545

**CRANE SAFETY
SEMINARS**

JEFF BRENDL

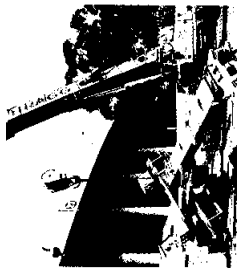

**EQUIPMENT
SAFETY
SERVICES**

10352 E. Sharon Drive
Scottsdale, AZ 85260
Phone: (480) 860-4329
Fax: (602) 530-2545

**CRANE SAFETY
SEMINARS**

JEFF BRENDL

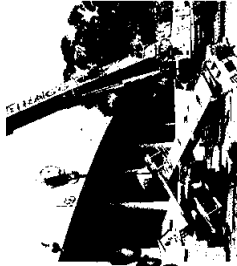

**EQUIPMENT
SAFETY
SERVICES**

10352 E. Sharon Drive
Scottsdale, AZ 85260
Phone: (480) 860-4329
Fax: (602) 530-2545

**CRANE SAFETY
SEMINARS**

JEFF BRENDL

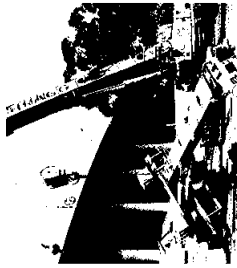

Bobby Gaudet
Project Coordinator

170 Industrial Parkway
Lafayette, Louisiana 70508
Office: 318-235-4224
Fax: 318-235-4213

ATTN: Harold Muncie

Email: bgaudet@gpmi.com

Forcenergy Inc

JAMES HENDERSON
Maintenance Supervisor

SATELLITE OFFICE:
3639 Ambassador Caffery Parkway
Petroleum Towers, Suite 335
Lafayette, Louisiana 70503
Phone: 318-984-7823
Fax: 318-984-8277

REGIONAL OFFICE:
3838 North Causeway Boulevard
Lakeway Three, Suite 2300
Metairie, Louisiana 70002
Phone: 504-838-7022
Fax: 504-838-7017

Vice President & Business Development

Brandon Bollinger

504/892-0056 892-4061 Fax
Covington, Louisiana 70434-1843
Industry Drive
P.O. Box 1843

Gulf Crane
SERVICES, INC.



Jan Vastvedt
Sales Engineer - VR

DIRECT: +47 51 20 21 31
E-MAIL: jan.vastvedt@hitecvision.com
MOBILE: +47 908 70 253

HITEC O AS - FABRIKKVEIEN 7 - P.O. BOX 8120 - 4068 STAVANGER - NORWAY
PHONE: +47 51 20 20 20 - FAX: +47 51 20 20 61 - WWW.HITEC-O.COM



KERRY L. MASSON
Mechanical Maintenance Supervisor

kmasson@hess.com
Pager: (800)299-4099 #2144

AMERRA HESS CORPORATION
One Allen Center
500 Dallas Street
Houston, Texas 77002

(713) 609-5927
Fax: (713) 609-5670

Bobby Gaudet
Project Coordinator



170 Industrial Parkway
Lafayette, Louisiana 70508
Office: 318-235-4224
Fax: 318-235-4213

Email: bgaudet@gpmi.com



Flow Petroleum Services, Inc.

KEVIN "BOO" THERIOT
Safety & Compliance Manager

510 Guilbeau Rd., Ste. D
Lafayette, LA 70506
Email: flowps@net-connect.net
Ph. (337) 981-4301
Fax (337) 981-1947
Pager (337) 270-8812



Gulf Crane
SERVICES, INC.

Industry Drive
P.O. Box 1843
Covington, Louisiana 70434-1843
504/892-0056 892-4061 Fax
Gulf Crane Services Nigeria Ltd.
Warr, Nigeria
Gulf Crane Fab. Y Serv S.A de C.V.
Ciudad Del Carmen, Campeche, Mexico
Charlie Bollinger, Jr.
President



William P. Hedrick

HSE Manager
Rowan Companies, Inc.
Suite 5450
2800 Post Oak Boulevard
Houston, Texas 77056-6196
e-mail: hill.hedrick@rowancompanies.com

Phone: (713) 960-7536
Fax: (713) 960-7511



HELMERICH & PAYNE INTERNATIONAL DRILLING CO.

DEAN BOYACI
DIVISION ENGINEER

HELMERICH & PAYNE
INTERNATIONAL DRILLING CO.
P.O. BOX 6173
PEARL, MS 39288-6173
OFFICE (601) 939-1589
FAX (601) 939-9122
PAGER 1-800-329-4591
EMAIL: dean.boyaci@hpidc.com

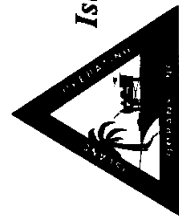

BOBBY BOUDREAUX
SENIOR PRODUCTION FOREMAN
Island Operating Co., Inc.
OIL & GAS PROPERTY MANAGEMENT

OFFICE: (318) 233-9594
(800) 366-9594
FAX: (318) 235-9657
PAGER: (800) 541-6188
MOBILE: (318) 344-3977

AMBASSADOR CAFFERY • I-10
P.O. BOX 61850
LAFAYETTE, LA 70586

EXON COMPANY, U.S.A.
P.O. BOX 61707
NEW ORLEANS, LA 70161-1707

T. S. BROOKS
ENVIRONMENTAL AND
REGULATORY AFFAIRS
(504) 561-4753
steve.brooks@exxon.com



HELMERICH & PAYNE INTERNATIONAL DRILLING CO.

CHRISTOPHER A. MAJOR
PROJECT ENGINEER

HELMERICH & PAYNE, INC.
UTICA AT TWENTY-FIRST
TULSA, OKLAHOMA 74114-1398
OFFICE (918) 748-0633
FAX (918) 742-0237



KERR-MCGEE OIL & GAS CORPORATION
16666 NORTHCHASE, HOUSTON, TEXAS 77060
OFFICE: 281/618-6843 SABINE OFF: 409/971-2731
FAX: 281/618-6030 SABINE FAX: 409/971-2769
PAGER: 888/548-0723 CELL: 281/705-8408
PAGER: 281/737-5843 • pin#101-7007 cyoung@kmg.com

C. H. "CHUCK" YOUNG, JR.
MAINTENANCE FOREMAN
OFFSHORE GULF OF MEXICO
TECHNICAL SERVICES



KERR-MCGEE OIL & GAS CORPORATION
16666 NORTHCHASE, HOUSTON, TEXAS 77060
HOUSTON: 281/618-6843 FAX: 281/618-6030
SABINE: 337/751-4918 FAX: 337/751-4914
CELL: 281/705-8408 cyoung@kmg.com

C.H. "CHUCK" YOUNG JR.
MECHANICAL MAINTENANCE SUPERVISOR



OFFICE: (504) 347-4585
1-800-348-5940
FAX: (504) 348-4230

EOUMA INDUSTRIES
A DIVISION OF LOR, INC.

P.O. BOX 685
HARVEY, LOUISIANA 70059
1725 DESTREHAN AVE.
HARVEY, LOUISIANA 70058

MICHAEL MILLS - FIELD SAFETY COORDINATOR



KERR-MCGEE OIL & GAS CORPORATION
16666 NORTHCHASE, HOUSTON, TEXAS 77060
OFFICE: 281/618-6827 FAX: 281/618-6040
PAGER: 281/737-6527 CELL: 281/737-4072
imecom@kmg.com

LARRY W. MECOM, CSP
SENIOR SAFETY SPECIALIST



JAMES P. TUMLINSON
PRODUCTION TECHNICIAN

Marathon Oil Company
P.O. BOX 53266 OCS
LAFAYETTE, LA 70509
Telephone 337/233-8240
Email: JPTumlinson@Marathonoil.com

A subsidiary of USX Corporation

1331 Lamar
Suite 800
Houston, Texas
77010-3088

Telephone 713 756-6206
Residence 281 852-2907
Pager 888 343-6870
Pager 713 612-1600
Fax 713 756-6002
Johnspe@ldng.com

Louis Dreyfus Natural Gas

Operations Manager
Arklatex/Offshore District

Patrick E. Johnson

1331 Lamar
Suite 800
Houston, Texas
77010-3088

Telephone 713 756-6206
Residence 281 852-2907
Pager 888 343-6870
Pager 713 612-1600
Fax 713 756-6002
Johnspe@ldng.com

Louis Dreyfus Natural Gas

Operations Manager
Arklatex/Offshore District

Patrick E. Johnson



DEBBIE LAGUENS
Audits & Inspections Supervisor

MARINE DRILLING COMPANIES, INC.
One Sugar Creek Center Blvd., Suite 600
Sugar Land, Texas 77478-5556
(281) 243-3014 (281) 243-3090 (fax)
e-mail: dlaguens@mardril.com

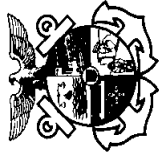

Lieutenant Commander
J.J. Plunkett
Chief, Inspections Department

Marine Safety Office Mobile
150 N. Royal Street
P.O. Box 2924
Mobile, AL 36652-2924

Tel: 334-441-5284
Fax: 334-441-5261
jplunkett@msomobile.uscg.mil

BARRY LEBOUF
Maintenance Manager
J. Ray McDermott, Inc.
Fabrication



P. O. Box 188
Morgan City, LA 70381
(504) 631-8462 FAX: (504) 631-8951
E-MAIL: barry.lebouf@jrmcdermott.com
WEBSITE: www.jraymcdermott.com



Gary Bourgeois
LA Service Manager

Crane & Eqpt. Co.®

gbourgeois@msicrane.com
dthraasher@msicrane.com

216 Millstone Road
Broussard, Louisiana 70518
(318) 837-5581 / FAX (318) 837-5603
Katy, Texas (281) 391-1493



Tim O'Neill
11981-A Spencer Rd (FM529)
Houston, TX 77041

tel 713.896.1115
fax 713.896.7575



Martec
a subsidiary of Sarnson Global Services™

MARTEC CRANE COMPANY, INC.

4322 Brookside Road
Pearland, TX 77581
TEL: (713) 433-3757
FAX: (713) 433-8332

1129 Hwy. 90 East
Broussard, LA 70518
TEL: (318) 365-5300
FAX: (318) 369-6568

CHUCK JOWERS
Operations Manager
mobile (318) 224-6940
pager (318) 293-1477

MORENO
& ASSOCIATES, INC
A Moreno Energy Services Company

Michael Bridges
Safety Consultant



201 Rue Beauregard
Post Office Box 53507
Lafayette, LA 70505
Office 318.237.9600
800.835.3121
Fax 318.237.7126
Pager 318.216.3523

MTBridges@aol.com



Gary Bourgeois
LA Service Manager

Crane & Eqpt. Co.®

216 Millstone Road
Broussard, Louisiana 70518
(318) 837-5581 / FAX (318) 837-5603
Katy, Texas (281) 391-1493



Alan Schaefer
11981-A Spencer Rd (FM529)
Houston, TX 77041

tel 713.896.1115
fax 713.896.7575

WILLIAM DICK
Wire Rope Coordinator
J. Ray McDermott, Inc.
Marine Division



P. O. Box 188
Morgan City LA 70381
2317 Hwy. 662 South Station S
Armetta LA 70340 FAX: (504) 631-8762
(504) 631-8957 FAX: (504) 631-8762
E-MAIL: wdick@jrmcdermott.com
WEBSITE: www.jraymcdermott.com

MORENO
& ASSOCIATES, INC
A Moreno Energy Services Company

Gary D. LoPiccolo, CSP
Consultant



201 Rue Beauregard
Post Office Box 53507
Lafayette, LA 70505
Office 337.993.4457
800.835.3121

Fax 337.993.4377 • Pager 337.295.0653
E-mail: Gary.LoPiccolo@oceanenergy.com
www.morenoenergy.com

or Ltpic@yahoo.com



Stephen Luke
Project Engineer

Crane & Eqpt. Co.®

Email address: Luke@emidspring.com
200 Bon Crest

Broussard, Louisiana 70518
(318) 837-5581 / FAX (318) 837-5603
Katy, Texas (281) 391-1493



David L. Thrasher
Texas Service Manager

Crane & Eqpt. Co.®

P.O. Box 973, Katy, TX 77492-0973
31203 Highway 90
Brookshire, TX 77423
(281) 391-1493 / FAX (281) 391-2808
Pager (281) 287-9133 / Email: dthrasher@msicrane.com



NABORS OFFSHORE CORPORATION

Bob Parbs

Maintenance Manager

3640 Peters Road
Harvey, LA 70058-1831
rparbs@nabors.com
504-362-8033
504-365-3219 (Direct)
504-365-3200 (Fax)
504-596-7348 (Pager)
504-251-6570 (Cell)

<http://www.igs.com>

Randy Ellis
~~CARLOS GAIN~~
Manager

PARTS & SERVICE
NEXCO@email.com

NEXCO CORP @ AOL.COM

NEXCO Corporation
HYDRAULIC MARINE CRANES

504-893-8181
504-893-8760 (Fax)

17440 Hard Hat Row
Covington, LA 70433

Jim - Cagle
MURPHY
EXPLORATION & PRODUCTION COMPANY
131 S. ROBERTSON STREET
P. O. BOX 61780
NEW ORLEANS, LA 70161

JIM CAGLE
~~BRIAN WEYDERT~~
Administrator - Safety/Security

2312
BUS. (504) 561-2818
FAX (504) 561-2836
TELEX 58-4124

Oriano - Weylert
MURPHY
EXPLORATION & PRODUCTION COMPANY
131 S. ROBERTSON STREET
P. O. BOX 61780
NEW ORLEANS, LA 70161

BRIAN WEYDERT
Administrator - Safety/Security

BUS. (504) 561-2918
FAX (504) 561-2836
TELEX 58-4124

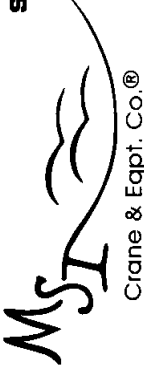

Stephen Luke
Project Engineer

200 Bon Crest
Broussard, Louisiana 70518
(318) 837-5581 / FAX (318) 837-5603
Katy, Texas (281) 391-1493

Eric Crawford
Training



NATCO

NATCO
1010 Highway 90 West
New Iberia, LA 70560
Office: (318) 365-9228
Fax: (318) 365-8135
Mobile: (318) 230-0422
Email: ecrawford@natco-us.com

CARLOS GAIN
Manager

PARTS & SERVICE
~~NEXCO@email.com~~

NEXCO CORP @ AOL.COM

NEXCO Corporation
HYDRAULIC MARINE CRANES

504-893-8181
504-893-8760 (Fax)

17440 Hard Hat Row
Covington, LA 70433



Merlin R. Prosper
Production Foreman

Newfield Exploration Company
Route 3 Box 1082
Abbeville, Louisiana 70510
Phone (318) 893-9795 or 9796
Fax (318) 893-7799



Tony Comeaux
Production Foreman

Newfield Exploration Company
Route 3 Box 1082
Abbeville, Louisiana 70510
Phone (318) 893-9795 or 9796
Fax (318) 893-7799

RANDY B. ELLIS
Director of Services

PARTS & SERVICE
NEXCO@email.com

NEXCO Corporation
HYDRAULIC MARINE CRANES

504-893-8181
504-893-8760 (Fax)

17440 Hard Hat Row
Covington, LA 70433



Darris Ponthieux
Maintenance Foreman

Ocean Energy, Inc. 3861 Ambassador Caffery Parkway, Suite 100
Lafayette, Louisiana 70503 (318) 993-4300 (318) 993-4306 fax

Parker Drilling

Greg Leger
Barge Operations
Parker USA Drilling Company
6111 Port Road
New Iberia, Louisiana 70560 USA
337-364-3122 ■ Fax 337-364-3152
Mobile 337-344-8601 ■ Pager 337-369-2564
A PARKER DRILLING COMPANY



Mitch Masterson
Health, Safety, & Environmental Specialist
(800) 425-9402 Pager
Mitch.Masterson@oceanenergy.com

Ocean Energy, Inc. 3861 Ambassador Caffery Parkway, Suite 100
Lafayette, Louisiana 70503 (337) 993-4572 (337) 993-4377 FAX

Oilfield

Production Contractors, Inc.
LEASE OPERATORS, HELPERS, I & E TECHNICIANS, REGULATORY
COMPLIANCE /PRE-INSPECTIONS & AUDITS, & COMPUTER SERVICES
ONSHORE & OFFSHORE

27 Professional Drive • Houma, Louisiana 70360
Rick Deare [Hitmail.com](mailto:Rick.Deare@hitmail.com) Bus: (504) 879-3082
RICK DEARE Fax: (504) 879-3075
Division Manager 1-800-448-3082



Jack A. Guidry
Maintenance Coordinator

Ocean Energy, Inc. 3861 Ambassador Caffery Parkway Suite 300
Lafayette, Louisiana 70503 (318) 993-4300 (318) 993-4306 fax

Darris Ponthieux
Maintenance Foreman

Ocean Energy, Inc. 3861 Ambassador Caffery Parkway, Suite 100
Lafayette, Louisiana 70503 (318) 993-4300 (318) 993-4306 fax



Carl Matt

Communications Consultant

Suite 115
850 Kaliste Saloom
Lafayette, LA 70508
cmatt@petrocom.com

PETROCOM

CELLULAR SERVICES

tel 318.234.4484
fax 318.234.2884



Michael J. Degeyter
Maintenance Foreman

100 Capital Drive, Suite 100
P.O. Box 80067
Lafayette, Louisiana 70598-0067
Main 316.237.7810
Fax 318.233.9616

PIONEER
NATURAL RESOURCES USA, INC.



Parker Drilling

Ed Tatum
Operations Manager, Jack-Up Rigs
Parker USA Drilling Company
P.O. Box 13530
New Iberia, Louisiana 70562-3530 USA
318-373-6388 ■ Fax 318-364-3152
Mobile 318-452-7905 ■ Pager 877-246-0461
Home 318-256-6272 ■ Home Fax 318-256-0793
E-mail: ed.tatum@parkerdrilling.com
A PARKER DRILLING COMPANY



Parker Drilling

Greg Leger [@Parkerdrilling.com](mailto:Greg.Leger@Parkerdrilling.com)

Greg Leger
Barge Operations
Parker USA Drilling Company
6111 Port Road
New Iberia, Louisiana 70560 USA
337-364-3122 ■ Fax 337-364-3152
Mobile 337-344-8601 ■ Pager 337-369-2564
A PARKER DRILLING COMPANY



JOHN M. SPENCER, C.S.P.
WELLSITE SAFETY & ENVIRONMENTAL SPECIALIST

AMERICA'S DRILLING
PHILLIPS PETROLEUM COMPANY
6330 WEST LOOP SOUTH
BELLAIRE, TX 77231

BUS: (713) 669-2128
PAGER: (800) 329-5648
FAX: (713) 669-3754
RES: (281) 277-2972
jmispenc@ppco.com



GORDON R. CAUGHMAN
HE & S SUPERVISOR

GULF COAST REGION
AMERICAS DIVISION
PHILLIPS PETROLEUM COMPANY
1405 W. PINHOOK, SUITE 210
LAFAYETTE, LA 70503

BUS: (318) 261-4114
PAGER: (318) 272-9656
gcaugh@ppco.com



PIONEER
NATURAL RESOURCES USA, INC.

Zie Thomas, Sr.
Maintenance Foreman

100 Capital Drive, Suite 100
P.O. Box 80067
Lafayette, LA 70598-0067
Main 318-237-7810
Fax 318-233-9616



PIONEER
NATURAL RESOURCES USA, INC.

Cal Girouard
Environmental Coordinator

girouarc@pioneerusa.com

100 Capital Drive, Suite 100
P.O. Box 80067
Lafayette, Louisiana 70598-0067
Main 318-237-7810
Fax 318-233-9616



PIONEER
NATURAL RESOURCES USA, INC.

Cal Girouard
Environmental Coordinator

100 Capital Drive, Suite 100
P.O. Box 80067
Lafayette, Louisiana 70598-0067
Main 318-237-7810
Fax 318-233-9616



BLAINE MARCANTEL
Manager, Compliance Services

PRODUCTION MANAGEMENT INDUSTRIES, INC.
CONTRACT OPERATIONS CONSTRUCTION SERVICES ENVIRONMENTAL SERVICES

900 South College Rd., Suite 301
P.O. Box 53485, O.C.S.
Lafayette, LA 70505
E-mail: marcantel@prodmgil.com
(337) 232-8770 ext. 2627
1-800-847-1575
Fax: (337) 269-9282
Pager: (337) 733-5860



Luther B. Johnson, CSP
Training Manager

R&B Falcon Drilling USA Inc.

Offshore Division
3735 Hwy. 90 East
Broussard, LA 70518
(318) 837-3555
Direct: (318) 837-0365
Fax: (318) 837-0353
Internet: www.rfalcon.com
Email: ljohnson@falconoffshore.com

Safety, Environmental & Operational Training, Inc.

1300 Bertrand Drive, Building B100 • Lafayette, Louisiana 70506
(318) 284-0323 • (800) 771-2762 • Fax: (318) 261-6903
Internet: <http://www.seot.com>

**Audits • Inspections • Policies & Procedures • Training
Occup. Health Testing • Safety & Substance Abuse Compliance
(DOT, MMS, OSHA, DEQ, EPA)**

Confined Space Entry • H2S/Atmosphere • ILS • Emergency Response • Medical First Aid/CPR • T2
Bloodborne Pathogens • Hazardous Waste • NOSH • PPE • Hazcom • Heavy Equipment • Etc.

Hoyed R. Lee, Jr.
Compliance Specialist
Home: (318) 229-6707
Email: hoyed@seot.com

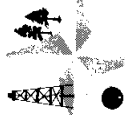

SENECA RESOURCES CORPORATION

R.T. (Bob) Evans
Assistant Vice President - Drilling and Production

(713) 654-2607
Fax (713) 654-2658
Home (409) 336-7357
Mobile (713) 823-4640
Pager (800) 913-6966

1201 Louisiana, Suite 400
Houston, Texas 77002



Victor Fleming

CORPORATE TRAINING COORDINATOR

Rowan Companies, Inc.

5450 Williams Tower
2800 Post Oak Boulevard
Houston, Texas 77056-6196

e-mail: victorfleming@cs.cum

Phone: (713) 960-7535
Pager: (800) 761-1403
Fax: (713) 968-6822

Doug Morrow

PO Box 840687
Houston, Texas 77284
Phone: 713 896 6500
Extension: 26
Fax: 713 896 6611
E-Mail: dmmorrow@seatrax.com



MARINE CRANES

RON MARGOT
SLIDELL # (504) 641-3853
FAX # (504) 641-3856



P.O. BOX 2035 - SLIDELL, LOUISIANA 70459

**CRANE INSPECTIONS MAINTENANCE CRANE REPAIRS
CRANE CERTIFICATIONS INSTALLATION OPERATOR TRAINING**
RMARGOT@PLATFORMCRANE.COM

**COMPLETE
CRANE SERVICE**



ROCTLAN SYSTEMS, INC.
SURVIVAL CRAFT SPECIALISTS
(504) 893-5663 ~ (504) 892-4031 FAX

**CAPABLE PARTS - REFURBISHED CAPSULES
INSPECTIONS - WEIGHT TESTS**

P.O. BOX 1491
MANDEVILLE, LA 70470-1491
OFFICE: (504) 893-5663
FAX: (504) 892-4031
PAGER: 888-550-5913

STAN ELMORE, V.P.
roctlan@roctlan.com

Samedan Oil Corporation

Steve Shuman
Offshore Production Supervisor

350 Glenborough
Suite 240
Houston, Texas 77067
(281) 876-6211
FAX (281) 874-6038

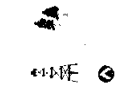

SENECA RESOURCES CORPORATION

John G. Kadlecik
Engineering Supervisor
Production

1201 Louisiana Street
Suite 400
Houston, Texas 77002-5604
jkadlecik@senecaresources.com
Phone: (713) 654-2633
Fax: (713) 654-2658
Pager: (713) 618-5546

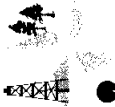

SENECA RESOURCES CORPORATION

R.T. (Bob) Evans
Assistant Vice President - Drilling and Production

(713) 654-2607
Fax (713) 654-2658
Home (409) 336-7357
Mobile (713) 823-4640
Pager (800) 913-6966
1201 Louisiana, Suite 400
Houston, Texas 77002



Houston, TX • (281) 579-3744
Fax (281) 579-3578
Lafayette, Louisiana 70508
(337) 235-4493 • Fax (337) 235-4494
U.S. 800-492-9335
www.RandySmith.com
Eric@RandySmith.com

RANDY SMITH
TRAINING SCHOOLS

Eric Guidry
Chief Financial Officer

201 Energy Parkway, Ste. 240
Lafayette, Louisiana 70508
(337) 235-4493 • Fax (337) 235-4494
U.S. 800-492-9335



Shell Offshore Inc.

Thomas Arceneaux
Central Resource Coordinator

One Shell Square
701 Poydras St.
New Orleans, La 70139
Room 2641A
E-mail: tparceneaux@shellus.com
Phone: 504-728-7712
Mobil: 504-518-1355
Fax: 504-728-0861
Pager: 504-546-1497

Michael L. Hebert
Sales Representative
New Orleans, LA
Office: 504-728-7712
Mobile: 504-518-1355
Fax: 504-728-0861
Pager: 504-546-1497

Schlumberger

Drilling & Production Services
519 Ambassador Road, Suite 400
Houston, TX 77002
Tel: 337-232-7754
Fax: 337-232-3944
Mobile: 337-577-7757
www.schlumberger.com



SENECA RESOURCES CORPORATION

Richard Timothy
Platform / Facility Supervisor

1201 Louisiana Street
Suite 400
Houston, Texas 77002-5604
Phone: (713) 654-2660
Fax: (713) 654-2658
Pager: (713) 542-2348



Shell Offshore Inc.
An affiliate of Shell Oil Company

Ard Rogers
Health, Safety & Environment
Drilling & Completions
Exploration & Development

Shell Robert Training Center
45314 Obbe Stevens Rd.
Robert, LA 70455
email: ardrogers@shellus.com
(504) 728-1234
Pager: (504) 572-5020
Mobile: (504) 691-8661
Home: (504) 475-7095



Shell Offshore Inc.
An affiliate of Shell Oil Company

One Shell Square
(504) 728-0198
Pager: (504) 546-0738
P.O. Box 61933
New Orleans, LA 70161
email: markdavis@shellus.com

M. W. (Mark) Davis
Sr. Regulatory Specialist
Exploration & Production
Strategic Resources



SPIRIT ENERGY
New Name. Same Spirit.
A Business Unit of Unocal

Jan J. Rogers, NREMT
Senior Staff HES Coordinator
East Central Gulf Operations

4021-4023 Ambassador Caffery Pkwy. • Lafayette, LA 70503
P.O. Box 69200 • Lafayette, LA 70596-9200
Telephone 318-295-6462 • Facsimile 318-295-6126
E-Mail: Jan.Rogers@unocal.com



SPIRIT ENERGY
New Name. Same Spirit.
A Business Unit of Unocal

Richard J. Morris
Drilling Environmental Coordinator

4021-4023 Ambassador Caffery Pkwy. • Lafayette, LA 70503
Telephone 318-295-6466 • Facsimile 318-295-6454

TECHNICAL EXCELLENCE



Jimmy 'Randy' Comeaux
HSE Trainer
Safety & Controls Group

113 North Pat St.
Scott, LA 70583
337 235 1515
337 268 4333 Fax
337 341 0982 Pager

SOLA COMMUNICATIONS
INCORPORATED



**Safety Compliance Consultants
Michael W. Smith**

PRESIDENT
P.O. Box 1352
Lafayette, LA, 70506
Office: 337-993-8298 Fax: 337-893-3076
www.starsafety.com Pager: 337-299-6363



Rocky Duplichan
MMS COMPLIANCE COORDINATOR

Hwy 92 Office: 318-993-8298
Maurice, LA, 70506 Pager: 318-299-6362
www.starsafety.com



New Name, Same Spirit.
A Business Unit of Unocal

Will Sellers
Maintenance Foreman
Offshore Operations

Intracoastal City Base, 24915 LA Hwy 333 - Abbeville, LA 70510
Telephone 318-898-4502 - Facsimile 318-898-4533
Beeper 318-265-4989 - E-Mail will.sellers@unocal.com

H. G. "Bud" Mills
Senior Safety Coordinator
Medical Review Specialist
Americas Region

Stolt Comex Seaway Inc.

A subsidiary of
Stolt Comex Seaway S.A.
1902 Diver Drive
New Iberia, LA 70560
USA

Tel: (318) 368-9040
Fax: (318) 368-9747
Pager: (318) 235-2060



E-MAIL - BDM@STOLTCOMEXSEAWAYUS.COM

H. G. "Bud" Mills
Senior Safety Coordinator
Medical Review Specialist
Americas Region

Stolt Comex Seaway Inc.

A subsidiary of
Stolt Comex Seaway S.A.
1902 Diver Drive
New Iberia, LA 70560
USA

Tel: (318) 368-9040
Fax: (318) 368-9747
Pager: (318) 235-2060



E-MAIL WRUSICH@SUPERIORENERGY.COM



Warren O. Rusich, Jr.
Safety Coordinator

1105 Peters Road
Harvey, LA 70058

Office: (504) 362-5558
Fax: (504) 362-4363

Dalton Barnhill
Safety Trainer
North Americas Region

Stolt Comex Seaway Inc.

A subsidiary of
Stolt Comex Seaway S.A.
1902 Diver Drive
New Iberia, LA 70560
USA

Tel: (337) 368-9040
Fax: (337) 368-1651
Home: (337) 891-1387



email: DTB@stoltcomexseawayus.com



Tommy Hebert
Plugging and Abandonment Manager

1105 Peters Road
Harvey, LA 70058

Office: (504) 362-5558
Fax: (504) 362-4363



Gerald Collins
EHS Professional
Contractor Safety
Management
Gulf of Mexico
Production Business Unit
Call life texaco.com



Call life texaco.com



Robert J. Mathews
Production and
Production Inc.



Marvin A Vining
Reliability Engineering
Coordinator
Texaco Exploration and
Production Inc
P.O. Box 60252 (70160 0252)
400 Poydras Street (70130)
New Orleans, LA
Office 504 680 4181
FAX 504 680 1410
Pager 800 425 3182
E-mail: viningma@texaco.com

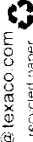

Francis C (Cook) Burke Jr
Regional Coordinator
Manufacturing Department
Texaco Exploration and
Production Inc
P.O. Drawer 1477
5904 Highway Ave
Morgan City, LA 70380
504 380 1245
504 380 1243 Fax
504 372 9883 Receiver

E-MAIL burkefc@texaco.com



I C Hunt Jr
Drilling Supervisor
Texaco Worldwide
Exploration & Production
P.O. Box 60252 (70160 0252)
400 Poydras Street (70130)
New Orleans, LA
504 680 4066
huntic@texaco.com

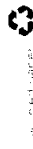

J R Stark
Sr Drilling Supervisor
Texaco Worldwide
Exploration & Production
P.O. Box 60252 (70160 0252)
400 Poydras Street (70130)
New Orleans, LA
504 680 1089
starkjr@texaco.com

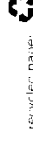

Miles J Becnel
Structural Coordinator
Operations Support Dept
Offshore Region
Texaco Exploration and
Production Inc
P.O. Box 60252
New Orleans, LA 70160 0252
504 680 1842
Fax 504 680 1472
Beepert 504 572 7135
Home 504 624 9540

Becnemj@Texaco.com



Robert "Bob" Filce
Safety & Health Coordinator
Gulf of Mexico Production Bus. Unit
Texaco Worldwide E&P
P.O. Drawer 1970
Morgan City, LA 70381-1970
504-380-1263 Office
504-380-1234 Fax
504-330-7081 Cellular
504-446-5915 Home
800-627-9034 Pager
E-Mail: filcera@texaco.com



Offshore

Jessie C. Scott
Production Supervisor
Offshore Producing USA
Gulf of Mexico
Texaco North American Producing
TNAP East
P.O. Box 60050 (70964-0500)
400 Poydras Street (70130)
New Orleans, La.
Office: 504 380 1391
Fax: 504 380 1337
Home: 504 796 5504
E-Mail: scottjc@texaco.com



CHUCK BERGERON
Service Manager

13189 HIGHWAY 190 W.
COVINGTON, LA 70435
E-mail: cbergeron@titancranes.com
Phone: (504) 893-1818
Fax: (504) 893-1879
Pager: (504) 867-7674

JAMES D. LANDRY
V.P. Operations



TITAN INDUSTRIES
HYDRAULIC MARINE CRANES

13189 HIGHWAY 190 W. • COVINGTON, LA 70435
(504) 893-1818 • (504) 893-1879 (FAX)
E-mail: JLANDRY@TITANCRANES.COM

JOHN PFISTER
Sales Representative



TITAN INDUSTRIES
HYDRAULIC MARINE CRANES

13189 HIGHWAY 190 W. • COVINGTON, LA 70435
(504) 893-1818 • (504) 893-1879 (FAX) • (504) 845-5516 (PG)
E-Mail: jpfister@titancranes.com



KEVIN MURPHY
DIVISION H S & E

TRANSOCEAN OFFSHORE INC.
GULF COAST DIVISION

LAKEWAY II

3850 N. CALISEWAY BOULEVARD, SUITE 500
METAIRIE, LOUISIANA 70002
(504) 849-3164 OFFICE (504) 849-3166 FAX
kmurphy@deepwater.com



A Unocal Business Unit
Intercoastal City Base, 24915 LA Hwy 333
Abbeville, Louisiana 70510
Telephone (337) 898-4565
Facsimile (337) 898-4533
Beeper (337) 285-4310
E-Mail: donald.gaspard@unocal.com



Donald Gaspard
Maintenance Foreman
Offshore Operations
Spirit Energy 76

U.S. Department
of Transportation
United States
Coast Guard



Michael E. Lee
Marine Inspector

409
Tel: (404) 766-3686
Fax: (404) 766-3685

601 Rosenberg, Room 309
Galveston, TX 77550

Marine Safety Unit
Galveston



T O R C H
R I G S E R V I C E S , I N C .
A Subsidiary of Torch Energy Advisors

JOE HOCAMP

Rig Supervisor
290 MAPLE COURT, SUITE 282, VENTURA CALIFORNIA 93003
TELEPHONE: 805.289.1661 FAX: 805.289.3558
PAGER: 805.359.3691 CELL PHONE: 805.340.8433
INTERNET: hocampj@VEN.TEAL.COM

Union Pacific Resources Company

Tommy Mueck
Maintenance Supervisor

201 Energy Parkway, Suite 310
Lafayette LA 70508
(318) 572-4008 (318) 267-7895 fax
(800) 509-3215 pager



Mike Babin
HSLP Manager

401 Whitney Avenue, Suite 400

Gretna, LA 70056

Website: www.torchinc.com

Email: m.babin@torchinc.com

Phone: (504) 367-7030
Fax: (504) 367-7075
Pager: (504) 823-3099
Watts: (800) 878-6724



SCOT RUDOLPH

TRAINING MANAGER NORTH & SOUTH AMERICA

TRANSOCEAN OFFSHORE DEEPWATER DRILLING INC.
4 GREENWAY PLAZA (77046)

POST OFFICE BOX 2765

HOUSTON, TEXAS 77256-2765

(713) 232-7749 OFFICE (713) 232-7750 FAX

(713) 819-3260 CELL

snrudolph@deepwater.com



A Unocal Business Unit
601-4023 Ambassador Cafery Pkwy, (70503)
P.O. Box 1000
Lafayette Louisiana 70506-9200
Telephone (337) 295-6850
Facsimile (337) 295-6126
Pager (800) 450-6348
E-Mail: o.l.j@unocal.com



O. L. (Johnny) Johnson, III
Maintenance Superintendent
Offshore Operations
Spirit Energy 76

U.S. Department
of Transportation
United States
Coast Guard



Marine Inspector.

Michael R. Manning
Chief Warrant Officer

Marine Safety Unit
601 Rosenberg, Rm. 309
Galveston, TX 77550

Phone: 409-766-3686
Fax: 409-766-3689



Mike Farrell

Chief, OCS Branch

Phone: (504) 380-5360
Fax: (504) 385-1687

U.S.C.G. Marine Safety Office
800 David Drive
Morgan City, LA 70380-1304

mfarrell@msmorgancity.uscg.mil

U. S. Coast Guard
Eighth Coast Guard District
Marine Safety Division



Joel K. Moore
Lieutenant
Asst. Chief, Facility and Offshore
Compliance

Phone: (504) 589-6260
Fax: (504) 589-4999
jmoore@d8.uscg.mil

CCGD8(moc)
501 Magazine St
New Orleans, LA 70130

Star Champagne



Vastar Resources, Inc.

J. Rusty Thibodeaux
Senior Coordinator
Regulatory Compliance and Environmental

Vastar Resources, Inc.

202 Rue Iberville
Lafayette, LA 70505
318.264-4279



Larry Robinson

Vastar Resources, Inc.

502 Ave. Iberville
Lafayette, LA 70505
337.484-1149
337.484-1153 Fax
337.484-1149



U. S. Department of the Interior
Minerals Management Service
Gulf of Mexico Region

WILLIAM H. MARTIN
Deputy for District Operations,
Field Operations

1420 South Clearview Parkway
New Orleans, LA 70123
Room 917
(504) 736-2849
FTS 680-9849
Home (504) 831-2923



U. S. Department of the Interior
Minerals Management Service

WILLIAM S. HAUSER
Engineering and Standards Branch
Petroleum Engineer

Mail Stop 4700
381 Elden Street
Herndon, VA 22070

(703) 787-1613
Fax (703) 787-1575



DAVID NUNNIZ

Vastar Resources, Inc.

DAVID NUNNIZ
VASTAR
DOM.



U.S. DEPARTMENT OF THE INTERIOR
MINERALS MANAGEMENT SERVICE

ERIC J. FONTENOT
INSPECTOR

620 ESPLANADE, STE. 200
MS 5271
LAKE CHARLES, LA 70607

TEL: (337) 480-4608
FAX: (337) 477-9889
E-MAIL: eric.fontenot@mms.gov



U.S. DEPARTMENT OF THE INTERIOR
MINERALS MANAGEMENT SERVICE
PACIFIC OCS REGION

Nabil F. Masri
Supervisory Petroleum Engineer
Chief, Operations, Safety and Enforcement Section
Office of Field Operations

Pacific OCS Region
770 Paseo Camarillo
Camarillo, CA 93010
Telephone: (805) 389-7581
Fax: (805) 389-7592
E-mail: nabil_masri@mms.gov