

1.	General	1
1.1	Introduction	1
1.2	Scope and Application.....	1
1.3	Structure of the RP	1
1.4	Definitions	1
1.5	Abbreviations	2
1.6	Symbols and explanation of terms.....	2
2.	Fluke Anchor Components.....	4
3.	General fluke anchor behaviour	4
4.	Methodology for fluke anchor design	5
4.1	General	5
4.2	Design charts	6
4.3	Analytical tools.....	6
5.	Recommended design procedure.....	6
5.1	General	6
5.2	Basic nomenclature and contributions to anchor resistance	7
5.3	Step-by-step description of procedure	9
5.4	Tentative safety requirements.....	9
5.5	Minimum installation tension.....	12
6.	Requirements to Soil Investigation	13
7.	References	13
Appendix A: Analysis tool for fluke anchor design		14
Appendix B: Anchors in layered clay.....		17
Appendix C: Installation and testing of fluke anchors		18
Appendix D: Effect of consolidation		20
Appendix E: Effect of cyclic loading		21
Appendix F: Uplift angle at the seabed		25
Appendix G: General requirements to soil investigation....		28

1. General

1.1 Introduction

This Recommended Practice features a substantial part of the design procedure developed in Part 1 /1/ of the joint industry project on *Design procedures for deep water anchors*, and it was developed further through a pilot reliability analysis in Part 2 /2/. An overview of this project is given in /3/.

1.2 Scope and Application

This Recommended Practice applies to the geotechnical design and installation of fluke anchors in clay for catenary mooring systems

The design procedure outlined is a recipe for how fluke anchors in both deep and shallow waters can be designed to satisfy the requirements by DNV.

According to this recommendation the geotechnical design of fluke anchors shall be based on the limit state method of design. For intact systems the design shall satisfy the Ultimate Limit State (ULS) requirements, whereas one-line failure shall be treated as an Accidental Damage Limit State (ALS) condition.

For the ULS, the failure event has been defined as the inception of anchor drag. Subsequent drag of any anchor is conservatively assumed to imply mooring system failure in the ALS. This avoids the complexity of including uncertain anchor drag lengths in the mooring system analysis. Thus, the ALS is formulated to avoid anchor drag, similarly to the ULS.

The line tension model adopted herein splits the tension in a mean and a dynamic component, see background in /4/, which differs from the line tension model adopted in the current DNV Rules for Classification of Mobile Offshore Units /5/

Traditionally, fluke anchors have been designed with the mandatory requirement that the anchor line has to be horizontal (zero uplift angle) at the seabed level during installation and operation of the anchors. This requirement imposes significant limitations on the use of fluke anchors in deeper waters, and an investigation into the effects of uplift on fluke anchor behaviour, as reported in /1/, has provided a basis for assessment of an acceptable uplift angle.

Until the design rule presented herein has been calibrated based on reliability analysis the partial safety factors will be tentative.

This recommendation is in principle applicable to both long term (permanent) and temporary moorings.

1.3 Structure of the RP

Definition of the main components of a fluke anchor is given in Chapter 2, followed by a description of the general behaviour of fluke anchors in clay in Chapter 3.

In Chapter 4 a design methodology based on calibrated and validated analytical tools is recommended in lieu of the current use of design charts.

The recommended procedure for design and installation of fluke anchors is presented in Chapter 5. The close and important relationship between the assumptions for design and the consequential requirements for the installation of fluke anchors is emphasized.

General requirements to soil investigations are given in Chapter 6.

The intention has been to make the procedure as concise as possible, but still detailed enough to avoid misinterpretation or misuse. For transparency details related to the various design aspects are therefore found in the appendices.

A number of **Guidance notes** have been included as an aid in modelling of the anchor line, the anchor and the soil. The guidance notes have been written on the basis of the experience gained through the joint industry project, see /1/ and /2/.

1.4 Definitions

<i>Dip-down point</i>	Point where the anchor line starts to embed.
<i>Fluke</i>	Main load bearing component.
<i>Fluke angle</i>	Angle between the fluke plane and a line passing through the rear of the fluke and the shackle (arbitrary definition).
<i>Forerunner</i>	Anchor line segment being embedded in the soil (preferably wire, but may also be a chain).
<i>Inverse catenary</i>	The curvature of the embedded part of the forerunner.
<i>Shackle</i>	Forerunner attachment point (at the front end of the shank).
<i>Shank</i>	Rigidly attached to the fluke.
<i>Touch-down point</i>	Point where the anchor line first touches the seabed.

1.5 Abbreviations

			Symbol	Term	Explanation of term
AHV	Anchor handling vessel	Used to set the anchors		friction	overcome during anchor installation
ALS	Accidental Damage Limit State		γ_{mean}	Partial safety factor on mean line tension	Accounts for the uncertainty in mean line tension
MBL	Minimum Breaking Load	Breaking load of anchor line segment	γ_{dyn}	Partial safety factor on dynamic line tension	Accounts for the uncertainty in dynamic line tension
ULS	Ultimate Limit State		k_c	Empirical factor	Used to estimate the cyclic degradation effect

1.6 Symbols and explanation of terms

Symbol	Term	Explanation of term			
α	Seabed uplift angle	Line angle with the horizontal at the dip-down point		L_F	Fluke length Related to fluke area: $L_F = 1.25 \sqrt{A_{fluke}}$ (approximation)
α_{max}	Maximum possible uplift angle	Uplift angle, which makes the anchor drag at constant tension without further penetration at the actual depth		L_s	Line length on seabed For the actual mooring line configuration and characteristic line tension T_C
α	Anchor adhesion factor	Accounts for remoulding of the clay in the calculation of the frictional resistance at the anchor members		$L_{s,i}$	Line length on seabed at anchor installation For the anchor installation line configuration between stern roller and anchor shackle, and the installation tension T_{min}
α_{min}	Minimum adhesion	Set equal to the inverse of the sensitivity, $\alpha_{min} = 1/S_i$		μ	Coefficient of seabed friction Average friction coefficient (both frictional and cohesive) over line length L_s or $L_{s,i}$
α_{soil}	Line adhesion factor	To calculate unit friction in clay of embedded anchor line		n	Exponent Used in empirical formula for loading rate effect
A_{fluke}	Anchor fluke area	Based on manufacturer's data sheet.		N_c	Bearing capacity factor for clay Corrected for relative depth of embedment, layering, orientation of respective anchor members, etc
β	Anchor penetration direction	Angle of the fluke plane with the horizontal		N_{eq}	Equivalent number of cycles to failure The number of cycles at the constant cyclic shear stress that will give the same effect as the actual cyclic load history (see Appendix E)
AB	Effective bearing area	Per unit length (related to anchor line segment in the soil)		OCR	Overconsolidation ratio Ratio between maximum past and present effective vertical stress on a soil element
AS	Effective surface area	Per unit length (related to anchor line segment in the soil)		q	Normal stress Related to embedded anchor line
c_v	Coefficient of consolidation	See Appendix G		θ	Orientation of anchor line element $\theta = 0$ for a horizontal element
d	Nominal diameter	Diameter of wire, rope or chain		Q_1, Q_2	Pile resistance Pile resistance at loading rates v_1 and v_2 , respectively
ds	Element length	Related to embedded anchor line		R	Anchor resistance Resistance in the line direction with reference to penetration depth z and including the contribution from the embedded anchor line up to the dip-down point.
e	Lever arm	Between shackle and the line of action of the normal resistance at the fluke		ΔR_{cons}	Consolidation effect Added to R_i .
f	Unit friction	Resistance, both frictional and cohesive, of embedded part of anchor line		R_{cons}	Consolidated anchor resistance Anchor resistance at the dip-down point, including effect of consolidation (at onset of cyclic loading)
γ_m	Partial safety factor on anchor resistance	Accounts for the uncertainty in ΔR_{cons} , ΔR_{cy} , ΔR_{fric} , s_u and $s_{u,r}$		ΔR_{cy}	Cyclic loading effect Added to R_{cons} .
$\gamma_{m,i}$	Partial safety factor on seabed	Accounts for the uncertainty in the predicted seabed friction to be			

Symbol	Term	Explanation of term	Symbol	Term	Explanation of term
R_{cy}	Cyclic anchor resistance	Anchor resistance at the dip-down point, including effects of consolidation and cyclic loading	τ_{cy}	Cyclic shear strength	Accounts for both loading rate and cyclic degradation effects on s_u .
R_C	Characteristic anchor resistance	Anchor resistance at the touch-down point with effects of consolidation, cyclic loading and seabed friction included	t_{cons}	Consolidation time	Time elapsed from anchor installation to time of loading
R_d	Design anchor resistance	With specified partial safety factors included	t_{cy}	Time to failure	Rise time of line tension from mean to peak level during the design storm (= 1/4 load cycle period)
ΔR_{fric}	Seabed friction	Over line length L_s	t_{hold}	Installation tension holding period	Period of holding T_{min} at the end of anchor installation
R_i	Installation anchor resistance	Set equal to T_i (if T_i is properly verified at installation)	t_{su}	Time to failure	Time to failure in a laboratory test for determination of the intact undrained shear strength (typically 0.5 – 2 hours)
$R_{L,\alpha}$	Anchor line resistance	Resistance of embedded anchor line for uplift angle α	T	Line tension	Line tension model following suggestion in /4/
$R_{L,\alpha=0}$	Anchor line resistance	Resistance of embedded anchor line for uplift angle $\alpha=0$	T_v, T_h	Components of line tension at the shackle	Vertical and horizontal component of the line tension at the anchor shackle for the actual anchor and forerunner
R_{ult}	Ultimate anchor resistance	The anchor drags without further increase in the resistance during continuous pulling, which also defines the ultimate penetration depth z_{ult} .	T_C	Characteristic line tension	Split into a mean and dynamic component
R_{ai}	Sum of soil resistance at anchor components	Excluding soil resistance at the fluke	T_{C-mean}	Characteristic mean line tension	Due to pretension and the effect of mean environmental loads in the environmental state
R_{FN}	Soil normal resistance	At the fluke	T_{C-dyn}	Characteristic dynamic line tension	The increase in tension due to oscillatory low-frequency and wave-frequency effects
R_{FS}	Soil sliding resistance	At the fluke	T_d	Design line tension	With specified partial safety factors included
Rm_{ai}	Moment contribution	From R_{ai}	T_i	Target installation tension	Installation tension at the dip-down point.
Rm_{FS}	Moment contribution	From R_{FS}	T_{min}	Minimum installation tension	Installation tension if $L_{s,i} > 0$ (for $L_{s,i} = 0$ $T_{min} = T_i$)
Rm_{TIP}	Moment contribution	From R_{TIP}	ΔT_{min}	Drop in tension	Double amplitude tension oscillation around T_{min} during period t_{hold}
R_{TIP}	Tip resistance	At anchor members	T_{pre}	Pretension in mooring line	As specified for the mooring system.
S_i	Soil sensitivity	The ratio between s_u and $s_{u,r}$, as determined e.g. by UU triaxial tests.	U_{cons}	Soil consolidation factor	$U_{cons} = (1 + \Delta R_{cons}/R_i)$, where ratio $\Delta R_{cons}/R_i$ expresses the effect of consolidation on R_i
s_u	Intact strength	For fluke anchor analysis, the direct simple shear (DSS) strength or the unconsolidated undrained (UU) triaxial strength is assumed to be the most representative intact strength.	U_{cy}	Cyclic loading factor	$U_{cy} = (1 + \Delta R_{cy}/R_{cons})$, where ratio $\Delta R_{cy}/R_{cons}$ expresses the effect of loading rate and cyclic degradation on R_{cons}
$s_{u,r}$	Remoulded shear strength	The undrained shear strength measured e.g. in a UU triaxial test after having remoulded the clay completely.	U_r	Loading rate factor	$U_r = (v_1/v_2)^B$
			v_1	Loading rate	Loading rate at extreme line tension
			v_2	Loading rate	Loading rate at the end of installation

Symbol	Term	Explanation of term
W_a'	Submerged anchor weight	Taken as $0.87 \cdot$ anchor weight in air
W_m	Moment contribution	From anchor weight W
W_l'	Submerged weight of anchor line	Per unit length of actual line segment
z	Anchor penetration depth	Depth below seabed of the fluke tip.
z_i	Installation penetration depth	For $R = R_i$.
z_{ult}	Ultimate penetration depth	For $R = R_{ult}$.

2. Fluke Anchor Components

The main components of a fluke anchor (Figure 1) are:

- the shank
- the fluke
- the shackle
- the forerunner

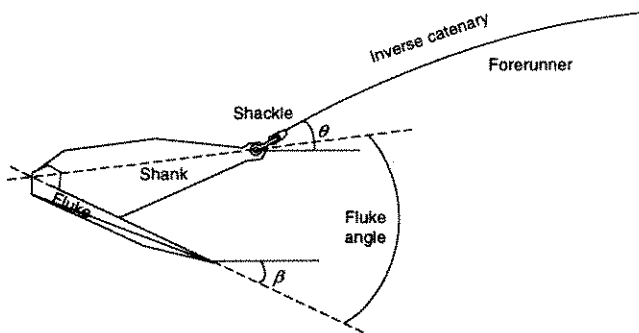

Figure 1 Main components of a fluke anchor.

The *fluke angle* is the angle arbitrarily defined by the fluke plane and a line passing through the rear of the fluke and the anchor shackle. It is important to have a clear definition (although arbitrary) of how the fluke angle is being measured.

Normally the fluke angle is fixed within the range 30° to 50° , the lower angle used for sand and hard/stiff clay, the higher for soft normally consolidated clays. Intermediate angles may be more appropriate for certain soil conditions (layered soils, e.g. stiff clay above softer clay). The advantage of using the larger angle in soft normally consolidated clay is that the anchor penetrates deeper, where the soil strength and the normal component on the fluke is higher, giving an increased resistance.

The *forerunner* is the line segment attached to the anchor shackle, which will embed together with the anchor during installation. The anchor penetration path and the ultimate depth/resistance of the anchor are significantly affected by the type (wire or chain) and size of the forerunner, see Figure 2.

The *inverse catenary* of the anchor line is the curvature of the embedded part of the anchor line, see Figure 2

3. General fluke anchor behaviour

The resistance of an anchor depends on the ability of the anchor to penetrate and to reach the target installation tension (T_i).

The penetration path and ultimate penetration depth is a function of

- the soil conditions (soil layering, variation in intact and remoulded undrained shear strength)
- the type and size of anchor,
- the anchor's fluke angle,
- the type and size of the anchor forerunner (wire or chain), and
- the line uplift angle α at the seabed level.

It should be mentioned that the penetration behaviour, and predictability, of the new generation fluke anchors is much improved compared to older types of anchors.

In a clay without significant layering a fluke anchor normally penetrates along a path, where the ratio between incremental penetration and drag decreases with depth, see Figure 2. At the ultimate penetration depth z_{ult} the anchor is not penetrating any further. The anchor is "dragging" with a horizontal (or near horizontal) fluke, and the tension in the line is constant. At the ultimate penetration depth the anchor reaches its ultimate resistance R_{ult} .

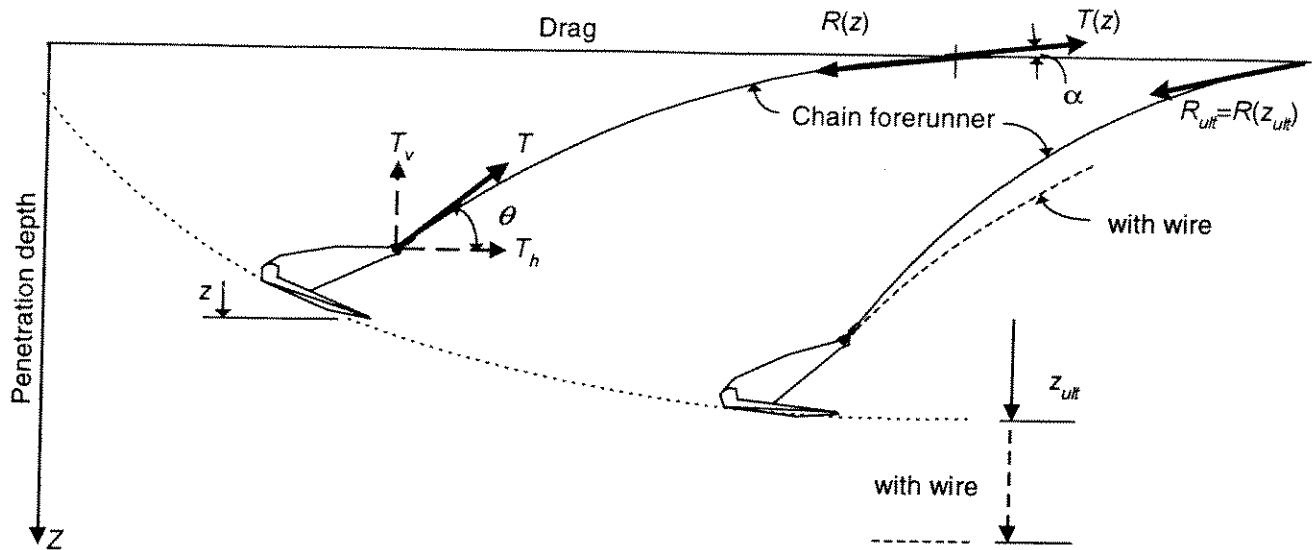

Figure 2 Illustration of fluke anchor behaviour, and definition of R_{ult} .

Since reaching the ultimate penetration depth is associated with drag lengths in the range 5 to 10 times the penetration depth, it is impractical to design an anchor under the assumption that it has to be installed to its ultimate penetration depth. A more rational approach is to assume that only a fraction of the ultimate anchor resistance is utilized in the anchor design, as illustrated by the intermediate penetration depth in Figure 2. This will also lead to more predictable drag, and should drag occur the anchor may have reserve resistance, which can be mobilized through further penetration.

The cutting resistance of a chain forerunner will be greater than the resistance of a steel wire, with the result that a chain forerunner will have a steeper curvature (inverse catenary) at the anchor shackle than a wire forerunner, i.e. the angle θ at the shackle is larger. This increases the upward vertical component T_v of the line tension T at the shackle with the consequence that a fluke anchor with a chain forerunner penetrates less than one with a wire forerunner, and mobilizes less resistance for a given drag distance.

It has been demonstrated in the JIP on deepwater anchors /1/ that a non-zero uplift angle α at the seabed, see Figure 2, can be acceptable under certain conditions as discussed in Appendix F. If the uplift angle becomes excessive during installation the ultimate penetration depth may be reduced. The anchor resistance $R(z)$ is defined as the mobilized resistance against the anchor plus the resistance along the embedded part of the anchor forerunner. However, for anchoring systems with a high uplift angle at the seabed the contribution from the anchor line to the anchor resistance will be greatly reduced, see Eq. (F-1).

4. Methodology for fluke anchor design

4.1 General

Traditionally, the methods used for design of fluke anchor have been highly empirical, using power formulae in which the ultimate anchor resistance is related to the anchor weight, but analytical methods are now gradually replacing these crude methods. The need for calibrating the methods used for fluke anchor design against good anchor test data will, however, be as great as ever.

The data base for fluke anchor tests is quite extensive, but there are gaps in many data sets, in the sense of missing pieces of information, which makes the back-fitting analysis and calibration less reliable than it could have been. In most cases there are uncertainties attached to the reported installation data, e.g. soil stratigraphy, soil strengths, anchor installation tension, contribution from sliding resistance along the anchor line segment on the seabed, depth of anchor penetration, possible effect of anchor roll during penetration, etc.

It is therefore of a general interest that future fluke anchor testing, and monitoring of commercial anchor installations be carefully planned and executed, such that the test database gradually improves, see guidance in Appendix C.

Extrapolation from small to medium size anchor tests to prototype size anchors should be made with due consideration of possible scale effects.

In the following the shortcomings with design charts and the requirements to analytical methods are discussed. It is recommended herein that the design practice based on design charts be replaced with analytical methods, which utilise recognised theoretical models and geotechnical principles.

4.2 Design charts

The design curves published by the American Petroleum Institute in /6/, which are based on work by the Naval Civil Engineering Laboratory (NCEL), give the ultimate anchor resistance R_{ult} of the respective anchors versus anchor weight. These relationships, which plot as straight lines in a log-log diagramme, suffer from the limitations in the database and the inaccuracies involved in simple extrapolation of the R_{ult} measured in small size anchor tests to larger anchors. The diagrammes assume an exponential development in the resistance for each type of anchor and generic type of soil based on the so-called Power Law Method. The anchor resistance resulting from these diagrammes is for ultimate penetration of the anchor and represents a safety factor of 1.0. As mentioned above, anchors are seldom or never installed to their ultimate depth, which means that the anchor resistance derived from these diagrammes must be corrected for depth of penetration, or degree of mobilization. After such correction the resulting anchor resistance may be comparable with the installation anchor resistance R_i , defined in this recommendation, although with the important difference that it represents only a predicted resistance until it has been verified by measurements during anchor installation. As shown in Section 5.2 consolidation and cyclic loading effects, and possible sliding resistance along the length of anchor line on the seabed, can be added to R_i .

Most of the anchor tests in the database, being the basis for the design charts, are with a chain forerunner. The effect of using a wire forerunner therefore needs to be estimated separately. Since the clays are divided in stiffness classes from very soft to very hard, an anchor penetrating into a clay where the shear strength increases linearly with depth, or is layered, may 'jump' from one stiffness class to another in terms of resistance, penetration depth and drag. There are many other limitations in the design methods relying on the Power Law Method, which justifies using a design procedure based on geotechnical principles.

4.3 Analytical tools

4.3.1 General

The analytical tool should be based on geotechnical principles, be calibrated against high quality anchor tests, and validated.

With an analytical tool the designer should be able to calculate:

- the relationship between line tension, anchor penetration depth and drag for the actual anchor and line configuration in the prevailing soil conditions

- how this relationship is affected by changing the type and/or size of the anchor, the type and/or size of the forerunner, or the soil conditions
- the effect on anchor resistance of soil consolidation from the time of anchor installation until the occurrence of the design event, see guidance in Appendix D
- the effects on the anchor resistance of cyclic loading, i.e. the combined effect of loading rate and cyclic degradation, see guidance in Appendix E
- the effect on the penetration trajectory and design anchor resistance of changing the uplift angle at the seabed, see guidance in Appendix F

4.3.2 Equilibrium equations for fluke anchor analysis

The analytical tool must satisfy the equilibrium equations both for the embedded anchor line and for the fluke anchor.

The inverse catenary of the embedded anchor line is resolved iteratively such that equilibrium is obtained between the applied line tension and the resistance from the surrounding soil, see /7/. For the fluke anchor both force and moment equilibrium is sought. The equilibrium equations for the anchor line and the anchor as included in an analytical tool developed by DNV are given in Appendix A.

5. Recommended design procedure

5.1 General

In the design of fluke anchors the following issues need to be addressed:

- a) Anchor resistance, penetration and drag vs. installation line tension.
- b) Acceptable uplift angle during installation and design extreme line tension.
- c) Post-installation effects due to consolidation and cyclic loading.
- d) Minimum anchor installation tension and installation procedures.

The philosophy and strategy for design of fluke anchors followed herein is simple and straightforward. The assessment of the resistance of an anchor is directly related to the ability of the anchor to penetrate and the installation line tension applied, which means that requirements to anchor installation will be closely linked to the anchor design assumptions. The installation aspects will therefore have to be considered already at the anchor design stage.

According to this recommendation the geotechnical design of fluke anchors shall be based on the limit state method of design. For intact systems the design shall satisfy the Ultimate Limit State (ULS) requirements, whereas one-line failure shall be treated as an Accidental Limit State (ALS) condition. The line tension model adopted herein splits the tension into a mean and a dynamic component, see background in /4/, which differs from the line tension model adopted in the current DNV Rules for Classification of Mobile Offshore Units /5/. Until the design rule has been calibrated based on reliability analysis the partial safety factors for the anchor design proposed herein will, however, be tentative.

The recommended procedure for design of fluke anchors is outlined step-by-step in Section 5.3. The procedure is based on the limit state method of design, and tentative safety requirements are given in Section 5.4. Anchor installation requirements are presented in Section 5.5, and guidance for installation and testing of fluke anchors is given in Appendix C.

Guidance for calculation of the effects of consolidation and cyclic loading and for assessment of a safe uplift angle at the seabed are given in Appendix D, Appendix E and Appendix F, respectively. Requirements to soil investigations are given in Chapter 6 and Appendix G.

In an actual design situation the designer would benefit from having an adequate analytical tool at hand for parametric studies, see Section 4.3 for requirements to such analytical tools.

Sound engineering judgement should always be exercised in the assessment of the characteristic resistance of a chosen anchor, giving due consideration to the reliability of the analytical tool and the uncertainty in the design parameters provided for the site.

5.2 Basic nomenclature and contributions to anchor resistance

The basic nomenclature used in the anchor design procedure proposed herein is shown in Figure 1.

The characteristic anchor resistance R_C is the sum of the installation anchor resistance R_i and the predicted post-installation effects of consolidation and cyclic loading, ΔR_{cons} and ΔR_{cy} , see Figure 3. To this resistance in the dip-down point is added the possible seabed friction ΔR_{fric} as shown in Figure 3b). Eq. (1) below shows the expression for R_C when $L_x > 0$.

$$R_C = R_i + \Delta R_{cons} + \Delta R_{cy} + \Delta R_{fric} \quad (1)$$

See guidance for assessment of the consolidation effect ΔR_{cons} in Appendix D, the cyclic loading effect ΔR_{cy} in Appendix E and the seabed friction contribution ΔR_{fric} in Appendix A.

Figure 3a) illustrates the anchor installation phase, with the length of line on the seabed equal to $L_{s,i}$. The installation anchor resistance R_i is equal to the target installation line tension T_i , assuming that T_i is adequately measured and documented. The required characteristic anchor resistance is then obtained by adding the predicted contributions ΔR_{cons} , ΔR_{cy} and ΔR_{fric} to R_i as demonstrated in Eq.(1).

The minimum installation tension T_{min} is the required installation tension in the touch-down point, which accounts for the installation seabed friction. The target installation line tension T_i (and by definition R_i) is then equal to

$$T_i = T_{min} - \mu \cdot W'_i \cdot L_{s,i} \quad (2)$$

The installation resistance R_i is thus dependent on a correct assessment of the length $L_{s,i}$ and the resulting seabed friction. If $L_{s,i} > L_{ss}$, see Figure 3, then the minimum installation tension T_{min} will have to be increased correspondingly such that the load transferred to the dip-down point is equal to the target installation tension T_i in that point, see Section 5.5 and Appendix C for guidance. The inevitable uncertainty in the assessment of the installation seabed friction requires the introduction of a partial safety factor to account for this, see Section 5.5.

Figure 3 c) and d) illustrate a situation when the anchor is installed under an uplift angle α_i (angle corresponding to final anchor penetration) and an uplift angle α (not necessarily equal to α_i) has been predicted also for the characteristic line tension. In this case Eq. (1) simplifies to

$$R_C = R_i + \Delta R_{cons} + \Delta R_{cy} \quad (3)$$

and T_i in Eq. (2) becomes equal to T_{min} .

The beneficial effect of soil consolidation and cyclic loading on the anchor resistance may be utilized in the design of the fluke anchors, such that the target installation load can be reduced by a factor corresponding to the calculated increase in the anchor resistance due to these two effects.

This effect may be accounted for by proper adjustment (in this case increase) of the undrained shear strength based on experimental data. The effect of repeated cyclic loading through a storm will, however, tend to reduce the shear strength such that the undrained shear strength for use in the anchor-soil interaction analyses should account for both these effects. The most appropriate characteristic strength would then be to use the cyclic shear strength $\tau_{i,cy}$. For normally consolidated and slightly overconsolidated clays cyclic loading will normally lead to a net increase in the undrained shear strength, see detailed discussion of the cyclic loading effect in Appendix E.

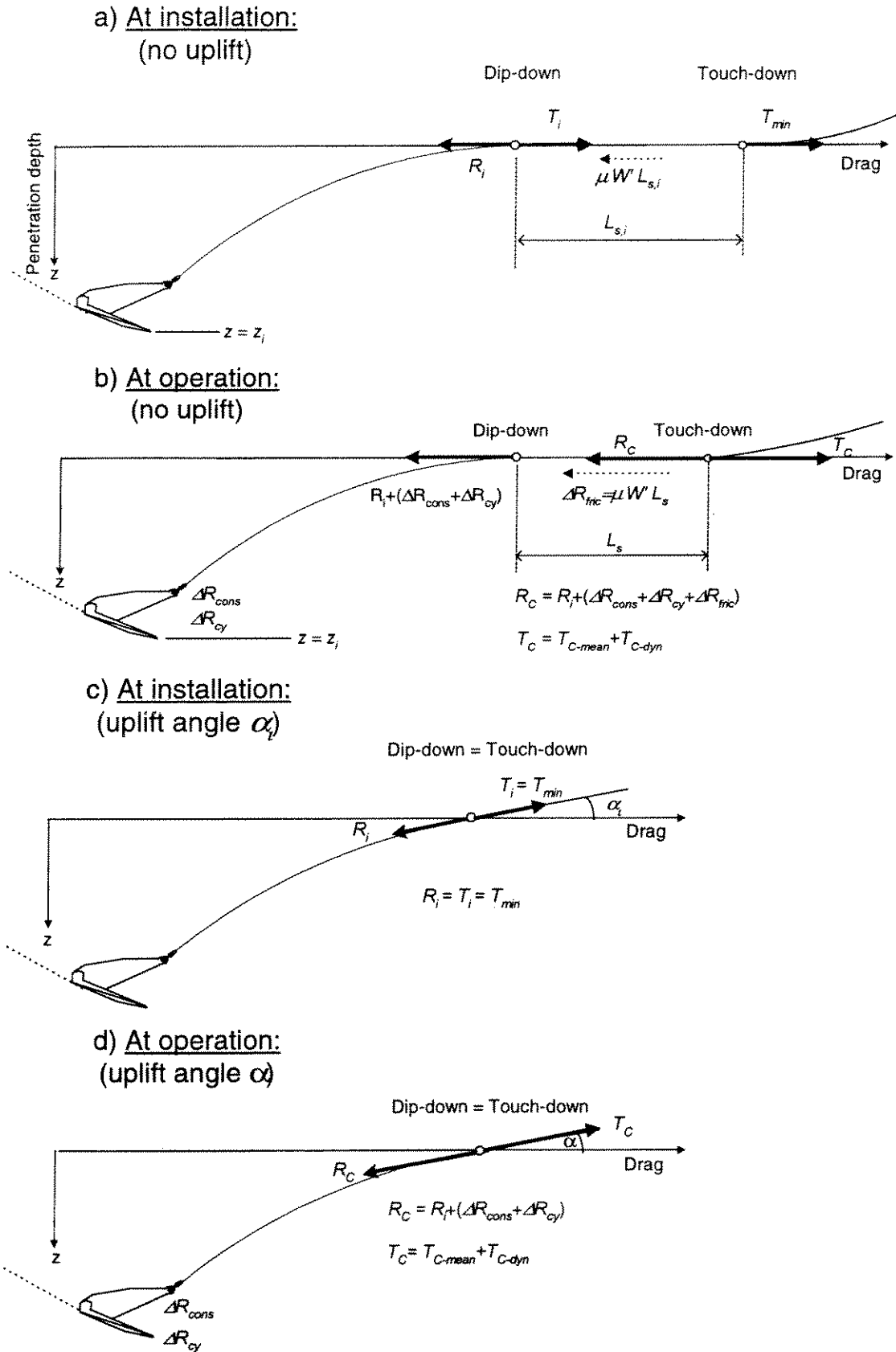

Figure 3 Basic nomenclature.

If the expected depth of anchor penetration is small, e.g. in layered soils as discussed in Appendix B, a conservative approach will be to disregard completely the effect of consolidation. The resistance in the direction of the line tension (break-out) may in these cases be governing for the anchor resistance, and needs to be checked, especially if the overlying soft layer is very weak.

The break-out resistance may also be of concern in the assessment of a safe uplift angle at the seabed, when small anchor penetrations are achieved in layered soils, see more about uplift in Appendix F.

5.3 Step-by-step description of procedure

The following main steps should be followed in the design of fluke anchors in clay without significant layering, see flowchart in Figure 4.

Step-by-step procedure:

- 1) Select mooring pattern.
- 2) Determine the design line tension T_d in the touch-down point, see Eq.(4).
- 3) Choose an anchor
- 4) Compute the penetration path down to the ultimate depth z_{ult} for this anchor, see Chapter 4 and Figure 2 for guidance.
- 5) Compute the design anchor resistance R_d according to Eq. (5) for a number of points along the path, concentrating on the range 50% to 75% of the ultimate depth.
 - Check if the design limit state can be satisfied, i.e. $R_d \geq T_d$, within this range of penetration.
 - Return to Step 1 or to Step 2 and select another mooring pattern and/or anchor if this is not the case.
- 6) Compute the minimum installation load T_{min} according to Eq. (6) for the smallest acceptable depth.
 - Check if T_{min} is feasible with respect to cost and availability of installation equipment.
 - The anchor design is acceptable if T_{min} is feasible.
 - Return to Step 1 or Step 3 and consider a different anchor or mooring pattern, if T_{min} is excessive.
- 7) Estimate the anchor drop point based on the computed drag length for penetration depth $z = z_i$, see Figure 3

Note 1. In case of significant layering reference is made to guidance in Appendix B.

Note 2. The acceptable uplift angle during design loading will be decided from case to case, see guidance in Appendix F.

Note 3. The uplift angle and the position of the touch-down point under design load should be computed by mooring line analysis for the design tension, not for the characteristic tension. Hence, these quantities may vary between the ULS and the ALS.

Note 4. The proposed partial safety factors for design of fluke anchors are tentative until the design rule proposed herein has been calibrated based on reliability analysis.

Note 5. Analytical tools used for prediction of anchor performance during installation and operational conditions should be well documented and validated, see guidance in Section 4.3 and Appendix A.

5.4 Tentative safety requirements.

5.4.1 General

Safety requirements for use together with the recommended procedure for (geotechnical) design of fluke anchors are for temporary use until a formal calibration of the partial safety factors has been carried out.

The safety requirements are based on the limit state method of design, where the anchor is defined as a load bearing structure. For geotechnical design of the anchors this method requires that the following two limit state categories be satisfied by the design:

- the Ultimate Limit State (ULS) for intact system, and
- the Accidental Damage Limit State (ALS) for one-line failure

The design line tension T_d at the touch-down point is the sum of the two calculated characteristic line tension components T_{C-mean} and T_{C-dyn} at that point multiplied by their respective partial safety factors γ_{mean} , γ_{dyn} , i.e.

$$T_d = T_{C-mean} \cdot \gamma_{mean} + T_{C-dyn} \cdot \gamma_{dyn} \quad (4)$$

where

- T_{C-mean} = the characteristic mean line tension due to pretension (T_{pre}) and the effect of mean environmental loads in the environmental state
- T_{C-dyn} = the characteristic dynamic line tension equal to the increase in tension due to oscillatory low-frequency and wave-frequency effects

The characteristic tension components may be computed as suggested in /4/.

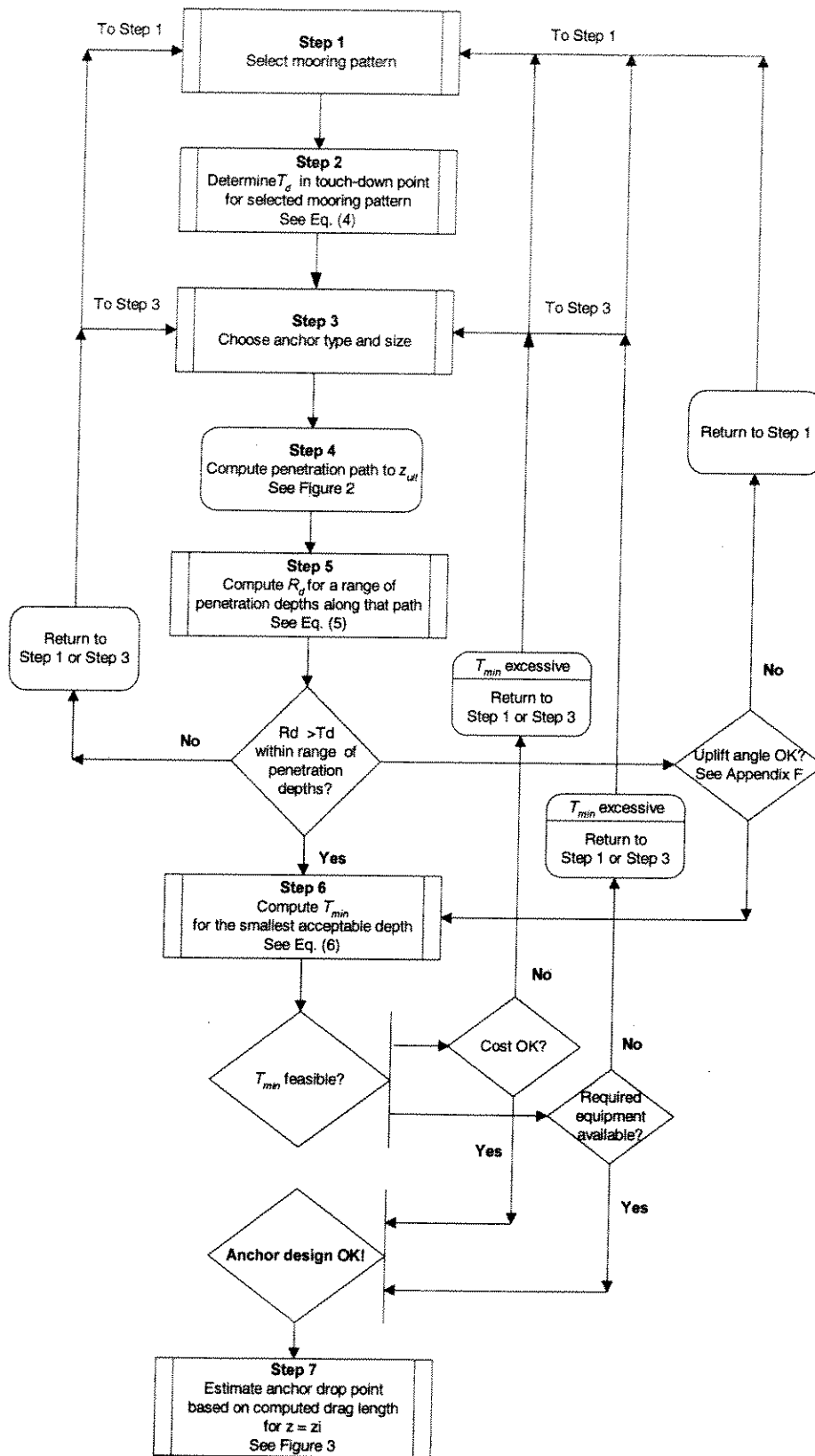

Figure 4 Design procedure - flowchart.

The design anchor resistance (R_d) is defined as

$$R_d = R_i + (\Delta R_{cons} + \Delta R_{cy} + \Delta R_{fric}) / \gamma_m \quad (5)$$

The purpose of the calculations or testing on which the design is to be based, is to maintain the probability of reaching a limit state below a specified value. In the context of designing a mooring system the primary objective with the ULS design is to ensure that the mooring system stays intact, i.e. to guard against having a one-line failure.

The primary function of an anchor, in an offshore mooring system, is to hold the lower end of a mooring line in place, under all environmental conditions. Since extreme environmental conditions give rise to the highest mooring line tensions, the designer must focus attention on these conditions. If the extreme line tension causes the anchor to drag, then the anchor has failed to fulfil its intended function. Limited drag of an anchor need not lead to the complete failure of a mooring system. In fact, it may be a favourable event, leading to a redistribution of line tensions, and reducing the tension in the most heavily loaded line. However, this is not always the case. If the soil conditions show significant differences between anchor locations, then a less heavily loaded anchor may drag first, and lead to an increase in the tension in the most heavily loaded line, which may cause failure in that line. Such a scenario would have to include a design analysis that allows anchors to drag, resulting in a much more complicated analysis, and is not recommended. Instead, the inherent safety margin in the proposed failure event should be taken into consideration when setting the target reliability level. Therefore, the event of inception of drag may be defined as a failure, and is the limit state definition used in the ULS.

Target reliability levels have to be defined as a part of the calibration of the design equations and partial safety factors. These levels will be chosen when more experience is available from a detailed reliability analysis.

For calibration and quantification of the partial safety factors for ULS and ALS design, probabilistic analyses will be necessary. Such studies have been carried out by DNV through the Deepmoor Project with respect to catenary moorings /8/, which work may be extended to taut moorings and synthetic fibre ropes. A pilot reliability analysis of fluke anchors, using the extreme line tension distributions from /8/ as a realistic load input, has been performed for one test case as part of the JIP on deepwater /9/.

Based on the mentioned pilot reliability analysis partial safety factors have been proposed for design of fluke anchors in clay. These safety factors, which are considered to be conservative, may be revised when a formal calibration of the design rule proposed herein has been performed.

5.4.2 Partial Safety Factors for the ULS - intact system

For the ULS case, tentative partial safety factors are suggested in Table 5-1 Partial safety factors for the ULS. The factor γ_m on the predicted contributions to the anchor resistance are intended to ensure no drag of the anchor for the design line tension.

R_i is known with the same confidence as T_i , and the partial safety factor is set equal to 1.0 under the assumption that the installation tension is measured with sufficient accuracy. If it cannot be documented that the installation tension T_{min} has been achieved the partial safety factor on that contribution will have to be set higher than 1.0.

Table 5-1 Partial safety factors for the ULS

Type of analysis	γ_{mean}	γ_{dyn}	γ_m
Dynamic	1.10	1.55	1.30
Quasi-static	1.70	1.70	1.30

The resistance factor γ_m shall account also for the uncertainty in the intact undrained shear strength, as far as it affects the calculation of the mentioned contributions to R_C . It is intended for use in combination with anchor resistance calculated by geotechnical analysis as described in Section 4.3. If the anchor resistance is based on simplified analysis, using design charts as discussed in Section 4.2, then modification of the expression for the design resistance R_d in Eq. (5) and a change in the partial safety factor γ_m may be needed.

5.4.3 Partial Safety Factor for the ALS - one-line failure

The purpose of the accidental damage limit state (ALS) is to ensure that the anchors in the mooring system provide an adequate amount of resistance to avoid subsequent mooring system failure, if one mooring line should initially fail for reasons outside of the designer's control. Such an initial mooring line failure may also be considered to include the possibility of anchor drag for that line.

Subsequent drag of any anchor is conservatively assumed to imply mooring system failure in the ALS. This avoids the complexity of including uncertain anchor drag lengths in the mooring system analysis. Thus, the ALS is formulated to avoid anchor drag, similarly to the ULS. Two consequence classes are considered for the ALS, defined as follows:

Failure is unlikely to lead to unacceptable consequences such as loss of life, collision with an adjacent platform, uncontrolled outflow of oil or gas, capsizing or sinking,

Failure may well lead to unacceptable consequences of these types.

The target reliability level for consequence class 1 should be set to avoid mooring system failure, but without a high level of conservatism, since the consequences are not unacceptable. The target reliability level for consequence class 2 should be higher in view of the consequences. It would seem reasonable to initially adopt the same target levels for the anchors as for the mooring lines. However, moderate anchor drag is usually perceived to be less serious than line failure, and some relaxation of the target levels may be possible.

Detailed analysis of the ALS has not been carried out yet, but some reduction of the resistance factor γ_m applied to the ULS seems appropriate for consequence class 1. The partial safety factors given in Table 5-2 Partial safety factors for the ALS are tentatively suggested when the characteristic anchor resistance is defined as for the ULS, i.e. with the zero drag requirement retained.

Consequence class	Type of analysis	γ_{mean}	γ_{dyn}	γ_m
1	Dynamic	1.0	1.25	1.0
2	Dynamic	1.30	1.80	1.3
1	Quasi-static	1.35	1.35	1.0
2	Quasi-static	1.80	1.80	1.3

Some drag could possibly be permissible in consequence class 2 also, but this would have to be quantified and the resulting offset of the mooring system be checked against the allowable offset of the system. The characteristic resistance would also have to be redefined for an anchor that is dragging. This case is not covered by the present version of this recommended practice.

5.5 Minimum installation tension.

The prescribed minimum installation tension T_{min} , see Figure 3, will to a great extent determine the geotechnical safety of the anchor as installed. In the case of no uplift on the seabed during anchor installation T_{min} may be assessed from Eq. (6) below. The line length on the seabed during installation $L_{s,i}$ may, however, be different from the length L_s assumed in the anchor design calculations, which is accounted for in Eq. (6).

$$T_{min} = T_d + \mu \cdot W_l \cdot L_{s,i} \cdot \gamma_{m,i} - (\Delta R_{cons} + \Delta R_{cy} + \Delta R_{fric}) / \gamma_m \quad (6)$$

The uncertainty in the predicted seabed friction from an installation resistance point of view is treated differently from the design situation:

At the stage of anchor installation the prescribed minimum installation load T_{min} in the touch-down point is intended to ensure that the target installation load T_i in the dip-down point is reached, accounting for the installation seabed friction over the length $L_{s,i}$. Therefore, the predicted seabed friction is multiplied by a partial safety factor $\gamma_{m,i}$. Tentatively this factor is set equal to γ_m for the predicted anchor resistance, i.e. $\gamma_{m,i} = 1.3$

When T_i has been verified by measurements during anchor installation, the anchor installation resistance R_i is known with the same degree of confidence. On this basis the partial safety factor on R_i is set equal to 1.0 as shown in Eq.(5). The other contributions, among them the seabed friction ΔR_{fric} , are predicted and must be divided by a partial safety factor γ_m , as shown in Eq.(5).

The installation anchor resistance R_i in the dip-down point based on the measured installation tension T_{min} , as given by Eq.(6) will then become

$$R_i = T_i = T_{min} - \mu \cdot W_l \cdot L_{s,i} \cdot \gamma_{m,i} \quad (7)$$

If the anchor can be installed with an uplift angle and uplift is allowed for also during design loading, the length of line on the sea bed will be set to zero (i.e. $L_s = L_{s,i} = 0$), which changes Eq. (6) to

$$T_{min} = T_d - (\Delta R_{cons} + \Delta R_{cy}) / \gamma_m \quad (8)$$

In practice, T_{min} will have to be calculated through an iterative process following the step-by-step procedure outlined in Section 5.3. The resulting T_{min} will then be evaluated and compared with the installation tension that can be achieved with the installation scenarios under considerations, see also Appendix C.

Eq. (6) and Eq. (8) assume implicitly that the installation line tension is measured with such an accuracy that the partial safety factor on T_i and thus on R_i can be set equal to 1.0. It is therefore imperative for achieving the intended safety level that adequate means for measuring the installation line tension versus time is available on board the installation vessel.

6. Requirements to Soil Investigation

The planning and execution of soil investigations for design of fluke anchors should follow established and recognized offshore industry practice. As a general guidance to achieve this quality of soil investigation reference is made to the NORSOK standard /5/, which makes extensive references to international standards. Some specific recommendations are given herein for soil investigations for fluke anchors.

For design of fluke anchors the soil investigation should provide information about:

- Seafloor topography and sea bottom features
- Soil stratification and soil classification parameters
- Soil parameters of importance for all significant layers within the depth of interest.

The most important soil parameters for design of fluke anchors in clay are the intact undrained shear strength (s_u), the remoulded undrained shear strength ($s_{u,r}$), the clay sensitivity (S_t), the coefficient of consolidation (c_v), and the cyclic shear strength ($\tau_{f,cy}$) for each layer of significance.

As a minimum, the soil investigation should provide the basis for specification of a representative soil profile and the undrained shear strengths (s_u and $s_{u,r}$) for each significant soil layer between the seabed and the maximum possible depth of anchor penetration. The number of soil borings/in situ tests required to map the soil conditions within the mooring area will be decided from case to case.

The ultimate depth of penetration of fluke anchors in clay varies with the size of the anchor and the undrained shear strength of the clay. It is convenient to account for the size of the anchor by expressing the penetration depth in terms of fluke lengths. In very soft clay the ultimate penetration may be up to 8-10 fluke lengths decreasing to only 1-2 fluke lengths in strong, overconsolidated clays. However, an anchor is never (or seldom) designed for full utilisation of the ultimate anchor resistance R_{ult} , because of the associated large drag distance.

The necessary depth of a soil investigation in a clay without significant layering will be a function of the size of the anchor, the degree of mobilisation of R_{ult} , and the shear strength of the clay. The upper few metres of the soil profile are of particular interest for the critical initial penetration of the anchor, and for assessment of the penetration resistance and the inverse catenary of the embedded part of the anchor line.

General requirements to the soil investigation for fluke anchor foundations, in addition to the recommendations in /10/ are provided in Appendix G.

7. References

- /1/ Dahlberg, R., Eklund, T. and Strøm, P.J. (1996), Project Summary - Part 1, Joint Industry Project on design procedures for deep water anchors, DNV Report No. 96-3673. Høvik.
- /2/ Dahlberg, R., Strøm, P.J., Ronold, K.O., Cramer, E., Mathisen, J., Hørte, T. and Eklund, T. (1998), Project Summary - Part 2, Joint Industry Project on design procedures for deep water anchors, DNV Report No. 98-3591. Høvik.
- /3/ Dahlberg, R. (1998), Design Procedures for Deepwater Anchors in Clay, Offshore Technology Conference, Paper OTC 8837, pp. 559-567. Houston.
- /4/ Egeberg, B., Mathisen, J., Hørte, T. and Lie H. (1998), Modifications to DNV Mooring Code (POSMOOR) and their Consequences, Conference on Offshore Mechanics and Arctic Engineering (OMAE), Paper 1460. Lisbon.
- /5/ DNV Rules for Classification of Mobile Offshore Units (1996), Position Mooring (POSMOOR), Pt.6 Ch.2, January 1996.
- /6/ *API Recommended Practice 2SK (1996), Recommended Practice for Design and Analysis of Stationkeeping Systems for Floating Structures, 2nd Edition, effective from March 1997.*
- /7/ Vivitrat, V., Valent, P.J., and Ponteiro, A.A (1982), The Influence of Chain Friction on Anchor Pile Behaviour, Offshore Technology Conference, Paper OTC 4178. Houston.
- /8/ Hørte, T., Lie, H. and Mathisen, J. (1998), Calibration of an Ultimate Limit State for Mooring Lines, Conference on Offshore Mechanics and Arctic Engineering (OMAE), Paper 1457. Lisbon.
- /9/ Cramer, E.H., Strøm, P.J., Mathisen, J., Ronold, K.O. and Dahlberg, R. (1998), Pilot Reliability Analysis of Fluke Anchors, Joint Industry Project on design procedures for deep water anchors, DNV Report No. 98-3034. Høvik.
- /10/ *NORSOK standard (1996), Common Requirements Marine Soil Investigations, G-CR-001, Rev. 1, dated May 1996.*

A1 General

An analytical tool for fluke anchor design should be able to calculate anchor line catenary in soil as well as the fluke anchor equilibrium itself. Further, the analytical tool should be able to assess the effect of consolidation as being an important design issue in soft clay. The following section describes in brief the principles for such an analytical tool developed by DNV /A-1/.

A2 Anchor line seabed friction

The resistance due to seabed friction ΔR_{fric} in Eq. (1) is expressed as follows:

$$\Delta R_{fric} = f \cdot L_s = \mu \cdot W'_l \cdot L_s \quad (A-1)$$

where

- f = unit friction (also of cohesive nature)
- L_s = line length on seabed for the characteristic line tension T_c
- μ = coefficient of seabed friction
- W'_l = submerged weight of the anchor line per unit length

Guidance Note

Based on the back-fitting analysis of data from measurements on chain segments reported in /A-2/ and estimated values for wire, the following coefficients of seabed friction are recommended for clay¹⁾:

Wire	Lower bound	Default value	Upper bound
μ	0.1	0.2	0.3
Chain	Lower bound	Default value	Upper bound
μ	0.6	0.7	0.8

1) The unit friction f along the embedded part of the anchor line as required for calculation of anchor line contribution to the anchor resistance R_t is given by Eq. (A-5).

--- End of Guidance Note ---

A3 Equilibrium equations of embedded anchor line

The equilibrium of the embedded part of the anchor line can be solved approximately by closed form equations or can be solved numerically by iterations [7]. The normal stress q and the unit soil friction f , which act on an anchor line element in the soil are shown schematically in Figure A-1.

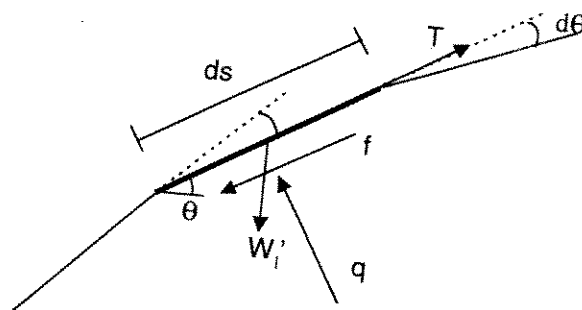

Figure A-1. Soil stresses at an anchor line segment in soil

The loss in line tension dT over one element length ds is calculated from the following formula:

$$\frac{dT}{ds} = -f \cdot AS - W'_l \cdot \sin(\theta) \quad (A-2)$$

where

- T = anchor line tension
- θ = orientation of anchor line element ($\theta = 0$ for a horizontal element)
- AS = effective surface of anchor line per unit length of line
- ds = element length

The angular advance from one anchor line element to the next is then solved by iterations from the following formula:

$$\frac{d\theta}{ds} = \frac{q \cdot AB - W'_l \cdot \cos(\theta)}{T} \quad (A-3)$$

where

- q = normal stress
- AB = effective bearing area of anchor line per unit length of line

Guidance Note

The following default values are suggested for the effective surface area AS and the effective bearing area AB :

Type of forerunner	AS	AB
Chain	$11.3 \cdot d$	$2.5 \cdot d$
Wire or rope	$\pi \cdot d$	d

where

6. Requirements to Soil Investigation

The planning and execution of soil investigations for design of fluke anchors should follow established and recognized offshore industry practice. As a general guidance to achieve this quality of soil investigation reference is made to the NORSOK standard /5/, which makes extensive references to international standards. Some specific recommendations are given herein for soil investigations for fluke anchors.

For design of fluke anchors the soil investigation should provide information about:

- Seafloor topography and sea bottom features
- Soil stratification and soil classification parameters
- Soil parameters of importance for all significant layers within the depth of interest.

The most important soil parameters for design of fluke anchors in clay are the intact undrained shear strength (s_u), the remoulded undrained shear strength ($s_{u,r}$), the clay sensitivity (S_t), the coefficient of consolidation (c_v), and the cyclic shear strength ($\tau_{f,cy}$) for each layer of significance.

As a minimum, the soil investigation should provide the basis for specification of a representative soil profile and the undrained shear strengths (s_u and $s_{u,r}$) for each significant soil layer between the seabed and the maximum possible depth of anchor penetration. The number of soil borings/in situ tests required to map the soil conditions within the mooring area will be decided from case to case.

The ultimate depth of penetration of fluke anchors in clay varies with the size of the anchor and the undrained shear strength of the clay. It is convenient to account for the size of the anchor by expressing the penetration depth in terms of fluke lengths. In very soft clay the ultimate penetration may be up to 8-10 fluke lengths decreasing to only 1-2 fluke lengths in strong, overconsolidated clays. However, an anchor is never (or seldom) designed for full utilisation of the ultimate anchor resistance R_{ult} , because of the associated large drag distance.

The necessary depth of a soil investigation in a clay without significant layering will be a function of the size of the anchor, the degree of mobilisation of R_{ult} , and the shear strength of the clay. The upper few metres of the soil profile are of particular interest for the critical initial penetration of the anchor, and for assessment of the penetration resistance and the inverse catenary of the embedded part of the anchor line.

General requirements to the soil investigation for fluke anchor foundations, in addition to the recommendations in /10/ are provided in Appendix G.

7. References

- /1/ Dahlberg, R., Eklund, T. and Strøm, P.J. (1996), Project Summary - Part 1, Joint Industry Project on design procedures for deep water anchors, DNV Report No. 96-3673. Høvik.
- /2/ Dahlberg, R., Strøm, P.J., Ronold, K.O., Cramer, E., Mathisen, J., Hørte, T. and Eklund, T. (1998), Project Summary - Part 2, Joint Industry Project on design procedures for deep water anchors, DNV Report No. 98-3591. Høvik.
- /3/ Dahlberg, R. (1998), Design Procedures for Deepwater Anchors in Clay, Offshore Technology Conference, Paper OTC 8837, pp. 559-567. Houston.
- /4/ Egeberg, B., Mathisen, J., Hørte, T. and Lie H. (1998), Modifications to DNV Mooring Code (POSMOOR) and their Consequences, Conference on Offshore Mechanics and Arctic Engineering (OMAE), Paper 1460. Lisbon.
- /5/ DNV Rules for Classification of Mobile Offshore Units (1996), Position Mooring (POSMOOR), Pt.6 Ch.2, January 1996.
- /6/ *API Recommended Practice 2SK (1996), Recommended Practice for Design and Analysis of Stationkeeping Systems for Floating Structures, 2nd Edition, effective from March 1997.*
- /7/ Vivitrat, V., Valent, P.J., and Ponteiro, A.A (1982), The Influence of Chain Friction on Anchor Pile Behaviour, Offshore Technology Conference, Paper OTC 4178. Houston.
- /8/ Hørte, T., Lie, H. and Mathisen, J. (1998), Calibration of an Ultimate Limit State for Mooring Lines, Conference on Offshore Mechanics and Arctic Engineering (OMAE), Paper 1457. Lisbon.
- /9/ Cramer, E.H., Strøm, P.J., Mathisen, J., Ronold, K.O. and Dahlberg, R. (1998), Pilot Reliability Analysis of Fluke Anchors, Joint Industry Project on design procedures for deep water anchors, DNV Report No. 98-3034. Høvik.
- /10/ *NORSOK standard (1996), Common Requirements Marine Soil Investigations, G-CR-001, Rev. 1, dated May 1996.*

Appendix A: Analysis tool for fluke anchor design

A1 General

An analytical tool for fluke anchor design should be able to calculate anchor line catenary in soil as well as the fluke anchor equilibrium itself. Further, the analytical tool should be able to assess the effect of consolidation as being an important design issue in soft clay. The following section describes in brief the principles for such an analytical tool developed by DNV /A-1/.

A2 Anchor line seabed friction

The resistance due to seabed friction ΔR_{fric} in Eq. (1) is expressed as follows:

$$\Delta R_{fric} = f \cdot L_s = \mu \cdot W_l' \cdot L_s \quad (A-1)$$

where

- f = unit friction (also of cohesive nature)
- L_s = line length on seabed for the characteristic line tension T_C
- μ = coefficient of seabed friction
- W_l' = submerged weight of the anchor line per unit length

Guidance Note

Based on the back-fitting analysis of data from measurements on chain segments reported in /A-2/ and estimated values for wire, the following coefficients of seabed friction are recommended for clay¹⁾:

Table A-1 Coefficient of seabed friction			
Wire	Lower bound	Default value	Upper bound
μ	0.1	0.2	0.3
Chain	Lower bound	Default value	Upper bound
μ	0.6	0.7	0.8

1) The unit friction f along the embedded part of the anchor line as required for calculation of anchor line contribution to the anchor resistance R_i is given by Eq. (A-5).

--- End of Guidance Note ---

2)

A3 Equilibrium equations of embedded anchor line

The equilibrium of the embedded part of the anchor line can be solved approximately by closed form equations or exactly in any soil strength profiles by iterations ///. The normal stress q and the unit soil friction f , which act on an anchor line element in the soil are shown schematically in Figure A-1.

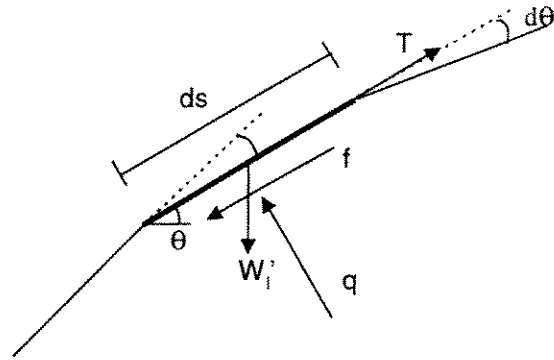

Figure A-1. Soil stresses at an anchor line segment in soil

The loss in line tension dT over one element length ds is calculated from the following formula:

$$\frac{dT}{ds} = -f \cdot AS - W_l' \cdot \sin(\theta) \quad (A-2)$$

where

- T = anchor line tension
- θ = orientation of anchor line element ($\theta = 0$ for a horizontal element)
- AS = effective surface of anchor line per unit length of line
- ds = element length

The angular advance from one anchor line element to the next is then solved by iterations from the following formula:

$$\frac{d\theta}{ds} = \frac{q \cdot AB - W_l' \cdot \cos(\theta)}{T} \quad (A-3)$$

where

- q = normal stress
- AB = effective bearing area of anchor line per unit length of line

Guidance Note

The following default values are suggested for the effective surface area AS and the effective bearing area AB :

Table A-2 Effective surface and bearing area		
Type of forerunner	AS	AB
Chain	$11.3 \cdot d$	$2.5 \cdot d$
Wire or rope	$\pi \cdot d$	d

where

d = nominal diameter of the chain and actual diameter of the wire or rope.

--- End of Guidance Note ---

The normal stress q on the anchor line is calculated from the following equation:

$$q = N_c \cdot s_u \quad (\text{A-4})$$

where

N_c = bearing capacity factor

s_u = undrained shear strength (direct simple shear strength s_{uD} is recommended)

Effect of embedment on the bearing capacity factor should be included.

Guidance Note

Based on the back-fitting analysis reported in /A-2/, the following bearing capacity factors are recommended for the embedded part of the anchor line in clay¹⁾:

Wire / Chain	Lower bound	Default value	Upper bound
N_c	9	11.5	14

¹⁾ See Guidance Note above for values of the effective bearing area AB , which is a pre-requisite for use of the bearing capacity factors given here.

--- End of Guidance Note ---

The unit friction f along the anchor line can be calculated from the following formula:

$$f = \alpha_{soil} \cdot s_u \quad (\text{A-5})$$

where

α_{soil} = adhesion factor for anchor line

Guidance Note

Based on the back-fitting analysis of data from measurements on chain segments reported in /A-2/, and estimated values for wire, the following coefficients of seabed friction are recommended for the embedded part of the anchor line clay¹⁾:

Wire	Lower bound	Default value	Upper bound
α_{soil}	0.2	0.3	0.4
Chain	Lower bound	Default value	Upper bound
α_{soil}	0.4	0.5	0.6

¹⁾ See Guidance Note above for values of the effective surface area AS , which is a pre-requisite for use of the adhesion factor given here

--- End of Guidance Note ---

A4 Equilibrium equations for fluke anchor

Moment equilibrium and force equilibrium can be solved for the fluke anchor for two different failure modes. One mode leading to further anchor penetration in a direction close to the fluke penetration direction, and a second mode leading to reduced or no further penetration. In principle, the soil resistance contributions are the same for the two failure modes, but in the first failure mode the soil resistance normal to the fluke may not take on the ultimate value. Using the symbols shown in Figure A-2 the necessary equilibrium equations are defined and explained in the following.

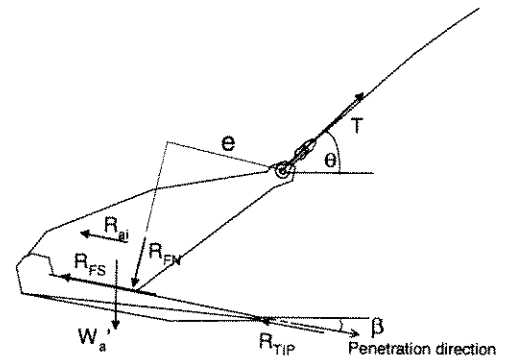

Figure A-2. Principal soil reaction forces on a fluke (anchor penetration direction coincides with fluke penetration direction).

For the range of possible penetration directions, the horizontal and vertical equilibrium should satisfy the following equations:

Horizontal equilibrium:

$$T \cdot \cos(\theta) = \sum_{i=1}^N R_{ai} \cdot \cos(\beta) + R_{FS} \cdot \cos(\beta) + R_{TIP} \cdot \cos(\beta) + R_{FN} \cdot \sin(\beta) \quad (\text{A-6})$$

Vertical equilibrium

$$T \cdot \sin(\theta) = R_{FN} \cdot \cos(\beta) + W_a' - \left(\sum_{i=1}^N R_{ai} \cdot \sin(\beta) + R_{FS} \cdot \sin(\beta) + R_{TIP} \cdot \sin(\beta) \right) \quad (\text{A-7})$$

where

T, θ = tension and corresponding orientation of anchor line at the shackle

R_{FN} = soil normal resistance at the fluke

R_{FS} = soil sliding resistance at the fluke

R_{TIP} = tip resistance at the fluke

R_{ai} = soil resistance at the remaining components of the anchor (separated through anchor geometry)

W_a' = submerged anchor weight

β = penetration direction of fluke

The normal resistance will be the normal stress times the bearing area of the anchor part being considered, and may need to be decomposed in the three orthogonal directions defined (one vertical and two horizontal). The normal stress can be calculated from the following formula:

$$q = N_c \cdot s_u \quad (\text{A-8})$$

where

N_c = bearing capacity factor

Sliding resistance will be the unit friction times the adhesion area of the anchor part being considered. The unit friction f along the anchor part can be calculated from the following formula:

$$f = \alpha \cdot s_u \quad (\text{A-9})$$

where

α = adhesion factor for anchor

The bearing and adhesion areas should in this case be modelled with due consideration of the actual geometry of the anchor.

Guidance Note

Based on the back-fitting analysis reported in /A-2/ the following values are tentatively recommended for the resistance towards the various anchor members in clay:

Bearing capacity factor ¹⁾ (N_c) for:		Adhesion factor (α) for:		
R_{FN}	R_{ai}	R_{TTP}	R_{TTP}	R_{FS}
12.5 ²⁾	12.5	12.5	1 / S_t	1 / S_t

¹⁾ Effect of shape, orientation and embedment of the various resistance members on the anchor should be included as relevant.

²⁾ Actual degree of mobilisation of this value as required to satisfy moment equilibrium.

--- End of Guidance Note ---

Due consideration should be given to the difference in adhesion for continuous penetration and inception of anchor drag (failure event). For the latter, an adhesion factor compatible with time available for consolidation should be assessed, see Appendix D.

Horizontal and vertical equilibrium for a certain fluke penetration direction can now be achieved for a number of fluke orientations and line tensions at the shackle. In order to determine the correct penetration direction and the corresponding line tension, moment equilibrium must be satisfied (here taken with respect to the shackle point):

$$\sum_{i=1}^N Rm_{ai} + Rm_{FS} + Rm_{TTP} - (Wm + R_{FN} \cdot e) = 0 \quad (\text{A-10})$$

where

Rm_{FS} = moment contribution from soil sliding resistance at the fluke e

Rm_{TTP} = moment contribution from tip resistance at the fluke

Wm = moment contribution from anchor weight

R_{FN} = soil normal resistance at the fluke

e = lever arm between shackle and the line of action of the normal resistance at the fluke

Rm_{ai} = moment contribution from soil resistance at the remaining components of the anchor (separated through anchor geometry)

When the anchor penetrates in the same direction as the fluke, any possible lever arm (e) and normal resistance that can be replaced by a realistic stress distribution at the fluke should be considered. When the anchor penetrates in another direction than the fluke, the centre of normal resistance on the fluke should act in the centre of the fluke area.

DNV has developed a computer programme for analysis and design of fluke anchors as part of the joint industry project on deepwater anchors /1/. This programme has been calibrated based on a number of back-fitting analyses of high quality anchor tests /A-2/. Through an iteration process the measured and predicted anchor behaviour is gradually improved until a satisfactory match is found. When several solutions are found, the one giving the lowest tension is selected.

Based on these calibrations the following tentative guidance is given for assessment of the contribution from sliding resistance to the total anchor resistance under the assumption that the soil sensitivity is known for the actual clay profile.

A5 References

- /A-1/ Eklund T and Strøm, P.J. (1998), *DIGIN Users's Manual ver. 5.3*, DNV Report No. 96-3637, Rev. 03, dated 20 April 1998. Høvik
- /A-2/ Eklund T and Strøm, P.J. (1998), *Back-fitting Analysis of Fluke Anchor Tests in Clay*, DNV Report No. 96-3385, Rev. 03, dated 16 September 1997. Høvik

Appendix B: Anchors in layered clay

B1 General

The general anchor behaviour addressed in Chapter 0 and Figure 2 is for fluke anchors in clay without significant layering. Guidance for assessment of the penetration ability of fluke anchors in layered clay is given in the following. Layering is understood herein as a soil layer sequence comprising a soft layer overlain and/or underlain by a relatively stiffer clay (or sand) layer.

Experience has shown that a fluke anchor will often penetrate through a surface layer of sand or relatively stiffer clay into an underlying softer clay layer, provided that the thickness of this surface layer is less than 30 to 50 % of the fluke length of the actual anchor. Although this cannot be taken as a guarantee, it can be used as guidance when various anchor alternatives are being evaluated. The prevailing soil conditions and possible past experience with fluke anchor installation in the actual area should be evaluated before the choice of anchor is made.

In a soft-stiff layer sequence the ability of an anchor to pick up the resistance of the underlying stiffer layer depends on the difference in soil strength between the two layers, the depth to the stiffer layer and the angle of the fluke plane when it meets the stiffer layer. If this 'attack' angle is too small the anchor will drag on top of the stiff layer at constant load. If it is too large the anchor may rotate and break out of the soil rather than continue along the initial penetration path. In both these cases the target installation load will not be reached. Changing the fluke angle or choosing another type and/or size of anchor may improve the situation.

A stiff-soft-stiff layer sequence involves the extra complication that penetration through the upper stiff layer may require a smaller fluke angle than desirable for penetration through the locked-in soft layer down to and into the second stiff layer. Again, the anchor should meet the deeper stiff layer at an angle, which ensures a grip and penetration also into that layer. If the thickness of the two first layers is such that the anchor approaches the deeper layer at an angle, which is too small, the anchor will just drag along the surface of that layer. This may be visualised by the fact that the drag becomes excessive, or non-tolerable, and the target installation load is never reached. In most cases, predictions may show that the penetration path improves in that respect, and becomes steeper for a given depth and a given fluke angle, if the anchor is increased in size. It may also be possible to find more optimal, non-standard, combinations between anchor size and fluke angle, which account both for the overlying and the underlying stiff layer.

From the above it is evident that layer thickness, depth to boundaries between layers, and soil strength need to be documented for proper design of a fluke anchor foundation and to avoid unexpected behaviour of the anchor during the installation phase, see Chapter 6 and Appendix G for requirements to soil investigation.

Appendix C: Installation and testing of fluke anchors

C1 General

Fluke anchor design is by tradition empirical as illustrated by the design charts published by the American Petroleum Institute /6/. The anchor tests being the basis for such design charts are of variable quality, and typically there are gaps in the test data, which makes it difficult to fully understand and rely on the test results. All reasonable efforts should therefore be made to ensure that the measurements are reliable and include the most crucial test data for maximum usefulness of the results and improvement of the database. This should be fully appreciated when installing both test anchors and prototype anchors.

C2 Minimum installation tension

The anchor installation should follow procedures, which have been presented and agreed to by all parties well ahead of the installation. By prescribing a minimum installation tension T_{min} , see Section 5, the intention is to ensure that the design assumptions are fulfilled during anchor installation. In other words, if the anchor is installed to T_{min} the design anchor resistance R_d has implicitly also been verified. This tension level should be held for a specified holding period, which period may be soil dependent. Any relaxation (drag) during this period should be compensated for, such that the required line tension is maintained as constant as possible. The anchor installation and testing log should document the events and the measurements taken from start to end of the installation.

C3 Monitoring of fluke anchor installations

C3.1 General

When installation of prototype, or test anchors, is being planned it is essential that the most essential boundary conditions for the installation be taken into consideration. Well ahead of the installation such background information should be compiled and documented.

If practical (e.g. if ROV assistance is available during anchor installation) it is recommended to check the position and orientation of the anchor, as well as the alignment, straightness and length on the seabed of the as laid anchor line, before start of tensioning. Significant misalignment of the installation anchor line will require extra line tension to reach the specified target installation tension T_t , which has to be estimated and accounted for.

During the anchor installation a number of parameters need to be measured to serve as a documentation of the installation. The more information that is recorded beyond the minimum documentation requirements, the more useful the installation data will become in the end.

Monitoring of the anchor installation should, as a minimum, provide data on

- line tension
- line (pitch) angle at the stern roller
- anchor drag

These items should be measured as a function of time from start to end of the installation using the clock on the PC as a reference time. A calibrated transducer, being a segment of the installation line, should preferably be used to measure the line tension.

If manual measurements are taken intermittently, see checklist below, they should be stored into the PC log at the time of the event.

The final installation measurements should at least document that the minimum installation tension T_{min} has been achieved and maintained during the specified holding time.

The checklist below indicates the type of information that should be focussed on before and during the installation and testing of fluke anchors. This checklist can be used as a guidance both for installation of both prototype and test anchors.

C3.2 Checklist

1) Before the installation.

- a) Assessment of the most likely soil stratigraphy at the anchor location and the soil strength of significant layers (from soil investigation report), see Chapter 6 for guidance.
- b) Specification of the anchor and the installation line configuration.
- c) Specification of the fluke angle(s) to be used, and how this angle is defined, see Section 2 and Figure 1 for guidance.
- d) Estimate of friction resistance at the stern roller.
- e) Equipment and procedures for anchor installation, e.g. type and tensioning system of the vessel, method of laying and tensioning the anchors, availability of ROV, etc.
- f) Type of measurements to be undertaken, and procedures to be applied, from check list below.

2) During the installation.

- a) Line tension (horizontal component measured at deck level)¹
- b) Drag (method of measurement, reference point)
- c) Penetration depth (method of measurement, at least the final depth)
- d) Line angle with the horizontal outside the stern roller (at least for the final line tension)
- e) Pull-in speed (vessel speed, drag and line angle at stern roller versus time)

3) Final installation measurements

- a) Maintaining T_{min} (during specified holding time $t_{hold} = 15$ to 30 minutes)
- b) Measure tension vs time during holding time (mean tension $\geq T_{min}$)
- c) Drag (corresponding to final penetration depth)
- d) Penetration depth (best estimate of final depth)

The database for fluke anchors loaded to their ultimate resistance R_{ult} is unfortunately limited to rather small anchors. The largest anchors tested in connection with offshore projects have normally not reached the R_{ult} , but for the future it would be fruitful for the industry if the most significant parameters (line tension, drag and final penetration depth) are recorded during all installations, at least in a few locations out of many.

In this connection it is important that all reasonable efforts are made to make the recorded data as reliable as possible, since the assessment of the safety of the anchoring system depends on such installation data.

C4 Anchor installation vessels

The bollard pull of the most powerful new generation anchor handling vessels is in the range 2 to 2.5 MN. Depending on the required minimum installation tension T_{min} at the touch-down point, one or two AHV's may be required. As an alternative to using AHV's the anchor tensioning can be done from a special tensioning vessel/barge or from the floater itself. If two opposite anchors are tensioned simultaneously line tensions up to 5 to 6 MN or even 10 MN can be reached.

The chosen scenario for anchor installation shall ensure that the specified minimum installation tension T_{min} can be reached. The bollard pull, winch capacity and minimum breaking load (MBL) of the installation wire on the actual vessel(s) will have to be assessed on this basis. If T_{min} cannot be reached due to pulling limitations set by the vessel(s), the design anchor resistance R_d according to Eq.(5), and thus the intended safety level of the anchors, will not be achieved.

It is essential that all parties involved in the decisions related to the anchor design appreciate the relationship between anchor resistance and installation tension. In deep waters, unless lightweight anchor lines are used, the weight and sea bed friction of the anchor lines limits the net line tension that can be used for anchor penetration, which must be considered when the requirements for the installation vessel are specified.

¹ It is recommended to measure the installation tension by means of a calibrated load cell linked to a PC.

Appendix D: Effect of consolidation

D1 General

During continuous penetration of the anchor, the friction resistance will be governed by the remoulded shear strength, $s_{u,r}$, in a narrow zone close to the anchor. In an analytical model this may be accounted for through the adhesion factor, α , which will depend on the soil sensitivity, S_t , i.e. the ratio between the intact (in situ) undrained shear strength, s_u , and $s_{u,r}$.

$$S_t = s_u / s_{u,r} \quad (D-1)$$

The minimum α -value is tentatively set equal to the inverse of the sensitivity, i.e.

$$\alpha_{min} = 1 / S_t \quad (D-2)$$

After an anchor has been installed to a certain installation tension (and depth), the remoulded soil will gradually reconsolidate and regain its intact shear strength. As a result the resistance against further penetration will increase. This effect is in the literature referred to as soaking, set-up or consolidation of the anchor and the anchor line.

D2 Assessment of the effect of consolidation

The effect of soil consolidation is that the installation anchor resistance R_i will increase as a function of the time elapsed since installation t_{cons} to a maximum value, which depends on the soil sensitivity S_t . For a particular anchor and depth of penetration this increase may be described through the consolidation factor U_{cons} , i.e.

$$U_{cons} = f(t_{cons}, S_t, \text{ and geometry, depth and orientation of the anchor}) \quad (D-3)$$

From a geotechnical point of view there should be no major difference between fluke anchors and e.g. piles or the skirts of a gravity base structure, when the effects of installation and subsequent reconsolidation on the clay undrained shear strength are considered. The consolidated resistance R_{cons} is the installation resistance with superimposed consolidation effect as shown in Eq. (D-4).

$$R_{cons} = R_i \cdot U_{cons} = R_i (1 + \Delta R_{cons} / R_i) \quad (D-4)$$

The degree of consolidation that can be applied to the frictional part of the resistance can be assessed by looking at the drainage characteristics in a zone adjacent to the anchor, which is influenced (remoulded) due to the anchor penetration. The length of this zone depends on the anchor geometry and the actual soil characteristics. Guidance for modelling and calculation of the consolidation effect can be obtained using the experience from e.g. tests on piles.

The consolidation factor U_{cons} related to the total anchor resistance will be much smaller than reflected by the sensitivity of the clay, since the frictional resistance only contributes to part of the total resistance. The relation between the consolidation factor U_{cons} and the increase in the frictional resistance depends on the geometry of the anchor, and its final depth of penetration into the soil during the installation phase. A reliable quantification of this effect can only be obtained by site-specific relevant full-scale tests or by adequate analytical tools. The analytical tools should be able to predict both the penetration part and the subsequent consolidated condition. It is essential that the analytical tool accounts for full force and moment equilibrium that is compatible with the failure modes in question, see Appendix A.

Caution is recommended in the assessment of the possible consolidation effect when the likely failure mode, following upon such consolidation, may either reduce or prevent further penetration. Overloading will in this case initiate anchor movement in the direction of the line tension, before the full effect from consolidation is utilised. When such movement has been initiated, the soil closer to the flukes will lose the effect from consolidation, and the anchor will continue to drag in remoulded soil conditions. This can in particular be expected close to the seabed, where the resistance in the direction of the line tension is limited, but may also be relevant at larger depths, if the anchor has penetrated with a very large fluke angle, or in layered soil if the fluke tip has penetrated partly into a stiffer layer underlying a soft layer.

In practice, the consolidation factor U_{cons} must be assessed on a case by case basis.

Guidance Note

Range of values for U_{cons} vs. typical soil sensitivity S_t

Soil sensitivity, S_t	Consolidation factor, U_{cons}		
	Lower bound	Default value	Upper bound
2	1.25	1.30	1.35
2.5	1.35	1.45	1.55

--- End of Guidance Note ---

Appendix E: Effect of cyclic loading

E1 Background

In order to understand how cyclic loading may affect the resistance of fluke anchors a parallel may be drawn between piles and fluke anchors. Important work on the effect of loading rate on axial pile capacity has been published by Bea and Audibert /E-1/, followed by Kraft et al /E-2/, and later by Briaud and Garland /E-3/. Fundamental work on the effects of cyclic loading on the undrained shear strength of clay and the cyclic response of gravity base foundations has been published by Andersen and Lauritzen /E-4/.

Cyclic loading affects the static undrained shear strength (s_u) in two ways:

During a storm, the rise time from mean to peak load may be about 3 - 5 seconds (1/4 of a wave frequency load cycle), as compared to 0.5 to 2 hours in a static consolidated undrained triaxial test, and this higher loading rate leads to an increase in the undrained shear strength

As a result of repeated cyclic loading during a storm, the undrained shear strength will decrease, the degradation effect increasing with the overconsolidation ratio (OCR) of the clay.

The following relationship is suggested in /E-3/ for description of the effect of the loading rate, v , on pile capacity, Q

$$(Q_1/Q_2) = (v_1/v_2)^n \quad (\text{E-1})$$

where Q_1 and Q_2 represent the pile capacity at loading rates v_1 and v_2 , respectively.

E2 Application to fluke anchor design

The rate of loading experienced by the anchor (and the clay surrounding the anchor) is normally higher during wave loading than during anchor installation, and the anchor resistance increases relative to the increase in rate of loading. Using the experience from pile testing as expressed by Eq. (E-1) a loading rate factor U_r may be introduced, which expresses the loading rate effect on the anchor resistance, i.e.

$$U_r = (v_1/v_2)^n \quad (\text{E-2})$$

One practical problem with Eq. (E-2) is to determine representative values for the loading rates v_1 and v_2 . Another problem is to assess the value of exponent n in the equation for U_r . In addition, Eq. (E-2) does not account for the strength degradation due to cyclic loading.

The most direct, and preferred, approach to account for both the loading rate effect and the cyclic degradation effect is to determine the cyclic shear strength $\tau_{t,cy}$ of the clay, following the strain accumulation procedure described in

The strain accumulation method utilises so-called strain-contour diagrammes to describe the response of clay to various types, intensities and duration of cyclic loading:

Given a clay specimen with a certain s_u and OCR, which is subjected to a load history defined in terms of a sea state and a storm duration, the intensity of that storm is gradually increased until calculations according to the strain accumulation method show that the soil fails in cyclic loading.

In a catenary mooring system the loads transmitted to the anchors through the anchor lines will always be in tension (one-way), which has a less degrading effect on the shear strength than two-way cyclic loading (stress reversal). The failure criterion for one-way cyclic loading is development of excessive accumulated permanent strains. The maximum shear stress the soil can sustain at that state of failure is equal to the cyclic shear strength $\tau_{t,cy}$.

The load history for use in the calculations should account for the combination of wave-frequency load cycles superimposed on low-frequency, slowly varying, load cycles, particularly the amplitude of cyclic loads relative to the average (or mean) load level.

If cyclic soil data, applicable for the actual site, are available, the cyclic strength $\tau_{t,cy}$ may be determined according to the procedure outlined in /E-4/. The cyclic strength $\tau_{t,cy}$ as defined in /E-4/ incorporates effects of both loading rate and cyclic degradation, provided that the cyclic load period is representative for the variation in line tension with time at the anchoring point. This would lead to a combined loading rate and cyclic degradation factor, or simply a cyclic loading factor U_{cy} as shown in Eq. (E-3) below.

$$U_{cy} = \tau_{t,cy}/s_u = f [t_{su}/t_{cy}, \text{ soil data, load history, etc}] \quad (\text{E-3})$$

where

$\tau_{t,cy}$	=	cyclic shear strength with time to failure
t_{cy}	=	(1/4)·(load period)
s_u	=	static undrained shear strength with time to failure
t_{su}	=	1 hour

If a fluke anchor has been subjected to consolidation for a certain period of time after the installation took place the reference anchor resistance for assessment of the cyclic loading effects will be the consolidated anchor resistance R_{cons} in Eq. (D-4). This leads to the following expression for the cyclic anchor resistance R_{cy} .

$$R_{cy} = (R_i \cdot U_{cons}) \cdot U_{cy} = R_i + \Delta R_{cons} + \Delta R_{cy} \quad (E-4)$$

The expression for U_{cy} then becomes:

$$U_{cy} = (1 + \Delta R_{cy} / R_{cons}) \quad (E-5)$$

If no relevant cyclic soil data exist for the site, and experience from better documented sites with similar soil conditions cannot be drawn upon, a conservative assessment of $\tau_{f,cy}$ may be made based on Eq. (E-2) corrected for the effect of cyclic strength degradation. In order to account for the possible strength degradation due to one-way cyclic loading, the net effect of loading rate ($U_r - 1$) should therefore be multiplied by a cyclic degradation factor k_c . The expression for U_{cy} is then changes to:

$$U_{cy} = 1 + k_c \cdot (U_r - 1) = 1 + k_c \cdot \{(v_1/v_2)^n - 1\} \quad (E-6)$$

k_c is a function of the line tension load history through a storm and the characteristics of the clay. The load history varies with water depth, type of rig and mooring line configuration. Therefore the value of k_c should be assessed from case to case.

Guidance for assessment of both the loading rate factor U_r and the cyclic loading factor U_{cy} can be found in the published information about cyclic behaviour of clay, e.g. tests on Drammen clay in /E-4/, on Troll clay /E-5/ and on Marlin clay in /E-6/. It is noted based on the test results presented for the Marlin clay that carbonate content may significantly affect the cyclic response of clay. Caution is therefore warranted in the use of experience from testing of non-carbonate clay, if the actual clay contains more than 10 % carbonate.

Guidance Note

Basis for an approximate assessment of the effect of cyclic loading is provided in the following.

Loading rate factor U_r

As outlined above the effect of cyclic loading is two-fold, the loading rate effect and the cyclic degradation effect. In a cyclic laboratory test on clay the cycle period is often set to 10 seconds, which means that the load rise time t_{cy} from mean level to the first peak load is 2.5 seconds ($= t_{cy}$). If the cycle amplitude is high enough to fail the clay specimen during that first quarter of the first load cycle ($N_{eqv} = 1$), the corresponding cyclic strength $\tau_{f,cy}$ of the clay divided by the static undrained shear strength $s_{u,D}$ is a measure of the loading rate factor U_r for the actual clay, i.e.

$$U_r = \tau_{f,cy} / s_{u,D} \quad (\text{for } N_{eqv} = 1).$$

Figure E-1 presents excerpts of published results from cyclic direct simple shear tests on the Drammen clay /E-4/, on the Troll clay /E-5/ and on the Marlin clay /E-6/. Figure E-1a) shows the loading rate factor U_r as a function of the average shear stress level $\tau_a / s_{u,D}$ during the test. It is worth noting that the loading rate effect is most pronounced for $\tau_a / s_{u,D}$ in the range 0.5 to 0.7, and that for higher shear stress levels the effect reduces at an accelerating rate, particularly for the carbonate type Marlin clay (Unit IIb), which has a carbonate content of 15 - 20 % according to /E-6/.

Based on the mooring analysis it will be possible to define the mean, low-frequency and wave-frequency components of the characteristic line tension, such that a basis is obtained for assessment of a likely range for the parameter $\square_a / s_{u,D}$. Typically the line tension in a catenary mooring system may generate an average shear stress level $\tau_a / s_{u,D}$ in the range 0.6 to 0.8. For this range $U_r = 1.4 - 1.75$ for four of the examples shown in Figure E-1a), but may be as low as 1.2 (or lower) as indicated by the curve for the Marlin carbonate clay.

Cyclic loading factor U_{cy}

Following the strain accumulation procedure as described in detail in /E-4/, and briefly summarised in this Appendix, the cyclic test data may be used for prediction of the cyclic loading factor U_{cy} .

In Figure E-1b) and c) the U_{cy} -factor is plotted for $N_{eqv} = 3$ and $N_{eqv} = 10$. In the latter case this means that if the calculations leads to failure in cyclic loading for a given cyclic load history the same effect will be achieved if 10 cycles of the extreme load amplitude in the same load history is applied to the clay. Experience has shown that the cyclic shear strength will often be found for $N_{eqv} = 5 - 10$, but unless site specific tests have been performed it is recommended to make conservative assumptions about the cyclic loading effect. By conservative is meant that the strength and plasticity properties of the clay should be evaluated and compared with the data base, that the stress history of the soil profile is assessed, that possible carbonate content is accounted for, etc. When looking at range of U_r and U_{cy} reported for the different clays in Figure E-1 it is evident that experience from testing of one clay will not necessarily be representative of the behaviour of another clay in another geological environment. Unless a site specific cyclic testing programme has been designed and executed, the empirical data like those shown in the figure and elsewhere in the literature should therefore be used with caution. As a further background for the results shown in Figure E-1 Table E-3 gives some characteristics of the tested clay.

Other effects

The cyclic laboratory tests behind Figure E-1 were carried out on normally consolidated clay ($OCR = 1-1.5$), but the effect of OCR on the cyclic behaviour for so-called one-way cyclic loading (no shear stress reversal), which is a relevant assumption when mooring line tension is considered, is moderate. Typically U_r and U_{cy} will be reduced by up to 5 % when OCR increases from 1 to 4, by up to 15 % when OCR increase from 1 to 7 and by 20 % when OCR increases from 1 to 10.

The cyclic response will also be affected by the frequency of loading, e.g. low-frequency versus wave-frequency tension components. The low-frequency component has typically a period, which is about 10 times longer than the wave-frequency component represented in the test results plotted in Figure E-1. Recognising the effect of loading rate an increase in the load rise time t_{cy} from 2.5 seconds to 25 seconds, i.e. one log-cycle change, will give a reduction in the net cyclic loading effect by about 10 %, e.g. a reduction from $U_{cy} = 1.3$ to $U_{cy} = 1.27$.

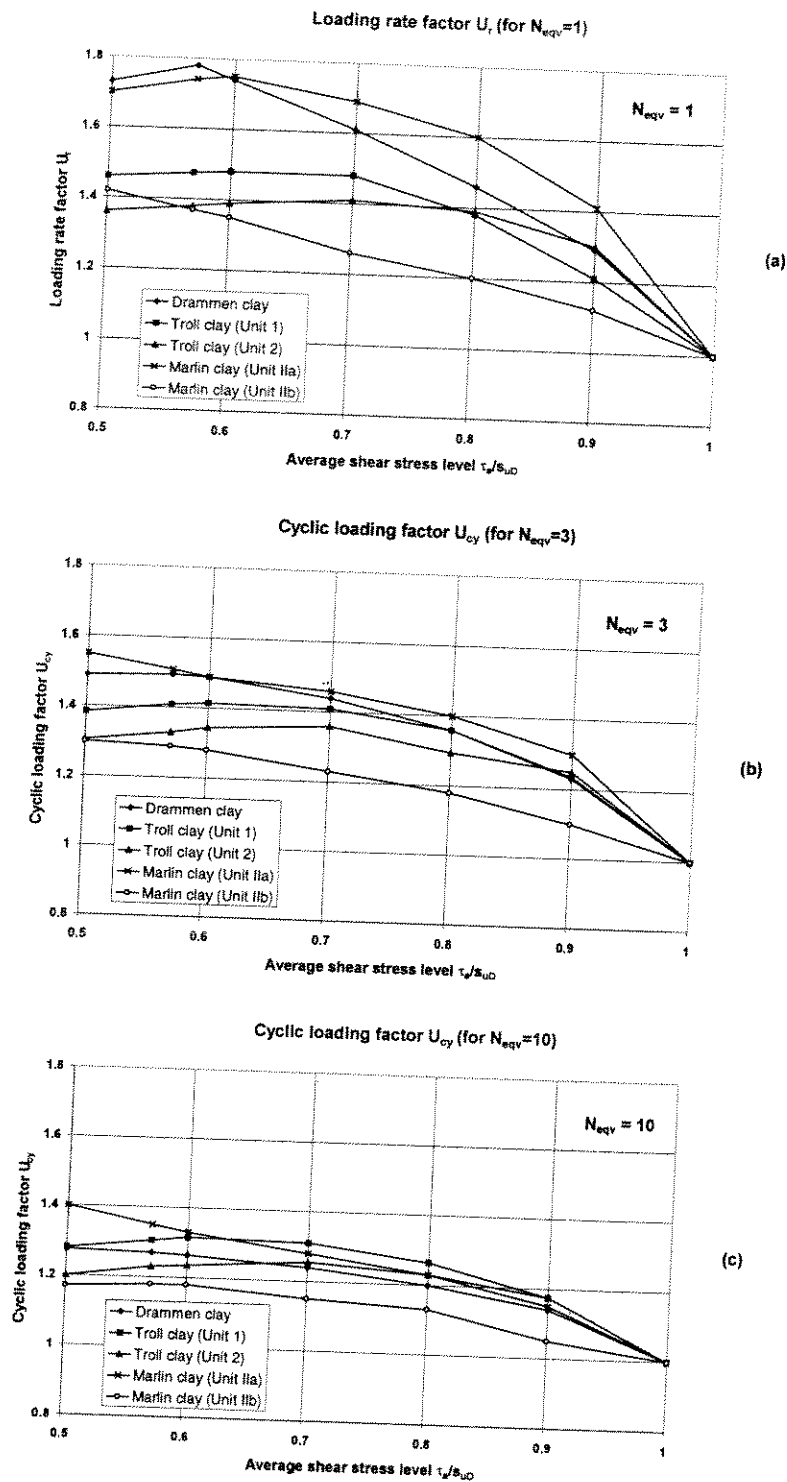

Figure E-1. Example of cyclic direct simple shear test data (from /E-4/, /E-5/ and /E-6/).

Table E-1 Characteristics of tested clay (ref. Figure E-1)					
Parameter	Drammen	Troll (Unit 1)	Troll (Unit 2)	Marlin (Unit IIa)	Marlin (Unit IIb)
s_{uD} [kPa]	8.6	≈20	≈90	≈10	≈30
OCR [-]	1	1.45	1.45	1	1
w [%]	52	47-70	18-26	60-90	40-65
PI [%]	27	37	20	35-60	30-42

--- End of Guidance Note ---

E3 References

- /E-1/ Bea, R.G. and Audibert, J.M.E. (1979), *Performance of dynamically loaded pile foundations*, Proceedings from BOSS'79, Paper No. 68, pp. 728-745. London.
- /E-2/ Kraft, L.M., Cox, W.R. and Verner, E.A. (1981), *Pile load tests: Cyclic loads at varying load rates*, American Society of Civil Engineers, Vol. 107, No. GT1, January 1981, pp. 1-19.
- /E-3/ Briaud, J-L and Garland, E. (1983), *Loading rate method for pile response in clay*, American Society of Civil Engineers, Vol. 111, No. 3, March 1985, pp. 319-335.
- /E-4/ Andersen, K. H. and Lauritzen, R. (1988), *Bearing capacity for foundations with cyclic loads*, ASCE Journal of Geotechnical Engineering, Vol. 114, No. 5, May, 1988, pp. 540-555.
- /E-5/ By, T. and Skomedal, E. (1992), *Soil parameters for foundation design, Troll platform*, Behaviour of Offshore Structures BOSS'92, pp. 909-920.
- /E-6/ Jeanjean, P, Andersen K.H. and Kalsnes B. (1998), *Soil parameters for design of suction caissons for Gulf of Mexico deepwater clays*, Offshore Technology Conference , Paper OTC 8830, pp. 505-519. Houston.

Appendix F: Uplift angle at the seabed

F1 General

The anchor line in a mooring system may be split into three parts, one part embedded in the soil, a second part resting on the seabed, and a third part suspended in water.

The length of anchor line lying on the seabed at any time during anchor installation will be a function of at least the following factors

- the configuration of the anchor line
- the actual length of line between the anchor shackle and the pulling source (stern roller)
- the actual line tension
- the anchor line catenary (suspended part)
- the inverse catenary of the line (embedded part)
- the penetration trajectory of the anchor (position of the shackle)

At some point the length of the seabed part becomes zero and a further increase in the line tension or decrease in distance will result in a situation where the anchor line intersects the seabed under an uplift angle (α), see Figure F-1. The characteristic anchor resistance is then given by Eq. (1) for $L_s = 0$.

Figure F-1 illustrates two situations after hook-up to the floater. If the seabed uplift angle during design loading approaches the angle θ at the anchor shackle established during installation (extreme uplift), the anchor force and moment equilibrium from the installation stage may be affected, which may reduce the anchor resistance. This situation must be avoided. Line 2 illustrates a situation, where the uplift angle after hook-up affects the inverse catenary only down to Point A, such that the anchor is not at all affected. An acceptable uplift angle should give a seabed uplift angle, which is significantly less than the angle θ at the anchor shackle. This would affect the installation shape (inverse catenary) of the line only to a limited depth below the seabed, indicated by Point A in Figure F-1. Guidance is given below for assessment of an acceptable seabed uplift angle.

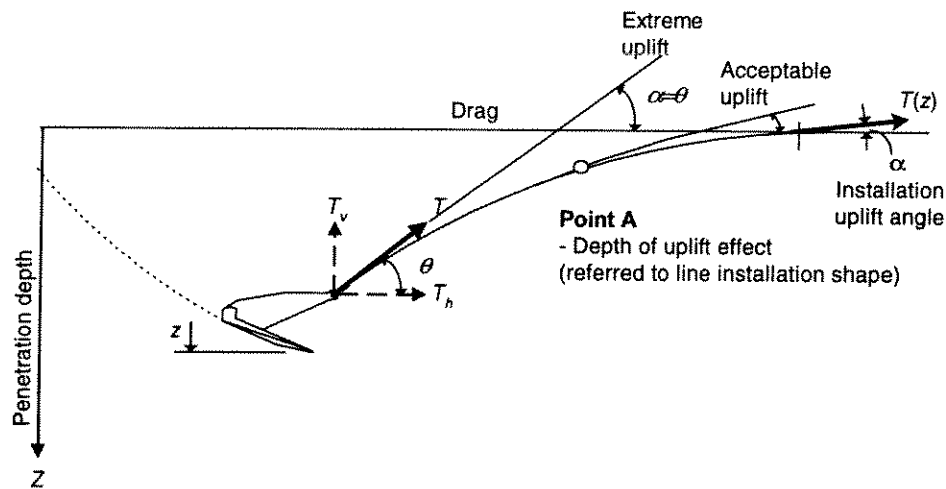

Figure F-1 Non-zero uplift angles in the dip-down point.

Historically both installation and operation of fluke anchors have been based on the requirement of zero uplift angle of the line at the seabed. Likely reasons for this traditional practice are listed below.

- Fluke anchors have traditionally been associated with moorings for ships and mobile drilling rigs, which often are equipped with anchors for a wide range of soil conditions, leading to minimum, or no, requirements for site specific soil investigations.
- In the mooring analyses the anchoring point has been modelled as a fixed point somewhere at the seabed, neglecting the fact that the fluke anchor embeds into the soil.
- The design approach for such anchors has been rather crude, reflecting the uncertainties in the boundary conditions, e.g. the soil data.
- Fluke anchors have been installed based on previous experience and empirical data, often extrapolated from small-scale tests.
- Only a few of the experimental data from installations have included uplift of the anchor line.

Accordingly, it has been difficult to take the step to allow for uplift, although it has been a recognised understanding for some time that fluke anchors can accept a certain degree of vertical loading. It has, however, not been possible to quantify the effect of uplift on the anchor behaviour.

Both with respect to anchor installation and later operation of a mooring system, there will be a potential for significant cost savings if a safe uplift angle can be documented and agreed upon. In the following, guidelines are given for assessment of a safe uplift angle in normally consolidated to slightly overconsolidated clay.

F2 Assessment of a safe uplift angle

There are two situations to consider with respect to assessment of a safe uplift angle, firstly during anchor installation and secondly during extreme environmental loading after hook-up of the anchors to the floater. Non-zero uplift angles during installation typically occur when anchors are installed using a short scope of wire either by bollard pull (and blocked line) or by winch pull (from a stationary vessel).

An anchor should under no circumstances be set with an anchor line giving an initial non-zero uplift angle from start of the installation. This would reduce the possibility for the anchor to enter the soil. As a minimum, the embedment of the fluke should be 2.5 fluke lengths (L_F) before uplift is applied. This will also limit the possible maximum uplift angle for all practical means considering the path reaching an ultimate depth. An uplift angle exceeding 10° should not be expected during installation of a fluke anchor according to this procedure, even if the anchor approaches its ultimate depth.

The penetration path is only slightly affected by the uplift angles following upon the adoption of the installation procedure described above. If the anchor was to be installed to the ultimate depth using this procedure, the ultimate depth reached would be reduced only by a few percent as a result of the increased uplift angle at the seabed. Considering that the anchor resistance is mainly a function of the penetration depth, this means that the change in anchor resistance for most installation cases is negligible.

The anchor line may have either a wire or a chain forerunner, and the effect of using one type of line or the other affects the behaviour of the anchor. An anchor penetrated with a wire will reach a larger ultimate depth than an anchor with a chain, since the soil cutting resistance is less for a wire than for a chain, see sketch in Figure 2. The maximum acceptable uplift angle for an anchor installed to the ultimate depth with a wire forerunner therefore becomes larger than with a chain forerunner.

Uplift angles for the permanently moored installation may be larger than those reached during anchor installation, since the installation vessel uses either long lines or a tensioner to maintain a zero, or small, uplift angle at the seabed. The scope used during hook-up to the permanent installation is often less than during anchor installation leading to higher uplift angles during storm loading than the anchor has experienced during installation. Provided that the uplift angle (α) at the seabed is significantly less than the line angle (θ) at the anchor shackle after installation the anchor resistance will not be adversely affected by this increase in uplift angle. The reason is that the shape (inverse catenary) of the forerunner below Point in Figure F-1 will not be changed for the situation illustrated.

Line tension exceeding the available anchor resistance at any time after anchor installation will be experienced by the anchor as a sudden change in uplift angle at the anchor shackle. If the load is high enough to set the anchor in motion, the anchor resistance will drop to R_t plus the loading rate effect representative of the actual overloading situation. The anchor will then, due to the higher uplift angle, follow a more shallow penetration path than during anchor installation. The penetration path becomes shallower the higher the uplift angle at the seabed is after hook-up to the floater. The maximum possible uplift angle (α_{max}) is the angle, which makes the anchor drag at a constant depth, and gradually pulls the anchor out of the soil for higher angles. Tentatively, a safe α -angle may be set to 50% of α_{max} , although limited to $\alpha = 10^\circ$. In practice, this can be achieved by limiting the uplift angle to 50% of the angle θ at the anchor shackle.

The effect on the anchor resistance of increasing the uplift angle after installation from 0° to $\theta/2$ may be assumed to vary linearly according to the following simple expression

$$R_{L,\alpha} = R_{L,\alpha=0} (1 - 2\alpha / \theta) \quad (\text{F-1})$$

(valid for $\alpha < \theta/2$ and $\alpha < 10^\circ$)

where R_L is the contribution to the anchor resistance R_t from the embedded part of the anchor line.

The design of a fluke anchor foundation, including hook-up considerations, should always ensure that extreme loads, which possibly may exceed the installation load will lead to a failure mode, which penetrates the anchor further down into the soil.

Appendix G: General requirements to soil investigation

G1 Geophysical surveys

The depth of sub-bottom profiling should correspond to the depth of rock or the expected depth of fluke anchor penetration. The seismic profiles should preferably be tied in to geotechnical borings within the mooring area, which will improve the basis for interpretation of the results from the geophysical survey.

Guidance note

It is recommended to survey at least 1.5 times the expected fluke penetration depth.

--- End of Guidance Note ---

G2 Geotechnical surveys

The soil investigation should be planned and executed in such a way that the soil stratigraphy can be described in sufficient detail for both the anchor and the anchor line analysis. The required depth coverage will vary from case to case, see Chapter 6.

The extent of the soil investigation, sampling frequency and depth of sampling/testing, will depend on a number of project specific factors, e.g. the number of anchor locations, soil stratigraphy and variability in soil conditions with depth and between the potential anchoring points, as highlighted by the results of the geophysical survey, water depth, sea floor bathymetry, etc.

Piezcone penetration testing (PCPT) normally brings valuable and useful information about soil stratigraphy, but the undrained shear strength derived from such tests will be uncertain if the PCPT results are not calibrated against laboratory strength tests on recovered soil samples. If generally adopted correlation factors are used the undrained shear strength derived will be affected by the uncertainty in this correlation factor.

If soil layering is such that the layer sequence and the variation of thickness and layer boundaries will become an important anchor design and installation consideration, it may be necessary to document the soil layer sequence at each anchor location. The thickness of all significant layers, and the thickness variation between the anchoring locations, should be known with reasonable accuracy prior to the design of the anchor foundation.

For the anchor design, most weight should be given to the undrained shear strength derived from direct simple shear (DSS) and unconsolidated undrained (UU) triaxial tests. These types of test are considered to give the most representative estimates of the intact undrained shear strength of the clay. Clay sensitivity (S_t) is also a significant soil parameter in the anchor design, which requires companion determinations (on the same soil specimen) of intact and remoulded shear strengths, either by UU triaxial tests or by fall-cone tests.

For assessment of the post-installation effect due to soil reconsolidation, the consolidation characteristics of the clay, particularly the coefficient of consolidation (c_v) should be gathered as part of the soil investigation.

For calculation of the effect of cyclic loading on the long term anchor resistance, it is recommended to carry out static and cyclic undrained DSS tests. These tests should be carried out on representative soil samples of high quality, which shall be subjected to stress conditions, which simulate the in situ conditions as closely as possible. A combined static/cyclic test programme should allow determination of the strength of the soil under the range of loading conditions to be covered by the anchor design, e.g. cyclic tests with a representative combination of average and cyclic shear stresses. The test programme should allow the construction of a strain contour diagramme, as required for calculation of the cyclic shear strength ($\tau_{f,cy}$), see /E-4/ and Appendix E for details. If site specific soil data are not provided for assessment of the cyclic loading effect, a conservative assessment of this effect is warranted.