

Analysis of Platform Vulnerability to Cratering Induced by a Shallow Gas Flow

by

Principal Investigator: Adam T. Bourgoyne, Jr., Ph.D.
Associate Researchers: Luis Rocha, Ph.D.
Catherine V. Bender
Darryl Bourgoyne
*Petroleum Engineering Department
Louisiana State University
Baton Rouge, LA 70803-6417*

May 26, 1995

"This study was funded by the Minerals Management Service, U.S. Department of the Interior, Washington, D.C., under contract Number 14-35-0001-30739."

**Analysis of Platform Vulnerability
to Cratering Induced by a Shallow Gas Flow**

Principal Investigator: Adam T. Bourgoyne, Jr.
Associate Researchers: Luis Rocha
Catherine V. Bender
Darryl Bourgoyne
*Petroleum Engineering Department
Louisiana State University
Baton Rouge, Louisiana 70803-6417*

ABSTRACT

A flow from an unexpected shallow gas sand is one of the most difficult well control problems faced by oil and gas well operators during drilling operations. Current well control practice for bottom-supported marine rigs usually calls for shutting in the well when a kick is detected if sufficient casing has been set to keep any flow underground. Even if high shut-in pressures are seen, an underground blowout is preferred over a surface blowout. However, when shallow gas is encountered, casing may not be set deep enough to keep the underground flow outside the casing from breaking through to disturb sediments near the platform foundations. Once the flow reaches the surface, craters are sometimes formed which can lead to loss of the rig and associated marine structures.

The sediment failure mechanisms that lead to cratering have been poorly understood. In addition, there has been considerable uncertainty as to the best choices of well design parameters and well control contingency plans that will minimize the risks associated with a shallow gas flow. The objectives of this study were (1) to identify and describe various possible sediment failure mechanisms that can lead to cratering, (2) develop improved correlations for estimating the break-down resistance of upper-marine sediments, and (3) to evaluate alternative well design procedures and well control contingency plans using the improved correlations. The goal of this research is to increase the safety of drilling operations, to reduce accidental discharges of hydrocarbons and formation brines to the environment, and to better conserve our natural resources.

Modern contingency plans for handling a shallow gas flow call for diverting the flow away from a bottom-supported rig using a diverter system. The diverter system is used to reduce the wellbore pressure so that it does not exceed the formation break-down pressure. However, results of this study indicate that use of diverter systems does not always prevent cratering. Crater formation during diversion can occur when the diverter is too restricted, allowing formation breakdown pressure to be exceeded even though the well is not shut-in. In addition,

cratering can occur at pressures below the hydraulic breakdown pressure when shallow unconsolidated water sands are present. Water production from shallow aquifers can carry large volumes of sand from the permeable zones exposed to the open borehole. This results in a rapid excavation of aquifer sediments near the wellbore. Subsequent collapse of overlying sediments into the excavated region can open a flow path to the surface.

The above concerns led us to re-examine the controlling design parameters for shallow casings in order to determine when shutting-in a shallow kick is technically and economically feasible. A recent paper by Arifun and Sumpeno (1992) with Unocal Indonesia has indicated that wells are being designed and drilled in their East Kalimantan operations with a well plan that calls for shut-in of all kicks from the surface to the total well depth. These new design concepts were reviewed. Recommended criteria for deciding when to divert and when to shut-in are presented.

SEVERITY OF CRATERING PROBLEM

Although cratering while drilling a well is not a frequent occurrence in the oil industry, when a crater does occur the consequences are usually catastrophic. Large rigs and platforms have been lost in craters with no sign of the rig remaining at the surface. The cost of regaining control of the well and replacing lost structures and equipment can reach hundreds of millions of dollars.

Complete statistics about cratered wells or broaching incidents are not available. However, since cratering is often related to shallow blowouts, statistics about shallow blowouts can be used to show the severity of such problems. Relatively recent blowout statistics were given by Hughes (1986), Adams (1991), Tracy (1992), and Danenberger (1993).

Hughes (1986) compiled information on 425 Gulf Coast blowouts events that covered the period between July 13, 1960 and January 1, 1985. The data was broken down by area and included 242 blowouts in Texas, 56 in Louisiana, 121 in Outer Continental Shelf (OCS), 3 in Mississippi and 3 in Alabama. Gas was present in 82% of the Texas blowouts. The two major operations that were underway when the blowout occurred were (1) coming out of hole (27%) and (2) drilling (25%). Seventeen (7.02%) Texan blowout reports noted that the well blew out around the casing. A total of twenty (8.26%) events reported that the underground flow reached the surface either to form a crater around the well, at a nearby surface site, or caused blowouts from nearby waters wells. All the blowouts that reached the surface outside of casing had a drilling depth to casing depth ratios greater than four.

The study of 56 Louisiana blowouts by Hughes (1986) showed that gas was present in 73% of wells that reported the type of blowout fluid. The rig operations reported to be underway at the time of the blowout included (1) workover operations(37%), (2) coming out of hole (21%), (3) circulating (13.2%) and (4) drilling (13.2%). Hughes does not give details about flows around casing or cratering for the Louisiana blowouts.

The statistics of 121 OCS blowouts reported by Hughes (1986) showed that gas was present in 77% of the cases. A description of the operation described when the blowout occurred was available for 46 events. The rig operations reported to be underway included (1) workover operations (28%), coming out of hole (24%), and drilling (20%). A total of 66 wells described the procedure used to control the blowout. The majority (55%) of the blowouts bridged on their own. About 49% of the 70 wells that listed both date of occurrence and date the well was killed were controlled within one day.

Danenberger (1993) performed a study of blowouts that occurred during drilling operations on the Outer Continental Shelf of the United States during the period 1971-1991. Eighty-three blowouts occurred during this period while drilling 21,436 wells for oil and gas. Four additional blowouts occurred while drilling for sulfur. Eleven of the blowouts resulted in casualties with 65 injuries and 25 fatalities. Fifty-eight of the blowouts that occurred while drilling for oil and gas came from shallow gas zones. Exploratory wells accounted for 37.4% of the wells drilled and 56.9% of the shallow-gas blowouts. Conversely, development wells accounted for 62.6% of the wells drilled and 43.1% of the shallow-gas blowouts.

According to Danenberger (1993), A shallow gas blowout in 1980 was the most serious blowout in the OCS, accounting for 6 of the 25 fatalities and 29 of the 65 injuries. However, there have been no casualties due to blowouts reported during the last seven years of the study.

Oil was not associated with the shallow gas blowouts and environmental damage has been minimal. Two blowouts prior to 1971 are known to have caused oil pollution in the portion of the Outer Continental Shelf under U.S. jurisdiction. An estimated 80,000 Bbl of crude oil was released in the Santa Barbara Channel and about 1,700 Bbl of condensate was released in the Gulf of Mexico.

Although no statistics are given for the OCS on the number of times a crater developed that undermined the foundation of the rig, Danenberger (1993) reported that 71.3% of the blowouts stopped flowing on their own when the well bridged naturally. This is thought to be due to collapse of the uncased portion of the borehole. Flow from 57.5 % of the blowouts ceased in less than a day and flow from 83.9 percent ceased in less than a week. A list of shallow gas blowouts compiled by Adams (1991) indicates that 18 bottom supported structures were damaged on the U.S. OCS by shallow gas blowouts during the 1971-91 period of the Danenberger study. Seven of the U.S. structures shown in the Adams study were reported to be a total loss and extensive damage was reported for another three cases. These ten cases of extensive damage to total loss reported by Adams account for 17.2 % of the 58 shallow gas blowouts reported by Danenberger (1993). Thus 10 lost structures out of 21,436 wells drilled is a rough estimate of the risk from significant cratering.

We were not successful in compiling an estimate of economic loss associated with cratering during shallow gas blowouts. However, an operator reported that the cost due to one event outside of the U.S. was approximately 200 million dollars.

MECHANICS OF CRATER FORMATION

A literature review was conducted to obtain insight into mechanisms possibly involved in establishing a flow path to the surface and in the formation of a crater at the surface. This was done by studying and analyzing a number of historical cases reported in the literature, and later establishing and proposing mechanisms for cratering formation. However, the literature review showed that there are few specific petroleum-related articles about underground blowout followed by cratering. With the exception of very old reports (early 1900's) and the excellent paper written by Walters (1991), most of the petroleum-related literature contains no specific information about cratering mechanisms. Much of the pertinent literature was found outside of petroleum engineering publications. The scarcity of literature led the research group to look for information by contacting a number of organizations such as oil companies and firefighting and blowout specialists. These contacts, the obtained literature, and the personnel of Louisiana State University, Colorado School of Mines, and University of Oklahoma supplied important information that allowed this work to draw important conclusions about possible cratering mechanisms.

The following sequence was chosen to present the information collected from the sources listed above: The discussion will include:

- (1) mechanisms for upward fluid migration that allows formation fluid to migrate upward outside the wellbore and reach shallow unconsolidated sediments; and
- (2) proposed mechanisms for crater formation.

Mechanisms for Upward Fluid Migration

Closing the well or restricting the fluid flow in the choke lines will cause the pressure in the well to increase. If the pressure in the well becomes too high, a failure could occur. A path could be established which allows the more highly pressured fluid from below to migrate upward. The primary failure mechanisms identified included: (1) casing failure, (2) failure of the cement bond between the casing and the sediments, (3) tensile sediment failure by hydraulic fracturing, (4) shear sediment failure in permeable zones, (5) wedging open of natural fault planes.

Upward Fluid Migration due to Casing Failure

Casing failure at a shallow depth during well control operations has been reported as the primary cause of a number of craters. Since each larger size casing present outside of inner casing is of lesser strength, after the inner casing string fails, the high pressure fluid will generally find a path to the shallow sediments. Very high pressures are sometimes present if the influx is from a deep, abnormally pressured zone. Proper casing design, pressure testing, and periodic casing wear inspections are the primary means used to prevent this type of failure.

Upward Fluid Migration Due to Failure of Cement Bond

Upward fluid migration through cement channels has also been responsible for a number of blowouts. Fluid seeping around the casing can cause erosion of the borehole-casing annulus, which eventually could lead to a crater. Proper design and planning of cement jobs are basic requirements to prevent upward gas migration around the casing. For this reason, a great deal of effort has been exerted by the petroleum industry to reduce the tendency for channels to form in the cemented annulus during cementing operations. However, the mechanisms involved in the channeling process are not fully understood and although a variety of solutions to the problem have been proposed, none have been consistently successful (Lockyear et. al., 1989).

Upward Fluid Migration Through Hydraulic Fracture

Rock strength is a function of its structure, compaction and type. Rock tensile strength varies in both vertical and horizontal directions. The forces tending to hold the rock together are the strength of the rock itself and the in-situ stresses on the rock. High-pressurized fluid, resulting from the well control operation, inside a wellbore generates hydraulic pressure at the wellbore wall or in the pore spaces of the rock. If the pressure increases, the force applied by the fluid pressure in the rock will become equal to the forces tending to hold the rock together. Any additional pressure applied will cause the rock to split or fracture (Martinez et. al., 1990). Thus, from a macroscopic point of view, hydraulic fracturing occurs when the minimum effective stress at the wellbore becomes tensile and equal to the tensile strength of the rock (Fjaer et. al., 1992).

The fracture will extend as long as sufficient pressure is being applied by injection of additional fluids (Haimson et.al., 1967; Martinez et. al., 1990). Fracture propagation is a function of several factors such as: (a) in-situ stresses existing in different layers of rock, (b) relative bed thickness of formations in the vicinity of the fracture, (c) bonding between formations, (d) mechanical rock properties (including elastic modulus and Poisson's ratio), (e) fluid pressure gradients in the fracture, and (f) pore pressure of different zones (Veatch et. al., 1989). Local stress fields and variations in stresses between adjacent formations are often considered the most important factors to control fracture orientation and fracture growth. Evidence from production logs and other evaluation techniques has suggested that hydraulic fractures usually start in a porous and permeable zone and often terminate before propagating far into the adjacent, impermeable (generally shale) layers. Clay-rich materials normally have higher horizontal stresses and often act as confining layers (Harrison et al., 1954; Warpinski and Teufel, 1984). Most formations are susceptible to hydraulic fracturing. Sand, limestone, dolomitic limestone, dolomite, conglomerates, granite washes, hard or brittle shale, anhydrite, chert, and various silicates are example of rocks for which fracturing operations have been reported as being successful. However, the plastic nature of certain soft shales and clays makes them more difficult to fracture (Martinez et. al., 1990).

Hydraulic fractures will generally propagate perpendicular to the direction of the minimum principal stress (Veatch et. al., 1989; ; Warpinski and Teufel, 1984; Warpinski and Smith, 1989). Thus, the local stress field will generally determine if a fracture will be vertical or horizontal. In most areas, horizontal stress is less than vertical stress, resulting in a vertical fracture.

In terms of well control operations, hydraulic fracturing may lead to the serious risk of allowing upward fluid migration through the fracture. If local conditions indicate that a vertical fracture is likely to occur and not be confined by a layer with a higher horizontal stress, and the permeability of the rock matrix surrounding the fracture is not great enough to dissipate the high pressure, the result can be upward migration of the pressured fluid through the fracture.

Upward Fluid Migration Through Shear Failure

Rock failure caused by shear stress can occur, for instance, when an impermeable formation overlays a permeable formation. In this case, massive shear failure due to the flow of highly pressured formation fluid can occur in the permeable formation before causing fracture of the overlying impermeable strata. The consequences of such massive failure include increase of sand production from the shear-damaged permeable formation, increase of rate of penetration when drilling these strata, and even compaction of these intervals (Walters, 1991).

Upward Fluid Migration Through Fault Planes

Existing fault planes crossing impermeable and sealing layers have been reported as responsible for upward fluid migration which ended in formation of craters (Adams and Thompson, 1989; Adams and Kuhlman, 1991; Walters, 1991). Flow through the fault planes will depend on many factors such as normal stress in the fault planes and permeability of the fault-plane-filling sediments. Possible mechanisms of flow through faults include:

- (1) the high-pressured fluid wedges open a fault plane at a pressure below that which will cause fracture of the sealing layer; and
- (2) increase of permeability due to induced shear dilatancy within the fault plane by the high pressure (Walters, 1991).

Cratering Mechanisms

The cratering mechanisms identified in this study includes (1) borehole erosion, (2) formation liquefaction, (3) piping or tunnel erosion, and (4) caving.

Borehole Erosion.

A number of reported historical cases have indicated that gas seeping around the surface casing is a typical occurrence leading to cratering. Gas or liquid flowing at high velocity around surface casing can cause erosion of shallow formation layers and is one of the mechanisms of cratering. Note also that significant erosion of the borehole wall not only can create a crater but

also can lead to a lower pressure in the flowing well, which in turn can be responsible for additional flow of formation fluids (normally water) into the well from all exposed permeable strata. Although erosion of the shallow formation by fluid flow has not been addressed by blowout-related literature, it has been studied in civil engineering problems such as erosion of river bottoms. A number of erosion experiments (Gaylord, 1989; Kamphuis and Hall, 1983) have shown that erosion caused by fluid flow is a function of the fluid velocity and shear stress at the eroding surface. The higher the velocity and shear stress, the higher is the erosion. These studies have concluded that erosion rate, which is defined as mass of eroded material divided by the time interval, is minimal and constant up to a certain value of velocity (critical velocity) or shear stress (critical shear stress). However, erosion rate increases rapidly as velocity increases for velocities above the critical value.

We have made erosion simulations based on erosion models taken from the literature. Our work has shown that as the eroded well bore diameter increases, fluid velocity drops, which caused the rate of erosion to decrease with time. The rate of growth is dependent on the formation erosion resistance and the properties of the flowing fluids. A gas liquid mixture would tend to erode quicker than single phase liquid or gas. However, our work indicated that craters due only to erosion would tend to be small. Shown in Figure 1 are typical results that we obtained.

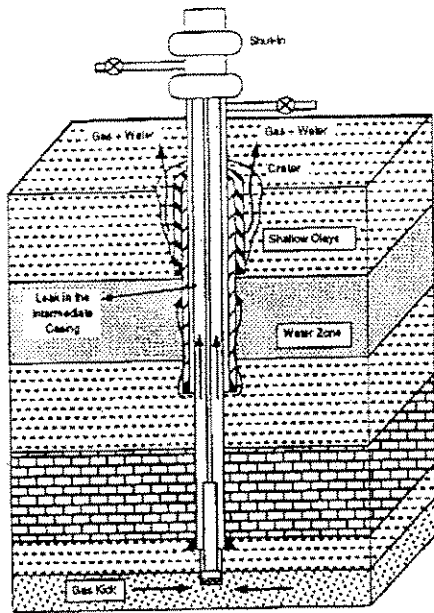

Figure 1 - Schematic of Example Well Configuration used in Borehole Erosion Simulation.

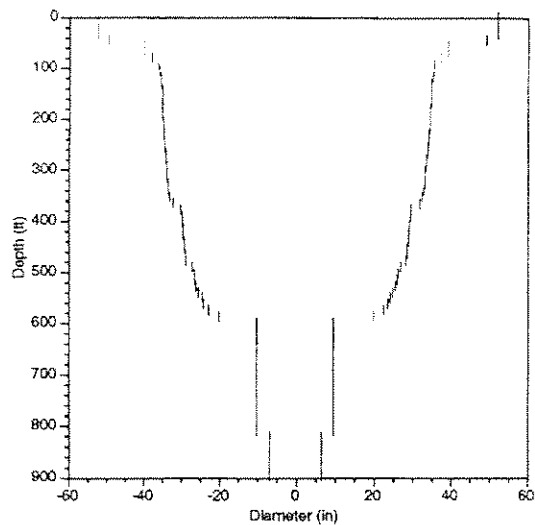

Figure 2 - Calculated Crater Profile due to Borehole Erosion after 5 days

Formation Liquefaction

Liquefaction (or quicksand or boiling) occurs when the vertical effective stresses vanish. Thus, the shear strength of cohesionless soils in the liquefied state is zero (Bell, 1983; Clough et. al., 1989; Lee et. al, 1983; Rocha, 1993; Scott, 1969; Seed et.al. 1981). The weight of the submerged soil is balanced by the upward acting hydraulic pressure gradient caused by the upward flow of fluids through the permeable sediments. This condition is also commonly referred to as a sandboil condition or quicksand condition. The pressure gradient at which liquefaction begins is called the critical pressure gradient (Bell, 1983). This cratering mechanism is thought to be possible only for essentially cohesionless and permeable sediments such as sands.

Liquefied sediments due to seepage forces are often found in excavations made in underwater fine sands subjected to upward fluid flow. As the velocity of the upward seepage force increases further from the critical gradient, the soil begins to boil more and more. If such a condition develops below part of a structure, the foundations of the structure would become unstable with part of it sinking into the liquefied sediments. The presence of a layered sequence composed of individual beds with different permeabilities can be particularly unfavorable if a finer grained cohesionless layer is underlain by more permeable sediments. Formation fluids can then flow through the very permeable layer with little loss of pressure. This results in a steeper pressure gradient in the upper zone.

Piping or Tunnel Erosion

The previous section discussed the potential of liquefaction of cohesionless soils by high-pressure formation fluid. However, if during an underground blowout the formation fluid reaches a cohesive sediment layer, another phenomenon called "piping" or "tunnel erosion" may occur. As the formation fluid flows through the sediments there is a reaction force applied to the matrix material. When formation fluid with sufficient velocity percolates through heterogeneous soil masses, it moves preferentially through the most permeable zones and issues from the ground as springs. Piping refers to the erosive action of some of these springs where sediments are removed by seepage forces. The removal of these sediments form subsurface cavities and tunnels. In order for piping to form, the soil must have some cohesion. Sediments with a larger cohesive strength can support a larger diameter tunnel without collapse (Bell, 1983). Also, for piping to occur in cohesive materials such as clay, it is necessary for a flaw or flow channel to be present to allow a concentrated fluid flow to develop. This could occur because of fracturing (Ghuman et. al., 1977). In the piping process, the formation fluid must be moving with sufficient volume and velocity to transport clay particles. This flow may be in a supersaturated layer with an underlayer of impermeable material, or along cracks or flaws in relatively impermeable sediments (Crouch, 1977). Piping may develop by backward erosion. In such a case, sediment erosion may grow from the exit toward the source of fluid supply (Bell, 1983). Finally, if erosion due to piping reaches a critical value, entire structures (dams, houses or drilling platforms) can collapse due to lack of support.

Caving

In this work, caving is defined as the collapsing of solids within and surrounding the well. This collapsing can be by borehole wall failure due to shear failure as the result of the reduction of the hydrostatic pressure in the wellbore, or by tensile failure due to excessive fluid production rate.

Caving due to shear failure can be understood by analyzing the origin of the stress concentration at the wellbore wall. Underground formations at a given depth are exposed to vertical and horizontal compressive stresses that generally are not fully compensated by the drilling fluid pressure after the well is drilled. Therefore, in the case of elastic formations, the load originally carried by the removed rock is partially transferred to the formations surrounding the borehole, creating a stress concentration around the borehole. Stress concentration generally does not present a problem if the well is drilled through competent rock. However, stress concentration in weak rocks or in some shale sections can lead to failure of the borehole.

Problems related to sand and silt production during a blowout include: (1) wear and erosion of production equipment, such as valves, (Fjaer et. al., 1992; Martinez et. al., 1990) and drilling equipment, such as diverter lines, and blowout preventers and (2) excavation of a permeable layer which can lead to the collapse of the overlying sediments. Caving as a result of sand and silt production during a blowout can vary from a few grams or less per ton of reservoir fluid to very large amounts (Fjaer et. al., 1992). One documented case of a cratered well mentions that the material expelled from the crater formed a deposit approximately 40-in thick at the edge of the crater and covered an area of about 99.7 acres (Hills,1932). In one reported case, an entire platform settled several feet after a shallow gas flow. The removal of large sand volumes due to sand production from permeable zones would explain this type of behavior.

SHALLOW-GAS CONTINGENCY PLAN

Developing a well plan that will minimize the risk of structural damage by an underground blowout involves at least three steps:

- (1) Obtaining sufficient geologic description and sediment strength data,
- (2) Developing a kick prevention plan, and
- (3) Selecting a well control strategy and developing a casing program with written contingency procedures for handling a shallow gas flow if the kick prevention plan fails.

Implementation of the contingency plan requires close coordination with the rig contractor and field personnel. Some of the most important areas of coordination include

- (1) Verifying through a systems analysis calculation that the diverter system is consistent with the well control plan,
- (2) Integration of clear statements of duties and responsibilities (in regard to shallow-gas contingency procedures) into the rig organizational structure, and

- (3) Conducting an appropriate training program to insure that the well control plans and contingency procedures are understood and can be carried out by the field personnel.

This report will address the three steps involved in developing the well plan.

GEOLOGIC DESCRIPTION AND SEDIMENT STRENGTH DATA

A prerequisite of any improved well design procedure for safe handling of shallow gas flows is knowledge concerning the breakdown strength and permeability of the upper marine sediments. Key parameters needed to estimate the breakdown strength are the overburden stress and the ratio of horizontal to vertical stress.

Ratio of Horizontal to Vertical Stress

Before fracture pressure can be predicted, the effective horizontal stress must be estimated. For sediments between the surface casing depth and the total well depth, the most common approach has been to correlate the minimum observed ratio of horizontal-to-vertical effective stress, F_σ , with depth. Leak-off test data and incidents of lost-returns have been used to develop empirical correlations for various geographic areas. The correlations were heavily weighted to represent the weaker sediments found at a given depth so that a conservative estimate of fracture pressure could be predicted for use in well design calculations. Once F_σ is obtained from the empirical correlation, the fracture pressure can be estimated using:

$$p_{frac} = F_\sigma \sigma_v + p = F_\sigma (s - p) + p \dots (1)$$

Shown in Figure 3 are several correlations commonly used to estimate the horizontal-to-vertical effective stress ratio for the Louisiana Gulf Coast Area. Note that the ratio decreases for the more shallow sediments and approaches a value of about 0.33 at the surface. Hubert and Willis (1957) determined this value for unconsolidated sands in sand-box experiments conducted in the lab. At deeper depths, the ratio F_σ approaches a value of one as the sediments become more plastic with increasing confining stress.

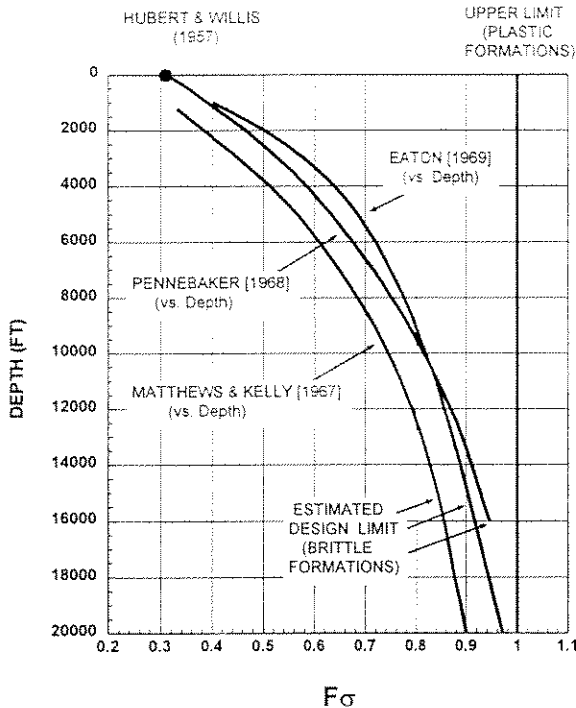

Figure 3 - Ratio of Horizontal to Vertical Stress for the Louisiana Gulf Coast Area

Extrapolation of the empirical correlations shown in Figure 3 to very shallow depths gives a low value of F_σ , and thus values for shallow fracture pressure are often significantly

under predicted. In reality, many shallow marine sediments behave plastically, with F_σ values near one. Use of the correlations shown in Figure 3 for these sediments can result in unrealistic formation breakdown pressures being used in the casing design calculations.

Shown in Figure 4 are F_σ values estimated from leak-off tests from 5 wells drilled in the Green Canyon Area, Offshore, Louisiana. Note that the average observed value of the horizontal-to-vertical effective stress ratio ranges from 0.8 to 1.4 and averages about one. The observed values in excess of one are likely due to: (1) experimental errors which occur while running and interpreting the leak-off tests, (2) the presence of stress concentrations in and around the borehole, and (3) the presence of non-zero tensile strengths in the sediments exposed during the test.

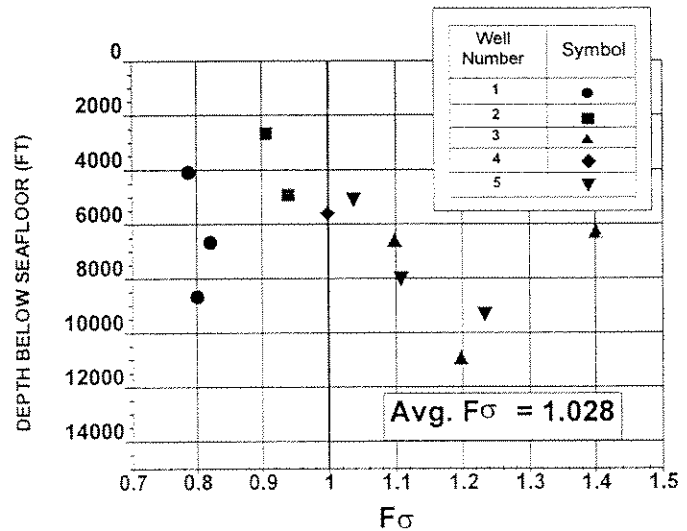

Figure 4 - Ratio of Horizontal to Vertical Effective Stress from Leak-Off Tests in the Green Canyon Area, Offshore Louisiana

Overburden pressure

The overburden pressure is the most important parameter affecting fracture pressure. The overburden pressure, s , at a certain depth can be thought of as the pressure resulting from the total weight of the rock and pore fluids above that depth. Since bulk density, ρ_b , is a measure of the weight of rock and pore fluids, the overburden pressure at a certain depth can be easily calculated by integration of the bulk density vs depth profile.

$$s = \int_0^{D_s} \rho_b g dD_s \dots\dots\dots (2)$$

Thus, one method for calculating the overburden pressure is to sum up the average interval bulk density times interval height for all intervals above the depth of interest.

For offshore sediments, hydrostatic pressure due to water depth must also be considered and Equation (2) becomes:

$$s = \int_0^{D_w} \rho_w g dD_w + \int_0^{D_s} \rho_b g dD_s \dots\dots\dots (3)$$

The best source of bulk density data is from in situ measurements made with a gamma-gamma formation density log. Unfortunately such data is seldom available for depths less than the surface casing setting depth. Accuracy of the formation density logs can be poor in large diameter holes, so that a pilot hole may be required to get good measurements in the shallow sediments. Logging-while-drilling (LWD) tools are now available that can measure formation density, but they also require hole diameters no greater than 14 in. Thus a pilot hole may be

required to get accurate density measurements in the upper marine sediments. This will often not be cost effective.

Sonic travel times determined from well logs or calculated using seismic data can also be used to estimate the formation bulk density. However, Rocha (1993) found that there was a poor agreement between density values obtained with sonic and density logs in the upper marine sediments. The difficulty stems from uncertainty about the proper choice of matrix travel time values for shallow clay sediments.

Cuttings density data obtained while drilling is sometimes available in the shallow sediments. However, the bulk density of cuttings can be highly altered by the release of confining pressure and by exposure to the drilling fluid.

Overburden stress as a function of porosity

Because of the problems discussed above, detailed information on bulk density is often not available at shallow depths. Thus, density at shallow depths must often be extrapolated from information obtained at deeper depths. This is typically done using porosity instead of bulk density.

Bulk density can be defined in terms of porosity, ϕ , and other variables using the following equation:

$$\rho_b = (1 - \phi)\rho_{matrix} + \phi\rho_{fluid} \dots\dots\dots (4)$$

From the above equation bulk density is primarily dependent on porosity since the other variables of grain matrix density and pore-fluid density usually do not have a wide range of values.

Porosity often decreases exponentially with depth, and thus a plot of porosity vs depth on semilog paper often yields a good straight-line trend. This exponential relationship can be described using the following equation.

$$\phi = \phi_0 e^{-KD} \dots\dots\dots (5)$$

The constants ϕ_0 , the surface porosity, and K , the porosity decline constant, are determined graphically or by the least-square fit method. Substituting Equation (5) into Equation (4) gives:

$$\rho_b = +(1 - \phi_0 e^{-kD_s})\rho_{matrix} + \phi_0 e^{-kD_s} \rho_{fluid}$$

which after substituting into Equation (3) and integrating, gives

$$s = \rho_{sw} gD_w + \rho_{matrix} gD_s - \frac{(\rho_{matrix} - \rho_{fluid})g\phi_0}{K} (1 - e^{-kD_s}) \dots\dots\dots (6)$$

Area	ρ_{matrix}	ϕ_0	K
Green Canyon	2.65	0.77	323 E-6
Main Pass	2.67	0.59	100 E-6
Ewing Bank	2.65	0.685	115 E-6
Mississippi Canyon	2.65	0.66	166 E-6
Rio de Janeiro Area	2.70	0.67	18 E-6

Table 1 - Values for Surface Porosity and Porosity Decline Constant for Several Orrshore Areas

Rocha, (1994) proposed that most shallow marine sediments found in the gulf coast exist in a plastic state of stress and that F_σ approaches one in Equation (1). As the matrix stress coefficient, F_σ , becomes unity, the effect of pore pressure vanishes and fracture pressure becomes equal to the overburden pressure.

$$P_{frac} = 1.0(s_{pob} - p) + p \dots \dots \dots (1b)$$

Leak-off tests were then used to calculate a pseudo-overburden pressure, s_{pob} , using Equation (1b). The constants of surface porosity, ϕ_0 , and the porosity decline constant, K , are determined by the best fit of the leak-off test data from Equation (6).

We have determined values for ϕ_0 and K for several areas in the Gulf Coast and Brazil. These values are given in Table 1. This approach is best suited for a limited area in which geologic conditions do not vary significantly and for which leak-off test data are available in the upper marine sediments. In sandy areas where F_σ becomes less than one, the correlation will become less accurate and show increased sensitivity to changes in pore pressure.

Shown in Figure 5a is the correlation obtained for the Mississippi Canyon Area of the Gulf of Mexico. The correlation was based on 66 leak-off tests. Note the good correlation obtained between actual leak-off pressure and the pseudo overburden pressure based on leak-off test observations. The same results expressed in terms of equivalent mud weight is shown in Figure 5b. Note that the spread in the data is about plus or minus one pound per gallon of equivalent mud density.

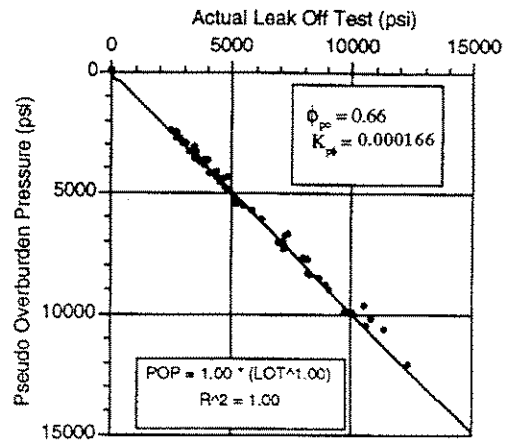

(a) Comparison of actual leak-off test pressure and pseudo-overburden pressure.

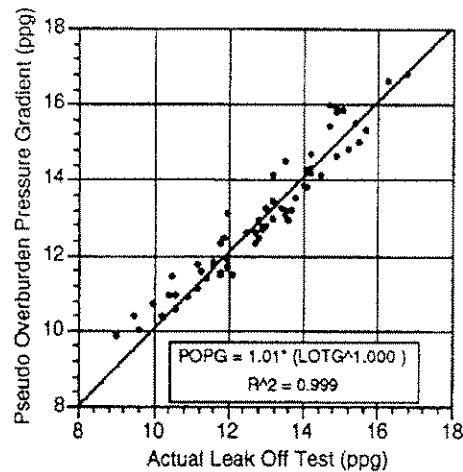

(b) Comparison of actual Leak-off equivalent mud weight to correlation

Figure 5 - Leak-off Test Correlation for Mississippi Canyon Area of Gulf of Mexico

Other correlations were attempted which considered effective stress in addition to overburden stress and thus took into account changes in pore pressure. A shallow transition zone to abnormal pressure was seen in these wells. However, no improvements in the correlation index could be achieved with this increased complexity. This may be since F_{σ} was found to be near one.

Use of Soil Borings Data

Work was also done to determine how soil borings can be used to help fill-in some of the missing data needed in designing the shallow portion of the well. Example data from the Green Canyon area of the Gulf of Mexico will be used to illustrate the recommended approach. Soil boring data are integrated with deeper well log data to provide a more accurate estimate of overburden stress and formation break-down pressure.

A number of tests are routinely run on soil borings by geotechnical engineers to determine the load bearing capacity of the shallow sediments. The physical properties tested generally fall into one of three categories:

- 1) weight/density measurements,
- 2) Atterberg limits, and
- 3) shear strength measurements.

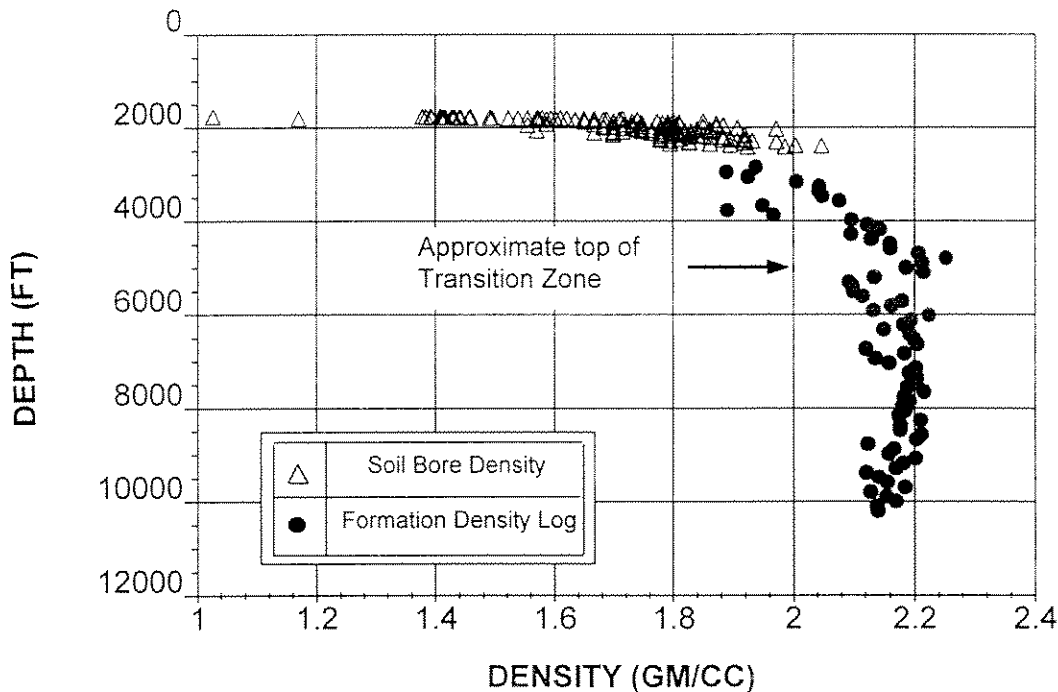

Figure 6 - Sediment bulk density vs. depth for the Green Canyon Area Example

Weight/density measurements include moisture content, wet unit weights, and dry unit weights. Atterberg limits tests measure plastic limits and liquid limits of the soil. Shear strength measurements are done with miniature vane, Torvane, Remote vane, Cone Penetrometer (CPT), and triaxial shear tests.

After being retrieved on the surface but before being extruded from the sample tube, miniature vane tests for shear strength are performed. The sample is then extruded from the sample tube and cut. Representative portions are carefully packaged, sealed, and sent to labs for further testing. The remainder of the sample is tested in the field. Normal field tests are the Atterberg limits tests, visual mineral and size classifications, and various strength tests. Lab testing includes unconsolidated and undrained tests for shear strength.

The hole from which the sample was taken can also be tested to obtain in situ values of shear strength, hydraulic fracture pressure, temperature, etc. using specialized tools at the bottom of a drill string.

Shown in Figure 6 is a composite density versus depth profile for a well in the Green Canyon area. The lower portion of the profile (circles) was obtained from a formation density log run in a nearby well. The upper portion of the profile (triangles) was obtained from wet unit weight data collected from soil borings. Integration of this profile produced the overburden pressure versus depth curve shown in Figure 7. Also shown in Figure 7 for comparison is the pseudo-overburden curve predicted by Equation(6) when using the surface porosity and porosity decline constant for the Green Canyon Area from Table 1 (from Rocha, 1993).

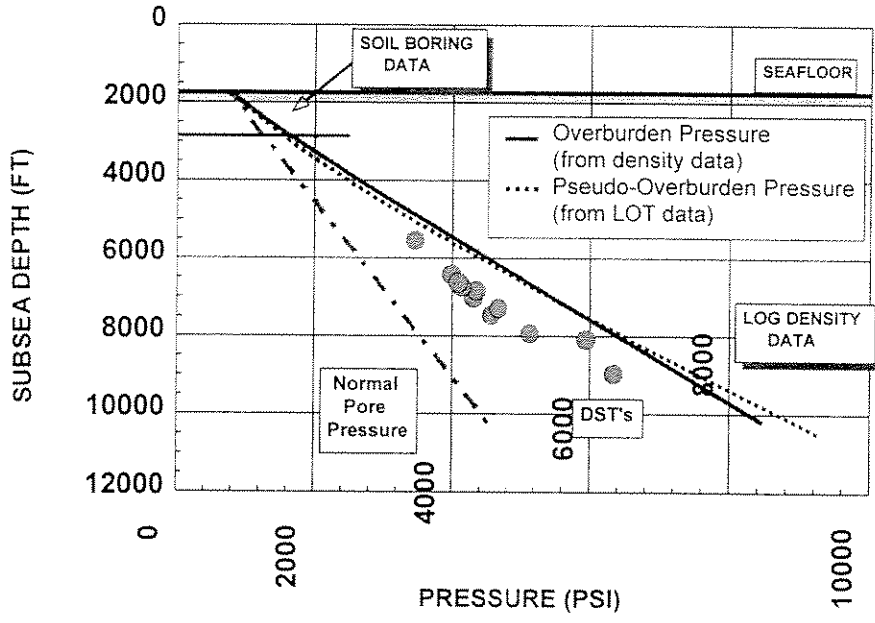

Figure 7 - Overburden Pressure and pore pressure vs depth for Green Canyon Example

Shown in Figure 8 are plots of moisture content, liquidity index, and shear strength versus depth. Also shown is a lithology description. These data show that the sediments penetrated by the soil borings are impermeable (only clay was found) and that the sediments are plastic. The clays are classified as very soft to soft, and the liquidity index dropped below zero only for a small interval near the bottom of the boring. This indicates the ratio of horizontal to vertical effective stress would be expected to be near one over the entire interval penetrated.

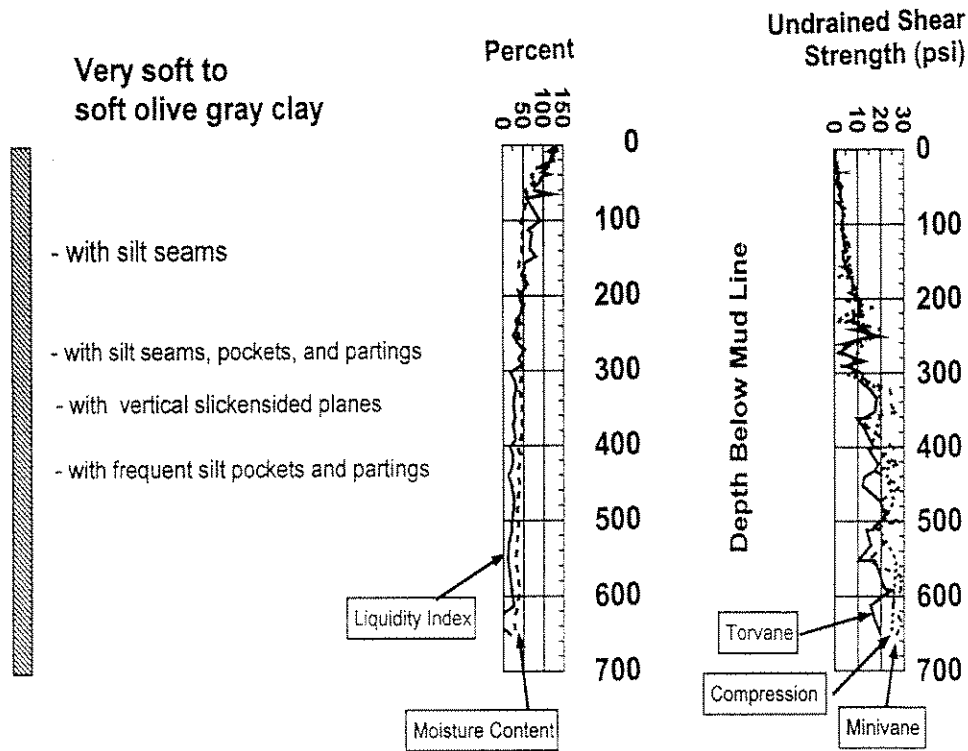

Figure 8 - Lithology, Liquidity Index, Moisture Content, and Shear Strength vs. depth for the Green Canyon Example

Measured shear strengths reach a value of about 25 psi near the bottom of the interval penetrated. Thus, a significant tensile strength would not be expected. Skempton's formula can be used as an empirical relation between shear strength and effective vertical stress for normally consolidated sediments. Skempton (1957) proposed the formula:

$$\frac{c_u}{\sigma_v} = 0.11 + 0.0037(LL - PL) \dots \dots \dots (14)$$

which says that the ratio of shear strength to effective vertical stress is about 11%, with a minor correction for liquid limit and plastic limit. At the bottom of the penetrated interval, the effective vertical stress is 210 psi, the liquid limit is 61 and the plastic limit is 22. Use of these values in Skempton's formula gives a value of 11.14% and predicts a shear strength of about 30 psi. Thus, Skempton's formula appears to be in reasonable agreement with the field data collected in the Green Canyon Area.

Shown in Figure 9 is a plot of the horizontal-to-vertical effective stress ratio, F_{σ} , as determined from the in situ hydraulic fracture tool run when the soil borings were being taken. Note that all of these results show values near one or in excess of one. Since the tool sees such a small sample of sediment (only a few inches), it is much less likely to encounter major flaws in the exposed sediment. Recall that the effect of stress concentrations in the borehole wall would allow F_{σ} to be as high as 2.0. The lower limit of F_{σ} (about one in this case) obtained using this type of tool would be a more representative value to use when a large interval of borehole is exposed.

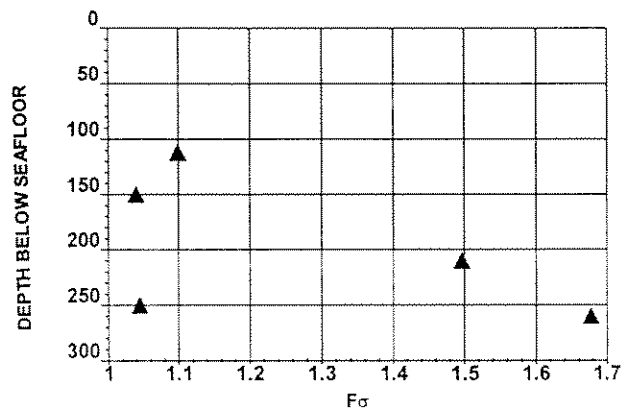

Figure 9 - Ratio of horizontal-to-vertical effective stress measured using insitu hydraulic fracture tool

Since F_{σ} appears to be near one, the calculated overburden pressure shown in Figure 7 is a reasonable estimate of formation break-down pressure for clay sediments for this example. The leak-off test results (Figure 4) tend to confirm that F_{σ} remains near 1.0 even for the deeper sediments. If well developed sands are known to be present, a lower value for F_{σ} should be used for those zones. In the absence of leak-off tests for the sand intervals of interest, the use of a minimum observed value for F_{σ} from the available leak-off test data should be considered. Note that the minimum value seen in Figure 4 was about 0.8.

KICK-PREVENTION MEASURES

Because of the difficulties in handling gas flows while drilling at shallow depths, considerable attention should be given to preventing such flows when planning the well. Seismic surveys can sometimes be used to identify potential shallow gas zones prior to drilling (Figure 10). If localized gas concentrations are detected by seismic analysis, hazards can be reduced when selecting the surface well location.

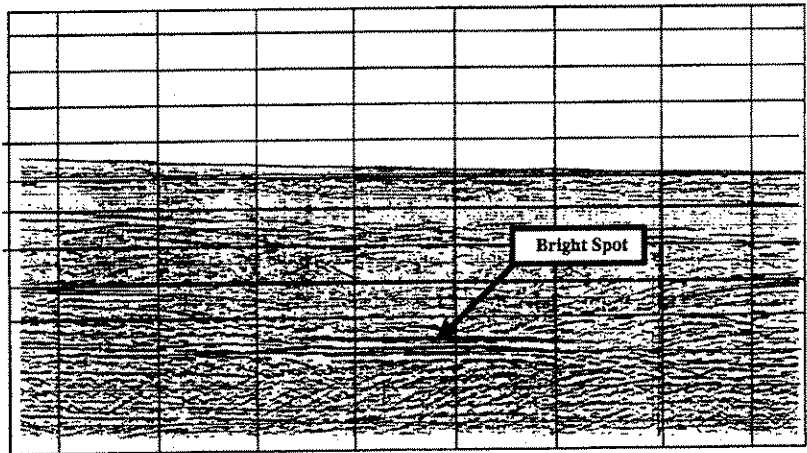

Figure 10 - Example seismic profile showing possible shallow gas accumulation as darker reflection or "bright spot." (Courtesy of ARCO)

When possible, empirical correlations should be applied to the seismic data to estimate formation pore pressures. This will sometimes permit the detection of shallow, abnormal pressure in the marine sediments. When formation pore pressures can be accurately estimated, an

appropriate mud density program can be followed to prevent gas from entering the borehole. One of the most effective ways to prevent shallow gas kicks is through use of an extra pound per gallon of mud density (over the pore pressure) in the shallow portion of the well.

The importance of running a seismic hazard analysis was learned the hardway in the Gulf of Mexico in 1964. The most serious drilling accident in U. S. waters happened while drilling conductor hole in about 150 ft of water at a depth of 461 ft below the mudline. The 30-in. structural casing was set at 121 ft below the mudline. A sudden violent gas flow was experienced which caught fire. Twenty-two lives were lost and twenty-three persons were injured. No shallow hazard surveys were performed prior to drilling and a diverter system was not installed on the rig. This example also illustrates that serious shallow gas hazards can be encountered at very shallow depths.

Drilling practices followed when drilling the shallow portion of the well can also impact the blowout risk. One of the most effective ways to prevent shallow gas kicks is through use of an extra pound per gallon of mud density (over the pore pressure) in the shallow portion of the well. Operations that can reduce downhole pressures, such as pulling the drill string from the well, should be carefully controlled to ensure that a pressure overbalance is always maintained in the open borehole. Pressure changes due to pipe movement tend to increase with decreasing hole size, and thus would be more of a problem when drilling small diameter pilot holes. At shallow depths, a small loss in borehole pressure can result in a significant loss in equivalent mud density. For example, a pressure loss of 50 psi when pulling pipe from a depth of 10,000 ft is equivalent to a loss in drilling fluid density of only 0.1 lb/gal, which can often be neglected. However, the same pressure loss at only 1,000 ft is equivalent to a loss in drilling fluid density of 1 lb/gal, which could be very dangerous. Trip-tank arrangements which keep the well completely full of drilling fluid at all times are better than those that require periodic refilling of the well. Modern top-drive rotary systems permit pumping down the drill-string while pulling pipe and can be used when necessary to eliminate the swabbing effect caused by pipe movement.

Gas-cut drilling fluid can also cause a loss in borehole pressure that can result in a significant reduction in equivalent mud density at shallow depths. For example, severe gas-cut mud observed at the surface can cause as much as a 100 psi reduction in bottom-hole pressure. This pressure loss is equivalent to a loss of only about 0.2 lb/gal at a depth of 10,000 ft which is usually within a normal safety margin. However, this same pressure loss at a depth of 1,000 ft would cause a loss in equivalent mud density of 2.0 lb/gal, which could be very dangerous. Thus, when drilling at very shallow depths, even the small pressure loss due to gas-cut mud can be significant. If gas-cut mud appears prior to setting surface casing, it is advisable to periodically check for flow and to clean the well by circulating. Some shallow gas flow events are thought to have been caused by cutting fault planes through which gas was actively migrating from deeper zones. These fault-cut zones behave as high pressure but low permeability zones which only tend to cause trouble when circulation is stopped for a long period of time.

Conditions favoring a shallow gas flow due to gas-cut mud become more severe with increasing hole size, increasing drilling rate, and increasing length of uncased borehole. En-

trained gas, entering the drilling fluid from the sediments removed by the bit at the hole bottom may reduce the hydrostatic pressure below the allowable safety margin opposite a more shallow sand. This potential problem can be controlled by limiting the penetration rate of the bit. An approximate relationship between penetration rate and loss of borehole pressure was previously presented by Bourgoyne, Hise, Holden and Sullins (1978).

CASING PROGRAM

One of the first steps in developing a well control contingency plan is to decide at what point during the drilling operations that it will become safe to close the blowout preventers during a threatened blowout. The most common current field practice for drilling from a bottom supported structure is to use the blowout preventers only after surface casing has been successfully cemented. Prior to that time, the well is put on a diverter if a kick is taken. Given below are examples that illustrate the history that led to this current field practice.

Case 1 - This example occurred in the 1960's on a platform set offshore of California in 200 ft of water. Casing had been set with about 200 ft of penetration below the mudline, and the well had been drilled directionally to a measured depth of about 3500 ft. A kick was taken while tripping out of the hole. The drill pipe was dropped in the well and the blind rams closed. The well then blew out around the casing creating an oil boil at the edge of the platform.

Case 2 - This example occurred in the 1970's on a jack-up drilling offshore Louisiana. After setting conductor casing, the well was drilled to the surface casing depth of about 3800 ft. A kick was taken while tripping out of the hole. A diverter was available but was not used. The drill-string was run back to bottom and a conventional well control operation was started. Returns from the well stopped and casing pressure fell to zero. Gas bubbles were initially seen breaking the surface about 70 ft from the rig. Later gas was surfacing on opposite sides of the rig and the rig was abandoned. The gas ignited about 3 hours later. Cratering progressed and the rig was lost. Flames were reported as high as 100 ft above the water.

Case 3 - This example occurred in the 1970's on a platform rig drilling offshore Louisiana in about 300 ft of water. Drive pipe was set with about 170 ft of penetration below the mudline and conductor casing was set with about 430 ft of penetration below the mudline. After losing 10 bbl of mud while drilling at about 3300 ft, lost circulation material was spotted before tripping out of the hole. The hole was kept filled with mud and seawater while coming out of the hole. The well began flowing on the drillpipe and was shut-in. An attempt was made to circulate the well through the choke, but about 300 bbl of 10 lb/gal mud was pumped with no returns. A boil that was about 50 ft in diameter was observed about 75 yards from the west side of the platform. Additional mud was pumped

having density of 12 lb/gal and later of 14 lb/gal. Eventually the platform was abandoned until the well bridged.

The use of diverters has not resulted in a trouble free operation. Diverters were installed on many rigs after the rig was constructed. Multiple bends were required to route the diverter lines to an overboard exit and many of the early systems had poorly designed valves and flexible hoses from the wellhead to the fixed piping. Numerous mechanical problems and severe erosion due to sand production have occurred when the diverter systems had to be employed. Early diverter systems were also undersized and could not handle high flow rates without causing the backpressure on the casing seat to exceed the breakdown pressure. Also, as discussed under cratering mechanisms, work done in this study has indicated that cratering due to caving can occur if shallow aquifers are exposed, even when the casing / diverter system is properly designed and sized.

The operational problems experienced with diverters have resulted in a reduced reliance on diverter systems by some operators, especially in floating drilling operations in which the drilling vessel can be moved off location and is not threatened by cratering. A recent paper by Arifun and Sumpeno (1994) with Unocal Indonesia has indicated that platform wells are being designed and drilled in their East Kalimantan operations with a well plan that calls for shut-in of all kicks from the surface to the total well depth. Other operators have decided to shut-in a kick first, but then switch to diverter operations if the surface pressure exceeds some upper limit, such as 100 psi.

Given below are examples that illustrate the history that appears to be leading us full circle in our approach to this difficult problem:

Case 1 - This example occurred in the 1970's on a jack-up rig drilling offshore Texas in about 200 ft of water. Drive pipe was set at about 190 ft below the mudline and conductor hole was drilled to a depth of about 800 ft below the mudline. After pulling two stands of drillpipe out of the well, it began to flow. Two 6-in. diverter lines were opened and both mud pumps were brought up to speed in an attempt at a dynamic kill. The rig began to list and all personnel were evacuated. When the site was inspected 15 hours later, the rig had collapsed.

Case 2 - This example occurred in the 1980's on a platform rig drilling offshore Texas in about 330 ft of water. Drive pipe having a 20-in. diameter was set about 180 ft below the mud line and the 16-in. conductor pipe was set about 560 ft below the mud line. The well had reached a depth of 2500 ft and drillpipe was being pulled from the hole when the well began to flow. The annular preventer was closed and an attempt was made to open the diverter. However, the diverter valves had been inadvertently locked closed with locking bars. When a diverter valve did open, the flexible hose connecting the wellhead to the diverter line failed and flooded the area with gas, which quickly ignited. Six crew members were killed and 29 were injured. The platform and rig were lost.

Case 3 - This example occurred in the 1980's on a jack-up rig drilling offshore Mississippi in about 100 ft of water. Drive pipe having a 48-in. diameter was set about 150 ft below the mudline and conductor casing having a 10.75-in diameter was set about 1100 ft below the mudline (1300 ft RKB). A formation integrity test was conducted at 1310 ft RKB to 350 psi surface pressure with a 8.9 lb/gal mud in the hole. The well was drilled to the planned surface casing depth of 2900 ft. Upon beginning to trip out of the hole, the well began to flow and was put on a diverter while continuing to pump mud. After pumping 500 bbl of mud, the gas units increased and the rig was evacuated. About 18 hours after the rig was evacuated, the diverter line failed due to sand erosion. About 30 hours after the rig was evacuated, the wellhead was cut-off by sand erosion and the blowout preventers fell. After about four days, the well bridged over. Sand piles were reported all over the rig.

Figure 11 - Decision Tree for Shallow Gas Design

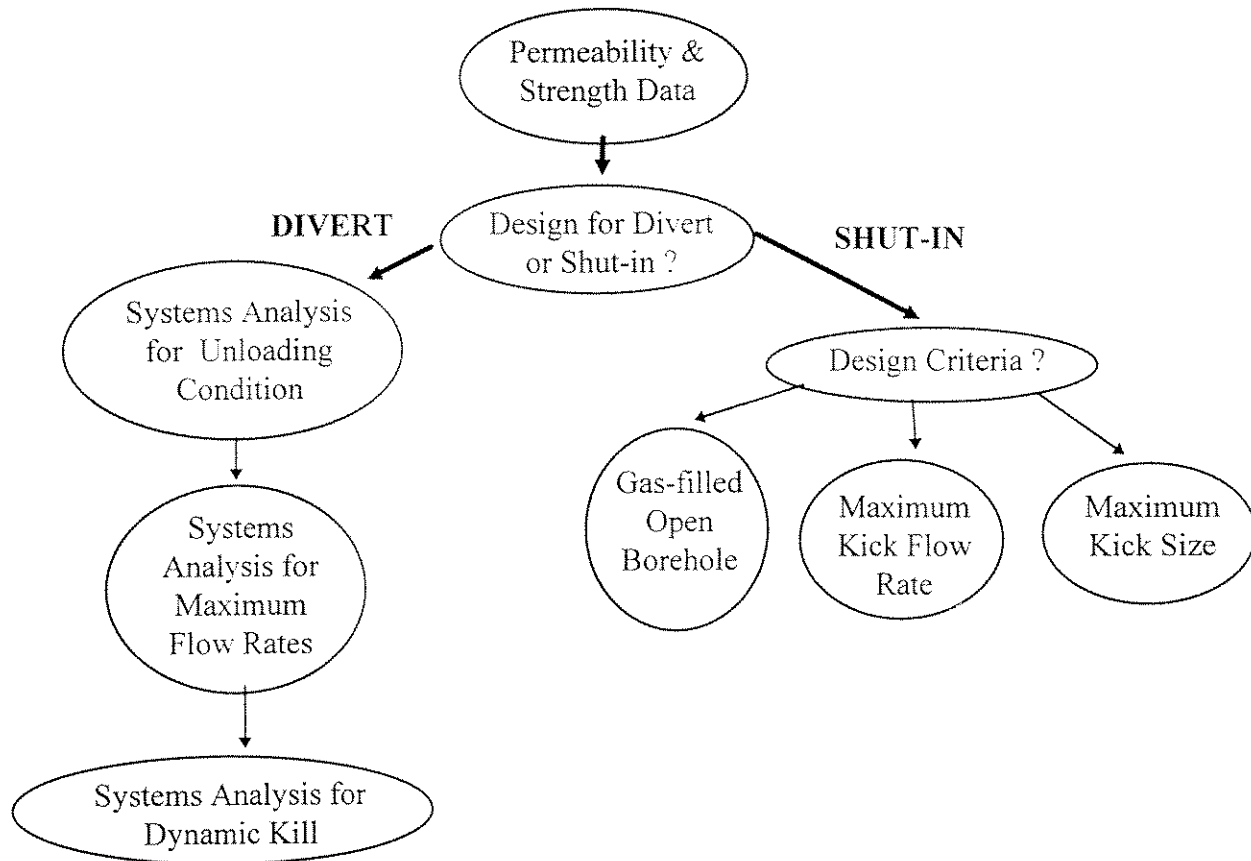

Like most other critical well design issues, the question of whether to design the shallow portion of a well to be shut-in or diverted is primarily a risk management decision in which cost must be balanced against the reduction in risk achieved. Shown in Figure 11 is a decision tree or design procedure which we believe organizes most of the major alternatives that should be evaluated. The items listed in this decision tree were judged to be pertinent based on the crater mechanisms identified in this study. There are several additional branches or decisions that must be made on both the “shut-in” and “divert” side of the tree. As more information is gained in an area, the decision path can be refined.

The thought process outlined in Figure 11 will be illustrated by means of an example. Most of the data included in this example were published by Arifin and Sumpeno (1994) for the Attaka field in Indonesia. The shallow sediments are similar to those found in the Gulf of Mexico, and the formation breakdown strength correlations obtained were very similar to those developed in this study for some Gulf of Mexico areas. Also, the casing programs previously used in this field were typical of those used in the Gulf of Mexico. In order to work some of the examples given, it was necessary to assume some additional information about the lithology.

Casing Program For Diverting Shallow Kicks

Figure 12 - Typical Casing Design for Diverting Shallow Gas Kicks

A typical casing program that had been previously used for wells drilled with bottom supported rigs in the Attaka field is shown in Figure 12. Structural casing having a 30-in. diameter was driven about 215 ft below the mud line. Conductor casing having a 20-in diameter was set at about 800 ft below the mudline. The next casing string was surface casing which was typically set at a depth of about 3200 ft. The nominal water depth is 200 ft and the nominal air gap is 85 ft.

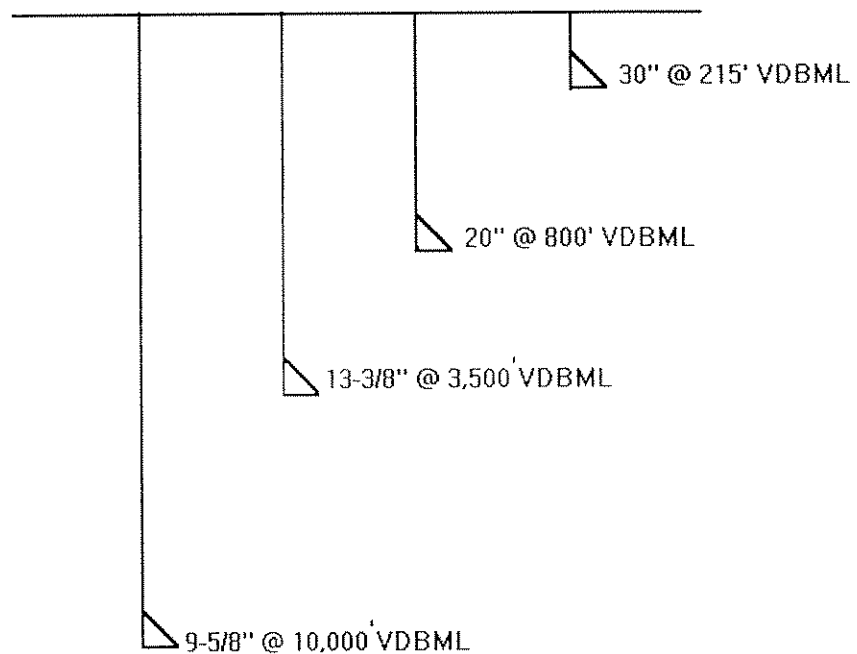

Soil borings data was available to a depth of about 330 ft. The first 100 ft of sediments had an average porosity of about 59% and the porosity observed at the bottom of the soil borings was about 50%. The soil boring showed mostly clay sediments except for a silty sand about 20 ft in thickness at about 165 ft below the mudline. The water content of the clay was above the plastic limit over the entire interval bored. The shear strength at the bottom of the boring was about 15 psi. For potential diverter operations, it would be best to protect the sand at 165 ft with drive pipe to reduce the risk of excavation of this area due to sand production from this potential aquifer. As discussed previously, collapse of overlying sediments into an excavated sandy stratum is one potential mechanism for cratering.

Shown in Table 2 is a spreadsheet calculation using the pseudo-overburden stress calculation based on Equation (6). The calculation assumes that the surface porosity is about 59%, the interstitial water has a specific gravity of 1.03, and the average matrix grain density is 2.65.

In addition, a nominal porosity decline constant of 150 E-6 ft^{-1} was assumed based on our experience with porosity versus depth trends from other areas of similar sediments. From the available data, the upper sediments appear to be mostly clay, and consequently the ratio of horizontal to vertical effective stress should be near one. Thus, the expected formation breakdown pressure is equal to the overburden pressure plus any tensile strength of the sediments. Plotted as a dashed line in Figure 13 are the formation breakdown pressures computed in Table 2 at various depths. Considerable leak-off test data for the area were published and are also shown in Figure 13. A final adjustment of the porosity decline constant to 100 E-6 ft^{-1} was made based on this leak-off data. The final adjusted formation breakdown pressure curve selected for the casing design is shown as a solid line.

Depth RKB	Depth Sub Surface	Porosity & Bound Water	Pseudo Overburden Stress + So	Pore Press	Effective Subsea Strength	D2/D1 Ratio
ft	ft		psi	psi	psi/ft	
285	0	59.00%	93	88		
400	115	58.33%	178	140	0.78	1.75
500	215	57.75%	252	184	0.76	1.71
1000	715	54.93%	629	408	0.76	1.69
1500	1215	52.25%	1015	631	0.76	1.71
2000	1715	49.70%	1410	854	0.77	1.73
2500	2215	47.28%	1814	1078	0.78	1.74
3000	2715	44.97%	2226	1301	0.79	1.76
2300	2015	48.23%	1651	989	0.78	1.74
2400	2115	47.75%	1733	1033	0.78	1.74
3500	3215	42.78%	2646	1525	0.80	1.78
4000	3715	40.69%	3074	1748	0.80	1.80
5000	4715	36.82%	3950	2195	0.82	1.83
6000	5715	33.32%	4853	2642	0.83	1.87
7000	6715	30.15%	5778	3088	0.85	1.90
8000	7715	27.28%	6725	3535	0.86	1.93
9000	8715	24.68%	7691	3982	0.87	1.95
10000	9715	22.33%	8674	4429	0.88	1.98

Table 2 - Spreadsheet output using Peuedo Overburden Stress Model to predict Fracture Pressure

Figure 13- Comparison of predicted hydraulic breakdown pressure and leak-off tests.

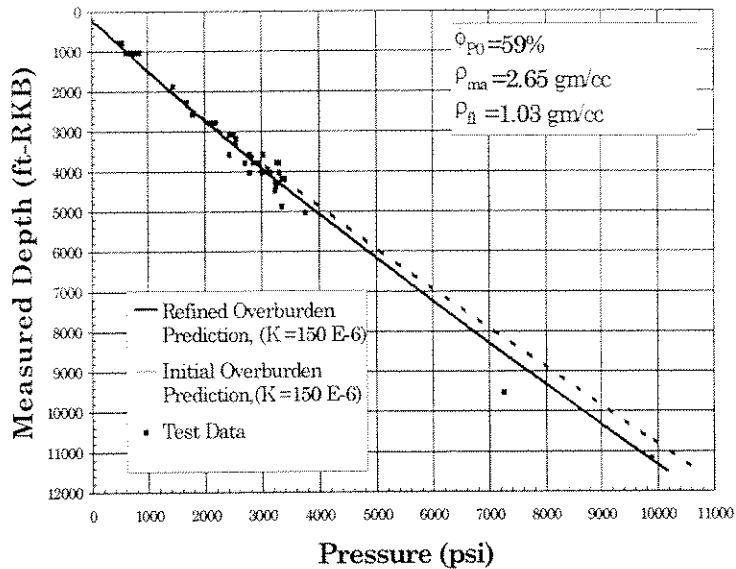

When the well plan calls for diverting shallow kicks, the selected shallow casing design and the available diverter system must be checked using a systems analysis approach described in a previous report. The analysis considers a shallow gas reservoir (at the depth of the next casing seat), the well hydraulic path, and diverter as one system. The maximum pressure observed at the casing seat for several design load conditions are calculated. The design loads are estimated (1) when the well is unloading, (2) when the flow reaches a maximum value, and (3) during possible dynamic kill operations (including the possible use of a relief well). If the well cannot withstand the expected design loads without cratering or if the dynamic kill requirements are not acceptable, the planned casing program/

diverter system is modified, and the systems analysis is repeated. The systems analysis procedure developed in our previous work will not be repeated in this report. However, it has been recently published as Chapter 10, in the book *Studies in Abnormal Pressure* edited by Fertl, Chapman, and Hotz.

Casing Program for Shut-in of Shallow Kicks

Until recently, it has been generally accepted that it was not economically feasible to design a shallow casing string for shut-in on a gas kick. As discussed previously, extrapolation of correlations for the ratio of effective horizontal stress to vertical overburden stress indicated the shallow sediments would have extremely low fracture extension pressures. Leak-off test data on shallow strings was rarely taken for fear of breaking down the casing seat and not being able to regain the integrity of the casing shoe. The ability to obtain an acceptable cement bond in soft sediments has also been questioned. This study has shown that the horizontal to vertical stress ratio is near one in many areas. This, as well as shallow leak-off test data released by Unocal, has indicated that the shallow sediments often have higher hydraulic breakdown pressures than previously believed.

The cost versus risk reduction benefit that can be achieved on an exploratory well by designing the casing for shut-in on shallow gas kicks will be illustrated using the following three design loads:

- (1) A large shallow gas kick is taken at a gas influx rate that is high enough to change the multiphase flow pattern in the well to mist-flow and completely displace all of the mud from the uncased portion of the well.
- (2) A gas kick is taken at a rate that is insufficient to change the multiphase flow pattern to mist-flow but is large enough to fill the entire uncased portion of the wellbore with the mud/gas mixture.
- (3) A gas kick is taken, but the well is successfully shut-in before a specified pit-gain is observed.

The first design load is the most conservative and --- at least theoretically --- would be the least susceptible to human error. The third design load is the least conservative, but the consequences of human error could be great.

Design Load based on Gas-Filled Open-hole at Shut-in (Worst Case Analysis)

Consider the conventional casing design of Figure 12, and assume that the surface casing setting depth of 3500 ft below the mudline (BML) is the minimum needed to provide the desired kick tolerance to reach the depth of the next casing string in a conventional casing design procedure. Furthermore, assume that 2500 ft is the amount of sediment penetration for which we feel certain that an underground blowout will remain underground. This is based on the presence

of a sand at 2500 ft with a thick, stronger claystone above that would act as a confining layer to a vertical fracture in the sand. It is further assumed that a hazard seismic survey indicated no potential gas zones were present in the upper 800 ft of sediments.

Shown in Figure 14 is the casing design required to contain 100% gas in the open borehole. The design process is started at the depth of the surface casing and proceeds in a stairstep manner as indicated by the arrowheads shown. For the average fracture gradient and normal pore pressure gradient of this example, the D_1/D_2 depth ratio of successive casing strings is about 1.8 (0.8 psi/ft / 0.45 psi/ft = 1.8). To reach a depth of 3500 ft-BML, casing would have to be set at 2025 ft-BML, which is less than the 2500 ft-BML

Figure 14 - Example design for gas filled open hole section

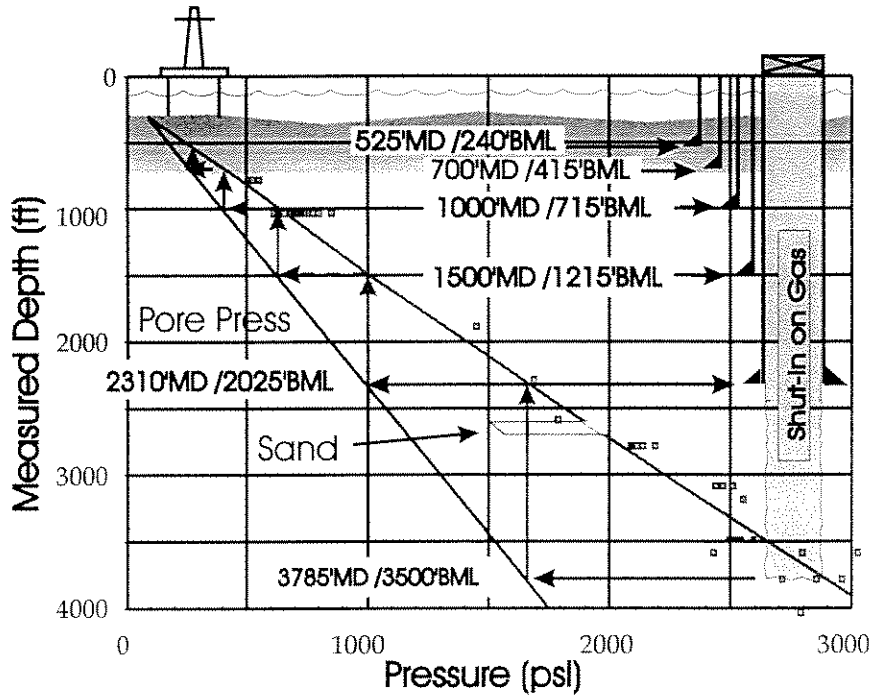

needed to keep a blowout underground. Although breakdown is possible at 2500 ft-BML, formation breakdown pressure would not be exceeded for any kick size at 2025 ft-BML. Casing would have to be set at 1215 ft-BML to reach a depth of 2025 ft-BML, at 715 ft-BML to reach 1215 ft-BML, and at 415-BML ft to reach 715 ft-BML. If the seismic analysis was uncertain, the absence of potential gas zones to a depth of 415 ft-BML could be verified by soil borings or a glory-hole to ensure this depth could be safely reached below drive pipe.

The additional costs associated with this casing design over the conventional design shown in Figure 12 was estimated to be \$330,000. The available statistics for the OCS indicate that about one exploration well in 243 drilled have experienced a shallow gas blowout. About 71% of these blowouts bridged naturally due to borehole collapse. Costs of these blowouts have been limited primarily to the loss of the well being drilled. About one exploratory well in 2000 drilled from bottom-supported structures during the past 20 years has had extensive, to total structural damage during the past 20 years. No casualties have been tied directly to cratering in this time period although some resulted from mechanical problems with early diverter designs. Also, pollution has been minimal due to the lack of associated oil. Multiplying the approximate additional cost by 243 yields \$80,000,000. Thus if this design procedure eliminated all blowouts due to shallow gas, the value of the well saved would have to be greater than \$80,000,000. to justify the additional expense per well. Multiplying the approximate additional cost by 2000 yields \$660,000,000. Thus if this design eliminated all cratering events that caused major

structural damage or total loss of the structure and associated wells, the value of the structure saved would have to exceed \$ 660,000,000 to justify the additional expense per well.

The critical gas velocity for mud droplet removal was estimated in a previous study to be about 600 ft/min (Bourgoyne et.al., 1994). For gas velocities higher than this, all of the mud can be removed from the well. To get a feel for the kick magnitude this corresponds to, consider that in a 17.5-in. hole with 5-in. drill pipe, the annular capacity is 0.27 bbl/ft. Thus, either the pit gain rate would have to exceed $600(0.27)=162$ bbl/min, or human error would have to let the well completely unload. For a 9.875-in. pilot hole, the annular capacity is 0.07 bbl/ft and the pit gain rate would have to exceed 42 bbl/min. The presence of a large enough gas zone to cause a flow of this magnitude and yet not be detected by a seismic hazard survey seems highly unlikely. Current practice already calls for setting casing prior to drilling known hydrocarbon bearing formations.

Based on the discussion above, we have concluded that although technically feasible for many cases, the use of this design load will generally be unnecessarily expensive for the potential benefit.

Design load based on Mud/Gas Mixing

The maximum rate of gas influx can be estimated from expected maximum formation permeability and thickness for the area. In a previous report, the maximum rate of pit gain for one area was estimated to be about 18 bbl/min in a 17.5-in. hole. For these conditions, the gas would bubble through and mix with the mud, displacing about 50% of the mud from the well. Based on experimental data we gathered in an earlier study (Bourgoyne et. al, 1994), this would result in an effective pressure gradient of 0.254 psi/ft in the mud gas mixture. The casing design for these conditions is shown in Figure 15. Note that the size of the kick does not matter once the top of the multiphase mixture reaches the previous casing seat. The additional costs of this design over the typical design shown in Figure 12 was estimated to be \$120,000. Multiplying this cost by 243 yields \$29,000,000 and by 2000 yields \$240,000,000.

Figure 15 - Example Casing Design Load for Mud/Gas Mixing

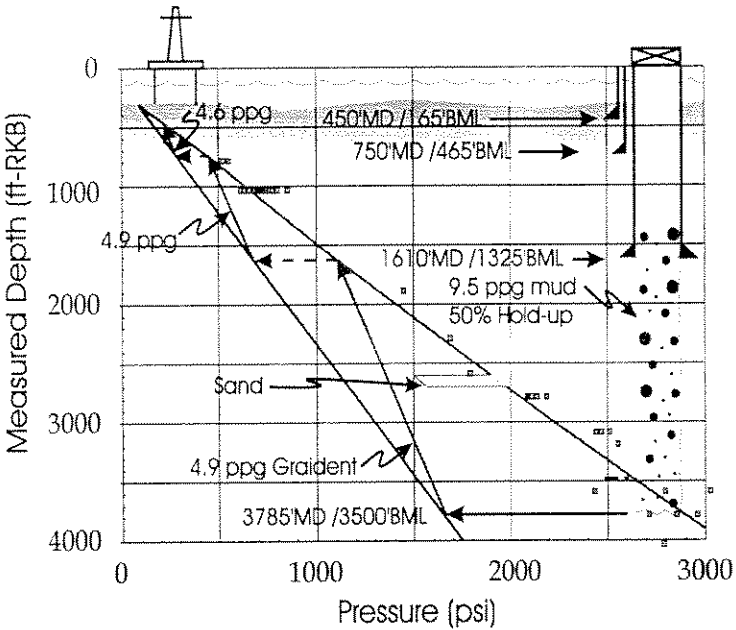

Design Load based on Maximum Pit Gain to Shut-in

The least conservative design load is obtained by assuming that the kick will be shut-in with a maximum total pit gain. The design shown in Figure 16 is based on a maximum tolerated pit gain at shut-in of 200 bbl. The additional costs associated with this design load was estimated to be about the same as the typical design shown in Figure 12.

The major problem with this method is that the potential consequences of human error are greater. If a kick is taken that is larger than the kick tolerance included in the design, there is a possibility that gas could surface under the rig prior to making an orderly rig abandonment. This would be especially true if no diverter was available to release the pressure as soon as gas bubbles appeared.

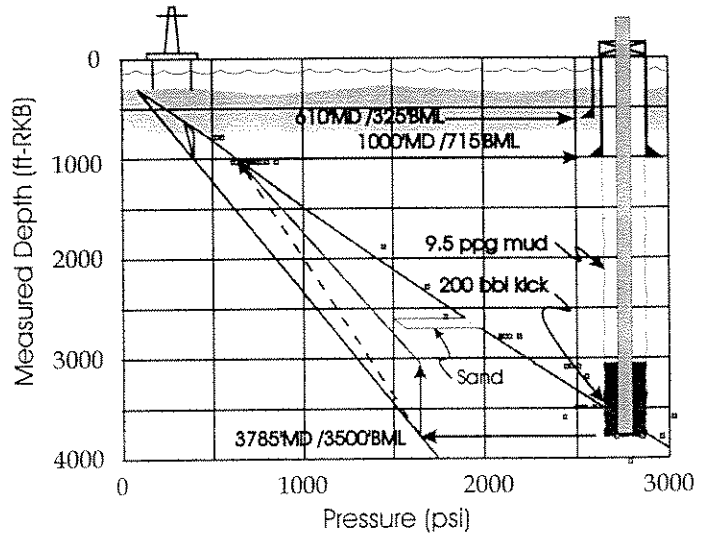

Figure 16- Example Casing Design for 200 bbl Kick Tolerance

SUMMARY AND CONCLUSIONS

This study focused on the vulnerability of a bottom supported marine structure to destruction by the formation of a crater in the sea floor associated with oil and gas drilling operations. Statistics were reviewed that allows the risk of crater formation to be quantified. The mechanisms through which failure of the sediments can occur were identified. Data were collected on the strength of the upper marine sediments in several geographic areas and a new method was presented for developing empirical correlations for hydraulic breakdown pressures of upper marine sediments. Available well design methods for avoiding cratering were reviewed and recommendations for design loads were given.

As a result of the study, the following conclusions were drawn:

1. Statistics gathered by MMS on drilling operations on the U.S. Outer Continental Shelf over the period 1972-92 indicated the following:
 - The primary cause of crater formation due to drilling operations is the unexpected penetration of shallow gas formations.

- One exploratory well out of 243 drilled and one development well out of 536 drilled experienced a shallow gas blowout.
 - One exploratory well out of 800 and one development well out of 1917 experienced a shallow gas blowout that did not stop flowing on its own (either due to depletion of the gas zone or bridging of the well due to borehole collapse).
 - Approximately one exploratory well out of 2000 and one development well out of 4500 experienced extensive damage or total loss of the structure due to a shallow gas blowout.
 - Oil has not been associated with shallow gas blowouts during this period and environmental damage has not been significant.
 - Twenty five fatalities and 65 injuries were caused by all types of blowouts during this period. None of these fatalities or injuries were associated with cratering of a bottom supported vessel.
 - There have been no casualties due to blowouts on the O.C.S. reported during the past seven years.
2. A multi-disciplinary literature study was conducted to identify the possible mechanism for cratering. The primary mechanisms found included:
 - Cement channels and borehole erosion
 - Formation liquifaction
 - Piping or tunnel erosion
 - Caving due to sand production
 3. Cratering can occur even when the well is placed on a diverter and the system is designed so that the hydraulic breakdown pressure of the sediments are not exceeded.
 4. Sources of good formation strength data for shallow sediments include:
 - Formation leak-off test data
 - Soil borings
 - Formation density log data
 5. Extrapolation of horizontal-to-vertical overburden-stress ratio correlations to shallow sediments often gives a misleadingly low estimate of formation breakdown pressure. The true horizontal-to-vertical overburden-stress ratio is often near one for shallow clay-rich marine sediments.
 6. Kick prevention is the best means of preventing structural damage due to cratering.
 7. Design options that could allow the well to be shut-in from surface to total depth are technically feasible.

NOMENCLATURE

ϕ = porosity

ϕ_0 = surface porosity

ϕ_{fric} = angle of internal friction

ρ_b = bulk density

ρ_{fluid} = pore fluid density

ρ_{matrix} = matrix or grain density

ρ_{sw} = density of the seawater

σ_{fail} = failure stress

σ_h = horizontal stress

σ_{min} = minimal effective (matrix) stress

σ_n = normal stress

σ_{rw} = principal wellbore stress in the r direction

$\sigma_{\theta w}$ = principal wellbore stress in the θ direction

σ_{zw} = principal wellbore stress in the z direction

σ_{ten} = tensile stress

σ_z = vertical effective (matrix) stress

τ_{fail} = failure strain

a_1, a_2, a_3 = constants (See Eq. (13) and Table 2)

c = cohesion

c_u = undrained shear strength

D = depth

D_w = water depth

D_s = depth of the sediment below the sea floor

F_{σ} = horizontal-to-vertical matrix stress coefficient

g = gravitational constant

K = the porosity decline constant

LL = liquid limit

PL = plastic limit

p = pore pressure

p_{frac} = fracture pressure

p_{init} = initial fracture pressure

p_w = wellbore pressure

S = overburden pressure

S_{poh} = pseudo-overburden pressure

σ_o - overburden pressure

g - gravity acceleration

D_u - water depth

ρ_w - water density

ρ_{bi} - bulk density in depth interval

$(D_i - D_{i,j})$ - depth interval

n - number of intervals

p - overburden pressure gradient

Δt - interval transit time

Δt_{matrix} - matrix interval transit time

Δt_{fluid} - fluid interval transit time - porosity

a, b - constants

K_{ϕ} - porosity declining constant

ϕ_{p0} - pseudo-surface porosity

$K_{p\phi}$ - pseudo-porosity declining constant

σ_{frac} - formation fracture

σ_{min} - minimum in-situ stress

σ_p - formation pore pressure

σ_z - vertical stress

F_σ - horizontal to vertical stress ratio

μ - Poisson ratio

$c_1 \dots c_6, X, A, M$ - constants used in Zamora's Method

K_T - kick tolerance

SF - kick tolerance safety margin defined by Pilkington

T_m - trip margin

ρ_{mud} - mud density

D_{Shoe} - casing depth

$P_{c \text{ max}}$ - maximum surface pressure

f_k - kick fraction

L_{mix} - mixed zone length

d_{bit} - bit diameter

d_{dc} - drill collar diameter

d_{dp} - drill pipe diameter

V_k - kick volume

ρ_{mix} - density in the mixed zone

V_{mix} - volume of the mixed zone

V_{dc} - hole-drill collar annular volume

EMW - equivalent mud weight

IBML - depth below mud line

Acknowledgments

The authors would like to acknowledge the valuable assistance of Martin Bethke of CONOCO, Inc., Van Pertin of Chevron, and Don Renson of Western Oceanic, Inc. with this project. Without their help, this work would not have been possible.

References

- Aadnoy, B.S. and Larsen K., "Method For Fracture-Gradient Prediction For Vertical And Inclined Boreholes", 1989, SPE Drilling Engineering, June 1989, pp 99-103, USA.
- Aadnoy, B.S. and Soteland T., "Casing Point Selection at Shallow Depth", 1989, SPE 18718, 12 p, USA.
- Adams N, and Kuhiman, L.G., 1991, "How to prevent or minimize shallow gas blowouts-Part 1", Word Oil, May 1991, pp 51-58, USA.
- Adams N, and Thompson, Joe, 1989, "How a geothermal blowout was controlled", Word Oil, June 1989, pp 36-40, USA.
- Arifun and Sumpeno, Wahyu H.: "A New Approach to Casing Setting Depth Selection in Unocal East Kalimantan Operations," Proceedings Indonesian Petroleum Association, 21st Annual Convention, October, 1992.
- Arifun and Wahyu H. Sumpeni, 1992, "A New Approach to Casing Setting Depth Selection in UNOCAL East Kalimantan Operations", Proceedings Indonesian Petroleum Association, Twenty First Annual Convention, October 1992, Indonesia.
- Bell, F. C, 1983, *Engineering Properties of Soils and Rocks*, Butterworths, 149 p, London.
- Best D., Wraight P., Holenka J., 1990, "An Innovative Approach to Correct Density Measurements While Drilling for Hole Size Effect", SPWLA 31st Annual Logging Symposium, June 24-27, 1989, USA.
- Bourgoyne, Adam T., 1989, "The Development of Improved Blowout Prevention System for Offshore Drilling Operations Part I - Shallow Gas Hazards", Final Report, MMS Contract 14-12-0001-30274, November 27, 1989, USA.
- Bourgoyne, Adam T.; Chenevert, Martin E.; Miliheim Keith K., and Young F.S. Jr, 1986, *Applied Drilling Engineering*, SPE Text Book Series, Vol 2.. USA.
- Breckels, I.M. and van Eekelen, H.A.M., 1982, "Relationship Between Horizontal Stress and Depth in Sedimentary Basins", Journal of Petroleum Technology, September 1982, pp 2191-2199, USA.

- Brennan R.M. and Annis M.R., "A New Fracture Gradient Prediction Technique That Shows Good Results in Gulf of Mexico Abnormal Pressure", SPE 13210, 6 p, USA.
- Cassagrande, A. : " Research of Atterberg Limits of Soils," Public Roads, Vol. 13, No. 8, 121-136,1932.
- Cesaroni, Renzo; Giacca Diego; Schenato Adelmo; and Thierree Bernard, "Determining Frac Gradient While Drilling", Petroleum Engineering International, June 1981, 11p. USA.
- Christman, S., 1973, "Offshore Fracture Gradients"~ J. Pet. Tech., August, 1973, pp 910-914, USA.
- Chuman O. S., Allen R. L., and McNeill R. L., 1977, "Erosion, Corrective Maintenance, and Dispersive Clays", in *Dispersive Clays, Related Piping, And Erosional In Geotechnical Projects*, ASTM Special Technical Publication 623, pp 172-190, USA.
- Clough, G. W., Iwabuchi, Jotaro, Rad, N. Shafii and Kuppusamy, T. (1989), "Influence of Cementation on Liquefaction of Sands", Journal of the Geotechnical Engineering, vol 115, n0 8, pp. 1102-1117, USA.
- Committee on Soil Dynamics of the Geotechnical Engineering Division, 1978, "Definition of Terms Related to Liquefaction", Journal of the Geotechnical Engineering Division, ASCE, pp 1197-1201, USA.
- Constant, W. David, and Bourgoyne, A. T., "Fracture-Gradient Prediction for Offshore Wells", SPE Drilling Engineering, June 1988, pp 136-140, USA.
- Crouch, R. J., 1977, "Tunnel-Gully Erosion and Urban Development: A Case Study", in *Dispersive Clays, Related Piping, And Erosional In Geotechnical Projects*, ASTM Special Technical Publication 623, pp 58-73, USA.
- Danenberger, E.P. (1993), "Outer Continental Shelf Drilling Blowouts, 1971-1991" OTC 7248, 25th Annual OTC in Houston, Texas, May 1993, USA.
- Das, Braja M.: *Principles of Geotechnical Engineering*, 3rd ed., Southern Illinois University at Carbondale, PWS Publishing Co., Boston, 1994.
- Eaton, B. A.: "Fracture Gradient Prediction and its Application in Oilfield Operations," J. Pet. Tech. (Oct., 1969), 1353-1360.
- Ewing M., Worzel, J.L., and Burk, C.A., 1969, "Initial Reports of the Deep Sea Drilling Project", Orange, Texas to Hoboken. N.J., August-September 1968, National Science Foundation, National Ocean Sediment Coring Program, USA.

- Fjaer, E.; Holt R.M.; Horsrud, P.; Raaen, A.M., and Risnes, R., 1992, *Petroleum Related Rock Mechanics*, Elsevier, New York, USA.
- Gaylord, E. W., 1989, "A Laboratory Study of The Effects Of Hydraulic on Hole Erosion", SPE 12118, 12 p, USA.
- Goins, W. C. and Ables, G.L., 1987, "The Causes of Shallow Gas Kicks", SPE 16128, 10p, USA.
- Haimson, Bezael and Fairhurst, Charles, 1967, "Initiation and Extension of Hydraulic Fractures in Rocks", SPE 1710, 9p, USA.
- Harrison, E., Kieschnick, W.F., and McGuirre, W.J., 1954, "The Mechanics of Fracture Induction and Extension", Trans., AIME, Volume 201, pp 252-263, USA.
- Hills, H. B., 1932, "Crater Wells Richland Gas Field Louisiana", Technical Paper 535, U.S. Bureau of Mines, USA.
- Hubbert, M. King and Willis David, G., 1957, "Mechanics of Hydraulic Fracturing", Petroleum Transactions (AIME), Volume 210, pp 153-166, USA.
- Kamphuis, J. W. and Hall, Kevin R. 1983, "Cohesive Material Erosion by Unidirectional Current", Journal of Hydraulic Engineering, ASCE, Vol. 109, N01, pp 49-61, USA.
- Kramer Steven L and Seed H Bolton, 1988, "Initiation of Soil Liquefaction Under Static Loading Conditions", Journal of Geotechnical Engineering, Vol 114, n0 4, pp 412-430, USA.
- Lee, Ian K.; White Weeks, and Ingles Owen C., 1983, *Geotechnical Engineering*, Pitman Books Limited, 508 p, London.
- Lockyear, C.F.; Ryan D.F., and Cunningham, 1989, "Cement Channeling: How to Predict and Prevent", SPE 19865, 64th Annual Technical Conference and Exhibition of the SPE, October 8-11, 1989, San Antonio, TX, USA.
- LSU, 1993, "LSU Well Control Manual", USA.
- Martinez, S. J., Steanson, R. E. and Coulter, A. W., 1990, "Formation Fracturing", SPE Reprint Series N0 28, USA.
- Matthews W.R. and Kelly, John, 1967, "How to Predict Formation Pressure and Fracture Gradient from Electric and Sonic Logs", The Oil and Gas Journal, February 20, 1967, pp 39-43, USA.
- Pennebaker, E. S.: An Engineering Interpretation of Seismic Data," SPE 2165 (1968), USA.

- Pilkington, Paul E. and Niehaus Henry A., 1975, "Exploding the Myths about Kick Tolerance", World Oil, June 1975, pp 59-62, USA.
- Prior, D.B.; Doyle, E.H., and Kaluza, M.J., 1989, "Evidence for Sediment Eruption on Deep Sea Floor, Gulf of Mexico", Science, Vol. 243, pp 517-519, January 27, 1989, USA.
- Redmann K.P., 1991, "Understanding Kick Tolerance and Its Significance in Drilling Planning and Execution", *SPE Drilling Engineering*, December 1991, pp 245-249, USA.
- Rocha, Luiz A. and Bourgoyne, A. T. : "Identifying Crater Potential Improves Shallow Gas Kick Control," Oil and Gas Journal, pp. 93-97, Dec. 27, 1993.
- Rocha, Luiz A. and Bourgoyne, A. T.: "A New Simple Method to Estimate Fracture Gradient," SPE 28710, SPE International Petroleum Conference, Veracruz, Mexico, October, 1994.
- Rocha, Luiz A. S.: "Mechanisms of Crater Formation While Drilling A Well," Ph.D. dissertation, Louisiana State University, December, 1993.
- Scott C. R., 1969, *An introduction to Soil Mechanics and Foundations*, Maclaren and Sons, England.
- Seed Bolton H., Idriss Izzat M. and Arango Ignacio, 1981, "Evaluation of Liquefaction Potential Using Field Performance Data", ASCE Convention and Exposition, October 26-31, 1981, St. Louis, MO, USA.
- Serra, O., 1986, "Advance Interpretation of Wireline Logs", Schlumberger, USA.
- Skempton, A. W.: "Discussion: The Planning and Design of New Hong Kong Airport," Proceedings, Institute of Civil Engineers, London, Vol. 7, pp. 305-307, 1957.
- Terzaghi Karl and Peck, Ralph, B., 1967, "Soil Mechanics in Engineering Practice", John Wiley & Sons, Inc., pp 459, USA.
- Tracy, Lloyd M., 1992, "Accidents Associated with Oil and Gas Operations-Outer Continental Shelf 1956-1990", MMS - U.S. Department of the Interior Minerals Management Service, OCS Report MMS 92-0058, USA.
- Veatch, Ralph W, Moschovidis, Zissis A. and Fast C. Robert, 1989, "An Overview Of Hydraulic Fracturing", in Recent Advances In Hydraulic Fracturing, SPE Monograph Volume 12, pp 1-38, USA.
- Walters, J. V., 1991, "Internal Blowouts, Cratering, Casing Setting Depths, and the Location of Subsurface Safety Valves", SPE Drilling Engineering, Dec. 1991, SPE 20909, pp 285-292, USA.

- Warpinski N.R. , Smith, Michael Berry, 1989, "Rock Mechanics and Fracture Geometry", in Recent Advances in Hydraulic Fracturing, SPE Monograph, vol. 12, pp 57-80, USA.
- Warpinski N.R. and Teufel L.W., 1984, "Influence of Geologic Discontinuities on Hydraulic Fracture Propagation" SPE 13224, 15 p. USA.
- Wessel, Michael and Tarr, Brian A., 1991, "Underground Flow Well Control: The Key to Drilling Low-Kick-Tolerance Wells Safely and Economically", SPE Drilling Engineering, December 1991, pp 250-256, USA.
- Wilder, Dale C. and Lin, Chung, Hsing, 1983, "Liquefaction Potential Assessment Based on Borehole Geophysical Logging Concept and Case History", SPWLA Twenty-Fourth Annual Logging Symposium, June 27-30, 1983, USA.
- Wraight, P.; Evans, M.; Marienbach, E.; Rhein-Knudsen. E., and Best, D., 1984, "Combination Formation Density and Neutron Porosity Measurements While Drilling". SPWLA Thirtieth Annual Logging Symposium. June 11-14. 1989, USA.
- Zamora, Mario, 1989, "New Method Predicts Gradient Fracture", Petroleum Engineering International, September 1989, pp 38-47, USA.
- Zeevaert, Leonard, 1973. *Foundation Engineering for Difficult Subsoil Conditions*, Van Nostradamus Reinhold Company, pp.175-215, USA.