



www.mms.gov

Safety Devices

The Minerals Management Service (MMS) actively participates with industry to ensure the safe evacuation of all offshore employees, protection of the facility, and inspection of safety devices on production equipment and pipelines. Through current regulations, annual above-water structural inspections, and 100-year storm design standards, MMS and the industry have developed significant improvements to the safety of the operations.

MMS also requires all wellbores in the Gulf of Mexico to consist of a downhole safety valve (DSV). A DSV isolates wellbore pressure and fluids in the event of an emergency or failure of surface equipment. In severe hurricanes, closing the DSV eliminates the potential for the escape of any oil, gas, or wellbore fluid into the Gulf.

Even though MMS performs rigorous inspections and enforces strict regulations, the possibility of an oil spill during a hurricane or tropical storm still exists. For this reason, MMS require all companies operating in the GOM to demonstrate they have the ability to respond and successfully contain and remove a 5,000 barrel-per-day spill. MMS periodically inspects the spill response equipment to ensure that it is readily available, well maintained, and appropriate for the area of operations.

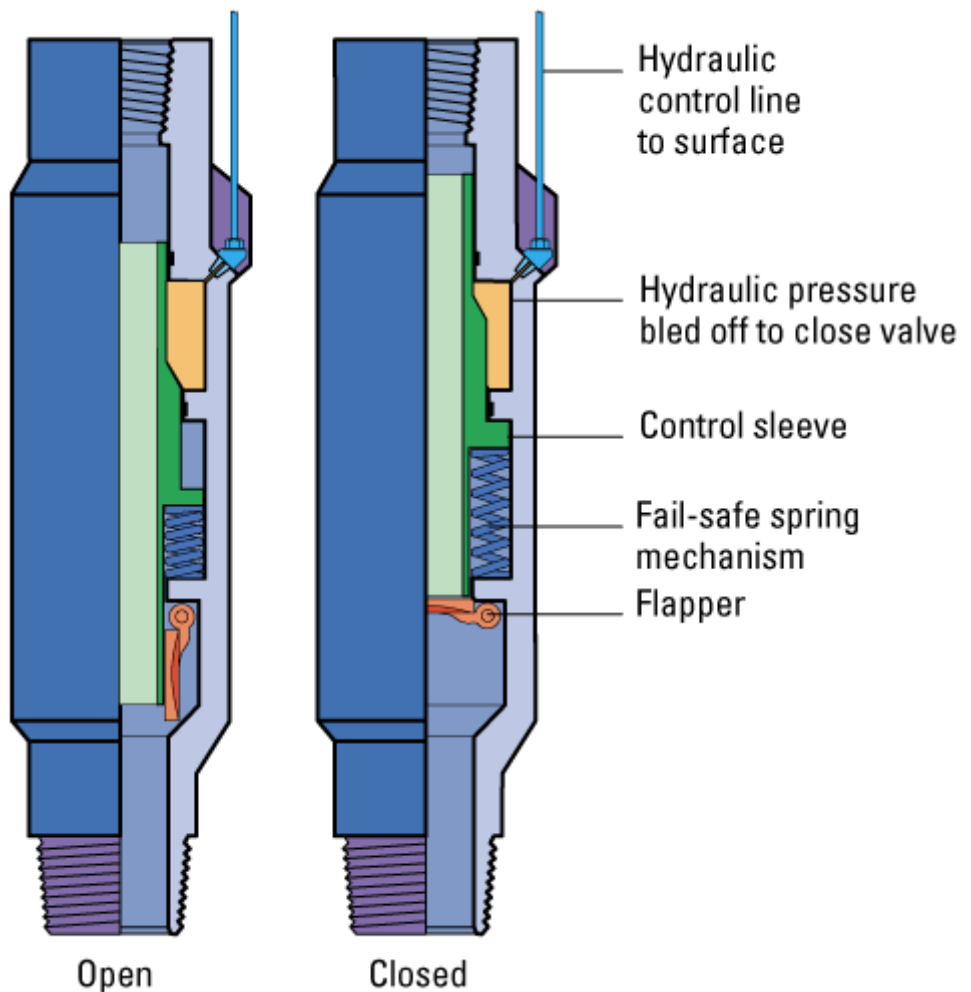

MMS Securing Ocean Energy & Economic Value for America

www.mms.gov

