

**PHILADELPHIA WATER DEPARTMENT
CROSS CONNECTION CONTROL PROGRAM
LISTINGS OF CITY APPROVED BACKFLOW ASSEMBLIES
(2008)**

SHUTOFF VALVES

The backflow prevention assemblies shown on this list have been approved by PWD with a specific set of shutoff valves as an integral part of the assembly. The specific shutoff valves shown in **bold type** are defined below. Other shutoff valves having similar performance characteristics which permit the assembly to meet the University of Southern California Foundation for Cross Connection Control and Hydraulic Research (USC FCCC&HR) FCCC&HR's specifications are approved by PWD and also shown immediately after the original shutoff valves.

Please note that the use of any shutoff valve on a specific assembly, other than those listed for that specific assembly is not approved by PWD. For other shutoff valves usage, an approval must be obtained from the PWD's CCC office before the installation.

Identification of shutoff valves:

- [a] American Figure 1 - QT
- [b] American Figure 17 - NRS RW
- [c] American Figure 37 - OSY RW
- [d] Apollo Series 7B - QT
- [e] AVK Series 25 - NRS
- [f] AVK Series 23 - OSY (Nibco F607RW OSY)
- [g] Clow R/W F6102 - NRS
- [h] Clow R/W F6136 - OSY
- [i] Fortune Figure 601 - QT
private labeled as: Ames Buckner Febco Flomatic Hersey Wilkins
- [j] Kennedy Ken Seal I - NRS
- [k] Kennedy Ken Seal I - OSY
- [l] Kennedy Ken Seal II - NRS
- [m] Kennedy Ken Seal II - OSY
- [n] Lee Brass - QT
- [o] Watts 405-RW
- [p] Watts 408-OSY
- [q] Mueller R/W HP NRS
- [r] Mueller R/W HP OSY
- [s] Toro/Orion Integral Ball Valve - QT
- [t] American Flow Control (Waterous) Series 500 - NRS
- [u] American Flow Control (Waterous) Series 500 - OSY
- [v] Watts Figure FBV (& FBV-E) - QT
- [w] Watts G4000FDA - QT
- [x] Watts Series 6080 (& 6080-E) - QT
- [y] Matco-Norca 100W
- [z] Matco-Norca 405 OSY
- [aa] American Flow Control Series 2500-NRS
- [bb] American Flow Control Series 2500-OSY
- [cc] M&H Model 4067-02 (NRS)
- [dd] M&H Model 4068-02 (OSY)
- [ee] Stockham Model G-610 (OSY)
- [ff] Febco Series 621 – QT
- [gg] Fortune Figure620U - QT
- [hh] Watts Figure S-FBV (& S-FBV-E) - QT
- [ii] Mueller Model A2360 – NRS
- [int] Shutoff valve is integral part of assembly
- [jj] Febco Series 621 – QT
- [kk] Febco Series 620U – QT
- [ll] Mueller Model R2360 – OSY
- [mm] Conbraco Series IBVE – 125 –QT
- [nn] Kennedy Ken Seal II Post Indicator/Tapping Valve
- [oo] Febco series 622 – QT
- [pp] Clow Series F6105 – NRS
- [qq] Clow Series f6138 – OSY
- [rr] Apollo Series 7B – 308 – 01 (& 7B-308 –31)
- [ss] Clow Series F6104 – NRS
- [tt] Clow series F6137 – OSY
- [uu] Apollo Series 7H – QT
- [vv] Clow R/W F6136 – OSY Post Indicator/Trapping Valve
- [ww] Clow R/W F6138 – OSY Post Indicator/Tapping Valve
- [xx] Febco Series 622U QT
- [yy] Victaulic Series 702 (Butterfly valves)

Identification of Assembly Flow Direction

DCV, DCD, RPZ, RPD

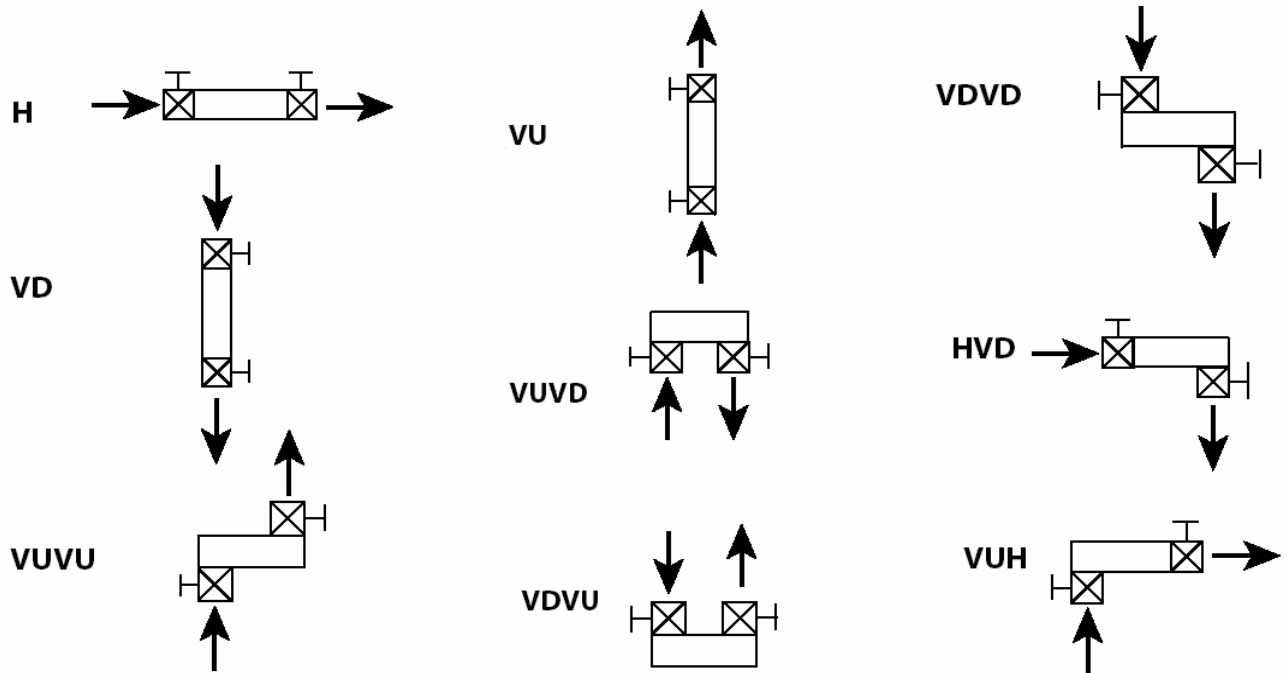

Key (H) Horizontal (D) Down
(V) Vertical (U) Up

 Shutoff Valve

 Direction of Flow

Sample

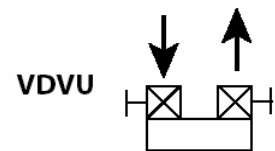

Inlet- Vertical flowing down
Outlet- Vertical flowing up

**PHILADELPHIA WATER DEPARTMENT
CROSS CONNECTION CONTROL PROGRAM
(2008)**

LIST OF APPROVED REDUCED PRESSURE ZONE (RPZ) ASSEMBLIES

The RPZ backflow prevention assembly used must be selected from the following listing. The Water Department shall regularly update the listing which shall be made available at L&I and the Water Department. Also all RPZ assemblies listed below are approved for the **ORIENTATION** indicated under **DIRECTION**.

<u>COMPANY</u>	<u>MODEL</u>	<u>DIRECTION</u>	<u>SHUTOFF VALVES</u>	<u>SIZE IN INCHES</u>
AMES	4000B	(H)	[v],[x] [oo] [hhh]	¾, 1, 1 ¼, 1 ½, 2
AMES	4000BM2	(H)	[v],[x] [oo] [hhh]	1
AMES	4000BM3	(H)	[v],[x] [oo] [hhh]	¾
AMES	4000CIV	(H)	[o],[g],[h],[l],[m],[p],[t],[u]	2 ½, 3, 4, 6, 8, 10
AMES	4000-RP	(H)	[t],[e],[f],[g],[h],[cc],[dd],[l],[m],[u]	4, 6, 8, 10
AMES	4000-SS	(H)	[t],[e],[f],[g],[h],[cc],[dd],[l],[m],[u]	2 ½, 3, 4, 6
AMES	400B	(H,VD)	[v],[x] [oo] [hhh]	¾, 1, 1 ¼, 1 ½, 2
AMES	400B-A	(VU VD)	[v],[x] [oo] [hhh]	¾, 1, 1 ¼, 1 ½, 2
AMES	400B-A	(VU VU)	[v],[x] [oo] [hhh]	¾, 1, 1 ¼, 1 ½, 2
AMES	400BFG	(H)	[yy]	4, 6
AMES	COLT 400	(H)	[pp], [qq],[zz],[aaa],[bbb],[ddd] [eee], [ggg],[kkk],[lll],[mmm],[nnn]	2 ½, 3, 4
AMES	COLT 400	(H)	[pp], [qq],[aaa],[bbb],[kkk],[lll], [mmm],[nnn]	6
AMES	COLT 400	(H)	[pp], [qq],[ss],[tt],[aaa],[bbb], [ccc], [ddd],[kkk],[lll],[mmm],[nnn]	8
AMES	COLT 400N	(VUVD)	[pp], qq, yy	2 ½, 3, 4
AMES	COLT 400Z	(VUVU)	[pp], qq, yy	2 ½, 3, 4
AMES	MAXIM 400	(H)	[pp], [qq],[zz],[aaa],[bbb],[ddd] [eee], [ggg],[kkk],[lll],[mmm],[nnn]	2 ½, 3
AMES	MAXIM 400	(H)	[pp], [qq],[aaa],[bbb],[kkk],[lll] [mmm], [nn]	4
AMES	MAXIM 400	(H)	[pp], [qq],[ss] [tt],[aaa],[bbb],[ccc] [ddd],[kkk],[lll],[mmm],[nnn]	6
AMES	MAXIM 400N	(VU,VD)	[pp], qq,	2 ½, 3
AMES	MAXIM 400Z	(VU,VU)	[pp], qq, yy	2 ½, 3
ARI	RP 500	H	(i)	¾, 1
CLA-VAL	RP-2	(H)	[n],[d]	¾, 1, 1 ¼, 1 ½
CLA-VAL	RP-4	(H)	[n]	2
CLA-VAL	RP-4	(H)	[g],[h],[q],[r]	2 ½, 3, 4, 6, 8, 10
CLA-VAL	RP4V	(VUVU)	[g],[h],[q],[r]	4
CLA-VAL	RP6LW	(H)	[i]	¾, 1, 1 ¼, 1 ½, 2
CLA-VAL	RP6VW	(H)	[i]	¾, 1, 1 ½, 2
CLA-VAL	RP7LW	(H)	[e],[l],[t]	2 ½, 3, 4, 6, 8, 10

<u>COMPANY</u>	<u>MODEL</u>	<u>DIRECTION</u>	<u>SHUTOFF VALVES</u>	<u>SIZE IN INCHES</u>
CLA-VAL	RP7LY	(H)	[f],[m],[u]	2 ½,3,4,6,8,10
CLA-VAL	RP8LW	(H)	[e],[l],[t]	2 ½,3,4,6,8
CLA-VAL	RP8LY	(H)	[f],[m],[u]	2 ½,3,4,6,8
CLA-VAL	RP8VW	(VUVD,VUVU)	[e],[l],[t]	2 ½,3,4,6,8,10
CLA-VAL	RP8VY	(VUVD,VUVU)	[f],[m],[u]	2 ½,3,4,6,8,10
CONBRACO	40-200-02	(H)	[t],[b],[e],[l]	3
CONBRACO	40-200-03	(H)	[u],[c],[m]	3
CONBRACO	40-200-05	(H)	[mm]	3
CONBRACO	40-204-A2S	(H)	[u]	¾
CONBRACO	40-204-02/T2/A2	(H)	[d]	¾
CONBRACO	40-204-TC2	(H)	[d]	¾
CONBRACO	40-204-A2U/TCU	(VUVD)	[d]	¾
CONBRACO	40-204-A2Z	(VUVU)	[d]	¾
CONBRACO	40-205-02/T2/A2	(H)	[d]	1
CONBRACO	40-205-A2S	(H)	[uu]	1
CONBRACO	40-205-A2U/TCU	(VUVD)	[d]	1
CONBRACO	40-205-A2Z	(VUVU)	[d]	1
CONBRACO	40-206-02-A2U	(VUVD)	[d]	1 ¼
CONBRACO	40-206-A2Z	(VUVU)	[d]	1 ¼
CONBRACO	40-207-02/A2/T2	(H)	[d]	1 ½
CONBRACO	40-207-A2U	(VUVD)	[d]	1 ½
CONBRACO	40-207-A2Z	(VUVU)	[d]	1 ½
CONBRACO	40-208-02/A2/T2	(H)	[d]	2
CONBRACO	40-208-A4	(H)	[rr]	2
CONBRACO	40-208-A2U	(VUVD)	[d]	2
CONBRACO	40-208-A2Z	(VUVU)	[d]	2
CONBRACO	40-209-02	(H)	[t],[b],[e],[l]	2 ½
CONBRACO	40-209-03	(H)	[u],[c],[m]	2 ½
CONBRACO	40-209-05	(H)	[mm]	2 ½
CONBRACO	40-20A-02	(H)	[t],[b],[e],[l]	4
CONBRACO	40-20A-03	(H)	[u] [c],[m]	4
CONBRACO	40-20A-05	(H)	[mm]	4
CONBRACO	40-20C-02	(H)	[t],[b],[e],[l]	6
CONBRACO	40-20C-03	(H)	[u],[c],[m]	6
CONBRACO	40-20C-05	(H)	[mm]	6
CONBRACO	40-20E-02	(H)	[t],[b],[e],[l]	8
CONBRACO	40-20E-03	(H)	[u],[c],[m]	8
CONBRACO	40-20G-02	(H)	[t],[b],[e],[l]	10
CONBRACO	40-20G-03	(H)	[u],[c],[m]	10

LIST OF APPROVED REDUCED PRESSURE ZONE (RPZ) ASSEMBLIES

<u>COMPANY</u>	<u>MODEL</u>	<u>DIRECTION</u>	<u>SHUTOFF VALVES</u>	<u>SIZE IN INCHES</u>
FEBCO	825Y	(H)	[i] [ff],[jj],[oo]	3/4,1,1 1/4,1 1/2,2
FEBCO	825YA	(H, VUVD, VUH, HVD)	[i] [ff],[jj],[oo]	3/4,1,1 1/2,2
FEBCO	825YR	(H)	[i] [ff],[jj],[oo]	3/4,1,1 1/2,2
FEBCO	825YAR	(H, VUVD, VUH, HVD)	[i] [ff],[jj],[oo]	3/4,1,1 1/2,2
FEBCO	825YD	(H)	[e],[f],[l],[m],[t],[u]	2 1/2,3,4,6,8,10
FEBCO	825YR	(H)	[i][ff]	3/4,1,1 1/2,2
FEBCO	860	(H)	[ff],[jj],[oo]	3/4,1,1 1/4, 1 1/2,2
FEBCO	860	(H)	[e],[l],[t],[f],[m],[u],[nn]	2 1/2,3,4,6,8
FEBCO	860U	(H)	[kk]	3/4,1, 1 1/4, 1 1/2,2
FEBCO	867	(H)	(oo), gg, hh,ll mm, pp tt,uu, yy, fff	2 1/2
FEBCO	867	(H)	(oo), gg, hh,ll, mm, pp, tt, uu, yy, eee, fff yy, fff	3
FEBCO	880	(VUVD)	[e],[l],[t],[f],[m],[u]	2 1/2,3,4,6,8,10
FEBCO	880V	(VUVD)	[e],[l],[t],[f],[m],[u]	2 1/2,3,4,6,8,10
FLOMATIC	RPZ	(H)	[i]	3/4,1,1 1/2,2
FLOMATIC	RPZ	(H)	[g],[h]	2 1/2,3,4,6
FLOMATIC	RPZ	(H)	[g],[h] [j],[kt],[l],[m],[ly] [z],[c],[d]	8
FLOMATIC	RPZE	(H)	[i]	3/4, 1, 1 1/2,2
FLOMATIC	RPZ-II	(H)	[i]	3/4
FLOMATIC	RPZ-IIIE	(H)	[i]	3/4
WATTS	009	(H)	[o],[g],[h],[p],[t],[u],[ee]	2 1/2,3
WATTS	009M2QT	(H)	[v],[x]	3/4,1,1 1/4,1 1/2,2
WATTS	009M2PCQT	(H)	[v],[x]	3/4,1,1 1/4,1 1/2,2
WATTS	009M3QT	(H)	[v],[x]	3/4
WATTS	009QT	(H)	[v],[x]	3/4
WATTS	009PCQT	(H)	[v],[x]	3/4,1,1 1/4,1 1/2,2
WATTS	909HW-QT	(H)	[v],[x]	3/4,1
WATTS	909HWM1-QT	(H)	[v],[x]	1 1/4,1 1/2,2
WATTS	909M1QT	(H)	[v],[x]	1 1/4,1 1/2,2
WATTS	909-M1-QT-FDA	(H)	[w]	8,10
WATTS	909QT	(H)	[v],[x]	3/4,1
WATTS	909M1	(H)	[o],[g],[h],[p],[t],[u]	8,10
WATTS	909BB	(H)	[o],[g],[h],[p],[t],[u]	2 1/2,3
WATTS	909	(H)	[o],[g],[h],[l],[m],[p],[t],[u]	2 1/2
WATTS	909	(H)	[o],[g],[h],[l],[m] [p],[t],[u],[ee]	3,4,6
WATTS	909PCHW-M1-QT	(H)	[v],[x]	1 1/4,1 1/2,2
WATTS	909PCHW-QT	(H)	[v],[x]	3/4,1

LIST OF APPROVED REDUCED PRESSURE ZONE (RPZ) ASSEMBLIES

<u>COMPANY</u>	<u>MODEL</u>	<u>DIRECTION</u>	<u>SHUTOFF VALVES</u>	<u>SIZE IN INCHES</u>
WATTS	909PC-M1-QT	(H)	[v],[x]	1 ¼, 1 ½, 2
WATTS	909PC-QT	(H)	[v],[x]	¾, 1
WATTS	909QT-FDA	(H)	[w]	2 ½, 3, 4, 6
WATTS	909QT	(H)	[v],[x]	¾, 1
WATTS	909QT	(VU)	[v],[x]	¾, 1
WATTS	909PC-QT	(VU)	[v],[x]	¾, 1
WATTS	919AQT	(VU VD)	(vv),xx,ooo,hhhh	¾, 1, ¼, 1 ½, 2
WATTS	919QT	H ,VD)	(vv),xx,ooo,hhhh	¾, 1, ¼, 1 ½, 2
WATTS	919ZQT	(VU VU)	(vv),xx,ooo,hhhh	1, ¼, 1 ½, 2
WATTS	957	(H)	[pp],[qq] [zz],[aaa],[bbb],[ddd], [eee] [fff],[ggg],[kkk],[lll] [mmm],[nn]	2 ½, 3, 4
WATTS	957	(H)	[pp],[qq] [aaa],[bbb], [lll] [mmm] [nn]	6
WATTS	957	(H)	[pp],[qq] [ss] [tt] [aaa],[bbb], [ccc] [ddd] [kkk] [lll] mmm],[nn]	8
WATTS	957N	(VUVD)	[pp],[qq],[yy] [zz],[aaa],[bbb],[ddd] [eee] ggg],[kkk],[lll] [mmm],[nn]	2 ½, 3, 4
WATTS	957Z	(VUVU)	[pp],[qq],[yy] [zz],[aaa],[bbb],[ddd] [eee] ggg],[kkk],[lll] [mmm],[nn]	2 ½, 3, 4
WATTS	967	(H)	[pp],[qq] [zz],[aaa],[bbb] [ddd] [eee] [fff],[ggg],[kkk],[lll] [mmm],[nn]	2 ½, 3, 4
WATTS	967	(H)	[pp],[qq] [ss] [tt] [aaa],[bbb], [ccc] [ddd] [kkk] [lll] mmm],[nn]	6
WATTS	967N	(VUVD)	[pp],[qq],[yy] [zz],[aaa],[bbb],[ddd] [eee] ggg],[kkk],[lll] [mmm],[nn]	2 ½, 3, 4
WATTS	967Z	(VUVD)	[pp],[qq],[yy] [zz],[aaa],[bbb],[ddd] [eee] ggg],[kkk],[lll] [mmm],[nn]	2 ½, 3, 4
WATTS	994	(H)	[t],[e],[f][g],[h], [i],[m] [o],[p] [uq],[cc] [dd],[ff] [ggg]	
WATTS	995QT	(H)	[int]	½, ¾, 1, 1¼, 1½
WATTS	FAE909HWQT	(H)	[v],[x]	1 ¼, 1 ½, 2
WATTS	FAE909QT	(H)	[v],[x]	1 ¼, 1 ½, 2
WATTS	LF919AQT	(VUVD)	[vv],[hhh]	1 ¼, 1 ½, 2
WATTS	LF919QT	(H)	[vv],[hhh]	¾, 1 ¼, 1 ½, 2
WATTS	LF919ZQT	(VU VU)	[vv],[hhh]	¾, 1 ¼, 1 ½, 2
WATTS	LFU919AQT	(VUVD)	[vv],[hhh]	¾, 1, 1 ¼, 1 ½, 2
WATTS	LFU919QT	(H)	[vv],[hhh]	¾, 1, 1 ¼, 1 ½, 2
WATTS	SS009QT	(H)	[hh]	1
WATTS	SS009M3QT	(H)	[hh]	¾, 1

LIST OF APPROVED REDUCED PRESSURE ZONE (RPZ) ASSEMBLIES

<u>COMPANY</u>	<u>MODEL</u>	<u>DIRECTION</u>	<u>SHUTOFF VALVES</u>	<u>SIZE IN INCHES</u>
WATTS	U909QT	(H)	[v],[x]	3/4, 1
WATTS	U909QT	(VU)	[v],[x]	3/4, 1
WATTS	U009APCQT	(H)	[v],[x]	3/4
WATTS	U009AQT	(H)	[v],[x]	3/4
WATTS	U909HWQT	(H)	[v],[x]	3/4, 1
WATTS	U009M1PCQT	(H)	[v],[x]	1 1/4, 1 1/2, 2
WATTS	U009M1QT	(H)	[v],[x]	1 1/4
WATTS	U009M2APCQT	(VUVD, VDVU, VUVU, VDVD)	[v],[x]	1, 1 1/2, 2
WATTS	U009M2AQT	(VUVD, VDVU, VUVU, VDVD)	[v],[x]	1, 1 1/2, 2
WATTS	U009M2PCQT	(H)	[v],[x]	1, 1 1/2, 2
WATTS	U009M2QT	(H)	[v],[x]	3/4, 1, 1 1/2, 2
WATTS	U009PCQT	(H)	[v],[x]	3/4
WATTS	U919AQT	(VU VD)	(vv),xx,ooo,hhhh	3/4, 1, 1/4, 1 1/2, 2
WATTS	U919QT	(VU VD)	(vv),xx,ooo,hhhh	3/4, 1, 1/4, 1 1/2, 2
WILKINS	375	(H)	[int],	3/4, 1
WILKINS	375	(H)	[g],[e],[t],[y],[h],[f],[u],[z]	2 1/2, 3, 4, 6, 8
WILKINS	375A	(H)	[pp],[qq],[ss],[tt],[ww],[yy]	4, 6, 8, 10
WILKINS	375G	(H)	[pp] [qq]	2 1/2, 3, 4, 6, 8
WILKINS	375GPI	(H)	[qq] #1SOV,[ww] #2SOV	4, 6, 8
WILKINS	375MS	(H)	[g],[e],[t],[y],[h],[f],[u],[z]	2 1/2, 3, 4, 6, 8, 10
WILKINS	375PI	(H)	[h]#1 SOV,[vv]#2 SOV	4, 6, 8
WILKINS	375XL	(H)	[int],	3/4, 1
WILKINS	475	(H)	[g],[h] [e],[t] [y],[f], [u],[z]	8
WILKINS	475MS	(H)	[g],[h] [e],[t] [y],[f], [u],[z]	2 1/2, 3, 4, 6, 8
WILKINS	475 MS	(VUVD)	[pp],[qq]	4, 6, 8, 10
WILKINS	475	(VUVD)	[g],[h] [e],[t] [y],[f], [u],[z]	2 1/2,
WILKINS	475	(VUVD)	[pp],[qq]	3, 4, 6, 8
WILKINS	475G	(VUVD)	[pp],[qq]	2 1/2, 3
WILKINS	475G	(VUVU)	[ss] [tt]	4, 6
WILKINS	475V	(VUVU)	[g],[h] [e],[t] [y],[f], [u],[z]	2 1/2, 3
WILKINS	475V	(VUVU)	[pp],[qq]	4, 6
WILKINS	475V	(VUVU)	[pp],[qq],[ss] [tt]	8
WILKINS	475V	(VUVU)	[pp],[qq],[ss] [tt] [w]	10
WILKINS	475VG	(VUVU)	[pp],[qq]	2 1/2, 3,
WILKINS	475VG	(VUVU)	[ss] [tt]	4
WILKINS	475VG	(VUVU)	[pp],[ss] [tt]	6
WILKINS	475VMS	(VUVU)	[g],[e] [f],[h] [t],[u],[y]	2 1/2, 3,
WILKINS	475VMS	(VUVU)	[pp],[qq],[ss] [tt] [w]	10
WILKINS	475VMS	(H)	[pp],[qq]	4, 6, 8
WILKINS	575	(H)	[g],[h] [e],[t] [y],	2 1/2, 3, 4, 6
WILKINS	575MOD III	(H)	[i],	1 1/4, 1 1/2, 2
WILKINS	575A	(H)	[i],	3/4, 1

LIST OF APPROVED REDUCED PRESSURE ZONE (RPZ) ASSEMBLIES

<u>COMPANY</u>	<u>MODEL</u>	<u>DIRECTION</u>	<u>SHUTOFF VALVES</u>	<u>SIZE IN INCHES</u>
WILKINS	575M10	(H)	[g],[e],[t] [y],	10
WILKINS	575M8	(H)	[g],[e],[t] [y],	8
WILKINS	975	(H)	[i]	$\frac{3}{4}$, 1, 1 $\frac{1}{4}$, 1 $\frac{1}{2}$, 2
WILKINS	975	(H)	[g],[e],[t],[y],[h],[f],[u],[z]	2 $\frac{1}{2}$, 3, 4, 6, 8, 10
WILKINS	975A	(H)	[i]	$\frac{3}{4}$, 1, 1 $\frac{1}{4}$, 1 $\frac{1}{2}$, 2
WILKINS	975G	(H)	[pp]	4, 6
WILKINS	975BMS	(H)	[g],[e],[t],[y],[h],[f],[u],[z]	2 $\frac{1}{2}$, 3, 4, 6, 8, 10
WILKINS	975MS	(H)	[g],[e],[t],[y],[h],[f],[u],[z]	2 $\frac{1}{2}$, 3, 4, 6, 8, 10
WILKINS	975XL	(H)	[i]	$\frac{3}{4}$, 1, 1 $\frac{1}{4}$, 1 $\frac{1}{2}$, 2
WILKINS	975XLBMS	(H)	[i]	$\frac{3}{4}$, 1, 1 $\frac{1}{4}$, 1 $\frac{1}{2}$, 2
WILKINS	975XLD	(H)	[i]	$\frac{3}{4}$
WILKINS	975XLMS	(H)	[i]	$\frac{3}{4}$, 1, 1 $\frac{1}{4}$, 1 $\frac{1}{2}$, 2
WILKINS	975XLSE	(VUVD, VUVU)	[i]	$\frac{3}{4}$, 1, 1 $\frac{1}{4}$, 1 $\frac{1}{2}$, 2
WILKINS	975XLSEU	(VUVD, VUVU)	[gg]	$\frac{3}{4}$, 1, 1 $\frac{1}{4}$, 1 $\frac{1}{2}$, 2
WILKINS	975XLU	(H)	[gg]	$\frac{3}{4}$, 1, 1 $\frac{1}{2}$, 2
WILKINS	975XLTCU	(H)	[ii]	$\frac{1}{2}$,
WILKINS	975XLTCU	(H)	[gg]	$\frac{3}{4}$, 1, 1 $\frac{1}{4}$, 1 $\frac{1}{2}$, 2
WILKINS	975XLU	(H)	[gg]	$\frac{3}{4}$, 1, 1 $\frac{1}{2}$, 2
WILKINS	975XLV	(VUVD, VUVU)	[i] [oo]	$\frac{3}{4}$, 1

**PHILADELPHIA WATER DEPARTMENT
CROSS CONNECTION CONTROL PROGRAM
(2008)**

LIST OF APPROVED DOUBLE CHECK VALVE (DCV) ASSEMBLIES

The DCV backflow prevention assembly used must be selected from the following listing. The Water Department shall regularly update the listing which shall be made available at L&I and the Water Department. Also all DCV assemblies listed below are approved for the **ORIENTATION** indicated under **DIRECTION**.

<u>COMPANY</u>	<u>MODEL</u>	<u>DIRECTION</u>	<u>SHUTOFF VALVES</u>	<u>SIZE IN INCHES</u>
AMES	2000B	(H)	[v],[x]	3/4,1,1 1/4,1 1/2,2
AMES	200B	(H,VD,VU)	[v],[x]	3/4,1,1 1/4,1 1/2,2
AMES	200B-A	(VU,VD)	,[x]	1,1 1/4,1 1/2,2
AMES	200B R10	(H,VD,VU)	v],[x]	3/4
AMES	2000B	(VU)	[v],[x]	3/4,1,1 1/4,1 1/2,2
AMES	2000B	(H,VU)	[v],[x]	1 1/4,
AMES	2000BM3	(H,VU)	[v],[x]	3/4
AMES	2000 CIV	(H)	[o],[g],[t],[p],[h],[l],[m],[u],[ee]	4,6,8,10
AMES	2000 CIV	(VU)	[o],[g],[t],[p],[h],[l],[m],[u],[ee]	4,6,8,10
AMES	2000-DCA	(H)	[t],[e],[f],[g],[h],[cc],[dd],[l],[m],[u]	4,6,8
AMES	2000-DC	(H)	[t],[e],[f],[g],[h],[cc],[dd],[l],[m],[u]	10
AMES	2000-G-DC	(H)	[t],[e],[f],[g],[h],[cc],[dd],[l],[m],[u]	10
AMES	2000-G-DCA	(H)	[t],[e],[f],[g],[h],[cc],[dd],[l],[m],[u]	4,6,8
AMES	2000 SS	(H)	[t],[e],[f],[g],[h],[cc],[dd],[l],[m],[u]	2 1/2,3,4,6,8,10
AMES	2000 SS-M	(H)	[t],[e],[f],[g],[h],[cc],[dd],[l],[m],[u]	4,6
AMES	2000 SE	(H)	[t],[e],[f],[g],[h],[cc],[dd],[l],[m],[u]	2 1/2,6,8
AMES	2000 SE	(H)	[t],[e],[f],[g],[h],[cc],[dd],[l],[m],[u]	2 1/2,6,8
AMES	COLT 200	(H,VU)	[pp],[qq],[yy]	2 1/2,3,4,6, 8
AMES	COLT 200A	(H,VU)	[pp],[qq],[yy]	2 1/2,3,4,6
AMES	COLT 200NA	(VUVD)	[pp],[qq],[yy]	2 1/2,3,4,6
AMES	DC	(H)	[o],[pp],[fff][ggg]	4,6,8
AMES	LF200B	(H,VD,VU)	[v],[hhh]	1,1 1/4,1 1/2,2
AMES	LF200BR10	(H,VD,VU)	[v],[hhh]	1/2, 3/4
AMES	LF200B-A	(VU VD)	[v],[hhh]	1,1 1/4,1 1/2,2
AMES	LFU200B	(H,VD,VU)	[v],[hhh]	1,1 1/4,1 1/2,2
AMES	MAXIM 200	(H,VU)	[pp],[qq],[yy]	2 1/2,
AMES	MAXIM 200	(H,VU)	[pp],[qq],[yy]	3,4
MAXIM	MAXIM 200	(H)	[pp],[qq],[yy]	6
AMES	MAXIM 200A	(H,VU)	[pp],[qq],[yy]	2 1/2,3,4
AMES	MAXIM 200NA	(VUVD)	[pp],[qq],[yy]	2 1/2,3,4
AMES	U200B	(H,VD,VU)	,[e],[f],[g],[h],[cc],[dd],[l],[m],[u]	1,1 1/4,1 1/2,2
AMES	U200BR10	(H,VD,VU)	,[e],[f],[g],[h],[cc],[dd],[l],[m],[u]	3/4
ARI	DC 500	(H)	[i]	3/4,1
CLA-VAL	D2	(H)	[n],[d]	3/4,1,1 1/4,1 1/2
CLA-VAL	D4	(H)	[n],[d]	2
CLA-VAL	D4	(H)	[g],[h],[q],[r]	2 1/2,3,4,6,8,10
CLA-VAL	DC6LB	(H,VU)	[l]	3/4

LIST OF APPROVED DOUBLE CHECK VALVE (DCV) ASSEMBLIES

<u>COMPANY</u>	<u>MODEL</u>	<u>DIRECTION</u>	<u>SHUTOFF VALVES</u>	<u>SIZE IN INCHES</u>
CLA-VAL	DC6LW	(H)	[l]	¾, 1, 1 ½, 2
CLA-VAL	DC7LW	(H)	[e],[l],[t]	2 ½,3,4,6,8,10
CLA-VAL	DC7LY	(H)	[f],[m],[u]	2 ½,3,4,6,8,10
CLA-VAL	DC8LW	(H)	[e],[l],[t]	4,6,8
CLA-VAL	DC8LW	(VU)	[e],[l],[t]	4,6
CLA-VAL	DC8LY	(H)	[f],[m],[u]	4,6,8
CLA-VAL	DC8LY	(VU)	[f],[m],[u]	4,6
CLA-VAL	DC8VW	(VUVD, VUVU)	[e],[l],[t]	2 ½,3,4,6,8,10
CLA-VAL	DC8VY	(VUVD, VUVU)	[f],[m],[u]	2 ½,3,4,6,8,10
CONBRACO	2 ½DC	(H,VU)	[l], [m]	2 ½
CONBRACO	2 ½DC-7	(H,VU)	[m] [#1 SOV], [qq] [#2 SOV]	2 ½
CONBRACO	2 ½DC8	(H,VU)	[pp]],[qq]	2 ½
CONBRACO	2 ½DCU	(VUVD)	[l],[m]	2 ½
CONBRACO	3DC	(H,VU)	[l],[m]	3
CONBRACO	3DC-7	(H,VU)	[m] [#1 SOV], [qq] [#2 SOV]	3
CONBRACO	3DC-8	(H,VU)	[pp]],[qq]	3
CONBRACO	3DCU	(VUVD)	[l],[m]	3
CONBRACO	4DC	(H,VU)	[l],[m]	4
CONBRACO	4DC-7	(H,VU)	[m] #1 SOV], [qq] [#2 SOV]	4
CONBRACO	4DC-8	(H,VU)	[pp]], [qq]	4
CONBRACO	4DCU	(VUVD)	[l],[m]	4
CONBRACO	6DC	(H,VU)	[l],[m]	6
CONBRACO	6DC-7	(H,VU)	[m] [#1 SOV], [qq] [#2 SOV]	6
CONBRACO	6DC-8	(H,VU)	[pp]], [qq]	6
CONBRACO	6DCU	(VUVD)	[l],[m]	6
CONBRACO	8DC	(H,VU)	[l],[m]	8
CONBRACO	8DC-8	(H,VU)	[pp]], [qq]	8
CONBRACO	40-100-02	(H)	[t],[b],[e],[l]	3
CONBRACO	40-100-03	(H)	[u],[c],[m]	3
CONBRACO	40-100-05	(H)	[mm]	3
CONBRACO	40-104-02/A2/A2T/T2/TC2	(H)	[d]	¾
CONBRACO	40-105-02/A2/A2T/T2/TC2	(H)	[d]	1
CONBRACO	40-106-02/A2/A2T/T2	(H)	[l],[m]	1 ¼
CONBRACO	40-107-02/A2/A2T/T2	(H)	[d]	1 ½
CONBRACO	40-108-02/A2/A2T/T2	(H)	[d]	2
CONBRACO	40-109-02	(H)	[t],[b],[e],[l]	2 ½
CONBRACO	40-109-03	(H)	[u],[c],[m]	2 ½
CONBRACO	40-109-05	(H)	[mm]	2 ½
CONBRACO	40-10A-02	(H)	[t],[b],[e],[l]	4
CONBRACO	40-10A-03	(H)	[u],[c],[m]	4
CONBRACO	40-10A-05	(H)	[mm]	4

LIST OF APPROVED DOUBLE CHECK VALVE (DCV) ASSEMBLIES

<u>COMPANY</u>	<u>MODEL</u>	<u>DIRECTION</u>	<u>SHUTOFF VALVES</u>	<u>SIZE IN INCHES</u>
CONBRACO	40-10A-06	(H)	[m] [#1 SOV], [nn] [#2 SOV]	4
CONBRACO	40-10C-02	(H)	[t],[b],[e],[l]	6
CONBRACO	40-10C-03	(H)	[u],[c],[m]	6
CONBRACO	40-10C-05	(H)	[mm]	6
CONBRACO	40-10C-06	(H)	[m] [#1 SOV], [nn] [#2 SOV]	6
CONBRACO	40-10E-02	(H)	[t],[b],[e],[l]	8
CONBRACO	40-10E-03	(H)	[u],[c],[m]	8
CONBRACO	40-10E-06	(H)	[m] [#1SOV], [nn] [#2SOV]	8
CONBRACO	40-10G-02	(H)	[t],[b],[e],[l]	10
CONBRACO	40-10G-03	(H)	[u],[c],[m]	10
CONBRACO	40-10G-06	(H)	[m] [#1 SOV], [nn] [#2SOV]	10
FEBCO	805Y	(H)	[i],[ff],[j],[oo]	3/4, 1, 1 1/2, 2
FEBCO	805YB	(VU)	[i],[ff]	3/4
FEBCO	805YD	(H)	[e],[f],[l],[m],[t],[u]	2 1/2, 3, 4, 6, 8, 10
FEBCO	805YR	(H)	[i],[f]	3/4, 1
FEBCO	850	(H)	[ff],[jj],[oo]	3/4, 1, 1 1/4, 1 1/2, 2
FEBCO	850	(H)	[e],[f],[l],[m],[t],[u],[nn]	2 1/2, 3, 4, 6, 8
FEBCO	850	(VU)	[ff],[jj],[oo]	3/4, 1, 1 1/4, 1 1/2, 2
FEBCO	850	(VU)	[e],[l],[t],[f],[m],[u],[nn]	2 1/2, 3, 4, 6, 8
FEBCO	850	(VD)	[ff],[jj]	3/4, 1, 1 1/4, 1 1/2, 2
FEBCO	850F	(H,VD VU)	[ff],[jj]	3/4
FEBCO	850U	(H,VDVU)	[kk]	3/4, 1, 1 1/4, 1 1/2, 2
FEBCO	857	(H,VU)	[t],[b],[q],[ii],[ll]	2 1/2, 3
FEBCO	870	(VUVD)	[e],[l],[t],[f],[m],[u]	2 1/2, 3, 4, 6, 8, 10
FEBCO	870V	(VUVD,VUVU)	[e],[l],[t],[f],[m],[u]	2 1/2, 3, 4, 6, 8, 10
FLOMATIC	DCV	(H)	[i]	3/4, 1, 1 1/2, 2
FLOMATIC	DCV	(H)	[g][h] [j],[k] [l],[m] [y],[z] [cc],[dd]	2 1/2, 3, 4, 6
FLOMATIC	DCV	(H)	[m][h] [j],[k] [l],[l] [g],[y] [z],[cc],[dd]	8
FLOMATIC	DCVE	(H)	[i]	3/4, 1, 1 1/2, 2
HERSEY/GRINNELL		(H)	[i]	2
HERSEY/GRINNELL		(H)	[t], [b],[q],[i],[l],	3, 4, 6, 8, 10
WATTS	709QT-FDA	(H)	[w] [fff]	2 1/2, 3, 4, 6, 8, 10
WATTS	709	(H)	[o],[g],[t],[p],[h],[u]	2 1/2
WATTS	709	(H)	[o],[g],[t],[p],[h],[u],[ee]	2 1/2, 3, 4, 6, 8, 10
WATTS	709	(VU)	[o],[g],[t],[p],[h],[u],[ee]	4, 6, 8, 10
WATTS	709BB	(H)	[o],[g],[t],[p],[h],[u]	2 1/2, 3
WATTS	719AQT	(VUVD)	[v],[hhh]	1, 1 1/4, 1 1/2, 2
WATTS	719QT	(H,VU VD)	[v],[hhh]	3/4, 1, 1 1/4, 1 1/2, 2

LIST OF APPROVED DOUBLE CHECK VALVE (DCV) ASSEMBLIES

<u>COMPANY</u>	<u>MODEL</u>	<u>DIRECTION</u>	<u>SHUTOFF VALVES</u>	<u>SIZE IN INCHES</u>
WATTS	719QTR10	(H,VU,VD)	[v],[hhh]	¾
WATTS	LF719AQT	(VUVD)	[v],[hhh]	1, 1 ¼, 1 ½, 2
WATTS	LF719QT	(H,VU,VD)	[v],[hhh]	1, 1 ¼, 1 ½, 2
WATTS	LF719QTR10	(H,VU,VD)	[v],[hhh]	¾
WATTS	LFU719QT	(H,VU,VD)	[v],[hhh]	1, 1 ¼, 1 ½, 2
WATTS	U719QT	(H,VU,VD)	[w],[hhh]	¾, 1, 1 ¼, 1 ½, 2
WATTS	007	(H,VU)	[o],[g],[h],[l],[m],[p],[t],[u]	2 ½, 3
WATTS	007M1QT	(H)	[v],[x]	1, 2
WATTS	007M1QT	(VU)	[v],[x]	1, 2
WATTS	007M1PCQT	(H)	[v],[x]	¾, 1, 2
WATTS	007M2QT	(H,VU)	[v],[x]	¾, 1 ¼, 1 ½
WATTS	007M2PCQT	(H,VU)	[v],[x]	1 ¼
WATTS	007M2PCQT	(H)	[v],[x]	1 ½
WATTS	007M3QT	(H,VU)	[v],[x]	¾
WATTS	SS007M1QT	(H,VU)	[hh]	1
WATTS	SS007M3QT	(H,VU)	[hh]	¾
WATTS	U007M1AQT	(H)	[v],[x]	¾, 2
WATTS	U007M1APCQT	(H)	[v],[x]	¾, 2
WATTS	U007M1PCQT	(H)	[v],[x]	¾, 1, 1 ½, 2
WATTS	U007M1QT	(H)	[v],[x]	¾, 1, 2
WATTS	U007M2AQT	(H)	[v],[x]	1 ½
WATTS	U007M2QT	(H)	[v],[x]	1 ¼, 1 ½
WATTS	757	(H)	[yy],[pp],[qq],[aa],[bb]	8
WATTS	757	(H,VU)	[yy],[pp],[qq],[aa],[bb]	6
WATTS	757DC	(H,VU)	[pp],[qq],[aa],[bb],[yy]	2 ½, 3, 4
WATTS	757a	(H,VU)	[pp],[qq],[yy]	2 ½, 3, 4, 6
WATTS	757Na	(VU,VD)	[pp],[qq],[yy]	2 ½, 3, 4, 6
WATTS	767	(H,VU)	[yy],[pp],[qq],[aa],[bb]	2 ½, 3, 4, 6
WATTS	767a	(H,VU)	[pp],[qq],[yy],[aa],[bb]	2 ½, 3, 4
WATTS	767DC	(H,VU)	[pp],[qq],[aa],[bb],[yy]	2 ½, 3
WATTS	767Na	(VU,VD)	[pp],[qq],[yy],[aa],[bb]	2 ½, 3, 4
WATTS	774	(H)	[ii]	¾, 1, 1 ¼
WATTS	774	(H)	[t],[e],[f],[g],[h],[l],[m],[o] [p],[u],[cc],[dd]	2 ½, 3, 4, 6
WATTS	774	(H)	[m],[e],[f],[g],[h],[l],[m],[o] [p],[u],[cc],[dd]	2 ½, 8
WATTS	774	(H)	[l],[m]	10
WATTS	774X	(H,VU)	[t],[e],[f],[g],[h],[h],[cc] [dd],[l],[m],[o],[p],[u]	2 ½, 6, 8
WATTS	775QT	(H,VU)	[int]	¾, 1, 1 ¼, 1 ½, 2

LIST OF APPROVED DOUBLE CHECK VALVE (DCV) ASSEMBLIES

<u>COMPANY</u>	<u>MODEL</u>	<u>DIRECTION</u>	<u>SHUTOFF VALVES</u>	<u>SIZE IN INCHES</u>
WILKINS	350	(H)	[g],[e],[t],[y],[h],[f],[u],[z]	2, ½, 3, 4, 6, 8, 10
WILKINS	350	(H, VU)	[g],[e],[t],[y],[h],[f],[u],[z]	1,
WILKINS	350	(VU)	[g],[e],[t],[y],[h],[f],[u],[z]	2 ½, 3, 4, 6, 8, 10
WILKINS	350G	(H, VU)	[pp] [qq]	2 ½, 3, 4, 6
WILKINS	350G	(H)	[pp], [qq]	8
WILKINS	350A	(H, VU)	[pp] [qq], [ss], [tt], [yy]	4, 6, 8, 10
WILKINS	350GPI	(H, VU)	[qq] [#1 SOV], [ww] [#2 SOV]	4, 6, 8
WILKINS	350PI	(H, VU)	[qq] [#1 SOV], [ww] [#2 SOV]	4, 6, 8, 10
WILKINS	350XL	(H, VU)	[lll]	¾,
WILKINS	450	(VUVD)	[g], [e] [f] [h] [t] [u] [y] [z]	2 ½, 3
WILKINS	450	(VUVD)	[pp], [qq] [yy]	4, 6, 8
WILKINS	450	(VUVD)	[pp] [qq]	10
WILKINS	450G	(VUVD)	[pp], [qq]	2 ½, 3
WILKINS	450G	(VUVD)	[ss] [tt]	4, 6
WILKINS	450G	(VUVD)	[qq] [pp] [ss] [tt]	8
WILKINS	550	(H)	[i]	¾, 1, 1 ¼, 1 ½, 2
WILKINS	550	(H)	[g],[e],[t],[y]	2 ½, 3, 4, 6
WILKINS	550A	(H)	[i]	¾, 1,
WILKINS	550M	(H)	[g],[e],[t],[y]	8, 10
WILKINS	950	(H)	[i]	¾, 1, 1 ¼, 1 ½, 2
WILKINS	950	(H)	[g],[e],[t],[y],[h],[f],[u],[z]	2 ½, 3, 4, 6, 8, 10
WILKINS	950G	(VU)	[g],[e],[t],[y],[h],[f],[u],[z]	4, 6, 8
WILKINS	950A	(H)	[i]	¾, 1, 1 ¼, 1 ½, 2
WILKINS	950G	(H, VU)	[pp]	4, 6
WILKINS	950XL	(H)	[i]	¾, 1, 1 ¼, 1 ½, 2
WILKINS	950XL	(VU)	[i]	¾
WILKINS	950	(H)	[i]	¾, 1, 1 ¼, 1 ½, 2
WILKINS	950	(H)	[g],[e],[t],[y],[h],[f],[u],[z]	2 ½, 3, 4, 6, 8, 10
WILKINS	950A	(H)	[i]	¾, 1, 1 ¼, 1 ½, 2
WILKINS	950G	(VU)	[g],[e],[t],[y],[h],[f],[u],[z]	4, 6, 8
WILKINS	950G	(H, VU)	[pp]	4, 6
WILKINS	950XL	(H)	[i]	¾, 1, 1 ¼, 1 ½, 2
WILKINS	950XL	(VU)	[i]	¾
WILKINS	950XLD	(H, VU)	[i]	¾
WILKINS	950XLT	(H)	[i]	¾, 1, 1 ¼, 1 ½, 2
WILKINS	950XLU	(H)	[gg]	¾, 1, 1 ½,
WILKINS	950XLTU	(H)	[gg]	¾, 1,

**PHILADELPHIA WATER DEPARTMENT
CROSS CONNECTION CONTROL PROGRAM
(2008)**

WARNING

The Double Check Detector Assemblies (DCD) and Reduced Pressure Principle Detector Assemblies (RPD) shown below have been evaluated with a specific meter as the detector element of the assembly. **Bold lettering** shown immediately after the size designation codes that specific meter. The coding of meters is shown in this Section. Other meters having similar performance characteristics to permit the assembly to meet the Specifications are shown immediately after the original evaluation meter. The use of any other meter or modified bypass piping invalidates the Approval.

Indication of meters:

- [A] Hersey Model F-F 5/8" x 3/4"
- [B] Carlon 5/8" x 3/4"
- [C] Dande' Model D-3 5/8" x 3/4"
- [D] Gamon-Calmet 5/8"
- [E] Hays Acumeter 5/8" x 3/4"
- [F] Arad 5/8" x 3/4" (Master Meter)
- [G] Schlumberger 5/8" x 3/4" Model MBRF
- [H] Rockwell (Sensus) SR-II 5/8" x 3/4"
- [I] Hersey Model 430 - 5/8"
- [J] ABB Model c700 5/8" x 3/4" (formerly Kent Model C700 5/8" x 3/4")
- [K] Precision 5/8"
- [L] Neptune Trident 8 5/8"
- [M.] Neptune T-10 5/8"
- [N] Badger Model 25 3/4"
- [O] Badger 5/8" x 3/4" Model M25
- [P] Hersey Model 430 Series II 5/8 "
- [Q] Hersey Model MVR-30 3/4"
- [R] Neptune T-10 1"
- [S] Neptune T-10 1 1/2"

**PHILADELPHIA WATER DEPARTMENT
CROSS CONNECTION CONTROL PROGRAM
(2008)**

LIST OF APPROVED DOUBLE CHECK DETECTOR (DCD) ASSEMBLIES

The DCD backflow prevention assemblies used must be selected from the following listing. The Water Department shall regularly update the listing which shall be made available at L&I and the Water Department. Also all DCD assemblies listed below are approved for the **ORIENTATION** indicated under **DIRECTION**.

<u>COMPANY</u>	<u>MODEL</u>	<u>DIRECTION</u>	<u>SHUTOFF VALVES/METERS</u>	<u>SIZE IN INCHES</u>
AMES	3000B	(H, VU)	[b] [8],[1],[2],[3],[4],[5],[6],[7] [9], [10],[11],[12],[14],[15],[16],[17]	2
AMES	3000CIV	(H)	[p],[h],[u],[ee] [14],[1],[2],[3],[4],[5],[6],[7] [8],[9] [10],[11],[12],[13],[15],[16],[17],	4, 6, 8, 10
AMES	3000CIV	(VU)	[p],[h],[u],[ee] [14],[1],[2],[3],[4],[5],[6],[7] [8],[9] [10],[11],[12],[13],[15],[16],[17]	4
AMES	3000CIV	(H)	[p],[h],[m],[u],[ee] [14],[5],[6],[7] [8],[9], [10],[11], [12],[13],[15],[16],[17]	10
AMES	3000CIV	(VU)	[p],[h],[m],[u],[ee] [8],[1],[2],[3],[4],[5],[6],[7],[9],[10], [11],[12],[13],[14],[15],[16],[17]	6, 8, 10
AMES	3000-DCDC	(H)	[u],[e],[f],[g],[h],[cc],[dd] [13],[2],[3],[4],[5],[6],[7],[8],[9], [10],[11],[12],[14],[15],[16],[17]	10
AMES (Watts 007M2QT-3/4, Ames 2000B - 3/4)	3000SS	(H)	[u],[e],[f],[g],[h],[cc],[dd],[i],[m],[t] [14],[1],[2],[3],[4],[5],[6],[7] [8],[9], [10],[11],[12],[13],[15],[16],[17],	2½, 3, 4
AMES (Watts 007M1QT-3/4)	3000SS	(H)	[u],[e],[f],[g],[h],[cc],[dd],[i],[m],[t] [14],[1],[2],[3],[4],[5],[6],[7] [8],[9], [10],[11],[12],[13],[15],[16],[17],	6
AMES (Watts 007M1QT-3/4)	3000SS	(H)	[m],[e],[f],[g],[h],[cc],[dd],[i],[t],[u] [13],[1],[2],[3],[4],[5],[6],[7],[8],[9], [10], [11],[12],[14],[15],[16],[17]	8

DOUBLE CHECK DETECTOR (DCD) ASSEMBLIES – 2008 (cont'd.)

<u>COMPANY</u>	<u>MODEL</u>	<u>DIRECTION</u>	<u>SHUTOFF VALVES/METERS</u>	<u>SIZE IN INCHES</u>
AMES (Ames2000B -3/4)	3000SS	(H)	[l],[m] [10], [3],[4],[5],[6],[7],[8],[9],[11] [12],[13],[14],[15],[16],[17]	10
AMES (Watts 007 M2QT, Ames 2000B – ¾)	3000SE	(H)	[m],[e],[f],[g],[h],[cc],[dd],[u],[l],[t] [13],[14],[15],[16],[17]	2½
AMES (Watts 007 M2QT– 3/4, Ames 2000B-3/4)	3000SE	(H)	[u],[e],[f],[g],[h] [cc],[dd],[l],[m],[t] [13],[1],[2],[3],[4],[5],[6],[7], [8],[9] [10],[11],[12],[14],[15],[16],[17]	6
AMES (Watts 007M1QT-3/4)	3000SE	(H)	[u],[e],[f],[g],[h] [cc],[dd],[l],[m], [t] [13],[1],[2],[3],[4],[5],[6],[7], [8],[9], [10],[11],[12],[14],[15],[16],[17]	8
AMES (Watts 007M2QT-1 1/2)	3000SS-M	(H)	[u], [e],[f],[g],[h],[cc],[dd],[l],[m],[t] [19]	6
AMES (Watts 007M1QT-3/4)	3000SS –WM1	(H)	[u], [e],[f],[g],[h],[cc],[dd],[l],[m],[t] [13], [1],[2],[3],[4],[5],[6],[7],[8],[9] [10],[11],[12],[14],[15],[16],[17]	2½, 3, 4, 6
AMES (Ames 2000BM3-3/4)	COLT 300A-BF	(H, VU)	[yy] [14], [7],[8],[9], [10],[11],[12], [13] [15],[16],[17]	2½, 3, 4
AMES (Ames 2000BM3-3/4)	COLT 300A-GV	(H, VU)	[zz] [14], [7],[8],[9], [10],[11],[12], [13] [15],[16],[17]	2½, 3, 4
AMES (Ames 2000BM3-3/4)	COLT 300-BF	(H, VU)	[yy] (N),G,H,I,J,K,L,M,O,P,Q	2½, 3, 4,6, 8
AMES (Ames 2000BM3-3/4)	COLT 300-GV	(H, VU)	[zz] [14], [7],[8],[9], [10],[11],[12], [13] [15],[16],[17]	2½,3,4,6,8
AMES (Ames 2000BM3-3/4)	MAXIM 300A-BF	(H, VU)	[yy] [14], [7],[8],[9], [10],[11],[12], [13] [15],[16],[17]	2½, 3

DOUBLE CHECK DETECTOR (DCD) ASSEMBLIES – 2008 (cont'd.)

<u>COMPANY</u>	<u>MODEL</u>	<u>DIRECTION</u>	<u>SHUTOFF VALVES/METERS</u>	<u>SIZE IN INCHES</u>
AMES (Ames 2000BM3-3/4)	MAXIM 300A-GV	(H, VU)	[zz] [14], [7],[8],[9], [10],[11],[12], [13] [15],[16],[17]	2½, 3
AMES (Ames 2000BM3-3/4)	MAXIM 300-BF	(H, VU)	[yy] (N),G,H,I,J,K,L,M,O,P,Q	2½, 3, 4
AMES (Ames 2000BM3-3/4)	MAXIM 300-BF	(H, VU)	[yy] (N), G, H, I J, K L, M, N, O, P, Q	6
AMES (Ames 2000BM3-3/4)	MAXIM 300-GV	(H, VU)	[ZZ] (N),G,H,I,J,K,L,M,O,P,Q	2½,3,4,6
CONBRACO Conbraco (1/2 DC –1/2)	21/2DCDA	(H, VU)	[I], [m] [13], [5],[6],[7],[8],[9],[10],[11] [12],[14],[15],[16],[17]	2½
CONBRACO Conbraco (1/2DC – 1/2)	21/2DCDA-6	(H, VU)	[m] - #1SOV , [ooo] - #2SOV [13],[5],[6],[7],[8],[9],[10],[11], [12],[14],[15],[16],[17]	2½
CONBRACO Conbraco 40-104-02-3/4)	21/2DCDAU	(VU, VD)	[I], [m] [13], [5],[6],[7],[8],[9],[10],[11],[12], [14],[15],[16],[17]	2½
CONBRACO Conbraco (1/2-DC-1/2)	3DCDA	(H, VU)	[I], [m] [13], [5],[6],[7],[8],[9],[10],[11],[12], [14],[15],[16],[17]	3
CONBRACO Conbraco (1/2DC-1/2)	3DCDA-6	(H, VU)	[m] - #1SOV ,[ooo] - #2SOV [13], [5],[6],[7],[8],[9],[10],[11],[12]	3
CONBRACO Conbraco (1/2DC-1/2)	3DCDAU	(VU, VD)	[I], [m] [13], [5],[6],[7],[8],[9],[10],[11],[12], [14],[15],[16],[17],	3
CONBRACO Conbraco(1/2DC-1/2)	4DCDA	(H, VU)	[I], [m] [13], [5],[6],[7],[8],[9],[10],[11],[12] [14],[15],[16],[17]	4

DOUBLE CHECK DETECTOR (DCD) ASSEMBLIES – 2008 (cont'd.)

<u>COMPANY</u>	<u>MODEL</u>	<u>DIRECTION</u>	<u>SHUTOFF VALVES/METERS</u>	<u>SIZE IN INCHES</u>
CONBRACO Conbraco (1/2DC-1/2)	4DCDA-6	(H, VU)	[I], [m] [13], [5],[6],[7],[8],[9],[10],[11],[12] [14],[15],[16],[17],	6
CONBRACO Conbraco (1/2DC-1/2)	4DCDAU-4	(VU VD)	[I], [m] [13], [5],[6],[7],[8],[9],[10],[11],[12] [14],[15],[16],[17]	4
CONBRACO Conbraco (1/2DC-1/2)	4DCDAU-6	(H, VU)	[I], [m] [13], [5],[6],[7],[8],[9],[10],[11],[12] [14],[15],[16],[17]	6
CONBRACO Conbraco (1/2DC-1/2)	6DCDA-6	(H, VU)	[I], [m] [13], [5],[6],[7],[8],[9],[10],[11],[12] [14],[15],[16],[17]	6
CONBRACO Conbraco(1/2DC-1/2)	6DCDA-6	(H, VU)	[m] - #1SOV ,[ooo] - #2SOV [13], [5],[6],[7],[8],[9],[10],[11],[12] [14],[15],[16],[17]	6
CONBRACO Conbraco(1/2DC-1/2)	6DCDAU	(VU VD)	[I], [m] [13], [5],[6],[7],[8],[9],[10],[11],[12] [14],[15],[16],[17]	6
CONBRACO Conbraco (1/2DC-1/2)	8DCDA	(H, VU)	[m], [I] [13], [6],[7],[8],[9],[10],[11],[12], [14],[15],[16],[17]	8, 10
CONBRACO (Conbraco 40-104-02-3/4)	40-600-C3	(H)	[u], [c],[m] [13], [1],[2],[3],[4],[5],[6],[7],[8],[9], [10],[11],[12],[14],[15],[16],[17],	3
CONBRACO (Conbraco 40-104-02-3/4)	40-600-E3	(H)	[u], [c],[m] [13], [1],[2],[3],[4],[5],[6],[7],[8],[9], [10],[11],[12],[14],[15],[16],[17],	3
CONBRACO (Conbraco 40-104-02-3/4)	40-60A-C3	(H)	[u],[c],[m] [13], [1],[2],[3],[4],[5],[6],[7],[8],[9], [10],[11],[12],[14],[15],[16],[17]	4
CONBRACO (Conbraco 40-104-02-3/4)	40-60A-C6	(H)	[m] - #1SOV ,[ooo] - #2SOV [13], [1],[2],[3],[4],[5],[6],[7],[8],[9], [10],[11],[12],[14],[15],[16],[17]	4

DOUBLE CHECK DETECTOR (DCD) ASSEMBLIES – 2008 (cont'd.)

<u>COMPANY</u>	<u>MODEL</u>	<u>DIRECTION</u>	<u>SHUTOFF VALVES/METERS</u>	<u>SIZE IN INCHES</u>
CONBRACO (Conbraco 40-104-02-3/4)	40-60A-E3	(H)	[u] , [c],[m] [13] , [1],[2],[3],[4],[5],[6],[7],[8],[9], [10],[11],[12],[14],[15],[16],[17]	4
CONBRACO (Conbraco 40-104-02-3/4)	40-60A-E6	(H)	[m] - #1SOV , [ooo] - #2SOV [13] , [1],[2],[3],[4],[5],[6],[7],[8],[9], [10],[11],[12],[14],[15],[16],[17]	4
CONBRACO (Conbraco 40-104-02-3/4)	40-60C-C3	(H)	[t] , [b],[e],[l] [13] , [1],[2],[3],[4],[5],[6],[7],[8],[9], [10],[11],[12],[14],[15],[16],[17]	6
CONBRACO (Conbraco 40-104-02-3/4)	40-60C-C6	(H)	[m] - #1SOV , [ooo] - #2SOV [13] , [1],[2],[3],[4],[5],[6],[7],[8],[9], [10],[11],[12],[14],[15],[16],[17]	6
CONBRACO (Conbraco 40-104-02-3/4)	40-60C-E3	(H)	[u] , [c],[m] [13] , [1],[2],[3],[4],[5],[6],[7],[8],[9], [10],[11],[12],[14],[15],[16],[17]	6
CONBRACO (Conbraco 40-104-02-3/4)	40-60C-E6	(H)	[m] - #1SOV , [ooo] - #2SOV [13] , [1],[2],[3],[4],[5],[6],[7],[8],[9], [10],[11],[12],[14],[15],[16],[17]	6
CONBRACO (Conbraco 40-104-02-3/4)	40-60E-C3	(H)	[u] , [c],[m] [13] , [1],[2],[3],[4],[5],[6],[7],[8],[9], [10],[11],[12],[14],[15],[16],[17]	8
CONBRACO (Conbraco 40-104-02-3/4)	40-60E-C6	(H)	[m] - #1SOV , [ooo] - #2SOV [13] , [1],[2],[3],[4],[5],[6],[7],[8],[9], [10],[11],[12],[14],[15],[16],[17]	8
CONBRACO (Conbraco 40-104-02-3/4)	40-60E-E3	(H)	[u] , [c],[m] [13] , [1],[2],[3],[4],[5],[6],[7],[8],[9], [10],[11],[12],[14],[15],[16],[17]	8
CONBRACO (Conbraco 40-104-02-3/4)	40-60E-E6	(H)	[m] - #1SOV , [ooo] - #2SOV [13] , [1],[2],[3],[4],[5],[6],[7],[8],[9], [10],[11],[12],[14],[15],[16],[17]	8
CONBRACO (Conbraco 40-104-02-3/4)	40-60G-C3	(H)	[u] , [c],[m] [13] , [1],[2],[3],[4],[5],[6],[7],[8],[9], [10],[11],[12],[14],[15],[16],[17]	10
CONBRACO (Conbraco 40-104-02-3/4)	40-60G-C6	(H)	[m] - #1SOV , [ooo] - #2SOV [13] , [1],[2],[3],[4],[5],[6],[7],[8],[9], [10],[11],[12],[14],[15],[16],[17]	10

DOUBLE CHECK DETECTOR (DCD) ASSEMBLIES – 2008 (cont'd.)

<u>COMPANY</u>	<u>MODEL</u>	<u>DIRECTION</u>	<u>SHUTOFF VALVES/METERS</u>	<u>SIZE IN INCHES</u>
CONBRACO (Conbraco 40-104-02-3/4)	40-60G-E3	(H)	[u] , [c],[m] [13] , [1],[2],[3],[4],[5],[6],[7],[8],[9], [10],[11],[12],[14],[15],[16],[17]	10
CONBRACO (Conbraco 40-104-02-3/4)	40-60G-E6	(H)	[m] - #1SOV , [ooo] - #2SOV [13] , [1],[2],[3],[4],[5],[6],[7],[8],[9], [10],[11],[12],[14],[15],[16],[17]	10
FEBCO (Febco 805Y-3/4)	806YD	(H)	[f] , [m],[u] [13] , [1],[2],[3],[4],[5],[6],[7],[8],[9], [10],[11],[12],[14],[15],[16],[17]	3
FEBCO (Febco 805Y-3/4)	806YD	(H)	[f] , [m],[u] [6] , [1],[2],[3],[4],[5],[7],[8],[9] [10],[11],[12],[14],[15],[16],[17]	4, 6, 8, 10
FEBCO (Febco 805Y-3/4)	856	(H, VU)	[f] , [m],[u] [13] , [2],[3],[4],[5],[6],[7],[8],[9], [10],[11],[12],[14],[15],[16],[17]	2½, 3, 4, 6, 8
FEBCO (Watts 007QT-1/2)	858	(H, VU)	[bb] [13] , [2],[3],[4],[5],[6],[7],[8],[9], [10],[11],[12],[14],[15],[16],[17]	2, 2½, 3,
FEBCO (Febco 805YB-3/4)	876	(VU VD)	[f] , [m],[u] [13] , [2],[3],[4],[5],[6],[7],[8],[9], [10],[11],[12],[14],[15],[16],[17]	2½,3, 4, 6, 8,10
FEBCO (Febco 805YB-3/4)	876V	(VUVD, VUVU)	[f] , [m],[u] [13] , [2],[3],[4],[5],[6],[7],[8],[9], [10],[11],[12],[14],[15],[16],[17]	2½, 3, 4, 6, 8
FEBCO (Febco 805YB-3/4)	876V	(VUVD, VUVU)	[e] , [l],[t],[f],[m],[u] [13] , [2],[3],[4],[5],[6],[7],[8],[9], [10],[11],[12],[14],[15],[16],[17]	10

DOUBLE CHECK DETECTOR (DCD) ASSEMBLIES – 2008 (cont'd.)

<u>COMPANY</u>	<u>MODEL</u>	<u>DIRECTION</u>	<u>SHUTOFF VALVES/METERS</u>	<u>SIZE IN INCHES</u>
WATTS (Watts 007QT-1/2)	007-DCDA	(H, VU)	[bb] [8] , [1],[2],[3],[4],[5],[6],[7],[9],[10] [11],[12],[13],[14],[15],[16],[17]	2
WATTS (Watts 007M2QT-3/4)	007-DCDA	(H, VU)	[p] , [g],[h],[l],[m],[o],[t],[u] [8] , [4],[5],[6],[7],[9],[10],[11] [12],[13],[14],[15],[16],[17]	2½
WATTS (Watts 007M2QT-3/4)	007-DCDA	(H)	[p] , [h],[m],[u] [8] , [4],[5],[6],[7],[9],[10],[11] [12],[13],[14],[15],[16],[17],	3
WATTS (Watts 007M1QT-3/4)	709-DCDA	(H)	[p] , [h],[u],[e] [14] , [2],[3],[4],[5],[6],[7],[8],[9] [10],[11],[12],[13],[15],[16],[17]	3
WATTS (Watts 007QT-1/2)	709-DCDA	(H)	[p] , [h],[u],[e] [14] , [1],[2],[3],[4],[5],[6],[7],[8],[9] [10],[11],[12],[13],[15],[16],[17]	4, 6
WATTS (Watts 007QT-1/2)	709-DCDA	(H)	[p] , [h],[m],[u],[e] [14] , [1],[2],[3],[4],[5],[6],[7],[8],[9] [10],[11],[12],[13],[15],[16],[17]	8
WATTS (Watts 007QT-1/2)	709DCDA	(VU)	[p] , [h],[u],[e] [14] , [1],[2],[3],[4],[5],[6],[7],[8],[9] [10],[11],[12],[13],[15],[16],[17],	4
WATTS (Watts 007QT-1/2)	709DCDA	(VU)	[p] , [h],[m],[u],[e] [8] , [1],[2],[3],[4],[5],[6],[7],[9],[10] [11],[12],[13],[14],[15],[16],[17],	6, 8, 10
WATTS (Watts 007QT-1/2)	709DCDA	(H)	[p] , [h],[m],[u],[e] [14] , [1],[2],[3],[4],[5],[6],[7],[8],[9] [10],[11],[12],[13],[15],[16],[17]	10
WATTS (Watts 007M3QT-3/4)	767-DCDA -BF	(H, VU)	[YY] (N),G,H,I,J,K,L,M,O,P,Q	2½,3,4,6
WATTS (Watts 007M3QT-3/4)	767-DCDA -GV	(H, VU)	[zz] (N), G, H, I J, K L, M, N, O, P, Q	2½,3,4,6
WATTS (Watts 007M1QT-3/4)	774-DCDA	(H)	[u] , [e],[f],[g],[h],[l],[m],[o],[p],[t],[cc],[dd] [13] , [1],[2],[3],[4],[5],[6],[7],[8] [9],[10],[11],[12],[14],[15],[16],[17],	2½, 3, 4, 6, 8

DOUBLE CHECK DETECTOR (DCD) ASSEMBLIES – 2008 (cont'd.)

<u>COMPANY</u>	<u>MODEL</u>	<u>DIRECTION</u>	<u>SHUTOFF VALVES/METERS</u>	<u>SIZE IN INCHES</u>
WATTS (Watts 007M2QT- 3/4)	774-DCDA	(H)	[l], [m], [10], [3],[4],[5],[6],[7],[8],[9],[11] [12],[13],[14],[15],[16],[17],	10
WATTS (Watts 007M1QT-3/4)	774X-DCDA	(H)	[m],[e],[f],[g],[h],[i],[j],[k],[l],[m],[n],[o],[p],[q],[r],[s],[t],[u],[v],[w],[x],[y],[z] [13], [14],[15],[16],[17]	2½
WATTS (Watts 007M1QT-3/4)	774X-DCDA	(H)	[u], e],[f],[g],[h],[i],[j],[k],[l],[m],[n],[o],[p],[q],[r],[s],[t],[u],[v],[w],[x],[y],[z] [13], [1],[2],[3],[4],[5],[6],[7],[8],[9] [10],[11],[12],[14],[15],[16],[17]	6, 8
WILKINS (Wilkins 950XLD-3/4)	350DA	(H,VU)	[h], [f],[m],[u],[z] [13], [1],[2],[3],[4],[5],[6],[7],[8],[9] [10],[11],[12],[14],[15],[16],[17]	2½, 3, 4, 6
WILKINS (Wilkins 950XLD-3/4)	350DA	(H,VU)	[h], [f],[m],[u],[z] [14],[6],[7],[8],[9],[10],[11] [12],[13],[15],[16],[17]	8, 10
WILKINS (Wilkins 950XLD-3/4)	350DAG	(H, VU)	[qq] [13], [1],[2],[3],[4],[5],[6],[7],[8],[9] [10],[11],[12],[14],[15],[16],[17]	4, 6, 8
WILKINS (Wilkins 950XLD-3/4)	350ADA	(H,VU)	[qq], [tt],[yy] [13], [1],[2],[3],[4],[5],[6],[7],[8],[9] [10],[11],[12],[14],[15],[16],[17]	6, 8
WILKINS (Wilkins 950XLD-3/4)	350ADA	(H,VU)	[qq], [tt] [13], [1],[2],[3],[4],[5],[6],[7],[8],[9] [10],[11],[12],[14],[15],[16],[17]	10
WILKINS (Wilkins 950XLD-3/4)	450DA	(VU VD)	[qq] [13], [1],[2],[3],[4],[5],[6],[7],[8],[9] [10],[11],[12],[14],[15],[16],[17],	4, 6
WILKINS (Wilkins 950XLD-3/4)	450DAG	(VU VD)	[qq] [13], [1],[2],[3],[4],[5],[6],[7],[8],[9] [10],[11],[12],[14],[15],[16],[17],	4

DOUBLE CHECK DETECTOR (DCD) ASSEMBLIES – 2008 (cont'd.)

<u>COMPANY</u>	<u>MODEL</u>	<u>DIRECTION</u>	<u>SHUTOFF VALVES/METERS</u>	<u>SIZE IN INCHES</u>
WILKINS (Wilkins 950XLD-3/4)	350DAGPI	(H, VU)	[qq] ,[#1SOV],[ww],[#2SOV] [13] , [1],[2],[3],[4],[5],[6],[7],[8],[9] [10],[11],[12],[14],[15],[16],[17],	4, 6
WILKINS (Wilkins 950XLD-3/4)	350DAPI	(H)	[h] ,[#1SOV],[wv],[#2SOV] [13] , [1],[2],[3],[4],[5],[6],[7],[8],[9] [10],[11],[12],[14],[15],[16],[17],	4, 6
WILKINS (Wilkins 950XLD-3/4)	450DAG	(VU VD)	[qq] [13] ,[3],[4],[5],[6],[7],[8],[9],[10] [11],[12],[14],[15],[16],[17],	6
WILKINS (Wilkins 950XL-3/4)	950DA	(H,VU)	[h] ,[f],[m],[u],[z] [13] , [1],[2],[3],[4],[5],[6],[7],[8],[9] [10],[11],[12],[14],[15],[16],[17],	2½,3,4,6,8,10
WILKINS (Wilkins 950XL-3/4)	950DAG	(H,VU)	[qq] [13] ,[5],[6],[7],[8],[9],[10],[11], [12],[14],[15],[16],[17],	4, 6, 8

**PHILADELPHIA WATER DEPARTMENT
CROSS CONNECTION CONTROL PROGRAM
(2008)**

The RPZD backflow prevention assemblies used must be selected from the following listing. The Water Department shall regularly update the listing which shall be made available at L&I and the Water Department. Also all RPZD assemblies listed below are approved for the **ORIENTATION** indicated under **DIRECTION**.

REDUCED PRESSURE ZONE DETECTOR (RPZD) ASSEMBLIES

<u>COMPANY</u>	<u>MODEL</u>	<u>DIRECTION</u>	<u>SHUTOFF VALVES/METERS</u>	<u>SIZE IN INCHES</u>
(BYPASS)				
AMES (Conbraco 40-204-02 - 3/4)	5000	(H)	[u], [e],[f],[g],[h],[c],[dd],[l],[m],[t] (M),A,B,C,D,E,F,G,H,I,J,K,L,N,O,P,Q	4,10
AMES (Conbraco 40-204-02 - 3/4)	5000	(H)	[u], [e],[f],[g],[h],[c],[dd],[l],[m],[t] (M),A,B,C,D,E,F,G,H,I,J,K,L,N,O,P,Q	6,8
AMES (Watts 909QT - 3/4)	5000CIV	(H)	[p],[h],[m],[u] (H),C,D,E,F,G,I,J,K,L,M,N,O,P,Q	2½
AMES (Watts 909QT - 3/4)	5000CIV	(H)	[p],[h],[m],[u],[e] (N),B,C,D,E,F,G,H,I,J,K,L,M,N,O,P,Q	3,4,6,8,10
AMES (Watts 919QT- 3/4)	Colt 500-GV		(zz) (N),H,I,J,K,L,M,N,O,P,Q	2½ 3,4,6
AMES (Watts 919QT- 3/4)	Maxim 500-GV		(zz) (N),H,I,J,K,L,M,N,O,P,Q	2½ 3,4
CONBRACO (Conbraco 40-204-02 - 3/4)	40-700-C3	(H)	[u], [c],[m] [13],[1],[2],[3],[4],[5],[6],[7],[8],[9] [10],[11],[12],[14],[15],[16],[17]	3
CONBRACO (Conbraco 40-204-02 - 3/4)	40-700-E3	(H)	[u], [c],[m] [13],[1],[2],[3],[4],[5],[6],[7],[8],[9] [10],[11],[12],[14],[15],[16],[17]	3
CONBRACO (Conbraco 40-204-02 - 3/4)	40-70A-C3	(H)	[u],[c],[m] [13],[1],[2],[3],[4],[5],[6],[7],[8],[9] [10],[11],[12],[14],[15],[16],[17]	4

REDUCED PRESSURE ZONE DETECTOR (RPZD) ASSEMBLIES – 2008 (cont'd.)

<u>COMPANY</u>	<u>MODEL</u>	<u>DIRECTION</u>	<u>SHUTOFF VALVES/METERS</u>	<u>SIZE IN INCHES</u>
CONBRACO (Conbraco 40-204-02 - 3/4)	40-70A-E3	(H)	[u], [c],[m] [13],[4],[5],[6],[7],[8],[9] [10],[11],[12],[14],[15],[16],[17]	4
CONBRACO (Conbraco 40-204-02 - 3/4)	40-70C-C3	(H)	[u], [c],[m] [13],[4],[5],[6],[7],[8],[9] [10],[11],[12],[14],[15],[16],[17]	6
CONBRACO (Conbraco 40-204-02 - 3/4)	40-70C-E3	(H)	[u], [c],[m] [13],[4],[5],[6],[7],[8],[9] [10],[11],[12],[14],[15],[16],[17]	6
CONBRACO (Conbraco 40-204-02 - 3/4)	40-70E-C3	(H)	[u], [c],[m] [13],[1],[2],[3],[4],[5],[6],[7],[8],[9] [10],[11],[12],[14],[15],[16],[17]	8
CONBRACO (Conbraco 40-204-02 - 3/4)	40-70E-E3	(H)	[u], [c],[m] [13],[1],[2],[3],[4],[5],[6],[7],[8],[9] [10],[11],[12],[14],[15],[16],[17]	8
CONBRACO (Conbraco 40-204-02 - 3/4)	40-70G-C3	(H)	[u], [c],[m] [13],[1],[2],[3],[4],[5],[6],[7],[8],[9] [10],[11],[12],[14],[15],[16],[17]	10
CONBRACO (Conbraco 40-204-02 - 3/4)	40-70G-E3	(H)	[u], [c],[m] [13],[1],[2],[3],[4],[5],[6],[7],[8],[9] [10],[11],[12],[14],[15],[16],[17]	10
FEBCO (Febco 825Y-3/4)	826YD	(H)	[f], [m],[u] [13],[3],[4],[5],[6],[7],[8],[9] [10],[11],[12],[14],[15],[16],[17]	2½,3,4,6,8,10
WATTS (Watts 009M2QT-3/4)	909RPDA	(H)	[o], [g],[t] [13],[1],[2],[3],[4],[5],[6],[7],[8],[9] [10],[11],[12],[14],[15],[16],[17]	2½

REDUCED PRESSURE ZONE DETECTOR (RPZD) ASSEMBLIES – 2008 (cont'd.)

<u>COMPANY</u>	<u>MODEL</u>	<u>DIRECTION</u>	<u>SHUTOFF VALVES/METERS</u>	<u>SIZE IN INCHES</u>
WATTS (Watts 009M2QT-3/4)	909RPDA	(H)	[o], [g],[t] [14],[1],[2],[3],[4],[5],[6],[7],[8],[9] [10],[11],[12],[13],[15],[16],[17]	3, 4, 6, 8, 10
WATTS (Watts 919QT-3/4)	957RPDA-GV	(H)	(zz) (N), H, I J, K L, M, N, O, P, Q	2½ 3,4,6,
WATTS (Watts 919QT-3/4)	967RPDA-GV	(H)	(zz) (N), H, I J, K L, M, N, O, P, Q	3,4,
WILKINS (Wilkins 975XLD-3/4)	375DA	(H)	[h], [f],[m],[u],[z], [13],[3],[4],[5],[6],[7],[8],[9] [10],[11],[12],[14],[15],[16],[17]	2½, 3, 4
WILKINS (Wilkins 975XLD-3/4)	375DA	(H)	[o], [g],[t] [f],[u],[z] [14],[3],[4],[5],[6],[7],[8],[9] [10],[11],[12],[13],[15],[16],[17]	6
WILKINS (Wilkins 975XLD-3/4)	375DAG	(H)	[o], [g],[t] [13],[3],[4],[5],[6],[7],[8],[9] [10],[11],[12],[14],[15],[16],[17]	4
WILKINS (Wilkins 975XLD-3/4)	375DAG	(H)	[o], [g],[t] [14],[3],[4],[5],[6],[7],[8],[9] [10],[11],[12],[13],[15],[16],[17]	6
WILKINS (Wilkins 975 RP-3/4)	375DAGPI	(H)	[qq] - #SOV, [ww] - #2SOV [13],[3],[4],[5],[6],[7],[8],[9] [10],[11],[12],[14],[15],[16],[17]	4
WILKINS (Wilkins 975XLD-3/4)	375DAGPI	(H)	[qq] - #1SOV , [ww] - #2SOV [14],[3],[4],[5],[6],[7],[8],[9] [10],[11],[12],[13],[15],[16],[17]	6
WILKINS (Wilkins 975XLD-3/4)	375DAPI	(H)	[qq] - #1SOV , [ww] - #2SOV [13],[3],[4],[5],[6],[7],[8],[9] [10],[11],[12],[14],[15],[16],[17]	4
WILKINS (Wilkins 975 RP-3/4)	375DAPI	(H)	[qq] - #1SOV , [ww] - #2SOV [14],[3],[4],[5],[6],[7],[8],[9] [10],[11],[12],[13],[15],[16],[17]	6

REDUCED PRESSURE ZONE DETECTOR (RPZD) ASSEMBLIES – 2008 (cont'd.)

<u>COMPANY</u>	<u>MODEL</u>	<u>DIRECTION</u>	<u>SHUTOFF VALVES/METERS</u>	<u>SIZE IN INCHES</u>
WILKINS (Wilkins 975XLD-3/4)	475DA	(VU VD)	[pp] , [qq], [14] , [6],[7],[8],[9]10],[11] [12],[13], [15],[16],[17]	4, 6, 8
WILKINS (Wilkins 975 XLD-3/4)	475DAG	(VU VD)	[qq] , [tt], [14] ,[6],[7],[8],[9]10],[11] [12],[13],[15],[16],[17]	4, 6
WILKINS (Wilkins 975 XLDP-3/4)	475DAV	(VU VU)	[pp] , [qq], [14] , [6],[7],[8],[9]10],[11] [12],[13], [15],[16],[17]	4
WILKINS (Wilkins 975 XLD-3/4)	475DAVG	(VU VD)	[qq] , [tt], [14] ,[6],[7],[8],[9]10],[11] [12],[13],[15],[16],[17]	4
WILKINS (Wilkins 975XLD-3/4)	975DA	(H)	[h] , [f],[u],[z] [13] ,[1],[2],[3],[4],[5],[6],[7],[8],[9] [10],[11],[12],[14],[15],[16],[17]	2½,3,4,6,8,10
WILKINS (Wilkins 975XLD-3/4)	975DAG	(H)	[qq] , [13] ,[1],[2],[3],[4],[5],[6],[7],[8],[9] [10],[11],[12],[14],[15],[16],[17]	4, 6

PHILADELPHIA WATER DEPARTMENT CROSS CONNECTION CONTROL PROGRAM

INSTALLATION REQUIREMENTS

Air-gap separation using receiving tanks

-The receiving tank shall be installed within the building and adjacent to the service connection (meter). The supply line between the meter and the tank shall be permanently exposed for inspection purposes. A facility with an air-gapped system which is located away from the service connection (i.e. a holding tank on the roof) must provide containment protection at the service connection.

-There shall be no outlet, tee, tap or connection of any kind to or from the supply pipe between the meter and the opening from which the water is discharged into the receiving tank.

-The free flowing discharge point shall be located at a distance of not less than two times the diameter of the inlet pipe (minimum one inch) above the flood rim of the tank.

PHILADELPHIA WATER DEPARTMENT

CROSS CONNECTION CONTROL PROGRAM

INSTALLATION REQUIREMENTS

DOUBLE CHECK VALVE (DCV) ASSEMBLIES

All DCV backflow prevention assemblies shall be installed in accordance with the manufacturer's specifications and the following Water Department instructions:

- DCV assemblies must be purchased with the manufacturer's approved inlet and outlet control valves and four (4) test cocks as a complete package unit.
- DCV assemblies shall be installed a minimum of 12" and a maximum of 60" above the floor in accessible locations with sufficient space to allow for testing and maintenance.
- If continuous, uninterrupted water service is desired, two smaller DCV assemblies may be installed in parallel. Parallel installation permits testing and maintenance of each individual DCV assembly without total service interruption. When the backflow preventers are used in parallel, the total rated capacity of the assemblies must equal or exceed the capacity of the main feed line.

Outdoor Installations:

- A DCV may be installed below ground level in a pit (vault) or chamber designed to prevent flooding. Preferably, all DCVs should be installed above ground. If installation is made in a meter (master) pit, the designer should refer to the Water Department's Meter Pit Standards.
- All DCV installations in pits or chambers must have the following provisions:
 - (a) There shall be no outlet, tee, tap or connection of any kind to or from the supply line between The meter and the backflow prevention device.
 - (b) The device shall be protected against freezing. Access for routine testing and maintenance shall be provided.
 - (c) If a drain in the pit or chamber is absolutely necessary there shall be no connection between the drain and a sewer or appurtenance which permits the passage of polluted water into the pit or chamber.

PHILADELPHIA WATER DEPARTMENT

CROSS CONNECTION CONTROL PROGRAM

INSTALLATION REQUIREMENTS

DOUBLE CHECK VALVE (DCV) ASSEMBLIES (continued)

Indoor Installations:

- Where possible, an approved DCV backflow prevention assembly shall be installed within a building on the service connection after but close to the meter. In certain cases, a backflow prevention assembly may be installed at an alternative location such as outdoors or at the discharge side of a booster pump. The device shall be protected from freezing, flooding and vandalism. Access for routine testing and maintenance shall be provided.
- There shall be no outlet, tee, tap or connection of any kind to or from the supply pipe between the meter and the DCV backflow prevention assembly. If a takeoff is absolutely necessary, it must be equipped with a proper backflow assembly designated by the Water Department.
- The DCV assembly shall be equipped with proper shutoff valves for maintenance and testing. Such shutoff valves shall be the type that are supplied by the same backflow assembly manufacturer or the type that are approved or manufactured to conform to standards set by AWWA, USC FCCC, ASSE, or UL/FM.
- If parallel or by-pass installation is desired, both lines shall be equipped with two same type DCV backflow prevention devices. The combined hydraulic capacity of the parallel lines/devices shall be equal or greater than that of the line that is being subdivided.
- The requirements for installation of DCV backflow prevention devices at alternative locations, in lieu of the service connection within a building, are given below.

Beyond the Service Connection

- (a) An approved DCV backflow prevention device may be installed on the discharge side of a pump system when a customer's water-pump system experiences or could experience operational problems due to low City-water pressures in the area surrounding the building.
- (b) There shall be no outlet, tee, tap or connection of any kind to or from the supply line between the meter and the DCV device.

PHILADELPHIA WATER DEPARTMENT

CROSS CONNECTION CONTROL PROGRAM

INSTALLATION REQUIREMENTS

REDUCED PRESSURE ZONE (RPZ) ASSEMBLIES

All RPZ backflow prevention assemblies shall be installed in accordance with the manufacturer's specifications and the following Water Department instructions:

- RPZ assemblies must be purchased with the manufacturer's approved inlet and outlet control valves and four (4) test cocks as a complete package unit.
- RPZ assemblies shall be installed a minimum of 12" and a maximum of 60" above the floor in accessible locations with sufficient space to allow for testing and maintenance.
- If continuous, uninterrupted water service is desired, two smaller RPZ assemblies may be installed in parallel. Parallel installation permits testing and maintenance of each individual RPZ assembly without total service interruption. When the backflow preventers are used in parallel, the total rated capacity of the assemblies must equal or exceed the capacity of the main feed line.

Outdoor installation:

- An RPZ must be installed above ground with a minimum 12" clearance. An on-site constructed or pre-manufactured shelter must be installed to provide additional protection against freezing and vandalism.

Indoor installation:

- Where possible, an approved RPZ backflow prevention assembly shall be installed within a building on the service connection after but close to the meter. In certain cases, a backflow prevention assembly may be installed at an alternative location such as outdoors or at the discharge side of a booster pump. The device shall be protected from freezing, flooding and vandalism. Access for routine testing and maintenance shall be provided.
- There shall be no outlet, tee, tap or connection of any kind to or from the supply pipe between the meter and the RPZ backflow prevention assembly. If a takeoff is absolutely necessary, it must be equipped with a proper backflow assembly designated by the Water Department.

**PHILADELPHIA WATER DEPARTMENT
CROSS CONNECTION CONTROL PROGRAM**

INSTALLATION REQUIREMENTS

REDUCED PRESSURE ZONE (RPZ) ASSEMBLIES (continued)

- The RPZ assembly shall be equipped with proper shutoff valves for maintenance and testing. Such shutoff valves shall be the type that are supplied by the same backflow assembly manufacturer or the type that are approved or manufactured to conform to standards set by AWWA, USC FCCC, ASSE, or UL/FM.

- If parallel or by-pass installation is desired, both lines shall be equipped with two same type RPZ backflow prevention devices. The combined hydraulic capacity of the parallel lines/devices shall be equal or greater than that of the line that is being subdivided.

- The requirements for installation of RPZ backflow prevention devices at alternative locations, in lieu of the service connection within a building, are given below.

Beyond the Service Connection

- (a) An approved RPZ backflow prevention device may be installed on the discharge side of a pump system when a customer's water-pump system experiences or could experience operational problems due to low City-water pressures in the area surrounding the building.

- (b) There shall be no outlet, tee, tap or connection of any kind to or from the supply line between the meter and the RPZ device.