

United States
Department of
Agriculture



Federal Crop
Insurance
Corporation



Product
Administration
And Standards
Division

FCIC-25770 (06-2006)

MINT PILOT LOSS ADJUSTMENT STANDARDS HANDBOOK 2007 and Succeeding Crop Years

**UNITED STATES DEPARTMENT OF AGRICULTURE
WASHINGTON, D.C. 20250**

FEDERAL CROP INSURANCE HANDBOOK	Number: 25770	(06-2006)
SUBJECT: MINT PILOT LOSS ADJUSTMENT STANDARDS HANDBOOK 2007 AND SUCCEEDING CROP YEARS	OPI: Product Administration and Standards Division	
	APPROVED: /S:/ Tim B. Witt Deputy Administrator, Product Management	DATE: 06/22/2006

THIS HANDBOOK CONTAINS THE OFFICIAL FCIC-ISSUED LOSS ADJUSTMENT STANDARDS FOR THIS CROP FOR THE 2007 AND SUCCEEDING CROP YEARS. ALL REINSURED COMPANIES WILL UTILIZE THESE STANDARDS FOR BOTH LOSS ADJUSTMENT AND LOSS TRAINING.

SUMMARY OF CHANGES/CONTROL CHART

The following list contains significant changes to this handbook, as determined by us. It may not represent all changes made. All changes made to this handbook are applicable regardless of whether or not listed

Major Changes: See changes or additions in text which have been **highlighted**. Three stars (***) identify where information has been removed.

Changes for Crop Year 2007 (FCIC-25770) issued **JUNE 2006**:

1. Throughout handbook: Made editorial and syntax changes so handbook text tracks with current RMA-approved handbook formatting.
2. Section 1: Added language to clarify that this handbook must be used in conjunction with the Loss Adjustment Manual (LAM).
3. Subsection 2 A: Added language to clarify the minimum distribution of forms completed by the adjuster and signed by the insured (or insured's authorized representative) for the loss adjustment inspection:
4. Subsection 2 B (3): Added the following abbreviations:

CAT	Catastrophic Risk Protection
CIH	Crop Insurance Handbook
NDR	No Discernable Rows
R	Discernable Rows

MINT LOSS ADJUSTMENT STANDARDS HANDBOOK

SUMMARY OF CHANGES/CONTROL CHART (Continued)

5. Section 3: Added language to clarify that Section 3 is not a complete list of insurability requirements.
6. Subsection 3 A (4): Added language to clarify that in lieu of the provisions in the Basic Provisions that prohibit insurance of a second crop harvested following the same crop in the same crop year, multiple harvests of mint in the same crop year on the same acreage will be considered as one mint crop.
7. Subsection 3 A (8): Added language to list causes of loss insurance is not provided for in addition to causes of loss excluded in the Basic Provisions.
8. Subsection 3 B: Added policy information about Winter Coverage Option.
9. Subsection 3 C: Removed the specific provisions that were stated as they are shown in the LAM. Instructed the adjuster to refer to the CIH and LAM for provisions and procedures not applicable to CAT.
10. Subsection 3 D: Added language to clarify that a basic unit will also include all acreage of the insured crop in the county for each type designated in the Special Provisions.
11. Subsection 4 B (4): Revised statement to instruct the adjuster to take not less than the minimum number (count) of representative samples required in **TABLE A** for each field or subfield.
12. Subsection 5 D (1): Added language to clarify how to determine the population of live mint plants to be counted from insurable acreage on the unit.
13. Subsection 5 D (2) (a): Deleted “Take not less than the minimum number (count) of representative samples required in **TABLE A** for each field or subfield. Refer to **EXHIBIT 1** for the grid measurement tool.” Already stated in Section 4.
14. Subsection 5 D (2) (b) 3: Added instructions on how to determine plant counts in fields with no distinguishable rows.
15. Subsection 7 A (3): Added language to clarify that separate appraisal worksheets are required for each unit appraised or farming practice.
16. Subsection 7 B, item 4: Clarified that the adjuster is to enter “**Crop Year**” as a four-digit number.

MINT LOSS ADJUSTMENT STANDARDS HANDBOOK

SUMMARY OF CHANGES/CONTROL CHART (Continued)

17. Subsection 7 C, item 4: Clarified that the adjuster is to enter “**Crop Year**” as a four-digit number.
18. Subsection 7 C, item 6: Revised NDR instructions to show square feet in the sample area.
19. Subsection 7 C, item 19: Revised NDR instructions to show square feet in the sample area.
20. Subsection 7 C, Appraisal Worksheet Example: Made necessary updates to reflect changes in written procedure.
21. Subsection 8 B, item 11: Clarified that the adjuster is to enter “**Crop Year**” as a four-digit number.
22. Subsection 8 B Section I – Item A.: Added first crop/second crop standard language: “**REFER TO THE LAM FOR INSTRUCTIONS REGARDING ENTRY OF FIRST CROP AND SECOND CROP CODES.**”
23. Subsection 8 B Section I, item E: Revised entry to match current approved language.
24. Subsection 8 B Section I, item H & I: Revised language concerning GLEANED ACREAGE to match the standard language.
25. Subsection 8 B Section I, item N: PRELIMINARY, FINAL – Deleted “AND WCO – W1.” No entry required.
26. Subsection 8 B Section I, Narrative item “u.” Revised language instructing the adjuster to document the name and address of the charitable organization when gleaned acreage is applicable, and refer to the LAM.
27. Subsection 8 B Section II – Item A₂ c.: Added first crop/second crop standard language: “**REFER TO THE LAM FOR INSTRUCTIONS REGARDING ENTRY OF FIRST CROP AND SECOND CROP CODES.**”

MINT LOSS ADJUSTMENT STANDARDS HANDBOOK

SUMMARY OF CHANGES/CONTROL CHART (Continued)

Control Chart For: Mint Loss Adjustment Standards Handbook						
	SC Page(s)	TC Page(s)	Text Page(s)	Reference Material	Date	Directive Number
Remove	Entire Handbook					
Current Index	1-4	1-2	1-34	35-36	06-2006	FCIC-25770

**MINT LOSS ADJUSTMENT HANDBOOK
TABLE OF CONTENTS**

PAGE

1. INTRODUCTION	1
2. SPECIAL INSTRUCTIONS	1
A. DISTRIBUTION.....	1
B. TERMS, ABBREVIATIONS, AND DEFINITIONS.....	1
3. INSURANCE CONTRACT INFORMATION	3
A. INSURABILITY.....	3
B. WINTER COVERAGE OPTION	4
C. PROVISIONS AND PROCEDURES NOT APPLICABLE TO CAT COVERAGE.....	5
D. UNIT DIVISION.....	5
4. MINT APPRAISALS	5
A. GENERAL INFORMATION.....	5
B. SELECTING REPRESENTATIVE SAMPLES FOR APPRAISALS.....	6
5. APPRAISAL METHODS	6
A. GENERAL INFORMATION.....	6
B. DEFERMENT OF MINT APPRAISALS BEFORE PHYSIOLOGICAL MATURITY.....	6
C. WEIGHT APPRAISAL METHODS.....	7
D. STAND COUNT APPRAISALS FOR WINTER COVERAGE OPTION.....	9
6. APPRAISAL DEVIATIONS AND MODIFICATIONS	11
A. DEVIATIONS.....	11
B. MODIFICATIONS.....	11
7. APPRAISAL WORKSHEET ENTRIES AND COMPLETION PROCEDURES	11
A. GENERAL INFORMATION.....	11
B. WORKSHEET ENTRIES AND COMPLETION INFORMATION (MINI-STILL).....	11
APPRAISAL WORKSHEET EXAMPLE (MINISTILL).....	14
C. WORKSHEET ENTRIES AND COMPLETION INFORMATION (WINTER COVERAGE OPTION).....	15
APPRAISAL WORKSHEET EXAMPLE (WINTER COVERAGE OPTION).....	18

**MINT LOSS ADJUSTMENT HANDBOOK
TABLE OF CONTENTS (Continued)**

	<u>PAGE</u>
8. CLAIM FORM ENTRIES AND COMPLETION PROCEDURES	19
A. GENERAL INFORMATION	19
B. FORM ENTRIES AND COMPLETION INFORMATION.....	20
SECTION I - ACREAGE APPRAISED, PRODUCTION AND ADJUSTMENTS	22
SECTION II - HARVESTED PRODUCTION.....	28
CLAIM FORM EXAMPLE	32
CLAIM FORM EXAMPLE - WINTER COVERAGE OPTION.....	33
9. REFERENCE MATERIAL	35
TABLE A - MINIMUM REPRESENTATIVE SAMPLE REQUIREMENTS	35
EXHIBIT I - COLLAPSIBLE GRID	36

1. INTRODUCTION

THIS HANDBOOK MUST BE USED IN CONJUNCTION WITH THE LOSS ADJUSTMENT MANUAL (LAM).

This handbook identifies the crop-specific procedural requirements for adjusting Multiple Peril Crop Insurance (MPCI) losses in a uniform and timely manner. These procedures, which include crop appraisal methods and claims completion instructions, supplement the general (not crop-specific) procedures, forms, and manuals for loss adjustment identified in the LAM.

2. SPECIAL INSTRUCTIONS

This handbook remains in effect until superseded by reissuance of **either** the entire handbook **or** selected portions (through slipsheets or bulletins). If slipsheets have been issued for a handbook, the original handbook as amended by slipsheet pages shall constitute the handbook. A bulletin can supersede either the original handbook or subsequent slipsheets.

A. DISTRIBUTION

The following is the minimum distribution of forms completed by the adjuster **and signed by the insured (or the insured's authorized representative)** for the loss adjustment inspection:

One legible copy to the insured. The original and all remaining copies as instructed by the **Approved Insurance Provider (AIP)**.

It is the **AIP's** responsibility to maintain original insurance documents relative to policyholder servicing as designated in the approved plan of operations.

B. TERMS, ABBREVIATIONS, AND DEFINITIONS

- (1) Terms, abbreviations, and definitions that are **general** (not crop specific) to loss adjustment are identified in the LAM.
- (2) Terms, abbreviations, and definitions **specific** to mint loss adjustment and this handbook, which are not defined in this section, are defined as they appear in the text.
- (3) Abbreviations:

CAT	Catastrophic Risk Protection
CIH	Crop Insurance Handbook
NDR	No Discernable Rows
R	Discernable Rows
WCO	Winter Coverage Option

(4) Definitions:

Adequate Stand:	A population of live mint plants that equals or exceeds the minimum required number of plants or percentage of ground cover, as specified in the Special Provisions.
Crop Year:	The period from the date insurance begins until harvest is normally completed, that is designated by the calendar year in which the mint is normally harvested.
Cutting:	Severance of the upper part of the mint plant from its stalk and roots.
Distillation:	A process of extracting mint oil from harvested mint plants by heating and condensing.
Existing Mint:	Acreage planted and intended for harvest during a previous crop year.
Ground Cover:	Mint plants, including mint foliage and stolon, grown on insured acreage.
Harvest:	Removal of mint from the windrow.
Mini-still:	A 6-stall research still.
Mint:	Planted perennial spearmint or peppermint, of the family Labiatae and the genus <i>Mentha</i> , grown for distillation of mint oil.
Mint Oil:	Oil produced by the distillation of harvested mint plants.
New Mint:	Acreage planted and intended for harvest for the first time.
Planted Acreage:	Land in which mint stolon have been placed in a manner appropriate for the planting method and at the correct depth into a seed-bed that has been properly prepared.
Stolon:	Special modified stem produced by mint plants that grow horizontal to the ground.

3. INSURANCE CONTRACT INFORMATION

The AIP is to determine that the insured has complied with all policy provisions of the insurance contract. The following is not a complete list of insurability requirements. Refer to the Basic, Crop, and Special Provisions for a complete list of insurability issues. Crop provisions which are to be considered in this determination include (but are not limited to):

A. INSURABILITY

- (1) The crop insured will be all the mint types in the county, in which the insured has a share, for which a premium rate is provided by the actuarial documents:
 - (a) That are planted for harvest and distillation as mint oil;
 - (b) That have an adequate stand by the date coverage begins;
 - (c) That have been:
 - 1 inspected and accepted by the AIP for the first crop year of insurance; or
 - 2 Certified by the insured as having an adequate stand by the date coverage begins after the first crop year insured. (For Winter Coverage Option, the AIP must notify the insured by November 15 if any acreage that they inspected is not insurable, otherwise coverage will be deemed to attach to that acreage.)
- (2) Mint that is interplanted with a cover crop will not be considered interplanted if the cover crop is destroyed prior to its maturity and is not harvested as grain.
- (3) Any oil distilled from plants growing in the mint will be counted as mint oil on a weight basis.
- (4) In lieu of the provisions in the Basic Provisions that prohibit insurance of a second crop harvested following the same crop in the same crop year, multiple harvests of mint in the same crop year on the same acreage will be considered as one mint crop.
- (5) Any acreage of mint that does not meet the rotation requirements or exceeds the age limitations for existing mint contained in the Special Provisions will not be insured.
- (6) Any acreage of new mint planted by the spring planting date must be certified by the insured within 2 weeks after planting, if the Winter Coverage Option (WCO) is elected.

- (7) Acreage for which a payment has been made under the WCO is no longer insurable for the current crop year.
- (8) In addition to causes of loss excluded in the Basic Provisions, insurance is not provided for loss of production due to damage that:
 - (a) Occurs after harvest;
 - (b) Is due to the insured's failure to distill the crop, unless such failure is due to actual physical damage caused by an insured cause of loss that occurs during the insurance period; or
 - (c) Is due to Verticillium Wilt disease.

B. WINTER COVERAGE OPTION

The WCO provides coverage equal to 60 percent of the guarantee determined under the Crop Provisions.

- (1) The insured must give notice of probable loss within 72 hours after discovery of any insured mint that is damaged and does not have an adequate stand, but no later than the date coverage ends for this option.
- (2) Losses will be determined for each unit on an acre basis. A payment for this option may be made if a covered loss of adequate stand occurs, and is at least the lesser of 20 acres or 20 percent of insurable planted acres in the unit.
- (3) Appraisals may be deferred until the date coverage ends under this option.
- (4) In the event of loss or damage to mint acreage covered by this option, the claim will be settled by:
 - (a) Multiplying 60 percent by the production guarantee per acre;
 - (b) Multiplying the result in (a) by the number of acres that do not have an adequate stand;
 - (c) Multiplying the result in (b) by the price election; and
 - (d) Multiplying the result in section (c) by the share.

EXAMPLE:

The insured has 100% share in 100 acres of mint;

The production guarantee is 50 pounds of oil per acre;

The price election is \$12 per pound; and

There is not an adequate stand on 50 acres by the date WCO coverage ends because an insured cause has damaged the stand.

The payment for this option would be calculated as follows:

- (a) 60 percent x 50 pound guarantee = 30 pound (WCO) guarantee per acre
- (b) 30 pound (WCO) guarantee per acre x 50 acres without an adequate stand = 1,500 pounds
- (c) 1,500 pounds x \$12 price election = \$18,000
- (d) \$18,000 x 100 percent share = \$18,000

- (5) Acreage for which a WCO payment has been made is no longer insurable under the Crop Provisions for the current crop year. Any mint production subsequently harvested from uninsured acreage for the crop year and not kept separate from production from insured acreage will be considered production to count from the insured acres.

C. PROVISIONS AND PROCEDURES NOT APPLICABLE TO CAT COVERAGE

*** Refer to the CIH and LAM for provisions and procedures not applicable to CAT.

D. UNIT DIVISION

Refer to the insurance contract for unit provisions. Unless limited by the Crop or Special Provisions, a basic unit, as defined in the Basic Provisions, may be divided into optional units if, for each optional unit, all the conditions stated in the applicable provisions are met. A basic unit will also include all acreage of the insured crop in the county for each type designated in the Special Provisions.

4. MINT APPRAISALS

A. GENERAL INFORMATION

There are two mint appraisal methods, weight method and stand count method. Potential oil production from acreage the insured does not intend to harvest is determined by harvesting and distilling a representative sample of the crop. Harvested appraisal methods rely on the AIP to designate portions of the field to be harvested and distilled by the insured. In counties where mini-stills are available within a reasonable distance, the insured and AIP may agree to collect representative samples using the weight method described in subsection 5 C (1) and distill the sample using the mini-still, if harvesting and distilling a representative sample using the method in 5 C (2) would create a hardship for the insured. The insured is responsible for the cost of distilling samples for loss adjustment purposes.

B. SELECTING REPRESENTATIVE SAMPLES FOR APPRAISALS

- (1) Determine the minimum number of required samples for a field or sub-field by the field size, the average stage of growth, age (size) and general capabilities of the plants, and variability of potential production and plant damage within the field or sub-field.
- (2) Split the field into sub-fields when:
 - (a) variable damage causes the crop potential (plant numbers or ground cover variation) to appear to be significantly different within the same field; or
 - (b) the insured wishes to destroy a portion of a field.
- (3) Each field or sub-field must be appraised separately.
- (4) Take not less than the minimum number (count) of representative samples required in TABLE A for each field or subfield.

5. APPRAISAL METHODS

A. GENERAL INFORMATION

These instructions provide information on appraisal methods for:

Appraisal Method....	Use....
Weight Appraisal Method	at maturity to determine weight of mint oil (Mini-still Appraisals and Representative Harvest Production Appraisals)
Stand Count Method	for winter coverage option

B. DEFERMENT OF MINT APPRAISALS BEFORE PHYSIOLOGICAL MATURITY

- (1) Defer all appraisals until the crop reaches maturity or the date harvest is general in the area, unless the mint crop has no production potential such as:
 - (a) the plants will not reach a height of 4 inches or more at maturity;
 - (b) has severe water damage; or
 - (c) has turned abnormal in color;

- (2) Complete the preliminary inspection with special attention to the type of damage and its severity.
 - (a) Inspect all fields thoroughly. It is important to note the acreage that is not damaged.
 - (b) Explain to the insured that, at this time, the amount of loss cannot be determined accurately.
 - (c) Do not attempt to estimate the damage for the insured.
- (3) Inform the insured that if the acreage is put to other use prior to final adjustment, the mint samples the **AIP** has specified must be preserved and cared for. Refer to the LAM.
- (4) Winter Coverage Option appraisals may be deferred until the date coverage ends to determine if an adequate stand is present.

C. WEIGHT APPRAISAL METHODS

- (1) Mini-still Appraisals:

The following devices used for representative samples can be constructed in each region. Materials needed and construction steps are as follows:

- (a) Round hoop with 3, 4, and 5 square feet inside area:

- 1 Material required for round hoop (3 square feet) is 73.7 inches of 2-inch inside diameter plastic hose and 3 inches of one-half inch wooden dowel.
- 2 Material required for round hoop (4 square feet) is 85.1 inches of one-half inch inside diameter plastic hose and 3 inches of one-half inch wooden dowel material.
- 3 Material required for round hoop (5 square feet) is 95.2 inches of one-half inch inside diameter plastic hose and 3 inches of one-half inch wooden dowel material.
- 4 Construction. Insert a 3 inch dowel pin in one end of a one-half inch hose, form a circle and connect together.

- (b) Collapsible wood frame with 4 square feet inside area:

- 1 Collapsible wood frame 24 inches inside.
- 2 Frame Material: Four 1 inch x 2 inches x 28 inches wood pieces. Four 3 inch x 2 inch stove bolts with wing nuts and 8 flat washers.

- (c) Collapsible grid shown in **EXHIBIT 1**.

- (d) Use one of the measuring devices described above to outline each sample area by tossing the device into representative areas of the field. Cut off all plants within each sample area (pruning shears or scissors) at mowing-machine height (not to exceed three inches above the ground).
 - (e) Weigh the samples and enter the total weight on the Appraisal Worksheet. If the total weight of all required samples for the unit is less than 20 pounds, take additional samples. If the stand is extremely thin and there is difficulty in obtaining 20 pounds, a minimum of 10 pounds can be used, but only in rare instances.
 - (f) Put all the samples in an onion sack or other acceptable porous sack, label it with the insured's name, unit number, adjuster's name and address, and deliver to the mini-still location.
 - (g) When the oil production results are received from the mini-still location, complete the remainder of the appraisal worksheet.
- (2) Representative Harvest Production Appraisals:
- (a) When the insured does not intend to harvest all mint acreage, the insured must timely harvest and distill an appropriate number of sample areas (refer to **TABLE A**) designated by the **AIP**. Refer to the LAM for additional instructions.
 - (b) The insured must harvest an adequate amount of mint plants so the distillation process will give an accurate appraisal.
 - (c) Mint plants from representative samples will be distilled **at the insured's expense**. Separate records must be kept for the harvested strips. The total amount of oil distilled will be divided by total sample acreage to calculate the production appraisal.

EXAMPLE:

A total area for all selected samples is determined to be .8 of an acre.
The insured distilled 2.4 pounds of oil from the total area sampled.
The result, in pounds of oil per acre, is:

$$2.4 \text{ pounds of oil} \div .8 \text{ acres} = 3 \text{ pounds of oil per acre.}$$

- (d) Record all calculations on a Special Report and results on the Production Worksheet.

D. STAND COUNT APPRAISALS FOR WINTER COVERAGE OPTION

(1) General Information

- (a) The population of live mint plants to be counted from insurable acreage on the unit will be not less than the population of live mint plants in an adequate stand for any acreage:
- 1 That is abandoned;
 - 2 That is put to another use without consent;
 - 3 For which the insured fails to meet the notice of loss requirements contained in the WCO provisions in the crop policy; or
 - 4 That is damaged solely by uninsured causes.
- (b) Use the methods in subsection D (3) below to determine if there is an adequate mint stand for the Winter Coverage Option.

(2) Selecting Representative Samples for Plant Count Determinations

- (a) Use the required number of viable plants per square foot established by the actuarial documents to determine if indemnity is payable.
- (b) Procedure
- 1 Select the appropriate number of samples from **TABLE A**.
 - 2 Determine the number of live mint plants within each representative sample area.
 - 3 To determine plant counts in fields with **no** distinguishable rows (**NDR**), count all plants within **three CONSECUTIVE**, 3 foot x 3 foot grid frames **totaling 27 square feet** (Refer to Exhibit 1).
 - 4 To determine plant counts in fields with rows, each representative sample must be 25 feet long.
 - 5 Calculate and record the results on the appraisal worksheet and or a Special Report if needed.

(3) Plant Count Methods

(a) Mint **not in** rows: When rows are not discernable, adequate plant counts will be determined by counting plants per square foot. The grid is placed over the sample area to be examined. A sample consists of three **CONSECUTIVE** grid frame counts totaling 27 square feet (flipping the grid over twice).

1 Determine and record the number of live mint plants found inside the grid frame for each sample.

2 When all samples are evaluated, sum the number of live mint plants.

3 Determine the number of plants per square foot by:

$(\text{Total mint plants counted} \div \text{number of samples}) \div 27 \text{ square feet per sample} = \text{Plants Per Square Foot}$

(b) Mint in rows: Newly planted mint, or mint with discernable field rows. Measure representative samples 25 feet long in the row to be evaluated. A count of live mint plants will be made to determine the number of plants per square foot:

1 Count the number of live mint plants in each 25 foot length of selected rows.

2 When all samples are evaluated, sum:

Plants counted in each sample taken.
The length of all samples taken (in feet to tenths).

3 $\text{Plants Per Square Foot} = (\text{Total Plant Count}) \div [\text{Total length of all Samples (ft.)} \times \text{Row Width (To tenths of a foot)}]$

EXAMPLE:

40 acres are appraised.
10 samples at 25 feet long each,
36 inch row width (3.0 feet)
1200 live plants counted.

The result is:

$1200 \text{ plants} \div [(25 \text{ feet/sample} \times 10 \text{ samples} = 250 \text{ feet}) \times (3.0 \text{ foot row width})];$

$1200 \text{ plants} \div [750] = 1.6 \text{ Plants Per Square Foot}$

6. APPRAISAL DEVIATIONS AND MODIFICATIONS

A. DEVIATIONS

Deviations in appraisal methods require FCIC written authorization (as described in the LAM) prior to implementation.

B. MODIFICATIONS

There are no pre-established modifications contained in this handbook. Refer to the LAM for additional information.

7. APPRAISAL WORKSHEET ENTRIES AND COMPLETION PROCEDURES

A. GENERAL INFORMATION

- (1) Include the AIP's name in the appraisal worksheet title if not preprinted on the AIP's worksheet, or when a worksheet entry is not provided.
- (2) Include the claim number on the appraisal worksheet (when required by the AIP), when a worksheet entry is not provided.
- (3) Separate appraisal worksheets are required for each unit appraised, and for each field or subfield or farming practice (applicable to preliminary and final claims). Refer to section 4 for sampling requirements.
- (4) Standard appraisal worksheet items are numbered consecutively in subsection B. An example appraisal worksheet is also provided to illustrate how to complete entries.

B. WORKSHEET ENTRIES AND COMPLETION INFORMATION **(MINISTILL)**

Verify or make the following entries:

**Item
No.**

Information Required

Company: Name of AIP, if not preprinted on the worksheet. (Company Name).

Claim No.: Claim number as assigned by the AIP.

1. **Insured's Name:** Name of the insured that identifies EXACTLY the person (legal entity) to whom the policy is issued.

2. **Policy Number:** Insured's assigned policy number.
3. **Unit Number:** Five-digit unit number from the Summary of Coverage after it is verified to be correct. (e.g., 00100)
4. **Crop Year:** Four-digit crop year, as defined in the policy, for which the claim has been filed.
5. **Type:** Type of mint being appraised and the three-digit code number, entered exactly as specified on the actuarial documents.
6. **Field ID:** Field or subfield Identification symbol.
7. **Acres to Tenths:** Acres to tenths as determined.
8. **Ounces to Tenths Per Sample:** Weight, in ounces to tenths, for each sample.
9. **Total Weight All Samples:** Total weight of plant cuttings from all samples, converted to pounds to tenths. (Total weight of all samples in Item 8 divided by 16 ounces.)
10. **Total ml. of Distilled Mint:** Total milliliters of distilled mint (in whole milliliters) from the samples cut in Item 9 for the field. This amount is determined at the mini-still site. Refer to subsection 5C.
11. **Number of Samples:** Enter the number of samples taken.
12. **Avg. ml. Oil Per Sample:** Result of dividing item 10 by item 11, rounded to tenths.
13. **Number Sq. Feet in Sample:** Number of square feet in the measuring device used. Refer to subsection 5C.
14. **Avg. ml. Per Sq. Ft.:** Result of dividing item 12 by item 13, rounded to the nearest tenth.
15. **Factor:** (82.86) MAKE NO ENTRY (factor of 82.86 is a constant used to convert milliliters of mint oil per square foot to pounds of oil per acre).
16. **Pounds Oil Per Acre:** Result of multiplying item 14 times the constant factor of 82.86 in item 15, to whole pounds. Production is entered as whole pounds of oil per acre.
17. **Remarks:** Remarks pertinent to the appraisal, sampling, conditions in general (e.g. - very hot and dry), etc. If additional space is needed attach a Special Report with the recorded information to the appraisal worksheet
18. **Adjuster's Signature, Code Number, and Date:** Signature of adjuster, code number, and date signed **after** the insured (or insured's authorized representative) has signed. If the appraisal is performed prior to signature date, document the date of appraisal in the Remarks/Narrative section of the Appraisal Worksheet (if available); otherwise, document the appraisal date in the Narrative of the Production Worksheet.

19. **Insured's Signature and Date:** Insured's (or insured's authorized representative's) signature and date. BEFORE obtaining insured's signature, REVIEW ALL ENTRIES on the appraisal worksheet WITH THE INSURED, particularly explaining codes, etc., which may not be readily understood.

Page: Page numbers (Example: Page 1 of 1, Page 1 of 2, Page 2 of 2, etc.)

(For Illustration Purposes Only) MINT APPRAISAL WORKSHEET (Ministill)				COMPANY: Any Company				1. INSURED'S NAME					
				CLAIM NO: XXXXXXX				I.M. Insured					
				2. POLICY NUMBER				3. UNIT NUMBER		4. CROP YEAR		5. TYPE	
				XXXXXX				00100		YYYY		Peppermint 080	

Field ID 6	Acres To Tenths 7	Ounces To Tenths Per Sample 8									Total Wt. All Samples 9	Total ml. Distilled Mint 10	Number of Samples 11	Avg. ml. Oil Per Sample 12	Number Sq. Feet in Sample 13	Avg. ml. Per Sq. Foot 14	Factor (82.86) 15	Pounds Oil Per Acre 16						
		1	2	3	4	5	6	7	8	9														
B	30.0	64.0	66.8	60.8	62.9	58.1	68.7																	
											= 23.8	7	+	6	=	1.2	+	4	=	.3	x	82.86	=	25

17. REMARKS

18. ADJUSTER'S SIGNATURE/CODE NUMBER I.M. Adjuster XXXXX	DATE MM/DD/YYYY	19. INSURED'S SIGNATURE I.M. Insured	DATE MM/DD/YYYY
--	---------------------------	--	---------------------------

C. WORKSHEET ENTRIES AND COMPLETION INFORMATION (WINTER COVERAGE OPTION)

Items designated “R” apply to appraisals with discernable rows. “NDR” apply to appraisals with no discernable rows. If no designation, item instructions apply to both.

Verify or make the following entries:

**Item
No.**

Information Required

Company: Name of AIP, if not preprinted on the worksheet. (Company Name).

Claim No.: Claim number as assigned by the AIP.

1. **Insured's Name:** Name of the insured that identifies exactly the person (legal entity) to whom the policy is issued.
2. **Policy Number:** Insured's assigned policy number.
3. **Unit Number:** Five-digit unit number from the Summary of Coverage after it is verified to be correct. (e.g., 00100)
4. **Crop Year:** Four-digit crop year, as defined in the policy, for which the claim has been filed.
5. **Row Width:**
R: Row width in inches, followed by “(R)”.
NDR: Enter “solid” followed by “(NDR)”.
6. **Sample Size:**
R: 25 feet (Refer to subsection 5D).
NDR: Square feet in the sample area (27 sq. ft.).
7. **Field ID:** Field or subfield identification symbol.
8. **Acres:** Determined acres to tenths.
9. **Practice:** Three-digit code number, exactly as specified on the actuarial documents, for the practice carried out by the insured. If “No Practice Specified,” enter appropriate 3-digit code number from the actuarial documents.
10. **Type:** Three-digit code number as specified on the actuarial documents, for the type grown by the insured. If “No Type Specified,” enter appropriate 3-digit code number from the actuarial documents.

11. **Number Live Plants In Each Sample:** Number of live mint plants counted in each sample taken.

12. **Total All Samples:** Total number of live mint plants in all samples.

13. **Number of Sample Plots:** Total number of samples taken (from Item 11).

14. **Length of Sample (Ft.):**

R: Enter 25.

NDR: MAKE NO ENTRY.

15. **Total Length All Samples:**

R: Item 13 times item 14 in whole numbers.

NDR: MAKE NO ENTRY.

16. **Row Width (Ft. to 10th):**

R: Row width converted to tenths of feet, (i.e. 36 inches \div 12 = 3.0 feet; 15 inches \div 12 = 1.3 feet).

NDR: MAKE NO ENTRY.

17. **Total Square Feet All Samples:**

R: Item 15 times item 16, to tenths of feet.

NDR: MAKE NO ENTRY.

18. **Total of All Samples:**

R: Entry from Item 12.

NDR: MAKE NO ENTRY.

19. **Total Sq. Ft. in All Samples or Sq. Ft. in Area:**

R: Entry from item 17.

NDR: Square feet in sample area (from item 6).

20. **Plants per Square Foot:**

R: Item 18 divided by item 19, to tenths.

NDR: Item 12 divided by item 13, divided by item 19, to tenths.

21. **Remarks:** Enter pertinent information about the appraisal. Include any appropriate calculations on a Special Report and attach to the claim when more space is needed.

22. **Adjuster's Signature, Code No., and Date:** Signature of adjuster, code number, and date signed **after** the insured (or insured's authorized representative) has signed. If the appraisal is performed prior to signature date, document the date of appraisal in the Remarks/Narrative section of the Appraisal Worksheet (if available); otherwise, document the appraisal date in the Narrative of the Production Worksheet.
23. **Insured's Signature and Date:** Insured's (or insured's authorized representative's) signature and date. **BEFORE** obtaining insured's signature, **REVIEW ALL ENTRIES** on the appraisal worksheet **WITH THE INSURED**, particularly explaining codes, etc., which may not be readily understood.

Page: Page numbers (Example: Page 1 of 1, Page 1 of 2, Page 2 of 2, etc.)

EXAMPLE I

(For Illustration Purposes Only) MINT APPRAISAL WORKSHEET (Winter Coverage Option)				COMPANY: Any Company				1. INSURED'S NAME I. M. INSURED							
				CLAIM NO.: XXXXXXXX											
				2. POLICY NUMBER XXXXXXXX				3. UNIT NUMBER 00100		4. CROP YEAR YYYY		5. ROW WIDTH 24 Inch (R)		6. SAMPLE SIZE 25 Feet	
7	8	9	10	11			12	13	14	15	16	17	18	19	20
Field ID	Acres	Practice	Type	Number Live Plants In Each Sample			Total All Samples	Number Sample Plots	Length Of Sample (Ft.)	Total Length All Samples	Row Width (Ft. To 10 ^{ths})	Total Square Feet All Samples	Total of All Samples	Total Sq. Ft. in All Samples or Sq. Ft. in Area	Plants per Square Foot
B	30.0	003	080	80	70	60	446	6	25	150	2.0	300.0	446	300.0	1.5
				96	64	76									

EXAMPLE II

(For Illustration Purposes Only) MINT APPRAISAL WORKSHEET (Winter Coverage Option)				COMPANY: Any Company				1. INSURED'S NAME I. M. Insured							
				CLAIM NO.: XXXXXXXX											
				2. POLICY NUMBER XXXXXXXX				3. UNIT NUMBER 00100		4. CROP YEAR YYYY		5. ROW WIDTH SOLID (ndr)		6. SAMPLE SIZE 27 Sq. Ft.	
7	8	9	10	11			12	13	14	15	16	17	18	19	20
Field ID	Acres	Practice	Type	Number Live Plants In Each Sample			Total All Samples	Number Sample Plots	Length Of Sample (Ft.)	Total Length All Samples	Row Width (Ft. To 10 ^{ths})	Total Square Feet All Samples	Total of All Samples	Total Sq. Ft. in All Samples or Sq. Ft. in Area	Plants per Square Foot
A	20.0	003	080	10	8	6	47	6						27	.3
				7	9	7									
21 REMARKS															
22. ADJUSTER'S SIGNATURE/CODE NO.				DATE				23. INSURED'S SIGNATURE				DATE			
I. M. Adjuster XXXXX				MM/DD/YYYY				I. M. Insured				MM/DD/YYYY			

8. CLAIM FORM ENTRIES AND COMPLETION PROCEDURES

A. GENERAL INFORMATION

- (1) The claim form, (hereafter referred to as “Production Worksheet”) is a progressive form containing all notices of damage for all preliminary and final inspections on a unit.
- (2) If a Production Worksheet has been prepared on a prior inspection, verify each entry and enter additional information as needed. If a change or correction is necessary, strike out all entries on the line and re-enter correct entries on a new line. The adjuster and insured should initial any line deletions.
- (3) Refer to the LAM for instructions regarding the following:
 - (a) Acreage report errors.
 - (b) Delayed notices and delayed claims.
 - (c) Corrected claims or fire losses (double coverage) and cases involving uninsured causes of loss, unusual situations, controversial claims, concealment, or misrepresentation.
 - (d) Claims involving a Certification Form (when all the acreage on the unit has been appraised to be put to another use).
 - (e) “No Indemnity Due” claims (which must be verified by an APPRAISAL or NOTIFICATION from the insured that the production exceeded the guarantee).
- (4) The adjuster is responsible for determining if any of the insured’s requirements under the notice and claim provisions of the policy have not been met. If any have not, the adjuster should contact the **AIP**.
- (5) Instructions labeled “**PRELIMINARY**” apply to preliminary inspections only. Instructions labeled “**FINAL**” apply to final inspections only. Instructions labeled “**WCO**” apply to **WCO** inspections only. Instructions not labeled apply to ALL inspections.
- (6) Account for all acreage on the unit when completing a **WCO** claim or a basic claim. Designate the acreage appropriately.
- (7) Enter “Winter Coverage Option” in the heading of the claim when completing a **WCO** claim.

B. FORM ENTRIES AND COMPLETION INFORMATION

Verify or make the following entries:

Item

No.

Information Required

1. **Crop/Code #:** "Mint" (0074)
2. **Unit #:** Five-digit unit number from the Summary of Coverage after it is verified to be correct (e.g., 00100).
3. **Legal Description:** Section, township, and range number or other legal description that identifies the location of the unit.
4. **Date of Damage:** First three letters of the month during which MOST of the insured damage (including progressive damage) occurred for each inspection. Include the SPECIFIC DATE where applicable as in the case of hail damage (e.g., AUG 11).
5. **Cause of Damage:** Name of insured cause of loss for **this crop** as listed in the LAM. If it is evident that no indemnity is due, enter "NONE." If an insured cause of loss is coded as "Other," explain in the "Narrative."

Refer to the Basic Provisions and the Crop Provisions **for the applicable crop** for information pertaining to the insured and uninsured causes of loss.
6. **Primary Cause %:**

PRELIMINARY: MAKE NO ENTRY.

FINAL AND WCO: Percent of damage for the cause of damage listed in item 5 above that is determined to be the primary cause of damage, to the nearest whole percent. The primary cause of damage must exceed 50 percent (e.g., 51%). Enter an "X" in the major secondary cause of damage.
7. **Company/Agency:** Name of Company and agency servicing the contract.
8. **Name of Insured:** Name of the insured that identifies exactly the person (legal entity) to whom the policy is issued.
9. **Claim #:** Claim number assigned by the **AIP**.
10. **Policy #:** Insured's assigned policy number.
11. **Crop Year:** **Four-digit crop** year, as defined in the policy, for which the claim is filed.

12. **Additional Units:**

PRELIMINARY: MAKE NO ENTRY.

FINAL AND WCO: Unit number(s) for ALL non-loss units for the crop at the time of final inspection. A non-loss unit is any unit for which a Production Worksheet has not been completed. Additional non-loss units may be entered on a single Production Worksheet.

If more spaces are needed for non-loss units, enter the unit numbers, identified as “Non-Loss Units,” in the narrative or on an attached Special Report.

13. **Est. Prod. Per Acre:**

PRELIMINARY AND WCO: MAKE NO ENTRY.

FINAL: Estimated yield per acre in whole pounds of all non-loss units for the crop at the time of final inspection.

14. **Date(s) Notice of Loss:**

PRELIMINARY AND WCO:

- a. Date the notice of damage was given for the unit in item 2.
- b. A third preliminary inspection (if needed) requires an additional set of Production Worksheets. Enter the date of the notice for a third preliminary inspection in the 1st space of item 14 on the second set.
- c. Reserve the “Final” space on the first page of the first set of Production Worksheets for the date of notice for the final inspection.
- d. If the inspection is initiated by the **AIP**, enter “Company Insp.” instead of the date.

FINAL AND WCO: Transfer the last date in the 1st or 2nd space to the FINAL space if a final inspection should be made as a result of the notice. Always enter the complete date of notice for the “FINAL” inspection in the FINAL space on the first page of the first set of Production Worksheets (month, day, year). For a delayed notice of loss or delayed claim, refer to the LAM.

15. **Companion Policies:**

- a. If no other person has a share in the unit (insured has 100 percent share), MAKE NO ENTRY.
- b. In all cases where the insured has LESS than 100 percent share of a loss-affected unit, ask the insured if the OTHER person sharing in the unit has a multiple-peril crop insurance contract (i.e., not crop-hail, fire, etc.). If the other person does not, enter “NONE.”
 - (1) If the other person has a multiple-peril contract and it can be determined that the SAME AIP services it, enter the contract number. Handle these companion policies according to AIP instructions.
 - (2) If the OTHER person has a multiple-peril contract and a DIFFERENT AIP or agent services it, enter the name of the AIP and/or agent (and contract number) if known.
 - (3) If unable to verify the existence of a companion contract, enter “Unknown” and contact the AIP for further instructions.
- c. Refer to the LAM for further information regarding companion contracts.

SECTION I - ACREAGE APPRAISED, PRODUCTION AND ADJUSTMENTS

Make separate line entries for varying:

- (1) Rate classes, types, or practices;
- (2) APH yields;
- (3) Appraisals;
- (4) Stages or intended use(s) of acreage;
- (5) Shares (e.g., 50 percent and 75 percent shares on the same unit); or
- (6) Appraisals for damage due to hail or fire if Hail and Fire Exclusion in effect.

Verify or make the following entries:

Item

No. Information Required

- A. **Field ID:** The field identification symbol from a sketch map or an aerial photo. Refer to the Narrative. In the margin (or in a separate column), enter the date of inspection for the last line entry of each inspection.

REFER TO THE LAM FOR INSTRUCTIONS REGARDING ENTRY OF FIRST CROP AND SECOND CROP CODES.

B. Preliminary Acres:

PRELIMINARY: The number of acres, to tenths, (include “E” if estimated), for which consent for other use has been given. Determine actual acreage, to tenths, when the boundaries of the appraised acreage may not be determined later.

FINAL AND WCO: MAKE NO ENTRY.

C. Final Acres: Refer to the LAM for definition of acceptable determined acres used herein.

Determined acres to tenths (include “E” if estimated) for which consent is given for other use and/or acreage is:

- a. Put to other use without prior consent;
- b. Abandoned;
- c. Damaged by uninsured causes; or
- d. For which the insured failed to provide acceptable records of production.

FINAL AND WCO: Determined acres to tenths.

Acreage breakdowns WITHIN a unit may be estimated (enter “E” in front of the acres) if a determination is impractical AND if authorization was received from the AIP. Document authorization in the “Narrative.”

ACCOUNT FOR ALL ACREAGE IN THE UNIT. In the event of over reported acres, handle in accordance with individual AIP’s instructions. In the event of under reported acres, draw a diagonal line in Column “C.”

- C₁ Enter the ACTUAL acres for the field or subfield.
- C₂ Enter the REPORTED acres for the field or subfield.

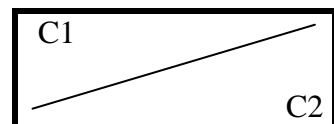

D. Interest or Share: Insured’s interest in the crop to three decimal places as determined at the time of inspection. If shares vary on the same UNIT, use separate line entries.

E. Risk: Three-digit code for the correct “Rate Class” specified on the actuarial documents. If a “Rate Class” or “High Risk Area” is not specified on the actuarial documents, make no entry. Verify with the Summary of Coverage and if the Rate Class is found to be incorrect, revise according to the AIP’s instructions. Refer to the LAM.

Unrated land is uninsurable without a written agreement.

F. Practice: Three-digit code number, entered exactly as specified on the actuarial documents, for the practice carried out by the insured. If “No Practice Specified,” enter the appropriate 3-digit code number from the actuarial documents.

G. Type/Class/Variety: Three-digit code number, exactly as specified on the actuarial documents, for the type grown by the insured. If “No Type Specified,” enter the appropriate 3-digit code number from the actuarial documents.

H. **Stage:**

PRELIMINARY: MAKE NO ENTRY.

FINAL AND WCO: Stage abbreviations as shown below.

STAGE	<u>EXPLANATION</u>
“P”.....	Acres abandoned without consent, put to other use without consent, damaged solely by uninsured causes, or for which the insured failed to provide records which are acceptable to the AIP .
“H”.....	Harvested
“UH”.....	Unharvested or put to other use with consent.
“W1”.....	Acres to be paid under a WCO claim . (Must be at least the lesser of 20 acres or 20% of the insurable planted acres in the unit.) TO BE USED FOR WCO CLAIMS ONLY.
“W2”.....	Acres NOT PAID under a WCO claim . TO BE USED FOR WCO CLAIMS ONLY.
“W3”.....	Acres previously paid under WCO .

GLEANED ACREAGE: Refer to the LAM for information on gleaning.

I. **Intended or Final Use:** Use of acreage. Use the following “Intended Use” abbreviations.

<u>USE</u>	<u>EXPLANATION</u>
“To Millet,” etc.	Use made of acreage
“WOC”.....	Other use without consent
“SU”.....	Solely uninsured
“ABA”.....	Abandoned without consent
“H”.....	Harvested
“UH”.....	Unharvested
“W3”.....	Acres previously paid under Winter Coverage Option

Verify any “Intended Use” entry. If the final use of the acreage was not as indicated, strike out the original line and initial it. Enter all data on a new line showing the correct “Final Use.”

GLEANED ACREAGE: Refer to the LAM for information on gleaning.

J. **Appraised Potential:**

PRELIMINARY AND FINAL: Per-acre appraisal in whole pounds, of POTENTIAL production for the acreage appraised. (Refer to appraisal methods for additional instructions.)

If there is no potential on UH acreage, enter “0.”

WCO: MAKE NO ENTRY

K₁. - L. MAKE NO ENTRY

M. + **Uninsured Cause:** EXPLAIN IN THE NARRATIVE.

a. Hail and Fire exclusion NOT in effect.

- (1) Enter NOT LESS than the insured's production guarantee per acre, in whole pounds, for the line (calculated by multiplying the elected coverage level percentage times the approved APH yield per acre shown on the APH form) for any "P" stage acreage:

On preliminary inspections, advise the insured to keep the harvested production from any acreage damaged SOLELY by uninsured causes separate from other production.

- (2) For acreage that is damaged PARTLY by uninsured causes, enter the APPRAISED UNINSURED loss of production per acre in pounds for any such acreage.

b. Refer to the LAM when a Hail and Fire Exclusion is in effect and the damage is from hail or fire.

c. Enter the result of adding uninsured cause appraisals to hail and fire exclusion appraisals.

For fire losses, if the insured also has other fire insurance (double coverage), refer to the LAM.

WCO: MAKE NO ENTRY

N. **Adjusted Potential:**

PRELIMINARY, FINAL: Column "J" plus Column "M".

WCO: MAKE NO ENTRY.

O. **Total to Count:**

PRELIMINARY, FINAL: Column "C" or "C₁" (**actual** acres) times Column "N," rounded to whole pounds.

WCO – W1: Enter zero ("0").

WCO – W2 and W3: MAKE NO ENTRY.

P. **Per Acre:**

PRELIMINARY, FINAL and WCO - W2: Per-Acre Guarantee - Enter the per acre production guarantee from the insured's policy.

WCO - W1: Enter the guarantee per acre adjusted by the WCO percentage reduction from the crop provisions, to whole pounds.

WCO - W3: MAKE NO ENTRY.

Q. **Total:** "C₂" (reported acres; "C" if acreage is not under-reported) times Column "P", to whole pounds.

WCO - W3: MAKE NO ENTRY.

16. **Total Acres:**

PRELIMINARY: MAKE NO ENTRY.

FINAL and WCO: Total Actual Acres. [Column "C" or ("C₁" if there are under-reported acres)], rounded to tenths.

FOR ITEM 17. WHEN SEPARATE LINE ENTRIES ARE MADE FOR VARYING SHARES, STAGES, APH YIELDS, PRICE ELECTIONS, TYPES, ETC., WITHIN THE UNIT, AND TOTALS NEED TO BE KEPT SEPARATE FOR CALCULATING INDEMNITIES, MAKE NO ENTRY AND FOLLOW THE AIP'S INSTRUCTIONS; OTHERWISE, MAKE THE FOLLOWING ENTRIES.

17. **Totals:**

PRELIMINARY: MAKE NO ENTRY.

FINAL and WCO: Total of Column "O" and Column "Q."

NARRATIVE:

If more space is needed, document on a Special Report, and enter "See Special Report." Attach the Special Report to the Production Worksheet.

- a. If no acreage is released on the unit, enter "No acreage released," adjuster's initials, and date.
- b. If notice of damage was given and "No Inspection" is necessary, enter the unit number(s), "No Inspection," date, and adjuster's initials. The insured's signature is not required.
- c. Explain any uninsured causes, unusual or controversial cases.
- d. If there is an appraisal in Section I, column M for uninsured causes due to a hail/fire exclusion, show the original hail/fire liability per acre and the hail/fire indemnity per acre.

- e. Document the actual appraisal date if an appraisal was performed prior to the adjuster's signature date on the appraisal worksheet, and the date of the appraisal is not recorded on the appraisal worksheet.
- f. State that there is "No other fire insurance" when fire damages or destroys the insured crop and it is determined that the insured has no other fire insurance. Also refer to the LAM.
- g. Explain any errors found on the Summary of Coverage.
- h. Explain any commingled production. Refer to the LAM.
- i. Explain any entry for "Production Not to Count" in Section II, column "O", and/or any production not included in Section II, column "B – E" entries or item I.
- j. Explain a "NO" checked in item 19.
- k. Attach a sketch map or aerial photograph to identify the total unit:
 - (1) If consent has been given to put part of the unit to another use.
 - (2) If uninsured causes are present;
 - (3) For unusual or controversial cases; or

Indicate on the aerial photo or sketch map, the disposition of acreage destroyed or put to other use with or without consent.
- l. Explain any difference between date of inspection and signature dates. For an ABSENTEE insured, enter the date of the inspection AND the date of mailing the Production Worksheet for signature.
- m. When any other adjuster or supervisor accompanied the adjuster on the inspection, enter the code number of the other adjuster or supervisor and date of inspection.
- n. Explain the reason for a "No Indemnity Due" claim. "No Indemnity Due" claims are to be distributed in accordance with the AIP's instructions.
- o. Explain any delayed notices or delayed claims as instructed in the LAM.
- p. Document any authorized estimated acres shown in Section I, column C as follows: "Line 3 "E" acres authorized by AIP MM/DD/YYYY."
- q. Document the method and calculation used to determine acres for the unit. Refer to the LAM.
- r. Specify the type of insects or disease when the insured cause of damage or loss is listed as insects or disease. Explain why control measures did not work.
- s. Note any acreage left for harvest under "Winter Coverage Option", but not insurable for basic coverage.

- t. Document the plants per square foot and that acreage qualifies for payment under the “Winter Coverage Option.”
- u. Document the name and address of the charitable organization when gleaned acreage is applicable. Refer to the LAM for more information on gleaning.
- v. Document any other pertinent information, including any data to support any factors used to calculate the production.

SECTION II - HARVESTED PRODUCTION

GENERAL INFORMATION

- (1) Account for ALL HARVESTED PRODUCTION (for ALL ENTITIES sharing in the crop) except production appraised BEFORE harvest and shown in SECTION I because the quantity cannot be determined later (e.g. released for other uses, etc.)
- (2) For production commercially stored, sold, etc., make entry in items B through E as follows: Name and address of storage facility or buyer.
- (3) If acceptable sales or weight tickets are not available, refer to the LAM.
- (4) If additional lines are necessary, the data may be entered on a continuation sheet. USE SEPARATE LINES FOR:
 - (a) Separate storage facilities.
 - (b) Varying names and addresses of buyers of sold production.
 - (c) Varying determinations of production (value, etc.).
 - (d) Varying shares: e.g., 50 percent and 75 percent shares on the same unit.
- (5) There will generally be no harvested production entries in columns “A” through “S” for preliminary or Winter Coverage Option inspections.
- (6) If there is harvested production from more than one insured practice (or type) and a separate approved APH yield has been established for each, the harvested production also must be entered on separate lines in columns “A” through “S” by type or practice. If production has been commingled, refer to the LAM.

Verify or make the following entries:

Item

No. Information Required

18. **Date Harvest Completed:** (Used to determine if there is a delayed notice or a delayed claim. Refer to the LAM.)

PRELIMINARY: MAKE NO ENTRY.

FINAL AND WCO:

- a. The earlier of the date the ENTIRE acreage on the unit was (1) harvested, (2) totally destroyed, (3) put to other use (4) a combination of harvested, destroyed, or put to other use, or (5) the calendar date for the end of the insurance period.
- b. If at the time of final inspection (if prior to the end of the insurance period), there is any unharvested insured acreage remaining on the unit that the insured does not intend to harvest; enter “Incomplete.”
- c. If at the time of final inspection (if prior to the end of the insurance period), **none** of the insured acreage on the unit has been harvested, and the insured does not intend to harvest such acreage, enter “**No Harvest.**”
- d. If the case involves a Certification Form, enter the date from the Certification Form, when the entire unit is put to another use etc. Refer to the LAM.

19. **Similar Damage:**

PRELIMINARY: MAKE NO ENTRY.

FINAL AND WCO: Check “Yes” or “No.” Check “Yes” if amount and cause of damage due to insurable causes is similar to the experience of other farms in the area. If “NO” is checked, explain in the narrative.

20. **Assignment of Indemnity:** Check “Yes” **only** if an assignment of indemnity is in effect for the crop year, otherwise, check “No.” Refer to the LAM.

21. **Transfer of Right to Indemnity:** Check “Yes” **only** if a transfer of right to an indemnity is in effect for the unit for the crop year. Refer to the LAM.

A₁. **Share:** Record ONLY VARYING SHARES on SAME unit to three decimal places.

A₂. **Field ID:**

- a. If only one practice and/or type of harvested production is listed in Section I, MAKE NO ENTRY.
- b. If more than one practice and/or type of harvested production is listed, and a separate approved APH yield exists, indicate for each practice/type the corresponding Field ID (from Section I, column “A”).
- c. **REFER TO THE LAM FOR INSTRUCTIONS REGARDING ENTRY OF FIRST CROP AND SECOND CROP CODES.**

B. - E. **Buyer or Processor:** For production sold or stored, enter the name and address of the buyer or storage location.

F. - H. MAKE NO ENTRY.

I. **Bu., Ton, Lbs., Cwt.:** Circle “Lbs.” in column heading. Production in whole pounds of distilled mint oil, as determined by delivery records, production recaps, sales receipts from processors (must be NET weight), etc.

J. - N. MAKE NO ENTRY.

O. **Production Not to Count:** Net production NOT to count, in whole pounds, WHEN ACCEPTABLE RECORDS IDENTIFYING SUCH PRODUCTION ARE AVAILABLE, from harvested acreage which has been assessed an appraisal of not less than the guarantee per acre.

Production from acreage that has been previously paid under the “Winter Coverage Option” will also be shown here. This production must have separate records to indicate it as uninsured acreage production.

THIS ENTRY MUST NEVER EXCEED PRODUCTION SHOWN ON THE SAME LINE. EXPLAIN THE TOTAL CONTENTS AND ANY “PRODUCTION NOT TO COUNT” IN THE NARRATIVE.

P. **Production:** Result of subtracting the entry in Column “O” from Column “I.” Enter the result in whole pounds.

Q₁. - R. MAKE NO ENTRY.

S. **Production to Count:** Enter result from Column “P” in whole pounds.

FOR ITEMS 22 - 24. WHEN SEPARATE LINE ENTRIES ARE MADE FOR VARYING SHARES, STAGES, APH YIELDS, PRICE ELECTIONS, TYPES, ETC., WITHIN THE UNIT, AND TOTALS NEED TO BE KEPT SEPARATE FOR CALCULATING INDEMNITIES, MAKE NO ENTRY AND FOLLOW THE **AIP'S** INSTRUCTIONS; OTHERWISE, MAKE THE FOLLOWING ENTRIES.

22. **Section II Total:**
- PRELIMINARY AND WCO:** MAKE NO ENTRY.
- FINAL:** Total of Column “S,” to whole pounds.
23. **Section I Total:**
- PRELIMINARY:** MAKE NO ENTRY.
- FINAL AND WCO:** Enter figure from Section I Column “O” total.
24. **Unit Total:**
- PRELIMINARY:** MAKE NO ENTRY.
- FINAL AND WCO:** Total of 22 and 23, to whole pounds.
25. **Adjuster’s Signature, Code #, and Date:** Signature of adjuster, code number, and date signed **after** the insured (or insured’s authorized representative) has signed. For an absentee insured, enter adjuster’s code number **ONLY**. The signature and date will be entered **AFTER** the absentee has signed and returned the Production Worksheet.
- Final indemnity and Winter Coverage Option inspections should be signed on the bottom line.
26. **Insured’s Signature and Date:** Insured’s (or insured’s authorized representative’s) signature and date. **BEFORE** obtaining insured’s signature, **REVIEW ALL ENTRIES** on the Production Worksheet **WITH THE INSURED**, particularly explaining codes, etc., that may not be readily understood.
- Final indemnity and Winter Coverage Option inspections should be signed on the bottom line.
27. **Page Numbers:**
- PRELIMINARY:** Page numbers – “1”, “2”, etc., at the time of inspection.
- FINAL and WCO:** Page numbers (Example: Page 1 of 1, page 1 of 2, Page 2 of 2, etc.).

1 Crop/Code # MINT - 0074	2 Unit # 00100	3 Legal Description	PRODUCTION WORKSHEET (FOR ILLUSTRATION PURPOSES ONLY)						8 Name of Insured I. M. INSURED			
4 Date of Damage JUL 10	5 Cause of Damage HAIL	6 Primary Cause % 100	7 Company <u>ANY COMPANY</u>						9 Claim # XXXXXXXX	11 Crop Year YYYY		
12 Additional Units 00200	13 Est. Prod Per Acre 50		Agency <u>ANY AGENCY</u>						10 Policy #	14 Date(s) Notice of Loss 1 st MM/DD/YYYY	2 nd	Final MM/DD/YYYY
15 Companion Policy(s)												

SECTION I – ACREAGE APPRAISED, PRODUCTION AND ADJUSTMENTS

ACTUARIAL										POTENTIAL YIELD					STAGE GUARANTEE	
A	B	C	D	E	F	G	H	I	J	K ₁ K ₂	L	M	N	O	P	Q
Field ID	Prelim Acres	Final Acres	Interest or Share	Risk	Practice	Type Class Variety	Stage	Intended or Final Use	Appraised Potential	Moisture % Factor	Shell and/or Quality Factor	+Uninsured Cause	Adjusted Potential	Total to Count (C x N)	Per Acre	Total (C x P)
M/D A IR		20.0	1.000		003	080	W3	W3								
M/D B NS		30.0	1.000		003	080	UH	UH	25				25	750	50	1500
M/D C NS		50.0	1.000		003	080	H	H							50	2500
16 TOTAL		100.0											17 TOTALS	750		4000

NARRATIVE (If more space is needed, attach a Special Report) **ACREAGE DETERMINED FROM PERMANENT FIELD MEASUREMENTS. FIELD A PREVIOUSLY PAID UNDER THE WINTER COVERAGE OPTION. FIELD B APPRAISED FROM REPRESENTATIVE STRIPS.**

SECTION II – HARVESTED PRODUCTION

18 Date Harvest Completed MM/DD/YYYY	19 Damage Similar to Other Farms in the Area? Yes <input checked="" type="checkbox"/> No <input type="checkbox"/>	20 Assignment of Indemnity? Yes <input type="checkbox"/> No <input checked="" type="checkbox"/>	21 Transfer of Right To Indemnity? Yes <input type="checkbox"/> No <input checked="" type="checkbox"/>
---	--	--	---

MEASUREMENTS					GROSS PRODUCTION					ADJUSTMENTS TO HARVESTED PRODUCTION									
A ₁ A ₂	B	C	D	E	F	G	H	I	J	K ₁ K ₂	L ₁ L ₂	M ₁ M ₂	N	O	P	Q ₁ Q ₂	R	S	
Share	Length or Diameter	Width	Depth	Deduction	Net Cubic Feet	Conve r-sion Factor	Gross Prod. (F x G)	Bu. Ton Lbs. Cwt.	Shell/ Sugar Factor	FM%	Moisture%	Test Wt.	Adjusted Production HorIxJxK ₂ xL ₂ xM ₂	Prod. Not To Count	Production(N – O)	Value Mkt. Price	Quality Factor	Production To Count (P X R)	
	ANY MINT CO. ANYTOWN, ANY STATE							450								450			450

I certify the information provided above, to the best of my knowledge, to be true and complete and that it will be used to determine my loss, if any, to my insured crops. I understand that this Production Worksheet and supporting papers are subject to audit and approval by the company. I understand that this crop insurance is subsidized and reinsured by the Federal Crop Insurance Corporation, an agency of the United States. I understand that any false or inaccurate information may result in the sanctions outlined in my policy and administrative, civil, and criminal sanctions under 18 U.S.C. §§ 1006 and 1014, 7 U.S.C. § 1506, 31 U.S.C. §§ 3729 and other federal statutes

22 Section II Total	450
23 Section I Total	750
24 Unit Total	1200

25 Adjuster's Signature	Code #	Date	26 Insured's Signature	Date
1 st Inspection	I. M. ADJUSTER	XXXXX	MM/DD/YYYY	1 st Inspection
2 nd Inspection				2 nd Inspection
Final Inspection	I. M. ADJUSTER	XXXXX	MM/DD/YYYY	Final Inspection
			I. M. INSURED	MM/DD/YYYY

Crop/Code #	2 Unit #	3 Legal Description	PRODUCTION WORKSHEET (FOR ILLUSTRATION PURPOSES ONLY) 7 Company <u>ANY COMPANY</u> Agency <u>ANY AGENCY</u>				8 Name of Insured I. M. INSURED				
MINT - 0074	00100						9 Claim # XXXXXXXXXX		11 Crop Year YYYY		10 Policy #
4 Date of Damage	JAN		WINTER COVERAGE OPTION				15 Companion Policy(s)				
5 Cause of Damage	CW										
6 Primary Cause %	100										
12 Additional Units											
13 Est. Prod Per Acre											

SECTION I – ACREAGE APPRAISED, PRODUCTION AND ADJUSTMENTS

ACTUARIAL										POTENTIAL YIELD					STAGE GUARANTEE	
A	B	C	D	E	F	G	H	I	J	K ₁ K ₂	L	M	N	O	P	Q
Field ID	Prelim Acres	Final Acres	Interest or Share	Risk	Practice	Type Class Variety	Stage	Intended or Final Use	Appraised Potential	Moisture % Factor	Shell and/or Quality Factor	+Uninsured Cause	Adjusted Potential	Total to Count (C x N)	Per Acre	Total (C x P)
A IR		20.0	1.000		003	080	W1	TO SOYBEANS						0	30	600
B NS		30.0	1.000		003	080	W2	TO HARVEST							50	1500
C NS		50.0	1.000		003	080	W2	TO HARVEST							50	2500
16 TOTAL		100.0											17 TOTALS	0	4600	

NARRATIVE (If more space is needed, attach a Special Report) ACREAGE DETERMINED FROM PERMANENT FIELD MEASUREMENTS. FIELD A **PAYABLE** UNDER THE WINTER COVERAGE OPTION. **PLANT STAND .3 PLANTS / SQ. FOOT.** FIELD B & C **NOT** PAYABLE UNDER THE WINTER COVERAGE OPTION. **PLANT STAND ON FIELD B, 1.5 PLANTS / SQ. FOOT.** MINIMUM PLANT STAND IN THE SPOI IS 1.5 PLANTS / SQ. FOOT. FIELDS **B & C** WILL BE TAKEN TO HARVEST.

SECTION II – HARVESTED PRODUCTION

18 Date Harvest Completed	19 Damage Similar to Other Farms in the Area? Yes <input checked="" type="checkbox"/> No <input type="checkbox"/>	20 Assignment of Indemnity? Yes <input type="checkbox"/> No <input checked="" type="checkbox"/>	21 Transfer of Right To Indemnity? Yes <input type="checkbox"/> No <input checked="" type="checkbox"/>
---------------------------	--	--	---

MEASUREMENTS				GROSS PRODUCTION						ADJUSTMENTS TO HARVESTED PRODUCTION								
A ₁ A ₂	B	C	D	E	F	G	H	I	J	K ₁ K ₂	L ₁ L ₂	M ₁ M ₂	N	O	P	Q ₁ Q ₂	R	S
Share	Length or Diameter	Width	Depth	Deduction	Net Cubic Feet	Conversion Factor	Gross Prod. (F x G)	Bu. Ton Lbs. Cwt.	Shell/Sugar Factor	FM% Factor	Moisture% Factor	Test Wt. Factor	Adjusted Production HorIxJxK ₂ xL ₂ xM ₂	Prod. Not To Count	Production(N - O)	Value Mkt. Price	Quality Factor	Production To Count (P X R)

I certify the information provided above, to the best of my knowledge, to be true and complete and that it will be used to determine my loss, if any, to my insured crops. I understand that this Production Worksheet and supporting papers are subject to audit and approval by the company. I understand that this crop insurance is subsidized and reinsured by the Federal Crop Insurance Corporation, an agency of the United States. I understand that any false or inaccurate information may result in the sanctions outlined in my policy and administrative, civil, and criminal sanctions under 18 U.S.C. §§ 1006 and 1014, 7 U.S.C. § 1506, 31 U.S.C. §§ 3729 and other federal statutes

22 Section II Total	
23 Section I Total	0
24 Unit Total	0

25 Adjuster's Signature	Code #	Date	26 Insured's Signature	Date
1 st Inspection			1 st Inspection	
2 nd Inspection			2 nd Inspection	
Final Inspection	I. M. ADJUSTER	XXXXX	MM/DD/YYYY	I. M. INSURED
				MM/DD/YYYY

9. REFERENCE MATERIAL

TABLE A - MINIMUM REPRESENTATIVE SAMPLE REQUIREMENTS

ACRES IN FIELD OR SUBFIELD	MINIMUM NUMBER OF SAMPLES
0.1 - 10.0	3
10.1 - 40.0	4

Add one additional sample for each additional 40.0 acres (or fraction thereof) in the field or subfield.

EXHIBIT 1

Collapsible Grid

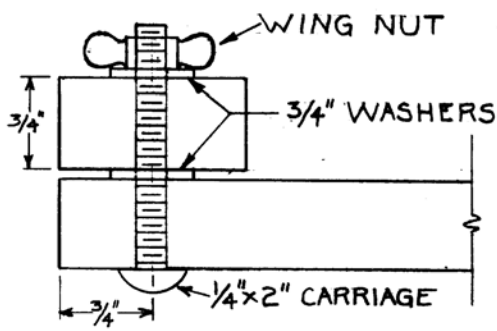
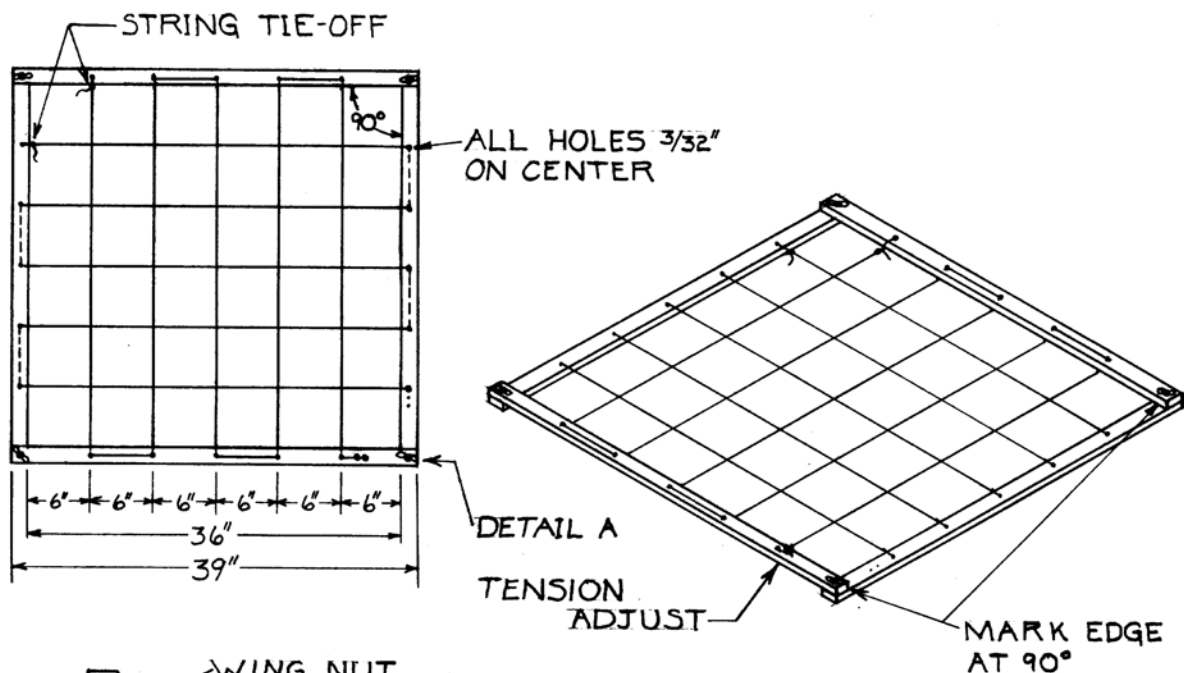

DETAIL A

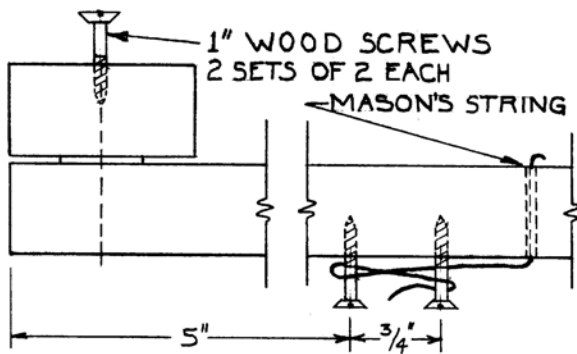

TENSION ADJUST

MATERIALS

QT.	DESCRIPTION
4	1"x2"x39" WOOD
4	1/4"x2" CARRIAGE BOLTS
4	WING NUTS
8	3/4" WASHERS
4	1" WOOD SCREWS
1	ROLL MASON'S STRING

NOTES:

- WIDER STOCK MAY BE USED
- INTERIOR DIM. CRITICAL.
- DO NOT INTER-LACE STRING.
- MARK JOINT EDGES AT 90° W/ PENCIL.

DWB 11/98