

REDESIGN, CONSTRUCTION,
AND
FIELD TESTING
OF A
PROTOTYPE FLOTATION SYSTEM
FOR A
WATER JET BARRIER

Environment Canada
RFP 4808-3-2

October 1992

Submitted to:

**Emergencies Engineering Division
River Road Environmental Technology Centre
3439 River Road
Ottawa, Ontario
K1A 0H3**

Submitted by:

**Fleet Technology Limited
311 Legget Drive
Kanata, Ontario
K2K 1Z8**

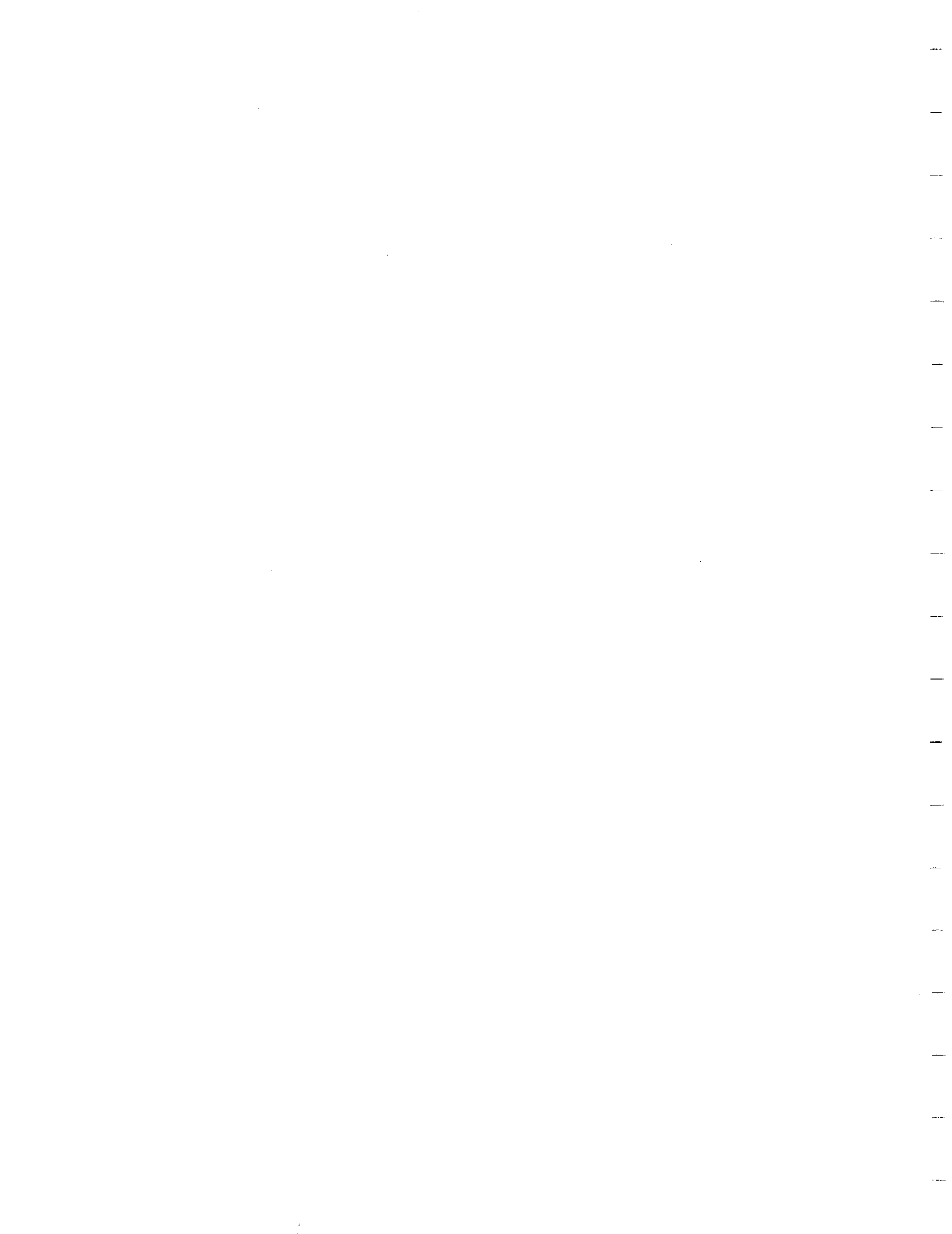

PROJECT TEAM

George Comfort - Project Manager
Bruce Paterson - Project Engineer
Andre Lemieux - Technician
The staff of the Materials Technology Centre ((MTC) at FTL.

DISCLAIMER

The contents of this report reflect the views of Fleet Technology Limited and not necessarily the official view or policies of Environment Canada.

Approved by: _____

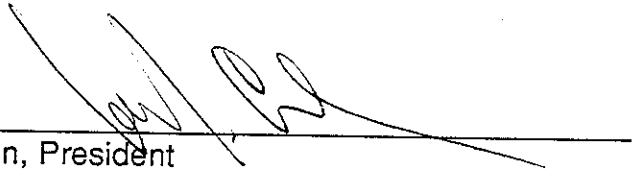
I.F. Glen, President

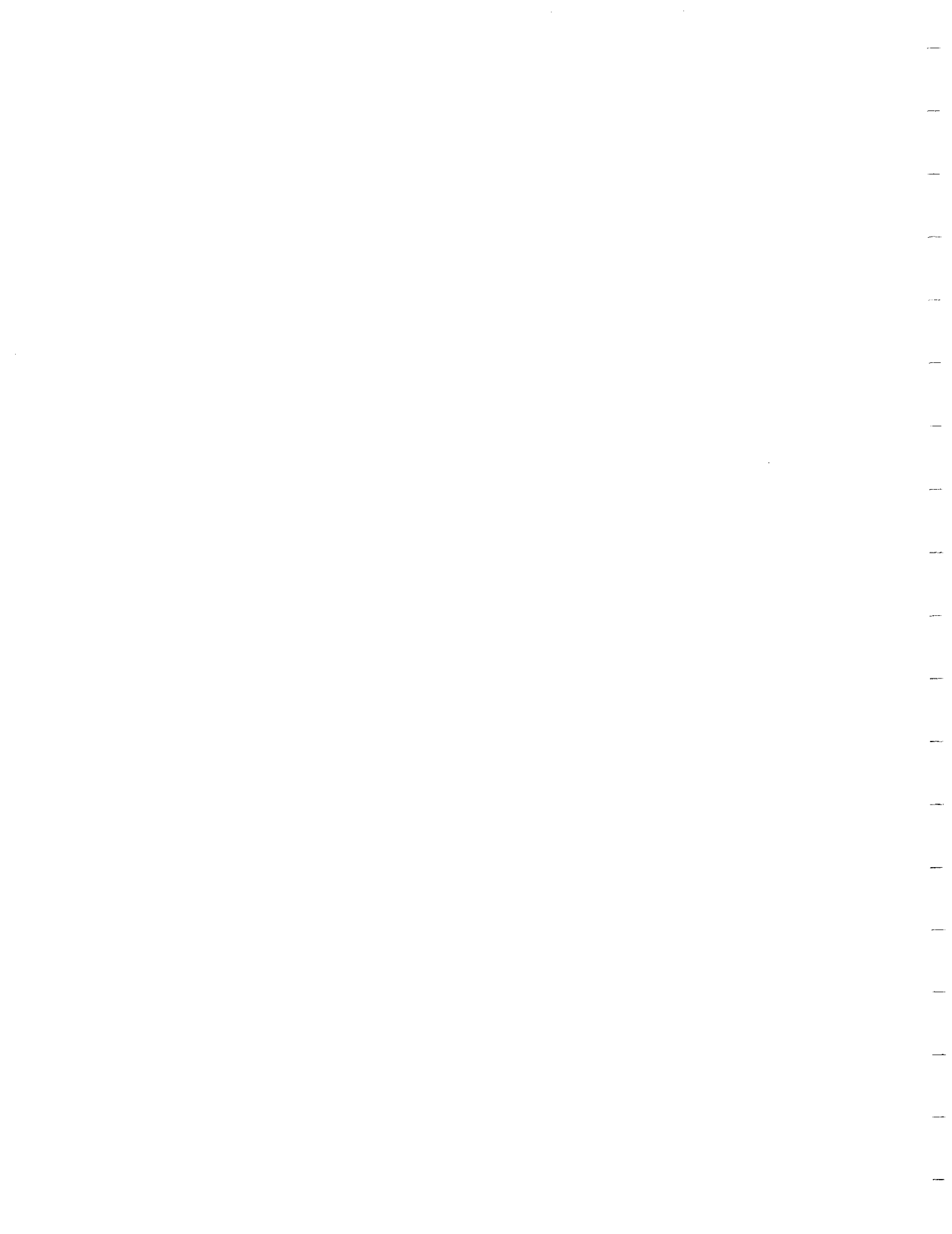

EXECUTIVE SUMMARY

An oil spill containment system based on high pressure waterjets is a concept that has shown promise in conditions where a high velocity water current or significant wave conditions are present, such as in rivers or tidal estuaries. Over the past decade, a number of projects have been sponsored by Environment Canada and the United States Minerals Management Service (MMS) to develop a system of this type. Additional funding was received for this project from the Marine Spill Response Corporation (MSRC). As the performance of the barrier has been limited by its flotation system during past deployments, recent work has been directed toward an improved, low drag, flotation system. This project was comprised of two phases:

1. a review of the past performance of the barrier and a redesign of the barrier's general arrangement and flotation system.
2. field deployments and testing of the revised waterjet barrier design.

During the first phase, towing tank tests were performed using full scale models of alternative float designs. The current-induced drag of the selected airfoil float design was significantly reduced, to 30% of the original disc floats. The floats were fitted with a skeg to facilitate "weathervaning" in a current over a limited range of angles. In addition to the re-design of the floats, a rigid support structure was designed for the hoses, with pin joint connections to allow movement in waves. This work is described in detail in a previous interim report. A number of features were introduced to facilitate the deployment of the boom. These included the use of an anchor, tether ropes, float weathervaning limits, and fittings for towing of the assembled boom.

For the trials conducted in the second phase of the project, a prototype system with boom arms 12m (40 ft.) long was constructed and a preliminary deployment took place in the St. Lawrence River at Prescott, Ontario during August 1991. From that experience, some modifications were identified and implemented.

A more comprehensive series of deployments occurred off Prescott in August of 1992. These trials involved planned deployments in three phases: in sheltered conditions; in waves and light current alongside the CCG Prescott quay; and in mid-river using a CCG support ship. A simulated spill using dyed canola oil was planned for the last two phases of the trial program. The tests in sheltered conditions and alongside the CCG quay were conducted successfully. A mid-river deployment, intended to expose the boom to high current conditions could not be conducted because of damage occurred to some of the flexible joints during towing of the boom, and this test had to be aborted. The test could not be rescheduled due to the limited availability of the support vessel. However the boom was repaired, including implementation of a rigid connection, and trials proceeded alongside the CCG quay.

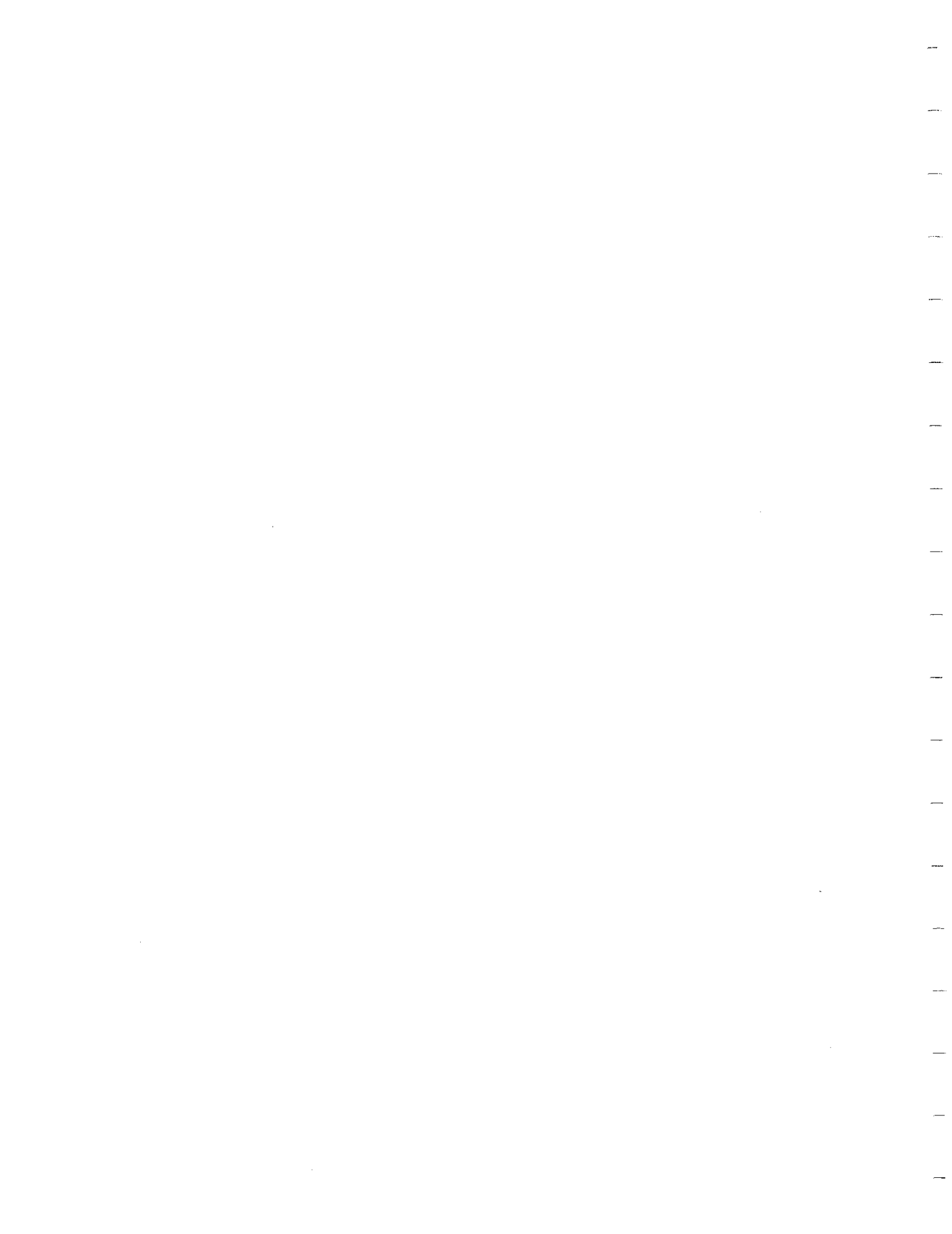

In the trials, the waterjet barrier demonstrated that it could be controlled and manoeuvred, and was able to contain oil in "realistic" wind and wave conditions, in a light river current. The oil containment capability of the barrier was demonstrated for a modest quantity (approx. 104 litres) of light oil, in waves and in calm water. The ability to direct and divert the spill was demonstrated. The minimal oil loss that occurred at the apex was effectively channelled into a narrow "strip" for clean-up by a skimmer. The waterjet barrier was demonstrated to be highly manoeuvrable when operating in a combination of moderate wind and waves, and light current. Mobility (and therefore oil containment) was constrained by the large pump system and a limited length of umbilical hose.

The definition of the performance envelope is essential to further development of the waterjet barrier. At this stage, the waterjet barrier has been demonstrated but the limits on performance have not been defined. The waterjet barrier is more complex than current oil spill barriers systems, and therefore must demonstrate superior performance capabilities in order to justify commercial development. The most efficient way of defining the performance envelope will be to conduct a series of systematic laboratory tests, where key parameters can be controlled and varied.

Based on the experience of the trials program, a series of recommendations concerning deployment procedures and a list of revisions for a "commercial" prototype have also been included in this report.

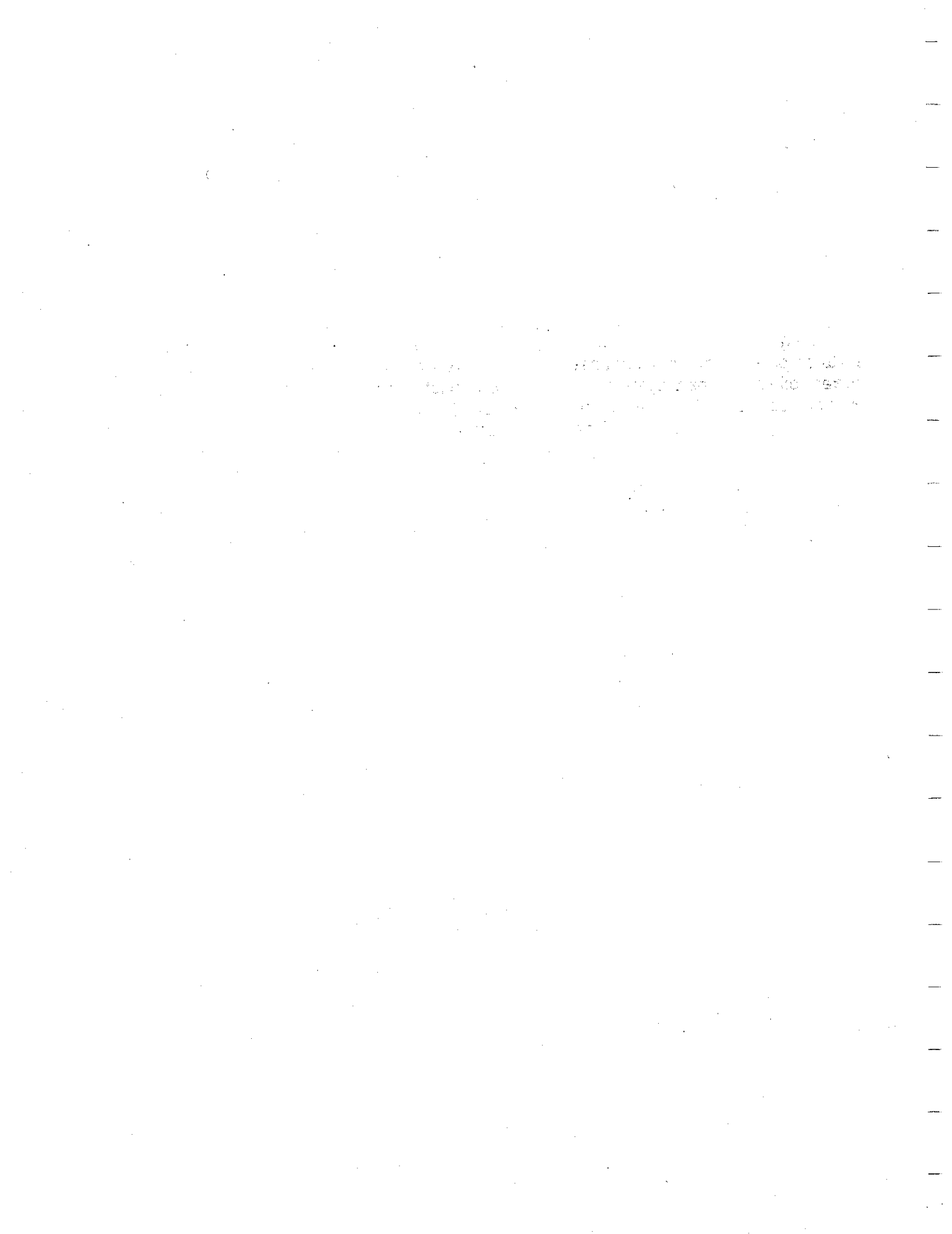

ACKNOWLEDGEMENTS

Fleet Technology Limited would like to acknowledge the assistance of the following groups, which provided invaluable assistance during the fabrication and testing programs.

Environment Canada, Emergencies Engineering Division; in particular Monique Punt, Caroline Ladanowski, Tony Lorenzo, and Andre Dumouchel.

The Environmental Emergencies Response Group from CCG Prescott, headed by Ray Amell.

NOTE

1. Because both materials and measurements involved a mixture of Imperial and SI units, data are quoted in both unit systems where appropriate.
2. The term "Boom" is used to describe the floating portion of the waterjet barrier, ie. the flotation system and rigid support structure, that was the principle focus of the project. The term "Barrier" or "Waterjet Barrier" is used to describe the fully assembled operating system, including floating components (the boom), the pump, and associated control manifold.

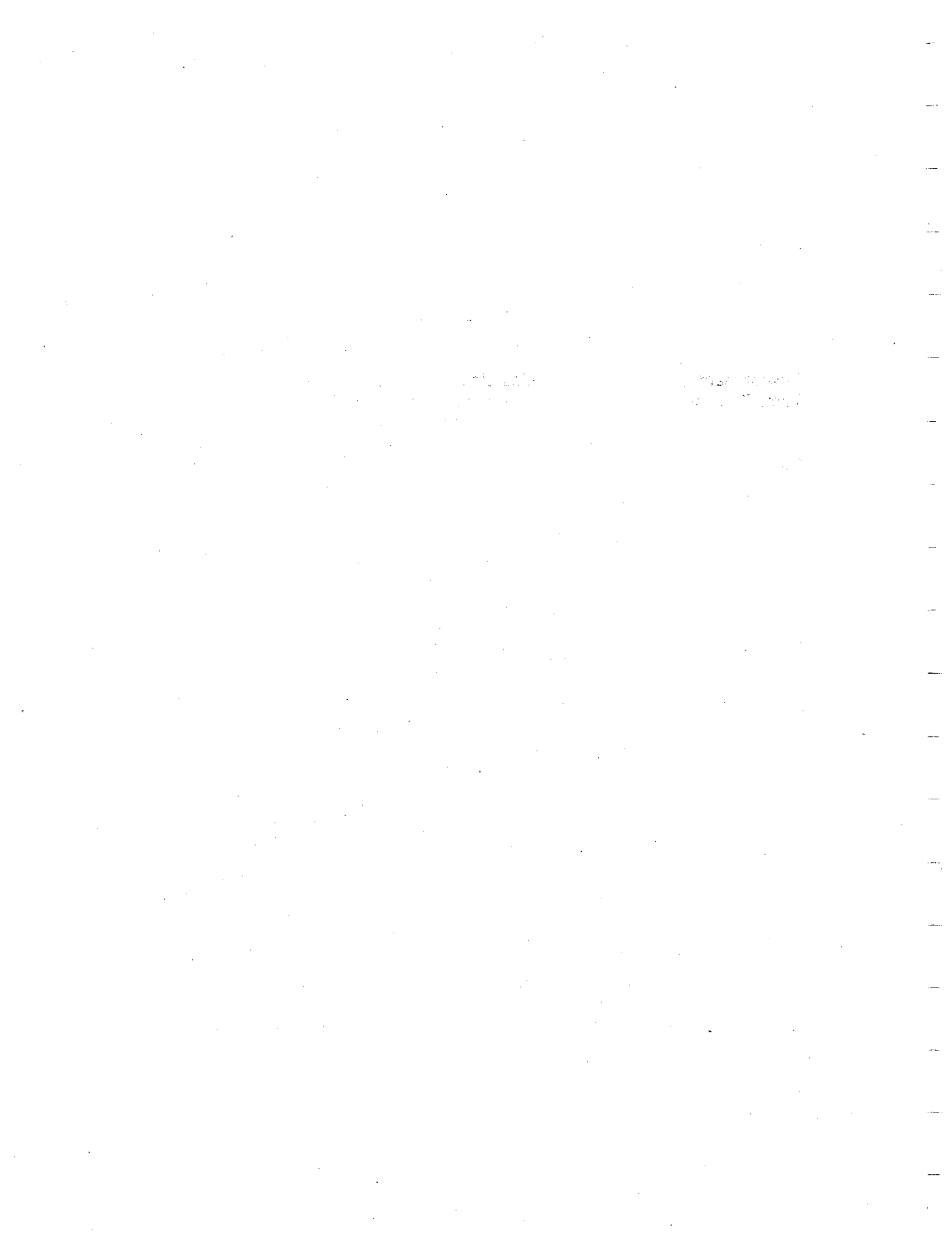
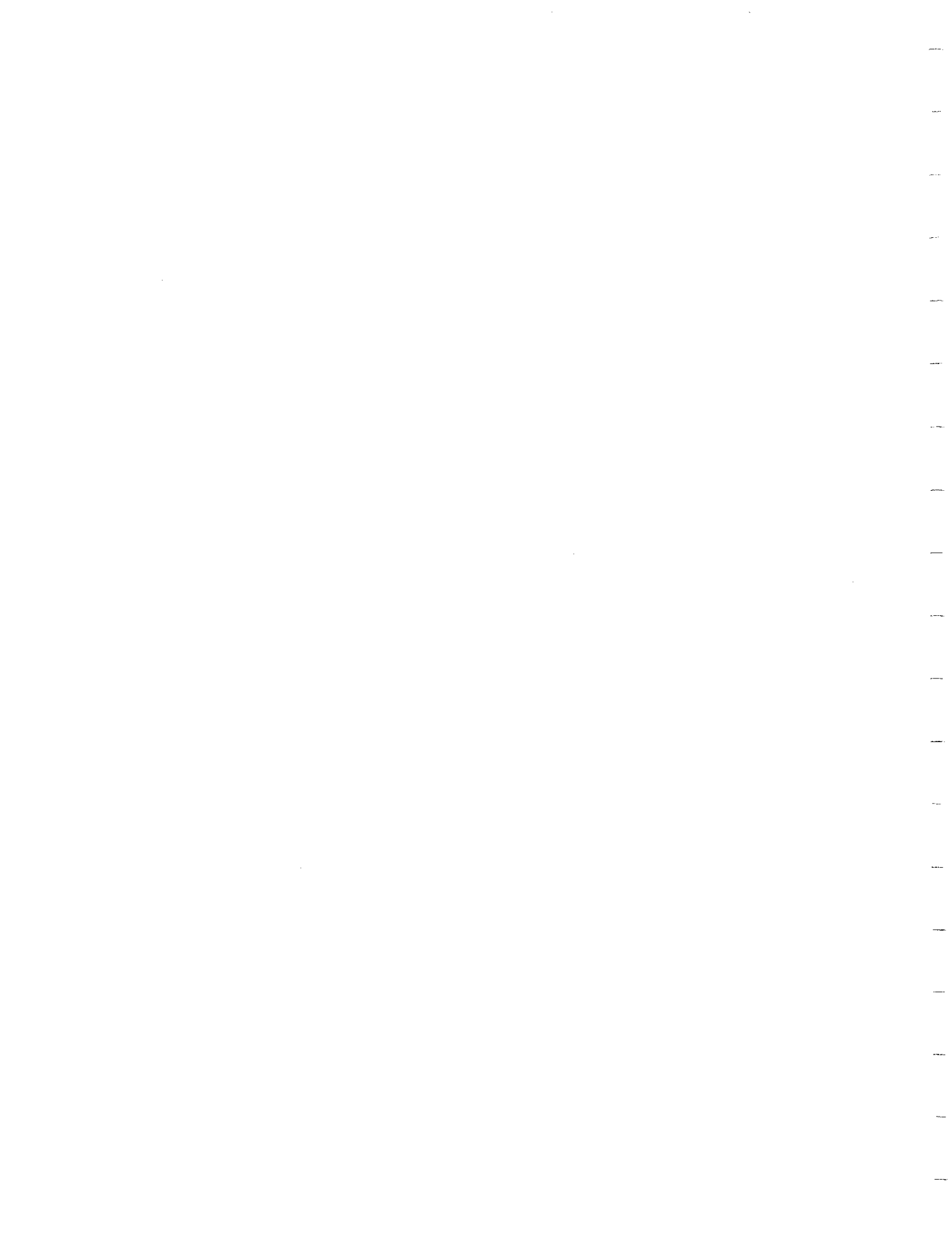

TABLE OF CONTENTS

	<u>PAGE</u>
1.0 INTRODUCTION	1
2.0 A GENERAL DESCRIPTION OF THE WATERJET BARRIER	3
2.1 Concept	3
2.2 Technical Description	6
3.0 PRELIMINARY DEPLOYMENT - August 1991	13
3.1 Objectives	13
3.2 Local Conditions	13
3.3 Problems Encountered	15
3.4 Test Results	17
3.5 Revision to Initial Design	19
4.0 THE AUGUST 1992 TRIALS	21
4.1 Objectives	21
4.2 Overview of Trials	24
4.3 Local Conditions	40
4.4 Trial Results	41
5.0 CONCLUSIONS AND RECOMMENDATIONS	47
5.1 Conclusions	47
5.2 Recommendations for Performance Evaluation	48
5.3 Issues concerning the Development of an "Operational Prototype"	50
6.0 REFERENCES	55

APPENDICES:

- A - August 1991 Trial Summary Memorandum
- B - Test Plan for 1992 Trials
- C - Summary of Waterjet Barrier Trials: 17-21 August 1992
- D - Wave Buoy Data, 17-21 August 1992
- E - Revised Waterjet Barrier Drawings



LIST OF FIGURES

	<u>Page</u>
1. Schematic of the Revised Waterjet Barrier.	5
2. Airfoil Float Design	7
3. Constraints on Float Weathervaning Action	9
4. Constraints for Control of Boom	10
5. Deployment of Revised Barrier in Small Craft Basin - CCG Prescott, August 1991	16
6. Revisions to Umbilical Hose Flotation System - 1992	18
7. Map of 1992 Trials Locations - CCG Prescott	23
8. Field Modifications to Flotation System	25
9. Trial Activities - Wednesday, 19 August 1992	27
10. Boom Deployed off CCGS SIMCOE - Wednesday, 19 August 1992	28
11. Modifications to Pin Joint Connections	30
12. Trial Activities - Thursday, 20 August 1992	32
13. Trial Activities - Friday, 21 August 1992	35
14. Photographs of Spill Simulation - Friday, 21 August 1992	37

LIST OF TABLES

1. Recorded Nozzle Pressures - Friday, 21 August 1992	34
2. Summary of Local Conditions:	39
2.1 Wave and Wind Observations	
2.2 Current Data	

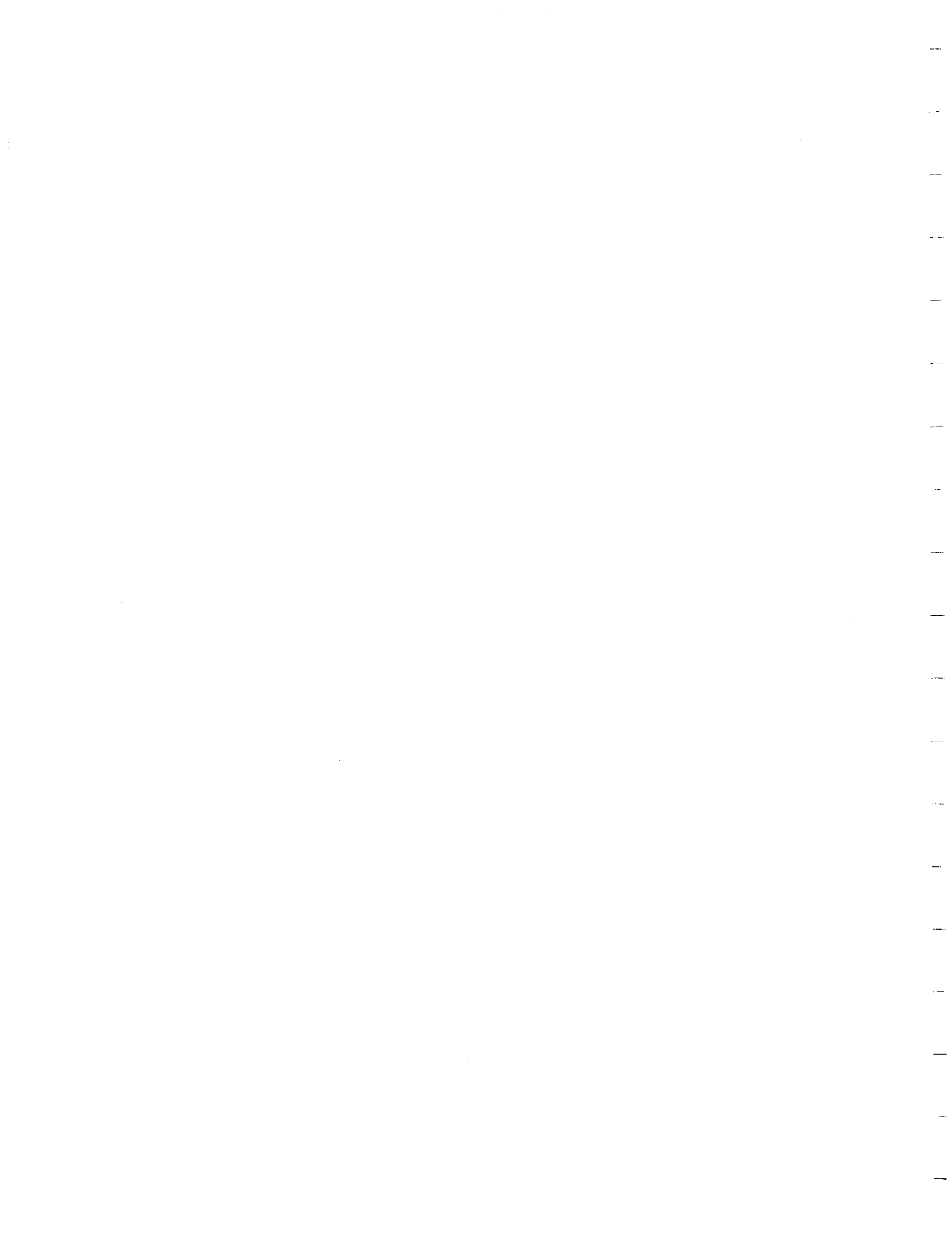

1.0 INTRODUCTION

This report is intended to document a set of trial deployments of a prototype waterjet barrier intended for oil spill containment during the period of August 1991 and August 1992, respectively. The trials were conducted at CCG base Prescott by Fleet Technology Limited (FTL), under a contract issued by Environment Canada on behalf of Environment Canada, the U.S. Minerals Management Service (MMS), and the Marine Spill Response Corporation (MSRC).

This contract called for the redesign and testing of a high pressure waterjet barrier system and was issued in late 1990. It was the most recent of a series of projects undertaken by Environment Canada to develop a high pressure water jet barrier for oil spill containment. The redesign of waterjet barrier has been documented in a previous report to Environment Canada dated March 1991 [Reference 1]. Subsequent revisions to the barrier design resulting from the 1991 trials are documented in this report.

The original contract called for a set of trials to be conducted at the Oil and Hazardous Materials Simulated Environmental Test Tank (OHMSETT) in New Jersey. However delays in commissioning of the tank forced a change in the trial site, to the Canadian Coast Guard (CCG) base located at Prescott, Ontario, on the St. Lawrence River. The change in test venue also altered the complexion of the trials somewhat, as the Prescott site involved realistic field conditions. The objectives of the test program changed from determining the performance limits of the barrier (as would have been the case during the planned OHMSETT trials) to a demonstration that the barrier could be deployed, manoeuvred and operated under field conditions. Thus the trials with the barrier, which was redesigned with the objective of reducing current drag, also encountered a series of variables which included high winds, floating debris, and towing problems, that would not have been encountered in a laboratory test program. The tests therefore involved a much steeper "learning curve".

2.0 A GENERAL DESCRIPTION OF THE WATERJET BARRIER

2.1 Concept

Currently available oil containment booms are unable to function effectively at sites where the water current exceeds about 0.5 m/s (1 knot) and/or the wave conditions exceed about Sea State 3. There is a need to contain oil spilled in higher currents and wave conditions such as may occur in rivers and harbours. In recognition of this requirement a series of projects have been sponsored by Environment Canada and the U.S. Minerals Management Service (MMS) to develop a high pressure waterjet barrier for oil spill containment. Laboratory tank tests [Ref.s 2 - 6] and trial field deployments [Ref.s 7,8] were conducted. These tests demonstrated that the waterjet barrier had promise as a means for oil spill containment in high current or more severe wave conditions.

In concept, the waterjet barrier consists of a series of nozzles mounted on floats to emit flat, fan-shaped, high velocity jets of water horizontally about 15 to 30 cm above the surface of an oil slick. The nozzles are spaced so that the sprays overlap to create a continuous front. A series of opposing nozzles are mounted on the "back" side of the barrier to balance the thrust from the forward nozzles. As the flow to the forward and back nozzles is separately controlled, the waterjet barrier can be manoeuvred in the field to suit local conditions (e.g., to respond to changes in winds, spill conditions, or tidal currents).

During past deployments the performance of the waterjet barrier has been limited by the effectiveness of its flotation system. As a result, FTL was contracted to redesign the flotation system and to produce a prototype for testing [Ref.1]. The objective of this work was to produce a flotation system that would improve the manoeuvrability, directional control, and the stability of the waterjet barrier in the presence of high velocity water current. The design work is reported in Ref.[1] and is summarized in the following section.

The following design criteria were identified for the revised system:

- a) **Station-keeping** - the barrier must keep station when it is operated in either the oil containment or the diversionary mode. For oil containment operations, it must also maintain a desired angle between the arms, conducive to oil containment (i.e., about 120°).
- b) **Manoeuvrability** - the barrier must be capable of manoeuvring in the presence of currents and/or sea states as desired to suit local conditions. Also, for oil containment operations, the system must allow the angle between the arms of the barrier to be varied.

- c) **Stability** - the barrier must remain upright during manoeuvring and maintain the nozzles at the correct attitude during waterjet operations.
- d) **Position of nozzles** - the floatation system should maintain the nozzles 15-30 cm above the water surface and keep the water jets horizontal as much as possible.
- e) **Ease of deployment and storage, simplicity and light weight** - only minimal ship support should be required to deploy and operate the waterjet barrier.
- f) **Durability** - including resistance to abrasion, mechanical damage and oil products.
- g) **Low cost** - should minimize total cost (including acquisition and maintenance costs).

The prototype developed under this contract was designed as a "concept demonstrator", with an emphasis on the following objectives:

- A. the drag on the floats for both the arms and the umbilical hose line of the barrier was to be reduced.
- B. the floats were to maintain stability within a range of weathervaning angles, relative to the barrier.
- C. the manoeuvrability of the barrier was to be improved. For oil containment operations, an improved capability was required to maintain the desired arm angle.

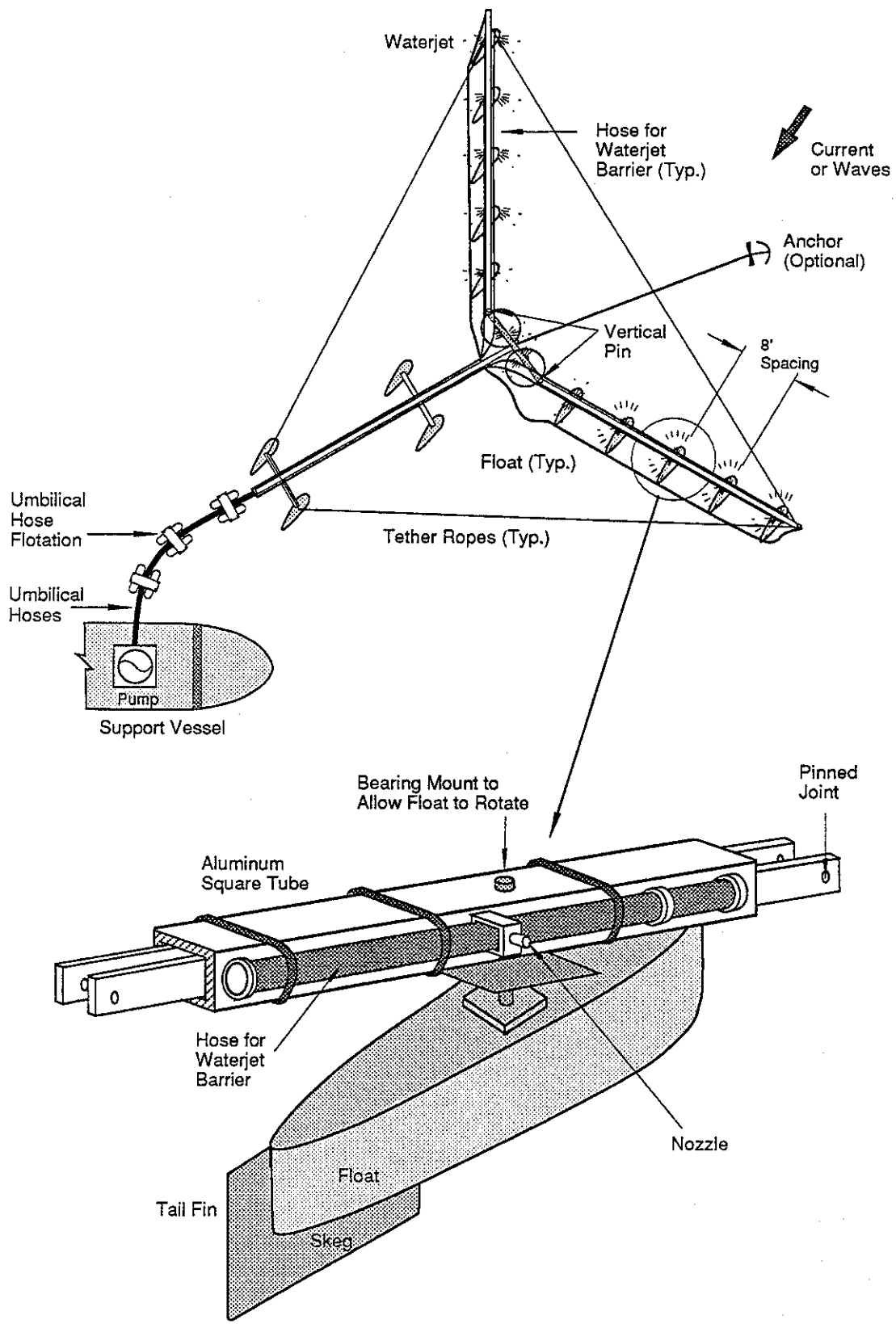

Figure 1: Schematic of Revised Waterjet Barrier

2.2 Technical Description

The "original" (ie. pre-1991) waterjet barrier system used flexible hydraulic hoses to feed water to the nozzles; disc-shaped floats supported the nozzles and hoses. There was no rigid structure joining individual floats or nozzles. For each operating configuration, the nozzles are located on 2.4 m (8 ft.) centres and are arranged such that opposing horizontal jets are produced. This general arrangement allows the arms of the barrier to be manoeuvred using differential water pressure, controlled from a central manifold off of the high pressure pump. It also acts to stabilize the system while operating.

The most recent deployment of the "original" system, based on the disk floats and flexible hoses, was conducted in 1990 at Prescott, Ontario [Ref.8]. A number of problems were experienced during that trial. The disc floats had excessive drag such that in a current of 0.5 to 0.75 m/s (1 - 1.5 knots) the barrier could not be manoeuvred and kept on station in the desired configuration (ie. with the desired angle between the arms of the barrier). The arms were also found to be too flexible, with the result that the system was difficult to control. Stability problems occurred as the disc floats overturned in some cases. Also the height of the nozzles above the water in the original system was less than that identified for optimal oil retention performance [Ref.5] in laboratory tests.

The revisions to the waterjet barrier introduced by FTL fell into two general categories, as follows:

- 1.) flotation system improvements, and:
- 2.) general arrangement improvements.

A schematic of the revised waterjet barrier is shown in **Figure 1**.

The **flotation system** revisions consisted of:

- a) the use of an "airfoil-type" float that was able to "weathervane" in the current.
- b) a reduction of the number of floats by spacing them at 2.4 m (8 ft.) centres, rather than at 1.2 m (4 ft.) centres as in the "original" design.

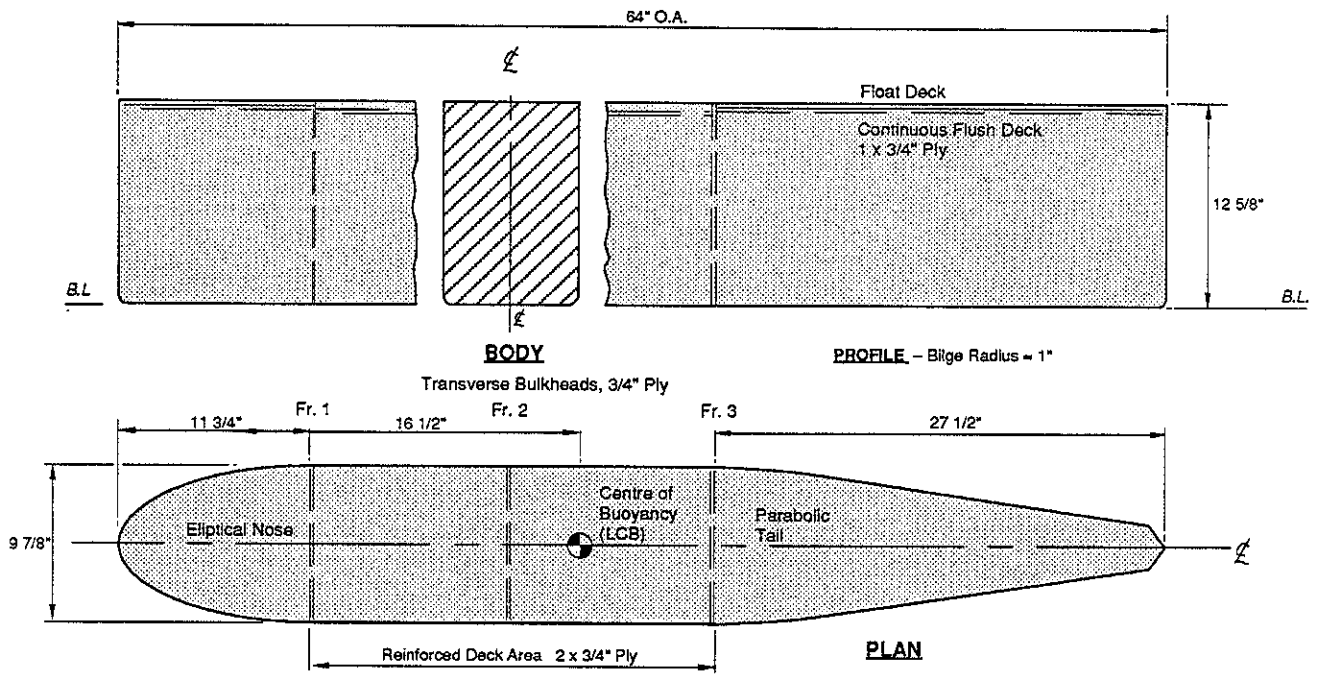

2a: General Arrangement of Float

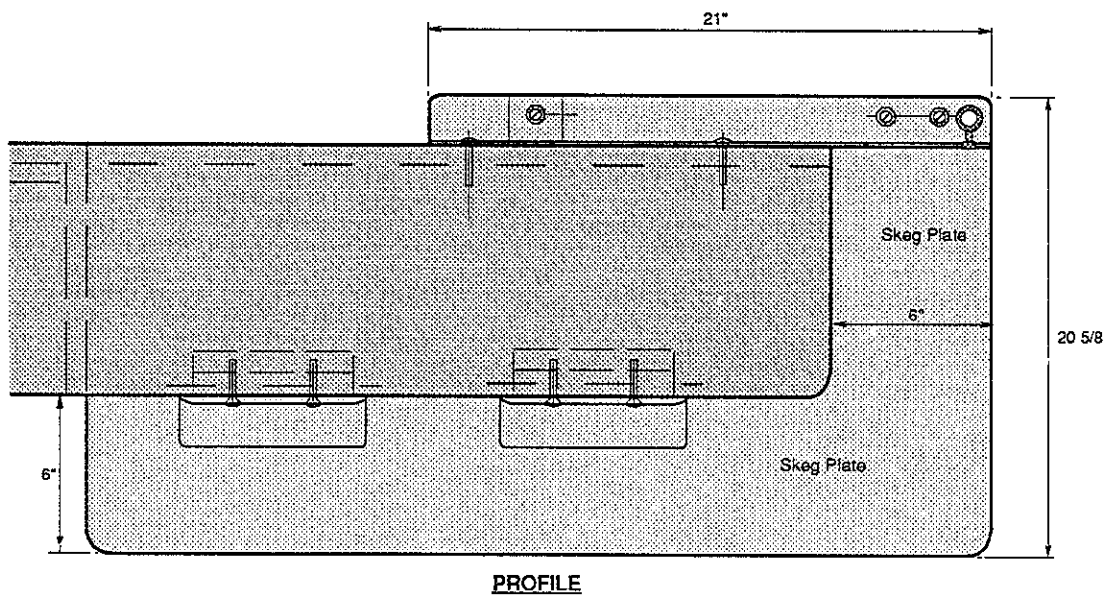

2b: Float Skag Details

Figure 2: Airfoil Float Design

The new floats were designed to meet three main performance objectives:

- i) Support the weight of the barrier and maintain a nozzle elevation of approximately 20cm (8") above the waterline.
- ii) Improve the stability of the barrier under the action of the water jets.
- iii) Reduce the drag of the floats in current up to about 2 knots (1 m/s).

The actual float configuration was driven by objective "iii", reduction of the float drag, although achievement of the first two objectives were necessary for any successful float design. The review of past designs indicated strongly that drag reduction was critical for providing acceptable station-keeping performance and controllability of the waterjet barrier.

A series of comparative model tests indicated that the airfoil float selected for the trials has approximately 30% of the drag of the baseline disk float at the design speed of 2 knots (1 m/s). This float design is shown in **Figure 2**. A skeg was designed to ensure the float had acceptable "weathervaning" properties over a range of current speeds.

Along the umbilical structure connecting the waterjet boom arms to the pump there are four hoses (instead of two) so the supporting floats have to be correspondingly larger. There was additional displacement required for the float at the junction of the "Y", because of the weight of structure located at the apex. It was proposed to obtain the added buoyancy using an identical float waterplane section with additional depth, rather than an overall increase in dimensions. The result was a deeper float which was much less stable than the boom arm floats but was very simple (and less costly) to construct, because a common glassing mould could be used.

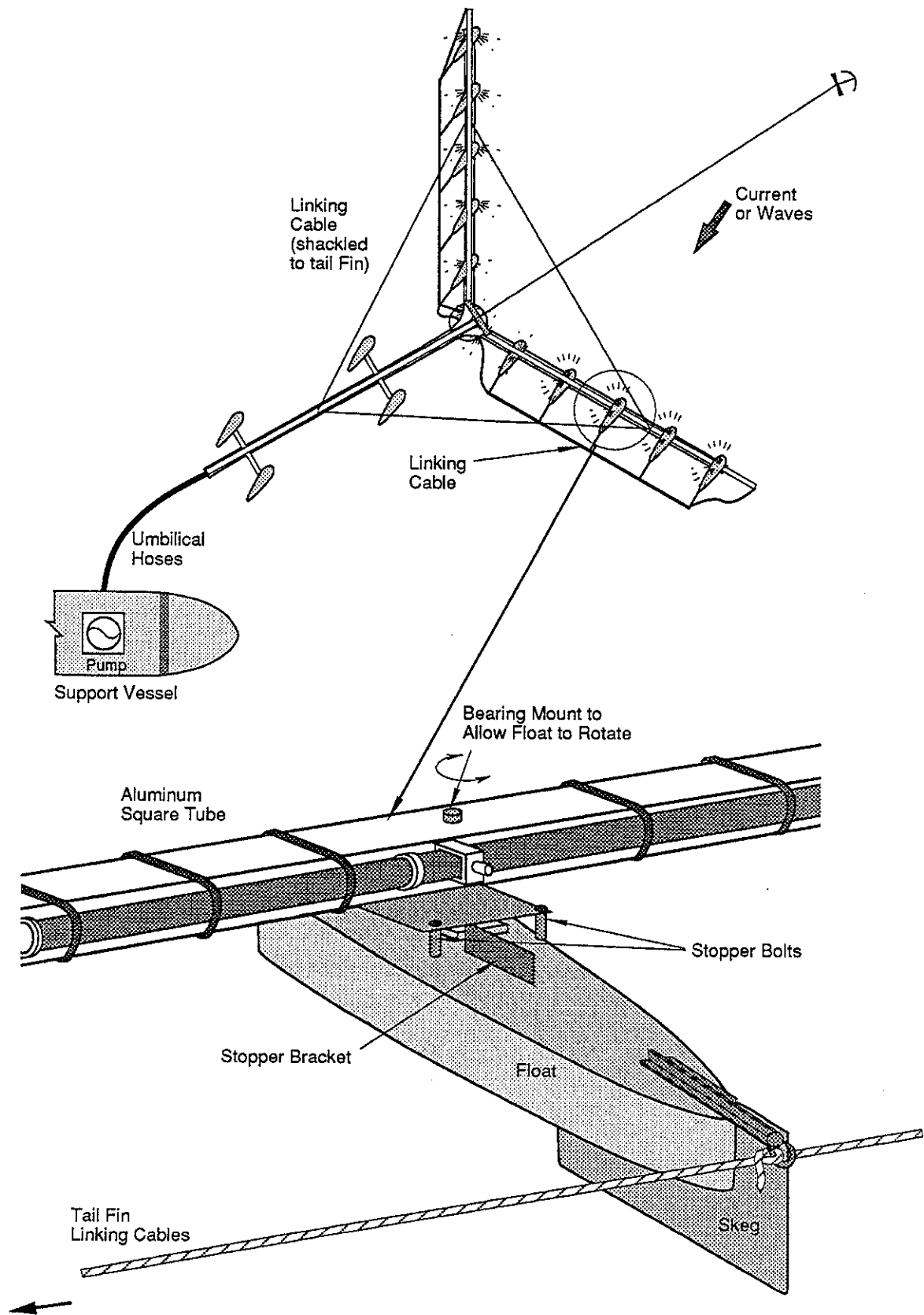

Figure 3: Constraints on Float Weathervaning Action

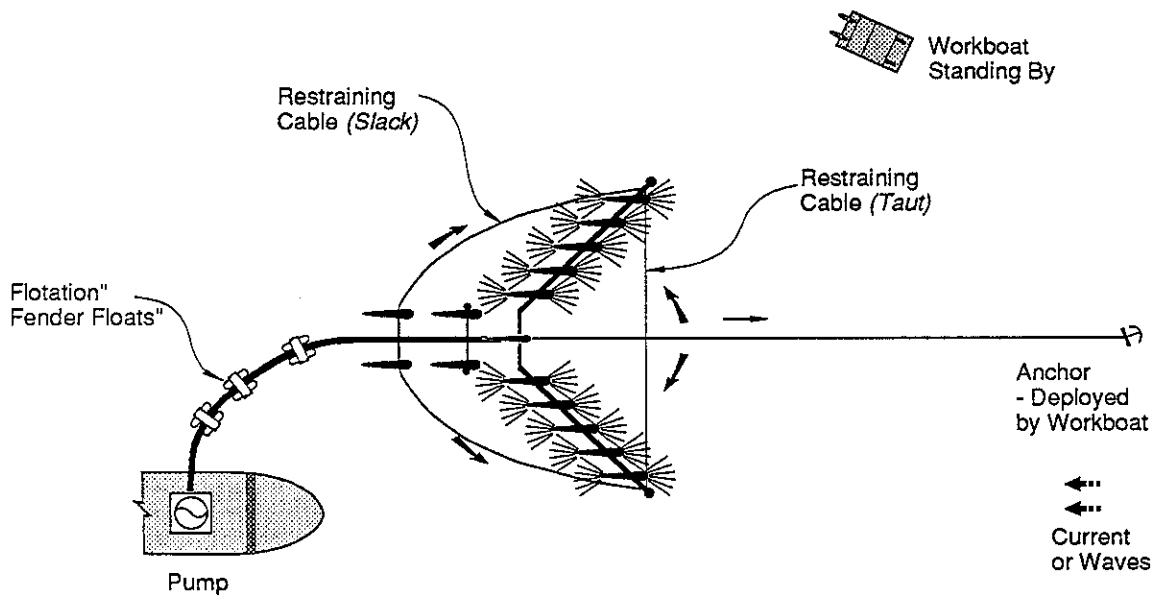

Figure 4: Constraints for Control of the Boom

The **general arrangement** of the system was also changed. To reduce the flexibility of the waterjet barrier and reduce the number of floats required, it was decided to support the hydraulic hoses rigidly with aluminum square tube sections between the floats. Each support section was pinned together to allow movements in the vertical direction. The intent was to limit the stress induced on the boom structure by wave action.

Past experience had shown that it is desirable to allow the angle of the arms at the apex to vary for improved oil retention performance. To achieve this, the arms of the barrier were pinned vertically at the apex structure.

It was expected that some constraint on the weathervaning action of the floats might be required, particularly during deployment and during low current conditions. Because the floats are slender, with weight of the boom arms well above their centres of buoyancy, the individual arm can capsize should the floats align too closely with the axis of the boom arm. Two types of float constraint were eventually fitted, which allow the float to weathervane through an angle of about 90°, centered on a line perpendicular to the boom arm:

- a) Stops fitted to each float, as shown in **Figure 3**.
- b) Linking cables joining each float at the tailfin, such that they weathervane in unison as shown in Figure 3. A level of redundancy is also introduced should a stop fail.

A review of the deployment problems with the earlier boom designs suggested that the reliance on the waterjets to maintain position and control was excessive. It was recognized that deployment would be simplified by physically constraining the movement of the arms and of the boom position; the waterjet action would then be used for "local" control of the boom position and orientation. Thus two types of constraint were introduced, as shown in **Figure 4**. The first was a set of tether cables linking the individual boom arms; when fully extended the boom is maintained at a specific limiting angle. The waterjet action allowed the operator to vary the boom opening angle from the limiting angle. The second means of constraint was to anchor the barrier to maintain the basic position of the boom. The waterjets allowed the operator to move the boom around the anchor position.

3.0 PRELIMINARY DEPLOYMENT - August 1991

3.1 Objectives

A preliminary deployment of the revised waterjet barrier took place over the period of 20 - 23 August 1991 at the Canadian Coast Guard (CCG) Base at Prescott, Ontario. As tests at the OHMSETT facility were still anticipated at that time, the objectives of the trial at Prescott were limited to a test of the general flotation system and control characteristics of the revised waterjet barrier design.

3.2 Local Conditions

No preparations were made to measure the prevailing wind and wave conditions during these trials, but the weather proved to have a significant impact on the trial. During the trial period the region was under the influence of a weather system resulting from hurricane "Bob", which resulted in high winds (+30 knots) and waves up to 1m. This provided the most severe conditions encountered during any of the trials.

Because this was the first deployment of the revised boom, only a single deployment was attempted under these conditions, in the shelter of a small boat basin at the base. Attempts to deploy the boom in another larger basin were severely impeded by the prevailing wind and wave conditions; eventually the entire boom structure was transferred to the smaller basin.

3.3 Problems Encountered

Most of the problems encountered during this trial occurred while attempting to deploy the barrier. It had been recognized that some of the floats would have to be tethered during assembly, in order to prevent a capsize when the arms were not attached to the apex structure. If all of the floats were permitted to align parallel to the arm axis, the weight of the arms and hoses was sufficient to cause the arm to capsize. Initially only the end floats were constrained. However the problem had been underestimated on two counts:

- a) The wind had the effect of orienting all the floats "broadside", ie. to the worst orientation, which meant that some restraint on all the floats was desirable, rather than just the end unit.
- b) Once initiated, the forces induced by capsize were substantial, such that the distortion of the restraining stopper bolts and the structure joints was possible. In addition, the wave action could induce chafing of restraining ropes against the float fins or adjacent dock. Thus heavy fittings of the highest quality were required.

These comments particularly applied to the deep floats, which were designed to support the four umbilical hoses. They were highly unstable and more unwieldy than the arm floats. It was also recognized that their high profile "sail" area of these floats was a potential source of control problems in high winds, although it was not a factor in this limited deployment.

As a result of this experience, a highly redundant system of ropes linking the skegs complemented by a system of pin-stoppers, illustrated in Figures 3 previously, was introduced for all of the floats. The pin stoppers were placed to allow the floats to weathervane through an angle of about $\pm 45^\circ$, relative to the float arm.

In general, the barrier was found to be difficult to assemble in the wave conditions encountered at the initial assembly point. At this location, waves were reflecting off the quayside, creating "beach surf" conditions at the assembly location. Assembly was hindered by the finely threaded hydraulic connections and the care required to deploy the floats. This suggested that a sheltered assembly area should be sought and then the assembled barrier should be towed to the spill site if necessary. The problem would also be alleviated somewhat if an alternative hose connection system was fitted.

Once assembled in the basin, the only problem encountered was that the pump proved difficult to start. Once this problem had been resolved, the trial proceeded smoothly. A crack in the pump intake pipe did not affect the trial, although it may have limited the pump performance.

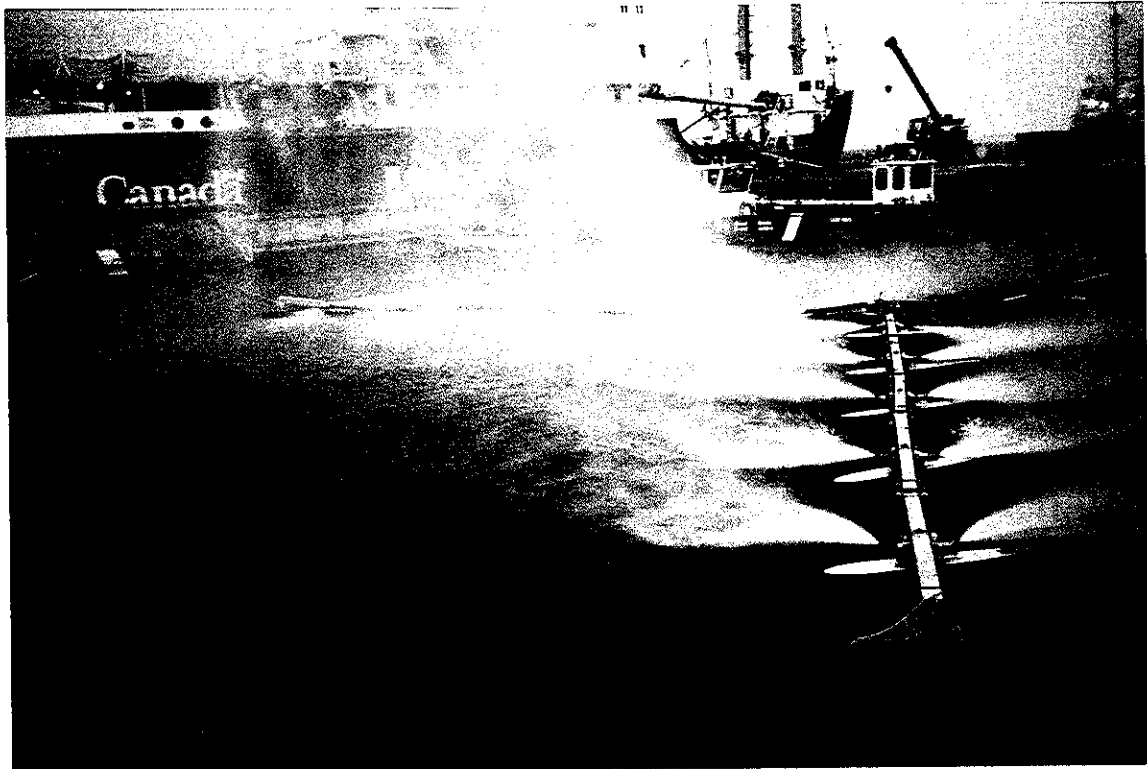

Figure 5: Deployment of Revised Barrier in Small Craft Basin – CCG Prescott, August 1991

3.4 Test Results

A photograph of the deployed boom is shown in **Figure 5**. Note that the boom was tethered from the ends of the boom arms. The barrier was operated for approximately 45 minutes, most of which was recorded on videotape. Pump pressures and engine revolutions were not recorded, but the pressure on the pump gauge was observed to vary between 800 - 1000 psi. A memorandum produced after the trial is reproduced in **Appendix A**.

The following conclusions were drawn from this deployment:

- a) It was demonstrated that the barrier could be controlled under calm conditions by varying the waterjet pressures. The boom opening angle and the orientation of the boom could be varied using differential waterjet pressure controlled from the pump manifold.
- b) The revised flotation system was found to float at the design waterline such that the waterjet nozzles were placed at the appropriate elevation above the water surface. See **Figure 5**.
- c) The individual boom arms were exposed to waves estimated to be 0.3- 0.6m during the assembly phase, and the wash from passing ships. The arms were observed to ride the waves and maintain a horizontal attitude.

Time constraints precluded the deployment of the waterjet barrier outside the small craft basin. However the results of this preliminary deployment were sufficiently encouraging to warrant further testing.

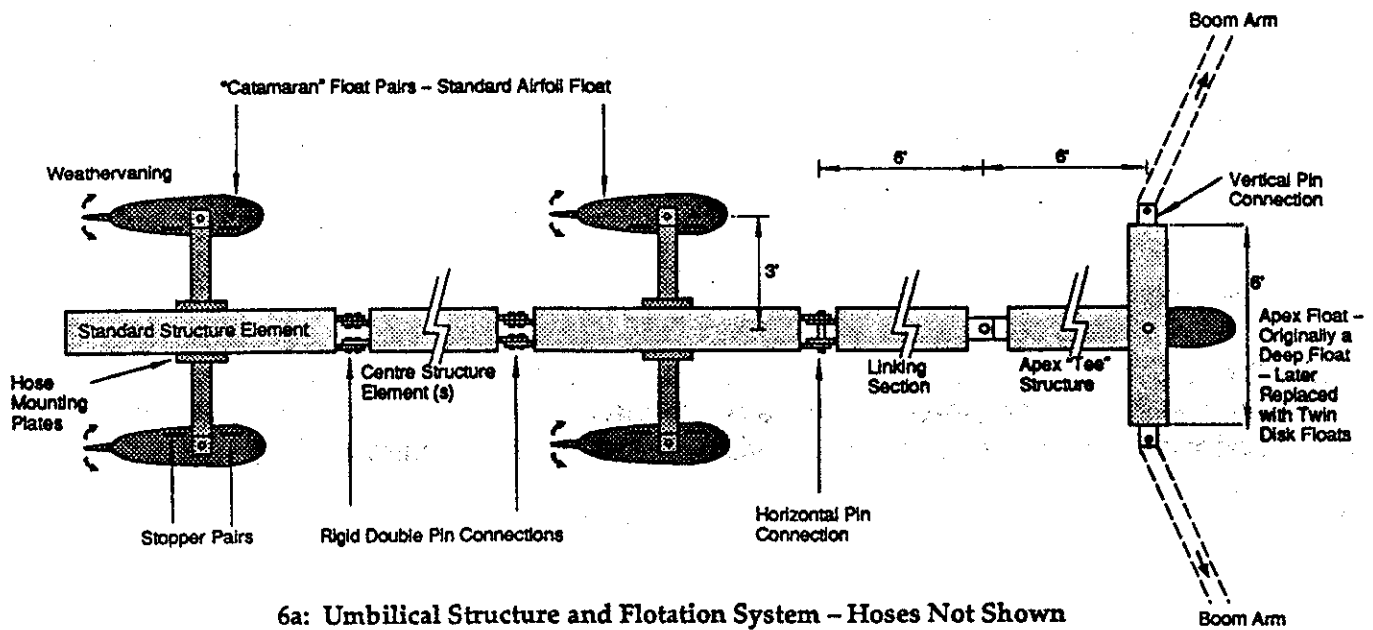

6a: Umbilical Structure and Flotation System - Hoses Not Shown

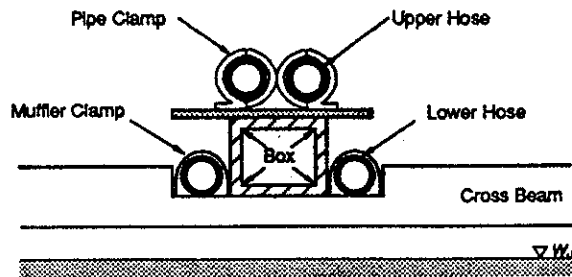

6b: Section Showing Hose Arrangement

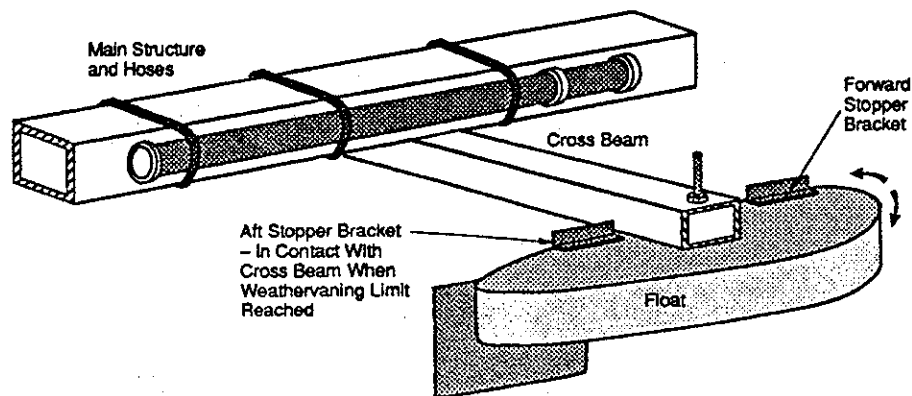

6c: Weathervaning Constraints on "Catamaran Floats"

Figure 6: Revisions to Umbilical Hose Flotation System - 1992

4.0 THE AUGUST 1992 TRIALS

4.1 Objectives

Encouraged by the experience obtained during the preliminary deployment, a more comprehensive set of trials was planned for 1992. In view of delays in the commissioning of the OHMSETT tank and the apparent value of conducting trials under operational conditions, the decision was made to conduct a further deployment at CCG base at Prescott, Ontario.

These trials were intended to encompass a series of phased deployments under field conditions that would evaluate the controllability of the boom under the prevailing current and wave conditions from a shore location and in mid-river from a base vessel. The containment effectiveness was to be assessed using canola oil to simulate an oil spill. Water pressures were to be monitored from the gauges fitted at the pump manifold.

The results of these trials were to be used to evaluate the overall effectiveness of the waterjet barrier concept and recommend improvements to the current waterjet barrier configuration.

The trial was planned as three sub-tasks, with each subsequent sub-task subject to the results of the previous test phase. The objectives of each sub-task is described below. The original test plan is reproduced in **Appendix B**. A certain level of flexibility was required in the schedule to allow for lost time due to weather and breakdowns. A total time of 5 days was projected for preparation and testing.

The general objectives of the trials were as follows:

- a) To test flotation and control of the barrier following the 1991 modifications to the original design.
- b) To record the operating water pressures and correlate with the boom movement in the prevailing test conditions.
- c) To test the ability of the barrier to confine a spill under the prevailing environmental conditions, using canola oil to simulate a modest oil spill. To determine the minimum operating pressure for effective confinement.

The trials were organized into three sub-tasks, based on the degree of exposure to current and waves. These three sub-tasks were:

Sub-Task 1: Deployment in Calm Water - in the Small Craft Basin at CCG Prescott.

Sub-Task 2: A shoreside deployment in the river off the CCG Prescott dock.

Sub-Task 3: Mid-River Deployment of Waterjet Barrier - off CCG Prescott using a large support vessel.

The prevailing environmental conditions were monitored using the following:

- a) A dedicated wave buoy, provided by the Department of Fisheries and Oceans (DFO), to monitor wave heights and wave lengths encountered during the trials.
- b) A current meter, supplied by CCG, to monitor current velocities and distributions around the test site.
- c) Weather reports from the local CCG radio station, which provided the prevailing wind conditions.

The principal means for recording the barrier performance was a videotape camera, augmented by still photographs. Pressure gauges were fitted to the hose manifold to record operating pressures, along with pump engine speed as indicated from the tachometer.

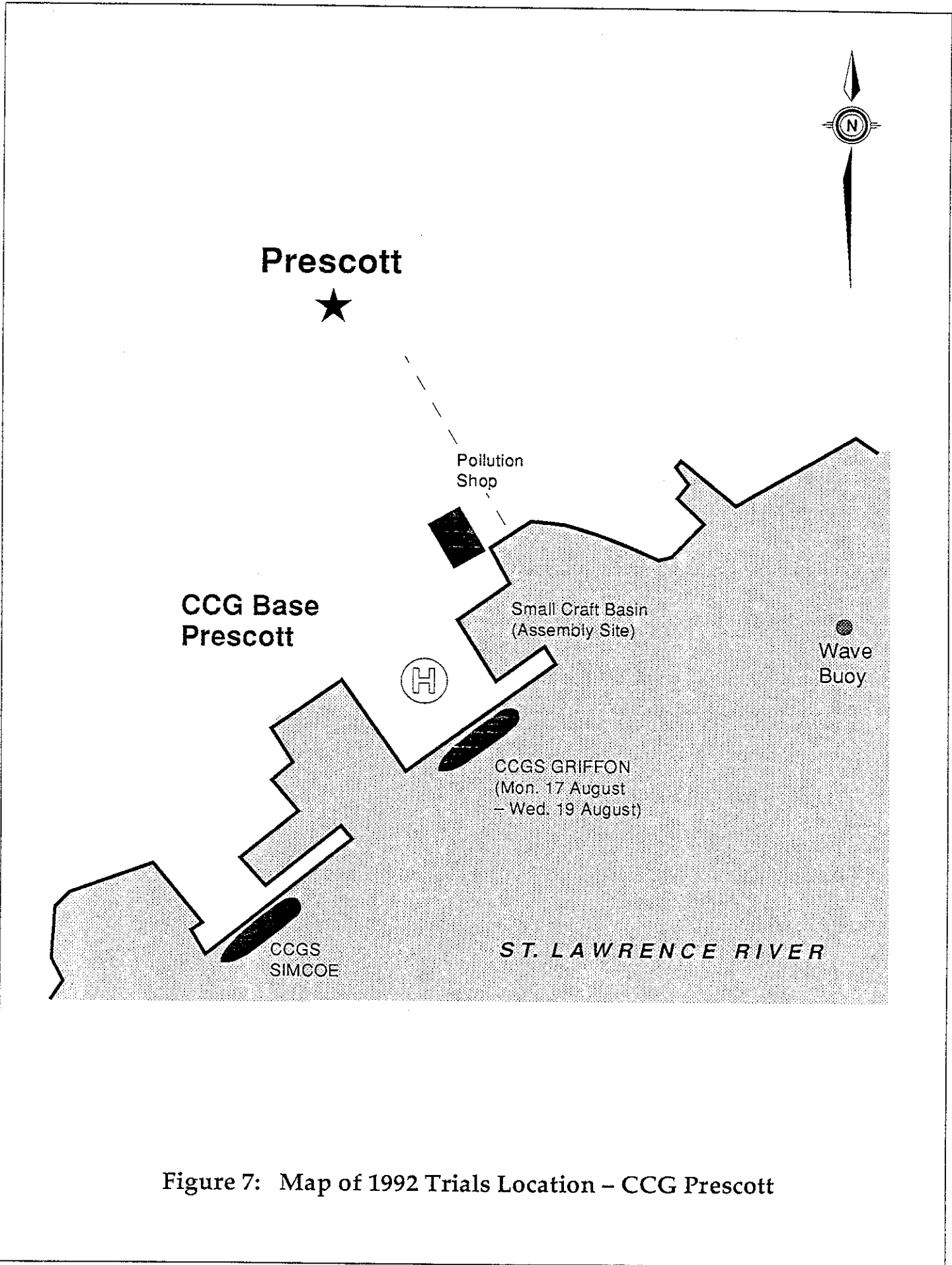

Figure 7: Map of 1992 Trials Location - CCG Prescott

4.2 Overview of Trials

A summary of the trial activities was produced following the conclusion of the tests; this report is presented in **Appendix C**. A map of the base area showing the locations of the trials is provided as **Figure 7**.

4.2.1 Overview of Activities

The following is a brief overview of the activities that occurred over the week of the 17th of August 1992:

- Monday, 17 August: Deployed boom arms, pump equipment in small craft basin, wave buoy in river.
- Tuesday, 18 August: Completed boom assembly in small craft basin. Operated boom, cleared and adjusted nozzles.
- Wednesday, 19 August: Towed boom alongside CCGS SIMCOE at dock. Manoeuvring trials alongside successful in windy conditions, light current. Mid-river trial with simulated spill aborted due to structural damage, towing problems.
- Thursday, 20 August: Boom structure repaired, modified. Simulated spill alongside CCG Prescott dock successfully contained in calm conditions, light current.
- Friday, 21 August: Boom positioned off dock in moderately windy conditions, light current. Manoeuvring trials successful and larger simulated spill contained.

As can be seen from the summary, Sub-tasks 1 and 2 as described in Section 4.1 were successfully completed. However Sub-task 3, the mid-river trial was not completed due to a combination of technical problems and scheduling limitations.

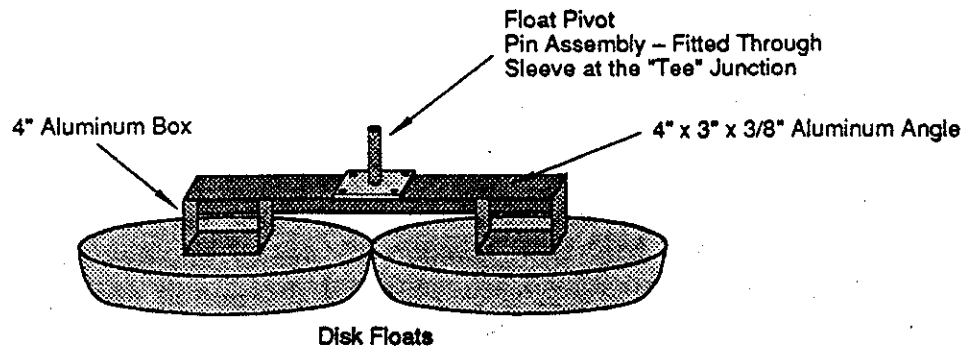

8a: Modified Apex Float Consisting of Twin Disk-Type Floats

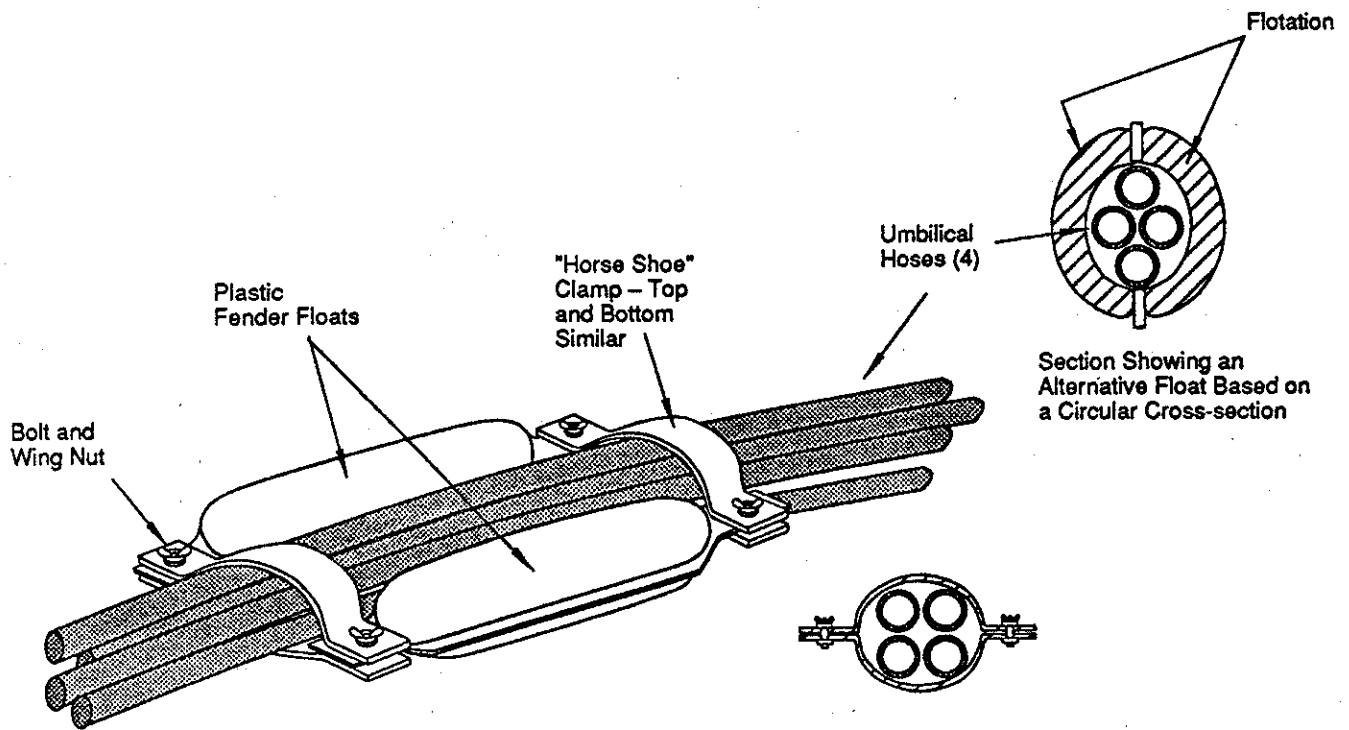

8b: "Clip-on" Fender Floats — On Loan from CCG

Figure 8: Field Modifications to Flotation System

4.2.2 Detailed Review of Trial Activity

Because much of the trial results are based on qualitative evaluation of the barrier performance, a detailed description of the activities on each trial day is provided below.

4.2.2.1 Monday, 17 August 1992

The principal activities on the first day consisted of preparation of the test area, deployment of the DFO wave buoy, and initial assembly of the waterjet barrier. The centre float modified to a twin "disk" float configuration for easier deployment, as shown in Figure 8a. There were some delay while waiting for a crane to swing the pump into position, and for a support "Sea Truck" boat used in the assembly of the arms. As a result the barrier was only partially assembled at the end of the day.

Another set of trials was still underway at the test area where the boom assembly was expected to occur. In addition, the CCGS GRIFFON was moored alongside quay where alongside trials (Sub-Task 2) had been intended to occur. The ship had apparently arrived late Saturday and was scheduled to remain alongside until late Wednesday. As a consequence, some time was spent investigating alternative test locations around the base, which also involved consideration of the wave buoy position.

We were also informed of the scheduling for CCGS SIMCOE, the support ship for the mid-river deployment. It was scheduled to be available for the Tuesday and Wednesday, and Thursday morning only; Friday was not scheduled.

4.2.2.3 Tuesday, 18 August 1992

The morning was spent assembling the revised boom "umbilical" structure and hoses. "Fender" floats were borrowed from CCG for flotation of umbilical hose off the umbilical structure; these proved quite successful and are shown in Figure 8b.

After assembly, the waterjet barrier was operated in the small craft basin. The waterjet nozzles were found to be badly blocked, and in need of adjustment. The remainder of the afternoon was spent clearing and adjusting nozzles, which suggests greater care is required in storing the barrier hoses.

Limited success was achieved in monitoring the pressures in the hoses, as 5000 psi capacity gauges were fitted to the manifold but the operating pressures were found to be of the order of 500 psi, at 1200 RPM. Thus only the most general pressure readings were obtained with these gauges. It was noted that a replacement valve fitted on the manifold gave far better control than the other three valves, and appeared to allow higher nozzle pressure (although nozzle condition may have been a factor). Although some adjustment of the nozzles was still required, Sub-Task 1 was considered completed.

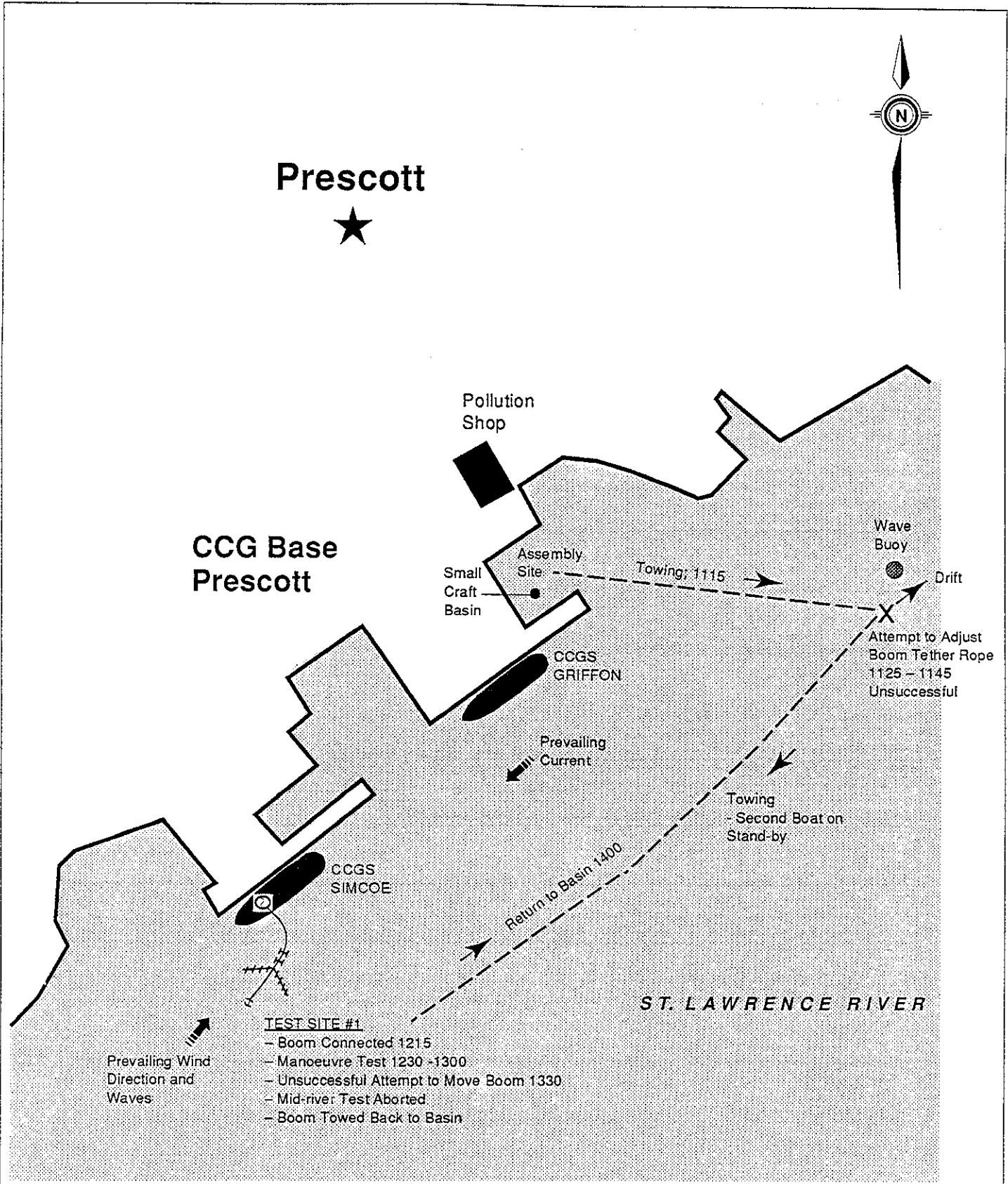

Figure 9: Trial Activity - Wednesday, 19 August, 1992



Figure 10: Boom Deployed off CCGS SIMCOE – Wednesday, 19 August, 1992

4.2.2.4 Wednesday, 19 August 1992

In view of the schedule of the CCGS SIMCOE, it had been decided that the alongside trial (Sub-Task 2) would be conducted from the working deck of the SIMCOE while moored along its quay. The assembled boom was to be towed from the small craft basin around to the vessel and connected alongside, as shown in Figure 9. Then, barring any difficulties with the alongside trial, the boom and vessel would proceed to a mid-river position to conduct the next phase of trials (Sub-task 3). The pump, manifold, and shore hoses were then transferred to the working deck of the CCGS SIMCOE.

The towing arrangements for the barrier consisted of a cable run from the apex of the boom to a Sea Truck. The tether lines between the boom arms were also connected. A large admiralty-type anchor, buoy, and cable were stowed on the Sea Truck for anchoring the boom off of the SIMCOE. The weather conditions were described as typical peak conditions for Prescott area by the CCG crew; winds were estimated at 20 - 25 knots and wave heights ranged from 0.3m - 0.6m (1-2 feet). An exact summary of the measured environmental conditions is provided in Section 4.3, below.

When exposed to the wave conditions, the boom assumed a skewed angle to the tow craft which resulted from a combination of: wind action on the structure; excessive constraint of weathervaning action of floats, and too much slack in the tether lines. Efforts to shorten the tether lines from a second Sea Truck were unsuccessful. As a result the boom was towed very slowly into position with one arm perpendicular to the tow direction; some structural damage to joints occurred; specifically, bending of the inner plate in pin joint and extrusion of the teflon bearings.

Despite the towing difficulties, the boom was successfully anchored off the SIMCOE and was connected to the pump manifold on the SIMCOE at approximately 1215. Weather conditions persisted, with winds approximately 45° off the port bow. The boom was anchored to face into the wind.

Manoeuvring tests with the waterjet barrier were conducted from approximately 1230 - 1300. The barrier was able to move up on the anchor position, change opening angle and direction despite the prevailing wind and wave conditions. Floats appeared to maintain steady "platforming" and weathervaning action in the waves, despite distortions in boom arm structure due to the towing damage. Photographs of the tests in Figure 10 indicate some of the distortion to the boom arms.

The currents measured at test site were quite low; a 0.1 m/s back eddy (upstream to the main current direction) was measured. The low velocity was also due to the deep water depth maintained off the quay for berthing the ships. The boom was in fact oriented away from the current direction to face into the wind, as the wind was expected to control the spill direction. Thus the weathervaning action of the outboard floats appeared somewhat "confused", as shown in the photographs in Figure 10.

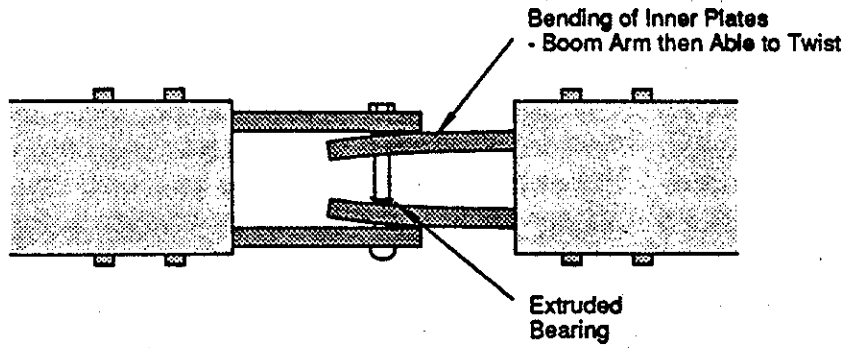

11a: Typical Towing Damage to Pin Joint Connections

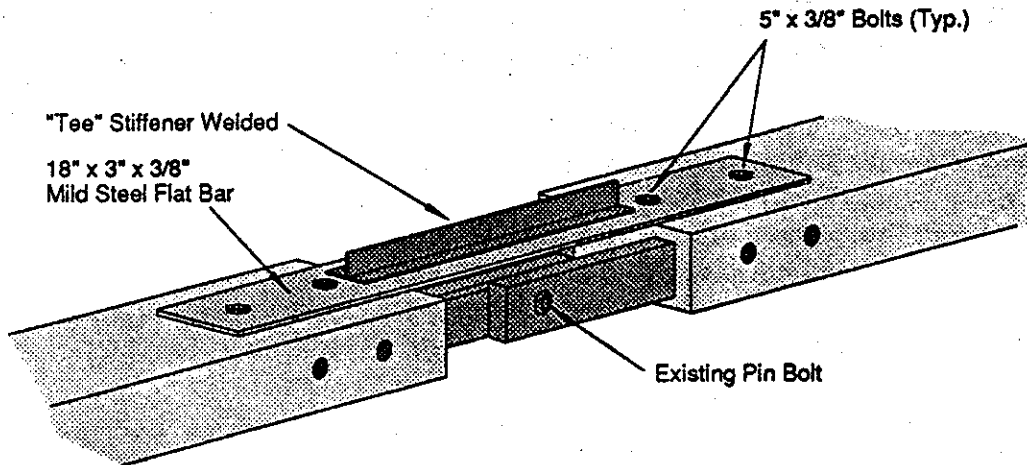

11b: Arrangement of Rigid Joint

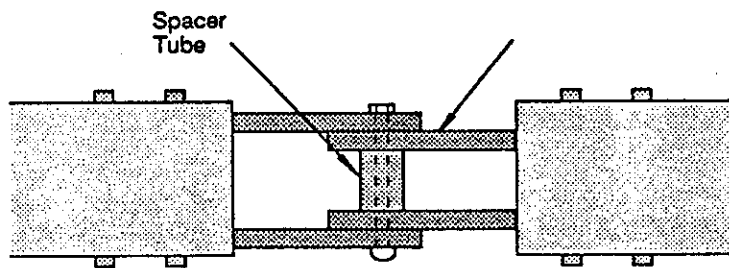

11c: Spacer Tube Fitted to Pin Joint

Figure 11: Modifications to Pin Joint Connections

After discussing the SIMCOE schedule with the CCG staff, it was decided to forgo the spill from the alongside position and attempt to proceed to a mid-river position to perform the spill containment test. Otherwise the delay would have forced the test to Thursday morning, and may possibly have forced postponement. The decision was reached knowing that there was some damage to the boom structure.

The boom was disconnected from the ship for towing, but problems were encountered raising the anchor due to fouling with weeds. During the process of raising the anchor, the boom drifted off on an angle to the towing direction. Attempts to restore control to the tow resulted in the fouling of the boom arm with the towing cable, which further twisted the boom structure and forced the tail section of some of the floats below the surface. Under freshening wind conditions, control of the tow could not be maintained and it was decided to abort the mid-river trial. The boom was towed into the small craft basin in a damaged condition.

A survey of the damage to the structure showed that some of the inner plates in the pinned joints had been bent and many of the Teflon bearings had been extruded out of the bolt holes. This is shown in **Figure 11**. The joints were modified by introducing spacers over the connection bolts to prevent bending of the inner plates. In view of the wave response characteristics demonstrated by the floats, it was decided to dispense with the flexible joints in the boom arms. A 3" (7.6cm) stiffened steel flat bar, was double bolted across the top of each joint in the boom arms. This arrangement is also shown in Figure 11. These modifications were prepared late Wednesday and fitted the next morning.

The test plan was modified to reflect the departure of the CCGS GRIFFON and the limited availability of the CCGS SIMCOE. It was decided that further trials involving spill tests would be conducted from the quay outside of the small craft basin, as shown in Figure 7 earlier. Thus a minimum of towing was required.

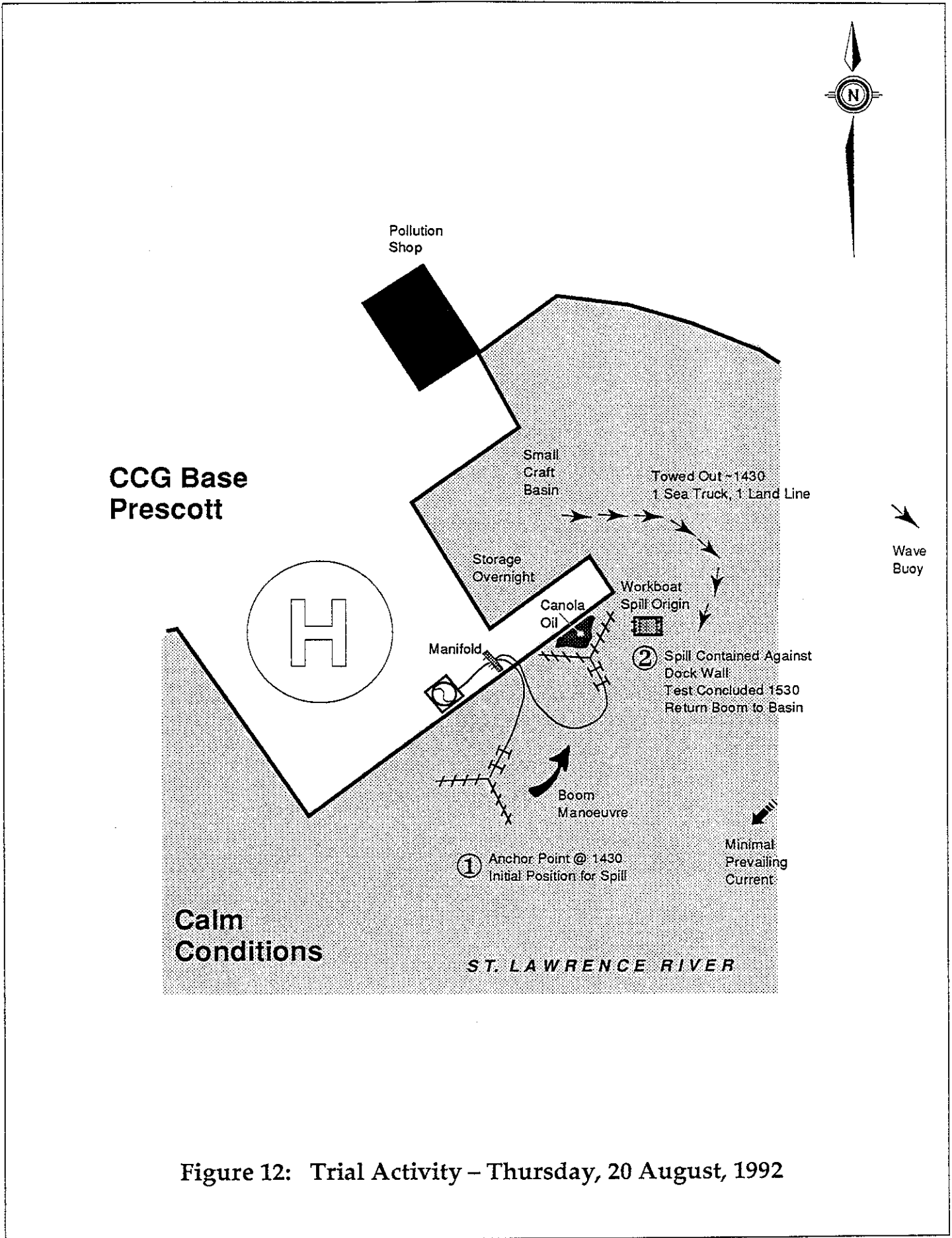

Figure 12: Trial Activity – Thursday, 20 August, 1992

4.2.2.5 Thursday, 20 August 1992

Thursday morning was spent completing the modifications to the boom structure. The pump and manifold were positioned on the quay adjacent to the test site.

When the modifications were complete the boom was towed out of the basin using one Sea Truck and a land line from the dock. Conditions were calm and very light currents, 0.1 - 0.2 m/s back eddy, were measured at the test site. The boom was connected to the pump without anchoring, in view of the calm conditions. The barrier was oriented away from prevailing back eddy in order to test the manoeuvring capability. One of the floats was fouled by a weed-covered tether rope, which was cleared away using the work boat.

The first stage of the trial was run with the barrier to monitor water pressures. Again, the results were limited as the large gauges were still fitted. However an effort was made to run the pump engine at higher speed, approximately 1600 RPM, which resulted in pressure measurements approaching 700 psi.

After the pressure trials, approximately 46 litres of canola oil was spilled from the Sea Truck, which followed the current weakly. The boom was very rapidly swung around to face the spill, and then was used to force the oil against the dockside. This tactic was employed to avoid dispersal of the oil, as the current and wave action were insufficient to hold the canola oil against the action of the waterjets; the oil would have eventually been driven beyond the reach of the barrier. A very small amount of oil was lost either due to starting the forward jets slightly too late, or the oil may have simply been driven over when moving the boom. The majority of the oil was held against dock wall with such force that some mixing/emulsion occurred. Oil was observed in the water column during the clean up activity. This experience suggests that the appropriate tactic in such situations is to use the waterjet barrier to force the oil to a containment site, and then back the boom away. A diagram of the trial is shown in **Figure 12**.

Following the spill, the boom was disconnected and towed back to small craft basin without incident and cleanup activities proceeded.

TABLE 1: RECORDED NOZZLE PRESSURES - Friday, 21 August 1992

<i>Comments</i>	Engine RPM	<i>Pressure Hose Position on Boom Arm</i>			
		Left Front	Right Front	Left Rear	Right Rear
<i>Valve Tests:</i>	1200	x	440	475	440
	-	440	x	475	440
	-	440	460	x	440
	-	440	460	500	x
	-	380	380	400	380
	-	480	480	x	x
	-	x	x	500	490
<i>Equilibrium:</i>	1200	400	480	250	40
	1650	x	x	1000	900
<i>Spill Test:</i>	1450	600 - 750	750	0-300	700

- Notes:**
1. "x" indicates manifold valve closed.
 2. "Equilibrium" is the setting required to maintain boom at a constant position.
 3. Refer to Table 2 for environmental conditions during pressure tests
 4. Pressure readings taken prior to 21/8/92 limited by oversize pressure gauges.

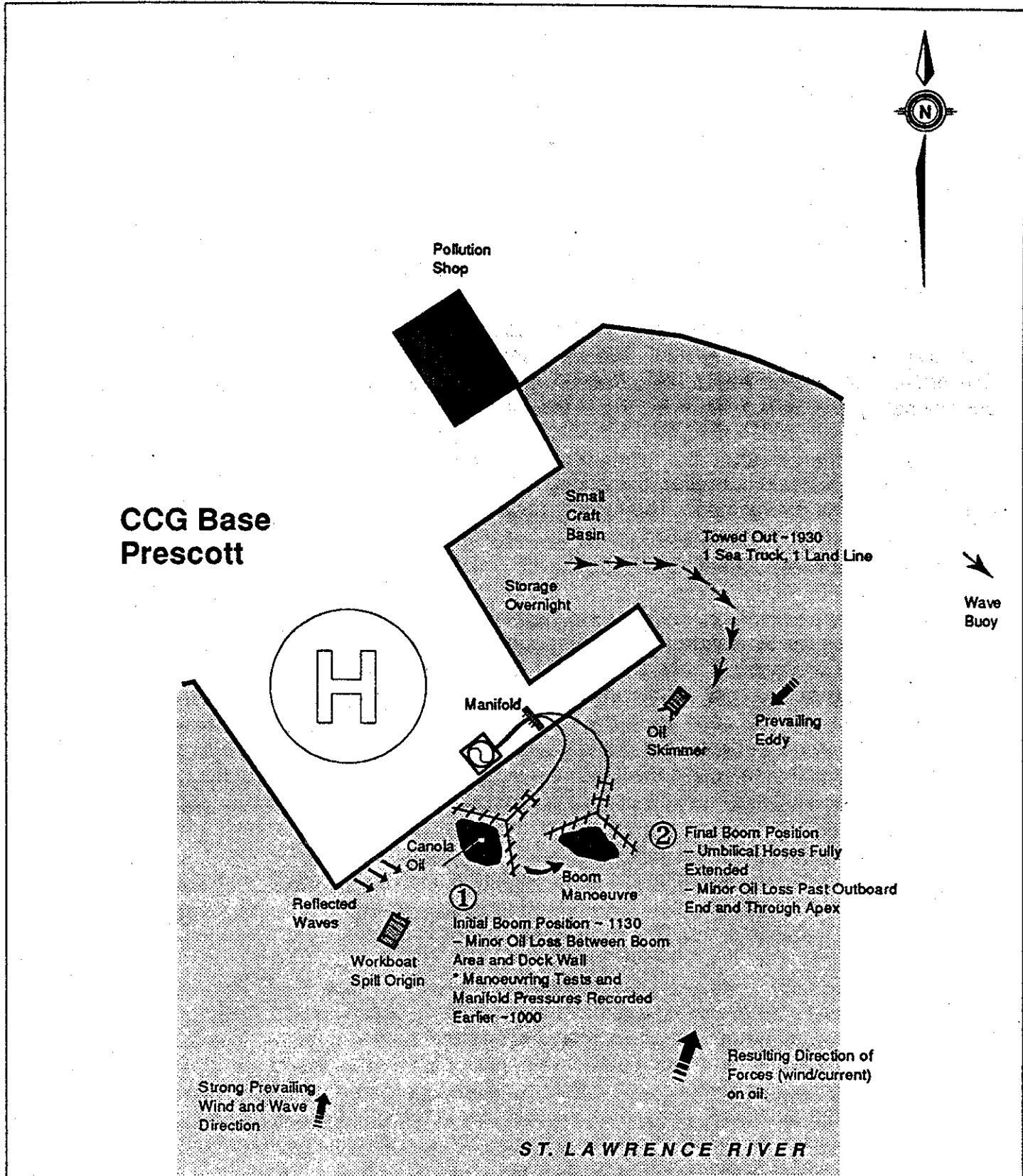

Figure 13: Trial Activity - Friday, 21 August, 1992

4.2.2.6 Friday, 21 August 1992

The boom was towed into position in the morning, again using Sea Truck and land line. The wind was estimated at 15-20 knots and wave heights were approximately 0.3m (1 foot). There was also a large amount of floating river weed. Some difficulty was encountered in towing due to the winds but primarily due to fouling of tether cables with weeds, which increased the drag on the lines sufficient to break a shackle, and caused fouling of the floats. The land line was also not attached to the same position on the boom as during the tow out conducted the previous day.

The boom was anchored in a position facing into the wind using a lighter anchor than used in the Wednesday test. Weeds were cut away from the fouled tether lines. The broken tether line was re-attached but at a position which reduced its length by approximately 2m, which restricted the closing of the boom.

As with the previous trial, a manoeuvring test was conducted with the waterjet barrier; again good control was maintained. The tether ropes were noted to assist in controlling the boom as, when taut, the prevailing thrust on one arm will act to pull opposite arm with it. This is of particular value when pressure must be maintained on the forward (containment) side of the boom.

Pressures were monitored for varying pump motor RPM, and nozzle combinations. The results are present in Table 1. Another set of pressure gauges were fitted, with a maximum range of 1000 psi. While awaiting arrival of skimmer, pressure to barrier was maintained. As can be seen from the data in Table 1, there was a relatively minor variation in pressure between the nozzle arms for any given combination of nozzles. However the magnitudes were sensitive to the motor RPM. The influence of the wind and waves on the boom can be seen from the pressures required to maintain an equilibrium position with boom centred on the anchor position, with slack on the anchor line.

While awaiting the arrival of the skimmer, the pump was left idling, with light water pressure from the nozzles, appropriately distributed to each arm to maintain an equilibrium position. Control of the barrier was maintained with light pressures, which were about 200 psi maximum at the manifold.

A spill was simulated using approximately 104 litres of canola oil spilled from a Sea Truck located upwind of the barrier, as the wind was the dominant factor. The sequence of events is diagrammed in Figure 13. The barrier was initially positioned close to the dockside, facing out into the river. Weather conditions persisted, with substantial wave reflection from the dock wall; this may have resulted in wave heights in excess of those measured at the wave buoy location due to constructive interference between the incident and reflected waves. Some oil escaped between the end of boom arm inshore and the dock wall until the spill was forced away from the wall.



Figure 14: Photographs of Spill Simulation – Friday, 21 August, 1992

It was later observed from the videotape that the spray action from the nozzles appeared to interact with the waves incident on the boom arms to create a standing wave in front of the waterjet barrier. This standing wave appeared to have a significant effect in containing the oil, although it may have more of a role in deflecting the oil. The float behaviour was also significant. Despite a relatively severe chop resulting from the interference of the incident waves with waves reflected from the dock wall, a steady spray action was maintained due to the low motion characteristics of the floats. This can be attributed to the small waterplane area of the floats. The weathervaning action of the floats was uneven due to the confused wave conditions and possibly some interference with the tether cables; there was no effect on the barrier performance.

The spill was carefully driven away from the wall into the river, until the umbilical hose was fully extended. At that point some oil began to escape around the outboard end of the boom. The boom angle and orientation was generally maintained by varying pressure on the back nozzles only, although at times it was necessary to reduce the pressure on the outboard forward nozzles by about 100 psi because of a lack of slack umbilical hose. No oil loss resulted from this pressure variation. The pressures recorded during the test are shown in Table 1; the pump engine was running at 1400 - 1600 RPM, depending on the manifold settings. Attempts to vary the angle between the boom arms, to force oil to the centre, were restricted by the tether cables (one of which had been shortened). The oil lost around the outboard end of the boom might have been contained with more umbilical hose, as it became impossible to either chase the oil or change the orientation of the boom because of the restricted hose length.

Some oil was eventually lost through the apex of the boom. Containment might have been prolonged with a more concentrated jet spray in the centre, but it is postulated that oil would eventually reach a sufficient concentration in the apex to force its way under the waterjet. This is not necessarily a problem, as an oil skimmer can position behind the apex to collect the oil; this tactic was demonstrated by the skimmer during this trial. The concentration of oil by the barrier should facilitate skimming.

It is conservatively estimated that 80 - 90% of the oil was contained between the boom arms. A videotape record was taken from the Sea Truck, complemented by still photographs from the dock; refer to **Figure 14**. The trial was conducted for about 25 minutes, until a steady containment, constrained by the umbilical hose length, was evident. Clean up by the skimmer then proceeded. The boom was towed back to the small craft basin without incident.

TABLE 2: ENVIRONMENTAL CONDITIONS ; 19 - 21 August 1992

Table 2.1: Observed Wind and Wave Conditions

Date:	Time	Principal Activity	Observed Wave Height (m)	Observed Wind Speed (knots)	Description (See Notes)	Beaufort Scale
19/8/92	1050	deployment	0.3 - 0.6	20 - 25	Fresh/Strong Breeze	5
19/8/92	1100 - 1215	towing	0.3 - 0.6	"	"	5
19/8/92	1230 - 1300	testing	0.3 - 0.6	"	"	5
19/8/92	1300-1330	in position	0.3 - 0.6	"	"	5
19/8/92	1330 - 1430	towing	0.3	10 - 15	Moderate Breeze	4
20/8/92	1420	deployment	0	0 - 5	Calm	0
20/8/92	1445 - 1530	towing	0	"	Calm	0
20/8/92	1530 - 1730	testing	0	"	Calm	0
20/8/92	1730 - 1800	towing	0	"	Calm	0
21/8/92	920	deployment	0.15 - 0.3	15 - 20	Moderate/Fresh Breeze	4
21/8/92	930 - 1000	towing	0.15 - 0.3	"	"	4
21/8/92	1000 - 1015	in position	0.3 - 0.6*	"	"	4
21/8/92	1015 - 1100	testing	0.3 - 0.6	"	"	4
21/8/92	1100 - 1145	in position	0.3 - 0.6	"	"	4
21/8/92	1145 - 1300	testing	0.3 - 0.6	"	"	4
21/8/92	1300 - 1345	towing	0.3 - 0.6	"	"	4

Notes:

1. Wave Description and Beaufort Scale taken from a Table referenced "Practical Methods for Observing and Forecasting Ocean Waves", NYU, 1958.
2. Waves heights generally lower than in reference table noted above, which applies to fully developed ocean waves..
3. Wave heights for 21/8/92 somewhat higher due to reflection effects from dock wall.

Table 2.2: Measured Current Data

Current Velocity (m/s)	Position of Measurement
0.1	30 metres off pier, from CCGS SIMCOE
0.1	5 metres off pier, Dockside pump position
0.2	50 metres off pier, Dockside pump position
0.3	Mid-Channel, off CCG base
0.1	At wave buoy position

4.3 Local Conditions

The local environmental conditions prevailing at CCG Prescott during the 1992 trials are reported in **Table 2**.

Wave data for the trials was recorded by a DFO omni-directional wave buoy. However, the processed data indicated a number of inconsistencies with the observed wave conditions, and it was agreed that the data would not be used in the main report. These inconsistencies included the following:

- a) a lack of variation in the significant wave heights recorded over the three test days, despite the fact that the conditions were observed to vary between flat calm and a moderate chop, as reported in the previous sections.
- b) a lack of correlation between the magnitudes of the recorded peak wave heights and the observed wave conditions.

As noted in Section 4.2, the buoy was located in a position where it was exposed to the same general wave conditions as the test sites. It was not exposed to some the wave reflection effects that were encountered, particularly during the final test day. Thus the barrier was operated in wave conditions that featured slightly steeper wave conditions with higher peak wave heights.

Thus the wave conditions reported in table are based on observations, and therefore are intended as general indicators of the wave conditions only. As can be seen from Table 2, the wave conditions varied between test days. In general, conditions were described as typical by the local CCG staff.

Current readings were taken using an electronic current meter deployed from one of the work boats. The current readings relative to a shore position are shown as part of Table 2. These current velocities were measured in the local back eddy prevailing off the CCG Prescott base, which is upstream to the main current direction of the river. Wind speeds were recorded from the CCG Radio weather report, and can be used as a check of the wave observations. Data from the local ship's anemometer was not obtained.

To summarize, the barrier was operated in a range of realistic conditions of winds and waves and current. It has not yet been operated in high currents or severe wind and wave, such that the performance of the barrier was directly limited. The conditions were severe enough to cause problems during deployment activity, but most of the problems resulted from design limitations with the "demonstration" prototype, which could be rectified in an "operational" prototype.

4.4 Trial Results

1. The objectives of Sub-Tasks 1 and 2 of the test plan were achieved during the trials. The waterjet barrier demonstrated that it could be controlled and contain oil in "realistic" wind and wave conditions, in light currents.
2. The oil containment capability of the barrier was demonstrated for a modest quantity of light oil, in waves and in calm water. The ability to direct and divert the spill was demonstrated. The small quantity of oil loss that occurred at the apex was sufficiently concentrated for clean-up by a skimmer.
3. The waterjet barrier was demonstrated to be highly manoeuvrable when operating in a combination of moderate wind and waves, and light current. Mobility (and therefore oil containment) was constrained by the large pump system and a limited length of umbilical hose. Further development of the waterjet barrier should consider elimination of a separate pump system and integration of the pump system into a support vessel, through the vessel's firefighting or bilge pumping systems. This would result in a mobile barrier/support vessel combination that would be fully capable of pursuing and controlling a slick. Ultimately, the support vessel might also contain the spill clean-up equipment. The size of the current pump system greatly reduces the mobility of the barrier system; there is a question as to the pump size required.
4. The mid-river deployment, intended to expose the boom to high current conditions (Sub-Task 3) was not achieved during these trials. The limits on operations in a high current should be part of any future trial program. In these trials, the support ship scheduling did not allow for the suggested flexibility in the test plan; risks were taken with the prototype that resulted in damage to the boom and cancellation of the mid-river trial. Ideally, if the ship were only available mid-week, the initial phases of the trials should have commenced the previous week.

Apart from the above general comments concerning performance, there were a series of observations regarding the performance of specific components of the waterjet barrier during the trials:

5. The airfoil floats demonstrated a capability to maintain adequate spray action in the prevailing wave conditions, by "platforming" in the waves. This raises doubts about the necessity for flexible connections between the boom structure elements; the introduction of rigid connections in the later trials did not have any negative effect and appeared to improve behaviour during towing. An "operational" prototype should include the use of simpler, rigid connections between elements, possibly with some flexible connections if the boom arm lengths are much larger than those tested.

6. The "weathervaning" characteristics of the floats was demonstrated in waves, light current, and manoeuvring. It was suggested that the limitation on the weathervaning angle may have been too restricted (ie. the stops were set too closely), as they were based on the previous 1991 experience during assembly. It was felt that some of the towing problem could be attributed to the fact that the floats were not free to weathervane sufficiently. This suggests that the limitation system might be revised; perhaps with different settings for assembly and for operation. Alternative limit arrangements are discussed in Section 5.
7. The float construction proved robust, and apart from some wear on the fibreglass shells due to contact with the cement quay during the 1991 trial, were undamaged. The strength of the float pin attachment was demonstrated during towing, when some of the floats were oriented perpendicular to the tow direction.
8. The replacement of the central apex "deep" float by a more stable float consisting of twin disks performed well throughout the trial. However there is a concern that drag and stability problems may occur during towing or during operation in high-velocity currents. The twin disks should probably be replaced by a pair of airfoil floats to reduce the drag.
9. The revised system for flotation of the umbilical hoses, consisting of "catamaran" airfoil floats worked well throughout the trials.
10. The use of "clip-on" floats using inflatable fenders to support the remainder of the umbilical hose also proved very successful. There is a concern about the drag of the specific arrangement used during these trials when operating in high velocity currents. An alternative based circular sections might have lower drag characteristics.
11. During the trials the water pressures measured at the pump manifold ranged from 400 - 750 psi with the pump operating at a normal speed (1200 - 1600 RPM). At no time during the spill exercise was the pressure on the forward (containment) nozzle lines allowed to drop below 500 psi. Pressure on the back nozzle line was varied widely to control the position and orientation of barrier. In each of the test conditions it was possible to set an "equilibrium" disposition of line pressures that would maintain a constant bearing and orientation of the boom. The pressure gauges on each line proved to be useful control devices and should be retained.
12. The three original valve controls on the pump manifold were found to be more difficult to operate than the replacement valve, which had a different handle arrangement and range of movement. Replacement of the other old valves should be considered.

13. The nozzles and hoses should be stored with care, as debris and dirt accumulate readily in them and seriously impair performance. A set of plastic caps for each nozzle and for the hose ends would have eliminated this problem.
14. The feasibility of anchoring the waterjet barrier (combined with the tethering of the arms) was demonstrated in these trials. It proved of particular value during the connection of the umbilical hoses to the pump, as it kept the boom in position despite the prevailing wind. Once the waterjet barrier was connected and operational, the movement of the boom was not restricted as there was sufficient slack in the anchor line.
15. It was also observed that once the waterjet barrier was operational, it could be kept on position (in the prevailing conditions) with relatively low line pressures (200 psi). There may be situations where large movement in the boom position are anticipated, such that it may be desirable to either disconnect the anchor or simply use the workboat to position the boom without anchoring, and employ the waterjet action (at low pressure) to maintain position. In addition, the experience off the SIMCOE where control of the boom was lost while trying to raise anchor suggests that use of a large anchor should be avoided.
16. The system of tethering the boom arms to restrict their movement to acceptable limits was also demonstrated successfully during the trials. This arrangement maintained the boom shape while the hose lines were disconnected. A further benefit was derived in manoeuvring the barrier when operational, as the boom could be controlled by varying the pressure on the back nozzles, which would then pull the opposite arm when the tether was taut. This allowed full pressure to be maintained on the forward (containment) nozzles, which should improve the containment efficiency [Ref.5]. There were problems with the tether system fitted to the prototype. The rope lengths may not have been correct, particularly for towing, and there was a tendency for the slack ropes to become fouled with weeds. In some cases the loads on the tethers were sufficient to fail the metal snap fittings. Heavier fittings and an alternative connection system are discussed in Section 5.
17. Towing of the waterjet boom into position will be an attractive deployment option, compared with the difficulty associated with assembling the boom in rough weather. However considerable difficulty was experienced in attempting to tow to the boom with a single vessel. Alternative towing arrangements were proposed, involving two vessels (or tow points) to both tow and maintain orientation of boom. Other modifications to facilitate towing may include increased weathervaning angles, reduction of tether rope length (for towing only), and possible increase in float fin area. Heavier fittings for towing the boom may also be appropriate. These are described in greater detail in Section 5.

18. Some of the current teflon bearings fitted in the pin connections of the boom arms were extruded or forced out of their seats under the stress of assembly/disassembly and from towing. Where the flexible joint system is to be retained, as at the apex, the current teflon bearings should be replaced by a more durable material. A "spacer" bar between to inner plates of the joints should also be introduced.

5.0 CONCLUSIONS AND RECOMMENDATIONS

5.1 Conclusions

1. An oil spill containment system based on high pressure waterjets and a revised flotation system was successfully demonstrated under realistic environmental conditions at CCG Prescott in August 1992. The essential components of this waterjet barrier design were:

- a) High pressure nozzles separated on 2.4m (8') centres, controlled from a central manifold.
- b) Streamlined floats, widely separated and free to weathervane over restricted range of angles.
- c) A rigid support structure for the hoses.
- d) A system of tether ropes to assist in control of the barrier.
- e) Optional use of an anchor to maintain boom position.

The system proved to be highly manoeuvrable and capable of containing light (canola) oil.

2. The performance of the waterjet barrier during these trials warrants further testing to establish the effective performance envelope for the system. Recommendations for such a test program are included in **Section 5.2** below.
3. The most serious problems encountered with the prototype occurred during assembly and deployment of the barrier. This aspect of the barrier performance was not addressed at this stage in the development of the design, but should be the subject of further study.
4. The prototype was developed as a "concept demonstrator". A number of aspects of the design would require revision or refinement in a commercial, "operational" model. Some of these features are discussed in **Section 5.3**.

5.2 Recommendations for a Performance Evaluation Test Program

The definition of the performance envelope is essential to further development of the waterjet barrier. To be commercially feasible, the complexity of the waterjet barrier system must be offset by a performance capability that exceeds current spill barrier technology. A drawback of field trials is that there is no control over the environmental conditions. The most efficient way of defining the performance envelope will be to conduct a series of systematic laboratory tests, where control parameters can be varied.

Among the parameters to be investigated in order to define the limits on control and containment effectiveness are:

A. Environmental Parameters:

1. Current Velocity.
2. Wave Heights - recognizing there is a relationship to wind speed, which cannot be modelled well in the lab.
3. Wave Steepness - height to wave length ratio, recognizing there may be an upper limit related to the mixing of the oil.

B. Spill Containment Effectiveness Parameters: to be varied with the environmental parameters.

1. Nozzle Pressures.
2. Arm containment angle.
3. Spilled liquid properties; density, viscosity.
4. Quantity of spilled liquid.

It is recommended that the tests proposed for OHMSETT attempt to define the performance limits to the extent possible. Further testing at OHMSETT, possibly supplemented by towing and seakeeping tests at a conventional model testing basin would also be recommended, until a definite limiting performance envelope is defined. A possible site for conventional (ie. no spill tests) trials would be at the Institute for Marine Dynamics (IMD) in St. John's, Newfoundland, which features both a large seakeeping basin and a towing tank. In addition there is the flume tank at the Marine Institute in St. John's.

Once the performance envelope is defined, the commercial feasibility of the concept can be determined. The feasibility will be demonstrated if it can be shown that the waterjet barrier can maintain a high degree of manoeuvrability and spill containment effectiveness in high currents and/or large wave conditions while operating at reasonable nozzle pressures. The experience of the field trials suggests that the waterjet barrier should be used as a mobile containment system, in tandem with a skimmer, referred to as a Type III sweep system boom in Reference [9]. A large scale version of the concept would face problems in maintaining nozzle pressures at the extremities, and deployment difficulties.

If feasible, the results of the tests can be used as general operating guidelines.

5.3 Issues concerning the Development of an "Operational" Prototype

In the process of designing, fabricating, and testing the waterjet barrier prototype used in this project, some thought was given to features that might be required to produce a "production-grade" version of the waterjet barrier. The objective of introducing these features would be to reduce the labour required to fabricate the barrier, and the total cost of the waterjet barrier; and to reduce the level of effort and time required to assemble and deploy the waterjet barrier. These features can be categorized into two classes:

- A. Revisions to major components.
- B. Changes in detail design.

There were four aspects of the waterjet barrier that were identified as areas that might benefit from a major revision. These were:

1. Elimination of, or a reduction in size, of the dedicated pump/diesel engine set. The current pump is the highest cost item of the waterjet barrier system, and the main restriction on mobility. Where appropriate, integration of the waterjet barrier into an existing ship's system, such as a firefighting or ballast pumping system should be investigated. This may introduce a requirement for a booster pump to meet the requirement for a high volume, high pressure system. Current pump arrangements on potential support vessels, such as fishing vessels, tugs, and buoy tenders should be investigated. Based on the trials experience, the ultimate system may integrate the skimmer/clean up craft with the waterjet barrier.

For shoreside operations in the absence of large support vessels, a dedicated pump will still be required. In this case, an alternate pumping system made of a combination of pumps would be more mobile. Compatibility with multi-use pumps or shore based fire-fighting units, or rental of pumps as required, may also be a more commercially attractive option.

2. Revision of the design of the current rigid structure, to reduce the volume and fabrication effort; ideally with some reduction of weight. The use of composite materials should be considered; it may be possible to filament-wind a composite shell around the high pressure hoses that would provide sufficient rigidity and strength. A set of laboratory mechanical tests could evaluate alternative structures.
3. Replacement of the current finely threaded hose connectors with a system that is more easily and rapidly connected, based on a "cam-lock" or a coarse interrupted thread. Again, alternative arrangements and materials could be evaluated in the laboratory.

4. Replacement of the current pin-joint connections, except at the apex, by a rigid connection that is simpler and more rapidly connected. Integration of the pin from the float pivot into the connection should be considered.
5. There were a series of detail changes identified during the trials, which have largely been alluded to in previous sections. These detail changes would include:
 - a) Revision of the weathervaning control systems on the boom arm floats. Primary control would be based on the tail fin cables. To reduce the risk of chafing on the fins, metal linkages should be fitted with the snap connectors. Two sets of snap connectors could be placed on the end of the tail fin cable; one that would be connected to restrict movement during assembly and then disconnected, and a second connector that would then be attached and would allow a larger weathervaning angle during operations. The pin-stop arrangement would only be retained as a redundant system in case the tail fin cables fail, and would not generally limit the weathervaning action. The weathervaning angles should be increased for operations, and oriented with respect to the angle of the boom arm.
 - b) Redesign the central float to consist of a pair of the standard airfoil floats; the stability of the twin disk float can be retained by adequate separation of the individual airfoil floats.
 - c) Obtain a set of "clip-on" floats based on a circular cross-section for flotation of the umbilical hoses aft of the barrier. These type of floats are used by dredging contractors to float their shore hoses.
 - d) Refurbishment and redesign of the pump manifold to incorporate: properly sized pressure gauges; new valves, similar to the current single replacement version; arrangement of the valve handles for ease of access; and labelling for the hoses. Ultimately a hydraulic remote control system should be consider that would permit operation of the barrier from a high vantage point such as the support vessel's bridge.
 - e) Obtain a set of plastic or metal caps for the nozzles and hose connections for protection during storage.
 - f) Revision of the tether rope system for the boom arms. Heavier connectors should be installed. A self-tensioning mechanism or the use of an elastic segment should be investigated as a means of taking the slack in a tether rope, to avoid the problem of fouling by weeds or debris. An additional set of connectors might also be introduced to permit shortening of the tether ropes for towing.
 - g) Installation of appropriate cleats and eye bolts to facilitate lifting and towing.

- h) Installation of spacer bars to the joints at the apex structure to prevent collapse of the pin bearing plates, and in the introduction of more durable pin bearings to replace the current soft teflon rings.

As can be seen from this discussion, considerable effort still remains to produce a commercial, production grade version of the waterjet barrier. This effort can only be justified by identification of a unique performance capability, that cannot currently be met by any other containment system.

6.0 REFERENCES

1. Comfort,G and Paterson,B., Redesign Of Waterjet Barrier Flootation System, Fleet Technology Limited (FTL) Report No.3922C, submitted to Environment Canada, March 1991.
2. Meikle,K., The Use Of High Pressure Waterjets For Oilspill Containment, Proceedings of the Sixth Arctic Marine and Offshore Pollution (AMOP) Technical Seminar, 1983.
3. Meikle,K., Whittaker,H., Laperriere,F., An Experimental High Pressure Waterjet Barrier, Proceedings of the American Oilspill Conference, 1985.
4. Hebron,K., Report On Stability And Drag Of Proposed Float Systems For EPS Water Jet Spray Boom, unpublished report to Environment Canada, 1985.
5. Phillips,L., Nawwar,A., Laperriere,F., Laboratory Testing To Optimize The Performance Of A High Pressure Waterjet Barrier, Proc. of the 10th AMOP Technical Seminar, 1987.
6. Laperriere,F., Whittaker,H., Yanagisawa,M., Suzuki,I., High Pressure Water Jet Testing For Oil Containment In Simulated Environmental Conditions, Proceedings of the 10th AMOP Technical Seminar, 1987.
7. Laperriere, F., High Pressure Waterjet Barrier Trial In Norman Wells, Spill Technology Newsletter, January-June 1985.
8. Punt, M., The Performance Of A Waterjet Barrier In A River, Oilspill Technology Newsletter, Vol.15, March 1990.
9. Proposed Guidelines for Response Authority Response Plans, issued by the Environmental Response and Emergency Planning Group of the Canadian Coast Guard, September 1992.

UNCITED REFERENCES

Comfort, G., and Punt, M., Oil Burning Tests in the Presence of a High Pressure Water Jet Barrier, Proc. of the 12th AMOP Technical Seminar, 1989.

Comstock, J.P. (Ed.), Principles of Naval Architecture, The Society of Naval Architects and Marine Engineers (SNAME), New York, 1967, pp. 288-324.

Hoerner, S.F., Fluid-Dynamic Drag, published by the Author, 1965, Chapter VI.

Paterson, B., Comfort, G., and Punt, M., Development of a Water Jet Barrier for Oil Spill Containment, Proc. of the 15th AMOP Technical Seminar, 1992.

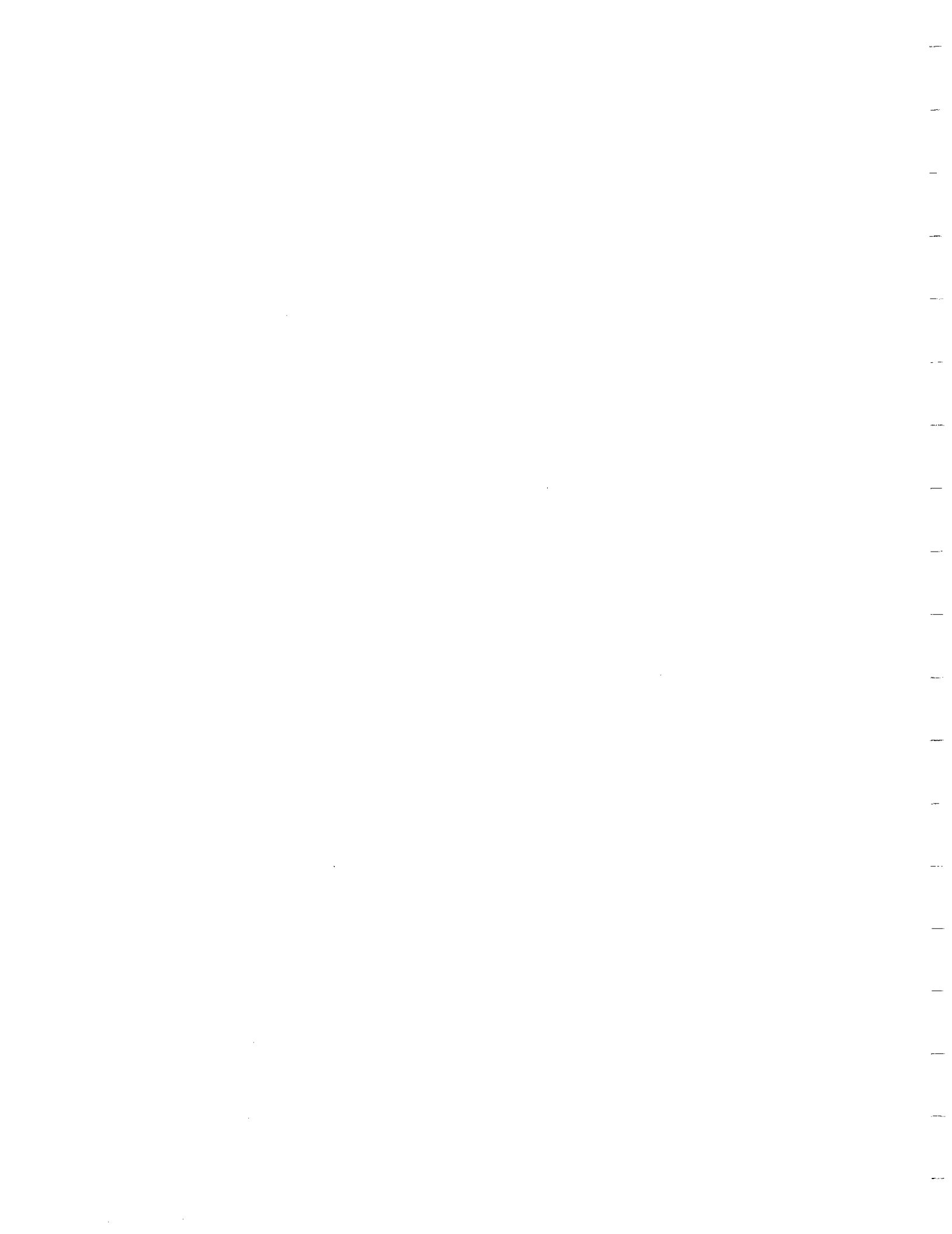

APPENDIX A:

August 1991 Trial

Summary Memorandum

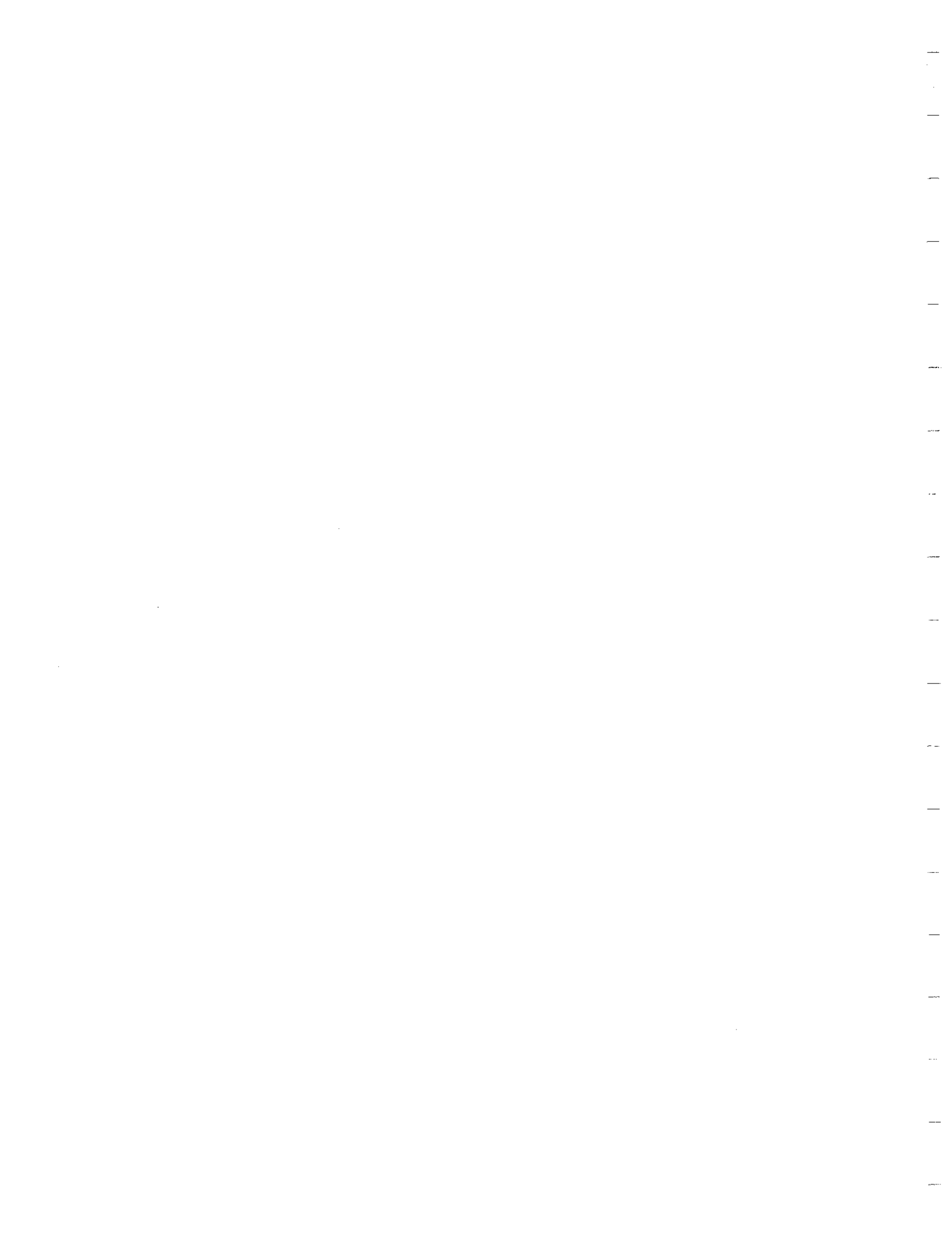

Meeting Minutes

Meeting Date and Location: August 26, Fleet Technology Limited's office in Kanata.

Attendees: M. Punt, Environment Canada
G. Comfort, Fleet Technology Limited
B. Paterson, Fleet Technology Limited

1. The status of the project was reviewed. The prototype waterjet barrier was completed and a preliminary deployment was conducted at Lac Deschenes on the Ottawa River on August 9. A number of problems were encountered and modifications were made to the barrier.

A more extensive deployment was then conducted at the CCG base in Prescott, Ontario during the August 20-23 period. These trials were attended by M. Punt (Env. Cda), J. Latour and R. Amell of CCG, R. Dallas (CPA) and G. Comfort and R. Abdelnour (of FTL). The barrier was initially assembled in an area that was subjected to wave action. Problems were encountered and another location with near-calm water conditions was selected as the deployment site.

Much was learned from this work, as summarized below:

- (a) In general, the deployment was successful. However, some refinements to the barrier are required.
- (b) Initially, the barrier had stability problems in the absence of a current and the presence of a wind as the floats tended to become oriented "broadside". They became aligned with the barrier arm and as a result, had low stability. The barrier flipped over in some cases.

This problem was resolved by installing limits on the floats to restrict their rotation to about ± 45 degrees. This allowed them to "weathervane" in the current to some extent but not to become aligned with the barrier arm.

- (c) The floats "weathervaned" freely when towed or the barrier was driven by the waterjets.
- (d) The barrier floats maintained an even trim and kept the nozzles about 8" above the water surface.
- (e) The umbilical floats were higher than anticipated in the water. This occurred as the umbilical hoses were continuous during the deployment as opposed to being segmented in 8' lengths with, hence, several more fittings which would add weight (which was the assumed design case). This produced a relatively large sail area which made it sensitive to wind action, and is hence, undesirable.

(f) The barrier was stable in waves up to about 0.6m high (after limits were installed on the floats) and waves passed through the barrier freely without inducing significant pitching motions.

(g) The pump was started and water was sprayed through the arms of the barrier. The arms of the barrier could be opened and closed as desired. A number of refreshments are required to the pump system as described in item 2.

refurbishments

2. The following recommendations were made for improving the waterjet barrier:

Floatation System - (a) The umbilical floats should be replaced with a smaller float (the existing Env. Cda disc floats were suggested) to reduce the freboard of the umbilical and to reduce its drag. *Le*

(b) The apex structure should be redesigned [required as a result of (a)].

Pump System - (a) The ^{float} float valve should be refurbished or replaced to avoid the requirement for priming the pump.

(b) The intake housing appears to be cracked (as water sprayed out of it) and should be repaired.

(c) Pressure gauges should be added at the manifold to each of the four water hoses for the waterjet barrier.

(d) The waterspray from the barrier arms was uneven and some of the nozzles were blocked. The nozzles should be cleaned and replaced as required.

(e) The diesel engine was difficult to start and the starter had to be "shorted" across its terminals. The ignition system should be checked over by a mechanic.

3. Approaches for continuing and completing the project were discussed. It was decided that testing at the OHMSETT facility was not the preferred approach as:

(a) Startup of this facility has been delayed and the OHMSETT tank is not expected to be operational until at least mid-November. This would probably cause the project to be delayed until 1992.

(b) The issues that are considered to merit the most attention are related to the operational performance (ie. stability, station-keeping, manoeuvrability) of the barrier in waves and currents. The OHMSETT tank is relatively narrow (ie. 65 ft. wide) which makes it difficult to perform this type of evaluation reliably for the waterjet barrier.



It was decided that testing should be continued at Prescott, Ontario. The following tasks were identified for Phase II of the project:

- Task 1 - Preliminary Deployments
- Task 2 - Barrier Modifications
- Task 3 - Trial Deployments at Prescott
- Task 4 - Reporting

It was decided to spill canola oil during ~~the~~ task 3 if the required approvals could be obtained. M. Punt undertook to obtain this.

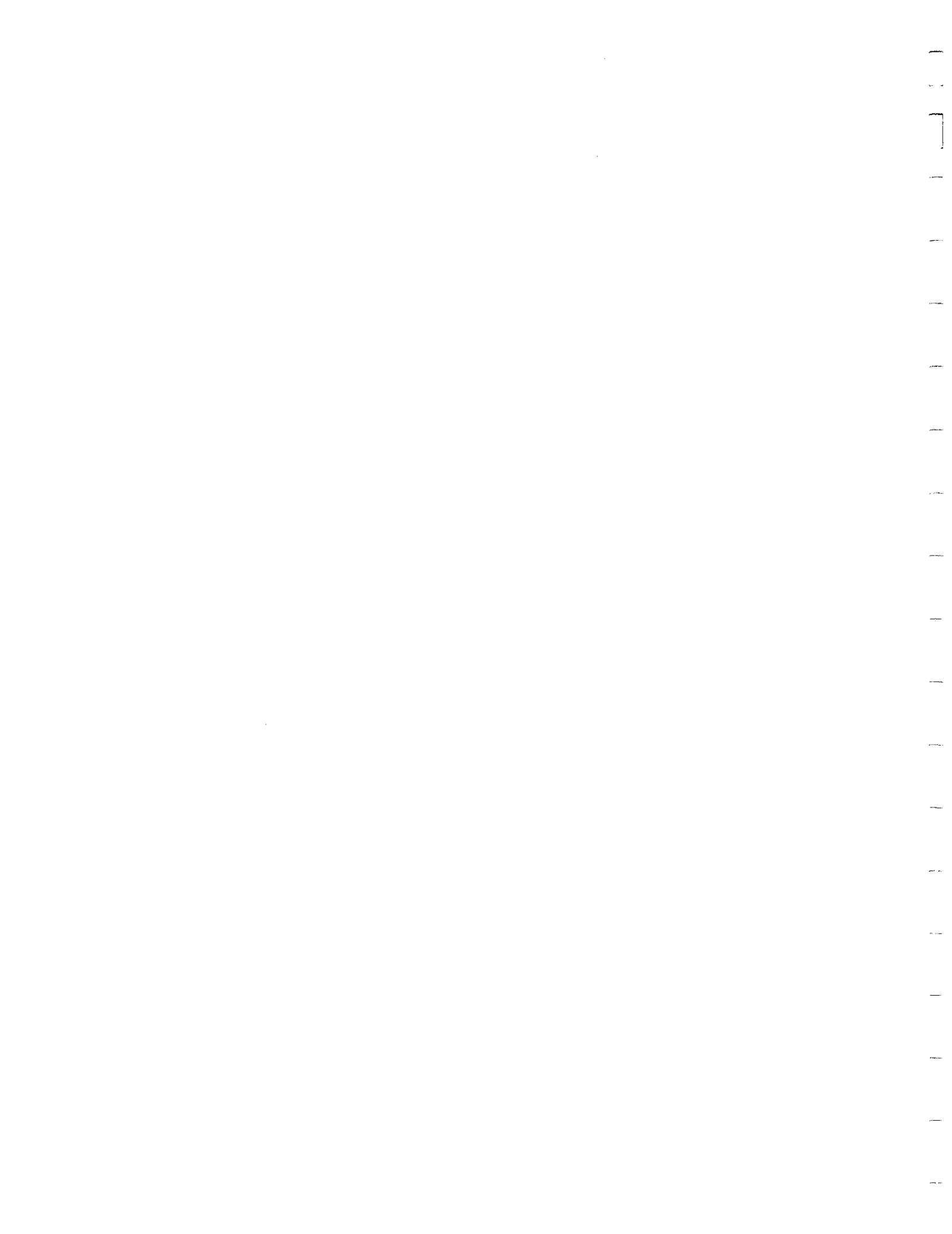



FLEET TECHNOLOGY LIMITED

BY FAX

Ms. Monique Punt
Environment Canada
River Road Environmental Technology Centre
3439 River Road
Ottawa, Ontario
K1A 0H3

FTL File: 3922

Re: Redesign, Construction and Testing of a
Prototype Waterjet Barrier

Dear Ms. Punt:

Minutes from our meeting have been prepared and are attached.

As requested, we have prepared a revised outline statement of work for Phase II of the project, as follows:

• Task 1 - Preliminary Deployment: The waterjet barrier will be deployed at Lac Deschenes and Prescott, Ontario to gain experience with several important operational aspects, such as:

- (a) Deployment methods and ease of deployment
- (b) Its stability, manoeuvrability and station-keeping in the presence of winds, waves and currents.
- (c) The operation and spray pattern of the waterjet barrier's arms

The performance of the waterjet barrier will be observed and documented.

• Task 2 - Modifications - Modifications will be made to the waterjet barrier as appropriate following the results of task 1 (as described in the attached minutes).

FTL will:

- (a) Replace the umbilical floats with the existing disc floats (of Env. Canada's). It is understood that the CCG will provide up to one manday of welder support for this work.

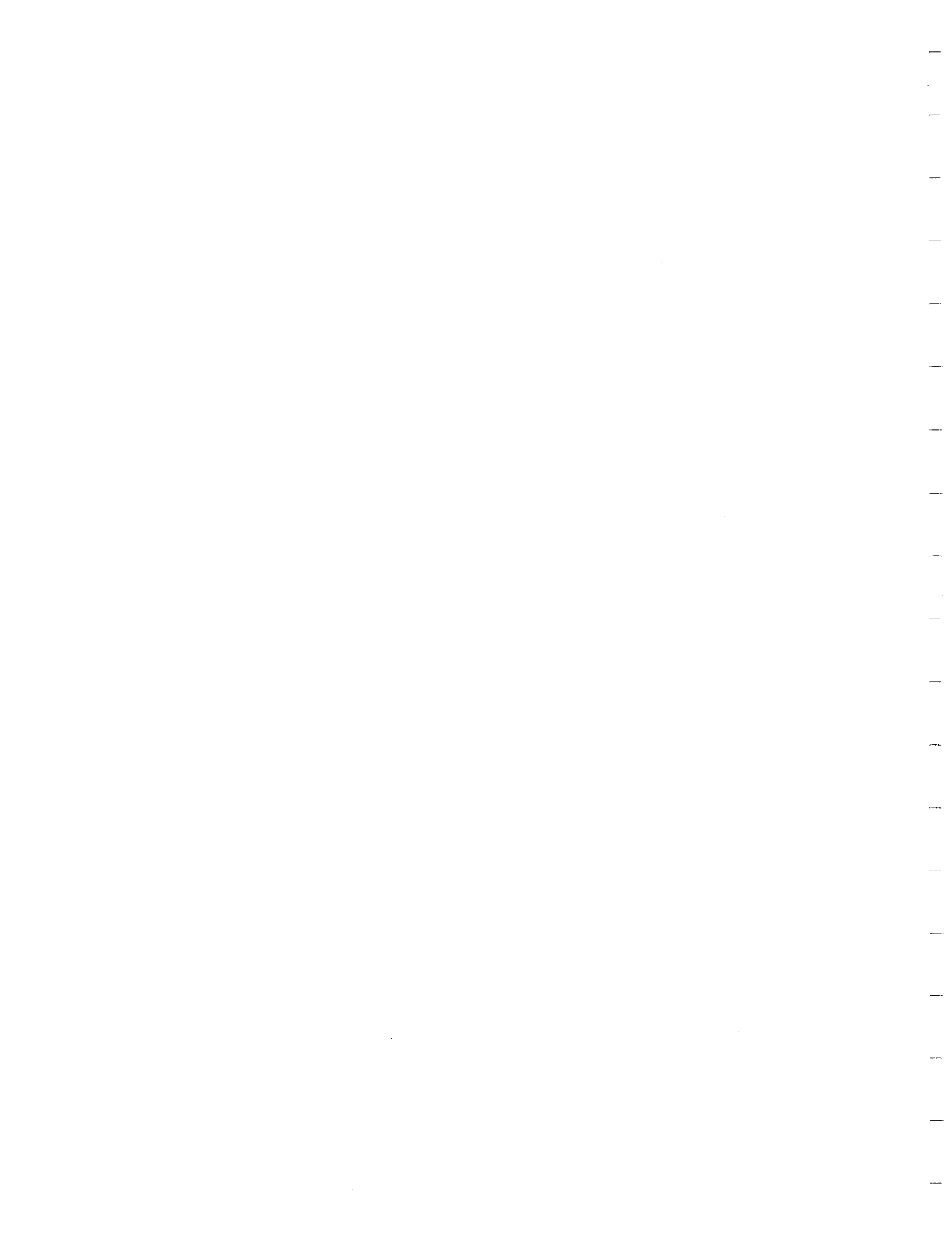

(b) Redesign and replace the apex structure.

It is understood that the other improvements (as described in the attached minutes) will be handled directly by Environment Canada.

- Task 3 - Trials At Prescott: The waterjet barrier will be reassembled and redeployed at the CCG base at Prescott. Canola oil will be spilled if the required approval can be obtained.

The waterjet barrier will first be deployed in a slip where there are relatively calm conditions. It will then be redeployed off the dock where currents and waves are present. Finally, it is proposed to deploy the barrier from a ship at the CCG base (depending on approval by the CCG).

- Task 4 - Reporting: An engineering report will be prepared in four copies to Env. Canada's standards that documents the scope, approach and results of the project. The report will document both phases of the project.

The proposed schedule for the above Phase 2 work is as follows:

Milestone	Date
Task 1 complete	Sept. 6, 1991
Task 2 complete	Sept. 30, 1991
Task 3 complete	Oct. 31, 1991
Task 4 complete	
• Draft report delivered	Dec. 15, 1991
• Comments received	Jan. 15, 1992
• Final report delivered	Jan. 31, 1992

A detailed cost breakdown for the revised Phase 2 work is attached. A firm price contract is proposed with invoices submitted following the achievement of the above project milestones. The invoice amounts for each task are shown on the attached cost breakdown.

We trust that this letter provides the information you require. Please do not hesitate to contact me if questions arise.

Yours truly,

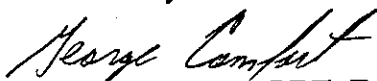
GEORGE COMFORT, P.Eng.
Manager, CRTC

GC:sh

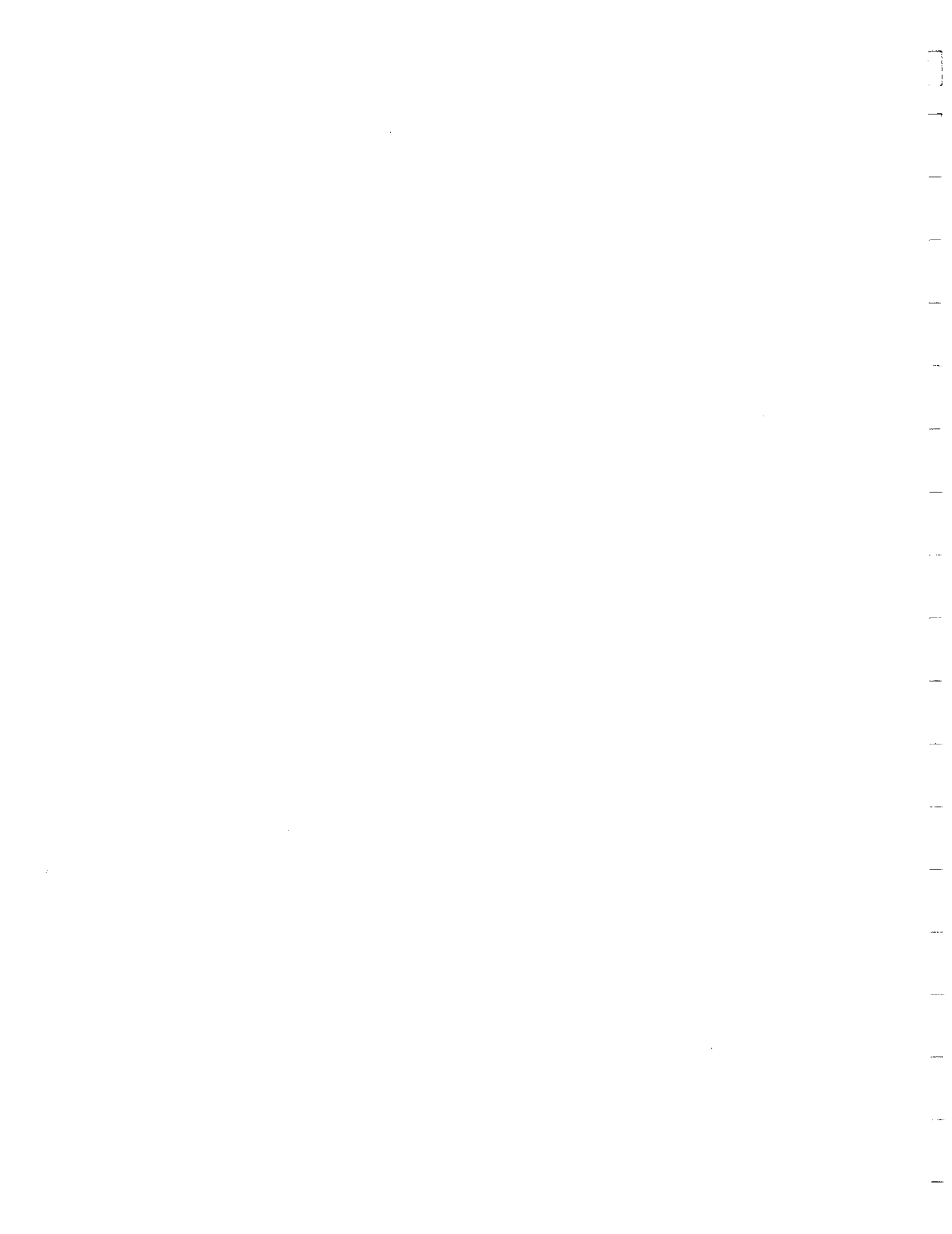

APPENDIX B:

Test Plan for

1992 Trials

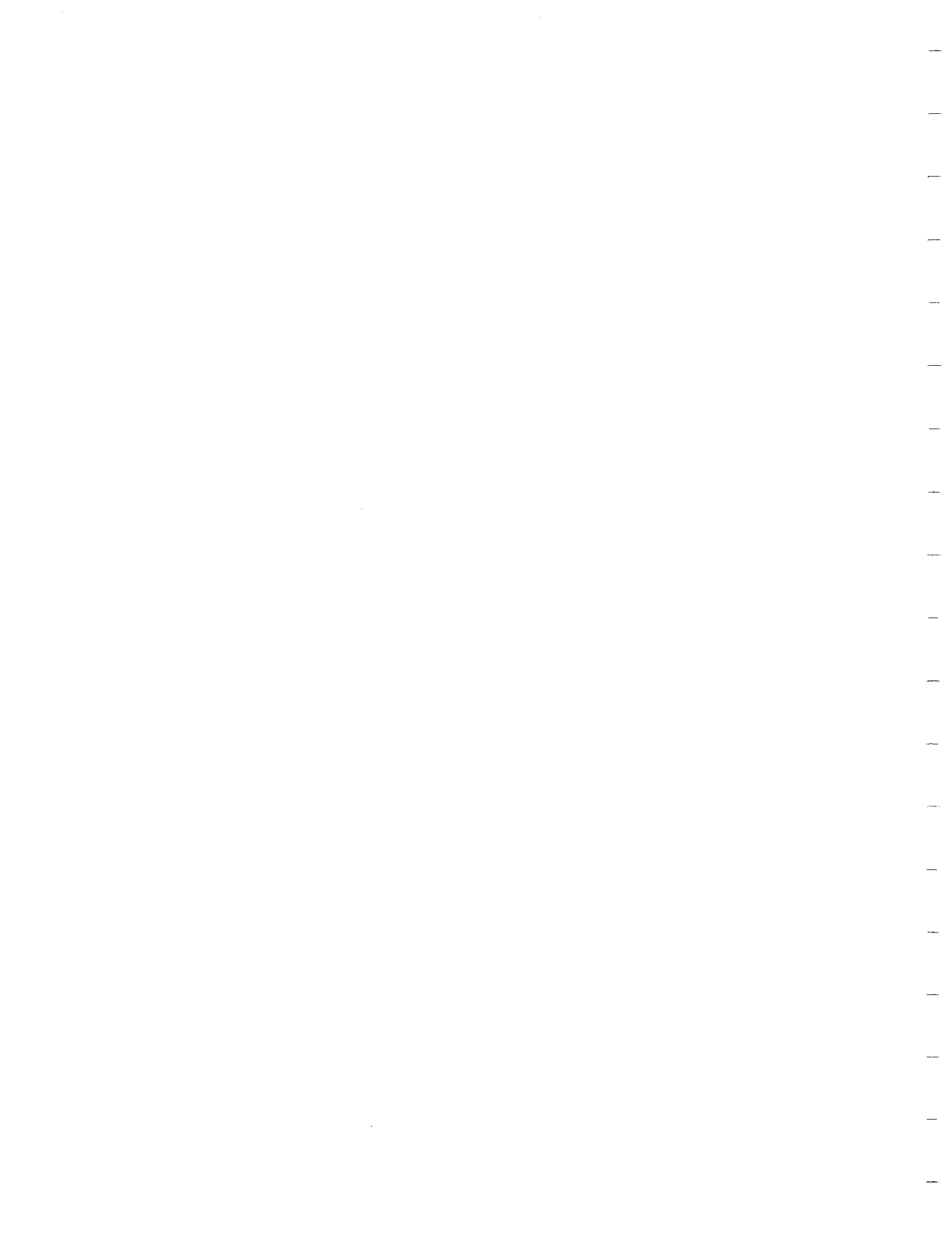

TEST PLAN FOR FIELD TRIALS OF WATERJET BARRIER

Location: CCG Prescott, Prescott Ontario

Expected Test Date: March 1992

Task Breakdown

It is anticipated that the trials will be conducted in three sub-tasks, with each subsequent sub-task subject to the results of the previous test phase. Each sub-task is described with individual tasks below.

A certain level of flexibility is required in the schedule to allow for lost time due to weather and breakdowns. A total time of 5 days is projected for preparation and testing.

Sub-Task 1 - Deployment of Waterjet Barrier in Small Craft Basin - CCG Prescott

Objectives:

1. To test flotation and control of the barrier following the 1991 modifications to the original design.
2. To record operating water pressures and correlate with boom movement in still water conditions.

Sub-Task 1 Tasks:

1 - Deployment of Barrier

The boom will be launched in the small craft basin. Effort will be directed at a "dry launch" ie. no personnel in the water. A work boat ("Sea Truck") will be required along with a small boat to facilitate deployment. Care will be taken to record the connection of the barrier hoses to the pump manifold for recording operating pressures.

2 - Barrier Operation

With the waterjet barrier in operation, flotation and attitude will be recorded with photographs and videotape. Videotape will also be used to record the mobility and control of the barrier under various pump manifold settings and pressures. Pressures will be recorded from the gauges on each hoses at the manifold. The barrier will be operated to:

- vary the boom containment angle
- change the barrier position against some shore references, to estimate speed.
- manoeuvred to change the barrier angle

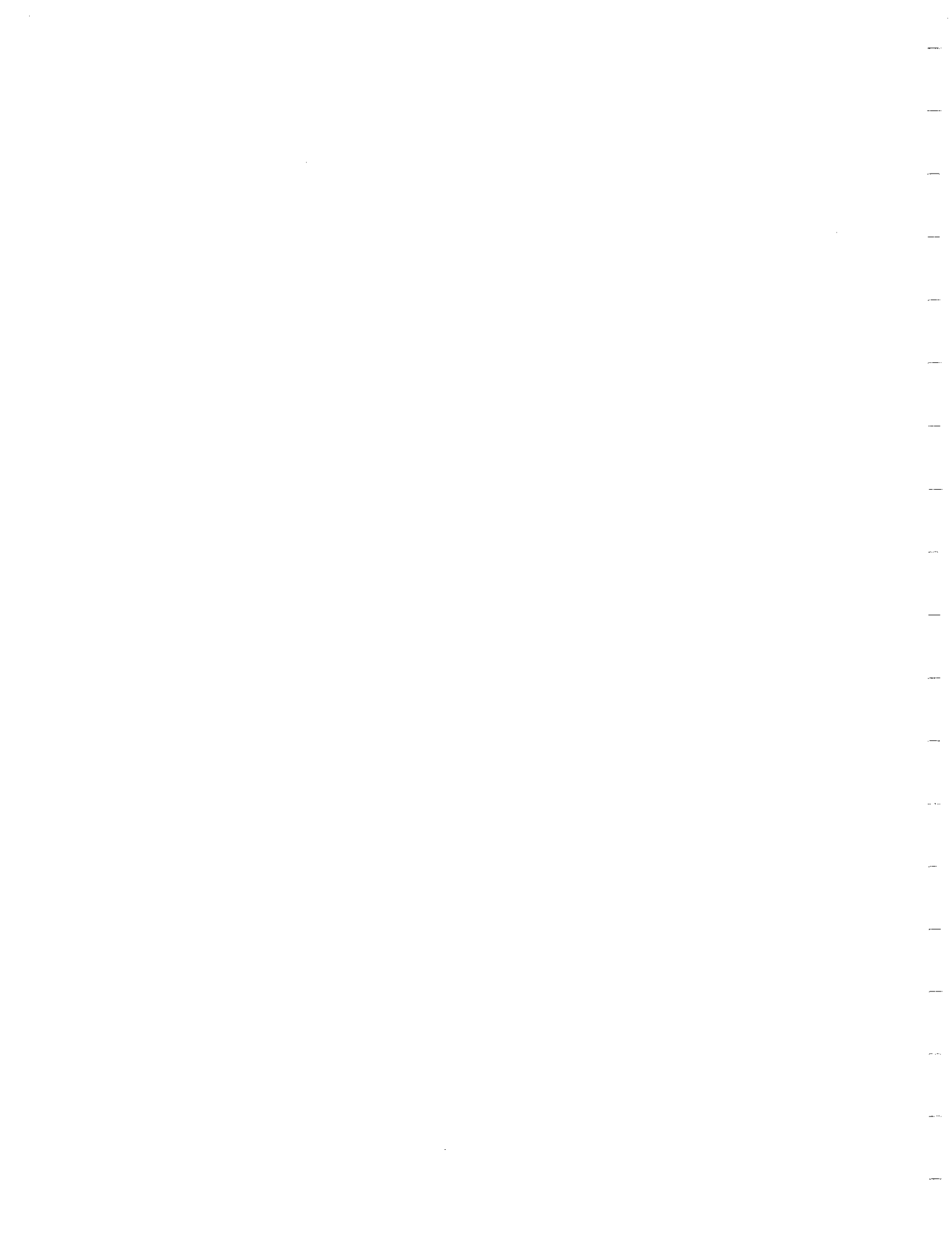

Sub-Task 1 (Continued)

3 - Performance Review

Review boom performance following the trial. Modifications may be identified, and implemented (if feasible) at the CCG base.

Duration: From experience, Tasks 1 and 2 may take an entire day. The review component of Task 3 will happen the following day and should take less than 2 hours. Modifications will only take place if they can be executed within that day or are absolutely essential for continuing the test program.

**Sub-Task 2 - Deployment of Waterjet Barrier in the River off the Jetty -
CCG Prescott**

Objectives:

1. To test flotation, stability, and control of the barrier in the prevailing current, wind, and waves from a shore location. Note: It is anticipated that the barrier will be anchored during this deployment. Rationale for using an anchoring system is provided below.
2. To record operating water pressures and correlate with boom movement under the prevailing environmental conditions.
3. To test the ability of the barrier to confine a spill under the prevailing environmental conditions, using canola oil to simulate a modest oil spill. To determine the minimum operating pressure for effective confinement.

Rationale for Anchoring the Waterjet Barrier:

From experience with previous deployments, it is felt that anchoring the waterjet barrier in position would improve the deployment procedure without significantly restricting the mobility of the barrier. The general idea is shown in **Figure 1**. A small boat anchor (or anchors) would be placed upstream from the barrier position such that it would hold the barrier in position prior to starting the pump. The shape of the barrier would be maintained with the assistance of some restraining ropes run between each boom arm. When the pump has been started and the waterjets are active, the barrier can be manoeuvred around the anchor position, or driven upstream over the anchor (conditions permitting).

Sub-Task 2 Task Breakdown:

1 - Preparation

- a) Load work boat(s) with current meter, anchor and cable, and canola oil.
- b) Prepare Wave Buoy for deployment. This will involve liaison with DFO personnel who will deploy the buoy.
- c) Prepare boom for towing. Disconnect from pump (attach flotation to umbilical hoses if necessary). Attach restraining ropes and anchor fitting to boom arms.
- d) Deploy video camera to vessel's crow's nest or to "cherry picker", as required.

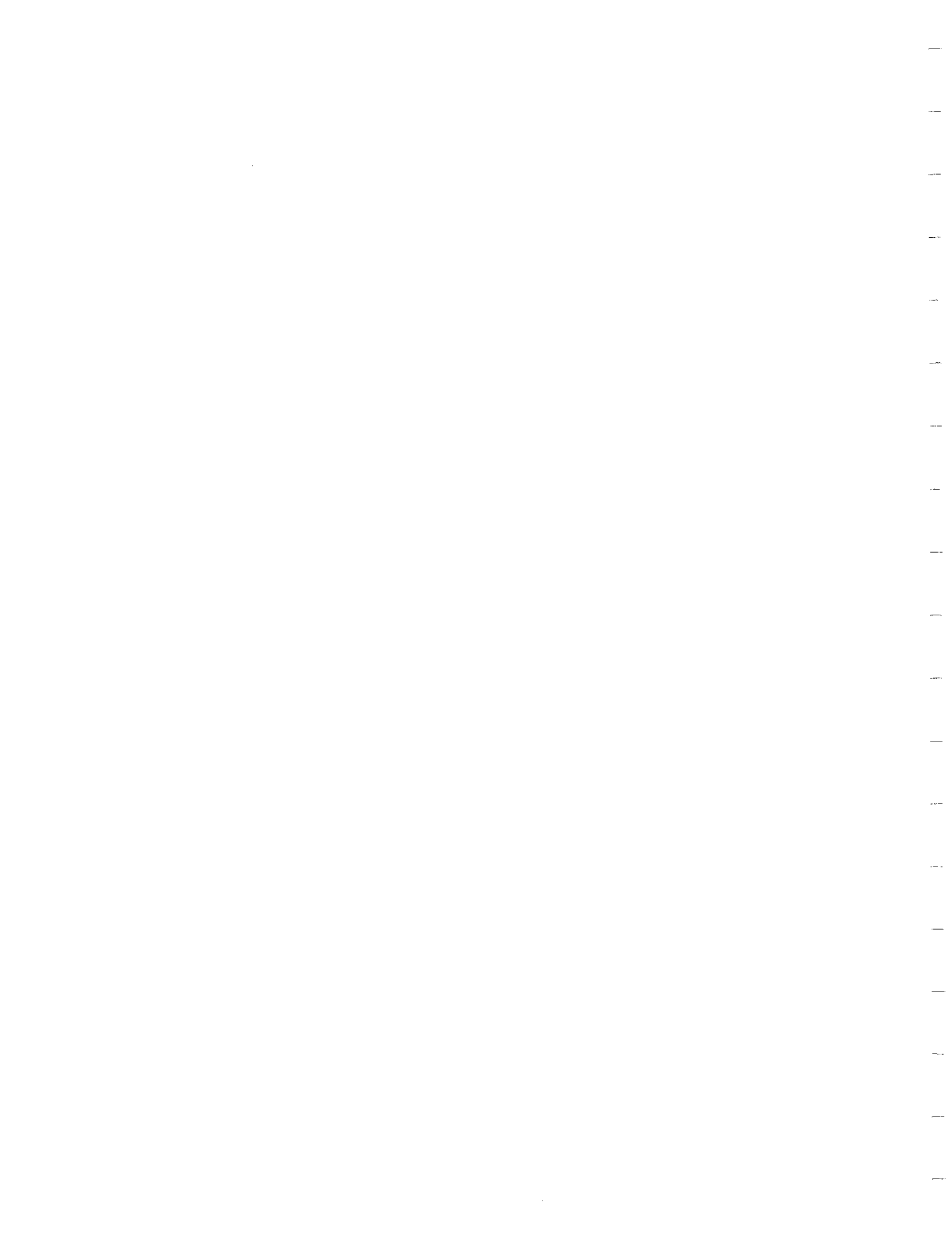

- e) Prepare containment measures for canola spill. It is expected that this will consist of a boom for shore protection.

Some of these tasks can occur concurrent with Task 3 of Sub-Task 1.



Sub-Task 2 (Continued)

2 - Move Pump

The pump will be moved from its location alongside the small craft basin to a better location for this stage of testing. Two options exist for re-locating the pump:

1. Place on the outer quay, as shown in the sketch, **Figure 2**.
2. Place on the working deck of the Buoy tending Vessel to be used in the Sub-Task 3 deployment - perform Sub-Task 2 trials while vessel is alongside the quay.

The decision will largely depend on the vessel positions and schedule at the time of the test. The ability to confine the canola oil will be another factor.

3 - Deploy Wave Buoy; Obtain Wind data

The wave buoy will be deployed prior to the tests in the position shown in Figure 2, with sufficient time to initialize the instruments and begin readings. A workboat will be required for deployment. To be operated by DFO personnel?

Wind speed and direction will be recorded from shore instruments.

4 - Positioning of Waterjet Boom

The waterjet boom will be towed out of the small craft basin by one or two workboats (subject to advice of CCG personnel). Extreme care will be required to avoid damage by striking the quay or by towing improperly; see sketch in Figure 1. The boom will be towed to the approximate position for the tests; then the anchor will be dropped and the boom moored in place. The work boat will then transfer the umbilical hoses for connection with the pump.

5A - Barrier Operation - Control Tests

With the waterjet barrier in operation, flotation and attitude will again be recorded with photographs and videotape. The mobility and control of the barrier under various pump manifold settings and pressures will be investigated, noting the influence of the environmental conditions on the behaviour of the barrier. Manifold water pressures will be recorded. As in the still water tests, the barrier will be operated to:

- vary the boom containment angle
- change the barrier position against some shore references, to estimate speed.
- manoeuvred to change the barrier angle to the current

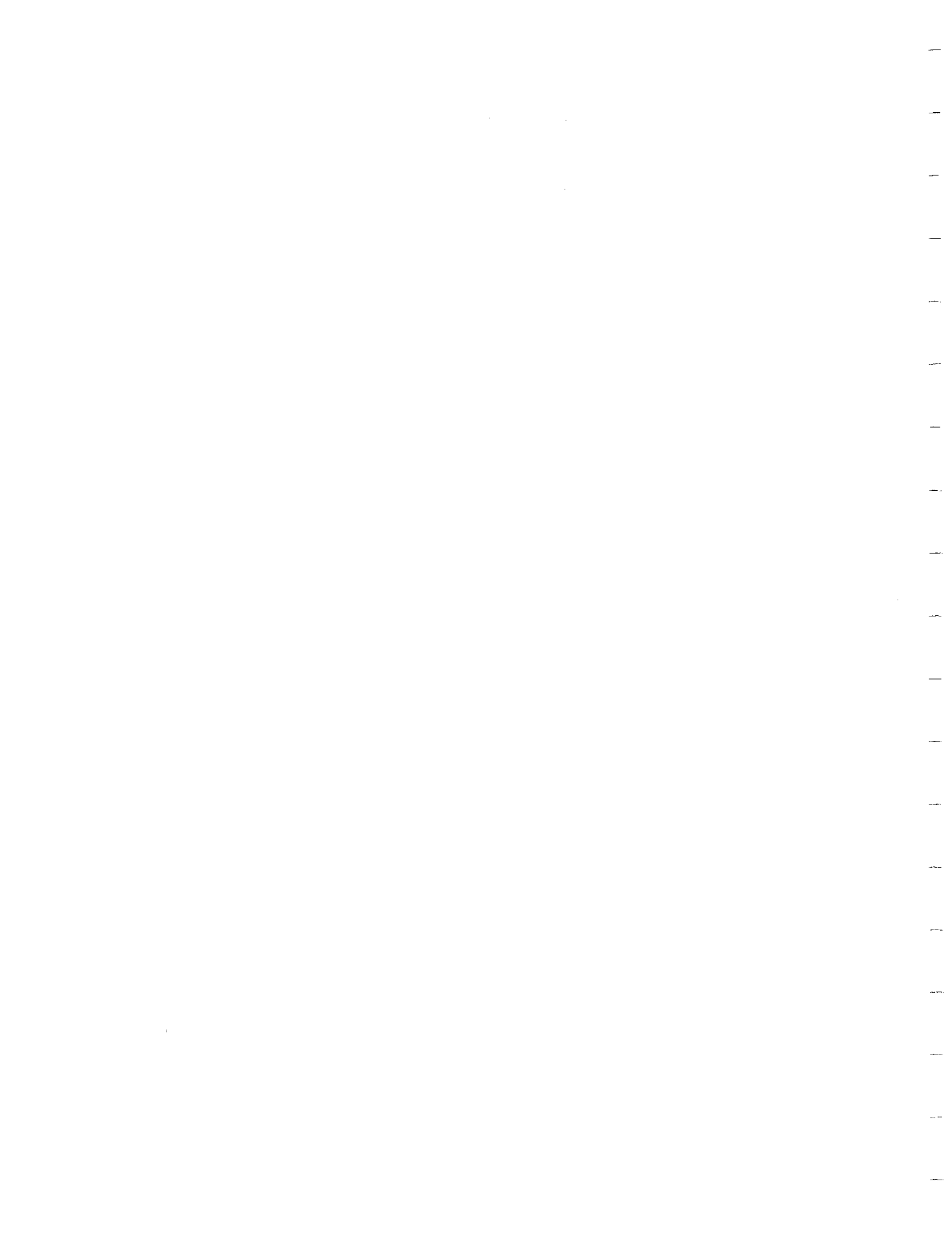

Sub-Task 2 (Continued)

5B - Barrier Operation - Spill Containment Test

Provided the waterjet barrier demonstrates adequate control behaviour (Task 5A), the next step will be to test its spill confinement capability under the prevailing environmental conditions. With the back-up spill protection measures in place, a work boat will proceed upstream of the waterjet barrier and begin spilling canola oil. The effectiveness of the barrier in containing the spill will be monitored using a high-angle videotape camera. Variables such as boom angle and waterjet pressure will be varied. Effectiveness will be defined by the amount of canola oil escaping from the barrier, and the location where the escape has occurred.

5C - Deployment of Current Meter (concurrent with Tasks 5A and 5B)

At various instances during the barrier operation, a (small) work boat will deploy the current meter at positions across the breadth of the barrier. Current velocity and approximate position will be recorded.

6 - Canola Spill Clean-up

7 - Dismantling of Waterjet Barrier

Subject to the weather and daylight remaining, there are two options for dismantling the barrier: disassembly alongside the quay or deployment vessel using a work boat (Sea truck); or tow the boom into a small craft basin for disassembly. The former option would provide practice for the Sub-Task 3 deployment and may be easier in more calm conditions; the latter option would allow postponement of the dismantling task to the following day. A decision will have to be made at the time.

8 - Performance Review

Review the boom performance following the trial in terms of control and containment effectiveness. The decision to progress to Sub-Task 3 will be made. Modifications or repairs may be identified, and implemented (if feasible) at the CCG base.

Duration: Because of the location of the tests, the deployment, testing, and recovery of the barrier (Tasks 3 - 7) must occur in one day. Most of the preparations and the movement of the pump can occur prior to the test day. Actual dismantling of the boom may occur the following day, if it is towed back into the small craft basin. The review component of Task 8 can happen the following day and again should take less than 2 hours. Modifications and repairs must take place within the Sub-Task 3 deployment vessel's activity schedule or if they are absolutely essential.

Sub-Task 3 - Mid-River Deployment of Waterjet Barrier - off CCG Prescott

Objectives:

1. To test flotation, stability, and control of the barrier in the prevailing current, wind, and waves in a mid-river location. Note: It is again anticipated that the barrier will be anchored during this deployment.
2. To record operating water pressures and correlate with boom movement under the prevailing environmental conditions in a mid-river location.
3. To test the ability of the barrier to confine a spill in a mid-river location under the prevailing environmental conditions, using canola oil to simulate a modest oil spill. To determine the minimum operating pressure for effective confinement.
4. To evaluate deployment of the waterjet barrier from a vessel in a deep water location.

Sub-Task 3 Task Breakdown:

1 - Preparation

- a) Load waterjet boom components on to deployment vessel; this may be the buoy tending vessel if the freeboard of the working deck is sufficiently low. Alternatively the boom will be loaded on a work boat (Sea truck) for deployment. A third alternative discussed below, involving transfer of the boom sub-assemblies from the buoy tender to a work boat for launching, would require loading on the buoy tender.
- b) Load work boat(s) with current meter, anchor and cable, and canola oil.
- c) Prepare Wave Buoy for deployment. Load on buoy tender. This item will be subject to the availability of DFO personnel for set-up procedures.
- d) Deploy video camera to vessel's crow's nest when required.

It is not expected that containment measures for the canola spill will be required.

Some of these tasks can occur concurrent with Task 8 of Sub-Task 2.



Sub-Task 3 (Continued)

1.1 - Transfer of Pump to Buoy Tending Vessel

If Sub-Task 2 was conducted with the pump located on the outer quay, the pump will have to be transferred to the buoy tender being used for the Sub-Task 3 deployment.

2 - Transfer to Test Location

Prior to the field trials, a location for the mid-river trials will have been selected and agreed upon by the agencies involved in the trials. A proposed site is shown in **Figure 3**. After loading of equipment, the vessels involved in the tests (1 buoy tender, 1 Sea truck, and 1 -2 other work boats) will move to the test site.

Ideally the buoy tender will anchor at some angle to the current and/or waves; this should provide a calmer area in the lee of the vessel for launching the boom. See **Figure 4**.

3 - Deploy Wave Buoy

The wave buoy will be deployed prior to the tests in the position shown in Figure 3, with sufficient time to initialize the instruments and begin readings. A workboat will be required for deployment. The use of the wave buoy in this sub-task will be subject to the availability of DFO support, as noted above.

4 - Waterjet Boom Assembly and Launch

Assembly of the waterjet rigid structure will occur on the working deck of the deployment vessel (either the buoy tender or a Sea truck). Another alternative may be used if the freeboard of the buoy tender is too high and there is insufficient deck area on the Sea truck. This would involve assembly of the structural units on the buoy tender deck, which would then be shifted down on to the Sea truck for attachment of the floats; the assembled boom arms would then be launched and connected from the Sea truck.

Once assembled the waterjet boom will be anchored in position and the umbilical hoses will be connected to the pump. Support for the umbilical hoses using the buoy tender's landing boom posts should be investigated.

Sub-Task 3 (Continued)

5A - Barrier Operation - Control Tests

With the waterjet barrier in operation, flotation and attitude will again be recorded (with photographs and videotape) to assess the influence of the prevailing current and weather conditions. The mobility and control of the barrier under various pump manifold settings and pressures will be investigated, and manifold water pressures will be recorded. As with previous tests, the barrier will be operated to:

- vary the boom containment angle
- change the barrier position against some ship-based reference points, to estimate speed and position away from deployment vessel.
- manoeuvred to change the barrier angle to the current

5B - Barrier Operation - Spill Containment Test

Provided the waterjet barrier demonstrates adequate control behaviour (Task 5A), the next step will be to test its spill confinement capability under the prevailing environmental conditions. A work boat will proceed upstream of the waterjet barrier and begin spilling canola oil. The effectiveness of the barrier in containing the spill will be monitored using the high-angle videotape camera. Variables such as boom angle and waterjet pressure will be varied. Effectiveness will be defined by the amount of canola oil escaping from the barrier, and the location where the escape has occurred.

5C - Deployment of Current Meter (concurrent with Tasks 5A and 5B)

At various instances during the barrier operation, a (small) work boat will deploy the current meter at positions across the breadth of the barrier. Current velocity and approximate position relative to the waterjet barrier will be recorded. Wind speed and direction will be obtained from the deployment vessel's anemometer.

6 - Canola Spill Clean-up

If and as required.

7 - Dismantling of Waterjet Barrier

If weather and time permit, dismantling the waterjet barrier will be the reverse of the assembly procedure. If pressed the individual arms could be lifted while still assembled onto the buoy tender with the assistance of the ship's crane.



Sub-Task 3 (Continued)

8 - Return to Base, Storage of Waterjet Barrier

9 - Post- Trials Assessment

Duration: Because of the location of the tests and the vessels involved, the deployment, testing, and recovery of the barrier (Tasks 2 - 8) must occur in one day. Most of the preparations and the movement of the pump can occur prior to the test day. Storage of the boom may occur the following day, but it will probably have to be removed from the buoy tender on the test day.

The post-trials assessment (Task 9) is expected to cover all the trials performed and would occur at either the FTL or Environment Canada offices.

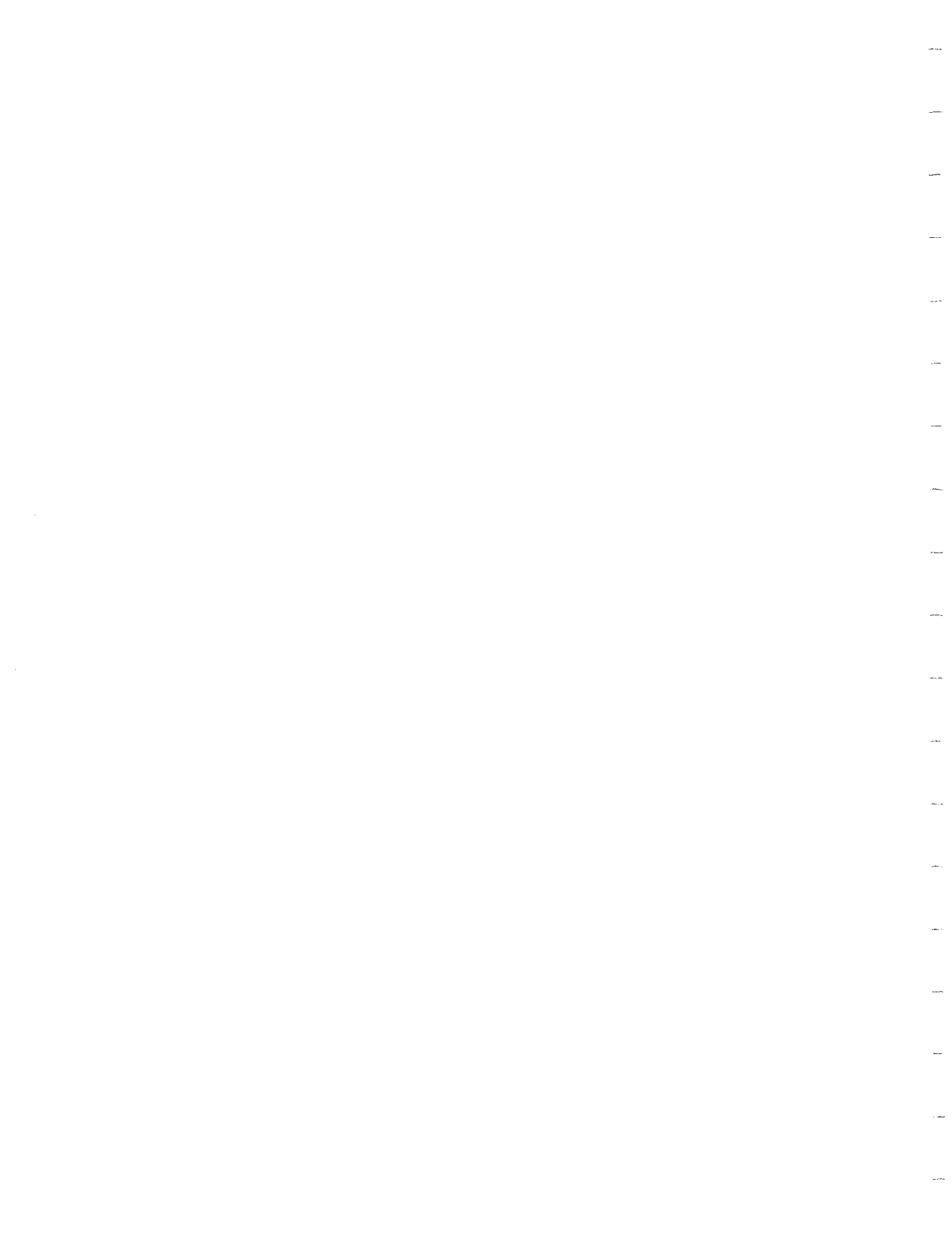

TEST PLAN FOR FIELD TRIALS OF WATERJET BARRIER - Page 9

Resources: A list of equipment required for each Sub-Task is provided below. The supplier will be indicated in brackets.

Sub-Task 1: Small Basin Deployment

Boats (CCG)

- 1 Sea truck
- 1 small boat (approx. 14')

Equipment

- 2 Videocameras (FTL/EC)

Miscellaneous (CCG)

- fork lift (to shift hose)
- small mobile crane

Sub-Task 2: Shore-side Deployment

Boats (CCG)

- 1 Sea truck; A-frame may be required for deploying wave buoy and boom
- 1 or 2 Work boat(s)
- 1 small boat (approx. 14') with outboard motor.

Also; use of Buoy tender (if available) as shore base for waterjet pump. For about 1 day.

Equipment

- 2 Videocameras (FTL/EC)
- 1 or 2 small boat anchors (CCG)
- 1 current meter (CCG)
- 1 Wave Buoy (supplied by DFO)
- Canola Oil (supplied by EC)
- 1 -2 Balloon Floats - for ends of umbilical hoses (CCG?)

Miscellaneous (CCG)

- Fork lift (to shift hose)
- Large mobile crane (to move pump unit)
- "Cherry Picker" - if no high-angle vantage point for video is available.
- Small hydraulic hand crane (as alternative to A-frame on Sea truck)

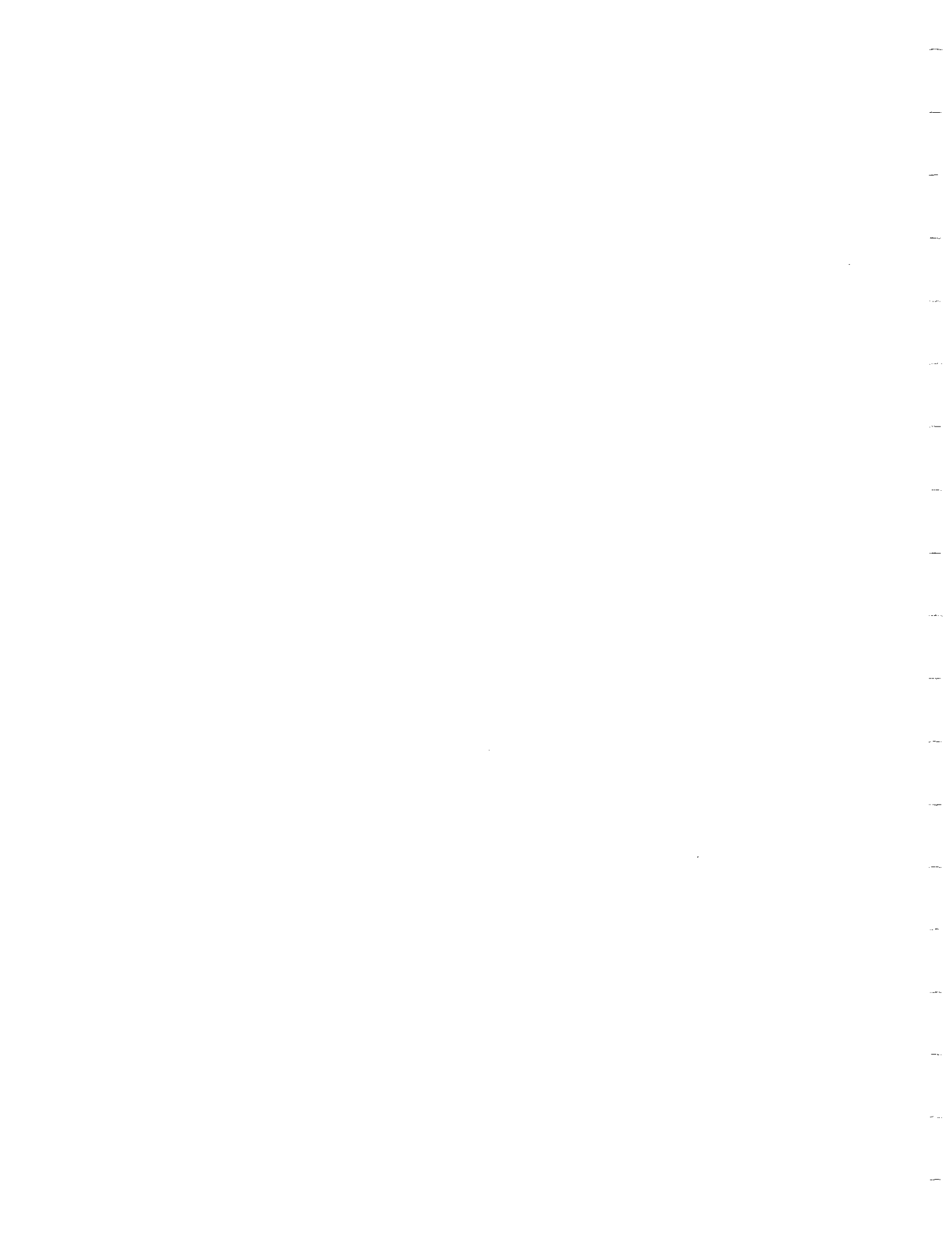

Resources: (Continued)

Sub-Task 3: Mid-River Deployment

Deployment Vessel

1 large Buoy Tender (CCGS SIMCOE?) - for 1 day trial, 0.5 day shoreside loading/unloading.

Boats (CCG)

1 Sea truck; A-frame may be required for deploying wave buoy and boom
1 Work boat (could be smaller than Sea truck)

Equipment

2 Videocameras (FTL/EC)
1 or 2 small boat anchors (CCG)
1 current meter (CCG)
1 Wave Buoy (supplied by DFO)
Canola Oil (supplied by EC)
1 -2 Balloon Floats - for ends of umbilical hoses (CCG?)

Miscellaneous (CCG)

Fork lift (to shift hose)
Large mobile crane (to move pump unit)
Small hydraulic hand crane (as alternative to A-frame on Sea truck)

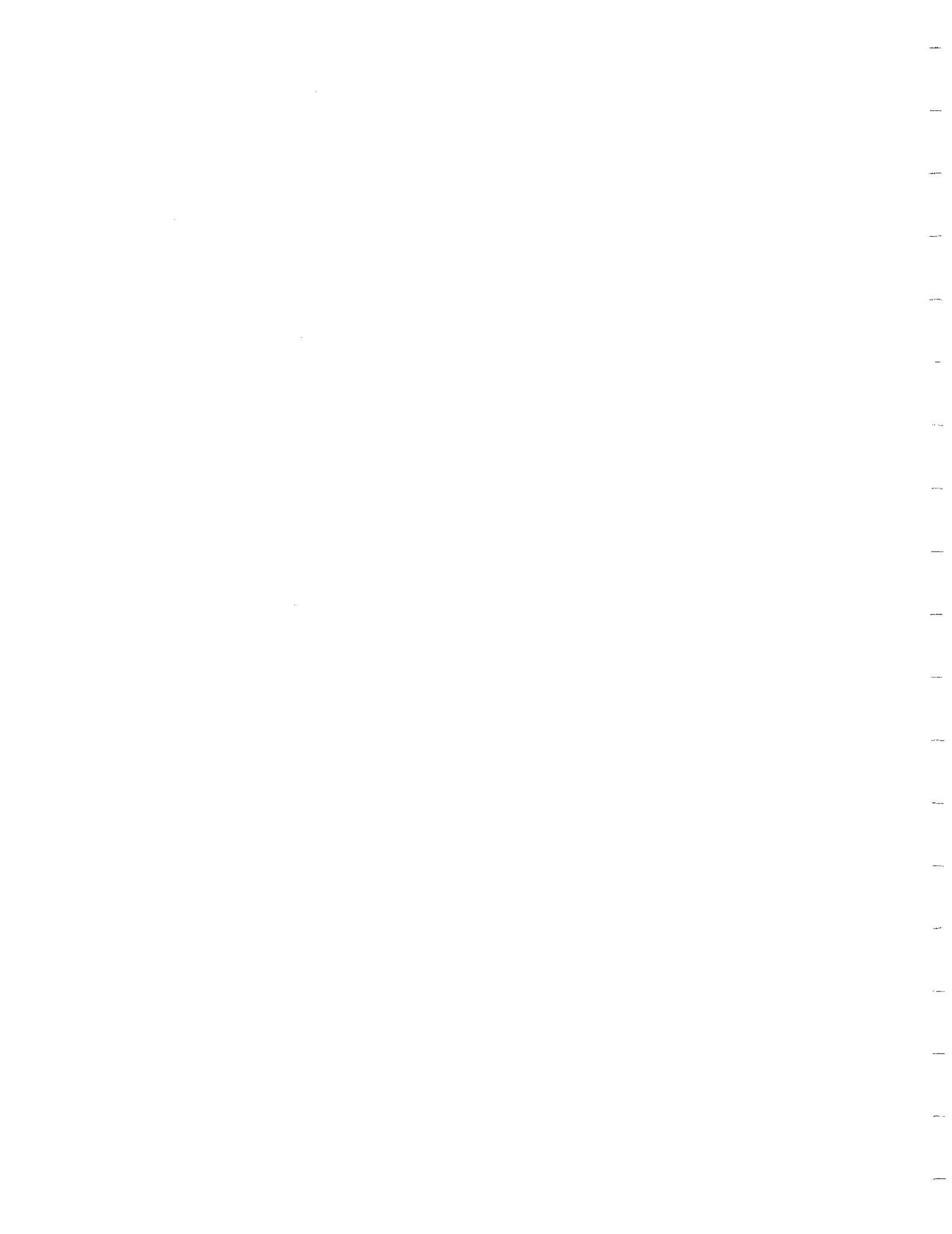

APPENDIX C:

Summary of Waterjet Barrier Trials

17-21 August 1992



SUMMARY OF WATERJET BARRIER TRIALS - AUGUST 17-21 1992

Overview of Activities: 17 - 21 August 1992, CCG Prescott

- Monday, 17 August: Deployed Boom arms, pump equipment in small craft basin, wave buoy in river.
- Tuesday, 18 August: Completed boom assembly in small craft basin. Operated boom, cleared and adjusted nozzles.
- Wednesday, 19 August: Towed boom alongside CCGS SIMCOE at dock. Manoeuvring trials alongside successful in windy conditions, light current. Mid-river trial with simulated spill aborted due to structural damage, towing problems.
- Thursday, 20 August: Boom structure repaired, modified. Simulated spill alongside CCG Prescott dock successfully contained in calm conditions, light current.
- Friday, 21 August: Boom positioned off dock in moderately windy conditions, light current. Manoeuvring trials successful and larger simulated spill contained, limited by constraints on boom mobility and size.

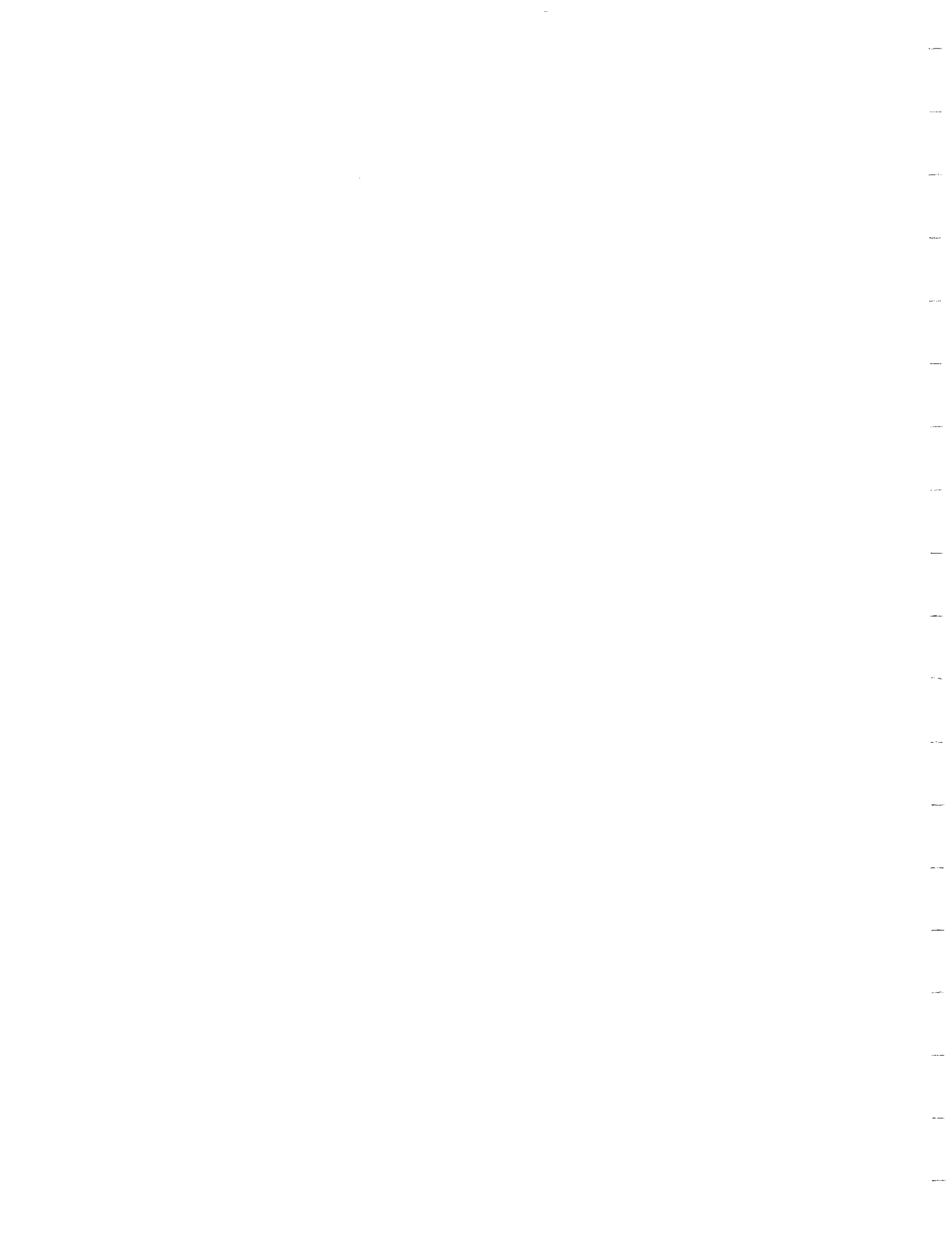

DETAILED REVIEW OF TRIALS:

Preliminary Notes:

Waterjet Barrier Components stored at CCG Prescott since Summer 1991.
Environment Canada Technologist refits pump and tests engine.
DFO Wave Buoy Equipment delivered Thursday, 13 August 1992
Fleet Technology Ltd (FTL) personnel inspect test area at CCG Prescott on Friday,
14 August 1992. No apparent problems.

Monday, 17 August 1992

Personnel: FTL: Bruce Paterson, Andre Lemieux
EC: Tony Lorenzo, Andre Dumouchel, Andrew Somers.
DFO: Jim Murphy and party of 8.
CCG: Ray Amell

Notes:

1. Arrived CCG Prescott, AM. "Lori" Skimmer trials still underway, equipment in small craft basin where waterjet boom intended for assembly. CCGS GRIFFON moored alongside quay where alongside trials had been intended to occur. Scheduled alongside until late Wednesday.
2. AM spent positioning gear, final shore assembly. Centre float modified to a twin "disk" float configuration for easier deployment. Tether ropes obtained from CCG stores.
3. Also investigated best position for wave buoy, alternative boom deployment location due to GRIFFON.
4. PM, crane swung motor/pump into position along small craft basin. Shore hoses and manifold connected. DFO wave buoy deployed using one available Sea Truck; delayed fabrication of boom in basin.
5. Sea truck brought alongside approx. 1430; boom arms assembled only before return to Ottawa.
6. Informed of scheduling for CCGS SIMCOE; available Tuesday, Wednesday; Thursday AM only; Friday AM not scheduled.

Tuesday, 18 August 1992

Personnel: FTL: Bruce Paterson, Andre Lemieux
EC: Caroline Ladanowski, Tony Lorenzo, Andre Dumouchel,
Andrew Somers.
CCG: Ray Amell

Notes:

1. AM spent assembling revised boom "umbilical" structure and hoses. One structural element removed due to excessive sag between floats. "Fender" floats borrowed from CCG for flotation of umbilical hose off the umbilical structure; quite successful. Final flotation check and tether ropes attached.
2. Waterjet boom operated in small craft basin; nozzles found to be badly fouled, needing adjustment. Remainder of PM spent clearing and adjusting nozzles.

Wednesday, 19 August 1992

Personnel: FTL: Bruce Paterson, Andre Lemieux
EC: Caroline Ladanowski, Tony Lorenzo, Andre Dumouchel, Greg
?.
CCG: Ray Amell, Gary Stevenson, Stan Moore; CCGS SIMCOE
standing by.
"Pelican 10" Skimmer crew.

Notes:

1. Early AM spend on final adjustments to waterjet spray; adjustment of one float.
2. Boom disconnected from pump; pump, manifold, hoses transferred to working deck of CCGS SIMCOE for trial alongside dock.
3. Towing cable run from apex of boom to Sea Truck for towing alongside SIMCOE. 100 lb. admiralty type anchor, buoy, and cable stowed for anchoring boom off vessel. Weather conditions for tow: winds estimated 20- 25 knots; wave heights 0.3m - 0.6m (1-2 feet), typical peak conditions for Prescott area.
4. On leaving small craft basin into exposed wave conditions, boom assumed skewed angle to tow craft resulting from combination of wind on structure; excessive constraint of weathervaning action of floats, and too much slack in tethers. Efforts to shorten tether line from second Sea Truck unsuccessful. Boom towed very slowly into position with one arm perpendicular to tow direction; some structural

damage to joints occurred, specifically bending of inner plate in pin joint and extrusion of Teflon bearings.

5. Boom successfully anchored off SIMCOE and connected to pump approx. 1215. Weather conditions persist, with winds approximately 45° off port bow. Boom anchored to face into wind; anchor was shifted to effect connection with pump. Disconnected tether rope re-attached.

Wednesday, 19 August 1992 (Continued)

6. Manoeuvring tests with boom conducted approx. 1230 - 1300. Boom able to move up on anchor, change angle and direction despite wind and wave conditions. Floats appear to maintain steady "platforming" and weathervaning in waves, despite distortions in boom arm structure.
7. After discussing SIMCOE schedule with CCG, decide to try to proceed to mid-river position to test spill containment, otherwise delay will force test to Thursday AM.
8. Boom disconnected from ship for towing, but problems were encountered raising the boom anchor, due to fouling with weeds. During process of raising anchor, boom drifted off on an angle to towing direction. Attempts to restore control to tow resulted in fouling of boom arm, further twisting of boom structure such that some floats immersed by tail section. Under freshening wind conditions, control of tow could not be maintained and it was decided to abort the mid-river trial. The boom was towed into the small craft basin in a damaged condition.
9. Currents measured in test site were quite low; a 0.1 m/s back eddy (upstream to the main current direction) was measured.

Actions:

- a) Survey of the damage to the structure showed that some of the inner plates in the pinned joints had been bent and many of the Teflon bearings had simply been extruded. In view of the wave response characteristics demonstrated by the floats, it was decided to dispense with the flexible joints in the boom arms. The joints were modified by introducing spacers over the connection bolts to prevent bending of the inner plates, and the introduction of 3" stiffened steel flat bar, double bolted across the top of each joint in the boom arms. These modifications were prepared late Wednesday.
- b) Alternative towing arrangements were proposed, involving two vessels (or tow points) to both tow and maintain orientation of boom. Other modifications to facilitate towing may include increased weathervaning angles, reduction of tether rope length (for towing only), and possible increase in float fin area.
- c) Test schedule was modified to reflect departure of GRIFFON and limited availability of SIMCOE. Further trials involving spill tests would be conducted from dock outside of small craft basin. Thus a minimum of towing was required.

Thursday, 20 August 1992

Personnel: FTL: Bruce Paterson, Andre Lemieux
EC: Tony Lorenzo, Andre Dumouchel, Andrew Somers
CCG: Ray Amell, Gary Stevenson, Stan Moore
"Pelican 10" Skimmer crew.

Notes:

1. AM spent fitting plates to boom arm structure. Pump and manifold positioned along dock.
2. PM, boom towed out of basin using one Sea Truck and a land line from dock. Calm conditions and very light currents, 0.1 - 0.2 m/s back eddy along dock.
3. Boom connected to pump, without anchoring. Boom oriented away from prevailing current. Some fouling of float with weed-covered tether rope, cleared away using work boat.
4. Trial was run with boom to monitor pressures; gauges really too large to accurately record pressures.
5. After trial run, approximately 7 litres of canola oil spilled, which followed current weakly. Boom was rapidly swung around and used to force oil against dockside. A small amount of oil lost either due to starting boom too late or may have simply been driven over when moving boom. Majority of oil was held against dock wall with such force that some mixing/emulsion occurred. Suggests that appropriate tactic in such situation is to use the boom to force the oil to a containment site, and then back the boom away.
6. Clean up by Pelican skimmer. Boom towed back to small craft basin.

Friday, 21 August 1992

Personnel: FTL: Bruce Paterson, Andre Lemieux
EC: Tony Lorenzo, Andre Dumouchel
CCG: Ray Amell, Gary Stevenson
"Pelican 10" Skimmer crew.

Notes:

1. AM, boom towed into position again using Sea Truck and land line. Weather conditions estimated at 15-20 knots and wave heights of 0.3m (1 foot). Some difficulty in towing due to winds but primarily due to fouling of tether cables with weeds, which increased drag (sufficient to break a shackle) and fouling the floats.
2. Boom was anchored in a position facing into the wind using a lighter anchor. Weeds were cut away from the fouled tether lines; broken line was re-attached, approx. 2m shorter which restricted closing of boom.
3. Manoeuvring trial was conducted with boom; again good control was maintained. Tether ropes were noted to assist in controlling boom as, when taut, the prevailing thrust on one arm will act to pull opposite arm with it. This is of particular value when pressure must be maintained on the forward (containment) side of the boom.
4. Pressures were monitored for varying motor RPM, jet combinations. While awaiting arrival of skimmer, pressure to barrier was maintained. Control of the barrier was maintained with light pressures, approx. 200 psi at manifold.
5. Spill was simulated using approx. 3/4 of barrel of canola oil. Barrier was initially positioned close to dockside, facing into the rivers. Weather conditions persisted, with substantial wave reflection from dock. Some oil escaped between end of boom and dock until the spill was forced away from the dock wall, until the umbilical hose was fully extended. There was also some oil escaped around the outboard end of the boom, and eventually through the apex of the boom. The skimmer was able to position behind each of these locations to collect oil. The oil lost around the outboard end of the boom might have been contained with more umbilical hose. It is estimated that 80 - 90% of the oil was contained between the boom arms. The trial was conducted for about 30 minutes, until a steady containment was evident.
6. Clean up by Pelican skimmer. Boom towed back to small craft basin. DFO wave buoy retrieved, PM.

APPENDIX D:
Wave Buoy Data
17-21 August 1992

Notes on Wave Buoy Deployment

Wave data for the trials was measured by a DFO omni-directional wave buoy, which measured wave heights for 8 minutes at 20 minute intervals. The post-processing of the collected spectral data was performed by the Marine Environmental Data Service (MEDS) of DFO. The wave data consists of:

- a) The mean significant wave height, calculated for the spectral wave height data measured over the time period of each trial.
- b) The maximum wave height measured at the time of each trial.
- c) The average modal period at the time of each trial.

Time histories of the wave height data were also obtained; a selection is presented as part of Appendix C. As noted in Section 4.2, the buoy was located in a position where it was exposed to the same general wave conditions as the test sites. However it was not exposed to some the wave reflection effects that were encountered, particularly during the final test day. Thus the barrier was operated in wave conditions that featured slightly steeper wave conditions with higher peak wave heights.

TABLE 2: ENVIRONMENTAL CONDITIONS ; 19 - 21 August 1992

Table 2.1: Wave Buoy Data

		Principal Activity	Significant	Maximum*	Modal	Observed
Date:	Time		Wave Height	Wave Height	Period	Wind Speed
			Hs (m)	Hmax (m)	Tm (s)	(knots)
19/8/92	1050	deployment	0.04	0.18	2.1	20 - 25
19/8/92	1120	towing	0.09	0.32	3.7	"
19/8/92	1150	towing	0.03	0.21	2.1	"
19/8/92	1220	testing	0.08	0.34	2.1	"
19/8/92	1250	testing	0.11	0.25	2.1	"
19/8/92	1320	in position	0.09	0.23	2.1	"
19/8/92	1350	towing	0.1	0.23	2.1	"
19/8/92	1420	towing	0.07	0.21	2.1	"
20/8/92	1420	deployment	0.02	0.07	3.2	0 - 5
20/8/92	1450	towing	0.02	0.06	2.1	"
20/8/92	1520	towing	0.02	0.06	2.4	"
20/8/92	1550	testing	0.07	0.23	3.2	"
20/8/92	1620	testing	0.04	0.1	2.4	"
20/8/92	1650	in position	0.03	0.13	2.1	"
20/8/92	1720	testing	0.02	0.04	28.6	"
20/8/92	1750	towing	0.02	0.04	28.6	"
21/8/92	920	deployment	0.03	0.07	4	15 - 20
21/8/92	950	towing	0.02	0.06	2.1	"
21/8/92	1020	testing	0.02	0.1	2.1	"
21/8/92	1050	testing	0.02	0.1	2.1	"
21/8/92	1120	in position	0.02	0.11	2.1	"
21/8/92	1150	testing	0.03	0.12	2.1	"
21/8/92	1220	testing	0.03	0.17	4.2	"
21/8/92	1250	testing	0.04	0.15	3.2	"
21/8/92	1320	towing	0.09	0.27	3.7	"
21/8/92	1350	towing	0.04	0.17	3.9	"

Notes:

1. Wave Data sampled for 8 minutes, starting every 20 minutes
2. Refer to Figure 7 in text for general location of Wave Buoy.
3. Maximum wave height defined as Maximum Zero Crossing Wave height.

Table 2.2: Measured Current Data

Current Velocity (m/s)	Position of Measurement
0.1	30 metres off pier, from CCGS SIMCOE
0.1	5 metres off pier, Dockside pump position
0.2	50 metres off pier, Dockside pump position
0.3	Mid-Channel, off CCG base
0.1	At wave buoy position

WATERJET BARRIER TRIALS - CCG PRESCOTT - 20 August 1992 - Wave Heights

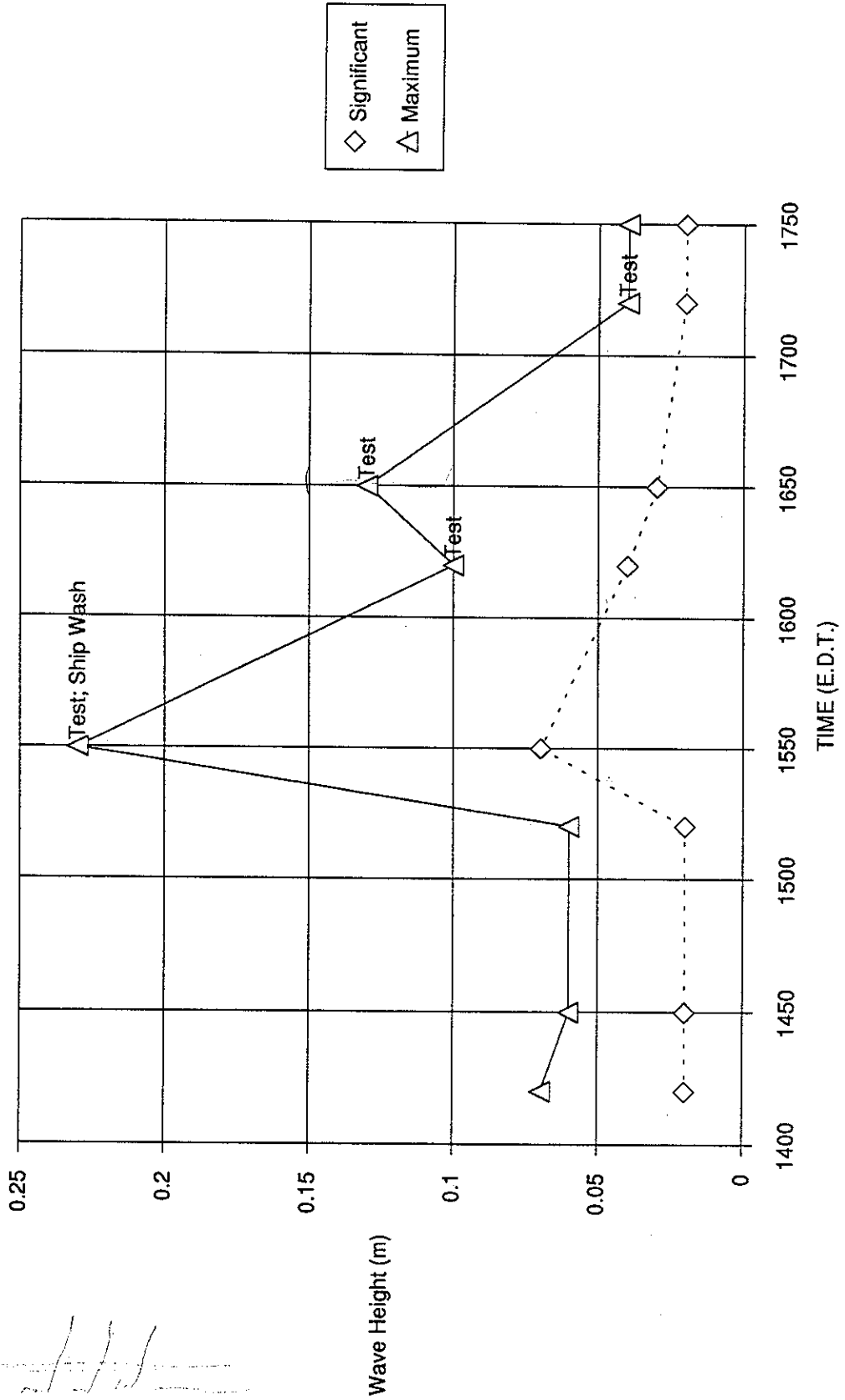

WATERJET BARRIER TRIALS - CCG PRESCOTT - 21 August 1992 - Wave Heights

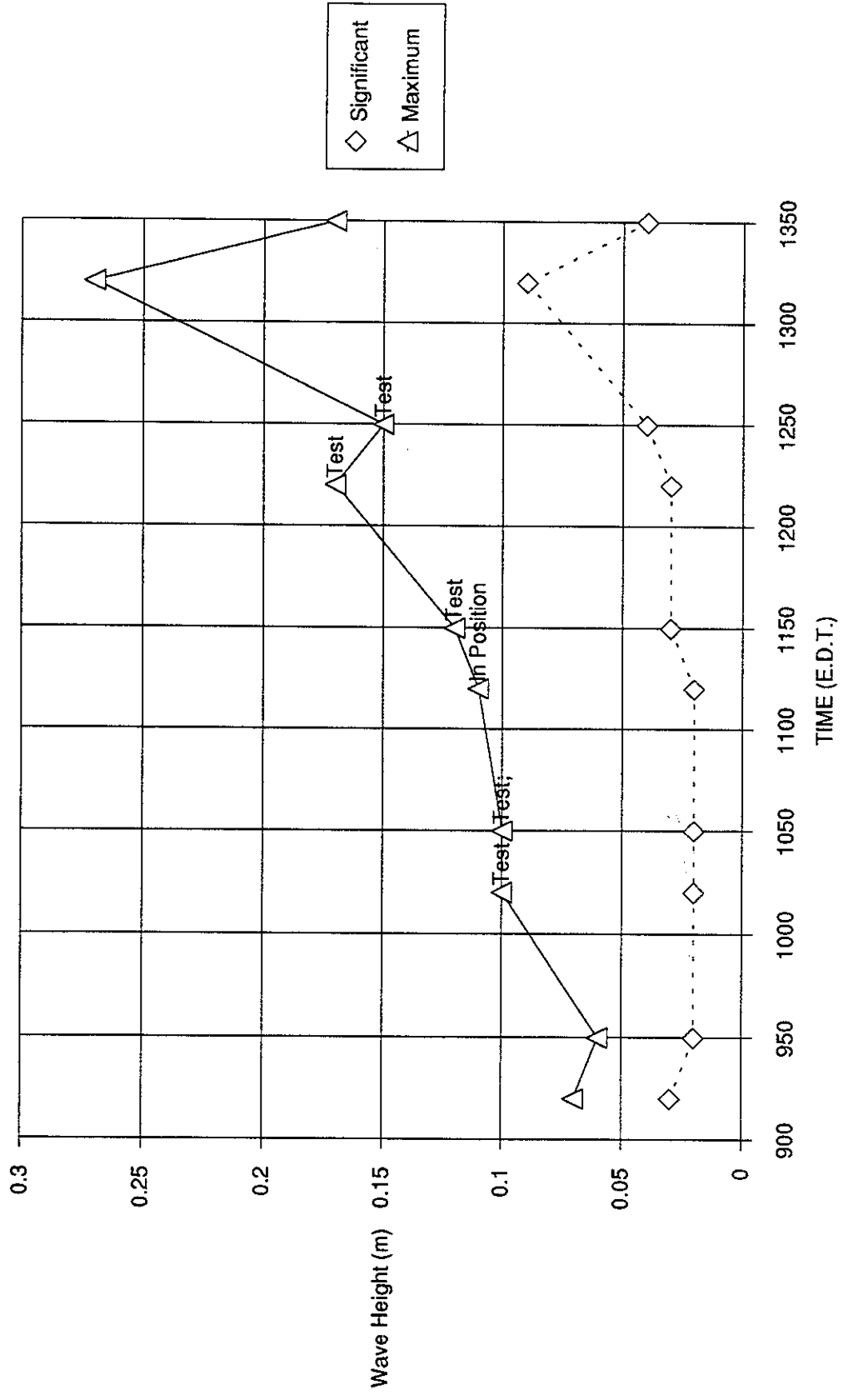

WATERJET BARRIER TRIALS - CCG PRESCOTT - 19 August 1992 - Wave Heights

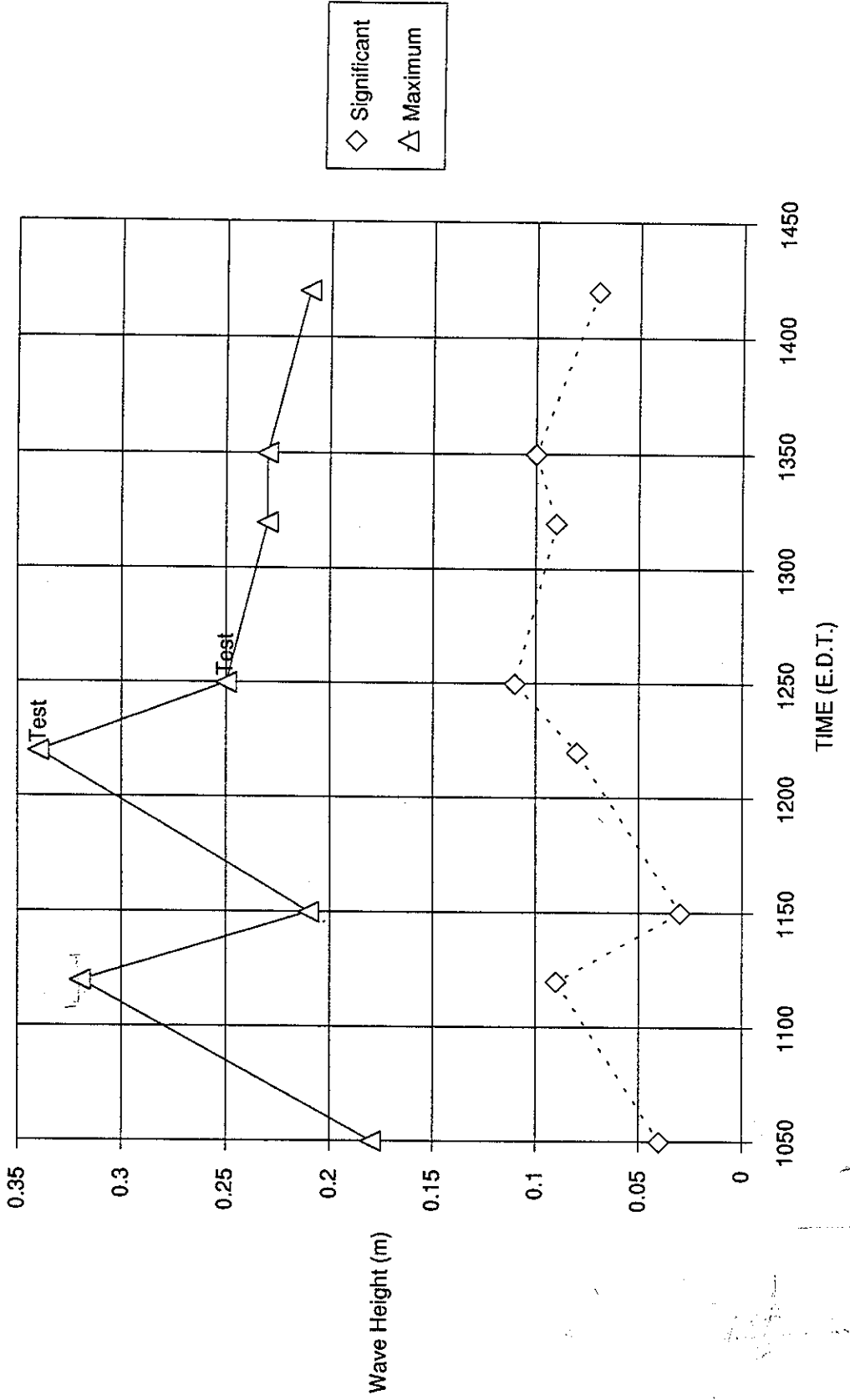

Station STN316 , Prescott Ontario AUG 92 44.707 N, 75.516 W

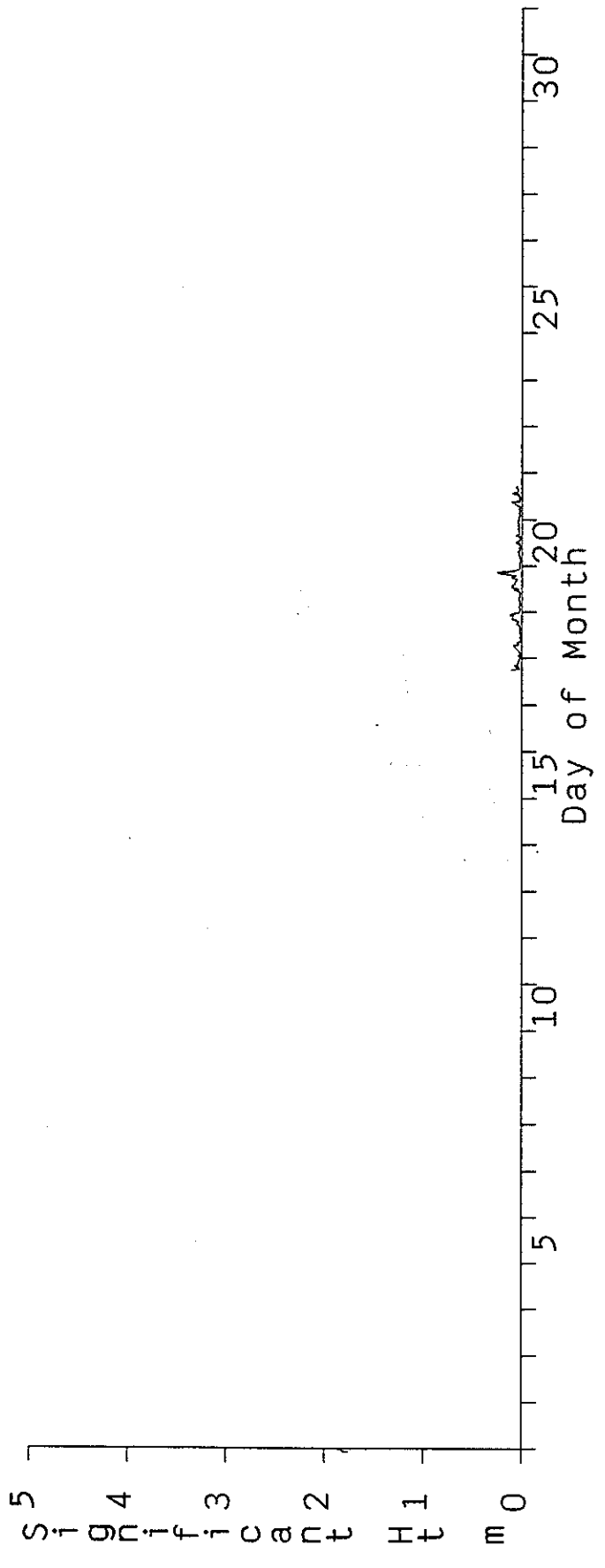
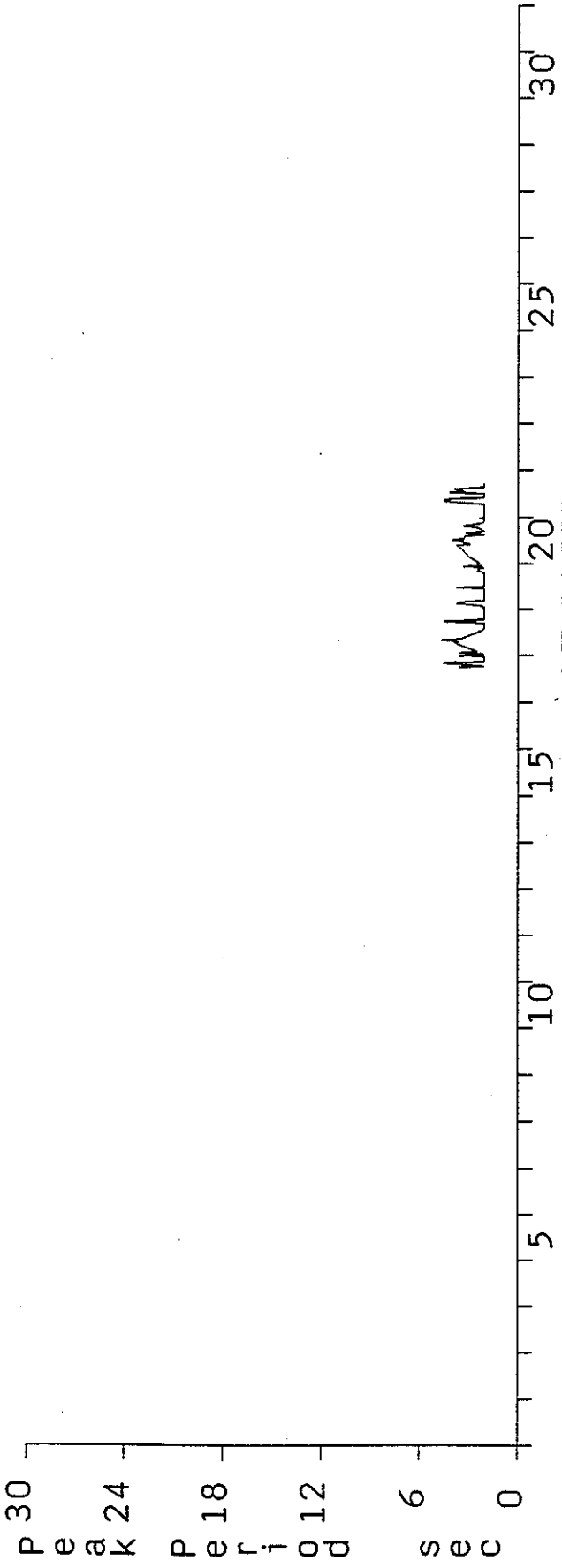

MARINE ENVIRONMENTAL DATA SERVICES

PLEASE NOTE THAT THE QUALITY OF THE DATA SUPPLIED IN RESPONSE TO YOUR REQUEST HAS BEEN REVIEWED USING TECHNIQUES AND STANDARDS CONSISTENT WITH GOOD SCIENTIFIC AND DATA MANAGEMENT PRACTICES. IT IS, HOWEVER, NOT POSSIBLE TO GUARANTEE THAT ALL ERRORS HAVE BEEN DETECTED AND EITHER CORRECTED OR FLAGGED. IT IS THE RESPONSIBILITY OF THE USER TO REVIEW THE DATA AND SUPPORTING INFORMATION TO DETERMINE ITS ACCEPTABILITY FOR THE APPLICATION AT HAND.

SERVICE DES DONNEES SUR LE MILIEU MARIN

VEUILLEZ NOTER QUE LA QUALITE DES DONNEES FOURNIES EN REPOSE A VOTRE DEMANDE A ETE ETUDIEE A L'AIDE DE TECHNIQUES ET DE NORMES CONFORMES AUX BONNES PRATIQUES SCIENTIFIQUES ET PRATIQUES DE GESTION DES DONNEES. TOUTEFOIS, IL N'EST PAS POSSIBLE DE GARANTIR QUE TOUTES LES ERREURS ONT ETE DECELEES ET, SOI CORRIGEEES, SOIT SIGNALEES. IL INCOMBE A L'UTILISATEUR D'ETUDIER LES DONNEES ET TOUT RENSEIGNEMENT A L'APPUI POUR DETERMINER S'IL SONT ACCEPTABLES AUX FINS DE L'APPLICATION PREVUE.

J. R. WILSON
DIRECTOR/DIRECTEUR
MARINE ENVIRONMENTAL DATA SERVICES BRANCH/
DIRECTION, SERVICE DES DONNEES SUR LE MILIEU MARIN
OCEAN SCIENCE AND SURVEYS/SCIENCES ET LEVES OCEANIQUES



**FLEET
TECHNOLOGY
LIMITED**

311 Leggett Drive
Kanata, Ontario
Phone: (613) 592-2830
FAX: (613) 592-4950

FAX TRANSMISSION

To:

NAME Ron Pajunen	DATE OF TRANSMISSION 22/10/92	PROJECT # 3922C
COMPANY DFO Wave Climate Study Division	FAX NUMBER 990-5510	

From:

NAME Bruce Paterson

Reference:

SUBJECT Prescott Wave Buoy Data

Message:

Please find attached 3 sets of the wave height data obtained from 12-21 August 1992. Also a table of the data used to generate the plot. To recap our phone call, I have a concern regarding the significant wave heights because:

- they are so small - are they within the resolution of the buoy?
- they are so much smaller than the peaks - not what I expected under relatively constant wind & wave conditions each day - i.e. winds weren't particularly gusty.
- there is so little variation between the three days despite observable differences in the weather - the 20th was a bit calmer while there was a decent bit of surging on the other days.

I am also concerned about the condition of the buoy after it was shifted. Was the calibration checked after the shift?

Bruce Paterson

FORMAT B FOR NON-DIRECTIONAL SPECTRAL WAVE DATA AND DERIVED PARAMETERS

VERSION FOR CODED TAPES

This format is to provide for derived parameters and for heave spectra for all types of wave buoys producing non-directional wave data. Note that when parameters are missing, fill the entire field with 9s. Each record type is read or written using a single read or write statement.

For each wave record there will be several 80 character records as follows.

1. Station Identification Record
2. Administrative Information Record
3. One or more Additional Parameters Records (Optional)
4. One or more Wave Height - Wave Period Records
5. Several Frequency-Bandwidth-Spectral Density Records

Station Identification Record

Station Type	10 char. field	A10	e.g. Hindcast, WAVEC buoy
Station Name	20 char. field	5X,A20	e.g. Tofino, Langara West
MEDS Station Ident	10 char. field	5X,A10	e.g. Cl, Waves Database

FORMAT (A10,5X,A20,5X,A10)

Administrative Information Record

Latitude	Real	F10.4	Negative is south latitude
Longitude	Real	F10.4	Negative is east longitude
Depth of Water	Real	F8.1	Meters
Date of Observation	Integer	I4	Year
	Integer	I2	Month
Time of Observation	Integer	I2	Day
Length of Recording	Integer	I6	HHMM
Sampling Frequency	Real	F8.1	Minutes
Qual. Code for Record	Real	E12.3	Hz.
No. of Additional Params	2 char. field	2X,A2	See Table I
No. of Wave Heights	Integer	I4	No. additional parameters
No. of Wave Periods	Integer	I3	No. wave height parameters
No. of Spec. Est.	Integer	I3	No. wave period parameters
	Integer	I4	No. of Spec. Est. following

FORMAT (2F10.4,F8.1,I4,2I2,I6,F8.1,E12.3,2X,A2,I4,2I3,I4)

Additional Parameters Record(s) (Optional)

Parameter 1	Real		See Table II for parameters
Parameter Code 1	4 char. field		

Parameter n	Real	
-------------	------	--

Parameter Code n 4 char. field

FORMAT (5(E12.5,A4))

Wave Heights-Periods Record(s)

Wave Height 1	Real	Wave Height (m)
Wave Height Code 1	4 char. field	Type of Wave Height(Table II)
-	-	-
Wave Height n	Real	Wave Height (m)
Wave Height Code n	4 char. field	Type of Wave Height(Table II)
Period 1	Real	Wave Period (sec)
Period Code 1	4 char. field	Type of Wave Period(Table II)
-	-	-
Period n	Real	Wave Period (sec)
Period Code n	4 char. field	Type of Wave Period(Table II)

FORMAT (8(F6.2,A4))

Frequency-Bandwidth-Spectral Density Records

Freq 1	Real	Hz.
Bandwidth 1	Real	Hz.
Density 1	Real	M**2/Hz.
-	-	-
-	-	-
Freq n	Real	Hz.
Bandwidth n	Real	Hz.
Density n	Real	M**2/Hz.

FORMAT (6E12.4)

TABLE I - QUALITY CODES

- The quality codes are based on the IGOSS quality codes.
- b (blank) 0 - No quality control (QC) has been performed
 - G (good) 1 - QC has been performed: record appears correct
 - D (doubtful) 3 - QC has been performed: record appears doubtful
 - E (erroneous) 4 - QC has been performed: record appears erroneous
 - 5 - The record has been changed as a result of QC
 - A (acceptable) 6 - QC has been performed: record seems inconsistent with with other records
 - 7 - Reserved
 - 8 - Reserved

[LIBRARY]WAVE CLIMATE
 Table II of Format-B
 Authors: J.R. Wilson, J.R. Keeley
 Last updated: 13 May, 1992

TABLE II - PARAMETER CODES

The following parameter codes are based on the standard GF-3 parameter codes or on MEDS assigned codes.

Administrative Parameter Codes

Parameter

ADNB	Number of Fourier Transform Blocks in Analysis
ADST	DIWAR Receiver Signal Strength
ADSV	DIWAR receiver signal strength variance
AST1	Internal temperature from the non-synoptic part of WRIPS buoy data. (Note that this is not a standard GF3 parameter)
AST2	Internal temperature from the synoptic part of WRIPS buoy data. (Note that this is not a standard GF3 parameter)
NBD1	The number of bad samples in a surface elevation time series. (Note that this is not a standard GF3 parameter)
RECD	The record number of the tape containing the raw data. (Note that this is not a standard GF3 parameter)
SIDE	The side number of the tape containing the raw data. (Note that this is not a standard GF3 parameter)
TAPE	The tape number of the tape containing the raw data. (Note that this is not a standard GF3 parameter)

Metereological Codes

Parameter

ATMS	Atmospheric pressure at sea level
DRYT	Dry bulb temperature (degrees C)
GSPD	Gust wind speed (m/sec)
GDIR	Direction from which gust wind is blowing
WDIR	Direction from which the wind is blowing.
WFR1	Wind frictional velocity. (Note that this is not a standard GF3 parameter) (m/sec)
WSPD	Horizontal Wind Speed (m/sec)

Oceanographic Codes

Parameter

SLEV	Observed sea level.
SST1	Average sea temperature from the non-synoptic part of WRIPS buoy data. (Note that this is not a standard GF3 parameter)
SST2	Average sea temperature from the

synoptic part of WRIPS buoy data. (Note that this is not a standard GF3 parameter)
Sea surface temperature

SSTP

Position Codes

Parameter

MAGN

Magnetic variation from true north (degrees)

Spectral information

Parameter

BAND

Bandwidth of spectral estimates.

FREQ

Frequency of spectral estimates.

VCXX

Autospectrum of north-south tilt (C22)

VCXY

Cospectrum of north-south and east-west tilt (C23)

VCYY

Autospectrum of east-west tilt (C33)

VCZX

Cospectrum of heave and north-south tilt (C12)

VCZY

Cospectrum of heave and east-west tilt (C13)

VQXY

Quadspectrum of north-south and east-west tilt (Q23)

VQZX

Quadspectrum of heave and north-south tilt (Q12)

VQZY

Quadspectrum of heave and east-west tilt (Q13)

VSDN

Spectral density (equivalent to C11)

VSMB

The ratio of spectral moments 0 and 1; (m0/m1)

Wave Direction Codes

Parameter

AED1

AES wave direction (from METOC hindcast). This is probably the wind direction. (Note that this is not a standard GF3 parameter)

SED1

WES sea direction. (Note that this is not a standard GF3 parameter)

SWDR

Direction from which swell is coming (relative to true north)

VMED

Wave Spectrum mean energy direction

VPED

Wave Spectrum peak energy direction

VSPR

Wave directional spread from cross spectra

Wave Height Codes

Parameter

SEH1

WES sea height. (Note that this is not a standard GF3 parameter)

SWHT

Swell height.

VAV1

Average heave from the non-synoptic part of WRIPS buoy data. (Note that this is not a standard GF3 parameter)

VAV2

Average heave from the synoptic part of WRIPS buoy data. (Note that this is not a standard GF3 parameter)

VCAR

Characteristic (Significant) Wave Height

VCH1

AES wave height (from the METOC hindcast). It is the maximum wave height found in the 5

VCMX	degree square. (Note that this is not a standard GF3 parameter)
VMNL	Maximum Zero Crossing Wave Height
VMXL	Depth of the deepest trough.
VMX1	Height of the highest crest.
VMX2	Maximum Zero Crossing Wave Height from the non-synoptic part of WRIPS buoy data. (Note that this is not a standard GF3 parameter)
VST1	Maximum Zero Crossing Wave Height from the synoptic part of WRIPS buoy data. (Note that this is not a standard GF3 parameter)
	Maximum wave steepness. (Note that this is not a standard GF3 parameter)

Wave Period Codes

Parameter

SEP1	WES sea period. (Note that this is not a standard GF3 parameter)
SWPR	Swell period
VAP1	AES wave period (from the METOC hindcast). (Note that this is not a standard GF3 parameter)
VTD1	Dominant period. (Note that this is not a standard GF3 parameter)
VTPK	Wave Spectrum Peak Period
VTZA	Average Zero Crossing Wave Period
VZA1	Average zero crossing period from the non-synoptic part of WRIPS buoy data. (Note that this is not a standard GF3 parameter)
VZA2	Average zero crossing period from the synoptic part of WRIPS buoy data. (Note that this is not a standard GF3 parameter)

EST PERIOD WAVE DATA RECORDS

Prescott Ontario STN316

44.7070 75.5160 7.0 92 819 920 26.7 0.128E+01 1 6 2 2 64
 J.32000E+01VERS 0.25600E+03ADNS 0.18601E+04ADST 0.11864E+00ADSV 0.80000E+01ADNB
 0.80400E+03NWAV

0.02VCAR 0.13VCMX 2.06VTPK 1.99VTZA

Prescott Ontario STN316

44.7070 75.5160 7.0 92 819 950 26.7 0.128E+01 4 6 2 2 64
 J.32000E+01VERS 0.25600E+03ADNS 0.18600E+04ADST 0.67797E-01ADSV 0.80000E+01ADNB
 0.76300E+03NWAV

0.02VCAR 0.12VCMX 28.57VTPK 2.09VTZA

Prescott Ontario STN316

44.7070 75.5160 7.0 92 819 1020 26.7 0.128E+01 1 6 2 2 64
 J.32000E+01VERS 0.25600E+03ADNS 0.18588E+04ADST 0.16949E+00ADSV 0.80000E+01ADNB
 0.75900E+03NWAV

0.02VCAR 0.16VCMX 2.06VTPK 2.10VTZA

Prescott Ontario STN316

44.7070 75.5160 7.0 92 819 1050 26.7 0.128E+01 1 6 2 2 64
 J.32000E+01VERS 0.25600E+03ADNS 0.18831E+04ADST-0.50847E-01ADSV 0.80000E+01ADNB
 0.70500E+03NWAV

0.04VCAR 0.18VCMX 2.06VTPK 2.26VTZA

Prescott Ontario STN316

44.7070 75.5160 7.0 92 819 1120 26.7 0.128E+01 1 6 2 2 64
 J.32000E+01VERS 0.25600E+03ADNS 0.18840E+04ADST 0.16949E-01ADSV 0.80000E+01ADNB
 0.63600E+03NWAV

0.09VCAR 0.32VCMX 3.74VTPK 2.51VTZA

Prescott Ontario STN316

44.7070 75.5160 7.0 92 819 1150 26.7 0.128E+01 1 6 2 2 64
 J.32000E+01VERS 0.25600E+03ADNS 0.18867E+04ADST-0.16102E+00ADSV 0.80000E+01ADNB
 0.83700E+03NWAV

0.03VCAR 0.21VCMX 2.06VTPK 1.91VTZA

Prescott Ontario STN316

44.7070 75.5160 7.0 92 819 1220 26.7 0.128E+01 1 6 2 2 64
 J.32000E+01VERS 0.25600E+03ADNS 0.18872E+04ADST 0.29661E+00ADSV 0.80000E+01ADNB
 0.79900E+03NWAV

0.08VCAR 0.34VCMX 2.06VTPK 2.00VTZA

Prescott Ontario STN316

44.7070 75.5160 7.0 92 819 1250 26.7 0.128E+01 1 6 2 2 64
 J.32000E+01VERS 0.25600E+03ADNS 0.18464E+04ADST 0.61017E+00ADSV 0.80000E+01ADNB
 0.76200E+03NWAV

0.11VCAR 0.25VCMX 2.06VTPK 2.10VTZA

Prescott Ontario STN316

44.7070 75.5160 7.0 92 819 1320 26.7 0.128E+01 1 6 2 2 64
 J.32000E+01VERS 0.25600E+03ADNS 0.18497E+04ADST 0.13390E+01ADSV 0.80000E+01ADNB
 0.78000E+03NWAV

0.09VCAR 0.23VCMX 2.06VTPK 2.05VTZA

Prescott Ontario STN316

44.7070 75.5160 7.0 92 819 1350 26.7 0.128E+01 1 6 2 2 64
 J.32000E+01VERS 0.25600E+03ADNS 0.18495E+04ADST 0.84746E+00ADSV 0.80000E+01ADNB
 0.78500E+03NWAV

0.10VCAR 0.23VCMX 2.06VTPK 2.03VTZA

Prescott Ontario STN316

44.7070 75.5160 7.0 92 819 1420 26.7 0.128E+01 1 6 2 2 64
 J.32000E+01VERS 0.25600E+03ADNS 0.18456E+04ADST 0.93644E+01ADSV 0.80000E+01ADNB
 0.81200E+03NWAV

0.07VCAR 0.21VCMX 2.06VTPK 1.97VTZA

Prescott Ontario STN316

44.7070 75.5160 7.0 92 819 1450 26.7 0.128E+01 1 6 2 2 64
 J.32000E+01VERS 0.25600E+03ADNS 0.18092E+04ADST 0.18305E+01ADSV 0.80000E+01ADNB

J.79500E+03NWAV

0.06VCAR 0.17VCMX 2.06VTPK 2.01VTZA

Prescott Ontario STN316

44.7070 75.5160 7.0 92 819 1520 26.7 0.128E+01 1 6 2 2 64
0.32000E+01VERS 0.25600E+03ADNS 0.18463E+04ADST 0.11695E+01ADSV 0.80000E+01ADNB
0.6000E+03NNAV
08VCAR 0.22VCMX 2.06VTPK 2.10VTZA

Prescott Ontario STN316

44.7070 75.5160 7.0 92 820 1420 26.7 0.128E+01 1 6 2 2 64
0.32000E+01VERS 0.25600E+03ADNS 0.18316E+04ADST 0.77119E+00ADSV 0.80000E+01ADNB
0.1500E+03NNAV
0.02VCAR 0.07VCMX 3.17VTPK 7.33VTZA

Prescott Ontario STN316

44.7070 75.5160 7.0 92 820 1450 26.7 0.128E+01 1 6 2 2 64
0.32000E+01VERS 0.25600E+03ADNS 0.18151E+04ADST 0.30678E+01ADSV 0.80000E+01ADNB
0.42800E+03NNAV
0.02VCAR 0.06VCMX 2.06VTPK 3.72VTZA

Prescott Ontario STN316

44.7070 75.5160 7.0 92 820 1520 26.7 0.128E+01 1 6 2 2 64
0.32000E+01VERS 0.25600E+03ADNS 0.18165E+04ADST 0.91525E+00ADSV 0.80000E+01ADNB
0.19900E+03NNAV
0.02VCAR 0.06VCMX 2.35VTPK 5.33VTZA

Prescott Ontario STN316

44.7070 75.5160 7.0 92 820 1550 26.7 0.128E+01 1 6 2 2 64
0.32000E+01VERS 0.25600E+03ADNS 0.18173E+04ADST 0.28475E+01ADSV 0.80000E+01ADNB
0.42900E+03NNAV
0.07VCAR 0.23VCMX 3.17VTPK 3.72VTZA

Prescott Ontario STN316

44.7070 75.5160 7.0 92 820 1620 26.7 0.128E+01 1 6 2 2 64
0.32000E+01VERS 0.25600E+03ADNS 0.18191E+04ADST 0.76271E+00ADSV 0.80000E+01ADNB
0.3900E+03NNAV
0.04VCAR 0.10VCMX 2.35VTPK 2.96VTZA

Prescott Ontario STN316

44.7070 75.5160 7.0 92 820 1650 26.7 0.128E+01 1 6 2 2 64
0.32000E+01VERS 0.25600E+03ADNS 0.18152E+04ADST 0.13246E+02ADSV 0.80000E+01ADNB
0.45000E+03NNAV
0.03VCAR 0.13VCMX 2.06VTPK 3.55VTZA

Prescott Ontario STN316

44.7070 75.5160 7.0 92 820 1720 26.7 0.128E+01 4 6 2 2 64
0.32000E+01VERS 0.25600E+03ADNS 0.18190E+04ADST 0.13559E+00ADSV 0.80000E+01ADNB
0.8800E+03NNAV
0.02VCAR 0.04VCMX 28.57VTPK 5.51VTZA

Prescott Ontario STN316

44.7070 75.5160 7.0 92 820 1750 26.7 0.128E+01 4 6 2 2 64
0.32000E+01VERS 0.25600E+03ADNS 0.18210E+04ADST 0.10169E+00ADSV 0.80000E+01ADNB
0.52300E+03NNAV
0.02VCAR 0.04VCMX 28.57VTPK 3.05VTZA

Prescott Ontario STN316

44.7070 75.5160 7.0 92 821 920 26.7 0.128E+01 1 6 2 2 64
0.32000E+01VERS 0.25600E+03ADNS 0.17468E+04ADST 0.17373E+01ADSV 0.80000E+01ADNB
0.48600E+03NNAV
0.03VCAR 0.07VCMX 4.00VTPK 3.28VTZA

Prescott Ontario STN316

44.7070 75.5160 7.0 92 821 950 26.7 0.128E+01 1 6 2 2 64
0.32000E+01VERS 0.25600E+03ADNS 0.17477E+04ADST 0.18475E+01ADSV 0.80000E+01ADNB
0.0500E+03NNAV
0.02VCAR 0.06VCMX 2.06VTPK 2.64VTZA

Prescott Ontario STN316

44.7070 75.5160 7.0 92 821 1020 26.7 0.128E+01 1 6 2 2 64
0.32000E+01VERS 0.25600E+03ADNS 0.17150E+04ADST 0.43220E+01ADSV 0.80000E+01ADNB

.70800E+03NNAV
 0.02VCAR 0.10VCMX 2.06VTPK 2.26VTZA
 Prescott Ontario STN316
 44.7070 75.5160 7.0 92 821 1050 26.7 0.128E+01 1 6 2 2 64
 .32000E+01VERS 0.25600E+03ADNS 0.17878E+04ADST 0.26356E+01ADSV 0.60000E+01ADNB
 0.59300E+03NNAV
 0.02VCAR 0.10VCMX 2.06VTPK 2.02VTZA
 Prescott Ontario STN316
 44.7070 75.5160 7.0 92 821 1120 26.7 0.128E+01 1 6 2 2 64
 .32000E+01VERS 0.25600E+03ADNS 0.17941E+04ADST 0.74576E+00ADSV 0.80000E+01ADNB
 .86500E+03NNAV
 0.02VCAR 0.11VCMX 2.06VTPK 1.85VTZA
 Prescott Ontario STN316
 44.7070 75.5160 7.0 92 821 1150 26.7 0.128E+01 1 6 2 2 64
 .32000E+01VERS 0.25600E+03ADNS 0.18233E+04ADST 0.11119E+02ADSV 0.80000E+01ADNB
 0.83000E+03NNAV
 0.03VCAR 0.12VCMX 2.06VTPK 1.93VTZA
 Prescott Ontario STN316
 44.7070 75.5160 7.0 92 821 1220 26.7 0.128E+01 1 6 2 2 64
 .32000E+01VERS 0.25600E+03ADNS 0.18154E+04ADST 0.93220E-01ADSV 0.80000E+01ADNB
 .74100E+03NNAV
 0.03VCAR 0.17VCMX 4.17VTPK 2.15VTZA
 Prescott Ontario STN316
 44.7070 75.5160 7.0 92 821 1250 26.7 0.128E+01 1 6 2 2 64
 .32000E+01VERS 0.25600E+03ADNS 0.18233E+04ADST 0.86441E+00ADSV 0.80000E+01ADNB
 0.77600E+03NNAV
 0.04VCAR 0.15VCMX 3.17VTPK 2.06VTZA
 Prescott Ontario STN316
 44.7070 75.5160 7.0 92 821 1320 26.7 0.128E+01 1 6 2 2 64
 .32000E+01VERS 0.25600E+03ADNS 0.18017E+04ADST 0.10254E+01ADSV 0.80000E+01ADNB
 .67300E+03NNAV
 0.09VCAR 0.27VCMX 3.74VTPK 2.37VTZA
 Prescott Ontario STN316
 44.7070 75.5160 7.0 92 821 1350 26.7 0.128E+01 1 6 2 2 64
 .32000E+01VERS 0.25600E+03ADNS 0.17989E+04ADST 0.13729E+01ADSV 0.80000E+01ADNB
 0.81600E+03NNAV
 0.04VCAR 0.17VCMX 3.74VTPK 1.96VTZA
 Prescott Ontario STN316
 44.7070 75.5160 7.0 92 821 1420 26.7 0.128E+01 1 6 2 2 64
 .32000E+01VERS 0.25600E+03ADNS 0.18152E+04ADST 0.55424E+01ADSV 0.80000E+01ADNB
 .73700E+03NNAV
 0.05VCAR 0.18VCMX 3.88VTPK 2.17VTZA
 Prescott Ontario STN316
 44.7070 75.5160 7.0 92 821 1450 26.7 0.128E+01 1 6 2 2 64
 .32000E+01VERS 0.25600E+03ADNS 0.18200E+04ADST 0.81356E+00ADSV 0.80000E+01ADNB
 0.85000E+03NNAV
 0.03VCAR 0.15VCMX 2.06VTPK 1.88VTZA
 Prescott Ontario STN316
 44.7070 75.5160 7.0 92 821 1520 26.7 0.128E+01 1 6 2 2 64
 .32000E+01VERS 0.25600E+03ADNS 0.18054E+04ADST 0.10254E+01ADSV 0.80000E+01ADNB
 .76300E+03NNAV
 0.04VCAR 0.18VCMX 2.06VTPK 2.09VTZA
 Prescott Ontario STN316
 44.7070 75.5160 7.0 92 821 1550 26.7 0.128E+01 1 6 2 2 64
 .32000E+01VERS 0.25600E+03ADNS 0.18076E+04ADST 0.44915E+00ADSV 0.80000E+01ADNB
 0.83800E+03NNAV
 0.04VCAR 0.17VCMX 2.06VTPK 1.91VTZA

DESCRIPTION OF OUTPUT FORMAT FOR SUMMARY WAVE FILES

Column	Description
1-5	Consecutive record number, right justified.
6-8	Blank
9-18	Meds identification number
19-38	Station name
40-41	Year (YY)
42	Blank
43-44	Month (MM)
45	Blank
46-47	Day (DD)
48	Blank
49-52	Time (HHMM)
53-59	Significant Wave Height (metres)
60-64	Peak Period (secs)
65	Blank
66	Meds Quality Flag 0=No Quality Checks (QC) done 1=QC done, record good 3=QC done, record doubtful 4=QC done, record erroneous 6=QC done, record inconsistent
67-70	Blank
71-73	Number of spectral densities in the record
74-75	Blank
76-81	Lowest frequency(Hz) in the record
82-89	Spectral density of the lowest frequency
90	Blank
91-97	Frequency of the maximum spectral density in the record
98-105	Maximum spectral density in the record
106	Blank
107-113	Highest frequency in the record
114-121	Spectral density of the highest frequency
122-123	Blank
124-128	Consecutive record number, right justified.

NOTE: In some cases, certain spectra have been flagged as erroneous, but are represented in the listing for completeness. Some of the associated values exceed the field sizes allocated in the format description. In this case, the field is filled with "9"s with the same number of decimal places as correct numbers.

Table 4-3. Wind and Sea Scale For Fully Arisen Sea

WIND AND SEA SCALE FOR FULLY ARISEN SEA													
WIND							SEA						
DESCRIPTION	BEAUFORT	RANGE (KNOTS)	WIND VELOCITY (KNOTS)	AVERAGE	SIGNIFICANT	AVERAGE 1/10 HIGHEST	WAVE HEIGHT FEET		PERIODS (SECONDS)	T (PERIOD OF MAXIMUM T _{max} ENERGY OF SPECTRUM)	L (AVERAGE "PERIOD")	MINIMUM FETCH (NAUTICAL MILES)	MINIMUM DURATION (HOURS)
							UP TO 12 SEC.	HIGHEST					
CALM	0	0-1	0	0	0	0	—	—	—	—	—	—	—
LIGHT AIR	1	1-3	2	0.05	0.08	0.10	UP TO 12 SEC.	0.7	0.5	10 IN.	5	8 MIN.	
LIGHT BREEZE	2	4-6	5	0.18	0.29	0.37	0.4-2.8	2.0	1.4	6.7 FT.	8	39 MIN.	
GENTLE BREEZE	3	7-10	8.5	0.5	1.0	1.2	0.8-5.0	3.4	2.4	20	98	17 HRS.	
			10	0.88	1.4	1.8	1.0-6.0	4	2.9	27	10	24	
MODERATE BREEZE	4	11-16	12	1.4	2.2	2.8	1.0-7.0	4.8	3.4	40	18	38	
			13.5	1.8	2.9	3.7	1.4-7.6	5.4	3.9	52	24	48	
			14	2.0	3.3	4.7	1.5-7.8	5.6	4.0	59	28	52	
			16	2.9	4.6	5.8	2.0-8.8	6.5	4.6	71	40	66	
FRESH BREEZE	5	17-21	18	3.8	6.1	7.8	2.5-10.0	7.2	5.1	90	55	83	
			19	4.3	6.9	8.7	2.8-10.6	7.7	5.4	99	65	92	
			20	5.0	8.0	10	3.0-11.1	8.1	5.7	111	75	10	
STRONG BREEZE	6	22-27	22	6.4	10	13	3.4-12.2	8.9	6.3	134	100	12	
			24	7.9	12	16	3.7-13.5	9.7	6.8	160	130	14	
			24.5	8.2	13	17	3.8-13.6	9.9	7.0	164	140	15	
			26	9.6	15	20	4.0-14.5	10.5	7.4	188	180	17	
MODERATE GALE	7	28-33	28	11	18	23	4.5-15.5	11.3	7.9	212	230	20	
			30	14	22	28	4.7-16.7	12.1	8.6	250	280	23	
			30.5	14	23	29	4.8-17.0	12.4	8.7	258	290	24	
			32	16	26	33	5.0-17.5	12.9	9.1	285	340	27	
FRESH GALE	8	34-40	34	19	30	38	5.5-18.5	13.6	9.7	322	420	30	
			36	21	35	44	5.8-19.7	14.5	10.3	363	500	34	
			37	23	37	46.7	6-20.3	14.9	10.5	376	530	37	
			38	25	40	50	6.2-20.6	15.4	10.7	392	600	38	
STRONG GALE	9	41-47	40	28	45	58	6.5-21.7	16.1	11.4	444	710	42	
			42	31	50	64	7-23	17.0	12.0	492	830	47	
			44	36	58	73	7-24.2	17.7	12.5	534	960	52	
WHOLE GALE	10	48-55	46	40	64	81	7-25	18.6	13.1	590	1110	57	
			48	44	71	90	7.5-26	19.4	13.8	650	1250	63	
			50	49	78	99	7.5-27	20.2	14.3	700	1420	69	
			51.5	52	83	106	8-28.2	20.8	14.7	736	1560	73	
STORM	11	56-63	52	54	87	110	8-28.5	21.0	14.8	750	1610	75	
			54	59	95	121	8-29.5	21.8	15.4	810	1800	81	
			56	64	103	130	8.5-31	22.6	16.3	910	2100	88	
HURRICANE	12	>64	>84	>80b	>120b	>164b	10-(36)	(26)	(18)	~	~		

* FOR HURRICANE WINDS AND OFTEN WHOLE GALE AND STORM WINDS MEASURED DURATION AND FETCHES ARE RARELY ATTAINED SEAS ARE THEREFORE NOT FULLY ARISEN

g) A HEAVY BOX AROUND THIS VALUE MEANS THAT THE VALUES TABULATED ARE AT THE CENTER OF THE BEAUFORT RANGE.

b) FOR SUCH HIGH WINDS, THE SEAS ARE CONFUSED. THE WAVE CRESTS BLOW OFF AND THE WATER AND THE AIR MIX.

FROM PIERSON, NEUMANN AND JAMES, "PRACTICAL METHODS FOR OBSERVING AND FORECASTING OCEAN WAVES" N.Y.U., 1958

APPENDIX E:
Revised Waterjet Barrier Drawings

As Tested August 1992

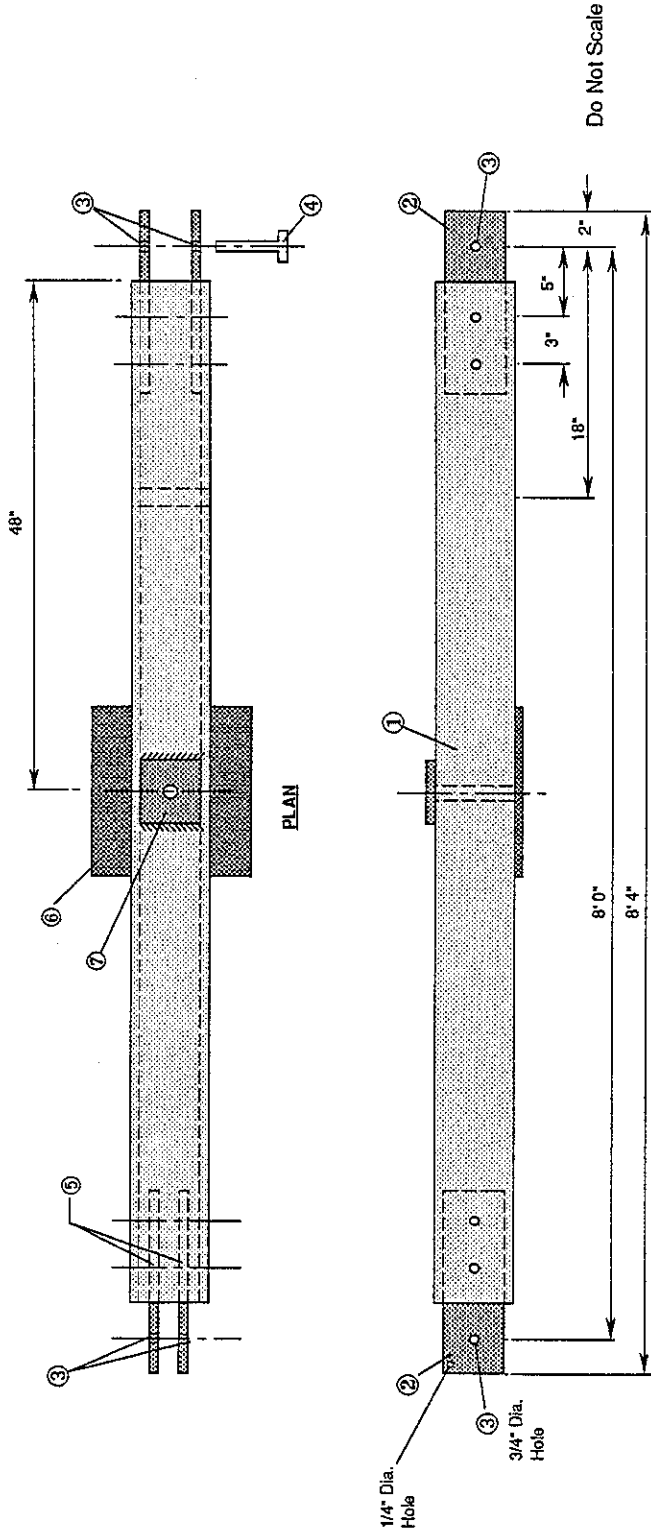

Parts List

No.	Item	Qty
①	4" x 4" x 0.25" 6061-T6 Aluminum HSS	1
②	2 1/2" x 15" x 0.5" Aluminum Plate	4
③	0.567" x 0.5" Teflon Cylindrical Bearing	3
④	0.567" Dia. Stainless Steel Bolt c/w Locking Nut	1
⑤	2.5" x 9" x 0.5" Aluminum Plate	2
⑥	12" x 12" x 0.25" Aluminum Plate	1
⑦	3.75" x 4" x 0.25" Aluminum Plate	1



Title:	Barrier Arm Support		
Project:	Waterjet Barrier		
Project No.:	3922C		
Dwg No.:	3922-1	Scale:	N/A
Date:	28/2/92	Rev.:	18/9/92

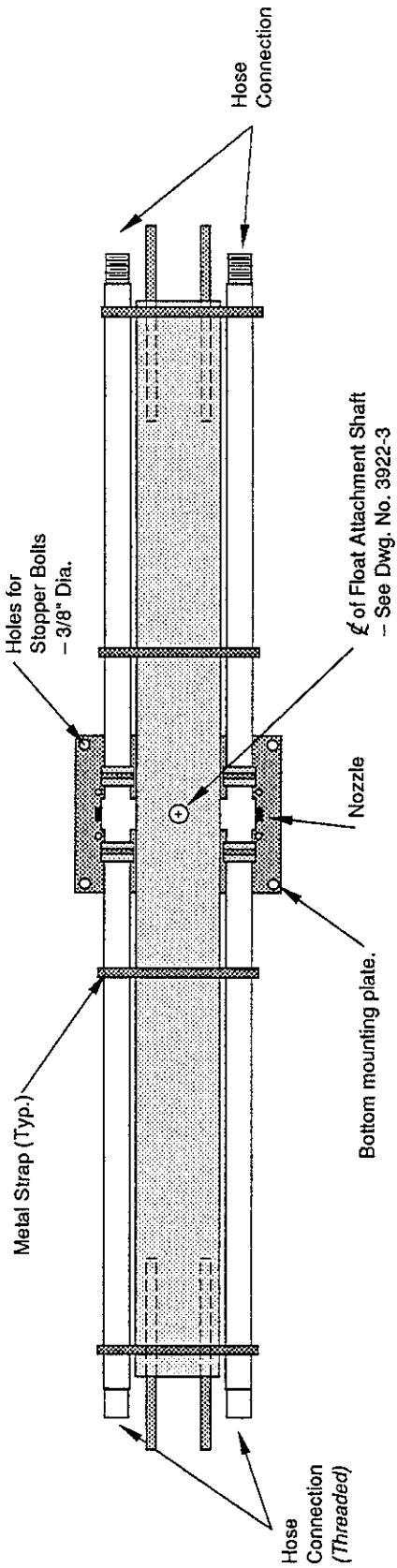

PLAN

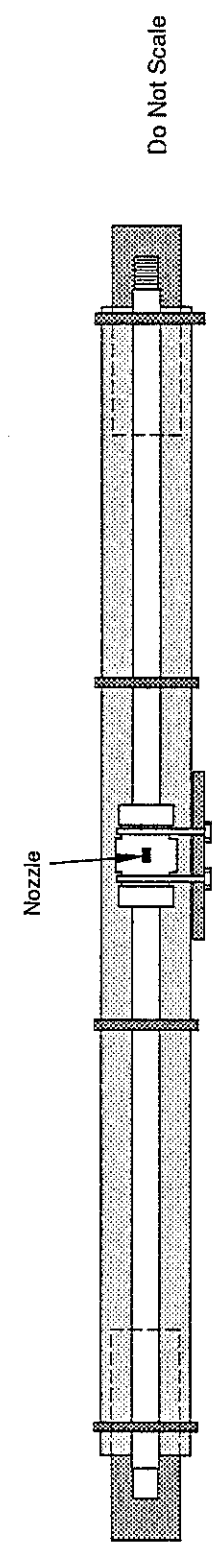

Do Not Scale

PROFILE

FLEET TECHNOLOGY LIMITED			
Title:	Attachment of Discharge Hose & Nozzle to Barrier Arm Support		
Project:	Waterjet Barrier		
Project No.	3922C		
Dwg No.:	3922-2	Scale:	N/A
Date:	28/2/92	Rev.	18/9/92

Section Showing Float Attachment Assembly

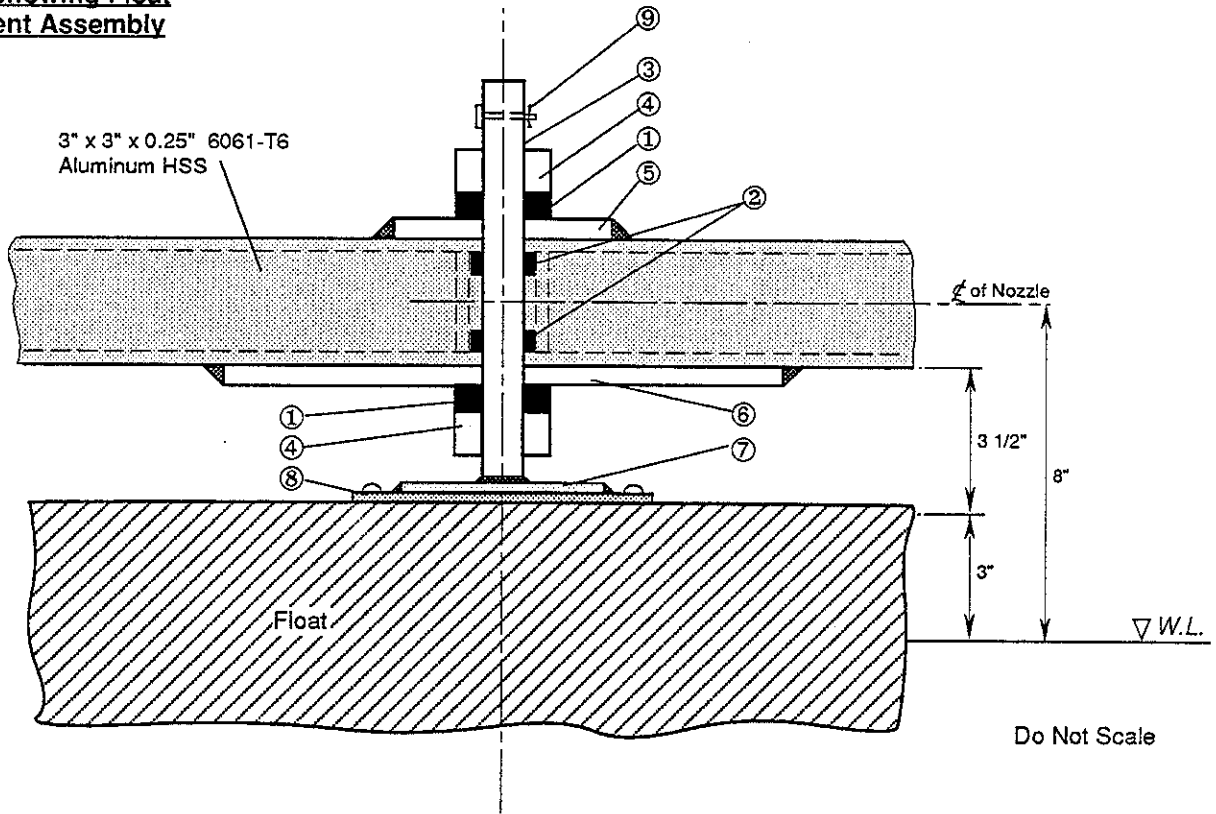

Do Not Scale

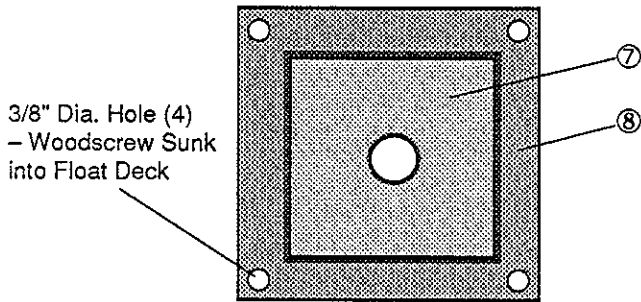

Plan of Float Post Mounting

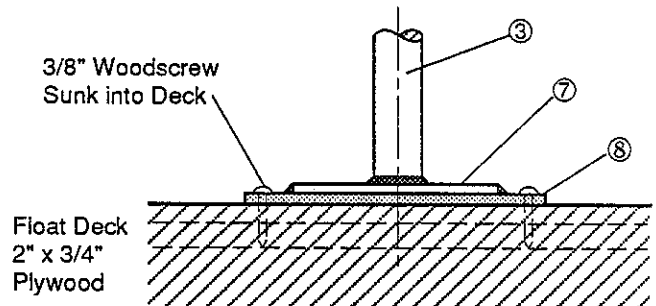

Profile Showing Float Post Attachment

Parts List

No.	Item	Qty
①	2" OD x 1" ID x 0.5" Teflon Thrust Bearing	2
②	1" ID x 0.75" Long Teflon Cylindrical Bearing	2
③	1" ID x 7" Long Stainless Steel Shaft	1
④	1" ID Stainless Steel Locking Collar	2
⑤	3.75" x 4" x 0.25" Aluminum Plate	1
⑥	12" x 12" x 0.25" Aluminum Plate	1
⑦	4" x 4" x 0.25" Stainless Steel Plate	1
⑧	6" x 6" x 0.25" Stainless Steel Plate	1
⑨	0.25" Dia. Aluminum Kotter Pin	1
⑩	1" ID 0.035" Wall Aluminum Tube	1

FTL FLEET TECHNOLOGY LIMITED			
Title:	Attachment of Float to Barrier Arm		
Project:	Waterjet Barrier		
Project No.:	3922C		
Dwg No.:	3922-3	Scale: N/A	
Date:	28/2/91	Rev.	18/9/92

PLAN

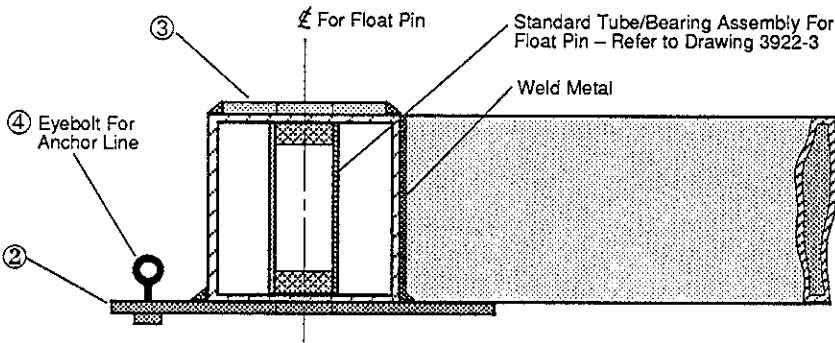
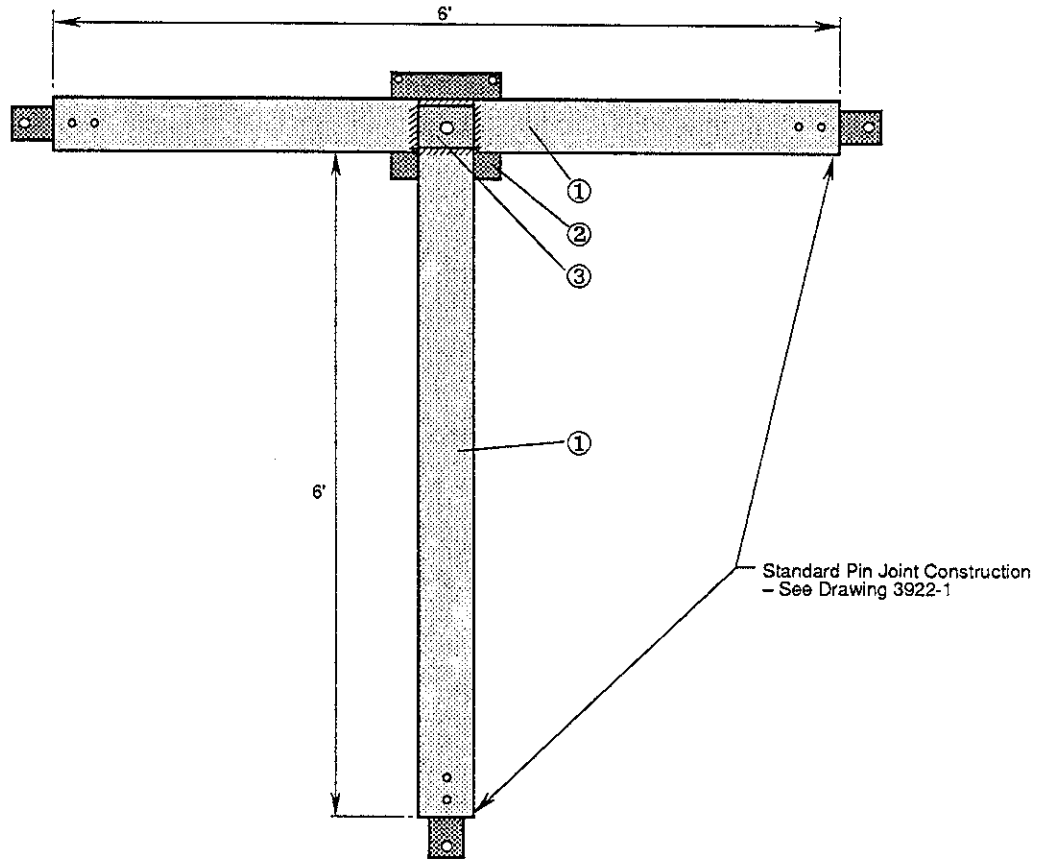

Profile Section at Apex

Note: This Drawing
Supersedes Previous
Drawings 3922-4 and 3922-5

Parts List

No.	Item	Qty
①	4" x 4" x 0.25" 6061 Aluminum HSS	2
②	8" x 8" x 0.25" Aluminum Plate	1
③	3.75" x 4" x 0.25" Aluminum Plate	1
④	3/8" Eyebolt	2

FTL FLEET TECHNOLOGY LIMITED

Title:	Revised Apex Structure	
Project:	Waterjet Barrier	
Project No.:	3922C	
Dwg No.:	3922-4*	Scale: N/A
Date:	18/9/92	

PLAN

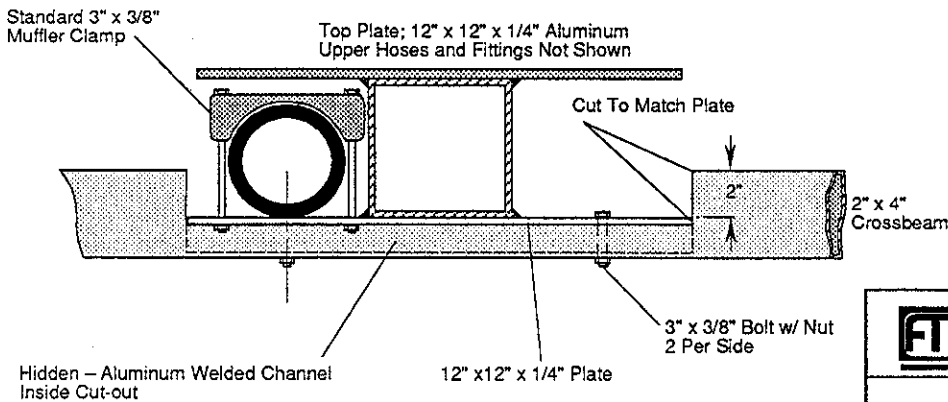
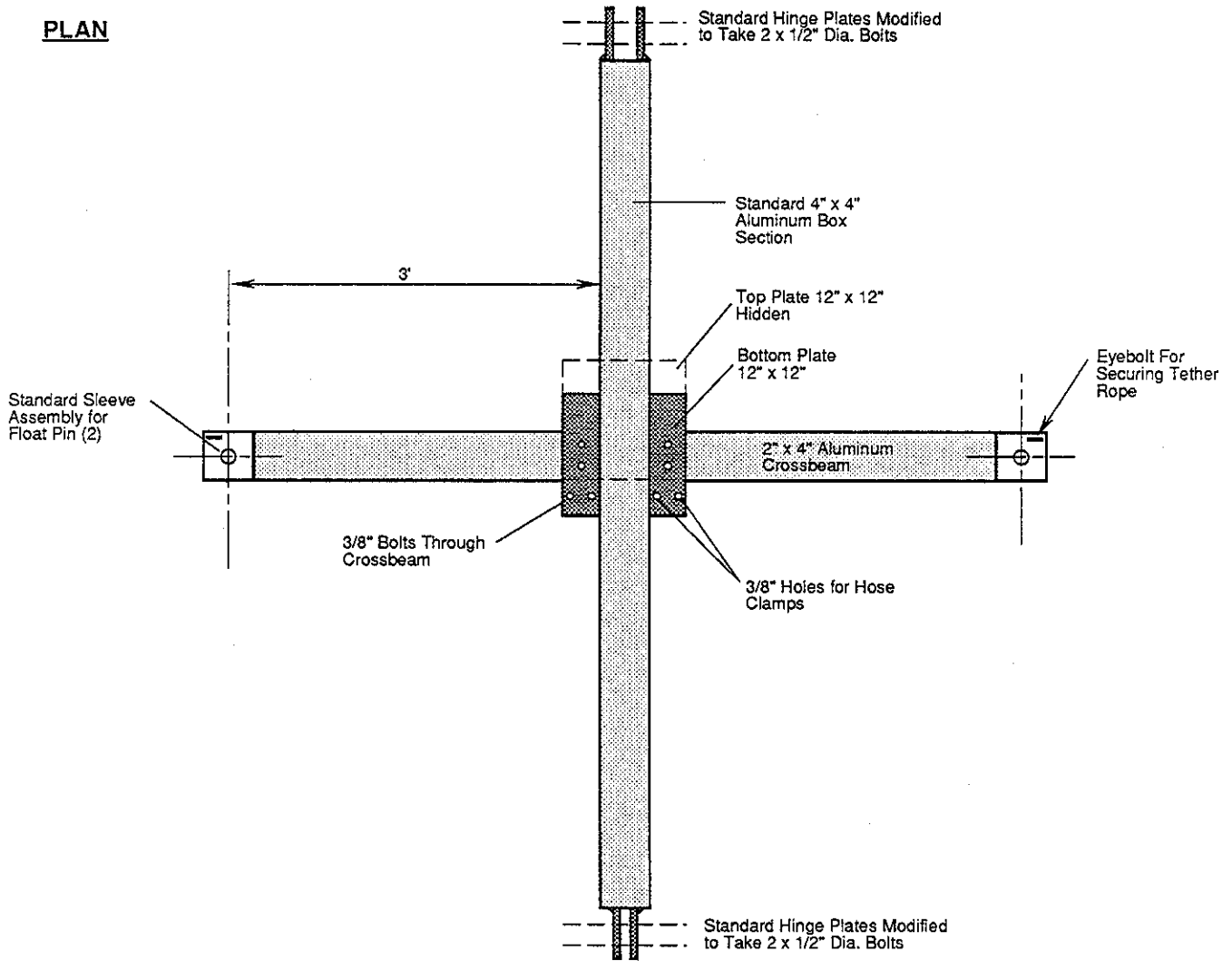

FLEET TECHNOLOGY LIMITED

Title:	Umbilical Float Structure	
Project:	Waterjet Barrier	
Project No.:	3922C	
Dwg No.:	3922-5	Scale: N/A
Date:	18/9/92	

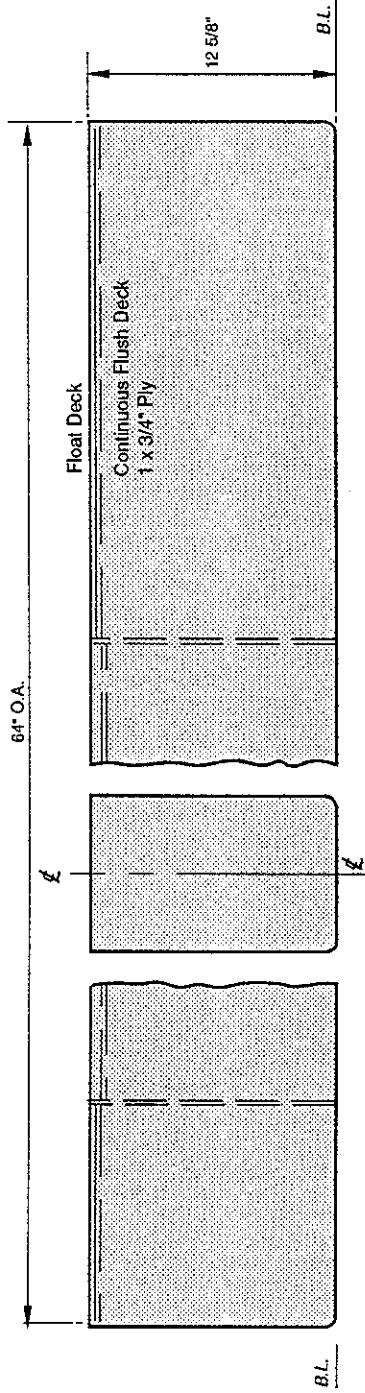

PROFILE - Bilge Radius = 1"

BODY

Transverse Bulkheads, 3/4" Ply

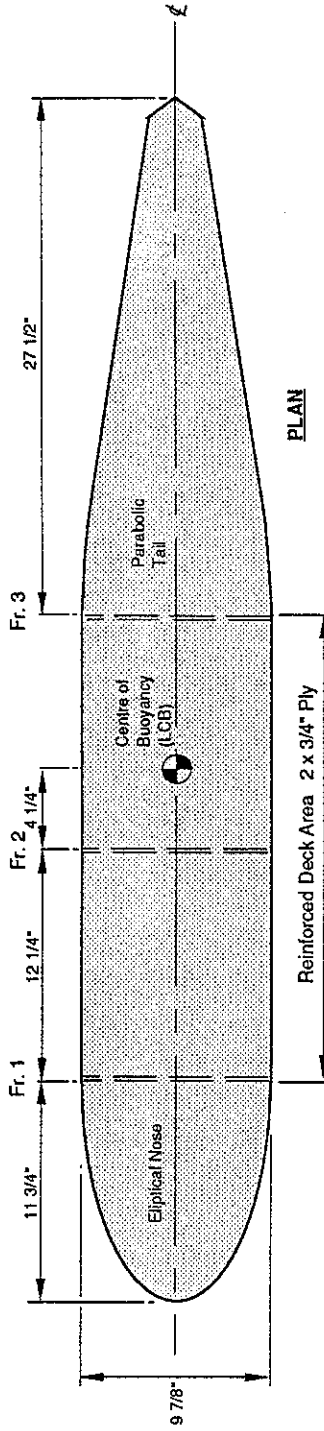

PLAN

Notes:

1. Dimensions converted from metric to nearest 1/8".
2. Floats fabricated as fibreglass shell with 3/4" plywood frames and deck.
3. Internal compartments filled with flotation foam.
4. Plate skag to be fitted aft (Ref. 3922-7)
5. Mounting plate for rigid boom to be screwed over LCB into reinforced deck, centred. (Ref. 3922-7)
6. Misc. Floats to be fitted with cleat on deck fwd.

References: 3922-7 Skag Details
 3922-3 Float Attachment Detail
 3922-4 Apex Structure



FLEET TECHNOLOGY LIMITED

Title: Barrier Float
 General Arrangement

Project: Waterjet Barrier
 Project No: 3922C

Dwg No.: 3922-6
 Scale: N/A

Date: 28/2/91
 Rev. 18/9/92

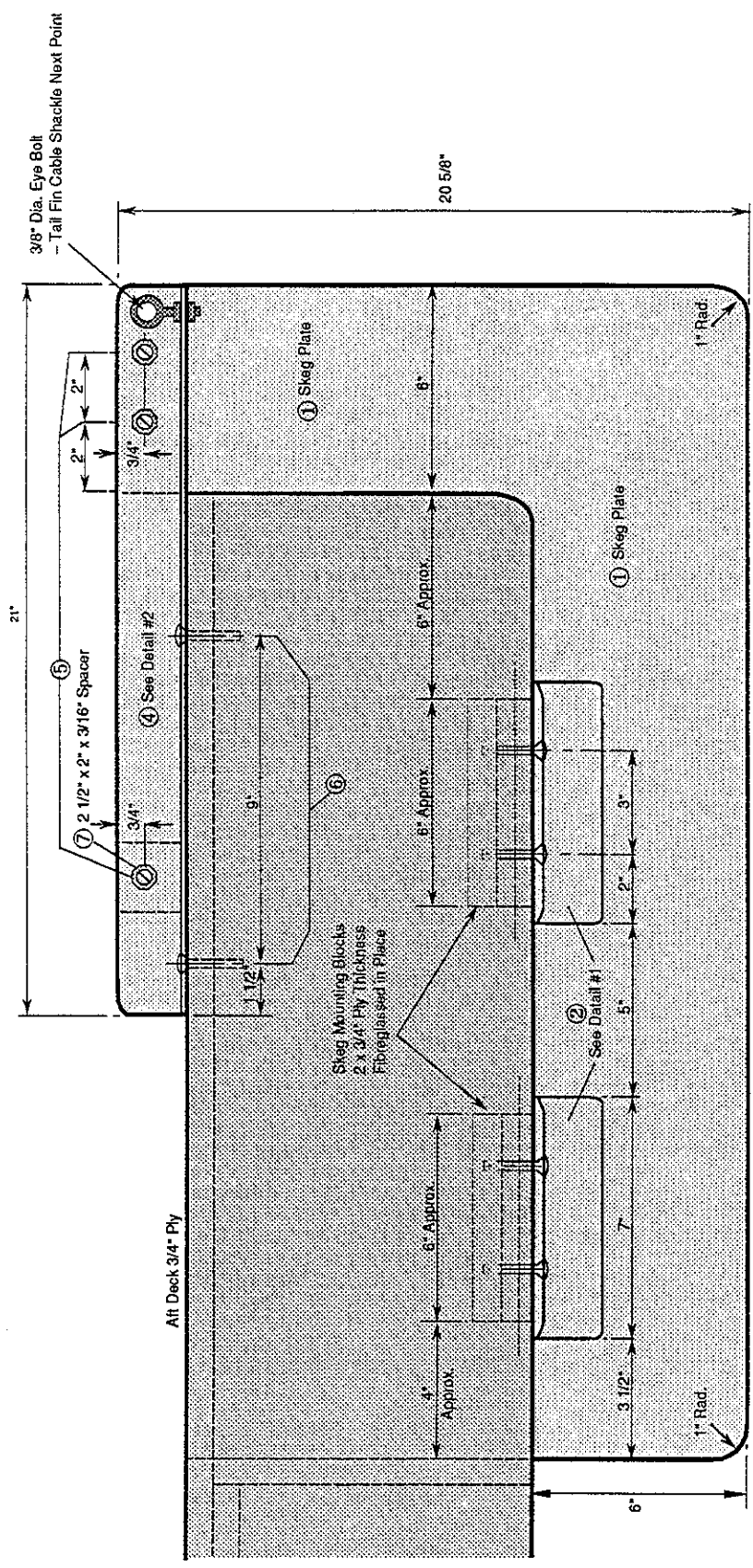

PROFILE

Parts List

No.	Item	Qty
①	Skeg Plate, 3/16" Aluminum Plate, Cutting Dimensions shown.	1
②	Keel Skeg Brackets, 2" X 2" X 1/4" Aluminum Angle, 7" Length.	4
③	1/4" Dia. Wood Screws, approx. 1 1/2" length, Aluminum.	8
④	Upper Skeg Brackets, 2" X 2" X 1/4" Aluminum Angle Cut To 21" Length.	2
⑤	1/4" Dia. Stainless Steel Bolts; Washers and Nut Not Shown.	3
⑥	1/4" Dia. Wood Screws, Approx 3/4" Length, Aluminum.	4
⑦	3/16" Aluminum Spacer Plate; Dimensions Shown.	1
Details #1 - #3 Shown in Drawing No 3922-7B.		

FTL FLEET TECHNOLOGY LIMITED

Title:	Float Skeg Details
Project:	Waterjet Barrier
Project No.:	3922C
Dwg No.:	3922-7A
Date:	28/2/91
Rev.:	18/9/92
Scale:	N/A

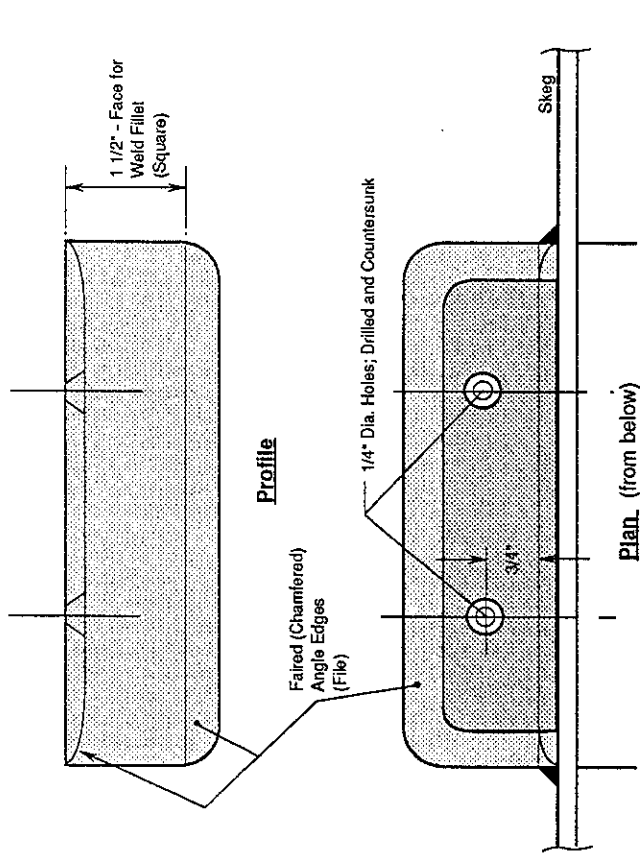

Detail #1: Keel Skeg Bracket

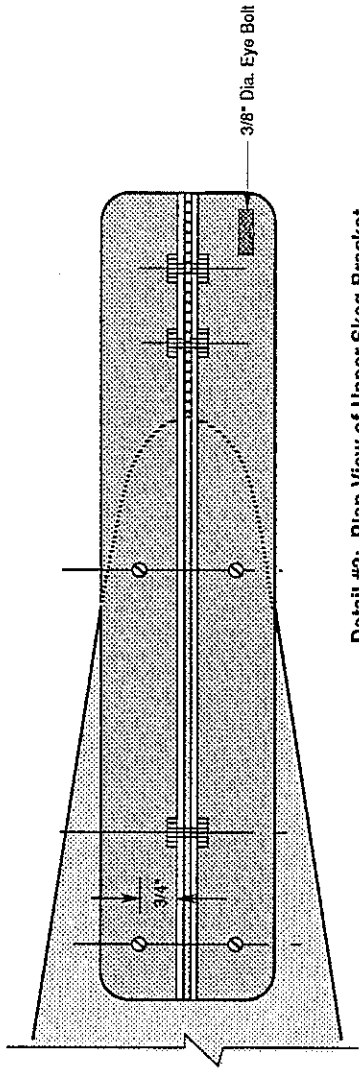

Notes:

1. All corners on plate angles to be rounded even where radius not shown.
2. Keel skeg brackets (item Ⓞ) to have all edges faired (chamfered) as shown; screw heads to be countersunk.
3. All screws to be drilled and sealed with silicone.

FTL FLEET TECHNOLOGY LIMITED	
Title:	Skeg Details for Barrier Floats
Project:	Waterjet Barrier
Project No.:	3922C
Dwg No.:	3922-7B
Date:	28/2/91
Rev.:	18/9/92
	Scale: N/A

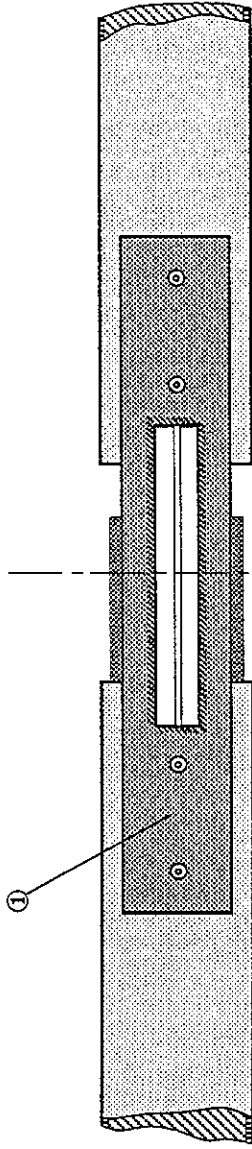

PLAN

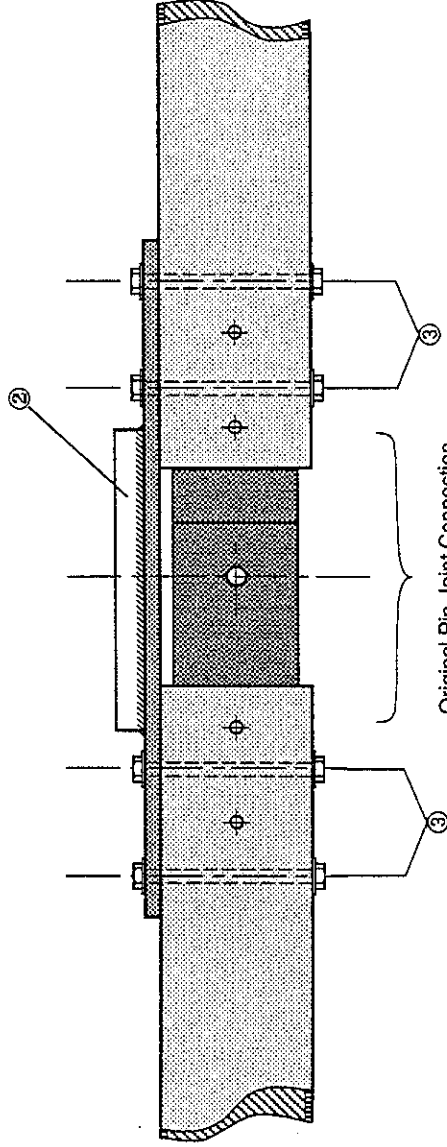

Original Pin-Joint Connection
 - Refer to Drawings 3922-1
 and 3922-2

PROFILE

Parts List

No.	Item	Qty
①	18" x 3" x 3/8" Mild Steel Flat Bar	1
②	1" x 1" x 1/4" "Tee", Mild Steel, Cut to 8"	1
③	4 x 5" x 3/8" Stainless Steel Bolt, C/W Lock Washer and Nut	4



FLEET TECHNOLOGY LIMITED	
Title:	Stiffened Bar Modification To Arm Pin-Joint
Project:	Waterjet Barrier
Project No.:	3922C
Dwg No.:	3922-8
Date:	18/9/92
Scale:	N/A
Rev.:	N/A