

6. Launch Vehicles and Earth Departure Stages

6.1 Introduction

The United States has embarked on a plan to explore the solar system, both by humans and robotic spacecraft, beginning with a return to the Moon. These first efforts will be followed by human missions to Mars and other locations of interest. A safe, reliable means of human access to space is required after the Space Shuttle is retired in 2010. As early as the mid-2010s, a heavy-lift cargo requirement in excess of 100 mT per flight will be required in addition to the crew launch capability to support manned lunar missions and follow-on missions to Mars.

6.1.1 Charter/Purpose

The Exploration Systems Architecture Study (ESAS) team developed candidate Launch Vehicle (LV) concepts, assessed these concepts against the ESAS Figures of Merit (FOMs) (e.g., cost, reliability, safety, extensibility), identified and assessed vehicle subsystems and their allocated requirements, and developed viable development plans and supporting schedules to minimize the gap between Shuttle retirement and the Crew Exploration Vehicle (CEV) Initial Operational Capability (IOC). The team was directed to develop LV concepts derived from elements of the existing Expendable Launch Vehicle (ELV) fleet and/or the Space Shuttle. A principal goal was to provide an LV capability to enable a CEV IOC in 2011. The team also strived to provide accurate and on-time support and consultation to meet overall ESAS objectives.

The ESAS team was tasked to provide clear recommendations to ESAS management concerning the most advantageous path to follow in answering the following questions:

- Which overall launch architecture provides the most viable options and paths to achieve the stated goals for safe crew transport to Low Earth Orbit (LEO) (Crew Launch Vehicle (CLV)) and meets lift requirements for exploration cargo (Cargo Launch Vehicle (CaLV))?
- What is the preferred CLV concept to provide safe and rapid human access to space after Shuttle retirement in 2010?
- What is the preferred heavy-lift CaLV capable of meeting lunar mission lift requirements and evolving to support Mars missions?
- What is the preferred option for transporting crew for exploration missions beyond LEO?
- What is the best launch option for the robotic exploration effort?
- What is the best launch option for delivering cargo to the International Space Station (ISS) subsequent to Shuttle retirement?

Specifications and analysis results for each of the LV options assessed are provided in **Appendix 6A, Launch Vehicle Summary**.

6.1.2 Methodology

The findings of previous studies, particularly the Exploration Systems Mission Directorate (ESMD) Launch Vehicle Study in 2004, had concluded that, while new “clean-sheet” LVs possessed certain advantages in tailoring to specific applications, their high development costs exceeded available budgets and lengthy development schedules would lead to a significant crew transport gap after Shuttle retirement. Therefore, ESAS management directed the team members to use existing LV elements, particularly engines, as much as practicable and to emphasize derivative element designs. New design elements were acceptable where absolutely necessary, but had to be clearly superior in safety, cost, and performance to be accepted. The Payload Fairings (PLFs) for the cargo vehicles are a prime example of a required new element. No existing PLF could accommodate the mass or volume requirements of some of the lunar vehicle elements currently under consideration.

Analysis tasks and technical assessments were focused in several key areas. Considerable effort was expended by the ESAS team to identify, assess, and document applicable vehicle systems, subsystems, and components that were candidates for use in the ELV- and Shuttle-derived vehicle concepts. This information was also used in the generation and assessment of viable development schedules and cost analysis. The team provided key input from the system assessment for safety and reliability analysis. The team developed candidate CLV and CaLV concepts for the study through parametric sizing and structural analysis, and assessed vehicle lift capability and basic induced environments through the generation of three-Degrees-of-Freedom (3-DOF) point-mass trajectory designs anchored by the sizing, structural, and subsystem assessment work. Output of the vehicle concept development work was forwarded to the operations, cost, and reliability/safety groups for use in their analyses. The ESAS team conducted analyses to determine the optimum range for Earth Departure Stage (EDS) main engine thrust levels, EDS configuration layouts, and other supporting analyses.

Candidate LV concept development was governed by the study’s overall ground rules and guidance from results of previous studies, including the ESMD Launch Vehicle Study, the ESMD Analysis of Alternatives (AOA), the ESMD Human-Rating Study, and several smaller studies—all of which were conducted in the 12 months preceding the inception of ESAS. The results of the ESMD Concept Exploration and Refinement (CE&R) studies were also evaluated and considered as part of the study. Previous interactions and exchanges with various teams from industry were incorporated, and the ESAS team also conducted and included ongoing interactions with industry teams during the study. Findings from in-house studies conducted in support of the Orbital Space Plane (OSP) Program were also used where applicable. Heritage documentation from the Apollo-Saturn and Space Shuttle Programs were consulted and utilized. Where no data was available for a particular payload-class vehicle, known vehicle elements such as engines, strap-on solids, and strap-on liquid boosters were used to generate representative concepts from LEO payload classes of interest to this study. The candidate concept was initially sized and then flown on a simulated optimized trajectory to assess its performance and to generate data to support an initial structural assessment. The results of the trajectory and the structural analysis were input into a follow-on sizing analysis, which provided an updated vehicle data set. This process was repeated until trajectory results and sizing results agreed within a specified tolerance. The results of this analysis were submitted to the operations, cost, and reliability/safety analysis groups for use in their assessments. Concepts were assessed using the ESAS FOMs provided in **Section 2, Introduction** and **Appendix 2E, ESAS FOM Definitions**.

The technical requirements for human rating were derived from NASA Procedural Requirements (NPR) 8705.2a, Human-Rating Requirements for Space Systems. The document applies human rating at the system level—identifying the system as LV and spacecraft. Allocation between the LV and spacecraft is provided for in subsequent system requirements documents for the elements. For this study, NPR 8705.2A is the basis for evaluating all ESAS LV concepts to ascertain the modifications and design approaches necessary for carrying crew to Earth orbit.

A depiction of the LV architecture analytical flow is shown in **Figure 6-1**. The ESAS team process flow is shown in **Figure 6-2**.

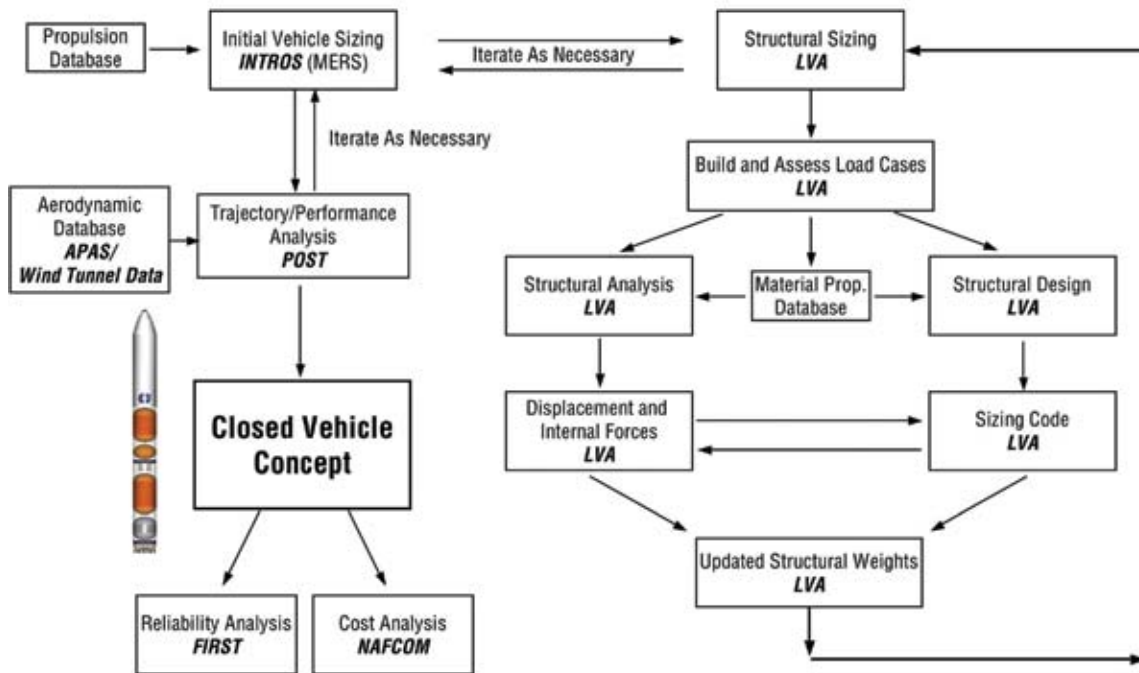

Figure 6-1. Vehicle Conceptual Sizing and Performance Analysis Flow for Earth-to-Orbit (ETO) LVs

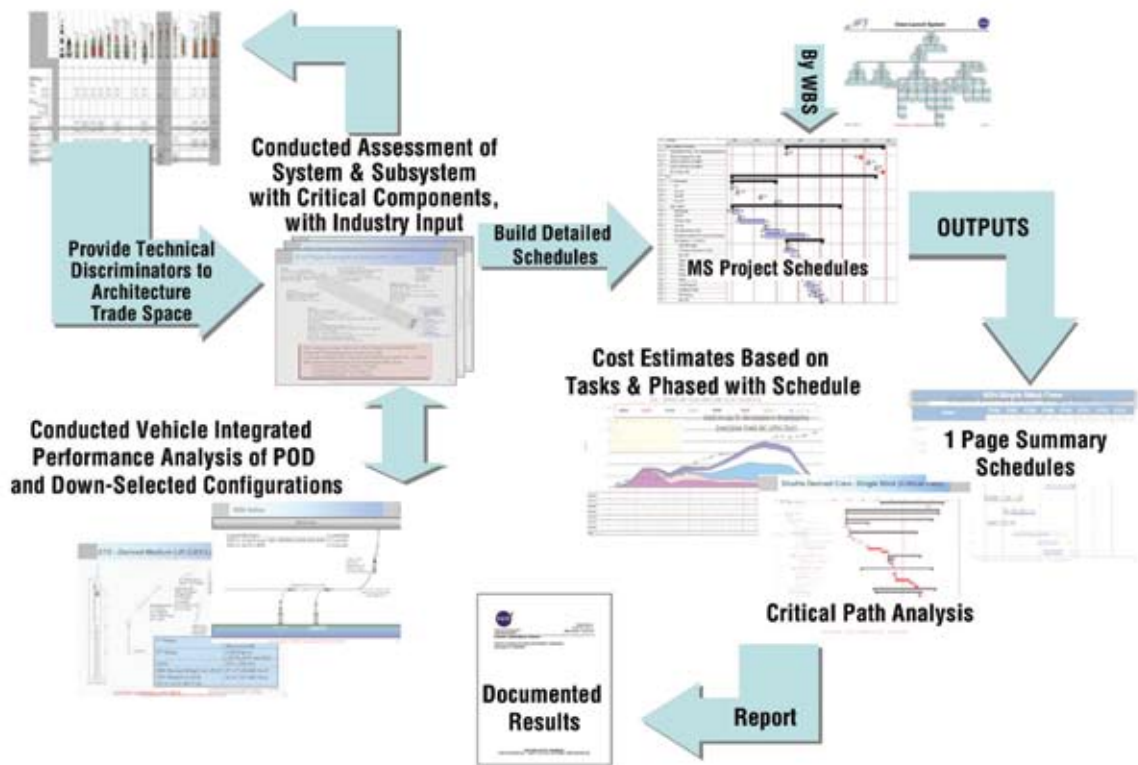

Figure 6-2. ESAS Team Process Flow

The analytical approach taken by the ESAS team was to use the sizing and trajectory data, along with the cost data from the cost group and subsystem data from discipline experts, and synthesize it for the ESAS team. This synthesis process included identifying real limits and risks for key subsystems such as main engines. It also involved characteristic and data comparisons between candidate stages and subsystems. Trends and observations were then reported to the ESAS team.

The conceptual analysis flow for EDS is shown in **Figure 6-3**.

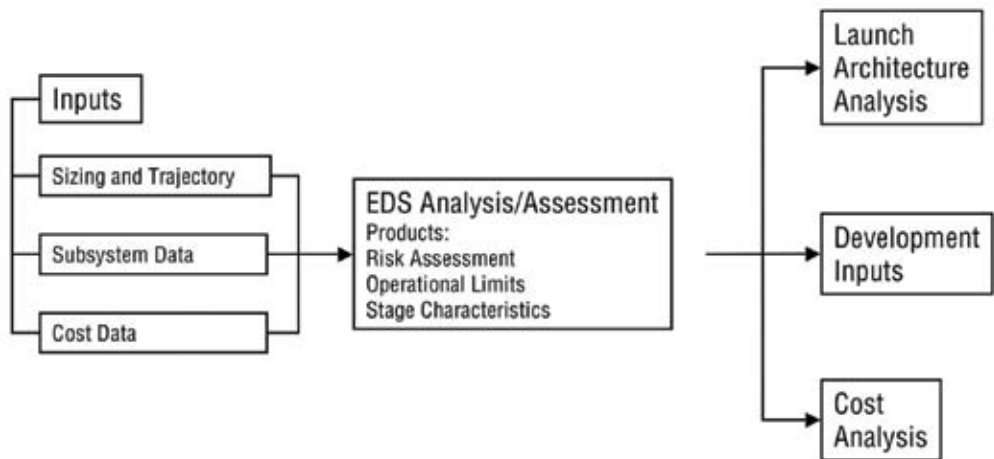

Figure 6-3. Conceptual Analysis Flow for EDS

6.1.3 Recommendations

6.1.3.1 Recommendation 1

Adopt and pursue a Shuttle-derived architecture as the next-generation launch system for crewed flights into LEO and for 125-mT-class cargo flights for exploration beyond Earth orbit. After thorough analysis of multiple Evolved Expendable Launch Vehicle- (EELV-) and Shuttle-derived options for crew and cargo transportation, Shuttle-derived options were found to have significant advantages with respect to cost, schedule, safety, and reliability. Overall, the Shuttle-derived option was found to be the most affordable by leveraging proven vehicle and infrastructure elements and using those common elements in the heavy-lift CaLV as well as the CLV. Using elements that have a human-rated heritage, the CaLV can enable unprecedented mission flexibility and options by allowing a crew to potentially fly either on the CLV or CaLV for 1.5-launch or 2-launch lunar missions that allow for heavier masses to the lunar surface. The Shuttle-derived CLV provides lift capability with sufficient margin to accommodate CEV crew and cargo variant flights to ISS and potentially provides added services, such as station reboost.

The extensive flight and test databases of the Reusable Solid Rocket Booster (RSRB) and Space Shuttle Main Engine (SSME) give a solid foundation of well-understood main propulsion elements on which to anchor next-generation vehicle development and operation. The Shuttle-derived option allows the Nation to leverage extensive ground infrastructure investments and maintains access to solid propellant at current levels. Furthermore, the Shuttle-derived option displayed more versatile and straightforward growth paths to higher lift capability with fewer vehicle elements than other options.

The following specific recommendations are offered for LV development and utilization.

6.1.3.2 Recommendation 2

Initiate immediate development of a CLV utilizing a single four-segment RSRB first stage and a new upper stage using a single SSME. The reference configuration, designated LV 13.1 in this study, provides the payload capability to deliver a lunar CEV to low-inclination Earth orbits required by the exploration architectures and to deliver CEVs configured for crew and cargo transfer missions to the ISS. The existence and extensive operational history of human-rated Shuttle-derived elements reduce safety risk and programmatic and technical risk to enable the most credible development path to meet the goal of providing crewed access to space by 2011. The series-burn configuration of LV 13.1 provides the crew with an unobstructed escape path from the vehicle using a Launch Abort System (LAS) in the event of a contingency event from launch through Earth-Orbit Insertion (EOI). Finally, if required a derivative cargo-only version of the CLV, designated in this report as LV 13.1S, can enable autonomous, reliable delivery of unpressurized cargo to ISS of the same payload class that the Shuttle presently provides.

6.1.3.3 Recommendation 3

To meet lunar and Mars exploration cargo requirements, begin development as soon as practical of an in-line Shuttle-derived CaLV configuration consisting of two five-segment RSRBs and a core vehicle with five aft-mounted SSMEs derived from the present External Tank (ET) and reconfigured to fly payload within a large forward-mounted aerodynamic shroud. The specific configuration is designated LV 27.3 in this report. This configuration provides superior performance to any side-mount Shuttle-derived concept and enables varied configuration options as the need arises. A crewed version is also potentially viable because of the extensive use of human-rated elements and in-line configuration. The five-engine core and two-engine EDS provides sufficient capability to enable the 1.5-launch solution, which requires one CLV and one CaLV flight per lunar mission—thus reducing the cost and increasing the safety/reliability of each mission. The added lift capability of the five-SSME core allows the use of a variety of upper stage configurations, with 125 mT of lift capability to LEO. LV 27.3 will require design, development, and certification of a five-segment RSRB and new core vehicle, but such efforts are facilitated by their historical heritage in flight-proven and well-characterized hardware. Full-scale design and development should begin as soon as possible synchronized with CLV development to facilitate the first crewed lunar exploration missions in the middle of the next decade.

6.1.3.4 Recommendation 4

To enable the 1.5-launch solution and potential vehicle growth paths as previously discussed, NASA should undertake development of an EDS based on the same tank diameter as the cargo vehicle core. The specific configuration should be a suitable variant of the EDS concepts designated in this study as EDS S2x, depending on the further definition of the CEV and Lunar Surface Access Module (LSAM). Using common manufacturing facilities with the Shuttle-derived CaLV core stage will enable lower costs. The recommended EDS thrust requirements will require development of the J-2S+, which is a derivative of the J-2 upper stage engine used in the Apollo/Saturn program, or another in-space high performance engine/cluster as future trades indicate. As with the Shuttle-derived elements, the design heritage of previously flight-proven hardware will be used to advantage with the J-2S+. The TLI capability of the EDS S2x is approximately 65 mT, when used in the 1.5-launch solution mode, and enables many of the CEV/LSAM concepts under consideration. In a single-launch mode, the S2B3 variant can deliver 54.6 mT to Trans-Lunar Injection (TLI), which slightly exceeds the TLI mass of Apollo 17, the last crewed mission to the Moon in 1972.

6.1.3.5 Recommendation 5

Continue to rely on the EELV fleet for scientific and ISS cargo missions in the 5- to 20-mT lift range.

6.1.4 Recommended Launch System Architecture Description

6.1.4.1 Crew Launch Vehicle (LV 13.1)

The recommended CLV concept is derived from elements of the existing Space Shuttle system and is designated as ESAS LV 13.1. It is a two-stage, series-burn configuration with the CEV positioned on the nose of the vehicle, capped by an LAS that weighs 9,300 lbm (pounds of mass). The vehicle stands approximately 290 ft tall and weighs approximately 1.78M lbm at launch. LV 13.1 is capable of injecting a 24.5-mT payload into a 30- x 160-nmi orbit inclined 28.5 deg and injecting 22.9 mT into the same orbit inclined 51.6 deg.

Stage 1 is derived from the Reusable Solid Rocket Motor (RSRM) and is composed of four field-assembled segments, an aft skirt containing the Thrust Vector Control (TVC) hydraulic system, accompanying Auxiliary Power Units (APUs), and Booster Separation Motors (BSMs). The aft skirt provides the structural attachment to the Mobile Launch Platform (MLP) through four attach points and explosive bolts. The single exhaust nozzle is semi-embedded and is movable by the TVC system to provide pitch and yaw control during first-stage ascent. The Space Transportation System (STS) forward skirt, frustrum, and nose cap are replaced by a stage adapter that houses the RSRB recovery system elements and a roll control system. Stage 1 is approximately 133 ft long and burns for 128 sec. After separation from the second stage, Stage 1 coasts upward in a ballistic arc to an altitude of approximately 250,000 ft, subsequently reentering the atmosphere and landing by parachute in the Atlantic Ocean for retrieval and reuse similar to the current Shuttle RSRB.

Stage 2 is approximately 105 ft long, 16.4 ft in diameter, and burns Liquid Oxygen (LOX) and Liquid Hydrogen (LH₂). (This was changed to 5.5 m in diameter at the close of the ESAS.) It is composed of an interstage, single RS-25 engine, thrust structure, propellant tankage, and a forward skirt. The interstage provides the structural connection between the Stage 1 adapter and Stage 2, while providing clearance for the RS-25 exhaust nozzle. The RS-25 is an expendable version of the current SSME, modified to start at altitude. The thrust structure provides the framework to support the RS-25, the Stage 2 TVC system (for primary pitch and yaw during ascent), and an Auxiliary Propulsion System (APS) that provides three-axis attitude control (roll during ascent and roll, pitch, and yaw for CEV separation), along with posigrade thrust for propellant settling. The propellant tanks are cylindrical, with ellipsoid domes, and are configured with the LOX tank aft, separated by an intertank. The LH₂ main feedline exits the Outer Mold Line (OML) of the intertank and follows the outer skin of the LOX tank, entering the thrust structure aft of the LOX tank. The forward skirt is connected to the LH₂ tank at the cylinder/dome interface and acts as a payload adapter for the CEV. It is of sufficient length to house the forward LH₂ dome, avionics, and the CEV Service Module (SM) engine exhaust nozzle. Stage 2 burns for approximately 332 sec, placing the CEV in a 30- x 160-nmi orbit. After separation from the CEV, Stage 2 coasts approximately a three-quarter orbit and reenters, with debris falling in the Pacific Ocean.

6.1.4.2 Cargo Launch Vehicle (LV 27.3)

The ESAS LV 27.3 heavy-lift CaLV is recommended to provide the lift capability for lunar missions. It is approximately 357.5 ft tall and is configured as a stage-and-a-half vehicle composed of two five-segment RSRMs and a large central LOX/LH2-powered core vehicle utilizing five RS–25 SSMEs. It has a gross liftoff mass of approximately 6.4M lbm and is capable of delivering 54.6 mT to TLI, or 124.6 mT to 30- x 160-nmi orbit inclined 28.5 deg.

Each five-segment RSRB is approximately 210 ft in length and contains approximately 1.43M lbm of Hydroxyl Terminated Poly-Butadiene (HTPB) propellant. It is configured similarly to the current RSRB, with the addition of a center segment. The operation of the five-segment RSRBs is much the same as the STS RSRBs. They are ignited at launch, with the five RS–25s on the core stage. The five-segment RSRBs burn for 132.5 sec, then separate from the core vehicle and coast to an apogee of approximately 240,000 ft. They are recovered by parachute and retrieved from the Atlantic Ocean for reuse.

The core stage carries 2.2M lbm of LOX and LH2, approximately 38 percent more propellant than the current Shuttle ET, and has the same 27.5-ft diameter as the ET. It is composed of an aft-mounted boattail that houses a thrust structure with five RS–25 engines and their associated TVC systems. The RS–25 engines are arranged with a center engine and four circumferentially mounted engines positioned 45 deg from the vertical and horizontal axes of the core to provide sufficient clearance for the RSRBs. The propellant tankage is configured with the LOX tank forward. Both the LOX and LH2 tanks are composed of Aluminum-Lithium (AL-Li) and are cylindrical, with ellipsoidal domes. The tanks are separated by an intertank structure, and an interstage connects the EDS with the LH2 tank. The core is ignited at liftoff and burns for approximately 408 sec, placing the EDS and LSAM into a suborbital trajectory. A shroud covers the LSAM during the RSRB and core stage phases of flight and is jettisoned when the core stage separates. After separation from the EDS, the core stage continues on a ballistic suborbital trajectory and reenters the atmosphere, with debris falling in the South Pacific Ocean.

6.1.4.3 Earth Departure Stage (EDS S2B3)

The recommended configuration for the EDS is the ESAS S2B3 concept, which is 27.5 ft in diameter, 74.6 ft long, and weighs approximately 501,000 lbm at launch. The EDS provides the final impulse into LEO, circularizes itself and the LSAM into the 160 nmi assembly orbit, and provides the impulse to accelerate the CEV and LSAM to escape velocity. It is a conventional stage structure, containing two J–2S+ engines, a thrust structure/boattail housing the engines, TVC system, APS, and other stage subsystems. It is configured with an aft LOX tank, which is comprised primarily of forward and aft domes. The LH2 tank is 27.5 ft in diameter, cylindrical with forward and aft ellipsoidal domes, and is connected to the LOX tank by an intertank structure. A forward skirt on the LH2 tank provides the attach structure for the LSAM and payload shroud. The EDS is ignited suborbitally, after core stage separation, and burns for 218 sec to place the EDS/LSAM into a 30- x 160-nmi orbit, inclined 28.5 deg. It circularizes the orbit to 160 nmi, where the CEV docks with the LSAM. The EDS then reignites for 154 sec in a TLI to propel the CEV and LSAM on a trans-lunar trajectory. After separation of the CEV/LSAM, the EDS is placed in a disposal solar orbit by the APS.

In connection with the sizing and performance predictions of the various EDS and LV combinations, the ESAS team explored the mission functional requirements on the EDS, such as using suborbital burning to place the payload into LEO. Using this approach, the EDS functions as a third stage for launch and as payload, as it will eventually perform the TLI burn.

6.1.5 Section Content Description

This section of the report offers the following products:

- Lift requirements and trade study and analytical results (**Sections 6.3, Lift Requirements, and 6.4, LV and EDS Performance System Trades**);
- CLV and CaLV concept descriptions with cost and development schedule assessments (**Sections 6.5, Crew Launch Vehicle, and 6.6, Lunar Cargo Vehicle**);
- EDS assessment (**Section 6.7, Earth Departure Stage**);
- An assessment of system safety and reliability (**Section 6.8, LV Reliability and Safety Analysis**);
- Vehicle subsystem descriptions and assessments (**Section 6.9, LV Subsystem Descriptions and Risk Assessments**);
- A discussion of conclusions drawn from the conduct of the study (**Section 6.10, LV Development Schedule Assessment**);
- A set of recommendations for the CLV, CaLV, EDS, and launch system support for robotic exploration and ISS resupply (**Section 6.11, Conclusions**).

A set of appendices (**6A–6H**) containing data summaries and a design assessment of the LV 13.1 CLV is provided separately.

6.2 LV Ground Rules and Assumptions

The LV Ground Rules and Assumptions (GR&As) used by the ESAS team are a subset of those provided previously in **Section 3, ESAS Ground Rules and Assumptions**, and are summarized in that section.

6.3 Lift Requirements

6.3.1 Lunar Missions

The lunar architecture lift requirements involve launching a lunar CEV, an LSAM, and the EDS. The CEV Crew Module (CM) provides a protective environment for the crew during ascent (including aborts), serves as the crew habitat during the lunar mission, and provides the Thermal Protection System (TPS) and recovery system to safely return the crew to Earth at the end of the mission. The CEV Service Module (SM) provides the propulsion system for the Trans-Earth Injection (TEI) burn to return the crew to Earth, life support consumables, power, and other systems required for the lunar mission. The EDS is an in-space rocket stage that burns during the final phase of the CaLV ascent to inject the EDS and the connected LSAM into orbit. The CEV will be placed in orbit by the CLV. The LSAM is attached to the CEV during lunar transit to provide an alternate crew habitat and serves as the primary crew habitat. Also, it provides propulsion and other systems for descent, landing, and ascent at the Moon. Additional details of lunar missions, including specific Design Reference Missions (DRMs), are contained in **Section 2, Introduction**.

6.3.2 CEV

The CEV is being considered for access to ISS in three variants, with additional variants for lunar and Mars missions. The block mass summaries for these variants are shown in **Figure 6-4**.

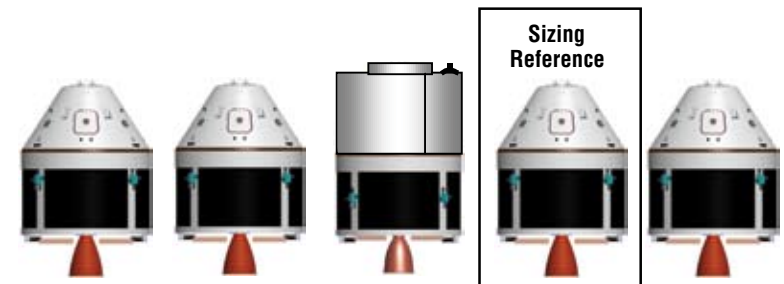

	Block 1A ISS Crew	Block 1B ISS Press Cargo	CDV ISS Unpress Cargo	Block 2 Lunar Crew	Block 3 Mars Crew
Crew Size	3	0	0	4	6
LAS Required	4,218	None	None	4,218	4,218
Cargo Capability (kg)¹	400	3,500	6,000	Minimal	Minimal
CM (kg)	9,342	11,381	12,200	9,506	TBD
SM (kg)	13,558	11,519	6,912	13,647	TBD
Service Propulsion System delta-V (m/s)	1,544 ²	1,098 ²	330	1,724	TBD
EOR-LOR 5.5-m Total Mass (kg)	22,900	22,900	19,112	23,153	TBD

Figure 6-4.
Block Mass
Summaries

Note 1: Cargo capability is the total cargo capability of the vehicle including Flight Support Equipment (FSE) and support structure.
Note 2: A packaging factor of 1.29 was assumed for the pressurized cargo and 2.0 for unpressurized cargo.
Extra Block 1A and 1B service propulsion system delta-V used for late ascent abort coverage

The crewed (and possibly uncrewed, pressurized cargo) versions of the CEV carry an LAS consisting of a monolithic Solid Rocket Motor (SRM) that provides an acceleration of at least 10 g's for 3 sec to propel the CEV CM away from a malfunctioning CLV. The LAS projects from the forward end of the CEV CM. It is jettisoned 30 sec after the CLV second stage has ignited. The LAS is used for regions of the ascent flight where high dynamic pressures exist, and where major events, such as staging, occur. The time for LAS jettison was chosen as a point in the ascent where dynamic pressure was dwindling, and the second-stage engine was operating fully in main stage. The baseline LAS total lift mass requirement is 4,152 kg (9,155 lbm). The CEV carries enough propellant to enable transatlantic and Abort-To-Orbit (ATO) options, which are addressed in **Section 5, Crew Exploration Vehicle**. The CEV has the potential capability to ATO during the final minute of powered ascent flight, which means that, if the LV could not safely deliver the CEV to orbit even after expending its flight performance reserve propellant (which covers approximately 100 m/s of underspeed), the CEV could place itself in a safe 24-hour orbit, from which the crew would return to Earth.

Additional details of ISS missions, including specific DRMs, are contained in **Section 2, Introduction**.

All systems are required to develop a plan that addresses the human-rating system requirements specified in NPR 8705.2A, Human-Rating Requirements for Space Systems, especially the following:

- Specifications and standards,
- Two-fault tolerant systems,
- Crew-system interactions,
- Pad emergency egress,
- Abort throughout the ascent profile,
- Software common cause failures,
- Manual control on ascent, and
- Flight Termination System (FTS).

6.3.3 Launch Window Impacts

When launching for a rendezvous with the ISS or another on-orbit vehicle, additional constraints are placed on the mission. This has an impact on the available launch times and lift capabilities. The first launch of a mission buildup will not be restricted to a specific orbit plane. The inclination will be predetermined, but the ascending node is not determined by the rendezvous requirements. Any subsequent launches must perform the rendezvous missions and must be launched into the orbit plane of the first component.

The effect of the Earth's rotation and the need to launch into the required orbit plane as the launch site rotates past the target orbit is shown as a payload penalty in **Figures 6-5 and 6-6**. **Figures 6-7 and 6-8** show the penalty as a percentage of the payload for each total launch window duration. In this study, the subsequent launches are allowed to optimize the launch azimuth as well as perform yaw steering after the first stage separates. The reference trajectory does not allow the yaw steering.

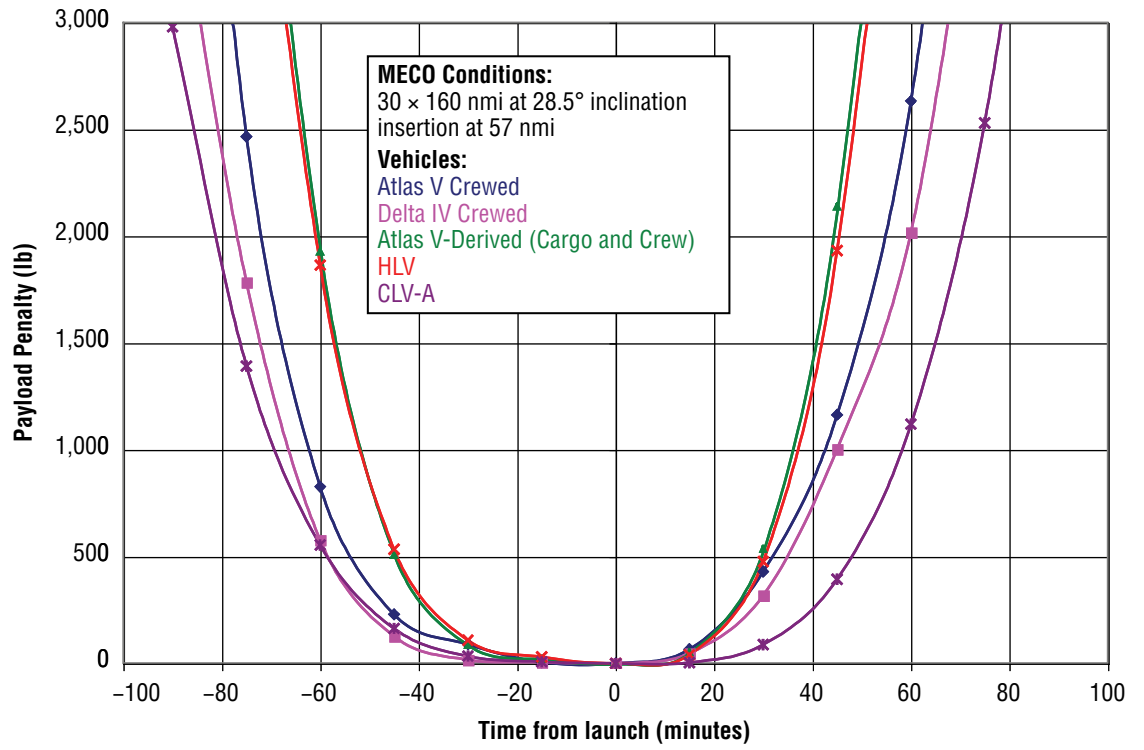

Figure 6-5. Launch Window Payload Penalties (Lunar Due East Launch)

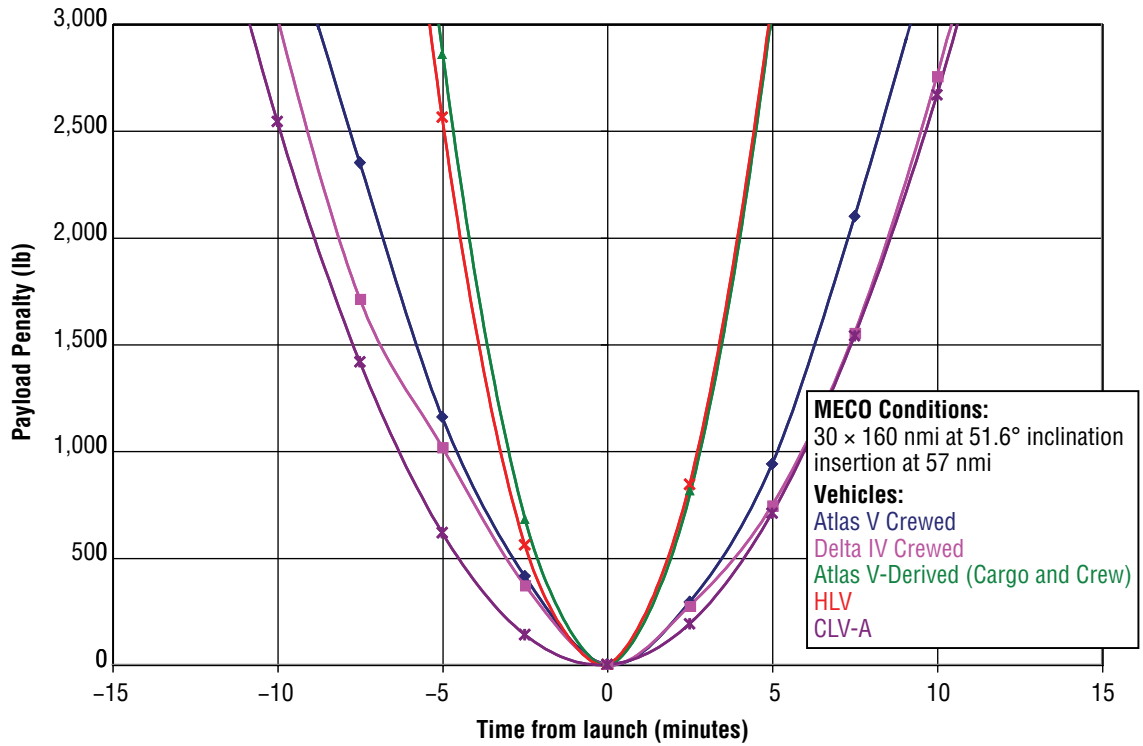

Figure 6-6. Launch Window Payload Penalties (ISS Mission)

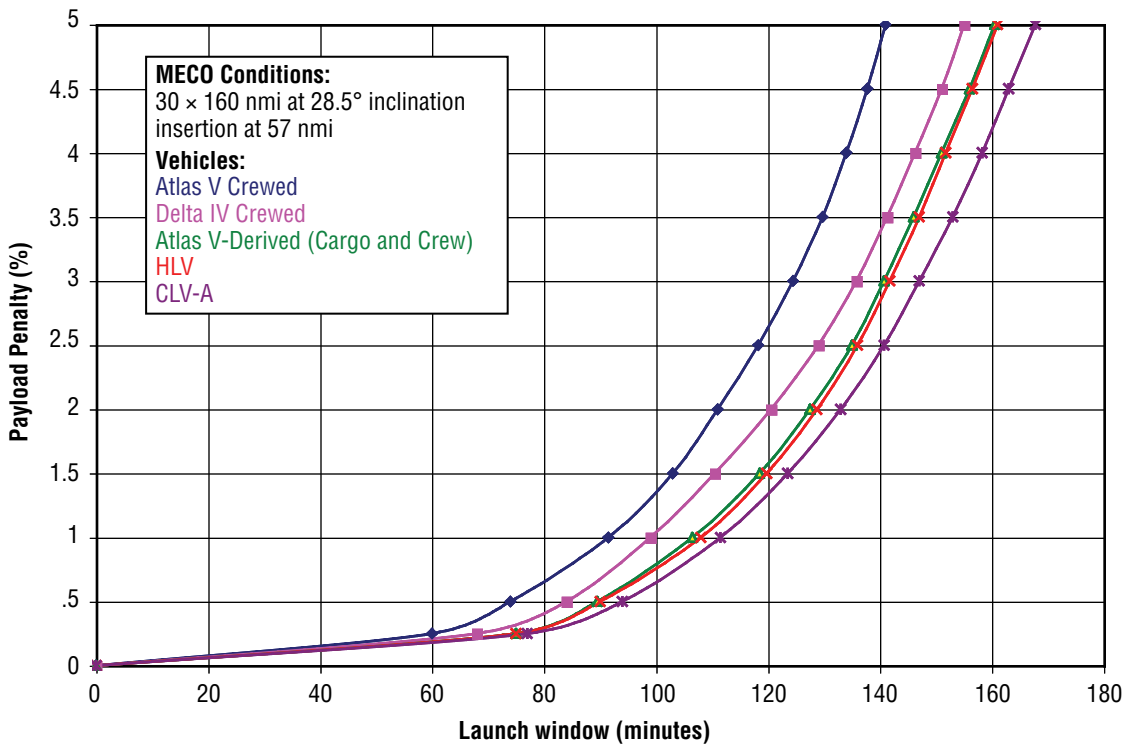

Figure 6-7. Percentage of Payload Lost (Lunar Due East Launch)

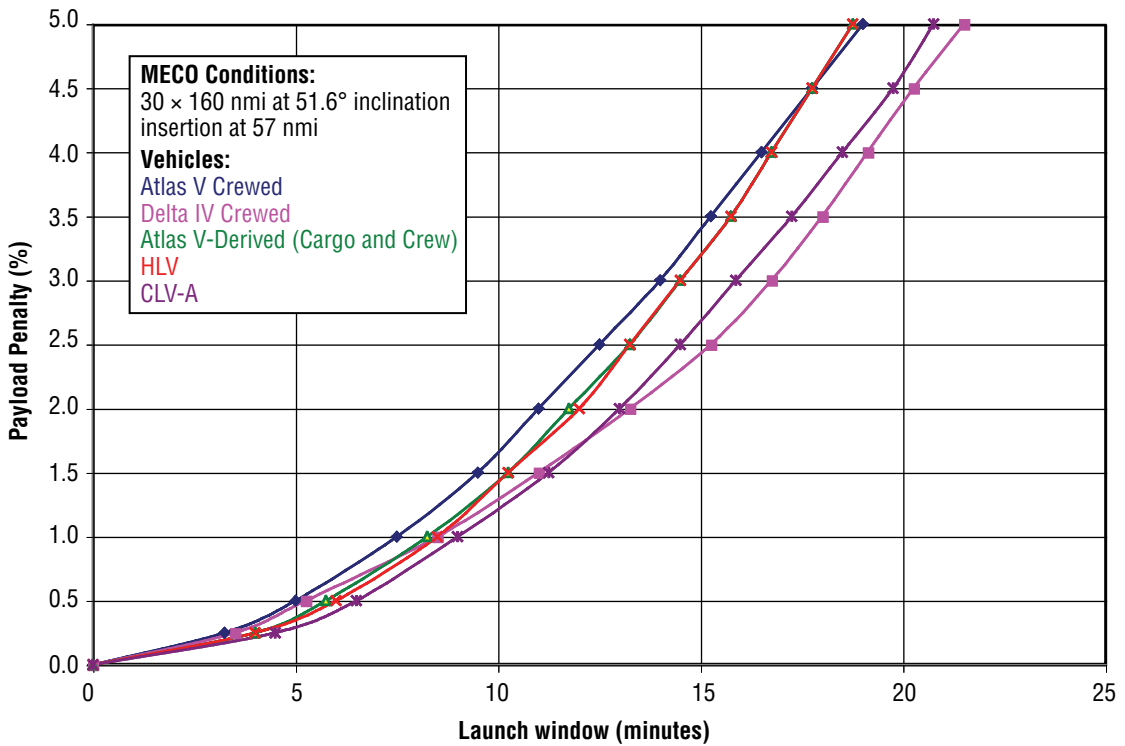

Figure 6-8. Percentage of Payload Lost (ISS Mission)

The vehicles represented in **Figures 6-5** through **6-8** were sized by the ESAS team and used as points of departure (PODs). **Table 6-1** shows the relationship to the study's nomenclature.

Vehicle	Study Nomenclature
Atlas V Crewed	Vehicle 2
Delta IV Crewed	Vehicle 4
Atlas Evolved (Crew+Cargo)	Vehicle 7.5
Heavy-Lift Vehicle (HLV) (CaLV)	Vehicle 27
CLV-A	Vehicle 15 (Results will be identical for LV 13.1)

By launching into a slightly higher inclination, the launch window for a due east mission can be increased with little additional payload penalty. The payload penalties for the two-stage CLV (LV 15) are shown in **Figure 6-9**. The penalty for each total launch window duration is provided in **Figure 6-10**. When the vehicle is launched into the 29.0 deg inclination, two launch opportunities are present within a short period of time. These opportunities represent the ability to launch into either the ascending leg of the orbit or the descending leg. This produces the payload penalty oscillation seen in **Figure 6-9**. Similar analysis was conducted for the in-line CaLV (LV 27). The results are shown in **Figures 6-11** and **6-12**. The penalties for this vehicle are greater than for the CLV.

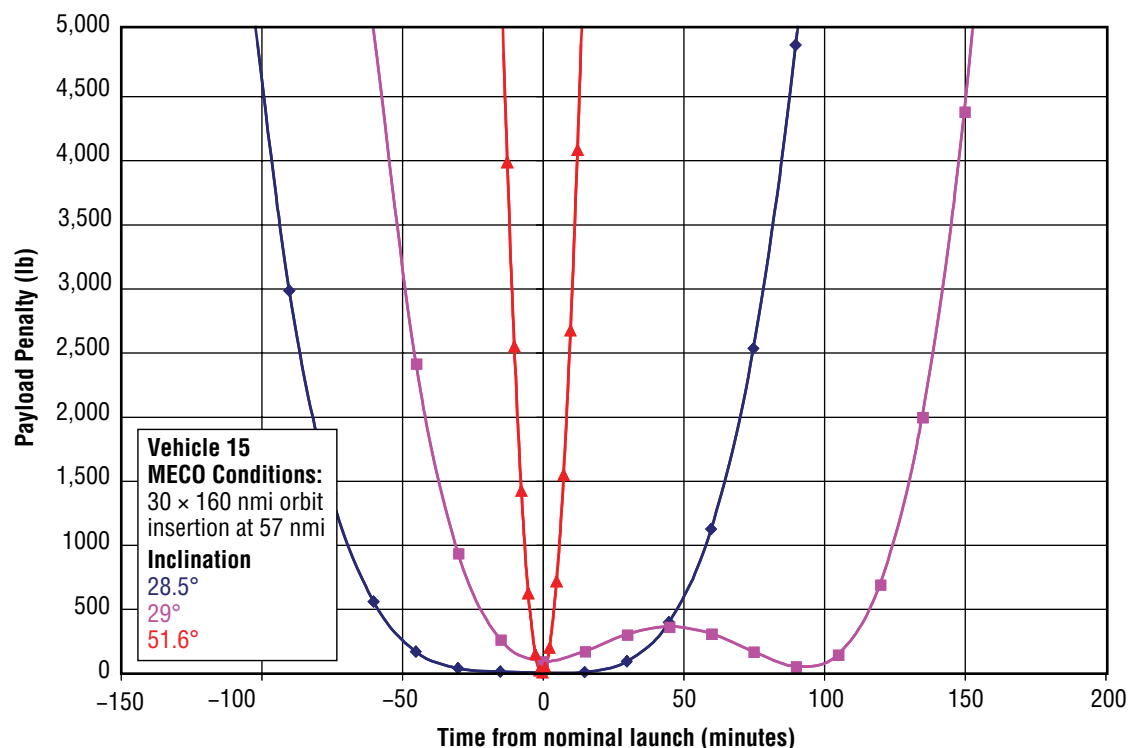

Figure 6-9. Payload Penalty for LV 15

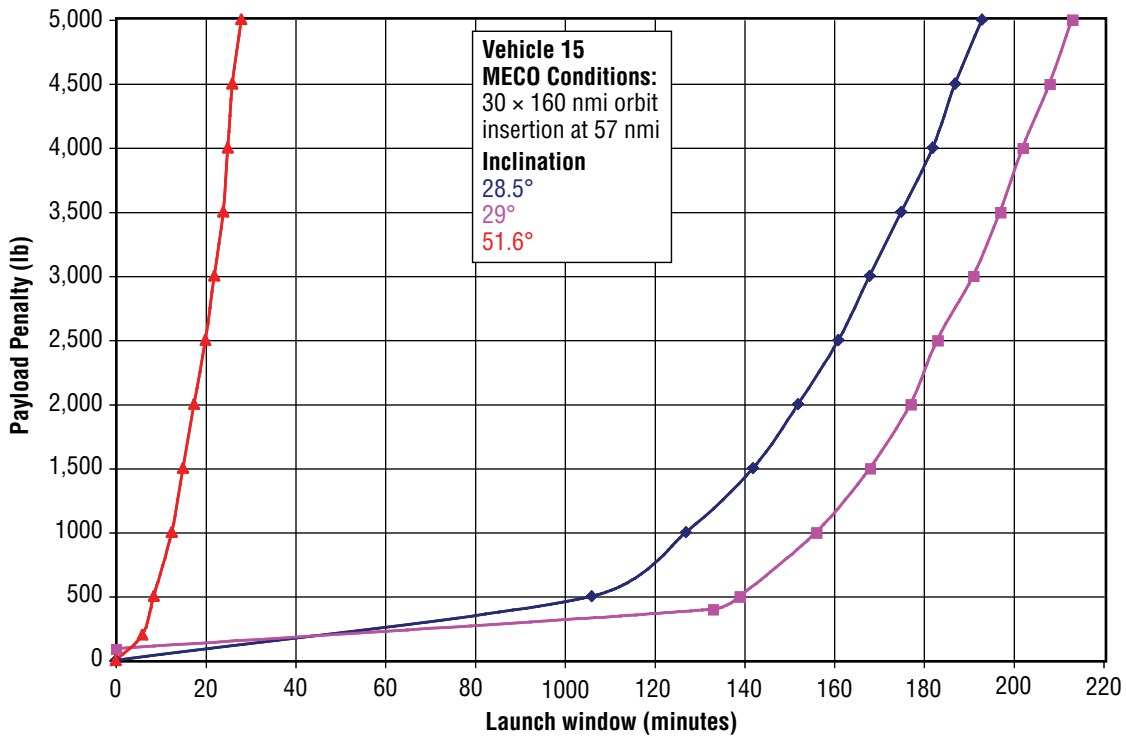

Figure 6-10. Launch Window Duration for LV 15

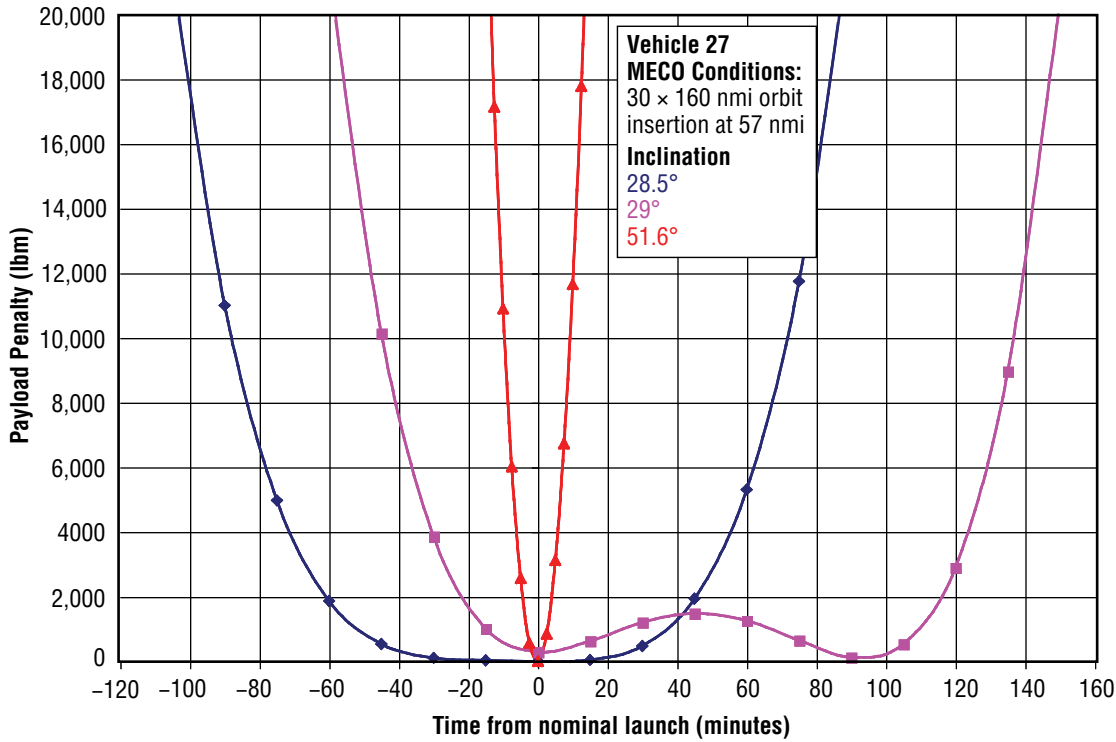

Figure 6-11. Payload Penalty for LV 27

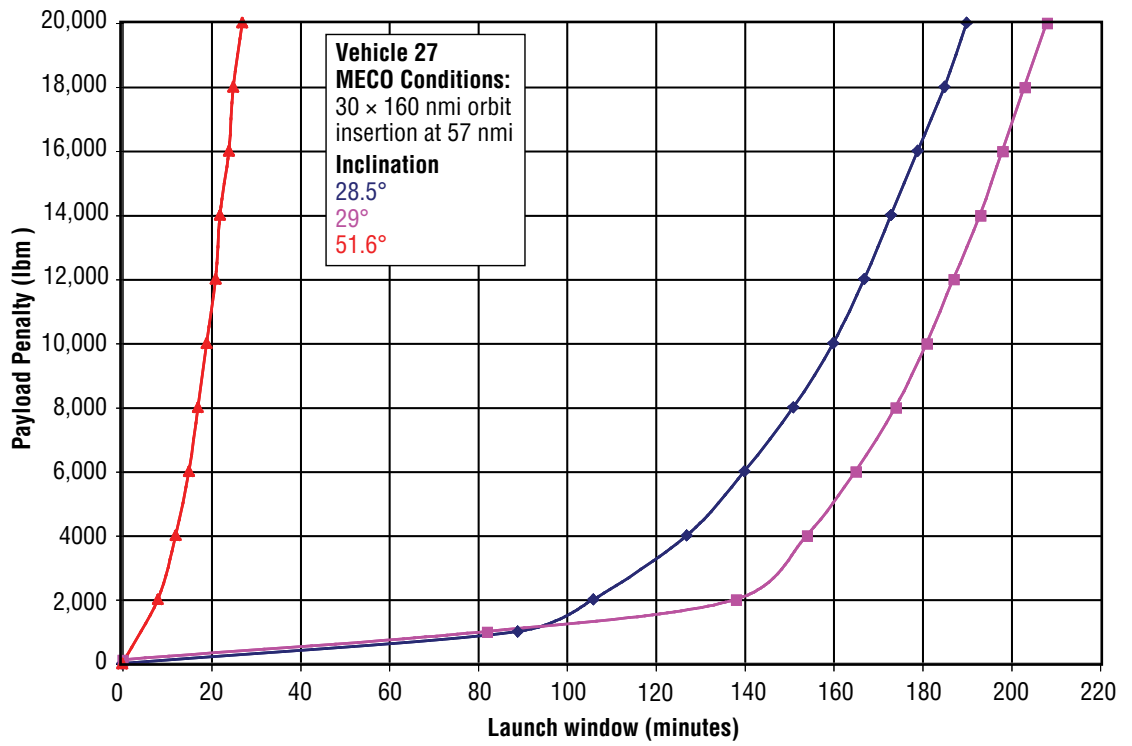

Figure 6-12. Launch Window Duration for LV 27

6.4 LV and EDS Performance System Trades

6.4.1 Launch Trade Tree Description

The options for LVs have become increasingly complex as technical strides are made in materials and systems design. The broad trade space currently available for ETO transportation for crew and cargo is shown in **Figure 6-13**.

Figure 6-13. Possible Range of Launch Trade Study

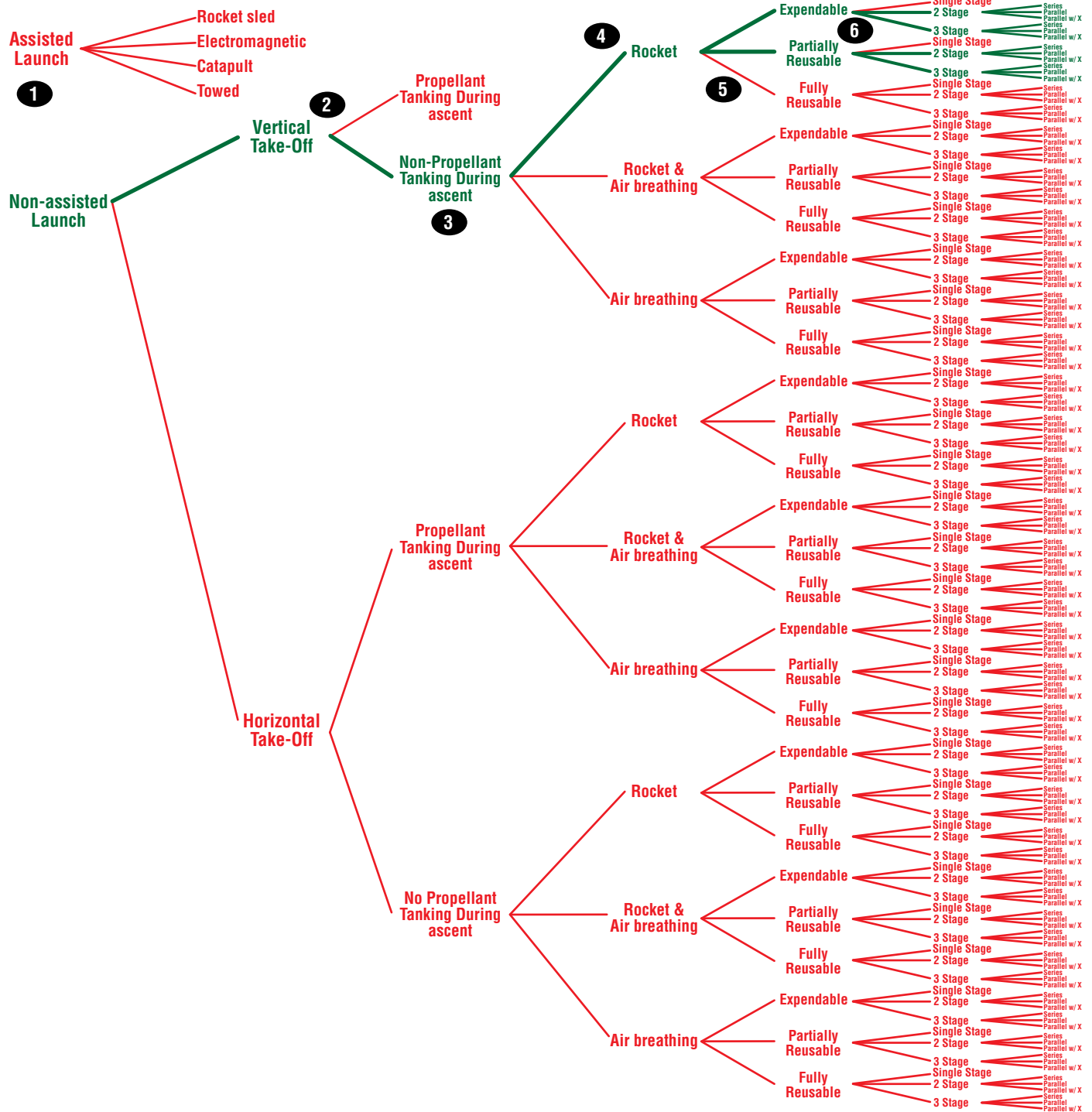

In order to arrive at a set of manageable trade options, an objective evaluation must consider the external influences on the concept decision process as well as the technical influences. Prime examples of external influences are:

- Cost: How much is it going to cost to build and field the new system, and how much will it cost to operate?
- Schedule: When is this new capability needed?

Technical influences will include:

- Safety,
- Reliability,
- Available infrastructure,
- Technology level,
- Mission, and
- Crew or cargo requirements.

Many of these influences are interrelated, such as the influence of the availability of infrastructure on the upfront cost to field the new system. For the ESAS, the launch architecture was considered as a whole through the concept-level trade tree. The crew and cargo transportation systems would be treated as an integrated system to take advantage of commonality between systems. Therefore, a common overall launch architecture was defined. A gross examination of the overall trade tree resulted in the branch shown in **Figure 6-14** as the focal point for further consideration, or “pruning.”

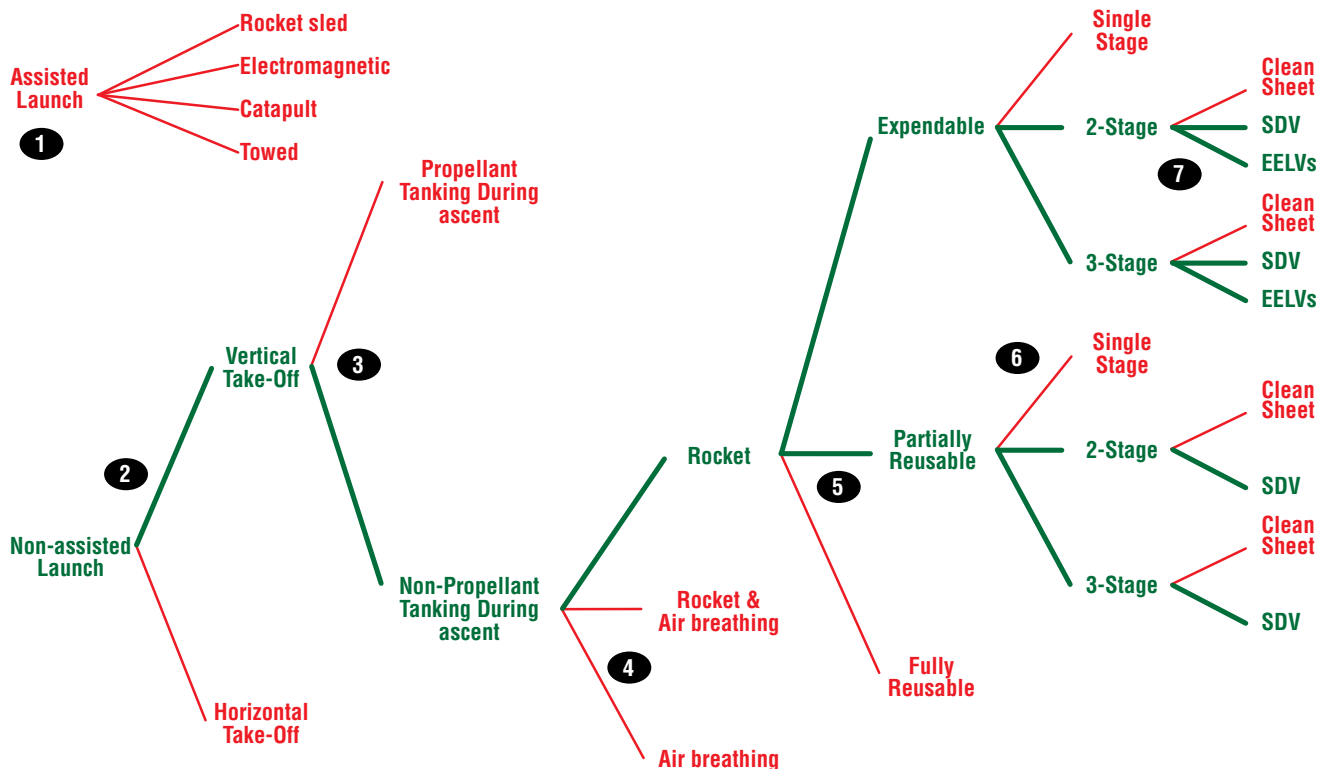

Figure 6-14. Integrated Trade Tree Pruning Rationale

The decision points of the branch are described below, with the subsequent study decisions and supporting rationale.

- Non-assisted versus Assisted Takeoff: Assisted launch systems (e.g., rocket sled, electromagnetic sled, towed) on the scale necessary to meet the payload lift requirements are beyond the state-of-the-art for near-term application. Therefore, Non-assisted Takeoff was chosen.
- Vertical versus Horizontal Takeoff: Current horizontal takeoff vehicles and infrastructures are not capable of accommodating the gross takeoff weights of concepts needed to meet the payload lift requirements. Therefore, Vertical Takeoff was chosen.
- No Propellant Tanking versus Propellant Tanking During Ascent: Propellant tanking during vertical takeoff is precluded due to the short period of time spent in the atmosphere (1) to collect propellant or (2) to transfer propellant from another vehicle. Therefore, No Propellant Tanking was chosen.
- Rocket versus Rocket and Air Breathing versus Air Breathing: Air breathing and combined cycle (i.e., rocket and air breathing) propulsion systems are beyond the state-of-the-art for near-term application and likely cannot meet the lift requirements. Therefore, Rocket was chosen.
- Expendable versus Partially Reusable versus Fully Reusable: Fully reusable systems are not cost-effective for the low projected flight rates and large payloads. Near-term budget availability and the desire for a rapid development preclude fully reusable systems. Therefore, Expendable or Partially Reusable was chosen.
- Single-stage versus 2-Stage versus 3-Stage: Single-stage concepts on the scale necessary to meet the payload lift requirements are beyond the state-of-the-art for near-term application. Therefore, 2-Stage or 3-Stage was chosen.
- Clean-sheet versus Derivatives of Current Systems: Near-term budget availability and the desire for a rapid development preclude clean-sheet systems. Therefore, Derivatives of Current Systems was chosen.

Note that the decision rationale is a combination of external and technical influences. The selected architecture is derived from existing launch systems and possesses the following attributes:

- Multistage,
- Expendable or partially reusable,
- Rocket-powered in all stages,
- Carries all of its required propellant from liftoff, and
- Takes off vertically with no assist from ground-based thrust augmentation.

With these features selected, two candidate existing launch systems were identified as having the potential to meet the ESAS requirements:

- Derivatives from the family of EELVs, and
- Derivatives from the Space Shuttle system.

The options sets were kept pure (i.e., elements of the Shuttle were not “mixed and matched” with elements of EELV) with a few exceptions. RS-68 engines were substituted for SSMEs to evaluate the performance difference. J-2S+ engines were used on both EELV and Shuttle-derived options. Findings from previous studies were examined at the beginning of the study to focus efforts on those concepts that provide the greatest potential for meeting the study goals. For example, the ESMD Launch Vehicle study considered several ET-derived CLV concepts that were near-Single-Stage-to-Orbit (SSTO) vehicles, which used an ET-derived first stage with four SSMEs, coupled with a very large CEV SM or small kick stage to inject the CEV into orbit. These concepts were not considered in the ESAS due to their poor performance (i.e., they did not meet the ESAS lift requirements). Also, very large cargo vehicles that used four Shuttle RSRBs were not considered due to the enormous cost of modifying the present launch infrastructure, the Quantity-Distance (QD) safety considerations in the Vehicle Assembly Building (VAB), and because the very high LEO performance of such vehicles was excessive for the intended application. Payload shroud concepts were common, and some cargo vehicle options used the same diameter core vehicle as the ET to take advantage of existing tooling at the Michoud Assembly Facility (MAF). For more information on all LVs assessed, see **Section 6.5, Crew Launch Vehicle**, and **Appendix 6A, Launch Vehicle Summary**.

6.4.1.1 CaLV Tree

Specific CaLV configuration selections were made based on a variety of practical considerations. Strap-on boosters were a part of each architecture option. Accordingly, strap-on boosters with a central core stage were selected as a POD. The set of major trades for the CaLV is provided in **Figure 6-15**.

6.4.1.2 CLV Tree

Specific CLV configuration selections were also made based on a variety of practical considerations. The set of major trades for the CLV is provided in **Figure 6-16**.

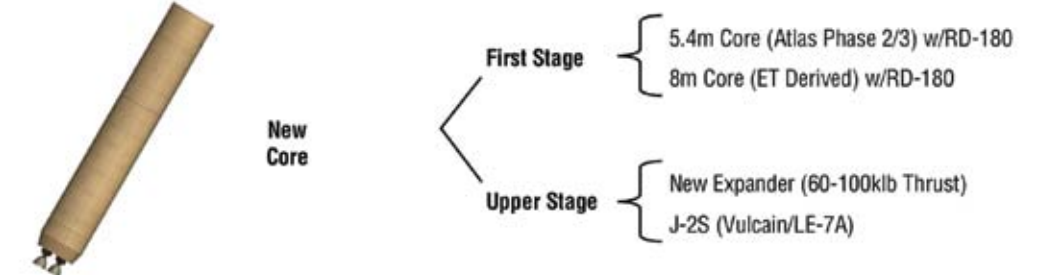
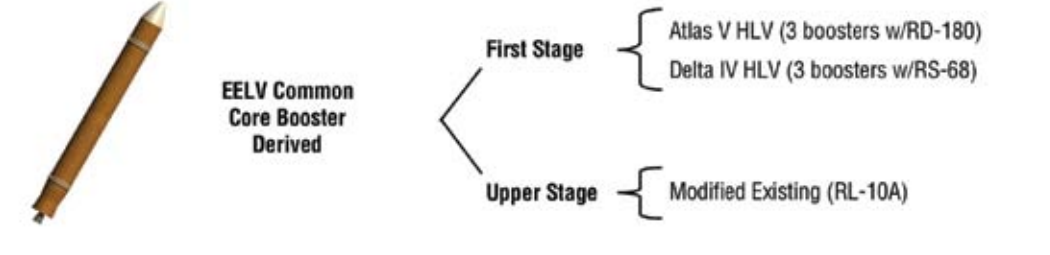
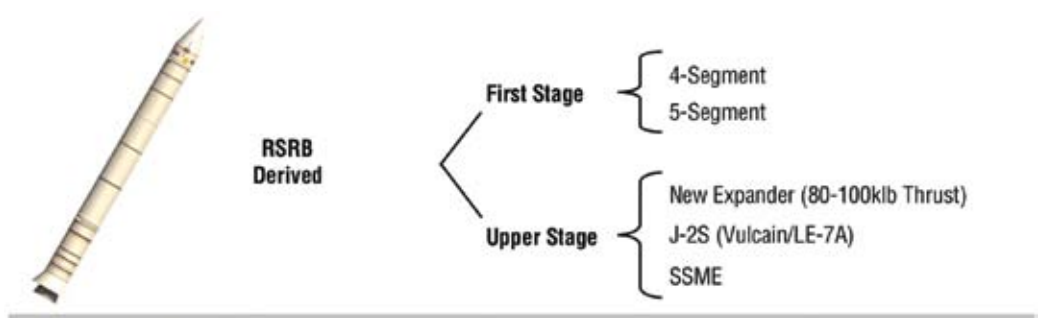
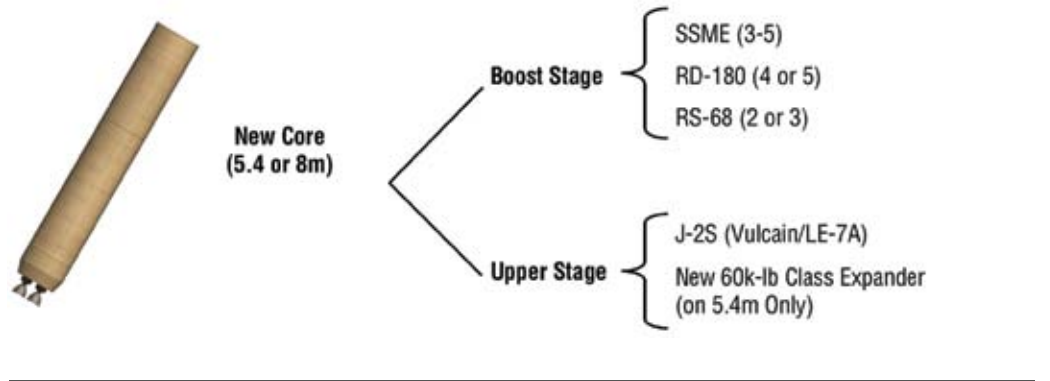
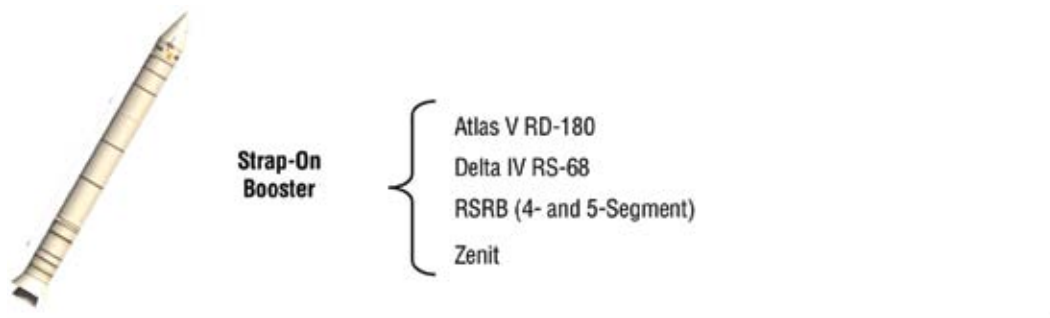

Figure 6-15. Lunar CaLV Trade Tree

Figure 6-16. Crew (LEO) Trade Tree

6.4.2 LV Trades Overview

6.4.2.1 Crew Launch Vehicle

A summary of the most promising CLV candidates assessed and key parameters is shown in **Figure 6-17**. (Note: cost is normalized to the selected option.)

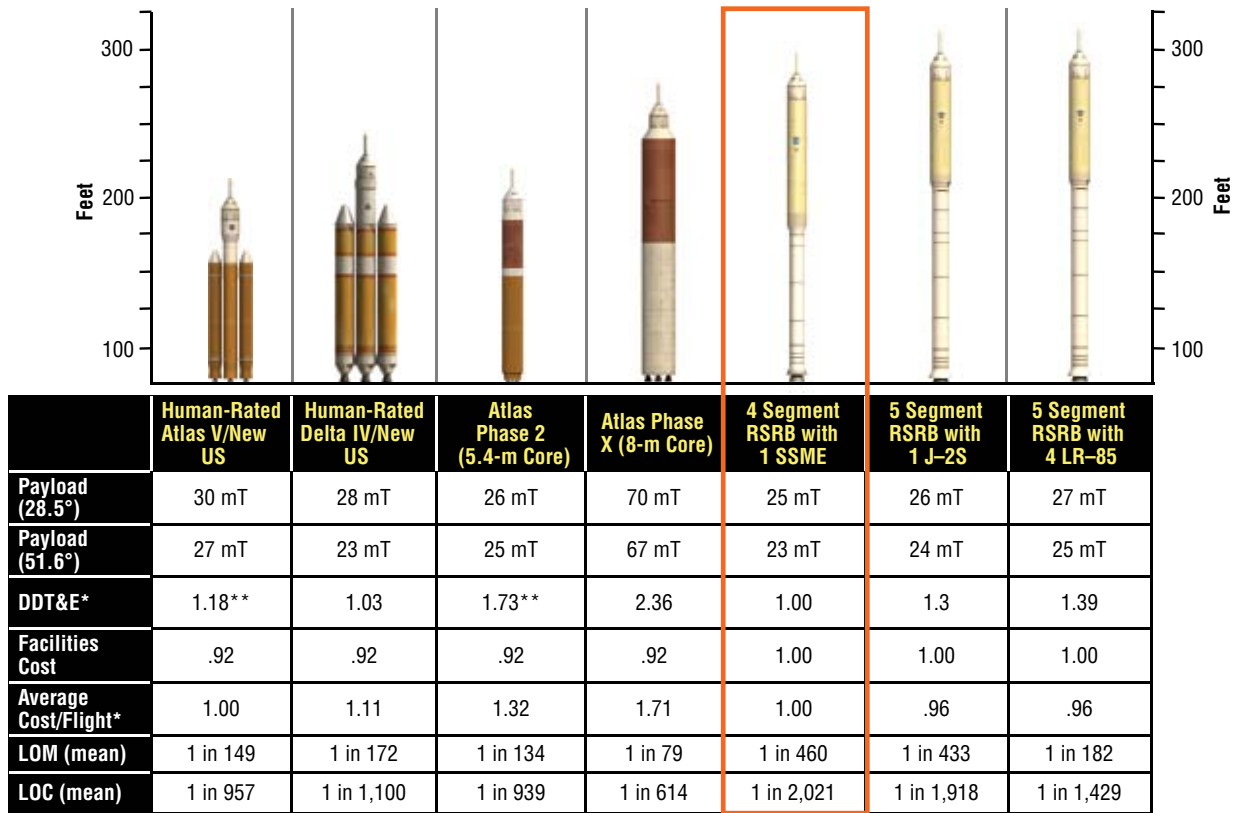

LOM: Loss of Mission LOC: Loss of Crew US: Upper Stage RSRB: Reusable Solid Rocket Booster

* All cost estimates include reserves (20% for DDT&E, 10% for Operations), Government oversight/full cost; Average cost/flight based on 6 launches per year.

** Assumes NASA has to fund the Americanization of the RD-180.

Lockheed Martin is currently required to provide a co-production capability by the USAF.

Figure 6-17. Comparison of Crew LEO Launch Systems

The EELV options examined for suitability for crew transport were those derived from the Delta IV and Atlas V families. The study focused on the heavy-lift versions of both Delta and Atlas families, as it became clear early in the study that none of the medium versions of either vehicle had the capability to accommodate CEV lift requirements. Augmentation of the medium-lift class systems with solid strap-on boosters does not provide adequate capability and poses an issue for crew safety regarding small strap-on Solid Rocket Motor (SRM) reliability, as determined by the OSP-ELV Flight Safety Certification Study report, dated March 2004. Both vehicles were assessed to require modification for human rating, particularly in the areas of avionics, telemetry, structures, and propulsion systems.

Both Atlas- and Delta-derived systems required new upper stages to meet the lift and human-rating requirements. Both Atlas and Delta single-engine upper stages fly highly lofted trajectories, which can produce high deceleration loads on the crew during an abort and, in some cases, can exceed crew load limits as defined by NASA Standard (STD) 3000, Section 5. Depressing the trajectories flown by these vehicles will require additional stage thrust to bring peak altitudes down to levels that reduce crew loads enough to have sufficient margins for off-nominal conditions. Neither Atlas V nor Delta IV with their existing upper stages possess the performance capability to support CEV missions to ISS, with shortfalls of 5 mT and 2.6 mT, respectively.

Another factor in both vehicles is the very low Thrust-to-Weight (T/W) ratio at liftoff, which limits the additional mass that can be added to improve performance. The RD-180 first-stage engine of the Atlas HLV will require modification to be certified for human rating. This work will, by necessity, have to be performed by the Russians. The RS-68 engine powering the Delta IV HLV first stage will require modification to eliminate the buildup of hydrogen at the base of the vehicle immediately prior to launch. Assessments of new core stages to improve performance as an alternative to modifying and certifying the current core stages for human rating revealed that any new core vehicle would be too expensive and exhibit an unacceptable development risk to meet the goal of the 2011 IOC for the CEV. Note the EELV costs shown in **Figure 6-17** do not include costs for terminating Shuttle propulsion elements/environmental cleanup. Finally, both the EELV options were deemed high-risk for a 2011 IOC.

CLV options derived from Shuttle elements focused on the configurations that used an RSRB, either as a four-segment version nearly identical to the RSRB flown today or a higher-performance five-segment version of the RSRB using HTPB as the solid fuel. New core vehicles with ET-derived first stages (without Solid Rocket Boosters (SRBs)) similar to the new core options for EELV were briefly considered, but were judged to have the same limitations and risks and, therefore, were not pursued. To meet the CEV lift requirement, the team initially focused on five-segment RSRB-based solutions. Three classes of upper stage engine were assessed—SSME, a single J-2S+, and a four-engine cluster of a new expander cycle engine in the 85,000-lbf vacuum thrust class. However, the five-segment development added significant near-term cost and risk and the J-2S+/expander engine could not meet the 2011 schedule target. Therefore, the team sought to develop options that could meet the lift requirement using a four-segment RSRB. To achieve this, a 500,000-lbf vacuum thrust class propulsion system is required. Two types of upper stage engine were assessed—a two-engine J-2S cluster and a single SSME. The J-2S option could not meet the 2011 target (whereas the SSME could) and had 6 percent less performance than the SSME-based option (LV 13.1). The SSME option offered the added advantages of an extensive and successful flight history and direct extensibility to the CaLV with no gap between the current Shuttle program and exploration launch. Past studies have shown that the SSME can be altitude-started, with an appropriate development and test program.

The 13.1 configuration was selected due to its lower cost, higher safety/reliability, its ability to utilize existing human-rated systems and infrastructure, and the fact that it gave the most straightforward path to a CaLV.

6.4.2.2 Cargo Launch Vehicle

A summary of the most promising CaLV candidates and key parameters is shown in **Figure 6-18**. (Note: Cost is normalized to the selected option.) The requirement for four or less launches per mission results in a minimum payload lift class of 70 mT. To enable a 2- or 1.5-launch solution, a 100- or 125-mT class system, respectively, is required.

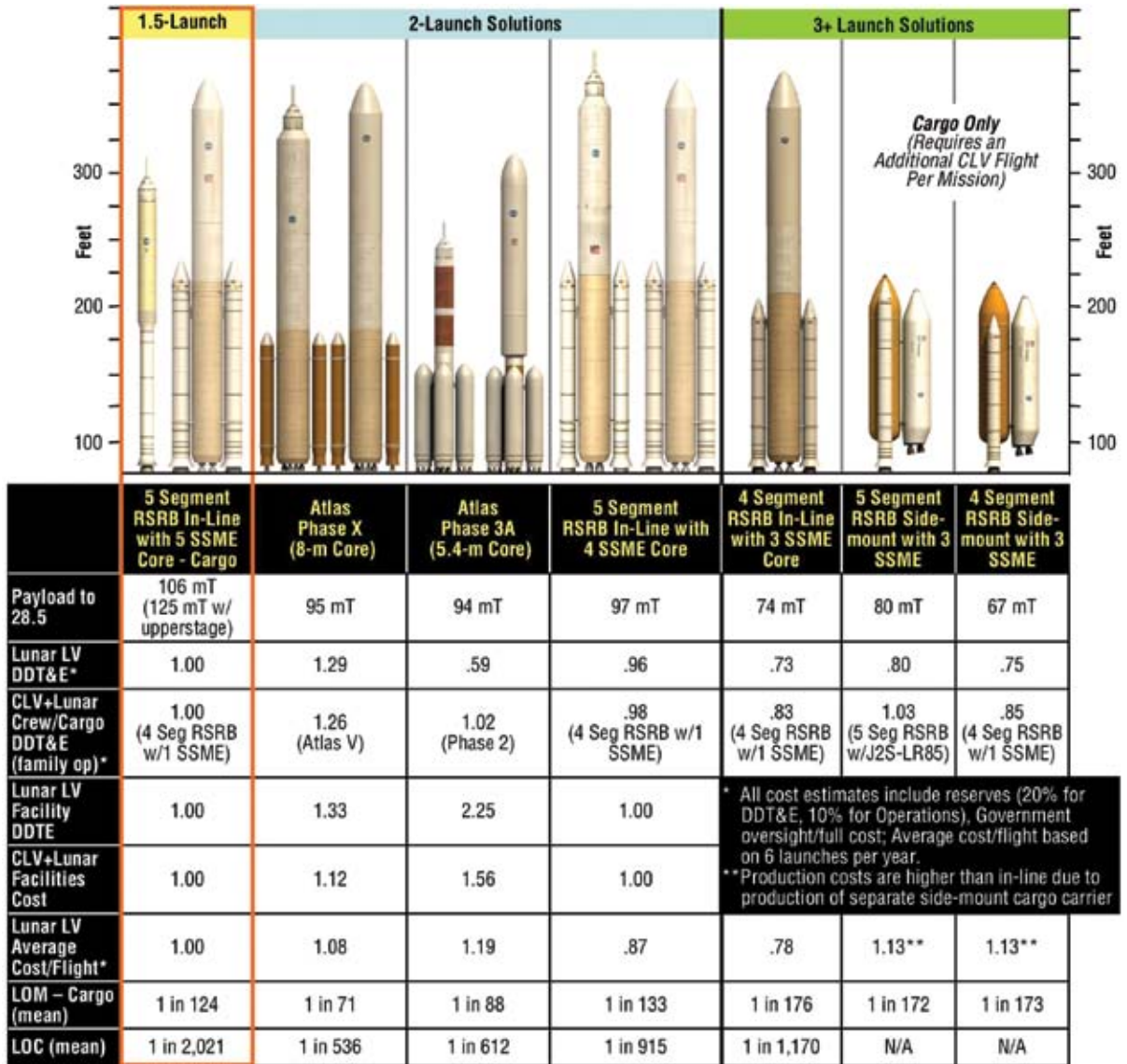

Figure 6-18. Lunar Cargo Launch Comparison

EELV-derived options for the CaLV included those powered by RD-180 and RS-68 engines, with core vehicle diameters of 5.4 and 8 m. No RS-68-powered variant of an EELV-derived heavy-lift cargo vehicle demonstrated the capability to meet the lunar lift requirements without a new upper stage and either new large liquid strap-on boosters or Shuttle RSRBs. The considerable additional cost, complexity, and development risk were judged to be unfavorable, eliminating RS-68-powered CaLVs. Hydrocarbon cores powered by the RD-180 with RD-180 strap-on boosters proved to be more effective in delivering the desired LEO payload. Vehicles based on both a 5.4-m diameter core stage and an 8-m diameter core were analyzed. A limitation exhibited by the EELV-Derived Vehicles (EDVs) was the low liftoff T/W ratios for optimized cases. While the EELV-derived CaLVs were able to meet LEO payload requirements, the low liftoff T/W ratio restricted the size of EDS in the suborbital burn cases. As a result, the Earth-escape performance of the EELV options was restricted. The 5.4-m core CaLV had an advantage in Design, Development, Test, and Evaluation (DDT&E) costs, mainly due to the use of a single diameter core derived from the CLV which was also used as a strap-on booster. However, the CLV costs for this option were unacceptably high. (See **Section 6.4.2.1, Crew Launch Vehicle**.) In addition, there would be a large impact to the launch infrastructure due to the configuration of the four strap-on boosters (i.e., added accommodations for the two additional boosters in the flame trench and launch pad). Also, no EELV-derived concept was determined to have the performance capability approaching that required for a lunar 1.5-launch solution. Finally, to meet performance requirements, all EELV-derived CaLV options required a dedicated LOX/LH2 upper stage in addition to the EDS—increasing cost and decreasing safety/reliability.

The Shuttle-derived options considered were of two configurations: (1) a vehicle configured much like today's Shuttle, with the Orbiter replaced by a side-mounted expendable cargo carrier, and (2) an in-line configuration using an ET-diameter core stage with a reconfigured thrust structure on the aft end of the core and a payload shroud on the forward end. The ogive-shaped ET LOX tank is replaced by a conventional cylindrical tank with ellipsoidal domes, forward of which the payload shroud is attached. In both configurations, three SSMEs were initially baselined. Several variants of these vehicles were examined. Four- and five-segment RSRBs were evaluated on both configurations, and the side-mounted version was evaluated with two RS-68 engines in place of the SSMEs. The J-2S+ was not considered for use in the CaLV core due to its low relative thrust and the inability of the J-2S+ to use the extended nozzle at sea level, reducing its Specific Impulse (Isp) performance below the level required. No variant of the side-mount Shuttle-Derived Vehicle (SDV) was found to meet the lunar lift requirements with less than four launches. The side-mount configuration would also most likely prove to be very difficult to human rate, with the placement of the CEV in close proximity to the main propellant tankage, coupled with a restricted CEV abort path as compared to an in-line configuration. The proximity to the ET also exposes the CEV to ET debris during ascent, with the possibility of contact with the leeward side TPS, boost protective cover, and the LAS. The DDT&E costs are lower than the in-line configurations, but per-flight costs are higher—resulting in a higher per-mission cost. The side-mount configuration was judged to be unsuitable for upgrading to a Mars mission LEO capability (100 to 125 mT). The in-line configuration in its basic form (four-segment RSRB/three-SSME) demonstrated the performance required for a 3-launch lunar mission at a lower DDT&E and per-flight costs. Upgrading the configuration with five-segment RSRBs and four SSMEs in a stretched core with approximately one-third more propellant enables a 2-launch solution for lunar missions, greatly improving mission reliability. A final variation of the Shuttle-derived in-line CaLV

was considered. This concept added a fifth SSME to the LV core, increasing its T/W ratio at liftoff, thus increasing its ability to carry large, suborbitally ignited EDSs. LV 27.3 demonstrated an increased lift performance to enable a 1.5-launch solution for lunar missions, launching the CEV on the CLV and launching the LSAM and EDS on the larger CaLV. This approach allows the crew to ride to orbit on the safer CLV with similar Life Cycle Costs (LCCs) and was selected as the reference. This configuration proved to have the highest LEO performance and lowest LV family nonrecurring costs. When coupled with the four-segment RSRB/SSME-derived CLV (13.1), Loss of Mission (LOM) and Loss of Crew (LOC) probabilities are lower than its EELV-derived counterparts.

6.4.3 EDS Performance Trades

Four variations of EDS missions were examined against four representative CaLVs. The LVs were:

- LV 25: Shuttle-derived in-line CaLV with two four-segment RSRBs and three SSMEs;
- LV 27 (and variants): Shuttle-derived in-line CaLV with two five-segment RSRBs and four SSMEs (five SSMEs on LV 27.3);
- LV 30: Shuttle-derived in-line CaLV with two five-segment RSRBs and four SSMEs and an upper stage with two J-2 engines; and
- LV 7.4: EELV-derived with two Atlas V strap-on boosters, a 5-RD-180 core vehicle with a 4-J-2S+ upper stage.

The mission trade variations were the four paired combinations of:

- Suborbital burn versus no suborbital burn, and
- Payload versus no payload.

A summary of coupled LV/EDS performance capabilities appears in **Appendix 6C, Launch Vehicles and EDS Performance Sizing**. The results of the EDS performance trades indicated that there were numerous EDS/LV combinations that would work for 2- and 3+-launch solutions for lunar missions. In assessing the 1.5-launch solution, a large, suborbitally ignited EDS capable of carrying an LSAM proved to be the most advantageous from a performance and cost perspective. The basic 1.5-launch EDS concept, S2B3/4/5, when coupled with LV 27.3, allows a 45 mT LSAM to be delivered with it to orbit. No other CaLV provided this capability. The addition of the fifth SSME and the large EDS eliminated the need for a separate upper stage and EDS. The high T/W of LV 27.3 (approximately 1.45) is a key factor in enabling the 1.5-launch solution.

6.4.4 Number of Launches and On-Orbit Assembly Assessment

6.4.4.1 Synopsis

To assess the merits and pitfalls of the number of launches required for exploration missions, an analysis was conducted of the key parameters: LV availability (including launch scrub recycle time and mission window), LV reliability, and automated rendezvous subsystem reliability. Concatenation of these parameters as a function of the number of LVs was evaluated using LOM (i.e., the failure to successfully complete one mission out of a number of missions) as the FOM. The results showed that, for any combination of parameters based on history, a very small quantity of very Heavy-Lift Launch Vehicles (HLLVs) was the path to acceptable values of LOM.

6.4.4.2 Problem Statement

Mission success for crewed lunar missions depends on three significant processes. First, launch availability relates to the architecture's ability to provide on-time launch of each of the mission elements. Second, LV reliability relates to the architecture's ability to successfully fly each LV to the destination orbit and release the payload, either cargo or crew. Third, Automated Rendezvous and Docking (AR&D) reliability relates to the architecture's ability to successfully conduct the on-orbit integration of all elements that require automated link-up prior to initiation of the lunar mission. The concatenation of these three processes provides a first-order estimate of the architecture's likelihood to succeed. This estimate is measured by LOM. This estimate does not include all aspects of the total mission; rather, it is truncated for the purpose of this analysis at the point of lunar departure.

6.4.4.3 Analysis Process

The following sections discuss each of the processes, explain the analytical methodology, provide results for each of the processes, and develop observations related to the combined results.

6.4.4.3.1 Availability Analysis

Availability is the probability that any LV in the chain required for a lunar mission will fly in the planned launch window. Many outside conditions and design features affect the value of availability. The lunar payload and LV must be designed to support rapid integration and yet require minimal support on the launch pad, including a rapid and reliable ability to be fueled. Both the range and the LV must be tolerant of a variety of weather conditions: temperature, winds both at the surface and at altitude, cloud cover, and lightning. The Russian Soyuz vehicle and infrastructure represents a good example. Finally, the range must have the ability to be rapidly and reliably reconfigured to minimize the time required to support each launch, whether lunar cargo or crew, ISS crew or cargo, or other Department of Defense (DoD) or commercial missions.

Although the ability to launch as scheduled contributes to the likelihood that a lunar mission is successfully launched, there are other embedded parameters that significantly influence the LOM measure. These significant parameters include the number of launches required, the mission window required for the launch of all elements, and the "recycle" time required following a scrub to prepare for the next launch attempt. This analysis assumed that the individual launch availability varies from 60 percent to 90 percent, that the number of launches could be as many as 10 to 20 (but greater than 1), that 4 to 5 months could be needed to put all elements in orbit, and the "mission clock" starts after the first successful launch. Assuming that each subsequent launch requires 2 weeks of preparation, the key independent parameter was the average recycle time. Since recycle times are due to diverse consequences and could vary from 1 day (weather-related) to 2 years (design-related), this analysis assumed an average over all scrubs of 3 to 7 days.

The time lines of two different architectural solutions (**Figure 6-19**) illustrate the implications of these parameters, where the individual LV availability was assumed to be 100 percent. The first architecture requires two launches over an 18-week period with 7 days on average between launch scrubs to provide all lunar mission elements. As can be seen in **Figure 6-19**, 14 launch scrub/recycle events still leave sufficient time to have both launches occur within the mission window. Conversely, a “9-launch” architectural solution allows for zero scrubs to meet the 4-month mission window.

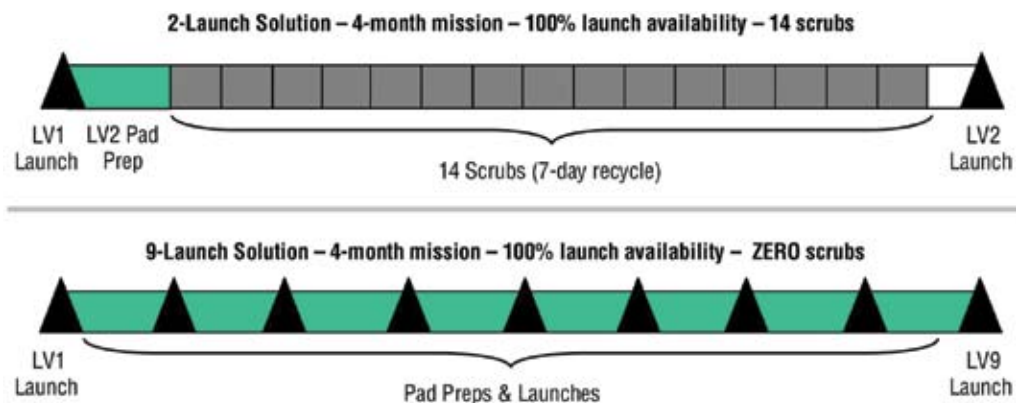

Figure 6-19. Description of 2-Launch versus 9-Launch Solutions

A summary of the analysis for the above assumptions is shown in **Figure 6-20**, where the measure is the cumulative probability of successfully launching all mission elements.

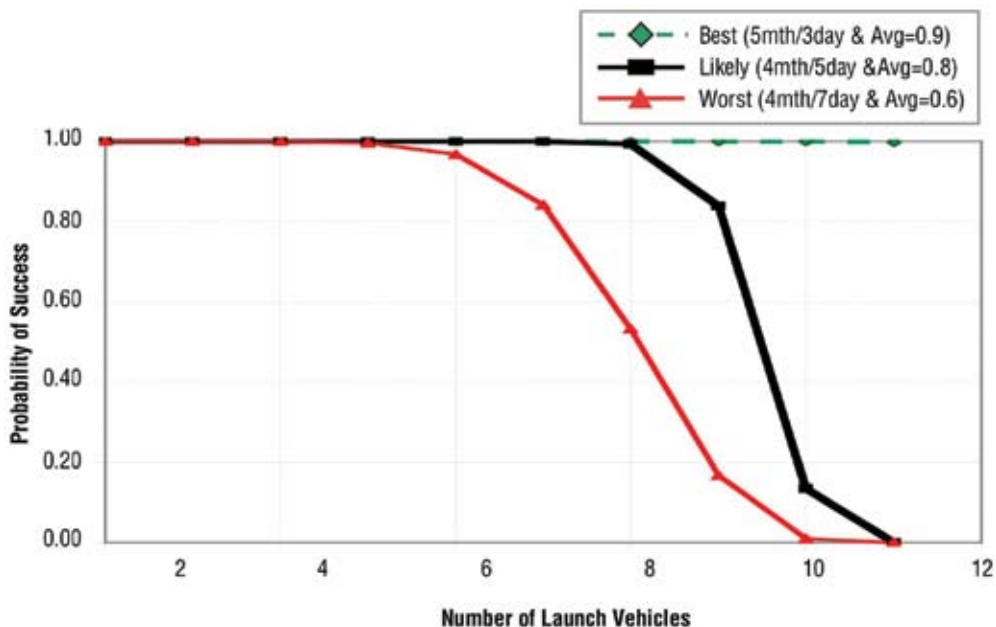

Figure 6-20. Probability of Mission Completion

Clear impacts can be observed from these data:

- Availability favors a fewer number of launches. If large numbers of launches are needed to support a lunar mission, the probability of success rapidly diminishes. Indeed, there are certain combinations of assumptions in which it is not possible to statistically achieve eight or more launches.
- The range would likely have to be dedicated to lunar mission support configuration until all elements are launched due to the time-critical nature of the on-orbit cryogenic propellants used and the nature of scrubs and recycles. Given the multiplicity of Eastern Range customers, this restriction would be undesirable, yet vital for lunar mission success. This restriction is exacerbated if multiple yearly lunar missions are considered.
- Twin launch pads would shorten the mission window and the range dedication.
- A dedicated range for lunar traffic models greater than one annual mission would be desirable.

6.4.4.3.2 LV Reliability Analysis

Although the reliability of specific CLV and CaLV configurations was analyzed parametrically, for the purposes of this analysis of number of launches, historical LV reliabilities were used. LV reliability varies significantly depending on the system: Soyuz reliability is approximately 97 percent over more than 1,000 launches, Delta 2 has 98 percent reliability in 100+ launches, the Shuttle demonstrated launch reliability of 99 percent, and Pegasus has less than 90 percent demonstrated reliability. Statistically, the chaining of launches using historical averages results in the LOM shown in **Figure 6-21**. For 10 LVs of current demonstrated reliability, the LOM due only to LV reliability would be one failed mission in 5 to 10—undesirable in terms of the expense of the launched assets lost. However, as the concatenation of the significant parameters show, LV reliability is not the dominant term and contributes the least to the overall LOM result.

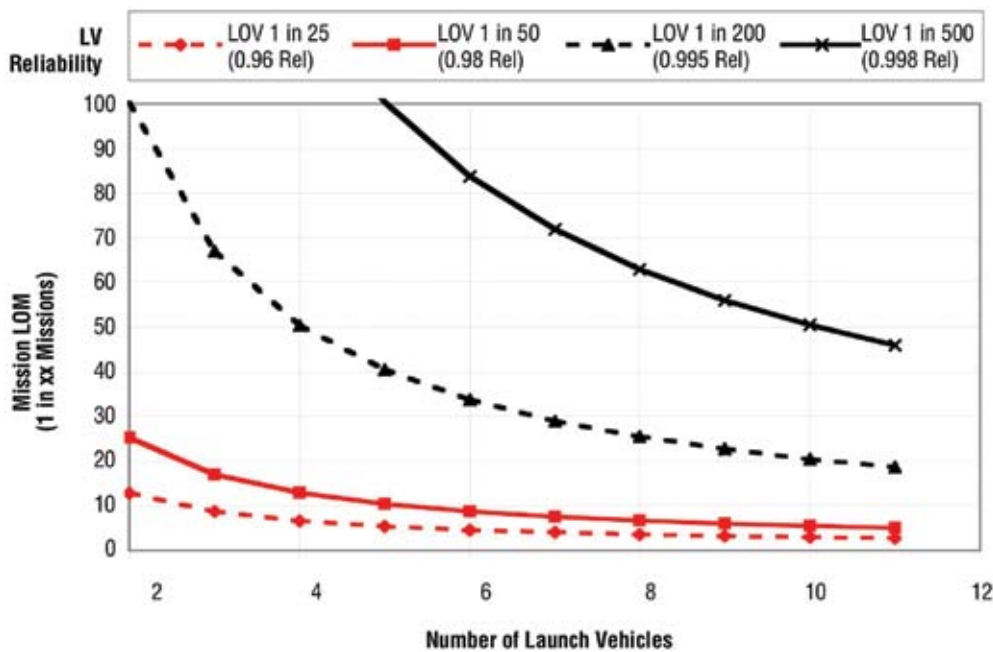

Figure 6-21. LOM Due Only to Average LV Reliability

6.4.4.3.3 AR&D Reliability Analysis

In most multi-launch vehicle lunar architectures, some of the mission elements must be linked without the presence of human aid, just as when Progress docks with ISS. An AR&D system, illustrated functionally in **Figure 6-22** below, is quite complex. As a flight element of the host in-space element, the system must plan for the orbital rendezvous path with contingencies, continuously measure with increasing precision the position of its host relative to the target, execute the guidance through propulsion on the chaser, communicate and display state and status data to many users, and make contact with the target that finally results in docking.

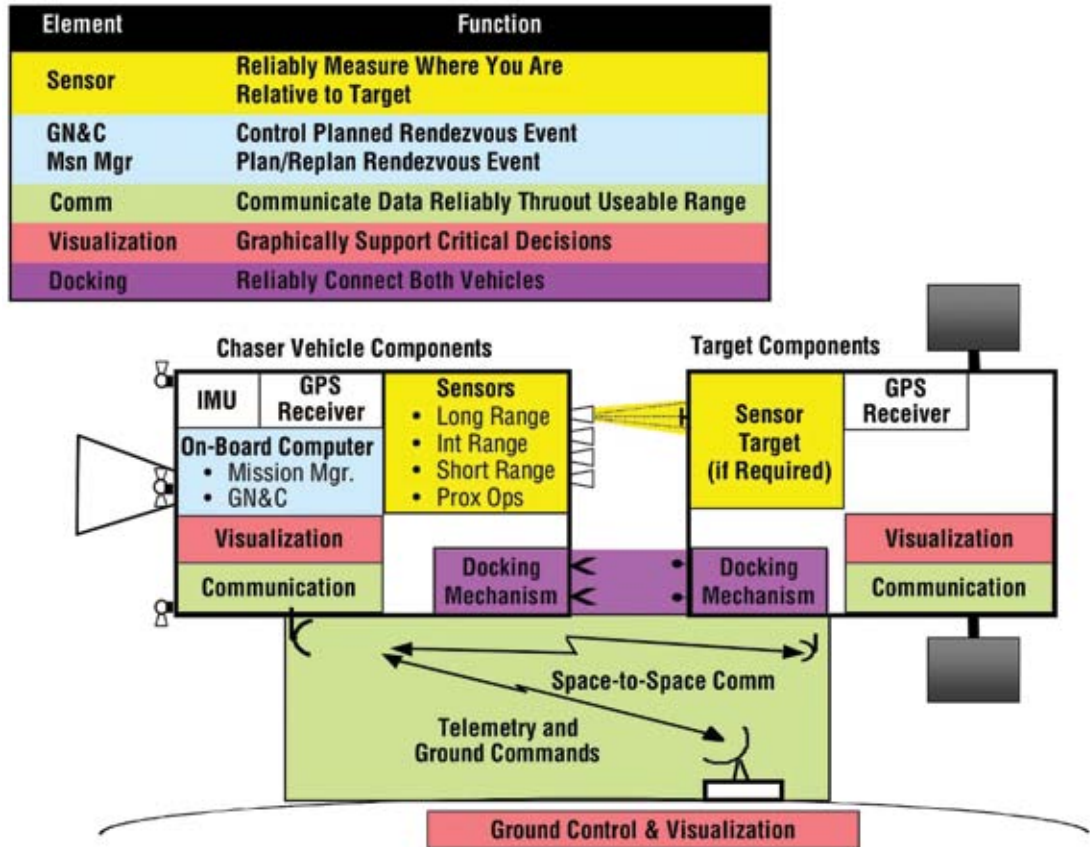

Figure 6-22. An AR&D System's Chaser and Target Components

Although the U.S. has conducted several flight experiments (with more planned), Russia has the only AR&D operationally proven system—Kurs. If the Kurs reliability data is carefully examined to focus on those dockings that were successful only in the automated mode, the reliability of this subsystem is approximately 85 percent. Assuming that the subsystem reliability is only a function of mechanical systems (i.e., that software does not contribute to reliability), a representative reliability allocation to lower-level subsystems can be developed, as shown in **Table 6-2**. When chained across several events, an 85 percent AR&D reliability would not support a viable lunar mission scenario. An unrealistic AR&D subsystem reliability of 99.95 percent (1 failure in 2,000 operations) causes orders of magnitude increase in the Mean Time Between Failure (MTBF) of lower-level subsystems. Based on existing technologies and projected improvements, an AR&D reliability of 95 percent appears realistic, given the hardware and software complexity and operational environment.

Table 6-2. Lower-level Subsystems Reliability Allocation

If AR&D Subsystem Reliability = 0.8500					If AR&D Subsystem Reliability = 0.9995				
Then the Subsystem Reliability Allocation Might Be	3 Dissimilar Sensors	Non-Redundant Control System	Common System	Docking System (10 min On Time)	Then the Subsystem Reliability Allocation Might Be	3 Dissimilar Sensors	Non-Redundant Control System	Common System	Docking System (10 min On Time)
MTBF (hr)	1,500	4,000	7,500	1,000	MTBF Increase Factor	3	100	667	100
# of 12-hour Missions	20	300	600	80	Factor Increase in # of 12-hour Missions	15	10	67	100

6.4.4.3.4 Concatenated Analysis

The previous three sections identified the significant parameters associated with lunar mission preparation. The mission success calculation for the phases prior to leaving Earth orbit requires a concatenation (chain product) of these parameters to determine the statistical LOM. Due to the number of variables, this discussion will focus on three cases that combine these variables into an “optimistic” case, a “most-likely” case, and a “worst-case” expectation. The independent variables include LV average reliability and the number of launches in an architecture. The analysis then assumes that an irrecoverable mission event causes an LOM. Irrecoverable events occur whenever there is an inability to launch all mission elements within the scheduled window, whenever a launch fails to deliver the payload to the destination orbit, or whenever two elements that require AR&D are unsuccessful in the automated mode.

The “optimistic” case results, shown in **Figure 6-23**, were developed to allow the sensitivity of LV reliability to be observed. Unfortunately, to achieve these results, unrealistic values for launch availability of 90 percent, a 3-day average for schedule recycles, a lengthy 5-month mission window, and AR&D automated reliability of 99.95 percent are required. Even a 10-launch architecture, for example, results in an LOM of 1 in 5 for EELV-like reliabilities and 1 in 10 for Shuttle-like reliability. Therefore, launch availability and AR&D reliability are obviously driving parameters that focus the architecture solution toward minimum numbers of launches.

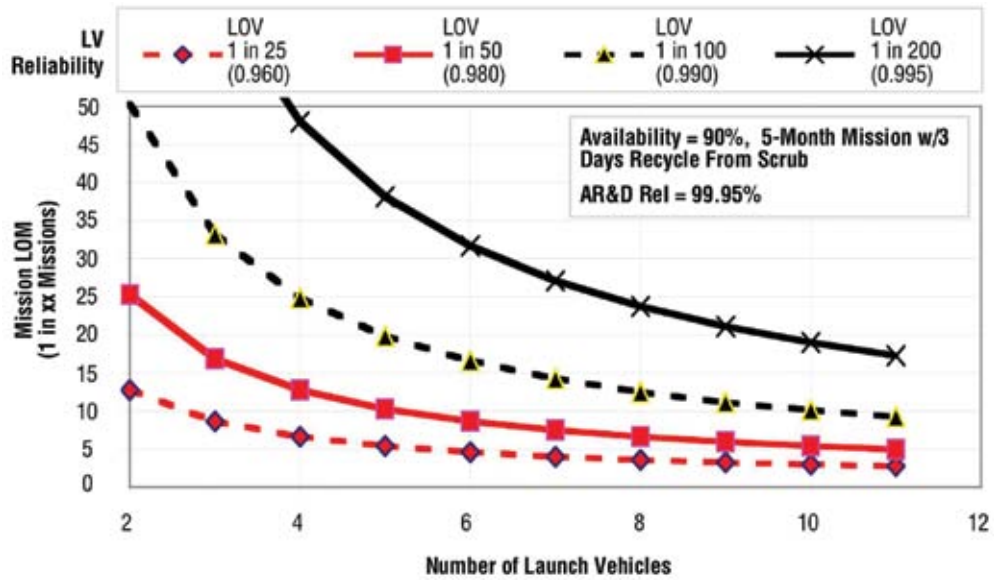

Figure 6-23. LOM Due to LV Reliability, Launch Availability, and On-Orbit Integration (Optimistic Case)

The “most-likely” case results, shown in **Figure 6-24**, should be achievable within current technology projections. Launch availability was assumed to be 80 percent with a 5-day average schedule recycle duration, a 4-month mission window, and an AR&D automated reliability of 95 percent. Here, LV reliability has a reduced role. The curves begin to develop a significant “knee” at a 3-launch architecture.

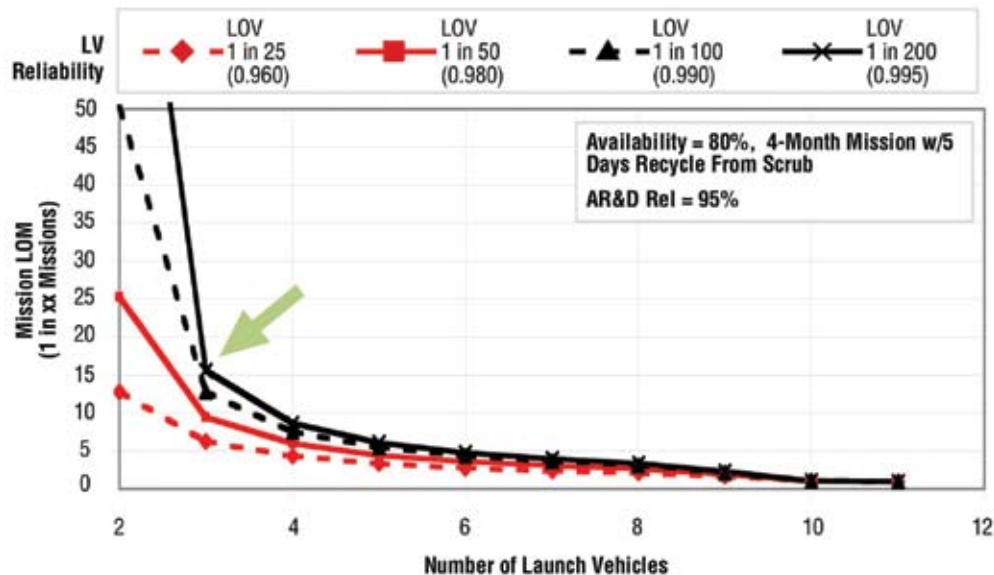

Figure 6-24. LOM Due to LV Reliability, Launch Availability, and On-Orbit Integration (Likely Case)

The “worst-case” results, shown in **Figure 6-25**, approximates Shuttle performance by assuming a launch availability of 60 percent with a 7-day average schedule recycle duration, a 4-month mission window, and Kurs-like AR&D automated reliability of 85 percent. For this case, LV reliability plays a significant role for all 2-launch solutions and the curves begin to develop a significant “knee” at a 3-launch architecture with a LOM of 1 in 5. The combination of docking reliability and inability to fit the launches within the mission window causes an LOM of nearly every attempt for architectures requiring more than eight launches and of every other attempt when six launches are required.

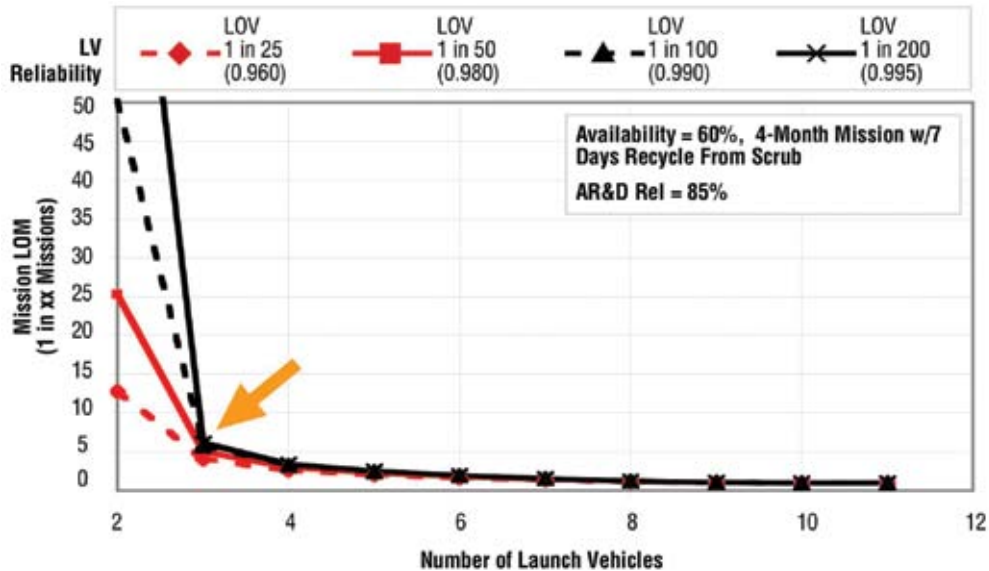

Figure 6-25. LOM Due to LV Reliability, Launch Availability, and On-Orbit Integration (Worst Case)

6.4.4.4 Summary of Results

Listed below are the results of the assessment of number of launches and on-orbit assembly:

- Launch scrubs are unfortunately a fact of rocketry. The average time between attempts is as much a function of weather as hardware and software glitches. Reducing hardware complexity reduces scrubs and recycles.
- AR&D operational systems do not currently provide reliable automated performance; only the near presence of human backup pilots on either ISS or in the crew cabin allows the Kurs system to provide high reliability.
- Existing ranges have other, equally time-critical customers. Dedicating a range configuration to support many launches for a single yearly lunar mission is improbable, and expecting the range to support multiple yearly missions can only occur if the range is dedicated to exploration.
- The architecture should limit the numbers of launches to a few (i.e., two) vehicles capable of lifting very heavy payloads. This approach allows adequate time to accommodate vehicle/payload integrations and launch scrub/recycles, minimizes the need for automated rendezvous, and supports exploration traffic growth without requiring a dedicated range.

6.5 Crew Launch Vehicle

An array of options was assessed to determine their individual abilities to meet the stated requirements for the CLV. Those that most closely support the necessary demands are provided here. The remaining CLV options that were not evaluated further are discussed in more detail in **Appendix 6A, Launch Vehicle Summary**.

Table 6-3. Shuttle-Derived CLV Options Assessed in Detail

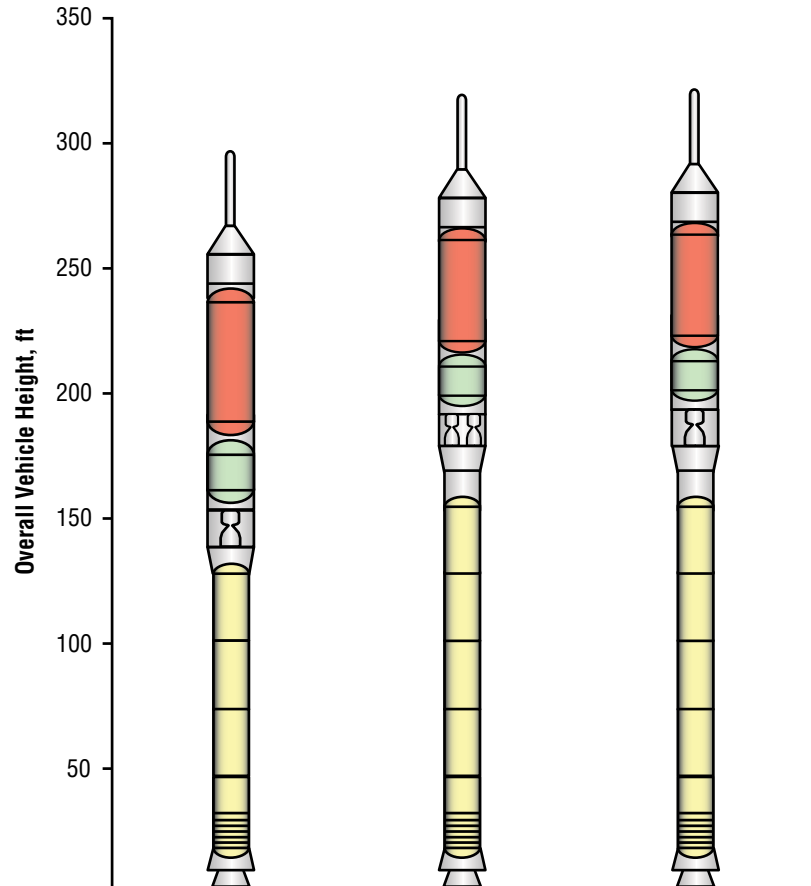

Vehicle Name		13.1	15	16
		4-Segment SRB with 1 SSME Crew	5-Segment SRB with 4 LR-85 Crew	5-Segment SRB with 1 J-2S+ Crew
Payload 28.5 Deg Inc*	Units			
Lift Capability	mT	27.2 mT	29.9 mT	28.7 mT
Net Payload	mT	24.5 mT	27.0 mT	25.8 mT
Payload 51.6 Deg Inc*				
Lift Capability	mT	25.4 mT	28.1 mT	27.0 mT
Net Payload	mT	22.9 mT	25.3 mT	24.3 mT
General Parameters				
Overall Height	ft	290.4 ft	309.4 ft	311.8 ft
Gross Liftoff Mass	lbm	1,775,385 lbm	2,029,128 lbm	2,014,084 lbm
Liftoff Thrust/Weight	G	1.38 g	1.77 g	1.78 g
Second Stage Thrust/Weight	G	1.03 g	0.91 g	0.77 g

*Delivered to 30X160 nmi Orbit

6.5.1 Candidate LV Options Summary

Table 6-3 provides the four Shuttle-derived options (LV 13.1, LV 15, and LV 16) that were assessed in detail in this study, including their anticipated dimensions, payload capabilities, and other parameters. The table also includes data for LV 14, LV17.1, LV 17.2, and LV 19.1, which were initially assessed.

Table 6-3. Other Shuttle-Derived Options Initially Assessed

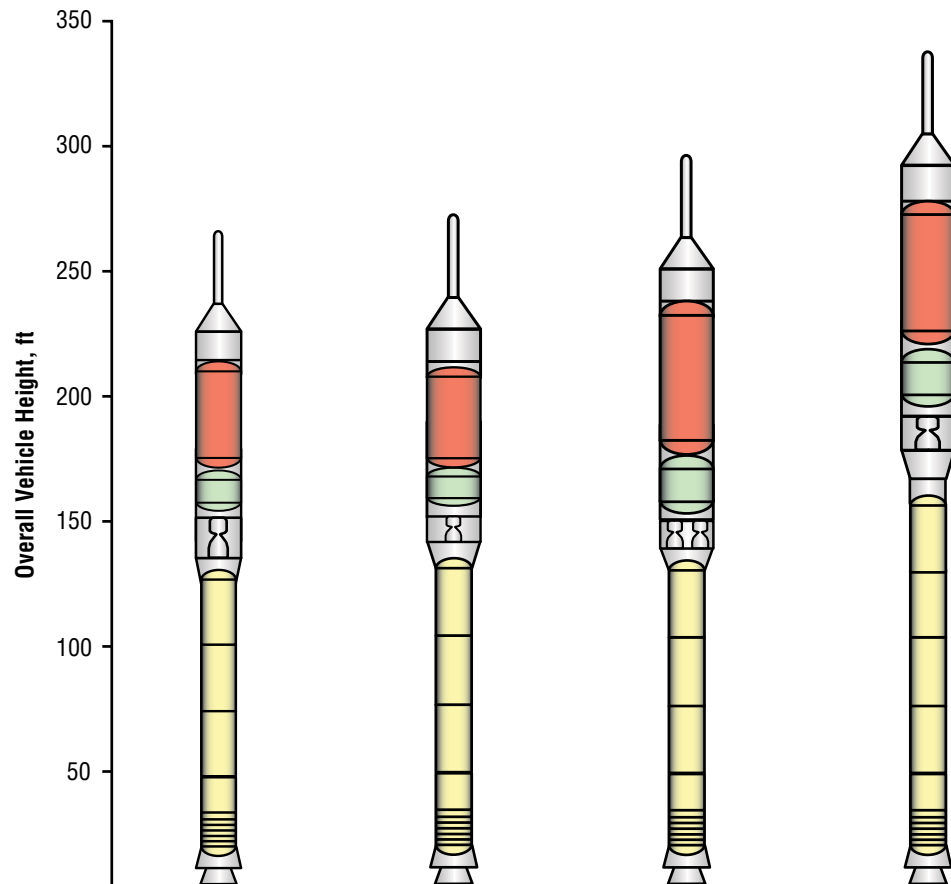

		14	17.1	17.2	19.1
Vehicle Name		4 Segment RSRB with 1 J-2S+ Crew	4-Segment RSRB w/ 1 J-2S (5.5m) – Crew	4-Segment RSRB w/ 2 J-2S (5.5m)– Crew	5-Segment RSRB w/ 1 SSME (5.5m) – Crew
Payload 28.5 Deg Inc*	Units				
Lift Capability	mT	21.6 mT	18.6 mT	25.3 mT	36.7 mT
Net Payload	mT	19.5 mT	16.8 mT	22.8 mT	33.0 mT
Payload 51.6 Deg Inc*					
Lift Capability	mT	20.3 mT	17.4 mT	23.6 mT	34.5 mT
Net Payload	mT	18.2 mT	15.7 mT	21.2 mT	31.0 mT
General Parameters					
Overall Height	ft	267.4 ft	262.9 ft	293.1 ft	329.1 ft
Gross Liftoff Mass	lbm	1,621,814 lbm	1,623,852 lbm	1,813,730 lbm	2,198,812 lbm
Liftoff Thrust/Weight	G	1.51 g	1.51 g	1.35 g	1.63 g
Second Stage Thrust/Weight	G	0.85 g	0.81 g	1.03 g	0.91 g

*Delivered to 30X160 nmi Orbit

Table 6-4 provides the same information for the four EELV-derived CLV options (LV 2, LV 4, LV 5.1, and LV 9) that were assessed in detail. Also included is data for LV 1 and LV 3.1, which were initially assessed..

Table 6-4. EELV-Derived CLV Options Assessed

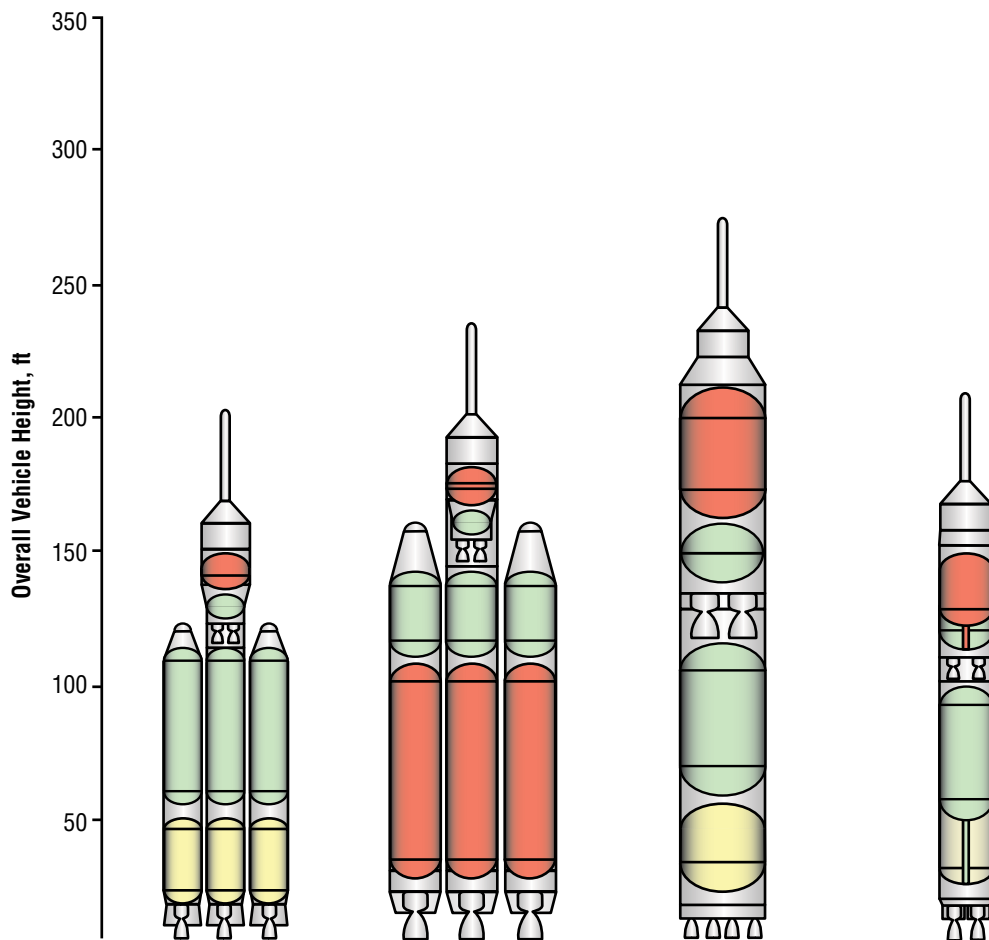

Vehicle Name		2	4	5.1	9
		Atlas V Heavy New Upper Stage Crew Human Rated	Delta IV Heavy New Upper Stage Crew Human Rated	Atlas Evolved (5RD- 180 & 4 J-2S+) Crew	Atlas Phase 2 Crew
Payload 28.5 Deg Inc*	Units				
Lift Capability	mT	33.4 mT	31.6 mT	78.3 mT	28.8 mT
Net Payload	mT	30.0 mT	28.4 mT	70.4 mT	25.9 mT
Payload 51.6 Deg Inc*					
Lift Capability	mT	29.5 mT	25.5 mT	73.7 mT	27.3 mT
Net Payload	mT	26.6 mT	22.9 mT	66.4 mT	24.5 mT
General Parameters					
Overall Height	ft	199.1 ft	228.6 ft	265.6 ft	205.7 ft
Gross Liftoff Mass	lbm	2,189,029 lbm	1,698,884 lbm	3,577,294 lbm	1,409,638 lbm
Liftoff Thrust/Weight	G	1.18 g	1.17 g	1.20 g	1.22 g
Second Stage Thrust/Weight	G	0.57 g	0.59 g	1.14 g	0.91 g

*Delivered to 30X160 nmi Orbit

Table 6-4. Other EELV-Derived Options Initially Assessed

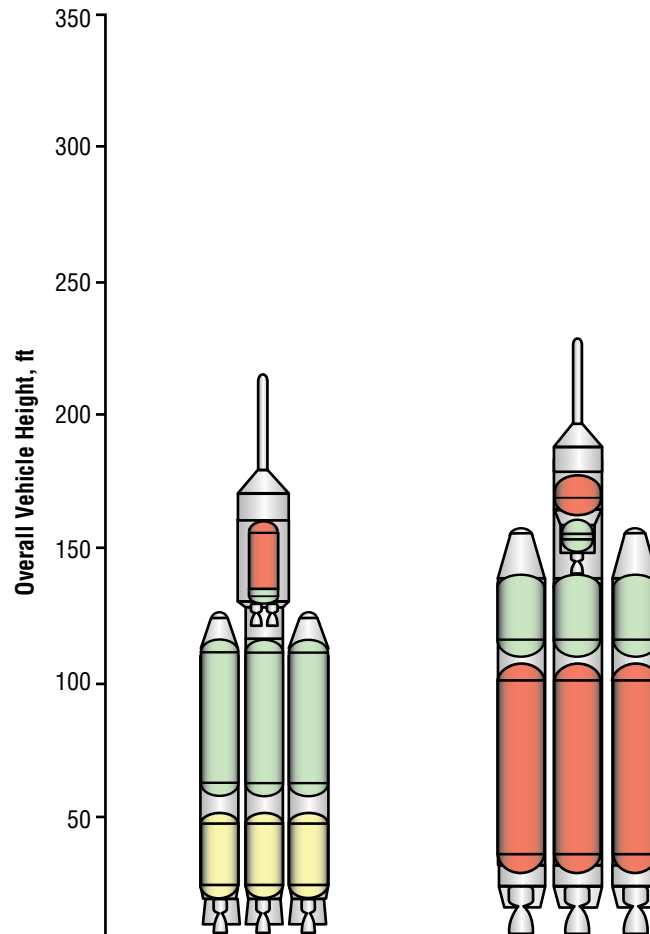

Vehicle Name		1	3.1
		Atlas V Heavy Crew Human Rated	Delta IV HLV Crew Human Rated
Payload 28.5 Deg Inc*	Units		
Lift Capability	mT	26.3 mT	26.5 mT
Net Payload	mT	23.7 mT	23.9 mT
Payload 51.6 Deg Inc*			
Lift Capability	mT	19.9 mT	22.5 mT
Net Payload	mT	17.9 mT	20.3 mT
General Parameters			
Overall Height	ft	207.3 ft	224.9 ft
Gross Liftoff Mass	lbm	2,170,687 lbm	1,663,255 lbm
Liftoff Thrust/Weight	G	1.19 g	1.20 g
Second Stage Thrust/Weight	G	0.37 g	0.19 g

*Delivered to 30X160 nmi Orbit

6.5.2 FOM Assessments

6.5.2.1 Shuttle-Derived Systems

A summary of the FOMs assessments for the Shuttle-derived CLV candidate vehicles is presented in **Table 6-5**. The assessment was conducted as a consensus of discipline experts and does not use weighting factors or numerical scoring but rather a judgment of high/medium/low (green/yellow/red) factors, with high (green) being the most favorable and low (red) being the least favorable.

Table 6-5. Shuttle-Derived CLV FOMs Assessment Summary

	LV	Shuttle-derived CLV		
		4-Segment RSRB with 1 SSME	5-Segment RSRB with 4 LR-85s	5-Segment RSRB with 1 J-2S+
		13.1	15	16
FOMs	Probability of LOC	1 in 2,021	1 in 1429	1 in 1,918
	Probability of LOM	1 in 460	1 in 182	1 in 433
	Lunar Mission Flexibility			
	Mars Mission Extensibility			
	Commercial Extensibility			
	National Security Extensibility			
	Cost Risk			
	Schedule Risk			
	Political Risk			
	DDT&E Cost	1.00	1.39	1.30
	Facilities Cost	1.00	1.00	1.00

The Shuttle-derived options were assigned favorable (green) ratings in the preponderance of the FOMs, primarily due to the extensive use of hardware from an existing crewed launch system, the capability to use existing facilities with modest modifications, and the extensive flight and test database of critical systems—particularly the RSRB and SSME. Each Shuttle-derived CLV concept exceeded the LOC goal of 1 in 1,000. The use of the RSRB, particularly the four-segment, as a first stage provided a relatively simple first stage, which favorably impacted LOC, LOM, cost, and schedule risk. The introduction of a new upper stage engine and a five-segment RSRB variant in LV 15 increased the DDT&E cost sufficiently to warrant an unfavorable (red) rating. The five-segment/J-2S+ CLV (LV 16) shares the DDT&E impact of the five-segment booster, but design heritage for the J-2S+ and the RSRB resulted in a more favorable risk rating.

Applicability to lunar missions was seen as favorable (green), with each Shuttle-derived CLV capable of delivering the CEV to the 28.5-deg LEO exploration assembly orbit. Extensibility to commercial and DoD missions was also judged favorably (green), with the Shuttle-derived CLV providing a LEO payload capability in the same class as the current EELV heavy-lift vehicles.

The five-segment RSRM/one-SSME SDV CLV variant (LV 19.1) was not considered in the final selection process because it had performance significantly in excess of that required for the ESAS CEV concepts. However, it is viewed as a viable follow-on upgrade. LV 17.2, with a four-segment first stage and 2 J-2s in the upper stage, was not selected because it does not support maintaining the SSME needed for the cargo vehicle. Its performance was below that needed for using a single SSME, and it was judged not capable of being ready for flight by 2011, and was high risk for being ready in 2012. LV14 variant using a four-segment RSRM first stage and a single J-2S+ in the upper stage did not meet the CLV performance goals and was dropped from consideration.

6.5.2.2 EELV-Derived Systems

A summary of the FOMs assessment for the EELV CLV candidate vehicles is presented in **Table 6-6**. The assessment was conducted using the same rating system as for the Shuttle-derived systems.

	LV	EELV-derived CLV			
		Atlas V HLV New Upper Stage Human-Rated	Atlas Evolved Crew	Atlas Phase 2 Crew	Delta IV HLV New Upper Stage Human-Rated
		2	5.1	9	4
FOMs	Probability of Loss of Crew	1 in 957	1 in 614	1 in 939	1 in 1,100
	Probability of Loss of Mission	1 in 149	1 in 79	1 in 134	1 in 172
	Lunar Mission Flexibility				
	Mars Mission Extensibility				
	Commercial Extensibility				
	National Security Extensibility				
	Cost Risk				
	Schedule Risk				
	Political Risk				
	DDT&E Cost	1.18	2.36	1.73	1.03
Facilities Cost	0.92	0.92	0.92	0.92	

Table 6-6. EELV-Derived CLV FOMs Assessment Summary

For the EELV-derived vehicles, the FOMs for flexibility for lunar missions and extensibility to commercial and DoD applications scored well. Because the Delta IV and Atlas V heavy-lift LV families were originally designed for DoD and commercial applications, particularly Geosynchronous Transfer Orbit (GTO) missions, the development of a new upper stage would only improve their capabilities in these areas.

Most EELV-derived CLVs came close to the goal of 1 in 1,000 LOC, but with less margin than the RSRM-derived options. The Atlas Phase 2 and Atlas-evolved CLVs utilize new multi-engine first stages, which require new tankage, avionics, and Main Propulsion Systems (MPSs). Of these two (5.1 and 9), the Atlas Phase 2 ranked higher for LOC, due to the lesser complexity of its first stage, with two engines. The human-rated Atlas V and Delta IV HLV CLVs with new upper stages (2 and 4) were evaluated to be safer and more reliable than the multi-engine first stage options, but the more complex strap-on staging event introduced failure modes that impacted LOC and LOM.

No EELV CLV candidate was judged to exhibit a favorable (green) rating for the risk incurred relative to cost and schedule. The determination was made that these options would be higher risk for a CEV IOC by 2011. The Atlas V HLV and Delta IV HLV share common risk areas of significant rework and modification for human rating and the development of a new multi-engine upper stage. The fact that Delta IV HLV has flown, while Atlas V HLV has not, would impact its relative cost and schedule risk. The Atlas Phase 2 would also require a new upper stage engine—adding to the cost and schedule risk.

The modified Delta IV and Atlas V HLV vehicles were evaluated to be favorable (green) in DDT&E costs, largely due to design heritage. Facilities modifications were judged to be in a similar scope to those required for a Shuttle-derived LV, and rated favorable (green). The new core options (5.1 and 9) have very high DDT&E costs, resulting in a low (red) rating.

6.5.3 Detailed Assessment Summary

6.5.3.1 Descriptions of Selected CLV

CLV variant, LV 13.1, (Figure 6-26) is a two-stage, series-burn LV for CEV launch. The first stage is a four-segment RSRB with Polybutadiene Acrylonitrile (PBAN) propellant. The concept was designed with a 10 percent reduction in the burn rate of the four-segment RSRB to reduce the maximum dynamic pressure the LV achieves on ascent. Earlier configurations similar to LV 13.1 with smaller LOX/LH2 second stages experienced maximum dynamic pressures greater than 1,000 psf. It was deemed desirable for crewed launches that this parameter be reduced to more benign conditions. Therefore, the reduced burn rate for the four-segment RSRB was implemented for all two-stage configurations of this type. (Later studies have shown this modification will not be required to achieve a reasonable maximum dynamic pressure.) The second stage for LV 13.1 is LOX/LH2 with one SSME for propulsion. This vehicle is flown to 30- by 160-nmi orbits at inclinations of 28.5 deg and 51.6 deg and inserted at an altitude of 59.5 nmi. The SSME is run at a throttle setting of 104.5 percent. The purpose of this analysis was to evaluate the performance of the SSME, modified for altitude-start, as an upper stage engine in comparison to a modified J-2S (J-2S+) engine.

6.5.3.2 Performance Summary

The net payload capability of LV 13.1 is 24.5 mT to a 30- by 160-nmi orbit at a 28.5 deg inclination. The net payload to 30- by 160-nmi at a 51.6 deg inclination is 22.9 mT. No GR&As were violated for this LV analysis. Special considerations required to analyze this vehicle included: (1) SSME was ignited at altitude and (2) a 10 percent reduction in the burn rate for the four-segment RSRB. (However, later more detailed assessments have shown this modification will not be necessary.)



Figure 6-26. LV 13.1
General Configuration

6.5.3.2.1 Vehicle Sizing

The mass properties for the second stage of LV 13.1 are shown in **Table 6-7**, calculated using the Integrated Rocket Sizing Program (INTROS). The mass properties for the four-segment RSRB were used as delivered with only two modifications. The current Solid Rocket Booster (SRB) nosecone was removed and an interstage was added to complete the vehicle configuration.

Table 6-7. LV 13.1
INTROS Mass
Summary

Mass Properties Accounting		
Vehicle: Four-Segment SRB with 1 SSME Crew – Blk 2		
Stage: Second (1 SSME)		
Item	Mass Subtotals	Mass Totals
	lbm	lbm
Primary Body Structures	17,147	
Secondary Structures	960	
Separation Systems	136	
TPSs	75	
TCSs	1,198	
MPS	12,501	
APS	203	
Power (Electrical)	1,868	
Power (Hydraulic)	415	
Avionics	513	
Miscellaneous	126	
Stage Dry Mass Without Growth		35,142
Dry Mass Growth Allowance	3,455	
Stage Dry Mass With Growth		38,597
Residuals	3,610	
Reserves	2,747	
In-flight Fluid Losses	69	
Stage Burnout Mass		45,022
Main Ascent Propellant	360,519	
Engine Purge Helium	41	
Reaction Control System (RCS) Ascent Propellant	300	
Stage Gross Liftoff Mass		405,882
Stage: First (Four-Segment SRB)		
Stage Burnout Mass		188,049
Main Ascent Propellant	1,112,256	
Stage Gross Liftoff Mass		1,300,305
Net Vehicle Total		
Payload	59,898	
LAS	9,300	
Upper Stage(s) Gross Mass	405,882	
Net Vehicle Gross Liftoff Mass		1,775,385

6.5.3.2.2 Structural Analysis

Figure 6-27 shows the CLV structural configuration. The loads plot (**Figure 6-28**) is a combined worst-case including prelaunch, liftoff, maximum dynamic pressure (max q), and maximum acceleration (max g). The compression loads show a major jump where the LOX tank loads are integrated into the outside structure. The bending moment shows a steady increase from the tip progressing aftward.

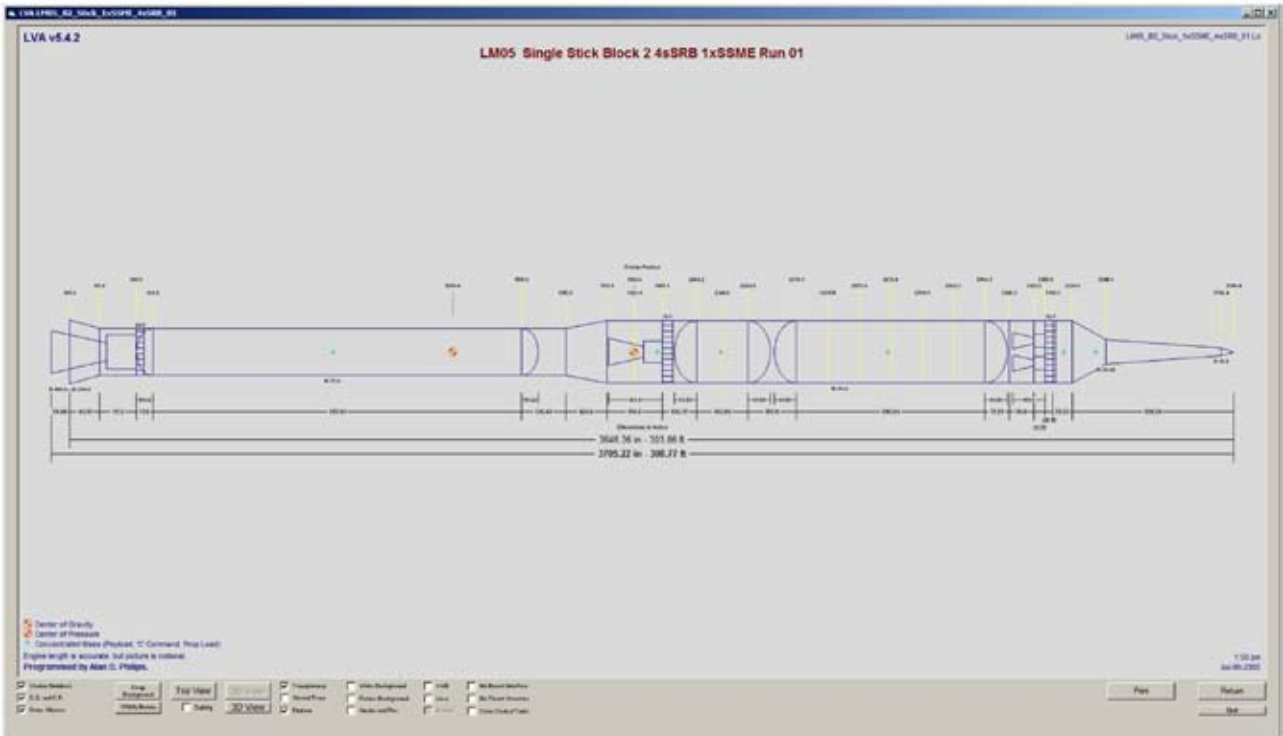
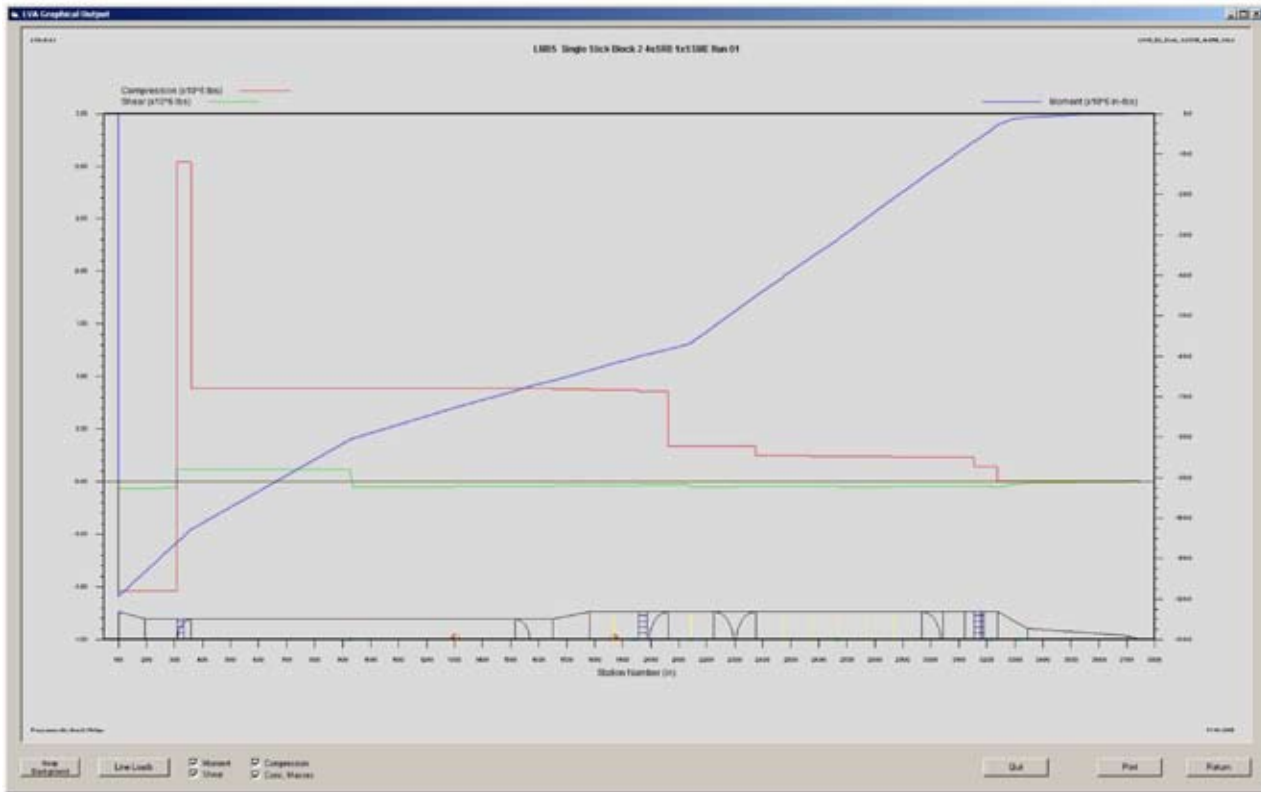

Figure 6-27. CLV Structural Configuration



6.5.3.2.3 Flight Performance Analysis and Trajectory Design

The closed-case trajectory summary results and LV characteristics are shown in **Figure 6-29**. Selected trajectory parameters are shown in **Figures 6-30** through **6-33**. The vehicle exhibits a 1.38 T/W ratio at liftoff. The maximum dynamic pressure is 576 psf at 59.2 sec in the flight. The maximum acceleration during the first stage is 2.26 g's and is 4.00 g's during the second stage. Staging occurs at 145.3 sec into the flight at an altitude of 166,694 ft and Mach 4.16. The T/W ratio at second-stage ignition is 1.03. Orbital injection occurs at 478.7 sec at 59.5 nmi.

Figure 6-28. CLV Structural Loads Analysis Results

4-Segment SRB with 1 SSME Crew

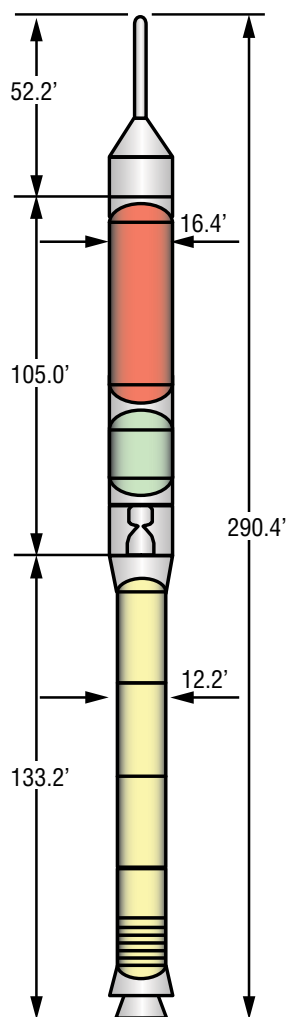

Vehicle Concept Characteristics

GLOW	1,775,385 lbf
Payload	5-m diameter CEV
Launch Escape System	9,300 lbm
Booster Stage (each)	
Propellants	PBAN
Useable Propellant	1,112,256 lbm
Stage pmf	0.8554
Burnout Mass	188,049 lbm
# Boosters / Type	1 / 4-Segment SRM
Booster Thrust (@ 0.7 secs)	3,139,106 lbf @ Vac
Booster Isp (@ 0.7 secs)	268.8 sec @ Vac
Second Stage	
Propellants	LOX/LH2
Useable Propellant	360,519 lbm
Propellant Offload	0.0 %
Stage pmf	0.8882
Dry Mass	38,597 lbm
Burnout Mass	45,022 lbm
# Engines / Type	1 / SSME
Engine Thrust (100%)	469,449 lbf @ Vac
Engine Isp (100%)	452.1 sec @ Vac
Mission Power Level	104.5%

Delivery Orbit	30 x 160 nmi @ 28.5°
Delivery Orbit Payload	59,898 lbm 27.2 mT
Net Payload	53,908 lbm 24.5 mT
Insertion Altitude	59.5 nmi
T/W @ Liftoff	1.38
Max Dynamic Pressure	576 psf
Max g's Ascent Burn	4.00 g
T/W Second Stage	1.03
Delivery Orbit	30 x 160 nmi @ 51.6°
Delivery Orbit Payload	56,089 lbm 25.4 mT
Net Payload	50,480 lbm 22.9 mT

Summary data for reference mission (30 x 160 nmi @ 28.5):

liftoff to SRM staging
max SRM accel = 2.26

time of max Q = 59.24 sec
max Q = 576 psf
mach = 1.13

after SRM jettison (core only)
tstg = 145.30 sec
alt@stg = 166,694 ft
mach@stg = 4.16

dynp@stg = 20 psf
dV1 = 8,430 ft/s
max core f/w = 4.00

LES jettison @t = 175.3 sec
alt @ jettison = 211,660 ft

at MECO / orbital insertion
time to MECO = 478.7 sec
MECO altitude = 361,539 ft
dVt = 30,046 ft/s

Figure 6-29. LV 13.1
Summary

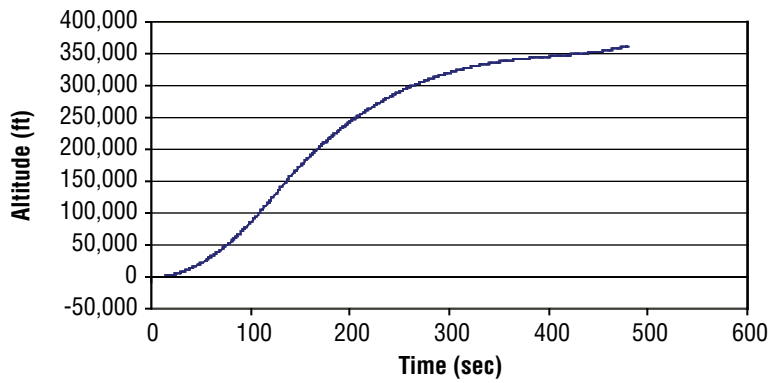

Figure 6-30.
Altitude versus Time

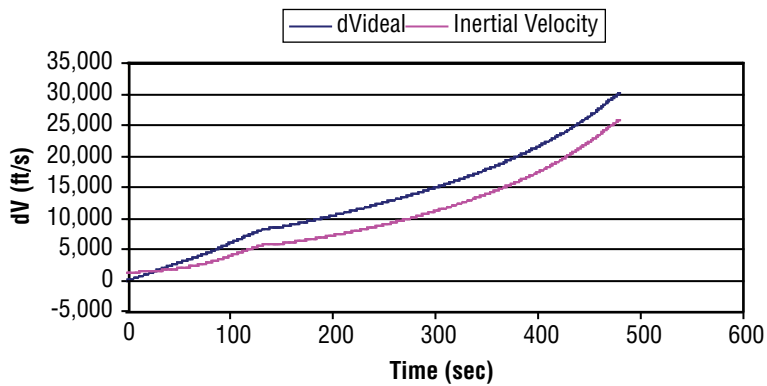

Figure 6-31.
Velocity versus Time

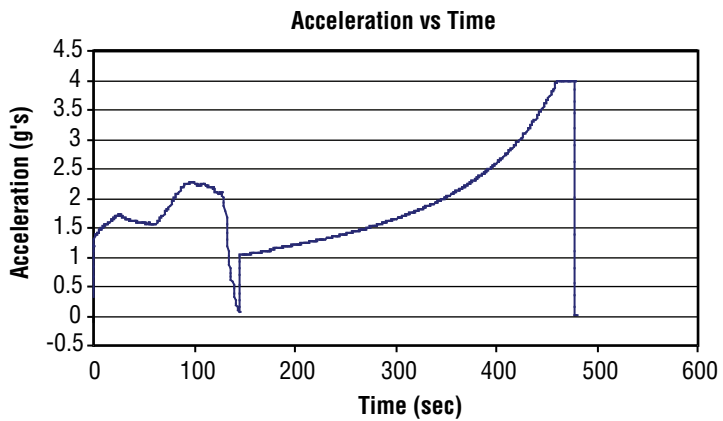

Figure 6-32.
Acceleration versus Time

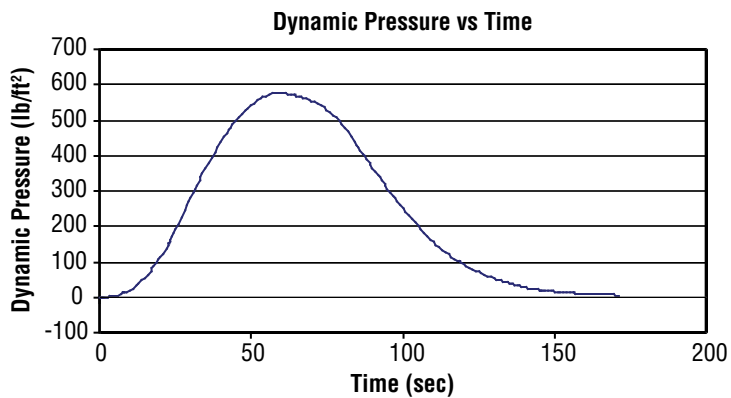

Figure 6-33. Dynamic Pressure versus Time

6.5.3.3 Cost Analysis Assumptions for CLVs (LV 13.1, LV 15, LV 16)

6.5.3.3.1 Inputs

The booster stage for these CLVs is either a four-segment RSRB or a five-segment RSRB. The four-segment RSRB is in production today. While the five-segment will draw heavily from the four-segment, some DDT&E will be needed.

Upper stages are used to deliver the payload to the desired orbit. In general, all of the upper stages are considered new designs using existing technology.

Structure and Tanks

Both metallic and composite intertanks, interstages, and thrust structures have been used on various programs. Design and manufacturing capabilities exist today. The critical elements will be the development of the separation system, a new interstage, and the payload adapter. Material is either 2219 aluminum or AL-Li. Shrouds are made of graphite-epoxy panels, based on Titan and Delta IV designs. Structures and tanks are well understood with sufficient manufacturing capability in existence. All structures have similar subsystems to EELV, Shuttle, or ET. The NASA and Air Force Cost Model (NAFCOM) cost estimate assumptions assumed a new design with similar subsystems validated in the relevant environment. Full testing and qualification will be required.

MPS—Less Engine

The MPS will take significant heritage from the existing SSME MPS subsystem. However, a new design is needed to accommodate one SSME. NAFCOM cost estimates assumed a new design with similar subsystems validated in the relevant environment. Full testing and qualification will be required.

Both the J-2S and LR-85 engines are equivalent to new engines, due to the length of time that has passed since the J-2 was in production, and the LR-85 is currently on paper only. Each will take heritage from the previously existing engine, but the MPS on the upper stage will be new. NAFCOM cost estimates assumed a new design with similar subsystems validated in the relevant environment. Full testing and qualification will be required.

Engine – SSME

Altitude-Start SSME

A 1993 study (NAS8-39211) and a 2004 Marshall Space Flight Center (MSFC) study examined the Block 2 engines for altitude-start. Both studies determined altitude-start will require minor changes, but is considered straightforward. Specialized testing for certification to the environment will be required. Development and certification of altitude-start for the Block 2 RS-25d engine is needed. The cost estimate is based on SSME historical actuals, vendor quotes, and estimates. It also assumes the Shuttle Program continues to pay the fixed cost of infrastructure through Shuttle termination.

Current Inventory SSME

At the conclusion of the STS Program, there will be 12 Block 2 (RS-25d) engines in inventory if the 28-flight manifest occurs, or 14 engines in inventory with a 16-flight manifest. In either case, the program plans to use at least 12 of the existing Block 2 assets for the early flights. Assembly, handling, and refurbishment of the existing engines and conversion of the reusable engine for upper stage use will be needed. Excluded from these costs are any sustaining engineering or Space Shuttle Program (SSP) hardware refurbishment. These early flights will incur some operations costs, which are yet to be determined.

Minimal Changes for Expendable Applications SSME

In addition to the minor changes required to altitude-start the SSME (RS–25d), it is desirable to make some engine improvements to lower the unit cost and improve producibility. Suggested improvements include low-pressure turbomachinery simplifications; a new controller; a Hot Isostatic Press (HIP) bonded Main Combustion Chamber (MCC); flex hoses to replace flex joints on four ducts; and simplified nozzle processing. In addition, process changes would be incorporated to eliminate inspections for reuse and accommodate obsolescence of the controller. Development and certification of these minimal changes is designated SSME RS–25e. The estimate is based on SSME historical actuals, vendor quotes, and estimates.

Engine: J–2S

Two different variants of the J–2S were analyzed for this study. The first assumed a design as close as possible to the original Apollo-era J–2S. The second variant was a J–2S redesign, specifically designed for optimal reliability and low production costs. Either could be used with a larger area ratio nozzle. Once again, cost analysis was performed using a bottom-up approach. All production costs were derived assuming a manufacturing rate of six engines per year.

Engine: LR–85

LR–85 is a conceptual design engineered to meet derived requirements from the program Human-Rating Plan. Production of the LR–85 was assumed to use domestic production capabilities. Parametric analysis was performed on the engine using the Liquid Rocket Engine Cost Model (LRECM). Major cost drivers to this model are the Isp and thrust. Options are available to include heritage from older engines.

Appropriate rate curves were applied to both manufacturing and refurbishment to reflect dynamics of the engine production rates with respect to the largely fixed nature of the costs. Theoretical First Unit (TFU) costs from NAFCOM or vendor data were used as a baseline point in the analysis. Historic RS–68, RL–10, and SSME data was also used to help generate Productivity Rate Curves (PRCs).

Avionics and Software

The avionics subsystem must support Fail Operational/Fail Safe vehicle fault tolerant requirements. Upon the first failure, the vehicle will keep operating. The second failure will safely recommend an abort. Crew abort failure detection and decision-making capabilities have been demonstrated and are ready for flight. All architectures will meet these requirements, either by adding a modification for instrumentation redundancy for the EELV health management system, or by providing the capabilities through the new design of the avionics for Shuttle-derived configurations.

Avionics hardware is divided into Guidance, Navigation, and Control (GN&C), and Command, Control, and Data Handling (CCDH). GN&C provides for attitude control, attitude determination, and attitude stabilization. CCDH provides all the equipment necessary to transfer and process data; communication for personnel, as well as spacecraft operations/telemetry data; and instrumentation for monitoring the vehicle and its performance. Both systems are tied together through the LV software system. LV hardware requirements are well understood.

During the benchmarking activity for NAFCOM, it was discovered that the Cost Estimating Relationships (CERs) for avionics were significantly different from the contractors' data. This difference led to NAFCOM developers reviewing the database and statistical analysis of the avionics CERs. One result of this exercise was to drop very old avionics data points as unrepresentative of modern avionics. In addition to the CER adjustment, the avionics Mass Estimating Relationships (MERs) used in the INTROS LV sizing program were revised. Previous MERs were derived from STS data, Centaur stage data, Shuttle C, Heavy-Lift Launch Vehicle (HLLV), and other studies, leading to a much heavier weight input into NAFCOM than would be expected with modern electronics. In recent years, avionics have changed considerably due to advances in electronics miniaturization and function integration. State-of-the-art avionics masses are considerably less than what was previously used in INTROS. Revised MERs were developed for GN&C, actuator control, Radio Frequency (RF) communications, instrumentation, data management/handling, and range safety. The revised MERs were used within NAFCOM as one input into the multivariate CERs.

The core booster does not guide and control the ascent. This function is in the upper stage. Core booster avionics include translators, controllers, Analog-to-Digital (AD) converters, actuator control, electronics, and sufficient CCDH hardware to interface with the upper stage. The upper stage avionics control ascent, separations, and flight. Upper stage avionics hardware includes the Inertial Measuring Unit (IMU), processors, communication, telemetry, and instrumentation. Software provides the separation commands, software for general flight, mission-specific flight algorithms, and launch-date-specific software.

Software also provides the commands that control the vehicle, viewed as one entity for the LV. As such, the software estimate is not divided between the core and upper stage. Software is normally located on the upper stage since it is the upper stage that controls the ascent of the LV. The software estimate for the LVs is based on a detailed breakdown of the functional requirements, which is provided in **Table 6-8**.

Table 6-8. Functional Breakout of Software Lines-of-Code (SLOC) Estimates

Events Manager (50 Hz) (approximately 500 to 1,000 SLOC)	
Manage Events Sequencer	
Manage Events Updates	
Navigation Manager (50 Hz) (approximately 8,000 to 15,000 SLOC)	
Provide Translational Navigation Estimates	
Provide Rotational Navigation Estimates	
Guidance Manager (1 Hz) (approximately 15,000 to 25,000 SLOC)	
Ascent Mode	
Provide Open-Loop Guidance	
Provide Closed-Loop Guidance	
Provide Circularization Guidance	
Abort Mode	
Provide Ascent Abort (IIP) (50 Hz) (Flight planning for avoiding undesirable landing areas using reduced capability)	
<i>Note: This could contain added capability; currently no defined requirements.</i>	
Control Manager (50 Hz) (approximately 8,000 to 15,000 SLOC)	
Manage Stage Separation Control	
Manage Ascent Vehicle Control	
Manage RCS Control	

Table 6-8. (continued)
Functional Breakout of
Software Lines-of-Code
(SLOC) Estimates

Command and Data Manager (50 Hz) (approximately 28,000 to 40,000 SLOC)	
Initialize Software	
Initialize Hardware	
Provide Payload Interface	
Provide Sensor Interface (GPS, INS, Gyro)	
Provide Telemetry Data	
Provide Ground Interface	
Provide Engine Controller Interface	
Provide Upper Stage Controller Interface	
Provide Booster Interface Unit Interface	
Provide TVC Controller Interface	
Provide Flight Termination System Interface	
<i>Note: This assumes a limited fault detection and notification/recovery capability.</i>	
Time Manager (50 Hz) (approximately 1,500 to 2,000 SLOC)	
Provide Time	
Power Manager (25 Hz) (approximately 2,500 to 4,000 SLOC)	
Provide Power System Management	
Vehicle Management Software (110K SLOC ± 50%)	
Abort Management System (70K SLOC ± 50%)	
Trajectory Replan Requests (10K SLOC)	
• Engine Operation	
• Stage Separation	
Status Payload (10K SLOC)	
• Abort Conditions	
• Health Indications	
Determination of Proper Scenario (50K SLOC)	
• Burn Remaining Engines Longer	
• Separate Upper Stage Early	
Launch Pad Interface (15K SLOC ± 50%)	
Data Gathering	
Communication with Launch Pad—ability to diagnose health of engine	
Fault Identification on Vehicle	
Onboard FTS Tracking (25K SLOC ± 50%)	
Trajectory Following	
RT Position Monitoring	
Compare Position Monitoring	
Abort Scenario Updates	
• Trajectory Modifications	
• Flight Termination Delay	
Communication with Range Safety to Request Flight Termination	
Total Flight Software SLOC estimate: 48,500 to 102,000	
Vehicle Management included: 55,000 to 165,000	
Total: 103,000 to 267,000	

Note: This estimate does not include Backup Flight Software (BFS). BFS estimated at 45,000 SLOC.

Software estimates are based on the above maximum SLOC, using the Software Estimation Model (SEER–SEM) tool for software estimation, planning, and project control. SEER–SEM is a recognized software estimation tool developed by Galorath Incorporated for use by industry and the Government.

Shuttle-Derived Avionics Hardware

The GN&C and CCDH subsystems for Shuttle-derived LVs are considered new designs. Because the subsystems and software are new, integrated health management and human-rating requirements are incorporated from the start. The avionics hardware assumed a new design with existing technology.

Shuttle-Derived Software

All Shuttle-derived software is considered a new software development, incorporating the functions identified above. The maximum SLOC estimate were used with the SEER-SEM model to arrive at a deterministic software estimate.

Other Subsystems

The basic thermal systems are ½- to 1-inch Spray-on Foam Insulation (SOFI), with cold plates and insulation for passive cooling of equipment and avionics. No new technology is planned. Heritage has normally been given to the thermal subsystem because it is well understood and used on existing systems today.

Electrical power is provided by silver-zinc batteries with a redundancy of two. Conversion, distribution, and circuitry are considered new designs with state-of-the-art technology. Hydraulic power is fueled by hydrazine, which is used in LVs today.

RCSs, when used, are the same type as those used in the Shuttle. Range safety will require modifications to the flight termination system to add a time-delay for abort. Human-rating requirements may require the removal of the autodestruct capability. All of these subsystems are similar to those already in existence, either on EELVs or Shuttle, and have been validated in the relevant environment. Full qualification and testing is estimated for all crew and cargo vehicles.

6.5.3.3.2 DDT&E

The lowest cost option, as shown in **Table 6-9**, uses the existing four-segment RSRB and the modified SSME. Of the two five-segment configurations, the vehicle that uses only one J–2S engine is cheaper than the vehicle that requires four LR–85s.

6.5.3.3.3 Production

LV 13.1, LV 15, and LV 16 are single SRB-based crew vehicles, with either a four- or five-segment booster modified from the current Shuttle SRBs. As described above, the modifications will enable the integration of the booster with an upper stage. The recurring production costs of these three concepts are very close and are within the accuracy of the model. Although the four-segment SRM is slightly cheaper to refurbish than the five-segment version (the cost of refurbishing and reloading a single motor segment is relatively small), the cost of the Expendable Space Shuttle Main Engine (eSSME) equipped upper stage more than offsets this savings, so that LV 13.1 has the highest recurring production cost.

6.5.3.3.4 Launch Operations

All of these concepts require the stacking of either a four- or five-segment SRB with a modified forward skirt and an interface to the interstage. The SRM segments are refurbished in the same manner as in the current Shuttle operation (described previously in **Section 6.5.3.3.3, Production**). A portion of the interstage is also a refurbished item. The upper stage, upper stage engine, and part of the interstage are newly manufactured hardware. The launch operations activities include receipt, checkout, stacking and integration, testing, transport to the launch pad, pad operations, and launch. As shown in **Table 6-9**, The cost of launch operations is lowest for LV 16 and greatest for LV 15. However, the difference at six flights per year is slight.

Phase	Relative Cost Position		
Vehicle	13.1	15	16
DDT&E	1.00	1.39	1.30
Production	1.00	0.92	0.93
Operations	1.00	1.03	0.85
Facilities	1.00	1.00	1.00

Table 6-9. Relative Comparison of SDV Crew Vehicle Costs

6.5.3.3.5 Facilities

The facilities costs include modifications to the Mobile Launch Platform (MLP), VAB, and launch pad to accommodate the different profile and footprint of the in-line SRB configuration. The cost is the same for all three concepts, as shown in **Table 6-9**.

6.5.3.4 Safety/Reliability Analysis (LV 13.1)

The Flight-Oriented Integrated Reliability and Safety Tool (FIRST) reliability analysis tool was used to determine the LOM and LOC estimates for the four-segment SRB with one SSME (RS-25) upper stage CLV (LV 13.1). These estimates were based on preliminary vehicle descriptions that included propulsion elements and a Space Shuttle-based LV subsystem with updated reliability predictions to reflect future testing and design modifications and a mature LV 13.1. A very simple reliability model using point estimates was used to check the results. A complete description of both models is included in **Appendix 6D, Safety and Reliability**. Likewise, a complete description of how reliability predictions were developed for the individual LV systems that were used in the analyses is provided in **Appendix 6D, Safety and Reliability**. LV 13.1 LOM and LOC estimates are shown in **Figure 6-34**. The results are for ascent only, with LOC calculated assuming an 80 percent Crew Escape Effectiveness Factor (CEEF) for catastrophic failures and a 90 percent CEEF for noncatastrophic failures. Also, the model applied a Command Module CEEF = 0 percent, but this may prove to be overly conservative as CM designs evolve. Other key assumptions included:

- No mission continuance engine-out capability on upper stage;
- Because second-stage engine shutdown or failure to start (altitude-start) is catastrophic to the vehicle, the model applies a CEEF of 80 percent;
- No mission continuance engine-out capability; and
- SSME is operated with current redlines enabled, but adjusted for altitude-start.

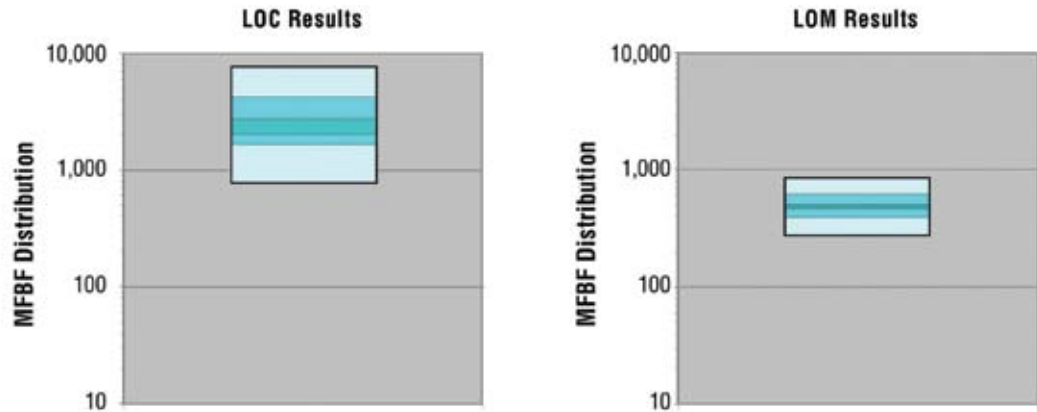

LOC 95th	LOC 75th	LOC (mean)	LOC 50th (median)	LOC 25th	LOC 5th
1 in 775	1 in 1675	1 in 2021	1 in 2711	1 in 4200	1 in 7610

LOM 95th	LOM 75th	LOM (mean)	LOM 50th (median)	LOM 25th	LOM 5th
1 in 273	1 in 394	1 in 460	1 in 500	1 in 626	1 in 850

Figure 6-34. LV 13.1 LOC and LOM Estimates

The reliability analysis used Space Shuttle Probabilistic Risk Assessment (PRA) data as a baseline that was reviewed by propulsion engineers to incorporate potential upgrades for this vehicle. This led to the propulsion system reliability estimates shown in **Table 6-10**.

Table 6-10. LV 13.1 Propulsion System Failure Probabilities

Engine	Failure Probability (Cat)	Failure Probability (Ben)	Failure Probability (Start)	CFF	Error Factor
SSME	2.822E-04	1.482E-03	3.000E-04	16.0%	2.6
RSRB (4-segment PBAN)	2.715E-04	N/A	N/A	N/A	1.7

The single RSRB reliability estimate is described in **Section 6.8.1, Reusable Solid Rocket Boosters**.

A key area for future analysis is the SSME altitude-start failure probabilities. With limited analysis time, these estimates were based on expert opinion and limited historic data. Aside from the specific altitude-start failure probabilities, it was assumed that the startup period, from ignition to full stable thrust, is instantaneous and the probability of catastrophic (uncontained) failure during engine startup is negligible. The altitude-start failure estimate for the upper stage engine was made based on preliminary engineering estimates for altitude-starting an SSME Block 2. Rocketdyne test data was updated assuming a 99 percent fix factor for startup problems resulting in a failure probability per engine of 1 in 661. Also, it was assumed that altitude-start redlines would be, for the most part, inhibited during the altitude-start sequence since a failure to start could be just as catastrophic to the vehicle as an uncontained engine failure. Further, it was assumed that a rigorous test program would be able to reduce the SSME altitude-start risk. These assumptions led to an altitude-start estimate of 3.0E-04, or 1 in 3,333, for a mature altitude-started SSME.

Figure 6-35 shows the LV 13.1 subsystem risk contributions. The risk is dominated by the second-stage engine (“liquid propulsion”).

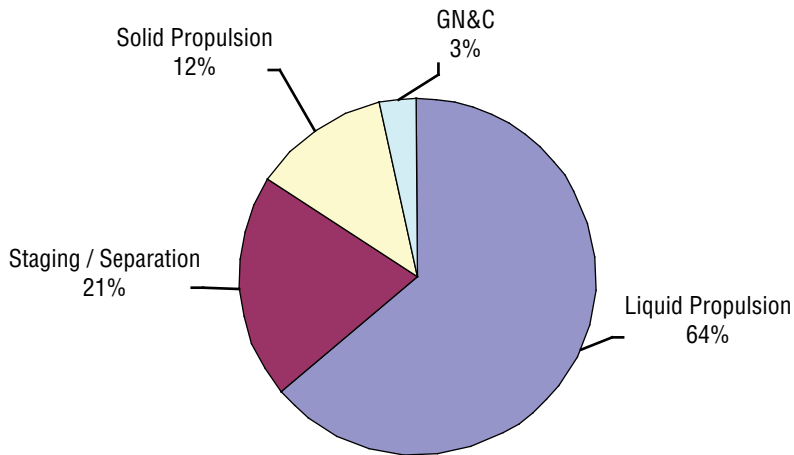

Notes: Percentages are based on the mean LOM failure probability. SSME burntime is 336 seconds.

	Mean Failure Probability	MFBF (1 in)
Liquid Propulsion	1.3824E-03	723
Solid Propulsion	2.7151E-04	3,683
GN&C	7.4112E-05	13,493
Staging/Separation	4.4804E-04	2,232
LOM (Loss of Mission)	2.1745E-03	460
LOC (Loss of Crew)	4.9473E-04	2021

Engine	Reliability (Cat)	Reliability (Ben)	Reliability (Start)	CFF	Error Factor
SSME	2.822E-04	1.482E-03	3.000E-04	16.0%	2.6
RSRB (4 Segment PBAN)	2.715E-04	N/A	N/A	N/A	1.7

Notes: Cat and benign based on default 515 second mission. Start risk is per demand. Error factor = 95th/50th.

Figure 6-35. LV 13.1 Subsystem Risk Contributions

To check these results, a simple mean reliability model was developed and is provided in **Appendix 6D, Safety and Reliability**. The model calculates FOMs by multiplying subsystem reliabilities. The MTBF results of this model for LV 13.1 yielded LOC = 2,855 and LOM = 516, which compare favorably with the results from FIRST, LOC = 2,021 and LOM = 460, thus affirming the reliability estimates for LV 13.1.

In addition, a preliminary sensitivity study was performed to investigate the LOC sensitivity to altitude-start reliability to CEEF. (See **Appendix 6D, Safety and Reliability**). Results indicate that reasonable and appropriate increases in the CEEF values applied to Delayed Catastrophic Failures (DCF) events (altitude-start and noncatastrophic engine shutdown) allow for significant variations in altitude-start reliability without compromising LOC. It is recommended that, as the LV 13.1 design matures and the subsystem reliability estimates gain more certainty, detailed abort analyses replace the simplified CEEF estimates used in this study.

6.5.3.5 Schedule Assessment

A detailed development schedule (**Section 6.10, LV Development Schedule Assessment**), was developed for the ESAS Initial Reference Architecture (EIRA) CLV (five-segment RSRB with an upper stage using a new expander cycle engine). The CLV schedule for the EIRA Shuttle-derived option resulted in a predicted launch date of the first human mission in 2014. The critical path driver was the LR-85 new rocket engine for the upper stage. In order to meet the 2011 launch date requirement, an engine with a very short development time was needed. This requirement was met using the existing SSME modified for an altitude-start or an RL-10. The RL-10 was ruled out because of its low thrust level. The J-2 or J-2S could not support the 2011 launch date requirement.

6.5.4 Human-Rating Considerations for EELV

The EELV Program was intended to provide for a reliable access for commercial and military payloads, hence considerations for flying crew were never factored into the original design of the vehicles. The Mercury and Gemini Programs used vehicles originally designed for other purposes for launching crews to orbit. In order to accomplish crewed operations, major modifications were performed to provide for increased reliability, redundancy, failure detection and warning, and removing hardware not necessary for the crew launch mission. The same considerations would be required to utilize the EELV fleet to launch crew to LEO.

6.5.4.1 Human-Rating Requirements Drivers

The main requirement drivers from NPR 8705.2A, Human-Rating Requirements for Space Systems, are:

- Specifications and standards,
- Two-fault tolerant systems,
- Crew-system interactions,
- Pad emergency egress,
- Abort throughout the ascent profile,
- Software common cause failures,
- Manual control on ascent, and
- FTS.

The EELV fleet was built primarily to company standards and processes. The EELV was developed to “high-level” system requirements, and few aerospace industry design practices and standards were imposed. At the time the program was implemented, high reliability was to be demonstrated with multiple commercial launches before committing Government payloads. In response to the collapse of the commercial launch market (and resulting loss of demonstrated and envisioned reliability gains), Government mission assurance was ramped up with support from the Aerospace Corporation and the National Reconnaissance Office (NRO). The new CY2005 Buy III EELV contract will now include Government mission assurance requirements and standards. For EELV, these standards would need thorough evaluation and approval against NASA standards and processes to be used for flying crewed missions, with changes and additions implemented to close known gaps in requirements.

One of the most important requirement drivers is the requirement for two-fault tolerance to loss of life or permanent disability. NPR 8705.2A also states that abort cannot be used in response to the first failure. This implies that the LV must be at least single-fault tolerant, and, for subsystems that are required for abort, it must be two-fault tolerant. EELV will require upgrades in certain areas to achieve single-fault tolerance.

In order to fly crew for any launch system, the crew must have certain situation awareness and be able to react to contingencies based on that awareness. As such, NPR 8705.2A contains many requirements that deal with the crew’s ability to monitor health and status and take appropriate actions as a result of that status, if required. This will require upgrades in the EELV avionics architecture to accommodate an interface with the spacecraft as well as to be able to accept commands from the crew. For the LV, these commands will primarily be for contingency situations and will be for events such as abort initiation, retargeting (i.e., ATO), and response to other contingencies. Manual control is also a response to a contingency, although its use would primarily be limited to second-stage operations, where structural and thermal margins allow manual control. The form of manual control would be the subject of future trade studies and could range from a classical “yoke” control to a series of discrete commands that allow retargeting and ATO scenarios.

Another important requirement is to provide for successful abort modes from the launch pad through the entire ascent profile. This will require the EELV to be modified to provide the data necessary for abort decision-making. The modifications to the EELV may also require a computer and software for making the decision, or the decision-making may reside with the spacecraft. The means for providing for abort decision-making is a subject for a future trade study. Regardless of the outcome of that trade, significant effort on the LV will be required for health management and abort decision-making.

Other requirements, such as protection against software common-cause failures and FTSs, are not as extensive, but require some effort on the LV to implement. Protection against common-cause software failures can take several forms and is discussed in NPR 8705.2A. In the case of FTS, the EELVs can use the autodestruct command with lanyard pull devices to initiate an FTS event. Human spaceflight has never used autodestruct, and the utility of using these devices needs to be examined. Lanyard pulls allow the booster (first stage) to not have a dedicated receiver and command decoder unit, because it is able to accept the commands from the second stage and capable of autodestruct in the event of an inadvertent separation. Removal of the autodestruct may require addition of a dedicated receiver and command decoder unit on the first stage.

6.5.4.2 EELV Modifications for Human-Rating Summary

The Atlas V HLV with the new upper stage and Delta IV HLV with a new upper stage were considered for assessing modifications for flying crew. In some cases, detailed assessments were possible, while, in others, only the type of issues and resultant potential modifications were identified, depending on the fidelity of data available from the commercial launch provider. In either case, the goal of the analysis was to make reasonable judgments to provide valid cost assessments and ascertain potential schedule issues. (Refer to **Appendix 6F, EELV Modifications for Human-Rating Detailed Assessment**, for more information.)

6.5.4.2.1 Atlas V HLV with New Upper Stage

Avionics and Software

The avionics and software for the vehicle was assumed to be primarily new; however, some heritage in the GN&C area from the existing Atlas vehicle was assumed.

Launch Vehicle Health Management (LVHM) implementation as a fully integrated system is shown in **Figure 6-36**.

The core avionics meets the minimum single-fault tolerant requirement. Those elements needed for abort are two-fault tolerant.

The SLOC for a new build avionics system was estimated as follows:

- Events Manager (50 Hz) 500 to 1,000 SLOC;
- Navigation Manager (50 Hz) 8 to 15 thousand software lines of code (KSLOC);
- Guidance Manager (1 Hz) 15 to 25 KSLOC (both ascent and abort modes);
- Control Manager (50 Hz) 8 to 15 KSLOC;
- Command and Data Manager (50 Hz) 25 to 40 KSLOC;
- Time Manager (50 Hz) 1,500 to 2,000 SLOC;
- Power Manager (25 Hz) 2,500 to 4,000 SLOC;
- Vehicle Management Software (55 to 165 KSLOC); and
- Total SLOC = 103 to 267 KSLOC.

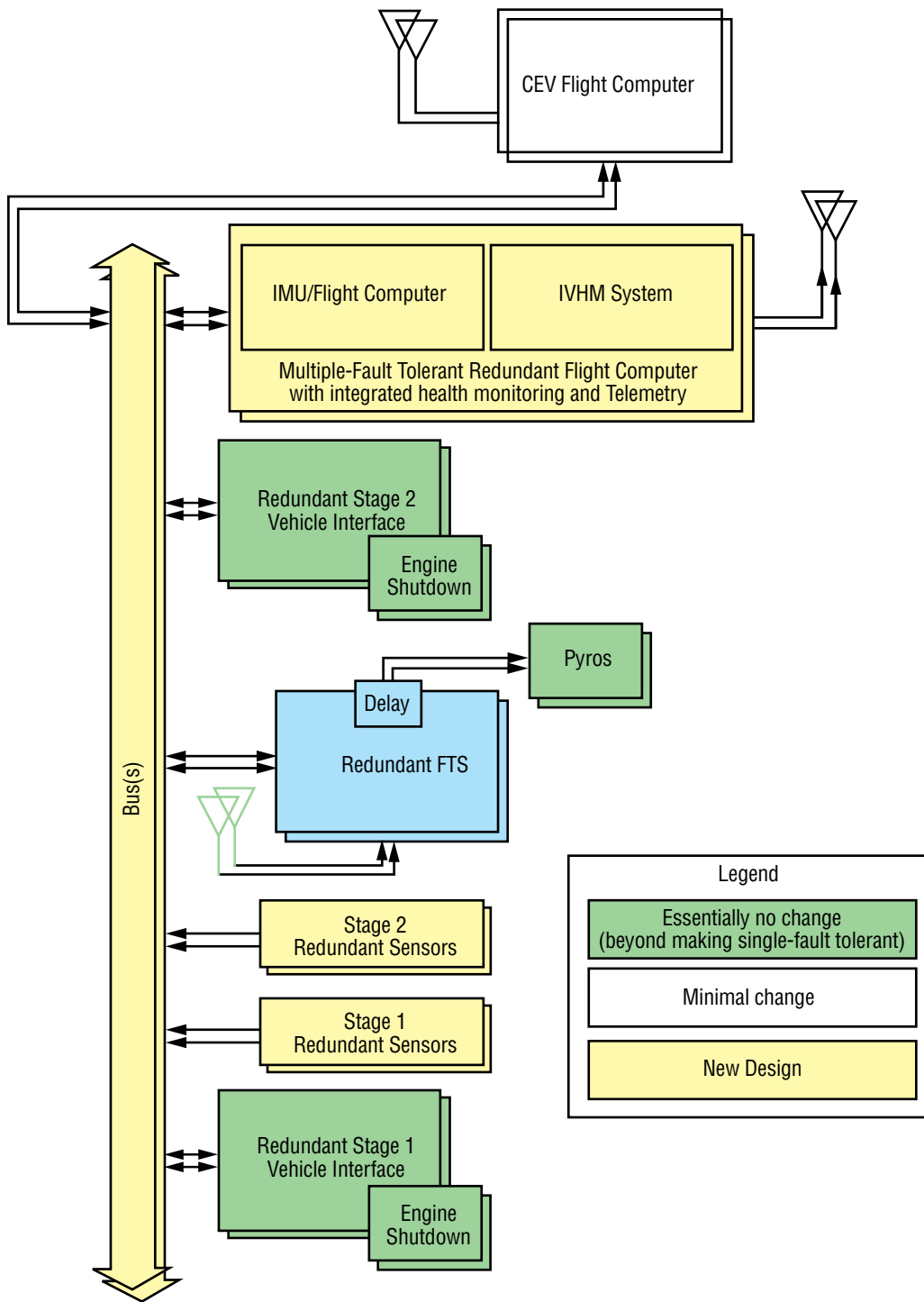

EELV Heritage with dual fault tolerant FC design (single fault-fly mission), Plus integrated Health Monitoring and Abort Capability built into EELV FC to add Abort on second fault capability: (Full redesign of FC and FC SW required. EELV FC capable of commanding abort as well as being controlled from CEV). EELV FC acting as its own backup computer.

Figure 6-36. Generic LVHM implementation

The large range in values is due to the vehicle management software, which incorporates the LVHM, Fault Detection, Isolation, and Recovery (FDIR), and abort decision-making. At present, there is uncertainty concerning the extent of LVHM that will be required, which will be the subject of future trade studies.

First Stage Main Propulsion

The primary focus of the effort was to examine changes required to the RD-180 for use in a human-rated system. The RD-180 was required to be built with U.S. production capability.

Second-Stage MPS

The second-stage MPS is new; however, modifications were assumed necessary for the RL-10A-4-2 engine to meet reliability and human-rating requirements.

Engine modifications were examined by considering the reliability enhancement program, along with consultation with vendors and discipline experts. The results were used to bound the cost estimates.

Structure

NPR 8705.2A imposes as an applicable document NASA-STD-5001, Structural Design and Test Factors of Safety for Spaceflight Hardware. This standard requires all structural Factors of Safety (FSs) for tested structures to be greater than 1.4. The commercial EELVs were designed to structural FSs of 1.25. NASA has taken exception to NASA-STD-5001 for FSs of less than 1.4 for well-defined loads. The process involves analyzing the load contribution (static versus dynamic) in assessing the required FS. For the purposes of bounding the problem in assessing costs for the modification of a structure, the criteria was used that for any structure with margins of less than 0.05 for an FS of 1.25, redesign would be required for EELV. Margins were assessed for actual flight loads. Since the Atlas has not flown in the heavy configuration, the 552 configuration (5-m core with five solids) was used for this assessment. The analysis results were used to bound the cost estimates for structural modification.

6.5.4.2.2 Delta IV with New Upper Stage

Avionics and Software

The basic Delta IV avionics system is single-fault tolerant, but some minor modifications were assumed. LVHM implementation was similar to the approaches previously discussed for the Atlas with a new upper stage vehicle where the LVHM function was integrated into the LV avionics (**Figure 6-39**). For the purposes of cost estimation, SLOC estimates were considered the same as for the Atlas case with a new upper stage.

Delta IV Booster MPS

The primary consideration for the Delta IV booster MPS was the upgrades for the RS-68 engine. Engine and MPS modifications were examined by considering the reliability enhancement program in consultation with vendors and discipline experts. The results were used to bound the cost estimates.

Upper Stage MPS

The upper stage MPS was assumed to be a new design utilizing the RL-10A-4-2 engine modified as discussed in **Section 6.5.4.2.1.3, Atlas V HLV with New Upper Stage**.

Structure

The Delta IV structure was evaluated using the same procedure as described for the Atlas V. As-flown margins of the Delta IV HLV booster were used for this assessment. The upper stage structure was all assumed new. The analysis results were used to bound the cost estimates for structured modifications.

6.6 Lunar Cargo Vehicle

As with the CLV, many possible launch systems were examined during the study to meet the stated requirements of the CaLV. These options were narrowed down to the following candidates. The architectures that were not evaluated further are discussed in **Appendix 6A, Launch Vehicle Summary**.

6.6.1 Candidate LV Options Summary

Table 6-11 shows the Shuttle-derived lunar options assessed (options assessed in detail and other options initially assessed), including their dimensions, payload capabilities, and other parameters. **Table 6-12** provides the same information for the EELV-derived options.

Table 6-11. Shuttle-Derived Lunar Options Assessed in Detail

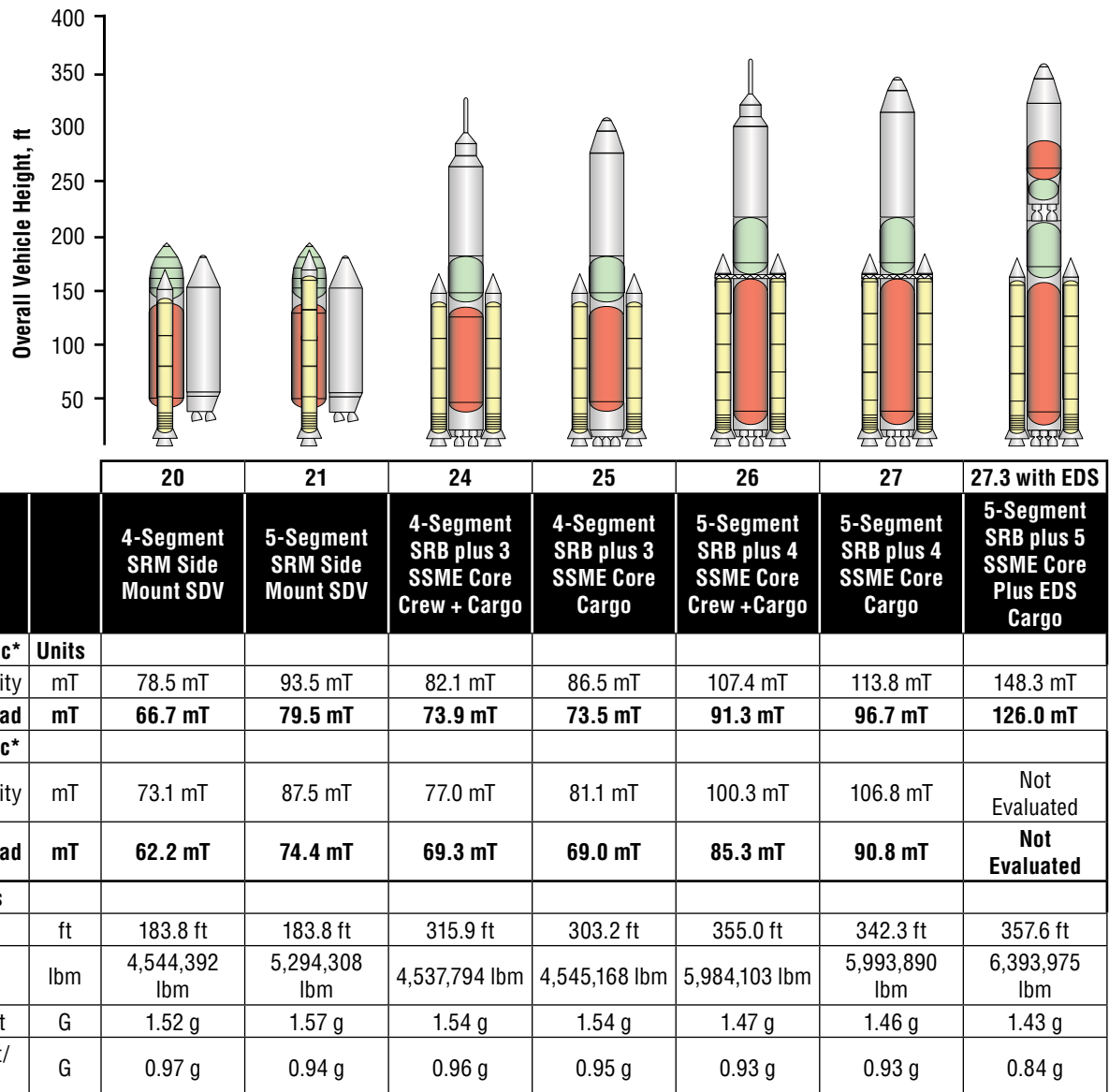

*Delivered to 30X160 nmi Orbit

Table 6-11 . Other Shuttle-Derived Options Initially Assessed

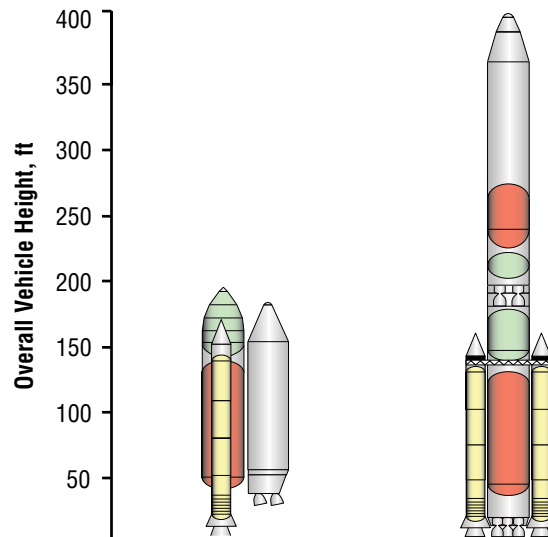

Vehicle Name		22		29	
		Shuttle Derived Side-mount 4-Seg. SRM & 2 RS-68		4-Segment SRBs 3RS-68 & 4 J-2S + Cargo	
Payload 28.5 Deg Inc*		Units			
	Lift Capability	mT	52.7 mT	mT	108.2 mT
	Net Payload	mT	44.8 mT	mT	91.9 mT
Payload 51.6 Deg Inc*					
	Lift Capability	mT	47.9 mT	mT	102.4 mT
	Net Payload	mT	40.7 mT	mT	87.1 mT
General Parameters					
	Overall Height	ft	183.8 ft	ft	399.7 ft
	Gross Liftoff Mass	lbm	4,492,706 lbm	lbm	5,401,018 lbm
	Liftoff Thrust/Weight	G	1.58 g	G	1.44 g
	Second Stage Thrust/Weight	G	1.05 g	G	1.09 g

*Delivered to 30X160 nmi Orbit

Table 6-12. EELV-
Derived Lunar Options
Assessed in Detail

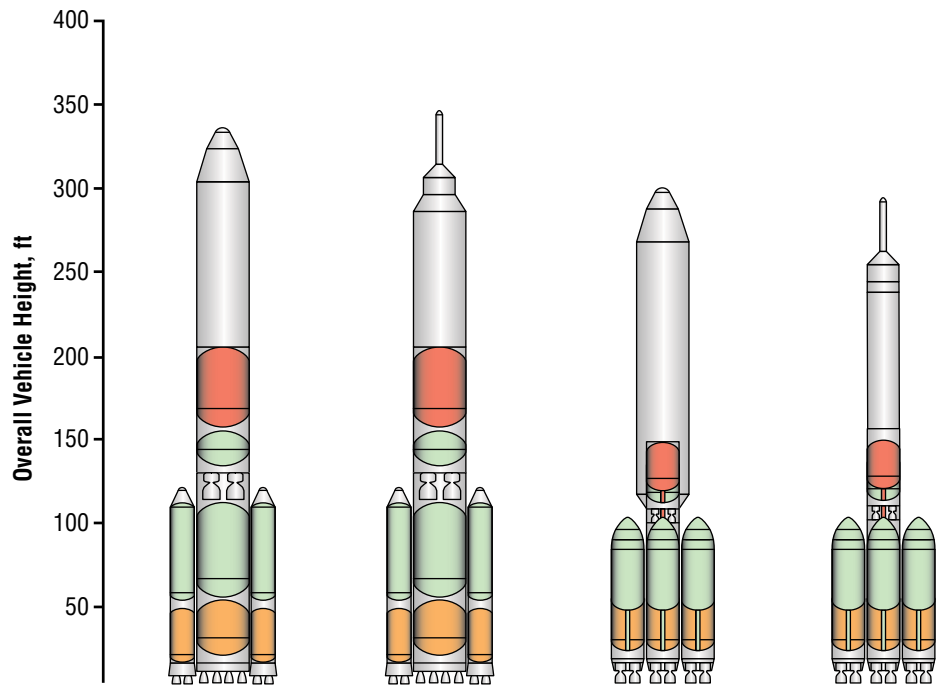

Vehicle Name		7.4 Atlas Evolved (8m Core) + 2 Atlas V Boosters Cargo	7.5 Atlas Evolved (8m Core) + 2 Atlas V Boosters Crew + Cargo	11 Atlas Phase 3A (5m CBC) Cargo	11.1 Atlas Phase 3A Crew + Cargo
Payload 28.5 Deg Inc*	Units				
Lift Capability	mT	111.9 mT	110.3 mT	110.4 mT	106.6 mT
Net Payload	mT	95.1 mT	93.7 mT	93.8 mT	90.6 mT
Payload 51.6 Deg Inc*					
Lift Capability	mT	106.1 mT	104.2 mT	104.4 mT	100.3 mT
Net Payload	mT	90.2 mT	88.6 mT	88.8 mT	85.3 mT
General Parameters					
Overall Height	ft	334.6 ft	347.6 ft	295.7 ft	290.1 ft
Gross Liftoff Mass	lbm	5,004,575 lbm	4,995,071 lbm	6,222,816 lbm	6,195,750 lbm
Liftoff Thrust/Weight	G	1.21 g	1.21 g	1.39 g	1.39 g
Second Stage Thrust/Weight	G	1.05 g	1.06 g	0.56 g	0.53 g

*Delivered to 30X160 nmi Orbit

Table 6-12. Other EELV-Derived Options Initially Assessed

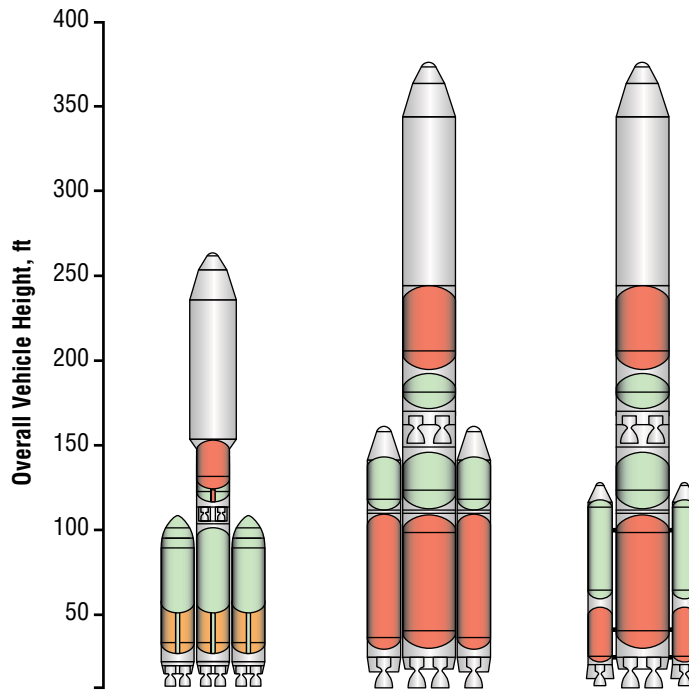

Vehicle Name		10	28	28.1
		Atlas Phase 2 - Cargo	4 RS-68 Core + 4 J-2S + 2 Delta IV Boosters Cargo	4 RS-68 Core + 4 J-2S + 2 Atlas V Boosters Cargo
Payload 28.5 Deg Inc*	Units			
Lift Capability	mT	73.6 mT	58.2 mT	64.1 mT
Net Payload	mT	62.6 mT	49.5 mT	54.5 mT
Payload 51.6 Deg Inc*				
Lift Capability	mT	69.5 mT	54.8 mT	60.6 mT
Net Payload	mT	59.1 mT	46.6 mT	51.5 mT
General Parameters				
Overall Height	ft	252.9 ft	368.5 ft	368.5 ft
Gross Liftoff Mass	lbm	3,811,194 lbm	3,207,626 lbm	3,601,955 lbm
Liftoff Thrust/Weight	G	1.36 g	1.24 g	1.22 g
Second Stage Thrust/Weight	G	0.64 g	1.19 g	1.17 g

*Delivered to 30X160 nmi Orbit

6.6.2 FOMs Assessments

6.6.2.1 Shuttle-Derived Systems

A summary of the FOM assessment for the Shuttle-derived CaLV candidate vehicles is presented in **Table 6-13**. The assessment was conducted as a consensus of discipline experts and does not use weighting factors or numerical scoring but rather a judgment of high/medium/low (green/yellow/red) factors, with high (green) being the most favorable and low (red) being the least favorable.

Table 6-13. Shuttle-Derived Cargo Vehicle FOMs Assessment Summary

		Shuttle-derived CaLV				
		4-Segment RSRB Side-mount Cargo	5-Segment RSRB Side-mount Cargo	4-Segment RSRB In-line SDV Cargo	5-Segment RSRB/4 SSME Core In-line SDV Cargo	5-Segment RSRB/5 SSME Core In-line SDV Cargo Variant
LV		20	21	24/25	26/27	27.3/13.1
FOMs	Probability of LOC	N/A	N/A	1 in 1170	1 in 915	1 in 2,021
	Probability of LOM	1 in 173	1 in 172	1 in 176	1 in 133	1 in 124
	Lunar Mission Flexibility					
	Mars Mission Extensibility					
	Commercial Extensibility	N/A	N/A	N/A	N/A	N/A
	National Security Extensibility	N/A	N/A	N/A	N/A	N/A
	Cost Risk					
	Schedule Risk	N/A	N/A	N/A	N/A	N/A
	Political Risk					
	DDT&E Cost (family)	.85	1.03	.83	0.98	1.00
	Facilities Cost (family)	N/A	N/A	N/A	1.00	1.00

The Shuttle-derived options rated moderate to favorable for LOC and favorable (green) for “family” DDT&E cost, largely due in each case to extensive use of flight proven hardware with extensive flight and test databases. A “family” DDT&E cost is derived for a CaLV that draws heavily from a CLV concept for some elements (e.g., booster engines). Essentially, this means that a development task is not repeated and paid for twice. For cost risk, the four-segment RSRB side-mount and in-line Shuttle-derived CaLVs were judged to be favorable (green), because the only new element to be developed is the cargo carrier. Five-segment RSRB development and new four- and five-SSME cores for LV 26/27 and LV 27.3, respectively, drive the cost risk for these vehicles to the yellow rating. No commercial or DoD extensibility was envisioned. The limitations of the side-mounted configuration in carrier vehicle geometry and payload lift capability restrict their extensibility for Mars missions, as well as flexibility for lunar missions to a lesser extent. No side-mounted SDV is capable of a 2-or-less lunar launch mission scenario. The four-segment/three-SSME SDV, LV 24/25, is not capable of launching lunar missions with two or less launches either. Favorable (green) rankings were given to the five-segment RSRB in-line SDV variants, LV 26/27/27.3, which possess the versatility required to accommodate changing lunar and Mars spacecraft architectures, because their configurations can accommodate a variety of payload geometries and increase lift capability relatively easily. LV 27.3, with five-segment RSRBs and five SSMEs in the core vehicle, enables the 1.5-launch solution (in conjunction with 13.1), which allows the crew to go to orbit on a CLV and have only one CaLV flight for the EDS and LSAM to LEO. Facilities costs were rated favorable (green) for the in-line Shuttle-derived CaLV variants, due to their continued extensive use of NASA Kennedy Space Center (KSC) Launch Complex (LC) 39. See **Section 7, Operations**, for more details on operations.

6.6.2.2 EELV-Derived Systems

A summary of the FOMs assessment for the EELV CaLV candidate vehicles is presented in **Table 6-14**. The assessment was conducted in the same manner as that for the Shuttle-derived vehicles.

	LV	EELV-Derived CaLV	
		8-m Core/RD-180/ 2 Atlas V Boosters w/ Upper Stage	Atlas Phase 3A (5.4-m CBC)
		7.4/7.5	11/11.1
FOMs	Probability of LOC	1 in 536	1 in 612
	Probability of LOM	1 in 71	1 in 88
	Lunar Mission Flexibility		
	Mars Mission Extensibility		
	Commercial Extensibility	N/A	N/A
	National Security Extensibility	N/A	N/A
	Cost Risk		
	Schedule Risk	N/A	N/A
	Political Risk		
	DDT&E Cost (family)	1.26	1.02
	Facilities Cost (family)	1.12	1.56

Table 6-14. EELV-Derived Cargo Vehicle FOMs Assessment Summary

Both EELV CaLV concepts rated unfavorable (red) for LOC as they do not approach the 1-in-1,000 goal. The use of multi-engine stages, multiple strap-on boosters, and relatively low-to-moderate design heritage from existing systems all were major contributors. Low T/W for LV 7.4/7.5 and limitations due to the 5.4-m core vehicle diameter for LV 11/11.1 limits the ability of each to provide flexibility to future lunar missions and extending the use of either vehicle for Mars missions. The four strap-on boosters with a central core configuration, LV 11/11.1, dictates the need for new facilities, as no present launch infrastructure at KSC can accommodate this configuration. LV 7.4/7.5 is more conventional in geometry, with two strap-on boosters, which could be accommodated with modification to KSC LC 39. No projected commercial or DoD missions require the use of this class of LV, so no FOM rating was applied. While both vehicles support a 2-launch lunar mission solution, neither demonstrated the ability to enable the 1.5-launch solution, necessitating each vehicle to be human rated. The delta CaLV options (LV 28 and LV 28.1) did not meet the threshold payload performance of 70 mT and were dropped from further consideration. Options using RSRBs required upper stages to meet performance goals. The Phase 3 Atlas, LV 11/11.1, draws more design heritage from CLV (option 9) and, as a result, demonstrates a more favorable family DDT&E cost than LV 7.4/7.5, with the 8-m core. However, the CLV costs for this option were unacceptably high. (See **Section 6.5.2.2, EELV-Derived Systems**) Use of an 8-m stage diameter for a CLV to derive family DDT&E costs adversely affects the initial CLV cost, which results in little or no overall savings. The Atlas Phase 2 variant utilizing two liquid strap-on boosters offered no advantages to the Atlas 3A, other than having a simpler configuration that reduced the scope of the launch infrastructure modifications, but still required the associated cost of a dedicated CLV.

6.6.3 Detailed Assessment Summary

6.6.3.1 Description of Selected LV

The preferred CaLV concept, LV 27.3, (**Figure 6-37**) is a 1.5-stage parallel-burn LV with an EDS that is optimized for cargo to TLI. This is an in-line Shuttle-derived concept that uses ET-diameter tankage and structure for the core and EDS. The general configuration is two solid strap-on boosters connected to a LOX/LH2 core stage. The two solid strap-on boosters are five-segment RSRBs (HTPB propellant). The LOX/LH2 core stage uses five SSMEs for propulsion. The EDS is LOX/LH2 with two J-2S+ engines and is burned suborbitally in the concept. (Later studies indicate this may be able to be reduced to one J-2S+ engine). This vehicle is flown to a 30- by 160- nmi orbit at an inclination of 28.5 deg and inserted at an altitude of 78.3 nmi. The SSMEs are run at a throttle setting of 104.5 percent. The J-2S+ engines of the EDS stage are operated at a 100 percent power level during the suborbital and TLI burns.

6.6.3.2 Performance Summary

The net payload capability of LV 27.3 plus EDS to TLI is 54.6 mT for the maximum TLI payload carried from liftoff (no orbital rendezvous).

Two other EDS cases were considered for this vehicle. In Case 1, LV 27.3 was assumed to have a 42.8-mT LSAM attached to the EDS at launch. The EDS propellant load was reoptimized for this case. The EDS with LSAM attached then rendezvoused with a CEV on orbit at a 160-nmi circular orbit that weighed 19.1 mT, for a total cargo stack mass of 61.9 mT in orbit. The EDS with LSAM and CEV then performed a TLI burn with the remaining EDS propellant. The TLI net payload capability for this case was determined to be 68.6 mT, which is 6.7 mT greater than the required delivery mass of 61.9 mT.

In Case 2, LV 27.3 was assumed to have a 44.9-mT LSAM attached to the EDS at launch. The EDS propellant load was also reoptimized for this case. The EDS with LSAM attached then rendezvoused with a CEV on orbit at 160 nmi circular orbit that weighed 20.6 mT, for a total cargo stack mass of 65.5 mT in orbit. The EDS with LSAM and CEV then performed a TLI burn with the remaining EDS propellant. The TLI net payload capability for this case was determined to be 66.9 mT, which is 1.4 mT greater than the required delivery mass of 65.5 mT. A graphical representation of TLI payloads and the relative masses of the LSAM and CEV are shown in **Figure 6-38**.

No GR&As were violated for this LV analysis.



Figure 6-37. LV 27.3
General Configuration

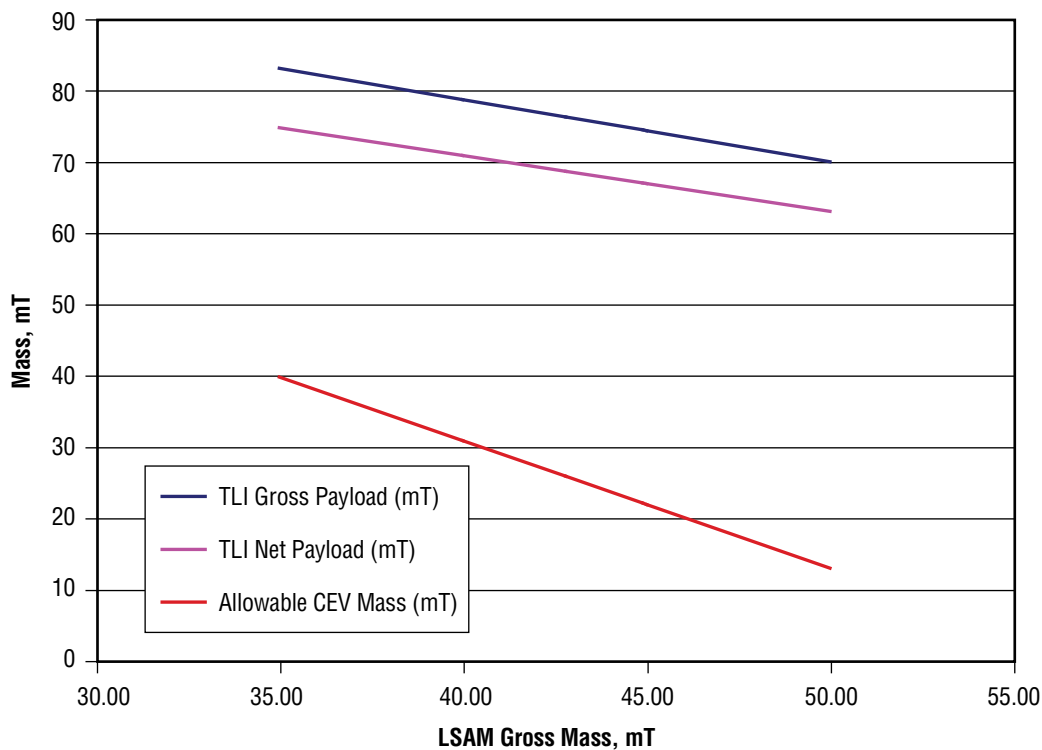

Figure 6-38. 1.5-Launch Solution Allowable Masses as a Function of LSAM Mass

6.6.3.2.1 Vehicle Sizing

The mass properties for the core stage and the EDS of LV 27.3 are shown in Table 6-15.

Mass Properties Accounting		
Vehicle: In-line Cargo – 5 SSME, 2 J-2S+, Five-Segment RSRB		
Stage: Strap-on Solid (Five-Segment RSRB)		
Item	Mass Subtotals	Mass Totals
	Primary	
	lbm	lbm
Stage Burnout Mass		221,234
Main Ascent Propellant	1,434,906	
Stage Gross Liftoff Mass		1,656,140
Stage: EDS (2 J-2S+)		
Primary Body Structures	19,592	
Secondary Structures	2,436	
Separation Systems	199	
TPS	317	
TCS	1,482	
MPS	12,642	
Power (Electrical)	1,413	
Power (Hydraulic)	404	

Table 6-15. Launch Vehicle 27.3 INTROS Mass Summary

Table 6-15. Launch Vehicle 27.3 INTROS Mass Summary (continued)

Mass Properties Accounting		
Vehicle: In-line Cargo – 5 SSME, 2 J-2S+, Five-Segment RSRB		
Stage: Strap-on Solid (Five-Segment RSRB)		
Item	Mass Subtotals	Mass Totals
	Primary	
	lbm	lbm
Avionics	430	
Miscellaneous	131	
Stage Dry Mass Without Growth		39,046
Dry Mass Growth Allowance	3,599	
Stage Dry Mass With Growth		42,645
Residuals	5,309	
Reserves	628	
In-flight Fluid Losses	59	
Stage Burnout Mass		48,640
Main Ascent Propellant	457,884	
Engine Purge Helium	52	
Stage Gross Liftoff Mass		506,576
Stage: Core Stage (5 SSME Blk 2)		
Primary Body Structures	102,965	
Secondary Structures	3,789	
Separation Systems	3,898	
TPS	574	
TCS	5,373	
MPS	58,015	
Power (Electrical)	2,922	
Power (Hydraulic)	1,804	
Avionics	670	
Miscellaneous	573	
Stage Dry Mass Without Growth		180,583
Dry Mass Growth Allowance	14,413	
Stage Dry Mass With Growth		194,997
Residuals	16,676	
Reserves	3,323	
In-flight Fluid Losses	262	
Stage Burnout Mass		215,258
Main Ascent Propellant	2,215,385	
Engine Purge Helium	251	
Stage Gross Liftoff Mass		2,430,894
Payload	133,703	
Payload Shroud	10,522	
Upper Stage Gross Mass	506,576	
Strap-ons, Gross Mass	3,312,279	
Vehicle Gross Liftoff Mass		6,393,975

6.6.3.2.2 Structural Analysis

The loads plot is a combined worst-case including liftoff, maximum dynamic pressure (max q), and maximum acceleration (max g). The tie-down loads are assumed to be carried by the RSRBs, as with the current Shuttle system. The compression loads show a major jump where the LOX tank loads are integrated into the outside structure, with a quick reduction of the loads where the introduced SRB loads counteract the compression. The bending moment shows a steady increase from the tip of the vehicle to the liftoff Center of Gravity (CG), then a steady decrease back to zero, as expected from an in-flight case. **Figure 6-39** shows the structural configuration of the CaLV, while **Figure 6-40** summarizes the structural load analysis.

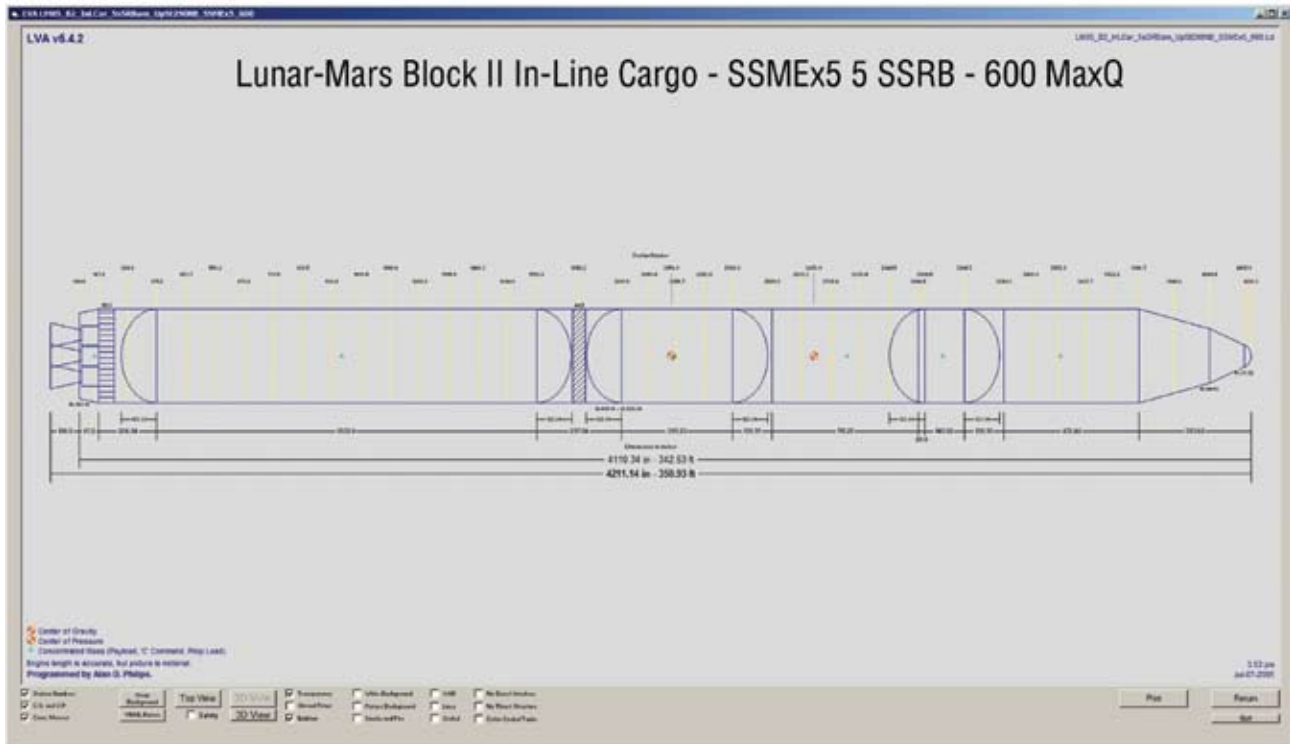

Figure 6-39. CaLV Structural Configuration

Considerable effort was used to optimize this particular vehicle for payload to TLI. A max q of 600 lb/ft² was used (as calculated by the Program to Optimize Simulated Trajectories (POST) tool) instead of the 750 normally used for this class of vehicle. Also, a more efficient conical thrust structure was used for the EDS instead of the standard cruciform. The core was also re-analyzed for the loads in this particular case.

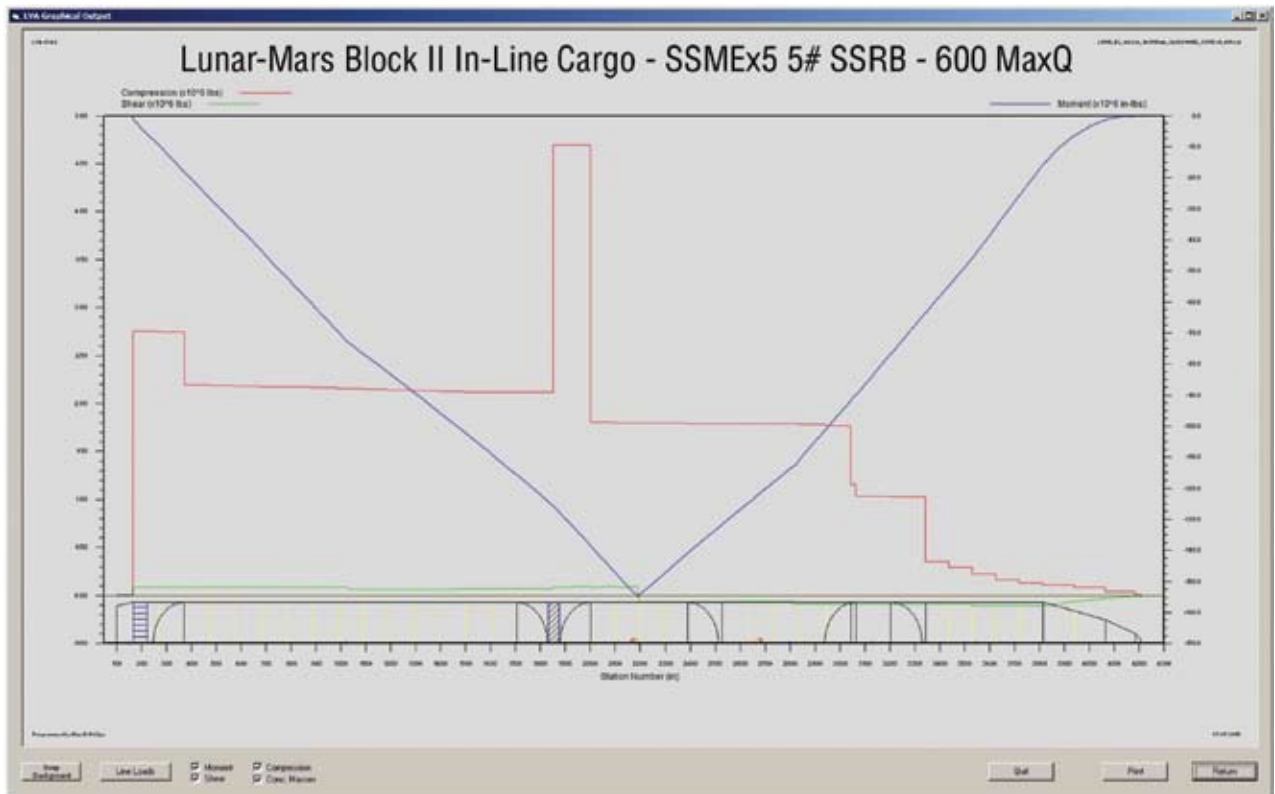
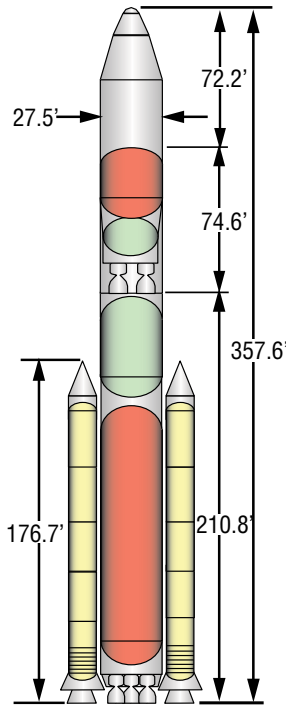

Figure 6-40. CaLV Structural Loads Analysis Results

6.6.3.2.3 Flight Performance Analysis and Trajectory Design

Major events in the trajectory and LV characteristics are shown in **Figure 6-41**. The analyses of the four EDS case studies are shown in **Figures 6-42** and **6-43**. Selected trajectory parameters are shown in **Figures 6-44** through **Figure 6-47**. This vehicle T/W ratio at liftoff is 1.43. The vehicle reaches a maximum dynamic pressure of 561 psf at 72.7 sec. The maximum acceleration with boosters attached is 2.32 g's, while the core hits a max of 2.83 g's before burnout, and the EDS stops accelerating at 1.46 g's prior to Main Engine Cutoff (MECO). The five-segment SRBs separate 132.52 sec into the burn at an altitude of 154,235 ft and Mach 3.9. The core burns out at 408.2 sec, having reached an altitude of 408,090 ft at Mach 12.1. From this point, the EDS ignites and burns 264,690 lb of propellant to reach orbit. The T/W ratio of the core after SRB separation is 1.04, and 0.84 after EDS ignition. Orbital injection occurs 626 sec after liftoff at 78.3 nmi.

5 SSME Core & 5-Segment SRB + 2 J-2S + EDS Cargo



Vehicle Concept Characteristics

GLOW	6,393,975 lbf
Payload Envelope L x D	39.4 ft x 24.5 ft
Shroud Jettison Mass	10,522 lbm
Booster Stage (each)	
Propellants	HTPB
Useable Propellant	1,434,906 lbm
Stage pmf	0.8664
Burnout Mass	221,234 lbm
# Boosters / Type	2 / 5-Segment SRM
Booster Thrust (@ 0.7 sec)	3,480,123 lbf @ Vac
Booster Isp (@ 0.7 sec)	265.4 sec @ Vac
First Stage	
Propellants	LOX/LH2
Useable Propellant	2,215,385 lbm
Propellant Offload	0.0 %
Stage pmf	0.9113
Dry Mass	194,997 lbm
Burnout Mass	215,258 lbm
# Engines / Type	5 / SSME Blk 2
Engine Thrust (100%)	375,181 lbf @ SL 469,449 lbf @ Vac
Engine Isp (100%)	361.3 sec @ SL 452.1 sec @ Vac
Mission Power Level	104.5 %

Earth Departure /Upperstage

Propellants	LOX/LH2
Useable Propellant	457,884 lbm
Propellant Offload	0.0 %
Stage pmf	0.9039
Dry Mass	42,645 lbm
Burnout Mass	48,640 lbm
# Engines / Type	2 / J-2S+
Engine Thrust (100%)	274,500 lbf @ Vac
Engine Isp (100%)	451.5 sec @ Vac
Mission Power Level	100.0 %

Delivery Orbit	30 x 60 nmi @ 28.5°	
Del. Orbit Payload	326,896 lbm	148.3 mT
Net Payload	277,862 lbm	126.0 mT
LEO payload Optimized Thru Propellant Offload in EDS of 40%		
Delivery Orbit	TLI (EDS Suborbital Burn)	
Gross Payload	133,703 lbm	60.6 mT
Net Payload	120,333 lbm	54.6 mT

Closed Case Summary Data for Reference Mission (30-160 nmi @ 28.5):

Liftoff to SRM staging f/w ₀ = 1.43 (@ t = 1 sec) max RSRM accel = 2.32 time of max Q = 72.7 sec throttle @ bucket = no change max Q = 561 psf mach = 1.52	Shroud Jettison @t = 447.0 sec alt @ jettison = 431,200 ft
After SRM jettison (Core stg1 + stg2) tstg = 132.52 sec alt @ stg = 154,235 ft mach @ stg = 3.85 dynp @ stg = 27 psf dv1 = 8,058 ft/s f/w1 = 1.041 max stg1 f/w = 2.83	After Stg1 jettison (stg2 only) tstg = 408.2 sec alt @ stg = 408,090 ft mach @ stg = 12.12 dynp @ stg = 0 psf dv1 = 22,656 ft/s f/w1 = 0.844 max stg2 f/w = 1.46
	At MECO / Orbital Insertion time to MECO = 625.9 sec MECO altitude = 475,827 ft dvt = 30,386 ft/s

Figure 6-41. LV 27.3 Summary

Vehicle Concept Characteristics
EDS+PL Gross @ Liftoff 640,282 lbf
EDS Gross @ Liftoff 545,924 lbf

EDS Stage

Propellants	LOX/LH2
Useable Propellant @ Liftoff	495,128 lbm
Useable Propellant @ 160 nmi cir.	223,826 lbm
Stage PMS	0.9070
Dry Mass	44,314 lbm
Burnout Mass	50,741 lbm
# Engines / Type	2/J-2S+
Engine Thrust (100%)	274,500 lbf @ Vac
Engine Isp (100%)	451.5 sec @ Vac
Mission Power Level	100.0%

TLI Delivery

CEV @ Liftoff	44,754 lbm	20.3 mT
LSAM Payload	94,358 lbm	42.8 mT
CEV Payload	42,108 lbm	19.1 mT
Margin Payload	31,480 lbm	14.3 mT
Gross Total Payload	167,946 lbm	76.2 mT
Net Payload	151,152 lbm	68.6 mT
Net Allowable CEV Mass	56,794 lbm	25.8 MT

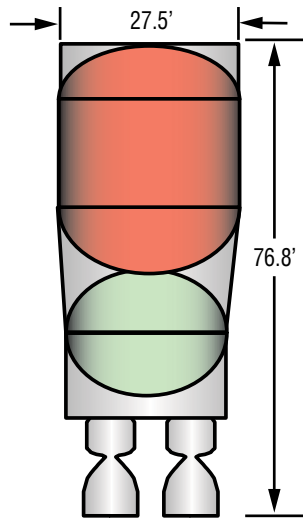

Figure 6-42. Case 1: LV
 27.3 SP + EDS (42.8 mT
 LSAM)

Vehicle Concept Characteristics
EDS+PL Gross @ Liftoff 640,281 lbf
EDS Gross @ Liftoff 541,294 lbf

EDS Stage

Propellants	LOX/LH2
Useable Propellant @ Liftoff	490,744 lbm
Useable Propellant @ 160 nmi cir.	219,443 lbm
Stage PMS	0.9066
Dry Mass	44,118 lbm
Burnout Mass	50,494 lbm
# Engines / Type	2 / J-2S+
Engine Thrust (100%)	274,500 lbf @ Vac
Engine Isp (100%)	451.5 sec @ Vac
Mission Power Level	100.0%

TLI Delivery

CEV @ Liftoff	48,061 lbm	21.8 mT
LSAM Payload	98,988 lbm	44.9 mT
CEV Payload	45,415 lbm	20.6 mT
Margin Payload	19,500 lbm	8.8 mT
Gross Total Payload	163,903 lbm	74.3 mT
Net Payload	147,513 lbm	66.9 mT
Net Allowable CEV Mass	48,525 lbm	22.0 mT

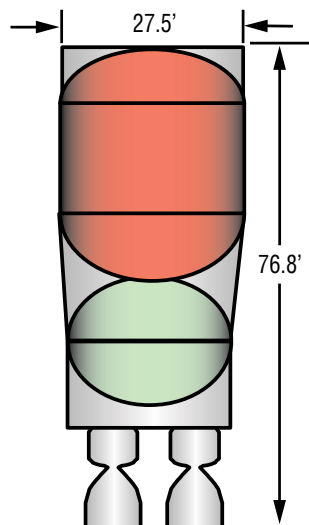

Figure 6-43. Case 2: LV
 27.3 SP + EDS (44.9 mT
 LSAM)

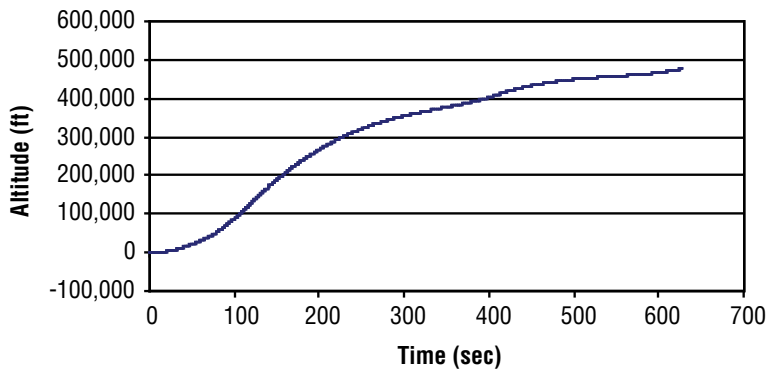

Figure 6-44. Altitude versus Time

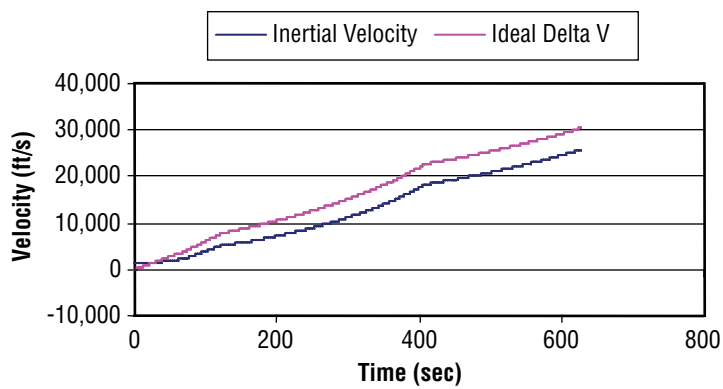

Figure 6-45. Velocity versus Time

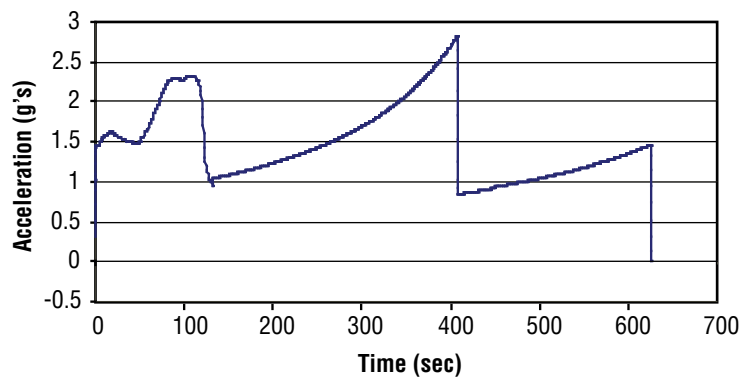

Figure 6-46. Acceleration versus Time

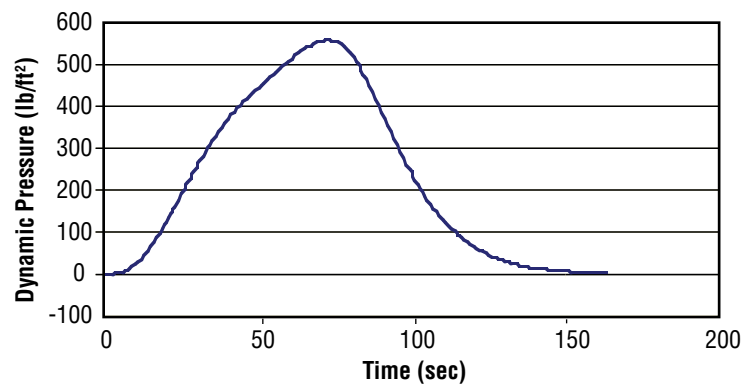

Figure 6-47. Dynamic Pressure versus Time

6.6.3.3 Cost Analysis Assumptions for CaLVs

6.6.3.3.1 Inputs – Core Stage

Structure and Tanks

All structures and tanks are considered a new design, but with no new technology. The stage diameter is the same as the ET. Materials are either 2219 aluminum or AL-Li. Shrouds are made of graphite-epoxy panels, based on Titan and Delta IV designs. Structures and tanks are well understood with sufficient manufacturing capability in existence. All structures are similar to EELV and ET and have been validated in the relevant environment. All vehicles will, however, require full testing and qualification.

Main Propulsion System

The MPS will take significant heritage from the existing SSME MPS subsystem. However, a new design is needed to accommodate the varying number of SSMEs. Cost estimates assumed a new design with similar subsystems validated in the relevant environment. Full testing and qualification will be required.

Engine–SSME

In addition to the minor changes required to altitude-start the SSME (RS–25d), it is desirable to make some engine improvements to lower the unit cost and improve producibility. Suggested improvements include: low-pressure turbomachinery simplifications, a new controller, an HIP bonded MCC, flex hoses to replace flex joints on four ducts, and simplified nozzle processing. In addition, process changes would be incorporated to eliminate inspections for reuse and accommodate obsolescence of the controller.

The next step in the evolution of the SSME for exploration involves improvements for low-cost manufacturing and operations for a fully expendable SSME. Improvements include a channel wall nozzle, simplified high-pressure pumps, and a cast and simplified powerhead. The estimate is based on SSME historical costs, vendor quotes, and estimates.

Avionics and Software

The avionics subsystem must support Fail Operational/Fail Safe vehicle fault-tolerant requirements, meaning that, upon occurrence of the first failure, the backup to the failed system will keep the vehicle operating nominally. Upon a second failure, the subsystem will safely recommend an abort. Crew abort failure detection and decision-making capabilities have been demonstrated and are ready for flight. All architectures will meet these requirements, either by adding a modification for instrumentation redundancy for the EELV health management system, or providing the capabilities through the new design of the avionics for Shuttle-derived configurations.

Avionics hardware is divided into GN&C and CCDH. GN&C provides for attitude control, attitude determination, and attitude stabilization. CCDH provides all the equipment necessary for transfer and processing of data; communication for personnel, as well as spacecraft operations/telemetry data; and instrumentation for monitoring the vehicle and its performance. Both systems are linked through the LV software system. LV hardware requirements are well understood.

The core booster does not guide and control the ascent. This function is controlled by the upper stage. Core booster avionics includes translators, controllers, AD converters, the actuator control, electronics, and sufficient CCDH hardware to interface with the upper stage. The upper stage avionics controls ascent, separations, and flight. Upper stage avionics hardware includes the IMU, processors, communications, telemetry, and instrumentation. Software provides separation commands and includes general flight, mission-specific flight algorithms, and launch-date-specific software.

Software also provides the commands that control the vehicle, viewed as one entity for the LV. As such, the software estimate is not divided between the core and upper stage. Software is normally located on the upper stage, because the upper stage controls the ascent of the LV. The software estimate for the LVs is based on the same detailed breakdown of the functional requirements, shown in **Table 6-8**.

Software estimates are based on the maximum SLOC, using the SEER–SEM tool for software estimation, planning, and project control. SEER–SEM is a recognized software estimation tool developed by Galorath Incorporated for use in industry and the Government.

Shuttle-Derived Avionics Hardware

The GN&C and CCDH subsystems for Shuttle-derived LVs are considered new designs. Because the subsystems and software are new, integrated health management and human-rating requirements are incorporated from the start. The avionics hardware assumed a new design with existing technology.

Shuttle-Derived Software

All Shuttle-derived software is considered new software development, incorporating the functions identified above. The maximum SLOC estimates were used with the SEER–SEM model to arrive at a deterministic software estimate.

Other Subsystems

The basic thermal systems are ½- to 1-inch thick SOFI, with cold plates and insulation for passive cooling of equipment and avionics. No new technology is planned.

Electrical power is provided by silver-zinc batteries with a redundancy of two. Conversion, distribution, and circuitry are considered new designs with state-of-the-art technology. Hydraulic power is fueled by hydrazine, which is used in LVs today.

RCSs, when used, are the same type as currently used in the Shuttle. Range safety will require modifications to the flight termination system to add time-delay for abort. Human-rating requirements may necessitate the removal of the autodestruct capability. All of these subsystems are similar to those already in existence, either on EELVs or the Shuttle, and have been validated in the relevant environment. Full qualification and testing is estimated for all crew and cargo vehicles.

For the side-mount Shuttle-derived vehicles, the existing ET is used.

6.6.3.3.2 DDT&E

The lowest cost options, as shown in **Table 6-16**, from this group of vehicles are the four-segment RSRB in-line with three SSMEs and the four-segment RSRB side-mounted SDV. The five-segment in-line SDV follows next. The most expensive DDT&E is LV 27.3. This vehicle includes an EDS used as an upper stage, which is included in the cost estimates.

Table 6-16. Relative Comparison of Shuttle-Derived Cargo Vehicle Costs

Phase	Relative Cost Position						
Vehicle	20	21	24	25	26	27	27.3
DDT&E	0.75	0.80	0.73	0.73	0.96	0.96	1.00
Production	1.33	1.33	0.88	0.88	0.96	0.96	1.00
Operations	1.07	1.07	0.96	0.96	1.00	1.00	1.00
Facilities	1.00	1.00	1.00	1.00	1.00	1.00	1.00
Number of launches for lunar mission	3+	3+	3	3	2	2	1.5

6.6.3.3.3 Production

LV 20/21, 24/25, 26/27, and 27.3 are four- or five-segment RSRB in-line or side-mounted configurations using modified/evolved Shuttle flight hardware. The recurring production costs of these four families of concepts are relatively close. The four-segment RSRB is slightly less expensive to refurbish than the five-segment version (i.e., the cost of refurbishing and reloading the two additional motor segments is relatively small), so that the main differences in cost relate more to the total number and TFU costs of other hardware pieces that must be produced (and integrated), such as separate tanks (for the side-mounted concepts) and engines in particular. SSMEs are significant drivers of production costs, thus the greater the number on the vehicle, the greater the production costs. As shown in **Table 6-16**, LVs 20 and 21 (side-mounts) have the greatest annual production cost at six flights per year, followed by LV 27.3 and LV 26/27, while the least expensive configuration to produce is LV 24/25.

6.6.3.3.4 Operations

All of these concepts require the stacking of either two four- or five-segment SRBs similar to the current Shuttle configuration. The SRM segments are refurbished in the same manner as in the current Shuttle operation. Core stages and engines are new manufacturable items. The launch operations activities include receipt, checkout, stacking and integration, testing, transport to the launch pad, pad operations, and launch. As shown in **Table 6-16**, the cost of launch operations is lowest for LV 24/25 and greatest for LV 20/21, because of the greater number of elements to be integrated. However, the difference at six flights per year is slight.

6.6.3.3.5 Facilities

The facilities costs include modifications to the MLP, VAB, and the launch pad to accommodate the different profile and footprint of the in-line configuration. The side-mounted concepts would require little modification. The facilities cost is greatest for LV 27.3. The relative cost position of the vehicles for DDT&E, production, launch operations, and facilities is summarized in **Table 6-16**. Detailed cost estimates are provided in **Section 12, Cost**.

6.6.3.4 Safety/Reliability Analysis (LV 27.3)

The same tool as previously discussed for LV 13.1 was used to determine the CaLV in-line core with five SSMEs and two five-segment RSRBs (LV 27.3) LOM estimates. These estimates were based on preliminary vehicle descriptions that included propulsion elements and Space Shuttle-based LV subsystems reliability predictions. A simple reliability model using point estimates was used to validate the results. A complete description of both models is included in **Appendix 6D, Safety and Reliability**. The LV 27.3 LOM estimates are shown in **Figure 6-48**. The LOM results are for ascent only. Other key assumptions included:

- No mission continuance engine-out capability;
- Engine shutdown is just as catastrophic to the vehicle as an uncontained failure; and
- SSMEs operated with current redlines inhibited. A 10 percent risk reduction of the overall LOM mean estimate is assumed due to the redlines being inhibited.

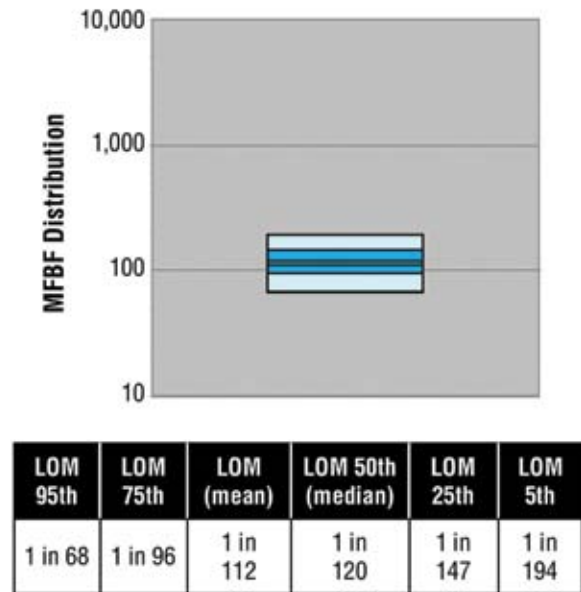

Note: LOM mean = 1 in 124 applying 10% risk reduction due to inhibiting engine redlines.

Figure 6-48. LV 27.3 Cargo Variant LOM Estimates

The reliability model used Space Shuttle PRA data that was reviewed by propulsion engineers to incorporate potential upgrades for this vehicle. This led to the propulsion system reliability estimates in **Table 6-17**.

Engine	Failure Probability (Cat)	Failure Probability (Ben)	Failure Probability (Start)	CFF	Error Factor
SSME	2.822E-04	1.482E-03	N/A	16.0%	2.6
RSRB (5-Segment HTPB)	3.484E-04	N/A	1.278E-05	N/A	1.8

Table 6-17. Launch Vehicle 27.3 Propulsion System Failure Probabilities

The use of dual RSRBs is assumed the same as the current STS configuration. The Space Shuttle PRA data for the four-segment PBAN RSRBs was modified for the incorporation of the five-segment HTPB RSRBs. See **Section 6.8, LV Reliability and Safety Analysis**, for a description of the methodology used for determining the reliability of the other RSRB configurations used in the study.

The payload shroud reliability used in the ESAS was generated from a separate off-line analysis. The complete reliability analysis results are presented in **Section 6.8, LV Reliability and Safety Analysis**.

Figure 6-49 and **Table 6-18** show the LV 27.3 subsystem risk contributions. The vehicle risk is dominated by the multiple SSMEs on the core stage.

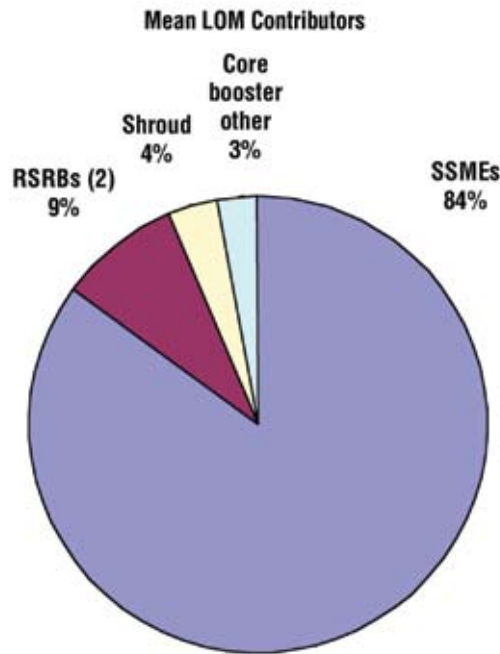

Figure 6-49. LV Subsystem Risk Contributions

Table 6-18. LV Subsystem Risk Contributions

	Mean Failure Probability	MFBF
RSRB (2)	5.7437E-04	1 in 1,741
RSRB Separation	2.1219E-04	1 in 4,713
Core Booster Engine Instantaneous Catastrophic Failure (ICF)	1.1075E-03	1 in 903
Core Booster Engine Benign Failure (BGN)	6.4955E-05	1 in 31,736
Core Booster APU	3.1510E-05	1 in 31,736
Core Booster TCS	1.0800E-09	1 in >1,000,000
Core Booster PMS	1.8401E-04	1 in 5,435
Core Booster TVC	2.3633E-05	1 in 42,314
Shroud	3.2464E-04	1 in 3,080
LOM	8.9246E-03	1 in 112

Note: LOM mean is 1 in 124 assuming 10% reduction due to inhibiting redlines. MFBF = Mean Flights Between Failures

To validate these results, a simple mean reliability model was developed. The model calculates FOMs by multiplying reliabilities for this quick illustration. The results of this model (LOM = 1 in 120 (1 in 133 with 10 percent risk reduction for inhibiting engine redlines)) compare favorably with the results of the FIRST model (LOM = 1 in 112 (1 in 124 with 10 percent risk reduction for inhibiting engine redlines)). This affirms the reliability estimates for LV 27.3. Complete results are provided in **Appendix 6D, Safety and Reliability**.

6.6.3.5 Schedule Assessment

There were no detailed development schedules generated for the CaLV options because they have a much later IOC than the CLV. The consensus was that the more clean-sheet EELV-derived design would require a longer development time than the Shuttle-derived solutions due to using well-characterized heritage systems (i.e., SRB, SSME). The additional upper stage required for the EELV concepts was also considered a driving factor. Assuming the traffic model for the first flight to be in 2017, the development would likely be 6–8 yrs, depending on the chosen option.

6.6.4 Cost Analysis Assumptions for Launch Families

The cost estimates developed for the family assessments continued to use NAFCOM for production of the DDT&E and TFU costs. However, rather than costing each vehicle as an independent, stand-alone concept, the family approach assumed an evolved methodology. Each family develops a CLV first. The first LV in the family will lift crew plus a limited amount of cargo per launch to the ISS. The second vehicle developed within the family will be used to lift heavy cargo and, in some families, crew also. Its development takes credit, wherever possible, for any development costs already paid for by the crew vehicle (engine development, software development, etc.). The cargo vehicle in the family may take some heritage credit where the subsystem is similar to the crew vehicle (i.e., thermal), thus reducing the development cost of the cargo vehicle. The discussion below deals with the DDT&E costs of the vehicle only. Facilities and test flight costs are not included. All launch family options using the Shuttle-derived CLV (LV 13.1) realize an additional savings from not incurring keep-alive costs for the SSME and RSRB facilities from STS retirement to CaLV development.

6.6.4.1 1.5-Launch Solution (LV 13.1 Followed by LV 27.3)

In the 1.5-launch solution family for lunar missions, the crew vehicle is the four-segment RSRB with a new upper stage using the SSME. The evolved vehicle in this family is an in-line HLV. The ET-based core uses five SSMEs, with two five-segment RSRBs as strap-ons. As an evolved vehicle from the crew vehicle, the cargo vehicle pays the development cost to make the SSME fully expendable. The crew vehicle paid for altitude-start and minimal changes to lower cost. In addition, some of the crew vehicle software can be either modified or reused. Test software, database software, and time/power management are a few of the functions that fall into this category. These savings are somewhat offset by the fact that the cargo vehicle must incur the development cost of the five-segment RSRB. The evolved cargo vehicle saves development costs as compared to stand-alone estimates. It should be noted that the cargo vehicle uses an EDS. This EDS is not included in the costs.

6.6.4.2 2-Launch Solution using Four-Segment RSRB as Core for Crew (LV 13.1 Followed by LV 26/27)

The 2-launch lunar mission solution family also begins with the four-segment RSRB with an SSME upper stage crew vehicle. The crew vehicle development pays for improvements to the SSME (altitude-start and minimal changes to lower cost). The evolved cargo vehicle is an ET-based core with four SSMEs and the five-segment RSRBs as strap-ons. The evolved vehicle pays the development cost to make the SSME fully expendable. In addition, some of the crew vehicle software can be either modified or reused. Test software, database software, and time/power management are a few of the functions that fall into this category. These savings are somewhat offset by the fact that the cargo vehicle must incur the development cost of the five-segment RSRB. The evolved cargo vehicle saves development costs as compared to stand-alone estimates.

6.6.4.3 2-Launch Solution Atlas Phase X (LV 2 Followed by LV 7.4/7.5)

This 2-launch lunar mission solution starts with a crewed version of the Atlas V HLV configuration that is human rated. The Atlas Phase X vehicle has an 8-m core stage, which uses five RD-180 engines. Two one-engine Atlas V boosters are used as strap-ons. The new upper stage uses four J-2S+ engines. Since it is known at the start of development that the Atlas Phase X vehicle will be used both as a crew and cargo vehicle, development costs include the shroud development. Some additional test hardware and testing will be needed to test for both missions. This provides savings over development of two similar vehicles.

6.6.4.4 2-Launch Solution Atlas Phase 3A (LV 2 Followed by LV 11)

This 2-launch lunar mission solution starts with a crewed version of the Atlas V HLV configuration that is human rated. This human-rated Atlas V has one RD-180 in a 4.3-m core, with four RL-10-4-A engines in the upper stage. The Atlas Phase 3A vehicle has a 5-m core stage, but uses two RD-180 engines. This new core is then used as four strap-ons in the follow-on vehicle. The new upper stage on the follow-on vehicle uses four LR-60 engines. Many of the subsystems will receive only minor changes for the new follow-on vehicle. More modifications will be needed for the MPSs due to the increased number of engines in the core and the new engines in the upper stage. This provides savings over development of two vehicles.

6.6.4.5 2-Launch Solution Atlas Phase 3A (LV 9 Followed by LV 11)

The crew vehicle of this 2-launch lunar mission solution family begins with the Atlas Phase 2, where the 5-m core stage uses two RD-180 engines. The new upper stage uses four new LR-60 engines. The follow-on cargo vehicle takes the 5-m core from the crew vehicle as the core of the cargo vehicle. With some minor development for separation systems and attachments, this same core is used for four strap-ons to provide the additional lift required for cargo. A new shroud is also developed for the cargo vehicle. The upper stage is essentially the same upper stage as the crew vehicle. A full structural test article was included. This family approach produced cost savings.

6.6.4.6 3-Launch Solution Four-Segment RSRB (LV 13.1 Followed by LV 25)

This 3-launch lunar mission solution family begins with the four-segment RSRB with an SSME upper stage crew vehicle. The crew vehicle pays for improvements to the SSME (altitude-start and minimal changes to lower cost). The cargo vehicle is an in-line ET-based core using three SSMEs. The crew vehicle paid for altitude-start and minimal changes to lower cost. In addition, some of the crew vehicle software can be either modified or reused. Test software, database software, and time/power management are a few of the functions that fall into this category. Attached to this core are two four-segment RSRBs and a new shroud. The family shares the SSMEs and the four-segment RSRBs, allowing for savings over separate estimates.

6.6.4.7 3-Launch Solution Four-Segment RSRB (LV 13.1 Followed by LV 20)

This 3-launch lunar mission solution family begins with the four-segment RSRB with an SSME upper stage crew vehicle. The crew vehicle pays for improvements to the SSME (altitude-start and minimal changes to lower cost). The cargo vehicle is a Shuttle-derived side-mounted configuration. The ET and two four-segment RSRBs provide boost capability. The ET is in production today. A new payload carrier using four SSMEs will be developed to carry cargo and will be attached to the side of the ET. This evolved approach saves money over estimating the vehicles separately.

6.6.4.8 3-Launch Solution Five-Segment RSRB (LV 15 Followed by LV 21)

This 3-launch lunar mission solution family starts with a five-segment single RSRB in-line crew vehicle. The new upper stage uses four new LR-85 expander cycle engines. The cargo vehicle is a Shuttle-derived side-mounted configuration. The ET and two five-segment RSRBs provide boost capability. The ET is in production today. A new payload carrier using four SSMEs will be developed to carry cargo. The payload carrier is attached to the side of the ET. Since the crew vehicle does not use SSMEs, the CaLV must incur the total cost of development of the engine and sustainment of the production capacity. The five-segment RSRB development cost is included in the crew vehicle. This evolved approach allows for limited cost savings over stand-alone estimates.

6.7 Earth Departure Stage

6.7.1 Summary of EDS Trades

The ESAS EDS studies covered three separate key trades: (1) the number of EDSs required to accomplish the lunar missions, (2) potential commonality between the EDS and the LV upper stages, and (3) the thrust level and number and type of engines on the EDS.

The EDS was initially considered to provide the propulsion delta-V function for four different mission phases of a lunar mission: LEO circularization from 30- by 160-nmi to 160-nmi circular, TLI, Lunar Orbit Insertion (LOI), and, finally, the lunar orbit plane change maneuver.

Figure 6-50 displays these mission phases. A fifth phase was added later to consider using the EDS during launch to place the payload including EDS into a 30- by 160- nmi orbit. The assumed delta-Vs (DVs) for each of these maneuvers are shown in **Table 6-21**. The delta-V for the LEO burn varied depending on LV performance.

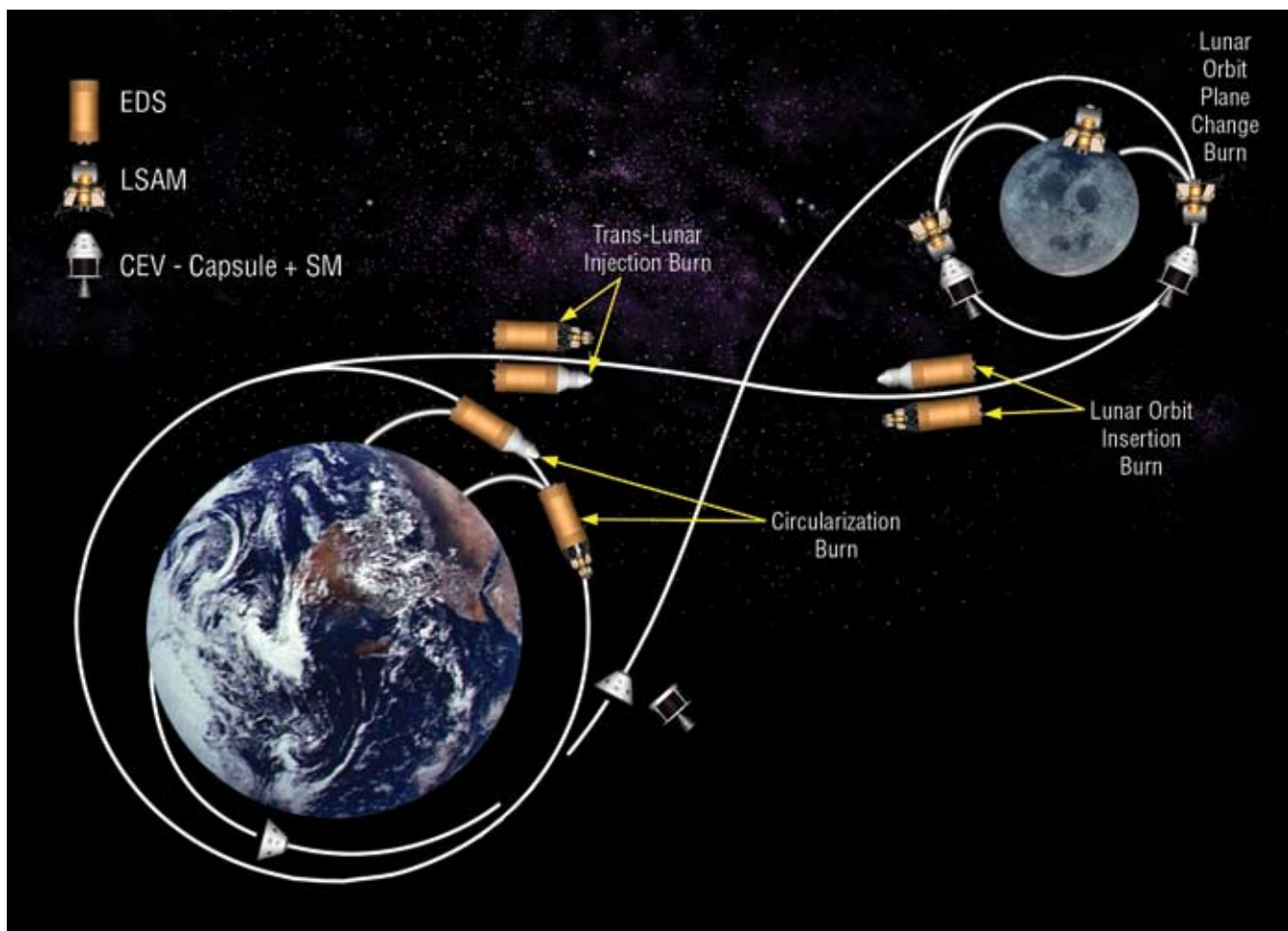

Figure 6-50. Potential EDS Mission Functions

Circ DV	78.6 m/sec (258 ft/sec) (30 x 160 nmi to 160 nmi)
TLI DV	3,120 m/sec (10,236 ft/sec)
LOI DV	890 m/sec (2,920 ft/sec)
Plane Change DV	510 m/sec (1,673 ft/sec)
Total Max DV	4,599 m/sec (15,087 ft/sec)

Table 6-19. Assumed Delta-Vs for Potential Mission Functions

6.7.2 Number of EDSs Required to Accomplish Lunar Mission

The objective of this trade was to define the bounds that set the desired number of EDSs for the EIRA lunar mission. To focus this trade, three key questions were identified that must be answered, including:

- What are the LV limits of mass to LEO?
- What are the in-space mission element masses for EIRA lunar mission (CEV, LSAM)?
- What effect does the concept of operations have on EDS design? For example, will the mission use split parallel flights to deliver the LSAM and CEV to the Moon or use a single-shot flight with combined LSAM and CEV in LEO?

The products from this trade consist of the data on the bounding constraints for selecting the number of EDSs per mission.

The LV limits were identified from the LV trades. Early in the vehicle study, it was decided to limit the number of launches to accomplish a mission to four launches. Later it was decided to discard vehicle options that could not lift at least 70 mT. **Figures 6-51 and 6-52** show the size relationship between the EDS and its lunar delivery capability with the identified LV limits.

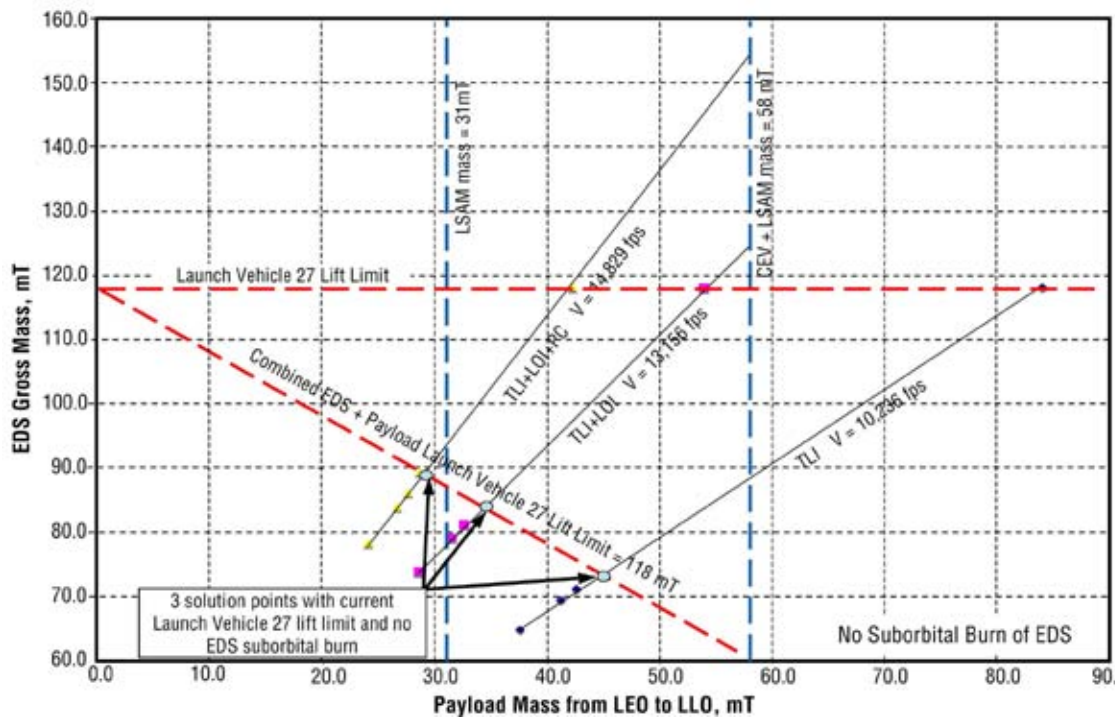

Figure 6-51. EDS Gross Mass Versus Payload Mass from LEO to LLO, mT

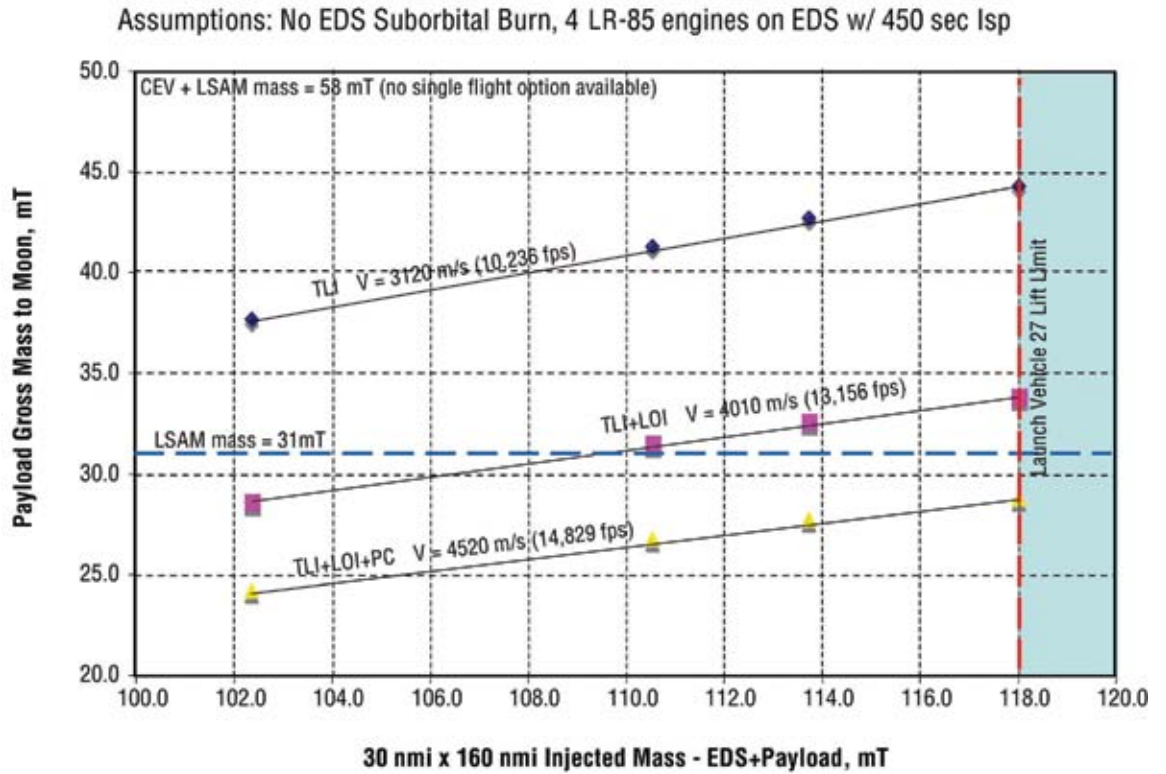

Figure 6-52. Payload Gross Mass to Moon Versus Total Injected Mass EDS + Payload

The EIRA masses for the CEV and the LSAM are 27 mT and 31 mT, respectively. The concept of operations for the EIRA architecture assumes two parallel flights with the LSAM carried with one EDS, and the CEV carried with another EDS. An alternative architecture approach uses one EDS pushing both CEV and LSAM in one all-up flight to the Moon, or it could use two EDSs burning in series with the CEV and LSAM together. With the LV lower lift limits that were set earlier, this means that no more than two EDSs are required per lunar mission.

There are several launch scenarios available to put up all the elements assembled for each mission. **Figure 6-53** depicts three potential launch solution sets for various mission concepts of operations. The actual sizes of the EDS depend on the specific LV option selected for the cargo and crew launches. **Figures 6-54** and **6-55** show the sizes of several options based on specific LV option lift constraints and the mission architectures described in **Section 4.2, Lunar Mission Mode**. A number of LV/EDS combinations were explored, providing essential architecture and vehicle trade sensitivities for the ESAS team.

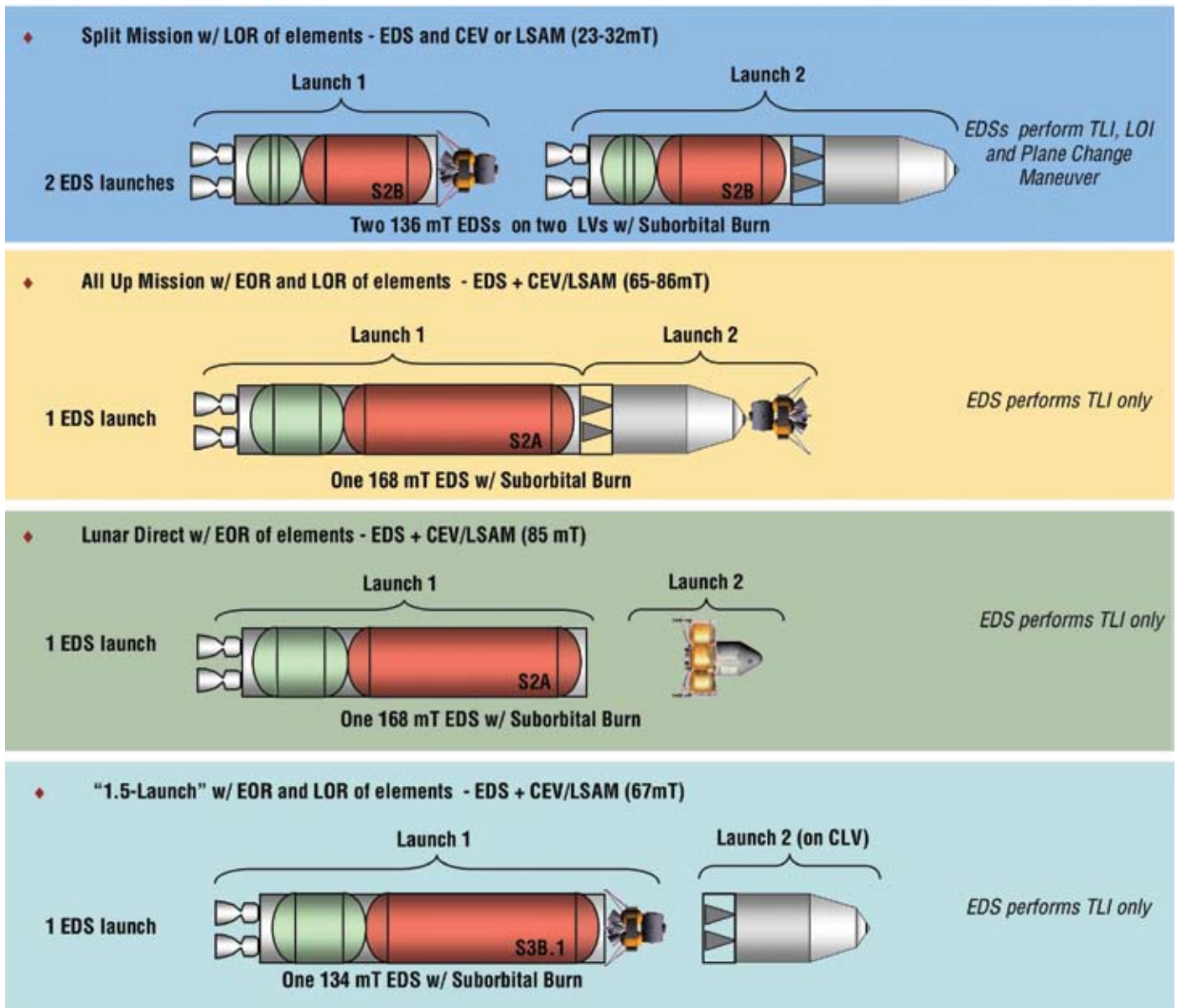

Figure 6-53. Potential Launch Solution Sets for Various Mission Concepts of Operations

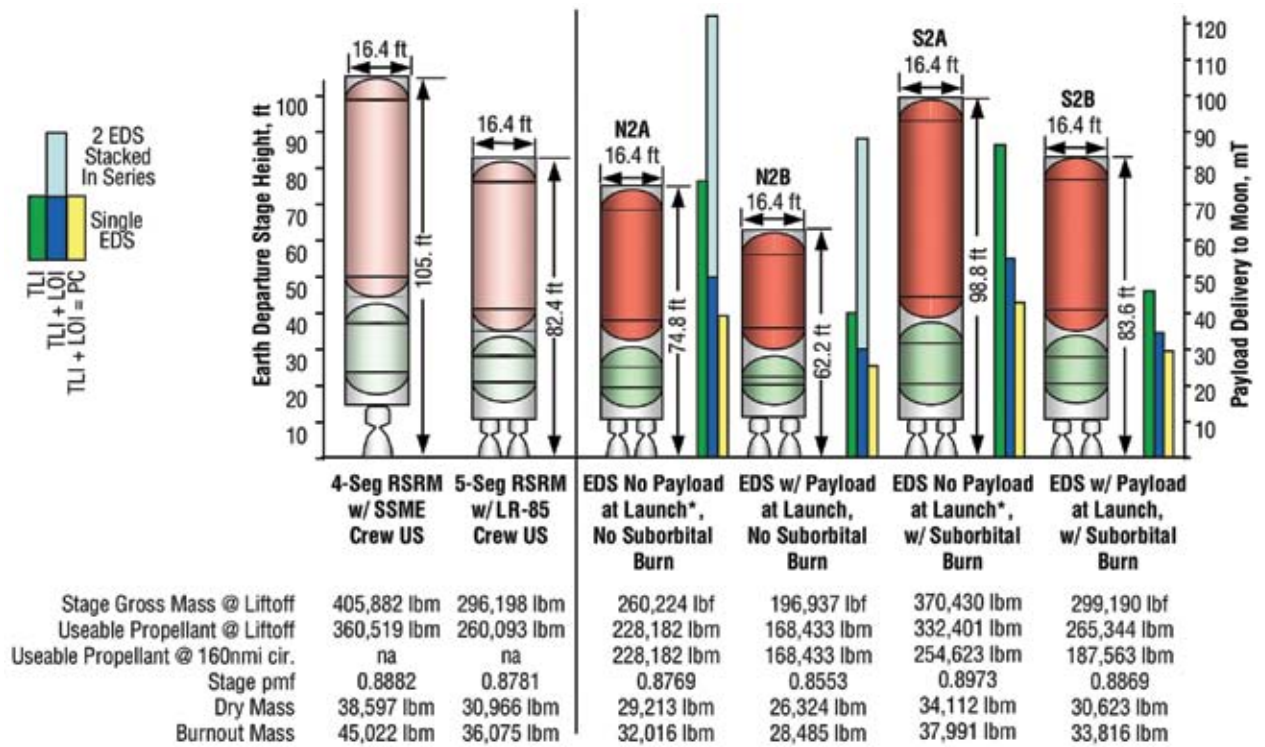

Figure 6-54. EDS Sizes Launched on In-Line SDV with 5-Segment RSRB

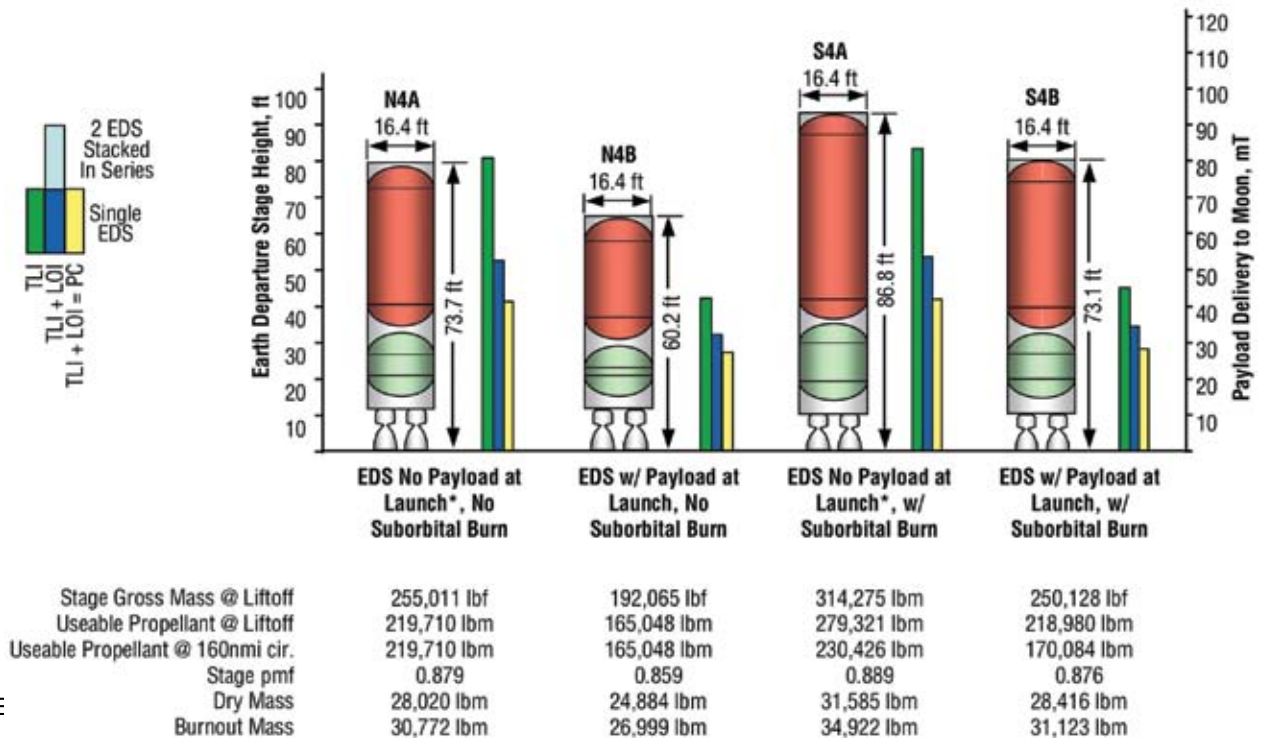

Figure 6-55. EDS Sizes Launched on Evolved Heavy Lift 8-m Core Vehicle

6.7.3 Potential Commonality between EDS and LV Upper Stages

A previous study performed during the summer of 2004 validated the potential benefits and feasibility of commonality between the EDS and the LV upper stages. The preliminary assessment data indicated that there are several possible evolutionary development scenarios that could save significant money and reduce program risk.

The objective of this study was to build on the earlier commonality study and identify specific commonality elements for the various candidate LV upper stages and the EDS. During this study, EDS configuration benefits were examined for tank and stage diameter commonality and propulsion system element commonality, and the cost savings were analyzed for several vehicle families. **Figure 6-56** shows three of the families examined, and **Table 6-20** shows the relative DDT&E costs for the various EDSs with and without commonality. **Table 6-21** shows the potential common elements that could be used between an LV upper stage and the EDS. **Table 6-22** shows new stage elements that will be required for an EDS if evolved from an LV upper stage.

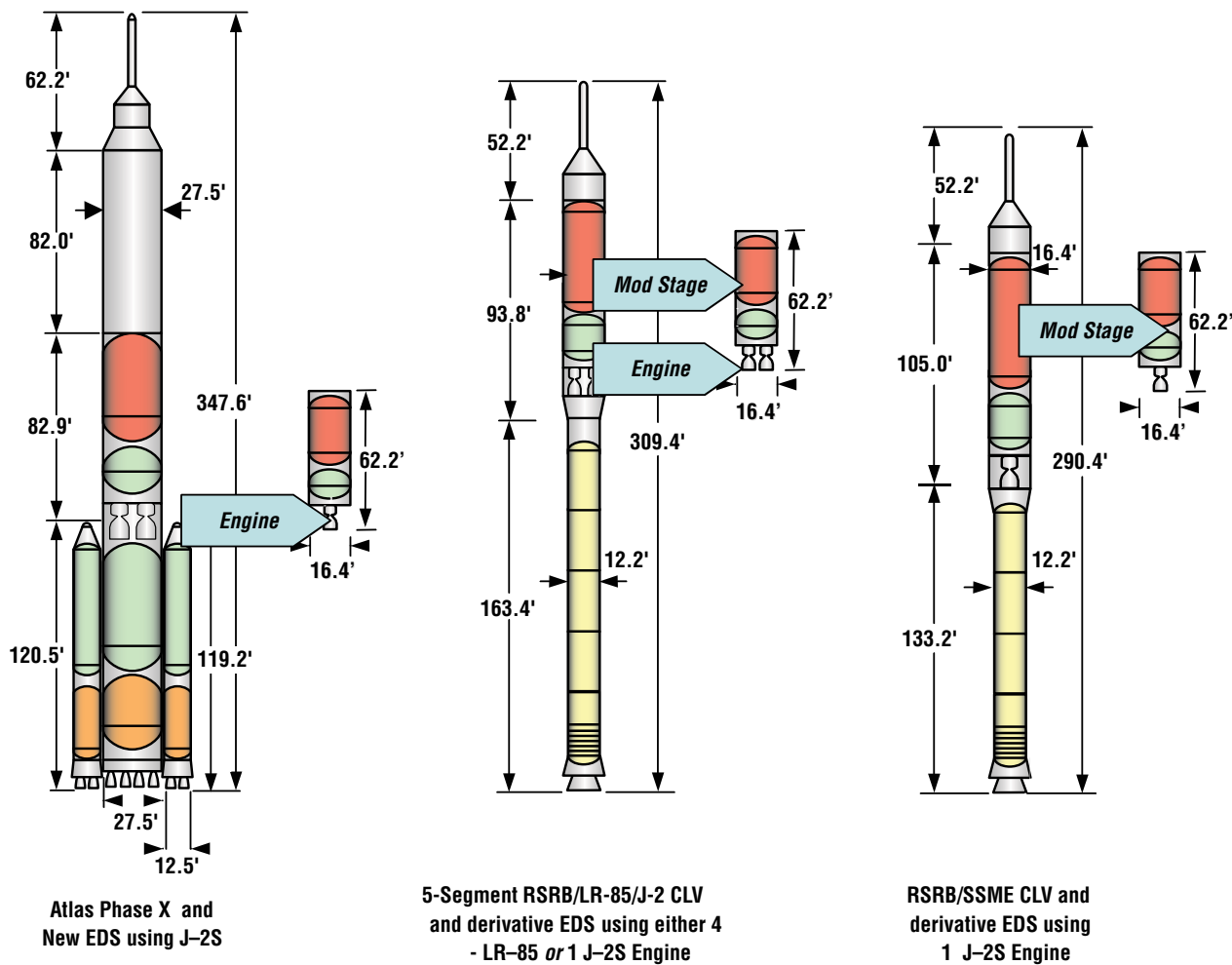

Figure 6-56. LV/EDS Commonality Family Combinations

Table 6-20. EDS Development Cost Comparison Between Clean-sheet and Family Commonality

WBS Element	EDS Development Cost					
	Atlas Phase X EDS Family		5-Segment RSRB/LR-85/J-2 CLV EDS Family		RSRB/SSME CLV EDS Family	
	Clean-sheet DDT&E	Family DEV DDT&E	Clean-sheet DDT&E	Family DEV DDT&E	Clean-sheet DDT&E	Family DEV DDT&E
EDS	2.630	1.598	2.630	1.931	2.630	1.000
EDS Subsystems	0.306	1.624	3.062	2.281	3.062	1.000
Structures and Mechanisms	1.620	1.620	1.620	1.000	1.620	1.000
TCS	1.000	1.000	1.000	1.000	1.000	1.000
MPS	1.000	1.000	1.000	1.000	1.000	1.000
Reaction Control Subsystem	0	0	0	0	0	0
Electrical Power and Distribution	8.823	8.823	8.823	1.000	8.823	1.000
CCDH	3.245	3.245	3.245	1.000	3.245	1.000
GN&C	3.627	3.627	3.627	1.000	3.627	1.000
Software	1.000	1.000	1.000	1.000	1.000	1.000
Range Safety	0	0	0	0	0	0
Liquid Rocket Engine- 1 J-2	6.636	0.307	6.636	6.636	6.636	1.000
EDS System Integration	1.480	1.527	1.480	1.000	1.480	1.000
Integration, Assembly, and Checkout (IA&C)	1.000	0.892	1.000	1.000	1.000	1.000
System Test Operations (STO)	1.000	1.000	1.000	1.000	1.000	1.000
Ground Support Equipment (GSE)	1.000	1.000	1.000	1.000	1.000	1.000
System Engineering and Integration (SE&I)	2.012	2.161	2.012	1.000	2.012	1.000
Program Management	1.689	1.778	1.689	1.000	1.689	1.000
Fee	2.630	1.597	2.630	1.930	2.630	1.000
Program Support	0	0	0	0	0	0
Contingency	0	0	0	0	0	0
Vehicle Level Integration	2.626	1.596	2.626	1.930	2.626	1.000

Table 6-21. Potential EDS Common Elements with a LV Upper Stage

Launch infrastructure
Production and handling infrastructure
Adapters, PLF, and separation system
Avionics
Tank sections (cylinder plugs could enable multiple lengths)
Aft umbilicals for simplified ground operations
Aft thrust structure
Engine mounts and gimbals
Propulsion systems (main engine and feed system)

<p>Avionics Basic avionics could be the same with upgrades for radiation hardening of avionics and power.</p>
<p>Cryogenic Fluid Management Passive cryogenic TPS [Mission Peculiar Kit (MPK) insulation (sun shield, Multi-Layer Insulation (MLI))].</p>
<p>TPS/Structures Micrometeoroid/Orbital Debris (MMOD) and radiation protection. Delta development cost for loads differences. Delta production cost for tank barrel length.</p>
<p>Propulsion (main engine, RCS, pneumatics and feed system) Production may have different number of same engines. May require new Main Propulsion Test Article (MPTA). RCS requirements for Upper Stage and EDS are very different. EDS has commonality with other in-space elements and In-Situ Resource Utilization (ISRU), which could drive propellant selection as well as long duration.</p>

Table 6-22. New EDS Elements Required if Evolved from LV Upper Stage

While examining common elements, some specific questions arose regarding the use of the SSME. First, could the SSME be used on an upper stage with an altitude-start? Second, could the SSME be used on the EDS with a suborbital burn and then restarted on orbit for the TLI burn? Finally, if the EDS evolved from the CLV upper stage that uses an SSME, what MPS changes would be required to replace the SSME with a J-2S?

Several studies have been conducted to address the first question. One study performed in 1993 looked at the Phase 2 version of the SSME and concluded that it was feasible to use the engine in an altitude-start arrangement. The most recent in 2004 looked at the current Block 2 version. The goal of each study was to minimize any required modifications to the current SSME configuration and operation to reduce risk. The development test program for SSME modifications would need to address at least three key operational issues: (1) engine thermal conditioning required for start, (2) engine pre-start purging, and (3) engine start sequence modifications caused by the different environments. **Table 6-23** lists a number of modifications that would be required along with the related specific analysis and testing. In summary, SSME altitude-start for use as an upper stage engine is feasible with reasonable risk.

<p>Modifications Modify augmented spark igniter orifice. Software updates for start sequence modifications (e.g., low main oxidizer valve ramp rate). Additional analysis required to determine operational modifications for LCCs, redlines, purges, chill down, etc.</p>
<p>Interface Requirement Pushback Require propellant settling motors, similar to SII (Saturn 2) and SIVB (Saturn V Third Stage), to ensure quality propellants at engine inlet. Recommended minimum propellant inlet pressures : LH2 36 psi; LOX 40 psi. Higher inlet pressures reduce start risk.</p>
<p>Development and Verification for Low Inlet Conditions During Altitude-Start Analyze Augmented Spark Igniter (ASI) to verify combustion ignition at low pressure (test in small vacuum facility). - Develop and demonstrate transients on NASA Stennis Space Center (SSC) Test Stand A1 with low inlet pressure (relocate existing small volume run tank to low evaluation). - Certify with altitude test. Ensures that issues associated with priming the MCC and nozzle cooling circuit are resolved (i.e., sensitivity of SSME start to fuel side oscillations that could result in high fuel side turbine temperature spikes).</p>

Table 6-23. SSME Modifications to Enable Altitude-start

While it is feasible to use the SSME as an upper stage with altitude-start, it is not recommended at this time to use the SSME with an in-space restart. The SSME is an intricate and sensitive system. After each operation, the engine requires extensive drying using purges to remove any moisture that accumulates from the combustion products of LOX and LH2. Additionally, pre-start thermal conditioning would be a post-operation concern. Time would have to be allowed for the engine to cool down and be reconditioned for a restart. Additional thermal concerns would arise from the in-space radiation heating of the SSME hardware and how it would affect the sensitive start sequence. All of this would require that additional LOX and LH2 be carried on the stage, along with helium and nitrogen for purging. Also, after flight, the engine typically goes through an extensive inspection and verification process to ensure that it is acceptable for another flight. This would not be possible with an in-space restart.

The ESAS team investigated why the SSME was so sensitive to restart when the J-2/J-2S engine was able to perform this function for the Apollo/Saturn vehicle. The SSME is a dual preburner staged combustion cycle engine versus the Gas Generator (GG) or tap-off cycle for the J-2/J-2S engine. Propellant conditioning for the dual preburner cycle is more complicated. Proper propellant conditions are necessary for three separate synergistic ignition systems, while the GG cycle has only two that are independent, and the tap-off cycle has only one. The J-2 series was also designed with a spin assist start system, while the SSME uses a tank head start and “bootstraps” up. (“Bootstrapping” is an engine start procedure whereby there is enough stored energy in the form of pressure to initiate and maintain the engine ignition procedure.) The SSME was also designed with boost pumps to allow for lower tank pressures and, thus, to save vehicle weight. The J-2 series did not require boost pumps. On a complicated synergistic cycle like the SSME, the boost pumps have a significant effect on the start sequence. Although it is not technically impossible to use the SSME in this manner, it is considered to be a very high-risk and costly development effort.

6.7.4 Thrust Level and Number of Engines on the EDS

This last trade study objective was to determine if there is an optimum thrust for a common main engine/propulsion system for crew and/or cargo upper stage and EDS applications for current LV configurations. The key questions addressed for this study included:

- What is the EDS total thrust requirement?
- What is the EDS individual engine thrust requirement?
- What limits, if any, are there on engine cycle?
- What is the benefit, if any, to engine-out?
- How does the optimum EDS engine thrust work on the upper stage options for the various CLVs and CaLVs?

The output consisted of data on the bounding constraints for selecting the number and thrust level for EDS main engines.

The number and size of the EDS main engines depends on LV trajectory parameters, architecture approach, and engine design parameters. The trajectory parameters that affect this trade are the GN&C accuracy requirements and acceleration limits, and the EDS gravity losses that are set by the EDS initial stage T/W ratio. The architecture approach, such as split parallel TLI flights or a single all-up TLI flight, determines the total mass that is pushed at a given time to the Moon. Additionally, the use of the EDS to perform other mission functional requirements, such as LOI, TEI, or lunar orbit plane change maneuvers, also affects the trade results. The engine design parameters include maximum and minimum burn times, throttle requirements, and envelope. Programmatic boundaries, such as commonality with LV upper stages and whether to use existing engines, were also considered.

Figure 6-57 shows the potential LOX/LH2 engines that could be used for either an upper stage or the EDS. Technical descriptions and other information about the key candidates are discussed in Section 6.9, LV Subsystem Descriptions and Risk Assessments.

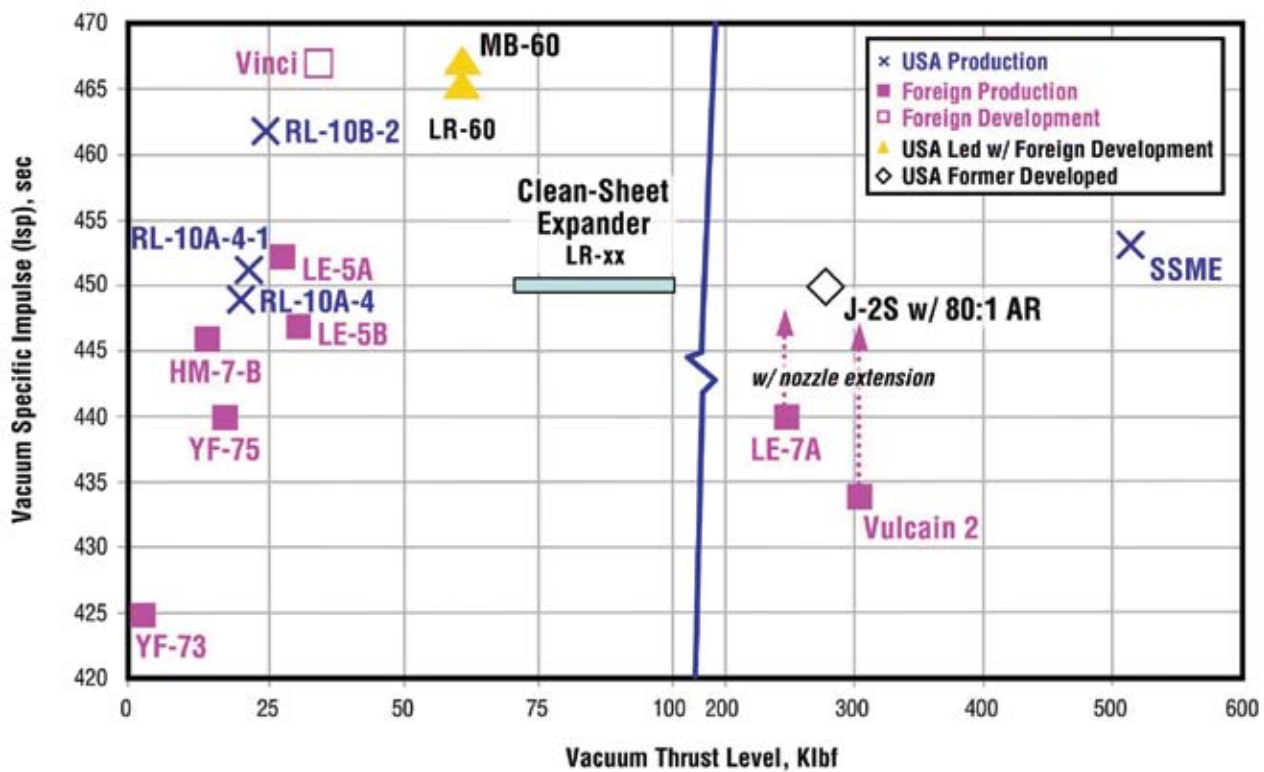

Figure 6-57. Candidate LOX/LH2 Engines for an Upper Stage and Earth Departure Stage Main Engine

From the LV conceptual design trade study, there are nine stage thrust classes. These are shown in **Table 6-24**. The stage thrust can be accomplished by several means. For example, the thrust requirement could be satisfied with a single engine or by multiple engines. For multiple engines, the stage could have engine-out or not. If the various combinations are determined for both the upper stages and the EDS, the data can be compared to determine the most probable desired thrust level. This comparison is shown in **Table 6-25**.

Table 6-24. LV Upper Stage Thrust Requirements

Stage Thrust (lbf)	Number of Engines	Type	Nominal Engine Thrust	Engine Power Level % to Achieve Stage Thrust
24,750	1	RL-10B-2	24,750	100.0
44,600	2	RL-10A-4-2	22,300	100.0
66,900	4	RL10A-4-2	22,300	75.0
240,000	4	LR-60	60,000	100.0
274,500	1	J-2S with 80:1 AR*	274,500	100.0
340,000	4	LR-85	85,000	100.0
400,000	4	LR-100	100,000	100.0
490,847	1	SSME	469,710	104.5
1,098,000	4	J-2S with 80:1 AR*	274,500	100.0

* Modified LE-7A or Vulcain 2 are international alternatives to J-2S.

Table 6-25: Comparison of Upper Stage and EDS Thrust Requirements

Stage Thrust Class, lbf	Engine Combinations	US Engine Thrust Levels, klbf	Split Parallel Flights w/72—180 klbf Thrust							Single TLI Flight Single EDS w/176—440 klbf							
			Number of Engines	1 NEO	4 NEO	4 NEO	3 NEO	3 NEO	2 NEO	2 NEO	1 NEO	4 NEO	4 NEO	3 NEO	3 NEO	2 NEO	2 NEO
			EDS Engine Thrust Levels, klbf	72–180	18–45	24–45	24–60	36–60	72–90	176–440	176–440	44–110	58–110	58–147	88–147	88–220	176–220
24,750	Single Engine NEO	24.8		•	•	•											
44,600	Single Engine NEO	44.6		•	•	•	•			•							
	2 Engines NEO	22.3		•													
66,900	Single Engine NEO	66.9						•		•	•	•					
	4 Engines NEO	16.7															
	4 Engines EO	22.3		•													
	5 Engines EO	16.7															
240,000	Single Engine NEO	240.0							•								
	4 Engines NEO	60.0				•	•	•		•	•	•					
	4 Engines EO	80.0	•					•	•	•	•	•					
	5 Engines EO	60.0				•	•	•		•	•	•					
274,500	Single Engine NEO	274.5							•								
	4 Engines NEO	68.6						•									
	4 Engines EO	91.5	•							•	•	•	•	•			
	5 Engines EO	68.6						•									
340,000	1 Engine NEO	340.0							•								
	4 Engines NEO	85.0	•					•	•	•	•	•					
	4 Engines EO	100.0	•							•	•	•	•	•			
	5 Engines EO	85.0	•					•	•	•	•	•	•				
400,000	Single Engine NEO	400.0							•								
	4 Engines NEO	100.0	•							•	•	•	•	•			
	4 Engines EO	133.3	•								•	•	•	•			
	5 Engines EO	100.0	•							•	•	•	•	•			
490,847	1 Engine NEO	490.8															
	2 Engines NEO	245.4							•								
	4 Engines EO	163.6												•			
	5 Engines EO	122.7	•									•	•	•			
1,098,000	4 Engines NEO	274.5							•								
	5 Engines EO	274.5							•								

Upper Stage Engine-Out accomplished by operating all engines throttled until one shuts down.

Upper Stage Engine-Out calculated by Stage thrust/(number of engines-1)

EDS Engine-Out accomplished by operating all engines at full thrust and accepting the lower thrust.

EDS Engine-Out calculated by minimum thrust for maximum engine burn of 600 sec.

The bounding trajectory parameter values that affect thrust were defined during the study. The upper limit on vehicle stage thrust is dictated by the GN&C accuracy requirement and any maximum acceleration load limits. The GN&C accuracy requirement sets the minimum engine burn time for each main propulsion burn maneuver at approximately 200 sec. The lower limit on vehicle stage thrust is dictated by the need to minimize the gravity losses. Increased gravity losses mean the need for additional propellant, and, thus, growth of the vehicle mass. **Figure 6-58** shows the delta-V loss as a function of stage initial T/W ratio. From this curve, the recommended lower limit on T/W ratio is 0.4. This value can then be multiplied to the total EDS plus payload mass to calculate the lower thrust limit for the EDS.

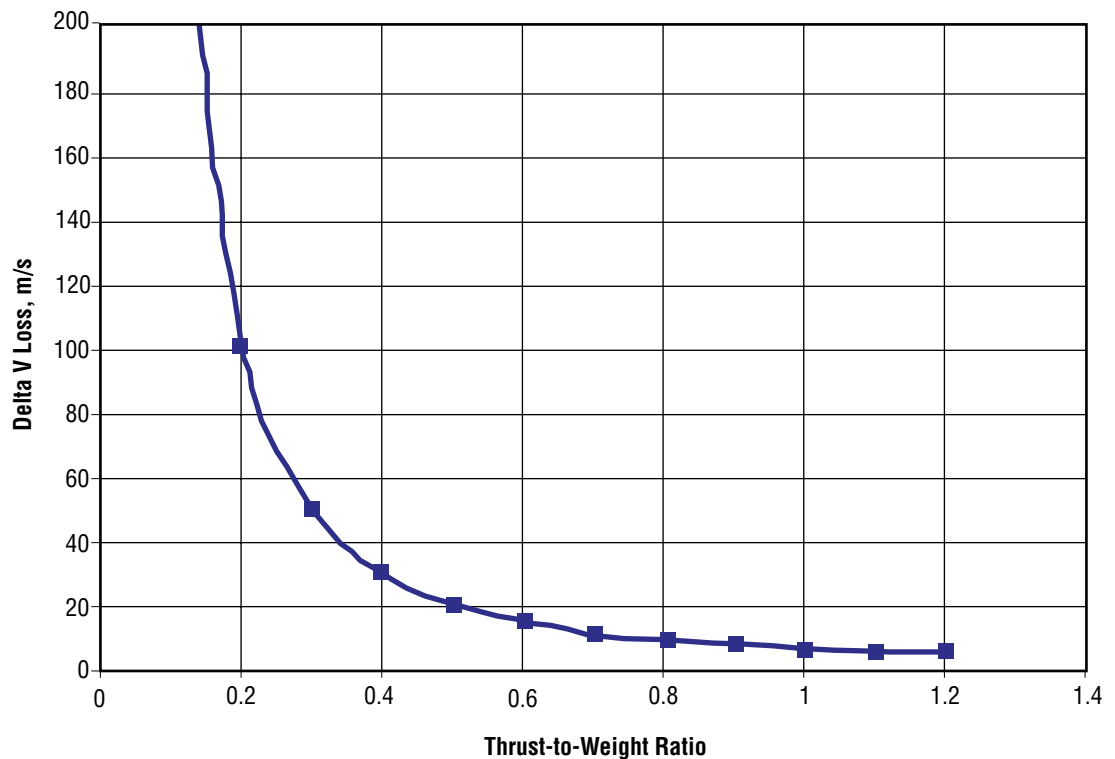

Figure 6-58. Gravity Losses for an EDS Single Burn from 400-km Circular LEO to TLI

The engine design parameters were set for the study based on historical experience. The maximum burn time has historically been approximately 600 sec. From a practical basis, the minimum burn time is set by the engine startup and shutdown sequences and this is generally approximately 5 sec. The engine throttle limit for pump-fed systems has been approximately 20 percent of full power, but this has only been demonstrated on a technology demonstration unit. The operational experience is with the SSME at 65 percent Rated Power Level (RPL). The 65 percent RPL value is actually 59 percent of the full power level of the SSME, which is 109 percent RPL.

When all these defining boundaries are taken into account, the stage and individual engine thrust levels can be set. **Figure 6-59** again shows the delta-V losses plotted against the stage T/W ratio, but with the addition of the defining limits. **Figure 6-59** also has the delta-V curves for the separate functional burns plotted instead of as one composite as in **Figure 6-58**. Combining the information of **Table 6-25** and **Figure 6-59** yields the information in **Figure 6-60**, which shows the various engine solutions for the range of EDSs being considered. An important observation from **Figure 6-60** led to a decision late in the study to have only the EDS perform the TLI burn. There was not a stage thrust level or individual engine combination that would allow the EDS to perform the LOI and plane change maneuvers without violating at least one of the bounding limits.

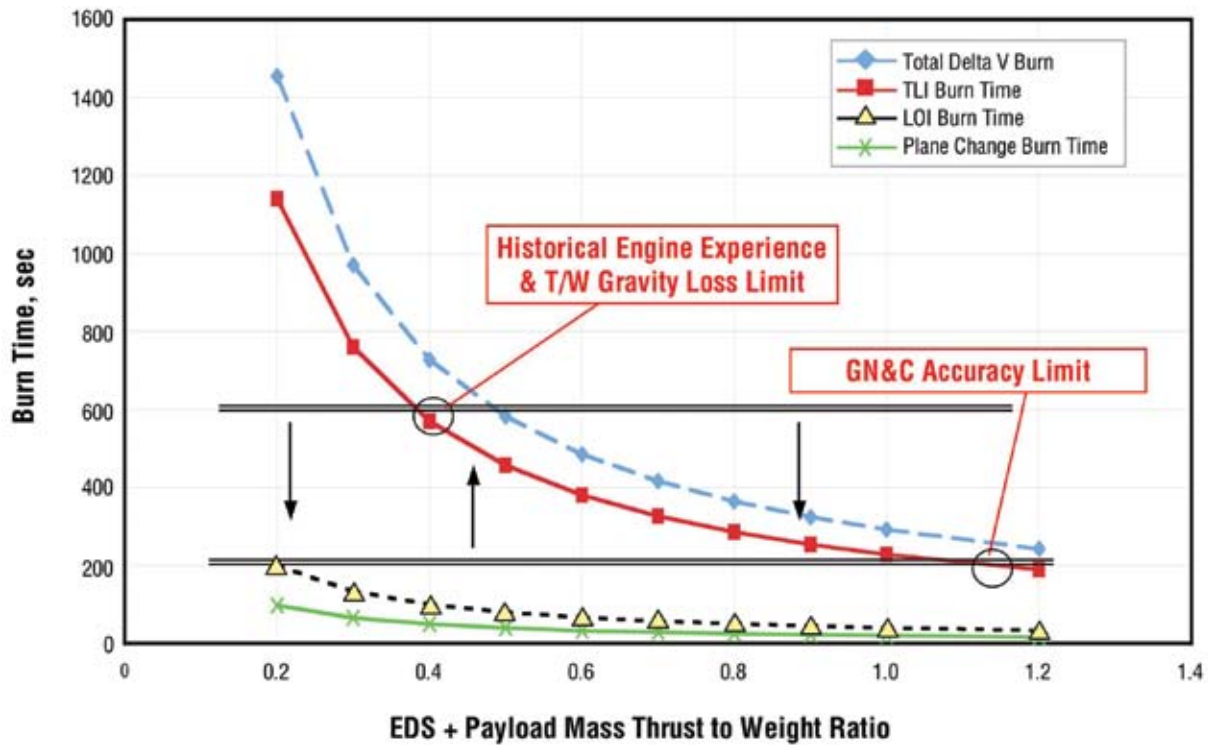

Figure 6-59. Bounding Limits on EDS Thrust and Engine Thrust

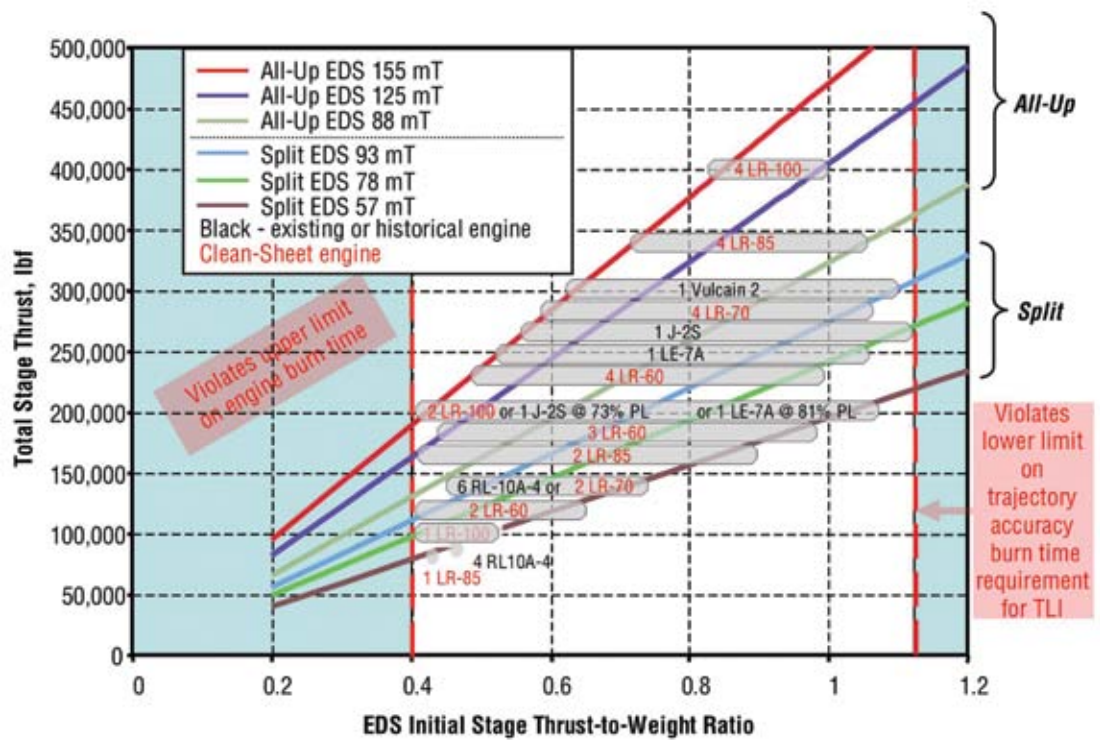
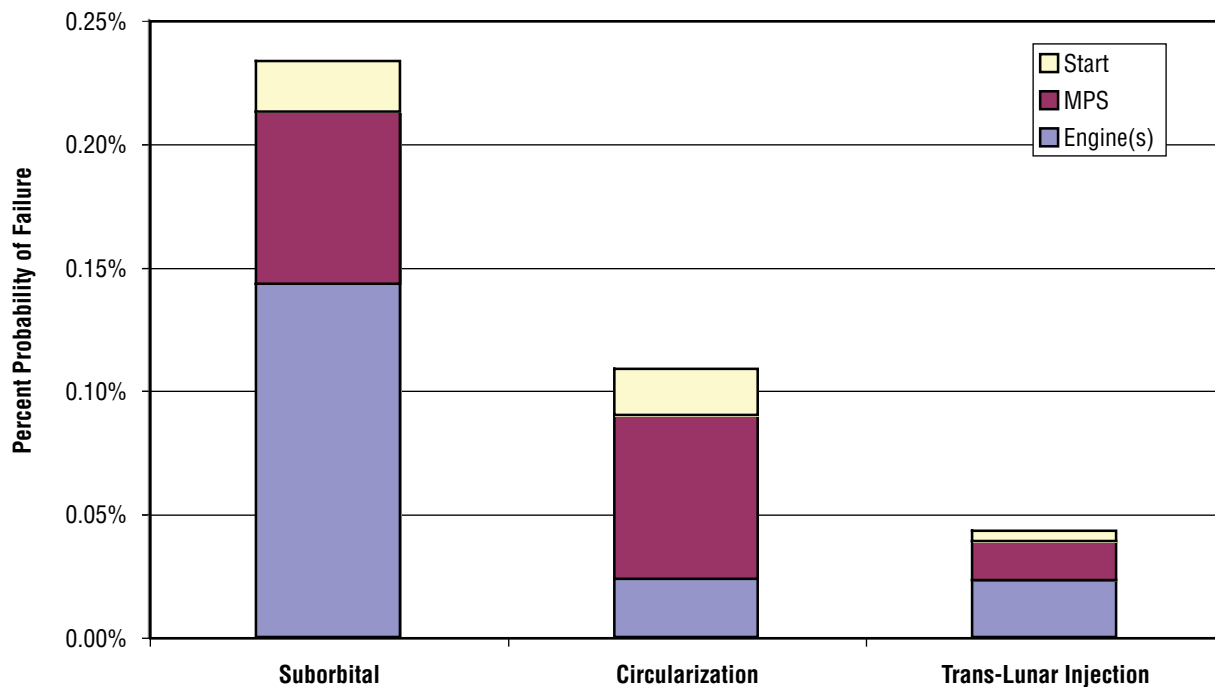

Figure 6-60. EDS Thrust Values

Note: All Up EDS delivers 58 mT payload
Split EDS delivers 31 mT payload

6.7.5 EDS Reliability Model

Appendix 6D, Safety and Reliability, outlines a stage reliability model that was developed to support the ESAS activity. The reliability model was applied to the 1.5-launch configuration described previously. Figure 6-61 shows the results of the model runs for the three engine burns required for the 1.5-launch configuration EDS. The results are broken out to indicate the contribution from MPS, engine start failures, and engine main-stage failures. The first two burns are the suborbital and circularization burns and do not have engine-out capability. Burn number 3 shows the best reliability due to engine-out capability for the TLI burn.



6.7.6 Results Summary

The final results from the EDS thrust and number of engine trade study are summarized in this section. A number of solutions work for both all-up and split missions. The all-up-mission EDS could use modified existing engines or designs (J-2S+, LE-7A, Vulcain 2) or multiple clean-sheet expander cycle engines (70- to 100-klbf of thrust). The split-mission EDS could again use modified existing engines or designs (RL-10A-4, 73-percent J-2S+, 81-percent LE-7A) or multiple clean-sheet expander cycle engines (70- to 100-klbf of thrust). If the EDS performs a suborbital burn, then maximum thrust would be set by this requirement, not the in-space TLI burn. Additionally, an assessment of potential engine-out benefits may set the number and thrust of engines. Finally, as mentioned previously, there is no solution that can satisfy GN&C minimum burn time for LOI and lunar plane change delta-V maneuvers with a single-engine propulsion for TLI. T/W values less than 0.2 (initial EDS + payload T/W) would be required. The required thrust ranges from 27 klbf for split missions to 67 klbf for all-up missions. If the GN&C accuracy is compromised and the minimum burn time dropped to the 100s, then the required thrust range becomes 53 to 133 klbf.

There are two possible solutions. Use multiple engines on the EDS (at least four) and only burn one of them for LOI and plane change; or the preferred approach of changing the delta V split between elements and using the CEV/LSAM propulsion for LOI and plane change burns.

Figure 6-61. 1.5-Launch Configuration EDS Reliability Results

6.8 LV Reliability and Safety Analysis

Reliability and safety analyses were performed on all of the LV propulsion components. These components consist of RSRBs, liquid propellant rocket engine systems, the MPS, the ET, APUs, separation systems, and the payload shroud. Each component is discussed in the following sections, along with some additional RSRB safety considerations.

6.8.1 Reusable Solid Rocket Boosters

6.8.1.1 Overview

The similarity model (FIRST) analysis uses the data from the Space Shuttle Quantitative Risk Assessment System (QRAS) 2000 failure estimates for the Space Shuttle four-segment RSRB pair using PBAN propellant. The QRAS model is composed of separate estimates for the RSRM and the SRB failures, and the ESAS (FIRST) model maintains this separation in the similarity analyses for the RSRBs in the study. The model allows users to select the propellant (PBAN or HTPB), the number of segments in a RSRM, and the number of RSRBs on the vehicle; then it provides a probability of failure per mission for the selection. ESAS examined vehicles using a single four-segment RSRB or a pair of five-segment RSRBs. Several corrections and assumptions were made to the QRAS RSRB for the ESAS vehicle models to account for the varying number of segments in the RSRM, the different propellants, the use of a single SRB (with grossly different impacts from a start failure than that for a Shuttle-like design), and modifications necessary for an in-line separation. The methodologies for determining the reliability of the SRBs used in the study are detailed in the following sections.

6.8.1.2 Similarity Analyses

QRAS failure probabilities of every component for a pair of RSRMs and SRBs were halved to represent a single RSRB. The single- and dual-RSRM/SRB component reliability estimates from QRAS are provided in **Appendix 6D, Safety and Reliability**. ESAS used failure probabilities of all RSRB components “as is,” with the exceptions described below.

6.8.1.2.1 Five-Segment RSRB

To account for the addition of an RSRM center segment for the five-segment RSRM, the QRAS probability of failure calculations are augmented with the addition of risks associated with an additional case field joint and case factory joint for the extra center segment, and scaling other failure values proportionally for the difference in propellant quantities, motor length, and exposed areas. Additionally, the use of the new propellant HTPB was included in RSRM modeling for the five-segment RSRB. Discussions with ATK Thiokol led to a preliminary conclusion that HTPB is considered intrinsically more reliable than the nominal PBAN propellant because its strain capability is 30 to 50 percent greater. This increased capability is due primarily to its smaller modulus of elasticity (2,000 psi versus 3,300 psi). Given the consensus that HTPB provides superior reliability and that researched material properties are consistent with this conclusion, the ESAS model (FIRST) quantifies improvements in safety resulting from HTPB with a 50 percent risk reduction to the QRAS failure mode “Propellant Energy” for the five-segment RSRM with HTPB propellant.

6.8.1.2.2 Single RSRB

The primary differences in RSRB-related failures on a vehicle with a single RSRB compared to the use of side-mount pairs on the Shuttle design are due to startup and separation.

For the two side-mount RSRBs on the Shuttle, any single RSRM startup failure would result in the catastrophic loss of the entire Space Shuttle vehicle stack due to the unbalanced thrust. For vehicles in this study with a single SRB, such as the in-line configuration, an RSRM startup failure would be merely a hold-down event. To account for this, the ESAS model (FIRST) removes the QRAS RSRM failure contributor “Igniter and Main Propellant Ignition” for a single RSRB in-line design.

Because the separation modes and mechanisms for a single RSRB in-line design are significantly different than for side-mount RSRBs, the portion of the QRAS RSRB estimate dealing with Shuttle RSRB separation is removed and applied independently to the modeling of separation systems. The QRAS SRB failure designations removed are “Separation System” and “Booster Separation Motor (BSM).”

6.8.1.3 RSRB Failure Probabilities

Table 6-26 represents the combined risk of the SRB and RSRM to form the RSRB risk values along with start probabilities and Error Factors (EFs). Note that the catastrophic rates do not contain the separation risk for the SRB, because the ESAS model calculates it outside the RSRB model, nor does it contain the startup risk (listed separately). The ESAS model accepts the EFs accompanying the original QRAS data but applies a higher EF for the newer propellant HTPB in the model.

EF is an abbreviated presentation of the uncertainty in a probabilistic distribution. Defined as the ratio of the 95th percentile to the 50th, EFs may be generated from historical data for components, or, in the case of components with inadequate historical data, EF may be estimated using similarity analyses and engineering judgment. In this case, a higher EF was assumed because less is known about the HTPB propellant and no test data was available.

Booster Type	P_{ICF}	P_{BEN}	P	CFF	EF
RSRB (4-Segment PBAN)	2.72E-04	N/A	1.28E-05	N/A	1.8
RSRB (5-Segment PBAN)	2.76E-04	N/A	1.28E-05	N/A	1.8
RSRB (4-Segment HTPB)	2.71E-04	N/A	1.28E-05	N/A	2.0
RSRB (5-Segment HTPB)	2.74E-04	N/A	1.28E-05	N/A	2.0

Table 6-26. RSRB Multi-Segment Risks for Two Propellants

Figure 6-62 shows how the model alters the RSRB QRAS data. Note that the various separation models are included in the flow and in the overall number.

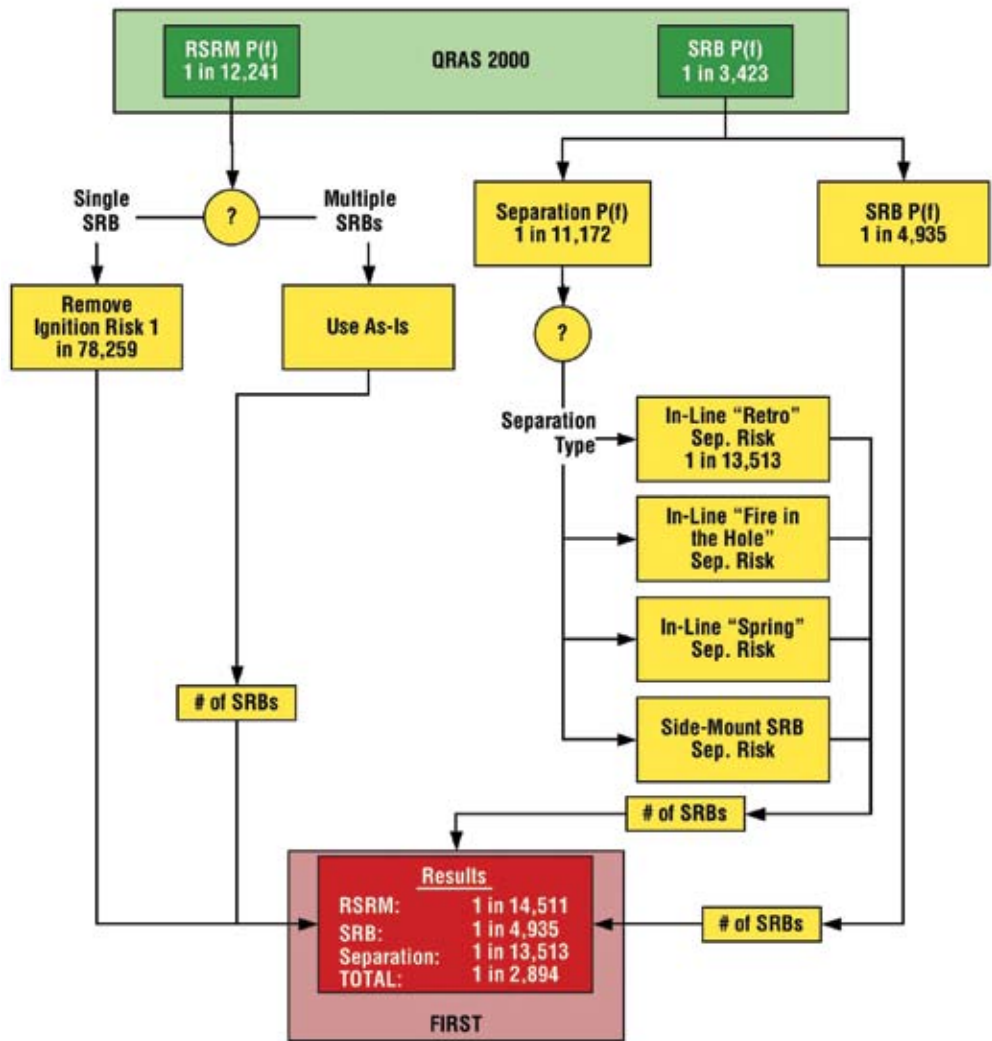

Figure 6-62. RSRB Risk Development from QRAS Results

6.8.2 Liquid Propellant Rocket Engine Systems

6.8.2.1 Overview

This safety and reliability summary delineates the trades and analyses that the ESAS team conducted. Benign and catastrophic failure probabilities and catastrophic failure fractions were generated as metrics in the analyses.

Relevant terms used in the study include:

- System Safety Analysis: The application of management and engineering principles, methods, models, and processes to optimize the safety (prevention of death and injury to personnel and protection of valuable assets) throughout the life cycle of the system.
- Reliability: Probability that an item will perform a required function under stated conditions for a stated period of time.
- Safety: The elimination of hazardous conditions that could cause death, injury, or damage to people or valuable property.

- Risk: The likelihood that an undesirable event will occur combined with the magnitude of its consequences.
- Catastrophic Failure: An immediate uncontained failure that leads to energetic disassembly of the engine and vehicle.
- Benign Failure: A failure that does not directly lead to loss of engine or vehicle, but may lead to an abort situation.
- Catastrophic Failure Fraction (CFF): The ratio of the catastrophic failure rate to the total probability of benign and catastrophic failures ($CFF = \text{Catastrophic} / [\text{Benign} + \text{Catastrophic}]$), reported as a fraction.

Propulsion systems and their components are heavy contributors to the unreliability of an LV. **Figure 6-63** shows element results from the Shuttle QRAS PRA, and **Figure 6-64** reflects component contributions to unreliability from SSME. It is notable, due to the nature of the QRAS PRA, that benign engine failures were not included in the analysis. Inclusion of benign failures would significantly increase the predominance of propulsion systems in unreliability predictions for the STS.

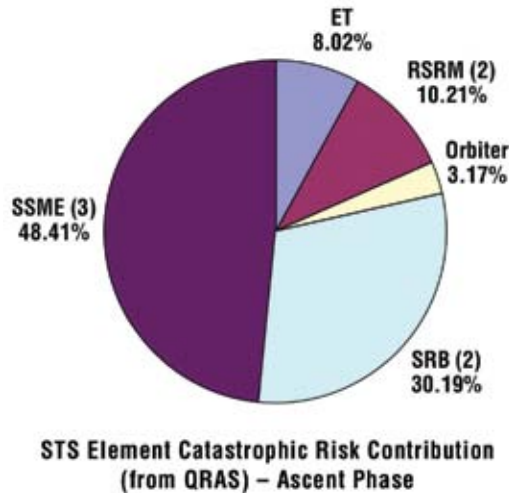

Figure 6-63. STS QRAS PRA Element Contributions

The analysis process involved a bottom-up review of the candidate engines, compared against SSME, which served as the baseline. SSME reliability is reflected by the QRAS data—a PRA conducted on all components of the engine down to part and failure mode level. The QRAS data applies to catastrophic failures and is a mix of very detailed probabilistic models and of top-level failure indicators (e.g., unsatisfactory condition reports). It is the most detailed failure assessment of any rocket engine in the world and reflects analysis and demonstrated data from approximately 20 years of Shuttle flights and approximately 30 years of propulsion system test and operations.

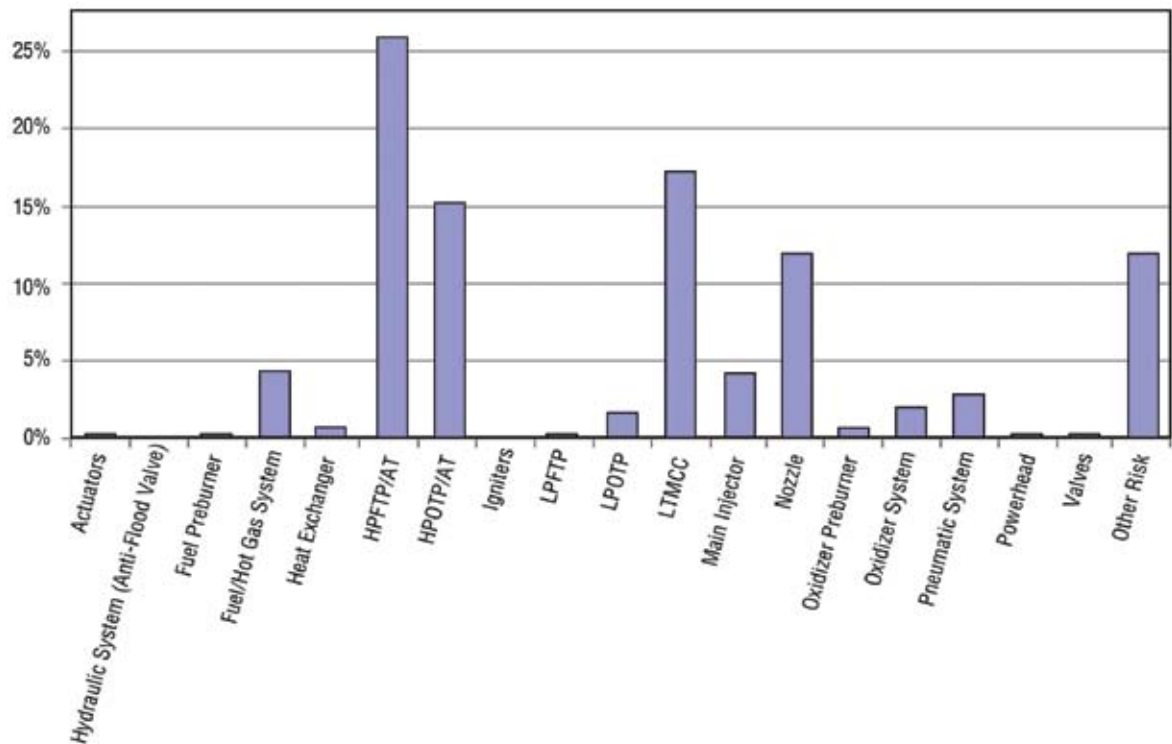

Figure 6-64.
Component
Contributions from
SSME

Figure 6-65 describes the process the ESAS team used. The team reviewed all available data on the candidate engines, including configuration, background, Failure Modes and Effects Analyses (FMEAs), critical items lists, reliability predictions, and collected risk items (i.e., known problems, lack of data issues, human-rating issues) to support a bottom-up assessment. Again, the SSME PRA established the baseline for comparison. All candidate engines were compared, component-by-component, by component experts against this baseline. The SSME PRA failure probabilities were adjusted through expert opinion into metrics for catastrophic failure probability, benign failure probability, and CFF. The failure probabilities were modified with the guidance of expert opinion to reflect the design and environment of the candidate engine hardware. The probabilities were modified at the lowest possible level, where more detail was available and the judgment more direct. While quantified failure probability metrics were calculated, relative rankings of the candidate engines against SSME were the real result, given that the probabilities were modified by comparison and based on expert opinion. With an analysis of this type, it is easy to bias against the baseline, in this case, the SSME. It is easier to remove risk from the baseline in cases where no comparable component exists (e.g., no low-pressure pump) than it is to add in an accurate amount of risk for a new component.

The failure probabilities generated by the expert comparative assessment were considered to be mature estimates because the SSME reliability results from more than 1 million seconds of engine testing. New design or restart engines, such as the LR-85 or J-2S, cannot be considered mature. Historically, engines demonstrate significant reliability growth after first flight. Thus, the candidate engine failure probabilities were adjusted based on the SSME reliability growth experience. Using this approach, all the newer engines had their probabilities adjusted based on SSME growth. Also, all new engines were given credit for being ready for first flight; it was assumed they had achieved 100,000 sec of test time, roughly the SSME experience.

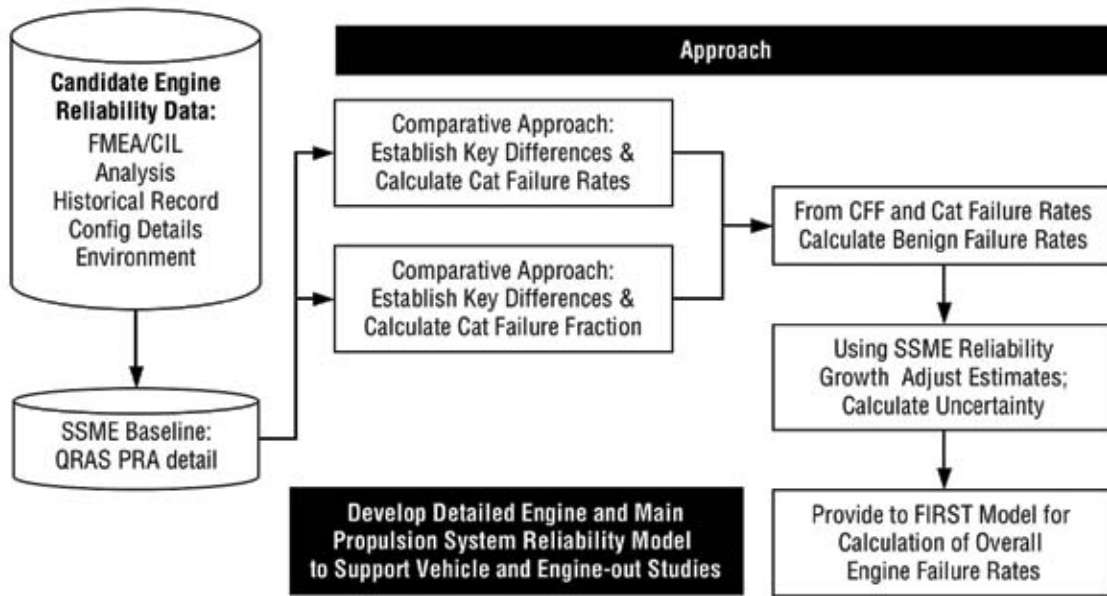

Figure 6-65.
Reliability Assessment
Methodology

These failure probabilities were used in the LV similarity model (FIRST). In this model, failure rates are derived and run in a time-based simulation. Algorithms accounting for thrust and size are also in the model.

Finally, the team also developed an engine and MPS reliability model and exercised it in support of vehicle and engine-out studies. MPS (valves, feedlines, etc.) reliability is a significant contributor to overall vehicle reliability and must be considered in any vehicle studies.

6.8.2.2 LV Liquid Rocket Engine Systems Methodology (FIRST)

For liquid rocket engines, three types of MPS failure modes are modeled in FIRST: (1) ICF, (2) DCF, and (3) BGN. The models used in FIRST for each of these is described in **Appendix 6.D, Safety and Reliability**, along with sections explaining the contributors to catastrophic vehicle failures. These sources include MPS failure through five root causes: (1) catastrophic failure of an engine, (2) loss of engine thrust, (3) loss of TVC in more than one-third of the total number of engines, (4) loss of stable propellant feed, and (5) engine altitude-start failure (for series-burn vehicles). The general vehicle level mean probability of failure due to MPS failure is computed by aggregating the element level failure probabilities together.

6.8.2.3 Comparative Analysis Results

Candidate engines for this phase of comparison included the RL-10, LR-60, LR-85, and LR-100 (all expander cycles), the J-2S (tap-off cycle), the RD-180 (single OX-rich preburner, staged combustion cycle), and the RS-68 (GG cycle). The baseline for comparison, the SSME, is a dual fuel-rich preburner, staged combustion cycle. **Figures 6-66 and 6-67** reflect the theoretical reliability benefits for the different cycles. For example, in **Figure 6-66**, LOX-rich combustion provides for more energy being released at the same temperature than in a fuel-rich preburner, thus there is a reliability benefit to the LOX-rich combustion if it can be accomplished at a lower temperature and still meet performance needs. This kind of information reflects overall cycle benefits independent of design specifics and provides for a sanity check on the relative rankings of the analysis.

	Dual Preburner Staged Combustion (Fuel-Rich)	Single Preburner Staged Combustion (LOX-Rich)	Gas Generator (Fuel-Rich)
Cycle Description	2 preburners – turbine drive gases stay in system	1 LOX-rich preburner; in LOX-rich, more energy released at same temp	1 gas generator; turbine gases dumped overboard
Complexity	Most complex – highest performance – capable of very high combustion temps	Complex – can lead to lower temps in engine	Less complex than staged combustion; lower performance
Environment	Highest temps and pressures; high pump speeds	Lower temps throughout engine due to LOX-rich combustion; LOX-rich issues	Lower temps and pressures than staged combustion
FMs, Effects & CFF	Many high critically FMs and catastrophic effects; highest ratio cat/benign	LOX-rich concerns with materials and combustion	Cycle more benign than staged combustion

Figure 6-66. Benefits of Boost Engine Cycles

Reliability Improvement Due to Cycle 

	Dual Preburner Staged Combustion (Fuel-Rich)	Tap-Off Cycle	Expander Cycle
Cycle Description	2 preburners - turbine drive gases stay in system	No GG or preburner, turbine drive gases tapped off of chamber	No GG or preburner, turbine drive gases collected from regen chamber and nozzle
Complexity	Most complex - highest performance - capable of very high combustion temps; concerns with air-start	Higher performing than expander - higher turbine drive temps	Simplest - lowest performance; propellant not wasted; tolerant to throttling; chamber pressure restricted
Environment	Highest temps and pressures; high pump speeds	Similar to expander but high temps tapped off chamber	Lower temps and pressures; lower concern with combustion stability
FMs, Effects & CFF	Many high critically FMs and catastrophic effects; highest ratio cat/benign	Similar to expander but high temps in hot gas system for turbine drive	Heat absorption is through benign process - few critical FMs and effects

Figure 6-67. Benefits of Upper Stage Engine Cycles

Reliability Improvement Due to Cycle 

Results of the comparative analysis are provided in **Appendix 6G, Candidate Vehicle Subsystems**, for the different engine candidates. Again, all assessments were made against the SSME. An example of supporting QRAS data for the comparison is presented in **Table 6-27**. The comparative results include the SSME risk by component and the engine rationale for changing the risk as derived by expert opinion. An example of the supporting data for this process is provided in **Table 6-27**, which reflects the level of detail available for the comparison from QRAS. Piece part failure mode and mechanism data were available to identify true risk concerns in each component. For example, turbine end vane failure due to thermal concerns causing Low Cycle Fatigue (LCF) and fracture contribute approximately 10 percent of the risk in the current High-Pressure Fuel Turbopump (HPFTP). Such information was used by the experts in comparing differences across engines. Data at this lowest level made for better comparisons and supported this bottom-up comparative analysis approach.

The percentages of risk reduction or increase were rolled up into an overall catastrophic reliability probability. The CFF was also generated from the expert comparative approach and presented in **Table 6-27**.

Table 6-29. SSME Failure Modes and Causes

Component	Component Contribution %	Failure Modes % Contribution	Description
Failure Modes			
Causes			
HPFTP/Alternate Turbopump (AT)	24.7725%		Could cause a turbine disk assembly failure, generating over-speed, burst, and case penetration leading to fire and explosion.
Turbine Disk Assembly Failure		14.39%	
Design (LCF/fracture due to vibration, thermal growth, material/manufacturing defect, overspeed, rub, loss of cooling)			
Second-stage Turbine Vane Failure		10.46%	Thermal gradients/stresses may induce cracks in the second stage vanes. Dynamic loading from preburner gas flow can aggravate cracks to the point of vane rupture. Vane rupture will release mass into the flow path and result in impacts with turbine blades. The loss of blades due to impact from vane material does not imply Loss of Vehicle (LOV)/LOC.
Design (LCF/fracture due to thermal gradient/stress)			
Second-stage Turbine Blade Failure		10.10%	Cracking of the blade due to material defects in conjunction with loading caused by thermal transients or other loads can lead to liberation of blade material. The liberated material could impact other blades, causing those blades to fracture, resulting in high temperatures due to a LOX-rich environment. This could lead to LOV; however, the HPFTP/AT has demonstrated the capability of surviving such a scenario with a benign shutdown.
Design (LCF/fracture due to material defects/loading)			
Interstage Seal (1–2 Damper) Failure		9.21%	The interstage seals function to control leakage of propellants between pump stages and to dampen vibrations in the rotating machines. The interstage seals function to control leakage of propellants between pump stages and to dampen vibrations in the rotating machinery. Clearance anomalies can result in reduced pump speed and/or high vibrations.
Design (LCF/fracture due to clearance anomaly)			
First-stage Turbine Vane Failure		8.91%	Thermal gradients/stresses may induce cracks in the first-stage vanes. Dynamic loading from preburner gas flow can aggravate cracks to the point of vane rupture. Vane rupture will release mass into the flow path and result in impacts with turbine blades. The loss of blades due to impact from vane material does not imply LOV/LOC.
Design (LCF/fracture due to thermal gradient/stress)			
First-stage Turbine Blade Failure		8.61%	Cracking of the blade due to material defects in conjunction with loading caused by thermal transients or other loads can lead to liberation of blade material. The liberated material could impact other blades, causing those blades to fracture, resulting in high temperatures due to a LOX-rich environment. This could lead to loss of vehicle; however, the HPFTP/AT has demonstrated the capability of surviving such a scenario with a benign shutdown.
Design (LCF/fracture due to material defects and loading/thermal transients)			
First Blade Outer Gas Seal (BOGS) Hook Failure		5.07%	Cracking of the first BOGS hook caused by thermal transients or other loads can lead to the BOGS dropping into the blade path, causing blade failure. The impact to the blades can result in high temperatures due to a LOX-rich environment. This could lead to LOV; however, the HPFTP/AT has demonstrated the capability of surviving such a scenario with a benign shutdown.
Design (LCF/fracture due to thermal transient/vibratory stress)			
Pump Discharge Housing Failure		4.59%	The primary concern of a pump discharge housing structural failure is loss of hydrogen flow and an external fire due to hydrogen leakage. The HPFTP/AT design eliminates many of the concerns of housing failures by eliminating many of the welds of the previous HPFTP that may precipitate potential structural failures.
Design (LCF/fracture due to stresses)			

From the catastrophic failure probability and the CFF, the benign reliability probability was derived. These catastrophic failure probabilities (by engine) and the CFF results are summarized in **Figures 6-68** and **6-69**. All comparisons were made using information on engines as currently available.

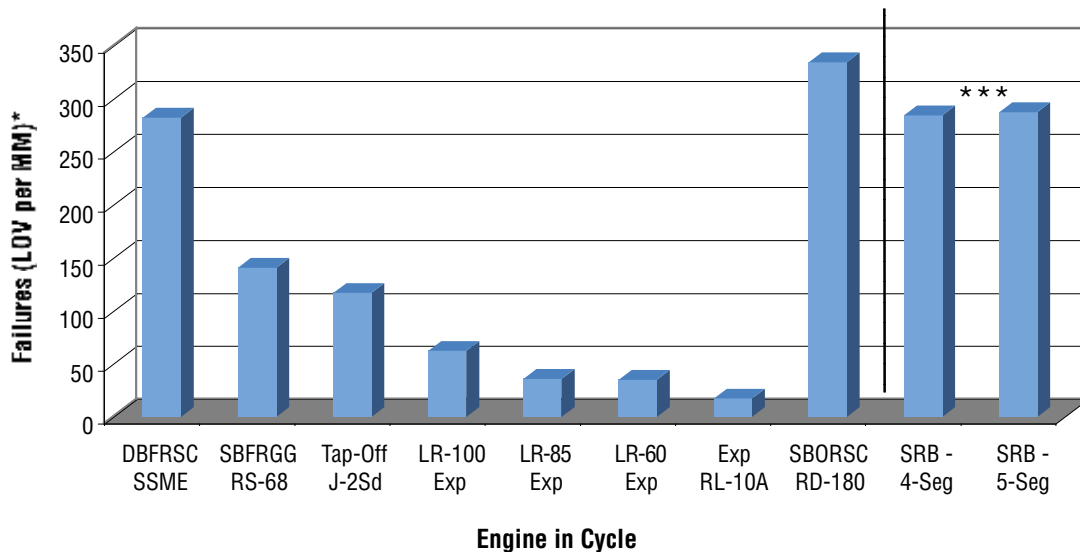

Figure 6-68. Engine Catastrophic MTBFs

* From FIRST Model with MSFC input; component lack of data issues with RD-180
 ** SSME-based – Assumes SSME-like red-line system.
 *** SRB assessment from FIRST model

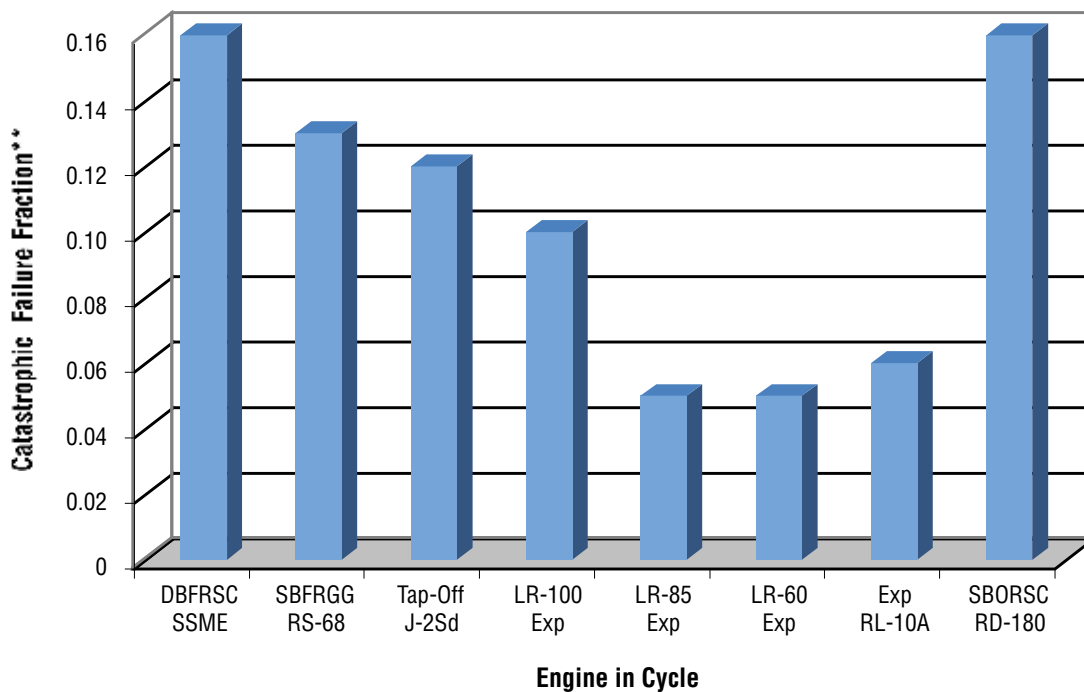

Figure 6-69. Engine Catastrophic Failure Fractions

* From FIRST Model with MSFC input; component lack of data issues with RD-180.
 ** SSME-based - Assumes SSME-like redline system
 ***SRB assessment from FIRST model.

The results in **Figure 6-68** reflect FIRST model output with MSFC-generated engine input. There was a concern about a lack of data (i.e., no FMEA, lack of certain component data) on the RD-180. In such a case, the risk on the comparable SSME component went unchanged. Also, the SSME PRA data included a redline system that supported engine cutoff under certain conditions. This means that the other comparative engine reliability data implicitly includes a similar redline system. In **Figure 6-68** the SRB reliability is included only for comparison purposes. This also reflects results from the FIRST model. In actuality, the SRB includes much more than an engine. The SRB has the MPS equivalent of a liquid propulsion system, as well as structure, TVC, and recovery systems.

6.8.2.4 Reliability Growth Modeling

After considering the similarity analyses performed by comparing a fully developed SSME to other engines, there was still the problem of dealing with the relative maturity of the engines. This problem was overcome by applying a reliability growth model to the engine values. Because everything was compared to a fully mature SSME, the resulting values for the other engines based on the similarity analysis were also “mature” values. However, because most of these engines were far from being mature, the “true” value for these immature engines was found by “backing out” the mature values using the SSME reliability growth curve. A detailed discussion of the reliability growth modeling and associated uncertainty is contained in **Appendix 6D, Safety and Reliability**.

Baseline comparative results were presented in **Figures 6-68** and **6-69**. The top image within **Figure 6-70** presents the associated reliability growth curves of SSME, F-1, and RS-68. The adjustments to the baseline numbers associated with the reliability growth of the SSME are presented in **Figure 6-71**. The SSME demonstrates a typical growth curve—steep at the beginning and flatter as the curve goes over the “knee.” This reflects fewer failures during the same amount of testing over time and demonstrates the engine reliability improvement as testing reduces failures and test/fail/fix cycles correct problems. The bottom image of **Figure 6-70** reflects the starting point for the reliability estimates of the candidate engines. All engines were given credit for having roughly 100,000 sec of test time at first flight. Additional test time was added as appropriate. Various versions of the RL-10 have more than 2 million sec of test time, and, thus, this engine is considered very mature.

Comparisons of RS-68, SSME and F-1 Programs

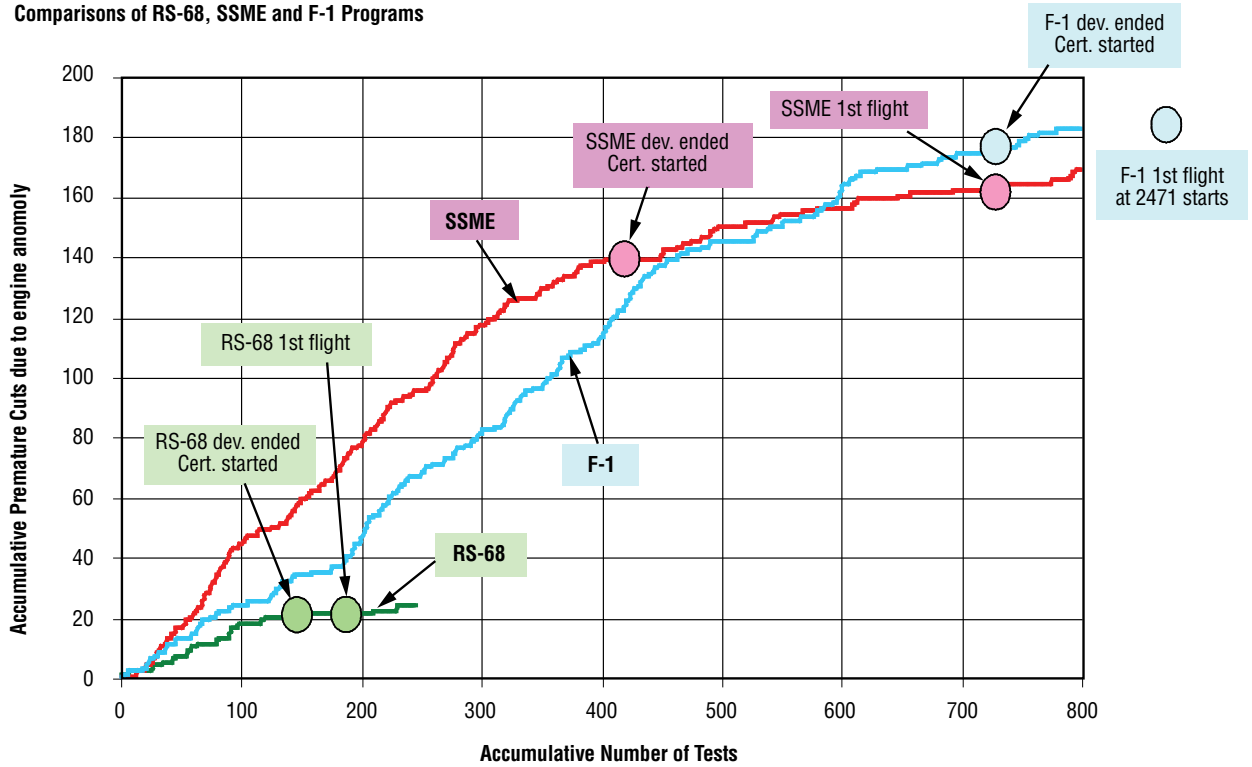

SSME Growth Curve

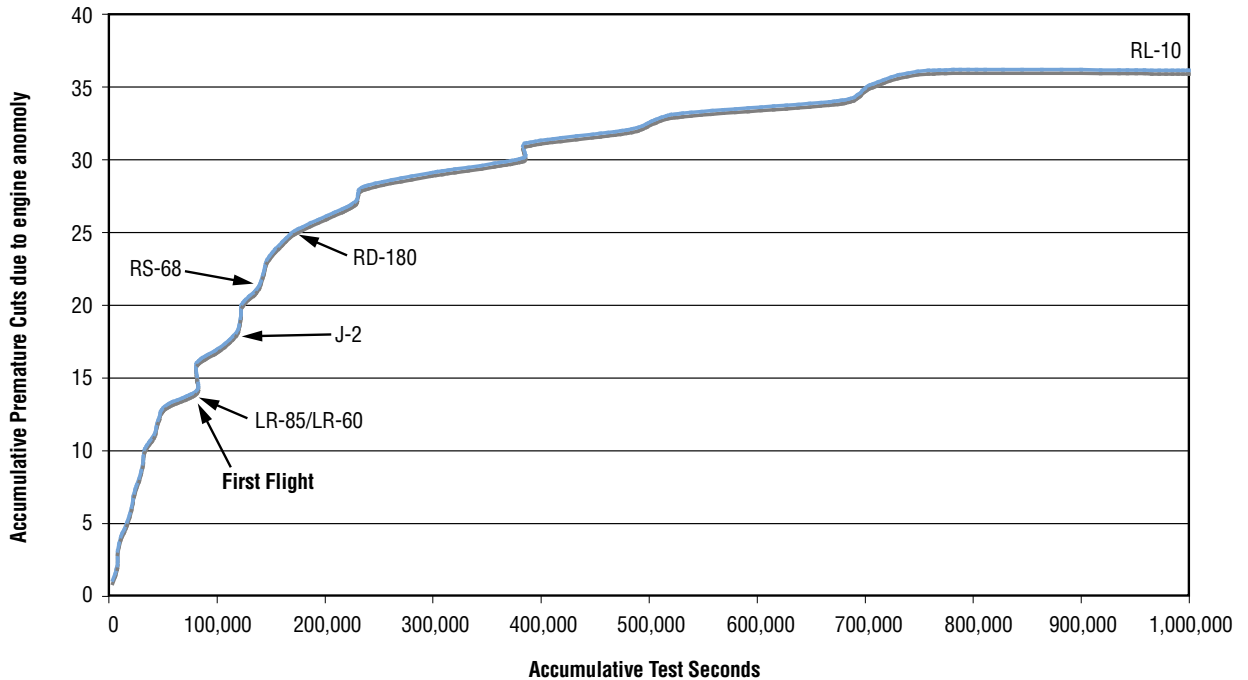

*All new/restart engines at first flight equivalent of 100k + test time.

Figure 6-70. Engine Reliability Growth Curves and Cumulative Failures by Test Seconds and Number of Tests

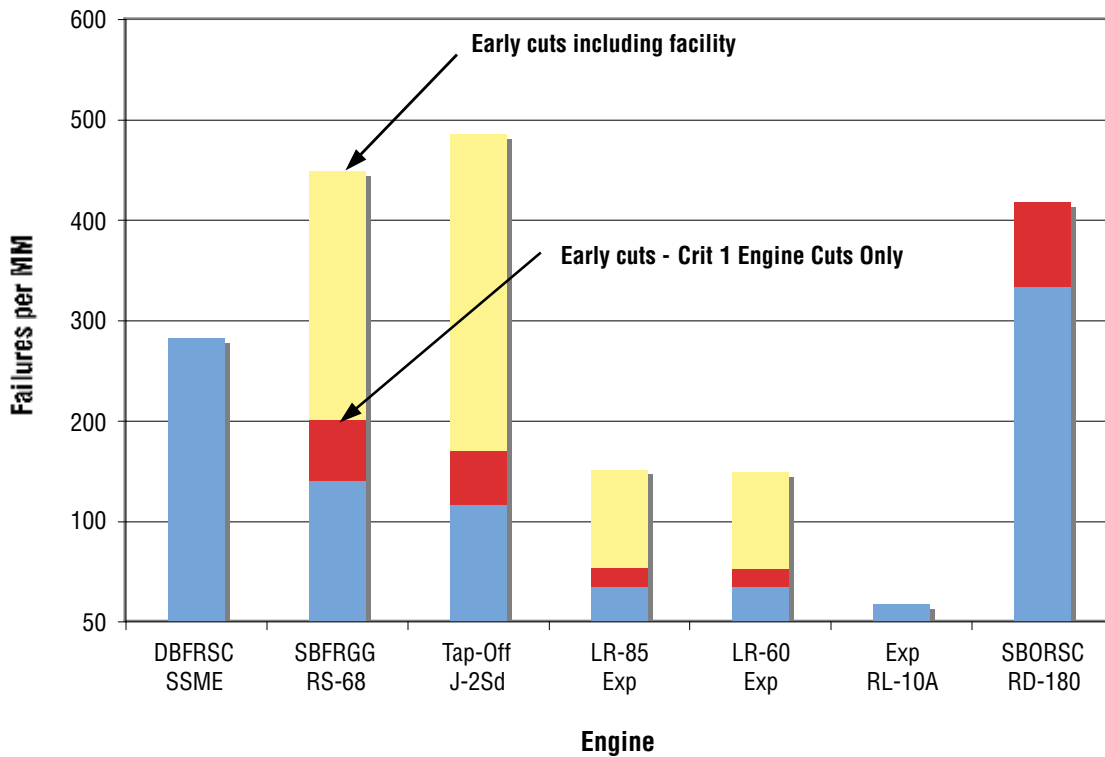

Figure 6-71. Adjustments to Baseline Estimates

The analysis provided in **Figure 6-71**, as discussed previously, utilized the SSME hot fire database. Two runs were completed and are presented in **Figure 6-71**. The red bar represents early engine-related cuts that reflect Criticality 1 failures only. The overall red and yellow bar reflects results from both early engine and facility-related cuts. Though the latter estimates were not analyzed any further, they could provide insight into engine and MPS failures or overall operational system reliabilities.

Finally, in terms of reliability growth, the RD-180 was assumed to need 50 percent regrowth with limited insight to become a mature engine. This is necessary given the “Americanization” that is required to support the insight needed for comparison to the SSME.

To this point, the reliability assessment estimates generated have been point estimates. Point estimates with a measurement of uncertainty are better assessment metrics. The uncertainty in the candidate systems should be assessed. The uncertainty will be higher in newer systems. Since the comparative approach used with point estimates was based on a comparison with SSME, a similar approach was used with the uncertainty estimates. The estimates are based on SSME values with adjustments to the amount of test history.

Figure 6-72 presents the logic behind the uncertainty estimates. Candidate engines with limited test time will have higher levels of uncertainty. Through selection of mature components, hardware development, and testing, the uncertainty was reduced to levels more closely approximating the SSME baseline, which has the most design and test data. The uncertainty can be represented with the 95th and 5th percentile, mean and median. Thus, appropriately, the reliability point estimates and uncertainties both reflect the influence of reliability growth.

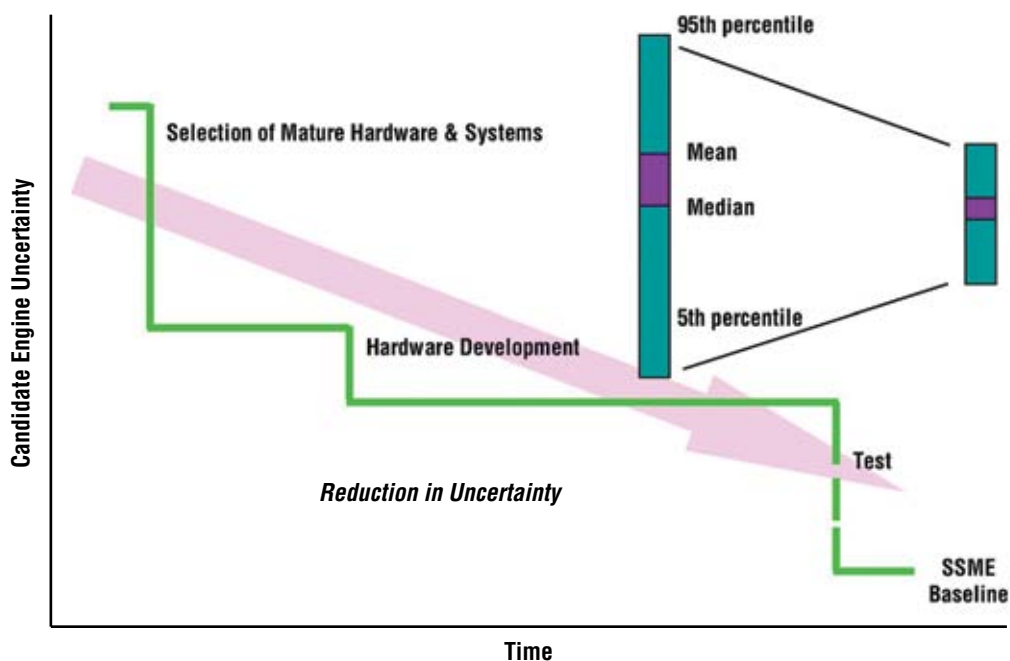

Figure 6-72. Point Estimates And Uncertainty

Table 6-28 provides the resulting measures of uncertainty, including percentiles and the EF, associated with the candidate engines. This approach was again based on reliability growth, where the extent of engine testing determines the size of the EF. Uncertainty is lowest for mature engines (e.g., SSME at 2.6; consistent with QRAS estimates) and highest for new engines (e.g., LR-60 at 9.22). As stated earlier, all new engines were given 100,000 sec of test time to be ready for first flight.

Table 6-28. Uncertainty Measures

Engine	Failures/MM	MTBF	Test Time	Eq Missions	Equivalent Failures	EF	Sigma	Mu	5th	Median	Mean	95th
RL-10	17.30	57799	1000225	1942	17.00	2.60	0.58	-11.13	5.62E-06	1.46E-05	1.73E-05	3.80E-05
LR-60	34.84	28702	100000	194	1.70	9.22	1.35	-11.18	1.52E-06	1.40E-05	3.48E-05	1.29E-04
LR-85	35.61	28082	100000	194	1.70	9.22	1.35	-11.15	1.55E-06	1.43E-05	3.56E-05	1.32E-04
LR-100	62.29	16053	100000	194	1.70	9.22	1.35	-10.60	2.72E-06	2.50E-05	6.23E-05	2.31E-04
RS-68	140.39	7123	134131	260	2.28	6.95	1.18	-9.57	1.01E-05	7.01E-05	1.40E-04	4.87E-04
J-2S	116.86	8557	126000	245	2.14	7.01	1.18	-9.76	8.26E-06	5.80E-05	1.17E-04	4.07E-04
RD-180	417.00	2398	140000	388	2.38	5.12	0.99	-8.27	4.98E-05	2.55E-04	4.17E-04	1.30E-03
SSME	282.22	3543	1000225	1942	17.00	2.60	0.58	-8.34	9.17E-05	2.38E-04	2.82E-04	6.20E-04

6.8.3 MPS Models

The ESAS team applied two different MPS models. The simplified MPS model used for LV reliability LOM and LOC predictions in this study is part of an LV analysis tool with models for all other subsystems. Although the incorporated model did not support MPS trade studies like the general MSFC MPS model described in **Appendix 6D, Safety and Reliability**, it did allow the rapid assessment of many complex LVs against a uniform standard using strictly standardized methodologies to support objective reliability comparisons at the vehicle level. A general liquid propulsion reliability model was also developed and applied to both LV and in-space propulsion stages. The model assumes a generic MPS architecture and relies exclusively on the Space Shuttle PRA for quantifying the failure events captured in the model. Each model's purpose and methodology is described in **Appendix 6D, Safety and Reliability**.

The MPS reliability model was developed to support the LV selection trades. Selected stage configurations with burn times were provided for analysis. **Figure 6-73** shows the results of the analysis of these configurations. **Figure 6-73a** shows the results for LV stages using engine failure parameters corresponding to a first build engine reliability. **Figure 6-73b** shows the results for LV stages using engine failure parameters corresponding to mature engine reliability. Note that the SSME and the RL-10 are both operational and mature; hence, the first build and mature failure probabilities are the same for these engines.

The results are broken out to indicate: (1) only the effects of the engine cluster, (2) the combination of the engine cluster and the MPS, and (3) the combination of the engine cluster, the MPS, and failure to start. Note that for boost stages, hold-down at launch is assumed. Thus, start failures are not included for boost stages. Results indicate that MPS failures can contribute from 15 to 50 percent of the overall stage unreliability depending on engine reliability and the number of engines. Start failures can contribute from 10 to 40 percent of the overall stage unreliability, again depending on engine reliability and the number of engines. For upper stages, results indicate that engine-out is a preferred capability. The bulk of the added MPS modes are benign, leading to an engine shutdown. The added redundancy appears to easily absorb these failures.

Results strongly indicate that, if engine-out is feasible (configuration, packaging, performance, etc.), then engine-out capabilities provide a significant reliability benefit. MPS and avionics unreliability may overwhelm the gain in reliability from using a pressure-fed engine. Stage development should include considerable efforts to improve MPS and avionics reliability.

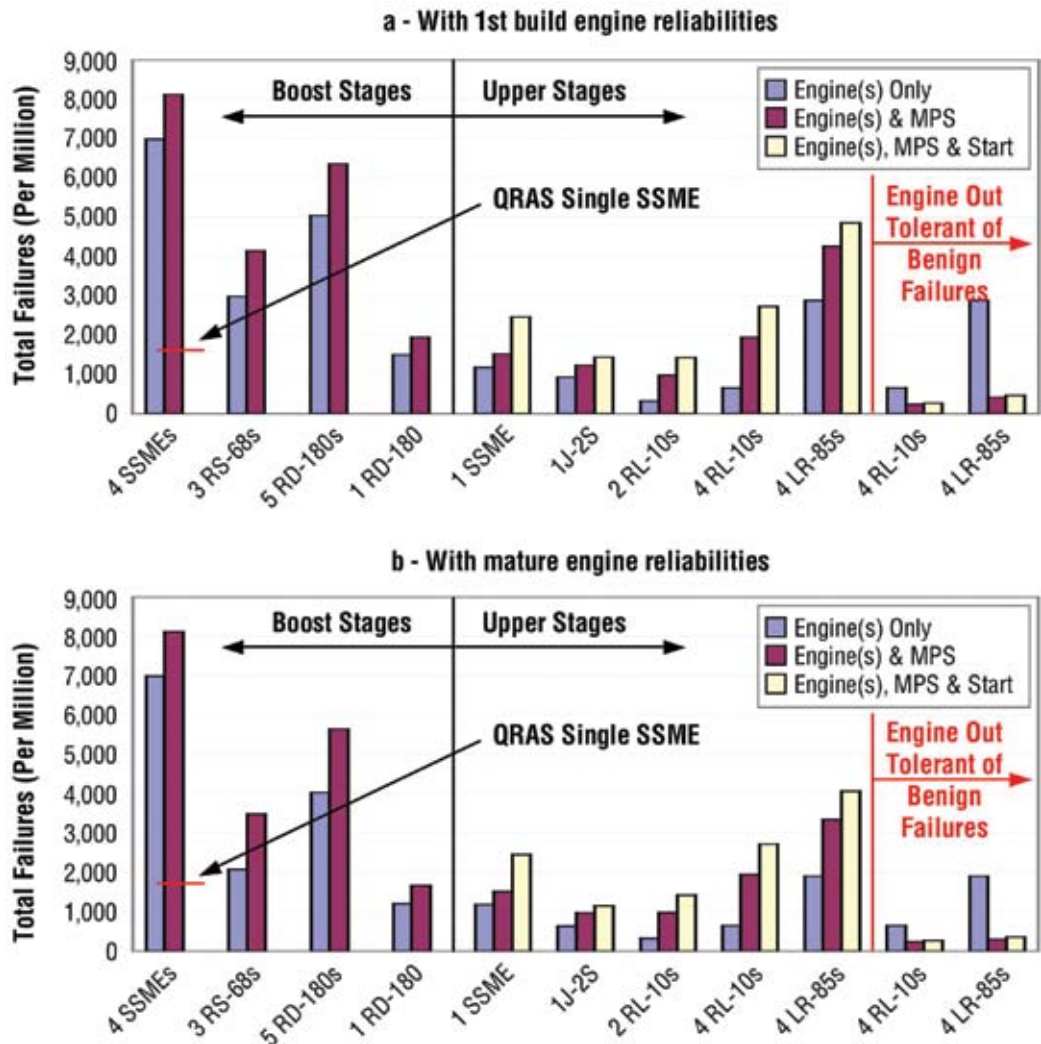

Figure 6-73. Launch Vehicle Stage Reliability Results

6.8.4 External Tank

The risk of failure for an ET, such as that used on the Space Shuttle to provide propellant to the SSMEs, is included in FIRST, while internal propellant tank risk is ground-ruled based on engineering judgment.

The probability of failure of an ET is based on the QRAS 2000 Space Shuttle estimates and is 1 in 6,442 MFBFs. This risk has been applied to Shuttle-derived side-mount vehicles only. This is a low-level contributor (on the order of 5 to 10 percent) of total vehicle risk.

6.8.5 Auxiliary Power Units

APUs provide power for valve actuation, TVC, general power, etc. They are used on core boosters, strap-on boosters, and upper stages. The risk estimates used in FIRST for the APU are based on top-level analysis of the state-of-the-art Space Shuttle system proportioned by the ascent time and the system fuel type. Hydrazine APUs were used on vehicles containing the SSME, RS-68, J-2, RL-10, LR-60, and LR-85. The RD-180 has a self-contained hydraulic system; therefore, no additional APU risk is required for this engine. Proton Exchange Membrane (PEM) fuel cells were chosen as the APU type for the CM.

It is assumed that today's Space Shuttle APUs are considered state-of-the-art, and, therefore, Shuttle APU risk estimates are used for hydrazine-powered APUs on vehicles in this study. However, the integration of hydrazine APUs into a new vehicle does add some level of uncertainty, thus the EF for this type of APU was increased by 50 percent (from the QRAS 2000 estimates) to a factor of 7.5. The results from the 1997 QRAS Study for the Space Shuttle APU yield a catastrophic failure probability on ascent of $3.95E-5$ (for a 515-sec burn time).

Non-hydraulic APUs are advanced power systems powered by PEM fuel cells. They are an advanced technology designed with high reliability and negligible risk. Using engineering judgment, the system risk is set to 1 in 1 million and is given an EF of 10 in FIRST.

The risk contribution from the APU subsystem is assessed in FIRST as follows:

Step 1: The APU risk for the Space Shuttle on ascent is divided by the Space Shuttles' ascent time (515 sec on ascent) yielding a per-second ascent risk estimate of $7.67E-8$.

Step 2: For APU ascent risk, the element ascent time (the amount of time from liftoff when the APU is powered on until the element separates from the vehicle) is multiplied by the per-second risk estimate from above. The number of engines does not affect the APU failure probability. Further, APU risk exposure time begins at liftoff, so the APU risk associated with an upper stage would also take into account the exposure time between liftoff and upper stage engine start.

6.8.6 Thermal Control System

The TCS is present on elements including the core boosters, strap-on boosters, upper stage, and CM. The risk estimate is adopted from a report that studied LOM failures of the active TCS, which considered only the ascent phase. The estimated failure probability for the TCS is $1.08E-9$ per element, with an associated EF of 10. When multiple elements exist, the failure probability is increased by the number of elements present.

6.8.7 Separation Systems

The model (FIRST) provides two types of element separation mechanisms, in-line and strap-on, to accommodate a number of LV configurations. The following sections detail the separation options, their availabilities, and their contributions to vehicle risk.

The in-line separation model provides risk estimates for all LV elements configured in series. It is available as a separation option to all core boosters. Three different methods of in-line element separation are available: fire in the hole, spring, and retro. However, only the retro was used for this study. Retro is an in-line stage separation mechanism that uses retro rockets on the lower stage to separate the two stages after explosive bolts have been blown. Retro separation reliability estimates are patterned after the Titan second-stage separation using QRAS 2000 data from Shuttle SRB separation components.

Probabilities of failure for all of the in-line separation models were reached by decomposing QRAS 2000 results for Shuttle SRB separation into two main components: explosive separation bolts and BSM clusters. Each Shuttle SRB uses one forward separation bolt and three aft separation bolts, and one BSM cluster is used at both the forward and aft separation points to push the SRB away from the ascending vehicle after separation. Using the reliability estimates for forward and aft bolts and BSMs, an average failure rate was determined for a single separation bolt and a single BSM. The per-unit failure rates are shown in **Table 6-29**.

Table 6-29. Per-Unit Failure Rates

Component	5th	50th	Mean	95th
1 Bolt	4.097E-06	1.129E-05	1.456E-05	3.558E-05
1 BSM Cluster	5.621E-06	1.330E-05	1.574E-05	3.332E-05

Using these component reliabilities, a model separation system was constructed for each of the above mentioned in-line separation methods by aggregating the appropriate number of bolts and thrusting elements, as shown in **Table 6-30**.

Table 6-30. In-Line Separation Risks

Method	Number of Bolts	Number of BSM Clusters	P(f)	Error Factor
Fire in the Hole	4	–	1 in 17,165	3.15
Retro	4	1	1 in 13,513	3.00
Spring	4	–	1 in 17,165	3.15

The strap-on separation model provides risk estimates for LV elements in a side-mounted, or parallel, configuration. Strap-on booster separation is the designated separation mechanism for side-mounted, multi-segment SRBs. It consists of three aft attachment points and one fore attachment point with exploding bolts separating the booster from a core stage. BSM solid rocket clusters at the fore and aft attachments provide the separation force.

The probability of separation failure for a strap-on booster is based on QRAS 2000 four-segment Shuttle SRB results. The QRAS SRB separation results are used as-is for four-segment SRBs, and have also been scaled to accommodate five-segment SRBs. For the addition of a center segment to the four-segment baseline configuration, booster separation bolt risk is increased by 15 percent, and BSM risk is increased by 25 percent. The resultant probabilities of separation failure are provided in **Table 6-31**.

Table 6-31. Strap-On Separation Risks

Number of Segments	P(f)	Error Factor
4	1 in 11,173	2.15
5	1 in 9,425	2.15

6.8.8 Payload Shroud Reliability Analysis

At the beginning of the study, the Payload Shroud Reliability model used a 1 in 891 probability of failure per launch, based on historical data displayed in **Table 6-32**. This model included the possibility of any type of payload shroud failure (structural, failure to separate, and inadvertent separation).

Table 6-32. Historic LV Data Used for Payload Shroud Failure Estimate

LV	Total Launch Attempts (1986–Dec. 31, 2003)	Launch Attempts Not Including Vehicle Failures Before PLF Separation Could Begin	PLF Separation Failures	Successful Launches Since Failure Occurred
Ariane	135	133	0	
Athena	7	6	1	1
Atlas	94	93	0	
Delta	116	113	0	
H-Series	20	18	0	
Long March	59	56	0	
Pegasus	34	33	0	
Proton	165	165	0	
Soyuz/Molniya	454	453	2*	80
Taurus	6	6	0	
Titan	60	57	0	
Tsiklon/Dnepr	115	114	0	
		1,247	3(1.4*)	
	Total PLF Attempts	1,247		
	Total PLF Failures	1.4		
		0.001122694		
		1 in 891		

*Failures due to manufacturing process. These failures are discounted assuming an 80% fix factor, hence each failure counts as only 0.2 of a failure.

The ESAS team directed an improved shroud risk estimate using a physics-based process for estimating shroud risk rather than historical statistical estimates. After research and investigation of shroud design technology and methods, it was determined that historical data remains the most accurate method for predicting shroud structural failures because:

- Shroud loads, material, required factors of safety, payload size and weight, etc., are inputs that lead to a shroud’s physical characteristics.
- In conceptual or preliminary stages of vehicle designs:
 - Shrouds (and other structures) are designed by analysis, and
 - Designs are not evaluated for reliability at given loads or environments, rather loads and environments determine shroud design.
- Each shroud is tailored to a particular payload and trajectory, and, if the shroud material, payload, or trajectory (aero loading) changes, the shroud design changes, (i.e., one shroud design would be just as reliable as another shroud design that was developed using the same design tool and process).
- For preliminary design, worst-case loads and minimum material strengths are assumed.
- Slight changes in material strength may significantly alter predicted structural reliability.
- Small variations in aerodynamic loads may significantly alter a shroud’s predicted reliability.

The ESAS team confirmed that attempting to relate predicted shroud reliability to design factors of safety or shroud physical characteristics at the current level of design detail would be very inaccurate. Based on this conclusion, the existing shroud model was refined by distinguishing the historical structural failures from those caused by inadvertent separation or failure to separate. Structural failure probability based on historical data could be combined with a PRA of the other two failure modes for a typical shroud design. A shroud failure fault tree is provided in **Figure 6-74**.

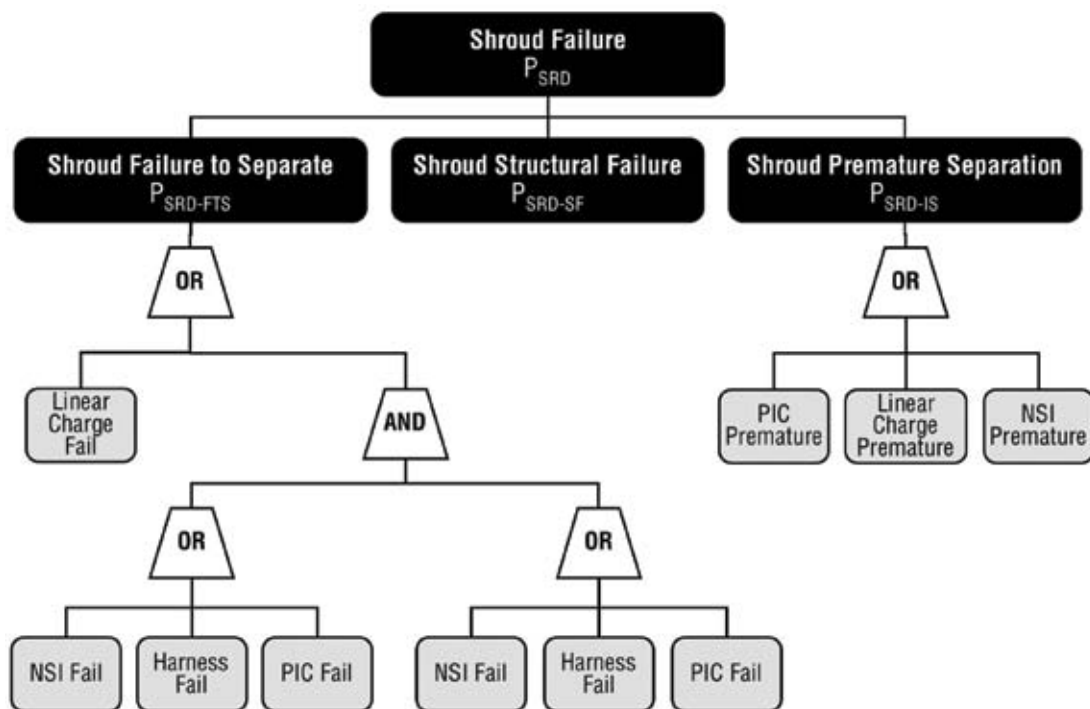

Figure 6-74. Payload Shroud Fault Tree

The revised historical model is summarized in **Table 6-33** below.

Table 6-33. Revised Payload Shroud Historical Data Set

International Launches 1986 – 2003	
Launches	1,247
Structural failures	Soyuz/Molniya - 2 x 0.2 (80% fix factor)
Failure Rate	0.4/1,247 ~ 1/3,100

The failure to separate model is provided in **Table 6-34**. This model provided a more realistic estimate for payload shroud failure (1 in 3,080) and was used to estimate LOM for all the payload LVs in the ESAS.

Baseline Data
Calculations
Final Result

Table 6-34. Updated Payload Shroud Reliability Estimate Model

Baseline Component Failure Probabilities	Failure to Separate			Premature Separation ³		
	Mean		EF ⁶	Mean		EF ⁶
Pyrotechnic Initiator Controller (PIC)	1 in 18,707 ¹	5.35E-05	1.015	1 in 1,000,000	1.00E-06	3.930
NASA Standard Initiators (NSIs)	1 in 375,375 ²	2.66E-06	9.100	1 in 1,000,000	1.00E-06	3.930
Linear Charge	1 in 1,000,000 ³	1.00E-06	3.930	1 in 2,000,000	5.00E-07	3.930
Wire Harness/System	1 in 3,105 ⁴	3.22E-04	2.416	N/A	N/A	N/A

Shroud Structural Failure		
1 in 3,118 ⁵	3.21E-04	6.30
	9.9968E-01	

Calculations	Failure to Separate		Premature Separation	
	Mean		Mean	
Success Probability per Chain	1-(1 in 2,644)	9.9960E-01	1 in 400,000	9.9900E-01
Failure Probability for two Parallel Chains	1 in 6,991,428	1.4300E-07	N/A	N/A
Success Probability w/ two Chains and Linear Charges	1-(1 in 874,866)	9.9900E-01	N/A	N/A
Probability of Failure	1 in 874,866	1.1430E-06	1 in 400,000	2.4990E-06

Primary Failure Modes Calculated Probabilities	Failure Probability	
	Mean	
Failure to Separate	1 in 874,866	1.1430E-06
Premature Separation	1 in 400,000	2.4999E-06
Structural Failure	1 in 3,118	3.2077E-04

Shroud Probability of Failure	Mean	EF
	1 in 3,080	3.2464E-04

1. PIC reliability based on demonstrated reliability—analysis is found in the Space Shuttle Analysis Report (SSMA-02-006 November 20, 2002) titled: Pyrotechnic Initiator Controller (PIC) Reliability and Maintenance Analysis.
2. NSI failure rate is based on 125,000+ firing without a failure. This data is based on lot acceptance firings through the years of Gemini, Apollo, (ASTP), and Shuttle. The 1 in 375,375 Mean is CARPEX-generated based on 0 failures in 125,000 trials (1/3 rule).
3. Linear charge failure rate and all premature separation failures assumed very unlikely due to system design. Failure rates for these are engineering judgment.
4. Wire harness reliability based on three partial failures of redundant wiring harness in the STS history (9,314 commanded firings) per SSMA-02-006, researched by Jeremy Verostico (Pyros/PIC JSC Safety and Mission Assurance (S&MA) Science Applications International Corporation (SAIC)).
5. Structural failure based on demonstrated reliability—all international launches 1986-2006. (See Para. 5 above.)
6. Error factors were calculated using CARPEX.

6.8.9 Additional RSRB Safety Considerations

6.8.9.1 Introduction

This section addresses, in more detail, the inherent characteristics that drive the predicted reliability and survivability (as described previously in **Section 6.8.1, Reusable Solid Rocket Booster**, of Shuttle-derived RSRBs as applied to the in-line CLV (LV 13.1) configuration. Because the CLV is currently in the conceptual phase of development, this assessment is based on evidence from a variety of sources, including the flight history of similar systems as well as relevant analytical modeling activities. Although there is uncertainty in the specific values of reliability and survivability, the results of this assessment indicate that the Shuttle-derived RSRB is a reliable concept whose failures are survivable, particularly in comparison to the liquid-core EELV alternative.

The value of the Shuttle-derived RSRB can be summarized in the following factors:

- **Simple, Inherently Safe Design:** The human-rated RSRB (post-51-L) first stage has been matured over 88 Shuttle flights (equivalent to 176 single RSRM flights);
- **Historically Low Rates of Flight Failure:** Only the Challenger event marred a perfect record of 226 SRB flights. This results in a 0.996 launch success rate (combined 50 flights of the SRM and 176 flights of the RSRM);
- **Design Robustness:** Test results and physics-based simulations show the SRB LV design is robust and resistant to crew adverse catastrophic failure, even for the most severe failure modes;
- **Non-Catastrophic Failure Mode Propensity:** SRB history and SRB design features suggest gradual failures that are less likely to threaten the crew;
- **Process Control and Inspection:** The proposed design offers benefits of propulsion suppliers with mature process control and inspection systems to minimize in-factory and post-manufacturing human error, a significant contributor to the current launchers' risk; and
- **Failure Precursor Identification and Correction:** The design capitalizes on the significant failure precursor identification and elimination from recovery and post-flight inspection of the recovered SRBs.

6.8.9.2 RSRB Description

The Shuttle RSRB is a four-segment, steel-case propulsion system that provides a peak sea-level thrust of 2,900,000 lbf and burns for 123 sec. At the end of burn, which is at 150,000 ft and a velocity of 4,500 ft/sec, it separates from the Shuttle and splashes down in the Atlantic, some 122 nmi downrange from the launch site. From there, it is towed back by recovery ships for refurbishment and it may be reused for up to 20 launches. The RSRB weighs 1,255,000 lb, of which 1,106,000 lb is solid propellant. It has an igniter in the forward segment and a nozzle at the aft segment. The igniter ignites the propellant inner surface, which burns at an engineered rate into the propellant volume. The basic elements of the RSRB are shown in **Figure 6-75**.

- ◆ Inner surface is ignited and propellant burns outward at an engineered rate
- ◆ 1,106,000 lb of solid propellant in four casting segments
- ◆ 1,255,000 lb prior to launch
- ◆ Peak thrust of 2,900,000 lb at sea level
- ◆ Burns 123 sec
- ◆ Separates from Shuttle vehicle at 150,000 ft with velocity at 4,500 ft/sec
- ◆ Splashes down in Atlantic 122 nautical miles down range
- ◆ Towed back by recovery ships to be refurbished and the motor case elements used up to 20 times

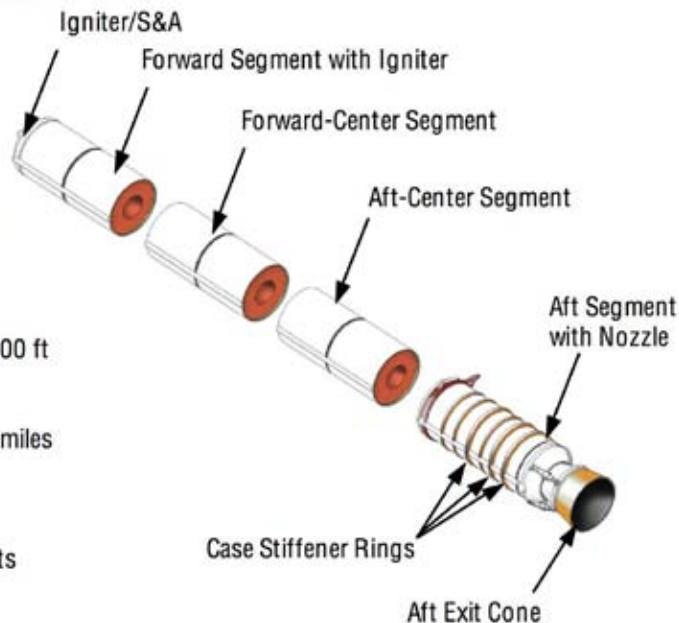

Figure 6-75. Basic Elements of a Shuttle RSRB

Table 6-35 presents the composition of the RSRB propellant. It is important to note that the propellant is not an explosive, and extensive testing has demonstrated the inability of the propellant to detonate, even under extreme accident conditions such as those produced by motor fallback. It is classified as Hazard Division (HD) 1.3 by the DoD and Department of Transportation (DoT), which, by definition, identifies the major hazard as mass fire.

Raw Material	Function	Main Grain Percentage
Ammonium Perchlorate	Oxidizer	69.70
Aluminum Powder	Fuel	16.00
PBAN Polymer	Binder	12.10
Epoxy Resin	Curing Agent	1.90
Iron Oxide	Burn Rate Catalyst	0.30

Table 6-35. Composition of RSRB Propellant

6.8.9.3 Solid Propulsion History

Assessment of Shuttle-derived RSRB reliability (and survivability) begins with a general review of propulsion history to develop baseline values to which it can be compared. Although the historical record is a valuable information set, caution must be used when extrapolating from past failures of systems that reflect varying degrees of similarity to the RSRB.

The most elementary distinction that can be made between propulsion systems is the gross propellant type (i.e., solid versus liquid propellant). As shown in **Figure 6-76**, solid propulsion systems have historically had lower rates of failure than liquid systems. From 1958 to the present, there have been 39 failures out of 2,133 attempts for liquid propulsion systems, whereas there have been 20 failures out of 3,535 attempts for solid propulsion systems. This corresponds to historical failure probabilities of 0.57 percent for solids and 1.8 percent for liquids, a factor of 3.2.

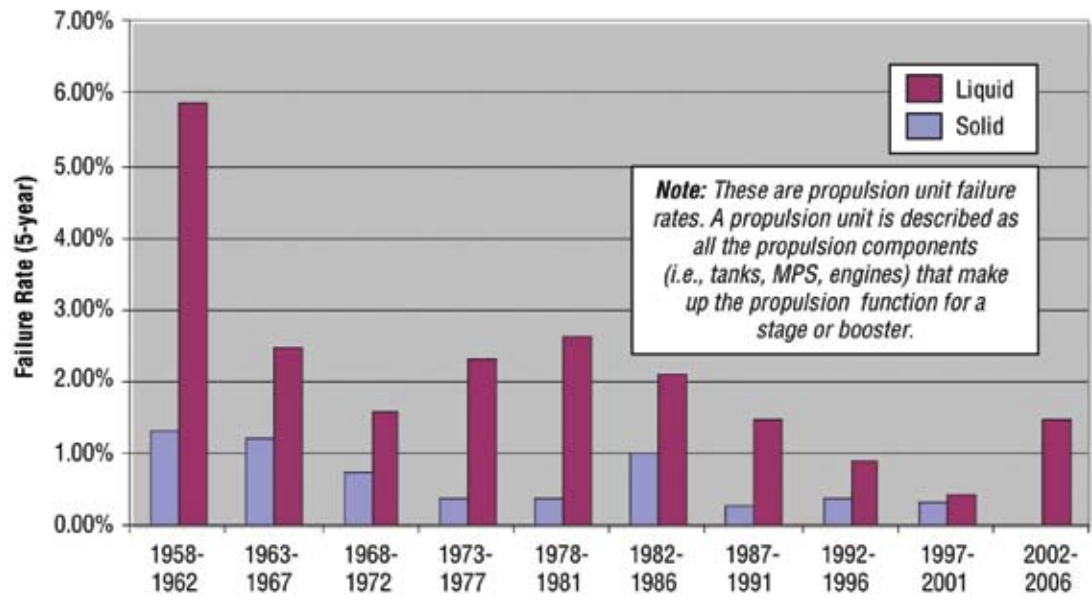

Overall Propulsion Unit Failure Rates from 1963-2004		Attempts	Failures
Liquid Propulsion	1.83%	2,133	39
Solid Propulsion	0.57%	3,535	20

*RSRM Influences on Reliability & Crew Survivability for a Human Rated SDLV
Nov 2004, David Hawkins, ATK Thiokol*

Figure 6-76. Failure Rates of Solid and Liquid Propulsion Systems

A more focused historical comparison can be made by looking at the failure history of large-throat SRBs, including Titan IV, Ariane V, and Shuttle SRB. A summary of these flights is presented in **Table 6-36** and shows an overall history of 3 failures out of 362 attempts, for a failure probability of 0.83 percent. However, the data also shows a marked difference between the failure rate of the Shuttle SRB and the Ariane and Titan SRBs. Historically, the Shuttle SRB has been 3.3 times more reliable than Titan IV and Ariane V (taken together), similar to the factor of 3.2 between solids and liquids, generally. This difference may be partially due to the larger number of Shuttle SRB flights, but it also suggests that Shuttle SRB reliability is achieved by design features other than just propellant type.

Table 6-36. Large-Throat SRB Flight Failure History

Large-Throat SRB Attempts and Failures (Flight Demonstrated Only)			
Vehicle	Flights	Attempts (Flights x 2)	SRB Failures
Shuttle	113	226	1
Total	113	226	1
Titan IV A	22	44	1
Titan IV B	14	28	
Titan 34D	15	30	1
Ariane V	17	34	
Total	68	136	2

Shuttle RSRBs have reliability drivers that are unique among SRMs. First, they have been designed from the ground up for human flight and, as a result, have been designed to greater margins of safety and built under more stringent process controls than other systems. Also, they are recoverable, which has allowed for failure precursor identification and correction, which has contributed to continual design improvements throughout the program. **Figure 6-77** highlights some of the safety enhancements that have resulted from post-flight inspection. As shown in **Figure 6-78**, post-flight inspection (along with the post-Challenger redesign to the RSRM) has been an integral part of an aggressive ongoing program of reliability improvement for the Shuttle RSRB.

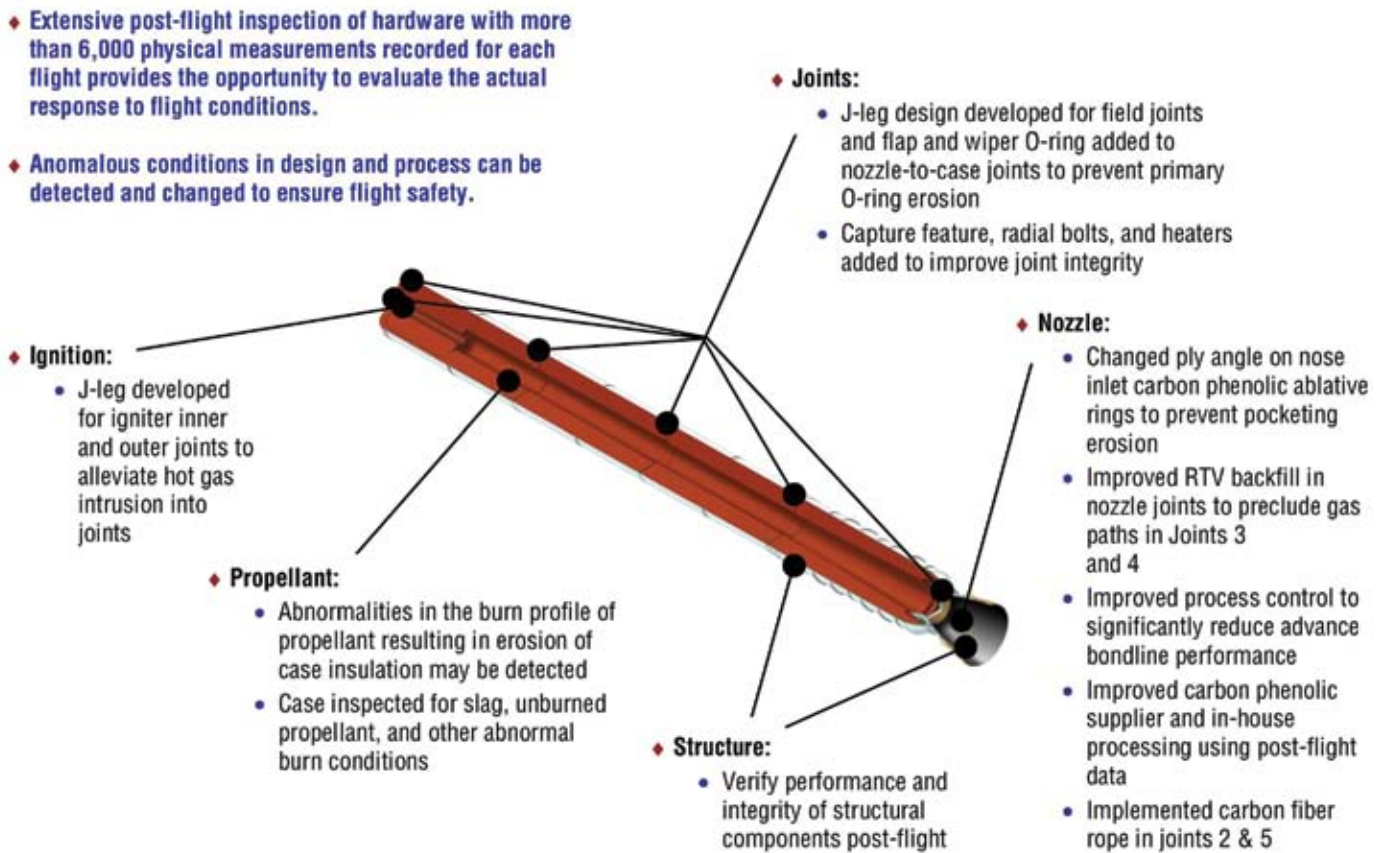
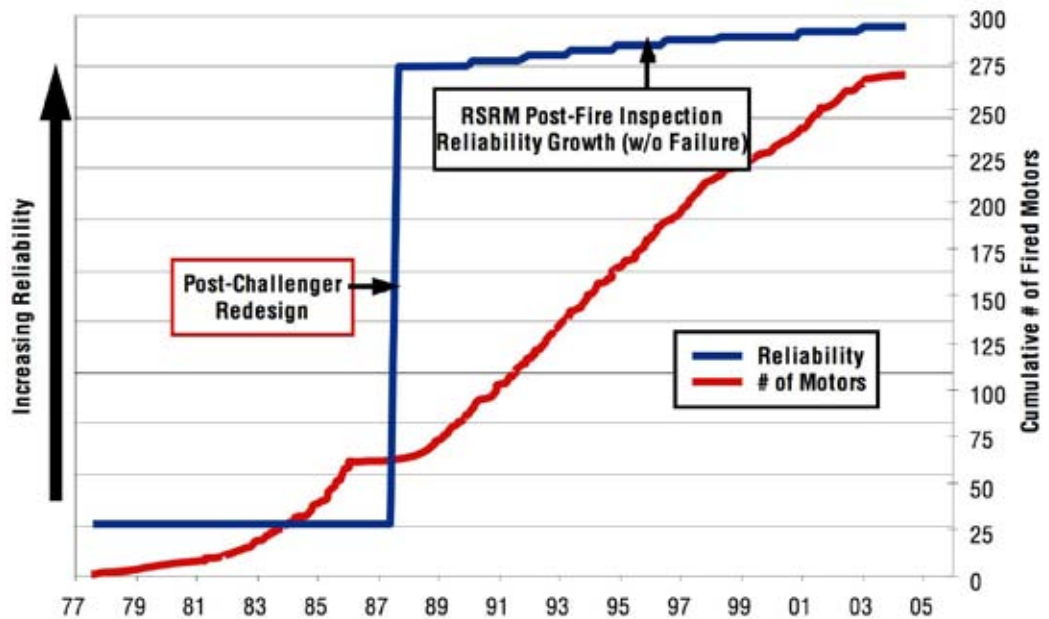

Figure 6-77. Safety Enhancements from Post-Flight Inspection

It is worth noting the significant design differences between a boost stage using Shuttle RSB and a boost stage using small strap-on solid motors such as the Delta Castor IV and Delta 2 GEM. These small strap-on motors have entered the human spaceflight debate as a result of the OSP–ELV Human Flight Safety Report Certification Study, which recommended against their use for crewed flight. The basis for this recommendation was that, although small strap-on solids are individually reliable (estimated at 0.9987), failures of these motors serve as undetectable initiators of liquid core explosion, which requires an estimated 2 sec of abort warning to escape. Additionally, since small strap-ons provide relatively little delta-V, multiple strap-ons are often required for performance reasons, multiplying their overall risk. The combination of reasonably high cumulative risk and their (assumed) undetectable failure modes makes them incompatible with crew survivability.



Reliability & Crew Survivability Aspects for a Human-Rated Exploration Launch Vehicle with RSRM, ASA/JSC - Feb 24-25, 2005, David Hawkins, ATK Thiokol

Figure 6-78. Historical Increase in RSRB Reliability

These concerns do not apply to the Shuttle-derived CLV configuration because a single RSRB provides the entirety of the first-stage performance; hence, the issue of cumulative risk over multiple units is not applicable. In fact, the RSRB failure risk replaces liquid core risk, as opposed to adding to it, as is the case for strap-ons. Moreover, as is discussed in **Section 6.8.9.5, RSRB Survivability**, the RSRB does not have the explosive potential of a liquid core stage, so the 2-sec abort warning requirement does not apply. Finally, RSRB failures are detectable (as demonstrated by the Challenger accident).

6.8.9.4 Solid versus Liquid Reliability Estimates

Predictions of future reliability must go beyond the raw data of history and capture the improvements in design, production, and management that tend to make the next flight more reliable than the average of the previous flights. A number of analyses have been completed or are in process to address this issue, including QRAS and the ongoing Shuttle PRA. Both analyses indicate that the Shuttle RSRM catastrophic failure rate is approximately three times less than that of the SSME, the only man-rated U.S. liquid propulsion system currently operating. However, the SSME also has a significant non-catastrophic failure probability of 1 in 640, resulting in a total SSME failure rate that is roughly 20 times higher than RSRM. Comparison of man-rated solid and liquid vehicle reliability estimates has also been performed using FIRST, which includes man-rated EELV reliability estimates, as shown in **Figure 6-79**.

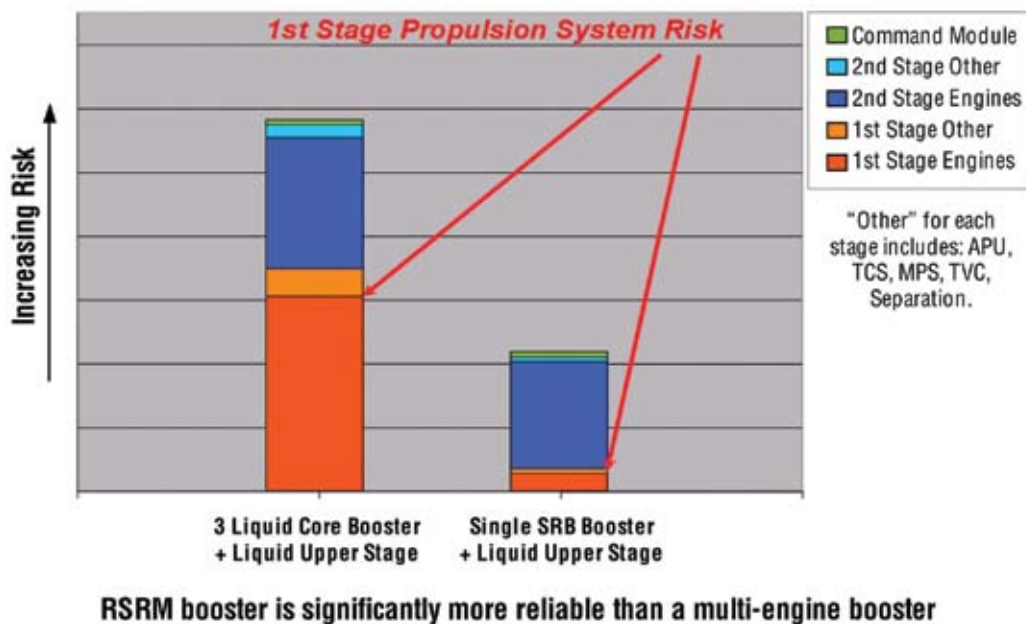

Figure 6-79. Comparison of Man-Rated Vehicle Risk Forecasts

6.8.9.5 RSRB Survivability

Although propulsion system reliability is a primary concern, especially with respect to crewed vehicles, crew survival is assured by an effective abort system that functions successfully in cases of LV failure. Survivability depends on the vehicle’s ability to detect failures as they unfold and initiate abort early enough to remove the crew from the hazardous environment of the failing LV. Assessment of survivability requires an understanding of the detectability of each failure mode and the accident stresses they produce.

6.8.9.6 RSRM Failure Environments

RSRM failures can be broadly categorized into two risk significant case failure types: case breach and case rupture. Case breach entails release of hot gases from the internal volume and has a number of potential consequences. It may initiate other failures of systems in the proximity of the breach, as was the case for Challenger, where a joint leak impinged on the ET, causing it to explode. It may create an imbalanced thrust, which may or may not be within the capability of the TVC system to counter. It may also be benign.

Case rupture entails the large-scale release of chamber pressure and can occur as a result of extreme pressure buildup due to large pieces of solid propellant breaking off and clogging the exhaust bore or due to a crack or flaw within the solid propellant that increases the burn area, creating extreme pressure gradients. It is important to note that the propellant does not explode, and a fireball is not created; chunks of burning propellant are released, and an over-pressure wave is produced as a result of the rapid depressurization of the chamber volume.

Of the two types of failure, case rupture creates the more extreme environment. However, even this bounding environment is significantly more benign than that of a liquid stage containing large quantities of propellant. **Figure 6-80** presents a comparison of the explosive energies of the two systems as a function of time. The left axis indicates the Trinitrotoluene (TNT) equivalent, representing the amount of TNT that would produce an explosion of comparable size. (“TNT equivalent” is a common method of normalizing explosive yields from a variety of materials under a variety of conditions and allows the use of empirical TNT overpressure equations.) The axis on the right indicates the critical distance associated with

the TNT equivalent. The critical distance is the required distance from the explosion origin in order not to exceed the CEV overpressure design limit—a nominal value of 10 psi was used for this analysis. It can be seen from **Figure 6-80** that the maximum explosive potential of the RSRM is six times less than that of Delta IV or Atlas V. It can also be seen from the In-Line Configuration (ILC) CLV icon on the right that the maximum RSRM critical distance is less than the distance between the forward RSRM segment and the CEV, indicating that abort lead time may not be needed for RSRM failures (assuming they do not propagate to the upper stage). This is not the case for the Delta IV, which has a critical distance that exceeds the entire height of the ILC CLV.

◆ **SRB and liquid stage rupture environments are a function of the energy available for release.**

- Can be expressed as a TNT Equivalent
- Supports comparison of hazard magnitudes

◆ **Given a CEV overpressure design limit, the critical distance can be determined.**

- The minimum separation distance between the CEV and the blast origin that assures survival
- Varies with
 - propellant mass (liquids)
 - chamber volume (solids)
 - chamber pressure (solids)
 - altitude
 - velocity

◆ **Accident stresses from SRB ruptures are significantly smaller than those from liquid propellant stage ruptures, throughout ascent.**

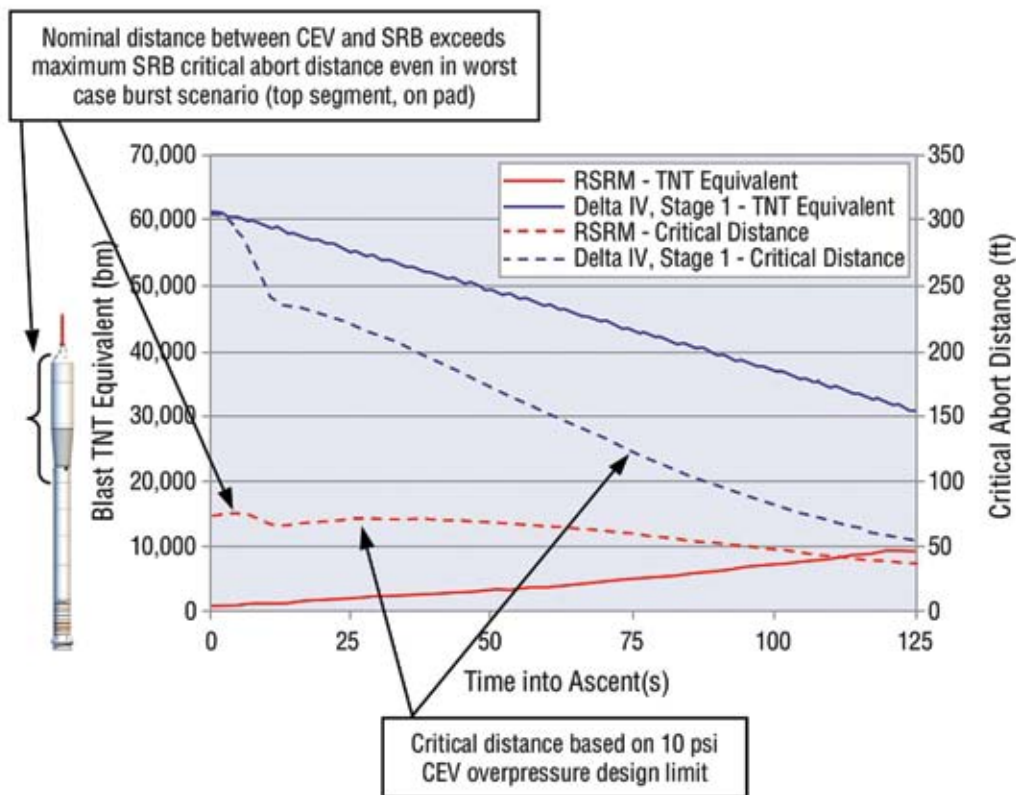

Based on Shuttle Derived Vehicle Dynamic Abort Risk Evaluator (SDV DARE) Analysis, SAIC Safety & Risk Section, 2005

Figure 6-80.
Comparison of RSRM
and Liquid Stage
Rupture Environments

This finding is corroborated by a high-resolution Computational Fluid Dynamics (CFD) analysis that was completed using a spectrum of rupture and flight conditions and showed that the overpressure experienced by the CEV on the stack would be negligible. Results of this study are shown in **Figures 6-81** and **6-82**.

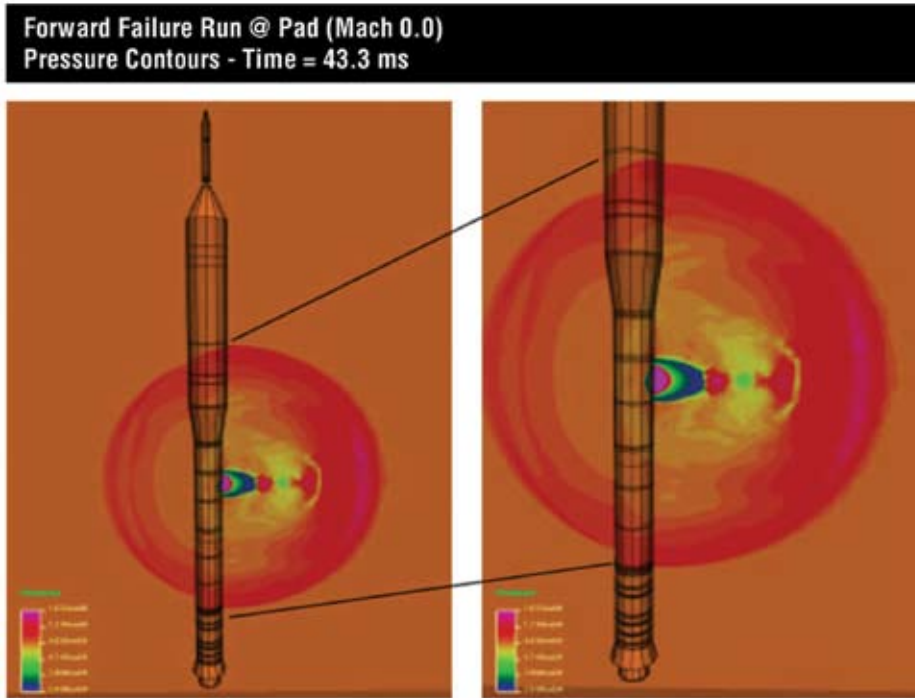

Figure 6-81. Worst-Case Condition of a Forward Segment Rupture on the Pad

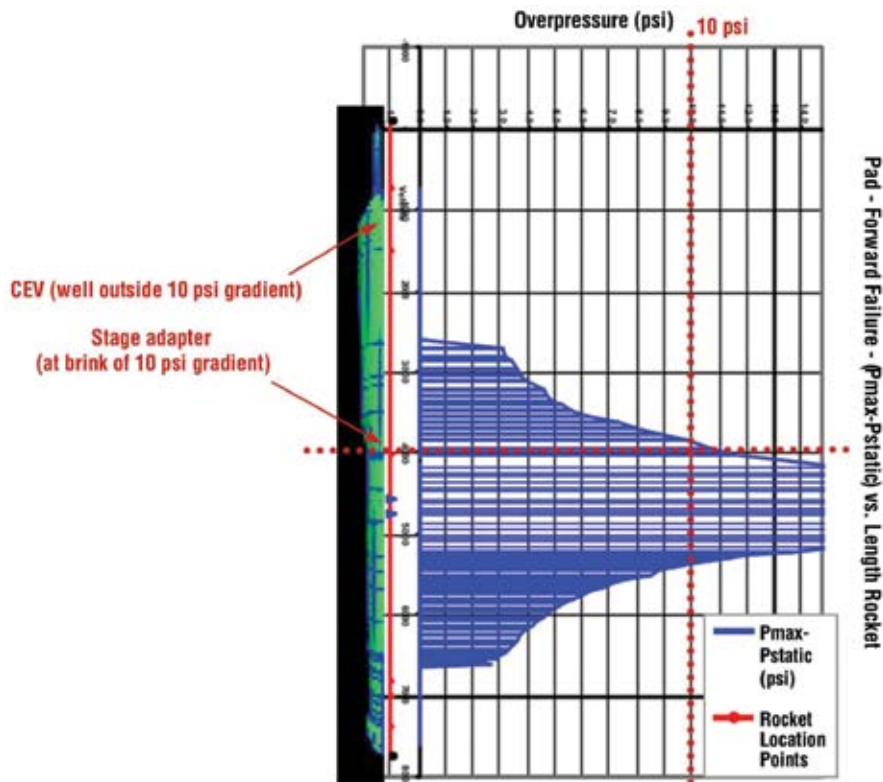

Figure 6-82. Overpressure as a Function of Distance from Rupture Origin

There is the additional consideration of failure propagation to the upper stage, which may exacerbate the stresses on the CEV as it attempts an abort. The propagation potential is failure mode dependent, and there is always the possibility of designing for more graceful failure (e.g., designing the aft SRB segment to rupture preferentially) or hardening against failure stresses (e.g., designing the interstage to withstand RSRM burst overpressures). The primary qualitative difference between SRB and liquid stage propagation potential is that bounding SRB accident stresses are likely to be amenable to mitigation (e.g., hardening), whereas bounding liquid stage accident stresses would likely overwhelm any practical mitigation.

6.8.9.7 Abort Lead Time

To develop a sense of the abort lead times that might be achieved by an Integrated Vehicle Health Management (IVHM) system against the RSRM failure modes, a so-called “Zero Warning Failure” study was conducted whereby detection lead time ranges were assigned to each RSRM failure mode identified in Shuttle PRA Version 1. The results of this study are summarized in **Table 6-37**, which shows that 44 percent of the RSRM risk is associated with very long abort lead times, while the remaining 56 percent is associated with lead times between 0–5 sec.

Table 6-37. Abort Lead Time Estimates for RSRM Failure Modes

RSRM Failure Modes	Potential Detection Method	Reaction Time (s)
Joints		
BB Rotor Joints Failure	Infrared (IR) Camera; Thermocouple (TC)	5–130
Flex Bearing Joint Failure	TC; Pressure Transducer (P)	30–130
Field Case Joint Failure	IR, Visual; Burn Through Wire; TC; P	5–130
Igniter Case Joint Failure	IR, Visual; Burn Through Wire; TC; P	5–130
Igniter Joint Failure	IR Camera	5–130
Nozzle Joint 1 Failure	Burn Through Wire; TC	5–10
Nozzle Joint 2 Failure	TC	5–130
Nozzle Joint 3 Failure	TC; P	5–130
Nozzle Joint 4 Failure	Burn Through Wire	5–130
Nozzle Joint 5 Failure	Burn Through Wire	20–130
Nozzle Case Joint Failure	Visual; Burn Through Wire; TC; P	5–130
OPT Joint Failure	IR; TC	5–130
Safe and Arm (S&A) Gasket Joint Failure	IR; TC	5–130
SII Joints Failure	IR; TC	5–130
Structure		
Case Segment Structural Failure	P; Strain Gauge	0–5
Igniter Structural Failure	P; Strain Gauge	0–5
Nozzle Housing Structural Failure	Strain Gauge	0–5
Thermal		
Case Insulator Failure	Visual; Burn Through Wire; TC; P	5–130
Igniter Insulation Failure	P; Strain Gauge	5–130
Nozzle Phenolics Failure	Only Aft Exit Cone—Visual; TVC	5–130
Performance		
Nozzle Failure	Only Aft Exit Cone—Visual; TVC	5–130
Motor Propellant Failure	P	0–5

Note: Current RSRM only has Pressure Transducers (P) in the forward end of the motor.

It is important to note that the range of 0–5 sec is very wide and does not indicate that the failure mode is unabortable. Instead, the analysis focuses attention on those failure modes that require additional investigation with respect to survivability, because the potential accident environment hazards cannot be dismissed solely on the grounds of lead time alone. Instead, the question becomes whether the critical distances exceed the actual CEV separation distances for the specific accident stresses and lead times associated with each of the four identified “zero warning” failure modes. This question was addressed using the Space Shuttle Dynamic Abort Risk Evaluator (DARE) abort modeling tool, which probabilistically samples abort lead times over the ranges provided previously, comparing the resulting separation distances and critical distances to generate an abort failure probability. The result is a mean SRB abort ability from an ILC CLV configuration of 95 percent, which includes a failure-mode-specific assessment of the potential for propagation to the upper stage. Because the 0–5 sec range is large, uncertainty is relatively high; nevertheless, the conclusion is that RSRB failures are likely to be detectable with sufficient time margin for successful abort.

6.8.9.8 Summary

History and analysis shows that RSRB failures are detectable and far less severe than catastrophic liquid engine failures, affording comparatively benign environments for crew escape. An estimated 95 percent of RSRB failures are detectable with sufficient time for successful abort. Moreover, the probability of RSRM failure is far less than the alternative liquid propulsion solutions. This is due in part to the relative simplicity of solid propulsion systems versus liquid systems, but also as a result of the conservative design and manufacturing standards under which the RSRM is built, and the extensive post-flight inspection process that has contributed to reliability growth through numerous upgrades. **Table 6-38** presents a summary comparison between the ILC and triple-core EELV configurations.

Table 6-38. Boost Stage Safety Comparison

Reliability Drivers	Single-Stick SRB	Shuttle	EELV (Triple Core)
Simplicity	Single element	2 SRBs plus 3 staged combustion engines	3 engines (with 2 turbopumps), 3 feed-back control systems, (1 staged combustion), 3 propellant management systems, 3 purging systems
Dynamics (moving parts)	1 TVC	5 TVCs, 6 high-performance turbopumps with Preburners	3 TVCs, 6 turbopumps, 3 throttle valves, numerous prop management valves
Understanding of the environment (margin)	226 flight operations, with post-flight inspection	113 flight operations	1 EELV HLV flight, conflagration during Delta launch, LOX-rich environment (RD-180)
Process control and feedback	Post-flight inspection, production process controls	Post-flight inspection, production process controls	No post-flight inspection; Rely on process control in flight (redlines)
Survivability Drivers			
Trajectory (g loads on abort reentry)	Crew escape system: Flat trajectory with mild g-loads	No crew escape system	Crew escape system: Requires more lofted trajectory with higher loads on crew (more so with Delta); can be mitigated with new upper stage
Detection lead time	~95% sufficient	N/A	84% to 90% sufficient
Accident environment	Low overpressure explosive environments, thrust augmentation typically leads to slow single-stack breakup	SRB thrust augmentation leads to immediate breakup and potential propellant mixing/conflagration	Potentially high overpressure/conflagration environments, thrust augmentation or engine shutdown can lead to interactions between cores

6.9 LV Subsystem Descriptions and Risk Assessments

6.9.1 Overview of Options Compared

The ESAS team made a comparative risk assessment of CLV options for ISS (and transition paths to EDS and CaLV for lunar missions). Both Shuttle-derived and EELV-derived configurations were assessed. The analysis focused on subsystems evaluations, including development risks and development schedule assessment. The following subset represents the CLV options studied by the team:

- Shuttle-derived options:
 - Five-segment RSRB with four LR–85 (new expander cycle) upper stage engines,
 - Four-segment RSRB with one RS–25d (altitude-start SSME) upper stage engine,
 - Five-segment RSRB with one RS–25d upper stage engine,
 - Five-segment RSRB with one J–2S upper stage engine, and
 - Five-segment RSRB/ET variant with four RS–25d engines.
- EELV-derived options:
 - Atlas V (new upper stage) with three RD–180 booster engines and four RL–10 upper stage engines, and
 - Delta IV (new upper stage) with three RS–68 booster engines and four RL–10 upper stage engines.

Each system was analyzed relative to its earliest availability date; first, second, and third level schedule critical path; development risk; acquisition strategy; mitigation schedule; and extensibility to EDS and CaLV. **Appendix 6G, Candidate Vehicle Subsystems**, provides a more detailed summary of the analysis results by system.

6.9.2 Shuttle-Derived Assessments

For the five-segment RSRB with four LR–85 upper stage engines (designated LV 15), a new upper stage with the proposed clean-sheet expander cycle engine was the major concern. The earliest availability of such a system was determined to be 2014, with possible schedule mitigation to 2013. Critical path items include the LR–85 upper stage engine, upper stage MPS, avionics, and flight software. The system was found to be extensible to the EDS, with partial extensibility to the HLLV. Overall development risk was determined to be medium, based on the need for an entire new upper stage and an upper stage engine.

For the preferred CLV using a four-segment RSRB with one RS–25 upper stage engine (designated LV 13.1), the major concern was that it would be a new large upper stage design. The schedule of 2013 was seen as attainable, with mitigation strategies applied for availability in 2011. The primary critical path was the MPS, followed by avionics, flight software, and the four-segment RSRB. The system was found to be partially extensible to the EDS. The RS–25 is not extensible to the EDS, but it is extensible to the HLLV. This vehicle concept is shown in **Figure 6-83**.

Several commonality options exist between the four-segment RSRB/one RS–25 upper stage and the envisioned EDS. Significant cost savings may be realized by this commonality. For example:

- Adapters, payload fairing, and separation system,
- Launch infrastructure,
- Production and handling infrastructure,
- Avionics (basic avionics could be the same),
- Tank (tank cylinder plugs enable multiple lengths),
- Umbilicals (aft umbilicals for simplified ground operations),
- Aft thrust structure,
- Engine mounts and gimbals, and
- Propulsion (main engine, feed system).

Overall development risk was scored as low, based on the availability of critical existing booster and RS–25 assets.

For the five-segment RSRB with one RS–25 upper stage engine, the same major concerns apply. Schedule availability of 2013 could potentially be mitigated to 2012. Critical path items were the same, except for the noted five-segment RSRB. The same acquisition strategy as the four-segment RSRB was applied. As was shown above for the four-segment RSRB with one RS–25, the system was determined to be partially extensible to the EDS. The RS–25 and the five-segment RSRB are extensible to the HLLV. Again, development risk was determined to be low, because it leveraged existing assets or upgrades.

In analyzing the five-segment RSRB with one J–2S upper stage engine (designated LV 16), the major concern was a new upper stage and upper stage engine development. Schedule availability of 2014 could be mitigated to 2012. The primary critical path item was the J–2S engine, followed by the MPS, avionics, and flight software. This configuration was found to be extensible to the EDS and partially extensible to the HLLV. Overall development risk was scored as medium, due to engine redevelopment and certification.



Figure 6-83. LV 13.1 Concept

6.9.3 EELV-Derived Assessments

The Atlas V outfitted with three RD-180s on the core and a new upper stage outfitted with four RL-10 engines (designated LV 2) was a major concern, because it is a modified vehicle with the need to Americanize and human rate the RD-180 booster engines, in addition to the margin, reliability, and safety upgrades needed to human rate the RL-10 and current vehicle designs. The schedule availability in 2014 could be mitigated to late 2012. The primary critical path driver was the RD-180, followed by the MPS and the RL-10. This vehicle was not extensible to the EDS, but was partially extensible to the HLLV (boosters and core propulsion). The development risk was scored as high. See **Section 6.5.4.2, EELV Modifications for Human-Rating Summary** for more details.

The major concerns with the Delta IV outfitted with three RS-68s and a new upper stage with four RL-10 engines (designated LV 4), are the new upper stage and human rating the RS-68, RL-10, and overall vehicle. The 2013 schedule could be mitigated to early 2012. Critical path items included the RL-10 engine, the MPS, and the RS-68 engine, in that order. This vehicle was not extensible to the EDS or to the HLLV. Overall development risk was assessed to be medium. See **Section 6.5.4.2, EELV Modifications for Human-Rating Summary**.

The results of the assessments are contained in **Appendix 6F, EELV Modifications for Human-Rating Detailed Assessment**, and contain extensive company-proprietary data.

6.9.4 Summary Assessment of the RS-25 as an Upper Stage Engine

The RS-25, shown in **Figure 6-84**, was recommended by the ESAS team as the most viable upper stage engine for the following primary reasons:

- The RS-25 is a technically feasible upper stage engine and was considered a low-risk approach.
- The RS-25 engine is a practical near-term engine schedule solution because it could be developed and certified in approximately 3 years and meets the calendar year 2011 first human launch date.
- The Rough Order of Magnitude (ROM) DDT&E costs to certify the present configuration for upper stage use are reasonable and much less than certification costs of a new engine.

Significant SSME flight hardware would be available to support early upper stage development and would provide a major cost savings. If the Shuttle flight manifest remains at 28, there are 12 engines available at the end of 2010. If the Shuttle manifest is cut to 16, an additional 2 engines are available, for a total of 14 available in early 2009. It is likely that one of three current development engines could be made available in 2007 to begin testing. The time needed to build long-lead components, such as nozzles, is approximately 5 years. The ESAS team assumption for this study is that there are 16 Shuttle flights remaining and there will be 14 Block 2 flight engines available for CLV use. Additional flight engines would be required to meet the proposed manifest, but bringing production to current capacity of six engines per year is possible, and this rate can support the proposed manifest.



Figure 6-84. RS-25
(Altitude-Start SSME)

6.9.4.1 RS–25 Altitude-Start Evaluation

A single RS–25 (Block 2 SSME) is recommended for the upper stage engine. The overall goal is to minimize modifications to the current configuration and operation. Since the engine must operate with no gravity head, the design goal is to minimize propellant tank pressures. The engine start would be at approximately launch-plus-2 minutes.

RS–25 modifications and objectives of the test program would address engine thermal conditioning, engine prestart purging, and engine start sequence, including achieving sufficient oxidizer inlet pressure in the absence of an oxidizer gravity head.

Although starting an RS–25 at altitude presents a risk, an evaluation conducted in 1993 looked at using the Phase 2 SSME for altitude-start. The results indicated that a new start sequence would be required and that higher turbine temperature spikes would be provided. A 2004 study indicated that additional start sequence updates would be required and the inlet conditions were not optimal. Further refinement is in progress. The overall conclusion is that RS–25 altitude-start for an upper stage application is feasible.

6.9.5 Space Shuttle SRB, Four-Segment SRB Derivative

More than 200 four-segment SRBs have been flown on the Space Shuttle Program, with a total of 42 SRM static-test firings, 18 of which are RSRM tests and ongoing production. The Shuttle Program currently has reusable assets for flight beyond 2020 with the current four-segment configuration, which is shown in **Figure 6-85**.



Figure 6-85. SRB Four-Segment Configuration in Production

Status is as follows:

- Four-segment production is performed at ATK Thiokol. KSC has supported up to 19 motors (8 flight sets and 3 static tests).
- Six production RSRM flight sets have been built. An additional 23 sets are available in the current contract scope.
- SRB hardware deliveries are set to support the Shuttle to 2010, but can be extended.
- This option has minimal “keep alive” issues.

Other considerations for use as a CLV include enhancements that may be required as intermediate block upgrades, including motor insulation material obsolescence, recovery systems, and propellant upgrades and nozzle extension for increased Isp. The development plan is based on minimal burn-rate reduction for dynamic pressure reduction and minor propellant grain modifications.

Motor specifications are given in **Table 6-39**. Given these parameters, this system is capable of delivering the performance needed for a CLV.

Table 6-39. Four-Segment SRB Performance Specifications

Propellant	PBAN
Total Isp (M lbf/sec)	296.3
Chamber pressure (psia)	625
Maximum Thrust (lbf)	3,331.400
Burn Time (sec)	123.5
Burn Rate (in/sec)	0.368
Initial T/W	1.52

The development schedule goal for this approach puts first human flight in 2011. This assumes that new avionics will be required (a 3.5-year schedule driver) and that the first crewed flight hardware delivery will be in 2010. This approach also assumes that there will be cost synergies gained from contract bridging to Shuttle production, with minimal “keep alive” costs due to current Shuttle hardware production projected to system retirement in 2011. This schedule is based on a production rate of 10 or more motors per year, with a capability for a total of 19.

Risks, Opportunities, and Watches (ROW) for the four-segment SRB development are listed in **Table 6-40**.

Table 6-40. Four-Segment SRB Development Risk Summary

Area	ROW	Notes
Asset Transition	Watch	Schedule and cost assumptions are based on existing hardware migration. Lead times for design and manufacturing of new case hardware is a key driver.
Avionics	Watch	Schedule driver for early flight. Aggressive with or without Shuttle hardware migration.
Obsolescence	Watch	Obsolescence historically required vigilance and continual funding. Planning should remain in place to address obsolescence issues.
System Design	Watch	Schedule assumes slight design changes and accelerated review/manufacturing. Does not address significant changes due to new loads, controls, etc.

The goal of using the SRB for the CLV is to take advantage of an existing booster with little risk to the manufacturing schedule and cost. Overall, development risk is low with utilization of existing assets and experience. Facilities and hardware risk is low, without significant vendor ramp-up. **Table 6-41** categorizes ROW items related to required changes.

Component	ROW	Notes
System	Opportunity	Mature design, experienced staff, and existing test stands with 150+ four-segment firings. Analytical tools and skills in place to support minor design changes.
Structures	Watch	Preliminary assessment shows margin for structures and joints.
Insulation	Watch	Chrysotile replacement certification for four-segment allows block upgrade without additional test program.
Separation System	Watch	Currently qualifying ATK as a new source for BSM. Design change is to be determined.
Avionics	Risk (Low)	Replacement/upgrade of outdated parts necessary during the life of the Exploration Program.
Recovery System	Watch	Minimal design change.

Table 6-41. Four-Segment SRB Change Risk Summary

The Space Shuttle system is a significant asset, with existing RSRM and SRB hardware in inventory that can be transitioned to the CLV for a cost and schedule benefit. Attrition rates are less than 10 percent. Both the booster and motor can support an 8-flight set throughput per year. Production supports the Shuttle transition with 10 to 14 extra motors built at the end of a 16-Shuttle mission schedule (at the current rate). This assumes current inventory and contract structure, four-segment baseline (no additional hardware needed), production ramping up to 10 motors per year from ATK beginning in 2006, refurbishment of hardware, and no additional attrition. A key factor is that no upgrades are needed to current capability.

Obsolescence and vendor issues are workable. Only one key obsolescence issue is not being addressed by the current Space Shuttle Program: the closing of the RSRM case segment manufacturing and heat-treatment facility. Relocation/reconstitution has a 2.5-year schedule to production. However, this affects only the five-segment SRB. In addition, SRB forward- and aft-skirt vendors no longer exist. Based on an SRB study conducted in 2000, it would take approximately 3 years to qualify a new vendor. Currently, the RSRM insulation (chrysotile) replacement activity in work is included in the RSRM Program Operating Plan through 2010. Although not required for the current manifest, it will be needed for flights in 2010 and beyond. The RSRM nozzle is a rayon material, with enough material available for 68 additional nozzles. Qualification of a new vendor is captured in the current Space Shuttle Program cost.

6.9.6 Upper Stage and Interstages Subsystems

6.9.6.1 Upper Stage RCS

The goal of a new upper stage RCS is to meet requirements for crew missions. A conceptual schematic is shown in **Figure 6-86**.

The upper stage RCS configuration of the reference LV 13.1 CLV is based on a hypergolic R4D-based architecture. Propellants are Monomethylhydrazine (MMH) and Nitrogen Tetroxide (NTO) (Mon-3), with a pressure-fed thruster configuration. System pressure is approximately 50 to 300 psia, and RCS thrust level is approximately 100 lbf. The upper stage RCS represents the state-of-the-art in space propulsion capability. Qualified vendors are available for RCS development. Considerations for use in a human-rated system include use of components that either have been human rated (such as the R4D thrusters), can accommodate human rating with new development (propellant and pressurant tanks), or are derived from existing state-of-the-art capabilities (other components). Test issues include availability of test stand and early test stand preparation. Overall, development risk is low, as shown in **Figure 6-86**.

Upper Stage RCS Configuration

- POD: Hypergolic R4D Based Architecture
- Propellants:
 - MMH and NTO (Mon-3)
 - Pressure-Fed Thruster Configuration
 - System Pressure~ 50-300 psia
 - RCS Thrust Level ~100 lbf

History/Status

- State-of-the-Art Space Propulsion Capability
- Qualified vendors available for RCS development

Considerations for use in Human-Rated System

- Components either have human-rating (R4D thrusters) or can accommodate human-rating with new development (propellant and pressurant tanks) or derived design development (components)

Development Path/Issues

- Typical development cycle can be accommodated in identified schedule with aggressive subsystem and hardware start
- High parts count necessitates early start

Risk

- Overall Low Development Risk

Test Issues

- Availability of test stand and early test stand preparation

Goal – New upper stage to meet mission requirements for crew

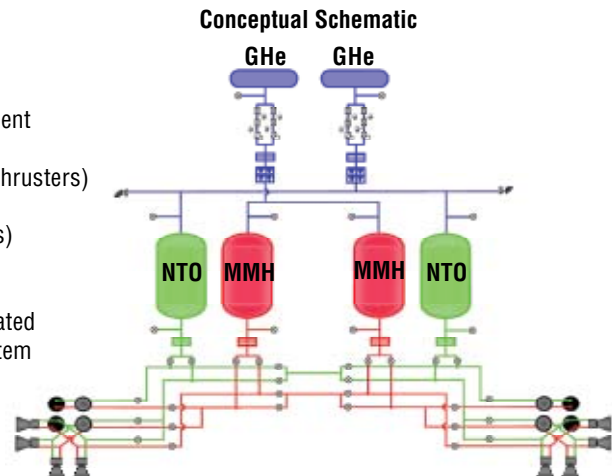

Figure 6-86. Upper Stage RCS Conceptual Schematic

Component	Low Risk
System	RCS subsystem design is similar to SOA designs and capabilities.
Tankage	Existing vendor base with new tank development, but within technology and SOA technical basis.
Thrusters	Existing vendor base with SOA thrusters.
Components	SOA or SOA-derived components.
Avionics	SOA avionics boxes.

6.9.6.2 Upper Stage Structures

The upper stage structural elements of the reference LV 13.1 CLV consist of the following load-bearing structures: LOX/LH2 tanks, intertank, forward skirt, aft skirt, and thrust structure. **Figure 6-87** shows the breakout of the upper stage structural elements. A systems tunnel is provided as a secondary structure.

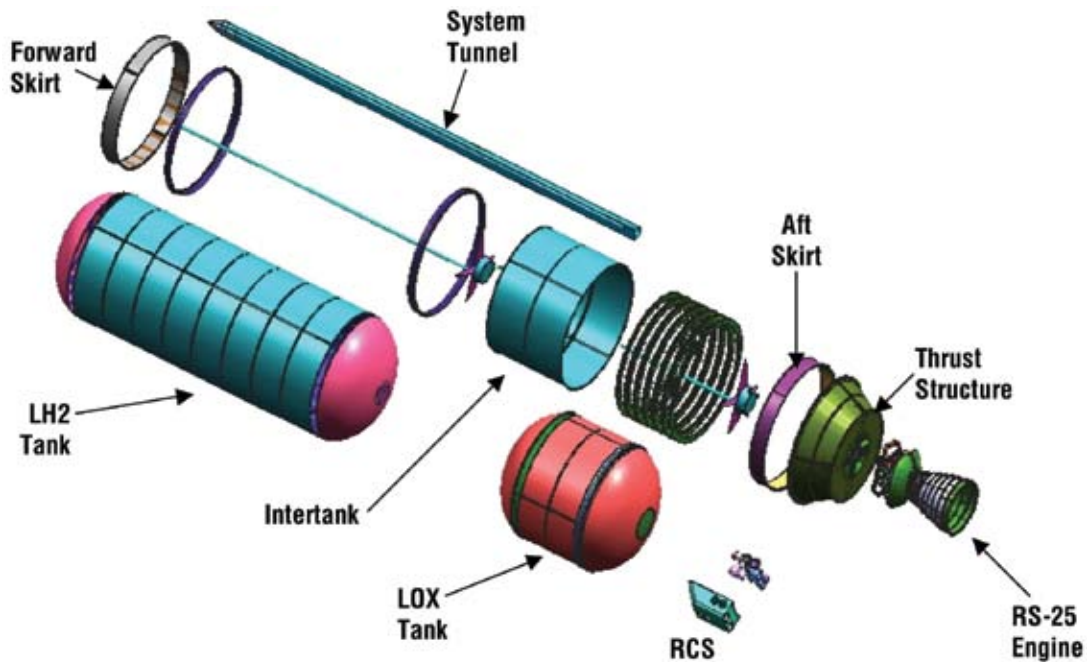

Figure 6-87. Upper Stage Structural Elements

6.9.6.2.1 Tanks and Primary Structures

The LH2 tank and the LOX tank provide the storage for the fuel and oxidizer for the MPS. The initial design was sized to carry 35,000 gallons of LOX and 93,000 gallons of LH2. The intertank is a cylindrical structure that serves as the load-bearing interface between the two tanks (LOX and LH2). It has integral stiffeners and can serve for the mounting of avionics, pressure bottles, and other elements.

The upper stage forward skirt provides the interface and load path for the LOX tank and the payload adapter. This cylindrical or conical structural element is integrally stiffened and may provide additional mounting for avionics. The aft skirt is the transitional structural interface between the LH2 tank and the thrust structure. It also provides attach points for other elements, such as the RCS.

The thrust structure is the primary load-carrying conduit for loads resulting from engine operations. It also provides the mounting surface for the engines.

Each of the primary structures leverages existing technology to minimize risks. Optimization of the stiffening components of each subassembly could act to decrease weight while satisfactorily meeting the established structural strength requirements.

During prelaunch, the TPS controls the propellant boil-off, stratification, and loading accuracy; prevents air liquefaction and ice/frost formation; maintains acceptable interface conditions; and provides acceptable structural margins at liftoff. Selection of TPS materials to be used on the various components is based on the above requirements and manufacturing concerns, such as TPS closeouts and TPS debris requirements.

Several key trades for the upper stage structural elements should be performed, including:

- Material selection;
- Fabrication techniques and methodology;
- Component- versus system-level test and verification;
- Open versus closed intertanks and interstages;
- Common/nested bulkhead versus separate tankage;
- Tank geometry effects on interstage to intertank purge requirements and umbilical requirements;
- Selection of TPS materials to be used on the various components based on ice/frost, stratification, cryogenic heat leaks, air liquefaction, TPS closeouts, and TPS debris requirements;
- Single versus multiple systems tunnel configuration;
- Instrumentation selection and redundancy approaches;
- Potential failure response and detection architectures;
- Optimized ground checkout strategies; and
- Hardware commonality and cost reduction evaluations.

Upper stage structures driving factors included material selection, stiffened panel configuration selection, and component integration selection. Below is a list of the key upper stage assumptions:

- Components to be designed and tested to 1.4 factor of safety (FS);
- Aluminum 2219 material used in sizing effort;
- Isogrid panel configuration for all barrel and cylinder components;
- Classic y-ring component integration with friction-stir weld; and
- Isogrid panel interstage cylinder.

6.9.6.2.2 Interstages and Secondary Structure

The interstages consist of several integral pieces of structural hardware that are necessary to connect the primary structures together into a total CLV. Specifically, the interstage elements connect the primary structures of the spacecraft/payload to the upper stage and the upper stage to the booster. This hardware is designated as the spacecraft/payload adapter, the interstage, and the forward frustum. In addition, the system tunnels and flight termination system are also included in the interstages. **Figure 6-88** shows the interstages structural elements within the upper stage.

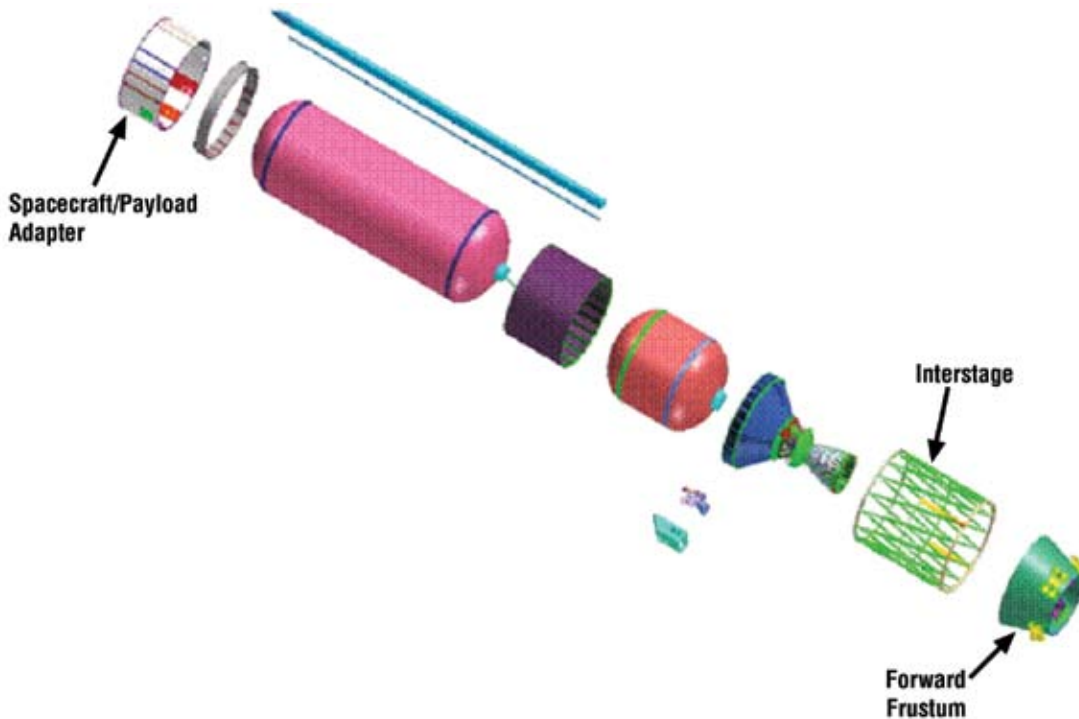

Figure 6-88. Interstages Structural Elements Within the Upper Stage

The forward frustum hardware consists of the forward frustum structure and its subsystems that include the booster RCS, the booster recovery system, booster avionics packaging, purge and vent, and any associated Government-Supplied Equipment (GSE). The booster RCS is shown in greater detail in **Figure 6-89**. It is a blow-down hydrazine system mounted as four replaceable units with four 900-pound thrusters each. It will be used for CLV roll control during ascent.

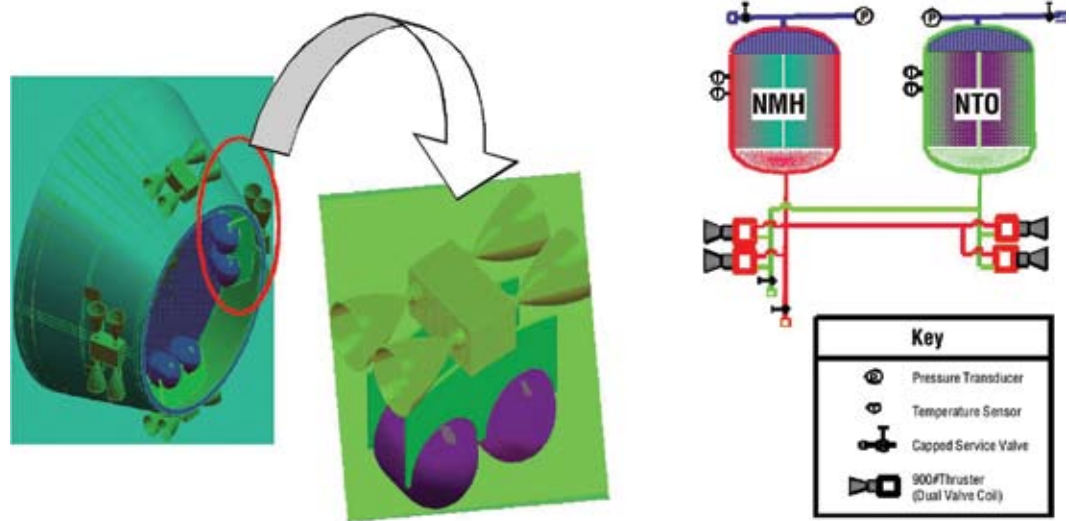

Figure 6-89. Booster RCS

The interstage itself is a cylindrically shaped structure that connects to the upper stage's thrust structure (forward) and the booster stage's forward frustum (aft). Its primary function is for the separation of the upper stage and booster stage. This segment, whether open truss work or a closed reinforced cylindrical shell, is key to the vehicle's mission. It not only provides the mechanism to withstand launch and flight loads, but, because the thrust structure houses the upper stage's engine and the forward frustum houses the booster RCS and other avionics hardware, the interstage's purge and vent system must be designed to facilitate proper operation of these subsystems. The ullage settling motors are also housed within the interstage.

The separation of the booster and upper stage takes place through the separation systems within the interstage structure. One such separation system, that of the booster from the interstage, will initially separate at the aft end of the interstage, with the interstage structure remaining connected to the upper stage. The second separation system is that of the interstage and the upper stage. This will jettison the interstage structure away from the upper stage after the engine reaches 100 percent thrust. The separation approach will leverage work completed for the Saturn Program and make use of separation concepts currently employed for Shuttle operations and ELVs. **Figure 6-90** shows the interstage structural element.

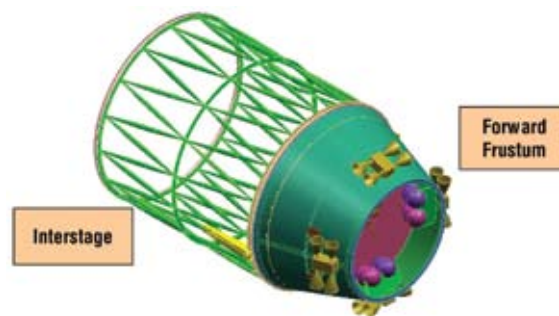

Figure 6-90. Interstage Structural Element Attached to the Forward Frustum

The Spacecraft/Payload Adapter (SPA) structural element is shown in **Figure 6-91**. The SPA is approximately 83 inches long with a 217-inch diameter. After receiving CEV configuration data, including the length of the CEV nozzle, this length was initially set to 105 inches. The SPA has a rigid connection to the upper stage and a separation system interface to the spacecraft. It also contains most of the avionics for control of the LV. On the pad, it will require a purge and an electrical umbilical, and it includes an access door. The baseline assumption is that passive cooling of the avionics is adequate. The SPA provides the mechanical and electrical interfaces between the CEV and the LV and also provides the appropriate accommodations for the LV avionics system. The SPA hardware consists of the spacecraft/payload structure, the upper stage avionics, the separation system, purge and vent, and any associated GSE.

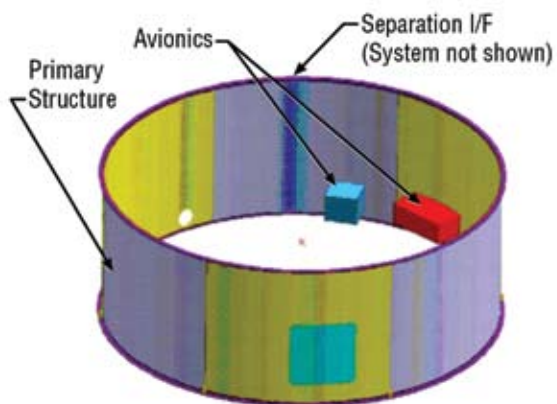

Figure 6-91. SPA Structural Element

6.9.6.3 Upper Stage and Interstage Schedule

The upper stage and interstages are not currently on the program critical path; however, there are several areas that are considered the schedule drivers for structures: (1) requirements; (2) major reviews of Preliminary Design Review (PDR) and Critical Design Review (CDR); (3) tooling modification for 5.5-m tank fabrication; (4) hardware manufacturing; (5) assembly and integration of primary structure and secondary structures with various subsystems required for Prototype Test Article (PTA)/Static Test Article (STA); and (6) modal and structural testing.

The upper stage major milestones and high-level development schedule are as follows:

- March 2009: Upper stage structures delivery to MPTA;
- May 2009: Upper stage structures delivery for STA;
- July 2009: Upper stage structures delivery for the second Risk Reduction Flight (RRF-2)/Certification Flight 1;
- September 2009: Upper stage structures delivery for RRF-3/Certification Flight 2; and
- November 2009: Upper stage structures delivery for first human flight unit.

Major components of the interstage structures that may support RRF-1 will include the forward frustum, booster recovery system, booster RCS for roll control, and separation systems for the upper stage to booster. The interstages major milestones and high-level development schedule include:

- March 2009: Interstages structures delivery to STA;
- To Be Determined: Interstages structures delivery to RRF-1;
- July 2009: Interstages structures delivery for RRF-2/Certification Flight 1;
- September 2009: Interstages structures delivery for RRF-3/Certification Flight 2; and
- November 2009: Interstages structures delivery for first human flight unit.

These milestones and the overall schedule are discussed in more detail in **Section 10, Test and Evaluation**, and **Section 11, Integrated Master Schedule**.

6.9.6.4 Upper Stage and Interstages Risks

Table 6-42 describes the key ROWs for the upper stage Primary and Secondary (PS) structure, along with the Interstage (IS) structures. Overall CLV Program risk for the development of this subsystem is recognized as low to medium due to the clean-sheet design, Government-led design and development through PDR, and the baselined 5.5-m tankage (driven by CEV interfaces) driving new fabrication tooling. Offsetting these potential risks is the utilization of existing fabrication processes and techniques.

Table 6-42. Upper Stage and Interstages Structures Risk Summary

Risk ID	Area	ROW	Description
PS-1	Clean-Sheet Design and Development Timeline	Watch	Clean-sheet DDT&E cycle is longer than using existing or modified system. Fluctuating vehicle requirements could extend development cycle.
PS-2	5.5-m Tank Fabrication	Watch	5.5-m tank fabrication is not synergistic with current 5.0-m tank fabrication performed for EELV. Ability to facilitate for production capability while sustaining current Shuttle ET fabrication requirements may impose program risk.
PS-3	Composite Structures	Watch	Current structures assumptions represent low-risk material selection. Decision to migrate to composite structure with low TRL would introduce additional program risk.
IS-1	Separation Systems	Risk (Medium)	Two separation systems are needed to complete mission objectives. Leverage existing systems to facilitate design, but integration issues remain. Debris generation models and alternate separation methods studies needed.
IS-2	Potential to use existing subsystem hardware designs or derived designs	Opportunity	Lengthy DDT&E can be avoided through the use of Shuttle hardware or derived hardware designs and qualification (where applicable).
IS-3	Transition to Prime Contractor	Risk (Low)	Transition of the interstage DDT&E at PDR could cause schedule slips from extended contract negotiations/award, requirements creep, etc.
IS-4	Government-led Activity	Risk (Medium)	Ability of the Government to perform initial program design and development phases while continuing to support Space Shuttle Program manifest.

6.9.7 Avionics Subsystem

6.9.7.1 Avionics Subsystem Description

The avionics subsystem for the baseline CLV, LV 13.1, is depicted in **Figure 6-92**. As shown in the diagram, the CLV avionics systems physically partitions into three primary vehicle elements: upper stage, boost stage, and the upper stage main engine.

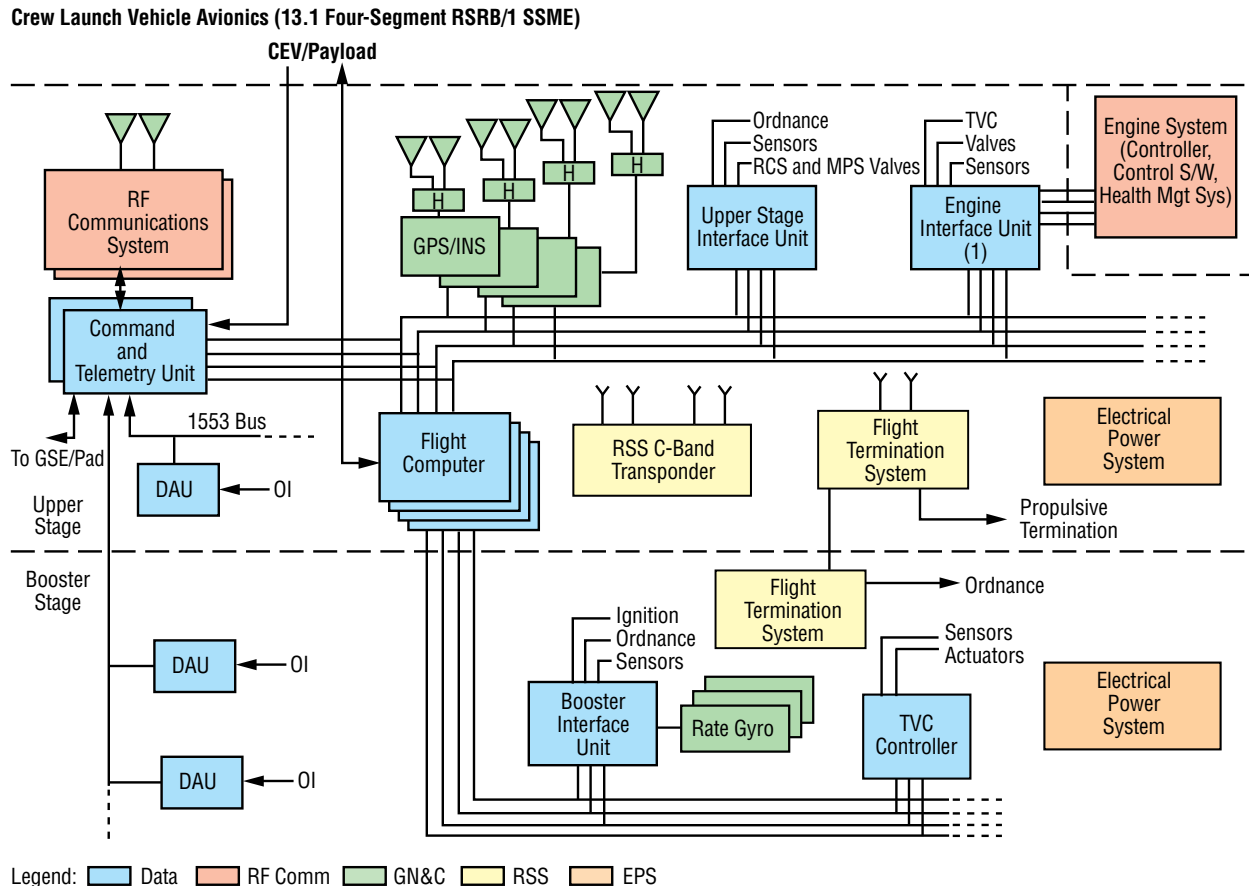

*Figure 6-92
Conceptual CLV
Avionics Architecture*

6.9.7.2 Avionics Subsystem Development

The current element-level development philosophy is that the boost stage element will require minimal modifications of the proposed avionics. Potential changes for this element, with respect to avionics, will be driven by either the propulsion engineers, the health management requirements, or designing out obsolete components. The upper stage element will be the most significant piece of DDT&E for the team. The ground rule is to utilize heritage subsystems to minimize development risk. The main engine for the upper stage is a heritage engine, and the avionics associated with the engine have a defined evolutionary path from the existing SSME.

The primary function of the CLV avionics is to safely guide and control the propulsion stages of the CLV and lift the CEV/CDV into the defined mission orbit. Flight avionics will consist of component subsystems, such as command and data handling, flight software, sensors and instrumentation, video, communications, vehicle management, power systems, electrical integration, and electrical GSE.

The avionics system will interface with the CEV, CDV, payloads, and ground support systems. These interfaces will be defined in program documentation, such as Interface Control Documents (ICDs) and Interface Requirements Documents (IRDs). Depending on program-level documentation structuring, there may be an Interface Definition Document, which would define the complete capability of the interface.

The key features of the conceptual avionics architecture are a traditional approach with heritage electronics that provides for a low-risk development; a practical vehicle management system with health function focusing on crew abort management and on board flight termination; a fail operational/fail safe avionics system architecture where the second major component failure safely recommends crew abort; an onboard range tracking function with the goal of eliminating dependency on the current Air Force ground-tracking sites and associated cost; and an independent flight control capability from the CEV. Additionally, the LV 13.1 conceptual avionics architecture lends itself to a high degree of commonality with the LV 27.3 CDV avionics. A design goal was to make the interfaces with the launch pad and CEV/CDV as clean and loosely coupled as possible. Although the avionics architecture depicts these interfaces as such, system-level requirements may drive these interfaces to be more complex. The initial design currently has no plan to distribute power across the interface between CLV and CEV/CDV.

6.9.7.3 Avionics Schedule

The team will implement a traditional, but accelerated, requirements development plan. Accelerated requirements development introduces risk and the possibility that avionics requirements development may be inconsistent with vehicle requirements. However, this approach optimizes the overall avionics development effort. The avionics system requirements lag the vehicle element and System Requirements Reviews (SRRs), and the avionics component SRRs and PDRs feed other vehicle system-level PDRs and CDRs.

Parallel development during requirements, preliminary design, and critical design phases will be necessary to achieve major program milestones. The avionics major milestones include:

- March 2009: Avionics Delivery for MPTA;
- August 2009: Avionics Delivery for RRF-1;
- December 2009: Avionics Delivery for RRF-2;
- April 2010: Avionics Delivery for RRF-3; and
- August 2010: Avionics Delivery for ISS-1.

These milestones and the overall schedule are discussed in more detail in **Section 10, Test and Evaluation**, and **Section 11, Integrated Master Schedule**. The avionics subsystem is not currently on the CLV program critical path; however, there are five major areas that are considered the schedule drivers for avionics: (1) flight software; (2) GN&C hardware; (3) Global Positioning System (GPS)/Inertial Navigation System (INS); (4) GN&C rate-gyro assembly; and (5) the flight computer.

6.9.7.4 Avionics Risk

The avionics development plan will follow a traditional avionics architecture approach and utilize existing avionics technologies for subsystem development, resulting in minimized risk when compared to a new technology development approach. However, all new avionics will be developed for this vehicle and will be subject to some low to medium risks identified in **Table 6-43** below.

Title	Risk Level	Risk Description
Avionics System	Low	Traditional avionics architecture with heritage electronics augmented by practical vehicle management. Avionics system requirements development lags vehicle system requirements and is susceptible to inevitable change. Software is a long-lead item tied to operations philosophy. Test program becomes compressed and potentially jeopardized.
Software	Medium	Software will be a critical path item. This software architecture will be challenged with requirements for (1) human rating, (2) vehicle management, and (3) operations concept.
Redundancy	Watch	Redundancy management is implemented across subsystem interfaces (operational, software, electrical, and mechanical) and becomes quite intricate. Requirements and testing are essential.
Electrical and Electronic Engineering (EEE) Parts	Watch	Part choices and selection are limited for space-rated electronic parts and usually require long-lead procurements.
Vehicle Management	Opportunity	Practical vehicle management provides three major vehicle functions: crew abort management, onboard flight termination system, and pad interface diagnostics.
Engine Controller (Delivered with Engine System)	Medium	The engine controller hardware and software will be a schedule risk based on previous engine experience. Engine health management is included in the engine controller.

Table 6-43. Avionics Risk Summary

6.10 LV Development Schedule Assessment

6.10.1 Schedule Approach

The requirements given to the ESAS team were based on three driving requirements: (1) first crewed flight to ISS in 2011; (2) the ESAS Traffic Model shown in **Figure 6-93**; and (3) the human-rating requirements derived from NPR 8705.2A, Human-Rating Requirements for Space Systems.

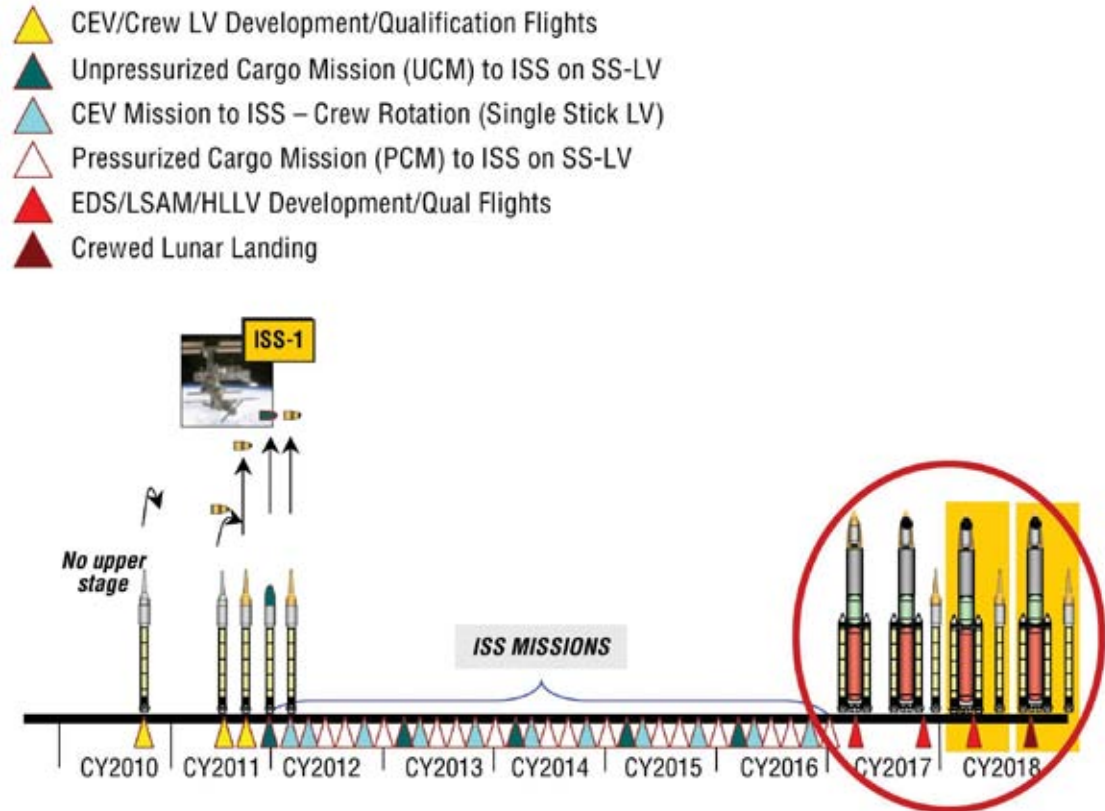

Figure 6-93.
ESAS Traffic Model

The team's approach to the schedule was to build a detailed development Integrated Master Schedule (IMS) with all long-lead critical design, fabrication, and test tasks for the CLV from the EIRA in a logically linked Microsoft Project schedule. Although high-level CaLV schedules were developed, detailed focus was on the CLV because it is a near-term, critical-path item in the ESAS architecture. This entailed engaging engineers who have experience in developing flight hardware and software systems, using their expert judgment to define the tasks, task durations, and task relationships for each subsystem and SE&I activities necessary to design and develop the EIRA CLV (i.e., five-segment RSRB with an upper stage using a new expander cycle engine). The schedule feasibility for other alternatives was performed using a comparison approach by modifying the EIRA CLV bottom-up development schedule details (e.g., replace one engine schedule with another). The tasks were organized by a team WBS, shown in **Figure 6-94**.

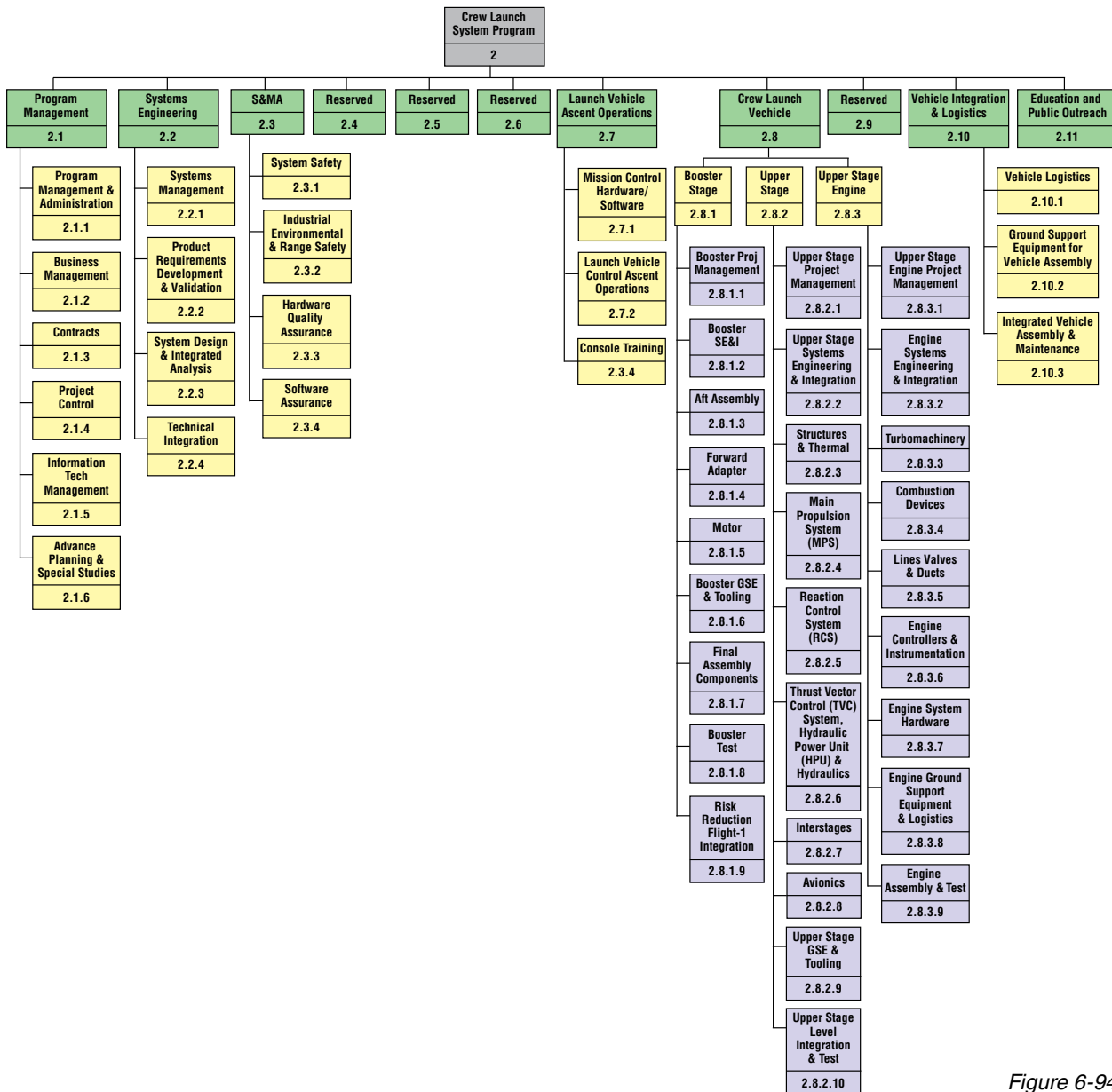

Figure 6-94. Team WBS

The CLV options evaluated by the team were:

- Shuttle-derived options: In-line four-segment or five-segment RSRB with a new upper stage with various engines (LR-85, J-2, J-2S, RL-10), and
- EELV options: Delta IV and Atlas V with new upper stage.

Once a detailed CLV IMS was built, the team evaluated the above alternatives against the driving requirements while also assessing the development feasibility of each of the proposed alternatives. For instance, the detailed schedule showed that a new upper stage engine development (LR-85) was the critical path driver for the EIRA CLV. The team then looked at alternatives to the engine development, such as J-2, SSME, and the RL-10. The schedule analysis focused on meeting a 2011 first human flight to LEO. Other technical and

programmatic FOMs were being evaluated in parallel (cost, technical performance, and reliability). The initial detailed schedule construction and analysis revealed a launch date for first mission of no earlier than 2014 for EIRA CLV. In evaluating alternatives, it should be noted that many tasks were common or very similar for the Shuttle-derived CLV options, such as avionics, SE&I and structures, and MPSs. The engine proved to be the significant schedule discriminator among Shuttle-derived CLV options.

6.10.2 IMS for the Selected CLV (LV 13.1)

The IMS consists of subprojects developed by the WBS leads and their supporting engineering disciplines at the subsystem level that are then mapped to the CLV WBS. These subprojects were logically linked into a master schedule. The schedule is discussed in more detail in **Section 10, Test and Evaluation**, and **Section 11, Integrated Master Schedule**.

The integration logic of the IMS was built around the flow down of requirements to the component level.

- LV system requirements are developed through an SE&I process resulting in an LV SRR.
- Requirements flowdown to the system elements (i.e., booster, upper stage, interstages) results in system element SRRs 3 months after the LV SRR.
- System element requirements flowdown to the subsystem level results in subsystem SRRs 3 months after system-element SRRs.
- Subsystem requirements flowdown to the components results in component requirements reviews, which then begin the preliminary design phase for each component.
- After the preliminary design phase, a PDR is conducted for each component.
- Component PDRs flow back up to a subsystem level and, 3 months later, a subsystem PDR is conducted.
- Subsystem PDRs flow back up to a system-element level and, 3 months later, a system-element PDR is conducted.
- System-element PDRs flow back up to the LV System and, 3 months later, the LV System PDR is conducted.
- The Critical Design and Design Certification phases follow the same path as the PDR, starting at the component and flowing back up to the LV Systems.

The primary critical path is driven by requirements flowing down from the LV System to system elements to subsystems to components. The driving component is in design cycles for valves and actuators for the MPS. MPS CDR drives the fabrication of feedlines for the MPS. The MPS is the schedule driver for integration of the upper stage MPTA. The MPTA is scheduled to perform 166 days of propulsion testing to qualify the upper stage. After the upper stage is qualified, greenrun tests are performed on the upper stages for RRF-2 and RRF-3 prior to shipment to KSC. These flights and the overall schedule are discussed in more detail in **Section 10, Test and Evaluation**, and **Section 11, Integrated Master Schedule**.

6.11 Conclusions

6.11.1 Crew Launch Vehicle

The Shuttle-derived in-line RSRB vehicle, LV 13.1, using a four-segment RSRB and a SSME-powered upper stage, provides the best option for meeting exploration crew transport goals, ISS crew transfer requirements, and ISS cargo resupply requirements. A summary of candidate CLVs and key parameters is shown below in **Figure 6-95**.

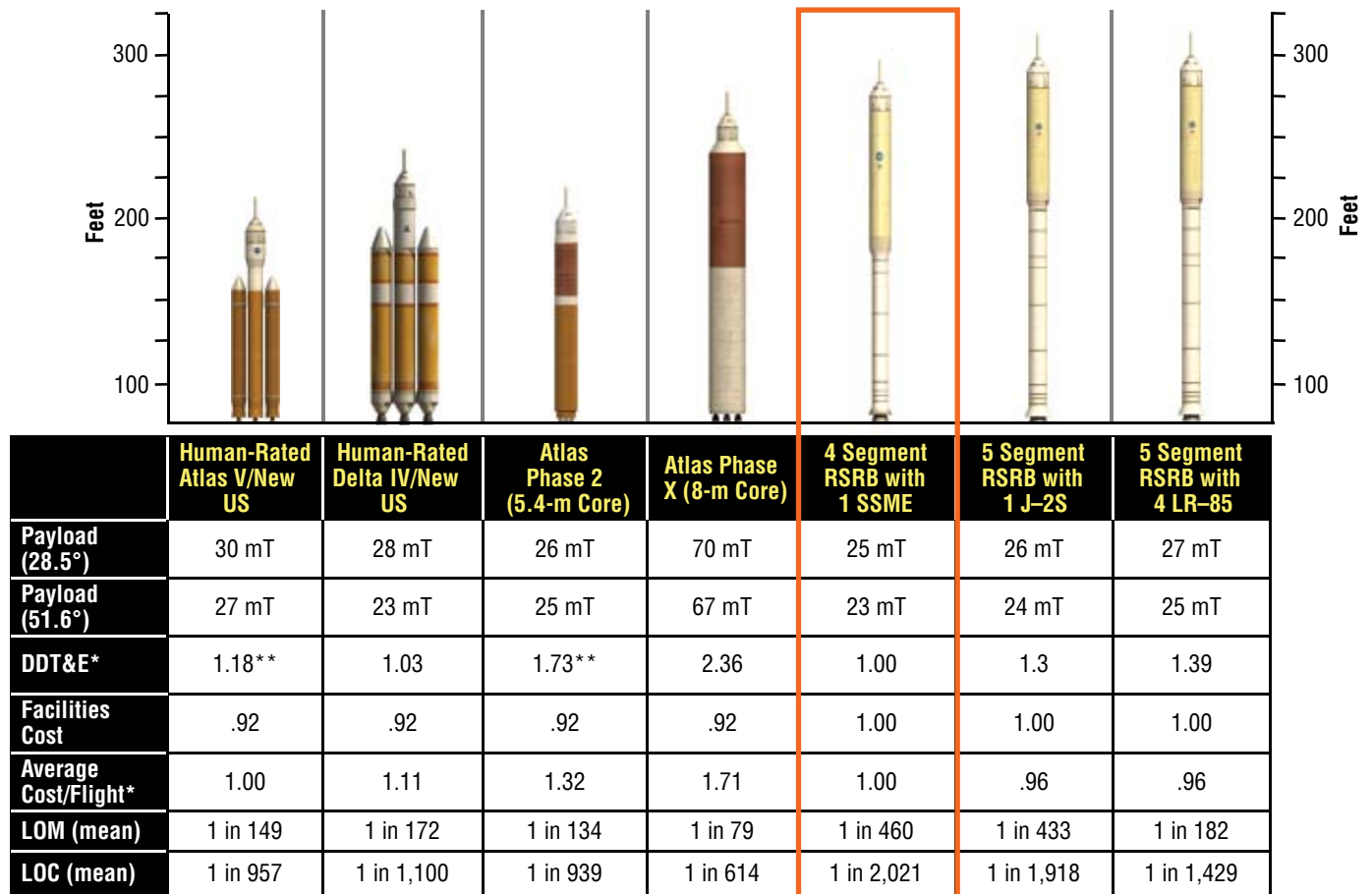

LOM: Loss of Mission LOC: Loss of Crew US: Upper Stage RSRB: Reusable Solid Rocket Booster

* All cost estimates include reserves (20% for DDT&E, 10% for Operations), Government oversight/full cost; Average cost/flight based on 6 launches per year.

** Assumes NASA has to fund the Americanization of the RD-180.

Lockheed Martin is currently required to provide a co-production capability by the USAF.

Figure 6-95.
Comparison of Crew
LEO Launch Systems

LV 13.1 exhibited the lowest predicted LOC probability and the lowest DDT&E cost of the options assessed. It provides a net delivered payload to exploration assembly orbits and ISS with sufficient margins to accommodate anticipated CEV masses. Infrastructure costs are slightly higher, approximately 8 percent, than EELV-derived options, and average cost per flight is comparable to EELV options (depending on flight rates) and 4 percent higher than other SDV options evaluated. Additionally, LV 13.1 provides key elements, particularly propulsion systems, vital to the development of the CaLV for lunar and Mars exploration. It also maintains the Nation's access to solid propellant production at current levels.

6.11.2 Cargo Launch Vehicle

The CaLV concept determined to offer the best option for meeting exploration goals is the Shuttle-derived in-line vehicle, LV 27.3, using two five-segment RSRBs and five SSMEs in the ET-diameter core vehicle. A summary of candidate CaLVs and key parameters is shown in **Figure 6-96**.

LV 27.3 is the only heavy-lift CaLV in the study trade space that enabled the “1.5-launch” solution for lunar missions for anticipated CEV and LSAM masses without the requirement to develop a two-stage core vehicle. The 125-mT lift capability increases mission safety and reliability by minimizing on-orbit assembly and multiple rendezvous and docking events. It exhibits LOM and LOC probabilities higher than EELV-derived options and has fewer discrete elements to develop than options derived from EELV elements. Previous studies did not show any advantage to new clean-sheet concepts, and, in fact, found them to be of significantly higher risk and cost, while not providing any advantage in lift capability, safety, or mission success. Only one 2-launch solution option, LV 27, exhibits a lower per-flight cost than LV 27.3, and it is the four-SSME core vehicle on which LV 27.3 is based. The LV family DDT&E is within 2 percent of the lowest 2-launch solution vehicle. Comparisons with 3+-launch solutions show savings of other options in both individual and family DDT&E costs, but per-mission costs would be significantly higher. The Shuttle-derived side-mounted vehicles provide the most commonality with the current Shuttle, but have significantly less lift capability (requiring at least four launches), exhibit higher production costs due to the carrier vehicle, and exhibit the least straightforward evolutionary path to Mars exploration lift requirements. The Shuttle-derived side-mounted is not considered to be a viable crewed configuration due to the requirement of the configuration to place the CEV within 10 feet of the LOX tank and a more-obstructed path away from the vehicle in the event of a launch abort. The in-line Shuttle-derived CaLV configuration provides enhanced safety for a crew (if needed), a straightforward upgrade path for Mars missions, and higher mission reliability for a small (2 percent) additional investment upfront for the CLV/CaLV combined development of LV 13.1 and LV 27.3, as compared to the lowest 2-launch solution combined option.

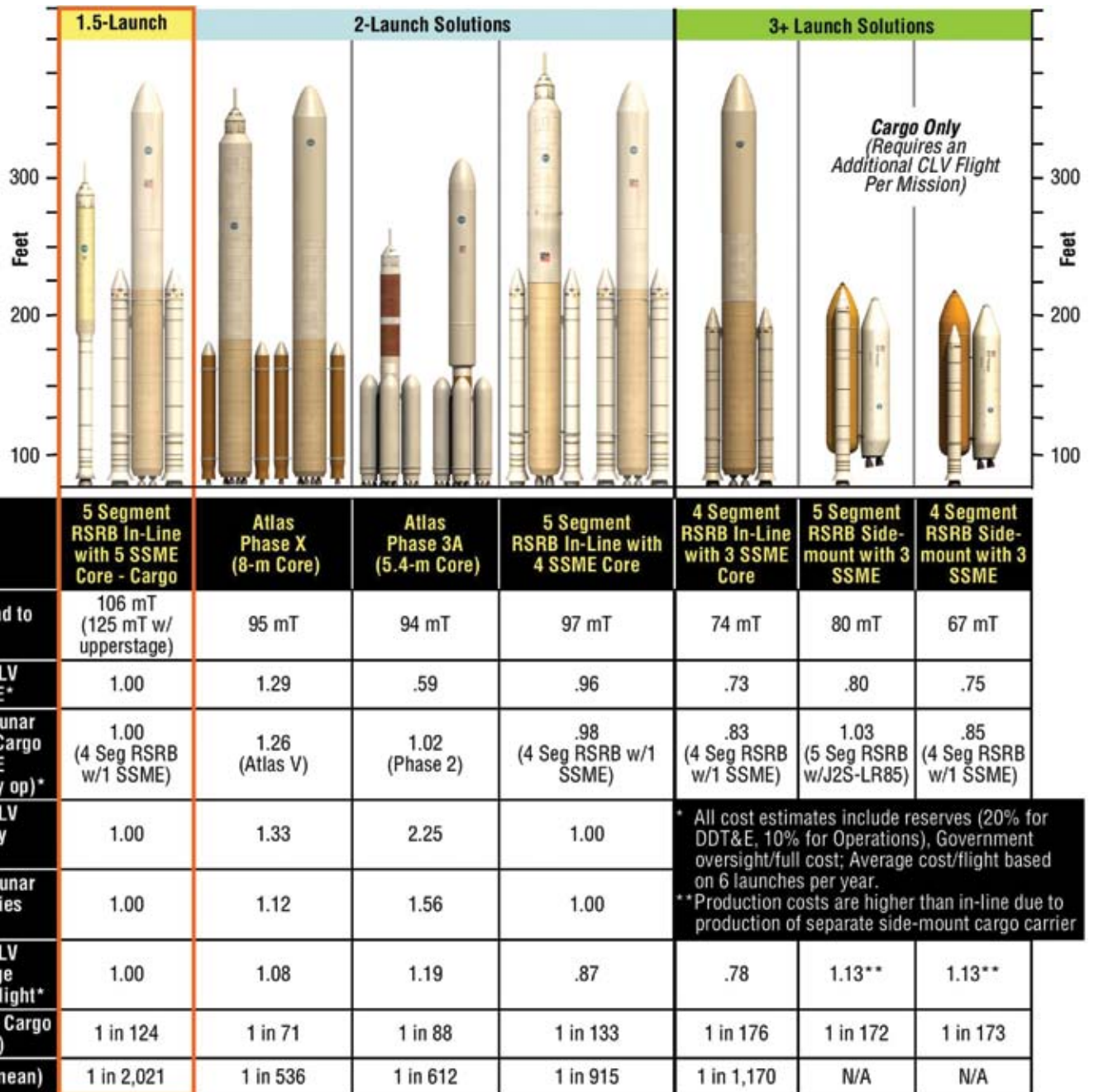

Figure 6-96. Lunar Cargo Launch Comparison

6.11.3 Earth Departure Stage

The EDS concept for LV 27.3, EDS S2B4, can deliver 125 mT to 160 nmi LEO when used as an upper stage. This provides growth to anticipated Mars mission launch masses with no additional DDT&E expenditure.

6.11.4 Integrated Launch System Considerations

The combined LV 13.1/27.3 architecture development approach provides the highest potential for meeting a CEV IOC of 2011 and a CaLV IOC of mid-2010s due to these attributes:

- Requires no new engine system development for the CLV;
- Relies on the most extensive, human-rated U.S. operational database in history for the CLV propulsion elements;
- Requires that only the CLV (LV 13.1) be human rated, while preserving the option to human rate the CaLV (LV 27.3).
- Facilitates CaLV development by using two of the three required engine/motor systems needed for LV 27.3 and its EDS;
- Minimizes keep-alive costs and schedule issues for SSME and RSRB by continuing in production and launch/recovery operations; and
- Both LV 13.1 and LV 27.3 vehicles will draw from the same, existing ground infrastructure.

6.11.5 Final Considerations

The combined development of LV 13.1 and LV 27.3 pairs the most reliable, safest CLV with the most extensible, most reliable, and highest performing CaLV. The development of the CLV based on LV 13.1 will provide the most straightforward, structured progression to the 1.5-launch solution lunar architecture, while providing the lowest risk CLV development to acquire and maintain crewed access to LEO and the ISS. The 1.5-launch solution CaLV provides payload performance to TLI exceeding that of the Saturn V of the 1960s with minimal development and certification of critical flight elements. The use of the SSME in the core stage of the CaLV allows this high performance without the requirement for an upper stage (beyond the EDS) for LEO. The use of key elements from the current Shuttle system allows a straightforward path to human rating of the CLV.