



# Reducing Heat Loss Due to Air Leakage

*This pamphlet is one in a series that describes residential energy conservation requirements of the Oregon Residential Specialty Code and Structural Specialty Code. Other pamphlets in this series may be downloaded from Oregon Department of Energy web site at <http://egov.oregon.gov/ENERGY/CONS/Codes/cdpub.shtm> or local building departments or from Oregon Building Codes Division.*

## Code requirements for air leakage control

Air leakage is random movement of air into and out of a building through cracks and holes in the building shell. In technical bulletins, air leakage is called “infiltration” (air moving into a building) or “exfiltration” (air moving out of a building). In everyday language, air leaks are called “drafts.”

To reduce heat loss due to air leaks, energy code establishes testing criteria for air tightness of windows and doors. Energy code also specifies construction joints that must be sealed during construction. Requirements for air leakage control remain unchanged from earlier versions of the energy code.

### Window and door air leakage

Laboratory testing establishes air leakage rates for windows and doors. Window leakage rates are given in cubic feet per minute (cfm) per linear foot of sash crack. Door air leakage is most commonly expressed as cfm per square foot of door area.

Window air leakage must not exceed 0.37 cfm per linear foot of sash crack. Swinging door air leakage must not exceed 0.37 cfm per square foot of door area. Sliding door air leakage must not exceed 0.37 cfm per square foot of door area.

These air leakage rates are not particularly stringent. Many manufacturers meet or exceed these standards.

To determine whether windows and doors meet these requirements, ask the retailer or manufacturer for product literature. Product literature should list performance data, including air leakage. The standard test to look for is ASTM (American Society of Testing Materials) E-283, “Standard Test Methods for Rate of Air Leakage Through Exterior Windows, Curtain Walls and Doors.” The air leakage test must be conducted under a 25 mph wind speed.

### Sealing the building envelope

Energy code specifies that the following construction joints must be sealed:

- Exterior joints around window and door frames
- Joints between wall cavities and window and door frames
- Joints between the wall and foundation
- Joints between the wall and roof
- Joints between wall panels
- Penetrations or utility services through exterior walls, floors and roofs

Code also requires sealing of “all other openings” in the building envelope “in a manner approved by the building official.”

### Exterior joints around window and door frames and between wall cavities and window and door frames

Air leaks can by-pass tightly closed windows and doors and create uncomfortable drafts. Sealing at windows and doors reduces air leakage through rough openings. Exterior caulking around the exterior trim or behind window fins helps reduce air leakage. On the inside, rough openings are stuffed with filler material such as insulation scrap then sealed over with caulk. Expandable foam caulk, polyethylene backer rod, or rope caulk are also used.



Figure 1:  
General wall air sealing

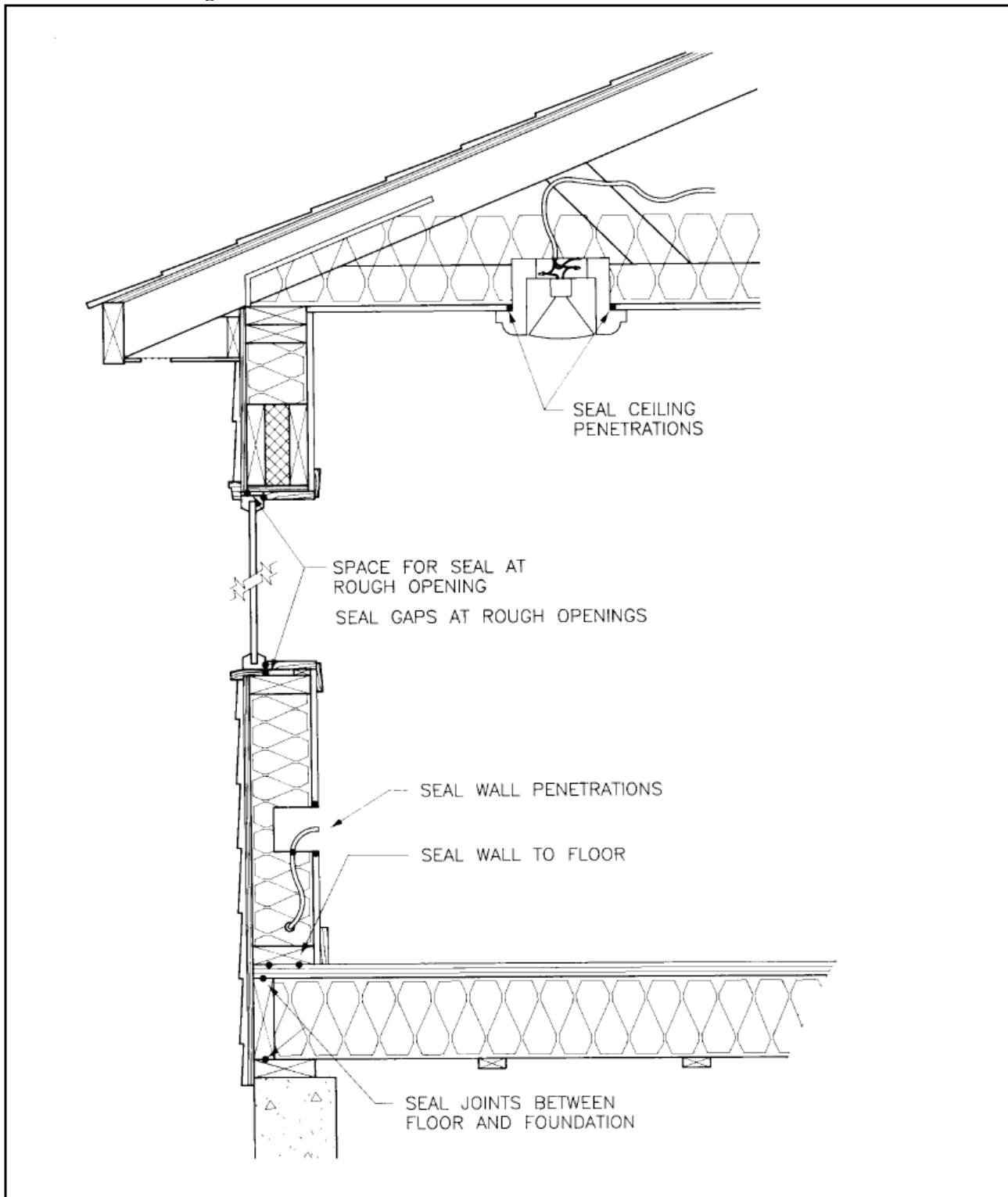

Figure 2:  
Sealing the tub penetration

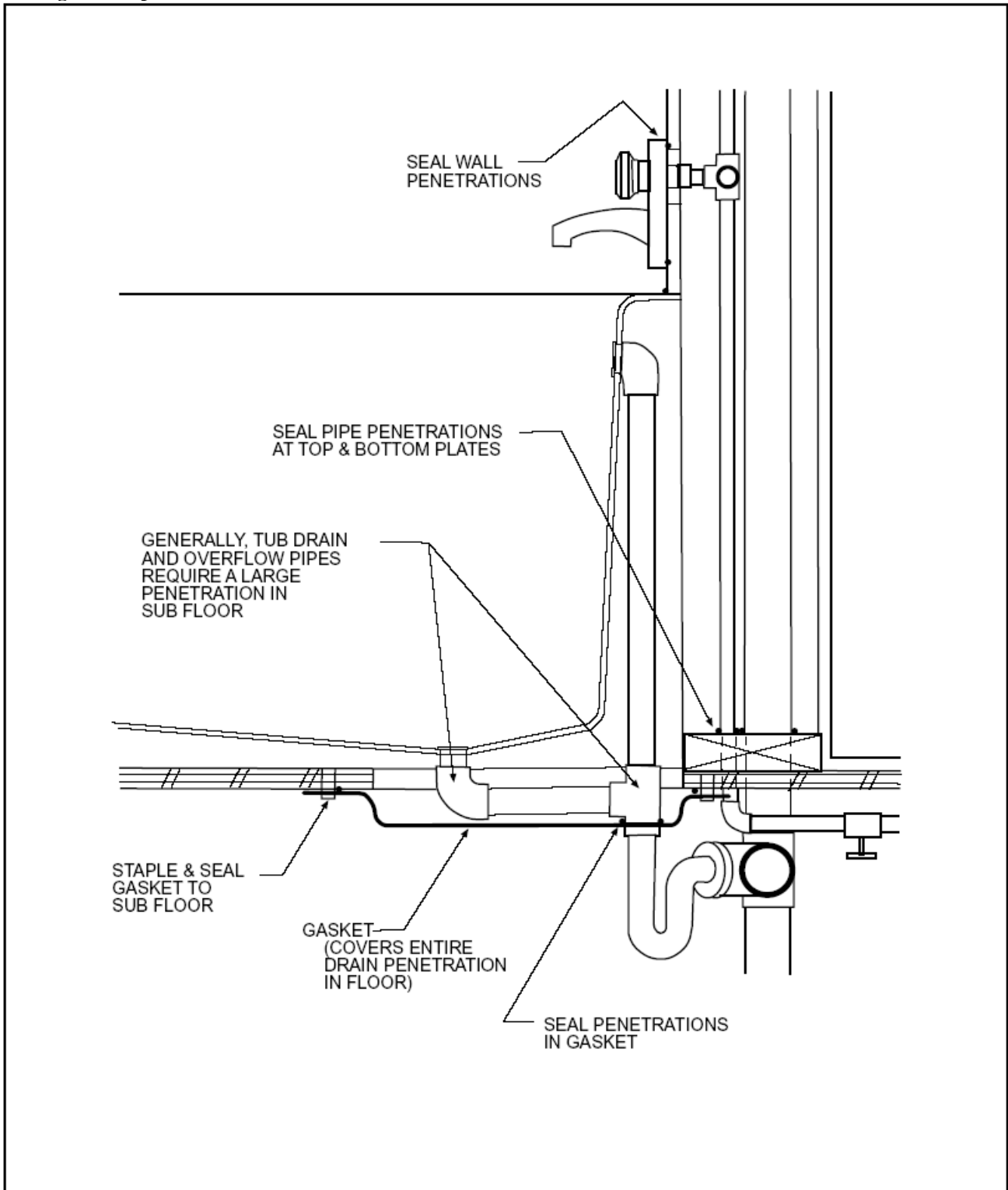
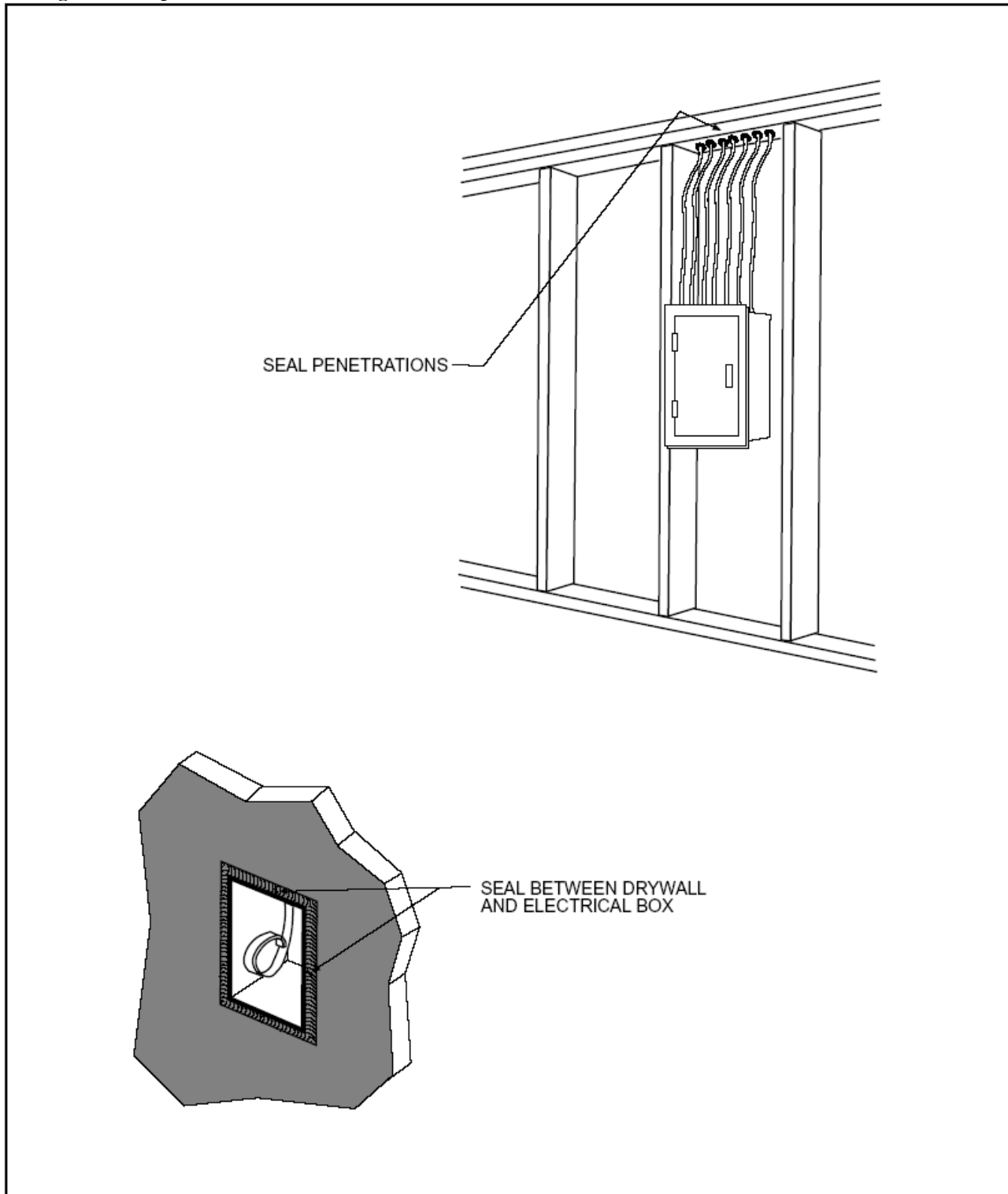

Figure 3:  
Sealing electrical penetrations



### Joins between the wall and foundation

Joins between the wall and foundation may include the wall-to-floor joint, the floor-to-mudsill joint, and the mudsill-to-foundation joint. All may be sealed with caulk either during assembly or before cover. The wall-to-floor joint may be best addressed after the building is closed in and dried out. Fiberglass strips below the mudsill are not effective at sealing the joint but may provide backing for caulking or foam sealant.

### Joins between the wall and ceiling

In most cases, drywall mud and tape seal the joint between the wall and roof. In some homes, however, drywall is not used for wall and ceiling finish, so other

sealing is needed to join finish ceiling and wall materials. For instance, caulking may be needed in open beam ceilings to prevent air leaks at beam pockets and to join the wall and ceiling together.

### Joins between wall panels

Joins between wall panels are usually sealed by drywall mud and tape. Mud and tape might not be applied if the wall will be covered with paneling or cabinets. If mud and tape are not used, some other sealant should be used to seal joints. Make sure that dissimilar wall finish materials are sealed at corners. Joins between wall panels must be sealed to prevent heat loss and minimize moisture penetration into wall cavities.

Figure 4:  
Sealing HVAC penetrations

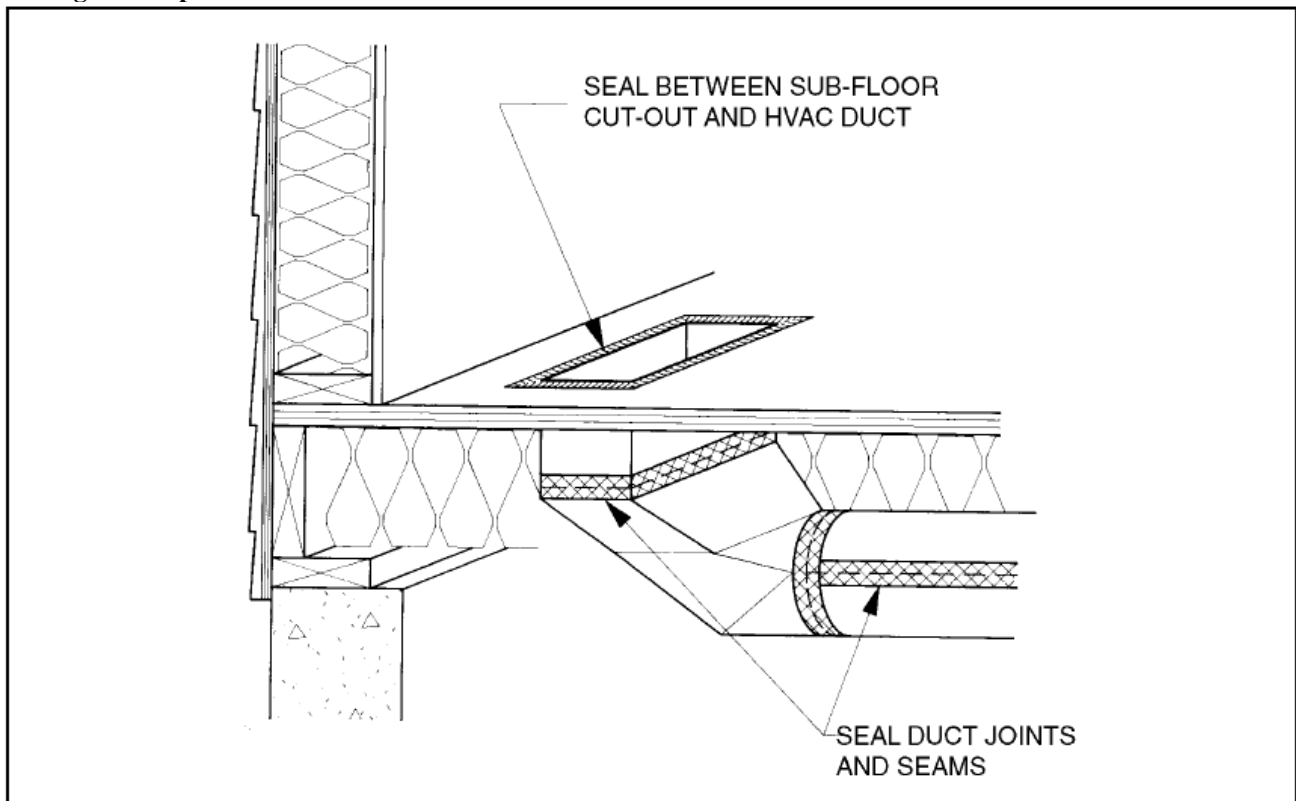

### Penetrations or utility services through exterior walls, floors and ceilings

Plumbing, wiring, and phone penetrations may create air leakage pathways from the crawl space, up through interior walls and into the attic. These pathways short-circuit insulation and air sealing in exterior walls. Stack effect in buildings increases air leakage rates through these “thermal by-pass” routes.

Penetrations in floors, walls, and ceilings must be sealed. The subcontractor who makes the hole can seal the penetration. Or holes can be sealed just prior to the rough mechanical/electrical/plumbing inspection.

### Finish sealing

Final caulking and sealing takes place after finish mechanical, electrical, and plumbing are complete. Outlet and switch boxes on exterior walls are sealed to the wall finish material. Vent fans and other recessed fixtures are sealed to the wall or ceiling finish. Gaps between registers and grills and finish materials also must be sealed.

### Duct system sealing

Duct air leakage is not specifically mentioned in the energy code. However, sealing is required by Residential Code M1601.2, “Joints and Seams of Ducts.”

Because air in the duct system is under pressure, duct leakage can be far more significant than leakage through the building envelope. Studies of Northwest homes have found that 20 to 40 percent of the heat produced by the furnace can be lost through the duct system.

Information presented in this publication supports the Oregon Residential Specialty Code. This publication does not include all code requirements. Refer to the code and check with your code official for additional requirements. If information in this publication conflicts with code or your local officials, follow requirements of code and your local officials.

For more information about the residential energy code, call the Building Codes Division at (503) 378-4133 or the Oregon Dept of Energy (503) 378-4040 in Salem or toll-free, 1-800-221-8035.

This publication was prepared by Alan Seymour, Energy Code Analyst, Oregon Department of Energy for the Oregon Building Codes Division. Illustrations are by Gene Stevenson. Funding was provided by Northwest Energy Efficiency Alliance.

### Building Codes Division



*Working with Oregonians  
to ensure safe building  
construction while  
supporting a positive  
business climate.*



OREGON  
DEPARTMENT OF  
ENERGY



Contains  
recycled  
materials

