

F E R M I N E W S

F E R M I L A B

A U.S. DEPARTMENT OF ENERGY LABORATORY



Putting Memory to Work 12

Photo by Jenny Mullins

Volume 24
Friday, June 29, 2001
Number 11



INSIDE:

- 2 HEPAP Subpanel Comes to Fermilab
- 6 Users' Meeting a Forum on the Future
- 8 CMS: Chasing Supersymmetry

In Medias Res

by Judy Jackson

It was a busy week at Fermilab. High-energy protons collided with antiprotons as Run II at the Tevatron at last began to gain steam. Fermilab physicists gathered on June 11 and 12 for their annual Users' Meeting at the laboratory. Graduate students vied for the Best Poster award in a traditional annual contest. The Italians threw a party in the Village Barn, with *cannoli* for all. And there in the midst of it was the future of particle physics in the United States—or at least the panel of physicists charged with defining it.

The DOE/NSF High-Energy Physics Advisory Panel Subpanel on Long-Range Planning for U.S. High-Energy Physics, chaired by physicists Jonathan Bagger and Barry Barish, likes to meet where the action is.

"We really want to hear what people have to say," Barish told an interviewer after the meeting. "Hearing from people is number one for us. It's why we came to Fermilab during the Users' Meeting."

Barish and his subpanel colleagues definitely got an earful. During a day and a half of public presentations in Fermilab's Ramsey Auditorium, the 24-member panel heard from present and former lab directors, Fermilab staff and users, graduate students and Nobel prizewinners. All shared their views, sometimes passionately, on the central question that preoccupies experimentalists, theorists and students alike: What will be the future of particle physics in the United States?

The subpanel, formed in response to a January 2001 request to High Energy Physics Advisory Panel Chair Fred Gilman, is charged with producing a long-range plan for the field.

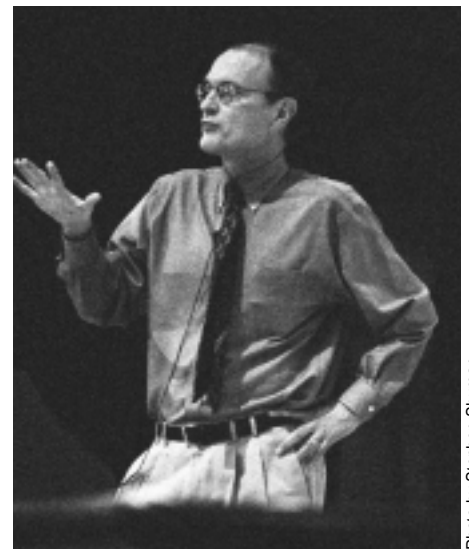

Photo by Stephen Shuman

Fermilab Director Michael Witherell told the subpanel that a decision on a future U.S. accelerator should not be delayed further and called for construction of a linear accelerator at Fermilab.

HEPAP SUBPANEL Comes to Fermilab, LISTENS



Photo by Jenny Mullins

Subpanel co-chairs Jonathan Bagger, of Johns Hopkins and Barry Barish of CalTech said they hope to come out of next month's Snowmass conference with "enough behind us to try to decide the major questions."

"We are charging the subpanel to undertake a long-range planning exercise that will produce a national roadmap for HEP for the next twenty years," says the letter to Gilman from then-Office of Science Director Mildred Dresselhaus of the Department of Energy and Assistant Director for Mathematics and Science Robert Eisenstein of the National Science Foundation. "The subpanel should describe the discovery potential and intellectual impact of the program and recommend the next steps to be taken as part of an overall strategy to maintain the United States in a leadership role in HEP."

Fermilab was the third stop in the Subpanel's tour of particle physics laboratories, following meetings at Stanford Linear Accelerator Center and Brookhaven National Laboratory.

"This is our third lab visit," Bagger said. "The full range of possibilities has been presented. We are starting to get a complete picture. The pieces are coming into focus. We wanted to be well educated when we went to Snowmass, and at the point where the panel was really working together. This visit to Fermilab has really helped with both of those goals."

The Subpanel's next meetings will occur at Snowmass 2001, a conference on "The Future of Particle Physics," to be held June 30-July 21

In Medias Res

in Snowmass, Colorado. More than a thousand scientists have registered to attend.

Barish agreed that the days at Fermilab were time well spent.

"We're making progress," he said. "The group dynamics are coming together. There are twenty-two subpanel members, plus the two of us, plus the DOE people. The group's arrows are beginning to point in the same direction—not in the sense that we've reached a conclusion. We haven't. But we're learning how to work together. The coherence and closeness has really been building over this visit to Fermilab."

The group is likely to need all the coherence that group dynamics can muster. The subpanel must address a number of difficult issues, including

formulation of the central physics questions that define the field and the identification of technology required to address them. However, perhaps their most challenging assignment is to recommend a U.S. strategy for reclaiming the energy frontier. Currently, Fermilab's Tevatron occupies this piece of prime high-energy real estate, but Europe's Large Hadron Collider at CERN will take over the neighborhood beginning in about 2007.

"The leading discovery tool in HEP in the 20th century, and as far into the future as one can see," reads the charge, "is the energy frontier accelerator/storage ring. In the context of the worldwide scientific effort in particle physics, formulate a plan that optimizes the U.S. investment of public funds in sustaining a leadership role at the high energy frontier, including a recommendation on the next facility that will be an integral part of the U.S. program."

The question of what to build next is hardly a new one for U.S. high-energy physicists. Indeed, since the failure of the Superconducting Super Collider in 1993, the future of the field has been a subject of constant debate among its practitioners. Earlier subpanels, most recently one chaired by HEPAP's Gilman, have recommended "a new facility at the energy frontier" as "an integral part of the long-term national high-energy physics program." Previous recommendations, however, stopped short of designating a particular design. Now, most (although not all) physicists agree, it's time to make a choice.

"This," said one subpanelist, "is where the rubber meets the road."

Contenders in the "next machine" Grand Prix include designs for an electron-positron linear collider, a muon storage ring and a Very Large Hadron Collider. Technological challenges appear to make the muon machine a long shot for early construction, leaving the LC and the VLHC as possible nearer-term options. The subpanel heard presentations on both the electron and hadron machines.



Photo by Stephen Shuman

Fermilab physicist Bill Foster described technology for a future hadron collider.



Technical Division Head Peter Limon presented results of a six-month study for a Very Large Hadron Collider.

While proponents differed on which machine the U.S. should build next, they nearly all agreed on what Fermilab Director Emeritus Leon Lederman called “Type I Truths.” Lederman defined Type I Truths as “Absolute truths that must be factored into any long-range policy. They are or should be noncontroversial.” (Type II truths are “the other kind.”) On Lederman’s Type I list are the need for an international policy in long-range planning for high-energy physics, the need for consensus in the world community of physics and the need for more funding for the field. Lederman also noted that any future machine would create a decade-long period of “interim physics of the small science category, so attractive to younger physicists” during construction of a new accelerator.

It’s the Type II truths that are likely to give the subpanel its greatest challenge. They represent the differing views of those who favor an electron machine and those who favor a hadron collider, views that the panelists must grapple with as they produce their report.

“We haven’t gotten to the hard questions yet,” Bagger said. “There is a crossover point between the information gathering and coming to grips with the information. We have defined a process, we are following it, we assume we’ll arrive. Snowmass is good timing for us. Our report is due in October. The panel has to start getting to grips with the questions. It is good to be able to do that at Snowmass when the community is there for three weeks.”

Meanwhile, both chairmen and panel members emphasized their need to hear from their colleagues.

“A lot of people are worried that our decision is a done deal,” said Columbia University physicist Janet Conrad, spokesperson of Fermilab’s MiniBooNE experiment and a subpanel member. “They wonder why they should be involved in the process. I can tell them that we are truly looking at all the options. Input is important. They should not feel that it is a done deal.”

Barish concurred.

“The most important message is that we are seeking input every way we can,” he said.

“This panel is not just window dressing. We want to hear what people have to say.”

On the Web

HEPAP Subpanel on Long-Range Planning for U.S. High-Energy Physics
http://hepserve.fnal.gov:8080/doe-hep/lrp_panel/index.html



Subpanel members, including physicist Norbert Holtkamp, right, heard from colleagues throughout the meeting, including Fermilab Associate Director Steve Holmes, left, and SLAC’s Tor Raubenheimer at the Fermilab Users’ Center.

FORUM ON THE FUTURE

Fermilab Users' Annual Meeting offers array of plans, proposals and perspectives

by Mike Perricone

With a 26-kilometer Linear Collider, a straight line surely represents the shortest distance to the future of the U.S. High-Energy Physics community.

Or maybe not.

A 233-kilometer-circumference Very Large Hadron Collider is the one proposed machine pointing with certainty to a major high-energy physics discovery in the century's second decade and beyond.

Or maybe not.

There is no time to lose in deciding between these two machines.

Or is there?

The Users' Annual Meeting at Fermilab always offers a platform for the exchange of data and ideas, but the gathering on June 11-12 took on added significance as a forum on the future. The DOE/NSF High-Energy Physics Advisory Panel's Subpanel on Long Range Planning For U.S. High-Energy Physics requested that the meeting focus on proposals for the next 20 years. The panel, co-chaired by Jonathan Bagger of Johns Hopkins University and Barry Barish of California Institute of Technology, is holding a series of advisory meetings across the country. Included are three "Town Meetings" at Brookhaven, SLAC and Fermilab where researchers are free to create their own agenda for presentations and proposals.

And so the two-day gathering of scientists from the lab's world-wide array of 90 research partner institutions continued the debate between LC and VLHC proponents—with other speakers addressing a new proton driver for Fermilab, continued consideration of a muon storage ring and neutrino factory, the expanding confluence of particle physics, astrophysics and cosmology, the importance of stressing Collider Run II of the Tevatron, and reminders that "small science" is critical for students to conduct their research while the big machines grab the headlines.

Two lab directors, Michael Witherell of Fermilab and Jonathan Dorfman of Stanford Linear Accelerator Center, supported the concept of a first-stage 500 GeV electron-positron Linear Collider as the next-generation machine, to be built in the U.S. by an international collaboration. Witherell further specified a location at or near Fermilab, focusing on its strong base of expert personnel and existing infrastructure.



Photo by Jenny Mullins

Fermilab Director Michael Witherell (right) and members of the judging committee Bill Foster (on Witherell's right) and Andreas Kronfeld (back row, left) stand with participants in the graduate students' New Perspectives 2001 poster session. First place in the "George Michail Memorial Poster Award" competition went to Michela Fratini of Fermilab ("A Device for Critical Current Measurements of Superconducting Cables"); second place went to Matthew Sharp of Columbia ("Supernova Detection with MiniBooNE") and third place went to Petra Krivkova of the University of Texas at Arlington ("DZero Forward Proton Detector—Fiber Detectors").

Witherell described research and development on VLHC technology as an important component of a balanced physics program over the next decade, while estimating a start for VLHC construction around 2012. But building the Linear Collider was essential for this decade, to begin operation in the next. Witherell described the physics case for the 500 GeV Linear Collider as “very strong,” in answering important questions of electroweak symmetry breaking.

Speaking by video presentation, Dorfman said a linear collider would “unravel the origins of electroweak symmetry breaking.” The machine, he said, was “an urgent need” as a companion for LHC research, and SLAC “commits itself to a central role” in the linear collider’s construction and operation. But he also indicated that a decision—and an appearance of decisiveness—would convey a sense of focus with symbolic and political importance.

“Those of us who spend a lot of time in Washington are perceived as not having a clear plan for high-energy physics, and that hurts us,” Dorfman said. “U.S. high-energy physics has flourished by making bold steps. The field has never required guaranteed payoffs, but the payoffs have been spectacular. This is not the time to be conservative. Conservative planning is a recipe for mediocrity.”

During the Town Meeting, a study group offered a detailed, multifaceted proposal for the Very Large Hadron Collider as successor to the Large Hadron Collider being built at CERN, the European Particle Physics Laboratory.

Peter Limon, Head of Fermilab’s Technical Division, asserted that “the big discoveries are produced by hadron colliders at the energy frontier, and a hadron collider is the only sure way to reach a major discovery.” He envisioned VLHC as “part of a world-wide plan that includes a lepton [linear] collider.” He proposed the big circular tunnel housing a first-stage 40 TeV collider, followed by an upgrade to 200 TeV—much as the Large Electron-Positron collider is now being supplanted by the LHC at CERN.



Photo by Stephen Shuman

Michael James Fitch (right), of the University of Rochester, receives the Fermilab/URA Thesis Award from Fred Bernthal, president of Universities Research Association, Inc. Fitch, working on the AZero Photoinjector project, wrote his thesis on “Electro-optic sampling of transient electric fields from charged particle beams.”

But the big machines aren’t the only discovery-producers. Columbia University graduate student Bonnie Fleming, a neutrino researcher, reminded users (and the HEPAP members) that “small experiments can make a big splash.” She specifically referred to DONUT, the Fermilab experiment that last year reported the first direct observation of the tau neutrino, completing the picture of the Standard Model.

And in a time of budget constraints, Louisiana State graduate student Morgan Wascko made a cogent case for cosmic ray experiments. Not only do cosmic rays represent “the true energy frontier,” he said, but “the beam is always on—and it’s free.” He added another telling point: “My Mom is always more interested in cosmology results than in accelerator results.”

The wry conclusion actually touched on a central issue: public support is crucial to the future of particle physics. No doubt about it. ☒

On the Web

Fermilab Users’ Meeting
http://www.fnal.gov/orgs/fermilab_users_org/users_mtg.html



Chasing *supersymmetry*

by Kurt Riesselmann

Discoveries of a new family of matter particles seem to happen only once per century:

- **England, 1897:** Joseph J. Thomson discovers the electron, the first subatomic particle;
- **United States, 1967:** Scientists at SLAC unravel the quarks, the first subnuclear particles;
- **Switzerland, 2006:** *A global collaboration of physicists celebrates the observation of the gluino, the first supersymmetric particle.*

Obviously, the third discovery hasn't actually happened yet, but the pace of discovery is accelerating. The Large Hadron Collider at the European particle physics laboratory CERN could make this dream come true if evidence for supersymmetry has not already appeared in Run II at Fermilab's Tevatron. Supersymmetry, a popular theoretical concept that predicts all force particles to have complementary matter particles, could emerge as a universal physics principle when LHC starts operations in 2006. The gluon, the messenger particle of the quark-binding force, would finally meet the gluino, its matter partner.

"You really have to be ready on Day One," said Fermilab physicist Dan Green. "Within a month of LHC operations you could find SUSY particles. SUSY is one of the things that really benefit from the much higher energy of the LHC compared to the Tevatron."

The LHC will create proton-proton collisions at energies seven times higher than the collisions produced by Fermilab's Tevatron accelerator. According to Einstein's famous energy-mass-relationship, $E=mc^2$, the LHC is capable of producing particles heavier than anything ever seen before. That could include SUSY particles.

Observing those particles requires a new generation of detectors. The LHC ring, 27 kilometers in circumference, will initially have two general purpose detectors: CMS and ATLAS. In a global effort, American universities and national laboratories are contributing hardware and software to both. Green is the project manager of the U.S. contributions to CMS. Funding comes from the Department of Energy and the National Science Foundation. DOE contributes a total of \$240 million to the two detectors, matched with \$80 million from NSF. Northeastern University professor Steve Reucroft manages the NSF funding for ten universities working on the CMS project.

Fermilab participates in design and construction of the CMS detector, which will be built around the largest superconducting magnet in the world, a 12-meter-long and 7-meter-diameter cylindrical coil called the Compact Muon Solenoid. The complete CMS detector will stand 15 meters high, measure almost 22 meters long and weigh about 12,500 tons.

MEASURING PARTICLE PROPERTIES

To identify SUSY or other unexpected particles produced in proton-proton collisions, scientists need to determine three properties of all particles escaping the interaction region: electric charge, energy and flight path.

The superconducting magnet at the core of the CMS design helps scientists to determine the particles' charge. Cooled to two kelvins and producing a four-Tesla magnetic field, the magnet bends the path of charged particles traversing its field. Depending on their charge, positive or negative, the magnet pushes the particles in different, easily distinguishable directions. Neutral particles are unaffected.

To determine the particles' kinetic energy, scientists use calorimeters. The CMS detector design features a calorimeter, called HCAL, consisting of two 500-ton cylinders made of brass plates. The brass structure, held together by 80,000 bolts, has slots filled with sheets of scintillating plastic.

Particles crossing the calorimeter interact with the high-density brass and produce light. The amount of light created is a measure of the kinetic energy of the particles. The scintillators collect the light and transform it into electrical signals that are recorded for analysis.

The design of the CMS experiment requires the 1,600-ton calorimeter to rest inside the cylindrical shell of the superconducting magnet.

"It is more complicated than building a bridge," said Igor Churin, a mechanical engineer who worked on the design. "Brass is not as stiff as steel. As a result, the barrels, which rest on beams attached on the side, tend to sag at the bottom. It took a lot of work to minimize this effect."

At the beginning of the year, the manufacturer of the barrels, the Spanish company Felguera, passed a crucial quality control test when it

successfully completed the trial assembly of the first barrel. It then disassembled the barrel and shipped it to CERN, where the final assembly will take place in August. Sliding the barrels into the shell of the superconducting magnet will be the next challenging job.

"We have to align the support beams of the barrels and the tracks inside the magnet's shell to better than one tenth of a millimeter," said Churin. "For that purpose we put each barrel onto a movable cradle. Heavy jacks will lift the barrels to the correct height. The challenge is to maintain the alignment while each barrel is sliding in and loads are shifting."

SILICON FOR PARTICLE TRACKING

Inside the cylindrical calorimeter, scientists will place a particle-detection system called the Tracker. It will record the tracks of particles emerging from the collision region. Extrapolating from the tracks, scientists can identify the decay of particles produced in a collision, including the decay of SUSY and even more exotic particles.

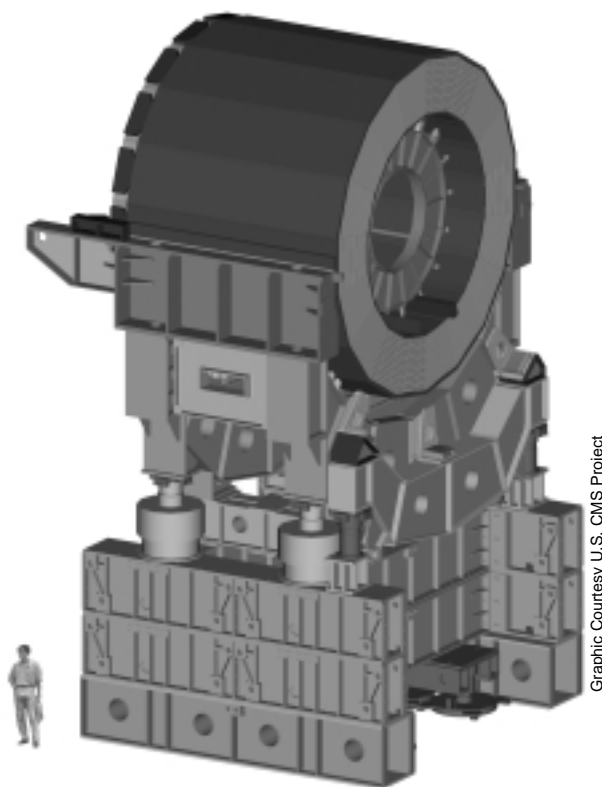

Graphic Courtesy U.S. CMS Project

Two 500-ton brass barrels are the centerpieces of the CMS calorimeter. Technicians will mount each barrel on a cradle (shown), from where it will slide with the precision of one tenth of a millimeter into the magnetic coil of the CMS detector.



Irina Sirotenko (above) is working with Lenny Spiegel and Bill Kahl to install the first of two robots that will help assemble more than 5,000 silicon modules for the CMS detector.

The Tracker contains, among other systems, a silicon microstrip detector. Its silicon sensors produce electrical impulses when charged particles cross. The CMS detector will feature 24,000 silicon panels that contain more than 500 microstrips each.

Precise positioning of the panels within the detector is important to obtain accurate measurements of particle tracks. Fermilab purchased the first of two robots that will glue pairs of panels to a support frame, which eventually will go into a cylindrical support structure. The first robot, which will be fully functional by the end of the summer, is capable of positioning the panels within two thousandths of a millimeter.

"We still need to install software," said Bill Kahl, a postdoc from Kansas State University. "Since no two robots are identical, we may need to make minor modifications to adjust for mechanical variations."

It will take a robot about five minutes to carefully glue two panels and an electrical circuit onto a U-shaped frame, producing a single module.

"The CMS detector will contain fifteen thousand silicon modules," said Lenny Spiegel, who is in charge of setting up the silicon production facility at the laboratory. "Fermilab is responsible for building five thousand of two-panel modules."

Using a process called micro-bonding, technicians next will apply electrical connections between the microstrips and the electronic chips that amplify and transmit the signals from particles for recording.

GLOBAL COMPUTING POWER

The electrical signals from the Tracker, the HCAL and all other CMS detection systems will go to a central data storage system located at the CERN Computer Center. During one second of LHC running, the data volume transmitted through the read-out network at CERN is equivalent to the amount of data moved in 1995 in one day. Scientists expect to store about one hundred megabytes of data per second – the equivalent of ten CD-ROMs per minute.

Analyzing this vast amount of data will require enormous computing

power, more than a single laboratory can handle. CMS has developed a tiered computing model, with only a third of the total off-line computing power at CERN, the "Tier 0" site. Another third will be in five "Tier 1" sites around the globe. Fermilab will be the U.S. Tier 1 center, with others in France, Italy, the United Kingdom and Germany. The final portion will be located in "Tier 2" sites. Five Tier 2 sites are planned for the U.S.

"Fermilab and Italy have already started working on their Tier 1 sites," said Vivian O'Dell, the head of the CMS computing group in Fermilab's Computing Division. "Those sites will be responsible for data handling and archiving in an easy format for physicists to use along with some Monte Carlo simulations. Then there are Tier 2 sites that mainly do final data analyses and Monte Carlo production, and provide data to individual physics groups. The first prototype Tier 2 site already exists, a joint project of UC San Diego and CalTech. And the University of Florida just started work on a second prototype."

Each Tier 1 center will spend about \$8 million for new computing hardware, roughly the equivalent

From Fermilab and the Midwest to CMS

cost to satisfy the computing needs for each of Fermilab's collider experiments for Run II, CDF and DZero.

PLANS FOR A PHYSICS CENTER

US/CMS project manager Green wants Fermilab to become more than just a computing network node in the CMS experiment.

"I've been pushing to have a CMS remote control room and physics center in the United States," said Green. "We would try to do the CERN night shifts from the U.S. during daytime. This is possible, since all operations are remotely controlled. Establishing an analysis center here at Fermilab also would make it easy for CDF and DZero physicists to join the CMS experiment when the time comes. The U.S. effort in the LHC will be *THE* effort in U.S. high-energy physics for quite some time. That's where people will be working."

At present, the CMS collaboration includes about 375 U.S. scientists from 38 universities. Green expects about 700 U.S. physicists to be working on CMS in 2006 when the LHC collider will have its first proton beams.

"ATLAS and CMS are now the largest capital-investment projects going on in U.S. high-energy physics," Green said. "To me, it's extremely important that we capitalize fully on this investment by doing the physics well in the U.S."

In return, the LHC and its two detectors would be primed to continue accelerating the pace of discovery. 🌐

On the Web:

CMS Activities in the United States:
<http://uscms.fnal.gov/pub/>

CMS worldwide:
<http://cmsinof.cern.ch>



Photo by Jenny Mullins

This team at Fermilab produced the first CMS Tier 1 computing farm. Front row: Yujun Wu, Hans Wenzel, Shafqat Aziz, Joe Kaiser, Shahzad Muzaffar, Natalia Ratnikova, Vivian O'Dell. Back row left to right: Ichiro Suzuki, Moacyr Souza, Pal Hidas, Jim Amundson, Greg Graham.

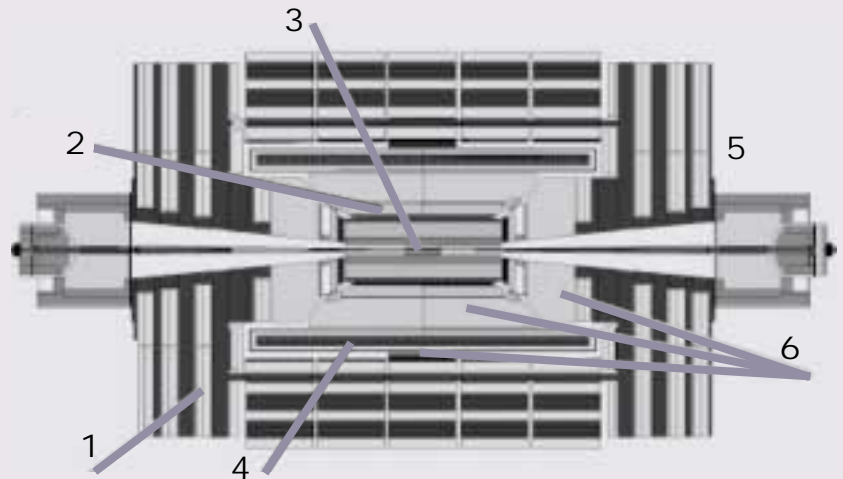

1. Muon Detector Endcaps
Alignment system: FNAL
Cathode Strip Chamber detectors and mechanics: UW
CSC assembly, installation, monitoring and services: FNAL, UW
2. ECAL Calorimeter
Purchase and quality control of APDs: UM
3. Silicon Detector/Pixels
Module mechanics: NU
Support structures and assembly: FNAL, NU, PU
4. Superconducting Magnet
Procurement: All
5. Trigger/Data Acquisition System
Calorimeter regional trigger: UW
CSC trigger: OSU
DAQ filter unit and event builder: FNAL, ISU
6. HCAL Calorimeter
Photodetectors: FNAL, UM, PU, UND, UI
Optics, calibration system, preproduction prototypes: UI, UND, FNAL, PU, UI, UM, ISU
Front-end electronics: UI, UND, FNAL, UM, PU
Trigger/DAQ electronics, detector control systems, voltage supply systems: FNAL, UI, ISU
Luminosity monitor: UN
7. Off-line Computing
All

KEY:

- ISU - Iowa State University, Ames
- UI - University of Iowa, Iowa City
- FNAL - Fermi National Accelerator Laboratory, Batavia
- UIC - University of Illinois at Chicago
- UM - University of Minnesota, Minneapolis
- UN - University of Nebraska, Lincoln
- NU - Northwestern University, Evanston
- UND - University of Notre Dame, South Bend
- OSU - Ohio State University, Columbus
- PU - Purdue University, West Lafayette
- UW - University of Wisconsin, Madison

TOTAL USA: 37 Institutions, 412 Collaborators

Putting MEMORY to Work

LHC MAGNETS
MOVE INTO
PRODUCTION STAGE
AND REVIVE FERMILAB
SUPERCONDUCTIVITY
EFFORTS

Prototype of the LHC magnet,
at the Industrial Center Building.

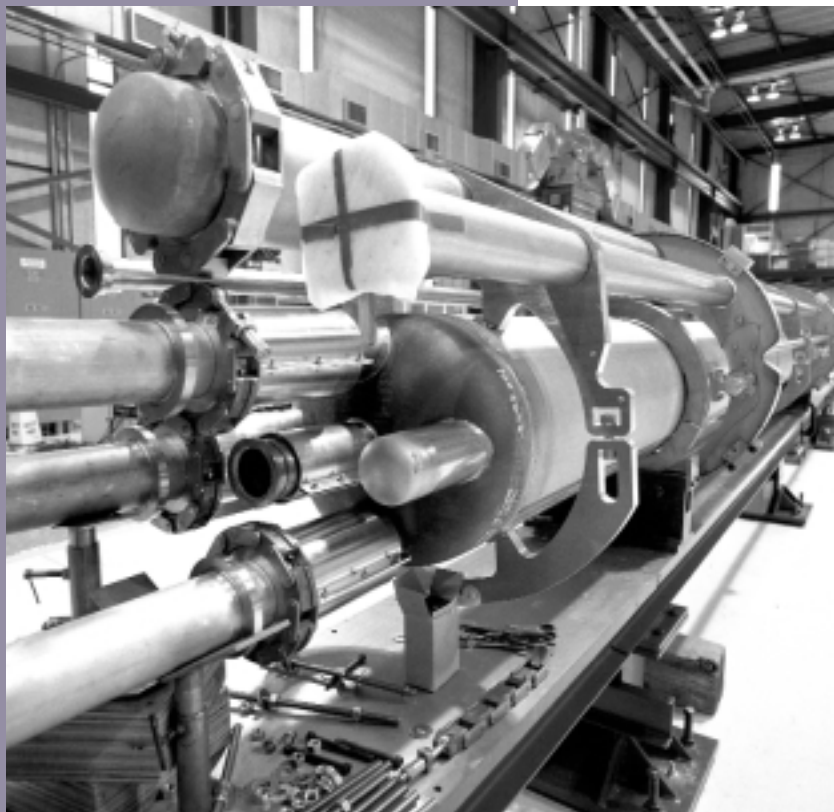

by Mike Perricone

Memory is a major player in the Fermilab project to produce the final focus quadrupole magnets for the interaction region of the Large Hadron Collider at CERN, the European Particle Physics Laboratory.

At the project scale, the lab is calling on the irreplaceable memory of physicists, engineers and technicians who helped build magnets for the Tevatron some 20 years ago at a time when Fermilab was the world leader in superconducting magnet technology and production. With the LHC magnets moving through model and prototype and now into the production stage, these veterans and the process itself are also instilling an invaluable quality of institutional memory into physicists, engineers and technicians who are relatively new to the lab and new to building superconducting magnets here.

As US/LHC collaboration project manager Jim Strait has said, reviving Fermilab's leadership in superconducting magnet development is "important for the lab's long-range health and for the future of high-energy physics."

At the individual magnet scale, memory is crucial to the very quality of superconductivity itself. A magnet is literally trained to remember its superconducting temperature range, and the best magnet is the one with the best memory.

"The question is whether a magnet is going to remember its training, or whether it's going to be a bad student and have to start the training again," said Mike Lamm of the Development and Testing Department of the lab's Technical Division. Lamm specifically oversees the electrical connections when the magnets are assembled, but Fermilab LHC project manager Jim Kerby describes Lamm as the project's unofficial senior scientist.

A magnet's training revolves around quenching, one of those particle physics terms that means close to the opposite of its usage in everyday language. Quenching a thirst is a satisfying experience. But quenching a superconducting magnet makes it resistive and wipes out its superconductivity. During operation, a superconducting magnet begins to quench when a small area begins to resist current flow and generates heat.

"The rate of heat generation is equal to current squared times resistance, just like a light bulb," Lamm explained.

The heat spreads to the rest of the magnet, leading to a wholesale loss of superconductivity, abruptly ramping down the electrical current and unleashing the energy stored within the magnet.



Photo by Stephen Shuman

"Everyone involved with this project deserves a big 'Thank you,'" said Fermilab LHC project manager Jim Kerby. "They're the finest people, all across the board. They pulled the prototype together on the first shot. That's a testimony to the quality of their work, which is a testimony to the quality of the people." Here, the inspection, tooling and cold mass groups on the first production magnet gather at the Industrial Center Building.

"A quench can be a pretty violent thing," Lamm said. "You want to avoid having this happen in an accelerator. The accelerator will go down for at least an hour—and possibly for many hours."

In training, a magnet is first cooled to its superconducting temperature of 1.9 Kelvins (1.9 degrees centigrade above absolute zero) with liquid helium, then electric current is run through its coils to generate the magnetic field. Essentially, magnetic field is directly proportional to current. The LHC magnets have a target current of about 12,500 amperes for their quench point, corresponding to a field gradient of about 220 Tesla per meter—providing a margin beyond the CERN design specification of 214 T/m.

After cooling to 1.9 Kelvins, a magnet is subjected to several quenches until it reaches an acceptably high current and field. Each quench event takes an hour or more for recovery, with the cryogenic system dispersing the heat released into the magnet and the liquid helium.

"A magnet may quench at too low a level the first time," Lamm said. "But it will actually perform better with subsequent quenches, and this is what's called training. One of the main reasons for a quench is that the cable is in an unstable mechanical arrangement. No matter how carefully the cable is wound and cured, there often seems to be a weak point. The force on the cable varies as the square of the current, so it's going to move around if it's unstable."

But as Lamm explained, quenching usually acts to settle the cable into a more stable state, in effect correcting the defect.

"So the next time you ramp up the current, you don't have this same weak spot," Lamm said. "You're able to get to a higher current next time. Then it quenches there and fixes itself—usually. Eventually, you get to a plateau where there isn't any further improvement. You hope this plateau occurs beyond the level where the magnet will be asked to perform."

The magnet has remained at cryogenic temperatures through the quenches. The next step is warming the entire magnet and cryogenic system to room temperature, then re-cooling to 1.9 Kelvins. Going from cryogenic temperature to room temperature and back to cryogenic temperature is called a "thermal cycle." Now another quenching is staged. If the magnet achieves a current beyond the target set for operating the accelerator, the magnet passes the test. As Lamm said, it has a good memory.

Five of the eight model magnets (about one-third the length of the full-sized prototype) passed their training tests. Construction and testing of the first full-length prototype magnet went so well that the Fermilab LHC project proceeded directly to the first production magnet instead of building a second prototype as planned. Skipping the second prototype saved the time and money that would have gone into the additional instrumentation used to measure its dimensions and performance, instrumentation not used in production magnets. The first production magnet is about half-completed, with coils and collars affixed.

Over the next three years, Fermilab will build 18 production magnets, jacket them with the cryostat container to hold the liquid helium, and send them to CERN. It's actually a three-way relay. Fermilab will build nine of the magnets onsite (each magnet consisting of two sections, connected by a corrector magnet supplied by CERN), and assemble the cryostats around nine more magnets supplied by Japan's KEK laboratory. The completed magnets then go to CERN for installation in the collider.

"We're devoting a lot of effort to keeping track of all the components coming from different places," said Phil Schlabach of Technical Division-Development and Test, whose specialty is magnetic field measurements. "We're hoping we don't have a situation where a lead from one lab won't fit a connector from another. But our situation is actually far less complicated than detector collaborations face, and they do it all the time."

The Fermilab LHC effort has fostered the expansion of the lab's magnet production capabilities, combining equipment used in building the Tevatron with tooling inherited from the ill-fated SSC, adding new facilities built for these magnets and for magnets still to come on future projects. As always, people are the primary resource.

"Five years ago, we had a small number of people who remembered building superconducting magnets, before we went out of that business when the SSC fell through," said Rodger Bossert of the Technical Division's Engineering and Fabrication team. "But we were lucky to have



Photo by Stephen Shuman

The cryostat design and test facility crew stand behind the prototype magnet on the test stand. "We had the right people on the right jobs," Kerby said.

that core of people who had been around since the Tevatron days and from the SSC. The technicians were probably the most important. They really had their hands on the process and knew how these magnets were assembled. Peter Limon [Head of the Technical Division] had to put together a new superconducting magnet team. He hired a lot of young people who will learn and carry on the program. Now we have the ability to build superconducting magnets again and move back to the forefront of the technology."

From start to finish, it's a project to remember. 🌟

How Jessica got her name

In 1987, the country held its breath for 58 hours during the rescue of 18-month-old Jessica McClure from a well in Midland, Texas. Though far less dramatic, and with no one's safety in jeopardy, the removal of magnet Q2P1 from the equivalent of a 30-foot well ranked as a significant rescue for the LHC Inner Triplet project.

Coils in a superconducting magnet are held in place by steel collars, attached under high pressure (as much as 20,000 psi) by a collaring press. A new press was installed in the floor of Fermilab's Industrial Center to handle the 19-foot-long prototype. The press required a narrow, 30-foot-deep excavation (covered with a removable steel plate). The magnet was suspended from a crane and lowered into the press, the collars were pressed into place, and keys were inserted under pressure to maintain the collars' configuration.

But at first, the magnet wouldn't come out. On succeeding tries, the fit was fine-tuned with forces as high as 25 tons applied on all four sides. Finally, the collars cleared the press, and the rescue of the prototype magnet was complete. The technicians who shepherded the process named the magnet "Jessica," honoring the earlier effort and celebrating a similar happy ending.

On the Web: US/LHC Project home page <http://www-td.fnal.gov/LHC/USLHC.html>



Photos by Jenny Mullins

LABNOTES

2001 URA SCHOLARSHIP AWARDS

RECIPIENT	INTENDED SCHOOL AND FIELD OF STUDY	FNAL PARENT/S
Leo J. Brown	Rutgers, The state University of New Jersey, New Brunswick, NJ Preparation for clergy	Walter E. Brown CD/Physics Analysis Tools
Mary K. Fritz	Beloit College – Beloit, WI Undecided	Barry Fritz BD/ES&H
Kari M. Gilbert	Purdue University, West Lafayette, IN Paleontology	Gregory S. Gilbert FES/Operations
Stephanie Holmes	University of Chicago, Chicago IL Undecided	Stephen Holmes, Directorate Catherine Newman Holmes, CDF Dept.
Elaine M. Lahn	Illinois Wesleyan University Biology	Paul Lahn FES/Engineering
Saul P. Lipton	University of Illinois, Urbana-Champaign, Urbana, IL Electrical Engineering	Ronald Lipton PPD/DO
Nidhin P. Mattappally	University of Illinois, Urbana-Champaign, Urbana, IL Computer Engineering	Prem Jose Mattappally FES/Operations
Judith Mendelsohn	Brandeis University, Waltham, MA Undecided	Michael Church, BD/BS-Tevatron Dept. Susan Mendelsohn, LS-Education Office
Vincent M. Moretti	Northwestern University, Evanston, IL Engineering	Alfred Moretti BD/BS-Proton Source
Babatunde O. Oshinowo, Jr.	Stanford University, Palo Alto, CA Electrical & Computer Engineering	O'Sheg Oshinowo PPD/Technical Centers
Tri Pham	University of Illinois, Urbana-Champaign, Urbana, IL Chemical Engineering	Thinh Pham CD/Electronic System Engineer
Erik A. Voirin	Waubensee Comm. College – Sugar Grove Northern Illinois University – DeKalb Chemical Engineering	John Voirin PPD/Mechanical Dept.
Yuan Xing Esther Wu	Loyola University - Chicago, Chicago, IL Honors Program pre-med biology with a minor in literature.	Weimin Wu, PPD/CMS (father) HengBao Zeng, Visitor from Rochester Univ. (mother)

LETTER TO THE EDITOR

TO FERMINEWS,

In the list of Fermilab Users on page 5 of the June 8 FERMINEWS ("User Demographics," vol. 24, no 10, June 8, 2001), I noticed no

mention of Fermi's affiliation with Northwestern University. If the on-site telephone directory can be used as a reliable source, NU should have 45 representatives. This would rank them first among Illinois institutions and 6th amidst all

international and domestic institutions. A contribution of this extent from a private institution merits our cordial recognition.

Mark Thompson

LUNCH SERVED FROM
11:30 A.M. TO 1 P.M.
\$10/PERSON

DINNER SERVED AT 7 P.M.
\$23/PERSON



FOR RESERVATIONS, CALL x4512
CAKES FOR SPECIAL OCCASIONS
DIETARY RESTRICTIONS
CONTACT TITA, x3524
[HTTP://WWW.FNAL.GOV/FAW/EVENTS/MENUS.HTML](http://www.fnal.gov/faw/events/menus.html)

LUNCH
WEDNESDAY, JULY 4

Closed

DINNER
THURSDAY, JULY 5

Closed

LUNCH
WEDNESDAY, JULY 11

*Pasta with Tomato Compote
and Fresh Mozzarella
Vanilla Flan with Berries*

DINNER
THURSDAY, JULY 12

*Seviche
Pork Tenderloin Adobo Style
Rice and Pigeon Peas
Plantain Slices
Lime Pie*

LUNCH
WEDNESDAY, JULY 18

*Danish Open Sandwiches
Cucumber Dill Salad
Cold Apricot Souffle*

DINNER
THURSDAY, JULY 19

*Gazpacho
Shellfish Paella
Watercress and
Red Onion Salad
Orange Almond Cake*

F E R M I
N E W S

F E R M I L A B
A U.S. DEPARTMENT OF ENERGY LABORATORY

Ferminews is published by
Fermilab's Office of Public Affairs.
Phone: 630-840-3351

Design and Illustration:
Performance Graphics

Photography:
Fermilab's Visual Media Services

Ferminews Archive at:
<http://www.fnal.gov/pub/ferminews/>

The deadline for the Friday, July 20, 2001,
issue is Tuesday, July 10, 2001. Please send
classified ads and story ideas by mail to the
Public Affairs Office, MS 206, Fermilab,
P.O. Box 500, Batavia, IL 60510,
or by e-mail to ferminews@fnal.gov.
Letters from readers are welcome.
Please include your name and daytime
phone number.

Fermilab is operated by Universities
Research Association, Inc., under
contract with the U.S. Department
of Energy.



CLASSIFIEDS

FOR SALE

- '91 Buick Skylark (silver) 110K. Runs well. \$1,000 o.b.o. Call Kent at 630-369-2127 after 6 p.m.
- '89 Ford Aerostar 3-door van, V6, automatic, 7 seat capacity, lt. blue, OS, AM/FM, CC, 156k changed oil every 3k, maintenance records provided, runs well \$1500 obo, 630-690-1560 ask for Ajay.
- Medela Pump-In-Style professional breast pump for nursing mothers. Housed in fashionable black shoulder bag. All wear components replaced within past year. Excellent condition. \$290 new, sell for \$100. Call Mike x2700.
- Women's Univega Bicycle. Hybrid style. Shimano indexed shifters. Upright riding position. Excellent condition. Includes removable fenders. Red.\$100. Mark x2253 or schmitz@fnal.gov

- 8" Schmidt-Cassegrain Telescope, Meade 8" LX50, mint condition (rarely used) w/ hand controller, equatorial wedge and tripod, two lenses (Meade MA25mm and Tele vue 10.5mm Plossl) and two filters (neutral density for viewing the moon, and blue). Price: \$1,500 o.b.o. (\$2,500 value new).
- Guitar effect pedal: Marshall ED1 Compression. \$45. Bicycle: Raleigh DL-1. British police/postman's bike. Large and heavy. Fully enclosed chaincase, rod and link brakes. \$300. Curtis x2394 or Crawford @fnal.gov

HOUSE FOR RENT

- BATAVIA: 3BR, 2BA ranch, w/bsmt & 2 car gar. All appls., big yard, excellent location, within 4 miles of Fermilab, no pets, non-smoker. Available in August. \$1,450/mo, 1 mo. sec dep & credit check. Call 630-761-3176

HOUSE FOR SALE

- Kaneville, 3 bedrooms, hardwood floors, 2 baths, tiled floors, large living room with wood burning stove, family room off kitchen, maple kitchen cabinets. Dishwasher, gas stove, A/C, Honeywell elec. air cleaner, full basement, 2-1/2 car garage, small barn, 1 acre lot. Asking \$195,000 phone 630-557-2397.

WANTED

- A permanent and loving home for a former homeless cat or dog. Homes for Endangered and Lost Pets (H.E.L.P.) is a non-profit, state licensed and all-volunteer organization that fosters the animals in our homes. Visit our website for more info and pictures of adoptable animals (www.geocities.com/help_the_animals/) or call 630-879-8500.

SERVICES OFFERED

- Furniture refinishing and restoration. Pick-up and delivery available. Call 815-695-5460

CALENDAR

Fermilab Arts Series

International Film Society Presents:
Gun Crazy

July 13, 2001, Ramsey Auditorium 8:00 pm, adults \$4, Dir: Joseph H. Lewis, USA (1950) 86 min.

Bart Tare, a man with a love for guns from childhood, falls for what he thinks is the perfect woman. A Bonnie and Clyde type adventure film that has become a film noir classic.

COLLEGE FAIR AT FERMILAB

Wednesday, July 18

The Training and Development Department will sponsor a College Fair in Ramsey Auditorium from 11:30 A.M. to 1:30 P.M. Representatives from 9 area colleges and universities will be

Website for Fermilab events: <http://www.fnal.gov/faw/events.html>

available to talk with employees about their programs. They will bring catalogs and course schedules. Information about the laboratory's Educational Support Program will also be available. Come and find out what college will best fit your educational needs.

ONGOING

NALWO

Free English classes in the Users' Center for FNAL guests, visitors and their spouses. The schedule is: Monday and Friday, 9:30 a.m. - 11:00 a.m. Separate classes for both beginners and advanced students.

DANCING

International folk dancing, Thursdays, 7:30-10 p.m., Village Barn, newcomers always welcome. Scottish country dancing, Tuesdays, 7:30 - 10 p.m., Village Barn, newcomers always welcome. For information on either dancing group, call Mady, (630) 584-0825 or Doug, x8194, or email folkdance@fnal.gov.

The Fermilab Barn Dance series, featuring traditional square and contra dances in the Fermilab Village barn, presents barn dances on Sunday, Admission is \$5 for adults, \$2 for age 12-18, and free for under 12 years old. Come with a partner or without; bring the family or not. For more information contact Dave Harding (x2971, harding@fnal.gov) or Lynn Garren (x2061, garren@fnal.gov) or check the WebPages at <http://www.fnal.gov/orgs/folkclub/>.

MILESTONES

BORN

Jenna Lydia Sasse, to Monica (BD-DH-Headquarters Staff) and Glenn Sasse; on June 12.

CORRECTION

■ Lavernzell Ruffin (wife of Jeffrey Ruffin BEAMS Division) graduated from Aurora University on June 3, 2001 with a MBA.

RETIRING

- Joseph O'Malley, ID 8427, BD-AS-Mechanical Support Dept. effective May 25, 2001
- Rudolph Dorer, ID 673 BS-MA-SU Support Coordinator June 29
- Lois Deringer, ID 2828 PPD-Support Service Team July 31
- Ivan Stauebsboll ID 4969, TD Machine Shop August 31
- Richard Leverage, ID 3644 PPD-Mechanical Dept. July 6

DIED

■ Garvie Grayson Hale (ID2257), on Sunday, June 17. Hale joined the Fermilab Physics Department on Nov. 7, 1973, remaining until he left to work on the SSC in September 1989. After the SSC shutdown, he remained in the Dallas area with his wife Phyllis Hale, another member of the Fermilab family.

<http://www.fnal.gov/pub/ferminews/>



F E R M I L A B
A U S . D E P A R T M E N T O F E N E R G Y L A B O R A T O R Y

Office of Public Affairs
P.O. Box 500, Batavia, IL 60510

First-Class Mail
U.S. Postage
PAID
Bartlett, IL
Permit No. 125